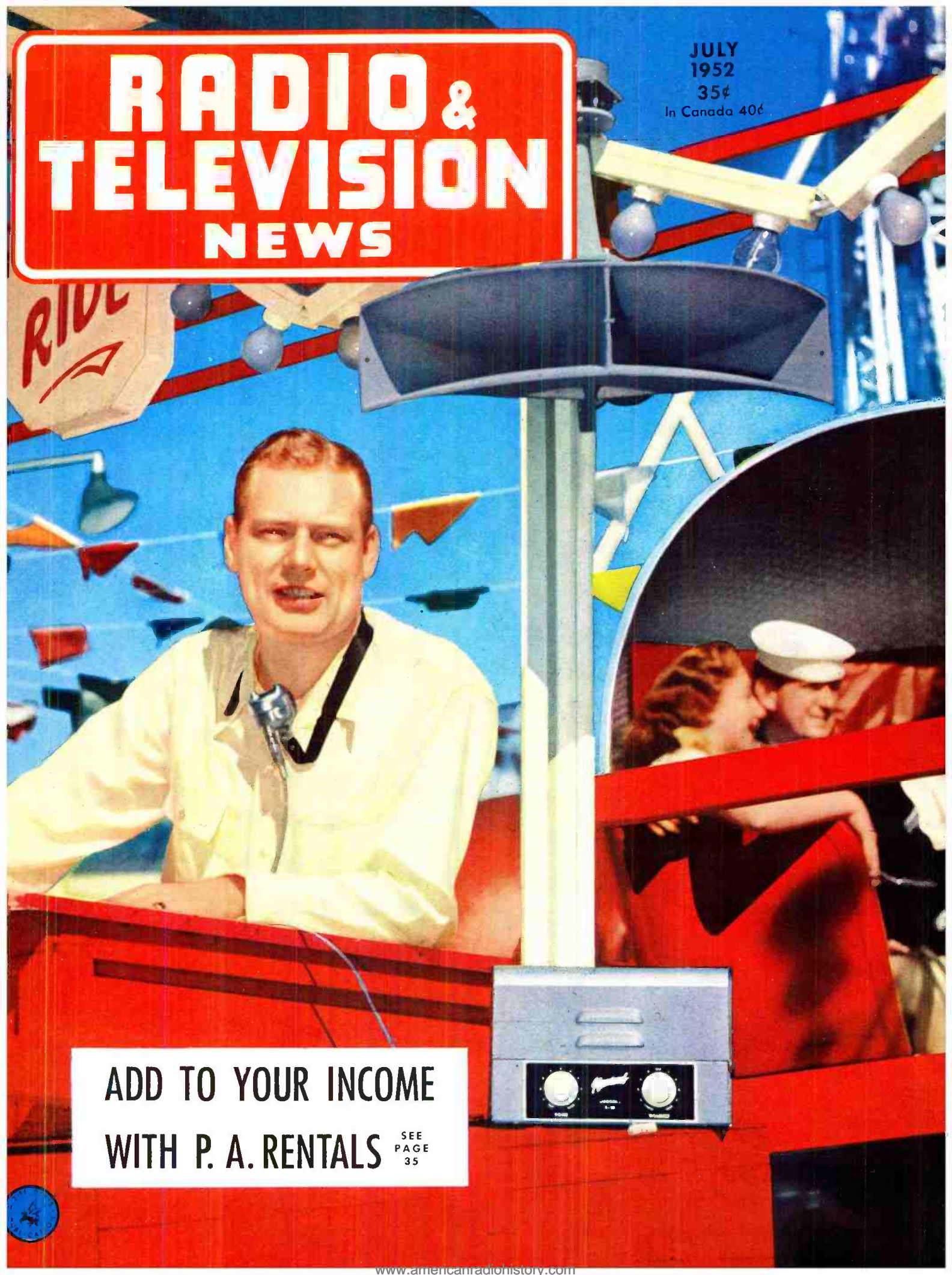

RADIO & TELEVISION NEWS

JULY
1952
35¢
In Canada 40¢

A man in a white shirt is operating a radio console at a fair booth. The booth is red and has a large circular window showing a woman in a sailor's uniform. The background is a blue sky with colorful pennants and a sign that says "RIDE".

ADD TO YOUR INCOME
WITH P. A. RENTALS

SEE
PAGE
35

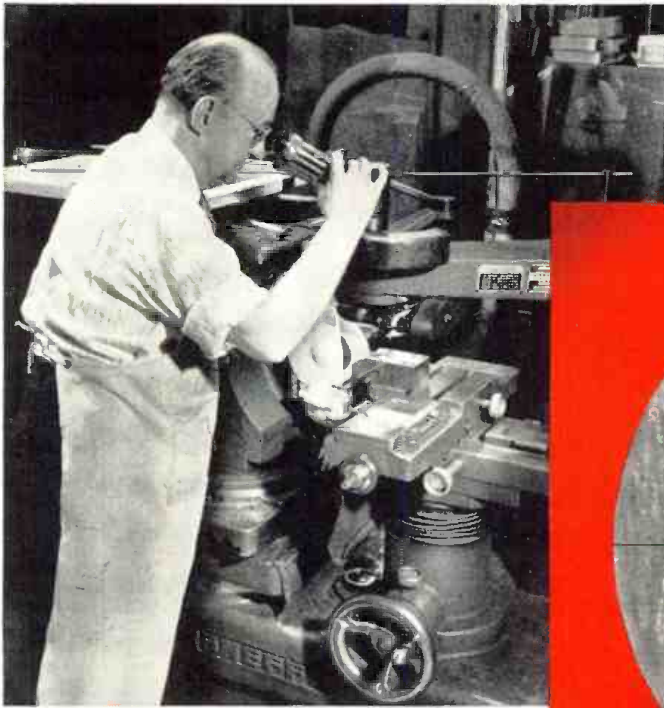

1. The machine that grinds the die.



2. The die that forms the cathode sleeve.

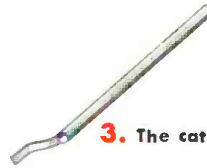

3. The cathode sleeve that helps make the tube.

Take a look at **quality** being born

DIMENSIONAL ACCURACY of the cathode sleeve is a vital factor in providing top-quality tube performance. And cathode-sleeve accuracy begins with the forming die.

What you see above are the two sections of a typical cathode-sleeve forming die, just as it is viewed by the die maker through a 30-power microscope. The die is finished in a

"profile grinder" which employs a 50-to-1 pantograph that traces a template and precisely guides the grinding operation. The result is a die accurate to better than one ten-thousandth of an inch!

Such painstaking precision finishing of dies used to stamp, punch, and form critical tube parts is one more step contributing to the top

quality of RCA Tubes. In this way, RCA closely guards its own reputation for quality ... and yours as well.

With RCA Kinescopes, as well as with RCA Receiving Tubes, TOP-QUALITY CONTROL makes the difference.



RADIO CORPORATION of AMERICA
ELECTRON TUBES

HARRISON, N. J.

TMKS. (R)

You Practice COMMUNICATIONS

I send you parts to build this transmitter

As part of my Communications Course you build this low power broadcasting transmitter, learn how to put a station "on the air," perform procedures demanded of Broadcast Station operators, make many tests.



This is just part of the equipment my students build. You keep all parts I send.

You Practice Radio SERVICING

on this modern radio you build with parts I send

As part of my Servicing Course, I send you the speaker, tubes, chassis, transformer, loop antenna, EVERYTHING you need to build this modern, powerful Radio Receiver! I also send parts to build many other Radio circuits. You use equipment for practical experience and to earn EXTRA money in spare time.



BE A RADIO-TELEVISION TECHNICIAN

NOW! Advanced Television Practice

New, special TV kits furnished to build high-definition SCOPE . . . RF OSCILLATOR with flyback power supply . . . complete TV set . . . many other units. You see pulse, trapezoidal, saw-tooth wave forms. Get valuable PRACTICAL EXPERIENCE locating and correcting TV troubles. Mail coupon for facts, pictures and prices!



I TRAINED THESE MEN

 "I have been operating my own Servicing business. In two years I did \$14,000 worth of business; net profit \$6,850. Have one full time employee, an NRI student."—PHILLIP G. BROGAN, Louisville, Ky.

 "Four years ago, I was a bookkeeper, with a hand-to-mouth salary. Now I am a Radio Engineer with a key station of the American Broadcasting Company network."—NORMAN H. WARD, Ridgefield Park, New Jersey.

 "When halfway through the NRI course, I made \$5 to \$8 a week fixing sets in my spare time. Am now selling and installing Television sets and antennas."—E. J. STREIT, ENBERGER, New Boston, O.

 "My first job was operator with KDLR, obtained for me by your Graduate Service Dept. I am now Chief Engineer of Police Radio Station WQOX. I never hesitate to endorse NRI."—T. S. NORTON, Hamilton, Ohio.

 **EXTRA PAY IN ARMY, NAVY, AIR FORCE** 

Knowing Radio, TV, Electronics can help you get extra rank, extra prestige, more interesting duty at pay up to several times a private's base pay. You are also prepared for good Radio-TV jobs upon leaving service. Mail Coupon TODAY.

Have Your Own Business

Many N.R.I. trained men start their own Radio-Television sales and service business without capital. Let me show you how you, too, can be your own boss, have a good income from your own shop. Send coupon for FREE book now!

Tested Way to Better Pay

Learn Servicing or Communications Practice at Home in Spare Time



J. E. SMITH, President National Radio Institute

Do you want good pay, a job with a bright future and security? Would you like to have a profitable shop or store of your own? If so, find out how you can realize your ambition in the fast growing, prosperous RADIO-TELEVISION industry. Even without Television, the industry is bigger than ever before. 90 million home and auto Radios, 3100 Broadcasting Stations, expanding use of Aviation and Police Radio, Micro-wave Relay, Two-way Radio for buses, taxis, etc., are making opportunities for Servicing and Communications Technicians and FCC-Licensed Operators.

Television is TODAY'S Good Job Maker

In 1950, over 5,000,000 TV sets sold. By 1954, 25,000,000 TV sets estimated. Over 100 TV Stations now operating. Authorities predict 1,000 TV Stations. This means more jobs, good pay for qualified men all over the United States and Canada.

Many Make \$10 Extra a Week in Spare Time

Keep your job while training. Hundreds of successful RADIO-TELEVISION TECHNICIANS I trained had no previous experience, some only a grammar school education. Learn Radio-Television principles from illustrated lessons. Get PRACTICAL EXPERIENCE—build valuable multimeter—experiment with circuits common to Radio and Television. Keep all equipment. Many students make \$5, \$10 extra a week fixing neighbors' Radios in spare time. SPECIAL BOOKLETS start teaching you the day you enroll.

Send Now For 2 Books FREE—Mail Coupon

Send now for my FREE DOUBLE OFFER. You get actual Servicing lesson to show you how you learn at home. Also my 64-page book, "How to Be a Success in Radio-Television." Read what my graduates are doing, earning; see equipment you practice with at home. Send coupon in envelope or paste on postal. J. E. SMITH, President, Dept. 2GE, National Radio Institute, Washington 9, D. C. Our 39th Year.

Good for Both—FREE

The ABC's of SERVICING



MR. J. E. SMITH, President, Dept. 2GE National Radio Institute, Washington 9, D. C.

Mail me Sample Lesson and 64-page Book about How to Win Success in Radio-Television. Both FREE. (No Salesman will call. Please write plainly.)

Name.....Age.....

Address.....

City.....Zone.....State.....

Approved for training under G. I. Bill

RADIO & TELEVISION NEWS is published monthly by the Ziff-Davis Publishing Company at 185 N. Wabash Ave., Chicago 1, Ill. Entered as second-class matter, July 21, 1948, at the Post Office, Chicago, Ill., under the act of March 3, 1879. Authorized by Post Office Department, Ottawa, Canada, as second-class matter. SUBSCRIPTION RATES: Radio & Television News—one year, U. S. and Possessions, Pan-American countries, and Canada \$4.00; all other foreign countries \$5.00; Radio-Electronic Engineering Edition—one year, U. S. and Possessions, Pan-American countries, and Canada \$6.00; all other foreign countries \$7.00. Postmaster—Please return undelivered copies under form 3589 to 64 E. Lake St., Chicago 1, Ill.

Editor
OLIVER READ, D.Sc., D.Litt.

Managing Editor
WM. A. STOCKLIN, B.S.

Technical Editor
H. S. RENNE, M.S.

Associate Editor
HAROLD BECKER

Service Editor
CHARLES TEPFER

Assistant Editor
P. B. HOFER

Television Consultant
WALTER H. BUCHSBAUM

Short-Wave Editor
KENNETH R. BOORD

Staff Artist
FRANK SAYLES

Draftsmen
A. A. GANS, W2TSP
J. A. GOLANEK

Advertising Manager
L. L. OSTEN

Midwest Adv. Manager
JOHN A. RONAN, JR.

Western Adv. Manager
JOHN E. PAYNE

Color Art Editor
HERMAN R. BOLLIN



COVER PHOTO: Modern p.a. equipment is rapidly supplanting lung-power at carnivals, outdoor fairs, etc. Such units must be rugged, portable, and operable by untrained personnel. (Ektachrome by P. J. Samerjan)

Chairman of the Board and Publisher
WILLIAM B. ZIFF

President
B. G. DAVIS

Secretary-Treasurer
G. E. CARNEY

Vice-President
H. J. MORGANROTH
Production Director

Advertising Director
LYNN PHILLIPS, JR.

Circulation Director
H. G. STRONG

BRANCH OFFICES
CHICAGO (1)
185 N. Wabash, AN 3-5200
LOS ANGELES (14)
815 S. Hill St., Tucker 9273

First in
radio-television-electronics
Average Paid Circulation over 200,000

RADIO & TELEVISION NEWS

Reg. U.S. Pat. Off.

Radio News Trademark Reg. U. S. Pat. Office • Television News Trademark Reg. U.S. Pat. Office.

CONTENTS

JULY, 1952

Ranch Radio.....	Stan Johnson, WØLBV	27
Eliminating Outside TV.....	John B. Ledbetter	30
Universal Design Curves for Tone-Control Circuits (Part I).....	M. B. Knight	32
Hams Again at Disaster Scene.....	Hal Sagert, W9BEF	34
Public Address Systems Aid Barkers.....	James Kauke	35
Improved Intercarrier Sound System.....	Walter H. Buchsbaum	36
Unique Magnetic-Tape Applications.....	Leon A. Wortman	38
Improved Broadband Converters.....	Alvin B. Kaufman, W6YOV	39
A Novel Multi-Band Tuning Circuit.....	David Zaayer, PAØUN	42
Vñich Tube for Audio?.....	Joseph Houle	46
U.H.F. Conversion Methods.....	Noel Edwards	47
Map Your Fringe Area Signal Level....	Edward M. Noll and Matthew Mandl	50
Television Signal Strength Calculation Charts for Proper Antenna Selection—Data-Print 3 (Insert).....		51
Multi-Layer Coil Calculator Nomograph.....	S. Yamasita	54
The "Q-Tee".....	Douglas H. Carpenter	56
Pulses in Sound Reproduction.....	Glen Southworth	59
Mac's Radio Service Shop.....	John T. Frye	61
A No-Cost Signal Generator.....	Philip Schlossberg and Louis Berkowitz	62
Radio-TV Service Industry News.....		86

DEPARTMENTS

For the Record.....	The Editor	8	What's New in Radio.....	78
Spot Radio News.....		14	Technical Books	104
Within the Industry.....		22	Reel Review	113
Short-Wave.....	K. R. Boord	58	Manufacturers' Literature	126



VOLUME 48 • NUMBER 1



Member
Audit Bureau of
Circulations

Editorial and Executive Offices, 366 Madison Ave., New York 17, N. Y.

SUBSCRIPTION SERVICE: All communications concerning subscriptions should be addressed to Circulation Dept., 64 E. Lake St., Chicago 1, Ill. Subscribers should allow at least two weeks for change of address.

CONTRIBUTIONS: Contributors are advised to retain a copy of their manuscripts and illustrations. Contributions should be mailed to the New York Editorial Office and must be accompanied by return postage. Contributions will be handled with reasonable care, but this magazine assumes no responsibility for their safety. Any copy accepted is subject to whatever adaptations and revisions are necessary to meet the requirements of this publication. Payment covers all author's, contributor's, and contestant's rights, title, and interest in and to the material accepted and will be made at our current rates upon acceptance. All photos and drawings will be considered as part of the material purchased.

Copyright 1952 by Ziff-Davis Publishing Company. All rights reserved.

RADIO & TELEVISION NEWS

"PREPARE NOW.. IN SPARE TIME AT HOME TO GET INTO

TELEVISION RADIO - ELECTRONICS "

says
ART LINKLETTER!



R-F SIGNAL GENERATOR



OSCILLOSCOPE

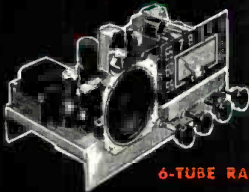

6-TUBE RADIO

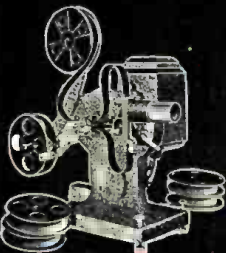

HOME MOVIES



MULTIMETER

ENJOY YOUR OWN HOME LABORATORY

In addition to modern lessons, you get the **PRACTICAL EXPERIENCE YOU NEED** from working over 300 electronic experiments at home, including building and keeping all of the electronic equipment shown above. You also get the use of a motion picture projector and 16 reels of visual film to help you learn important points **FASTER . . . EASIER** at home. And upon completing training, you also have the optional privilege of building and keeping a **17-INCH TV SET** of moderate added cost. Send for full facts. Mail coupon today!



MILITARY SERVICE!

If subject to military service, the information we have for you should prove very helpful. Mail coupon today.



JACK DEMPSEY Tells Why

FORMER WORLD'S HEAVYWEIGHT CHAMPION

He's Proud To Be With D. T. I.

1. I have been greatly impressed with D.T.I.'s wonderful spirit of friendliness and sincere determination to help its students make good in Television-Radio-Electronics.
2. I admire its remarkable 20 year record of helping men build brighter futures.
3. I also admire the business policy of its management and the thoroughness of its large faculty of instructors.
4. Never have I heard young men praise a school as enthusiastically as do the students and graduates of D.T.I. They are its best boosters.

"ONE OF AMERICA'S FOREMOST TELEVISION TRAINING CENTERS"



De FOREST'S TRAINING, INC.
AFFILIATED WITH
De VRY Technical INSTITUTE
CHICAGO 14, ILLINOIS



ACT NOW! MAIL COUPON TODAY!
Get BOTH of these publications FREE!

DE FOREST'S TRAINING, INC.
2533 N. Ashland Ave., Chicago 14, Ill.

I would like your Opportunity News Bulletin showing "89 Ways to Earn Money in Television-Radio-Electronics"; also, the folder showing how I may prepare to get started in this thrilling field.

Name _____ Age _____
Address _____ Apt. _____
City _____ Zone _____ State _____

RN-7-1

**Select your hardware
in these new, handy, plastic,
re-usable containers**

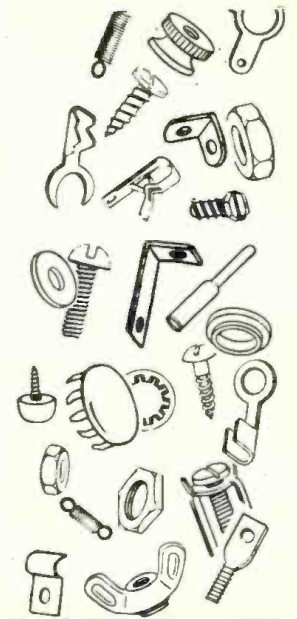

New WALSCO 50 LINE

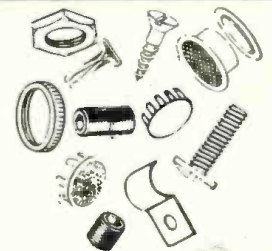

It's the smart way to buy hardware...it's the convenient way to store hardware...it's the economical way to use hardware. The new WALSCO 50 LINE is attractively packaged in transparent, plastic containers. The part number, the contents, and its uses are all plainly visible on each container, making it easy for you to select your hardware in a jiffy. The new 50 LINE eliminates the waste of small, loose hardware items being misplaced... keeps your busy work bench free from congestion. Now, all your hardware items can be neatly stacked in sturdy, re-usable containers. Available at your jobber. Select all your hardware from the new, self-service 50 LINE display.



Walsco quality earned its reputation



WALSCO

Walter L. Schott Co.
3225 Exposition Place
Los Angeles 18, Calif.
Branch: Chicago 6, Ill.

In Canada
Atlas Radio Corp., Ltd.
Toronto, Canada

**praised to the skies...
for precision**

hallicrafters

Everyone in radio knows that Hallicrafters is the Brand Name for "precision". Priced from \$49.50 to \$199.50, these four receivers have in common the utmost performance to be found at each price level. This performance is achieved only through the matchless engineering and precision craftsmanship that is the tradition of Hallicrafters.



TOP HAM PERFORMANCE—The **SX-71**—Expressly designed for the advanced amateur, Communications Receiver SX-71 is a double conversion set, built-in NBFM limiter stage. 538 kc to 35 Mc, 46-56 Mc in 5 bands. Temperature comp.; voltage regulator. 1 r-f, 2 conversion, 3 i-f stages. Xtal. filter, 3-position selectivity. 115 V AC, 11 tubes, regulator, rectifier \$199.50



"FIRST IN SELECTIVITY"—The **S-76**—Hallicrafters new communications receiver with amazing selectivity. Double conversion with 50 kc 2nd i-f. Giant 4-in. "S" meter. 540-1580 kc, 1.72-32 Mc in 4 bands. 1 r-f, 2 conversion, 2 i-f stages. 5 position selectivity. Phono input jack, 3 watt output. 115 V. AC 9 tubes, regulator, rectifier. \$169.50



MEDIUM-PRICED COMMUNICATIONS RECEIVER—**S-40B**—540 kc to 43 Mc in 4 bands. Electrical band spread. Temperature compensated. 1 r-f, 2 i-f. 3 watt output. Built-in speaker. 115 V AC only, 7 tubes, plus rectifier. (S-77—same as S-40B, for 115 V. AC or DC) \$99.95



OVER HALF A MILLION SOLD!—The **S-38C**—Value-packed with performance, the S-38C is the outstanding low priced set on the market. 540 kc to 32 Mc in 4 bands. Maximum sensitivity per tube—far outperforms ordinary broadcast sets. Built-in speaker. 115 V. AC or DC. 4 tubes plus rectifier \$49.50

WORLD'S LEADING MANUFACTURER OF PRECISION
RADIO AND TELEVISION • CHICAGO 24, ILLINOIS



Baline
TRADE MARK

10 ELEMENT YAGI

illustrated: JFD No. 10Y2S-10Y6S
 Stocked Baline

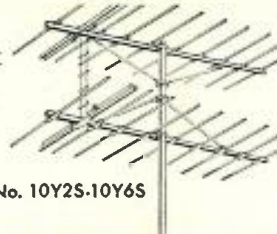

FACTS...
not fairy tales
Performance is your proof!

10 db* (gain of stacked JFD BALINE over a tuned folded dipole)

7-1/2 db* (gain of single JFD BALINE over a tuned folded dipole)

actual field tests prove it!

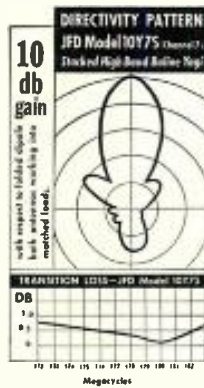
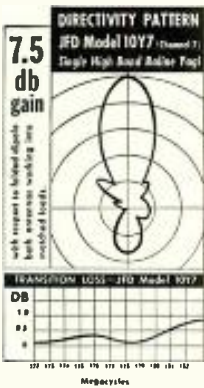

* Gain and impedance matching characteristics, tested and attested to by the Hazeltine Corporation, leading electronic research laboratory.

Single JFD High Band BALINE Yagis

Channels	Models	List Price
7-13	10Y7-10Y13	\$13.85

Stacked JFD BALINE Yagis

Channels	Models	List Price
2	10Y2S	} \$63.70
3	10Y3S	
4	10Y4S	
5	10Y5S	} 56.90
6	10Y6S	51.40
7-13	10Y7S-10Y13S	27.70

Include JFD Baline matching transformers at no extra charge

Single JFD Low-Band BALINE Yagis

Channels	Models	List Price
2	10Y2	} \$31.85
3	10Y3	
4	10Y4	
5	10Y5	} 28.45
6	10Y6	25.70

Write for Form No. 163 for full information

JFD MFG. CO.
 BROOKLYN 4
 BENSONHURST 6-9200

World's Largest Manufacturer of TV Antennas and Accessories



For the **RECORD.**
 BY THE EDITOR

OBSERVATIONS AT THE MAY SHOWS

SEVERAL innovations, designs, and techniques were introduced this year at the annual May Parts Show held in Chicago at the Conrad Hilton (formerly the Stevens) Hotel. One of the most spectacular was the huge *Electro-Voice* trailer truck, completely equipped with high fidelity sound systems for on-the-spot demonstrations in any city, town, or hamlet. The basic idea is to provide real sales cooperation between the manufacturer and his retail outlets in selling music systems to the masses. If this new medium is successful, and we are sure that it will be, more demonstration trucks will be added to increase the coverage on a nation-wide basis.

Audio topics, especially home music systems, continue to increase rapidly in popularity and acceptance. We saw more new audio components than any other product. It is unfortunate, we feel, that the annual Parts Show has become a "closed corporation," knowing that literally thousands of technicians, engineers, and others would greatly benefit from a visit to the vast exhibitions displayed at this important show.

An interesting demonstration was held in the towers of the hotel where through the combined efforts of *Jensen*, *Radio Craftsmen* and *Magnecord* binaural audio was demonstrated to a press conference. A special broadcast of high fidelity music was arranged and was transmitted over stations WGN (AM) and WGNB (FM) transmitters and picked up with *Craftsmen* tuners and amplifiers. Two special channels were employed, beginning with the placement of the FM microphone on one side of the orchestra and the AM microphone on the opposite side. At the receiving end, two identical three-way loudspeaker systems were set up with a separation between of approximately 20 feet. This was not the first time that we had heard a binaural demonstration and it was our feeling while listening to the program that the effect would have been far more realistic and startling if headphones had been employed as a comparative test to the loudspeakers. The use of headphones in the home, however, is not practical even though it does more accurately produce a binaural illusion. The sponsors are to be congratulated on this worthwhile endeavor.

Right on the heels of the Parts Show came the Audio Fair. Some 60 room displays were literally scattered over three huge floors of the world's largest hotel. The entire Fair could have been conveniently grouped on one floor. Two

of the floors were littered with packing crates and debris remaining from the Parts Show and many of the exhibitors were practically lost in out-of-the-way corridors. With adequate planning and with proper promotion the 1952 Audio Fair could have been more of a success than it was. Many of the visitors (estimated at 3500) stated that until they heard the previous night's broadcast over WGN-WGNB they had no knowledge of the Audio Fair.

Many new audio products were displayed and demonstrated and several innovations appeared. Loudspeaker enclosures continued their bid for the audio spotlight. One trend is to employ multi-woofers (three 18-inch speakers) in addition to a mid-range horn and a tweeter. Another is to employ single speakers of from 5 to 8 inches in modified corner cabinets such as the *Klipsch*. Some remarkable reproduction was heard from many of these small, compact speaker systems. Space does not permit an analysis of all that we saw and heard. For the discriminating there was a wide choice of deluxe enclosures and reproducers providing the ultimate in reproduction.

Amplifiers, too, were seen in new and modified form. One new approach introduced by *Holl* (non-exhibiting) was the use of 16 triodes in push-pull parallel in the output stage. According to the designer, the plate resistance becomes 481 ohms per side. The use of 6SN7GTA's in push-pull parallel provides a mu of 20 and a transconductance of 83,000 micromhos for both halves.

Magnetic recorders were seen in ever-increasing numbers and priced to satisfy any listener's budget. It was interesting to observe the repackaging of many standard items. In particular were new preamplifier equalizers with etched metal enclosures and modern-type knobs. It is amazing in many cases how a "new look" will add to the appeal of a product.

Believing this to be true, **RADIO & TELEVISION NEWS**, beginning with the August issue, will have a completely new cover design. This publication has deviated but slightly from its original cover of July, 1919 and we think a new face is in order. The new design will increase the effective use of 4-color photography and its reproduction. Heretofore, as our readers well know, we have utilized the full dimensions of the cover for picture reproduction. By changing to a more compact design, we will eliminate the problem of having important subject matter run into the logo. We hope you will like our new look O.R.

the only complete catalog
for everything in Radio,
TV & Industrial Electronics



your **1952** **free!**
ALLIED 212-page
value-packed catalog

Send for it today!

Here's the *one* authoritative, complete, up-to-date Buying Guide to TV, Radio and Industrial Electronics. Make your selections from the world's largest stocks of quality equipment at lowest, money-saving prices. See the latest and most complete presentation of electronic apparatus: new TV, AM and FM receivers; High-Fidelity Custom Sound components; latest P.A. Systems and accessories; recorders; fullest selections of Amateur receivers and station gear; specialized industrial electronic equipment; test instruments; builders' kits; huge listings of parts, tubes, tools, books—the world's *most complete stocks* of quality equipment.

ALLIED gives you *every* buying advantage: speedy delivery, expert personal help, lowest prices, liberal time payment terms, assured satisfaction. Get the latest 1952 ALLIED Catalog. Keep it handy—and save time and money. Send for your **FREE** copy today!

**the world's
largest stocks**



- Radio Parts Unlimited
- Test Instruments
- Television & Home Radios
- P.A. and Hi-Fi Equipment
- Amateur Station Gear
- Builders' Supplies
- Equipment for Industry

quick, expert service

ALLIED IS YOUR TV and HI-FI HEADQUARTERS

TV Count on ALLIED for the latest in TV! If it's made—we have it for quick delivery. We specialize, too, in High-Fidelity sound components—everything in amplifiers, speakers, tuners, phono gear and accessories. For TV or Hi-Fi—think of ALLIED!

HI-FI



free

**SEND TODAY FOR RADIO'S
LEADING BUYING GUIDE**

ALLIED RADIO
the World's Largest Radio Supply House
EVERYTHING IN ELECTRONICS

ALLIED RADIO CORP., Dept. 1-G-2
833 W. Jackson Blvd., Chicago 7, Illinois

Send FREE 212-page 1952 ALLIED Catalog No. 127.

Name _____

Address _____

City _____ Zone _____ State _____

103 BIG PRIZES FOR

To be given in G.E.'s great **B\$S\$B***

THREE BRAND-NEW



LOOK AT THESE BEAUTIFUL PRIZES YOU CAN WIN!



MEN'S CALENDAR WATCH, a handsome Benrus with gold expansion band, plus gold wind-proof cigarette lighter and matching gold cuff links and tie bar. All fitted in a smart and distinctive case.



LADIES' WRIST WATCH, a beautiful Benrus hinged-cuff "Embraceable" with safety chain; also, chic gold earrings and a stunning pendant-and-brooch combination. Can be a wonderful gift from you.

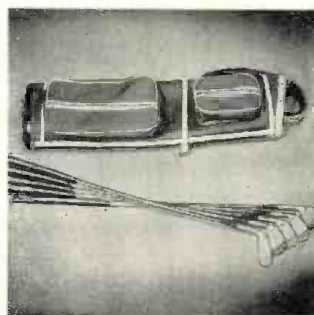

MATCHED GOLF IRONS, Wilson, with long-lasting nylon Wilson golf bag. Nos. 2, 5, 7, 9, and putter, Gene Sarazen Stroke-master model. Clubs, nationally distributed, can be filled in any time.

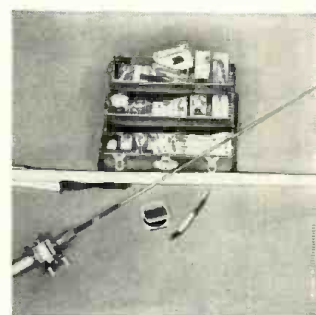

FISHING KIT, 27 items in a double-tray cork-lined tackle box. Gep glass casting rod, Green Hornet level-wind reel, fish rule and scale, Pflueger spoons and spinners, plugs, hooks and leaders.

RADIO & TELEVISION NEWS

SERVICE DEALERS!

Promotion Contest topped by

'52 DODGE TRUCKS!

***B. S. B.—Bigger Summer Business** tells the story! Increase your profits and walk off with a brand-new Dodge panel truck! General Electric's B. S. B. Contest offers you this double bonus.

The contest's loaded with 103 prizes! It's primed with new sales-getting helps for you, as shown at right. Contest starts now and ends August 15—weeks that are summer radio-TV check-up time for millions.

Yardstick of the contest will be how successfully you promote your own service business in terms of *planning, originality, and results*. G. E. will support you with special full-page tie-in ads in national magazines read by 35,000,000.

First prize to each of the three top winners will be a new '52 Dodge panel truck, handsomely lettered with your name and address.

100 other prizes—all big values, all mighty attractive!

ENTER NOW—HERE'S HOW!

● **Phone, write, or see your G-E tube distributor** for (1) descriptive folder that gives all details about the contest, (2) streamers, mailers, and other promotion items to help you win!

From the folder you will learn exactly what the contest covers, how to obtain and fill in your entry blank, how to make your promotion a success, what records to keep, and what type report to send in when the contest is over.

Five men of national prominence in the radio-TV service industry will serve as judges. Their names and positions are given in the contest folder. Act today! Profits plus a costly prize are waiting for you!



GENERAL  ELECTRIC

The Nationally Advertised



Bonded Electronic Technician Program — with its cash-

protected Bond, its code of Business ethics, and tremendous public appeal — builds business and profits by creating customer confidence in you . . .



*Better look into it today.
This sales stimulating program
costs you nothing if you
can qualify.*



*Ask your Raytheon Tube Distributor for complete information.

Excellence in Electronics

RIGHT...FOR SOUND AND SIGHT



RAYTHEON MANUFACTURING COMPANY

Receiving Tube Division

Newton, Mass., Chicago, Ill., Atlanta, Ga., Los Angeles, Calif.

RECEIVING AND PICTURE TUBES • RELIABLE SUBMINIATURE AND MINIATURE TUBES • GERMANIUM DIODES AND TRANSISTORS • RADIAC TUBES • MICROWAVE TUBES •



In quest of the "skeleton of speech"

In the famous Quiet Room at Bell Laboratories, this young volunteer records speech for analysis. Scientists seek to isolate the frequencies and intensities which give meaning to words . . . stripping away non-essential parts of word sounds to get the basic "skeleton" of speech.

A child or an adult . . . a man or a woman . . . an American or an Englishman—all speak a certain word. Their voices differ greatly. Yet listeners understand the word at once. What are the common factors in speech which convey this information to the hearer's brain?

Bell scientists are searching for the key. Once discovered, it could lead to new electrical systems obedient in new ways to the spoken word, saving time and money in telephony.

Chief tool in the research is the sound spectrograph which Bell Telephone Laboratories developed to make speech visible. Many kinds of persons record their voices, each trying to duplicate an electrically produced "model" sound. While their voice patterns are studied, a parallel investigation is made of the way human vocal cords, mouth, nose and throat produce speech.

Thus, scientists at Bell Laboratories dig deeply into the fundamentals of the way people talk, so that tomorrow's telephone system may carry your voice still more efficiently—offering more value, keeping the cost low.

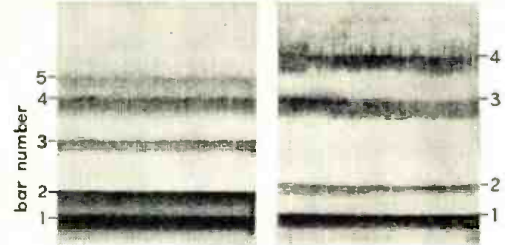

time 0.6 seconds

Spectrograms of young girl's voice (right) and man's voice making "uh" sound as in "up." Horizontal bars reveal frequencies in the vocal cavities at which energy is concentrated. The top of the picture is 6000 cycles per second. Pictures show how child's resonance bars are pitched higher than man's.

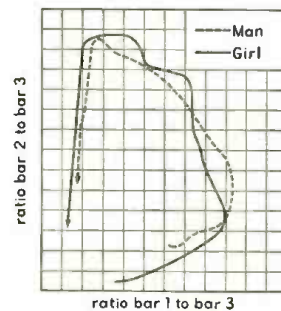

The word "five." Graph shows ratio of frequency of spectrogram bars. The solid line is for a girl and the dotted line is for a man. Note the similar patterns despite pitch differences. Human hearing extracts the speech sounds from this sort of pattern in the identification of words. Scientists aim at machines that can do the same.



BELL TELEPHONE LABORATORIES

Improving telephone service for America provides careers for creative men in scientific and technical fields.

SO IMPORTANT — it was
 Featured in Special Article
 in
The New York Times

Jan. 28, 1952
 FREE copy
 of article on request



* Presenting latest information on the Radio Industry.

By RADIO & TELEVISION NEWS'
 WASHINGTON EDITOR

**UNIT REACTIVATES
 TV PICTURE TUBES**

Small Electronic Device Tests
 Sets at Home and May Add
 Year or More of Use

By T. R. KENNEDY Jr.

A small electronic device that can be applied to home television receivers to test and reactivate the picture tube without removing the tube from the set, resulting in renewed brightness in many and considerably longer useful life, has been placed on the market for the first time by a New York manu-

In some cases, it was said, the picture tube may be made almost as good as new and given as much as a year's useful life before replacement is necessary.

The instrument is small and compact. It weighs three pounds, as large as the average lunch box, and is simple to use. Picture tubes, some of which are new and never in a receiver, are shown remarkable improvement in brilliance and definition after a few minutes of reactivation here in the last few days.

Although the principle of its operation is not new—cathode-ray tube manufacturers have used it for years in the initial making of picture tubes—its incorporation

The almost need for such an also soon may be produced in form for home assembly, is apparent. Eight to ten million TV picture tubes, Transvision engine picture tubes, have now been used for three to four years and are estimated to be used for more and "probably are in need of test and reactivation to restore their brightness. Unfortunately, loss of brightness can be detected only after the tube has been out of set, seldom can be detected by comparing the old tubes with new ones in lately produced sets.

Furthermore, picture tubes in their original cartons in stores may have lost some of their brightness due to "aging process" to which they are subjected. Such large cathode-ray tubes used in the current sets most in use today, cost from \$25 to \$65. New picture tubes can be tested and reactivated without removing them from their cartons, and tubes in TV sets without removing the tubes from the receivers. It is done by attaching a standard picture-tube socket to the tube, and turning a switch on the instrument, turning a switch on the glow of a small neon bulb as a test. The tester is watched. The picture on the dial of the tester, which is plugged into an AC home electric socket. The receiver, meanwhile, is not turned on. In some cases the test and reactivation is accomplished in less than ten minutes.



**1 TRANSVISION CR TUBE
 TESTER-REACTIVATOR**
 performs 2 vital functions:

- Tests Picture Tubes
- Renews Brightness of Dim Picture Tubes

It's a TESTER:

Without removing picture tube from set, you apply this precise instrument to:—

- Measure Cathode emission
- Locate shorts between elements
- Locate high resistance shorts or leakage as high as 3 megohms

It's a REACTIVATOR

for dim CR Picture Tubes

Revives dim TV Picture Tubes, without removal of tubes from sets. Reactivation works on tubes with low light output, if there's no mechanical break in tube, 110 V—60 cycles. Weighs only 3 lbs. One or two applications pays for instrument.

SATISFACTION GUARANTEED or money refunded if you return the instrument in 10 days in good condition. **\$19.95 NET**

RUSH THIS COUPON
TRANSVISION, INC.
 DEPT. RN-7 NEW ROCHELLE, N. Y.

() Send me _____ CR Tube Tester-Reactivator(s).
 () Enclosed find \$_____ deposit. Balance C.O.D.
 () Enclosed find \$_____ in full. Send prepaid.

Name _____
 Address _____
 City _____ State _____

THE GOLDEN ERA OF TV, which it was believed would be ushered in immediately with the release of that encyclopedic allocation document, may not burst on the horizon for several months now, because of discontent among applicants and possible law suits.

Strong evidence of this delay appeared in briefs filed by several prospective telecasters and particularly in a talk by the prexy of the Federal Communications Bar Association, Arthur Scharfeld, which noted that the new standards suffered from a basic flaw; the grant of permission to use maximum power anywhere . . . "regardless of the area in and around the community which should be served in the public interest." Declaring that the broad provision seems to have been included to simplify administration, the Washington legal specialist added that there appeared a legal question as to whether the Commissioners have not shelved their responsibility to act in the interest of the consumer. The fact that the new schedule did not require any of the existing stations to shift to the ultra-highs, was also viewed as a point which might be contested in the courts. The bar association head also stated that channels could not be assigned to any community, hereafter, unless a new rule was established, through extensive hearings. In this case, he reported, a prospective applicant may spend . . . "money, time, and energy in convincing the Commission that a certain channel should be reassigned, but there is no certainty that the applicant (whose efforts result in a channel reassignment) will be the one who gets the channel." Criticizing the setting of technical standards, as the allocations were being prepared, instead of prior, Scharfeld said that this procedure was unfair, robbing communities and telecasters of channels without notice.

One large midwestern set maker, who operates a TV station, also served notice on the Commission that it would argue the decision to change the allocation of its station from Channel 4 to 2. The antenna height provision also prompted some attorneys and stations to question the legality of the move. Not only did some of the legal set and applicants strike away at the Sixth Report, removing the freeze, but the gentleman who wrote that biting dissent, Commissioner Robert Jones,

also continued to display his anger. In a talk before the Ohio Association of Broadcasters Management Clinic in Columbus, Jones told his audience that he thought that the . . . "Commission has made grievous errors." In his opinion the decision to assume that . . . "every city and hamlet in the United States will use maximum powers and antenna heights . . ." was a basic fault. The Commission assumes, he continued, that . . . "Athens needs the same signal level as New York City. . . They don't assume that Lima, Marion, and Mansfield have Empire State Buildings, but they do assume that they will build antennas 1000 feet high. . . Accordingly, they have assigned the channels throughout the nation as if New York-sized facilities would occupy the channels in each median and small-sized city."

Lashing out at the assignments made in '45 to 158 of the largest metropolitan centers in the country, the Commissioner said that little or no thought had then been given to the efficient use of the channels. And today, he continued . . . "the Commission tries to justify all of these assignments . . . on the erroneous ground that v.h.f. channels have a greater potential to cover wide areas than the u.h.f. channels." This move, he felt, was like pulling a . . . "new rabbit out of the hat to substantiate the 1945 assignments to the largest cities . . . v.h.f. can cover rural areas better than v.h.f. stations in the largest cities." In his opinion, this view was ". . . about as sensible as measuring the depth of a well by the length of the pump handle." He regarded this as . . . "fallacious reasoning from an engineering standpoint because either group of channels, v.h.f. or u.h.f., can be made to cover wider areas than the other."

Describing the . . . "hard and fast mileage separations (and the resultant separation circles) based on a New York-sized maximum power and antenna height for the smallest cities in the country . . ." as meaningless, the Commissioner said that the circles . . . "have no relationship to service areas . . ." or to the . . . "natural trading areas, or the areas of cultural influence of the cities included in the plan."

Continuing his pounding essay, Jones declared that the new plan . . . "cheats many cities out of having any local television facilities." He noted that the schedule . . . "excludes all local

TRAIN

for Security! Good-Paying Jobs! MAKE THE MONEY YOU'VE ALWAYS DREAMED OF!



LEARN RADIO -TELEVISION AND ELECTRONICS BY EASY SHOP METHOD TRAINING AT HOME!

You get all the parts—even tubes!—
for this modern Superheterodyne Receiver. You learn to build it step by step. And you keep it! Get all the facts. Mail coupon now.

Let **NATIONAL SCHOOLS**—a resident-training school for nearly 50 years—train you at home for today's unlimited opportunities in Radio-Television-Electronics. National Schools is one of the largest schools of its kind. It is located in Los Angeles—the center of Radio and TV world! It has four large buildings of modern shops and labs. Its faculty is considered tops in the business.



You learn from lessons prepared by experienced instructors and engineers. Men who are successful Radio and Television technicians. Men who have trained 1000's of men like YOU!



Only National Schools Gives You This Professional Multi-Tester!

You get this amazing, new testing instrument—factory-made and tested—complete—ready to use! Simple to operate. Accurate and dependable. An instrument every Radio-TV man needs. Light enough to carry around—so you can use it at home or on service calls. You'll be proud to own this valuable equipment.

Here are only a Few of the Good-Paying Jobs You Can Choose

Radio Station Engineer, District Service Manager, Aircraft Radio Inspector, Own Your Own Repair Shop, Inspector Technician, Service Specialist, Special Government Jobs, Complete TV Service, Sound Truck Operator. Many more!

National Schools graduates have secure, good-paying jobs like these! So don't wait—mail the coupon today. Now—while you're thinking about it!

Attention! Men Going into Service Soon!

National Schools' course quickly prepares you for many important jobs in the Armed Services. With National Schools Training you have an opportunity to get into *special* service classifications—with higher pay and grade—immediately!

FREE SERVICE FOR GRADUATES

National Schools uses its great influence and prestige to help you find your place in the field of your choice. Don't put it off! Start yourself toward a skilled trade! Get the big pay you've always wanted!

NATIONAL SCHOOLS

LOS ANGELES 37, CALIFORNIA • ESTABLISHED 1905
In Canada: 193 Hastings St., Vancouver 4, B.C.

MAIL THIS COUPON TODAY—WITHOUT FAIL!

NATIONAL SCHOOLS, Dept. RH-72
4000 South Figueroa Street
Los Angeles 37, California

Mail in envelope
or paste on
penny post card.

Mail me FREE the book mentioned in this ad. Also a free sample lesson. I understand no salesman will call on me.

NAME _____ AGE _____

ADDRESS _____

CITY _____ ZONE _____ STATE _____

Check here if you were released from the Service less than 4 years ago.

You Train At Home—In Your Spare Time

National Schools Shop Method Home Training gives you basic and advanced instruction in *all* phases of Radio-TV-Electronics. And remember—your training is based on resident school training principles. You learn *fast* from hundreds of diagrams and pictures. All instructions are written by experienced technicians who work in Radio and TV every day. All instructions have been developed and tested in National Schools' own labs and studios, which are equipped with the latest RCA equipment. No wonder this National Schools' course is so up-to-date, practical, interesting. And so easy to learn! And no wonder it is held in such high regard by leaders of American industry! Approved for eligible Veterans.

We Teach You How To Make Welcome Extra Money—While You Learn!

Many National Schools students—men like you—make plenty of extra dollars each week in spare time! Fixing neighbors' radios, appliances—and other ways we teach you. You start learning and earning from the day you enroll. From the very first lesson!

WE SEND YOU LOTS OF PARTS LIKE THIS!

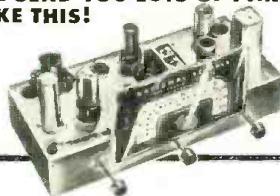

With National Schools Shop Method Home Training, you get basic principles and plenty of *practical* training. *You learn by doing.* No wonder you learn so fast!

We send you many parts—all of professional, modern quality. You do lots of practical experiments. You advance day by day, step by step. Until you can even build the modern Superheterodyne Receiver you see above—plus other important testing units. The free book tells you all about it. The free sample lesson shows how easy the training is. Use the coupon. Send today — without fail!

**DON'T PUT IT OFF!
GET THE BIG SALARY YOU HAVE ALWAYS WANTED!**

Today's Shortage of Trained Technicians Creates Chance of a Lifetime For You!

Think of it! With guided missiles, radar, and other electronic devices so important to national defense! With big, new developments in TV. With over 90,000,000 home and auto radios, over 12,000,000 TV sets. With more than 3100 radio stations...over 100 TV stations—and more building every day...yes, imagine the great opportunity you have today! YOU are wanted in Radio-Television-Electronics! America's fastest-growing field. High-pay jobs—the kind you've always wanted—are waiting for YOU!

Job Security! Big Money! For YOU! in Today's Expanding Industries!

Trained Radio and Television technicians really make important money these days. Thousands of National Schools graduates—men just like you—are earning good money all over the country. Why not you? And—National Schools graduates get the personal satisfaction of being highly-skilled technicians. Men people respect. Men who *enjoy* their work—rather than having to drag along in just any old job.

National Schools Has Trained 1000's of Successful Men! Why Not YOU?

In almost every state—and many foreign countries—National Schools graduates are filling big jobs with famous companies. Or running their own successful businesses. What are YOU waiting for? National Schools training is *complete* training. So when you graduate you can take advantage of today's big opportunities in Radio-Television-Electronics—fast.

Famous Guns

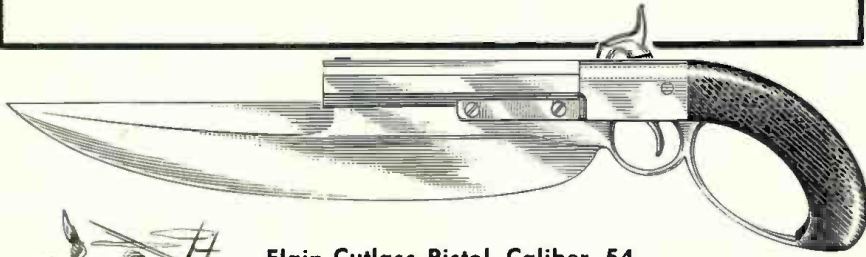

Elgin Cutlass-Pistol, Caliber .54, 1837 Model, made by C. B. Allen. Invented by George Elgin of New York, this formidable arm was intended to take the place of the cutlass and pistol commonly used by naval boarding parties. One of several variations of this weapon is the shorter Bowie-Knife Pistol.

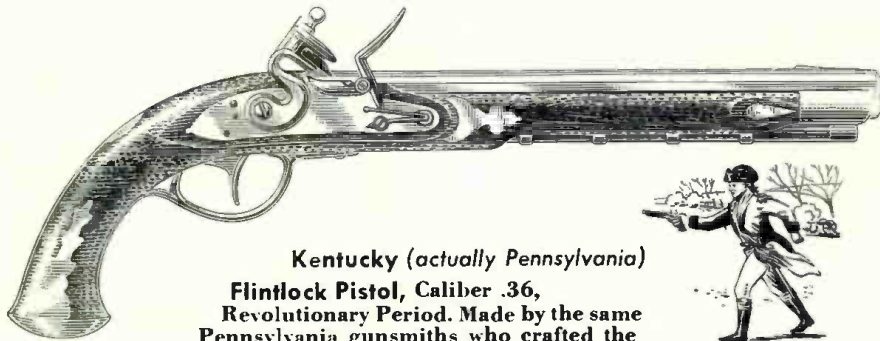

Kentucky (actually Pennsylvania) Flintlock Pistol, Caliber .36, Revolutionary Period. Made by the same Pennsylvania gunsmiths who crafted the famous "Kentucky" rifles, these full-stocked pistols actually were rifles-in-miniature. Every "Kentucky" pistol is unique: the same gunsmith never made two alike.



Instant-heating Weller Soldering Gun

for light or heavy work. Dual heat greatly increases tip life. Switch instantly to high or low heat as job requires. Pre-focused spotlights end "blind soldering". Exclusive tip-fastening arrangement assures full, constant heat. Shatter-proof plastic housing. Perfect balance. Low-cost, replaceable tips. Pays for itself in a few months. See at your Distributor or write for Bulletin direct.

Get **SOLDERING TIPS**, new Weller Handy Guide to faster, easier soldering. 20 pages fully illustrated. Price 10c at your Distributor, or order direct.



Weller BETTER FROM GRIP TO TIP!

SOLDERING GUNS 810 Packer Street, Easton, Pa.

The Finest Soldering Tool for the Finest Craftsmen

television service from every city in the nation, except the favored 1274 included in the plan. . . . It provides 889 cities with just one local channel, notwithstanding the fact that the touchstone of the Communications Act is competition."

Commenting on the advertised advantages of the u.h.f. over man-made noise, the fighting Commissioner said that the areas where noise might be a problem and solved by the use of ultra-highs. have received few u.h.f. assignments. Instead, he said, the higher frequencies were assigned to rural areas, where the only noise to overcome might be that from . . . "an occasional milking machine, feed grinder, and farm tractor."

Noting that as . . . "long as . . . the order . . . remains a mere paper document, however bad, little harm is done. . . ." The Commissioner added that the harm will come . . . "as it is translated into brick for building, steel for towers, and all the elaborate electronic devices necessary to put the plan into operation." He saw the period immediately following the date of the order as the most critical . . . "because then if new and better methods should come to our attention, the mere blueprint or preliminary construction can be changed without undue distress. . . . The longer this plan stands and the more authorizations we grant under it, the more difficult and expensive it will be to change it. . . . And in that most important first year, the Commission has determined that it will refuse to consider any proposals for any change of any consequence."

Network executives did not appear to be too distressed at the delay implications forecast by attorneys and engineers. They felt that it would not be long before TV will become a nationwide medium, which according to the prexy of NBC would result not only in . . . "improved programs . . ." but also . . . "technical advances." According to House committee chairman, Rep. Robert Crosser, the report of the FCC . . . "will prove to be good."

AS THE LEGALITY of the freeze lift was being debated, one of the Commissioners who approved the report, Rosel H. Hyde, currently serving as vice-chairman, was told by the President that he was being renominated for a seven-year term. While at this writing, the official sanction of the appointment by the Senate Interstate and Foreign Commerce Committee had not been made, there was little doubt that the veteran member of the Commission would meet any opposition. In fact, it was said that his appointment would receive unanimous approval, since he has had a commendable record not only as a Commissioner, but as a member of the legal staff, and even as an aide on the early Federal Radio Commission.

The renaming episode prompted many to comment on the plans of Hyde's former fellow Commissioner
(Continued on page 72)



Safe, Rugged TOWERS

by Channel Master

- Steel tubular uprights.
- Built-in ladder with no obstructions.
- One standard interchangeable section which can be used as a top, middle or bottom section.
- Universal base mount.
- Dual purpose mast or rotor mounting brackets.

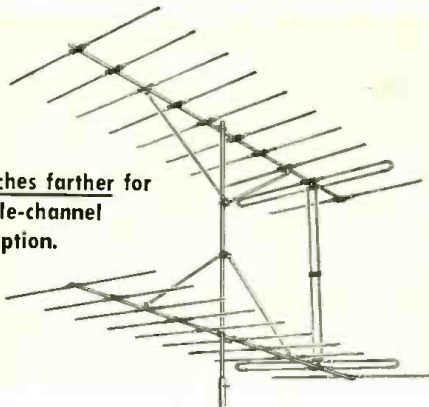

Reaches farther for single-channel reception.

- "Boom Braced" on the low band to prevent picture flicker.

the **BIG 10**
is terrific!

Fabulous 10 Element Z-Match Yagi

- Highest gains in TV history: 12 DB single, 14½ DB stacked (78% stacking gain!).
- Eliminates mismatch to 300 ohm line, single and stacked.
- You don't pay for stacking bars!

Here's the most sensitive 5 Element Yagi of them all

600 Series Z-Match Yagi

- Perfect match to 300 ohm line, single and stacked.
- Wider spread elements for higher gain.
- Over 9 DB single, 12 DB stacked (100% stacking gain!)
- You don't pay for stacking bars!

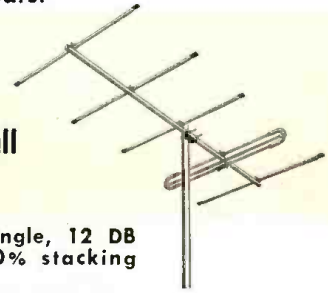

All antennas completely preassembled.

developed by

CHANNEL MASTER



For "Far Reaching" Results

There's only ONE

SUPER FAN

313 Series

The most widely used antenna in the nation.

The highest gain broad-band antenna ever developed.

New reinforced fibreglas inserts in all elements and reflectors.

Write for new catalog

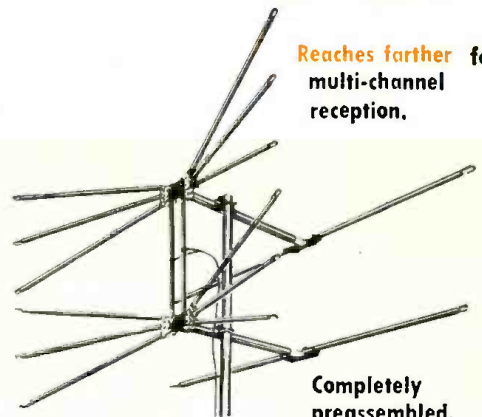

Reaches farther for multi-channel reception.

Completely preassembled.

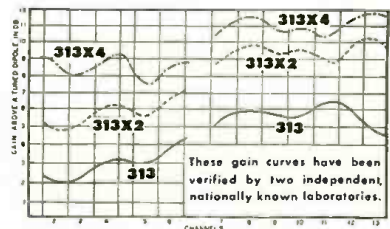

CHANNEL MASTER CORP. ELLENVILLE, N. Y.

ANOTHER AIREX FIRST!

**AVAILABLE
Only at Airex**

INTRODUCING THE IMPROVED NEW AIREX "630 FA" TV CHASSIS

Tube Mfg.
Brackets
\$6.50

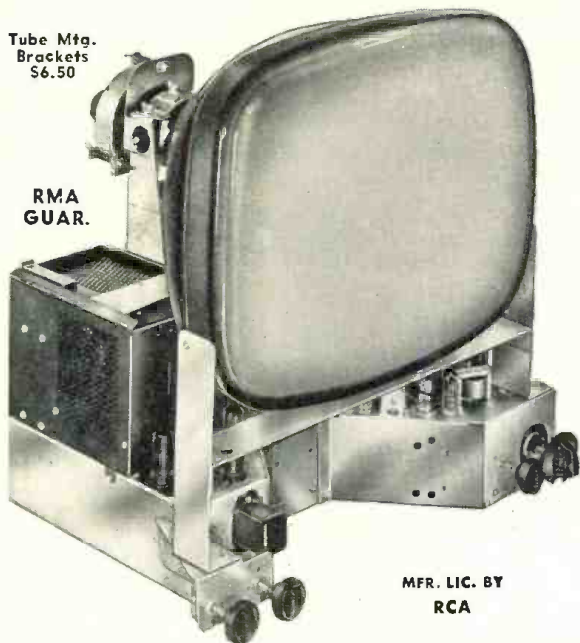

RMA
GUAR.

MFR. LIC. BY
RCA

**... DESIGNED SPECIALLY
FROM RECOMMENDATIONS
OF TV SERVICEMEN AND EN-
GINEERS all over the country**

This amazingly advanced 30 tube TV chassis is years ahead in engineering and gives you the ultimate in TV viewing and listening pleasure. To assure you trouble free TV our engineering staff has incorporated into the "630 FA" design the experiences of hundreds of TV servicemen and engineers. Receiving range includes stations up to 200 miles away. Nothing has been spared to bring you this finest of TV chassis. Only the best and most expensive parts are used. There is no other chassis that compares with the "630 FA." * For fringe area.

✓ CHECK THESE EXCLUSIVE FEATURES ✓

- 10 WATT push-pull audio output. Frequency range from 60 to 12,000 cycles • Link coupled Standard Coil Cascade Tuner prevents radiation • Retrace Blanking Circuit allows you to raise the brightness without the annoying vertical retrace lines • Heavy duty front focus control • Automatic gain control potentiometer allows you to adjust the threshold sensitivity as low as 4 microvolts & still keep the full 4MC band width • Separate high & low frequency sync amplifiers • Set aligned for 21.75 MC. New Ham band will not interfere • Improved fused high voltage power supply gives full 14.5 KV under load • Will handle all picture tubes up to 24 inch with full sweep • Improved video amplifier has a gain of 32 • All moulded plastic condensers give long life & trouble-free operation • New T10GA tube. Thermal delay allows filaments & parts to warm up before B+ is applied—preventing parts & small tubes from breaking down because of surge voltage. Protects cathode emission of picture tubes & gives longer tube life • Easily adapted to new UHF stations in 2 minutes by just changing a strip in the tuner • Extra heavy duty power transformer with large safety factor • 6CB6 tubes in Video IF to give full gain • Extra filtering in power supply for hum & ripple free operation • Color connection on chassis which is adaptable to the cathode follower circuit of color converter • Phono Connection & switch on chassis allows you to play your phonograph or tuner through the built-in 10 watt hi-fidelity amplifier • Extra heavy duty focus coil, which runs cool.

\$164⁹⁵
Less CR
Tube

Complete with
12" RCA
Hi-Fi Speaker
FED. TAX INCL.

**SUPER 630 DX 30 TUBE TV CHASSIS
WITH STANDARD COIL
CASCADE TUNER.**

\$149⁹⁵
Fed. Tax
Incl.

INCLUDES 12" RCA HI-FI SPEAKER

Complete Service Manual
For "630FA" or Super 630DX—\$1 | SEND FOR FREE NEW TV PARTS &
HI-FI AUDIO EQUIP CATALOG

38 Bargain Priced Cabinets for the 630 and Other TV Chasses

Send for FREE folder and price list of full line of beautiful table models, consolettes, consoles and TV-radio-phonograph combinations. Modern, period and chinese styles in mahogany, walnut and blonde.

**SENSATIONAL SPECIAL OFFER OF THE
AIREX SUPER DX COMPLETE TV SETS . . .
THE FINEST SET VALUE IN ITS PRICE GLASS**

These outstanding sets were specially designed to meet our rigid specifications to assure you many pleasant hours of trouble free TV at an unequalled price. The mfr. is licensed by RCA. RMA guarantee. All you have to do is plug in and play.



17"—\$154.95
20"—\$179.95

AIR KING 6-TUBE CHASSIS
Superhet. AC-DC for custom installation. Complete with loop antenna, all tubes and extra IF stage. Ready to play. Reg. \$25.
MATCHING PLASTIC CABINET . . . \$3.95
\$11⁹⁵

Includes These Features

- Has standard coil Cascade tuner that brings in reception up to 200 miles • 20 tubes • Large HI-FI speaker • Hand rubbed, satin finished genuine mahogany cabinet • AGC • Moulded plastic condensers • Black, glareless picture tube, guaranteed for 4 months • Adaptable for UHF and color • Synchronized FM audio system • 5 hour heat run at factory • Factory wired, aligned and tested • Mounted in cabinet.



17"—\$174.95
20"—\$199.95

All merchandise is brand new, factory fresh & fully guaranteed. Mail & phone orders filled upon receipt of certified check or money order for \$25 as deposit on TV chassis, 20% on other items. Balance C.O.D., F.O.B. N. Y. Prices subject to change without notice. No Fed. taxes to pay. Prices lower than OPS Regs.

AIREX RADIO CORP. 171 Washington St., N.Y.C. 7, N.Y.
Phone WOrth 2-4029

TV TUBE EXTRA

Standard Brands—Black, Glareless.
Factory New—1st Qual.—Guar. 1 Year

7JP4* . . . \$14.95	17BP4 . . . \$27.95
10BP4 . . . 17.95	20" TV Tube . . . 34.95
16GP4* . . . 24.95	21" TV Tube . . . 39.95
16JP4* . . . 24.95	24" TV Tube . . . 69.95

Ring and Sleeve for 24" Tube . . . \$7.50
*Guaranteed for 6 months only

TV GOLD PLASTIC MASKS
16" & 17", \$4.95; 20" & 21", \$7.95;
24", \$14.95

SSS SAVING SPECIAL BARGAINS

- GI 3 Speed Record Changer . . . \$ 18.95
- RCA Victor 33 1/2-78 rpm Changer Turnover Cart . . . 19.95
- RCA 6" Accordion Cone Speaker . . . 4.95
- Resistors, 100 Asst., 1/2 to 2w \$2.49; 1000 Asstd. 22.00
- 300 OHM TV wire, 100 ft., \$1.89; 1,000 ft. 17.95
- "Now You Can Fix Your Own TV Set" (Book) 1.00
- Espey 7C FM-AM Radio, 12 Tubes 69.95
- Standard Coil Cascade Tuner . . . 24.95
- Regency Booster, Mdl. DB520 . . . 19.11
- 5 Watt AC Amplifier Kit 9.95
- Radio Craftsman C10 FM-AM Tuner 131.50
- Radio Craftsman C2 Amplifier . . . 42.90
- Radio Craftsman C500 Amplifier 99.50
- Bell 2122A Amplifier 49.95
- 12" GE 1201D Speaker 19.95
- 12" University 6200 Speaker 21.00
- 12" University 6201 Coaxial 43.95

COMPLETE LINE 630 PARTS
RADIO TUBES 50% TO 70% OFF LIST

SEND POSTCARD TO BE
PUT ON FREE MAILING LIST

Don't miss Sylvania's unbeatable 3-way Service Helper—"SIT-'N-FIXIT'"

FREE

WITH 16 SYLVANIA PREMIUM TOKENS



Entire kit folds into a neat compact carrying case.



Sylvania now offers you the world's handiest and most complete servicing kit. Nothing else like it! It'll speed your work, spare your back, impress your customers!

Here, in a neat sail-cloth carrying case, is a sturdy, aluminum and canvas, folding stool. Equipped with zippered pocket for tools and parts. Also open pockets for Sylvania Wrench Kit and Pliers Kit. And get this! The unzipped case opens out to a broad, turned-up-edge drop-cloth.

How to get your "Sit-'N-Fixit"

You get this complete servicing kit FREE for only 16 Sylvania Premium Tokens shown above. One of these tokens is yours free with every Sylvania Picture Tube or with every 25 Sylvania Receiving Tubes purchased from your distributor. When you have 16 tokens, take them to this distributor and pick up your "Sit-'N-Fixit." *Note, these tokens will be honored only by the one distributor where you buy all your tubes.*

Don't delay

This is a special summer offer. Good only from July 1st to August 31st. So, call your Sylvania Distributor and get in those tube orders TODAY!

SYLVANIA



RADIO TUBES; TELEVISION PICTURE TUBES; ELECTRONIC PRODUCTS; ELECTRONIC TEST EQUIPMENT; FLUORESCENT TUBES, FIXTURES, SIGN TUBING, WIRING DEVICES; LIGHT BULBS; PHOTOLAMPS; TELEVISION SETS

PRESENTING COLLINS AM-FM "PRE-FAB" TUNERS

NOW you can
build a Collins
AM-FM tuner from
the Pre-Fab units
shown below!

COMPLETE VERSATILITY is the byword in this new tuner design. Through the addition of the AM circuit, the Collins tuner will meet all requirements for home music systems and installations where a fine tuner is required.

ECONOMY: The very finest in tuner design is offered you at exceptionally low prices. Collins quality is your assurance of a fine product that will work to your complete satisfaction. You cannot duplicate this tuner in its completed form at twice the price!

**3 Ways to purchase
COLLINS Tuner . . .**

1. As an AM tuner kit
2. As an FM tuner kit
3. As an AM-FM tuner kit

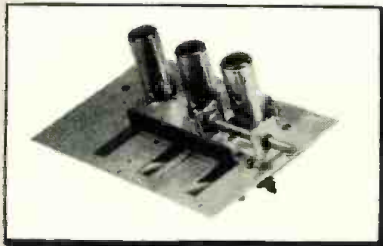

FM Tuning Unit **\$15.25**

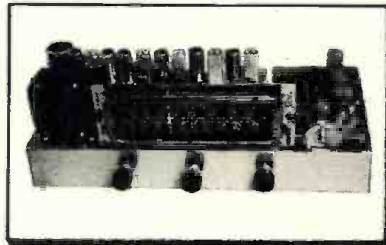

The Collins FM-AM Pre-Fab Tuner Kit As It Looks
After You Assemble It (Total Kit Cost **\$69.00**)

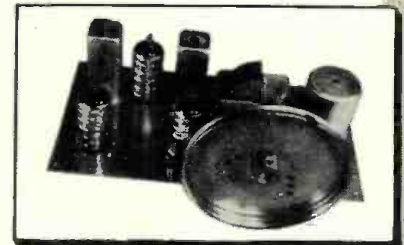

AM Tuning Unit
(Includes IF and
Audio Amplifier) **\$19.25**



FM IF Amplifier **\$19.75**

Tuning Eye Kit
Available At **\$2.85**



UC-2 Universal Chassis Kit **\$14.75**

ALL PRE-FAB UNITS ARE ASSEMBLED, WIRED, TESTED, AND ALIGNED AT FACTORY. PRICES SHOWN INCLUDE TUBES.

The FM tuning unit employs a 6J6 dual triode RF amplifier; 6AG5 converter, and 6C4 oscillator. Permeability tuned, stable, and drift-free. High sensitivity of between 6 and 10 microvolts. Dimensions: 7 1/4" x 4 1/2". The IF amplifier for FM uses 6 tubes: 6BA6, (4) 6AU6, and 6AL5 discriminator. High gain, wide band response for highest fidelity reception. Frequency response of FM section, plus or minus 2 DB, 20 to 20,000 cycles. Distortion less than 1/2 of 1%. Dimensions: 11 3/8" x 2 1/2".

The AM tuning unit utilizes a super-het circuit employing three tubes: 6BE6 converter, 6BA6 IF amplifier, and 6AT6 detector. Extremely high sensitivity and selectivity is accomplished through the use of new, high gain iron-core transformers. Careful alignment provides widest response available from this type of circuit. If builder desires, triode amplifier section of 6AT6 tube may be used as first audio stage.

Chassis Kit includes all necessary parts. Nothing else to buy! Instruction Manual included with detailed, step-by-step procedure, pictures and schematic diagrams. Chassis measures 8" x 17" x 2 1/2". Overall, the tuner, when assembled, measures 8" x 17" x 6".

**MAIL ORDER COUPON
TODAY!**

TO: COLLINS AUDIO PRODUCTS CO. INC.
P.O. Box 368, Westfield, N.J.

Enclosed Find Check Money Order For

AM Tuning Unit

FM Tuning Unit

FM IF Amplifier

UC-2 Chassis Kit

M-1 Tuning Eye Kit

NAME _____

ADDRESS _____

CITY _____

STATE _____

ANOTHER CBS-HYTRON FIRST YOU'LL BE BUYING SOON



CBS-HYTRON 1AX2

NEW HEAVY-DUTY TV HIGH-VOLTAGE RECTIFIER CAN TAKE IT!

TV high-voltage rectifiers take a beating: Terrific variations occur in applied filament voltage . . . 0.8 to 2.4 volts! Sudden arcs in the rectifying system place destructive electromechanical stresses on the filament. And the increasingly larger TV picture tubes demand peak emission and peak inverse voltage simultaneously. The new CBS-Hytron 1AX2 was especially designed to take such rough treatment and come up smiling.

1AX2 DATA

The CBS-Hytron 1AX2 is a compact, 9-pin miniature TV pulse rectifier. Plate is brought out to top cap and filament is oxide-coated. Absolute maximum ratings are: peak inverse plate voltage, 25,000 volts; d-c load current, 1.0 ma.; and steady-state peak plate current, 11.0 ma.

Typical Operation — TV Pulse Rectifier

Filament voltage	1.4 v \pm 10%
Filament current	650 ma
Positive-pulse plate voltage	20,000 v
Negative-pulse plate voltage	5,000 v
Peak inverse plate voltage	25,000 v
D-c output voltage	20,000 v
D-c load current	300 μ a

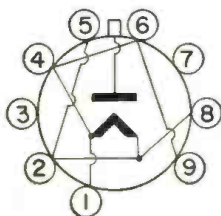

BOTTOM VIEW
OF SOCKET

ADVANTAGES OF NEW CBS-HYTRON 1AX2

- 1** Rugged, high-wattage filament of CBS-Hytron 1AX2 has adequate peak emission for the new, larger TV picture tubes. 1AX2 may be run simultaneously at both its peak inverse voltage and maximum d-c current.
- 2** Higher load of 1AX2 filament on transformer tends to regulate filament voltage. Eliminates need for limiting resistor. Yet lower plate-to-filament capacitance (0.7 μ mf) of 1AX2 prevents loss of high voltage.
- 3** Insulated tension bar (patent applied for) through center of 1AX2 coiled filament limits destructive movement of filament by electro-mechanical stresses.
- 4** Filament of 1AX2 is located in base and shielded to eliminate bombardment of cool ends of filament by gas molecules.
- 5** An overloaded 1X2A may be replaced with its big brother, the CBS-Hytron 1AX2, by simply removing the limiting resistor. In rare cases, it may be necessary to add another turn to the secondary of the filament transformer to obtain the required 1.4 volts for the 1AX2.



MAIN OFFICE: SALEM, MASSACHUSETTS

ATR

AUTO RADIO VIBRATORS

have Ceramic Stack Spacers



A COMPLETE LINE OF VIBRATORS . . .

Designed for Use in Standard Vibrator-Operated Auto Radio Receivers. Built with Precision Construction, featuring Ceramic Stack Spacers for Longer Lasting Life. Backed by more than 20 years of experience in Vibrator Design, Development, and Manufacturing.

ATR

NEW MODELS
NEW DESIGNS
NEW LITERATURE

"A" Battery Eliminators, DC-AC Inverters
Auto Radio Vibrators

See your folder or write factory

AMERICAN TELEVISION & RADIO CO.
Quality Products Since 1931
SAINT PAUL 1, MINNESOTA-U.S.A.

Within the INDUSTRY

NORMAN FYLER has been appointed supervisor of development TV picture tubes for *Hytron Radio & Electronics Co.*, a division of *Columbia Broadcasting System, Inc.* The appointment follows the announcement of an organization change in *Hytron's* picture tube manufacturing division.



Mr. Fyler was formerly associated with *Sarkes Tarzian, Inc.* and *RCA's* Princeton Laboratories. His group will carry on advanced development that will supplement the work of the Factory Engineering Department which continues under the supervision of A. Harcher, chief factory engineer.

SYLVANIA ELECTRIC PRODUCTS INC. is negotiating a lease for a 50,000 square foot factory building to be erected in the York, Pa. area. The new plant will be used for the fabrication of metal parts and will be operated as a unit of the company's Parts Division, which has headquarters in Warren, Pa. . . .

TELEVISION UTILITIES CORP., manufacturers of video monitoring equipment, has moved to new and larger quarters at 1315 Jericho Turnpike, New Hyde Park, Long Island. The move was necessitated by the increased demand for the company's products . . . **LEWIS AND KAUFMAN, INC.**, manufacturers of the *Los Gatos* brand of electron tubes, has added 6400 square feet of production space with the acquisition of a long-term lease on a hangar-type skating rink building at 657 University Avenue, Los Gatos, California . . .

NEWARK ELECTRIC COMPANY has opened a new and larger store at 223 West Madison Street in Chicago. The new quarters permit the company to warehouse its entire stock under a single roof while providing a more efficient selling area for customers. The new facilities include demonstration rooms as well as the sales areas . . . **HERMAN RADIO SUPPLY CO.** of Miami has moved to new and less congested quarters at 23rd Street and 14th Avenue, Northwest. The new distributing outlet will be operated "super-market" style to speed customers' orders while the new location will provide better parking facilities for those who do business with the firm . . . **COOK RESEARCH LABORATORIES** has doubled its former space by building new and larger quarters at 8100 Monticello Avenue, Skokie, Illinois . . . A contract for the construction of the new 15,600 square foot **ELECTRIC REGULATOR CORPORATION** plant in Norwalk, Conn. has

been placed, with completion planned for August of this year. The new building will be used for the production of the company's electric circuit controller, the "Regohm."

DAVID SARNOFF, chairman of the board of directors of *Radio Corporation of America*, has been elected as the first recipient of the RTMA's Annual Award for outstanding contributions to the advancement of the radio-television industry, by the Association's Board of Directors. The award was presented to Mr. Sarnoff at the RTMA industry banquet held June 26 in Chicago in connection with the organization's annual convention.

The award was established by the RTMA Board of Directors in February and will be made annually to the person, company, or organization which the RTMA directors consider has performed an outstanding service for the industry.

J. T. McALLISTER has been named factory sales manager for *Hoffman Sales Corp.* in Los Angeles.



A graduate of the Milwaukee School of Engineering, Mr. McAllister spent 3½ years in the navy after which he was employed at the Naval Research Laboratory in Washington, D. C. as an engineer specializing in high-frequency equipment.

He joins *Hoffman* after serving as manager of *RCA's* factory-operated service organization in Hollywood for 5½ years. In his new position, he will supervise one of the largest service departments in the Los Angeles area.

BERT KOHL has been named assistant sales manager and **WILLIAM P. LEVISON, JR.** has been appointed advertising manager for *Pyramid Electric Company*, New Jersey condenser manufacturer . . . **ARTHUR E. WELCH** is the new assistant general manager of the radio-television and broadcast receiver division at *Bendix*. He was formerly national merchandising manager for *Raytheon Manufacturing Company*, a post he relinquished recently to accept his new position . . . **A. W. KEEN** has been appointed manager of application coordination at *Sylvania Electric Products Inc.* He will head a new department whose function it will be to investigate the advanced applications of the electronic products manufactured by several of the company's divisions . . . **ARTHUR F. MERRIGAN**, formerly

RADIO & TELEVISION NEWS

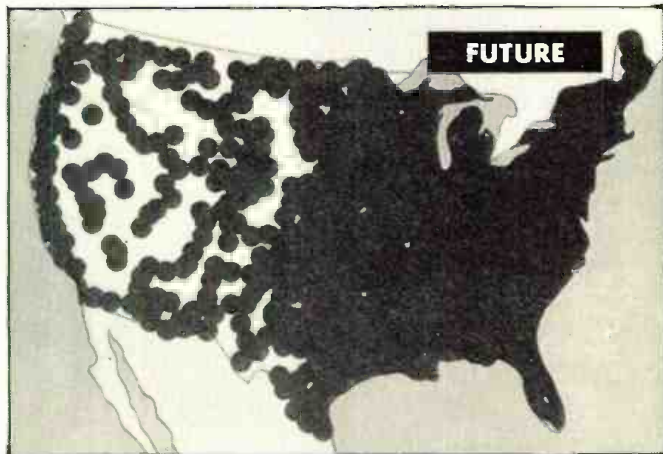
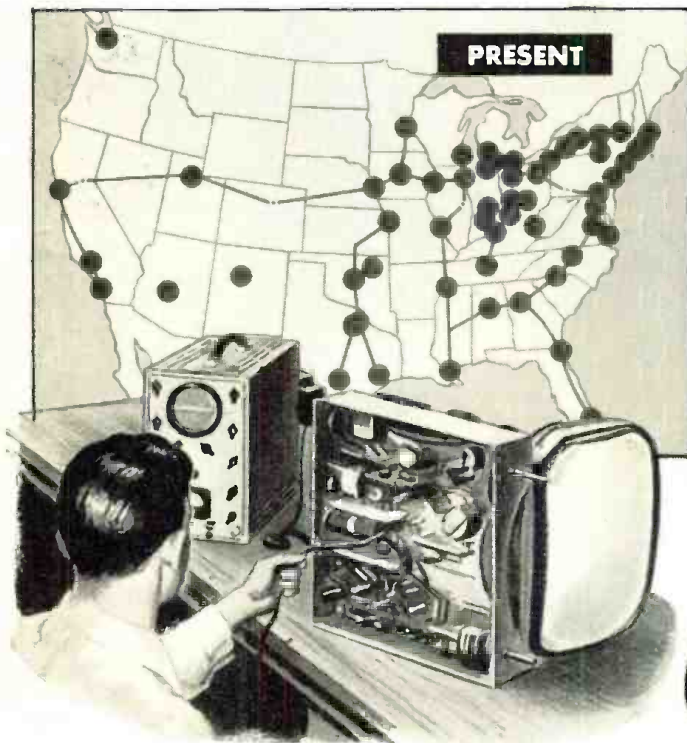

FUTURE—How new TV stations are expected to cover the nation.
PRESENT—Chart shows extent of current coverage.

Cash in on this Great Opportunity

... for good-pay jobs in TV SERVICING

YES, thousands of opportunities are going begging right now for good-pay jobs in TV Servicing.

The lifting of the "freeze" on new television stations clears the way for the expansion of the industry for 2,053 new stations, in 1,291 communities in the United States, its territories and possessions. There are only 108 stations telecasting now.

This is your golden opportunity to get all set for a good job that can mean employment security and a bright future for years to come. It's a great opportunity that can lead you, as a trained and experienced TV Serviceman, into establishing a profitable business of your own.

Big shortage of TV Technicians creates opportunities—NOW

Industry experts have estimated over 130,000 experienced TV technicians will be needed for the installation, trouble-shooting and repairing of television receivers in use by 1955. There are fewer than 50,000 fully trained TV service technicians available today. What an opportunity this creates for you!

Here are some of the good-pay jobs you can

choose—installation and trouble-shooting of TV receivers in homes . . . bench technician in radio-TV service shops . . . inspector, tester, repairman, field serviceman for TV receiver manufacturers, distributors and dealers . . . testing and servicing with electronic instrument manufacturers and companies with military contracts for electronic equipment . . . civilian serviceman with U. S. Military Bases . . . your own TV service shop—and many more.

RCA Institutes home study course trains you in your spare time

If you are associated with the radio-electronics industry, with no experience in TV servicing, the addition of the RCA Institutes Home Study Course in TV Servicing to your present experience will quickly qualify you to step out and grasp the good jobs now open in television.

The RCA Institutes course gives you a sound knowledge of television fundamentals . . . intensive practical instruction on the proper maintenance and servicing of TV receiver circuits . . . teaches you the "short cuts" on TV installation and trouble-shooting. Learn TV servicing (based on actual experience of hundreds of skilled technicians) from RCA engi-

neers and experienced instructors—pioneers and leaders in radio, television and electronic developments.

RCA Institutes home study course planned to your needs

You keep your present job. In your spare time, you study at home. You learn "How-to-do-it" techniques with "How-it-works" information in easy-to-study lessons prepared in ten units. Cost of RCA Home Study Course in Television Servicing has been cut to a minimum—as a service to the industry. You pay for the course on a "pay-as-you-learn" unit lesson basis. You receive an RCA Institutes certificate upon completion of the course. The RCA Institutes Home Study Course in Television Servicing is approved by leading servicemen's associations.

Don't pass up this lifetime opportunity for financial security and a bright future in TV.

SEND FOR FREE BOOKLET

Mail the coupon—today. Get complete information on the RCA INSTITUTES Home Study Course in Television Servicing. Booklet gives you a general outline of the course by units. See how this practical home study course trains you quickly, easily. Mail coupon in envelope or paste on postal card.

RCA Institutes conducts a resident school in New York City offering day and evening courses in Radio and TV Servicing, Radio Code and Radio Operating, Radio Broadcasting, Advanced Technology. Write for free catalog on resident courses.



RCA INSTITUTES, INC.
 A SERVICE OF RADIO CORPORATION of AMERICA
 350 WEST FOURTH STREET, NEW YORK 14, N.Y.

July, 1952

MAIL COUPON NOW!

RCA INSTITUTES, INC., Home Study Department RN-752
 350 West Fourth Street, New York 14, N. Y.

Without obligation on my part, please send me copy of booklet "RCA INSTITUTES Home Study Course in TELEVISION SERVICING." (No salesman will call.)

Name _____ (please print)

Address _____

City _____ Zone _____ State _____

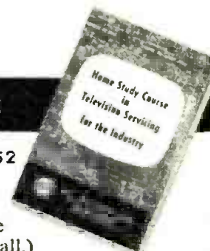

inside this package on your Jobber's shelf...



is the world's toughest transformer



CHICAGO

C-TYPE

With 10" color-coded leads brought out through fibre board base cover. Lead ends are stripped and tinned for easy soldering. Flange-mounted unit.

there's nothing tougher than **CHICAGO**

"Sealed-in-Steel" construction

CHICAGO "New Equipment" transformers (available in 3 mountings) feature one-piece drawn-steel cases—the strongest, toughest, best-looking units you can buy. The one-piece seamless design, enclosing an electronically perfect construction, provides the best possible electrostatic and magnetic shielding, with complete protection against adverse atmospheric conditions. For every application: Power, Bias, Filament, Filter Reactor, Audio, MIL-T-27, Step-down—ask your electronic parts distributor for CHICAGO "Sealed-in-Steel" Transformers—the world's toughest with that extra margin of dependability.

Free "New Equipment" Catalog

Get the details on CHICAGO's New Equipment Line—covering "Sealed-in-Steel" transformers for every modern circuit application. Write for your Free copy of this valuable catalog today, or get it from your distributor.



M-TYPE

Hermetic sealing meets all MIL-T-27 specs. Steel base cover is deep-seal soldered into case. Ceramic bushings. Stud-mounted unit.



S-TYPE

Steel base cover fitted with phenolic terminal board. Convenient numbered solder lug terminals. Flange-mounted unit.



CHICAGO TRANSFORMER
 DIVISION OF ESSEX WIRE CORPORATION
 3501 ADDISON STREET • CHICAGO 18, ILLINOIS

associated with *Remington Rand*, has been named president of *Wirt Company*, Philadelphia manufacturers of electrical and electronic components. He succeeds **PAUL G. DURVEA** who has retired . . . **ROBERT I. GAINES** has been promoted to the post of export manager for the newly-created International Division of *Allen B. Du Mont Laboratories, Inc.* He will supervise all export activities of the company . . . **GEORGE J. SCHAD** and **ROBERT C. OVERSTREET**, treasurer and secretary respectively, have been named vice-presidents of *Tinnerman Products, Inc.* Both men will continue to serve the company in their former capacities in addition to assuming the duties of vice-presidents . . . **WILLIAM P. STRATTON** is the new manager of contract administration and director of advertising and sales promotion for *Transco Products, Inc.* He was formerly associated with *Kaiser Aluminum and Chemical Sales, Inc.* and *Daystrom, Inc.* . . . *Lenkurt Electric Company* has named two new vice-presidents, **PHILIPS B. PATTON** and **GEORGE F. KOTH**. Mr. Patton will continue his present administrative duties as commercial manager in addition to his new duties as a vice-president while Mr. Koth will continue as works manager . . . *Berlant Associates*, of Los Angeles has named **DAVE GURY** to the post of national sales manager. The company manufactures "Concertone" magnetic tape recorders . . . **J. T. CATALDO** is the new assistant general manager of *International Rectifier Corp.* of El Segundo, California. He was associated with the Signal Corps Engineering Laboratories at Fort Monmouth prior to joining the rectifier firm . . . **SAM KAPLAN**, vice-president and controller of *Zenith Radio Corporation*, has been elected treasurer of the corporation. He has been with the firm for over twenty-five years . . . **FRED ABRAMS** has been named to the post of assistant to the treasurer of *Emerson Radio and Phonograph Corporation*. His former position as general manager of the Parts Sales-Service Division is being filled by **FLOYD MAKSTEIN** who has been with the firm since 1945.

* * *

JAMES R. BUTLER has been named sales promotion manager for *Belmont Radio Corporation*, manufacturer of *Raytheon* television and radio receivers.



He joined the company in March of this year after having been associated with the *Free Sewing Machine Co.* as national sales promotion manager. He has also been associated with *Westinghouse Electric Corporation*, the *Norge Division* of the *Borg-Warner Corporation*, and *Prest-O-Lite Storage Battery Co.*

Mr. Butler, who will make his headquarters in Chicago, spent six years in the armed forces.

-30-



Learn RADIO TELEVISION

**-New Package Unit Plan- PAY AS YOU LEARN
NO MONTHLY PAYMENT CONTRACT TO SIGN!**

**I Send You
18 BIG
KITS
OF RADIO-
TELEVISION
EQUIPMENT**

**TRAIN IN 10 MONTHS OR LESS
At Home in Your Spare Time**

Now . . . be ready for Radio-Television's big pay opportunities in a few short MONTHS! Frank L. Sprayberry's completely new "Package" training unit plan prepares you in just 10 MONTHS . . . or even less! Equally important, there is NO monthly payment contract to sign . . . thus NO RISK to you! This is America's finest, most complete, practical training—gets you ready to handle any practical job in the booming Radio-Television industry. In just 10 months you may start your own profitable Radio-Television shop . . . or accept a good paying job in this fascinating expanding field at work you've always wanted to do. Mr. Sprayberry has trained hundreds of successful Radio-Television technicians—and stands ready to train you in

less than one year, even if you have no previous experience. You learn by DOING . . . actually working with your hands with equipment of special design to illustrate basic theory instead of relying on books alone.

VALUABLE EQUIPMENT INCLUDED WITH TRAINING

The new Sprayberry "package" plan includes many big kits of genuine, professional Radio-Television equipment. While training you actually perform over 300 demonstrations, experiments and construction projects. In addition, you build a powerful 6-tube standard and short wave radio set, a multi-range test meter, a signal generator, signal tracer, many other projects. All equipment is yours to keep . . . you have practically everything you need to set up your own service shop. The interesting Sprayberry book-bound lessons and other training materials . . . all are yours to keep.

EARN EXTRA MONEY WHILE YOU LEARN!

All your 10 months of training is AT YOUR HOME in spare hours. Keep on with your present job and income while learning . . . and earn EXTRA CASH in addition. With each training "package" unit, you receive extra plans and ideas for spare time Radio-Television jobs. Many students pay for their entire training this way. You get priceless practical experience and earn generous service fees from grateful customers. Just one more reason why the Sprayberry new 10 MONTH-OR-LESS training plan is the best Radio-Television training in America today. If you expect to be in the armed forces later, there is no better preparation than good Radio-Television training.

FREE 3 BIG RADIO TELEVISION BOOKS

I want you to have ALL the facts about my new 10-MONTH Radio-Television Training—without cost! Act now! Rush the coupon for my three big Radio-Television books: "How to Make Money in Radio-Television," PLUS my new illustrated Television Bulletin PLUS an actual sample Sprayberry Lesson—all FREE with my compliments. No obligation and no salesman will call on you. Send the coupon in an envelope or paste on back of post card. I will rush all three books at once!

SPRAYBERRY ACADEMY OF RADIO
Dept. 25-L, 111 North Canal St., Chicago 6, Ill.

**Mail
Coupon
Today!**

SPRAYBERRY ACADEMY OF RADIO, Dept. 25-L
111 North Canal St., Chicago 6, Ill.

Please rush to me all information on your 10-MONTH Radio-Television Training Plan. I understand this does not obligate me and that no salesman will call upon me.

Name.....Age.....

Address.....

City.....Zone.....State.....

Please check Below About Your Experience

Are You Experienced? No Experience

Approved for
Veterans Under
the G. I. Bill

**IF YOU ARE
EXPERIENCED IN RADIO**

Men already in Radio who seek a short intensive 100% TELEVISION Training with FULL EQUIPMENT INCLUDED are invited to check and mail the coupon at the right.

**NO OBLIGATION
No Salesman
Will Call**

EICO
TEST INSTRUMENTS

Guard

CBS-Columbia Inc.
HIGH STANDARDS OF
TELEVISION PRODUCTION QUALITY



In the CBS-Columbia design laboratories, Al Goldberg takes some important readings with the EICO Model 221 Vacuum Tube Voltmeter and Model 555 Multimeter, as Harry R. Ashley looks on.



Mr. Al Goldberg, Assistant Chief Engineer of CBS-Columbia and Harry R. Ashley, President of EICO, inspecting the use of the EICO Model 221 Vacuum Tube Voltmeter and Model HVP-1 High Voltage Probe at the Sweep Frequency Troubleshooting Position on the CBS-Columbia Television production lines.



NEW
221K VTVM KIT \$25.95
WIRED \$49.95



HIGH VOLTAGE
PROBE \$6.95



NEW 425K 5" PUSH-PULL
SCOPE KIT \$44.95. WIRED \$79.95

KITS
WIRED INSTRUMENTS



NEW 565K MULTIMETER
KIT \$24.95. WIRED \$29.95
20,000 ohms/volt



320K SIG.
GEN. KIT \$19.95. WIRED \$29.95

NEW 322K SIG. GEN.
KIT \$23.95. WIRED \$34.95



NEW 950K R-C BRIDGE &
R-C-L COMP. KIT \$19.95
WIRED \$29.95



NEW 1040K BATTERY ELIM.
KIT \$25.95. WIRED \$34.95



511K VOM
KIT \$14.95
WIRED
\$17.95



NEW 315K DELUXE SIG.
GEN. KIT \$39.95
WIRED \$59.95



NEW 536K MULTI-
METER KIT \$12.90
WIRED \$14.90
1000 ohms/volt

NEW 1171K RES.
DECADE BOX KIT
\$19.95
WIRED \$24.95



145K SIG.
TRACER KIT
\$19.95
WIRED
\$28.95



NEW 825K
TUBE TESTER KIT
\$34.95. WIRED \$49.95
NEW GRA CR ADAPTOR
FOR ABOVE \$4.50



360K SWEEP GEN. KIT \$34.95
WIRED \$49.95



New 377K Sine & Square Wave
AUDIO GEN. KIT \$31.95 WIRED \$49.95

*For Laboratory Precision at Lowest Cost—
the Leaders Look to EICO!*

WHY does CBS-Columbia, Inc., today's headline-maker in Television set production, use EICO Test Instruments on its Television production lines and in its design laboratories?

BECAUSE — like Emerson, Tele-King, Teletone, and many another famous TV manufacturer coast to coast, CBS-Columbia knows that ... *Only EICO Test Equipment delivers All 10 EICOnomical Features!*

1. Laboratory Precision
2. Lowest Cost
3. Lifetime Dependability
4. Speedy Operation
5. Rugged Construction
6. Quality Components
7. Latest Engineering
8. Super-Simplified Assembly and Use Instructions
9. Laboratory-Styled Appearance
10. Exclusive EICO Make-Good Guarantee

Before You buy any higher-priced equipment, look at the EICO line — *in Wired and Kit form!* Each EICO product is jam-packed with unbelievable value. Compare, see *EICO instruments today—in stock at your local jobber—and SAVE!* Write NOW for FREE newest Catalog R-7

**FOLLOW THE LEADERS
... INSIST ON EICO!**

EICO

Reg. U.S. Pat. Off.

ELECTRONIC INSTRUMENT CO., Inc.

84 WITHERS STREET, BROOKLYN 11, NEW YORK

RADIO & TELEVISION NEWS

©1951, Electronic Instrument Co., Inc. Prices 5% higher on West Coast. Due to unstable conditions, prices and specifications are subject to change without notice.

RANCH RADIO

By STAN JOHNSON, WOLBV

THE rancher stood by a gate—watching a bank of tumbling, black clouds building up in the west. A few feet from him, a combine stood in the wheat field—idle.

The man's eyes were dark with worry. For the black clouds were hail clouds. In a few minutes, they might spill hail down onto the ripe grain. Should this happen, the year's crop—worth many thousands of dollars—would be pounded into the ground.

The rancher's eyes brightened as he saw a pick-up truck racing towards him down the rocky, dusty road. The truck should be bringing a V-belt—the part needed to get the combine back into the field cutting grain again.

A young man, a member of the crew traveling with the combine, jumped from the truck. "They didn't have the belt, or anything close to it. I'll have to go get one. Should I go to LaJunta, or Trinidad?"

The rancher's face became grim. LaJunta was 65 miles away. Trinidad 75 miles.

"At least we could phone ahead, and find out which town has the belt," said the young man.

"That's the trouble out here," the rancher replied, wearily. "There's no telephone, no telegraph, no way on earth to call."

He looked anxiously at the sky. "Well, we will have to do the best we can. You go to Trinidad. I'll go to LaJunta and Springfield. Mebbe one of us can find a belt in time."

Episodes like this were all in a day's work in Kim, Colorado, until recently. For Kim, by some accident of nature, sits all by itself, near the center of an oasis of rich wheat and cattle land—in the midst of a region which is almost a desert. A desert—except when sudden storms make the few roads, dusty and rough in dry weather, virtually impassable.

These roads, until recently, were the only contact between the town—and the cattle and wheat ranches surrounding it—and the outside world. Radio has changed the picture com-

George Lazear, executive manager of the Wyoming Hereford Ranch, "rides range" in a V-8 equipped with a mobile radio unit.



Isolation in the West is going the way of the buffalo, thanks to modern two-way radio gear.

pletely—and back of that change is a story of a community and a big corporation teaming up to provide a desperately needed service.

Years ago, Kim did have a telephone system of sorts—a single wire local system connecting a few subscribers in Kim with the office of a little independent company in Branson, New Mexico. But the system worked so poorly even for local calls that it was finally abandoned. The people in Kim hoped that some miracle would put a main telephone line within striking distance of their town. But no line came through. Kim remained isolated.

Periodically, through the years, Kim people discussed with representatives of the *Mountain States Telephone and Telegraph Company* the possibility of running lines to hook Kim into the *Bell System*. But the problem was always the same: cost. For example, one possibility was to run a line to the county seat, Trinidad, along 75 miles of county road. Simply running the line would take a lot of money. And the area is so beset by fierce electrical storms during the summer that maintenance was certain to be an extremely tough problem.

Fortunately for Kim, the company's commercial representative, A. H. Stewart, and executives in the engineering and plant departments did not give up easily—for they knew how badly the service was needed. They decided that the one chance was to forget about using a telephone line and substitute radio.

By radio, the distance would be

shorter—about 65 miles. But since the circuit would have to use high frequency FM radio (nobody wants static crashes mixed up with a telephone conversation) the technical problems were formidable. For, as any ham knows, crossing 65 miles of country with a signal which is the equivalent of "S-9 plus" at both ends, any time of the day or night, winter or summer, takes some real doing.

Preliminary tests, with temporary set-ups at both ends, proved that the radio link was possible, *providing* the antennas were really put up in the air.

At the Trinidad end, the engineers had one thing in their favor: Simpson's Rest (known to local lovers as Passion Point!). Simpson's Rest, named for George Simpson, pioneer and Indian scout, rises approximately 400 feet above the city—right at the edge of town—close enough to make it entirely practical to build an antenna system and transmitting unit upon it and connect the whole thing to the telephone exchange in Trinidad.

Out at Kim, the country is billiard-table flat, although there is some rough country between the two cities. So at Kim, the antenna system had to be up on some kind of structure. The answer proved to be monster 90 foot telephone poles, which had to be trucked nearly 300 miles from Denver, over routes worked out with the cooperation of the highway department and the state police.

While the radio installations were being made, the farmers and ranchers in the Kim area, working under the supervision of telephone company men,



Rancher W. Tom Rose finds that a telephone system, made practical by a v.h.f. radio circuit, has completely changed the living habits of the isolated community in which he lives.



Owen Oslund, office manager at the Wyoming Hereford Ranch, can contact vehicles out on the range by means of this fixed station transmitter-receiver and the mobile units in the trucks.

put up poles and strung the wires needed to tie the ranches together into a telephone system. By donating their labor, Kim men kept costs down. Yet the finished system, inspected by telephone company experts, compares favorably with *Bell System* standards. The completed exchange is one of the largest in area—if not *the* largest—in the world, covering 1152 square miles to reach just 88 subscribers. As a comparison, the New York City exchange, with millions of subscribers, is comprised of only 320 square miles.

At Kim, the exchange is strictly a cooperative venture, owned and operated by Kim people. The sheriff, for example, doubles in brass as maintenance chief. In operation, the system is much like any other up-to-the-minute dial system. In making a long distance call on one of the phones, the average user would have no idea that radio was being used to push the signal across 65 miles of space. But here is what actually happens when a call is made.

Dialing "O" on a Kim telephone turns on the carrier on one of the transmitters. This is received in Trinidad on one of the FM receivers. The incoming signal operates a relay, which in turn lights a light on the switchboard in the Trinidad office. The telephone operator answers the call, and then goes ahead and patches the call into the long distance telephone system in the usual manner.

The procedure (as this article is written) for placing a call to Kim is somewhat different. The operator in Trinidad rings the Kim operator by means of the radio circuit. The Kim operator completes the call, after learning which subscriber is wanted. Dial equipment, Trinidad to Kim, is now being installed.

The FCC assigned four frequencies in the 152 to 158 megacycle range for the Kim-Trinidad link. This makes possible two channels, which means, of

course, that it is possible for two conversations to be going on simultaneously. Since telephone conversations are "duplex"—not monologues like ham conversations or most other commercial radio contacts—two transmitters and two receivers are in operation for *each* channel.

Surprisingly little power has been used for the link, the transmitters being 50 watt units mounted in metal boxes at the foot of the telephone poles carrying the five-element yagi antennas. At the Trinidad end, it is planned to replace the transmitters with larger 250 watt units, to give extra power during the thunderstorm season, when the noise level becomes higher than the telephone company regards as being up to its high standards for telephone conversations. But the system has been working—and very well—with the 50 watt units.

What does it mean to a community, completely isolated from the rest of the world as far as fast communication is concerned, to have a modern system?

"It means just about everything in the world," says W. Tom Rose, rancher and president of the local school board. "We actually didn't know what we were missing—or how much simpler life could be. You know," he smiled, "I still catch myself hopping into the pick-up, starting off someplace—then remembering that now all I have to do is to make a phone call."

North and east of Kim is another community in which radio is changing the lives of the people who live there: Cheyenne Wells. Up here the problem is somewhat different from that at Kim. Cheyenne Wells is tied in by phone line to the *Bell System*, but some of the ranches in the area are so far apart that linking them by rural phone lines had never seemed practical. So the telephone company decided to put in a strictly experimental hook-up in which eight ranches would

be tied to the exchange in Cheyenne Wells through radio circuits—without the usual poles and wires.

As finally worked out, four of the ranches were hooked up to a fifth with telephone lines—and then this ranch, and three others, were each equipped with transmitting and receiving units. The equipment is housed in a cabinet roughly the size of a console radio. Power comes from vibrator packs operating off 32 volt farm plants—kept charged by windchargers.

The receivers must be "on" all of the time, so the vibrators must be running constantly. Even so, by modifying them slightly (by removing the cases to get rid of the rubber damping material) they often run for a year.

The equipment is checked every 3 months—with frequency checks every 6 months.

The system used is necessarily quite complex to avoid two transmitters operating on the same frequency at the same time—and still not require use of a large number of frequencies. Actually, the system uses only three frequencies. Here's how it works:

Let's start with a call originating from one of the ranches, the Klines, who are calling to the Blackwelders on another ranch.

Lifting the telephone at the Klines' home turns on the transmitter, sending an unmodulated carrier (49.0 megacycles) to a receiver in Cheyenne Wells, where it is picked up by a receiver, causing a light to appear on the board. The operator receives the call and instructs the party at the Klines to hang up while the Blackwelders are being rung.

To ring, the 44.2 megacycle transmitter at Cheyenne Wells is pulsed at a 20-cycle rate. This pulsed signal is picked up by all receivers in the system and the signal, through a relay, causes all of the telephones on the system to ring, as on a "party" line.

When the Blackwelders, in response

to their ring (for example, two longs and two shorts) take down their telephone handset, another relay hook-up, actuated by the receiver, shifts the frequency of their transmitter from 49.0 megacycles to 49.2 megacycles. This is necessary to avoid heterodynes with the Kline transmitter, which is already on the air.

The signals going back from the Blackwelders is picked up at the switchboard—as is the signal from the Klines—and *both* are fed to the same transmitter, which operates on 44.2 megacycles, through a mixing circuit known to telephone men as a “hybrid.” This “hybrid” also makes it possible to tie in the switchboard operator’s voice—so that either of the subscribers, or the operator, can talk over the single transmitter at the exchange.

Of course, only one conversation can go on at a time among the 8 subscribers, otherwise there will be heterodynes.

From the standpoint of the subscribers at Cheyenne Wells the radio hook-up is a complete success and the telephone system has become a part of day-to-day living. But the telephone company still regards the system as highly experimental and not likely to be duplicated anywhere else for some time. Technically it works like a charm. But still to be overcome are problems of economics—each of the radio-equipped ranches is a radio broadcasting station, with complex and expensive receiving gear thrown in to boot. The sheer cost of such installations is certain to limit their use until such time as it is possible to cut down on the size and cost of the equipment needed to do the job.

(Continued on page 128)

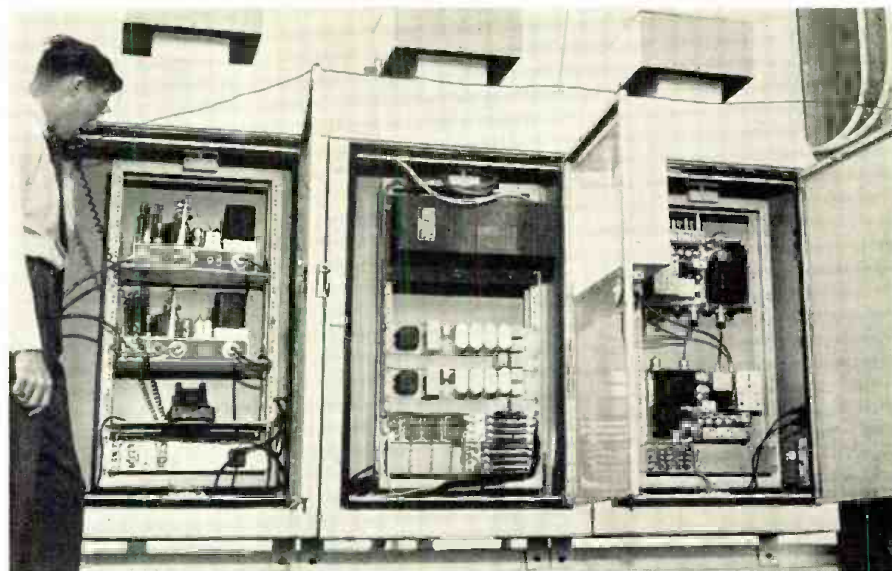

Transmitters and receivers at Trinidad, Colorado, part of the radio setup which links the Trinidad exchange of Mountain States Telephone and Telegraph Company with Kim, Colorado, 65 miles away. Marvin Runner is responsible for this gear.

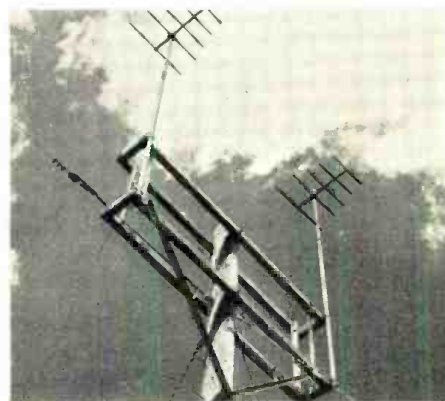

Five element yagi arrays are used for the Trinidad-Kim radio link—one of the longest “one shot” commercial radio hook-ups on v.h.f. operating in the United States.

At Kim, Colorado, the yagi arrays are supported atop 90-foot telephone poles. Moving these poles from Denver required the combined efforts of Mountain States Tel. & Tel., the highway department, and police.

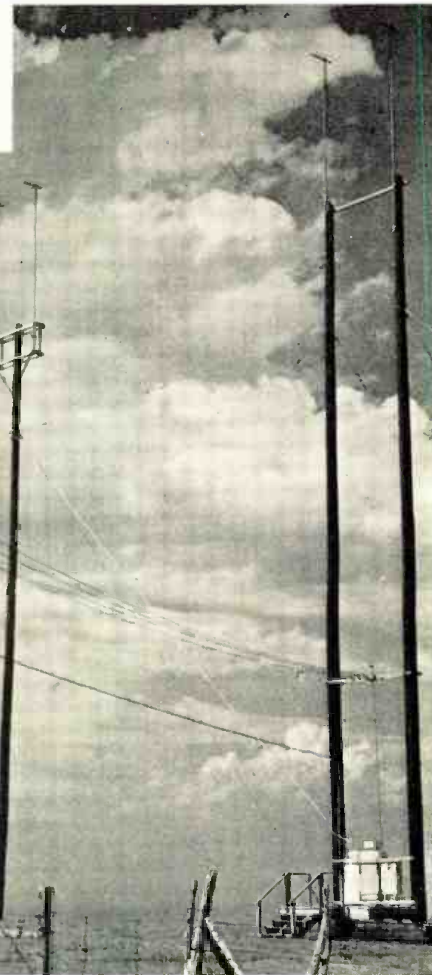

A wheat rancher and his son inspect one of the combination receiver-transmitters used in the Cheyenne Wells hook-up.



ELIMINATING OUTSIDE TVI

By

JOHN B. LEDBETTER

Engineer, WKRC-TV



Fig. 1. One form of oscillator radiation interference characterized by horizontal lines.



Fig. 3. This is how r.f. interference appears on screen. Oblique lines and haziness are present.

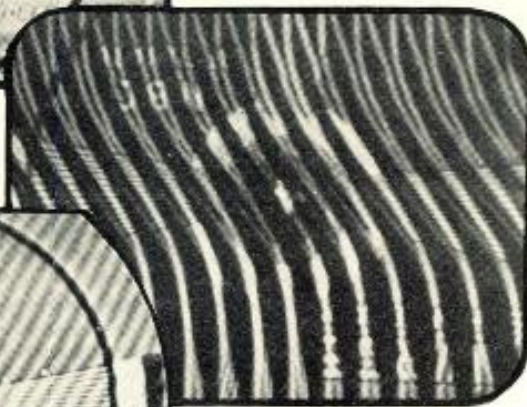

Fig. 2. Another form of this type interference in which zig-zag or S-shaped lines appear on screen.

Some practical hints for combating a familiar but rapidly-increasing television servicing problem.

INTERFERENCE from outside sources usually enters the receiver through the antenna, lead-in, or a.c. power line. (In a few cases it can be picked up by or may actually originate from a defective or unshielded part in the set.) Identification usually is simple, while locating the source may be more difficult. In some cases, elimination will be surprisingly easy; in others you will have to use ingenuity, unlimited patience, and a combination of "cut-and-try" remedies. Then, too, there are a few types of interference (severe oscillator radiation, etc.) which cannot be eliminated by any present method.

The following hints and corrective measures will produce satisfactory results in the majority of cases. Their use or listing may suggest other remedies which are equally, if not more, effective.

TYPE: Oscillator Radiation.

EFFECT: Black horizontal lines or bars, zig-zag or "S"-shaped lines, diagonal lines, "pinwheels," "chicken-wire," mesh or herringbone patterns (see Figs. 1 through 5). Strong interference of this type may completely obliterate the picture. (Usually, only one local channel is affected.)

SOURCE: Nearby TV receiver. (In-

terference may vary when sets warm up or when the fine-tuning control on either is adjusted.)

REASON: The local oscillator frequency in receivers using a 25 mc. i.f. falls within the TV band. When the receiver is tuned to Channels 2, 3, 7 or 9, its oscillator will beat or fall within the video frequency of Channels 5, 6, 11, 12, or 13. If the oscillator stage is not completely shielded or isolated from the r.f. and antenna circuits, it is capable of radiating over a considerable distance (actually up to several hundred feet). (The RTMA-suggested 40-45 mc. i.f. eliminates oscillator radiation problems within the v.h.f. band but will possibly introduce another problem by subjecting the receiver to possible interference from the new proposed high-power police stations assigned to the 45 mc. band.)

REMEDIES: Oscillator radiation interference often can be reduced or eliminated by one of the following methods. Experimenting may be necessary since all receivers will not react the same.

1. *Install a booster at the offending receiver.* This is the most effective since it isolates the radiating oscillator from the antenna circuit, but it requires full cooperation from the owner

of the interfering set. In many cases this will be difficult to obtain even if the complainant offers to pay for the booster. Diplomacy and a satisfactory explanation of the trouble will be necessary.

2. *Shield the offending receiver.* This is sometimes effective but also requires the owner's cooperation. Satisfactory results can often be obtained by lining the offending set's cabinet with copper screen or aluminum foil (*Reynolds Wrap*) and grounding it to the chassis. A good common antenna-receiver ground system is required here (improper or inefficient grounding may make the interference worse).

3. *Readjust the antenna.* Reorienting either antenna, even slightly, may shift the affected receiver out of the path of the radiated signal. Try moving either or both receivers slightly or relocate one in another part of the room (with the owners' permission).

4. *Ground the receiver.* This is recommended in all cases unless the chassis was not designed for grounding. A few (i.e., those with series-filament circuits) must be kept above ground. Check the schematic or consult the distributor if you are not familiar with the circuit or have reasonable doubts.

5. *Install a high-gain, highly-directional antenna.* The yagi, "In-Line," "Circle-X," "Double-V" and "Paracon" types are very good in rejecting radiation from the back and sides of the antenna. The conical usually is not so good from this standpoint because of its four small pickup lobes toward the sides. In a number of local cases, excellent results have been obtained with an *inside* conical or an *inside* loop, either as the sole antenna or in parallel with the regular outside unit. In one particular case, the *inside* conical (in parallel with an *outside* conical) completely eliminated all traces of oscillator interference where every other method had failed. (This probably represents an isolated condition, but similar results have been obtained in other cases. A condition of perfect phasing appears to be the answer.)

6. *Shift the i.f. frequency of the offending set.* In a few cases, realigning the interfering receiver's i.f. about 1

RADIO & TELEVISION NEWS

kc. lower has corrected the trouble. (This is not practical on the majority of receivers because it affects bandwidth, sensitivity, and stability to some extent.) Such a change also requires cooperation of the owner and may place you in a ticklish position if trouble should later develop in the set.

7. *Install a wavetrapp across the antenna terminals.* A $\frac{1}{4}$ wavelength open stub or high-pass filter may work if the interference is not too strong. Otherwise, part or all of the desired signal may be eliminated along with the radiated signal.

TYPE: *Electrical Interference.*

EFFECT: Black and white streaks (Figs. 6 and 7); may be accompanied by flashes or varying brightness, picture tearing, or momentary loss of sync.

SOURCES: Automobile and truck ignition systems. Smoke precipitators. Neon signs. Electric machinery (power saws, generators, lathes, drill presses, pumps, etc.). Electrical appliances (food mixers, vacuum cleaners, heating pads, ultraviolet lamps, electric blankets, electric shavers, hair dryers, beauty shop equipment, fans, refrigerators, washers, oil-burners, stokers, etc.). Defective or loose light bulbs, lamp sockets, plugs, or wall outlets. (Old-type filamentary light bulbs may interfere with a local TV channel, as may other appliances. A local case involving severe interference on Channel 4 was traced to an electrically-operated steam wallpaper cleaner.)

REASON: Any electrical equipment with a switch, thermostat, brush-type motor, or other rotating or vibrating device produces interfering pulses whose fundamental or harmonic frequencies fall within the bandpass limits of the TV receiver. (The same applies to neon lights and other oscillatory circuits.)

REMEDIES: For outside interference (automobile ignition systems, electrical machinery, etc.), try raising the antenna, reorienting it slightly or, in extreme cases, relocating it on another part of the roof (a directional type must be used here). Run the lead-in as far away from the source of interference as possible and twist it every foot or so. (Shielded cable or coaxial line may be necessary in some cases, but the above procedure should be tried *first*. The twin-lead line is more efficient, has less line losses, and usually can be made to work if the installation or rerouting is carefully done.)

Interference from electrical equipment (appliances, etc.) should be corrected at its source if possible. First, check all lamp bulbs, sockets, appliances, etc., in the customer's home. If this source is clear, ask neighbors, nearby stores, garages, etc., for permission to check electrical equipment, fans, lights, cash registers, adding machines, pressure pumps, neon flashers, etc. (A portable TV receiver or battery-operated AM receiver with a built-in exploring loop is your best ally

in locating electrical interference.) When the source is found, ground the metal case of the equipment if possible, and install a low-pass filter in the a.c. power line (as close to the offending motor or moving contacts as possible). A simple filter (.01 to .1 μ fd. condensers from each side of line to chassis) will work in most cases. Stubborn, hard-to-cure interference can be caused by defective, worn-out motors or brushes. A filter may not help in these cases, and replacement of the worn unit may be the only remedy.

TYPE: *Diathermy Interference.*

EFFECT: Jagged horizontal bars which move slowly up and down the screen, sometimes accompanied by a low-pitched hum or tearing noise in the sound (Fig. 8).

A strong signal may cause impairment or complete loss of sync.

SOURCE: Diathermy equipment in hospitals, doctors' offices, etc.

REASON: A radiated signal from diathermy equipment covers a very wide band of frequencies. (Interference, however, is limited mostly to prewar diathermy equipment. Modern equipment is well-shielded and radiated strength is kept within FCC requirements.)

REMEDIES: Interference should be corrected by shielding and installing a low-pass filter on the equipment itself. If the source is located, notify the owner. Reporting the trouble to the FCC should be done only as a last resort.

(Continued on page 115)

Fig. 4. Mesh or herringbone pattern which is typical of an oscillator radiation interference condition.



Fig. 5. This "chicken-wire" pattern often is characteristic of osc. radiation interference.

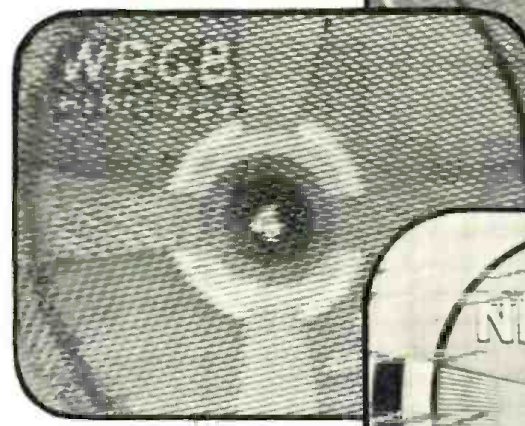

Fig. 6. Electrical interference often appears as black streaks, accompanied by momentary flashing.

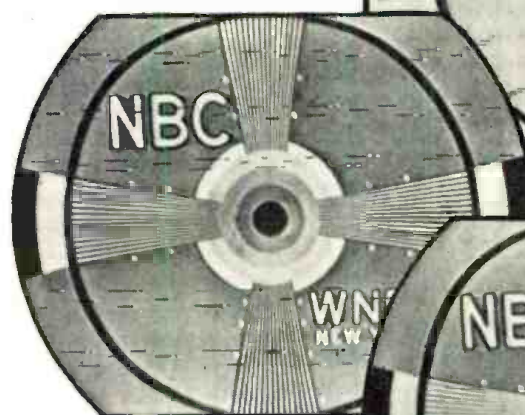
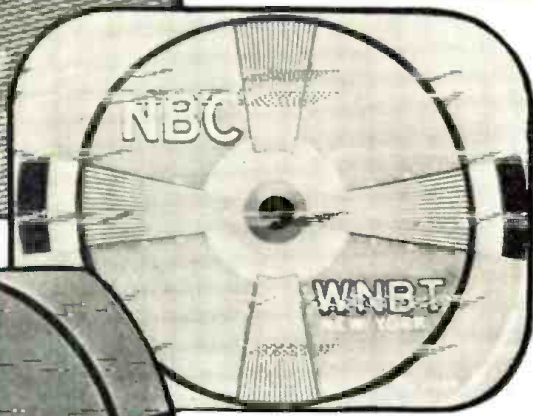

Fig. 7. Ignition interference causes no loss of sync, but annoying streaks on the picture.



Fig. 8. This familiar type of interference is caused by diathermy equipment operated in vicinity.

UNIVERSAL DESIGN CURVES

for Tone-Control Circuits

By
M. B. KNIGHT
RCA Victor Division
Harrison, N. J.

Part 1. The technician or audio enthusiast can use this practical design data for home-built equipment.

THIS article, the first of a series, is an expanded treatment of the author's discussion on practical RC tone-control circuits which originally appeared in the November 1951 issue of this magazine. The present series will describe simple circuit arrangements suitable for particular types of tone control and include frequency-response curves obtained with each circuit. The curves permit rapid evaluation of the ability of a circuit to fulfill specific design requirements. They also indicate the preferred potentiometer taper and facilitate the choice of component values.

The article in the November issue included two simple tone-control circuits; one for fixed or variable treble attenuation or fixed bass boost, and another for fixed or variable treble boost or fixed bass attenuation. This article covers a circuit designed primarily for variable treble attenuation.

Fig. 1 shows a tone-control circuit for fixed or variable treble attenuation or fixed bass boost. It was shown in the November article that a disadvantage of this circuit when used for variable treble tone control is its inability to provide a gradual tone adjustment over the full range of the potentiometer. Fig. 4 shows an equivalent circuit for a variable treble-attenuating tone control which, when properly applied, permits a smooth adjustment even with a linear pot.

This circuit is often used as shown in Fig. 1. In this circuit the resistance R is the effective parallel value of the plate load resistor, R_p , and the plate resistance, r_p , of the tube V_1 ; the potentiometer R is used as the grid resistor, R_g , and is much larger than R . As a result, this circuit behaves much like the circuit shown in Fig. 2 and has the same disadvantages. To obtain gradual tone adjustment, it is desir-

able to make R small compared to R_1 . Because a reduction in the value of the grid resistor would result in an objectionable loss in gain, the logical solution is to use the potentiometer as the plate load resistor, as shown in Fig. 5. With this arrangement R_1 is equal to

$$\frac{1}{\frac{1}{r_p} + \frac{1}{R_g}}$$

and will usually vary between the limits of one-fifth R (if V_1 is a triode) and five times R (if V_1 is a pentode). The frequency-response curves for this circuit, shown in Figs. 3, 6, 7, 9, and 10, indicate that a potentiometer with a logarithmic taper is desirable if V_1 is a triode, but if V_1 is a pentode a linear pot is usually preferable.

When the circuits shown in Figs. 1, 2, and 5 are used in high-level stages, care must be taken to avoid excessive distortion. Where high frequencies are being attenuated appreciably, the a.c. load impedance presented to tube V_1 is quite low and, as a result, the maximum permissible grid swing is reduced. It is not advisable, therefore, to attempt to obtain the maximum output voltage indicated in the "Resistance-Coupled Amplifier Charts" found in tube handbooks. Particular care must be taken not to attempt to obtain too much output voltage when the circuits are used for fixed bass boosting. When the circuits are used for treble attenuation, the distortion may not be objec-

Fig. 1. Application of the circuit of Fig. 4 with R much larger in value than R_1 .

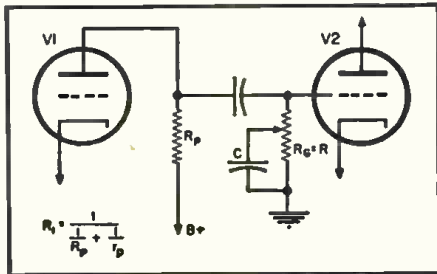

Fig. 2. Circuit providing fixed or variable treble attenuation and fixed bass boost.

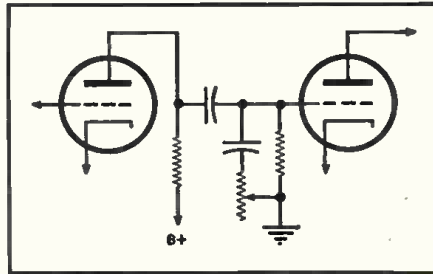

Fig. 4. Equivalent circuit for a variable treble attenuating type of tone control.

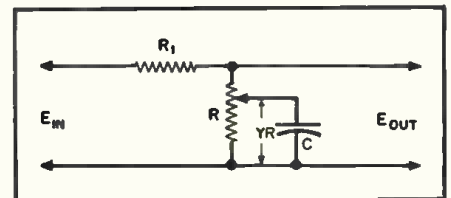

Fig. 5. Preferred application of the circuit of Fig. 4 with the potentiometer used as plate load resistor.

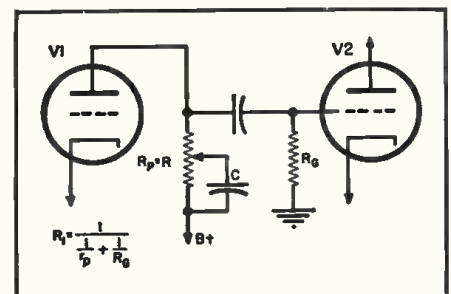
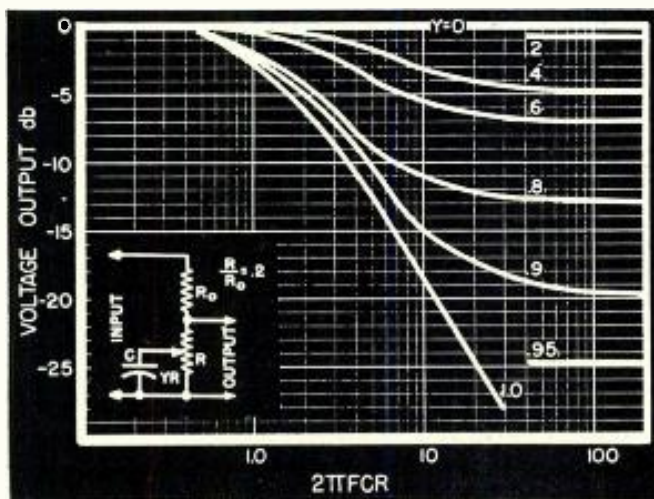

Fig. 3. Universal design curves for circuit of Fig. 5 when R/R_1 is equal to .2.



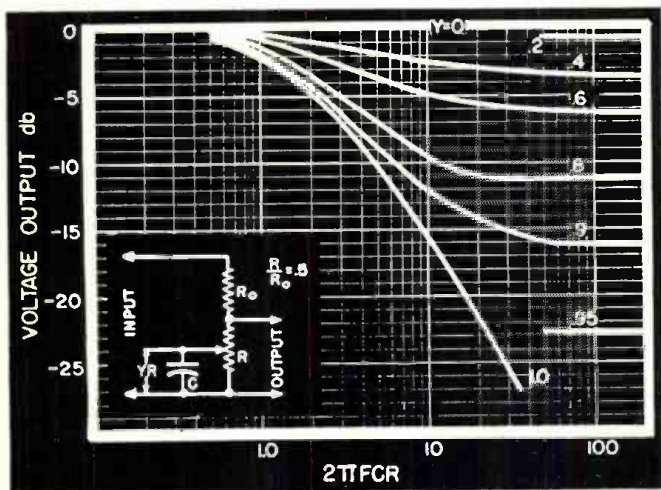

Fig. 6. Design curves for circuit of Fig. 5 when $R/R_0 = .5$.

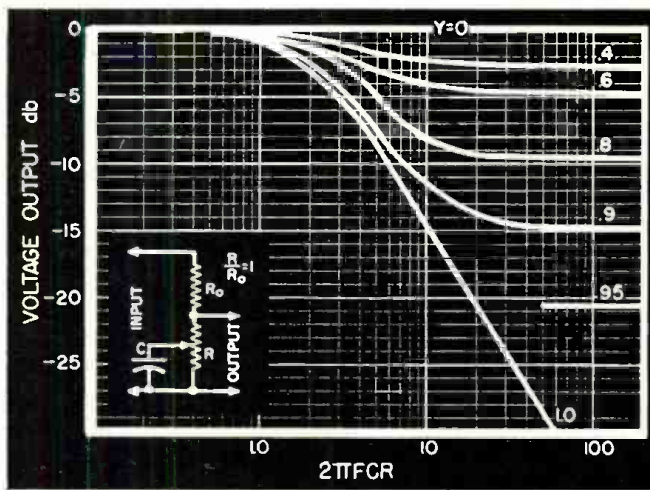

Fig. 7. Design curves for circuit of Fig. 5 when $R/R_0 = 1$.

tionable because of the coincident attenuation.

Distortion may be minimized by methods other than simply using the circuits in relatively low-level stages. The experienced designer can adjust the grid bias on tube V_1 to compromise between the relatively high a.c. load impedance at low frequencies and the lower load impedance at high frequencies. This compromise can usually be achieved by a slight decrease in bias. Another method, which reduces the gain, however, is the addition of resistance in series with the plate of V_1 . This latter method may be particularly useful with the circuit of Fig. 5 if V_1 is a triode because it may permit smooth tone control with a linear potentiometer.

To illustrate the use of the design curves, let us design tone controls for both a triode and a pentode, using the circuit given in Fig. 5. In each instance we shall assume that we want the maximum treble attenuation ($y = 1$) so that attenuation of 3 db is obtained at 1500 cycles. (The letter y denotes the setting of the tone control and is defined to mean the fraction of the total resistance of R included across condenser C .)

For a triode tone-control circuit, sup-

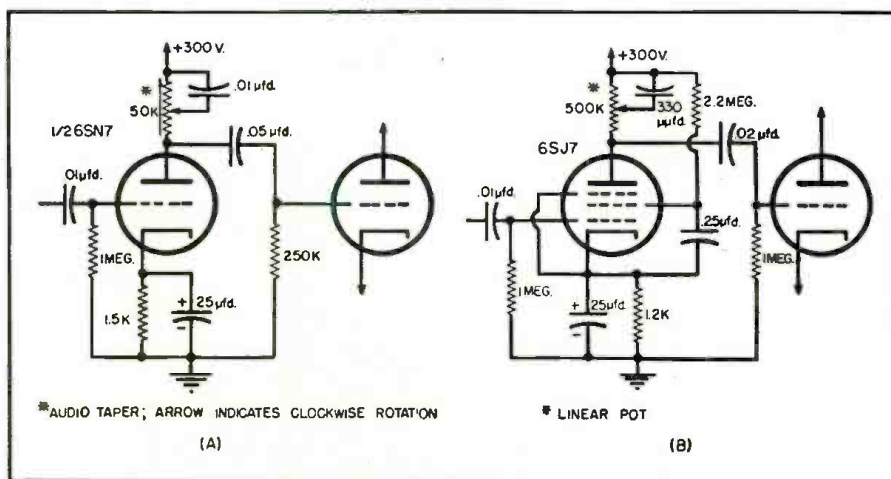

Fig. 8. (A) Typical triode tone control capable of providing 3 db of attenuation at 1500 cps. (B) Pentode tone control for 3 db attenuation at 1500 cps.

pose we are using a 6SN7GT in accordance with operating conditions given in the Resistance-Coupled Amplifier Charts. The plate load resistor, R_p , is 50,000 ohms, the grid resistor, R_g , of the following stage is 250,000 ohms, and the plate supply voltage is 300 volts. The cathode resistor, R_k , is 1500 ohms and the value of μ , obtained from the tube data, is 20. In order to

determine the value of R_0 , we first calculate the value of R_0 , the effective parallel value of the grid resistor, R_g , the plate load resistor, R_p , and the plate resistance, r_p , of tube V_1 . As was mentioned in the preceding article, we have found a formula which may be used to calculate R_0 directly with fair accuracy. (It must be remembered

(Continued on page 111)

Fig. 9. Design curves for circuit of Fig. 5 when $R/R_0 = 2$.

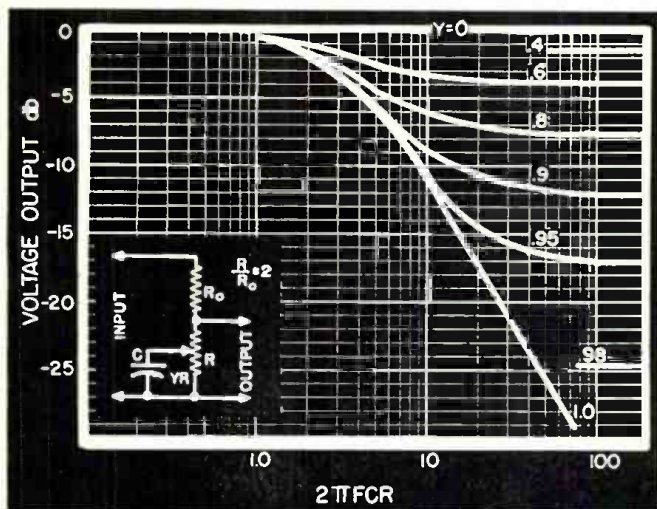
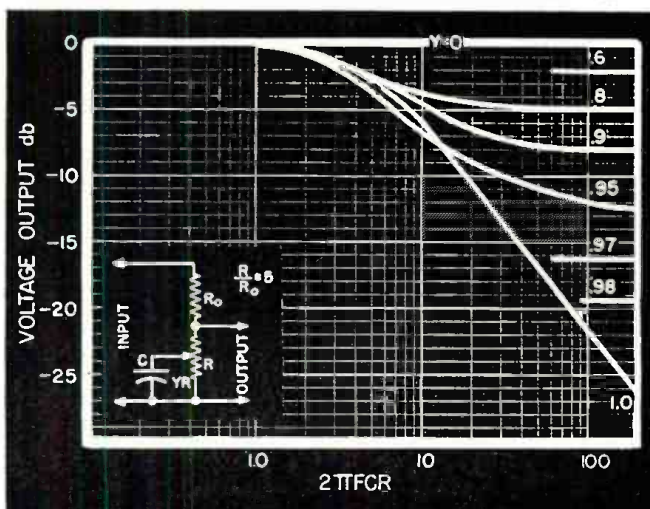

Fig. 10. Design curves for circuit of Fig. 5 when $R/R_0 = 5$.



HAMS AGAIN at DISASTER SCENE

By HAL SAGERT, W9BEF
Comm. Engr., Chicago, Rock Island & Pacific R. R.



A patrolman, equipped with a two-way radio, reports on the condition of the dikes which were thrown up around the North Omaha pumping station during flood.

Amateurs win new laurels for their tireless battle against the Midwestern floodwaters.

TWO-WAY communications equipment, in many instances manned by hams, played a decisive role in the epic struggle between the Missouri floodwaters and persons whose homes lined its banks.

While the hams who spent countless hours at the mobile and fixed transmitters expect no official recognition of their sacrifices, they do deserve a resounding "Well done!"

In Omaha and Council Bluffs, hams, industry representatives, as well as local and federal agencies worked together as a team to coordinate defense and rescue efforts. For ten days and nights hams operating on the Union Pacific Railroad frequency of 160.29 mc. manned stations set up in the Omaha City Hall and the Union Pacific headquarters building. From these stations were dispatched the emergency crews which were then rushed to the scene of possible breakthroughs. Vital information on the condition of the dikes was relayed periodically by patrolmen who walked the levees and reported their observations by means of portable two-way radio units.

-30-



Mobile station receiving orders from the net control with Harry Snyder of Fremont, Neb., as operator.



Amateur radio control station with Roy McCabe, W0UVU of Fremont at the controls and Mrs. I. Conklin, W0NXW, of Manilla, Iowa, about to take the "graveyard" shift.

One of the dike patrolmen making his half-hourly report to the flood control headquarters over his Motorola "Walkie-Talkie." These men maintained 24-hour watch on the dikes to report leaks, signs of weakness, and incipient collapses.

Radio maintainer straps handset to shoulder strap where handset receiver permits continuous monitoring of 160.29 mc. channel. Note that the dike patrolman wears a life jacket in addition to his compact transmitter-receiver carrying case.



PUBLIC ADDRESS SYSTEMS



AID BARKERS

By
JAMES KAUKE

THE day of the leather-lunged barker is rapidly drawing to a close with the widespread adoption of small public address systems by carnivals, bingo games, sideshows, and other similar attractions.

Formerly the barker or operator depended a great deal on the volume of his voice. With the use of a small public address system, voice volume is no longer important, and any desired crowd or gathering may be covered with little effort on the part of the operator.

With the high noise level of the average sideshow or carnival, only those in the immediate vicinity of the barker could hear the "pitch," with the result that the maximum crowd was not attracted. With a public address system, almost any size crowd may be covered with the same effort.

For carnival or sideshow use, the maximum usable volume is determined by the proximity of the neighboring attractions, and the noise level. To avoid conflict with the other shows, either a staggered operating schedule must be used, or the volume held down to the minimum necessary for coverage. For the majority of applications of this nature, relatively low output power is adequate, and amplifiers in this service usually develop between three and twenty watts of power, with the average unit having an output of about ten watts.

The personnel using equipment of this type are non-technical, and consequently the equipment must be simple to operate and have a minimum of controls. As the equipment may be subject to rough handling it must be designed to operate satisfactorily under almost any conceivable condition.

In most outdoor installations it is necessary to dismantle the equipment at the close of business each day, and this requires that the installation be

***Earn extra income by renting or selling compact
p.a. systems for hall, church, or carnival use.***

as simple and lightweight as possible. Bulky equipment or complicated installation will defeat the "simple" appeal, and tend to build sales resistance on the part of the customer.

It is a common practice to use music to fill in the intervals between shows and act as an added attraction. This music can be easily supplied by a small phonograph connected to the phono input of the amplifier if the amplifier has provision for such input.

The amplifier shown on this month's cover fulfills these requirements adequately. It is a ten watt model E-10 manufactured by the *Newcomb Audio Products Company*, and is furnished with both microphone and phono input. A carrying case with a self-contained speaker is also available for portable applications. A tone control circuit allows the operator to adjust the tone for the best coverage.

Multiple output connections are available to allow the use of speakers of various impedances, or different combinations of speakers.

In the matter of microphones for use in such installations, the user has a wide selection of types from which to choose.

A hand-held unit has many advantages in this type of work as its use is not limited to a single person but can be passed around as required.

The microphone shown on this month's cover, the *American Microphone Company's* D4G, is another such possibility. It is a "chest" type which uses a leather-covered spring steel strap to hold the microphone in correct relation to the user's mouth.

Desk and floor-stand models, while

allowing less freedom of movement for carnival barkers, etc., are excellent for banquet speakers, pulpit installations, and such. Lapel mikes offer still another possibility, especially for indoor and relatively quiet installations, but may be less effective in outdoor locations because of the background noise picked up.

A great many different types of speakers may be used, depending on the particular application. For indoor installations, any of the several conventional speakers mounted in baffles or carrying cases may be used with the housing selected on the basis of a temporary or permanent installation.

In outdoor installations, the speaker requirements are more exacting, especially if the installation is of a permanent nature. The speaker should be selected for its weatherproof quality and field of coverage.

Various types of speakers are available for outdoor installations. The most popular are the trumpet, radial reflex, and the wide-angle type shown in the cover photo. The exact type selected will vary with the area to be covered, and should be chosen on this basis. The unit pictured is an *Altec-Lansing* speaker which is especially suited for wide angle coverage. In other applications it is probable that another type would be better suited.

The convenience of small p.a. systems in applications of the type illustrated has done much to increase the appeal of carnivals and other types of sideshows, and offers an additional source of revenue for the service technician and dealer in equipment of this type.

-50-

Improved Intercarrier Sound System

By

WALTER H. BUCHSBAUM

Author, "Television Servicing"

Circuit details and alignment data on a sound system being used in many of the 1952 model television receivers.

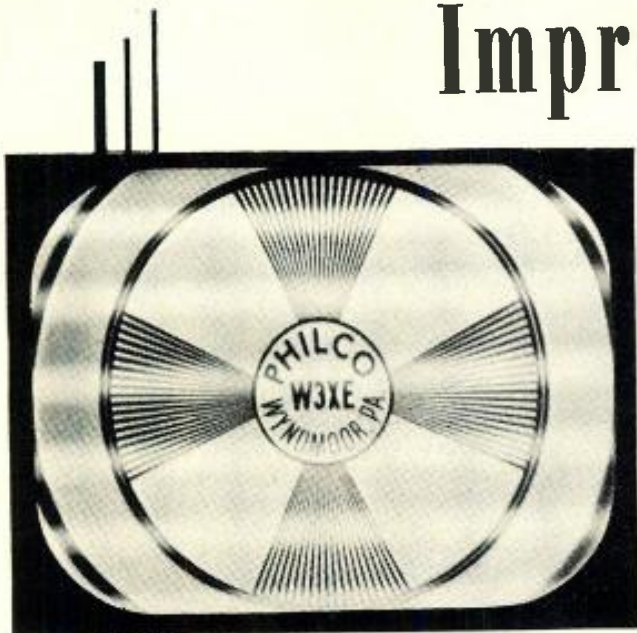

Fig. 1. A type of interference due to slope detection. This circuit fault was fairly common in the early intercarrier video sets.



IN PRESENT television broadcasting the picture signal is transmitted on an amplitude modulated carrier while the sound signal is sent along on a frequency modulated carrier, 4.5 mc. higher than the picture carrier. At the receiver the local oscillator beats with both picture and sound carrier and produces an i.f. signal in which the sound carrier is 4.5 mc. lower than the picture carrier. Most old type television receivers separate the sound and picture carriers in the i.f. section and amplify and detect them in different sections of the receiver. In the intercarrier system both sound and picture carrier are amplified together through all i.f. stages. At the second detector the sound and picture carrier produce a beat signal of 4.5 mc. and this beat signal carries the frequency modulated sound as well as some of the amplitude modulated picture signal. Although no second local oscillator is used here it is correct to consider this a double superheterodyne system because effectively two i.f. frequencies are used. The 4.5 mc. i.f. signal is then amplified and the FM sound signal which it carries is detected in either a ratio detector or discriminator circuit.

The obvious advantage of the intercarrier system is the fact that the 4.5 mc. i.f. which is fed to the FM detector remains at exactly that frequency regardless of local oscillator drift or misadjustment of the fine tuning control. As a matter of fact in many intercarrier receivers the fine tuning control is omitted. Another great advantage of the intercarrier system is that it is possible to detune the receiver

for extremely weak signal areas and still get clear and undistorted sound. Just how this helps out in a fringe location is shown in Fig. 2. The dotted lines represent the normal location of the picture and sound carrier on the i.f. response curve. Shown in solid lines is the arrangement obtained by detuning slightly and sliding the picture carrier up on the i.f. response. A picture signal increase of 2:1 can be achieved here and although this results in some loss of fine detail, this loss is often tolerated to get more contrast. If such detuning were attempted in a "split-sound" receiver the sound i.f. would be incorrect and the FM detector would produce only a garbled and distorted noise.

Early Intercarrier Sets

As most TV technicians have observed, older intercarrier receivers are subject to a number of annoying de-

Fig. 2. Normal location of the picture and sound carrier on i.f. response curve (dotted lines) and arrangement obtained by detuning slightly and sliding the picture carrier up on i.f. response (solid lines).

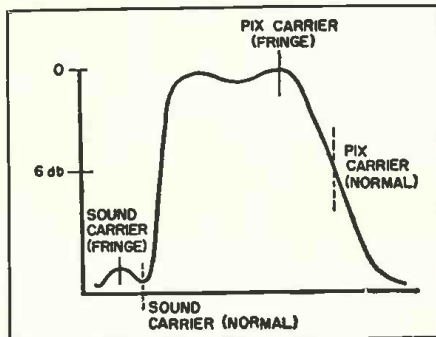

fects. Probably the most notorious is buzzing. The symptoms are quite easy to recognize and often very difficult to cure. The sound system produces an audible buzz or hum which is especially bad on strong stations. Sometimes this buzz can be reduced by careful alignment of the ratio detector and all 4.5 mc. circuits, sometimes nothing seems to help. When viewed on the oscilloscope this buzz turns out to be the regular 60-cycle vertical synchronizing pulses which are being amplified along with the FM sound signal. As mentioned before, the 4.5 mc. beat signal contains both the FM sound carrier and the picture carrier of which the 60-cycle pulses are the most pronounced feature. Another drawback of some earlier intercarrier systems was the appearance of a fine, grid-like interference pattern on the screen. This was the 4.5 mc. signal becoming visible due to an overly broad video amplifier response curve. The other extreme, a narrow video response curve, resulted in loss of fine picture detail and a dull and fuzzy appearance. One other disadvantage of the earlier intercarrier circuits was the operation of the ratio detector under strong ignition noise. Because of the fairly large electrolytic condenser, often 10 μ fd., strong noise pulses appeared to "punch holes" in the sound by silencing the detector circuit for audibly long periods. The "split-sound" receivers used a discriminator circuit which suppressed noise pulses but did not exhibit any long silent periods.

One more drawback of the earlier intercarrier sets was the limited bandwidth used both in the i.f. and video amplifier sections. In the i.f. this was done to avoid slope detection of the sound signal. If the video detector, by slope detection principles, removes the FM sound modulation this sound signal is amplified by the video amplifier and looks like the 400-cycle bar interference shown in the photograph of Fig. 1. In older receivers the i.f.

RADIO & TELEVISION NEWS

bandpass is so arranged that the sound i.f. is at the flat bottom portion of the i.f. curve. To reduce 4.5 mc. interference in the picture, the video frequency response of some low cost receivers appeared like the curve in Fig. 3A. The curve in Fig. 3B is closer to the ideal and will give much snappier pictures and finer detail.

Because of these shortcomings intercarrier circuits were used mainly in inexpensive receivers where the fact that one or two tubes could be eliminated outweighed the poor performance of the set. Recent developments, however, have shown that an intercarrier system can be designed which exhibits all of the advantages and none of the shortcomings of the earlier models. There are no substantial savings in parts or labor in this improved system, but its superior performance has caused it to be adopted by practically all nationally-known TV manufacturers. The improvements made in the original system are not all as obvious as adding another 4.5 mc. i.f. amplifier tube. Some of these new features can be incorporated in older sets and eliminate some chronic complaints, others may require excessive modification. Understanding the principles involved and their application in circuits will help the technician with older sets as well as with the 1952 models now using these circuits.

Intercarrier Improvements

The most outstanding and most beneficial change is the addition of a second 4.5 mc. i.f. stage and the removal of the 4.5 mc. i.f. directly at the second detector. The additional i.f. amplifier provides much greater selectivity to the 4.5 mc. signal and more effective rejection of lower frequency video signals. Instead of the two tuned circuits shown in the block diagram of Fig. 4A, the new version, give improved sound sensitivity as well as less interference. In the first system the ratio detector is driven by a single tube which usually was designed to provide some limiting on very strong noise pulses. When weaker signals reached its grid, no limiting occurred. Thus the entire burden of rejecting amplitude modulation fell on the ratio detector circuit. This circuit, however, rejects AM signals best on medium strength signals. When either very weak or very strong signals are used, AM rejection is not too good. Note that in the improved intercarrier version the tube immediately preceding the ratio detector works as a true limiter, which is possible because it receives sufficient signal to build up a high grid bias. Low screen voltage, together with high grid-leak bias, clip and limit much of the AM portion of the 4.5 mc. i.f. This permits the ratio detector to do a much better job of removing the remaining AM components, especially since the signal coming from the limiter is almost constant in amplitude, regardless of the received signal strength. The gain in the first 4.5 mc.

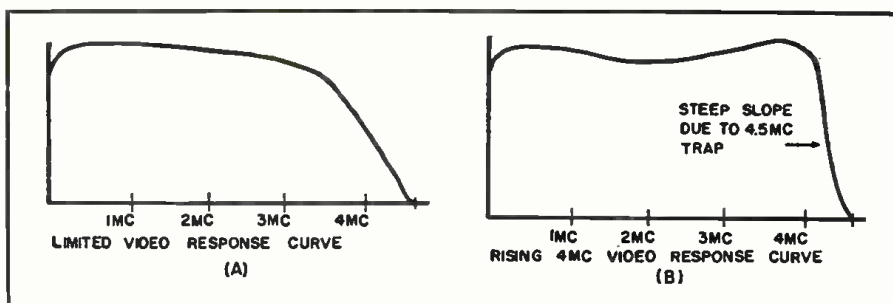

Fig. 3. (A) Limited video response curve, and (B) rising 4 mc. video response curve.

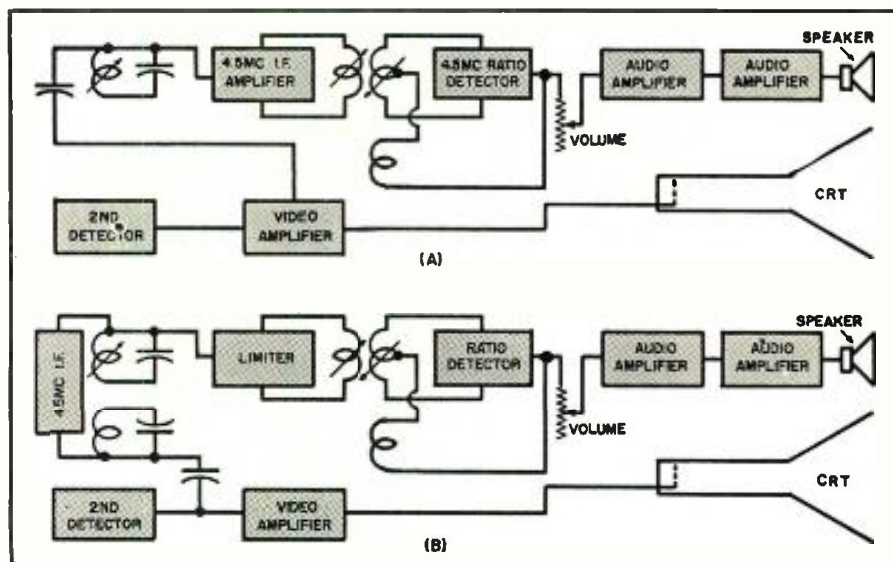

Fig. 4. (A) Block diagram of early-type intercarrier circuit. (B) New version (see text).

i.f. amplifier need only be from 20 to 30 times to give enough signal for the limiter and ratio detector. Pentode i.f. amplifiers like the 6AU6 which is most often used in this circuit, usually provide at least a gain of 30 times.

Since the 4.5 mc. signal is taken off at the detector, much less of it is amplified in the video amplifier section. But to make absolutely sure no 4.5 mc. interference can occur, a series or parallel trap is often used in the video amplifier. With the use of such a trap it is possible to extend the video amplifier response curve to about 4 mc. and yet provide a sharp dip at 4.5 mc. Such a curve is shown in Fig. 3B, and

will invariably add greatly to the snap and resolution of the picture. On large screen tubes the difference in video response curve is quite pronounced.

The circuit of Fig. 5 is typical of the improved versions of the intercarrier system. The ratio detector section is the balanced type and differs from older circuits mainly in the use of a 2 μ fd. condenser for C_{10} . The smaller value helps reduce "holes" due to ignition noise. The 6AU6 limiter tube operates at low screen voltage, usually about 60 volts, and grid leak bias is developed across R_4 , the 120,000 ohm grid resistor. In the circuit shown (Continued on page 120)

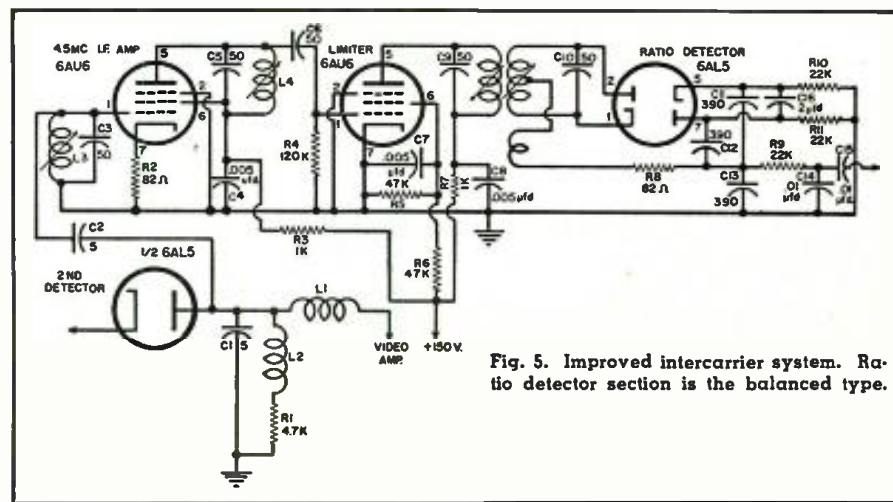

Fig. 5. Improved intercarrier system. Ratio detector section is the balanced type.

Unique Magnetic-Tape Applications

By **LEON A. WORTMAN**

Director of Adv. and Sales Promotion
Audio & Video Products Corporation

AS "REEL REVIEW," a monthly feature in this magazine, gains recognition, more interesting information and unique applications of magnetic tape are brought to our attention. One of the most unusual, and rather interesting, applications we have encountered is the way in which the "Ice Capades" show uses *pre-recorded* magnetic tapes.

The "Ice Capades" is an itinerant unit, traveling around and across the entire nation several times a year. It is continually faced with the problems of setting-up and tearing-down. The cast of "Ice Capades" is quite large, enabling the presentation of extravaganzas on ice. Such presentations as "Snow White," "Student Prince," and "Cinderella" are staged with music, singing, dialogue, and special dance routines. The problems of feeding a public address system are obviously extremely difficult and quite unusual. The technical directors of the "Ice

Capades" found the solution to this particular problem in pre-recorded magnetic tape.

The cast of actors and singers pre-record all singing and dialogue on magnetic tape. Continuous rehearsals and applications of the art of editing, so practical with magnetic tape, provide the show with the best possible audible elements of the productions. During the actual performance, the magnetic tape is fed into a mixing console. Microphone pickups are placed in front of the huge orchestra which travels with the "Ice Capades." The orchestra, following the conductor's baton, then plays in synchronism with the tape recorded vocals. The performers on the ice "mouth" the pre-recorded vocals and dialogue as they

go through the skating routines. Everything is amplified and piped through horns suspended above the rink. Therefore, during the performance the audience sees skaters, actors, and a live orchestra all going through the motions of a live performance while a good portion of the sound is actually coming from the magnetic tape. John A. Harris, president of the "Ice Capades," writes that the illusion is perfect, enhanced by the fact that no microphones can be seen on or above the ice. Microphones would represent a real hazard to skaters and their use would, therefore, be undesirable.

Several questions regarding magnetic tape were submitted to Mr. Harris: Do you have confidence in the durability of magnetic tape and the recording equipment? How much usage have you given your present equipment? How often do you service the equipment? Mr. Harris replied that his machine has worked three full seasons and traveled more than 30,000 miles, doing an average of 360 shows a year. He states they are quite satisfied with the job that magnetic equipment has done and that it has certainly stood up well. Once each year the machine is checked over completely and the only important replacements have been those that would have been necessary anywhere, such as brake bands and mechanical parts that just wear out from use.

Donna Atwood, star of the "Ice Capades," added, "I had great concern in our first year of the presentation of the dialogue because we were using discs. Regardless of how many discs they used, there was always the surface sound present and in so many cases scratches would develop but, most of all, the fact that the slightest
(Continued on page 112)

Donna Atwood, star of Ice Capades of 1952, gives her reaction to the Ice Capades' unique use of pre-recorded tape. The Ampex Model 200 has traveled more than 30,000 miles and recorded and played back an average of 360 shows a year. The equipment is still in use.



A diversified group of organizations have adopted magnetic tape to solve special sound problems.

Robert J. Coar, coordinator of the Joint Senate and House Recording Facility in Washington, is shown with Senator Joseph C. O'Mahoney of Wyoming in the tape recording room. The Facility is made available to members of the House and Senate for recording progress reports for the benefit of their constituents.



IMPROVED BROADBAND CONVERTERS

By
ALVIN B. KAUFMAN,
W6YOV

THE author's article on broadband converters which appeared in the March 1950 issue of *RADIO & TELEVISION NEWS* was received with so much enthusiasm by the SWL and amateur, that the author felt that new design improvements should be passed along to the reader. The modifications for improvement require no major overhaul for those who built the two-tube converter and, for the newcomer, complete construction details are supplied on a converter that may be built with limited finances and without any of the bugs or complications encountered in many such units.

The reader will be pleased by the simplicity and straightforward design of this converter, which may be used on the 75, 40, 20, or 10 meter amateur bands as well as on aircraft, police, or civil defense frequencies.

In general, there are two types of converters presently in use. By far the most common is the tunable converter wherein the receiver is tuned to a fixed point and the converter oscillator frequency is varied so as to produce a conversion or mixed frequency, always at the same frequency to which the receiver is tuned. The other type of converter, not commonly in use, employs a wide-band r.f. input and output and a fixed-frequency oscillator. This is the "broadband converter." Its output frequency varies with the frequency of the incoming signal and must be detected by tuning the receiver rather than the converter. The converter to be described is of the "broadband" variety with another important innovation added, i.e., crystal control.

One common complaint about practically all high-frequency converters is frequency drift and, for the builder without a signal generator, difficulty in securing proper operation. Crystal control eliminates both of these troubles. There are no tricky adjustments and no difficulties encountered in tuning or finding the frequency range covered by this converter. With the proper crystal frequency your car or



Side view of converter. Oscillator adjustment screw is on top while mike jack and r.f. input adjustment can be seen on the right.

This new version of the unit originally described in the March 1950 issue features lowered background noise, better signal-to-noise ratio, and an improved over-all gain.

house radio tunes the ham band as a perfect "bandsread" unit. Transmitting or receiving type crystals are used in the converter; the crystal frequencies to use for the different bands will be indicated during a discussion of the converter. The crystals used are not expensive as an accurate frequency is not required. No special frequency unit is required for the ten-meter band.

A two-tube converter of this type admittedly does not have the gain of a four- or five-tube unit, but neither is it as expensive. In its field of operation its good points certainly outweigh any objections to its lessened sensitivity or slight loss of bandwidth when used on the ten-meter band. On the ten-meter band the author has received signals from all over the country and considers the sensitivity satisfactory.

There is one prerequisite that *must* be met when a broadband converter is used. The broadcast receiver tunes in the converted signal as if it were on the broadcast band. This means that the BC receiver must be completely "dead" at nearly full volume when the antenna is not connected. Car radios, being well shielded, generally have no pickup, but the average inexpensive a.c.-d.c. set may have excessive pickup in which case it would interfere with the short-wave signal. In any case a shielded cable must be used from the converter into the broadcast receiver. This cable should be of the low-loss coaxial type such as RG 29/U, RG 58A/U, or RG 62/U, etc. With the

converter connected to the receiver a small amount of broadcast signal may come through until the converter warms up and supplies a signal and background noise to operate the a.v.c. in the receiver.

The converter employs two tubes, one as a crystal-controlled oscillator and one as mixer. Starting at the antenna the r.f. signal may be tapped into the r.f. coil a few turns from the bottom or fed in through the coupling antenna coil as shown in the schematic. This coil is of the high-"Q" type. A *National XR-50* coil form is wound with sufficient wire so that with its variable iron core and the tube's input capacity it will tune through any band selected. The coil windings for 75 meters and the lower frequency may be either layer or scramble wound without apparently affecting the broadband converter performance. For the higher frequencies it is desirable to space the winding the length of the XR-50 coil form but by experience it has been found that when this coil form is used the winding is not critical, making only a few hundred kc. difference in the tuning range allowed by the slug adjustment. The additional capacity introduced into the r.f. grid coil circuit by the coupling coil and shielded lead, etc. may, in some cases, necessitate the removal of several turns on the higher frequency coil in order to obtain the best tuning range. In all cases the best "Q" is secured when the tuning slug is as far out of the coil as possible. If necessary, the grid coil should have its

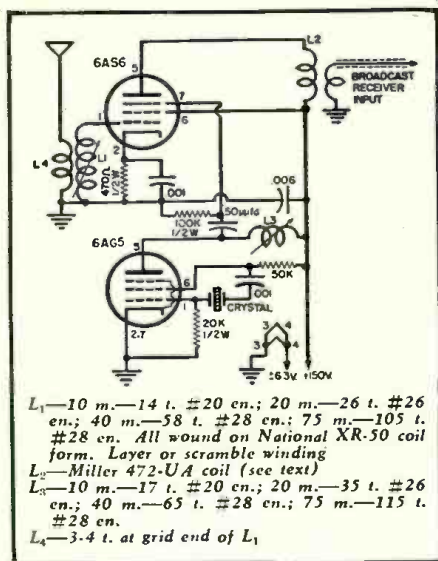

Fig. 1. Circuit of the "improved" broadband converter. See Fig. 2 for schematic of original unit. The 6AS6 specified in the parts list, while widely used in commercial equipment and generally available at wholesalers, may be difficult to obtain. In this case, the new 6BN6 may be used as a substitute.

winding reduced from the turns given in the coil table accompanying Fig. 1.

The coil shows high "Q" over a wide frequency range, falling off rapidly from the selected frequency out some distance. Rather than lower the "Q" by loading the coil with a resistor, which would "broaden the response" to the detriment of the center frequency gain, no loading devices were used. In television where a flat response over a wide frequency range is required, loading is employed even though loading effectively lowers the resonant frequency gain of the coil. Summed up in simpler words, the unit will be "hottest" near the peaked frequency of the coil. This coil's iron core should be

adjusted after it is connected to the antenna so that it will resonate close to the frequency at which your transmissions are taking place or at that section of the band where peak performance is desired. In actual practice the performance over the entire band is quite satisfactory.

The plate of the 6AS6 is connected to a Miller 472-UA r.f. coil. The Miller 472-UA coil is a broadband broadcast coil designed to couple an antenna to the grid of the first r.f. tube, which is untuned. Here it is used in reverse. The grid winding is used as the plate winding in the converter, while the antenna coil feeds the converter output into the broadcast receiver antenna input. See Fig. 3. This coil must be modified slightly from the manufacturer's configuration to fit this circuit. The grid return and bottom of the antenna coil are connected and are common on one post. These must be unsoldered and one wire shifted to the unused lug on the Micarta strip. The aluminum shield can which houses this coil may be dispensed with, as was done on the author's unit, to provide a more compact converter.

The special 472-UA coil is available at most wholesale radio stores, but may also be secured from the J. W. Miller Company, 5917 South Main Street, Los Angeles 3, California.

The use of a broadband broadcast frequency coil in the plate circuit of the converter makes special shielding unnecessary. Where both the plate and grid circuits are tuned to the same frequency (as in some converters) careful shielding is required or the circuit may "take off" into tuned-plate, tuned-grid oscillator action.

The crystals used in the converter may be either of the transmitting or receiving type. Westline transmitting crystals were used by the author. The

crystal frequency selected should preferably be at the low frequency end of the band. This is done so that as the incoming short-wave signals increase in frequency the resultant conversion frequency is also higher and thus the receiver is tuned to a higher frequency. On certain bands this permits adding a factor to the broadcast receiver dial setting and reading it directly in the short-wave frequency! The crystals should be of the following frequencies. A 3000 kc. crystal should be used for the 75-meter band. Here the low frequency end of the band, 3500 kc., will appear at 500 kc. on the broadcast receiver while 4000 kc., the high frequency end of the band, will appear at 1000 kc. on the dial, etc. Thus for the 75-meter band a factor of 3000 would be added to the dial indication. Any crystal frequency and such crystals may be found in surplus or may be ground on special order for a few extra dollars. A 2500 kc. crystal could be used, in which case the 75-meter band would fall between 1000 and 1500 kc. on the receiver. The crystal frequency selected depends, to a large degree, on how accurately you wish the broadcast dial to reflect the short-wave frequency. For the 40-meter band a crystal frequency of 5800 to 6500 kc. can be used. A 6000 kc. unit is preferable as the low frequency end of the band would appear at 1000 kc. on the receiver and the broadcast dial could be read directly in short-wave frequency by adding a factor of 6000. The 20-meter band could be covered by a crystal frequency of 6450 to 6750. Again 13,000 kc. would be best, the low frequency end of the band appearing at 1000 kc. on the receiver. A factor of 13,000 would be added to make this band track on the receiver. In this case a 6500 kc. crystal would be used, and its second harmonic of 13,000 kc. injected into the mixer tube. These lower frequency bands present no problem of frequency coverage as they are only 300-500 kc. wide and thus the radio receiver gives more than adequate coverage and sufficient band-spread. The 10-meter band, being 1700 kc. wide, cannot be entirely covered by a broadcast receiver, but the band-spread action is excellent as the band covers more of the dial. Actually for a given increment of dial movement the receiver would tune the same frequency difference on any bands and there would be no difference in selectivity on any of these bands. The proper crystal frequency for 10-meter coverage depends upon which section of the band you wish to receive. My choice is from 28.5 megacycles to 29.6 megacycles. This calls for a 7000 kc. crystal. Its fourth harmonic falls at 28 megacycles and thus by adding 28 to the receiver dial a 28.5 mc. signal appearing at 500 on the dial would be read 28,500. The factor would be 28 or 28,000. An advantage here is that 7000 to 7010 kc. crystals are easily obtainable as they are in the 40-meter

Bottom view showing placement of parts. As mentioned in text, the mike jack, transmitter button, and "s.w.b.c. switch" are not required but are merely accessories.

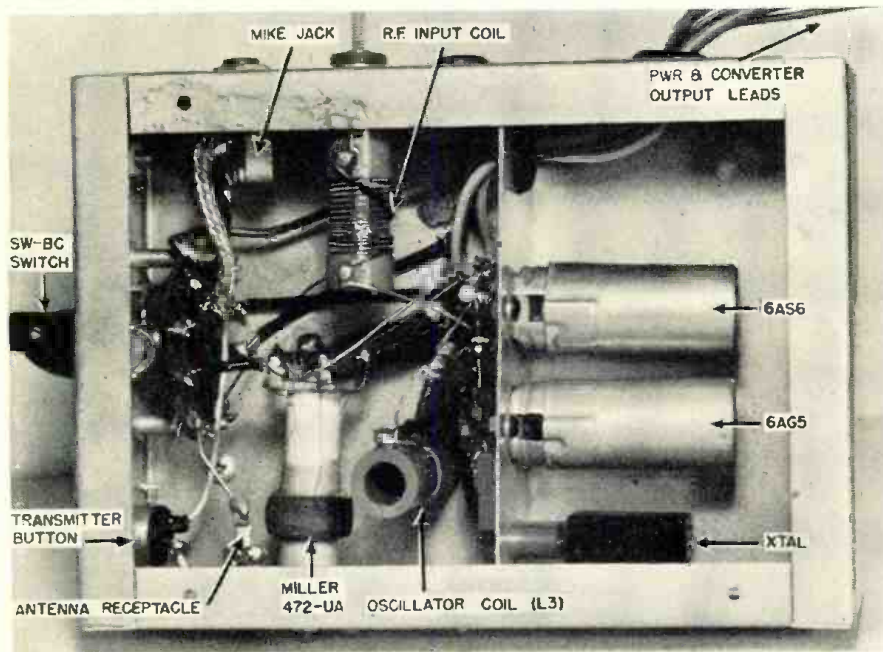

band. To cover from 29,700 kc. down, a 7050 kc. crystal is necessary.

A 10-meter version of the converter was constructed and installed in the author's car to complete a mobile station. Although the previous information regarding crystals, coils, etc. applies to this unit, as well as the old dual 6AG5 converter (Fig. 2), there are additional new features requiring explanation of adjustment or theory. During experimental development of this converter it was determined that the popular 6AK5 tube was not satisfactory as a converter oscillator for two reasons. This tube is rated at 180 volts maximum plate supply and the tubes tested were gassy enough to ionize at the admittedly high supply voltage of 250 volts d.c. The worst feature was the wide change in transconductance when the tube was subjected to vibration. The 6AG5 possesses neither of these objectionable features. Of course, this does not condemn 6AK5 tubes for other uses.

The oscillator section of the converter consists of a single 6AG5 tube whose screen grid circuit is wired as a Pierce oscillator and whose plate circuit is resonated to the fundamental or harmonic frequency required. A low frequency crystal is used for the high frequency bands, as outlined previously, and the plate circuit of the oscillator is tuned to a multiple of the crystal frequency. Both the oscillator coil and the r.f. input coil are tuned while operating the converter into a receiver.

The receiver must have either an "S" meter, no a.v.c., or a very weak input signal applied to it. If a signal generator is not available any signal may be tuned in by the receiver on the ham band. Even without alignment there will be enough signals coming through for this purpose. After a signal or carrier is tuned in, the r.f. oscillator coils are tuned by their iron cores for maximum receiver output. It is advisable to disable the a.v.c. circuit in the receiver if the receiver does not have an "S" meter or peak tuning may be almost impossible. Where a high gain ham receiver is used for this tuning operation, a certain amount of broadcast leakage may be expected which will not appear with a car or home-type receiver.

The antenna may be coupled into the converter by tapping directly into the coil, or by means of the variable impedance antenna coupler as shown in the dual 6AG5 converter schematic (Fig. 2), or by using an antenna coupling coil (Fig. 3). The variable impedance antenna coupling has been used on many other signal boosters, but the author has found the coupling coil gives best results, causing less r.f. input losses and detuning.

The dual 6AG5 converter, like all converters employing grid injection of the oscillator signal, must have the converter tube biased near cut-off or plate current saturation in order to operate on a nonlinear section of the plate curve so that mixing action will

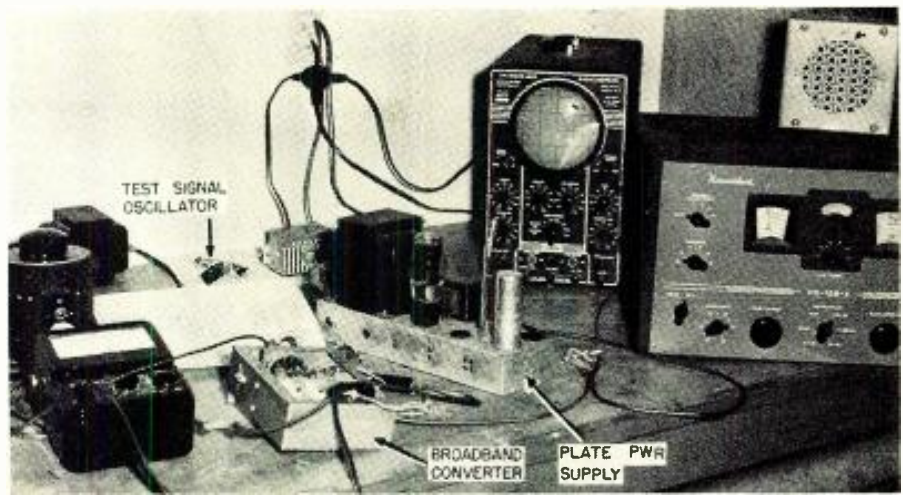

A "design-measurement" setup for use in checking the broadband converter unit.

occur. This type of operation has two disadvantages. With the tube biased near cut-off excessive tube shot effect or random noise output (hiss) occurs, while biasing in the other direction may shorten tube life due to high plate currents, in addition to demanding much more from the d.c. power supply. Further, the tube g_m is practically non-existent at either of these two bias points, resulting in no amplification of the r.f. signal, merely a mixing action, generally with poor signal-to-noise ratio. Even with the pentagrid oscillator mixing tubes this condition exists due, however, to other factors. Class A biasing of the mixer tube can be employed for the grid injection circuit providing sufficient oscillator power is available to drive the mixer to cut-off on the negative portion of the oscillator cycle. This is not usually possible, and even where possible results in excessive oscillator radiation unless an r.f. stage is employed. With this new circuit background hiss has been lowered sharply but cannot be completely eliminated, except in the presence of a signal, due to the wide range of random noise pickup over the wide r.f. band to which the input stage of this unit is sensitive. A sharply-tuned r.f. stage lowers this type of hiss or random noise but entails another tuning operation and when tried experimentally was not deemed of sufficient merit to be incorporated. It was also noted that this new circuit was more impervious to ignition noise, while the old grid injection unit amplified the strong positive peaks of ignition r.f.

The 6AS6, 6AG5 converter eliminates these factors by employing a new principle described by Vernon Aske of *Sylvania Electric Products Inc.* in his article, "Gain Doubling Frequency Converters," in the January 1951 issue of *"Electronics."*

Fundamentally the biggest change is the method by which the oscillator signal is mixed in the converter tube. The cathode, first grid, and screen of the 6AS6 operate as a class A r.f. amplifier, while the suppressor grid is alternately driven positive and nega-

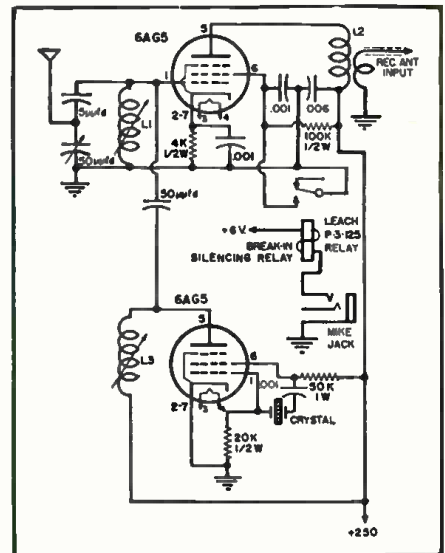
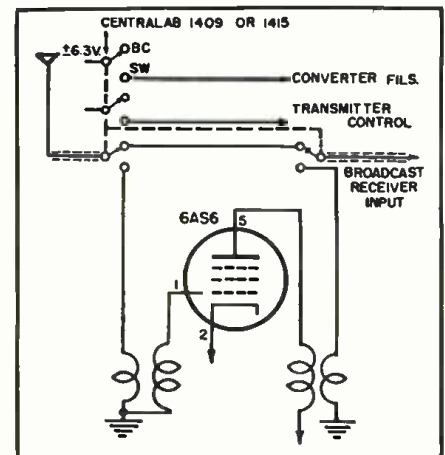

Fig. 2. The original broadband converter as covered in the March 1950 issue. Note the differences between this and the revised version shown schematically in Fig. 1.

tive by the local 6AG5 oscillator. This results in amplification of the r.f. signal. This change of plate current is then modulated by the r.f. signal applied to the suppressor grid. The sup-
(Continued on page 118)

Fig. 3. Circuit diagram of the converter's broadcast antenna switching arrangement.



A Novel Multi-Band TUNING CIRCUIT

By
DAVID ZAAYER, PAOUN

Philips Research Laboratories
Eindhoven, Holland

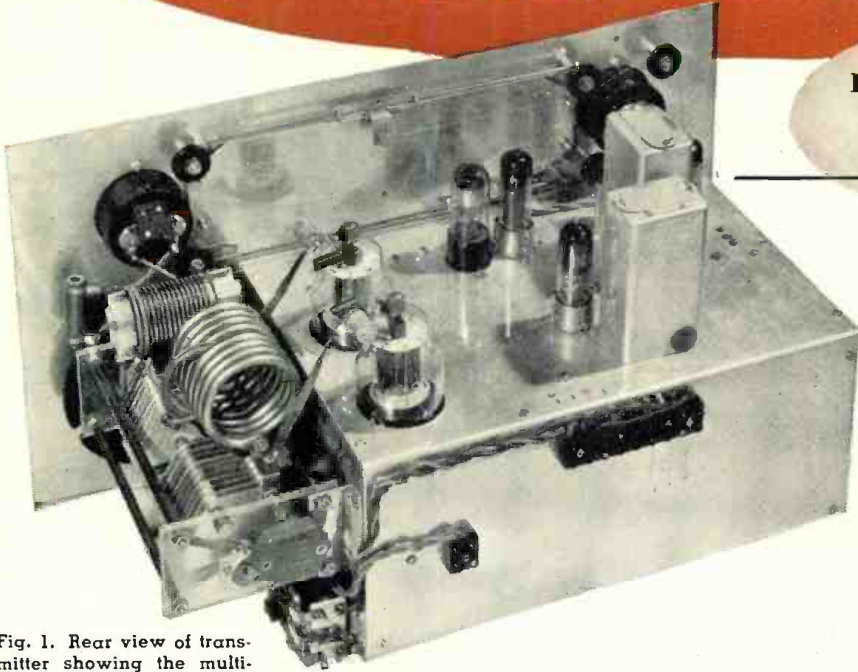

Fig. 1. Rear view of transmitter showing the multi-band tank circuit at left.

A unique bandpass tank circuit permits operation on all ham bands by merely flipping a switch.

THE first multi-band tank circuit developed by the *National Company* several years ago used a four-gang condenser and had two push-pull circuits in series on 14, 21, and 28 mc.¹ Later articles showed the same circuit cut in half and applied to a single stage.²

The push-pull version of the circuit with the two push-pull tanks in series has consequently twice the circuit losses of a single push-pull circuit. However, the even harmonics are more or less cancelled out.

The single-ended version, which has the advantage of requiring only a two-gang condenser, has normal circuit losses, but all harmonics are developed equally.

A new multi-band circuit,³ shown in Fig. 2, uses two tubes which operate in push-pull on 28, 21, and 14 mc. and in parallel on 7 and 3.5 mc. The changeover from push-pull operation to parallel operation is automatically achieved as resonance is reached on each band. Circuit losses are normal as one push-pull circuit is in operation on the higher frequency bands and a single-ended circuit on 7 and 3.5 mc.

In addition, due to the in-phase ex-

citng voltage on the low frequency range, it is impossible to develop harmonics in the high frequency range as the latter tunes only in push-pull.

Hence 3.5 and 14 mc. may tune at the same spot on the scale as well as 7 and 28 mc. The tuning range can be made smaller than with the other published multi-band circuits for this reason.

Many of us have probably applied the principle of this multi-band circuit, though with other coil dimensions.

The circuit is given in Fig. 2. When L_2 is an r.f. choke, this circuit is the well-known push-pull final in which the d.c. is removed from the condenser. L_1 is very small in comparison with L_2 as the latter is usually a 2.5 mhy. choke. For lower frequencies we may say that L_1 puts C_1 and C_2 effectively in parallel to tune L_2 to some very low frequency (say 300 kc.).

Both tubes must be excited in-phase for amplification at this frequency. However, excitation is never applied at this frequency and consequently there is no voltage developed in the output circuit.

However, if L_2 is given a value so

that the in-phase resonance falls within one of our lower frequency bands, we then have a single-ended tank circuit and both tubes are automatically in-phase.

With C_1 and C_2 in series, L_1 will resonate from 13.5 to 30.5 mc.; 28, 21, and 14 mc. fall within this range. As the 7 and 3.5 mc. bands also tune 1:2 in frequency, L_2 can be made such that C_1 with C_2 in parallel tune the range 3.45 to 8 mc., covering the two lower frequency bands.

For the low frequency range both tubes operate automatically in parallel and should, of course, get in-phase excitation.

As already stated, the condenser C_1 - C_2 tunes through two frequency ranges simultaneously, one range being 13.5-30.5 mc. and the other 3.45-8 mc. To arrive at these ranges the minimum capacitance of the sections C_1 - C_2 is of major importance. As the output capacitance of the transmitting tubes is in parallel with the minimum circuit capacitance, it must be taken into consideration. If we can keep this minimum low then the maximum capacity will also be small.

Let's consider the case for a pair of 807's. The output capacity of an 807 is 7 μfd . An acceptable value of minimum capacity for one section of the condenser is 15 μfd . For stray capacitances we add 5 μfd , which brings the total to 27 μfd . for one half of the push-pull circuit. As our frequency ranges are varying in the ratio 1:2.3 we need a capacity variation of 1:5.3, so the maximum capacity must be 143 μfd . On the 7 and 3.5 mc. bands, the two sections of the condenser are working in parallel, which doubles the minimum and maximum capacity. The currents through both halves of L_1 are then in-phase and practically cancel the inductance of L_1 . This makes it easy to calculate the necessary inductance. When 8 mc. is chosen as the highest frequency, the lowest must be 3.45 mc. for full coverage of both bands. The two ranges can be shifted on the scale by changing the inductance of one of the coils. However, one need not be afraid that harmonics of

the lower frequency bands tune at the same setting as a high frequency resonance. This is due to the fact that on low frequencies both tubes get in-phase excitation and as the high frequencies are all amplified in push-pull at the plates it is impossible to develop any r.f. on the harmonics.

In practice, not even the slightest dip can be detected when the drive is on 7 mc. and the push-pull plate circuit is tuned through 14, 21, or 28 mc. For convenience only, we shift the frequency bands near each other to get a regular scale. However, the frequency ranges can be narrowed a bit if we let the bands overlap. One must bear in mind that for other tubes with a larger output capacity the maximum capacity of each section must be increased as the minimum capacity of the circuit is raised. The circuit may be used only with tetrodes or pentodes, as it is impossible to have proper neutralization on both frequency ranges with triodes. A push-pull final using this circuit is shown at the right in Fig. 4.

The condenser used was a rebuilt National TMC 100D, built up to 10 plates on each rotor and 10 on each stator. The metal end plates of aluminum were replaced by polystyrene sheet slightly less than $\frac{1}{4}$ " thick. This was done to lower the minimum capacity of the sections. It also permits wider separation of the two stator sections, since they can be brought closer to the polystyrene plates without increasing the capacity. As the capacitance variation is 1:5.3, every 1 $\mu\text{fd.}$ reduction in the minimum capacity results in a 5.3 $\mu\text{fd.}$ decrease in the maximum capacity.

The 14 mc. range is tuned with near maximum (approximately 70 $\mu\text{fd.}$) capacity. The circuit losses will be higher than normal due to the higher r.f. currents. For a "Q" of 12 we need only 20 $\mu\text{fd.}$

To minimize these losses the coil should have low r.f. resistance. A coil of $\frac{1}{4}$ " copper tubing, tuned with 70 $\mu\text{fd.}$ for 14 mc. (push-pull) will have about a 6 watt r.f. loss when the plate voltage is 600 volts and the estimated power output 70 watts. One can use larger tubing, of course, but for a 100 watt rig, $\frac{1}{4}$ " copper tubing is suitable.

On the lower bands, both sections work in parallel and 250 $\mu\text{fd.}$ on 3.5 mc. is a suitable value. The wire for the low frequency coil can be either No. 12 or No. 14.

The low frequency coil is tapped onto the middle of the push-pull coil L_{15} , which makes it necessary to have two antenna coupling coils, one for L_{15} , and one for L_{11} . This is no disadvantage, as most hams use different antennas for the low and the high frequency bands. The coils can be selected by means of a switch on the front panel. It can also be accomplished by means of a relay which can be connected by a switch contact fastened to the shaft of the condenser, making contact at places where one of the coupling coils is needed.

In the transmitter described, the bandswitch, which had one unused set of contacts, is used to switch the coupling coil relay.

A transmitter incorporating this tank circuit is shown in the photographs. Operation of this transmitter is very simple as only three controls are required. One knob tunes the v.f.o., one knob operates the bandswitch, while the third knob tunes the multi-band tank.

A five-position, two-section band-switch is used to select one of the five different bandpass filters and connect it to the grids of the final.

The proper amount of grid drive is definitely fixed by the overcoupled bandpass filters and damping resistors where needed.

When QSYing with this rig, it is only necessary to touch the v.f.o. and the final tuning controls. In contests and traffic handling this is important. The author gave it a fair try in a recent ARRL contest, with gratifying results.

The exciter portion is shown at the left of Fig. 4.

The oscillator grid circuit tunes from 3500 to 3715 kilocycles. In Europe, hams are not permitted to operate on the 27 mc. band. The highest frequency is the eighth harmonic or 29.7 mc., which falls within the range of the oscillator. For the consistent DX man, the lower part of the 80 meter band is not of much interest, and in Europe the band ends at 3800. Without much difficulty one can extend the range to 3800 or even 4000 kc. if necessary. When the range is extended to 4000 kc. the 3500 kc. bandpass filters must be more tightly coupled. All the other filters remain unchanged. The oscillator tube is a 6BX6 in the well-known Clapp circuit. The plate voltage is stabilized with a VR150. The plate is capacity coupled

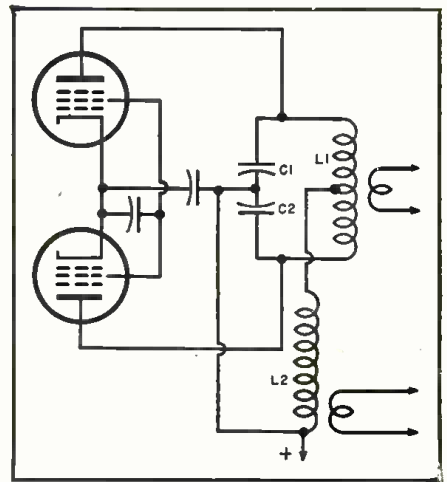

Fig. 2. Diagram of new multi-band circuit.

to the buffer stage, which also uses a 6BX6. This buffer stage works in class A and is a very convenient point to apply blocked grid keying. This eliminates a special keyer tube. Grid bias for blocking the grid is obtained by means of voltage divider R_5 , R_6 , R_7 . With a simple RC filter, the shape of the keying pulse can be varied to suit the individual user.

Since the stages following the keying stage use cathode resistors, they are biased well within their rated plate dissipation when the key is up. None of them, however, is biased to cut-off. This would be dangerous as it might alter the shape of the keying. Even the final stage is drawing some plate current as the screen grid is connected to relay tube V_5 when the key is up.

The third stage uses a 6AG7. The coupling between the second and third stages is accomplished by a bandpass filter designed for 3.5-3.72 mc. When using tubes like the 6AG7 as an amplifier or frequency multiplier, it is advisable to make the screen bypass ca-

Fig. 3. Front view of transmitter using multi-band tank circuit. The large knob at the left tunes the v.f.o. and operates the upper pointer on the dial. The large right-hand knob tunes the final stage (multi-band tank) and operates the lower pointer on dial. The upper knob in the middle of the panel selects the bandpass couplers while the bottom knob is the metering switch. The panel measures 19"x10 1/2".

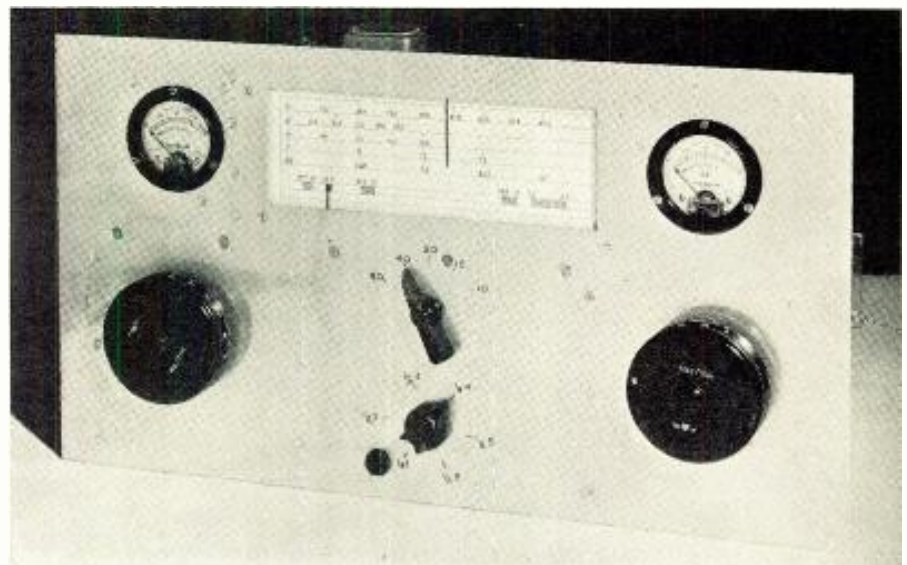

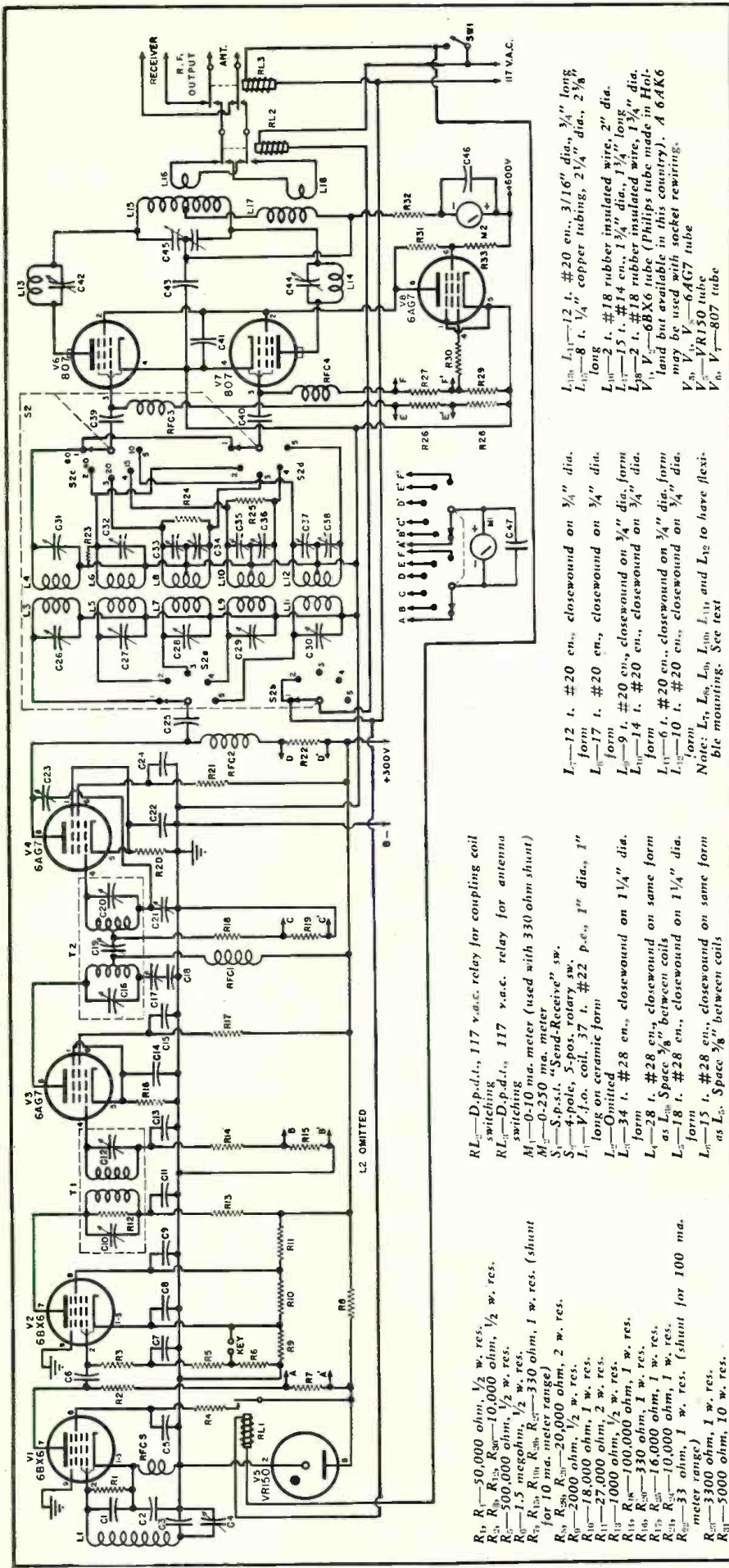

- R₁—50,000 ohm, 1/2 w. res.
- R₂—R₃—R₄—10,000 ohm, 1/2 w. res.
- R₅—500,000 ohm, 1/2 w. res.
- R₆—1.5 megohm, 1/2 w. res.
- R₇—R₈—R₉—R₁₀—R₁₁—330 ohm, 1 w. res. (shunt for 10 ma.)
- R₁₂—R₁₃—20,000 ohm, 2 w. res.
- R₁₄—R₁₅—20,000 ohm, 1/2 w. res.
- R₁₆—18,000 ohm, 1 w. res.
- R₁₇—27,000 ohm, 2 w. res.
- R₁₈—1,000 ohm, 1/2 w. res.
- R₁₉—R₂₀—100,000 ohm, 1 w. res.
- R₂₁—R₂₂—330 ohm, 1 w. res.
- R₂₃—R₂₄—16,000 ohm, 1 w. res.
- R₂₅—R₂₆—10,000 ohm, 1 w. res.
- R₂₇—33 ohm, 1 w. res. (shunt for 100 ma. meter range)
- R₂₈—3,400 ohm, 1 w. res.
- R₂₉—3,000 ohm, 10 w. res.
- R₃₀—100 ohm, 10 w. res.
- R₃₁—15,000 ohm, 10 w. res.
- C₁—C₂—700 µfd., 600 v. mica cond.
- C₃—C₄—100 µfd., 600 v. mica cond.
- C₅—50 µfd. midget var. cond.
- C₆—C₇—C₈—C₉—C₁₀—C₁₁—C₁₂—C₁₃—C₁₄—C₁₅—C₁₆—C₁₇—C₁₈—C₁₉—C₂₀—C₂₁—C₂₂—C₂₃—C₂₄—C₂₅—C₂₆—C₂₇—C₂₈—C₂₉—C₃₀—C₃₁—C₃₂—C₃₃—C₃₄—C₃₅—C₃₆—C₃₇—C₃₈—C₃₉
- C₃₀—C₃₁—2,000 µfd., 600 v. mica cond.
- C₃₂—C₃₃—C₃₄—C₃₅—C₃₆—C₃₇—C₃₈—C₃₉
- C₃₈—C₃₉—2-30 µfd. trimmer cond.
- C₄₀—Neutralizing mica cond.
- C₄₁—50 µfd. mica cond.
- C₄₂—200 µfd. (See text)
- C₄₃—C₄₄—C₄₅—C₄₆—600 v. mica cond.
- C₄₇—4,000 µfd., 1000 v. mica cond.
- C₄₈—145/145 µfd. split-stator cond.
- T₁—Bandpass coupler. Pri. 100 t., #31 en., 3/8" dia., 7/8" long. (85 µhy.), Sec. 100 t., #31 en., 3/8" dia., 5/8" long, 7/8" dia., 7/8" long, closewound (85 µhy.)
- T₂—Bandpass coupler. Pri. 50 t., #27 en., 3/4" long (23 µhy.), Sec. 50 t., #27 en., 3/4" dia., 3/8" long, closewound, (23 µhy.). Both pri. and sec. center-tapped.
- RFC₁—RFC₂—RFC₃—RFC₄—1 mhy. r.f. choke
- RL₁—S.p.s.t., 117 v.a.c. relay for switching out v.f.o. when receiving

- RL₂—D.p.d.t., 117 v.a.c. relay for coupling coil switching
- RL₃—D.p.d.t., 117 v.a.c. relay for antenna switching
- M₁—0-10 ma. meter (used with 330 ohm shunt)
- S₁—S.p.s.t. "Send-Receive" sw.
- S₂—4-pole, 5-pos. rotary sw.
- L₁—V.f.o. coil, 37 t., #22 p.s., 1" dia., 1" long on ceramic form
- L₂—Omitted
- L₃—34 t., #28 en., closewound on 1 1/4" dia. form
- L₄—28 t., #28 en., closewound on same form as L₃
- L₅—Space 3/8" between coils
- L₆—18 t., #28 en., closewound on 1 1/4" dia. form
- L₇—15 t., #28 en., closewound on same form as L₆
- L₈—Space 3/8" between coils

- L₉—12 t., #20 en., closewound on 3/4" dia. form
 - L₁₀—17 t., #20 en., closewound on 3/4" dia. form
 - L₁₁—9 t., #20 en., closewound on 3/4" dia. form
 - L₁₂—14 t., #20 en., closewound on 3/4" dia. form
 - L₁₃—6 t., #20 en., closewound on 3/4" dia. form
 - L₁₄—10 t., #20 en., closewound on 3/4" dia. form
- Note: L₉, L₁₀, L₁₁, L₁₂, and L₁₃ to have flexible mounting. See text

- L₁₅—12 t., #20 en., 3/16" dia., 3/4" long
- L₁₆—8 t., 1/4" copper tubing, 2 1/4" dia., 2 3/4" long
- L₁₇—2 t., #18 rubber insulated wire, 2" dia.
- L₁₈—15 t., #14 en., 1 3/4" dia., 1 3/4" long
- V₁—V₂—#18 rubber insulated wire, 1 3/4" dia. land but available in this country). A 6AK6 may be used with socket rewiring.
- V₃—V₁—VR150 tube
- V₄—V₇—6AG7 tube
- V₆—V₇—807 tube

capacity no larger than 50 µfd. This value is sufficient for good amplifying or multiplying and gives a certain amount of negative feedback which stabilizes the stage. Both 6AG7's use 50 µfd. at the screen grid.

The third stage acts as a doubler to 7 mc. The plate of this stage uses a 7 mc. bandpass filter of unusual design. It is a push-pull job with a capacity connected between the midpoints of the two coils. This capacity does not influence the operation of the bandpass coupler on 7 mc., but acts as a capacitive coupling on 3.5 mc. Hence the d.c. connections to the center taps of the primary and secondary have been made by an r.f. choke and a 100,000 ohm resistor, respectively. The bandpass coupler is enclosed in a screening box, while one of the coils is mounted on a stiff wire so that its position can be varied. The second 6AG7 thus gets excitation on 3.5 and 7 mc. simultaneously.

It is possible to make this tube work as a straight amplifier, doubler, tripler, or quadrupler. The tube gets high bias and sufficient r.f. drive for good multiplying.

On 7 mc. with straight amplification, the stage must be neutralized for adequate stability. We now can profit from an additional feature of the push-pull bandpass coupler, as it has excitation on the secondary which is 180 degrees out-of-phase with the grid voltage. A small capacity of the value of the C_{op} is connected between the plate and the lower half of the grid circuit.

On 3.5 mc., the coupling is strictly capacitive and can be adjusted with the variable condenser C₁₅ between the two midpoints of the bandpass coupler. C₁₅ should be no larger than is necessary to provide sufficient drive to the grids of the final stage.

It is worth mentioning that for good stability, the bandpass couplers between the second and third stages and

Fig. 4. Complete schematic diagram of transmitter includes a 5-band exciter with a v.f.o. on 3.5 mc. and a final amplifier with the new multi-band circuit. Five band-pass couplers, with bandswitch, are used in the grid of the final. Although it has not been tried, the author suggests that 6AQ5 tubes may give better performance than the 6AG7's shown for V₄ and V₇.

the one between the third and fourth stages should be shielded. The circuits are high "Q" and can pick up r.f. energy from the following stages. The coil of the v.f.o. should also be shielded.

In order to get the most constant drive over the 28 and 3.5 mc. bands, the response of the two bandpass couplers is not the same. T_1 , which has a range of 3.5 to 3.72 mc., is adjusted to a little over the critical coupling, and the output voltage falls off at each end.

The second filter, T_2 , is overcoupled and has the well-known double-hump response. Both filters combined give a practically straight line response curve of the driving voltage on 7 mc. at the grid of V_4 . As the grid leaks are quite high in V_2 and V_3 , the grid current in these stages is a proper picture of the exciting grid voltage. Dimensions for the bandpass couplers are given in the parts list. When placing the screening cans over the bandpass filters the coupling is increased. Since this is the case, one of the coils of each coupler is flexibly mounted to permit the best position to be determined experimentally.

The most successful way of accomplishing this is to make the coupling loose and tune both coils to the middle of the band. Then tighten the coupling until the desired response is obtained and then loosen the coupling a little. Now the shield can is replaced and the grid current measured again over the whole range. A little retuning with the shield can in place will sometimes be necessary in order to retain the proper response.

In the final stage (the right-hand portion of Fig 4) we have a bandpass coupler between the driver stage and the final for each band. Each of the five bandpass couplers can be selected with a switch. This eliminates the drawbacks of the other method, as there is only one resonant circuit in the plate circuit of the driver tube. Thus, only one frequency is reaching the grids of the final.

The switch is a five-position, four-pole type. On 3.5 and 7 mc., both grids of the final are put in parallel by interconnecting the fixed contacts of each section. The circuits of the bandpass couplers are both single ended on these frequencies. On both sides of the couplers, the d.c. is removed from the coils by means of parallel feed. For proper division of the driving voltage on each tube of the final, each grid has its own grid resistor. This allows the grid current to be measured separately.

On 28, 21, and 14 mc., the secondaries of the couplers must be push-pull circuits. The coils for these bands are all wound on polystyrene forms and mounted flexibly; i.e., mounted on the polystyrene strips by their leads. This makes the adjustment of the coupling between the coils of each coupler relatively simple.

The push-pull bandpass couplers are mounted around the periphery of the switch and parallel to the axis of

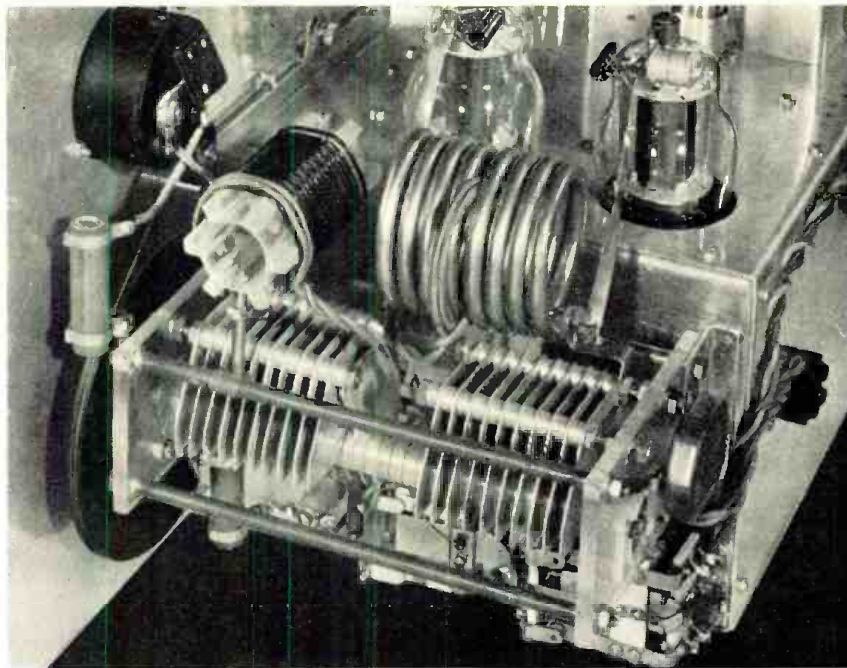

Fig. 5. Close-up view of the new multi-band tank circuit installed in transmitter.

the bandswitch. This gives the symmetrical layout necessary for proper balance of the stage.

The 3.5 and 7 mc. couplers are mounted near the front panel with the axis of the coils perpendicular to the axis of the switch.

The midpoints of the secondaries of the push-pull couplers (L_8 , L_{10} , L_{12}) should be connected to the midpoint between the tuning trimmers, $C_{23}-C_{21}$, $C_{25}-C_{26}$, $C_{27}-C_{28}$, and then connected to ground. This is necessary as otherwise it is impossible to maintain balance of the grid drive over each tuning range.

To adjust for the necessary amount of grid current in each 807, the secondaries of the couplers were shunted by resistors, R_{23} , R_{21} , and R_{25} .

To keep the screens of the final

stage at low potential when the key is up, a variation of the usual hookup was tried. A pentode relay tube is used (V_5) which operates with the screen at a higher voltage than the plate. This is accomplished by connecting the screen grid of V_5 to the junction between the two 807 screen dropping resistors, R_{31} and R_{32} . Convenient resistor values are 5000 ohms and 15,000 ohms. The voltage can be kept down to 7 to 12 volts with different tubes. Any tetrode or pentode can be used as an effective relay tube.

Measurements of the useful output with an input of 110 watts into a pair of 807's show the following figures:

7 mc.—78 watts r.f.; 3.5 mc.—75 watts r.f.; 21 mc.—75 watts r.f.; 28 mc.—75 watts r.f.; and 14 mc.—70 watts r.f. (Continued on page 105)

Fig. 6. Bottom view of transmitter. Round can on right is the v.f.o. coil shield.

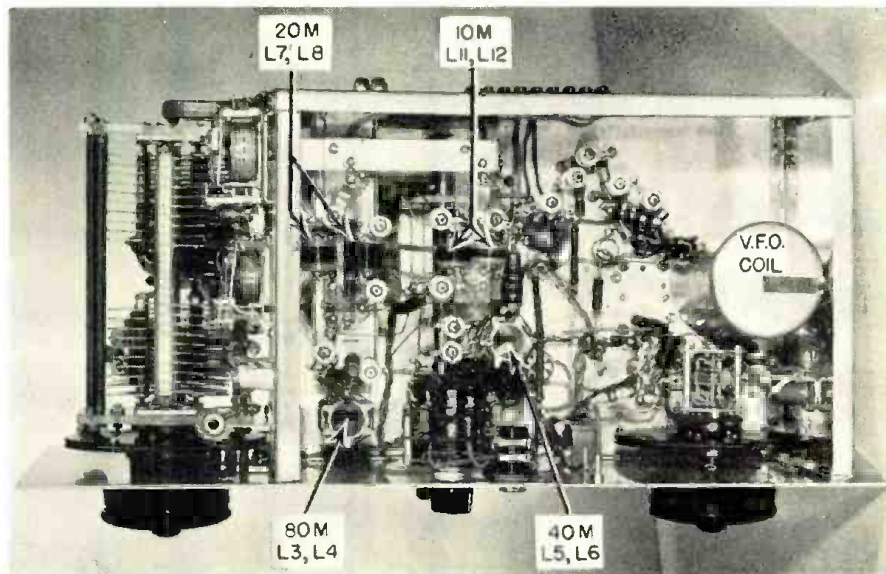

WHICH TUBE

for AUDIO?

By

JOSEPH HOULE

A resumé of the principles involved in selecting tube types for audio output and voltage amplifiers.

WITH hundreds of types of tubes in dealers' catalogues, dozens on the preferred lists, and new types appearing at the rate of eight or ten a week, the hobbyist planning a new piece of gear has cause to feel frustrated and confused. The biggest question is "What's new that's good?" The answer, as far as radio is concerned, is that there are no new types that have been proved to make a really significant difference to the home constructor, but there is a lot of room for experiment.

This article is addressed primarily to the audio enthusiast, and will attempt to cover the elementary principles of selecting tube types for audio output and voltage amplifiers.

If one is primarily interested in building a good music reproducing system for home entertainment, the first rule is to be conservative, and stick to types that have been tried and proved over several years' time. The same, incidentally, applies to circuits. If one is experimentally inclined, there is a host of special-purpose and TV types that offer a promise of higher efficiency, but not drastically higher. Let us consider the standard tubes first.

Power Tubes

Table 1 is a comparison of available power output for several common types of power tubes under arbitrary standard conditions. In some cases it was necessary to interpolate published conditions, since the recommended plate voltage and degree of cut-off differ from type to type. The table, however, is a guide to the type to use for the desired power. The 6V6 triodes are excellent for TV sound and other moderate-level listening in the living room, as noted by Lawrence Fleming in describing a small, high-quality amplifier ("Quality Amplifier for TV Sound") in the May 1951 issue of *RADIO & TELEVISION NEWS*. 6L6's as triodes are not too desirable, because their high μ limits the power available at moderate plate voltages. If a high voltage is used in conjunction with a tube which is rated to take it, *i.e.*, the 807, we have the famous *Williamson* amplifier. 2A3's and their 6-volt equivalents are good but require a lot of signal voltage on

the grids which introduces distortion from the driver stage.

There are several small power pentodes which are similar or slightly inferior to the 6V6, to wit, the 6K6GT, 7B5 (same as 6K6), 6F6, and the older types 41, 42, 2A5. Beam power tubes are essentially improved pentodes, not really different kinds of tubes.

There are no particular variations of the 6L6 designed for audio service, but there are many variations intended for special purposes, all of which work fine for audio: the 6BG6 TV sweep tube, rated for high peak voltages; the 807; the new high-reliability type 5881; the 1619, etc. All have essentially the same characteristics as the 6L6 but differ in maximum voltage rating, plate dissipation, heater voltage, or uniformity.

For low plate-voltage service, such as in a.c.-d.c. amplifiers, we have a series of high-heater-voltage, small beam power tubes. The 25L6 was the first, then the 50L6, identical except for heater resistance. The 35L6 and the miniature 35B5, 35C5 have slightly lower ratings, as do the 50B5 and 50C5. All give an output of about 1.5 to 1.9 watts at 117 plate volts. The 6Y6G and the miniature 6AS5 are 6-volt tubes which give good output at low plate voltage, but have rather high distortion. Only the 25L6, 50L6, and 6Y6G have high enough plate dissipation ratings to permit operation at over 200 volts. All these low plate voltage types are generally considered to have more distortion than the reg-

ular tubes designed for operation at 250 volts or more.

Triodes vs Pentodes

Triodes offer the most foolproof way to high fidelity. A good push-pull triode amplifier without any feedback can give excellent performance, but pentodes without feedback are very poor. Pentodes without feedback are used only in home radios and the cheapest p.a. amplifiers.

With about 12 db or more feedback, pentodes can give excellent results. When applying feedback around the output transformer, however, frequency response measurements must be made over a very wide range. The amplifier must be checked for peaks which indicate incipient oscillation at the far ends of the spectrum.

The main advantage of the pentode is its high efficiency, both as to plate input and grid signal voltage. This is very important to a manufacturer because it saves money on parts. To the hobbyist, the money-saving angle may be outweighed by the ease of construction and high reliability of the less efficient triodes. The question of how much power is needed is still moot. Speaker efficiencies vary and published material on this point is rarely available from the manufacturers. It is up to the individual to decide whether he wants high power or not; the first step in any case is to buy a good speaker with a heavy magnet, and determine the power desired for that speaker by means of listening tests.

Plate Curves

The process of calculating power output from the family of plate characteristic curves of a tube is covered in all the books, and explained very well in the "*RCA Receiving Tube Manual*." Rather than go over it here, it may be of interest to point out some of the reasons for tubes doing what
(Continued on page 106)

Table 1. Approximate outputs of various commonly-used audio power tubes for push-pull operation, 300 volt plate supply, self bias, class AB₁.

TYPE	PENTODE CONNECTION		TRIODE CONNECTION	
	OUTPUT	GRID SIGNAL	OUTPUT	GRID SIGNAL
6V6, 6AQ5	10 w.	12.5 v.	4 w.	25 v.
6L6	20 w.	20 v.	6 w.	35 v.
2A3, 6A3, 6B4G	10 w.	50 v.

U. H. F. Conversion Methods

By
NOEL EDWARDS

THE u.h.f converter is basic and uncomplicated. It is easy to install, align, and service. The actual design and production preparation was far more difficult than the adaptation of the converter to a standard v.h.f. receiver.

U.H.F. Tuned Circuits

A number of problems need to be overcome in the development of a tuner-converter for the u.h.f. 470 to 890 megacycle spectrum. The scope of these difficulties is apparent when we consider that this span of frequencies will contain 70 television channels, bringing the total count of v.h.f. and u.h.f. channels to 82. Certainly a 70 or 82 channel selector switch arrangement presents problems in handling over this range of operation. To add to the difficulties, the frequency range is somewhere between the end of the range at which lumped constants can be made to operate efficiently and the range at which microwave practices can be introduced. The choice of tuned circuits and tubes is critical. Tuned circuits take on rather peculiar shapes to obtain the necessary frequency range.

The task of tracking a number of these tuned circuits is present. One-knob tuning of the various resonant circuits requires mechanical ingenuity. The absence of an r.f. stage and the use of a crystal mixer has helped considerably to simplify the tracking problem.

The factors that restrict the use of standard miniature tubes and lumped-constant tuned circuits are tube capacities, lead inductances, and transit time. Tube capacities, small as they might be, present a very low reactance on the u.h.f. band. For example, a $5 \mu\text{fd}$. capacity has a reactance of approximately 40 ohms at 800 megacycles. A small lead inductance has a high reactance on the u.h.f. band. These two factors, therefore, set and limit the highest frequency to which any externally attached resonant circuit can be tuned. Acorns and subminiature tubes show great possibilities because of their smaller

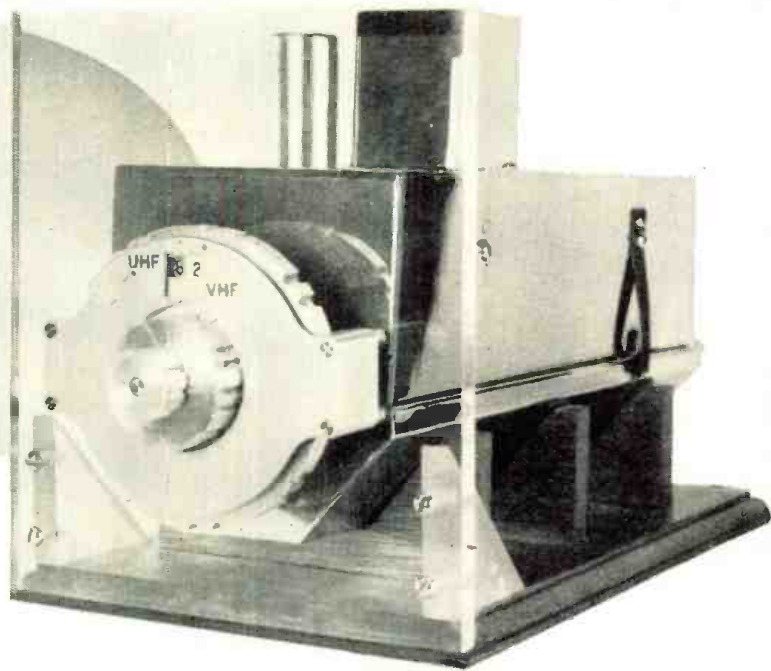

Fig. 1. Standard Coil Company's experimental v.h.f.-u.h.f. 82-channel tuner which uses switched coil-condenser combinations. A two-section dial covers all TV bands.

Part 2. An analysis of some commercially-available converters and a discussion of u.h.f. test equipment.

parameters (size, capacity, and inductance). The 6F4 acorn and its miniature tube base counterpart the 6AF4 are common in the initial lines of u.h.f. converters. Other tubes which operate well in u.h.f. converter circuits are the 2367A, 1165E, 6BK7, 6B7, and 6V8.

As far as transit time is concerned, it places a low impedance resistive-capacitive shunt across the grid input of the tube, which limits the highest frequency at which a tube can oscillate or function as an amplifier. The transit time loading is caused by in-phase (resistive) and leading (capacitive) components of the grid current. This current flow is the result of the

finite time of travel of electrons flowing over the cathode-grid-plate path in the tube. Ordinarily this time of travel is insignificant, but at the u.h.f. frequency it becomes appreciable with respect to the period of the u.h.f. wave. Consequently, the flow of current within the tube can not follow coincidentally with grid voltage changes and grid current flow results.

Tuned Circuit Types

The u.h.f. resonant circuit is a critical combination in establishing efficient u.h.f. operation. There will be a number of basic types.

1. Perhaps, initially, the most common type of resonant circuit will be

Fig. 2. The tuned lines as used in the General Electric Company's u.h.f. converter.

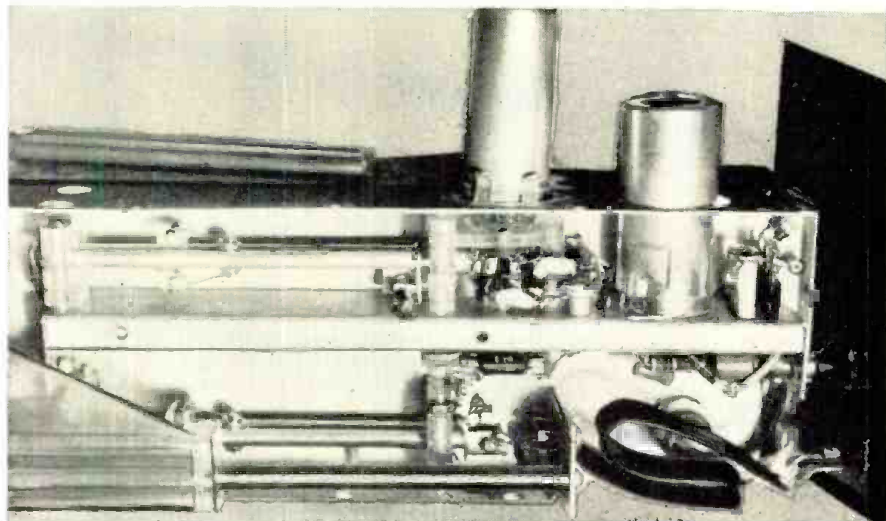

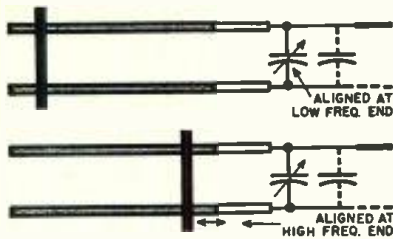

Fig. 3. Tuned lines as resonant circuits.

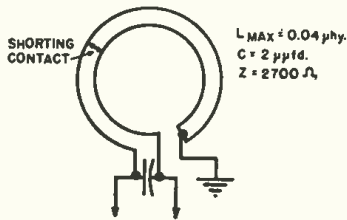

Fig. 4. Tuned lines in form of an arc.

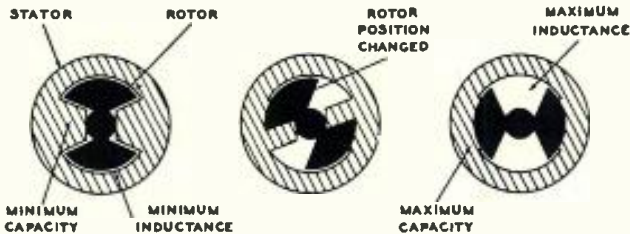

Fig. 5. A "butterfly" type of resonant circuit as used in u.h.f. converter units.

HIGHEST ← FREQUENCY → LOWEST

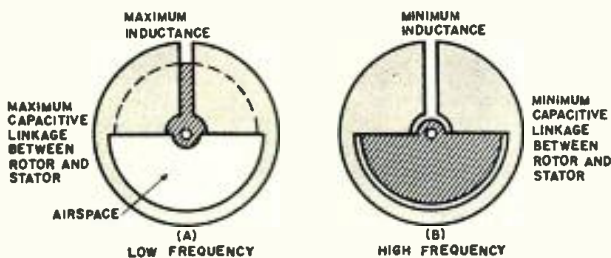

Fig. 6. The basic semi-butterfly circuit. (A) Rotor position at low and (B) high frequency settings.

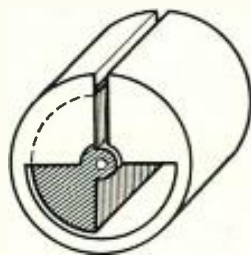

Fig. 7. Cylindrical "butterfly."

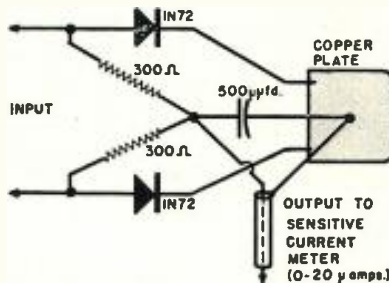

Fig. 8. Output indicator circuit by G-E.

the quarter-wave shorted section of line, Fig. 2. Parallel resonance at a given u.h.f. frequency is obtained by moving a shorting bar along the line. A mechanical arrangement permits simultaneous movement of shorting bars on the two or three tuned lines needed in a typical u.h.f. converter.

Dimensions of the lines must be chosen to permit operation over a wide span of frequencies. The line lengths and lead inductances determine the total inductance of the resonant circuit while the total capacity is a function of the lines, circuit components, and tube capacities. To reach the very high end of the band, the total capacity must be held to a minimum. This means the circuit can then be brought to resonance with a satisfactory value of inductance (though small) to establish a suitable L to C ratio and circuit "Q" at the high end of the band, Fig. 3. Consequently, the high-end frequency limit can be tracked on each line by adjusting for the minimum inductance required to

bring the line to resonance with whatever circuit capacity exists. The low-end frequency limit is obtained by using the over-all length of the line and whatever added capacity is needed to reach the low-frequency point with suitable "Q" and bandwidth.

Another factor in the use of lines as resonant circuit elements is the local oscillator which must operate on a frequency lower than the mixer and/or the antenna input lines. Lower frequency range operation can be obtained by changing the dimensions of the line or, if for mechanical reasons it is desired to keep the line dimensions uniform, a tunable capacity can be added across the line. High and low frequency end adjustments must also be incorporated to establish proper oscillator tracking and calibration.

Tuned lines can also be formed into an arc instead of stretching out in a straight line. This expedient conserves space and serves as a convenient means of ganging and tracking a number of tuned u.h.f. circuits. In this

arrangement, Fig. 9, a shorting contact at the end of an insulated arm slides along the circular lines. In a typical converter, three of these tuned sections with associated arms and shorting contacts are attached to a single shaft to provide continuous tuning over the u.h.f. band.

A typical resonant circuit, Fig. 4, of this type has an inductance of 0.04 μ hy. and a capacity of 2 $\mu\mu$ fd. or a self-resonant frequency of approximately 530 mc. With just 1 $\mu\mu$ fd. of added circuit capacity, the low frequency minimum becomes approximately 460 megacycles, near the low frequency limit of the u.h.f. band. Proper frequency range and tracking is obtained by controlling the width and shape of the tuned line strips of each resonant section. Minor tracking and bandwidth adjustments can be made with small external condensers.

2. The butterfly tuned circuit, so named because of its appearance, is an effective high frequency tuned circuit because as the rotor is turned both the inductance and capacitance of the resonant circuit change. Thus a more uniform "Q," bandwidth, and possible tracking can be established. The stator plates of the butterfly, Fig. 5, act as an inductive turn or loop while the rotor acts as both a variable condenser and an inductance shunt. Consequently, as the rotor moves the capacity as well as the inductance of the stator changes.

In its first position the inductance is minimum as the rotor almost completely closes the inductance loop. For example, a flat washer-shaped ring, as opposed to a turn of thin wire with the same circumference, would have substantially less inductance. Capacitance is also minimum in this position as there is the least capacitive linkage between the rotor and stator. This position, then, represents the highest resonant frequency of the butterfly. When the rotor is in a position directly over stator, as in the right-hand drawing of Fig. 5, the resonant frequency is minimum. In this position there is maximum capacitive linkage between the rotor and the two sides of the stator. At the same time the air space in the stator has been opened and there is maximum inductance. The center drawing shows an intermediate frequency point. With this type of tuned circuit both capacitance and inductance decrease when tuning toward the high frequency end, permitting a greater frequency range with a uniform "Q" and bandwidth. Another advantage of this type of circuit is the absence of any moving contacts with their attendant noise and lack of positive contact.

3. A modified or semi-butterfly has been used by *Du Mont* in an experimental u.h.f. converter. With a semi-butterfly, the stator acts as a single turn inductor, Fig. 6, while the rotor changes both the circuit capacity and the inductance of the stator. As illustrated in Fig. 6A, the stator is a single turn coil with an open air space at the

bottom and a definite capacitive linkage between the rotor and the two sides of the stator (each side of the slot). This is the maximum-inductance, maximum-capacitance, low-frequency position. When the rotor is moved through 180 degrees, Fig. 6B, it closes in air space, thus increasing the effective surface area of the stator and lowering the inductance. Likewise, there is a minimum capacitance linkage between the two sides of the stator and the rotor in this position. This is the high frequency limit of the tuned circuit. Other positions of the rotor would tune to intermediate frequencies.

To further lower the minimum inductance, the surface area of the stator turn can be increased into a cylindrical shape. Fig. 7, thus raising the high frequency limit of the tuned circuit still higher. The top of the cylinder can be flattened to provide a mounting position for a tube socket and associated components, Fig. 12.

4. Still another type of tuned circuit is the cylinder type, Fig. 11. It consists of two slotted cylinders, one rotating inside the other. The cylinders represent a simple means of circuit mounting as the tube and components can be connected across the slot of the outer cylinder. As indicated schematically, Fig. 10, one side of the slot is connected to the grid; the other side of the slot is capacitively coupled to the plate.

In a cylinder circuit, the frequency is maximum when the two slots coincide. In this position there is minimum capacity across the slot of the outer cylinder, permitting a very high frequency limit because of the very low inductance of the cylindrical turn. As the inner cylinder is rotated a capacity exists between one side of the outer cylinder and the inner cylinder. The inner cylinder now spans across the slot of the outer cylinder, thus introducing a capacity across the slot. In effect, we have two condensers in series across the slot—each side of the slot to the inner cylinder. The effective capacity across the slot is highest when the inner slot faces exactly opposite to the slot in the outer cylinder. This position represents the low-frequency limit of the tuned circuit.

We can expect to find any one of these basic types of tuned circuits in u.h.f. converters, u.h.f. test equipment, and, eventually, in combination u.h.f.-v.h.f. receivers.

Standard Coil Tuner

Standard Coil has developed an experimental v.h.f.-u.h.f. 82-channel tuner using switched coil-condenser combinations. It is unique because it uses lumped coils and condensers instead of the usual type of u.h.f. tuned circuit. A two-section dial is used, Fig. 1, one section counting in tens, the other in units. To set the tuner on Channel 36, for example, the "tens" dial is set on 3 while the "units" dial is set on 6.

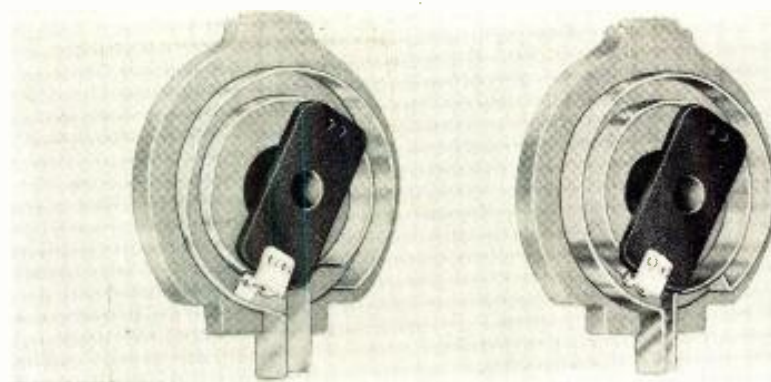

Fig. 9. The tuned circuits used by P. R. Mallory in its u.h.f. converter.

"Tens"	Frequency	Channels
1	470-510	14-19
2	510-570	20-29
3	570-630	30-39
4	630-690	40-49
5	690-750	50-59
6	750-810	60-69
7	810-870	70-79
8	870-890	80-83

Table 1. How the Standard Coil tuner "tens" dial is used to cover the 470-890 mc. range.

The general plan of the tuner, Figs. 13 and 14, is to employ eight specific u.h.f. positions, each approximately 60 megacycles wide, covering the entire 470-890 megacycle range as indicated in Table 1.

Thus the u.h.f. section, in accordance with the "tens" dial setting, opens the input over a ten channel span of frequencies. If the "tens" dial is set on 4, the signal from any channel between 630-690 megacycles reaches the u.h.f. mixer. The choice of the proper one of the ten channels is made by the "units" dial section which sets the frequency range of the tunable cascode i.f. amplifier. The cascode i.f. stage can be set on any one of the ten 6-megacycle ranges that include Channels 7 through 13. For example, the channels from 40-49 could fall in, as indicated in Table 2, using a fixed u.h.f. local oscillator frequency (one fixed frequency out of a choice of eight).

The table indicates that the u.h.f. local oscillator need not be tunable but needs only to be switched to eight preset fixed frequencies (plus some limited variation for alignment or fine tuning). The actual "unit" channel selection is made by shifting the i.f. frequency of the cascode first i.f. amplifier rather than the frequency of the local oscillator.

The output of the cascode i.f. is applied to a second mixer-local oscillator combination (v.h.f. section) and then to the second conventional i.f. amplifier of the receiver.

For v.h.f. operation, the v.h.f. antenna is attached to the input of the cascode i.f. amplifier which selects Channels 2 through 13 with the same calibrated dial and without additional switching. The entire operation is automatic and the user is not aware that v.h.f.-u.h.f. switching has taken place when the dual-dial is changed

(Continued on page 82)

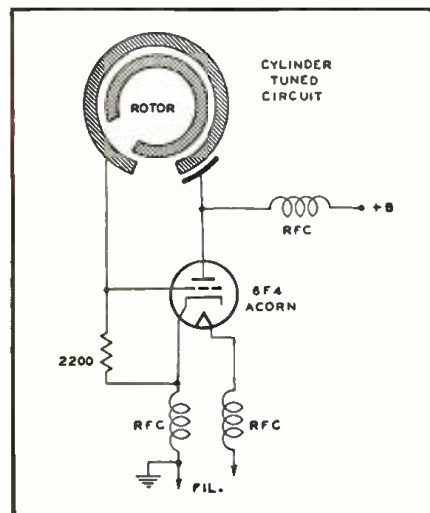

Fig. 10. Schematic diagram of a u.h.f. oscillator with cylinder-type tuned circuit.

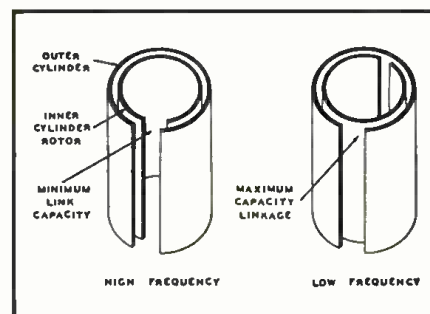
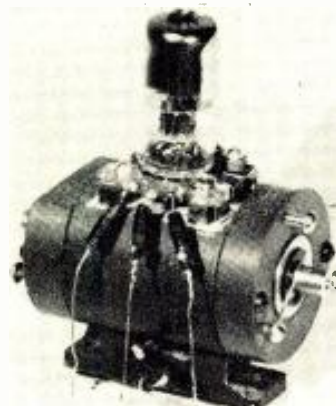

Fig. 11. Cylinder-tuned circuits showing the high and low frequency positions.

Fig. 12. Du Mont's u.h.f. oscillator.



MAP YOUR FRINGE AREA SIGNAL LEVEL

By
EDWARD M. NOLL
and
MATTHEW MANDL

**Practical information on measuring and plotting
signal levels to facilitate TV installation work.**

IN A fringe or near-fringe area service organization, it is important for both the sales and service departments to know the signal level distribution (for each channel) throughout the district. Such information is of help in choosing a suitable receiver, deciding whether or not a booster is necessary, and selecting the correct antenna type for the location.

There has been a definite need for a practical and useful link between propagated signal levels, service type field strength meters, and receiver performance. The signal level "Data-Print" on the facing page, together with the measuring equipment and measurement standards here introduced, represent a practical plan for predicting and solving signal level problems in a given locality.

The charts can be used to predict local channel signal levels as a function of distance. Antenna gain and height can be linked directly to the chart information, thus assuming a more understandable significance. The method of making such measurements is simple and permits the service organization to take sample measurements in its own locality. The information thus obtained can be added to

the "Data-Print" charts to give more specific data concerning stations in its own area. The "Data-Print" will then reflect the signal level variations due to terrain differences, climatic conditions, etc. Using the charts, range maps can then be prepared showing the location of specific signal level contours for each station. Finally, a sectionalized map of a single community or district can be prepared with finely calibrated contours and terrain height corrections. Such a map will enable a service organization to select the proper antenna and a booster, if necessary, for any installation without further measurement.

Field Strength Equipment

The equipment used to take the field strength measurements for this article consisted of a field strength meter (the *Transvision FSM-1A*), a power converter, a "Variac," and a folded dipole, mounted on a thirty-foot mast, for each of the channels measured. The power converter was a *Cornell-Dubilier Model 6R5* which converts 6 volts d.c. to 117 volts a.c. The power plug and cord were the type used with an auto trouble light so the 6 volts for

the converter could be obtained by plugging into the cigar lighter receptacle of the car. The "Variac" was used to supply constant voltage to the field strength meter for each measurement. Thirty feet of 300-ohm twin-lead was used between the antenna and the meter. It was found advisable to keep the car engine running whenever measurements were taken to keep the car battery charged.

Measurement sites must be chosen carefully. The antenna used for the measurements must be erected in the clear and away from large metallic objects, power lines, and telephone wires. In urban areas, lots, open fields, athletic fields, etc., are likely locations for taking readings and erecting the mast (use three ten-foot bolted or locked telescoping sections). Fringe area measurements can be conveniently made along the flat stretches of a turnpike and at various distances around the outskirts of small towns. Two ten-foot mast sections on a ten-foot rise or embankment will give the required thirty-foot elevation.

It is important to realize that the more measurements made, the better the variables will average out. This permits construction of a smooth average curve of signal decline because of the many plot points.

Signal Range Maps

The signal decline charts on the "Data-Print" indicate the type of plot that can be constructed for any television area. Measurements were taken and charts plotted for Channels 3 (Philadelphia), 5 (New York), 9 (New York) and 10 (Philadelphia). The chart covers two channels in the low-frequency and two in the high-frequency television bands. For those channels not specifically covered, use the chart for the closest channel. For example, for the signal range of Channel 2, use the chart given for Channel 3; for Channel 7 use the Channel 9 chart, etc. The strength of the signal (in microvolts) can be obtained by taking a few sample measurements in your area and using the signal decline charts to predict signal levels at any given distance. For ex-

(Continued on page 55)

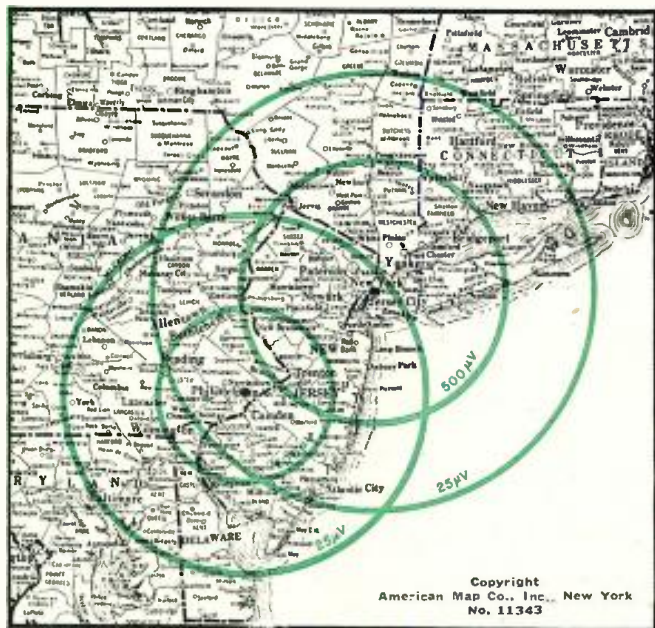

Fig. 1. Signal range map for Channel 5 (N. Y.) and Channel 3 (Philadelphia). The receiving antenna for these measurements was a standard dipole, cut for each channel. For Channel 5, the 500 μ v. radius is 60 miles from the transmitter; the 25 μ v. radius is 104 miles. For Channel 3, the 500 μ v. radius is 38 miles; the 25 μ v. circle is the signal level 81 miles from the transmitter site.

Copyright
American Map Co., Inc., New York
No. 11343

NEVER BEFORE SUCH ANTENNA NEWS!

5 BRAND NEW WARD ANTENNAS

WARD, the oldest, largest and leading manufacturer of antennas, has done it again. The new 1952-53 exciting WARD SIGNALINE will put you years ahead. Not 1 . . . not 2 . . . but 5 ingeniously designed, radically different and sensationally better TV antennas. Now, your WARD LINE is the only line that completely covers every application.

WARD THE ONLY COMPLETE LINE

Plus a brilliant promotion program to help you sell the complete WARD LINE of TV-Auto-Communication and FM Antennas.

HAVE YOUR WARD
DISTRIBUTOR
SHOW YOU
THIS BOOK—

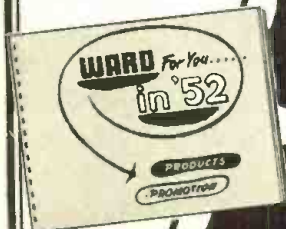

WARD Signaline

Trombone

U-See

Lucky 4

5 Star

MUSKETEER

ZIP-HI

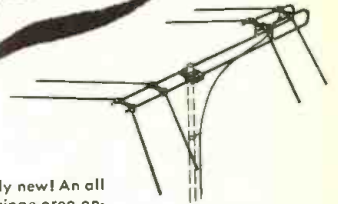

Completely new! An all channel fringe area antenna that actually outperforms Yagis on many channels! For use on both VHF and UHF. Opens up new markets with new ideas of good pictures! Light and rugged! Completely preassembled!

The first and only 3-in-1 antenna—for UHF, VHF—UHF and VHF. Protects your customers on new UHF stations, while giving them the best in VHF today! High gain, all-channel, completely preassembled.

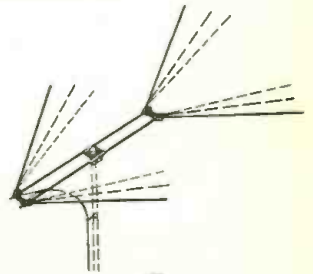

The first major advance in conicals! Higher gain! Better impedance match! Completely preassembled! With six extra features!

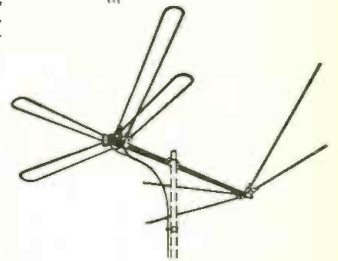

The Yagi with the radar-proved T match and exclusive offset elements! Extra gain, extra efficiency, plus rugged preassembled construction.

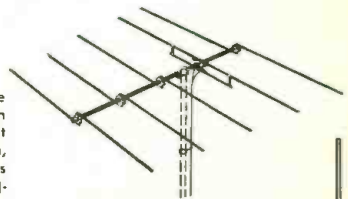

The first true broad-band Yagi—covers channels 3, 4, 5 and 6 with uniformly high gain! The first triple-driven Yagi. Completely preassembled!

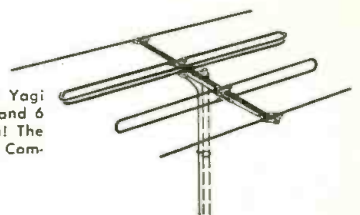

The new WARD telescopic mast made from corrosion-proof PERMATUBE! Four different heights, all with exclusive anti-collapse feature. Can be erected by one man. Comes in 2, 3, 4, and 5 section models.

THE WARD PRODUCTS CORPORATION

DIVISION OF THE GABRIEL COMPANY

1523 EAST 45 STREET • CLEVELAND 3, OHIO

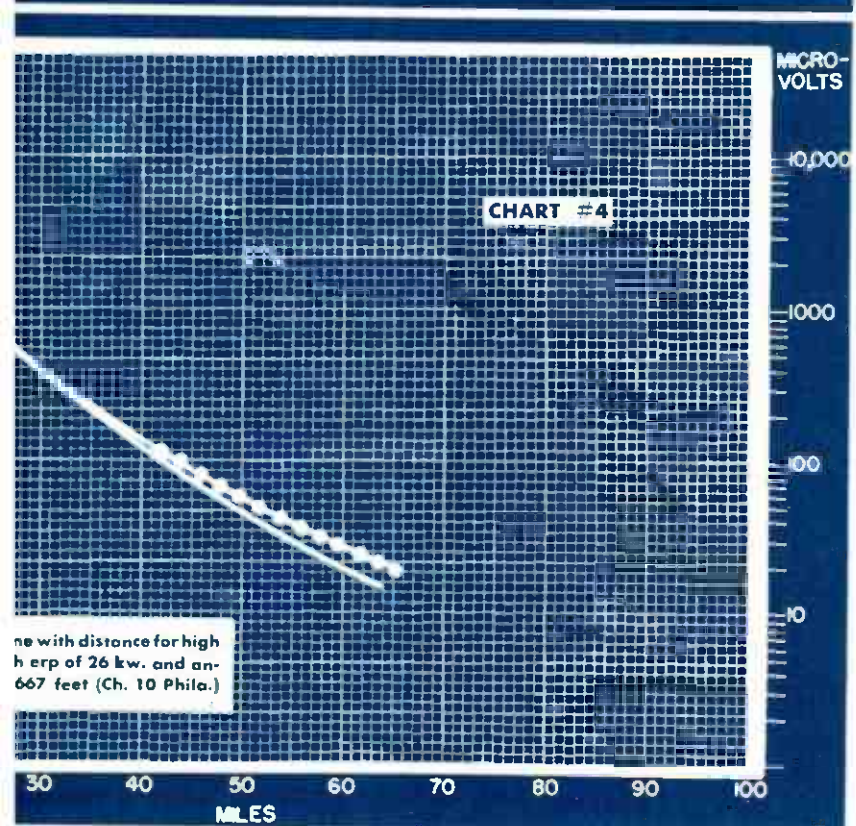
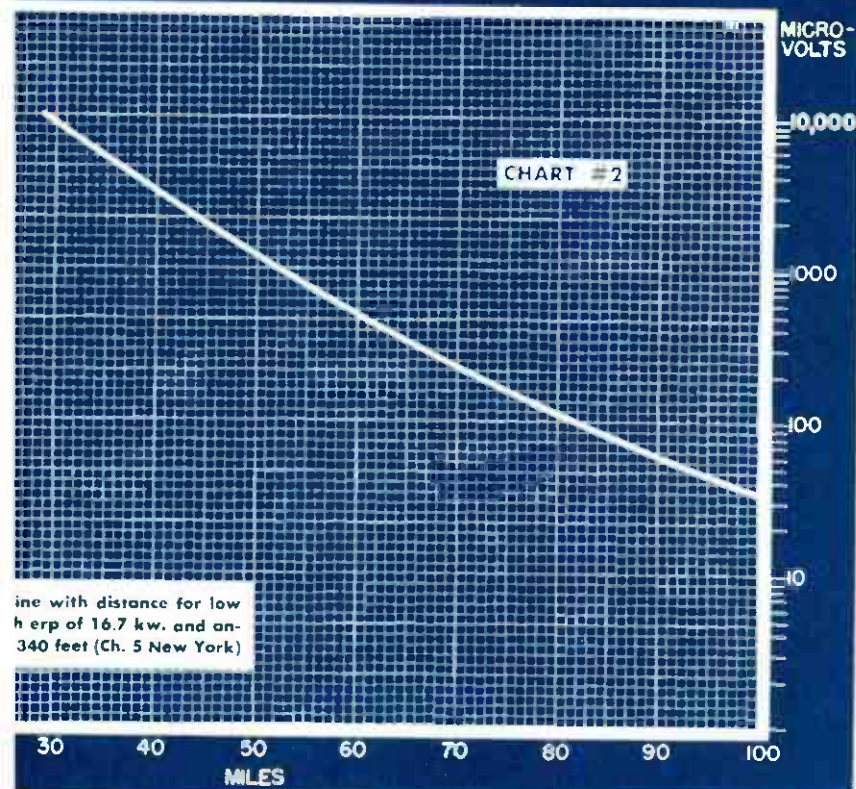

TYPICAL CHART APPLICATIONS

How to predict signal levels in your area using the charts.

1. Take a sample measurement of the field strength of your local television station at a prescribed distance from the transmitter. Choose a position of average terrain height in your district and use the standards suggested.
2. Locate this point on the curve (intersection of distance range calibration with the curve) representing the channel nearest in frequency to the one with which you are concerned. This locates a single point of measurement on the curve.
3. Determine the db differential for that point between your measured value and the chart value. Look up the voltage ratio for this differential.
4. Microvolts at other distances can be found by multiplying the microvolt reading on the chart for those distances by the microvolt ratio as determined in Step 3.
5. Another method is to find the distance at which 10,000 microvolts is delivered by the station. Locate this point on the graph representing the channel nearest in frequency to the one with which you are concerned.
6. Draw a new curve on the graph that is parallel to the curve already on the chart, starting from the 10,000 microvolt reference point of Step 5. With this method, the microvolt scale on the right hand side of the chart can be used, eliminating Step 4.

How to select the proper gain antenna system for a low signal area installation.

1. Using the chart you have corrected for your specific channel and area condition, look up the microvolt level indicated for the distance at which the installation is to be made.
2. Find on the chart the db difference between this level and the minimum microvolt sensitivity of the television receiver to be installed. This db differential is the db gain required of the antenna, or of an antenna, mast, and booster combination.
3. To raise the gain of the signal at the receiver, either a gain antenna can be used alone, if its gain is sufficient, or used with a booster. The use of a mast, of course, will increase the microvolt level at the receiver. If a receiving antenna is raised to sixty feet, the signal will be approximately twice that shown on the chart for any specified distance (since these measurements were taken with an antenna thirty feet high).

Measurements were taken under average-to-poor propagation conditions in the atmosphere. Night reception conditions are better—particularly beyond the distance represented at 1000 microvolts. The dotted curve on Chart #4 shows the influence of atmospheric conditions on fringe signal levels. This curve is the result of measurements made just a few hours past midday, and shows the start of a signal level rise that extends into the evening hours. The percentage of increase is greater with distance. Installations should be planned to handle weak signals adequately for performance reliability. Thus, it is advisable to present the average-to-poor conditions.

Charts #1 to #4 are signal decline charts. Chart #5 shows the relation between db and signal voltages. For example, if between 24 and 32 miles on one of the decline charts the signal drops -6 db, it means that the voltage at 32 miles is one-half the voltage at 24 miles.

RADIO & TELEVISION NEWS

DATA-PRINT #3

(Copyright 1952)



TELEVISION SIGNAL STRENGTH CHARTS

FOR PROPER ANTENNA SELECTION

CHART #5

VOLTAGE RATIO - DB CHART

DB	Voltage Ratio
+ 10	3.16
+ 9	2.82
+ 8	2.5
+ 7	2.24
+ 6	2
+ 5	1.78
+ 4.5	1.67
+ 4	1.58
+ 3.5	1.49
+ 3	1.41
+ 2.5	1.33
+ 2	1.26
+ 1.5	1.19
+ 1	1.12
+ 0.5	1.06
0	1.00
- 0.5	0.943
- 1	0.893
- 1.5	0.84
- 2	0.793
- 2.5	0.752
- 3	0.707
- 3.5	0.671
- 4	0.632
- 4.5	0.598
- 5	0.562
- 6	0.5
- 7	0.446
- 8	0.4
- 9	0.354
- 10	0.316
- 15	0.178
- 20	0.1
- 25	0.056
- 30	0.0316
- 35	0.0178
- 40	0.01
- 50	0.0032
- 60	0.001

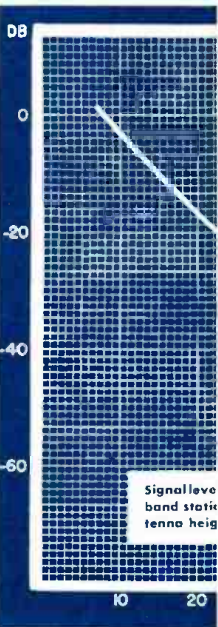
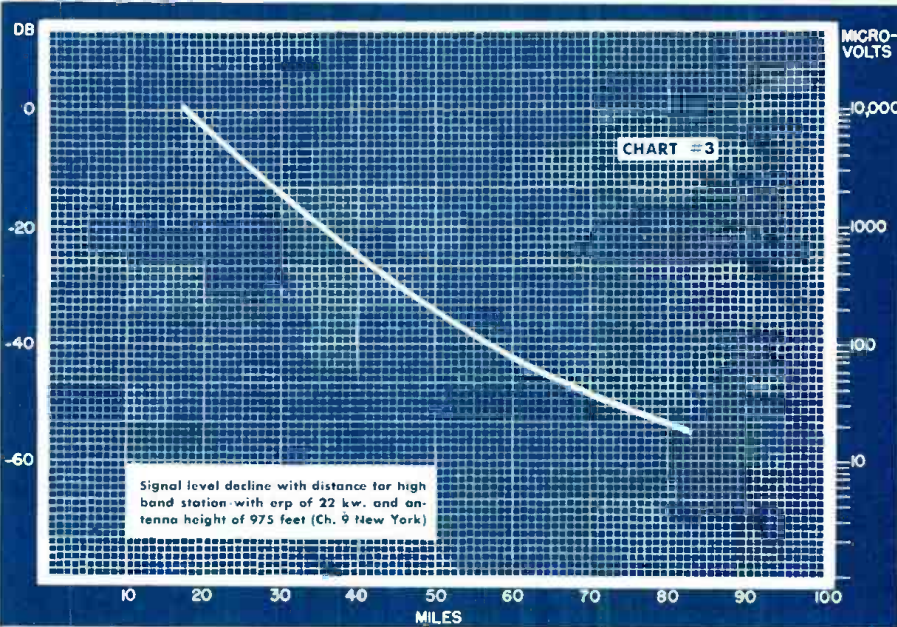
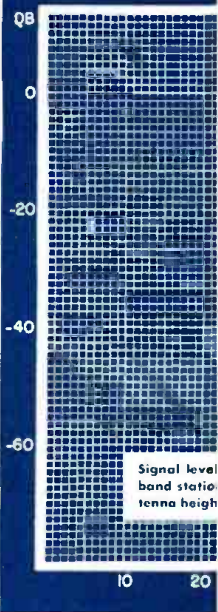
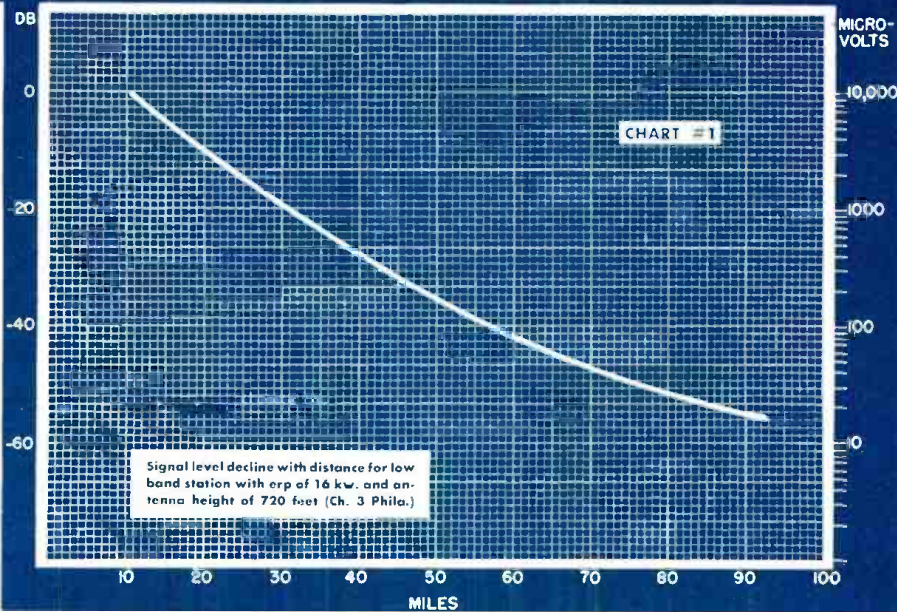

SIGNAL LEVEL DECLINE CHARTS

These signal level charts show the decline of signal level in db and in absolute microvolts for typical high- and low-frequency band television stations measured as a function of distance from the stations. It should be noted that the absolute values of the signal in microvolts is a function of transmitter power, transmitter antenna height and gain, frequency, terrain, and receiver antenna height and gain. However, the signal decline in db is essentially constant for the two low-band stations and for the two high-band stations and therefore have universal application.

In the preparation of the charts, the zero db reference point was chosen for a signal level of 10,000 microvolts. The absolute microvolt readings were based on an antenna height of 30 feet, with a standard folded dipole for each specific channel measured. The transmission line used was 300-ohm twin-lead, 30 feet long. A Transvision Model FSM-1A field strength meter, accurately calibrated, was used for the measurements, together with

a Cornell-Dubilier Model 6R5 power converter (to convert from an automobile battery to 117 volts a.c.), and a Variac.

If another type of antenna is used, the absolute readings charts should be increased by a factor determined by the antenna. For example, if the antenna used has a gain of 3 db the microvolt scale should be increased by a factor of 1.41.

Since, as a rough approximation, signal voltage varies as the square root of the receiving antenna height (in the clear) doubling the antenna height will double the signal all along the microvolt scale.

The charts permit you to predict average signal levels at any distance from a station if a reading can be taken at some point within the range indicated using the same standards of measurement. The absolute values indicated in the charts were recorded during midday hours under average propagation conditions. In general, it can be said

MULTI-LAYER COIL CALCULATOR NOMOGRAPH

By S. YAMASITA

A nomograph for determining multi-layer coil inductance on the basis of the H. A. Wheeler inductance equation.

AN EXAMPLE will serve to illustrate the use of this nomograph. Assume a coil of one inch mean diameter ($2a$) and a width and thickness of one-half inch (b and c), wound with 500 turns of no. 27 d.c.c. wire. A line is drawn through the "mean diameter" and "width" scales to the reflect axis, then back to the "mean diameter" scale through the "thickness" scale. A line is then drawn vertically until it intercepts

the curve, and then horizontally to the right-hand side of the graph. From this point, a line is drawn to the proper point on the "mean dia." scale, thus locating a point on the "cross axis." A straight line through this point and the proper point on "total no. of turns" scale locates the inductance. By proper manipulation, the nomograph can assist greatly in designing a coil of a specified inductance.

$$L = \frac{.8 a^2 n^2}{6a + 9b + 10c} = \text{MH.}$$

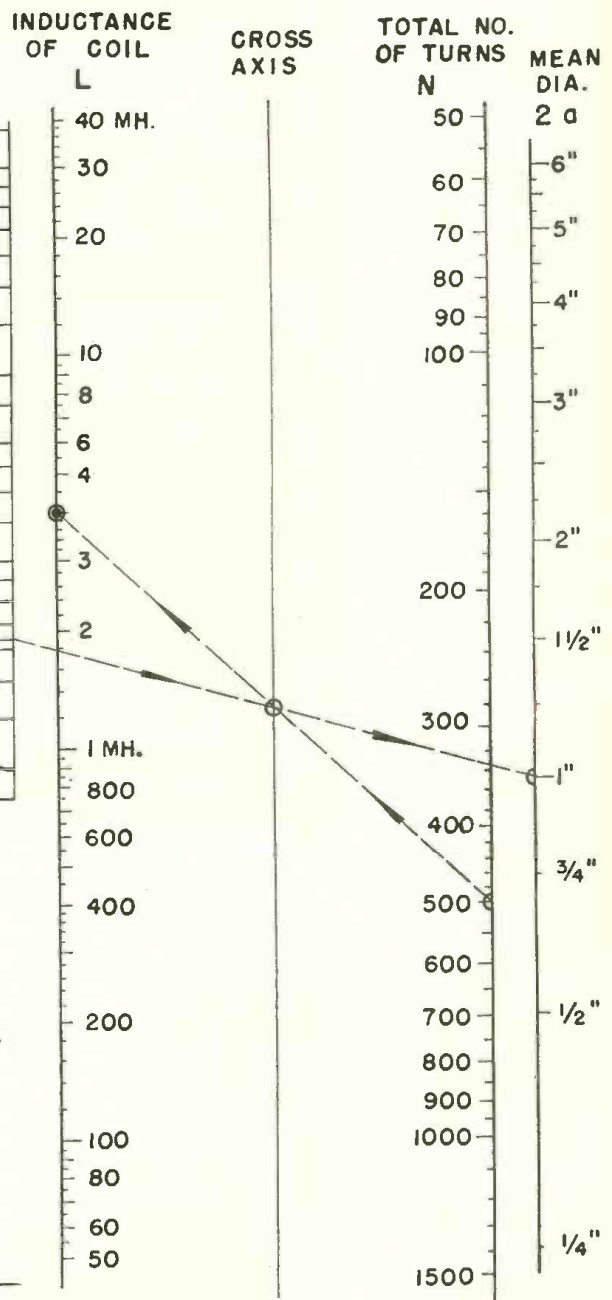
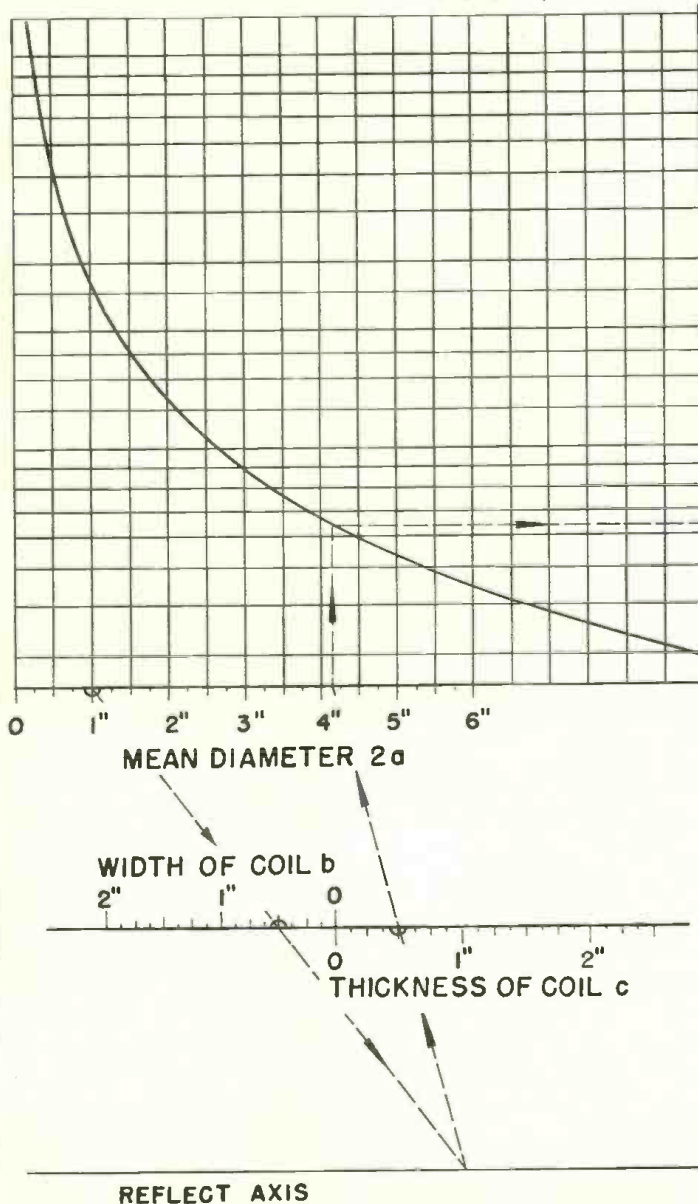
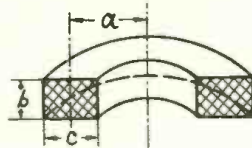

ample, if the signal level obtained from your local Channel 5 station is only 500 microvolts at fifty-three miles instead of the 1000 microvolts (refer to Channel 5 signal decline chart), the entire microvolt scale is simply halved. The microvolt scale is changed by whatever ratio exists between actual and chart readings for the range at which the sample measurement is made.

The signal range maps are constructed from the information given in the signal decline charts. Each contour represents a certain signal strength for a particular station at a given distance from the transmitter location, as obtained from the chart for that station. The first signal range map (Fig. 1) depicts 500 and 25 microvolt contours for New York's Channel 5 and Philadelphia's Channel 3. These signal levels represent actual microvolts applied to the input of a receiver or to the 300-ohm input of a service type field intensity meter that has been calibrated accurately. It should be noted that similar microvolt contours for New York's Channel 5 and Philadelphia's Channel 3 are at different distances from the station. This is a result of different erp's, antenna heights, and terrain conditions. Thus, the factors of erp and transmitting antenna height have appreciable significance in the fringe range of a station.

An explanation of the 500 and 25 microvolt choice is instructive. For the average television receiver manufactured during the last few years an input signal of 1000 microvolts (at the tuner input) was the level at which the receiver noise became apparent by

very close observation of the line structure of the picture adjusted for normal contrast (first appearance of faint snow effect). When the signal level is at 50 microvolts, the snow effect is severe and the picture is near a point at which it cannot be considered tolerable for satisfactory viewing. With the new cascade low-noise type of tuner, levels of 500 and 25 microvolts are a better approximation. The maps show extended range possibilities of lower noise levels. It is true that these noise conditions vary from receiver to receiver and from channel to channel. Nevertheless, the values chosen represent an ultimate practical value.

In summary, such maps will tell you, as a function of channel (low or high band) and erp of station, etc., the approximate microvolts of signal that can be expected at the receiver input at a given distance from the station.

The logic behind the choice of a dipole reference is demonstrated in Fig. 2. Normally, gain figures of various commercial-type receiving antennas are given (or should be) with reference to the signal delivered by a standard dipole. For example, if an antenna with a gain of 6 db was used instead of a reference dipole in the case of New York's Channel 5, there would be twice as much voltage at the receiver input for each of the contour distances from the station. Likewise, readings taken from the microvolt scale on the signal level chart for Channel 5 on the "Data-Print" must be doubled. This indicates that the actual contour values of Fig. 1 are further separated from the station transmitters as a

function of the gain of the antenna.

This range extension factor is demonstrated in Fig. 2 for a conventional conical-reflector type of antenna with a gain of 3.5 db on Channel 5 and 2.5 db on Channel 3. Just how much farther the contours fall can be calculated from the signal level charts on the "Data-Print." Simply raise the curve by the db gain introduced by the antenna and read the microvolt-distance figures directly off the chart for the new curve. With these new figures, draw the new contour. The service organization can follow this same procedure for whatever type antenna used.

For example, the 500 microvolt contour for Channel 3 is 38 miles out, using a standard dipole with the measurement standards specified. This point on the chart is at the -26 db level (chart 1). With a conical-reflector at this distance, the signal level at the receiver would be 1.33 times 500 or 665 microvolts (2.5 db antenna gain). The actual 500 microvolt level for the conical-reflector would be located at a distance represented by a signal decline of 28.5 db (26 plus 2.5). On the chart, this level is located at the 40½ mile point.

The New York's Channel 9 portion of Fig. 3 shows the 500 and 25 microvolt points for this station. Notice that these contours are nearer to the station location than they were for the low-band stations although transmitting powers are higher.

To demonstrate further the influence of antenna gain on microvolt contours, the Channel 10 (Philadel-

(Continued on page 64)

Fig. 2. A signal range chart for Channel 5 (N. Y.) and Channel 3 (Philadelphia) using a conical reflector receiving antenna to obtain the readings. Channel 5, whose transmitter is at the Empire State Building, delivers a 25 μv . signal over a radius of 112 miles and a 500 μv . signal at a radius of 64½ miles. Channel 3 (which is transmitted from a suburban Philadelphia location) delivers a 25 μv . signal at a radius of 90 miles and a 500 μv . signal at a distance of 40½ miles from the transmitter as shown by the concentric circles on the chart.

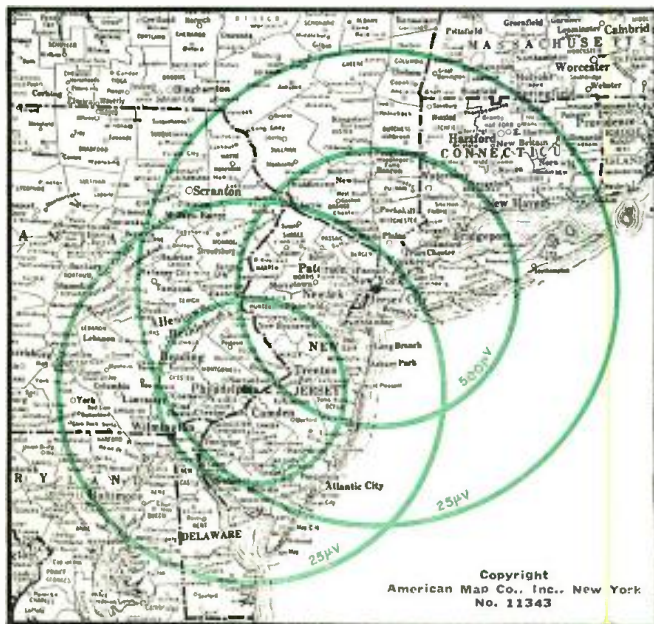
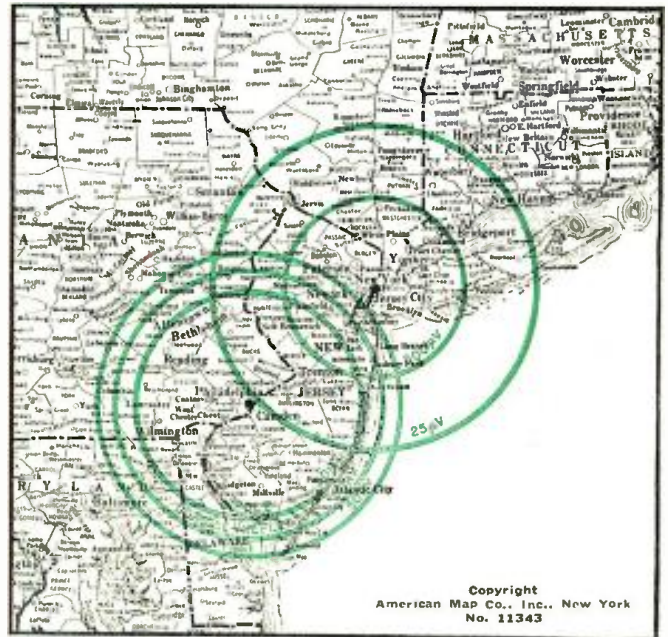

Fig. 3. Signal range map for Channel 9 (N. Y.) and Channel 10 (Philadelphia). For Channel 9, the 500 μv . radius is 41 miles from the transmitter; the 25 μv . radius is 76 miles. The 50 μv . radius for Channel 10 was determined using dipole, conical reflector, and yagi antennas. The circles show the effect of using successively higher gain antennas. The yagi antenna will supply the receiver with a 50 μv . signal at 68 miles from the transmitter; the conical reflector at 62 miles; and the standard dipole will provide this figure at a distance of 49 miles.



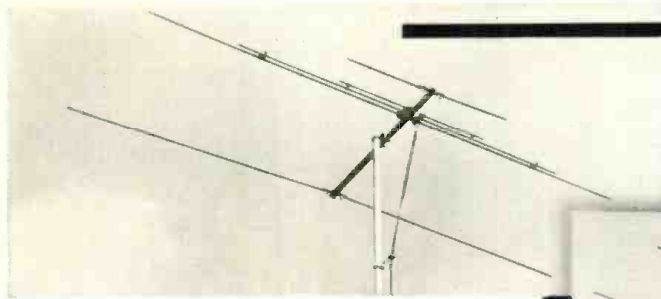
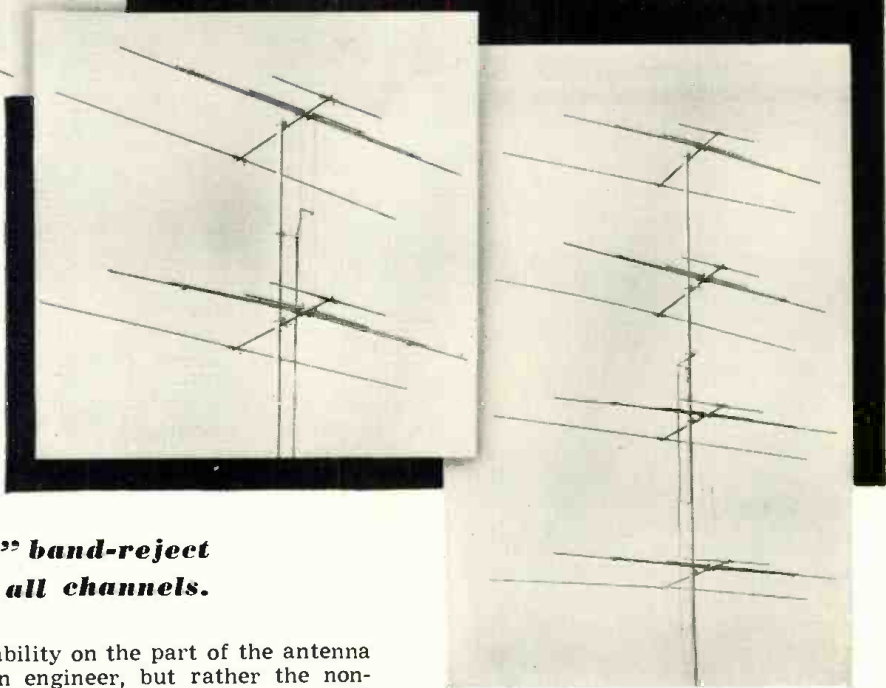

Fig. 1. Three different combinations of the Vee-D-X "Q-Tee" television antenna.



The "Q-TEE"

By

DOUGLAS H. CARPENTER

Engineering Division
The LaPointe-Plascomold Corp.

New antenna uses "printed circuit" band-reject filter. Matches 300-ohm line on all channels.

SINCE the widespread and popular acceptance of commercial telecasting, many forms of receiving antennas have dotted the nation's landscapes. Progress in the art of antenna design has, unfortunately, revolved around variations of a limited number of basic forms. These have been well known to the engineer long before the manufacturing of television antennas became the great industry it is today. Gradual standardization by service technicians across the country resulted in the selection and purchase of two specific types to satisfy two entirely different installation requirements. Metropolitan and near fringe reception dictates the use of a broadband antenna that will receive all channels and maintain a fixed directivity pattern. The second requirement is that of the fringe installation (or single-channel area) where it is necessary to obtain as much power gain on one channel as possible. For this situation there is no substitute for the yagi. There are, of course, other types being used, but for the same amount of material it is practically impossible to get equal results. For reasons of gain, assembly convenience, and all-around performance, the yagi is pretty well entrenched as the undisputed champion of single-channel reception. It is fairly unlikely that another antenna will be developed to supplant the yagi in its specific job. Research intensified by television demand has not as yet produced a superior type or even a good rival.

It might be well at this point to state that the greatest reason for the absence of new models in the antenna field is not a lack of research or crea-

tive ability on the part of the antenna design engineer, but rather the non-existence of a secondary element with which he may work. The electronic design engineer concerned with circuitry, for instance, will many times create a new improvement in the art. First, because of careful forethought, and second, because he is working with a flexible set of constants that may be rearranged in form and function. Up until now the antenna engineer has had at his disposal only one element, conductive material. This basic limitation has always confined such engineering activity to improvement of existing forms, rather than development of radically superior types.

To review progress in the field of broadband reception, we again observe a well-known form in new dress. The conical, or derivation of the "V" antenna, has been pretty generally accepted as the type that should be used where both high and low channel reception is desired. The conical works on the old and well-known principle of electrically enlarging the receiving

element to lower its "Q" and broaden its effective frequency response. This is accomplished by fanning out the receiving elements so that their individual fields intercouple when excited by a signal. This arrangement simulates a more or less "filled in" area similar to a large diameter tube. The purpose of tilting the receiving elements forward is to superimpose the major third harmonic lobes so they add in voltage and present good directivity on Channels 7-13. In all broadband antennas, an increase in performance in one part of the spectrum usually results in a loss at some other frequency. In the case of the conical, tilting of the elements results in a broadening of the directivity pattern on Channels 2-6 with resultant loss of gain and with increased susceptibility to interference and reflected signal pickup.

A markedly new approach to the problem of broadband reception has been developed by the Vee-D-X engineering staff, at long last employing the "secondary element" to achieve outstanding electrical performance. The "secondary element" has been nationally described as an "electronic channel separator," but in radioman's language is actually a specialized form of band-reject filter. The ratio of L to C , and the "Q" of the dielectric material, have been very carefully combined to work between the individual impedance points of separate receiving elements, and to provide a high insertion loss throughout the range of 160 to 230 mc. In the range

Fig. 2. "Q-Tee" construction details. See text for explanation of element functions.

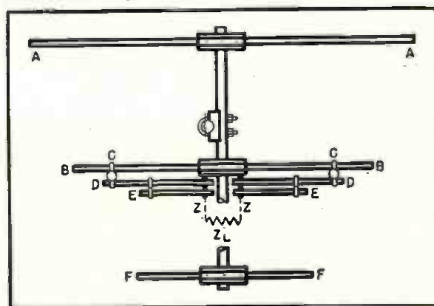

of 54-88 mc., the residual short circuit impedance (inductive) of the filter is extremely small and, as will be pointed out later, is actually used to balance the match to the low channel receiving element. The total filter is printed to maintain proper circuit "Q", and to insure electrical similarity between all units. The printed circuit and connecting lugs are housed in a sealed case of polystyrene. The printed filter and housing are illustrated in the photograph of Fig. 5. In final assembly the filters are connected between elements *B,B* and *D,D* at points *C*.

The electrical function of the total antenna can be explained by reference to the drawing of Fig. 2. If the operation of the high frequency section is considered first, we may forget about the low frequency reflector *A*. Element *D,D* is a full-wave antenna (half-wave each side) resonant at the center of the high channels. Element *E,E* is a "T" matching transformer, and element *F,F* the high channel director. *Z_t* is, of course, the transmission line impedance to be matched throughout the entire range. A full-wave antenna has a center impedance on the order of 2000 ohms making it an impractical match to standard 300-ohm ribbon line. A full-wave antenna has, on the other hand, a voltage gain of 1.4 over that of a half-wave dipole. Between the center feed points of a full-wave antenna and the opposite ends, the impedance varies from the 2000 ohm value to a theoretical 0, and then back to a high value again. The problem was to tap into the proper points in element *D,D* through the matching transformer *E,E* to get a proper match to the line while retaining the high power gain of the full-wave antenna. The high-channel director *F,F* was purposely designed as an electrical half wave. If a full-wave director were used, the center impedance of the full-wave antenna would increase with coupling and the points of theoretical 0 would be higher than those practical to match through the "T" transformer system. The band-reject filters *C,C* isolate the points of contact between elements *D,D* and *B,B*. Thus we have, essentially, a "T" matched full-wave antenna with a half-wave director. This combination by itself should not provide broadband reception, nor should it necessarily have high gain or a particularly sharp directivity pattern. As happens once in every 10,000 electronic experiments, it was discovered that we had something more than calculated; an extremely broad response, and the maintenance of a sharp directivity characteristic over the entire high-channel range. Further analysis of the intercoupling effects of the total assembly indicated a high degree of proximity coupling between the low-channel receiving element, high-channel receiving element, transformer elements and high-channel director. As can be appreciated, a mathematical explanation of this phenomenon is necessarily complex, since conditions change radically as frequen-

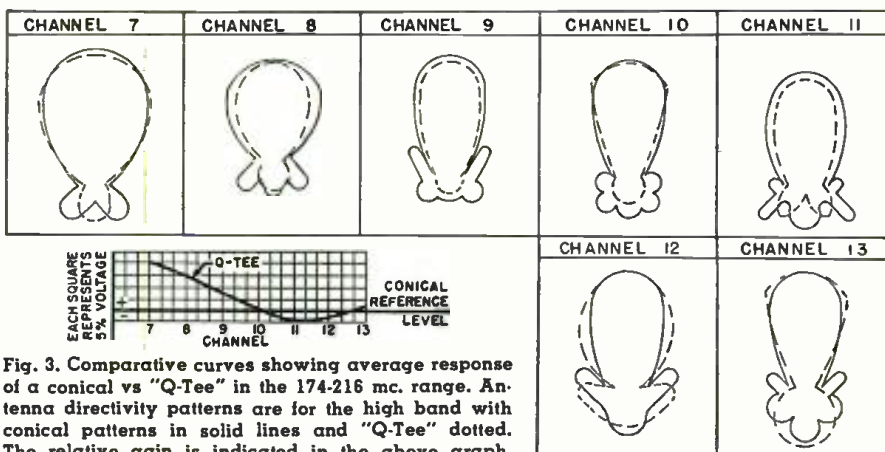

Fig. 3. Comparative curves showing average response of a conical vs "Q-Tee" in the 174-216 mc. range. Antenna directivity patterns are for the high band with conical patterns in solid lines and "Q-Tee" dotted. The relative gain is indicated in the above graph.

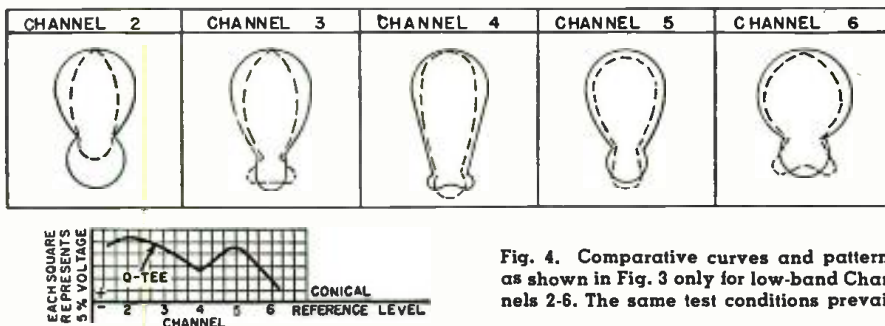

Fig. 4. Comparative curves and patterns as shown in Fig. 3 only for low-band Channels 2-6. The same test conditions prevail.

cy is varied throughout the high-channel range. A simpler explanation, which is generally correct, is to say that because of this coupling we have accomplished an effect very similar to that which exists in the conical; an electrical enlarging of all controlling elements resulting in lowered "Q" and consequent broadband characteristics. Reference to Fig. 3 tells the story on the high channels. The graph of Fig. 3 shows comparative curves plotted for average responses of the conical type antenna vs the "Q-Tee" throughout the range of 174-216 mc. The comparative horizontal directivity patterns

for the two are shown with the conical antenna patterns in solid lines and the "Q-Tee" dotted.

Operation on Channels 2-6 requires a little mental orientation as to the electrical function of the high-channel receiving elements just described. In this range we are primarily concerned with the half-wave, low-channel receiving element *B,B* and half-wave reflector *A,A*. Again, by itself, this combination could not be considered a broadband array. Starting from the transmission line feed points *Z,Z* elements *E,E* and *D,D* now become a

(Continued on page 109)

Fig. 5. "Printed circuit" band-reject filter used by Vee-D-X in the "Q-Tee" antenna.

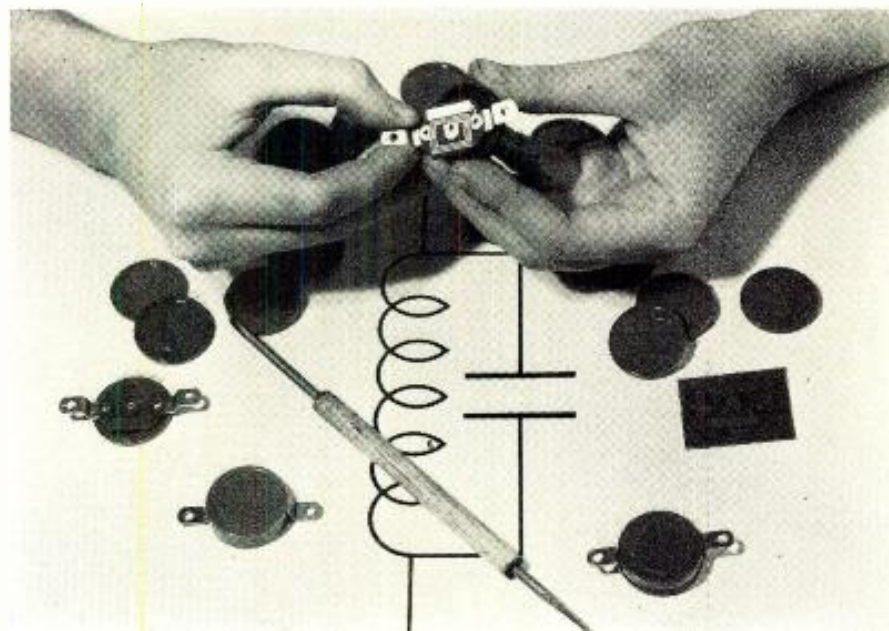



International SHORT-WAVE

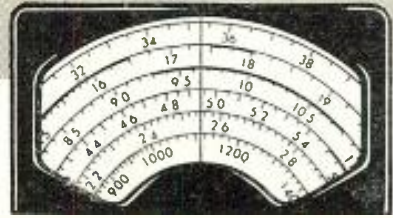

Compiled by **KENNETH R. BOORD**

THE World Friendship Society of Radio Amateurs will welcome magazines and other periodicals of any kind—technical or recreational—for its "Bedfast Club" members; QRA is WFSRA, % Bob Kenny, 30, Churchbury Road, Enfield, Middlesex, England. WFSRA now has a Membership Chairman to whom all inquiries regarding membership should be sent—E. Mitchell, 27, Fir Close, Willand Nr. Cullompton, Devon, England.

Sweden—A new DX club is "Never B4 12," Ostervagen 24, nb. Selna I, Sweden; chairman is Gunnar Karlsson. (Radio Sweden)

USA—The annual outing of the United 49'ers Radio Society will be held on Sunday, July 27, at the home of President Edw. Broome, Vincetown, New Jersey; all members and friends are invited to attend. The Maple Leaf Chapter will hold its outing on Sunday, July 27, at the home of Director Robert (Bob) Vance, 117 Wellington Street, North Woodstock, Ontario, Canada. (Boice, Conn.)

The 1952 Summer Convention of the Newark News Radio Club was held Sunday, June 22, on the grounds of the Montgomery County Sportsmen's Club, Green Lane, Pa.; the committee in charge was headed by Dick Daneker, Lansdale, Pa., and Vincent C. Stasen, Philadelphia, Pa. The NNRC recently chose these officers—Irving R. Potts, Union, N. J., president; G. Dudley Clarke, Verdun, Quebec, Canada, Canadian vice-president; Walter L.

Townley, Little Falls, N. J., treasurer; Albert J. Sauerbier, Jersey City, N. J., executive secretary; Benjamin Feinstein, Hillside, N. J., assistant executive secretary; Peter J. McKenna, Albuquerque, N. M.; Henry T. Tyndall, Burlington, Vt.; Louis Hahn, Rutherford, N. J.; Roger Legge, Jr., Scarsdale, N. Y.; Harold W. Robinson, Green Lane, Pa.; Abe Cohen, Seattle, Wash.; Charles S. Sutton, Toledo, Ohio; Eugene S. Allen, Vallejo, Calif.; Charles P. Atherton, Exeter, N. H.; Earl R. Roberts, Indianapolis, Ind.; Sheldon Dunham, Jr., Cary, N. C.; and Harold S. Williams, Seymour, Conn., all vice-presidents.

Due to press of business interests, Don Gross, Oregon, has had to give up his position as short-wave editor for the Universal Radio DX Club; he has been succeeded by Marvin E. Robbins, 5230 Cornelius Ave., Indianapolis, Ind., according to Charles Norton, Hayward, Calif., president of URDXC.

* * *

This Month's Schedules

Albania—Radio Tirana, 7.852A, still has news 1615. (Pearce, England)

Algeria—Radio Algerie, noted with good signal 1430 in Arabic, and signing off 1800 with "La Marseillaise." (DX-Radio, Sweden) Is again using 9.570 in French 1300-1800 while 6.145 carries Arabic on the same schedule. (Pearce, England)

Andorra—Radio Andorra, 5.995A, noted 1300 with popular recordings.

(Lepple, Germany, via URDXC) Heard in Scotland around 1607-1623 with light music. (Rodger)

Anglo-Egyptian Sudan—Although the station claims use of 7.325 for experimental purposes, has been heard on 7.380-7.385 by Pearce, England, on Fridays 1230-1300 with the weekly *English* period.

Angola—Luanda, 11.862A, closes 1730 weekdays, 1530 Sundays. (Niblack, Ind.) Heard in Sweden parallel on 9.632 around 1600. (NATTUGGLAN, Sweden) In verifying, also listed 7.142. (Kary, Pa.) CR6RJ, 10.050A, Radio Clube de Huila, Sa da Bandeira, noted 1450 when tuned; signed off 1530A with "A Portuguesa." CR6RB, 9.165, Benguela, noted 1310 to after 1445. (Pearce, England)

Argentina—Latest schedules for SIRA sessions include LRA, 1030-1230 in Portuguese for Brazil, 17.720; 1235-1530 in French, 17.720; 1605-1700 in German, 17.720; 1730-2030 in *English* for Eastern North America, 17.720; 2100-0100 in Spanish for the Caribbean, 15.345. LRU, 1300-1400 for Spanish America, 15.290; 1400-1545 in *English* for Great Britain, 15.290; 2300-0100 in *English* for Western North America, 15.290. LRS, 0800-1300 in Portuguese for Brazil, 11.880; 1300-1400 in *English* for Great Britain, 11.880; 1400-1500 in Swedish, 11.880; 1505-1600 in Italian, 11.880; 1605-1700 in German, 11.880, and 1700-0100 in Portuguese to Brazil, 11.880. (Golden, Mass., others) LRS2, 9.320, noted in Spanish 1914. (O'Sullivan, England) LRX, 9.66, heard at high level around 2022-2102. (Oestreich, Wash. State)

Austria—Blue Danube Network, 5.080, Salzburg, noted with music 1440-1500. (DX-Radio, Sweden) Heard on 9.617 with request program 0700. (O'Sullivan, England)

Azores—CSA92, 11.090, Ponta Delgada, noted on summer schedule of 1400-1500. (Ferguson, N. C.)

Bechuanaland—ZNB, 8.230, Mafeking, is heard in Germany around 1500 using *English*; bad CWQRM. (Lepple, via URDXC)

(Continued on page 92)

These buildings house "Radio Tetuan," Spanish Morocco. It operates on 6.037 mc.



(Note: Unless otherwise indicated, all time is expressed in American EST; add 5 hours for GCT. "News" refers to newscasts in the English language. In order to avoid confusion, the 24 hour clock has been used in designating the times of broadcasts. The hours from midnight until noon are shown as 0000 to 1200 while from 1 p.m. to midnight are shown as 1300 to 2400.) The symbol "V" following a listed frequency indicates "varying." The station may operate either above or below the frequency given. "A" means frequency is approximate.

Fig. 1. Experimental bass control circuit designed to be the electrical counterpart of the "Air Coupler" speaker baffle. Resonant frequencies of 40, 60, and 120 cycles are employed.



PULSES IN SOUND REPRODUCTION

By GLEN SOUTHWORTH

**Methods of pulse control and pulse broadening used
to improve the bass reproduction in audio equipment.**

IN THE early development of sound reproducing equipment a number of detailed studies were made regarding the characteristics of the tones produced by various musical instruments. These studies, usually made with equipment employing selective resonant circuits, indicated that many orchestral instruments produced prominent harmonics or overtones and, in frequent instances, were accompanied by relatively wide-band noise components. As a logical consequence, it was believed that natural sounding reproduction would require a system having relatively flat static frequency response characteristics over a wide range in order to obtain proper emphasis of important harmonic components.

Unfortunately for the development of the audio art, data supplied by a wave analyzer may be interpreted quite differently than that supplied by an oscilloscope. Where a wave analyzer may indicate a fundamental tone with strong harmonics, an oscilloscope may show merely a series of simple pulses. Similarly, wide-band noise, indicated by a wave analyzer, may show up on an oscilloscope screen as a single or group of nonperiodic pulses. As a result, the fact that an audio system has good static frequency characteristics is no guarantee that it will accurately reproduce "harmonics" or noise sounds, in fact many of the expedients used to obtain wide-band response make it certain that accurate reproduction of pulses will not be achieved.

Although transient response has received increasing attention in recent years, it has been largely identified with the reproduction of sounds such as those produced by the timpani, cymbals, or the so-called noise instruments. Actually, the sounds produced by such instruments are usually fairly long damped wave trains which, due to

their duration, can be reasonably well reproduced by equipment having a moderate amount of electrical or physical inertia. A somewhat more serious problem may be encountered in the reproduction of instruments that produce a reasonably steady tone with pulse-like characteristics. In this classification fall nearly all of the instruments in the lower register, even the organ, and the inability of much reproducing equipment to handle this type of transient is very often the cause of the frequent complaint of poor bass reproduction.

In dealing with the reproduction of pulses there are a number of very interesting characteristics that may be observed. Probably the most important of these is the way in which the pulse shape is strongly influenced by its acoustic or electrical environment. For example, the initial tone produced by strings or horns may consist of a series of relatively narrow pulses, which when heard at close range may sound relatively weak and colorless due to the transient characteristics of the listener's ear. However, when such instruments are played in a large room, such

as a concert hall, wall reflections may arrive at the listener's ear in sequence, producing the effect of a much broadened pulse, such as shown in Fig. 2C. The broadened pulse approaches the characteristics of a sine wave and therefore has both increased depth of tone and greater loudness. The pulse broadening produced by acoustics makes it possible to simulate very low frequency fundamental tones from an instrument with relatively limited radiating area and is a very important factor in apparent bass characteristics and auditory "balance" between different sections of an orchestra.

Another interesting characteristic of pulse waveforms is the fact that the peak amplitudes involved are frequently much less influenced by acoustics than are the peak amplitudes of sine waves. In the case of pulses, wall reflections either mean pulse broadening or occasionally pulse narrowing, while in the case of sine waves wall reflections usually mean reinforcement or cancellation of peak intensities, with cancellation problems becoming serious at low frequencies where room dimensions become comparable to the wavelengths of the generated tones. This factor has apparently influenced the design of musical instruments and even in the case of organs low frequency tones may be modulated at a rate of from three to eight cycles-per-second in order to reduce the effects of destructive interference from wall reflections.

Turning to the problems involved in reproducing pulses, probably the major one encountered is due to the physical

Fig. 2. (A) Initial pulses generated by musical instrument or other source. (B) Initial pulses and delayed pulses produced by wall reflections. (C) Combination of initial and reflected pulses showing a tone which contains much greater average energy and low-frequency content than (A) or (B).



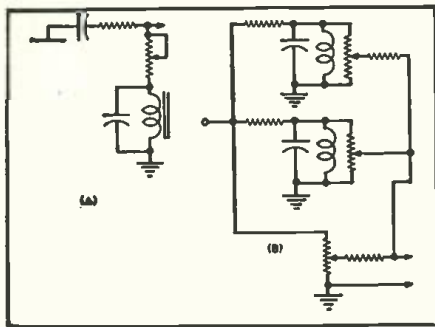

Fig. 3. (A) The simplest method of using a resonant circuit for bass boost and pulse broadening. (B) One of the methods of mixing several resonant circuits which are tuned to different audio frequencies.

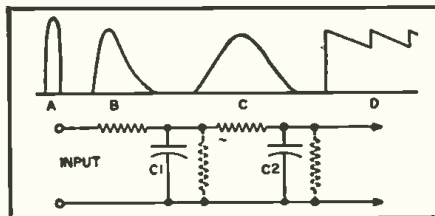

Fig. 4. How acoustic pulse broadening is simulated by simple RC circuits. Initial pulse at point A is transformed into a saw-tooth type waveform at B by the relatively slow discharge of condenser C₁. The slow charging characteristic of condenser C₂ tends to round off the initial steep slope of the saw-tooth resulting in waveform shown at C. D is the distortion that may occur if the discharge rate of condensers is too slow. This may cause a subsonic component in output capable of causing distress in the following amplifier stages or the loudspeaker. The resistance shown in the broken lines may be employed to reduce this particular effect.

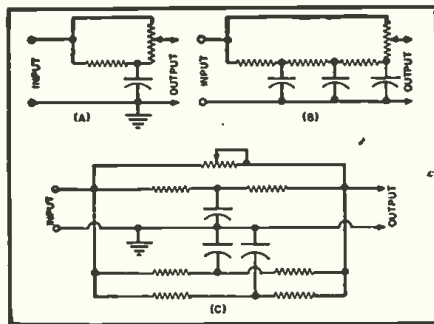

Fig. 5. (A, B, and C) Pulse waveforms obtainable from the pulse forming circuit of Fig. 8. (D) The effect of a low "Q" resonant circuit on pulse input C.

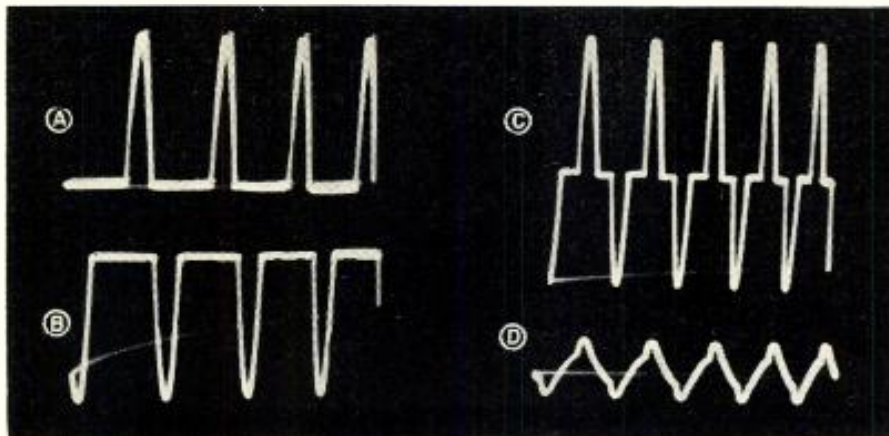

Fig. 7. Several known types of speaker baffles in which back radiation is used and influences reproduction of pulses. The acoustic delay path is shown dotted.

inertia of the loudspeaker, which causes pulses to be reproduced at a considerably lower level than sine waves and also can lead to serious deformations of the pulse's initial shape. Undoubtedly a large number of listener complaints regarding "one-note bass" or speaker "boom" can be traced to the pulse distortion produced by the speaker system. Two reasons for this are the fact that the speaker's pulse response will usually be best at or below its primary resonant frequency, and secondly, pulse broadening may be produced by speaker resonance or baffle arrangements. The result of these effects is that pulses having a repetition rate related to the frequency of the speaker or cabinet resonance may be reproduced at an intensity far above that of tones which do not bear such a relationship. In the reproduction of a badly distorted recording this factor will also apply to originally pure tones due to the deformed waveshape. In addition, a very annoying form of distortion may be produced when pulse type waveforms cause speaker or cabinet resonances to ring at a frequency several cycles removed from the repetition rate of the pulses, the resultant low frequency beats usually being very disagreeable.

One current solution to speaker "boom" and "one-note bass" is the highly damped speaker. Unfortunately this frequently leads to no bass at all,

Fig. 5. Several of the many possible methods of obtaining pulse broadening with RC networks. (A) Variation of a conventional bass-boost circuit. (B) Delay line with considerable amount of phase shift which can be used to attenuate low frequency sine-wave response while passing pulses and short-duration transients. (C) Combination of several circuits such as in (A) but with different time constants for maximum effectiveness over a wide range.

inasmuch as the poor pulse response of the speaker is not supplemented by the pulse broadening and higher consequent efficiency, produced by resonance. A similar effect is produced by lowering the speaker resonance frequency as pulse response usually falls off above this point.

Fortunately it is not necessary to wait until speakers without mechanical inertia are perfected in order to achieve musical bass reproduction, as a number of corrective steps may be taken. Probably the first of these is to convert pulse-like waveforms into near-sine waveshapes which the loudspeaker can handle with much greater efficiency and less discrimination. The easiest way to do this is to place a recording microphone at the rear of the concert hall in order that the natural pulse broadening, produced by the acoustics, may be utilized. Pulse broadening may also be obtained by placing a number of microphones at varying distances from the musical source.

Lacking control over microphone placement, the average listener has two alternatives. The first and most flexible of these is pulse shaping in the electrical portions of his reproducing equipment with tone controls or equalizers of proper design. The second method, which has been receiving considerable attention in the last year or two, is pulse shaping through the use of specially designed speaker baffles or acoustic arrangements.

Pulse control in an audio amplifier is a convenient and flexible way of compensating for loudspeaker characteristics or even deficiencies in the initial recording. For example, the resonant characteristics of a sixteen-foot organ pipe may be much more easily simulated through use of simple electrical resonant circuits than through carpentry, and accordingly, changes in characteristics are much easier to make. The simplest type of pulse broadening is probably the low-"Q" resonant circuit and good pulse broadening over a limited range may be obtained without objectionable "ringing" if the "Q" of the circuit is held to about two. Although almost all resonant tone control circuits use only one LC combination in a given frequency range, an improvement in performance may be achieved by using two or more resonant circuits fairly closely spaced in a particular range. This allows pulse broadening to be effective over a wider range and also permits the use of higher "Q" circuits due to the fact that ringing will occur over a much wider range and the limited frequency bands are not unduly accentuated. This seems to be especially true if the resonant circuits are coupled to each other in such a way that an exchange of energy takes place. A circuit of this type is shown in Fig. 3.

A non-resonant form of pulse stretching may be obtained through use of simple resistance-capacitance delay networks of different electrical lengths (Fig. 4). A number of variations are illustrated in Fig. 5. The

pulse characteristics obtainable by this method are very desirable and can actually represent an improvement over what the listener would hear if he were present at the original performance. The reason for this is that a fairly close microphone pickup may be made which captures a maximum of detail and the missing bass resulting from such a practice may then be supplied by the pulse stretcher, which seems to produce a somewhat smoother sound than does acoustic pulse broadening.

Pulse control after the loudspeaker may be secured by special baffle design. Probably the most common, and misused, example of this is the bass reflex cabinet. In this case there is usually a short delay path between the back of the speaker and the radiation from the front which introduces modifications in pulse shape as well as the static frequency characteristics. Some baffles, such as some of the corner horn designs, make use of back radiation (Fig. 7) from the speaker over a delay path. Other speaker baffles influencing pulse characteristics are the resonant column, the multiple resonant column, and the resonant box. In addition, notable improvement in apparent bass response may often be achieved through use of wall reflections in a large room, although in such a case the bass may seem to disappear as the listener approaches the speaker system.

No matter what type of system is used, the various low frequency resonances should be properly spaced for best listening results and reinforcing resonances should be kept to a minimum. For example, some phonograph pickup arms will resonate at about the same frequency as some of the larger diameter loudspeakers, and the resulting wide variation in sound pressure should be avoided. One method that the author used with success in the case of loudspeakers with fairly high resonant frequencies was to use an LC circuit in the amplifier, tuned about an octave lower. The resultant simplification of low frequency waveforms greatly improves the smoothness of the bass response and, in several instances, provided very good reproduction of organ pedal notes from small groups of six-inch speakers in simple baffles.

(Continued on page 64)

Fig. 8. A simple circuit in which a 6H6 duo-diode tube is used to obtain either a positive, negative, or a combination of pulses from an audio oscillator.

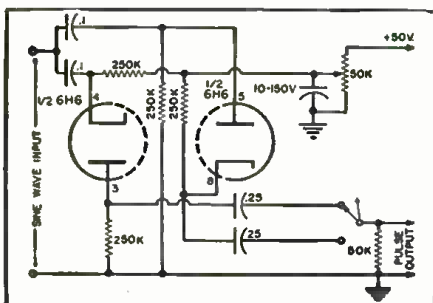

Mac's RADIO SERVICE SHOP

By JOHN T. FRYE

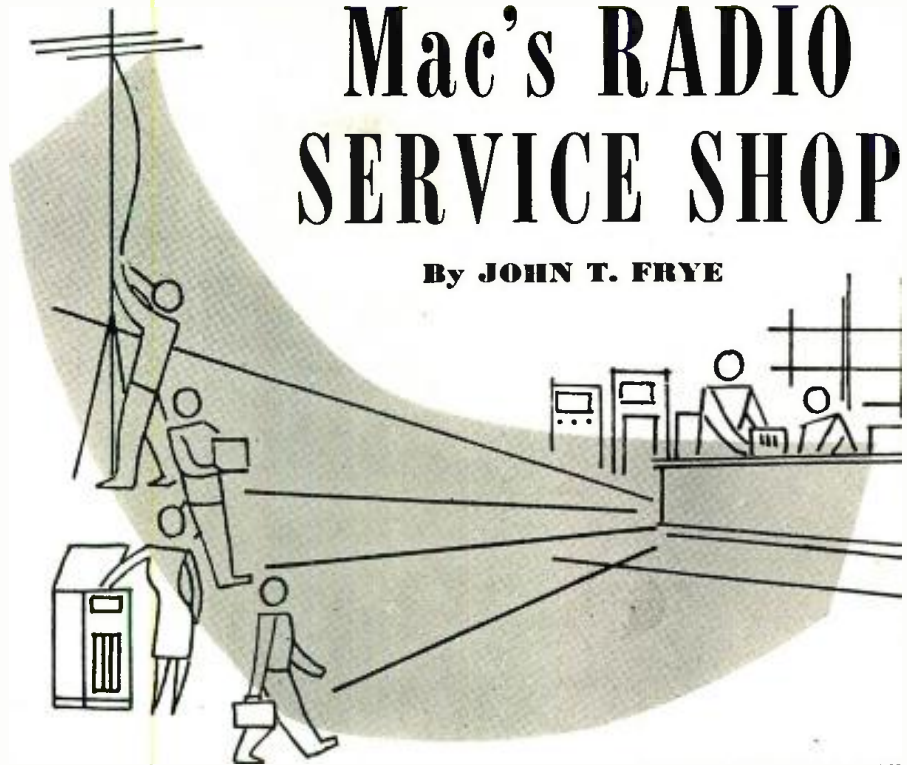

"OPEN WIRE LINES"

THE sticky, sultry heat took away a person's appetite, and Barney used only a few minutes of his lunch hour to down a sandwich, a frosted malt, and a double-decker ice cream cone; then he fortified himself with a giant lemon *Coke* "for the road" and went back to the service shop. The inside of the shop felt cool and comfortable after the glaring heat outside, he thought to himself, as he passed through the empty front of the store to the service department at the rear.

Mac, his boss, looked up from where he squatted tailor-fashion on the service bench in the direct path of a humming electric fan that rustled the litter of papers, letters, magazines, and books about him. A slide rule was balanced on one knee, and he was chewing reflectively on a stub of pencil.

"Well, this is a switch: getting back early!" he remarked to his red-headed assistant. "You sick or something?"

"No," Barney replied as he collapsed on the other end of the bench. "I just love my work. What are you doing? Trying to dope out who the president is going to be?"

"Not exactly. I'm boning up on open wire transmission lines."

"Why the sudden interest in that?" "For one thing, you may have noticed that they are becoming increasingly popular; but more important than that is my guess that they will get a lot more usage when u.h.f. TV stations really get going."

"Why, Daddy?" Barney asked in a rasping falsetto.

"Because the losses of ordinary flat twin-lead go up rapidly as the frequency increases. For example, at 500 megacycles, the dry-line loss is 3.2 db

per hundred feet, and the wet-line loss zooms up to 20 db per hundred feet. Opposed to this is an open wire transmission line loss of only .78 db when dry and not much greater than this when wet."

"How about tubular twin-lead?"

"There is not too much difference in the dry-line loss, but the wet-line loss of tubular twin-lead is only 6.8 db per hundred feet at 500 megacycles. Even so, that is about eight times the loss of open wire line."

"Where are you getting all this information?"

"From a lot of sources: The good old *'The Radio Amateur's Handbook'* has a lot of good stuff on open wire lines; so does *Terman* in his *'Radio Engineering.'* I also went back through our magazine files and dug out all the articles on transmission lines that were published in the past ten years. Still, though, there were a lot of practical points I wanted to know about actually using the lines, and I decided the best place to go for the answers was to the men who built them. *Gonset* was the originator of the 450-ohm open wire line for TV use; so I wrote to them and got a fine letter back from W. W. Smith, chief engineer of the company. *Radio Merchandise Sales*, usually called *'RMS'*, is another big outfit that makes this line and several accessories for it; so I also wrote to them and received a prompt and detailed answer from their chief engineer, Martin Bettan. Thanks to the courtesy and help of these men and also to the books and magazine articles I have been reading, I am full up to here on open wire transmission lines. Just try and stump me!"

(Continued on page 122)

A No-Cost Signal Generator

By
PHILIP SCHLOSSBERG, USN (Ret.)
 and
LOUIS BERKOWITZ
 Head, Radio Department
 Mass. Trades Shops Schools

How a midget superhet can be converted into a signal generator covering from 1006-2056 kc.

IF YOU are in need of a signal generator and are short of funds try one of these; one, called the "low cost" signal generator, gives good results for less than a dollar. Another, called the "ultra low cost" signal generator, gives good results for only a few pennies. There are many experimenters, amateurs, hobbyists, and part-time technicians who have need for a signal generator but feel that the expense involved would not warrant their investing thirty dollars or more in an instrument for which they have such limited use.

This article will show you how to construct a good, practical signal generator having a variable radio frequency range of from 1006 kc. to 2056 kc., also 456 kc.; all frequencies modulated by a 400-cycle audio tone.

This frequency range is practical for aligning the intermediate frequency amplifiers of most broadcast superheterodynes; and for aligning the radio frequency stage of the receiver at 1400 kc. or 1600 kc. Short-wave alignment frequencies may also be obtained by using harmonics of the fundamental generator frequencies.

Many servicing and testing operations can be performed with this "no cost" signal generator, such as alignment, signal injection, troubleshooting, approximate stage gain measurement, and locating dead stages in a receiver.

The amazingly low cost or no cost of this utility signal generator requires only that you have available an a.c.-d.c. midget superheterodyne receiver.

The construction of this signal generator is simplicity itself. It involves



Fig. 1. Receiver used as a signal generator.

the conversion of the oscillator section of the radio which is to be used as the signal generator. The oscillator section of a superheterodyne usually consists of a Hartley type circuit with a low value grid leak, approximately 20,000 ohms for self bias. By increasing the grid leak resistance, self-modulation of the oscillator is made to take place at an audible rate. Fig. 2A shows the original grid leak circuit of the oscillator section.

In order to convert the circuit, all that is necessary is to unsolder the grid leak resistor from the tube socket, at the cathode end of the grid leak, and place a 15 megohm, one-half watt resistor in series with the original grid leak as shown in Fig. 2B.

15 megohms should give approximately a 400-cycle note; however, if a higher or a lower pitched audio frequency is desired the added grid leak

Fig. 2. (A) Original grid leak circuit of receiver's oscillator section. (B) Circuit showing conversion for generator use.

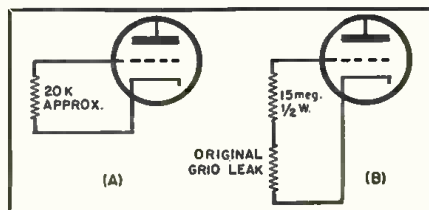

ohmic value may be changed to a lower or higher value. If the experimenter desires to build this signal generator at actually no cost he should follow this procedure: Take two ordinary paper clips and solder a five inch piece of hook-up wire to each clip; now take an ordinary business card and cut a strip two inches long by one-half inch wide; then draw several continuous black pencil lines on the card; next fasten the paper clips to the card to make contact with the pencil marks. This card is now a variable resistor of several megohms. Solder the ends of the hook-up wire into the oscillator grid circuit as shown in Fig. 2B. Turn on your signal generator and then vary the resistance of the card by sliding the paper clips back and forth until a pleasing audio tone is heard in another receiver which you must have to pick up the signal generator frequency (see Fig. 1).

Test the operation of the signal generator by slowly turning the generator dial from 550 kc. to about 1200 kc., while at the same time following the signal on the dial of the second radio from about 1010 kc. to 1600 kc.

To use the signal generator the following procedure is suggested.

For radio frequency. Turn on the signal generator; determine the frequency you desire, then subtract 456; next set the dial of the signal generator to that number.

For obtaining a 456 kc. signal. Connect a test lead through a 0.1 μ fd. blocking condenser to the signal generator at its second detector diode plate and, if necessary, another connection between the signal generator chassis and the chassis of the radio being tested, using a 0.01 μ fd. blocking condenser. Any dial setting of the signal generator will give 456 kc. with this connection, assuming that a station is being received on the signal generator.

For audio frequency. Connect across the voice coil of the signal generator loudspeaker. This gives you a strong audio signal of approximately 400 cycles. The strength of the audio signal can be controlled with the regular volume control on the signal generator.

For radio frequencies. The signal radiated is quite strong and needs no direct connection to the radio being tested. If a stronger signal is desired, wind three turns of any small size wire on the oscillator coil form of the signal generator and bring a test lead from these three turns to the circuit being tested.

Other uses for these practical little devices will suggest themselves as the experimenter discovers for himself that these so-called gadgets actually give excellent results and, while no claim is made that they are "just as good" as their more expensive "big brother" signal generators, they are most certainly worth a try—and use—until such time as you can better afford the cash expenditure for the more conventional type of signal generator.

TV DEVELOPMENT ENGINEERS DEPEND ON ACCURATE G-E LABORATORY TEST EQUIPMENT

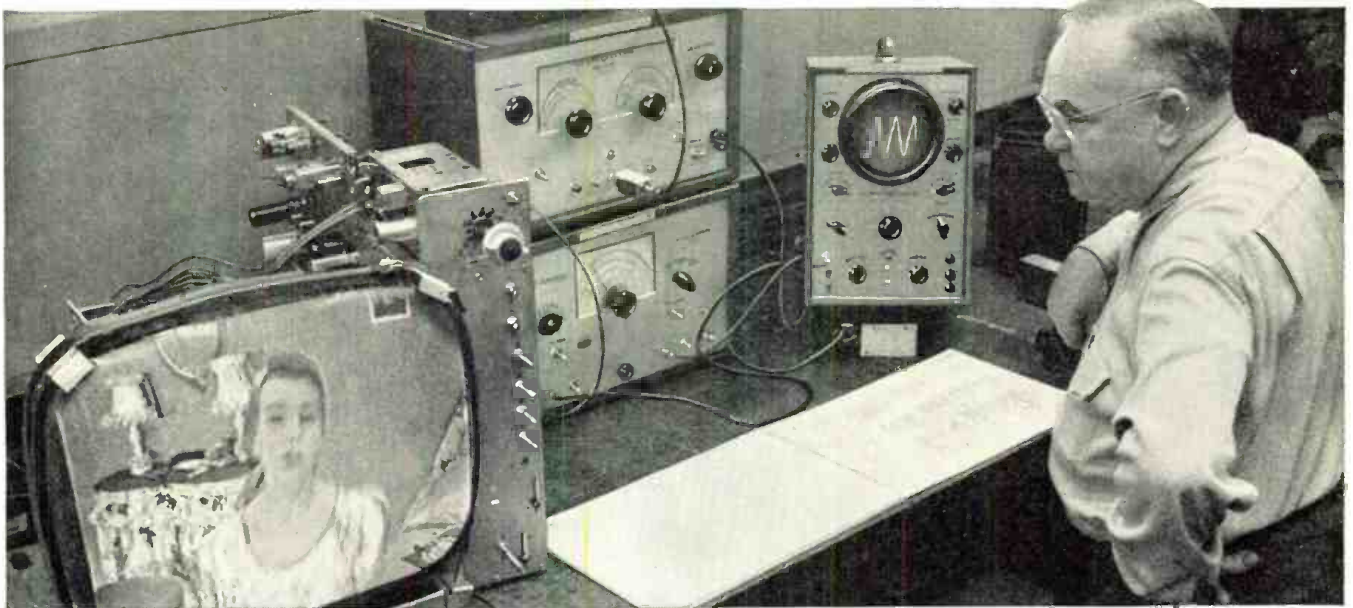

CIRCUIT DESIGN. Making frequent changes in circuits, the TV design engineer appreciates the unique flexibility of this G-E equipment. For example, General Electric's continuous coverage permits him to examine in detail any segment of

the spectrum. Phase shift control on the sweep output provides for full 360° rotation. Extreme electrical flexibility and stability make these instruments highly useful to engineers designing broad band electronic equipment.

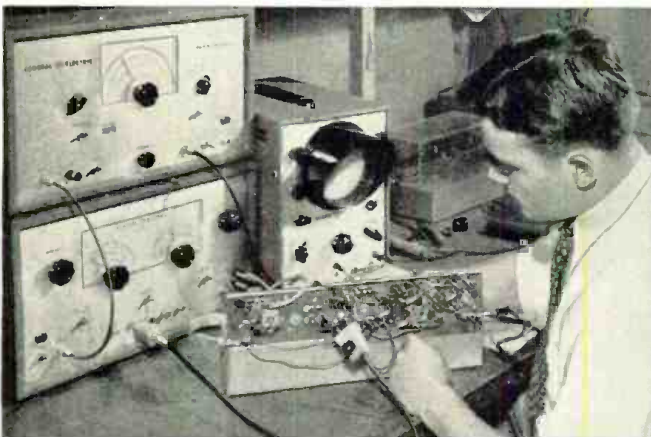

FACTORY TEST ALIGNMENT. Only 2 cables are connected to receiver during alignment. When receiver oscillators are lined up with the G-E crystal-controlled marker generator, the local station signal will fall where it belongs. The General Electric variable permeability sweep provides long-term extremely stable operation.



LABORATORY TIME-SAVER. Accurate, hand-calibrated dial permits development engineer to do 95% of his work without frequent reference to the crystal calibrator. No listening for or counting of "birdies." No time wasted making allowance for a printed dial, since the hand calibration matches precisely its associated capacitor.

FREE—NEW POWER SUPPLY CATALOG! Photos and specifications of 14 new G-E units, ranging from 200 to 1500 volts. Write us for your copy. *General Electric Company, Section 972, Electronics Park, Syracuse, New York.*

GENERAL  ELECTRIC



THE "BAY" . . . that streamlined, highly effective Mobile Antenna!

The "BAY" is that new, streamlined, center-loaded antenna that is providing such excellent performance for 75 meter, (and CAP) mobile stations throughout the country. Handsome, it's also weatherproof due to the glass-fibre sealed covering on top whip and center-loading section and you operate in any weather without fear of detuning. All exposed metal parts are brass, fully protected by beautiful Chrome plating. If you operate 75 meter mobile, (or CAP) this is the antenna for you! Send now for new, free data sheet completely describing this outstanding antenna.

The "BAY" \$19.95 net.

110V, AC POWER SUPPLY FOR ANY 274-N RECEIVER

Just plug it into the rear of your 274-N RECEIVER . . . any model. Complete kit and black metal case, with ALL parts and diagrams. Simple and easy to build in a jiffy. Delivers 24 volts plus B voltage. No wiring chunxes to be made. Designed especially for the 274-N receiver. Only \$3.95. Filament trans. for 274N receivers. Pri. 110V, 60 cy. AC. Sec. 24V @ .6A. An excellent buy at. \$1.95 ea.

O-R exclusive . . . tuning knobs for 274N Receivers, a hard-to-obtain item. Only 89c ea.



The New Gonset "COMMANDER"

35 to 50 watt, multi-band, transmitter.

Here is a real mobile transmitter offering the ultimate in compactness for under-dash mounting without compromise with efficiency. Output circuit will work into all conventional feedlines, co-ax, ribbon, open-wire, direct to low impedance loaded antenna. Dozens of new features including Class AB2 modulator with hi-level clipping.

Frequency control: Crystal. (Provisions for external VFO)

Power required: 6.3V. (AC or DC) @ 3.15A. 100V, DC @ 200-225 ma. (Phone)

Mike: Any standard carbon or PA type hi-impedance dynamic or crystal.

Tubes: RF, 6AG7 into 6146. AUDIO. 12AT7 into 2-6AQ5's.

Size: 5 7/8" high, 8 1/8" wide, 7 1/8" deep.

Completely wired and tested with all tubes and including two hi Q final coils that cover 10-11. 15-20, 40-75-80 meters. \$124.50 net.

LOOK! NO HANDS!



This mike leaves both hands free for mobile QSO's. Fastens to operator by simple snap strap. Adjustable. Double action sw. operates push-to-talk or holds on. Only \$2.00 ea.

CONDENSER TESTER

One of our best sellers! Useful, versatile laboratory item, in kit form. Simple and easy to build in less than an hour. Checks condenser leakage and continuity up to 8 megs. Will test any paper, electrolytic, mica or oil capacitor from 50 mmf. to 50 mfd. Self-contained power supply and neon bulb indicator with socket and bezel. Drilled metal cabinet. Complete instructions and diagrams included with each kit. Only \$5.00.

TRANSFORMERS-CHOKES:

325-0-325 @ 225 ma. 6.3 @ 5A. 5V @ 3A. Pri. 110V, 60 cy AC. Size, 4 1/8" x 4 1/8" x 3 1/4". Only \$6.95 ea.

920-0-920 or 740-0-740 AC @ 200 ma. Pri. 115V, 60 cycle, AC. Upright shielded case. Excellent for 807's. Only \$10.80 ea.

5V, 25A. Pri. 115V, 60 cy. AC. A real rugged job excellent for 304TL—4-250A etc. Limited quantity. Only \$4.50 ea.

10H, 200 ma choke. Hermetically-sealed steel case! Also has lum-bucking tap. A beautiful item only \$1.98.

Power transf. Pri. 115V, AC, 60 cy. Sec. 520-0-520 @ 200 ma. \$5.25 ea.

350-0-350 @ 300 ma. 6.3 @ 4A. 6.3 @ 8A. 5V @ 1A. Pri. 115V, 60 cy. AC. only \$7.95 ea.

450-0-450 @ 200 ma. Pri. 115V, 60 cy. AC. 5V @ 1A, 6.3 @ 5 amp. In shielded case. Only \$6.90 ea.

350-0-350 @ 350 ma. 6.3 @ 10A. 5V @ 6A. Pri. 115V, 60 cycle. Only \$8.95 ea.

Minimum order \$2.00. All items subject to prior sale. All prices subject to change without notice. 20% deposit must accompany all orders, balance C.O.D.

OFFENBACH & REIMUS CO.

1564 MARKET ST.
SAN FRANCISCO, CALIF.

Sound Reproduction

(Continued from page 61)

Although considerable space might be devoted to the effects of various pieces of equipment and circuit arrangements on pulse reproduction, it seems desirable to describe a simple pulse generator which may be used with an oscilloscope to make tests on the specific equipment in which the reader is interested. A diagram of such a generator is given in Fig. 8. It is used in conjunction with a conventional audio oscillator. Essentially, a 6H6 diode is biased in such a manner that only the sine-wave peaks are conducted through the tube. Either positive or negative peaks or a combination of both may be obtained in this way (Fig. 6) and the effective pulse width may be easily altered by varying the bias applied to the rectifier tube. A system of this nature has the advantage that the pulse repetition rate is easily determined from the setting of the audio oscillator and can be made to have a pulse shape of constant characteristics over a wide range of frequencies.

In making tests of pulse response, both relative amplitude of the pulses with respect to sine waves and pulse deformation should be checked. The pulse-type waveform may also be used as a sensitive method for detecting ringing resonances in loudspeakers or other devices as the pulse will tend to be smoothed out to a near sine wave when the repetition rate is the same as that of the ringing or some fraction such as one-half or one-third.

All tone controls investigated by the pulse method showed some alteration of the pulse shape, and the complaint that the use of tone controls sometimes lead to highly audible distortion was traced to this factor. Specifically, the worst trouble seemed to occur when a signal with appreciable asymmetry was fed into a bass boost circuit of the RC type and synthetic subsonic components were "detected" by the bass boost circuit due to the long time constant of the RC network. Most frequent cases of this kind are noted with some soprano voices, but second harmonic distortion preceding the tone control may cause this effect on other program material. Sometimes resistance-coupled amplifier stages may give similar trouble which is not easily noticed with sine- or square-wave tests, but may be more readily detected through use of asymmetrical pulses. In particular, the equipment should be checked to see that it will pass pulses with the same maximum amplitude as sine waves. Listening tests with a properly designed resonant bass boost circuit indicated appreciably cleaner reproduction than with a conventional RC network. This was attributed to the fact that the resonant circuit did not give an exaggerated saw-tooth effect to irrelevant noise pulses, which tends to greatly in-

crease the low-frequency noise level and consequent masking of musical sounds. The resonant circuit likewise has the advantage of producing a more symmetrical pulse shape, and of providing a fairly sharp low-frequency cut-off which prevents generation of unwanted d.c. components.

In conclusion, it seems very likely that problems of pulse reproduction are of considerable importance in high quality sound, particularly where a firm musical bass is desired. Likewise it appears necessary to reproduce pulses in their proper amplitude and width in order to provide proper auditory "masking" of noise components, otherwise unnatural harshness may result or, in the case of some tape recorders, excessive modulation noise may be detected. Pulse control offers a definitely useful tool for the audio engineer, listener, or musician. —30—

Signal Level

(Continued from page 55)

phia) portion of Fig. 3 shows the 50 microvolt contours for a dipole, a standard conical-reflector, and a Channel 10 yagi. Notice how the 50 microvolt contour can be extended further and further from the station with antenna gain.

A number of important facts are revealed by the signal decline charts and range maps.

The rate of signal decline is much faster than the practical rate at which gain can be added to an antenna system. For example, using the Channel 3 signal decline curve we note that the 1000 microvolt contour is at 31 1/2 miles. Just 26 miles beyond this, or at a range of 57 miles, an antenna with a phenomenal gain of 20 db would be needed to bring the signal up to the 1000 microvolt level. The signal decline averages one decibel per mile over most of the range.

We cannot expect too much from antenna systems in fringe reception. For example, let us assume we have a good quality receiver that does not show any effect for a 500 microvolt signal. Now, at a range of 70 miles (Channel 3) we have a signal of approximately 45 microvolts. This level produces a useful signal but one with high snow content. Suppose, in our enthusiasm, we decide to double the antenna height (up to 60 feet) and use a high-gain yagi (12 db). This more elaborate installation raises our signal by perhaps 15 db (assuming a conservative 3 db line, installation, and mismatch losses). This brings the signal level up to approximately 350 microvolts which is a decided improvement but still not high enough to take the snow effect out of the picture. This example also indicates why you should not expect too much from the increasing antenna height—it is quite a jump from a 30 footer to a 60 footer. The improvement is there and is worthwhile but don't expect miracles. —30—

THE ONLY WAY to make tv servicing easy

Here is the key to easy tv servicing... based on practical what-to-do and how-to-do-it information.

Naturally, every set manufacturer wants his receiver repaired correctly. Once he sells a receiver, he'll go to great lengths to keep it operating properly. That's why he prepares such a wealth of servicing data. Data that deals with practical facts... what-to-do and how-to-do-it. It is this data which Rider publishes in complete, unedited form - because it is this data that makes tv servicing easy!

Here's an example: On Hallicrafter receiver models 805, 806, 810 and 810C (chassis number M800S) the manufacturer issued 32,8½" x 11", pages of servicing data. (We published all 32 pages in Rider TV Manual Vol. 8, and in Rider Tek-File Pack 6.) These models were manufactured in 7 production runs. To give you all the data you need, individual bottom views are given for runs 1, 2, 3 and for 4, 5, 6, 7. To show the difference between the receivers, the manufacturer prepared, and we reprinted, four different schematics. One of these is for run 1; another shows the receiver as produced in runs 2 and 3. Still another schematic shows the runs 4, 5, 6 and 7... but this schematic applies to the receivers using EM (electromagnetic) focus coils. The fourth schematic applies to production runs 4, 5 and 6 for receivers using PM (permanent magnetic) focus coils.

The variations introduced by different runs displayed a major effect on the tube operating voltages. In many instances they varied by as much as 100 per cent. Can you imagine yourself determining whether the operating conditions were right or wrong on these Hallicrafter models without this vital complete data!

This is only one example in thousands of how complete servicing

data makes your job easy. And it is this data which appears in Rider Servicing Data. From large, easy-to-follow schematics... circuit explanations... stage by stage alignment curves... page after page of troubleshooting test patterns... waveforms... clear, enlarged chassis views... circuit changes... to complete unpacking instructions; Rider Data is the only publishing source for complete, factory-issued, official servicing data... in accurate, organized, unedited form. NOW, WITH THESE TWO IMPORTANT FEATURES:

Manufacturers' Trouble Cures

These 3" x 5" standard index cards called Rider Handies contain vital manufacturer-issued permanent trouble cures plus production changes. Each Handy is identified with a manufacturer and a receiver model. With Rider Handies you save countless hours of diagnosis and repair time... because Handies contain the data you must have to make permanent repairs on many manufacturers' models. (Rider Handies information appears in Rider TV Tek-File packs, and Rider TV Manuals beginning with Vol. 9.)

Guaranteed Replacement Parts Listings

Beginning with Rider T.V. Manual 10 and Rider T.V. Tek-File Pack 57, replacement parts listings are included. All the replacement parts listed in Rider tv servicing data meet the physical and electrical performance ratings of the original equipment!

Rider Servicing Data available in two forms:

Rider T.V. Manuals.

Vols. 1 to 9. *Pictured Below*



Each contains full data for manufacturers' receivers produced during a certain period. (The latest, T.V. 9, just published, covers October 1951 through February 1952.) Each manual has over 2,000 (8½" x 11") pages in permanent binder, with an index covering the contents of all manuals. Rider manuals are perfect for shop use and permanent reference. Price - \$24 each.

Rider T.V. Tek-Files. Packs 1 to 60

The contents of a typical T.V. Tek-File pack are shown below. In Rider Tek-File packs you buy complete Rider servicing data for only one, two, or a few manufacturers... according to your needs. Notice that each pack consists of handy, standard file folders for easy use. Only \$2 each pack.

FREE Rider T.V. Tek-File indexes covering the contents of all published packs are at your jobber's. If he's out, write us.

DON'T BE SWITCHED!

Rider Tek-File is DEFINITELY NOT the same as any other publisher's service. If your jobber doesn't carry them, DON'T BE SWITCHED. Write us direct... we'll sell you. (Please include your jobber's name.)

TRY A PACK.

Prove to yourself that Rider Tek-File makes tv servicing easy. Buy one pack for the next receiver you service. If you



don't agree it's better than anything you ever used, return the pack to us within seven days... we'll send you a full refund!

OUT SOON.

Rider RADIO Tek-Files! Same style as T.V. Tek-Files. Now, get your complete radio servicing data this easy economical package way. Ask your jobber.

John F. Rider Publisher, Inc., 480 Canal St., New York 13, New York. West Coast Office: 4216-20 W. Jefferson Blvd., Los Angeles, California.

The NEW 1952 Heathkit OSCILLOSCOPE KIT

MODEL O-7
SHIPPING WT.
29 LBS.

\$435.00

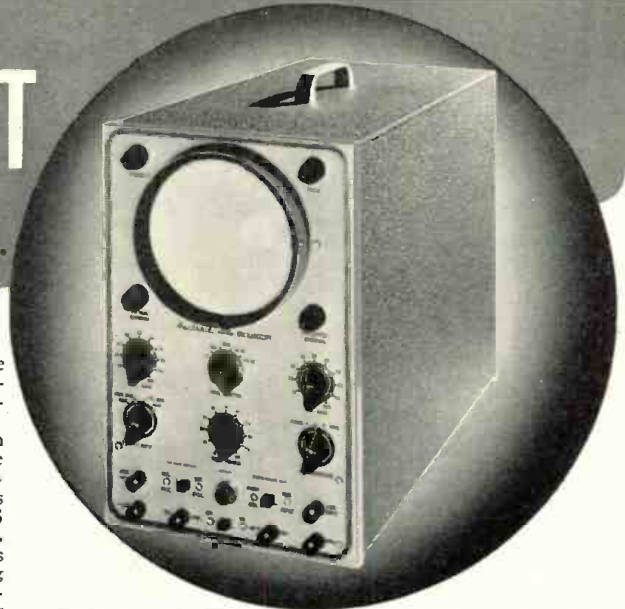

The Heathkit O-7 Oscilloscope with its 10 tube lineup (including CR tube) and carefully engineered circuit using highest quality components is truly the most outstanding scope value on the market today.

The "spot shape" (astigmatism) control working in conjunction with the focus control assures clear, sharp focusing... extended sweep range and faster retrace time permits the study of high frequencies... step-attenuated frequency-compensated cathode follower vertical input contributes to the excellent frequency response of the vertical channel... .03V RMS per inch vertical sensitivity makes weak input signals easy to study... push-pull operation of both vertical and horizontal deflection plates reduces pattern distortion... specially designed extra-wide CR tube mounting bracket places vertical cascade amplifier, vertical phase splitter, and deflection amplifiers near base of CR tube to reduce distributed wiring capacity and increase high frequency response.

Ideal for TV servicing—steep wavefronts encountered in TV work are easily handled. Fine for production line testing—rugged quality components can stand up under continuous hour-after-hour use. Excellent for laboratories—electrical performance comparable to scopes costing 4 and 5 times as much.

You'll like the complete instructions showing all details for easily building the kit—includes pictorials, step-by-step construction procedure, numerous sketches, schematic, circuit description. All necessary components included—transformer, cabinet, all tubes (including CR tube), completely punched and formed chassis—nothing else to buy.

- New "spot shape" control for spot adjustment—to give really sharp focusing.
- A total of ten tubes including CR tube and five miniatures.
- Cascaded vertical amplifiers followed by phase splitter and balanced push-pull deflection amplifiers.
- Greatly reduced retrace time.
- Step attenuated—frequency compensated—cathode follower vertical input.
- New mounting of phase splitter and deflection amplifier tubes near CR tube base.
- Increased frequency response—useful to 5 Mc.
- Tremendous sensitivity .03V RMS per inch Vertical—.6V RMS per inch Horizontal.

MODEL
S-2



Heathkit ELECTRONIC SWITCH KIT

SHIPPING WT.
11 LBS.

\$19.50

The companion piece to a scope—Feed two different signals into the switch, connect its output to a scope, and you can observe both signals—each as an individual trace. Gain of each input is easily set (gain A and gain B controls), the switching frequency is simple to adjust (coarse and fine frequency controls), and the traces can be superimposed for comparison or separated for individual study (position control).

The kit is complete with tubes, switches, cabinet, power transformer and all other parts, plus a clear detailed construction manual.

NEW Heathkit AUDIO FREQUENCY METER KIT

MODEL AF-1
SHIPPING WT. 15 LBS.



\$34.50

The ideal instrument for determining frequencies from 20 cycles to 100 KC. Set the selector switch to the proper range—feed the signal into the input terminals—and read the frequency from the meter—completely simple to operate, and yet dependable results.

Quality Simpson 200 microampere meter has two plainly marked scales (0-100 0-300). These scales read in conjunction with the seven position selector switch, give full scale readings of 100, 300, 1000, 3000, 10,000, 30,000, and 100,000 cycles. Convenient ranges for fast and easy readings.

For greatest accuracy, the 1-3-10 ratio of ranges is maintained and each range has an individual calibrating control.

A signal voltage anywhere between 2 and 300V can be fed directly into the instrument and a change in signal voltage between these limits will not affect the meter reading. In addition, input wave shape is not critical (the unit will read the frequency of either sine wave or square wave input).

The tube complement consists of a 6SJ7 amplifier and clipper, 6V6 amplifier and clipper, 6H6 meter pulse rectifier, 6X5 power supply rectifier, and OD3/VR150 voltage regulator.

Construction is simple, and quality components are used throughout.

Heathkit INTERMODULATION ANALYZER KIT



MODEL IM-1
SHIPPING WT. 18 LBS.

\$39.50

Intermodulation testing of audio equipment is rapidly being accepted by more and more engineers and audio experts as the best way to determine the characteristics of audio amplifiers, recording systems, networks, etc.

The Heathkit Intermodulation Analyzer supplies a choice of two high frequencies (approx. 3000 cycles and 7000 cycles) and one low frequency (60 cycles). Both 1:1 or 4:1 ratios of low to high frequencies can be set up for IM testing, and the ratios are easily set by means of a level control and the instrument's own VTVM. An output panel control and the instrument's own VTVM. An output panel control supplies the mixed signal at the desired level with an output impedance of two thousand ohms. The Analyzer section has input level control and proper filter circuits feeding the instrument's VTVM to read intermodulation directly on full scale ranges of 30%, 10% and 3%. Built-in power supply furnishes all necessary voltages for operating the instrument.

YOU SAVE BY ORDERING DIRECT FROM MANUFACTURER—USE ORDER BLANK ON LAST PAGE

EXPORT AGENT
ROCKE INTERNATIONAL CORP.
13 E. 40th ST.
NEW YORK CITY (16)
CABLE APLAB N Y

The **HEATH COMPANY**

... BENTON HARBOR 15, MICHIGAN

THE *New* 1952 Heathkit

VTVM KIT

MODEL V5-A
SHIPPING WT. 7 LBS.

\$24.50

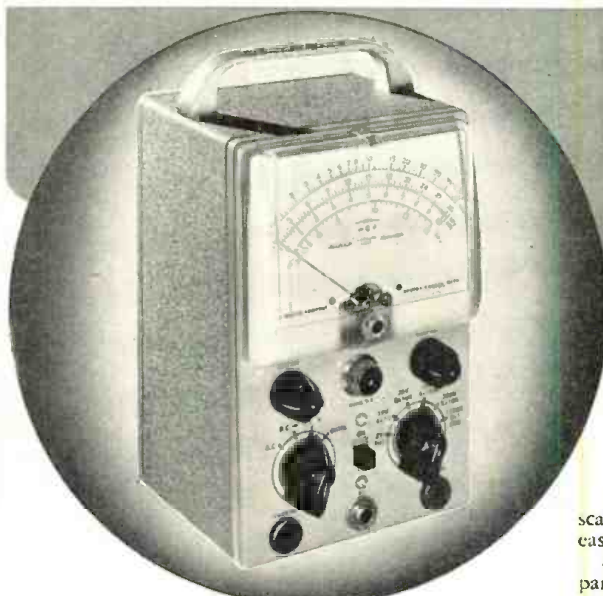

- New styling, — formed case for beauty.
- New truly compact size. Cabinet 4 1/8" deep by 4-11/16" wide by 7-3/8" high.
- Quality 200 microamp meter.
- New ohms battery holding clamp and spring clip — assurance of good electrical contact.
- Highest quality precision resistors in multiplier circuit.
- Calibrates on both AC and DC for maximum accuracy.
- Terrific coverage — reads from 1/2V to 1000V AC, 1/2V to 1000V DC, and .1 to over 1 billion ohms resistance.
- Large, clearly marked meter scales indicate ohms, AC Volts, DC Volts, and DB — has zero set mark for FM alignment.

Designed to take up a minimum of space, yet designed to be the most important and useful instrument on your workbench. Really handsome looking — note the rounded edges on front panel and rear cover. New compact size has cabinet dimensions of only 4 1/8" deep x 4 11/16" wide x 7 3/8" high.

Tremendous coverage — will read from 1/2V to 1000V AC, 1/2V to 1000V DC, .1 to over 1 billion ohms resistance, and Db. Meter scale has zero-set mark for FM alignment — all scales clearly marked for easy and fast readings and Db scale is in red for easy identification.

Simple to operate. Ohms adjust and zero adjust controls located on front panel along with selector and range switches. Selector switch has four positions: AC, DC-, DC+ and Ohms to set up the instrument for type of reading desired. DC- position allows negative voltages to be taken without reversing test prods. AC and DC voltage ranges are full scale 3V — 10V — 30V — 100V — 300V — 1000V and resistance ranges are RX1, X10, X100, X1000, X10M, X1 Megohm. Convenient ranges for fast and accurate readings.

Strictly highest quality components used throughout — 1% precision resistors in multiplier circuit, Simpson 200 microampere meter movement, sturdy cabinet, excellent positive detent smooth acting switches, etc. New miniature tube used in meter balancing circuit and new battery holding clamp and spring clip assure good contact to ohms string of resistors.

Kit comes complete — and the instruction manual with its step-by-step instructions, pictorials, figures, and schematic makes assembly a pleasure.

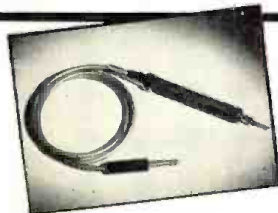

Heathkit R F PROBE KIT

Extends range of Heathkit VTVM to 250 MC ± 10%. Designed for taking RF measurements. All parts furnished including probe housing and crystal diode detector. Shipping Weight 1 lb.

\$5.50

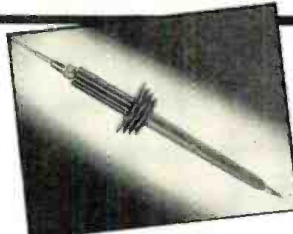

Heathkit 30,000 V DC PROBE KIT

For taking readings up to 30,000 V DC when used with the Heathkit VTVM (or any standard 11 megohm VTVM). Comes with two color molded plastic probe body and all parts. Shipping Wt. 2 lbs.

\$5.50

Heathkit A. C. VACUUM TUBE VOLTMETER KIT

Now — as a Heathkit — at a price anyone can afford, an AC VTVM. Makes possible those sensitive AC measurements required by audio enthusiasts, laboratories, and experimentors. The kit audio men have been looking for. Ten ranges consisting of full scale .01, .03, .1, .3, 1, 3, 10, 30, 100, 300 volts RMS assure easy and more accurate readings. Ten ranges on DB provide for measurements from -52 to +52 DB. Frequency response within 1 DB from 20 cycles to 50 KC.

The ingenious circuitry incorporates precision multiplied resistors for accuracy, two amplifier stages using miniature tubes, a unique bridge rectifier meter circuit, quality Simpson meter with 200 microampere movement, and a clean layout of parts for easy wiring. A high degree of inverse feedback provides for stability and linearity.

Extremely compact, cabinet size — 4-1/8" deep x 4-11/16" wide x 7-3/8" high. Newly designed cabinet makes this the companion piece to the VTVM.



MODEL AV-1
SHIP. WT. 5 LBS.

\$29.50

Heathkit SQUARE WAVE GENERATOR KIT

The Heathkit Square Wave Generator is an excellent square wave frequency source with features you won't want to be without. Especially notable is the wide range of the instrument — 10 cycles to 100 kilocycles continuously variable. This wide range makes it useful for television and wide band amplifier work as well as audio experimentation. The output impedance is low, and the output voltage is continuously variable between 0 and 20 volts. Because a multivibrator stage cannot be accurately calibrated, terminals on the front panel can be used for synchronization to an external source should it be desired.

The circuitry consists of a multivibrator stage, a clipping and a squaring stage, and a cathode follower output stage. The power supply is transformer operated and utilizes a full wave rectifier tube with 2 sections of LC filtering.

For a good, wide range, and low priced square wave generator, the SQ-1 just can't be beat.



MODEL SQ-1
SHIP. WT. 14 LBS.

\$29.50

YOU SAVE BY ORDERING DIRECT FROM MANUFACTURER—USE ORDER BLANK ON LAST PAGE

EXPORT AGENT
ROCKE INTERNATIONAL CORP.
13 E. 40th ST.
NEW YORK CITY (16)
CABLE 48244-N.Y.

The HEATH COMPANY

... BENTON HARBOR 15, MICHIGAN

Heathkit SIGNAL GENERATOR KIT

Model SG-6
Shipping Wt. 7 lbs.

The new Heathkit Signal Generator Kit has dozens of improvements. Covers the extended range of 160 Kc to 50 megacycles on fundamentals and up to 150 megacycles on useful calibrated harmonics; makes this Heathkit ideal as a marker oscillator for TV. Output level can be conveniently set by means of both step attenuator and continuously variable output controls. Instrument has new miniature HF tubes to easily handle the high frequencies covered.

Uses 6C4 master oscillator and 6C4 sine wave audio oscillator. The kit is transformer operated and a husky selenium rectifier is used in the power supply. All coils are precision wound and checked for calibration making only one adjustment necessary for all bands.

New sine wave audio oscillator provides internal modulation and is also available for external audio testing. Switch provided allows the oscillator to be modulated by an external audio oscillator for fidelity testing of receivers. Comes complete, all tubes, cabinet, test leads, every part. The instruction manual has step-by-step instructions and pictorials. It's easy and fun to build a Heathkit Model SG-6 Signal Generator.



\$19.50

Heathkit CONDENSER CHECKER KIT

Only
\$19.50

Model C-2
Shipping Wt. 6 lbs.

Checks all types of condensers — paper — mica — ceramic — electrolytic. All condenser scales are direct reading and require no charts or multipliers. Covers range of .00001 MFD to 1000 MFD. A Condenser Checker that anyone can read. A leakage test and polarizing voltage for 20 to 500 V provided. Measures power factor of electrolytics between 0% and 50% and reads resistance from 100 ohms to 5 megohms. The magic eye indicator makes testing easy.

The kit is 110V 60 cycle transformer operated and comes complete with rectifier tube, magic eye tube, cabinet, calibrated panel and all other parts. Has clear detailed instructions for assembly and use.



NEW Heathkit SIGNAL TRACER AND UNIVERSAL TEST SPEAKER KIT

\$19.50

Model T-2
Shipping Wt. 7 lbs.

The popular Heathkit Signal Tracer has now been combined with a universal test speaker at no increase in price. The same high quality tracer follows signal from antenna to speaker — locates intermittents — finds defective parts quicker — saves valuable service time — gives greater income per service hour. Works equally well on broadcast, FM, or TV receivers. The test speaker has an assortment of switching ranges to match phones, pickups and PA systems. Comes complete: cabinet, 110V 60 cycle power transformer, tubes, test probe, all necessary parts, and detailed instructions for assembly and use.

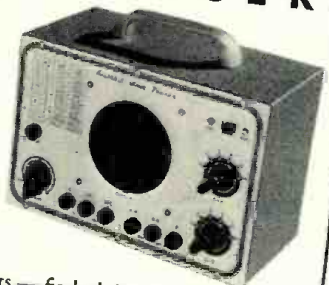

Model TC-1
Shipping Wt. 12 lbs.

\$29.50

Heathkit TUBE CHECKER KIT

The Tube Checker is a MUST for radio repair men. Often customers want to SEE tubes checked, and a checker like this builds customer confidence. In your repairing, you will have a multitude of tubes to check — quickly. The Heathkit tube checker will serve all these functions — it's good looking (with a polished birch cabinet and an attractive two color panel) — checks 4, 5, 6, 7 prong Octals, Loctals, 7 prong miniatures, 9 prong miniatures, pilot lights, and the Hytron 5 prong types. AND IT'S FAST TO OPERATE — the gear driven, free-running roll chart lists hundreds of tubes, and the smooth, acting, simplified switching arrangement gives really rapid set-ups.

The testing arrangement is designed so that you will be able to test new tubes of the future — without even waiting for factory data — protection against obsolescence.

You can give tubes a thorough testing — checks for opens, shorts, each element individually, emission, and for filament continuity. A large BAD-?-GOOD meter scale is in three colors for easy reading and also has a "line-set" mark.

You'll find this tube checker kit a good investment — and it's only \$29.50.

YOU SAVE BY ORDERING DIRECT FROM MANUFACTURER—USE ORDER BLANK ON LAST PAGE

EXPORT AGENT
ROCKE INTERNATIONAL CORP.
13 E. 40th ST.
NEW YORK CITY (16)
CABLE ARLAR N Y

The HEATH COMPANY

... BENTON HARBOR 15, MICHIGAN

NEW 1952 *Heathkit* BATTERY ELIMINATOR KIT



- Can be used as battery charger.
- Continuously variable output 0 - 8 Volts — not switch type.
- Heavy duty Mallory 17 disk type magnesium copper sulfide rectifier.
- Automatic overload relay for maximum protection. Self-resetting type.
- Ideal for battery, aircraft and marine radios.
- Dual Volt and Ammeters read both voltage and amperage continually — no switching.

The new Heathkit Model BE-3 incorporates the best. Continuously variable output control is of the variable transformer type with smooth wiper type contacts.

There are no switches or steps and voltage between 0 and 8 Volts is available at 10 Amperes continuous and 15 Amperes intermittent. Maximum safety from overloads and shorts provided by automatic overload relay which resets itself when overload is removed.

The new rectifier is a 17 plate Mallory magnesium copper sulfide type. This is the most rugged type available for long trouble-free use.

Output is continuously metered by both a 0 - 10 Volt Voltmeter and a 0 - 15 Amp Ammeter. Shorted vibrators indicated instantly by ammeter.

Equip now for all types of service — aircraft — marine — auto and battery radios — this inexpensive instrument vastly increases service possibilities — better be ready when the customer walks in.

Model BE-3
Shipping Wt. 17 lbs.

NEW *Heathkit* SINE AND SQUARE WAVE AUDIO GENERATOR KIT

Designed with versatility, usefulness, and dependability in mind, the AG-7 gives you the two most needed wave shapes right at your fingertips — the sine wave and the square wave.

The range switch and plainly calibrated frequency scale give rapid and easy frequency selection, and the output control permits setting the output to any desired level.

A high-low impedance switch sets the instrument for either high or low impedance output — on high to connect a high impedance load, and on low to work into a low impedance transformer with negligible DC resistance.

Coverage is from 20 to 20,000 cycles, and distortion is at a minimum — you can really trust the output wave shape.

Six tubes, quality 4 gang tuning condenser, power transformer, metal cased filter condenser, 1% precision resistors in the frequency determining circuit, and all other parts come with the kit — plus, a complete construction manual — A tremendous kit, and the price is truly low.

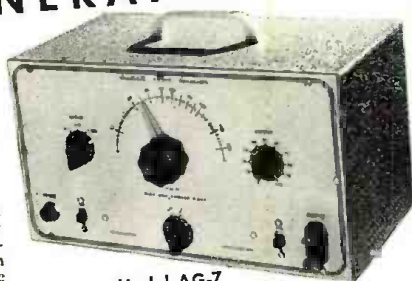

Model AG-7
Shipping Wt. 15 lbs.

\$34.50

THE NEW *Heathkit* HANDITESTER KIT

A precision portable volt-ohm milliammeter. Uses only high quality parts — All precision 1% resistors, three deck switch for trouble-free mounting of parts, specially designed battery mounting bracket, smooth acting ohm adjust control, beautiful molded bakelite case, 400 micro-amp meter movement, etc.

DC and AC voltage ranges 10 - 30 - 300 - 1000 - 5000V. Ohms range 0 - 3000 and 0 - 300,000. Range Milliamperes 0 - 10 Ma, 0 - 100 Ma. Easily assembled from complete instructions and pictorial diagrams.



\$13.50

Model M-1
Shipping Wt. 3 lbs.

NEW *Heathkit*

T.V. ALIGNMENT GENERATOR KIT

Here is an excellent TV Alignment Generator designed to do TV service work quickly, easily, and properly. The Model TS-2 when used in conjunction with an oscilloscope provides a means of correctly aligning television receivers.

The instrument provides a frequency modulated signal covering, in two bands, the range of 10 to 90 Mc. and 150 to 230 Mc. — ALL ALLOCATED TV CHANNELS AS WELL AS IF FREQUENCIES ARE COVERED.

An absorption type frequency marker covers from 20 to 75 Mc. in two ranges — therefore, you have a simple, convenient means of frequency checking of IF's, independent of oscillator calibration.

Sweep width is controlled from the front panel and covers a sweep deviation of 0-12 Mc. — all the sweep you could possibly need or want.

And still other excellent features are: Horizontal sweep voltage available at the front panel (and controlled with a phasing control — both step and continuously variable attenuation for setting the output signal to the desired level — a convenient instrument stand-by position — vernier drive of both oscillator and marker tuning condensers — and blanking for establishing a single trace with base reference level. Make your work easier, save time, and repair with confidence — order your Heathkit TV Alignment Generator now!

Model TS-2
Shipping Wt. 20 lbs.

\$39.50



YOU SAVE BY ORDERING DIRECT FROM MANUFACTURER — USE ORDER BLANK ON LAST PAGE

REPORT AGENT
ROCKE INTERNATIONAL CORP.
13 E. 40th ST.
NEW YORK CITY (16)
CABLE APLAD-N.Y.

The **HEATH COMPANY**

... BENTON HARBOR 15, MICHIGAN



Model 1B-1B
Shipping Wt. 15 lbs.

Heathkit IMPEDANCE BRIDGE KIT

This Impedance Bridge Kit is really a favorite with schools, industrial laboratories, and serious experimenters. An invaluable instrument for those doing electrical measurements work. Reads resistance from .01 Ohms to 10 meg., capacitance from .0001 to 100 MFD, inductance from 10 microhenries to 100 henries, dissipation factor from .002 to 1, and storage factor from 1 to 1000. And you don't have to worry about selecting the proper bridge circuit for the various measurements—the instrument automatically makes the correct circuit when you set up for taking the measurement you want. Bridge utilizes Wheatstone, Hay, Maxwell, and capacitance comparison circuits for the wide range and types of measurements possible. And it's self powered—has internal battery and 1000 cycle hummer. No external generator required—has provisions for external generator if measurements at other than 1000 cycles are desired. Kit utilizes only highest quality parts, General Radio main calibrated control.

\$69⁵⁰

Mallory ceramic switches, excellent 200 microamp zero center galvanometer, laboratory type binding posts with standard 3/4 inch centers, 1% precision ceramic-body type multiplier resistors, beautiful birch cabinet and ready calibrated panel. (Headphones not included.)

Take the guesswork out of electrical measurements—order your Heathkit Impedance Bridge kit today—you'll like it.

Heathkit LABORATORY RESISTANCE DECADE KIT



\$19⁵⁰

Shipping Wt. 4 lbs.

An indispensable piece of laboratory equipment—the Heathkit Resistance Decade Kit gives you resistance settings from 1 to 99,999 ohms IN ONE OHM STEPS. For greatest accuracy, 1% precision ceramic-body type resistors and highest quality ceramic wafer switches are used.

Designed to match the Impedance Bridge above, the Resistance Decade Kit has a beautiful birch cabinet and attractive panel. It's easy to build, and comes complete with all parts and construction manual.

Heathkit LABORATORY POWER SUPPLY KITS

Limits:

No load.....	Variable	150-400V DC
25 MA.....	Variable	30-310V DC
50 MA.....	Variable	25-250V DC

Higher loads: Voltage drops off proportionally
Every experimenter needs a good power supply for electronic setups of all kinds. This unit has been expressly designed to act as a HV supply and a 6.3 V filament voltage source. Voltage control allows selection of HV output desired (continuously variable within limits outlined), and a Volts-Ma switch provides choice of output metering. A large plainly marked and direct reading meter scale indicates either DC voltage output in Volts or DC current output in Ma. (Range of meter 0-500V D.C., 0-200 Ma. D.C.). Instrument has convenient stand-by position and pilot light.



\$29⁵⁰

Model PS-1.....Ship. Wt. 20 lbs.

Comes with power transformer, filament transformer, meter, 5Y3 rectifier, two 1619 control tubes, completely punched and formed chassis, panel, cabinet, detailed construction manual, and all other parts to make the kit complete.

Heathkit ECONOMY . . . 6 WATT AMPLIFIER KIT



MODEL A-7
Shipping Wt. 8 lbs.

\$14⁵⁰

- Choice of 4-8-15 ohm output impedances.
- Response flat $\pm 1\frac{1}{2}$ db from 20—20,000 cycles.
- 6 watts output.
- Good fidelity at low cost.
- Output tubes working in push pull.
- Volume, bass, and treble controls.
- Two separate inputs.

The purpose of this kit is to provide to the kit builder a low cost amplifier with excellent fidelity. The circuit consists of four tubes with following functions: a 12SL7, one section working as an amplifier and one as a phase splitter, two 12A6 output tubes working in push pull, and a 5Y3 rectifier in a full wave rectifier circuit.

The unit operates from a husky power transformer, and has good output transformer with a choice of 4-8-15 ohm output impedances. (Speaker not included).

The kit provides excellent listening pleasure and the price is really low. Compare it with all others. You won't find a better buy.

MODEL A-7: For tuner and crystal phono inputs. Has two position selector switch for convenient switching to type of input desired.

Model A-7-A: Has a 12SH7 preamplifier stage with special compensation network for operation with reluctance phono input. Shipping Wt. 8 lbs. \$16.50

Heathkit HIGH FIDELITY 20 WATT AMPLIFIER KIT



MODEL A-8
Shipping Wt. 18 lbs.

\$33⁵⁰

The A8 (or A-8A) is a high quality amplifier for those who want high fidelity output at moderate cost. Frequency response within ± 1 db from 20-20,000 cycles. Distortion at 3db below maximum power output (at 1,000 cycles) is only .8%. Kit has a Chicago power transformer in drawn steel case and a Peerless output transformer with output impedances of 4-8-16 ohms. Bass and treble controls permit listener to select output with tonal qualities of his own liking.

The tube lineup is composed of a 6SJ7 voltage amplifier, a 6SN7 amplifier and phase splitter, two 6L6's in push-pull output and a 5U4G rectifier. All parts furnished (speaker not included) and the construction manual makes assembly easy.

MODEL A-8: For tuner and crystal phono inputs. Has two position selector switch for convenient switching to type of input desired.

MODEL A-8A: Features an added 6SJ7 stage (preamplifier) for operating from variable reluctance cartridge phono pickup, mike input, and either tuner or standard crystal phono pickup. A three position selector switch provides flexible switching. Shipping Wt. 18 lbs. \$35.50

YOU SAVE BY ORDERING DIRECT FROM MANUFACTURER—USE ORDER BLANK ON LAST PAGE

EXPORT AGENT
ROCKE INTERNATIONAL CORP.
13 E. 40th ST.
NEW YORK CITY (16)
CAREY ARCADE-N.Y.

The **HEATH COMPANY**

. . . BENTON HARBOR 15, MICHIGAN

Heathkit RECEIVER & TUNER KITS for AM and FM



Model BR-1 Broadcast Model Kit covers 550 to 1600 Kc. Shipping Wt. 10 lbs.

\$19.50



Model AR-1 3 Band Receiver Kit covers 550 Kc. to over 20 Mc. continuous. Extremely high sensitivity. Shipping Wt. 10 lbs.

\$23.50

TWO HIGH QUALITY *Heathkit* SUPERHETERODYNE RECEIVER KITS

Two excellent Heathkits. Ideal for schools, replacement of worn out receivers, amateur and custom installations. Both are transformer operated quality units. The best of materials used throughout—six inch calibrated slide rule dial—quality power output transformers—dual iron core shielded. I.F. coils—metal cased filter condenser. The chassis has phono input jacks. 110 Volt output for phono motor and there is a phono-radio switch on panel. A large metal panel simplifying installation in used console cabinets is included. Comes complete with tubes and instruction manual incorporating pictorials and step-by-step instructions (less speaker and cabinet). The three band model has simple coil turret which is assembled separately for ease of construction.

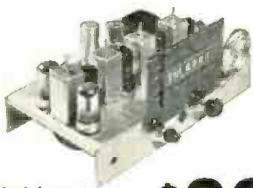

Model FM-2
Ship. Wt. 9 lbs.

\$22.50

TRUE FM FROM *Heathkit* FM TUNER KIT

The Heathkit FM Tuner Model FM-2 was designed for best tonal reproduction. The circuit incorporates the most desirable FM features—true FM. Utilizes 8 tubes: 7E5 Oscillator, 6SH7 mixer, two 6SH7 IF amplifiers, 6SH7 limiter, two 7C4 diodes as discriminator, and 6X5 rectifier. The instrument is transformer operated making it safe for connection to any type receiver or amplifier. Has ready wound and adjusted RF coils, and 2 stages of 10.7 Mc IF (including limiter). A calibrated six inch slide rule dial has vernier drive for easy tuning. All parts and complete construction manual furnished.



MAIL TO THE
HEATH COMPANY
BENTON HARBOR 15,
MICHIGAN

ORDER BLANK

From _____

- SHIP VIA
- Parcel Post
 - Express
 - Freight
 - Best Way

Quantity	Item	Price	Quantity	Item	Price
	Heathkit Oscilloscope Kit — Model O-7			Heathkit H.V. Probe Kit — No. 336	
	Heathkit VTVM Kit — Model V-5-A			Heathkit R.F. Signal Gen. Kit — Model SG-6	
	Heathkit FM Tuner Kit — FM-2			Heathkit Condenser Checker Kit — Model C-2	
	Heathkit Broadcast Receiver Kit — Model BR-1			Heathkit Handitester Kit — Model M-1	
	Heathkit Three Band Receiver Kit—Model AR-1			Heathkit Power Supply Kit — Model PS-1	
	Heathkit Amplifier Kit — Model A-7 (or A-7-A)			Heathkit Resistance Decade Kit — Model RD-1	
	Heathkit Amplifier Kit — Model A-8 (or A-8A)			Heathkit Impedance Bridge Kit — Model IB-1B	
	Heathkit Tube Checker Kit — Model TC-1			Heathkit A.C. VTVM-KIT — Model AV-1	
	Heathkit Audio Generator Kit — Model AG-7			Heathkit Intermodul. Analyzer Kit—Model IM-1	
	Heathkit Battery Eliminator Kit — Model BE-3			Heathkit Audio Freq. Meter Kit — Model AF-1	
	Heathkit Electronic Switch Kit — Model S-2			Heathkit Square Wave Gen. Kit — Model SQ-1	
	Heathkit T.V. Alignment Gen. Kit — TS-2				
	Heathkit Signal Tracer Kit — Model T-2				
	Heathkit R.F. Probe Kit — No. 309				

On Parcel Post Orders, include postage for weight shown and insurance. (We insure all shipments.)

On Express Orders, do not include transportation charges—they will be collected by the Express Agency at time of delivery.

Enclosed find Check Money Order for _____

Please ship C.O.D. Postage enclosed for _____ lbs.

ALL PRICES SUBJECT TO CHANGE WITHOUT NOTICE

EXPORT AGENT
ROCKE INTERNATIONAL CORP.
13 E. 40th ST.
NEW YORK CITY (16)
CARE: 62-143-112

The **HEATH COMPANY**

... BENTON HARBOR 15, MICHIGAN

HIGH FIDELITY is here!

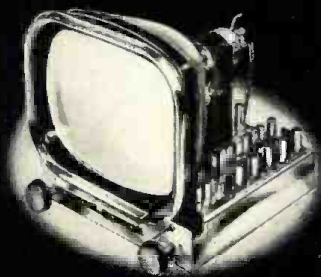

Finest made for your custom installation the CRAFTSMEN 202

ALL THE LATEST FEATURES

- **Cascade turret tuner.** Good news for fringe areas—sensitivity double that of earlier models!
- **Chassis accommodates** 21-in. cylindrical-face tube. Largest rectangular tube available, eliminates reflections. Also accommodates low voltage, electrostatic focus kinescope, permitting easier installation, focus adjustment, and maintenance of optimum focus, even with line voltage variations.
- **Push-pull audio** output provides 5 watts with less than 2% distortion. Frequency response: 20-20,000 cps.
- **Keyed AGC** prevents picture flutter due to outside interference.
- **Vertical retrace** line erase circuit.
- **Low distortion audio** channel uses double limiter and Foster-Seeley balanced discriminator.

All CRAFTSMEN TV chassis with turret tuners accommodate UHF simply by replacing tuner channel cartridges.

Write for information, or send \$0c for instructions and schematics.

THE RADIO
craftsmen INC.

Dept. R-7, 4401 N. Ravenswood Ave.
Chicago 40, Ill.

Spot Radio News (Continued from page 16)

and boss, too, Wayne Coy, recently harshly criticized on the floor of the Senate by Senator Herman Welker, who said that Coy's resignation and employment within twenty-four hours as a radio-TV consultant at a substantial salary should be explained. Declaring that . . . "It seems in this case we have a man who is very well acquainted with the present members of the Commission," the Senator added that it might be said that the former headman was being retained . . . "not for his great television ability, but because of his former connection with the FCC."

The former FCC chieftain joined stations KOB-AM-TV in Albuquerque, New Mexico, shortly after he resigned from the Commission. KOB-AM-TV was sold to a national weekly publisher who, in turn, sold a fifty per-cent interest in the license to Coy for \$75,000. Half of this sum was paid by the former headman out of personal funds and the remainder was guaranteed under a bank loan. When the transactions were completed, Coy was named general manager of these two Albuquerque stations at a salary of \$26,000 on an eight-year contract. In addition, he will receive \$24,000 as a radio-TV consultant to the publisher.

The Senator had told his colleagues that he wanted to know where Coy secured funds to buy the station. The application revealed the answer, disclosing in detail all of the assets of the former Commissioner, which more than covered the price that will be paid for the AM and TV facilities.

RADIO'S contributions to air navigation received quite a handsome tribute in the annual report of the Air Navigation Development Board. It was noted, for instance, that the provision of ground-based radar in terminal areas has made possible the greatest single improvement in traffic control in the last decade. Successive approach intervals of three minutes are now routine at those airports having radars and trained radar controllers, the report indicated.

The recent improvements in traffic control efficiency have come about, it was said, through the ability of radar to provide controllers with instantaneous, accurate, and unambiguous position data. It is expected that the next major step toward better traffic control will be in the introduction of simple airborne transponder beacons, which will provide longer distance radar coverage, freedom from ground echoes and simple aircraft identification.

Reviewing the possibilities of ground surveillance radar, supplemented by airborne transponders, used in conjunction with VOR and DME (v.h.f. omnirange and distance measuring equipment), the report declared that

these facilities will be sufficient to handle traffic of mixed aircraft types at a rate of 30 operations per hour on a single runway, and single-type aircraft traffic at a rate of 45 per hour. For higher traffic rates, it was noted, the basic traffic control radar will have to be supplemented by somewhat more refined data reduction devices. These might take the form of radar automatic tracking circuits (which will also measure ground speed), filtered displays showing aircraft location and identity, and sequencing devices which automatically select the most efficient order of aircraft arrival at entry to final approach, and the most efficient intervals between successive aircraft.

There are 426 omnidirectional stations in the country and possessions planned with 305 now in operation. All operate on the very-highs. At each of these sites, according to the report, ultra-high distance measuring equipment will be installed soon. The coverage and accuracy of these systems have been studied carefully, and it has been found that except in the vicinity of unusual terrain conditions, aircraft position can be determined with a precision of two to three degrees in azimuth, and one half of one-per-cent of distance-to-station out to distances of 100 miles from the ground station. When the test aircraft was shielded from the station by mountains, considerable deterioration in accuracy, as well as signal attenuation was experienced. However, it was noted, these measured accuracies appear to be completely adequate for en route and terminal-area navigation for any traffic densities foreseen for the next ten years. In the long-term future, higher traffic densities may demand higher navigational accuracies. It was believed this type of precision control can be provided by the ultra-high distance measuring equipment without change, together with a very-high omnirange, with a modified transmitting antenna. The report revealed that development of such an antenna was under way, showing promise of increasing the omnirange accuracy to three-quarters of one degree. It was expected, from the standpoint of accuracy, that there will be no need for a replacement for the very-high/ultra-high combination, in the foreseeable future.

Describing the uses of ILS fixed-beam approach aids, particularly when monitored by precision approach radar (PAR), the ANDB review noted that these facilities have proved satisfactory down to operational minima of 200 feet ceiling and one-half mile visibility. Under worse weather, approach lights have been found necessary. It appears as if the limitation (which is shared by PAR) is due to the inability of the system to provide sufficiently accurate guidance with respect to a flared glide path, or a heading reference sufficient to allow killing drift just prior to touchdown. In addition, it was noted, ILS and PAR impose limitations on airport acceptance rate because of the relatively long straight

SPECIAL INTRODUCTORY OFFER!

the Sensational New

GONSET

ROCKET

ALL CHANNEL
TV ANTENNA

Tomorrow's Antenna Today!

Another First

By the originators of TV Open Wire Line, Radar Type All-Channel TV Antennas, pre-assembled Cone Antennas.

Combining the principles of a folded dipole on the low channels and a rhombic array on the high channels together with features of the cone and arrow type antennas, the new GONSET "ROCKET" sets new standards of comparison. Single bay is ideal for all ordinary installations, two or four bays for fringe areas.



Oldest and largest TV antenna manufacturers in the west

COMPARE THESE FEATURES

AGAINST "CONICAL," "V," "ARROW," and OTHER ALL-CHANNEL TYPES...

LOCKED ELEMENTS (all elements locked in by thru screws)

PERFORMANCE (gain, impedance match, front-to-back ratio, etc.)

MECHANICAL DESIGN (rugged construction, stability, speed of installation, etc.)

APPEARANCE (streamlined - pleases the eye)

PRE-ASSEMBLED (folds open)

LOW COST (see coupon below)

SEE YOUR JOBBER

If not yet stocked by your jobber rush coupon below, together with name of nearest jobber.

GONSET CO., 801 S. Main St., Burbank, California.

Please RUSH SAMPLE GONSET "ROCKET" on 2 week MONEY BACK basis.

		List	Net
#1506	<input type="checkbox"/> one GONSET "ROCKET" (less mast)	\$ 6.45	\$ 3.87
#1508	<input type="checkbox"/> one GONSET "ROCKET" (with 8' mast)	9.35	5.61
#1510	<input type="checkbox"/> one GONSET "ROCKET" (2 Bay, less mast)	15.02	9.01
#1511	<input type="checkbox"/> one GONSET "ROCKET" (4 Bay, less mast)	29.85	17.91
	<input type="checkbox"/> Send bulk quantity net price list		

All prices F.O.B. Burbank, Calif.

Name _____

Address _____

City _____ Zone _____ State _____

Jobber's Name _____

Address _____

City _____ Zone _____ State _____

AMPHENOL
—INLINE*
ANTENNA



a better picture
with the Amphenol Inline Antenna

Because the Amphenol Inline Antenna operates on a fundamental frequency in both the high and low bands, you get the same steady, uninterrupted picture from channels 2 through 13. Designed by antenna specialists, the Amphenol Inline has consistently proved its superiority through four years of use in the highly competitive television field. The single forward receiving lobe of this broadbanded antenna literally probes the sky to return with the signal you want, uninfluenced by side radiations and reflected signals.

and the Amphenol Tubular Twin-Lead

Over and over again, the Amphenol Tubular Twin-Lead has been established as the one satisfactory answer to the need for an economical TV lead-in for use in those trouble areas where conventional twin-lead cannot be used. The tubular construction of high grade polyethylene provides a protected area, using air as the dielectric, between the conductors. This provides low-loss and constant impedance at all times, unaffected by any exterior condition.

This book contains . . .

a complete, yet condensed evaluation of the various types of antennas on the market today, graphs and illustrations clarifying their various characteristics, and information on the use of rotators, lightning arrestors, etc. Obtain your free copy from your Authorized Amphenol Distributor.



AMPHENOL

AMERICAN PHENOLIC CORPORATION
 1830 SOUTH 54TH AVENUE • CHICAGO 50, ILLINOIS

approach path which must be flown by all aircraft. These limitations, the ANDB admitted, will make it necessary to replace ILS and PAR, at least at busy terminals, within the next decade.

THE VOICE OF AMERICA, which has become so vital a factor in our international program, has certainly spread its wings since the wintry days of '42 when the first broadcast, a German-language affair, was made from New York by trans-Atlantic telephone to London and then relayed to Germany over seven transmitters operated by the BBC. At the end of the war in Europe, Voice of America programs were being beamed to the Continent from twenty-six short-wave transmitters on the Atlantic seaboard and to the Far East from ten short-wave transmitters on the Pacific Coast. At that time, many of the programs were also being relayed from transmitters in London, Algiers, Luxembourg, Hawaii, Saipan, and the Philippines. Currently, there are thirty-eight short-wave transmitters in operation in this country, with power ratings of from 50 to 200 kilowatts.

The VOA broadcasts are also relayed and rebroadcast by a chain of relay bases in Munich, Tangier, Salonika, Honolulu, and Manila. In Munich there are six short-wave and one medium-wave transmitters in operation; the s.w. units operate on 100 and 7.5 kilowatts, while the medium-wave affair has a power rating of 150 kilowatts. The Tangier stations are all short-wave types, with powers ranging from 35 to 100 kilowatts. Seven transmitters are used in this African outpost. Only one medium-wave station, of 50-kilowatt strength, is used in Salonika. In Honolulu, there are two short-wave stations with 100-kilowatt outputs, while in Manila, three short-wave and one medium-wave stations are employed. The s.w. setups use powers of 7.5 and 50 kilowatts, while the medium-wave transmitter is a 50-kilowatt type.

BROADCASTING on the very-highs has become an extremely active medium in Germany, according to a report recently filed in the *EBU* bulletin by Doctor Werner Nestal, technical director of Nordwestdeutscher Rundfunk.

Superregeneration is featured in low-priced v.h.f. receivers and adapters. To eliminate the possibilities of interference, two-tube adapter circuits are used with a single-envelope pentode and triode. The actual receiving circuit employs a triode. Following the super stage is an audio-frequency filter and equalizer, consisting of a condenser and resistor, the output of which is directly coupled to the audio system of a standard receiver.

There are seventy transmitters now in operation in Western Germany. In addition, this autumn will see four to five TV stations on the air transmitting about three hours daily. Now under construction is a relay system which will provide for the transmission of programs between Hamburg and Munich, via Cologne, Frankfurt, and Stuttgart. Operating between 174 and 215 megacycles, on six channels, the CCIR standards of 625 lines will be followed on all German telecasts.

THE SENSATIONAL daily-press long-distance claims for a new method of v.h.f. TV transmission, involving the scattering effect of signal phenomenon, under study at the Bureau of Standards' receiving station at Sterling, Virginia, received little support on the professional front, the consensus being that the received signals were of very low intensity, and in addition extremely directional rhombics were required for transmission and reception. At the Commission, it was admitted that it was known that such transmission and reception possibilities were known, but its commercial applications to TV were small, since extremely high powers would be required to provide any kind of a consistent picture on a 6-megacycle band.

Both the Commission and the Bureau were flooded with calls when the newspaper stories appeared. Dealers were also swamped with inquiries and sales slumped sharply for several days, until it was revealed that the tests would not affect the allocation tables and TV would continue to be a Channel 2 to 83 operation for many, many years to come, notwithstanding the breathless predictions appearing in the columns of newspapers. . . . L.W.

ARE YOU ONE OF THESE MEN?

WALTER ASHE RADIO CO.
TEST EQUIPMENT

HERE'S MY CHANCE TO GET INTO A PART TIME SERVICE BUSINESS AT A PRICE I CAN AFFORD!

I'M GONNA GET COMPLETE INFORMATION ON EICO EQUIPMENT FROM Walter Ashe TODAY!

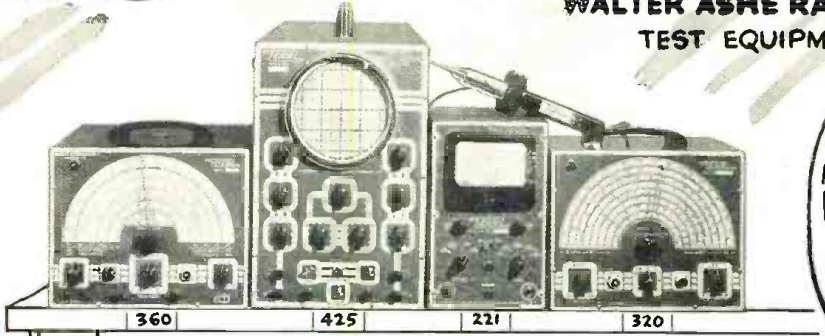

NOW! COMPLETE EICO TV SERVICE LAB IN KIT FORM — ONLY \$132.75

YOU'RE RIGHT. IT COST ME 3 TIMES THAT TO GET STARTED

TELEVISION RADIO SERVICE

BROWN MFG. CO. Maintenance Division

MY BOSS WILL BE INTERESTED IN THIS LOW COST EQUIPMENT TO MODERNIZE OUR SHOP

Here's the full list of 24 famous EICO matched instruments and kits — for laboratory precision at **LOWEST COST!** Buy your EICO selections from Walter Ashe **NOW!**

MODEL		KIT PRICE	WIRED PRICE	MODEL		KIT PRICE	WIRED PRICE
113A	Multi-Analyst with Probe		\$89.95	565	20,000 Ohm Per Volt VOM, 4 1/2" Meter	24.95	29.95
145	Multi-Signal Tracer	\$19.95	28.95	566	1,000 Ohm Per Volt VOM, 4 1/2" Meter	14.90	18.95
221	Vacuum Tube Voltmeter	25.95	49.95	625	Tube Tester	34.95	49.95
315	Signal Generator (Deluxe)	39.95	59.95	950	Resistance-Capacitance Bridge & R-C-L Comparator	19.95	29.95
320	Signal Generator	19.95	29.95	1040	Battery Eliminator & Charger	25.95	34.95
322	Signal Generator	23.95	34.95	1171	Resistance Decade Box	19.95	24.95
360	Sweep Generator	34.95	49.95	HVP-1	High Voltage Probe for Model 221		6.95
425	5" Push-Pull Oscilloscope	44.95	79.95	P75	R. F. Probe, crystal type, for any VTVM	3.75	5.95
511	Multitester	14.95	17.95	P76	R. F. Probe, for any scope or VTVM	3.75	5.95
526	1,000 Ohm Per Volt Multimeter	13.90	16.90	C5	Crystal (5MC)		3.95
536	1,000 Ohm Per Volt, VOM, 3 1/2" Meter	12.90	14.90	CRA	Cathode Ray Adapter		4.50
555	20,000 Ohm Per Volt Multimeter	29.95	34.95				
556	1,000 Ohm Per Volt VOM, 4 1/2" Meter	16.90	23.50				

ALL PRICES F. O. B. ST. LOUIS • CHESTNUT 1125 • FREE CATALOG!

Walter Ashe
RADIO CO.
1125 PINE ST. • ST. LOUIS 1, MO.

Walter Ashe Radio Company
1125 Pine St., St. Louis 1, Mo. RN-52-7

Rush the following EICO instruments or kits _____
(describe Eico equipment desired)

Remittance for \$ _____ is enclosed

Rush free copy of your 1952 catalog.

Name _____

Address _____

City _____ Zone _____ State _____

SEND FOR YOUR COPY TODAY!

MAKE McGEE YOUR HEADQUARTERS FOR MONEY-SAVING VALUES!

ESPEY 12-TUBE FM-AM CHASSIS, \$64.50

- ★ BUILT-IN PRE-AMP FOR G.E. VARIABLE RELUCTANCE PICK-UP
- ★ WIDE RANGE AUDIO
- ★ WHY NOT ORDER WITH A COAXIAL SPEAKER AND A RECORD CHANGER? SEE OUR SPECIAL OFFERING

McGee's new 1952 model 12-tube FM-AM chassis, latest design with phono inputs for all types of record players, crystal or G.E. variable reluctance. Receives standard broadcast 550 to 1700 kc and FM 88 to 108 mc. Wide range audio response (push-pull 6V6 output) and bass boost tone control. Loop antenna for broadcast and 300 ohm line type FM antenna may be stapled in cabinet. Attractive lighted slide rule dial. Chassis size, 3 1/2" x 9" high and 9" deep. Complete with tubes: 6BE6, 6BA6, 12A7T, 6S11T, 6AL5, 6SQ7, 6S07, 12A7T, 2-12" PMGT and 3VGT rectifier. Shipping weight 20 lbs. Stock No. 7C-X Espey 12-tube FM-AM chassis. Sale price, \$64.50, less speaker. Output matches voice coil of our 12" or 15" coaxial speakers.

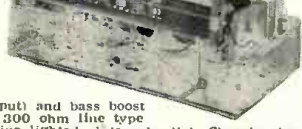

ESPEY DEAL (1), \$104.95
Espey 7-C chassis complete with 12" coaxial PM speaker CU-14V and VM-950 G.E. 3-speed changer equipped with G.E. turnabout variable reluctance cartridge. A better home music system than ordinarily available. Deal #1. Sale price \$104.95. With 15" coaxial PM speaker P15-CR instead of CU-14V. \$10.00 extra.

ESPEY DEAL (2), \$118.95
Espey 7-C chassis complete with 12" coaxial PM speaker CU-14V and the English Garrard 3-speed changer equipped with a G.E. variable reluctance turnabout cartridge. Our best home music system. Espey Deal #2. Sale price \$118.95. With 15" coaxial PM speaker P15-CR instead of CU-14V. \$10.00 extra.

ESPEY DEAL (3) \$138.95
Espey 7-C chassis complete with THREE 12" coaxial PM speakers CU-14V (these three 12" coaxial speakers give a cone area equal to an 18" speaker) and a Garrard 3-speed changer with G.E. variable reluctance turnabout cartridge. Espey Deal #3. Sale price \$138.95.

TERRIFIC FLUORESCENT FIXTURE SALE

IS YOUR SERVICE DEPT. PROPERLY LIGHTED? SAVE 50% ON THIS 4-LIGHT FIXTURE WITH LAMPS

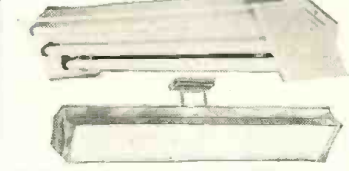

TOP ILLUSTRATION—This is the finest value in a fluorescent fixture that we have ever offered. Constructed of heavy gauge metal with lustrous white enamel finish. Furnished with General Electric 36", 30 watt white fluorescent lamps. Fixture may be mounted next to the ceiling or suspended on chains. These fixtures are beautifully constructed. Use them over your service bench, in your display room or in your office. Brand new in factory cartons properly packed for shipment. These fixtures sold for up to \$10.00. We bought 6 stock loads and are passing our bargain on to you. Why pay more than this to modernize your shop. Shipping weight 26 lbs. each. Shipped via Express. Rail Freight or Truck only. Stock No. MK-430 fixture complete. Net \$12.95; 2 for \$25.00.

DELUXE MODEL WITH GLASS, \$14.95; CEILING CANOPY, \$1.95

Bottom Illustration
Deluxe Model No. MK-430X, same as No. MK-430 described above with the exception that it has translucent glass over the lamps to diffuse the light. CEILING CANOPY that is shown. \$1.95 extra. Shipping weight 33 lbs. Net price \$14.95; 2 for \$28.00.

Canopy for suspending either of the above fluorescent fixtures from the ceiling. For use where it isn't advisable to mount fixture flush or suspend it on chains. Canopy kit is completely finished metal box cover with hardware for mounting to any outlet box and 2-30" lengths of 3/4" white enameled tubing. Shipping weight 3 lbs. Fixture canopy kit. No. MK-430, \$1.95.

CAPEHART CABINET, \$79.95

BLANK OR CUT TO FIT ESPEY CHASSIS

Buy this cabinet with Espey chassis and the VM changer listed above and have a fine radio-phonograph combination for less than the value of the cabinet alone. This beautiful cabinet was intended for a Capehart \$800.00 combination. It is the finest possible furniture quality cabinet workmanship. 37" wide, 10" deep and 21" front to back. Hinged top lifts in two sections. 25 1/2" lid covers the changer compartment and 14 1/2" is the width of the radio compartment. Changer mounting panel is furnished blank. Radio panel is shipped ready cut to fit the 7-C Espey chassis. Baffle is cut to hold 2-12" speakers. Made of top quality mahogany veneer. 7 1/2" material used throughout. Shipped via truck, rail or express. Shipping weight 32 lbs. Stock No. C-175, with panel cut to fit Espey 7-C. \$79.95. Stock No. B-175B, with blank changer and radio panel. \$79.95. Buy 2-12" 32 oz. Alnico PM speakers for use in this cabinet for only \$45.00 (\$7.50 each).



Stock No. C-175, with panel cut to fit Espey 7-C. \$79.95. Stock No. B-175B, with blank changer and radio panel. \$79.95. Buy 2-12" 32 oz. Alnico PM speakers for use in this cabinet for only \$45.00 (\$7.50 each).

SENSATIONAL 50-WATT BOOSTER AMPLIFIER, \$39.95

2 MIKE PRE-AMP, \$12.95 EXTRA



50-WATT BOOSTER A sensational 50 watt booster amplifier with push-pull pentode output tubes. Connect to your present amplifier as a booster or use with the PA-25 25 watt amplifier. Includes 2-6" mikes and one low level input. The booster amplifier has a one input 100 ohm input gives 50 watts of audio. Booster has a 6 lb. ported case high fidelity tone. Booster has a 225 ohm voice coil, also 60 ohm and 250 ohm line. 7N7 and 5U4. The two variable controls are for master volume control and tone control. Size 8 1/2" x 11 1/2". Stock No. PA-55X. Shipping weight 26 lbs. Sale price

McGEE'S \$62.50 LIST 15" COAXIAL SPEAKER, \$24.95

21 OZ. ALNICO V MAGNET—5" TWEETER

This is the finest 15" coaxial PM speaker value that we have ever offered. New 1952 production, of a famous manufacturer of fine speakers. The 15" speaker has a 2 1/2" oz. Alnico V magnet, equal to 68 oz. of the Alnico 5 type magnet. The cone is free floating, of one piece construction. Will reproduce low frequencies down to 20 cps. The 5" tweeter is coaxially suspended and has a rigid cone to reproduce into the high frequencies. It will respond up to 17,500 cps. The high pass filter is concealed under the top cover, leaving only two wires to connect both the tweeter and the 15" speaker to any 8 ohm output transformer of a radio or music lover's amplifier. Stock No. P15-CR, shipping weight 13 lbs. Net price \$24.95; 2 for \$47.95.



12" COAXIAL SPEAKER, \$12.95

McGee offers the new 1952 model 12" coaxial PM speaker. Quality you would put in your finest sets if you were a manufacturer. 12" woofer has 8.8 oz. Alnico V magnet. Tweeter is coaxially suspended and has a metal diffuser. High pass filter is under the top cover. Only two wires to connect to your radio or audio amplifier. 8 ohm with 18 watt peak and 10 watt average. Shipping weight 8 lbs. Response from 30 to 17,500 cps. Stock No. CU-14V. Sale price \$12.95 each; 2 for \$25.00.



Another McGee Scoop! Jensen Concert 12" 1 1/2" oz. Alnico V magnet, 8 ohm voice coil. Will take 25 watt audio. You save dollars on this speaker. Just 100 to sell. Shipping weight \$29.95. Stock No. P-12P. Sale price \$15.95; 2 for \$30.00.

2-MIKE PRE-AMP.

Pre-amplifier plugs in directly to the PA-55X Booster-amplifier. It enables use of 2. Crystal or Dynamic Mikes plus one low level input. Furnished with 4 foot cables and plugs for remote control of the 55 watt Booster Amplifier. Small chassis size 5 1/2" x 4 1/2". Stock No. PR-2X, with tubes 7F7 and 7N7. Net price \$12.95.

TERRIFIC VALUES IN SPEAKERS AND BAFFLES

8" PM AND LEATHERETTE BAFFLE, \$4.95

LOTS OF 10, \$4.75

The finest Leatherette Baffle we have ever offered. New self-supporting plastic grill material. Baffle is covered top with matching grill. Offered with a good heavy duty 8" Alnico V PM speaker with 3.2 ohm voice coil. Stock No. 118 Speaker and Baffle. \$4.95 ea.; lots of 10, \$4.75. Baffle only. Stock No. NV-8. \$2.29 ea.; 2 for \$4.95.

12" PM AND WALNUT BAFFLE, \$9.95

LOTS OF 3, \$8.95

The finest built 12" Walnut plywood wall baffle we know of. Factory cost the finest value in the industry. Manufacturer's cost \$7.00. We offer with a 12" PM for little more. You pay only \$9.95 in single lots. Buy 3 lots for both a 12" Quam Alnico V PM with 3.2 ohm voice coil. Stock No. 118 Speaker and Baffle. \$9.95 ea.; lots of 3, \$8.95 ea. 12" Baffle only. #SEG-12, \$4.95 ea.

12" JENSEN PM, \$15.95

Another McGee Scoop! Jensen Concert 12" 1 1/2" oz. Alnico V magnet, 8 ohm voice coil. Will take 25 watt audio. You save dollars on this speaker. Just 100 to sell. Shipping weight \$29.95. Stock No. P-12P. Sale price \$15.95; 2 for \$30.00.



8" EXTENSION SPEAKER WITH VOLUME CONTROL, \$7.95

You get a heavy 8" PM speaker in a leatherette-covered plywood baffle with 20 feet of connecting cable and variable volume control for use with radio or amplifier. Just connect to any 3 to 8 ohm output transformer secondary. Stock No. 11D-52. \$7.95 each; 2 for \$15.00. Shipping weight 6 lbs.

MIKES AND STANDS AND TRUMPETS

4D-T, high impedance dynamic mike with 12 feet of cable. Sale price, \$10.95. 35 to 40 watt floor stand for mike, \$5.88. 30 watt driver and trumpet, 15 ohms. Ideal for our 50 watt booster. Trumpet has 18" bell, 3/4" fl. reflex air column. Driver unit screws on. Stock No. XX100-IRK35. Sale price \$22.95. RE-17X, 25 watt paging speaker for voice only. \$16.95 each.

3-SPEED CHANGERS ON SALE AT McGEE

WEBSTER CHICAGO MODEL 100-2 ONLY \$26.95

For the first time we offer the world famous Webster-Chicago, model 100-2. Features a newly designed spindle, that drops the records flat; air-cushioned to the turntable. Pickup arm sets down automatically after the last record is played. Plays all records automatically, 33 1/3, 78 and 45 rpm. New balanced tone arm with Electro-Voice 30-A-Made cartridge with dust neoprene. Ordinarily costs over \$47.00. McGee offers them for only \$26.95 each. Base size 12" x 12 3/4". Shipping weight 14 lbs.



V.M. 3-SPEED MODEL 406 \$22.95
VM model 406, deluxe 3 speed automatic record changer. Plays them all. Intermixes records of the same speed. Equipped with a flip over crystal pickup with twin needles. Base size, 12 1/4" x 13". Shipping weight 12 lbs. VM-406. Net price \$22.95.

G.I. 3-SPEED CHANGER WITH G.E. \$22.95

VARIABLE RELUCTANCE TURN-ABOUT CARTRIDGE
Another tremendous McGee Scoop! Brand new General Instrument 3-speed automatic record changers. Complete with RPX-050 G.E. variable reluctance cartridge with turn-about stylus. Plays all 3 speeds automatically: 78, 10" or 12" records. Has reject button. Repeats last record. Base size, 12" x 12 3/4". Shipping weight 14 lbs. Stock No. 700-GE. Scoop price, \$22.95.

ELECTRONIC RADIO and TV TUBES

- 6 MONTHS' GUARANTEE • INDIVIDUALLY CARTONED
- IN RED AND BLUE DE LUXE VARNISHED CARTONS
- EVERY TUBE SET TESTED FOR YOUR PROTECTION

ORDER 50 ASSORTED—TAKE 10% OFF. Prices as Low as 36c

024	59	6A15	49	6S07	59	7Z4	49
028	59	6A05	59	6S07GT	59	12A7E	49
124	79	6A76	49	6S07GT	59	12A7T	69
136	69	6A06	59	6S57GT	59	12AU7	69
145	59	6A07	59	6S57GT	59	12AV6	69
164	69	6B8G	69	6S07	69	12AX4GT	69
174	59	6B8A	59	6S57GT	69	12AX6	69
184	59	6B87	59	6S57GT	69	12BA7	69
1C5	79	6B85	59	6S17GT	69	12BB6	69
1E3	79	6B86	59	6S7GT	69	12BE6	69
1G5	69	6B8G	1.29	6S7GT	69	12BF6	69
1N5	79	6B86	59	6U7G	69	12J5GT	69
1R5	59	6B16	59	6U8	69	12K5GT	69
1S5	59	6B6GT	95	6U8T	59	12K7GT	69
174	59	6C4	49	6W4GT	59	1207GT	69
1X4	59	6C6	59	6X4	49	1217GT	69
1Y4	59	6B87	59	6Y7G	49	12K7GT	69
204	69	6C6DG	1.49	6Y7G	49	12S5GT	69
304	69	6H6GT	59	6Y55G	69	12S7GT	69
314	69	6H6GT	59	6Y55G	69	12S7GT	69
344	69	6K6GT	59	7E7	69	12S07GT	69
354	69	6K6GT	59	7E7	69	12S7R	69
514	59	6L6	1.09	7H7	79	14A4	69
574	1.49	6K7GT	59	7E7	79	14B6	69
584	69	6L6	1.09	7H7	79	14C5	1.09
594	69	6L6	1.09	7H7	79	14D6	69
604	69	6P5GT	69	7V7	79	14Q7	69
6A5	69	6L7	1.09	7X7	79	19T8	69
6B5	69	6L7	1.09	7Y4	79	25B6GT	99
6A5	69	6L7	1.09	7Y4	79	25B6GT	99
6A5	69	6L7	1.09	7Y4	79	25B6GT	99

100 Molded Plastic Bypasses \$9.95

100 molded plastic tubular bypass condensers. All 600 volt. Available in the same nationally known mfg. Regular dealers' net is over two and one-half times our 20th Anniversary sale price. You'll chuckle when you look these over. Here's what you get: 10—001, 10—002, 50—005, 20—010, 20—02, 10—05 and 10—1. Our big deal No. RN-202, 100 plastic tubulars. Shipping weight 2 lbs. Net price, \$9.95.

SELENIUM RECTIFIERS

65 mil Selenium Rectifier, net. \$9.95 each
100 mil Selenium Rectifier, net. .75c each
150 mil Selenium Rectifier, net. .50c each
200 mil Selenium Rectifier, net. \$1.19 each
250 mil Selenium Rectifier, net. \$1.29 each
350 mil Selenium Rectifier, net. 1.59 each
450 mil Selenium Rectifier, net. 1.79 each
McGee offers you the finest in Selenium rectifiers. All standard 130 volt.

5 OZ4 TUBE & 5 VIB. \$9.50 DEAL NO. RN-V5

Here's a red-hot deal for you fellows that do a lot of auto radio service. 5 standard brand metal OZ4 tubes and 5 of our famous 4-prong serrated can vibrators. This vibrator is the latest design, for long life. Standard diameter can, short enough to fit all Chrysler auto sets, also fits Motorola, etc. Our 20th Anniversary, big deal No. RN-V5. You can get 5 OZ4 metal tubes and 5 4-prong vibrators, all for \$9.50. Shipping weight 3 lbs.

McGEE RADIO COMPANY
Prices F.O.B. K.C. Send 25% Deposit with Order, Balance Sent C.O.D. With Parcel Post Orders, Include Postage
TELEPHONE VICTOR 9045. WRITE FOR FLYER 1422 GRAND AVE., KANSAS CITY, MISSOURI

SMASH HIT!



*Lic. A.A.K.
Pats. 2,422,458;
2,282,292,
others pending

Look for these patented*
bright red Electronic
Channel Separators that
incorporate a printed circuit
for the first time in
any antenna.

REVOLUTIONARY

ALL-CHANNEL
Q-TEE

WITH PATENTED* BUILT-IN

Channel Separators

Here it is—the antenna that is taking the TV industry by storm. With its sensational Electronic Channel Separators employing a printed circuit for the first time in antenna history, the Q-TEE is fast replacing other types of all-channel antennas. With its powerful performance, clean-cut silhouette, light weight, and pre-assembled construction, the Q-TEE incorporates everything the finest all-channel antenna should have. Available in three series for every reception need — Q-TEE Single Bay — for primary areas; Q-TEE Double — two-bay array for near-fringe areas; Q-TEE Quad — four-bay stacked array for fringe areas.

VEE-D-X

makers of
the world's
most powerful
TV antenna
systems

THE LaPOINTE-PLASCOMOLD CORP. N7
Windsor Locks, Connecticut

Gentlemen:

- Send complete Q-TEE literature
 Send copy of new Vee-D-X catalog

Name

Street

City Zone.....State.....

WHAT'S *New in Radio*

For additional information on any of the items described herein, readers are asked to write direct to the manufacturer. By mentioning RADIO & TELEVISION NEWS, the page, and the issue number, delay will be avoided.

SCOPE CALIBRATOR

Simpson Electric Company, 5200 W. Kinzie Street, Chicago, Illinois has developed a new lightweight oscilloscope



calibrator which has been designed as a companion piece to the company's Model 476 Mirroscope.

The Model 276 calibrator is completely self-contained and operates from 117 volts, 50 or 60 cycles. It may be used with any oscilloscope. The unit has a sine-wave output which is used directly on the 4½ inch meter. The meter is calibrated directly in r.m.s., peak, and peak-to-peak values. Six ranges are provided with peak-to-peak full scale values of 1, 2.5, 10, 25, 100, and 250 volts with an accuracy of 3%. Each range is continuously adjustable from zero to full-scale values.

EICO MULTIMETER

Electronic Instrument Co., Inc., 84 Withers Street, Brooklyn 11, New York has added a new multimeter to its line of test equipment.

The Model 566 multimeter is a 1000



ohms-per-volt unit which is available in either kit or factory-wired form. It has a 4½", 400 µa. meter movement and features 31 different 1000 ohms-per-volt ranges.

Specifications include a.c. and d.c.

voltage in six ranges (0-1, 5, 10, 50, 500, and 5000); a.c. current in four ranges (0-1, 10 ma., .1 amp. and 1 amp.); ohms in three ranges (0-500, 100,000, and 1 megohm); and six db ranges (-20 to +69).

The unit is housed in a high-impact Bakelite case measuring 6¼" x 5¼" x 3". In kit form, the multimeter has been designated as the Model 566K.

LIGHTWEIGHT HEADSET

Telex, Inc., Telex Park, St. Paul 1, Minnesota has developed a specially designed headset which incorporates several new features.

The new "Dynaset" model, with under-the-chin styling, weighs 1.25 ounces. According to the company, the headset has a higher fidelity range, permitting more exact reproduction of highs and lows of both music and speech.

The unit is suitable for radio mon-

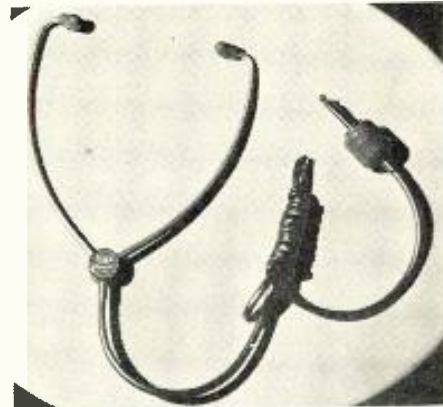

itoring, ham radio, electronic laboratories, commercial communications, etc.

EQUALIZER-PREAMP

Hermon Hosmer Scott, Inc., 385 Putnam Avenue, Cambridge 39, Massachusetts is currently introducing a new equalizer-preamplifier which has been designated as the 120-A.

This new unit provides versatile remote-control and compensation for music reproduction. Professionally, the instrument is used by broadcast stations and, for home use, it may be used with existing power amplifiers or with the company's 220-A amplifier.

The record-compensator adjusts for virtually all recording characteristics and levels. Treble roll-off and bass turnover equalization are provided on 8 positions, including 5 for standard records and 3 for long-playing records. Combined with the equalization is a 3-position input-selector for a tuner, TV, etc. Featured are 3-channel, continuously adjustable treble and bass

RADIO & TELEVISION NEWS

BUY TEST EQUIPMENT ON THIS RADICALLY NEW TIME PAYMENT PLAN

NO INTEREST!! - NO CARRYING CHARGES!!

USE CONVENIENT TIME PAYMENT ORDER BLANK BELOW

Superior's New JUNIOR SUPER-METER

MOST COMPLETE AND COMPACT MULTI-SERVICE INSTRUMENT EVER DESIGNED

- Measures: * Voltage * Decibels
* Capacity * Resistance
* Current * Inductance
* Reactance

Specifications: D.C. Volts: 0-7.5/75/150/750/1500 Volts. A.C. Volts: 0.15/150/300/1500/3000 Volts. Resistance: 0-10-1000/100,000 ohms. 0-10 Megohms. D.C. Current: 0-7.5/75 Ma. 0-7.5 amps. Capacity: .001 Mfd.-2 Mfd. 1 Mfd.-20 Mfd. Electrolytic Leakage: Reads quality of electrolytics at 150 Volt test potential. Decibels: -10 Db to +18 Db. +10 Db. to +38 Db. +38 Db. to +58 Db. Reactance: 15 ohms-25 K ohms 15 K ohms-2.5 Megohms. Inductance: .5 Henry-50 Henries 30 Henries-10 K Henries. Plus Good-Bad scale for checking the quality of electrolytic condensers.



Handsome round cornered molded bakelite case 3 1/4" x 5 7/8" x 2 1/4" complete with all test leads and instructions

\$2140 NET

Superior's New Model 670-A SUPER-METER

A COMBINATION VOLT-OHM MILLIAMMETER PLUS CAPACITY REACTANCE INDUCTANCE AND DECIBEL MEASUREMENTS

SPECIFICATIONS:

D.C. VOLTS: 0 to 7.5/15/75/150/750/1,500/7,500 Volts.
A.C. VOLTS: 0 to 15/30/150/300/1,500/3,000 Volts
OUTPUT VOLTS: 0 to 15/30/150/300/1,500/3,000 Volts.
D.C. CURRENT: 0 to 1.5/15/150 Ma. 0 to 1.5/15 Amperes.
RESISTANCE: 0 to 1,000/100,000 Ohms 0 to 10 Megohms
CAPACITY: .001 to 1 Mfd. 1 to 50 Mfd. (Quality test for electrolytics)
REACTANCE: 50 to 2,500 Ohms 2,500 Ohms to 2.5 Megohms
INDUCTANCE: .15 to 7 Henries 7 to 7,000 Henries
DECIBELS: -6 to +18 +14 +38 +34 to +58



The Model 670-A comes housed in a rugged, crackle-finished steel cabinet complete with test leads and operating instructions. Size 6 1/4" x 9 1/2" x 4 1/2".

\$2840 NET

The Model 670-A includes a special GOOD-BAD scale for checking the quality of electrolytic condensers at a test potential of 150 Volts.

ADDED FEATURE:

New Model 200 AM and FM SIGNAL GENERATOR

Provides complete coverage for A.M.-F.M. and TV alignment



* Tubes used: One 954 as oscillator; one 954 as modulated buffer amplifier; T-2 as modulator; 7193 as rectifier.

The Model 200 comes complete with output cable and operating instructions

\$2185 NET

Superior's New Model TV-11 TUBE TESTER



Operates on 105-130 Volt 60 Cycles A.C. Hand-rubbed oak cabinet complete with portable cover

\$4750 NET

• Uses the new self-cleaning Lever Action Switches for individual element testing. Because all elements are numbered according to pin number in the RMA base numbering system, the user can instantly identify which element is under test. Tubes having tapped filaments and tubes with filaments terminating in more than one pin are truly tested with the Model TV-11 as any of the pins may be placed in the neutral position when necessary. • Uses no combination type sockets. Instead individual sockets are used for each type of tube. Thus it is impossible to damage a tube by inserting it in the wrong socket. • Free-moving built-in roll chart provides complete data for all tubes. • Phono jack on front panel for plugging in either phones or external amplifier detects microphonic tubes or noise due to faulty elements and loose external connections.

Superior's New TV BAR GENERATOR



Power Supply: 105-125 Volt 60 Cycles. Power Consumption: 20 Watts. Channels: 2-5 on panel, 7-13 by harmonics. Horizontal lines: 4 to 12 (Variable). Vertical lines: 12 (Fixed). Vertical sweep output: 60 cycles. Horizontal sweep output: 15,750 Cycles.

Throws an Actual Bar Pattern on Any TV Receiver Screen!!

Two Simple Steps:

1. Connect Bar Generator to Antenna Post of any TV Receiver.
2. Plug Line Cord into A.C. Outlet and Throw Switch.

RESULT: A stable never-shifting vertical or horizontal pattern projected on the screen of the TV receiver under test.

TV Bar Generator comes complete with shielded leads and detailed operating instructions. Only

\$39⁹⁵ NET

NEW TIME PAYMENT PLAN ORDER BLANK

MOSS ELECTRONIC DISTRIBUTING CO., INC. Dept. B-28, 38 Murray Street, New York 7, N. Y.

Please send me the units checked below. I am enclosing the down payment with order and agree to pay the monthly balance as shown. It is understood there will be no carrying, interest or any other charges. Provided I send my monthly payments when due. It is further understood that should I fail to make payment when due, the full unpaid balance shall become immediately due and payable.

- JUNIOR SUPER METER.....Total Price \$21.40 \$5.40 down payment. Balance \$4.00 monthly for 4 months.
- MODEL TV-11.....Total Price \$47.50 \$11.50 down payment. Balance \$6.00 monthly for 6 months.
- MODEL 670-A.....Total Price \$28.40 \$7.40 down payment. Balance \$3.50 monthly for 6 months.
- TELEVISION BAR GENERATOR.....Total Price \$39.95 \$9.95 down payment. Balance \$5.00 monthly for 6 months.
- MODEL 200.....Total Price \$21.85 \$5.85 down payment. Balance \$4.00 monthly for 4 months.
- I enclose \$..... as down payment.
- Ship C.O.D. for the down payment.

Signature.....

Name.....

Address.....

City..... Zone..... State.....

controls, each of which comprise 3 conventional tone circuits, one boosting, one flat, and one attenuating.

A free bulletin giving complete specifications on the 120-A is available from the company on request.

WIRE STRIPPER

The *C and M Manufacturing Company*, Eastondale, Massachusetts is now in production on a new precision wire stripper which has been trademarked "Strip-It."

Designed especially for the electronics industry, the compact new tool fits in tight spots, cuts as well as strips, and provides speedy handling of all wire sizes. The tool will handle both wire and cable.

A data sheet giving complete details will be forwarded on request.

AUDIO CONSOLE

A new and compact console which has been designed for two-studio station use and for elaborate p.a. and recording installations has been introduced by *Altec Lansing Corporation* of 9356 Santa Monica Boulevard, Beverly Hills, California.

Known as the 230B, the unit is entirely self-contained and a.c. operated. There are four separate preamplifiers, two booster amplifiers, a line amplifier, and a monitor amplifier, all mounted on a single chassis. Miniature plug-in power supplies for plate and filament supply and for relay and signal light operation are easily re-

movable for servicing or replacement.

The console is equipped with six mixing potentiometers, four of which are connected through switching keys to eight low-level microphone or turntable inputs. The other two are connected with four line inputs, providing a total of twelve inputs, any six of



which may be mixed simultaneously. *Graybar Electric Company, Inc.* is handling the distribution of this unit and complete specifications can be obtained from *Graybar* or the company.

H.V. RECTIFIER

Hyttron Radio & Electronics Co. of Salem, Massachusetts has introduced a new high voltage rectifier tube, the 1AX2.

In order to overcome the inherent disadvantages encountered in the high voltage rectifiers currently available, the new tube incorporates several features designed to prolong service life. The position of the filament has been changed and is now located in the base of the structure, surrounded by a shield

which eliminates bombardment of its cool ends by gas molecules. The filament itself is made more rugged by using a spiral of a special nickel alloy ribbon. The use of this filament wire permits true welding of this filament to its supports. In addition, an insulated tension bar is passed through the center of the coiled filament to limit the amount of movement that can be caused by electrostatic stress.

Specifications on the 1AX2 are now available from the company.

UNGER "TRIPLETS"

Unger Electric Tools, Inc., Los Angeles 54, California has introduced two new soldering accessories that are of particular interest to the trade.

The first of the developments is a new, interchangeable thread-in unit which combines the features and advantages of three separate soldering tips. The unit, which has been trademarked "Elkaloy Triplets" is actually three soldering tips in one, a trio of individual tips designed to thread into a single heating unit, which in turn, fits into the company's "light-as-a-feather" handle. The new "Elkaloy Triplets" consist of No. 535 thread-in heating unit, plus the No. 331 pencil "Triplet," the No. 332 offset "Triplet," and the No. 333 chisel "Triplet."

The second development is an increased-wattage thread-in unit which has been especially designed for use with the new "Triplets." The No. 1235

(Continued on page 98)

HOW TO GET MORE FIDELITY FROM PHONOGRAPH RECORDS

10 WATT HI-FI PUSH-PULL AMPLIFIER



\$32.95
with Tubes
Stock No. RA-102

- Bass & Treble Boost.
- Inputs for crystal and magnetic pickups, radio tuner and crystal mike.
- Aluminum Chassis.

Bombshell Value! It's unbelievable. A full 10 watt Hi-Fi Amplifier, completely assembled and ready to play. Has built-in PRE-AMP for G.E. and similar types of magnetic pickups. 4 inputs: 1 crystal phono, 1 magnetic phono, 1 radio, 1 mike. 4 Controls: 1 Bass, 1 Treble, 1 Volume, 1 Phono-radio Switch. Output Impedance: 4, 8, 16 ohms. Peak power output 17 watts. Order this amplifier today and see what brilliant, realistic tone it will deliver. Supply is limited. Everyone in factory sealed carton. You couldn't buy the parts alone for this price. Remember this is a full size amplifier, transformer operated, not an AC-DC job. Frequency response 20 to 20,000 cps at less than 1% of 1% distortion. 5 Tubes: 1-6SL7, 1-6SC7, 2-6V6, 1-5Y3. Complete with tubes. Size 12"x6 1/2"x3 1/2". Shpg. wt. 15 lbs. Can be used with any phono or speaker but you should take advantage of the Combination Deal offered below.

12" CO-AXIAL SPEAKER



\$12.95
Stock No. S-168

Our new 1952 Model. Guaranteed to outperform any speaker in its price class. Equipped with two "high concentration"

Alnico 5 magnets and a high frequency diffuser. The 12" section delivers the bass while the inner 3" tweeter speaker section delivers the treble tones. Together they give you "living tone." This speaker is unconditionally guaranteed to satisfy even the most critical user or Olson promises to refund your money. Only two wires to connect to any radio or amplifier. Voice coil impedance 8 ohms. Frequency response 30 to 17,500 cps. SHPG. wt. 10 lbs.

FAMOUS 3-SPEED AUTOMATIC RECORD CHANGER

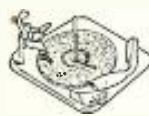

\$19.99
Stock No. RA-69

Completely automatic—one of the most famous brands in changers. Everyone in original factory backing. 100% guaranteed to please or money back! It's one of Olson's most sensational bargains. The changer has a select lever and a control for selecting 33 1/3, 45 or 78 RPM speeds. Plays all 7", 10" and 12" records. Equipped with a crystal cartridge and a long life needle. Records drop gently and smoothly—just like velvet. Operates on 115 volts, 60 cycles AC. Base 12x12 1/2 x 5 1/2" above plate and 3 1/2" below. Shpg. wt. 15 lbs. Limited quantity. When these are gone—no more.

Order this matched outfit consisting of one each of the RA-102 Hi-Fi Amplifier, S-168 12" Co-Axial Speaker and 3-Speed Recorder No. RA-69. Can be built into any cabinet or bookcase. Shpg. wt. 35 lbs. Special price for all—\$63.95. Order Combination No. AS-62.

COMBINATION DEAL

Amplifier, Speaker Record Changer as Shown Above **\$63.95**



OLSON RADIO WAREHOUSE • 275 E. Market St., Akron 8, Ohio



CRYSTAL MIKES

Astatic high output crystal mike for PA systems and recorders. Equipped with handle base and 7' shielded cable. Shpg. wt. 5 lbs. **\$5.95**
M-67, each

M-66, same but with on-off switch built into handle . . . **\$6.95**



PHONO AMPLIFIER

Stock No. RA-19

\$3.98
Less Tubes

A real high efficiency 3-tube amplifier of modern design. Connect to any crystal phono arm and speaker. Has volume and tone controls 7"x3 1/2"x2". Shpg. wt. 2 lbs. SET OF TUBES FOR AMPLIFIER 12SQ7, 50L6, 35Z5. **\$2.64**
No. AS-22

PHONO PRE-AMPLIFIER



For use with G.E. and other low level magnetic pickups. Can be attached to any radio or amplifier. Built on aluminum chassis. finest workmanship throughout. A m p l e bass boost provided. Operates on 115 volt AC. Sizes 4 1/4" x 2 1/4" x 3 1/2". Complete with 12AX7 tube. Shpg. wt. 2 lbs.

Stock No. RA-101
\$8.95

MOTOR and ARM



A BIG VALUE
\$3.99

STOCK NO. RA-51

COMBINATION OFFER
You get an Alliance Rim Drive 78 RPM Phono Motor with turntable PLUS a Pickup Arm with high Output Cartridge. Shpg. wt. 6 lbs.

BUILD YOUR OWN RECORD PLAYER



Single Speed Model

This fine kit contains a 78 RPM rim drive motor with velvet finish turntable, crystal pickup arm, all purpose needle, 4" PM speaker, matching output transformer, 2 tube AC-DC amplifier and a set of tubes (6SQ7, 50L6 and 35Z5). SHPG. wt. 8 lbs. **Stock No. AS-52. \$8.95**

DELUXE 3-SPEED MODEL

Like above except kit has 3 speed phono motor to play all 33 1/3, 45 and 78 RPM Discs. Shpg. wt. 8 lbs. **Stock No. AS-53. \$11.95**

TELEPHONE PICKUP



Stock No. M-80
\$4.50

Record or amplify both sides of a telephone conversation. No connection to telephone necessary. Just lay pickup under any cradle type phone and connect lead to hi-impedance input of any disc, wire or tape recorder or any amplifier. Operates by induction.

USE ORDER BLANK ON NEXT PAGE →

WAREHOUSE CLEARANCE SALE LOWEST PRICES EVER!!

(Note our new address below)

G.E. RELAY CONTROL

Contains a sigma midget 8,000 ohm. relay, (trips at less than 2 MA), high impedance choke, bi-metal strip, neon pilot and many useful parts. The sensitive relay alone worth much more than the total low price of \$1.25 each. 10 for..... \$9.90

POWER TRANSFORMER BARGAINS

(110 V. 60 cycle primaries)
750 volts CT @ 200 MA. 6.3V @ 10 amps.
5V @ 3A. Fully cased, removed from TV equipment. Guaranteed. Each \$2.95

FILTER CHOKE BARGAIN

Fully cased 5 Henry 200 M.A., removed from TV Equipment Guaranteed. .95 each

FILTER CONDENSER BARGAIN

8x8 M.F.D. 600 vdc oil compound filled. .98 each
Only

POWER SUPPLY KIT

Uses Power Transformer, choke, and 8x8 mfd Filter Condenser described above.
All for \$3.98

SCOPE TRANSFORMER BARGAIN

2500 V @ 3 ma, 2.5 V @ 2 A, 6.3 V @ .6 amp. Removed from TV equipment. Guaranteed. Terrific value @ \$1.49

SENSITIVE RELAY

D'Arsonval moving coil type, mounted in meter case. Adj. 700 microamps to 1 ma. Made by Triplett. ea. \$5.75

PANEL METERS

NEW GOV'T SURPLUS
*Special Scale

2" METERS

0-10 MA. AC. \$2.95
0-4 AMP RF 2.95

3" METERS

0-2 MA 4.50
0-2.5 AMP RF 5.95
0-500 MA 4.50
0-100 VDC (1 MA). 5.95
0-200 VDC (1 MA). 5.95
0-250 VDC (1 MA). 5.95

FILTER CHOKES

6 Hx 90 MA. \$0.79
6 Hx 500 MA. 4.95

PIGTAIL MICAS

M.M.F.: 5, 20, 50, 60, 100,
250, 300, 400, 500, 750,
800, 1000, 2000, 3000,
4000, 5000, 6000,
10000. \$0.09 ea.

BAKELITE CASED MICAS

MFD VDC Price	MFD VDC Price
.001 600 \$1.18	.024 1500 \$0.65
.002 600 .24	.033 1500 .75
.01 600 .26	.02 2KV .90
.02 600 .26	.005 2500 .55
.01 1KV .45	.004 2500 .45
.002 1200 .35	.00015KV .70

WIRE WOUND RESISTORS

5 watt ohms: 25-50-84-200-2500 \$0.09 ea.
10 watt ohms: 25-40-1325-2K-4K15 ea.
20 watt ohms: 150-300-750-1K-1.5K, 2.5K-2.7K-10K-20K20 ea.
30 watt ohms: 100-2500-5300-18K22 ea.

ADJUSTABLE SLIDER RESISTORS

20 Watt: 1, 5, 300 ohms \$0.25
75 Watt: 100, 150, 200 ohms39

PEAK ELECTRONICS CO.

378 Great Neck Rd., Great Neck, New York
Phone Great Neck 2-0082

U.H.F. Conversion

(Continued from page 49)

from the u.h.f. to the v.h.f. ranges and vice versa.

A schematic of the u.h.f. oscillator, Fig. 15, illustrates the eight-position method of switching the local oscillator frequency range using incremental coils and condensers. The fixed fundamental frequency can be in the 400 megacycle range and is resonated at this frequency by two small coils in parallel (#16 wire on 1/4" form). Higher frequencies are obtained with shunt inductors; lower frequencies with shunt condensers. Frequency deviation is not great and a trimmer circuit position is sufficient to correct for tube capacity and component dissimilarities.

Kingston U.H.F. Tuner

The Kingston tuner, Fig. 16, also uses the circular tuned line method though with a greater radius than that employed in the Mallory type tuned lines. The antenna is coupled to one end of the mixer-tuned line; the crystal to the other. Consequently, the proper degree of coupling can be obtained at each end without direct interaction as is the case in some designs because of the close proximity of the antenna and mixer circuits. Two trimmers on the preselector line permit tracking adjustments at both ends of the u.h.f. band. A cascode i.f. stage has its output frequency adjusted to the Channel 10-11 frequency range instead of the more common Channel 5-6 range.

Test Equipment Problem

Initially, the alignment of u.h.f. strips and converters will not be difficult. They are basically rather simple units and very little additional test equipment of an elaborate type will be necessary. Test units required will include a signal source, perhaps a source of modulation for that signal, and finally an indicating device. Initially only one or two stations will come on the air in a given area. It is very possible that the station signal and its modulation can be used as a signal source to do the entire u.h.f. section alignment job. Bandwidth is not too trying a problem on the u.h.f. band because six megacycles is small in comparison with the center frequency of hundreds of megacycles. Consequently,

Fig. 13. Block diagram of v.h.f.-u.h.f. tuner.

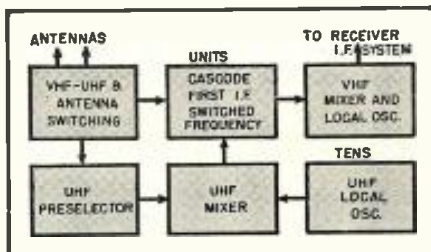

Get These New Bulletins

ANTENNAS

for CD, Amateur, Marine

Efficient, low-cost Antennas for your Civil Defense, Fire, Police, CAP, Mobile and Marine installations—tested and tried equipment that meets severe demands for communications.

PREMAX PRODUCTS

DIVISION CHISHOLM-RYDER CO., INC.

5205 Highland Ave., Niagara Falls, N. Y.



TWIN-TRAX*

Selected in International Competition by the Olympic Purchasing Commission

Because of their quality, dependability and exceptional value, Twin-Trax* Recorders were selected exclusively for all recording and re-broadcasting of this year's Olympic Games. Engineers of Finland's Purchasing Committee circled the globe while visiting every manufacturer of tape recorders and testing their products. They chose Twin-Trax* to guarantee perfect recording, and give them maximum value for their money.

You, too, can own a Twin-Trax* Recorder, discriminately chosen for the greatest recording project of all time. As a Twin-Trax* owner, you will be in good company — with thousands of government agencies, broadcast stations, schools, and critical music lovers who have also made Twin-Trax* their "official and exclusive" recorder. *Trade Mark Reg.

Write today for Catalog #5324, containing complete specifications and direct factory prices.

AMPLIFIER CORP. of AMERICA

398 Broadway New York 13, N. Y.

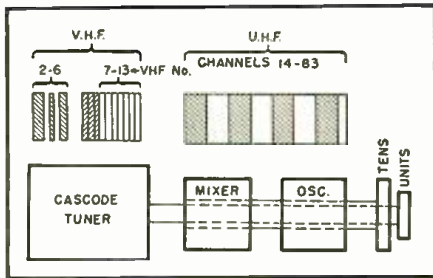

Fig. 14. Channel selection plan used in the Standard Coil v.h.f.-u.h.f. TV tuner unit.

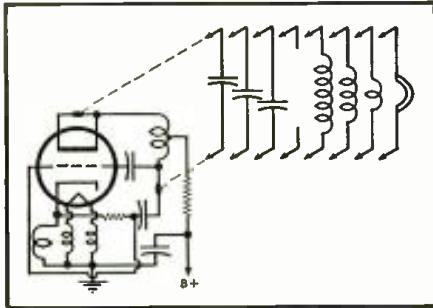

Fig. 15. The u.h.f. local oscillator switching circuit used for the "tens" dial scale.

single-peaked tuned circuits have a six megacycle bandpass; and double-humped characteristics are not necessary. Thus, a simple peaking of the resonant circuits for a maximum is all that is necessary.

Another source of signal can be the harmonic output of your present signal generator (sweep and/or marker). The v.h.f. generators with a high fundamental range have been found to have a high-to-just-usable output on their u.h.f. harmonics. Still a third possibility is to construct a small u.h.f. oscillator to operate on your assigned u.h.f. channel or channels. The oscillator can be calibrated with an accurate wavemeter or harmonic generating crystal-controlled oscillator. Test instrument manufacturers will gradually market u.h.f. sweep signal generators with marker facilities. To summarize, the following signal sources are possibilities—a u.h.f. station, the harmonic output of present v.h.f. generators, a home-constructed u.h.f. oscillator, or a commercial u.h.f. instrument.

It is very possible that a single frequency alignment will suffice for most of the initial u.h.f. converters. Modulation of the signal source is or is not required as a function of the type of indicator used. For single frequency

Table 2. How channels from 40 to 49 fall in with the "tens" dial set on 4. One fixed u.h.f. local oscillator frequency is used (one out of a possible eight).

"Units" Dial	Channel Frequency	Local Osc. Freq.	Cascode I.F. Frequency
0	626-632	470	156-162
1	632-638	470	162-168
2	634-644	470	168-174
3	644-650	470	174-180
4	650-656	470	180-186
5	656-662	470	186-192
6	662-668	470	192-198
7	668-674	470	198-204
8	674-680	470	204-210
9	680-686	470	210-216

LOOK—NO NOISE!

Boosts the signal . . . not local lead-in noise!

Gives higher signal-to-overall-noise ratio!

Exclusive broadband circuit gives uniformly high all-channel gain!

Eliminates effect of external interference

Tenna-Top TV BOOSTER

AUTOMATIC SELF-TUNING

SINGLE TWIN-LEAD LINE* CARRIES POWER UP— AND SIGNAL DOWN

Pictures are Sharper, Brighter! Sound is Clearer!

You can *see* and *hear* the difference when you hook up the TENNA-TOP. Because it is mounted at the antenna ahead of the lead-in...it amplifies only the wanted TV signals, not any local noise interference produced by automobile ignition systems, neon signs, diathermy, or other external noise picked up by the lead-in. You have the further advantage of E-V low-noise circuit. All this guarantees the best possible results with any TV set anywhere...even in toughest fringe areas or in all noisy locations. The TENNA-TOP is completely automatic. Turns "On" or "Off" with the TV receiver switch. It is easy to install, highly stable, trouble-free.

Model 3010 Tenna-Top TV Booster. List Price . . . \$88.00



Tuneo-Matic TV BOOSTER

Famous E-V broadband booster—proved in thousands of installations! Uniform high gain—low noise circuit. Automatic self-tuning for all channels. Easily concealed.

Model 3000, 4-stage, List \$57.50
Model 3002, 2-stage, List \$39.50

Electro-Voice

TV BOOSTERS • MICROPHONES • HI-FI SPEAKERS • PHONO-PICKUPS

Send for Free Bulletin

Electro-Voice, Inc., Dept. N7-2
 410 Carroll St., Buchanan, Michigan
 Send Free Bulletins 163-165

Name _____ (PLEASE PRINT)

Address _____

City _____ Zone _____ State _____

Serviceman Installer Dealer TV Fan

*Patent Pending.

HARVEY

Where You Always Find
THE FINEST....

WILLIAMSON HR-15 AMPLIFIER KIT

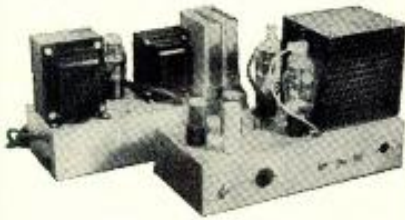

The famous, original Williamson HR-15... still acclaimed the leader... in kit form, with the original Partridge Transformers. Assemble this kit, and in 3 hours or less, enjoy the finest sound you ever heard. Operates from a tuner, phono-preamp, crystal pick-up, or other signal source. Absolute gain is 70.8 db with 20 db of feedback. Frequency response: $\pm .5$ db, from 10 to 100,000 cps. Output impedances to match all speakers from 1.7 to 109 ohms. Kit is complete with 5 tubes (1-5V4, 2-6SN7, and 2-6BK6 or 807), 2-Punched Chassis, 2-Resistor Mounting Strips, Sockets, Partridge WWFB Output Transformer, Assembly Instructions, and All Other Necessary Parts\$76.50

HR-15, as above, but with Partridge CFB Output Transformer (Hermetically Sealed)\$90.00

PARTRIDGE OUTPUT TRANSFORMERS—Available Separately
WWFB.....\$26.00 CFB.....\$40.00

SONAR MOBILE RECEIVER Model MR-3

Complete coverage for 10-11-20-75 meters. 8 tubes, 4.5 watts audio output. Uses: 12AT7 RF stage and B.F.O., 608 oscillator mixer, (2) 6CB6 I.F. stages, 6AL5 2nd detector and noise limiter, 6AT6 1st audio, 6AQ5 audio output, 0B2 voltage regulator. 1 Microv signal produces 0.5 Watt audio output. A.N.L. and B.F.O. are push-button operated. Requires 250 Volts at 60 to 80 mls. Size: 4-9/16" x 5-3/16" x 5-11/16". Complete with tubes... less power supply and speaker.....\$89.95



IN STOCK for IMMEDIATE DELIVERY

RAYTHEON TRANSISTORS
Type CK716 \$18.00

ELMAC A54

Under-dash
Mobile Xmtr.



For Carbon Mike Input Net \$139.00
For Dynamic or Crystal Mike Net 149.00
Power Supply, 110 volts AC Net 39.50

NOTE: In view of the rapidly changing market conditions, all prices shown are subject to change without notice and are net, F.O.B., N.Y.C.

Telephone **hrc** Luxembourg 2-1500

HARVEY
RADIO COMPANY, INC.
103 West 43rd St., New York 36, N. Y.

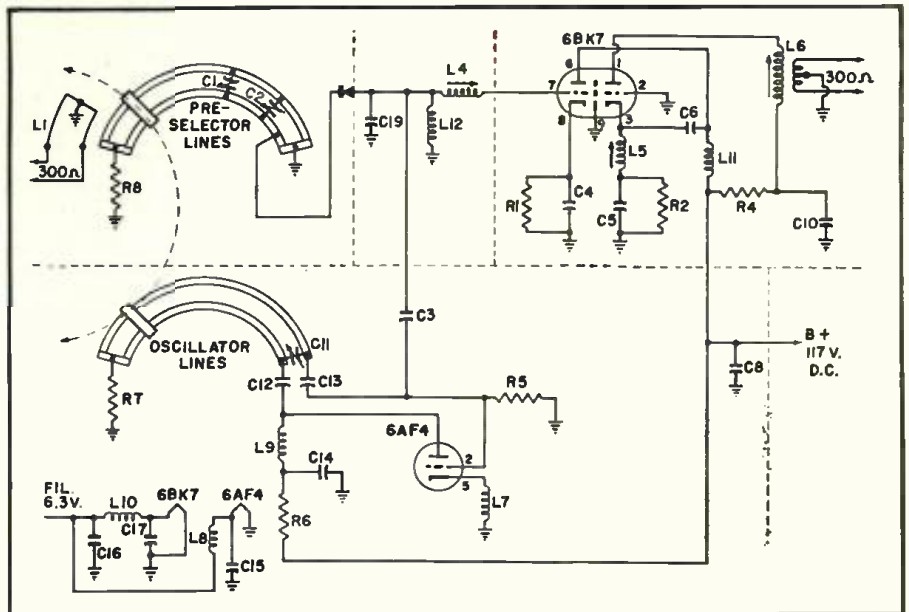

Fig. 16. Circuit diagram of the Kingston Model 5-3 u.h.f. tuner unit.

alignment there are a number of indicator systems, depending on what you have available. Inasmuch as the output of the u.h.f. converter is in the v.h.f. range, an r.f. measuring device can be used.

An excellent indicator is the conventional field strength meter used for v.h.f. signal level measurements. This type of instrument can be attached to the output of a u.h.f. converter, set on correct channel frequency, and serves as a good sensitive peak indicator. It also gives an approximate reading, in microvolts, of the converter output signal voltage.

Some other possibilities are an a.c. vacuum tube voltmeter with r.f. probe and a sensitive current meter. If modulation of the signal source is possible a crystal detector probe and scope can be used. *General Electric* suggests the balanced crystal detector and meter attached to the output of the converter or a v.t.v.m. attached to the out-

put of the video detector in the v.h.f. receiver.

Alignment Trend

Alignment of the first converters and strips will not be difficult. In the alignment of a typical converter, Fig. 17, the i.f. amplifier is first peaked and then the u.h.f. tuned circuits are aligned at the high and low ends of the band.

First a v.h.f. signal generator is applied to the input of the cascade i.f. amplifier and the stage is peaked on the particular v.h.f. channel to be used during u.h.f. reception. Next a source of u.h.f. signal (generator or station signal) is applied to the antenna input and the converter is tuned to the low end of the band where a pair of controls are peaked on the output indicator. Next, the signal source and converter are set to a frequency at the high end and another pair of controls are peaked to complete the alignment.

-30-

Fig. 17. The General Electric u.h.f. converter and alignment connections.

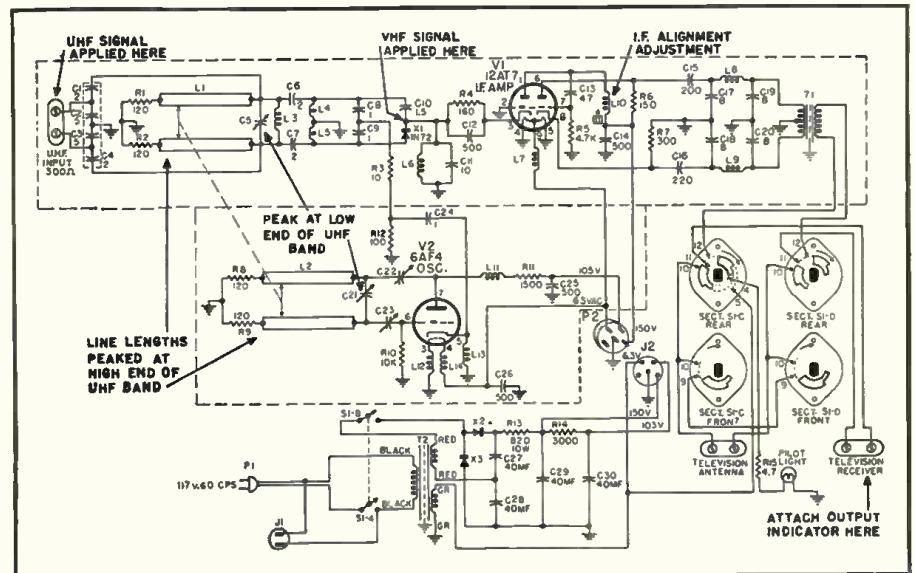

**New Low Prices
Largest Stock**

TUBES and PARTS

All TUBES are guaranteed for one year . . . individually boxed.
10% DISCOUNT on orders of 100 tubes or more, all brands.

TUBE SPECIALS!

6AU6 . . . ea. 59c
6BK7 . . . ea. 98c
6BQ6GT ea. 85c
6CD6G ea. \$1.69
6U8 . . . ea. 89c
12AU7 . . . ea. 65c

0Z4 49c	5T4 \$1.40	6BA7 \$.69	6L5G \$.95	6W4GT 49c	7Y4 73c	12SR7GT . . . \$.59	45Z5 \$.59
0Z4G 49c	5U4G49	6BC559	6L6G 95c	6X4 49c	7Z4 73c	12Z395	46 89c
1A5GT65	5V4G87	6BC779	6L6GA69	6X5GT69	12A7 1.15	14A789	47 89c
1A759	5W4 49c	6BD5GT89	6L769	6Y6G69	12A859	14AF793	50A589
1B3GT69	5W4GT 49c	6BE649	6N6G 1.40	7A459	12AH7 1.45	14B6 89c	50B5 59c
1B565	5X4G65	6BF559	6N7GT 69c	7A589	12AT649	14B8 89c	50C5 59c
1C7G 29c	5Y3GT45	6BF659	6P5GT69	7A689	12AT789	14C5 1.07	50C6G 1.04
1E7 29c	5Y4G54	6BG6G 1.49	6Q7GT49	7A7 73c	12AU659	14C798	50L649
1H5GT49	5X4G 81c	6BH6 59c	6R7GT69	7A8 73c	12AU769	14F789	50X679
1J5GT69	5Z3 81c	6BJ649	6S449	7B4 73c	12AV649	14F8 1.30	50Y659
1L459	6A3 1.15	6BN689	6S7GT 1.15	7B573	12AV789	19BG6G 1.49	70L789
1LA4 1.19	6A7 1.21	6BQ689	6S8GT69	7B673	12AW695	19T889	71A87
1LA6 1.19	6A8GT59	6BQ7 1.49	6SA7GT59	7B773	12AX769	20 1.40	75 59c
1LC569	6AB7 1.15	6C449	6SC759	7B873	12BA649	24A59	77 59c
1LC6 1.19	6AC5GT 89c	6C5GT 59c	6SD7GT99	7C4 1.30	12BA769	25AC5GT 1.04	78 1.10
1LD595	6AC769	6C659	6SF549	7C5 73c	12BE6 49c	25BQ6GT 1.15	8045
1LE5 1.19	6AG569	6C8G 1.15	6SF5GT49	7C6 73c	12BF6 49c	25L6GT49	83 1.45
1LH4 1.19	6AG789	6CB659	6SH759	7C7 73c	12BH769	25W4GT59	8579
1LN5 1.19	6AH6 1.40	6CD6G 1.49	6SH7GT59	7E659	12C8 1.15	25X5 1.04	117L7 1.40
1NSGT59	6AK589	6D659	6SJ7 49c	7E769	12F5GT 65c	25Z6GT59	117N789
1P5GT69	6AK6 1.08	6D8G 1.15	6SJ7GT59	7F789	12H6 65c	32L7GT 1.15	117P7 1.40
1Q5GT 69c	6AL5 59c	6E559	6SK7GT59	7F8 1.47	12J5GT54	35A599	117Z349
1R5 59c	6AQ5 59c	6F5GT 49c	6SL7GT69	7G769	12K7GT59	35B5 59c	117Z669
1S5 59c	6AQ681	6F6GT 49c	6SN7GT59	7H759	12Q7GT49	35C5 59c	807 1.55
1T4 59c	6AR574	6F8G 1.15	6SQ7GT 49c	7J759	12SA7GT59	35L649	813 8.95
1U4 59c	6AT649	6G6G95	6SQ7 49c	7K7 1.07	12SC759	35W445	1294 29c
1U549	6AS590	6H6GT49	6SS7GT49	7L769	12SF5GT 59c	35Y4 99c	1299 29c
1X2A69	6AU5GT69	6J5GT49	6SS772	7N7 59c	12SF7 59c	35Z399	161945
2A3 1.15	6AU6 49c	6J6 1.04	6TTG 1.15	7Q7 59c	12SH7GT59	35Z449	162929
2A579	6AV659	6J7G59	6T889	7R789	16SJ7GT49	35Z545	2050 2.00
3LF4 1.19	6B4G 1.44	6J8G 1.15	6U559	7S7 1.07	12SK7GT59	35Z6G95	2051 1.15
3Q459	6B569	6K5GT69	6U6GT 59c	7V769	35 5179	4172	2051 1.15
3Q5GT 1.08	6B6G79	6K6GT49	6U7G 59c	7W7 1.07	12SN7GT99	4259	719387
3S4 59c	6B8GT 1.15	6K7GT59	6V6GT59	7X689	12SQ7 49c	4359	VT51 29c
3V4 59c	6BA649	6K8GT69		7X769	12SQ7GT 49c	45 72c	VT52 29c

Finest TV CHASSIS

Complete with TUBE!

12 1/2" picture tube with complete chassis . . . \$79.50

16" picture tube with complete chassis . . . \$99.50

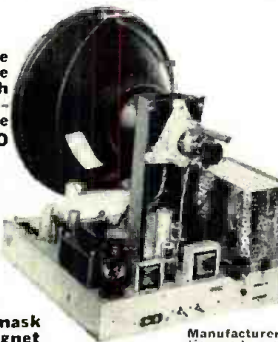

- INCLUDES:**
- beautiful bronze metal mask
 - permanent magnet 12" speaker
 - all tubes aligned perfectly
 - ideal for fringe areas . . . works better than other receivers and where others can't
 - ultra-sensitive fringe area tuner
 - standard 90-day guarantee on all tubes and parts
 - full band reception and output
 - gated AGC—line automatic gain control
 - COMPLETE . . . READY TO OPERATE

OUTPUT TRANSFORMERS

Standard Replacement
For 50L6, 35L6, 50A5, 35A5, 117L7 . . . 39c ea.
For 6V6, 6F6, 3Q5, 3Q4, 3S4, 3V4, 41, 42, 6K6, 2A3, 45, 6L6 . . . 49c ea.
Universal Output Transformer Special . . . 79c ea.
Up to 12 watts to any speaker (While They Last)

CHIMNEY MOUNTS

for TV Antenna . . . 98c each

TUBE KITS

BEST BRANDS AT BEST PRICES

3Q4, 1T4, 1R5, 1S5. List Value 58.00. Tube Kit only . . . \$1.98
3S4, 1T4, 1S5, 1R5. List Value 57.80. 4 Tube Kit . . . \$1.98
1U4, 3S4, 1S5, 1R5. List Value 57.80. All Four Tubes for . . . \$1.98
3V4, 1R5, 1S5, 1T4. List Value 57.80. All for . . . \$1.98
117Z3, 1U5, 3V4, 1R5, 1T4. AC-DC Portable Kit. All for . . . \$2.49
12AT6, 12BA6, 12BE6, 35W4, 50B5. 5 Tubes for . . . \$2.59
50L6GT, 3.5Z5GT, 12SQ7GT, 12SK7G, 12SA7G. 5 Tubes for . . . \$3.22

Fringe Area DOUBLE "V" TV ANTENNA KIT

High Gain, Best Pictures Possible! . . . complete with 300 ohm line, insulators, guy wire, hardware, full size antenna with double length 9 ft. mast . . . \$6.95 complete

TV PICTURE TUBES

Six month guarantee

10BP4 . . . \$12.95
12LP4 . . . \$16.95
12LP4A . . . \$16.95
14BP4 . . . \$22.95
7JP4 . . . \$15.95
16AP4 . . . \$22.95
16BP4 . . . \$23.95
16GP4 . . . \$23.95
16JP4 . . . \$29.95
16RP4 . . . \$18.95
16TP4 . . . \$18.95
17BP4A . . . \$24.95
19AP4A . . . \$27.95
19AP4B . . . \$27.95

PILOT LIGHT SPECIAL

No. 47—Box of 100 for only . . . \$2.95

Box of ten for . . . 39c

3 speed G. I. CHANGER complete, ready to install . . . \$24.95

TWIN LEAD

300 ohm twin lead 55 Web virgin polyethylene, in either clear or brown, the finest available.

1000 ft. \$1.85 | 100 ft. \$1.95

Get our special sales bulletins . . . write TODAY!

6 FOOT LINE CORD

UL apprvd. cord and plug—10 for . . . \$1.95
TV Tubular Capacitor .05 mfd, 6000-VDC Only . . . 79c ea.



P. M. SPEAKERS

12" Coaxial PM Speakers . . . \$12.95 ea.

High fidelity with high pass filter attached. 20 watt; 40-17500 cps. response; 8 ohm VC.

Very best quality—NATIONAL BRANDS Individually Packed

3" . . . \$1.26 ea. 8" . . . \$3.23 ea.
4" . . . 1.36 10" . . . 5.10
5" . . . 1.59 12" . . . 6.54
6" . . . Special Price . . . \$1.59 ea.

RESISTOR KITS

Insulated 1/2, 1 and 2 watt assortment of most used values, best brands. 100 for \$2.95

TERMS: 20% DEPOSIT with order, balance C. O. D. All shipments F. O. B. Chicago.

FREE DELIVERY on all orders of \$10.00 or more. Insurance and shipping charges prepaid anywhere in Continental U. S.

PREMIER Radio Tube Division 551 W. Randolph St.
CONTINENTAL CORPORATION Chicago 6, Illinois
ANDover 3-1590

Become an Electrical Engineer



MAJOR IN ELECTRONICS



- B. S. Degree in 36 Months
- Radio-Television Technician Certificate in 18 Months

By 1954 there will be at least two positions for every engineering and technician graduate. This College offers a tested plan that permits you to enter these vast employment opportunities at an early date. First — you save a valuable year through optional year-round study. Second — you can receive *advanced credit* for prior training gained in the armed forces, other schools or field experience.

Enter Both Radio and Television Through This Plan

12 months or one-third of the B. S. degree course (Electronics major) — also brings you the *Radio Technician's* certificate. An added 6-month course qualifies you for the *Radio-TV Technician's* Certificate. Recent developments open unlimited opportunities for TV technicians and engineers.

The Proven "UNIT CHASSIS SYSTEM"

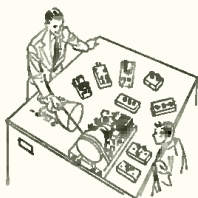

of teaching was developed here. It "breaks down" the TV set by stages. You learn every component of all types and makes — and are prepared for future design changes, including the advent of color.

General Preparatory Course

Exclusive 3-month course is tailor-made to help young men fulfill academic deficiencies and meet engineering admission requirements. **Terms open October, January, April, July** Over 48,000 former students from all states and 23 overseas countries. Faculty of trained specialists. Modern laboratories and equipment. Nonprofit technical institute and college in its 49th year.

MILWAUKEE SCHOOL OF ENGINEERING

FREE — Write for "Occupational Guidance Bulletin," "Your Career" booklet, and catalog.

Milwaukee School of Engineering
 Dept. RN-752, 1025 N. Milwaukee
 Milwaukee, Wisconsin
 Without obligation send Catalog for
 Electrical Engineering, B. S. Degree,
 major in Electronics; Power; "Your
 Career"; Occupational Guidance Bulletin
 on: Radio-TV; Electrical Power;
 Welding; Heating, Refrigeration Air Conditioning
 Mechanical Engineering, B. S. Degree; Preparatory.

Name: _____ Age: _____
 Address: _____
 City: _____ Zone: _____ State: _____
 If veteran, indicate date of discharge: _____

RADIO-TV Service Industry News

AS REPORTED BY THE TELEVISION TECHNICIANS LECTURE BUREAU

THE constant scourge of the radio-television servicing industry is the misuse of labor charges in the hopes of selling more service jobs—or more sets. Although the cost of competent technical labor is fixed by competitive and economic factors beyond the control of any individual businessman or group of businessmen, there seems to be a continuing stream of men who, through design or ignorance, think they can outsmart their competition by offering labor at below cost prices as a sales gimmick. This is especially true of television because the set owning public has yet to learn through costly experience that competent, efficient, reliable service cannot be "cheap" service. As the general public gains more actual experience with service on their TV receivers they will learn to recognize the "sucker" ads that use cheap labor as a "bait" and only the most gullible of them will bite. This process of public education on what to expect from and to pay for efficient television service can be accelerated, and made less costly to the public, by the combined efforts of all elements of the industry in disseminating factual information about the requirements for good service.

Three Trouble-Makers

The three major offenders in the manipulation of service charges, and in cheating, that stem from the use of low labor charges as a sales gimmick are: (1) The racketeers and chisellers who purposely use sub-standard labor charges as a lever to get service jobs on which they can levy unconscionable charges for parts; (2) Manufacturers or dealers who, in trying to create a demand for weak sister sets, make labor commitments beyond the customary and accepted standard manufacturer's warranty period; and (3) The service operator or technician who has no concept or understanding of his economic obligations or knows the actual costs of doing business and who usually prices his work on the basis of his immediate need for a few dollars.

Of these three the service racketeer is the worst offender in bilking the public and in bringing discredit to the entire servicing industry. However,

his activities become known rather quickly through complaints to the local Better Business Bureau and other agencies. In cities where a strong association of ethically operated service businesses is functioning, the racketeers can be brought to justice and their depredations eliminated through the combined efforts of the interested agencies of legitimate business.

TISA of Chicago

For a long time the city of Chicago had been comparatively free from fast dollar operators on television service. Early this year, however, a number of new "TV Service Companies" started operations there offering service calls for \$3.00. On the heels of these offers there followed a growing number of complaints from set owners about having to pay up to \$85.00 in service charges to get their sets returned.

This situation became of major concern to the Television Installation Service Association (TISA) of Chicago. The Association set up a special Fraud Investigating Committee to study the activities of these low-priced service advertisers. The results achieved by TISA through the work of this committee were reported recently by Frank Moch, president of the Association:

"TISA has instituted a comprehensive investigation of TV service racketeers who have suddenly invaded the Chicago area. The first target is the \$3.00 service call. It should be obvious to any that such offers are only schemes. In this scheme, entry is gained to the home by offering to do service for \$3.00, daytime, nighttime, Sundays, and holidays. The alleged technician who calls, generally an incompetent student, attempts to pull every set into a highly questionable shop. Estimate requests and other usual procedures are ignored. Set owners are then required to 'ransom' sets for fees as high as \$85.00. No itemized bills are issued and defective parts never returned. If the owner won't permit the set to leave his home the would-be technician charges the customer with as many as six tubes, very few of which are actually used. Even a needed tube is seldom new.

RADIO & TELEVISION NEWS

Checks are never accepted and no records are kept.

"TISA obtained hundreds of sworn statements from bilked set owners and from past and present employees of the companies involved. Sets were set-up with very obvious, natural type defects. Every step of these set-ups was witnessed and sworn to by the owners and qualified, competent experts. These sets were submitted for service to suspected companies. The results confirmed the reports of set owners. The Chicago Better Business Bureau, some newspapers, and the State Attorney's office cooperated fully. A special investigator and special prosecutors were assigned to the case. The first of the companies was subpoenaed to appear before the Cook County Grand Jury. The investigation is proceeding on schedule. As a result of the investigation, four companies have closed their doors and ceased operations. Other offenders will be brought to trial as soon as the first case is disposed of. A permanent Grievance Committee is now functioning to continuously police service operations."

TSA of Detroit

The Television Service Association of Michigan, Inc., has been carrying out an aggressive program to clean up the television service industry in Detroit. Working with the Better Business Bureau, the OPS, and the prosecutor's office the Association has been successful in ousting some bad actors from the newspapers and in getting two convictions for fraud.

TSA has been successful in building up a growing interest in active service association participation among service businessmen throughout the State of Michigan. More than 1300 people attended the two management meetings which they recently sponsored. To enable technicians to gather a great deal of important technical information in a short period of time, TSA has been sponsoring two-day service clinics. They have received excellent cooperation from local set distributors each of whom displays latest chassis with competent distributor or factory service personnel in attendance to answer questions on design, adjustments, or servicing.

Service as a Gimmick

Fortunately, most manufacturers realize that the key to consistently good TV viewing is reliable, efficient service. There is a feeling, too, that the average TV set owner will be more "brand conscious" when he buys a new TV set than he was at the time he bought his first one. The quality and character of service he was able to get on his first set will greatly influence his choice when he makes a change.

However, there are still a few manufacturers who, in trying to sell slow-moving sets, have been picking on service as the gimmick to interest buyers. Ads recently appeared in some areas offering "Lifetime service at the cost of the regular 90-day warranty service" and claiming that buyers

July, 1952

3 MICROPHONES DESIGNED FOR YOU...

BA-109... Flat frequency response from 40 to 10,000 cps. Nondirectional in the horizontal plane... output of 54 db below 1 volt/dyne/cm². Fits standard stand. List... \$22.50.



BA-106... Essentially flat frequency response from 40 to 6,000 cps. Output level - 50 db below 1 volt/dyne/cm². List... \$19.75.



BA-116... Hand or desk model. Can be used with standard stand if desired... uniform response from 50 to 6,000 cps. Finest of the low priced microphones. List... \$14.75.



No matter how good your ham rig, your P. A. system or your tape recorder, you can only get out of it what your mike puts into it. You want a sensitive, wide range mike with flat response, yet you want a mike that is sturdy and trouble-free.

Brush had you in mind when they designed their line of microphones. Each Brush mike is engineered to do an outstanding job in its class. All use the exclusive Metalseal Crystal* which assures protection from both high and low humidity.

The 3 Brush microphones illustrated as well as the Brush Vibromike* and the Brush Lapel microphone are available from your local radio parts jobber.

Brush headphones—for the first time combine all the most wanted headphone features. See them at your dealer.

*T. M. Reg.

THE **Brush**
DEVELOPMENT COMPANY



Piezoelectric Crystals and Ceramics
Magnetic Recording Equipment
Acoustic Devices
Ultrasonics
Industrial & Research Instruments

3405 Perkins Avenue • Cleveland 14, Ohio

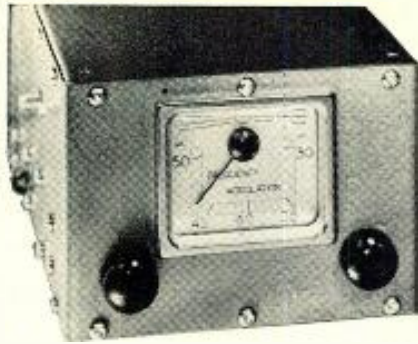

Model M-51

for emergency communications

USED BY HUNDREDS OF MUNICIPALITIES FROM BOSTON, MASS., TO ALHAMBRA, CAL.

POLICALARM MONITORADIO

Says S. L. Grant, City Manager, Winchester, Virginia . . .

"I think you have a receiver that is well built, and I see no reason why it should not be in demand by all public works departments that have a transmitter available."



Users of FM 2-Way Radio Communications equipment throughout the entire nation, find Polic-Alarm and Monitoradio a welcome innovation to low-cost mobile communications radio .

5 Models For All Systems

6 VOLT MOBILE

M-51

Tuneable 30-50 MC

M-101

Tuneable 152-163 MC

115 VOLT AC-DC

PR-31

Tuneable 30-50 MC

PR-8

Tuneable 152-163 MC

AIRCRAFT

AR-1

AM Tuneable 108-132 MC

115 Volt AC-DC

For Complete Information: See Your Jobber—Or Write Us Today

RADIO APPARATUS CORPORATION

55 N. NEW JERSEY ST., INDIANAPOLIS 4, IND., PHONE: ATLANTIC 1624

IMMEDIATE DELIVERY

Federated offers
industry's most useful
testing instrument!

THE NEW

RCA MASTER VOLTOHMYST



For direct measurement of:

- peak-to-peak values of unsymmetrical complex waves from 0.2 volt to 2,000 volts
- peak-to-peak values of symmetrical complex waves from 0.2 volt to 4,200 volts
- rms values of sine waves from 0.1 volt to 1,500 volts
- dc voltages from 0.02 to 1,500 volts
- resistance over the range of 0.2 ohm to 1,000 megohms
- small currents from 10 microamperes to 500 milliamperes, dc
- large currents from 500 ma up to 15 amperes, dc

For servicing, production, research: Accurate 8½" meter.

Complete specifications on request.

Federated Purchaser
INCORPORATED
THE ONLY COAST TO COAST ELECTRONICS DISTRIBUTOR

GABLE FEDERPURCH

New York City 66 Day St. Dlgbly 9-3050	Newark, N. J. 114 Hudson St. Market 3 3035	Allentown, Pa. 1135 Hamilton St. Phone 3-7441	Easton, Pa. 925 Northampton St. Phone 4259
--	--	---	--

would have "No Labor Charges (to pay)—Ever." Of course, if the buyer of such a set carefully reads the guarantee he is given he will find that what he is given "for free" will be only a small part of what he will be charged for service calls on the set.

The unfortunate effect that such advertising claims tend to produce is to further distort the general opinion among set owners that TV service is over-priced. Good service cannot be cheap or "free service". Public opinion must be up-graded in the facts of television service and what it costs to render the kind of service good TV viewing needs and deserves. A recent TISA bulletin pin-pointed the facts of service that must be gotten across to the set-owning public:

"If TV set owners would but realize that TV service, because of its complexity, requires the services of highly trained technicians with years of schooling and experience and that men of this caliber command a wage of \$2.00 to \$2.50 and more per hour, they will begin to learn that service cannot be cheap. Further, traveling cost to get to the home amounts to another 50 cents minimum and when you add to this the cost of extensive insurance coverage, taxes, office expense, expensive test equipment, tools, technical data, rent, light, heat, it is obvious that no one can perform a service call for \$3.00. Actually, a nation-wide, authentic survey reveals that the actual expenses of service are such that a call must cost the customer somewhere between \$5.00 and \$6.00 for service alone."

Consumer Booklets

The Association of Better Business Bureaus and the Radio-Television Manufacturers Association recently announced their joint sponsorship of a booklet providing basic information necessary for purchasers or owners of television receivers.

The new 11-page booklet is a revised edition of a booklet which originally was issued by the Better Business Bureau of New York City. The revised edition, "Things You Should Know About the Purchase and Servicing of Television Sets," was prepared by the RTMA Service Committee in cooperation with the Television Service Committee of the Association of Better Business Bureaus.

Issued as a public service by the two organizations, the booklet is designed to point out problems which may arise in the purchase and operation of a TV receiver.

Copies of the BBB-RTMA booklet may be obtained through the Better Business Bureaus.

ARTSD of Columbus

The Associated Radio & Television Service Dealers of Columbus, Ohio, has launched a campaign to make clearance by the Better Business Bureau a prerequisite for display advertising in the yellow directory of the telephone book. Pointing out that the

Six Months from Today Which will YOU hold?



ADD TECHNICAL TRAINING TO YOUR PRACTICAL EXPERIENCE

GET YOUR FCC LICENSE IN A HURRY!

Then use our Amazingly Effective
JOB-FINDING SERVICE

Get this Valuable Booklet **FREE**



TELLS HOW YOU CAN GET A **FREE** TELEVISION ENGINEERING COURSE

TELLS HOW—

WE GUARANTEE

TO TRAIN AND COACH YOU AT HOME
IN SPARE TIME UNTIL YOU GET
YOUR FCC LICENSE

If you have had any practical experience—Amateur, Army, Navy, radio repair, or experimenting.

TELLS HOW—

Employers make

**JOB OFFERS Like These
to Our Graduates Every Month**

Letter from Chief Engineer, Broadcast Station, North Carolina. "Need men with radio-telephone 1st class licenses, no experience necessary. Will learn more than at average station for we are equipped with Diesel Electric power, transmitting and studio equipment."

Telegram from Chief Engineer, Broadcast Station, Wyoming. "Please send latest list available first class operators. Have November 10th opening for two combo men."

These are just a few samples of the job offers that come to our office periodically. Some licensed radioman filled each of these jobs . . . it might have been you!

**HERE'S PROOF FCC LICENSES ARE OFTEN
SECURED IN A FEW HOURS OF STUDY WITH
OUR Coaching AT HOME in Spare Time.**

Name and Address	License	Lessons
Lee Worthy 2210 1/2 Wilshire St., Bakersfield, California	2nd Phone	16
Clifford E. Vogt Box 1010, Dania, Florida	1st Phone	20
Francis X. Foersch 38 Beutler Pl., Hergenfield, New Jersey	1st Phone	38
S/SGT. Ben H. Davis 317 North Roosevelt, Lebanon, Illinois	1st Phone	38
Albert Schoell 110 West 11th St., Escondido, California	2nd Phone	23

CLEVELAND INSTITUTE OF RADIO ELECTRONICS
SMITH, E. E., Consulting Engineer, President
Desk RN-43, 4900 Euclid Bldg., Cleveland 3, Ohio

July, 1952

TELLS HOW—

Our Amazingly Effective JOB-FINDING SERVICE

Helps CIRE Students Get Better Jobs
Here are a few recent examples of Job-Finding results:

GETS CIVIL SERVICE JOB

"Thanks to your course I obtained my 2nd phone license, and am now employed by Civil Service at Great Lakes Naval Training Station as an Equipment Specialist."
Kenneth R. Leiser, Fair Oaks, Mtd. Del., McHenry, Ill.

GETS STATE POLICE JOB

"I have obtained my 1st class ticket (thanks to your school) and since receiving same I have held good jobs at all times. I am now Chief Radio Operator with the Kentucky State Police."
Edwin P. Healy, 264 E. 3rd St., London, Ky.

GETS BROADCAST JOB

"I wish to thank your Job-Finding Service for the help in securing for me the position of transmitter operator here at WCAB, in Pittsburgh."
Walter Koschik, 1442 Ridge Ave., N. Braddock, Pa.

GETS AIRLINES JOB

"Due to your Job-Finding Service, I have been getting many offers from all over the country, and I have taken a job with Capital Airlines in Chicago, as a Radio Mechanic."
Harry Clare, 4537 S. Drexel Blvd., Chicago, Ill.

Your FCC Ticket is recognized in all radio fields as proof of your technical ability

**OURS IS THE ONLY
HOME STUDY
COURSE WHICH
SUPPLIES FCC-
TYPE EXAMINA-
TIONS WITH ALL
LESSONS AND
FINAL TESTS.**



Get All 3 FREE

MAIL COUPON NOW

CLEVELAND INSTITUTE OF RADIO ELECTRONICS
Desk RN-43—4900 Euclid Bldg., Cleveland 3, Ohio
(Address to Desk No. to avoid delay)

I want to know how I can get my FCC ticket in a minimum of time. Send me your FREE booklet, "How to Pass FCC License Examinations" (does not cover exams for Amateur License), as well as a sample FCC-type exam and the valuable booklet, "Money-Making FCC License Information."
 Tell me how I can get your Free Television Course.

NAME

ADDRESS

CITY..... ZONE..... STATE.....

Paste on two-cent postcard or send air mail

INDISPENSABLE! PHOTOFACT BOOKS



Photofact Television Course. Covers TV principles, operation and practice. 216 pages; profusely illustrated; 8½ x 11". Order TV-1.....Only \$3.00

Television Antennas. New 2nd edition. Describes all TV antenna types; tells how to select, install, solve troubles. Saves time; helps you earn more. 200 pages; illustrated. Order TAG-1.....Only \$2.00

Television Tube Location Guide. Volume 2. Accurate diagrams show position and function of all tubes in hundreds of TV sets; helps you diagnose trouble without removing chassis. 224 pages; pocket-size. Order TGL-2. Only \$2.00

Television Tube Location Guide. Vol. 1. Over 200 pages of TV receiver tube position diagrams on hundreds of models. Order TGL-1.....Only \$1.50

Making Money in TV Servicing. Tested proved methods of operating a profitable TV service business. Covers all important phases. Authoritative, valuable guide to success. Over 130 pages. Order MM-1.....Only \$1.25

Servicing TV in the Customer's Home. Shows how to diagnose trouble using capacitor probe and VTVM. Short-cut methods help save time, earn more on outside service calls. Order TC-1.....Only \$1.50

1949-1950 Record Changer Manual. Vol. 3. Covers 44 models made in 1949, including multi-speed changers and wire and tape recorders. Original data based on actual analysis of equipment. 286 pages; 8½ x 11"; paper-bound. Order CM-3.....Only \$3.00

1948-1949 Changer Manual. Vol. 2. Covers 45 models made in 1948-49. Paper bound. Order CM-2. Only \$4.95

1947-1948 Changer Manual. Vol. 1. Covers 40 post-war models up to 1948. Order CM-1.....Only \$3.95

Recording & Reproduction of Sound. 2nd Edition. New, completely revised and vastly enlarged edition of the outstanding original volume. The most authoritative treatment of all phases of recording and amplification ever written. Over 800 pages. 6 x 9". Order RR-2. Only \$7.95



Audio Amplifiers. Vol. 3. Clear, uniform, accurate data on 50 important audio amplifiers, plus full coverage of 22 FM and AM tuners, produced during 1950. 362 pages, 8½ x 11". Order AA-3.....Only \$3.95

Audio Amplifiers. Vol. 2. A complete analysis of 104 well-known audio amplifiers and 12 tuners made 1949-50. 368 pages, 8½ x 11". Order AA-2.....Only \$3.95

Audio Amplifiers. Vol. 1. 102 amplifiers and FM tuners made through 1948. 352 p. Order AA-1.....Only \$3.95

Auto Radio Manual. Complete service data on more than 100 post-war auto radio models. Covers over 24 mfrs. 350 pages, 8½ x 11". Order AR-1.....Only \$4.95

Communications Receiver Manual. Complete analysis of 50 popular communications models. 246 pages, 8½ x 11". Order CR-1.....Only \$3.00

Radio Receiver Tube Placement Guide. Accurate diagrams show where to replace each tube in 5500 radio models, covering 1938-1947 receivers. 192 pages, pocket-size. Order TP-1.....Only \$1.25

Dial Cord Stringing Guide. Vol. 2. Covers receivers made from 1947 through 1949. Shows you the one right way to string a dial cord in thousands of models. Pocket-size. Order DC-2.....Only \$1.00

Dial Cord Guide. Vol. 1. Covers sets produced 1938 through 1946. Order DC-1.....Only \$1.00

Order from your Parts Jobber or write direct to
HOWARD W. SAMS & CO., INC., 2201 E. 46th St., Indianapolis 5, Indiana

HOWARD W. SAMS & CO., INC.

public has been pretty well sold on the idea of "shopping through the yellow pages of the telephone directory," Fred Colton, president of ARTSD, said "the telephone company has created a prestige position for the advertisers in the telephone directories. We felt that they, too, should be very much interested in keeping racketeers out of the business and, since television is still so new and mysterious to the people who own sets, service companies that are granted the right to use display advertising space should be known to be reliable and capable of giving dependable, efficient TV service."

The Columbus association has made its emblem of Certified Service widely known throughout the city for the best in TV installation and service. They have had excellent cooperation from the Columbus newspapers and they work closely with the Better Business Bureau. The pay-off is that more and more Columbus set owners inquire when they call a company for TV service, "Are you certified?"

NARDA Booklet

Another useful booklet prepared for consumer education on TV operation and service was recently announced by the National Appliance & Radio-TV Dealers Association. This 8-page pamphlet was written by Mort Farr, president of NARDA, and one of the best informed dealers in the industry on service business operation and problems.

The booklet covers the most common TV sore spots with consumers, such as: Television Is Not Normally Trouble-Free; Ghosts Do Not Denote Defects; Ghost Problem Can be Solved; Indoor Antennas are Second Best; Diagnosis May Be Difficult; etc.

Information about the NARDA booklet may be obtained by writing to: The National Appliance & Radio-TV Dealers Association, Suite 1141, Merchandise Mart, Chicago 54, Ill.

Service Business at a Profit

The successful management of even the smallest kind of a business today is a complex activity. Our relatively small businesses that have evolved to handle TV installation and service place the entire responsibility for all phases of management on the shoulders of one or two men. To manage these businesses successfully these men must possess unusual talents and abilities. They must be versatile and ingenious and comprehend the technical as well as the business operating phases of this business. In addition to the many operational and technical problems that must be handled they must preserve the substantial investment that had to be made to provide the facilities for giving competent, reliable service. To preserve that investment the business *must* be operated at a profit.

The remarks made by Mr. A. W. Robertson, finance committee chairman and director of the Westinghouse Electric Corporation, in a recent speech on

the "Role of 'Profit Makers' in the Nation's Economy," deserve careful study by every man engaged in managing any type of a business—and particularly those in the business of servicing radio and television receivers:

Mr. Robertson described profits as the "incentive which justifies and encourages men to take the trouble to improve conditions of their fellow men. Without profits poor men, no matter how able, could never improve their position, could never bring something worthwhile to the attention of the public.

"Henry Ford once was a poor man with an idea. His idea was to make an automobile so simple and so cheap that it would be within the reach of all men. He didn't have money with which to attain his goal, but out of the profits of his early ventures he succeeded in starting the mighty *Ford Motor Company* which did place cheap automobiles within the reach of almost all of us.

"The true significance of the right of an individual to enter into an enterprise for profit is being lost sight of. By some mysterious method, the very word *profit* has taken on a sinister aspect to the extent that one of the worst things that anyone can be called is a 'profiteer.'

"Businesses that operate at a profit don't simply spring out of the ground like an oak from an acorn or golden-rod from seed. It takes hope, ambition, ingenuity, courage, foresight, and the use of thousands of materials and thousands of skills—all coordinated to a common end—to produce something which people, known as customers, may like well enough to buy at a price which results in a profit after all expenses are paid.

"It isn't easy to plan, supervise, and operate a business for profit. Those who can do so are obviously able and fortunate. But they also are benefactors of the human race because they must necessarily have pleased customers or they would not have sold their product.

"Business for profit is a game which may need a referee to keep contestants within the rules, but it is in no sense an evil, anti-social activity."

Operational Costs

The Pittsburgh TSA Newsletter recently carried the following itemized list of the factors of cost that enter into the operation of an efficient TV Service Business:

"Below are listed many of the costs, seen and unseen, which should go into the charges for television service. When they are considered it is remarkable that the reasonable charges of capable and responsible service operators can be kept at such low levels as they are today. Every television owner ought to have this picture of costs every time he considers a TV service bill:

"Rent, heat, light; Telephones; Wages of non-productive employees; Technical books and magazines; Wages of

PLATT B-R-A-N-C-H-E-S OUT... OPENS NEW DOWNTOWN STORE!!



For the convenience of his many customers who like to shop in person, PLATT has opened a brand new branch store at 159 GREEN STREET, N. Y. C. (Mail Orders are to continue going to the main store and warehouse at 489 Broome St., N. Y. C.)

The new PLATT Store is easily reached by the B.M.T., I.R.T., Hudson Tubes, and Independent Line. So why not visit PLATT's Bargain Store today? You'll find many additional values that space does not allow us to list here.

SPECIAL SALE TO CELEBRATE OPENING!

TUBES		BRAND NEW! JANI BOXED! TUBES	
826	39c	1629	22c
1625	29c	7193	19c
VT-127	98c	801A	19c
3C24	98c	841	29c
RK34	99c	864	29c
3047H	\$5.95	954	13c
1616	19c	E1148	49c
1619	19c	2C26	9c
1626	19c		



ARC-5/R-28 2 MTR RCVR \$29.95

Here is the 2-meter superhet you have been looking for! Absolutely one of the BEST available today! (Easily converted to continuous tuning.) Tube lineup is as follows:
717A—R.F., 717A—Mixer, 2-12SH7—1st and 2nd K.F. 10, 10 Mc.
12SH7—Det. AVC Speech, 12SL7—1st audio-speech amplifier.
12A6—2nd audio, 12SH7—R.F. Osc.—4th Harmonic Gen.
717A—Tripl. 12th Harmonic Gen., 717A—Dblr.—12th Harmonic.
Excellent, used \$29.95

TURBO AMPLIFIER

4 tube Amplifier used by U. S. Air Force, 115 V. input at 400 cycles. Without tube—**\$119**
..... SPECIAL



NEW SUPPLY ARRIVED! LIMITED QUANTITY TRANSMITTER-RECEIVER Navy Model ABA-1 (CG-43AAG)
Army Model SCR-515A, known as the BC-645 450 MC — 15 Tubes
BRAND NEW—ORIGINAL CARTON
Can be easily converted for phone or CW 2-way communication. Covering for the following bands: 420-450 MC ham band, 450-460 MC for fixed or mobile, 460-470 MC for citizens, 470-500 MC television experimental. Size 10 1/2 x 15 1/2 x 4 3/4. Contains 15 tubes—7F7, 4—7H7, 1—7E6, 2—6F6, 2—955, 1—WR-316A door knob.
Price includes Dynamotor, Control Box, Mount, Tubes. **\$34.95**
Complete set of spare parts, tubes and plugs for above. **\$22.95**

MN-26Y INSTALLATION
MN-26Y Receiver—Remote control commercial type navigational. Indicates direction of any desired transmitting station. Frequency range: 150 to 325 KC, 325 to 695 KC, 3.4 to 7 megacycles in 3 bands. Has 12—6V type tubes. (GOOD—used (Original Cost \$60.00).
YOUR PRICE ONLY \$24.95



ARMY TEST UNIT 1-236

Meter is contained in a metal box 5 1/2" long x 3 3/4" wide x 3 1/4" deep. Comes complete with test leads and instruction book. Can be used for testing between AC and DC measuring resistances of circuits, checking fuses and testing capacitors.
SPECIAL \$4.19

Multimeter Foundation BIAS METER 1-97A

Contains a zero center 3 1/2" round Marion voltmeter calibrated 0-100 volts each side. Movement is one mill each side of center. The unit is mounted in a steel box 7" x 5" x 4 1/2" and contains 8 contact push button, line cord dual 100 MF at 200 V DC condenser, a potentiometer 6 1/2 K 1% wire wound non-inductive resistors: one 100 ohm, two 250 ohm, one 5000 ohm, one 10,000 ohm, one 15,000 ohm. For building a zero center multimeter with ranges of 1, 10, 100, 1000 volt.
COMPLETE BRAND NEW \$5.95

Field Telephones
Army surplus, completely reconditioned and electrically tested, using 2 flashlight cells and a pair of interconnecting wires. U. S. A. T. F. E. D.—like new.
\$20.95

FIRE EXTINGUISHER TIRE INFLATOR
Made by leading Detroit Auto Mfr. Especially recommended for all. Easy to use. Guaranteed by mfr. against defects. Order two—one for your home; one for your car in case of flats or blow-outs.
ONLY \$2.29 each

VHF Excellently Reconditioned Guaranteed

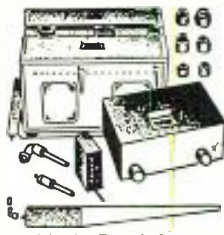

SCR-522 AIRBORNE COMMAND EQUIPMENT
Frequency Range 100 to 156 mcs. in 4 channels receiver and transmitter. Crystal controlled. Complete equipment. Consists of trans/rec. control box BC-602, dynamotor PE-94, AN104A antenna, plugs, etc. Power input with PE-94 is 28 v.
Electrically Tested—Complete as Shown. **Only \$129.50**
BRAND NEW—PRICES ON REQUEST

BC-221 Frequency Meter

Real Value! QUANTITY IS LIMITED—so first come, first served. They are just like new, with original calibration charts. Range 125-20,000 KC with crystal check points in all ranges. Complete with crystal and modulated tubes **\$129.50**
MODULATED TYPE **\$159.50**
MODULATED TYPE WITH AC POWER SUPPLY **179.50**
These Frequency Meters are factory tested, checked for frequency alignment and GUARANTEED.



PRE-AMPLIFIER MODEL K-1
The K-1 is used to amplify output level for microphones and phonographs. Operates on 24-28 VDC, can be converted to 110 AC. Comes complete with PL 55 plug and 2-foot 110-B cord, 2 terminal blocks and instruction book.
BRAND NEW SPECIAL! \$3.95

NEW! SHIP-TO-SHORE BC-223 TRANSMITTER
A 30 watt Transmitter, ideal for ship-to-shore or Ham Rig. Crystal or MO control on four pre-selected channels. 2000 to 5250 KC. Use of 3 plug-in coils, five tubes: 2—801 and 3—46, and TU 17-18-25 tuning units.
..... \$39.95

TUNING UNITS (TU-17 2000-3000 KC; TU-18 3000-4500 KC; TU-25 3500-5250 KC)—NEW IN ORIGINAL CASES 5.50
PE125 POWER SUPPLY for BC-223—12 or 24V input; output 475V 50 ma—BRAND NEW 20.95
SPARE VIBRATOR and TUBE KIT for PE125—NEW 6.95
CABLE between TRANSMITTER and POWER SUPPLY—NEW 3.95

TIME CLOCKS
12 and 24 hour cycle timing. Unlimited uses. Needs minor repairs. AN EXCELLENT BUY—HOW CAN YOU GO WRONG!
ONLY \$9.95

20 POUNDS OF ASSORTED RADIO PARTS AT A TERRIFIC BUY ONLY ... \$2.79

HEADSETS
HS-33 low impedance with eord and plug, used, fine condition **\$2.79**
HS-25 high impedance, BRAND NEW with ear pads **4.95**
HS-33 low impedance, BRAND NEW with ear pads, cord and PL54 plug **4.95**
CD-307A Cords, 6 ft. NEW **.89**
H-16 high impedance, includes two receiving units **3.95**
HS-16 high impedance—used **2.49**

Control Box BC-434-A
Used with Radio Compass Receiver R-5/ARN-7, Bendix ADF Equipment.
Used \$1.95

CD-307A CORDS
with PL55 Plug and JK 26 Jack, long cord.
SPECIAL 79c

MINIMUM ORDER \$2.00
Immediate Delivery—Send 25% deposit on C.O.D. orders. All shipments F.O.B., N.Y.C. (N.Y.C. residents add sales tax to your remittance.)

NOTE REDUCED PRICES!!

SCR-274N COMMAND and ARC-5 EQUIPMENT

	EXCELLENT	
	USED	NEW
RECEIVERS		
BC-453—190 to 550 KC.....		\$29.95
BC-454—3 to 6 MC.....	\$8.95	9.95
BC-455—6 to 9 MC.....	9.95	11.95
116.95		\$16.95
TRANSMITTERS		
A-958—2.1 to 3 MC.....		29.95
BC-458—5.3 to 7 MC.....	7.95	9.95
ARC5-T-19—3 to 4 MC.....		24.95
BC-459—7 to 9.1 MC.....	13.95	15.95
24.95		
ADDITIONAL EQUIPMENT		
BC-456 Modulator.....	2.49	2.95
BC-450 Control Box (3 Receiver).....	1.49	1.95
BC-451 Control Box (Transmitter).....	1.29	1.79
BC-442 Relay Unit (ANT).....	2.39	2.89
Plugs: PL-147, 148, 151, 152, 153, 154, 156—EACH.....		1.25
Flexible Shifting with gear to fit receiver.....		2.69
3 Receiver Rack.....	1.79	2.29
2 Transmitter Rack.....	1.69	2.39
Single Transmitter Rack.....		3.97
DM-32 Dynamotor for Command Set.....		3.95
DM-33 Dynamotor for Command Set.....		2.95
Shock Mounts for 3 Receiver Rack.....		
2 Trans. Rack, Modulator or Antenna Relay Unit.....	1.95	2.45

LIMITED QUANTITY
COMMAND SET BC-455—6 to 9.1 MC. Excellent, 95% completely wired—a few minor parts included require assembling. Instructions included. **ONLY \$7.95**

COMMAND TRANSMITTER—Navy and Army Type-3 to 4 MC. 75% complete spare parts—LIMITED QUANTITY..... **\$10.95**

AIRBORNE EQUIPMENT Designed for Aircraft
Y-85/APT-5 UHF Transmitter Radar Set AN/APT-5 operates on 80 or 115 volts A.C. at 400 to 2600 cycles requiring 640 volts amperes at 0.90 power factor. Complete with all tubes. Brand new in original packing.
\$149.50

Radio Compass R5/ARN-7
Primarily used for aircraft navigation. Frequency range: 100 KC to 1750 KC in 4 bands. Operates on 115 volts, 400 cycles A.C. Complete installation consists of the following: Radio Compass Receiver R-5/ARN-7, Radio Control Box C4/ARN-7, Loop LP-21, Loop Dehydrator, Indicator I-81-A and I-82-A, Relay BK-22, Coupling MC-203, Cord CD-365, Plugs PL-112, 118, 122. Thoroughly tested and reconditioned by experienced personnel presently engaged in manufacturing for defense.
ONLY \$189.50

RA 10 DA 4 BAND RADIO COMPASS & COMMUNICATION RECEIVER—Frequency range: 150 to 400 KC, 400 to 1100 KC, 2 to 5 MC, 5 to 10 MC, Input 28V DC—Excellent..... \$21.95
RA 10 D—Same specs. as above..... Used 19.95

T9/APQ-2 RADAR TRANSMITTER
80/115 V 400-260-26 VDC. Designed primarily for aircraft operation.
NEW \$19.95

Ranger Aircraft Interphone Receiver Model 114-C
A 6 tube super-heterodyne interphone receiver designed for operation directly from a 2-1 V battery. Frequency coverage: 200-550 KC, Audio output: 275 milliwatts. Weight of receiver and jack box: 2 lbs. 22 ozs.
2 cables are furnished, one connecting receiver to jack box and the other shielded cable for connecting receiver to battery.
Set comes complete with receiver, jack box JB-2, cables, and operating manual.
BRAND NEW—LIMITED QUANTITY ONLY \$14.95
INTERPHONE AMPLIFIER BC-347-C \$1.95
LOCALIZER RECEIVER 733-D—NEW \$39.95

PLATT ELECTRONICS CORP.
DEPT. A, 489 BROOME ST., NEW YORK 13, N. Y.
PHONES: WO 4-0827 and WO 4-0828

Bargains

Wire Wound Resistors

Ohms	Watts	Pr. Ea.	Ohms	Watts	Pr. Ea.
10	.5	\$0.29	1000	.50	\$0.49
2	.50	.29	1000	.50	.49
2	2	.89	2000	1	.79
2	2	.89	2000	1	.79
2	2	.89	2000	1	.79
3	.75	.49	2400	1.00	.69
4	.5	.13	3000	75	.49
5	.100	.69	4000	25	.24
10	.10	.13	5000	25	.24
12	.10	.13	5000	10	.19
12	.25	.19	7000	10	.19
15	.25	.19	7000	20	.24
20	.10	.13	7010	10	.17
21	.25	.24	7500	10	.19
30	200V	.89	7500	25	.29
36	.5	.19	8000	10	.19
40	.10	.13	10,000	20	.24
42	.10	.13	10,000	10	.19
40	.5	.13	10,000	50	.49
43	.5	.19	11,500	25	.35
45	.20	.19	15,000	20	.29
100	.10	.17	20,000	50	.49
100	.50	.29	20,000	20	.24
150	.10	.17	25,000	10	.19
200	.10	.17	40,000	20	.24
424	.10	.17	100,000	100	.49
700	.10	.17	100,000	40	.49

Transmitting Mica Condensers

MFD	VDCW	Pr. Ea.	MFD	VDCW	Pr. Ea.
.00015	400	\$0.27	.0005	1500	\$0.40
.001	400	.45	.0008	1500	.40
.005	400	.45	.002	1500	.50
.006	400	.45	.003	1500	.50
.01	400	.35	.005	1500	.55
.02	400	.45	.008	1500	.55
.03	400	.70	.004	2500	.75
.033	400	.70	.001	2500	.75
.033	1000	.35	.002	2500	1.05
.01	1000	.75	.003	2500	1.05
.001	1200	.55	.004	2500	1.15
.0022	1200	.40	.005	2500	1.15
.005	1200	.55	.006	2500	1.15
.0042	1200	.40	.00004	3000	.95
.01	1300	.75	.00007	3000	.95
.025	1300	.80	.00011	3000	.95
.000175	1500	.25	.0004	5000	1.75
.0002	1500	.35	.0005	5000	1.75
.00025	1500	.35	.0003	8000	1.95

OIL FILLED CONDENSERS

MFD	VDCW	Pr. Ea.	MFD	VDCW	Pr. Ea.
.05-.05-.05	300	\$0.45	1	1000	\$0.65
1-1-1	400	.75	2	1000	.90
2-2-2	400	1.50	4	1000	1.95
.875-.875	400	.75	8	1000	3.25
1.75	400	.95	8-8	1000	4.50
.05-.05-.05	500	.95	1	1200	.85
.1	500	.55	1-1-1	1200	1.85
.5	500	.85	2	1500	2.00
1-1	600	.95	5	2000	1.50
.25-.25-.25	600	1.45	1-1	2000	.95
1	600	.40	2	2000	1.20
2	600	.70	1	3000	3.40
2.5-2.5-5	600	2.75	1-1	3000	5.50
3	600	.95	5	3000	4.50
4	600	1.65	2-2-2-2	4000	2.95
5	600	1.75	2	4000	6.95
8-8	600	1.95	2	7500	19.50
10	600	2.15	40	120VAC	1.15
.25	1000	.75	15	330VAC	4.50
.5	1000	.75	4	330VAC	1.95
5-5	1000	1.25	.00025	25KYDC	2.50

Miscellaneous Equipment

Part No.	PART DESCRIPTION	Price	QTY.
FL-8	1020 CYCLE FILTER	2.45	
HS-18	HEADSET	1.25	
J38	KEY	.98	
MN-203	LOOP ANTENNA	6.95	
CO-307	HEADPHONE EXTENSION CORD	1.98	
CO345	TRANS. LINE FOR LP-21	1.49	
M-359	RIGHT ANGLE COAX CONNECTOR	.19	
F 10	FAIRLEAD FOR TRAILING ANTENNA	1.99	
ST 165	JENSEN 5 INCH SPEAKER	1.45	
ST 431	JENSEN 6 INCH SPEAKER	1.98	
ST 538	JENSEN 4 INCH SPEAKER	.19	
SA 1	SWITCH FOR APN-1	1.95	
J37	KEY	.79	
BC 488	RECEIVER LESS TUBES	4.50	
BC-489	TRANSMITTER LESS TUBES	4.50	
BC 979	INDICATOR COMPLETE	19.50	
MC 432	ANTENNA LOADING UNIT	.98	
SA 13	ANTENNA CHANGEOVER SWITCH DPDT	.98	
BC 273	TRANSMITTER	19.95	
VLC 80	GUD 80 METER COIL	1.95	
IN-88	STRAIN INSULATOR	.13	
AN-694	UHF ANTENNA—PER PAIR	.98	
FT-154	MOUNT FOR BC 240	1.98	
RD-1	INDICATOR FOR APN ALTIMETER	6.50	
X 205	SOCKET FOR 3" SCOPE TUBE	.49	
TL 207	INSULATED ALIGNMENT TOOL	.19	
RU 30	ELEMENT FOR HS-30 HEADSET	.49	
MT 138	LIFE RAFT REFLECTOR	4.95	
M 308	SIGNAL LAMP 1/2" GIBSON GIRL SHIELD FOR 3" CR TUBE	1.19	

Minimum Order \$5.00 25% Deposit On C.O.O.'s

DAVE RUMPH CO.
P. O. BOX 4178
FORT WORTH 6, TEXAS

technicians; Mailing charges, postage; Depreciation of trucks; Public Liability insurance; Taxes and licenses; Advertising; Bad account losses; Donations; Holidays and other unworked time; Social Security taxes; Unemployment Insurance taxes; Workmen's Compensation insurance; Association dues; Depreciation of equipment and tools; Loss of tools and equipment; Truck insurance including liability; Call-backs; Fire and casualty insurance; Property damage; Stationery and office supplies; Cost of transportation; Unproductive time; Waste and spoilage allowances; Non-productive supervisory time; Stock depreciation through obsolescence, breakage, and deterioration; and Miscellaneous expenditures." —50—

International Short-Wave

(Continued from page 58)

Belgian Congo—Radio Leo, Leopoldville, is scheduled Sundays only 0300-0500 on 11.270, 15.170, with 5 kw.; all-French. (WRH) OTM2, 9.380A, noted 0300 with French session of news, music. (Sanderson, Australia) Heard in Texas 1530 at fair level with slight QRM. (Hoelscher) OTC2, 9.767, is strong signal during news 2130. (Lund, Iowa)

Brazil—Radio Jornal do Commercio, 11.825, noted around 1830-2120A sign-off; identifies in both Portuguese and English. (Niblack, Ind.) Heard in N. Y. at good level 1900. (Mast) PRL7, 9.72, Rio de Janeiro, noted 2145 with music. (Hoffman, N. Y.) Radio Tamandare, Recife, Pernambuco, of Emissoras Associadas, lists ZYK21 on 3.265 with 1 kw. (Catch, England) PRB22, 9.505, Radio Record, Sao Paulo, noted 2022 heterodyning XEWW, Mexico City, 9.500, (Harris, Calif.) ZYB5, 4.935, Natal, is heard well early evenings (EST). (Robbins, Ind.) PRL4, 9.770, is now inactive; instead, PRL5, 11.950, is used 0450-0700, 1000-2130. (WRH)

British Honduras—WRH says Radio Belize is operating on 4.950 with 0.2 kw. at 1315-1400, 2000-2100, with news 1330 and 2015. Not confirmed.

British New Guinea—VLT7, 7.28, Pt. Moresby, noted to 0745 sign-off. (Stark, Texas)

Bulgaria—Radio Sofia, 7.671A, noted with news 1600. (Sanderson, Australia; O'Sullivan, England) Should also have English 1500.

Canada—VED, 7.320, Edmonton, Alberta, logged 2055-2130; suffers from severe CWQRM. (Patterson, Ga.) QSL from CBNX, St. John's, Newfoundland, listed schedule of 0530-2200 on 5.970, 300 watts. (Golden, Mass.)

Canary Islands—EASAB, 7.518A, Radio Clube de Tenerife, noted with music 1700. (O'Sullivan, England)

Ceylon—Radio Ceylon logged on 17.820 at 0545. (Sanderson, Australia) Heard on 11.975 with BBC news relay 1100 and signed off 1146 with "Strike Up the Band." (Black, Pa.)

Chile—CE960, 9.593A, noted recently

around 1915 with Latin American tunes; man announcer in Spanish; fair level, no QRM, but some fading. (Bellington, N. Y.) WRH lists this one now as on 9.192 daily 1030-2200.

China—Radio Peking noted on 15.060V with English 0400 and announcing 6.100, 11.690, 10.260, 15.170 as parallel; said next English would be 0830 on 11.690, 15.060, and at 1730 on 11.690, 15.060. (Pearce, England) Heard mornings (EST) on 6.100. (Stein, Calif.)

Colombia—HJEX, 6.054, Cali, Radio Pacifico, noted signing off 2300. (Baitzel, N. J.) HJDE, 6.145, has fair level from 2100 tune-in to 2400 sign-off. (Saylor, Va.) HJBB, 4.815, Cucuta, noted 1920 with Latin American music, fair level in Britain. (Catch) HJCQ, 4.955, noted signing off 2400 with National Anthem. (del Pozo G., Cuba)

Costa Rica—Radio Athenea, 11.972A, good level in Cuba 1010-1230. (del Pozo G.) Lately has been lower—around 11.965. (Stark, Texas)

Cuba—COCY, 6.450, Havana, noted 1930 at rather weak level in England. (Catch) COBH is currently on measured 11.796; previous measurement was 11.800. (Oskay, N. J.)

Curacao—Willemstad, 5.014A, has English on Wednesdays 2000-2030. (Kolberson, N. J.)

Czechoslovakia—Prague, 9.55, noted in English to North America 1930-2000. (Niblack, Ind.; Mast, N. Y., others) Heard again on 11.760 with Russian 0400; Swedish is now radiated on 9.505 at 1330-1400. (Radio Sweden) Still has news 1400 on 9.505; on 11.840 at 0715. (Pearce, England) Noted closing English period 1422 on 9.505 and had announcement of "The Voice of Peace;" said further English would be at 1600. (Hoffman, N. Y.)

Denmark—Copenhagen now uses 9.52 instead of 7.26 for the broadcast to the Faroe Islands. (ISWC, London) Noted on 15.180 with news 0845. (Saylor, Va.)

Dominican Republic—HI9B, 4.917A, noted around 2000. (Stark, Texas, others)

Ecuador—HCJB, Quito, recently changed its 31-m. channel from 9.970A to 9.745A; heard some days as late as 0245. (Bellington, Kroll, N. Y., others) Guentzler, Ohio, says announces new channel as 9.745; measured by Oskay, N. J., as 9.7435 at 0640. Mast, N. Y., notes the 17.890 channel signing off 1730. Oskay, N. J., recently measured HC2RL, 6.632, noted on a Tuesday 2135 (only day scheduled).

Egypt—Cairo, 9.715, still signs on 1345; has news 1400; runs to 1700. (Pearce, England) SUX, 7.865, Cairo, peaks at fair level around 1505 (in Arabic). (Kary, Pa.)

Ethiopia—Radio Addis Ababa, 15.047A, still signs on in Amharic 1130; usually closes now 1305 after news in native; no English heard of late. (Pearce, England) Heard in N. C. leaving the air 1342 at fair level. (Ferguson)

Fiji Islands—According to the N. Z. DX Times, Fiji will not begin opera-

tions of its projected transmitter until early 1953 and will operate on 6.135, 9.535. (Bellington, N. Y.)

Finland—Helsinki still noted with news 0715 on 17.800, 15.190. (Fried, Mich.)

France—Paris heard signing off 1030 with "La Marseillaise" on 15.400 after French session. (Pearce, England) Noted signing on 1830 with "La Marseillaise" on 9.620A and continuing with French program, strong level. (Robertson, Mass.) The 11.700 channel noted in parallel. (Bellington, N. Y.) Paris, 7.105, heard to 1556 sign-off after relay of Home Service. (Kary, Pa.)

French West Africa—Radio Dakar, 11.896A, noted with recordings 0215; news in French 0230. (Pearce, England) Noted with news in French 1500, 1700. (Kary, Pa.)

Germany—Hamburg, 6.270, noted around 0225-0500 or later; news in German 0300. (Pearce, England) Received attractive QSL from Frankfurt, Hessischer Rundfunk, listed 48.47 m. (Golden, Mass.)

Greece—Radio Athens is now scheduled on 7.300 at 2330-0300, 1030-1400, 1530-1700 to the Balkans and the Near East; on 9.607 at 2000-2100 to USA-Canada (news 2035A), at 0430-0830 to Balkans and the Near East, 1430-1500 to Western Europe (news 1430). (WRH) Larissa, 6.745, noted recently 0115. (Pearce, England)

Greenland—OXI, 7.094, Godthaab, noted 1740 with talk in Icelandic; at 1750 began orchestral recordings. (Pearce, England)

Guatemala—The Mailbag Program on Wednesdays 2230-2300 from TGNA, 9.668, 11.850, is now called "Script By You." (Niblack, Ind.) Heard recently at 1720 testing on 11.850. (Guentzler, Ohio)

Haiti—4VRM, Port-au-Prince has been "wandering" again from 9.963A up to 9.990A. Signs off 2157A with anthem. (Stark, Texas; Bellington, N. Y.) 4VM, 6.005A, Port-au-Prince, noted 1818-1833 with severe QRM from HJKD, Colombia; uses chimes between announcements. (Patterson, Ga.)

Holland—Radio Nederland is scheduled for English at 1100-1140 to South Asia and Africa, 17.775, 15.22, 6.025; 1630-1710 to Europe and North America, 11.73, 9.59, 6.025; 2130-2210 to North America, Australia, New Zealand, 11.73, 9.59; the Happy Station Programs on Sundays are listed 0530-0700, 21.48, 17.775, 15.22, 6.025, to Far East, Pacific Area, Europe 1100-1230, 15.22, 11.73, 9.59, 6.025, to Near and Middle East, Europe; 1630-1800, 11.73, 9.59, 6.025, to South and Central America, and 2130-2300, 11.73, 9.59, to North America. Baetz, Ill., notes the 9.59 channel at good level 1630.

Hong Kong—ZBW3, 9.525, heard 0530 at good level with news, weather report, music. (Sanderson, Australia)

Hungary—Radio Budapest, 9.833, noted 1600 with news; on Sundays has Mailbag session 1818. (Hoffman, N. Y.) Heard on 11.910 around 1940 with English. (Bellington, N. Y.)

Publication Reveals How
Fast-Acting Dealers Get
Special Low Prices

NEW Penn Telescoping Tower Can Be Erected By 1 Man.. Costs Less

Get special low prices on your telescoping towers without making any "deals." How? Write today for a free copy of Teletowers latest publication—a brand new bulletin on Penn's brand new, high-test telescoping tower. Compare the accompanying price list *competitively*. Then you'll know how!

If you also want to know *why*—why Penn can cut price on a tower that tops all other telescope types (*by actual tests*)—consider this: Penn is the largest buyer of steel tubing in the antenna support industry. Savings in material costs are applied to gain a price advantage.

Services Without Climbing . . .

Reduces Inventory

Only one man . . . and only simple equipment . . . are required to erect this telescoping tower in heights to 60 feet. To service, simply lower . . . you needn't climb a single rung! Nesting of sections reduces both inventory and freight . . . gives more pounds of tower per foot of space. Tower is constructed of electrically welded 1" tubular steel . . . erected with permanent pressure clamps . . . reinforced at stress points.

Fast-acting dealers will get delivery priority. Mail the coupon now.

CANADIAN REPRESENTATIVE: Atlas Radio Corp., Ltd., 560 King Street, W. Toronto, Canada

Penn Boiler & Burner Mfg. Corp.
Department N., Lancaster, Pa.

Please send me free bulletin and price list on Penn's New Telescoping Tower.

Name

Address

.....

PENN

Teletowers
Lift towers
Penn-Mast
Hardware

PENN BOILER & BURNER MFG. CORP., LANCASTER, PA.

Men who know *Quality* .. know **TECH-MASTER**



C. G. McPROUD,
Editor of **AUDIO**
Engineering, writes:

"I assembled my own home TV receiver from a standard Techmaster kit. I was amazed at the speed and simplicity with which this could be done. So gratifying was the result, that I have since

for Top TV Performance!

been obliged to assemble several more Techmaster receivers for friends who marvelled at the picture quality of my own. In each case the results were excellent and have provided their owners with uninterrupted top quality, trouble-free performance..."

Experts Everywhere Concede the Superiority of the Techmaster 630 Type Circuit!

The TECHMASTER 630 has been advanced in every detail of modern engineering and design. Every component is the best available, and rigid factory and test standards are your assurance of years of trouble-free performance. Prefabricated unit construction, factory pre-adjusted and pre-aligned make assembly an utterly simple and enjoyable procedure with a minimum of tools.

More leading engineers and technicians have chosen Techmaster Kits and Techmaster Chassis, than any other television.

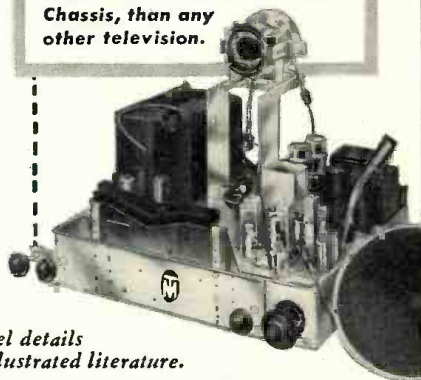

See your local Jobber for model details or write direct to factory for illustrated literature.

TECH-MASTER PRODUCTS COMPANY • 443-445 BROADWAY, N. Y. 13, N. Y.

ANNOUNCING THE VTMM* KIT

At last every Engineer, Technician, Serviceman and Experimenter who owns a Simpson 260, Triplett 630 or similar multimeter can have a vacuum tube voltmeter at a very nominal cost. The sensational VTMM plugs directly into your multimeter to convert it into a DC VTVM with an 11 megohm input resistance. Measures DC volts to 300 volts. Accommodates a crystal diode type probe for AC and RF voltage measurements. Self contained transformer type power supply for complete isolation. Highly degenerative circuit offers excellent stability. Very compact in size, 5 1/4" x 3" x 2 1/2".

Complete kit including tubes. Model MM-1K **\$13.95**. Crystal diode probe completely assembled. Model CP-1 **\$5.95**. Specify your meter make and model.

Send check with order, we pay postage.



* Vacuum tube meter modifier.

AIR-O-TRONICS

Box 31

LANCASTER, Calif.

TUBES

Every
Critical
Type

STANDARD BRANDS • GUARANTEED • INDIVIDUALLY BOXED

1S5
1U5
5U4G
6BA6
6BE6
6CB6
6S4
6V6GT
12BA6
12BE6
25L6GT
35L6GT



1R5
1T4
1U4
3S4
3V4
6AB4
6AG5
6SN7GT
12AT7
12AU7



1B3GT
1X2A
3Q4
6AC7
6AK5
6AU5GT
6AV5GT
6J6
6T8
12BH7
12BZ7
25AV5GT



6AH6—88c; 6BG6G—\$1.44; 6BQ6—99c; 6CD6G—\$1.65

Many other types equally low priced—include all your tube needs with your order. One of the largest stocks in the country.

Min. Order \$25.00. Terms: 25% with order, balance C.O.D. All merchandise subject to prior sale, F.O.B. New York City

TeleVision Materials Corp.

125 Cedar St., New York 6, N. Y. • Cortlandt 7-4307

India—VUD11, 11.850, Delhi, signs on 2030 and begins transmission in Persian or Afghan-Persian; weak to fair, severe flutter-QSB. (Kary, Pa.) This one has improved level in news 1930. (Mast, N. Y., others) Noted on 11.940 with news 1030. (Rosenauer, Calif.)

Indo-China—Radio France-Asie, 11.924A, Saigon, noted 2030 with French program of news and music; on 15.444A at 0430 with news, music. (Sanderson, Australia) The 11.924A channel noted closing down 1053. (Harris, Calif.) The 9.754A channel logged with news in French 1015, signing off 1030 with "La Marseillaise." (Lepple, Germany, via URDXC) Noted on 6.116 at 1730 and testing to Europe around 1035-1100 on 15.430A (measured 15.428 by Hutchins, Radio Australia), asking for reports to P.O. Box 412, Saigon. (Pearce, England) The N. Z. DX Times says Saigon is using 15.420 at 0415-0515; news 0500; new address is 86, Rue Marechel de Lattre de Tassigny, Saigon, or P.O. Box 412, Saigon; English newscasts are now listed as 1730-1745 on 6.116 (to Europe), 1900-1915, 9.750 (to S. E. Asia), 2030-2045 on 11.920 (to India), 0500-0515, 15.420 (to Australia-N. Z.); 0900-0915 on 11.920 (to India-South Africa). (Cushen, N. Z.)

Radio Hue, 7.205, noted 0215-0245 sign-off with all-French session; news in French 0230. (Saylor, Va.) "Voice of Vietnam," 7.090A, Saigon, noted 1800 with oriental music; woman announcer. (Pearce, England)

Iran—EPB, 15.100, Teheran, noted with call 1430; German 1430; French 1445; English 1500; Russian 1515; signs off 1530; calls these sessions "The European News Service." (Pearce, England) Ends Home Service relay 1430 (Kary, Pa.)

Iraq—Radio Baghdad, 11.724A, is heard occasionally with English 1415-1500 sign-off; has bad QRM (squeezed). (Kary, Pa.)

Ireland (Eire)—ISWC, London, says Radio Eireann now broadcasts news bulletins 1330-1350 over 15.120 and 1710-1730 over 9.595. Not confirmed.

Israel—4XB24, 8.170, Haifa, noted 1530 with religious service. (Sanderson, Australia) 4XB44, Galei-Zahal, 6.725, is on the air this summer 1030-1400; QRA is A.P.O. 162, Israel; is Forces Station. (O'Sullivan, Pearce, England) Tel-Aviv now has news 1415 on 9.010, 6.830; announces next regular English period for these channels at 0545, and "Voice of Zion" (English) session for 9.010 at 1515; is summer schedule. (Pearce, England) Noted closing 1600 on 9.010. (Ferguson, N. C.)

Italy—Rome, 21.560, 15.400, noted with news for Far East 0600; to Great Britain and Ireland signing on 1350, closing 1435, best on 11.91A, 6.010 (also audible from 1415 on 9.57A). (Pearce, England) Rome heard with English for North America around 1900 on 9.575, some CWQRM, parallel with 11.905A. (Hoffman, N. Y.) Noted on 17.800 at 1145 with news in Italian. (Bishop, Ohio)

RADIO & TELEVISION NEWS

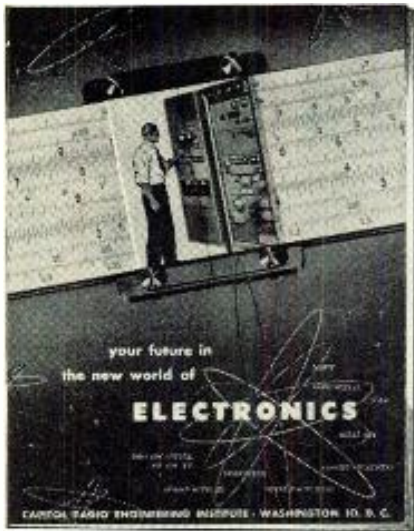

← *The data that Launched Thousands of Careers is yours FREE . . . to show*

HOW YOU CAN BE SUCCESSFUL IN RADIO-TV-ELECTRONICS

YOU CAN plod along for years, getting a paltry increase now and then, enjoying a little security, finding your work dull and drab.

Then something happens. Things look up. You become more confident. Your earnings rise. You feel more important.

"Luck," some may say.

"Contacts," others may suggest.

But in your heart, you will know the answer: "Training." And it all may have started the moment you filled out a coupon requesting a copy of a free booklet named "Your Future in the New World of Electronics." From this data you get knowledge of where you stand in Electronics. Tremendous expansion leaves this gigantic industry pleading for trained men. In the defense build-up alone, more than \$7 billion in electronics contracts have been awarded. Top manufacturers sold about \$3 billion worth of electronics merchandise in 1951. By 1960, the radio-electronics industry should do no less than 10 billion dollars per year, not counting military orders.

Today there are over 50,000 radio-equipped police cars; an even larger number of taxis are radio equipped (at least 65,000); 23,000 civilian planes have radio; 27,000 American ships have radio; there are 9,200 industrial radio network installations.

Today there are over 100,000,000 radios in use. There are 16,785,044 TV sets and 109 TV stations in operation. The freeze-lifting will make possible several thousand more TV stations and untold number of TV sets. Countless positions must be filled—in development, research, design, production, testing and inspection, manufacture, broadcasting, telecasting and servicing. To fill these posts, trained men are needed—men who somewhere along the line take time to improve their knowledge, their skills. Men who, today, perhaps, take two minutes to send for a booklet.

"Your Future in the New World of Electronics" shows you how CREI Home Study leads the way to greater earnings through the inviting opportunities described above.

However, CREI does not promise you a "snap." With an accredited technical school such as this, you must *study* to convert your ambition into technical knowledge you can sell in the fabulous Electronics market.

Since its founding in 1927, CREI has provided thousands of professional radio men with technical educations. During World War II CREI trained thousands for the Armed

Services. Leading firms choose CREI courses for group training in electronics at company expense, among them United Air Lines, Canadian Broadcasting Corporation, Trans Canada Airlines, Sears, Roebuck and Co., Bendix Products Division, All-American Cables and Radio, Inc., and RCA Victor Division.

CREI courses are prepared by recognized experts, in a practical, easily understood manner. You get the benefit of time-tested materials, under the personal supervision of a CREI Staff Instructor, who *knows* and *teaches* you what industry wants. This is accomplished on your own time, during hours selected by you, and controlled by your own will power. This complete training is the reason that graduates find their CREI diplomas keys-to-success in Radio, TV and Electronics. CREI alumni hold top positions in America's leading firms. At your service is the CREI Placement Bureau, which finds positions for advanced students and graduates. Although CREI does not guarantee jobs, requests for personnel far exceed current supply.

Now is the time of decision for you. Luck will not propel you forward unless it finds you trained. Contacts won't budge you an inch unless you have the skill to back them up. The answer is: Technical Training . . . and

willingness to learn. Together they will bring you increased earnings in this new Age of Electronics. Fill out the coupon and mail it now. We'll promptly send you your free copy of "Your Future in the New World of Electronics." The rest—your future—is up to you.

CREI Resident Instruction (day or night) is offered in Washington, D. C. Here work is done with the latest equipment, in ideal surroundings, under close personal supervision. New classes start once a month. For a CREI Residence School catalog, check the last line of the coupon below.

MAIL COUPON FOR FREE BOOKLET

CAPITOL RADIO ENGINEERING INSTITUTE

Dept. 117D, 3224 16th St., N.W., Washington 10, D. C.

Send booklet "Your Future in the New World of Electronics" and course outline.

CHECK TV, FM & Advanced AM Servicing Aeronautical Radio
 FIELD OF Practical Television Engineering Engineering
 GREATEST Broadcast Radio Engineering (AM, FM, TV)
 INTEREST Practical Radio Engineering

Name

Street

City Zone State

If residence school in Wash., D. C., preferred, check here

**Back Again By Popular Request!
Special Purchase FM Radio Chassis**



88-108 MC

Complete with 6 tubes. Built-in Antenna and Speaker. Product of Famous Radio & TV Manufacturer whose name we promised not to mention.

TUBE LINEUP

1-12BA7 1-12S8
2-12BA6 1-35W4
1-35B5

Regularly \$29.95
Brand New

\$16.95

May also be used as an FM Tuner by picking signal off detector.

Maroon Plastic Cabinet for above..... **\$5.95**

**HERE'S
A
REAL
BUY**



Two Station Intercom System

Less than half the original price. Built for America's leading dept. store chain, whose name we cannot mention because of this low price. Consists of master station, remote station and 20 ft. of 3 conductor wire. Can be used as a private or non-private system. 115V. AC or DC. Brand New. Now only \$17.95. Additional wire, per ft., 5c.

**BRAND
NEW**

now only
\$17.95

VARIABLE CONDENSERS
From SCR-5-22
2-GANG 25 MMF
Per Section \$1.29
3-GANG 25 MMF
Per Section \$1.59

Brand New with Concentric Air Trimmers

**SPECIAL PURCHASE Record Changer
Gen. Instruments 3-speed Automatic**

Reg. \$34.95
Brand New

\$19.97



With all purpose cartridge & needle. Plays 33 1/3-45 RPM records automatically.

Manufacturer's Closeout!

EVERY READER KNOWS THIS FAMOUS MAKER OF WIRE WOUND FIXED AND VARIABLE RESISTORS. MARKED GENERAL ELECTRIC.

We've bought up a tremendous supply of these and now you can buy them below manufacturer's 5000 lot prices.

10 WATT FIXED		10 WATT ADJ.	
1-1000 ~ List...\$.75	1-1000 ~ List...\$1.47	1200 ~ List...\$.95	1200 ~ List...\$.97
1100-500080	2500-8000 1.53	6000-10,00092	6000-10,000 1.12
6000-10,000 1.03	Your Cost. Each .39	12,000-20,000 1.22	12,000-20,000 1.20
11,000-20,000 1.08		25,000-50,000 1.22	25,000-50,000 1.37
22,500-25,000 1.22		30,000-50,000 1.22	30,000-50,000 1.58
Your Cost. Each .24		5-1000 ~ List...\$.95	5-1000 ~ List...\$.97
25 WATT ADJ.		20 WATT FIXED	
1-1000 ~ List...\$1.87	12,500-20,000 1.20	6000-10,000 1.12	6000-10,000 1.20
1250-5000 1.88	25,000-40,000 1.37	12,000-20,000 1.22	12,000-20,000 1.58
6000-10,000 2.03	45,000-80,000 1.83	25,000-50,000 1.22	25,000-50,000 1.83
12,000-20,000 2.08	85,000-100,000 2.11	80,000 ~ List...\$1.83	80,000 ~ List...\$1.83
25K ~ List...\$2.28	Your Cost. Each .36	100,000 ~ List...\$2.11	100,000 ~ List...\$2.11
Your Cost. Each .47		50 WATT ADJ.	
100 WATT ADJ.		1-1000 ~ List...\$2.37	1-1000 ~ List...\$3.58
1250-5000 2.47	1500-5000 3.87	6000-10,000 2.83	10,000-20,000 3.87
12,000-20,000 2.83	15,000-20,000 4.12	25,000-40,000 3.08	25,000-40,000 4.37
25,000-40,000 3.30	30,000-40,000 4.75	50,000-60,000 3.67	50,000-60,000 5.53
80,000 ~ List...\$3.67	75,000 ~ List...\$4.75	80,000 ~ List...\$3.92	80,000 ~ List...\$4.95
100,000 ~ List...\$3.92	100,000 ~ List...\$4.95	Your Cost. Each .69	Your Cost. Each .79

Product 100% lots of 100 or more. Deduct 20%—lots of 1000 to 10,000. Minimum Order—\$2.00.

Attention Prospective Novice Hams!!
Code Oscillator Kits—All Parts—Phones
Key—Battery—Instructions... Complete **\$7.95**

TERMS: All items F.O.B., Washington, D. C. All orders \$30.00 or less, cash with order. Above \$50.00, 25 per cent with order, balance C.O.D. Foreign orders, cash with orders, plus exchange rate.



Italian Somaliland—According to verification, *Radio Mogadishu* operates its 300-watt transmitter on 7.420 at 0530-0645, 0915-1015, 1200-1300 in Somali and Italian; however, the frequency seems nearer 7.383; has bad QRM. (Radio Sweden)

Jamaica—*Radio Jamaica*, 3.360, still noted closing down 2300A. (Baetz, Ill.) The 4.950 channel is good level around 1100 in Cuba. (del Pozo G.)

Japan—JOB, 6.069, noted 0600 with news; JOA, 7.180, heard parallel. (Sanderson, Australia) Is heard with weak level in Michigan in *English* 0600, 0700 on 7.180. (Fried) *Radio Japan* sent schedules for North America 0000-0100, JOA4, 15.235, JOB2, 11.705; for North China 0600-0700, JOB, 6.069, JOA, 7.180; for Central China 0700-0800, JOB, 6.069, JOA, 7.180; for Philippines and Indonesia 0900-1000, JOB2, 11.705, JOA2, 9.675; for India 1030-1130, JOB2, 11.705, JOA2, 9.675. (Demattei, Calif.) Changes noted also by McPhadden, Calif.; Oestreich, Wash. State, others. NHK, Tokyo, is now heard 0400 on 6.175, parallel 4.930, 7.285. (Rosenauer, Calif.)

Kashmir—*Radio Kashmir*, Srinigar, now operates 2130-2330 on 3.335; 0100-0230 on 6.110; 0630-1200 on 3.335. (N. Z. DX Times)

Kenya Colony—Nairobi, 4.855, noted closing 1500 with "God Save the Queen." (Pearce, England)

Lebanon—Beirut, 8.036A, still has *English* period daily 1000-1100. (Pearce, England)

Liberia—ELBC, 6.028, Monrovia, noted signing off 1846; fair level but heavy QRM. (Ferguson, N. C.)

Luxembourg—*Radio Luxembourg* has dropped the 19-m. (15.350) channel and now transmits on 6.090 at 0600-0800 in Flemish, 1300-1900 in *English*. (WRH)

Malaya—BFEB, 15.435, Singapore, noted at good level around 0758; had BBC news relay 0800. (Ferguson, N. C.) Current (announced) schedules are to India and Pakistan 0800-0900, 17.755; 0915-1030, 15.435; 1030-1135, 17.755, 15.435. To Burma and Thailand 0800-0815, 11.955; 0815-0900, 7.120; 0900-1030, 11.955; 1030-1135, 11.955, 7.120. (Catch, England)

Mexico—XEX, 6.065, noted opening 0800. (Stark, Texas) XEEP, 6.155, Mexico City, heard around 2115-2200 with bad QRM. (Robbins, Ind.)

Monaco—Monte Carlo, 6.035, 9.785, still noted Fridays with *English* program ("Back to the Bible") 1730-1800A sign-off. (Bellington, N. Y.)

Mozambique—When this was compiled, Lourenco Marques was still using 9.79A for its Portuguese session starting 0000. (Bellington, N. Y.)

New Zealand—Schedules of *Radio New Zealand*, received airmail, include to Australia 1300-1545, ZL2, 9.540; 1600-0145, ZL10, 15.220; 0200-closedown, ZL2, 9.540. To the Islands, 1300-1545, ZL8, 9.620; 1600-0145, ZL4, 15.280; 0200-closedown, ZL8, 9.620. Closedown at present is 0545 weekdays; 0620 Sat.; 0500 Sun. Demattei, Calif., notes the 11.78 channel quite



Maximo D. Atienza is station manager of the Far East Broadcasting Company, Manila. "Call of the Orient" uses six transmitters and 32 languages and dialects to "bring the Orient the Gospel of Christ."

strong 2300-0130; Bishop, Ohio, finds the 15.280 channel reasonably good around 2105-2130.

Nicaragua—YNEQ, Managua, *La Voz de Victoria*, is still on 6.065; identifies 0725. (Stark, Texas)

North Korea—GDX-aren, Sweden, reports Pyongyang on 4.400A around 1550 to sign-off 1800; relays *Radio Moscow's* Korean program 1730-1759.

Outer Mongolia—Ulan-Bator-Choto noted on 6.430 parallel 5.265 around 1830-1935. (GDX-aren, Sweden)

Pakistan—*Radio Pakistan* noted opening 2015 with announcement "You are listening to a test transmission from Radio Pakistan directed to Southeast Asia on 11.885 and 15.?? (probably 15.270) in the 25- and 19-meter bands"; weak level on 11.885. (Niblack, Ind.) Heard in Australia on 11.885 at 0500 with news and music in Home Service; on 15.270 at 2130 with *English* news, music; on 7.010 at 1535. (Sanderson) Noted signing on 1430 in *test* to Turkey; from 1515-1600 to United Kingdom; on 7.010, 9.484. General Overseas Service in slow-speed news noted 1210-1230 now on 7.010, 9.484; Western music heard with *English* announcements from Dacca, 15.620, at 0400-0430; still *tests* to Indonesia 0630-0715 at 17.835, 15.270. (Pearce, England)

Panama—*Radio Programas Continental*, 5.99A, noted 2230; news in Spanish 2245. (Niblack, Ind.) A harmonic of this one has been found around 11.990. (Stark, Texas) HOLA, 9.505, Colon, signs off weekdays 2300 but runs on Saturdays to 0200 (Sun.)

Peru—OAX4T, 9.562, Lima, noted 0015 at excellent strength in Spanish program of music and news. (Sanderson, Australia) Noted parallel with 6.080A recently around 2300 and signing off 0053. (Bellington, N. Y.) Lima, 15.105, heard with music and announcements in Spanish when tuned 1940; identified 1945. (Ferguson, N. C.)

Philippines—Sanderson, Australia, reports DZH7 on 9.755 with religious

program 0430; DZB2. 3.320, at 0500 with news music. Stark, Texas, notes DZH5, 9.690, fading in 0800; *English* heard to after 0830.

Poland—Warsaw noted at good level on 7.145 in *English* 1615-1645; also audible on 7.205, 9.556. (Pearce, England) Noted on 11.74 at 1700-1800 in *English*. (Baetz, Ill.) Good level in *English* to North America 0715-0800 on 15.120. (Fried, Mich., others)

Portugal—Radio Clube Portuguese, Parede, uses CSB51, 12.865, at 0400-0800, 1300-1900 (Sun. 0400-1900); all-Portuguese with newscasts 0500, 0700, 1330, 1845. (WRH) Lisbon, 9.745, 11.962A noted lately running as late as 1830 closedown. (Niblack, Ind.; Bellington, N. Y., others)

Portuguese India—Radio Goa, 9.610, is heard in Sweden some days 1030-1100 with "Bringing Christ to the Nations" (*English*). (NATTUGGLAN, Sweden) Noted on 17.895 at 0230 with request program of popular tunes and commercial announcements; heard to 0400 at fair strength. (Sanderson, Australia) Normally runs to 0430A but sometimes is used 0435-0450 for a transmission to Portugal. (Radio Australia)

Roumania—Bucharest can be heard 1400 with *English* session on 9.252. (Radio Sweden; Pearce, England)

Sierra Leone—According to "Radio Amateur," Freetown, the experimental station at Freetown has closed down, due to lack of funds. Experimental broadcasts, mostly relays from the BBC, were carried out until July 14, 1951, around 0600-0900, 1300-1700, over 9.630 using a Cossor Type 1509 transmitter of 300 watts output and a half-wave dipole antenna running N-S at 700 feet ASL.

South Africa—SABC airmailed these current schedules—**Johannesburg**—*English* program, 4.80 at 2345-0130 (Sun. 0055-0130); 7.229, 0315-0715 (Sat. 0315-0830, Sun. 0315-0800); 4.80, 0900-1320 (Sat. 0840-1315, Sun. 0810-1315); 3.29, 1330-1605 (Sat. 1325-1700, Sun. 1325-1605). Afrikaans program, 4.89, 2345-0130 (Sun. 0055-0130); 7.275, 0315-0715 (Sat. 0315-0830, Sun. 0315-0900); 4.89, 0900-1350 (Sat. 0840-1350, Sun. 0910-1355); 3.45, 1200-1605 (Sat. 1200-1700, Sun. 1200-1605). Commercial Program ("Springbok Radio"), 4.945, 2300-0130 (Sun. 0000-0130); 7.295, 0130-0900; 4.945, 0900-1330; 3.356, 1330-1700 (Sun. 1330-1600).

Cape Town—Afrikaans program, 5.89, 2345-0130 (Sun. 0055-0130); 9.615, Mon.-Fri., 0315-0715, 0900-1330; Sat. and Sun. 0315-1330; 5.89, Mon.-Fri. and Sun., 1345-1605, Sat. 1345-1645. *African Service* (experimental transmitter)—Johannesburg Program, 15.23, Mon.-Fri., 0330-0715, Sat. and Sun. 0330-1045; 11.937, daily, 1300-1505; carries Afrikaans Program, Sun., Mon., Wed., Fri., and *English* Program Tues, Thur., Sat. *Experimental Transmitter* (to South West Africa)—Johannesburg (*English*) Program, 9.68, at same times as Johannesburg *English* programs listed above.

(Continued on page 101)

TV DIRECT FROM THIS GREAT FACTORY TO YOU

BRINGS YOU

Finest Quality at Lowest Prices



TRANSVISION

TV KITS, WIRED CHASSIS, and SETS
CABINETS, COMPONENTS, INSTRUMENTS, and ACCESSORIES

NEW LOW PRICES

on Top Quality TV Picture Tubes:

• FREE—VALUABLE PREMIUMS:

With every Transvision tube you buy, you get a Merchandise Premium Coupon of real value. Write for list.

• TRADE-IN ALLOWANCE

on old tubes: Make from \$2.50 to \$5.00 glass allowance on each "dud."

• FULL 2 YR. GUARANTEE:

Only Transvision gives you a Guarantee for 24 months.

COMPARE: Get the full details on the Transvision tube deal today.

FREE BOOKLET: "INSIDE CRT, or What You Should Know About Picture Tubes." Written by CRT experts, illustrated. It will MAKE MONEY FOR YOU. WRITE FOR IT NOW.



New... TRANSVISION Picture Tube PRICES

Tube Type	Cost, WITH GLASS allowance	Cost, WITHOUT GLASS allowance
10BP4	\$11.80	\$13.80
12Y4 Glass (any type)	13.45	15.75
12Y4 Metal (any type)	13.95	15.25
14RP4	16.50	18.25
16" Metal (any type)	19.90	23.20
16" Round or Rect. (any type)	18.90	22.25
17BP4	18.90	22.25
17" Metal or Glass (any type)	23.95	28.95
20CP4	23.95	31.95

Make Big Money with Transvision's TESTER-REACTIVATOR

FOR PICTURE TUBES

Tests Picture Tubes and Renews Brightness of Your Dim Picture Tubes. Without removing picture tube from set, measure Cathode emission... locate shorts between elements... locate high resistance shorts or leakage as high as 3 megohms. Then, REACTIVATE dim picture tubes if there's no mechanical break in tube. 110V-60 cycles; weighs 3 lbs.

\$19.95 net

Fully Guaranteed.



FIELD STRENGTH METER AT NEW LOW PRICE

Improve TV installations; save half the work with the Transvision Field Strength Meter. Especially good for fringe areas—measures field strength as low as 10 microvolts. \$59 net Model FSM-1, complete with tubes.

\$59 net



BEAUTIFUL TV CONSOLES

Ideal for Custom-Building or Conversion. Factory prices start from \$49. Send for Cabinet Catalog now.



MULTI-SET CONNECTORS

feed up to 5 TV Sets from 1 Antenna
Prices: Multi-Set Conn. for 2 sets... \$4.95 list*
For 3 or 4 sets... 7.95 list*
*Dealers, write for discounts

U. H. F. ADAPTERS

will be available for all Transvision Sets and Kits.

Write for Transvision's Factory Agent Plan and complete literature

FREE: EXTRA INCOME EVERY MONTH from hints in "TV and Electronics Notes." Request addressograph plate and mailing for FREE sample copy. Or send 50c to cover cost of Subscription. Monthly issues are gold mines of info on New Products, Sales, Service, Conversion, etc. WRITE DEPT. RN7 TODAY!

TRANSVISION, INC. NEW ROCHELLE, N. Y.

Available from stock
at **TRIAD**
jobbers!

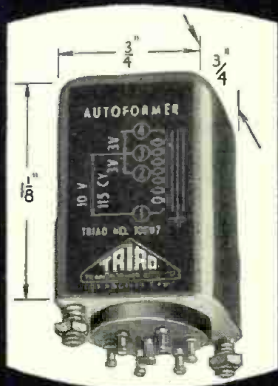

"The World's Smallest
Hermetically Sealed
Transformer"

Miniaturization has become increasingly important in the design of all types of electronic equipment. Use of improved core materials and better winding techniques in our JAF series permits these great reductions in size and weight of low level audio transformers. TRIAD JAF Transformers, as listed below, are "the world's smallest hermetically sealed transformers." All have 45 db. shielding and are available in MIL standard AF case as shown above. Carried as stock items at all Triad jobbers.

Type No.	Impedance		Req. Resp.	List Price
	Primary	Secondary		
JAF-1	600/250/50	50000	100-10000	\$14.50
JAF-2	600/250/50	250000	300-3000	15.30
JAF-3	600/250/50	60000 C.T.	100-10000	15.30
JAF-11	15000	50000	100-10000	13.60
JAF-12	15000	60000 C.T.	100-10000	14.50
JAF-13	15000	95000 C.T.	350-5000	15.30
JAF-21	15000	600/250/50	100-10000	14.50
JAF-22	15000	600/250/50	350-5000	14.50
JAF-23	20000 C.T.	600/250/50	100-10000	15.30
JAF-31	600/250/50	600/250/50	100-10000	14.50
JAF-101	50 h.-1 Ma.			11.60

Maximum level +10 dbm. except JAF-1, 2 and 3 (0 dbm.) *DC in primary.

Write for Catalog TR-52A

TRIAD
TRANSFORMER MFG. CO.

Plant, General Offices: 4055 Redwood Ave.
Venice Area, Los Angeles, Calif.
Address correspondence to: Box 17813
Los Angeles 34, Calif.

What's New in Radio

(Continued from page 80)

high-heat element is particularly well-suited for production-line work and with the three "Triplets" is adaptable to a wide variety of production line applications.

Complete data on these new units is available from the company's distributors or from the company direct.

POWER SUPPLY

McIntosh Laboratories, Inc. of Binghamton, New York has introduced a new power supply, the D-101.

The new unit can be used whenever a separate power supply is required to power the company's AE2-A preamplifier-equalizer, when this unit is to be

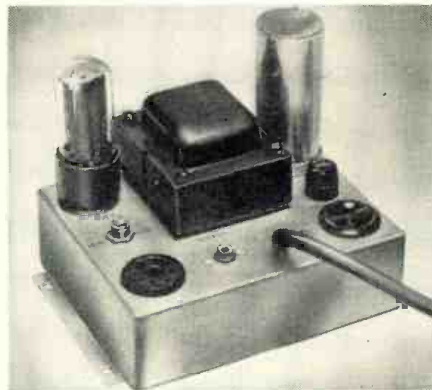

operated as a remote control panel at a distance greater than 30 feet from the power amplifier, or whenever a general purpose power supply is needed.

The power transformer and rectifier tube are capable of delivering d.c. current up to 40 ma. and by properly modifying the filter circuit, the usefulness of this supply can be extended to this increased current rating. The ripple frequency voltage output level is less than 800 microvolts.

TRANSISTORS AVAILABLE

Federated Purchaser, Inc. of 911 S. Grand, Los Angeles 15, California now has available stocks of the new junction-type transistor manufactured by Germanium Products Corp. of Jersey City, New Jersey.

The transistor consists of three tiny crystals of germanium compounds, placed end to end and embedded in clear plastic.

While the initial output of transistors from Germanium Products Corp. will most likely be channeled

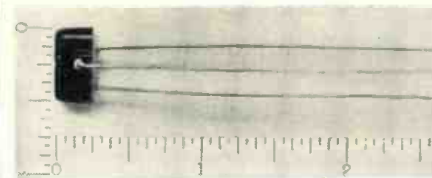

to top priority development in the field of guided missile flight, etc., accelerated delivery schedules will soon make these units available for civilian markets.

For full details on these transistors and delivery data, write to the national distributor, Federated Purchaser, Inc.

HORNS AND SPEAKERS

Racon Electric Co., 52 East 19th Street, New York 3, New York has released a new line of horns and loudspeakers which have been designed especially for use in sound systems requiring high intelligibility combined with mechanical and electrical ruggedness and wide horizontal angle of coverage. All of the models incorporate husky, non-resonant cast aluminum bells.

The COB-15 and COB-16 are of re-entrant design, will handle 25 watts of program material continuously and are provided with driver units enclosed in watertight covers. Response range is 350 to 11,000 cps; horizontal dispersion is 60 degrees; and vertical dispersion 30 degrees.

The Model RE-32 is of "straight" horn design with a nominal cut-off at 500 cycles which results in crisp, highly articulate quality. Horizontal dispersion is 90 degrees, and vertical dispersion is 60 degrees.

The Model CHU is a 15,000 cycle driver unit for use with the RE-32 horn when the latter is employed as a tweeter in two- and three-way high-fidelity systems. When coupled to the proper crossover network, 15-20 watts of program material can be handled.

Technical data sheets on these and other units in the company's line are available on request.

RADIO HARDWARE

Walter L. Schott Co., 3225 Exposition Place, Los Angeles 18, California has introduced a line of radio and tele-



vision hardware which has been designated as the "Walsco 50 Line."

The new line is housed in attractive plastic containers which have unlimited uses on every busy, congested work bench. Each container is clearly marked, and the items are plainly visible, which makes it easy for the technician to select his hardware rapidly.

The "Walsco 50 Line" is now being shown by jobbers throughout the country.

BOOSTER-CONVERTER

Sutton Electronics Company, Inc. of Lexington, Ky. has developed a new booster-converter combination unit which houses both a v.h.f. booster and a u.h.f. converter in a single cabinet.

RADIO & TELEVISION NEWS

LEARN Practical RADIO AT HOME



COMPLETE ONLY . . .

\$19⁹⁵

BUILD 15 RADIOS

ABSOLUTELY NO PREVIOUS TRAINING NEEDED
EXCELLENT BACKGROUND FOR TELEVISION

10-DAY MONEY-BACK GUARANTEE

WHAT THE 1952 PROGRESSIVE RADIO "EDU-KIT" OFFERS YOU:

This is a practical home radio course. You learn theory, construction, operation, trouble shooting, code. You build RECEIVERS, TRANSMITTERS, AMPLIFIERS, CODE OSCILLATOR, SIGNAL TRACER.

You start with a simple radio circuit, and gradually advance to more complex circuits. No previous background is required. No instructor is needed. All parts and instructions are included and every single step is clearly explained.

All parts are guaranteed, individually packaged, identified, and explained. There is nothing extra to buy. You receive all parts, tools and instructions at once. You keep everything; there is absolutely nothing you return to us.

You can easily pay for the kit in a short time by repairing radios. Use the tester and signal tracer for servicing. The signal tracer alone is worth more than the price of the entire kit.

USED BY RADIO SCHOOLS AND GOVERNMENT AGENCIES!

The Progressive Radio "Edu-Kit" includes tubes, paper condensers, mica condensers, electrolytic condensers, variable condensers, selenium rectifiers, chassis, hardware, tie strips, tube sockets, solder, wire, soldering iron, tubing, coils, instruction book, radio tester, etc.; in brief, everything you need in a practical radio course.

Send for further information and receive FREE Radio & TV Trouble-Shooting Guide. Or order direct from this ad and receive FREE Code Oscillator Key (Value \$2.95) in addition to Radio and TV Trouble Shooting Guide.

Postage prepaid on Cash orders—C.O.D. orders accepted in U.S.A.

PROGRESSIVE ELECTRONICS CO.
497 UNION AVE. DEPT. RN-7 BROOKLYN, NEW YORK

FREE RADIO TESTER & SOLDERING IRON

GET A WELL-PAYING JOB



GO INTO A PROFITABLE BUSINESS AND PLAN FOR A FUTURE



"BIG JACK" performs where other high gain antennas fail!

The world's highest gain all-band antenna. The "Big Jack" gives you station cut Yagi performance—yet—you receive all channels 2 through 13. Field tested in many areas by

reliable TV technicians, each test proved the ability of "BIG JACK" to deliver sufficient signal to the TV set where other high gain antennas have failed.

▶ Radiation lobe:

High band:
6° left to right

Low band:
8° left to right

▶ Gain ratio in comparison to dipoles cut to station

High band:
8 times dipole

Low band:
9 times dipole

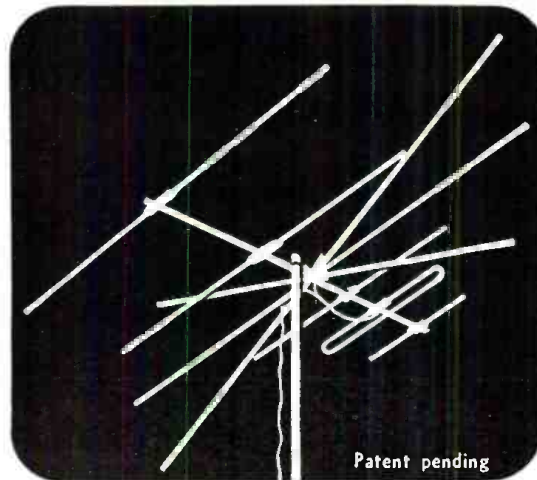

Patent pending

MODEL BJ 1: This model is packed complete with stacking bars in 1 and 2 bay units.

▶ Half wave dipoles featured for HIGH GAIN

▶ Fanned to 45° for 300 ohm impedance

▶ Directive reflector for additional GAIN

▶ 7/16" aluminum tubing: Crimped ends: Oak Dowel pins

▶ Aluminum Cross Arm

At your local jobber or distributor

KAY-TOWNES Antenna Co.

ROME, GEORGIA

For sound trucks • parades
carnivals • resorts • busses
outdoor meetings

ECONOMICAL MOBILE AMPLIFIERS

by

Newcomb



MODEL E-25MP

Newcomb mobile amplifiers are carefully built for the rugged conditions of mobile use and to deliver consistently the top quality performance you expect from any Newcomb amplifier. Dollar for dollar they give you more good service, more convenient operational features and more all around, long-time satisfaction.

MODEL E-25MP delivers 25 watts from either 6 volt battery or 117 A.C. It has a standby switch, separate power and phono switches and inputs for 2 mikes and 1 phono. Heavy duty plugs. 2000 volt hermetically sealed buffer condenser. Phase correction capacitor for phono motor.

MODEL E-25M is the same amplifier without phono top.

MODEL E-10M is a rugged, low cost, 10 watt unit also for either battery or A.C. power. Has standby switch, inputs for 1 mike, 1 phono. Special mounting simplifies installation and removal.



E-10M

Send for full
information
today!

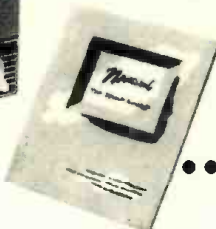

NEWCOMB

AUDIO PRODUCTS CO.

Dept. F, 6824 Lexington Ave., Hollywood 38, Calif.

100

According to the company, installation consists merely of connecting the antenna lead-in from the television receiver to the terminal board at the rear of the unit.

The new unit has its own power supply, a crystal mixer, and two tubes (a



6AF4 and a 6J6). The power supply, which is at the rear of the chassis, operates on 110-117 volt a.c. The 6J6 is used in a balanced push-pull amplifier circuit and a selenium rectifier is used to provide "B+."

Operation of the booster-converter is by means of three control knobs on the front panel, the knob controlling the v.h.f. booster operation is on the left, the u.h.f. channel number indications are at the right, with the tuning knob in the center.

PHONE PLUG

Carter Parts Co., 213 West Institute Place, Chicago 10, Illinois has introduced a miniature phone plug which has been tradenamed the "imp."

The tip and sleeve of the new plug fit standard 2-conductor jacks but the molded Bakelite handle has been reduced to about half normal size. Added convenience and important savings in space are obtained with this new design, according to the manufacturer.

CROSLY "ULTRATUNER"

The Crosley Division of Avco Manufacturing Corporation, Cincinnati, Ohio has demonstrated a production model of its "Ultratuner," an ultra-high-frequency adapter which will enable every television receiver ever built by the company to cover all channels in the



present v.h.f. and proposed u.h.f. ranges.

The tuner is housed in a small, attractive plastic case and incorporates a built-in antenna for the u.h.f. band. Provision is made for connecting an outside antenna if required. A flick of the control knob on the front of the

"Ultratuner" automatically places either the v.h.f. or u.h.f. antenna in operation.

Although designed for Crosley receivers, the new adapter can be used with any continuous tuner set at 127 mc. as the i.f. for the conversion.

NOVICE XMITTER KIT

Arrow Electronics Inc., 82 Cortlandt Street, New York 7, New York has introduced a compact, inexpensive, crystal-controlled, two-tube transmitter which has been designed especially for the beginning ham.

The new transmitter comes in kit form complete with power supply. This 10-watt unit covers the 80-meter band and features a 350-volt power supply, a 0-100 ma. d.c. visual meter, built-in antenna tuner, built-in keying jack, and crystal control between 3700-3750 kc. Tubes used are a 6AG7 and a 6X5 in the power supply. A feature of this unit is that any length of wire up to 125 feet can be used as an antenna.

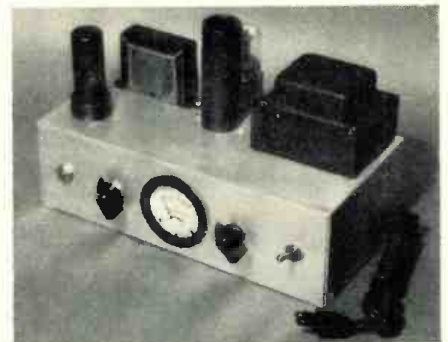

The kit comes complete with all parts except the 80-meter crystal which is available at a slight additional charge.

ELECTRONIC VOLTMETER

Ballantine Laboratories, Inc. of Boonton, N. J. is in production on its new Model 314 electronic voltmeter.

This latest development in the field of sensitive, wide-band electronic voltmeters measures a.c. voltages from 100 microvolts to 1000 volts in the frequency range 15 cycles to 6 mc. Its accuracy of 3% up to 3 mc. and 5% above is the same at all points on the single logarithmic voltage scale.

With its probe, the input impedance is 6 μ fd. shunted by 11 megohms and the voltage range is 1 millivolt to 1000 volts in 6 decade ranges. Without the probe the instrument may be used to measure down to 100 microvolts but the input impedance is reduced to 25 μ fd. shunted by 1.1 megohms.

One of the unique features of the unit is its probe which has a self-holding connector tip and also a ground clamp especially designed to insure a low impedance ground return.

TV-FM GENERATOR

Radio City Products Co., Inc. of 152 West 25th Street, New York 1, New York is currently in production on a TV-FM generator which has been tradenamed the "Do-All."

This easily-portable instrument provides for the checking of front ends

RADIO & TELEVISION NEWS

and i.f.'s, horizontal linearity, vertical linearity, picture size, picture position, focus coil, and ion trap. The unit covers all television and FM bands on fundamentals.

Specifications on this compact instrument are available on request from the company.

-30-

International Short-Wave
(Continued from page 97)

"Springbok Radio," 4.945, logged 2335-0015; terrific aircraft QRM; many commercials and frequent time checks noted, also various types of popular music. (Patterson, Ga.)

South Korea—Taegu, 4.770, and Pusan, 7.935A, relay VOA at 0600-0700. (ISWC, London)

Southern Rhodesia—ZEAF, Salisbury, sent schedule of 3.320, 7.5 kw., 7.285, 7.5 kw., 9.490, 1 kw., Sundays 0300-0700, 1100-1500, weekdays 0400-0700, 1000-1500; additional period of BBC news is relayed daily *except* Sundays and public holidays on 3.320, 7.285 at 0100. (Catch, England)

Spain—Radio Nacional de Espana en Malaga, 7.022, has news in Spanish 1545. (Lepple, Germany, via URDXC) Madrid, 9.363, noted with *English* for North America at 1800 and 2215. (Worley, Calif.) Noted signing off 2245 at good level in N. Y. (Shuker)

Sweden—Radio Sweden, 15.155, noted 0900 with news, like a local in Conn. (Babcock)

Switzerland—Berne, 7.210, noted at good level in Fla. around 2030-2130. (Wade)

Syria—Damascus, 11.913A, good level in *English* period 1630-1730 closedown. (Baitzel, N. J.) Uses French on 7.145 at 0230. (Radio Sweden)

Taiwan—"Voice of Free China," 11.920A, Taipeh, noted to Europe around 1400-1530 (when is buried by Damascus signing on); news is around 1420-1445. (Pearce, England) Radio Sweden says this one can be heard daily 1400-1600. In verifying the 7.133A channel, Taipeh listed BED6, 11.735; BED7, 7.130; BED29, 6.095; BED2, 670 kc.; BED3, 15.235, and BED4, 11.725; ownership as "The Broadcasting Corporation of China"; sent attractive card in blue and yellow. (Kary, Pa.)

Thailand—Bangkok, 11.910, noted closing in *English* 1025. (GDX-aren, Sweden)

Trans-Jordan—Although the Hashimite Jordan Broadcasting Service Ramallah still lists its frequency as 7.010, it is actually heard in England on 6.995A in Arabic from around 1200 to 1430 closedown. (Pearce)

Trinidad—VP4RD noted on 3.270 to 2200 with good level but terrific QRN. (Robbins, Ind.)

Turkey—Radio Ankara now uses 9.465 and 15.160 for the *English* period for Europe 1600-1645. (Pearce, England) The 15.160 outlet is like a local in West Virginia. (Dalton) Heard signing off 1700 on 9.465. (Guterman, N. J.) Still noted to North America 1815-1900

July, 1952



MN26C BENDIX RADIO COMPASS

... complete with tubes, MN28C control box, loop transmission cable, MN20F loop, flexible cables, plugs, etc. **\$67.50**

SCR 625 Famous Mine Detector
For Prospectors, Miners, Oil Companies, Plumbers, etc.

This unit is being offered now at a considerable reduction in price. Recently advertised at \$79.50 it is now available in the same brand new wrappings in suitcase style carrying case (less batteries) at

\$59.50 WHILE THEY LAST!

Check these Items - Write for Prices!

BC-733-D LOCALIZED RECEIVER. Complete with tubes and crystals.
DM-53-A DYNAMOTOR for above.
FT-293 MOUNT for 733
BC-732 CONTROL BOX for 733.
PLUGS for 733.
ARN-7 AUTOMATIC DIRECTION FINDER. Complete installation.
SCR-269-G AUTOMATIC DIRECTION FINDER. Complete installation.

SCR-522 VHF TRANSMITTER & RECEIVER. Available as complete installation or just transceiver.
R89/ARN-5 GLIDE PATH RECEIVER.
R57 GLIDE PATH RECEIVER.
BC-638-A FREQUENCY METER.
BC-376-H TEST OSCILLATOR.
ID6/APN-1 LOHAN INDICATOR.
R9/APN-4 LOHAN RECEIVER POWER SUPPLY.
RT34/APN-13 TRAIL-WARNING TRANSCIEVER. 420 MC.

COMMAND EQUIPMENT (SCR-274N)

	Used	New		Used	New
BC-442 ANTENNA RELAY. Less cond.	\$ 1.95		BC-453	\$7.95	\$19.95
BC-451 TRANSMITTER CONTROL BOX	\$ 1.50		Less tubes	14.95	
BC-450 3-RECEIVER REMOTE CONTROL BOX	2.95		MC-211 90° ANGLE COUPLING UNIT		\$0.95
MC-215 MECHANICAL DRIVE SHAFT. Per length	2.95		FT-234 MOUNTING RACK for single transmitter	2.95	3.50
BC-496 2-POSITION RECEIVER CONTROL BOX	2.95		FT-277 MOUNTING RACK for 2 receivers		3.95
BC-459 Less tubes	12.95		FT-221 MOUNTING PLATE for FT-220		1.50
BC-455 6-B MC RECEIVER. With tubes	9.95	14.95	FT-220 MOUNTING RACK for 3 receivers		2.25
			FT-225 MOUNTING PLATE for BC-456		2.25
			BC-456 MODULATOR. For SCR-274		4.50

Monthly Specials!

2 TRANSMITTERS
BC-457 (4-5.3 MC) and BC-458 (5-3.7 MC). Command transmitters. Shipment just in. Limited Quantity. Less tubes and X'tals. Good cond. EACH \$4.95 PER SET 9.50

REVERSIBLE MOTOR

RL-42 24 VDC. With antenna reel and clutch.
USED \$4.50
NEW 6.75

MOTOR

24 VDC. Series wound, reversible, with clutch. Turns 11,000 RPM, geared to 1,100 RPM. Complete with junction box, 2 adjustable hand switches. Good condition. **\$9.95**

ARC-4 TRANSCIEVER

140-144 MC. Complete with control box, tubes, 12/24 VDC dynamotor. This is a special reduction for this month only. **\$32.50**
Like new

Miscellaneous Specials!

T-32—DESK STAND MICROPHONE. Good used condition. \$ 2.75
HS-30—HEADSET. Featherweight type, low impedance. New, \$2.49. Used, 1.49
HS-32—HEADSET. Used, excel. condition. \$1.49. New, 2.25
HS-23—HEADSET. High imp. New, \$4.95. HS-33—HEADSET. Low imp. New, 6.95
CD-307—EXT. CORD for HS-23-33. New, 95c. LIP MIKE. Navy type, new, .98
EXTENSION CORD and SWITCH ASSEMBLY for lip and throat mikes. New, .98
RS-38—MIKE. New, \$4.95. RS-38—MIKE. Used, 1.75
I-97—BIAS METER. New, \$3.95; Used, 2.95
TU-6—TUNING UNIT. (3-4.5 MC) for BC-376 and BC-191. Used, 2.95
PE-125—AV POWER SUPPLY for BC-223 Xmtr. 12/24 VDC input. New, 14.95
TU-17—TUNING UNIT (2-3 MC.) for BC-223 Transmitter. Used, 2.95
TU-25—TUNING UNIT (3.6-5.2 MC) for BC-223 Xmtr. Used, 2.95
I-70—"S" TUNING METER. New, \$2.50. IN-4A—L/R TUNING METER. Used, 3.95
J16/ARC-5—PILOT MIKE CONTROL BOX. New, .95
MN-52—CRANK DRIVE with azimuth scale. New, 6.95
BC-709—INTERPHONE AMPLIFIER. Battery operated, light wt. Complete with tubes, shock mount and Instruction Manual. New, 3.95
RC-43—MARKER BEACON ANTENNA INSTALLATION KIT. Complete with plugs and insulators. Less wire. New, 1.95
BC-1023—75 MC. MARKER BEACON RECEIVER. Complete with tubes, mtg. rack. New, 10.95
BK-22—RELAY JUNCTION BOX. Used, \$2.50. BC-629—JACK BOX for SCR-522. New, 1.75

MC-217

LOOP MOTOR AND AUTOSYN TRANSMITTER ASSEMBLY. Complete with instructions for matching to I-82 Indicator. Used, excellent condition.

Only **\$12.50**

COMBO

BC-624 VHF RECEIVER. Freq. range 100-156 MC. Less tubes & crystals, with conversion dope. Used, good cond. **\$19.95**
BC-625 VHF TRANSMITTER. Freq. range 100-156 MC. Less tubes & crystals, with conversion dope. Used, good condition. **\$12.95**
BOTH TRANSMITTER & RECEIVER. Per Set **\$29.95**

INDUSTRIAL CORPORATIONS
Write or wire for our new Catalogue listing complete line of Military Electronics Equipment.

\$5.00 MINIMUM ORDER ACCEPTED. All shipts. F.O.B. whole. Cal. residents add sales tax with remittance. 20% dep. Specify shpg. instructions.

ARROW SALES, INC.

7460 N. Varna
North Hollywood, California
SUunset 3-7319

Cable Address: ARROWSALES



RELAYS ... WORLD'S LARGEST STOCK!



Your requirements of large or small quantities of relays can be quickly supplied from our huge stock.

Wide variety of types, all made by leading manufacturers. Each relay is brand new, inspected and fully guaranteed by Relay Sales.

- ✓ STANDARD TELEPHONE RELAYS
- ✓ SHORT TELEPHONE RELAYS
- ✓ DUAL TELEPHONE RELAYS
- ✓ SLOW ACTING RELAYS
- ✓ SEALED RELAYS
- ✓ ROTARY RELAYS
- ✓ MIDGET RELAYS
- ✓ KEYING RELAYS
- ✓ DIFFERENTIAL RELAYS
- ✓ PLATE CURRENT RELAYS
- ✓ ANTENNA SWITCHING RELAYS
- ✓ "BK" SERIES
- ✓ STEPPERS & RATCHET RELAYS
- ✓ LATCHING & INTERLOCKING RELAYS
- ✓ MECHANICAL ACTION RELAYS
- ✓ VOLTAGE REGULATORS
- ✓ OVERLOAD & CIRCUIT BREAKERS
- ✓ REVERSE CURRENT RELAYS
- ✓ AIRCRAFT CONTACTORS
- ✓ MOTOR & CONTROL DEVICES
- ✓ TIMERS
- ✓ SOLENOIDS
- ✓ RELAY ASSEMBLIES



New
RELAY SALES CATALOG NOW READY

WRITE FOR YOUR COPY TODAY



833 W. CHICAGO AVE.
Dept. 8, Chicago 22, Ill.

over TAT, 9.515, good level in New Hampshire. (England)

Uruguay—CX19, 11.835, Montevideo, noted around 1800 in Spanish. (Mast, N. Y.)

USI (Indonesia)—"Voice of Indonesia," Djakarta, noted with *English* for India-Pakistan 0930-1030 on 15.150, parallel 11.77, 4.910; at 1030 the 11.77 channel closed but continued in Hindi over 15.150, 4.910; noted for Europe and New Zealand 1400-1500 over 11.770, parallel 15.150 (repeat of 0930-1030 session). (Pearce, England) The Indonesian noted around 0645-0930 on 11.093A is believed to be Amboina, Ambon. (Stark, Texas)

USSR—Moscow noted on 5.960 with *English* talk 1738-1742. (Rodger, Scotland) Heard on 15.180 signing on to South East Asia in *English* 0900. (Kary, Pa.) Brydges, N. C., reports Moscow on approximately 15.250 at 1133. Kary, Pa., notes *Espana Independiente* on 12.080A at 1450 in Spanish with strong level; announced 20, 21, and 24 meters.

Vatican—HVJ, 15.120, noted to 1030 sign-off or fade-out; *English* 1000. (Kary, Pa.) Heard on 5.968A with Slovak language session 1600; QRM'd by jammer. (O'Sullivan, England)

Venezuela—YVOC, 4.713, Coro, has splendid signal evenings to at least 2130. (Howe, D. C., via URDXC) YVMS, 4.850, Barquisimeto, noted with *English* recordings 1910. (Catch, England) YVLI was *measured* recently on 3.440 at 2150, moved up from 3.430. (Oskey, N. J.)

Yugoslavia—*Radio Yugoslavia*, 11.895A, noted with news in French 0200; news in *English* 0215. (Sanderson, Australia; Pearce, England) Noted on 9.505 with call 0930, followed by news in Russian. (Pearce) By now should be *testing* its new 100 kw. transmitter, to be used for beams to North America.

* * *

Press Time Flashes

Radio Africa, 7.125A, noted 0920 with Spanish music and songs; signed off this period 1104. (Pearce, England)

The transmitter of the Physical Institute of Istanbul University, Turkey, was built as a meteorology station and is being *tested* irregularly; may broadcast from 7.1 to 7.3 and from 15.1 to 15.45; output 0.6 kw.; a regular transmitter for the University is under construction, to be 0.5 kw. Schedule is Mon., Wed., Fri. 0600-0700. Tue., Thur., Sun., 1330-1500; programs consist of recorded music. The Technical School of Istanbul operates around 7.1 with an output of 0.05 kw. daily 1230-1330 using recorded Turkish and Western music. *Radio Izmir*, Smyrna, has 0.4 kw. and uses 6.4A at 1100-1430; relays news 1200 and commentary 1315 from *Radio Ankara* (presume this is Turkish—K. R. B.); transmissions are irregular. (WRH)

The British Far Eastern Broadcasting Service, Singapore, is now using 11.820 at 0800-0830 to relay BBC news to *Radio Australia*. (Hutchins, Radio Australia)

Radio Jornal do Commercio, Recife, Pernambuco, is now using ZYK2, 15.145, noted 1130 and signing off 1300 with announcements in *English*. (Boice, Conn.)

Radio Free Asia has added another Chinese dialect (Hakka) to its sessions to Asia; Hakka is heard 0910-0920; is on the air now daily *except* Mon. 0700-1020 on 9.490, 11.940, 6.110, and also uses Cantonese, Mandarin, *English*. The 6.110 and 11.940 channels are relays via Manila, while 9.490 is relayed from Guam.

Sutton, Ohio, reports the *Free Greek Radio* on 9.457A in native 1300-1325, S7.

Radio Sweden's latest schedules are—*Overseas Service*—To Eastern Seaboard of North America 1900-2145, 11.880; 0700-0745, 15.155. To Western North America, 2300-2345, 11.705; 1600-1700, 15.155. To South America 1900-2100, 11.705; 0600-0645, 15.155; 1800-1900, 11.705. To Far East, 0800-0845, 15.155; 1800-1845, 15.155. To South East Asia and Western Australia, 2300-2345, 15.155; 0900-0945, 15.155; 0945-1030, 15.155. To Middle East, 2200-2245, 11.705; 1200-1245, 15.155. To Africa, 0000-0100, 15.155; 1300-1345, 15.155. *European Service*—Swedish 1400-1430; German 1430-1500; *English* 1500-1530; French 1530-1545, all on 9.620. *Swedish Home Service*—0000-0500 (Sun. 0000-0400), 6.065; 0500-1110 (Sun. 0400-1110), 11.705; 1110-1700, 6.065; the Swedish Home Service also is broadcast from Motaia, 12 kw., on 7.270. The Overseas Service uses 100 kw.

A station measured on 7.114, noted 1645 tune-in, is believed to be Praia, Cape Verde Islands; closed with "A Portuguesa" 1700. (Ferguson, N. C.)

Radio Free Europe has been using these *measured* channels—5.970, 5.985, 6.122, 6.150, 6.225, 7.145, 7.190, 7.284, 9.248, 9.608, 9.696, 11.450, 11.917, 12.190. (WRH)

Predicted Zurich sunspot number for July is 51, the same as for February; March-June prediction was 52. (Stark, Texas)

At press time, Warsaw seemed to be using 11.815 for its "evening" (*EST*) sessions to North America in *English* around 1700-1800, 1930-2000, 2315-2345, 0030-0100. (Bellington, N. Y., others)

Regional stations in Iran are listed by Bluman, Israel, as Tabriz, 6.092, 0930-1300 in Persian and Azerbaijani; Meshed, 8.015, at 0830-1015 fade-out (oriental); Shiras, 6.845, at 0830-0945 fade-out (Persian and oriental); Isfahan, 7.960, at 0830-1130 sign-off, uses 12-tone interval and has interference from the Kozani, Greece, outlet.

Radio Tetuan, Spanish Morocco, now operates on 6.037; heard after 1600. (Radio Sweden) WRH lists these summer schedules for Prague, Czechoslovakia—6.010, 2315-2355; 9.505, 0100-0200; 9.550, 1500-1530, 1600-1630, 1700-1820, 1930-2030; 11.760, 0400-0430; 11.840, 0545-0745; 17.830, 0750-0800; *English* 0715-0745 on 11.840, 1400-1425 on 9.505, 1930-2000 on 9.550.

Japanese Time is now 14 hours ahead

COMMUNICATIONS EQUIPMENT CO.

UPRIGHT OIL CAP

MFD	Each
220VAC/600VDC	
6.2	\$ 1.29
15	3.49
330VAC/1000VDC	
15	3.79
1000VDC	
5	.69
5-5	1.19
1	1.49
4.1-5	2.19
1.5	1.39
1500 WVDC	
1	1.59
1.5	1.59
2	1.79
2000 WVDC	
1	1.79
2500 WVDC	
.5	2.98
4000 WVDC	
.15	6.95
4800 WVDC	
.1-1	4.79
6000 WVDC	
.1	3.69
.15-15	3.89
1.5	10.98
7000 WVDC	
.1-1	3.79
1	9.95
8000 WVDC	
.075-.075	3.79
10K VDC	
1	28.95
15K VDC	
.0016	7.95
16K VDC	
.015	9.50
20K VDC	
.25	17.50
25K VDC	
1	85.00
.5	65.00

AIR TRIMMERS

3-15 uf. 8-85 uf. 3-35 uf. 5-50 uf. 3-10 uf. 3-7 uf. \$0.32 ea.

SPECIALS

BC366 Interphone Jack Box	5	1.79
AW-109-A Antenna		1.94
C-30/ARC-5 Control Box		2.35
EE-89A Telephone Repeater		12.50
EE-85A Telephone Test Set		50.00
ID24/ARN-9 Cross Point Indicator		6.95
TU-8 Tuning Unit G-7-Tmc		4.95
BC496-A Dual Revr. Con'l. Box		1.75
A-1304-A Antenna		1.49
BC704 Indicator CR Tube		22.50
BN929 Indicator CR Tube		22.50
MC211 Right Angle Drive		29.50
NOISE FILTERS, 100 AMP. G.E.		1.39
IF TRANSFORMERS, 112 KC		.69
IF TRANSFORMERS, 1600 KC		.69
MD-7 MODULATOR for ARC-5		.79
ARC-5 XMTTR. Tuning Cond.		7.95
ARC-5 XMTTR. M.O. Trimmer		1.49
ARC-5 1000		1.29
BUFFER OR OSC. Coil, 160 meters		5 pr.
5 pr. S.T.D. Socket, Out. 160me		.79
BIRCHER TUBE CLAMPS		
926B-18	926C-19	
926K-2	926G-15	@ 22c ea.
COILS FOR BC 230 XMTTRS.		
C-203 1250-1500 kc	Each	.97
C-382 3200-4000 kc	Each	.97
C-181 4-5mc (w/11h 4495kc	Xtal.)	1.95
C-481 5-6.2mc	Xtal.)	.97
Dial Coil Set, C-139 for HC-129 Revr.	Range: 201-398 kc and 1.25-4.7mc	1.29
BC-306 ANTENNA TUNING UNIT, NEW		56.95
RD/APN-4 New, With Tubes		75.00
126/APN-4 New, With Tubes and Crystal		75.00
A-62 Phantom Antenna		8.50
2 Meter Choke, 1000 MA.	20-144.8	1.00
Supersonic Crystal Head, M1-2	22-77KC	M1-2
Underwater Microphone, Model JIR, Z-50W		24.50
Dynamic Mike & Headset Combo, H-10, New		3.75
H5-30 Inserts, M-300, \$3.50 per M		
AN/ARC-4 VHF Trans-Revr.		75.00
IE 36 Test Set, New		37.50
SCR 274 Test Set, 1-104		42.25
Carbon Pile Reg., 18V, 3V		25.00
ART-13 Driver Trans. 6V6 to 6P6		81.74
OM 34 Dynamotor, 14V In., 220V OR MA out.		12.95
Sens. Relay, 3.5MA, 13K ohms.		21ST, 2A
		26

AUDIO TRANSFORMERS

AT201 50L6 output (4000 ohms) to V.C. (3 Ohms)		\$0.40
AT 518 Subwoofer, Multismatch, 200 ohms to 15 K ohm C.T. and 100 K ohm Grids		\$0.69
AT781 H.F. Plate (1500 ohm C.T.) to V.C. (10/3 ohms) 20-15K		\$3.29
AT501 H.F. Sprocket: PRI: 3000 ohms P.P./Sec: 4/10/12/50/200 ohms 60-10,000 CY. 10 W 6V6 to 6P 805's		\$3.49
AT152 H.F. Driver Pri: 10,000 ohms Sec: 40,000 ohms P.P. Grids 50-15 KC/1lb		\$1.49
AT062 Output to H.S. or Line PH: 14-200 ohms SEC: 8000/800 ohms		\$4.10
AT449 H.F. Driver (5000 ohms) to P.P. output grids (4,000 ohms) 100-10,000 CY. 10 W 6V6 to 6P 805's		\$2.39
AT666 Intercom Input: Shkr (-4-8 ohms) to grid (250,000 ohms)		\$0.69
AT415 Plate (18,000 ohms C.T.) to line (125 ohms) 175 W-500-600 CY. \$1.95		
AT858 Plate (10,000 ohms C.T.) to line (125 ohms) 125130 ohms H.F.-10 W		\$6.95
AT070 Mike-or-Line (250 ohms) to grid (250,000 ohms C.T.)		\$1.20
AT-694 H.F. Output: 3 Watts, 8500 Ohms P.P. to V.C. (15 Ohms) 15-15K Paj 1 lb		\$1.49
AT-649: Line (500 ohms) to Grid (75K Ohms)		\$0.89
AT-44R: Line (800 ohms) to V.C. (6 ohms) 17.4 db Level		\$1.19
AT-631: Mike-or-Line (200 ohms) To Single or P.P. Grids (50K Ohms)		\$0.39



DYNAMOTORS

Type	Volts	Input Amps	Output Volts	Output Amps	Set
PE86	28	1.25	0.60	RC35	
DM416	14	6.2	330	1.70	RU 19
DM33A	28	7	540	2.50	BC 456
PELOIC 13/26	12.6	4.6	100	1.35	SCR515
			6.3	800	.020
DBAR 9328	3	3.25	375	1.50	APN-1
23350	27	1.75	250	0.85	BC-375
ZA0515 12/24	4/2	500	0.50		
B-19 pack 12	9.4	275	1.10	MARK11	
			800	.020	
O-104	12	300	225	1.00	
			440	2.00	
OA-34	28	10	500	0.60	SCR522
			150	.010	
			24.5	.5	APN-1
S053	28	1.4	250	0.85	BC-375
PE73CM	28	19	1000	.350	
CPW21AA	18	12.6	400	1.35	
			6.3	800	

SCOPE TRANSFORMER

PRI: 115V, 60 Cy., Sec. 3000V/5 MA, 6.3V/0.7A, 6.4V/6A, 5V/3A, 36V/200 MA, 1.25V/3A		\$3.95
---	--	--------



POWER TRANSFORMERS

Comb. Transformers—115V/50-60 cps Input		
CTJ5-2-600VCT/2A, 5V/6A		\$5.95
CT-15A 550VCT .085A 6.3V/6A, 6.3V/1.8A		2.35
CT-164 4200V.002A/12KV Test, 5VCT/3A/12KV Test, 6.3V/0.6A/5400V Test, 12.95		
CT-341 1050 10 MA.—625V @ 5 MA, 26V @ 4.5A, 2x2.5V/3A, 6.3V @ 3A		22.50
CR-25 360VCT .340A 6.3VCT/3.6, 6.3VCT/3A		3.95
CT-626 1500V .160A 2.5/12/30/100, 9.95		
CT-071 110V .200A 33/200, 5V/10, 2.5/10		4.95
CT-367 580VCT .050A 5VCT/3A, 2.25		
CT-99A 2x110VCT .010A 6.3/1A, 2.5VCT/7A		3.25
CT-403 350VCT .026A 5V/3A, 2.75		
CT-931 585VCT .086A 5V/3A, 6.3V/6A, 4.25		
CT-610 1250 .002A 2.5V/1.75A, 4.95		
CT-137 350VCT .026A 5V/3A, 2.75		
CT-866 330V .065A 6.3V/1.2, 1.75		
CT-456 390VCT 30MA 6.3V/1.3A, 5V/3A, 3.45		
CT-160 800VCT 100MA 6.3V/1.2A, 5V/3A, 4.95		
CT-931 585VCT 86MA 5V/3A, 6.3V/6A, 4.95		
CT-442 525VCT 75MA 5V/2A, 10VCT/2A, 50V/200MA, 3.85		
CT-720 550-0-550V/250 MA, 6.3V/1.8A, 8.95		
CT-43A 600-0-600V/.08A, 2.5VCT/6A, 6.3VCT/1A		6.49
Filament Transformers—115V/50-60 cps input		
Item	Rating	Each
FT-674	8.1V/1.5A	\$1.10
FT-157	4V/16A, 2.5V/1.75A	2.95
FT-101	6V/25A	.79
FT-924	5.25V/21A, 2x7.75V/6.5A	14.95
FT-824	2x26V/2.5A, 16V/1A, 7.2V/7A, 6.4V/10A, 6.4V/2A	8.95
FT-463	6.3VCT/1A, 5VCT/3A, 5VCT/3A, 5.49	
FT-55-2	7.2V/21.5A, 6.5V/6.85A, 5V/6A, 5V/3A	8.95
FT-986	16V @ 4.5A or 12V @ 4.5A	3.75

1 PER CENT PRECISION RESISTORS

OHMS	OHMS	OHMS
5	150	7,500
5.05	250	10,000
101	430	12,000
18	468	17,000
82	800	20,000
120	920	30,000
125	1100	35,000
128	4300	84,000
30c EACH	10 FOR \$2.50	
100K 120K 150K	220K	
40c EACH	10 FOR \$3.50	
1 MEGOHM	EACH 75c	

ELECTROLYTICS

Cap. Mfd	WVDC	Price
8	450	\$0.16
30	300	.18
40	450	.38
50	600	.36
60	300	.21
80	150	.29
80	500	.43
8-8	450	.24
30-20	25	.16
20-10	150	.23
80-80	300	.20
90-10	350	.21
80-10	450	.49
150-50-25	150	.49
80-10-10-10	350	.21
40-40-20-2	150	.28
30-15-15-15	300	.28
80-10-10-10	350	.32
4/10	450/350	.55
40/20	150/25	.21
40/50	400/300	.28
80/50	450/50	.65
250/1000	10/5	.30
8-8-10	450/25	.26
10-10-10	150/25	.23
10-10/20	450/25	.26
10-15/20	350/25	.18
15-15/10	450/350	.23
16-16/25	450/50	.23
80-40/150	400/50	.45
120-60/20	150/25	.45
30-30-15/30	300/50	.39
40-40-20/20	350/15	.28
60-40-20/50	300/25	.28
60-40-20/200	150/10	.39
80-40-30/20	150/25	.36
80-40-30/100	150/25	.36
8/8/8	475/100/100	.23
10/50/100	350/100/50	.23



131 Liberty St., New York 7, N. Y. Dept N-7, Chas. Rosen Phone: Digby 9-4124

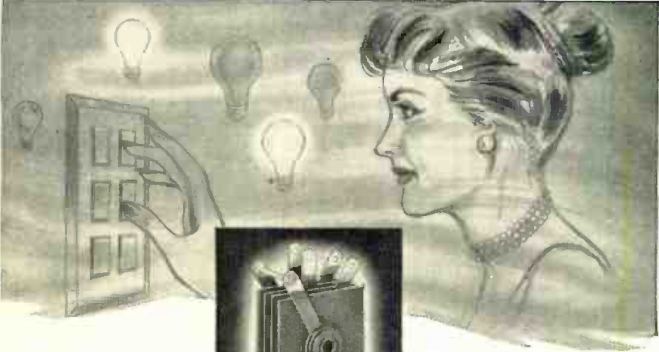

Another Unusual Seletron Application

Touch-Plate Mfg. Co. of Long Beach, Calif. considers the rectifier in each of its control units a highly important "artery" of the system. That's why, after severe tests for temperature, load capacity and longevity, they have chosen SELETRON Selenium Rectifiers.

The rectifier incorporated in "Touch-Plate" (Just touch it and the lights go on anywhere in the house) is SELETRON's Model P1B/E/C, 1.3/16" cell size, and rated at 26V AC input. It converts AC to DC for the "Touch-Plate" relay.

SELETRON Selenium Rectifiers are available in ratings from a few mils, up to thousands of amps! New industrial electronic uses are constantly turning up for these versatile and dependable rectifiers—both in miniature sizes and heavy stack assemblies—and of course SELETRON is the choice of a growing list of manufacturers in communications and TV.

Modern new low-voltage remote control light switch systems employs



May we help with your rectification problems? Write us without obligation. Our engineering department can be of real assistance. And please ask for our helpful Bulletin No. 104-N-3.

IT'S A SHAME to throw away that beautiful old Console . . . replace the obsolete radio with a modern, easily-installed

ESPEY AM/FM CHASSIS and your console is "right-up-to-date"



It is not necessary to spend a large sum of money to modernize your old radio or to become a "High Fidelity" enthusiast. ESPEY chassis provide the Highest Quality at moderate prices.

Fully licensed under RCA and Hazeltine patents. The photo shows the Espey Model 511-C, supplied ready to play. Equipped with tubes, antenna, speaker, and all necessary hardware for mounting.

NEW FEATURES—Improved Frequency modulation circuit, drift compensated • 12 tubes plus rectifier, and pre-amplifier pick-up tubes • 4 dual purpose tubes • High quality AM-FM reception • Push-pull beam power audio output 10 watts • Switch for easy changing to crystal or variable reluctance pick-ups • Multi-tap audio output transformer supplying 4—500 ohms.

Write Dept. RN-7 for literature and complete specifications on Model 511-C and others.

Makers of fine radios since 1928
ESPEY TEL. Trefalgar 9-7000
MANUFACTURING COMPANY, INC.
 528 EAST 72nd STREET, NEW YORK 21, N. Y.



SELETRON DIVISION
RADIO RECEPTOR COMPANY, INC.

Since 1922 in Radio and Electronics
 SALES DEPT. 251 West 19th Street, New York 11, N. Y. FACTORY: 84 North 9th Street, Brooklyn 11, N. Y.

TEST-ADJUST TELEVISION SETS AT *Your* CONVENIENCE

Even without station test pattern or in remote, weak signal areas!

A television set will produce a picture only when it is supplied with a COMPOSITE VIDEO SIGNAL. To check any TV set properly, you must have a COMPOSITE VIDEO SIGNAL.

Every TV station sends a COMPOSITE VIDEO SIGNAL when telecasting a program or a test pattern. This COMPOSITE VIDEO SIGNAL is composed of—(1) a synchronizing and blanking signal to lock the free running raster into a frame of two interlaced fields, and —(2) a video signal to control the amount of light and produce the picture (which may be a program scene or a test pattern for analysis purposes).



SUPREME MODEL 665

The SUPREME COMPOSITE VIDEO GENERATOR provides the same type of sync and blanking signal as the TV station—even the equalizing pulses. In addition, it incorporates a video section which generates a special test pattern for analysis and adjustment of TV sets. Other patterns or pictures can be presented by using auxiliary equipment connected to the special "gated" video input section of this versatile instrument. The Model 665 should not be confused with the cross-hatch or bar-pattern generators. The Supreme Model 665 supplies a COMPOSITE VIDEO SIGNAL.

Why lose time and money waiting for that ideal scene or test pattern to check a TV set? In fringe or weak signal areas, you are strictly in the "driver's seat" with a SUPREME COMPOSITE VIDEO GENERATOR. Write SUPREME, Inc., Dept. A-7, GREENWOOD, MISSISSIPPI for descriptive folder.

Our 25th Year

SUPREME

Testing Instruments

"SUPREME BY COMPARISON"

TUBE TESTERS • OSCILLOSCOPES
SIGNAL GENERATORS • MULTI-METERS
FOR RADIO AND TELEVISION

104

of EST throughout the year; the Summer Time system has been dropped. (WRH)

Summer schedules of Berne, Switzerland, include to North America 2030-2300, 6.165, 7.210, 9.535, 9.665, 11.865; to South Africa 0945-1130, 15.305; to Eastern Australia, New Zealand, 0215-0300, 11.865, 15.305, 17.784; to Western Australia, Far East, 0400-0445, 11.865, 15.305, 17.784; to South East Asia, Japan, 0745-0930, 11.865, 15.305, 17.784; to India-Pakistan, 0945-1030, 11.865, 17.784; to the Middle East, 1145-1230, 11.865, 15.120; to United Kingdom, Ireland, 1345-1530, 9.665, 6.055. Spanish and Portuguese, 1545-1715, 9.665, 6.055. To Latin America (Portuguese 1800-1815; Spanish 1830-2000), 11.865, 11.715, 9.665, 9.535, 7.210. For Europe 0015-0140, 0500-0830, 1000-1730, 6.165, 9.535. For Africa 0015-0140, 15.305; 0500-0730, 17.784; 1130-1730, 15.305.

JBD4, Kawachi, Japan, noted at high level on 15.235 at 0105. (Tarr, Wash. State) Budapest, 11.91, Hungary, noted 1720 in *English*. (Lund, Iowa) GDY-aren, Sweden, reports CR6RG, *Radio Diamang*, Dundo, Angola, is now on 6.860, heard around 1300-1430. And says Forces Broadcasting Station, 7.950A, Kozani, Greece, is heard in Sweden 0100-0130.

American representative of the Arctic Listeners Club, Tromso, Norway, is "Robby" Brown, 32 Kingsbury Road, New Rochelle, New York, to whom inquiries as to membership should be addressed. This new club issues a periodic bulletin called "Nordlyset" ("Northern Lights"); it soon will carry some articles in *English* in addition to Norwegian.

Radio Bucharest, Roumania, now operates four m.w. channels and s.w. 5.932; *Radio Roumania Libera* broadcasts on 6.210, 9.254, and new 12.032 (formerly 11.910). (Radio Sweden)

Rome, 15.400, noted with news 1245; *Radio Sweden*, 15.155, good level 1300 in *English* for Africa. (Leary, Ind.) VP4RD, 9.625, Port of Spain, Trinidad, noted 0700 with sponsored programs. (Robinson, N. Y.)

Belgrade, 9.505, Yugoslavia, noted afternoons to sign-off 1800A; no *English* heard. Stockholm's 9.62 outlet noted around 1520 with *English* session in European Service. Madrid, 9.363, recently announced it is installing 120 kw. short-wave transmitters. Copenhagen 9.52, is scheduled to North America 2030-2130 and 2200-2300. *Radio Free Europe* officials advise that most transmissions are confined to channels of 5.970, 5.985, 6.020, 6.095, 6.150, 7.145, 7.192, 9.607, although some other channels are being used irregularly for experimental purposes. (Bellington, N. Y.)

Radio Progreso de Honduras, 6.239, San Pedro Sula, Honduras, is heard by 1900 and runs past 2230. (Stark, Texas)

* * *

Acknowledgment

Thanks for the fine reports. Keep them coming to Kenneth R. Boord, 948 Stewartstown Road, Morgantown, West Virginia, USA. . . . K.R.B.

Technical BOOKS

"TRANSMITTING VALVES" by J. P. Heyboer and P. Zijlstra. Published by Philips Gloeilampfabrieken, Eindhoven, Netherlands. 281 pages. Price \$6.25. Available in the United States from Elsevier Press Inc., 402 Lovett Blvd., Houston 6, Texas.

Although the subject matter of this book covers a relatively limited field of electronic engineering its appearance fills a long-existing hiatus in the literature.

The discussion has been confined to the use of pentodes, tetrodes, and triodes in transmitter circuits with the result that each tube type is covered thoroughly and painstakingly.

The book itself is divided into nine chapters and an appendix. The chapters cover the technology of transmitting tubes, the classification of such tubes, the triode as an r.f. power amplifier, the tetrode and pentode as r.f. power amplifiers, modulation of the r.f. power amplifier, transmitting tubes as oscillators, transmitting tubes as frequency multipliers, special tube data, and the use of transmitting tubes in high frequency applications.

The appendix includes Simpson's law, the a.f. amplifiers operating class A and class B, and constant current characteristics.

Both the advanced student and the professional engineer will find a wealth of practical data at his fingertips with this book in his library.

* * *

"SURVEY OF RADIO-FREQUENCY TRANSMISSION LINES AND WAVE GUIDES" by E. S. Winlund. Published by The Radio Club of America, Inc., New York. 65 pages plus catalogue section. Price \$1.50. Paper bound.

This compact publication is, in reality, Vol. 28, No. 2 of the "Proceedings of The Radio Club of America, Inc." but because of the widespread interest in the subject matter of this particular issue, copies are being offered to the general public.

The book contains a comprehensive historical survey of the field of transmission lines and wave guides, plus essential technical data condensed from articles on the subject published between 1919 and 1936. A 17-page bibliography lists additional sources of information on the topics.

Charts, tables, diagrams, and photographs form an essential part of this discussion and they, along with the necessary mathematical formulas, enable the author to present a great amount of material in a relatively few pages.

For persons whose vocational or avocational interests lie in the field of transmission lines and wave guides, this book offers a wealth of pertinent information.

—30—

RADIO & TELEVISION NEWS

Multi-Band Circuit

(Continued from page 45)

The stability of this transmitter is excellent, which is mainly due to: 1. Use of bandpass couplers throughout; 2. Class A buffer following the v.f.o.; 3. Shielding of the low-level couplers; and 4. All decoupling connections to one point on the chassis for each tube.

Even on 3.5 mc. it is possible to tune the final through resonance without loading or without noticeable drift of the v.f.o. One must realize that the oscillator is on the same frequency as the final amplifier. The use of the bandpass couplers eliminates any unwanted driving voltage at harmonic frequencies, which is important in avoiding TVI. On the high frequency bands we still have push-pull operation which keeps the even harmonics down to a low level.

The ease with which this rig, with only two controls, can be operated for QSYing in a band is well worth the labor involved in constructing the bandpass couplers.

Almost any exciter can be adapted to this multi-band tank circuit. The essential features which such an exciter should have include availability of output on all the desired bands and the inclusion of the final grid and plate circuits as shown.

REFERENCES

1. QST, March 1949.
2. CQ, April 1950 and QST, August 1950.
3. Patent applied for.

—30—

PROTECT PICTURE TUBES

By H. LEEPER

CATHODE-RAY tubes from TV receivers will roll if placed unguarded on the service bench. An open metal ring, shown in the photograph, will keep the tube from rolling and bumping against another tube or part.

The open or half-ring was cut from a discarded photographic diffuser but even the handle from a paint bucket could be so utilized.

The ring is fastened with a screw to a heavy wooden block but may be attached to the bench itself if room can be spared for it.

Such an open ring will hold the tubes of older receivers, i.e., those mounted separately from the chassis, while the set is in operation on the bench.

While the half-ring shown is about 11 inches across, it will catch the larger tubes at some point where they may be held.

Half-ring keeps CR tube from rolling.

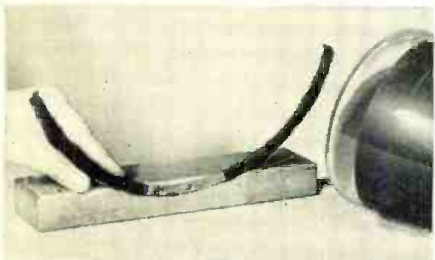

July, 1952

SUPER-SURPLUS VALUES



NEW 12 VOLT BATTERIES

For Mobile or light Airplanes, in original factory boxes. Weight: 37 Lbs. Size: 5 1/2" wide x 10" long x 10" high. Signal Corps Type

BB-63, 12 Volt, 34 AH.

A REAL TERRIFIC SURPLUS VALUE WHILE THEY LAST \$995 EA. ALL NEW.....

ARC 5 EQUIPMENT:

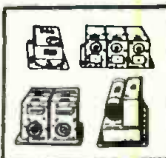

RECEIVERS

190 to 550 KC \$16.95
3 to 6 MCS. 9.95
6 to 9 MCS. 9.95

All above Receivers complete with all tubes and dynamotor. In excellent condition.

TRANSMITTERS

3 to 4 MCS. \$14.95
4 to 5.3 MCS. 8.95
5.3 to 7 MCS. 7.95

All above complete with all tubes and dynamotor. In excellent condition.

R-4/ARR-2 RECEIVER—234-258 MCS Complete with all tubes and dynamotor. Excellent condition. \$19.95

COMPONENTS

MOUNTING RACKS
Single Trans. \$1.00 Ea.
Double Trans. 1.75 Ea.
Trilite Rec. 2.25 Ea.
RE-2ARC-5 ANTENNA RELAY UNIT
Comp. with Meter and 50 MMFD vac. cap. \$4.50
MD-7/ARC-5 PUSH PULL MODULATOR UNIT w/ tubes and dynamotor. Exc. cond. \$11.50

RADIO DIRECTION FINDER

MODEL DZ-2. Tubes from 150 KC and 100-1750 KC. Complete unit, operating on 28 Volts D.C. Receiver Loop Assembly and Pedestal and 28 Volt D.C. Set Dynamotor. All Brand New. \$75.00

CAPACITORS • FIXED OIL FILLED

Solar Pyranol. C.D., Etc.		ALL D.C. VOLTAGE RATINGS	
2 MF. 400 V.	\$0.79	2 MF. 1000 V.	\$1.25
3X3 MF. 400 V.	1.95	8 MF. 1000 V.	3.95
10 MF. 400 V.	2.95	10 MF. 1000 V.	4.95
1 MF. 600 V.	.75	1 MF. 1500 V.	1.50
4 MF. 600 V.	1.95	4 MF. 500 V.	2.25
5 MF. 600 V.	1.95	6 MF. 1500 V.	2.95
6 MF. 600 V.	1.95	1 MF. 2000 V.	1.95
7 MF. 600 V.	1.95	2 MF. 2000 V.	1.95
8 MF. 600 V.	1.95	3 MF. 2000 V.	3.50
8X8 MF. 600 V.	2.25	4 MF. 2000 V.	3.95
10 MF. 600 V.	2.95	1 MF. 3000 V.	3.95
15 MF. 600 V.	2.95	4 MF. 3000 V.	5.95
20 MF. 600 V.	2.95	1 MF. 5000 V.	5.95
1 MF. 1000 V.	1.00		

CAPACITORS TRANSMITTING VARIABLE

K 1 MMFD. to 75 MMFD. 1/2" Spacing. \$1.95
D 12 MMFD. to 125 MMFD. 3000 V. Peak. 3.50
E 28 MMFD. to 150 MMFD. 5000 V. Peak. 3.95
F 12 MMFD. to 130 MMFD. 3000 V. Peak. 3.50
A 7 MMFD. to 80 MMFD. 1500 V. Peak. 1.00
4 With National "Velvet" Vernier Dial.
All New Hammerlund, Cardwell, Etc.



BC-1206 BEACON RECEIVERS

Manufactured by Detroit Radio. 200 to 500 KC. For Direction Finder. Contains 2-251G, 1-6SA7, 1-6X7, 6SK7, 1-6K7. Excellent condition. Complete \$7.95

Use same way as Hand Key with freedom of hands. No batteries or power source required for operation. Excellent Condition. \$11.95



PROP PITCH MOTORS

For your Beam Antenna: 20 Volt to 32 Volt A.C. or D.C.
1/2 H.P. Motor: 11 1/4 RPM Gear Reducing to 600 r.p.m.
ALL BRAND NEW. \$13.95
1/4 H.P. PROP PITCH MOTORS (Small Size) \$16.95
20 to 32 Volt A.C. or D.C. Gear Ratio: 6000 to 1. All Brand New. \$16.95

J-48 Standard Hand Keys enclosed in box with cord and PL 85 Plug. All New. \$1.25
J-5A Flameproof Key. \$0.79 Ea.

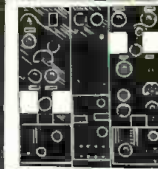

MODEL G0-9 TRANSMITTER

All brand New. 100 Watts CW or MCW emission. Operates from 110 V., 500 Cycle, easily converted to 600 cycle operation. Low frequency range, 300 KC. to 600 KC. High frequency 300 KC. to 18,000 KC. using an E.C.O. We furnish complete conversion data with each transmitter. Complete with schematics. \$59.95

MIDGET SELSYNS

AY6 type operates from 6-12 Volts 60 Cycle. Use as both transmitter and receiver. These compact little units draw almost no current and work fine for all remote position indicating applications. QD 21423402. Has spring return shaft. All New (Appr. wt. 1 lb.) \$2.50
AY-1 Type of AY-6 Type, same as above but has continuous rotating shaft. These compact units are all new. \$4.95

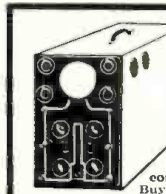

NOW BACK IN STOCK 3" TRIUMPH OSCILLOGRAPH

Complete Test Scope, with built-in Wobulator, so as to be used on TV or FM servicing. Operates from 110 to 115 V. A.C. Limited Supply. All these units have been carefully checked and are in excellent condition. A Real Buy. SPECIAL \$34.95 Ea.

12-24 VOLT TRANSFORMER
Open frame type 0-12-24 Volts @ 2 Amps. 115 Volts. 60 Cy. input. Limited Quantity. All New. \$3.50 Ea.



WILLARD 2 VOLT RADIO BATTERY

NEW. Uncharged (Appr. wt. 4 lbs.) TYPE 20-2. \$2.50
Complete set of three with Box and Connections to make a 6 volt. 20 Amp. Hrs. Battery Uncharged \$8.95 (Appr. wt. 15 lbs.) Set

2 VOLT VIBRATORS. VBRA Synchronous Type. Used in all portable radios having 2 Volt wet cell supply. All new. \$1.00 Ea.



MC-125 REMOTE TUNER UNIT

Part of RU-10 Receiver 40-1 Gera Reduced Shine Drive. All New. \$1.00 Ea.

6 GANG TUNING CONDENSER
Variable with National 20:1 Worm Drive. 300 MMFD. per section. Each rotor insulated from frame. A TERRIFIC VALUE. \$7.95 Each



REVERSIBLE MOTOR

1/40 H.P. Ball-bearing 3450 R.P.M. in Blastproof case. Needs only a capacitor for starting. All Brand New. 110 V., 60 Cy. Special Low Price. \$4.95
Starting Capacitor. \$0.69 Ea.

BC 375 TUNING UNITS
200 KC-500 KC: 4500 KC-6200 KC: 6200 KC-7700 KC: 7700 KC-10000 KC: 10000 KC-12500 KC. With Vernier Dial and tuning bars which alone are worth 5 times our Low Price of \$2.50 per unit

HI AMP. TRANSFORMER
11 Volt 65 Amp. Output—1.5 Volt 60 Cy. Input. Ideal for welding or Heavy Fil. Tubes or Heat. Invg. Approx. Wt. 50 Lbs. SPECIAL at \$15.95 Ea.

25 FT. TELESCOPIC ANTENNA
All Aluminum in four 6 Ft. Telescoping sections. Complete with deck and wall stand-off. Insulators. All New. \$16.95 Ea.

BD-LQ-61 DC VOLTAGE CONTROL PANEL
3 Circuit Voltage Distribution for use up to 50 Volts D.C. Generator. Can be used as Battery Charger Control Panel or Motor Control. Has one 0-50 V.D.C. Meter; three 0-15 Amp. D.C. Meters; three 10 Amp. fuses; three 10 Amp. Magnetic Breakers. The Panel is mounted in a steel box with 2 doors. All NEW. \$35.00 Each

SCR-522 TRANSCIEVER
100-150 MCS.—HOTTEST 2 METER BUY OF THE YEAR. VHF MOBILE or FIXED. Complete with all Tubes and 24 Volt Supply. Excellent Cond. \$52.50

COAXIAL CABLE
52 OHM Transmission Cable. Made to J.A.N. Specification. 17534. Same as RG-8U. All insulated on back of approximately 1,000 Ft. 100 Ft. .9c per Ft.
1,000 Ft. .8c per Ft.
10,000 Ft. .7c per Ft.

MICA CAPACITORS			
CAP.	W. VOLTS	PRICE	
.003	3000	\$1.50	
.005	5000	1.00	
.005	3000	2.50	
.006	3000	1.25	
.001	5000	1.50	
.0015	5000	1.85	
.002	5000	1.75	
.002	5000	2.25	
.002	5000	2.95	
.00375	5000	2.50	
.004	5000	2.35	
.005	5000	2.75	
.006	5000	3.25	
.0072	5000	3.35	
.0075	5000	2.75	
.008	5000	3.25	
.001	5000	3.25	
.0011	5000	2.95	
.0015	5000	3.25	
.002	5000	3.25	
.002	5000	3.50	
.0025	5000	3.50	
.005	5000	3.75	
.006	6000	3.50	
.0075	5000	3.50	
.001	7500	2.95	
.001	7500	3.95	
.00015	600	.75	
.01	1000	.35	
.01	1200	.75	
.001	1200	.65	
.001	1200	.50	
.002	2500	1.50	
.02	2500	1.00	
.005	2500	.65	
.00025	2500	.75	
.0005	2500	.75	

AY6 type operates from 6-12 Volts 60 Cycle. Use as both transmitter and receiver. These compact little units draw almost no current and work fine for all remote position indicating applications. QD 21423402. Has spring return shaft. All New (Appr. wt. 1 lb.) \$2.50
AY-1 Type of AY-6 Type, same as above but has continuous rotating shaft. These compact units are all new. \$4.95

All Mail Orders Promptly Filled, F.O.B. San Francisco. All California Orders—Add 3% Sales Tax. Do not send postage stamps. Write for new 1952 free booklet listing our stock and prices on Radio, Electronics, Tools, Hardware, Motors, Wire, Meters, Batteries, Aluminum Sheets, etc. 20% Dep. on all C.O.D. orders. All items subject to prior sale and prices subject to change without notice.

STANDARD SURPLUS

1230 Market St., San Francisco 3, Cal.
Telephone HEMlock 1-3106

**GOING OVER BIG—NEW
DAVIS SUPER-VISION
ALL-CHANNEL ANTENNA
FOR FRINGE AREA or DX
with ELECTRONIC DIAPOLE SEPARATORS
"THE ONLY TV ANTENNA SOLD WITH A
MONEY-BACK GUARANTEE"**

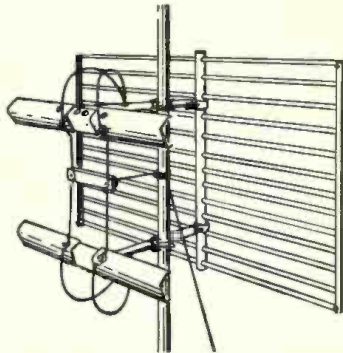

10 OUTSTANDING FEATURES:

1. EXCELLENT FOR FRINGE AREA and DX RECEIVING—and broad band receiving with high gain on all channels—2 through 13.
2. CLEARER PICTURES UP TO 125 MILES OR MORE—from the station.
3. GHOST PROBLEMS REDUCED or eliminated due to excellent pattern.
4. PROVIDES 10 DB OR MORE GAIN ON HIGH CHANNELS where gain is needed most.
5. EXCELLENT FRONT TO BACK RATIO on all channels. Eliminates co-channel interference.
6. MINIMIZES INTERFERENCE: Airplane Flutter—Diathermy and Ignition—F.M.—Neon Signs—X-Ray—Industrial—Etc.
7. ELIMINATES DOUBLE STACKED ARRAYS, and out-performs 2 bay yagis on low band and 4 bay yagis on high channels.
8. ONLY ONE TRANSMISSION LINE NECESSARY.
9. NO WORRY OVER POSSIBLE CHANNEL CHANGES on either high or low channels.
10. CAN BE TIPPED WITHOUT TILTING MAST to take advantage of horizontal wave lengths.

AT YOUR JOBBERS, OR WRITE TO:

DAVIS ELECTRONICS 1-11
4313 West Magnolia Blvd., Burbank, California
SIRS: RUSH INFORMATION TO ME AS CHECKED BELOW:
 Send Free Technical Data on new SUPER-VISION ANTENNA.
 Send Name and Address of NEAREST JOBBER.
Name _____
Street _____
City _____ State _____



**RESISTOR KIT
SPECIAL**

50 brand new 1/2 watt resistors—all standard values—no "dog's"—no, short leads. A great Acorn value! **50 FOR \$1**

**HI-FI SPEAKER SPECIAL
JENSEN 12" PM 12 RX**

Extended range for all hi-fi and P.A. applications. 11 watts, 6-ohms, 1" diam. i.c. Individually boxed. List \$23.80. **\$10.95**
Resale, special

SPECIAL VALUES IN SPEAKERS	12" PM, RCA, Alnico V Magnet	\$3.95
	6" PM, Alnico V Magnet	1.99
	5" PM, Alnico V Magnet	1.79
	4" PM, Alnico V Magnet	1.49

—CARTER DYNAMOTOR—



BRAND NEW
Stock No. 4037A5
DC input 6VDC;
output 400 V @
375 mls DC.
Perfect for mobile communications in car, plane or boat.
List price \$73.40
NEW LOW PRICE \$26.95

SPECIAL! CASCODE TV TUNER \$21.49

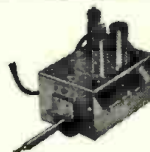

Type 2223—Has four times the sensitivity of ANY previous tuner. Less snow—less noise—more brilliant picture on all channels. Uses new 6BQ7—For use with any 630 or similar type set. 21.25 MC sound IF—25.75 MC pix IF. STANDARD TV 201 TUNER. Over 3 million in use. **\$18.95** SPECIAL.

Williamson Type High-Fidelity Output Transformer

Primary: 9000 ohms
Frequency Ranges —30cy to 20Kc ± 1/2 db. Used for Push-Pull 807's or English KT66's 8 ohm Voice Coil. **4.89** Terrific Value
Made by Chicago Transformer Co.



POWER TRANSFORMERS

STANCOR: Pri. 110v. 125v. 50-60 cy. Sec. 900v c.t. @ 325 mls; 6.3v @ 5.5 amps; 6.3v @ 4.5 amps; 5v @ 6 amps, upright mt. **\$8.95**
Ship. Wt. 21 lbs. Reduced to.....
RCA: Pri. 115v. 50-60 cy. Sec. 750v c.t. @ 225 mls; 6.3v @ 8 amps; 6.3v @ 1.2 amps; 5v @ 3 amps. Half-shell mtg. **\$5.99**
Ship. Wt. 13 lbs. Reduced to.....
PHILCO: Pri. 115v. 50-60 cy. Sec. 650v c.t. @ 150 mls; 6.3v @ 4.5 amps; 6.3v @ .3 amps; 5v @ 3 amps. Half-shell mtg. **\$3.69**
Ship. Wt. 9 lbs. Reduced to.....

TERMS: 20% cash with order, balance C.O.D. unless rated. Prices F.O.B. our warehouse in N.Y.C. Minimum order \$3. NOTE: Due to conditions beyond our control, prices are subject to change.

Phone Worth 4-3270

ACORN ELECTRONICS CORP.
76 Vesey St., Dept. N-7, New York 7, N. Y.

Which Tube for Audio?

(Continued from page 46)

they do, with the aid of such a set of curves. Fig. 1 is a set of curves for a hypothetical medium-mu triode. Assume the grid operating point to be—24 v. (225 v., 32 ma.). The dotted line, AB, is the load line. The power output is one-eighth the area of the triangle ABC, about 1.1 watt. The question of how to get more power is one of how to enlarge this triangle. The main barrier is the zero-grid-bias line. We can't go to the left of this line without drawing grid current.

One way is to drive the grid positive. Then we would be operating over the line A'B', the power output would be proportional to the area of the larger

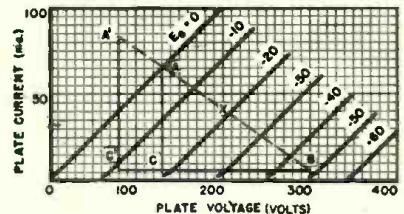

Fig. 1. Power output calculation for a hypothetical triode of the medium-mu type showing the reasons for its low power output.

triangle A'BC', and the operating point would be X, giving class AB₂ operation.

Another way is to use a lower-mu tube. This is shown in Fig. 2. The zero-bias plate curve is now much steeper. We can draw a load line DE which is considerably longer without going to the left of the zero-bias line. Power output is now about 2 watts. Note however that it takes about a 32-volt peak signal to drive this low-mu tube, while the high-mu tube of Fig. 1 took only 18 volts.

This leads us to a consideration of what makes a good output tube. The first thing is that it should draw lots of plate current at zero bias. This condition is met by the low-mu tube of Fig. 2. It is also met, incidentally, by pentodes. Look up the curves on a 6V6 or 6AQ5; the 6V6 will draw 120 ma. at zero bias with 250 volts on the screen. This is why pentodes are efficient.

The second thing is that it shouldn't have too low a mu or it will take too much driving voltage. That is the trouble with the 6AS7G as an audio tube. It has splendid plate efficiency with its mu of 2, but it takes around 100 volts to swing the grid. No resistance-coupled amplifier will deliver 100

Fig. 2. Power output calculations as in Fig. 1 only for a low-mu, higher power output.

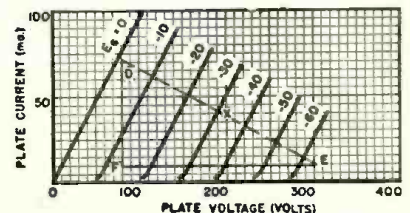

Keep Posted! Read RADIO & TELEVISION NEWS Every Month

**R.C.A. SOUND POWERED PHONES
TV STATIONS AND FOR INVENTORY CONTROL**

RCA MI-2475 BRAND NEW EXPORT PACKED
complete with 22' rubber covered cable with clip on jacket switch that can be locked in or used for press to talk, these phones are light weight, the mic is on a swivel boom that can be moved to any position in front of face. Reg. cost \$62.00 each.

\$18.95 EA. 2 FOR \$37.50

No batteries or external voltage. Good up to several miles with only 2 wires. Several sets can be connected together for multiple operation. Will match any other sound-powered phones. These phones can be had with a Navy waterproof locking plug at extra cost. Shipping weight, 4 lbs. Send check or money order unless rated.

McCONNELL'S 3834 Germantown Ave. Phila., Penna. RA 5-6033



volts with ordinary plate supply voltages without a lot of distortion.

What we need, really, is a high or medium-mu triode which will draw a lot of plate current at zero bias. This combination of qualities is found in high-perveance tubes.

High-perveance is not designed into receiving-type audio output tubes particularly, because the same combination of qualities is found in pentodes and beam power tubes. This parameter is high when the cathode area is large and the grid-cathode spacing is small.

Another point is that the efficiency of triodes goes up quite rapidly as the plate voltage is raised. The higher the mu, the higher the plate voltage should be for reasonable efficiency. The maximum voltage is usually determined by the plate dissipation rating of the tube. For a triode-connected 6V6, for example, it is better to get an input of 10 watts at 300 volts and 33 ma. than at 200 volts and 50 ma.

Voltage Amplifiers

Voltage amplifiers fall into two categories—low level and high level. For the former the main consideration is hum and microphonics; for the second it is distortion.

The best all-around high-level voltage amplifier tube is the 6SN7 (two 6J5's). These tubes will deliver 20 volts r.m.s. at about 1 per-cent distortion, and 60 volts at 4 per-cent, using the tube manual resistance-coupled-amplifier constants, with a 300-volt plate supply. Matters improve as the plate supply voltage is raised. Omitting the cathode bypass condenser cuts both the gain and the distortion about in half.

The 12AU7 (two 6C4's) is not quite as good, giving about one and a half times the distortion of the 6SN7.

Audio pentodes such as the 6SJ7, when resistance-coupled, have very nearly the same voltage output capabilities as the triodes just mentioned and the same distortion characteristics. Like the triodes, the distortion is mostly second harmonic. There is no particular choice between pentodes and triodes for high-level resistance-coupled operation, except in the matter of gain. The 6SJ7 and the 6AU6 are the best for audio service.

High-mu triodes such as the 6SF5, 6AT6, and 6SL7 at high levels fall in between the 6SN7 and the 12AU7.

There is a host of diode-triode types listed in tube manuals, e.g., 6BF6, which can be safely ignored.

Low-Level Amplifiers

Microphonics and hum are characteristics that vary a lot from tube to tube and which cannot be depended on to stay put even in the same tube. Experience is the best guide, therefore, and there are many newer tube types whose characteristics in these respects are not established because no one has wanted to try them on a commercial scale.

ORDER BY MAIL From WHOLESALE RADIO

SAVE with "Automatic" Custom Built Auto Radios!
All with 6 Tubes! 3 Gang Condensers!

Model	Year	Price	Dealer Net
F-100	'49, '50 Ford	39.97	
D-200	'49, '50 Dodge-Plymouth	39.97	
C-300	'49, '50 Chevrolet	41.97	
F-151	'51 Ford	39.97	
F-152	'52 Ford	39.97	
D-251	'52, '51 Dodge	39.97	
C-351	'52, '51 Chevrolet	39.97	
H-451	'52, '51, '50, '49, '48 Hudson	39.97	
S-551	'52, '51, '50 Studebaker	39.97	
P-651	'52, '51 Plymouth	41.97	
K-751	'51 Henry J.	39.97	



FOR ALL PASSENGER Cars & Trucks
Model A-15
Five tubes
Universal Mtg.
\$27.97

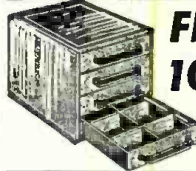

FREE STEEL CABINET WITH KIT OF 103 ASS'T MOLDED CONDENSERS

\$14.95

90 molded, 600 volt Sangamo condensers including 7-.001; 7-.002; 7-.003; 7-.004; 7-.005; 7-.006; 10-.01; 10-.02; 7-.03; 10-.05; 7-.1; 4-.25; 12 Ceramic discs including 3-.001; 3-.002; 3-.005; 3-.01; 1 mica 500 mmf 20KV. Universal Hi-voltage cond. with 10 ass't. fittings. Plus free steel cabinet 6" wide, 6 1/2" high, 8" deep. Four drawers with removable compartments.

Get Snyder's Amazing New

360° MOTORLESS TV AERIAL

Same Clear Pix As Motor Rotating Aerial Systems Costing Triple This Price

FOR FRINGE AREA Only **\$16.95**

Complete with beam selector switch and 75 ft. 3 conductor cable.

Electronically beams in complete 360° rotation to give clear picture on all channels. You choose direction with Directronic selector switch mounted on or near TV set. Complete double-stacked arrays with 18 hi-tensil double-alloy aluminum elements. Model TX-599 same as above plus three 3 1/2 ft. mast sections, guy ring and mounting base. . . . \$18.95

No More Monkeying Around NEW, ALL DIRECTIONAL INDOOR TV AERIAL

Most Powerful Indoor Aerial Ever Made!

Hide it anywhere. Adheres to any surface. Ceiling, attic, closet, etc. Electronically switch beamed to cover 360° area. Flick of switch clears picture on any channel. Order Snyder Model ID-303. Complete, nothing else to buy. Ant. selector switch, 25 ft. lead-in included. **\$5.95**

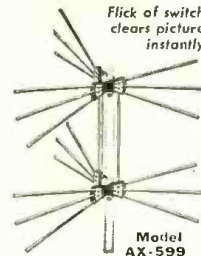

YAGI TV ARRAYS



For Fringe & Ultra Fringe

Low Channels = 2 or 3
HVS
4-RV4
5-RV5
6-RV6

High Channels = 7-RV7
8-RV8
9-RV9
10-RV10
11-RV11
12-RV12
13-RV13

\$7.95

\$4.95

TIE RODS for stacking 2 Yagi Arrays Specify Hi or Lo hand. Pair **85c**

"PRECISE" RF-AF-TV MARKER GENERATOR KIT



Fundamental thru 110 mc. 330 mc on Harmonics. Audio: 20-20,000 cycles. Cathode follower output: variable per cent modulation. Stepping attenuator. External modulation. Speech amplifier, crystal marker. 630 K Kit. **\$33.95**

With pre-assembled RF head. 630 KA. **\$38.95**

Completely factory wired. 630 W. **\$53.95**

Price Slashing Closeout Famous Make TV BOOSTER

Made by one of America's most famous electronic houses. Takes 300 ohm twin lead or 75 ohm coaxial. Two 6J6's and select. One tuning control. U.L. app. **\$16.95**

Reg. \$40 List



Address Orders to Dept. RN-7

Write for Free FYI Bulletin

WHOLESALE RADIO PARTS CO., Inc.

311 W. BALTIMORE ST., BALTIMORE 1, MD.

NEW! MOSLEY DUAL MATCH TV COUPLER...

... OPERATES 2 TV SETS FROM 1 ANTENNA!

IDEAL FOR:

- Two-Family Homes • Apartments
- Other Multi-Set Installations

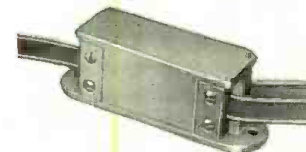

The Dual-Match is available at most TV Dealers and Jobbers. Ask for Catalog Number 902—the New MOSLEY Dual-Match TV Coupler. List Price, only. **\$3.95**

Here's a real convenience for folks who have an extra TV set in their play-room, den, or elsewhere. It's the new MOSLEY Dual-Match TV Coupler that permits two TV sets to operate from just one antenna—without one set interfering with the other. The Dual-Match is efficient, compact and low in price. It is easily installed without solder to standard 300 ohm transmission line.

MOSLEY ELECTRONICS

2125 Lackland Road Overland, Missouri

THE
Original
WRENCH
WITH THE
SCREWDRIVER ACTION!

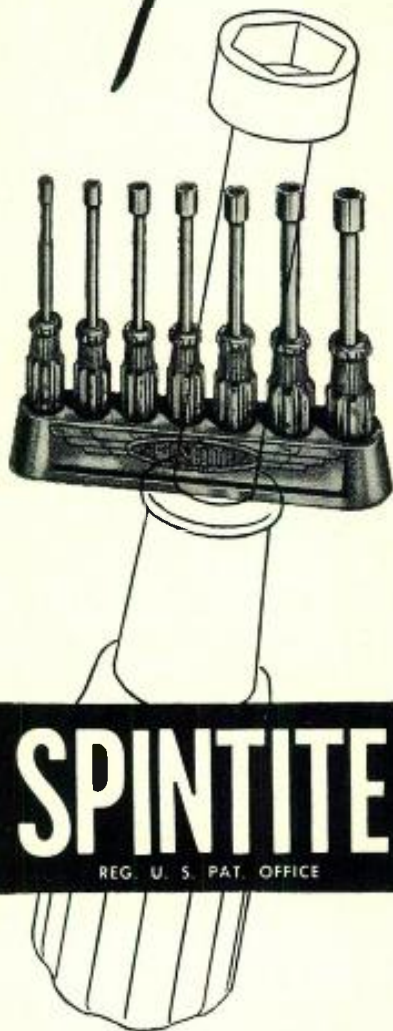

SPINTITE

REG. U. S. PAT. OFFICE

120 STYLES and SIZES

for

- ASSEMBLY WORK
- REPAIR WORK
- RADIO
- TELEVISION
- INDUSTRIAL
- AIRCRAFT



STEVENS WALDEN, Inc.
WORCESTER 4, MASS.

The old top-cap 6J7 is the standby of the broadcast industry for low-level service, i.e., for microphone preamplifiers and so on. The miniature 6AU6 is used in some of the newer audio gear, and measurements made by Lawrence Fleming ("Controlling Hum in Audio Amplifiers," *RADIO & TELEVISION NEWS*, November 1950) have indicated that the 6AU6 is considerably better. This tube can be triode-connected to give a good triode with a mu of 40. Use a 100,000 ohm plate load and a 2200 ohm cathode resistor. A 6J7, triode-connected, is similar to a 6C5. Both of these tubes are quieter than the 6J5.

Among double triodes, the 6SC7 is considered quieter than the newer 6SL7, but proof is lacking.

The two leading modern types that are especially designed for low noise in audio work are the *RCA* 5879 and the *G-E* 12AY7. The 5879 is a voltage amplifier pentode somewhat similar, electrically, to the old 6J7 and the 12AY7 is a medium-high-mu (60) dual triode; both are nine-pin miniatures. The retail price of each is around three dollars.

The signal level below which one has to worry about using a low-noise tube is around 20 millivolts, that is, for microphone, variable-reluctance phonograph pickups, and tape playback inputs, one should use a quiet tube. All the succeeding stages can be other types.

"Hot" tubes having a high transconductance and designed for video i.f. service and the like, are not considered good for low-level audio service. This includes the 6AK5, 12BH7, 6CB6, and all the others found in TV front ends, i.f. stages, and video stages. The 6AU6 appears to be an exception. However, not too many standard types have been investigated for hum characteristics, and any departure from regular usage must be considered experimental.

The way to find the approximately correct cathode bias resistor for a type not in the resistance-coupled amplifier charts is to select a plate load resistor value used for the nearest listed type, then vary the bias resistor until half the plate supply voltage is dropped across the plate load, the other half across the tube. 47,000 ohms is a good plate load for medium-mu triodes such as 6C4, 6J5, 12AT7, 6J6; 220,000 ohms for the high-mu triodes such as the 12AX7 and 12BZ7.

Power Supply Rectifiers

The old standard 5Y3 is the longest-lived and most reliable as well as the cheapest tube extant when used well within its ratings. For heavier current loads, use the 5U4G and for higher voltages the 5R4GY, an unusually well-made tube. All these types have a drop of around 50 or 60 volts, as does the newer 6AX5. When less voltage loss is desired, use a 5V4G. This is a heater-cathode type rectifier that is directly interchangeable with the 5Y3 but gives about 40 volts more d.c. output. However, this tube has very close

cathode-plate spacing, and the writer has seen some of these tubes short out by particles of the cathode coating material coming loose and shorting the cathode to the plate. This does not happen often enough to be serious.

Selenium and germanium power rectifiers are here to stay and will probably gradually replace the tube rectifiers at higher voltages as they already have in a.c.-d.c. sets. At present the selenium stacks require too many plates in series to stand the higher voltages, and are therefore not economical.

Room for Experiment

There are many tubes not designed for audio that seem to have very promising characteristics for such applications. Individual experimenters can do a lot of good by trying out these tubes. (The 6C4-12AU7, incidentally, was not originally designed for general-purpose use, but as a v.h.f. power amplifier).

The 6J6 is a husky, long-lived dual triode which might make a superior audio voltage amplifier. Recent production tubes have double mica spacers inside to reduce microphonics, because of microphonic troubles encountered in these tubes when used as oscillators in TV front ends. The tube has a folded heater, rather than a double-helix, and so may tend to hum at audio frequencies.

The article by Fleming, mentioned previously, reported good results on 12AT7's as low-level amplifiers, but tube manufacturers are unhappy about this type because the extremely close mechanical spacings inside make it very difficult to produce. There may be a trend away from the 12AT7 in spite of its excellent characteristics. The 12AT7 electrically is almost identical with the 6J6, except that it has separate cathodes.

The new 12BH7 is a husky dual triode, designed for TV vertical deflection service, which should be better than the 6SN7 for driving audio power stages. Three other new types are the recently advertised 12A4, 12B4, and 12BZ7, designed for TV sweep and sync separator applications. The 12A4 is a very high-perveance triode with a mu of 16, the 12B4 similar but with a mu of 6.5. Both should make superior high-level voltage amplifiers, and the 12B4 looks like a lulu of a small power output triode, except for its too-low plate dissipation rating of approximately 6 watts.

The 12BZ7 combines a very high mu of 100 with an abnormally high plate current at zero bias. It may possibly replace many older high-mu dual triodes, combining as it does the capabilities of high gain and high output. All these high-perveance tubes should be advantageous for driving class AB₁ amplifier grids (particularly the 12A4 and 12BH7), and for driving class AB₂ tubes with fixed bias, where low-value grid leaks of 50,000 or 100,000 are required.

-30-

The "Q-Tee"
(Continued from page 57)

series-type "T" matching transformer. A half-wave antenna has a center impedance of roughly 72 ohms. This impedance increases toward opposite ends of the antenna, and at some points there exists a match impedance of 300 ohms. In the low-channel range the high-channel receiving element *D,D* no longer has the same impedance value (because of current distribution vs length) as it did on Channels 7-13. The filters *C,C* are now almost perfect electrical short circuits, having only small residual series impedances. A match is now effected from the low channel receiving element *B,B* through filters *C,C* and the series matching transformer *D,D-E,E*. Reflector *A,A* has a definite effect on total impedance, and flat response is obtained only through co-adjustment of reflector spacing and positioning of the filter tap points.

Comparison of the conical type antenna and the "Q-Tee" on Channels 2-6 shows an even better average increase in signal gain (Fig. 4). The proximity coupling that produced the unusual results throughout the high channels again makes possible broad-band results in the low-channel range. The "Q-Tee," fortunately, does not have the inherent limitations of the conical, as no tilting of elements is necessary with consequent degradation of the horizontal pattern. The comparative horizontal directivity patterns of Fig. 4 illustrate this difference.

For readers more familiar with electronic circuits, the explanations of Figs. 6A and 6B are presented as electrical equivalents. Tuned circuit *B* may be considered a parallel resonant source (in Fig. 6A) capacitively coupled (proximity) to like circuit *D*. Circuit *B* is representative of the low-channel, half-wave dipole *B,B* and circuit *D* that of the high-channel, full-wave antenna *D,D*. Electrically, the two are separated except for condensers

Fig. 6. (A) Electrical equivalent of the "Q-Tee" at the high and (B) low bands.

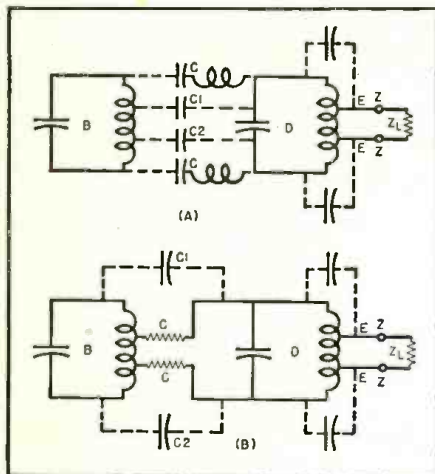

REAL BUYS!

BC 604 FM Transmitter—20-27 mc. 10 Channel crystal controlled push-button, excellent for conversion to 10 and 11 meters, small quantity on hand, in good used condition, less dynamotor, some missing side covers, etc.—otherwise complete, **\$7.95** including tubes. Like new \$12.95

	Used	New
BC-453, less tubes	\$10.95	
BC-454, 3-6 mc receiver, less tubes	5.95	
BC-455, 6-9 mc receiver, with tubes	9.95	\$14.95
less tubes, as is	5.95	
BC-457, 4-513 mc transmitter, less tubes	4.95	
BC-458, less tubes, as is	4.95	
BC-459, less tubes, as is	10.95	
BC-496, 2 position Rec. Control Box		1.95
MC-215 Mechanical Drive Shaft, per length		2.45
BC-450 3 Receiver Remote Control	1.29	2.95
BC-451 Transmitter Control Box	.69	1.50
BC-442 Antenna Relay, less condensers—used	1.29	

16JP4-\$19.95 16DP4-\$19.95
90-DAY GUARANTEE

RA 52—RECTIFIER

A transtat controlled rectifier to produce high voltage DC from 110 VAC 60 cycle source. Up to 11,500 volts DC at 50 watts. Metered high voltage (0-15KV) and current (0-20 MA). **\$74.50** New
Some available with small repair or minor part replacement, less tube..... only \$49.50

RT7/APN1 TRANSCIVER UNIT—Used as an altimeter, it may be converted for signaling control circuits, etc. Complete with 14 tubes and dynamotor they are in good used condition at the amazingly low price of..... **\$24.95**
Used, less tubes, with wobulator..... 14.95

MONTHLY SPECIAL

RT 34/APS 13 Transceiver used as a tail warning radar on 415 MC. Containing a 30MC IF Strip and various other parts, these units have been stripped of RF sections and all tubes but are an excellent buy if only for parts and IF Strip. Used..... **\$6.95**

REAL BUYS!

	Used	New
RL 42 Antenna Gearbox Motor and Reel	\$ 4.95	\$7.50
PE-101 Dynamotor	2.75	
BC-1023 Marker Beacon Receiver, complete with tubes, shock mount and instruction manual		9.95
SC 206 Inverter	4.95	8.95
Scott Hi-Fi output transformer		1.49
PE-218 Inverter		29.95
BC-709, battery operated, 11 wt., inter-phone amplifier, complete with tube, shock mount and manual, brand new, ea.		\$3.95
Transceiver—100-156 mc, 2 meter, used, excellent condition, less dynamotor, with tubes		\$32.95

Shipments FOB warehouse. 20% Deposit on orders. Minimum order \$5.00. Illinois residents, add regular sales tax to remittance. Prices subject to change without notice.

SCR 625 Famous Army Mine-Detector
For Prospectors, Miners, Oil Companies, Plumbers, etc.

This unit is being offered now at a considerable reduction in price. Recently advertised at \$79.50 it is now available in the same brand new wrappings in suitcase style carrying case (less batteries) at **\$59.50** WHILE THEY LAST! Used, like new, \$39.50

MIKES and HEADSETS

HS-33 Low Impedance Headset, exc.	\$2.95	new \$5.50
CD-307 Ext. cord for HS 23-33		like new 1.29
Throat Mike—T 30		New .98
Lip Mike—Navy Type		New .98
Extension Cord and Switch Assembly for lip and throat Mikes		New .98
CW 49505 High Impedance headset complete with leather headband and rubber cushions.		Used \$1.95
RS-38, Microphone		new \$4.95
TS 10 sound powered HAND SET	used, ea.	5.95
HS-38	exc.	\$1.95 new 2.29
HS-30, miniature headset		new 2.49 used 1.49
HB-7 Headband, used, exc		1.25

WOBULATOR

See page 43—December "Radio News" \$5.95 ea.

I. D. 6/APN4

LORAN INDICATOR SCOPE
less tubes, like new

\$29.95

ONLY \$29.95
R9/APN4, complete with tubes, like new \$17.95

BC 624 receiver (SCR 522), less tubes,	used	\$19.95
BC 625 transmitter (SCR 522) less tubes,	used	14.95
SCR 522 transceiver, complete in case with top bracket, less tubes		29.95
BC 376H Test Oscillator, used		59.50
TS170/ARN5 glide path test set, excellent, less tubes and crystals		59.50
BC-1033 Marker Beacon Receiver (convertible to BC-1333), exc. cond.		19.95
LP21LM ADF loop, excellent cond.		79.50
MC124 Flexible Cable, per length		2.95
TS10/APN Altimeter Test Set, new, contains about 300 ft. of RGBU cable		24.95
TS16/APN Altimeter Test Set, new		24.95
TS184/AP Signal Generator, new		29.50

Complete MN26C

200-1750KC, manual directional finder, complete with all parts..... \$79.50

SURPRISE PACKAGE

20 pounds of assorted radio parts. A real value at..... \$2.45

WANTED!

All TS, APR, APS, ARC, ARN, ART, SCR, R89 and BC equipment... write today!
Quote prices in your first letter.

R W ELECTRONICS Dept. N, 1712-14 S. Michigan Ave., Chicago 16, Ill.

PHONE: HARRISON 7-9374

TRAIN AT HOME FOR UHF-TV AND



Learn practical, professional type TV Servicing without leaving your present job. Included are money-making extras such as set conversion, master antenna installation, UHF-TV, field servicing short cuts. You can start earning Television money after first few lessons. You learn to test, trouble shoot and repair all types of TV sets.

HERE'S HOW YOU GET EXPERIENCE!

You train on a large screen, modern TV receiver, furnished with the course and yours to keep! As an optional feature you can get two weeks actual experience with Chicago's largest independent servicing organization. You learn by doing! Age is no barrier. Many students are over 50! ACT NOW! Send for FREE Catalog and SAMPLE LESSON today!

TELEVISION COMMUNICATIONS INSTITUTE
205 W. Wacker Dr., Dept. 1-Y, Chicago 6, Ill.

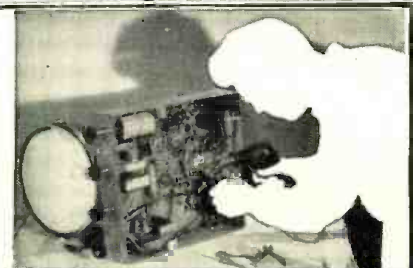

MAIL NOW FOR FREE BOOKLET

MILTON S. KIVER, President
TELEVISION COMMUNICATIONS INST.
205 W. Wacker Dr., Dept. 1-Y, Chicago 6, Ill.
Rush FREE Catalog and Sample Lesson. I am not obligated. Salesman will not call.
Name..... Age.....
Address.....
City..... Zone..... State.....
 BEGINNERS check for 1-re-TV Itadio Course.

Don't worry about CHANNEL CHANGES

AMAZING ALL CHANNEL Reception
Replace Those Old TV Antennas

with the Famous **Rocket DIRECTRONIC** MOTORLESS TV ANTENNA

- 360° Electronically Switched Beam
- No Motors
- No Roof Orientation
- No Electric Power
- No Ghosts

Flick of Switch Clears Picture Instantly

The Directronic 18-element 360° antenna is the finest for ultrafringe or metropolitan reception. The Hi-PAC molded insulator is a material of extreme tensile strength not affected by weather or temperature either mechanically or electrically. Included in the AX-599 "Servicemen's Array" are:

- 18 hi-tensile aluminum alloy elements.
 - Universal U Clamps for masts to 1 1/2".
 - Directronic Beam Selector.
 - 75 feet of Tri-X Cable.
- AX-599 Directronic 9-element Single \$10.35



AX-599 Directronic. As shown. \$16.95

Install Rocket ALL-CHANNEL CONICALS

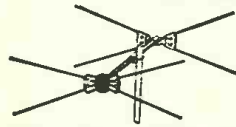

This sturdy, all-aluminum constructed TV antenna is designed for broad-band reception on all TV channels, plus FM. High Gain. 4 to 1 front to back ratio. All Channels 2-13. For use with 72-150-300 ohm lines. Low reception angle. Complete with all hardware—less mast.

NOW AT LOWEST PRICES IN HISTORY
Single Bay \$3.35 Stacked Array with Tie Rods \$7.40

NOW An All-Channel Indoor Directronic TV Antenna \$5.95 Complete Model ID-303 Nothing Else To Buy



360° coverage. Finest reception on all channels. No ghosts. Clearer, sharper pictures. Hidden installation. Steadier focusing. Strongest signal. Minimum noise or interference. Beam selector switch for best picture on every channel. Kit contains three CLONET Beam Selector Switch, 25 feet Tri-X Cable, and Twin-X Cable Extension.

Rocket Yagi 5-Element TV ANTENNA

Excellent Pictures in Fringe Areas
High gain. Minimum interference from ghosts and noise due to directive pattern. 3 heavy aluminum elements clamped top and bottom include one folded dipole, one reflector, three directors. Extra strong molded insulator. Special design mast clamps prevent antenna canting or tuning. Completely pre-assembled. Prices are less mast.

Channels 2 or 3... \$7.95 each Channels 4, 5, or 6... \$6.95 each Channels 7 to 13... \$3.95 each

EACH CHANNEL requires a DIFFERENT Yagi. When-ordering specify exact channel number desired.

WE WILL NOT BE UNDERSOLD ON TV ACCESSORIES

Mast Steel (Dualcoated 5') Crimped 1 1/4" O.D.	\$ 1.03
Mast Steel (Dualcoated 10') 1 1/4" O.D.	1.93
Mast Steel (Zinc Plated 10') 1 1/4" O.D.	1.53
Mast Connectors for 1 1/4" O.D. Mast—10'	.49
Chimney Mount Complete with Straps	1.19
Peak Roof Saddle (will take up to 1 1/2" O.D.)	1.49
Lightning Arrestor—TV	.69
Galvanized Guy Wire—6 strand ±20'	5/8¢ ft.
Galvanized Guy Wire—11 strand ±20'	1 1/2¢ ft.
300 ohm Twin Lead 7/22 Stranded (500' Reel)	2¢ ft.
\$7.50	\$22.50
100 ohm Open Line Twin Lead—500' Reel	2.50 C
Mast Stand-off Insulators—2"	2.75 C
Stand-off Screw Insulators—3"	5.50 C
Stand-off Screw Insulators—7"	5.50 C

Rocket Products sold only by mail by National Electronics

Prices Subject to Change Without Notice
All PRICES F.O.B. CLEVELAND, OHIO
Do not remit more than complete purchase price. Pay shipping charges on receipt of goods. 25% deposit on C.O.D. orders, please. Money-back guarantee.

FREE CATALOG OF BARGAINS
TV antennas, accessories at lowest prices. Tells about our fast service, free installation help. Send name, address now.

National Electronics
OF CLEVELAND
THE HOUSE OF TV VALUES
107 DELCO BUILDING, CLEVELAND 3, OHIO

C₁ and C₂. Obviously, there is a loading effect of one circuit upon the other with a resultant lowered "Q" and broader frequency response. The equivalent of reflector A,A and director F,F may be neglected, as their only function is to affect the relation of individual circuit impedances, and are of a fixed value. The total function of filters C, C (although high impedances in this case) is to further broaden the frequency response of circuit D by "end loading" due to physical attachment. Matching transformer E,E matches the appropriate impedance Z_L (transmission line) to circuit D. This, of course, is for the high-frequency condition for reception of Channels 7-13.

Fig. 6B illustrates the equivalent condition for reception on Channels 2-6. It must be remembered that in this range filters C, C are small series impedances tapped in at a point on circuit B at approximately 300 ohms. The actual impedance across C, C is actually less than 300 ohms because of match requirements (additive) of the series impedances C, C and the residual shunt impedance of circuit D. The only function of transformer E, E as in the high frequency case is that of impedance balance and capacitive loading. External coupling still exists between circuit B and D-E, E, but in the low-frequency case the line connection through C, C lowers the "Q" of circuit D, and prevents this from operating as an independent element. It might well be asked why these circuit parameters are drawn as individual elements rather than single resistances. Since it is not intended to imply that this particular antenna combination has a standing wave ratio of 1, the predominant reactive component must be considered for impedance analysis. This affects impedance as the frequency under consideration is changed from the theoretical resonance of 63 mc. on the low-band and 195 mc. on the high-band channels.

To return to the practical aspects of antenna operation, it can be seen that compared to a standard 10-element conical, the "Q-Tee" has better average gain on all v.h.f. channels. Comparing the horizontal directivity patterns of the two, the "Q-Tee" has a sharper beam width, no major secondary lobes, and a better average front-to-back ratio. The figures given are for single bay comparison using standard RTMA testing procedures.

A further disadvantage of the conical type antenna is the inability to realize the theoretically possible 3 db increase by doubling the antenna bays. To obtain such an increase, the complete separation between the physical elements comprising the individual bays must be at least one-half wavelength at the frequency under consideration. In the case of the conical, the "fanning" of the receiving elements narrows the physical separation between the bays, and makes portions of the adjacent bays do the same work. Full gain from each bay may only be

obtained when the individual pick-up area of the bays does not overlap. Overlapping or close spacing results in a reduced total area of signal acceptance and, of course, less gain. The "Q-Tee" has no "fanned out" elements, and as a result will deliver an average of 3 db gain when double stacked. An additional 3 db over the double stack is obtained when the 4-stack array is used. The "Q-Tee" is limited to near-fringe reception only in the single-bay form. Stacking allows use in fringe areas with no impairment of flat response. Horizontal and vertical directivity patterns are greatly improved by such arrangements.

The mechanical construction of the "Q-Tee" is patterned along the lines of preassembled yagi types. The elements swing out from the boom and are quickly secured by tightening the wing nuts associated with the three sections. The center insulating support blocks are molded from a bakelite derivative of polystyrene. This material is excellent from the standpoint of low moisture absorption and high mechanical strength. Fig. 1 clearly shows the neat appearance of the three different combinations of the "Q-Tee."

In summarizing the basic advantages of the "Q-Tee" over former types, we must give first priority to its all-around excellent electrical performance. Reduction in size and weight, and the elimination of attendant mechanical problems (responsible for costly callbacks) should appeal to the overworked service technician. —50—

HAMS ACTIVE IN N.W.I.

WITH the re-authorization of ham transmissions in the Netherlands Antilles, the Aruba section of "VERONA" (Vereniging voor Experimenteel Radio Onderzoek in de Nederlandse Antillen) has been reactivated.

This group, although not fully licensed as yet, is making elaborate plans for its membership. A news bulletin, to be edited by George J. Heeringa, is in preparation and will be distributed to the membership to stimulate interest in the resumption of ham activities. —50—

GERMAN RADIO SHOW

AFTER a hiatus of two years, the annual German Radio and Television Exhibition will again be held in Dueseldorf from August 22nd to 31st.

All West-Germany and West-Berlin manufacturers of television and radio receivers, facsimile equipment, and phonograph records are expected to participate in the exhibition.

Featured exhibits at the show will include new ultra-short-wave radio receivers for operation in the spectrum below 30 mc. and television receivers designed to meet the CCIR standard of 625 lines.

New types of short-wave antennas, wire and magnetic tape recorders, and a series of precision test equipment will also be on display.

The German Amateur Radio Club will man a transmitter at the exhibition and special colorful QSL cards will be sent to those reporting reception of this station. —50—

Design Curves
(Continued from page 33)

that this formula is empirical; it applies only to triode-type tubes operated in accordance with the values given in "Resistance-Coupled Amplifier Charts."

$$R_o = 0.17 \mu R_k + 5000 \text{ (ohms)}$$

$$= 0.17 (20) (1500) + 5000$$

$$= 5100 + 5000 = 10,100 \text{ ohms.}$$

Then, since

$$R_o = \frac{1}{\frac{1}{R_p} + \frac{1}{R_g} + \frac{1}{r_p}}$$

and, in this circuit,

$$R_1 = \frac{1}{\frac{1}{r_p} + \frac{1}{R_g}}$$

then

$$R_o = \frac{1}{\frac{1}{R_1} + \frac{1}{R_p}}$$

and

$$R_1 = \frac{1}{\frac{1}{R_o} - \frac{1}{R_p}}$$

$$= \frac{1}{\frac{1}{10.1 \times 10^3} - \frac{1}{50 \times 10^3}}$$

$$= \frac{1}{(0.099 - 0.02) \times 10^{-3}}$$

$$R_1 = 12,700 \text{ ohms.}$$

Since R_1 is approximately $\frac{1}{2} R$ ($R_p = 50,000$ ohms in this example), we will use the curves of Fig. 10. R_1 in this example is the same as R_o in Fig. 10. On the curve for $y = 1$, 3 db of attenuation occurs at an abscissa value of 5.4. We may now solve for the value of condenser, C .

$$2\pi fCR = 5.4$$

$$C = \frac{5.4}{2\pi fR} = \frac{5.4}{2\pi (1500) (50,000)}$$

$$C = 1.15 \times 10^{-8} = 0.0115 \mu\text{fd.}$$

We would select the nearest available value of 0.01 microfarad for C . It is desirable to use a tapered potentiometer in this case. If the usual audio taper is used, the pot should be connected so that the treble attenuation is increased with counterclockwise rotation. These component values are shown in the complete circuit for this example in Fig. 8A.

For a pentode tone-control circuit, let us use a 6SJ7 with a plate load resistor of 0.5 megohm and a grid resistor for the following stage of 1 megohm. The r_p of the pentode is so high that it may be neglected; therefore, the effective value of R_1 is equal to R_p , or one megohm. Since R (0.5 megohm in this example) is equal to $\frac{1}{2} R_1$, we use the curves of Fig. 6. The value of R_1 is the same as R_o of Fig. 6. On

SEE LEO FIRST FOR

hallicrafters

I can SAVE you money . . . Liberal Trade-ins



SPECIAL NOTICE - NEW SX-73 NOW AVAILABLE AND IN STOCK - \$975.00



\$169.50

S-76 RECEIVER

Extra selectivity with double superheterodyne circuit. One RF, two conversion and 3 IF stages. Range 550-1550 Kc, 1.7-34 Mc in four bands. 8 tubes plus voltage regulator and rectifier. Complete with tubes, less speaker.



\$199.50

SX-71 RECEIVER

Double Conversion sharp selectivity, plus built-in NBFM at moderate cost. 11 tubes plus voltage regulator and rectifier. Low down payment.

NAME YOUR TERMS • LOW DOWN PAYMENTS • PERSONALIZED SERVICE

HALLICRAFTERS RECEIVERS AVAILABLE FOR IMMEDIATE SHIPMENT

S-38B	\$49.50	S-72 Portable	\$109.95
S-40B	\$99.95	SX-62	\$289.50
S-81	\$49.50	S-78A	\$89.50
S-82	\$49.50	R-46 Speaker	\$19.95

Famous WRL RADIO REFERENCE MAP 25c



CU on 10-20 & 75 Meters

NEW LOG BOOK 25c

For mobile or fixed station. Spiral binding. Full column log listing all FCC required info. Will accommodate 1,325 stations. "Q" signals, phonetic alphabet, amateur international prefixes.

PHONE 7795

WRITE—WIRE



JUST OFF THE PRESS!

WRL 1952 CATALOG

Send for your copy today. Contains everything new in radio and television. Jam-packed with bargains. Leo I. Meyerson, WØGFO



FREE

WORLD RADIO LABORATORIES
744 West Broadway
Council Bluffs, Iowa

R-7

Please send me:

- Radio Map
- New Catalog
- Used Equipment List
- S-76 Info
- SX-71 Info
- New Log Book

Name

Address

City..... State.....

MAKE THIS YOUR HOME FOR IMPORTANT ! WORK UNDER IDEAL CONDITIONS !

- TEST & INSPECTION ENGINEERS
- ELECTRONIC ENGINEERS
- TV RECEIVER DESIGN ENGINEERS
- FIELD ENGINEERS
- LAB. TECHNICIANS

NEEDED TO WORK ON: YOU BENEFIT FROM high wages, a Radar, G. C. A., Mobile modern, air-conditioned plant, paid Radio, Auto Radio, Airborne vacations and holidays, group insurance Communication & Navigation and a good chance for advancement. Equipment, Television, Housing immediately available in the Antennas, Microwave beautiful suburban and country areas Equipment, Servo Mechanisms and Guided Missiles. that surround the Bendix Radio plant.

Write, Phone or Wire Mr. E. O. COLE, Dept. O

Bendix Radio

DIVISION OF BENDIX AVIATION CORPORATION
BALTIMORE 4, MARYLAND

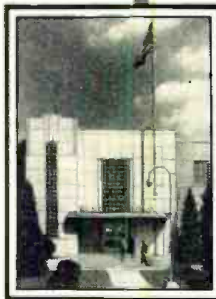



Special Offer On This Complete **RADIO ENGINEERING LIBRARY**

New, Up-To-Date Edition of Famous Library Covers Whole Field of Radio Engineering. Places Latest Facts, Standards, Data, Practice, and Theory At Your Fingertips.

THE five big volumes of the new edition of the Radio Engineering Library now include the very latest facts, standards, data, and practice. This Library will help solve hundreds of problems for designers, researchers, engineers, and students in any field based on radio.

Written by leading radio engineers, these books cover circuit phenomena, networks, tube theory, vacuum tubes, amplification, measurements, etc.—give specialized treatment of all fields of practical design and application. They provide you with a complete and dependable encyclopedia of facts.

5 Volumes • 3872 Pages • 2770 Illustrations

- Eastman's FUNDAMENTALS OF VACUUM TUBES, 3rd Edition.
- Terman's RADIO ENGINEERING, 3rd Edition.
- Everitt's COMMUNICATION ENGINEERING, 2nd Edition.
- Hund's HIGH FREQUENCY MEASUREMENTS, 2nd Edition.
- Henney's RADIO ENGINEERING HANDBOOK, 4th Edition.

SEND NO MONEY

Special Low Price • Easy Terms

On this special offer you get this Library for \$34.50, instead of \$39.00. You save \$4.50 and may pay on easy terms. Mail coupon below to examine the Library FREE for 10 days. No obligation. These books are recognized as standard works; you are bound to need them. So take advantage of this special money saving offer. *Mail coupon at once!* McGraw-Hill Book Co., Dept. RTN-7-52, 327 W. 41st Street, New York City.

McGraw-Hill Book Co., Dept. RTN-7-52
327 West 41st St., New York 18, N. Y.

Send for 10 days' FREE trial, the RADIO ENGINEERING LIBRARY. If not satisfied I will return books. Otherwise I will send \$4.50, plus delivery charges, then; and \$5 a month for 6 months. (Reg. price \$39.00; you save \$4.50).

Name.....

Home Address..... RTN-7-52

City & State.....

WE'LL PAY DELIVERY CHARGES if you enclose \$4.50 first payment WITH coupon. Same return privilege for full refund.

the curve for $y = 1, 3$ db of attenuation occurs at an abscissa value of 1.45. We may now solve for C .

$$2\pi fCR = 1.45.$$

$$C = \frac{1.45}{2\pi fR} = \frac{1.45}{2\pi(1500)(500,000)}$$

$$C = 3.08 \times 10^{-10} = 308 \mu\text{fd.}$$

The nearest available value for C is 330 micromicrofarads. In this case a linear potentiometer will give smooth control. A complete circuit of the tone-control stage designed in this example is shown in Fig. 8B.

(To be continued)

Magnetic Tape

(Continued from page 38)

vibration would cause the needle to jump to another point in the dialogue would, of course, throw us off completely. Our tape recorder is so perfect that we never have any of those difficulties. I actually feel as if it were my very own voice I was hearing rather than a recorded version. Thanks for making it possible for us to do new ideas in the ice show business."

Another interesting application of magnetic tape recording has been brought to our attention. It is the Joint Senate and House Recording Facility installed in the Old House Office Building in Washington, D. C. Under the technical direction of Mr. Robert J. Coar, coordinator, magnetic tape recording facilities are made available to members of the Senate and House, for the government archives, and for government officials' uses in reporting progress to their constituents back home.

In the photograph (lower left) Senator Joseph C. O'Mahoney is being supplied with a copy-reel excerpted from a debate on the Senate floor in which the Senator figured. In all probability, the Senator will make copies of this tape and supply them to radio stations and civic organizations in his home state. These esteemed gentlemen frequently record commentaries for broadcast purposes. Typical is Senator Kefauver who recently recorded his 25,000th mile of magnetic tape, enough words to encircle the globe with tape!

-30-

ARKANSAS HAMFEST

THE Conway Amateur Radio League of Conway, Arkansas is sponsoring an Arkansas Hamfest Sunday, July 13th, at the 6500-acre Lake Conway, 8 miles south of Conway, Ark. on U. S. 65.

The hamfest will be picnic style and all hams in the vicinity are invited to join the festivities. Officials of the Civil Air Patrol have been invited to give a brief resume of communications activities in the CAP.

Further information on this affair is available from Joe G. Robert, WN5TIC, chairman of the hamfest committee.

-30-

Television MASTS

MODEL 130
Telescoping Mast
Economical telescoping 30' steel mast, for simple one man erection. All hardware, including apex roof MODEL mount, pins and guy rings furnished. Weight including all hardware 25 lbs. Collapses to 10' 6".

Your Cost **\$14.95**

MODEL 140
Telescoping Mast
Economical telescoping 40' steel mast same as Model 130, except with extra 2'x10' bottom section. All hardware included. Weight, including all hardware, 35 lbs.

Your Cost **\$19.45**

10% Cash with Order

ALMO RADIO CO.
509 ARCH ST. & 6205 MARKET ST.
Philadelphia, Pa.
6th & ORANGE STS. • Wilmington, Del.
4401 VENTNOR AVE. • Atlantic City, N. J.
1133 HADDON AVE. • Camden, N. J.
219 Highland Ave. • Salisbury, Md.



FREE PRE-AMP.

for G.E. Variable Reluctance cart. Complete, ready to operate.

BECAUSE...

we want you to be one of the thousands of our satisfied customers.

Famous GENERAL ELECTRIC Triple Play VARIABLE RELUCTANCE CARTRIDGE

Model RPX050
plays 33, 45, 78 r.p.m. records without changing its position in the arm. Simply depress and turn red button to change sapphire stylus, which is replaceable.

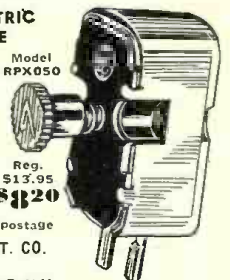

Remit with order, we pay Postage
JAN ELECTRONIC DIST. CO.
DEPT. RNI
222 Fulton St., New York 7, N.Y.

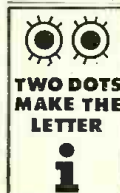

GET in on the fun of operating your own licensed transmitter. I guarantee you will memorize the International Morse Code alphabet within two hours by my simple picture method, or return method within five days and I will refund your money.

COMPLETE COURSE ONLY \$1
NOTHING ELSE TO BUY!
OTTO LUTHER, NEW PRESTON, CONN.

BUILD YOUR OWN GEIGER COUNTER!

It's EASY to build your own Searchmaster Geiger Counter with this COMPLETE kit. Contains everything you need! Headset, tubes, batteries, metal case. Fully guaranteed! Sensitive to both beta and gamma radiation! Illus. instructions. FREE radioactive specimen.



MODERN SCIENCE LABS \$29.95
8049 St. Clair • North Hollywood, Calif.

Write for FREE Catalog "Creative Tools for the Scientist of Tomorrow"



PERHAPS it is time we reported, in reviewing commercially-available pre-recorded magnetic tape reels, some of the mechanical aspects of the tapes. In attempting to make it convenient for the user to play his magnetic tape programs, *A-V Tape Libraries* has introduced several unusual "gadgets," including a couple of novel and interesting packaging "tricks."

On each reel, at the center of the reel, there is affixed a 1½" diameter circular label containing the company name and trademark, and a space whereon is stamped the number of the reel, thus preventing loss or confusion. This same number is stamped on the edge of the tape box. An adhesive tab is affixed to the free end of the tape to seal it when not in use, thus avoiding loose ends. A large label is affixed to the back of the box and contains the program number, a simple explanation of the number system employed, and a list of the selections contained on that particular reel. Instructions and copyright notices are printed on the inside of the box while the box itself is of the hinged-type.

Tapes of the Month

A-V #1012 (CONCERT HALL)

Part 1. Overture to the Tempest (Tchaikowsky)

Symphony No. 6 ("Pastorale") (Beethoven)
Part 2. Symphony No. 6 ("Pastorale") (Concluded)

Austrian Symphony Orchestra, Kurt Woss, conductor

(Available in 7.5" single-track; 7.5" double-track; or 3.75" double-track)

The manufacturer claims that the fidelity of the double-track tapes is exactly the same as that of the single-track tapes, no differences being detectable either by the unaided ear or with laboratory instruments.

This particular reel has both good and bad points, musically and technically. Taking the bad points first, this critic was rather disturbed by the performance of the Tschaikowsky overture. Perhaps it was a matter of budget to which art was sacrificed. In this particular performance, it appeared as though the musicians were not allowed sufficient time for rehearsal to permit them to perform as a group. During the emotional passages, moments when there must be unison, the recording sounded like a group of soloists rather than a symphony. Very disturbing also is the microphone placement for this recording; much too much presence; too many solo microphones. The recording engineer is to be condemned for over-use of solo-presence microphones, but is to be commended for his control of the levels and balances. The Beethoven performance is adequate. The recording, from the standpoint of fidelity and distortion, is wonderfully

July, 1952

Tube Prices SMASHED!



Dependable performance and economical service are two outstanding features overshadowing even these sensationally low-low priced, high quality, fully guaranteed tubes. Every tube must pass rigid tests in our plant. You can compare RAD-TEL tube performance and quality with any standard tube anywhere.

80% to 90% off list!

All Tubes Individually Boxed! Same Day Service!

Check this list for Fully Guaranteed Tubes

Type	Price	Type	Price	Type	Price	Type	Price	Type	Price
OB3	.98	354	.46	6BC5	.44	65J7GT	.41	125J7	.45
1A5GT	.48	3V4	.47	6BD5GT	.59	65K7GT	.41	125K7GT	.48
1A6	.59	5AZ4	.39	6BE6	.39	65L7GT	.48	125L7GT	.47
1A7GT	.47	5U4G	.40	6BF5	.41	65N7GT	.52	125N7GT	.52
1AB5	.59	5V4G	.54	6BF6	.37	65Q7GT	.37	125Q7GT	.44
1B3GT	.49	5X4	.40	6BG6G	.94	6T8	.56	125R7	.49
1B5	.59	5Y3GT	.32	6BH6	.46	6U5	.44	1486	.40
1B7GT	.59	5X4	.32	6BJ6	.39	6V6GT	.39	198G6G	.95
1C5GT	.43	5Y4G	.35	6BL7GT	.59	6W4GT	.44	19T8	.79
1E7GT	1.09	3Z3	.39	6BQ6GT	.59	6W6GT	.44	258Q6GT	.62
1H5GT	.40	6A3	.59	6BQ7GT	.72	6X4	.37	25L6GT	.39
1L4	.46	6A7	.59	6C4	.37	6X5GT	.37	25Z5	.40
1L6	.43	6A8	.50	6C5GT	.39	6Y6G	.48	25Z6GT	.37
1LC5	.51	6AB4	.44	6C86	.44	7A4	.47	32L7	.85
1N5	.46	6AG5	.43	6CD6G	1.11	7A7	.48	35B5	.40
1P5	.57	6AJ5	.90	6E5	.48	7AF7	.53	35C5	.39
1Q5GT	.69	6AK5	.75	6F5GT	.39	7B4	.44	35L6GT	.41
1R5	.45	6AL5	.38	6F6G	.39	7C6	.40	35W4	.37
1S5	.39	6AQ5	.39	6F6GT	.37	7F7	.59	35Z4	.37
1T4	.45	6AQ6	.37	6G6G	.52	7X6	.39	35Z3GT	.37
1T5	.53	6AR5	.37	6H6GT	.41	7X7	.69	41	.42
1U4	.45	6AS5	.46	6J5GT	.37	12A8GT	.46	42	.42
1U5	.39	6AT6	.37	6J6	.52	12AL5	.37	43	.55
1X2	.63	6AU6	.38	6J7G	.43	12AT6	.37	45	.55
2A5	.47	6AV6	.37	6K5GT	.48	12AT7	.56	50B5	.39
2X2	.59	6AX4	.53	6K6GT	.37	12AU6	.38	50C5	.39
3A4	.45	6B4G	.64	6K7G	.44	12AU7	.43	50C6	.59
3E5	.46	6B5	.64	6K7GT	.44	12AV6	.39	50L6GT	.41
3Q4	.48	6BA6	.39	6L6G	.64	12AV7	.59	50X6	.53
3Q5GT	.49	6BA7	.57	6Q7G	.45	12AX4	.48	50Y6GT	.48
				6Q7GT	.45	12AX7	.48	50Y7	.50
				6S4	.38	12BA6	.38	70L7GT	1.09
				6S8	.53	12BA7	.46	75	.41
				6SA7GT	.43	12BH7	.52	76	.44
				6SD7GT	.41	12K7GT	.46	78	.47
				6SG7GT	.41	12Q7G	.39	80	.35
				6SH7GT	.73	12SA7GT	.44	117Z3	.37



"Integrity Is Our Chief Asset"

TERMS

A 25% deposit must accompany all orders—balance C.O.D. All shipments FOB Newark warehouse. Orders under \$10—\$1.00 Handling Charge. Subject to prior sale.

Now In New, Enlarged Quarters at
**115 COIT STREET
IRVINGTON 11, N. J.**

BMC TRANSCRIPTION PLAYER

FOR HIGH FIDELITY RECORD REPRODUCTION



16" Synchronous
Model TP16E \$126.00
Model TP16D \$84.00
Model TP12H \$58.50
(F.O.B. Port Chester, N. Y.)

Export: Rocke International Corporation.
13 East 40th Street New York 16, N. Y.

Meets the rigid demands of Army-Navy requirements, even Navy salt-spray test. Used by U. S. Signal Corps all around the world, in Veterans' Hospitals, and most radio stations, transcription services, etc., for realistic reproduction of transcription records up to 16 inches, 78 and 33½ r.p.m. It conforms fully to the N.A.B. performance standards.

Descriptive Bulletin HS3-1, upon request.
Available Through Authorized Jobbers.

RADIO-MUSIC CORPORATION
PORT CHESTER • NEW YORK

USE PHOTOFAC

the world's best Radio and TV Service Data...



WE'LL PROVE YOU'LL SAVE TIME and EARN MORE WITH PHOTOFAC

FREE Service Technicians: We'll send you any Photofact Folder listed in the "PF INDEX and Technical Digest." If you haven't a... Index, get a free copy from your local Photofact distributor or write for it today. To obtain Free Folder, be sure to state Photofact Set and Folder Number as shown in the Index.

NOW—learn for yourself how PHOTOFAC makes your Radio and TV work quicker, easier, more profitable! Just get and use an actual PHOTOFAC Folder. Discover why over 35,000 successful service technicians count on this invaluable data daily. No other service gives you PHOTOFAC's completeness, accuracy, uniformity and lowest cost. PHOTOFAC is the only Radio-TV service data prepared from laboratory analysis on the actual equipment. Get your FREE Folder now. Examine, use, compare. See why you can't afford to be without PHOTOFAC!

NOTE: Our FREE Folder offer is limited to Service Technicians only. Attach coupon below to your letterhead and mention your jobber's name. Experimenters and others may obtain the Photofact Folder by remitting amount shown below.

HOWARD W. SAMS & CO., INC.

HOWARD W. SAMS & CO., INC.
2201 E. 46th St., Indianapolis 5, Ind.

I am a Service Technician. Send me Free Folder No. which appears in Photofact Set No. (as listed in the PF Index).

I am an Experimenter. Enclosed \$ Send me Folder No. which appears in Photofact Set No. (TV—\$1.00. AM/FM—50c. Record Changer or Communication Receiver—75c)

Name.....

Address.....

City..... Zone..... State.....

EASY PAY PLAN!

PAY AS YOU EARN! Ask your distributor about this amazing plan. Only \$18.39 puts the entire profit-boasting Photofact library in your shop now!

clean. Thanks are due the tape duplication engineer for allowing a generous length of leader tape on this one.

A-V #1013 (CONCERT HALL)

Part 1. Symphony No. 2 in D Major, Opus 73 (Brahms)

Austrian Symphony Orchestra, Hans Wolf, conductor

Part 2. Symphony No. 2 in D Major, Opus 73 (Brahms) (Concluded)

Overture to Ruy Blas (Mendelssohn-Bartholdy)

Austrian Symphony Orchestra, George Singer, conductor

William Tell Overture (Rossini)

Austrian Symphony Orchestra, Kurt Woss, conductor

(Available in 7.5" single-track; 7.5" double-track; or 3.75" double-track)

Those of us who consider Brahms a "must" in our library of musical recordings will delight in these two recordings. The recording engineer masterfully blended the strings and bass, making the piano passages sweetly comforting to the listener, disarming him so effectively that the forte passages which quickly follow exert a swift emotional impact, as I am sure the master, Brahms, intended them.

A-V #1014 (CONCERT HALL)

Part 1. Concerto for Piano and Orchestra No. 20 in D Minor, K 466 (Mozart)

Salzburg Mozarteum Orchestra, Fritz Weidlich, conductor and soloist

Part 2. Symphony No. 4 in C Minor ("Tragic") (Schubert)

Austrian Symphony Orchestra, Kurt Woss, conductor

(Available in 7.5" single-track; 7.5" double-track; or 3.75" double-track)

For some reasons, this one differs from the others in fidelity. It is so heavy with bass that it required roll-off during the playback. However, I fear that the tape was recorded close to magnetic saturation with resultant distortion. Lots of audio level on this one—but distorted. As for the performance, the piano solo passages are truly excellent. The artist, Fritz Weidlich, performs with true dexterity and understanding of Mozart. The Salzburg Mozarteum Orchestra, under

his direction, has captured the Mozart mood. Note that, if you are building your library with the "A" series, Parts 1 and 2 are on separate reels and if you do not want both of these works, you can obtain them separately since they are each complete on one reel.

A-V #1015 (CONCERT HALL)

Part 1. Concerto for Violin and Orchestra in D, Opus 35 (Tchaikowsky)

Austrian Symphony Orchestra, Kurt Woss, conductor, Michele Auclair, violinist

Part 2. 1812 Overture, Opus 49 (Tchaikowsky) Les Preludes (Liszt)

Austrian State Symphony, George Singer, conductor

(Available in 7.5" single-track; 7.5" double-track; or 3.75" double-track)

This is one of the better reels (speaking only of Part 1). The recording quality is both technically and musically superb; however, something went wrong with Part 2. The copy received for review was full of "wow" or "flutter," making the listening quite uncomfortable. It is gratifying to know that the critic is not receiving specially-selected reels for review. Perhaps mine was a "lemon."

A-V #1016 (CONCERT HALL)

Part 1. Symphony No. 7 in A, Opus 92 (Beethoven)

Austrian State Symphony, Kurt Woss, conductor

Part 2. Symphony No. 7 in A (Concluded) Concerto for Violin and Orchestra, No. 1 in D, Opus 6 (Paganini)

Austrian State Symphony, Kurt Woss, conductor, Ivry Gitlis, soloist

(Available in 7.5" single-track; 7.5" double-track; or 3.75" double-track)

This reel contains the best microphone pickup placement of all the reels reviewed this month. In addition to the pleasant, full tone achieved, this reel also contains the widest dynamic range of all those yet heard. It is characteristic of the others that the engineer "rides gain" just a bit too closely, not taking as much advantage of his recording medium as he can. However, this one is much better. Perhaps another engineer was assigned to this particular recording job. —30—

An artist's sketch of the "steerable" radio telescope which will be built for Manchester University at Jodrell Bank, Cheshire, England. Costing the equivalent of \$940,800, the new unit will have a parabolic dish 250 feet in diameter, and will measure 185 feet to the top of the horizontal axis. The radio telescope will weigh over 1270 tons. The new giant radio telescope, said to be the world's largest, will permit the expansion of radio astronomy techniques into more distant regions.

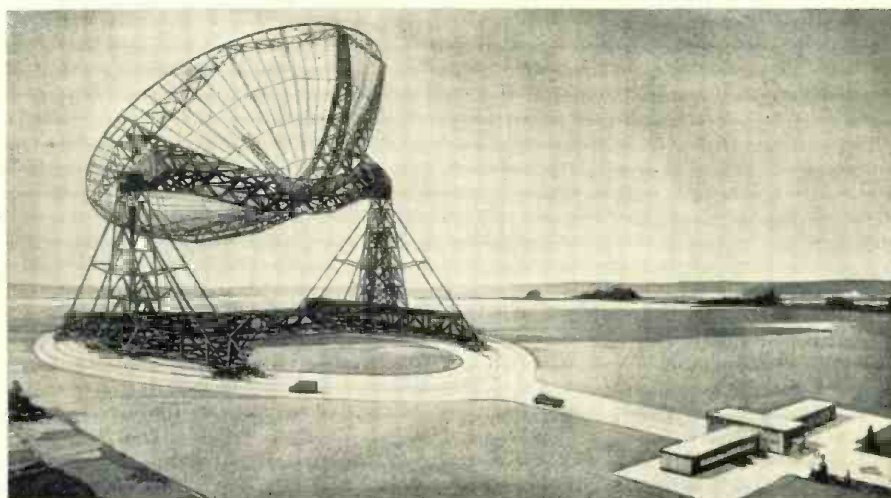

Eliminating TVI

(Continued from page 31)

At the receiver, try lining the inside, top, and bottom of the cabinet with copper screening. Ground the screen to the chassis and to a good outside ground. A low-pass filter for the a.c. power line and a high-pass filter for the lead-in will eliminate many cases of diathermy interference. In severe cases, a tuned trap, resonated at the equipment's operating frequency (and completely shielded), may help.

TYPE: Industrial Interference.

EFFECT: The general effect, as well as the remedies, are the same as for diathermy equipment.

SOURCE: Ultraviolet sterilizing or paint-drying lamps, r.f. heating equipment, neurosurgical or radiotherapy equipment, etc.

TYPE: R.F. Interference.

EFFECT: Herringbone pattern (Fig. 4) or black and white diagonal bars (Fig. 3). These may vary or change direction. If transmission is by code, the picture may flash, roll, wash out, or invert (become negative in polarity) with each dot and dash. This may also be accompanied by irregular popping noises in the sound.

SOURCES: Short-wave transmitters (FM broadcast, international short-wave, public utilities, police, mobile telegraph, point-to-point, aviation, and other emergency services).

REASON: Operating frequency or harmonic of interfering station falls within the r.f. or i.f. frequency limits of the receiver.

REMEDIES: Try installing a wave trap between the lead-in and receiver terminals, as close to the tuner as possible. Commercially-built traps may be used, but a simple 1/2-wavelength shorted stub or 1/4-wavelength open stub (made of 300-ohm twin-lead) will usually be just as effective. Also try reorienting the antenna, rerouting the lead-in, or shifting the receiver to a different location. Shielded, properly-grounded transmission line is one answer.

TYPE: R.F. Interference.

EFFECT: Both the effect and the reason are the same as those just described.

SOURCE: Amateur radio stations. (If the receiver does not have good shielding or if it has no r.f. stage, it can pick up amateur stations legally operating in the 20, 10, and 2-meter bands. Invariably, the amateur operator is willing to cooperate with you in eliminating the interference, although his equipment may be operating properly. In a few cases, inadequate shielding or tuning adjustments at the station are to blame. If properly notified, the amateur will be glad to correct it.)

REMEDIES: If you are able to identify the signal by call-letters or by checking with hams in the community, contact the amateur and explain the difficulty. In most cases, shielding the

ANTENNA EQUIPMENT

MAST BASE—INSULATED



MP-132 BASE—as illustrated at left. 1" heavy coil spring. 2" insulator. Overall length: 11 1/2". Weight: 2 1/2 lbs. Price.....\$3.95

MAST SECTIONS FOR ABOVE

BASE—Tubular steel, copper coated, painted, in 3 foot sections, screw-in type. MS-63 can be used to make any length, with MS-52-51-50-49 for taper. Price for any section.....50c Ea.

BLOWERS—115 VAC 60 CYCLE

COMPACT TYPE: 108 CFM, motor built inside squirrel cage, 4 1/2" intake; 3 3/8" x 3" Dis. Comp. size: 4 1/2" W x 8 3/8" H x 8 3/4" D. Order No. RN-800.....\$13.50

FLANGE TYPE: 140 CFM, 3 1/2" Intake; 2 1/2" Dis. Comp. size: 7 1/2" W x 7 1/4" H x 6 3/4" D. Order No. RN-865.....\$12.95

SINGLE TYPE: 100 CFM, 2 1/4" Intake; 2" outlet. Complete size: 6" x 6". Order No. RN-520.....\$7.99

DUAL TYPE: 100 CFM, 4" Intake; 2" Dis. Each Side. Complete size: 8" x 6". Order No. RN-800.....\$12.95

FLANGE TWIN: 275 CFM, 4 1/2" Intake; 3 1/4" x 3" Dis. Comp. size: 11 1/4" W x 8 3/8" H x 8 3/4" D. Order No. RN-134.....\$20.95

BC-223 TRANSMITTER—With Tubes & TU-17 Tuning Unit. Gov't Reconditioned.....\$26.50

CABLE—Transmitter to Power Supply.....\$2.00

3500-3250 KC.—TU-17—2000-3000 KC. TU-25—\$3.50 EACH

OPERATING MANUAL for BC-223AX.....2.50

SHOCK MOUNTING for PE-125.....1.50

FT-173 MOUNTING for BC-223.....2.50

POWER SUPPLIES:

VIBRATOR TYPE—6 Volt DC input; output 230 Volt DC 50 MA.—not filtered—w/tube. Ideal for Command Receiver operation as receiver is filtered internally. Size: 4 1/2" x 4 1/4" x 3 3/4".....\$4.95

PE-157 POWER SUPPLY—2 Volt Vibrator Supply, operates from BB-54 2 Volt Batteries mounted in Case. Output voltage 1.4 V. 1/2 Amp 125 V. 50 MA. Less Battery, Speaker, & External Power Cord—with Vibrator.....\$4.95

BB-54 2 Volt Dry Battery.....2.95

AMPLIFIERS

BC-367—Uses two 6V6GT Tubes. Carbon Mic. Input. Tapped output. Ideal for Intercom. With Tubes & Schematics, less Dyn. and Case—Used.....\$4.95

BC-605—With Tubes, Used.....3.95

BC-109—W/Tubes—New: \$4.95.....Used: 3.95

BC-347—Less Tubes—New: \$2.95.....Used: 1.95

GEAR MOTOR

110 Volt 60 cycle for slow motion light displays or production work. Machine cut brass gears. Size: 5 1/2" H. x 2 1/2" W. x 1 1/2" D. Shaft: 3/16" x 1". Choice of 3, 8 or 24 RPM. Specify RPM desired. Price.....\$8.75

Address Dept. RN • Minimum Order \$5.00 • Prices F.O.B., Lima, O. • 25% Deposit on C.O.D. Orders

DYNAMOTORS:

DYNAMOTOR and BLOWER: 9 Volts DC input; output 450 Volts 60 MA. 4500 RPM. At 6 Volts DC input; output 260 Volts 65 MA. 3000 RPM. \$4.95 Price.....

INPUT:	OUTPUT:	STOCK No.:	PRICE:
14 V. DC	600 V. 300 MA.	BD-86	\$9.95
12 V. DC	220 V. 70 MA.	DM-24	6.95
12 V. DC	220 V. 100 MA.	DM-18	4.95
14 V. DC	375 V. 150 MA.	DM-375	8.95
14 V. DC	330 V. 135 MA.	DM-330	7.95
14 V. DC	500 V. 500 MA.	DB-59	14.95
12 or 24 V. DC	275 V. 110 MA.	USA/0516	3.95
12 V. DC	250 V. 50 MA.	DM-25	8.95
28 V. DC	250 V. 60 MA.	DM-32	(Used) 2.95
12 or 24 V. DC	500 V. 50 MA.	USA/0515	3.95
14 V. DC	1000 V. 350 MA.	BD-77	8.95
28 V. DC	1000 V. 350 MA.	PE-73	(Used) 6.95
28 V. DC	250 V. 60 MA.	PE-86	5.95

CORDS—CABLES

CD-501 Cord 1/4" 35 Generator	\$2.50
CD-318 Cord w/PL-68 & SW-141 & JK-48P	.89
CD-307 Cord—6.5 Ft. w/PL-55 & JK-26	.89
CD-604 Cord w/C-410 Trans. & PL-54 Plug	.89
CD-365 Cord for LP-21 Loop	1.50
MC-215 Tuning Shaft for 274N	2.00

TRANSFORMERS AND CHOKES

TRANSFORMERS—110 V. 60 CYCLE PRIMARIES:	
Sec. 6.3 Volt 1 Amp.	\$1.25
Sec. 24 Volt 1/2 Amp.	1.50
Sec. 24 Volt 1 Amp.	1.95
Sec. 24 Volt 6.5 Amp.	5.95
Sec. 6-24 or 30 Volt 8 Amp.	5.95
Sec. Two 12 V. 4 A. windings—gives 12 V. 8 A. or 24 V. 4 A.	5.95
Sec. 6.3 V. 6 A.—6.3 V. 4 A.	2.25
Sec. 440 VCT/70 MA—5 V/2 A—6.3/4 A.	3.35
Sec. 700 VCT/120 MA—5 V/3 A—6.3/4 A. 32 V./2 A.	4.75
Sec. 490 VCT/60 MA—5V/2 A—6.3/4 A. 6.3/2 A	3.25
Sec. 460 VCT/90 MA—5 V/3A—6.3/4 A.	3.75

CHOKES

8 Henries 500 MA Filter, 5000 V. Ins.	\$8.95
7.5 Henries—300 MA., 60 ohms, 5000 Ins.	6.95
6.2 Henries—300 MA., 82 ohms, 5000 Ins.	4.95
15 Henries—300 MA., 260 ohms.	4.75
8 Henries—500 MA., 80 ohms, 5000 Ins.	8.95
4-12 Henries—300 MA., 110 ohms, 1000 Ins.	3.95

AERIAL WIRE—Phosphorus Bronze #16 Stranded. 200 lb. test. Weatherproof. 150 Ft. on Reel. RL-3 w/Clips.....\$1.50
Telephone Wire—3 Cond. copper & steel, 525 Ft. 5.95

85 KC IF COIL 7267—1/BC-453.....\$1.50 Ea.
RFO—85 KC.....75c 1415 KC—1P.....1.50 Ea.
TU-7-8-9-10-26 for BC-101/BC-375.....Used: 3.95

MISCELLANEOUS

Leg and Seat Assy. for Hand Generator....\$ 3.50
BC-230 Transmitter, with Tubes.....4.95
T-20 ARC-5/BC-457 Trans.—4 to 5.3 MC.....12.95
RT-7/APN-1 Transceiver—Excelln. & Cord.....18.95
R-1/ARR-1 Rec. f/conversion to 220 MC.....4.95

FAIR RADIO SALES

132 SOUTH MAIN ST.
LIMA, OHIO

WE'LL PAY SWEET PRICES for Your RADIO & AIRCRAFT EQUIPMENT

We want to buy your parts or equipment—and we'll pay top dollar to get it! Just send us the dope on your equipment, its type and condition—and your asking price. You'll get fast, profitable action. It's just like taking "Candee" from a baby! Write today.

CANDEE-AIRCO, Dept. T-3
3306 Burbank Blvd. Burbank, California

RADIO COURSES

- RADIO OPERATING • CODE
 - RADIO SERVICING • ELECTRONICS
 - F.M. TELEVISION
 - PREPARATION FOR CIVILIAN, MARITIME, ARMY AND NAVY LICENSE REQUIREMENTS.
- Write for Catalog T.S.

TRADE & TECH. SCHOOL 15 W. 63 St., N. Y. 23
ENdicott 2-8117

Available Now . . .

ARC4 VHF TRANSCEIVERS

A sensational all-purpose unit, 2 Meter or Civilian Defense Frequency range 140-144 MCs. Easy to convert to 148 MCs. Less tubes and dynamotor only.

\$19.95

RADCOM BUYS ENTIRE PARTS INVENTORY of FINCH FACSIMILE

We are setting up a complete inventory by part number of all integral genuine FINCH PARTS and will be equipped to handle all your replacement requests IMMEDIATELY.

WANTED

RADCOM pays highest prices for surplus equipment, parts and tubes. We need TCS-7 and up; SCR 274-N; SCR 399 equipment; SCR 508 equipment; BC 312, 342 and 348 Receiver; SCR 522 equipment; SCR 211 frequency meters and RA-34 rectifiers.

Bigelow 2-6666

Always Right With Earl White

RADCOM Engineering Co. 8 Livingston St. Newark 3, N. J.

TV RECEPTION UP TO 200 MILES

ON ACTUAL FIELD TESTS WITH
NEW DX630 CHASSIS

USING THE CASCADE TUNER

will operate in fringe areas or in localities remote from TV broadcast stations up to 200 miles.

HAS 4 MICROVOLT SENSITIVITY—10 times any other TV receiver. Will pick up distant stations without use of booster or special antenna arrays—and with less noise. Will operate any tube including 24" greater brilliance, improved keyed AGC circuit (eliminating flickering and fading). Uses the best materials with a high factor of safety to insure trouble-free operation. STD. RTMA GUARANTEE free replacement of defective parts or tubes for 90 days. Completely factory-wired chassis ready to operate with 12" P.M. Speaker. **\$144.50**
Price Including Excise tax.

TELEVISION PICTURE TUBES Standard Brands

ONE-YEAR GUARANTEE

12½" (Black or White)	\$22.50	Glass 16" Round (Black)	\$28.50
Glass 14" Rectangular (Blk.)	\$23.50	Glass 16" Rectangular (Blk.)	\$27.25
17" Rectangular (Blk.)	\$25.95		
19" Round (Blk.)	\$39.95		
20" Rectangular (Blk.)	\$38.35		
21" Rectangular (Blk.)	\$42.95		
24" Metal	\$67.25		

Console cabinet of beautiful design made of the finest veneers and good finish. Size 39" high x 24" wide x 22¼" deep. Finished in mahogany or walnut. Cut for 630 chassis with 12" speaker; will take either 16, 17, or 20" tube. (Please Specify Size.)

Price including mask and excise tax.....\$43.95
Extra for glass.....\$2.75

For the various other cabinets in our large selection we will furnish photos and other NECESSARY INFORMATION, ON REQUEST.

TELEVISION COMPONENT SPECIALS

"Faster Than Hotcakes!"

That's how these original 13-channel RCA Tuners are selling. Uses 3-6J6 tubes. Sold as is, less tubes, only **\$3.95**

NEW STANDARD COIL CASCADE TUNER

The tuner that will give you stronger, better and clearer reception. Uses 1-6J6 and 1-6BK7 Inter-carrier **\$19.95**

New—DuMont Tru Focus Conversion Kit

Convert your old set for even focus over entire screen.

DuMont 70" Yoke, Model Y2A1—distributed winding	\$6.57
DuMont 70" Flyback Transformer Model H1A1	\$6.57
DuMont Linearity Control—for above units	\$0.75
DuMont Width Coil—for above units	\$0.75

AUTOMOBILE RADIOS

Custom-Built for any of the following 1949-1950-1951-1952 automobiles—Dodge, Plymouth, Chevrolet, Hudson, Studebaker, Henry J. and Ford. Every Radio is a powerfully built, 6 tube superhet with R.F. Stage and 3 gang condenser. Each radio is Custom Built and can be mounted in the dashboard within 4 minutes. Your price including aerial \$38.47 ea.

All Merchandise Subject to Prior Sale. All Prices Subject to change without Notice.

WRITE FOR COMPLETE CATALOG N-5

EDLIE ELECTRONICS INC.

154 Greenwich St. New York 6, New York

receiver or installing a wave trap will cure the trouble. Readjustment and installation of harmonic filters at the transmitter will usually clear up the interference if it is originating there.

NOTE: On many occasions, amateur stations are blamed for interference which actually is caused by other short-wave services. If the interference is not readily located, check in the neighborhood or community for mobile telephone or governmental relay stations, or transmitters operated in military reserve training centers.

TYPE: FM Receiver Radiation.

EFFECT: Similar to that caused by oscillator radiation from TV receivers (Figs. 1 to 5) but usually affecting only Channels 5 and 6.

SOURCE: Local oscillator radiation from a nearby FM receiver.

REASON: 2nd harmonic of FM oscillator falls within the affected channels.

REMEDIES: Same as that for TV oscillator radiation. (A piece of 300-ohm twin-lead, cut as a quarter-wavelength section of the FM oscillator's frequency and used as an open-stub wave trap, sometimes will eliminate this trouble.)

TYPE: Co-Channel Interference.

EFFECT: "Windshield-wiper" effect (picture from the interfering station continually moves back and forth, sometimes up and down, behind the desired station's picture.)

SOURCE: Another TV station operating on the same channel.

REASON: The interfering signal is noticeable when its strength is 1 percent or more of the desired station's strength. Movement is caused by slight differences in blanking and sync signals at the two stations.

REMEDIES: Reception of either station can be extremely difficult, especially if the customer lives in a weak-signal area about half-way between each station. Try a yagi, "Radarray," "Para-con," "Double-V," or other similar directional antenna and adjust carefully for maximum rejection of the undesired station. If both stations are desired, install a rotator.

NOTE: This type of interference is sometimes possible between two strong local stations operating on different channels. In this case, try a wave trap or check the i.f. trap adjustments (one of these may be defective or mis-adjusted).

TYPE: AM Broadcast Station Interference.

EFFECT: Black horizontal bars (Fig. 1), vertical bars (Fig. 2) or mesh (Fig. 5). If the interfering signal is strong enough, the video signal may invert or blank out entirely.

SOURCE: Nearby AM broadcast transmitter.

REASON: AM frequencies are included in the video i.f. passband. Powerful local stations may ride through if their signals are sufficiently strong, are not trapped out, or if the receiver is not adequately shielded.

REMEDIES: If the trouble appears suddenly, try to identify the station by

RADIO Surplus Buys

CONTACT
MIKE ASSEMBLY
BRAND NEW!

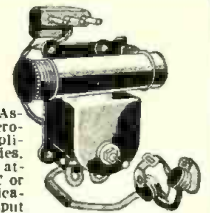

Complete Contact Mike Assembly includes: Two microphones, on-off switch, amplifier transformer, batteries, battery case. Connector to attach to any radio. AC, DC or battery portable. Amplification up to full volume output of radio or sound system used. FB for watch or clock repair. Diesel engine **\$3.95** etc. Specially Priced at..... Postpaid

TUNER FROM
NAVY "BN"
EQUIPMENT

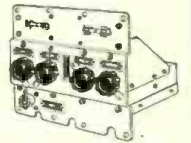

Simply modified into 2-meter converter for car or communications receiver. Uses 1-6J6, 1-6BH7, 1-9006, 1-6J5 (Not Furnished). Slug is tuned from 157 to 187 Megacycles. Includes schematic diagram for "BN" equipment. Now—A New LOW Price..... **\$4.95**

ALL EQUIPMENT F.O.B. PASADENA UNLESS OTHERWISE SPECIFIED. PLEASE ENCLOSE FULL AMOUNT WITH ORDER

C & H SALES CO.

BOX 356-YT East Pasadena Station, Pasadena 8, Calif.



SOUND POWERED
PHONES RCA-MI-2454

Complete with 24' of Rubber Covered Wire. NEW EXPORT PACKED Shipping weight 6 lbs.

**\$9.95 per set
2 for \$19.50**
EACH SET GUARANTEED

Brand New, Gov't. Cost. \$42.00
INCLUDE POSTAGE WITH ORDER

McCONNELL'S
3834 Germantown Ave.
Phila., Pa. RA 5-6033



Be a
TELEVISION CAMERAMAN

Work with "live" equipment in station-size studios. TRAIN with "Big Name" TV instructors. Graduates employed at leading TV stations. Easy payment plan. Free National Placement Service. Housing accommodations secured. Approved for Vets.

Send for FREE Booklet R
TELEVISION WORKSHOP

1782 Broadway, New York 19, N. Y. PLaza 7-3721

\$ RESISTOR KITS \$

100 ASSORTED POPULAR SIZES

½ Watt, 10% All Latp Type Insulated IRC—Stackpole—Speer **2.00**
—Ohmite. Cash with Order. Shipped Pre-Paid

DRILLICK ELECTRONIC SALES CO.

\$ 5281 W. Pico Blvd. Los Angeles 19, Calif. \$

RADIO ENGINEERING DEGREE IN 27 MONTHS

Radio engineering is a big field. There's room for you in it—if you're good. Get first-class training at Indiana Tech. intensive specialized course, including strong basis in mathematics and electrical engineering, advanced radio theory and design, television, electronics, modern laboratories. Low rate. Also B.S. DEGREE IN 27 MONTHS in Aeronautical, Chemical, Civil, Electrical and Mechanical Engineering. G.I. Gov't approved. Enter Sept., Dec., March, June. You can earn part of your expenses right here in Fort Wayne while you are studying.

INDIANA TECHNICAL COLLEGE

972 E. Washington Blvd., Fort Wayne 2, Indiana
Please send me free information on B.S. Engineering Degree in 27 months as checked.

Radio-Television Aeronautical
Civil Mechanical Electrical

Name

Address

RADIO & TELEVISION NEWS

call-letters or by the program. (This is sometimes possible by varying the fine-tuning control.) Then report the trouble to the chief engineer or engineering department. (While the trouble may be in the receiver, it may also be due to temporary trouble at transmitter. A check might save unnecessary work for you. If the interference is due to some change in the receiver or has always been present due to the receiver's proximity to the transmitter, install a wave trap in the lead-in (as close to the tuner as possible). Use a parallel-resonant trap (range 540-1600 kc.). Shielding here is extremely important. (If interference is very strong, shield the bottom of the TV chassis and possibly the r.f., i.f., and video amplifier stages. Copper screening or aluminum foil is best for this purpose. Make sure the screen makes good, firm contact with the chassis. In extreme cases, line the entire cabinet with copper screening. (This will often relieve or eliminate interference coming from several different sources.)

TYPE: R.F. Interference.

SOURCE: High-power police stations operating in the 45 mc. band. Receivers using 45 mc. i.f. frequencies will be wide open to interference from this source when and if these services are placed in operation.

REMEDIES: These will have to be worked out with one or more of the remedies just described. A combination of directional antenna, shielded lead-in, proper grounding, etc., may be required.

Interference similar to that described in this article can also be caused by conditions *inside* the receiver. These and other similar types should not be overlooked.

TEST TAPE USE

By J. GORDON HOLT

FOR maximum high frequency response from a high-quality tape recorder, plus the assurance that its tapes will play back equally well on another machine, it is essential that the slits on both the record and playback heads be exactly at right angles to the direction of tape travel.

Therefore, whenever the record and playback heads have been removed from the recorder they must be realigned with the tape when they are replaced.

A test tape that greatly simplifies this adjustment may be made by recording a 15,000 cycle signal on a tape, using a new full-track machine on which the heads may be trusted to be in precise alignment.

To adjust a replaced playback head, the test tape is played through the head and the adjustment is made for maximum output from the head.

The record head may then be aligned by recording a 15,000 cycle tone onto another tape and using the output level from the previously aligned playback head to adjust the record head.

If the recording head is not putting the signal on the tape in such a way that it passes the aligned playback head exactly at a right angle there will be a definite loss of high frequencies.

-30-

TRIO the TROUBLE PROOF TV ROTATOR



For years of dependable, unfailing service—in good weather and bad—you can't beat the new TRIO Model TR-2M TV ROTATOR and DIRECTION INDICATOR.

Sturdy and completely weatherproof, the TRIO ROTATOR will support the heaviest TV arrays—even in 80 MPH winds! Its sound design and construction has been proven by three years of extensive field testing under every extreme of weather. The TRIO ROTATOR will not freeze up!

Two 24 volt motors are used—one for each direction of rotation. Thus, each motor operates just 50% of the time—cannot burn out! Positive electrical stops at both ends of 360° turn eliminates lead damage.

The TRIO ROTATOR is precision built to extremely close tolerances. Housing is die-cast aluminum for greater strength, lighter weight and perfect alignment of parts. Will fit any mast, 1" to 2" diameter.

The smartly styled TRIO DIRECTION INDICATOR is housed in a sturdy plastic cabinet that harmonizes with any furniture style. Easy operation is assured by the new "finger-tip" control and the easy-to-read dial that clearly, instantly indicates exact antenna position.

See the new TRIO ROTATOR at your jobber today! It's tops for TV—ideal for ham arrays too!



Trio MANUFACTURING COMPANY
GRIGGSVILLE, ILLINOIS

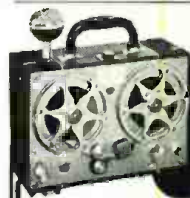

IT'S NEW!

10-POUND PORTABLE
BATTERY-OPERATED
TAPE RECORDER

THE MAGNEMITE* NEW DRY BATTERIES

Inexpensive flashlight-type cells that last 100 operating hours.

NEW SPRING MOTOR

Governor-controlled constant speed motor runs 15 minutes per winding.

NEW PLAYBACK & MONITORING

Feeds directly into headphones or external amplifier and speaker.

NEW SENSITIVITY

Crystal-clear recordings up to 100 feet from the microphone.



Field recording is now as easy as studio recording, with the Magnemite* Portable series. There's a midjet battery-powered spring-motor Magnemite* model for every recording need—speech, music and sound effects. Write today for descriptive literature and direct factory prices.

*Trade Mark Reg.

AMPLIFIER CORP. of AMERICA
398 Broadway New York 13, N. Y.

LEARN

**Television-Radio
Electricity**
REFRIGERATION-ELECTRONICS
IN THE GREAT SHOPS OF **COYNE**

**TRAIN QUICKLY! OLDEST, BEST
EQUIPPED SCHOOL of ITS KIND in U.S.**
Draft Age and Older Men...

Come to the Great Shops of Coyne in Chicago. Get practical training in TELEVISION-RADIO or ELECTRICITY—vital in Defense Program. Prepare now for a better job or better service rating.

START NOW—PAY LATER

You can finance most of your tuition, pay for it later in easy monthly payments. Special plan for men of Draft Age. Part time employment service available.

FREE BOOK Clip coupon for Big Free Illustrated Book. Indicate below, course that interests you. No salesman will call. Act NOW.

COYNE B. W. Cooke, President
A TECHNICAL TRADE INSTITUTE CHARTERED
NOT FOR PROFIT
Established 1899
500 S. Paulina, Chicago

ELECTRICITY ★ TELEVISION
RADIO ★ REFRIGERATION ★ ELECTRONICS

B. W. COOKE, Pres.
COYNE School
500 S. Paulina St., Chicago 12, Ill. Dept. 82-85H

Send FREE BOOK and full details on:

TELEVISION-RADIO ELECTRICITY

NAME.....

ADDRESS.....

CITY..... STATE.....

DOW SURPLUS

TELECHRON SYNCHRONOUS MOTOR
Type C2M 115V-60 cycle Model 822 M-6—
RPM—Removed from new Surplus.....\$3.95

MISCELLANEOUS ITEMS—ALL NEW
Rubber Grommets—100 asst.\$0.89
BC 461 control box with counter 1.49 ea.
T44C mike and plug95 ea.
Leeds & Nordrop Gray Paper, Type 578
0 to Infinity, Boxed per Roll..... .98
APC condensers, all sizes 4.99 ea.
1000-ft. #14-130 twisted Telephone wire..... 4.95
50 Watt—Tube Sockets—new..... .95
Antenna Insulators—10 for..... .60
6 V VIBRAPACK KIT, Vibrator plus non-
sync transformer with two outputs: 345
V, 145 ma for plates, and 15 v for bias,
BOTH FOR..... 1.98
FILAMENT TRANSFORMERS—110V-60 cycle
input, output 9V to 13V in 1V steps—out-
put, rated 3 amps..... 1.89
G.E. Solenoids—14V DC—25 ohms—Mycalox
arm, many applications—new..... .49

GP7 TUNING UNITS, A TO F, for ECO, \$2.95 ea.

PANEL METERS, NEW STANDARD BRANDS SPECIAL SCALE 50-SQUARE CASE		RHEOSTATS	
3" METERS		Watts	Ohm ca.
0-150 V AC	5.95	25	50.98
0-130 V AC	5.95	25	50.98
0 to 120 V AC	3.95	25	50.98
0-8 V AC WES	2.95	25	50.98
0-2 V DC	3.95	100	1.95
0-1.5 V DC	3.95	25	50.98
0-1 Mill DC 50	6.95	25	50.98
100-0-100 DC Mill	3.95	100	1.95
Freq. 350 to 450 cycles, 115 V.	17.95	100	1.95
		150	5000
		150	5000

BUY TUBES HERE

SURPLUS		OIL CONDENSERS	
Part No.	Price	Part No.	Price
1LD5	5.99	32 mfd. Four 8 mfd. sec.	50.95
3HP7	1.00	32 mfd. Four 8 mfd. sec.	50.95
5FP7	1.95	32 mfd. Four 8 mfd. sec.	50.95
6AK5	1.19	32 mfd. Four 8 mfd. sec.	50.95
6AL5	1.19	32 mfd. Four 8 mfd. sec.	50.95
6SN7GT	.79	32 mfd. Four 8 mfd. sec.	50.95
6J57	.59	32 mfd. Four 8 mfd. sec.	50.95
13-A	1.49	32 mfd. Four 8 mfd. sec.	50.95
15E	.59	32 mfd. Four 8 mfd. sec.	50.95
41	.59	32 mfd. Four 8 mfd. sec.	50.95
RK73	.79	32 mfd. Four 8 mfd. sec.	50.95
RKR73	.79	32 mfd. Four 8 mfd. sec.	50.95
801A	1.49	32 mfd. Four 8 mfd. sec.	50.95
837	.39	32 mfd. Four 8 mfd. sec.	50.95
843	.39	32 mfd. Four 8 mfd. sec.	50.95
958A	1.95	32 mfd. Four 8 mfd. sec.	50.95
1616	1.95	32 mfd. Four 8 mfd. sec.	50.95
1625	.59	32 mfd. Four 8 mfd. sec.	50.95
1626	.39	32 mfd. Four 8 mfd. sec.	50.95
1629	.39	32 mfd. Four 8 mfd. sec.	50.95
2051	1.19	32 mfd. Four 8 mfd. sec.	50.95
2121A	8.95	32 mfd. Four 8 mfd. sec.	50.95
3BP1	3.95	32 mfd. Four 8 mfd. sec.	50.95
5BP1	3.95	32 mfd. Four 8 mfd. sec.	50.95
5BP4	.69	32 mfd. Four 8 mfd. sec.	50.95
6C4	8.95	32 mfd. Four 8 mfd. sec.	50.95
250R	8.95	32 mfd. Four 8 mfd. sec.	50.95
RK39	3.95	32 mfd. Four 8 mfd. sec.	50.95
304TL	9.95	32 mfd. Four 8 mfd. sec.	50.95
531	3.95	32 mfd. Four 8 mfd. sec.	50.95
803	3.95	32 mfd. Four 8 mfd. sec.	50.95
804	6.95	32 mfd. Four 8 mfd. sec.	50.95
807	1.50	32 mfd. Four 8 mfd. sec.	50.95
849	1.95	32 mfd. Four 8 mfd. sec.	50.95
850	3.95	32 mfd. Four 8 mfd. sec.	50.95
861	19.95	32 mfd. Four 8 mfd. sec.	50.95
8U12	1.45	32 mfd. Four 8 mfd. sec.	50.95

KEYS		FUSES	
Part No.	Price	Amp.	Type
J-5A	.50	1/2	SAC
J-30	1.25	1	SAC
J-32	1.25	1	SAC
J-38	1.25	1	SAC
J-41A	.89	1/2	SAC
J-47	1.25	1	SAC
J-48	1.25	1	SAC

VARIABLE CONDENSERS—ALL NEW
Dual 35 mmfd per Section, Miniature.....\$1.49
Dual-100 mmfd..... 1.49
3 Gang 365 per Section..... .98
4 Gang 147 mmfd per Section..... 1.25
5 Gang 365 per Section..... 2.95

Part No.	Price	Part No.	Price
5K ohm 20W.	50.15	JK26-PL54	Set 50.49
5K ohm 50W.	.69	3 AG fuse post	.25
6K ohm 25W.	.35	4 AG fuse post	.25
10K ohm 10W.	.15	8 AG type HJM	.20
10K ohm 150W.	1.25	807 Tube Sockets	.29
250K ohm 2W., 3 for	.10	Accorn Sockets	2.21
65K ohm 2W., 3 for	.10	MG149F	49.50
		MG153F	3 Phase
		115V 600 Cycle Out-	
		put	5149.50

SHOCK MOUNTS
Most Types. Send us your requirements for price.
12V and 24V Soldering Iron.....\$2.95 ea.

EDWARDS BUZZERS
#1892-115 V-60 cycle
05 amp..... 50.98
#15-size 0-12V DC works on 6V less cover. Fine for Code Practice Sets, Ea. 69c
10 for..... \$4.95

Write us for your meter wants. Over 3,000 in stock. Write for Our 16-Page Bulletin.

DOW RADIO, INC.
1759 E. Colorado St. Pasadena 4, Calif.
PHONE: 5VCamgro 3-1196
\$1.50 min. order 25% deposit with orders
Send full remittance to save C.O.D. charges
All merchandise fully guaranteed. Subject to prior sale.

Broadband Converter (Continued from page 41)

pressor alternately cuts off and increases the current to reach the plate of the 6AS6 while scarcely affecting the cathode current controlled by the first grid and screen grid. This results in the signal being mixed only in the plate circuit because it is driven into the nonlinear portions of the plate current curve. As the plate and screen currents are 180° out-of-phase, doubling of the conversion transconductance occurs merely by placing a tuned circuit between the plate and screen, because the action of the suppressor grid causes the plate and screen currents to rise and fall 180° out-of-phase at the oscillator frequency. A negative variation of the suppressor grid causes a decrease in plate current and an increase in screen current, due to electrons turned back to the screen, and vice versa. Thus, effectively, a push-pull circuit exists which will give twice the conversion gain.

It is obvious, then, that a special tube must be used for the mixer. In the discussion of this circuit in other publications, a subminiature *Sylvania* #5636 was indicated for use for this service. Very few tubes have suppressor grids which will control the plate current to any extent with reasonable potentials. For this reason the *Sylvania* tube was investigated but at the present time it is available only on defense priority. Tubes with fairly good suppressor grid characteristics are available in the G, GT, and larger dimensional envelopes, but these were not deemed practical.

An investigation was made of the 6CB6 and other miniature pentode tubes of that type with negative results. Suppressor potentials as high as 45 volts had negligible effect. The fact that the 6AS6's net price is close to four dollars is a deterrent to the modification of the converter, but results seem to indicate that the expense is fully justified. The 6AS6 has about a 3 ma. plate current change for a 3 volt d.c. suppressor grid change under normal operating conditions. This represents roughly a 50% change of plate current for a small change of suppressor voltage. A negative 15 volts on the suppressor is required for complete cut-off.

For ten-meter operation where the mixer suppressor grid is driven by an amplified harmonic, there isn't sufficient voltage to drive the suppressor grid. For this reason a resistor is used in the suppressor grid ground return. This takes advantage of suppressor grid current drawn on the positive oscillator r.f. cycle, causing greater grid voltage swing. An r.f. choke cannot be used, except possibly on frequencies at which the plate section of the 6AG5 is also operating on the fundamental crystal frequency. In this case sufficient r.f. oscillator voltage exists permitting the substitution of a 2½ mhy.

Below MANUFACTURER'S COST!

PERM-O-FLUX
12" PM
HIGH FIDELITY
AND P.A. SPEAKER



12-WATT 6.8 OZ.
ALNICO MAGNET
EXTENDED FREQUENCY RANGE

List \$27.50
\$399
our price only 10 for 37.50

Send for FREE catalog of other bargains

GREEN TELE-RADIO DISTRIBUTORS, INC.
Dept. R-7, 472 Sutter Ave., Brooklyn, N. Y.
67-15 Fresh Pond Road, Queens, N. Y.

Unlimited Opportunities in RADIO ENGINEERING

DEGREE IN 27 MONTHS
Complete Radio Engineering course, including Telev., U.H.F. and F.M. Bachelor of Science Degree also in Mech., Civil, Elect., Chem., and Aero. Eng. Bus. Adm., Acct. Extensive campus, modern buildings, well equipped labs. Low cost. Prep courses. Personalized, practical instruction. Founded 1884. Placement service. Growing shortage of engineers. Prepare now for unlimited opportunities ahead. Enter September, January, March, June. Write for catalog.

TRI-STATE COLLEGE
1672 College Ave. ANGOLA, INDIANA

TUBES 50¢

AN INTRODUCTORY OFFER
5U4G 5Y3GT 6AU6 6AL5 6W4
654 6BQ6GT 35Z5 6AG5 50L6GT
The tubes listed above are only a few of the many tubes listed in our current flyer of "BARGAIN BUYS." Send for your copy today.
CROWN TELEVISION
P. O. Box 194 Hicksville, N. Y.

A SMALL AD—BUT B-I-G MONEY!
Here's What I'll Pay for the Following:
BC-348 or BC-312..... up to 570.00
ATC or T-47 TYPE ART-13..... up to 250.00
BC-921 or B5-ALN-7..... up to 45.00
TS-251..... up to 175.00
FL-90 or P-21/ARA-9 audio filters, each up to 6.00
Also want TS-147, TS-148, MG-149, RTA-1B or parts.
I'll buy almost anything—and I'm not kidding.
Write or wire:
BOB SANETT, 4668 Dockweiler, Los Angeles, Calif.
Telephone: YOrk 4637

From the earliest days of Radio...
to the present era of Television...
CORNISH WIRES
"Made by Engineers for Engineers"
CORNISH WIRE CO., Inc. — 50 Church St., N. Y. C. 7

r.f. choke. Operating the suppressor grid at zero d.c. bias rather than grid-leak bias results in a greater g_m and conversion transconductance, but sufficient oscillator voltage must be impressed to swing the plate current into saturation. The exact value of the r.f. oscillator mixing voltage, under load, is not critical, but should exceed ten volts. This has been provided in the converter design.

Practically no trouble was encountered by the builders of the three previously presented converters. Where trouble was encountered it almost always can be traced to the section involving the 472-UA coil. Coils of the "UT" type, or those of other manufacturers were used by the experimenter with the result that there was either excessive broadcast leakage or inferior performance. To the author's knowledge *there is no substitute for this coil.* Interstage broadband coils, used in some receivers, are not satisfactory because the high impedance primary (used as a secondary) cannot match the broadcast receiver antenna input, acting instead as an r.f. choke and causing broadcast leakage.

The supply voltage for the converter is not critical. Laboratory tests made with a one-tube oscillator, the converter, and a HQ-129X receiver indicated that the supply voltage could be varied from 100 to 250 volts with but little effect on the conversion gain, and no noticeable effect on the conversion output frequency. However the 6AS6 is rated at a maximum of 140 volts on the screen, so it is advisable to use a 150 volt plate supply.

In accordance with several suggested designs, such as using a center-tapped output coil between the plate and screen of the 6AS6, the *J. W. Miller Company* was kind enough to make two such coils #9769-UA-1, and #9769-UA-2. It was expected that better conversion might be obtained, but actual experimentation indicated that the 472-UA was superior. It was noted that when using the push-pull output coil the circuit would break into oscillation. Examination of the circuit showed its similarity to a Hartley oscillator. Stable action could only be obtained with lowered gain or shielding, etc., and the best results were not as good as with the simpler untapped coil arrangement.

The photographs of the converter may make it appear more complicated than it is. This is because additional equipment, not required for converter operation, was mounted in the same box. An antenna switch was added for transmitter operation, and to allow simple selection of the broadcast radio for either SWL or BC service. The antenna switch can be of the double-pole, tone-control type when a transmitter is not to be used in conjunction with the converter. Here it is used for antenna switching, converter and transmitter filament switch, and as a safety to prevent the transmitter high voltage from being applied until filament voltage is applied.

THE 3 Bs... BEETHOVEN, BRAHMS AND BACH

they're different
they're improved
they're better than ever!

Yes, Bach, Beethoven and Brahms are now better than ever—we don't mean we've improved their music, but we do mean we've improved the reproduction of their recorded music.



It's the new, improved Pickering Cartridges that give credence to this claim. Yes, Pickering Cartridges are different. They're improved. They're better than ever. Pickering patented Cartridges with Dynamic Coupling* are superior in every way, by providing: HIGHER FREQUENCY RESPONSE • NEGLIGIBLE INTERMODULATION DISTORTION • BETTER TRACKING CHARACTERISTICS

*DYNAMIC COUPLING ASSURES

constant stylus contact with the record grooves over the entire audio spectrum (20-20,000 cps) • full frequency response • full transient response • no resonances • no mistracking • no grinding of groove walls

PICKERING and company, incorporated



Pickering High Fidelity Components are available through leading Radio Parts distributors everywhere; detailed literature sent upon request. Address Department C

Oceanside, L. I., New York



★ STAR-SPECIALS

NEWEST ITEMS! LOWEST PRICES!



PERMOFLUX REAR DECK SPEAKER KITS

Easy to install; provides greater radio enjoyment in your car. Requires only connection to speaker terminals in auto radio. 3-way wired switch permits speakers to operate separately or together. Complete with metal grille and protective speaker screen. Hardware, template, instructions, etc.

RS46A 4" x 6" Speaker Kit..... \$7.94
RS96J 6" x 9" Speaker Kit..... \$10.29



NOVICE TRANSMITTER KIT

Ideal for beginning amateur or for use as a stand-by rig. Operates on 80 and 11 meters. Big pictorial and schematic diagrams for easy assembly by anyone. Complete with two punched chassis, coil forms and wire, tuning indicator, and all other assembly parts plus standard telegraph key and tubes (6V6, 6L6 and 5Y3GT). Less crystal and small amount of hookup wire and solder required.

Novice Transmitter Kit..... \$32.58

BARGAIN LOW PRICE FLYBACK TRANSFORMER (Similar to GE 77J 1)

Regular \$11.00 list price high voltage transformer similar to General Electric 77J1. Used for general replacement in many sets up to 14KV and with up to 19" tubes. Not available elsewhere at our low price!

A-1827 Flyback Transformer..... \$2.49

COMPLETE STOCKS All Standard Brands: Just off the press BIG BARGAIN BULLETIN

STAR ELECTRONIC DISTRIBUTORS, INC.
Dept. RN-7-7736 S. Halsted, Chicago 20, Ill.

New! Up-to-date!



TELEVISION SERVICING

by Walter H. Buchsbaum

340 pages
170 illustrations



Symptoms of defective operation easily recognized, quickly corrected by illustrations, diagrams and how-to-do-it facts in this new book.

Get this brand new, complete handbook for sure-fire working knowledge of TV installation, maintenance and troubleshooting. Tells you step-by-step procedures for audio IF alignment, video IF alignment, aligning RF amplifiers, mixers, oscillators, etc. All possible defects classified for ready reference, thoroughly analyzed to show what is wrong and why... and what to do to correct the defect. No mathematical knowledge needed! Practical, authoritative, up-to-the-minute, the perfect handbook for set owners, trainees, and repairmen.

USE IT 10 DAYS FREE

Coupon below brings you "Television Servicing" on FREE trial for 10 days, without obligation. Mail it NOW.

PRENTICE-HALL, Inc., Dept. M-RTN-752
70 Fifth Ave., New York 11, N. Y.

Send me, for 10 DAYS' FREE TRIAL, "Television Servicing." I will return it in ten days and pay nothing—or keep it and send \$1.35 down (plus postage) and \$2 monthly for 2 months.

NAME.....
ADDRESS.....
CITY..... STATE.....

SAVE! Send \$5.35 with this coupon, and we'll pay postage and packing.

SUMMERTIME BUYS

NOVICE 80 METER CW XMTR

Here's a neat and compact surplus item which converts very simply to 3700-3750 KC crystal controlled. Condition? Guaranteed suitable. Instructions? Yes, we furnish them! Complete, comprehensive, step-by-step; nothing left to guess at. This is 5-3-7, the command transmitter which has been such a favorite with old-timers. By the time this ad appears, the RC-457, described in November QST, will be all gone, so we worked out the conversion on 5-3-7. If had to be converted anyway, so why not convert the lower priced and available unit for just as good. Now don't wait until these are all gone! ONLY.....\$7.95

NOVICE 2-METER VOICE XMTR-RECEIVER ARC-4 A standard for two meter conversion. Excellent used, all tubes, conversion instruc. \$42.50
Less Dynamotor.....\$12.50
12 or 24 volt ARC-4 dynamotor.....\$12.50

80 METER RECEIVER

3-6 MC Command, with schematic, excellent electrically, but shop worn. Satisfaction guaranteed. \$14.95

COMMAND EQUIPMENT

With free dope sheets and schematics

RECEIVERS

3-6 mc. (see above) \$14.95

BC-455, 6-0 mc. **GOOD USED**..\$7.95

T-19/ARC-5, 3-4 mc., Excellent. Like new \$17.95

BC-457 or T-20/ARC-5, 3-3 mc., Excellent used 12.95

BC-458 or T-21/ARC-5, 5.3-7 mc., Excellent used 7.95

MOD BC-456, Brand new \$5.95, Excellent used 2.49

As is for parts 1.29

274N PLUG, 7-prong male plug to fit back of command

rcvrs. and xmtrs. This is the same plug as used in the

rack. NEW. Each \$1.50

Local Control Adapter Parts for 274N or ARC-5 revr.

Exact pot, switch, knobs, etched plate, and instruction

data. Ready to go. \$1.29

SPLINE TUNING KNOB.....\$1.79c

FOR HORSE TRADERS ONLY

Would You Like a:

PENTRON Tape Recorder, latest current model.
GARRARD Record Changer, latest current model.
Sure you'd like to own one of these gorgeous gadgets. But you're kinda short of cash, eh?
Well, tell you what we're gonna do. We're gonna allow you **UNBELIEVABLE** trade-in allowances on your War Surplus electronics or good current commercial gear. So sit down right now and write us what you have in mind. We'll give you \$1.00 for ATC, dynamotors for same, or other surplus or commercial stuff. Test equipment, receivers, transmitters, odd-ball tubes, etc.

BUILD TV-FM-AM SWEEP GENERATOR

(See Dec. Radio & TV News)

Now you can build that **VERSATILE SWEEP FREQUENCY GENERATOR**! We've got a few more of those vital APN-1 magnetic units. With reprint of the article.....\$6.95

4 USES—4 DOLLARS

The most versatile dynamotor in surplus! The best dynamotor for conversion to 8 v. Multiple windings! After conversion you can choose of 190 or 350 v. 120 MA or 250 v at 100 MA. No brushes to shift around. No mechanical work. Or use it as a 2:1 or 2:2 step-up or step-down transformer for DC voltage. Changes 6 to 12, or 12 to 24, or vice versa, up to 3 A. Or use it as a GENERATOR. Turn with motor, get 2 v. DC at 12.6 A or 24 v. DC at 0.5 A plus high voltage. Includes easily removable self-contained 800:1 sealed-in oil gear reduction unit. Complete dope sheet furnished. **BRAND NEW**.....\$4.00

SUPER HI-FI HEADSET BUY!

Uses annular-grooved plastic fibre cones with voice coils as in speakers, and padded chamolite ear muffs to obtain spacing for correct acoustical load. Gives finest music reproduction, flat far beyond upper and lower limits of auditory perception. Pair in series has measured impedance of 600 ohms at 1000 cycles, obtained with built-in high quality transformers. However, severe mismatching makes no apparent difference. Far superior to crystal phones. Manufacturer's net price is \$45.00 per pair. Each unit can also be used as high quality dynamic mic with 300 ohm output impedance. They come to you checked out with freshly laundered chamolite pads in cellophane bag, our original Navy lot sold out immediately, but we managed to get some in Hawaii. Seems that's all that's left, so bet-ter not wait! Get yours now.....\$7.95

CHAMOLITE HEADSET PADS. Clean, in glassine bag. They're a real pleasure to wear.....Pr. \$2.00

BROADCAST BAND & AERO

MN-26-C Remote Controlled navigational direction finder and communications receiver. Manual DF in any one of three freq. bands, 150 to 1500 KC. 24 V. Self contained dynamotor supply. Complete installation, including receiver, control box, loop, azimuth control, Left-Right Indicator, plugs, loop transmission line, and flex. shafts. **BRAND NEW, ORIG. PACK**.....\$69.50
MN-26-C alone, New.....\$39.50
MN-20-E Loop, Brand new.....6.95
MN-52 Crank drive, New.....2.50

PORTABLE POWER KITS

1. Includes 2 volt, 20 AH wet cell, lightweight transparent plastic, fibrite separators, 3 ball hydrometer, 4" x 3" x 5 1/2" high, shipped dry; also 2 volt synchronous vibrator, no tube needed; also 2 volt charger, 11.5 v 60/60 cy in. This high quality unit uses step-down transformer and dry disc rectifier, with Pilot lamp in output to indicate and regulate charging rate. With evedropper type battery filter and instructions. **ALL 4 ITEMS, BRAND NEW**.....\$4.95
2. Three 2 volt 20 AH wet cells and box CH-281 made for them. This box is a masterpiece of compact, lightweight construction, and includes inter-cell wiring and vent tube. Set-up gives you six volts. Boxes may be snap clasped together for multiple units. **ALL NEW \$6.95**
3. Six volt Vibrapak kit. Vibrator plus non-sync transformer with two outputs, 345 v, 145 v for plates, 15 v for bias. With schematic. **BRAND NEW \$2.95**

ANTENNA MAST SECTIONS, MS-49, 50, 51, 52, 39c
55. New, original packing.....Each

G.I. ELECTRONICS

905 S. Vermont Ave., Los Angeles 6, Calif.
All Prices F.O.B. Los Angeles Calif. Buyers Add Sales Tax
SEND FOR OUR CATALOGUE.

Intercarrier Sound

(Continued from page 37)

here, a single-coil i.f. amplifier is used, although some receivers feature transformers in either the grid or plate circuit. Transformers have some advantage in giving voltage step-up, thus providing more grid driving voltage. This is especially useful in the take-off from the second detector. The detector load is quite low and a good step-up ratio will give much higher voltage to the i.f. grid. In Fig. 5 this take-off circuit uses a simple 5 μ fd. coupling condenser, C_2 , and the 4.5 mc. tuned circuit L_1-C_3 . The video peaking coils L_1 and L_2 are designed to reject the 4.5 mc. sound i.f. signal. Variations of this circuit are included in the new Emerson design which features a video peaking coil and sound take-off transformer in a single unit.

Under the shortcomings of intercarrier receivers we listed the restricted picture i.f. bandwidth often found in older sets. Later we showed how intercarrier operation permits shifting the picture carrier to the top of the i.f. curve and thus adds contrast on very weak signals. There is one more important consideration in the picture i.f. response curve which affects the intercarrier system. That is the relative gain of the picture components and the sound carrier. Calculation and experiments show that the AM content of the 4.5 mc. sound signal will be very high unless the sound i.f. carrier, usually at 21.25 mc., is at least 38 db below the flat portion of the i.f. response curve. If the sound carrier is maintained below that level, AM interference such as buzzing will not be a problem. Fig. 6 shows the proper i.f. response curve which promises no buzzing in an intercarrier system. The 21.25 mc. sound i.f. carrier is 38 db or 28 times down from the top. A simple way of checking this in a receiver is with a signal generator having a calibrated output. Note the amount of signal required to give one volt d.c. at the detector at a frequency near the flat portion of the curve (approximately 23 mc.). When tuning the generator to the sound i.f. carrier frequency it should be necessary to put in 28 times as much signal to get a 1 volt reading. To achieve this 38 db step at the sound carrier most new designs feature one or more traps in the i.f. section, tuned to the sound carrier. How these traps

can be aligned simply and accurately is shown in the following section on alignment.

Simple Alignment Procedure

Many service technicians realize the difficulty of using a 4.5 mc. generator for aligning the intercarrier sound section. Inaccurate generators, drift, dial errors, etc., all tend to prevent accurate alignment. Yet the TV transmitter sends out the sound and picture carrier at exactly 4.5 mc. apart and there is no fine tuning or other simple adjustment in the receiver to compensate for poor alignment. The picture i.f. alignment is never quite so critical and errors of less than 1/2 mc. can be compensated with the fine tuning or local oscillator adjustment. For the purpose of this discussion let us assume that the picture i.f. curve is approximately correct and the traps for the sound i.f. carrier set close to the correct sound i.f. frequency. Now it remains to align the 4.5 mc. sound i.f., limiter, and ratio detector and to retouch the sound i.f. traps accurately. To do all this we need only a v.t.v.m. and a fairly good signal from a TV station. First connect the positive lead of the v.t.v.m. to a ground near the limiter tube. Then connect the negative lead through a 220,000 ohm resistor to the grid of the limiter, pin #1 on a 6AU6. The 220,000 ohm resistor should be close to the tube pin to minimize grid loading. First set the v.t.v.m. to about 3 to 5 volts d.c. and tune the 4.5 mc. take-off and i.f. coils for maximum v.t.v.m. indication. During this operation the receiver should be tuned to a station and the fine tuning should be adjusted for best picture, regardless of sound. The limiter grid voltage may go up to 10 or 15 volts, depending on signal strength. After the 4.5 mc. coils are adjusted for maximum, readjust the sound i.f. traps for minimum reading on the v.t.v.m. These traps should need only slight corrections; if more than two or three are required, the picture i.f. curve should be re-examined.

Next connect the positive lead of the v.t.v.m. to a ground near the electrolytic condenser in the radio detector circuit (C_{10} in Fig. 5) and connect the negative lead, through the 220,000 ohm resistor, to the negative terminal of the electrolytic condenser. Now adjust the plate coil of the ratio detector for maximum v.t.v.m. reading. Since this reading may reach up to 30 or 50 volts, be sure to switch scales when moving the v.t.v.m. from the limiter grid. In many receivers the plate or primary coil of the ratio detector transformer can be tuned from the bottom and unless you know definitely which adjustment is top or bottom start with the bottom slug. After tuning for maximum v.t.v.m. reading, move the negative lead of the v.t.v.m. to the sound output terminal, the junction of R_9 and C_{14} in Fig. 5. Now the v.t.v.m. may read either positive or negative voltage. Adjust the ratio detector secondary, the top slug in many receivers,

Fig. 6. Correct intercarrier response curve.

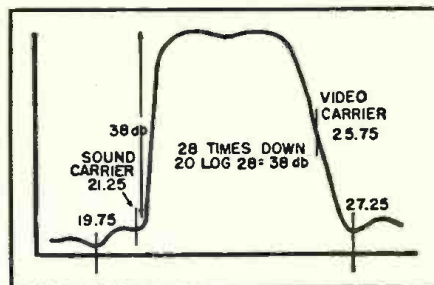

until the v.t.v.m. reads zero. A slight turn in one direction should result in negative voltage while in the opposite direction positive voltage should be read. Be sure and make this adjustment very carefully. If it appears impossible to bring the v.t.v.m. through zero and both a strong positive and negative voltage, chances are you have adjusted the wrong slugs on the ratio detector can. Repeat adjustment for maximum voltage at the electrolytic condenser, using the other slug now. When proper zeroing is achieved, connect the v.t.v.m. back to the electrolytic and again adjust the primary. Then recheck the zero adjustment. In most ratio detectors the adjustment of either primary or secondary will have considerable effect on the other coil.

Once the ratio detector is correctly aligned there should be no need to touch up any of the other circuits. If they are readjusted, however, be sure to return the v.t.v.m. lead to the limiter grid. It is not possible to accurately align any circuit preceding the limiter by using the voltage in the ratio detector as indication.

To align the 4.5 mc. rejection trap in the video amplifier without instruments is often possible only with a reasonably strong signal. Tune the trap first for minimum inductance, i.e., with the slug out of the coil area. Then adjust the fine tuning or oscillator so that the fine grain 4.5 mc. interference becomes visible. Now turn the trap tuning slug inward until the 4.5 mc. interference disappears. Retract it slightly to let it re-appear and then turn it just enough to remove the interference. Turning it further inwards will reduce the video response curve and result in loss of fine detail.

Conclusion

Now that the shortcomings of earlier intercarrier systems have been resolved and great improvements in receiver performance have been obtained, most TV manufacturers will use this system. As a matter of record, practically all major manufacturers feature the improved intercarrier system in their current models. The 1952 Philco, RCA, Admiral, G-E, Emerson, Westinghouse, etc., models are all intercarrier receivers and can be adjusted and aligned as described in this article.

-30-



July, 1952

110V. AC THYRATRON REMOTE CONTROL

For Less Than Cost of the Relay Alone!

A \$16 Value — Yours for \$3.88

MANUFACTURED BY NATIONALLY FAMOUS FIRM—SORRY WE CAN NOT MENTION NAME



SIZE 5 3/4" x 5" x 3 1/4"

Here's absolutely the greatest electronic buy in years! We were able to pick up these amazing units at a fraction of the manufacturer's cost and we're passing on this tremendous savings to radiomen who appreciate a genuine bargain. Adapt them for 1,001 uses, or use 'em for parts. Total value of its parts alone is \$16.50—yet for only \$3.88 (less tubes) you get a completely wired and tested 110 volt, 60 cycle AC Thyatron Circuit Remote Control.

These fine Thyatron precision thermostatic

Remote Control Unit Contains:
 Plate Relay, worth\$ 4.00
 Filament Transformer, worth 2.50
 Controls, Resistors, Sockets,
 Condensers, Chassis, worth 10.00
 Total Value, Parts Alone. \$16.50

\$3.88

No C.O.D. Post-paid in U.S.A. only.

FREE

A complete circuit diagram sent with each unit.

controls can be modified by you easily and quickly for electronic remote control of: Transmitters; Turn Radio or TV on and off; Remote Control of Appliances, Machinery, Power Tools; Remote Control for Model Railroads, Planes, Boats, Trucks; Burglar, Fire, Temperature and Rain Alarms; Poultry Brooder Controls; Remote Thermostatic Controls, etc. Your own ingenuity can devise many more interesting and practical uses which this remarkable unit can control for you. Send check or money order only (10 days net to rated firms).

MANUEL KLEIN CO. 94-N CHAMBERS ST. NEW YORK 7, N. Y.

WHEN THE JOB IS ALL FINISHED, THEN UP JUMPS A

NOISY

CONTROL OR SWITCH

THAT'S WHEN YOU NEED



TV AND RADIO'S FINEST

LUBRICANT & CLEANER

ITS MAGIC ACTION TAKES THE NOISE OUT OF CONTROLS & SWITCHES WITHOUT

REMOVAL FROM CHASSIS ORDER FROM YOUR DISTRIBUTOR MFD. BY

QUIETROLE COMPANY

SPARTANBURG, SOUTH CAROLINA

AMPERITE

Studio Microphones at P.A. Prices

Ideal for BROADCASTING RECORDING PUBLIC ADDRESS

"The ultimate in microphone quality," says Evan Rushing, sound engineer of the Hotel New Yorker.

- Shout right into the new Amperite Microphone—or stand 2 feet away—reproduction is always perfect.

- Not affected by any climatic conditions.
- Guaranteed to withstand severe "knocking" around."



Models RBLG—200 ohms RBHG—Hi-imp. List \$42.00



"Kontak" Mikes Model SKH, list \$12.00 Model KKH, list \$18.00

Special Offer: Write for Special Introductory Offer, and 4-page illustrated folder.

AMPERITE Company, Inc.

561 BROADWAY • NEW YORK 12, N. Y.

Canada: Atlas Radio Corp., Ltd., 560 King St. W., Toronto

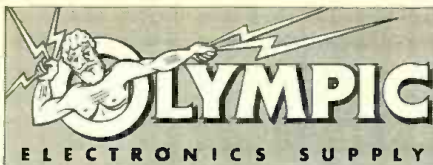

ELECTRONICS SUPPLY

GREATEST BARRAGE OF RADIO VALUES EVER LET LOOSE! EYE 'EM! 'BUY 'EM!

K-TRAN HIGH VOLTAGE FLYBACK TRANSFORMERS



Standard Replacement: Ea. \$1.65

FUSE HOLDERS

3AG Extractor type. Mounts 2" behind panel. Easy to mount. THIS MONTH SPECIAL... Ea. 15c

PUSH-ON KNOB KIT

De luxe assortment of 40 receiver type knobs in 11 different styles! Match any cabinet styles. Service-man or set builder—THIS IS FOR YOU! Kit only... 89c

TV FOCUS COILS

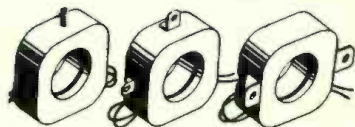

Standard replacement. Priced to SAVE the serviceman and builder REAL MONEY! For 16"-19" tubes.

500-ohm: male stud mounting... \$1.65
500-ohm: 3-angle brackets...
370-ohm: side angle brackets... each

VOLUME CONTROLS

With switches. 10,000, 250,000, 500,000 ohms. 1 meg., 2 meg. Each ONLY... 49c
In lots of 10. Each ONLY... 44c



70° TV DEFLECTION YOKES

Major brand names. Most popular types at LOWEST PRICES! Ea. ONLY... \$1.45

PAPER CONDENSERS

Midget, tubular types. 100 V. or more. Many are less than 1/4" diam. EACH ONLY... 3c
10 for... 25c
(Specify value: .001, .002, .003, .005, .01, .015, .02, .03, .04.)

PILOT LIGHT SOCKETS

Miniature, bayonet-base type. With spring type mounting clip. Load up at this low price. EACH ONLY... 3c
10 for... 27c

OUTPUT TRANSFORMERS

25L6... Ea. 29c
6L6... Ea. 59c
6V6... Ea. 49c

TUBES! ROCK-BOTTOM PRICES!

OZ4A... 49c 5U4G... 49c 6K7G... 49c
1A5GT... 49c 6J7G... 49c 8W4... 60c
1A3... 79c 6K6GT... 59c 6U7G... 39c

SPECIAL!

16 AP4A CR TUBE. New. Name brand... \$22.50

MISCELLANEOUS SPECIALS!

T.V. INDOOR ANTENNA... \$1.49
6-volt VIBRATOR (0ak)... 1.29
2-volt VIBRATOR... .49
MIDGET I.F. TRANSFORMER. 456 KC... .49



SENSATIONAL SPEAKER VALUES

Most Popular types for replacement and new construction!

4-inch PM... \$1.39 10-inch PM... \$2.69
5- " PM... 1.49 12- " PM... 3.49
6- " PM... 1.69 8- " Electro...
4x6- " PM... 1.49 dynamic 1.49
6x3- " PM... 2.49 10- " 500 ohm 1.89
8- " PM... 2.29 12- " 1,000 ohm 2.29

All orders F.O.B., Los Angeles, and all goods subject to prior sale. 25% deposit required with all orders.

Olympic Electronics Supply
1440 West Olympic Blvd., Dept. RN
LOS ANGELES 15, CALIFORNIA

Mac's Service Shop

(Continued from page 61)

"Okay, why did they make the lines 450 ohms? Why not make it 300 ohms so it would match most existing antennas and receivers?"

"If the line were reduced to the spacing necessary for 300 ohms, the capacitive losses would render it useless as low-loss lead. The only advantage it would then have over ordinary twin-lead would be the difference in the dielectric losses, and this would probably be offset by the effect of slight irregularities in spacing that would cause more difficulty when the wires were closer together.

"The 'free space' line loss goes down with increasing impedance up to the point where line radiation becomes appreciable; so it might seem that it would be a good idea to make the impedance of the line much higher, say up to 1000 ohms. There are, however, several good reasons for not doing this: first, the increased spacing would make the line bulkier and harder to handle and support; secondly, the field about a wider-spaced line would be more intense, and this would mean it would have to be kept farther away from other objects if losses were to be avoided; thirdly, as the spacing was increased, the tendency of the line to pick up noise would increase; and finally, the one-inch spacing of 450-ohm line seems to be a good compromise because its impedance is so close to that of ordinary 300-ohm twin-lead that, in most cases, the two can be used interchangeably."

"How about that? Can you just ignore the fact that you are using a 450-ohm line to connect a 300-ohm antenna to a 300-ohm TV receiver?"

"In most cases, yes. After all, that is only a mismatch of 1 1/2 : 1, and a mismatch of 2 : 1 can be withstood without serious defect. One thing you must keep in mind is that the receiver and the antenna have a 'nominal' impedance of 300 ohms. Actually, they may vary widely from this figure. If it happens that the receiver impedance is substantially below 300 ohms, then the use of a 450-ohm line may result in a noticeable loss of signal or even bad standing waves on the line."

"What do you do about that?"

"Match the impedance of the line to the nominal impedance of the receiver. If you are only interested in receiving one TV station—and in many areas, that is all you can get—matching the impedances can be done by means of a quarter-wave matching transformer. Such a transformer is just a length of line that is a quarter wavelength long at the frequency being received and that has the proper impedance to act as a transformer from the 450-ohm line to the 300-ohm receiver."

"What would that proper impedance be?"

"The impedance of the quarter-wave section should be equal to the square

WEBSTER-VM-G.I.

3-SPEED RECORD CHANGERS

Fully automatic. Plays all size records 7", 10", 12". BRAND NEW. G. I. CHANGER



OUR PRICE \$15.95

Immediate Delivery

\$47.50 List. 12" x 12 3/4" Long life needle incl. ORDER YOURS TODAY. Comes with RCA plug to attach to your radio or TV set. Metal base for above \$3.50. Fully guaranteed. Original factory cartons.

REPLACE YOUR OLD CHANGER NOW!

RCA VIGTOR—2-SPEED CHANGER
Same as VM Model 950. 2 Needles... 17.95
VM #950 Flip Cart. 3 speed... 22.95
WEBSTER #100 Flip Cart. 3 speed... 23.95
WEBSTER 100 Int. Cartridge... 29.95
VM #950 with G.E. triple play variable reluctance cartridge... 28.95
Pre-Amp with tube for G.E. Cart... 4.95

METAL BASE for Webster or VM 3-TUBE AMPLIFIER \$8.95

3 tube amplifier 5" speaker volume and tone control with tubes. Ready to operate. Same as used in portable units... \$8.95

Send for descriptive literature. Please include shipping charges.

Come in or order by mail—\$10 on C.O.D. orders.
JAN ELECTRONIC DIST. CO., Dept. RN 1
222 Fulton St. New York 7, N. Y. Wo. 4-0632

"WE'RE TEARING OUR HAIR OUT..."



TO BUY THIS EQUIPMENT!

WE NEED	WE'LL PAY	WE NEED	WE'LL PAY
ATC or T-47 type		RS/ARN-7... up to	\$ 45.00
ART-13... up to	\$250.00	TS-251... up to	175.00
BC-348... up to	70.00	FL-30 or F-21	
BC-312... up to	70.00	ARA-9 Audio	
BC-221... up to	45.00	Filters... up to	6.00 ea.

WANTED ALSO: TS-147, TS-148, RTA-1B, MG-149, plus parts or components. In fact, we'll buy practically anything in this field. Phone, wire or write:
V & H RADIO & ELECTRONICS SUPPLY CO.
2033 W. Venice Blvd., Los Angeles 6, Calif.
Telephone: REpublic 3-1127

LEARN TELEVISION

ELECTRONICS and RADIO
Engineering Laboratory and Classroom
Training. Day and Evening Classes.

White for illustrated Catalog
ELECTRONICS INSTITUTE, Inc.
21 HENRY, DETROIT 1, MICH.

GARRARD

The World's Finest

MODEL RC 80
\$42.30 net
less cartridges



Can be used with your present set.
Garrard Sales Corp. Dept. R7
164 Duane St., N. Y. 13, N. Y.
Send GARRARD Fact Sheet.
Name.....
Address.....
City.....Zone.....State.....

root of the product of the two impedances being matched. In this case that would be the square root of 300 times 450 or, u-n-n-m-m—" he hesitated as he manipulated the slide rule, "about 368 ohms. Since the impedance of an open line is simply a function of the size of the conductors and the spacing between them, it is no big job to make up such a transformer from the impedance charts given in any good handbook."

"What if you want to match the 450-ohm line to a 50- or 75-ohm input?"

"Those lower inputs are usually intended for coaxial lines; so the problem is not just one of matching impedances, but you also have to convert from a balanced to an unbalanced line at the same time. The device known as the 'balun' is the ticket for that, and the March, 1952, issue of the technical section of 'Sylvania News' contains complete constructional information on making such a gadget for matching 450-ohm line to either of those unbalanced impedances you mentioned," Mac said as he slid a paper across to Barney.

The youth looked it over casually for a few seconds and then said:

"You say the quarter-wave transformer is all right for one frequency when going from 450 to 300 ohms, but what if you want to receive several TV stations widely separated in frequency?"

"Then a tapered-line transformer is the best answer. In fact, it is probably the best answer in any case. Such a transformer is simply a section of transmission line in which the spacing between the conductors changes in a linear fashion from a spacing that would be right for the higher impedance down to a spacing that is correct for the lower impedance. The 450-ohm line is connected to the wide end, and the 300-ohm line or the receiver input is connected to the narrow end of the tapered line. A wave traveling through this tapered section has its voltage-current ratio gradually transformed in accordance with the change in characteristic impedance, and so there are no reflected waves produced."

"How long does that tapered section have to be?"

"That depends upon the lowest frequency you want to receive. Terman says that the tapered line will give almost perfect impedance transforming action from very high frequencies down to a frequency at which the length of the tapered section is about a wavelength. At lower frequencies, particularly when the tapered section is less than a half wavelength, the tapered section becomes an abrupt change in impedance and standing waves are set up. The exact point at which this unfavorable condition becomes serious depends somewhat on the ratio of the impedances being matched. At a 2:1 ratio, the critical length of the tapered section is between one-half and a full wavelength. As the ratio becomes smaller, the tapered section can be

Heathkit AMPLIFIER KIT

WILLIAMSON TYPE

AMPLIFIER Features

- First Williamson Type Amplifier supplied with matching preamplifier.
- Uses Altec Lansing Peerless output transformer.
- Practically distortionless — Harmonic and intermodulation distortion both less than 1/2 of 1% at 5 watts output.
- Frequency response ± 1 db from 10 cycles to 100 kc.
- Output impedance 4, 8, or 16 ohms.

The new Heathkit Williamson Type Amplifier kit is the best obtainable in amplifiers today — the choice of the really discerning listener. You can hear the difference and measurements actually bear out the superb performance. Frequency response ± 1 db from 10 cycles to 100 kc allow you to hear the highs and lows with equal crispness and clarity. Harmonic and intermodulation distortion both less than 1/2 of 1% at 5 watts output eliminate the harsh and unpleasant qualities which contribute to listening fatigue.

The circuit is similar to the one published in Audio Engineering Magazine for November, 1949, and is considered by engineers throughout the audio field as one of the best ever developed. The Main Amplifier (which may be purchased separately) consists of a voltage amplifier and phase splitter using a 6SN7, a driver stage using a 6SN7, and a push-pull output stage using a pair of 807 tubes. The output transformer is manufactured by the Peerless Division of Altec Lansing, and is built to their highest standards. Output impedances of 4, 8, and 16 ohms are available. The power supply uses a separate chassis with husky Chicago Transformer power transformer and choke, and 700V Mallory filters for long life free operation. A 5V4G rectifier is used.

The main amplifier and power supply are each on a chassis measuring 7" high by 5 1/2" wide by 11" long.

PREAMPLIFIER AND TONE CONTROL UNIT KIT

The preamplifier kit consists of: a 12AX7 (or 12AV7) dual triode first amplifier stage with a turn-over control for I.P. of 4, 8, and 16 ohms, and a 12AU7 amplifier stage with individual bass and treble tone controls which each provide up to 15db of boost or attenuation. A switch on panel selects either magnetic, crystal or tube input. Preamplifier also is well suited to custom installations — it will operate in either vertical or horizontal position, and special notched slots of the controls and switches allow a variety of shaft lengths to be selected. Dimensions: 2 1/4" high by 10 1/4" wide by 7 1/4" deep.

WRITE FOR
Free
CATALOG



The HEATH COMPANY
BENTON HARBOR 15,
MICHIGAN

WA-A1 Amplifier kit — Combination 1 — (Main Amplifier and Power Supply) complete with WA-P1 Preamplifier kit. Total Ship. Wgt., 34 lbs. (Shipped Express only) **\$69.50**

WA-A1 Amplifier kit only — Combination 4 — (Main Amplifier and Power Supply). Less WA-P1 Preamplifier. Total Ship. Wgt., 29 lbs. (Shipped Express only) **\$49.75**

WA-P1 Preamplifier Kit only. (less power supply) (Tubes included). Total Ship. Wgt., 7 lbs. (Shipped Express or Parcel Post) **\$19.75**

ALL-CHANNEL TV-FM BOOSTER — BEAT POOR "FRINGE AREA" RECEPTION!
Top quality McMurdo-Silver Pre-amplifier (=801). Features: Band Width Control, Sel. Direct By-Pass to rev. in HF, 90% Pilot Light, 115V. AC. **\$9.95**

Leotone "E-I" TRANSFORMER LAMINATIONS — Hi-perm. silicon steel 3 1/2" x 3 1/2" x 1/8" 24 sets **\$1.00**

50-200 MMF DUAL MICA TRIMMERS . . . 15c; 8 1.00

3P5-17A TUNING UNITS for BC-222, 250, 255, 256, 257, 258, 259, 260, 261, 262, 263, 264, 265, 266, 267, 268, 269, 270, 271, 272, 273, 274, 275, 276, 277, 278, 279, 280, 281, 282, 283, 284, 285, 286, 287, 288, 289, 290, 291, 292, 293, 294, 295, 296, 297, 298, 299, 300, 301, 302, 303, 304, 305, 306, 307, 308, 309, 310, 311, 312, 313, 314, 315, 316, 317, 318, 319, 320, 321, 322, 323, 324, 325, 326, 327, 328, 329, 330, 331, 332, 333, 334, 335, 336, 337, 338, 339, 340, 341, 342, 343, 344, 345, 346, 347, 348, 349, 350, 351, 352, 353, 354, 355, 356, 357, 358, 359, 360, 361, 362, 363, 364, 365, 366, 367, 368, 369, 370, 371, 372, 373, 374, 375, 376, 377, 378, 379, 380, 381, 382, 383, 384, 385, 386, 387, 388, 389, 390, 391, 392, 393, 394, 395, 396, 397, 398, 399, 400, 401, 402, 403, 404, 405, 406, 407, 408, 409, 410, 411, 412, 413, 414, 415, 416, 417, 418, 419, 420, 421, 422, 423, 424, 425, 426, 427, 428, 429, 430, 431, 432, 433, 434, 435, 436, 437, 438, 439, 440, 441, 442, 443, 444, 445, 446, 447, 448, 449, 450, 451, 452, 453, 454, 455, 456, 457, 458, 459, 460, 461, 462, 463, 464, 465, 466, 467, 468, 469, 470, 471, 472, 473, 474, 475, 476, 477, 478, 479, 480, 481, 482, 483, 484, 485, 486, 487, 488, 489, 490, 491, 492, 493, 494, 495, 496, 497, 498, 499, 500, 501, 502, 503, 504, 505, 506, 507, 508, 509, 510, 511, 512, 513, 514, 515, 516, 517, 518, 519, 520, 521, 522, 523, 524, 525, 526, 527, 528, 529, 530, 531, 532, 533, 534, 535, 536, 537, 538, 539, 540, 541, 542, 543, 544, 545, 546, 547, 548, 549, 550, 551, 552, 553, 554, 555, 556, 557, 558, 559, 560, 561, 562, 563, 564, 565, 566, 567, 568, 569, 570, 571, 572, 573, 574, 575, 576, 577, 578, 579, 580, 581, 582, 583, 584, 585, 586, 587, 588, 589, 590, 591, 592, 593, 594, 595, 596, 597, 598, 599, 600, 601, 602, 603, 604, 605, 606, 607, 608, 609, 610, 611, 612, 613, 614, 615, 616, 617, 618, 619, 620, 621, 622, 623, 624, 625, 626, 627, 628, 629, 630, 631, 632, 633, 634, 635, 636, 637, 638, 639, 640, 641, 642, 643, 644, 645, 646, 647, 648, 649, 650, 651, 652, 653, 654, 655, 656, 657, 658, 659, 660, 661, 662, 663, 664, 665, 666, 667, 668, 669, 670, 671, 672, 673, 674, 675, 676, 677, 678, 679, 680, 681, 682, 683, 684, 685, 686, 687, 688, 689, 690, 691, 692, 693, 694, 695, 696, 697, 698, 699, 700, 701, 702, 703, 704, 705, 706, 707, 708, 709, 710, 711, 712, 713, 714, 715, 716, 717, 718, 719, 720, 721, 722, 723, 724, 725, 726, 727, 728, 729, 730, 731, 732, 733, 734, 735, 736, 737, 738, 739, 740, 741, 742, 743, 744, 745, 746, 747, 748, 749, 750, 751, 752, 753, 754, 755, 756, 757, 758, 759, 760, 761, 762, 763, 764, 765, 766, 767, 768, 769, 770, 771, 772, 773, 774, 775, 776, 777, 778, 779, 780, 781, 782, 783, 784, 785, 786, 787, 788, 789, 790, 791, 792, 793, 794, 795, 796, 797, 798, 799, 800, 801, 802, 803, 804, 805, 806, 807, 808, 809, 810, 811, 812, 813, 814, 815, 816, 817, 818, 819, 820, 821, 822, 823, 824, 825, 826, 827, 828, 829, 830, 831, 832, 833, 834, 835, 836, 837, 838, 839, 840, 841, 842, 843, 844, 845, 846, 847, 848, 849, 850, 851, 852, 853, 854, 855, 856, 857, 858, 859, 860, 861, 862, 863, 864, 865, 866, 867, 868, 869, 870, 871, 872, 873, 874, 875, 876, 877, 878, 879, 880, 881, 882, 883, 884, 885, 886, 887, 888, 889, 890, 891, 892, 893, 894, 895, 896, 897, 898, 899, 900, 901, 902, 903, 904, 905, 906, 907, 908, 909, 910, 911, 912, 913, 914, 915, 916, 917, 918, 919, 920, 921, 922, 923, 924, 925, 926, 927, 928, 929, 930, 931, 932, 933, 934, 935, 936, 937, 938, 939, 940, 941, 942, 943, 944, 945, 946, 947, 948, 949, 950, 951, 952, 953, 954, 955, 956, 957, 958, 959, 960, 961, 962, 963, 964, 965, 966, 967, 968, 969, 970, 971, 972, 973, 974, 975, 976, 977, 978, 979, 980, 981, 982, 983, 984, 985, 986, 987, 988, 989, 990, 991, 992, 993, 994, 995, 996, 997, 998, 999, 1000

PORTABLE RADIO-AMPLIFIER CABINET ALL-STEEL. Exc. for: Test, Medical or Industrial Eqpt. Walnut finish; hinged front panel. Overall: **\$2.49**

METAL UTILITY CAN (4" x 3 1/2" x 1 1/2") Moisture-Proof, snap lid. For: BATTERIES, SML. COMPONENTS, ETC. ea. 10c; 12 **\$1.00**

NAVY HYDROPHONES (=CPK51065), magnetic-stricture type. Overall: 12" x 2 1/4" O.D. **\$3.95**

2 1/2" SQ. METER FRAME & GLASS bakelite **.89**

R5-1 U COAX CABLE 58 ohm, 25 ft. coil **1.29**

PL-259A CO-AX PLUGS, on 4-ft. RG-8, 1 set **.98**

MAGNETIC CONTACTOR (Guardian =BRG-3400) 24VDC, 200W, cont. 20 ohm **2.95**

SUPER-FLEXIBLE "KINKLESS" BRAID WIRE braided copper; 1E-30AWG; cotton core & outside sleeve. WITHSTANDS CONTINUOUS BENDING as in Helays, spkrs., etc. 20 ft. coil 98c; 100 ft. 53.75; 1000 ft. **32.50**

50W-25 OHM W.W. "DIVIDOM" RESISTORS **1.29**

RHEOSTATS: 50W-32ohm-\$1.69; 50W-15ohm **.39**

TRANSMITTING MICAS 22mmf-250WV, ea. **1.29**

HEARING AID TYPE SINGLE HEADSET ber curlplug, tipped 1/16" O.D. silk cord. **2.49**

TUBE CARTONS, plain white. Prices per 100 Min 1" sq. 2 3/4" sq. **2.95**

sq. x 3 3/4" sq. **1.45**; Med (1 1/2" sq. x 4 1/4" sq.) **1.65**; Large (2" sq. x 5" sq.) **1.98**; Extra Large (2 1/2" sq. x 6 1/2" sq.) **3.95**

HIGH FIDELITY CRYSTAL MIKE shock-mtd. (H-inpud. 18" x 1 1/2" Less housing) **1.29**

ALUMINUM HOUSING for crystal mikes. FULL HAND MIKE CASE, moulded bakelite. **.98**

"BARGAINS IN KITS" NEW, IMPROVED ALUMINO RADIO PARTS KITS. FULL I.B.S. OF: COILS, SOCKETS, WIRE, RESISTORS, CONDENSERS, SWITCHES **3.95**

ROTARY SELECTOR SWITCHES, Incl. mul-tideck, 6 asstd. 1 to 8 pin. 12 asstd. **51.75**

WAFER SOCKETS 1 to 8 pin. 12 asstd. **.49**

MOULDED BAKELITE CONDENSERS 0.0002 to .2 mfd. 200-600 WV. 50 asstd. **1.98**

DIAL CASES, acetate & glass. 20 asstd. **.98**

DIAL WINDOWS, glass & acetate. 12 asstd. **1.29**

MICA PADDERS & TRIMMERS, Incl. com-plete. 13 asstd. **.69**

W.W. RESISTORS 5W to 20W. 12 asstd. **.98**

VOLUME CONTROLS, less switch, asstd. **1.98**

"DIRECT FACTORY SPEAKER REPAIRS SINCE 1927" Min. Order \$3.00. Only 20% deposit req. on all C.O.D.'s. Full remittance with foreign orders. Please add sufficient postage—express refunded.

LEOTONE RADIO CORP.
67 Dey Street
New York 7, N.Y.

South River NEWS



COMBINATION ADJUSTABLE WALL BRACKET Model WB3-18A

Permits mounting by use of brackets fastened to eave and wall. All aluminum construction provides guarantee against corrosion and staining. Special "U" bolts provide most accommodation up to 1 1/2" O.D. and prevent mast from turning in high winds. Complete with hardware.

South River Antenna Mounting Accessories are carried by every leading TV Parts Jobber from coast to coast. New catalog mailed to all Dealers and Service Men. Write, if you haven't received yours!

SOUTH RIVER METAL PRODUCTS CO., INC.
SOUTH RIVER, N. J.

PIONEER AND OUTSTANDING PRODUCER OF FINEST LINE OF ANTENNA MOUNTS

July, 1952

123

www.americanradiohistory.com

Columbia

GEM OF THE SURPLUS

HOTTEST BUYS OF JULY!

COLUMBIA MARINER: 100 W. 4-channel, x-tal controlled, FCC approved, 12 or 24 V. input. COMPLETE, READY TO GO. \$349.50
Unconditional 90-day guarantee.

JOHNSON MARINE TRANSMITTER: 12, 24, 32, 115 V.D.C. input. EASY TO OPERATE. COMPLETE, ONLY \$299.95
Unconditional 90-day guarantee.

BC-223 TRANSMITTER: 25 W. 4-channel, x-tal controlled, 12 or 24 V. input. Less crystals. A SUPER BUY \$85.00

ARB RADIO COMPASS RECEIVER: 195-9005 kc. MOST COMPLETE MARINE RECEIVER MADE! Checked out with ALL accessories. \$85.00

DU-1 LOOP for above item. ONLY \$27.50

JEFFERSON-TRAVIS 5 W. MARINE RADIO TELEPHONE: 6 V. input. COMPLETE, less crystals. SPECIAL \$89.95

THUMBNAILED INFO ON NEW REDUCTIONS!

TRANSMITTER: 125 W. CW or Phone with 3 tuning units & Control Box NEW \$57.50

DYNAMOTOR: PE-103, 6 or 12 V. input. 500 V. 160 ma. With filter base and cords. Excel. cond. \$24.95

T-23 VHF ARC-5 TRANSMITTER: 2 meters, novice, CAP. Excel. cond. With ALL tubes. 37.50

RESISTORS: 100 assorted, 1/2, 1/4, & 1 W. \$5.00

MARKER BEACON RECEIVER: BC-357, used \$5.00

THROAT MIKE: 30, New. 1.25

ARC-4 VHF TRANSDUCER: For novice, CD or 2-meter. With tubes \$32.50

BC-659 10 METER FM MOBILE TRANSDUCER: Power supply, hand set and antenna. Complete \$55.00

DYNAMOTOR: PE-73 24 V. input: 1000 V @ 350 ma. out. Used. \$14.95

DYNAMOTOR: BD-77 24 V. input: 1000 V @ 350 ma. out. Used. \$14.95

SCR-625 MINE DETECTOR: New \$59.50

Like New \$39.50

HS-30 HEADSET: New \$1.95

FILAMENT XFMR: 9-13 V. @ 3 amp. \$1.89

SURPRISE PACKAGE!

15 lbs. of radio equipment—tubes, condensers, coils, resistors, 100 assorted, 1/2, 1/4, & 1 W. etc., etc., etc. PER PACKAGE \$1.50

BEAT COMMAND EQUIPMENT: Limited quantity! Sold as is, less tubes. Rebuild 'em or use for parts.

3-4 MC. \$7.95 5-3.7 MC. \$2.95

4-5.3 MC. 2.95 7-9.1 MC. 5.50

MD-7 PLANT MODULATOR \$6.50

TUBE KIT FOR COMMAND XMT. \$1.25

OIL-FILLED SPRAGUE CONDENSERS!

1 mfd. @ 7,000 VDC. Type B-8-B-1170. \$ 5.89

2 x .15 mfd. @ 8,000 VDC. Type D-4491. 10.95

TELEPORTABLE TRANSDUCER: Good for parts or packy-talkie foundation. Some with tubes, meters, etc. AS IS. Only \$6.95

ARC-5 OR 274-N TRANSMITTERS

2-1-3 mcs. \$19.95

4-5-3 mcs. Used, good cond. 6.95

5-3-7 mcs. 5.99

7-9-1 mcs. 12.50

ARC-5 OR 274-N RECEIVERS

.55-1.5 mcs. Brand new \$49.50

1.5-3 mcs. Brand new \$24.50

3-5-1 mcs. Brand new \$19.95

RACK FOR DUAL TRANSMITTER (274-N) 2.95

RACK FOR DUAL TRANSMITTER ARC-5 3.95

TRIPLE RECEIVER RACK with 50 mfd. condenser. Excel. cond. 3.95

AIRCRAFT EQUIPMENT

ARN7 MN-26-C SCR-269 ARR-5

ARR-7 HS-33 Headset VHF ARC-5 MN24C

FL-8 Filter—New and used

APN-0 ARR-3 APR-4 Loop (CAA)

ART-13 RTA-1B SCR-322 APR-5

NOTE: We stock most complete line of TS Rear in West Coast. Write us for prices and tubes available. **MONEY TALKS!** Especially when you're planning a vacation! If you need DOUGH sell YOUR new or used radio Rear to us! We pay top buck—SO WRITE US FIRST!

All orders F.O.B. Los Angeles. 25% deposit required. All items subject to prior sale.

COLUMBIA ELECTRONIC SALES

522 South San Pedro Street
LOS ANGELES 13, CALIFORNIA

NEW TUBES GUARANTEED

0B2	51.39	574	51.98	450TH	539.50
0B3/VR90	1.10	6AK6	1.10	CK512AX	1.98
0C3/VR105	1.25	6AN5	3.99	702A	2.75
0D3/VR150	1.95				703A	4.95
1B22	2.25				705A	1.95
1B23	7.95				707A	7.95
1B24	12.95				707B	14.95
1B35	12.95				708A	3.95
1N23	1.25				715B	8.95
1N23A	9.95				721A	1.95
2AP1	29.50				722A	13.95
2C40	8.50				723A/B	16.95
2C43	24.50	6AS6	53.30	724B	2.75
2C44	1.19	6A57G	4.50	725A	6.95
2C52	3.92	6J4	6.95	803	3.75
2D21	1.49	6M	810	807	1.59
2E22	1.95	15E	1.95	813	8.50
2E25	2.25	35T	2.25	814	3.85
2E30	1.98	8K6/1641	2.25	829B	1.95
3A5	1.59	75T	6.50	832	7.95
3ABGT	3.19	83V	1.10	832A	9.95
3AP1	9.95	850TH	833A	834	34.95
3B24	4.95	304TH	8.95	884	1.75
3B26	4.25	304TL	8.95	95549
3B28	6.50	307A/RK75	6.50	958A	1.50
3BP1	5.95	350A	6.95	959	1.50
3BP2	5.95	350B	6.95	1631	1.25
3C24/24G	1.50	350H	4.50	9551	1.19
3C33	9.95	417A	8.50	8005	4.95
3FPY	1.15	446A	1.19	8020	1.25
3Q5GT	1.15				8021	1.25
4C35	24.50				9001	1.50
4E27	1.50				9002	1.25
4X150A	35.00				9003	1.50
5B11	4.50				900469
5B14	5.50				9005	3.50
5D21	19.95				900649
5GP1	4.50						

YOUR SURPLUS WANTED
Highest Prices!

Vacuum Capacitors
50-15 \$ 5.95
12-20 6.50
12-50 12.50

J. S. H. SALES CO.
Complete Line of Transmitting & Receiving Tubes. Send Cash With Order and Save C.O.D. Charges!

shorter without increasing the standing waves; and since we are matching impedances with a ratio of 1½:1, that is in our favor."

"Can you buy a tapered line transformer?"

"Yes. RMS, for one, makes such a transformer and recommends that it be tried both at the antenna and receiver when installing 450-ohm line. When a noticeable improvement results, it should be left in; but if no change can be seen, it can be omitted."

"How about making your own? Some of the guys have told me that they just split twin-lead for about a foot and fan it out to meet the spacing of the 450-ohm line."

"From what I have just told you about the minimum length of the tapered section, I doubt if that practice is a good one, especially for the low-frequency channels. Gonset recommends that you remove five spacers from the end of their line by snipping the spacers with diagonal cutters from the back parallel to the wires. Then cut the wires to exactly thirty inches from the last spacer. Strip and splice to 300-ohm ribbon, using solder or 'Stakon' solderless connectors. Keep the tapered section taut by mounting in such a manner that tension is kept on this section and twisting is prevented. They say this results in a very efficient tapered line impedance transformer."

"How do you support the 450-ohm lead-in?"

"Use regular stand-offs where the line goes down the mast or the side of a building. The spacer is slipped into the opening of the grommet intended for coax, and then if necessary the ring is pinched tight with gas pliers. Care should be taken to see that the ring is evenly spaced from each of the conductors. Where you have long horizontal runs, say across a ravine or down the side of a hill, RMS makes and recommends a spring-type stand-off for keeping an even tension on the unsupported span. Gonset suggests that if spans of more than 150 feet (or 100 feet when icing or strong winds are present) are used, the line be supported by a galvanized steel messenger wire, with the line at least six inches below it. When you want to turn a corner, you turn the line up on edge with a 90-degree twist and support it vertically at the end.

"Keeping in mind that a higher impedance line has a larger field around it, at least seven-inch stand-offs should always be used, and care should be taken to see that the line stays well clear of gutters, downspouts, and other metallic objects."

"How do you get the line into the house?"

"You could saw two ditches in the window frame, lay the wires in these, and then fill the cuts with plastic wood; but a better system is to use a tapered line transformer just at the point where the line is to enter the house and then come on in with regular 300-ohm ribbon. Since the rib-

Finest FRINGE AREA Antenna

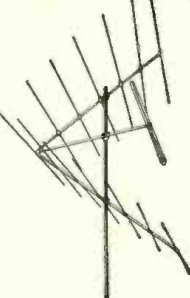

VELA

- CORNER REFLECTOR**
- HIGH GAIN 12 db
 - BROAD BAND CHANNELS 2 to 6
 - HIGH FRONT TO BACK RATIO
 - RUGGED CONSTRUCTION

ORDER NOW!

Immediate delivery LIST

\$54.50

VIDEO ELECTRONICS

1220 1/2 Grand Ave. Des Moines, Ia.

TRAIN FOR A SUPERVISORY POSITION IN ELECTRONICS

Thorough 2-year course covers electrical circuits and machinery, basic electronics and industrial electronics. Franklin Technical Institute graduates are in demand as junior engineers for research and test work, sales engineering, supervisory work on production lines and drafting room design work. Other engineering and technical courses. Coed. Day, evening. 44th year. Write for catalog.

FRANKLIN TECHNICAL INSTITUTE
46 Berkeley Street Boston 16, Mass.

QUALITY • SERVICE • DEPENDABILITY
PERFECTLY CENTERED
DUMONT
COMPLETELY MOLDED CAPACITORS
Sold and Preferred Everywhere

DUMONT Electric Corp.
308 Dyckman Street, New York 34, N. Y.

WANTED!

ALL TYPES AIRCRAFT, RADAR, RADIO SETS, COMPONENTS, DYNAMOTORS AND ASSOCIATED EQUIPMENT SUCH AS BC-348, BC-312, BC-221, RS/ARN-7, TS-251, FL-30 or F-21/ARA-9 Audio Filters, TS-147, TS-148, RTA-1B, MG-149, etc.

We Pay Top Dollar!
WEST REGION ELECTRONICS, Dept. RW-1
1437 S. Norton Ave. Los Angeles 19, California

ON-THE SPOT BATTERY RECORDER

WALKIE-RECORDALL 5 lb. miniature BATTERY RECORDER-PLAYBACK Continuous, permanent, accurate, indexed recording at only 5c per hr. Instantaneous, permanent playback. Picks up sound up to 60 ft. Records conferences, lectures, dictation, 2-way phone & sales talks; white walking, riding or flying. Records in closed briefcase with "hidden mike"! Write for Detailed Literature.

MILES REPRODUCER CO., INC.
812 BROADWAY Dep't RN-8 NEW YORK 3, N. Y.

SELL Jensen PHONO NEEDLES For Any Type Record Player

Please send me FREE Jenselector. Picks the proper replacement needle.

Name _____
Address _____
City _____ State _____

Jensen Industries, Inc., 336 S. Wood St., Chicago 12

bon will be inside, out of the weather, any losses it adds will be negligible."

"What if the antenna is a rotating kind? You can't go wrapping that 450-ohm lead around, can you?"

"No, but in a new installation you could use a motor of the sort that carries the antenna connections through the rotating mechanism on slip rings. Otherwise, the best thing to do would be to again use a tapered line transformer right at the top of the tower and then go from that point on up to the antenna with a good quality twin-lead that will withstand flexing. Since this twin-lead section will be short, it will not add very much loss, even in foul weather."

"Do you twist the line coming down the tower?"

"Mr. Smith of *Gonset* says that from the standpoint of theory and actual tests, there is no point in twisting the line to reduce noise pickup—something I've been suspecting for quite a while. As a matter of fact, transposing any balanced line precisely every half wavelength will actually increase the noise pickup broadside to the line."

"How long a run do you think it takes to make using 450-ohm line worthwhile?"

"On the v.h.f. channels, and under conditions of dry weather, and considering *only* the signal loss, it would probably not be worthwhile to use 450-ohm line for a length less than 100 feet. But when you consider how sharply the loss of ribbon line goes up when it gets wet, and when you consider the permanence of the open wire line, it can easily be worth-while even on shorter lengths. This is especially true where sea coast salt or industrial area soot quickly impairs the initial efficiency of ribbon lines."

"And now that we have to start thinking about u.h.f. installations where transmission line losses really become serious, I am confident installers are going to turn more and more to the 450-ohm open wire line."

"It figures," Barney agreed as he smothered a prodigious yawn and slid from the bench. "And on top of that Margie, my one-and-only, says she thinks they are cute because they remind her of little ladders that the TV signals can use in climbing down from the antenna!"

GRAPH PLOTTING AID

By JAMES R. FORD

A TRANSPARENT celluloid sheet (or other plastic such as the 8½" x 11" acetate clear-view, loose-leaf sheet protectors) fastened securely to a tube characteristic or other "working" graph provides a handy, rapid, and neat method of utilizing the graph.

By using grease pencils, of various colors if desired, to scribe load lines, or other useful information on the transparent sheet, it is possible to get full use of the graph without having to be careful not to spoil the original. By simply wiping off the transparent sheet with a blotter or cloth, it is possible to use the same graph over and over.

how to enjoy NEW REALISM from your records or radio!

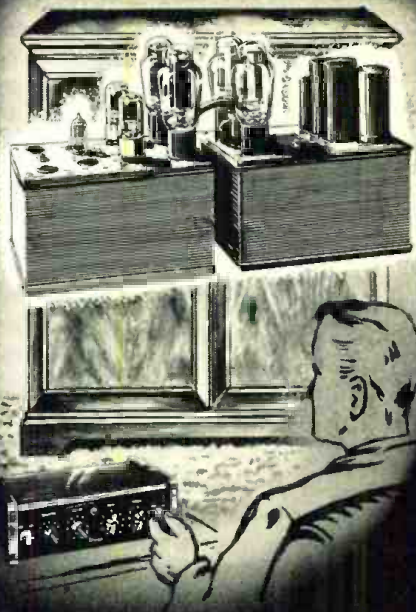

Shown are the McIntosh 50W-2 amplifier and AE2A remote controller. Your dealer can help you make them a part of your present system or guide you in the selection of related components. WRITE TODAY, for free booklets and name of nearest dealer.

... from patient years of laboratory research has come a basically new audio amplifier—the McIntosh 50W-2. To you, this means new heights of enjoyment—magnificent realism of the music you treasure, on records or tape. And the versatile McIntosh brings "living presence"—a new naturalness of sound to your present radio or TV set.

Only McIntosh gives such distortion-free performance over the entire range of human hearing, with the reserve of power essential for completely adequate reproduction.

McIntosh

LABORATORY, INC.

322 Water Street
Binghamton, N.Y.

HAM-R-PRESS

by
PIONEER
HAMMER
BLOW
POWER

Model H75 (shown)
7½" throat

\$19.95 net

H120-12" throat—\$26.95
H240-24" throat—\$39.95

Punch & Die Extra

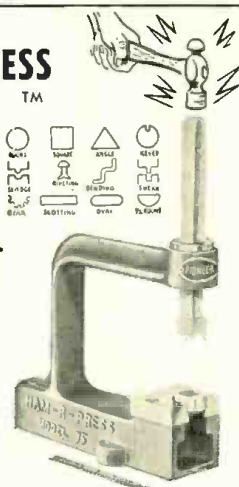

NOW chassis punching in almost every size and shape may be done in your own workshop with the unique NEW PIONEER "HAM-R-PRESS." Punch nailing hole for ANY electronic part. Easily. No drilling. Slip punch on ram. Insert die in work table. Lower ram to chassis and strike top of ram with hammer. Hole complete. Features include: SIMPLE OPERATION. PRECISION ALIGNMENT. DEEP THROAT. LOW COST. No starting hole needed.

ROUNDS	PUNCHES	DIES
1/8, 3/16, 1/4, 5/16, 3/8, 1/2, 5/8, 3/4, 7/8, 1, 1 1/8, 1 1/4, 1 1/2, 1 3/4, 2, 2 1/4, 2 1/2, 2 3/4, 3, 3 1/4, 3 1/2, 3 3/4, 4, 4 1/4, 4 1/2, 4 3/4, 5, 5 1/4, 5 1/2, 5 3/4, 6, 6 1/4, 6 1/2, 6 3/4, 7, 7 1/4, 7 1/2, 7 3/4, 8, 8 1/4, 8 1/2, 8 3/4, 9, 9 1/4, 9 1/2, 9 3/4, 10, 10 1/4, 10 1/2, 10 3/4, 11, 11 1/4, 11 1/2, 11 3/4, 12	\$1.00 1.20 1.35 1.40 1.60 1.65	\$.75 .80 .90 1.10 1.35 1.30
KEYED—1/8, 1/4, 3/8, 1/2, 5/8, 3/4, 7/8, 1, 1 1/8, 1 1/4, 1 1/2, 1 3/4, 2, 2 1/8, 2 1/4, 2 1/2, 2 3/4, 3, 3 1/8, 3 1/4, 3 1/2, 3 3/4, 4, 4 1/8, 4 1/4, 4 1/2, 4 3/4, 5, 5 1/8, 5 1/4, 5 1/2, 5 3/4, 6, 6 1/8, 6 1/4, 6 1/2, 6 3/4, 7, 7 1/8, 7 1/4, 7 1/2, 7 3/4, 8, 8 1/8, 8 1/4, 8 1/2, 8 3/4, 9, 9 1/8, 9 1/4, 9 1/2, 9 3/4, 10, 10 1/8, 10 1/4, 10 1/2, 10 3/4, 11, 11 1/8, 11 1/4, 11 1/2, 11 3/4, 12	1.50 3.75 3.95	1.50 3.75 3.95
RIVETING SET—Requires adaptor HAD-5.		1.50
SHEARING SET—(1" length of cut)		3.75
DIE RAISER—3" high		3.95
HAD-5 ADAPTOR—for 1/8" and under dies		1.00

PIONEER TOOL CO.

5008 W. Jefferson Blvd., Los Angeles 16, Calif.

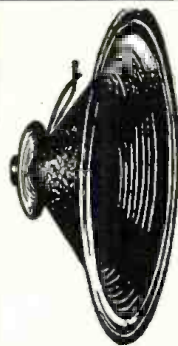

WALDOM

SUPERIOR COMPONENTS

WALDOM CONES...R.M.A. warranty, true low frequency response, unconditionally guaranteed.

Waldom also supplies quality CRONAME parts



TUBE SOCKETS
Standard and J.A.N. Types



INTERLOCK ASSY.



TV ANODE CONNECTORS



KNOB

FREE
Catalog #5C2
Electronic Components & Croname Products

Catalog #52
Replacement Speaker Cone Manual

ELECTRONICS, INC.

911 N. Larrabee St., Chicago 10, Ill.



Mfrs. of
PICTURE TUBES
and
ELECTRONIC
EQUIPMENT

Custom-Quality CR Tubes at NEW LOW PRICES!

Ask Your Jobber for EBCO Prices

"EBCO" Dual-Purpose CHECKER-REACTIVATOR for TV Picture Tubes

A MONEY MAKER
FOR SERVICEMEN:

Check picture tubes for shorts, cathode emission, leakage, etc., without removing tube from TV set. Also PUT NEW LIFE into weak tubes with the REACTIVATING power of this instrument. Lightweight, portable; 110V-60 cycles. Factory-guaranteed. ASK YOUR JOBBER.



Model 10
net \$19⁹⁵

Dynamic Analyzer

for TV Picture Tubes

NEW—EBCO Dynamic Analyzer makes your Vacuum Tube Voltmeter the finest CRT Tester. It's the ONLY instrument that performs all vital dynamic tests: Checks all socket voltages; checks emission of tube; gives related emission; checks open elements, shorted elements, leakage. Pat. pend. FREE—Service Engineer's Manual for CRT Testing, with each instrument. NET only..

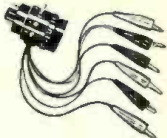

\$795

2-SET CONNECTORS

Two-set Connector for TV.....Net \$2.95
Four-set Connector, operates 3 or 4 sets
from 1 antenna.....Net 4.95

ASK YOUR JOBBER!

ELECTRONIC BEAM CORP.



923 Old Nepperhan Ave.
YONKERS, N. Y.
Phone: YOnkers 3-3514

RADIO and TELEVISION ELECTRONICS



in all Technical Phases
New Classes (Day and
Evening) Start 1st of
Dec., Mar., June, Sept.

Free Placement Service for Graduates
For Free Catalog write Dept. RN-52

RCA INSTITUTES, INC.

A Service of Radio Corporation of America
350 WEST 4th ST. NEW YORK 14, N. Y.

SPEAKER RECONING

Complete line Cones, Spiders, Rings
and Voice Coils. Custom Built Voice
Coils. Low prices. Write for Parts
List and Reconing information.

WESTERN ELECTRONICS CO.

3164 West Colfax Denver 4, Colo.

RADIOS

1, 2 & 3 band Electric and/or battery

TELEVISION

AC/DC Operation

TEST INSTRUMENTS

Write for FREE Catalog

ARKAY—Radio Kits, Inc.

120 Cedar St., New York 6, N. Y.

Manufacturers' Literature

Readers are asked to write directly to the manufacturer for the literature. By mentioning RADIO & TELEVISION NEWS, the issue and page, and enclosing the proper amount, when indicated, delay will be prevented.

BBB-RTMA BOOKLET

The Association of Better Business Bureaus and the Radio-Television Manufacturers Association have jointly announced the publication of a booklet providing basic information necessary for purchasers or owners of television receivers.

The new 11-page booklet is a revised edition of a booklet which was originally issued by the BBB in New York. The revised edition, entitled "Things You Should Know About the Purchase and Servicing of Television Sets," was prepared by the RTMA Service Committee in cooperation with the Television Service Committee of the BBB.

Written in non-technical language and slanted for the layman, copies of this booklet are now available from Better Business Bureaus and from various retail television dealers throughout the country.

ELECTRICAL TAPES

Insulation Manufacturers Corporation, 565 West Washington Boulevard, Chicago 6, Illinois, has just issued a 16-page catalogue giving detailed information on characteristics, uses, and technical data on "Permacel" pressure-sensitive electrical tapes.

Cotton cloth, crepe paper, flatback paper, acetate cloth, acetate film, acetate cloth film combination, and vinyl film electrical tapes are covered in the catalogue. Some of these tapes are of the heat curing type for heat and solvent resistance.

A special section is devoted to non-electrical paper, cloth, glass-reinforced paper, cellophane, and acetate fiber tapes.

Copies of this catalogue may be obtained free of charge from the Publications Department of the company.

TERMINAL DATA

Triad Transformer Manufacturing Co., 2254 Sepulveda Blvd., Los Angeles 64, California, has issued a new catalogue covering its line of single and multiple terminals.

The catalogue, which has been designated as the TH-52, contains full-size illustrations, specifications, and dimensional drawings, plus recommended installation procedure, general information, and several typical installation applications.

Copies of TH-52 are available without charge to those making their requests direct to the company.

TV ANTENNA GUIDE

Channel Master Corporation, Ellenville, N. Y., has issued a new 12-page booklet which describes more than 50

different types of antennas, accessories, and kits.

Entitled "Your Guide to Channel Master Television Antennas," the two-color booklet is concise and easy-to-read. It describes the specific reception problems that each antenna is designed to solve. It lists the latest types of antennas in the company's line including the new 10-element impedance-matching yagi.

Every item described in the catalogue is fully illustrated with gain curves; polar diagrams are included for many of the antennas. Copies of this new publication are available to installation and service technicians without charge.

NEW CONNECTORS

An 8-page catalogue which describes the company's line of compact connectors for electronic and aircraft use, has been released by Hugh H. Eby, Inc., 4700 Stenton Avenue, Philadelphia, Pa.

Included in this new publication are dimensional drawings, and a detailed description of male and female rack and panel connectors having 3, 4, 7, 8, 11, 14, 15, 18, or 34 pins; miniature 5, 7, and 9 pin connectors; and watertight and universal binding posts.

A copy of "Catalogue Supplement No. 1" is available without charge upon request to the company.

DRY TRANSFORMERS

Magnatran Inc., 248 Schuyler Avenue, Kearney, New Jersey, has issued a new 4-page bulletin covering its line of indoor and indoor-outdoor dry type transformers.

The newly-designed transformers described in the publication incorporate easy-to-install features and meet all standards such as the AIEE, ASAMEMA, and UL. Ratings listed are 600 volts and below, single phase, 3 kva. to 200 kva.

When requesting copies of this catalogue, please specify No. 6-01.

MOUNTING DEVICES

T. R. Finn & Co., Inc. of 333 Jackson Avenue, New York 54, New York, now has available a 4-page illustrated bulletin covering its line of airborne electronic mounting bases, vibration isolators for these mounting bases to JAN-C-172A specifications, Type M shock mounts for Signal Corps specifications, and fire control shock mounts for naval vessels.

The section dealing with airborne mounting bases has explanatory diagrams with complete detailed specifications for all sizes and uses. Com-

plete load ranges are shown for the vibration isolators which are used in conjunction with the airborne mounting bases.

The section on shock mounts for Signal Corps equipment or naval vessels also has explanatory diagrams covering specifications and technical characteristics.

When requesting a copy of this bulletin please specify Catalogue MB-110.

"HOW TO SOLDER"

The *Federated Metals Division of American Smelting and Refining Company*, 120 Broadway, New York 5, New York, has published a new 16-page booklet on the fundamentals of soldering.

Entitled "How to Solder," the little booklet contains simple instructions and illustrations designed to make soldering better and easier. Since the strength of the soldered joint depends on the type of solder and the soldering method used, the booklet covers every step from the choice of alloy through the application of the solder.

The booklet is available without obligation from the company direct.

SPEAKER INDEX

The Tube Department of *Radio Corporation of America* has issued a novel flip-type index which is designed to place basic electrical and mounting information on *RCA* radio and television speakers at the fingertips of service dealers.

This handy, compact index, which is less than six inches square, provides all the data necessary for the installation of any one of 22 different *RCA* speakers. The index can be mounted on a wall or atop a service bench.

Each of the 22 speakers listed is illustrated by a physical outline drawing and a halftone photograph. The necessary mounting information and such basic electrical data as voice-coil impedance, power-handling capability, resonant frequency, and magnet weight, are also included.

The index is available to radio and TV service dealers and service technicians through their *RCA* electronic components distributors.

CONTROL BULLETIN

Wirt Company, 5231 Greene Street, Philadelphia 44, Pa., now has available for distribution copies of its Bulletin #177 which describes the company's complete line of wirewound potentiometers, wirewound rheostats, and slide switches.

The bulletin gives all pertinent details on potentiometers and rheostats rated at from 3 to 5 watts, made with bakelite housings in values from 5 to 100,000 ohms, and supplied with shaft and bushings as may be required. Also covered are potentiometers and rheostats rated at from 1.5 to 2 watts with metal housings and bushings or with slotted rotors and rivet mounting.

The company's line of slide switches for radio and television receivers, phonographs, and instruments is also described in detail.

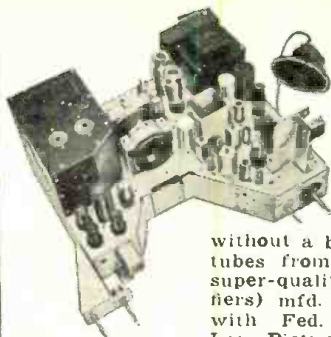

WORLD'S FINEST "630 DX" CHASSIS

Now at New Low Price!

\$148⁵⁰

New **CASCADE** tuner assures best reception in fringe areas without a booster. Handles all Cathode Ray tubes from 16" to 24". Improved 30 tube super-quality TV receiver (including 3 rectifiers) mfd. under license by *RCA*. Complete with Fed. Taxes paid. Less Picture Tube

- FEATURES:** 4 microvolt sensitivity • Keyed AGC • 3 stage sync. separator and clipper • Automatic brightness control • Mc band width • AFC horizontal hold • Discriminator-type FM Sound system • Stabilized vertical hold • Highest quality parts • Standard brand tubes • Factory wired, aligned and tested.



TRAV-LER 3-WAY PORTABLE

Lots of **\$14⁸⁵**
3 ea.

A.C., D.C. or batteries. Built-in loop antenna. Luggage style cabinet. Excellent value.

Less than 3, each \$15.85
Batteries\$1.90

STANDARD BRAND TUBES

Individually Boxed and Guaranteed (Manuf. of tubes refuse permission to mention name because tubes are FAR BELOW FAIR TRADE).

1A7	\$.98	6BH6	\$.86	12AT6	\$0.65
1B3	.99	6BK7	1.15	12AT7	.99
1H5	.89	6BQ6	1.29	12AU7	.86
1R5	.87	6BQ7	1.15	12AV7	1.19
1S5	.82	6C4	.69	12AX7	.99
1T4	.79	6CB6	.81	12BA6	.69
1U5	.83	6CD6	2.39	12BE6	.69
1X2A	.94	6J5	.59	12BH7	.77
3Q4	.89	6K6	.98	12SA7	.99
3Q5	.99	6K7	.74	12SK7	.77
5U4	.89	6SA7	.76	12SN7	.99
5V4	.63	6SH7	.89	12SQ7	.68
5Y3	.47	6SJ7	.76	14A7	.99
6AC7	1.12	6SK7	.74	14B6	.94
6AG5	.79	6SL7	.96	25BQ6	1.29
6AH6	.79	6SN7	.89	25L6	.85
6AK5	1.29	6SQ7	.89	25W4	.78
6AL5	1.49	6T8	.69	25Z6	.74
6AQ5	.72	6V6GT	.99	35L6	.86
6AT6	.68	6W4	.66	35W4	.55
6AU6	.76	6X5	.59	35Z5	.55
6BA6	.69	7C5	.89	50A5	.96
6BC5	.86	7F7	.99	50C5	.79
6BE6	.79	7K7	1.19	50L6	.79
6BG6	1.76	7N7	.99	11Z3	.78

Above partial plate list. listing only. Send for complete list.

STEVE-EL ELECTRONICS CORP.

VISIT OUR
NEW STORE

Dept. N-7 61 Reade St., New York 7, N. Y. COrlandt 7-0086

STAY ON THE AIR WHEN POWER FAILS...with an ONAN Electric Plant



**AUTOMATIC
START & STOP**

Model 10EL, 10KW A.C.

When storms, floods, or fires interrupt electricity and force you off the air, you lose listeners and income. Guard against loss, assure vital public service during emergencies by installing an Onan Electric Plant. Onan Standby Electric plants serve many network and private stations. Automatic models to 35,000 watts.

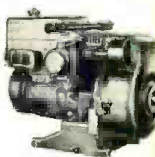

PORTABLE ELECTRIC PLANTS FOR MOBILE RADIO USES
Supply A.C. power for broadcasting at scene of events. Light in weight. Can be carried by hand or in trunk of car. A.C. models: 400 to 3,000 watts.

Write for **FREE Folder**



D. W. ONAN & SONS INC.
4819 University Avenue
Minneapolis 14, Minnesota

Trav-Electric miniature Converter

Input 6 Volts D.C.—
Output 110 V. 60 Cycle 40 Watts



\$15.95

Size—
2 1/2" x 2 1/2" x 3 1/2" List Price

Operates—

- Radios—Short and Broadcast Band
- Phono—Turntables
- Small Dictating Machines
- Test Equipment
- Electric Shavers
- Incandescent Lights

Just Plug in Cigar Lighter

THOUSANDS IN USE
Fully Guaranteed

See Your Dealer or Jobber—or Write Direct

TERADO CO. 1058 RAYMOND AVE.
ST. PAUL 8, MINN.

STAN-BURN ELECTRONICS

ANTENNA SPECIALS

CIRCLE X Limited quantities	\$2.98 each.	12 Or More
DOUBLE V 3/8"	\$2.98	\$2.20
DOUBLE V 1/2"	3.45	2.45
DOUBLE V 3/4"	3.95	2.95
10 Element Conical 3/8"	3.55	2.55
Folded III Straight Low Quick Rig		
3/8" elements	4.25	3.25
WINDOW CONICALS	4.95	3.75

MASTS

5 FOOT SWEDGED79	.69
10 FOOT PLAIN	1.39	1.29

TV WIRE

55 Mil. 300 OHM	\$14.95	M Ft.
72 OHM COAXIAL	45.00	M Ft.

CATHODE RAY TUBE SPECIALS

10BP4 ZETKA	\$14.95	16TP4A DUMONT	\$26.00
10BP4 N. U.	19.95	17BP4A FEDERAL	23.00
10BP4A N. U.	19.95	17BP4A DUMONT	26.00
12LP4 ZETKA	18.95	18AP4 SHELTON	29.95
12LP4 THOMAS	19.95	18AP4A GE	39.95
12AP4 ZETKA	26.00	18BP4A THOMAS	39.95
16AP4A GE	38.00	20CP4A DUMONT	39.95
16DP4A THOMAS	28.80	20CP4A SHELTON	37.00
16GP4A RAULAND	33.00	21EP4A DUMONT	42.95
16IP4 ZETKA	26.00	24AP4A SHELTON	63.00
16IP4 THOMAS	28.80	24AP4A GE	76.00
16RP4A GE & NU	26.00	Single Ion Traps	39c
		Double Ion Traps	59c

CHASSIS 830 REGAL with Cascade Tuner.....\$139.50
 211 TO FLY BACK (Similar to RCA).....2.98
 OPEN FACE CABINET.....39.00

TRANSFORMERS

RCA type for 16"	\$3.85
G.E. type for 16" to 24" X045	3.85

DEFLECTION YOKES

COSINE FERRITE TOOD YOKE 70"	\$4.20
------------------------------	-------	--------

SPECIALS

4 Prong Vibrators, each	5 1.29
Lot of 12 or more	1.19
Standard TV Tuners	1.39
12" Heavy Slug Speaker	Special 4.98

AUDIO DEVICES, DISCS and TAPE IN STOCK

Audio Plastic Red Oxide Plastic tape—	\$2.30
Half hour spool	3.30
One hour spool	3.30

WIRE RECORDERS IN STOCK

Model 973C—2-speed Tape Recorder	Net \$116.68
WILCOX GAY—Model 2A10	89.97

RADIO CRAFTSMAN

Model RC2—HiFi Amplifier	Net 42.05
Model RC10—AM-FM Tuner	Net 128.27
Model CS—Williams Amplifier	Net 97.51

Cascade Guaranteed Tuners (with tubes) SPECIAL! While they last.....\$21.95
 AUTHORIZED DISTRIBUTORS for: General Electric, Kenrad, Tung-Sol, National Union, Jewel, De Wald, Regal, Automatic and Satchel Carlson.
 We carry a complete line of popular makes of Radio and TV tubes, at 50% discount. Also many other special purpose and transmitting types, and all electronic parts and equipment at lowest prices. Send us a list of your requirements for prompt quotations.
 Terms: 20% with order. Balance COD. All prices FOB, NEW YORK. Minimum order \$5.00.
 Write for our latest price list to Dept. RN7

STAN-BURN RADIO and ELECTRONICS CO.
 (C.B.S. THEATRE BLDG.)
 1697 BROADWAY • NEW YORK 19, N.Y.

EVERY RADIOMAN Can Use These SERVICE HINTS!
 Valuable Manual Yours—FREE!

Every page of "How to Simplify Radio Repairs" is packed with on-the-bench practical ideas. Contains photos, charts, diagrams—no fluff—no vague theory. In plain every-day language it gives you priceless suggestions—new servicing ideas. You'll use and benefit from the experience of experts. Partial list of contents: How to Localize Trouble; How to Service Amplifiers; How to Test for Distortion; How to Test Audio Circuits; How to Test Speakers; How to Find Faults in Oscillators; How to Test Radio Parts—and it's all yours—FREE! No obligation.

FEILER SEND COUPON OR GOVERNMENT POSTCARD FOR YOUR FREE COPY TODAY!

FEILER ENGINEERING CO., Dept. 7H2
 8026 N. Monticello Ave., Skokie, Ill. (Suburb of Chicago)
 Please RUSH my FREE copy of "How to Simplify Radio Repairs."
 Name _____
 Address _____
 City _____ Zone _____ State _____

Ranch Radio (Continued from page 29)

Hooking up ranches and isolated towns with the rest of the world is a dramatic use for radio—but in the West there is still another need. Some ranches are so big that communication between various parts of the ranch itself is a king size problem and ranchers are turning to radio for this purpose, too.

In Southern Wyoming there is a big spread which has "gone radio"—the Wyoming Hereford Ranch. This beautiful ranch, which reminded the writer of the spic-and-span thoroughbred horse farms near Lexington, Kentucky, was once privately owned. Now it is held by a three-man trusteeship—and the profits go to a religious institution.

The ranch covers about 65,000 acres, and is still growing. The "heart" of the ranch is a cluster of white houses and red barns along a stream. The offices where visitors are received—and thousands of visitors have parked their cars and walked around the landscaped grounds—are as business-like and efficient-looking as a manufacturing plant or wholesale firm.

But the business is raising Hereford cattle. And the WHR brand is known wherever the breed is known—because their herds are world-famed. As a matter of fact, the records of the American Hereford Association reveal that out of the first sixty-odd "Register of Merit" bulls—the highest award in the industry—ten came from this ranch.

When you see the cattle—and particularly the short-legged, curly-haired bulls (which may weigh a ton and— even to the untutored eye of a radio man—are obviously "Bulls of Distinction") you know that they receive extremely careful handling. And it is no wonder, for one of the best, the fabulous Helmsman III, was "not for sale" even though a prospective buyer offered \$100,000.

Keeping this galaxy of prize cattle well-fed and well-cared-for is naturally a round-the-clock business. Orders from the main ranch often need to be transmitted in a hurry to the two outlying ranches—or to a mobile unit out somewhere on the 100 square mile ranch. To do this job—and to be ready should another crisis arise as it did about 2 years ago when a roaring grass fire threatened a part of the ranch—WHR decided to install two-way radio equipment.

The radio equipment is the kind of straightforward gear which makes a ham feel right at home. The trim transmitter at the office, operating on 43.1 megacycles, feeds a ground plane antenna. This combination puts out a healthy signal which can be picked up in every corner of the ranch. Similar rigs are installed at the outlying ranches. The mobile gear provided is very similar to that used in police radio hookups.

How does the installation work? "It

INSULATED COPPER WIRE

for your Production Needs

#22 SOLID PLASTIC INSULATED 1/2 WALL U. L. **\$476** Per M Ft.

NOW IN STOCK

- JANC-76 Hookup Wire
- ANJC-48A Aircraft Wire
- ANC-168 Shielded Wire
- RG Coaxial Cables
- Many other Gov't spec. and commercial wires in stock

"Your Best Bet for Wire"

STANDARD WIRE & CABLE CO.
 3442 Overland Ave. Los Angeles, Calif.

Easy to make
 Saves flash bulb cost
 Stops action

Build your own ELECTRONIC FLASH

Sprague booklet C-703 shows you how to build up-to-the-minute Electronic Photo Flash units using the very latest low-voltage circuits. Step-by-step instructions. Send 35¢ today for this invaluable guide for the advanced amateur and professional photographers.

SPRAGUE SPRAGUE PRODUCTS COMPANY
 51 Marshall St., North Adams, Mass.

CODE SENDING RECEIVING SPEED

HIGH SPEED WITHOUT NERVOUS TENSION

REVEALING BOOK shows how "crack" operators develop high speed and proficiency. Learn code for Amateur or Commercial Radiotelegraph License, or improve your sending and receiving.

with the Candler System which develops radio-telegraph experts and code champions. FREE CANDLER SYSTEM CO. BOOK

Box 928, Dept. 2-H, Denver, Colo.

T-V TUNERS

Continuous Tuning Printed Circuit Type

Rendered unserviceable by manufacturer. IDEAL FOR PARTS INCLUDING 1:5 VERNIER DRIVE AND MISCELLANEOUS CONDENSERS, RESISTORS, ETC. Sold as is. No refunds. Postpaid

\$1.00 each, 3 for \$2.50
 Add 50c for minimum postage and handling. Cash with order. Immediate delivery.

FRANK W. DECRY AND ASSOCIATES
 11842 W. Jefferson Blvd. Culver City, Calif.

WANTED FOR LABORATORY

Phase Inverter MC-411-A	Goniometer CFT 47372
Phase Inverter MC-413-A	Receiver BC-1147-A
Goniometer MC-472-A	Receiver CFT 4623-A
Goniometer MC-412-A	Indicator BC-1159-A
Goniometer CFT 47263-A	Indicator CFT 55092-A

State quantity, condition, price. Reply Box No. 528
 Federal Telecommunications Labs., Inc.
 500 Washington Ave. Nutley, N. J.

SCHEMATICS—CONVERSIONS FOR SURPLUS GEAR

NEW LIST! MANY ADDITIONS!

Send stamped, self addressed envelope for List #. Add 25c for chart explaining AN nomenclature.

R. E. BOX 1220
GOODHEART BEVERLY HILLS, CAL.

works so well that we don't think much about it," says George Lazear, executive manager of the ranch. "It saves us time and money. Guess that's about all you could ask."

But down at Kim, Colorado, where this story began, they want something else. Vic Waters, crusading editor of the "Kim Country Weekly," who helped "sell" the ranchers on raising the money needed to put in the radio-linked phone system, explains it this way.

"It was a wonderful thing to have the radio and telephone system go in. It was something which we had dreamed about for years.

"But," and his eyes twinkled, "there is one thing missing. I brought the matter up at a committee meeting the other night."

"And what is that?"

"We need an 'ejector.' These women who get on the line. Sometimes it's mighty hard to get 'em off. In fact..."

Women, it seems, are women, be it in the Bronx or on an isolated western ranch. Anybody know a good, simple, diplomatic, "ejector" circuit?

-30-

HEADPHONE BANDS

By ARTHUR TRAUFFER

WHEN cloth-covered headbands have become worn, torn, or soiled, replace them with soft natural-rubber tubing, as shown in the photo. Natural-rubber tubing is soft, sanitary, and it can be cleaned with soap and warm water, or with alcohol. Use tubing 1/4" o.d., or larger, sold by hospital supply or chemical apparatus supply houses. With the type of headbands shown, it's a simple matter to remove the old covering and slip on the rubber tubes by simply removing the two small screws on one side of the frame. If yours uses rivets, file the rivets flush with the plate and drill out the rivets, or drive them out with a small punch. After slipping on the rubber tubes, reassemble the frame using rivets or small R.H. machine-screws and nuts. Some headband frames are made so that they cannot be taken apart easily. In this case, remove the old coverings with a hacksaw and razor blade, slit the rubber tubes length-wise and slip them onto the frames. Assembled in this way, the tubes do not come off easily, but if desired, you can wrap a couple of turns of transparent cellulose tape around each end of each tube and also in the center of each tube.

-30-

Replace headphone bands with rubber tubing.

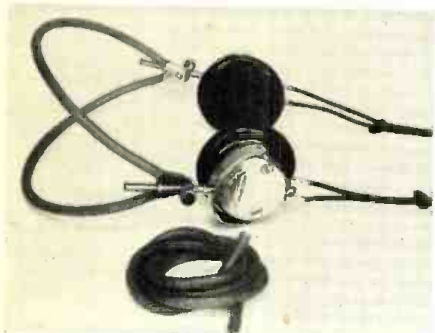

July, 1952



in TV INSTALLATIONS
in any locality use the new

Simpson MODEL 488 TV FIELD STRENGTH METER

Ideal for antenna orientation, comparison of antenna systems, adjustment of TV signal boosters, checking antenna and lead-in installations and many other functions... the 50 microvolt full scale range is an outstanding feature for those concerned with fringe area installations where maximum efficiency must be attained... the 500, 5,000 and 50,000 microvolt ranges extend the usefulness of the Simpson Model 488 into areas of higher signal strength.

SIMPSON ELECTRIC COMPANY

5200 WEST KINZIE STREET, CHICAGO 44, ILL.

Phone: COlumbus 1-1221

In Canada: Bach-Simpson, Ltd., London, Ontario

FOR PERFECTION



BURTON BROWNE ADVERTISING

ROUND, SQUARE, KEY and "D"
OPENINGS QUICKLY MADE
with Greenlee
Radio Chassis Punches



Save hours of hard, tedious work... cut accurate holes in chassis for sockets, plugs, controls, meters, panel lights, etc. with GREENLEE Punches. In 1-1/2 minutes or less make a smooth hole in metal, bakelite or hard rubber up to 1/16" thick. Easy to operate... simply turn with ordinary wrench. Wide range of sizes. Write for details. Greenlee Tool Co., 1887 Columbia Avenue, Rockford, Ill.



SUMMER SALE PRICES SLASHED

T.V. TUBES—ROCK BOTTOM PRICES

6B66 99c	6B66 74c
19B60 99c	6A03 49c
12AX7 59c	6CD6 \$1.29
6BD6 59c	6S4 49c
6AK5 79c		

Westinghouse Kuprox Rectifier 0.64 Amp. 28 Volts. Reg. \$11.00 ea. Special... \$1.95

12 BRAND NEW 10" PHONO RECORDS—Asst. Jazz—Popular, Rhythm—Blues. Please specify \$1.79

Single Pole—10 Pos. 2 Gang Switch... 29c

2 piece, 5 pole Male and Female separable Amphenol plugs. Both with Flex. shielded cables. Approx. 5 ft. long. 35c pair... 3 pr. for \$1.00

Grind your own Crystals. Pure Brazilian Quartz. Various sizes and thicknesses. 1/2 lb. pkg... \$1.00

4 Tube Drilled Chassis, 4 1/2" x 6 1/2" x 1 1/2". 29c each

4 Inch P.M. SPEAKER... \$1.50

5 in. 450 ohm Dynamic Speaker... \$1.35

Signal Corps Phones—2 M. Ohms (8 M. Ohms Imp.)... \$1.25

2 Ft. Ext. Cord (and Plug)... 40c

TOBE TUBULAR ELECTROLYTICS

20-20 MFD. 150 V... 49c 30-30 MFD. 150 V... 57c

40-40 MFD. 150 V... 59c

Low-Loss Short Wave Lock Type Air Trimmer Variable Condensers

5 Pl.—20Mmfd. ... 14c

7 Pl.—25-30 Mmfd. ... 15c

8 Pl.—30-35 Mmfd. ... 16c

14 Pl.—56 Mmfd. ... 24c

3 GANG T.R.F. VARIABLE CONDENSERS

000365 Con. 65c

D.P.D.T. SLIDE SWITCH... 15c

1,000 OHM WIRE WOUND POTENTIOMETER... 15c

30 HY-FILTER CHOKE SHIELDED... 3 for \$1.25

PIEZO CRYSTAL HOLDERS... 12 for \$1.00—\$6.00 per C

RCA Band Switches—3 Gang, 3 pos. 3 band. 30c 6 Gang, 4 pos. 4-5 band. 40c

Trimmer-Padder Asst.—all isolantite—singles, dual, triples—100 ass't... \$2.25

Philo push button Rotary Switch Double Pole... 35c

ATTENTION: Prospectors, Explorers for Hidden Treasures! Construct a U.S. Army Type of Metallic Mine Detector Amplifier. Amplifier unit only (less tubes and batteries) with cables, headphone cord, and jack. Army wiring diagram. Type AN/PRS-1... \$1.95

RCA Ass't Mica By-Pass Cond. .001. 100 for... 95c

8 or 9 Gang Push Button Switch... 49c

DRILLED CHASSIS FOR 5-6 tubes 5" x 10" x 1 1/2". 25c

PHONE JACKS—OPEN & CLOSED AUTO... 18c

156-1 RATIO VERNIER DIALS—4 in. 3/4 in. Hub. 35c

SALE—PIANO RECORD ALBUMS—12"—3 comp. 15c; 10"—3 comp.—13c; 4 comp. 20c; 12 comp. 69c

VULCAN HEAVY DUTY 100 WATT SOLDERING IRON. Built for U.S.N.—Brand New—Eouiv. sells for \$8.50... OUR PRICE \$2.99

MINIMUM ORDER \$3.00—NO C.O.D. SHIPMENTS—PLEASE INCLUDE POSTAGE

NEWARK SURPLUS MATERIALS CO.

324 Plane Street Dept. JY NEWARK 1, N. J.

1219

Prerequisite to

Natural Reproduction of Music

THE **BROOK**
ALL TRIODE HIGH QUALITY
AUDIO AMPLIFIER

The BROOK will play at extremely low volume, yet retain full naturalness of tone; or, recreate in your home the full volume of a symphony, or dance band, clear and clean. You will hear and FEEL live music and voices.



For TV RECORDS RADIO

Write for technical data, booklet "Better Listening" and name of local dealer. Dept. RG-2

BROOK ELECTRONICS, INC.
34 DeHART PLACE, ELIZABETH 2, N.J.

PHOTOCON SALES

417 N. Foothill Blvd. SYcamore 2-4131
Pasadena 8, Calif. RYan 1-6751

FREE 24-PAGE SUMMER SURPLUS SALES CATALOG

WANTED new or clean used electronic surplus. Please state exact description of the condition and details of modification. Include lowest price in first letter.

Audio Oscillator Hewlett-Packard 200BR 20-90,000 c.p.s.	Exc.	\$110.00
4286 Kelvin Bridge Ohmmeter, Leeds & Northrup, 0001-11 ohms.	Exc.	100.00
8041X-1 Signal Generator UHF 8-330mc. Exc.		425.00
TS-13/AP X-Band Signal Generator, Wave-meter, Wavemeter	PUR*	
1-96A Signal Generator SCR-522 Test Equipment. Like New.		350.00
LM & BC-221 Frequency Meter with cal. book, crystal, and tubes.	Exc.	99.50
TS-352/U Weston Test Set.	Exc.	150.00
TS-174/U Frequency Meter 20-280 mc. with cal. book, and crystal.	Exc.	450.00
TS-173/UH Frequency Meter 90-450 mc. Complete with crystal, cal. book, & 115 VAC. Power Supply.	Like New	600.00
TS-146/UP X-Band Signal Generator.	PUR*	
TS-34/AP Portable Oscilloscope.	Exc.	350.00
Industrial Circuit Tester Weston Model 785.	Exc.	125.00
Electronic Analyzer Weston 769.	Like New	225.00
APR-4 Search Receiver.	PUR*	
Tuning Units for APR-4 Receiver.	New & Like New	PUR*
BC-348, BC-312, BC-342 Receivers.	New & Like New	PUR*
Communication Receivers—made by Haillcrafters, National, & Hammarlund. Many models.	Prices Start	79.50
T-47/ART-13 Transmitter.	PUR*	
Measurements Corp. Signal Generator Model 84 300-1000mc.	Exc.	PUR*
PU-14 Inverter Input 24 VDC, Output 115 V., 3 Phase, 400 C.P.S., 5 amps.	Exc.	PUR*
T-17 Hand Microphone with cord and PL-68.	Exc.	4.50
HS-23 8000 ohm.	Used	\$2.95, New 5.95
HS-18 8000 ohm.	Used	1.75, New 2.25
HS-33 600 ohm.	Used	3.50, New 6.95
HS-38 600 ohm.	Used	1.75, New 2.25

*PUR—Price upon request.

NOTE: One of the largest and most complete electronic surplus stocks in the country. We have thousands of tubes, capacitors, plugs, accessories, transmitters-receivers, test equipment, etc. Send us your requirements.

TERMS: Prices F.O.B. Pasadena, California, 25% on all C.O.D. orders, Californians add 3% Sales Tax. Prices subject to change without notice.

Classified

Rate 50c per word. Minimum 10 words

RADIO ENGINEERING

COMPLETE radio, electronics theory & practice: television; broadcasting; servicing; aviation, marine, police radio. 12 or 18 months. Catalog, Valparaiso Technical Institute, Dept. N, Valparaiso, Ind.

SALE

WILLIAMSON type high fidelity amplifiers, dual chassis, 807 outputs, Stancor transformers, \$67.50. Partridge, Acrosound transformers, KT66 tubes additional. Overrated components used throughout. Write Electronic Wiring, Dept. T7, Seiden, L. L., N. Y.

HEARING Aids, Zeniths, Western Electrics, Reconditioned. Make miniature transmitters or receivers. Complete with ear piece and cords, \$16.00 each. Gloria Davis, 2135 Caten Ave., Brooklyn, New York.

HEARING aids, used, Zeniths, less accessories, \$7. One-piece Nationals, \$10. One-piece overhauled, with accessories, \$20.00. Shelby Instrument, 321 W. 7th St., Long Beach, Calif.

DIAGRAMS Radio, Record Changers, Recorders, 75c: Television with Service Data, \$1.25 up. State manufacturer and model number. Kramer's Radio Service, Dept. N8, 36 Columbus Ave., New York 23, N. Y.

IMMEDIATE delivery: Power supplies for Bandmaster Transmitters, \$39.50 F.O.B. Alco Electronics, 102 Marston, Lawrence, Mass.

TV and FM Antennas, Yagi, Conical, Bow-Tie, Mounts, accessories. Lowest prices. Wholesale Supply Co., Dept. H, Lunenburg, Mass.

TUBES and equipment bought, sold, and exchanged. For action and a fair deal, write B. N. Gensler, W2LNI, 136 Liberty, N. Y. 6, N. Y.

ENJOY television with a 3 color filter screen. Thirty seconds to attach. Reduces glare, blur, and snow. Send only \$1. Mention screen size. Zingo Products, Dept. B, Johnstown, N. Y.

RIDERS Manuals, volumes 1 thru 16. (Vol. 1-5 abridged.) Good condition. \$100. Worth Barker, Airport, Va.

SENSATIONAL bargains! Standard brand tubes, bought, sold. Free list. Mark, P. O. Box 14, New York City 72.

WANTED

WANTED: AN/TRC-1 equipments, T14 transmitters, R19 receivers, TS32 test oscillators. Any condition or quantity. Box 525, Radio & Television News, 185 N. Wabash, Chicago 1, Ill.

WANTED: RD110 Telephone Switchboards, BD100 Telegraph Switchboards, BD90 Power Boards, EE101 V-F Ringers, BE72 Cabinets, FM19 Frames, RA43, REC30, K85988, RA87, RA91 Rectifiers, BD101 Test Boards, SB6 Switchboards, Type CF1A, CF3A, CF2B Carrier Equipments. Any condition and quantity. Box 527, c/o Radio & Television News, 185 N. Wabash, Chicago 1, Ill.

WANTED: Top prices paid. Navy Selsyns 1F, 1G, 1CT, 5F, 5G, 5CT and BC-348, BC-221, AN/ART-13, AN/ARC-1, AN/ARC-3, RTA-1B. Lectronic Research, 719 Arch St., Philadelphia.

AN/APR-4, other "APR-" "ARR-" "TS-" "IE-" ARC-1, ARC-3, ART-13, everything surplus: Tubes, Manuals, Laboratory equipment. Describe, price in first letter. Engineering Associates, 434 Patterson Rd., Dayton 9, Ohio.

WANTED: Surplus stocks of every description. Must be new condition. Electrical, radio, telephone, etc. etc. Please airmail written F.O.B. offers to: Dominion Sales (London), 6 Finsbury Square, London, E. C. 2.

CORRESPONDENCE COURSE

USED Correspondence Courses and Books sold and rented. Money back guarantee. Catalog free. (Courses bought.) Lee Mountain, Pisgah, Ala.

PASS FCC Amateur Radio Exams. Leads to profitable career. Simple, quick recorded, home study course for theory and code, lowest cost. Details free. American Electronics, Dept. RN, 1451 Wilkins Ave., N. Y. C.

MISCELLANEOUS

SPEAKERS repaired, wholesale prices, guaranteed workmanship. Amprite Speaker Service, 70 Vesey St., New York City 7.

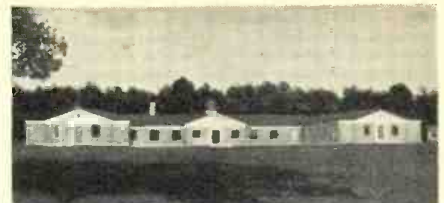

RADIO ENGINEERING TELEVISION ELECTRONICS

Thorough training in all phases of radio and electronics, open to high school and junior college graduates. Old established school specializing in Radio training exclusively. Modern laboratories and courses. Enrollments limited. Approved veteran training.

VALPARAISO TECHNICAL INSTITUTE
Dept. RD Valparaiso, Ind.

EASY MONEY!!

If you don't get our postcards telling the cash we'll pay for that surplus gear you bought when the buying was good, then YOU ARE LOSING MONEY! So send us your name and address NOW and GET ON OUR MAILING LIST!
G. L. ELECTRONICS
905 S. VERMONT AVE, LOS ANGELES 6

EASY TO LEARN CODE

It is easy to learn or increase speed with an Instructograph Code Teacher. Affords the quickest and most practical method yet developed. For beginners or advanced students. Available tapes from beginner's alphabet to typical messages on all subjects. Speed range 5 to 40 WPM. Always ready—no QRM.



ENDORSED BY THOUSANDS!

The Instructograph Code Teacher literally takes the place of an operator-instructor and enables anyone to learn and master code without further assistance. Thousands of successful operators have "acquired the code" with the Instructograph System. Write today for convenient rental and purchase plans.

INSTRUCTOGRAPH COMPANY

4711 SHERIDAN ROAD, CHICAGO 40, ILLINOIS

PEN-OSCIL-LITE

Extremely convenient test oscillator for all radio servicing; alignment • Small as a pen • Self powered • Range from 700 cycles audio to over 600 megacycles u.h.f. • Output from zero to 125 v. • Low in cost • Used by Signal Corps • Write for information.

GENERAL TEST EQUIPMENT
38 Argyle Buffalo 22, N. Y.

WALKIE TALKIES \$4.99 Set of 2

POCKET SIZE



—ELECTRONIC VOICE POWERED
No tubes, batteries, adjustments, license or permit needed!
Guaranteed to work anywhere up to 1/4 mile with extra wire. Swell for garage to house, etc.! Your own private, talk-listen phone. Not war surplus—Brand new. Solid Aluminum Case. Two complete units with wire—READY TO USE! SEND ONLY \$1.00 deposit and pay postman \$3.99 C.O.D. or send \$4.99 for PP delivery. Sold only by mail from: MIDWAY CO., Dept. WRT-7, KEARNEY, NEBRASKA.



Another Outstanding Jobber

M. SCHWARTZ & SON
710-12 BROADWAY SCHENECTADY, N.Y.

EICO has all 17 KITS & INSTRUMENTS in stock!

See EICO ad on Page 26

RADIO & TELEVISION NEWS

JULY 1952
INDEX OF Advertisers

While every precaution is taken to insure accuracy, we cannot guarantee against the possibility of an occasional change or omission in the preparation of this index.

NAME	PAGE
Acorn Electronics Corporation	106
Airex Radio Corporation	18
Air-O-Tronics	94
Allied Radio Corporation	9
Almo Radio Company	112
American Phenolic Corporation	72
American Television & Radio Co.	82
Amperite Company, Inc.	121
Amplifier Corporation of America	82, 117
Arkey-Radio Kits, Inc.	126
Arrow Sales, Inc.	101
Ashe Radio Company, Walter	75
Barry Electronics Corp.	131
Bell Telephone Laboratories, Inc.	13
Bendix Radio	111
Brook Electronics, Inc.	130
Brush Development Company	87
C & H Sales Co.	116
Cander-Aireo	115
Candler System Company	128
Capitol Radio Engineering Institute	95
Channel Master Corporation	17
Chicago Transformer Company	21
Cleveland Institute of Radio Electronics	89
Collins Audio Products	20
Columbia Electronic Sales	124
Communications Equipment Company	103
Cornish Wire Company	118
Coyne Electrical School	117
Crest Laboratories, Inc.	131
Crown Television	118
Davis Electronics	106
DeCray & Associates, Frank W.	128
DeForest's Training, Inc.	5
Dow Radio, Inc.	118
Drillick Electronic Sales Company	116
Dumont Electric Corporation	121
Editors & Engineers, Ltd.	131
Eddie Electronics, Inc.	116
Electronics Institute, Inc.	122
Electronic Beam Corporation	126
Electronic Instrument Company, Inc.	Third Cover, 26, 130
Esney Manufacturing Company, Inc.	103
Fair Radio Sales	115
Federated Purchaser, Inc.	88
Federal Telecommunication Labs., Inc.	128
Feiler Engineering Company	128
Franklin Technical Institute	124
G. L. Electronics	120, 130
Garrard Sales	122
General Electric Company	10, 11, 63
General Test Equipment	130
Goodheart, R. E.	128
Gouset Company	73
Greenlee Tool Company	129
Green Tele Radio Distributors	118
Hallerasters Company, The	7
Harvey Radio Company, Inc.	81
Health Company	66 thru 71, 123
Hytron Radio & Electronics Company	21
Indiana Technical College	116
Instructograph Company	130
J. F. D. Manufacturing Company	8
J. S. H. Sales Company	124
Jan Electronic Distr. Co.	112, 122
Jensen Industries, Inc.	124
Kay-Townes Antenna Company	99
Klein Company, Mammel	121
LaPointe Placemold Corporation	78
Leontone Radio Company	123
Luther, Otto	112
McConnell's	106, 116
McGee Radio Company	76, 77
McGraw-Hill Book Company	112
McIntosh Laboratory, Inc.	125
Mallory & Company, P. R.	Fourth Cover
Midway Company	130
Miles Reproducer Company, Inc.	124
Milwaukee School of Engineering	86
Modern Science Labs.	112
Mosley Electronics	107
Moss Electronics Distributing Co., Inc.	79

**DON'T throw it away...
 Weak Picture Tubes CAN
 be Saved!**

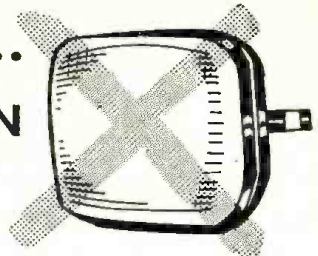

Use a
**Picture Tube
 Rejuvenator**

Simple Plug-in Unit
 Permanent Hook-up
 No Exposed Wires
 Usable on All Size Tubes
 Automatically Operated
 Only \$3.85 Dealer Net
 Available at Local Jobbers

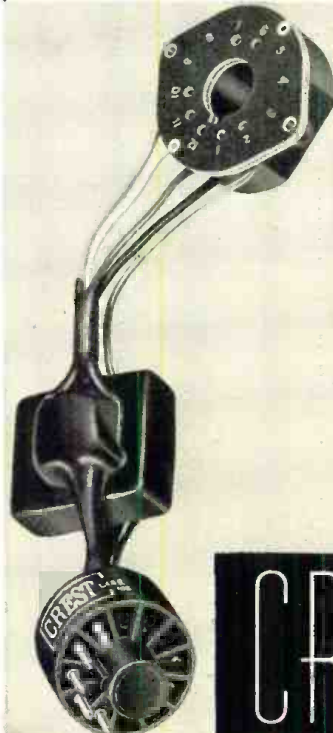

CREST LABORATORIES, INC.
 WHITEHALL BUILDING
 FAR ROCKAWAY, NEW YORK

Standard R.M.A. Warranty	TUBES	New Monthly Listing
0A2	\$.09 6AJ5	1.65 6SC7
0B2	1.10 6AK5	.75 6SH7
0Z4	.59 6AK6	1.10 6SJ7-GT
1A7GT	.98 6AL5	.45 6SJ7-M
1B3GT	.83 6AN5	2.00 6SK7-GT
1AE4	1.10 6AQ6	.90 6SL7-GT
1L4	.79 6AUC6	.85 6SN7-GT
1N21-B	.79 6AV6	.45 6V6-GT
1N23	1.35 6BB	.65 6X4
1N23-A	2.45 6BC5	.65 6X5-GT
1N23-B	3.70 6BD6	.86 6Y6-G
1N34	.64 6BE6	.45 7A6
1N34-A	.88 6BG6-G	1.20 7A8
1N54	.89 6BM6	.65 7C5
1U4	.49 6BK7	1.00 7C7
1X2-A	.89 6BY6G	1.10 7H7
2B7	.75 6C4	.40 12A6
2E24	.35 6CB6	.45 12C8
2E26	3.19 6CD6G	1.49 12H6
2E30	2.19 6F6-M	.88 12AT7
3A4	.59 6F7	.98 12AU7
3D6	.50 6G6-G	.95 12AV6
3Q4	.49 6J5GT	.49 12BA6
3Q5GT	.99 6J6	.59 12BA7
354	.80 6J7	.75 12BD6
5P9T	1.65 6K6GT	.66 12BE6
5V4G	.59 6K7-M	.70 12SA7
5V4G	.99 6L6GA	1.19 12SF5
5X4G	.85 6L7	.98 12SH7
5Y3GT	.49 6S7	.98 12SK7
5Z3	.89 6SC7	.99 12SL7
6AC7	.98 6SD7	.79 12SL7
6AH6	1.00 6SF5	.85 12SN7

• Carter Dynamotors. 6 V in.—400 V out @ 375 ma. 7"x4"x3". New. Only \$28.00

UNIVERSAL RECTIFIER
 Permits a single stack to work as a half-wave rectifier, full-wave center-tap, or bridge rectifier merely by proper connections to the contacts. Full hook-up.

2 Amps. \$ 3.75 10 Amps. 12.25
 5 Amps. 7.50 12 Amps. 14.25

SELENIUM RECTIFIERS—FULL-WAVE BRIDGE TYPES

Current (Continuous)	18/14 Volts	36/28 Volts	54/42 Volts	130/100 Volts
1 Amp.	\$ 2.10	\$ 2.10	\$ 2.10	\$ 8.95
2 Amps.	5.20	3.60	6.50	10.50
4 Amps.	3.75	6.75	8.75	...
5 Amps.	5.00	8.00	13.00	32.00
10 Amps.	6.75	12.00	20.00	45.00
12 Amps.	8.50	16.00	25.50	52.50
20 Amps.	13.25	24.00	36.00	90.00
24 Amps.	16.00	31.00	39.50	98.00
30 Amps.	18.50	36.00
36 Amps.	25.50	45.00

100,000 plates stocked for standard and special rectifiers, rectifier supplies, and XFORMS. Write or call.

• New, Selenium Rectifier Transformers

PRI: 115 V., 60 cycles in. 4 Amps. \$ 8.75
 SEC: 9, 12, 18, 24, and 36 12 Amps. 16.75
 volts 24 Amps. 35.75
 • 115V. PRI.—5V. @ 190 Amp. SEC. 59.95
 • 115 230 V. 60 cy. PRI. SEC.: 1.5, 30.5, 33.5, and 36.5V @ 4 AMPs. Herm. sealed. \$6.50

BARREY ELECTRONICS CORP.
 136 Liberty Street, N. Y. 6, N. Y. Rector 2-2563
 Terms: 25% with order, balance C.O.D.—Send a few cents for postage—All merchandise guaranteed F.O.B. N.Y.C. Remember, you may order tubes not listed!

Editors and Engineers
PUBLICATIONS

Radio Handbook. Giant 13th Edition. A one-volume library of radio information with extensive, simplified theory. Detailed how-to-build-it data on dozens of items of practical radio equipment. 734 pages. Order Book No. E&E-RH13 \$6.00*

Radio Handbook. 12th Edition. Selected constructional items only. English Edition: Order Book No. E&E-RH12 \$3.00*

Spanish Edition: Order Book No. E&E-RHSP12 \$4.00*

Antenna Manual. A practical, comprehensive book on antennas, for everyone interested in transmission and reception. Over 300 pages. Order Book No. E&E-AM1 \$3.50*

Better TV Reception (in fringe and low-signal areas). The standard guide for installation technicians. A popular text for all TV enthusiasts. Order Book No. E&E-TR1 \$2.50*

Radiotelephone License Manual. Typical study questions with concise answers for any commercial U.S.A. radiotelephone operators license. Order Book No. E&E-RL1 \$3.75*

World's Radio Tubes. (Brans' Vade Mecum.) Lists over 15,000 tubes from every tube making country. Printed in 16 languages. New 9th Edition. Order Book No. E&E-VM9 \$5.00*

Surplus Radio Conversion Manual, Volume 1. Practical conversions. Write for list of contents. Order Book No. E&E-SM1 \$2.50*

Surplus Radio Conversion Manual, Volume 2. Companion to Volume 1. Order Book No. E&E-SM2 \$2.50*

*Plus any tax.

BUY FROM YOUR DISTRIBUTOR
 ADD 10% ON DIRECT MAIL ORDERS TO
EDITORS AND ENGINEERS, LTD.
 BOX 689A, SANTA BARBARA, CALIF.
 Bookstores order from BAKER & TAYLOR, Hillside, N.J.

WANTED WANTED

Test Sets TS-12, 13, 14, 33, 35, 146, 147, 174, etc. Radio Radar Equip. ARC-1, 3, ART-13, ATC, APS-10, 15, 33, 34, TPQ-2, BC-348, 342, BC-1016 Recorders, etc.
WRITE! WIRE! CALL!



PANEL METERS

2" SQUARE WESTON—SANGAMO
 0-20 Volts D.C. \$2.95 0-5 Ma \$2.95
 0-40 Volts D.C. 2.95 0-500 Microamp. 4.95
 0-5 Amp R.F. 2.95
 0-100 Ma (0-300 scale) 2.95

RADAR—COMMUNICATIONS AND TEST EQUIPMENT

FLUXMETER

Portable Gauss Meter with range of 500-4000 Gauss. Used to test Magnatron and other magnets. Probe has a gap of 1/4". Complete. Brand New \$32.50

TS-34/AP SYNCROSCOPE AND OSCILLOSCOPE. Used to test and service airborne and ground radars. Complete in portable carrying case with all probes, cables and accessories. Input 110v 60-2600 cyc. Excellent.

TS-16 Altimeter Test Set. Used to check various altimeters or as an accurate wavemeter. New \$29.95

TS-61/AP S-band Echo Box. Using meter provided, it is possible to maximize the XMTR adjustment and determine relative power output. Complete with probe and cable. Very good condition. \$140.00

TS-13/AP Xa band signal generator. wave meter, wattmeter. Precision lab microwave. Test set will provide either pulsed or CW output in Xa band. Input 115v 60-800 cye.

TS-226/AP used to measure peak power output of any xmmitter in the range of 200-1000 mcs. Has provision for oscilloscopic signal observation and built in calibration. Part of AN/APM-29.

TS-69/AP freq. meter covering range of 400-1000 mcs. complete with calibration charts, antenna & crank. In metal carrying case. Excellent \$72.50

TS-170/ARN-5 XTAL controlled test osc. with the following freq. ranges: 332.6, 333.8, 335.0 depending on XTAL in use. This set is used to align glide path receivers. Batteries and antenna are self contained. Excellent condition.

TS-89/AP Voltage Divider. 1:10 and 1:100 ratios. Wide band for true pulse shape. Output to scope. Complete with cables and dummy antenna \$35.00

TS-12/AP V.S.W.R. Test Set for X-band. Complete with amplifier, slotted line, termination, adaptors, etc. in 2 carrying cases. Excellent.

TS-45/APM-3 X-band signal generator. 8400-9600 mcs. pulsed & CW output. Used to check APS4 and similar sets.

TS-36/AP X-band Power Meter. Consists of power measuring circuit, Horn antenna, co-ax to wave guide adaptor, connecting cable and probe. Will measure either absolute or relative power. Nominal band of usefulness is approx. 8.5-9.7 KMC.

TS-3/AP S-band Frequency and Power Meter. Portable. Battery operated. Complete with all cables.

TS-33/AP X-band Frequency Meter. 8500-9600 mcs. Contains crystal detector and indicating meter. Output to scope will indicate pulse wave shape.

TS-62/AP X-band Echo Box. 8400-9600 mcs. tuned and untuned. Will indicate resonance on meter. Complete with pick up antenna and cable.

IE-19 TEST SET. V.H.F. portable equipment covering 100-156 mcs. Used to test SCR-522, ARC-1, ARC-3, etc. Complete with signal generator, field strength meter and accessories. In carrying case. Excellent.

BC-221 PRECISION FREQ. METER. Covers 150kc-20,000kc. Can be supplied with or without modulation. Portable. Complete with calibration book and crystal. Excellent.

S-BAND SIGNAL GENERATOR. Laboratory test set using 70" Klystron in Klystronally Cavity. Has precision attenuator and wave meter. Complete with cables. Mfg'r. Western Electric. Input 110v 60-2600 cye. \$400.00

OTHER TEST SETS

TS-278/AP TS-189/U LM
 TS-102/AP TS-110/AP IE-36
 TS-47/APR TS-164/AR TS-59/APN
 TS-184/AP TS-19/APQ-5 TS-23/APN
 TS-268/UP TS-98/AP TS-18/AP
 1-130 TBN-3EV Thermister Bridge

AN/TPS-3 PORTABLE RADAR

Lightweight Portable Search Radar for detection of aircraft, in the frequency range of 600 MCS. power input: 115v 400 cye, 1330 watts, 28V DC 400W. Complete installation.

PE-104 VIBRAPACK for SCR-284. Overseas packed in original cartons with spare vibrator. Large quantity available. New.

SO-13 S-BAND MARINE RADAR

Compact Sea Search Radar for small vessels. P.P.I. indication is provided. Complete in original cases with complete sets of spares. Excellent condition.

We maintain a completely equipped reconditioning shop and development laboratory. All equipment is reconditioned and checked out to original specs. Our laboratory facilities, technical and production know-how and thirty thousand feet of space is available for electronic subcontracts.

AN/APS-15A RADAR

High resolution X-band Navigation and Blind Bombing Radar. Can be used for high or low altitude blind bombing, precision navigation and to home on X-band ground beacons. Can also be used for ground installations. Available with or without the flux gate gyro stabilizing system. Presentation is a 5" P.P.I. a 3" A scope and a 5" remote P.P.I. Power input is 28v and 110v 400 cye. The following units are supplied: transceiver RT-15A, indicator R-78A, antenna AS-18, control C-33, amplifier AM-19/APA-14, range unit CP-11, computer CP-10, remote P.P.I. ID-30/APS-2, junction box J-15 and J-14, all plugs and connectors. With the flux gate system AN-21 and CN-4 are supplied in addition. Weight is approx. 375 lbs. installed. Electrical characteristics are as follows: freq. X-band, power output approx. 40 KW, range 5, 30, 50 and 100 mile search and beacon. Precision ranging and bombing on 5 to 30 miles. Antenna beam width, 45°. Precision expanded beacon range from 10-200 miles. Supplied from stock, reconditioned and checked out.

SCR-555 DIRECTION FINDER

Freq. range 18—65 mcs. Complete installations available including the quonset hut. Bearing indication is aural-null or left-right bearing on a meter type indicator. Power input is 12v. Weight of complete installation, approx. 2500 lbs.

AN/UPN 1 & 2 PORTABLE RADAR BEACONS

S-band beacons that can be interrogated by any S-band radar in a 45 mile range and will answer with a coded reply which can be changed as desired. The UPN-1 is battery operated. The UPN-2 is 110v 60-2600 cye. Weight is approx. 65 lbs. complete.

APR-1 MICROWAVE RECEIVER

We can supply from stock AN/APR-1 receivers and 3 tuning units to cover the freq. range of 38-1000 mcs. These receivers are almost identical to the APR-4 equipment and the tuning units are directly interchangeable. These sets have outputs for panadapter and pulse analyzer which can be supplied on request.

AN/TPS-1 SEARCH RADAR. This is a pack portable ground search radar for the detection of aircraft up to 100 miles. Range and azimuth data is displayed on a 7" P.P.I. and a 5" "A" scope. This set was called the G.I.'s radar because of its ruggedness, dependability and ease of servicing. Complete tech data is as follows:

Range	Max. 100 Mi.	P.P.R. 200 Per Sec.
	Min. .25	
Azimuth Mech.	360°	Pulse Width 2 Micro
Automatic	360°	Sec.
Accuracy	±3°	
Scanning Manual		Beam Width 3° Horiz.
Automatic		13° Vert.
Presentation	7" P.P.I.	
	5" A Scope	
I.F.F. not provided but has provision for.		Power Input 1100 W
Frequency 1074-1086 Mcs.		at 115V 400 Cye.
		and 180 W at 27V D.C.
Power output		Weight: 1,518 Lbs.
150 K.W.		

AN/APS-3 Alrborne X-band Search and Homing radar. Complete. Contains RF head, modulator, synchronizer, control boxes, plugs, antenna, etc. 115v 400 cye.

SQ 10 CM PORTABLE RADAR. This set is a very compact search radar. Complete installation available. New in carrying cases. Tech. data as follows:
 power input: 90-130v synch. output available:
 cye.; pulse rate: 800 accuracy ±5%; power out-
 cye.; range: 8, 15, 45 put 1 KW; beam width:
 miles; pulse width: 1.1 8° horiz.; 35° vert.;
 microsec.; 300 yds. min. presentation: A, B, P, P.I.
 range, all ranges: I.F.F.

AN/ARC-1 TRANS/REC.

Provides Radio-Telephone Communication between Aircraft or Aircraft and Ground. Complete with Shock Mount and Control Box. Input: 28V DC. Excellent condition. Available in either 10 or 20 Crystal Controlled Channels 100-156 MCS. checked out.

SCR-269/G Automatic Radio Compass. Freq. range 200-1750KC. Complete with BC-433-G receiver, BC-434, LP-21, 1-81, 1-82, BK22, etc. Very good condition \$129.95

TCS Marine Radio Telephone and Telegraph Xmitting and Receiving Equipment. Freq. range 1500 12000KC. Consists of xmmitter, receiver, antenna loading coil, remote control box, power unit, cables, etc. Power input is 12 or 32v DC. We can supply an 110v AC power supply for stationary use at additional cost. Excellent condition.

SCR-536 Xmmitter-Receiver (handy talkie). Freq. range 3885-5500KC. Complete with coils, tubes, crystals. Very good condition. Pair. \$185.00

AN/APA-10 Panoramic Adaptor for use with any receiver with following IF's: 455KC, 5 mcs, 30 mcs. Unit will give panoramic presentation (1 mc wide for 455KC input) (100KC for 5MC input) (2MC for 30 mcs input). Power input 115v 400 cye. but can be changed with the addition of a proper power transformer. Excellent condition \$175.00

10 CM R.F. package, 2700 mcs. Consists of BC-1007 modulator and BC-1091 RF head. Power output approx. 40 KW. Complete with tubes \$125.00

AN/CRT-3 Victory Girl. Dual frequency emergency lifeboat xmmitter. Complete with xmmitter, kite hydrogen generator, etc. New in knapsack. C.A.A. approved

AN/APR-5 Radar Search Receiver. Freq. range 100-3100 mcs. Will detect signals up to 10,000 mcs. with reduced sensitivity. Contains oscillator and mixer cavity. IF strip, power supply. Input 60-2600 cye. 115v. Excellent condition.

T-50 Radiotelegraph Transmitter complete with power supply and all accessories with spares. Portable. New in cases. \$275.00

AN/APT-5 300-1500 mcs. xmmitter with oscillator using 3C22 lighthouse tube. Power output 30 wats. Noise modulated. Excellent condition. Complete with all tubes. \$169.50

SK-1M Radar Receiver Indicators. Freq. 195 mcs. 2 R.F. stages, 3 IF stages. 1 video, etc. New condition \$97.50

SCR-522 VHF Airborne Command Equipment. Freq. range 100-156 mc. in 4 channels. Complete with transmitter. Crystal controlled. Complete equipment. Consists of trans/rec. control box BC-602, dynamotor PE-94, AN104A antenna, plugs, etc. Power input with PE-94 in 28v. We can supply PE-98 dynamotor for 12v input at additional cost.

AN/ARR-2X RECEIVER

Secret Transmission Receiver for reception of double modulated carrier. Will receive 235-258 mcs signals that have been modulated by a 600-750 KC signal. When carrier is heard on a standard receiver no modulation is heard on the carrier when actually speech is being transmitted. 12V DC input.

MISCELLANEOUS

Sound powered chest and headsets MI-2454-B type O, mfg. RCA. Brand new. Pair. \$ 29.95
 R-57/ARN-5 receiver 29.50
 AS-32/APX-1 antenna 2.50
 H5-30 headsets. Good 3.95
 RA-52 power supply for SCR-522. 165.00
 RA-34 power supply for BC-434 250.00
 BC-1206 beacon rec. 200-4000. 28v in. excc. 24.95
 MN-26-Y compass receiver. Excellent. 4.95
 H5-30 headsets. Good 4.95
 BC-1046 tape recorder. Complete. New 29.95
 BC-733D receiver w/tubes 425.00
 C-3 Navy microscope in carrying case. Uses flashlight batteries 69.95
 BC-1284 lighthouse tube preamplifier. 22.50
 AN/ARC-4 2 meter trans/rec. 59.00
 AN/APA-17 radar direction finding antenna. back to back parabola; freq. range 300-1000 mcs. horizontally and vertically polarized. 9.95
 BC-995 interphone amplifier 6.95
 RL-42 motor antenna reel 24.95
 30 MC I.F. strips using 6AK5 135.00
 RD-7/APA-23 recorder for APR 4.95
 AS-27/ARN-5 antenna. Excellent 24.95
 ARA-500-1500 KC receiver 129.95
 ID-80/APA-17 indicator. Excellent. 34.95
 R-28/ARC-5 100-156 mc. receiver. 17.95
 BC-639 receiver. New 13.95
 ID-28 remote control. New 4.95
 BC-455 6-9 mc receiver. 39.95
 BC-454 3-6 mc receiver. 49.50
 BC-800B xmmitter receiver. 32.50
 BC-950 100-156 mc xmmitter 3.95
 RA-300 FM exciter (mfg. Tempco). New 2.65
 FL-8 filter. Less cables. Fair 19.95
 FL-5 filter. Less cables. Fair 4.95
 3C-16-D G5AP gun camera computers with all accessories in carrying case. Excel.
 AT-2A/APN-2 antenna. Fair
 We have a large stock of TS-34A/AP spares.

SEE OUR TUBE AD OPPOSITE PAGE

PHONE: DIGBY 9-0347-8-9

TELETYPE: NY1-771

CABLE: HAMSHACK NEWYORK

WRITE FOR QUANTITY PRICES

Prices subject to change without notice. F.O.B. NYC minimum order \$10.00. 20% deposit required. All merchandise guaranteed.

RADIO HAMSHACK Inc
189 GREENWICH STREET, NEW YORK, N. Y.

NAME	PAGE
National Electronics of Cleveland	110
National Radio Institute	3
National Schools	15
Newark Surplus Materials	129
Newcomb Audio Products Co.	100
Offenbach & Reunis Company	64
Olson Radio Warehouse	80, 81
Olympic Electronics Supply	122
Osann & Sons, D. W.	127
Peak Electronics	82
Penn Boiler & Burner Manufacturing Co.	93
Photocore Sales	130
Pickering & Company, Inc.	119
Pioneer Tool Company	125
Platt Electronics	91
Premax Products	82
Premier Radio Tube Company	85
Premier-Hull, Inc.	119
Progressive Electronics Company	90
Quietrole Company	121
RCA Institutes, Inc.	23, 126
R W Electronics	109
Radcom Engineering Company	113
Radio Apparatus Corporation	88
Radio (corporation of America) Second Cover	72
Radio Craftsmen, Inc.	72
Radio Ham Shack, Inc.	132, 133
Radio-Music Corporation	113
Radio Receptor Company, Inc.	103
Rad-Tel Tube Company	113
Raytheon Manufacturing Company	12
Rider Sales	102
Reley Publishers, Inc., John	65
Rumph Company, Dave	92
Sams & Company, Howard W.	90, 114
Sanett, Bob	118
Schott Company, Walter L.	4
Simpson Electric Company	129
South River Metal Products Co., Inc.	123
Sprague Products Company	128
Sprayberry Academy of Radio	125
Stan Burn Radio & Electronics	128
Standard Surplus	105
Standard Wire & Cable Co.	128
Star Electronic Distr., Inc.	119
Steve-El Electronics Corp.	127
Stevens-Wilden, Inc.	108
Sun Radio of Washington, D. C.	96
Supreme, Incorporated	101
Sylvania Electric Products	10
TAB	131
Tech-Master Products Company	91
Television Communications Institute	100
Television Materials Corporation	91
Television Workshop	116
Terado Company, The	127
Transvision, Inc.	14, 97
Triad Transformer Manufacturing Co.	98
Trio Manufacturing Company	117
Tri-State College	118
V & H Radio & Electronics	122
Valparaiso Technical Institute	130
Video Electronics	124
Waldon Electronics, Inc.	125
Ward Products	53
Weller Electric Corporation	16
Western Electronics Company	126
West Region Electronics	121
Wholesale Radio Parts	107
World Radio Laboratories, Inc.	111
YMCA Trade & Technical School	115

PHOTO CREDITS	
Page	Credit
30 (Fig. 1), 31 (Fig. 6)	Radio Corporation of America
30 (Figs. 2 & 3), 31 (Figs. 4, 5, 7, 8), 47 (bottom)	General Electric Company
34 (top right)	Motorola Inc.
34 (center left)	R. A. Fried
34 (bottom)	Leo Meyerson
36	Phileo Corporation
38	Audio & Video Products Corporation
47 (top)	Standard Coil Products Company
49 (top)	P. R. Mallory & Co., Inc.
49 (bottom)	Allen B. Du Mont Laboratories, Inc.
56, 57	The LaPointe-Plascomold Corp.
58	Radio Tetuan, Spanish Morocco
96	Far East Broadcasting Company
114	British Information Services

Coaxial Relay K-101 SPDT—24V DC5..... 5 4.95
 Set of 83-1SP Coax-Connectors for Above..... 1.35
 1000 KC Crystal BT cut..... 3.95
 V8-2 Vacuum Switch..... 6.95
 Signa Plate Relay 8000 ohm SPDT..... 2.49
 RG-31/U Coaxial Cable—75 ohm.....
 150' roll.....\$11.95. 300' roll..... 22.50
 3" Scope Shield..... 1.29
 15 1/2" @ 800 MA Choke..... 6.95
 2 mfd 3000 V Condenser..... 4.25



TUBES!! BRAND NEW! STANDARD BRANDS! TUBES!!

We are clearing our tremendous tube stock at the lowest prices ever. Take advantage of this opportunity to stock up. Transmitting—Cathode Ray—Magnetrans—Photo Electric—Klystrons—Special Purpose—Receiving.

0A3/VRT5	\$1.04	5J4A	\$24.45	809	\$1.69	FG105	\$17.95	5Y4G	\$0.87	7K7	\$1.10
0B3/VRO0	2.19	5J23	12.25	810	9.95	FG148	8.95	5Z3	.85	7L7	.85
0C3/VRI05	1.19	5J29	12.25	811	2.85	FG172	33.50	5Z4	.85	7N7	.85
0D3/VR150	.95	5J30	49.50	812	2.75	FG451	4.95	6A3	.85	7Q7	.75
1B23	2.15	5J39	12.25	813	7.75	FG582	37.80	6AL5	.85	7T7	.85
1B24	9.75	5L1	22.50	814	2.69	GL434A	29.95	6AG	.82	7S7	.95
1B25	9.75	5NP1	5.50	815	2.35	GL502A	1.79	6AR7	.82	7U7	.95
1B27	14.95	6AN3	2.75	816	1.05	HF100	8.95	6BGT	.98	7W7	.95
1B29	2.45	6AS7	4.45	828	9.95	HF300	22.45	6AC7	.98	7X7	.99
1B32	2.95	6B2	22.50	829	10.35	HY114B	.69	6ABC7	1.05	7Y4	.99
1B36	19.95	6B4	6.25	829B	12.95	HY117	.69	6AC7GT	1.29	8A	.85
1B38	28.75	6J1	7.55	830B	2.75	KC4	37.50	6AE6G	.79	12A	.90
1B39	4.75	6J7	6.55	836A	2.49	KU610	6.15	6AG6	.65	12B7GT	.85
1N21	xtal.	7DP4	14.50	832A	9.45	ML101	47.50	6AG5	.82	12ABGT	.69
1N21A	1.59	9GP7	13.75	833A	42.50	REL21	1.95	6AG7	1.45	12ABGTGT	1.19
1N21B	2.15	9J1	13.75	836B	4.49	RK48A	4.59	6AH3	1.29	12AL5	.85
1N22	1.19	9LP1	14.95	837	1.45	RK50	1.35	6AJ5	1.95	12AT3	.95
1N23	1.25	9LP7	4.95	841	8.41	RK60/1641	2.25	6AK5	1.30	12AT7	1.10
1N23A	2.33	9P1	17.35	842	1.45	RK65	26.50	6AK6	1.09	12AU6	.75
1N23B	3.69	10Y	.39	843	.27	RK72	2.45	6AK8	1.09	12B6	.85
1N26	6.95	12DP7	14.75	845	4.25	RK73	.48	6AQ5	.57	12C6	.69
1N27	1.55	12GP7	14.75	849	27.50	RK21A	2.49	6AQ6	.65	12BA6	.69
1N28A	1.97	12HP7	14.75	851	47.50	RU100	12.95	6AR5	.65	12C8	.69
1P21	37.50	12LP4	20.95	852	27.50	TZ40	3.75	6AT6	.85	12CB	.69
1P23	3.95	15E	1.35	860	3.95	V70D	6.95	6AU5	1.19	12FGT	.65
1P24	2.95	15R	6.99	862	22.50	VR100	.25	6AV8	.55	12H6	.65
1P36	2.69	19T8	.99	864	.27	VR91	.95	6B4G	1.25	12J5GT	.50
1S21	6.85	23D4	.45	865	1.35	VR92	.25	6B4G	1.25	12J7GT	.75
2C21	2.95	28Y1	2.75	866A	1.95	VT157A	2.45	6B6G	.85	12K6	.65
2C21/RK33	.45	30 special	.45	866B	1.29	VT158	13.95	6B8G	.75	12K8	.72
2C22/7193	.29	35TQ	3.25	869B	35.00	VU29	2.49	6BA6	.65	12Q7	.65
2C23A	2.95	45 special	2.95	872A	8.25	W11	1.95	6BA6	1.29	12R7GT	.85
2C34 RK34	.55	53A	5.95	874	1.19	VX33	3.95	6BE6	.65	12S7	.85
2C39	32.50	757L	6.25	876	.27	VX41	6.95	6BF6	.75	12S7S	.75
2C43	14.95	100TH	7.95	884	1.75	WL46B	19.95	6BF6	1.29	12T7	.85
2C44	1.19	121A	2.39	885	1.39	WL531	5.95	6BH6	.95	12S7GT	.68
2C45	1.95	200A	5.95	892A	1.95	WL532	2.45	6BQ6	1.25	12S7GTGT	.69
2C51	6.95	204A	69.50	905	3.25	WL578	6.95	6C4	.65	12S7GTGT	.69
2D21	1.35	211	.69	908	9.95	WL616	34.50	6C5	.60	12S7GTGT	.75
2E24	4.65	215A	49.50	918	9.95	WL619	18.95	6C6	.59	12S7GTGT	.85
2E26	3.15	217C	8.49	922	1.25	WL607	2.79	6C8	.85	12S7GT	.72
2E30	8.95	249C	5.99	923	1.95	ZB3200	145.00	6CB6	.72	12S7GT	.72
2J22	7.75	250R	9.45	930	1.20	0A2	.95	6D6	.72	12Z3	.72
2J26	24.50	250TH	21.95	931A	4.50	0A3	1.00	6E6	.75	12Z3	.72
2J27	27.50	274A	3.95	934	1.20	0B2	1.39	6F5	.75	14A7	.75
2J30	27.50	274B	3.95	935	.35	0A4	.95	6F6	.85	14B6	.85
2J31	27.50	274C	3.95	956	.35	1A3	.70	6F8G	.97	14F8	.85
2J32	27.50	274D	3.95	957	.35	1A4P	.75	6GG6	.95	14H7	.85
2J33	27.50	276A	9.75	958	.39	1B5GT	.39	6H6	.95	14K7	.85
2J34	27.50	293A	2.69	959	3.95	1A8	.65	6H6GT	.85	14N7	.85
2J35	10.95	300A	9.95	961 Ne16	4.95	1A7GT	.85	6J5	.75	14Q7	.75
2J37	11.95	300B	9.95	1803	.45	1B3/8016	.82	6J6	.95	14R7	.85
2J38	11.95	304TH	8.95	1813	.79	1B4P	.79	6J7	.95	14S7GT	1.85
2J39	10.95	304T	8.95	1814	.79	1B5/255	.82	6K2	.95	14T7	.85
2J40	39.50	305A	34.95	1816	.29	1C6	.85	6K6GT	.95	25Z7GT	.85
2J46	39.50	307A/RK75	4.45	1819	.69	1C5GT	.75	6K7	.75	26	.47
2J48	39.50	310A	16.95	1822	.69	1C8	.69	6K8	.75	30	.30
2J49	34.50	318A	.65	1824	1.45	1C7G	.69	6L5G	.75	32	.32
2J50	21.50	323A/B	23.95	1825	.35	1D5CP	.65	6L6	2.25	31	.50
2J54B	32.50	327A/3C37	4.45	1826	.35	1D7G	.65	6L6G	1.39	32	.50
2J59	44.50	331A	11.95	1828	.35	1D8GT	.65	6L8GA	1.39	32	.50
2J61	44.50	331A	11.95	1830	.69	1E3GT	.69	6L7	.85	33	.47
2J62	47.50	350A	6.45	1831	1.75	1E7G	.95	6L7G	.85	34	.57
2K2	28.75	368AS	7.50	1833	.69	1F4	.75	6M7GT	.85	35	.65
2K2B	32.50	371A	.95	1834	.69	1F5G	.65	6M7	.75	35A	.65
2K2C	32.50	371B	.95	1838	2.7	1G6GT	.65	6H7	.79	35B5	.75
2K33A	310.00	388A	1.45	1838	.43	1H4G	.62	6H7G	.95	35C7	.65
3AP1	9.95	393A	7.95	1841/RK60	2.25	1H5GT	.72	68A7GT	.85	35S4	.53
3B23 EL	4.69	417A	8.75	1854	2.89	1H6GT	.75	6AS	.95	35Y4	.60
3B23 RK22	4.69	417A	8.75	1854	2.89	1H6	.75	6SD7GT	.85	35Z7	.60
3B24	5.25	434A	27.50	1855	1.50	1L4	.67	6SF5	.77	35Z7	.60
3B24W	4.45	446A	3.75	1855	1.55	1L4A	.67	6SF7	.77	35Z7	.60
3B25	4.39	446B	3.75	1851	1.55	1L6	.95	6SF7	.77	36	.44
3B26	3.59	450TH	39.75	1D60	.65	1B4	.98	6SG7	.75	37	.59
3B27	3.75	450TH	39.75	1D61	.65	1LC5	.95	6SH7	.65	39/44	.25
3B28	8.39	471A/B21	2.45	2050	9.95	1C6	.95	6S17	.75	41	.69
3BP1	5.95	527	12.45	2051	1.18	1LD5	.79	6SK7GT	.72	41	.69
3C22	12.45	535A	3.35	5670	1.18	1LE3	.79	6SL7GT	.75	42	.65
3C23	10.95	562	97.50	6003	6.75	1L65	.75	6SN7GT	.65	43	.69
3C24 24G	1.75	575A	13.45	800B	5.95	1LH4	.87	6SQ7	.65	45	.75
3C27	7.95	701A	3.75	8011	1.75	1LN5	.75	6SR7GT	.68	45Z3	.54
3C31/C1B	2.75	702A	5.25	8012	2.65	1NSGT	.75	6SR7	.68	45Z5	.60
3C45	16.95	703A	5.25	8013	2.59	1P5GT	.69	6ST7	.98	47	.76
3CP1	1.95	704A	.95	8014	28.75	1Q5GT	.68	6SU7GYT	2.75	47	.76
3CP1S1	1.55	708A	6.45	8020	1.95	1R4	.69	6SV7	.98	49	.75
3DP1	4.45	708BY	35.00	8025	5.45	1R5	.65	6T7G	.85	48	1.25
3DP1A	6.95	708CY	35.00	8007	1.50	1S4	.69	6TB	1.05	50A5	.89
3DP1S2A	1.95	708BY	39.50	8009	1.50	1S5	.65	6UB5	.85	50B5	.75
3D21A	1.65	708CY	39.50	9003	1.65	1T4	.65	6U6GT	.85	50C5	.67
3E20	13.95	707B	13.95	9004	1.25	1T5GT	.68	6U7G	.85	50LGT	.65
3E27	22.95	7245	3.25	9005	1.45	1U4	.65	6V5G	.75		



PRECISION RESISTORS

Over 2 1/2 Million in Stock

"TAB" - Specialists in Precision Resistors No Mfrs Choice - We Ship Types in Stock

0.116	286	1260	3500	17500	115000
0.42	285	1300	3600	18000	120000
0.625	299	1350	3600	18000	120000
0.407	300	1400	3700	18300	130000
0.7	313	1450	3700	18300	130000
1.03	311.5	1495	3700	18500	140000
1.3	320	1500	3900	18800	140000
1.75	325	1500	4000	19000	145000
2.5	330	1518	4030	19500	147000
3.83	340	1600	4200	20000	150000
5.1	345	1600	4200	20000	150000
4.35	366	1650	4300	21000	165000
5.7	370	1670	4300	21500	167500
5.025	375	1680	4400	22000	167000
6.25	380	1710	4440	22500	169200
7.5	389	1712	4500	22900	175000
7.5	390	1740	4720	23000	180000
7.8	400	1770	4750	23150	180600
7.9	410	1800	4850	23500	185000
8.5	414.3	1818	4885	23400	186600
10.38	418.8	1830	4900	23500	190000
11.5	425	1840	4920	24000	195000
13.52	426.9	1865	5100	24600	200000
14.2	427	1892	5210	25000	201000
14.5	432	1910	5235	25000	205000
15	440	1895	5270	25400	210000
16	450	1896	5300	25833	215000
18	450	1900	5320	26000	220000
19.2	460	1898	5300	26500	225000
19.5	470	1899	5730	26600	229000
20	475	1910	5740	27000	230000
22	478	1901	5910	27500	235000
23	480	1902	6000	28000	238000
24	483	1909	6030	28500	242000
25	500	1904	6125	28500	245000
25	510	1905	6180	29000	250000
28	510	1905	6220	29500	250000
30	525	1907	6300	29990	268000
31.5	540	1908	6495	30000	270000
32	545	1910	6500	31000	275000
48	560	1910	6800	31500	294000
50	570	1911	6840	32000	300000
51.78	580	1912	6880	32000	305000
55.5	588	1913	7000	35000	311000
57	600	1914	7320	36000	314000
63	620	1917	7500	38000	325000
68	620	1917	7717	38500	330000
74	643	1918	7900	39000	335000
75	640	1919	7930	39500	350000
80	645	1920	8000	40000	350000
81.4	645	1924	8000	41400	375000
88	649	1926	8094	42000	380000
95	650	1927	8100	42000	385000
100	657	1980	8250	45000	400000
101	665	2000	8500	47000	402000
102	670	2000	8500	47000	402000
103	673	2080	8770	48000	422000
105.7	675	2095	9000	48660	425000
106	680	2100	9000	49000	425000
110	681	2142	9445	50000	450000
120	684	2145	9500	51000	458000
125	684	2160	9500	51000	458000
125	697	2160	9800	55000	472000
130	699	2180	9900	56000	478000
135	705	2190	9900	56000	478000
147.5	711	2195	10000	58333	510000
150	733	2200	10430	60000	520000
160	740	2200	10430	60000	520000
165	750	2300	10600	62000	525000
170	800	2400	10900	64000	543000
175	800	2400	10900	64000	543000
179	820	2463	11000	66600	560000
180	850	2485	11400	66650	570000
185	875	2490	11500	67500	570000
182.4	899	2500	11690	68000	600000
200	900	2525	12000	70000	620000
205	900	2525	12000	70000	620000
210	917	2625	12800	73500	654000
216	946	2635	13100	75000	660000
220	946	2635	13100	75000	660000
220.4	1000	2750	13550	82000	690000
225	1030	2850	13600	84000	700000
225	1056	2900	13600	84000	700000
235	1059	2870	14250	85750	761300
240	1067	2900	14400	88000	800000
245	1100	2900	14400	88000	800000
245.4	1110	3100	14550	91000	820000
250	1160	3163	14600	93000	850000
250	1155	3155	14600	93000	850000
270	1182	3290	14600	95000	900000
271	1200	3300	16500	100000	910000
275	1225	3400	16800	11000	930000
280	1250	3384	17000	95000	950000

Any Size Above, Each 35c; Ten for \$3.29

MEGOMHS

1.	1.579	2.8	6.7	10
1.1	1.85	2.75	4.23	7.11
1.25	1.75	2.75	4.25	7.11
1.3	1.85	2.85	5.62	12.83
1.3	1.9	2.85	5.74	13
1.35	2.1	3.3	5.1	8.13
1.4	2.11	3.3	5.8	10.2
1.4	2.2	3.673	6.5	8.5
1.5	2.25	3.75	6.5	9.05
1.57	2.25	3.75	6.5	9.05

Any Size Above, Each 70c; Ten for \$6.49

DYNAMOTORS

DM4	12x24V	out 225V/100ma.	11.98
	440V/200ma.		
DA3A	28V/10.5A	out 300VDC/260ma.	8.75
	150VDC/10A	out 100VDC/10A	
	W/DYNA DABA, (SCR522)		8.98
	MAGMOTOR inpt 6V out 500VDC/		1.54
	29.95		
	Inpt 8V out 200V/100MA.		3.75
	Inpt 28VDC out 250V/60MA.		3.95
	PE97 Plate Supply Unit, Less Tubes		3.98

SELSYNS

2JH1	GE Selsyn	2 for \$6.98
2J1F3	GE brand New	
	115V/400cy. ea.	9.75
C78249	Sync. Diff. 15V/60cy. 2 for 25.00	
C78248	Sync. Trans. 115V/60cy. 2 for 29.95	
	Synchro Repeater 115V/60cy. Type	
	11-4 Brand New \$13.95. 2 for 25.00	
	Bendix Autosyn AY & AY-2 for 4.95	
	C69405-2 Trans Type 1-1. 2 for 50.00	

UHF ANTENNA

UHF ANTENNA 12"/30CM AT5/ARR1 Usable Citizn & Ham Band Invs Coax Term Silv Plt Cont Wpf GAG & H. Mobile. Mfg. New. 39c. 4 for \$1.00

PL259 for above. \$1.25/50PK. 1000 to 65 MCROWAVE (1000 to 65) MCROWAVE 3400Mc w/UG38U Term. In-Built. In-Built Flange Mtg Incl. Hw. \$5.98

ANT AN1308, 11 ft. 8 sec. 3.98

ANT AN1314, 11 ft. 8 sec. 3.98

MS49-52, Sectional Antennas \$1.69

MS49-53, 16 ft. 2.49

BASES... MP22, \$3.98; MP48 \$3.98

MODEL HF-1 OSCILLOSCOPE

Laboratory Features, 5 MC Bandwidth, 10MV Sens, PFC Horiz Amp, Cathode Coupled Multi Vib. Swp. Int. Retrace, Cathode Ray Exp. Int. Vert. & Horiz. Amp. Non-Freq. Discrim. Gain Ctrl. Cal. Compensated Attenuators, Sync Pos or Neg. Int. or Ext. In. In-Built Cathode Fltr for Sig. Tracing with Phosor. Tech. Manual. 3 1/2 Tube, Line up. 3-6C4, 1-6AG5, 2-6AG7, 2-6X5, 1-6BN, 1-3BP1. "TAB" SPECIAL \$59.50

"TAB" THAT'S A BUY

Infrared Snopscopes Image-Converter Tube HiSensitivly simplified design 1/2" dia. Willemite screen-Resolution up to 350 Lines/in. Complete data & tube, each \$4.98; 2 for \$9.49

SNOPSCOPE PWR SUPPLY 35MA using Voltage DblR Circuit Incl. Trans., Rectifiers, Sockets, Resistors, Condensers. Diagram \$6.98

HIGH CURRENT MICA CNDRSR. CYLINDRICAL-SIMILAR TYPE G

Mfd.	No.	Kv	Amps	Mc	Each
01	30	30	3	49.50	
0025	20	22	3	45.00	
004	20	22	3	45.00	
005	15	20	3	37.50	
0025	12	20	3	28.95	
001	30	30	3	110.00	

RHEOSTATS

2 ohm 50W Ohmite	\$2.59
1/2 ohm 75W Ohmite	3.74
20 ohm 50W Ohmite	2.35
60 ohm 50W Wair-L	2.29
100 ohm 50W Ohmite	2.65

TV PICTURE TUBES

10 inch Round	\$14.95
12 inch Round	17.95
14 inch Rectangular	20.95
16 inch Rectangular	23.95
17 inch Rectangular	24.85
18 inch Rectangular	25.95
20 inch Rectangular	29.95
21 inch Rectangular	31.95
24 inch Rectangular	39.95
24 inch Metal	67.00

Your old pict tube is worth money. Write for trade-in allowance on RMA coded and dated tubes with one year guarantee. Ship your defective picture tubes prepaid only.

"TABS" Tube Specials BROKEN KEYS-ELECTRICAL PERFECT

1B3GT, 6H6, 6K6GT, 6SN7GT, 12SN7GT	Each 50c; 5 for \$2.00
6BG6, 6BQ6GT, 12SG7, 19B6, 6L6G, 6L6GA	Each 79c; 3 for \$2.00

TUBES

"TAB" TESTED & GUARANTEED Write for Complete Listing. (Prices Subject to Change)

0A2	.98	GAC87/1B53	1.39	65F5	.89	F123A	7.90
0A3	1.23	GAC87	1.09	65F7	.89	F125	12.49
0A4G	1.45	GAC9C	1.49	65H7	1.39	F127A	19.98
082	1.57	GAC7	.99	65H7	1.09	F128	19.98
083	VR90	1.29	65G7	.89	CV148	4.98	
0C3	VR105	1.19	6A07G	1.49	65T58	14.49	
0C3	VR150	.98	6AF6G	1.33	65L7C7	8.90	
184P	.89	GAC7	1.99	65N7WCT	2.25	250TH	22.25
185	295	.99	GAC7	1.49	65N7C7	8.90	
186	295	.99	GAC7	1.49	65N7C7	8.90	
187	295	.99	GAC7	1.49	65N7C7	8.90	
188	295	.99	GAC7	1.49	65N7C7	8.90	
189	295	.99	GAC7	1.49	65N7C7	8.90	
190	295	.99	GAC7	1.49	65N7C7	8.90	
191	295	.99	GAC7	1.49	65N7C7	8.90	
192	295	.99	GAC7	1.49	65N7C7	8.90	
193	295	.99	GAC7	1.49	65N7C7	8.90	
194	295	.99	GAC7	1.49	65N7C7	8.90	
195	295	.99	GAC7	1.49	65N7C7	8.90	
196	295	.99	GAC7	1.49	65N7C7	8.90	
197	295	.99	GAC7	1.49	65N7C7	8.90	
198	295	.99	GAC7	1.49	65N7C7	8.90	
199	295	.99	GAC7	1.49	65N7C7	8.90	
200	295	.99	GAC7	1.49	65N7C7	8.90	
201	295	.99	GAC7	1.49	65N7C7	8.90	
202	295	.99	GAC7	1.49	65N7C7	8.90	
203	295	.99	GAC7	1.49	65N7C7	8.90	
204	295	.99	GAC7	1.49	65N7C7	8.90	
205	295	.99	GAC7	1.49	65N7C7	8.90	
206	295	.99	GAC7	1.49	65N7C7	8.90	
207	295	.99	GAC7	1.49	65N7C7	8.90	
208	295	.99	GAC7	1.49	65N7C7	8.90	
209	295	.99	GAC7	1.49	65N7C7	8.90	
210	295	.99	GAC7	1.49	65N7C7	8.90	
211	295	.99	GAC7	1.49	65N7C7	8.90	
212	295	.99	GAC7	1.49	65N7C7	8.90	
213	295	.99	GAC7	1.49	65N7C7	8.90	
214	295	.99	GAC7	1.49	65N7C7	8.90	
215	295	.99	GAC7	1.49	65N7C7	8.90	
216	295	.99	GAC7	1.49			



DEDICATED TO YOU!

This great new **EICO**
FACTORY... these **NEWEST**
EICO INSTRUMENTS...

YOU made them possible with your
CONFIDENCE in EICO. We pledge to strive
 with all our power, product-wise and
 service-wise, to continue to merit your
 trust in us.

Harry R. Ashley
 President



6 NEW V-O-M KITS and Instruments

FOR LABORATORY PRECISION AT LOWEST COST



EICO New Model 536—
 1000 Ohms/Volt Multimeter
 Wired \$14.90. KIT \$12.90.

- 31 full scale ranges!
- DC/AC Volts: Zero to 1, 5, 10, 50, 100, 500, 5000.
- DC/AC Current: 0.1 ma, 10 ma; 0.1 A, 1 Amp.
- Ohms: 0-500, 100K, 1 meg.
- 6 DB Ranges: -20 to -69.
- Large 3" 400 ua meter movement.
- High-Impact Bakelite case. 6 1/4 x 3 3/4 x 2".

EICO New Model 526 1000 Ohms/Volt Multi-
 meter KIT \$13.90. Wired \$16.90. As above, with 1%
 precision resistors.



EICO New Model 566 1000 Ohms/Volt Multimeter KIT
 \$14.90. Wired \$18.95. Ranges: same as Model 536 (left), plus
 7 output voltages. Large 4 1/2" 400 ua meter movement.

EICO New Model 556 1000 Ohms/Volt Multimeter KIT
 \$16.90. Wired \$23.50. Ranges: same as Model 536 (left), plus
 7 output voltages. Large 4 1/2" 400 ua meter movement and 1%
 precision resistors.

Compare these value-crammed EICO V-O-Ms with
 any others at any price—at your local jobber—and
 SAVE! Write NOW for FREE newest Catalog 7 RA



New Model 565

20,000 Ohms/Volt Multimeter KIT \$24.95.
 Wired \$29.95.

- 31 full scale ranges!
- DC/AC/Output Volts: 0-2.5, 10, 50, 250, 1000, 5000.
- DC Current: 0-100 ua; 10, 100, 500 ma; 10 Amp.
- Ohms: 0-2000, 200K, 20 meg.
- 5 DB Ranges: -12 to +55.
- Large 4 1/2" 50 ua meter movement.
- High-impact Bakelite case. 6 3/4 x 5 1/4 x 3".

EICO New Model 555 20,000 Ohms/
 Volt Multimeter KIT \$29.95. Wired
 \$34.95. As above, with 1% precision res-
 istors.

ONLY **EICO** GIVES YOU ALL
 10 **EICO** NOMICAL FEATURES

- Laboratory Precision • Lowest Cost • Life-
 time Dependability • Speedy Operation
- Rugged Construction • Quality Compon-
 ents • Latest Engineering • Super-Simplified
 Assembly & Use Instructions • Laboratory-
 Styled Appearance • Exclusive EICO Make-
 Good Guarantee.



Prices slightly higher on West Coast. Due to unstable conditions, prices and specifications are subject to change without notice.

ELECTRONIC INSTRUMENT CO., Inc. 84 Withers Street, Brooklyn 11, New York

UHF



*All UHF channels...
for all TV sets*

MALLY UHF CONVERTER

The Mally UHF converter is right for *all* your TV customers because it can be used with *any* TV set... in *any* UHF broadcast area. And it's easy to install—no adjustments or connections to make in the TV set... just connect power lines and antenna leads.

These Mally features mean real customer satisfaction... real sales for you in the new UHF market—

- Reception of all UHF channels
- No sacrifice of VHF channels
- Built-in UHF antenna
- High quality picture definition
- Fast, easy installation

No larger than a small portable radio, the Mally UHF converter is precision-built for long, trouble-free service. Get complete details today on the Mally UHF converter from your Mally distributor.

P. R. MALLY & CO. Inc. **MALLY** CAPACITORS... CONTROLS... VIBRATORS...
SWITCHES... RESISTORS... RECTIFIERS...
VIBRAPACK* POWER SUPPLIES... FILTERS
*Reg. U.S. Pat. Off.

APPROVED PRECISION PRODUCTS

P. R. MALLY & CO., Inc., INDIANAPOLIS 6, INDIANA

*Make Sure...
Make it Mally*