

RADIO & TELEVISION NEWS

SEPTEMBER
1951
35¢
In Canada 40¢

AMATEUR
K4USA

WASH DC

LONDON

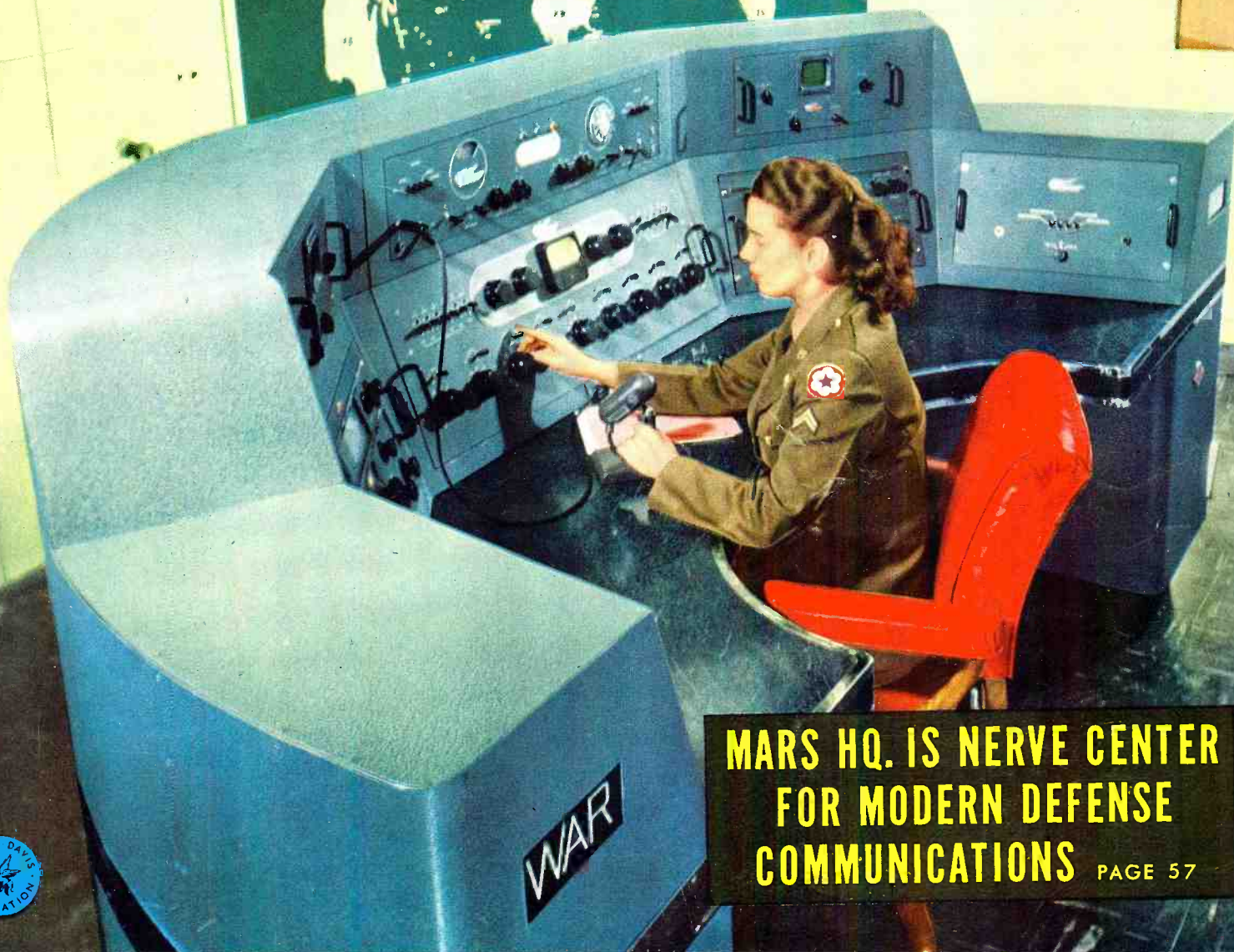

**MARS HQ. IS NERVE CENTER
FOR MODERN DEFENSE
COMMUNICATIONS** PAGE 57



THE QUALITY OF RCA TUBES IS UNQUESTIONED



4,500,000



1946

1952

Best Sellers!

Life expectancy... plus!

RCA kinescopes incorporate
the experience of the
oldest mass-producer of
picture tubes in the industry



It is a well-established fact that more RCA kinescopes are now in active service than any other brand . . . over 4½ million since the advent of commercial television, when RCA pioneered the first large-scale production of kinescopes.

Significantly, many RCA kinescopes installed *four and five years ago are still giving good performance today*, providing continuous reliable service year after year. Yes, RCA picture tubes of all types have consistently given outstanding performance.

RCA's kinescope quality means substantial savings to dealers and servicemen, in fewer call-backs and "out-of-pocket" replacements. In the long run, it amounts simply to this . . . stocking RCA picture tubes is good business . . . as any long-term user of RCA kinescopes will tell you.

Your local RCA Tube Distributor carries a complete line of RCA picture tubes. See him the next time you buy kinescopes for replacement.

Keep informed . . . keep in touch with your RCA Tube Distributor



RADIO CORPORATION of AMERICA
ELECTRON TUBES
HARRISON, N. J.

NEW PARA-CON ANTENNA COMBINES PARABOLIC & CONICAL PRINCIPLES



Barbara Lee—Rising TV Star, WEWS Cleveland

Sight Sells It

After all, people buy TV sets to enjoy the picture. It just makes sense that the antenna bringing in the best picture brings in the best entertainment and the most customer satisfaction. Hook a Para-Con onto any set and you'll agree—it sells on sight.

Solves 9 out of 10 Installation Problems—Challenges Comparison

Two best features are incorporated into one BEST antenna. The praiseworthy features conical type aerials possess for supplying full audio and full video bandwidth reception are used with a parabolic design that gives the Para-Con a concentration of signals. Para-Con is engineered to concentrate the maximum wave energy on the antenna by providing all-around, unmatched performance . . . perfect picture clarity . . . long customer satisfaction.



Any TV Set Performs Better With a Para-Con Antenna

Every set performs better when conditions are better. Install Para-Con when older sets are starving for a stronger signal. Install a Para-Con when any set is being drowned in a sea of local interference. In the majority of set installations, Para-Con makes both old and new sets perform at their peak. To be on the safe side every time, install the sensationally performing new Para-Con antenna and forestall TV troubles at both the reception and the service end.

One Antenna Covers All Channels

The Para-Con antenna reaches out and grasps all channels. The Ward Para-Con has an exceptionally low standing wave ratio combined with a spectacular high gain advantage on all channels.

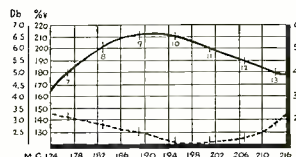
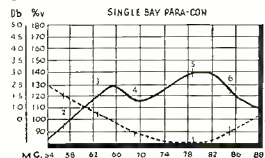

Proved in Thousands Of Installations

Spectacular success has been achieved in practically every installation. Even in locations far removed and in difficult terrain where other more elaborate arrays were tried and failed, PARA-CON aerials not only bring in brighter, clearer pictures but seize and channel in stations where dependable reception has not been possible with an ordinary antenna. Ward's new PARA-CON Antenna has been field tested in thousands of installations . . . proved far and away better.

No Ghost Hunts

No more skeletons in your customer's TV closets. Scientifically determined direct impedance matching characteristics eliminate many ghosts. Para-Con's revolutionary design transfers the maximum power from the antenna to the receiver with a minimum of reflections.

Profit-Wise Dealers Prefer Para-Con*

The antenna is one of the most important and critical components of a TV receiver. Nearly 20% of all TV service calls result from faulty antennas. The general all-around, high performance of Ward's Para-Con antenna gives customer satisfaction right from the initial installation. Expensive call-backs due to antennas are slashed. Ruggedly built for long lasting trouble-free service Para-Con withstands winds and weather. Easy to handle and quick to install . . . saves time and expense.

See your distributor for Ward's answer to your antenna problems. *Trade Mark

The First In TV To Use Parabolic Principle

Parabolic antennas have long been used in special applications for concentrating weak signals onto driven elements. The brilliant results of Ward Para-Con are now setting new performance standards on all channels and in most every area. Ward's Para-Con Antenna is different. It's new. Now it is possible for one antenna to meet and solve many of the local problems of installation and reception.

Ideal For All Band Fringe Areas

In fringe areas where selection of a number of channels is available, Ward's stacked Para-Con models provide the ideal compromise antenna for maximum results on all bands. Stacked in either two or four bay arrays, the Parabolic design reflectors reach out, gather and concentrate maximum energy on the antenna elements.

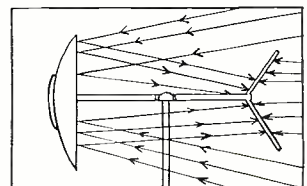

Diagrammatic sketch showing how parabolic reflectors gather in and concentrate energy on conical elements.

Singles Out The Stations High Front to Back Ratio

The new Para-Con design achieves an unusual capacity to obtain sharp directivity over all the television spectrum. Para-Con principles afford greater power and less interfering noise on each channel.

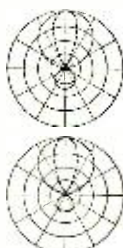

WARD

PARA-CON

(Combining Parabolic and Conical Principles)

ANTENNAS

THE WARD PRODUCTS CORPORATION, Division of The Gabriel Co.
1523 E. 45th Street, Cleveland 3, Ohio
IN CANADA: ATLAS RADIO CORP., LTD., TORONTO, ONT.

Editor
OLIVER READ, D. Sc., D. Litt., W9ET

Managing Editor
WM. A. STOCKLIN, B.S.

Technical Editor
H. S. RENNE, M.S.

Associate Editor
RAY FRANK, W9JU

Eastern Editor
HAROLD BECKER

Assistant Editor
P. B. HOEFER

Television Consultant
MILTON S. KIVER

Short Wave Editor
KENNETH R. BOORD

Staff Artist
R. S. KUPJACK

Chief Draftsman
B. L. NEWMAN, W9ROB

Associate Advertising Director
M. J. CULLIGAN

Advertising Manager
L. L. OSTEN

Midwest Ady. Manager
JOHN A. RONAN, JR.

Western Ady. Manager
JOHN E. PAYNE

Art Director
HERMAN R. BOLLIN



COVER PHOTO: Cpl. Mary Lafler at the control desk of the Headquarters stations of Army and Air Force MARS. These modern stations are housed in a special building constructed within the Pentagon in Washington. (Signal Corps Photo, U.S. Army)

Chairman of the Board and Publisher
WILLIAM E. ZIFF

President
B. G. DAVIS

Secretary-Treasurer
G. E. CARNEY

Vice-Presidents
MICHAEL H. FROELICH
Dir. Eastern Div.

H. J. MORGANROTH
Production Director

LYNN PHILLIPS, Jr.
Advertising Director

H. G. STRONG
Circulation Director

BRANCH OFFICES

NEW YORK (17)
 366 Madison Ave., Murray Hill 7-8080

LOS ANGELES (14)
 815 S. Hill St., Tucker 9213

RADIO & TELEVISION NEWS

Reg. U.S. Pat. Off.

Radio News Trademark Reg. U. S. Pat. Office • Television News Trademark Reg. U.S. Pat. Office.

First in
radio-television-electronics
 Average Paid Circulation over 200,000

CONTENTS

SEPTEMBER, 1951

Do You Want More Business?.....	H. E. Kranhold	35
Repair That Speaker.....	W. E. LaFarra	38
A Deluxe Pulse Generator.....	Louis E. Garner, Jr.	40
Simulating a CBS Color Signal.....	Murray Barlowe	43
A New FM Communicati Tuner.....	Woodrow Smith	46
Audio Simplified (Part I).....	David Fidelman	48
New TV Components.....		51
A Miniature H-F Portable Transmitter-Receiver.....	M. Kirchoff, W2FAR & D. D. Bulkley, W2QUJ	52
Triple Your Phone Power for Five Dollars.....	Fred F. Everett, W0YTY	56
MARS' Pentagon Headquarters.....		57
Proportional Radio Control.....	Howard G. McEntee, W2SI	58
A Novel Horn-Loaded Speaker.....	Wm. E. Johnson	63
TV Test Equipment for Outside Service Work.....	M. B. Long	64
Mac's Radio Service Shop.....	John T. Frye	66
Voltage Regulators.....	Joseph E. Williams, W8AME	68
Practical Sound Engineering (Part 7).....	H. M. Tremaine	70
A High-Frequency Double Conversion Superhet for I.F. Frequencies Above 500 KC.	Fred J. Lingel, W2ZGY	82
An Improved Tone Control Circuit.....	Joseph A. Szabo	86
Electronic Definitions.....	Ed Bukstein	108
Radio-TV Service Industry News.....		116

DEPARTMENTS

For the Record.....	The Editor	8	What's New in Radio.....	98
Spot Radio News.....		16	Technical Books	141
Within the Industry.....		24	Manufacturers' Literature	145
Short-Wave.....	K. R. Boord	67	New TV Products.....	164



COPYRIGHT 1951
 ZIFF-DAVIS PUBLISHING COMPANY
 185 North Wabash Ave., Chicago 1, Ill.
 VOLUME 46 • NUMBER 3



RADIO & TELEVISION NEWS is published monthly by the Ziff-Davis Publishing Company at 185 N. Wabash Ave., Chicago 1, Ill. Copyright under international copyright convention. All rights reserved. Entered as second-class matter July 21, 1948, at the Post Office, Chicago, Ill., under the act of March 3, 1879. Entered as second-class matter at the Post Office Department, Ottawa, Canada. **SUBSCRIPTION RATES:** in U. S., Canada, Mexico, South and Central America and U. S. Possessions, \$4.00 for twelve issues; in British Empire, \$5.00; all other foreign countries, \$5.00 for twelve issues. **RADIO-ELECTRONIC ENGINEERING EDITION SUBSCRIPTION RATES:** in U. S., Canada, Mexico, South and Central America and U. S. Possessions, \$6.00 for twelve issues; in British Empire, \$7.00; all other foreign countries, \$7.00 for twelve issues. Subscribers should allow at least two weeks for change of address. All communications about subscriptions should be addressed to the Director of Circulation, 185 N. Wabash Ave., Chicago 1, Ill. **CONTRIBUTIONS:** Contributors are advised to retain a copy of their manuscripts and illustrations. Contributions must be accompanied by return postage and they will be handled with reasonable care, but this magazine assumes no responsibility for their safety. Any copy accepted is subject to whatever adaptations and revisions are necessary to meet the requirements of this publication. Payment covers all author's, contributor's and contestant's rights, title, and interest in and to the material accepted and will be made at our current rates upon acceptance. All photos and drawings will be considered as part of the material purchased.

RADIO & TELEVISION NEWS

**NOW... GET EVERYTHING YOU
NEED TO LEARN AND MASTER**

TELEVISION RADIO-ELECTRONICS AT HOME!

Use REAL commercial-type equipment to get practical experience

Your future deserves and needs every advantage you can give it! That's why you owe it to yourself to find out about one of the most COMPLETE, practical and effective ways now available to prepare AT HOME for America's billion dollar opportunity field of TELEVISION-RADIO-ELECTRONICS. See how you may get and keep the same type of basic training equipment used in one of the nation's finest training laboratories... how you may get real STARTING HELP toward a good job or your own business in Television-Radio-Electronics. Mail the coupon today for complete facts — including 89 ways to earn money in this thrilling, newer field.

D.T.I., ALONE, INCLUDES BOTH MOVIES and HOME LABORATORY
In addition to easy-to-read lessons, you get the use of HOME MOVIES — an outstanding training advantage — plus 16 big shipments of Electronic parts. Perform over 300 fascinating experiments for practical experience. Build and keep real commercial-type test equipment shown at right

Get BOTH of these information packed publications FREE!

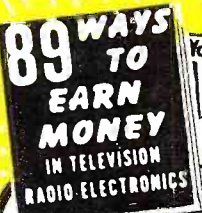

MODERN LABORATORIES

If you prefer, get all your preparation in our new Chicago Training Laboratories—one of the finest of its kind. Ample instructors, modern equipment. Write for details!

MILITARY SERVICE!

If you're subject to military service, the information we have for you should prove doubly interesting. Mail coupon today.



Here's the REAL THING!

SET UP YOUR OWN HOME LABORATORY



Multimeter



Oscilloscope



R-F Signal Generator

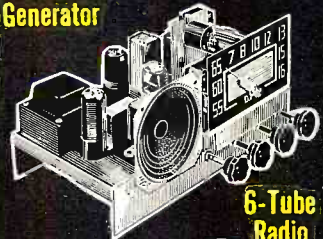

6-Tube Radio

HOME MOVIES



ACT NOW! MAIL COUPON TODAY!

DE FOREST'S TRAINING, INC., RN-9-H
2533 N. Ashland Ave., Chicago 14, Ill.

Without obligation, I would like your Opportunity News Bulletin showing "89 Ways to Earn Money in Television-Radio-Electronics"; also, the folder showing how I may prepare to get started in this thrilling field.

Name..... Age.....
 Address..... Apt.....
 City..... Zone..... State.....

De FOREST'S TRAINING, INC.

CHICAGO 14, ILLINOIS

A De VRY INSTITUTION

NEW! COLLINS 'PRE-FABS'

A NEW AND FASCINATING IDEA IN RADIO TUNERS—

COLLINS "PRE-FABS" IS SOMETHING ENTIRELY NEW!

Enjoy the pleasure of constructing your own Collins FM tuner from precision made components which have been wired, tested, and aligned at our factory. Thrill to really high-fidelity reception that only Collins tuners can give you. All that is necessary is to assemble these units into the punched chassis, wire up the power supply, and it's ready to operate! No tedious wiring of miniature tube sockets or special layouts. This has all been done for you. Whatever units you choose, from the selection shown below, will fit into the universal chassis and work perfectly with each other. Any combination selected will outperform other tuners costing many dollars more.

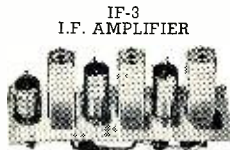

\$8.75

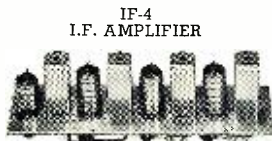

\$12.25

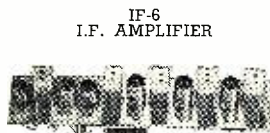

\$18.50



THE COLLINS ▽ PRE-FAB ▽ TUNER
ASSEMBLED

All Prices Shown Include Tubes

FMF-2
TUNING UNIT

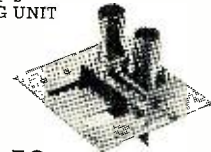

\$11.50

FMF-3
TUNING UNIT

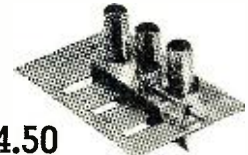

\$14.50

UC-1
CHASSIS KIT



\$13.50

QUALITY

ECONOMY

RESULTS

TUNING UNITS

The FMF-2 and FMF-3 tuning units both employ permeability tuning which is known for its superior performance at FM frequencies. The FMF-2 has two tuned stages using a 6AK5 converter and 6C4 local oscillator. The FMF-3 has three tuned stages which includes a 6J6 RF amplifier, 6AK5 converter, and 6C4 oscillator. Naturally, the RF stage provides great additional gain; and this unit is more sensitive than the FMF-2.

IF AMPLIFIERS

The IF-3 I.F. amplifier employs three tubes terminating in a new type ratio detector circuit. The IF-4 also employs a ratio detector but has an extra I.F. stage for added gain. The IF-6 is our de luxe I.F. amplifier having three IF stages, two limiters, and a discriminator type of detector. The IF-6 amplifier has, we believe, the highest gain and sensitivity of any such amplifier on the market today. In combination with the FMF-3 tuning unit, the highest order of sensitivity can be attained reaching 6 microvolts or better. All these units have very low distortion and full frequency audio response from 20 cycles to over 20,000 cycles per second. All units are beautifully constructed and will add a professional touch to your receiving equipment.

CHASSIS KIT

The UC-1 chassis kit comprises a punched chassis, handsome slide-rule tuning dial, oversize power transformer, filter condenser, rectifier tube and socket, hardware, volume control and switch, knobs, terminal strips, AC line cord and plug.

Full instructions are supplied for complete assembly of the tuner and wiring of the power supply.

Think of it—a complete Collins tuner for as little as \$33.75!

ORDERING INFORMATION: In order to construct one of these Collins pre-fab tuners, you will require the UC-1 universal chassis kit, a tuning unit (either FMF-2 or FMF-3) and one of the IF amplifiers, IF-3, IF-4, or IF-6, making a total of three components. For example, if you select the FMF-3 tuning unit, its cost is \$14.50; next, perhaps, the IF-4 amplifier at \$12.25, then add \$13.50 for the chassis kit, and that's it. A total of \$40.25 will bring you a superb tuner, many dollars less than you would expect to pay. Other combinations may be selected at a range in price from \$33.75 to \$46.50. Can you think of a more practical way to bring the famous Collins tuners into your home?

A detailed instruction manual accompanies each tuner to assist you in making your Collins tuner.

SEND CHECK OR MONEY ORDER TO:

COLLINS AUDIO PRODUCTS COMPANY INC.

P. O. BOX 368

TEL.: WE-2-4390

WESTFIELD, N. J.

PLANT LOCATED ON ROUTE 29, MOUNTAINSIDE, N. J.

Another Raytheon



Another proof of Raytheon dependability!

LIFETIME GUARANTEE*

on Raytheon's famous

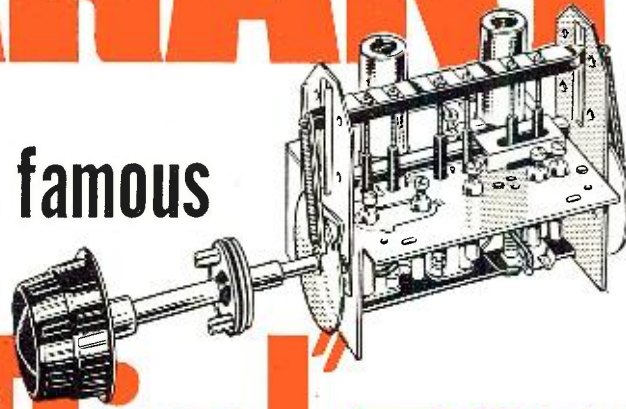

the **HEART** of the TV set!

Ray-Dial TUNER

HERE'S ANOTHER PROOF of the dependability of Raytheon TV! For now . . . Raytheon offers a lifetime guarantee on all parts except the tubes in its famous "Ray-Dial" Continuous Tuner!

THERE'S GOOD REASON for this offer. Because Raytheon engineered and builds its own "Ray-Dial" Tuner. It's a unique mechanism, designed for trouble-free performance . . . a minimum of moving parts, less things to get out of whack. And it's a *continuous* tuner . . . you tune TV just like you'd dial a radio . . . simply, easily, accurately.

THE HEART OF THE TV SET, the tuner is mighty important to any TV buyer. And this lifetime guarantee on the "Ray-Dial" Tuner can be mighty important to you! So tell the story . . . and sell more Raytheon TV. For further information, contact your Raytheon distributor or write us.



BELMONT RADIO CORP.

5921 W. Dickens Ave., Chicago 39, Ill.
Subsidiary of RAYTHEON MANUFACTURING CO.

* Guarantee applies only to original registered owner. Covers replacement only on all parts except tubes.

It pays to push

Raytheon tv

THE CONSTELLATION

—Model C-2006—big 20" rectangular TV, fine mahogany console cabinet, 26 3/4" wide, 38" high, 22 1/2" deep.



Raytheon TV Presents
JOHN CAMERON SWAYZE
Sundays on NBC. See local paper for time and station.

DUAL SPOTLIGHTS
Banish All Shadows

With New Light Duty Soldering Gun

It's the newest convenience in soldering. *Twin Spotlights* on your new 135-watt WELLER Soldering Gun completely eliminate shadows; you see clearly even in the darkest chassis.

Pull the trigger of your WELLER Gun, heat and light come on together—in just 5 seconds!

No more waiting, wasted current, or blind soldering. Your WELLER Gun pays for itself in a few months!



Specially Designed for TV and Radio Work

- **DUAL SOLDERLITE**—Two prefocused spotlights completely eliminate shadows—let you see clearly what you are soldering.
- **OVER/UNDER DESIGN**—Tube construction braces tip and improves visibility.
- **5-SECOND HEATING**—No waiting. Saves power. Pull the trigger and you solder!
- **LONGER REACH**—Slides easily into deep chassis, reaches the tightest corners.
- **GREATER CAPACITY**—Smaller, lighter, with greater soldering capacity.
- **TRIGGER-SWITCH CONTROL**—Adjusts heat to the job. Saves current—no need to unplug gun between jobs.
- **DUAL HEAT**—Single heat 100 watts; dual heat 100/135 watts; 120 volts, 60 cycles. Handles all light-duty soldering.

See new Models WS-100 and WD-135 at your distributor, or write for bulletin direct.

- **SOLDERING GUIDE**—Get your new copy of "Soldering Tips"—revised, up-to-date and fully illustrated 20-page booklet of practical soldering suggestions. Price 10¢ at your distributor, or order direct.



WELLER
ELECTRIC CORP.
810 Packer Street, Easton, Pa.

For the **RECORD.**

• BY THE EDITOR

IN A previous editorial (September, 1950) we stressed the need for adequate and accurate construction data to accompany merchandise sold in the electronic field. Recently there has come to our attention a major headache caused by inaccurate and careless preparation of instructions for the assembly and wiring of electronic test equipment in kit form. We are not referring to the large companies who specialize in kits and who are providing the necessary instructions with their kits so that they may be satisfactorily built and used—even by the novice.

Any kit to be popular and simple to build must include not only a complete array of parts, but every hole used for the mounting of parts must be factory drilled and indicated on suitable illustrations.

Having a need for a compact grid dip meter, and having built and used many instruments from kits with good success, we purchased a recently introduced grid dipper kit from a local jobber. One of the opening statements made in the instruction book is "—Dipper is furnished complete with all the material necessary for the construction of the unit." We hadn't gone very far into the construction before we discovered that we would need to purchase a tube of cement, Nos. 24, 41, and 48 drills, and some *Scotch* tape. Many builders of kits do not have a table of drill sizes nor a cross-reference of standard drills in steps of $\frac{1}{32}$ " or $\frac{1}{64}$ ". The schematic, with several inked-over corrections, was checked with the parts list as there appeared to be discrepancies. Resistor R_5 , for example, across the tube filament, is listed as 300 ohms on the parts list. Reference to a tube manual shows the filament rating for a 9002 tube is 6.3 v. at .15 amp. Hence, a 300 ohm resistor shunted across the filament would operate the tube at about 10 volts, after warm up. This would be most misleading to the novice, and if he did not check the resistors that accompanied the kit, might elect to use a 300 ohm resistor from available supply so that the value would agree with the parts list. Fortunately for us, the kit included a 39 ohm resistor which, according to Ohm's Law, is about right for the circuit.

The jack furnished with the kit had to be replaced with a midget type as it was too large to fit into the assembly. After mounting the meter according to instructions, we found it almost impossible to reach the tube socket pins (even with a skinny soldering pencil) without burning something. Further discrepancies between instructions and diagrams appeared. If assembled and wired as stated, a direct

short would result across the grid resistor. Mention is made to "mount C so and so in proper position." We searched for something to indicate this "proper position." No layout drawings are included so reference was made to the planographed photos. Even these were so lacking in detail as to be practically worthless.

At last—and after needless waste of time checking and cross-checking—the wiring was completed. It was then necessary to drill both the top and bottom pieces which complete the mechanical assembly of the case, and the drill sizes previously mentioned used. After carefully assembling the case we found that the plates of the variable condenser were rubbing due to mechanical distortion caused by bending of the thin metal box on which the condenser is mounted. More time was wasted in making correction.

Next came the coils. All one needs is a tube of cement, *Scotch* tape, a hacksaw, No. 24 and No. 48 drills and lots of time and patience. Before the coils are mounted, it is necessary to drill a plain plastic mounting strip and to insert banana jacks which are self-holding. After the cement has set overnight we come to the next step, which is not even mentioned in the instructions. The problem is to solder the coil leads to the banana jacks without melting the plastic or setting fire to the cement. Too much heat obviously would ruin the coils.

After sawing off the condenser shaft to a practical length and after assembling the dial, we calibrated the grid dipper. The performance of the completed meter is satisfactory, but it is unfortunate that the builder must guess all during its initial construction.

The purpose of this criticism, which we intend to be constructive, is to reiterate that any and all instructions, illustrations, and diagrams accompanying a kit, no matter how simple, must be exactly right, especially for the tyro. Large producers of kits have spent much time, money, and effort to make their instructions accurate and easy to follow. They know from long experience that each and every hole must be drilled at the factory. They have learned that their customers will reorder their kits with confidence and will also recommend their products.

But if a customer finds himself spending needless time and money to build an incomplete kit, he soon discovers that for a few dollars more he could have purchased a ready-to-use instrument of a similar type.

The success or failure of the kit business depends almost entirely on the accuracy and clarity of the instructions that accompany the packaged item. . . . O.R.

the only complete catalog
for everything in Radio,
TV & Industrial Electronics

your 1952 **free!**
ALLIED 212-page
value-packed catalog



Send for it today!

Here's the *one* authoritative, complete, up-to-date Buying Guide to TV, Radio and Industrial Electronics. Make your selections from the world's largest stocks of quality equipment at lowest, money-saving prices. See the latest and most complete presentation of electronic apparatus: new TV, AM and FM receivers; High-Fidelity Custom Sound components; latest P.A. Systems and accessories; recorders; fullest selections of Amateur receivers and station gear; specialized industrial electronic equipment; test instruments; builders' kits; huge listings of parts, tubes, tools, books—the world's *most complete stocks* of quality equipment.

ALLIED gives you *every* buying advantage: speedy delivery, expert personal help, lowest prices, liberal time payment terms, assured satisfaction. Get the latest 1952 ALLIED Catalog. Keep it handy—and save time and money. Send for your FREE copy today!

**the world's
largest stocks**

- Radio Parts Unlimited
- Test Instruments
- Television & Home Radios
- P.A. and Hi-Fi Equipment
- Amateur Station Gear
- Builders' Supplies
- Equipment for Industry

quick, expert service

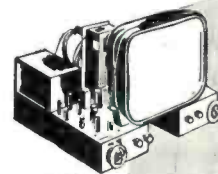

ALLIED IS YOUR TV and HI-FI HEADQUARTERS



Count on ALLIED for the latest in TV! If it's made—we have it far quick delivery. We specialize, too, in High-Fidelity sound components—everything in amplifiers, speakers, tuners, phono gear and accessories. For TV or Hi-Fi—think of ALLIED!



ALLIED RADIO
the World's Largest Radio Supply House
EVERYTHING IN ELECTRONICS

free

**SEND TODAY FOR RADIO'S
LEADING BUYING GUIDE**

ALLIED RADIO CORP., Dept. 1-J-1
833 W. Jackson Blvd., Chicago 7, Illinois

Send FREE 212-page 1952 ALLIED Catalog No. 127.

Name _____

Address _____

City _____ Zone _____ State _____

3 Important Rauland Policies

...Are they
paying off for you?

1 Did you know that Rauland's Replacement Picture Tube Warranty and Adjustment Policy provides a 6 months warranty from the date of purchase by the consumer? And that all Rauland replacement tubes now carry a triple registration card providing protection for jobber, dealer and consumer?

2 Did you know that Rauland provides a full 120-day price protection on distributor inventory of replacement picture tubes? That Rauland distributors can carry a stock adequate for their territories without risk of loss through price adjustment?

3 Did you know that Rauland offers valuable premium points for the prompt return of warranty registration cards? Each card returned promptly entitles dealer and distributor to premium points redeemable in valuable merchandise prizes.

If you have not received full details on all of the above, write, phone or wire your distributing contact on Rauland tubes. If you have not received your prize merchandise catalog, use the coupon below today.

THE RAULAND CORPORATION



Perfection Through Research

4245 N. KNOX AVE. • CHICAGO 41, ILLINOIS



The Rauland Corporation
4245 N. Knox Ave., Chicago 41, Illinois

Please rush premium merchandise catalog and full information on:

Earning Premium Prizes 6 Months Warranty
 Distributor Price Protection

Name _____

Address _____

City _____ State _____

RADIO & TELEVISION NEWS

GET INTO RADIO-TELEVISION

ELECTRONICS By Shop-Method Home Training

GOOD JOBS AWAIT THE TRAINED RADIO-TV TECHNICIAN

There is a place for *you* in the great Radio-Television-Electronics industry when you are trained as National Schools will train you at home!

Trained technicians are in growing demand at good pay—in manufacturing, broadcasting, television, communications, radar, research laboratories, home Radio-TV service, and other branches of the field. National Schools Master Shop-Method Home Training, with newly added lessons and equipment, trains you in your spare time, right in your own home, for these fascinating opportunities. **OUR METHOD IS PROVED BY THE SUCCESS OF NATIONAL SCHOOLS TRAINED MEN, ALL OVER THE WORLD, SINCE 1905.**

EARN WHILE YOU LEARN

Many National students pay for all or part of their training with spare time earnings. We'll show you how you can do the same! Early in your training, you receive "Spare-time Work" Lessons which will enable you to earn extra money servicing neighbors' and friends' Radio and Television receivers, appliances, etc.

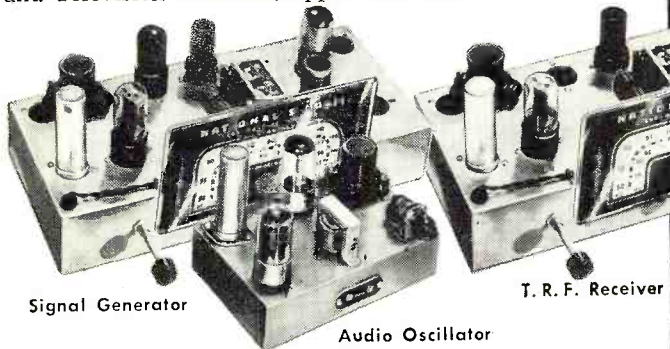

Signal Generator

Audio Oscillator

T. R. F. Receiver

National Schools Training Is All-Embracing

National Schools prepares you for your choice of many job opportunities. Thousands of home, portable, and auto radios are being sold daily—more than ever before. Television is sweeping the country, too. Co-axial cables now under construction will soon bring Television to every city, town, and farm! National Schools' *complete* training program qualifies you in all fields. Read this partial list of opportunities for trained technicians:

- Business of Your Own • Broadcasting
- Radio Manufacturing, Sales, Service • Telecasting
- Television Manufacturing, Sales, Service
- Laboratories: Installation, Maintenance of Electronic Equipment
- Electrolysis, Call Systems
- Garages: Auto Radio Sales, Service
- Sound Systems and Telephone Companies, Engineering Firms
- Theatre Sound Systems, Police Radio
- And scores of other good jobs in many related fields.

TELEVISION TRAINING

A complete series of up-to-the-minute Television lessons is an important part of your course. They cover all phases of Television repairing, servicing and construction. The same lesson texts used by resident students in our own modern and complete Television broadcast studios, laboratories and classrooms!

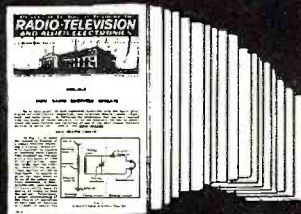

MASTER ALL PHASES!

Get Master Shop-Method Home Training from an Established Practical Resident School with its own Training Shops, Laboratories, and Studios—and almost 50 Years of Successful Experience in Training Ambitious Men.

We Bring National Schools To You

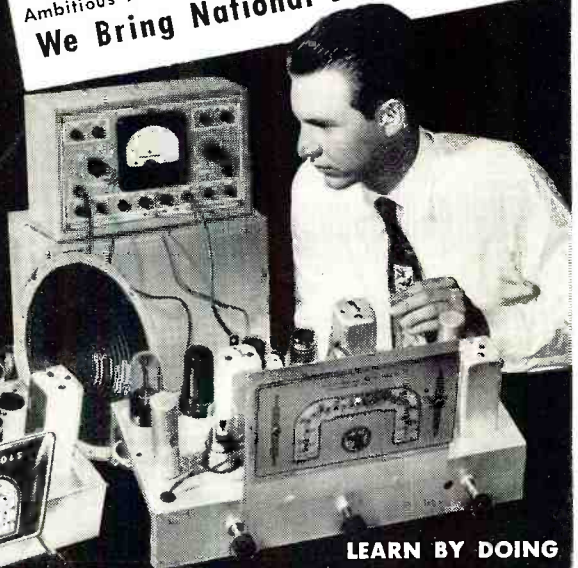

LEARN BY DOING

You receive and keep all the modern equipment shown above, including tubes and valuable, professional quality Multitester. *No extra charges.* You build the fine Superheterodyne Receiver with parts we send you.

FREE! These 2 Free Books give you all the facts. Send today for National Schools' new, illustrated Book of Opportunity in Radio-Television-

Electronics, and an actual Sample Lesson. No cost—no obligation. Use the coupon now—we'll answer by return airmail.

BOTH RESIDENT and HOME STUDY COURSES OFFERED



NATIONAL SCHOOLS

LOS ANGELES 37, CALIF. • EST. 1905

FIND OUT NOW... MAIL COUPON TODAY

National Schools, Dept. 9-RN
4000 South Figueroa Street
Los Angeles 37, California

Mail in envelope or paste on penny postal.

Send me your FREE Book "My Future in Radio-Television Electronics" and the sample lesson of your course. I understand no salesman will call on me.

NAME _____ AGE _____
ADDRESS _____
CITY _____ ZONE _____ STATE _____

READY NOW FOR YOU: THE NEW



ADVANCED
COURSE

in

Television Servicing

GIVES YOU THE PRACTICAL KNOW-HOW FOR PROFITS!

- ... How to locate and correct troubles.
- ... How to get the most out of your test equipment.
- ... How to make TV-set conversions.

Post-graduate throughout—with actual TV-service problems discussed and solved for your guidance—this home-study course by G.E. is both an aid to better repairwork, and an income-booster.

Trouble-shooting. By means of photographs, drawings, and text, you're shown the common faults you will encounter in TV operation . . . their causes . . . how to find and eliminate them.

Test equipment. Your test apparatus can, and should, pay dividends. G.E.'s Advanced Course explains in detail how to use test equipment for efficient and profitable TV servicing.

Conversions. You're told how to convert TV sets to larger screen sizes—how to estimate costs on this remunerative work. You're also shown how conversions can be used as a means to make additional sales of tubes and parts.

G.E.'s original service course laid a solid foundation of TV principles. This new Advanced Course helps you turn your knowledge into dollars. Register *today* through your G-E tube distributor! *Electronics Department, General Electric Company, Schenectady 5, New York.*

EARN THIS STERLING-SILVER EMBLEM—
along with a distinctive wall-plaque
that bears your name—by completing
G.E.'s Advanced Course! These are the
symbols of the television expert!



SEE YOUR G-E TUBE DISTRIBUTOR FOR FULL DETAILS!

GENERAL  ELECTRIC

181-KA9



the Volt-Ohm-Milliammeter

that needs no introduction!

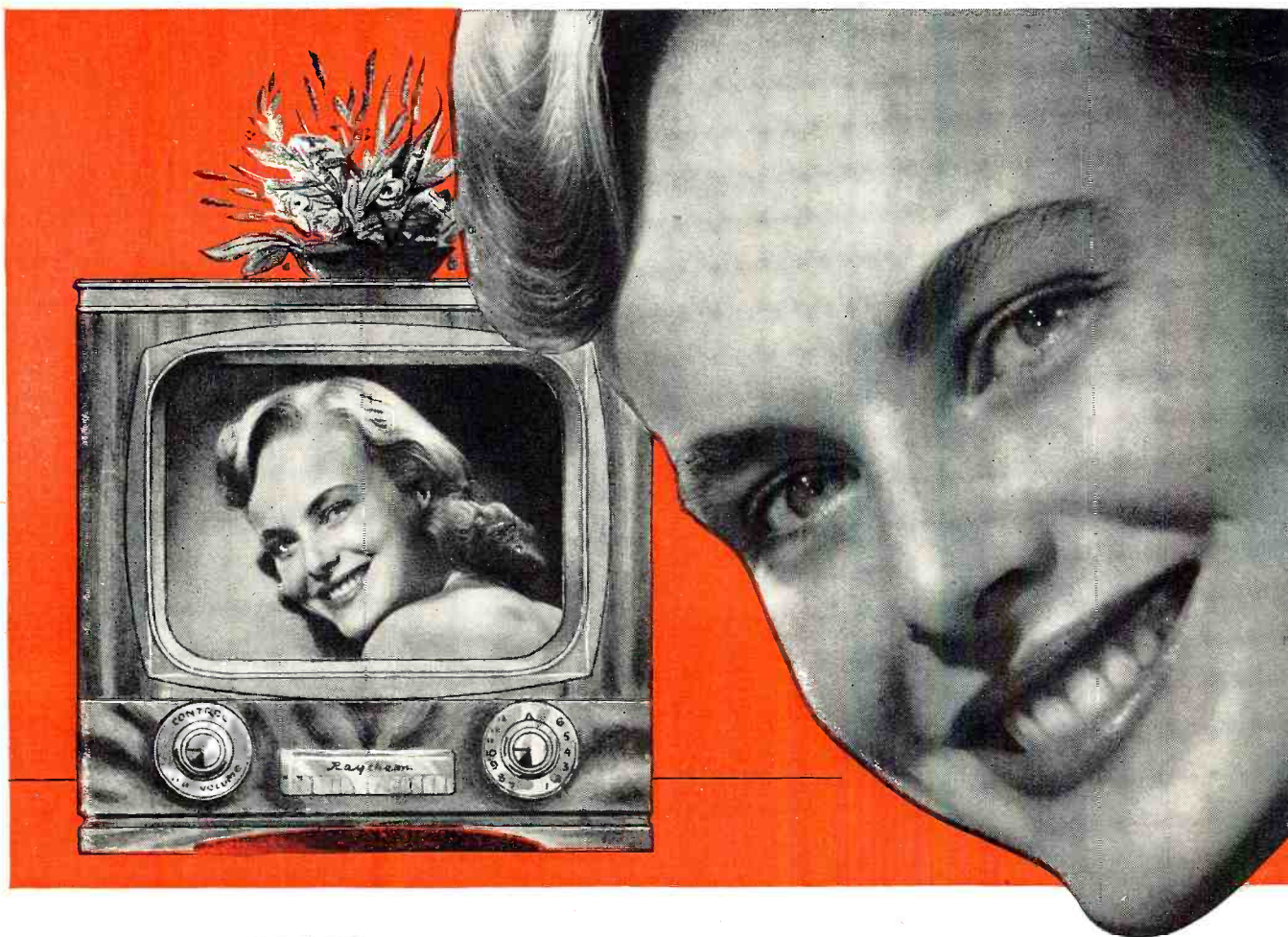

THERE ARE "101" REASONS WHY I LOOK MY BEST ON

RAYTHEON TELEVISION PICTURE TUBES

The reasons are the 101 rigid quality tests and inspections that Raytheon Television Picture Tubes must pass before shipment. At every stage of their assembly — the components, the chemicals, the processing, — Raytheon Tubes are checked and rechecked to insure electrical and mechanical perfection of finished tube.

This strict control of quality is an old story at Raytheon. For more than twenty-five years they have pioneered and manufactured almost every type of electronic tube — always to the highest standards of quality and performance known to the industry.

Logically, this vast experience and knowledge applied to Raytheon Picture Tubes guarantees superior quality and performance, makes them Right for Sight!

That's why you can replace with Raytheons with

complete confidence that you are giving your customers the finest tubes on the face of the earth — the finest pictures on the face of a tube. See your Raytheon Tube Distributor today.

A "MUST" for SERVICE DEALERS!

8 pages of the latest information on all Television Picture Tubes

The new RAYTHEON Television Picture Tube Characteristics Chart lists over 110 television picture tubes, including the new 14", 17" and 20" electrostatic focus tubes. It contains complete basing information, technical data, safety handling precautions plus a section covering factors concerning interchangeability. Write for your free copy of this valuable booklet, today. Address Dept. Raytheon Mfg. Co., Receiving Tube Division, 55 Chapel Street, Newton 58, Massachusetts.



Excellence in Electronics

RADIO AND TELEVISION RECEIVING TUBES, CATHODE RAY TUBES, SPECIAL PURPOSE TUBES, SUBMINIATURE TUBES, MICROWAVE TUBES

RAYTHEON MANUFACTURING COMPANY

Receiving Tube Division

Newton, Mass., Chicago, Ill., Atlanta, Ga., Los Angeles, Calif.

COPYRIGHT 1957

SOMETHING TO
REMEMBER
ABOUT
SPRAGUE
TWIST-LOK*TV
CAPACITORS



• **M**ore twist-prong electrolytic capacitors are made by Sprague than by any other manufacturer . . . And Sprague naturally lists the largest, most complete line for exact TV replacement applications.

• And when you use a Sprague Twist-Lok TV Capacitor, you can be sure it's dependable. No costly call-backs will jeopardize your profit or your reputation. Your business judgment will tell you to *accept no substitutes.*

*Trademark

**GET YOUR
NEW
SPRAGUE TV CAPACITOR
REPLACEMENT MANUAL TODAY!**

Just off press, this NEW 3rd edition of the famous Sprague Manual is jam-packed with up-to-the-minute replacement recommendations for critical capacitors in practically every TV set on the market today! FREE from your Sprague parts distributor or send 10¢ directly to Sprague to cover handling and mailing costs.

SPRAGUE
PRODUCTS COMPANY

51 Marshall St.
NORTH ADAMS, MASSACHUSETTS
(Distributors' Division of the Sprague Electric Company)

Spot Radio News

★ Presenting latest information on the Radio Industry.

By RADIO & TELEVISION NEWS*
WASHINGTON EDITOR

THE FRIGID LOCK on TV's golden gate to a world of over 2000 stations, which has been on the threshold of removal practically every other month during the past thousand-odd days, will, Congress has now been told, really be cast off, with the early fall set as the historic moment of banishment.

The roaring news, streaking through the famous G-16 hearing room of the Senate, during a session of the Interstate Commerce Committee, was offered by none other than FCC Headman Wayne Coy who was reporting on what the Commission has been doing and intends to do on such matters as color, the freeze, allocations, clear channels, defense, and so on. Noting that not only was it denitely felt that it will be possible to remove all barriers to allocations in September or October, Coy added that there is every indication that in about a year from now, there will be many new stations in operation in the high and low lanes of the ether. To assure the fulfillment of such a program, he declared, the National Production Authority will be asked to provide releases for materials for transmitters and buildings. To save steel, centralized community towers for antennas will be recommended, the five-station Empire State project being offered as an example.

In a reply to a barrage of questions on the approach which would be used to expedite the allocation hearings and insure a speedy removal of the freeze, the Commission's chieftain said that a streamlined attack featuring studies of written statements, in lieu of the lengthy oral procedures, should turn the trick and permit the ice-barrier's removal.

The written testimony plan, originally proposed by the National Association of Radio and Television Broadcasters, was believed by many to be an ideal accelerated technique. Even the fiery Federal Communications Bar Association found merit in the plan which revolved about the elimination of the city-by-city hearings and specific attention to firm applications to minimize the delays caused by oral alternate proposals. In addition, the FCBA said, the plan should bring about wholesale mutual compromises on the normal assortment of conflicting matters, and prevent the usual extensive comparative hearing debates which prevail during these round-the-clock sessions.

All did not feel that the short-cut idea would provide the satisfactory answers to the too-few channel problems cited by many communities. *Du Mont*, for instance, declared that they wanted a full public hearing on their alternate proposal which involved the entire country and foreign areas, as well. A memorandum to the secretary of the Commission disclosed that a detailed oral argument was imperative, in their opinion, since there were too many major factors to consider, which could not be possibly covered in mail transmittals.

The sizzling freeze issue also prompted one of radioland's distinguished citizens, the "father" of the famous Communications Act of 1934, ex-Senator Clarence C. Dill, to scold the Commission for its provoking delays. Said the former member of Congress in a letter to Wayne Coy: "Nearly three years is too long to delay action on at least enough applications to serve regions without television. . . . Surely the Commission could process some . . . applications . . . for use of frequencies . . . available to certain sections. . . . It is not necessary to provide for all small towns immediately. . . . It is highly unjust not to provide for at least one station for thickly populated areas."

Pointing out that the Commission should take immediate action, the former legislator, now a practicing attorney in the state of Washington, declared: "May I respectfully suggest that your Commission seriously consider doing something about this situation by making exceptions to the freeze order at once, for those regions that do not have and cannot have any television stations under the present conditions. Cut down the time of the hearings and act without months of delay." Ending of the freeze, the ex-Senator said, was extremely important. "If I were in the Senate," he declared, "I would address that body on this subject and introduce a resolution that would bring your members (*the Commission*) before the Senate Committee on Interstate Commerce for the purpose of impressing them and Congress with the injustice of the orders of the Commission by the continuation of this freeze order."

COLORCASTING, although cited by government statute as officially approved insofar as the wheel method is

RADIO & TELEVISION NEWS

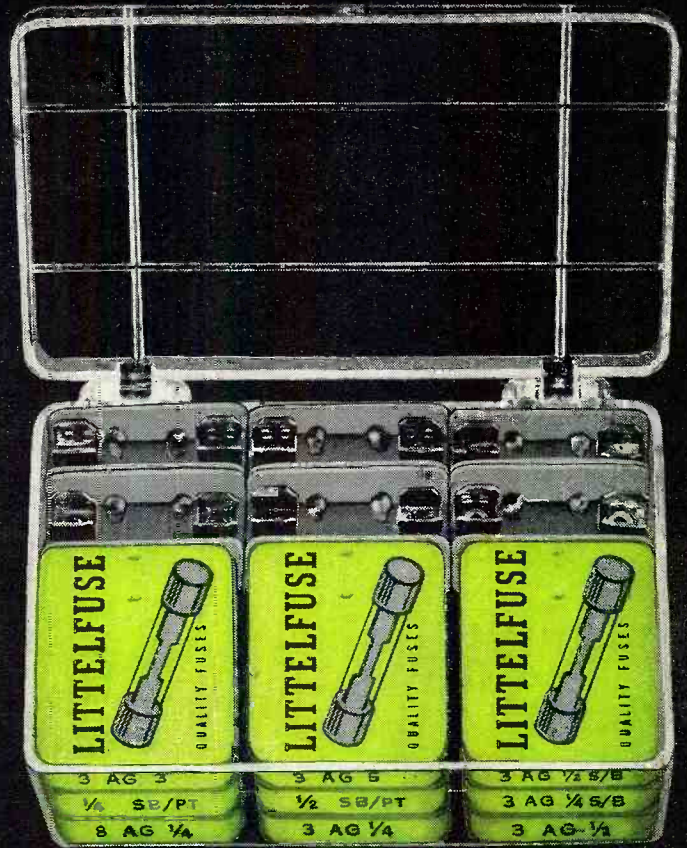

Servicemen can cover 94% of fuse replacements with this kit



*One-Call Kit Contains 45 TV fuses
(6 most in demand types) and 6 TV
snap on fuse holders in a clear
plastic hinged-cover bench box.*

*Another **LITTELFUSE** first.*

*Call your jobber today. Littelfuse, Inc.,
4757 Ravenswood, Chicago 40.*

LONGbeach 1-4970.

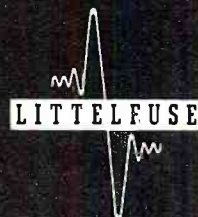

BURTON BROWNE ADVERTISING

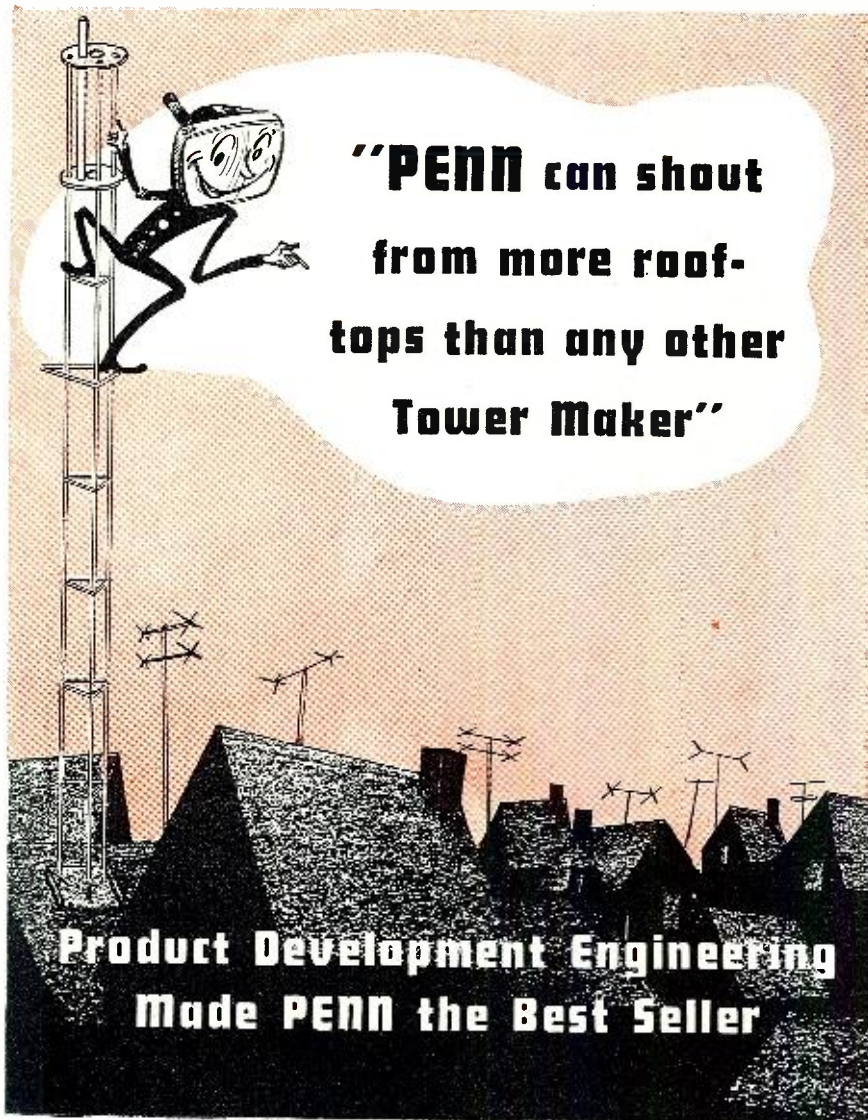

The roofs of America "sprout" more towers by Penn than by any other manufacturer. The reason? Penn's constant product development engineering which has produced the following:

- (1) The Teletower itself (2) the Thrifttower (3) the Tenna-Mast Hardware Line (4) the adjustable roof mount (5) the universal motor mount (6) the built-in base (7) Penn's new self-supporting tower that carries two hundred fifty pounds head load without guying.

STAY TUNED IN . . . WITH TELETOWERS!

PENN

T

teletowers
thriftowers
tenna-Mast
Hardware

PENN BOILER & BURNER MFG. CORP., LANCASTER, PA.

concerned, is still quite an item on the books of the air patrolmen in Washington, and many months, perhaps even a year, may pass before all will be quiet on the hue front. Notwithstanding the regular field-sequential program schedules, most of industry has wrapped itself up in an intensive development project which they feel will bring electronic compatible color to the land and outmode the approved method.

The first step in the campaign, involving the demonstration of prototype equipment with sixteen and twenty-one inch tri-color tube receivers, was initiated in midsummer at RCA's exhibition hall in New York City. In a striking exhibition, the press and members of industry saw remote and studio programs, aired by NBC's experimental station KF2XJZ. The field program was particularly unique, with a microwave relay, operating on 6962.5 megacycles, picking up diving sequences at Palisades Park, located high up above the Hudson River. The signals were beamed across the river to the RCA Building and fed to a color-vision room on the third floor. The results were excellent, according to many leaders in industry. Dr. Allen B. Du Mont pointed out that the picture was good enough . . . "to start commercial operations immediately." Others who waxed enthusiastic were Philco's Prexy William Balderston; Dr. W. R. G. Baker, vice-president in charge of G-E electronics; Jack Binns, Hazeltine president; and R. W. Durst, executive vice-president of Hallicrafters.

In a second step, to bring electronic color to the public, there'll be a series of showings, which it is expected will begin shortly before this issue comes off the press and continue for a few weeks.

Subsequent steps in the race to bring tube color to Mr. and Mrs. America are also under way. The panels of the National Television Systems Committee, whose plans were outlined last month, have been holding continuous meetings to discuss their activities in the field and lab. Describing this important program, during a meeting of the National Association of Music Merchants in Chicago, Glen McDaniel, RTMA's new president, said that industry was taking the Commission's comment that the . . . "door is not closed and never was closed" insofar as the possible adoption of any new practical compatible system is involved, at its word, and striving to perfect a color method which meets the requirements set up by the boys in Washington. McDaniel added that the views of Senator Johnson, which cited that . . . "the Commission has no right under the law to foreclose the public from the fruits of progress of the television art and the Commission will not attempt to do so . . ." were also serving as an incentive for industry to press for a more acceptable approach to the color problem.

(Continued on page 121)

Now... a NEW Junior VoltOhmyst* ...the WV-77A

For all regular measurements and specialized measurements as illustrated.

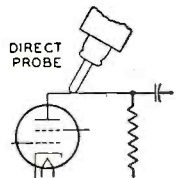

MEASURES AC VOLTS . . . such as signal voltage on plate of tube.

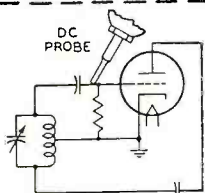

MEASURES DC VOLTS . . . such as oscillator grid bias. One-megohm resistor in probe prevents circuit loading.

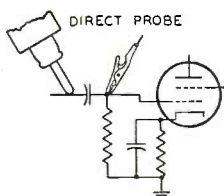

MEASURES RESISTANCE . . . such as leakage in coupling capacitor up to 1000 megohms.



Just one probe cable and one slip-on probe handle all measurements.

Check these important features . . .

- ✓ Accurate laboratory calibration.
- ✓ Meter electronically protected against burn-out.
- ✓ Metal case shielding . . . extra stability in rf fields.
- ✓ Sturdy 200-microampere meter movement.
- ✓ Carbon-film 1% multiplier resistors . . . dependability plus.
- ✓ Zero-center scale . . . for discriminator alignment.
- ✓ Frequency response flat from 30 cps to approximately 3 Mc.
- ✓ High ac input resistance for greater accuracy.
- ✓ Constant dc input resistance . . . 11 megohms on all scales.
- ✓ Negative feedback circuits for greater over-all stability.
- ✓ Ohms cable always positive . . . for quick leakage measurements of electrolytic capacitors.
- ✓ Polarity reverse switch . . . eliminates cable switching.
- ✓ $\pm 3\%$ over-all accuracy on +dc scales, and $\pm 5\%$ on ac and -dc scales.

An all-electronic ac-operated vacuum-tube volt-ohmmeter by RCA
ONLY \$47.50.

Includes DC probe, AC direct probe and cable, ground lead, and alligator clip.

The RCA WV-77A VoltOhmyst* provides the extra features you have tried to find in an inexpensive VTVM. Using the famous Volt-Ohmyst electronic bridge circuit, 200-microampere meter movement, and carbon-film multiplier resistors, the WV-77A incorporates features you would expect to find only in more expensive instruments. Sturdily built . . . calibrated against laboratory standards . . . and backed by a 12-month warranty . . . the WV-77A has the durability, versatility, and accuracy to please discriminating customers such as service technicians, engineers, amateurs, and military personnel.

As a DC Voltmeter it measures dc from 0.05 volt to 1200 volts in five ranges. Uses 1-megohm resistor in isolating probe; probe has less than 2-uuf input capacitance. Has 11-megohm input; useful for measuring high-resistance circuits such as oscillator, discriminator, and avc.

As an AC Voltmeter it measures ac from 0.1 volt to 1200 volts rms in five ranges.

Uses high-impedance diode tube as signal rectifier. Frequency range is more than adequate for measurement of power line, audio, and ultra-sonic frequencies.

As a wide-range Ohmmeter the WV-77A measures resistance from 0.2 ohm to 1 billion ohms in five ranges. Requires only 1.5-volt battery as burn-out protection in measuring such low-power elements as battery-type tube filaments.

The all-new RCA WV-77A VoltOhmyst comes completely equipped with probes and cables as illustrated. For complete details, see your RCA Test Equipment Distributor today . . . or write to RCA, Commercial Engineering, Section 52IX, Harrison, N. J.

Accessories Available on Order

The WG-289 High-Voltage Probe and WG-206 Multiplier Resistor extend the dc range of the WV-77A to 50,000 volts.

The WG-264 Crystal-Diode Probe extends frequency range of the WV-77A to 250Mc.

*Reg. U. S. Pat. Off.

Available from your
RCA Test Equipment
Distributor



RADIO CORPORATION of AMERICA
TEST EQUIPMENT
HARRISON, N. J.

Which Do You Want?



Get Your FCC Ticket
Then Use Our
Amazingly Effective
Job-Finding Service
To Get a Better Job



EDW. H. GUILFORD
Vice President

I can train you to pass your FCC License Exams in a minimum of time if you've had any practical radio experience—amateur, Army, Navy, radio servicing, or other. My time-proven plan can help put you, too, on the road to success.

Just fill out the coupon and mail it. I will send you free of charge, a copy of "How to Pass FCC License Exams." Plus a sample FCC-type Exam, and the amazing new booklet, "Money Making FCC License Information."

How to Pass FCC License Exams

Commercial Radio Operator



FREE

Tells where to apply for and take FCC examinations, location of examining offices, scope of knowledge required, approved way to prepare for FCC examinations, positive method of checking your knowledge before taking the examinations.

Get this Amazing Booklet FREE

TELLS HOW — WE GUARANTEE — TELLs HOW —

TO TRAIN AND COACH YOU AT HOME IN SPARE TIME UNTIL YOU GET YOUR FCC LICENSE



Our Amazing Effective JOB-FINDING SERVICE Gets Better Jobs for Graduates

Here is just one recent example of Job-Finding Results

GETS FIVE JOB-OFFERS FROM BROADCAST STATIONS

"Your 'Chief Engineer's Bulletin' is a grand way of obtaining employment for your graduates who have obtained their 1st class license. Since my name has been on the list I have received calls or letters from five stations in the southern states, and am now employed as Transmitter Engineer at WMMT,"

Elmer Powell, Box 274, Sparta, Tenn.

Your FCC Ticket is always recognized in all radio fields as proof of your technical ability.

OURS IS THE ONLY HOME STUDY COURSE WHICH SUPPLIES FCC TYPE EXAMINATIONS WITH ALL LESSONS AND FINAL TESTS.

TELLS HOW — Employers make JOB OFFERS Like These to Our Graduates Every Month

Telegram, August 9, 1950, from Chief Engineer, Broadcast Station, Pennsylvania, "Have job opening for one transmitter operator to start immediately, contact me at once." Letter, August 12, 1950, from Dir. Radio Div. State Highway Patrol "We have two vacancies in our Radio Communication Division. Starting pay \$200; \$250 after six months' satisfactory service. Will you recommend graduates of your school?"

These are just a few examples of the job offers that come to our office periodically. Some licensed radioman filled each of these jobs . . . it might have been you!

HERE'S PROOF FCC LICENSES ARE OFTEN SECURED IN A FEW HOURS OF STUDY WITH OUR COACHING AT HOME IN SPARE TIME

Name and Address	License	Lessons
Lee Worthy 2210 1/2 Wilshire St., Bakersfield, Cal.	2nd Phone	16
Clifford E. Vogt Box 1916, Dania, Fla.	1st Phone	20
Francis X. Forch 38 Beucier Pl., Bergenfield, N. J.	1st Phone	38
S/Sgt. Ben H. Davis 317 North Roosevelt, Lebanon, Ill.	1st Phone	28
Albert Schoell 110 West 11th St., Escondido, Cal.	2nd Phone	23

CLEVELAND INSTITUTE OF RADIO ELECTRONICS
Desk RN-33, 4900 Euclid Bldg., Cleveland 3, Ohio.



Get All 3 FREE

MAIL COUPON NOW

CLEVELAND INSTITUTE OF RADIO ELECTRONICS
Desk RN-33, 4900 Euclid Bldg. Cleveland 3, Ohio
(Address to Desk No. to avoid delay)

I want to know how I can get my FCC ticket in a minimum of time. Send me your FREE booklet, "How to Pass FCC License Examinations" (does not cover exams for Amateur License), as well as a sample FCC-type exam and the amazing new booklet, "Money-Making FCC License Information."

NAME

ADDRESS

CITY..... ZONE..... STATE.....

Paste on penny post card or send air mail

CRT TESTER

AND CIRCUIT ANALYZER

CHECKS CRT & CRT CIRCUIT IN TV SET

DISTRIBUTORS

ALABAMA
Forbes Dist. Co., Birmingham
Nelson Radio & Supply Co., Inc., Mobile

CALIFORNIA
Arrowhead Radio Supply, San Bernardino
Kierulff & Co., Los Angeles
Radio Parts Sales Co., L.A.
Silvergate Radio Supply, San Diego

CONNECTICUT
Bond Radio Supply Inc., Waterbury
Hatry & Young, Hartford
Hatry & Young, New Haven
Hatry & Young, Bridgeport
Moses Radio Electronics Co., Hartford
Stamford Radio Supply, Stamford

DELAWARE
Almo Radio, Wilmington

DISTRICT OF COLUMBIA
Kenyon Radio Supply Co.
FLORIDA
Herman Radio Supply Co., Miami
Kinkade Radio Supply, Jacksonville
Radio Parts Inc., Miami
Welch Radio Supply, St. Petersburg

GEORGIA
Peaslee-Gaultbert Corp., Atlanta
Southeast Radio Parts Co., Atl.
Specialty Distributing Co., Atl.
ILLINOIS
Allied Radio Corp., Chicago
Lukko Sales Corp., Chicago
Radio Parts Outlet, Chicago

INDIANA
Associated Distributors, Indianapolis
Radio Distributing Co., Indianapolis
Radio Distributing Co., South Bend
Terre Haute Radio, Terre Haute

IOWA
Farnsworth Radio & Television, Waterloo
Gifford-Brown, Cedar Rapids
Radio Supply Co., Des Moines
Ray-Mac Supply Co., Waterloo
World Radio Labs., Council Bluffs

KENTUCKY
P. I. Burks & Co., Louisville
Kentucky Radio Supply Co., Lexington

LOUISIANA
Pee Jay Radio Co., New Orleans
Walker Bros. Co., Inc., New Orleans
Louisiana Radio & TV Distributors, Inc., Baton Rouge

MARYLAND
Henry O. Bertram Co., Baltimore
D & H Dist. Co., Inc., Baltimore
Dealers Wholesale Radio, Salisbury

MASSACHUSETTS
Radio Electric Service Co., Ball.
DeMambo Radio Supply Co., Boston
DeMambo Radio Supply Co., Worcester

Hatry & Young, Lawrence
Hatry & Young, Boston
Hatry & Young, Springfield
A. W. Mayer Co., Boston
Melrose Sales Co., Melrose
Radio Shack Corp., Boston

MICHIGAN
Lifesy Distributing Co., Flint
Radio Parts, Inc., Grand Rapids
Radio Supply & Engineering Co., Inc., Detroit

MINNESOTA
Bauman Co., Minneapolis
E. G. Clinton Co., Minneapolis
F. C. Hayer, Minneapolis
Stark Radio Supply Co., Minneapolis

MISSOURI
Burslein-Applebee, Kansas City
Van Sickle Radio Co., St. Louis

NEW JERSEY
Allen-Hurley, Trenton
Almo Radio, Atlantic City
Continental Sales Co., Newark
Columbia Distributors, Inc., Columbia

Joe's Radio Shop, Bridgeton
Kirch-New Jersey, Inc., Newark
Myltelka & Rose, Inc., Newark
Monmouth Radio Supply Co., Newark
Nidisco, Inc., Jersey City



**MODEL 101
SUBSTITUTION TESTER**

Substitutes 5 paper and 2 electrolytic condensers, 4 resistors, potentiometer, loudspeaker and output transformer.

Size: 5 3/4 x 4 x 2 1/4"

Dealers Net—\$17.95

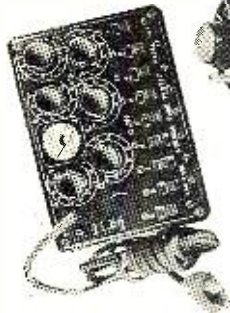

**MODEL 107
DYNAMIC TYPE TUBE TESTER**

Complete tube tester supplying plate, screen grid and filament voltages to check all receiving type tubes. 1.4, 2.5, 5, 6.3, 12.6, 18.9, 25, 35, 50 and 117 V filaments. Size: 5 1/2 x 3 3/4 x 2 1/4".

Dealers Net—\$49.95



**MODEL 103
SIGNAL GENERATOR**

Generates a wide range of modulated or unmodulated precision R. F., I. F., and audio-video signals for signal tracing or aligning TV receivers. (54-216 m.c., 20-48 m.c., 4.5 m.c. and 500 cycles).

Size: 5 3/4 x 4 x 2 1/4"

Dealers Net—\$33.50

Another
OAK RIDGE
Portable "Miniature"
FIRST!

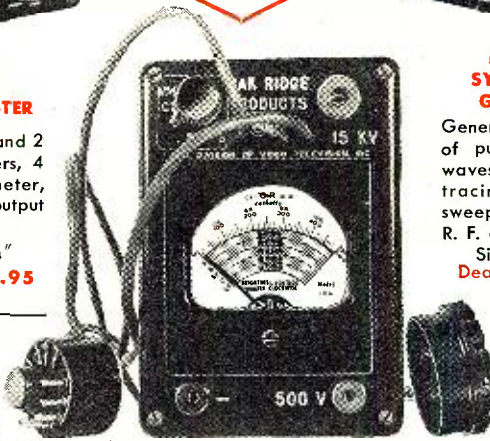

MODEL 106 CRT TESTER*

CHECKS:

- Magnetic and Electrostatic Focussed Circuits
- High Voltage Breakdown or Leakage
- Gas between elements in Electron Gun
- Gas between High Voltage Anode and Electron Gun
- Conductance between Cathode and Control Grid
- Conductance between Control Grid and Screen Grid
- Filament Continuity
- High Voltage on Anode
- Screen to Control Grid Voltage from set
- Control Grid to Cathode Voltage from set
- Brightness Control Voltage

Size: 5 1/2 x 3 3/4 x 2 1/4"

Dealers Net—\$29.95

* Pat. Pend.



**MODEL 104
SYNCRO-SWEEP
GENERATOR***

Generates a combination of pulses and sawtooth waves for adjusting or tracing linearity, sync, sweep, and HV circuits. R. F. or mod. output.

Size: 5 3/4 x 4 x 2 1/4"

Dealers Net—\$44.50

* Pat. Pend.



**MODEL 105
20,000 OHM per VOLT
MULTITESTER**

1% resistors throughout. 6 DC ranges: 0-2.5V-5KV; 6 AC ranges: 2.5V-5KV; 4 current ranges: 100UA-500 MA; 3 resistance ranges: 0-2000-20 meg. Easy to read 3 1/2" Multiscalemeter. Size: 5 1/2 x 3 3/4 x 3"

Dealers Net—\$38.95



MODEL 102 HIGH VOLTAGE METER

10,000 ohms per volt HV meter. D. C. voltages: 0-500V, 15KV, 30KV with 30KV insulated probe.

Size: 5 3/4 x 4 x 2 1/4" Dealers Net—\$17.95

DISTRIBUTORS

Radio Electric Service Co., Camden
Radio Wire Television Co., Newark

NEW YORK
Arrow Electronics Inc., N.Y.C.
Chief Electronics, Poughkeepsie
H. L. Dais, N.Y.C.
Fisher Dist. Co., Inc., N.Y.C.
Fl. Orange Radio Distributing Co., Albany

Green Radio Distributors, Bklyn.
General Electronic Distributing Co., Albany
Graylock Electronic Supply Co., N.Y.C.

Fred C. Harrison, Elmira
Hunter Electronics, Rochester
Island Radio Distributors, Hempstead, L. I.
Lafayette Radio, N.Y.C.
Melville Radio Corp., Flushing.

PA.
Melville Radio Corp., White Plains
Midway Radio & TV Corp., N.Y.C.
Norman Radio Distributors, Inc., Jamaica, N.Y.

Radelco, Inc., Mt. Vernon
Radio Equipment Co., Buffalo
Stan-Burn Radio & Electronics Co., Brooklyn
Standard Parts Corp., Hempstead

Westchester Electronics, White Plains
Vi-Tel Dist., Inc., Astoria

NEW HAMPSHIRE
DeMambo Radio Supply Co., Manchester
Evans Radio, Concord

NORTH CAROLINA
Dalton-Hege Radio Supply Co., Winston-Salem
Dixie Radio Supply Co., Inc., Charlotte

Johannson Electric Co., Inc., Greensboro
Meridian Electronic Equipment Co., Durham

Shaw Distributing, Charlotte
Southeastern Radio Supply Co., Greensboro

OHIO
Chambers Electronics, Cincinnati
General Electric Supply Corp., Cincinnati

Holub & Hogg Co., Cincinnati
Hughes-Peters Inc., Dayton
Hughes-Peters Inc., Columbus
Hughes-Peters Inc., Cincinnati
Lifetime Electronics, Toledo
Morrison Radio Supply, Ashtabula

Pioneer Radio Supply Co., Cleveland
Srepcic, Inc., Dayton
G. W. Taylor, Cleveland

Warren Radio, Toledo
Whitehead Radio Co., Columbus
Winteradio, Cleveland

OKLAHOMA
Electronic Supply Co., Okla. City
Electronic Supplies, Tulsa

PENNSYLVANIA
A. C. Radio Supply Co., Phila.
A. G. Radio Parts Co., Phila.
Almo Radio Co., Philadelphia
George D. Barbey Co., Inc., Reading

Barnett Bros. Radio Co., Phila.
Barro Radio Co., McKeesport
D. & H. Dist. Co., Wilkes-Barre
D. & H. Dist. Co., Harrisburg
J. V. Duncombe Co., Erie

Eshelman Distributors, Lancaster
Kratz Bros., Norristown
M. V. Mansfield Co., Pittsburgh
Moyer Electronic Supply Co., Inc., Hazleton

Fred P. Purcell, Scranton
Radio Service Co., Wilkes-Barre
Radio Electric Service Co., Phila.
Tydings Co., Pittsburgh
Warren Radio Co., Erie

RHODE ISLAND
Wm. Dandretta & Co., Providence
DeMambo Radio Sup. Co., Prov.

TENNESSEE
Shobe, Inc., Memphis

VIRGINIA
Mattsons, Richmond
Radio Equipment Co., Norfolk
WISCONSIN
Electronic Expeditors Co., Mil.
G. M. Popkey, Green Bay
G. M. Popkey, Marinette
Morley-Murphy Co., Milwaukee
Standard Radio Parts Co., Racine

SEND FOR COMPLETE LITERATURE TODAY!



OAK RIDGE PRODUCTS

37-01 VERNON BLVD., LONG ISLAND CITY 1, N. Y.

manufacturing division of Video Television, Inc.



No CUSS

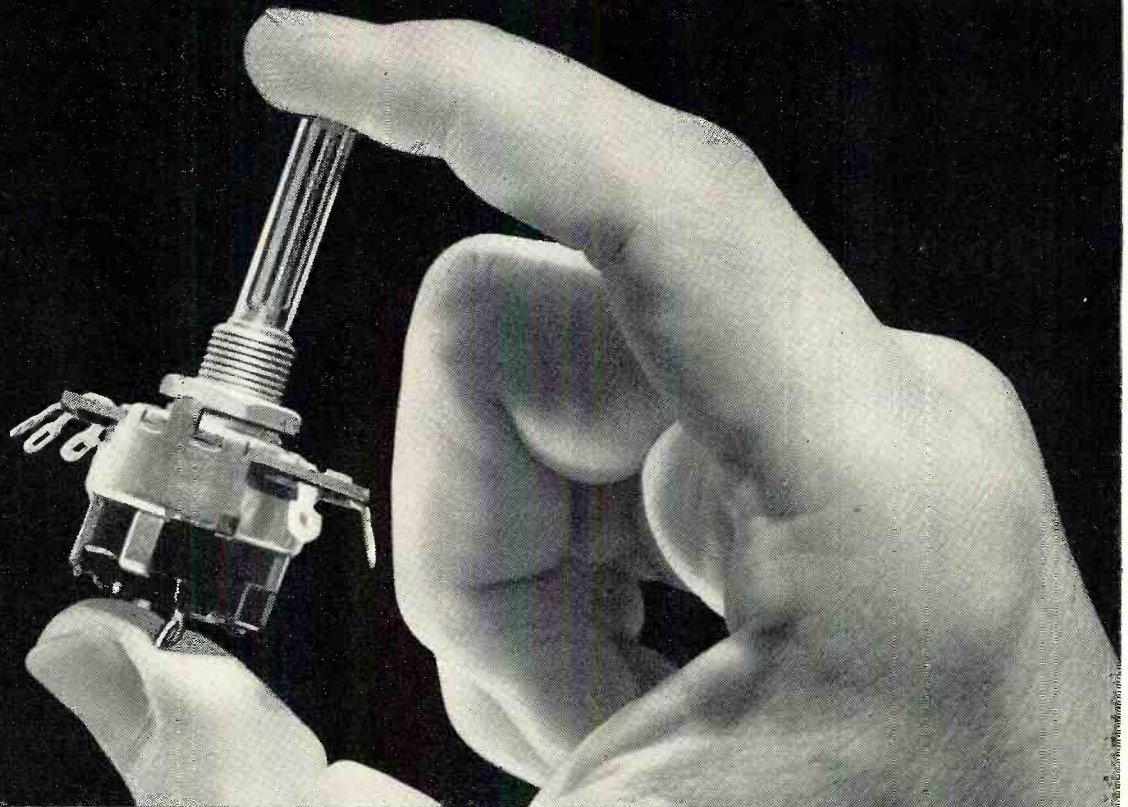

Blue Shaft Controls with attached switches are your smartest service buy! Why? Because they save you valuable bench-working time — by being truly your quickest-for-servicing replacements. These factory attached and tested switches are high amperage, universal units. That means they can be used as SPST — DPST or 3 wire.

For quickest servicing, standardize on Centralab Blue Shaft and Custom Controls.

No fuss



When you use
Centralab's

Exact Replacement Controls



Why waste time "tinkering" with kits . . .



when you can get exact, quickest-for-servicing,
custom replacement controls for TV - AM - FM . . .

There's a Centralab Custom Control — or Standard *Blue Shaft* Unit that's Quickest for Service.

Service Engineers! Centralab's famous Blue Shaft and Custom Controls are exclusive service items. You'll find Blue Shafts available in a complete line of plain and switch types with resistance ranges from 500 ohms to 10 megs. in a wide variety of tapers and

tapped units! All Centralab controls are packaged singly. Blue Shafts are also available in handy plastic boxes of 12 and in a special metal cabinet containing 22 controls. NO EXTRA charge for the cabinet.

Check These LOW PRICES on Popular Blue Shaft Controls!

Cat. No.	Ohms Max. Resistance	Taper	Circuit Location	List Price
B-60	500,000	C-2 (audio)	Volume or Tone	\$1.00
B-60-S*	500,000	C-2 (audio)	Volume or Tone	\$1.50
B-70	1 megohm	C-2 (audio)	Volume or Tone	\$1.00
B-70-S*	1 megohm	C-2 (audio)	Volume or Tone	\$1.50

*Switch Type

Ask your jobber or write direct for Bulletin 42-106 on Blue Shaft Controls. Send 25c for Centralab's TV and Custom Control Guide.

Centralab

Division of GLOBE-UNION Inc.

910 E. Keefe Ave. • Milwaukee 1, Wisconsin

new!



ACTUAL SIZE

PYRAMID TINY TYPE 85LPT TUBULAR PAPER CAPACITORS

Fit anywhere!
Suitable for
85°C. operation!

CAPACITANCE RANGE:
.0001 TO .5 MFD.

VOLTAGE RANGE:
200 TO 600 V., INCLUSIVE

Sturdily built in phenolic-impregnated tubes. Ends are plastic-sealed.

WRITE FOR COMPLETE LITERATURE
Representatives and Distributors
Throughout the U.S.A. and Canada



PYRAMID

PYRAMID ELECTRIC COMPANY

1445 Hudson Boulevard
North Bergen, N. J., U. S. A.

TELEGRAMS: WUX North Bergen, N. J.
CABLE ADDRESS: Pyramidusa

Within the

INDUSTRY

DR. JAMES W. McRAE has been appointed vice-president of *Bell Telephone Laboratories* and succeeds A. B. Clark in charge of the systems development organizations for the laboratories.



Dr. McRae has been associated with the laboratories since 1937 when he received his doctorate from the California Institute of Technology. His early work was concerned with transoceanic radio transmitters and microwave research which brought him into contact with various military projects, including several early radar developments.

In 1942 he was commissioned a major in the Signal Corps and was assigned to the Office of the Chief Signal Officer in Washington. In 1944 he was made chief of the engineering staff of the Signal Corps Engineering Laboratories at Bradley Beach, N. J. Later he became deputy director of engineering and attained the rank of colonel before returning to civilian life at the end of 1945.

* * *

RALPH T. BRENGLE, sales manager of *Potter & Brumfield*, has been appointed chairman of the newly-formed 13-man Relay Industry Advisory Committee of the Munitions Board.

Other members of the committee include: Col T. M. Natt, government chairman; H. W. Pfeffer, president of *Struthers-Dunn*; Edward Gillette, president of *Allied Control Company*; Dan Dooley, vice-president of *C. P. Clare & Company*; Emory Howe, *Comar Electric Company*; John Rowell, sales manager of *Guardian Electric Company*; Joseph F. Clark, *Leach Relay Company*; J. Crissinger, *North Electric Mfg. Company*; James Roughan, sales manager of *Price Electric Co.*; Richard Fischer, president of *Sigma Instruments*; A. C. Keller, *Western Electric Co.*; Harold L. Olesen, *Weston Electrical Instrument Corp.*; and F. H. Clark, *Westinghouse Electric Corp.*

* * *

GLEN McDANIEL, president of the Radio-Television Manufacturers Association, has announced the addition of two new staff members and the promotion of a third.

Ray S. Donaldson, administrative assistant to Senator Homer E. Capehart, has joined the RTMA staff as attorney. Tyler Nourse, former copy editor of *"Broadcasting Magazine"* has been named assistant to Peter H. Cousins, the recently-appointed director of information for the Association.

Ralph M. Haarlander, who for the past four years has been staff assistant to the RTMA transmitter division, has been given additional duties and the title of assistant secretary. He will assist James D. Secrest, general manager and secretary, in an administrative capacity.

Further additions will be made to the Washington staff and service to members will be expanded when the Association moves its offices to the Wyatt Building, 14th Street and New York Avenue, sometime early in the fall.

* * *

BRIG. GEN. V. A. CONRAD, chief of the Army Communications Service Division, Office of the Chief Signal Officer, has been elected chairman of the MARS Advisory Committee, succeeding Major Gen. Frank H. Griswold, USAF.

Serving with Gen. Conrad is Lt. Col. H. H. Moreland, USAF, vice-chairman of the committee.

The MARS Advisory Committee is made up of representatives from the Armed Services, other interested governmental agencies, the ARRL, and the American Red Cross. The group meets quarterly to discuss amateur radio problems.

* * *

SCOTT MORENCY has been appointed Washington representative of the War Contracts Division of *Zenith Radio Corporation* of Chicago.



The division, which is under the supervision of L. C. Truesdell, vice-president in charge of household receivers, is responsible for procurement and administration of the company's war contracts with the various divisions of the Armed Services, other governmental agencies, and certain prime contractors.

Mr. Morency, who will make his headquarters in Washington, has been associated with the *Western Automatic Machine Screw Company* of Elyria, Ohio for four years. During the war he joined the Marine Corps as a private and was separated from the Navy in 1946 with the rank of ensign.

* * *

NATIONAL TELEVISION SYSTEMS COMMITTEE, which recently released an interim report on a new color television system, has reorganized and established nine new panels, according to Dr. W. R. G. Baker, chairman of the committee.

Dr. Elmer Engstrom, vice-president in charge of research for the *RCA*

RADIO & TELEVISION NEWS



Here's how YOU can sell more Picture Tubes WITH **HYTRON'S NEW** **EASY BUDGET PLAN!**



GUESS YOU NEED A NEW PICTURE TUBE - THAT'LL COST YOU ABOUT \$50.00.



OUCH, I CAN'T AFFORD IT - I DON'T HAVE THAT MUCH CASH.



DON'T LET THAT BOTHER YOU. WITH THE **HYTRON EASY BUDGET PLAN**, YOU CAN HAVE YOUR HYTRON PICTURE TUBE RIGHT NOW.

ANOTHER HYTRON FIRST FOR YOU!

No need to miss that profitable picture-tube sale — just because the customer doesn't have the cash. The original Hytron Easy Budget Plan saves the sale. Gives you a competitive edge. Hytron has arranged the details for you. A national credit organization, with facilities in all TV areas, stands ready to serve you.

Find out how *you* can put this wonderful, timely Hytron plan to work right now! Write for complete information today.



WHAT A WONDERFUL PLAN. WE'VE GOT OUR PICTURE TUBE . . . AND UP TO TWELVE MONTHS TO PAY.

ANOTHER HELPFUL SERVICE FOR YOU FROM . . .



Hytron Radio and Electronics Co.
Salem, Massachusetts

Please rush me details on the Hytron Easy Budget Plan.

Name (please print)

Street

City..... State.....

3 Grand Mikes!

CATCH EVERYTHING FROM A BABY'S VOICE TO A SYMPHONY ORCHESTRA



HAND OR DESK
MODEL
BA-116

BA-109

ALL-PURPOSE
MODEL
BA-106

BA-109 . . . A popular-priced, high-fidelity microphone for PA systems, home recording or other amateur use. Frequency response from 40 to 10,000 cps. Exclusive "Metalseal"* crystal assures protection from high humidity. Nondirectional in the horizontal plane . . . output of 54 db below 1 volt/dyne/cm². Fits any standard 5/8" 27-thread stand. List **\$22.50.**

BA-116 . . . Unbeatable at the price . . . rugged, and uniform in response; does not need a stand, but can be used with standard 5/8" 27-thread stand if desired. Brown metallic finish. List, **\$14.75.**

BA-106 . . . Uses the exclusive "Acoustical"* cartridge with the "Metalseal" crystal. Essentially flat frequency response from 40 to 6,000 cps. Output level—50 db below 1 volt/dyne/cm². List, **\$19.75.**

*Trade Mark Registered.

THE BRUSH DEVELOPMENT COMPANY
3405 Perkins Avenue Cleveland 14, Ohio

Laboratories Division, was named vice-chairman of the committee. The nine new panels and their chairmen include: "Subjective Aspects of Color," Dr. A. N. Goldsmith; "Color System Analysis," Mr. Fink; "Color Video Standards," A. V. Loughren, *Hazeltine Electronic Corp.*; "Color Synchronizing Standards," D. E. Harnett, *General Electric Company*; "Compatibility," Dr. D. E. Noble, *Motorola Inc.*; "Field Testing," Dr. T. T. Goldsmith, *Allen B. DuMont Labs, Inc.*; "Network," Frank Marx, *American Broadcasting System*; "Coordination," Mr. Smith, *Philco Corporation*; and "Definitions," Dr. R. M. Bowie, *Sylvania Electric Products Inc.*

* * *

BEN SELSBY, formerly associated with *South River Metal Products, Inc.*, has joined *Haygren Electronic Mfg. Inc.*, Brooklyn manufacturer of electronic components.



In his new post, Mr. Selsby will be in charge of all sales activities for the company. Coincident with the expanded sales activities

the company's existing line of television installation accessories is being revamped and expanded.

To carry out this phase of the expansion program Herbert Dannemann has been added to the staff as design engineer.

* * *

NATHANIEL B. NICHOLS has been named manager of the Research Division of *Raytheon Manufacturing Company* of Waltham, Massachusetts. His specialty is servomechanisms and automatic controls . . . **KAREL VAN GESSEL** has been named to the newly-created post of coordinator of foreign manufacturing affiliates for *Sylvania Electric Products Inc.* He will act as liaison between the company's foreign affiliates and its operating divisions in the United States on matters of engineering and manufacturing . . .

DANA W. ATCHLEY, JR., is the new coordinator of technical research for *United Paramount Theatres, Inc.* He was formerly associated with *Tracerlab, Inc.*, and *Sylvania Electric Products Inc.* . . . **CHESTER H. LANG**, a vice-president of *General Electric Company* since 1941, has been appointed to a new post in charge of public relations. He will maintain his headquarters at the company's New York office . . .

DALE McFEATTERS heads the newly-formed Department of Information Services for *Westinghouse Electric Corporation*. All functions of public relations, employee relations, and related activities will be handled by this new department . . .

MARTIN BETTAN is the new chief engineer for *Radio Merchandise Sales, Inc.* He will be responsible for the technical development of the company's line of antennas, boosters, and other television accessories . . . **DAVID C. PRINCE**,
(Continued on page 138)

RADIO & TELEVISION NEWS

Be Sure of Your Installations Get the *Aptitude-Tested* RG/U TRANSMISSION LINE CABLES

• You know what you are doing when you use Belden RG/U Transmission Line Cables—they're aptitude rated. They are designed to provide desirable electrical characteristics, and rigid control assures constant quality.

Specify Belden Radio Wires.

Belden Manufacturing Co.
4681 W. Van Buren Street
Chicago 44, Illinois

APTITUDE RATING No. 8236

Frequency (Mc)	Attenuation per 100 ft
100.	2.65
200.	3.85
300.	4.80
400.	5.60

APTITUDE RATING No. 8237

Frequency (Mc)	Attenuation per 100 ft
100.	2.10
200.	3.30
300.	4.10
400.	4.50

APTITUDE RATING No. 8238

Frequency (Mc)	Attenuation per 100 ft
100.	1.90
200.	2.85
300.	3.60
400.	4.35

APTITUDE RATING No. 8239

Frequency (Mc)	Attenuation per 100 ft
100.	2.90
200.	4.20
300.	5.50
400.	6.70

APTITUDE RATING No. 8241

Frequency (Mc)	Attenuation per 100 ft
100.	3.75
200.	5.60
300.	7.10
400.	8.30

APTITUDE RATING No. 8240

Frequency (Mc)	Attenuation per 100 ft
100.	4.10
200.	6.20
300.	8.00
400.	9.50



Belden
Radio WIRE

The
Aptitude-Tested LINE

TV Means Jobs—*Good Paying Jobs*—for Technically Trained Men



★ **ENGINEERS**



★ **OPERATORS**



★ **CAMERAMEN**



★ **TECHNICIANS**



★ **INSTALLERS**

Here's How CREI Home Study Training
Prepares You for a Better Job in
TELEVISION

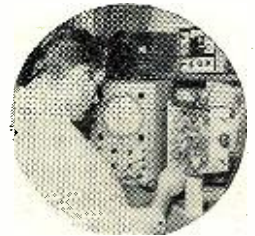

★ **SERVICEMEN**

WHAT YOU DO to keep yourself abreast of new developments is what counts toward advancement in television. Obviously, everyone cannot qualify. *Those who do are well rewarded.* The television industry offers almost unlimited opportunity to trained engineers and technicians. CREI training helps all levels, from novice to experienced engineer, because its specialized individual instruction brings out the best in a man and takes him as far as his own aptitude and effort will let him go.

CREI is an accredited technical institute founded in 1927. Its home study graduates fill important jobs throughout the radio, television and electronics industries. Leading industrial firms—RCA Victor, Pan American Airways, United Air Lines, to name only a few—have used or are now using CREI group training

programs. Industry welcomes CREI grads—CREI training is recognized as a respected reference.

Make your own opportunity in television! Add CREI technical training to your present experience—start either at the beginning or at an advanced stage. Get yourself a better TV job—make more money—enjoy increased security. The next two years can be the most important of your lifetime. Write today for complete information. The cost is popular, the terms easy.

NOTE TO MEN WHO EXPECT TO BE IN UNIFORM SOON:

TV-Electronics training is excellent background for vitally important radar, communications and navigation work in the Armed Services. If you expect to enter service, prepare now to qualify for a higher rating in interesting technical work via CREI home study.

THE THREE BASIC CREI COURSES:

- ★ **PRACTICAL RADIO ENGINEERING**
Fundamental course in all phases of radio-electronics
 - ★ **PRACTICAL TELEVISION ENGINEERING**
Specialized training for professional radiomen
 - ★ **TELEVISION AND FM SERVICING**
Streamlined course for men in "top-third" of field
- ALSO AVAILABLE AS RESIDENCE SCHOOL COURSES

CAPITOL RADIO ENGINEERING INSTITUTE

An Accredited Technical Institute Founded in 1927
Dept. 119C, 16th & Park Rd., N. W., Washington 10, D. C.
Branch Office: San Francisco (2) 760 Market St.

MAIL COUPON FOR FREE BOOKLET

CAPITOL RADIO ENGINEERING INSTITUTE

Dept. 119C, 16th & Park Road, N. W., Washington 10, D. C.

Gentlemen: Send booklet, "Your Future in the New World of Electronics," together with details of your home study training, CREI self-improvement program and outline of course. I am attaching a brief resume of my experience, education and present position.

Check the Field of Greatest Interest:
 Practical Television Engineering.
 Practical Radio Engineering.
 TV, FM & Advanced AM Servicing.

Aeronautical Radio Engineering.
 Broadcast Radio Engineering.
 (AM, FM, TV).

NAME _____ AGE _____
 ADDRESS _____
 CITY _____ ZONE _____ STATE _____

If Residence School in Wash., D.C. Preferred, Check Here



You Can't Miss

with these

TV PROFIT MAKERS

The perfect Rotator-Booster combination!

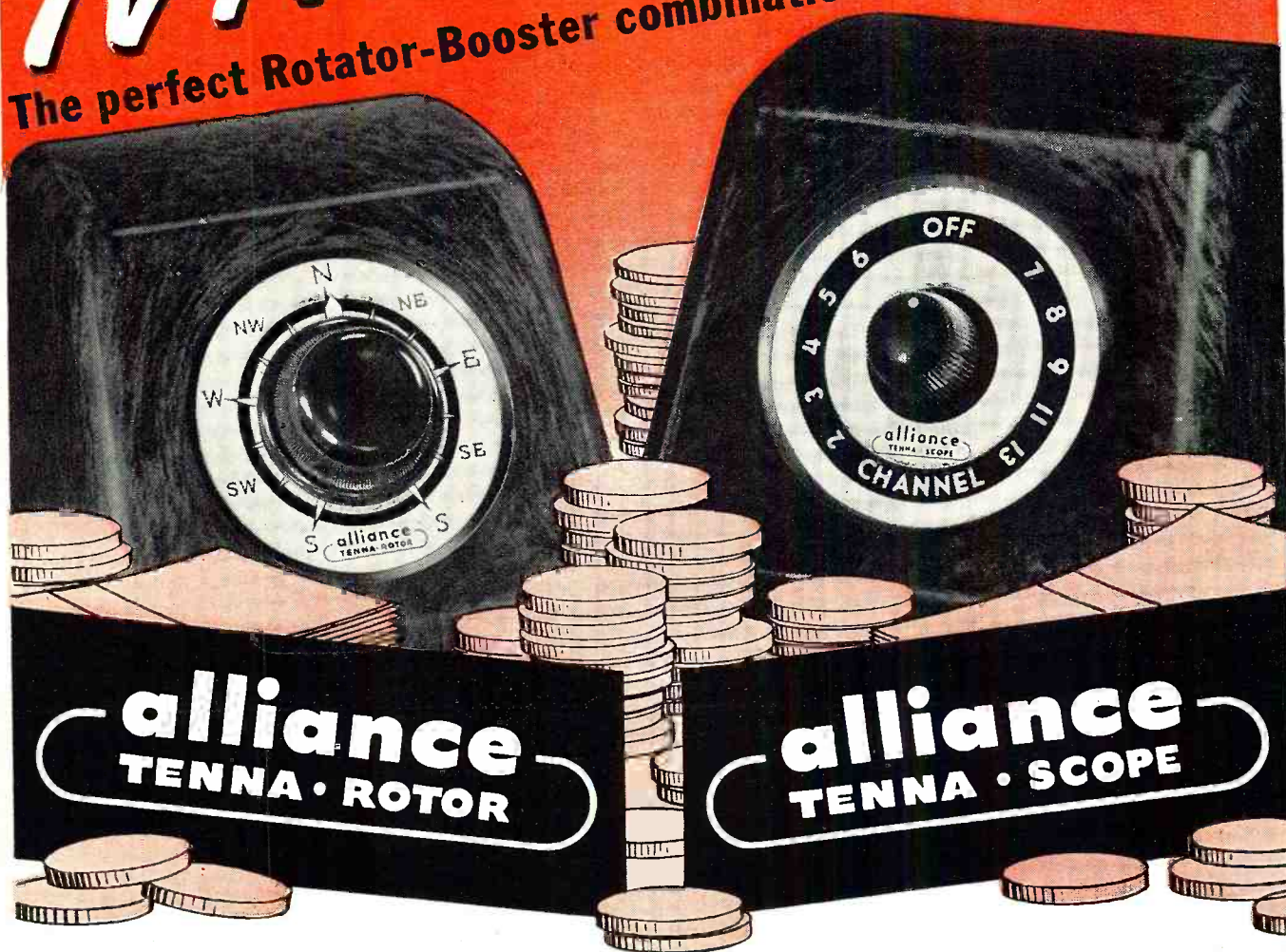

ALLIANCE TENNA-ROTOR is in a class by itself! No other TV accessory sold to the consumer can equal Tenna-Rotor in volume of sales, public acceptance or in proved performance in the field! More than 600,000 are in use! The new deluxe Model HIR (illustrated above) is fully automatic.

ALLIANCE TENNA-SCOPE is a Booster with one simple control. Gives maximum, uniform high gain on all channels—is instantly installed and makes an ideal companion item to Tenna-Rotor. Incidentally, Tenna-Scope, like Tenna-Rotor, is a favorite everywhere!

NATIONAL TELEVISION AND NEWSPAPER ADVERTISING PRE-SELLS! For more than two years, Tenna-Rotor has been backed by a powerful, continuous TV campaign in every major TV area. Hundreds of thousands of future customers see the eye-compelling Alliance TV spots right in their own homes. That's why Tenna-Rotor and Tenna-Scope offer an unbeatable team of profit makers. Preference for them is already established.

ALLIANCE MANUFACTURING COMPANY • Alliance, Ohio

bringing
a
giant
down
to
size

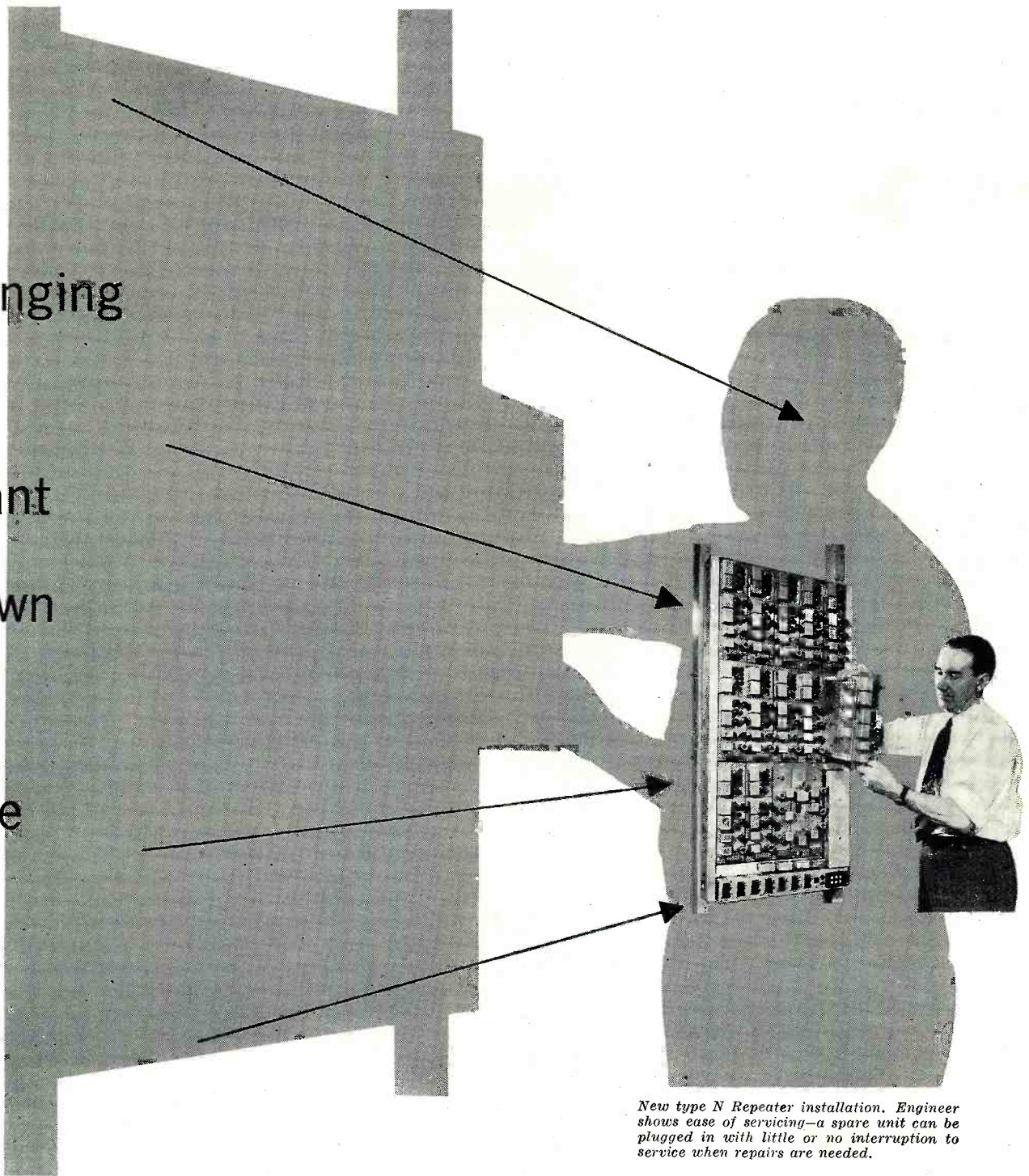

New type N Repeater installation. Engineer shows ease of servicing—a spare unit can be plugged in with little or no interruption to service when repairs are needed.

“CARRIER SYSTEM” telephony is economical, because many voices use the same pair of wires. But the extra equipment needed formerly limited it to the longer distances.

Now Bell Laboratories have developed new short-haul carrier, economical down to 25 miles, sending 12 conversations on two pairs of wires in a cable.

Keys to the new system are new circuits, miniature tubes, pocket-size wave filters and Permalloy “wedding ring” transformer cores that will barely slip over a man’s finger. New

manufacturing processes were developed in co-operation with the Western Electric Company. Components are pressed into a plastic mounting strip with heat, a score at a time, instead of being mounted separately.

With this new carrier system more service can be provided without laying more cables. Tons of copper and lead can be conserved for other uses. It’s another example of how science takes a practical turn at Bell Telephone Laboratories, to improve service and to keep its cost down.

BELL TELEPHONE LABORATORIES

WORKING CONTINUALLY TO KEEP YOUR TELEPHONE SERVICE ONE OF TODAY’S GREATEST VALUES



RADIO & TELEVISION NEWS

2-YEAR ALL-WEATHER TESTS

Show G-E Speakers Unsurpassed for Long-Life!



Twenty-seven sizes to choose from... and they're all G-E!

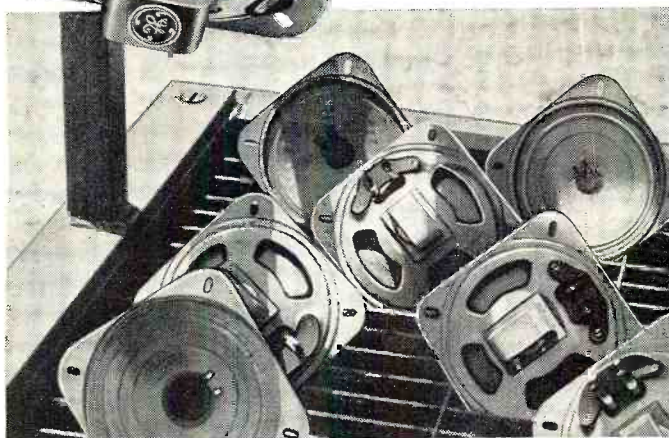

▲ **Unretouched photo** shows only slight tarnish on speakers. Special G-E plating gives excellent protection to steel frames, none of which were corroded after grueling tests.

★ After two years exposure to hot sun, rain, sleet and snow — with no shelter whatever in any season — 7 out of 8 General Electric speakers played well enough to perform in your radio set!

These recent tests at Electronics Park subjected the speakers to many times the abuse they would receive under years of actual playing conditions, indoors or out. It boils down to one more dramatic proof of this fact: *You can depend on General Electric quality — in design, in engineering, in construction.*

Your customers are entitled to this quality. How are your stocks of General Electric speakers?

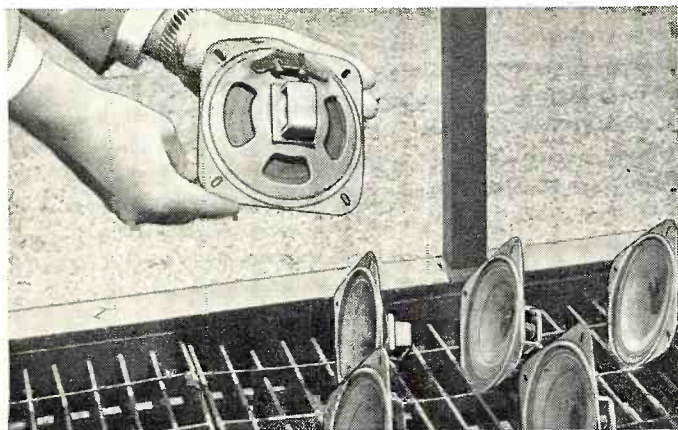

▲ **Racked on exposure tray**, speakers were checked at intervals for 2 years, then taken apart and examined for wear. Outdoor-type cones were warped only slightly, G-E aluminum voice coils were like new.

STYLUS and CARTRIDGE REPLACEMENT GUIDE

General Electric Co., Section 991
Electronics Park, Syracuse, N. Y.

Yes — send me latest speaker information plus new booklet on G-E Styli and Cartridges.

NAME _____

ADDRESS _____

CITY _____ STATE _____

You can put your confidence in —

GENERAL ELECTRIC

To Servicemen Who want to protect their future in Television Servicing

MEN who are interested in continuing their careers as TV service technicians and desire to increase their earnings, will find the information in this page calls for serious thought—and for action.

Your future, the future of your business in television servicing depends on what you do about it.

LICENSING OF SERVICEMEN IS A GOOD REASON WHY YOU SHOULD ACQUIRE TECHNICAL KNOWLEDGE NOW

In New York City, it is proposed that licenses and permits be required of TV contractors, subcontractors, service shops, technicians and apprentices. Once licensing becomes law in New York City this requirement is sure to spread to other municipalities. Licensing and permits mean passing a technical examination. Stiff penalties are cited in the licensing bill upon conviction of a violation. The required technical knowledge can easily and quickly be learned through study of the RCA Institutes Course in Television Servicing. One of the advantages of the RCA Institutes Course, to you as a working serviceman, is that you can study this course at home, in your spare time, and still keep working on your regular job. Now is the time to prepare for license examinations and protect your future in TV servicing.

TELEVISION SERVICING IS SPREADING TO NON-TV AREAS

The Federal Communications Commission recently announced plans for setting up 1,807 new TV broadcasting stations, most of them in the new UHF channels. This will open up areas that have never been touched by television. Radio servicemen in those locales should take a

lesson from servicemen in areas now served by television. In these areas, TV servicing has substantially replaced radio servicing as a means of income. Practical experience in radio servicing is not the important qualification for a successful and profitable career in TV servicing. Practical radio experience *plus* the technical training of the RCA Institutes Home Study Course in Television Servicing, will put you on the right track to be successful in TV servicing.

PRACTICAL, PRE-TESTED DATA MAKES TV SERVICING EASY

The RCA Institutes Home Study Course in Television Servicing is a "down-to-earth" course in the underlying principles of television. It is printed and illustrated in easy-to-understand, non-mathematical language. You learn pre-tested "How-to-do-it" techniques interwoven with "How-it-works" information. The course is based on the actual experience of the RCA Service Company in servicing thousands of home television receivers. You learn the "short-cuts" in TV trouble-shooting that enable you to do a good job in less time, saving you many hours of on-the-job labor. *This up-to-the-minute course contains material on the latest developments in color TV and UHF.*

APPROVED BY LEADING SERVICEMEN'S ASSOCIATIONS

Such well-known associations as—National Appliance & Radio Dealers Association; Television Contractors Association; National Alliance of Television & Electronic Service Associations—are already using the RCA Institutes course for upgrading the standing of their members. *Tell the Secretary of your local or State association to write us for low rates for group enrollment.*

RCA Institutes conducts a resident school in New York City offering day and evening courses in Radio and TV Servicing, Radio Code and Radio Operating, Radio Broadcasting, Advanced Technology. *Write for free catalog on resident courses.*

Send for FREE BOOKLET

Mail the coupon—today. Get complete information on the RCA INSTITUTES Home Study Course in Television Servicing. Booklet gives you a general outline of the course by units. See how this practical home study course trains you quickly, easily. Mail coupon in envelope or paste on postal card.



MAIL COUPON NOW!

RCA INSTITUTES, INC.
Home Study Department, RN-951
350 West Fourth Street, New York 14, N.Y.

Without obligation on my part, please send me copy of booklet "RCA INSTITUTES Home Study Course in TELEVISION SERVICING." (No salesman will call.)

Name _____ (Please Print)

Address _____

City _____ Zone _____ State _____



RCA INSTITUTES, INC.
A SERVICE OF RADIO CORPORATION of AMERICA
350 WEST FOURTH STREET, NEW YORK 14, N.Y.



Sensationally NEW for 1952!
MIDWEST TELEVISION



A Magnificent New Line of Beautiful CONSOLES and Complete CHASSIS featuring the Mammoth

20-Inch
 RECTANGULAR
 PICTURE TUBE

FACTORY-TO-YOU



THE New 1952 MIDWEST "VIDEO GRAND"

20-Inch
 TELEVISION-
 RADIO-PHONO
 CONSOLE

In addition to its mammoth 20-Inch Rectangular Picture tube, this luxurious instrument offers a powerful, long-distance AM-FM Radio plus the newest-type 3-Speed Automatic Intermix Record-Changing Phonograph.

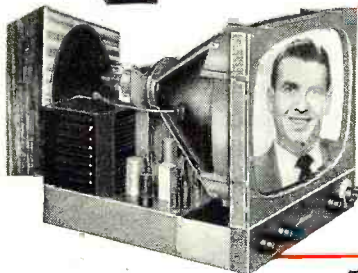

MIDWEST
 20-Inch
 TELEVISION
 CHASSIS
 and SPEAKER
 —for easy installation
 in your own cabinet.



30 DAYS TRIAL

New 1952 MIDWEST "CONSTELLATION"
 20-Inch TELEVISION CONSOLE

Also—Powerful New 1952 World-Ranging
MIDWEST Series of RADIOS
 For Beautiful Consoles and Complete Chassis

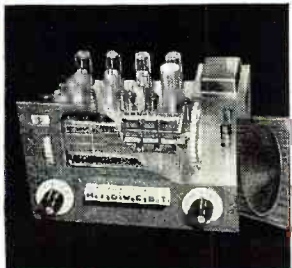

An entirely new line of radios featuring the powerful Series 16 five wave band AM-FM Radio Chassis and the magnificent Symphony Grand Radio-Phonograph with 3-Speed Automatic Intermix Record Player.

Easy Terms

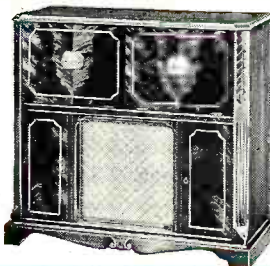

WRITE or PHONE
 For This NEW 1952
FREE MIDWEST
RADIO CATALOG



If You Live In One of These Cities
 Phone and Ask for Your Catalog

- NEW YORK MURRAY Hill 2-6810
- CHICAGO STATE 2-5600
- PITTSBURGH GRANT 1-0609
- CLEVELAND PROSPECT 1-7450
- DETROIT WOODWARD 3-1233
- ST. LOUIS GRAND 1161
- PHILADELPHIA LOCUST 4-1035

or Send Coupon Below

• WRITE IN NAME AND ADDRESS (PLEASE PRINT) ON COUPON OR 1c POSTCARD •

MIDWEST RADIO & TELEVISION CORP.
 Dept. 372, 909 BROADWAY • CINCINNATI 2, OHIO

Please send me your new FREE 1952 Catalog.

NAME _____
 ADDRESS _____
 CITY _____ ZONE _____ STATE _____

MIDWEST RADIO & TELEVISION CORP.
 DEPT. 372, 909 BROADWAY, CINCINNATI 2, OHIO

EICO
TEST INSTRUMENTS

Guard

CBS-Columbia Inc.
COLOR TELEVISION PRODUCTION QUALITY

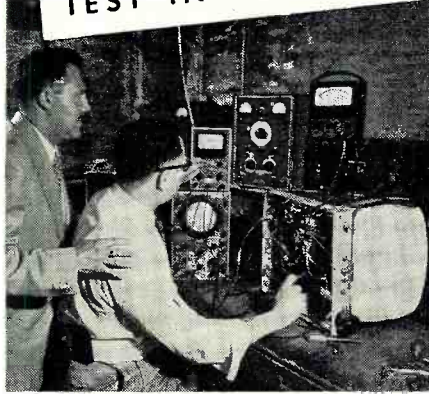

In the CBS-Columbia design laboratories, Al Goldberg takes some important readings with the EICO Model 221 Vacuum Tube Voltmeter and Model 555 Multimeter, as Harry R. Ashley looks on.



Mr. Al Goldberg, Assistant Chief Engineer of CBS-Columbia, and Harry R. Ashley, President of EICO, inspecting the use of the EICO Model 221 Vacuum Tube Voltmeter and Model HVP-1 High Voltage Probe at the Sweep Frequency Troubleshooting Position on the CBS-Columbia Color Television production lines.



NEW
221K VTVM KIT \$25.95
WIRED \$49.95



HIGH VOLTAGE
PROBE \$6.95



NEW 425K 5" PUSH-PULL
SCOPE KIT \$44.95 WIRED \$79.95

*For Laboratory Precision at Lowest Cost—
the Leaders Look to EICO!*

WHY does CBS-Columbia, Inc., today's headline-maker in Color Television set production, use EICO Test Instruments on its new Color Television production lines and in its design laboratories?

BECAUSE — like Emerson, Tele-King, Teletone, and many another famous TV manufacturer coast to coast, CBS-Columbia knows that ...

*Only EICO Test Equipment delivers
All 10 EICOnomical Features!*

1. Laboratory Precision
2. Lowest Cost
3. Lifetime Dependability
4. Speedy Operation
5. Rugged Construction
6. Quality Components
7. Latest Engineering
8. Super-Simplified Assembly and Use Instructions
9. Laboratory-Styled Appearance
10. Exclusive EICO Make-Good Guarantee

Before You buy any higher-priced equipment, be sure You look at the *EICO* line—in *Wired as well as Kit form!* Each EICO product is jam-packed with unbelievable value. YOU be the judge—compare, see *EICO-instruments* today — in stock at your local jobber — and **SAVE!** Write NOW for FREE newest Catalog 9-R.

FOLLOW THE LEADERS ... INSIST ON EICO!

KITS
WIRED INSTRUMENTS



NEW 555K MULTIMETER
KIT \$29.95 WIRED \$34.95
20,000 ohms/volt



320K SIG.
GEN. KIT \$19.95 WIRED \$29.95

NEW 322K SIG. GEN.
KIT \$23.95 WIRED \$34.95



NEW 950K R-C BRIDGE &
R-C COMP. KIT \$19.95
WIRED \$29.95



NEW 1040K BATTERY ELIM.
KIT \$25.95 WIRED \$34.95

©1951, Electronic Instrument Co., Inc. Prices 5% higher on West Coast. Due to unstable conditions, prices and specifications are subject to change without notice.



511K VOM
KIT \$14.95
WIRED \$17.95



NEW 526K MULTI-
METER KIT \$13.90
WIRED \$16.90
1000 ohms/volt



NEW 1171K RES.
DECADE BOX KIT
\$19.95
WIRED \$24.95



NEW 315K DELUXE SIG.
GEN. KIT \$39.95
WIRED \$59.95



145K SIG.
TRACER KIT
\$19.95
WIRED \$28.95



NEW 625K
TUBE TESTER KIT \$34.95
WIRED \$49.95

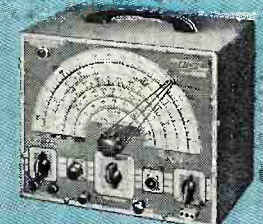

360K SWEEP GEN. KIT \$34.95
WIRED \$49.95

EICO

ELECTRONIC INSTRUMENT CO., Inc.
276 NEWPORT STREET, BROOKLYN 12, NEW YORK

RADIO & TELEVISION NEWS

DO YOU WANT MORE BUSINESS?

By
H. E. KRANHOLD
Brown & Bigelow

There are thousands of advertising novelties available. Whether your business is large or small, there are items priced to meet your budget. These novelties, either for Christmas or as a birthday remembrance, are ideal good-will builders. They can mean more business for you. Include your company's name, phone number, and address on each item for maximum results. If you use a slogan, choose one which identifies your business and one that can be easily remembered by all of your customers.

REGARDLESS of the size of your business, you have three basic advertising jobs which must be accomplished to keep the profit side of the ledger healthy. This basic trio is particularly important in these days of higher taxes, shortages in some lines, and generally higher prices.

Check your present advertising policies against these fundamental tenets:

1. You must build name identity. You are interested in only those who can use your products or service within your own market.
2. You must hold good customers. These are the ones you will look to for business next year and they are your competitors' best prospects.
3. You must continuously invite more business. You must invite this business from your old customers who are actually your firm's life-blood and you must invite business from new customers to insure your continued growth.

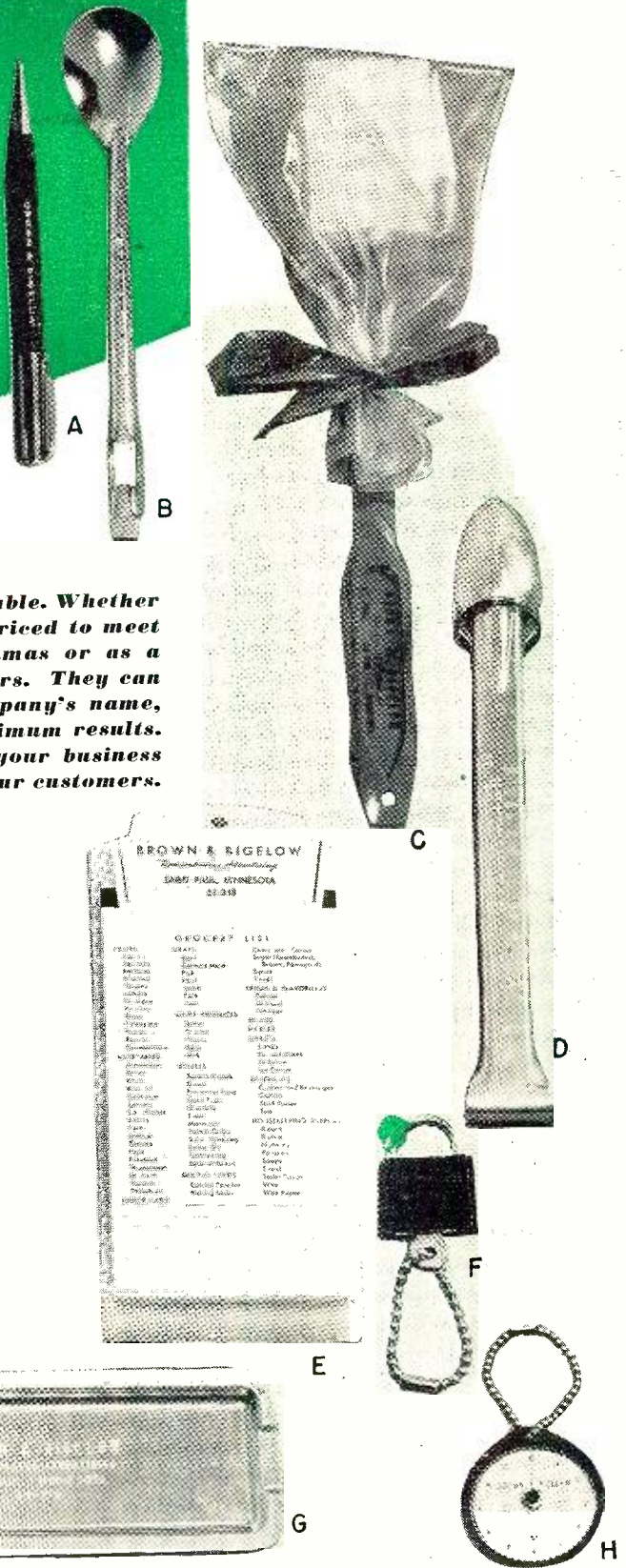

(A) Sport clip "Redipoint" pencil, minimum quantity 50. (B) Mixing spoon, bottle opener, and lid lifter, minimum quantity 100. (C) Speedy sponge, minimum quantity 100. (D) Aluminum "Handitongs," minimum quantity 100. (E) Plastic "Rediclip" pad, minimum quantity 100. (F) Padlock key chain, minimum quantity 100. (G) Spoon tray, minimum quantity 100. (H) Time reminder key chain, minimum quantity 100. (I) Imprinted playing cards, minimum quantity 250. All of the items shown on this page are available from Brown & Bigelow, St. Paul, Minnesota. Obviously, these are only a few of the many hundreds of merchandising items available. For prices check with the nearest Brown & Bigelow representative or write direct to the company.



The above items are merchandised by Esquire, Inc., of 65 East South Water Street, Chicago, Illinois. Again, these are only a few of the many advertising novelties in their line. The playing cards, available in either pinochle or bridge deck, cost \$1.20 per pack imprinted with your name, address, and phone number in minimum lots of 36. The "Esqy" pads are available as memo type pads as shown or as canasta, bridge, or gin rummy scoring pads. Minimum quantity is 150 and prices range from 4 to 9 cents per pad, including your personal imprinting.

Dealers, technicians, jobbers, and distributors vary in size and location, but they have the same problems in building name identity.

The basis of all advertising is a sign telling who you are, where you are, and what you have to sell. It is not enough to place your sign on your building, stationery, and trucks. To build name identity, you must project your sign in such ways as to place it before as many logical prospects and customers as you can at a reasonable cost.

In the advertising specialty field, we usually think of advertising space in terms of space in a man's pocket, on his office walls, on his desk, or in his home. One other highly important advertising space is available to the business firm that wants to reach prospects and customers in a most effective way—advertising playing cards.

A recent independent survey conducted by a large marketing service for *Brown & Bigelow* revealed these facts about card playing:

1. Two out of three families said they played cards regularly.
2. Ninety-five and five-tenths per-cent (95.5%) of all card-playing families said they would be glad to accept and use advertising playing cards.
3. Sixty-five per-cent (65%) of the housewives interviewed recalled correctly the name of the advertiser on their playing cards when asked at the door.
4. Seventy-three and five-tenths per-cent (73.5%), or three out of every four families, said they would like to receive playing cards as a premium.
5. Three out of four families said they would like to do

business with a firm that used playing cards as a premium. Advertising specialties range from calendar cards costing less than a postage stamp to the more expensive items for office, home, and travel, running into as high as the \$100 per item bracket. Advertising playing cards, carrying the essentials of a business sign on the back of each card in the pack, telling who you are, where you are, and what you have to sell, can be purchased in reasonable quantities at something less than \$1.00 per pack.

Playing cards go into the quiet of a home where there is no competition for attention, when family and friends gather for sessions of their favorite card games. There each pack, actually consisting of 52 or more colorful miniature billboards, claims the attention of your customers and their friends for periods of time ranging from two to three hours, or even more on each of many occasions.

During these intimate family and friends sessions, your sign becomes the center of attention for hours at a time, it invites conversation about your firm and your products and services. Recommendations follow, and new customers are created for you.

In the advertising specialty field, we frequently hear the expression: "We don't give away gadgets." The use of the term, "give away," merits analysis. By presenting a key chain carrying your sign, for example, you are actually helping yourself to space in the pocket of a good customer or prospect—space which would not be for sale under any circumstances.

Many radio and television dealers have found that well-chosen gifts can be a real boon to their businesses.

One Philadelphia technician makes it easy for his top commercial accounts to get in touch with him by sending them a deluxe, automatic telephone index. The user simply presses one of the alphabetically arranged keys and the index opens to the corresponding listing of frequently called phone numbers. Heading the listing on its proper page is the name and phone number of the television service company. Because of the deluxe appearance of this item and because of its utility, this type of gift is a welcome one which always commands desk space.

A Pawtucket, Rhode Island radio and television dealer doesn't let his customers and prospects forget who he is and where he is located. He presents each buyer and good prospect with a unique padlock key chain which carries his name, address, and telephone number.

A manufacturer of television parts was faced with the problem of acquainting his customers with his new address and phone number in New York. He solved the problem by sending attractive and useful bronze letter openers to all his accounts. His name and new address and phone number were stamped on the handle of the letter opener. For some of his top accounts, he used an attractive ash tray with his new location and phone number stamped on the plate of the ash tray.

In Dalton, Illinois, a television sales and service dealer purchased an attractive and useful plastic pad designed to hold a pad of paper for notes. This clever and useful pad will be distributed during the holidays as a "thank you" to his good customers. The top of the clip holding the pad carries his name, address, and phone number for the convenience of his customers in calling for television and radio service work.

It has been demonstrated repeatedly that a handy kitchen item, offered through a post card or an advertisement in a magazine or local newspaper, can pull people into an appliance store. After it has increased store traffic, the specialty goes on indefinitely doing a job of building preference by keeping the store's name and sales story constantly before the housewife.

Consider calendars. When you distribute calendars reproducing exclusive pictures by famous artists, you are utilizing a medium which will hang for a minimum of twelve months on the office or home wall of a good customer or prospect. Are you giving something away or are you helping yourself to valuable advertising space?

As long as one day follows another, clocks will mark the minutes and hours—calendars the days and months.

This is the utility side of the chart on the wall of the kitchen, office, or store. In addition to its utilitarian

function, calendars can provide many extras which are appreciated by your customers. Memo space, recipes, religious and geographical information can be carried, along with your advertising message.

A national survey by this company showed that 93 percent of all homes have calendars and that the urge for calendars is so strong that nearly half (47.4 per-cent) of the housewives made a trip to some business establishment to obtain a calendar. The survey also showed that while the average home has two calendars, the housewives interviewed indicated that if they had additional calendars they would use them.

Many people want and appreciate a pocket calendar with loose-leaf pages. This type of gift is available in several sizes with specialized information for use in city and farm homes. These calendars feature pockets for receipts, grocery slips, milk tickets, etc.; a handy pencil for quick notations; menu suggestions; and practical recipes, while the loose-leaf feature permits the recipes and notes to be saved for future reference.

Wall-type calendars are available with a wide variety of illustrations. Some of the country's top-flight artists supply original paintings which are reproduced on these calendars. Thus in selecting the calendar to carry your advertising message into that home, or office, or store, you are also providing a fine reproduction of a good painting by a well-known artist. Is it any wonder, then, that calendars make such acceptable remembrances for your customers?

Fine leather pieces for pocket or desk, metal or plastic lighters, writing instruments, telephone indexes and similar items can be tangible evidence of appreciation for business from good customers. Used properly, they can be a form of good customer insurance, certainly not a "give away."

An intelligent direct mail series depends for its pull on the interest it creates and the utility it gives. Information on direct mail can be helpful as well as interesting. A blotter can have even more utility if it creates interest through a pleasing picture or a set of pertinent facts.

While the holidays are the commonly accepted time of the year for saying "Thank you, come again" to good customers as well as for inviting potential customers, there now are a number of ingenious plans for distributing remembrances throughout the year.

One of the finest examples of something different is the Birthday Plan. Under this plan, the birthdates of your good customers are obtained in an unobtrusive way. On his birthday, your customer or top prospect receives a fine remembrance like a billfold, lighter, fine etching, or beautiful two-pack set of playing cards.

An important consideration in the selection of the birthday remembrance is this: most businessmen prefer something they can take home and share with their family and friends.

One of the finest ways to insure repeat business is through the use of the playing card premium plan. The plan is simple. A purchase or an order for a fixed amount earns a coupon. An accumulation of coupons over a comparatively short time earns a deck of playing cards. These bear the advertiser's name, location, and identification of product or service.

Under this plan, the continuity of purchases is encouraged, and frequency of purchases is stepped up. Surveys show that the universal appeal of "something for nothing" brings people far out of their way to patronize the firm issuing playing card coupons.

Orders for advertising specialties should be planned months ahead. Advertising specialty manufacturers must prepare their merchandise in large quantities well in advance of the receipt of individual orders. This gives the specialty buyer the advantage of large quantity prices even though he buys in limited quantities.

The specialty buyer has the further advantage of utilizing the big names in the field of illustration and sports, like Norman Rockwell, Richard E. Bishop, Christy Walsh, and many others. All that remains to be done after his order is received, is the imprinting or stamping of his own sign and advertisement.



Another novel advertising medium, and one that is bound to cause comment, is the "personalized" cigarette pack carrying your ad, your name, your slogan or sales message on the front and the back, and your name, initials, or slogan on each cigarette. Emblems, trademarks, or special artwork can be carried in addition to your printed message. The minimum quantity is 10 cartons (100 packs). Prices vary with quantity ordered. For 250 packs the cost is 29 cents per pack plus the applicable state tax. Your Name Cigarettes, 125 W. Hubbard, Chicago 10.

Although we have attempted to suggest and illustrate a representative group of advertising novelties, the reader should not infer that this list in any way exhausts the possibilities. There are literally thousands of different types of items that can be used to carry your advertising message to your customers.

Metal ashtrays, always a popular item, have been purposely omitted from this article because as the magazine goes to press many companies have been forced to withdraw these units because of the metal shortage. Keep checking with your supplier as the situation may ease by Christmas.

One basic point to remember, no matter what type of gift you select for your customers, is that to be effective and to provide the desired result, every item should carry your message clearly and forcefully. "Remembrance Advertising" is only effective if you constantly remind the recipient of the donor, his product, and his place of business.

Matchbooks can carry your advertising message far and wide. They can be used the year around or as Christmas greetings. An almost infinite variety of designs is available and range from special "Window-Paks" carrying six books in a specially designed carton to the individual match folder in various sizes. The folders shown are merely representative of the different ways matchbooks can be used to carry your advertising message. Matches with your name or initials can serve as a reminder to your customer even if they do not carry advertising. Such matchbooks are obtainable throughout the country. The assortment shown here is from the Diamond Match Company, N. Y.



REPAIR THAT SPEAKER

By
W. E. LaFARRA



This is all of the "equipment" required to make the speaker repairs described herein by the author.

Thinner poured carefully around the cone facilitates removal of the cone. To control the amount of thinner, pour from the cap.

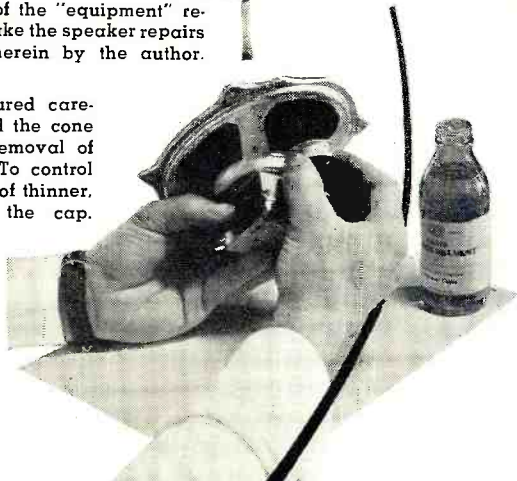

Cut around the cone with a razor blade to save time and to avoid the possibility of damaging the cone. Although this is not a professional method, it is one way in which the same cone can be used, thus eliminating the problems involved in obtaining a replacement. When the cone is replaced, the cement will hold the cone securely to the cardboard ring. Should the cone be badly torn a replacement is obviously necessary.



Replacing the shim is a simple process. A piece of ordinary paper will do nicely.

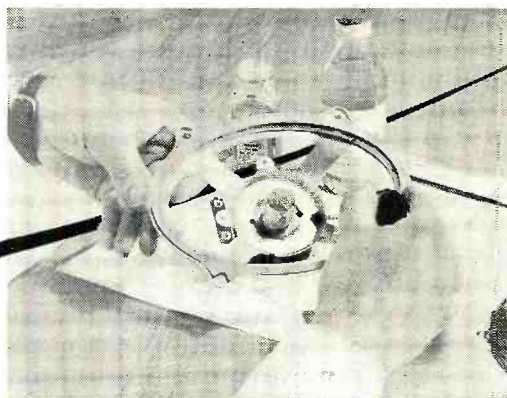
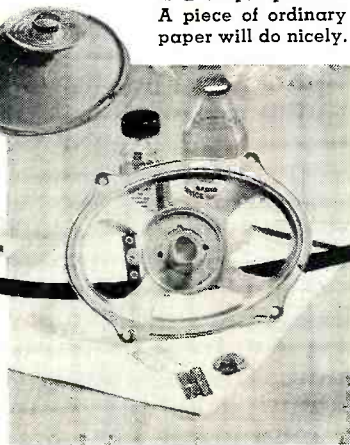

Cement is next applied to the area where spider hits. Note the gap left in shim.

A bottle of cement and thinner is all that is required for repairing that rubbing voice coil. It is easy to fix!

IN THESE DAYS of shortages, technicians are finding it necessary to repair many units that heretofore have been replaced. Speakers, long a "bugaboo", can be repaired with a little effort and ingenuity and while the speaker market may be good, the ability to repair speakers in special mounts is always desirable.

The ability to make such repairs is not, however, something that can be learned overnight but with practice, many of them can be repaired. Taking into consideration the fact that the speaker would have to be replaced anyway, a successful repair job turns into quite a profitable venture.

The real secret of such repairs is in the cement used. Such cement is purchased in a very thick state and when dry, will give a very stiff, white colored finish. By diluting this mixture with cement thinner to an almost watery consistency, good results can be obtained. This point can be determined by allowing some of the mixture to dry on an old cone. It should dry clear; if it turns white, it is too thick.

After mixing your cement, remove the speaker from the cabinet or chassis and place it on a perfectly clean workbench. Disconnect the voice coil leads and, using a small brush, saturate the area around the glued portion of the spider with thinner. If this area is not readily accessible, pour your thinner down around the spider, taking care not to allow the thinner to run over the area where the cone and spider are glued together. While this thinner is dissolving the glue, take a sharp single edged razor blade and by using the cushion as a brace, cut completely around the outside edge of the cone. This is done simply because it is virtually impossible to un-cement the cone without tearing it, although, if torn, the cone may be replaced.

Minor repairs can be made at this stage. A drop of cement is often all that is needed.

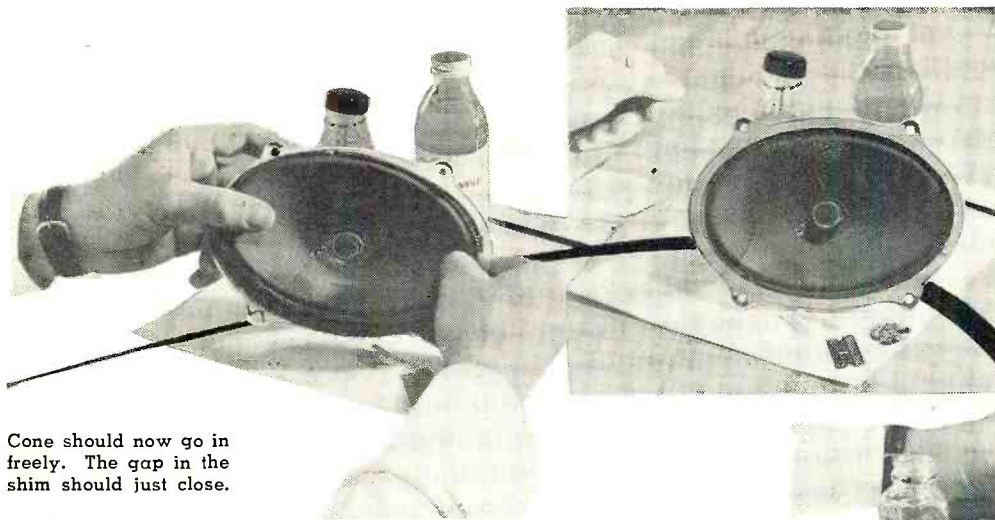

Cone should now go in freely. The gap in the shim should just close.

The cone should fit in its original position if job is done right.



Rotating speaker on its rim facilitates cementing the outer rim.

By now the spider should be loose or ready for a second coat of thinner. Ease up on the cone, taking care not to bend or tear it. If the spider is still stuck, a screwdriver can be of help in easing it away from the frame. Cleaning out around the cone offers a problem since many shops do not have a high pressure air supply. In such case, simply take the unit to a service station and blow it out thoroughly with an air hose. A few filings can be fished out by using a brass shim but if care is taken and a clean spot to work is selected, the chances of picking up filings is slim.

If the paper voice coil form is warped, easing a cork in the paper form will straighten it and by applying a thin coat of glue, it can usually be kept straight.

The dust cover will usually tear off and should be saved as a replacement. Do not try to remove with thinner since this will soften the cone and give trouble. Small rattles can be repaired while the cone is out, these probably originate with tears in the cone, as a result of the spider being loose from the cone, or perhaps the paper loose from the voice coil wire form. These points should be touched up with a small dab of cement. The latter trouble gives a high-volume rattle that is hard to locate and the paper, if loose, should be pulled away from the wire enough to permit some cement to run down and make good contact between paper and wire. Don't, however, over-do your cementing.

The best shims available can be made from ordinary paper, such as the page you are reading. A small rectangular piece should be cut so that when it is formed into a circle, will just about make a complete loop around pole piece. Put a thick layer of cement around the circle where the spider will hit. When pushing the voice coil over the paper shim around the pole piece, take care that it doesn't buckle. Ease the cone down to its original position, taking care not to force it. The cone should fit exactly where it was originally. Tilting the speaker up on its rim is an aid in cementing the outer edge of the cone. Be careful not to get cement out too far on the corrugated section, but stay close to the edge. Turning the speaker to keep the area being worked on down will keep the cement from running out and on to the cone. After drying, remove the paper shim and hook the unit up. If properly done, the speaker will sound as good as new. If you fail, you can always replace the speaker, something that most technicians would have done anyway.

I have repaired several hundred speakers that would have normally been replaced, once completing five out of six successfully, a feat I consider a pretty fair record. The larger the speaker, the better your chance of repairing it. As a suggestion, you might make a start on six and seven inch models and then proceed to the four and five inch jobs. If you tear them up, just remember that you would have had to replace them anyway!

If the repair job comes off successfully, you have saved one more hard-to-get-speaker and have made another of your customers very happy.

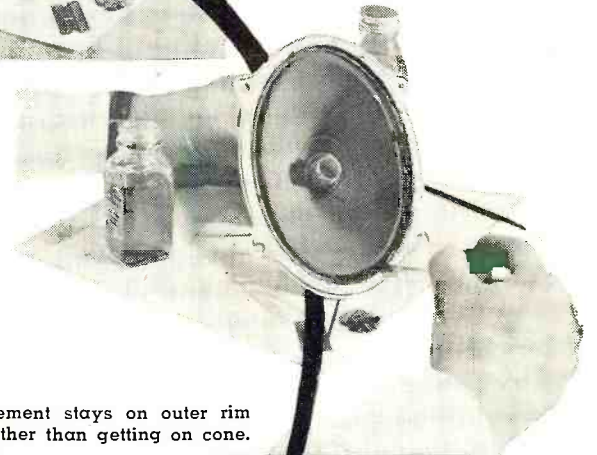

Cement stays on outer rim rather than getting on cone.

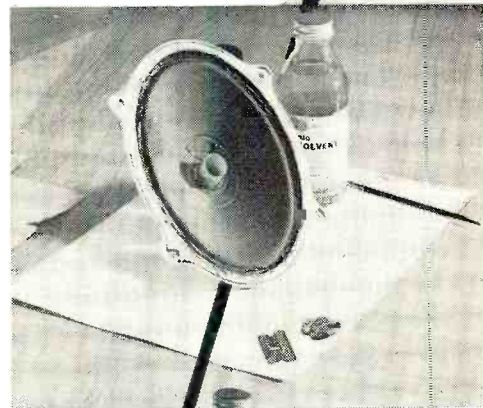

Shim should now be removed.



Replace the dust cover and make a test run on speaker.

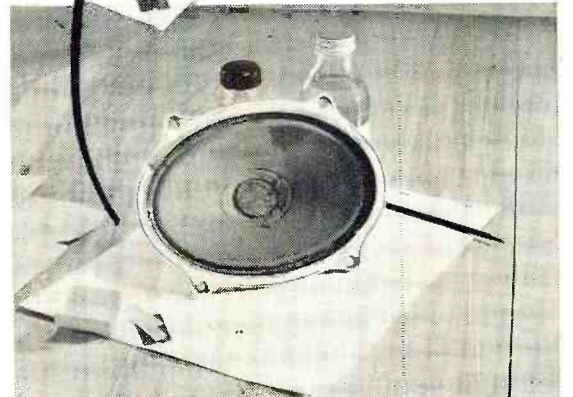

By
LOUIS E. GARNER, JR.

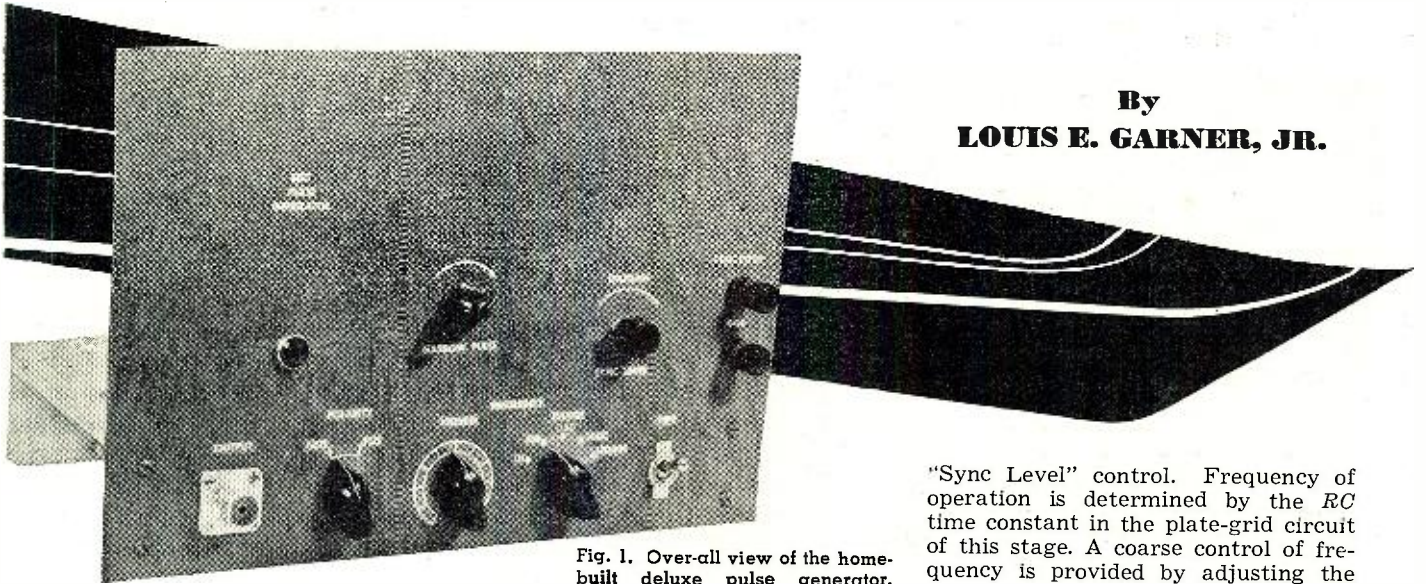

Fig. 1. Over-all view of the home-built deluxe pulse generator.

A Deluxe PULSE GENERATOR

Complete construction details on a useful test instrument, including data on delay lines and their use, and basic material on pulse analysis.

ANY of the basic applications of the pulse generator have been described previously^{1, 2}, and circuits for a pulse-forming device and an inexpensive pulse generator given. However, as an experimenter works with a pulse generator, he soon finds himself demanding more and more features which contribute to the usefulness of the instrument. Such features include provision for "locking-in" the pulses with an external signal, continuous pulse repetition rate coverage, a pulse width control that will permit maintaining constant pulse width regardless of repetition rate, and an extremely narrow output pulse. An instrument incorporating these features is shown in Figs. 1 and 4, while

the complete schematic diagram is given in Fig. 3.

The operation of this pulse generator may best be understood by referring both to the schematic diagram and to the simplified block diagram given in Fig. 2. Signal wave shapes in various parts of the circuit are given in Fig. 2.

A conventional "Potter" cathode-coupled multivibrator is used to supply a fairly broad negative-going pulse signal. This stage (V_1) may be "synced" with an external signal fed to its grid from R_1 , which acts as the

¹ Garner, Louis E., Jr.; "An Inexpensive Pulse Generator," Radio & Television News, February 1951.

² Garner, Louis E., Jr.; "The Pulse-Former," Radio & Television News, August, 1951.

Fig. 2. Simplified block diagram of pulse generator and associated signal wave shapes.

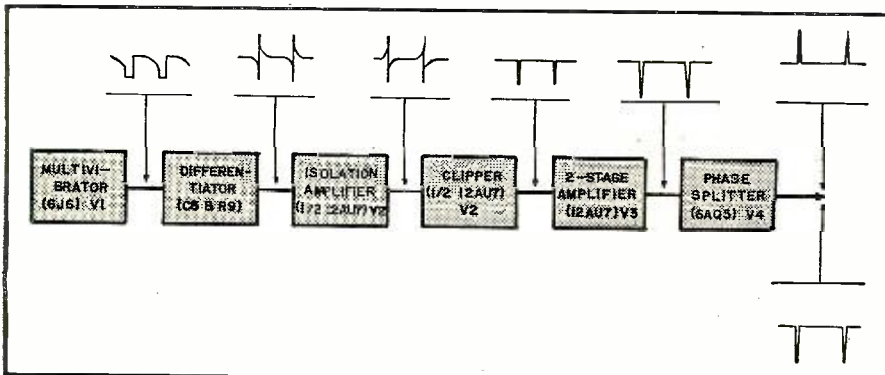

"Sync Level" control. Frequency of operation is determined by the RC time constant in the plate-grid circuit of this stage. A coarse control of frequency is provided by adjusting the grid condensers (C_3 , C_4 , C_5 , C_6 , and C_7) by means of S_2 , while exact frequency is determined by changing the grid resistor R_5 (*Vernier Frequency Control*). The pulse width of this signal varies with frequency, so the signal is applied through a differentiating circuit consisting of C_8 and R_8-R_9 .

Both positive- and negative-going pulses are obtained at the output of the differentiator, with pulse width depending on the time constant of C_8 and R_8-R_9 . By adjusting the size of R_9 , the pulse width can be varied. Thus, R_9 acts as the *Pulse Width* control (on the photo, Fig. 1, this is designated "Narrow Pulse").

These pulses are passed through a triode buffer amplifier ($\frac{1}{2}$ of V_2) and thence through a clipper-amplifier (remaining $\frac{1}{2}$ of V_2). The clipper is biased almost to cut-off by means of the large cathode resistor R_{13} , and only the positive halves of the applied double pulse cause a change in current flow in the plate circuit. Hence, half of the pulses are "stripped" and only unidirectional pulses appear in the output.

Additional amplification and shaping of the pulses occur in the two stage resistance-coupled amplifier V_3 , and the pulses are finally applied to the phase splitting circuit V_4 , where both positive- and negative-going pulses may be obtained in the output. Either may be selected by S_3 , and passed through d.c. blocking condenser, C_{17} , to the output.

Power to operate the entire device is obtained from a conventional full-wave rectifier and filter type of power supply, which need not be regulated unless desired for maximum stability of operation.

Decoupling filter R_7-C_2 serves to stabilize the circuit by isolating the oscillator. R_7 performs the additional function of limiting the cathode current drawn by V_1 thus keeping this tube from operating above its maximum ratings.

An approximate idea of the layout used by the author may be obtained by referring to Fig. 4. Layout is not critical, however, and the builder may use

any arrangement that meets his chassis and space requirements as long as normal high frequency precautions are observed.

Wiring is not particularly critical, although certain basic rules should be observed. The input and output of stages should be kept as widely separated as possible. Distributed wiring capacities must be kept to a minimum if good pulse waveshape is to be maintained. Long signal leads should not be run, not only because of the increased capacity to ground, but also because lead inductance may lead to "ringing" with its resultant distortion of the output signal.

Provision has been made for a voltage regulated power supply, if such is desired to insure maximum stability of operation. Either two type 0A2 tubes, or two type VR-150's may be used for V_6 and V_7 . In any case, R_{24} should be chosen experimentally so that no more than 30 ma. flows through the voltage regulator tubes with the power transformer used.

The completed instrument may be given a "professional" appearance by using a wrinkle finish on the front panel and applying commercially available decals to mark the various controls and terminals.

Specifications

The amplitude of the output pulses obtained is about the same, regardless of whether positive- or negative-going pulses are used. However, there is some variation of pulse amplitude with frequency of operation (PPS), with the average being about 8 volts peak.

The minimum pulse width at the 70% point is slightly less than 0.2 microsecond, and this may be maintained regardless of pulse repetition rate over the entire range of operation by adjusting the "Pulse Width" control. Rise time is about .11 microsecond, while decay time is about .18 microsecond.

Pulse repetition rate depends on the setting of S_2 and R_5 . The approximate ranges of each switch position (minimum and maximum PPS) in pulses-per-second are given in Table 1.

As can be seen from the table, the number of pulses-per-second may be taken from less than one to more than 100,000 by adjusting only two controls. There is adequate overlap on each range.

The sharpness of the pulses obtained may be easily seen by referring to Fig. 5A, where a tracing of the 100,000 PPS pulses is given, as observed on a Tektronix Model 511AD oscilloscope, using a 50 microsecond sweep. The positive-going pulses are shown here, but the negative-going pulses are almost identical in amplitude and waveshape.

An expanded view of the .100 kc. pulse of Fig. 5A is shown in Fig. 5B, where a 1 microsecond sweep is used (triggered). A .25 microsecond delay is used so the leading edge of the pulse is clearly visible. In Fig. 5B the pulse is shown with maximum pulse width,

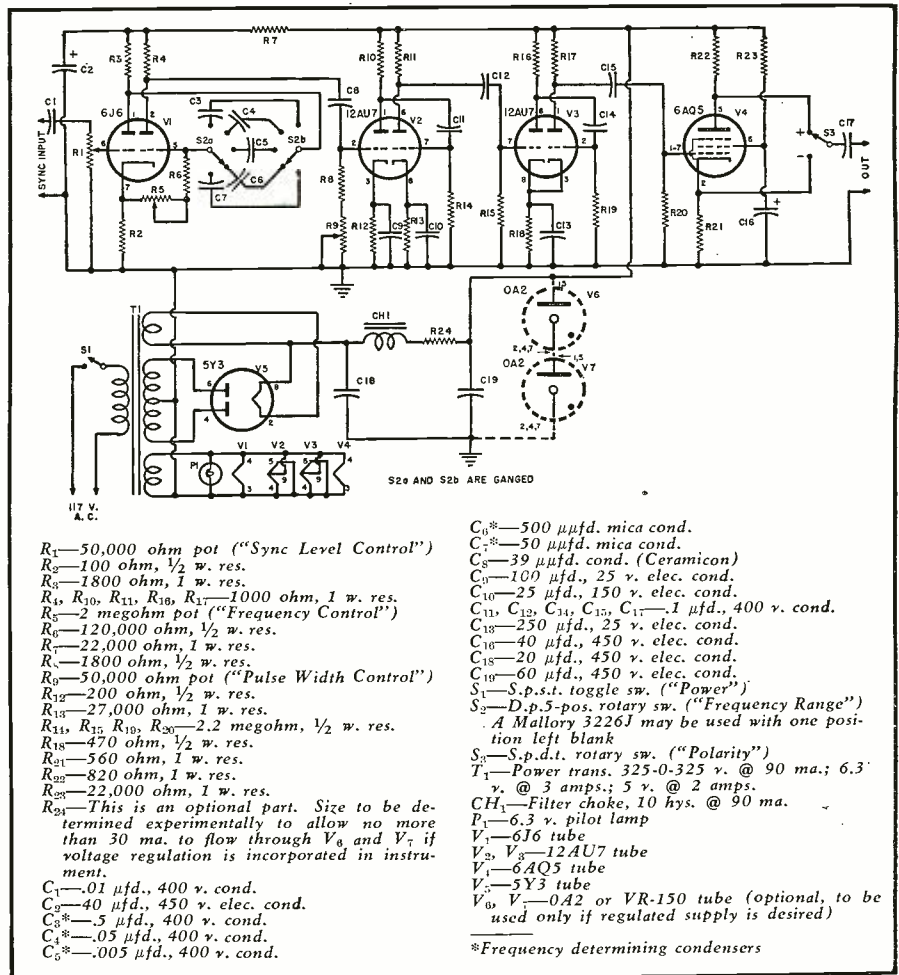
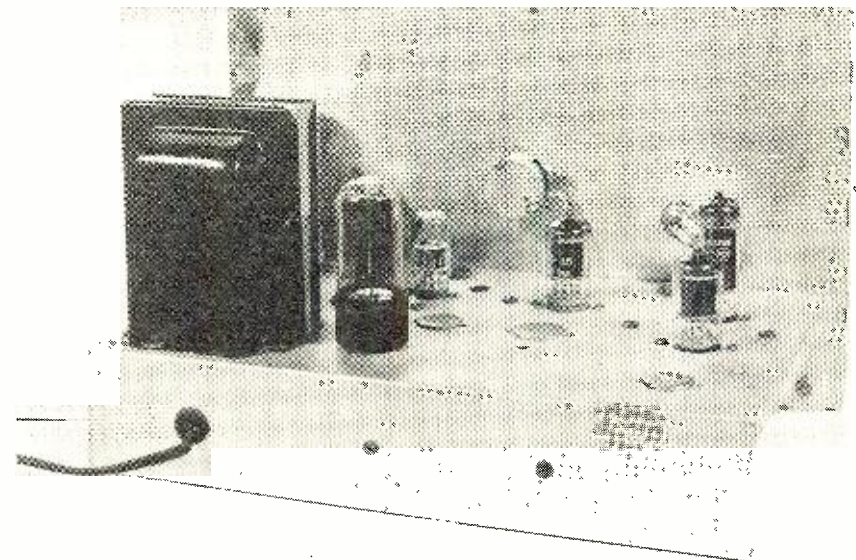

Fig. 3. Complete schematic diagram of the deluxe pulse generator built by the author.

S_2 POSITION	CONDENSER	MINIMUM PPS	MAXIMUM PPS
1	C3— .5 μ fd.	Less than 1	20
2	C4— .05 μ fd.	10	150
3	C5—.005 μ fd.	110	1600
4	C6— 500 μ fd.	1100	16,000
5	C7— 50 μ fd.	11,000	140,000

Table 1. Approximate ranges of switch positions in pulses-per-second (PPS).

Fig. 4. Rear view of instrument showing recommended layout of component parts.



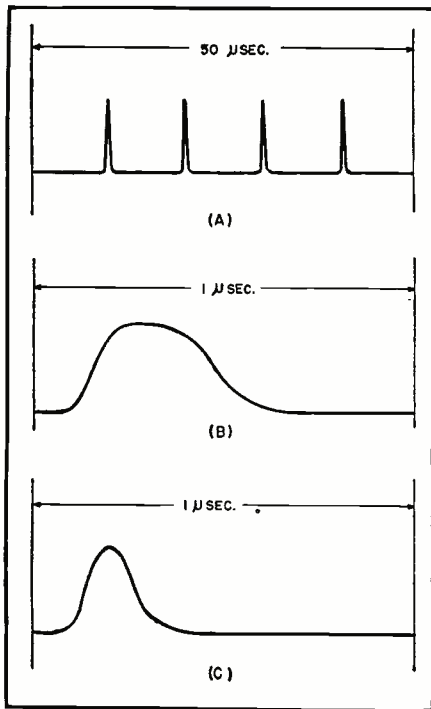

Fig. 5.

while the appearance of the pulse with minimum pulse width (other conditions the same) is given in Fig. 5C.

Delay Lines

As mentioned previously, a .25 microsecond delay was used to show the leading edges of the pulses shown in Figs. 5B and 5C. The necessity for such a delay can be seen by referring to Fig. 6.

Fig. 6.

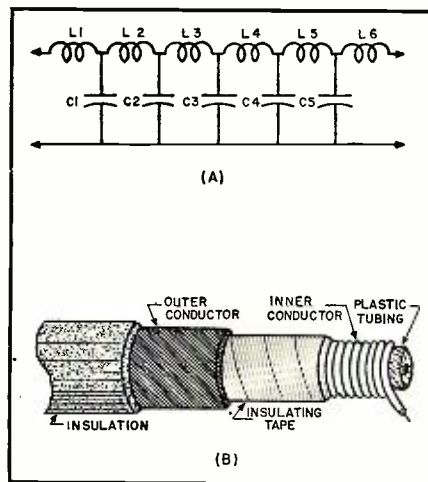
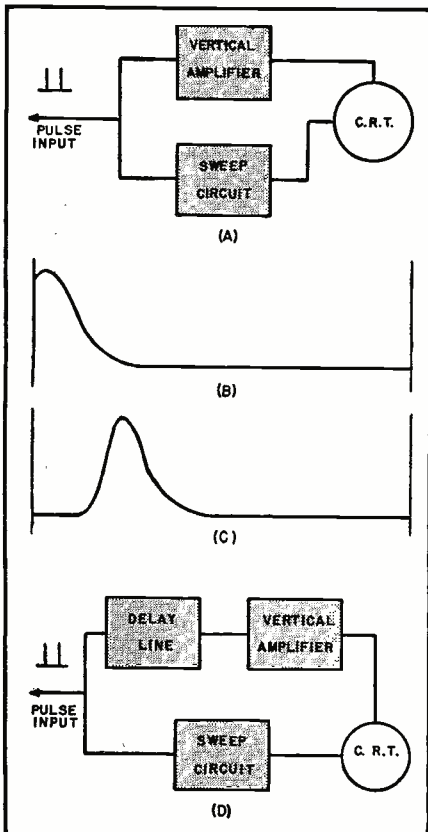

Fig. 7.

A simplified block diagram of an oscilloscope circuit is given in Fig. 6A. When a pulse is applied to the input, as shown, the sweep circuit is "triggered" as the pulse reaches a certain minimum value, and the sweep moves the electron beam across the screen, permitting the pulse passing through the vertical amplifier to be observed on the scope.

If the rise time of the pulse is short, then the leading edge of the pulse may be "lost" and the appearance of the pulse on the screen of the CRO is as shown in Fig. 6B. If it were possible to "delay" the pulse in the vertical amplifier until after the sweep starts, then the entire pulse becomes visible on the screen of the oscilloscope as shown in Fig. 6C.

In practice, this can be accomplished by introducing a "delay line" between the pulse input and the vertical amplifier (or between stages in the vertical amplifier) as shown in Fig. 6D.

The operation of such a "delay line" is comparatively simple. The "delay line" consists of a real or artificial "long" transmission line. The delay introduced in the signal is due to the time of transmission along the "long" line. The longer the line, the greater the delay.

Such lines may consist of "lumped parameters", i.e., inductances and condensers connected to simulate the electrical characteristics of a long line as shown in Fig. 7A, or of "distributed parameters," a long, thin inductance coil wound on a piece of plastic and

surrounded by a metallic braid to give capacity, as shown in Fig. 7B. The shielding braid of a commercial "distributed parameter delay line," as shown in Fig. 7B, is generally made up of insulated wire to reduce eddy current losses to a minimum.

Since the delay line is essentially a low-pass filter in form (see Fig. 7A), it may be expected to distort a complex signal waveform. This actually occurs in practice, and a delay line, in addition to introducing a delay in the signal, may also cause a "rounding" of sharp-cornered pulses. Thus, a sharp pulse applied to the input of such a line, as shown in Fig. 8A, may appear as shown in Fig. 8B in the output. This rounding is due to the loss of high frequency signal components in the line.

A certain amount of signal attenuation also occurs in delay lines. Nevertheless, even though attenuation and distortion of complex waveforms may be expected, delay lines must be used if pulses with a short rise time are to be observed on an oscilloscope using a triggered sweep.

Observation and Analysis

When sharp pulses are to be observed on an oscilloscope, a triggered sweep is almost mandatory, as is the use of "delay lines," if the leading edge of a single pulse is to be studied. In addition, the CRT should have a high accelerating voltage and high spot brightness if an extremely sharp pulse with a comparatively low repetition rate is to be observed.

Otherwise, the pulse may rise and fall so rapidly, compared to the time of sweep duration across the face of the tube, that the pulse "fades out completely."

Pulse repetition rate is generally given as the number of pulses-per-second, abbreviated PPS.

The *equivalent frequency* of a pulse may be determined by considering the pulse to be one-half a cycle of a signal, as in Fig. 9. The time of pulse duration (pulse width or T_p in Fig. 9) is equal to $\frac{1}{2}$ the time for a complete cycle (T_c in Fig. 9). Thus, if pulse width is given in microseconds, it is only necessary to multiply by 2 and divide the product into one million to obtain the equivalent frequency of the pulse in cps. A pulse having a width

(Continued on page 134)

Fig. 8.

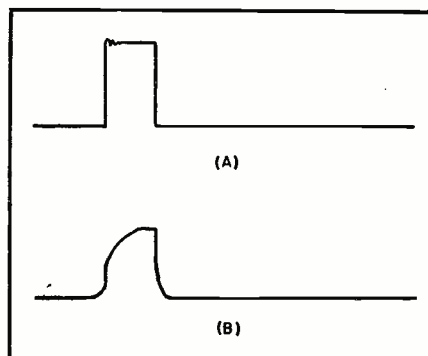
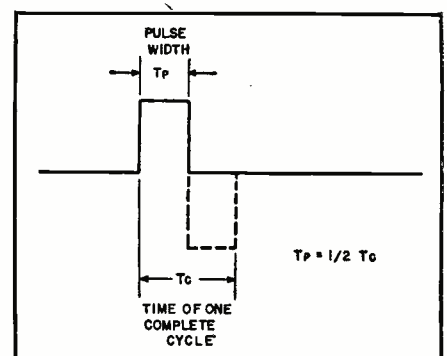

Fig. 9.



Simulating

A CBS COLOR SIGNAL

Original design or conversion work on color sets need not stop for lack of CBS signals. Equipment described, based on flying spot scanner, produces a suitable color test pattern in your lab or shop as required.



Fig. 1. Complete set-up of equipment used in color demonstration presented at the Radio Electronics School of New York.

By
MURRAY BARLOWE

Color Development Eng.
Tele-King Television Corp.

THE decision by the FCC to adopt the CBS color system was the spark that set off the biggest controversy that the radio-television field has experienced in years. An overwhelming demand for information about color television, both by the public and the technician, resulted. It was in response to this demand that the author, with the full cooperation of the staff of the *Radio Electronics School*, set up a series of public demonstrations and lectures on color television.

Since CBS was not transmitting color signals at the time, the problem was solved by constructing a "flying spot scanner" (Fig. 8) to take the place of the color camera.

Basically, the equipment consists of a high intensity CRT with its associated high voltage power supply and deflection circuits, a photoelectric pickup tube, and a high gain video amplifier. The picture to be transmitted is in the form of a transparency which is placed on the face of the CRT. The raster on the face of the CRT is produced by a rapidly moving spot of light. At any one instant, only one spot on the face of the CRT is giving off light. This spot of light passes through the transparency and falls on the photoelectric pickup tube. The phototube converts the light into an electrical voltage proportional to the intensity of the light. As the spot of light moves across the tube, the amount reaching the phototube will increase or decrease, depending upon the density of the different parts of the transparency.

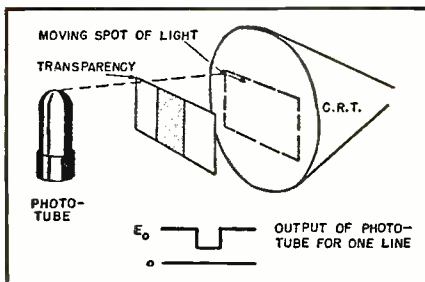

Fig. 2. Intensity of the light from the moving spot impinging on phototube, varies with any change in transparency density.

EDITOR'S NOTE: This setup was originally used as a closed-circuit system for demonstrating color television. From the ideas presented it is possible for manufacturers or service organizations who are doing work on color receivers to build a test unit so that work can continue even in the absence of on-the-air CBS signals. For additional details on constructing a flying spot scanner, see J. R. Popkin-Churman's article "Simplified Ham TV Station" appearing in the May, June, and July 1950 issues of this magazine.

As each line is scanned, a voltage is generated by the phototube which varies in amplitude directly as the light and dark variations on the transparency, Fig. 2. The output of the phototube is amplified and is the video signal containing all of the picture information. To adapt this principle to produce a color video signal, a color transparency is used in place of the black and white transparency and a color filter wheel is inserted between the transparency and the phototube. See Fig. 3. A simple color transparency, consisting of three vertical bands

of color, will be used in place of a full color picture in our analysis of how the system works. As the spot of light moves across the first line from left to right, a section of the color filter wheel moves between the transparency and the phototube. Assuming the first section to be a red filter, which will allow only red light to pass through, the output of the phototube will increase when the spot of light passes through the vertical red strip in the beginning of each line, as indicated in Figs. 4A and 4B. Each filter section of the color wheel will be between the transparency and the phototube for the time required for the light spot to scan an entire field. For a color signal conforming to the CBS standards, this time interval would be 1/144th of a second. During this interval, all of the red portions of a color image will pass through the color filter and produce a video signal representing the red image. At the start of the next field, the spot of light will be in the upper left hand corner and a blue section of the color wheel will now be coming into place. It will only allow the blue light to pass through and so the video signal produced during this field will repre-

Fig. 3. To obtain color signal, a color transparency and disc are inserted as shown.

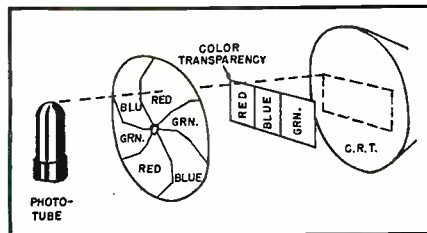

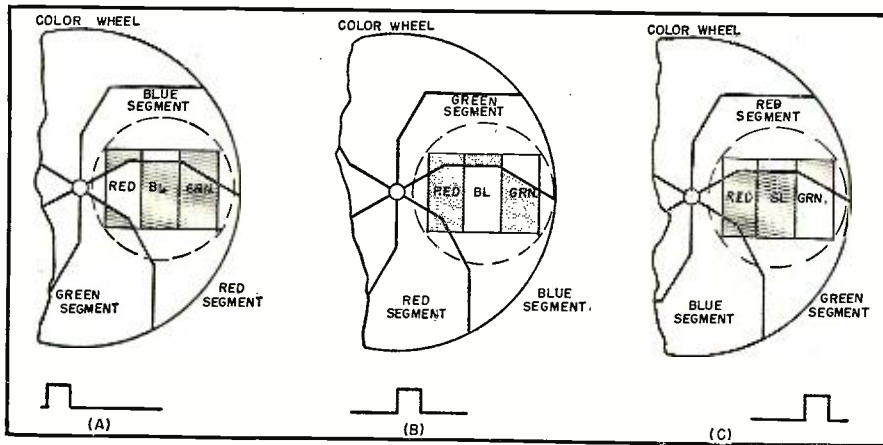

Fig. 4. Scanning sequence. Output of phototube is shown in (A) for red, (B) for blue, and (C) for green. Color disc rotates at a speed of 1440 revolutions per minute.

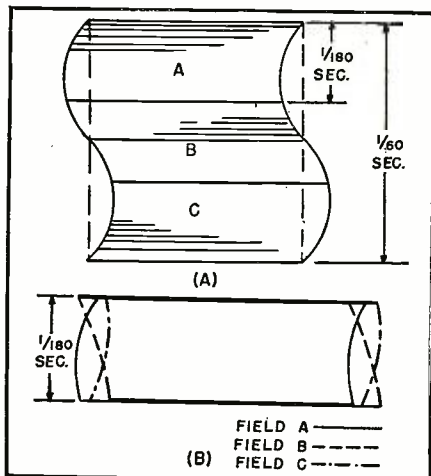

Fig. 5. Curvature caused by a 60-cycle magnetic field when operating at 180 field/sec.

Fig. 7. Over-all view of the color receiver used by author in his simulated CBS color system. The color wheel consists of twelve segments with every other segment opaque. The sequence is red color filter, opaque segment, blue filter, opaque segment, green filter, opaque segment, etc., with a total of six color filter segments and six opaque segments. In developing the shape of the color filter segments it was apparent that light from the CRT did not pass through every part of the wheel but rather through "half moon" shaped areas. Since this was the case, it was not necessary for the wheel to be entirely transparent. Balance weights and metal strips used for generating the reference sync pulse were mounted on the opaque or unused areas. Opaque segments were finally deemed unnecessary and eliminated on later models.

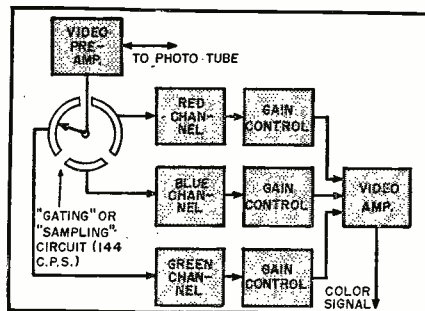
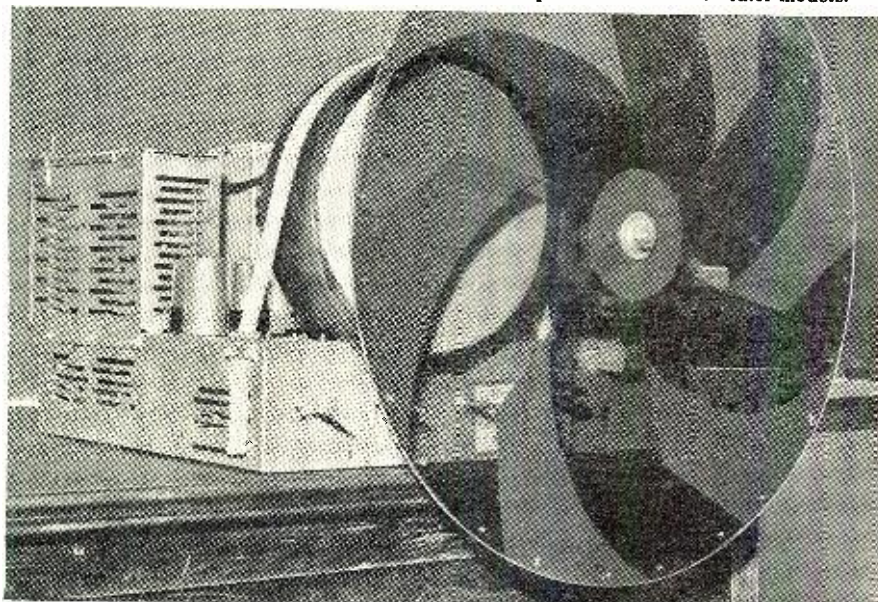

Fig. 6. Block diagram showing how gated circuit is used to select the proper channel.

sent the blue image. Next, the green filter comes into place and the process is repeated, producing the green video signal. In practice, a full color transparency takes the place of the three vertical color bars and the video sig-

nals produced during each field would have a more complex waveform.

The output of the video amplifier is applied to the grid of the CRT in a TV receiver.

Sync pulses from the sweep circuits of the flying spot scanner are used to synchronize the sweep circuits of the receiver. During each field a picture is produced on the face of the CRT which is a black and white version of the primary color image being scanned at the time. If we look at this black and white image during the red field through a red filter, we would see a true reproduction of the red information in the transparency. The red filter tints the black and white image to its correct color. By using a color filter wheel at the receiver similar to the one at the flying spot scanner, and having it rotate in synchronism, the full color images are first separated into their primary colors, transmitted as black and white versions of the primary colors, tinted by the color wheel at the receiver, and reproduced in full color.

In the CBS system, the color fields are scanned at the rate of 144 per second. A color wheel containing six color filter segments, two each of the three primary colors, is rotated at a speed of 1440 revolutions per minute by a synchronous motor. (Since 1440 rpm synchronous motors are not available, an 1800 rpm motor with a 4 to 5 speed reduction is used to obtain the required speed of 1440 rpm.) This is equivalent to 24 revolutions per second. Since there are six equal segments in the wheel, the time required for a single segment to pass a given point would be one sixth of a 24th of a second, or a 1/144th of a second. This is the time required for a single color field.

By using a horizontal sweep frequency of 29,160 cps, interlaced at 144 fields per second, a 405 line picture is produced.

More than the usual amount of power supply filtering was necessary. This is a problem that technicians making color conversions of transmitting or receiving equipment will have to contend with. In the present black and white system using 60 fields per second, hum in the horizontal deflection circuits could cause the vertical sides of the raster to have a slight curvature as illustrated in Figs. 9A and 9B. This hum may be due to magnetic fields (60 cycle) from the power transformer or to the 120 cycle ripple due to insufficient filtering in the power supply. This curvature is hardly noticeable when the vertical sweep frequency is 60 cps. At sweep frequencies of 144 or 180 per second, the visible effect becomes serious. Figs. 5A and 5B illustrate the effect (intentionally exaggerated) when the interference is from a 60 cycle magnetic field and the equipment is operating at 180 fields per second. Three fields would occur in the time previously required for one field. Superimposing the three fields, as they would appear on the face of the CRT, it becomes apparent that

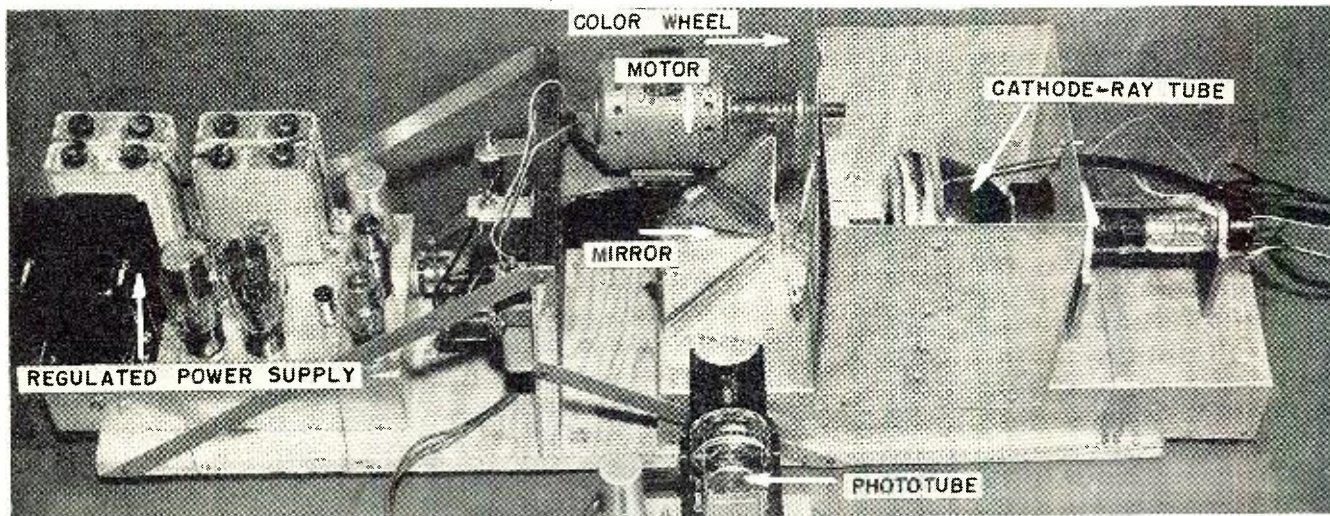

Fig. 8. Over-all view of flying spot scanner.

they are displaced with respect to each other. This makes it impossible for the three colors to "register" properly, producing a picture that is constantly shimmering, and one which has very poor detail.

To keep this from happening it is necessary to thoroughly filter the "B" supply, and protect the CRT against the influence of stray magnetic fields. A mu-metal shield around the picture tube and a heavy copper band around the power transformer are some of the possible solutions to the problem.

Color Balance

The spectral response of the 931A phototube used as the pickup device drops off rapidly at the red end of the spectrum. To correct this, a thin sheet of very lightly tinted red acetate was permanently fastened to the face of the CRT used in the flying spot scanner. This cut down the intensity of light of the colors other than red to compensate for the lack of sensitivity of the phototube to red. A better method might be to use two or more 931A phototubes feeding the video amplifier with a red color filter permanently mounted in front of one tube thus making it sensitive only to red light. This would boost the level of the video signal produced by the red image. Our equipment is presently being modified to include a "gating" circuit operating at the field frequency which will switch the output of the phototube to a separate video amplifier every time a different color filter segment of the color wheel comes into place (Fig. 6). This will connect the video signal output of the phototube to the red video amplifier for the duration of the red field. Immediately after the red field the signal is switched to the blue video amplifier for the duration of the blue field, and finally to the green video amplifier for the duration of the green field. By adjusting the gain of the video amplifier for each color channel, the relative amplitudes of the color signals can be properly balanced.

Synchronizing the System

Proper sync and phasing of the complete system is accomplished in the fol-



Fig. 9. An example of the curvature of the vertical edges of the raster caused by (A) 60 cycle and (B) 120 cycle interference.

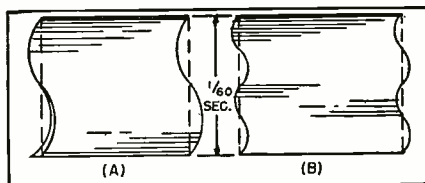
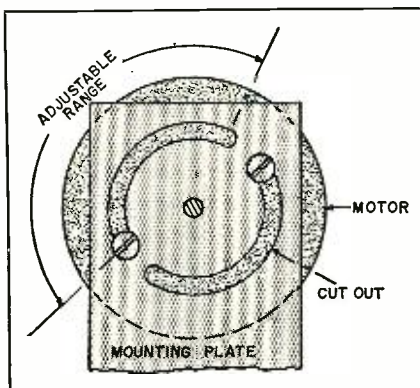

Fig. 10. Provision must be made for rotation of the motor in order to obtain the proper color phasing at the TV receiver.



lowing manner. Six thin pieces of soft iron are fastened along the outside edge of the color wheel at the flying spot scanner (Fig. 11). The pickup coil from a magnetic phonograph pickup is mounted close to the edge of the wheel. As the iron segments move past the pickup coil, a pulse is produced. Since there is a piece of iron for every

color segment, the output of the pickup coil will be a series of pulses at the field frequency. These pulses are used to synchronize the vertical sweep circuits and thereby control the timing of the entire system. A phase shifting network is connected between the magnetic pickup coil and the vertical sweep generator. By adjusting this control the start of each field can be varied with respect to the position of the color wheel. Once set, this control usually doesn't have to be readjusted, unless the position of the pickup coil is changed.

Color phasing at the receiver is accomplished by mounting the motor which rotates the color wheel so that it can be rotated through approximately 160 degrees, as illustrated in Fig. 10. The motor is rotated until the segment of the color test pattern marked "blue" becomes blue.

-50-

Fig. 11. Mechanical details of synchronizing system. Six pieces of soft iron are fastened to outside edge of color disc.

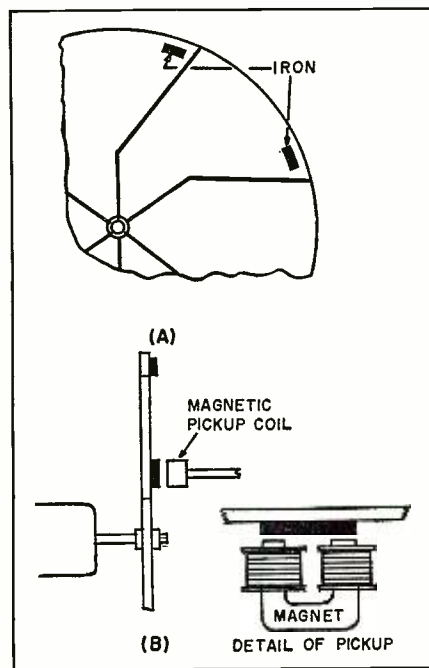

A NEW FM COMMUNICATIONS TUNER

By
WOODROW SMITH
Chief Eng., Gonset Co.

Compactness of this new
FM communications tuner
facilitates mounting under
dash or on steering post.

▼ HERE are many applications in the rapidly-growing public safety radio services (police, fire, civilian defense), in land transportation radio services (taxicabs, etc.), and in industrial radio services (power, petroleum, etc.) in which the performance of an expensive communications-type FM receiver exceeds requirements and the price exceeds budget limitations. In addition, there are some applications, such as civilian defense, where it is desirable to be able to tune the receiver to two or more stations.

The recently-announced *Gonset* FM communications tuners are designed to provide, in conjunction with an ordinary automobile or house radio or p.a. amplifier, an inexpensive, tunable FM receiver for monitoring applications in which image and adjacent channel interference problems are not unusually severe. Sensitivity approaches that of the more expensive FM mobile communications receivers. Adjacent channel selectivity and image rejection are only fair, as would be expected in a low cost receiver of this type, but in many localities this is not a problem or is a problem in thickly populated areas only when receiving certain channels. If image response should prove troublesome on a desired channel in a certain area, it usually can be corrected by having the i.f. changed at the factory to a frequency slightly higher or lower than the standard 10.7 mc. frequency.

The tuner shown in the photographs measures just 3 $\frac{3}{8}$ inches by 5 $\frac{1}{8}$ inches by 5 $\frac{1}{4}$ inches deep over-all and mounts on the steering post or under the dash in mobile applications. Models covering the 30-40, 40-50, 152-162, and 162-

174 megacycle bands are available at the present time.

An 88-108 mc. version for FM broadcast reception has been produced in limited quantity but will be produced in volume if the demand warrants. The prototype of the 88-108 mc. broadcast version was demonstrated to a representative of the FCC at their request in 1949, in order to determine the commercial feasibility of mobile reception of FM broadcasts on such a tuner. While the report has not been made public, it may be said that the reaction was favorable as regards over-all performance. Consistent, program-quality reception has been obtained in flat country at distances well over 100 miles from Mt. Wilson (California) stations and well over 50 miles from stations of more modest elevation.

The schematic of the Model 152-162 is shown in Fig. 1. Other models are similar except for slight changes in the front end, which employs a 12AT7 tube in all models. Two stages of 10.7 mc. i.f. are followed by a combination limiter and semi-squelch stage which provides additional gain. Screen voltage, instead of being taken from a conventional divider, is obtained from a high value of dropping resistor. On all except weak signals, the drop in plate current resulting from grid excitation with grid leak bias causes a substantial increase in screen voltage, thus "opening up" the limiter and providing

increased gain on signals strong enough to provide complete quieting. Above a critical value of signal input to the limiter, the screen voltage no longer increases, thus providing the instantaneous a.v.c. action inherent in a conventional limiter.

In addition to eliminating a separate tube, thus minimizing size and cost, this form of semi-squelch avoids the possibility of missing weak signals which might not trigger the squelch on a conventional receiver on which the squelch is set too "tight" or a tube has become weak.

With the a.f. gain control adjusted to give normal volume on moderately strong signals, the squelch action in this system is sufficient to drop the no-signal background noise to a level that is not annoying although audible. Weak signals still can be heard, although it may be necessary to advance the volume control for greater intelligibility. Warning of an inoperative receiver is given immediately by a complete lack of background noise, a feature that would not be obtained with complete squelch.

Exhaustive tests with various demodulator circuits, including a ratio detector and a 6BN6 gated beam tube, indicates the superiority of the limiter plus conventional discriminator arrangement for this particular application. Maintenance of proper discriminator adjustment requires only

This compact, well-designed tuner covers v.h.f. FM bands. It can be attached to auto receiver for mobile use or home receiver for fixed station use.

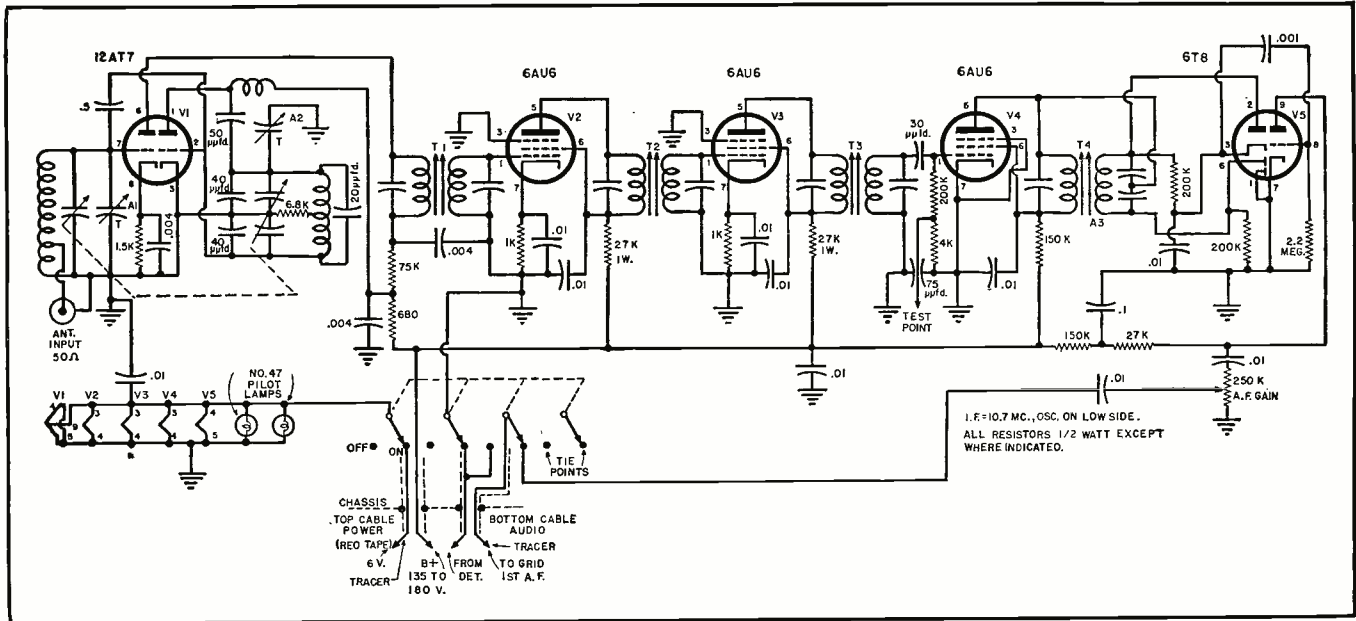

Fig. 1. Schematic diagram of the Gonset FM communications tuner covering 152-162 megacycles. Models covering other frequency ranges are similar except for minor variations in front end circuitry and component values.

occasional adjustment of the secondary trimmer for minimum background noise with no station tuned in.

To insure adequate over-all gain even with receivers having low audio gain, a single stage of audio is provided in the tuner by employing a 6T8 for both discriminator and a.f. voltage amplifier functions. The gain of this stage is deliberately held down because the full potential gain of the triode section would never be required.

Power for the tuner is taken from the receiver (other than an a.c.-d.c. type) or a.c. amplifier with which the tuner is used. The stability of the oscillator is such that no voltage regulator tube is required. Because of this and by means of careful design, the "B" drain has been held to less than 15 ma. at the plate voltages typically employed. Experience in the manufacture of amateur converters over many years has shown that this amount of additional current may be taken from any well-designed automobile receiver without significantly shortening vibrator life or endangering other power supply components.

Use of a grounded cathode oscillator with negative compensation minimizes warm-up drift and it should not be necessary to "zero in" a station more than once after a cold start. The overall stability of the tuner is such that once a station is logged carefully on the fine increments of the 0-100 scale, the tuner can then be reset at any time to the desired station with the assurance that if the station comes on it is sure to be heard (if within range) even though it may be necessary to touch up the tuning slightly in order to get the station "zeroed in" properly. It was ascertained early in the development of the tuner that any tunable receiver which did not have sufficient stability and "resetability" to assure the operator that he would be certain to hear the station when it came on would be

worthless for monitoring communication channels which transmit only intermittently.

A quarter-wave whip antenna of the type employed by police and taxicab services, available from the larger radio parts houses, is connected to the tuner by means of RG-58/U coaxial line. For 30-40 and 40-50 mc. work the whip is mounted on the rear bumper for mobile applications and on the top of the car for 152-162 and 162-174 mc. applications. If the whip is cut to resonate about 3 mc. inside the low end

of the band to be covered, the whole band can then be covered with negligible variation in performance.

A test point is provided on the rear lip of the chassis to permit reading the limiter grid current. This permits use of the tuner-receiver combination as a relative-reading field strength meter for making coverage surveys or for use in making adjustments to a transmitting antenna. It also facilitates adjustment of the r.f. (antenna) trimmer to the optimum setting for the particular receiving antenna employed. —50—

Tuner utilizes miniature components and dual purpose tubes to conserve space. Although the chassis is compact, careful parts placement has precluded undue crowding.

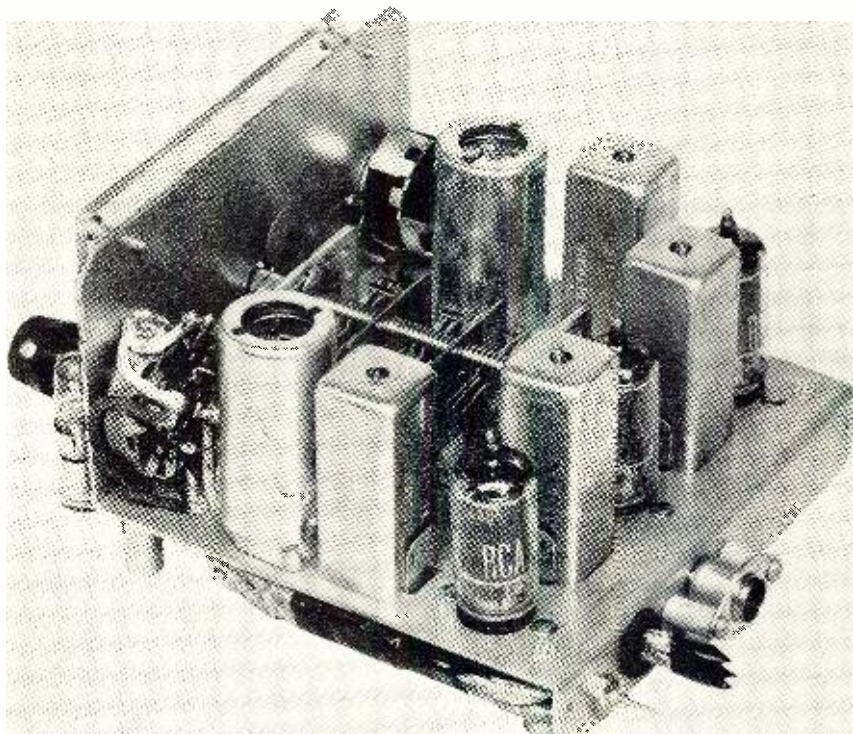



Built-in bookcases and cabinets offer excellent facilities for housing custom audio equipment. In this installation speaker is mounted in upper section of bookcase and is not visible.

By

DAVID FIDELMAN

Part I. An introduction to the various problems which must be considered when designing or setting up any reproducing system. Future articles will cover the application of these basic principles in the actual design of audio equipment.

URING the past few years, many people have begun to realize that their enjoyment of speech and music reproduction can be greatly increased when the program material is faithfully reproduced without appreciable distortion. Until a few years ago, only a relatively small group paid any attention to the quality of the sound which was being produced by their radios, phonographs, and amplifiers. These few were generally audio engineers or technicians whose specialization in the field of sound reproduction had taught them the advantages and increased enjoyment to be gained from good reproduction. The majority of listeners were quite satisfied with the quality of reproduction which could be obtained from small table-model receivers with no appreciable low-frequency reproduction, or from large consoles with very little output above about 4000 or 5000 cycles-per-second.

Since the end of the war, there has been a great increase in public interest in good reproduction of sound, and today every music lover and record collector is anxious to obtain the best reproduction he can get. Now the average layman who is interested in good sound quality can, with relatively little difficulty and expense, have a reproducing system which will compare very favorably with the best that could be built before the war. With the increased programming of classical and

light-classical orchestral music in AM and FM radio broadcasting, on records, and in concert halls everywhere, the general public has had a greater opportunity than before to listen and compare good with bad reproduction. This opportunity to listen and compare has probably been the major reason for the increasing interest in good reproduction among discriminating listeners.

Among those interested in good audio are many amateur experimenters—and many engineers and technicians who are not experts in audio—who would like to construct or set up their own sound reproduction systems, and want to take the opportunity to determine for themselves which type of sound reproduction they prefer. This series of articles is intended for these experimenters and is designed to provide some of the information and techniques which are, at the present time, known only to the audio specialist, and to help them attain sufficient background in audio to experiment on their own initiative.

From the engineering and scientific point of view, there are two different problems involved in sound reproduction. One is to develop and perfect equipment which will produce the best sound at the lowest cost. The other is a much more basic and fundamental problem—to discover what good sound reproduction actually is. Almost since the earliest days when it was possible

to reproduce the human voice and music with reasonable accuracy, the question arose as to what was most to be desired in the reproduction of sound, and what basis to use for judging the results. This question has been the subject of many experiments which attempt to obtain quantitative data that would represent the quality of reproduction. Closely tied in with this is the additional question of whether to attempt to improve on what may be faults in the original sound.

Any such tests always start with the human ear as the fundamental measuring instrument. The results depend upon statistics obtained from a large number of average listeners, with the preference of the greatest number of listeners representing the best type of reproduction. This is perfectly logical and reasonable, since public acceptance is the ultimate criterion. Earliest measurements tended to indicate that the average listener preferred reproduction having a restricted frequency range, rather than wide-range reproduction. This result was offered as an explanation as to why most radio receivers in the home are found to have the tone-control knob set for minimum high-frequency response, and seemed to justify the manufacturers who designed their receivers with practically no response above 5000 cycles. (However, this inference does not agree with other known facts. Experience has shown that when the tonal quality of a musical instrument does not completely satisfy public taste, it is gradually changed to make it more acceptable. Modern instruments have reached their present form and remain as they are because this is how they are preferred, since they could readily have been changed if it were desired.)

Improved listener-preference tests in

which only the frequency range was changed, *with all other factors kept constant*, show that in the absence of other disturbing factors the listener prefers the widest frequency range in reproduction of sound. These findings confirm the opinion that the best type of sound reproduction is that in which the listener hears, as nearly as possible, an exact reproduction of the original sound, and that it should not be "improved" by the reproduction system.

Close observation of the results of the various listener-preference tests shows that frequency-range is only one of the important factors in the reproduction of sound. Several other factors are involved, some of them considerably more important than frequency range in determining the acceptability and fidelity of reproduction. These other factors are the various forms of *distortion* which may occur in the reproduction process. Distortion is any difference between the reproduced and the original sound. Restricted frequency range in reproduction is one form of distortion, but there are also several others which may occur. The following list includes all the types of distortion which are at present known to have an important effect on the quality of the reproduced sound:

- (a) Frequency-amplitude distortion
- (b) Reproduction noise
- (c) Harmonic distortion
- (d) Intermodulation distortion
- (e) Transient distortion
- (f) Phase distortion
- (g) Frequency modulation distortion (wow and flutter)

These distortions occur within the electronic system, and are capable of measurement and analysis. However, there are certain other fundamental limitations which are present in any attempt to reproduce sound, and might properly be called *acoustic* distortions:

- (h) Differences in acoustics between the room in which the sound originates and the room in which it is reproduced
- (i) Spatial distribution effects
- (j) Limited dynamic range in reproduction

The acoustic distortions are not strictly defects of the audio system, since they are inherent in any attempt to reproduce sound from one place to another.

At one time the main criterion of good reproduction was thought to be the width of the frequency range. The "high-fidelity" enthusiast would, for example, judge the excellence of a phonograph system by the amount of high-frequency needle scratch he could hear. Thus, the more high-frequency noise and record scratch, the better the quality of reproduction! This type of judgment has by now become more or less obsolete, since it is now pretty well realized that for true high-fidelity reproduction all other forms of distortion must also be eliminated and the original sound reproduced as accurately as possible in all respects. Some of the other distortions are much more distasteful to the ear than loss of high

and low frequencies, and when they are present the listener usually prefers the restricted frequency range which reduces their effects. (This explains the results of the earliest tests in which listeners were found to prefer narrow-band reproduction, since in these tests no attempts were made to remove the various distortions which are related to the frequency range.)

The noise introduced by the reproducing system is generally the most obvious form of distortion, and must be kept as low as possible, both because it limits the dynamic range and because of its disagreeable quality. The highest noise level is usually found in the reproduction of phonograph records, due to the record scratch introduced by the surface of the disc. Other parts of a high-quality system should introduce practically no noise.

Harmonic and intermodulation distortion are extremely important factors in most of the equipment in current use. These distortions occur whenever the amplifier is not perfectly linear (that is, the output is not perfectly proportional to the input signal). This "non-linearity" gives rise to spurious harmonics which are not present in the original signal, and causes modulation of the high frequencies by the low-frequency components. It is usually the intermodulation rather than the harmonic distortion which is responsible for the disagreeable quality when a system is overloaded, since the intermodulation products contain frequencies which are generally discordant with the original sounds. At the present time these are perhaps the most important and troublesome forms of distortion since when they are high they tend to mask other distortions because their effects are more unpleasant.

When the noise and distortion of the system are within the limits required for good reproduction, then the various other forms of distortion are not masked and become important. It has been found that two systems with identical frequency and non-linear distortion characteristics may often sound quite different when they are used to reproduce speech or music. This generally occurs when one of the systems has good transient response, and the other has poor transient response. Very few natural sounds (including speech and music) are sustained for any long period of time—the various components generally occurring in bursts of short duration. This can easily be observed by watching an oscilloscope trace (swept at about 20 to 50 times per second) and noticing how the various components are constantly being generated and disappearing. It is, therefore, extremely important that for good reproduction the entire system must have good transient as well as steady-state characteristics, and should have no undamped vibrations which will appear for a dynamic signal and produce undesired hangover that distorts the effect of the sound. This is an important factor which is

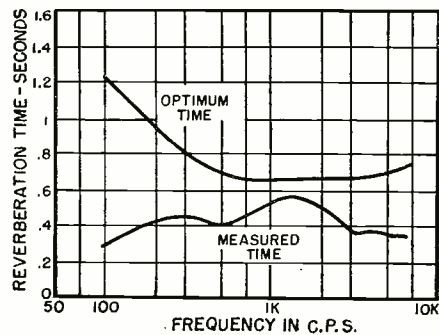

Fig. 1. Optimum and measured reverberation time as a function of frequency for the living room of average home.

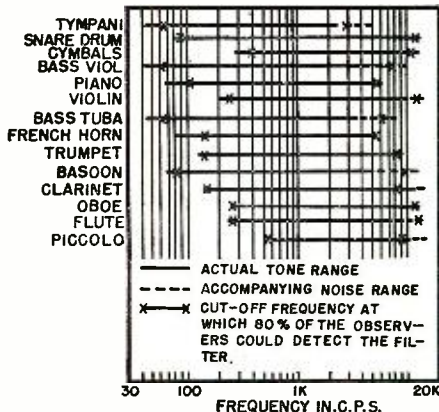
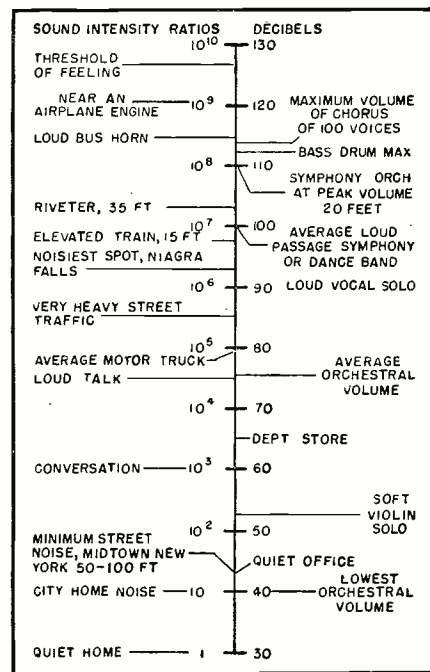

Fig. 2. Audible frequency ranges of various musical and percussion instruments.

generally overlooked by many experimenters and technicians who are not sufficiently familiar with the requirements of good reproduction.

When sound is reproduced from disc or magnetic recordings the frequency of the output sound is determined by the relative speeds of the recording and reproducing drive motors. When these motors do not run at absolutely constant speed, there is heard a *flutter*

Fig. 3. Noise levels in various locations.



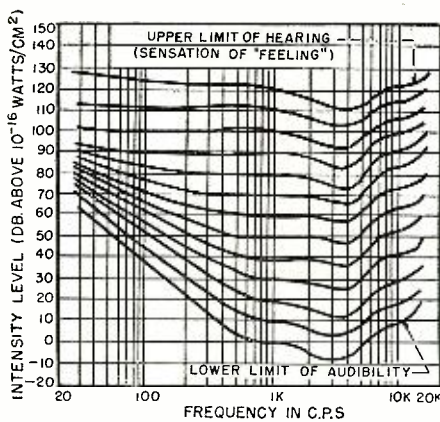

Fig. 4. Equal loudness contours showing intensity levels at various frequencies required to produce effect of equal loudness.

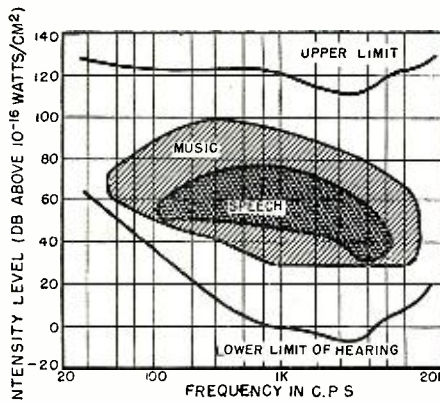

Fig. 5. Curves showing the frequency and volume ranges of both music and speech.

or *wow* in the frequency of the reproduced sound which is quite annoying and serious. These effects are apparent in the reproduction of sustained steady tones, where variations in pitch can be most easily detected. Such speed variations can also be heard in the reproduction of percussive tones in disc recordings, where the sharp transients impose very heavy loads upon the driving motor and may cause it to change speed due to this variation in load.

The results of the listener-preference tests show that the various electronic distortions must be kept down to inaudible or barely audible levels for good reproduction. However, the situation is different in the case of the acoustic distortions, since many psychological factors enter into the ques-

tion of listening to sound in a location different from where it originates. Since listening to the sound of a full orchestra in the average living room is completely different from listening to it in the concert hall, the listener may feel free to go in for considerable experimentation to decide which type of reproduction he prefers for himself. Dynamic range may be increased by the use of volume expanders. Experiments to correct for the difference in spatial distribution of the sound may be performed by several methods which have been tried for obtaining stereophonic reproduction. The reverberation and absorption of sounds of different frequencies can also be controlled by changing the absorptive and reverberant properties of the room, and by means of artificial reverberation systems.

Although the psychological factors involved in the transfer of sound to a new location are often a matter of individual preference, the most logical procedure is to try to make the final effect upon the ear as much as possible like that obtained from the same sound in the location where it originates. The best way to do this can be seen by glancing at some of the curves shown in Figs. 4 and 5.

Normally, the sound heard from an orchestra in the concert hall is considerably louder than is practical for the average listener to obtain from his loudspeaker in the home—especially if he lives close to his neighbors or in an apartment house. However, the ear does not have the same response for different acoustic levels, therefore some compensation must be made for this difference. Fig. 4 shows the effect of the intensity level at various frequencies on the ear. Each curve shows the intensity at different frequencies to give the effect of a certain loudness. A loudness level of 80 to 100 db is heard almost uniformly over the entire audio range, but a frequency of 60 cycles has to be heard at a 60 db level to have the same loudness as 1000 cycles at a 20 db level. Thus there should be considerable bass boost when listening at normal home levels to give the same effect as the actual orchestra's performance.

The physical systems which exist at the present time for the reproduction of sound are, unfortunately, not capa-

ble of producing without distortion all the sounds which are required from them. This may be better understood when it is realized that vacuum tube amplifiers are not strictly linear in their response, sometimes cannot be used over the complete frequency range, and can be overloaded. In addition, the electromechanical components of the system, particularly the loudspeaker, are required to duplicate at one time all the sounds which can be produced by every instrument in a large orchestra—which is by no means a simple achievement. Therefore some compromise must be made between the requirement of perfect fidelity of reproduction and the physical limitations of the reproducing system.

The electronically generated distortions must always be kept to an absolute minimum (except in the case of the intentionally introduced frequency-amplitude distortions, such as "tone controls"). There are practically no occasions where it would be desirable to accept such distortions as intermodulation, for example, and these distortions are permitted only to the extent that it is a physical impossibility to eliminate them entirely.

By proper design and setup of the system these distortions can be kept below the level at which their effects can be detected by the average listener. Tests and experience have indicated certain distortion levels which may be accepted as the requirements for good reproduction, and the extent to which a system meets these requirements may be considered a measure of the quality of reproduction.

Complete reproduction of all the fundamentals and harmonics which are present in the music produced by a symphony orchestra would require a frequency range of approximately 20-14,000 cycles. However, for almost all practical purposes a frequency range of 40-10,000 cycles with satisfactory distortion characteristics has been found quite acceptable to about 90 percent of the listeners to all types of speech and music. While such a reduction of bandwidth will remove some of the highest frequencies present in the original sound, this difference cannot be detected by large numbers of listeners even on the basis of direct comparison, and is in general felt to be not objectionable.

For a system of good quality the noise and hum level should be of the order of 50 to 60 decibels below full output, whereas the noise level from a phonograph record will generally not be better than about 35 to 40 db below peak signal.

At one time it was believed that 5 percent total harmonic distortion was acceptable in a high-quality system, but today it is felt that this figure is too high (especially in amplifiers using beam-power tubes or pentodes, since 5 percent total harmonic distortion from them appears to be much more objectionable than 5 percent from triodes).

(Continued on page 135)

Table 1. Acceptable limits of various electronic distortions and the type of signal which can be used to detect these distortions.

RESPONSE OR DISTORTION BEING MEASURED	TYPE OF SIGNAL WITH WHICH MEASURED	ACCEPTABLE LIMITS	
		GOOD REPRODUCTION	ACCEPTABLE REPRODUCTION
Frequency Response	Steady sine wave	20-14,000 cps	40-10,000 cps
Noise Level	Zero	-60 db below full output	-50 db below full output
Harmonic Distortion	Steady sine wave	2% total harmonics	2-8% total harmonics
Intermodulation Distortion	Sum of high freq. and low freq. steady sine waves	5%	10%
Transient Response	Square wave or tone burst	No set standards	
Wow and Flutter	Steady sine wave	0.1%	1%

NEW TV COMPONENTS

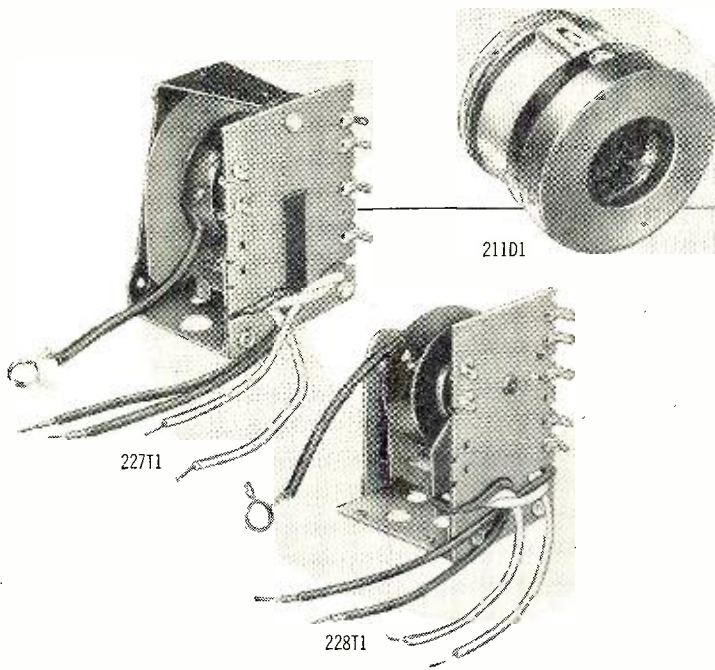

Electrostatically focused tubes will become more popular as shortages of copper and cobalt increase. Here are details on several new parts and their circuitry to be used with these tubes.

THE Tube Department of Radio Corporation of America has recently introduced three new television components which are of particular interest to the service industry. They are of interest in view of the fact that they will be included in many of the television receivers released in the future.

In addition, these components can, in many cases, be used where it is desired to convert receivers from small picture tube operation to large tube sizes.

The 227T1 and the 228T1 horizontal deflection output and high voltage transformers shown in the photographs

above will provide high voltage of 14,000 volts (227T1) and 16,000 volts (228T1). They are designed to be used with any *electrostatic focus* picture tube having a horizontal deflection angle of about 66 degrees. Note particularly that the above refers to *electrostatic focus* picture tubes and not the more common magnetic focus tubes.

Electrostatic focus picture tubes are not too readily available as yet, however, they are in production and will, no doubt, become quite popular in future video receiver designs.

With these tubes the magnetic focus coil is eliminated entirely and in its place a potential of from 3000 to 5000

volts, obtained from an additional rectifier tube, is used on the picture tube for focusing. This technique is in line with the government's conservation of materials program. The more critical the supply of copper wire and cobalt becomes, the sooner sets using the electrostatic focus tubes will hit the market.

Utilizing a ferrite core for high efficiency operation, light weight, and compactness, each of these transformers is designed for use with a single 6BQ6GT horizontal deflection amplifier tube; a single rectifier tube, such as the 1B3GT, for the high voltage supply; a single rectifier tube, like the 1V2, for the focusing voltage supply; the RCA 209R1 horizontal linearity control; the 6W4GT damper diode tube; and the RCA 209D1 or the 211D1 magnetic deflecting yokes which also have ferrite cores.

Both of these new units have two
(Continued on page 136)

Fig. 1. Circuit diagram of the horizontal oscillator and deflection and high voltage system using the 227T1. 14,000 volts is obtained.

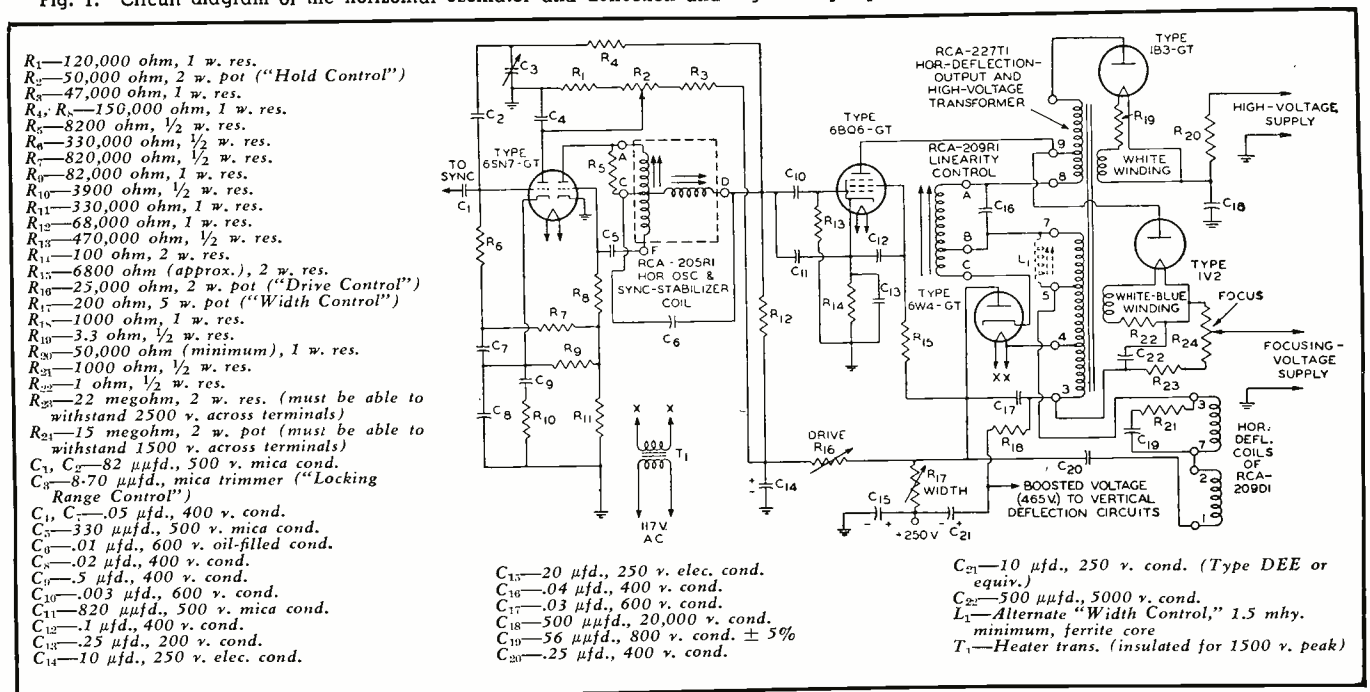

A Miniature H-F Portable TRANSMITTER- RECEIVER

By

M. KIRCHHOFF,
W2FAR

Columbia Broadcasting System
and

D. D. BULKLEY,
W2QUJ

International Telephone & Telegraph Corp.

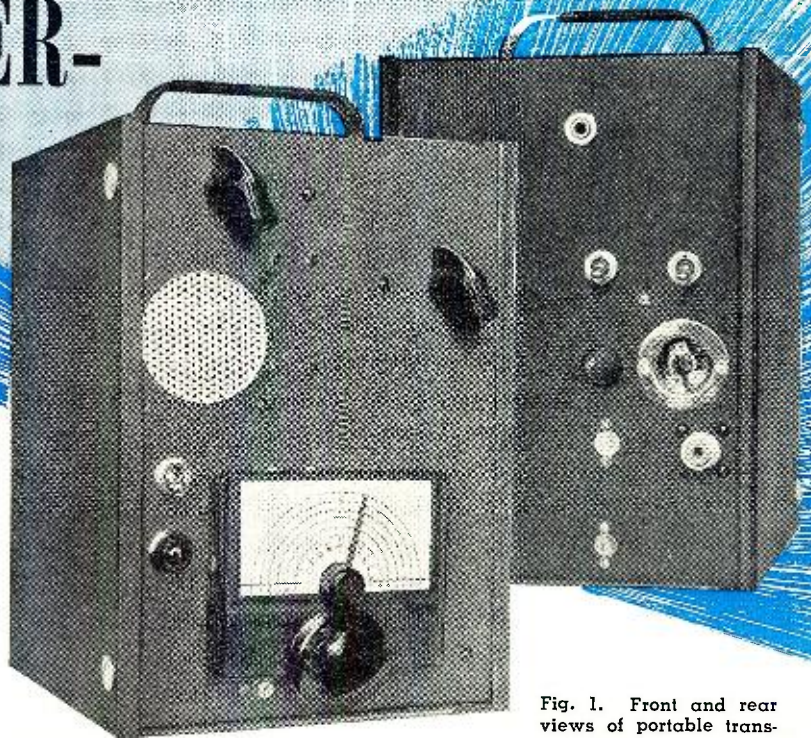

Fig. 1. Front and rear views of portable transmitter-receiver. In the

front view the audio gain control is located at the upper left while the i.f. gain control is seen in upper right-hand portion of photo. The b.f.o. switch is mounted below speaker. The rear view shows toggle switch (left) which operates filaments and the right-hand switch which controls plate voltage. Mike jack is near top of unit.

CIVIL DEFENSE activities are taking a more important position in the life of every citizen of our nation today. For the amateur, with his background of technical know-how and operating ability, it is an opportunity to participate in a new phase of his hobby wherein he may perform a real service for his community.

In every local and regional Civil Defense Network, numerous small, dependable, easily-transportable stations are needed which may be set up with a minimum of delay and effort. These portable communication units, in the event of an emergency, are invaluable for relaying information from the scene of the disaster to outlying control stations.

The transmitter-receiver described here provides this communication facility and still retains flexibility which will allow its application to many other low-power high frequency amateur activities.

A dependable and efficient unit, this high frequency companion to "A 2 Meter Transmitter-Receiver for Civil Defense Operation" described in the August, 1951 issue of RADIO & TELEVISION NEWS meets all requirements demanded of Civil Defense communication equipment. It is contained in a small metal cabinet 9½ inches high, 7 inches wide, and 6½ inches deep, and weighs less than 12 pounds. Although the "Miracle Miniature" is designed for 117 volt operation, power consumption is low. A miniature vibrator power converter unit such as the "Travellectric" may be utilized for operation away from 117 volt supply lines. The "Travellectric" provides an output of 110 volts, 60 cycles at 40 watts, from any six-volt storage battery. This is ample power to operate the transmit-

Complete construction details for building a compact unit for portable, mobile, or emergency operations.

ter and receiver for portable, mobile, or emergency operations.

The equipment consists of a seven tube, single conversion superheterodyne which provides stable and selective reception in all amateur phone bands from 3 to 30 megacycles, and a two-stage, 25 watt, crystal-controlled transmitter with its associated modulator. Both transmitter and receiver utilize miniature tubes and components. Although certain parts utilized in building this equipment were surplus items, readily available commercial equivalents may be substituted where surplus parts are not obtainable.

The receiver consists of a mixer, three 455 kc. i.f. amplifier stages, a second detector, b.f.o., one audio stage, and a beam power output stage which drives a self-contained two-inch loudspeaker.

Two midget plug-in coils are used for each band. The mixer-grid tank condenser is set at the middle of the band in use, and the oscillator is tuned, providing single dial tuning. An i.f. as well as an audio gain control is included to eliminate overloading of the

second detector on strong local signals. The b.f.o. operation is provided for reception of c.w. signals. A simple b.f.o. arrangement is used. Its application is described later.

An r.f. stage was omitted to simplify coil design and to eliminate serious tracking problems.

The transmitter consists of a modified Pierce crystal oscillator driving two parallel 6AQ5 r.f. amplifier tubes. Should one amplifier tube fail during a critical operating period the transmitter will operate with the remaining tube. This arrangement also permits power reduction (through removal of one amplifier tube) where transmission conditions do not demand full power output or when operating away from 117 volt a.c. mains. Use of one final amplifier tube when operating this equipment from the miniature vibrator power supply insures that the power rating of the vibrator supply will not be exceeded.

The first stage of the modulator is a low-impedance, grounded-grid triode. Although this stage provides no appreciable amplification, it eliminates the

necessity of a microphone transformer as well as the necessity for microphone voltage. The input stage feeds a single speech amplifier which drives a pair of push-pull 6AQ5's as modulators. These tubes adequately modulate the final amplifier whether one or two r.f. tubes are used.

As this transmitter was designed for voice operation, only the 75, 20, and 10 meter phone bands were provided. No keying facilities were incorporated, but if c.w. operation is desired the transmitter cathode circuits may be re-routed to ground through a key.

The power supply utilizes a highly efficient voltage doubling selenium rectifier circuit. Simple and compact, it is adequately stable for application in this equipment. If the feature of having the chassis above ground is undesirable, an inexpensive isolation transformer may be used in the 117 volt power input line.

Chassis Layout

Referring to Fig. 2, the receiver may be seen on the left-hand side of the photograph, and the transmitter on the right. The power supply is in the center portion of the photograph.

The equipment is mounted in the handy metal cabinet formerly housing the surplus ARR-1 u.h.f. test oscillator. This cabinet has two "snaplock" side covers. Removal of the right-hand "snaplock" cover reveals the vacuum tubes, plug-in coils, etc., while removal

of the left "snaplock" cover allows access to the under-chassis and wiring. A carrying handle on the top of the cabinet provides convenient transportability. The antenna output terminates in a coaxial fitting which is mounted on the rear of the cabinet.

The receiver line-up starts at the bottom left-hand side in Fig. 2 where the 6BE6 mixer stage will be found. The mixer grid tank condenser may be seen diagonally to the right of the mixer tube. This condenser is provided with screwdriver adjustment. The mixer feeds three stages of i.f. amplification utilizing 6BA6's. Next in order is a 6AV6 second detector/audio amplifier. The triode section of this tube is used as the first audio amplifier which drives the 6AK6 beam power output stage. A two-inch permanent magnet loudspeaker, mounted on the front panel, delivers ample audio output under ordinary conditions. For reception of c.w. signals, a b.f.o. stage with a type 6C4 is used. This stage is located directly to the right of the third i.f. amplifier tube. The two midget receiver plug-in coils may be seen in the lower left hand corner, one below and the other to the right of the mixer tube.

The transmitter tube line-up starts in the lower right-hand corner of Fig. 2 where a type 6AQ5 modified Pierce crystal oscillator may be seen. This drives the final amplifier which consists of two 6AQ5's in parallel for 75, 20, and 10 meter output. As mentioned

previously, only one 6AQ5 is used when less than full power output is required. For emergency operation this is necessary for the conservation of battery power and to assure operation within the output rating of the miniature vibrator power supply. The two midget transmitter plug-in coils are located at the left of the oscillator tube and at the left of the amplifier tube.

The type 6C4 grounded-grid microphone input stage will be found at the upper right corner of Fig. 2. This stage is followed by a type 6C4 speech amplifier. The speech amplifier drives a pair of push-pull 6AQ5's as modulators. The modulation transformer is seen in the photograph directly below the 6AQ5 modulator tubes while the driver transformer for the 6AQ5's is directly above them.

The power supply will be seen in the center of Fig. 2. The large condenser can is a dual 40 μ fd. with sections in parallel to provide a completely hum-free filter circuit. The two smaller cans directly above the filter are single 40 μ fd. units used in the voltage doubling circuit. It is necessary to insulate C_{50} (Fig. 4) from the chassis or the power supply will be shorted to ground. The selenium rectifier stacks are mounted beneath the chassis; they may be seen in Fig. 3. Above the two voltage doubling condensers appears a three section condenser used for bypassing in the audio cathode circuits and a small can containing the cathode

Fig. 2. Top view of chassis. Removal of the right "snaplock" side cover reveals the vacuum tubes and coils while removal of the left "snap lock" cover permits access to under-chassis.

Fig. 3. Bottom view. Note the antenna changeover relay next to filament transformer at bottom of photograph. The b.f.o. assembly can be seen alongside the output transformer at the top.

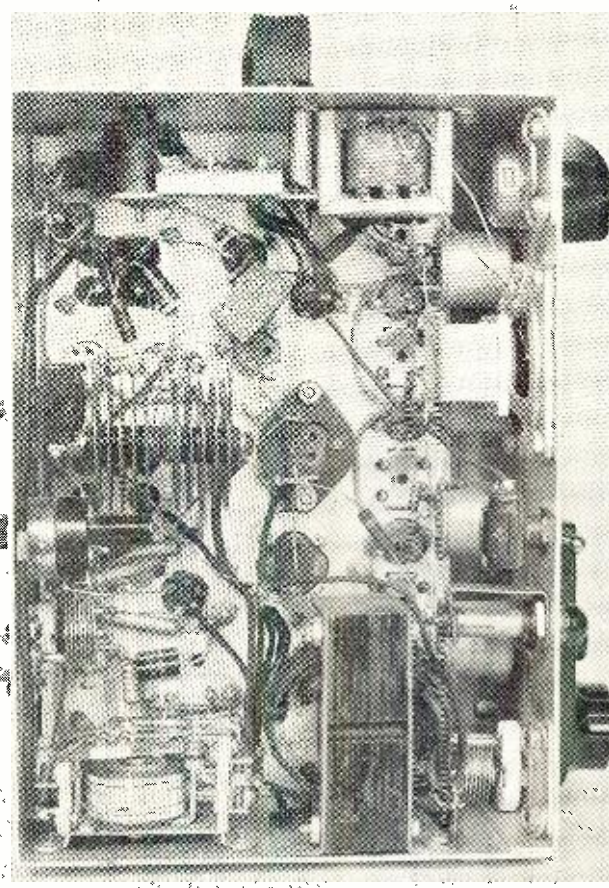
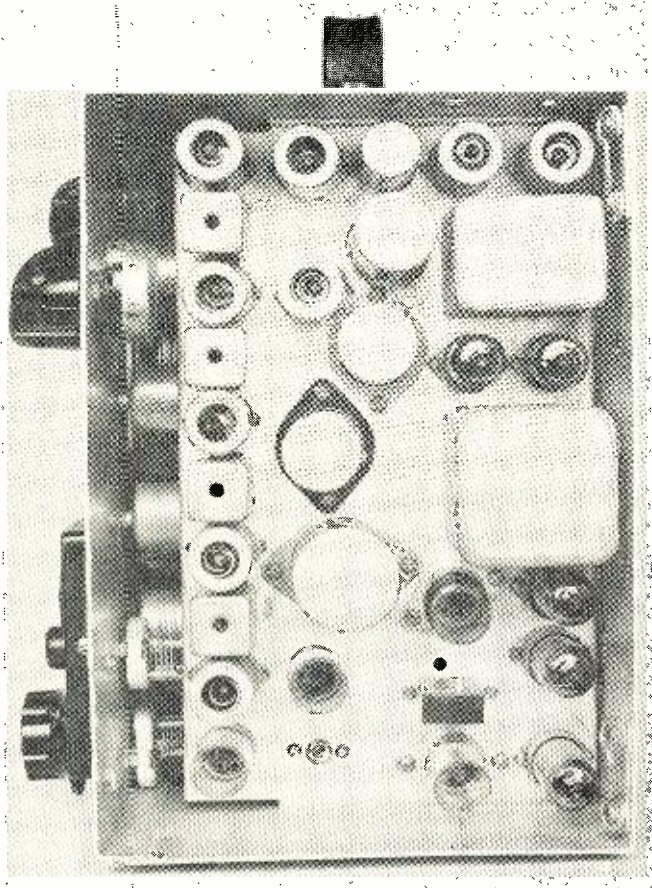

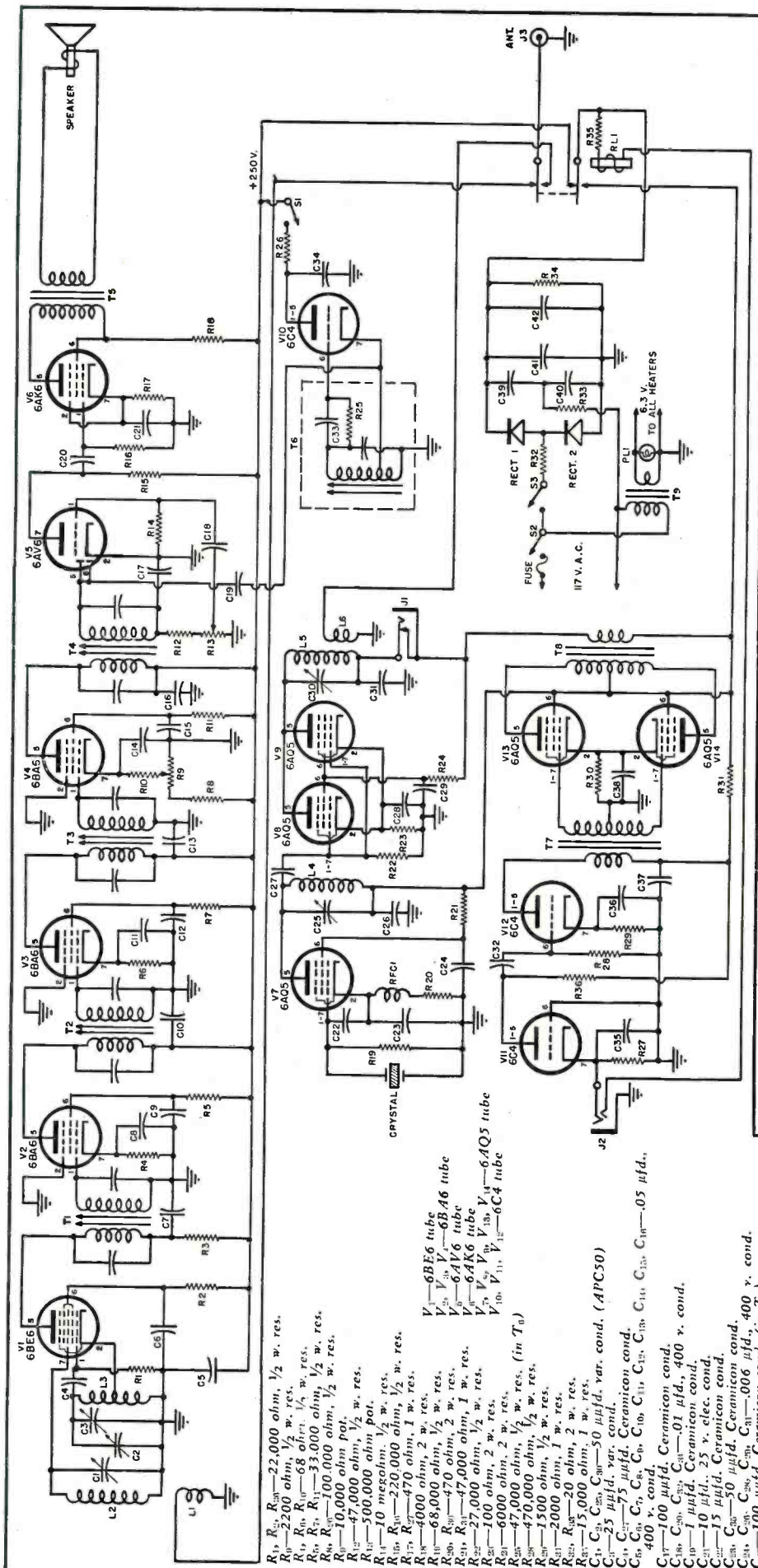

bypass for the receiver audio output stage.

Construction

The equipment is constructed with care given to physical layout to provide short connections. This eliminates the possibility of forming v.h.f. oscillatory circuits which may cause annoying spurious emissions.

All bypass condensers should be mounted directly to the point being bypassed or as close to it as possible. This is particularly true with the receiver i.f. stages as they provide high gain and, if bypassed improperly, will oscillate.

Screwdriver adjustment is provided for all but the most necessary tuning controls. This precludes the possibility of knocking either the transmitter or receiver out of adjustment when working in the field.

A unique antenna and power change-over relay circuit is utilized. In order to maintain low power consumption it would not be practicable to utilize the conventional type of relay as this would consume excessive current. Therefore, an *Advance* type 1003B relay with a 10,000 ohm, 115 volt d.c. coil is employed. R_{35} provides the necessary voltage drop to operate the 115 volt d.c. coil of the relay. With this coil less than 10 milliamperes of current is drawn. A microphone switch actuates R_{L1} , transferring the antenna as well as power supply voltages from the receiver to the transmitter. This switch may be of the press-to-talk variety incorporated as an integral part of the microphone or it may be mounted on the front panel of the equipment. The former method is recommended for the sake of operating convenience.

In order to permit employment of a standard b.f.o. transformer without encountering space difficulties, the b.f.o. assembly was removed from its shield can. It was then mounted in the cabinet as shown in the upper left-hand corner of Fig. 3.

▲ a midget multi-match modulation

Fig. 4. Complete circuit diagram of compact, high-frequency transmitter-receiver unit.

- R_{11} , R_{12} , R_{13} —22,000 ohm, 1/2 w. res.
- R_{14} —2200 ohm, 1/2 w. res.
- R_{15} , R_{16} , R_{17} —68 ohm, 1/2 w. res.
- R_{18} , R_{19} , R_{20} —33,000 ohm, 1/2 w. res.
- R_{21} , R_{22} , R_{23} —100,000 ohm, 1/2 w. res.
- R_{24} —10,000 ohm pot, 1/2 w. res.
- R_{25} —47,000 ohm, 1/2 w. res.
- R_{26} —500,000 ohm, 1/2 w. res.
- R_{27} —10 megohm, 1/2 w. res.
- R_{28} , R_{29} —220,000 ohm, 1/2 w. res.
- R_{30} —4000 ohm, 1/2 w. res.
- R_{31} —68,000 ohm, 1/2 w. res.
- R_{32} —470 ohm, 1/2 w. res.
- R_{33} —47,000 ohm, 1 w. res.
- R_{34} —27,000 ohm, 1/2 w. res.
- R_{35} —100 ohm, 2 w. res.
- R_{36} —6000 ohm, 2 w. res.
- R_{37} —47,000 ohm, 1/2 w. res.
- R_{38} —1500 ohm, 1/2 w. res.
- R_{39} —2000 ohm, 1 w. res.
- R_{40} , R_{41} , R_{42} —15,000 ohm, 1 w. res.
- R_{43} —20 ohm, 2 w. res.
- R_{44} , R_{45} , R_{46} —50 μ fd. var. cond. (APC50)
- C_1 , C_2 , C_3 —75 μ fd. Ceramicon cond.
- C_4 , C_5 , C_6 , C_7 , C_8 , C_9 , C_{10} , C_{11} , C_{12} , C_{13} , C_{14} , C_{15} , C_{16} , C_{17} —0.5 μ fd., 400 v. cond.
- C_{18} , C_{19} , C_{20} , C_{21} —0.1 μ fd., 400 v. cond.
- C_{22} —1 μ fd. Ceramicon cond.
- C_{23} —10 μ fd., 25 v. elec. cond.
- C_{24} —15 μ fd. Ceramicon cond.
- C_{25} , C_{26} , C_{27} , C_{28} , C_{29} , C_{30} , C_{31} —0.06 μ fd., 400 v. cond.
- C_{32} —100 μ fd. Ceramicon cond.
- C_{33} , C_{34} , C_{35} —20,20/20 μ fd., 350/350/25 v. elec. cond.
- C_{36} , C_{37} —40 μ fd., 350 v. elec. cond.
- C_{38} , C_{39} —40/40 μ fd., 350 v. elec. cond.
- R_{FC} —2.5 mh. r.f. choke
- RL_1 —D.p.d.t. relay, 10,000 ohm coil (*Advance* Type 1003B—see text)
- PL_1 —6.3 v. pilot light
- Fuse—1 amp. fuse (3AG)
- S_1 , S_2 , S_3 —S.p.s.t. toggle sw.
- Rect.—Rect.—200 ma. selenium rectifier
- J_1 —Closed circuit jack (must be insulated from chassis)
- J_2 —3-conductor jack
- J_3 —Coaxial connector
- T_1 —Permanent magnet (any size)
- Crystal—See Table I
- T_2 , T_3 —455 kc. i.f. trans. (Miller Type 12-C1)
- T_4 —455 kc. i.f. trans. (Miller Type 12-C2)
- T_5 —Output trans. (Stancor A3856)
- T_6 —B.j.o. trans. (Any 455 kc. trans. will give satisfactory results—see text)
- T_7 —Input trans. (Stancor A4721. Use primary tap combination to give 10,000 ohm impedance)
- T_8 —Mod. trans. (Stancor A3891. Use 10,000 ohm tap combination on primary and 4000 to 5000 ohm tap on secondary)
- T_9 —Fil. trans., 6.3 v. @ 5 amps

transformer is used. Primary taps are chosen to give 10,000 ohms impedance and secondary taps to provide 4000 ohms impedance.

Operation

The i.f. alignment may be accomplished using standard procedures with a 455 kc. signal source, although tuning each i.f. transformer for maximum noise will give satisfactory results.

Receiver r.f. alignment is best accomplished with a grid dip oscillator. If coils are wound to the exact specifications outlined in Table 2 no difficulty will be experienced in r.f. alignment. The 75 meter band should be aligned first as it is the simplest of the three. The appropriate coils are placed in their sockets and the grid dip oscillator is adjusted to a frequency in the center of the desired band. Holding the grid dip oscillator close to L_2 , tune C_1 with a screwdriver for a dip in the meter reading. The r.f. section of the mixer is now adjusted for the center of the band. Indicate the condenser setting by placing a spot of colored pencil (each band to have a different color) on the chassis to facilitate resetting the mixer r.f. condenser when changing bands. It is not necessary to change the tuning of this condenser unless bands are changed. The grid dip oscillator is next used as a field strength meter so the grid dip oscillator plate switch should be turned off. The frequency is then set approximately 455 kilocycles higher or lower than the original or mixer frequency. With the bandspread condenser C_2 half-meshed the oscillator padding condenser C_3 is tuned with a screwdriver until maximum reading is obtained with the test instrument held near L_3 . This indicates proper tuning of the oscillator and mixer for the center of the band. Calibration of C_3 and the main tuning dial may now be effected using a signal generator or other accurate signal source.

The aforementioned operations are then repeated for each of the other bands.

Initial transmitter tuning should be done with a grid dip oscillator to make certain that the stage is tuned to the correct frequency or harmonic. Changing bands may then be accomplished readily with the use of a 1/2 watt neon bulb to indicate resonance.

For most efficient operation, the chart in Table 1 indicates the recommended manner of operation for each stage. Refer to this chart before tuning the transmitter.

It might be well to note at this point that an overtone crystal should not be used. The modified Pierce circuit will not operate with anything but a fundamental cut crystal.

With appropriate crystal and coils in the transmitter, set the grid dip oscillator at the crystal oscillator stage output frequency (as noted in Table 1) and hold it near L_1 . Tune the crystal oscillator tank condenser with a screwdriver for maximum output. The condenser setting should then be noted on



Fig. 5. Midget plug-in coils provide full coverage of the 75, 20, and 10 meter bands.

CRYSTAL OUTPUT	CRYSTAL OSCILLATOR OUTPUT	FINAL AMPLIFIER OUTPUT
75 meters	75 meters	75 meters
80 meters	40 meters	20 meters
40 meters	20 meters	10 meters

Table 1. Recommended transmitter operation for the miniature transmitter-receiver.

the chassis with a spot of colored pencil to enable approximate resetting when changing bands. Next, set the grid dip oscillator on the output frequency as indicated in Table 1. Holding the instrument near L_5 , tune C_{30} with a screwdriver until a maximum reading is again noted on the meter. The condenser setting should be indicated on the chassis with colored pencil as was done in the case of the crystal oscillator. The transmitter is now in resonance for one band. The two remaining bands may be tuned in the same fashion.

With an antenna connected to the equipment and a milliammeter plugged into J_1 the antenna coupling (L_6) is adjusted for optimum output. When operating mobile or portable, using a miniature vibrator power source, the final amplifier should not be loaded to a current greater than 35 milliamperes. A half-wave dipole fed with 72 ohm line or a folded dipole fed with 300 ohm line provides the best antenna match. However, any random length of wire will provide satisfactory local communication.

It is probable that results would be improved somewhat if an antenna tuner were used with wires of random length as this would permit the optimum loading and probably result in better over-all performance.

Tuners that would serve satisfac-

torily have been described in many magazine articles, or may be found in the amateur handbooks.

Another possibility that would permit the feeding of almost any piece of wire is the use of the Collins system.

The final tank circuit of the transmitter may be readily converted to this system by using parallel feed on the final, and substituting a 250 μ fd. midget variable for C_{31} . The rotor plates of C_{30} should be returned to ground in this case, with the connection to the antenna made to the bottom end of the final tank coil L_5 . Tuning of this type of network is covered in the amateur handbooks.

Operation with this unique and serviceable transmitter-receiver has given very satisfying results. Although the equipment was designed for short-range operation, exceptional signal reports have been received on all bands. Considerable distances have been covered using the simplest type of antenna installation.

This transmitter-receiver combination is an excellent adjunct to the high power station. Extremely compact and easily portable, the "Miracle Miniature" is an attractive package, not only for use in Civil Defense and emergency operations, but also for Field Day or summer vacation "hamming" away from home.

-50-

Table 2. Complete specifications for winding the plug-in coils for portable unit.

	75 METERS	20 METERS	10 METERS
L_1	12 t. #28 en.	6 t. #24 en.	3 t. #24 en.
L_2	55 t. #28 en.	15 t. #24 en.	7 t. #24 en.
L_3	44 t. #24 en., tap 7 t. from gnd. end	10 t. #24 en., tap 3 t. from gnd. end	4 t. #24 en., tap 1 t. from gnd. end
L_4	44 t. #24 en.	25 t. #24 en.	12 t. #24 en.
L_5	42 t. #24 en.	9 t. #24 en.	5 t. #18 en.
L_6	8 t. #24 en.	4 t. #24 en.	3 t. #18 en.

Notes: All coils are closewound on Amphenol 3/4" dia. Type 24-5H coil forms.

L_1 is spaced 1/4" from L_2
 L_6 is spaced 1/4" from L_5 (see text)

TRIPLE YOUR PHONE POWER For Five Dollars

By
FRED F. EVERETT
WOYTY

Simplified version of an old idea—a low level peak clipper which can be used with any ham transmitter.

THE following is not a particularly new idea, but rather a simplified version of an old one. Yes, it's simplified and it works! As seen from the schematic diagram, the idea is a shunt-type, low-level peak clipper and associated filter. The simplification evolves from the use of crystal diode rectifiers and a simple capacitive roll-off filter. The writer has previously shied away from speech clippers, even with their known advantages, mainly because of the rather elaborate sharp cut-off filters believed necessary. Recent articles and experiments have led to considerable doubt as to the need for such sharp cut-off filters, hence it was decided to try the simplest type—a straight capacitive bypass to ground in conjunction with a simple shunt peak clipper. Before continuing, it is pointed out that the circuit as shown has been thoroughly tested for narrow bandwidth, effective increase in modulation level, distortion, etc., in the writer's 100 watt, 10 and 20 meter amateur transmitter, with gratifying results. Local and distant contacts are unanimous in the effectiveness of the clipper.

A few words of caution before trying this, or any other low-level clipper circuit, are in order. The audio stages AFTER the clipper stage must be first rate, with good response, low distortion, and low phase shift, if maximum benefit of peak clipping is to be ob-

tained. This requirement is particularly demanding of audio transformers, so it behooves one to use resistance coupling where possible, to use good driver and modulation transformers, and to use tubes of adequate capacity to prevent overloading at clipping levels. Technical reasons and theory for this are published in various manuals and will not be detailed here, but to sum up: First, if low frequency phase shift is present, and it will be, the flat tops of the clipped wave peaks will be slanted, or canted, to a degree depending upon the amount of phase shift present. The more the cant of the flat top, the greater the output level of the clipper stage must be reduced to prevent overmodulation on peaks. Second, the more the distortion following the clipper stage, the wider the bandwidth taken up by the transmitter output, regardless of the efficiency of the clipper filter constants. Third, if your driver and/or modulator stage is working at maximum peak power output before clipping, there obviously will not be enough audio power available to faithfully reproduce the flat, clipped waveform output from the clipper stage. If you must compromise on any of these basic requirements, expect a similar compromise on the results obtained. If you must compromise on all of them, unsatisfactory results will be obtained with any type of low-level clipping circuit.

While the schematic of the circuit is more or less self-explanatory, a few points should be emphasized. It will be noted that a .0005 μ fd. condenser is used at the input of the clipper stage. There are two primary reasons for using such a small size condenser, the first of which is to reduce the bass response to the clipper and following stages, since that bogey, phase shift, will be most troublesome at the lower audio frequencies. In addition, since the capacitive roll-off filter gives an increasing attenuation above 3000 cycles per second, a reduction in bass response is necessary to prevent bassy sounding modulation. The value chosen, in conjunction with the roll-off constants used, seems to give good balance for the average male voice. In regard to the .003 μ fd. filter, the writer used a .003 μ fd. paper condenser, paralleled by a .0008 μ fd. mica condenser which, in addition to giving the desired audio roll-off, makes the circuit relatively insensitive to r.f., a very desirable condition, need it be said.

The cathode of the first rectifier is biased to about 2 volts positive which is also applied to the plate of the second rectifier. Therefore, it is necessary to apply about 4 volts positive potential to the cathode of the second rectifier as shown. This value of bias will cause clipping and limiting of both positive and negative peaks to about 2 volts maximum. The 25 μ fd. bypass condenser from the cathode of the second rectifier to ground was found necessary for good flat top waveform on both peaks and should not be omitted.

It was found that the addition of loading across the output of the clipper, such as too low a value of grid resistor on the following stage, led to an uneven clipping level on positive and negative peaks. Likewise, variations in the crystal rectifiers were found to cause uneven clipping, but this was corrected where it developed by slight adjustment of the bias voltage on one or the other of the crystals. If matched crystals are used (1N35), and reasonable care in handling and soldering (don't overheat the crystals) is exercised, the voltage divider values given will result in well balanced clipping.

The circuit is easy to adjust for the desired amount of clipping and percentage of modulation if the input voltage is adequate and if the audio gain following the clipper is designed for a minimum input of about 2 volts peak. In making the adjustments, it

(Continued on page 94)

Schematic diagram of low level peak clipper. The input coupling condenser and the gain control should be standard values. A .1 μ fd. and $\frac{1}{2}$ megohm pot are customary.

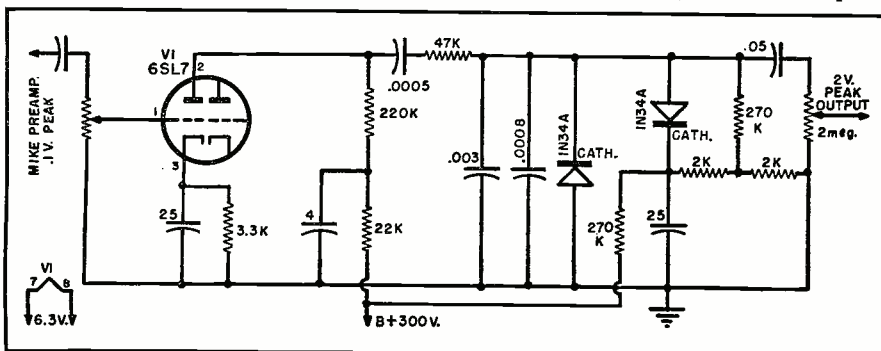



Over-all view of the headquarters stations of the Military Amateur Radio System (MARS) for the Army and Air Force, located in the Pentagon in Washington. Inset shows Sgt. Eugene Mendoza, U.S. Army Signal Corps, MARS operator, receiving message traffic from Cpl. Mary Lafler, receptionist. All personal message traffic is logged and assigned message number by receptionist.

MARS' PENTAGON

HEADQUARTERS

THE contributions of amateur radio to national defense and public service are nowhere more in evidence than in the Military Amateur Radio System. MARS is a joint Army-Air Force project designed to: Create interest and further training in amateur radio; coordinate practices and procedures of amateur radio operations with those of military radio communications; and provide an additional source of trained radio communications personnel in the event of a local or national emergency.

The Headquarters stations for Army and Air Force MARS are housed in a single building, specially constructed on the concourse of the Pentagon, Washington, D. C. The custom installation was built by *Transmitter Equipment Manufacturing Company*, according to MARS specifications. Engineered by Al Hart (W3AX), WAR and AIR (military call signs of K4USA and K4AF, respectively) are geared to serve the present needs of amateur radio, but are planned so as to be adaptable to flexibility requirements of modern warfare and modern defense.

Each station has a 1000 watt transmitter and associated equipment, a master console, and two individual operating (QSO) booths.

Two equipment racks, one on either side of the transmitter, are mounted into the wall in each of the master control rooms.

Rack 1 contains an antenna multi-coupler, a *Magnecord* recorder and control panel, a beam control panel, transmitter control panel, and a BC 221 frequency meter. Rack 2 contains a *Hallcrafters* S-36A receiver, a *Hammarlund* SP 600JX receiver, patching panel, *Collins* 32-V1, and a *Plex-10* (expander compressor) amplifier.

The Master Control consists of a nine-position, two-channel audio mixing amplifier capable of utilizing inputs from microphones, turntables, remote lines and recorders; two *Collins* 75-A receivers, each with its own "Pandaptor"; a *Collins* 32-V2, used as driver for the local transmitter; single sideband selector which may be used with either of the receivers; and a control panel with controls providing beam rotation and indication, speaker selection, speaker volume control, transmitter control, remote control of tape recorder; and associated items such as "mike" receptacles, plug receptacles for keys, etc.

-30-

MARS' new, custom-built installation is geared to serve present amateur radio needs, yet it can be easily adapted to meet the flexibility requirements of modern warfare and defense.

Cpl. Lafler patches a keying line from the local transmitter (center bank) into an adjoining studio at headquarters station.

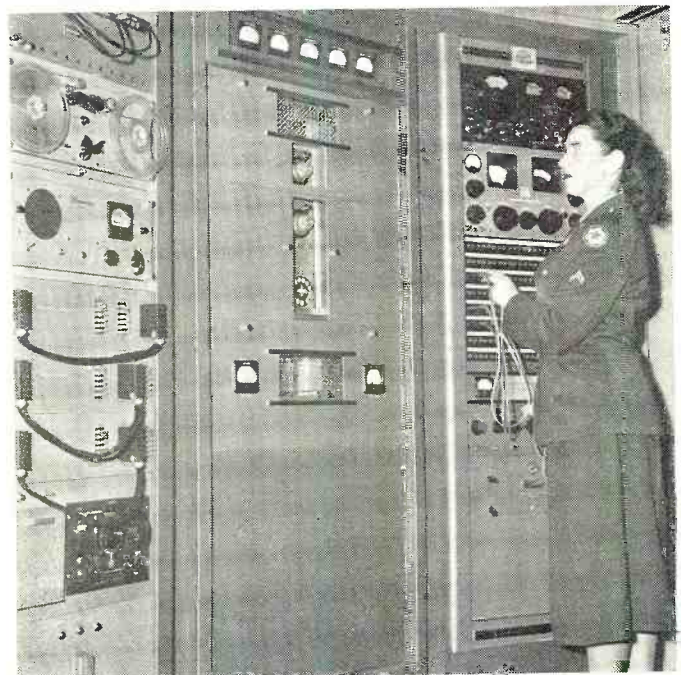

Proportional RADIO CONTROL



By
HOWARD G. McENTEE,
W2SI

This 55" span plane carries the proportional equipment. Power is .199 cu. in. engine. A vertical antenna works well in this case.

Construction details on the radio control equipment for a model airplane. Precision flying is possible with this novel, 50 mc. transmitter and control unit.

RADIO control of remote objects, particularly model airplanes, has increased by leaps and bounds since 1945, but even today, with all the radio control activity, most builders stick to the rubber-driven magnetic escapement to operate their model control surfaces. While the escapement is simple and reliable, it has several drawbacks, one of which is that the control is an "all or nothing" proposition (some escapements allow a halfway position, although not many modelers make use of it)—you either have neutral or "hard over." Also, of course, there is the disadvantage of remembering the escapement sequence; it must be stepped from neutral to right, back to neutral, to left, then back to neutral, right again, and so on.

While many hundreds of model plane fliers have mastered the escapement and flown beautifully with it, some of them have wished for something more flexible—a system, for example, where you could get a little right rudder, lots of left, then a little left, etc.—in other words, right or left rudder in any desired degree, and not in any predetermined sequence. Well, there is such a system. It's called proportional control, and the action is simply that the controlled surface exactly follows the movement of the ground station control stick. If you hold the stick at center, the plane rudder will remain neutral; move the stick a little to the left and the rudder follows; push it way over to the left and the rudder flaps over to its limit. It hardly needs to be pointed out that this allows real precision flying. This smooth and accurate control is appreciated when you are trying your hand at "aerobatics."

You can have all this and it isn't too difficult either. The main equipment difference between escapement control surface operation and proportional control is that a motor driven control box is required at the transmitter, and a special device is needed to move the rudder or other control surface in the airplane. The radio link, that is, the transmitting and receiving equipment are the same in either case, and proportional control can be adapted to almost any existing radio control system. Even the motor-driven ground control box might not be included as an extra requirement in the shift from escapement to proportional control; many advanced fliers are already using what is generally called a "beep box" for their escapement operation. This unit is a "motor-driven memory" which automatically counts out pulses to the escapement. It still doesn't allow the infinite variation of control positions as does proportional operation, however.

A control system, affording an ap-

proach to proportional action, was described in the August, 1950 issue of RADIO & TELEVISION NEWS. The author pointed out that his system would give right or left rudder at will, and the rudder could be held in neutral or any other position as desired. This arrangement could be advanced to true proportional control by a simple addition to the rudder drive, and by changing the transmitter pulsing system so that the length of "on-signal" to "off-signal" pulses might be varied at will. One extreme would be a steady signal and the other no signal, while neutral would be pulses and spaces of equal length as in the arrangement referred to above. A simple motor-driven pulser similar to that outlined in Fig. 1 would do the trick. Pushing the control lever full right or left would give full rudder motor speed in either direction; placing the stick at any intermediate point between neutral and hard-over would give various slower speeds of rudder motor action.

To change over to true proportional action, the rudder motor and gear train require the addition of a pair of springs, so arranged that as the rudder moves farther away from neutral in either direction, the spring pressure tending to push the arm back to neutral increases. (It's best to have no worm gears in the train, as the back pressure causes a binding action.) When the springs are properly tensioned this system will give you real

Fig. 1. Simple motor-driven pulser.

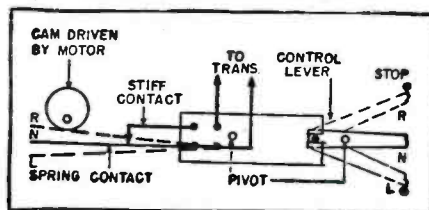

proportional control. Move the stick a little left and hold it there—the rudder will move a little left and stop, returning to neutral when you center the stick. The springs can be set so that the rudder follows the stick very closely.

The motor-driven and geared down rudder-operating unit has been used successfully by several experimenters with proportional control. In fact, Jim Walker, who holds several patents on proportional equipment, won the Radio Control event at the Nationals in 1946 with a geared-down motor drive rudder control, and almost repeated again in 1947. However, a much simpler and lighter control unit for model airplanes was developed by George Trammel, who used it with great success at the 1948 Nationals. George calls his development simply an "actuator." It can be likened to a permanent magnet motor without a commutator. For ease of construction, the position of magnet and winding is usually reversed, so that the rotor is a magnet and the winding is placed on the stationary field core. Such a gadget will turn about 180° with a complete reversal of current direction. Its action is naturally much faster than that of a geared-down motor, and although its power is not as great, it is adequate for control surface operation, even with very low input power. The unit we use is shown in simplified sketch form in Fig. 3. A frame of iron (*F*, *G*) has a winding (*H*) on an iron core, and semi-circular iron pole pieces (*D*, *E*) above. A disc permanent magnet (*C*), magnetized across the diameter, turns freely with shaft (*B*), supported in two brass bearings (*J*, *I*). Arm (*A*) has several holes along its length to drive the rudder through a wire link.

This actuator has been found more than adequate to drive a rudder of about 6 sq. in., when supplied with only 100 ma. current. It is quite a bit heavier than need be, and in fact, was made in a great rush out of available parts. The basic element was the disc magnet (*C*) which had a bronze center bushing; the unit was built around this magnet and weighs 2.9 oz.

Although the photograph of Fig. 3 shows separate magnet coils, and would normally be used with two batteries, we felt it more practical to use two windings as shown by (*H*) in the drawings (Fig. 3); this way only one battery is needed. Two sets of batteries seldom "run down" evenly in use, and if they are uneven, the center or neutral position will drift badly. The single battery (two medium flashlight cells) with double-coil actuator gets around this nicely, and with the 100 ma. intermittent current drain, lasts a long time.

Full dimensions are also given in Fig. 3. The iron parts of the unit are all of special magnetic core iron, but any soft iron should work well. Before you start work on such a unit, procure the magnet disc (*C*) first. Be sure your disc is magnetized with only two poles—some of these discs have as many as

six poles! The pole pieces should fit the disc closely with only 1/32" to 1/64" clearance. If you can get a disc with a center hole, you are lucky—these Alnico discs can't be drilled. A plain disc with no center hole can be used by fastening a stub shaft to a brass disc soldered on each side of the magnet. Suitable disc magnets 3/4" x 3/4" can be obtained (from Ronald Eyrich, Box 849, Milwaukee, Wisc.) for about 25c each. They have no center hole, but make up into an actuator of ample power. Be sure to use only brass for the bearing pieces.

We fastened all joints of the unit shown with 2-56 screws, and after assembly, when all parts were adjusted satisfactorily, every frame joint was made permanent with soft solder.

The bakelite coil form (*H*) came from a defunct relay. The double winding is put on a form built up from 5/16" i.d. bakelite tube with three fiber washers held on by *Duco* cement. Each coil has 780 turns of #32 enamel wire and both are wound in the same direction.

The disc magnet (*C*) is soldered to

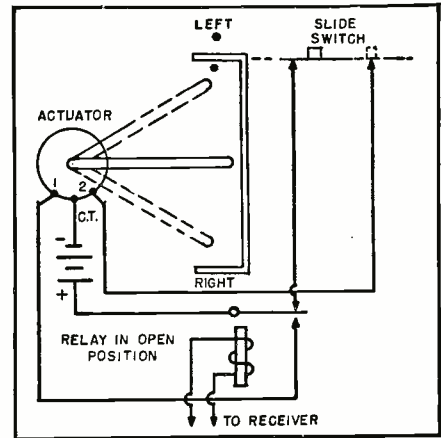
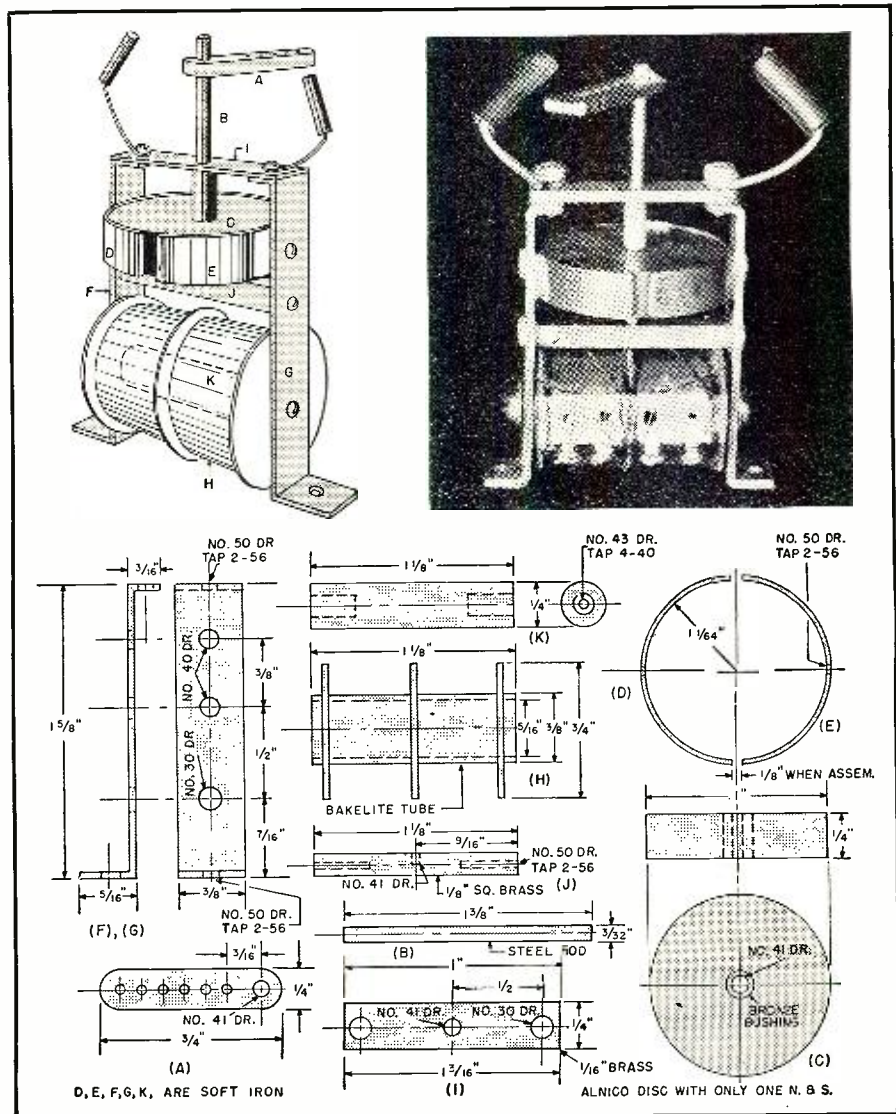

Fig. 2. Actuator wiring diagram. A 3-volt battery is suggested; however, depending on size of plane, this may or may not be too high. To obtain smooth rudder action a resistor of 10 to 20 ohms may be tried in series with the battery. The relay shown is the same as RL₁ in Fig. 6.

the shaft, but the arm should be left loose until you have checked the actuator to find out the exact center posi-

Fig. 3. Complete details on construction of actuator built by the author. The stop arms are made of soft copper wire with rubber tubing bumpers.



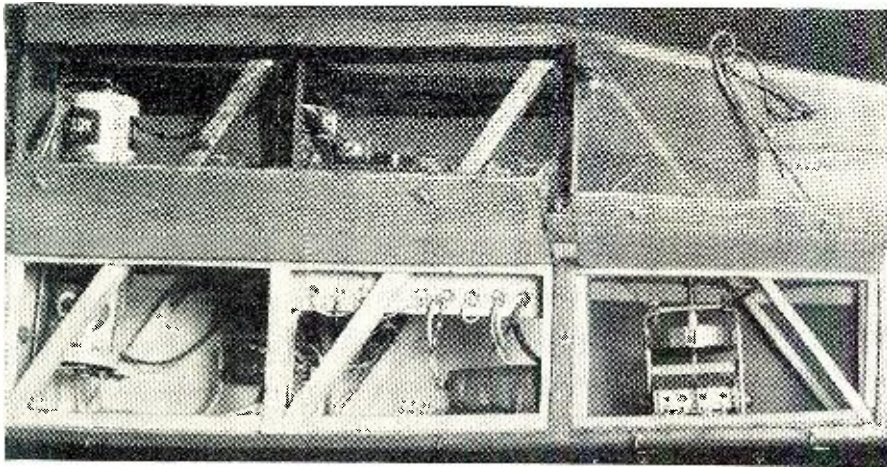

Fig. 4. Side view of plane looking into the hull. The actuator is mounted on the plywood cabin floor. Its power supply consists of the flashlight cells shown at left. Receiver is just visible above the large hatch cover of unit.

tion; then it can be soldered fast. To locate center, remove the winding (*H*) and its core (*K*) and you'll find the rotor (*C*) snaps to one position—this is neutral, or center rudder; this position is not as pronounced with the winding core in place, for the latter acts as a sort of magnetic shunt.

Two stops are held by the 2-56 screws on the top bearing. These stops are bent back so that they are not touched by the arm during its normal range of movement. They simply prevent the arm from snapping around to the wrong side.

As noted before, this is a heavy duty unit and would swing a much larger model plane rudder, or even a boat rudder. We drive it with a 3 volt battery (see Fig. 2). The two windings (*H*, Fig. 3), of course, must be connected to give opposite reaction as the relay (Fig. 2) shifts.

It is only fair to warn the reader that proportional control has one bad feature. If some link in the radio system fails, the rudder immediately assumes a hard-over position. In boats

or cars this might be nothing but an annoyance; in model aviation it is usually fatal! When proportional control is fitted, model airplanes are normally rigged with more than ample rudder action. When a plane is flying under power, however, if the rudder is held hard over—especially to the left—the plane usually winds up in a screaming spiral dive that can have but one ending—utter disaster! There is a way out of this, though, and Fig. 2 shows you how. The most dangerous condition in most model planes is full left rudder, as propeller torque accentuates the left turn. We set the system up so that loss of signal will cause the sensitive relay to open, as will any failure in the receiver circuit. The actuator arm will fly over to the full left position, forcing the yoke against the upper (left) pin and mechanically opening the slide switch, which is always closed under normal operating conditions. No power reaches either actuator winding now, and the normal centering action of the actuator, plus airstream on the rudder, will force the

latter to a near-center position and save the ship from spinning-in. Should control be regained, full right on the stick will restore the yoke to normal (downward) position and control may then be resumed. Of course, with this type of safety device you must take care not to push the control stick to the full left limit, or the device will operate even though your control system is functioning satisfactorily. Unexpected operation of the safety cut-off could be very disconcerting if you were engaged in some tight maneuvers. This can be prevented by setting up your control box stops so that you cannot reach the full no-signal position.

The actuator type of proportional control is self-centering. After you have the system properly balanced, the rudder will always return to neutral if the ground control stick is centered. This makes flying a real thrill and is a safety feature, too. If your plane gets into some unwanted maneuver, you just let the control stick snap to center position, and, with its rudder neutral, the ship's inherent stability will right it. This feature is great for beginners suffering from "pilot trouble"!

It must be admitted that most fliers using proportional control—the writer not excepted—don't use the safety system we have described. However, our particular ship is grounded until the arrangement shown in Fig. 2 can be added. We feel it's foolish to tempt fate any longer!

Now, let's see what kind of a control box is needed to pulse the transmitter and provide variable pulse width and spacing as required. The control box is illustrated in Fig. 5. The drive motor is a surplus job labelled "Delco 5069625—120 rpm—27 v. d.c." It's a series type motor with a governor system designed to hold speed constant over a wide voltage range. The governor doesn't operate below about 15 volts but we left it intact. The motor runs nicely on as low as $4\frac{1}{4}$ volts and we use it this way in the control box pictured; some experiments were made with different pulse speeds which were secured by the wirewound resistor at the right of the unit. The pushbutton to left of the "stick" shorts out the resistor and applies $5\frac{3}{4}$ volts to the motor. The motor turns at about 5000 rpm on the normal $4\frac{1}{4}$ volt input, giving about 380 pulses per minute; when the resistor is shorted out, the pulse rate goes up to about 690. A rate of from 300 to 400 pulses per minute is adequate. The rudder can be seen to wiggle a little, though the movement is so fast the plane doesn't follow it, but pursues a perfectly smooth course.

The output shaft with bearing and gear was discarded, as was the next gear in the train; this left two gears in the case, and the final ratio was about 13 to 1. On the shaft of the larger gear a brass disc $\frac{1}{2}$ " diameter and $\frac{1}{8}$ " thick was pressed. The hole in the disc was bored $\frac{1}{16}$ " off-center, so the disc acts as a cam with $\frac{1}{8}$ " total movement.

A *Micro-Switch* provides the contacts; the one we used came with a

Fig. 5. Complete details on constructing the control unit. The resistor for varying the speed is shown at the right in the photograph. The pushbutton switch, used to short out this resistor, protrudes from upper left of case.

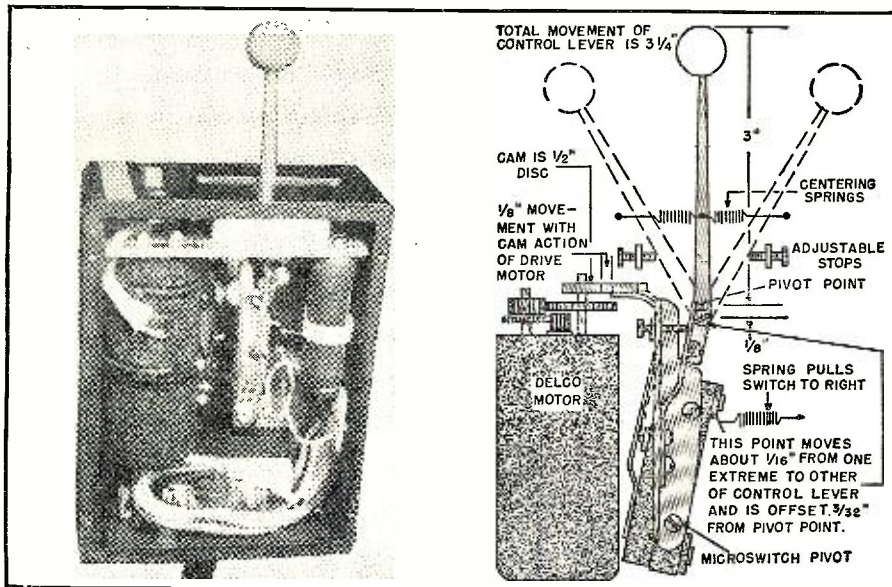

long spring bronze arm that projects about an inch beyond the end of the switch case. This arm was bent over at the end and a 1/2" diameter ball-bearing riveted on. The ball-bearing rides on the brass cam. This *Micro-Switch* is pivoted by a close-fitting pin through one of the mounting holes (the lower of the two screws in the photo, Fig. 5). Bolted firmly to the *Micro-Switch* is an adjustable arm bearing upon the control lever. A light spring keeps them in contact at all times.

Since this control box was intended for experimental purposes, every possible part was made adjustable or movable. We certainly wouldn't suggest that anyone copy this unit exactly. However, as a guide to other builders, Fig. 5 gives the essential details and ranges of movement. It will be noted that the cam action between control lever and *Micro-Switch* is "off-center"—the contacts are moved much more on one side of center than on the other. It was found, with the original set-up where the movement was equal both sides of center, that right rudder could be had in any degree from just off-center to full-over. Left rudder, however, was pretty abrupt and virtually jumped from just off-center to hard-over. Offsetting the action cured this nicely, although we intend to find out just where in the system the lag, or whatever causes the effect, is located. It's in the radio system somewhere, and all r.f. systems will probably differ in this respect—so just remember the offset trick.

It goes without saying that all moving parts of the control box must be well fitted, with minimum "sloppiness." If they are not, you will find your neutral position shifts every time you move the lever, a positive preventative to accurate or even enjoyable flying.

While a s.p.s.t. contact arrangement is all you need in the control box, it's helpful to have s.p.d.t. contacts, for then you can check results with an actuator connected directly to the control box and a battery, without wasting radio batteries. The proportional system will work with any radio equipment now on the market for radio control purposes, although we presume most readers of these columns will dream up their own radio apparatus. The point is, you can adapt any existing radio plane and r.f. equipment to proportional control; just substitute the control box and actuator for the present pushbutton and escapement.

Having used the RK-61, and its predecessor, the RK-62, for some years, we have often thought of going back to a receiver system that was popular before the miniature gas triodes were developed. It was felt that with "hard" tubes we could obtain the desired control action with less critical adjustment, less sensitivity to dropping battery voltages, and greatly extended tube life. A receiver we had built back in 1939 was dragged out and put through its paces again. The second a.f. tube has a rather high grid leak,

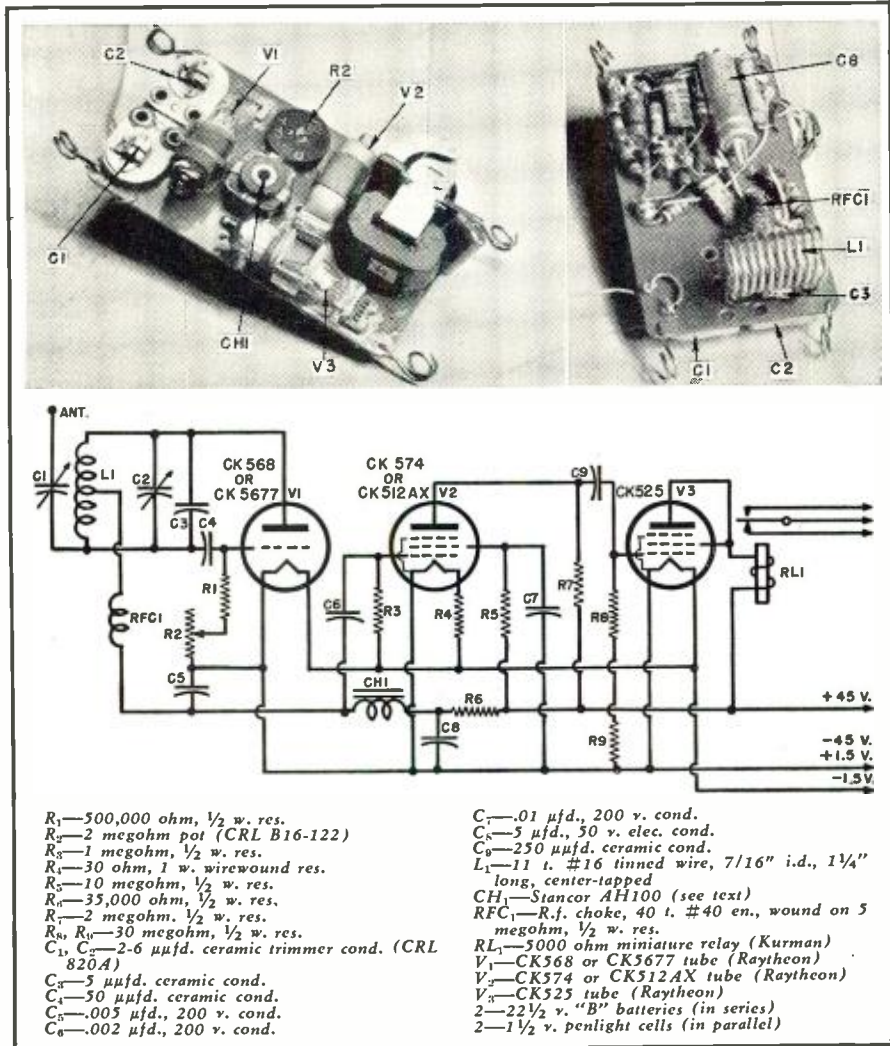

Fig. 6. Top and bottom views and the complete schematic diagram of the receiver.

and the normal rush noise of the detector, amplified by the first audio stage, is sufficient to drop the plate current of this last tube to a low value. When a signal comes in, the rush stops, the bias is reduced, and the last tube draws much higher current, closing a relay in the plate circuit.

An up-to-date version (Fig. 6) of this old idea was worked up using modern subminiature tubes and other midget components, and is illustrated here. Using the lightweight *Kurman* sensitive relay, and the tiniest parts available from the usual radio supply sources, the finished job measures 3 1/4" x 2" x 1 1/2" and weighs only 3 oz. These figures are not much higher than those of current commercial one-tube radio control receivers, and the little 3-tuber has worked without a hitch.

Besides the advantages mentioned above, this receiver ties in with proportional control particularly well, since, unlike most present day radio control receivers, the plate current is low with no signal. Thus the relay, *RL1*, is open (or making on the upper contact) until the transmitter goes on, whereupon it closes. This is ideal for the safety system in Fig. 2; the actuator is connected so that no-signal gives left rudder. The rudder also

moves left if either the transmitter or receiver (also batteries, wiring, etc.) fails, thereby actuating the left cut-off switch and allowing the rudder to return to neutral.

The tube sockets (Fig. 6) are cemented into oblong slots, and the tubes themselves are held in small fuse clips. Eyelets are employed to hold on many parts, including the fuse clips, ceramic trimmers, L_1 and CH_1 , etc.

Inductance CH_1 is a hearing aid output choke with the entire core removed. Four of the "I" strips from the discarded core are inserted through the winding bobbin and bent around the outside; thus providing four individual closed cores.

To save the last fraction of an ounce, we even removed the mounting bracket on the *Kurman* relay and tapped into the iron core to fasten it to the "chassis." This work wasn't worth the trouble, but another modification is definitely required. The two curved contact arms are rather flexible, and under certain conditions of receiver operation, a strong audio vibration could be noted in the relay. A strip of brass, soldered from the lug end of each contact and running out to as near the end as possible, completely cured this difficulty.

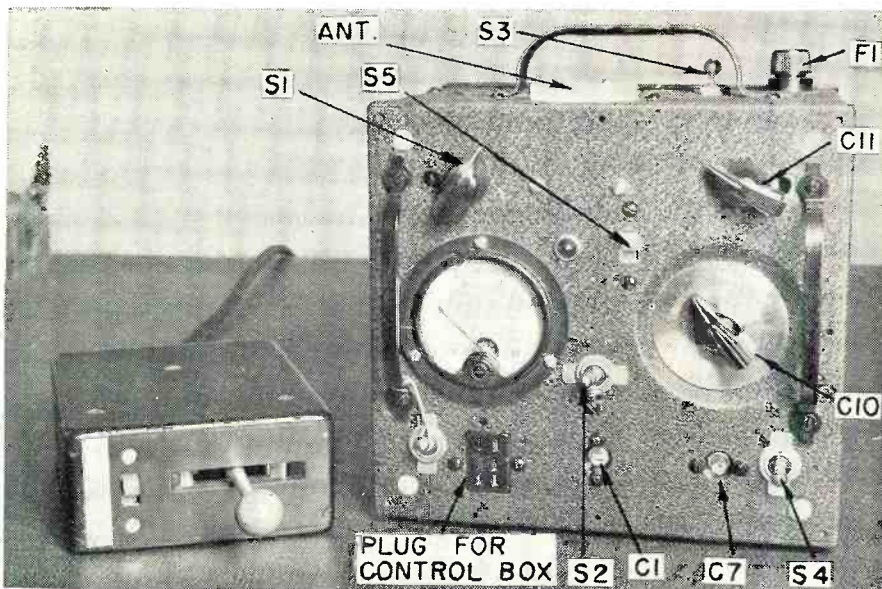

Fig. 7. Over-all view of transmitter with the control box shown at left. The vertical antenna plugs in through the plastic disc at the top of the case. For identification of component parts see transmitter schematic, page 90.

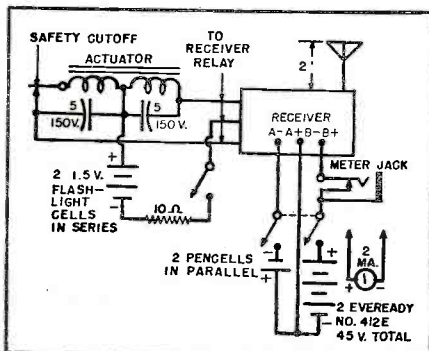
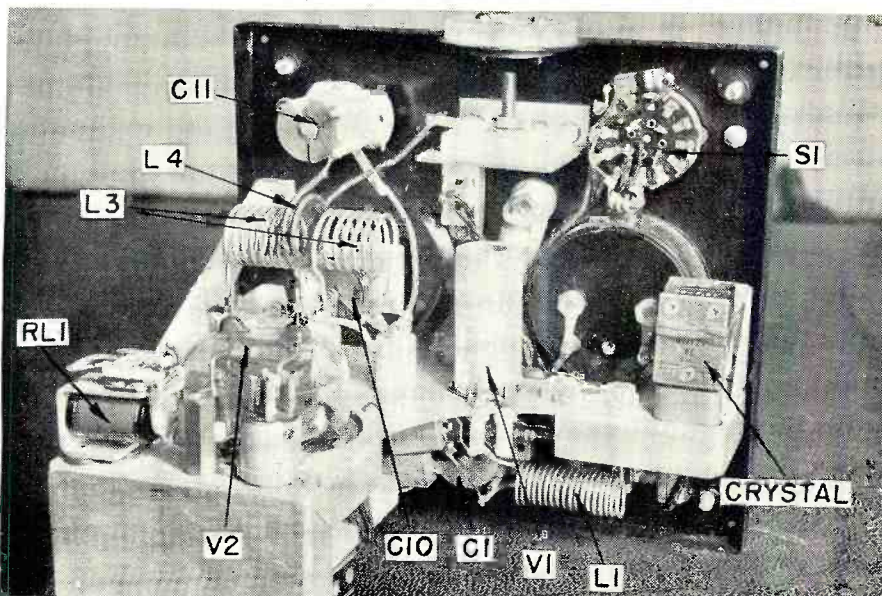

Fig. 8. Wiring diagram showing how miscellaneous equipment in plane is connected.

It will be seen that an electrolytic condenser, C_s , is incorporated; this was found necessary to cure a.f. oscillation when the "B" battery internal resist-

ance increases with age. Unfortunately the leakage current of C_s is as high as the whole current drain of the receiver under the no-input condition. However, as the receiver was intended to be relatively unfussy over lowering battery voltage, this condenser is a necessity; R_2 drops the leakage current considerably. It was found that if R_2 (which establishes operating conditions for the whole receiver) were set properly, the "B" voltage could drop to 38 from the original 45 volts, and the "A" to 1 volt from 1.5, and the set would still operate reliably. The plate current for the entire receiver normally is set at 4 ma. by adjusting R_2 and C_1 ; the latter never requires change once it is set properly. The relay is adjusted to operate at about .7 ma. and open at .9; the plate current goes up around 1 to 1.7 ma. depending upon transmitter

Fig. 9. The large cutout in the chassis is provided to permit clearance of vertically mounted dynamotor. Note two crystals in double socket at right. See transmitter diagram, Fig. 10, page 90, for identification of parts.



proximity. Distance checks up to $\frac{1}{4}$ mile on the ground have proved entirely successful.

There are no tricks required to put the receiver into use. After the input is tuned to the transmitter (the latter operating with very low output and no antenna), condenser, C_1 , is decreased until it tends to cause a rather rapid plate current rise; a 0-2 ma. meter is used in the receiver "B+" lead for convenience—not in the plate circuit of V_3 . The antenna may have to be altered in length so that C_1 will cause the proper loading at mid-range. R_2 is then varied to bring the plate meter to .4 ma. That's all there is to it. If R_2 is set to raise the plate current too high, the meter needle will waver quite a bit, while if too low, the plate current with signal will not increase enough to work the relay reliably.

This receiver has proven very satisfactory, and has given no trouble whatever. It has survived several crack-ups that tore it loose from its mountings (it is suspended by rubber bands as is common radio control practice). We feel sure it will work well on the higher ham bands, as V_1 is rated by the manufacturer as operable up to "several hundred mc." V_1 can be replaced by Raytheon's CK5676, a very similar tube using a 120 ma. filament, which is said to be usable as high as 350 mc. Total filament drain of the receiver, as we show it, is about 100 ma.

The three tubes in this receiver total up to considerably more in cost than a single RK61, as used in the majority of radio control receivers, but their life is measured in hundreds of hours, rather than the under-ten hour life of the 6L. Furthermore, they have recently appeared on the surplus market at around \$1.50 each! (TAB, N.Y.C.).

The complete circuit of the airplane equipment is seen in Fig. 8. The only unusual feature is the use of 5 μ fd., 150 volt electrolytic condensers across the relay contacts. The relay requires quite a sensitive setting and during first trials it would often unaccountably "stick." No arcing could be seen at the contacts, nor did they show any pitting. The inductive kick of the actuator coils was the cause, and the electrolytics cured the trouble. They must be properly polarized, of course.

The transmitter (Figs. 7, 9, and 10) does not require a great deal of description as it follows regular amateur practice. It is entirely self-contained in a case $7\frac{1}{4}$ " wide by $7\frac{1}{2}$ " high by $6\frac{1}{2}$ " deep. Practically every part in it was gleaned from the surplus markets, including the dynamotor—a 9 volt type that gives 275 volts under full load of the set, with about $5\frac{1}{2}$ volts at the input brushes. It measures about $3\frac{1}{4}$ " diameter by 6" long and is placed vertically in the case on small shock mounts. The chassis is cut out to fit and it must be admitted that some juggling was needed to get the transmitter parts in the space left!

All components associated with V_1 are under the chassis except the crystals (Continued on page 90)

A Novel HORN-LOADED SPEAKER

By
WM. E. JOHNSON

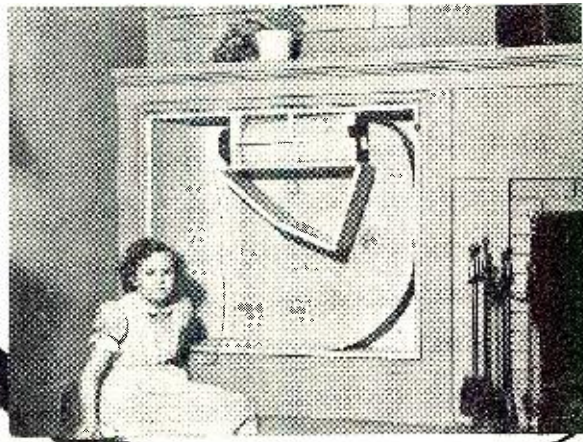

Two views of the horn-loaded speaker as built by the author. The unit is removable, a desirable feature in rented quarters.

For those who have a fireplace-bookcase combination of this type, it is an easy task to build this inconspicuous unit. Add a horn to your present speaker to provide smoother performance. It will extend the unit's low frequency response considerably.

AS MOST of you know by now, there is no substitute for a horn for true sound reproduction. The corner horn has been developed to achieve the necessarily heroic dimensions while providing something you can stuff in your living room.

I had to be convinced of the value of a corner horn, but after listening to two of them, the convincing was done. All I had to do was find a corner to put one in. We recently moved, and one of the things I looked for in our house-hunting was a corner in which to put a speaker. Houses aren't usually built with such specifications in mind so we had to settle on a house that met our other requirements.

We now had a house that was unsuited for a conventional corner type horn and, in addition, we didn't have the money to spend on the high-priced woofer and tweeters for a two- or three-channel system. We did have a fireplace at one end of our living room with bookshelves on each side that extended to the corners and we also had a very fine eight-inch speaker, the *Western Electric 755-A*. A little plywood, a little linoleum, a little imagination, and a lot of work, and there was our corner horn.

It probably isn't the master, or even the equal, of the more elaborate jobs but it provides substantial improvement for an already fine speaker. Horn loading smooths and greatly extends the bass response. High frequency radiation is largely from the rear, through the center pole piece,

and wide dispersion is accomplished by reflection from the curved, vertical piece of linoleum. Those of you who are familiar with this speaker know that its normal high frequency radiation is confined to quite a tight beam directly on its axis. The difference in various parts of the room is now al-

most undetectable. Tests with the younger members of the family show very good response well beyond my cut-off of about 14,000 cycles. As shown in the photograph, the high frequency source is above chair height, so furniture arrangement is quite independent of sound considerations.

Room appearance and flexibility of furniture arrangement were important considerations in designing this system. It was decided that a compromise in sound quality would be more desirable than a perfect sound-

(Continued on page 144)

Details of construction. Linoleum and plywood are the only materials required.

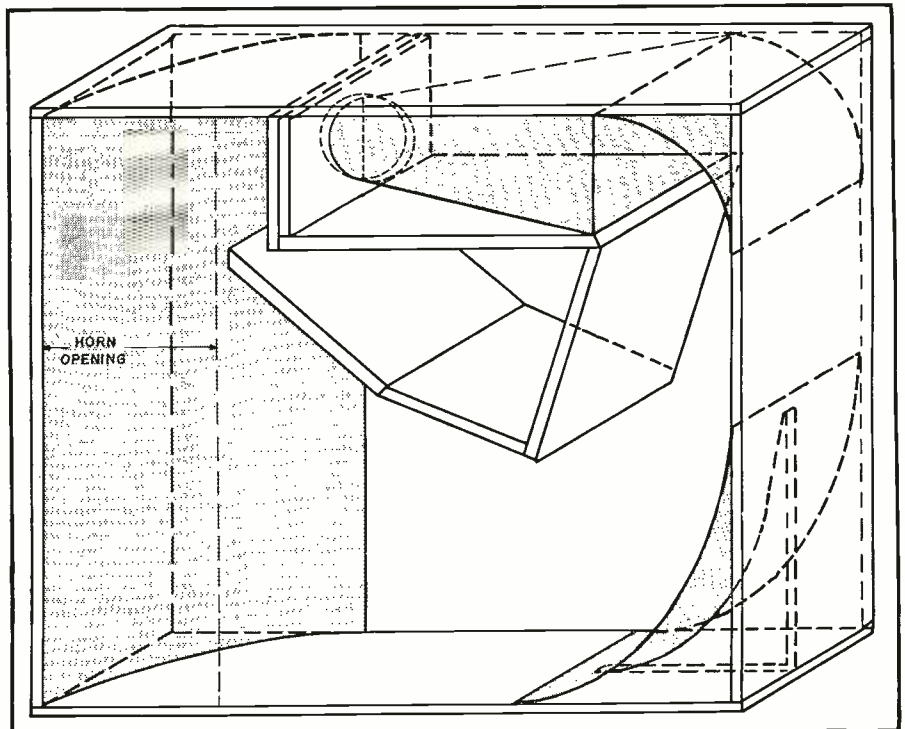

TV TEST EQUIPMENT For Outside Service Work

By
M. B. LONG

About 75% of all house calls involve tube replacement. For the balance, a 20,000 ohms-per-volt voltmeter or a v.t.v.m. is the most practical unit.

MOST outside television service work can usually be handled with just a tube replacement kit. It can be fairly stated that approximately 75 per-cent of all TV service calls are a result of tube failure. As for the 25 per-cent that do not respond to the tube "treatment," these are the ones that cause the grey hair. To service these sets efficiently in the customer's home, since the removal of a set is both time consuming and costly, a good vacuum tube voltmeter or at least a 20,000 ohms-per-volt meter is a necessity.

A v.t.v.m. is the ideal instrument to cope with sets exhibiting characteristics of component part failure, where condensers short or open, resistors burn or change value, etc.

Let's discuss a few typical examples. A particular set boasts of a bright horizontal line across the center of the picture tube; the rest of the screen is dark. Obviously this is an indication of "no vertical sweep." After replacing tubes the technician should turn his attention to the vertical sweep circuits. What are the possible sources of this trouble? The parts of the circuit involved are the vertical sweep oscillator, the vertical amplifier, the vertical output transformer, or the vertical coils in the deflection yoke. With sets having electrical centering controls, a quick check can be made before the chassis is removed from the cabinet to determine whether the trouble is in the vertical output transformer or deflection yoke. The centering control is used to vary the amount of d.c. flowing through the deflection yoke, which

produces the centering action. If either the secondary of the vertical output transformer or the vertical coils in the deflection yoke are open, there won't be any vertical sweep, nor could the amount of centering current through the yoke be varied. As a result, when the centering control is turned, it won't affect the position of the bright horizontal line. If the line moves up and down when the control is turned, this indicates that the output circuit is complete and that the technician can go on to the vertical oscillator and amplifier.

A quick test to see if the vertical oscillator is working would be to check for negative voltage between grid and cathode. All oscillators—whether vertical sweep, horizontal sweep, local oscillator, Hartley, Colpitts, etc.—have one important characteristic in common. When oscillating, they always produce a negative voltage on the grid with respect to the cathode. To measure this voltage a meter that will not load the circuit and upset it is required. This means a 20,000 ohms-per-volt unit or a vacuum tube voltmeter. Loading the circuit with a 1000 ohms-per-volt meter may cause the circuit to stop oscillating as long as the meter leads are connected, thereby giving the impression that the circuit is inoperative.

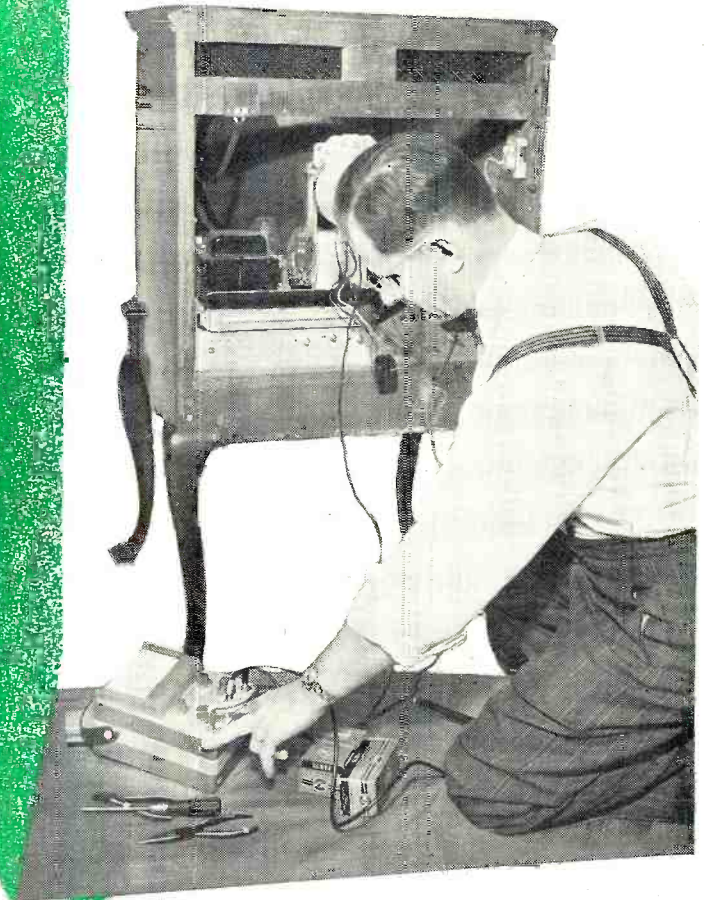

The key to successful servicing is a technician who can diagnose the trouble quickly and make necessary repairs systematically.

A word of caution—be sure to check between grid and *cathode*, rather than to ground, because quite often the grid and cathode may be tied to a point that is negative with respect to ground and, as a result, a negative reading would be obtained whether the circuit was working or not. If the oscillator is not working, a few quick checks with the voltmeter for plate or screen voltage would probably indicate the source of trouble. Assuming the oscillator is working, the next step would be to trace the signal to the vertical amplifier. Since the signal generated by the vertical oscillator is low in frequency (60 cycles) it can be measured and traced with the a.c. ranges of the v.t.v.m. This signal must eventually be applied between the grid and cathode of this stage, so the ground lead of the v.t.v.m. should be clipped to the cathode. Moving the test lead from the plate of the oscillator through the coupling circuits and then to the grid of the vertical amplifier permits actual "signal tracing" of the complete vertical sweep circuits with the v.t.v.m. Loss of signal along the line might indicate an open coupling condenser. So much for the vertical sweep circuits.

Suppose the complaint indicates trouble in the sync circuits. If replacing tubes doesn't cure the fault, the

average outside technician is inclined to pull the set in to the shop, because trouble in the sync circuits usually requires signal tracing with a scope. Actually, a good percentage of these troubles could be located and repaired in the customer's house with the aid of the v.t.v.m. Most sync clippers, sync levelers, and sync separator stages are grid-leak biased. That is, the grids of the tubes used in these stages are usually driven positive by the signal, causing grid current to flow, thereby producing a bias which adjusts itself to the amplitude of the applied signal. No signal—no grid current—no negative bias voltage! Simply check for negative bias voltage with the v.t.v.m. It is as easy as that! To be sure that the voltage being measured is due to the signal, the preceding tube should be removed. If the voltage disappears, we can be reasonably certain that it is produced by the signal. This method permits the "signal tracing" of the sync circuits and the location of open coupling condensers or stages that aren't working.

Horizontal automatic frequency control circuits are usually serviced with a scope in the shop, but they can be handled quite easily in the home with a v.t.v.m. Fig. 1 is a block diagram of a typical "syncrok" circuit containing three stages. Basically, these stages function as follows. The horizontal oscillator generates the sweep signal. Some of this signal is applied to a discriminator or "comparer" circuit. Horizontal sync pulses received from the transmitter are also applied to this circuit. The two signals are compared as to their frequency and phase. If they are "in step," the output of the discriminator is zero. If the frequency of the oscillator is higher than that of the sync pulses, the discriminator output is a small negative voltage. If the oscillator is lower, the output voltage is positive. These "control" voltages are applied to the grid of the control tube. This control tube acts as a variable inductance in parallel with the oscillator coil. If the grid is made positive, its effective inductance is increased. If it is made negative, its inductance would appear to decrease. This change in effective inductance varies the frequency of the horizontal oscillator. If the horizontal oscillator frequency were to drift from its correct value, the discriminator would produce a control voltage which would affect the control tube which, in turn, would correct the frequency of the oscillator. As a result, the frequency of the horizontal oscillator is kept locked in step with that of the sync pulses.

A breakdown in the discriminator or control tube circuits would result in "no horizontal sync." Now let's see how the v.t.v.m. could be used to localize trouble in this circuit. Referring to Fig. 2, it will be noticed that the grid of the control tube has two volts of negative bias applied from the negative power supply. This, then, would be the normal operating voltage if the discriminator output was zero. Assum-

ing that the system isn't operating and that the picture can't be "locked" horizontally—the first problem would be to isolate the defective stage. Since there is a picture, the horizontal oscillator is operating. Thus, the trouble must be either in the discriminator or control tube circuits. The first step would be to short the grid of the control tube to ground and note the effect on the picture. Let's stop to see what shorting the grid to ground does. Normally there should be two volts negative on the grid. Shorting it drops this voltage to zero. The control voltage on the control tube has been changed and this should produce a change in the horizontal oscillator frequency. The visible effect on the picture should be the same as if the setting of the horizontal hold control were changed. If a change is noticed, it indicates that the control tube circuit is working and the trouble lies in the discriminator circuit. No visible change would indicate that the control tube circuit is at fault. Now the v.t.v.m. can be used to verify these findings. The v.t.v.m. should be connected from the control tube grid to ground. Set the horizontal hold control to the middle of its range. Note the voltage on the grid. Then rotate the hold control from one extreme to the other. Doing this increases the frequency in one direction and decreases it in the other direction. This should produce a changing control voltage at the output of the discriminator, which should appear on the grid of the control tube. If the grid voltage changes when the control is rotated, it indicates that the discriminator circuit is operating and the trouble lies in the control tube circuit. If

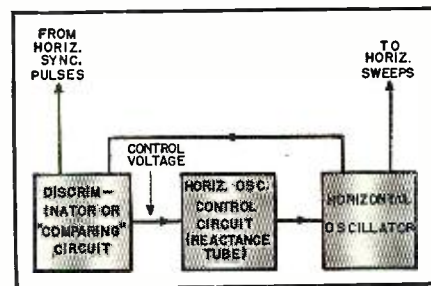

Fig. 1. Block diagram of conventional automatic frequency control circuit.

the voltage doesn't change, the trouble is in the discriminator circuit. Once the defective stage is isolated a few quick checks with the v.t.v.m. "plate voltage, screen voltage, bias, resistance" should spot the defective component.

These are just a few examples of what can be done in TV service work in the home with just a replacement tube kit and a v.t.v.m. The 20,000 ohms-per-volt unit has one possible advantage over the v.t.v.m. in which the outside service man might be interested. It is self-powered. Whether or not this is a real advantage would have to be decided by the individual, bearing in mind the cost and inconvenience of battery replacement.

Additional service equipment that the outside technician might want to carry, which could be classed as "not absolutely necessary, but nice to have," would be a scope. With a scope he could actually see the picture signal and trace from the video detector, through the video amplifiers, right up to the grid of the picture tube. He

(Continued on page 94)

Fig. 2. Diagram of a conventional discriminator and horizontal oscillator of a TV receiver.

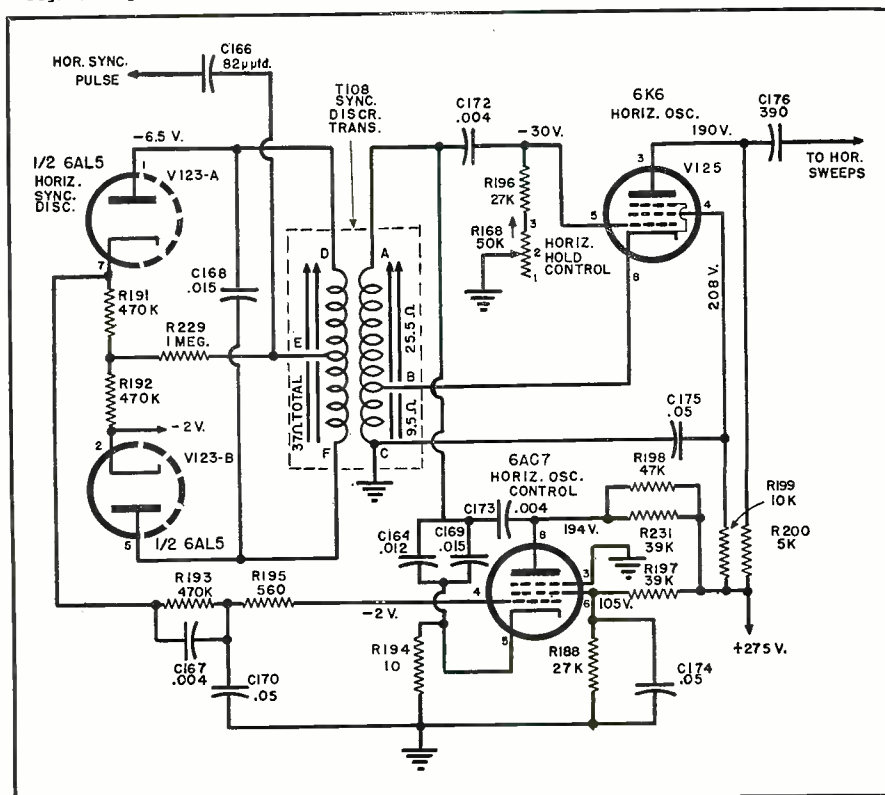

Mac's RADIO SERVICE SHOP

By JOHN T. FRYE

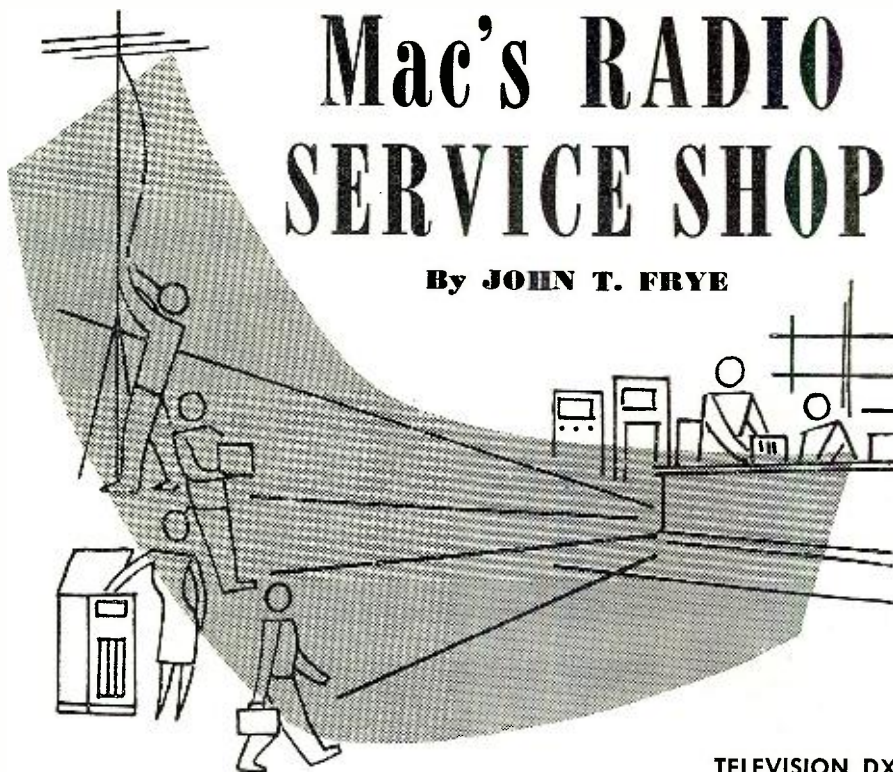

TELEVISION DX

SUDDENLY Barney, the "hired hand" of Mac's Radio Service Shop, slammed his solder gun down on the bench and demanded of his boss: "Mac, what's so doggone funny? You've been grinning like a television toothpaste commercial ever since you came back from lunch."

"Well," Mac explained, "by the time I got over to the Dutchman's this noon, all of the counter stools were taken, and I had to sit in a booth. While I was eating I couldn't help but overhear a hot antenna argument going on between a couple of rabid TV fans in the booth behind me. Each guy was whooping it up for his antenna system and using as evidence the distant television stations he pulled in during that 'opening' we had around last Decoration Day. Number One gave all the credit to his battery of yagis, while Number Two was convinced that his colinear array was what enabled him to yank in the DX."

"And that's side-splittingly funny?" Barney questioned with arched eyebrows.

"In a way it is. I kept thinking how amusing it would be if I butted in and related my own experience during that period. You will remember that I had just received my new television chassis at the time and was waiting on a cabinet. However, I was so eager to try out the high-fidelity amplifier on a couple of speakers I had at home that I unpacked the chassis and set it on top of the shipping carton, cut a twin-lead folded dipole roughly for the FM band and tossed it on a desk beside the set, slid in a picture tube, and turned on the set.

"While I was adjusting the ion trap on the seventeen inch tube I was using, I began to notice pictures on the

screen. In the next couple of days, using that very poor antenna, a yardstick for an antenna tower, without any booster of any sort, and at this Northern Indiana location seventy miles from the nearest TV transmitter, I logged Cuban stations on Channels 4 and 6; Miami and Jacksonville, Florida, stations on 4; Chicago stations on 4, 5, 7, and 9; San Antonio, Texas, on 4 and Houston on 2; Milwaukee on 3; Louisville, Kentucky, on 5; and Indianapolis on 6. While there was fading on some of the signals, both sound and picture were received in each case with sufficient clarity to make identification easy and positive. In many cases, the reception was perfect, without the slightest snow or noise."

"You don't suppose you could have stumbled on some kind of a super antenna in that twin-lead job, do you?" Barney suggested hopefully.

"Not a chance," Mac replied with a chuckle. "Just to make sure, while Cuba was rolling in on Channel 4, I took off the antenna and touched one of the terminals with a screwdriver. 'Television Para Todo' came in almost as well as it had with the antenna.

"No," he continued, "the point of the whole thing is that the antenna efficiency seems to mean little during these periods of freak reception. In fact, a low antenna may actually do a better job of picking up DX at such a time than will an antenna mounted on top of a high tower. Either refraction or reflection causes the distant signals to come in at pretty steep angles. The fact I could pick them up down in the bottom of this river valley proves that. Signals from fairly close stations, on the other hand, are usually not subject to so much distortion and continue to be picked up better by more elevated

antennas. As a result, an antenna that is really up in the air picks up enough signal from a nearby station to interfere seriously with a DX signal. A low antenna, on the other hand, gets the distant signal just as strongly and without the interference from the close station."

"Then you think that when one of these freak DX periods start, the thing to do is to start looking for faraway stations with a tuning knob in one hand and a folded dipole in the other."

"It's worth a try, anyway," Mac said, smiling at the graphic picture Barney's words evoked. "One thing in favor of such a system is that it allows you to switch the antenna around much quicker than can be done with a rotating motor, and that is a distinct advantage in this freak reception. The signals from Texas were received best with the ends of my folded dipole pointing southwest and northeast—exactly opposite to what a person would normally expect and indicating that the signal was arriving by way of a most devious route. Furthermore, I counted as many as five separate ghost images on the signal from Houston, some displaced from the main signal by as far as three inches on the sixteen-inch screen. These ghosts kept moving back and forth behind the main signal, and by turning the antenna, the chief signal and one of the ghosts could sometimes be made to exchange roles. Often the signal arrived in the form of closely-spaced waves of strength, and being able to whirl the antenna about quickly during the peak of the wave permitted the best position to be readily determined.

"Next time, though, I intend to use a special antenna I am making up just for freak DXing," Mac continued. "It consists of a folded dipole with end sections that telescope like the slide on a slide-trombone. A telescoping reflector is also used, and both units are mounted so that the space between them can be easily varied without upsetting their relative alignment. The element sections and the 'boom' are marked so that the array can be quickly set up for any channel."

"Why go to all that trouble when you say the efficiency of the antenna is unimportant when the DX signals are really piling in?"

"I'm not trying to increase the efficiency of the antenna," Mac explained. "What I want is an antenna that is more one-directional to help in establishing more accurately from just which direction the signal arrives; furthermore, by being able to tilt the simple array, I hope to get a rough idea of the angles at which the signals come in. Still another hoped-for advantage lies in the possibility of doing a better job of separating several stations likely to be found occupying a single channel during one of these unusual periods. You should have heard five different stations battling it out on Channel 4 like cats fighting over a fish-head as I did last May 30th. That

(Continued on page 163)



International SHORT-WAVE

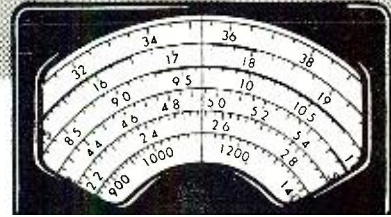

Compiled by **KENNETH R. BOORD**

IT IS A pleasure this month to dedicate the *ISW DEPARTMENT* to radio in Canada. Thanks go to F. P. Johnson, Senior Engineer, International Service, *Canadian Broadcasting Corporation*, for this fine data.

In November 1936, when the newly-formed *Canadian Broadcasting Corporation* took over the Canadian Radio Broadcasting Commission facilities, with its establishment of 20 employees in Montreal, network broadcasting consisted of six hours of programming daily. Today, less than 15 years later, the *CBC's* new Radio-Canada Building in Montreal, Quebec, represents the latest link in one of the largest radio systems in the world. From its 26 ultra-modern studios flow programs in 14 different languages to Canada and the world 18 hours a day.

In an average year, the Radio-Canada Building supplies nearly 6000 hours of network programming within Canada—more than any other *CBC* production center. These are carried on the *CBC's* Trans-Canada and Dominion Networks to *English*-speaking Canadians across Canada, and on the French network (which has its headquarters in the building) to French-speaking Canadians.

The International Service also has its headquarters in the Radio-Canada Building and shares studios with the National Service. From these studios, then, the *Voice of Canada* is carried over 600 miles of land line to the two powerful IS transmitters at Sackville, New Brunswick, which sends it around

the world. The total output from the 26 studios goes to eight separate transmitters.

Out of the Radio-Canada Building, too, come recordings of *CBC* programs for a number of French-language stations across Canada and for foreign countries.

Soon the new building will be the center of still another service—television. In the building's five-story television wing, TV programs from three studios for *English* and French audiences in the Montreal area will be produced. These programs will be broadcast from atop Mount Royal.

In addition to all of these outgoing services, the Radio-Canada Building also is the center of seven incoming radio networks.

These are the radio activities which make *CBC's* new Radio-Canada Building one of the busiest—as well as the most modern—radio centers on the North American continent.

Despite problems of scattered population and vast distances, the *CBC* has established itself as the largest operating entity of its kind in the world. Today, the *CBC* operates more extensive networks and broadcasts in more time

zones (6½ of the world's 24 are in Canada) than any other radio system in the world.

The *CBC* operates a total of 55 transmitters for its National and International Services. In Canada alone, these transmitters help to make it possible for more than 95 per-cent of the country's population to hear network radio programs. Of these 55 transmitters, 20 are standard band AM stations (8 with a power of 50 kw. to give adequate service in rural areas); five FM stations are operated (in Montreal, Toronto, Ottawa, and Vancouver). Four short-wave transmitters (on 11 frequencies) carry service to remote areas in Canada, and 24 low-power relay transmitters have been installed to serve listeners in sparsely-populated sections along the Trans-Canada network. Four more of these relays now are being installed. The International Service employs two 50 kw. transmitters (on 15 frequencies) to beam programs abroad. These transmitters broadcast the strongest signal reaching Europe from this side of the Atlantic, *CBC* reports.

The short-wave transmitting station at Sackville, New Brunswick, is a modern two and a half story structure of reinforced concrete. The main equipment—for the two short-wave transmitters and for the standard broadcast band station CBA—is installed in separate rooms on each side of the main control room and the standby power supply enclosure. In the right

(Continued on page 127)

Radio-Canada's modern soundproof recording room where any of 50 programs passing through master control can be chosen automatically for recording. Each recorder (disc or tape) has its own control panel, clock, light, and overhead speaker. All fourteen of these machines can be used to record program material simultaneously or separately.

Acknowledged as one of the most modern on the continent, the new master control at *CBC's* Radio-Canada Building also carries the heaviest load. Capable of handling 5 transmitters, 8 outgoing networks, 7 incoming networks, and 26 studios, it is designed for operation by one man. The center of the building's 100-clock system is at the right.

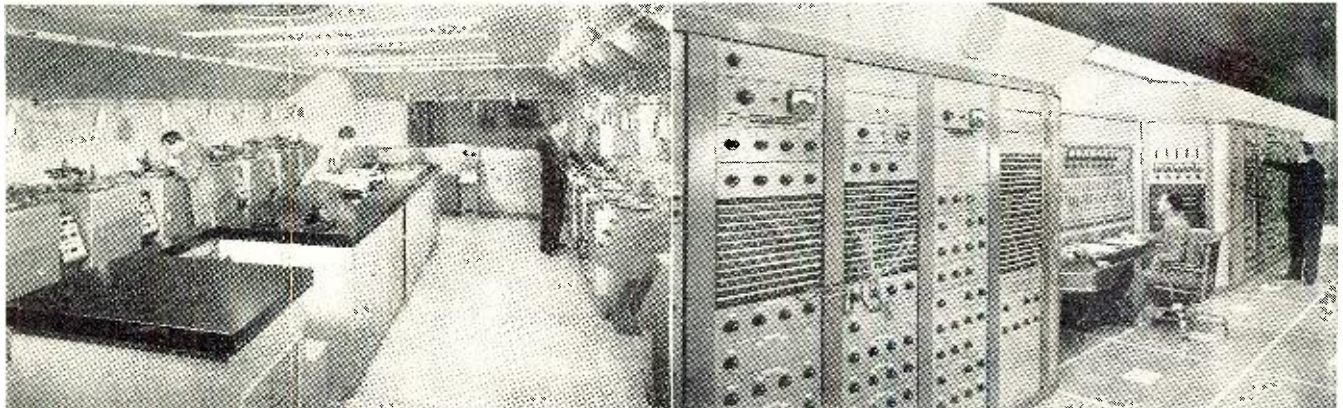

VOLTAGE REGULATORS

By JOSEPH E. WILLIAMS, W8AME

Ideas on designing your own voltage regulators. There is a choice of designs that will handle reasonable loads at any desired output voltage.

IN COMMON with many radio amateurs and experimenters who enjoy trying out new electronic circuits, the writer has often required power supplies for different voltages. Often, when the right voltage was obtained, the regulation was so poor that the characteristics of the circuit under test were severely affected. A power supply capable of handling a reasonable load with good regulation over a continuously variable, wide-range choice of output voltages would have been particularly valuable during such experimentation. A review of the subject indicated that such a unit was both possible and practical. This article has been written with the thought that others might get useful ideas from the writer's attempts to answer this problem, even though they do not actually construct either of the two units described.

Among the power supplies having regulation of a sort, one has a choice of batteries, ballast tubes, choke input filters, voltage regulator tubes, and electronic voltage regulators. Of these, the electronic voltage regulator showed

Fig. 1. Basic diagram of an electronic voltage regulator. See text for explanation.

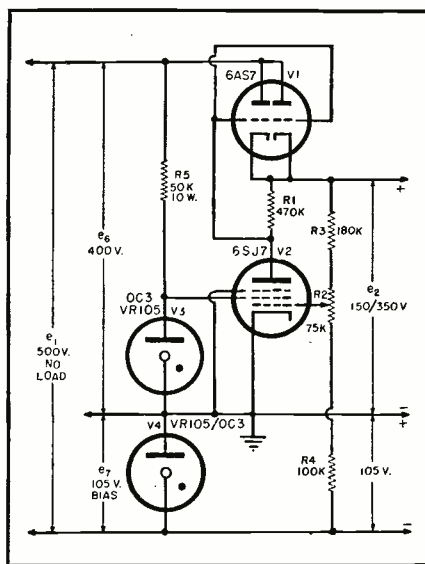
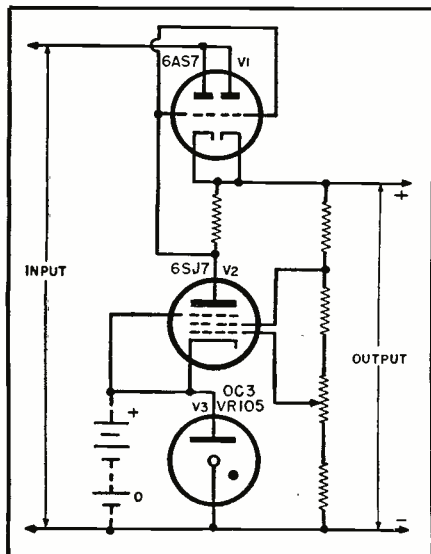

Fig. 2. Modified form of the electronic voltage regulator circuit shown in Fig. 1.

the most promise. Actual use of this type of equipment produced amazing stability. Voltage variations of less than 1% are usually realized and the power limits can be quite high, depending on the number and type of regulator tubes used. The main trouble encountered was the voltage range available, usually from 150 to 350 volts, or from 250 to 450 volts. If the unit is capable of covering these ranges why not regulation for voltages below 150?

The basic circuit for the electronic voltage regulator is shown in Fig. 1 while a modification is shown in Fig. 2. In these circuits the regulation and choice of output voltage are obtained through changes in the series resistance of the low-mu regulator tube, V_1 , which occur with changes in grid bias. The grid bias of V_1 is controlled in turn by a high gain, sharp cut-off pentode, V_2 , which is connected so that any variation in the output voltage of the regulator is reflected on the grid of that tube. The control tube, V_2 , has its cathode held at a fixed reference potential by a battery, or as in this cir-

cuit, a voltage regulator tube. Any tendency for the output voltage to rise swings the grid of the control tube in the positive direction, causing it to draw more plate current thereby increasing the voltage drop through resistor, R_1 . R_1 is in the regulator tube V_1 grid circuit and the resulting increase in bias increases the series resistance of that tube and opposes the tendency for the output voltage to rise. The tendency for the output voltage to drop below the chosen setting causes reverse action. The action takes place either with changes in supply voltage or in load.

The factors which determine the voltage range of the circuit in Fig. 2 work out as follows:

1. The maximum output voltage, e_2 , will generally be 50 volts less than the input voltage, e_1 , due to the minimum voltage drop through the regulator tube, V_1 .

2. The maximum range for the output voltage, e_2 , is limited by the maximum plate voltage which can be applied to the regulator tube, V_1 . This will be around 250 volts for tubes ordinarily used in this service.

3. The minimum output voltage, e_2 , is limited to the total of the reference voltage, e_4 , plus the bias voltage, e_5 , necessary for cut-off bias for the regulator tube, V_1 . It will be around 250 volts if a VR105 is used for V_4 .

4. The maximum input voltage, e_1 , is limited to the total of the minimum output voltage plus the maximum plate voltage for the regulator tube, V_1 . It will be around 500 volts for this circuit. Also, it should check reasonably close to the total of the reference

Fig. 3. Voltage regulator design for 650 volt input. The input voltage (e_1) is the sum of e_1 plus voltage rating of V_5 . More than one VR tube can be used in series with V_5 for higher voltage. Circuit is grounded at its lowest negative point.

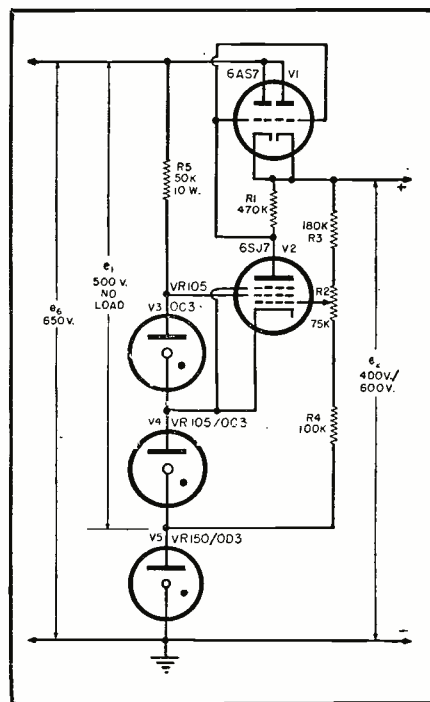

voltage, e_1 , plus the maximum rated plate voltage for the control tube, V_2 , plus the minimum voltage drop through V_1 . If a 6SJ7 is used for V_2 that total is also 500 volts.

5. The maximum load current is limited to the maximum rated plate current for the regulator tube, V_1 , and its plate dissipation. The 6AS7 is designed specifically for this service. It is very low- μ and will deliver from 125 ma. continuous service to 200 ma. for short periods. These limits may be increased by connecting additional regulator tubes in parallel as required. The input power supply must have a corresponding power capability.

The circuit of Fig. 2 is a unit which can be inserted in series with the load and across the output of a power supply to obtain a regulated 250 volt adjustable variation in the output voltage. If the power supply delivers 500 volts it is a natural match for the regulator as that total voltage is required by the circuit with the components ordinarily used.

If the power supply is rated at more than 500 volts it becomes necessary to make up the difference by adding a stabilized voltage element, such as a voltage regulator tube, in series with the regulator unit across the power supply. Fig. 3 shows the regulator unit adapted for use with a 650 volt supply by the addition of a VR150 regulator tube. A 200 volt regulated range can be obtained from higher voltage supplies by adding more voltage regulator tubes in series with the regulator unit.

The same principle applies for power supplies of lower voltage. The difference between the 500 volts required by the regulator unit and the power supply voltage must be made up by a stable voltage element.

The circuit of Fig. 4 is a familiar one which can be found in most texts and manuals. A 400 volt supply is used with the negative lead connected to the cathode of the control tube, V_2 . The additional 100 volts required for the regulator circuit is supplied from an auxiliary bias supply. The output voltage is regulated over a range from

(Continued on page 140)

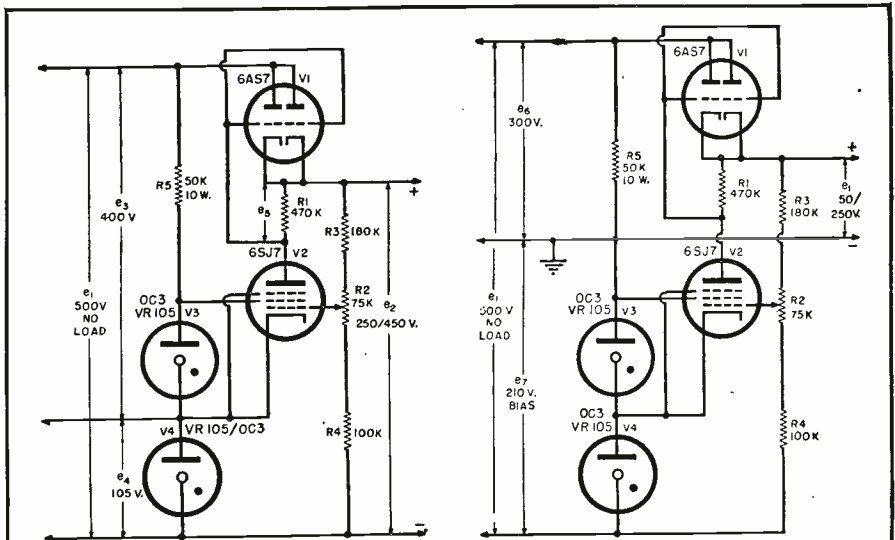

Fig. 4. Circuit diagram of a voltage regulator grounded at the control tube level. Both power and bias supplies are required.

Fig. 5. Voltage regulator grounded at the control tube screen level. Output voltage range is 100 volts below that of Fig. 4.

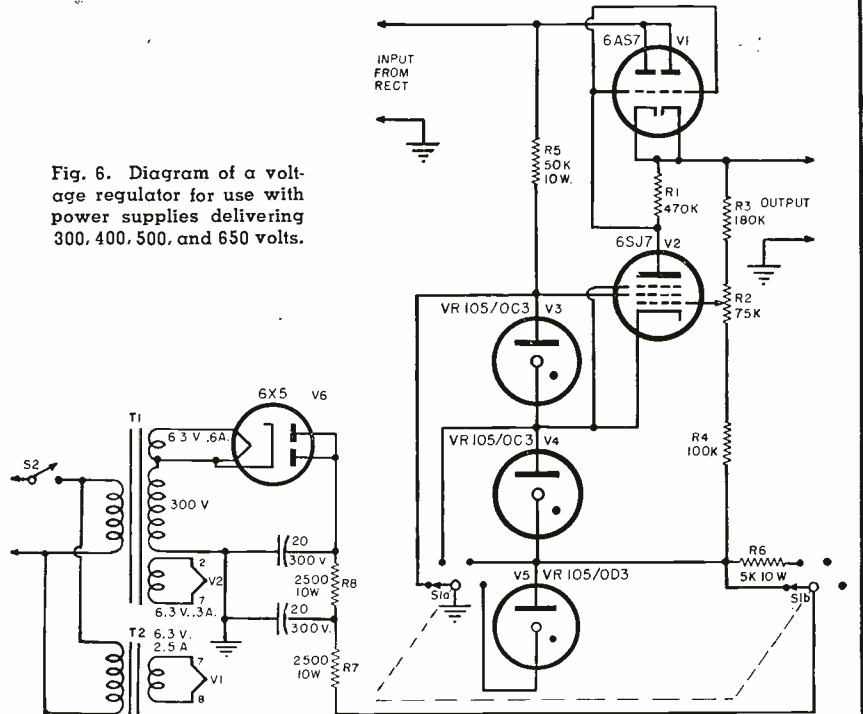

Fig. 6. Diagram of a voltage regulator for use with power supplies delivering 300, 400, 500, and 650 volts.

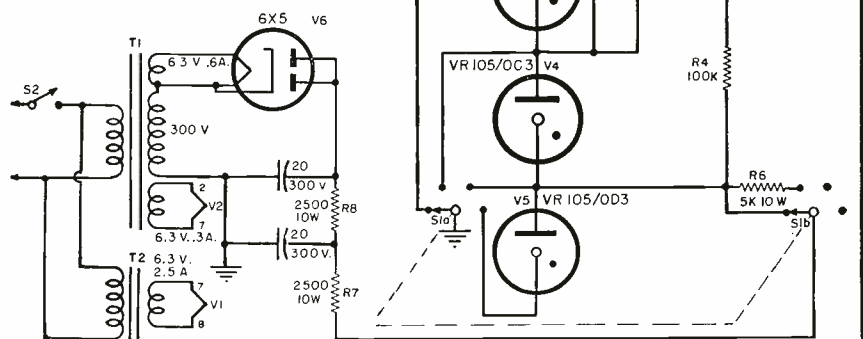
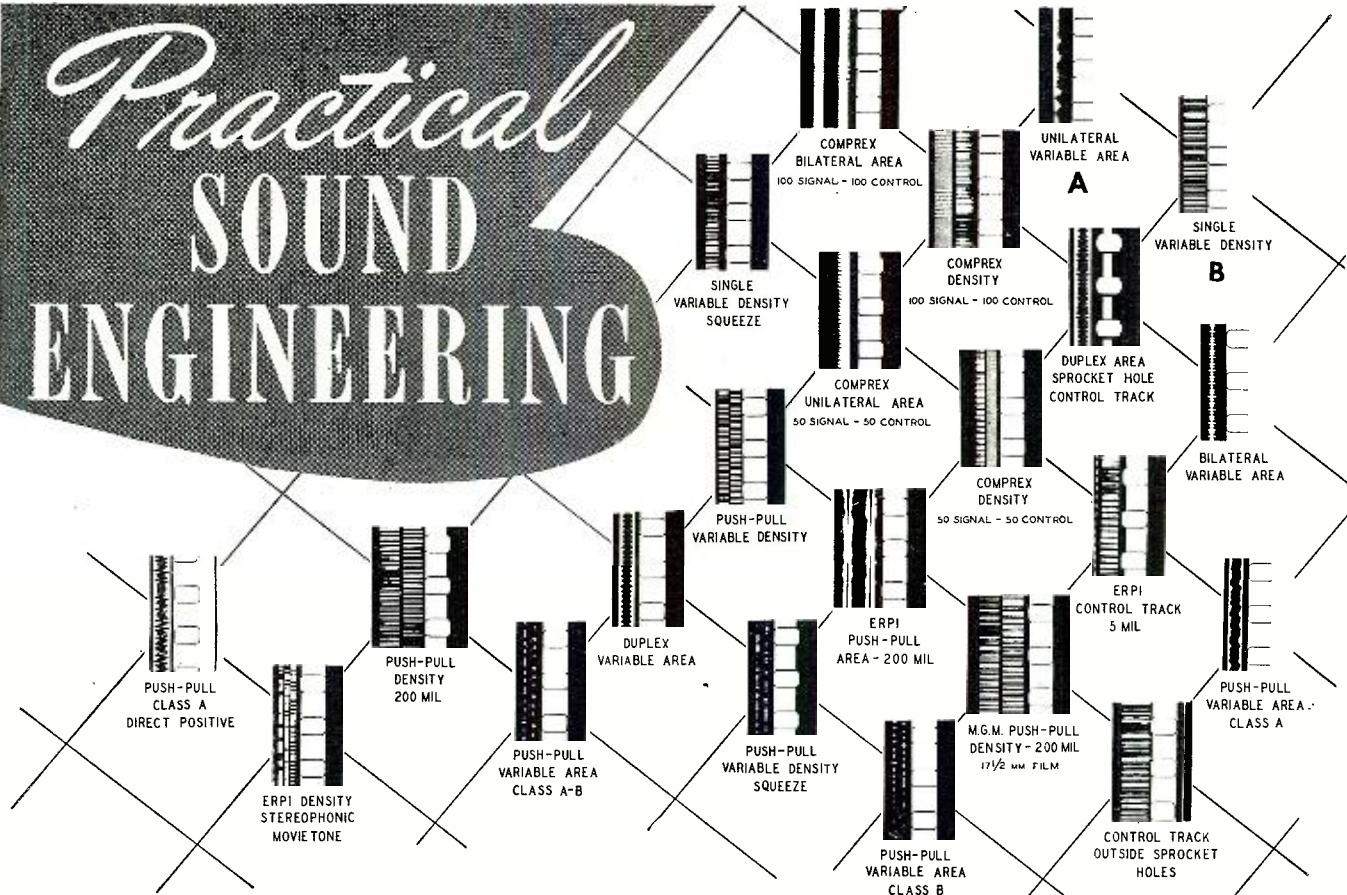

Fig. 7. Schematic diagram of a voltage regulator delivering 125 to 150 ma. at a voltage from 0 to 450.

- R_1 —50,000 ohm, 10 w. res.
- R_2, R_3 —470,000 ohm, 1/2 w. res.
- R_4, R_5, R_{11} —2500 ohm, 10 w. wirewound res.
- R_6 —150,000 ohm, 1/2 w. res.
- R_7 —200,000 ohm rheostat
- R_8 —2.5 megohm, 1/2 w. res.
- R_9 —50,000 ohm, 1/2 w. res.
- R_{10} —75,000 ohm, 1/2 w. res.
- C_1, C_2 —8 μ d., 325 v. elec. cond.
- C_3, C_4 —16 μ d., 450 v. elec. cond.
- C_5 —1 μ d., 200 v. cond.
- S —S.p.s.t. toggle sw.
- CH_1 —8-30 hy., 150 ma. filter choke
- CH_2 —30 hy., 150 ma. filter choke
- T_1 —Power trans. 450-0-450 v. @ 250 ma.; 5 v. @ 3 amps.; 6.3 v. @ .6 amp.
- T_2 —Fil. trans. 6.3 v. @ 2.5 amp.; 6.3 v. @ 2.5 amp.
- T_3 —Fil. trans. 6.3 v. @ .3 amp.; 6.3 v. @ .3 amp.; 6.3 v. @ current to be determined by equipment used
- M_1 —250 ma. d.c. milliammeter
- M_2 —500 v. d.c. voltmeter
- V_1 —5U4 tube
- V_2 —6X5 tube
- V_3, V_4 —6AS7 tube
- V_5 —6J5 tube
- V_6 —6SJ7 tube
- V_7, V_8 —VR105/OC3 tube

Practical SOUND ENGINEERING



By
H. M. TREMAINE, D.Sc.
 College of Audio Engineering
 University of Hollywood

Part 7. A discussion of compressor-limiters and various devices fed by the bridging bus.

EARLY in the development of the art of sound recording it was recognized that certain types of recording, such as dialogue or sound effects, are of such a volume range that they cannot be reproduced to the best advantage. When reproduced, the loud passages are too loud, and the low passages too low. Under such conditions, the low level sounds are lost in the surrounding ambient noise level of the auditorium, and the high level passages appear to be exaggerated, thus giving unnatural reproduction.

Manual compression of the program material by the mixer during the recording has not been too successful. This led to the development of an automatic electronic device for controlling the gain of recording circuits. Such devices are known as "compressors", or "electronic limiters." Experience has proved that when a compressor is properly adjusted and used, a definite improvement in the intelligibility of the dialogue and volume range is obtained. This is the result of the smoothing effect of the compressor.

A compressor will allow a higher average level to be recorded, thus improving the signal-to-noise ratio. Although the compressor restricts the

volume range, it also flattens out peaks and dips in the program material.

A block diagram of a typical compressor-limiter amplifier used by the motion picture industry is shown in Fig. 1. A compressor amplifier may be likened to an automatic volume control in a radio set, and accomplishes its purpose in a similar manner. The compressor consists of two push-pull stages in tandem. The first stage is a pair of 6SK7 tubes operating as a variable gain stage. This is followed by a fixed gain stage using two 6SJ7 tubes. Across the output of the fixed stage is bridged a single triode stage which drives a diode rectifier. This stage rectifies the audio signal which is then used to bias the first push-pull stage.

As the input audio signal varies in amplitude, so will the bias on the first stage. Therefore, the gain of the first push-pull stage is made to vary in accordance with the amplitude of the incoming signal. An initial adjustment of the bias will allow the gain to be set to a point where the output signal level will not increase as much proportionately with an increase of input signal level, i.e., the signal will be "compressed." The point where compression

starts is called the "breakaway" point. A fixed amount of bias is always present in the first push-pull stage to prevent an increase in plate current until the signal voltage exceeds the initial bias.

The d.c. voltage obtained from the rectifier circuit is filtered to reduce the ripple voltages. The acting and release time of the compressor is controlled by the amount of capacity in the filter circuit. Since it is necessary that the output reduction in gain take place in the shortest possible time, the filter capacity must be kept small. The average operating time is 1 to 10 milliseconds, and approximately 100 milliseconds for release.

Balancing pots are included in both push-pull stages to reduce the effect of ripple voltages from the rectifier circuit. It is imperative that the tubes in both push-pull stages have identical electrical characteristics, and be aged at least 50 hours before being put into use.

Two types of compression are in general use, gradual and limiting. See Fig. 3. Gradual compression is set to give a slope of 2 to 1 as shown by the curve A,B,E. A limiting curve is generally set for a slope ratio of 4 to 1,

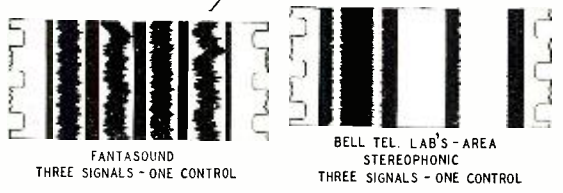

similar to curve *A,C,F*. A switch is provided in the circuit to remove the compressor action if desired, allowing the device to be operated as a conventional amplifier. This is shown as the "manual" curve, *A,B,C,D*.

Compression ratios are expressed by stating the breakaway point, as shown by the points *B* and *C*, which are relative to 100 per-cent modulation of the system.

The 100 per-cent modulation of the system is defined as being the level for 100 per-cent modulation of the light valve, recording galvanometer, cutting head, or magnetic recorder when the bridging bus is a plus 4 dbm.

The compressor breakaway point is defined as the point where compression can just be detected, or where it affects the system 0.50 db.

Curve *A,B,E* of Fig. 3 represents a compression ratio of 20 db into 10 db at an output level of plus 4 dbm. Curve *A,C,F* represents a compression ratio of 17 db into 3 db at an output level of plus 4 dbm. The expression "20 db into 10 db" means that the output signal level will increase only 10 db above the breakaway point for an increase of 20 db at the input of the compressor.

Compressors are generally of the *no gain* type, and may be inserted in the system without disturbing previously set levels. However, some manufacturers provide means for increasing the gain if required, thus eliminating the line amplifier and combining both into one unit. This is quite satisfactory if the device is to remain a permanent part of the system. Due to the flexibility required in a large installation, it is better to keep it a separate piece of equipment.

When compression is used with dialogue recording, equalization of high frequencies may be desirable to prevent extreme sibilance. Compressors used without equalization show an excessive amount of sibilants. This is caused by the fact that the sibilants, due to their low inherent energy, do not actuate the compressor to the same extent as do the vowels or consonants. Therefore, equalization is included in the rectifier circuit to increase the high frequency response, thus increasing the compression above 1000 cps where the greatest sibilance occurs. This results in a smoother recording. The required equalization will fall between 3 and 8 db at 6000 cycles.

When recording straight dialogue with the compressor, the low and high-pass filters are placed after the compressor, to prevent a change in their frequency characteristics, caused by the action of the compressor. This is accomplished by patching from the master gain control to the compressor, to the filters, and then to the line amplifier, which will then feed the bridging bus.

The low frequency equalization used with dialogue recording provides protection for the compressor, as it suppresses the low frequencies and prevents thumping due to any unbalance

in the compressor push-pull stages.

Compressors have a tendency to smooth out the frequency characteristics of the system, resulting in an automatic effort equalizer, because when voices are raised in volume, the amount of low frequency attenuation is reduced, thus helping to prevent the voices from becoming harsh.

A variable pad referred to as a "ceiling control" is connected in the output of the compressor to provide a convenient means of controlling the compression ratio. Increasing the loss in the ceiling control changes the gain following the compressor and will control the amount of compression to the recording system. As the loss of the ceiling control is increased, the signal at the input of the compressor has to be increased to obtain the same output level at the bridging bus; thus the amount of compression is increased. The ceiling control is generally placed at the mixer console for convenience of operation.

Most compressor amplifiers may also be operated as limiter amplifiers. This characteristic is obtained by the adjustment of the bias control to the first push-pull stage, and the gain control of the rectifier amplifier. As a rule compression is not used when recording straight music, as it restricts the dynamic range; however, limiting may be used to a good advantage.

When dialogue is to be recorded and only one compressor-limiter amplifier is available, the compressor may be patched ahead of the mixer as shown in Fig. 2. The line amplifier then feeds the bridging bus.

It will be noted the compressor is placed *after* the mixer pot and followed by the ceiling control, which is patched into the mixer combining network in place of the mixer pot. Connecting the compressor in this manner

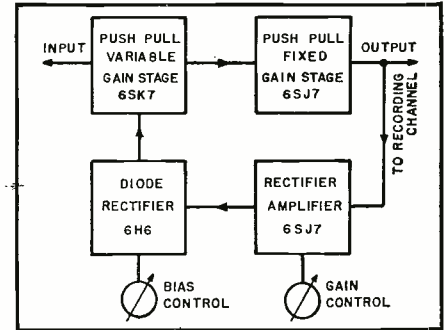

Fig. 1. Simplified block diagram of a typical compressor-limiter amplifier as used by the motion picture industry.

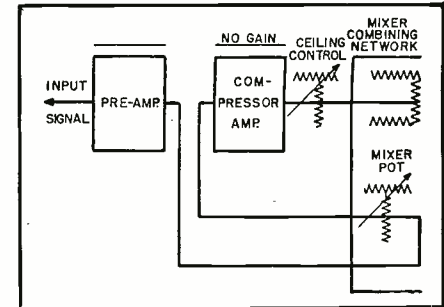
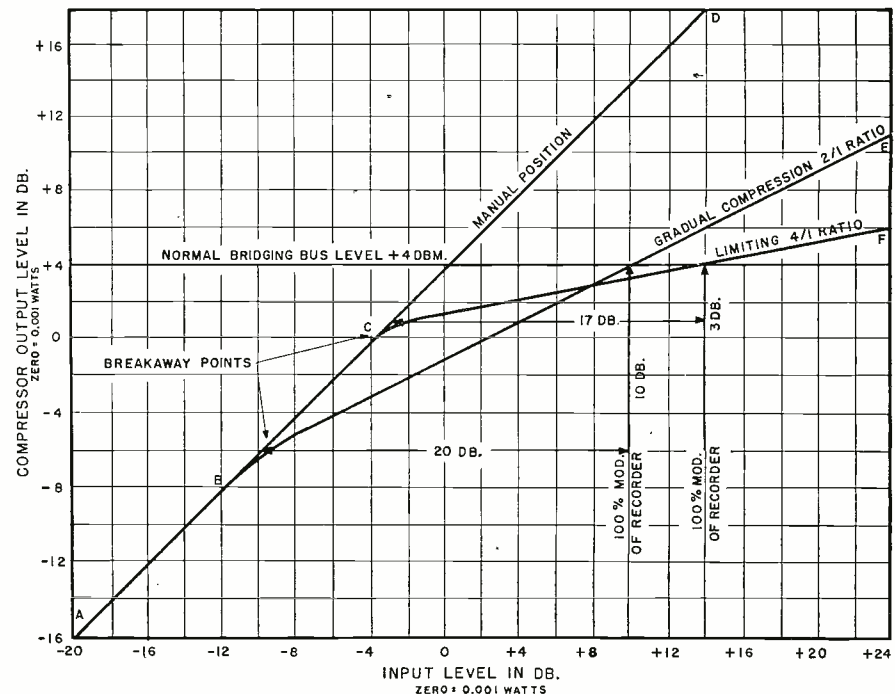

Fig. 2. Arrangement for recording dialogue when only one compressor is available.

prevents the mixer pot from acting as a ceiling control, which would be the case if the compressor output was fed directly into the mixer pot.

This connection requires that at least one of the mixer pots in the mixer console be connected through "normal" jacks so that the pot may be "lifted" out of the network for use with the compressor. When the compressor is used in this manner, low frequency attenuation is supplied by the low frequency attenuators in the mixer network as shown in Fig. 5. If a sec-

Fig. 3. Graph showing the two types of compression generally used—gradual and limiting.



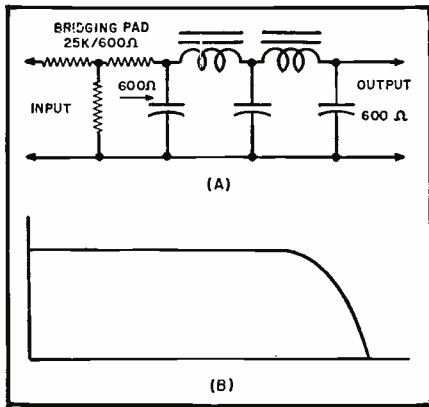

Fig. 4. (A) Circuit diagram and (B) frequency roll-off characteristics of the monitor low-pass filter network.

ond compressor amplifier is available it may be set for limiting, and patched in a normal manner.

Referring again to the block diagram, Fig. 5, leaving the compressor output we now come to the "bridging bus," the point of signal distribution for the system. Here the signal takes two routes, one to the monitoring

equipment and one to the recording equipment.

The bridging bus is, in reality, a load impedance for the amplifier driving the bus. This load consists of the several devices to the right of the bus, and the two vu meters to the left. In parallel with these devices is a bridging bus terminating resistor. The value of this resistor is such that when it is paralleled with the devices constituting the load, the correct load impedance is seen by the device driving the bus.

Devices designed for bridging purposes generally use an input impedance of 25,000 or 30,000 ohms, which has been standardized by the industry. The bridging bus terminating resistor is calculated for the *minimum* bridging load requirements. This will then allow several more pieces of equipment to be paralleled across the bus without lowering the load impedance to a dangerous value. If the device driving the bus requires a load impedance of 600 ohms, a terminating resistor is used that will present a load of 600 ohms with the minimum bridging load. When additional equipment is paralleled across the bus, the impedance pre-

sented by the bus should not be allowed to drop more than 10 per cent of normal, or 540 ohms. The use of 30,000 ohm input circuits will allow quite a latitude. Devices of higher impedance may be patched across the bus if desired, but not lower.

One device shown connected across the bus requires special mention relative to its input impedance. This is the monitor low-pass filter. This filter is employed when monitoring directly from the bridging bus, and is desirable if certain definite listening characteristics are required. It can be used to establish the average listening characteristics for whatever product is being recorded.

At the input of this filter is a bridging pad with an impedance ratio of 25,000 to 600 ohms, which allows it to be connected directly across the bridging bus. Of course this introduces a loss ahead of the filter, but is compensated for by increasing the monitor amplifier gain. The circuit for this device is shown in Fig. 4A, and its frequency characteristics in Fig. 4B.

Although an ungrounded bridging (Continued on page 158)

Fig. 5. Block diagram of a composite sound channel for recording and reproducing. Disc, magnetic tape, and film recorders are included.

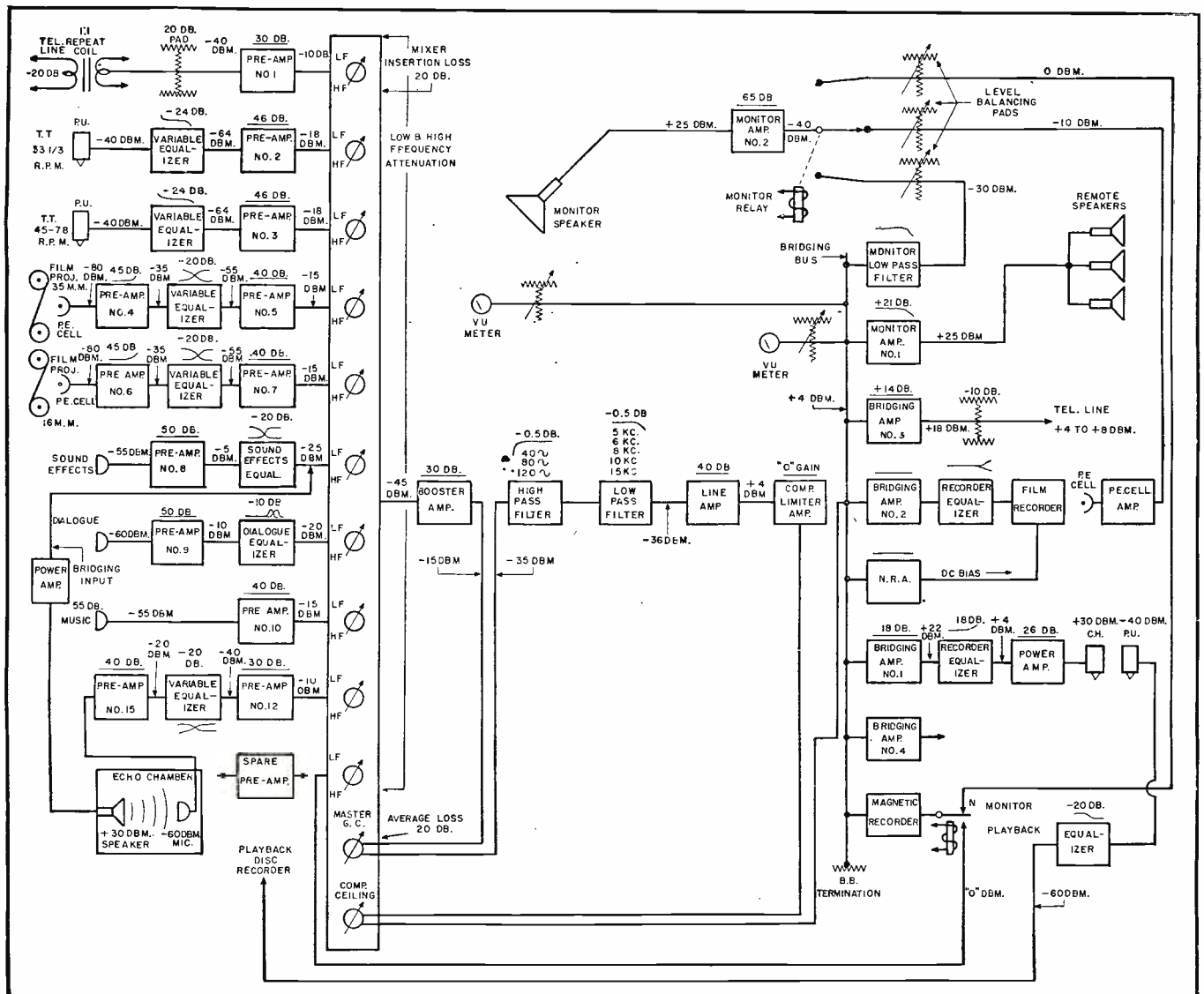

TRIPLETT

Load-Chek introduces Servicing by Power Consumption

MODEL 660

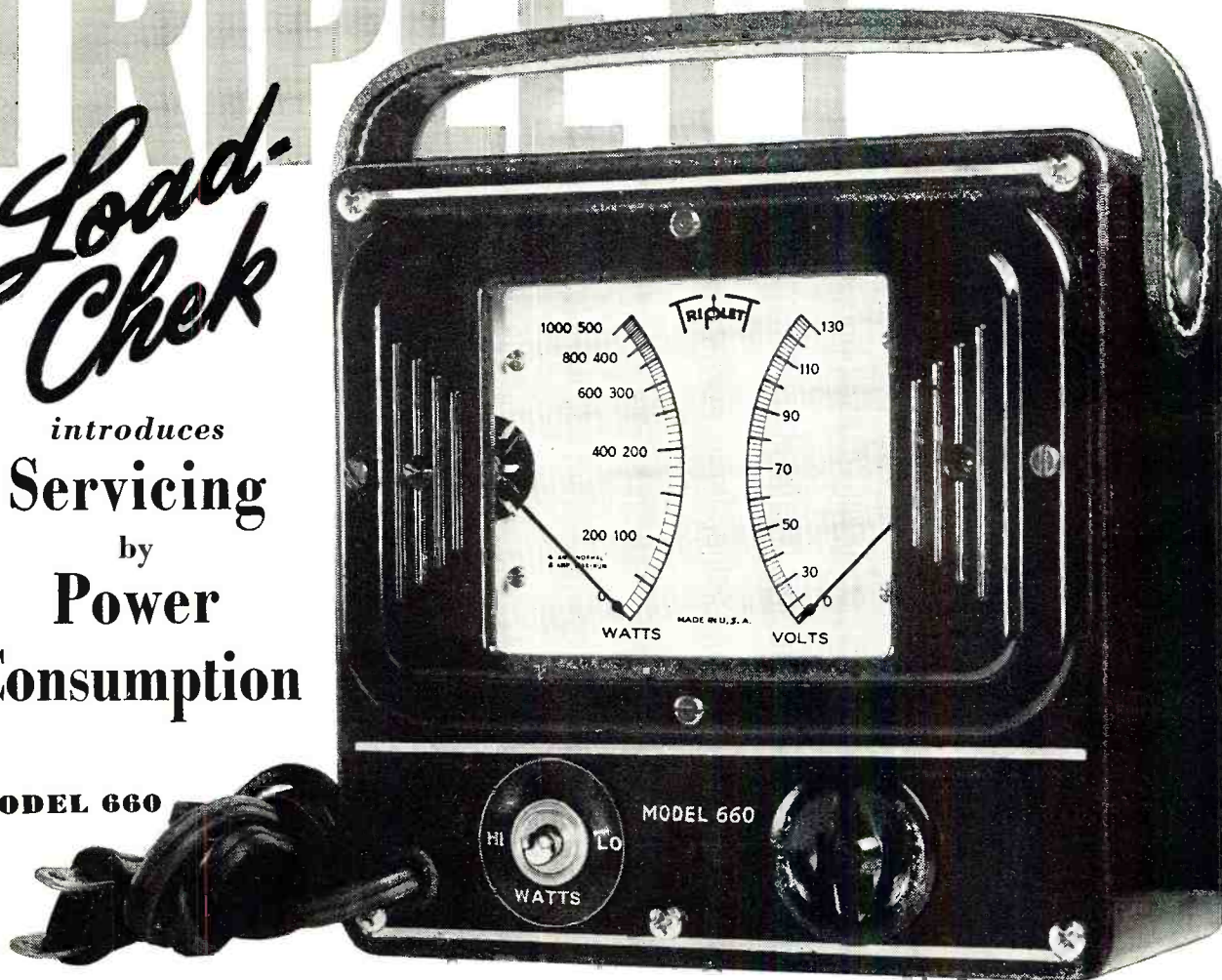

LOAD-CHEK for the first time makes it possible for every technician to utilize what is perhaps the simplest and quickest of all service methods—Servicing by Power Consumption Measurements.

Power consumption measurement has long been proved by auto-radio servicemen as a rapid method of localizing troubles in auto radios. But Triplet's new LOAD-CHEK is the first Wattmeter to be produced at moderate cost, and with the proper ranges, to bring this short-cut method within the reach of every radio and TV service man.

Basis of the LOAD-CHEK method is the tag or label on every radio and TV chassis which shows the normal power consumption. The following examples are only two of many time-saving uses of this new instrument.

LOCATING A SHORT—The chassis tag may show a normal consumption of 225 Watts. Simply plug the power cord of the chassis into LOAD-CHEK (there are no loose ends to connect or be in the way). Note the reading—which should be possibly 350 Watts. By removing the

rectifier tube you can determine at once which side of the tube the short is on. With a soldering iron and long-nosed pliers you can check through the chassis, locate and correct the trouble without having to lay down tools or to check with lead wires!

REPLACING BURNED OUT RESISTORS—With the chassis to be repaired plugged into a LOAD-CHEK MODEL 660, note the wattage reading with the burned out resistor circuit open. Now replace the resistor. Should the increase in watts be greater than that of the resistor rating being installed, it indicates that an extra load has caused the trouble which has not been cleared.

LOAD-CHEK is made-to-order for the busy service man and can help stop costly "come back" repair jobs. It's a profit-maker because it's a Time-Saver. And at its moderate cost LOAD-CHEK can be standard equipment on every service bench. By all means, inspect this versatile instrument at your distributor and place your order, for under present conditions we must fill all orders on a basis of "First Come, First Served."

SEE MODEL 660 LOAD-CHEK AT YOUR DISTRIBUTOR'S

FOR THE MAN WHO TAKES PRIDE IN HIS WORK
Triplet
TRIPLETT ELECTRICAL INSTRUMENT COMPANY - BLUFFTON, OHIO, U.S.A.

Features OF THE NEW 1952



PROOF OF THE NEW O-7 OSCILLOSCOPE'S OUTSTANDING PERFORMANCE

Below are actual, unretouched photographs showing the outstanding frequency response characteristics of the NEW 1952 HEATHKIT OSCILLOSCOPE, MODEL O-7. To the left is a 10 KC square wave — to the right a 4 MC sine wave as they actually appear on the screen. Two highly severe tests to make on any scope (only the best of scopes will show traces like these) — and the O-7 really comes through.

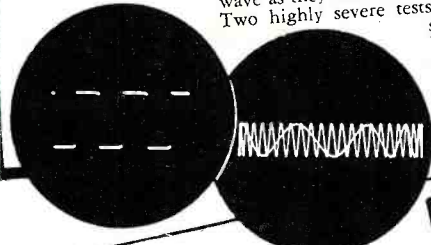

COMPANION VACUUM TUBE VOLTMETERS

Here are the two NEW 1952 VACUUM TUBE VOLTMETER COMPANION PIECES. Matched instruments of new design to open up the whole field of DC, AC, and resistance measurements for you. The new greatly reduced size combines style, beauty, and compactness — The V-5 and AV-1 have the new panel and cabinet construction as shown on the right. A tremendous pair of voltmeters. Small in size but virtual giants in the range of measurements they make.



NEW STYLE AND BEAUTY

Style that's modern, yet functional — that's the trend of today — and Heathkits are right up to the minute. Note the cur showing the new V-5 and AV-1 cabinet and panel construction. The front panel and rear cover slide right over the recessed flange of the case thereby eliminating sharp edges and pointed corners. The voltmeter kits aren't "shelf" or "mounted" instruments — they're moved about on the bench a lot and thus the new compact size and specially designed cabinets — Another 1952 Heathkit feature.

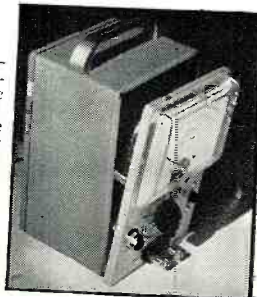

A STATEMENT FROM SIMPSON ELECTRIC CO.

In choosing Simpson Meters for their Heathkit VTVM, the Heath Co. has set a new high standard of kit meter quality. The same high quality of material, workmanship and design that has given Simpson the reputation for building "Instruments That Stay Accurate" is found in the Heathkit Meter Movement.

SIGNED
SIMPSON ELECTRIC CO.

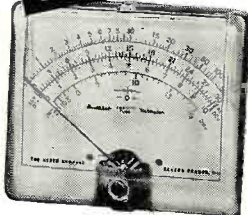

A STATEMENT FROM CHICAGO TRANSFORMER

It is indeed gratifying to note the outstanding sales records you are building with your Heathkits.

This sales success is readily understandable, since we are cognizant of the high quality standards you have established for your component suppliers.

We at Chicago Transformer are proud that our product has contributed to the recognized quality and increasing popularity of Heathkits.

CHICAGO TRANSFORMER DIVISION
Essex Wire Corporation

L. S. RACINE
Vice-President and Sales Manager



HEATHKIT PRECISION RESISTORS

Where exact resistance values are required for instrument accuracy, the Heath Co. has spared no effort in supplying the finest resistors available. Precision resistors as manufactured by Continental Carbon Inc., and Wilcor Corp., meet the rigorous JAN (Joint Army-Navy) specifications and are small in size, extremely non-inductive, highly stable, have a low temperature coefficient, and can be held to great accuracy. You'll find quality components in Heathkits.

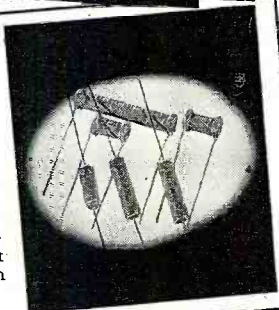

COLLEGES USE HEATHKITS

Colleges and Universities throughout the country are using Heathkits in their electrical engineering, radio, and physics laboratories — Heathkits are the answer to good test equipment at low cost, plus being rugged, dependable, and accurate. Trade schools are having their students build Heathkits to obtain a first hand working knowledge of test equipment and to get the practical experience gained by construction. Heathkits fill school needs.

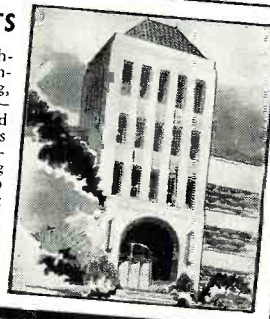

YOU SAVE BY ORDERING DIRECT FROM MANUFACTURER—USE ORDER BLANK ON LAST PAGE

EXPORT AGENT
ROCKE INTERNATIONAL CORP.
12 E. 40th ST.
NEW YORK CITY (16)
CABLE: ARLAB-N.Y.

The **HEATH COMPANY**

... BENTON HARBOR 15, MICHIGAN

New LABORATORY LINE HEATHKITS



MODEL AV-1
Shipping weight 5 lbs.

NEW Heathkit A.C. VACUUM TUBE VOLTMETER KIT

Now — as a Heathkit — at a price anyone can afford, an AC VTVM.

A new kit to make possible those sensitive AC measurements required by audio enthusiasts, laboratories, and experimentors. Here is the kit that the audio men have been looking for. Its tremendous range of coverage makes possible measurements of audio amplifier frequency response — gain or loss of audio stages — characteristics of audio filters and attenuators — hum investigation — and literally a multitude of others. Ten ranges consisting of full scale .01, .03, .1, .3, 1, 3, 10, 30, 100, 300 volts RMS assure easy and more accurate readings. Ten ranges on DB provide for measurements from -52 to +52 DB. Frequency response within 1 DB from 20 cycles to 50 KC.

The ingenious circuitry incorporates precision multiplier resistors for accuracy, two amplifier stages using miniature tubes, a unique bridge rectifier meter circuit, quality Simpson meter with 200 microampere movement, and a clean layout of parts for easy wiring. A high degree of inverse feedback provides for stability and linearity.

Simple operation is accomplished by the use of only one control, a range switch which changes the voltage ranges in multiples of 1 and 3, and DB ranges in steps of 10.

The instrument is extremely compact, cabinet size — 4 1/8" deep x 4-11/16" wide x 7 3/8" high, and the newly designed cabinet makes this the companion piece to the VTVM. For audio work, this kit is a natural.

\$29.50

NEW Heathkit AUDIO FREQUENCY METER KIT

MODEL AF-1
Shipping weight 12 lbs.



\$34.50

A NEW Heathkit Audio Frequency Meter — the ideal instrument for determining frequencies from 20 cycles to 100 KC. Set the selector switch to the proper range — feed the signal into the input terminals — and read the frequency from the meter — completely simple to operate, and yet dependable results.

Quality Simpson 200 microampere meter has two plainly marked scales (0-100 0-300). These scales, read in conjunction with the seven position selector switch, give full scale readings of 100, 300, 1000, 3000, 10,000, 30,000, and 100,000 cycles. Convenient ranges for fast and easy readings.

For greatest accuracy, the 1-3-10 ratio of ranges is maintained and each range has individual calibrating control.

Input impedance is high (1 megohm) for negligible circuit loading. A signal and a change in signal voltage between these limits will not affect the meter frequency of either sine wave or square wave input. The tube complement consists of a 6S17 amplifier and clipper, 6V6 amplifier and clipper, 6H6 meter pulse rectifier, 6X5 power supply rectifier, and OD3/VR150 voltage regulator.

Construction is simple, and quality components are used throughout.

NEW Heathkit INTERMODULATION ANALYZER KIT

Intermodulation testing of audio equipment is rapidly being accepted by more and more engineers and audio experts as the best way to determine the characteristics of audio amplifiers, recording systems, networks, etc. — shows up those undesirable characteristics which contribute to listening fatigue when all other methods fail.

The Heathkit Intermodulation Analyzer supplies a choice of two high frequencies (3000 cycles and a higher frequency (60 cycles) and one low frequency (60 cycles). Both 1:1 or 4:1 ratios of low frequencies can be set up for IM testing, and the ratios are easily set by means of a panel control and the instrument's own VTVM. An output level control supplies the mixed signal at the desired level with an output impedance of two thousand ohms. The Analyzer section has input level control and proper filter circuits feeding the instrument's VTVM to read intermodulation directly on full scale ranges of 30%, 10% and 3%. Built-in power supply furnishes all necessary voltages for operating the instrument.

You won't want to be without this new and efficient means of testing



MODEL IM-1
Shipping wt. 18 lbs.

\$39.50

NEW Heathkit SQUARE WAVE GENERATOR KIT

The new Heathkit Square Wave Generator Kit with its 100 KC square wave opens an entirely new field of audio testing. Square wave testing over this wide range will quickly show high and low frequency response characteristics of circuits — permit easy adjustment of high frequency compensating networks used in video amplifiers — identify ringing in circuits — demonstrate transformer characteristics, etc.

The circuitry consists of a multivibrator stage, a clipping and squaring stage, and a cathode follower output stage. The power supply is transformer operated and utilizes a full wave rectifier tube with 2 sections of LC filtering.

As a multivibrator cannot be accurately calibrated, a provision is provided to allow the instrument to be accurately synchronized with an accurate external source when extreme accuracy is required.

The low impedance output is continuously variable between 0 and 25 volts and operation is simple. You'll really appreciate the wide range of this instrument, 10 cycles to 100 kilocycles — continuously variable. Kit is complete with all parts and instruction manual, and is easy to build.



MODEL SQ-1
Shipping wt. 14 lbs.

\$29.50

YOU SAVE BY ORDERING DIRECT FROM MANUFACTURER—USE ORDER BLANK ON LAST PAGE

EXPORT AGENT
ROCKE INTERNATIONAL CORP.
12 E. 40th ST.
NEW YORK CITY (16)
CABLE: ARLAN-N.Y.

The HEATH COMPANY

... BENTON HARBOR 15, MICHIGAN

Heathkit SIGNAL GENERATOR KIT

Model SG-6
Shipping Wt. 7 lbs.

The new Heathkit Signal Generator Kit has dozens of improvements. Covers the extended range of 160 Kc to 50 megacycles on fundamentals and up to 150 megacycles on useful calibrated harmonics; makes this Heathkit ideal as a marker oscillator for TV. Output level can be conveniently set by means of both step attenuator and continuously variable output controls. Instrument has new miniature HF tubes to easily handle the high frequencies covered.

Uses 6C4 master oscillator and 6C4 sine wave audio oscillator. The kit is transformer operated and a husky selenium rectifier is used in the power supply. All coils are precision wound and checked for calibration making only one adjustment necessary for all bands.

New sine wave audio oscillator provides internal modulation and is also available for external audio testing. Switch provided allows the oscillator to be modulated by an external audio oscillator for fidelity testing of receivers. Comes complete, all tubes, cabinet, test leads, every part. The instruction manual has step-by-step instructions and pictorials. It's easy and fun to build a Heathkit Model SG-6 Signal Generator.



\$19.50

Heathkit CONDENSER CHECKER KIT

Only
\$19.50

Model C-2
Shipping Wt. 6 lbs.

Checks all types of condensers — paper — mica — ceramic — electrolytic. All condenser scales are direct reading and require no charts or multipliers. Covers range of .00001 MFD to 1000 MFD. A Condenser Checker that anyone can read. A leakage test and polarizing voltage for 20 to 500 V provided. Measures power factor of electrolytics between 0% and 50% and reads resistance from 100 ohms to 5 megohms. The magic eye indicator makes testing easy.

The kit is 110V 60 cycle transformer operated and comes complete with rectifier tube, magic eye tube, cabinet, calibrated panel and all other parts. Has clear detailed instructions for assembly and use.



NEW Heathkit SIGNAL TRACER AND UNIVERSAL TEST SPEAKER KIT

\$19.50

Model T-2
Shipping Wt. 7 lbs.

The popular Heathkit Signal Tracer has now been combined with a universal test speaker at no increase in price. The same high quality tracer follows signal from antenna to speaker — locates intermittents — finds defective parts quicker — saves valuable service time — gives greater income per service hour. Works equally well on broadcast, FM, or TV receivers. The test speaker has an assortment of switching ranges to match either push-pull or single output impedances. Also tests microphones, pickups and PA systems. Comes complete: cabinet, 110V 60 cycle power transformer, tubes, test probe, all necessary parts, and detailed instructions for assembly and use.



Model TC-1
Shipping Wt. 12 lbs.

\$29.50

Heathkit TUBE CHECKER KIT

The Tube Checker is a MUST for radio repair men. Often customers want to SEE tubes checked, and a checker like this builds customer confidence. In your repairing, you will have a multitude of tubes to check — quickly. The Heathkit tube checker will serve all these functions — it's good looking (with a polished birch cabinet and an attractive two color panel) — checks 4, 5, 6, 7 prong Octals, Loctals, 7 prong miniatures, 9 prong miniatures, pilot lights, and the Hytron 5 prong types. AND IT'S FAST TO OPERATE — the gear driven, free-running roll chart lists hundreds of tubes, and the smooth acting, simplified switching arrangement gives really rapid set-ups.

The testing arrangement is designed so that you will be able to test new tubes of the future — without even waiting for factory data — protection against obsolescence.

You can give tubes a thorough testing — checks for opens, shorts, each element individually, emission, and for filament continuity. A large BAD-?-GOOD meter scale is in three colors for easy reading and also has a "line-set" mark.

You'll find this tube checker kit a good investment — and it's only \$29.50.

YOU SAVE BY ORDERING DIRECT FROM MANUFACTURER—USE ORDER BLANK ON LAST PAGE

EXPORT AGENT
ROCKE INTERNATIONAL CORP.
131 E. 40th ST.
NEW YORK CITY (16)
CABLE: ARLAB-N.Y.

The HEATH COMPANY

... BENTON HARBOR 15, MICHIGAN

NEW *Heathkit* T.V.

ALIGNMENT GENERATOR KIT



\$39.50

Model TS-2
Shipping Wt. 20 lbs.

Here is an excellent TV Alignment Generator designed to do TV service work quickly, easily, and properly. The Model TS-2 when used in conjunction with an oscilloscope provides a means of correctly aligning television receivers.

The instrument provides a frequency modulated signal covering, in two bands, the range of 10 to 90 Mc. and 150 to 230 Mc. — thus, ALL ALLOCATED TV CHANNELS AS WELL AS IF FREQUENCIES ARE COVERED.

An absorption type frequency marker covers from 20 to 75 Mc. in two ranges — therefore, you have a simple, convenient means of frequency checking of IF's, independent of oscillator calibration.

Sweep width is controlled from the front panel and covers a sweep deviation of 0-12 Mc. — all the sweep you could possibly need or want.

And still other excellent features are: Horizontal sweep voltage available at the front panel (and controlled with a phasing control) — both step and continuously variable attenuation for setting the output signal to the desired level — a convenient instrument stand-by position — vernier drive of both oscillator and marker tuning condensers — and blanking for establishing a single trace with base reference level. Make your work easier, save time, and repair with confidence — order your Heathkit TV Alignment Generator now!

NEW *Heathkit* SINE AND SQUARE WAVE AUDIO GENERATOR KIT

Designed with versatility, usefulness, and dependability in mind, the AG-7 gives you the two most needed wave shapes right at your fingertips — the sine wave and the square wave.

The range switch and plainly calibrated frequency scale give rapid and easy frequency selection, and the output control permits setting the output to any desired level.

A high-low impedance switch sets the instrument for either high or low impedance output — on high to connect a high impedance load, and on low to work into a low impedance transformer with negligible DC resistance.

Coverage is from 20 to 20,000 cycles, and distortion is at a minimum — you can really trust the output wave shape.

Six tubes, quality 4 gang tuning condenser, power transformer, metal cased filter condenser, 1% precision resistors in the frequency determining circuit, and all other parts come with the kit — plus, a complete construction manual — A tremendous kit, and the price is truly low.



Model AG-7
Shipping Wt. 15 lbs.

\$34.50

THE NEW *Heathkit* HANDITESTER KIT

A precision portable volt-ohm milliammeter. Uses only high quality parts — All precision 1% resistors, three deck switch for trouble-free mounting of parts, specially designed battery mounting bracket, smooth acting ohm adjust control, beautiful molded bakelite case, 400 micro-amp meter movement, etc. DC and AC voltage ranges 10-30-300-1000-

5000V. Ohms range 0-3000 and 0-300,000. Range Milliampers 0-10 Ma, 0-100 Ma. Easily assembled from complete instructions and pictorial diagrams.



\$13.50

Model M-1
Shipping Wt. 3 lbs.

NEW *Heathkit* BATTERY ELIMINATOR KIT

A few auto radio repair jobs will pay for the Heathkit Battery Eliminator Kit. It's fast for service. The voltage can be lowered to find sticky vibrators or raised to ferret out intermittents. Provides variable DC voltage 5 to 7½ Volts at 10 Amps. continuous or 15 Amps. intermittent.

Also serves as storage battery charger. A well filtered, rugged power supply uses heavy duty selenium rectifier, a husky choke, and a 4000 MFD electrolytic condenser for clean DC. 0-15V voltmeter indicates output which is variable in eight steps. Better be equipped for all types of service — it means more income.

Model BE-2
Shipping Wt. 19 lbs.

\$22.50



YOU SAVE BY ORDERING DIRECT FROM MANUFACTURER—USE ORDER BLANK ON LAST PAGE

EXPORT AGENT
ROCKE INTERNATIONAL CORP.
13 E. 40th ST.
NEW YORK CITY (16)
CABLE: ARAB-N.Y.

The HEATH COMPANY

... BENTON HARBOR 15, MICHIGAN



Model 1B-1B
Shipping Wt. 15 lbs.

Heathkit IMPEDANCE BRIDGE KIT

This Impedance Bridge Kit is really a favorite with schools, industrial laboratories, and serious experimenters. An invaluable instrument for those doing electrical measurements work. Reads resistance from .01 Ohms to 10 meg., capacitance from .00001 to 100 MFD, inductance from 10 microhenries to 100 henries, dissipation factor from .002 to 1, and storage factor from 1 to 1000. And you don't have to worry about selecting the proper bridge circuit for the various measurements — the instrument automatically makes the correct circuit when you set up for taking the measurement you want. Bridge utilizes Wheatstone, Hay, Maxwell, and capacitance comparison circuits for the wide range and types of measurements possible. And it's self powered — has internal battery and 1000 cycle hummer. No external generator required — has provisions for external generator if measurements at other than 1000 cycles are desired. Kit utilizes only highest quality parts, General Radio main calibrated control.

\$69⁵⁰

Mallory ceramic switches, excellent 200 microamp zero center galvanometer, laboratory type binding posts with standard 3/4 inch centers, 1% precision ceramic-body type multiplier resistors, beautiful birch cabinet and ready calibrated panel. (Headphones not included.)
Take the guesswork out of electrical measurements — order your Heathkit Impedance Bridge kit today — you'll like it.

Heathkit LABORATORY RESISTANCE DECADE KIT



\$19⁵⁰

Shipping Wt. 4 lbs.

An indispensable piece of laboratory equipment — the Heathkit Resistance Decade Kit gives you resistance settings from 1 to 99,999 ohms IN ONE OHM STEPS. For greatest accuracy, 1% precision ceramic-body type resistors and highest quality ceramic wafer switches are used.

Designed to match the Impedance Bridge above, the Resistance Decade Kit has a beautiful birch cabinet and attractive panel. It's easy to build, and comes complete with all parts and construction manual.

Heathkit LABORATORY POWER SUPPLY KITS

Limits:

No load Variable 150-400V DC
25 MA Variable 30-310V DC
50 MA Variable 25-250V DC
Higher loads: Voltage drops off proportionally



\$29⁵⁰

Model PS-1 Ship. Wt. 20 lbs.

Every experimenter needs a good power supply for electronic setups of all kinds. This unit has been expressly designed to act as a source. Voltage control allows selection of HV output desired (continuously variable within limits outlined), and a Volts-Ma switch provides choice of output metering. A large plainly marked and direct reading meter scale indicates either DC voltage output (Range of meter 0-500V D.C., 0-200 Ma. D.C.). Instrument has convenient stand-by position and pilot light.
Comes with power transformer, filament transformer, meter, 5Y3 rectifier, two 1619 control tubes, completely punched and formed chassis, panel, cabinet, detailed construction manual, and all other parts to make the kit complete.

Heathkit ECONOMY . . . 6 WATT AMPLIFIER KIT



Model A-4
Ship. Wt. 8 lbs.

\$12⁵⁰

No. 304 12 inch speaker . . . **\$6.95**

This fine Heathkit Amplifier was designed to give quality reproduction and yet remain low in price. Has two preamp stages, phase inverter stage, and push-pull beam

power output. Comes complete with six tubes, quality output transformer (to 3-4 ohm voice coil), husky cased power transformer and all other parts. Has tone and volume controls. Instruction manual has pictorial for easy assembly. Six watts output with response flat $\pm 1\frac{1}{2}$ db from 50 to 15,000 cycles. A quality amplifier kit at a low price. Better build one.

Heathkit HIGH FIDELITY . . . 20 WATT AMPLIFIER KIT

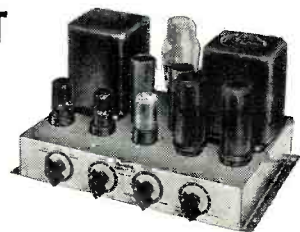

\$33⁵⁰

Shipping Wt. 18 lbs.

Our latest and finest amplifier — the model A-6 (or A-6A) is capable of a full 20 Watts of high fidelity output — good faithful reproduction made possible through careful circuit design and the use of only highest quality components. Frequency response within ± 1 db from 20-20,000 cycles. Distortion at 3 db below maximum power output (at 1000 cycles) is only .8%. The power transformer is rugged and conservatively rated and will deliver full plate and filament supply with ease. The output transformer was selected because of its exceptionally good frequency response and wide range of output impedances (4-8-16-150-600 ohms). Both are Chicago Transformers in drawn steel case for shielding and maximum protection to windings. The unit has dual tone controls to set the output for the tonal quality desired — treble control attenuates up to 15 db at 10,000 cycles — bass control gives bass boost up to 10 db at 50 cycles.
Tube complement consists of 5U4G rectifier, 6SJ7 voltage amplifier, 6SN7 amplifier and phase splitter, and two 6L6's in push-pull output. Comes complete with all parts and detailed construction manual. (Speaker not included.)
MODEL A-6: For tuner and crystal phono input. Has two position selector switch for convenient switching to type of input desired.

MODEL A-6A: Features an added 6SJ7 stage (preamplifier) for operating from variable reluctance cartridge phono pickup, mike input, and either tuner or standard crystal phono pickup. A three position selector switch provides flexible switching.
Shipping Wt. 18 lbs. **\$35.50**

YOU SAVE BY ORDERING DIRECT FROM MANUFACTURER—USE ORDER BLANK ON LAST PAGE

EXPORT AGENT
ROCKE INTERNATIONAL CORP.
121 E. 40th ST.
NEW YORK CITY (16)
CABLE: ARLAB-N.Y.

The HEATH COMPANY

. . . BE TON HARBOR 15, MICHIGAN

Heathkit RECEIVER & TUNER KITS for AM and FM



Model BR-1 Broadcast Model Kit covers 550 to 1600 Kc. Shipping Wt. 10 lbs.

\$19.50

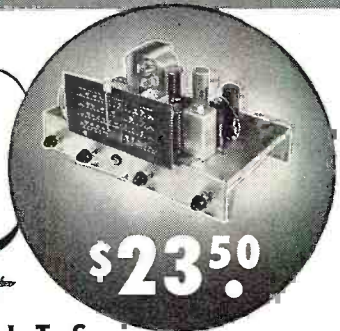

Model AR-1 3 Band Receiver Kit covers 550 Kc. to over 20 Mc. continuous. Extremely high sensitivity. Shipping Wt. 10 lbs.

\$23.50

TWO HIGH QUALITY Heathkit SUPERHETERODYNE RECEIVER KITS

Two excellent Heathkits. Ideal for schools, replacement of worn out receivers, amateur and custom installations. Both are transformer operated quality units. The best of materials used throughout—six inch calibrated slide rule dial—quality power output transformers—dual iron core shielded. I.F. coils—metal cased filter condenser. The chassis has phono input jacks, 110 Volt output for phono motor and there is a phono-radio switch on panel. A large metal panel simplifying installation in used console cabinets is included. Comes complete with tubes and instruction manual incorporating pictorials and step-by-step instructions (less speaker and cabinet). The three band model has simple coil turret which is assembled separately for ease of construction.

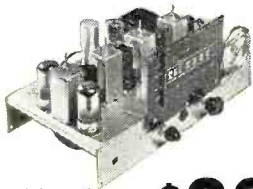

Model FM-2
Ship. Wt. 9 lbs.

\$22.50

TRUE FM FROM Heathkit FM TUNER KIT

The Heathkit FM Tuner Model FM-2 was designed for best tonal reproduction. The circuit incorporates the most desirable FM features—true FM.

Utilizes 8 tubes: 7E5 Oscillator, 6SH7 mixer, two 6SH7 1F amplifiers, 6SH7 limiter, two 7C4 diodes as discriminator, and 6X5 rectifier.

The instrument is transformer operated making it safe for connection to any type receiver or amplifier. Has ready wound and adjusted RF coils, and 2 stages of 10.7 Mc IF (including limiter). A calibrated six inch slide rule dial has vernier drive for easy tuning. All parts and complete construction manual furnished.



MAIL TO THE
HEATH COMPANY
BENTON HARBOR 15,
MICHIGAN

ORDER BLANK

From _____

SHIP VIA

- Parcel Post
- Express
- Freight
- Best Way

Quantity	Item	Price	Quantity	Item	Price
	Heathkit Oscilloscope Kit — Model O-7			Heathkit H.V. Probe Kit — No. 336	
	Heathkit VTVM Kit — Model V-5			Heathkit R.F. Signal Gen. Kit — Model SG-6	
	Heathkit FM Tuner Kit — FM-2			Heathkit Condenser Checker Kit — Model C-2	
	Heathkit Broadcast Receiver Kit — Model BR-1			Heathkit Handitester Kit — Model M-1	
	Heathkit Three Band Receiver Kit—Model AR-1			Heathkit Power Supply Kit — Model PS-1	
	Heathkit Amplifier Kit — Model A-4			Heathkit Resistance Decade Kit — Model RD-1	
	Heathkit Amplifier Kit — Model A-6 (or A-6A)			Heathkit Impedance Bridge Kit — Model IB-1B	
	Heathkit Tube Checker Kit — Model TC-1			Heathkit A.C. VTVM-KIT — Model AV-1	
	Heathkit Audio Generator Kit — Model AG-7			Heathkit Intermodul. Analyzer Kit—Model IM-1	
	Heathkit Battery Eliminator Kit — Model BE-2			Heathkit Audio Freq. Meter Kit — Model AF-1	
	Heathkit Electronic Switch Kit — Model S-2			Heathkit Square Wave Gen. Kit — Model SQ-1	
	Heathkit T.V. Alignment Gen. Kit — TS-2				
	Heathkit Signal Tracer Kit — Model T-2				
	Heathkit R.F. Probe Kit — No. 309				

On Parcel Post Orders, include postage for weight shown and insurance. (We insure all shipments.)

On Express Orders, do not include transportation charges—they will be collected by the Express Agency at time of delivery.

Enclosed find Check Money Order for _____

Please ship C.O.D. Postage enclosed for _____ lbs.

ALL PRICES SUBJECT TO CHANGE WITHOUT NOTICE

EXPORT AGENT
ROCKE INTERNATIONAL CORP.
13 E. 40th ST.
NEW YORK CITY (16)
CABLE: ARAB-N.Y.

The HEATH COMPANY

... BENTON HARBOR 15, MICHIGAN

PEAK BARGAINS

1000 KC CRYSTAL

Accurate to .02% or better. Mounted in plug-in holder.
Only..... **\$2.98**

CHOKE BARGAIN

500 MA Filter Choke. 6 Henrys, 30 ohms DC resistance.
Fully Cased..... **\$4.95**

PANEL METERS

GE—General Electric
WH—Westinghouse
W—Weston S—Simpson
*—Special Scale
SQ—Square Case

2" Meters

0-100 U.A. GR.	\$6.95
0-150 U.A. S.	5.75
0-1 MA. S.	4.75
0-5 MA. C.E.	4.75
0-100 MA. W.	2.49
0-200 MA. S. W.	2.95
0-5 AMP. R.F. S.	2.95
0-2 AMP. R.F. S. Q.	2.95
0-4 AMP. R.F. S. Q.	2.95
0-30 AMP. D.C. S. Q.	3.95
0-300 VDC (0-1 ma)	3.45

3" Meters

0-4 KV. DC. RS.	\$7.95
0-100 U.A. Galv.	7.95
0-2 MA. S.	4.50
0-15 MA. GE. S.Q.	3.95
0-20 MA. WH*	2.95
0-20 MA. S.	2.95
0-30 VOLT DC. DA	2.75
0-200 MA. GE.	4.50
0-250 MA. S.	3.95

PIGTAIL MICAS

MMF:	5, 20, 50, 60, 100, 250, 500, 400, 3000, 800, 1000, 2000, 3000, 4000, 5000, 6000, 10000	\$0.09 ea.
------	---	------------

Silver Mica Capacitors
MMF: 10, 50, 100, 750, 780, 1000, \$0.12 ea.

Non-Inductive Resistors

Ohms: 500, 2000, 12,500
100 watts \$0.75

Heavy Duty 4 Conductor Rubber Covered Cable.
.10 per foot

RAYTHEON SWINGING CHOKE

2 to 12 Henrys, 1 Amp to 100 Ma. 15 Ohms DC fully cased. High voltage insulation, ceramic insulators. Very conservatively rated. Weight 60 Lbs.
..... **\$16.95 ea.**

Meter Multipliers

1 Meg. 1/5 of 1% Cage Enclosed 1 KV.	\$2.95
2 Meg 1/2 of 1% Tubular	2.95
4 Meg 1/2 of 1% Tubular	3.95
4 KV	3.95

OIL CONDENSERS

3.75 mfd	660 vac	\$2.45
1.75 mfd	400 vdc	.39
1 mfd	600 vdc	.59
5 mfd	600 vdc	1.95
10 mfd	600 vdc	1.95
8x8 mfd	600 vdc	1.79
20 mfd	600 vdc	2.95
4 mfd	1000 vdc	1.95
15 mfd	1000 vdc	3.95
1 mfd	1500 vdc	.89
1.5 mfd	1500 vdc	.95
4 mfd	1500 vdc	2.75
1 mfd	2000 vdc	1.50
6 mfd	2000 vdc	3.95
8 mfd	2000 vdc	4.95
10 mfd	2500 vdc	2.95
4 mfd	2500 vdc	4.95
2 mfd	5000 vdc	7.95
.1 mfd	7000 vdc	2.95
1 mfd	7500 vdc	1.95
2 mfd	6 KV DC	12.95

FILTER CHOKE BARGAINS

10 Hy. 350 Ma. Cased	\$3.95
10 Hy. 175 Ma. Cased	1.95
10 Hy. 175 Ma. Cased	1.75
10 Hy. 250 Ma. Uncased	2.25

Ceramicons

MMF: 20, 120, 500 \$0.05 ea.

MOBILE DYNAMOTORS (Small Size)

5.6 400 175 MA	\$19.52
5.6 400 300 MA	19.50
5.6 400 300 MA	27.95
6.6 500 300 MA	28.50
6.6 600 150 MA	22.50
6.6 590 250 MA	26.50
12 680 210 MA	12.75

1% W. W. Resistors
Ohms: 2K, 5K, 8500, 50K, 100K \$0.35 ea.

GE KV METER

0-15 KV DC. 3 1/2" SQ. Bakelite case. 500 U.A. movement. Includes 30 Meg. 1% Ext. multiplier \$15.75 ea.

BAKELITE CASSED MICAS

MFD	VDC	Price	MFD	VDC	Price	MFD	VDC	Price
.001	600	\$1.18	.024	1500	.65	.001	5 KV	\$1.60
.002	600	.24	.033	1500	.90	.0015	5 KV	1.60
.01	600	.26	.02	2 KV	.35	.003	5 KV	1.90
.02	600	.26	.005	2500	.45	.005	5 KV	2.50
.01	1 KV	.45	.002	2500	.45	.0003	8 KV	2.50
.002	1200	.35	.0001	5 KV	.70	.0005	8 KV	2.90

WIRE WOUND RESISTORS

5 watt ohms:	25-50-200-2500	\$.09 ea.
10 watt ohms:	25-40-80-400-1325-2K-4K	.15 ea.
20 watt ohms:	50-70-100-30-750-1K-5K	.20 ea.
2.5K-2.7K-5K-16K-20K		.20 ea.
30 watt ohms:	100-2500-5300-18K	.22 ea.
100 watt ohms:	100-3750-150K-2K, 10K, 20K, 25K-50K	.59 ea.

GUARDIAN LATCHING RELAY

SPDT, 110 V 60 cy Coil, 15 Amp Contacts \$1.95

ADJUSTABLE SLIDER RESISTORS

20 Watt: 1, 50 Ohms	\$0.25
50 Watt: 50 Ohms	.35
75 Watt: 100, 150, 200 Ohms	.39
100 Watt: 50, 100 Ohms	.49

MISCELLANEOUS BARGAINS

25 ohm 675 watt Rheostat	\$2.95
50 meg 35 watt Resistor	.99
15 mmfidget Var. Ceramic Ins.	.99
4PST Lever Switch Mossman	.89
Ceramic RF Switch SP 11 Pos.	.89
4PDT Relay, 4500 Ohm DC Coil	1.95
.05 600V Oil Tubular	.12 for .99
10K, 15K Pots	4 for .99
5-20 mmf Ceramic Variable	.24
1.5-7 mmf Ceramic Variable	.29
SPST Push Button Switch	.29
5x5 MFD 400 VDC Oil	.59
1x1x1 MFD 1200 VDC	.59
Fil Transf. 2 1/2 V CT, 40 AMPS, 110V CY.	6.95
Air Padder 50 MMF, APCSO	.39

HIGH WATTAGE ANTENNA RELAY

110/220 Volt 60 Cy. coil, 5000 Volt, 15 Amp contacts, DPST. Ceramic insulation \$9.95 ea.

PEAK ELECTRONICS CO.

188 WASHINGTON ST., NEW YORK 7, N. Y.

Phone COrtlandt 7-6443-4

A HIGH-FREQUENCY DOUBLE CONVERSION SUPERHET FOR I.F. FREQUENCIES ABOVE 500 KC.

Instead of rewinding coils the author simply used the second harmonic of the BC-453 local oscillator as the mixing frequency.

By

FRED J. LINGEL, W2ZGY

MANY amateurs have wanted to use a Q5'er but have hesitated because their receiver's i.f. frequency was beyond the range of the BC-453. The obvious answer is to rewind the r.f. amplifier, the oscillator, and the mixer coils of the BC-453 to cover the higher intermediate frequency, but this is quite a job. It is not only difficult but it also makes the BC-453 unsuited for its original range, should it later be necessary to work at a lower intermediate frequency.

A simple solution to this difficulty is to use the second harmonic of the local oscillator in the BC-453 as the mixing frequency. To do this connect a lead from the last i.f. stage of your amateur band receiver to a 7-45 μ fd. ceramic trimmer condenser. Connect the other end of the condenser to the top cap of the 12K8 mixer in the BC-453 as shown in Fig. 1. Leave the regular contact to the 12K8 tube cap in position to provide a grid return. Unplug the 12SK7 r.f. amplifier tube located right next to the 12K8 in order to reduce stray pickup from the antenna terminal of the BC-453. Wire the tube filaments in parallel for 12 volt operation, otherwise removing the 12SK7 will also disconnect the filament on the 12K8 mixer tube.

To adjust the BC-453 for second harmonic operation on your particular intermediate frequency, proceed as follows:

1. Tune your regular receiver in the usual way to a strong phone signal.
2. Disconnect the headphones from the output of your regular receiver and connect them instead to the output terminals of the BC-453.
3. Tune the BC-453 until you hear the phone signal in the headphones.

If your receiver has an i.f. of 915 kc., the dial setting on the BC-453 will be around 415 kc. You may also hear the signal at 2 or 3 other spots because of 3rd or 4th harmonic mixing, but the 415 kc. point will be the strongest.

It works like this: With the dial of the BC-453 set at 415 kc. its local oscillator is running at 415 plus 85 or 500 kc. (The i.f. frequency of the BC-453 is 85 kc.) The second harmonic of the oscillator is two times 500 kc. or 1000 kc. When your 915 kc. intermediate frequency beats against this 1000 kc. you get 1000 minus 915 or 85 kc. This is the intermediate frequency of the BC-453. Be sure to use the rated

275 volts on the BC-453 to insure ample second harmonic output of its local oscillator.

This system has been used very successfully on my custom-built ham installation using a 2 to 10 mc. ARB aircraft receiver. Here the i.f. is picked off the last i.f. tube by wrapping a wire around the plate tube pin. A volume control is brought to the panel from the BC-453. This, in addition to the regular control from the receiver, gives better control of signal-to-noise ratio. The c.w. oscillator in the BC-453 is shorted out at all times and the regular beat oscillator in the main receiver is switched on or off as necessary.

The BC-453 does not have a.v.c. and as the normal receiver i.f. is not in use in this application, the reception on phone signals leaves something to be desired.

A worthwhile change is the addition of a.v.c. to the BC-453. An examination of the circuit will show that this may be easily accomplished. Briefly the operation consists of using the 12SR7 second detector to furnish the a.v.c. bias in the conventional manner.

For exact details as to the method for accomplishing this refinement the reader is referred to the article, "Conversion of SCR-274N Receivers," which appeared in the June, 1948 issue of RADIO & TELEVISION NEWS.

50

Fig. 1. The correct method for connecting Q5'er (BC-453) for a receiver i.f. of 915 kc.

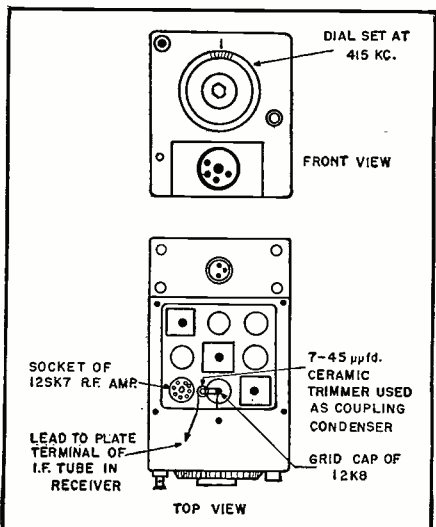

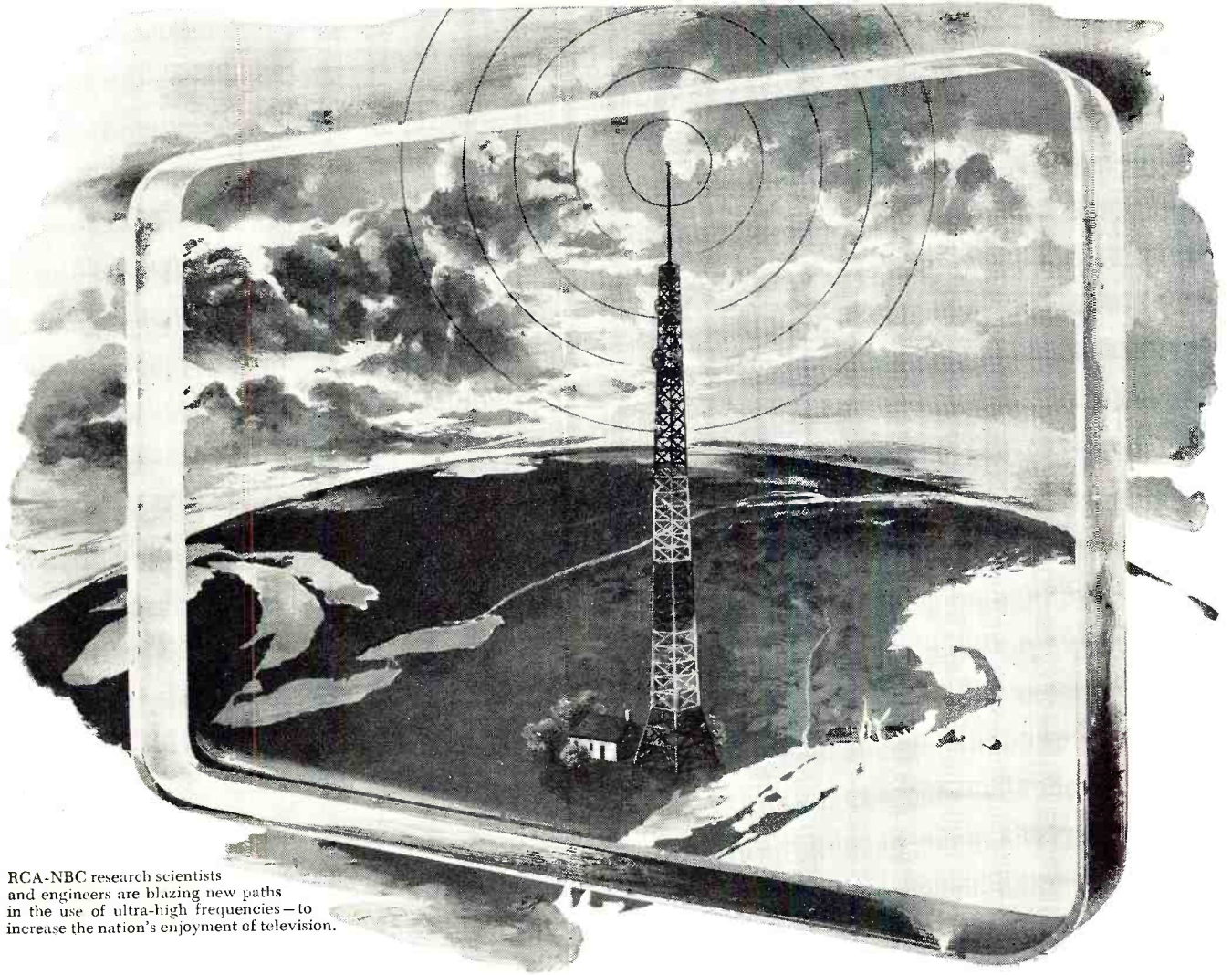

RCA-NBC research scientists and engineers are blazing new paths in the use of ultra-high frequencies—to increase the nation's enjoyment of television.

*World's first custom-built UHF station
—points the way to more TV for more people*

Although television now reaches 45 million people in more than 12 million homes, thousands of communities are still too far from existing stations to be reached by *any* programs. Moreover, under present conditions, many cities with limited program service want, but can't have, additional TV stations.

In preparation for the establishment of a country-wide television service, RCA has pioneered for many years in ultra-high-frequency (UHF) research.

Today—an experimental station built by RCA at Bridgeport, Conn., is supplying the practical experience and engineer-

ing facts needed to design the best UHF equipment—including transmitters, receivers, and converters. NBC programs on the air during the full broadcast day are used by RCA—and other manufacturers, too—for large-scale field tests.

From results of this pioneering, RCA engineers have determined that practical UHF equipment can be built to serve the public, and that present RCA Victor television sets can be readily adapted to give equally fine performance on both UHF and VHF.

* * *

See the latest in radio, television, and electronics at RCA Exhibition Hall, 36 W. 49th St., N. Y. Admission is free. Radio Corp. of America, RCA Building, Radio City, N. Y. 20, N. Y.

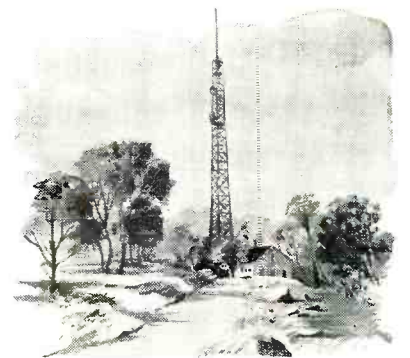

Built by RCA at Bridgeport, Conn.—first UHF transmitter to operate on a regular schedule.



RADIO CORPORATION of AMERICA

World Leader in Radio — First in Television

OLSON CLEAN SWEEP Sale

We won't get rich on these tubes. Olson bought some tremendous tube inventories from THREE BIG DEALERS who were overstocked. This is a beautiful deal. Every tube is brand new, individually boxed. Brands include Ken-Rad, Tung-Sol, Raytheon, Philco, Sylvania, etc. Now is your chance to get the most popular tubes at prices that are unbelievably low. You can't lose. STOCK UP NOW.

5Y3GT	59¢	02A	69¢
6J5		6AR5	
6N7GT		6AV6	
35W4		35Z5	

1U5	6W4GT	79¢
6AL5	12SA7	
6AU6	12SK7	
6BA6	12SQ7	
6K6GT	50L6	
6S4		

6CB6	89¢	6K7GT	99¢
6V6GT		6SN7	
25W4GT		7N7	

1B3GT	\$1.19	5U4G	\$.074
1X2		6BG6G	\$2.19
6AG5		6BQ6GT	\$1.49
12AU7		6CD6	\$2.79
		6J6	\$1.39



ALL AMERICAN TUBE KIT
Kit contains one each of the following:
12SA7—12SK7—12SQ7—35Z5—50L6
Buy popular tubes this easy way and save loads of money. Tubes are brand new fresh stock, famous brands. Packed in handy carton. **\$3.85**
Order No. AS-11, per kit.

RECORDING TAPE—Famous Mfr's Close-Out!

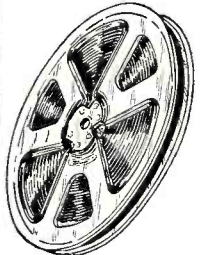

Get the buy of your life. Save up to 64% on high quality RECORDING TAPE. A large manufacturer had to sell his inventory and he unloaded the whole deal. Olson now offers you this high grade recording tape at prices which defy competition. Standard 1/4" wide, 1200 ft. long. Frequency response 50 to 8,000 cy. Plastic Reel included with each.

PAPER BASE—
1200 ft.
Stock No. X-248
Single, each \$1.69
Lots of 10, each **\$1.49**

PLASTIC BASE
1200 ft.
Stock No. X-249
Single, each \$2.19
Lots of 10, each **\$1.99**

GENUINE UNIVERSITY REFLEX SPEAKERS



25 WATT DRIVER UNIT
No. S-165 **\$1.470**
each

Unit is breakdown proof, will handle 25 watts continuously and is guaranteed for 1 year. Hermetically sealed, complete protection from outdoor exposure. Has dual 16 ohm voice coil and genuine bakelite diaphragm. Fits trumpet shown below or any other standard trumpet. Brand new factory sealed cartons. Shpg. wt. 6 lbs.



REFLEX TRUMPET
No. S-164 **\$1.441**
each

Trumpet is heavy gauge metal finished with corrosion resistant paint. Equipped with famous adjustable UNIVERSITY "U" BRACKET. Mounts in any position. 16 1/2" diameter. Has heavy rubber rim for improved tone. Brand new factory sealed cartons. Shpg. wt. 15 lbs.

Get both Driver Unit and Reflex Trumpet. Genuine University matched set **\$29.11**

BUILD YOUR OWN RECORD PLAYER

PHONO AMPLIFIER
RA-19.
\$3.98
LESS TUBES

A real high efficiency 3-tube amplifier of modern design. Connect to any crystal phono arm and speaker. Has volume and tone controls 7"x3 1/4"x2". Shpg. wt. 2 lbs.

SET OF TUBES FOR AMPLIFIER
12SQ7 50L6 35Z5 **\$2.64**
No. AS-22

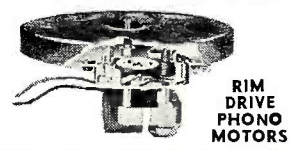

RIM DRIVE PHONO MOTORS

Nationally famous brand. Self starting, complete with turntable. Operates on 115 volt AC 60 cy. Shpg. wt. 5 lbs.

SINGLE SPEED 33 1/3 RPM **\$3.79**
Stock No. M-52

3 SPEED 33 1/3, 45, 78 RPM **\$5.99**
Stock No. M-63

PICKUP ARMS
For 78 RPM discs. With Astatic cartridge. Shpg. wt. 2 lbs. **\$2.99**
M-56



PHONO CARTRIDGE

Universal replacement for Astatic L-70, L-72, L-82, etc. 3 volts. Fresh Stock. XC-30 single each **\$1.78**
Lots of 10, each **\$1.29**

3 SPEED PICK-UP ARM
Cartridge flips by means of a lever. Equipped with dual cartridge, one side plays 33 1/3 and 45 and other 78 RPM. Double needle included. **\$4.95**
M-64. Each

HIGH OUTPUT CARTRIDGE
Similar to above but delivers 9 volts. Can be used on 33 1/3, 45, and 78 RPM discs. XC-47 single each **\$2.19**
Lots of 10, each **\$1.99**

ASTATIC MIKE
High output crystal mike for P.A. systems and recorders. Equipped with handle base and 7' shielded cable. Shpg. wt. 5 lbs.
M-67, each **\$5.95**
M-66, same but with on-off switch built into handle. **\$6.95**

NEW CRYSTAL MIKE
Nationally famous make. Smart New Design, easy to hold. Used in many tape, wire and disc recorders. Can be used on P. A. systems, amplifiers, etc.
M-71 **\$4.29**
Olson's Special

10 WATT RESISTOR KIT
We mean to move 80,000 fine 10 watt wire wound resistors during this sale. **REGULAR LIST PRICE \$15.00. Each kit contains 20 popular insulated resistors, with tinned copper leads. Shpg. wt. 2 lbs. AS-46. Kit of 20 \$2.49**

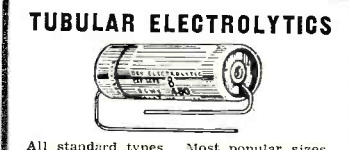

TUBULAR ELECTROLYTICS

All standard types. Most popular sizes. Aluminum tube with cardboard insulating sleeve. Olson was Johnny-on-the-Spot and he got a bargain—you can cash in. Every condenser unconditionally guaranteed a full year.

20 MFD. 150 V **25¢**
STOCK NO. C-628

40 MFD. 150 V **27¢**
STOCK NO. C-629

50-30 MFD. 150 V **49¢**
STOCK NO. C-630

8 MFD. 450 V **33¢**
STOCK NO. C-631

20 MFD. 450 V **40¢**
STOCK NO. C-632

40 MFD. 450 V **45¢**
STOCK NO. C-633

FP CONDENSER KIT
Assortment of 15 popular FP condensers, double and triple sections. Capacities from 10 mfd to 50 mfd; from 25 to 450 volts. Shpg. wt. 3 lbs. **\$3.98** each

HOOKEUP WIRE KIT
AS-19 **\$4.95**

500 ft. of high grade wire, various insulations: plastic, rubber, cotton, etc. Contains 5 rolls, each 100 ft., solid and stranded. Shpg. wt. 5 lbs.

OUTPUT TRANSFORMERS
Matches 50L6, 35L6, 25L6, etc. to any 3.2 ohm V.C. Size 1 1/4" X 1 1/4". Shpg. Wt. 1 lb. No. T-92 Single each **69¢**
Lots of 10, ea. **49¢**

MAGNAVOX & RCA SPEAKERS

12" and 8" Sizes

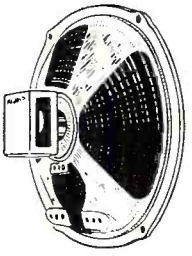

Think of it! Genuine Magnavox and RCA Speakers at a fraction of their real value. Yes—Olson really made a deal—a good deal—and you can cash in. These speakers are brand new, equipped with Alnico 5 magnets and dust-proofed 3.2 ohm voice coils.

STOCK UP NOW—THIS IS REAL VALUE

12" PM Speaker Individually boxed **\$5.95**
Stock No. S-140

8" PM Speaker Individually boxed **\$2.99**
Stock No. S-123



OLSON RADIO WAREHOUSE • 73 E. Mill St., Akron 8, Ohio



CO-AXIAL RELAY
Allied Control Type RA
SPDT, 6VDC operated.
Designed to handle a
maximum of 75 watts
at 150 MC. U.S. &
standard coax con-
nectors. Can be used
in conjunction with
0.1 μ mobile antenna
listed below

\$5.95 Each

COMPONENT BARGAINS

Dual 10 Amp, 115 V, 60 Cy. Circuit Breaker	\$2.95
5 Screw Term. Strip (6/32 Screw)	10/ 1.20
Barrier Strip Yellow Blkt. 6 Term.	10/ 1.50
5 Way Binding Post, Red or Black	ea. .40
7 Pin Min. Sock. Base, Shld.	10/ 1.75
Octal Sock., MIP, Mica Filled	10/ 1.00
3/8" Fluted Knob, brass insert	10/ 1.20
Erie CB Sil. Mica Button Cap. 50 mmf.	10/ 1.50
Erie PA Sil. Mica Button Cap. 50 mmf.	10/ 1.50
Erie PA Sil. Mica Button Cap. 500 mmf.	10/ 1.50
Sang. type M, Sil. Mica 5%, 2400 mmf.	10/ .75
Erie Feed Thru Ceramic	50 mmf. 10/ 1.50
Erie Stand Off Ceramic	15 mmf. 10/ 1.50
.03MF 400V Metall Cased On Tub. Cap.	10/ 1.99
.1MF 600V Metall Cased Oil Tub. Cap.	10/ 2.49
.5MF 600V Metall Cased Oil Tub. Cap.	10/ 4.50
.1 x .1MF 600V Aerovox Bath-tub St.	10/ 5.00
.5 x .5MF 600V C-D Bath-tub St.	10/ 9.95
1MF 600V Bath-tub St.	ea. .99
1 x 1MF 200V Bath-tub St.	.75
2MF 600V Bath-tub St.	1.25
4MF 600V C-D Oil Cap. Top Type	5/ 2.99
1MF 400V Aerovox 484 Tub. Cap.	10/ 2.50
Muter KS136B 2-8MMF Var. Cap.	10/ .99
.002 MF 500V Pigtal Mica	10/ 1.50
.0024 Sil. Mica, Flat	ea. .35
.003 MF 800V Pigtal Mica	10/ 1.80
.01 MF 500V Pigtal Mica	ea. .35
.001MF 600V Trans. Mica Cap.	.80
.01 MF 1200V Trans. Mica Cap.	.99
.003MF 2500V Trans. Mica Cap.	.99
.005MF 2500V Trans. Mica Cap.	1.40
.01 MF 2500V Trans. Mica	1.90
.002MF 3500V Trans. Mica Type 9	1.25
Four Quadrant Phase Shifter	3.50
C-H Luminous Tip Bat Handle Aircraft Togg. SW., SPDT, 5A 125 V.	ea. .30
SPST As Above	ea. .25
SPST As Above, momentary only	ea. .25
SPDT AS ABOVE, neutral center	ea. .49
SPST Rotary Switch, water type	2/ .75
6 Pos., Ceramic Rotary Sw.	ea. .59
GE Relay 115 VAC DPDT, 20 amp. CTS	4.95
1000 KC Crystal	ea. 6.95
Precision 100KC Xtal.	ea. 6.95
12HY 160 MA CHOKES	\$1.25 ea. 2/ 1.98
IRC 50K 10W fixed, 2.5K 10W ADJ. Pr.	1.25
Rheostats—50 ohm 2W, 100 ohm 2.5W	ea. .75
Pilot Light Assembly, Polaroid Dimmer type, Red, Green, Amber, White	ea. .24

MOBILE ANTENNA

152-162 MC.

G.E. Model 4EY1C1 VHF Antenna Kit. 18 1/2" Adjustable Dipole, 12 ft. RG58-U Coax cable, 83-18P Connector, with UG-176/U Adaptor & RG-6/U Cable. Complete with installation hardware

\$3.95 Each

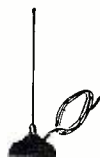

STEP DOWN TRANSFORMERS

INPUT cord & plug—OUTPUT, built-in socket.	
220/110 V, 50-60 CY, 50 Watt	ea. \$5.50
220/110 V, 50-60 CY, 250 Watt	ea. 9.50
220/110 V, 50-60 CY, 500 Watt	ea. 9.50

UNIVERSAL OUTPUT TRANSFORMERS

For single or Push-Pull Impedances 1K to 20K ohms, to any Speaker Voice Coil.

4 Watt—\$1.10
15 Watt—\$1.75

OIL CAPACITORS

5 MF 330 VAC	51.95	6 MF 1500 VDC	\$3.50
7 MF 330 VAC	2.50	1 MF 2000 VDC	2.15
2 MF 600 VDC	.99	2 MF 2000 VDC	2.95
4 MF 600 VDC	1.50	4 MF 2000 VDC	2.45
6 MF 600 VDC	1.85	8 MF 2000 VDC	5.95
7 MF 600 VDC	1.99	5 MF 2500 VDC	1.75
8 MF 600 VDC	2.15	1 MF 3000 VDC	2.45
8x8 MF 600 VDC	2.75	1 MF 3000 VDC	4.25
10 MF 600 VDC	2.95	2 MF 3000 VDC	5.50
2 MF 1000 VDC	1.99	2 MF 3000 VDC	7.95
5 MF 1000 VDC	2.95	1 MF 5000 VDC	5.50
10 MF 1000 VDC	4.95	2 MF 5000 VDC	12.50
15 MF 1000 VDC	9.95	2x.1 MF 7000 VDC	2.95
4 MF 1500 VDC	2.95	1 MF 7500 VDC	2.95

CHOKES

200 HY 6 MA, Cased	\$1.75
5 HY 50 MA, 200 Ohm, Cased	.90
6 HY 70 MA, 215 Ohm	.95
9 HY 90 MA, 250 Ohm	1.10
7 HY 125 MA, Cased	1.49
10 HY 150 MA, 200 Ohm	1.85
4-16 HY 200 MA, 140 Ohm SW. CH., Cased	5.10
10 HY 200 MA, 150 Ohm, Cased	4.95
3 HY 250 MA, 15 Ohm, Cased	1.95
15 HY 250 MA, 65 Ohm, Cased	3.49
3-14 HY 300 MA, 80 Ohm, SW. CH., Cased	7.00
8 HY 300 MA, 80 Ohm, Cased	6.95
6 HY 450 MA, 80 Ohm, Cased	6.95

115V FILAMENT TRANSFORMERS 60 CY

2.5 VCT 10A, 10 KV Insulation	\$3.15
2.5 V @ 6A, 5 V @ 6A, Cased	3.45
5 VCT 3A, 2.5 KV Insulation	2.95
5 V @ 3A, 6.3 VCT @ 3.5A	2.95
5 VCT 12A, 2.5 KV Insulation	5.95
5 VCT 20A, 2.5 KV Insulation	7.95
6.3 VCT 1A, 2.5 KV Insulation	.99
6.3 VCT 3A, 2.5 KV Insulation	1.99
6.3 V @ 4A, 6.3 V @ 4A, Cased	2.95
6.3 VCT @ 6A, 2.5 KV Insulation	2.75
6.3 V 12A, Cased	4.50
6.3 V 12A, 2.5 V 2A Herm. Seal	4.95
10 VCT 10A, 2.5 KV Insulation	6.00
24 V 1A, 2 KV Insulation	3.95

115V POWER TRANSFORMERS 60 CY

300 V 20 MA (Half Wave)	\$1.25 ea. 2/ \$2.00
435 VCT 145 MA, 6.3 V 2A, 5 V 2A	3.95
650 VCT 40 MA, 6.3 V 2A, 5 V 2A	3.25
700 VCT 70 MA, 6.3 V 2.5A, 5 V 3A	3.50
700 VCT 90 MA, 6.3 V 3A, 5 V 3A	4.25
700 VCT 120 MA, 6.3 V 4A, 5 V 3A	4.95
740 VCT 185 MA, 6.3 V 4A, 5 V 3A	5.95
800 VCT 200 MA, 6.3 V 5A, 5 V 3A	5.95
800 VCT 300 MA, 6.3 V 10A, 5 V 6A, 5 V 2A	9.50
750-600-0-600-750 VDC, 225 MA.	9.95
3200 VCT 350 MA	29.50

SEND FOR POLY-GRAM

POLY-TECH

919 Dawson Street • New York 59, N. Y.
Tel. Murray Hill 6-2650

An Improved TONE CONTROL CIRCUIT

Simple and easy to install—provides 15 db boost at either or both bass and treble frequencies.

By JOSEPH A. SZABO

RESISTANCE-capacity tone control circuits are used almost universally because of their many advantages over L-C-R networks.

The advantages are cost, size, weight, freedom from induced hum, and absence of ringing and transient effects.

In spite of the many advantages, their performance usually leaves much to be desired. Considerable investigation and development has brought out the following facts.

It is desirable to provide a true bass and/or treble boost. The usual "cut" or "droop" action of the typical R-C network fails to provide the true psychological effect of "boost." Often this factor is overlooked and yet it seems to be extremely important. Objective operating and listening tests by non-technical listeners have proved this point. However, the answer seems to lie in human engineering and not in audio engineering. Technicians and engineers may love to argue the point but the bald fact is that people like boost-type tone control circuits.

It is desirable to provide separate adjustment of bass and treble boost without interaction between the two controls. But several common circuits that provide for separate adjustment have annoying interactive effects.

It is desirable that the input impedance be reasonably high. Several of the well known circuits will cause severe loading of normal vacuum tube amplifiers and they may require special circuits to drive them.

It is desirable that the resultant response curve be smooth and free from "steps." Many common circuits cause a step in the response curve when they are adjusted for flat response.

It is desirable that the tone control circuit provide an easily identified flat position. This factor is often overlooked but cannot be over-emphasized. Twin tone controls can lead to an almost infinite combination of settings that leave the operator hopelessly confused.

The circuit presented in this article has been designed with all these points in view and meets all of the requirements to an unusual degree. The circuit values shown allow a boost of up to 15 db for both bass and treble. The bass and treble controls are independent and do not interact. The response

is flat when both controls are set at the full counter-clockwise position. The response curve is free from steps. A true boost effect is noted when one or both of the boost controls are advanced. The input impedance is around 100,000 ohms and the circuit can be driven easily by any of the common low-mu triodes. The circuit values shown are for a maximum boost of 15.6 db and for high and low boost frequencies of 200 and 2000 cycles respectively.

The following relations may be used to design the circuit for any specific application.

Choose the desired amount of boost in decibels. This will also equal the insertion loss of the network.

Next, a reasonably large value of R_1 should be chosen. The input impedance over most of the range will be very nearly equal to R_1 .

Then R_2 is calculated from the desired amount of boost and the chosen value of R_1 .

$$R_2 = \frac{R_1}{\left(\text{Antilog}_{10} \frac{db}{20} \right) - 1}$$

F_L is the low frequency at which the boost will be 3 db from maximum and F_H is the corresponding high frequency.

$$C_1 = \frac{1}{2\pi R_1 F_L} \quad R_3 = \frac{10}{2\pi C_1 F_L}$$

$$R_4 = 10 R_1 \quad R_4 C_2 = C_3 R_3$$

$$C_2 = \frac{1}{2\pi R_4 F_H} \quad \frac{R_4}{R_1} = \frac{R_5}{R_2}$$

—30—

Circuit diagram of tone control.

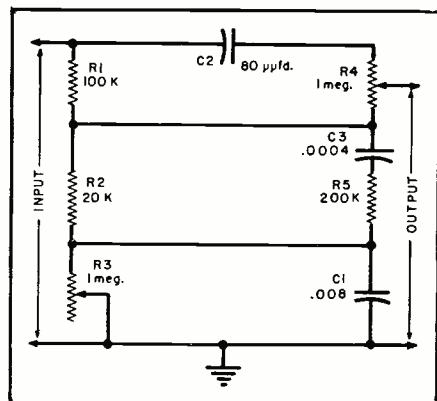



NOW-Be a Fully Trained, Qualified RADIO TELEVISION TECHNICIAN IN JUST 10 MONTHS OR LESS

**I Send You
18 BIG
KITS
OF RADIO-
TELEVISION
EQUIPMENT**

**New "Package" Unit Training Plan
PAY AS YOU LEARN—YOU SET THE PACE!**

No Monthly Payment Contract to Sign!

Now . . . be ready for Radio-Television's big pay opportunities in a few short MONTHS! Frank L. Sprayberry's completely new "Package" training unit plan prepares you in just 10 MONTHS . . . or even less! Equally important, there is NO monthly payment contract to sign . . . thus NO RISK to you! This is America's finest, most complete, practical training—gets you ready to handle any practical job in the booming Radio-Television industry. In just 10 months you may start your own profitable Radio-Television shop . . . or accept a good paying job in this fascinating expanding field at work you've always wanted to do. Mr. Sprayberry has trained hundreds of successful Radio-Television technicians—and stands ready to train you in less than one year, even if you have no previous experience. You learn by DOING . . . actually working with your hands with equipment of special design to illustrate basic theory instead of relying on books alone.

VALUABLE EQUIPMENT INCLUDED WITH TRAINING

The new Sprayberry "package" plan includes many big kits of genuine, professional Radio-Television equipment. While training you actually perform over 300 demonstrations, experiments and construction projects. In addition, you build a powerful 6-tube standard and short wave radio set, a multi-range test meter, a signal generator, signal tracer, many other projects. All equipment is yours to keep . . . you have practically everything you need to set up your own service shop. The interesting Sprayberry book-bound lessons and other training materials . . . all are yours to keep.

EARN EXTRA MONEY WHILE YOU LEARN!

All your 10 months of training is AT YOUR HOME in spare hours. Keep on with your present job and income while learning . . . and earn EXTRA CASH in addition. With each training "package" unit, you receive extra plans and ideas for spare time Radio-Television jobs. Many students pay for their entire training this way. You get priceless practical experience and earn generous service fees from grateful customers. Just one more reason why the Sprayberry new 10 MONTH-OR-LESS training plan is the best Radio-Television training in America today. If you expect to be in the armed forces later, there is no better preparation than good Radio-Television training.

FREE 3 BIG RADIO TELEVISION BOOKS

I want you to have ALL the facts about my new 10-MONTH Radio-Television Training—without cost! Act now! Rush the coupon for my three big Radio-Television books: "How to Make Money in Radio-Television," PLUS my new illustrated Television Bulletin PLUS an actual sample Sprayberry Lesson—all FREE with my compliments. No obligation and no salesman will call on you. Send the coupon in an envelope or paste on back of post card. I will rush all three books at once!

SPRAYBERRY ACADEMY OF RADIO
Dept. 25-A, 111 North Canal St., Chicago 6, Ill.

**TRAIN AT
HOME IN
SPARE HOURS!**

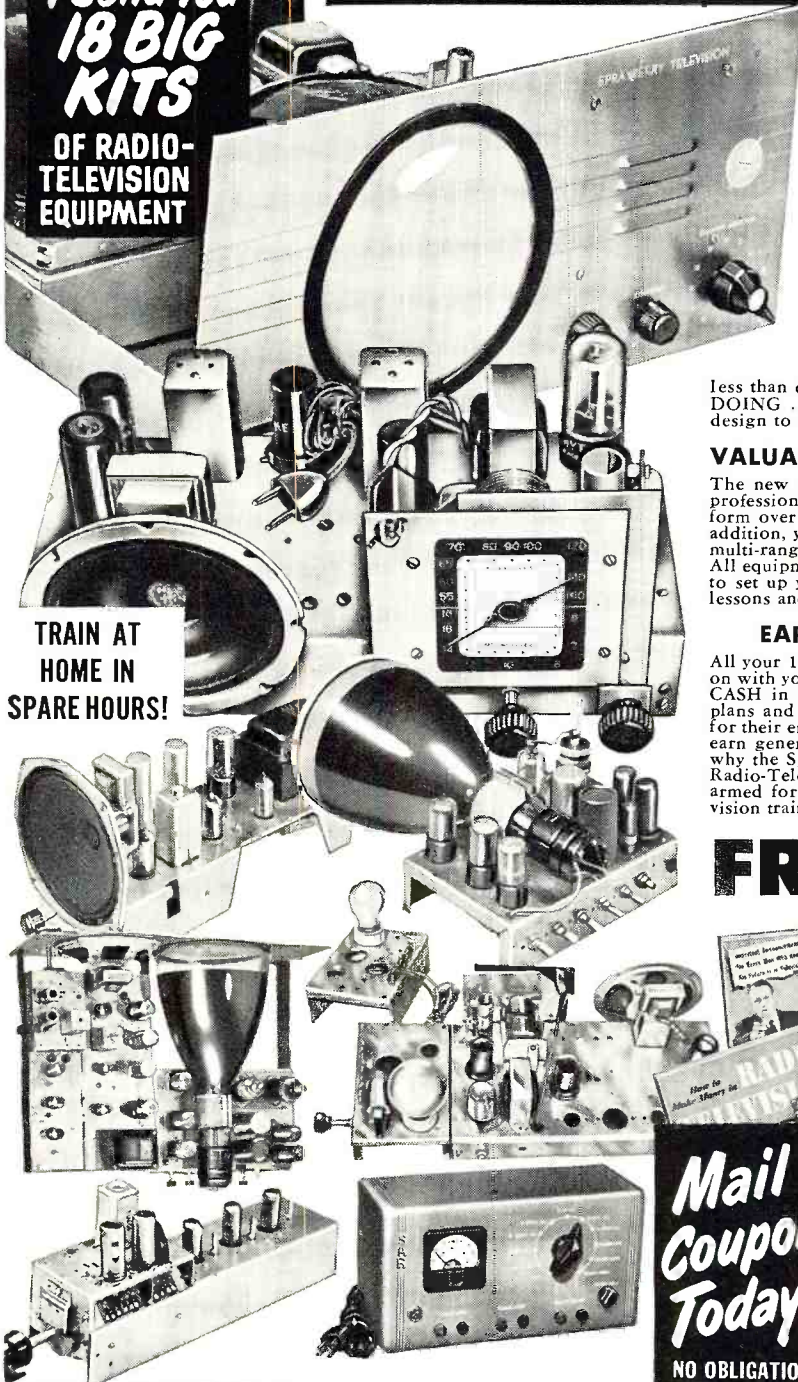

**IF YOU ARE
EXPERIENCED IN RADIO**

Men already in Radio who seek a short intensive 100% TELEVISION Training with FULL EQUIPMENT INCLUDED are invited to check and mail the coupon at the right.

**Mail
Coupon
Today!**
NO OBLIGATION
No Salesman
Will Call.

**SPRAYBERRY ACADEMY OF RADIO, Dept. 25-A
111 North Canal St., Chicago 6, Ill.**

Please rush to me all information on your 10-MONTH Radio-Television Training Plan. I understand this does not obligate me and that no salesman will call upon me.

Name..... Age.....

Address.....

City..... Zone..... State.....

Please check Below About Your Experience
 Are You Experienced? No Experience

USE PHOTOFAC

the world's best Radio-TV service data—it pays for itself every working day



Try PHOTOFAC!

FREE We'll send you any Photofact Folder listed in the Photofact Cumulative Index*

WE'LL PROVE YOU'LL SAVE TIME and EARN MORE WITH PHOTOFAC

NOW—learn for yourself—at our expense—how PHOTOFAC makes your Radio and TV work quicker, easier, more profitable! Examine an actual PHOTOFAC Folder. Use it. You'll learn first-hand why over 35,000 successful service technicians use PHOTOFAC daily. You'll learn that no other service gives you PHOTOFAC's completeness, accuracy, uniformity, and lowest cost. PHOTOFAC is the only radio and TV service data prepared from laboratory analysis of the actual equipment. Know the facts—get your FREE Folder now. Examine, use, compare—learn why no modern service shop can afford to be without PHOTOFAC!

Except those followed by asterisk () or letter A.

WRITE FOR FREE INDEX

PAY AS YOU EARN! Ask your distributor about this amazing plan. Only \$18.39 puts the entire, profit-boosting Photofact library in your shop now!

NOTE: Our FREE Folder offer is limited to Service Technicians only. Attach coupon below to your letterhead and mention your jobber's name. If you have no letterhead, send coupon to your jobber. Experimenters and others may obtain the Photofact Folder by remitting amount shown below.

HOWARD W. SAMS & CO., INC.
2201 E. 46th St., Indianapolis 5, Ind.

- Send FREE Photofact Cumulative Index
 Send Full Easy-Pay Details

I am a Service Technician:

- Send FREE Folder for set model.....

I am an Experimenter: Enclosed \$.....

- Send Folder for set model.....

TV-\$1.00. Record Changer or Comm. Receiver-75c. AM/TM-50c

Name.....

Address.....

City.....Zone.....State.....

Proportional Control

(Continued from page 62)

tals (there are two of them with a selector switch not shown on Fig. 10. The second crystal is used as a spare to permit operation on another frequency in case of interference by another operator), while L_3 , L_4 , C_{10} , and C_{11} are above deck. The crystal oscillator is of the harmonic type and the frequency output is triple the crystal frequency; the second section of V_1 doubles this and the final works straight-through. The only tricky points in getting V_1 to operate are in setting the tap on L_1 , and making sure you are feeding the 3rd crystal harmonic to the doubler. If the tap is too near the plate end, the tube will self-oscillate without benefit of the crystal; if too far the other way, harmonic output will be low or the crystal will refuse to oscillate. The unbalanced input to V_2 works perfectly if the rotor of C_7 is left floating. Purists can add capacity to the lower end of L_2 , to balance it up, but this isn't really necessary. A shield was fitted around the lower part of V_2 as the tube people recommend. The 832A works nicely and is perfectly stable.

Switch S_1 puts the 1.5 ma. meter in

the doubler grid return (scale is 1.5 ma.), in the final grid return (shunted to read 3 ma. full scale), or the final cathode. R_5 was made of rheostat wire, of the proper length to give 75 ma. full scale reading, and the meter indicates combined grid, screen, and plate current of V_2 in the third position.

S_2 is a "Hi-Lo" power switch that puts R_7 in series with the V_2 cathode; power output is practically nil, but still is plenty to check the receiver within a hundred feet or so. Incidentally, it will be noted the entire transmitter is keyed; attempts to key only the final, or the final and doubler, didn't pan out. Enough 50 mc. output leaked through to operate the receiver at quite a distance. The regenerative crystal circuit keys very nicely, though, even at a rate as high as 600 ppm.

The transmitter operating characteristics are: Osc., 155 v. at 10 ma.; doubler, 180 v. at 8 ma. on plate, 1 ma. grid current; final grid current 2 ma. (These figures with no plate or screen voltage on V_2 .) With the final showing 60 ma. cathode current—as it is normally run—the total battery drain is 9.2 amperes. Actual final plate current is about 50 ma., giving a final plate input of 13 watts. No close checks of power output have been made, but it has proven ample for our purposes.

Fig. 10. Complete schematic diagram and parts list for radio-control transmitter.

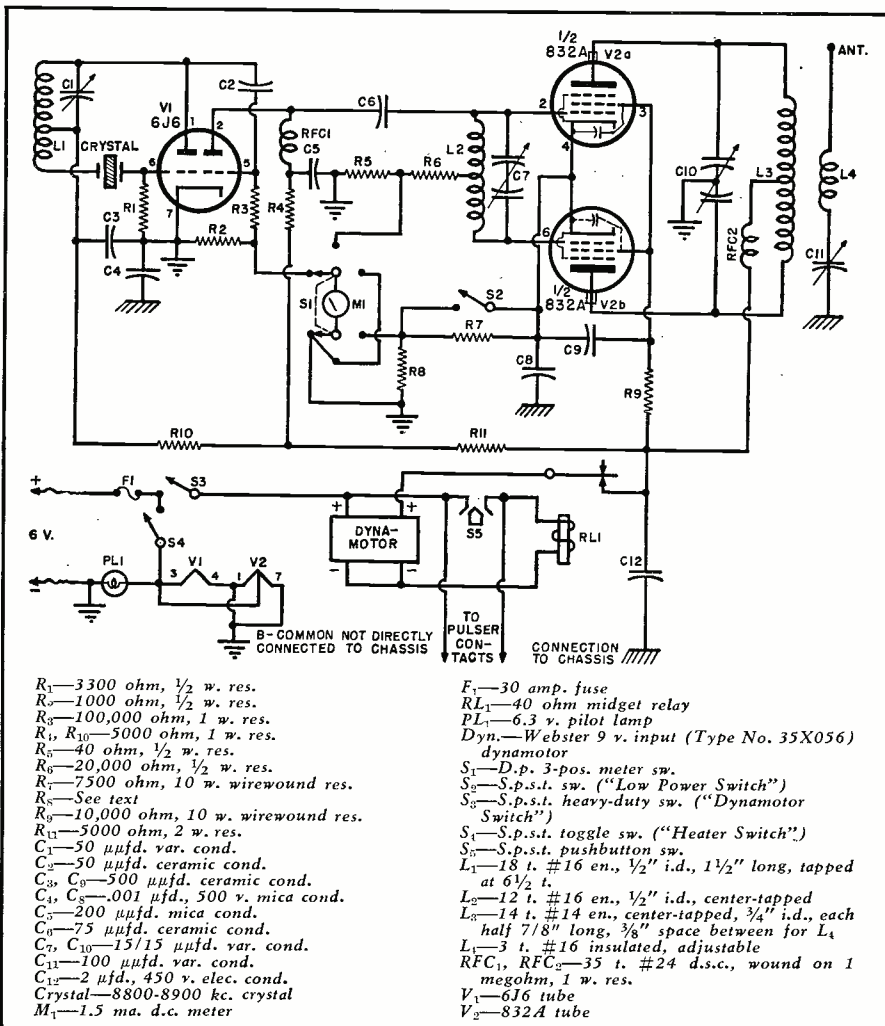

J. E. SMITH,
President,
National Radio
Institute,
Wash., D. C.

I Will Show You How to Learn RADIO-TELEVISION

by Practicing at Home in Spare Time



You Practice **SERVICING** with Equipment I Furnish

You build the modern Radio (at left) as part of my Servicing Course. I send you speaker, tubes, chassis, transformer, loop antenna, everything you need. You use it to make many tests, get practical experience you need to make EXTRA money fixing Radios. I send you many other kits of parts with which you build other circuits common to Radio and Television, some of which are pictured on the next page. All equipment is yours to keep. See and read about them in my FREE 64-PAGE BOOK. Mail card below.

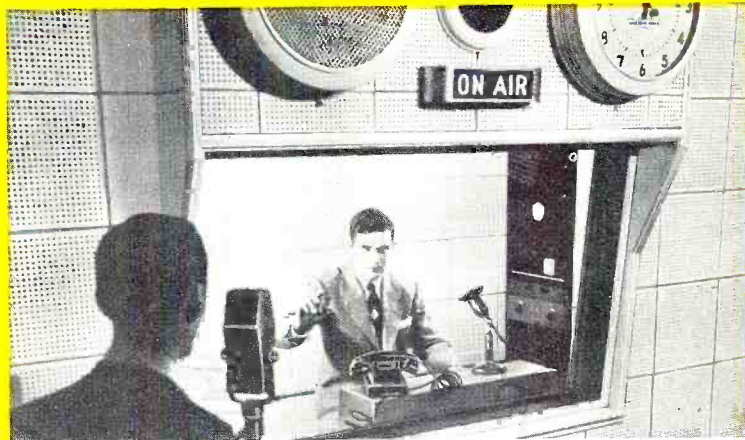

You Practice **COMMUNICATIONS** with Equipment I Furnish

As part of my Communications Course I send you kits of parts to build the low power broadcasting transmitter shown at the right and many other circuits common to Radio and Television. You use this equipment to get practical experience putting a station "on the air," performing procedures demanded of Broadcast Station operators. I train you for your FCC Commercial Operator's License that puts you in line for good pay in Radio or Television Broadcasting. Mail card below.



**NEW! Advanced
Television Practice!**

New, special TV kits furnished to build high-definition SCOPE... RF OSCILLATOR with flyback power supply... complete TV SET... many other units. You see pulse, trapezoidal, saw-tooth wave forms. Get valuable PRACTICAL EXPERIENCE locating and correcting TV troubles. Mail coupon for facts, pictures and prices!

CUT OUT AND
MAIL CARD
NOW!

SEE OTHER SIDE THE TESTED WAY
TO BETTER PAY

NO POSTAGE NEEDED

Both FREE

Sample Lesson & 64-Page Book

ACT NOW! Send for my DOUBLE OFFER FREE. This card entitles you to Sample Lesson on Servicing; shows how you learn Radio-Television at home. You'll receive my 64-page Book, "How To Be a Success in Radio-Television." Mail card now! No postage needed. J. E. SMITH, President, National Radio Institute, Washington 9, D.C. Our 38th year.

Mr. J. E. SMITH, President, Dept. 1RRRR
National Radio Institute, Washington 9, D. C.

Mail me Sample Lesson and 64-Page Book, "How to Be a Success in Radio-Television." (No Salesman will call. Please write plainly.)

NAME..... AGE.....

ADDRESS.....

CITY..... ZONE..... STATE.....

The ABC's of
SERVICING

How to Be a
Success
in RADIO-
TELEVISION

Television Is Today's Good Job Maker

In 1946 only 6,000 TV sets sold. In 1950 over 5,000,000. By 1954, 25,000,000 TV sets estimated. Over 100 TV Stations now operating. Authorities predict 1,000 TV Stations. This means more jobs, good pay for properly trained men. Mail this Postage-Free card NOW for FREE book and sample lesson.

BE A RADIO-TELEVISION TECHNICIAN *Train at Home in Spare Time*



J. E. SMITH, President,
National Radio Institute,
Washington, D. C.

There's a Bright Future For You In America's Fast Growing Industry

Do you want good pay, a job with a bright future and security? Would you like to have a profitable shop or store of your own? If so, find out how you can realize your ambition in the fast growing RADIO-TELEVISION industry. Even without Television, the industry is bigger than ever before. 90 million home and auto Radios, 3,100 Broadcasting Stations, expanding use of Aviation and Police Radio, Micro-Wave Relay, Two-Way Radio for buses, taxis, etc. are making opportunities for Servicing and Communications Technicians and FCC Licensed Operators.

You Learn by Practicing with Kits I Furnish

With both my Servicing Course and my NEW Communications Course I send you many Valuable Kits of Parts. They "bring to life" theory you learn in my

illustrated texts. Some equipment from both courses is shown below and on previous page. All equipment I send is yours to keep. Among equipment you build is a Tester. Use it to make extra money fixing neighbors' sets while training. Special booklets show you how.

Training Features Television

Both my Servicing and Communications training include up-to-date lessons on TV principles. Throughout the country my graduates are filling jobs, making good money in both Radio and Television. Remember the way to a successful career in Television is through experience in Radio.

Send NOW for 2 Books FREE— Mail Card

Send the Postage-Free card now for my FREE DOUBLE OFFER. You get Sample Servicing Lesson to show you how you learn at home. Also my 64-page book, "How to Be a Success in Radio-Television." Read what my graduates are doing, earning; see equipment you practice with at home. Mail card now. We pay postage. J. E. SMITH, President, National Radio Institute, Washington 9, D. C. Our 38th Year.

Read What Successful NRI Graduates Say:



Radio Operator with ABC

"I was a bookkeeper with a hand-to-mouth salary. Now, a Radio Operator."—N. H. Ward, Ridgefield Park, N. J.



Can Step Into FM, Television

"When I enrolled with N.R.I., was a laborer. Now I have a position paying over \$10 a day."—R. Ford, Phila., Pa.



Is Broadcasting Operator

"Now employed at station WHAW as operator. I have also opened my own Radio business."—R. J. Bailey, Weston, W. Va.



\$10 Week In Spare Time

"Before finishing your course, I earned \$10 a week in Radio servicing in my spare time."—S. J. Petrucci, Miami, Fla.



\$10 to \$15 Week Spare Time

"4 months after enrolling averaged \$10-\$15 a week spare time servicing Radios. Now have business."—W. B. Weyde, Brooklyn, N. Y.



Lost Job, Now Has Own Shop

"Got laid off. Best thing that ever happened as I opened a Radio shop."—E. T. Slate, Corsicanna, Texas.

Make Extra Money While Learning

Keep your job while training. Learn Radio-Television principles from illustrated lessons. Get Practical Experience experimenting with circuits common to Radio and Television. Many students make \$5, \$10 a week extra fixing neighbors' Radios in spare time while learning. I send you special booklets that start teaching you the day you enroll.



IMPORTANT!
See Other Side

Extra Pay in Army, Navy, Air Force

Knowing Radio, TV, Electronics can help you get extra rank, extra prestige, more interesting duty at pay up to several times a private's base pay. You are also preparing for good Radio-TV jobs upon leaving service. Mail Coupon NOW.

You Build These and many more for Practical Experience



MAIL POSTAGE FREE CARD TODAY

Want Your Own Business?

Let me show you how you can be your own boss. Many N.R.I.-trained men start their own business with capital earned in spare time. Robert Dohmen, New Prague, Minn., whose store is shown at right, says, "Am now tied in with two television outfits and do warranty work for dealers. Often fall back to N. R. I. textbooks for information on installing Television sets."



FIRST CLASS
Permit No. 20-R
(Sec. 34.9 P L & R)
Washington, D. C.

BUSINESS REPLY CARD

No Postage Stamp Necessary If Mailed In The United States

4c POSTAGE WILL BE PAID BY

NATIONAL RADIO INSTITUTE

16th and U Sts. N. W.

Washington 9, D. C.

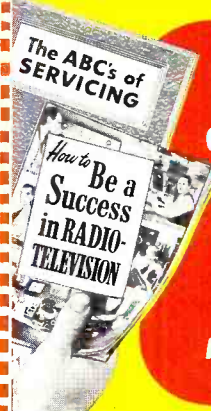

**SAMPLE LESSON
and 64-PAGE BOOK
Both FREE**

Cut out and mail
postage-free card now!

A vertical antenna about 55" long loads the final nicely. Loading can be adjusted by variation of C_{11} . While many radio control enthusiasts frown on the use of vertical antennas, we find them very convenient, and have not experienced any dead spots with the airplane directly overhead.

The entire radio system has operated very well. While it is considerably more complicated than the average radio control rig, its stable operation is a revelation, and enabled us to focus full attention on the proportional control problems. It seems odd, but very, very few model plane fliers, even those with shop equipment and the necessary know-how, have tried proportional control. Just why, we cannot imagine, for once you fly a well adjusted plane with proportional, you won't again be satisfied with escapements or any other "all or nothing" form of control. Maybe the notes we have given here will persuade experimenters to try this system, not only on model planes, but for boats, cars, and other uses as well.

-30-

HAM LICENSE RENEWALS

THE FCC has requested that we call your attention to the fact that hams who have filed timely applications for renewal of their operator and station licenses may continue operating their amateur stations beyond the normal date of expiration of these licenses pending receipt of formal Commission notice of action on their renewal applications.

This privilege is of importance to insure that hams can continue to participate in civil defense drills, field days, and other activities while the FCC processes pending applications. This general notice is issued in lieu of replying to individual inquiries that would divert personnel from the work of processing applications.

The procedure is as follows: Any ham who files, in accordance with the requirements of Section 12.27 of Part 12, an appropriate and timely application for renewal of station or operator license and prior to the normal date of expiration of the license does not receive a new license or notification from the Commission that action has been taken on the application, may continue to operate in accordance with the terms of the license to be renewed until such a time as a new license or notification of action on the renewal application is received. Persons who file application for renewal after expiration of license but during the grace period provided by Section 12.27 are governed by that rule and may not operate pending action on the renewal.

Amateurs are cautioned to make an appropriate notation in the station log at the time the application for renewal is filed, to keep a copy of the application, or to keep a copy of the letter transmitting the application with the station records as evidence of the timely filing, in good faith, of an appropriate application for renewal.

The Commission will process all applications as expeditiously as possible in order of their receipt. In order to avoid lapse of operating authority, hams are urged to file for renewals at the earliest permissible date.

-30-

September, 1951

LOOK-NO HANDS!



AUTOMATIC SELF-TUNING

SUPER Tune-O-Matic TV BOOSTER

- NO SEPARATE BOOSTER TUNING
- UNIFORMLY HIGH USABLE GAIN
- LESS "SNOW"—BETTER PICTURES
- EXCLUSIVE 4-STAGE BROADBAND CIRCUIT
- EASILY CONCEALED—HIGHLY STABLE

Connect it...and forget it! Anyone... even a child... can get his favorite programs with a clarity of picture and sound like never before... on any channel... automatically... without any booster tuning!

Exclusive E-V all-electronic broadband circuit gives superb low-noise performance... provides higher effective gain on all channels... works where others have failed, even in tough fringe areas. Furthermore, the booster can be easily concealed. Installation is quick and simple. Plugs into 50-60 cycle a.c. outlet. Thousands of installations have proved it completely trouble-free. There's nothing like it!

Model 3000 TUNE-O-MATIC. List... \$59.50

Electro-Voice

TV BOOSTERS • MICROPHONES • HI-FI SPEAKERS • PHONO-PICKUPS

Patent Pending

Electro-Voice, Inc., Dept. N9-1
410 Carroll St., Buchanan, Michigan
Send Free Bulletin No. 163

Name _____
(PLEASE PRINT)

Address _____

City _____ Zone _____ State _____

Serviceman Installer Dealer TV Fan

Tenna-Top

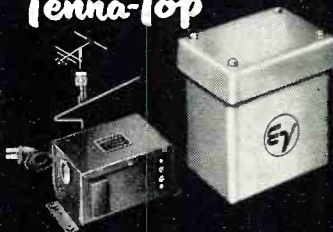

First all-channel, low-noise, antenna-mounted, self-tuning TV Booster! Mounts on antenna mast ahead of the lead-in. Automatically boosts the signal—not any local noise picked up by the lead-in. Clearly brings in telecasts you could never get before. Finest booster for tough fringe areas or noisy locations in primary areas.

Model 3010 TENNA-TOP.
List Price\$89.50

Send for

FREE BULLETIN TODAY!

NEW for '51

Automatic Radio CUSTOM-BUILT AUTO RADIOS

RECORD SMASHING VALUES!

1949, 1950 and 1951 FORD AUTO RADIOS

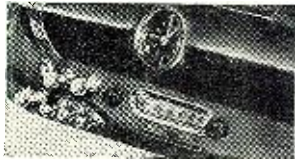

List Price\$59.95

1949, 1950 and 1951 PLYMOUTH-DODGE RADIOS



List Price\$59.95

ATTRACTIVE DISCOUNTS TO DEALERS

1949, 1950 and 1951 CHEVROLET RADIOS



List Price\$59.95

CUSTOM-BUILT RADIOS

1948-49-50-51 HUDSON 1951 HENRY J 1949-50-51 STUDEBAKER List Price\$59.95

Each auto radio is specifically designed to fit all 1949 and 1950 cars shown above and all incorporate the same outstanding features. . . . Six-tube superheterodyne. Six-volt storage battery operation. Two dual-purpose tubes. Eight-tube performance. Installation in a few minutes. Three-gang tuning condenser and tuned R.F. stage for extreme sensitivity. Permanent magnet dynamic speaker with Powerful Alnico #5 magnet. Low battery drain. Weight 10 lbs.

SPECIAL

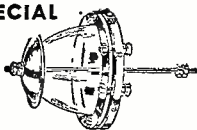

Navy entering type insulator. Porcelain flanged bowl with brass rod and fittings and aluminum shield. Dimensions: 4 3/8" high, 6-5/16" O.D. at base. New\$4.50 Spare Bowl\$.95

CAPACITORS

Table listing various capacitor models and their prices. Includes Upright Mount, Wax, and Oil Filled and GE Pyranol.

OIL FILLED AND GE PYRANOL

Table listing oil filled and GE Pyranol capacitors with their respective specifications and prices.

ELECTROLYTICS

Table listing electrolytic capacitors with their specifications and prices.

TIME DELAY SWITCHES

Table listing time delay switches with their specifications and prices.

TRANSFORMERS

Table listing various transformer models with their specifications and prices.

MICROWAVE EQUIPMENT. 10CM Echo Box Frequency Range 2890MC-3170MC. Direct Reading Micrometer Head. Ring Fraction Scale Plus 9% to Minus 9%. Type "N" Input. Resonance Indicator Meter with Accessories and 10CM Directional Coupler and Spares—Brand New.

Table listing various vacuum tube models and their prices.

TRANSMITTING MICA. .065 MFD 1800 VDC \$0.65 .006 MFD 2000 VDC .65

Ceramic Rotary Switches. Pole Position Section Shaft Price \$0.60

RELAYS. 12 VDC DPST Allied Control Box #32 \$1.25 24 VDC 3 PDT 8 Amp. .95

VALUES. De-Ion Line Start'er DPST 15V 60 Cy 15A West. Nev. \$6.95

ROUND PANEL METERS. LEADING BRANDS. 0-5 RF Amps—Westing 3/4" \$4.50 0-100 MA DC—Simpson 2 1/2" 3.75

PORTABLE METERS. 0-10 Amps DC—Weston 489 9.50 0-3-6-30 Volts DC—Weston 280 19.95

CARRY-ALL TV and RADIO SERVICE CASE \$12.50

Table for Linear Potentiometers showing Ohms, Watts, and prices for various models.

POWER EQUIPMENT. Voltage Regulator Raytheon 95/130 V 60 Cy 1.25 Amp \$12.50

SPECIALS. 80.86 KC Crystal with Holder \$2.50 CD-501A Cord Connects BC-654

TERMS: Minimum order \$5.00—Mail orders promptly filled—All prices F.O.B. Boston, Mass. SEND FOR OUR CATALOGUE Inquiries from Dealers, Schools and Industrial Firms Invited COMET ELECTRONIC SALES CO. 22 Washington St. • Beacon 2-7863 • Brighton 35, Mass.

Triple Phone Power (Continued from page 56) is necessary to have available an accurate method of indicating overmodulation. An oscilloscope is the best instrument, but is not imperative. To set up for operation, the input gain control should be opened first to a fairly advanced position. Then the output control is opened until test voice peaks are reaching the desired percentage of modulation. Next, using your own monitor, or better yet, utilizing the help of a local ham, advance, or decrease the input gain control as required, until a discernible, but not too objectionable, distortion is heard. This will give, in the broadest of terms, 10 to 15 db of clipping. More or less clipping can be used as desired merely by changing the input gain control. Readjustment of the output control will probably be necessary to realize the desired modulation level which then will not be exceeded no matter how loud a signal enters the clipper stage. Although not tested, this limiting feature should be of value for frequency modulated tones, in holding the deviation to the optimum level. -30-

could check the actual gain-per-stage in the video amplifiers, trace the sync pulses through the sync circuits and check to see if the sync clippers are actually clipping the sync. No doubt about it, a scope is a handy thing to have around. Now, of course, the sixty-four dollar question becomes: "What kind of a scope?" Since this unit has to be carried from the car to the customer's home, we can immediately cross off the list the 7 inch models with "cast iron" chassis. Portability is the most important factor. This automatically eliminates all types but the 3 inch or 2 inch "pocket-scope" variety. The smaller and more compact the unit is, the more attractive it is for this particular application. The deflection sensitivity should be good enough to produce a satisfactory picture of the signal at the video detector. This calls for a deflection sensitivity of at least one-half volt-per-inch at the vertical input terminals. Naturally, the greater the deflection sensitivity, the more desirable the unit, especially if the scope is also to be used in the shop for alignment work. The frequency response of the vertical amplifier is controversial. For about 90% of all TV service work, a scope having a vertical amplifier frequency response out to 100 kc. is adequate. Its only failing is in accurately reproducing the waveform of the horizontal sync pulses and some of the waveforms in the horizontal deflection circuits. Since the scope is going to be used for maintenance and not for design work, very accurate reproduction is not absolutely necessary.

IN TUNE WITH THE TUNER!

NEW...IMPROVED

**"STANDARD
TV
BOOSTER"**

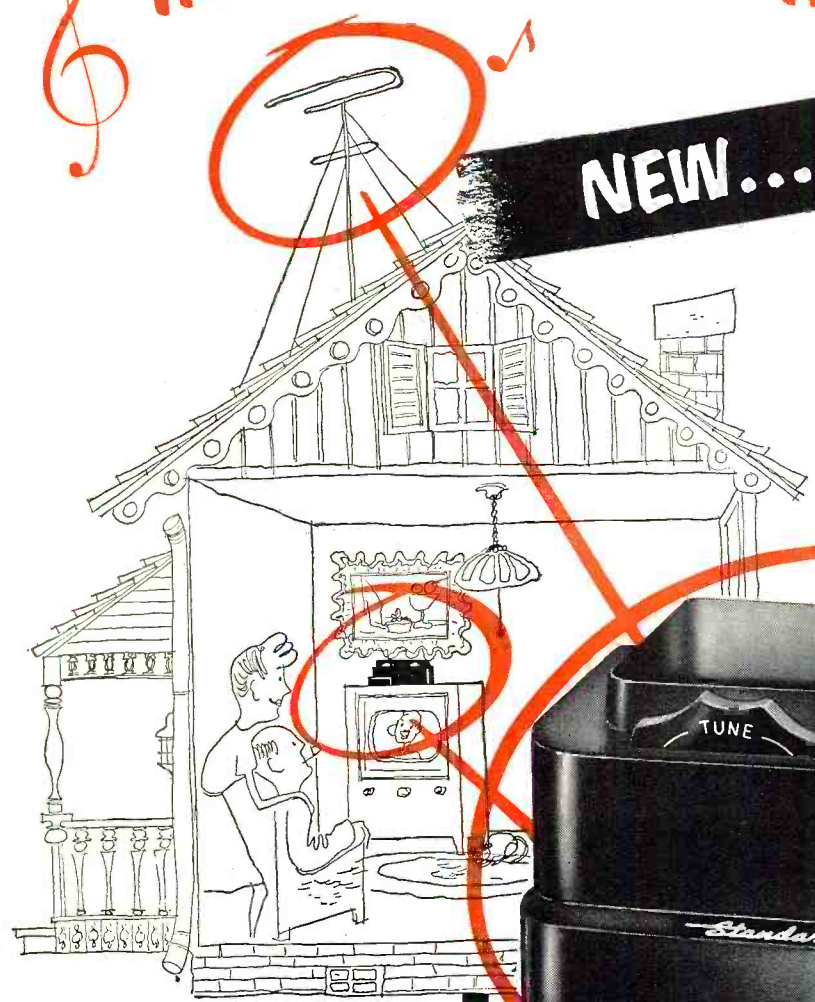

MODEL B-51

Millions of "Standard Tuners"

Now In Use

Used by over 75
TV Set Manufacturers



The new "Standard Booster" will increase the TV signal strength to a degree that will make possible "city" reception in areas remote from the TV transmitter. It reduces the "snow" or noise and interference to give a clearer, sharper picture and improved sound reception. It also makes possible receiving a picture in very remote areas or "blind" areas in close-to-transmitter locations where the TV set alone will not — makes a TV set a real enjoyment!

Standard COIL PRODUCTS CO. INC.
CHICAGO • LOS ANGELES • BANGOR, MICH.



Optical comparator is used to check mica disc specifications to thousandth-inch accuracy.

ONE STANDARD

**-The best that can
be made-for
Initial Equipment
and Replacement**



TUNG-SOL
RADIO, TV TUBES, DIAL LAMPS

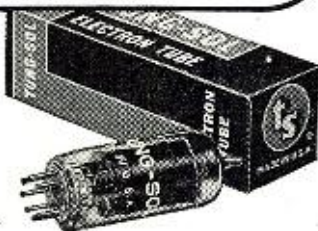

TUNG-SOL LAMP WORKS INC. Newark 4, N. J.
Sales Offices: Atlanta • Chicago • Dallas • Denver •
Detroit • Los Angeles • Newark

WHAT'S

New in Radio

For additional information on any of the items described herein, readers are asked to write direct to the manufacturer. By mentioning RADIO & TELEVISION NEWS, the page, and the issue number, delay will be avoided.

LOW-COST MULTIMETER

To meet the demand by service technicians for low-cost test equipment, *Electronic Instrument Co., Inc.*, of 276 Newport Street, Brooklyn 12, New



York, has recently introduced a new multimeter which is available in both kit form and factory wired.

The Model 526 (Model 526-K in kit form) has 31 different ranges with a zero-to-one volt range on both its a.c. and d.c. voltage ranges. The 3½" meter has a 400 microampere movement and all resistors have 1 per-cent or better accuracy. The integral dual rectifier has separate low and high voltage calibration on a.c. ranges while the ohm ranges are specifically designed to insure minimum battery drain. There are separate jacks for high current and high voltage positions.

GEIGER COUNTER

Precision Radiation Instruments, Inc., 4113 W. Jefferson Blvd., Los Angeles 16, California, is currently marketing a low-priced Geiger Counter unit which has been designated "The Snooper."

Small enough to fit in the palm of the hand or in a hip pocket, the counter is easy to use and maintain. The instrument is powered by an ordinary



flashlight battery and comes complete with earphone, radioactive sample, and operating instructions.

A miniature amplifier gives a loud audible signal whenever the instrument comes near radioactivity wheth-

er from uranium ore, cosmic rays, radium, x-rays, or atomic explosion.

"The Snooper" measures 1½"x3"x5" and weighs 1¼ pounds. The company will furnish additional details on request.

NEW TERMINALS

The *Thomas & Betts Co., Incorporated* of 28-A Butler Street, Elizabeth 1, New Jersey, has developed a new line of terminals that effectively ends the risk of short circuits between closely spaced wires.

Known as Self-Insulated Sta-Kon Terminals, the new units are integral, one-piece assemblies combining a metallic portion that grips both the wire and the wire insulation tightly and permanently with a single staking operation, and a translucent, firmly anchored terminal insulator of specially formulated nylon.

Engineering data bulletin No. S4, giving complete mechanical details on these new terminals, is available from the company on request.

50-WATT AMPLIFIER

Newcomb Audio Products Co. of 6824 Lexington Ave., Hollywood 38, California, has recently added a new low-cost utility amplifier to its E-Series line.



The new Model E-50D provides two individual 25-watt output channels on separate controls for a total of 50 watts of undistorted audio power. The unit's flexibility makes it suitable for installations in which individual control is desirable for two different size areas with varying volume requirements. It has inputs for three microphones and one phonograph. Distortion is less than 5 per-cent for each 25-watt channel.

DIPOLE ANTENNAS

Communication Products Company, Inc., Broadway and Clark Streets, Keyport, New Jersey, is in production on a new line of half-wave dipole antennas which have been especially designed for both transmitting and receiving.

The power handling capacity of these units is limited only by the power rat-

RADIO & TELEVISION NEWS

School's in and Prof Platt's BARGAINS ADD UP to Real Value!

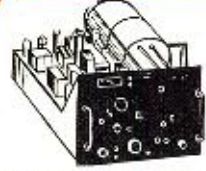

**AIRBORNE EQUIPMENT
DESIGNED FOR AIRCRAFT**
T-85/APT-5 UHF TRANSMITTER
Radar Set AN/APT-5 operates on 80 or 115 volts A.C. at 400 to 2600 cycles requiring 640 volts amperes at 0.80 power factor. Complete with all tubes. Brand new in original packing. **\$99.50**
A TERRIFIC BUY AT ONLY \$99.50

RADIO COMPASS AN/ARN-7

Primarily used for aircraft navigation. Frequency range: 100 KC to 1730 KC in 4 bands. Operates on 115 volts, 400 cycles A.C. Complete installation consists of the following: Radio Compass Receiver R./ARN-7, Radio Control Box C4/ARN-7, Loop LP-21, Loop Dehydrator, Indicator I-31-A and I-82-A, Relay BK-22, Coupling MC-203, Cord CD-365, Plugs PL-112, 118, 122. Thoroughly tested and reconditioned by experienced personnel presently engaged in manufacturing for defense. **ONLY \$149.50**



**AN80A
Antenna
for
BC-645
49c**



BOMBSIGHT Used Exclusively with B29 Planes

This bombsight is a buy-of-a-lifetime! It was developed by Sperry Gyroscope Co. in conjunction with other leading U.S. firms. Here is a veritable gold mine of costly parts! Excellent for experimenters, schools, and for advanced development. **Consists of 3 Assemblies. Total shipping weight—350 lbs. SPECIALLY PRICED \$299.00**



APN/I Radio Altimeters

Was used in conjunction with automatic pilot system, providing direct measurements of altitude by a radio beam. Designed to operate from 24 volts DC. Equipped with double range altitude indicator ID-14 and ID-14A, power switch and range switch. DC operation—22 to 29.5 volts, consuming approximately 2.6 amperes with 20 volts delivered to the battery input receptacle of radio transmitter receiver. Weight—24 lbs. BRAND NEW and complete in original government cases with operating instruction manual. **\$49.95**
FOR IMMEDIATE SHIPMENT \$49.95

A FIRST WITH PLATT!!

RADIO SET SCR-583

Has following 3 installations: 2 in pack animal, 1 on t h e ground, in a motor vehicle. Designed to provide 2-way communication. Frequency Range: Transmitter 2.2 to 4.6 Mc. Receiver 2.2 to 4.6 Mc. Types of Signals emitted CW and Voice. Types of Modulation A.M., F.P.F. CW
Distance Range Phone Miles CW Miles
Low Power 10 15
High Power 35 65
Auxiliary Power 40 80
Supply 40 80
Complete, brand new, equipped for immediate installation. **\$429.00**



RADIO SET SCR-694C

Presently manufactured complete ready for installation pack ground and mobile. Operating range 15 miles voice, 30 miles CW. Frequency Range 3800 KC to 6500 KC. As supplied to the Government, outlined in Manual, less spare parts. **\$1250.00**

TRANSMITTER-RECEIVER

Navy Model ABA-1 (CG-43AAB) 450 MC 15 Tubes
Army Model SCR-515A, known as the BC-645
Can be easily converted for phone or CW 2-way communication. Covering for the following bands: 420-430 MC ham band, 450-460 MC for fixed or mobile, 460-470 MC for citizens, 470-500 MC television experimental. Size 10 1/2 x 13 1/2 x 4 3/4. Contains 15 tubes: 4-7F7, 4-7H7, 2-7E6, 2-6R6, 2-9X5—WE-311A det. tube. Complete as shown above. **\$24.95 ONLY**



**SCR-27N
COMMAND and
ARC-5 Equipment**

	USED	NEW
BC-453—	\$17.95	\$37.50
BC-454—3 to 6 MC.	11.95	18.95
BC-455—6 to 9 MC.	8.95	11.95

RECEIVERS	USED	NEW
BC-457—4 to 5.3 MC.	7.95	12.95
BC-458—5.3 to 7 MC.	8.95	13.95
BC-459—7 to 8 MC.	16.95	19.95
BC-459—7 to 9.1 MC.	16.95	27.50

TRANSMITTERS	USED	NEW
BC-457—4 to 5.3 MC.	7.95	12.95
BC-458—5.3 to 7 MC.	8.95	13.95
BC-459—7 to 8 MC.	16.95	19.95
BC-459—7 to 9.1 MC.	16.95	27.50

ADDITIONAL EQUIPMENT	USED	NEW
BC-456 Modulator	3.95	6.95
BC-459 Control Box (Receiver)	1.45	2.95
BC-451 Control Box (Transmitter)	1.29	2.49
BC-442 Relay Unit (ANT)	1.29	3.95
Plugs: PL-147, 148, 151, 152, 153, 154, 156—EACH.	1.25	
Flexible Shafting with gear to fit Receivers		1.69
3 Receiver Rack	2.25	
2 Transmitter Rack	1.69	

HEADSETS

HS-33 low impedance with cord and plug, used, fine condition. **\$1.89**
HS-23 high impedance, BRAND NEW with ear pads. **3.95**
HS-33 low impedance, BRAND NEW with ear pads, cord and PL54 plug. **4.95**
HS-30 with ear plugs, low impedance, used, good condition. **1.69**
CD-307A Cords, 6 ft., NEW. **.89**

ALSO AVAILABLE!

SCR-284
Brand new, ready for installation. **\$329.00**

BC-348 RECONDITIONED GUARANTEED LIKE NEW

All letters. Frequency Range 200 to 500 KC. 1 1/2 to 18 meg. O L D RELIABLE EQUIP. OF WORLD WAR II. **SPECIAL! \$165.00**

BEACON RECEIVER BC-1206-C

Manufactured by Satchell-Carlson
Frequency Range—195 KC to 420 KC, IF Frequency—135 KC, Receiver Sensitivity—3 Microvolts for 10 Milliwatts output, Output Impedance—300 Ohms and 4000 Ohms to be selected internally, Power Output—230 Milliwatts, Volume Control—RF Gain Control, Power Supply—24-28 Volts Aeroplane Battery, Current—.75 Amperes. **\$10.95**
BRAND NEW—ONLY \$10.95

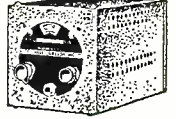

UNSURPASSED VALUE!

SHIP-TO-SHORE BC-223 TRANSMITTER

A 30 watt Transmitter, ideal for ship-to-shore or Ham Rig. Crystal or MO control on four pre-selected channels, 2000 to 5250 KC. Use of 3 plug-in coils, five tubes: 2—801 and 3—46, and TU 17-18-25 tuning units.
TRANSMITTER \$39.95
TUBES \$5.95
TUNING UNITS Each \$4.25
PE-125 VIBRATOR POWER SUPPLY FOR BC-223 \$18.95

Multitester Foundation BIAS METER 1-97A

Contains a zero center 3 1/2" round Marion voltmeter calibrated 0-100 volts each side. Movement is one mill each side of center. The unit is mounted in a steel box 7"x5"x4 1/2" and contains 8 contact push button, line cord dual 100 MFD at 200 V DC condenser, a potentiometer 6 1/2 KC wire wound non-inductive resistors: one 400 ohm, two 2500 ohm, one 5000 ohm, one 10,000 ohm, one 15,000 ohm. Excellent for building a zero center multitester with ranges of 1, 10, 100, 1000 volt. **COMPLETE BRAND NEW \$7.95**



FIELD TELEPHONES



Army surplus, plus, completely reconditioned electrically tested, using 2 flash light cells and a pair of a t e connecting wires. GUARANTEED—like new. **ONLY \$16.95**
The K-1 is used to amplify output level for microphones and phonographs. Operating on 24-28 VDC, can be converted to 110 AC. Comes complete with PL 55 plug and 2 foot 119-B cord, 2 terminal blocks and instruction book. **BRAND NEW SPECIAL \$4.95**

ARC-5/R-28 2 MTR RCVR \$29.95
Here is the 2-meter superb you have been looking for! Absolutely one of the BEST available today! Tunes from 100 to 156 Mcs. in four crystal channels. (Easily converted to continuous tuning.) Tube lineup is as follows: 717A—R.F., 717A—Mixer, 2-12SH7-1st and 2nd K.F., 16J9 Mixer, 12SL7—Del. AVC Spuclen, 12SL7-1st audio-speech amplifier, 12A6—2nd audio, 12SH7—R.F. Osc.—4th Harmonic Gen., 717A—Trip, 12th Harmonic Gen., 717A—Dblr.—12th Harmonic. Sealed Cartons **\$29.95**
FREE one copy of Vol. 2 "Surplus Radio Conversion Manual" (Reg. price \$2.50). This volume contains circuit diagram and full description of above receiver.

ARC-5/T23 XMTR \$49.95
FAMOUS AIRCRAFT 2MTR EXTR.
COMPANION TO ABOVE RECEIVER
Order Your Pre-amplifier NOW!
WRITE FOR OUR FREE CIRCULAR!
Order two—one for your home, one for your car in case of flats or fires. **ONLY \$2.29 each**



BC-221 Frequency Meter

Real Value! QUANTITY IS LIMITED—so first come first served. They are just like new, with original calibration charts. Range 125-20,000 KC with crystal check points in all ranges. Complete with crystal and tubes. **ONLY \$99.50**



THIS IS PLATT ELECTRONICS

Yes, friends, here is a part of Platt Electronics that very few people get a chance to see. Here you find highly skilled personnel working on defense contracts, as well as reconditioning electronic equipment for Home, Radio Men and Experimenters. It pays you to play it safe—BUY FROM PLATT AND BE SURE!

Minimum Order \$2.00

Immediate Delivery—Send 25% deposit on C.O.D. orders. All shipments F.O.B. N.Y.C. (N.Y.C. residents add sales tax to your remittance.)

PLATT ELECTRONICS CORP.

DEPT. A, 489 BROOME ST., NEW YORK 13, N. Y.
PHONES: WO 4-0827 and WO 4-0828

DUAL PURPOSE EMERGENCY UNIT

• Fire Extinguisher
• Tire Inflator
Made by leading Detroit Auto Mfr. Especially recommended for oil, gas and electrical fires. Tested and stamped in accordance with I.C.C. regulations. Guaranteed by mfr. against defects.
Order two—one for your home, one for your car in case of flats or fires. **ONLY \$2.29 each**

NOW! Fill Your Battery Only Twice a Year
with Automatic Battery Filter
Made by leading Detroit Auto Mfr. Double battery life over ordinary care, prevents battery breakdowns, fits all cars, instantly installed. **ONLY \$1.95 complete**



TUBES and PARTS

RESISTORS

Insulated 1/2 and 1 watt assortment of most used values, best brands, **\$3.95**
100 for

50 assorted for \$2.25
25 assorted for 1.50

RESISTORS

You pick them, we ship them.
Insulated—best U. S. brands.

ANY RESISTANCE

	10 for		10 for
1/2 watt	{ 20%... 35c	1 watt	{ 20%... 42c
	{ 10%... 50c		{ 10%... 75c
	{ 5%... 95c		{ 5%... \$1.50
2 watt—20%.....	10 for 60c		
2 watt—10%.....	10 for 95c		
2 watt—5%.....	10 for \$2.15		

BY-PASS CONDENSERS

Tubular condensers. Nationally advertised brands. High quality. Overstock sale price: **\$5.00**
.001-600V per hundred
.002-600V

100 assorted by-pass condensers, most popular values from .001-600V **\$6.95**
up to .5-600V.....

TV CONVERSION KIT

Convert 10" and 12" sets to 14"—includes 14BP4 Tube 70 Degree Deflection Yoke and Attractive Lucite Mask to eliminate all finish work on cabinet. Complete **\$29.95**

17" CONVERSION KIT

Consisting of rectangular tube, 70 Degree Yoke, Beautiful Mask and Fly-back Transformer. Complete **\$37.95**

Order from
"Premier"

Your reliable source
Since 1926

Premier RADIO TUBE CO. 551 W. Randolph St. Chicago 6, Illinois ANdover 3-1590

ANTENNAS

"Look at the Prices!"

TV "Perfect Balance Antenna"

High-low, 6 element Yagi TV antenna, cut for all channels, stack it or mount in line, complete with 8 foot mast, ind. boxed. **\$6.98**
6 for \$6.49 ea.

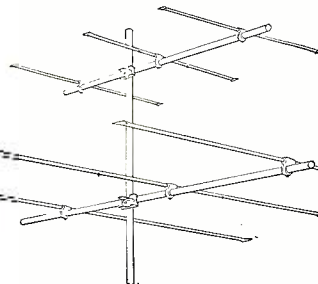

TV INLINE FOLDED DIPOLE ANTENNA
At this price we cannot mention manufacturer's name, complete with mast, ind. boxed **\$7.98**
6 for \$7.29 ea. **\$** each

TWIN LEAD

300 ohm twin lead 55 Web virgin polyethylene, in either clear or brown.

1000 ft. **\$18.50** 100 ft. **\$1.95**

6 FOOT LINE CORDS

will be scarce—UL approved cord and plug—10 for **\$1.95**

TV PICTURE TUBES

10BP4.....	\$12.95	16JP4.....	\$29.95
12LP4.....	\$19.95	16RP4.....	\$29.95
14PB4.....	\$22.95	16TP4.....	\$29.95
7JP4.....	\$17.95	17BP4A.....	\$31.95
		19AP4A.....	\$39.95

TUBE KITS

3Q4, 1T4, 1R5, 1S5. List Value \$8.00. Tube Kit only	\$2.39
3S4, 1T4, 1S5, 1R5. List Value \$7.80. 4 Tube Kit	\$2.39
1U4, 3S4, 1S5, 1R5. List Value \$7.80. All Four Tubes for	\$2.39
3V4, 1R5, 1S5, 1T4. List Value \$7.80. All for	\$2.39
117Z3, 1U5, 3V4, 1R5, 1T4. AC-DC Portable Kit. All for	\$2.89
12AT6, 12BA6, 12BE6, 35W4, 50B5. 5 Tubes for	\$2.95
50L6, 35Z5, 12SQ7, 12SK7, 12SA7. 5 Tubes for	\$3.22

Get our catalog of filter condensers, by-pass condensers, speakers, volume controls, output transformers, IF transformers.
TERMS: 20% DEPOSIT with order, balance C.O.D. \$1.00 handling charge for orders less than \$5.00. All shipments F.O.B. Chicago. Our parts and tubes are warranted to be 100% replacements for the prototypes in the listings above. Prices are subject to revision without notice. **SATISFACTION GUARANTEED.** Illinois residents add 2% sales tax. **ORDER TODAY!**

ing of the transmission line feeding them. They consist of two coaxially arranged elements, each cut to approximately one-quarter wavelength and center fed with 72 ohm transmission line.

Bulletin 106, containing complete construction data, detailed specifications, and operational information, is available from the company on request.

FINGERTIP WRENCHES

The Tube Department of *Radio Corporation of America* is offering a unique set of fingertip wrenches which have been especially designed to aid the radio and television technician in working "tight spots" in chassis.

Offered as part of the Tube Department's new promotion campaign, these

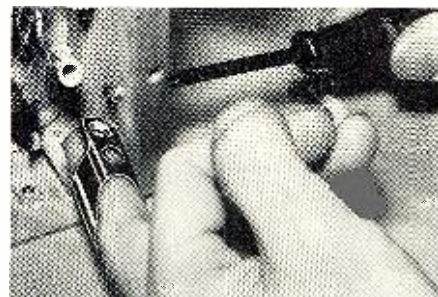

new tools are practical time-saving devices which help solve the problem of holding, placing, and adjusting nuts in receivers. The wrenches are worn on the finger and are used to steady the nut or bolt as it is tightened or loosened. Each set consists of five wrenches for the most commonly used nut and bolt sizes: 3/16", 1/4", 5/16", 11/32", and 3/8". The wrenches are made of steel and are nickel-plated for rust resistance. They are adjustable to individual finger sizes.

Local *RCA* tube distributors are handling these wrench sets.

METAL CUP CERAMICS

Herlec Corporation of 422 N. 5th Street, Milwaukee 3, Wisconsin, a subsidiary of *Sprague Electric Company*, is currently in production on a new line of metal cup ceramic condensers which are especially designed for applications requiring rigid frequency control.

According to the company, the outstanding advantages of these new units include capacitance stability, high "Q," and excellent retrace characteristics. They are small in size, hermetically sealed against atmospheric humidity, and are easy to mount securely against the effects of vibration and shock.

Bulletin No. 603, which provides complete details on these new ceramics, is available from the company without charge.

AMPLIFIER SYSTEM

Altec Lansing Corporation of Beverly Hills, California, is currently in production on a new amplifier system which has been designed especially for use in home music installations.

The new system consists of the A-433A preamplifier and the A-333A power amplifier. These units are arranged so that all operating controls are located on the small, compact, portable preamplifier which connects to the power amplifier by 6 foot flexible cables. These controls include a three-step selection of record crossover frequencies, control of the rise and droop in both treble and bass, equalization for variable reluctance pickup, filter for 33 1/2 rpm recording characteristic rise, a three input selector switch, and a continuously variable volume control.

Frequency response is flat to plus zero, minus 1 db from 20 to 20,000 cycles and is within 3 db of flat response up to 100,000 cycles. The system will deliver 27 watts of audio power at less than 5 per-cent harmonic distortion, 20 watts at less than 2 per-cent harmonic distortion, and 15 watts at less than 1/2 per-cent harmonic distortion.

NEW PREAMPLIFIER

Fisher Radio Corporation, 41 East 47th Street, New York, New York, has designed a new quality preamplifier which can be used with *G-E, Pickering, Audax, Clarkstan*, and other low-level magnetic pickups. It can also be used as a microphone preamplifier.

The unit uses two stages of triode amplification and features a novel feedback circuit to produce low frequency equalization. The preamplifier is self-powered and comes in a completely enclosed chassis which measures 3 3/4" x 3 3/4" x 3 3/4".

It features a hum level of better than 60 db below 1 volt output on phono

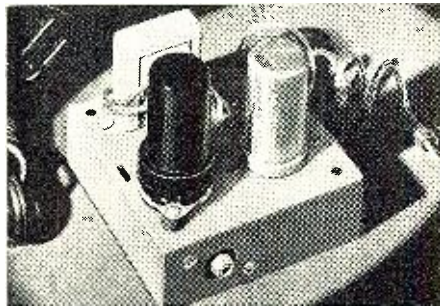

and microphone. Frequency response is uniform within 2 db from 30 to 20,000 cycles on both phono and microphone. An installation and service manual is furnished with each of these units.

METALLIZED PAPER TUBULARS

Cornell-Dubilier Electric Corporation of South Plainfield, New Jersey, has introduced an improved and complete metallized paper tubular line for general purpose use.

Among the features of this new line are compactness and light weight, combined with high insulation resistance, low power factor, and self-healing characteristics.

The new line is available in three basic types, the "Pup," "Sealpup," and "Metapup" which come in a wide range of capacities and operating voltages. Bulletins covering these units are available from the company. Ask for

TUBES

Radio and TV

FREE! \$20.00 List Value
Cornell-Dubilier,
Mallory, Aerovox, Sprague, Filter
Condensers—Ten good filters **FREE**
with each 100 tubes.

TUBES and PARTS

Individually Boxed—All Brands—Standard Factory Guarantee

29c ea. 65c ea. 72c ea. 87c ea. \$1.04 ea.

11L4
1B5
1C7G
1E7
1H6
VT51
VT52
1294
1299
1629

45c ea.

5Y3GT
35W4
80
1619

54c ea.

5Y4G
6AT6
6AV6
6J5GT
6SQ7
6X4
6X5GT
12AT6
12AV6
12J5GT
12SQ7
35Z4GT
35Z5GT
117Z3

59c ea.

0Z4
0Z4G
5U4G
5W4
5W4GT
6AR5
6BF6
6C4
6C5GT
6F5GT
6F6GT
6H6
6K6GT
6SF5
6SQ7GT
12BF6
12SQ7GT
25Z5

1A5GT
1H5GT
1U5
5X4G
5Z3
6AQ6
6BA6
6BE6
6H6GT
6Q7GT
6S4
6SF5GT
6S17
6S17GT
6SR7GT
6W4GT

7A6
7A7
7A8
7B4
7B5
7B6
7B7
7B8
7C5
7C6
7C7
7Y4
7Z4

72c ea.

12BA6
12BE6
12F5GT
12H6
12Q7GT
12SJ7GT
25L6GT
35A5
35L6GT
35Y4
35Z3
45Z5GT
50L6GT
50Y6GT

72c ea.

1N5GT
1R5
1S5
1T4
1U4
3S4
3V4
6AL5
6AQ5
6A55
6AU6
6BC5
6BH6
6BJ6
6CB6
6SA7GT
6SC7
6SF7
6SK7GT

6S57
6U5
6V6GT
7A4
7H7
7Q7
12AU6
12SA7GT
12SF5GT
12SF7
12SK7GT
25W4GT
35B5
35C5
41
42
43
45
50B5
50C5
50Y7GT
75
77
78

79c ea.

1A7
2A5
3Q4
6A8GT
6B6G
6BC7
6BF5
6C6
6D6
6E5
6J7G
6K7GT
6SH7GT
6SN7GT
6U6GT
6U7G
6U6GT
7A5
7E6
7F7
7N7
7R7
7X6
12A8GT
12K7GT
12SC7
12SH7GT
12SN7GT
12SR7GT
14A7
14B6
14B8
14F7
24A
25Z6GT
35/51
50A5
50X6
85

3Q5GT
5V4G
6AK6
6BA7
6K5GT
6K8GT
6L7
6N7GT
6P5GT
6SL7GT
6Y6G
12AU7
12AX7
12BA7
12BH7
12SL7GT
14AF7
14C7
71A
117Z6GT
7193

95c ea.

1B3GT
1J5GT
1LA4
1LA6
1LC6
1LD5
1LE3
1LH4
1LN5
1P5GT
1Q5GT
1X2A
3LF4
5Z4
6AB5/6N5
6AG5
6AU5GT
6G6G
6L5G
6R7GT
6S8GT
7E7
7G7
7J7
7K7
7L7
7Z3
7S7
7W7
7X7
12AH7GT
12AW6
12S8GT
12Z3
14C5
14X7
35Z6G

6AC5GT
6AC7
6J6
6SD7GT
12AT7
19T8
25AC5GT
25Y5
46
47
50C6G

\$1.15 ea.

1H6G
2A3
6A3
6AB7
6AG7
6B4G
6B5
6B8GT
6BD5GT
6BN6
6BQ6
6C8G
6D8G
6F8G
6J8G
6S7GT
6T7G
6T8
7C4
7F8
12A7
12AV7
12C8
14F8
25BQ6GT
32L7GT
2051

\$1.40 ea.

5T4
6AH6
6AK5
6N6G
20
70L7GT
117L7
117N7GT
117P7GT

6BG6G ea. \$1.73
6BQ7 ea. 1.58
6CD6G ea. 2.15
19BG6G ea. 2.15
807 ea. 1.95
813 ea. 9.95
2050 ea. 2.00

5c
per Tube
extra for
less than
50 tubes

NOTICE: we have complete stocks of filter condensers, by-pass condensers, speakers, volume controls, output transformers, IF transformers ... at less than standard prices.

Order Today!

Catalog of tubes and parts included with each order.

Premier RADIO TUBE CO. 551 W. Randolph St. Chicago 6, Illinois ANdover 3-1590

Famous Products by

Jensen



Concert Series



H-510 Coaxial with Acoustic Lens



Speechmaster Reproducers



G-610 Triaxial

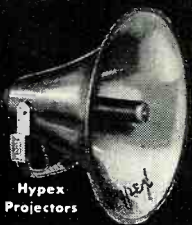

Hypex Projectors



VIKING economy speakers

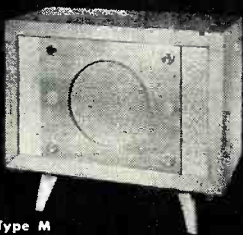

Type M Reproducer Cabinet



Extended Range



Standard Series

Jensen MANUFACTURING COMPANY

Division of the Motor Company
6601 S. LARAMIE AVENUE • CHICAGO 38, ILLINOIS

BRITTON BROWNE ADVERTISING

No. 142 on the "Pup" tubulars, No. 143 on the "Sealup" units, and No. 144 for the "Metapup" condensers.

"LOAD-CHEK"

The Triplett Electrical Instrument Co. of Bluffton, Ohio, has recently introduced a new test instrument, the "Load-Chek" Model 660.

This unit facilitates servicing by

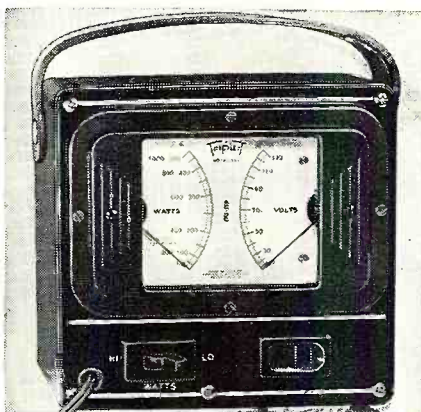

means of power consumption measurements. The instrument indicates shorts or opens in the circuit, localizes the trouble, yet requires no involved interconnections between the unit and the appliance being tested.

The Model 660 has ranges of 0-500-1000 a.c.-d.c. watts and 0-130 a.c.-d.c. volts. It is housed in a portable case which measures 6" x 5½" x 2½" and comes with a leather strap handle. The unit weighs just 2 pounds.

A data sheet on the Model 660 is available on request.

PORTABLE SCOPE

The Hickok Electrical Instrument Company, 10677 Dupont Avenue, Cleveland 8, Ohio, has announced a new portable 3" oscilloscope, the Model 380 "Miniscope."

The new instrument has a frequency coverage to 2.5 mc. and features a sensitivity of .1 r.m.s. volts per inch. The unit has direct connection to the cathode-ray tube elements, provision for Z-axis modulation, and a telescopic

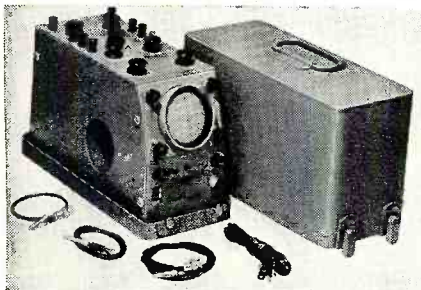

light shield. It is shock mounted and housed in a strong moisture-proof aluminum case which measures 6" wide, 9" high, and 13½" in depth. The scope weighs 14 pounds and comes complete with leads.

COIL FORM KIT

Of interest to design engineers, laboratory technicians, and experimenters is a new coil form kit just released by

Cambridge Thermionic Corporation of 463 Concord Avenue, Cambridge 38, Massachusetts.

The kit contains representative samples of ceramic coil forms manufactured by the company. It contains three each of five different ceramic coil forms, each coil form in each group being provided with a different powdered iron slug. Extra slugs of silver-plate brass for each coil form are provided as alternates to the iron slugs.

Coil forms vary in diameter from 3/16" to 1/2" and in over-all mounted heights from 1 1/8" to 1 1/16". Types included are LST, LS5, LS6, LS7, and LS8.

VARIABLE CONDENSER

The E. F. Johnson Company of Waseca, Minnesota, has announced the availability of a new, small-sized variable condenser which has been designated as the Type "R."

Plates are of brass with a highly corrosion resistant bright alloy plating. Standard spacing is ordinarily .0245" for maximum capacitance ranges up to 325 μfd. Other spacings up to .0715" can be obtained. Dimensions of the unit are 1 5/8" wide by 1 1/16" high with the plates extended.

Although these new units are cur-

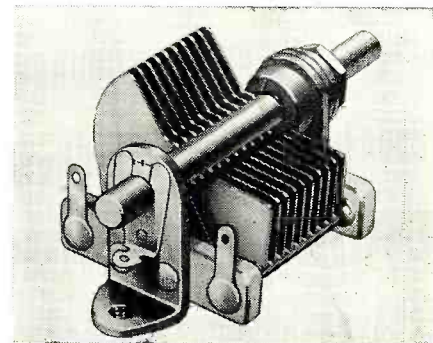

rently available only on special order in production quantities, full details may be secured from the company.

CLAROSTAT CONTROLS

Clarostat Mfg. Co., Inc. of Dover, N. H., has developed a volume control replacement unit with a 1 5/16" diameter shaft.

Prior to the release of these new units the company's Series G and AG controls have been available in the 1 5/16" size but the "Ad-A-Switch" unit has not. Now the Series SWB or 1 5/16" "Ad-A-Switch" is obtainable in s.p.s.t.; three-way no "off" position s.p.d.t.; and d.p.s.t. A T-shaped section of the control's dust cap is simply pried off, turned 90 degrees and removed, exposing the switch-throwing mechanism.

FM TUNER CHASSIS

Collins Audio Products Co., Inc., P.O. Box 368, Westfield, New Jersey is in production on a new FM tuner chassis, the RD-1C.

The tuner comes mounted on an aluminum plate measuring 7¼" x 4½" which can be fitted into any chassis of the user's choice. By proper placement

RADIO & TELEVISION NEWS

IMMEDIATE DELIVERY OF

Top Quality MINIATURE SWITCHES

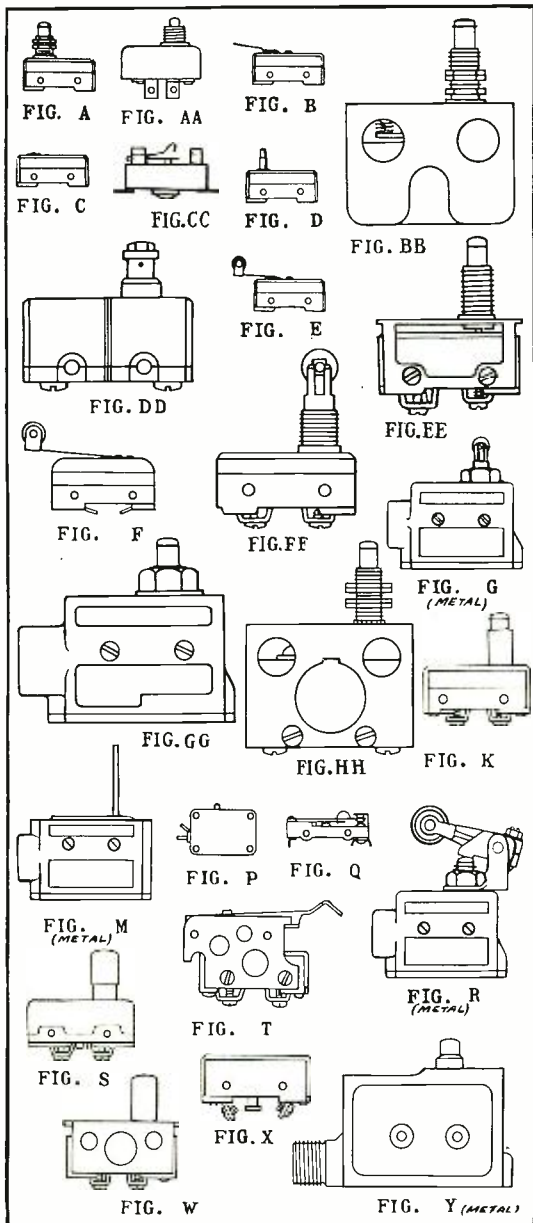

This list of brand new standard brand miniature switches represents only a few of many types in stock at Wells. Large quantities of most types are on hand for your immediate requirements. Write or wire for quotations on switches not listed.

Stock #	Mfr.	Type #	Contact	Fig.	Price	Stock #	Mfr.	Type #	Contact	Fig.	Price
41MC2	ACRO	2M03.1A	NO	P	.50	41MD53	MICRO	WP5M5	NC	AA	.50
41MM2	MU	AC2101BB	SPDT	W	.85	41MC27	MICRO	W22RST	NC	D	.55
41MC6	MU	APB236	SPDT	A	1.15	41MD48	MICRO	W22RT	NC	C	.65
41MC26	MU	APG210	NO	A	.80	41MD33	MICRO	W23PW2	NC	F	.80
41MC17	MICRO	B-1	NC	Y	1.45	41MD16	MICRO	W27R	NC	C	.55
41MC16	MICRO	B-1T	NC	DD	.90	41MD43	MICRO	W27RQ1T	NC	A	.70
41MC7	MICRO	B-14	NO	HH	1.70	41MC15	MICRO	W27RQ2T	NC	A	.70
41MD62	MICRO	B-R	SPDT	C	.70	41MD36	MICRO	W27RST	NC	D	.55
41MD46	MICRO	B-RL18	SPDT	B	.95	41MC24	MICRO	W27RQTN	NC	Y	1.45
41MD63	MICRO	B-RS36	SPDT	D	.80	41MC23	MICRO	W27RQTN	NC	R	3.75
41MD23	MICRO	BD-RL32	SPDT	B	.95	41MD54	MICRO	W2R8X	NC	X	.80
41MLH	MICRO	BZRQ41	SPDT	W	.85	41MC9	MICRO	W2R31	NC	C	.65
41MD51	MICRO	BZ-R37	SPDT	C	.70	41MD57	MICRO	W2R31	NC	T	.70
41MD2	MICRO	BZE7RQ2	SPDT	GG	1.70	41MD31	MICRO	W2RD	NC	C	.55
41MD21	MICRO	BZ-7RST	SPDT	D	.80	41MD19	MICRO	W2RL8	NC	B	.70
41MD38	MICRO	BZE2RQ9TN1	SPDT	G	2.65	41ML3	MICRO	W2RQ41	NC	W	.65
41MD6	MU	CUM 24155	NO	E	.80	41ML2	MICRO	W2V7RQ9T1	NC	G	2.25
41ML1	MU	D	NO	BB	1.50	41MC21	MICRO	X757	NC	C	.55
41MC12	MICRO	D in case	NC	Y	1.45	41MD37	ACRO	XC1A	NC	C	.55
41MD34	KLIXON	ES692070	NC	CC	.50	41MC5	ACRO	XD45L	SPDT	B	.95
41MD65	MICRO	G-R26	NO	C	.60	41MD4	MICRO	YZ	NO	C	.75
41MD60	MICRO	G-RL	NO	B	.80	41MD40	MICRO	Y2A2RLE4D13	NO	B	.70
41MC11	MICRO	G-RL 5	NO	B	.80	41MD24	MICRO	Y22YLTC1	SPDT	B	.95
41MD61	MICRO	G-RL35	NO	B	.80	41MC1	MICRO	Y22YST	SPDT	D	.60
41MD41	MICRO	G-RL43	NO	B	.80	41MD13	MICRO	Y23R3	NO	C	.60
41MD64	MICRO	G-RS	NO	D	.55	41M056	MICRO	Y23RLTC2	NO	B	.80
41MD66	MICRO	G-RS36	NO	D	.60	41MC14	MICRO	Y23RW2T	NO	F	.90
41MC32	ACRO	HRO 7.1P2TSP1	NO	K	.65	41MD49	MICRO	Y27RQ9TG	NO	FF	.85
41MC19	ACRO	HRO 7.4P2T	NO	S	.60	41MD32	MICRO	Y27RST	NO	D	.60
41MD8	ACRO	HRRC 7.1A	NC	C	.55	41MC13	MICRO	Y27RA6	NO	EE	1.00
41MD27	ACRO	HRRO 7.1A	NO	C	.60	41MD25	MICRO	YZRQ1	NO	A	.80
41MC31	MICRO	LN-11 H03	SPDT	M	1.70	41MC20	MICRO	YZRQ4	NO	S	.60
41MC18	MU	MLB 321	SPDT	B	.95	41M059	MICRO	YZRQ41	NO	W	.75
41MD1	MU	MLR 643	NC	B	.70	41MD20	MICRO	YZ7RQT	NO	K	.65
41MD55	PHAO.	PS 2000	SPDT	C	.85	41MD42	MICRO	YZRTX1	NO	X	.95
41MC28	ACRO	RC71P2T	NC	A	.70	41MC27	MU	Z	NC	Y	1.45
41MD45	ACRO	RO1P2T	NO	A	.80	41MD44	ACRO	Blue Stripe	SPDT	C	.70
41MD22	ACRO	RO2M	NO	E	.80	41MD52	MU	Blue Dot	SPDT	E	.90
41MD28	ACRO	RO2M12T	NO	E	.80	41MC8	MU	Red Dot	NC	C	.65
41MC25	MICRO	R-RS	NC	D	.50	41MD18	MICRO	Open Type	SPDT	Q	.50
41MD47	MICRO	R-RS13	NC	D	.50	41MD39	MU	Green Dot	NO	B	.80
41MD9	MICRO	SW-186	NC	D	.50	41MC29	MU	Green Out	NO	D	.55
41MC10	MICRO	WP3M5	NC	AA	.50	41MD26	MAXSON	Precision	SPDT	B	.95
41MC4	MICRO	WP5M3	NC	AA	.50						

SWITCHETTE All Rated 10A-230 VAC



Stock #	Mfr. Type #	Contacts	Terminals	Price
41SF2	CR1070C103-A3	N.C.	SIDE	\$0.53
41SF3	CR1070C103-B3	N.O.	END	.53
41SF8	CR1070C103-C3	1-N.O. 1-N.C.	END	.53
41SF7	CR1070C103-E3	N.O.	SIDE	.53
41SF9	CR1070C103-F3	1-N.O. 1-N.C.	SIDE	.53
41SF12	CR1070C123-B3	N.O.	END	.53
41SF10	CR1070C123-C3	1-N.O. 1-N.C.	END	.53
41SF5	CR1070C123-D3	N.C.	SIDE	.53
41SF4	CR1070C123-J2	SPDT	END	.53
41SF11	CR107 C124-M4	SPDT	SIDE	.53
41SF1	CR1070C128-C3			

MANUFACTURERS
AND DISTRIBUTORS:
Write for Catalog

SEELEY 8-4143



WIDE SELECTION OF ELECTRONIC COMPONENTS AT WELLS
• Resistors • Condensers • Wire and Cable • Relays
• Co-ax Connectors • Rectifiers • Transformers • Chokes
• Micro Switches, Toggles • Antennas • Accessories
• Electronic Assemblies • Dial Light Assemblies

Order Direct or Through Your Local Parts Jobber.

833 W. CHICAGO AVE. DEPT. R, CHICAGO 22, ILL.

THE SELECTOHM

CALIBRATED LINEAR POTENTIOMETER FOR PRECISION LABORATORY AND SERVICE WORK 0 to 100,000 ohms at 25 Watts

The Selectohm serves as a resistance substitute in a circuit to determine the value of a blackened, burned out resistor. It is constantly useful as a precision rheostat, shunt or multiplier. Two or more Selectohms can be quickly set up in highly flexible bridge circuits.

The Selectohm is precision built to critically high standards. List price \$7.50.

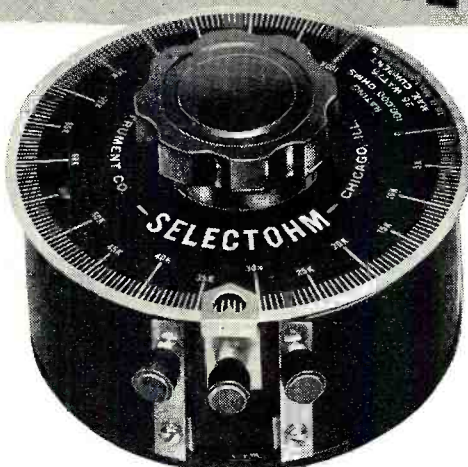

Accurately calibrated direct-reading scale gives you the correct answer to innumerable resistance measurement problems.

and mounting it may be directly coupled to a tuning dial assembly such as those manufactured by *National* or *Millen*, or used independently.

One feature of particular note is the fact that no separate i.f. amplifier is

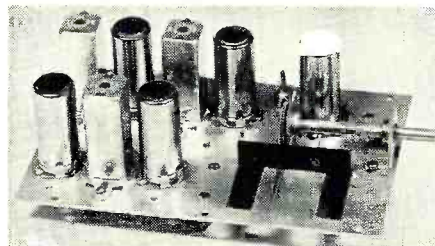

required. The tuner is complete with only filament and plate voltages required to put the tuner into operation with an amplifying system.

The set uses five tubes, has an antenna input of 300 ohms, an average sensitivity of 20 microvolts, permeability tuning, and an audio output of approximately 1 volt. A convenient terminal board is supplied under the chassis to which antenna and other energizing voltages may be connected.

Full details on the RD-1C are available from the company on request.

FUSE EXTRACTOR POST

Littelfuse Inc. of 4757 N. Ravenswood, Chicago, Illinois has developed a new fuse extractor post for 3AG fuses which is said to offer seven distinct advantages to the user.

According to the company, the new unit features a reduction in behind-the-panel distance of 1 inch, bakelite construction, leaf-spring tension lock which reduces voltage drop between

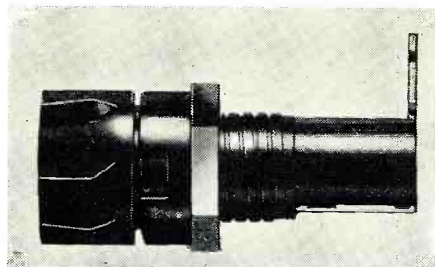

the knob contact and the fuse, an all-purpose terminal, a knife-edge bottom contact, a side terminal and internal metal ring made in one piece, and ease of testing by means of a special hole in the top of the knob.

MINIATURE SWITCHES

Centralab, Division of *Globe-Union Inc.*, 900 E. Keefe Avenue, Milwaukee, Wisconsin has recently introduced a new line of miniature rotary switches.

Available in a variety of multi-pole, multi-position, and multi-section types, the new units are also obtainable in combination with a.c. line switches and variable resistors.

Two groups are currently being offered. The Series 20 is available in bolted construction with phenolic or grade L-5 steatite insulation and staked construction with a maximum of two sections in phenolic insulation only.

The second group is the Series 30

Chicago **INDUSTRIAL INSTRUMENT CO.**
636 W. ELM STREET, CHICAGO 10, ILLINOIS
MANUFACTURERS OF VACUUM TUBE VOLTMETERS AND TEST EQUIPMENT

Order directly from Factory

Don't You Agree With These Men?



"It takes actual practice on real equipment to learn any job well!"



"I learn faster, easier and remember longer when my hands help me think."

Yes... YOU NEED PRACTICAL TRAINING TO DO THE KIND OF TV SERVICING!
That Means **BIG PAY!**



"I want practical facts, not long-winded lectures and complicated mathematics."



"If I want to learn a trade I'll go to someone in that business for practical help. They know from experience."

Prepare Now for Color TV and UHF!

You can't learn Television Servicing from books alone. The right way . . . the only way to learn to test, trouble shoot, repair and adjust television sets is by actually doing this work. That's how you learn with T.C.I. PRACTICAL TELEVISION TRAINING! This easy-to-follow training is based on practical experience.

Look How Practical This Course Is!

You train on a large screen modern television receiver, furnished as part of the course. You build this set . . . service it . . . trouble shoot it . . . adjust it . . . keep it! As an optional feature you can get two weeks of actual field experience with Chicago's largest independent TV servicing organization. You learn set conversion, master antenna installation, COLOR TV, COLOR CONVERSION, money-saving short cuts practiced by expert TV servicemen.

SEE FOR YOURSELF how this practical training can help you get ahead faster in the big-money TV field. Write for FREE Catalog and SAMPLE LESSONS. Age is no barrier. Many T.C.I. students are over 40. ACT NOW!

LEARN BY DOING WITH MILTON S. KIVER!*

* Active president of T. C. I., registered professional engineer, Television Consultant, internationally known author of TV books and magazine articles.

- ★ You build and train on modern large screen TV set.
- ★ You can get 2 weeks experience with leading service organization.
- ★ You learn testing, trouble shooting, repair of all types of TV sets.
- ★ You learn COLOR TV, including conversion and UHF. We guarantee to supply you with latest facts on these phases of television.

MAIL COUPON FOR BOOKLET

Milton S. Kiver, President
TELEVISION COMMUNICATIONS INSTITUTE
205 W. Wacker Dr., Dept. 1-N, Chicago 6, Ill.

YES, MR. KIVER! Rush FREE Catalog and Sample Lesson on your practical course in TV Servicing. I am not obligated. Salesman will not call.

Name Age

Address

City Zone State

() BEGINNERS: Check here for facts on Pre-TV radio course.

TELEVISION COMMUNICATIONS INSTITUTE
205 W. Wacker Dr., Dept. 1-N • Chicago 6, Illinois

ONLY

HAS

Niagara Radio

TUBES



AT 50% TO 90% OFF

ALL NEW • BRANDED • FULLY GUARANTEED

Table listing vacuum tube types and prices, categorized into RECEIVING and TRANSMITTING sections. Includes tube types like 600A, 6A4, 6X4, etc., and their corresponding prices.

Digby 91 1132-3-4

Niagara Radio Supply Corp.

160 Greenwich Street, New York 6, N.Y.

WRITE DEPT. R-91

Minimum order \$5. 20% deposit with orders unless rated. F.O.B. N.Y.C. Prices subject to change without notice.

Replace Your Old TV Aerial
With Snyder's Amazing New

360° MOTORLESS TV AERIAL

Same Clear Pix
As Motor Rotator
Aerial Systems
Costing Triple
This Price

Only \$16.95
less
mast

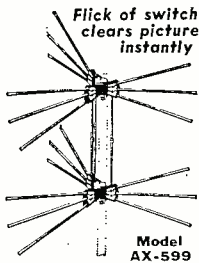

ORDER 360° MODEL AX-599
For Ultra Fringe Areas

Electronically beams in complete 360° rotation to give clear picture on all channels. You choose direction with Directronic selector switch... mounted on or near TV set. Complete double stacked arrays with 18 hi-tensil 3/4" aluminum elements. 75 ft. of 3 conductor cable, and beam selector switch.

ORDER 360° MODEL AX-59
For Metropolitan Areas

Electronically rotates 360° same as AX-599. Single array of 9 elements. Complete with 75 ft. of 3 conductor cable and beam selector switch LESS MAST... \$10.35

Snyder's Powerful 5 Element

YAGI TELEVISION ARRAYS

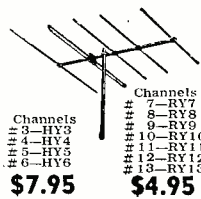

For Fringe & Ultra Fringe

Highly directional and closely tuned to each channel. Cuts interference and noise to a minimum. Five elements; one folded dipole, three directors and one reflector. Individual array for each channel. Specify model desired.

Channels	7-RY7	\$2.19
2-9-HV3	8-RY8	1.35
4-HV4	9-RY9	1.19
5-HV5	10-RY10	1.59
6-HV6	11-RY11	3.75
	12-RY12	.45
	13-RY13	

Get Hi-Gain at Low Cost
ASTATIC BOOSTER



MODEL BT-1 \$19.50

Uniform hi-gain in all channels. Low noise design and construction. On-off switch for cutting in and out of circuit. Selenium rectifier. Single 6AK5 tube. 72 or 300 ohm impedance input or output. Metal cabinet with rich mahogany woodgrain finish.

Extra Voltage for Big-Screen Conversion

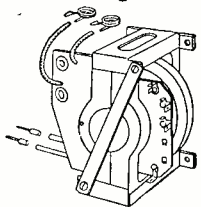

H.V. TRANSFORMER

For use with tubes up to 20". Operates in nearly every make set. Fits original flyback transformer mounts. With a single 1B3 rectifier the "8129" will deliver 14KV. with 63 to 70° sweep. The "8129" and a 20,000 V. 500 mmf condenser completes all circuit replacements. "8129" Only... \$6.60

WRITE FOR FREE "FY1" BULLETIN
Address orders to Dept. RN-9
or Call MULberry 2134

WHOLESALE
RADIO PARTS CO., Inc.
311 W. Baltimore St.
BALTIMORE 1, MD.

with dual concentric shaft and staked construction which can be furnished with a variable resistor in front, rotary switch in between, and an a.c. line switch in the rear. Variations on this arrangement are also available.

EXTENSION SPEAKERS

Permoflux Corporation, 4916 W. Grand Avenue, Chicago, Illinois has added two new rear seat auto extension speaker assemblies to its line.

The Model RS46A is a 4 x 6 inch speaker and the Model RS69J is a 6 x 9 inch unit. Both models are furnished as complete assemblies, ready for installation. The three-way switch supplied with the speakers is prewired at the factory and the assembly includes all necessary mounting hardware, an attractive metal grille in a neutral shade, and complete installation instructions.

HI-FI TUNER

The Sargent-Raymont Co., 212 Ninth Street, Oakland 7, California has begun the national distribution of a high fidelity tuner which has been especially designed for custom installation.

Designated the SR51, the new unit is a 14 tube tuner which covers both the AM and FM bands. The AM section consists of a pre-stage tuned r.f. section and a broadband stage of i.f. terminating in a new low distortion detector. A "Null T" type 10 kc. filter eliminates adjacent station whistle without impairing maximum frequency response.

The FM section employs a tuned r.f. stage preceded by an input coupling tube for added sensitivity and stability. An a.f.c.-controlled triode oscillator and two stages of permeabil-

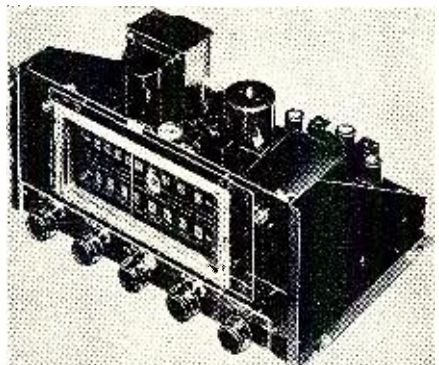

ity-tuned i.f. are included for improved performance in addition to a fully-balanced, static-free ratio detector.

A data sheet giving complete specifications on this new tuner is available from the company on request.

DYNAURAL PREAMP

Herman Hosmer Scott, Inc., 385 Putnam Avenue, Cambridge 39, Massachusetts has recently announced the availability of a new Type 112-B "Dynaural" preamplifier.

The new unit, which features improved circuits and controls, includes such features as a "Dynaural" noise suppressor which reduces record surface noise without sacrificing musical

quality, a preamplifier for low-level magnetic pickups, a variable turnover control to compensate for different recording characteristics, an adjustable

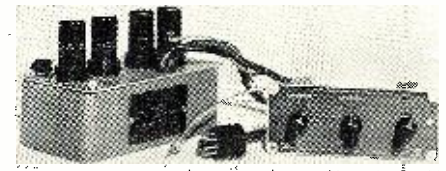

record distortion filter, and an input level adjustment for use with the noise suppressor and external automatic loudness controls.

The remote control panel is bronze with an antique etched finish. The unit can be attached to most existing installations by means of three simple plug-in connections. The frequency response is flat from 30 to 15,000 cycles and the usable response is from 20 to 20,000 cycles. A bulletin covering the Type 112-B is available on request.

BASIC CHASSIS

Alden Products Company of 117 N. Main Street, Brockton 64, Mass., has introduced a basic chassis which permits circuit elements to be laid out and fabricated as unit sub-assemblies.

The new unit has been designed for maximum accessibility to all components, for wiring and assembly using high speed production methods, and for easy servicing of completed equipment by even inexperienced personnel.

The basis of the chassis is a terminal mounting board system whereby tube sockets and all associated circuitry are mounted and interwired as an individual sub-assembly for mounting in basic chassis. Mounted on both sides of the chassis, the terminal boards are accessible for inspection or removal. Hundreds of prepunched holes on the terminal boards permit an almost unlimited number of circuit patterns to be wired without modification.

Manufacturers may obtain full details by writing N. Curtis at the company address given above. -30-

RCA SERVICE AID

AS a service to the television technicians of the country the RCA Service Company has turned over to the industry's independent television service organizations the field-tested methods for conserving critical materials and the data on the use of alternate parts and tubes which it has developed during its own materials conservation program.

This material has been compiled into a compact booklet which has been entitled "Handbook on Conservation of Materials." One of the outstanding features of the handbook is a listing of alternate receiving tubes and component parts for use in the operation and maintenance of TV receivers. More than 300 pre-tested and approved alternates are listed for approximately 50 different uses.

Copies of this booklet are being mailed to all television service associations and individual technicians can receive their copies through their service groups. -30-

Preview

...THE NEW 1952 FALL LINE OF TV CHASSIS AND CABINETS

Lic. Under RCA Pat.

Chassis Mounting Brackets \$4.95

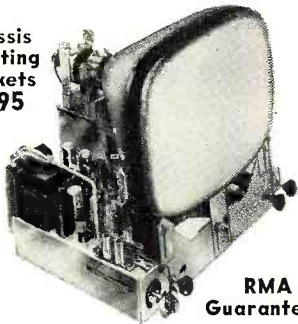

RMA Guarantee

Factory Wired, Aligned & Tested Before Shipment

Beware!—Let the buyer beware!

There are many different qualities of 630 chassis and TV tubes. All our merchandise is 1st quality, factory new. No seconds, no rebuilds and no rejects. You get honest dollar value!

THE AMAZING NEW SUPER DX-2 "630" 30 TUBE CHASSIS! PERFECT FOR FRINGE AREA RECEPTION

WILL HANDLE ALL TUBES FROM 16" TO 24". Thousands of our Super DX sets are giving new viewing thrills to TV watchers all over the country. Now... the NEW Super DX-2 extra powerful chassis brings you sharper, clearer pictures than ever before because it is designed with fringe areas in mind. Has improved, keyed AGC; 15 KV output; 3 stage Sync separator and clipper; moulded, plastic condensers; uses new, improved high voltage system; 5 hour minimum heat run at factory; high gain front end—down to 5 microvolts; synchro lock; freedom from arcing and corona leakage; Armstrong FM sound system; improved linearity adjustment and second horizontal linearity control; phono connection and switch on chassis. DIRECTLY ADAPT-ABLE FOR COLOR. Available with Dumont Inputuner, includes FM Radio and 12" Speaker—\$149.95.

\$139.95

With Hi-gain Standard Coil Tuner and RCA Hi-Fi 12" Speaker Complete with Fed. Taxes LESS CATHODE TUBE

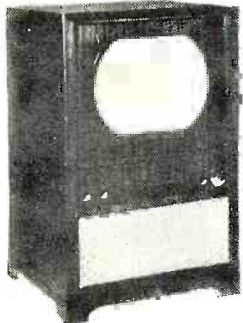

ECONOMY—41x25x23. 16" to 20" Tube. Mahogany—\$59.95. For 24"—\$71.95. Blond—\$10 Additional.

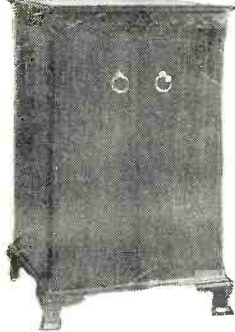

HAMPSHIRE—42x26x26. Beautiful Mahogany grain—\$74.95.

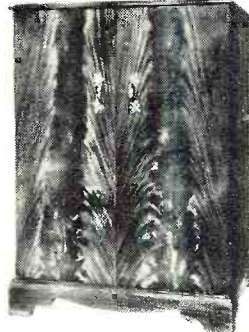

STRATFORD—40x28 1/2 x23 1/2. Genuine crotch mahogany doors—\$79.95.

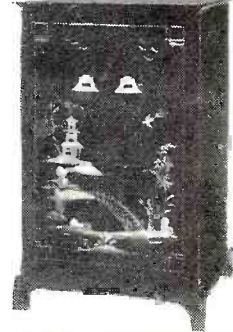

MANDARIN—42x24x24. Ebony finish. Gold & colored raised hand painting—\$84.95.

PRICE SMASHING VALUES IN TV CABINETS FOR THE "630"

Beautiful, richly piano finished, hand rubbed genuine mahogany cabinets to suit every taste. They are designed to house the "630" Chassis, 12" speaker and up to 20" TV tube. The combination cabinets will hold up to a 20" TV tube, radio and Webster record changer, with ample record storage space. All cabinets, except the Economy, come with gold plexiglass mask. The Economy has an open type mask. Complete with all brackets and instructions. The perfect chassis deserves a perfect cabinet. It will be a focal point of beauty in your home. Other models in stock. Send for FREE circular.

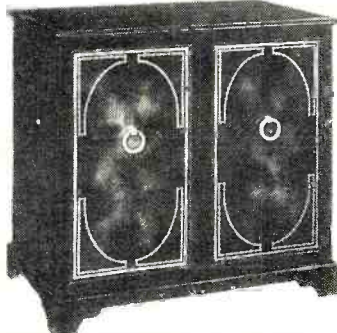

ELITE (combination)—39x40x23 1/2. Red antique gen. leather. Gold leaf hand tooling—\$149.95. Above in limed oak, gold colored leather—\$159.95.

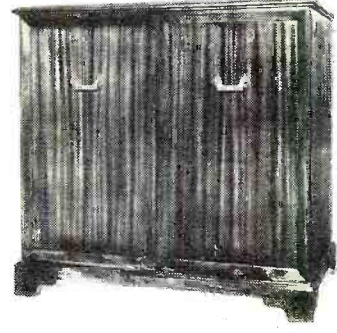
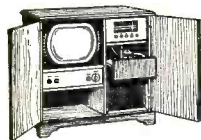

REGENT (combination) 39x40x23 1/2. Selected, grained mahog. picture box doors—\$129.95. Above in limed oak—\$139.95.

TV TUBE SCOOP THOMAS-SHELDON-ZETKA 1st Quality

12 1/2" round	\$22.50
14" rectangular	23.95
16" rect. or round	29.95
17" rectangular	32.95
20" rectangular	42.95
24" round, metal	79.95
Ring & sleeve for 24"	7.50

Also Dumont in Stock All tubes carry 6 mos. mfrs. guar.

Regency Booster MODEL DB-410



Improves reception in Low Signal Areas. All channel tuning. 1 knob control Turns set on and off.

\$18.95

SPECIAL VALUES

- Dumont Inputuner, for FM & TV bands.....\$23.85
 - Standard Coil Tuner..... 19.95
 - TV Masks—16&17" \$4.95;
 - 20"\$7.95; 24"..... 14.95
 - 300 OHM TV Wire, 100 feet. 2.89
 - Standard Coil Booster..... 18.95
 - Espey FM-AM Radio, 12 tubes, push-pull output... 74.95
- We carry a complete line of 630 component parts. Write for price list.

RECORD CHANGER SALE

WEBSTER 3-SPEED SERIES 100 \$29.95

Plays 12 records automatically. All sizes. All speeds. 33 1/3-45-78 RPM. Permanent point needle. In original carton. Reg. \$48.00



All merchandise is brand new, factory fresh & fully guaranteed. Mail & phone orders filled upon receipt of certified check or money order for \$25 as deposit on TV chassis. 20% on other items. Balance C.O.D., F.O.B., N. Y. Prices subject to change without notice. No Fed. taxes to pay. Prices lower than OPS Regs.

Send Post Card with Name and Address to Be Put on Our Mailing List

AIREX RADIO CORP.

171 Washington St. New York 7, N. Y.
Phone WORTH 2-4029

NOVICE CLASS XMTR KITS

80M CW OSC. & POWER SUPPLY—ALL PARTS, CHASSIS, XTAL. KEY ANTENNA, AND INSTRUCTIONS

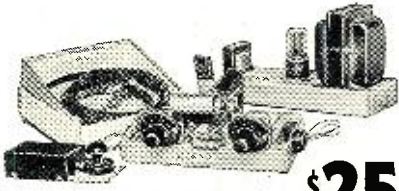

\$25

Complete—Nothing Else To Buy—ALL FOR ONLY

LOW FREQ. XTALS—FT 241A		SCR 522	BC-610
For SSB, lattice filter, etc. 1/2" spc. 54th or 72nd harm. channels. Listed by fund. Fractions omitted		Xtals 1/8" pins 1/2" spc.	2 banana plugs 1/2" spc
372 407 429 497	400 452	5910	2045 2532
374 403 431 503	440 462	6370	2105 2545
375 404 433 504	441 465	6407.9	2125 2557
376 405 434 505	442 468	6450	2145 2569
377 406 435 507	443 472	6470	2155 2575
379 409 436 509	445 474	6522.9	2220 2627
380 411 438 511	446 477	6547.9	2252 2659
381 412 441 516	448 479	7480	2260 2622
383 413 443 514	450	7580	2282 2610
384 414 444 519		7810	2300 2620
386 415 445 525			2305 2650
387 416 446 530			2320 2670
388 418 448 531			2360 2680
390 419 451 533			2352 2685
391 420 452 537			2415 2695
392 422 453 534			2435 2695
393 423 456			2442
394 424			
395 425			
396 426			
401 427			
	99c ea. 10 for \$9.00	\$1.29 each	
	SPECIAL		
	200 kc xtals without holders		
	49c ea. 10 for \$4.50	69c ea. 3 for \$2.00	\$1.29 each

HAM XTALS—FG 243 HOLDERS—1/2" pin spc.	
4190 6773 7806	3735 5840 6450 6740 7573
5030 6873 7840	5305 5850 6473 6806 7640
5485 6906 7873	5677 5873 6475 7340 7673
6006 6973 7973	5706 5906 6506 7440 7706
6040 7740 8273	5740 5940 6540 7473 7806
6773 7773 8306	5750 5973 6573 7506 8340
6106	5760 6273 6606 7540
6140	5773 6373 6640
6173	5806 6406 6673
6206	5825 6440 6705
	99c each 10 for \$9.00

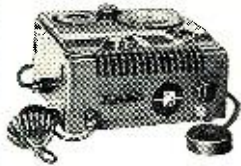

WEBSTER MODEL 18 WIRE RECORDER

Brand New Discontinued Model

DICTIONATION • TRANSCRIPTION • PLAYBACK

- Automatic stops—shut off machine at end of wire
- Pushbutton record—listen switch
- Immediate playback thru 2 inch speaker
- Neon recording volume indicator
- Removable take-up drum
- Elapsed time indicator

Includes microphone with stand, 1/4 hour spool wire, plastic dust cover, and removable foot switch. Drastically reduced from Original price of \$135.00 to an all time low of only \$89.50

RECORDING WIRE			\$89.50
1 hour	1/2 hour	1/4 hour	
\$3.50	\$2.10	\$1.40	

Special Purchase FM Radio Chassis

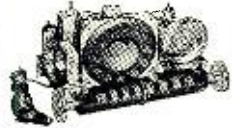

88-108 MC Complete with 6 tubes. Built in Antenna and Speaker. Product of Famous Radio & TV Manufacturer whose name we promised not to mention.

TUBE LINEUP		Regularly 29.95
1-12BA7	1-1258	
2-12BA6	1-35W4	Brand New
1-35B5		\$16.95

May also be used as an FM Tuner by picking signal off detector.

TERMS: All items E. O. B., Washington, D. C. All orders \$30.00 or less, cash with order. Above \$30.00, 25 per cent with order, balance C.O.D. Foreign orders cash with orders, plus exchange rate.

SUN RADIO
OF WASHINGTON, D. C.
938 F STREET, N. W. WASH. 4. D. C.

ELECTRONIC DEFINITIONS

The unfamiliar terminology of industrial electronics should not deter technicians. Here are the equivalent radio terms.

By **ED BUKSTEIN**

Northwestern Vocational Inst., St. Paul

THE increased use of electronic controls in industry has aroused the interest of many technicians. More and more, the radio service technician is encountering this type of equipment. It may be brought into his shop for repair, or he may be requested to construct an electronic device for a specified application. At this point, the service technician usually decides to check into the literature of industrial electronics. When he does, he is often unpleasantly surprised by the profusion of unfamiliar terms. Even the symbols on the circuit diagrams differ from those with which he is acquainted. The less-persistent technician often becomes discouraged by

the prospect of wandering over unfamiliar ground. Such discouragement is not at all necessary. Actually, the principles, the parts, and even many of the circuits of industrial electronics are "old friends" of the service technician. The difficulty lies in the fact that they are presented in a slightly different terminology. This confusion is rapidly dispelled when the technician learns to correlate the differing terminologies. He learns, for instance, that *phiotron* is the industrial name for an amplifier tube, that a gas-filled diode is called a *phanotron*, and that an induction heater is nothing but an r.f. oscillator.

The following is a listing of terms from the vocabulary of the industrial electronics technician. The radio service technician will recognize in these definitions many familiar concepts and

Symbols used in radio diagrams and their industrial electronic equivalents.

COMPONENT	INDUSTRIAL SYMBOL	EQUIVALENT RADIO SYMBOL
FIXED RESISTOR	OR	
TAPPED RESISTOR		
RHEOSTAT		
POTENTIOMETER	OR	
FIXED CAPACITOR		
VARIABLE CAPACITOR		
COIL OR INDUCTOR	OR	
TRANSFORMER	OR	
NORMALLY OPEN CONTACTS	OR	
NORMALLY CLOSED CONTACTS	OR	
MAGNETIC CONTACTOR (RELAY)		
FUSE		

'Tell Yuh
What I'm
Gonna Do'



Here's More For Your Money
With a "SURPRISE" Trade-In
Allowance On Used Test
and Communication Equip-
ment For One Of The New
HALLICRAFTERS Receivers.

Yuh say you're not satisfied with other
trade-in offers. Yuh say you want more
for your money. Okay boys, tell you what
we're gonna do! For the bargain of your
life just tell us what (factory-built) equip-
ment you have to trade. Indicate by
model number the Hallicrafters Receiver
of your choice. Back will come our satis-
fying, money-saving deal. Wire, write,
phone or use the handy coupon today!

hallicrafters

RECEIVERS

Walter Ashe
RADIO CO.
1125 PINE ST. • ST. LOUIS 1, MO.

Walter Ashe Radio Co., 1125 Pine St., St. Louis 1, Mo. RN-51-9
 O. K. Walter, Rush "Surprise" Trade-in offer on my _____
 for _____
 (show make and model No. of new equipment desired)
 Rush Free Copy of your new 164 page Catalog.
 NAME _____ ADDRESS _____
 CITY _____ Zone _____ STATE _____

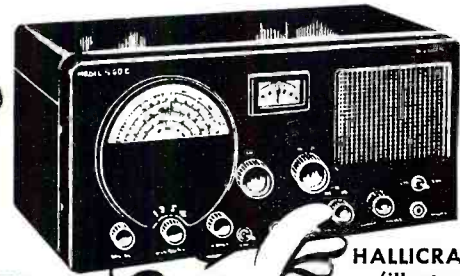

HALLICRAFTERS S-40B
(illustrated above)
Shpg. wt. 32 lbs.
Only \$99.95

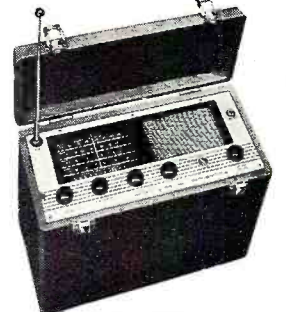

HALLICRAFTERS S-72
Shpg. wt. 16 lbs.
Only \$109.95 (less battery)



HALLICRAFTERS SX-62
Shpg. wt. 68 lbs
Only \$289.50



HALLICRAFTERS SX-71
Shpg. wt. 33 lbs.
Only \$199.50
R-46 spkr. Only \$19.95

FREE
CATALOG!

150 value-crammed pages of
everything in Radio, Electronics
and Television for homes, schools,
amateurs, industries, servicemen,
laboratories and radio stations.

All prices F. O. B. St. Louis
Phone: Chestnut 1125

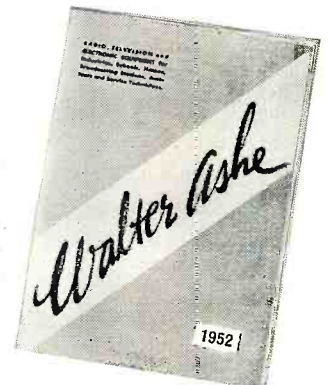

TECH-MASTER

TELEVISION

New TECH-MASTER developments!

LO-PRICED
Universal KIT

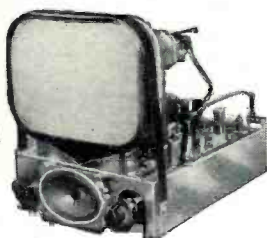

FOR TUBES UP TO 14" RECT.

First LOW-COST TV Receiver Kit completely engineered exclusively by TECH-MASTER. Features 2-knob control and small, lightweight chassis.
Model 5116 \$89.50
Set of circuit-matched TUBES tested with each individual kit \$16.25

Advanced
630 Type KIT

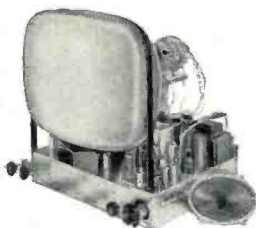

FOR ALL TUBES 12" Rd. to 20" Rect.

The greatest advance in TV Kits developed by TECH-MASTER!
Model 630D19 (DeLuxe) Principal components assembled.
Resale Price \$159.50
Model 630S19 (Standard) Unassembled.
Resale Price \$154.50

Above Kits supplied with tubes, parts, speaker and six tube mounting brackets (less Kine, wire and solder).

CONTACT YOUR JOBBER or write Dept. RN-9 for literature.

TECH-MASTER PRODUCTS CO.

443-445 Broadway, New York 13, N. Y.

More leading engineers and technicians have built Tech-Master for their own use than any other Television Kit.



for flawless reproduction
NO OTHER CARTRIDGE CAN PERFORM LIKE A PICKERING

Pickering patented design
provides **DYNAMIC COUPLING***
throughout the entire audible range

* DYNAMIC COUPLING ASSURES

- constant stylus contact with the record grooves over the entire audio spectrum (20-20,000 cps)
- full frequency response
- full transient response

**NO RESONANCES
NO MISTRACKING
NO GRINDING OF GROOVE WALLS**

Pickering Cartridges transmit all of the sounds in the musical spectrum, without loss of definition, just as a fine optical lens passes all of the colors in the rainbow.

For literature address Dept. C

Well-informed engineers and technicians, schooled in the science of electro-mechanics, know that only wide-range frequency response provides full transient response; the electronic phenomena which enables the reproduction of orchestral music with all the subtle sounds that give each musical instrument its individual character.

Pickering engineers and designers have but one objective . . . to produce products that will please the music lovers' insatiable appetite for the flawless recreation of recorded music . . . for the utmost in quality insist upon Pickering Audio Components.

Pickering
& COMPANY, INCORPORATED
OCEANSIDE, NEW YORK

circuits. Familiarity with these terms will enable him to approach this field with confidence.

Amplitude Controlled Rectifier: A circuit employing thyatron tubes as rectifiers and whose output can be varied by changing the d.c. bias on these tubes.

Back-to-Back Circuit: Two tubes connected in parallel but in opposite directions, i.e., the cathode of one tied to the anode of the other and *vice versa*. This arrangement is used to control the flow of alternating current and is popular in resistance welding circuits.

Black Light: Ultraviolet is referred to as black light because the eye does not respond to its wavelength. An ultraviolet source is sometimes used in conjunction with a phototube in burglar and intrusion alarms.

Carrier Current Control: A remote control system in which the output of an r.f. oscillator is fed into the power lines. A receiver, located at a distance and operating from the same power lines, picks up the r.f. signal and actuates a relay.

Capacity Operated Relay: An oscillator containing a relay in its plate circuit. The grid circuit is connected to a pickup electrode such as a door handle, bank vault, metal plate, etc. When anyone approaches the pickup electrode, the grid circuit capacity is altered and the plate current is changed sufficiently to actuate a relay.

Dielectric Heating: An electronic method of heat treating any material which is a nonconductor of electricity. The material to be heated is placed between two metal plates so that it becomes the dielectric of a condenser. The output of a high power r.f. generator is applied to the metal plates. The rapidly alternating electric field produces molecular agitation in the work, causing it to heat. This technique is used for heating and molding plastics, curing rubber, drying lumber, bonding plywood, etc.

Electric Eye: Popular name for the phototube. The current flow through this tube depends upon the amount and color of the light striking its cathode. It is used for counting objects passing on a conveyer belt, opening garage doors when an automobile approaches, inspecting beverages for the presence of foreign particles, color matching, etc.

Electronic Micrometer: A thickness measuring device in which the material to be measured is held between two metal plates. These plates serve as the tank condenser of an oscillator circuit. With this arrangement, the frequency of the oscillator is determined by the spacing between the plates, which in turn depends upon the thickness of the material. A frequency meter connected in this circuit can be calibrated to read material thickness.

Electronic Sewing: A method of "welding" thin sheets of plastic for book-jackets, aprons, raincoats, pouches, etc. This is a form of dielectric heating.



NEW FALL ITEMS AT LOWEST PRICES

MODEL GO-9 TRANSMITTER

All brand New, 100 Watts CW, or MCW, emission. Operates from 110 V., 300 Cycle, easily converted to 60 Cycle operation. Low frequency range, 300 KC. to 600 KC. High frequency 3,000 KC. to 18,000 KC. using an E.C.O. We furnish complete conversion data with each transmitter. Complete with schematics. **\$59.95**

SOUND POWERED HAND SETS

TS-10 type—Various manufacturers. No batteries needed for operation. Use in pairs with wire. Audible up to 10 miles. Ideal for TV antenna installations, etc. Excellent condition. Pair **\$17.95**

SOUND POWERED HEAD AND CHEST SET

Use same way as Hand Set except you have freedom of hands. No Batteries or Power source required for operation. Excellent Condition **\$11.95**

RU 16 RECEIVERS

RU 16 RECEIVERS **\$5.95 Ea.**
 Plug-in Coils.
 9 Ranges 190-13570 KC **1.50 Ea.**
 BC 439 Transmitter **5.95 Ea.**
 Plug-in Coils for Trans.
 2 MEG-9 MEG **1.50 Ea.**
 12 Volt Dynamo for above.
 330 Volt @ 170 MA. **7.95 Ea.**
 RU-19 Control box **1.00 Ea.**

METERS

Westinghouse—G.E. Weston

MILLIAMPERE D.C.

2"-0 to 15	\$3.50 Ea.
2"-0 to 100	3.50 Ea.
2"-0 to 300	3.50 Ea.
2"-0 to 500	3.95 Ea.
2"-0 to 9R Amp	3.50 Ea.
3"-0 to 50	3.95 Ea.
3"-0 to 100	3.95 Ea.
3"-0 to 150	3.95 Ea.
3"-0 to 200	3.95 Ea.
3"-0 to 250	3.95 Ea.
3"-0 to 500	3.95 Ea.

TIME HOUR METERS

99999.9 Hrs.
 10-12 Volts, 60 Cycle 3 Inch **\$6.95 Ea.**

KILOVOLT D.C.

3"-0 to 400 DC	\$3.95 Ea.
3"-0 to 120 Amps	\$3.95 Ea.
3"-0 to 4	3.95 Ea.

(All are 1 Ma. full scale, require external multiplier.)

VOLT METERS

2"-0 to 15 V., A.C.	\$2.95
3"-0 to 8AC.	2.95 Ea.
3"-0 to 15 AC.	2.95 Ea.
3"-0 to 30 DC.	3.95 Ea.
3"-0 to 150 DC.	3.95 Ea.

2" WESTON SPECIAL

0 to 30 V. DC and 0 to 120 Amps	\$3.95 Ea.
0 to 30 V. DC and 0 to 240 Amps	DC 3.95 Ea.

GIBSON GIRL

The Emergency Radio Transmitter. Send S O S signals automatically on 500 KC. 150-mile range. No batteries required. Has handcrank generator, tubes, carrying case. New. It's only **\$4.95**

BC 456 MODULATION UNIT

Part of SCR274N. Equipment contains Relays, Transformers and 12A5, 1B2S and VR 150 (ODS) Tubes. Less Tubes **\$1.50**
 With Tubes **2.95**

2 VOLT WET CELL RADIO BATTERY

NEW. Uncharged (Appr. wt. 4 lbs.)
 TYPE 20-2 **\$1.45**
 Complete set of three with Box and Connections to make a 6 volt, 20 Amp. Hrs. battery. Uncharged (Approx. wt. 12 lbs.) **Set \$9.95**

MG-149F INVERTER

Input 24 Volt DC 36 Amps, 110 v. 400 Cy. AC. 500 V.A. Output at 90% P.F. Used, excellent condition **\$8.95 ea.**

MIDGET SELSYNS

AY type operates from 6-12 Volts 60 Cycl. Use as both transmitter and receiver. These compact little units draw almost no current and work fine for all remote position indicating applications. OD 2 1/2" x 2 1/2". All New (Appr. wt. 1 lb.) **Each \$2.50**

3" TRIUMPH OSCILLOGRAPH

Complete Test Scope, with built-in Wobulator, so as to be used on TV or FM servicing. Operates from 110 Volt, 60 Cy. A.C. Limited Supply. All these units have been carefully checked and are in excellent condition. A Real Buy. **SPECIAL \$34.95 Ea.**

REVERSIBLE MOTOR

1/40 H.P. Ball-bearing 3450 R.P.M. in Blast-proof case. Needs only a capacitor for starting. All Brand New, 110 V., 60 Cy. **\$3.95**
 Special Low Price.....

TANK PERISCOPES

Type M9 Contains 2 glass prisms, one at each end of the periscope. Use them for looking over crowds, at parades, ball games, races, etc. or use prisms separately for optical work. Low priced. All Brand New **\$1.95**
 All Mail Orders Promptly Filled, F.O.B. San Francisco stock and prices on Radio, Electronics, Tools, Hardware,

PROP PITCH MOTORS

For your Beam Antenna: 20 Volt to 32 Volt, A.C. or D.C. 1/2 H.P. Motor: 1 1/4 RPM Gear Reduction, 7000 to 1.
ALL BRAND NEW..... \$13.95 ea.

1/2 H.P. PROP PITCH MOTORS

20 to 32 Volt, A.C. or D.C. Gear Ratio: 9000 to 1
 All Brand New **\$17.95**

GYRO MOTOR UNITS

Dual gyro unit. Both gyro motors mounted on single base. Wired in parallel for 12 or 24 volts. Excellent condition. (Please specify if you wish the 12 or 24 volt) **\$4.95**

G.P.7 TUNING UNITS

5 Ranges: A-350-800 KC. B-800-1500 KC. D-3000-4325 KC. E-4525-6300 KC. F-6200-9050 KC.
 Also contains Capacitors, Resistors, Vernier Dials and many other parts. A REAL BUY while they last. Each unit range **\$4.95**

HAND SIRENS

All New, with canvas cover carrying strap. Can be heard for many miles. Ideal for Civil Defense, Camps, etc. A bargain at **\$9.95**

ALTIMETERS

Sensitive type—ideal for planes or automobiles. 0 to 40,000 ft. Operate on low vacuum pressure. No special hookup needed. Excellent condition. Low priced at **\$7.95**

BRASS SELSYNS

Heavy Duty Bendix Selsyns. 110 volts 60 Cycles AC..... Pair **\$9.95**

PE 110 POWER SUPPLY

This unit was used as part of BC669 transmitter. Input 110 volts 60 watts; Output 345 volt @ 455 ma. for transmitter and 100 volt supply for Receiver and Filaments. Uses 4-523 tubes for high voltage and 1-80 tube for low voltage. Also contains a 12 volt vibrator pack for Receiver voltages. This supply is well filtered and regulated and is ideal for your Ham transmitter. Low priced at **\$34.95**

INTERVOMETERS

This unit was used to release bomb loads at different time intervals and now can be used ideally for dark room timers, etc. Complete with two 2D50 tubes; four sensitive relays and other related parts. Excellent Condition **\$4.95** Each

2 VOLT VIBRATORS

VBSA Synchronous Type. Used in all portable radios having 2 Volt wet cell supply.
 All new **\$1.50** Ea.

TG-5 CODE OSCILLATOR

Battery operated Code Practice Oscillator. Use singly for practice or can be used in pairs for practice or sending messages over wire through two points. Uses a 2 1/2 volt dry cell battery and 2 flash light coils. Contains keying relay and 1000 Cy. tone buzzer and head set. All brand new, with canvas carrying case **\$9.95** Ea.

CAPACITORS • FIXED • OIL FILLED

Solar, Pyranol, C. D., Etc.

2 MFD.	400 V. D.C.	\$0.79
1 MFD.	600 V. D.C.	.75
4 MFD.	100 V. D.C.	1.25
8 MFD.	600 V. D.C.	1.95
10 MFD.	600 V. D.C.	1.95
1 MFD.	1000 V. D.C.	1.00
2 MFD.	1000 V. D.C.	1.25
4 MFD.	1000 V. D.C.	1.75
1 MFD.	1000 V. D.C.	1.50
2 MFD.	2000 V. D.C.	1.95
3 MFD.	2000 V. D.C.	3.50
4 MFD.	2000 V. D.C.	3.50
2 MFD.	4000 V. D.C.	5.95

CAPACITORS • TRANSMITTING • VARIABLE

K 1 MMFD.	To 75 MMFD.	1/4" Spacing	\$1.95
ED 12 MMFD.	To 125 MMFD.	3000 V. Peak	3.50
J 28 MMFD.	To 110 MMFD.	5000 V. Peak	3.95
EP 12 MMFD.	To 150 MMFD.	3000 V. Peak	3.50
A 2 MMFD.	To 8 MMFD.	1500 V. Peak	1.00

* With National "Velvet Vernier" Dial.
 All New, Hammerlund, Cardwell, Etc.

MINE DETECTOR, AN/PRS-1

Easy to operate, easy to carry. Can be used for detecting ore deposits, both metallic and non-metallic. Now being used extensively by Miners, Prospectors, Beachcombers, and Explorers. These sets are brand new and come complete with Detector head with antenna, Reflector meter and housing and exploring rod; a bag for carrying equipment while operating and a wooden case for storing or transporting unit when not in use. These units contain Tubes, and instruction books. Shipping weight is 125 lbs. Weight when operating unit is 22 lbs. All New—Complete with Batteries and ready to operate **Set \$29.95**

DYNAMOTORS

5DY 81A B12 Input 14 V. @ 46 Amp. Output 515V./1030 V. 2V./8V. @ 215-260 MA. All Brand New Original Cartons **\$17.95**
 All California Orders—Add 3% Sales Tax **Do not send postage stamps. Write for our free booklet listing our Motors, Wire, Meters, Batteries, Aluminum Sheets, etc. 20% Dep. on all C.O.D. orders. All items subject to prior sale.**

RU-19 RECEIVERS

For the first time on surplus, we can now offer this versatile Receiver. All complete and ready for 24 volt operation. These units are ideal for ship-to-shore receivers, ADP, and mobile operation. They come complete with 9 coils covering frequency range of 195 KC to 13570 KC. 24 volt Dynamo coils, spare tubes, tuning meter, instruction manual, junction box, mounts, etc., etc. **Nothing else to buy. ALL BRAND NEW, COMPLETE \$34.95**

COMMAND RECEIVERS

3 MC to 6 MC	\$ 9.95 ea.
6 to 9 Meg.	11.95 ea.

Approx. weight of each 12 lbs. Excellent condition complete with tubes.

COMMAND TRANSMITTERS

4 to 5.3 Meg.	\$8.95 ea.
5.3 to 7 Meg.	\$4.95 ea.
7 to 9 Meg.	\$14.95 ea.

Complete with Tubes and Crystals, excellent condition. ARC 5 VHF Transmitter Chassis Less Tubes and Crystals. Used, fair condition. **\$14.95**

FL-8 FILTER

Range or Voice for 1020 cycles Audio. Switch mounted on Filter. Excellent for C W **\$1.25**

WALKIE TALKIE BATTERIES

BA 37-1 1/2 volt-A	\$.50c
BA 38-1 1/2 volt-B	\$1.29
Both for	\$1.50

SOLDERING IRONS

Famous Name Manufacturer. 85 watt Iron. Only special purchase permits this low price, which is much less than standard advertised price. **\$2.95**
 All brand new.....each

DC GENERATOR

12 Volt DC Output @ 4 Amp. Must be belt-driven @ Approx. 2000 RPM. In good condition **\$4.95** Ea.

JEOP GENERATORS

12 Volt DC Output @ 60 Amp. Complete with Voltage Regulator and Ammeter. Ideal for Boats, Trucks or Mobile Radio use. Excellent condition **\$49.95**

12 VOLT WET CELL BATTERY

Aircraft Type, 12 Volt, 34 Amp. HR. Made by Exide. Completely inclosed with removable top. Dry Charged. All Brand New **\$14.95**

12 VOLT BLOWER MOTOR

Trade Winds Blower—Operates from 12 Volts DC @ 6.6 AMPS. Diameter of cage 7". Ideal for Boats or Trucks. In good condition **\$4.95**

POLE INSULATORS

Class 2" Insulator with 3" screw overall length 5" for telephone use **\$10.00** Hundred

MISCELLANEOUS SPECIALS

9 Channel Push Button Switch, spring back type	\$1.00
300 OHM Twin Lead	.04 per Ft.
67 1/2 Volt Radio-Phy. Batt.	1.00 Ea.
1 Lb. Roll Rosin Core Solder	.95 Roll
BC606G Handphone Switch Box	.59 Ea.
RG 7U COAX 950 OHM	.06 per Ft.
J-5A Hand Keys, Flameproof, New	.69 Ea.
RG 59U COAX 52 OHM	.08 per Ft.

TUBES

8025	\$4.95	8020	\$2.95
3FP7	1.95	6N17	1.25
5FP7	2.25	6Y5	1.25
5BP4	2.50	6GU7	.75
6SJ7	1.00	6B8	.75
12SR7	.90	83V	1.25
6AC5	1.50	6SK7	.50
6AK3	1.75	71B3	.50
6AC7	1.50	6SN7	1.75
4E27	12.95	30ATL	7.95

BC-438 BEACON RECEIVERS

Similar to BC 1206. Manufactured by Detroit Radio. 200 to 500 KC. For Direction Finder. Contains 2-251G, 1-6SA7, 1-6SF7, 1-6SK7, 1-6K7. Excellent condition. Complete **\$7.95**

BC-357 FREQUENCY RANGE, 60 to 80 Meg.

Operates from 24 Volts D.C. Complete with Tubes. **\$3.95**

STEEL STORAGE BOXES

Heavy Duty Boxes to be used for foot lockers or storage boxes or for safe keeping of valuable items. Hinged Top with Hasp for padlock. 2 Sizes: All Brand New.

18" x 12" x 12"	\$4.95
24" x 15" x 12"	\$8.95

FRICITION TAPE

Army Surplus 3/4" Tape in Vacuum Sealed Cans. 6 Rolls to the can..... **\$1.25** per can

STANDARD SURPLUS

1230 Market St., San Francisco 3, Cal. Telephone HEmlock 1-3106

UP TO 200 MILES TELEVISION RECEPTION

with the new DX 630 chassis!

The famous 630 TV chassis has now been improved for excellent long distance television reception beyond the "Fringe" Area.

The DX 630 has 4 microvolts sensitivity—10 times the sensitivity of standard TV receivers. It will pick up distant TV stations without the use of boosters or special antenna arrays—and with less noise.

• Greater Brilliance

Assured by the new 14-16 KV power supply.

• Flicker-Free Reception

Assured by the new Keyed AGC circuit—no fading or tearing of the picture due to airplanes, noise or other interference.

• Greater Sensitivity

Assured by the new Standard Tuner, which has a pentode RF amplifier and acts like a built-in High-Gain Television Booster on all channels! THE ADVANCED 630 CHASSIS will operate where most other sets fail, giving good performance in fringe Areas, and in noisy or weak locations.

• Larger—Clearer Pictures—for 16", 17", 19", 20" or 24" Tubes

Assured by advanced circuits. Sufficient drive is available to easily accommodate any tube.

• Trouble-Free Performance

Assured by use of the finest materials such as quality condensers, overrated resistors, RCA designed coils and transformers, etc.

• RMA Guarantee

Free replacement of defective parts or tubes within 90-day period. Picture tube guaranteed fully for six months at no extra charge!

PRICE COMPLETE **\$129.95**

LESS PICTURE TUBE.....NET \$129.95
For city TV reception, our standard 630TV chassis is available at the same price.

NO ADDITIONAL TAXES TO PAY

TELEVISION PICTURE TUBES Standard Brands

SIX-MONTH GUARANTEE

12 1/2" (Black or White).....	\$23.95	Glass 16" Round (Black).....	\$34.50
Glass 14" Rectangular (Blk.).....	\$23.50	Glass 16" Rectangular (Blk.).....	\$34.50
17" Rectangular (Blk.).....	\$31.95		
19" Round (Blk.).....	\$39.95		
20" Rectangular (Blk.).....	\$39.95		
24" Metal.....	\$69.95		

NEW DUMONT TUNER

Combining all the advantages and features of the famous DUMONT TUNER, the new Series XT-3-C Input Tuner has detents for quick location of all TV channels and still permits pickup of standard F-M Broadcast!

Fits all 630 chassis perfectly. Has high sensitivity and full coverage. Complete with 1-6BC5 and 1-6J6 tubes. Price..... **\$30.87**

TELEVISION COMPONENT SPECIALS

"Faster Than Hotcakes!"

That's how these original 13-channel RCA Tuners are selling. Uses 3-6J6 tubes. Sold as is, less tubes and dial, only..... **\$3.95**

NEW DEFLECTION YOKE RCA 201D1, with network, only..... **\$1.95**

NEW FOCUS COIL 240 Ohms, RCA type 202D1 only..... **\$1.25**

NEW PM/EM FOCUS COIL, 1200 ohm winding only..... **\$.89**

All Merchandise Subject to Prior Sale. All Prices Subject to Change without Notice.

WRITE FOR COMPLETE CATALOG N-9

EDLIE ELECTRONICS INC.

154 Greenwich St. New York 6, New York

Electrostatic Precipitation: A method of controlling small particles of matter by endowing them with an electric charge so that they will be attracted to a collector plate bearing an opposite charge. This type of equipment is used to clear the air of dust, soot, cigarette smoke, etc. It is also used to reclaim minute particles of valuable chemicals that might otherwise pass up through factory chimneys.

Energy Storage Welding: A welding system in which energy is stored for a period of time, and then the stored energy is released to produce the weld. The energy is stored either in a bank of condensers or in the magnetic field of an inductance (see "Resistance Welding").

Flame Failure Control: An electronic device used in conjunction with oil or gas burning furnaces. This device shuts off the fuel supply if the pilot burner should accidentally become extinguished, preventing a dangerous accumulation of unburned fuel. One type of flame failure control uses a phototube to "watch" the pilot burner. In another type, the resistance of the flame is used as part of the circuit. If the flame should go out, the circuit constants are changed sufficiently to actuate a magnetic valve.

Fluoroscope: An x-ray unit in which the image is formed on a fluorescent screen. This unit is used to detect the presence of foreign particles in packaged foods, to check the alignment of the conductor in insulated wire, etc.

Gas Amplification: The ratio between the current flow through a gas-filled phototube and the current through an equivalent vacuum phototube operating under the same lighting conditions. Gas amplification makes the former type more sensitive than the latter.

Grid Controlled Rectifier: A variable output power supply employing thyratrons as the rectifying elements. The output is controlled by changing the grid voltage of the thyratrons. Grid controlled rectifiers fall into two classes: (1) the magnitude controlled types which use d.c. grid voltage and (2) the phase controlled types which use a.c. grid voltage.

Ignitron: A high-current type of tube capable of carrying hundreds, even thousands, of amperes. This tube uses a pool of liquid mercury as its cathode. The envelope of the ignitron is a double-walled steel jacket. The tube is cooled by circulating water between these walls. The ignitron can be used as a rectifier or, when connected in a back-to-back circuit, to control the flow of alternating current. Many types of resistance welding machines employ this tube.

Induction Heating: An electronic method of heat treating metals. The metal to be heated is placed inside a copper coil, and the output of an r.f. generator is applied to this coil. The coil thus acts as a primary and the metal as a secondary of a transformer. The currents induced in the metal raise its temperature. Induction heating is

FLOCKED GRILLE SCREEN... Gold, Tan, Buff, Dk. Brown or Red. Any size to 36" sq. ft. 65c
Beautiful Brown-Tan Diamond Design (1 1/2" x 1 1/2") 12"x15" 95c; 15"x24" \$1.79

Leotone RADIO HARDWARE
TREASURE FULL FOUND CAN OF NUTS, SCREWS, LUGS, ETC. 68c 3/\$1.98

W. E. HEADPHONES... hi-imped. 5 ft. cord. \$3.95
HS-30 HEADPHONES... new. Less extra. 1.49
HS-30 MATCHING TRANSFORMER (C-410). 1.49
HS-30 HEADBANDS... ea. 15c; 8/1.00
2V. TRICKLE CHARGER KIT... for 2V. Willard batts. 2 amps. With Instructs. 6.95

#20 Push-Back Wire... Red. 100 ft./89c
Vel. Blue Black. 100 ft./89c
Midget Output Xfmr. 1 1/2" x 1 1/2" 2.49
1/2" 500B; etc. to V.C. 6/ 2.49
Midget Audio Choke... (3/4" x 1 1/2") 2.49
Hearing Aid Amplifier (2 Tube) MAKE A REAL NEST POCKET RADIO adding simple tuner 1 1/2" x 2" x 3" WITH SCHEMATIC FOR 2 or 3 TUBE SET. Less tubes, case. 2.49
Hearing Aid Tubes... set. 2.75
Hearing Aid Bone Conduction Receiver. Exc. MUSICAL CONTACT MIKE. Min Spkr. (1/2" x 2 3/4" x 1 1/2"). Lo-imped. 2.49



#30 P.E. Magnet Wire... 400 ft. roll. .23c; 5/1.00
#28 SCE Magnet Wire... 500 ft. roll. .29c; 4/ 1.00
#10B Field Wire... rolls 100-400 ONLY 1/2c ft.
SCOPE DEFLECTION YOKE (Navy #352-7050). 2.95
RUBBER SHOCK MOUNTS... 8 lbs. 1 3/8" mtg. .12c
Heavy Duty 100 lbs. 2 1/2" mtg. 49c; 6/ 2.49
25W. RHEOSTATS... Ohms: 10, 100, 200 or 400 .79
HANDY CARBON MIKE (RS-83) Press-to-Talk. 1.49
HIGH FIDELITY CRYSTAL MIKE... Hi-imped. Shock-Mtd. 1 3/4" x 3/4". Less housing. 1.29
ALUMINUM HOUSING for crystal mike. .15
ROTARY SELECTOR SWITCHES... 2 deck. 1/4" shafts... 3 pos. D.P. or 6 pos. S.P. .39

!MORE FOR YOUR MONEY! NEW "JIM-BO RADIO PARTS KIT" 17 FULL POUNDS OF COILS, WIRE, RESISTORS, CONDENSERS, SOCKETS, ETC., ETC. ONLY (Ship. weight 20 lbs.) \$3.95

DM-36 DYNAMOTOR... 24V to 220V, 80ma. \$2.49
SCR-511/PE-157 TECH. MANUAL..... .75
TS-173 FREQ. METER TECH. MANUAL..... .39
R-89/ARN-5A SCHEMATIC DIAGRAM..... .25
TUBE CARTONS... Plain white. Prices per 100 Min (1" sq. x 2 3/4")—\$1.20; GT (1 1/4" sq. x 3 1/4")—\$1.45; Med. (1 1/2" sq. x 4 1/4")—\$1.65; Large (2" sq. x 5")..... 1.98
32Mf/450V ELECTROLYTIC... can 4"x2" 49c; 6/ 2.49
MOULDED BAKELITE CONDENSERS... .00001 to .2mf. 200-600V. 50 ass'd. 1.98
"FACTORY SPEAKER REPAIRS SINCE 1927"

Write for FREE Speaker Parts Manual
Min. order \$3.00, 20% deposit req. on all C.O.D.'s. Full remittance with foreign orders. Please add sufficient postage—excess-refunded.

LEOTONE RADIO CO.
65 Deo Street
New York 7, N.Y.

The New GONSET FM COMMUNICATIONS TUNER



PROVIDES A SENSITIVE RECEIVER
FOR 2 WAY FM RADIO-TELEPHONE
COMMUNICATIONS

- Excellent for mobile or fixed operation
- Used with your auto or fixed radio
- Receives police, fire, taxi, etc.
- Compact (5 1/2" x 3 1/2" x 5 1/2")
- High sensitivity
- 5 tubes

\$59.50 net Models available



30-40 MC
40-50 MC
88-108 MC
152-162 MC
see your distributor or write direct
GONSET CO., BURBANK, CALIF.

used for soldering and brazing, tempering steel springs, degassing electron tubes, etc. At higher frequencies, skin effect causes the surface of the metal to heat while the interior remains relatively cool. This feature makes the equipment useful for surface hardening operations.

Kenotron: A vacuum diode rectifier tube.

Magnitude Control: Same as "Amplitude Control."

Motor Speed Control: A circuit for varying the speed of an electric motor. Most types employ a grid controlled rectifier to supply the motor's armature current. Such speed controls are used in conjunction with wire reeling and drawing, precision grinding, governor testing, etc. If a small generator is coupled to the motor shaft and the output of this generator used to bias the thyratrons, the motor will maintain a constant speed under varying load conditions.

Peaking Transformer: A transformer designed to saturate at low values of current. This transformer is used to convert a sine wave into a narrow pulse waveform.

Phanotron: A gas-filled diode rectifier tube.

Phase Controlled Rectifier: A circuit employing thyatron tubes as rectifiers and whose output can be varied by shifting the phase of the a.c. applied to the grids.

Photocathode: The type of cathode used in phototubes. This cathode is covered with a light-sensitive material which emits electrons when illuminated.

Photoelectric Pyrometer: A temperature measuring device which utilizes the color-sensitive properties of the phototube. The phototube "looks" into the furnace through a special window. As the metal inside heats, its color changes through various shades of red and white. The output of the phototube, as indicated by a meter, is therefore proportional to the temperature of the heated metal.

Photomultiplier: A tube in which electrons emitted from a photocathode strike, in sequence, a number of plates known as dynodes. Each dynode emits secondary electrons, and the total plate current is therefore greatly increased. The type 931 photomultiplier employs nine dynodes and is capable of amplification in the order of a quarter of a million.

Phototube: A light-sensitive tube employing a photocathode (see "Electric eye").

Pin-Hole Detector: A photoelectric device used to detect and mark the location of small holes in sheet steel.

Pliotron: An amplifier tube.

Pool Tubes: Those tubes employing a pool of liquid mercury as the cathode.

Radiography: X-ray inspection in which the image is formed on a photographic film. This technique is employed to locate internal flaws in metal castings, to check the alignment of the elements in electron tubes, and to inspect the quality of welds.



Years ahead in listening pleasure

When you own a Newcomb amplifier you own more than just a carefully built piece of electronic equipment that measures up to the most exacting mechanical requirements. You also own... what you *really* want... the phonograph amplifier that's designed to give you *the most in listening quality*.

Let your own ears be the judge. When you listen to a Newcomb you hear your favorite recordings or radio and television shows come gloriously to life. These superb amplifiers are subjected to rigorous testing procedures throughout their production to insure mechanical and electrical perfection. BUT... *more than that*... they must meet the most critical *listening quality* tests.

Newcomb Model KXLP-30 is a 20-20,000 cycle, low distortion, 30 watt phonograph amplifier providing the reserve power to make full use of its special tone control circuits. Superbly balanced electrical design, the result of many years experience, gives you remarkable *listening quality*. The *Magic Red Knob* four stage record condition compensator frees tone controls from the function of controlling surface noise. Thus any desired tonal balance may be obtained under any condition of operation at any volume level. Adaptable for use with AM-FM radio tuners, TV, wide range loudspeakers and magnetic or crystal pickups, it is engineered for *your listening pleasure*.

Write for complete descriptive literature

Newcomb

THE SOUND THAT QUALITY BUILT

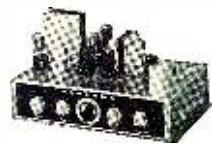

Model HLP-14, 14 watt
Phonograph Amplifier



Model P-10A, 10 watt
Phonograph Amplifier



Model R-12, Three Speed
Portable Phonograph



Model RC-12, Three Speed
Portable Phonograph



Model B-100 Radio

NEWCOMB AUDIO PRODUCTS CO., DEPT. F, 6824 LEXINGTON AVENUE, HOLLYWOOD 38, CALIFORNIA
MANUFACTURERS OF P.A., PHONOGRAPH, MOBILE, INSTRUMENT AND WIRED MUSIC AMPLIFIERS
PORTABLE SYSTEMS, PHONOGRAPHS, RADIOS, TRANSCRIPTION PLAYERS AND RACK EQUIPMENT

➔ **CASH IN** ➔
FRINGE AREA SALES
 with the sensational

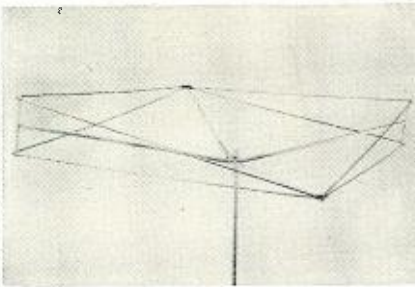

**SUPER RHOMBIC
 ANTENNA**

- ➔ Eliminates ghosts!
- ➔ Eliminates costly stacked arrays!
- ➔ Gives all-channel coverage with gain of over 12 DB!
- ➔ Features exclusive 15-degree tilt to take advantage of horizontal wave lengths.
- ➔ Extensively lab and field tested. Constructed with aluminum alloy elements that out-perform copper wire rhombics.
- ➔ Space tapered elements construction gives automatic match to all commonly used lead-ins without matching transformer.
- ➔ Super-sensitive 12-degree directivity for maximum distance (DX) reception and ghost elimination.
- ➔ Pre-assembled, lightweight construction cuts installation time to minutes!

**The Perfect Solution
 to Fringe, DX and
 Ghost Area Problems!**

Mail Handy Coupon Today!

TO: DAVIS ELECTRONICS,
 3047 W. Olympic Blvd., Los Angeles 6, Calif.
 Sir: Rush information to me as checked below:

Send free technical data on Super Rhombic Antenna.
 Send name and address of nearest jobber.

Name _____
 Street _____
 City _____ State _____

DAVIS ELECTRONICS
 3047 W. Olympic Blvd.
 Los Angeles 6, California

Register Control: A device used to maintain the correct relative position of a strip of cloth, paper, metal or other material passing through a machine. A phototube is used to detect changes in the position of the material. The output of the phototube is then amplified and fed to a positioning motor which restores the material to its correct position. Register control is used in conjunction with multicolor printing presses to assure alignment of successive colors.

Resistance Welding: The joining together of metals by passing a high current through them. The heat developed as a result of this current melts the metals together. Ignitron tubes, connected back-to-back, are often used to control the intensity and duration of the welding current. The metals to be welded are held between a pair of electrodes. If these electrodes are rod-shaped, the result is a spot weld. A seam weld is produced by using a pair of roller electrodes and passing the work between these rollers.

Saturable Core Reactor: An iron-core inductor containing two windings. Direct current is passed through one of these windings in order to saturate the core. The inductive reactance of the other winding depends upon the degree of core saturation. As the core becomes more saturated, the inductive reactance decreases. The saturable reactor is used in many control applications, in light dimming circuits for instance. In this application, the reactor is connected in series with the lighting system. The lights are dimmed by decreasing the current through the d.c. winding. This increases the inductive reactance of the other winding and limits the current to the lights.

Sequence Timer: An electronic timing circuit which automatically applies and disconnects power at a controllable rate and for preset lengths of time. In resistance welding, for instance, the power should be disconnected for the length of time required to bring the work into position. Power is then applied for the duration of time required to produce the weld. This is followed by another "power off" interval during which the work cools while still under the pressure of the electrodes. The timing accuracy is extremely critical; in some cases, the welding current is allowed to flow for only a few cycles. The sequence timer accurately and automatically controls the "power on" and "power off" intervals (see "Time Delay Relay").

Stroboscope: A device which facilitates the study of rotating or reciprocating machinery by making it appear stationary. It consists basically of a high intensity light source which flashes on and off at a controllable rate. If the flashing rate is properly adjusted, the machine will always be in the same position when the light comes on. Since the machine is always seen in the same position, it appears to be stationary. This device is extremely useful for vibration studies.

Temperature Control: A device for

maintaining a constant temperature in a furnace or oven. In one type of temperature control, a thermocouple located in the furnace develops a voltage proportional to the temperature. This thermocouple voltage changes the bias on a tube whose plate current saturates the core of a saturable reactor. The altered reactance of the saturable reactor changes the value of current flow through the heating element of the furnace. In another type of temperature control, a material whose resistance varies with temperature is used as one arm of a bridge. When the temperature changes, the bridge is unbalanced and the resulting voltage is amplified and used to control the heating mechanism.

Thickness Control: A device for maintaining a constant thickness of a strip of manufactured material such as paper or steel. The material passes between two plates which serve as the tank condenser of an oscillator circuit. Variations of material thickness change the plate spacing and consequently the frequency of the oscillator. An FM type discriminator detects this change of frequency, and its output controls the thickness-determining portion of the machinery.

Time Delay Relay: A circuit in which a relay is actuated a predetermined length of time after a switch is opened or closed. Most types operate on the condenser charging principle. A condenser, charging through a resistor, varies the bias of a tube until the plate current has changed sufficiently to operate a relay. The length of the time delay depends upon the time required to charge the condenser which, in turn, depends upon the values of capacitance and resistance. Some types of time delay relays employ an initially charged condenser which is then discharged in the required length of time. The sequence timer is made up of a number of time delay circuits connected in cascade.

Vane Controlled Oscillator: An oscillator containing a relay in its plate circuit. A metal vane inserted between the coils impairs feedback and stops oscillation. When oscillation ceases, the plate current increases and energizes the relay. Some types employ a detuned tuned-grid, tuned-plate oscillator, and the metal vane passes between the turns of one of the tank coils. This changes the inductance sufficiently to bring the circuit into oscillation. The vane controlled oscillator can be used to sound an alarm when the liquid in a tank has reached a certain level. In this application, the vane is floated so that it will rise and fall with the liquid level, and the coils are mounted on the wall of the tank. The vane controlled oscillator can also be used in elevator leveling equipment. The metal vane is mounted under the elevator platform and coils are mounted at each floor level. When the elevator is properly leveled, the vane passes between the coils. At this time, the relay operates to release the door opening mechanism.

ARROW "The Home of Values!"

COMMAND (SCR 274 N) EQUIPMENT

	Used	New
ARA (same as command receiver) 1.5 to 3 MC, like new with tubes, less dynamotor, black crackle finish		\$19.95
BC-455 6-9 mc receiver	\$7.95	14.95
BC-457 4-5.3 mc transmitter	4.95	
T-19 ARC 5, 3-4 mc transmitter	10.95	
T-22 ARC 5, 7-9.1 mc transmitter	7.95	
BC-496, 2 position Rec. Control Box		1.95
MC-215 Mechanical Drive Shaft, per length		2.45
BC-450 3 Receiver Remote Control		1.95
BC-451 Transmitter Control Box	.69	1.50
BC-442 Antenna Relay, complete		2.95
3 Receiver Rack		1.95

TUBES!

01A	1E7GT	2C26A	33	954
01B	1F4	3B7	34	1619
01C	1F5G	3D6/1299	38	1625
1A6	1G1	10Y	39/44	1626
1B4P	1C6GT	15R	49	
1B5/255	1H4G	19	CRP 72	
1C6	1H6G	30 spec.	843	

39¢

024A	6J7G	6Z7G	12F5	12J5GT	211
2V3G	6T7G	12A6	12H6	77	957

49¢

CK1005	2X2	6L7G	6ST7	705 A
1A5GT	6J5GT	6R7GT	6W7G	

69¢

1B26	1S4	6AC7	6K8C	717A
1B32	2A4G	6AL5	6SH7	1613
1LD5	3S4	6C4	6V6GT	9002
1LN5	5W4	6K6GT	VR90	9003

89¢

\$1.59	100TH	9.95	805	\$3.29
6AG5	6L6G	304TH	14.95	807
6AK5	1624	304TL	14.95	813
6AK6		307A	4.95	813
		803	2.89	866A

CATHODE RAY TUBES

3FP7..	\$1.95	5GP1..	\$3.95	16P4	\$19.95
4AP10..	.95	5BP4..	3.95	16DP4	19.95
5FP7..	1.95	5CP1..	4.95		

CABINET CH-118

Olive drab in color, this cabinet has a full length interlock access door on the rear. The front takes the standard 19" panels with 60 inches of height and 20 inches deep. It is shock mounted on a heavy steel platform and has a two-inch protrusion fully covering one side to accommodate wave trap and wiring. Louvered vents allow air circulation top and bottom.

\$34.50

Each F. O. B. Chicago.

RA 52-RECTIFIER

A transistor controlled rectifier to produce high voltage DC from 110 VAC 60 cycle source. Up to 11,500 volts DC at 50 watts. Metered high voltage (0-15KV) and current (0-20 MA).

\$74.50

New.

BC 768

Radio Receiver Chassis. Complete except for 13 tubes. This chassis with standard 19" panel front contains the receiver for 493.5 MC complete with power supply and an additional low voltage power supply that originally supplied the keyer BC 770. 110 VAC 60 cycles is the primary voltage.

Five 10 mfd—600 VDC oil filled GE condensers are used as filters. Five stages of 49 MC IF's. Two of 10.4 MC, 6.3 VAC Transformer and of course power transformers—chokes and miscellaneous parts.

All units are in good condition as removed from new equipment. Even the salvage value is a great deal more than the low price.

\$9.95

MN 26Y COMPASS RECEIVER

Twelve stage superhet covering frequencies of 150 to 325 KC; 325 to 695 KC, and 3400 to 7000 KC in three bands. These units are brand new but with Dynamotor, Band Switch motor and tubes removed. Schematic Furnished. While they last, ea.

\$4.95

Shipments FOB warehouse. 20% Deposit on orders. Minimum order \$5.00. Illinois residents, add regular sales tax to remittance. Prices subject to change without notice.

MIKES and HEADSETS

HS 23 High Impedance Headset	new	\$4.95
HS 33 Low Impedance Headset	new	4.95
HS 30 Miniature Headset	new	1.50
	used	.75
CD-307 Ext. cord for HS 23-33	like new	.59
J41 Key	new	.98

T-32 Desk Stand microphone. Good used cond.	\$2.95
Throat Mike—T 30—New	.98c
Lip Mike—Navy Type—New	.98c
Extension Cord and Switch Assembly for lip and throat Mikes—New	.98c
CW 49505 High impedance headset complete with leather headband and rubber cushions.	98c
Used.	

SCR 625 Famous Army Mine-Detector

For Prospectors, Miners, Oil Companies, Plumbers, Etc.

This unit is being offered now at a considerable reduction in price. Recently advertised at \$79.50 it is now available in the same brand new wrappings in suitcase style carrying case (less batteries) at

\$59.50

WHILE THEY LAST!



MONTHLY SPECIALS!

EX 769 Transmitter. Part of RC 100 equipment.	\$5.50
BC 770 Keyer Part of RC 100.	\$3.95

These items, described in previous advertisements, are being offered this month only at these prices on an "as is" basis, less tubes. An excellent parts value, both items may be purchased at a combination price of \$8.25.

OIL FILLED CONDENSERS

.00025 mfd. 25,000 VDC, oil-filled, new	\$2.95 ea.
1.75 mfd. 330 VAC, 60 cycle, G. E. Pyranol motor starting condenser with mounting bracket, NEW	59c ea.
4 mfd 500 VDC	39c 3 for \$1.00
1-1-1 mfd 1200 VDC	59c 2 for 1.00
.5 mfd 750 VAC	39c 3 for 1.00
.5 mfd 1500 VDC	39c 3 for 1.00
.25 mfd 600 VDC B/T	24c 5 for 1.00
40 mfd 25 VDC Electrolytic	24c 5 for 1.00
50 mmfd 5000 VDC vacuum condenser, NEW	\$1.29

SURPRISE PACKAGE

20 pounds assorted radio parts. A real value at.

\$1.95

RECORD PLAYER

Original Government cost \$150.00. Contains husky three tube Amplifier, Large PM Speaker and two speed (33 1/3 & 78 RPM) 110 Volt AC and DC motor. In portable leatherette carrying case.

Good operating condition. \$19.95 each Or with repairs required, as is. 12.95 each Also available straight AC with one speed 33 1/3 RPM motor.

Good operating condition. \$17.95 each Repairs required. 11.95 each

AM 61 Indicator amplifier—New with blower and all parts except tubes. \$7.95

BC 709

Battery operated lightweight interphone amplifier. Complete with tube and shock mount, but less battery. New. \$3.95 ea.

AS-138/ARN

10 inch streamline loop as used with direction finding receivers. Fixed position, it is ideal for planes, boats, automobiles. New. \$1.95

AD-1 MOTOR 24 VDC—1/12 HP 6000 RPM 98c

Intermittent Duty
PE 97 or **PE117** Vibrator Power Supply for BC 620 and BC 659. Used—Less Tubes, **\$2.95** Vibrator and Condenser
PE 120 Vibrator Power Supply for BC 620 and BC 659 with Tubes, etc.—Complete for 6 or 12 Volt operation. Used **\$6.95**

PE 218 Inverter, 24VDC input; output 115 VAC, 400 CPS at 13 amps. (1.5 KVA). new **\$15.00** like new **12.50**

CHOKES

10 Henry 20 MADC	29c	4 for	\$1.00
10 Henry 50 MADC	39c	3 for	1.00

MISCELLANEOUS SPECIALS!

	Used	New
RA 10 DA Receiver	\$17.50	\$24.95
BC 347 Interphone Amplifier		2.95
BC 442 Less Condenser	1.49	1.95
APS 13 UHF Antenna, Pair		.98
I-97 Bias Meter	3.95	4.95
RL 42 Antenna Gearbox Motor and Reel	4.95	7.50
Circuit Breaker 40 Amps		.59
Collins VFO Dial—5 calibrated ham bands form 3.2 Mc to 32 Mc; complete with pointer, gears, logging dial and flywheel. Scale 6" on 8" plate, each		.95
I 82 F Five Inch 360 degree compass indicator and Selsyn receiver		4.95
A-81-2 Transmitters Selsyn for 182 indicator (both 182F & Trans. Selsyn for \$7.00)		2.45
PE-101 Dynamotor		2.75
Model 507, Thermal-converter Weston Type D, range .12 amp		.59
BC-1023 Marker Beacon Receiver, complete with tubes, shock mount and instruction manual		9.95
BC-923 27-38 MC. FM Receiver, complete with tubes		24.50
BC-924 27-38 MC. FM Transmitter, complete with tubes		19.95
BC-684 27-38 MC. FM Transmitter, less dynamotor		19.95
BC-610 10 meter modification kit		3.95
SCR-183 complete 12 volt set with all coils, tubes, dynamotor and control units		49.50
ARB Control Box		1.95
ARR2 Control Box		.89

COMPASS INSTALLATION

MN-26C—Remotely controlled commercial type navigation receiver. Freq. range 150 to 1500 KC in three bands. Has twelve 6 volt tubes, 24 V dynamotor and band switch motor, **\$39.95**

MN-28C Control box for above, New. \$9.95

MN-52 Loop control unit, New. 4.45

MN-20E Loop (manually rotatable), New. 9.95

Loop transmission cable 168" long, new. 9.95

MC-124 Mechanical cabling, New, per lgt. 2.45

IN-4D Left-right indicator, New. 9.95

Plugs, set of three, New. 3.75

Manual, covering complete set, New. 1.95

SCR 508 EQUIPMENT

BC 603 Receiver e/dyn. \$24.95 Exc. Used

BC 604 Transmitter e/dyn. 12.95 Exc. Used

BC 605 Amplifier e/dyn. 4.95 New

BC 606 Control Box. .95 Exc. Used

FT 237 Mounting. 9.95 Exc. Used

MP 48 Mast Base. 2.95 Exc. Used

DM 34, Dynamotor. 10.95 Exc. Used

DM 35, Dynamotor. 14.95 Exc. Used

DM 37, Dynamotor. 14.95 Exc. Used

TM 11-600 Tech Manual. 1.95

Crystals, Set of 80. 19.95

PE 206 INVERTER

24 VDC to 80 VAC at 800 CPS 500 VA Used **\$3.95**

SCOTT HI-FI OUTPUT TRANSFORMER

Made for Scott Navy Receiver. Fully Potted. Primary 5000 ohms. Secondary: 600 ohms center tapped and 60 ohms center tapped with inverse feedback. New **\$1.49**

TS-10 Sound powered phones. Brand New, each. \$9.95

Used \$5.95 ea.

VIBRATORS

2 Volt—7 Prong Synchronous. 69c 10 for **\$6.00**

6 Volt—4 Prong Non-synchronous. 98c 10 for **9.00**

ARROW SALES, Inc. Dept. N, 1712-14 S. Michigan Ave., Chicago 16, Ill.
PHONE: HARRISON 7-9374



LEARN Radio-TELEVISION

Through The Time-Proven UNIT CHASSIS SYSTEM

The exclusive "Unit Chassis System" of teaching television was developed at this 48-year-old institution of higher learning. The TV set is divided into stages on separate chassis. You study one stage at a time, intimately learning the functions of every component of all types and makes of receivers. You are fully prepared to cope with future design changes, including the advent of color television.

You can become a Radio Technician in 12 months

Train here for positions such as Radio Shop Operator or Serviceman, Supervisor of Service Personnel. The Radio Technician's certificate is awarded. You may then advance immediately or at a future date into courses described below.

Earn a Radio-Television Technician Certificate in 6 additional months

and be prepared for such work as Radio-TV Service—Audio, Transmitter or Communication Technician—and Broadcast Operator (upon passing FCC examination).

ALSO...Your Technician Courses are credited toward the B. S. Degree in ELECTRICAL ENGINEERING

The Radio Technician course, while complete in itself, is one-third of the college program (major in electronics). Further, you may select as an elective: design, research, manufacturing and production, or engineering sales and management.



B.S. Degree in 36 months. Military, practical or prior academic training evaluated for advanced credit. Terms open October, January, April, July.

MILWAUKEE SCHOOL of ENGINEERING

Technical Institute • College of Electrical Engineering

FREE—Write for "Occupational Guidance Manual" and 1951 Catalog.

MILWAUKEE SCHOOL OF ENGINEERING
Dept. RN-951,
Milwaukee 1, Wis.

Without obligation, mail Occupational Guidance Manual,

- 1951 Catalog Your Career Bulletin on Radio-TV
 Electrical Engineering, B. S. Degree in Electronics
 Electrical Power. Also bulletin on Electrical Service
 Welding Refrigeration, Heating, Air Conditioning

Name.....Age.....

Address.....

City.....State.....

RADIO-TV Service Industry News

AS REPORTED BY THE
TELEVISION TECHNICIANS LECTURE BUREAU

DURING the spring and summer months while inventories of completed television receivers mounted as the slack market for new TV sets continued, trade association officials, manufacturers, and dealers all looked forward to the coming of the fall months for a resurgence of consumer interest in new video receivers.

The lack of buying interest was largely attributed to the restrictions on credit terms as imposed by Regulation W which, coupled with the sharply rising cost of necessities, dried up the market represented by the "average income" family. Those families that were financially able to pay cash for new TV sets already owned one or more receivers and no radical change in cabinet styling nor noticeable improvement in picture quality had come along to impel them to trade in their old sets for new models.

Excess inventories plagued set distributors, dealers, and parts distributors and many businessmen had good cause to ponder over the surplus stocks they acquired in 1950 in anticipation of the "critical" shortages of tubes, parts, equipment, and supplies expected in 1951.

In June the *Columbia Broadcasting System* inaugurated the first commercial color television broadcast which originated in New York City and was networked to stations in Boston, Philadelphia, and Washington. Since practically all manufacturers had taken a "wait and see" attitude on color television while the issue was in the courts, not many color-equipped receivers nor conversion and adaptation parts and accessories were available when the color telecasts started.

The Bureau has been in a unique position to gauge the extent of the interest in color television as more and more service operators were exposed to color telecasts.

Color TV Problems

It is obvious that color television will pose more problems for the independent servicing industry than any previous development in the radio or television industry. True, back in 1945, '46, and '47, the general opinion was that the independent servicing industry would be unable to cope with the problems of monochrome television installation, ad-

justment, and service. Yet the record shows that it was the independent television service operators, most of whom were previously radio service operators, who rapidly became the backbone of the television installation and service business. Many former radio service dealers who expanded their businesses to retail television receivers wisely developed their own TV installation and service departments, and have been able to weather the slump in set and appliance sales with income from their service departments.

But color is a new dimension in television that will present some distinctly new problems.

Neither color receivers nor adapter and conversion equipment will be available in quantity until late September or October. Once enough sets and conversion equipment become available to permit aggressive promotion of color video and public interest develops there will be a greater demand for color receivers than the manufacturers can supply. It is possible that there will be consumer "pressure" on television service companies for the adaptation and conversion of receivers. For instance, the successful color televising of one outstanding football game during September might create a demand that would swamp the industry with orders for color receivers. The general buying public is like that—they want what they see and like, and want it immediately.

Color TV Lecture Programs

In anticipation of the need for practical instruction in color television receiver circuitry, the Bureau, in cooperation with the Editors of *RADIO & TELEVISION NEWS*, has developed an extensive program of instruction both through general lectures and individual instruction which will be made available to the radio-television servicing industry beginning in September.

Starting in those areas where color telecasts are being given regularly, a series of lectures on the adaptation and conversion of present sets to reproduce color TV pictures will be given by the Industry's foremost service lecturers. It is planned to show actual color TV receivers in operation so that seasoned TV technicians can get the "feel" of color TV receiver operation and main-

RADIO & TELEVISION NEWS

OUTSTANDING VALUES NOW AVAILABLE

PRE-AMPLIFIER for RELUCTANCE CARTRIDGE



Made by Magnavox. Complete with tubes 6SG7, 6SQ7, 6J7. All wired, ready for use. A remarkable value!

ONLY.....\$2.95

HARD-TO-GET TUBES

Fully Guaranteed

Quantities Limited—Subject to Prior Sale.

1B3GT...\$1.06	6K6GT...\$.59
5Y3GT... .49	6BC5.... .79
6AK5.... 1.47	6CB6.... .79
6AL5.... .79	6BH6.... .89
6AQ5... .79	6BJ6.... .79
6AU6.... .79	12AT7... 1.29
6AV6.... .65	12AU6... .79
2X2A....\$.55	

SNYDER DIRECTRONIC MOTORLESS TV AERIAL SYSTEM

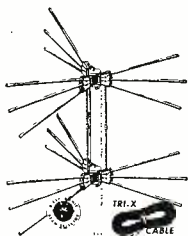

Receive fine signal from all directions. No longer necessary to use Yagi antennas for each band. No longer necessary to use antenna rotors. SWITCH AT SET CONTROLS ELEMENTS IN EFFECT. Simple to install, easy to use.

- All channels for ultra-fringe areas.
- Hi-tensile 3/8" aluminum alloy elements.
- 1 set connecting stubs.
- Universal U clamp for masts up to 1 1/2".
- Directronic Beam Selector.
- 75 feet of TRI-X cable.

COMPLETE....\$16.95

PHONO CARTRIDGES—Brand New—Will replace 95% of all cartridges.
1 volt—Standard Mounting.\$1.75 ea.
3 1/2 volt—Standard Mounting.\$1.85 ea.

MOST AMAZING SPEAKER MADE! THE "JUNIOR TWELVE"

Size: 5 1/4". Standard Mounting. 2.15 oz. Alnico V Magnet. 3/4" Voice coil impedance 3.2 ohms. Get 12" speaker performance in smaller radio sets, phonographs, TV sets, and sound systems!—at 5" speaker prices! Fundamental resonance of the "Junior Twelve" centers around 85 cycles. Response of the "Junior Twelve" is that of the conventional 12" PM.

NOW ONLY....\$2.79 ea.

REDUCE YOUR TV RECEPTION TROUBLE



THE TURRET BOOSTER

- Fully concealed within set.
- Comes on when receiver is turned on.
- No wiring necessary—simple as removing a tube.
- Improves reception—increases video output at least 15%.

Just the thing for fringe area boost or in local areas where antennas are not allowed. PRICE.....\$9.95 (Special discount to dealers)

BUFFER CONDENSERS

.005 —2000 V...)	25c each
.006 —1600 V...)	10 for \$2.25
.0075—2000 V...)	100 for \$19.50
.01 —2000 V...)	

OZ4 Tubes. Fully Guaranteed.
69c each. 10 for \$6.50

SPEAKER BUYS OF THE YEAR

4" PM Alnico V Magnet } \$1.49 each
5" PM Alnico V Magnet } 10 assorted for \$14.25

THE PERFECT SPEAKER FOR REPLACEMENT OR SOUND WORK

10" PM 3.15 oz. Alnico V Magnet. Rated at 15 watts....\$3.95 each.
6 for \$3.75 each.

TUBE CARTONS

Made of heavy red stock. For miniature tubes.

\$1.25 for 100.
\$11.00 for 1000.
GT OR METAL TUBES
100 for \$1.50
1000 for \$12.50

CUSTOM BUILT AUTO RADIOS

Easily installed. Fine, top quality. Ready to place in your car. Designed for each specific car.

All sets—6 tube. 3 gang; super heterodyne. Extra sensitive circuit. Low battery drain. Beautiful finish and dial. These models now available:

1951—Ford	1948-49-50-51—Hudson
1949-50—Ford	1951—Henry J
1951—Chevrolet	1951—Dodge, Plymouth
1949-50—Chevrolet	1949-50—Dodge, Plymouth
1950-51—Studebaker	

List Price, \$59.95

YOUR PRICE.....\$41.95

HERE'S A REAL TOOL BUY



This handy, useful 6-piece set with unbreakable, shockproof, nonflammable amber handles, with flange aluminum screw chuck. Blades hardened, tempered and fully polished. In attractive leatherette pouch. NOW ONLY \$1.11 each.

Case of 12 sets.....\$12.00

NOW! 20" PICTURE FROM YOUR SMALLER SCREEN SETS

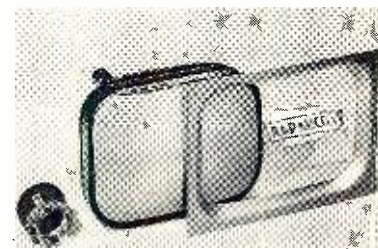

Raparco 20" conversion kit at an all-time low price!

Includes 20CP4 tube, 20" gilt edged mask, matching 70° yoke and 15KV HV transformer. All finest quality components. COMPLETE for.....\$69.95

CHIMNEY MOUNTS—2 piece heavy-duty, rust-proof brackets. No drilling or guy wire needed. Includes strapping. \$1.30 each 12 for \$1.20 each

Radio Parts Company, 614 RANDOLPH ST., CHICAGO 6, ILL.

Hold your hat -- this new audio amplifier is 99.99%* distortion-free. Its name: the Craftsmen 500 with the famous Williamson all-triode circuit. We had to invent a new word to describe its performance. The word is **ULTRA-FIDELITY**. Which means: The finest audio amplifier ever built, at any price. And your own good ears will prove it.



C500 amplifier features

- Freq. response: ± 0.1 db., 20 cps to 20,000 cps. ± 2 db. 5 cps to 100,000 cps.
- Power response: 12 watts ± 2 db., 10 cps. to 50,000 cps.
- Total H. Distortion: Less than 0.1% at 10 watts, at mid-freqs.; 0.01%* at av. listening level below 1 watt.
- Tube complement: (2)6SN7GTA; (2)KT66 power output; 5V4G rectifier.

for information, write

THE RADIO
Craftsmen
INCORPORATED

Dept. R-9 4401 N. RAVENSWOOD AVE. • CHICAGO 40, ILL.

Easy, fast way to cut "Key" and "D" openings in chassis



...with new GREENLEE Radio Chassis Punches

Now, in 1½ minutes or less make perfect "Key" or "D" holes for sockets and other equipment. Simply insert GREENLEE Punch and turn with an ordinary wrench... get a "clean" opening in a hurry! Write today for details on these as well as GREENLEE Radio Chassis Punches for round and square openings. Greenlee Tool Co., 1889 Columbia Ave., Rockford, Illinois



No. 732 "Key" Punch



No. 733 "D" Punch



RED ARROW FOR BETTER BARGAINS

FILTER UNIT

This unit is an excellent buy for the parts alone. Some parts are worth more than were asking for the whole unit.

- 1-40 MFD @ 450V
- 1-1600 MFD @ 12V
- 1- .5 MFD @ 400V
- 2- .5 MFD @ 50V
- 1- .01 MFD @ 400V
- 2-20 Watt Resistors
- 2-Filter Chokes
- 2-RT Chokes
- 1DPSST Toggle Switch
- Miscellaneous hardware, wire, etc.



BRAND NEW, ORIGINAL PACKING, 89c ea. (10 for \$7.50)

TERRIFIC KIT SALE

- Kit of 50 Assorted KNOBS \$1.19
- Kit of 100 Ass'd. PAPER TUB. COND. 5.75
- Kit of 10 Assorted VOLUME CONTROLS. . . 2.75
- Kit of 100 MICA CONDENSERS 4.95
- Kit of 50 TRIMMERS 1.98
- Kit of 100 CERAMICON CONDENSERS 4.95
- Kit of 12 Ass'd. TRANS. MICAS 2.89

GRAB BAG! 10 LBS. RADIO PARTS

Transformers, Chokes, Condensers, Switches, Resistors, Sockets, Knobs, Insulators, etc. HOW CAN YOU GO WRONG? ONLY \$1.79

BC-456 MODULATOR

Good, used, with tubes. ONLY \$1.89

CORDS

- CD478-5 ft. long with Alligator Clips...29c pair
- CD307A with PL55 and JK26 79c each
- SLEEVING-3 ft. lengths 10 for 25c

TRANSMITTING MICAS—TYPE F2L

- .0001 @ 5000 V 59c each
- .00025 @ 5000 V 59c each

FP TYPE CONDENSERS

- 10 MFD @ 400 V, 20-20 MFD @ 50 V 69c
- 1000 MFD @ 15 V 49c
- 10 MFD @ 250 V 39c

DYNAMOTORS

- PE 73—used, F/BC 375 \$4.95
- PE 94—used, F/SCR 522 4.95
- DM 33A—brand new, original carton 4.95
- DM 53A brand new, original carton 4.75

MINIMUM ORDER—\$2.00. Send 25% deposit with order, balance C.O.D. Shipped F.O.B., N.Y.C. (N.Y.C. residents add 3% sales tax.)

RED ARROW SALES CO.

DEPT. A
214 STANTON ST., NEW YORK 2, N. Y.
Phone: GRamercy 7-4762-3

tenance problems while they are being discussed.

However, many technicians will want a chance to work on color circuits under the supervision of expert, qualified instructors, instruction which is not possible in an open lecture presentation. So, for experienced technicians an intensive three-day course of practical work and instruction in color circuitry will be provided in all of the major TV areas as rapidly as color telecasts spread and the necessary instructional equipment can be procured.

It is hoped that through the medium of these programs the independent servicing industry will be adequately prepared to cope with the technical problems involved in the conversion, installation, and maintenance of color television receivers.

As was pointed out in this department in last month's issue, color television will be available to users in three ways!

First, by adding the necessary component parts to present monochrome receivers to *adapt* them to the CBS system scanning rates and then adding a color *converter* to reproduce the pictures in color.

Second, by adding a second unit which is equipped with and operates as a *slave* to the present receiver. This slave set is attached to the master receiver by means of tube adapters and is used only in viewing color television pictures. The user can view black-and-white pictures on the master receiver.

And the third method, of course, is by means of a complete, factory-built color television receiver.

The first method will add a tremendous dollar volume to the business of qualified television service contractors who have the facilities, personnel, and "know-how" to adapt and convert receivers for color.

The second will probably require more installation time than present black-and-white receivers while the third will be handled about the same as a good installation of a monochrome receiver.

In the independent service industry we are prone to consider new developments only in the light of the new technical problems they will present. Naturally, we must have available in any radio or television shop, men who possess the technical knowledge and practical servicing "know-how" to handle the technical requirements in the installation, maintenance, and servicing of receivers.

TV Service Business

The growing dollar volume of business in installation and service adds increasing emphasis to the *business operating* aspects of a service shop. Television service is now important, big business. The successful management of a television service business requires the practical operating "know-how" that is essential to the continued existence of any good retail business.

The numerous business "squeezes" that have been applied to the TV serv-

ice industry, in major television areas during the past four years have washed out the bulk of the inefficient TV service contractors and service shop operators. The "shoe-string" television technician still poses many problems but only as a nuisance in causing user complaints against the service industry and not as a factor in the over-all service business handled by competent service business operators.

New Areas to be Opened by U.H.F.

It is in the new areas that will be created by u.h.f. television that many of the mistakes made by the service industry in the early days of television will be repeated—unless present independent service shop operators and service dealers prepare themselves in advance to cope with the problems of installation and service when telecasting starts.

The same pattern of almost non-interest in TV seems to prevail in potential u.h.f. television areas that was observed in present television areas prior to the start of telecasting. In almost all of the present major television areas there existed an attitude of "wait until television arrives and then we'll learn all about it." However, when the first station announced its official date to start telecasting and dealers started to sell receivers there arose a loud hue and cry from the independent service operators over their failure to study this new giant before he moved in.

When telecasting actually starts in a new area the business moves too fast for a dealer or technician to stop and study anything that he could have learned previously.

Recent announcements from the Federal Communications Commission indicate that the station freeze may be lifted early in the fall. Although many predictions state that the first u.h.f. stations probably won't be on the air until late in 1952, it is well to remember that v.h.f. television moved ahead about three times as fast as was anticipated after it got started in 1946.

Licensing of TV Service

Efforts to pass legislation to license television servicing keep popping up in various parts of the country. In Milwaukee there has been a determined attempt to put through a service licensing ordinance that would require the payment of an annual license fee of from \$100 to \$500 to engage in television servicing. And in Pennsylvania two state bills seeking the creation of a State Board of Examiners for service technicians are before the House of Representatives.

The mad scramble of local and state politicians for new tax monies may result in some abortive legislation that would effectively close the door of television service to men who have the will, perseverance, and technical and business know-how to start in a small way and build up successful small businesses for themselves. And it wouldn't solve any of the problems of service—it

GET YOUR BIG, NEW 1952 CONCORD Catalog

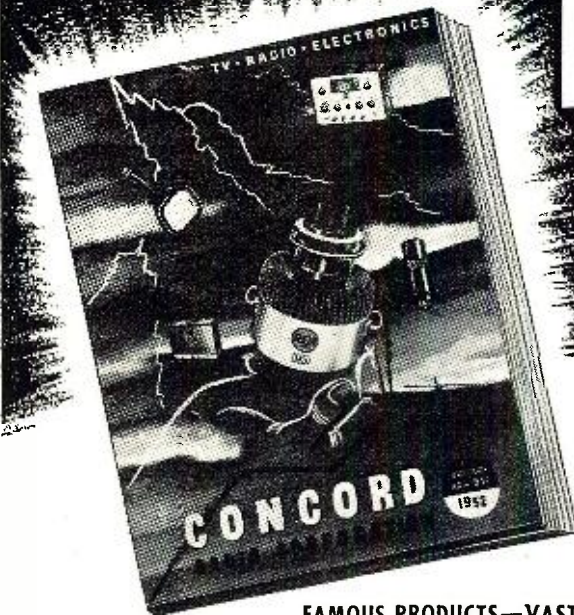

FREE!

Send for it NOW!

ALL-NEW COMPLETE BUYING GUIDE for Every Need!

FAMOUS PRODUCTS—VAST STOCKS—LOWEST PRICES

TV • RADIO • ELECTRONICS

You save time and money—with this bigger, better 1952 Buying Guide! Here is page-after-page full of the latest and greatest values in Television, Radio and Electronics. It brings right to your finger tips one of the world's largest stocks of nationally known guaranteed quality parts and equipment. You find it quick and easy to get whatever you need—at the very lowest prices! Send for your FREE Concord Catalog today! Have it handy for quick reference!

Supplies for Industry, TV and Broadcast Stations, Schools, Servicemen, Hams, Government, Experimenters and Builders

CONCORD RADIO

901 W. JACKSON BLVD. • CHICAGO
Over 30 Years of Service to the Radio World

CONCORD RADIO CORP., Dept. RJ-51

901 W. Jackson Blvd., Chicago 7, Illinois

Rush FREE Big, New 1952 CONCORD Catalog No. 951

Name _____

Address _____

City _____ Zone _____ State _____

HIGH FIDELITY TV & RADIOS PHONOS & RECORDERS SOUND SYSTEMS HAM GEAR TEST EQUIPMENT ELECTRONIC TUBES PARTS, BOOKS, KITS

FAST DELIVERY
Large and varied stocks insure quick shipment on thousands of items.

HELPFUL SERVICE
Our technical experts give personal attention to your problems!

INDUSTRIAL DIVISION
Experienced staff and centralized efficiency speed service on supplies to Industry!

HIGH FIDELITY
Complete systems and custom components for finest reproduction!

EXPORT DIVISION
Special Export Division gives prompt service on orders and inquiries.

POSITIVE SATISFACTION
CONCORD'S policy of quality and value assures you of complete satisfaction!

FREE SEND FOR IT TODAY!

MOST POPULAR RADIO & TV TUBES

At Better Than 50% Off List Price!

STANDARD BRANDS — FULLY GUARANTEED

OZ4	\$.77	6SG7	.94
1A5GT	.94	6SH7	1.04
1A7GT	1.03	6SJ7GT	.77
1B3GT	1.27	6SK7GT	.84
1H5GT	.77	6SL7GT	1.14
1LA6	1.27	6SN7GT	1.04
1LB4	1.27	6SQ7GT	.69
1LC5	1.27	6SS7	.94
1LC6	1.27	6T8	1.39
1LD5	1.27	6U5	.94
1LE3	1.27	6V6GT	.94
1LH4	1.27	6W4GT	.84
1LN5	1.27	6X4	.69
1N5GT	.94	6X5GT	.69
1Q5GT	1.27	7A5	1.04
1R5	.94	7A8	.84
1S4	1.03	7B4	.84
1S5	.84	7B5	.84
1T4	.94	7B6	.84
1T5GT	1.27	7B7	.84
1U4	.94	7C5	.84
1U5	.84	7C6	.84
1X2	1.27	7F7	1.04
3Q4	1.04	7F8	1.54
3Q5GT	1.14	7Q7	.84
3S4	.94	7V7	1.27
3V4	.94	7Y4	.84
5T4	1.16	12AH7GT	1.27
5U4G	.69	12AL5	.94
5V4G	1.14	12AT6	\$.69
5W4	.77	12AT7	1.39
5Y3GT	.52	12AU7	1.14
5Y4G	.69	12AX7	1.14
5Z3	.77	12BA6	.84
6A7	1.04	12BE6	.84
6A8GT	1.04	12J5GT	.69
6AB4	.94	12K7GT	1.04
6AB7	1.56	12SA7GT	.84
6AC7	1.39	12SF5	.94
6AG5	1.27	12SF7	.94
6AG7	1.54	12SG7	.94
6AH6	1.89	12SJ7GT	.77
6AK5	1.89	12SK7GT	.84
6AL5	.94	12SL7GT	1.14
6AL7GT	1.27	12SN7GT	1.04
6AQ5	.94	12SQ7GT	.77
6AQ6	.84	12SR7	1.04
6AQ7GT	1.14	14A7	1.04
6AS7G	3.98	14B6	1.04
6AT6	.69	14Q7	1.04
6AU6	.84	19BG6G	2.94
6AV6	.69	19T8	1.39
6AX5GT	.77	25A6	1.27
6BA6	.84	25L6GT	.84
6BE6	.84	25W4GT	.94
6BG6G	2.32	25Z5	.77
6BC5	.94	25Z6GT	.69
6BH6	.94	35A5	.84
6BQ6GT	1.54	35B5	.94
6C4	.77	35L6GT	.84
6C5GT	.77	35W4	.62
6C6	1.04	35Y4	.84
6CD6G	2.94	35Z3	.84
6D6	1.04	35Z5GT	.62
6E5	1.04	41	.94
6F5GT	.77	42	.94
6F6GT	.77	43	.94
6H6GT	.84	45	.94
6J5GT	.69	47	1.39
6J6	1.39	50A5	1.04
6J7GT	.94	50B5	.94
6K5GT	1.14	50L6GT	.77
6K6GT	.77	75	.77
6K7GT	1.04	76	.77
6L6G	1.72	77	.94
6N7GT	1.14	78	.94
6Q7GT	.84	80	.61
6SA7GT	.84	117L7GT	1.89
6SC7	.94	117N7GT	1.89
6SF5GT	.84	117Z3	.69
6SF7	.94	117Z6GT	1.14

BROOKS RADIO & TELEVISION CORP.
84 VESEY ST., DEPT. B, NEW YORK 7, N.Y.

would only add to the consumers' cost of service.

Reconditioned TV Receivers

There has always been considerable speculation as to whether a "reconditioned TV receiver" business might develop along the lines of the "reconditioned used car" industry. The American public has been conditioned to "want" new things and it has seemed reasonable to assume that someday receiver manufacturers would develop trade-in plans that would keep TV sets from becoming heirlooms in homes that could afford to have the latest and best in television reception.

Recently a distributor for one of the larger receiver manufacturers launched a program to encourage the trade-in of small screen sets for the later model large screen units. They reported an exceptionally good response from set owners.

The traded-in sets are reconditioned, with the exception of the cabinet and picture tube. Sales efforts in selling the reconditioned sets are directed toward placing them as second sets in TV-equipped homes.

The practice of trading in monochrome receivers may become a factor in color television areas when the supply of color television receivers requires aggressive retail selling campaigns. Such receivers may be reconditioned and channeled into non-color TV areas where they would become an important competitive influence to the sale of new monochrome TV sets.

Set Conversions for U.H.F.

It appears that the conversion of present monochrome receivers for the reception of programs telecast in the new u.h.f. channels will not present any serious problems.

In a recent demonstration sponsored by the RTMA for the benefit of the FCC Commissioners and staff members, eight of the leading set manufacturers demonstrated u.h.f. converters they have developed for their own receivers.

Unfortunately, however, receiver manufacturers are still tied to the philosophy that the service technician must be eliminated from the picture in order to interest buyers in new equipment. Far too much of the u.h.f. converter publicity reads like this, "The unit can be installed by the customer in just a few minutes," even though the chassis may have to be removed from the cabinet and the conversion strip mounted in the tuner assembly.

Service Organization News

The television service industry was well and ably represented at the recent annual meeting of the RTMA Service Committee in Chicago. Officers of recognized national and local associations were invited to attend the sessions of the Committee and to present papers on problems of the servicing industry, together with suggestions for their solution.

Service organization officers who at-

KITS! KITS! KITS!

- Popular Brands! Clean stocks!
- 100—Carbon Resistors 1/2 & 1 W.
- 100—Paper Tubular Cond.
- 100—Mica Condensers
- 100—Ceramic Condensers
- 100—Ass't Term. Strips
- 50—Oil Filled Bathing Condensers
- 20—Filter Condensers
- 25—W. W. Resistors 5-100 W.

\$395 ea.

ASSORTED PARTS PACKAGE

Approximate 15 pounds \$1.49

STANCOR POWER TRANSFORMER

P-4352, 700 V. Ct. @ 90 Ma. 5 V. 3 A 6.3 V. Ct. 3.5 A \$3.95

HERMETICALLY SEALED CHOKE

150 Ohm 7 Hy. 325 Ma. Conservative rating 2000 Volts \$2.95

FILAMENT TRANSFORMERS

GL-856, Prim. 115/230 V. Sec. 4.5 to 34 V. in 4 V. steps at 2 amps. Cased, NEW \$2.95
W.E.-T1071, 115/230 50-60 cyc. Delivers 11.5 V. @ 3 amps or 23 V. @ 4 amps. 100 V. A. Prim. @ completely shielded. NEW \$3.95

MODULATION TRANSFORMER A-1972

1.575:1 ratio (Ct.). Prim. Z-5700 ohms 150 Ma. D.C. Sec. Z-2280 ohms 180 Ma. D.C. Aluminum case, permalloy core material. Standoff terminals. Size 3 1/16" H. x 3 1/16" x 2 9/16" D. Ideal for 50-75 watt mod. NEW \$3.50

*HEAVY CABLE 14 CONDUCTOR WEATHER PROOF

14 conductors, rubber and fabric covered, #14 stranded and tinned. Enclosed in heavy outer rubber jacket. Heavy brass 14 contact plugs on either end Cable is 1" O.D. Shipping weight—110 lbs. New 100 foot coils \$12.95

ELECTROLYTIC MALLORY CONDENSERS

ES-693	8 Mfd.	650 V.	\$1.55
FPS-1-2	10 Mfd.	450 V.	.45
HC-3-C	10 Mfd.	250 V.	.85
HC-2-B	30 Mfd.	250 V.	.85
HC-1-A	50 Mfd.	250 V.	.85
HC-2-B	30 Mfd.	450 V.	1.25
VH-2-0	40 Mfd.	450 V.	.85

V.H.F. TRANSCEIVER ASSEMBLY

Has ceramic ins. 15 Mmf. tuning cond., 2 filament chokes, 1-acorn socket and filament bypass cond. Mounted on Poly. panel 1 3/4" x 3 1/4" x 1 1/4". Mounts upright with two 6-32 screws in bottom. New. Each 75¢, 2 for \$1.50

BC-191 AND BC-375 TUNING UNITS

TU-26, 200-500 Kc.; TU-10, 10 Mc.—12.5. NEW. ea. \$2.49

WRITE FOR OUR FREE FLYER

25% deposit required with all orders. Prices subject to change without notice.
• Railway Express only.

UNITED SURPLUS MATERIALS

312 South Halsted Street Chicago 6, Ill.



A SOUND INVESTMENT FOR FINE MUSIC



50 Watts (peak) 1001 50W-2 ... \$249.50

McINTOSH, the world's most advanced amplifier, is unequalled for quality reproduction of any sound source. Highest Efficiency — over 65%; Less Than 1% Distortion at Peak Power; Dynamic Range: Over 70 db; Frequency Response: 20-20,000 cps.

AE-2 Amplifier Equalizer... \$74.50



SEND FOR Free CATALOG Dept. F-2

McINTOSH ENGINEERING LABORATORIES, INC.

320 Water St., Binghamton, N. Y.

tended the meetings and delivered papers on problems of the servicing Industry included Albert M. Haas, president of TCA of Philadelphia; Frank Moch, president of TISA of Chicago and NATESA; E. J. Barton, president of the Television Service Contractors Association of Detroit; and Dave Krantz, representing the National Electronic Technicians & Service Dealers Associations.

NATESA recently announced the formation of a new service association in St. Louis—the “Association of TV Service Companies of Greater St. Louis.” Officers of this new association are Vincent Lutz, president; Jay Brown, vice-president; Dave Allen, secretary; and Art Monnig, treasurer.

NARDA Certified Service

One of the best programs for stimulating set owner interest in reliable, capable service shops that has come to the attention of the editors of this department is the one prepared and sponsored by the National Appliance & Radio Dealers Association (NARDA).

The NARDA plan is based on a Code of Ethics in service business operation to which each cooperating service dealer or contractor must agree before he is permitted to participate in the plan described as “Certified Television Installation and Service.” The promotional and publicity material that is furnished to focus the attention of the TV set owning public on organizations participating in the NARDA program is excellent.

Information on the “Certified Television Installation and Service Program” may be obtained from: The National Appliance & Radio Dealers Association, Merchandise Mart, Chicago 54, Ill.

-30-

Spot Radio News

(Continued from page 18)

Reviewing the possibilities of color set production, RTMA's new leader said that . . . “It is only to be expected that large scale color cannot be achieved overnight. The situation is similar to the inauguration of black and white television. The standards for black and white TV were authorized on July 1, 1941. After only five months of work, Pearl Harbor came. The war ended in August, 1945. Yet, in the entire year of 1946, only 6476 sets were produced. And in 1947, only 178,000 sets were made. Even by 1948, the industry had failed to produce as many as a million sets. In the light of this experience, the estimate of 50,000 (color sets) would seem to be a remarkable feat of production (for the remainder of the year), if it is realized.”

WITH THE APPEARANCE OF COMMERCIAL disc color, there has also appeared a revived interest in the patents, covering the techniques used in the CBS methods, and the royalty schedules set up for reimbursement to Columbia.

You may wonder why
I'm sending you this . . .

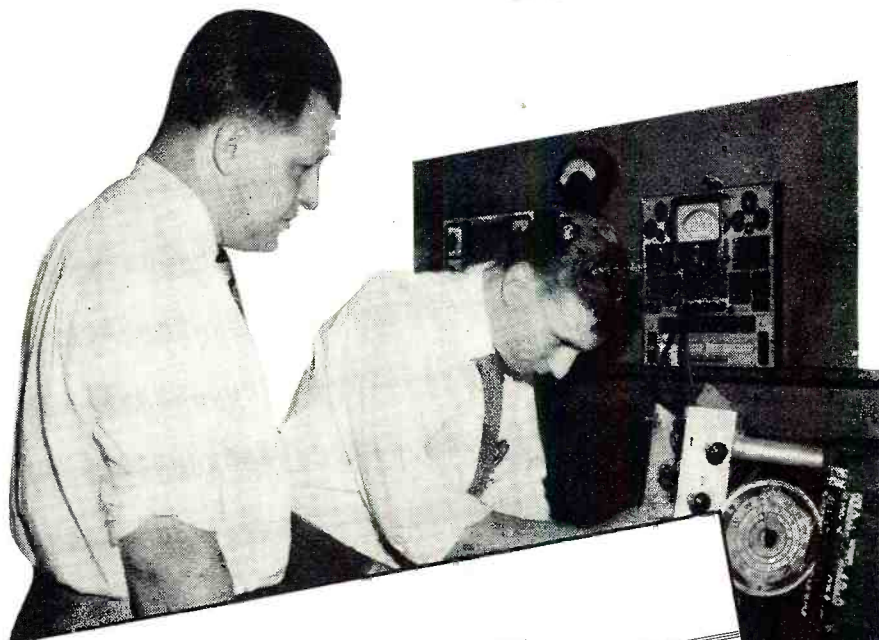

RADIO - TELEVISION

Repairs and Installations

TELEPHONE
HY 4-7-506

February 13, 1951

MADLINGER • 299 DEVOT ST.
BROOKLYN, N. Y.

Workshop Associates, Inc.
135 Crescent Road
Needham 94, Massachusetts

Gentlemen:

Ever since you first advertised your Dubl-Vee antenna, I've been installing nothing else after I saw the results. In quite a few fringe areas the reception I received was a little short of perfect. As you know, channel 9 and 13 are generally the toughest stations to receive in the Metropolitan area. However, after installing this antenna I had no difficulty. The clarity and definition received on 9 and 13 was as good as any channel on the air. I doubt whether there is an antenna on the market today which can compare with your Dubl-Vee.

You may wonder why I'm sending you this complimentary letter. Well after using the antenna so often and getting the same excellent results, I can't help but tell you the engineering genius I see in this antenna.

Sincerely yours,
William Madlinger
William Madlinger

We might add that the Workshop DUBL-VEE is the original patented DUBL-VEE antenna. For outstanding TV reception be sure to specify it.

The **WORKSHOP ASSOCIATES**

DIVISION OF THE GABRIEL COMPANY

Specialists in High-Frequency Antennas

135 Crescent Road, Needham Heights 94, Massachusetts



Do you know that
ALTEC
makes ...

Microphones
6 MODELS



Loudspeakers
14 MODELS



Horns
18 MODELS

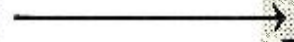

Theater Systems
9 MODELS



Transformers
159 DESIGNS



Amplifiers
22 MODELS

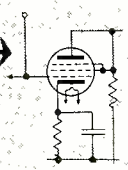
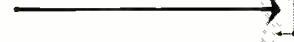

—plus hundreds of special audio devices and transformers for the Armed Forces, the United States government, Research organizations and leading testing laboratories.

... the best investment

9356 Santa Monica Blvd.
Beverly Hills, CA 90210
161 E. 4th Avenue
New York 11, N.Y.



According to the exhibits filed with the Commission, five transmitter and two receiver patents were cited as basic to the system. In the sending methods are involved a swept back segment color filter disc, color mixing, and color control for correct or desired color rendition, scanning so that color carryover or undesired color mixing does not occur in pickup tubes, multiple lens motion-picture film scanner and non-multiple relationship between number of colors and interlaced fields scanned. The receiver patents also involve the disc and color relationship factors.

The royalty plan provides for payments of twenty-five cents on receivers retailing at less than \$100; fifty cents on chassis priced at between \$100 and \$180; seventy-five cents on sets selling between \$180 and \$250; and one dollar on models selling for more than \$250.

FCC's legal authority to assign channels on a geographical block basis, challenged by the FCBA, has been upheld by the Commission who declared the prerogative was within their jurisdiction. The FCC noted that they had the right to classify stations, prescribe the nature of the service to be rendered by each class of stations, determine the location of classes of stations or individual stations, and establish areas or zones to be served by any station. This authority, they said, is expressly directed to be exercised from time to time as public convenience, interest, or necessity requires.

The argument that the proposed assignment plan was different and could be distinguished from other types of rule making activity was without merit, the Commission pointed out. In their opinion, the proposed table is clearly applicable generally to all persons wishing to establish a station in any given community. The fact that the assignment made to one city would not be applicable to persons wishing to apply for some other city was cited as no more depriving the rule of its general nature than the fact that rules relating to those applying for standard broadcast licenses on clear channels would not be applicable to persons wishing to apply for local stations on different channels.

Historic testimony on the floor of the Senate by ex-Senators Dill and White, who were chiefly responsible for the enactment of the Radio Act of 1927 and the '34 Communications Act, was also cited by the Commission to support their official decision on the allocation table. According to the report on these sessions, White had declared: "... One of the most difficult problems we had to deal with was whether there should be any preferences written into the law with respect to any particular character of service. At the time we were working on the legislation, the agricultural land-grant colleges were very insistent that they should have a privileged status. There were various other groups that were just waiting to advance their claims if we gave any recognition to a prior

right. We had to write it in very general terms, vesting discretion in authority in the Radio Commission to make the best distribution they could or we had to undertake to make an allocation to services in the legislation, which would be rigid, and which would be fruitful of interminable discussion in the legislative body. It was hopeless to try and work it out in the legislation."

Commissioner Jones did not agree with his colleagues and in a dissenting opinion pointed out that the 82 channels allocated do not meet any of the five priorities substantially. (Priorities are: 1. To provide at least one television service to all parts of the United States. 2. Provide each community with at least one television broadcast station. 3. Provide a choice of at least two television services to all parts of the United States. 4. Provide each community with at least two television broadcast stations. 5. Any channels which remain unassigned under the foregoing priorities will be assigned to the various communities depending on the size of the population of each community, the geographical location of such community, and the number of television services available to such community from television stations located in other communities.) Jones noted that there are many communities without any service according to the plan: 909 cities have one station; 169 cities, two stations; 74 cities, three stations; 46 cities, four stations; 25 cities, five stations; 11 cities, 6 stations; and 11 cities, 7 or more. It is obvious, he declared, that the Commission violated its table of priorities so materially that by its own proposed criterion, it cannot be sustained in court. The Commissioner felt that the two-three- and four-channel cities, as compared to the five or more channel cities, spell mediocrity, if not doom, for two or more networks. "Although networks, according to the Act have no bearing on the grants of licenses," Jones added, "the television art and the expense of construction, maintenance, and operation has made networking the backbone of TV station operation. . . . The Commission in its licensing policies has recognized this in the proposals of licenses to affiliate with networks rather than serve the communities in which they are located as local outlets of communications. . . . It is clear that an inflexible geographical assignment plan does not meet the criteria of the Commission asserted as a basis for it, and therefore it is illegal."

Continuing his blast at the ruling, Jones noted that the Commission's problem of assigning channels . . . is based on factors so varying in nature that they are too difficult to be captured within the boundaries of a hard and fast pattern." Therefore, he said, if the geographical allocation plan can qualify as a general rule . . . television is so specialized and its characteristics so varying in nature when applied city by city, with varying factors

the MOST COMPLETE TV CONTROL REPLACEMENT MANUAL

- ★ Almost 3000 control listings of 350 different TV set models and chassis, produced by 75 different manufacturers.
- ★ Alphabetically and numerically listed.
- ★ Replaced by 327 different controls — 222 RTV or Exact-Duplicate and 105 Standard numbers.

Clarostat's done it again! Here's the outstanding compilation of TV control replacements. In a jiffy, you can spot the *right replacement* for any wornout or defective TV control. Simple as ABC — like this:

1. Look up particular TV set manufacturer listed alphabetically.
2. Find given TV set model or chassis, arranged in numerical order.
3. Identify defective or wornout control and/or description or function.
4. Note Clarostat Standard or RTV (Exact-Duplicate) replacement avail-



able. As a double check, listing includes manufacturer's stock and parts numbers.

5. Order Clarostat replacement from nearest or favorite Clarostat distributor.

GET YOUR COPY!

Send us a dollar bill and start saving time, trouble, money, in TV servicing. Or get your copy from your Clarostat distributor.



Controls and Resistors

CLAROSTAT MFG. CO., INC. • DOVER, NEW HAMPSHIRE
IN CANADA: CANADIAN MARCONI CO. LTD., MONTREAL, P. Q., AND BRANCHES

TOP QUALITY! LOW COST!

FISHER

HIGH QUALITY Phonograph Preamplifier

■ Here is the *top quality, reasonably priced* preamplifier you have always wanted. The FISHER provides exact equalization for low-level magnetic pickups of *any* make, such as GE, Pickering, Audax, Clarkstan and others; also used as a microphone preamplifier.

Net price only \$12.57

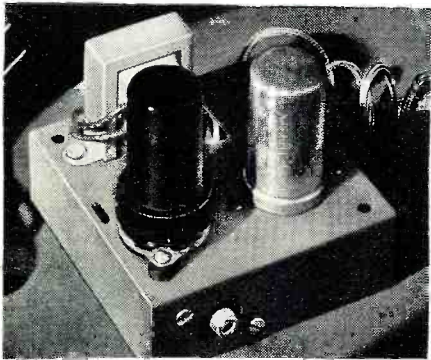

Outstanding Features:

- Uniform response**, 30 to 20,000 cycles. Self powered. Two stages of triode amplification. Extremely low hum.
- Full low-frequency equalization.** High gain. Completely enclosed chassis with bottom cover. Plugs supplied.
- Output cable** can be up to 50 feet in length. size: 3¼ x 3⅝ x 3⅝ high.

WRITE FOR FULL DETAILS

FISHER RADIO CORPORATION
39 E. 47TH ST., NEW YORK

of terrain, tropospheric transmission, and areas of development of communities, the Commission cannot reasonably foresee their solution in the public interest." There is not sufficient scientific data on the books on reception or transmission in every city, he felt, to warrant . . . "rigidifying . . . tentative judgment into a hard and fast rule."

IF CONGRESS HAS ITS WAY, TV programs may be subjected to minute scrutiny in the future. During a recent hearing on a bill calling for the creation of a National Citizens Advisory Board on radio and television, one of the fathers of the bill, Senator William Benton, declared that he believed that now . . . "at the time when television is still in its resilient infancy, would be the best time to do some wise and thorough thinking about what we are going to do with television, so that we can now lay down the optimum guide-lines for its development. If we miss it now, we may not only miss it for a generation, but for keeps." Congress, he felt, should arrange for this planning through the offices of a special board, whose advice . . . "would include an annual review of how the licensees of radio and television stations are living up to their responsibilities for public service and education, on how they are performing in line with promises made when they applied for the licenses and how they can better perform . . ." Noting that there is no listeners' and viewers' lobby in Washington and that the FCC . . . "has neither the time nor the authority actively to seek out, marshal, and crystallize public opinion . . ." it is important that authority to provide such policing be provided by Congress.

An address before the NARTB program standards committee in Washington by FCC's boss, Wayne Coy, revealed that many others also were concerned about the content of programs and were considering steps which might have to be taken to provide control. Reviewing the contents of numerous reports he has received from groups throughout the country, Coy declared that the bulk of the opinions presented were not only extremely critical of the types of shows now being offered, but vowed that something will have to be done. The views were not being offered by inexperienced or biased persons, it was said, but rather by those charged with the responsibility of maintaining public health and general welfare. For instance, he declared, James V. Bennett, director of the Federal Bureau of Prisons, who is also secretary of a section on criminal law of the American Bar Association, recently noted in a letter, describing the section's campaign for improvement in television programming, that the amount of crime material should be reduced and that its timing . . . "be such so as to occur during a period when juvenile viewers will not be sitting by their sets." He also said that much of the . . . "more gory incidents can be eliminated entirely . . ." and

**YOU CAN'T
AFFORD
TO
"SECOND GUESS!"**



Things happen fast in electronics. What's new today may be out-of-date tomorrow—you've got to be right the first time . . .

which is why you've turned to
authoritative

SUBSCRIBE



TODAY!

for guidance

RADIO & TELEVISION NEWS is tops in the field—your best bet for complete up-to-the-minute coverage of all phases of electronics. Every issue is vital to you!

**USE MONEY-SAVING ORDER CARD
FACING THIS PAGE**

ZIFF-DAVIS PUBLISHING COMPANY • 366 MADISON AVENUE • NEW YORK 17, N. Y.
Publishers also of: RADIO-ELECTRONIC ENGINEERING Edition of RADIO & TELEVISION NEWS * POPULAR PHOTOGRAPHY * PHOTOGRAPHY ANNUAL 1952 Edition * FLYING * MODERN BRIDE * FICTION GROUP * ZIFF-DAVIS COMICS

NEW! VOL. 2

OF THE BOOK THAT SAVES YOUR TV SERVICING TIME!

HOWARD W. SAMS' "TELEVISION TUBE LOCATION GUIDE"



Gives Tube position and function in hundreds of important TV receivers... saves you hours of TV servicing time

FIND THE TROUBLE—REPLACE TUBES WITHOUT REMOVING THE CHASSIS

You've asked for more—and here it is—the second volume that brings you right up-to-date. There's nothing like it! The *only* book that shows the *position* and function of tubes in hundreds of TV receivers. Helps you save TV servicing time. Often an operational check in the customer's home—looking at the picture and listening to the sound—gives you a clue to the trouble. Many times only a tube failure is the cause. This invaluable Guide makes trouble diagnosis and tube replacement quick and easy, in most cases *without removing the chassis!* Each TV model has its own clear, accurate diagram. Book is fully indexed for quick reference. All new diagrams—takes up where Vol. 1 leaves off—no duplication. 224 pages, handy pocket size 5½x8½". Pays for itself on the first job!

ORDER TGL-2. Only **\$2.00**



VOL. 1. "TELEVISION TUBE LOCATION GUIDE"

This is the initial volume owned and used daily by thousands of TV Service Technicians. Includes tube location and function diagrams of hundreds of important TV receivers made by 56 manufacturers. Saves hours of servicing time—permits diagnosis of trouble and tube replacement without removing chassis.

Over 200 pages; handy pocket size. Order copies for outside calls and for your bench. Own *both* volumes for complete TV tube location data! **\$1.50**

ORDER TGL-1. Only **\$1.50**

HOWARD W. SAMS & CO., INC.

Order from your Parts Jobber today, or write direct to HOWARD W. SAMS & CO., INC., 2201 East 46th Street, Indianapolis 5, Ind.

My (check) (money order) for \$..... enclosed. Send the following books:

- TGL-2 "TV Tube Location Guide" \$2.00
- TGL-1 "TV Tube Location Guide" \$1.50

Name.....

Address.....

City.....Zone.....State.....

that . . . "any broadcast which blueprints crime in such form that it can be imitated, must be stopped."

Quoting from a survey on the program situation, made by the Southern California Association for Better Radio and Television, representing 200,000 persons, Coy said that the listeners and viewers reported that . . . "the average child in the television home sees death inflicted by violence more than 40 times every single week." In addition, the survey noted that . . . "the effects of this immoderate viewing of crime and violence follow one of two courses: Some children are upset emotionally; others become immune, callous, and indifferent to the sight of death, injury, and suffering inflicted upon others."

It was the opinion of this group and many others, too, that both radio and television stations are . . . "operating with a complete disregard for the welfare of the child audience . . . Children are being exploited at the expense of the security, dignity, and good taste which should be a part of every American home." . . . Solemn views which should be studied diligently by every broadcaster and sponsor from coast to coast, with immediate steps taken to remedy this extremely unpleasant situation . . . L.W.

VERMONT HAMFEST

THE Fifth Annual Vermont Hamfest and State ARRL Convention will be held Sunday, September 16, in the Community Bldg., Main Street, Brattleboro, Vermont.

Sponsored by the Tri-County Amateur Radio Club, with members from Windham County (Vt.), Cheshire County (N.H.), and Franklin County (Mass.), a diversified program has been planned.

Advance registration is \$4.50 with a September 10th deadline. Tickets are \$5.00 at the door. Write Hamfest, P.O. Box 78, Brattleboro for details. **-30-**

NEW G.D. METER USE

By MELVIN H. DUNBRACK, W1BHD

I HAVE a Millen grid dip meter and I have found that in addition to its numerous "conventional" functions it may be used as a secondary frequency standard employing crystals.

A study of the circuit diagram reveals that if the crystal is connected to the two coil jacks the unit becomes a form of the old Pierce oscillator. No coils are required, just the crystal. A crystal adapter may be made up from a 5-prong tube socket and two coil pins. Most crystals fit a socket of this type but special adapters may be made if required.

Tests made with numerous amateur and commercial crystals, ranging from 2 to 15 mc., indicated that almost all of them oscillated with ease. The tuning condenser is adjusted for best stability. The meter will show readings and may be used to peak tune the oscillator. Using a frequency standard crystal of 1000 kc., the tuning condenser will allow adjustment to zero-beat with WWV.

Don't overlook the possibility of using the grid dip meter as a low-powered, crystal-controlled transmitter for short haul and possible emergency work. **-30-**

THE **BROOK**

High Quality

AUDIO AMPLIFIER . . .

ALL TRIODES

Distortion and intermodulation extremely low

Wide frequency range, flat from 20 to 20,000 cycles within .5 db

Attractive remote-control pre-amplifier

Compensation for various inputs; Phono, Tuner, Television or Microphone

Exclusive BROOK circuits and transformers



YES, ALL THESE FEATURES . . . but primarily LISTENING PERFORMANCE heretofore not achieved . . .

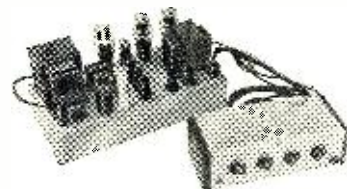

Write for free Technical Bulletin, detailed Distortion Analysis & booklet "Better Listening"

BROOK ELECTRONICS, INC. Dept. R1-1
34 DeHart Place, Elizabeth 2, New Jersey

TUBES

QUALITY, TESTED TUBES, NEW & GUARANTEED

In Stock Now—Write for Others Not Listed

0Z4 \$0.50	6AV6 . . . \$0.55	12AV6 . . \$0.55
0Z4G50	6BA665	12AU7 . . .70
1B3GT65	6BE655	12BA6 . . .65
1R565	6BD660	12BE6 . . .65
1U465	6BQ6GT . .75	12BH7 . . .75
1X2A75	6CD6G . .1.50	25A5GT . .70
3A465	6SH760	25L6GT . .50
3A565	6J5GT . . .50	35C565
3D650	6R875	35L6GT . .50
3Q460	6T875	35Z5GT . .50
5U4G50	6SD7GT . .75	50C560
5Y3GT . . .50	6SN7GT . .60	50L6GT . .55
6AB475	6U4GT . . .75	8090
6AL545	6V6GT . . .55	304-TL . .13.95
6AG575	6W4GT . . .50	304-TH . .13.95
6AS575	6X455	872-A . . .1.95
6AU655	6X5GT . . .55	95550

SELENIUM RECTIFIERS

Full-Wave Bridge Types

Current (Continuous)	18/14 Volts	36/28 Volts	54/40 Volts	110/100 Volts
1 Amp.		\$ 2.75		
2 Amp.	\$ 2.40	\$ 3.75	\$6.95	\$9.95
4 Amp.	3.85	7.00	9.00	
6 Amp.	5.85			
8 Amp.	5.90	9.95		
12 Amp.	7.50	14.00		
24 Amp.	14.00	27.00		

117VAC Selen. Rect. XFMR—6, 12, 18, 24, 30, 36 Volts at 4 Amps. **\$3.95**

WRITE FOR QUOTATIONS ON OTHER TYPES OF SELENIUM RECTIFIERS

BARRY

ELECTRONICS CORP.

136 Liberty Street N. Y. 6, N. Y.
REctor 2-2563

Terms: 25% with order; balance C.O.D.—F.O.B. N.Y.C.—All Merchandise Guaranteed.

International Short-Wave
(Continued from page 67)

section are the program and line control facilities, the master control and recording rooms, CBA talk studio, and three separate control booths. An office section at the front completes this floor. Further expansion is possible by extending the building on the left, thus lengthening the main control room and providing space on each side of it for additional transmitter units.

The two short-wave transmitters operate from a primary power supply of 2300 volts, 3-phase, 60-cycles and deliver at least 50 kw. of carrier power into the transmission line at any frequency between 6 and 21.75 mc. The transmitters are capable of full modulation by any audio frequency in the range of 30 to 10,000 cycles per second. The power amplifier of each transmitter uses two Type 880 tubes connected push-pull in a high efficiency class C circuit. Amplitude modulation of the carrier is accomplished in the plate circuit, using a class B modulator which also employs Type 880 tubes. The final amplifier operates at 10,000 volts d.c. with a current of 7.1 amperes. All transmitter tubes, except the 880's in the r.f. amplifiers and modulators, are air-cooled. The Type 880 tubes are water-cooled—using a closed distilled water system.

The antenna arrays used at Sackville are all of the multi-element curtain type; the European array is composed of four vertical stacks of four horizontal elements. Each element has an electrical length of one half wavelength and each element is provided with a reflector. The reflectors are identical to the radiators so that it is possible to interchange the two by means of a switch, thus reversing the radiated beam by 180 degrees in the horizontal plane. Furthermore, these arrays are all arranged for slewing or changing the direction of the beam by a limited amount on either side of its normal position. This is done by shifting the phase of the current in the two vertical bays of the radiating curtain. The European beam uses five distinct arrays—one array for each of the five frequency bands—6, 9, 11, 15, and 17 megacycles.

A separate antenna array is used to cover Africa which, in its reversed direction, covers Western Canada and Australia. A third antenna array is used to cover South America. Both the African-Australian and South American arrays consist of two vertical stacks of four horizontal elements and, with the exception of the 6 mc. array, are of the dual-frequency type; that is, one for 9 and 11 mc. and one for 15 and 17 mc. Separate antennas of the 4/4 type are used to cover Africa and South America on the 21 mc. band.

The European antenna has a length of 1220 feet and is supported between four steel towers, two of which are 379 feet high, one 217 feet, and one 175 feet. The towers rest on tapered rein-

the world's toughest transformers

must "take" this torture, before they take on your tough jobs...

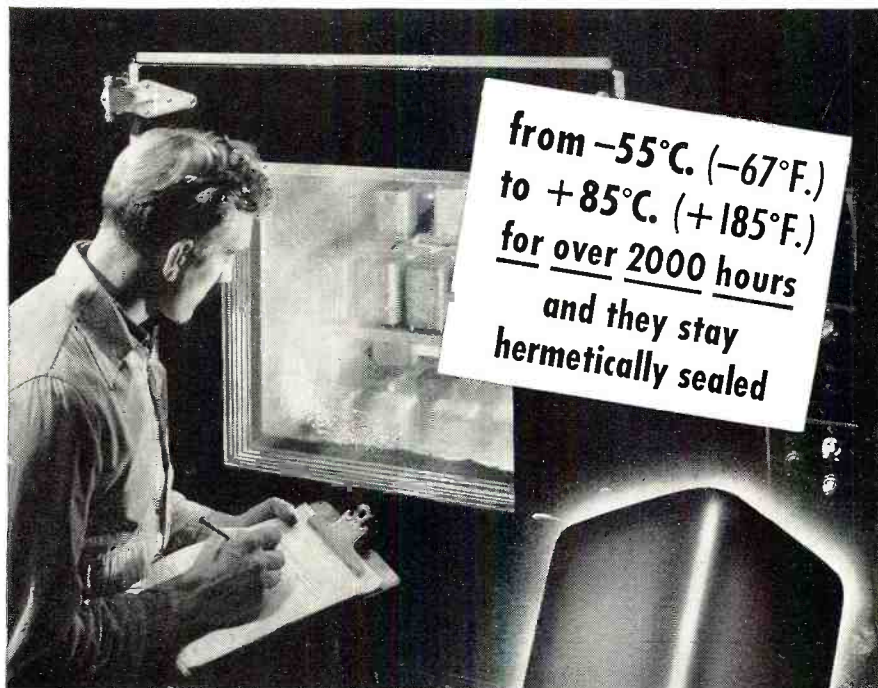

from $-55^{\circ}\text{C.} (-67^{\circ}\text{F.})$
to $+85^{\circ}\text{C.} (+185^{\circ}\text{F.})$
for over 2000 hours
and they stay
hermetically sealed

CHICAGO



MIL-T-27 transformers are really rugged
the complete line that meets military specifications

CHICAGO MIL-T-27 Transformers win their spurs in every conceivable "torture chamber" test. Two hundred and forty-seven cycles of alternating heat and cold for over 2400 hours fail to break the seal or cause failure of these rugged CHICAGO units expressly designed for military and special applications. CHICAGO's unique bushing design and construction, and exclusive process of bonding steel base covers in seamless drawn-steel cases by deep-seal soldering—insure perfect sealing, complete dependability and continuous service under the most adverse conditions. Your electronic parts distributor can supply the complete range of CHICAGO MIL-T-27 Transformers: Power, Bias, Filament, Filter, Audio. These stock transformers may be incorporated in your equipment with full assurance that they will *completely* meet all MIL-T-27 specifications.



SEND FOR FREE CATALOG

Have the full details on CHICAGO'S New Equipment Line—covering all MIL-T-27 units as well as famous Sealed-in-Steel transformers geared to today's circuit requirements. Write for your free copy of this valuable catalog today, or get it from your distributor.

CHICAGO TRANSFORMER

DIVISION OF ESSEX WIRE CORPORATION

3501 ADDISON STREET • CHICAGO 18, ILLINOIS





EQUIPMENT WANTED

* Get rich quick on an investment of 3¢! Send us a note telling us what equipment you have to sell!
 * We're buying all types of radio gear. And shelling out dough like mad! Here are SOME items we * want to buy:
 BC-348 TS-147 TS-148
 APR-4 APR-5 ARC-1
 ARC-3 T-47A/ART-13 TS-33
 * WRITE COLUMBIA FIRST! WE CAN AND DO PAY MORE!

SPECIAL ANNOUNCEMENT!

* BY A STROKE OF LUCK we bought a job-lot of commercial radio equipment... at such a low price, we still don't believe it. We've got a building full of parts, potentiometers, FM speakers, 60 cyc. 115 V transformers, variable condensers, IF cans, and Lord knows what else. We've cut prices we haven't even opened yet! Please! TODAY! NOW!! Tell us what items you want and we'll dig them out for you... at prices so low you'll be glad you're not in P.S.-Mention job-lot when writing.

HOPALONG CASSIDY RADIO

This is the set that regularly sells for \$24.95. Boxed, brand new, limited quantity, made by Arvin. Fully guaranteed! An X-tra set at an X-tra low price: **\$12.50**

TUBES! SAVE BY BUYING NOW!

S32A\$8.95	VR105\$0.79
S298.95	VR17079
6L6C79	5B1P43.95
VRT579	902P1 (2API)3.95

ASSORTMENT DEALS!

- 5 POTS: 10, 20, 50, 250 k & 2 meg. ALL FOR ONLY **\$1.25**
- 4 BATHTUB CONDENSERS: 2x1 mfd 400 VDC, 3x1 mfd 400 VDC, .5 mfd 60 VDC. ALL FOR ONLY **\$1.09**
- 20 POSTAGE STAMP CONDENSERS & 20 RESISTORS: All for only **\$1.50**
- 2 TUBE FILTER CONDENSERS: 2x5 mfd and 2x5 mfd 600 VDC..... **\$1.75**

ARC-5 OR 274-N TRANSMITTERS COMPLETE

5-3-7 mcs. Used, excel. cond. Less xtals. **\$4.50**
 7-9.1 mcs. Used, excel. cond. Less xtals. **10.95**

ARC-5 OR 274-N RECEIVERS

1.5-3 Command Receiver with dynamotor. **\$24.50**
 NEW 6-1 NEW with dynamotor..... **12.50**
 190-550 kes., excel. cond. **12.50**
 Command Receiver 28V dynamotor. **.79**
 12 V. Command dynamotor. **9.95**
 MD7/ARC-5 Plate Modulator. Less dyn. **7.95**

Ahoy! Marine Gear Specials! Look Alive!

- COMMAND SET MARINE RECEIVER. 1.5-3 mcs. Brand new with dynamotor. **\$24.50**
- TCS XMTR & REC. COMBO. Complete with all tubes. Covers 1.5-12 mcs. MO or xtals. control. 12 V. input; 33 W. output. Includes dynamotor and antenna loading box. Excel. cond. Less xtals. **\$175.00**
- MARINE TRANSMITTER & RECEIVER COMBO. 12 V. BC-223 25 W. 800-5000 2 band receiver. Complete with tubes, power supply, cable and marine tuning unit for M.O. or 4-channel xtal controlled. NEW! Includes telephone type hand set. Less xtals. THE WHOLE DEAL ONLY **\$124.95**
- DU-1 MDF LOOP. New. This month with schematic and conversion dope. **27.50**
- COMPLETE SCR-269 MARINE ADF COMPASS DON'T GET LOST AT SEA! Includes 24 V. inverter, loop, compass indicator, control box, relay, plugs, flex cable and rack. Excel. cond. Plus FREE tech. manual! Only **\$95.00**
- JEFFERSON-TRAVIS "Emerson Radio Corp." RADIO TELEPHONE—5 W. marine. This is it. Brand new. NOT SURPLUS! The latest thing for emergency stand-by or small boat gear. Covers 2-3 mcs., x-tal controlled, ship-to-ship and ship-to-shore. Will run or will run 8-10 hours on its own self-charging 6 V. battery pack. Needs no special installation. A kid can operate. Has built-in speaker. Comes in small metal case with carrying handle. Size: 10 1/2 x 8 x 13 1/2 inches. Wt. 30 lbs. Complete with mike, 110 V. recharging unit, instructions. Ready to go less xtals and battery **\$79.50**

- MN-26C RECEIVER: Freq. 150-500 kc. 28 V. with control box, flex. cable, tuning loop, loop cable, EXTRA HOT for aircraft or marine use. Most parts brand new. With left-right indicator & plug. FOR FAST ACTION ONLY. **\$45.00**
- DYNAMOTOR: BD-77 12 V. input; 1000 V. 350 mls. Used **9.50**
- DYNAMOTOR: PE73-C 24 V. Brand new. **7.95**
- APN-1 TRANSCEIVER: 418-462 mcs. 24 V. input. Has FM wobbler and necessary sweeps. Fair cond. WITH schematic, less tubes. **\$5.95**
- APQ-2 TRANSMITTER: UHF. Freq. range 375-575 mcs. Has silver plated tuning cavity. Uses pair of 388 doorknob tubes in final. Great for UHF experimentation or 420 meter ham or citizens' band. Good cond., less tubes. **\$7.50**
- A STEAL AT THIS LOW PRICE..... **\$7.50**
- BC-221 FREQUENCY METER CASE: Wood or metal. Good cond. Ea. **\$2.95**
- BC-375 TUNING UNIT: NEW! Excluding TU-5 ONLY **\$3.50**

METERS! OUR BARGAIN SPECIALS!

- 0-200 amp. AC 4 in. rd. Weston. CT ratio. 200:5. Only **\$4.50**
- 0-100 VDC movement with 20-0-20 scale. 2 in. sq. Simpson. Used **2.25**
- 0-20 Kilovolt DC 3 in. rd. Westinghouse. FS equals 1 ma. Use external multiplier. Only **4.95**
- 0-50 amp. AC 2 in. sq. Triplett. **2.99**
- 0-25 MADC 2 in. rd. Weston **2.99**
- 0-2 amp. RF 2 in. rd. Thermocouple type. **2.99**
- 0-9 amp. RF 2 in. rd. Westinghouse. **2.99**

TS-16 APN SIGNAL GENERATOR: Used with radio-aircraft altimeter for checking and aligning sets. Complete. Excel. cond. **\$39.95**

All orders F.O.B. Los Angeles. 25% deposit required. All items subject to prior sale.

COLUMBIA ELECTRONIC SALES
 522 South San Pedro Street
 LOS ANGELES 13, CALIFORNIA

forced concrete bases, the largest of which measures 19'x19'x11'6" and weighs 185 tons. The whole system, including both the towers and curtains, was designed with a minimum safety factor of three to meet a wind pressure corresponding to an indicated velocity of 120 miles per hour and an ice coating of half an inch thickness on all members.

Each array may be reversed or slewed either side by remote control from the main transmitter room by means of motor-driven switches mounted in weatherproof enclosures, erected on poles at the base of each array. Either of the two short-wave transmitters can be connected to any one of the transmission lines by means of manually-operated four-pole, double-throw switches of special design, assembled on frames in the antenna-switching room at the rear of the transmitter building.

While for normal operation, the programs of the International Service of the CBC are fed to the Sackville station by wire lines from Montreal, as a measure of protection, in case of line failure, sufficient studio facilities have been provided to permit program originations from the transmitter station itself.

Although Canada "aims" her short-wave broadcasts primarily at certain countries or areas, letters arrive at the Radio-Canada Building in Montreal from the earth's four corners, testifying to the strength of Canada's voice and the international interest in Canadian affairs.

Six years ago (in 1945), the late Prime Minister, Mr. Mackenzie King, inaugurated the CBC International Service and his first remarks were addressed appropriately to Canada's armed forces "serving on and beyond the seas." Mr. King spoke of the historic importance of the nation's new short-wave service, neatly summing up the reasons why it was brought into being: "It will bring the voice of Canada to her own sons and daughters in

other lands. It will also bring Canada into closer contact with other countries. . . . Tonight, Canada enters the world radio arena."

More than 150,000 letters from listeners the world over have been received since the International Service began; and the letters arrive regularly now at a rate of between 3000 and 4000 a month.

The amount of news, political commentaries, semi-political talks and general informative material varies with the country for which the broadcast is intended. This applies to musical and dramatic content, as well; but few of these straight entertainment programs go out. In the over-all picture, 30 per-cent of programs sent out daily by Radio Canada is news; 20 per-cent political commentaries; about 13 per-cent semi-political talks, and approximately 26 per-cent general programs projecting Canada and Canadians. The remainder, roughly 10 per-cent, is composed of programs for young people and children, music, drama, and audience-mail programs.

CBC's National Service depends chiefly on radio license fees for its livelihood, while the International Service depends entirely on special appropriations by Parliament. The International Service works closely with the Department of External Affairs.

Each month, Radio Canada publishes a program schedule—one for European listeners in English, French, Dutch, Danish, Norwegian, Swedish, Finnish, German, Italian, Czech, and Russian; the other for Latin-American and Caribbean listeners in Spanish, Portuguese, English, French, and Dutch. The combined circulation of this free schedule is nearing the 100,000 mark and is still growing. The program schedule is available direct from International Service, P.O. Box 7000, Montreal, Quebec, Canada.

Latest schedule of the International Service of CBC, effective September 2, 1951, is as follows:

European Service—0850-1130, CKNC,

Transmitter building of Radio-Canada's International Service, located at Sackville, New Brunswick, is a modern two and a half story structure of reinforced concrete. Two 50 kw. short-wave transmitters are used and the antenna arrays are all of the multi-element curtain type. For normal operation, the programs of the International Service of the CBC are fed to the Sackville station by wire lines from Montreal. As a measure of protection, in case of line failure, sufficient studio facilities have been provided in the transmitter building so that programs can originate on the spot.



SPACE was at a premium
**...YET EFFICIENCY
 HAD TO BE HIGH**



THAT'S WHY GRAY CHOSE SELETRON!

There's no room in The Gray Manufacturing Company desk model Audiograph* Electronic Sound Writer for components without a big payload factor.

Gray engineers found SELETRON's tiny new selenium rectifier No. 16Y2 a powerhouse of efficiency for all its half-inch square cell size, and incorporated it into the Audiograph's compact design. . . It functions direct at 120 volts to operate the back spacer. No. 16Y2 is rated at 130V input, 100V output, .050 output amps. Weighs less than half an ounce!

Millions of dependable SELETRON Selenium Rectifiers are in service. They are available for every purpose from the miniatures used in radio, TV and other electronic circuits, all the way up to the giant stack assemblies required for heavy industrial purposes.

SELETRON engineers are successful in solving rectification problems. Write us today without obligation. . . And have you our new 16 page rectifier guide for handy reference? Please request Bulletin 104-N-9

*Audiograph, T.M. of The Gray Mfg. Co., Hartford, Conn.



**SELETRON DIVISION
 RADIO RECEPTOR COMPANY, Inc.**
Since 1922 In Radio and Electronics

SALES DEPARTMENT, 251 WEST 19TH STREET, NEW YORK 11, N. Y. • FACTORY, 84 NORTH 9TH STREET, BROOKLYN 11, N. Y.

**Now... Get ALL Your DRIVERS
 FROM VACO**

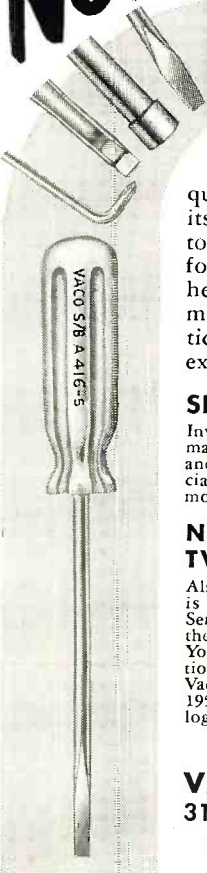

Only Vaco offers you the complete, fine quality line of drivers that daily is proving its superiority in service shops and on factory production lines. . . in terms of performance at low cost. Made of specially heat treated chrome vanadium blades mounted in break-proof, shock-proof plastic handles, Vaco drivers are the choice of experts in TV and radio.

SPECIAL RADIO AND TV DRIVERS

Investigate Vaco's new non-metallic aligners, non-magnetic beryllium copper focalizer screw drivers and other unusual products. They are made especially for radio and TV and have proved themselves most practical in delicate adjustment work.

NEW 27 PIECE TV SERVICE KIT

Also available from Vaco is a new 27-piece TV Service Kit made up at the request of TV men. You'll find a full description of this kit and other Vaco products in the new 1951 Vaco 3-color catalog. Send for it, today.



At Your Supplier or Write to:

VACO PRODUCTS COMPANY
 317 East Ontario Street, Chicago 11

In Canada: Vaco-Lynn Products Co. Inc.,
 1212 Notre Dame St., W., Montreal 3, Que.

IF YOU BUY, SELL OR INSTALL TV ANTENNAS
 YOU KNOW THE COST OF A DISSATISFIED
 CUSTOMER. ONE CALL-BACK TO REPAIR OR
 REPLACE A FAULTY ANTENNA IMMEDIATELY
 REDUCES OR ELIMINATES YOUR PROFIT.
 MORE THAN 1 MILLION TROUBLE-FREE
 WALSCO ANTENNAS ARE INSTALLED
 THROUGHOUT THE NATION. JOBBERS,
 DEALERS, SERVICEMEN TRUST THE QUALITY
 OF WALSCO ANTENNAS TO GIVE CUSTOMERS
 LASTING SERVICE AND OUTSTANDING PER-
 FORMANCE AT A FAIR PRICE. USE ANY ONE
 OF THE FAMOUS WALSCO MODELS... IT'S
 THE PRODUCT OF THE LEADER. TO BE SURE,
 SPECIFY WALSCO.

WALTER L. SCHOTT CO.
 3225 Exposition Place, Los Angeles 18, Calif.



VIBRATORS!
By every test

ATR

is Best!

ATR

AUTO RADIO VIBRATORS

have Ceramic Stack Spacers



Free

A COMPLETE LINE OF VIBRATORS . . .

Designed for Use in Standard Vibrator-Operated Auto Radio Receivers. Built with Precision Construction, featuring Ceramic Stack Spacers for Longer Lasting Life.

Backed by more than 19 years of experience in Vibrator Design, Development, and Manufacturing.

ATR PIONEERED IN THE VIBRATOR FIELD.

NEW MODELS NEW DESIGNS
NEW LITERATURE

"A" Battery Eliminator, DC-AC Inverters
Auto Radio Vibrators

See your folder or write factory

ATR

AMERICAN TELEVISION & RADIO CO.
Quality Products Since 1931
SAINT PAUL 1, MINNESOTA—U.S.A.

CKCX; 1130-1515, CKNC, CKCS; 1515-1530, CKCS; 1530-1545, CKCS, CHOL; 1545-1600, CHOL; 1600-1630, CHOL, CKLO; 1630-1645, CHOL; 1645-1835, CKCS, CHOL. *Caribbean and Latin American Service*—1950-2050, CKCX, CKRA; 2050-2105, CKRA; 2105-2240, CKRA, CKLO (*English* at 2105-2135). *Australasian Service*—2300-2335 (*except Sat., Sun.*), CHOL, CKLO; 0340-0450 (*Sun. and Wed. only*), CHOL, CKLO. Stations are CKNC, 17.82; CKCS, 15.32; CKCX, 15.19; CKRA, 11.76; CHOL, 11.72, and CKLO, 9.63.

Our best wishes for the future go to the International Service as it sends the *Voice of Canada*, sounding loud and clear along the international channels of short-wave broadcasting, carrying a definite, emphatic message from a Western democracy—our Good Neighbor to the North!

* * *

Good Reports

Arne Skoog, DX Editor, *Radio Sweden*, recently asked for comments from listeners in answer to the question: "What makes one reception report better than the other?" The first reply quoted by *Radio Sweden* was from the secretary of the Danish DX Club, Mr. Rabe.

First of all, according to Mr. Rabe, the report should be readable—whether written in pen and ink or on a typewriter. And it also should be easy to survey. Another important point of the question, says Mr. Rabe, is the extent of a report. He points out that it should not be longer than necessary, as the staffs of radio stations seldom have the time to read "long novels" written by DX-ers. However, there should be adequate details concerning the date, time, frequency or wavelength, and some excerpts from the program itself to prove reception of the station reported; and some comments as to the technical quality, such as strength, readability, and interference. There also should be reference to the type of receiver used and number of tubes, and kind of antenna. Finally, Mr. Rabe believes radio stations also like comments on the program content heard, and probably also "suggestions and proposals."

Mr. Skoog cited on a broadcast that in Sweden almost every DX club issues printed report forms (in Swedish and *English*) which "make all reports from their members readable, easy to survey, complete in details, and yet limited in length; in other words, these printed forms will make 'perfect' reports, according to Mr. Rabe's outline," Mr. Skoog commented.

Anyone else having views on this subject can express them by writing direct to DX Editor, *Radio Sweden*, Stockholm 7, Sweden.

* * *

"Berne" List

By this time, the 16th Edition of the Frequency List (commonly known as "the Berne List") should have been published by the International Telecommunication Union, Palais Wilson, Geneva, Switzerland. For price and other details, write direct to the Union.

WORLD famous

ANTENNAS

ELINCOR

SEND FOR LITERATURE

ELECTRONIC INDICATOR CORP.

67 N. 11th ST. • BROOKLYN 11, N. Y.

STAY ON THE AIR
WHEN POWER FAILS...with
an ONAN Electric Plant



AUTOMATIC START & STOP

Model 10EL, 10KW A.C.

When storms, floods, or fires interrupt electricity and force you off the air, you lose listeners and income. Guard against loss, assure vital public service during emergencies by installing an Onan Electric Plant. Onan Standby Electric plants serve many network and private stations. Automatic models to 35,000 watts.

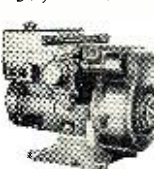

PORTABLE ELECTRIC PLANTS FOR MOBILE RADIO USES
Supply A.C. power for broadcasting at scene of events. Light in weight. Can be carried by hand or in trunk of car. A.C. models: 400 to 3,000 watts.

Write for FREE Folder

D. W. ONAN & SONS INC.
4814 University Avenue
Minneapolis 14, Minneapolis

RADIO & TELEVISION NEWS

Cost should be around 120 Swiss francs, the Union estimated to me recently.

Club Notes

USA—DX enthusiasts in Piketon, Ohio, have started a new club known as "The United Short Wave Listeners of the World" (USWLW); when this was compiled, the club had upwards of 20 members. Harold Buchert is president of the group and Patrick Crandell is treasurer. QRA is USWLW, Box 76, Piketon, Ohio.

The United 49-ers Radio Society recently held its annual meeting at the home of President Edward Broome, Vincentown, N. J.

At the recent annual convention-outing of the Newark News Radio Club, "The Man of the Year" award was made to Vice-President John W. Reichert by Les Kraemer, chairman of the club's awards committee. The award is in the form of a handsome, engraved plaque, donated each year by Vice-President Harold Robinson. It goes to the member who, in the committee's opinion, has done the most for the club during the past year. Irving R. Potts, editor of NNRC's Bulletin, says: "Vice-President Reichert, one of the founders of the NNRC back in 1927, as a member, director, and officer has been an indefatigable worker for the club ever since its inception. John is the type of tireless and loyal member responsible for the club's success down through the years." Incidentally, NNRC has just announced the appointment of Ernest L. Norman, Pompton Lakes, N. J., and LeRoy Waite, Ballston Spa, N. Y., to the club's editorial staff; Ernest will assist Editor Carroll H. Weyrich of the Broadcast Band Section and will be in charge of members' reports, while Roy will cooperate with Editor Sheldon Dunham of the Amateur or Ham Section.

* * *

This Month's Schedules

Albania—Radio Tirana is reported heard on 5.825 relaying m.w. service to closedown 1700; bad modulation (Short Wave News, London)

Anglo-Egyptian Sudan—A Swedish listener in NATTUGGLAN, Sweden, reports hearing Radio Omdurman on 17.950 around 1400.

Argentina — LRX, 9.660, Buenos Aires, heard after TGN A signs off 2230. (Cox, Ala.) This one noted around 1900 announcing "LRU, LRX, LRX1, Radio El Mundo." (Machwart, Mich.) LRT, 11.84, Tucuman, can be heard mornings to 0900 or later. (Stark, Texas) LRA, 17.720, noted with SIRA program in Spanish when tuned 1020. (Ferguson, N.C.) LRA, Radio del Estrado, 6.065, Buenos Aires, has been logged to closing 2355 with signature tune "Lights Out," followed by the Argentina National Anthem. (Cushen, N. Z.)

Azores—Ponta Delgada, 4.845, noted signing on 1600 with clock chiming the hour. (Pearce, England) Noted on the 11.090 channel from tuning 1439 to 1500 sign-off. (Machwart, Mich.)

We're Practically Giving the Stuff Away at These Prices!

LATEST 30 TUBE—630 TV CHASSIS—Ready to Work

STANDARD BRAND TUBES
Receiving • Special Purpose
Television

All Guaranteed

VR90	1.40	317C	8.89	813	7.95
VR150	1.40	331	1.95	814	3.90
CGJ	5.85	221A	.99	815	2.95
2A4G	4.84	331B	1.18	827R	8.95
2B3	4.35	331B	1.22	830B	3.74
1B29	4.69	274B	1.50	832	6.95
2C31	1.63	276A	9.75	837	1.36
2C32	1.63	632B	8.25	838	3.75
2C26	.24	304TH	11.95	841	.44
3C40	6.50	304TH	11.95	843	.37
2A2	27.85	371B	2.30	845	27.75
2E32	1.59	393A	9.50	864	.35
2J21A	9.50	417A	9.25	865	1.35
2A4	11.40	417A	4.25	869	2.39
2J26	36.50	446A	1.15	872A	2.39
2J27	36.50	446B	6.95	876	.57
2J30	37.51	465A	2.58	879	1.30
2J33	36.50	507AX	9.50	885	1.69
2J34	47.95	517L	19.50	954	.24
2K32	34.75	532/1B32	3.79	956	.48
2V3G	.96	615	2.15	974	.39
2K27/879	1.75	615A	1.22	974A	.95
3A4	.54	703A	7.89	959	1.15
3C24	2.19	704A	7.89	991	.37
3C28	10.50	705A	12.25	1005	1.00
3D23	4.75	707A	4.69	1616	1.85
4B25	8.75	708A	4.69	1616	1.85
4C23	4.23	708B	11.95	1625	.48
5BP1	4.85	715A	6.95	1626	.47
1A6	1.09	714Y	11.95	1629	.39
15E	1.09	715C	19.95	1630	.95
15R	4.95	718AY	48.50	1633	.72
5F52	4.45	732A	4.85	1639	1.35
24R	4.95	718CY	48.50	1641	.95
RK34	5.25	718DY	48.50	1642	.95
53A	1.50	719A	1.65	2031	1.69
RK72	.55	720E1	15.95	2031	.94
HF100	11.95	721A	5.69	8012	1.25
F153A	1.80	722A	2.50	8475	1.28
VT158	13.95	725A	9.95	8020	5.85
203A	5.49	800	1.95	9004	.75
205B	1.59	801A	1.95	9006	.75
311	.74	803	2.95	9006	.75
217A	7.95	805	3.94	7193	.34

TV TUBES—All Black

Sheldon, Zetka & Standards only

14" rect.	523.25	16" rect. or rd.	531.95
17" rect.	37.49	19" rd. metal	51.50
20" rect.	49.95		

Factory Guaranteed—Individually Boxed

Extra Discounts—25 or more 5%; 100 or more 10%

024A	.64	6BA6	.79	TN7	1.10
1A7	1.10	6BC5	1.18	7N7	1.10
1A7GT	1.10	6BC5	.99	7Y4	.89
1B3GT	1.22	6BD6	1.35	7Z4	.84
1B3GT/25S	1.51	6BE3	1.45	7Z4	.84
1C8	.74	6BG6G	1.94	12AARGT	1.10
1C7G	.74	6BH6	.99	12AL5	1.19
1D7G	.74	6B16	2.15	12AR5	.90
1D8GT	1.00	6BN6	1.59	12AT7	1.32
1F4	.74	6BQ6GT	1.44	12AU7	1.09
1F5G	.74	6C5G	1.45	12B6	.89
1G4GT	.74	6C6B	.99	12BA6	.84
1G6	.74	6CD6G	2.99	12BB6	.84
1G7G	.74	6E5B	1.00	12BF7	1.99
1L4	.74	6F6G	.90	12C8	.89
1LA6	1.30	6G6G	1.32	12H6	.89
1L5	1.19	6H6	.79	12SGT	.99
1L6B	1.30	6J6/6J5GT	.59	12J7GT	1.10
1L85	1.00	816	1.36	12K8Y	1.32
1L9	1.00	817G or GT	.81	12L6	.89
1N5GT	1.00	818G or GT	1.49	12SA7GT	1.08
1R5	.99	8K5G	.75	12SF5	.90
1S4	.99	8L6	1.45	12SGT	1.11
1S5	.89	8K7	.82	12SGT	1.12
1T4	1.00	8K8	1.48	12SH7GT	1.10
1U3	.89	8L6	1.45	12SHT	.82
1U5	.89	8L6GA	1.98	12SK7GT	.89
1V	.75	8L7/6L7GT	1.19	12SL7GT	1.20
1X2-1X2A	1.49	8M7/8N7GT	1.15	12SL7GT	1.49
2A3	1.49	607GT	1.15	12SQ7GT	.89
2A4C	.84	616G	1.28	12SR7	.89
2A5GT	.44	6R7	.90	12SR7	.89
2A7	.44	684	1.32	14A4F	1.09
2A8	.44	688	.92	15A7GT	.99
3A3GT	2.49	6S7 or GT	1.00	15B6	1.09
304	.89	6S87Y	1.19	14B8	1.10
305	1.15	6SC7	.99	14C7	.99
306	.99	6SD7	1.23	14D7	1.23
3V4	.99	6SF7	.99	14F8	1.09
5T4	1.72	6SG7	.99	14Q7	1.09
5U4C	.89	6SH7 or GT	.84	14R7	1.27
5V4G	1.05	6S17 or GT	.90	14W7	1.27
5W4	.83	6SK7 or GT	.76	19B6G	3.00
5Y4	.89	6S7GT	1.18	19T6	1.34
5Y3GT	.62	6SN7GT	.95	25B06GT	1.59
5Y4G	.75	6SQ7GT	.92	25L6GT	.89
5Z3G	1.09	6SR7	1.45	25W4GT	1.00
5Z4	1.18	6SS7	.79	25Z6GT	.74
6A6	1.32	6T8	1.39	28D7	1.29
6A7A	1.19	6U7GT	1.23	30A5	1.23
6A7B	1.39	6V4GT or GT	.99	32L7GT	1.59
6A7C	1.36	6W4GT	.66	33A5	1.09
6A7G	1.19	6W6GT	.99	33B7GT	.89
6A7G/8	1.29	6X5GT	.99	33W4	.62
6A7G/7	1.60	6X5GT	.74	33V4	1.01
6A7G/6	.79	6X6GT	.84	34A5	.89
6A7G/5	1.59	6X6GT	.84	39/44	.79
6A7G/4	1.19	7A7	.89	43	1.09
6A7G/3	.89	7B7	.89	47	1.09
6A7G/2	.84	7B7A	.89	47	1.44
6A7G/1	.92	7B6	.89	50A5	1.04
6A8	.95	7C4	1.49	50B5	.99
6A78	5.39	7C6	1.19	50L6GT	.84
6A76	.72	7C6	.99	56	.89
6A55GT	1.21	7D6	1.01	56	.89
6A7G/8	.85	7E2	.99	56	.89
6A7G/7	1.31	7F7	1.01	76	.89
6A7G/6	.74	7B7	1.79	80	.89
6B4G	1.50	7G7	.99	85	1.09
6B7	1.21	7H7	.99	85	1.09
6H8	1.49	7J7	1.48	11N7R	2.50

Battery Operated Signal Tracer Kit
Complete with steel cabinet, speaker, 3 tubes, all other components, and easy-to-follow instructions. (Less Batteries) **\$9.95**

TERMS: 20% cash with order, balance C.O.D. Prices F.O.B., New York City warehouse. Min. order \$5. NOTE: Availability of merchandise subject to prior sale. Prices subject to change without notice.

STEVE-EL ELECTRONICS CORP.

Dept. N-9, 65 Reade St., New York 7, N. Y. • COrlandt 7-0086 • Free Catalog

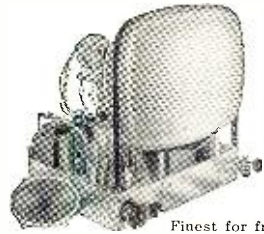

Nickel plated chassis. All molded, high quality condensers, and molded sockets. All standard brand tubes. Pretested before shipment. Complete with hardware.

Finest for fringe area reception. R.C.A. Licensed. Takes all picture tubes from 16" to 24" round or rectangular.

Complete with 12" R.C.A. Speaker and with Hi-Gain Standard Coil Tuner. (Less C.R. Tube) **\$133.50**

Available with DuMont Input Tuner FM Radio. (Less C.R. Tube) **\$138.50**

Chassis Mounting Bracket for Picture Tube \$4.95 Extra.

PARTS SPECIALS

Controls	F P Type Condensers
1 Meg w/sw 3/4" Shaft...54c	Nationally Famous Brands
500 K w/sw 3/4" Shaft...54c	20x20x100-20/20 x .51c
1 Meg w/FP Switch	1" Knurl Shaft...49c
1" Knurl Shaft...49c	500 Mfd x 15V...66c
10K w/sw 3/4" Shaft...39c	50x20x100...37c
100K w/sw 3/4" Shaft...39c	20x50V...59c
100K Control	Buy 10 Assorted-Save
250K Control	10%
3/4" Milled Shaft...24c	Tubular Electrolytics
3/4" Milled Shaft...24c	Nationally Advertised
500K Control 2" Shaft...26c	8 Mfd-150 V...19c
Stand 4 Prong 6 Volt.	10 Mfd-150 V...24c
Ea.\$1.19	40/20-150 V...37c
T.V.—H.V. Cartwheel	25 Mfd-25 V...19c
500 Mmf. 10KV...49c	Buy 10 Assorted & Save
500 Mmf. 20KV...69c	10%
Famous Make P.M. Speakers	TLA Type Oil Filled Condenser
Alnico	4 Mfd 600 V...\$1.55
#5 Each or more	Bathub Condenser
4" \$1.59 \$1.44	Buy 20 Assorted & Save
6" 1.92 1.73	10%
8" 3.49 3.05	.01-600 V...18c
10" 5.39 4.99	.03-600 V...15c
12" 6.85 6.17	15-600 V...35c
P.M. Speakers with 50L6 Output Tx.	.25-600 V...40c
Each 10 or More	300 Ohm Twin Lead
4" \$2.10 \$1.90	10 ft.\$ 2.89
5" \$2.20 2.00	1000 ft.24.95
EXTRA SPECIAL	Sockets
8" Dynamic Speaker 450 ohm field with 50L6 output tx.	Min. Pin
Each 10 or More	Wafer
\$2.69 \$2.45	Min. 7 Pin
Replacement Output Transformers	Octal Molded...12c 1.05
for 50L6, 3Q, 354, 6K6, 6V6, 6F6	Loctal Wafer
Each.49c	.5c .45
Push-Pull Output Transformers	Loss
for 50L6, 25L6, 6K6, 6V6, 6F6	Wire Wound Resistors
Each.49c	5 Watt...17c Ea.
Phono Motors	Buy 25 Assorted & Save
78 R.P.M. with Turntable	10c. Minimum 5 of a type
Ea. \$2.49	Ohms
Mica Kits	Ohms
10 Assorted...89c	12 100 500
100 Assorted...\$6.95	28 200 500
Ceramic Kits	75 300 6K
10 Assorted...79c	90 450
100 Assorted...\$5.95	10 Watt
Resistor Kit	Ohms
10 Assorted...49c	1.5 26.7 300
100 Assorted...\$3.79	3-78 50 450
Paper Tubular Kits	18-2 86
10 Assorted...79c	22.5 100 2K
25 Assorted...\$3.79	23.1 150 3500
Webster Chicago Automatic 3-Speed Record Changer	25.3 300 Tipped 7K
Type 100 Series. Plays 12, 10 or 7 inch records at 33 1/3, 45 or 78 R.P.M. Needle-Tip (included) for standard or micro-groove records.\$24.50	26.6 150 10K
	28 Watt
	Ohms
	2 124 11K
	7 230 20K
	25 Watt 1500
	Ohms
	2 240 20K
	5 300 20K



WEBSTER CHICAGO Automatic 3-Speed RECORD CHANGER

Type 100 Series. Plays 12, 10 or 7 inch records at 33 1/3, 45 or 78 R.P.M. Needle-Tip (included) for standard or micro-groove records.\$24.50

Mica Condensers
All Standard Advertised Brands. 1/2 and Postage Stamp
Sizes Each .50c-.10c and 20c.

Price Each	.50	.10
Size	Size	Size
2 Mmf	30 Mmf	70 Mmf
5 "	33 "	70 "
7 "	40 "	"
10 "	45 "	"
12 "	50 "	"
15 "	60 "	"
18 "	70 "	"
20 "	75 "	"
25 "	100 "	"
30 "	150 "	"
40 "	200 "	"
50 "	250 "	"
60 "	300 "	"
70 "	400 "	"
80 "	500 "	"
100 "	600 "	"
150 "	700 "	"
200 "	800 "	"
300 "	900 "	"
400 "	1000 "	"
500 "	1100 "	"
600 "	1200 "	"
700 "	1300 "	"
800 "	1400 "	"
90		

TRIPLE-PLAY EXTRA SPECIAL!

BC-223 Transmitter with marine-freq. tuning unit, PE-55 12v Dynamotor, Connecting card between the two, and schematic and instruction sheet. Repairable condition. As is. \$49.50

SUPER-SENSITIVE RELAY

WESTON SENSITROL, coil sensitivity only 10 microamps! Built like meter. At two AC line swings over into permanent magnet which grips it to close contacts rated 1 ampere. Perfectly damped; vibration will not close contacts. Built-in reset relay unclashes contacts when 12 to 24 volts AC or DC is momentarily applied to reset leads. The Sensitrol works directly from photocells, thermocouples, or any source of minute current. No electronic amplifier needed! Now you can make a control device that consumes no power until it is triggered. Brand new. Here is a \$12.95 \$69.50 device for only.

THE HEART OF COLLIN'S TCS

3-Gang condenser assembly with 4" precision dial etched 1.5-12 mc in 3 bands plus reference scale, with triangular plastic headline indicator. 50:1 ratio drive assembly. Tuning lock. Two side spaced 250 mmf and one double-spaced 260 mmf sections, all ceramic insulated. Overall 7 long x 4 3/4 x 4 3/4. New from bulk spares. With schematic TCS-12 xmtr. \$3.49

PORTABLE POWER

Look at These Combination Kits!

- 2 volt, 30 amp. hour wet cell BB-54. Light-weight transparent plastic. Non-spill. Fibrite separators. 3-ball hydrometer, 4" x 3" x 5 1/2" high overall. Shipped dry, with filling and charging instructions.
- 2 volt synchronous Vibrator. No tube needed. 2 volt charger, 1.15 v, 50/60 cy in. High quality unit, uses step-down transformer and dry-disc rectifier, with pilot lamp in output to indicate and regulate charging rate. With instructions. Eyedropper-type meter.
- 3 BB-54 and new box CH-291 made for them. Set-up gives you 6 volts, for ONLY.

COMMAND EQUIPMENT

With free dope sheets and schematics.

- RECEIVERS**
- BC-454. 3-6 mc. Used. Checked OK. \$7.95
Same less tube cover plate. 7.45
BC-455. 6-9 mc. NEW \$12.95, GOOD USED. 7.95
- COMMAND TRANSMITTERS**
- BC-457. 4-5.3 mc. excellent used. \$ 4.95
BC-458. 5-3.7 mc. excellent used. 5.95
T-23/ARC-5. Excellent used. 24.95
Good used, less tubes. 7.95
MD-7/ARC-5. Push-pull mod. excellent. 9.95
MOD BC-456. Brand New \$5.95, Excellent used 2.49
As is, for parts. 1.29
- 274N PLUG.** 7-prong male plug to fit back of command recvr. and xmtrs. This is the same plug as used in the racks. NEW, each, 21c; five for. . . \$1.00
- Local Control Adaptor parts for 274N or ARC-5 recvr.** Exact pot, switch, knobs, etched plate, and instruction dial. Ready to mount. \$1.29
Spline tuning knob.79c
- OIL FILLED 4x8 mfd.** 600 v. condenser, in one case, common ground, with mtg hooks, as used in Army Super-Pro power supply. NEW. \$2.89

4 USES—4 DOLLARS

The most versatile dynamotor in surplus! The best dynamotor for conversion to 6v. Multiple windings! After conversion you get choice of 180 or 350 v at 50 MA or 200 v at 100 MA. With audio modulation, no mechanical work. Or use it as a 2:1 or 1:2 step-up or step-down transformer for DC voltage! Changes 6 to 12, or 12 to 6 A or 12 to 6 V. Or use it as a GENERATOR. Turn with motor, get 12 v DC at 12.6 A or 24 v DC at 6.3 A, plus high voltage. Includes easily removable self-contained 800:1 sealed-in-oil gear reduction unit. Complete dope sheet furnished. BRAND NEW. \$4.00

FREQ. METER BC-438. Easily converted to precision lab. xtal calibrated heterodyne-type freq. meter and sig. gen. 20 to 440 mc. With audio modulation. We furnish simple instructions for conversion and calibration. Has power supply, tubes, and lab. standard xtal. Start where your BC-221 or LM ends. Excellent cond., complete as described. \$27.50
While they last.

METALLIC MINE DETECTOR SCR 625 with BA-38 battery. For non-ferrous or ferrous metals. Also operates under water. Brand new, export backed. \$59.50

GUARANTEED HOTTEST 10-METER RECEIVER! Money back if you disagree! Easily adapted for mobile or AC. Instructions and schematic furnished. Also contains a built-in self-contained 800:1 sealed-in-oil gear reduction unit. Receives AM and FM. 27-38.9 mc. Double-conversion superhet. Self-contained speaker. BC-223. Only \$39.50

A-27 PHANTOM ANTENNA. Use on 160 or 80 meters or for marine freq. 2 to 4.3 mc. Contains: 1 Var. Capacitor, xmtr. type, 18-157 mmfd., 2-fixed Vitrohm plaque wire-wound, non-inductive resistors, 12 ohms (5%), 40 w. In neat metal case with calibration charts and instruction manual. \$1.59
Brand New

RF AND AF SIGNAL TRACER BZ-5. Tiny dual vibrator gives beautiful 1400 CPS tone with harmonics to 40 mc. NEW, with schematic and instr. 79c

R-9A/APN-4. 160-meter Loran receiver plus high (for scope) and low voltage power supply. Three chans. Tunable 1.6-3.3 mc. 1 chan., tunable 7.58-11.75 mc. With schematic and instructions for 60 cy. \$4.50
Excellent used, less tubes.

SURPRISE! Many valuable items thrown into big surprise package. 95c

WANTED!

Your Spare Surplus Equipment and Tubes, Dynamotors, Recvrs., Xmtrs., Test Equipment. Send List, stating condition and rock bottom price.

G.L. ELECTRONICS

905 S. Vermont Ave., Los Angeles 6, Calif.
All Prices F.O.B. Los Angeles
Calif. Buyers Add Sales Tax.

SCHEMATICS—CONVERSIONS FOR SURPLUS GEAR

NEW LIST! MANY ADDITIONS!

Send stamped, self addressed envelope for List B. Add 25c for chart explaining AN nomenclature.

R. E. BOX 1220
GOODHEART BEVERLY HILLS, CAL.

Signs on 1400. Fairs, England, informs *Radio Australia* that the callsign CSA93 has been assigned to 4.845; CSA92 is the callsign on 11.090.

Belgian Congo—OTC2, Leopoldville, appears to have settled down on 9.767 again for its evening (*EST*) programs (*English* news at 2200), but at times may use approximately 9.745 during certain broadcasts.

OTM1, 6.295, Leopoldville, heard signing on 0000; news in French at start; weak lately. (Cox, Ala.)

Bolivia—La Paz, 9.497, recently was noted with *English* announcement, by woman, at 2115 closedown. (Stark, Texas)

British Guiana — Although ZFY, Georgetown, still lists its frequency as 6.000, it actually is heard on 5.985.

Bulgaria—*Radio Sofia* announces *English* for Europe for 1500-1515 and 1600-1630 on 6.070, and for North America 1900-1930, 0000-0015 on 15.330. (Pearce, England, others) Asks for reports to *English Announcer*, Radio Sofia, Sofia, Bulgaria. (Cox, Ala.) Has strong signal evenings (*EST*) when relaying Moscow's North American (*English*) programs over 15.330.

Burma—*World Radio Society*, Sweden, says Rangoon is heard on 6.035 around 0030-0050 with QRM from London, Monte Carlo, and Stuttgart.

Cape Verde Islands—Noted moved from 5.928 to approximately 5.885; signs on 1530 and closes 1700; news in Portuguese 1630. (Pearce, England)

Ceylon—Commercial Service of *Radio Ceylon*, 11.975, noted with "Voice of America" relay 1030-1100. (Pearce, England; Rosenauer, Calif.) Noted on the 15.12 channel 0100 with music. (Pearce, England) The 15.12 outlet signs on 2045 with recording of "Strike Up the Band;" good level in Wisconsin. (Shanahan)

Chile—CE1190 has moved from 11.900 to 11.938, heard mornings, afternoons, evenings (*EST*); has QRM at times from harmonic of the Dominican Republic station, 11.940; also CWQRM. (Stark, Texas; Bellington, N. Y.)

CE1174, 11.7435, Santiago, noted around 0730 with music and announcements in Spanish; CE960, 9.593, Santiago, heard 2050 with concert; identified in Spanish 2115. (Russell, Calif.) CE1515, 15.15, Santiago, noted 2058 with announcement of "Radio Corporacion, Santiago de Chile." (Machwart, Mich.)

China—*Radio Peking* sent letter and full schedule by airmail; schedule was listed *English* 0430-0500, 640 kc., 700 kc., 720 kc., 6.100, 10.260, 11.690, 15.060;

0830-0900, 700 kc., 11.690, 15.060; 1700-1730, 640 kc., 700 kc., 720 kc., 10.260, 6.100, 11.690, 15.060. Listed standard Chinese at dictation speed 1030-1200 on 640 kc., 700 kc., 720 kc., 6.100, 7.500, 9.040, 10.260, 11.690, 15.060. (Pearce, England)

Dilg, Calif., others, have noted a Communist Chinese on 15.17 (probably old Chungking?) lately in parallel with *Radio Peking* with *English* 0430-0500; however, during the 0835-0900 *English* period, the 15.17 outlet has Chinese. Dilg reports the 9.040 channel recently was at good level when tuned 0735; North Shansi?

Russell, Calif., reports a Communist Chinese on 5.989 (Nanking or Shanghai?) with woman commentator in Chinese 0800.

Chungking, 6.155, has fair signal 0800. (Dilg, Calif.) Nanking's 31-m. outlet was measured recently as 9.733. (Hutchins, Radio Australia) Unidentified Communist Chinese station noted recently on 10.670 at 0800-0950 sign-off; some CWQRM but had good level in Calif. (Rosenauer)

Colombia—HJEX, 7.054, Cali. "Radio Pacifico," heard recently 2200-2230 with recorded music; identified 2200; verified by card in 30 days; usually has excellent signal. (Whitman, Ill., others) Relays m.w. HJER, 1030 kc.; QRA is Radio Pacifico, Apartado Nacional 559, Cali, Colombia, South America; is on until 0000 or later. (Sklenar, Cuba)

HJCX, 6.02, noted signing off 0302 with *English* announcement by man, followed by short announcement in Spanish, then anthem; strong and with no QRM. (Bellington, N. Y.)

Curacao—PJC, 5.010, Willemstad, noted on a Monday 2000 with Dutch folk songs and announcements in *English*. (Ferguson, N. C.) The 2.46 outlet, PJC2, is heard but at weak level. QSL lists frequencies as 2.46 and 5.017, both with 3 kw. (Bellington, N. Y.)

Czechoslovakia — Prague, 11.875, heard 1930-1958 with *English*. (Patterson, Ga.) Noted with *English* in progress 1607 on 9.55, 11.875. (Bellington, N. Y.) Prague is on a new channel of 6.095 at 1200 in German. (Radio Australia, others)

Dominican Republic—HI2T, 9.740, noted recently on a Wednesday with *English* in progress 2220. (Ferguson, N. C.) And on a Friday on both 5.97, 9.735; may also be on Mondays. (Bellington, N. Y.) This *English* feature usually starts 2200.

Ecuador—Officials of HCJB, Quito, write—"At present, HCJB is in the

Say you saw it in RADIO & TELEVISION NEWS

PEN-OSCIL-LITE

Extremely convenient test oscillator for all radio servicing; alignment • Small as a pen • Self powered • Range from 700 cycles audio to over 600 megacycles u.h.f. • Output from zero to 125 v. • Low in cost • Used by Signal Corps • Write for information.

GENERAL TEST EQUIPMENT
38 Argyle Buffalo 22, N. Y.

RHOMBIC TV ANTENNAS

Power Gains of 100 and More for consistent extreme fringe area reception.

BUILD YOUR OWN—USE OUR RHOMBIC TV ANTENNA BOOK

- Complete Simplified Building instructions and drawings for 24 sizes.
 - Use and Design of open wire lines.
 - Information on Stacked Rhombics.
- \$1.50 Richard J. Buchan
Postpaid WOTJF Bricelyn, Minn.

NOW! The KLIPZON MINI-PROD CONNECTOR

CLIPS ONTO WIRES IN
HARD-TO-REACH PLACES

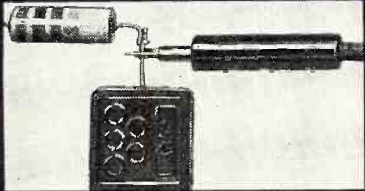

NEEDLE-SHARP POINT
PIERCES INSULATION



FITS INTO PIN-JACKS



CLIPS ONTO MINIATURE
SOCKET TERMINALS



IT'S A MINIATURE CLIP . . . it's
a MINIATURE TEST PROD, too!
STREAMLINED FOR MODERN ELECTRONICS

FOR
LABORATORY,
SERVICE SHOP,
PRODUCTION
LINE
TESTING

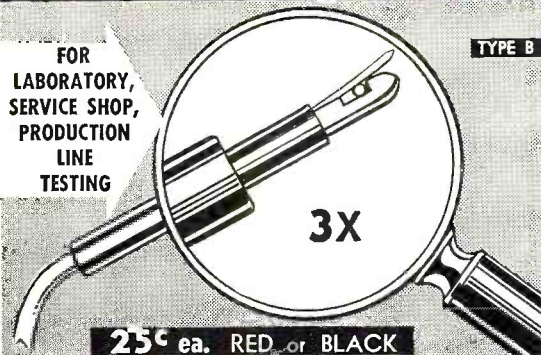

TYPE B

25¢ ea. RED or BLACK

Only one year old, but over
250,000 in service!

Used by Leading TV, RADIO and
ELECTRONIC MANUFACTURERS

SOLD NATIONALLY BY MORE THAN
600 RADIO PARTS DISTRIBUTORS

Ask for KLIPZONS at YOUR Local Distributor
Write for FREE FOLDER #12 describing
MINI-PRODS and Other KLIPZON Products.

FITS INTO BINDING POSTS

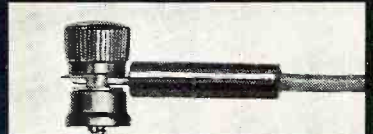

CLIPS ONTO CLOSE SPACED
LUGS AND TERMINALS



CONNECT EASILY TO EACH OTHER
FOR EXTENSION OF LEADS

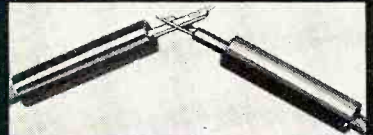

EASY TO WIRE. SOLDERLESS
CONNECTION IN PLASTIC HANDLE

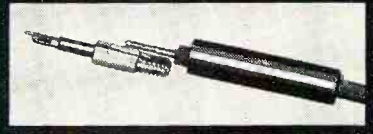

Engineers

UNITED TECHNICAL LABORATORIES

Manufacturers

MORRISTOWN, N. J.

New TRAV-ELECTRIC Model

STURDY
MINIATURE
CONVERTER

2½" x 2½" x 3½"
60 CYCLE AC.
40 WATTS
110 VOLTS

Just
plug into
CIGAR
LIGHTER



operates

Radios, Shavers

Turn-

Tables

Small

Dictating

Machines

etc.

\$15.95

Model
6-1160

List Price

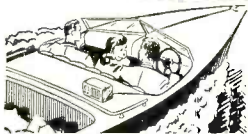

IN BOATS



IN THE CAR - IN THE TRUCK



AT PICNICS - OUTINGS



ELECTRIC SHAVER



PORTABLE PHONOGRAPH



Dictating MACHINE

Terado Company-1068 Raymond, St. Paul 8, Minn.

SAVE

THAT GOOD LOOKING OLD CONSOLE—
REPLACE YOUR OBSOLETE RADIO
with a modern, easily installed

ESPEY AM/FM CHASSIS

and your favorite console is "right-up-to-date"

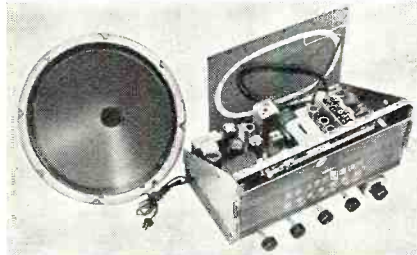

Rated an excellent
instrument by Ameri-
ca's foremost elec-
tronic engineers. Fully
licensed under
RCA and Hazeltine
patents. The photo
shows the Espey
Model 511-B, sup-
plied ready to play.
Equipped with tubes,
antenna, speaker,
and all necessary
hardware for mount-
ing.

NEW FEATURES—Improved Frequency modulation circuit, drift
compensated • 12 tubes plus rectifier, and pre-amplifier
pick-up tubes • 4 dual purpose tubes • High quality AM-
FM reception • Push-pull beam power audio output 10
watts • Switch for easy changing to crystal or variable
reluctance pick-ups • Multi-tap audio output transformer
supplying 4—8—500 ohms.

Makers of fine radios since 1928.

Write for literature RN
for complete speci-
fications on Model 511-B
and others.

ESPEY
MANUFACTURING COMPANY, INC.
TEL. TRafalgar 9-7000
528 EAST 72nd STREET, NEW YORK 21, N. Y.

COMPLETE TRAINING

FOR BETTER JOBS
in Radio-Electronics



ONLY
\$14

5 MONTHS TO PAY!

Here are three world-famous books so thoroughly covering radio theory, troubleshooting and servicing methods; so clearly explaining every phase of the work that, with a minimum of time, you'll soon be able to handle repairs on any type of Radio-Electronic Equipment and qualify for better jobs, bigger pay checks! You couldn't get a finer, more complete or easier to understand training course AT ANY PRICE. Remember! These are the same Ghirardi books that were more widely used for wartime radio-electronic training than any other books or courses of their type!

Ghirardi's BIG-3

RADIO SERVICING LIBRARY

These three big books contain a total of 3016 pages and 1214 illustrations covering the complete range of basic radio-electronic and service subjects:

1—RADIO PHYSICS COURSE

Complete basic training for beginners. Makes even the most difficult subjects easy to understand! 972 pages, 508 illus. Price \$5.00.

2—MODERN RADIO SERVICING

The 1300-Page book that teaches you to work by truly professional methods. Explains all about test instruments, how to use them, circuit analysis, component replacements and dozens of other subjects. 1300 pages, 706 illus. Price \$5.00.

3—RADIO TROUBLESHOOTER'S HANDBOOK

The great Ghirardi book that cuts service time in half on most jobs. Tells what to do, exactly, how to do it in making quick repairs on over 4800 specific radio models. 744 manual-size pages, \$5.00.

Let A. A. Ghirardi train you for Radio-Electronics—AT AN ABSOLUTE MINIMUM COST! Starting with the fundamentals of basic electricity, these 3 books take you step-by-step through the efficient radio testing, adjustment and repair procedures that mean time saving and more profitable work. Hundreds of working data on tubes, color codes, transformers, resistors, capacitors, record changers and other components help you solve job snags in record time.

NEW LOW PRICE . . . Easy Terms

Bought singly, the books in this fact-packed library would cost you \$15. Under this special offer, you save \$1 and also have the privilege of paying in easy monthly installments, while you use the books. No waiting for monthly lessons. You learn fast—and you learn right!

10 DAYS' MONEY BACK EXAMINATION

Dept. RN-91, RINEHART BOOKS, Inc.,
Technical Division,
232 Madison Ave., New York 16, N. Y.

Send me GHIRARDI'S BIG-3 Radio-Electronics Library. I enclose \$2 as my first instalment and will send you \$3 a month for four months until the total special price of only \$14 is paid. It is understood I may read the books for 10 days. Then, if not satisfactory, I will return them postage paid and you agree to refund my \$2 and cancel the remaining instalments. (Outside U.S.A. send full cash with order. Same 10-day return privilege.)

Name.....
Address.....
City, Zone, State.....
Occupation.....

midst of an Advance Program, which we trust will greatly alter the technical picture by giving us an increased power to a total of 100 kw. output." (Baughn, Ky.) Saylor, Va., says HCJB is announcing 15.100 for its 19-m. outlet instead of (listed) 15.115.

Egypt—Cairo, 10.055, appears to have a religious (Arabic) service on Thursdays around 1915-2030; other days, too? (Bellington, N. Y.) Also heard by Oskay, N. J. SUX, 7.866, Cairo, heard 1618 by Cox, Ala., with native chanting; weak and much QRM.

Falkland Islands—Port Stanley is operating on 3.440 at 1300-1400; output is 300 watts. (WRH Bulletin) Can anyone confirm this and is the station actually ever "heard?"—KRB.

France—Paris noted signing off nightly 2030 or 9.560. (Lucas, N. Y.) Noted on 7.24 and 11.70 with Arabic 1700-1730; best on 11.70. (Bellington, N. Y.)

French Equatorial Africa—"Radio AEF" can be heard on 17.845 and 9.960 at 1300-1500 sign-off; programs consist of music and news in French. (Lundin, Sweden)

French Guinea—Overseas sources report Radio Guinea, Conakry, heard on 10.230 weekdays only at 0715-0730. Short Wave News, London, says has had CWQRM.

French West Africa—Schedules from Radio Dakar lists 11.885 and 15.346 at 1400-1600 beamed to France; lists news in French for 0215, 0245, 0700, 0730, 1415, 1515, 1755; English for 1400-1415; lists morning program as 0200-0300, 0600-0830; evening program as 1300-1800. (Talbert, Australia) Machwart, Mich., says English news is now 1410-1420 instead of 1400-1410.

Germany—Baden-Baden, 6.320, noted 0020 with symphony music; weak, high noise level. (Cox, Ala.)

Radio Free Europe, 6.130, noted with call 1700 followed by broadcast in an Eastern European language; noted another day 1345 with bell tolling, call, then program in Bulgarian. Stuttgart, 6.030, heard with closing announcements in English and German 1809. "Hier ist Deutschlandsender Berlin." 6.115, noted 0045, German news 0100, at 1400 with symphony music; is heard parallel on 7.150 but that channel is jammed at times; is in Russian Sector and gives news and views of "the Deutsche Demokratische Republik." Hamburg, 7.29, noted 0810-0900 with light music; another day 0110 with early morning music; often has programs from Cologne when gives call "Nordwestdeutscher Rundfunk Cologne;" ordinarily, call is "Nordwestdeutscher Rundfunk Hamburg." (Pearce, England) Hamburg, 7.29, and Osterloog, 11.795, noted parallel 1810 with piano music; 11.795 strong around 2300. (Bellington, N. Y.) Wants reports, especially on the 11.759 (Osterloog) outlet. (Pearce)

Leipzig, 9.728, seems to sign on regularly now around 2227; good level. (Ferguson, N. C.; Bellington, N. Y.)

(Continued on page 149)

Pulse Generator

(Continued from page 42)

of 0.2 microsecond is equivalent to a signal of $2 \times .2$ or

$$1,000,000/.4 = 2,500,000 \text{ cps}$$

If the pulse is rectangular, as shown, it may contain harmonics as high as the tenth or twentieth, or to 25 or 50 megacycles, respectively, depending on the "sharpness" of the pulse.

Rise time is the time it takes a pulse to rise from 10% to 90% of its peak value, as shown in Fig. 10A.

Decay time is the time it takes a pulse to fall from 90% to 10% of its peak value, and thus is similar to "rise time" (see Fig. 10A).

Pulse width is the time of duration of the pulse, or of a rectangular pulse whose energy and peak power equal those of the pulse. (See Fig. 10B). For rounded pulses, such as those obtained from the pulse generator, the pulse width may usually be taken as the time of duration between the 70% points on the slopes of the pulse.

Pulse bandwidth is the bandwidth in a circuit necessary to transmit the pulse. As we have seen, if the pulse is considered to be a half-cycle of a square wave, this bandwidth may be equal to the tenth or twentieth harmonic of the equivalent frequency of the pulse, and may be quite high if the pulse width is small. Pulse bandwidth may also be determined by the following relationship:

$$F_{bw} = \frac{1}{2}t$$

where F_{bw} is the bandwidth in megacycles and t is the rise or decay time. Either rise or decay time may be used, whichever is smaller.

Although considerable advanced mathematics may be required for a detailed analysis and study of pulsed waveforms, a basic understanding is quite easy to obtain without advanced mathematical explanations. Experimental work with pulses and pulse shaping and forming circuits offers a fertile field for the interested experimenter, and a pulse generator capable of delivering pulses suitable for even advanced experimental work is not too difficult to construct.

Construction details on a waveform clipper that can be used separately or in conjunction with this generator will be given next month. —50—

Fig. 10.

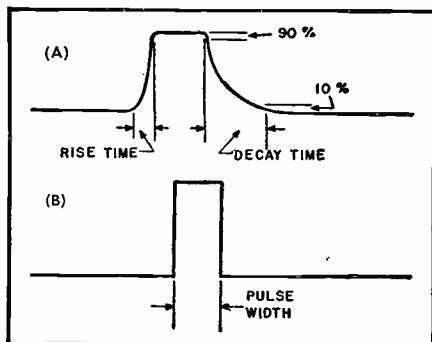

Audio Simplified (Continued from page 50)

Present thinking is that the total harmonic distortion should not exceed 2 per-cent. From general experience it seems reasonable to rate an amplifier having 10 per-cent intermodulation with 2 per-cent harmonic distortion as fair quality, and one having 5 per-cent intermodulation with 2 per-cent harmonic distortion as good.

Although no standards have as yet been determined, it is known that a good system should have good transient as well as steady-state characteristics, and should have no undamped vibrations when a square-wave is applied to the input of the system. In general the system should have a smooth response with a minimum number of peaks and dips in the response curve, for good reproduction of transients. This factor is especially important in the electromechanical components of the system (particularly in the loudspeaker).

Flutter and wow in the reproduction of disc and magnetic recordings can be serious and annoying—the ear being quite sensitive to this type of distortion, since it seldom occurs in nature. Under some conditions the ear can detect the presence of as little as 0.001 per-cent flutter. The best systems which are being used in broadcast and recording studios at the present time maintain constant speed to about 0.1 per-cent or better. About 1 per-cent flutter or wow is acceptable for a home reproducing system.

The above distortion information is summarized in Table 1, which gives a list of the various electronic distortions and their acceptable limits, and also the type of signal with which the amount of this distortion may be detected. When these factors are taken into account in the design and setup of the reproducing system, and the various distortion limits carefully considered, the audio experimenter's aim of almost-perfect sound reproduction will have come a long way toward realization.

(To be continued)



Real values on hard-to-obtain items

Give These Items a Careful Look!

TRANSFORMERS-CHOKES:

5V, 25A. Pri. 115V, 60 cy. AC. A real rugged job excellent for 304TL—4-250A etc. Limited quantity. Only \$4.50 ea.

2.5V, 10A. 10KV insulation. Suitable for 866, 836, etc. Reduced to \$3.39 ea.

10H, 200 ma choke. Hermetically-sealed steel case. Also has hum-bucking tap. A beautiful item only \$1.98.

10H, 50 ma choke. Strap mounting. Handy for dozens of applications. Reg. 98c, reduced to 65c. Charger or fil. trans. Pri. 110V, 60 cycle. Secondary, 9-10-11-12-13 volts @ 1.2 A. Fully cased. A buy at \$1.49.

Fil. transf. Pri. 110V, 60 cy AC. Sec. 24V @ .6A. only \$1.95 ea.

Power Transf. 350-0-350 @ 70 ma. 5V @ 3A, 6.3 @ 3A. Pri. 110V, 60 cy, AC. Upright mtg. \$3.25 ea.

Power transf. Pri. 115V, AC, 60 cy. Sec. 520-0-520 @ 200 ma. \$5.25 ea.

Power transf. Pri. 115V, 60 cy. AC. Sec. 310-0-310 at 50 ma. Cased, upright mount. only \$1.95 ea.

Output transf. 50L6 to voice coil. 79c ea.

Choke, 6 henry, 200 ma. Strap mtg. only \$1.95 ea.

390-0-390 @ 300 ma. Pri. 115V, 60 cy, AC. 5V @ 3A, 5V @ 3A, 6.3V @ 1.6A, 6.3V @ 8A. Completely cased with external copper elect. shield. Made by RCA. Really a beautiful transf. A buy at \$7.95 ea.

450-0-450 @ 200 ma. Pri. 115V, 60 cy. AC. 5V @ 3A, 6.3 @ 5 amp. In shielded case. Only \$8.90 ea.

920-0-920 or 740-0-740 @ 200 ma. Primary 115 or 230V 60 cy. AC. Upright shielded case. Excellent for 807 RP or mod. Only \$10.80 ea.



NEW! PORTABLE GEIGER COUNTER

A small light-weight unit (2 pounds), with sensitivity that compares favorably with instruments many times its purchase price. Rugged and dependable and intended for professional use. Batteries used provide long life and low replacement cost. Each Geiger counter comes complete ready for use with instructions and radio-active ore sample for comparison tests. \$35.00

836 hi-vacuum rectifiers, 2 for \$1.50

FONE PATCH!

Now available, the superior new O-R, #6008 phone patch. Provides you with exactly what you need to patch your phone into transmitter or receiver. Featuring a hi-impedance input suitable for xt mike. Both hi and lo impedance outputs to insure proper match to your particular receiver. Unit is complete—"sure-fire"—ready to go to work for you. Only. \$4.95 ea.



PLUG SETS—SPECIAL PLUGS

Plug set for BC-645. (11 plugs.) NEW. only \$3.95 set
PE-103 plugs. NEW. 98c ea.
8 pr. female. Fits SCR-284 equip. 35c ea.
PLQ-103 for BC-348. NEW. 75c ea.
R8-ARN8. Two special plugs. \$1.00 set
Also, complete spares for BC-645

VACUUM TUBE SPECIALS

6SN7 \$1.32 net
6H699 net
8012 . . . UHF triode 1.50 ea.
WE-717A 1.00 ea.
WE-316A . . . Trans. doorknob.75 ea.
WE-388A . . . Large doorknob. 1.00 ea.
815 . . . twin-beam tet. 2.50 ea.
6L6 . . . metal 2.25 ea.
6L6G 1.95 ea.
6L6GA 1.95 ea.
1636 . . . VHF converter. 1.00 ea.
Hytron HY-61530 ea.



LOOK! NO HANDS!

This mike leaves both hands free for mobile QSO's. Fastens to operator by simple snap strap. Adjustable. Double action sw. operates push-to-talk or holds on. BRAND NEW only \$2.00 ea. POSTPAID in U.S.A. and CANADA.

NOW! POSITIVELY IDENTIFY U-235 IN THE FIELD!

O-R now offers you a simple and positive method for identifying U-235 . . . in the field! Save assaying charges—know what you have without delay. The kit contains all necessary chemicals, torch, etc., for treatment of specimens for examination under ultra-violet light. Kit also contains special "black light" tube, starter, switch, resistor and necessary hardware for excellent portable U-V source. This unit operates from 180 volts DC obtained from standard type B batteries. (Not supplied) Unit is very simple to assemble and complete instructions enable anyone to perform necessary operations leading to positive identification of Uranium 235 when present in the specimen.

Complete kit, (less batteries and housing) . . . only \$11.95 (shipped by express only).

U-V LIGHT SOURCE

8 watt ultra-violet light source. In kit form including Sylvania black-light tube, (for U-V light in the 3660 Angstrom unit region) ballast, starter, mounting panel, reflector, line cord/plug, hardware, instructions. An invaluable device for schools, labs, service shops, home workshop, etc. Here is a genuine value.

Complete kit, (less outer housing) . . . only \$4.95

SENSITIVE RELAY

Miniature type (1 1/2" overall) SP-ST contacts. Coil resistance 6500 ohms. (2 ma.) An excellent relay for voice control or model applications. Only \$1.50 ea.

Power Supply for Any 274-N Receiver

A shipment of the special transformers has just been received and this popular power supply is now once again available. Just plug it into the rear of your 274-N RECEIVER any model. Complete kit and black metal case, with ALL parts and diagrams. Simple and easy to build in a jiffy. Delivers 24 volts plus B voltage. No wiring changes to be made. Designed especially for the 274-N receiver. All necessary parts for conversion of rest of receiver also included. ONLY \$8.95.

TUNING KNOB for 274-N Receiver, 59c ea.

EE89 REPEATERS

See previous ads. Only a few left. NEW! Regularly \$9.95 ea. now \$6.95 ea.

SOUND-POWERED HANDSETS

Type TS-10—Brand new, limited quantity \$25.95 pair

HANDSET HANGER

Beautiful cast aluminum shell finished in black wrinkle. Takes all makes and models. An extremely useful, well-made item. only \$1.95 ea.

HS-24 HI-QUALITY HEADSETS

Made by W-E. Often used for BC monitoring. Each receiver same as receiver unit in TS-10. Can also be used as fine dynamic mike. Complete with cord and headband. only \$4.95

HV VACUUM CAPACITORS

VC-50 — 50 MMF \$ 3.95 ea.
VC-150 — 150 MMF 10.95 ea.
VC-200 — 200 MMF 13.95 ea.
All Brand New Merchandise—Excellent Values.

274N/ARC-5 ACCESSORIES

Mounting rack, holds three receivers. Easily modified for single receiver—NEW. only \$1.95 ea.
274N/ARC-5 Spline tuning knobs. 59c ea.
Same as above except with deluxe tuning crank 89c ea.
Tuning crank. Fits RU 16-17, BC 433 etc. for manual tuning 89c ea.

3 section control head for ARC/5 receivers \$2.25 ea.

CONDENSER TESTER

• One of our best sellers! Useful, versatile laboratory item, in kit form. Simple, and easy to build in less than an hour. Checks condenser leakage and continuity up to 8 megs. Will test any paper, electrolytic, mica or oil capacitor from 50 mmf. to 50 mfd. Self-contained power supply and neon bulb indicator with socket and bezel. Drilled metal cabinet. Complete instructions and diagrams included with each kit. Only \$5.00.



NOTE NEW ADDRESS!

Minimum order \$2.00. All items subject to prior sale. All prices subject to change without notice. 20% deposit must accompany all orders, balance C.O.D.

OFFENBACH & REIMUS CO.

1564 MARKET ST., SAN FRANCISCO, CALIF.

Colortone Television

IS PROUD TO ANNOUNCE A PRECISION ENGINEERED

COLOR

ADAPTER FOR ALL TV SETS NOW AVAILABLE

LIST PRICE **\$19.95**

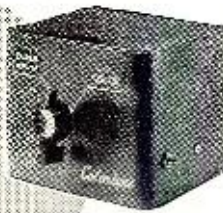

After two years of unending research, COLORTONE TELEVISION CO., INC., now brings you this precision engineered, low cost Color Adapter for all popular TV set models! For both electronic and mechanical color systems.

ATTENTION DEALERS: Be prepared to meet the unprecedented nation-wide demand for color television! Make no mistake about it—COLOR TV IS HERE TO STAY!

CALL, WRITE OR WIRE TODAY FOR COMPLETE DETAILS ON HOW YOU CAN BECOME FIRST IN YOUR AREA TO CONVERT TO BLACK & WHITE TV TO COLOR! FRANCHISE TERRITORIES OPEN — WRITE FOR PARTICULARS.

Color wheel and color wheel motors (official CBS specifications) available

Colortone Television Co., Inc.

238 William Street, New York 38, N. Y. • Cortlandt 7-5160

WANTED

YOUR SPARE SURPLUS EQUIPMENT
DYNAMOTORS • SELSYNS • AUTOSYNS • INVERTERS
TRANSMITTERS • RECEIVERS • TEST EQUIPMENT
Please send list stating condition and lowest price
No Quantity Too Small or Too Large!

C & H SALES COMPANY

Box 356-SR East Pasadena Station

Pasadena 8, California

MARK THESE VALUES!

6SN7 .79c Top Standard Brands Only 100% Guaranteed

1R3 .94c	6AG5 \$1.09	6J6 \$1.24	12AT7 \$1.29
5U4 .59c	6BG6 1.49	6T8 1.19	95T .29
6AL5 .49c	6BD6 1.29	12AU7 .84	Free List
6AU6 .65c	6CD6 2.19	25% Dep. Bal. C.O.D.	

SELL US YOUR SURPLUS TUBES F.O.B., New York City

MARK electronics 535 E. Tremont New York 57, N. Y.

RADIO COURSES

- RADIO OPERATING • CODE
 - RADIO SERVICING • ELECTRONICS
 - F.M. TELEVISION
 - PREPARATION FOR CIVILIAN, MARITIME, ARMY AND NAVY LICENSE REQUIREMENTS.
- Write for Catalog T.S.

YMCA

TRADE & TECH. SCHOOL

15 W. 63 St., N. Y. 23
ENdickoff 2-8117

TUBES Price - Slashed!

Receiving & Transmitting

RMA Guaranteed—Standard Brands

0A2\$1.59	0Z4\$.59	12AT7 ...\$1.19	TV PICTURE TUBES
0B21.69	1R589	12AU7 ...1.19	BLACK FACE
0C3/VR105 1.29	5U479	12BH7 ...1.19	10BP4 ..\$22.50
0D3/VR150 1.19	5V4 1.39	12SA779	12LP4 ..\$23.50
2E25A/	5Y349	12SK779	14BP4 ..\$24.50
HY65/ ..4.89	6AC7 1.29	12SQ769	16GP4 ..\$32.50
3EP15.39	6AG5 1.29	35A598	16HP4 ..\$32.50
3HP73.49	6AL579	35L689	17BP4 ..\$32.50
5FP147.89	6AU679	35W469	19AP4 ..\$36.50
7BP77.89	6B6G 1.89	35Y489	20CP4 ..\$39.50
7CP112.49	6BQ6 1.59	35Z559	24AP4 ..\$74.50
304TH12.49	6BN6 1.39	50A598	
304TL12.49	6BU6 1.59	50B598	
8032.49	6C589	50L675	
8052.99	6BG6 1.89		
8851.29	6BN6 1.39		
9052.29	6BQ6 1.59		
95429	6K759		
16241.49	6SA769		
162935	6SN7\$1.09		
719329	6V689		
80201.25	7C4/1203A .89		
90031.89			
900629			
GL471A79			
CK100579			

Minimum order: \$5.00. 25% deposit with order, balance C.O.D. Include postage with order. All merchandise subject to prior sales, F.O.B. New York, N. Y.

ELECTROLYTIC CONDENSERS

EA.	Per 10	Per 100
20 x 20-150V...S	.39	\$3.70
40 x 40-150V...	.45	4.30
50 x 30-150V...	.45	4.30
25-25V...	.19	1.50
20-250V...	.29	2.59
8-450V...	.39	3.69
10-450V...	.39	3.69
16-450V...	.59	5.99

All Guaranteed Fresh Stock!

Sensational Savings!

SPEAKERS

All Alnico V—Priced Extra Low

4" PM\$1.59	4" x 6" 1,500 ohm\$1.69
5" PM1.69	8" Auto 4-6 ohm2.89
4" x 6" PM 1.79	8" PM3.25
6" PM1.89	12" PM6.69
6" 62 ohms with output trans.. 2.79	

SPECIAL OFFER!

DEDUCT 5% from the price of any speaker in lots of 10 or more. Can be assorted.

GENUINE MOLDED CONDENSERS

Fresh Stock—All Mineral Oil Filled
100% Contigrid—Meets Jan C91 tests
ALL 600 VOLTS

Cap.	Per 10	Per 100
.001	\$.79	\$ 6.90
.002	.79	6.90
.005	.79	6.90
.01	.89	7.90
.02	.89	7.90
.05	1.09	9.90
.1	1.25	11.50

FREE: Write for catalog... tubes, parts and accessories for radio and TV! Also special electronic instruments catalog.

Fig. 2. Wiring diagram using the 228T1 horizontal deflection output and high voltage transformer. The balance of the diagram is identical with that shown in Fig. 1. The high voltage output obtained from this unit is 16,000 volts. Parts list shows the additions and changes in component values over those shown in Fig. 1.

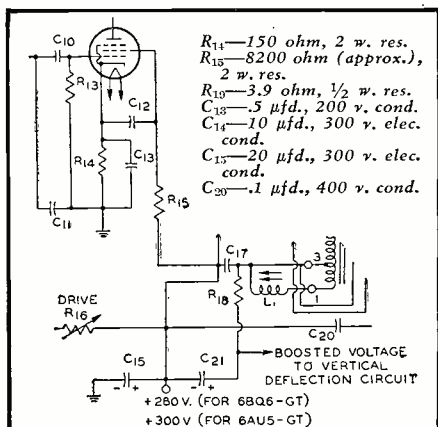

New TV Components

(Continued from page 51)

separate filament windings. One of these provides power to the filament of the rectifier tube for the high voltage supply and the other furnishes the power to the filament of the rectifier tube for the focusing voltage supply.

The 227T1 produces a maximum of 14,000 volts at no load and has been especially designed for use with the 14GP4 and 17GP4 picture tubes. It could be used, as mentioned before, with any other electrostatic focus picture tubes having a horizontal deflection angle of approximately 66 degrees. Fig. 1 is the circuit of the horizontal oscillator and deflection and high voltage system which uses this coil. The focusing voltage d.c. output obtained at no load, with the beam current and potentiometer adjusted for maximum output, is approximately 3800 volts.

The 228T1 operates at 16,000 volts at no load and is designed for the 17GP4, 20GP4, or other electrostatic focus types having a horizontal deflection angle of approximately 66 degrees. Fig. 2 shows the required changes in wiring when this unit is used instead of the 227T1. However, in this case the focusing voltage d.c. output at no load is 4400 volts.

The horizontal deflection output tube may be either a 6BQ6GT or a 6AU5GT in this circuit. When the 6BQ6GT is used, the "B" supply must be 280 volts. When the 6AU5GT is employed, a 300 volt "B" supply is required.

The third new unit in this recently-introduced series of components is the 211D1 deflecting yoke. It is a magnetic type which has been developed for use with rectangular picture tubes having neck diameters of 1 7/16", horizontal deflecting angles of 66 degrees, and diagonal angles of 70 degrees. A wiring diagram of this yoke is shown in Fig. 3.

Among the features claimed for this yoke is improved side and corner res-



THE ROSE COMPANY

BIGGER, EVEN BETTER THAN THE '51 EDITION!

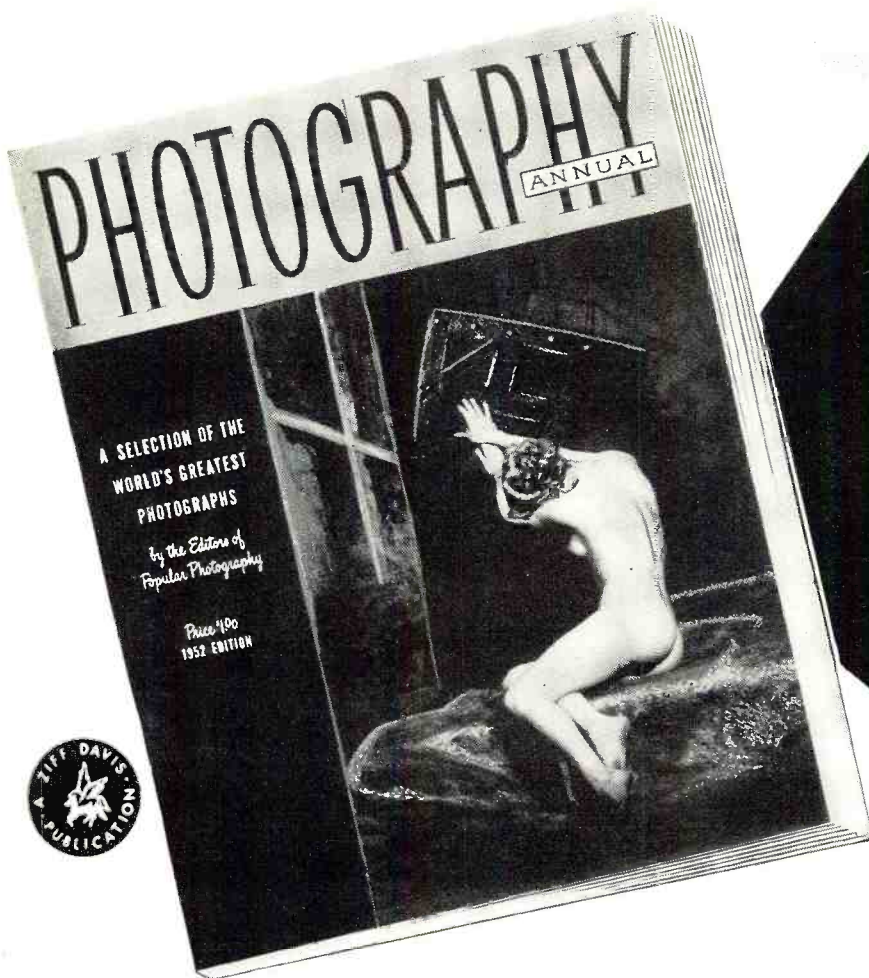

**HERE IS
Your
New**

PHOTOGRAPHY ANNUAL

- Beautiful Long Lasting Cover
- Special Color Features!
- Outstanding Photos!
- Top-notch Articles!

284 Pages Loaded With **NEW** Techniques On

- THE CAMERA
- THE FAST SHUTTER
- THE SLOW SHUTTER
- THE LARGE APERTURE
- THE SMALL APERTURE
- FOCUSING
- DARKROOM MAGIC
- PRINT TONING
- STORY-TELLING PICTURES
- PHOTO PROBLEMS
- FILTER EFFECTS
- ANGLES—HIGH AND LOW
- PUTTING THE SUN TO WORK
- PICTURES AFTER DARK
- THE CAMERA INDOORS
- LIGHTING THE PICTURE
- FLASH PHOTOGRAPHY
- TRICKS AND EFFECTS
- THE VERSATILE LENS
- THE FILM

Concise! Simple! Every technique discussed brilliantly clarified by photographic examples. Over 200 Photos!—Gorgeous Color! Exquisite Gravure!

PHOTOGRAPHY ANNUAL—1952 Edition—the year's best photography value!

IDEAL AS GIFTS!

NOW ON SALE

At Your Newsdealer—Camera Store—Bookshop

Publishers also of: POPULAR PHOTOGRAPHY • FLYING • RADIO & TELEVISION NEWS • RADIO-ELECTRONIC ENGINEERING EDITION OF RADIO & TELEVISION NEWS • MODERN BRIDE • FICTION GROUP • ZIFF-DAVIS COMICS

ZIFF-DAVIS PUBLISHING COMPANY—185 NORTH WABASH AVENUE, CHICAGO 1, ILLINOIS

September, 1951

137

SURP US

COAXIAL CONNECTORS

83-1AC \$.42	83-1R \$.40	83-22AP \$1.10
83-1AF .30	83-1RTY .65	83-22B .68
83-1F 1.30	83-1SP .50	83-22SP 1.15
83-1H .10	83-1SPN .50	83-168 .15
83-1J .80	83-1T 1.30	83-185 .15

FULL LINE OF JAN APPROVED COAXIAL CONNECTORS IN STOCK

UHF	N	BN	BNC
UG-7	UG-27A	UG-98	UG-171
UG-12	UG-29	UG-102	UG-175
UG-18	UG-30	UG-103	UG-176
UG-19	UG-34	UG-104	UG-185
UG-21	UG-37	UG-106	MX-195
UG-21B	UG-57	UG-108	UG-197
UG-22	UG-58	UG-109	UG-201
UG-22B	UG-85	UG-146	UG-206
UG-23	UG-86	UG-166	UG-236
UG-24	UG-87	UG-167	UG-245
UG-27	UG-88		UG-306

M-358 MC-277 PL-259A PL-325
M-359 MC-320 PL-274 SO-239
M-359A PL-258 PL-284 SO-264
M-360 PL-259 PL-293 TM-201

93-C 49120 D-163950 ES-685696-5
93-M 49121A D-166132 ES-689172-1

SOUND POWERED TELEPHONES
U. S. NAVY TYPE M HEAD AND CHEST SETS
U.S.I. A-260 W.E. D-173013
A.E. GL832BA0
ANY TYPE—\$14.88 EACH
TS-10 Type Handsets.....\$8.92 ea.

F. W. BRIDGE SELENIUM RECTIFIERS

AC Volts Input.....18	DC Volts Input.....40
DC Volts Out.....14.5	DC Volts Out.....34
1.3 Amps.....\$3.85	0.6 Amps.....\$4.60
2.4 Amps.....4.95	1.2 Amps.....5.95
6.6 Amps.....7.75	3.2 Amps.....8.95
13.0.....12.75	6.0.....15.50
17.5.....15.75	9.0.....17.50
26.....22.75	12.....26.95
39.....35.50	18.....32.50
52.....38.50	25.....42.50
70.....49.50	36.....55.50

130 VAC 1/2 WAVE STACKS

75MA...\$.88	150MA...\$1.30	250MA...\$1.75
100MA...1.10	200MA...1.57	400MA...2.60

GENERATORS

• Eclipse-Pioneer type 716-3A (Navy Model NEA-3A) Output—AC 115V 10.4A 800 to 1400 cy. 1g; DC 30 Volts 60 Amps. Brand New.....\$38.50
• Eclipse-Pioneer type 1235-1A. Output—30 Volts DC 15 Amps. Brand New—Original Packing \$15.50

METERS

3 MA DC 2 1/2" R—Simpson black scale.....\$3.35
500 Microamps, DC—2 1/2" round—Sun.....4.30
1 ma. DC Fan type—4" scale (rem. from equip) 3.95
500 ma. DC 2 1/2" R—General Electric.....2.95
2 amp. RF 2 1/2" Sq.—Simpson.....3.15
5 amp. AC 4 1/2" R—Simpson.....4.11
10 amp. RF 3 1/2" R—Simpson.....4.95
50 amp. AC 3 1/2" R—General Electric.....4.11
3 amp. RF 3 1/2" R—Weston.....6.00

OIL FILLED CONDENSERS

MFD	VDC	Price	MFD	VDC	Price
2	600	\$.45	1-1	2500	\$.69
4	600	1.65	32	2500	3.85
6	600	1.85	3x.2	4000	2.95
8	600	R'd 1.85	5000		4.88
8-8	600	R'd 1.95	.01-.03	6000	1.65
1	1000	.82	1045	16KV	4.70
2	1000	.89	.05	16KV	4.95
4	1000	1.85	.075	16KV	8.95
8	1000	2.45	.25	20KV	18.95
1	1500	.89	50	220VAC	4.95
4	1500	2.95	7	660VAC	4.25
1-1.5	2000	.87	8	660VAC	4.50
1	2000	1.95			

HIGH VOLTAGE TRANSFORMERS

G.E.—Pri. 115V 60 cy
Sec. 6250V 80 MA—12.5 KV Ins.....\$18.50
G.E.—Pri. 115V 60 cy. Sec. 6250/3850/2600V 56 MA
12.5 KV Ins.....\$18.50
Raytheon—Pri. 115V 60 cy. Sec. 8500/6450V CT 43
Ma Hermetically sealed.....\$22.50

CRYSTAL DIODES

1N21 \$1.19	1N23 \$1.49	1N34 \$.79
1N21A 1.69	1N23A 3.25	1N38 1.66
1N21B 4.00	1N23B 5.25	1N45 .94
1N22 1.09	1N27 1.79	1N52 1.05

SYNCHROS

Size 1, 3, 5, 6, 7 and 8 generators, motors, control transformers, differential generators, and differential motors in stock.

AY-101D	5G	N	C-78248
AY-120D	5N	X	C-78249
AY-130D	6DG	2J1F1	C-78410
1F	6G	2J1G1	C-78411
5B	7DG	2J1H1	C-78415
5CT	7G	C-44968-6	C-79331
5D	A	C-56701	C-78254
5DG	B	C-69405-2	C-78670
5F	M	C-69406-1	

SEND FOR COMPLETE LISTING SYNCHRO CAPACITORS IN STOCK

LECTRONIC RESEARCH LABS.

715 Arch St., Phila. 6, Pa.

Phones—Market 7-6771-2-3
All prices F.O.B. Phila.

Terms—Net 10 Days to well rated accounts or cash with order. Minimum order—\$3.00.

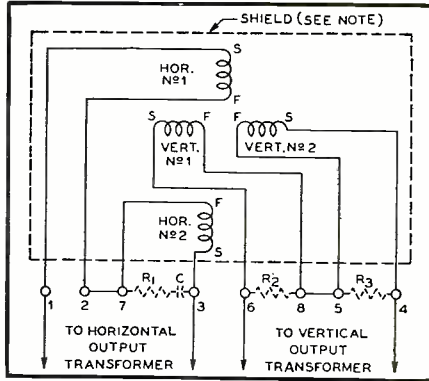

Fig. 3. Wiring diagram for the 211D1 deflecting yoke. Provision should be made for grounding the shield which is internally connected to the mounting bracket. The resistors and condensers shown are not supplied with the unit but the following values are suggested. R₁=1000 ohm, 1/2 w. res. ±10%; R₂, R₃=560 ohm, 1/2 w. res. ±10%; and C=62 μfd., 1500 v. cond. ±5%.

solution without sacrificing the ability to reproduce vertical and horizontal lines with a small amount of bowing. By utilizing a ferrite core, the yoke has both high deflection sensitivity and compactness.

It has been designed specifically for use with magnetic focus type horizontal deflection output and high voltage transformers (the 224T1 for 13,000-14,000 volt operation and the 225T1 for 15,000-16,000 volt use) and for the new electrostatic focus types described in this article.

Within the Industry

(Continued from page 26)

a vice-president of the *General Electric Company* on the president's staff and formerly head of the company's General Engineering and Consulting Laboratory, has retired after 32 years of service. He will enter the consulting engineering field with headquarters in Schenectady... **FRED ABRAMS** has been appointed head of the national Parts Sales-Service Division of *Emerson Radio and Phonograph Corporation*... *Jerrold Electronics Corporation* has named **SYDNEY J. MASS** to the post of sales manager and appointed **EDMUND D. LUCAS, JR.** as manager of advertising and public relations. Mr. Lucas was formerly associated with *Philco Corporation* where he was manager of publicity... **CARL E. SMITH**, formerly supervisor of equipment sales service for the Radio Tube Division, has been appointed supervisor of factory sales service for *Sylvania Electric Products Inc.*... **LT. GEN. ALBERT C. WEDEMAYER** has retired after 32 years of military service and has been named a vice-president and director of *Avco Manufacturing Corporation*... **PAUL V. GALVIN**, president of *Motorola Inc.*, was awarded an honorary Doctor of Laws degree by Loyola University, New Orleans for his service to his community and for operating his business in accordance with the "highest social principles"... **L. B.**

TUBES

RADIO & TELEVISION

Complete Line of
TOP STANDARD BRANDS

- RCA • G.E. • N.U.
- HYTRON • KENRAD
- RAYTHEON • SYLVANIA
- WESTINGHOUSE

Before You Buy, Check Our
LOW, LOW PRICES!

Our Prices Are Hard to Beat

IMMEDIATE SHIPMENT

Same Day Order Is Received

Remember! Manfred will always serve you lowest prices in critical times.

Convince Yourself!
Send for Our
PRICE LIST

MANNFRED ELECTRONICS CO.

136 Liberty St., N. Y. C. 6
Barclay 7-6565-6

TESCO

SINGLE REFLECTOR CONICALS

- 1259—Single Bay 3/8" elements. 3.19
- 1256—Single Bay 1/2" elements. 3.89
- 1254—Double Bay 3/8" elements. 6.68
- 1258—Double Bay 1/2" elements. 7.89
- 1257—Four Bay 3/8" elements. 14.89
- 1253—Four Bay 1/2" elements. 17.19

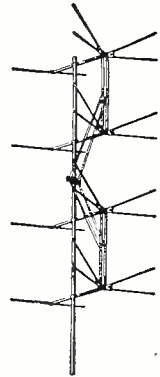
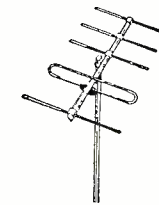

FIVE ELEMENT YAGI BEAMS

- 2002 to 2006—any lo channel..... 8.69
- 2007 to 2013—any hi channel..... 3.19
- 1236—Single Bay Twin-V..... 3.76
- 1237—Double Bay Twin-V..... 7.49
- 1231—Four Bay Conical..... 16.99
- 1230—Double Bay Conical..... 7.89
- 1243—Swift Rig Folded Hi Folded Low..... 3.89
- 1240—Single section conical—lots of 6..... 1.69
- 1244—Swift Rig Folded Hi Straight Low..... 3.49
- 1210—Deluxe Indoor Antenna..... 1.99
- 1860—Chimney Mount..... Dozen Lots 1.19
- 1905—3 1/2" Mast Snap-On Standoff..... Per 100 3.60
- 1873—3 1/2" Mast Standoff Insulator..... Per 100 5.50
- 1872—4" Nail-In Insulator..... Lots of 50 .02
- 1870—3 1/2" Wood Screw-Eye Insulator..... Lots of 50 .02
- 1229—Single Bay Conical..... 3.75
- 1861—5 Ft. 1 1/4" Diam. Galv. Steel Mast..... .82

Send for quantity prices and complete list

TELEVISION SUPPLY CO.

Box 13 Greenpoint Station Brooklyn, N. Y.

CALAMARAS, executive secretary of the National Electronic Distributors Association, has been named executive vice-president of the Association by the board of directors. In his new position he will represent NEDA in all government activity affecting the radio and television replacement parts industry . . . *Kay Electric Company* has promoted **LOUIS A. GARTEN** to the post of sales manager. He was formerly associated with *RCA International* . . . **OSCAR S. TYSON**, founder and chairman of the board of *O. S. Tyson and Company, Inc.*, passed away recently . . . **WILLIAM T. RAPP** is the new assistant vice-president of *Federal Telecommunication Laboratories, Inc.*, the research unit of the *International Telephone and Telegraph Corporation* . . . **RAY A. MORRIS** has been named chief engineer for *I.D.E.A.* of Indianapolis, manufacturers of the "Regency" booster. He was formerly associated with *Meissner, Ferrocart, and Guthman* . . . **PHIL NARDELLA**, formerly branch manager of *Harrison Radio's* Jamaica, N.Y. branch, has joined the industrial sales department of *Chanrose Distributors, Inc.* of Jamaica. He has been associated with the electronics distributor field for over fifteen years.

FREDERICK W. TIMMONS, JR. has been appointed sales manager for the Cathode-Ray Tube Division of the *Allen B. Du Mont Laboratories, Inc.*



He has been associated with *Du Mont* since 1946 and is well-known in the cathode-ray tube sales field. Since 1947 he has been active in the introduction and sale of large screen cathode-ray tubes to major television receiver manufacturers.

A native of Cambridge, Massachusetts, Mr. Timmons will make his headquarters at the company's cathode-ray tube plant in Allwood, New Jersey.

RAYTHEON MANUFACTURING COMPANY is building a \$2,000,000 factory at Waltham, Mass., which will house facilities for the manufacture of the company's line of power tubes. The new factory will permit the company to double its output of this type of tube . . . **EDWIN I. GUTHMAN & COMPANY, INC.**, has opened a new plant in Attica, Indiana for the manufacture of coils and other electronic components . . . **GENERAL ELECTRIC COMPANY** has announced that construction has begun on a new \$6,000,000 receiving tube plant in Anniston, Alabama. Over 2000 people will be employed when the plant's 150,000 square feet of floor space is fully activated . . . **TEL-A-RAY ENTERPRISES, INC.**, has purchased the Stemming District Tobacco Association Building in Henderson, Kentucky, and will use it for the production of television and FM antennas and

What'll You Have?

AN-104A Antenna—100-156 MC.....	\$ 2.00
AN-117 Whip Steel, 6 Ft.	1.50
AN-109A Whip Steel, 5 Ft. w/Base.....	1.50
AT-37A/AIT Stub—113-150 MC.....	5.95
AS-27/ARN-5 Ram's Horn, 110 MC. USED:	5.95
FL-8 Filter, 1020 cycle Audio Filter. USED:	1.50
Leg & Seat Assembly for Iland Generators..	3.50
CD-501 Cord for GN-45 Generator.....	2.00
MIR-9C Control Box f/RA-10 Rec. w/Plug. NEW: \$12.50 USED:	6.75
C-87/ART-13 Control Box f/ART-13 Trans. NEW: \$6.95 USED:	4.95
CD-318 Cord f/Throat or Lip Mikes.....	.59
CD-307 Cords 65" w/PL-55 & JK-26.....	.99
CD-604 Cord w/C-410 Trans. & PL-54 Plug..	.89
Head & Chest Set w/Plug for KE-8. USED:	2.95
Microphone & Headset, Dynamic type f/MARK 11: NEW: \$2.95 USED:	1.95
BC-375 Tuning Units—TU 5, 6, 7, 8, 9, 10, or 26 Each:	3.95
TA-12B Transmitter w/Tubes USED:	29.50
RA-10 CA or DA Receiver w/Tubes. USED:	17.95
BC-605 Amplifier ..NEW: \$ 5.95 USED:	3.95
BC-347 Amplifier w/Tube. NEW: 2.95 USED: 1.95	
BC-709 Amplifier ..NEW: 4.95 USED: 3.95	
C4/ARN-7 Control Box. NEW: 12.50 USED: 8.50	
BC-434 Control Box. NEW: 8.95 USED: 5.95	
BC-732 Localizer Control Box. NEW: \$2.95 USED: 1.95	
MC-211 Right Angle Adapter f/MC-215.....	.50
MC-215 Tuning Shaft for 274 N—96".....	2.00
MC-124 Tuning Shaft f/Radio Compass— 12 ft.	3.95
MC-163 Fairlead Clamp50
FA-10 Fairlead	1.00
BC-455 Comm. Receiver, 6-9.1 MC. USED:	7.95
BC-457 Comm. Transmitter, 4-5.3 MC. USED:	5.95
BC-458 Comm. Transmitter, 5.3-7 MC. USED:	5.95

BLOWERS:

115 Volt 60 cycle BLOWER (pictured), approx. 100 CFM Dis. 2 1/4" intake; 2" outlet. Quiet running. Motor size: 2 1/2" x 3 1/4". NEW—not Gov't surplus. Order No. RN-520..



\$7.99

DUAL BLOWER—Same as RN-520 above, except has blower assembly on each side of motor. Order No. RN-800.....

WHIP ANTENNA EQUIPMENT

MAST BASES—INSULATED:

MP-48 Base (Illustrated at right) Insulated type with heavy coil spring. Requires 1 3/8" mounting hole. Weight: 11 lbs. Price.....	\$4.95
MP-132 Base (Illustrated at left) 1" heavy coil spring. 2" insulator. Overall length: 11 1/2". Weight: 2 1/2 lbs. Price.....	\$3.95
MP-22 Base—Spring action direction of bracket. 4" x 6" mounting. Price.....	\$2.95

MAST SECTIONS FOR ABOVE BASES:

Tubular steel, copper coated, painted, in 3 foot sections, screw-in type. MS-53 can be used to make any length. with MS-52-51-50-49 for taper. Price, each, for any section

(Ea.) **\$0.50**

WHIP ANTENNA—9 1/2 Ft. rigid mount. Uses three screw-in sections: MS-49-50-51 and rigid mount w/ antenna connection.....

GUY CABLE

Regular Aircraft Control Cable, 3/16" x 7x7—49 Strands galvanized weatherproof, 320 lb. Test. Ideal for television or radio mast guying. Prices:

2 3/4¢ per Ft.—1000 Ft. or more: 2 1/2¢ per Ft.

TELEVISION ROTOR MOTOR CONTROL CABLE—4 WIRE, FLAT.....

6-VOLT POWER SUPPLY

VIBRATOR TYPE—6 Volt DC input; output 230 Volt DC 50 MA. filtered w/tube. Size: 6 1/2" x 4" x 5 1/2" Price

\$6.95

VIBRATOR TYPE—6 Volt DC input; output 230 Volt DC 50 MA.—not filtered—w/tube. Ideal for Command Receiver operation as receiver is filtered internally. Size: 4 1/2" x 4 1/4" x 3 3/4"

Address Dept. RN • Minimum Order \$2.00 • Prices F.O.B., Lima • 25% Deposit on C.O.D. Orders

FAIR RADIO SALES

132 SOUTH MAIN ST.
LIMA, OHIO

Read RADIO & TELEVISION NEWS Every Month

OFFICIAL MILITARY 35mm SLIDES



RUSSIAN T-34 TANK

AVAILABLE NOW AT SENSATIONAL LOW COST!

Authentic Army Air Force reconditioned 35 mm. slides of military equipment of all nations. Gov't. surplus, brand new B. & W. slides, each heavy 4 ply mounted, numbered, and fully identified. Terrific bargain at only 3¢ each, available in sets of 50 slides in any of three classifications: 1. NAVAL SHIPS, 2. MERCHANT SHIPS, 3. ARMORED VEHICLES. When ordering, please specify which classification is desired. Set of 50 SLIDES. U.S.A.

\$3.00

BC-223 TRANSMITTER

30 Watt Transmitter with Crystal or MO control on four pre-selected channels. CW, MCV cover frequency range 2000-5200 KC by use of plug-in coils. Complete with tubes and choice of one Tuning Unit (listed below), Less Mtg. Prices: NEW: \$32.50.

USED (Gov't Reconditioned).....

\$26.50

CABLE—Trans. to Power Supply.....

TUNING UNITS: TU-17—2000-3000 KC. TU-18—3000-4500 KC.; TU-25—3500-5250 KC. **\$3.50 EACH**

SPARE TUBE KIT in metal box, f/BC-223... **\$4.95**

PE-125 POWER SUPPLY f/BC-223—12/24 Volt input; output 500 Volt 150 MA.NEW: **\$14.95**

SPARE VIBRATOR & TUBE KIT f/PE-125... **\$5.95**

SHOCK MOUNTING for PE-125..... **\$1.50**

FT-173 MOUNTING for BC-223..... **\$2.50**

BC-223 TRANSMITTER—Incomplete, for parts. No front panel or meters. Price—As is:..... **\$4.95**

3/4 RPM ANTENNA ROTATOR MOTOR

High torque, reversible motor—operates directly from 110 Volt 60 cycle by use of condenser. Light weight, quiet running, ruggedly built, positive stop, easily mounted. Normally operates from 110 Volt 400 cycle. Complete—with instructions. NEW....

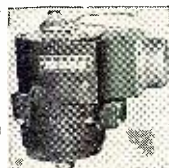

\$4.95

10 MFD 400 Volt Cond. **\$1.00.** SPDT Switch: **35¢**

DYNAMOTORS:

DYNAMOTOR AND BLOWER

9 Volts DC input, output 450 Volts 60 MA., 4500 RPM. At 6 Volts DC input, output 260 Volts 65 MA., 2000 RPM. Price

INPUT: OUTPUT: STOCK No.: PRICE:

12 V. DC 220 V. 70 MA. DM-24 **\$6.95**

12 V. DC 220 V. 100 MA. DM-18 **4.95**

12 or 24 V. DC 440 V. 200 MA. & 220 V. 100 MA. D-104 **9.95**

12 V. DC 600 V. 300 MA. BD-86 **7.95**

14 V. DC 500 V. 500 MA. PE-59 **14.95**

PERMANENT MAGNET FIELD DYNAMOTORS:

12 or 24 V. DC 275 V. 110 MA. USA/0516 **\$3.95**

12 or 24 V. DC 500 V. 50 MA. USA/0515 **2.95**

@ 6 V. DC 240 V. 50 MA.

Tell Us Your Dynamotor, Inverter, & Motor Needs!

AERIAL WIRE:

Aerial Wire—Phosphorus Bronze #16 Stranded. 200 lb. test. Weatherproof. 150 feet on Reel. RL-3 with Clips

\$1.50

RECEIVER (MOBILE-BOAT-AIRCRAFT)

BENDIX RA-10 RECEIVER—8 Tube Set covering frequency range 150 to 1100 KC. and 2000 to 10000 KC. in four bands by use of remote control unit. Set size: 18 1/2" L. x 10 1/2" W. x 8 3/4" H. Wt. 32 1/2 lbs. Comes complete with remote control unit, dynamotor, and plugs. BRAND NEW.

Order RA-10 CA f/14 Volt DC operation. **\$49.95**

Order RA-10 DA f/28 Volt DC operation.

GEAR HEAD MOTOR



Geared 324-1. Approx. 12 RPM Left angle drive. 27 Volt DC input 4050 RPM. Motor Size: 5" x 3 1/2". Shaft Size: 3/8" x 5/8". Price.....

\$8.95

**ARMY - NAVY -
AIR FORCE - MARINES
Here's Help!**

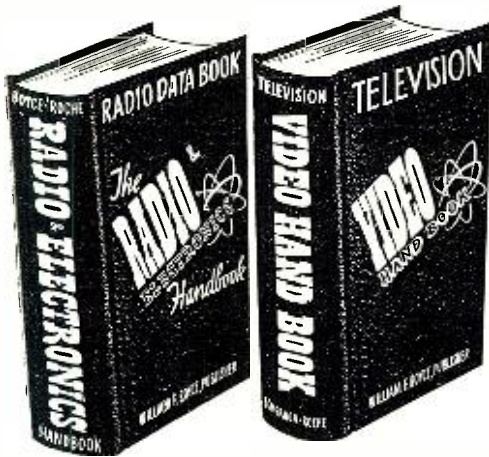

**GET AHEAD FASTER IN
RADIO
TELEVISION
ELECTRONICS**

Two great books assist you in every operation in radio, television and electronics. Give you the fundamentals, complete ground work, understanding of all types of radio, television, electronic gear and their circuits, including theory of operation.

Show you expert methods of planning, building, installing, operating, testing, adjusting, and servicing. The know-how of radio, television and electronics presented in plain language and simple terms with easy to understand pictures and working diagrams.

You get 1800 pages of basic knowledge, methods and data of radio, television, electronics completely illustrated with over 2000 pictures, drawings, codes, charts and graphs.

Written by the Boyce-Roche experts who make electronic manuals for the U. S. Signal Corps.

SPECIAL OFFER—Save Two Dollars
Send for both books together and get them at the special combination price of only \$12.00!

RADIO & ELECTRONICS HANDBOOK provides instruction and reference on fundamentals, parts, tubes, circuit elements, receivers, transmitters, amplifier systems, power supplies, antennas, meters, test equipment, and accessories, with complete Data Section. \$7.00

VIDEO HANDBOOK teaches television and provides complete handbook reference on all phases with full sections on principles of television, receivers, antennas, test equipment, servicing, pattern interpretation, transmitters, show production and more. \$7.00

SEND NO MONEY—10-DAY FREE EXAMINATION COUPON. (Good only while special combination offer lasts.)

BOYCE-ROCHE BOOK CO.
CALDWELL 29, NEW JERSEY

Send () Both books together @ \$12.00
() Radio & Electronics Handbook @ \$7.00
() Video Handbook @ \$7.00

In ten days I will send you price plus postage or I will return book(s) postpaid. (Offer good only in U. S.)

Name.....
Address.....
City, Zone, State.....

Employed by.....
SAVE POSTAGE. We pay postage if you enclose full price now. Money back on same return privilege.

boosters. The company's previous plant was destroyed by fire in May of this year . . . **HYTRON RADIO & ELECTRONICS CO.,** is building a new plant in Danvers, Mass., for the manufacture of receiving tubes. Operation is expected to begin early in 1952 . . . **GENERAL ELECTRIC COMPANY** has announced plans to build a 20,000 square foot manufacturing building near Springfield, New Jersey to house **PRECISION LABORATORIES, INC.,** now located in Irvington, New Jersey. The firm is the manufacturing unit of the company's components division . . . **SYLVANIA ELECTRIC PRODUCTS INC.,** has selected the city of Nelsonville, Ohio, as the site of a plant for the manufacture of welded lead-in wires for lamps, radio tubes, and other electronics devices. The company is presently operating in a rented factory.

DR. C. J. BREITWIESER has been named executive assistant to Dr. F. R. Hensel, vice-president in charge of engineering at *P. R. Mallory & Co., Inc.*



He joins the company after serving as chief of electronics and head of the engineering laboratories for *Consolidated Vultee Aircraft Corporation,* Lindbergh Field, San Diego.

Dr. Breitwieser, who is a graduate of the California Institute of Technology, has been associated with *United Sound Products Company, DeForest Research, Inc.,* and *Memovox Corporation* in addition to holding several academic posts and consulting engineering positions.

NEW ERA TELEVISION COMPANY has been formed recently to handle the national sale of custom-built television-radio-phonograph units with glass and mirror combined with wood, fabrics, and bamboo. The new firm, which is located at 315 East 47th Street, New York 17, New York, will serve as the sales organization for the **NEW ERA GLASS COMPANY . . . CONTROL INSTRUMENT COMPANY, INC.,** of Brooklyn, New York, designers and manufacturers of electronic instruments, has been acquired by **BURROUGHS ADDING MACHINE COMPANY.** The instrument company will continue to operate as a separate corporation.

JOHN H. CASHMAN, president of *The Radio Craftsmen, Inc.* of Chicago, has been elected chairman of the Association of Electronic Parts and Equipment Manufacturers at the organization's annual meeting.

Francis F. Florsheim, president of *Columbia Wire and Supply Co.,* was named vice-chairman, and Helen Stansland Quam, *Quam-Nichols Co.,* was re-elected for her sixteenth term as treasurer.

Kenneth C. Prince, Chicago attorney, was renamed executive secretary of the association.

Voltage Regulators

(Continued from page 69)

150 to 350 volts. This particular circuit has the added advantage that the heater supply for the control tube is at ground potential and can be used for other purposes.

The circuit of Fig. 5 carries the trend of the above modification one step lower in output voltage range. A 300 volt power supply can be used if its negative lead is connected to the screen of the control tube, V_2 . An auxiliary 200 volt bias supply is needed to supply the over-all total of 500 volts for the regulator unit. The output voltage in this case will be from 50 to 250 volts. This is a very useful range for testing and for use with any of the present-day low voltage miniature tubes.

It will be noticed that the basic circuit of Fig. 2 appears without internal change in the circuits of Figs. 3, 4, and 5. This suggests the possibility of a practical voltage regulator unit capable of being used with various power supplies. Fig. 6 diagrams such a unit. It combines a bias supply integral with the regulator unit. It will deliver up to 150 ma. from 50 to 600 volts with appropriate power supplies, in four ranges. Power supplies with reasonably good regulation should be used.

While the regulator unit of Fig. 6 would serve many uses, it fails to accomplish the original requirement. It would not cover the full range without switching and it required several power supplies. It seemed that a unit which would have a single control and include its own power supply should be possible. It would be if the limiting factor of the maximum rated plate voltage of the regulator and control tubes could be raised. Series arrangements suggested themselves and the circuit of Fig. 7 was worked out. In this circuit two 6AS7 regulator tubes are used in series. The voltage divider, R_2 and R_3 , applies proportionately bias voltages on the regulator tubes so that the voltage drop across them is divided equally. A 6J5 is added in the control branch. Equal division of the plate voltage between the 6J5 and the 6SJ7 is obtained by the use of resistors R_6 and R_7 . Control of this circuit uses a variable resistor, R_1 , instead of the potentiometer, R_2 , in Fig. 2. This was considered necessary because the output voltage now varies over a range of some 450 volts.

The voltage regulated power supply shown in Fig. 7 was constructed and tested. It was found to have a useful range from almost zero to a little over 450 volts and it can be set anywhere within that range by adjusting a single control. True, it is wasteful of power in the low voltages but that feature is more than offset by the flexibility of the unit. It should prove to be a very handy piece of equipment on the test bench.

Technical BOOKS

"THE RADIO AMATEUR'S HANDBOOK" by the Headquarters Staff of the ARRL. Published by *The American Radio Relay League*, West Hartford, Conn. 768 pages including catalogue section and index. Price \$2.50. Paper bound. 28th Edition.

This perennial favorite of hams and experimenters is now available in a new and revised edition which covers the field of amateur radio from every angle.

The early chapters in the manual cover radio and electrical fundamentals which form the basis for all ham operation. Other chapters in the book discuss and describe such topics as high frequency receivers and transmitters; the design and construction of single-sideband suppressed carrier radiotelephone transmitters; mobile techniques; antennas; transmission lines; v.h.f., u.h.f., and microwave techniques and equipment; and data on building and adjusting all types of ham equipment.

An up-to-date vacuum tube data section and a new and expanded catalogue section complete this edition.

This "bible" of the ham fraternity is even bigger and better than previous editions and amateurs will want to add this latest volume to the reference shelves in their ham shacks.

"MUSICAL ACOUSTICS" by Charles A. Culver. Published by *The Blakiston Company*, Philadelphia. 210 pages. Price \$4.25. Third Edition.

This is a basic text written for the musician or the technician concerned with the recording and/or the reproduction of sound.

Written in easy-to-understand style, this book is based on a course in musical acoustics offered music students at Carleton College. The author has deliberately avoided the use of involved mathematics and highly technical terminology with the result that the subject matter may be easily grasped by the veriest tyro.

The book covers the nature and transmission of sound, interference, hearing, resonance, pitch, quality, musical intervals and temperament, consonance and dissonance, musical strings, stringed instruments, vibrating air columns, wind instruments, vibrating rods and plates, the acoustics of rooms, electronic musical instruments, and the recording and reproduction of music.

Since increased knowledge of the "why's" and "how's" of sound can only engender an increased appreciation of music this book should appeal to the active musician as well as the passive music lover.

"TELEVISION ANTENNAS" by Donald A. Nelson. Published by *Howard W. Sams & Co., Inc.*, Indianapolis. 223 pages. Price \$2.00. Paper bound.

September, 1951

SAVE UP TO 95% SENSATIONAL SURPLUS VALUES!

We Need 'em! We Pay Plenty!

TOP \$\$ FOR HANDIE-TALKIES

Complete or Chassis of BC-611

This is your chance to make a big profit in your BC-611 or parts. Send us complete information and we'll reply promptly!

274-N & ARC-5 EQUIPMENT

RECEIVERS

36 MC. Used. Originally \$30. NOW... \$6.95
6-9.1 MC. Used... \$8.95

TRANSMITTERS

T-22 ARC-5, 7-9 Megs. Used xint... \$14.95
T-23 ARC-5 100-156 Megs. 4 channel Xtal. Used. Complete with tubes. Internally Perfect... \$39.50
MD7-ARCS Modulator Plate and Screen for T23ARCS with Dynamotor... \$15.00
T-21 ARC-5, 3-7 MC. New. Orig. \$40. Now... \$25.95
4-5.3 MC. Used. Orig. \$30.00. Now... \$16.95
2.1-3 MC. LN. Orig. \$40. Now... \$19.95
T-19 ARC-5, 3 to 4 Megs R-23 ARC-5, 190 to 550 KC, Loop or Straight wire antenna input... \$18.95
R28-ARC-5 VHF Rcvr. XLnt Cond... \$40.00



US MARINE CORPS HANDESET, Type MTS-1. Late model French Phone Set curved fit head contour. Push-to-talk switch in handle. Has 20' 4-conductor hvy. duty rubber cord. Equipped with mike and earphone tube covers for comfort, shock insulation. Used. excellent cond... \$8.95

Sept. Only! New I.F. Transformers

- 1 I.F. Transformer. 2nd. Det. #SA-91 for Super Pro. 465 KC. NCV... \$1.49
- 1st & 2nd. I.F., BC-654, 455KC. New... \$1.89
- 2nd. I.F., MN-26, 112 KC... \$1.99
- 3rd I.F., BC-348, 915 KC... \$2.75
- MIC Adaptor, M-299, New... \$3.75
- DM-35 Dynamotor 12V input, 600V output. Used... \$12.95

TEST SETS

TS-3	LZ	APA-11	\$125.00
TS-10	I-203	APA-6	\$75.00
TS-12	I-138	AN/UPN1	
TS-13	RC-256	TS-143	\$225.00
TS-16	LAF	BC-221	
TS-23	IE56	TS-56	
TS-19	\$125.00	TS-67	RF4 AP Phantom Antenna, 10 CM, new... \$20.00
TS-127	\$69.50	1-95	
TS-226	\$45.00		

RADAR SETS & COMPONENTS

- APS-4
- APS-6, APG-13, APT-4, APA-23 Recorder
- S07-M, All spare parts in stock
- APS-15
- 3 OM Beacon & Local Oscil. Assem \$25.00
- 725 Magnetron Mounting Assemblies with Filament Transformer, Pulse Fittings... \$9.95

SOUND POWER HEAD & CHEST SET. Type M, Stock No. D-173013... each \$9.95 or \$17.50 pr.

APN-4 ACCESSORIES. Consists of complete set of cables with plugs, antenna switch, FT446 and FT447, Brand new... \$16.00

K-7 GUN MOUNT. Xint rotating device for antennas of all types. Used... \$4.95

EXPORT INQUIRIES INVITED! We carry an unusually large stock of Airline Equipment, Test Equipment, Radar Sets, etc. Write for our low prices and complete information. We furnish immediate answers to all inquiries! Write today.

CONVERSION & REPAIR SHOP FACILITIES

We are equipped to convert and repair all types of electronics equipment. No job too small or too large. All work unconditionally guaranteed. Xint. references. Prompt replies to all estimate requests.

IMPORTANT! NO ORDER LESS THAN \$5.00. Send 30% deposit. All merchandise subject to prior sale. Prices subject to change at any time. All Foreign orders add \$1 minimum service charge.

If You Don't See What You Want, Write Us! We'll either have it in our warehouse, or we'll get it for you. Drop us a line and send us your requirements and we'll answer immediately! No item too small or too large!

RECEIVERS!

- APR-1, APR-5, APR-4, Price on order
- Scott RCH Rcvr. 80-560 KC and 1.9 to 24 megs. Operates 110V AC, 60 Cycle. New... \$165.00
- Hammerlund BC-1269, 145 to 300 Megs, 300 to 600 Megs. FM or AM... \$285.00
- BC-683, 27/39 Megs. FM. Xint. condition... \$39.00
- ILS System. RC-103, ARN-5
- Marine Band 1.5 to 3 megs. New... \$36.50
- ARR-2, 234 to 238 Megs. Used... \$14.95
- ADF, ARN-7 or SCR269, MN26
- BC-357 Marker. Beacon. 75 MC. Used. with plugs... \$2.95
- BC1206A, 200 to 400 KC. Operates on 220V, DC. Used. good condition... \$4.95
- RBR Pocket Receiver. Crystal controlled. 2-9 megs. Lightweight, portable. Uses 67 1/2 V. B Battery or 2 flashlight cells. New, original boxes... \$15.00
- BC-470 Direction Finder Receiver. Continuous tuning, 200 KC, 18 Megs. less loop, used... \$50.00
- Marker Beacon ARN-8. Used... \$15.00
- BC-373 Fairchild Lightweight ADF Rcvr. Used... \$14.95
- VHF BC-639 A RA-42, 100-156 megs. 110V, AC... \$275.00

TRANSMITTERS

- BC-325 2 to 18 Megs. Band switching. Operates 110/220 60 cycles. 500 watts CW. 100 Watts phone.
- TQD VHF Airport 4 Crystals, 100-156 megs. 45 W. output. 110/220 AC, 60 cycles.
- BC-684 FM Transmitter. 12V. dynamotor, 27/39 megs. 10 channels. Crystal controlled. Used... \$38.00
- T-47, T-47A, ATC Collins Frequency Transmitter. Quantities available.
- BC-446J Transmitter (parts only)
- TBW Lo Freq. Transmitter. 350-1000 KC., 100 Watts CW. With 800 cycle power supply. Used... \$8.95
- GO-9 Transmitter. New. 3 to 18 MC and 300-600 KC. New... \$72.50
- APT-5... \$125.00

DYNAMOTORS

- BY-17 New (Price on Request)
- BC-77, New... \$12.95
- DM-35 Used... \$15.00
- PE-115, New... \$17.50
- PE118, Used... \$17.50
- MG-149, New... \$69.50
- PU-7, Used... \$120.00
- APS-13, New... \$1.95
- MOTOR GENERATOR, 115 DC to 110 AC, 1 KW. G.C. Used... \$100.00
- Motor Generator, 220 DC to 110 AC, 1 KW with starter. New... \$125.00
- RC-266 Radar Antenna. New. Complete Part of SCR-717... \$49.50
- Gas Engine Generator, Hercules 4 cylinder engine. Output 28V, DC, 175 amps. Used... \$295.00

TRANSCEIVERS

- TBS 60-80 megs. Crystal controlled. 50 watts output, for operation 230 DC, 440 AC.
- Portable FM. Operates on 6 V DC. Fixed crystal. 34 megs. transmitter

NEW! SPOT LIGHT ANIMATORS

Rotating Beam Light with Twin-Clock Indicator. Perfect for Target Practice, Burglar Alarms, Production Line Checking, Etc.



Gun-like photo-cell picks up roving movements of sharp light beam focused on any screen, wall or object. Twin clocks record running time and time photo cell picks up light beam. Originally designed for gunnery practice—but great for checking movement of production line and equipment, alarms, etc. Consists of 3 units: Projection Lamp, Control Panel and Photo-Cell Pick-Up Gun. The parts alone are worth at least \$50. But the Entire Unit, in good, unused condition, is priced at just... \$69.50

NEW STANDARD BRAND CHOKES

HY	SWINGING CHOKES				CASE	WT.
	MILS	OHMS	PRICE	VOLTAGE		
8-40	175	100	2.75	3KV	Closed	3.5
8-30	200	80	3.25	3KV	Closed	4.5
5-25	200	100	4.95	2KV	Closed	5
5-25	300	90	9.95	5KV	Closed	18
8-25	300	80	5.95	5KV	Open	8 1/2
5-25	300	80	4.95	3KV	Open	4
5-25	500	60	12.95	7KV	Closed	28
8-40	1 amp	50	39.95	10KV	Closed	58

HY	SMOOTHING CHOKES				CASE	WT.
	MILS	OHMS	PRICE	VOLTAGE		
7	500	600	4.95	2KV	Closed	4
7	150	200	1.25	2KV	Open	2
10	500	60	12.95	7KV	Closed	28
12	300	80	5.95	5KV	Closed	9
12	375	105	3.95	5KV	Closed	8
12	400	400	6.95	2KV	Closed	15
15	200	120	2.95	3KV	Open	4.5 lbs.
20	300	80	4.95	3KV	Closed	9 lbs.

SAVE \$ ON POWER SUPPLIES

Chokes with Hum Bucking Tap

HY	MILS	OHMS	PRICE	VOLTAGE	CASE	WT.
20 Series	1A	50	39.50	10K	Closed	80
5 Parallel	2A	12.5				
16 Series	175	96	5.95	2.5K	Closed	15
4 Parallel	350	24				
26 Series	200	112	6.95	3.5K	Closed	15
6.25 Parallel	400	28				

V&V RADIO & ELECTRONICS SUPPLY DEPT. R-25, 2033-37 W. VENICE BLVD., LOS ANGELES 6, CALIFORNIA

We Pay Top \$ \$ \$ For Parts & Equip • Write To Us Now!

VIDEO-VEND

COIN OPERATED TELEVISION

Get in on the ground floor of this SENSATIONAL PROFITABLE business. For small investment we can show you large returns. Requires only a few hours a week. Write—

Coin Radio & Television Corp.
190A Duane St. Dept. R New York City

CODE SENDING

NERVOUS TENSION

REVEALING BOOK shows how "crack" operators develop high speed and proficiency. Learn code for Amateur or Commercial Radiotelegraph License, or improve your sending and receiving.

with the Candler System which develops radio-telegraph experts and code champions.

CANDLER SYSTEM CO. FREE BOOK
Box 928, Dept. 2-K, Denver, Colo.



THE
**MIGHTY
MIDGET**

THE BIGGEST
RECEIVER VALUE
IN AMERICA!

National's entire initial production run of the sensational new SW-54 receiver was exhausted in just a few short months after production! Now, at last, the "Mighty Midget" is once more available.

This amazing receiver tunes the entire frequency range from 540 kcs. to 30 mcs., voice and code, with big set sensitivity, yet measures only 11" x 7" x 7"! Has edge-lighted slide rule dial calibrated in 4 bands with foreign, ship, amateur and police frequencies clearly marked and unique plastic bandspread knob. Has new miniature tubes. Housed in smart modern metal cabinet with tough velvet-gray finish.

See and hear it today!

Write for name of nearest dealer.



This handy, pocket-size manual contains information on the design, construction, installation, and troubleshooting of various television antennas. This second edition has been brought up-to-date and includes all of the latest information needed by the installation technician.

The book is divided into five sections dealing with antenna principles, antenna construction, commercially-built antennas, installation, and troubleshooting. The material presented is of a practical nature and covers situations most often encountered by the technician. On the subject of installation, the text goes into some detail on roof and wall structures, mast construction, methods of securing mounting brackets to various types of construction materials, etc.

A brief introductory chapter gives important information on television transmission, the video receiver, frequency allocations, and the networks. The text material throughout the book is well illustrated with line drawings and photographs of commercially-available antenna equipment.

Technicians will undoubtedly find this a practical aid when tackling some of those extra-troublesome antenna installations.

* * *

"ELEMENT VIII—SHIP RADAR TECHNIQUES" by Milton Kaufman. Published by *John F. Rider Publisher, Inc.* 30 pages. Price \$0.78. Paper bound.

This little book is a supplement to the publisher's "Radio Operator's License Q & A Manual" (Second Edition), and covers the material included in Element VIII of the FCC examinations.

In accordance with the usual practice in such examinations, the answers to the various questions in this element have been kept as brief as possible and explanatory material is held to a minimum.

This book is not intended to be a text book on the subject of ship radar and the student will have to seek elsewhere for his background material. However, as an aid in preparing for the license exam, this handbook is excellent and should be of real assistance to the candidate.

* * *

"ELECTRICAL-RADIO WIRING DIAGRAMS" (Automotive Manual). Compiled by the E. I. Electrical School Staff. Published by *E. I. Electrical Press, Hinsdale, Illinois.* 87 pages. Price \$2.00. Paper bound.

Service technicians who specialize in or work on auto radios will find this manual particularly helpful as the compilation includes electrical wiring diagrams and radio schematics on all of the leading postwar automobiles, with particular emphasis being placed on 1949 and 1950 models.

Prepared in cooperation with the manufacturers, the book contains information on *Chrysler, DeSoto, Dodge, Plymouth, Crosley, Ford, Lincoln, Mercury, Buick, Cadillac, Chevrolet,*

**NEW LABCO
TV CABINET**

**Ideal for Conversions
Custom Chassis—Kits**

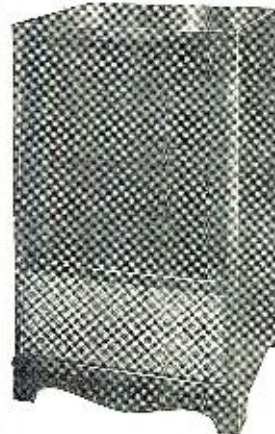

Only
\$49.50

Model 800
H—40"
W—24"
D—24"
Immediate
Delivery

A masterpiece of fine cabinet making—mahogany veneers hand-rubbed to a high satin luster. Has no equal for conversions, custom chassis, and kits. Ideal for 630 RCA-type chassis. Blank front panel easily removed for cutting to any shape CR tube to 20" size. Complete with adjustable CR tube cradle, adjustable yoke assembly shelf, masonite ventilated back. Handsome console at an exceptional price.

20% with Order, Balance C.O.D.
F.O.B. Factory

LABCO ELECTRONICS, INC.
2216 MARKET ST. - PHILA. 3, PA.

LEARN

**Television
-Radio
OR
Electricity**
IN THE GREAT SHOPS OF **COYNE**



**TRAIN QUICKLY!
OLDEST, BEST EQUIPPED
SCHOOL OF ITS KIND in U.S.**
Young and Older Men

Come to the Great Shops of Coyne in Chicago. Get practical training in TELEVISION-RADIO or ELECTRICITY—vital in Defense Program. Prepare now for a better job or better service rating.

START NOW—PAY LATER

You can finance most of your tuition, pay for it later in easy monthly payments. Special plan for men of Draft Age. Part time employment service available. **GI APPROVED**

FREE BOOK Clip coupon for Big Free Illustrated Book. Indicate below course that interests you. No salesman will call. Act NOW.

An Institution not for Profit

B. W. COOKE, Pres.
COYNE Electrical & Television-Radio School.
500 S. Paulina St., Chicago 12, Ill. Dept. 61-85H

Send FREE BOOK and full details on:

TELEVISION-RADIO ELECTRICITY

NAME.....

ADDRESS.....

CITY..... STATE.....

RADIO & TELEVISION NEWS

Oldsmobile, Pontiac, Hudson, Kaiser-Frazier, Nash, Packard, Studebaker, and Willys cars, and radios manufactured by General Electric, Motorola, Philco, RCA, and Zenith.

The information is presented in easy-to-use form and there is no extraneous material to clutter up the pages or distract the user. -50-

NEW BELL TRANSISTOR

THE Bell Telephone Laboratories has recently announced the development of a new type of transistor which operates with exceedingly small power consumption.

According to the company, in audio oscillator applications the unit requires a power supply of only 6 microamperes at .1 volt. The power handling capacity and particularly the efficiency of these transistors is high. The design can be varied to permit the required amount of power dissipation up to at least 2 watts. The static characteristics are such that class A efficiencies of 48 or 49 out of a possible 50 per-cent can be realized. The efficiencies for class B and class C operation are correspondingly high, reaching as much as 98 per-cent.

The new type of transistor is compact and rugged. It is enclosed in a hard plastic bead about 3/16 inch in diameter. Inside the bead three electrical connections are fastened to the germanium and are brought out as pigtailed through the bead. This gives a sturdy unit which withstands severe shock tests. The input and output impedances are always positive, whether the transistor is connected grounded-emitter, grounded-base, or grounded-collector. This permits a wide latitude in circuit design and makes it possible, by choosing the appropriate connection, to obtain a considerable variety of input and output impedances.

Vibration tests in the audio frequency range produce no measurable microphonic noise.

Other salient characteristics of the new junction-type transistor are its relatively low noise figure (1000 times less than that of its predecessor) and its high gain.

While early tests indicate that collector capacitance limits the frequency response at full gain to a few kilocycles, it is possible by using a suitable impedance mismatch to maintain the frequency response flat to at least one megacycle while securing a useful amount of gain.

At 1000 cps, most of the units measured in the laboratory have a noise figure between 10 and 20 db. Power gains in the order of 40 to 50 db per stage have been obtained. -50-

Over-all view of the new Bell Telephone Laboratories' transistor. The miniature vacuum tube, which performs about the same job, is included to permit size comparison.



September, 1951

a model
to fit any
application

the antenna job hasn't
been found that a C-D SKYHAWK
ANTENNA can't handle.

Skyhawk
TV ANTENNAS



CORNELL-DUBILIER offers you, the discriminating serviceman, a line of antennas unequalled in completeness. Regardless of the application, regardless of the situation, there is a C-D SKYHAWK ANTENNA to fill the bill. Don't risk inferior substitutes when you can be sure of the painstaking construction and outstanding performance of CORNELL-DUBILIER antennas.

CORNELL-DUBILIER
ELECTRIC CORP.
SOUTH PLAINFIELD, N. J.

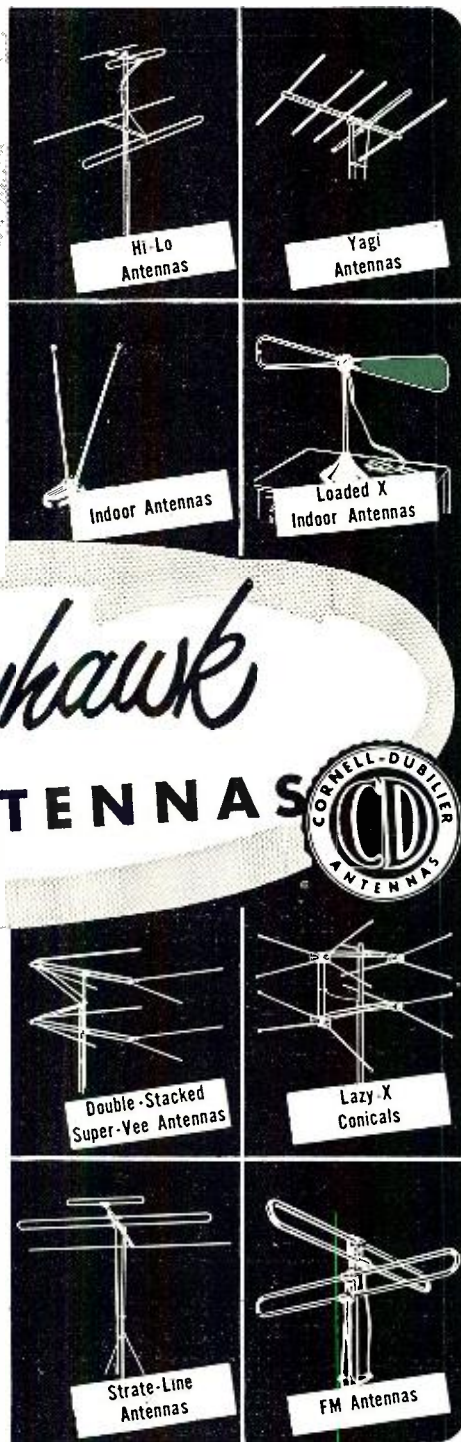

Free NEW
BIG RADIO
CATALOG



Ready now. Complete with everything in radio, television and electronics. Newest parts, as well as old, standard lines. Paste coupon on penny postcard and mail today!

Lafayette Radio

DIVISION: RADIO WIRE TELEVISION, INC.

NEW YORK 13 NEWARK 2 BOSTON 10 BRONX 58
100 Sixth Ave. 24 Central Ave. 110 Federal St. 542 E. Fordham Rd.

LAFAYETTE RADIO,
Dept. RI-1
100 Sixth Avenue, N. Y. 13

Please rush Free catalog to:

Name.....

Address.....

City..... State.....

PASTE ON PENNY POSTCARD

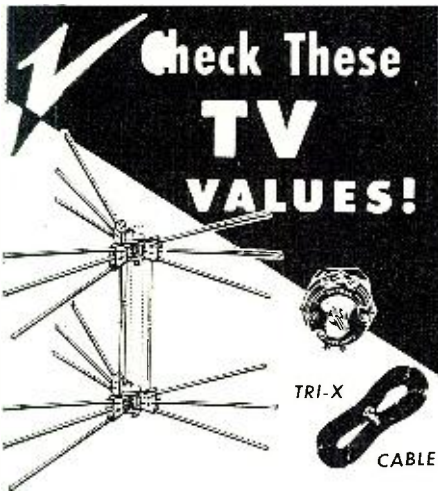

DIRECTRONIC MOTORLESS
360° Electronically Switched Beam

- No Motors • No Electric Power
- No Roof Orientation • No Ghosts

The Directronic 18 element, 360° antenna is the finest for ultrafringe or metropolitan reception. The HI-PAC molded insulator is a material of extreme tensile strength not affected by weather or temperature, either mechanically or electrically. Included in the AX-399 "Servicemen's Array" are:

- 18 hi-tensile aluminum alloy elements
 - 1 set of connecting stubs (3)
 - Universal U Clamps for masts to 1 1/2"
 - Directronic Beam Selector
 - 75 feet of Tri-X Cable
 - 1 stacked array per carton
- | | |
|---|--------------|
| AX-599 Directronic, Weight 8 lbs |\$21.75 |
| AX-566 Directronic, 6 element Single, Weight 4 3/4 lbs. | 10.50 |
| AX-566 Directronic, 12 element Stacked, Weight 7 lbs. | 19.75 |
| AX-59 Directronic, 9 element Single, Weight 5 1/2 lbs. | 12.25 |
- All above antenna prices include Tri-X Cable and Switch.

5 ELEMENT TV ANTENNA
Excellent Pictures in Fringe Areas

Here is a highly directive antenna that is the real solution to perfect pictures in fringe areas because it is closely tuned to each channel and cuts interference and noise to the minimum. Five elements include one folded dipole, three directors and one reflector. Supplied less mast. Specify channel array desired. Channels 2 to 6—\$6.95 Channels 7 to 13—\$3.95 Shipping Weight—3 1/2 lbs. Lx-Band. Shipping Weight—3 1/2 lbs. Hi-Band.

ALL CHANNEL CONICALS

This conical TV is designed for broad-band reception on all TV channels plus FM. The conical has proved high signal-to-noise ratio and excellent front-to-back ratio; matches 72, 150 or 300 ohm input impedance. This metropolitan area, high quality TV antenna is engineered for super performance. The all-aluminum construction provides maximum strength and eliminates rust and weight problems. The N44 is built solid and cannot slip or twist on the mast.

Single Bay . . . \$4.25 each	Stacked Array with Tie
Shipping Weight 3 1/2 lbs.	Shipping Weight 7 1/2 lbs. each
Lots of 6, single carton . . . \$3.95 each	Lots of 6, single
Shipping Weight 18 lbs.	Shipping Weight 19 lbs.

- | | |
|---|-------------|
| 1 1/4" O.D. | |
| Mast Steel (Dualcoated) 5' Crimped . . . | \$ 1.05 |
| Mast Steel (Dualcoated) 10' Crimped . . . | 1.95 |
| Mast Steel (Zinc Plated) 10' Crimped . . . | 1.59 |
| Mast Connectors for 1 1/4" O.D. Mast . . . | .29 |
| 10' Long . . . | 20.53 |
| Motors—Alliance DIR . . . | 26.43 |
| Alliance HIR . . . | 26.43 |
| Radiant TR2 . . . | 26.70 |
| Walec WR0-4 . . . | 28.50 |
| Motor Wire | |
| 3-Conductor (Walec) . . . | .03 ft. |
| 4-Conductor (Alliance) . . . | .04 ft. |
| 8-Conductor (Radiant) . . . | .06 ft. |
| Peak Roof Saddles (will take up to 1 1/2" O.D.) . . . | 1.49 |
| Twin Lead 300 Ohm—#70 Mil—Solid . . . | .02 ft. |
| Twin Lead 300 Ohm—#80 Mil—7/28 Stranded . . . | .02 1/2 ft. |
| Side Wall Mounts—3" Extension . . . | .75 |
| Side Wall Mounts—6" Extension . . . | 1.25 |
| Side Wall Mounts—12" Extension . . . | 1.75 |
| Side Wall Mounts—18" Adj. . . | 3.50 |
| Tie Rods for Stacking Antennas . . . | .70 pr. |
| Double Stacking Assembly—for stacking 2-XX arrays . . . | 1.70 set |
| Aluminum Guy Line 7/16" Stranded 300' coil . . . | 4.95 |
| Arrestors (TV—Lightning) . . . | .69 |
| Auto Radio (6 tube Universal Underdash) . . . | 34.97 |
| Chimney Mount—Complete with Straps . . . | 1.19 |
| Coax—72 Ohm . . . | .06 |
| Elements 3/8" x 1 1/4" or 48" . . . | .90 pr. |
| Elements 1/2" x 45" or 48" . . . | 1.20 pr. |
| Guy Wire—Galvanized—4 Strand #20 . . . | .00 1/2 ft. |
| Guy Wire—Galvanized—6 Strand #20 . . . | .00 3/4 ft. |
| Guy Wire—Galvanized—11 Strand #20 . . . | .01 1/2 ft. |
| Indoor Antennas (Popular Brands) Rabbit Ears . . . | 1.75 |
| Boosters—Acho—101-75 . . . | 22.50 |
| Astatic—BT-1 . . . | 19.50 |
| Tec—S-503 . . . | 26.97 |
| Stand-off Screw Insulators—3" for 300 Ohm . . . | 2.75 C |
| Stand-off Screw Insulators—7" for 300 Ohm . . . | 5.50 C |
| Strap Clamp Stand-off Insulators—3" . . . | 8.50 C |
- PRICES SUBJECT TO CHANGE WITHOUT NOTICE.

Chas. E. Freshman & Co.
4019 PROSPECT AVENUE
Cleveland 3, Ohio • Phone EX 1-8723

Horn-Loaded Speaker
(Continued from page 63)

ing, obnoxious looking, bulky contraption. Of course, the "Better Half" had some influence in that decision! In this design, most of the construction errors are hidden. As it turned out, there wasn't much compromise. It is a source of considerable satisfaction to have other high-fidelity enthusiasts listen to it, then start figuring how they can build one like it.

The horn is made as a unit in a box. It slips in the opening where the shelves slipped out. Thus restoration of the original bookshelves is a simple matter when we move, an item that deserves consideration. Actual construction is really quite simple. Being anything but a master wood craftsman, it won't be hard to improve on my model. The size of the available opening in which the assembly is to be built will determine the length of horn which can be enclosed. That in turn will determine the rate of opening. In my case, the cross section area was doubled every two feet. This provides loading to 32 cycles. Intermediate cross sections were gauged by eye, and some improvement could probably be made by expending more effort to get more accuracy. For example, the basic unit could be divided by 3, then the rate of opening would be as follows:

UNITS OF LENGTH	MULTIPLICATION CROSS-SECTION AREA
1	1.26
2	1.59
3	2.00
4	2.51
5	3.16
6	3.98
7	5.01
8	6.31
9	7.94
10	10.00

Considerable care should be used in

Two views of the horn-loaded speaker showing placement of linoleum baffling. Over-all inside dimensions are 41" wide, 35" high, and 10" deep. The front panel is made of 1/2" plywood cut to fit opening.

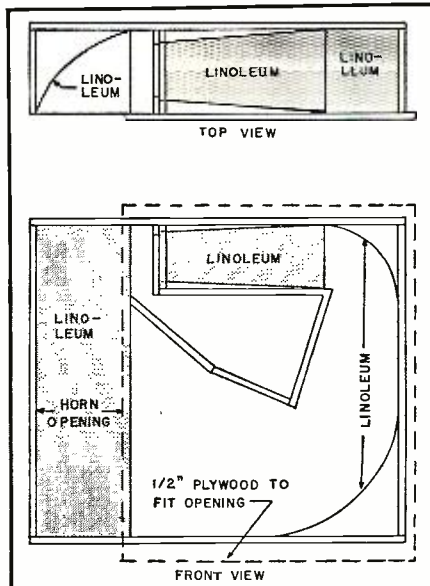

forming the curves of linoleum to insure good results. If this is not done, very objectionable reflections will occur and the results will be poor. Linoleum was chosen to form the curves because it is inexpensive, easily worked, and quite inert. Scrap pieces can usually be picked up at a furniture store at very low cost.

As would be expected, there is some interference between front and back radiation of the single speaker. This can be practically eliminated by loosely forming cotton around the rear of the speaker frame, being careful not to cover the central core opening.

The W.E. 755-A, now made by Altec-Lansing, is not the only speaker adaptable to this design, but whatever unit is used it must have an opening in the core for high frequency radiation from the rear.

SERVICE TIP

By NICHOLAS B. COOK

THE inner conductor of a 25-foot, nearly-new mike cable was open. Inspection of terminal connectors showed no trouble at these points. Removal of connectors revealed nothing but apparently perfect mechanical continuity. Yet the line was open. Where?

The open was quickly found by the use of an ohmmeter, a needle-pointed probe, and a technique learned from the celebrated Greek philosopher Zeno, who "proved" that Achilles could never overtake the tortoise.

The method is as follows: Call the ends of the line "A" and "B." Clip one probe on end "A." Push the sharp needle of the other probe through to the inner conductor at a point halfway between "A" and "B."

Assuming that there is only one "open," this test shows either open or closed and eliminates one half of the entire length. If open, the fault lies in the "A" half; if closed, in the "B" half.

The next test is taken in the bad section at a point halfway between test point No. 1 and the end. The probe clip may be left at "A." However, an open test from the "A" end can be verified as a closed test from the "B" end. The double check is conclusive and takes very little more time.

In this manner, halving the remainder each time, only five tests are required in a 25-foot cable to narrow the faulty section down to 9 inches.

In the actual case that inspired this "Service Tip," the open was found at a distance of 7 inches from the end. Lucky!

But the method works equally well if the open is near the middle. See Fig. 1 for details on how the operation is performed.

Rapid method for locating an "open" in a length of microphone or similar cable.

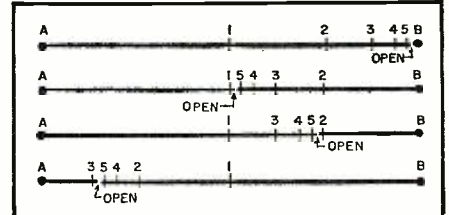

Manufacturers' Literature

Readers are asked to write directly to the manufacturer for the literature. By mentioning RADIO & TELEVISION NEWS, the issue and page, and enclosing the proper amount, when indicated, delay will be prevented.

PICTURE TUBES

Zetka Television Tubes, Inc. of 131-137 Getty Avenue, Clifton, New Jersey is now offering a 12-page, two-color catalogue covering its line of 16, 17, 19, and 20 inch picture tubes.

Every tube described in the new catalogue is thoroughly detailed with descriptive copy and diagrammatic drawings.

Requests for the catalogue should be addressed to Murray Shindel, sales manager of the firm.

TIMER CATALOGUE

The Sessions Clock Company of Forestville, Conn., is currently offering copies of its new catalogue covering clock movements and switch timers.

Designed as a buying and engineering guide for specialty clock manufacturers, design engineers, and all users of clock timing movements, this 12-page bulletin gives complete specifications and dimensional drawings on all of the units in the company's line.

Copies of Bulletin No. CM-11 are available from Dept. 16 of the company.

NEW NEWARK CATALOGUE

Newark Electric Company, 323 W. Madison Street, Chicago, Illinois has just published a comprehensive parts catalogue which lists only current and readily available items.

The catalogue carries listings of test equipment; industrial equipment and supplies; high fidelity systems and components; television chassis; tape, wire, and disc recorders; phonographs; tools; books; p.a. and intercom systems; transcription players; and a large selection of ham equipment.

TV REPLACEMENT GUIDE

Cornell-Dubilier Electric Corporation of South Plainfield, New Jersey has just issued a comprehensive manual listing over 400 of the most important TV twist-prong electrolytics.

Known as the "Television Replacement Guide TVR 7", the new guide is divided into sections covering manufacturer, model number, and C-D replacement numbers in various forms for easy reference. Other listings show the physical and electrical characteristics of over 400 C-D replacements and a cross index of older twist-prong electrolytics and their present equivalent part numbers.

The guide is available from the com-

IS YOUR RECTIFICATION PROBLEM LISTED HERE?

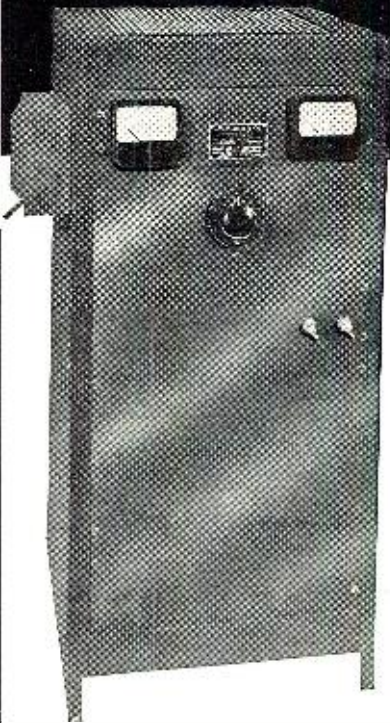

MODEL GPA 28100*

- Battery Charging
- Battery Elimination
- Business Machines
- Carbon Arc Lamps
- Dynamotors
- Electroplating
- Elevators
- Exciter Lamps
- General Laboratory Use
- Generator Fields
- Magnetic Brakes, Chucks, Separators
- Motors
- Relays
- Solenoids
- Telephones

Whatever your particular application of D.C. may be, it need not be a problem. The OPAD-GREEN COMPANY is prepared to offer its services in designing and constructing Selenium Rectifier power supplies and equipment for your specific needs.

Write today for our Power Supply Specification Form which will assist you in establishing your requirements. Our proposals and recommendations will be forwarded promptly upon receipt of this data. There is no obligation for this service.

*Custom Power Unit rated 0-28 Volts D.C. at 100 Amperes; maximum ripple 5%.

OPAD-GREEN COMPANY

71-3 WARREN ST., NEW YORK 7, N. Y. PHONE: BEekman 3-7385-6

WANTED WE NEED YOUR Surplus Electronic Equipment
WE PAY TOP \$\$\$ FOR:
 Radio Receivers Transmitters ARC-1 ARC-3 ART-13 Control Boxes Indicators
 An Connectors Clamps Plugs Cords Relays Telephone Materials We Buy Anything!!
WRITE, WRITE TODAY!
TELL US WHAT YOU HAVE
BOX #517
 Radio & Television News
 366 Madison Ave., New York 17, N. Y.

EASY TO LEARN CODE

It is easy to learn or increase speed with an Instructograph Code Teacher. Affords the quickest and most practical method yet developed. For beginners or advanced students. Available tapes from beginner's alphabet to typical messages on all subjects. Speed range 5 to 40 WPM. Always ready—no QRM.

ENDORSED BY THOUSANDS!

The Instructograph Code Teacher literally takes the place of an operator-instructor and enables anyone to learn and master code without further assistance. Thousands of successful operators have "acquired the code" with the Instructograph System. Write today for convenient rental and purchase plans.

INSTRUCTOGRAPH COMPANY
 4711 SHERIDAN ROAD, CHICAGO 40, ILLINOIS



**MOST
POWERFUL
COMBINATION**
for
**SINGLE
CHANNEL
RECEPTION**

VEE-D-X

THE LAPOINTE-PLASCOMOLD CORPORATION
Windsor Locks, Conn.

pany's jobbers or direct from the company's Jobbers' Division. The price is 50 cents.

TELEVISION COMPONENTS

Standard Transformer Corporation, 3580 Elston Avenue, Chicago 18, Illinois has announced the availability of a new television catalogue and replacement guide which lists more than 1500 models and chassis built under 79 brand names.

In addition to listing all replacement items by model number, manufacturer's part number and *Stancor* stock number, the guide identifies each part by code number which indicates the unit's function in the television circuit.

SHURE REPLACEMENT MANUAL

Shure Brothers, Inc., 225 West Huron, Chicago, Illinois has issued its replacement manual No. 66 which lists over 1500 phonographs, radio-phonograph combinations, and radio-television-phono combinations using *Shure* crystal and ceramic cartridges.

The manual refers to sets by manufacturer's name and model number with the *Shure* model number for each cartridge replacement. In addition to all the current models, the listing includes brands dating back to 1938.

AUDIO EQUIPMENT

Cinema Engineering Company, 1510 West Verdugo Avenue, Burbank, California has recently issued a 32-page catalogue covering its line of attenuators and related audio accessories.

The information included in the catalogue is concise but complete, in many instances the material is presented in tabular form for quick reference. The products are pictured and described and include such items as volume indicator units, db and vu meters, decade resistance boxes, jacks, patch cords, plugs, relay racks, terminal blocks, miscellaneous parts and supplies.

CONDENSER REPLACEMENTS

A new 16-page catalogue recently issued by *Sprague Products Company*, North Adams, Massachusetts contains a comprehensive listing of condensers for practically every radio and television service, amateur radio, experimental, laboratory, and other needs.

Of particular interest to television technicians are the sections covering the company's "Telecap" molded tubulars, the "Twist-Lok" prong mounting dry electrolytics, "Ceramate" disc ceramics, "Bulplate" multiple ceramics, and "Doorknob" high voltage ceramics.

Copies of Catalogue C-607 are available either from the company or from the company's parts distributors.

TUBE TESTING DATA

The Hickok Electrical Instrument Company, 10677 Dupont Avenue, Cleveland 8, Ohio is currently offering copies of a new 16-page booklet which illustrates and describes the different theories and the four basic methods of tube testing.

The publication includes circuit dia-

SURPLUS SPECIALS

TUBES We carry a complete line of Standard Brand, New, Receiving and Transmitting TUBES—all at Very Low Prices.

Just a Few of Our Specials—All Brand New

35Z5	\$.55	9001	\$1.69
50L669	9002	1.35
12SQ7GT69	9003	1.69
12SA7GT79	900489
12SK7GT79	9005	1.75
6SN7GT79	900639
5U4G59	6AL559

Write or Call for Additional Tubes Not Listed

DYNAMIC MICROPHONES

No. 7, used with Mark II Transmitter & receiver. Complete with 6 ft. rubber line cord. Ideal for transmitters & amps. **\$2.95** Special complete

Willard STORAGE BATTERIES—Brand New

NT6 6 V., 3 amps	2 3/8" x 3 3/8" x 1 1/4"	\$2.95 ea.
20-2 2 V., 20 amps	5" x 3 3/4" x 3"	2.95 ea.
NP-15-3 6 V., 15 amps	6" x 4 1/2" x 4 1/2"	5.95 ea.
ER-40-6 6 V., 40 amps	4 1/2" x 7 1/8" x 6 3/4"	5.95 ea.

Brand New DYNAMOTORS

DM 21, 12 V. in, 235 out 90 ma.	ea. \$6.95
PE 135AX, 12 or 24 V. in, 500 V. out, 200 ma.	ea. \$19.95

THROAT MIKES. #T30V	ea. 69c
DYNAMIC MICROPHONE, units #T44A	ea. 89c
J-3S. PROFESSIONAL TELEGRAPH KEYS	ea. 98c

Write for Complete, New Catalog
All prices F.O.B., New York City. 25% deposit required.

WILLIAMS ELECTRONICS CO.
62 Cortlandt St., New York, N. Y.
HANover 2-7468

**The Largest Selling
LIGHTNING ARRESTER
At Any Price!**



Protects Home and TV Set Against Lightning Hazards **\$2.25** LIST
U.S. Patent No. D-4664

- Installs anywhere
 - No wire stripping, cutting or splicing
- (Complete with strap and ground wire.)
OVER 1,000,000 IN USE TODAY!
See Your Jobber or Write for Form No. 84

JFD MANUFACTURING CO., Inc.
6205-1 16th AVENUE, BROOKLYN 4, N. Y.
FIRST in Television Antennas and Accessories

grams and formulas, a summary of a survey on the nature of failures of TV receiver tubes, and information about the company's line of tube testers. Copies of the booklet are free of charge.

VIBRATOR REPLACEMENTS

James Vibrapowr Company, 4036 N. Rockwell Street, Chicago 18, Illinois now has available a new vibrator replacement guide which is being offered to technicians and others interested in the application of vibrators.

The listing includes the company's complete line of vibrators, base wiring diagrams, and other pertinent information.

TUBE CHARACTERISTICS

Raytheon Manufacturing Company, 55 Chapel Street, Newton 58, Massachusetts has just issued a new 8-page bulletin covering special purpose tube characteristics.

Information on subminiature, magnetron, klystron, rectifiers, voltage regulators, radiation counter, transmitting, etc. type tubes is presented in easy-to-use tabular form. A terminal and basing connection chart is also included for reference.

MAGNECORD CATALOGUE

Magnecord Inc., 360 N. Michigan Avenue, Chicago, Illinois now has available for distribution copies of its new illustrated catalogue which describes the company's line of magnetic tape recording equipment and the facilities available for building special equipment to individual requirements.

"SLIDE-RULE" GUIDE

Jensen Industries, Inc., 329 S. Wood Street, Chicago, Illinois has developed a simplified phonograph needle chart and replacement guide for use by the retail and jobbing trade.

Designed to fit either pocket or service kit, the new needle guide provides the answer to the problem of the proper needle replacement for every make of phonograph and cartridge.

The guide resembles a graphic calculator type of slide rule and includes all the necessary variables and characteristics required in the absence of the exact model or replacement number.

RECORDING RATE CARD

Audio & Video Products Corp., 1650 Broadway, New York 19, New York is offering a pocket-size card covering its facilities and rates for tape recording editing, multiple tape recording, instantaneous, and master disc recording.

Copies are available without charge to those using recording media.

NEEDLE REPLACEMENTS

Electrovox Co., Inc., 60 Franklin Street, East Orange, New Jersey is currently offering copies of its new "Walco" phonograph needle replacement chart to jobbers and dealers.

The 11"x17" chart shows not only all of the phonograph needles in use by leading record player manufacturers, but cartridge makers as well. The

*Save Time
Save Money
with these...*

New STANCOR REFERENCES

The big new Stancor 1951 Mid-Year Catalog lists 441 Stancor transformers ... the most complete catalog line in the industry. All transformers, including television components, are classified and indexed so you can easily locate the unit you need. Each listing includes electrical specifications, dimensions, weight and list price. Clear illustrations show each mounting type in detail.

★ ★ ★

The 8th Edition of the Stancor Television Catalog and Replacement Guide provides you with quick, easy-to-read replacement information on 1511 TV models and chassis made under 79 brand names. All manufacturers are listed alphabetically and the models and chassis are listed in numerical order. A separate section lists all Stancor TV transformers and related components by part number.

Both of these up-to-date references are now stocked by your Stancor distributor, or write Stancor directly for your free copies.

★ ★ ★

AUDIOPHILES—Use Stancor transformers to build the famous Williamson High Fidelity Amplifier. Circuit diagrams and complete parts lists are available in Stancor Bulletin 382 at your Stancor distributor.



*Most Complete Line
in the Industry*

STANDARD TRANSFORMER CORPORATION

3584 ELSTON AVENUE, CHICAGO 18, ILLINOIS

BUILD 15 RADIOS ... Only \$19.95

- Absolutely No Knowledge of Radio Necessary
- No additional Parts Needed • Tools Included
- Excellent Background for Television

10-DAY MONEY-BACK GUARANTEE

The Progressive Radio EDU-KIT is a Home Radio Course offered in Kit Form at a rock-bottom price. No previous knowledge of radio is required. All necessary parts, tools and instructions are included. All parts are individually packaged for easy identification. Instructions are simple and extremely easy to follow.

Radio Theory, Construction, and Trouble-Shooting are included. You will construct 15 Radios, including Receivers, Transmitters, and Audio Amplifiers. You begin with a simple circuit and gradually progress to more advanced circuits. Each of these radios operates on 110 volts AC or DC.

The Progressive Radio EDU-KIT has been used successfully by many thousands of individuals with no previous background in radio, by various Radio Clubs, Radio Schools, and by the Veterans' Administration for job training. The kit actually pays for itself in a few weeks because even a complete beginner can make use of this practical training to do repair jobs for friends and neighbors.

The price of \$19.95 is not a down payment. IT IS THE COMPLETE PRICE OF THE PROGRESSIVE RADIO EDU-KIT, including the FREE EXTRAS listed below. You keep everything, including all parts, tools, instructions, etc.

FREE 1951 EXTRAS:

- ELECTRICAL AND RADIO TESTER
- ELECTRIC SOLDERING IRON
- BOOK ON TELEVISION
- RADIO TROUBLE-SHOOTING GUIDE
- MEMBERSHIP IN RADIO-TV CLUB
- QUizzes
- CONSULTATION SERVICE

ORDER YOUR PROGRESSIVE RADIO "EDU-KIT" TODAY, OR SEND FOR FURTHER INFORMATION.

POSTAGE PREPAID ON CASH ORDERS. C.O.D. ORDERS ACCEPTED IN U.S.A.
PROGRESSIVE ELECTRONICS CO. 497 Union Ave., Dept. RN-9, Brooklyn 11, New York



COMPARE OUR PRICES!

Don't be misled—Ours are Standard Brands These are all top brands. Many in Original Factory Boxes. All individually boxed.

SPECIAL!

1B3 .. \$0.95	6BQ6 .. \$1.20	12AT7 .. \$1.09
6AL5 .. .65	6T7 .. .88	12AU7 .. .80
6AU6 .. .65	6W4 .. .54	12BH7 .. .72

STANDARD BRANDS

OZ4 .. \$0.66	6AH6 .. \$1.56	6Y6 .. \$0.96
1A5 .. .80	6AK5 .. 1.56	12AX7 .. .96
1A7 .. 1.00	6AQ5 .. .75	12BA6 .. .72
1H5 .. .80	6ARS .. .72	12BA7 .. .96
1N5 .. 1.00	6AV6 .. .66	12BE6 .. .72
1Q5 .. 1.06	6BA6 .. .72	12SA7 .. .85
1R5 .. .85	6BG6 .. 1.92	12SK7 .. .80
1S5 .. .85	6B16 .. 1.20	12SQ7 .. .72
1U4 .. .80	6CD6 .. 2.40	14Y4 .. .96
1U5 .. .80	6J6 .. 1.16	25A7 .. 1.80
1X2 .. 1.06	65A7 .. .80	25L6 .. .80
3Q5 .. 1.10	65H7 .. .65	32L7 .. 1.28
5U4 .. .66	65K7 .. .72	35L6 .. .80
5V4 .. .96	65N7 .. .88	35W4 .. .50
5Y3 .. .50	6B16 .. 1.20	3Z5 .. .60
6AC7 .. 1.16	6V6 .. .80	47 .. 1.16
6AG5 .. 1.06	6W6 .. .88	50L6 .. .80
6AC7 .. 1.28	6X5 .. .60	11Z6 .. .96

Order other types not listed, our prices are lower!

TELEVISION ANTENNAE

CONICAL 8 ELEMENT	\$2.99 ea.
DOUBLE Bay Conical with stacking rods ..	6.58 ea.
QUICK Rig folded high and folded low ..	3.99 ea.
INLINE (Six to a carton this & all above items)	3.99 ea.
INDOOR V (Individually cartoned) ..	1.99 ea.

ANTENNAE ACCESSORIES

CHIMNEY MOUNTS, special	\$.99
3 1/2" wall mount, special29
7" wall mount, special89
12" Eave Bracket, special	1.99
5 ft. masts, special89
10 ft. masts, special	1.79

SPECIAL 300 OHM—1st quality 55 mil web, 22 gauge pure polyethylene and 7 strand pure copper. \$17.50

SPEAKERS (Standard Brands)

4" PM Alnico #5	\$1.29
5" PM Alnico #5	1.49

VOLUME CONTROL "SPECIAL"

1/2 meg. with switch Standard 2 1/2" shaft. .49c

OUTPUT TRANSFORMERS (Standard Brands)

To match any of the tubes below
50L6—6V6—6K6—6F6—354—3V4—3Q5
ALL AT ONE PRICE. .45c

MINIATURE I.F. TRANSFORMER

Standard "K" Trans. 456KC—Complete with mounting clip and adapter.
Input. .59c Output. .59c

DIAL LAMPS (Standard Brands)

#47 G.E.—10 to box. \$4.95 for 10 boxes
.55 per box of 10

ALLIANCE 3-SPEED PHONO MOTOR

Complete with turntable (Special)

3-TUBE PHONO AMPLIFIER

With tone and volume controls—uses 12SQ7—50L6—35Z5.
Less tubes and output transformer. \$2.89
With tubes

SELENIUM RECTIFIER (Top Quality)

Full Wave Bridge Types

Up to 18 v. in/up to 14 v. out.	Up to 36 v. in/up to 28 v. out.
2 amp. \$ 2.50	1 amp. \$ 2.75
4 amp. 3.75	2 amp. 2.75
8 amp. 5.75	4 amp. 5.50
12 amp. 7.75	8 amp. 7.50
24 amp. 11.50	12 amp. 10.00
	24 amp. 22.00

115 v. in 100 v. out—2 amp.—\$9.49. Complete Power Supplies Built to Order. Special Rectifiers Built to Order. "FAST SERVICE!"

CONDENSERS (Standard Brands)

ELECTROLYTIC TUBULAR TYPE

Mfd.	W. V.	Price
50-80	150v.	49c
	F. P. TYPE	
40-40	400-475	\$1.10
20-20-20	450-450-25	.69
	PAPER TUBULAR	
.01	600v.	8c
.05	600v.	10c
.1	600v.	12c

TELEVISION HI-VOLT CERAMIC CONDENSERS
.005 10KV 49c
.005 20KV 69c

10% Deposit with Order, Balance C.O.D. All Shipments F.O.B., N.Y.C.

ASK FOR COMPLETE CATALOG

ATLAS TEL-RAD PARTS

153 CHAMBERS ST., DEPT. RN-9, NEW YORK 7, N.Y.
Phone HANover 2-5813

chart gives the name of the maker, the needle model by maker's number, a picture of the needle, and the "Walco" replacement number and list price.

G-E REPLACEMENT GUIDE

The Receiver Division of *General Electric Company*, Electronics Park, Syracuse, New York is currently offering copies of a new publication, "Stylus and Cartridge Replacement Guide," which has been designed especially for dealers and technicians.

The new guide charts the complete use of styli and cartridges in G-E as well as competitive phonograph combinations and depicts the advantages of the company's variable reluctance cartridge with the baton stylus.

Copies of this guide are now available from the company's parts distributors.

"HAM NEWS"

The Tube Divisions of *General Electric Company* have announced the availability of a cloth-bound volume of "Ham News" containing a copy of every issue published from May-June 1946 up through the November-December 1950 issue.

Hams and experimenters may obtain copies by writing the Tube Divisions of the company at Schenectady, New York. The price is \$2.00 per copy.

ASTATIC CATALOGUE

The *Astatic Corporation* of Conneaut, Ohio has recently published a general catalogue which covers all of the products manufactured by the company for the civilian market.

Included are illustrations of the products, descriptive information, and performance data on TV and FM boosters, microphones and stands, phonograph pickups and cartridges, needles, recording heads, and related equipment.

Copies of Catalogue 51 are available from the company's Sales Department.

—30—

The success of this year's convention of the Audio Engineering Society and The Audio Fair was uppermost in the minds of these gentlemen who met recently to lay plans for these events. As in previous years the three-day session will be held at the Hotel New Yorker, beginning November 1st. Meeting with Harry N. Reizes, Fair manager (left), were (from left to right): F. Sumner Hall, acting secretary; C. J. LeBel, past president; C. G. McProud, executive vice-president; John D. Colvin, president; and Ralph A. Schlegel, AES treasurer. The Audio Fair will be open to the public but convention sessions will be closed.



YOUR COPY of NEW 1951 COMPLETE GREYLOCK TELEVISION CATALOG

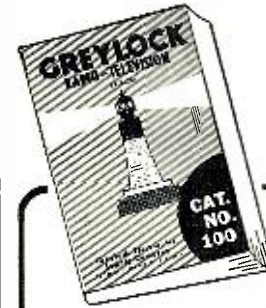

IS NOW **READY!**
SEND FOR IT TODAY!

68 Pages crammed full of Radio—Electronic—Television

quality merchandise at terrific savings! Many standard lines carried, including:

- BOGEN Challenger Line, Boosters
- JACKSON Instruments
- RIDER Publications
- CORNELL-DUBILIER Vibrators, Converters, Rotators
- SPRAGUE • HYTRON • BURGESS
- REGENCY • ELECTRO-VOICE • JENSEN

High quality Greylock Tubes still available at some of Today's best prices. If you sell or service Radio, TV or Electronics equipment, you can't afford to be without this GREAT BUYING GUIDE! Write NOW for your copy (unless already on our mailing list).

GREYLOCK ELECTRONICS SUPPLY CO.
115 Liberty Street - New York 6, N. Y.

EMPLOYERS NOW BIDDING FOR TELEVISION TRAINED MEN WE TRAIN YOU AT HOME IN SPARE TIME

TV-Radio-FM Service Technicians in Big Demand! Get top pay faster through RTTA practical shop-training methods right in your own home. We supply everything.

EARN WHILE YOU LEARN! RTTA Furnishes Everything! Tubes, Batteries, Large TV Picture Tube!
YOU BUILD AND KEEP THIS GIANT SCREEN TELEVISION SET!

Your choice of 10, 12 1/2 or 16" Picture Television Tube
WE PREPARE YOU FOR FCC LICENSE! U.S. GOV'T. NEEDS FCC MEN

FREE At No Extra Cost YOU GET A ROUND TRIP TO NEW YORK CITY

After completing home study training, your transportation both ways from any point in U. S. or Canada will be paid by RTTA. You visit our affiliated facilities in N.Y.C. as part of your 2 weeks of practical training on newest equipment at RTTA.

NO PREVIOUS EXPERIENCE NECESSARY

FREE EMPLOYMENT HELP
RTTA helps you earn while you learn! Open to men of all ages! RTTA prepares you for BIG PAY EXTRA. GOSH YOU BUILD THESE AND FOUR OTHER UNITS

DRAFT AGE MEN
Special "SPEED-UP" Radio Technician program here! You get BETTER SERVICE RATING—BETTER PAY! You can find out by return mail! Send Coupon TODAY!

FREE "SPEED-UP" OFFER—COUPON

MULTITESTER **SIGNAL GENERATOR** **5-TUBE RADIO**

YOU GET 15 BIG TELEVISION RADIO KITS AT MOD. EXTRA COST! YOU BUILD THESE AND FOUR OTHER UNITS

Radio Television Training Association
515 Clinton Ave., Dept. 39, Newark 1, N. J.
Rush me FREE Sample Lesson and Catalog "How to Make Money in Television," in spare time, AT HOME, while learning. Also "Speed-Up" Service Rating Plan. I'm under no obligation.

Name.....Age.....
Address.....
Approved by Commissioner of Education of State of N. J.

International Short-Wave
(Continued from page 134)

Noted at fair level in German with music around 2300. (Hoogerheide, Wisc.)

Greece—Greek station noted near 7.580 with recordings 1330; signs off 1531 with Greek National Anthem. May be Kavala, (Pearce, England) Cushen, N. Z., lists Kavala on 7.580, 250 watts, scheduled 0000-0130, 0500-0515, 1130-1500. (Radio Australia) Larissa, 6.745. noted 0100; no English heard lately on Thursday 1530 as scheduled, but has had recordings to closedown 1600. (Pearce, England)

Current schedules from *Radio Athens* are 2000-2100 on 11.718 to USA; 2330-0830 on 7.300 Greek; 0915-0930 on 15.345 news in Russian; 1030-1300 on 7.300 Greek; 1300-1400 on 7.300 in Balkan languages; 1430-1445 on 11.718 English; 1445-1500 on 11.718 French, and 1530-1700 on 7.300 Greek; power remains 7.5 kw.; news in English nightly is around 2040 on 11.718. (Lucas, N. Y.) No longer uses 6.177 or 9.607. (Radio Sweden)

Guatemala—TGNA has moved from 6.040, by official permission, to 5.955 where is parallel with 9.660A; would like reports, especially on the new 5.955 outlet. (Boice, Conn., others) Has English 2200-2230.

Haiti—4VRW, 9.838, is heard with English Mon., Wed., Fri., around 2130 (may vary); announces "Voice of the Republic of Haiti;" bad CWQRM around 2130. (Lucas, N. Y.) 4VN noted on about 6.013, strong 2100 tune-in when gave call letters in French; classical music started 2101 (Bellington, N. Y.)

Holland—In the North American (English) transmission 2130-2210, "Letterbox" is Tuesdays 2200; frequencies are 9.59, 11.73. (Shanahan, Wisc., others)

Hong Kong—ZBW3, 9.525, fair signal with Chinese 0645; BBC news relay 0700. (Stein, Calif., others)

Hungary—Budapest has English for Europe 1600-1630; 1710-1740 for North America; frequencies currently are 11.910, 9.833, 7.220. (Pearce, England) Relays *Radio Moscow* widely—afternoons and evenings (EST).

India—AIR, 15.29, noted with news 1045. (Russell, Calif.) This channel is widely reported with news 1930, good level. The 15.16 frequency continues with good signal in all-native musical program 2030-2200 daily. (Fuller, R. I., others)

Delhi sent these current schedules via airmail: *General Service*—To East and Southeast Asia. Australia, 1930-2015, 15.290, 11.850; 2030-2200, 17.830, 15.160; 0200-0330, 21.510, 17.830; 0600-0815, 17.740, 15.190; 0830-0945, 17.740, 15.290. To Middle East, Central Europe, United Kingdom, 0200-0330, 21.510, 17.830; 0230-0330, 17.740, 15.190; 0600-0700, 17.740, 15.190; 0830-0945, 17.740, 15.290. To Burma, Philippines, 0200-0330, 21.510, 17.830. To China,

September, 1951

SEE LEO FIRST FOR
hallicrafters

I can SAVE you money . . . Liberal Trade-ins



LEO I. MEYERSON W6GFO

A TAILOR-MADE SET FOR THE BEGINNING AMATEUR OR NOVICE...



\$89.95

New SR-75 TRANSCEIVER

Receives on 540 Kc through 32 Mc — Transmits on 10, 11, 20, 40, or 80 meter bands. 5 tubes plus regulator. Housed in grey steel cabinet. Shipped with coils, less crystals. Low down payment.

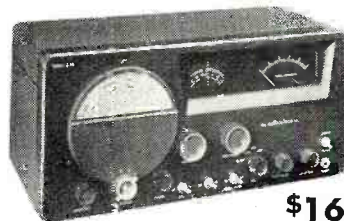

\$169.50

New S-76 RECEIVER

Extra selectivity with double superheterodyne circuit. One RF, two conversion and 3 IF stages. Range 550-1550 Kc, 1.7-34 Mc in four bands. 8 tubes plus voltage regulator and rectifier. Complete with tubes, less speaker.

R-46 Speaker \$19.95

HALLICRAFTERS RECEIVERS AVAILABLE FOR IMMEDIATE SHIPMENT

S-38B \$49.50
S-40B \$99.95

S-72 Portable \$109.95
SX-62 \$289.50

Famous WRL RADIO REFERENCE MAP 25c FREE



CU ON 10-20 & 75 METERS

SEND FOR WRL COMPLETE PARTS CATALOG.



NEW LOG BOOK 25c

For mobile or fixed station. Spiral binding. Full column log listing all FCC required info. Will accommodate 1,525 stations. "Q" signals, phonetic alphabet, amateur international prefixes.

PHONE 7795

WRITE—WIRE



COUNCIL BLUFFS, IOWA

NAME YOUR TERMS LOW DOWN PAYMENTS PERSONALIZED SERVICE

Trade for a new Hallicrafter Receiver. I'll allow you more for your present equipment. WRL buys more equipment . . . WRL sells more equipment. Our large volume of sales means faster turnover, greater savings for you! We finance our own paper—no red tape!

WORLD RADIO LABORATORIES

744 West Broadway Council Bluffs, Iowa

RN-9

Please send me:

- Radio Map
- New Catalog
- Used Equipment List
- SR-75 Info
- S-76 Info
- New Log Book

Name

Address

City

State

COLOR TV FILTERS

Sensational Tri-Color Film to Go Over the Face of the CR Tube

BLUE SKIES • SEA GREEN FLESH TONES

WIRE NOW FOR IMMEDIATE DELIVERY

Model	Size	Price
1920	16" x 20"	\$4.05
1617	17" x 18 1/4"	3.95
1214	13" x 11 1/2"	3.50
710	12" x 10"	2.95

National Agency

Rainbow Plastics Company

883 Boylston Street Boston, Mass.

COpley 7-5620

5% Discount if Check or Money Order Accompanies Order

Collector's Item

Choice of Leading Music Critics!

GARRARD

World's Finest 3 Speed Record Changer



Write for FREE literature. GARRARD SALES COMP., 164 DUANE ST., NEW YORK 13

Gentlemen:

I am interested in learning what to look for when purchasing a 3-speed record changer. Please send me, without obligation, your FACT SHEET.

NAME

ADDRESS

CITY

ZONE STATE

9N

**736
PAGES
of
FACTS**

**THE NEW, GREAT
ONE-VOLUME
LIBRARY OF RADIO
INFORMATION**

Giant Thirteenth Edition
RADIO HANDBOOK

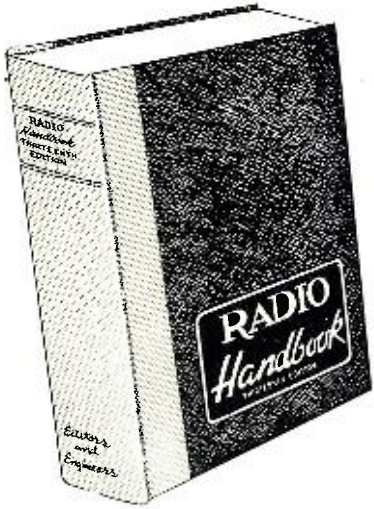

For Practical Radio Men:

How to design, construct and operate standard types of radio transmitting and receiving equipment... both at standard frequencies and in the v.h.f. range. Information you must have where you can find it quickly... now in a complete one-volume library, the RADIO HANDBOOK!

For TV and Radio Technicians:

Reference data galore, the latest in theory and practice, and a wealth of information on the operation of vacuum tubes as amplifiers in all frequency ranges. Profusely indexed for easy finding, clearly illustrated and described for easy reading, all within easy reach for owners of this one-volume RADIO HANDBOOK!

For Advanced Amateurs:

In addition to all this, you'll find new information on simplified TVI-proofing, bandswitching fixed-station and mobile transmitters, a remotely-tuned v.f.o. for mobile or fixed-station use and a multitude of new ideas and suggestions for improved operation. Also, more study material has been added to help you obtain your first licenses, or a higher class of amateur or commercial license... it's all in the new RADIO HANDBOOK!

You can't afford to be without this beautifully bound one-volume "encyclopedia of radio information"... the largest RADIO HANDBOOK ever published... 736 pages of vital information... at a cost of less than one cent per page!

\$6.00 AND WORTH IT!
BY MAIL FROM US, \$6.25; FOREIGN, \$6.50



ANTENNA MANUAL

The most practical, comprehensive book on antennas. 300 pages of down-to-earth help on antenna feed line, radiation and propagation for all frequencies up to 1000 Mc. including FM and TV. Plain language; no need to brush up on math. A necessity for everyone interested in transmission or reception.

\$3.50 AT YOUR DEALER—On mail orders from us, \$3.60 postpaid. Add tax in Cal. Foreign, \$3.75



BETTER TV RECEPTION

THE "Fringe Area TV" Reference Book By W. W. Smith and R. L. Dawley TV signal propagation, evaluation of TV antenna, making a TV signal survey, types of masts and towers and recommended installation practices. Full data on rhombics, how to use open-wire feed line, how to eliminate ghosts, minimizing fading, TVI, etc.

\$2.50 AT YOUR DEALER—On mail orders from us, \$2.60 postpaid. Add sales tax in California.

AT YOUR FAVORITE DEALER
OR DIRECT BY MAIL FROM
Editors and Engineers
LIMITED
1302 KENWOOD ROAD, SANTA BARBARA, CALIFORNIA

Japan (on Sat., Sun. only), 0530-0600, 17.760, 15.160. To East and South Africa, Mauritius, 2300-0015, 17.740, 15.160; 1045-1215, 15.290, 11.830. To West Indies, 1830-1930, 15.290, 11.850, 9.550, 7.155. *Eastern Service*—To Burma, 1945-2000, 11.710, 9.720; 0615-0700, 21.660, 15.160. To China, 0430-0545 (to 0530 only on Sat., Sun.), 17.760, 15.160. To Indonesia, 1745-1800, 11.790, 9.720; 0700-0730, 21.660, 15.160. To East and Southeast Asia, 1930-2015, 15.290, 11.850; 2030-2200, 17.830, 15.160; 0200-0330, 21.510, 17.830; 0600-0815, 17.740, 15.190; 0830-0945, 17.740, 15.290. *Western Service*—To Fiji, 0200-0330, 21.510, 17.830. To West Pakistan, 2245-2300, 11.850, 9.670, 7.120, 6.190; 0945-1000, 7.155, 6.010. To Afghanistan, 2215-2230, 9.565, 7.225; 0030-0130, 9.565, and (Fri. only) 7.225; 0845-0930, 6.010; 1130-1230, 9.720, 7.155, 5.990, 4.940. To Persia, Afghanistan, 1230-1330, 9.720, 7.155, 5.990, 4.940. To Saudi-Arabia, Egypt, Lebanon, Syria, North Africa, Trans-Jordan, the Sudan, 2230-2315, 15.130, 11.760; 0000-0045, 17.830, 15.210; 1230-

1430, 9.550, 7.120. To East and South Africa, Mauritius, 2300-0015, 17.740, 15.160; 1045-1215, 15.290, 11.830. To Europe, 1400-1500, 9.720, 7.155; 0230-0330, 17.740, 15.190. *English News Service* is listed 1400-1410, 9.720, 7.155; 1930-1945, 15.290, 11.850; 2315-2330, 17.740, 15.160; 0300-0310, 17.740, 15.190; 0830-0840, 17.740, 15.290; 1045-1100, 15.290, 11.830.

Indo-China (Vietnam)—*Radio France-Asie*, 11.83, Saigon, noted with news recently 0500-0515 sign-off; fair level. (Rosenauer, Calif.) When this was compiled, *Radio France-Asie* listed its current channels as 11.78, 11.83, 7.23, 9.524, 9.754. (Gay, Calif.) Although listed 9.754, had been using 9.74 for the two weeks prior to this compilation. Is a "wanderer" lately. (Balbi, Calif.) Listed *English* broadcasts for 1730-1745 on 9.524; 1900-1915, 2030-2045 on 9.800; 0500-0515 on 11.830; 0900-0915 on 11.780; French for 1715-1730 on 9.524, 1815-1845, 1915-1930 on 9.524, and 9.800; 2045-2100, 2345-0000, 0615-0630, 0700-0730, 1015-1030 on 9.800.

GETTING A.V.C. FROM A BIASED DETECTOR

By CHARLES E. COHN

THE advantages of the biased detector family, which includes the plate detector and the infinite impedance detector, have long been recognized. Both types have the major advantage of high input impedance, meaning that unlike the ubiquitous diode, they do not ruin the selectivity of their tuned circuit. In addition, the infinite-impedance detector has less distortion than the diode on highly modulated signals.

Given these major benefits, why is it that this type of detector has not been used more extensively? The answer is that it has always had a major drawback, which was the apparent impossibility of making it produce a signal for automatic volume control. Since a v.c. is regarded as a necessity in the modern receiver, this has precluded the use of the biased detector in the majority of sets. Attempts have been made to overcome this obstacle, but the arrangements involved have either ruined the inherent selectivity of the system or necessitated unacceptable circuit complication.

However, the solution to this problem becomes quite simple if we merely remember that the biased detector is nothing but a form of r.f. amplifier. It is a very poor one, to be sure, but it is still an r.f. amplifier. Therefore, there should be r.f. voltage at the plate. In that case, why not use this r.f. voltage to provide a.v.c., instead of bypassing it uselessly to ground, as is usually done?

A circuit for utilizing this idea in the case of a plate detector is shown in the diagram of Fig. 1. It will be noted that the greater part of the circuit is conventional, with a few important additions. The r.f. choke, RFC₁, placed between the plate and the audio load resistor, acts as a load impedance for the r.f. component of the detector output. The r.f. voltage developed across RFC₁ is capacitively coupled by means of C₂ to an ordinary a.v.c. rectifier circuit. The rectifier (V₂) diode can be either the thermionic or crystal type. Many plate detectors already have in the position of RFC₁ an r.f. choke or resistor by-

passed at both ends for the purpose of r.f. filtering. In such a case, this can be used for the r.f. load impedance, with the plate bypass removed. The case of the infinite-impedance detector is also easily handled, the choke RFC₁ being placed between plate and "B+", with C₂ connected to the plate. If a set already has a biased detector with a separate a.v.c. circuit operating from an r.f. or i.f. plate, an improvement in performance can be realized by transferring the a.v.c. connection to the detector plate, in the manner here described.

Despite the simplicity of this circuit, it is an excellent performer. Not only does it maintain the high input impedance of the detector, but it also gives improved a.v.c. action, due to the amplification of the r.f. signal. In short, this system appears to be the key to effective utilization of the biased detector.

-30-

Fig. 1.

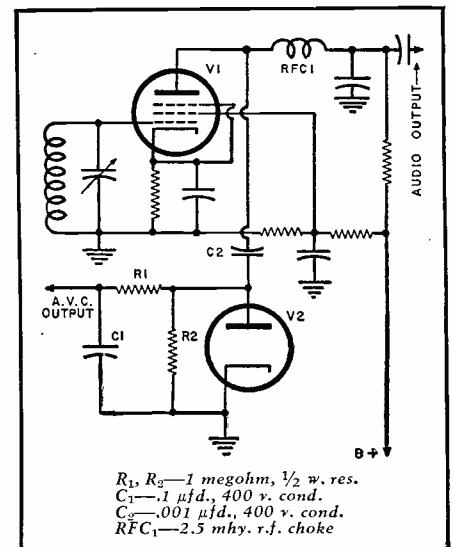

R₁, R₂—1 megohm, 1/2 w. res.
C₁—1 μfd., 400 v. cond.
C₂—0.01 μfd., 400 v. cond.
RFC₁—2.5 mhy. r.f. choke

(Cushen, N. Z.) Still noted with news 0900 on 11.780.

"Voice of Vietnam" noted on measured 9.619 concluding *English* session 0925, followed by native music to 0930 sign-off. (Russell, Calif.)

Iran—Radio Tabriz sent letter and schedules via registered mail; frequency is approximately 6.095; schedule is 2115-2315, 0315-0715, 1015-1315; on Fridays, second session starts 0015. (Pearce, England) *Radio Teheran* noted on 15.100 in parallel with 6.155 with news. (Pearce, England) Seems to have dropped the Russian news period at 1515 (which was jammed) and often closes now around 1508 to 1510 following *English* newscast. (Bellington, N. Y., others) EQB, 9.660, has been logged 0300 relaying the Home Service. (Radio Sweden)

Israel—Israeli Forces, 4X4EA, Tel Aviv, heard 1330 with recordings; woman announcer; signs off with bugle sounding "Lights Out" at 1400 (was 1500 earlier this year). Tel Aviv, 9.010A, still has "Voice of Zion" session in *English* daily 1615-1700 closedown; on some days, ends this period with a Hebrew Lesson. (Pearce, England, others) When this was compiled the new 50 kw. transmitter (due to have opened in May) was not yet reported on the air.

Italy—Rome's 11.905 and 15.420 channels heard with news 1900-1915; also news 2145 over 17.800, 15.420, 15.120, 11.905, 11.810. (Lucas, N. Y.)

Japan—AFRS, Tokyo, has moved its 25-m. channel from 11.800 to 11.815 where it has improved signal, is in the clear now; noted around 0300; sign-off time is 0430. (Rosenauer, Calif.) In the 49-m. band has moved from 6.175 to 6.080, still parallels 4.86, and schedule is unchanged. (Balbi, Calif.) JKJ, 7.285, strong signal early mornings with NHK network programs; JKM2, 9.695, is especially strong mornings (EST). (Stein, Calif.)

Kashmir—The *Indian Listener* lists *Radio Kashmir* at 2130-2330 on 989 kc. and 4.860, news daily 2130 (presumably relayed from AIR, Delhi); 0100-0230 on 989 kc. and 7.270; and 0700-1200 on 989 kc. and 4.860, news 1030 (also probably an AIR relay). Location is Srinagar. Has talk in *English* scheduled 0900 on Thursdays.

Kenya Colony—Nairobi, 4.855, noted with orchestra music and closing 1400. (Pearce, England) Dary, Kans., has received this data from D. J. L. Garbutt, Capt., R. Signals, Station Commander, Forces Broadcasting Station Number 2, P.O. Box 116, Mackinnon Road, East African Command, Kenya—"Lately we have not been using 7.180 but we are using 6.115 and we are on the air at the following times—2200-0000, 0430-0630, 0900-1400 weekdays; 0900-1500 on Sats., and 0100-1400 on Suns. The language in use is *English* with the exception of two 30-minute periods of Swahili each week."

Korea (South)—At the time this was compiled, HLKA, Seoul, was reported back on the air on 7.935; heard weakly 0715-0815; at 0730-0800 organ music,

Tubes Reduced Terrifically

!! Prices Smashed !!

TRT tubes undergo rigid tests before leaving the TRT plant. This guarantee of testing is but one assurance of quality. Rugged construction, dependable performance and economical service make TRT tubes more desirable. Compare performance and quality with any standard tube.

✓ Check This  List For Fully Guaranteed Tubes

Type	Price	Type	Price	Type	Price	Type	Price	Type	Price
OZ4	.63	5AX4	.47	6BL7	1.10	6T8	1.10	12SA7GT	.68
1AB5	1.22	5AZ4	.54	6B16	.76	6U5	.76	12SG7	.76
1A6	1.22	5Y3GT	.39	6BN7	1.22	6V6GT	.76	12SK7GT	.68
1A7GT	.84	5Y4G	.57	6BQ6GT	1.22	6W4GT	.68	12SL7GT	.91
1B3GT	1.01	5U4G	.57	6BY5	1.01	6W6GT	.76	12SN7GT	.84
1B5	1.22	5X4G	.68	6C4	.63	6X4	.57	12SQ7	.57
1B7GT	1.22	5Z3	.63	6CB6	.76	6X5	1.01	12SR7	.76
1C5GT	.84	6AC7	1.10	6CD6G	2.28	6X5GT	.57	19B6G6	2.28
1H5GT	.63	6AB4	.76	6E5	.84	6Y6G	.91	19T8	1.10
1L4	.76	6AG5	.91	6F5GT	.63	7C5	.68	25BQ6GT	1.22
1L6	1.01	6AK5	1.48	6F6G	.63	7E6	.84	25AV5	1.01
1LA6	1.01	6AL5	.68	6H6GT	.68	7F7	.84	25L6GT	.63
1LC5	1.01	6AQ5	.76	6J5GT	.57	7J7	1.01	35A5	.68
1LC6	1.01	6AQ6	.68	6J7G	.84	7Q7	.68	35B5	.63
1LH4	1.01	6AT6	.57	6J8G	1.22	7X6	.84	35C5	.63
1LN5	1.01	6AU6	.76	6K6GT	.57	7Y4	.68	35L6GT	.63
1R5	.76	6AV6	.57	6L6G	1.10	7Z4	.68	35W4	.47
1S5	.68	6AX5GT	.63	6L6GA	1.10	12A8GT	.84	35Y4	.68
1T4	.76	6B4G	1.22	6S4	.68	12AT6	.57	35Z5GT	.47
1T5	.91	6BA6	.68	6S8	1.01	12AT7	1.10	42	.76
1U4	.76	6BA7	.91	6SA7GT	.68	12AU6	.76	45	.76
1U5	.68	6BC5	.76	6SD7GT	1.10	12AU7	.91	50B5	.76
1X2	1.01	6BD5GT	1.22	6S7GT	.63	12AX7	1.10	50C5	.76
2A3	1.22	6BE6	.68	6SK7GT	.68	12AX7	.91	50L6GT	.63
3E4	1.82	6BF8	.84	6SL7GT	.91	12BA6	.68	50X6	.84
3Q4	.84	6BF6	.63	6SN7GT	.84	12BA7	.91	70L7GT	1.48
3S4	.76	6BG6G	1.82	6SQ7GT	.57	12BE6	.68	80	.54
3V4	.76	6BH6	.76	6SR7	.68	1258	1.08	117Z3	.57
								807	1.98

Save 5% Discount on Orders of 100 or More!

EXTRA BONUS **15% OFF** ON ALL ORDERS
This Offer Expires Sept. 30, 1951

PICTURE TUBES

Type	Price	Type	Price
17BP4	23.95	16RP4	22.95
16TP4	23.50	14BP4	17.50

TERMS: A 25% deposit must accompany all orders—balance C. O. D. All shipments F. O. B. Newark warehouse. All tubes guaranteed for 90 days. Orders under \$5.00—\$1.00 Handling Charge. Subject to prior sale.



TELEVISION and RADIO TUBE Co.
412 HALSEY STREET NEWARK 2, NEW JERSEY

TV ANTENNA SALE! ONLY \$4.50 EACH!

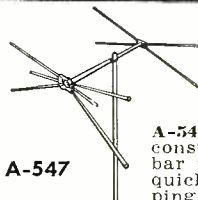

A-547

\$4.25 EACH IN LOTS OF 10
\$3.75 EACH IN LOTS OF 100
(QUANTITIES MAY BE ASSORTED)



A-1128

A-547. High gain and directivity on all channels. Aluminum construction; unbreakable polystyrene insulators. Square cross bar prevents rotation and misalignment of elements. One-man quick assembly! U-bolt for mast has tooth-grip to prevent slipping. Shipped less mast. Greatest conical value ever offered!

A-1128. Pre-assembled Vee-Beam for easy installation. High gain and excellent directional characteristics on all channels. Shipped less mast. An unbeatable buy at our bargain low price. Meets most installation requirements. Buy now!

Popular 300-Ohm
Twin-Lead,
only \$19.95 per 1000 ft.

WRITE FOR OUR
NEW BARGAIN CATALOG!

In Stock! Standard
Brand TV and
Receiving Tubes!

STAR ELECTRONIC DISTRIBUTORS, INC.
Dept. RN-9 • 7736 S. HALSTED STREET • CHICAGO 20, ILLINOIS

NOW! GET THE FACTS

COLOR TELEVISION UHF TELEVISION TV TUNERS

Here's your opportunity to purchase, through the mails, the outstanding series of Technical Notebooks published by the Television Technicians Lecture Bureau. Written and edited by Edward M. Noll, nationally prominent lecturer on television servicing and other related service problems. This series gives the service operator and technician the most complete factual, practical coverage of the three most needed information subjects—Color Television, UHF Television, TV Tuners.



COLOR TELEVISION Vol. 1,

by EDWARD M. NOLL.

A complete story on the basic elements of Color Television; the adaptation of standard television receivers for black and white reception of color signals; the CBS, RCA, CTI and other color TV systems; tricolor picture tubes; color wheel assembly and control units; adapters and converters; large color picture methods; tabular summaries of the performance characteristics of different color TV systems.

Price \$1.00

COLOR TELEVISION Vol. 2,

by CBS
Engineering Dept.

A practical, easy-to-understand analysis of receiver circuitry for the CBS system. The first section covers receiver circuitry for the CBS scanning system and possible picture defects and their causes. The second section is a complete description of a companion receiver with circuits, applications information and other important data.



Price \$1.50

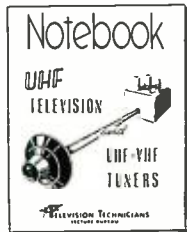

UHF TELEVISION and UHF-VHF TUNERS

by EDWARD M. NOLL.

A factual survey of UHF Television and UHF-VHF Tuners, which includes: Propagation at UHF and Characteristics, Polycasting, Converter Methods, UHF Antennas, VHF-UHF Television-Spectrum Utilization, Proposed Channel Allocations—VHF-UHF

Television, Alignment Procedures of Typical Commercial Tuners, Fringe Area Alignment and Tuner Troubles.

Price \$1.25

SEND FOR THEM NOW!

Order all three books—a \$3.75 value—at our special combination purchase price of **\$3.00**

Send check or money order to:

COUPON

GENERAL SALES COMPANY
60 East 42nd St.
New York 17, N. Y.

Send () Color Television, Vol. 1, \$1.00
() Color Television, Vol. 2, \$1.50
() UHF TV and UHF-VHF Tuners, \$1.25
() Special Combination Offer, \$3.00

Name

Address

call at 0800 in Korean, but with call letters in *English*—"HLKA, Seoul." (McPhadden, Calif.)

Lebanon—Beirut, 8.035, is scheduled 0000-0115, 0515-0800, and 1000-1600; *English* 1000-1100. (ISWC, London)

Madagascar — *Radio Tananarive*, 9.515, still noted signing on 2233 with "La Marseillaise." (Machwart, Mich.) Sent schedule of 6.172 and 9.515 in French weekdays 2230-0030, 0400-0600, 1000-1430, Sundays 2300 (Sat. *EST*)-0245, 0330-0600, 0915-1430; on 7.374 and 9.693 in Malgache weekdays 2230-0000, 0330-0531, 0900-1200; Sundays 2330 (Sat. *EST*)-0000, 0330-0530, 0900-1200. (Kroll, N. Y.)

Malaya—At the time this was written, *Radio Malaya*, Singapore, Blue Network, had just moved from 7.200 to 7.210 where had fair level 0800 with news. (Balbi, Calif.) BFEBS, 15.300, noted recently 1030-1100 with strong signal; announced as coming on 17.755 at 1045 but this one could not be located. (Boice, Conn.) The 9.690 channel noted recently 0600 with BBC news relay. (Ferguson, N. C.)

Mexico—Call on short-wave of the 15.205A Mexican is definitely XESC; XEMC is the m.w. call. (Rastorfer, Bellington, N. Y.; Stark, Texas, others)

Received QSL card from XEBT, 9.625; power output listed 10 kw.; m.w. outlet is XEB on 1220 kc. with 100 kw.; QRA is Calle Buen Tone 6, Apartado Postal 7944, Mexico, D. F., Mexico. Also received QSL card from XEXE, 11.900; pictured transmitter and antennas; said "Many thanks for an amiable report." (Kroll, N.Y.)

Mozambique — Lourence Marques noted near 4.820 with recordings, chimes and call 1445 followed by news in Portuguese; closed down 1500. Heard over CR7BU, near 4.92, with sponsored *English* program 1515; at 1555 gave closing announcements in *English*, times of re-opening, followed by playing of Ted Lewis' "Good Night Song;" after announcement in Portuguese, closed 1600 with "A Portuguesa." (Pearce, England) The outlet on approximately 9.840 has been good lately in Portuguese programs around 0000-0100. This one noted in Texas to after 0630; the 9.775 channel heard in *English* to after 0630. (Stark) The 11.764 channel still heard with *English* (commercial) programs from 2300 but is much weaker now; 4.92 which should parallel not audible lately. (Cox, Ala.)

New Caledonia — Noumea, 6.035, noted signing off 0530 with "La Marseillaise." (Stein, Calif.)

New Zealand—Wellington noted recently 0200 on 9.620 and 11.780, good signals in Ky. (Baughn) Heard signing off 0552 on 9.54 and 9.62; weak. (Guentzler, Ohio) ZL4, 15.28, noted recently 1800-1845 with music; seldom audible that early. (Sutton, Ohio)

Northern Rhodesia—Lusaka is now on the air daily 1100-1430 and Sundays 0600-0800 on 3.914, 7.220. (Radio Sweden)

Norway—Oslo uses 9.61, 11.735, 15.17, and 190 meters daily 2000-2100

The New RCP MODEL 730

Universal SIGNALIGNER

AF-AM (RF)-FM SIGNAL GENERATOR

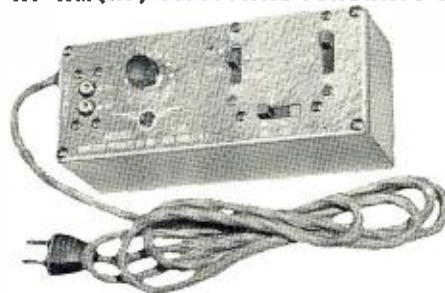

MODEL 730
Universal SIGNALIGNER . . . \$34.50

THE FM section is frequency modulated for use with ratio detectors. Simplicity and speed is accomplished by fixed frequency points at which circuits are calibrated. Attenuator provides smooth control from high signal level to a high degree of attenuation. Perfect operation from either AC or DC lines with equally high accuracy and stability. Entirely safe as the chassis and case are completely isolated from the line. Broadcast band alignment is provided by fixed frequencies of 1500 KC and 550 KC. Intermediate frequencies of 456 KC and 465 KC are also supplied. Calibration provides for alignment of 460 KC-IF systems. FM band alignment is provided by fixed frequencies at 85 MC and 108 MC which are the ends of the band. Fixed frequencies of 10.7 MC and 9.1 MC provide for I.F. alignment. R.F. frequency deviation is plus and minus 500 KC. Audio frequency modulation is provided for AM at 400 C.P.S. A separate audio output of 400 cycles is also provided. Calibrated to be accurate within 1%. Suitable trimmers permit recalibrating. Complete with tubes, shielded output cables, line cord and plug ready to use—attractive panel and case. Size 7"x2 1/4"x2 3/4". Weight 2 lbs.

Buy from Your Jobber • Insist on RCP Instruments • Write for Catalog RN-9

RADIO CITY PRODUCTS CO., INC.
152 West 25th Street, New York 1, N. Y.

New, revised up-to-date—Third Edition

HOW TO PASS RADIO LICENSE EXAMINATIONS

By CHARLES E. DREW

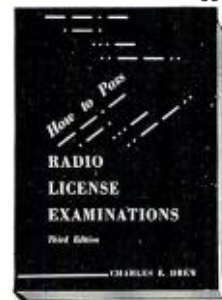

Covers commercial telegraph and 'phone licenses

The radioman's standard study guide for ten years—now completely modernized to include all the recent changes in FCC examinations. Answers the entire range of hundreds of questions in nearly every category; gives detailed explanations of many important points.

CONTENTS

Basic Law • Basic Operating Practice • Basic Radiotelephone • Advanced Radiotelephone • Basic Radiotelegraph • Advanced Radiotelegraph • Appendixes: FCC Rules • Extracts from Radio Laws • Q Code and Abbreviations • Miscellaneous

Ready in October

Prob. \$5.00

Reserve Your Approval Copy Now

Please include name, address and firm's name.

John Wiley & Sons, Inc., Dept. RT-957
440 Fourth Ave., New York 16, N. Y.

for North America in Norwegian with *English* announcements; on Sundays an *English* program called "Norway This Week" extends the broadcast 2100-2115, sometimes to 2120. (Bellington, N. Y., others)

Outer Mongolia—Stations noted on 5.265 and 6.390, in dual, around 0700, are believed Ulan-Bator. (Dilg, Calif.)

Pakistan—Radio Pakistan noted with news 0110-0120 and 0210-0220 on 17.770; at 1015-1030 on 11.725; also news at dictation speed 1210-1230 on 11.725; recently said that (announced) 11.726 is now being used instead of 11.650 but that there is no change in the 41-m. band (possibly 7.010 or 7.263?) for the Overseas Service. (Pearce, England)

Panama—HOJA, 9.650, Chitre, "Radio Provincias," noted 2147-2203 sign-off with all-Spanish program. (Patterson, Ga.) The outlet on 9.607 opens 0700. (Stark, Texas) Bellington, N. Y., reports *Radio Programas Continental* on a new channel of 5.995A, noted around 2100 to 2359 sign-off with them.

Peru—OAX4J, Lima, still noted on old channel of 9.330; heard on a Sunday 0014 and again 0215; announces "Radio Colonial" after almost every musical number. OAX4W, 9.405, also Lima, heard 2340 to 0001 when left air abruptly without announcement; this one announces "Radio America, La Voz del Nuevo Mundo." (Machwart, Mich.)

Philippines—DZH8, 15.300, Manila, noted 0500-0515 with news. (Rosenauer, Calif.) DZH7 was measured recently as 9.736. (Hutchins, Radio Australia) Manila, 9.500, seems to have Tagalog at 0650 but by 0750 is buried by XEWW, Mexico City, same channel. (Stark, Texas)

Poland—Warsaw has *English* for North America 1745 on 11.815, repeated 2315 on 9.570; at 1930 on 11.815, repeated 0030 on 9.570; sent attractive QSL from Polskie Radio, English-Language Transmission, Aleja-Stalina 21, Warsaw, Poland. (Drittler, N. Y., others)

Portugal—Lisbon is now on 15.130 (moved from 15.380), noted closing there 0900 and opening again 0915; uses 11.995 at 1230-1530 and 11.958 at 1600-1800. (Pearce, England)

Portuguese China—Unconfirmed reports continue on a new station "Radio Villa Verde" on 9.500, located at Macau; details lacking.

Portuguese India—When this was written, Graham Hutchins, DX Editor, *Radio Australia*, informed me that he believes *Radio Goa* is still using 9.610 instead of 9.260 where it had been reported as heard by (unconfirmed) overseas sources.

Roumania—Bucharest, 9.250 and 6.210, heard 1500-1530 in French; 1530-1600 in *English*. (Radio Australia)

Sao Tome—The 17.677 channel noted on Sundays around 0735-0800 when closes with "A Portuguesa." (Pearce, England) Heard opening 0702; faded out by 0730 in N. C. (Ferguson) The 4.8075 outlet noted 1500

some olks don' WANT better TV reception!

But these are the folks who live within a mile or two of the TV transmitter . . . and it's out in the fringe areas where the new Turner TV Booster is really wowin' the customers.

The Turner Model TV-I Booster gives a usable picture when many other boosters won't even lock the picture in. This better picture, without objectionable snow, is a result of famous Turner engineering and the utilization of the low noise level "Cascode" circuit.

Simplified continuous tuning permits finest adjustments for best reception of both sound and picture. The Turner Booster also functions for FM, aviation radio and mobile radio services.

The handsome cabinet is solidly constructed and designed to harmonize with any television set. Only the finest of materials and component parts are used, and this, plus world-renowned Turner workmanship, means the Model TV-I will provide years of TV enjoyment.

Write for complete details about the new leader in the TV booster field . . . the Turner Model TV-I.

List price \$57.50

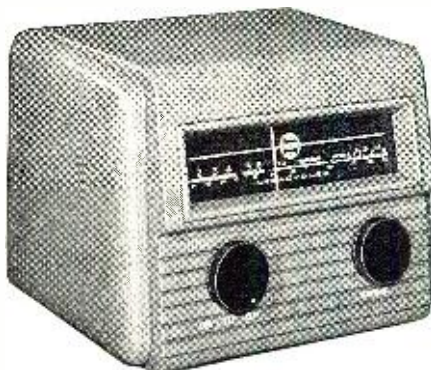

The Turner Model TV-I

THE TURNER COMPANY

900 17th Street N. E.

Cedar Rapids, Iowa

IN CANADA: Canadian Marconi Co.

Toronto, Ont., and Branches

Advance with ELECTRONICS

You need firm grasp of fundamentals to keep pace with these complex, fast-growing fields. In thorough 2-year course learn electricity, electronics, physics, mathematics, drafting, etc. Employers want Franklin graduates. Coed. G.I. approved. Day, evening. 43rd year. Write for Catalog.

FRANKLIN TECHNICAL INSTITUTE
46 Berkeley Street Boston 16, Mass.

ON-THE SPOT BATTERY RECORDER

WALKIE-RECORDALL 8 lb. miniature BATTERY RECORDER-PLAYBACK
Continuous, permanent, accurate, indexed recording at only 5c per hr. Instantaneous, permanent playback. Picks up sound up to 60 ft. Records conferences, lectures, dictation, 2-way phone & sales talks; while walking, riding or flying. Records in closed briefcase with "hidden mike"! Write for Detailed Literature.

MILES REPRODUCER CO., INC.
812 BROADWAY Dep't RV-10 NEW YORK 3, N. Y.

Speaker Reconing Service

Expert Guaranteed Speaker Reconing Service. Eight Hour Service on Rush Jobs. Factory Methods and Service.

Size	List	Net Dealer
3"	\$2.50	\$1.30
4"	2.60	1.40
5"	2.75	1.50
6"	3.50	1.65
7"	3.75	1.95
8"	4.00	2.20
10"	4.50	2.70
12"	6.00	3.00
15"	7.50	4.50
4x6"	3.75	1.90
5x7"	4.00	2.20
6x9"	4.50	2.50

There is going to be a terrific shortage of speakers in the near future. We advise saving the old speaker for Reconing and later use. This service available only in the United States and Canada.

SPEAKER DIVISION
Meunier Radio Supply Co.
524 North Illinois Street, Indianapolis, Ind. LI. 8884



Special Offer On This Complete RADIO ENGINEERING LIBRARY

New, Up-To-Date Edition of Famous Library Covers Whole Field of Radio Engineering. Places Latest Facts, Standards, Data, Practice, and Theory At Your Fingertips.

THE five big volumes of the new edition of the Radio Engineering Library now include the very latest facts, standards, data, and practice. This Library will help solve hundreds of problems for designers, researchers, engineers, and students in any field based on radio.

Written by leading radio engineers, these books cover circuit phenomena, networks, tube theory, vacuum tubes, amplification, measurements, etc.—give specialized treatment of all fields of practical design and application. They provide you with a complete and dependable encyclopedia of facts.

5 Volumes • 3872 Pages • 2770 Illustrations

- Eastman's FUNDAMENTALS OF VACUUM TUBES, 3rd Edition.
- Terman's RADIO ENGINEERING, 3rd Edition.
- Everitt's COMMUNICATION ENGINEERING, 2nd Edition.
- Hund's HIGH FREQUENCY MEASUREMENTS, 2nd Edition.
- Henney's RADIO ENGINEERING HANDBOOK, 4th Edition.

SEND NO MONEY

Special Low Price • Easy Terms

On this special offer you get this Library for \$34.50, instead of \$39.00. You save \$4.50 and may pay on easy terms. Mail coupon below to examine the Library FREE for 10 days. No obligation. These books are recognized as standard works; you are bound to need them. So take advantage of this special money saving offer. *Mail coupon at once!* McGraw-Hill Book Co., Dept. RTN-9, 327 W. 41st Street, New York City.

**McGraw-Hill Book Co., Dept. RTN-9,
327 West 41st St., New York 18, N. Y.**

Send for 10 days' FREE trial, the RADIO ENGINEERING LIBRARY. If not satisfied I will return books. Otherwise I will send \$4.50, plus delivery charges, then; and \$5 a month for 6 months. (Reg. price \$39.00; you save \$4.50).

Name.....

Home Address..... RTN-9

City & State.....

WE'LL PAY DELIVERY CHARGES if you enclose \$4.50 first payment WITH coupon. Same return privilege for full refund.

with news in Portuguese, then music; at 1557 gave call, closing announcements in Portuguese, interspersed with guitar music; off 1559 with "A Portuguesa." (Pearce, England)

South Africa—ISWC, London, reports Johannesburg, 9.870, has news 1500 prior to closing 1505. Bluman, Israel, in an ISWC bulletin, says that Pretoria, 17.748, is scheduled 0330-0700, 0900-1045 (Sat. and Sun. 0330-1045); also 1100-1505 on 11.940.

QSL card from SABC lists ZRH as call for its 11.937 outlet; power 10 kw. (Oskay, N. J.)

Southern Rhodesia—Salisbury, 3.320, heard with dance music 1445; at 1501 said end of transmission "until morning at 7:55" (local time); gave no frequencies; closed with anthem. (Pearce, England)

Spain—Radio SEU, Madrid, is now noted around 1630 on about 7.145 with Spanish program. (Pearce, England) **Radio Nacional de Espana**, Madrid, listed 9.369, has been varying in frequency a great deal; noted low as 9.335. (Wilson, Ill., others)

Sweden—SBT, 15.155, Stockholm, noted with much improved signal in "Sweden Today" (English) 2000-2015. (Ferguson) Currently, Stockholm lists active channels as SBT, 15.155; SBP, 11.705; SDB2, 10.780; SBO, 6.065. (Kroll, N. Y.)

Syria—Damascus calling Europe noted 1630-1730 in English; 1730-1830 closedown in French; frequency is 11.915. (Pearce, England) Heard in USA with some QRM from Budapest, 11.910, relaying Radio Moscow. Measured by Oskay, N. J., as 11.913. An-

A LOW-COST SINGLE-TUBE AM RECEIVER

This unique circuit makes use of a special tube property which manifests itself when tube is operated below normal voltages.

By CHARLES ERWIN COHN

DESPITE the vast amount of research that has been done on vacuum tubes, one field seems to have been neglected, *i.e.*, an investigation of the properties of tubes with lower-than-normal electrode voltages. During such an investigation on a small scale, the author developed the circuit shown in the diagram and it has proven to be quite efficient.

The circuit voltages shown have been determined experimentally to be optimum and these values should be adopted. The "A" battery, of course, is made up of two dry cells. Either flashlight cells or the larger "A" batteries can be used, the latter living longer and giving more consistent performance. The "A" drain is about .1 ampere. At this heater voltage, the only perceptible glow is the one seen at the top of the tube. The tube takes a couple of minutes to come to operating temperature after the heater is switched on.

The optimum "B" voltage is 13-15 volts. This can be obtained, for example, from two 7½ volt "C" batteries or three 4½ volt "C" batteries. The "B" current drain is quite low, being about 20 microamperes with no signal or weak signal. Strong signals increase this drain to about 100 microamperes.

The tuned circuit, L_1C_1 , is made up of a standard broadcast antenna coil and a 350 μfd . variable condenser. Be sure to get the best coil you can afford as the quality of the coil is the factor which determines the selectivity of this receiver. Shielded coils should be avoided, however, since the shields reduce the efficiency. Any of the standard crystal set tuners described in the literature can also be used. The phone bypass, C_2 , is not absolutely necessary but does provide some increase in volume.

As yet I have not been able to figure out a complete and logical explanation as to why this circuit works as it does but it seems to result from some grid-blocking action. However, explainable or not, the performance is excellent. With a 15 foot indoor antenna I can receive and separate six of the major Chicago stations with good headphone volume.

The selectivity characteristics of this set seem to be similar to those of the plate detector which makes it more sensitive and selective than most nonregenerative one-tubers. The circuit is not at all tricky and provides a good quality of reproduction.

It is an excellent first set for the beginner or a nice unit for the crystal set fan. The application of regeneration might improve this set even further. Since identical results were obtained from two 6J5GT's of different makes, this circuit doesn't seem to be critical as to tube choice. —30—

Circuit diagram of a compact AM radio which provides unusually good reception.

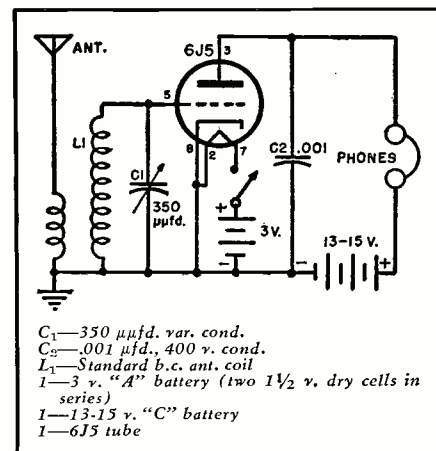

nounces "This is the S.B.S., the Syrian Broadcasting Service."

Current schedules of *Radio Damascus* are daily on 6.167 at 2330-0200, 0630-0800, 1100-1630; on 9.555 at 2330-0200, 0430-0830, 1100-1300, 1315-1415, 1430-1600; on 11.915 for Europe in *English* 1630-1730, and in French 1730-1830 sign-off; on 17.865 at 0945-1045 (may be Sundays only); output of these channels is 20 kw.; there also is a 7.5 kw. transmitter used on 15.395 at 0430-0640 on Sundays only for programs in *English* and French. (Radio Sweden)

Tahiti—*Radio Tahiti*, 6.135, Papeete, continues on schedule of 2300-0130. (Bellington, N. Y., others)

Taiwan—Recently received verie from "The Voice of Free China Calling the World, Taiwan Broadcasting Station Operated by the Broadcasting Corporation of China." The front of Taipeh's card has a Great Circle Map of the world centered on Taiwan. It is printed in blue, yellow, and white. Back of card had this data—BED6, 11.735; BED7, 7.130; BED29, 6.095; BED2, 670 kc.; BED3, 15.235, and BED4, 11.725. (Guentzler, Ohio; Stein, Calif.)

Tangiers—*Radio Sweden* reports *Pan-American Radio* logged on a new channel of 7.520 or 7.525 signing off 1700; however, *WRH Bulletin* lists this one currently as on 7.400 at 0700-1100, 1500-1900.

Trans-Jordan—The Hashimite Jordan Broadcasting Service, Ramallah, on 7.110, is scheduled daily 0000-0100 in Arabic; 0600-0630 in *English*; 0630-0730 in Arabic; 1000-1100 in *English*, and 1100-1530 in Arabic. (Radio Sweden)

Turkey—TAT, 9.515, Ankara, continues with strong signal in North American Service (*English*) 1815-1900; TAU, 15.165, heard 1430-1445 with Arabic music; 1500-1545 in *English* (some days to 1600). (Whitman, Ill., others)

USI—Menado, Celebes, noted on 9.840 with music 0812; identified in Indonesian 0815; no *English* noted. (Cox, Ala.)

USSR—Soviets noted 1657 with chorus singing on 7.245, 11.755, 11.78, then left air. (Bellington, N. Y.) Tiflis, 5.040, Georgia, noted 0900-1605 sign-off. Kiev, Ukraine, noted on 9.665 at 1215 in Sweden. Asjhabad, Turkmenian, 6.180, noted 1200-1300 with native program and later with relay from Moscow. (*NATTUGGLAN*, Sweden) Stalinabad on 7.200 begins its broadcast with relay from *Radio Moscow*, but has own program after 2030. (Radio Sweden)

Vatican—HVJ now noted on 15.120 with news in *English* 1000. (Pearce, England)

* * *

Press Time Flashes

Dilg, Calif., notes an AIR outlet, location not definite, on 7.170A; seems to sign on 0815; identifies as "AIR" at 0900; has CWQRM.

A clandestine station, probably Bulgarian, is heard daily 1300-1400 on 6.300A. *Radio de la Grece Libre* is heard in French 1200-1212 on 9.455.

Sam's Surplus Sells For Less

COMMAND AND/OR ARC5 TRANSMITTERS and RECEIVERS			
BC-442 Antenna Relay, Less Vac. Cond.	USED \$ 1.95	NEW	
BC-450 3 Receiver Control	1.49		
3-6 MC Receiver	5.95	\$11.95	
6-9.1 Receiver	6.95	9.95	
Triple Receiver Rack	\$1.95		
V.H.F. ARC5 Transmitter or Receiver, Complete w/tubes	24.95		
2.1-3 MC Transmitter with tubes	14.95		
4-5.3 MC Transmitter with tubes	5.95		
5.3-7 MC Transmitter with tubes	5.95		
7-9.1 MC Transmitter with tubes	9.95	19.95	
3-4 MC Transmitter with tubes	18.95		
28V Receiver Command Dynamotors	\$0.97		

MODULATORS			
BC-456 with Tubes, less dyn.	2.95		
MD-7/ARC5 Plate Modulator	7.95		
MD-7 Modulator Dynamotor, 28V	3.95		

USED NEW			
BC-433 Receiver—w.o. tubes	\$12.95		
with tubes	24.95		
MN-26C Compass Receiver	24.95	\$39.50	
BC-1206 Receiver 200-400 kc.	5.95	9.95	
BC-357 Marker Beacon Rec. W.O. Tubes		4.95	

RAX RECEIVER			
Consists of 2 separate superhets which have 8 tubes, 1 antenna and 2 R.F. sections. Frequency range of Set No. 1: 200-1500 kc. Set No. 2: 7000-27000 kc. Used, good cond. Electrically perfect. Per set			
			\$15.95

GP-7 NAVY TRANSMITTER: 100 watt master os. Can use on any freq. from 850-950 kc. by using proper plug-in. With 1 tuning unit.			
			\$13.33

LOOP ANTENNAS			
DU-1 Has 2 tube amplifier	New	\$25.95	
MM-20-E	New	7.95	
LP-21 A	New	12.95	

FL8 Filters—A's, B's, C's	New	\$ 1.95
FL5 Filters	New	.95
Hand Keys—J-38	New	.79
TSC TRANSMITTER & RECEIVER with 12V Power Supply and Cables, Good—used		179.50
Heinemann Circuit Breakers, 115 V., 20 amp.		1.39
		115 V., 5 amp.
		.97
Prop Pitch Motors	New	13.95
Prop Pitch Motors—with Transformer	New	19.95
Prop Pitch Transformer, only	New	6.95
RT-7APN-1 Transceiver, tubes & dyn.	Used	9.95

TRANSFORMERS			
12V 24V 2 am 110V primary			\$2.95
ARC-4 2 Meter Transceiver, tubes—good, used			\$29.95
522 2 Meter Transceiver with tubes—good, used			59.50
HC-434 Control	Used—	\$1.95	2.95
Code Practice Tapes for TG-10 15 rolls	New	7.95	
HC-908 Absorption Type Freq. Meter Range 150-225 mc. 0-500 DC Meterom.	Used—	\$11.50	14.95
Field Phones E-E S's. Used	\$15.95 pr.	New	\$34.50 pr.
Mobile Relay, SP.-ST. Leach 6 V or 12 V.	New		1.49

CASH WITH ORDER. PRICES SUBJECT TO CHANGE WITHOUT NOTICE
 California Orders Please Include 3 1/2 % Sales Tax
PLEASE INCLUDE APPROXIMATE POSTAGE—EXCESS WILL BE REFUNDED
WHAT HAVE YOU IN SURPLUS? SUBMIT
ESEGE SALES COMPANY INC.
 1306 BOND STREET, at PICO LOS ANGELES 15, CALIFORNIA

HARVEY WELLS AIRCRAFT TRANSMITTER

Complete with 12 Volt Vibrator Supply, can be modified to 6 Volt for mobile operation. Internal Crystal Controlled. 3105 KC. Consists of 7C5 Pierce Oscillator, 7C5 R F A M P, 2 7C5 Modulators. Excellent for 75 meters—or Marine. Complete with Instruction Manual. NEW..... \$37.50

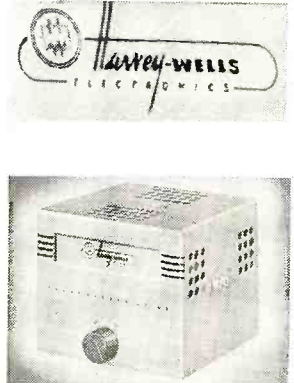

DYNAMOTORS			
PE-108 NEW, ORIGINAL CASE			\$29.95
PE-103 NEW, Less Base—Dynamotor			19.95
DM-32A Input 28V. Output 250 DC, .06 amps	Used		1.95
DA-1A Input 28V @ 1.6 amps. Output 230 DC @ 1 amp	Used		5.95
PE-73 29V @ 20 amps. output 1000V @ 350 amps	New		9.95
PE-77 14V @ 40 amps output 1000V @ 350 amps	New		15.95
SPEC. 27V @ 400V @ 7.50 mil 750V 350 mil	New		12.95
PE-94 or SCR—522 24V. Used—	\$5.95	New	14.95
PE-94 Dynamotor only			4.95
DM-34 12V @ 2.8 amps. Output 220V @ 160 amps	New		9.95
SPEC. 9V @ 450V output @ 80 ma.	New		5.95
SPEC. 12V @ 320V output @ 80 ma.	New		4.95
SPEC. 6V @ 250V output @ 80 ma.	New		5.95
SPEC. 12V @ 440V output @ 200 ma.	New		8.95
ARC-1 DY-7/ARC-1	Used		11.50
ARC-1 DY-10-12V	Special		9.50
14 Volt Input—425 Volt Output at 163 mils. Starting Filter and Relays in base	Like New		3.95

683 FM Receiver 26 to 39 mc FM Receiver with tubes—used—	\$29.95	New	\$39.50
RL-42B Antenna Reel Ass. Less wire	New		9.95

OIL CONDENSERS			
Standard Makes—New			
2 mfd 600V	\$0.49	10 mfd 600V	\$ 1.95
4 mfd 600V	1.39	2 mfd 2500V	2.95
1 mfd 1000V	.69	2 mfd 4000V	5.95
3 mfd 4000V	7.95	2 mfd 5000V	8.95
		2 mfd 7500V	29.95

T-30 Throat Mikes	3 for	\$0.50
CD-307 Head Set Extension Cord		.89

HEAD SETS			
HS-30 New			\$1.95
HS-23	Used—	\$1.29;	New—2.95
Matching Transformer for HS-30			.69
BC-348 Mounting Base			\$2.49
RG-7U Coax Cable, 97.5 ohms.			foot .08
MIKE CHEST SET "F-1" button			New 2.95

RCA RADIO and TELEVISION
 Thorough training for men and women in all Technical phases
WEEKLY RATES DAYS—EVENINGS
 APPROVED FOR ELIGIBLE VETERANS
 Free Placement Service For Graduates
 For Free Catalog write Dept. RN-51
 RCA INSTITUTES, INC.
 A Service of Radio Corporation of America
 350 West 4th St., New York 14, N. Y.

2-WAY WALKIE TALKIES
 POCKET SIZE—Electronic Voice Powered
 No tubes, batteries, adjustments, license or permit needed!
 Guaranteed to work anywhere up to 1/4 mile with extra wire. Swell for garage to house, etc! Your own private, talk-listen phone. Not war surplus. Brand new. Solid Aluminum Case. Two complete units with wire—READY TO USE! SEND ONLY \$1.00 deposit and pay postman \$4.99 C.O.D. or send \$4.99 for PP delivery. Limited supply. MIDWAY COMPANY, Dept. WRT-9, KEARNEY, NEBRASKA.

No Experience Needed To
PRINT YOUR OWN POST CARDS
 The GEM STENCIL DUPLICATOR saves money... gets results quickly! Hundreds of uses for every type of business and organization. We ship the GEM complete with all supplies. Guide Board for accurate printing and 60-page Book of Ideas at the special low price of only \$8.50 (a \$15.00 value)
 Our 21st Year
FREE TRIAL OFFER
 Use the GEM FREE at our expense! SEND NO MONEY. Write and complete GEM outfit will be sent you postpaid. After ten days, send us only \$8.50 or return the GEM. You must be satisfied! WRITE TODAY.
BOND EQUIPMENT CO. Dept. 52
 6633 Enright • St. Louis 5, Mo.



LISTENING COMFORT

Modern, lightweight, durable—Telex Headsets are easy on the ears . . . No uncomfortable ear pressure . . . Easily adjustable and built for hard usage . . . Telex Headsets effectively block out background noises . . . 5 ft. standard cord or special cord with built-in volume control . . .

TWINSET*

Weights only 1.6 oz.



C.A.A. Approved

MONOSET*

Weights only 1.2 oz.



Write **T** for free folder—Or see your Parts Jobber.

Telex

hearing at its best

ELECTRO-ACOUSTIC DIV.—DEPT. E-12
TELEX PARK—ST. PAUL 1, MINN.

In Canada, Atlas Radio Corp., Toronto

*TRADEMARK *STANDARD OF THE WORLD FOR QUALITY HEADSETS

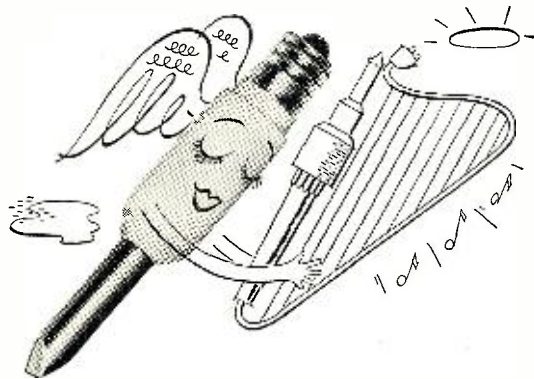

Ungar's Little Angels

STILL HARPING ON THE SAME SWEET SONG

From minor repairs to high-speed production soldering, 8 talented muses to remember are

Ungar's Little Angels. Each versatile, job-designed tip fits the trim, slim Ungar

Pencil to strum a tune in perfect harmony with most soldering requirements. Ask your supplier for the lyrics to this merry melody.

No. 1236 5/16" HI-HEAT Pyramid, 37 1/2 Watts

Used and recommended for radio, radar and TV repair and maintenance, but because of greater tip temperature and more heat capacity, they are used on production lines for smaller work. Tip material is special pre-tinned alloy. Loss of tip material at high temperatures is less than with copper alloys.

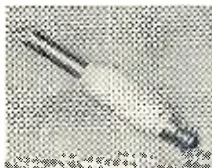

Write for Catalog No. 400

Ungar ELECTRIC TOOLS, INC., Los Angeles 54, Calif.

(Radio Sweden) The *Yugoslav Station* is being heard on approximately 6.280 at 1700. (Radio Australia)

WRH Bulletin says the Western Service (Home Service) of *Radio Ceylon* has begun relay of the Commercial Service programs on 6.075; scheduled there 2030-0030, 0130-0330, 0600-1230; the Commercial Service programs are relayed 0145-0030, 0130-0230.

The Home Service of the Israel Broadcasting Service (Kol Israel) is radiated on 6.830 and from 1245 (Mon., Fri. 1200, Wed. 1300) to 1430 on an additional frequency of 9.000 (actually 9.010A); news in Hebrew 2300, 0530, 1230, 1425; in *English* 0600, 1415; in Arabic 0000, 0615, 1115; in French 0700. Kol Israel also broadcasts a special program for new immigrants daily on 9.000 at 1100 in Yiddish, at 1120 in Judeo-Spanish, and at 1140 in French. A program for overseas listeners called "The Voice of Zion" can be heard on 9.000 at 1515-1600 in French and 1615-1700 (sign-off) in *English*. (*WRH Bulletin*)

Dilg, Calif., flashes that the 4.775A South Korean outlet—believed Pusan—relays "Voice of America" program in Korean language 0745; that outlet is now parallel with 7.935, believed Seoul back on the air, signing off 0830; last 30 minutes is news in Korean at dictation speed; both transmitters have fairly good signals in Calif. A station heard by Dilg mornings (*EST*) on 4.285A is believed to be North Korea.

WRH Bulletin says "A station with callsign ZCQ on 5.770 is operated by the Seychelles Government; schedule not yet known; if anyone can favor us with further details about this station, it will be much appreciated." (Seychelles is a group of British islands in the Indian ocean; 153 square miles; capital is listed Victoria.—KRB)

A station heard with weak signal on 8.800A may be Indo-China; signs off 0830. One heard around 6.270A at 0800, weak to fair level, may be *Radio Kashmir*. A Communist Chinese outlet, location unknown, is noted on 6.650A at 0630 and later. (Dilg, Calif.)

Radio International Red Cross noted testing on 7.210 in several languages—including *English*—at 1700; reports requested to International Red Cross, Geneva, Switzerland.

Radio Australia reports Mauritius now on 24.75 m. (approximately 12.120) with general programs weekdays 2200-0015, 0300-0430, 0930-1230; Sundays 0115-0300, 0930-1230; Indo-Urastian programs weekdays 0800-0930, Sundays 0300-0345 (Thurs. 0430-0515), and "other" programs for Thursday 0730 to closedown 1230.

By this time, *Radio France-Asie*, Saigon, Indo-China (Vietnam), should have effected a series of "French by Radio" lessons on Tuesdays, Fridays 0515 on 11.83 and 0800 on 11.780; "guides" for the lessons are available on request (preferably via airmail) to the station. (Radio Australia) At press time, Stark, Texas, noted *RFA* signing on with French and *English* identification 0800 on 11.830.

At press time, I learned direct from Korea that HLKA, 800 kc., 500 watts, and HLKG, 4.7775, 300 watts, are the only two stations operating in the Pusan area of South Korea; scheduled 1530-1730, 2100-2330, 0300-0530; *Radio Korea* has no *English* programs. However, West Coast listeners report South Korea is heard lately on 7.933 (old Seoul channel for HLKA) in parallel with 4.7775A to 0830 sign-off.

At the time this was compiled, *Radio Damascus, Syria*, had just concluded satisfactory tests to North America on 11.915 (measured 11.913 by Oskay, N. J.) and 15.395 (measured 15.3636 by Oskay, N. J.) at 1900-2000 and on (announced) 15.395 for South America at 2000-2100. *May soon have regular service to the Americas*. During tests, the 19-m. channel was best, in the clear except for light CWQRM; the 25-m. outlet was good strength but had bad CWQRM and some QRM from Budapest on 11.910. Reports are desired by the Directorate-General, Syrian Broadcasting Service, Damascus, Syria.

Radio Teheran seems to have "reinstated" the Russian news period 1515-1530 sign-off on 15.100; *English* still at 1500. (Ferguson, N. C.; Bellington, N. Y.)

Radio Australia says that Samoa (probably Western Samoa) is to test shortly on 3.41 and 6.03.

"Choice of Vietnam," Saigon, Indo-China (Vietnam), has moved from 7.105 to 7.090; noted parallel with 9.620 in

English 0830. may close 0900 now in
 Brazil, of listed
 Guapore;
 Brazilian outlet
 QRA is c/o Go-
 Guapore, Porto
 strong QRM from HJCQ,
 around 1900. To be on
 air soon is *Radio Relogio Federal*
 Niteroi, Brazil, 4.905, with call
 ZYZZ21 and 1 kw. power; will transmit
 only correct official time, every minute,
 and short commercials in Portuguese;
 on the air 24 hours a day; office QRA is
 Avenida Presidente Vargas, 417-A, 22
 Andar, Rio de Janeiro, Brazil. ZYK21
 is call of *Radio Tamandare*, 3.265, Re-
 cife. (Serrano, Brazil)

At press time, Dilg, Calif., had just
 noted that *Radio Peking*, for the first
 time, was giving POW messages during
 the "late" (0830-0900) *English* period
 over 11.69A and 15.06A.

The "Mailbag" program of *Radio
 Ankara*, Turkey, on Sundays, now
 seems to be 1530 for Europe over 15-
 165 and 9.465; for North America on
 9.515 around 1845; is *English*. (Fer-
 guson, N. C.)

4VEH, Haiti, is now verifying with
 a nice QSL card; uses 9.75 at 0600-1830
 and from 1830 is on 9.756.

WRH Bulletin says a new "power-
 ful" short-wave transmitter at Seville,
 Spain, will begin test transmissions in
 the near future.

In a recent newscast, *Radio Austra-
 lia* said a new high-frequency trans-
 mitter is to be built at Suva, Fiji Is-
 lands, 500 watts, to be ready next year
 (1952). (Richards, Sask.)

An Indonesian outlet on 4.840, heard
 mornings (*EST*), is believed to be Den-
 pasar, Island of Bali. (Dilg, Calif.)
 Rosenauer, Calif., reports a new Dja-
 karta, Indonesia, outlet on 6.135
 around 0630-0800; all-Indonesian pro-
 grams; good signal.

Djeddah, Saudi-Arabia, noted with
 fair level 2300-2350A on 11.850. (Lucas,
 N. Y.)

4V2S, 5.957, Port-au-Prince, Haiti,
 has *English* Mon., Wed., Fri., around
 2130-2150. (Russell, Calif.) Managua,
 6.055, Nicaragua, by now should have
English at 2230-2400. (Callarman,
 Ore.)

Direct from Tokyo, NHK confirms
 that JK14 has moved from 11.815 to
 11.800. (Russell, Calif.)

Bucharest, Roumania, noted 1535-
 1555 with music on 6.215. (Rodger,
 Scotland)

Radio Sweden reports Belgrade,
 Yugoslavia, has dropped 9.505 and is
 using only 6.100 now. *WRH Bulletin*
 gives new schedule as 2215-2315, 0000-
 0045, 0430-1630.

* * *

Acknowledgement

Thanks, fellows, for the continued
 fine cooperation. As better reception
 comes along this autumn, keep those
 FB reports coming to 948 Stewarts-
 town Road, Morgantown, West Vir-
 ginia, USA. KRB.

September, 1951

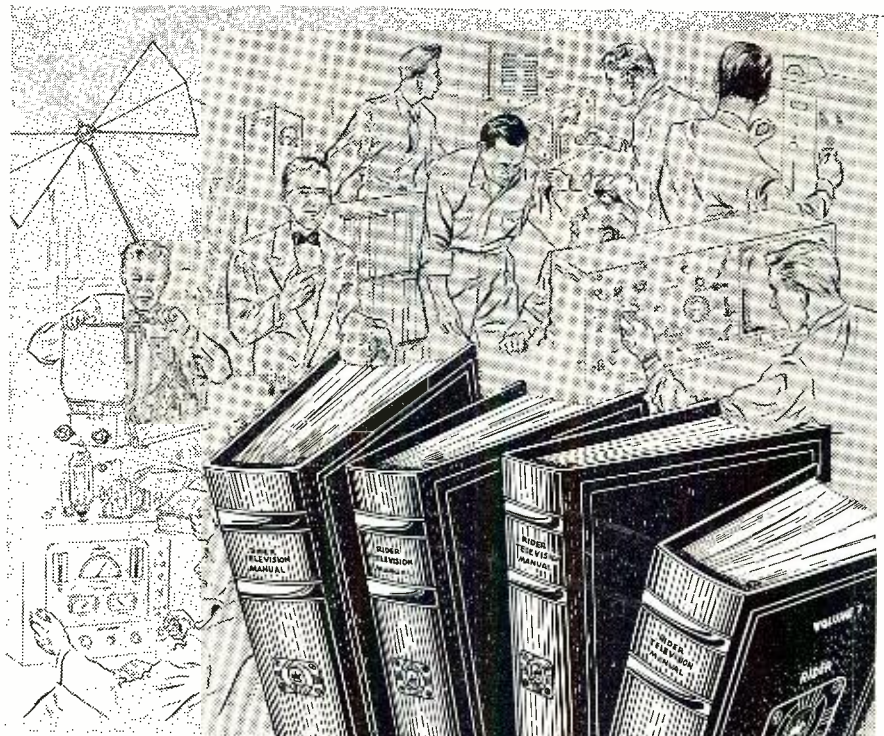

How To Make More Money

Take less time per call...do a better job. The secret is knowing the complete, accurate, factory-approved answers to every Television and Radio problem. There's only one source for this staggering amount of information...Rider TV Manuals. The only complete television and radio manuals in the world. You'll find that dollar-for-dollar, page-for-page the Rider manual is far less expensive than any other source... and far more valuable for you. Ask your jobber for TV 7...today!



JOHN F. RIDER Publisher, Inc.
 480 Canal Street, New York 13, N. Y.

LEARN DAY and EVENING CLASSES
TELEVISION
ELECTRONICS-RADIO
 Modern Laboratory
 Instruction in
 • SERVICING
 • BROADCAST
 OPERATING
 • ELECTRONIC and
 TV ENGINEERING

G.I. APPROVED

WRITE FOR ILLUSTRATED CATALOG
ELECTRONICS INSTITUTE, Inc.
 21 HENRY, DETROIT 1, MICH.

WE PAY TOP DOLLAR \$
 for all types of
SURPLUS ELECTRONIC EQUIPT.
 Regardless of Condition. Ready Cash for:

• ART-13 Xmitter	• 1-100 Test Sets
• DY-17 Dynamotor	• BC-348 Rcvr.
• TS-12 Test Sets	• BC-788A, AM, B or C
• TS-13 Test Sets	• I-152A, AM, B or C
• MN-26 J or K	• ARC-1
• BC-342	• ARC-3
• BC-312	• Teletype Equipment
• BC-611 Handie	• Any Test Equipment
Talkie (or any part)	• TS-67

Plus anything you have in Electronics Equipment.
 Send your complete list, present condition and asking price to:

WEST REGION ELECTRONICS
 Dept. V-5
 1437 S. Norton Ave. Los Angeles 19, Calif.

HICKOK

NEW TELEVISION Videometer



MODEL 650

VISUALLY IDENTIFIES TROUBLE IN ANY SECTION OF A TV RECEIVER

The HICKOK Model 650 Videometer is the first instrument of its kind to accurately and rapidly solve your servicing problems with the necessary tests to visually identify trouble in any section of a TV receiver.

FEATURES:

- An all-purpose video generator. Provides an electronically accurate bar or dot pattern on the screen of any TV receiver— independent of station operation.
- Can be used as a TV transmitter to simultaneously transfer a program to any number of TV receivers—on any desired channel.
- RF output, directly calibrated in microvolts for sensitivity measurements.
- Substitute Video Amplifier with gain of 0 to 10.
- Crystal controlled timer for greater accuracy.
- Fast, accurate, the ideal instrument for all area servicing.
- Increases TV maintenance profits—allows you to trouble shoot many more installations per day.
- Built only by HICKOK. Contains highest quality components throughout for lasting accuracy and dependability.

Write for the new, complete Hickok Test Instrument Catalog today.

THE HICKOK ELECTRICAL INSTRUMENT COMPANY

10524 Dupont Avenue • Cleveland 8, Ohio

Sound Engineering

(Continued from page 72)

bus is shown in the diagram, the bus may be operated with a ground on one side, providing the inputs of the various devices patched across the bus are designed to work in such a manner. As a rule, large installations use an ungrounded bridging bus and *symmetrical* bridging input circuits to increase the flexibility of the system. If desired, the bridging bus may be balanced to ground as shown in Fig. 6. However, this again complicates the situation as each piece of equipment paralleled across the bus must have a symmetrical input or be balanced to ground. Circuits balanced to ground reduce the flexibility of the system and increase the possibility of the wrong type input circuit being patched across the bus, which may short out the bus completely or introduce an unbalance, resulting in a high noise level.

Below the monitor low-pass filter is shown a second monitor amplifier feeding additional monitor speakers. This monitor network may be set up with a series of switches and terminating resistors similar to a selective paging system, as the speakers are only used for general monitoring and cueing. The frequency response of this monitor amplifier is set for a characteristic that is acceptable for all purposes.

Bridging amplifier number 1 has a twofold purpose; first to isolate the recording equalizer for the disc recorder, and second to compensate for the insertion loss of the equalizer. The gain of the bridging amplifier when working from the bus must be equal to the insertion loss of the equalizer, which is 18 db for this problem. However, the output stage of the bridging amplifier must have sufficient power output to raise the signal level high enough to overcome the loss of the equalizer. As the bridging bus level is plus 4 dbm, the output level of the bridging amplifier will be a plus 22 dbm. Generally, bridging amplifiers will produce a power output in excess of plus 30 dbm.

If the recorder cutting head requires a plus 30 dbm for 100 per-cent modu-

Fig. 6. This circuit shows how bridging bus may be balanced to ground.

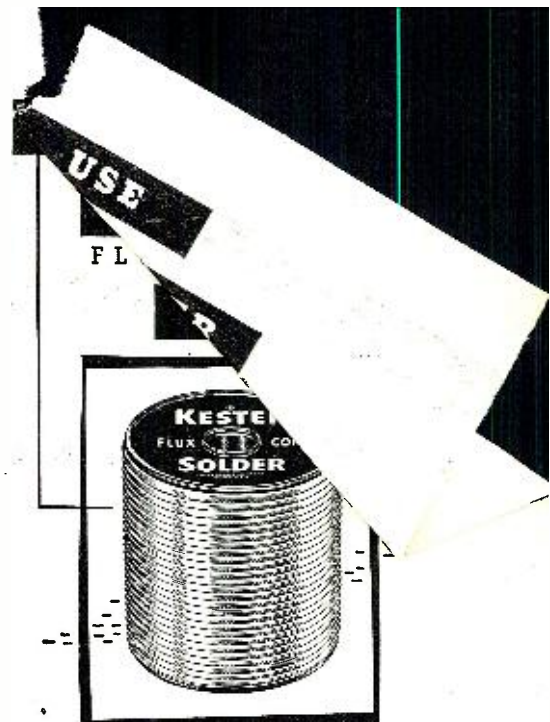
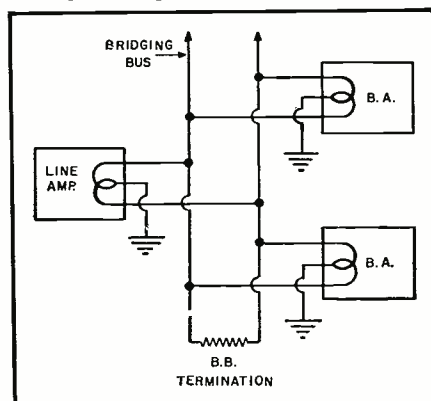

FOR TV AND RADIO WORK—Kester Plastic Rosin Core Solder and Kester "Resin-Five" Core Solder. Kester Solders are made from the finest grades of tin and lead commercially available.

KESTER SOLDER COMPANY

4235 Wrightwood Ave.
Chicago 39

Newark, N.J. Brantford, Canada

KESTER SOLDER

PHOTOCON SALES

1060-2 N. Allen Ave. Sycamore 4-7156
Pasadena 7, Calif. RYan 1-8271

Write for Our New 24 Page
SURPLUS SALES CATALOG

WE WILL BUY YOUR NEW OR CLEAN USED ELECTRONIC SURPLUS: ARC-1, ARC-3, BC-224, BC-348, BC-312, BC-342, ATC, ART-13, APS-13, BC-221, LM's, TS-12, TS-13, TS-23, TS-34, TS-35, IE-19A, I-222, SCR-522, TS-100, or any BC, I, IE, TS, APR.

WRITE FOR PRICES

APR4, APR5A, APR7, TS-34, 804CS2, APA-38, BC-348, ART-13, TS-12, ARC-1

DuMont 208 5" Oscillograph	EXCELLENT	\$225.00
Precision ES500 5" Oscillograph	NEW	135.00
804B General Radio Signal Generator 8-330 mc.	EXCELLENT	350.00
BC-464 Target Receiver—5 channel control, sensitive relays, battery case, antenna 68-73 mc.	NEW	14.95
BC-463 Target Transmitter for use with BC-464	EXCELLENT	150.00
APN-1 Altimeter Indicator 0-1 ma. shunt, 250° dial	NEW	2.95
LM Frequency Meter with cal. book, crystal, and tubes	EXCELLENT	99.50
Variac-General Radio Type 50A 0-135V. @ 50 amps.	EXCELLENT	95.00
Hallcrafters S-36 27.8-143 mc. AM & FM	EXCELLENT	200.00
RU19 Receiver complete	NEW	29.50
SCR-578 Gibson Girl	NEW	12.50
SCR-625 Mine Detector	USED	39.50
	NEW	69.50
AN/APN4B Complete	EXCELLENT	150.00
AN/APN4A Complete	EXCELLENT	125.00
2" Aircraft Meter 1-0-1 milliammeter scale calibrated 50-0-50	NEW	1.95
PE-218 Inverter 400N	NEW	29.50
PE-206 Inverter 800N	NEW	12.50
PU7 Inverter 400N	GOOD	29.95
Weston Model 545 Tach. Meter	NEW	17.50

One of the largest and most complete electronic surplus stocks in the country. We have thousands of tubes, capacitors, plugs, accessories, transmitters-receivers test equipment, etc. Send us your requirements.

TERMS: Prices F.O.B. Pasadena, California. 25% on all C.O.D. orders. Californians add 3% Sales Tax. Prices subject to change without notice.

RADIO & TELEVISION NEWS

ates the
 re a gain of
 and NARTB re-
 is to be used, the
 will require a mini-
 output of 40 watts. It
 be capable of producing this
 at the higher frequencies. As
 leaves no safety factor, an ampli-
 fier of at least 60 watts' power output
 should be used.

Shown near the cutting head is a pickup unit for making playbacks from the recorder. This is a standard pickup with an equalizer using a characteristic to compensate for the recording characteristic. The playback is patched directly into the main monitor amplifier, thus avoiding the compressor, filters, etc.

Bridging amplifier number 2 is also followed by an equalizer, which compensates for the light modulator characteristics in the film recorder. This equalizer may have one of two characteristics, one with a rise at the high end and the other with a drop at the high end, depending on the characteristics of the modulator unit. The level at the recorder input will vary from a plus 9 dbm to a plus 18 dbm, again depending on the light modulator design.

At the right of the film recorder is shown a "photocell amplifier," commonly known as a "P.E.C." monitor. This monitoring system is incorporated in the film recorder and consists of a photocell placed at the rear of the film where it picks up the modulations of the light valve directly through the film, or in the case of the galvanometer, the photocell picks up the modulations by a system of mirrors before it reaches the film.

The output of the photocell is amplified by a preamplifier which terminates at the monitor relay. The signal is then picked up by the monitor amplifier and passed on to the mixer monitor loudspeaker. The P.E.C. preamplifier is generally equalized for a response that will be comparable to that taken from the bridging bus.

Below bridging amplifier 2 is a "noise-reduction-amplifier," (N.R.A.) used in conjunction with the film recorder. This amplifier supplies a variable d.c. bias to the light modulator for reducing the exposure on the film during periods of low or no modulation. The gain of this amplifier will vary depending on the output level of the photocell.

Among the many problems of the sound engineer in the early days of film recording was the problem of "background noise." This was due (and still is) to small particles of dirt, scratches, and small pin point specks in the sound track. This problem indicated that some system of reducing the noise during periods of low or no modulation should be devised, and resulted in the development of the noise-reduction-amplifier.

Two methods of recording on film are in use at the present time. They are the variable area and the variable density systems. In the variable area

FREE! WRITE TODAY FOR YOUR GIANT 1952 RADIO SHACK CATALOG ALL NEW! 192 PAGES! OVER 15,000 PRODUCTS! LOWEST NET PRICES

IF YOU ARE

- a designer
- an engineer
- a purchasing agent
- an experimenter
- a manufacturer
- a technician
- an instructor
- a serviceman
- a broadcaster
- a radio amateur
- a custom builder

you need this CATALOG



- **COMPLETE**—"Academy to Zephyr"—presenting all the "blue-chip" lines of instruments, components, apparatus, tools, kits, books; for all electronic and electrical development, production, radio, TV, amateurs, and hi-fi sound.
- **DETAILED**—gives pictures and full descriptions of over 15,000 items—with more technical data than ever before offered in a catalog of this kind.
- **UP-TO-THE-MINUTE**—includes latest information on radiation instruments, radar, miniature and subminiature equipment.
- **TIME and MONEY SAVER**—gives you a single, low-cost dependable, rapid, mail-order source for all your requirements.
- **BACKED UP**—by the largest stocks, strongest capitalization, largest plant, most suppliers, greatest number of "blue chip" lines, lowest prices, and best delivery service anywhere in the East.

FREE! MAIL THIS COUPON TODAY

Radio Shack Corp. Dept. RN
 167 Washington St., Boston 8, Mass.
 Please send me your FREE 192-page catalog
 Issue date Sept. 1, 1951
 I am a
 NAME
 ST. and NO.
 CITY ZONE..... STATE.....



Prepare Now!

RADIO ENGINEERING

B.S. DEGREE IN 27 MONTHS

Complete Radio Engineering course incl. Telev., U.H.F., and F.M. BS Degree Courses also in Mech., Civil, Elect., Chem. and Aero Eng.; Bus. Adm., Acct. Extensive campus, modern buildings, well equipped labs. Low cost. Prep courses. Personalized instruction. Heavy demand for graduates. Placement service. Founded in 1884. Prepare now for the civil and military opportunities ahead. Enter Sept., Jan., March, June. Write for Catalog.

TRI-STATE COLLEGE
 1691 COLLEGE AVE. ANGOLA, INDIANA

FORGEKRAFT... WIRE STRIPPED

\$1.00
 POSTPAID TODAY

ADJUSTABLE SPEEDS UP WIRE STRIPPING

Here's an ideal wire stripper that's Fast—Simple—Safe—Instantly adjustable to strip 15 different sizes of wire. Strips 2" in 2 seconds. Swell for "tight spots".

MAKES WASHER CUTS
 Send \$1.00 TODAY and see how much time and trouble you save. — Department RTN.

DIX MANUFACTURING COMPANY
 3447 EAST PICO BLVD. LOS ANGELES 23, CALIF.

INDISPENSABLE! PHOTOFACT BOOKS



Photofact Television Course. Covers TV principles, operation and practice. 216 pages; profusely illustrated; 8½ x 11". Order TV-1.....Only \$3.00

Television Antenna. New 2nd edition. Describes all TV antenna types; tells how to select, install, solve troubles. Saves time; helps you earn more. 200 pages; illustrated. Order TAG-1.....Only \$2.00

Television Tube Location Guide. Volume 2. Accurate diagrams show position and function of all tubes in hundreds of TV sets; helps you diagnose trouble without removing chassis. 224 pages; pocket-size. Order TGL-2.....Only \$2.00

Television Tube Location Guide. Vol. 1. Over 200 pages of TV receiver tube position diagrams on hundreds of models. Order TGL-1.....Only \$1.50

1949-1950 Record Changer Manual. Vol. 3. Covers 44 models made in 1949, including multi-speed changers and wire and tape recorders. Original data based on actual analysis of equipment. 286 pages; 8½ x 11"; paper-bound. Order CM-3.....Only \$3.00

1948-1949 Changer Manual. Vol. 2. Covers 45 models made in 1948-49. Paper bound. Order CM-2.....Only \$4.95

1947-1948 Changer Manual. Vol. 1. Covers 40 post-war models up to 1948. Order CM-1.....Only \$3.95

Recording & Reproduction of Sound. A complete authoritative treatment of all phases of recording and amplification. 6 x 9". Order RR-1.....Only \$5.00

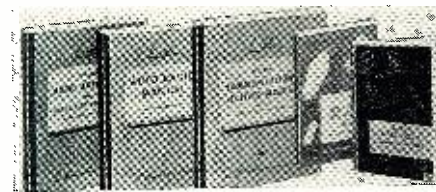

Audio Amplifiers. Vol. 3. Clear, uniform, accurate data on 50 important audio amplifiers, plus full coverage of 22 FM and AM tuners, produced during 1950. 362 pages, 8½ x 11". Order AA-3.....Only \$3.95

Audio Amplifiers. Vol. 2. A complete analysis of 104 well-known audio amplifiers and 12 tuners made 1949-50. 368 pages, 8½ x 11". Order AA-2.....Only \$3.95

Audio Amplifiers. Vol. 1. Covers 102 amplifiers and FM tuners made through 1948. 352 pages. Order AA-1.....Only \$3.95

Auto Radio Manual. Complete service data on more than 100 post-war auto radio models. Covers over 24 mfrs. 350 pages, 8½ x 11". Order AR-1.....Only \$4.95

Communications Receiver Manual. Complete analysis of 50 popular communications models. 246 pages, 8½ x 11". Order CR-1.....Only \$3.00

Radio Receiver Tube Placement Guide. Accurate diagrams show where to replace each tube in 5500 radio models, covering 1938-1947 receivers. 192 pages, pocket-size. Order TP-1.....Only \$1.25

Dial Cord Stringing Guide. Vol. 2. Covers receivers made from 1947 through 1949. Shows you the one right way to string a dial cord in thousands of models. Pocket-size. Order DC-2.....Only \$1.00

Dial Cord Guide. Vol. 1. Covers sets produced 1938 through 1946. Order DC-1.....Only \$1.00

Making Money in TV Servicing. Tested proved methods of operating a profitable TV service business. Covers all important phases. Authoritative, valuable guide to success. Over 130 pages. Order MM-1.....Only \$1.25

Order from your Parts Jobber or write direct to
HOWARD W. SAMS & CO., INC., 2201 E. 46th St., Indianapolis 5, Indiana
HOWARD W. SAMS & CO., INC.

system, the exposure of the sound track is held constant and the area of exposure varied. In the variable density system, the area is held constant and the exposure varied. The principles of noise reduction to be discussed are applicable to both methods of film recording.

Several different types of sound tracks are illustrated on page 70. The two we are most concerned with are the "basic" variable area at A and the variable density at B. These sound tracks are shown without noise reduction.

An elementary schematic of a noise reduction amplifier for variable density recording is shown in Fig. 7A. At the left, the signal from the bridging bus is applied to a bridging amplifier, which drives the light valve. The noise reduction amplifier below receives the signal at the same instant, which it rectifies to d.c. and uses to control the opening and closing of the light valve during periods of low or no modulation, thus reducing the exposure of the film. A centertapped transformer matches the low impedance of the light valve "ribbons" to the output impedance of the bridging amplifier. The resistor R is equal to the light valve ribbon resistance and is connected in series with one side of the light valve to balance the circuit and reduce interaction between the audio signal and the bias current.

During periods of no modulation, a fixed d.c. bias is applied to the light modulator ribbons to reduce their opening to some predetermined amount. The rectified signal voltage is polarized to cancel a portion of this fixed bias, relative to the amplitude of the applied audio signal. This causes the light modulator to open wider, to accommodate a greater signal amplitude. In the rectifier circuit is a resistance-capacity filter for removing the ripple components of the rectified signal voltage. The time constant of the filter circuit will control the opening and closing time of the noise reduction system.

ductio
the ini
distortio
squaring
noise redu
opening time
as it may cau
the reproduction
ing time be made
clip the last few n
closing time is too
ground noise will be in
develop a "hush-hush" s
particularly noticeable
density recording. The att
both the variable area and de
tems is on order of 18 to 32
seconds at 1000 cps for an 80% opening of
the light modulator. The closing time
at 100 cps for variable density system
will be approximately 50 milliseconds,
and 250 milliseconds for the variable
area types.

The circuit of the N.R.A. in Fig. 7B is used with variable area recording, and is similar to that described for variable density except that it supplies the bias voltage to coil A in the recording galvanometer. The second coil, B, carries only the audio signal which actuates the recording mirror in the galvanometer. In some type variable area recorders, the N.R.A. bias voltage is applied to a pair of "shutters" placed in the path of the optical system in such a manner that they reduce the area of exposure during the periods of low or no modulation, thus obtaining a reduction in exposure of the film. When shutters are employed, the bias coil in the galvanometer is not used.

Figs. 8A and 8B are plots of the opening and closing times for a typical variable area noise reduction system using galvanometer bias. It will be seen why it is so necessary for the noise reduction system to get out of the way of the modulation to prevent clipping of the initial and closing modulations. However, regardless of the design or how the N.R.A. is adjusted, some clipping of the initial and closing modulations will take place.

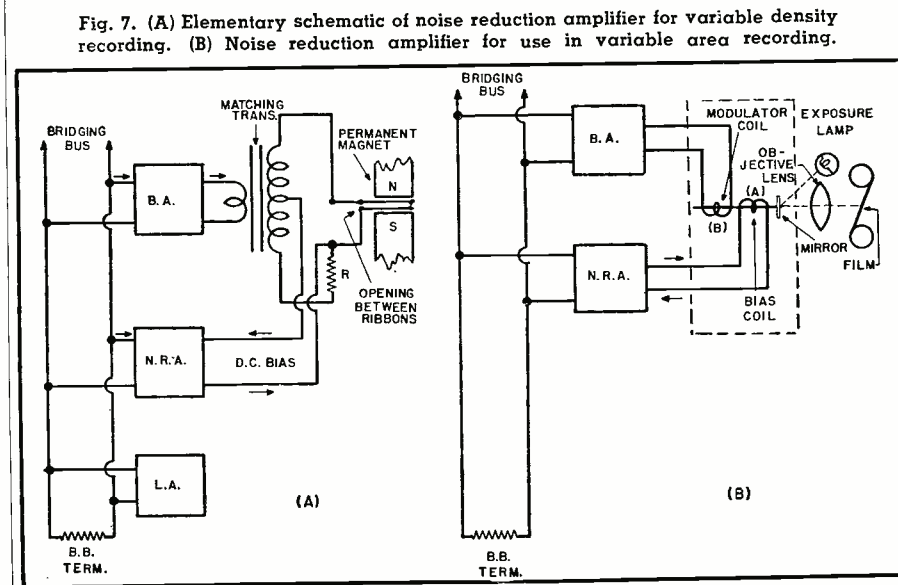

Fig. 7. (A) Elementary schematic of noise reduction amplifier for variable density recording. (B) Noise reduction amplifier for use in variable area recording.

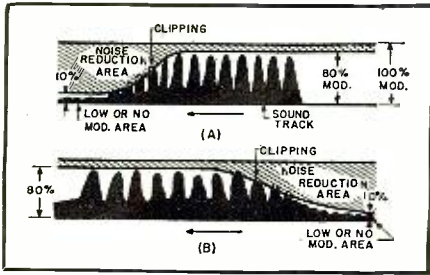

Fig. 8. Plots of the opening (A) and closing (B) times for a variable area noise reduction system using galvanometer bias.

When the N.R.A. is initially set up, the amount of fixed bias is adjusted to bring the light valve ribbons or galvanometer to about 10 per-cent of full track with no modulation. The gain of the N.R.A. is then set to cancel the fixed bias when the track is about 80 per-cent modulated.

Because of the time lag in noise reduction systems, a "margin" of safety must be included in the initial adjustment. After the fixed bias and the gain of the N.R.A. have been set, the gain of the N.R.A. is increased slightly to operate the noise reduction element a greater amount than required by the signal, or given a "lead." The amount of margin will vary with the type system and program material. Generally, a margin of 2 to 3 db is used with variable area systems. For variable density, the margin for dialogue will approximate 3 db and for music and sound effects, 4 to 6 db. The frequency response of the N.R.A. should be uniform over the recording range.

The purpose of the margin setting is to prevent the clipping of the signal peaks thus causing distortion of the more staccato tones. During periods of no modulation in the variable density system, the light valve ribbons, being about 10 per-cent open, result in a light grey exposure of the film. This exposure is often referred to as "silent sound track." In the variable area system during periods of no modulation, a thin line of exposure approximately one-half mil in width appears and is known as the "bias line." This line of exposure is created by the setting of the fixed bias current, which allows a small amount of light to reach the film. The average signal-to-noise ratio is 40 db for 35 mm film and 38 db for 16 mm film.

Phasing is quite important for the proper operation of a film noise reduction system, therefore, manufacturers of complete film recording systems mark one terminal of the input and output circuits with a plus-minus mark to indicate that for an instantaneous voltage of a given polarity at the input, a corresponding voltage will result at the output terminals. If the recorder is to be used with existing equipment, the proper phasing between the N.R.A. and the light modulator will have to be determined by experiment. Complete phasing of the system from microphone to the light modulator is recommended to facilitate substitution of equipment.

NATIONALLY ADVERTISED TUBES FULLY GUARANTEED

RCA—Kenrad—Sylvania—
Tung-Sol—National Union
—G.E.—Philco—Hytron.

All new tubes. Individually
Boxed. 100% guaranteed.

Tubes	Price	Tubes	Price	Tubes	Price	Tubes	Price
01A	\$0.73	2A5	1.07	6BD5	1.54	617G	1.54
0A3/VR75	1.39	2A6	1.29	6BD6	.99	617G	1.54
0A4G	1.29	2A7	1.29	6BE6	.89	605	.99
0R3/VR90	1.29	2B7	1.29	6BF5	1.07	606GT	.99
0C3/VR105	1.29	2E5	1.29	6BF6	1.29	606GT	.99
0D3/VR150	1.29	2X2A	2.09	6BG6G	2.39	606GT	.99
OY4	2.34	2Z2/G84	1.89	6BH6	.99	607G	1.07
OZ4, G	.79	3A4	2.09	6BJ6	.99	607G	1.07
1A3	1.07	3A8GT	2.29	6BK6	.73	607G	1.07
1A4P	1.89	6B7	1.79	6BL7GT	1.39	607G	1.07
1A5GT	.89	3C6/XXB	1.54	6BN6	1.54	607G	1.07
1A6	1.49	3D6	1.29	6BO6GT	1.54	607G	1.07
1A7	1.07	3E5	1.17	6BT6	.73	607G	1.07
1A8	1.49	3FL4	1.29	6BY6	1.29	607G	1.07
1A9	1.89	3Q4	1.07	6C4	1.07	607G	1.07
1B3	1.89	3Q5GT	1.07	6C4 GT	.79	607G	1.07
1B5 25S	1.89	3Q5GT	.99	6C6	1.07	607G	1.07
1C5GT	1.09	3V4	.99	6C8G	1.54	607G	1.07
1C6	1.54	3Z4	2.99	6CR6	1.54	607G	1.07
1C7G	1.07	5R4G	2.99	6D6	1.07	607G	1.07
1C8	1.07	5T4	2.29	6D6G	2.95	607G	1.07
1D5GP	1.89	5U4G	.79	6D6	1.07	607G	1.07
1D7G	1.07	5X4	1.07	6D8G	1.54	607G	1.07
1D8GT	1.89	5W4	.79	6E5	1.07	607G	1.07
1E5GT	1.89	5X4G	.89	6E6	1.29	607G	1.07
1E7GT	1.89	5Y2G	.89	6G6	1.29	607G	1.07
1F4	1.29	5Y4G	.73	6F5	.99	607G	1.07
1F5G	1.29	5Z3	.89	6F5 GT	.79	607G	1.07
1F6	1.89	5Z4	1.29	6F6	.99	607G	1.07
1F7G	1.89	6A3	1.54	6F8G	1.54	607G	1.07
1G4GT	1.29	6A4	1.54	6G6G	1.29	607G	1.07
1G6G	1.29	6A5G	1.89	6H8G	1.54	607G	1.07
1G6GT	1.29	6A6	1.29	6H6	.79	607G	1.07
1H4G	1.07	6A7	1.07	6J6	.73	607G	1.07
1H5GT	1.89	6A8	1.07	6J6 GT	.89	607G	1.07
1H6GT	1.54	6A84	.99	6J7	1.07	607G	1.07
1J5G	1.29	6AB6	1.29	6K6G	1.17	607G	1.07
1J6G	1.54	6A87	1.54	6K6GT	.79	607G	1.07
1L4	.99	6AC5GT	1.39	6K7	1.07	607G	1.07
1L6	1.29	6AC7	1.39	6K8	1.29	607G	1.07
1L64	1.29	6AD7G	1.54	6L6	1.29	607G	1.07
1L6A	1.29	6AE6G	.89	6L6, GA	1.54	607G	1.07
1L84	1.29	6AF6G	1.29	6L6G	1.54	607G	1.07
1L8E	1.29	6AK5	1.89	6N6	1.29	607G	1.07
1LC6	1.29	6AG7	1.54	6N7 GT	1.17	607G	1.07
1LD5	1.29	6AH6	1.89	6P6GT	1.29	607G	1.07
1LE	1.29	6AS5	1.29	6P6	1.54	607G	1.07
1LG5	1.29	6AK6	1.17	6P6 GT	.99	607G	1.07
1LH4	1.29	6ALS	.99	6Q7 GT	.99	607G	1.07
1LH7	1.29	6A7 GT	1.17	6R7GT	1.29	607G	1.07
1NSGT	.99	6AQS	.99	6S7	1.29	607G	1.07
1PSGT	1.29	6A0G	.89	6S7 GT	1.17	607G	1.07
1R4	1.29	6A7GT	1.17	6S8G	1.29	607G	1.07
1R4	1.29	6A55	.99	6S8T	1.17	607G	1.07
1S4	1.17	6AV5GT	1.29	6S87 GT	.99	607G	1.07
1S5	.89	6A06	.99	6S87 GT	.99	607G	1.07
1S6	1.07	6AV5GT	1.29	6S87 GT	.99	607G	1.07
1T4	.99	6AV6	.79	6S87 GT	.99	607G	1.07
1T5GT	1.29	6AV6G	1.29	6S87 GT	.99	607G	1.07
1T6	1.07	6AV5GT	1.29	6S87 GT	.99	607G	1.07
1U4	.99	6B4G	1.29	6S87 GT	.99	607G	1.07
1U5GT	.89	6B5	1.54	6S87 GT	.99	607G	1.07
1V2	1.73	6B6G	1.07	6S87 GT	.99	607G	1.07
1V5	1.07	6B8	1.54	6S87 GT	.99	607G	1.07
1W5	1.07	6B8A	.89	6S87 GT	.99	607G	1.07
1X2	1.29	6B87	1.17	6S87 GT	.99	607G	1.07
2A2	1.54	6B5	.99	6S87 GT	.99	607G	1.07
2A4G	1.54	6B7	1.29	6S87 GT	.99	607G	1.07
		6B7	1.29	6S87 GT	.99	607G	1.07
		6B7	1.29	6S87 GT	.99	607G	1.07
		6B7	1.29	6S87 GT	.99	607G	1.07
		6B7	1.29	6S87 GT	.99	607G	1.07
		6B7	1.29	6S87 GT	.99	607G	1.07
		6B7	1.29	6S87 GT	.99	607G	1.07
		6B7	1.29	6S87 GT	.99	607G	1.07
		6B7	1.29	6S87 GT	.99	607G	1.07
		6B7	1.29	6S87 GT	.99	607G	1.07
		6B7	1.29	6S87 GT	.99	607G	1.07
		6B7	1.29	6S87 GT	.99	607G	1.07
		6B7	1.29	6S87 GT	.99	607G	1.07
		6B7	1.29	6S87 GT	.99	607G	1.07
		6B7	1.29	6S87 GT	.99	607G	1.07
		6B7	1.29	6S87 GT	.99	607G	1.07
		6B7	1.29	6S87 GT	.99	607G	1.07

TERMS: 25% with Order, Balance C.O.D., F.O.B. Chicago.
Prices subject to change without notice. Minimum order \$10.00

FRANKLIN-ELLIS COMPANY

226 W. Randolph Street
Chicago 2, Ill.



TRANSMITTING AND ELECTRONIC TUBE SPECIALS

NO.	PRICE	NO.	PRICE
2A1	\$4.95	836	\$2.95
15-E	2.95	865	2.95
RKR-72	2.95	876	1.95
RKR-73	2.95	879	.95
114-E	1.35	954	1.95
REL-36	2.95	955	2.95
2N2-879	.95	956	2.25
215	1.25	957	1.95
227A	2.75	1626	.95
233A	1.75	1616	2.95
274	2.95	1642	1.49
327A	3.25	7193	1.15
316A	1.75	8011	1.95
393A	6.95	8016	1.50
417A	3.95	9001	1.25
615	1.25	9002	.95
705	2.95	9004	.95
713A	1.75	9006	.75
715	14.95	159781	1.25
801	1.95	38233	1.25
815	2.95	GL451	1.25
826	3.25	2JB51	1.25

10% Cash With Orders

ALMO RADIO CO.
509 ARCH ST. & 6205 MARKET ST.
Philadelphia, Pa.
6th & ORANGE STS. • Wilmington, Del.
4401 VENTNOR AVE. • Atlantic City, N. J.
7133 HADDON AVE. • Camden, N. J.



Can Use These SERVICE HINTS!

Valuable Manual Yours—FREE!



Every page of "How to Simplify Radio Repairs" is packed with on-the-bench, practical ideas. Contains photos, charts, diagrams—no fluff-no vague theory. In plain every-day language it gives you priceless suggestions—new servicing ideas. You'll use and benefit from the experience of experts. Partial list of contents: How to Localize Trouble; How to Service Amplifiers; How to Test for Distortion; How to Test Audio Circuits; How to Test Speakers; How to Find Faults in Oscillators; How to Test Radio Parts—all free—all yours—FREE! No obligation.

FEILER

SEND COUPON OR PENNY POSTCARD FOR YOUR FREE COPY TODAY!

FEILER ENGINEERING CO., Dept. 9H1
8026 N. Monticello Ave., Skokie, Ill. (Suburb of Chicago)

Please RUSH my FREE copy of "How to Simplify Radio Repairs."

Name

Address

City

Zone

State

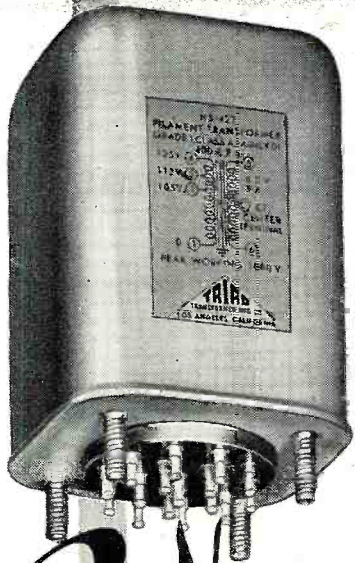

2 New Groups of Triad Transformers

- A Series of 400-cycle Power Transformers
- Miniaturized Voice Frequency Audio Transformers

FEATURING:

- Minimum size and weight.
- MIL-T-27 standard cases.
- New core materials.
- New winding and impregnating techniques.
- Available from your jobber.

Ideal for military prototypes where MIL-T-27 construction is specified.

Write for Bulletin 451



Above the bridging amplifier No. 2 is bridging amplifier number 3, which is used to transmit signals from the bridging bus to a remote point. At the output of the bridging amplifier is the line "isolation" pad described in Part 6.

The magnetic recorder input is patched directly across the bus and requires no bridging amplifier, as the majority of such recorders are supplied with a bridging input. A relay operated from the mixer console is connected in the output of the recorder playback circuit for switching to either the monitor system or through the mixer, for re-recording purposes. The output level from the average magnetic recorder is zero dbm.

Two vu meters are provided, one at the mixer console for monitoring the levels, and a second at the bridging bus for "lining up" the channel. It is the practice in large installations to check the noise reduction system twice daily, and the levels at the disc and magnetic recorder before each recording session.

It has been assumed in the block diagram that the bridging bus level is plus 4 dbm. A 1000 cps signal of approximately minus 20 dbm is applied to the mixer through one of the pots and adjusted until the level indicated by the vu meters indicates a plus 4 dbm or, if the meter scale is calibrated in percentage modulation, at the 100 percent mark. (See November 1950 RADIO & TELEVISION NEWS, "Power Level and Volume Indicator Meters.")

After the bus level has been set, the levels are read at the recorders. If any variation in level is noted, the gain of the various amplifiers driving the recorders is adjusted. It is necessary that such measurements be made at the same frequency of 1000 cps each time, to avoid errors due to equalizer and filter characteristics.

With the signal still on the bridging bus, the level at the output of the monitoring amplifier is measured by patching a vu meter across its output. The level of each monitoring system is then adjusted for the same output within plus-minus 0.50 db. It is quite important that the monitoring level be measured daily if quality checks are to be made from day to day. Setting the levels to within 0.50 db will allow the monitoring system to be switched from one source to another during takes without disturbing the level. The monitor amplifier feeding the auxiliary speakers is not critical and is set for the best listening level.

A talkback system between the mixer console and the recording department should also be provided. This may be made a part of the auxiliary monitoring system, utilizing the speakers only; however, a separate system is desirable. The talkback system should be so arranged that "selective talking" is provided; that is, when the mixer talks to the recording department the talkback speaker to the stage is off, and vice versa. This is generally accomplished by the use of key switches and a group of relays.

(To be continued)

THE WILLIAMSON AMPLIFIER

WITH

Acrosound

TRANSFORMER*

(Described in Dec. 1950 R & TV News)

PROVIDES

- The cleanest, smoothest, most natural sound available at any price!
- Lowest possible distortion
- Widest band width
- Outstanding transient response

The heart of this fine amplifier is the Acrosound TO-290 (12,000 ohms: 4, 8, 16 ohms) \$15.75 potted in seamless steel case with silver gray hammertone finish.

Other output transformer models and high fidelity circuits are also described in free descriptive literature.

Data on the famous Williamson Amplifier with Acrosound transformer sent on request.

Prices F.O.B. Phila.
*Pat. Pend.

25% Deposit
on C.O.D.'s

ACRO PRODUCTS COMPANY

369 Shurs Lane, Roxborough, Phila. 28, Pa.

BRAND NEW TUBES

003	5D21	.. \$19.95	417A	.. \$13.50	
VR105	5.130	6AB7/1853	1.19	W1530	.. 19.95
OD3	6AJ5	.. 1.89	700A/B/D	.. 16.50	
VR150	1.00	6AK5	.. 1.39	706CY	.. 39.50
1A3	1.10	6BB5	.. 1.39	706Y	.. 39.50
183GT	.. 1.15	6BL7GT	.. 1.20	707B	.. 14.95
1B22	.. 3.25	6C5	.. .79	715B	.. 12.95
1B24	16.95	6J4	.. 5.99	717A	.. 1.19
1B27	.. 19.95	6J5GT	.. .50	723A	.. 7.50
1N23	.. 1.29	6L6M	.. 2.25	723A/B	.. 14.50
1R4/1294	.. 1.10	6S7	.. 1.10	724B	.. 2.75
175GT	.. .98	6S7GT	.. 1.19	725A	.. 7.50
2C40	.. 6.75	6SH7GT	.. .89	726A	.. 6.50
2C43	.. 23.00	6S17	.. .89	726B	.. 29.50
2J21A	.. 9.50	6SL7GT	.. .89	809	.. 2.25
2J22	.. 9.95	6ST7	.. .89	829	.. 8.95
2J31	.. 35.00	7C23	.. 59.50	829B	.. 13.95
2J32	.. 49.50	7F7	.. 1.00	832A	.. 9.95
2J33	.. 39.50	7V7	.. 1.19	836	.. 5.50
2J48	.. 24.50	12A6	.. .80	851	.. 52.50
2J56	.. 179.50	12K6	.. .89	860	.. 3.50
2J62	.. 38.95	12SK7	.. .69	872A	.. 2.75
2K25	.. 33.95	12SL7GT	.. .69	874	.. .95
2K28	.. 29.95	12SN7GT	.. .79	884	.. 1.75
2K29	.. 29.95	12SR7	.. .89	923	.. 1.65
3A5	.. 4.50	246/3C24	.. 1.75	935	.. 1.49
3B24	.. 59.50	28D7	.. 1.29	1616	.. .95
3C22	.. 8.50	RR72	.. 1.65	1622	.. 2.00
3C23	.. 12.50	RR73	.. 1.65	1624	.. 1.75
3C33	.. 14.50	3AP1	.. 9.95	1625	.. .45
3E29	.. 14.50	250R	.. 9.95	2050	.. 1.75
3Q4	.. .89	304TH	.. 12.50	80TH	.. 1.25
3E4	.. .89	304TL	.. 9.95	8025	.. 5.95
4E27	.. 17.50	307A	.. .90	9001	.. 1.50
4J31	.. 89.50	KK725	.. 5.50	9002	.. 1.25
5BP1	.. 5.95	350A	.. 6.95	9003	.. 1.25
5BP4	.. 5.94	350B	.. 5.95	9005	.. 1.75
7BP7	.. 7.95	394A	.. 4.50		

Send us your inquiries! We carry a complete stock of Radio and TV Tubes & electronic parts. WE PAY HIGHEST PRICES FOR YOUR OVERSTOCK AND SURPLUS!

J. S. H. SALES CO.

Dept. R-4, 7552 Melrose Ave., Los Angeles 46, Calif.

KAAR RADIOPAK

THE MOBILE
RADIOTELEPHONE
KAAR ENGINEERING CO.
PALO ALTO, CALIFORNIA

RADIO & TELEVISION NEWS

Mac's Service Shop

(Continued from page 66)

certainly makes you want something to help unscramble them."

"What produces DX like that, anyway?" Barney asked.

"I don't know," Mac readily admitted. "As a ham, you are, of course, familiar with the theory that clouds of ionization frequently appear about fifty miles above the earth and reflect back to earth high frequency signals that ordinarily would never be returned. This 'Sporadic-E Ionization' as it is called may happen any time, but it occurs most frequently during May, June, and July. That could explain my experience except for one thing: that the signals from Texas seemed to be arriving from either the southeast or northwest—exactly opposed to the southwest direction in which Texas lies from here.

"Some of my friends," he went on slowly, "who know a lot more about such things than I do, tell me that there is a growing theory that under certain favorable circumstances a current of air under exactly the right conditions of moisture, barometric pressure, and temperature can actually act as a huge waveguide and 'pipe' a high frequency signal from one part of the earth to another. Maybe that is the answer. At least it would permit the signal path to have a bend in it, as that one from Houston seemed to have.

"At any rate," he continued, "I'm going to do all the 'observing' I can every time one of these openings occurs. Hams have been doing that for years, but their numbers are very small compared to the millions looking at TV screens every day. If only a small percentage of these TV fans become interested in noting some of the factors that affect abnormal DX signals, perhaps we can learn enough about them to enable us to control these conditions."

"Could be," Barney agreed with a shrug. "Today's miracle is tomorrow's normal occurrence. I keep remembering that at one time they gave the whole spectrum above two hundred meters to the hams because they thought these frequencies would never be of any practical value—the Indian givers! Next time the TV channels get hot, just let Old Barney know, and he will be right in there waving a folded dipole alongside you!" —30—

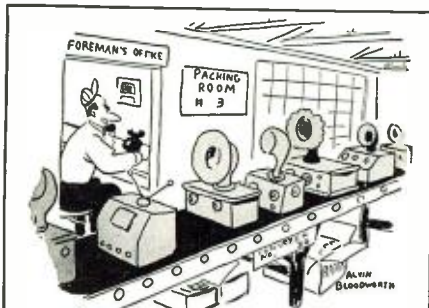

"Get me the Assembly Dept., quick!"

RIGHT!

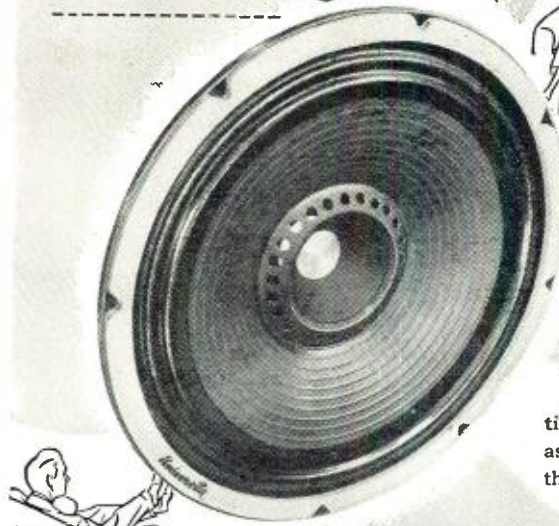

Write today for Bulletin 62N73
— address inquiries to Desk 63.



— from any angle

A challenging answer to low cost, wide-angle high fidelity reproduction. Diffusicone-12 is a newly engineered speaker with exclusive dual concentric cone design, which diffuses the normally beam-like high frequencies. Results in exceptionally uniform response . . . assures full range reception over the entire listening area.

THE NEW

University DIFFUSICONE-12

An Engineering Achievement of UNIVERSITY LOUDSPEAKERS INC.
80 So. Kensico Ave., White Plains, New York



What Do You Want to Trade In on a New hallicrafters?

I have a complete stock of Hallicrafters receivers and transmitters. We will give you the best doggone trade-in in the world because we need used receivers badly for our trade. What do you have? Write me about it. I give you prompt delivery, 90-day FREE service and the world's lowest credit terms. Write, wire, phone, or visit either store today for the best deal. Export orders solicited.

Bob Henry
WPARA



LOW COST HALLICRAFTERS Model S-77

Temperature compensated oscillator; tuned r-f stage, two i-f stages for better selectivity. Covers 540 kc to 43 Mc in four bands. Sensitivity, volume, three-position Tone, BFO Pitch, controls; AVC, BFO, Rec./Standby, and Noise Limiter switches. Built-in PM speaker. Gray steel cabinet, 18 1/2" wide, 9" high, 9 1/2" deep. Piano hinge top. External power, remote control connections. 7 tubes plus rect. This is AC/DC version of popular S-40B. For 115 V. AC/DC. \$99.95



NEW DUAL-CONVERSION RECEIVER HALLICRAFTERS Model S-76

Note these features: Dual conversion (1650 Kc and 50 Kc)—more usable selectivity than the best crystal. Giant 4-in. "S" Meter—calibrated in microvolts and "S" units. Four bands 538-1580 Kc, 1720 Kc to 32 Mc. Calibrated electrical bandspread. 5 position selectivity. Sensitivity 2 microvolts or better with 5 watt output. 9 tubes plus regulator, rectifier. \$169.50.

Butler 2, Missouri

HENRY RADIO STORES

11248 Olympic Blvd.
LOS ANGELES 35
CALIF.

"WORLD'S LARGEST DISTRIBUTORS OF SHORT WAVE RECEIVERS"



ACORN

Famous Make!

- HIGH GAIN
- WIDE BAND

5" OSCILLOSCOPE

NOT A KIT—But a Complete Instrument

Regular Value \$279

BRAND NEW \$129.50

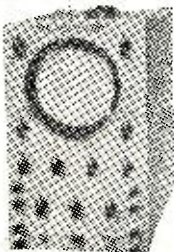

FEATURES:

- # 1: Vertical Bandwidth 10 Cy to 2 Mc., 3 db down
 - # 2: Vertical Sensitivity .06 RMS volts/inch
 - # 3: Decade Type Frequency Compensated Attenuators
 - # 4: Horizontal Bandwidth 2 Cy to 900 KC-6db down
 - # 5: Horizontal Sensitivity .15 RMS volts/inch
 - # 6: Push Pull Deflection Amplifiers
 - # 7: Direct Connection to Deflection Plates Available
 - # 8: Internal Synchronization of Either Polarity
 - # 9: Z Axis Input (Intensity Modulation)
 - # 10: Calibrated 60 Cy Test Signal
- Tube Complement:
2-6AG7, 3-6SN7, 1-6AC7, 1-5Y3, 1-2X2, 1-884, 1-5CP1

SCOTT CHOKE

30 Hy, 220 ma. Upright Mount, chrome finish. 115 ohm D.C. resistance.

\$3.95

DUMONT 4-CIRCUIT INPUTUNER

Featuring FM BAND reception, as well as 13 TV channels. Fits into dual channel IF system Type 630 receivers without alteration.

Higher gain 2-1 ratio on high channels, low noise, input impedance 300 ohms. 21.25 mcs. sound center IF. Continuous tuning. Complete with TUBES and KNOBS. Drastically reduced to...

TS-3A1

\$19.95

G.E. SCOPE TRANSFORMER

1500 v. tapped @ 2.5 v., 6.3 v., @ 4 amp., 2.5 v. @ 3 amp. Cased, upright mtg.

\$6.95

CARTER DYNAMOTOR

Stock No. 4037AS
DC input 6VDC.
output 400 V @ 375
ma 1/8 DC. Perfect
for mobile com-
munications in car,
plane or boat.
BRAND NEW.
List \$71.40. Our
Price

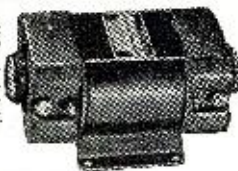

\$34.95

PIONEER GEN-E-MOTOR

Type E-3: Input 14 VDC @ 8 amps \$14.95
DC. Output 550 V @ 120 mils
SF-125: Input 28 VDC @ 2.2 amps \$6.95
DC. Output 270 V @ 120 mils
OS-125: Input 28 VDC @ 1.2 amps \$4.95
DC. Output 260 V @ 60 mils

BENDIX DYNAMOTOR

Type DA-1A: Input 28 VDC @ 1.6 amps DC. Output 230 V @ 100 mils. \$5.95

VIBRATOR TRANSFORMER

Pri. 6 V. Sec. 600 V. C. T. @ 90 ma. Upright Mount. \$1.99

G.E. LOW VOLTAGE STEP-DOWN TRANSFORMERS

Pri. 115 V—50-60 cy. \$4.95
Sec. #1—15 V @ 12 amp. Channel mtg.
Pri. 115 V—50-60 cy. \$4.95
Sec. #1—10 V @ 12 amp. Channel mtg.

RCA TRANSFORMER

Pri. 115 V—50-60 cy.
Sec. #1—750 V. C. T. @ 225 ma.
#2—6.3 V @ 8 amp.
#3—6.3 V @ 1.2 amp.
#4—5 V @ 3 amp. \$6.95
Half Shell Mount.

TERMS: 20% cash with order, balance C.O.D., unless rated. Prices F.O.B. our warehouse in N. Y. C. Minimum order \$5. NOTE: Due to conditions beyond our control, prices are subject to change.

Phone Worth 4-3270

ACORN ELECTRONICS CORP.
76 Vesey St., Dept. N-9, New York 7, N. Y.

NEW TV PRODUCTS on the Market.

PLASTIC PROTECTION

Krylon, Inc. of Philadelphia, Pa. is currently packaging "Krylon," an acrylic plastic, under a special label for use in the television service field.

The material, which is sprayed by fingertip control from a pressurized can, forms a durable, transparent coating which protects television antennas against rust, corrosion, and pitting, and eliminates corona from high voltage connections.

The company also suggests the use of this plastic on all metal antenna parts which might rust and discolor outside paints.

NEW TV TUNER

Kingston Products Corporation of Kokomo, Indiana has announced the development of a new type of television tuner which differs mechanically from existing tuners.

While classified as a turret type tuner, the new unit retains the economy features of the switch type tuner. The basic mechanical design permits

The Model 43A includes a wide-range variable frequency multivibrator which drives a two-stage clipper circuit to produce negative-going square



waves. No external driving voltage is required although a synchronizing input circuit and buffer amplifier are provided to allow the generator to be operated synchronously with other equipment. A separate output sync signal is also available for triggering purposes. It covers a frequency range of from 6 cycles to 1 mc. with the self-contained generator.

For full details on the Model 43A, write direct to the company.

COLOR RECEIVER

Chromatic Television Laboratories, Inc., 1501 Broadway, New York 18, New York has announced the development of an automatic black and white color television receiver which incorporates a 16" or 21" direct view tri-color "Chromatron" picture tube.

According to the company, the receiver will automatically tune for reception of either color television transmissions based on the CBS type color field sequential standards or standard black and white transmissions.

The heart of the new receiver is the tri-color "Chromatron" picture tube which features a single gun, standard-shape cathode-ray tube containing a color grid capable of displaying television pictures or other electronic signals in color.

The company claims that the new tube will work in conjunction with any known color television system but that its use in color receivers operating on the CBS standard is significant inasmuch as it eliminates the need for the color disc or drum.

TV TUBE RECOVERY

H & A TV Picture Tube Co., 3547 West Montrose Avenue, Chicago 18, Illinois is now offering a new service to television technicians on a nationwide basis.

The new service involves the electrical repair of burned out picture tubes. According to the company, approximately 65% of the tubes formerly discarded as "dead" can be recovered and put into operation. The repaired

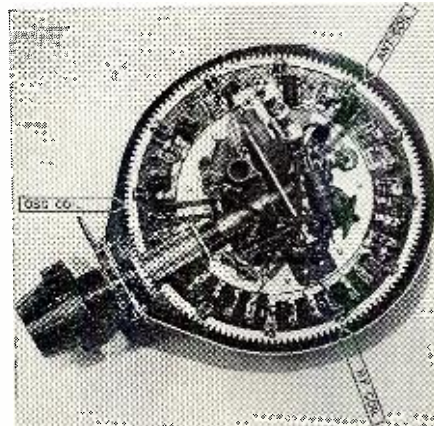

the oscillator to be isolated from the r.f. and antenna circuits in order to reduce oscillator radiation.

The television switch has twelve indexed positions with continuous rotation, each index having its individual preset coils for the channel corresponding to the position. The tube complement includes a 12AT7 dual-triode used as a converter oscillator and a 6CB6 employed as an r.f. amplifier. The output i.f. transformer is included in the tuner which is completely shielded in a drawn metal case.

Manufacturers may obtain full details on this new tuner by writing the company.

SQUARE WAVE GENERATOR

Electro-Mechanical Research, Inc. of Ridgefield, Conn. has developed a new square wave generator which is designed for testing audio, video, and r.f. amplifiers and networks.

Users' Reports Prove THE OUTSTANDING PERFORMANCE of the STRAIN-SENSITIVE PHONOGRAPH PICKUP!

Enthusiastic letters from users all over the country are unanimous in praising the quality of reproduction obtained with the new STRAIN-SENSITIVE Pickup made by the Pfanstiehl Chemical Company.

There are good reasons why this amazing new transducer brings out the brilliance of great voices and orchestras... the latent music on your records that other pickups leave untouched.

- The STRAIN-SENSITIVE PICKUP is an amplitude transducer with a CONSTANT RESISTANCE of about 250,000 ohms.
- Signal output is at a practically CONSTANT IMPEDANCE LEVEL.
- Excellent Transient Response.
- NO DISTORTION, phase shift or evidence of intermodulation is audible.
- LINEAR RESPONSE, free from peaks or resonances.

Cartridges are available for both standard and micro-groove, and can be had with Famous PFANSTIEHL M47B Precious Metal Alloy or diamond tipped styli.

A special preamplifier is necessary to provide the correct D.C. voltage for the pickup element and to provide the first stages of signal gain. Four styles are ready, or, if you prefer, you can build your own from the circuit in the literature.

Ask your radio supply man, or write today for complete FREE INFORMATION.

PFANSTIEHL CHEMICAL COMPANY

107 Lake View Avenue, Waukegan, Illinois

Why FRETLINE?

Fretline is the best in transmission line because of its low loss and its ability to withstand atmospheric conditions permanently. In remote signal areas Fretline has been the answer to installation problems. Ask someone using Fretline.

Immediate Delivery from
Your Jobber or Write for In-
formation, Dept. RN.

FRETCO
TELEVISION COMPANY
1041 Forbes Street, Pittsburgh, Pa.
Mass Producers of Fretline

tube carries with it a guarantee that the tube life will meet RTMA specifications.

Prices vary according to the size of the tube being serviced. The company will supply cost information and other data on request.

FRINGE AREA TV

Mattison Television and Radio Corporation, 893 Broadway, New York 3, New York has recently introduced a

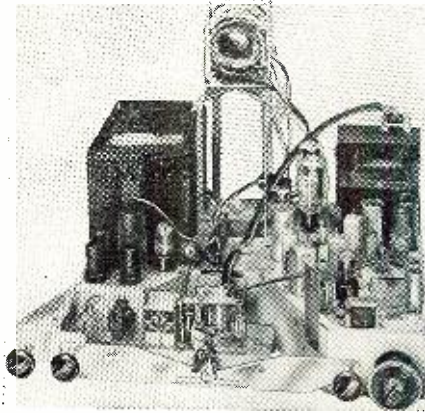

new television chassis which has been designed especially for super-fringe areas.

Known as the "Super Rocket Super Rural Chassis," the new set features a built-in booster which is designed to increase the signal strength on Channels 2 to 13 by a ratio of up to 10:1 without increasing noise or reducing the picture quality.

This chassis is available either with or without a cabinet and full details will be supplied by the company on request.

COSINE YOKES

Merit Transformer Corporation, 4427 N. Clark Street, Chicago, Illinois is currently in production on two new cosine yokes, the MDF-70 and the MDF-30.

The MDF-70 is a newly designed unit with distributed winding for edge-to-

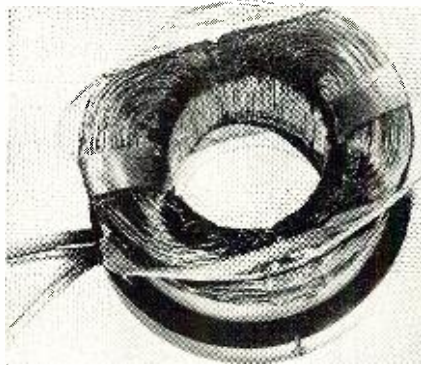

edge picture focus. A high efficiency ferrite core permits its use with all 70 degree picture tubes up to and including 24" sizes. It is recommended for use with the HVO-6 and HVO-7 ferrite core flybacks.

The MDF-30 has the same design features as the MDF-70 but has high

HARVEY

Features the Finest Brands
At Most Reasonable Prices!

WILLIAMSON HR-15 AMPLIFIER KIT

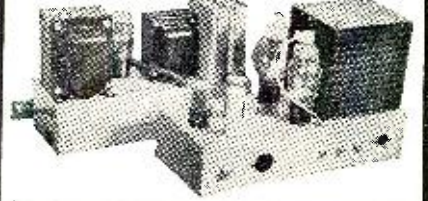

The famous Williamson HR-15 amplifier circuit... now available with the original Partridge transformers built to Williamson's specifications. Build this kit in 3 hours or less, and enjoy sound of a quality you never heard before. The HR-15 is a 2-Chassis power amplifier for use with tuners or other front ends having own volume and tone controls. All American triodes, 2-6SN76GT, 2-807, or 6BG6G in PP output, 5V4G rectifier. Response ± 5 db, 10-100,000 cycles. Output impedances 1.7 to 109 ohms in 8 steps. Absolute gain 70.8 db. 20 db. of feedback around 4 stages and the output transformers. Kit is Complete with Tubes, Punched Chassis, Pre-wired Resistor Board, Sockets, Genuine Partridge Output Transformer, and All Necessary Parts.....\$75.00

As Above, with CFB Transformer.....\$85.00

PARTRIDGE OUTPUT TRANSFORMER
WWFB, as used in above Kit, available separately.....\$24.50

WILLIAMSON KIT, with all TRIAD Transformers,
using potted output transformers.....\$75.00

As Above, with Hermetically Sealed Output Trans-
formers.....\$85.00

New Partridge CFB Series



Frequency response 3db down
at 3 cycles and 95,000 cycles.
Power rating 30 to 30,000
cycles at 60 watts with less
than 1% distortion without
negative feedback. Write for
descriptive literature.
\$35.00 net

A Truly Remarkable Value!

Western Electric 755-A 8" PM Speaker

Will handle 8 watts of power. Uses a very heavy magnet. This speaker has built into it more loud-speaker quality than has been available in a unit of this size, power and cost. Only 3 1/8" deep, therefore, it offers extremely small space requirements for full range frequency coverage and wide angle distribution of high frequencies. \$24.60

Western Electric 639-B Microphone

Widely used by recording studios, broadcast stations and wherever a high quality cardioid microphone is required. \$169.50

Prices Subject to Change Without Notice

Telephone: **703** LUXemburg 2-1500

HARVEY
RADIO COMPANY INC.
103 West 43rd St., New York 18, N. Y.

TRANSVISION

CAN SHOW YOU HOW TO
GET IN ON THE
GROUND FLOOR of
COLOR TV

Now . . . get **COMPLETE** information on *Color Techniques, Color Kits, Sets, Technical Information, etc.* Send 25c to cover cost of handling and mailing.

MAKE MONEY
with Transvision TV Aids:—

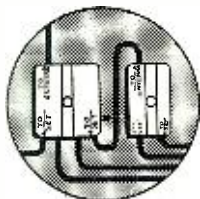

**MULTIPLE
TV SET
CONNECTOR**

Increases Sales!

For homes, garden apartments, dealers, bars, etc. Feed as many as 5 TV sets from 1 antenna.
PRICES: Multi-Set Connector for 2 sets, \$4.95 list*
Multi-Set Connector for 3 or 4" 7.95 list*
*Dealers, write for discounts.

**NEW LIFE
for Dim TV
CR TUBES**

with Transvision's



CR TUBE REACTIVATOR

No need to remove picture tube. It's profitable—first use often pays for instrument. Reactivates many dim CR Tubes, or tubes with low light output, if there's no mechanical defect. 110V-60 cycles; weighs 3 lbs.

\$14.95
NET

**BETTER TV
INSTALLATIONS**
with Transvision's
**FIELD STRENGTH
METER**

Saves 1/2 the Work!

NEW LOW PRICE **\$59.00**
Model FSM-1, complete with tubes. only NET

SAVE UP TO 50%

on TV KITS, SETS, PARTS, etc.

Write for details on amazing
Transvision **FACTORY AGENT PLAN!**

FREE: Subscription to Transvision's "TV-and-Electronics NOTES." Send 50c to cover cost of making addressograph plate and mailing.

TRANSVISION, INC.

Dept. RN NEW ROCHELLE, N. Y.

horizontal and low vertical inductance which permits its use with the HVO-8 air core flyback in direct drive systems.

Both yokes are equipped with networks and leads.

CROSLY COLOR CONVERTER

The Crosley Division of Avco Manufacturing Corporation has recently demonstrated a color converter designed to be used with the company's standard television receivers.

The new unit is housed in a mahog-



any finished cabinet and employs a 10" picture tube. The picture is enlarged by a magnifier to about the size of those seen on a 12 1/2" tube. The color wheel is 22 1/2" in diameter and is constructed of laminated plastic. Sound for the color reception is received through the master set.

Production of these converter units will be started when public demand and program schedules warrant it.

TARZIAN U.H.F. TRANSLATOR

The Tuner Division of Sarkes Tarzian, Inc., Bloomington, Indiana has developed a u.h.f. translator which is adaptable to any set now in use.

The full-band UT1 tuning unit does not interfere with the v.h.f. channels. It is self-powered and is easily connected to the receiving set by means



of a piece of 300 ohm line. The translator covers the full band from 460 to 900 mc. (Channels 14 to 52).

21" TRI-COLOR TUBE

Radio Corporation of America recently demonstrated a 21" tri-color picture tube at a technical symposium held in New York for 231 radio and television manufacturers.

The new tube was used to back up RCA's contention that there are no external limiting factors to picture size



International
RADIO & TELEVISION PARTS CO.

639 N. FAIRFAX AVE.
LOS ANGELES 36, CALIF.

RESISTOR KIT
Consisting of 100
1/4 watt, 1/2 watt, 1
& 2 Watt Resistors **\$1.98**

Webster 3-Speed
Record Changer
Latest Model 100 **\$22.75**

SCOOP!
10 MFD @ 500 WV
600 HV
10 FOR
\$2.90

SEND FOR OUR
**BARGAIN
FLYER
OF OUR
MILLION
DOLLAR STOCK**

TELEVISION

PREPARE FOR A GOOD JOB!

BROADCAST ENGINEER
COMMERCIAL OPERATOR (CODE)
RADIO SERVICEMAN

Television Servicing

(Approved for Veterans)
SEND FOR FREE LITERATURE
BALTIMORE TECHNICAL INSTITUTE
1425 EUTAW PLACE, BALT. 17, MD.

New! Up-to-date!

TELEVISION SERVICING

by Walter H. Buchsbaum



340 pages
170 illustrations



Symptoms of defective operation easily recognized, quickly corrected by illustrations, diagrams and how-to-do-it facts in this new book.

Get this brand new, complete handbook for sure-fire working knowledge of TV installation, maintenance and troubleshooting. Tells you step-by-step procedures for audio IF alignment, video IF alignment, aligning RF amplifiers, mixers, oscillators, etc. All possible defects classified for ready reference, thoroughly analyzed to show what is wrong and why . . . and what to do to correct the defect. No mathematical knowledge needed! Practical, authoritative, up-to-the-minute, the perfect handbook for set owners, trainees, and repairmen.

USE IT 10 DAYS FREE

Coupon below brings you "Television Servicing" on FREE trial for 10 days, without obligation. Mail it NOW.

PRENTICE-HALL, Inc., Dept. M-RN-951
70 Fifth Ave., New York 11, N. Y.

Send me, for 10 **DAYS' FREE TRIAL**, "Television Servicing." I will return it in ten days and pay nothing—or keep it and send \$1.35 down (plus postage) and \$2 monthly for 2 months.

NAME

ADDRESS

CITY..... STATE.....

SAVE! Send \$5.35 with this coupon, and we'll pay postage and packing.

RADIO & TELEVISION NEWS

in the company's compatible, all-electronic color TV system.

The company also announced the availability of samples of the 16" basic developmental model of the tri-color tube and kits of associated circuit components and parts for use by RCA-licensed manufacturers in laboratory work on color tubes and receivers.

COLOR CONVERTER KIT

Celomat Corporation, 521 W. 23 St., New York, New York is marketing a color converter kit which will permit the reception of CBS color television pictures.

Known as the "Vue Scope," the kit contains parts and instructions for home assembly. A deluxe kit which will produce a 12½" picture will also be available shortly.

The converter kit, which is intended for use with receivers which have been adapted to the CBS system, contains a color disc, a manual synchronizing unit, a fractional horsepower motor, assembly brackets, and complete instructions for assembling the unit.

TV BAR GENERATOR

Superior Instruments Co., 227 Fulton Street, New York 7, New York is currently marketing a television bar generator for servicing applications.

According to the company, it is only necessary to connect the bar generator to the antenna post of any TV receiver, plug the line cord into an a.c. outlet,



and throw the switch. The receiver under test will have a stable vertical or horizontal pattern projected on the screen which can be used for servicing when no station pattern is on the air.

The new unit is supplied with shielded leads and detailed operating instructions.

TV ROTATOR

Trio Manufacturing Company, Griggsville, Illinois has just put a new television rotator on the market which is capable of supporting the heaviest TV arrays, according to the company.

Designed for trouble-free and dependable operation, the rotator utilizes two heavy-duty 24 volt motors, one for clockwise and the other for counter-clockwise rotation. This feature prevents motor burnout even if the rotator is left on accidentally. A positive acting electrical stop at each end of the 360 degree turn eliminates lead damage.

Other features of the new rotator

Superior's *new* TELEVISION BAR GENERATOR



THROWS AN ACTUAL BAR PATTERN ON ANY TV RECEIVER SCREEN!!

TWO SIMPLE STEPS

1. Connect Bar Generator to Antenna Post of Any TV Receiver.

2. Plug Line Cord into A.C. Outlet and Throw Switch.

RESULTS—A stable never-shifting vertical or horizontal pattern projected on the screen of the TV receiver under test.

AT YOUR RADIO PARTS JOBBER

DEALERS NET PRICE

only **39⁹⁵**



Manufactured and Guaranteed by

SUPERIOR INSTRUMENTS CO.
227 Fulton Street • New York 7, N. Y.

✓ CHECK THESE MONEY-SAVING SURPLUS "BUYS"!

OUT GOES OUR ENTIRE STOCK

During this Fabulous, All-Out, Clear-Out WAREHOUSE CLEARANCE SALE!

COMPARE THESE PRICES!

All merchandise has been priced at cost, near cost and below cost to make room for our expanding Aircraft Division. Some items are used, some new, all are in fair to excellent condition. But every item, whether you buy singly or our entire inventory, is an outstanding bargain. If you don't find what you want listed here, see our previous ads or write us. Prompt replies to all inquiries.

JUNCTION BOXES & CONTROL UNITS

Quantity On Hand	Description	Single Price	Entire Stock
1	RM-12 Remote	\$24.95	
6	RM-6 Remote		\$74.50
6	Controls	14.95	35.00
1	RM-27	7.49	
1	RM-27	14.95	
1	RM-45A	24.95	
800	BC-606G Inter-Control Boxes	.98	400.00
35	U3/APA-19	4.95	100.00
30	BC-45/ARC-1	9.95	200.00
100	BC-45	1.95	100.00
25	J17/ARC-5	2.95	35.00
2	J60-ANT-2	14.95	20.00

TEST EQUIPMENT

5	BC-753A Course Directors	25.00	\$100.00
1	I-145	25.00	
3	I-122 Signal Generators	65.00	200.00
8	BE-67	20.00	150.00
1	I-149	25.00	
9	TS-92-AP	125.00	1000.00
1	TS-B Signal Generator	60.00	
10	BC-949A Range Calibrators	12.50	100.00
3	ME-73A Alignment Sets	7.50	20.00
5	TS-126 Synchroscopes	125.00	500.00
1	BC-1203-B	100.00	
9	I-223 Signal Generators	60.00	500.00
2	I-233 Range Calibrators	25.00	45.00
3	TS-110/AP	65.00	150.00
12	TS-204 (Cases)	25.00	250.00
40	TS-223 (Cases)	10.00	100.00
20	TS-176	5.00	175.00
50	I-139 Test Meters	75.00	1300.00
20	TS-15	10.00	350.00
30	TS-14	25.00	800.00
40	TS-13	20.00	500.00
80	TS-12	9.00	150.00
40	IE-21	125.00	400.00

MISC. PARTS & EQUIPMENT

Quantity On Hand	Description	Single Price	Entire Stock
6	GR 815A Standards	\$ 10.00	\$ 50.00
1	TS-154/AP	100.00	
1	TS-189/U	65.00	
11	BC-1155A, ICS Tubes	9.95	75.00
2	AN/PPN-2		
2	Complete, new	99.95	150.00
2	BC-307A Transmitters	17.50	30.00
20	AN/CRC-3 Handie Talkie	24.95	400.00
6	MAB Walkie Talkies	34.95	175.00
19	AM-4-APT Hi-Pwr 2 meter final	9.95	150.00
6	TI-6/APT5A	69.00	350.00
12	AN/PPN1	49.50	500.00
7	AM23A		
	ARQS Noise Generators	9.95	50.00
2	BC797 VHF Airport Transmitter & 2 201A Recvrs.	395.00	700.00
3	BC1068A Receivers	39.00	100.00
3	AN/CRC3 Gibson Girls (CAA Approved)	59.50	150.00
	Reels	3.95	75.00
2	BC902 75MC Marker Transmitters	99.50	150.00
100	BC306 Antenna Tuning Units	1.95	90.00
100	BC929	12.95	750.00
13	100A Radar Modulators	14.95	100.00
2	SCR610 (New, Boxed) Complete	89.90	150.00
250	GP-5 MFD-5000PF Pyranol Condensers	2.49	400.00
15	APG15 Antennas	9.95	100.00

THOUSANDS OF ITEMS NOT LISTED HERE! SEND US YOUR REQUIREMENTS OR SEE OUR PREVIOUS ADS!

ALVARADIO SUPPLY CO.

DEPT. A-17, 341 S. VERMONT, LOS ANGELES 5, CALIF., DUnkirk 8-2211

ORDER DIRECT FROM THIS AD!
Prompt, speedy shipments. Cash with order. Minimum order \$3.00. 25% deposit on C.O.D. orders. Shipments by truck, or by express collect, or by express please add state buyers tax. All prices subject to change. All merchandise subject to prior sale.

AUTUMN SALE ALL PRICES CUT TO BONE

Don't Buy Tubes until you get our prices. Quantities Limited. Prices Subject to Change Without Notice. Low Prices.

RADIO & TELEVISION TUBES

These prices apply only on orders for 12 or more tubes. Orders for less than 12, write for quotation.

1B3—\$1.33	6BA6—\$.72	6X4—\$.60
1L4—.80	6BA7—.96	12AT6—.75
1R5—.80	6BE6—.72	12AT7—1.16
155—.72	6BG6—1.92	12AU6—1.00
174—.80	6BH6—.80	12AU7—1.20
1U4—.80	6BQ6—1.28	12AX7—.96
1U5—.72	6CB6—.80	12BA6—.90
3Q4—.88	6CD6—2.75	12BE6—.90
354—.80	6C4—.66	19BG6—2.40
3V4—.80	654—.72	19T8—1.16
6AK5—1.56	6SD7—1.16	25BQ6—1.28
6AL5—.80	6SK7—.90	25L6—.72
6AQ5—.80	6SN7—1.10	35C5—.80
6AT6—.60	6T8—1.28	50C5—.80
6AU6—1.00	6V6—.90	117Z3—.75
6AV6—.60	6W4—.72	

All Other Types at Vast Reductions

Westinghouse Kuprox Rectifier 0.64 Amp. 28 Volts. Reg. \$1.90 ea. Special. . . . \$1.95
TUBE SALE—#2A7-55-37-85-31-56-57. No Mixed Ass't. 6 of Any Type. . . . 2.25
 12 BRAND NEW 10" PHONO RECORDS—Ass't. Jazz—Popular. Please specify. . . . \$1.79
 Single Pole—10 Pos. 2 Gang Switch. . . . 29c

FRESH EVEREADY BATTERIES IN STOCK FOR PORTABLES, ETC.

'B'—'A' 'B' Batts. . . . \$1.75	71770c
4671.75	72039c
4821.58	72446c
4902.28	72649c
7533.96	73660c
7553.68	74274c
7564.03	74663c
850 Flash Cells 48 for. . . . \$3.90	

3 Ft. 5 Wire Shielded Cable with Amphenol Connection. . . . 8 for \$1.00
 Signal Corps Phones—2 M. Ohms (8 M. Ohms Imp.) \$1.00
 2 Ft. Ext. Cord (and Plug) 40c
 2 MFD—1000 V Upright Bottom Lug Oil Cond. . 89c

TOBE TUBULAR ELECTROLYTICS

20-20 MFD. 150 V. . . . 59c
 30-30 MFD. 150 V. . . . 57c
 40-40 MFD. 150 V. . . . 59c

Low-Loss Short Wave Lock Type Air Trimmer

Variable Condensers

3 Pl.—12-15 Mmf. . . . 12c	3 GANG T.R.F. VARIABLE CONDENSERS \$1.00
7 Pl.—25-30 Mmf. . . . 15c	
8 Pl.—30-35 Mmf. . . . 16c	D.P.D.T. SLIDE
14 Pl.—56 Mmf. . . . 24c	TOGGLE
27 Pl.—100-110 Mmf. . . . 35c	SWITCH 15c

4 PR. WAFER SOCKETS—\$1.49 per C. each. . . . 39c
 5-6 PRONG WAFER SOCKETS. . . . \$2.50 per C
 100 ASST. SOCKETS—4-5-6-7 \$3.50 per C
 1,000 OHM WIRE WOUND POTENTIOMETER. . . 15c
 30 HY-FILTER CHOKE SHIELDED. . . . 3 for \$1.25
 UNSHIELDED. . . . 3 for 1.00
 2,000 ohm Wire Wound Rheostat. . . . 20 OHM
 CARTER WIRE WOUND C.T. VARIABLE . . . \$1. per doz.
RESISTORS
 GEN. ELEC. WESTINGHOUSE, etc. . . . 85c per doz.
 HOUR METERS, slightly used, perfect condition, same as used in your home. 110-125 volts. . . \$3.95
 5 Amps. . . .

PIEZO CRYSTAL HOLDERS.
 12 for \$1.00—\$6.00 per hundred—\$50.00 per 1,000

RCA Band Switches—
 3 gang, 3 pos. 3 band. 30c 6 gang, 4 pos. 4-5 band. 40c
 Trimmer-Padder Ass't.—all isolantite—singles. dual: triples—100 asst. pieces. . . . \$2.25
 Philco push button Rotary Switch Double Pole. . . 35c

ATTENTION: Prospectors, Explorers for Hidden Treasures!
 Construct a U.S. Army Type of Metallic Mine Detector Amplifier. Amplifier unit only (less tubes and batteries) with cables, headphone cord, and Jack. Army wiring diagram. Type AN/FRS-1. . . . \$1.95

RCA Ass't Mica By-Pass Cond. .001, 100 for. . . 95c
 or 9 Gang Push Button Switch. . . . 49c
 DRILLED CHASSIS FOR 5-6 tubes 5"x10"x1 1/2". . . 25c
 PHONE JACKS—OPEN & CLOSED AUTO. . . . 18c
 EBAY SPEAKER VOL. CONTROL—60 OHMS. . . . 15c
 SALE—PHONO RECORD ALBUMS—12"—3 comp. 15c;
 10"—3 comp.—15c; 4 comp. 20c.

6 Prong Amphenol Sockets. . . . \$4.00 per C
 AMERTRAN FILAMENT TRANSFORMER—6.3 V. 1 Amp. Encased Isolantite Terminal Posts. . . \$1.50
 VULCAN HEAVY DUTY 100 WATT SOLDERING IRON. Built for U.S. Army—Brand New—Equiv. sells for \$8.50. . . . OUR PRICE \$2.99

AMERTRAN AUDIO OUTPUT XFORMER—Pri. 10,000 @ 15 MA; Sec. 300, 6-1 Ratio. . . . \$1.49
 AMERTRAN MIXER AUDIO XFORMER—Pri. 600-10,000 Ohms \$1.00
 156-1 RATIO VERNIER DIALS—4 in. 3/4 in. Hub. 35c

LIVE VOLTAGE NOISE ELIMINATOR—Plugs in Between Radio and Elec. Socket. . . . 35c
 12 in. MAGNAVOX SPEAKER. 1100 Ohms. . . \$2.95
 HEARING AID CORDS—Assortment of 12 for. . . \$1.00

BY-PASS COND. ASST.—25 Cans, Bake., Paper, etc. . . . \$1.00

MINIMUM ORDER \$3.00—NO C.O.D.
 SHIPMENTS—PLEASE INCLUDE POSTAGE

**NEWARK
SURPLUS MATERIALS CO.**
 Dept. SE

324 Plane Street NEWARK 1, N. J.

include a cast aluminum mast holder and a 11/16 strut shaft that withstands 4500 pounds bending movement, an automatic electromechanical brake that reduces coasting to a minimum, an all-aluminum case, numbered terminal boards on rotator and indicator, and ball bearing end thrusts on the shafts. The unit may also be used for 10, 6, and 2 meter amateur antennas.

U.H.F. TRANSLATOR

General Electric Company, Syracuse, New York has demonstrated its new u.h.f. translator for the FCC.

The Model UHF 101 provides continuous tuning, covering the u.h.f band

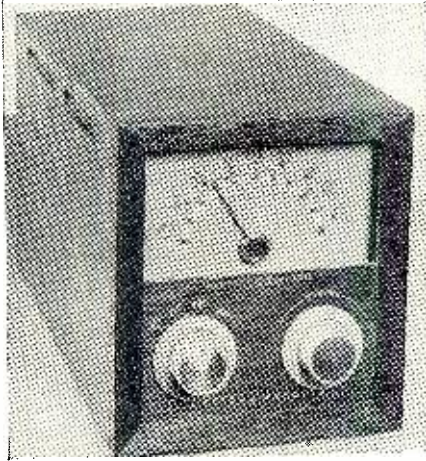

from 475 to 890 mc. The translator is housed in a compact wood cabinet constructed of mahogany veneers. The dial scale is in a semi-circular design. Below the megacycle numerals is a logging scale for added convenience in tuning. One of the features of this unit is a traveling dial light which automatically spot-illuminates each numeral on the dial face when the station pointer is rotated and can be turned off when the set is in operation.

COLOR TV TRANSFORMERS

RAM Electronics Sales Company, South Buckhout Street, Irvington-on-Hudson, New York has begun production of color television flyback transformers and deflection yokes. These new components are designed and constructed in conformance with the latest CBS color specifications and come complete with all circuit and conversion information.

The new units are designed for both original installation and as replacement units for set conversion.

INDOOR ANTENNA

Spirling Products Co., 62 Grand Street, New York 13, New York is now marketing two new indoor antennas, the "Super-Phantom" and the "Phantom-Tenna".

Both of these units feature an impedance matching stub which matches the 300 ohm impedance of the antenna to any TV set and an "Adjusta-Knob" which permits fine tuning of the antenna by means of a fingertip control.

The "Super-Phantom" (Model TV

IF YOU BUY ON SPECIFICATIONS



and tops in value, you'll buy the

TWIN-TRAX* TAPE RECORDER "Choice of Engineers Everywhere"

Compare the guaranteed specifications of a Twin-Trax Tape Recorder with any other recorder in any price class. You'll find that Twin-Trax gives you more features, better all-around performance and more value for your money. Complete specifications, performance ratings and direct factory prices in our catalog 5109. Send for it today.

*Trademark Reg.

AMPLIFIER CORP. of AMERICA
 398 Broadway, New York 13, N. Y.

EASY MONEY!!
 If you don't get our postcards telling the cash we'll pay for that surplus gear you bought when the buying was good, then YOU ARE LOSING MONEY! So send us your name and address NOW and GET ON OUR MAILING LIST!
G. L. ELECTRONICS
 905 S. VERMONT AVE., LOS ANGELES, 6

YOUR SERVICE BUSINESS NEEDS!!

TELEVISION SERVICE REPORT.	\$3.95
(Box of 100—3 copy business form)	
TELEVISION SERVICE PLAN.	2.25
(Book of 100 TV service contracts)	
TELEVISION JOB TICKET.	1.60
(Book of 100 TV job tickets)	
TELEVISION SERVICE CALL BOOK.75
(Sales book of 50 triplicate sets)	
RADIO SERVICE RECORD.	1.50
(Book of 100 Radio job tickets)	
RADIO WORK SHEET.60
(Pad of 50 repair sheets)	
RADIO SERVICE STANDARD RATE BOOK.	1.00
TROUBLE TRACING IN AC-DC RADIOS.	1.00

See them all your RADIO PARTS DISTRIBUTOR or write for Illustrated Catalog 2A

OELRICH PUBLICATIONS
 4135 N. Lawler Ave. Chicago 41, Ill.

RADIO ENGINEERING DEGREE IN 27 MONTHS

Radio engineering is a big field. There's room for you in it—if you're good. Get first-class training at Indiana Tech. Intensive specialized course, including strong basis in mathematics and electrical engineering, advanced radio theory and design, television, Modern laboratory. Low tuition. Also 27-month courses in Aeronautical, Chemical, Civil, Electrical and Mechanical Engineering. Approved for G.I.'s. Enter September, December, March, June. You can earn part of your expenses right here in Fort Wayne while you are studying.

INDIANA TECHNICAL COLLEGE
 991 E. Washington Blvd., Fort Wayne 2, Indiana
 Please send me free information on B.S. Engineering Degree in 27 months as checked.

Radio-Television Aeronautical
 Civil Mechanical Electrical

Name
 Address

503) has telescopic dipoles and the "Phantom-Tenna" (Model TV-501) has fixed dipoles. Information on either or both of these units is available from the company.

WESTINGHOUSE CONVERTER

The Television-Radio Division of Westinghouse Electric Corporation recently demonstrated a u.h.f. converter for use with the company's standard television receivers.

The converter is housed in a mahogany finished wood cabinet and in-



corporates a continuous tuner which provides for reception of any u.h.f. telecast in any area without additional modification while permitting reception of all standard channels.

The unit has a horizontally-mounted u.h.f. dial and a three-position switch for converting to u.h.f. reception. The circuit is a single superheterodyne circuit operating into a 44 mc. i.f. system.

PHOTO CREDITS

Page	Credit
35	Brown & Bigelow
36	Esquire, Inc.
37 (top)	Your Name Cigarettes
37 (bottom)	Diamond Match Company
46, 47	Gonset Co.
48	Vector Laboratories
51, 136 (Fig. 2), 138 (Fig. 3)	Radio Corporation of America
57	Signal Corps Photo, U. S. Army
67, 128	Radio-Canada
143	Bell Telephone Laboratories
148	Audio Engineering Society

ERRATA

In the article "Converting the RCA-730 TV1 and TV2" by Roland Kempton, appearing on page 46 of the August issue, one of the part numbers covering suitable 70 degree replacement deflection yokes was listed incorrectly. The Merit number should be an MD-70 unit.

In the article "The 'Childs' Custom-Built Amplifier" the circuit (Fig. 3, page 40, July 1951 issue), except for the loudness control and the cathode follower output stage, is identical to the "Drisko" preamplifier and equalization circuit which was first used in 1947 and described in 1949 by P. W. St. George and B. B. Drisko in their article "Versatile Phonograph Preamplifier" appearing in the March 1949 issue of "Audio Engineering" and reprinted in the "Audio Anthology" for the year 1950.

The cross coupled phase inverter incorporated in the diagram, Fig. 1 on page 38, first appeared in the article "A Cross Coupled Input and Phase Inverter Circuit" by J. N. Van Scoyoc which was published in the November 1948 issue of the Radio-Electronic Engineering Edition of RADIO & TELEVISION NEWS.

The omission of these references from the original article was unintentional and the authors of the abovementioned articles deserve more than passing recognition for their excellent designs.

IT'S SENSATIONAL! CLEARBEAM'S NEW ALL-CHANNEL RHOAMBIIC

Electronically Engineered for LONG DISTANCE (DX) RECEPTION and SHARP DIRECTIVITY over the entire TV SPECTRUM

SENSITIVE
7-strand copper receiving elements

STURDY
Heavy-duty Alum. casting frame. Alum. reinforced structural grade waterproof Douglas Fir.

PREASSEMBLED
for ease in installation

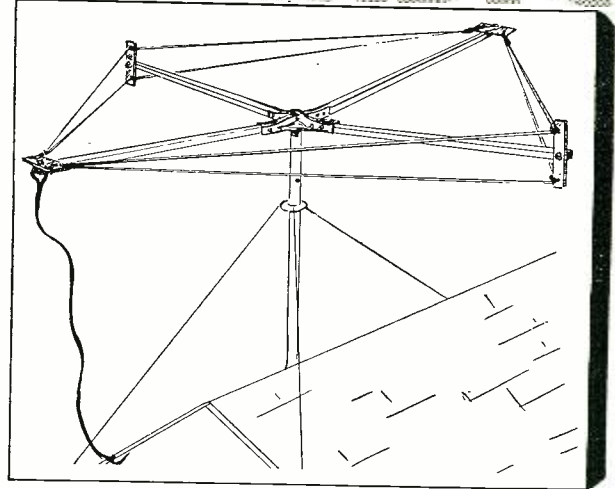

"Remember the Rhombic" has long been the phrase used by electronic engineers wherever the problem involved long distance (dx) and sharp directivity. Now Clearbeam has engineered this all-time favorite in an exclusive design to cover the entire high and low TV band—bringing you a Horizontal, Multi-Wire Rhombic TV Antenna with exceptionally high gain for low signal areas, and unusually sharp directivity to rid reception of ghosts! Get the facts on Clearbeam's Rhombic today!

Clear Beam TV ANTENNAS & ACCESSORIES

NOW IN OUR NEW HOME: 100 Prospect Ave., Burbank, Calif., ROckwell 9-2141, CHarleston 0-4886

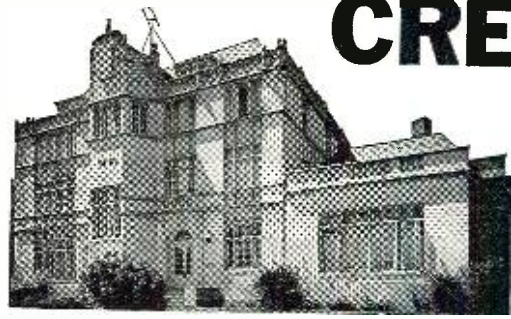

CREI Prepares You for a Professional Career, with Industry-Recognized Training in a Minimum of Time

RADIO-ELECTRONICS TELEVISION ENGINEERING

Graduates of the Capitol Radio Engineering Institute residence school are preferred by industry because of their training and ability. This recognition is the reason that CREI men quickly find good jobs in radio-electronics-television engineering.

With 24 years of practical teaching experience in these highly technical fields, CREI offers an outstanding faculty, modern and complete laboratories, shops and equipment in Washington, D. C.

The basic courses require an average of 21 months to complete, depending on the ability of the individual.

CREI is recognized as one of the country's leading technical institutes. Its work is of college level. It prepares young men for good jobs in the giant electronics industry in a minimum of time.

To insure your profitable, interesting career, ACT NOW. Send today for free catalog.

MAIL COUPON FOR FREE CATALOG

CAPITOL RADIO ENGINEERING INSTITUTE, Dept. 139 C

16th & Park Road., N. W., Washington 10, D. C.
Please send FREE Residence School Catalog

Name

Street

City Zone..... State..... Age..

Send details about Home Study Courses

ELIMINATE COSTLY RETURNS... SELL

Adjust-A-Cone
QUAM
SPEAKERS



Built by the World's Largest Speaker Manufacturer—First in the Replacement Field and for Original Equipment as well—when you sell Quam Speakers you are selling the Built-in Quality that means perfect, trouble-free performance—fewer costly returns!

Only QUAM has the adjustable voice coil that permits careful and accurate centering—the last operation before it is packed for shipment. Rubbing voice coils are unheard of on QUAM Adjust-a-Cone Speakers.

When you sell speakers, sell QUAM, the speakers that are First in the Replacement Field, First for Original Equipment.

For Speaker Replacement, Always Sell Quam

QUAM-NICHOLS COMPANY
522 E. 33rd Place Chicago 16, Ill.
MAKERS OF QUALITY SPEAKERS FOR 27 YEARS, UNDER THE SAME MANAGEMENT

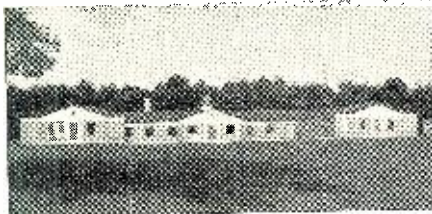

RADIO ENGINEERING TELEVISION ELECTRONICS

Thorough training in all phases of radio and electronics, open to high school and junior college graduates, exclusively. Modern laboratories and training courses. Enrollments limited. Approved veteran training.

VALPARAISO TECHNICAL INSTITUTE
Dept. RD Valparaiso, Ind.

INDEX OF Advertisers

SEPT. 1951

While every precaution is taken to insure accuracy, we cannot guarantee against the possibility of an occasional change or omission in the preparation of this index.

ADVERTISER	PAGE	ADVERTISER	PAGE
Acorn Electronics Corporation	164	Manfred Electronics Company	138
Aero Products Company	145	Mark Electronics	136
Airex Radio, Inc.	107	Meunier Radio Supply Company	153
Alliance Manufacturing Co.	29	Midway Company	155
Allied Radio Corporation	9	Midwest Radio & Television Corp.	33
Almo Radio Company	161	Miles Reproducer Company, Inc.	153
Altee Lansing Corporation	122	Milwaukee School of Engineering	144
Alvarado Supply Company	167	National Company, Inc.	114
American Television & Radio Co.	130	National Radio Institute	91, 92
Ampex Electric Corporation	171	National Schools	11
Amplifier Corporation of America	168	Newark Surplus Materials	168
Arrow Sales, Inc.	115	Newcomb Audio Products	113
Ashe Radio Company, Walter	109	Niagara Radio Supply Corporation	105
Atlas Tel-Rad Parts	148	Oak Ridge Products Company	21
Baltimore Technical Institute	166	Oelrich Publications	168
Barry Electronics	126	Offenbach & Reimus Company	135
Belden Manufacturing Co.	27	Olson Radio Warehouse	84, 85
Bell Telephone Laboratories	30	D. W. Onan & Sons	130
Belmont Radio Corporation	7	Opad-Green Company	145
Bond Equipment Company	155	Peak Electronics Company	82
Boyce-Roche Book Company	140	Penn Boiler & Burner Mfg. Company	18
Brook Electronics, Inc.	126	Pfanstiel Chemical Company	165
Brooks Radio & Television Corp.	120	Photocon Sales	158
Brush Development Company	26	Photography Annual	137
Buchan WOTJE, Richard J.	132	Pickering & Company, Inc.	110
C & H Sales	136	Platt Electronics Corp.	99
Candler System Company	141	Poly-Tech Company	86
Capitol Radio Engineering Institute	28, 169	Premax Products	171
Centralab, Inc.	22, 23	Premier Radio Tube Company	100, 101
Chicago Industrial Instrument Company	104	Prentice-Hall, Inc.	166
Chicago Transformer Company	127	Progressive Electronics Company	147
Clarostat	124	Pyramid Electric Company	24
Clear Beam Television Antennas	169	Quam Nichols Company	170
Cleveland Institute of Radio Electronics	20	RCA Institutes, Inc.	32, 155
Coin Radio & Television Co.	141	Radio & Television News	125
Collins Audio Products Co., Inc.	6	Radio City Products Company	152
Colortone Television	136	Radio Corporation of America	19, 83, Second Cover
Columbia Electronic Sales	128	Radio Craftsmen, Inc. The	118
Comet Electronic Sales Co.	94	Radio Ham Shack, Inc.	96, 97
Communications Equipment Company	123	Radio Parts Company	117
Concord Radio Corporation	119	Radio Receptor Company, Inc.	129
Cornell-Dubilier Electric Corporation	143	Radio Shack Corp. of Boston	159
Coyne Electrical School	142	Radio Television Training Association	148
Davis Electronics	114	Rainbow Plastics Company	149
DeForest's Training, Inc.	5	Rauland Corporation, The	10
Dix Manufacturing Company	159	Raytheon Manufacturing Company	15
Dumont Labs, Allen B.	3rd Cover	Red Arrow Sales Co.	118
Editors & Engineers, Ltd.	150	Rider, Publishers, Inc., John F.	157
Eddie Electronics, Inc.	112	Rinehart Books, Inc.	134
Electro Voice, Inc.	93	The Rose Company	136
Electronic Indicator Corporation	130	Sams & Company, Howard W.	90, 126, 160
Electronic Instrument Co., Inc.	34	Schott Company, Walter L.	129
Electronics Institute, Inc.	157	Simpson Electric Company	14
Esege Sales Company, Inc.	155	Sprayberry Academy of Radio	87
Espey Manufacturing Company, Inc.	133	Sprague Products Company	16
Fair Radio Sales	139	Stan Burn Radio & Electronics	171
Feller Engineering Co.	161	Standard Coil Products Company, Inc.	95
Fisher Radio Corporation	124	Standard Surplus	111
Franklin-Ellis Company	161	Standard Transformer	147
Franklin Technical Institute	153	Star Electronics Distr., Inc.	151
Freshman and Company, Charles	116	Steve-El Electronics	131
Fretoe Television Company	165	Sun Radio of Washington, D. C.	108
G.L. Electronics	132, 168	Superior Instruments, Co.	167
Garrard Sales	149	TAB	172
General Electric Company	12, 13, 31	Tallen Company	166
General Sales Company	152	Tech-Master Products Company	110
General Test Equipment	132	Television Communications Inst.	104
Gonset Company	112	Television & Radio Tube Company	151
Greenlee Tool Company	118	Television Supply Company	138
Greylock Electronics Supply Company	148	Telex, Inc.	156
Harvey Radio Company, Inc.	165	Terado Company, The	133
Heath Company	74 Thru 81	Transvision, Inc.	166
Henry Radio Stores	163	Triad Transformer Mfg. Company	162
Hickok Electrical Instrument	158	Triplett Electrical Instrument Company	73
Hytron Radio & Electronics Corp.	25	Tri-State College	159
Indiana Technical College	168	Tung-Sol	98
Instructograph Company	145	Turner Company	153
International Radio & TV Parts Company	166	Ungar Electric Tools Company, Inc.	156
J.F.D. Manufacturing Company, Inc.	146	United Surplus Materials	120
J.S.H. Sales Company	162	United Technical Laboratories	133
Jensen Mfg. Co.	102	University Loudspeakers, Inc.	163
KAAR Engineering Company	162	Vaco Products Company	129
Kester Solder	156	V & H Radio & Electronics Supply	141, 157
Labco Electronics, Inc.	142	Valparaiso Tech. Institute	170
Lafayette Radio Corporation	143	Ward Products Corp.	3
LaPointe-Plascomold Corporation	146	Weller Electric Corp.	8
Leotron Research Labs.	138	Wells Sales, Inc.	103
Leotone Radio Company	112	Wholesale Radio Parts, Inc.	106
Littlefuse Incorporated	17	Wiley & Sons, Inc., John	152
McGee Radio Company	88, 89	Williams Electronics Company	146
McGraw-Hill Book Company, Inc.	154	Workshop Associates, Inc.	121
McIntosh Engineering Laboratories	120	World Radio Laboratories, Inc.	149
Mallory & Company, P. R.	Fourth Cover	YMCA Trade & Technical School	136

Classified

Rate 50c per word. Minimum 10 word

RADIO ENGINEERING

RADIO Engineering Broadcasting, Aviation and Police Radio, Servicing, Marine Operating and Electronics taught thoroughly. Expenses low. Write for catalog, Valparaiso Technical Institute, Dept. N, Valparaiso, Ind.

SALE

DIAGRAMS Radio, Record Changers, Recorders, 75c; Television with Service Data, \$1.25 up. State manufacturer and model number. Kramer's Radio Service, Dept. N8, 36 Columbus Ave., New York 23, N. Y.

TUBES, top manufacturers, lowest prices. Free list. Betz, 73 Caroline Avenue, Yonkers 5, N. Y.

FIVE element TV Yagi Beams, Aluminum Tubing, Etc. Write for prices. Willard Radcliff, Fostoria, Ohio.

HOTTEST surplus list in the country. Electronics-Hydraulics, Aircraft-Gadgets. Dick Rose, Everett, Wash.

53 OHM Coax; 300 ohm twin; reasonable. Inquire: Harry Van Dick, Little Falls, N. J.

WANTED

AN/APR-4, other "APR," "ARR," "TS," "IB," ARC-1, ARC-3, ART-13, everything surplus; Tubes, Manuals, Laboratory equipment. Describe, price in first letter. Littell, Fairhills Box 26, Dayton 9, Ohio.

WIRE Recorder Dealers. Become the "Voice" station in your community. Special facilities are not needed. For details, write to Voice, Incorporated, 3662 Coral Way, Miami 34, Fla.

SOUND Specialists. A national sound equipment manufacturer offers you free a valuable wall chart useful in the solution of sound distribution problems in return for information. Write, listing brands and types of amplifiers generally used and where bought. State whether sound selling is a full or part time occupation. If employed, by whom? Write Box 518, Radio & Television News, 185 N. Wabash, Chicago 1, Ill.

NEED ART-13; ARC-1; ARC-3; DY-17; TS-12; TS-13; MN-26 J or K; BC-312; BC-312; BC-611 Handle Talkie (or any part): I-100; BC-348; BC-788 A, AM, B or C; I-152A, AM, B or C; TS-67; teletype, test or any other equipment. Will trade. Write: Bob Sanett (W6REX), 4668 Dockweiler, Los Angeles, Calif.

HELP WANTED

ENGINEERS & Technicians. Land-Air, Inc., engaged in a major expansion program, has immediate and near future requirements at Holloman Air Force Base (vicinity Alamogordo, New Mexico) for electronic, mechanical and optical engineers and technicians to work with cinetheodolites, special optical instruments, recorders, radars (and special electronic telemeters) devices as used for guided missile test instrumentation in field measurement. Work consists of operation, maintenance, design, development and construction with time spent both in the laboratory and on the range. Salary offers, based on application or personal interview, are commensurate with education, training, experience, position responsibility and other factors. Monthly salary ranges: Engineers, \$460-\$740; Technicians, \$360-\$480. Personal and family transportation reimbursed, paid group insurance and other benefits. Write for application form to: Land-Air, Inc., Holloman Air Force Base, New Mexico.

CORRESPONDENCE COURSE

USED Correspondence Courses and Books sold and rented. Money back guarantee. Catalog free. (Courses bought.) Lee Mountain, Pisgah, Ala.

RADIO Servicing Course shows latest short cut methods. Lessons easy to follow. Only \$3.00, postpaid in U.S.A. Buyers Syndicate, 30 Taylor St., Springfield, Mass.

AMATEUR Radio License Preparation. Correspondence course. Low cost. Personal coaching. Federal Electronics Institute, 34 E. Putnam, Dept. D, Greenwich, Conn.

PATENT ATTORNEYS

"COLOR Television Patents." Study first hand information, including Columbia System. Send \$1.00. Patent Service, 945-C5 Pennsylvania Avenue, Washington 4, D. C.

MISCELLANEOUS

WANTED: Presto or Rec-O-Cut recording turntable and cutting mechanism. Give price and condition. C. W. Rossow, Rt. 1, Mission, Texas.

September, 1951

Finest in Audio Recording Reproduction

MODEL 300

... Every Ampex Model 300 is guaranteed to meet published specifications •

Every Ampex Model 300 is guaranteed to give uniform performance • Precision manufacture assures quick interchangeability of parts • Model 300 is the recognized leader in the field of High Fidelity Recording.



Precision \otimes Performance

Write for complete specifications today.

AMPEX ELECTRIC CORPORATION
Redwood City California

AMPEX
Magnetic Tape
RECORDERS

STANDARD OF THE GREAT RADIO SHOWS

PREMAX

POINT-TO-POINT ANTENNAS FOR CIVIL DEFENSE

Follow the lead of military communications experts and use the easy-to-erect, efficient and economical vertical antennas for those point-to-point frequencies in the 160, 80 and 75 meter bands, plus CAP, MARS and joint disaster channels.

Premax can supply aluminum, stainless steel and steel Antennas at heights up to 35 feet with base and standoff insulators. Also coil-loaded Antennas at 9½ and 17-foot heights which give super-efficiency with smaller size.

Vertical Antennas with their omnidirectional coverage work better with vertically equipped mobiles.

See your distributor or write for Catalog.

PREMAX PRODUCTS
DIVISION CHISHOLM-RYDER CO., INC.

5101 Highland Ave., Niagara Falls, New York

STAN-BURN EDWARDS

ANTENNAS	
Conicals	\$2.98 less mast
Circle X	2.98 less mast
Double V	2.98 less mast
Chimney Mounts 1-12	50.95
100 ft. roll strapping	12 or more .89
Mast standoffs	.03
10 ft. masts	each 1.59
12 or more	each 1.49
55 mil. 300 ohm wire white or black	\$19.97 1000 ft.
CHASSIS-630-K2-Famous make	\$129.50

CATHODE RAY TUBE SPECIALS			
12LP4	\$19.95	16AP4A	\$39.00
121P4A	19.95	16RP4A	26.00
14BP4A	19.95	17BP4A	27.00
16DP4A	26.00	20CP4	39.95
16GP4	33.00		

G.E. Tubes	
19AP4A	\$47.95
19DP4A	47.95
24AP4A	83.20
Single Ion Traps	.39
Double Ion Traps	.59

SPEAKER SPECIALS			
4" P.M.	\$1.64	4X6 P.M.	\$2.19
5" P.M.	1.75	6X9	3.73
6" P.M.	2.41	5X7	3.43
8" P.M.	3.41	10" P.M.	5.48
12" P.M.	6.33		

OUTPUT TRANSFORMERS	TV CORDS
6L6 & 6V6-8 Watt	TV CORDS
.98	AC-DC CORD 6"
.69	hanked
.59	6" Cube Tapped
	EXT.
	9" Cube Tapped
	EXT.
	39

COLORTONE ADAPTERS-List \$19.95. Cost \$13.30
REGENCY TV SIGNAL BOOSTER-Model DB 410
List \$32.50. Net Price \$19.11

We carry a complete line of popular makes of Radio and TV tubes. Also many other special purpose and transmitting types, and all electronic parts at lowest prices.
Terms: 20% with order. Balance C.O.D. All prices F.O.B., New York Warehouse. Minimum order \$5.00.
Write for our latest price list to Dept. RN-9.

STAN-BURN RADIO and ELECTRONICS CO.
(C.B.S. THEATRE BLDG.)
1697 BROADWAY • NEW YORK 19, N.Y.

i 's revolutionary!

The New

du mont

*Selfocus
Teletron*

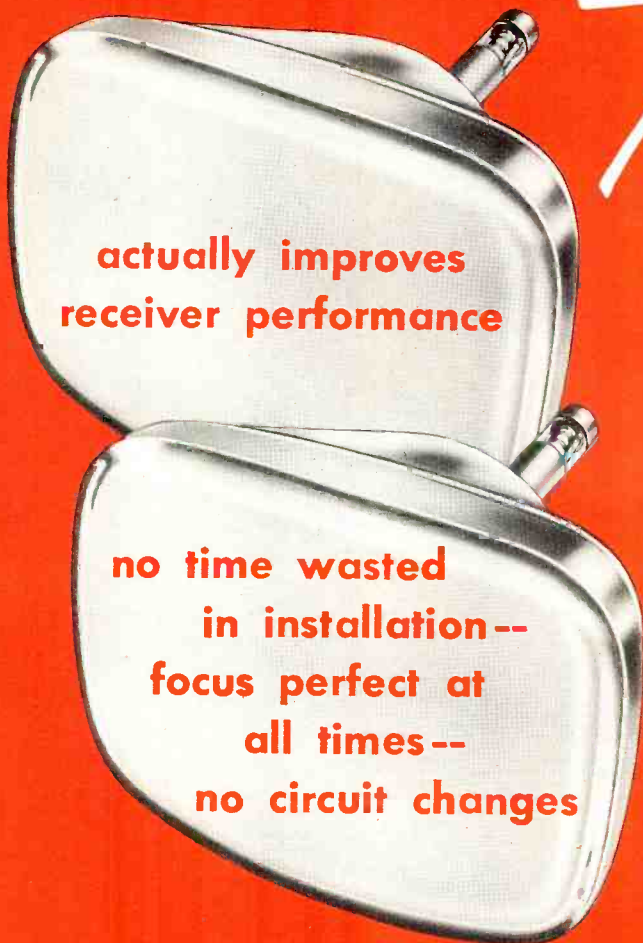

**actually improves
receiver performance**

**no time wasted
in installation--
focus perfect at
all times--
no circuit changes**

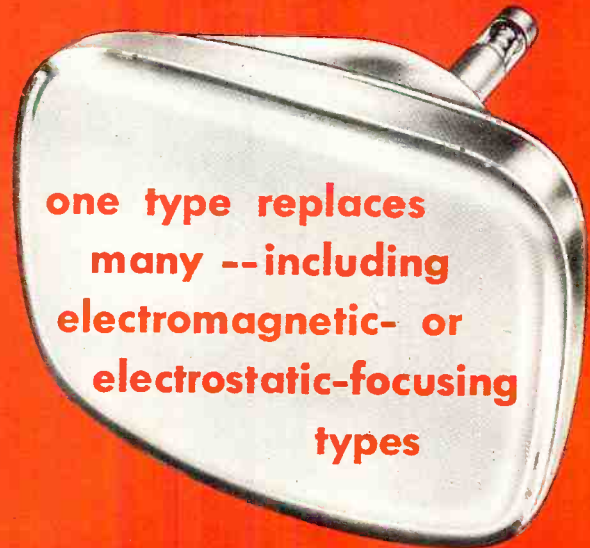

**one type replaces
many --including
electromagnetic- or
electrostatic-focusing
types**

write for complete information:
CATHODE-RAY TUBE DIVISION,
ALLEN B. DU MONT LABORATORIES, INC.,
CLIFTON, N. J.

DU MONT

Teletrons *

*Trade-mark



Don't Take Unnecessary Chances

An overwhelming majority of servicemen say that *performance* is what they want most in a capacitor. If you agree, and if you don't want to take chances, your best bet is . . .

Make Sure! Make it Mallory!

Performance is the one big reason why more than half of the hundreds of servicemen interviewed in a recent survey use Mallory Capacitors.

Despite excessive operating temperatures and higher ripple currents, Mallory Capacitors have taken the rugged service of TV operation

in stride. The far superior heat dissipating characteristic for which Mallory FP Capacitors have long been known is the reason for this trouble-free performance. And Mallory Plascap* plastic tubulars are suited for the same 185° F. (85° C.) operation.

When you are looking for performance, don't take a chance on just any capacitor. Make it Mallory . . . and make sure! It costs you no more to play safe.

MALLORY PLASCAP



The plastic tubular specifically designed to meet your field service problems. Available in a complete range of ratings.

Depend on your Mallory Distributor for precision quality at competitive prices.

*Trade Mark

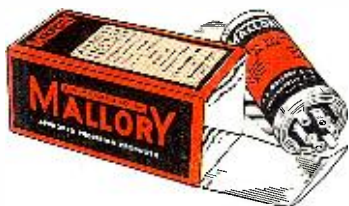

P. R. MALLORY & CO. Inc. MALLORY

CAPACITORS • CONTROLS • VIBRATORS • SWITCHES • RESISTORS
• RECTIFIERS • VIBRAPACK* POWER SUPPLIES • FILTERS

*Reg. U.S. Pat. Off.

APPROVED PRECISION PRODUCTS

P. R. MALLORY & CO., Inc., INDIANAPOLIS 6, INDIANA