

# RADIO NEWS

NOVEMBER  
1946  
35c

NEW TRANSMITTER FOR  
AMATEUR RADIO page 39.

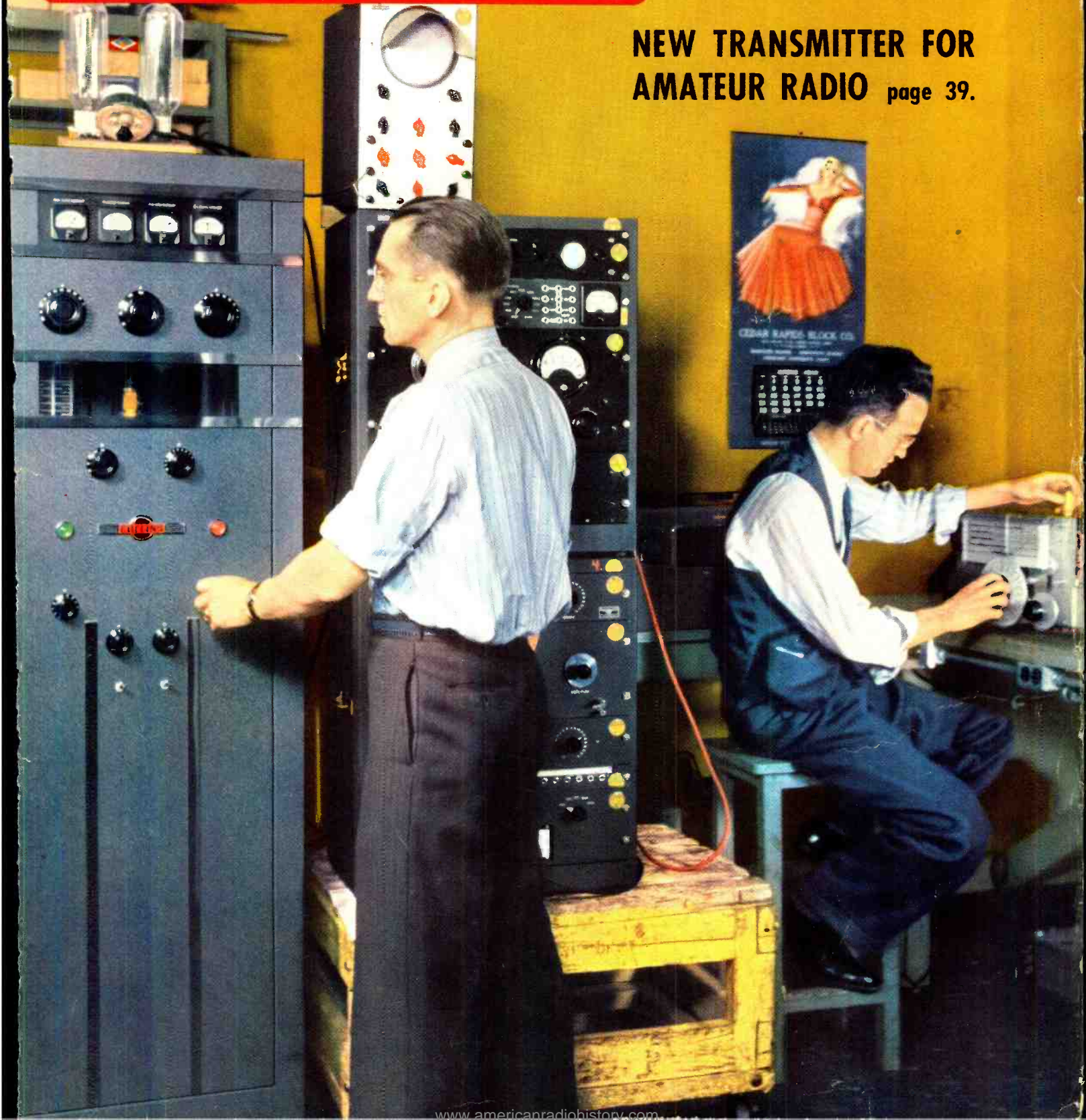

# New!

## Series 200

# A RELAY BY GUARDIAN with Interchangeable Coils

### BUILT IN TWO PARTS

A.C. Coil Assemblies available  
for 6 v., 12 v., 24 v., 115 v.  
D.C. Coil Assemblies available  
for 6 v., 12 v., 24 v., 32 v., 110 v.

★ Two basic parts—a coil assembly and a contact assembly—comprise this simple, yet versatile relay. The coil assembly consists of the coil and field piece. The contact assembly consists of switch blades, armature, return spring, and mounting bracket. The coil and contact assembly are easily aligned by two locator pins on the back end of the contact assembly which fit into two holes on the coil assembly. They are then rigidly held together with the two screws and lock washers. Assembly takes only a few seconds and requires no adjustment on factory built units.

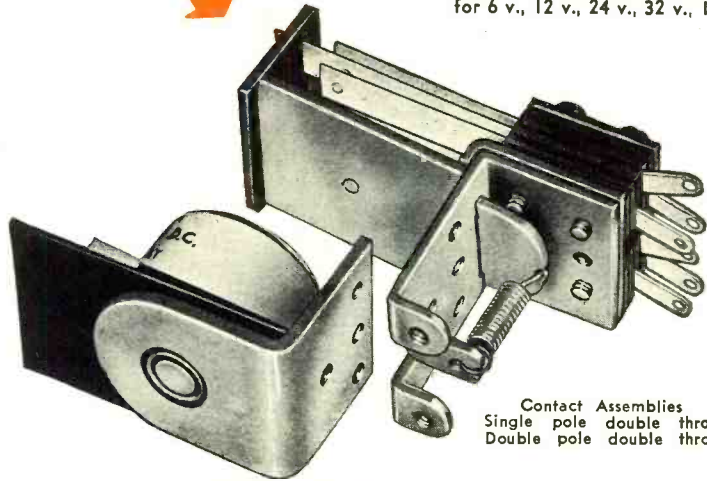

Contact Assemblies  
Single pole double throw  
Double pole double throw

SERIES 200 RELAY

## On Sale at Your Nearest Jobber NOW!

See it today! . . . this amazing new relay with interchangeable coils. See how you can operate it on any of nine different a-c or d-c voltages—simply by changing the coil. Ideal for experimenters, inventors, engineers.

### TWO CONTACT ASSEMBLIES

The Series 200 is available with a single pole double throw, or a double pole double throw contact assembly. In addition, a set of Series 200 Contact Switch Parts, which you can buy separately, enables you to build dozens of other combinations. Instructions in each box.

### NINE COIL ASSEMBLIES

Four a-c coils and five d-c coils are available. Interchangeability of coils enables you to operate the Series 200 relay on one voltage or current and change it over to operate on another type simply by changing coils.



Your jobber has this sensational new relay on sale now. Ask him about it. Or write for descriptive bulletin.

# GUARDIAN ELECTRIC

1630-M W. WALNUT STREET CHICAGO 12, ILLINOIS  
A COMPLETE LINE OF RELAYS SERVING AMERICAN INDUSTRY

J. E. SMITH,  
PRESIDENT  
National Radio  
Institute  
32nd Year of  
Training Men  
for Success  
in Radio

# I WILL TRAIN YOU TO START A SPARE TIME OR FULL TIME RADIO SERVICE BUSINESS WITHOUT CAPITAL

## You Build These and Many Other Radio Circuits with 6 Kits of Parts I Supply

By the time you've conducted 60 sets of Experiments with Radio Parts I supply, made hundreds of measurements and adjustments, you'll have valuable PRACTICAL Radio experience for a good full or part-time Radio job!

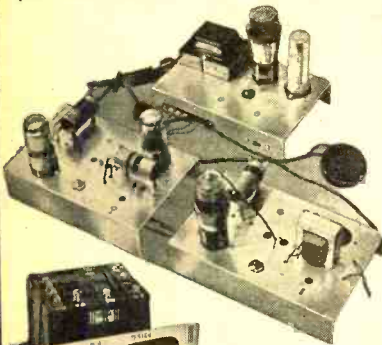

You build MEASURING INSTRUMENT above early in Course, useful for Radio work to pick up EXTRA spare time money. It is a vacuum tube multimeter, measures A.C., D.C., E.F. volts, D.C. currents, resistance, receiver output.

Building the A. M. SIGNAL GENERATOR at right will give you valuable experience. Provides amplitude-modulated signals for test and experimental purposes.

You build the SUPERHETERODYNE CIRCUIT above containing a preselector oscillator-mixer-first detector, i.f. stage, diode-detector-a.v.c. stage and audio stage. It will bring in local and distant stations. Get the thrill of learning at home evenings in spare time while you put the set through fascinating tests!



The men at the right are just a few of many I have trained, at home in their spare time, to be Radio Technicians. They are now operating their own successful spare time or full time Radio businesses. Hundreds of other men I trained hold good jobs in practically every branch of Radio. Doesn't this PROVE my "50-50 method" of home training can give you BOTH a thorough knowledge of Radio principles and the PRACTICAL experience you need to help you make more money in the fast-growing Radio industry?

Let me send you facts about opportunities in the busy Radio field. I see how knowing Radio can give you security, a prosperous future... lead to jobs coming in Television, Electronics. Send coupon NOW for FREE Sample Lesson and 64-page, illustrated book. Read how N.R.I. trains you at home in spare time. Read how you practice building, testing, repairing Radios with SIX BIG KITS of Radio parts I send you.

### Many Beginners Soon Make Extra Money in Spare Time While Learning

The day you enroll I start sending EXTRA MONEY JOB SHEETS. You LEARN Radio principles from my easy-to-understand, illustrated lessons—PRACTICE what you learn by building, testing and experimenting with parts I send—USE your knowledge to make EXTRA money fixing neighbors' Radios in spare time while still learning! From here it's a short step to your own full-time Radio Shop or a good Radio job!

### Future for Trained Men is Bright in Radio, Television, Electronics

It's probably easier to get started in Radio now than ever before, because the Radio Repair Business is booming. Trained Radio Technicians also find profitable opportunities in Police, Aviation, Marine Radio, Broadcasting, Radio Manufacturing, Public Address work. Think of even greater opportunities as Television, FM, and many new, war-developed Electronic devices become available to the public! Soon, there will be more Radio equipment to install, operate, maintain and repair than ever before in all history! Get the facts on all these opportunities. Send for FREE books now!

### Find Out What NRI Can Do For You

Mail Coupon for Sample Lesson, "Getting Acquainted with Receiver Servicing," and my FREE 64-page book. It's packed with facts about Radio opportunities for you. Read the details about my Course. Read letters from men I trained, telling what they are doing, earning. See how quickly, easily you can get started. No obligation! Just MAIL COUPON NOW in an envelope or paste it on a penny postal. J. E. SMITH, President, Dept. 6MR, National Radio Institute, Pioneer Home Study Radio School, Washington 9, D. C.

### I Trained These Men

### SPARE TIME RADIO BUSINESS



"I have a spare time Radio and Electrical business of my own which has been very profitable, due to the efficient training I received from your Course. Last year I averaged over \$50 a month." —FRED H. GRIFFIE, Route 3, Newville, Pa.

"I am doing radio work in my spare time, and find it a profitable hobby. My extra earnings run about \$10 a week. I certainly am glad I took your N.R.I. Course." —FERDINAND ZIRBEL, Chaseley, North Dakota.



"About six months after I enrolled I started making extra money in radio. I am a farmer and just work on radio evenings and stormy days. That brought me a profit of \$600 in the last year." —BENNIE L. ARENDS, RFD 2, Alexander, Iowa.

### I Trained These Men

### FULL TIME RADIO BUSINESS



"Not long ago I was working 16 hours a day in a filling station at \$10 a week. Now I have my own radio business and average over \$60 a week. The N.R.I. course is fine." —ALBERT C. CHRISTENSEN, 116-10th Avenue, Sidney, Neb.

"Previous to enrolling for your radio training I made \$12 per week in a hardware store. Now I operate my own repair shop, and often clear \$35 to \$45 a week." —FREDERICK BELL, 76 Golf Ave., St. Johns, Newfoundland.



"Am making over \$50 a week profit from my own shop. Have another N.R.I. graduate working for me. I like to hire N.R.I. men because they know radio." —NORMAN MILLER, Hebron, Neb.

## SAMPLE LESSON FREE

I will send you a FREE Lesson, "Getting Acquainted with Receiver Servicing," to show you how practical it is to train for Radio at home in spare time. It's a valuable lesson. Study it—keep it—without obligation! Tells how Superheterodyne Circuits work, gives hints on Receiver Servicing, Locating Defects, Repair of Loudspeaker, I.F. Transformer, Gang Tuning, Condenser, etc. 31 illustrations.



My Radio Course Includes  
**TELEVISION • ELECTRONICS  
FREQUENCY MODULATION**

## GOOD FOR BOTH 64 PAGE BOOK SAMPLE LESSON FREE

J. E. SMITH, President, Dept. 6MR  
National Radio Institute, Washington 9, D. C.

Without obligating me, mail your Sample Lesson and 64-page book. FREE. I am particularly interested in the branch of Radio checked below. (No salesman will call. Please write plainly.)

- My own Radio Service Business
- Spare Time Radio Servicing
- Service Technician for Radio Stores or Factory
- Aviation Radio
- Operating Broadcasting Station
- Industrial Electronics
- Public Address Systems
- Ship, Harbor, Gov't. Military Radio

(If you have not decided which branch you prefer—mail coupon for facts to help you decide.)

Name ..... Age .....

Address .....

City ..... Zone ..... State .....

Approved for Training under GI Bill



**For the AMATEUR**

All Wave Signal Generator..... *A. A. Goldberg, W2HKU* 32  
 Converting the SCR-522 Transmitter..... *Ray Frank, W9JU* 35  
 New Transmitter For Amateur Radio.....  
 ..... *W. Bruene, W0TTK and N. Hale, W0JIH* 39  
 200 Watt All-band Transmitter..... *Harry D. Hooton, W8KPX* 40  
 A Linear Sweep Generator..... *W. J. Haywood, W2OQB* 78  
 10-Meter Vertical Coaxial Antenna..... *C. V. Hays, W6RTP* 88

**For the SERVICEMAN-DEALER**

Planning an Aircraft Radio Installation..... *J. D. Scalbom* 25  
 Sound Conditioning Spurs Sales..... *J. J. Rowland* 30  
 New Selenium Rectifiers for Home Receivers..... *George Eannarino* 45  
 High Fidelity Receiver..... *J. C. Hoadley* 46  
 Low Cost Audio Oscillator..... *Robert W. Ehrlich* 50  
 Trouble Shooting the Television Receiver..... *Edward M. Noll* 52  
 Subscription-Lease Plan..... *Paul H. Wendel* 54  
 Income Tax Saving Facts For Radio Dealers..... *Harold J. Ashe* 58  
 The RN Circuit Page..... 64  
 Should Agencies be Used to Collect Delinquent Accounts?.. *J. A. Harold* 126

**OF GENERAL INTEREST**

Electronic Metal Analyzer..... *S. R. Winters* 28  
 Try this 1946 Treasure Finder..... *W. E. Osborne* 36  
 Possibilities of Home Facsimile..... *Sidney Feldman* 49

**DEPARTMENTS**

For the Record.... <i>The Editor</i>	8	Letters from Our Readers....	94
Spot Radio News. <i>Fred Hamlin</i>	12	Technical Books.....	125
QTC..... <i>Carl Coleman</i>	38	Within the Industry.....	128
What's New in Radio.....	66	Manufacturers' Literature.....	158
International Short-Wave.....		<i>Kenneth R. Boord</i>	44

COPYRIGHT, 1946 ZIFF-DAVIS PUBLISHING COMPANY  
185 N. Wabash Ave., Chicago 1, Ill.

BRANCH OFFICES: NEW YORK, WASHINGTON, LOS ANGELES, TORONTO



<b>WILLIAM B. ZIFF</b> <i>Publisher</i>		
<b>B. G. DAVIS</b> <i>General Manager</i>	<b>C. R. TIGHE</b> <i>Asst. to the Publisher</i>	<b>GEORGE BERNER</b> <i>Advertising Director</i>
<b>HERMAN R. BOLLIN</b> <i>Art Director</i>	<b>H. G. STRONG</b> <i>Circulation Director</i>	<b>H. I. MORGANROTH</b> <i>Production Director</i>

**EDITORIAL**

**OLIVER READ, W9ETI**  
*Editor*

**WM. A. STOCKLIN**  
*Associate Editor*

**H. S. RENNE, Ex. W8PTS**  
*Technical Editor*

**RAY FRANK, W9JU**  
*Amateur Editor*

**FRED HAMLIN**  
*Washington Editor*

**PAUL H. WENDEL**  
*Eastern Editor*

**P. B. HOEFER**  
*Assistant Editor*

**ARTHUR E. HAUG  
WALTER STEINHARD**  
*Staff Photographers*

**E. H. SEHNERT**  
*Chief Draftsman*

**R. S. KUPJACK**  
*Staff Artist*

**ADVERTISING**

**L. L. OSTEN**  
*Advertising Mgr.*

**JOHN A. RONAN, JR.**  
*Midwest Adv. Mgr.*

**WM. L. PINNEY**  
*Western Adv. Mgr.*



COVER PHOTO  
BY JOHN RIDGE

Testing the new Collins 30K, 500 watt amateur transmitter. W0EIT is running the performance test while W0JIH is shown at right adjusting a Collins 310Z amateur band exciter unit.

RADIO NEWS is published monthly by the Ziff-Davis Publishing Company, 185 N. Wabash Ave., Chicago 1, Ill. Subscription Rates: in U. S. and Canada \$3.00 (12 issues), single copies 35 cents; in Mexico, South and Central America, and U. S. Possessions, \$3.00 (12 issues); in British Empire, \$4.00 (12 issues)—all other foreign countries \$4.00 (12 issues). Subscribers should allow at least 2 weeks for change of address. All communications about subscriptions should be addressed to: Director of Circulation, 185 N. Wabash Ave., Chicago 1, Ill. Entered as second class matter March 9, 1938, at the Post Office, Chicago, Illinois, under the Act of March 3, 1879. Entered as second class matter at the Post Office Dept., Ottawa, Canada. Contributors should retain a copy of contributions and include return postage. Contributions will be handled with reasonable care but this magazine assumes no responsibility for their safety. Accepted material is subject to whatever revisions and by-line changes that are necessary. Payment made at our current rates, covers all authors', contributors', or contestants' rights, title, and interest in and to accepted material, including photos and drawings.

Other Ziff-Davis Publications: Radio-Electronic Engineering, Plastics, Flying, Popular Photography

# The first hundred sets are the hardest...

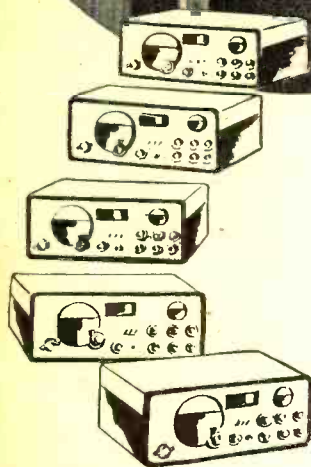
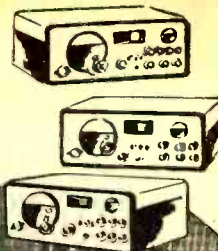
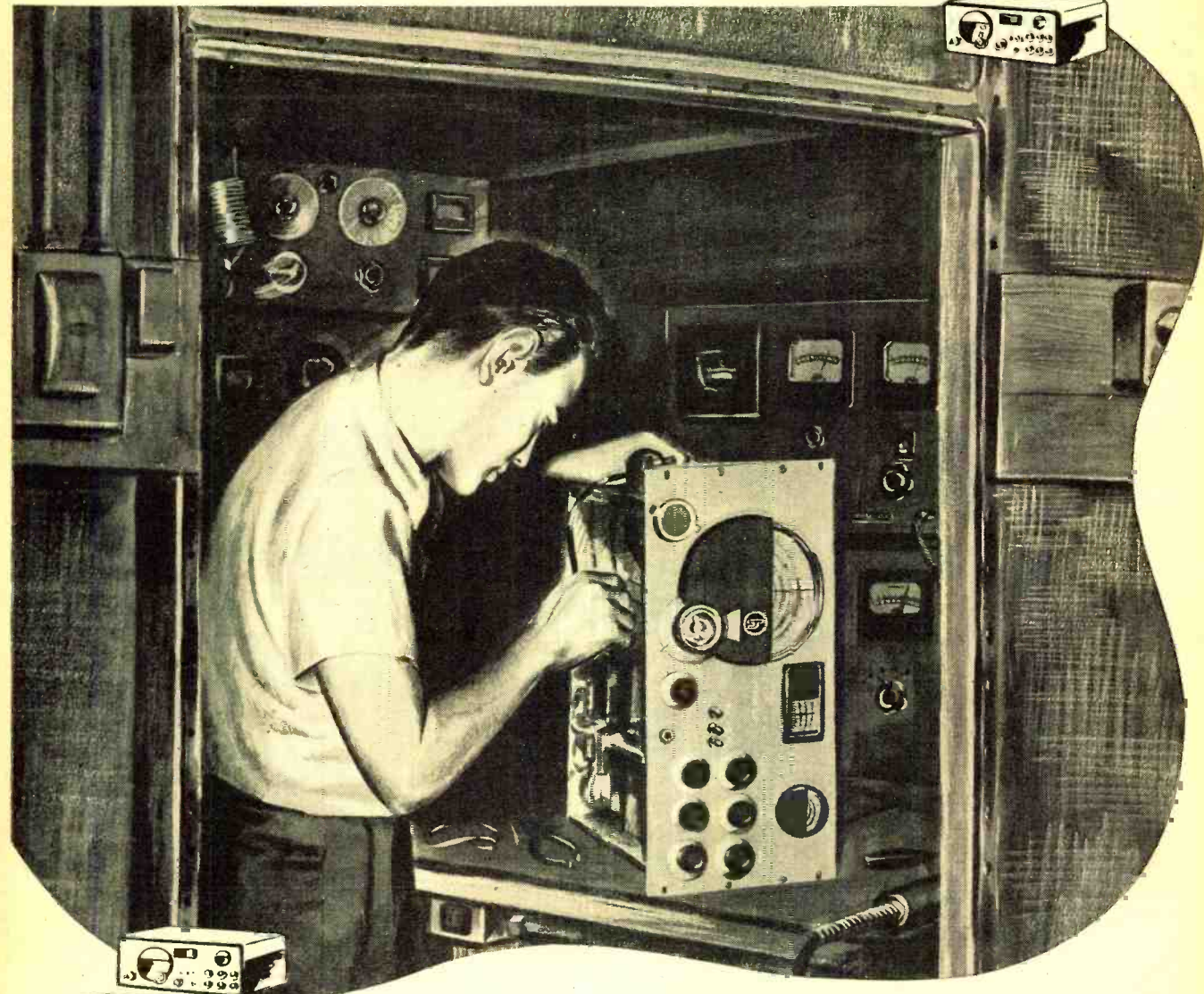

YOU can take it from Hallicrafters: the first hundred radio sets of any new model are the hardest. Hallicrafters is completing a run of 100 of the new Model SX-42. This extraordinary set has been more than a year in the making and behind it are more than 20 years intensive experience in the manufacture of high frequency communications equipment. The first 100 SX-42's have been checked, re-checked in a thousand and one testing operations. Because the set covers from 540 kc to 110 Mc continuously in six bands it must be as delicately balanced and precisely aligned as an expensive watch. One out of every five persons on the SX-42 assembly line is an inspector, watchdog over the strictest Hallicrafters standards. The first 100 SX-42's are now being placed in the hands of radio technicians, engineers, amateurs all over the world. These qualified critics will submit to Hallicrafters detailed reports. This final field testing of this great new receiver will bring the SX-42 one step closer to reality for you. Watch for the SX-42, wait for the SX-42... the radio man's radio... the radio that's remembered by the veteran... preferred by the amateur...

BUILDERS OF

*Skyfone*

AVIATION RADIOTELEPHONE

## hallicrafters RADIO

THE HALLICRAFTERS CO., MANUFACTURERS OF RADIO AND ELECTRONIC EQUIPMENT, CHICAGO 16, U. S. A.

Sole Hallicrafters Representatives in Canada: Rogers Majestic Limited, Toronto - Montreal

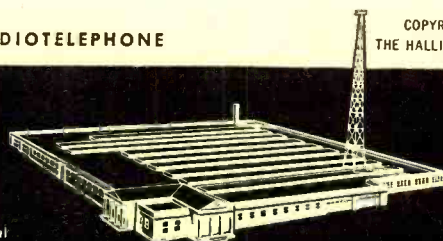

COPYRIGHT 1946  
THE HALLICRAFTERS CO.

November, 1946

**AGAIN**  
**FADA**  
**SHOWS THE WAY!**

*Now*

**THE FADA DELUXE  
 PORTABLE**

**RADIO AND PHONOGRAPH COMBINATION**

with **AUTOMATIC RECORD CHANGER**

Superheterodyne AC deluxe portable radio phono-  
 graph with automatic record changer. Durable and  
 attractive! New fidelity of tone both in recordings  
 and broadcasts.

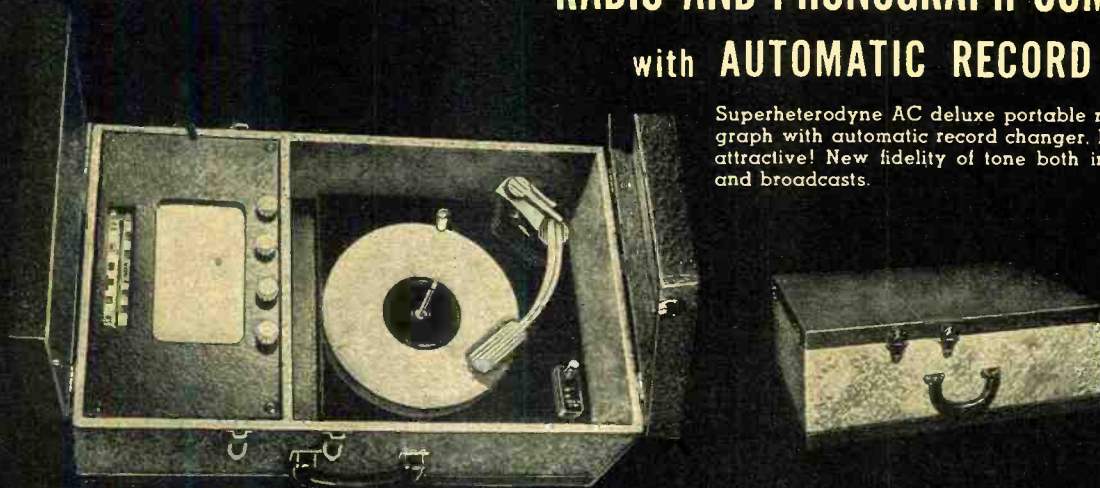

**COMING SOON . . .**

Additional Attractive Combinations in Beautiful Mahogany veneer with non-warping Mahogany Top. "Another FADA FIRST!"

**Enthusiastic  
 Consumer  
 Acceptance!**

**YOU CAN ALWAYS DEPEND ON**

**FADA**  
**Radio**

*Famous Since Broadcasting Began!*

FADA's lovely table models are  
 tops in consumer acceptance. They  
 combine beauty of appearance and  
 tone.



**6 TUBES  
 1000 SERIES**



**6 TUBES  
 752 SERIES**



FADA 6 tube models are  
 equipped with the new  
 FADA "Sensitive-Tone"  
 . . . assuring greater sen-  
 sitivity and clearer re-  
 ception.

**FADA RADIO AND ELECTRIC COMPANY, INC., LONG ISLAND CITY, N. Y.**

# NOW SPRAYBERRY RADIO TRAINING

## GIVES YOU 8 BIG KITS OF RADIO EQUIPMENT



WITH A COMPLETE 6 TUBE SUPER-HETERODYNE RECEIVER

**YOU LEARN RADIO SERVICING THROUGH INTENSIVE "SHOP-BENCH" PRACTICE**

### YOU DO EXPERIMENTS, CONSTRUCTION, TROUBLE-SHOOTING

I'll show you how to perform over 175 instructive Experiments—how to build countless Radio Circuits. You'll learn a new, fast way to test Radio Sets with-out mfg. Equipment.



I give you a fine, moving-coil type Meter Instrument on Jewel Bearings—with parts for a complete Analyzer Circuit Continuity Tester. You learn how to check and correct Receiver defects with professional accuracy and speed.

You'll get valuable experience and practice building this Signal Generator and multi-purpose Tester. Makes a breeze out of fixing Radios and you don't have to spend money on outside, ready-made equipment.



Soldering, wiring, connecting Radio parts . . . building circuits with your own hands—you can't beat this method of learning. When you construct this Rectifier and Filter, Resistor and Condenser Tester, etc., you get a really practical slant on Radio that leads to a money-making future.



### HERE'S THE LATEST, SIMPLEST WAY TO TRAIN at HOME for a GOOD LIVING in RADIO-ELECTRONICS & TELEVISION

I train your *mind* by putting you to work with your *hands* on a big 6-Tube Superheterodyne Receiver. And, believe me, when you get busy with real Radio Parts—8 big Kits of them—you really LEARN Radio and learn it RIGHT! You get the practical stuff you need to be useful in Radio, and that's what it takes to make money. You don't have to worry about what to do with these 8 Kits of

with real "Shop" practice, makes every subject plain and easy to understand and remember.

#### A BUSINESS OF YOUR OWN . . . OR A GOOD RADIO JOB

Soon after you begin Sprayberry Training, I'll send you my sensational BUSINESS BUILDERS. You'll find out how to get and do neighborhood Radio repair jobs for nice profits and rich experience while learning. This sort of work can easily pave the way for a Radio Service business of your own. But with Sprayberry Training, you're not limited. You can swing into any one of the swiftly expanding branches of Radio-Electronics INCLUDING Radio, Television, FM, Radar, Industrial Electronics. Be wise! Decide now to become a fully qualified RADIO-ELECTRONICIAN. Get full details about my Training at once! Mail coupon below for my 2 big FREE Books.

Parts. Step by step, I show you how to build circuits, test, experiment, trouble-shoot. And you don't need any previous experience. The Sprayberry Course starts right at the beginning of Radio! You can't get lost! Simplified lessons, coupled

### SEND FOR THESE FREE BOOKS



"How to Read Radio Diagrams and Symbols"

Here's a valuable and wonderfully complete new book which explains in simple English how to read and understand any Radio Set Diagram. Includes translation of all Radio symbols. Send for this volume at once! It's free! Along with it, I will send you another Big Free book describing in detail my Radio-Electronic Training.

#### SPRAYBERRY ACADEMY OF RADIO

F. L. Sprayberry, President, Room 25116, Pueblo, Colorado

Please rush my FREE copies of "How to MAKE MONEY in RADIO, ELECTRONICS and TELEVISION," and "HOW to READ RADIO DIAGRAMS and SYMBOLS."

Name ..... Age .....

Address .....

City ..... State .....

(Mail in envelope or paste on penny postcard)

**MAIL COUPON TODAY!**

November, 1946

*"The Standard  
by Which  
Others  
Are Judged  
and Valued"*

AUDAX has mastered wide-range so thoroughly that, today, even the lowest priced MICRODYNE has a range to 7000 cycles—(other models over 10,000 cycles). True,—wide-range makes for naturalness but,—it is highly objectionable if without quality. For example, of two singers, each capable of reaching high C, one may have a pleasing voice—the other, not at all. It is the same with pickups. To achieve EAR-ACCEPTABILITY, all other factors must be satisfied. Of these, VIBRATORY-MOMENTUM is most important. The only way to test EAR-ACCEPTABILITY of a pickup is to put it to the EAR-TEST. The sharp, clean-cut facsimile performance of MICRODYNE—regardless of climatic conditions—is a marvel to all who know that EAR-ACCEPTABILITY is the final criterion.

**Audax**  
**RELAYED-FLUX**

*Microdyne*  
TRADEMARK

Send for complimentary copy of  
"PICK-UP  
FACTS"



**AUDAX COMPANY**  
500 Fifth Avenue,  
New York 18

"Creators of Fine Electronic-Acoustical  
Apparatus since 1915"

*For the RECORD.*

BY THE EDITOR

**I**N A few densely populated areas of these United States the fortunate possessors of prewar television sets are able to see and hear the passing parade of important events, as they occur, while comfortably seated in the privacy of their own homes. Each evening when the whim impels they can relax comfortably at home and enjoy a theatrical presentation which, to all practical purposes, is presented for their exclusive enjoyment.

Commercial television has been with us for several years now—black and white television. After struggling through the morass of technical difficulties for several years, television began to find firm ground by 1940 when several manufacturers were in production on video receivers which were being well received by the buying public.

War-born necessity practically froze television activities at the peak of their 1941 advance. However, the technical demands of a scientific war challenged the most fertile thinking of the best of Yankee and Allied electronic experts. Electronic mapping, radar scanning, and a host of radio applications contributed a new fund of knowledge and fact to television's backlog of experience. These advances will be reflected in the first of the post-war television sets which soon will be appearing on the market.

Those of us who have been privileged to see the postwar models which will soon be produced on a quantity basis, and sold at prices that the least affluent of us can afford, have been very much impressed with the excellent pictures we have seen. Pictures with the sparkling clarity of fine screen cuts on good coated stock paper, will be available in comparatively low-priced sets.

Technically, commercial black-and-white television has been proven successful in the area of the originating station's operations. The economically feasible way to relay these programs for rebroadcast throughout the country is yet to be fully developed and proven.

Into this picture now has been thrust television in color. We long ago learned not to fear new developments. We have also learned not to let the vision of something new for tomorrow rob us of the pleasures of what is available for us today. We welcome the advances being made in color television.

But, how close are we to having color television at prices that can be afforded by the common man? Let's "look at the record" and see how far color television has advanced as a

practical means of entertainment.

Last December, members of the Press were invited to Princeton, N. J., to a preview of RCA's television advances. We were shown a series of black-and-white television receivers including representative models of the best of RCA's prewar receivers, the production models of their first post-war TV receivers and a research model of the RCA projection receivers which, it was hoped, would be in production by 1947.

The tremendous advances in the post-war TV receivers over the best prewar receivers was strikingly obvious. In passing, it should be mentioned that all of these receivers were reproducing a program then being telecast from the WNBT transmitter forty-odd miles away. The reception was excellent.

The second part of this preview was to witness the RCA developments in color television. The receiver was a laboratory model. The studio and transmitter were located two miles away. The operating frequency of the transmitter was way upstairs in the microwave spectrum—10,000 megacycles. RCA made this test the hard way—they telecast a live show. Further, they threw the book on colors used in the program.

Most of us who witnessed this demonstration considered the RCA color images only slightly inferior to technical color film productions. We also recognized that RCA had, in televising a live talent show, colorfully staged, endeavored to show the present limitations of this medium in the form of the ultimate requirements that will be demanded of it by those who will eventually buy home receivers for color television programs.

At the conclusion of the demonstration RCA officials said, in effect, "That's our story on color television, boys. We feel that it will not be ready for the public for about five years."

During the first week of February CBS invited the members of the Press to a preview of the much-heralded CBS color television. Ushered into one of the CBS studios, the writers were shown three television receivers housed in very attractive, streamlined cabinets. Then there followed a demonstration of CBS color television.

The CBS demonstration consisted of one motion picture film and a series of slides—both in color. The program was telecast from the CBS television antenna atop the Chrysler building. The carrier employed was in the 490 megacycle region, with a modulated video bandwidth of 10 megacycles.

(Continued on page 167)



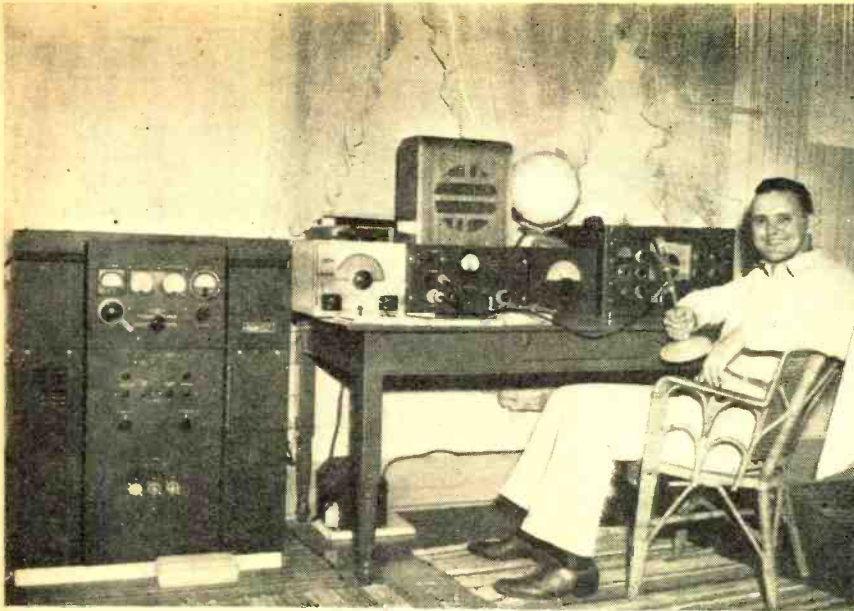

## Salute to W5SH

Post-war W5SH—equipped by ALLIED.  
Listen for him on 10 and 20 meter phone.

### Communications Equipment

for earliest delivery order from ALLIED

Time Payments Available

Trade-Ins Accepted

**NEW! HALLICRAFTERS SX-42 . . . \$250.00. Order yours now!**

Hallicrafters S-38 . . . . .	\$39.50	RME DB-20 Preselector . . . . .	\$ 68.20
Hallicrafters S-40 . . . . .	79.50	Hammarlund HQ-129X . . . . .	168.00
National NC-46 . . . . .	97.50	RME-45 . . . . .	186.00
NC-46 Speaker . . . . .	9.90	National HRO . . . . .	274.35
RME-84 . . . . .	98.70	National NC-240D . . . . .	225.00
RMV VHF-152 Converter . . . . .	86.60	Hammarlund SPC-400X . . . . .	342.00

Net F. O. B. Chicago. Prices subject to possible change.

### ALLIED HAM "SCOOP"!



#### MECK T60-1 60-WATT TRANSMITTER IMMEDIATE DELIVERY—A REAL BUY!

Here's a great performer for use on any amateur band, 10 to 80 meters, phone or CW. Compact, single unit design, only 15" x 11" x 9". Features: Combined plate and screen modulation; any crystal or high impedance dynamic mike may be used; 2 complete built-in 60-cycle power supplies, 1 for final RF, and 1 for Modulator, Speech Amplifier and Oscillator; built-in antenna change-over relay; provision for plug-in battery or vibropac operation; meter switching to final amplifier grid or plate circuits for tuning; crystal socket on front panel. Complete with 1 set of coils covering 10 and 11 meter bands (coils for other bands available at \$5.50 per band); includes 5-6LG6, 2-6SN7 GT/G, and 2-5U4G tubes. Only **\$150.00**

**ALLIED RADIO**  
*Everything for the HAM*

November, 1946

This month, our hats are off to Edwin C. Shaw, W5SH, Ft. Worth, Texas . . . first, for his fine-looking rig; second, for his stimulating activity on the air. And we want to add our thanks, too, for his recent friendly note that expresses, among other things, his "complete satisfaction not only with the equipment but also with the extremely courteous treatment I have received from your good company."

No need to thank us, W5SH. That's what we're here for. We get our satisfaction out of serving you. Whether you're an amateur starting "from scratch," rebuilding, or newly licensed, you can count on ALLIED for all the help you need—for earliest delivery of the latest available gear, for guaranteed quality at the lowest prevailing prices, for preferred personal service from ALLIED'S staff of licensed hams, each of whom shares your interest in amateur radio.

#### Send for Allied's 1946 Radio Catalog **FREE**

Here's the latest, most complete Buying Guide to everything in radio! Includes newest communication receivers, Ham gear, code apparatus, parts, kits, tubes, tools, books, test instruments, public address and other equipment. Get your **FREE** copy now!



ALLIED RADIO CORP., D. L. Warner, W91BC  
833 W. Jackson Blvd., Dept. 1-LL-6  
Chicago 7, Illinois

- Enter order for . . . . . Model . . . . .
- Enclosed \$ . . . . .  Full Payment  
 Part Payment (Balance C.O.D.)
- Send full information on Communication Receivers and Time Payment Plan, without obligation.
- Send **FREE** 1946 ALLIED Catalog.

Name . . . . .

Address . . . . .

City . . . . . Zone . . . . . State . . . . .



# THE WORLD'S OUTSTANDING RADIO and ELECTRONIC BOOKS

... all from a single source... with "instant service"  
**RUSH SERVICE—Same-day shipment**  
 from Illinois or Calif.

Send orders only to Santa Barbara; those of \$10 or more for Eastern and Central points will be TELETYPE to Illinois warehouse orders teletyped for 35c extra; others forwarded by AIR MAIL to warehouse. Complete stocks at Santa Barbara for Western orders.

## THE OUTSTANDING PRACTICAL HANDBOOK



### NEW, ENLARGED, TENTH EDITION

Radio's outstanding practical text. How-to-build-it descriptions of dozens of tested-and-tried types of transmitting, receiving, and test equipment. Supplemented by basic electrical and radio theory in the simplest possible language for those without mathematical or technical training.

Illustrated with hundreds of diagrams and large photographs showing details of construction. Has the most complete tube tables to be found in any book.

New edition contains expanded U.H.F. sections, more test equipment which can be home-built, enlarged and modernized receiving and transmitting tubes tables, grounded-grid amplifier data, speech clipping, splatter suppressor, cathode follower data, pulse-time modulation, transformerless power supplies, wave guides, cavity resonators, butterfly circuit, klystron, U.H.F. crystal diode, radar, and highly-efficient mobile antennas.

The ideal text for the practical radioman.

Over 700 pages, durably clothbound, gold-stamped Book No. RH \$2.00 postpaid in continental U.S.A. \$2.25 elsewhere, postpaid.

## Leading Engineering Handbooks

### RADIO ENGINEER'S HANDBOOK

by F. E. Terman

The wealth of technical data contained in this handbook makes it indispensable as a complete reference work on radio and electronics. Charts, tables, circuit diagrams, and concise text material simplify the solution of complex, as well as simple problems.

Tables, Mathematical Relations, and Units. Circuit Elements. Circuit Theory. Vacuum Tubes and Electronics. Vacuum-Tube Amplifiers. Oscillators. Modulation and Demodulation. Power Supply Systems. Radio Transmitters and Receivers. Propagation of Radio Waves. Antennas. Radio Aids to Navigation. Measurements.

Book No. TM10 1019 pages \$7.00\*

### RADIO ENGINEERING HANDBOOK

by Keith Henney and Others

An extensive reference book prepared by 28 specialists. Contains abundant explanatory material, diagrams, formulas, and tables in each branch of the radio field.

Mathematical and electrical tables. Electric and Magnetic Circuits. Resistance. Inductance. Capacitance. Combined L, C and R Circuits. Measurements. Vacuum Tubes. Oscillators. Modulators. Detection. A. F. and R. F. Amplifiers. Receiving Systems. Power Supplies. High Frequencies. Code Transmission and Reception. Aircraft Radio. Antennas. Television. Facsimile. Broadcasting. Loud speakers and Acoustics.

Book No. MM10 945 pages \$6.00\*

### STANDARD HANDBOOK FOR ELECTRICAL ENGINEERS

by A. E. Knowlton and a staff of specialists

This 2303-page volume is the leading reference work for electrical engineers. Prepared by a staff

of over 100 specialists, it contains 26 sections covering every phase of electrical engineering from units and conversion factors to electrophysics.

Book No. KM10 2303 pages \$9.00\*

### Commercial Operating PRACTICAL RADIO COMMUNICATION

by A. R. Nilson and J. L. Hornung

A complete radio manual covering subjects of interest particularly to the commercial radio operator. Topics include basic electricity; transmitters, receivers, and associated apparatus; and operating instructions. FM and ultra-high frequencies are included in this new edition. May be mastered by the average high school or trade school student.

Book No. NC10 927 pages \$6.50\*

### HOW TO PASS RADIO LICENSE EXAMINATIONS

by C. E. Drew

A well illustrated and long-used question and answer manual for the coaching of candidates for the commercial radiotelegraph and radiotelephone operator license examinations.

Book No. DH20 320 pages \$3.25\*

### RADIO OPERATING QUESTIONS AND ANSWERS,

by A. R. Nilson and J. L. Hornung

A practical study guide of the question-and-answer type useful for preparing for any of the radiotelegraph, radiotelephone, or amateur operator license examinations.

Book No. NQ10 415 pages \$3.50\*

### U.H.F., F.M., and Television

**U.H.F. RADIO SIMPLIFIED,** by Milton S. Kiver  
 U.h.f. radio simply and clearly explained, in plain English, without mathematics. Covers principles, applications, and equipment; adapted for home study.

Book No. KU30 242 pages \$3.25\*

**TELEVISION SIMPLIFIED,** by Milton S. Kiver  
 A simplified explanation of modern television, especially as it pertains to the operation and maintenance of television receivers. A "simple language" text readily understood by those with fair radio knowledge.

Book No. KT30 432 pages \$4.75\*

### Theory

**FUNDAMENTALS OF RADIO,** by F. E. Terman  
 A first book and also a good refresher for all radio students and workers. This text has been widely used in civilian and military classes. Requires no knowledge of complex mathematics.

Contents: The Fundamental Components of a Radio System. Circuit Elements. Resonant Circuits and Circuit Analysis. Fundamental Properties of Vacuum Tubes. Vacuum-tube Amplifiers. Power Amplifiers. Vacuum-tube Oscillators. Modulation. Vacuum-tube Detectors. Sources of Power for Operating Vacuum Tubes. Radio Transmitters. Radio Receivers. Propagation of Radio Waves—Antennas. Radio Aids to Navigation. Television. Acoustics.

Book No. TF10 58 pages \$4.00\*

**PRINCIPALS OF RADIO,** by Keith Henney  
 A basic course in radio which may readily be comprehended by high-school or trade-school students and may be used in independent home study. Well illustrated.

Contents: Fundamentals. Direct-Current Circuits. Electrical Meters and Measurements. Production of Current. Magnetism and Electromagnetism. Inductance. Capacitance. Properties of Alternating-Current Circuits. Resonance. Properties of Coils and Condensers. Vacuum Tubes. The Tube as an Amplifier. Rectifiers and Power Supply Apparatus. Audio Amplifiers. Detection. Receiver Systems. Oscillators. Transmitters. Antennas and Electromagnetic Radiation. Frequency Modulation. Ultra-High Frequency. Phenomena. Electronic Instruments.

Book No. MP20 534 pages \$3.75\*

### Radio Mathematics

**RADIO ENGINEERING,** by F. E. Terman  
 Probably the most popular foundation engineering textbook for all serious radio courses and libraries. Thoroughly revised.

Contents: The Elements of a System of Radio Communication. Circuit Constants. Properties of Resonant Circuits. Fundamental Properties of Vacuum Tubes. Vacuum-tube Amplifiers. Power Amplifiers. Vacuum-tube Oscillators. Modulation. Vacuum-tube Detectors. Sources of Power for Operating Vacuum Tubes. Radio Transmitters. Radio Receivers. Propagation of Radio Waves. Antennas. Radio Aids to Navigation. Television. Sound and Sound Equipment.

Book No. TE10 813 pages \$6.00\*

### MATHEMATICS FOR ELECTRICIANS AND RADIOMEN, by N. M. Cooke

This book presents all of the mathematics needed for a clear understanding of a. c., d. c., and high-frequency circuit and of electron tube operation. The text material covers the entire subject from simple arithmetic to logarithms, trigonometry, and vectors. It is an excellent book for the radioman who wishes to prepare himself for a more rigorous mathematical course. A wealth of illustrative examples and problems demonstrate applications of mathematical procedure and reasoning to radio circuit investigation.

Book No. CM10 604 pages \$4.50\*

### We Also Regularly Stock These Books

Send stamp for complete catalog

- Elementary Theory
- "Basic Elec. for Commun.," Timble, . . . \$3.75\*
  - "Elements of Radio," Marcus, . . . 4.00\*
  - "Fundamentals of Radio," Everitt, . . . 5.00\*
  - "Understanding Radio," Watson, . . . 2.80\*
  - "Electrical Commun.," Albert, . . . 5.50\*
  - "Electrical Fundamentals," Albert, . . . 4.00\*
  - "Basic Radio," Hoag, . . . 3.50\*
  - "Basic Radio Principles," Swern, . . . 3.80\*
  - "Radio Physics Course," Ghisardi, . . . 5.00\*
  - "Electrical Essentials of Radio," Slurberg and Osterheld, . . . 4.50\*
- Intermediate and Advanced Theory and Engineering
- "Radio Engineering," Terman, . . . \$6.00\*
  - "Fund. of Engng. Electronics," Dow, . . . 5.50\*
  - "Prin. of Radio Commun.," Morecroft, . . . 8.50\*
  - "Engineering Electronics," Fink, . . . 4.00\*
  - "Applied Electronics," M. J. T. Staw, . . . 6.50\*
  - "Communication Engineering," Everitt, . . . 5.50\*
  - "Electronics," Millman and Seely, . . . 5.50\*
  - "Electronics for Engineers," Markus, . . . 6.00\*
  - "High-Frequency A. C.," Eastman, . . . 6.00\*
  - "Radio Receiver Design," Sturley, . . . 5.00\*
  - "Technique of Radio Design," Zepher, . . . 4.00\*
  - "Prin. of Radio Engineering," Glasgow, . . . 4.50\*
  - "Electron Engineer's Handbook," Fender, . . . 6.00\*
  - "Radiotron Designer's Handbook," . . . 1.00\*
- Electron Tubes and Industrial Electronics
- "Electron Tubes in Industry," Henney, . . . \$5.50\*
  - "Electr. Control," Guckell, . . . 2.75\*
  - "Electronics in Industry," Chute, . . . 5.00\*
  - "Theory and Appl. of Electron Tubes," Reich, . . . 5.50\*
  - "Principles of Electron Tubes," Reich, . . . 4.00\*
  - "Inside the Vacuum Tube," Fildes, . . . 4.50\*
  - "Fund. of Vacuum Tubes," Eastman, . . . 5.00\*
  - "High-Freq. Thermionic Tubes," Harvey, . . . 3.50\*
  - "Theory of Thermionic Vacuum Tubes," . . . 6.50\*
  - "Electric Circuits," M. J. T. Staw, . . . 7.50\*
  - "Photoelects and Their Applications," . . . 3.50\*
  - "Electr. Optics and the Electr. Micro," . . . 10.00\*
  - "Gaseous Conduction and Electronics," . . . 10.00\*
  - "Electronic Control," Chute, . . . 4.50\*
- Radio Mathematics
- "Mathematics of Radio Commun.," Wang, . . . \$3.30\*
- Ultra-High Frequencies
- "Communication Circuits," Ware, . . . \$3.75\*
  - "Hyper and U.H.F. Engr.," Sarbacher, . . . 6.00\*
  - "Fields and Waves," . . . 5.50\*
  - "Transm. Lines, Antennas, and W. Guides," . . . 3.50\*
  - "Electromagnetic Engr.," King, . . . 6.00\*
- Commercial Operating Practice
- "Radio Direction Finders," Bond, . . . \$3.50\*
  - "Prin. Aero. Radio Engr.," Sandretto, . . . 4.00\*
  - "Aircraft Radio Engr.," . . . 4.50\*
  - "Radio Navigation for Pilots," . . . 2.75\*
  - "The Radio Manual," Sterling, . . . 6.50\*
  - "Radio Code Manual," . . . 2.75\*
- Radio Servicing
- "Modern Radio Servicing," Ghisardi, . . . \$5.00\*
  - "Prin. and Prac. of Radio Servicing," Hicks, . . . 4.00\*
  - "Radio Service Trade Kinks," Simon, . . . 3.50\*
  - "Radio Troubleshooter's Handbook," . . . 5.00\*
- F.M. and Television
- "Television Standards and Prac.," Fink, . . . \$5.50\*
  - "Frequency Modulation," Mund, . . . 4.50\*
  - "Electron Optics in Television," Malow, . . . 4.00\*
  - "Television Simplified," Kiver, . . . 4.75\*
  - "Microwave Transmission, Slaters, . . . 2.00\*
  - "Ultra High Frequency Techniques," . . . 10.00\*
  - "Television," Zworykin and Morton, . . . 7.00\*
  - "Principles of Television Engineering," Fink, . . . 5.50\*
- Miscellaneous
- "Ref. Data for Radio Engineers," . . . \$2.00\*
  - "The Industrial Electronics Authority," . . . 2.50\*
  - "Electronics Dictionary," Cole, . . . 5.00\*
  - "Meas. in Radio Engineering," Terman, . . . 4.50\*
  - "High-Frequency Measurements," Mund, . . . 5.50\*
  - "Radio-Freq. Electrical Measurements," Brown, . . . 4.50\*
  - "Radio-Freq. Measurements," Hartshorn, . . . 4.75\*
  - "Pulsed Linear Networks," Frank, . . . 3.00\*

\*Add 3% (minimum, 10c) for postage and packing; foreign, 10%. In Ill. and Calif. add sales tax. Prices are in U. S. dollars and are subject to change without notice.

**HOW TO ORDER:** TO AVOID ERRORS give both author's surname and book title. REMIT by draft, money order, or check; currency, etc., is at your risk; foreign remittance, must be in U. S. dollars. FASTER SERVICE when full remittance accompanies order; C.O.D.'s accepted but take longer to handle, and cost an extra fee.

Editors and Engineers 1302 KENWOOD ROAD Santa Barbara CALIFORNIA

# CALRAD "hard-to-get" RADIO VALUES!

## WEBSTER RECORD CHANGER

Model 56  
Complete



**\$25<sup>95</sup>**  
each

Built to last. Fast change cycle. Simple, foolproof operation. Automatic shut-off. Feather light needle pressure. Longer life for records. Quiet running Webster 4 Pole motor-cushion mounted. Webster Model 50 **\$19.95 ea.**

## TWO GANG SUPERHET VARIABLE CONDENSERS

Cut Oscillator Section Standard Capacity.

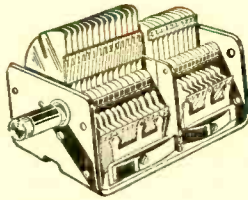

**\$1<sup>35</sup>**  
each

## T-17B MICROPHONE



Made of durable plastic. Complete with 5 ft. rubber coated cord and plug PL-68. Press-to-talk button. Can be used with most radio sets as home broadcaster mike for entertainment.

**\$1<sup>85</sup>**  
each

SUPPLY IS LIMITED!  
ACT QUICKLY

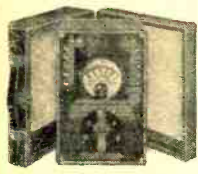

Limited Quantity

Brand New  
WESTON VOLT  
Ohmmeter  
MODEL 663

Complete with carrying case and leads.

List \$71.50 **\$39<sup>50</sup>**  
Special

## A. C. PHONO MOTOR

60 Cycles, 115 Volts with Turntable and Standard Make Crystal Pickup.

**\$5<sup>95</sup>** pair

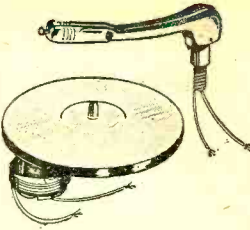

VARIABLE CONDENSERS  
Single Gang 440 Mfd Variable Condensers **95¢ ea.**

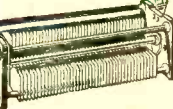
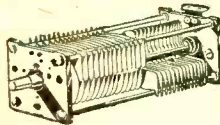

Dual Spaced 110, 110 Mfd Variable Condensers. **95¢ ea.**  
Dual Spaced 170, 170 Mfd Variable Condensers. **95¢ ea.**

## 5 TUBE SUPER AC-DC PARTS KIT

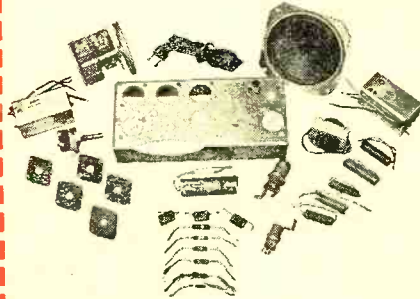

Kits include: Stamped Chassis—Dynamic Speakers — Output Transformer — Volume Control and Switch—2 Shielded I.F. Coils—Antenna and Osc. Coils—Two-gang Super Variable—5 Octal Sockets 20x20 Mfd. 150 Volt Filter—5 Tubular Condensers —3 Mica Condensers—6 Resistors—6 ft. AC Cord and Plug—Circuit Diagram.

WHILE THEY **\$8<sup>95</sup>** LOTS OF **\$50<sup>00</sup>**  
LAST ea. 6



TURNER  
CRYSTAL MIKE

With 100 ft. Shielded Mike Cable. **\$6<sup>95</sup>** ea.

## SPECIAL

Make any record player wireless with brand new

## TWO-TUBE PHONO OSCILLATOR KIT

Operates as far as 100 ft. from a radio and can be used with Automatic Record Changers, Players or Microphone. Uses 1-125H7 and 1-12H6 Tubes.

Complete with tubes. Supplied in kit form with "easy-to-follow" instructions for assembly. Complete with all parts, instructions and tubes. **\$4<sup>95</sup>** Net

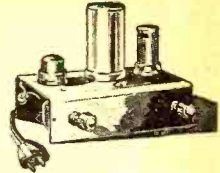

## SIGNAL CORPS DUAL HEADSETS

8000 ohms high impedance, with two rubber ear cushions, cord and phone plug, individually boxed, \$12.50 list.

**\$1<sup>85</sup>** each



## BRAND NEW WILLARD #20-2 2 VOLT STORAGE BATTERY

Used in General Electric model #530 charge A PACK portables. Suitable for all Farm Radio Sets. Individually boxed. List price \$8.95

Special **\$3<sup>95</sup>** each



## V. M. TWO POST AUTOMATIC RECORD CHANGER



This Record Changer is a well made mechanism, will play either 10 in. or 12 in. records. The pickup uses a crystal cartridge. Size 14 in. x 14 in. Packed 2 to a factory sealed carton, factory guaranteed.

CARTON **\$35<sup>00</sup>** Special **\$18<sup>95</sup>**  
OF 2 ea.

## 4 PRONG 6 Vo. UNIVERSAL AUTO VIBRATOR

Choice of Electronic, or Utah. Individually boxed. Fits 80% of all replacements. **\$1<sup>25</sup>** each



Push Pull 6L6 Shielded Output Transformer 30 Watt Peak, to 2-4-6-8-16-250 and 500 ohm line. **\$3.45 ea.**  
Lots of 12 **\$3.25 ea.**  
Push Pull Input Transformer, 10,000 ohm plate to push pull 6L6—\$1.10 ea. Lots of 12, **\$1.00 ea.**  
Midget Universal Output Transformer, push pull plate to 2-4-6-8-10-16 ohm voice coil. **95¢ ea.**  
Lots of 10 **85¢ ea.**  
10 Watt Large Universal Output **\$1.35 ea.**  
Lots of 10 **\$1.20 ea.**  
Single Pentode Midget Output—for 50L6, 6V6, 6F6, etc. **55¢ ea.**  
50 Mill Filter Choke 300 ohm **65¢ ea.**  
Lots of 10 **60¢ ea.**  
75 Mill Filter Choke 250 ohm **95¢ ea.**  
Lots of 10 **85¢ ea.**  
100 Mill Filter Choke 250 ohm **\$1.10 ea.**  
Lots of 25 **\$1.00 ea.**

DYNAMIC AND P.M. SPEAKERS  
4 in. 450 Ohm Dynamic **\$1.75 ea.**  
4 in. P.M. Heavy Slug **\$1.50 ea.**

5 in. P.M. Heavy Slug **\$1.55 ea.**  
6 in. P.M. Heavy Slug **\$2.25 ea.**  
TUBULAR ELECTROLYTIC CONDENSERS  
10 Mfd. 50 Volt **21¢ ea.**  
25 Mfd. 50 Volt **24¢ ea.**  
50 Mfd. 50 Volt **28¢ ea.**  
100 Mfd. 50 Volt **35¢ ea.**  
16 Mfd. 150 Volt **25¢ ea.**  
20 Mfd. 150 Volt **29¢ ea.**  
24 Mfd. 150 Volt **30¢ ea.**  
30 Mfd. 150 Volt **32¢ ea.**  
50 Mfd. 150 Volt **35¢ ea.**  
10 Mfd. 450 Volt **39¢ ea.**  
20x20 Mfd. 150 Volt **43¢ ea.**  
30x20 Mfd. 150 Volt **47¢ ea.**  
40x20 Mfd. 150 Volt **55¢ ea.**  
50x30 Mfd. 150 Volt **65¢ ea.**

FINEST QUALITY MIDGET MICAS  
.001-.0001 .005-.00005 **\$ 5.00 per 100**  
.002-.00025 .006-.0005 **\$40.00 per 1000**  
Astatic Low Pressure, Curved Arm, Crystal Pickup

with Sapphire Stylus Permanent Needle, has cartridge which replaces LP6-LP21-LP23. **\$3.50 ea.**  
Lots of 10 **\$32.50...**  
456 K.C. Antenna, Oscillator and R.F. Coils **25¢ ea.**  
456 K.C. I.F. Coils Input & Output, medium size can. **59¢ ea.**  
Kit of 50 Assorted Bakelite Knobs for 1/4" shaft, with set screws. **\$2.50 per kit**  
Midget Ceramic Trimmers—3-30 mmf **6¢ ea.**  
Rubber Sheathed "Mike" Cable, shielded, single Conductor. **100 ft. for \$ 5.95**  
**500 ft. for \$25.00**  
Single Bearing Midget Condenser 14 plate—100 Mfd. **50¢ ea.**  
10 Watt Wire Round Resistors, your choice of sizes 25 Ohm to 25,000 Ohm **20¢ ea.** 17.50 per 100  
Buffer Condensers (Famous Make) .005, .01, .02, 1700 Volts. **19¢ ea.**  
Lots of 50 **15¢ ea.**  
Signal Corps Telegraph Keys. Lots of 10 **60¢ ea.**  
Lots of 50 **50¢ ea.**

MAIL ORDERS FILLED:

25% Deposit, Balance C.O.D., F.O.B. Los Angeles. Orders Under \$10.00 Please Remit in Full. References—Bank of America, Santa Monica & Vermont Aves., Los Angeles, California

# CALIFORNIA RADIO & ELECTRONICS CO.

Dept. No. N. 711 No. Vermont Ave., Los Angeles 27, California

Designed for



Application

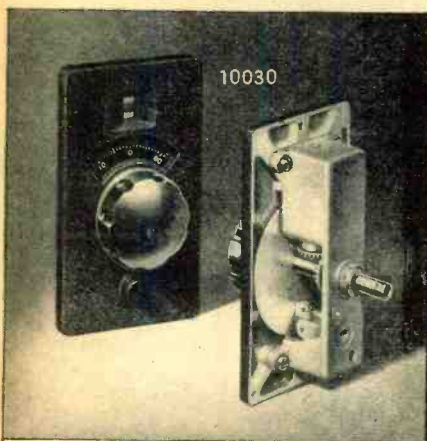

The No. 10030  
**INSTRUMENT DIAL**

An extremely sturdy instrument type indicator. Control shaft has 1 to 1 ratio. Veeder type counter is direct reading in 99 revolutions and vernier scale permits readings to 1 part in 100 of a single revolution. Has built-in dial lock and 1/4" drive shaft coupling. May be used with multi-revolution transmitter controls, etc. or through gear reduction mechanism for control of fractional revolution capacitors, etc. in receivers or laboratory instruments.

**JAMES MILLEN  
MFG. CO., INC.**

MAIN OFFICE AND FACTORY  
**MALDEN  
MASSACHUSETTS**



# Spot Radio News

★ Presenting latest information on the Radio Industry.

By **FRED HAMLIN**

Washington Editor, RADIO NEWS

**HOTTEST POTATO** on the fall Congressional investigation calendar may turn out to be work by the Slaughter committee on the disposal of Army electronics surpluses. The committee figured in the late-summer news when it investigated charges made in Atlanta, Ga., that some million dollars worth of electronics materiel had been sold for \$600 as junk from the Warner Robins Air Materiel Area with approval of the War Assets Administration. In September, committee chairman Roger C. Slaughter and his colleagues investigated the charge that Thunderbird airport had been "given away" to a private citizen. They planned to return to radio equipment as soon as Thunderbird was disposed of and the talk in Washington is that electronics may keep the committee busy for the rest of the winter.

**RADIO WAR SURPLUS** having thus reached the headlines, WAA has begun to clean house and to turn for advice on the problem to experts in the industry. This was done effectively in the Slaughter investigation of the Atlanta case, when both hams and small radio dealers were called on to testify. What they said, in effect, was that the least expensive way for the government to get rid of the Atlanta surplus was to do exactly what was done—sell it as junk. To be sure, there were some salvage parts in the materiel that was junked. But to separate it from the useless equipment would have cost more than it was worth. The materiel which was sold as junk, it was brought out, had already been screened repeatedly for valuable parts. The Slaughter committee came back to Washington convinced that the disposal had been one of those inevitably wasteful but practical jobs that always are necessary at the end of a war. Committee members went further and stated that the public should be made aware that war-built electronics equipment was expensive, that commercial specifications make little of it valuable for peacetime use, and that salvaging usable parts is often too difficult to be worth-while.

**WAR ASSETS**, fountain-head of surplus disposal policies, following the first news stories on the Atlanta case, and even before the Slaughter com-

mittee swung into action, began to clean house. Administrator Robert M. Littlejohn ordered "drastic changes" in the administration of electronics disposal. Complete reorganization of the electronics division, which sells surplus radio and radar equipment, followed. Short-cuts were authorized in the handling of inventories, sales agents' agreements were revamped or, if too raw, completely abrogated, and the division was put under James A. Mollison, a deputy administrator who had already gained a reputation in WAA for cleaning up the once-dubious administration of aircraft disposal. George H. Moriarty, formerly in charge of aircraft component sales, was made Mollison's assistant in carrying out the work, and scores of field workers were fired. Both administrators announced that the new program called for "close coordination with industry, and frequent conferences with industry representatives." The industry, which had been watching the Federal disposal program in electronics with skepticism, willingly volunteered experts to help clean up the mess. Everything considered, the Slaughter committee may turn up a negative but heartening fact—electronics disposal is at last being put on a business-like, honest basis.

**FIRST GOOD** by-product of the investigation and WAA's housecleaning was the WAA announcement that "top priority" would be given veterans in purchasing surplus materiel. Veterans, however, were warned that, while there are huge stacks of unwanted surpluses, wanted items have proven far short of even the veteran demand.

**ANYONE IN RADIO**, ham or professional, can open up a radio station on the moon and welcome to it, according to our best War Department and FCC sources. War Department is particularly generous in the offer after recent news stories stating that Army planned to shoot a rocket to the moon in about eighteen months and another yarn saying a radio station might be sent aboard the rocket. Army spokesmen, when queried for particulars on these stories, became as hot as the noonday sun on the moon (estimated at 250 degrees F). They say that they'll not shoot at the moon because we have no enemies

**RADIO NEWS**

**MOST -  
OFTEN -  
NEEDED**

# RADIO DIAGRAMS



## 1946 4 OUT OF 5 DIAGRAMS YOU WILL EVER NEED

Find radio faults quickly. Make the needed repairs in any radio in minutes instead of hours. Save time on every job. This large, inexpensive diagram manual has the circuit for every popular 1946 radio set made since V-J day. Large manual, 8 1/4 x 11 inches, 192 pages. Just out. Price postpaid, only..... **\$2.00**

**1942** Clearly printed circuits, alignment data, parts lists, service hints are the facts you need to speed up radio servicing. Repair radios quickly and properly—follow the factory instructions given in these manuals. 1942 Manual has 351 models of 40 largest manufacturers. 192 fact packed pages. Large size. 8 1/4 x 11 in. Manual style binding. Order manuals you need today..... **\$2.00**

## LOW-PRICED DIAGRAM MANUALS

**1941** These easy-to-apply, inexpensive manuals will help you repair radios faster. This volume covers 1941 models, with alignment data, I.F. peaks, and replacement parts lists. Compiled by M. N. Beitman, radio serviceman for many years, author and teacher. Be an expert in radio servicing; simplify your work. **\$2.00** 192 pages, 8 1/4 x 11 inches. Only



**1940** Let this important manual give you over 80% of all 1940 circuits you will ever need, acquaint you with new developments, train you to service quickly and efficiently millions of sets. Data on F.M., portables, recording, etc. 417 models of 43 manufacturers. 208 large pages of helpful data..... **\$2.00**

**Most Popular Models Made By:**  
Philco, RCA, Zenith, Sears, GE, Emerson, Belmont Radio, Detroit, Fada, United Motors, Westinghouse, Arvin, Majestic, Stewart-Warner, Admiral, Delco, Stromberg-Carlson, Western-Auto, Sparton, Wards, Motorola, Gamble, and many others.

**1939** Another handy manual of most-popular diagrams you need. Circuit data, hints and information are time-savers and money-makers for you. Let these diagram manuals guide you to easier service work. Why try to get along without helpful diagrams? Use this volume with 192 pages of diagrams of 39 makes. Order these manuals today. The 1939 Manual is priced at only..... **\$2.00**

**1926-1938** The most popular volume of the series. Will pay for itself with the time saved during the first day of use. Includes all the popular old timers. Save hours on every job. 427 diagrams of the most-serviced radios of this period, with parts lists and alignment information. 240 pages, 8 1/4 x 11 inches. Sold with a money back guarantee. Price..... **\$2.50**



Compiled by M. N. Beitman, radio engineer, teacher, author, and serviceman.

**SAVE HOURS ON EVERY JOB**  
Be ready to make repairs in minutes instead of hours. You will be called upon to fix hundreds of models listed in these easy-to-use manuals. Tackle each job with the needed help found in these service manuals. Greatest bargain in diagram books. Send your order today. Plan to use these manuals this week.

## Other Practical Radio Manuals



### RADIO SERVICING COURSE

Learn new speed-tricks of radio fault finding, case histories of common troubles, servicing short-cuts, extra profit ideas. Many large lessons on the use of regular test equipment, explanation of signal tracing, television to the minute, recording dope. Many active servicemen used this reduced price radio training for brush-up and study of new service methods. Reprinted in 1945 with new information on signal-tracing, television, visual

alignment, P.A., photocells, and every other fact you must know to be more expert in your work. Complete, 22 lessons, size 8 1/4 x 11 in. With self-testing questions. Great bargain in home-study radio training. Postpaid, only..... **\$2.50**

### SIMPLIFIED RADIO SERVICING BY COMPARISON



New, revolutionary different COMPARISON technique permits you to do expert work on all radio sets. Most repairs can be made without test equipment or with only a simple meter. Many point-to-point, cross-reference, circuit suggestions locate the faults instantly. Covers every radio set—new and old models. This new servicing technique presented in handy manual form, size 8 1/4 x 11 inches, 84 pages. Over 1,000 practical service hints. 24 large, trouble-shooting blueprints. Charts for circuit analysis. 114 tests using a 5c resistor. Six editions, 48,000 copies sold to date. Only..... **\$1.50**

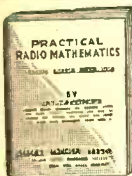

### PRACTICAL RADIO MATHEMATICS

Introduces and explains the use of arithmetic and elementary algebra in connection with units, color code, meter scales, Ohm's Law, alternating currents, ohmmeter testing, wattage rating, series and parallel connections, capacity, inductance, mixed circuits, vacuum tubes, graphs, curves, the decibel, etc., etc., and has numerous examples. Low price, only..... **25c**

See Your Radio Jobber or Send Coupon →

# Supreme Publications

PUBLISHERS OF RADIO BOOKS, MANUALS, AND DIAGRAMS

## NO RISK TRIAL ORDER COUPON

SUPREME PUBLICATIONS, 9 S. Kedzie Ave., Chicago, Ill.

Ship the following manuals: (Money back guaranteed).  Radio Math  
 1946  1942  1941  1940  1939  1926-38  
 Radio Servicing Course.  Simplified Radio Servicing by Comparison  
 I am enclosing \$....., send postpaid.  
 Send C.O.D. I am enclosing \$..... deposit.

Name: .....

Address: .....



The Original  
**SPINTITE  
WRENCH**

SPINS With  
Ease and Speed

Encourages nimble hands  
along the assembly line.  
Made in eleven sizes from  
3/16" to 5/8" square, hex  
or knurled . . . . .

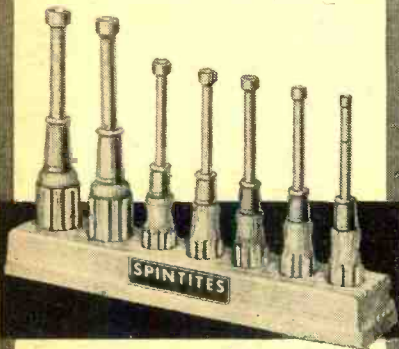

POPULAR Wood  
**SPINTITE** Handles  
T-73 SET

A useful Tool in every  
Radio and Electrical Shop.

Deluxe T-8 SET the same  
with Plastic Handles

Send for Catalog  
141 picturing Air-  
craft Radio and  
Automobile Tools.



**STEVENS WALDEN, INC.**  
468 SHREWSBURY STREET  
WORCESTER, MASSACHUSETTS

there. As for the radio station, they want to be left out—nothing official to say. Dr. J. A. Hutcheson, associate director of the *Westinghouse Research Laboratories*, on the other hand, has plenty to say. In fact, he is already designing a 100-watt, 50 pound short-wave transmitter, battery-powered and capable of signaling from moon to earth. He wants to rig it so that it will broadcast only one minute every hour and to accompany it with other instruments that will broadcast signals telling what the lunar weather is. Just to round out the picture, we checked with FCC to see if Dr. Hutcheson or anybody else with a moon station would need a license. The answer is no—FCC has no jurisdiction over the moon to date. And for whatever it's worth, this may be added; we talked to a number of very serious gentlemen, in and out of uniform, in collecting this information—the kind of men who take things very seriously and never heard of Superman or Buck Rogers. Pop questions to them ten years ago about rocketing to the moon and broadcasting therefrom, and they would undoubtedly have laughed at you or called for a straitjacket. But nowadays it's different.

**EVEN THE SIDEWALKS** seem destined to share in the current radio fantasia—don't be surprised if the silent man at your elbow as you go to the office some morning suddenly bursts into sounds like, "Calling Dr. Kildare!" That is the dream of one Sherman Amsden of New York City, who has been granted a construction permit by FCC for an experimental station to test a radio signalling service in the vicinity of his home town. Amsden plans a specialty—"radio paging" service for doctors and other professional clients. If you're a client, you'll carry a special vest-pocket-sized receiver tuned to Amsden's frequency. Listening in at stated times, you'll be able to hear your code number if you're wanted for dinner, bridge, or the emergency ward. You can find out which by calling Mr. Amsden from the nearest 'phone booth. He's going to call the service the "Telephone Answering Service."

**HAMS LISTENING IN** on this column are begged herewith to answer a couple of questions which came in the mail recently from our favorite correspondent, Mrs. Frances G. Mulchahey, of Westfield, New Jersey. Mrs. Mulchahey, an avid short-wave listener, reports that "in my eighty-two years on this heaving old world" she has been unable to discover the answers, and we admit we're stumped. Here they are: "When hams want to leave the air, why don't they go? One ham will say he is going to bed, then he talks for ten or more minutes on all things he forgot to say—the other one does the same. They give calls, stations, and stand at the

front door shaking hands until I want to give them a push out and shut the door." Number two: "Before the war, about 2 a.m. one night, a young chap was talking to an older man about his true love. The girl evidently tried to put over a severe reconstruction job and he rebelled. The boy said he liked to dance, he liked to drink once in a while, but he didn't like to spend all his time in church, as his girl demanded. I have often wondered what ever happened to that youngster." Any answers to either question will be transmitted to Mrs. Mulchahey.

**OPA, AS INDICATED** in last month's column, approved retail price increases averaging 3 per-cent on radios and electric phonographs toward the end of the summer. As was also indicated, further price increases are not imminent, and decontrol is still a thing of the dim future. In announcing the late-summer advances in retail prices, Price Administrator Paul A. Porter summed up OPA's attitude when he stated that the Administration's action to increase prices was "mandatory" under the Price Control Extension Act. "There appears to be some misapprehension in the minds of the public that these increases are being granted at OPA's discretion," he said. "This is not the case. The public should understand that these increases are necessary to comply with the law." It follows that OPA policy will accentuate holding ceilings where they now are. Says Porter: "OPA will follow the standards laid down by Congress in such a manner as to afford the maximum protection to the buying public that is possible. We anticipate that this is the last adjustment that will be necessary because of the new law. Where we are obligated to carry out other provisions of the statute, we will hold increases to the minimum." He adds that prices resulting from the increases "are still considerably below what prices would be if they were permitted to rise to the full extent of today's heavy demand and limited supplies." In sum, OPA will oppose further price rises in the radio field.

**CHALLENGING THE OPA** attitude against decontrol in the foreseeable future is the production score being marked up by the radio industry, a record which another government agency—the Civilian Production Administration—has hailed as indicating the arrival of a near-peacetime economy. "The stop-and-go output of materials and parts which has been obstructing volume manufacturing," said John D. Small, CPA administrator, recently, "has now been replaced by continuous, high-level production. That means that industry is within sight of full production of finished goods if industrial peace continues." Radio production bears out his statement, the monthly totals still being  
(Continued on page 102)

SOON WE'LL PHONE HOME FROM AUTO

RADIO INDUSTRY POISED FOR BIG BOOM

Big Boom in FM Broadcasting Seen

MARKET FOR 100 MILLION RADIOS REVEALED BY SYLVANIA SURVEY

COAST TO COAST NETWORK BEING PLANNED FOR FM

RADAR FUTURE

Let TODAY'S HEADLINES Guide You to TOMORROW'S OPPORTUNITIES

# Learn RADIO ELECTRONICS this MODERN "A-B-C" WAY .. at Home



YOU CAN BUILD 133 FASCINATING EXPERIMENTS WITH THIS EQUIPMENT

Plan your future the way business men do: Watch the headlines! Pick a field that's "in the news"—one with many opportunities for interesting, PROFITABLE EMPLOYMENT or a good chance for establishing a BUSINESS OF YOUR OWN with little capital. Pick a field that offers a variety of interesting opportunities—a field with one of America's most promising futures . . . and see how you may MAKE YOUR START TOWARD A PLACE IN THIS FIELD BEFORE JOB COMPETITION BECOMES ACUTE. Write for Our Big, Free, Illustrated Book—"VICTORY FOR YOU." Learn how DeForest's Training, Inc. prepares you at home, in your leisure time—without interfering with the work you are now doing—then helps you make your start in the vast BILLION DOLLAR Radio-Electronics field.

## You Get EMPLOYMENT SERVICE

Our Employment Service offers you the advantage of long and favorable contacts with some of America's foremost Radio-Electronics concerns. "VICTORY FOR YOU" tells you how this service has helped many to their start in Radio-Electronics. You'll see how our students and graduates are prepared to win and to hold good paying jobs—how they start businesses of their own with little, if any, capital.

## A You "LEARN-BY-DOING" at Home with Practical Equipment

Enjoy a "Home Laboratory." We provide you with 8 BIG KITS OF RADIO ASSEMBLIES AND PARTS to give you valuable practical experience at home. Build modern Radio Receivers and Circuits that operate. Build Electric Eye Devices, an Aviation Band Receiver, a Public Address System, a Wireless Microphone and numerous other fascinating experiments—in fact, 133 in all, in your spare time at home. NEW colorful Kit Supplement tells you about our "Home Laboratory," and how you use valuable Radio parts and sub-assemblies to get real practical experience as you learn.

## VETERANS!

Big things are happening at DeForest's Training, Inc. for veterans! See how you can prepare yourself WITHOUT COST for a GOOD JOB or a BUSINESS OF YOUR OWN in the vast Radio-Electronic opportunity field.

## C ILLUSTRATED LOOSE-LEAF LESSONS

You also receive modern loose-leaf lessons that are easy to read and are well illustrated with many helpful pictures and diagrams. ACT PROMPTLY! See how you can learn radio this modern A-B-C way by Reading . . . by Doing . . . by Seeing—at Home. Mail Coupon Now!

## B Home MOVIES Help You Learn FASTER...EASIER



You also use a 16 mm. Motion Picture Projector and exciting training films to help you learn some of Radio's fundamentals FASTER . . . EASIER. SEE what happens inside of many circuits you are working on. SEE how electrons function. SEE how RADIO waves are changed into sound. Get our big, free book! Use it as a key to show you the way to Radio-Electronics job opportunities of today and tomorrow—the opportunities the headlines tell about.

SEND FOR FREE BOOK & SUPPLEMENT TODAY!

# DeFOREST'S TRAINING INC., Chicago, Ill.

DeFOREST'S TRAINING, INC., 2533-41 N. Ashland Ave., Dept. RN-C11 Chicago 14, Illinois, U. S. A. Send me both your big book "VICTORY FOR YOU" and Kit Supplement, showing how I may make my start in Radio-Electronics with your modern A-B-C home training plan. No obligation.



Name . . . . . Age . . . . .  
 Address . . . . . Apt. . . . .  
 City . . . . . Zone . . . . . State . . . . .  
 If under 16, check here for special information  If a discharged veteran of World War II, check here.

**SILVER**

**"VOMAX"**

*Proved Best  
and...  
Cheapest*



Thousands upon thousands of "VOMAX", the truly universal vacuum-tube volt-ohm-milliammeter . . . in service today in ranking laboratories ranging from the U. S. Bureau of Standards on through the roster of radio's elect . . . bought by Veterans Administration and other school training programs . . . consistently selected by America's top-profit service organizations . . . conclusively prove it is the best. "VOMAX" is also the cheapest . . . not only because the best is always cheapest in the long run . . . but in first cost, too! Increasing production in response to increasing demand enables us . . . despite continually increasing material costs . . . to hold its price down.

"VOMAX" alone gives you the profit-priceless ability to measure every voltage in radio servicing . . . at meter resistance so astronomically high it does not upset measured circuits . . . 24 d.c. voltage ranges 0 through 3000 volts at 51 and 126 megohms input resistance . . . 6 ranges 0-1200 volts a.c., a.f., i.f., r.f. to over 100 megacycles at 6.6 megohms honest input resistance . . . decibels from -10 through +50 . . . resistance from .2 ohms through 2,000 megohms . . . direct current from 50 microamperes through 12 amperes. No other instrument at any price gives you all that "VOMAX" does. Its value is unequalled . . . it's the standard of comparison . . . the overwhelming choice of those "in the know" . . . is radio's outstanding buy . . . at only \$59.85.

**"SPARX" DYNAMIC SIGNAL TRACER**

Next to the universal volt-ohm-milliammeter . . . "VOMAX" is the ideal universal d.c. through u.h.f. meter . . . what the radio service profession most needs is a good dynamic signal tracer. Ability to trace the signal through every successive receiver circuit reduces "trouble-shooting" to basic fundamentals . . . banishes forever the hard-to-service "toughies" . . . turns loss jobs into quick profits. Designed by radio's only International Grand Prize winner, "SPARX" is the aural-visual signal tracer you have been clamoring for. Not only does "SPARX" trace r.f., i.f., a.f. signals from 20 cycles to over 200 megacycles . . . it is your shop test-speaker as well. It also tests microphones, phono pickups, P.A. amplifiers, speakers . . . registers presence or absence of d.c. and a.c. operating voltages, too. With new radar crystal diode probe, 3-stage 65 db. gain a.f. amplifier, ground-insulating transformer power supply and PM dynamic speaker, it's the instrument you've dreamed of . . . like all SILVER instruments will earn its cost in no time at all. Yet "SPARX" costs you only \$39.90.



**"904" LABORATORY CAPACITANCE RESISTANCE BRIDGE**

Not only does Model 904 C-R Bridge cover the tremendous range of 1/4 mmfd./ohm up through 1000 mfd./megohms . . . give you truly laboratory accuracy in measurement of capacitors and resistors . . . provide 0-500 volts continuously variable built-in d.c. polarizing voltage for electrolytic and other capacitors . . . give power factors measurement 0-50% . . . but it brings something quite new to radio measurements. With Model 904 C-R Bridge you can at last measure capacitance of any type of condenser . . . air, paper, oil, electrolytic, ceramic . . . with d.c. operating voltage applied during measurement! Think what this means in increasing your efficiency . . . in finding those "intermittents" which cause so much trouble . . . in speeding your work and increasing your profits. Measuring capacitors and resistors to ±3% laboratory accuracy . . . matching "VOMAX" and "SPARX" in size, post-war style, top quality components and construction . . . it's the same amazing bargain at only \$49.90 net as "VOMAX" . . . value which has forced 500% expansion in our plant facilities in less than one year.

*And*

See these "must" instruments . . . and new SILVER amateur transmitters, receivers, kits, parts which were sensations at the 1946 Trade Show at your favorite jobber. Act fast . . . demand continues far in excess of supply . . . for SILVER products are the profit tools used by your smart competitors. Send postcard for new post-war catalog.

OVER 35 YEARS OF RADIO ENGINEERING ACHIEVEMENT

*McMurdo Silver Co., Inc.*

1249 MAIN STREET • HARTFORD 3 • CONNECTICUT



# WAR SURPLUS EQUIPMENT

At A Fraction of Their Original Cost!



**TRANSMITTER BC-375E** Here is the famous airborne transmitter made by General Electric Co. It's ideal for hams. Has 7 tuning units, antenna tuning unit, heavy duty 24/38 volt dynamotor. Complete with tubes but less cables. F.O.B. Boston or Chicago. Prepaid in full . . . yours for . . . \$46.45



## Portable Amplifying MEGAPHONE

Manufactured for Army Signal Corps. Projects your voice 1/2 mile; Complete in Portable carrying case with: Electric megaphone and microphone, pistol grip and trigger switch, additional hand microphone and switch, portable tripod, combination amplifier and battery case. At a fraction of original cost.

\$59.97

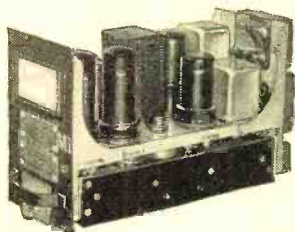

## SPERRY AMPLIFIER

Manufactured by Sperry Gyroscope Co., as an elevator servo control amplifier for the U. S. Army Air Forces . . . tooled to exacting design these amplifiers contain 2 beam power output tubes (1632) similar to 25L6, 2 twin triodes (1633 and 1634) similar to 6SC7, 2 mica condensers, dozens of color coded half watt resistors, 3 bathtub condensers, 2 dual bathtub condensers, 1 bathtub condenser with 4 sections, 3 hermetically sealed transformers, 2 wafer shielded rotary switches with resistor assembly, 1 volume control, 4 octal sockets, measurements 9 1/2" x 5 1/2" x 3 1/2". These units are brand new in their original factory cartons. They are beautifully designed and may be easily converted to an audio amplifier . . . brought to you at a very small fraction of their original cost with the radio parts worth many times the total purchase price. ORDER EARLY TO INSURE GETTING ONE. Complete with tubes. . . . \$3.95

• All items F.O.B., Washington, D. C. All orders \$30.00 or less cash with order. Above \$30.00, 25 percent with order, balance C.O.D. Foreign orders cash with all orders plus exchange rate.



**TUNING UNIT** This "RF" tuning unit designed and manufactured for the United States Army to their rigid specifications is offered at a fraction of their original cost . . . Guaranteed in excellent condition . . . less \$4.95 tubes . . .

- No. TUSB, 1500 to 3000 KC
- No. TU6B, 3000 to 4500 KC
- No. TU7B, 4500 to 6200 KC
- No. TU8B, 6200 to 7700 KC
- No. TU10B, 10,000 to 12,500 KC

Please specify model

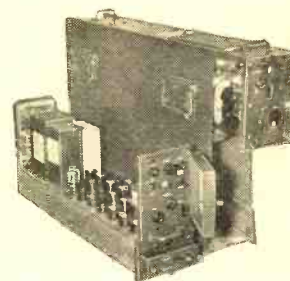

**WAVEMETER Interconnection Unit BC-1073A** Wavemeter BC1073A. These units are only slightly used and are guaranteed in good condition. They contain a high quality resonant cavity wavemeter, oscillator, heterodyne amplifier, electric tuning eye, complete with nineteen tubes, 110-volt A.C. power supply. These units tune from 150 to 210 megacycles. Original cost \$550.00, your cost . . . \$24.95



## HEADPHONES

Signal Corps 4000 ohm magnetic headphones. This double headphone set comes complete with Phono Plug, cord and leather-covered headband . . . Brand New. Please enclose 30c in stamps or coin to cover mailing and handling.

A \$14.50 value . . . \$1.87



**MICROPHONE** U. S. Army brand new single button carbon hand microphone "Shure" type with push to talk switch. Please enclose 30c in stamps or money order to cover mailing and handling. . . . \$1.99

WRITE FOR OUR BOOKLET

1/2 Million Dollars in War Surplus Equipment. Write for Free Catalog.

# SUN RADIO

OF WASHINGTON, D. C.

938 F STREET, N. W. WASH. 4, D. C.

.. for awhile, I was saying:  
**I'm Being Gypped!**

I was paying a high-priced technician to test my tubes, and he didn't even work up a sweat .

So I called the bird aside and asked him, "How come?" Then he told me about the time-saving RCP Tube Tester #322. He can test more tubes, more quickly with less effort than ever before. He saves me money on equipment bills, too, because of this instrument's unique versatility and low-obsolescence features.

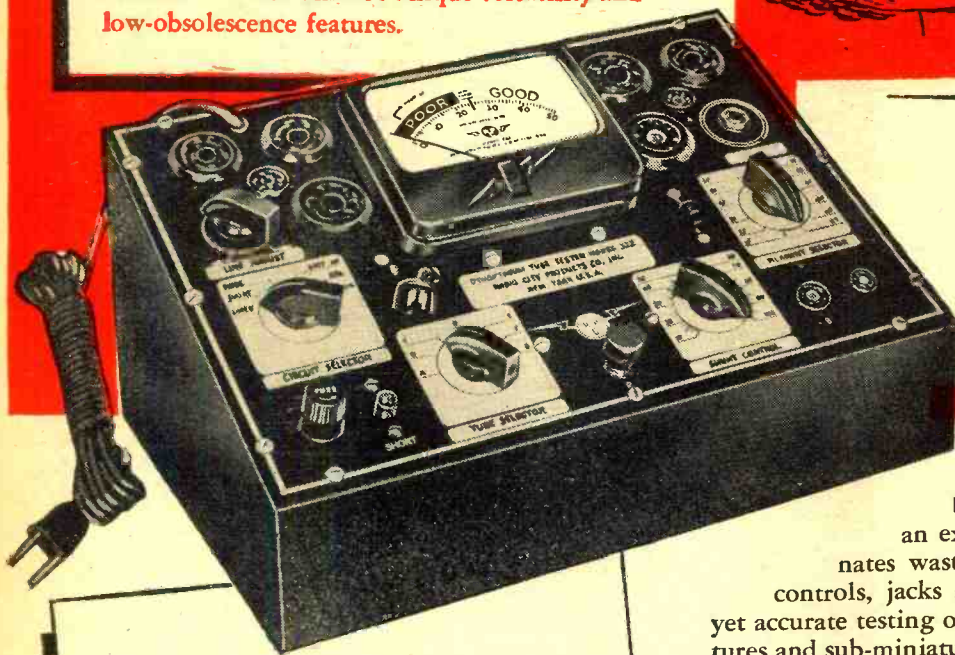

★ Checks all types of receiving tubes on market today. ★ Especially adapted for checking individual sections of multi-purpose tubes. ★ Headphone for noisy, swinging, or high resistance connections. ★ Closer tolerances are obtained due to extremely low voltage drop of test circuit. ★ 4 1/2" square compact, sturdy construction. ★ Neon lamp for rapid short and leakage tests between elements.



## DYNOPTIMUM TUBE TESTER MODEL 322

RCP's DYNOPTIMUM circuit, an exclusive RCP feature, eliminates waste switching motion. Fewer controls, jacks and switches permit speedy yet accurate testing of all tubes, including miniatures and sub-miniatures. Incorporates the newest tube developments to provide a low-cost, long range utility tube-tester for the laboratory, inspection booth or service shop.

COUNTER MODEL NO. 322 { complete with sloping steel case, about \$41.50  
 PORTABLE MODEL NO. 322P { complete with oak case and handle, about \$45.50

**NOW AVAILABLE**

ORDER FROM YOUR LOCAL JOBBER OR WRITE DIRECT FOR OUR NEW CATALOG NO. 129.

**RCP TEST INSTRUMENTS—BEST FOR EVERY TEST**

# RADIO CITY PRODUCTS COMPANY, INC.

127 WEST 26th STREET

NEW YORK CITY 1, N.Y.

MANUFACTURERS OF PRECISION ELECTRONIC OHM-MILLIAMMETERS, SIGNAL GENERATORS



LIMIT BRIDGES, VACUUM TUBE VOLTMETERS, VOLT-ANALYZER UNITS, TUBE TESTERS, MULTI-TESTERS.

**RADIO NEWS**



STANDARDS ARE SET BY  
**TRIPLET**

*A New*  
**TRANSCONDUCTANCE**  
**READING**  
*Tube Tester*

## For the Man Who Takes Pride in His Work

Micrhm (Dynamic mutual conductance) readings and simplified testing—are two of the 20 exclusive features in the new model 2425 tube tester. A new approach to transconductance checking is made possible through a simple measurement directly proportional to Gm and a properly calibrated measuring instrument. There is no possibility of grid overloading due to excessive signal. "Short" and "open" tests of every tube element, including shield, inter-element connections and taps. Gas Test rounds out full check of all tubes. R.M.A. numbering of three-position lever switches gives instant reference for special tube testing. Switching flexibility allows full coverage of present and future tubes. No hunting—individual socket for each tube base type eliminates error. Excellent design, portability and appearance, amplified by Triplet engineering through all 20 features, make Model 2425 the outstanding 1947 tube tester.

### *New Easy-Test*

#### **ROLL CHART ATTACHMENT**

*Has all the advantages of both roll chart and book chart in adding new data. The location is right and settings can be made easily and quickly. Fits in carrying compartment in tester cover when not in use.*



*Precision first*

# Triplet

*...to last*

**ELECTRICAL INSTRUMENT CO. BLUFFTON, OHIO**



# ESSE SPECIALS



**BC-654-A Receiver and Transmitter**  
 Truly the best buy of Army surplus. Frequency Range 3800 to 5800 KC.—Calibration every 10KC. with crystal oscillated check every 200 KC.—Power output 17 watts, voice or C.W. Seven tubes in receiver, five tubes in transmitter. Used, but in good condition. Weight, 45 lbs. **\$22.50**  
 P.E.-104 Vibrator power supply for operation of BC-654A receiver from 6 V. or 12 V. storage battery. New **\$3.95**  
 P.E.-103-A Dynamotor operates BC-654-A transmitter. 6 V. or 12 V. dc. input, 500 V., .160 amp. output. New **\$16.75** each Used **\$13.95** each

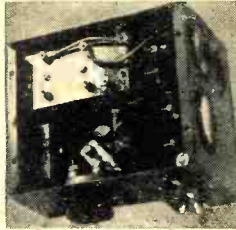

**Control Box**  
 Use for parts, etc.

Contains: 30-0-30 dc. amp. 2½" meter, 0-300 ac. 2½" voltmeter, 3 binding post, generator cutout, 60 amp. push button switch, .01 and .3 mfd. 600 V. cond., 10 mfd. 50 V cond., 2 ohm rheostat, 15 amp. filter choke, etc. Price **\$4.85** each



**Kyptron Lamp X-408**

Used with vehicle flasher unit S-1098 or other high voltage power supply for photography, signaling, etc.  
 Price—as shown **\$9.50** each

**Condensers:**

**Cornell-Dubilier Type TJH**

8 Mfd. 1000 V. Dc.	\$ 2.65 each
2 Mfd. 5000 V. Dc.	8.65 each
1 Mfd. 5000 V. Dc.	4.85 each
1 Mfd. 10,000 V. Dc.	21.50 each

**Insulators: Ceramic**

**Strain:**

7¼ in. length 6" between holes	
1" dia. 400 lbs.	\$ .30 each
14½ in. length 12" between holes	
1½" dia. 800 lbs.	.65 each

**Stand-off:**

1½" high 2" base 3 mtg. holes	
¾" top ¼" hole.	\$ .10 each

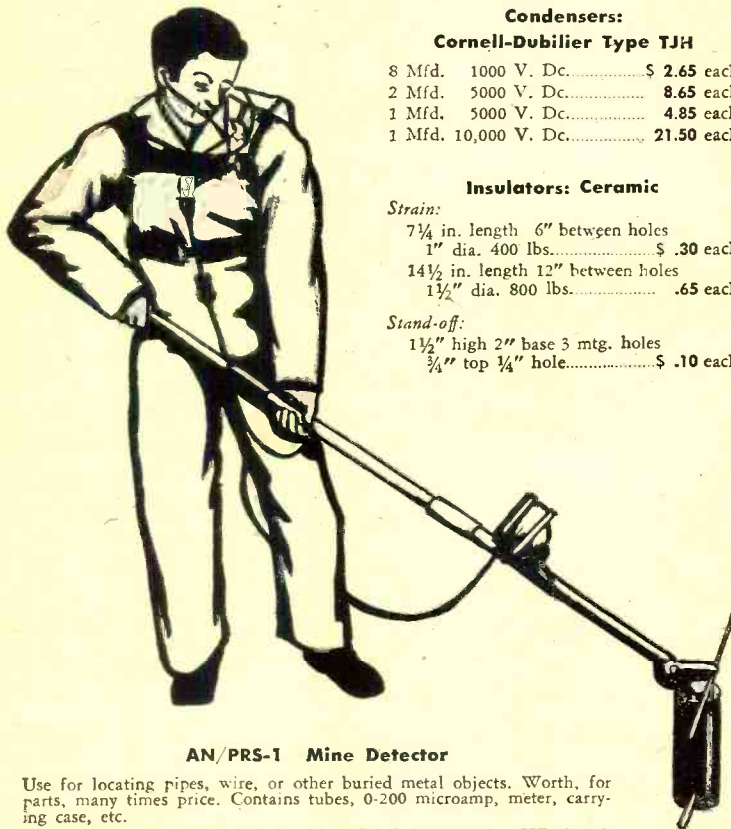

**AN/PRS-1 Mine Detector**

Use for locating pipes, wire, or other buried metal objects. Worth, for parts, many times price. Contains tubes, 0-200 microamp, meter, carrying case, etc.  
 Price, new in overseas shipping box, complete less batteries **\$17.50** each

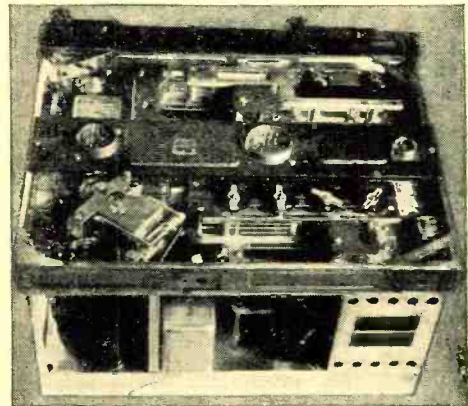

**SCR-522 100-156 Mc. Receiver and Transmitter**

Transmitter output 8-9 watts, voice amplitude modulated on any one of our crystal-controlled frequencies. Receiver is readily switched to either one of the four pre-set crystal-controlled channels.  
 Tubes used: 2-832; 3-12A6; 1-6G6; 2-6SS7; 1-12J5GT; 1-12C8; 1-9002; 3-9003; 1-12AH7GT; 3-12SG7.  
 Price new—complete as shown **\$67.50**  
 Price used—complete as shown **47.50**  
 Dynamotor unit for 24V operation **New \$17.50**  
 Used **\$10.00**  
 Control box BC-602-A **\$3.50**

*Terms cash with order or 25%  
 Balance C.O.D.  
 All items shipped collect.*



# RADIO COMPANY

130 W. NEW YORK STREET • INDIANAPOLIS 4, INDIANA

**For Efficient Radio Electronic Arteries...**

**Choose Amphenol Components!**

Amphenol is known, and relied upon, by amateurs and professionals in every branch of radio and electronics. The encyclopedic array of more than 8,000 *different* Amphenol components completely serves the entire range of frequencies in use today.

Amphenol engineers steadily are helping to pierce the veil of the unknown in the higher television and FM frequencies. They have been among the pace-setters in achieving the higher standards of mechanical efficiency and electrical correctness upon which progress in these fields depends.

Teamed with top-flight production facilities, Amphenol research has continuously developed new products to keep the Amphenol line of cables, plugs, connectors, fittings sockets, antennas and plastic components the most complete available from any one source in the world today.

Wherever you find electrons at work, you'll find Amphenol components recognized as the standard of performance.

**AMERICAN PHENOLIC CORPORATION, CHICAGO 50, ILLINOIS**

In Canada • Amphenol Limited • Toronto



COAXIAL CABLES AND CONNECTORS • INDUSTRIAL CONNECTORS, FITTINGS AND CONDUIT • ANTENNAS • RF COMPONENTS • PLASTICS FOR ELECTRONICS



The Collins 32V-1 Ham-band Transmitter

You **CAN** take it with you!

The Collins 32V is the last word in compact, efficient, and versatile transmitters for amateur radio. It is small enough to set right on your operating desk. It is light enough to take anywhere—all you need to put it on the air are a 115 volt a-c power source, key or microphone, and an antenna. The 32V has more desirable features per cubic inch than any previous equipment.

For instance, compare these features with your desires: 150 watts input on CW, 120 watts on phone, v.f.o. control, band switching, direct frequency reading dial, push to talk, clean keying, 6 bands. A pi network is in-

cluded for output coupling—and it's easy to use. One control tunes the final and another control loads it into the antenna.

The v.f.o. is so accurate you'll be using it to calibrate your receiver. It's permeability tuned, and can be set to within 500 cycles on the 80 meter band. The overall accuracy and stability are within one dial division.

Be one of the first to own this brand new job. You'll be proud of its excellent performance and attractive appearance. \$475.00 with tubes. Let us send you an illustrated bulletin with complete details.

FOR RESULTS IN AMATEUR RADIO, IT'S . . .



**COLLINS RADIO COMPANY, CEDAR RAPIDS, IOWA**

11 West 42nd Street, New York 18, N. Y.

• 458 South Spring Street, Los Angeles 13, California

**MAKE MORE MONEY**

**IN Radio TELEVISION & ELECTRONICS**

**Now!**

**GET THESE 2 BIG BOOKS**

**FREE!**

You men already in Radio know how great the demand is for trained, experienced servicemen, operators and technicians. You know how fast the field is growing and how important it is to keep up with developments—F.M. Receivers, Electronics and Television. You know, too, a fellow cannot learn too much about any industry for REAL SUCCESS. Whether you have experience or are merely INTERESTED in radio as an amateur, you must recognize the WONDERFUL OPPORTUNITY right within your grasp to cash in on your natural abilities. Make them pay dividends. Get into the EXPERT RADIO SERVICE FIELD. Be an F.M. and TELEVISION specialist—OWN A BUSINESS OF YOUR OWN, if you prefer. Fill out and mail the coupon below for all the details of our plan.

Get the Latest Inside Information—Short Cuts—Trade Secrets by

Here's Just a Few of the Interesting Facts you Learn with the FREE MANUAL.

1. Routine for Diagnosing Radio Troubles.
2. Preliminary Inspection of Receivers.
3. How to Check Power Supply.
4. How to Identify Various Stages of Receiver.
5. How to Trace the Circuit and Prepare Skeleton Diagram.
6. How to Test and Measure Voltages.
7. How to Test Speaker in Audio Stages.
8. How to Test Detector, I. F., R.F., and Mixer Stages.
9. Complete Reference Table for Quickly Locating Receiver Troubles.

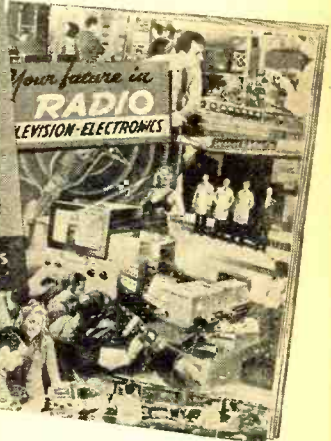
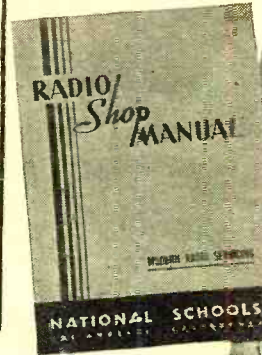

**SHOP METHOD HOME TRAINING**

FROM A REAL ESTABLISHED RESIDENT SCHOOL  
Now the famous National Schools brings its exclusive Shop-Method of training right into your own home. You can learn the most up-to-date, approved projects, systems and circuits step by step in your spare time. This is the sound practical training you want and need—the development of experienced instructors working with thousands of students right in shops, NEW F.M. broadcast studios and experimental laboratories of NATIONAL SCHOOLS—one of the most advanced trade educational centers in the world.



**LEARN BY DOING**

Work with Real Experimental Equipment Furnished without Extra Cost as Part of Your National Training

Experience is the best teacher. You learn by experience with the exclusive National Shop-Method of Home Training. In the course of your study you actually build various types of receivers—a powerful superheterodyne, a signal generator, an audio oscillator and others—you make tests and conduct experiments that show you the why and how of things. You understand what makes the various elements of electronics operate because you actually see them work for you. Not only do you gain marvelous experience by this method of learning but you receive valuable equipment you will use on the job in the practice of your profession as an electronics expert. Mail the coupon and learn what this means to you.

Send the Coupon and prove to yourself what YOU can do in RADIO!

**National Trained Men Now Making the Best Money in History**

The real value of National training shows up on the quick progress our men make on the job. Incomes that seemed fantastic only a short time ago are now being reported by National graduates. And this is only a sample of what the future holds for the MAN WHO KNOWS RADIO, ELECTRONICS, F.M., TELEVISION and allied subjects. National is proud of the progress its graduates are making all over the world. Read the facts—the actual proof in the books we send you FREE.



**Be Sure of Your Success And Security**

Don't let your post-war ambitions lag. Don't let YOUR future depend on others. Build a career for yourself. Never in all history has the returning serviceman, or war worker been confronted with such a great future if he reaches out and grasps it NOW. Here is a new world opening before you. You can soon step into an essential, well paid position or, with little capital, GET INTO BUSINESS FOR YOURSELF. It isn't a bit too soon to start now. Radio men are vitally needed. Fill out and mail the coupon immediately and examine the NATIONAL SHOP METHOD HOME TRAINING COURSE carefully, without obligation.

**NATIONAL SCHOOLS**

LOS ANGELES 37, CALIFORNIA EST. 1905



**MAIL OPPORTUNITY COUPON FOR QUICK ACTION**

National Schools, Dept. RN-11

(Mail in envelope or paste on penny post card)

4000 South Figueroa Street, Los Angeles 37, California.

Mail me FREE the two books mentioned in your ad, including a sample lesson of your course. I understand no asterisks will call on me.

NAME.....AGE.....

ADDRESS.....

CITY.....ZONE.....STATE.....

Check here if Veteran of World War II.

**FREE LESSON INCLUDED**

Examine the exclusive National Shop Method of Home Training. See for yourself how sound and practical it is. Be convinced that you can learn Radio, Electronics, Television—quickly and easily in your spare time. You can't tell until you try. This trial is ABSOLUTELY FREE. Fill out the coupon immediately while you are thinking about it and drop it in the mail at once.

With the coupon here for the books that tell you the complete story of the marvelous new system of training in Radio, Electronics and Television. Learn the facts of this exclusive shop-method of home training. See for yourself! DECIDE FOR YOURSELF!

This is the MODERN SYSTEM OF TRAINING: it matches the rapid progress constantly being made in Radio, Television and Electronics. It is TIME TESTED, too. National Schools has been training men for more than a third of a century. It is the very same training that has helped thousands to more pay and greater opportunity.

You owe it to yourself—your future—to read the book "Your Future in Radio, Electronics and Television"—FREE to you when you send in the coupon.

November, 1946

# The Eye That Never Closes

You are looking at a thermistor — a speck of metallic oxide imbedded in a glass bead hardly larger than a pin-head and mounted in a vacuum. The thermistor was developed by Bell Telephone Laboratories to keep an eye on the amplification in long-distance telephone circuits.

When a thermistor is heated, its resistance to electric current changes rapidly. That is its secret. Connected in the output of repeater amplifiers, it heats up as power increases, cools as power decreases. This change in temperature alters the resistance, in turn alters the amplification, and so maintains the desired power level. Current through the wire at the left provides a little heat to compensate for local temperature changes.

Wartime need brought a new use for this device which can detect temperature changes of one-millionth of a degree. Bell Laboratories scientists produced a thermistor which could "see" the warmth of a man's body a quarter of a mile away.

Thermistors are made by Western Electric Company, manufacturing branch of the Bell System. Fundamental work on this tiny device still continues as part of the Laboratories program to keep giving America the finest telephone service in the world.

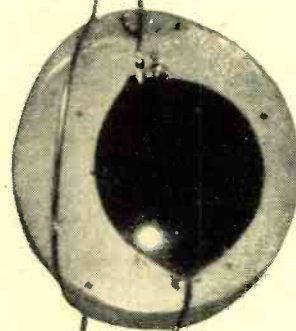

**BELL TELEPHONE LABORATORIES**

EXPLORING AND INVENTING, DEVISING AND PERFECTING FOR CONTINUED IMPROVEMENTS AND ECONOMIES IN TELEPHONE SERVICE





Fig. 1. Beechcraft model D185 all-metal, twin-engine 6 to 10 place monoplane.

# Planning an Aircraft RADIO INSTALLATION

By J. D. SCALBOM

Sales Eng., Bendix Radio Division of  
Bendix Aviation Corporation

***The owner's desires, facilities available, and the type of plane are factors which must be carefully considered.***

**T**HIS discussion is planned to bring to the reader's attention the practical points to be considered in the planning of an aircraft radio installation. With large fleets of identical aircraft, such as in airline operations, it is possible to arrive at a set of highly useful and accurate data. When the variety of aircraft types encountered increases, the most practical results are obtained through the application of good sense and ingenuity, coupled with past experience and acquaintanceship with the equipment being considered for the installation. This is particularly true of the antenna types and placement.

The problems involved in planning an installation of radio gear in the small, two or three place "family" type aircraft requires considerable care and thought. The entire problem is not nearly so complex as with the larger aircraft that are being put into use for private transportation by many large organizations. This latter group will be dealt with because the former class will then be covered automatically. *The first phase of the planning resolves into what choice of facilities is required or desired by the owner*; and these specifications must then be met as completely as is practical, considering the aircraft in question, etc.

The aircraft used as "executive" transports are comparable to the commercial airline craft in speed and their ability to fly under very adverse weather conditions. Due to the nature

of the flight operations these aircraft must be equipped with a radio "system" which will allow full use to be made of the government and private navigational and safety facilities. The high degree of reliability achieved in commercial airlines operations is very dependent upon these same aids. Without a complete coverage of the available aids much of the usefulness of the aircraft is sacrificed. The "executive" transport must be capable of going anywhere, and at any time that commercial airlines are operating.

#### Radio Facilities Available

Navigational and safety aids operating within the frequency range of 200 to 400 kilocycles include several types. Airways range stations are the best known of these. Each range station consists of an antenna system keyed by "A" (di-dah) and "N" (dah-dit). In the "quadrants" either an "A" or "N" is received while along a range leg or "beam" the field strengths of the antenna towers approach equality. With equal signals the "A" and "N" keying blends into a steady audio signal. At regular, short intervals an identification code is transmitted. Airways charts show the placement of each range station and the direction of the range legs from that station.

At designated times during each hour weather broadcasts are made from these stations. They may also be contacted for weather and traffic information. Emergency services are handled, too, but not messages of a

personal nature. Much has been written covering this highly important network so that no more need be said here concerning it. In addition to the range stations non-directional homing stations are located at strategic points to provide aural-null direction finding (DF), or automatic direction finder (ADF) fixes. These are of particular use for traffic "holding" points adjacent to large airports. Airways and airport control towers also operate in this frequency range, 200 to 400 kilocycles.

Very-high frequency (v.h.f.) facilities are being installed to serve the same purposes as just mentioned. To date only a small portion of the airways have been converted for v.h.f. navigational usage. However, the CAA (Civil Aeronautics Authority) towers are equipped and are standing by for communications on v.h.f. By July, 1946 all CAA towers and at least 100 range stations were ready with v.h.f. for communications. Navigational facilities will require some time for completion, however. The low frequency radio ranges are still entirely intact, and will remain in service for an indeterminate period. Of course new radio gear must also be developed to make full use of the potentialities which v.h.f. offers. The frequency range of 108 to 132 megacycles has been assigned for this service. Immediately available for use by the itinerant or private pilot are 131.9 megacycles for air-to-ground airport control tower contacts and 131.7 megacycles for air-to-ground airways communications station contacts. For the time being ground-to-air transmissions remain in the 200 to 400 kilocycle band.

These v.h.f. itinerant flyer's frequencies were assigned on a temporary basis, but final permanent allocations

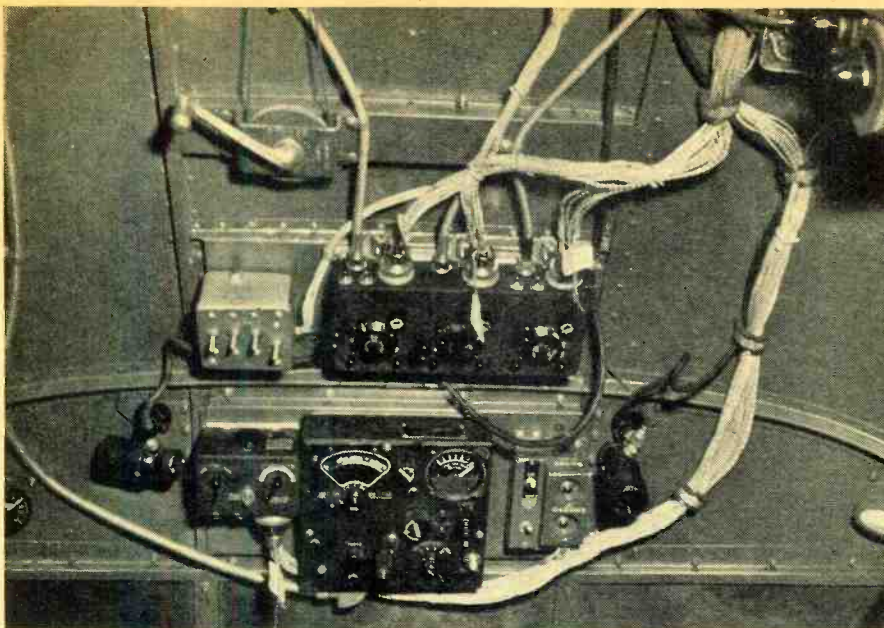

Fig. 2. Beechcraft C-45 cockpit with military type radio controls installed.

have been recently announced by the FCC. The permanent assignment for airport control towers is 122.5 mc. and for airways communications stations, 122.1 mc. The CAA has announced that as of January 1, 1947 its facilities will be guarding these new frequencies, but until that date guard will be maintained on 131.9 and 131.7 mc. Aircraft radio station licenses in force on v.h.f. at the time of changeover will be automatically carried over to the permanent frequencies without reapplication by the license holder.

Of great importance to navigation and safety is the system of "marker beacons" operating on 75 megacycles. Several functions are served by these marker beacons. The "Z" marker located at the range station site has a field strength pattern vertical and conical so as to give a positive indication of range station location. (This is opposite to the "cone of silence" which is a negative indication in that the range receiver signal momentarily reduces over the range station. This phenomenon is due to signal cancella-

tion between the radio range station antenna field patterns.) "Fan" markers located at distances varying between approximately 10 and 30 miles from range stations adjacent to major airports and along the range legs provide the pilot with absolute "fixes" especially useful in instrument approach problems. The "Airways" or "Fan" and the "Z" markers are modulated by 3000 cycle audio and by means of audio filters, etc., employed in the marker receiver a white "Airways" indicator light is made to light up giving a visual indication in addition to the audio signal. A marker receiver is indispensable to instrument flight operations. In like manner "Outer" and "Inner" markers are located on the instrument approach path to an airport. The "Outer" marker is distinguished by a 400 cycle audio note and a blue indicator light; the "Inner" marker by a 1300 cycle audio tone and an amber light.

3105 kilocycles and 6210 kilocycles are the itinerant flyer frequencies in addition to the recently allocated v.h.f. channels. The commercial airlines operate on frequencies between 2.8 and 12.5 megacycles.

Little use has been made of the "ship-to-shore" radio network linking shipboard telephones with landlines, but it is expected that advantage will be taken of the personal type of service offered since no personal messages can be handled by the facilities so far mentioned. Most of these stations operate in the 2.0 to 2.5 megacycle range.

#### A Proposed Minimum Radio System

The preceding outline of services has been made to show the need for each of the pieces of gear recommended as a complete, minimum radio "system" to be carried aboard the "executive" class of aircraft. Additional v.h.f. instrument approach gear might be considered in the large aircraft in the DC-3 class; however, such equipment is far beyond practical consideration for the medium sized 6 to 8 place aircraft. The following units comprise a minimum for "night instrument" operations:

1. An ADF (automatic direction finder) covering a frequency range of at least 200 to 400 kilocycles. (550 to 1200 kilocycles in addition is desirable). ADF bearings on frequencies higher than approximately 1200 kilocycles are questionable although "homing" is usually satisfactory.
2. A second receiver having a frequency range of at least 200 to 400 kilocycles for tower and airways contacts while the ADF is used for navigation, and for range flying. The use of a fixed or rotatable antistatic loop antenna, too, is highly recommended for use with this receiver. Aural-null bearings may be taken with such a loop antenna.
3. A 75 megacycle marker receiver having audio as well as visual indication. At least a single indicator light which responds to all of the marker

Fig. 3. Antenna arrangement on typical executive and light transport type aircraft.

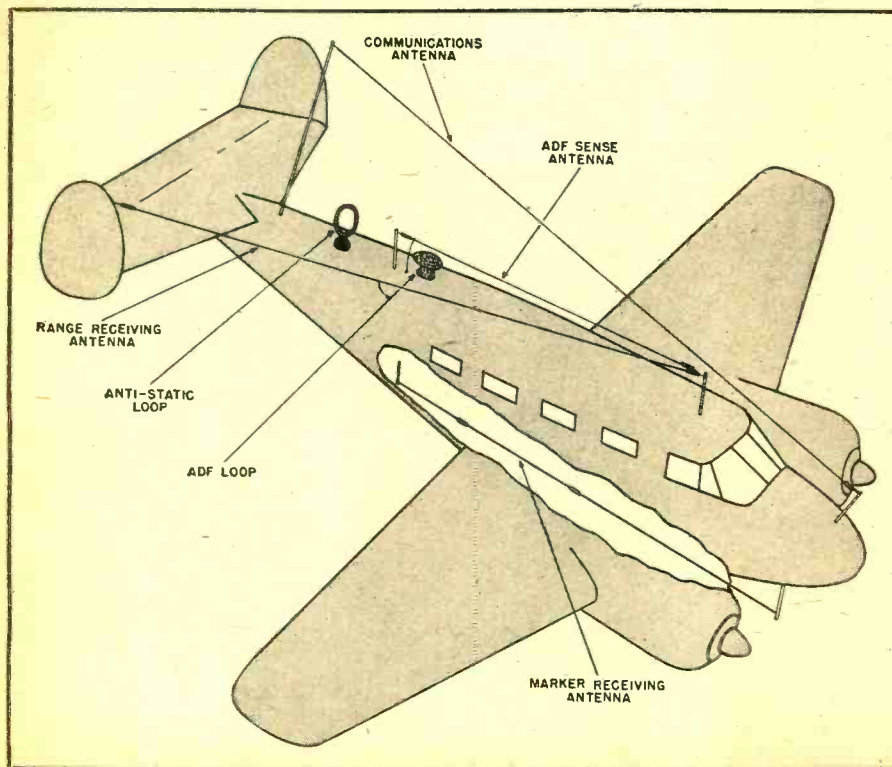

beacons ("Airways," "Inner" and "Outer" markers) without giving spurious indications (as when passing over power lines, or showing a light when the transmitter aboard the aircraft is operated), must be part of this piece of gear.

4. A transmitter operating on 3105 and 6210 kilocycles having a reliable range equal to 20 minutes flight at cruising speed of the aircraft. Antenna efficiency rather than transmitter power is a limiting factor in fulfilling this requirement.

5. A control, or set of controls and associated parts which tie the above four equipments together in such a way as to allow complete selection of the desired functions from at least the pilot and co-pilot positions. Selection without interference between either station must be attained. These controls must be easily accessible and easily seen from either position.

Depending upon the past experiences of the pilots who are in charge of the aircraft, the radio system may be either increased or decreased and otherwise modified according to the type of operations these men expect to carry on. Obviously it would be foolish not to equip an aircraft of unlimited operating ability with a complete set of radio gear—and the opposite also holds true.

Very-high frequency is rapidly being put into use and a complete system will require the addition of a low power v.h.f. transmitter having five channels. Two of these can be used

immediately, 131.9 megacycles for air-to-ground control tower contacts, and 131.7 megacycles for air-to-ground airways communications station contacts. The three additional channels will be designated for congested areas as soon as traffic warrants it. An output power of less than one watt will give complete reliability at 40 to 50 miles at altitudes of 1500 to 2000 feet. Range naturally increases with increase in altitude over the terrain. Ground-to-air contacts will remain in the 200 to 400 kilocycle band and present equipment is far from being obsolete since a gradual transition period of at least five to eight years is contemplated.

#### Modification of Military Equipment

Most of the aircraft purchased from the military have a radio system installed in them which is unsatisfactory from several standpoints. The failings can be overcome in some degree by modification and rework, however it is almost impossible to obtain a completely satisfactory radio setup. Compromises of more or less consequences must be made in every case. The transmitters require modification to provide crystal control. But then the power is often low and modulation is seldom a full 100%. Coverage is usually far below that required by high speed aircraft. The receivers themselves are very good and have adequate frequency coverage. The ADF's are fully satisfactory.

Perhaps one of the greatest difficulties of the military radio system aside from the transmitter is the inflexibility of the switching of the audio circuits and the range-voice filters. Paralleling of the pilot and co-pilot audio outputs cannot be prevented when each receiver has only a single audio output channel. This is the case with each of the military radio receivers, and transmitter sidetone and interphone. In addition, the control boxes and switches are in several separate units that are placed throughout the cockpit. A clean appearance and fully satisfactory cockpit arrangement is practically out of the question. This is not disparaging to the modifications that have been made since it is simply a fact that the "tools" available do not lend themselves to the job as well when they have been designed to do many things, as when they are designed to do a particular job.

Illustrated in Fig. 5 is a C-45 Beechcraft which was modified to overcome as far as possible the failings just pointed out. The new rectangular control box takes the place of the triple control formerly used for three military type receivers. Within this new control box are the following controls:

1. Individual range-voice filter switches, located at each end of the box.

2. "On-Off," channel selector and "Transmit-Interphone" switches, and indicator lights for a ten channel, crystal controlled, communications unit,

(Continued on page 134)

Fig. 4. Radio gear mounted in the nose of a Lockheed Lodestar.

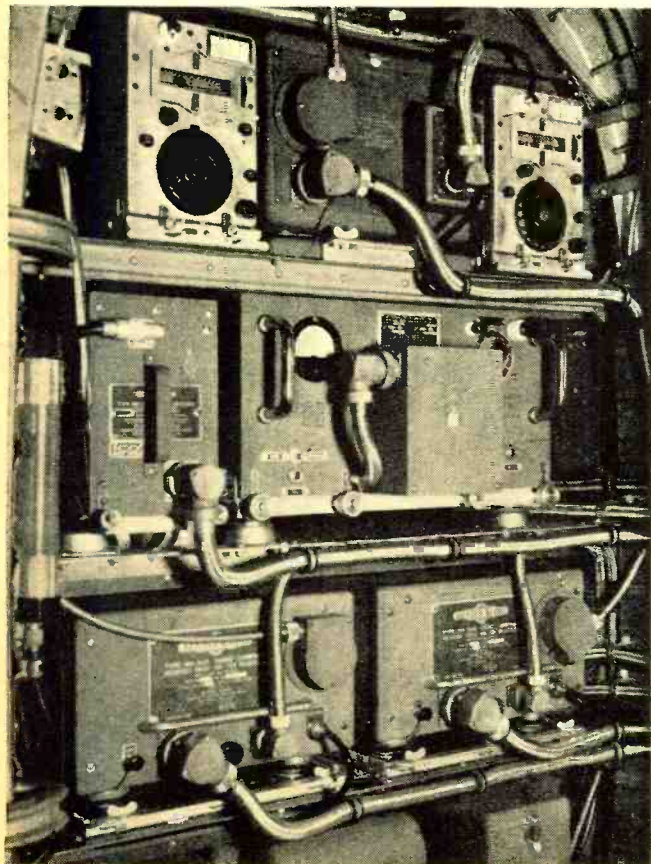
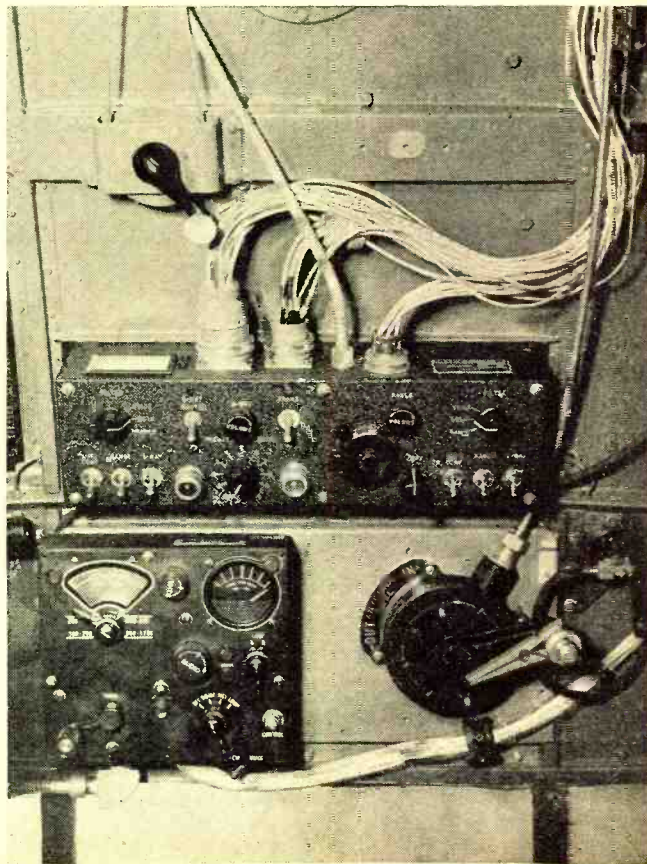
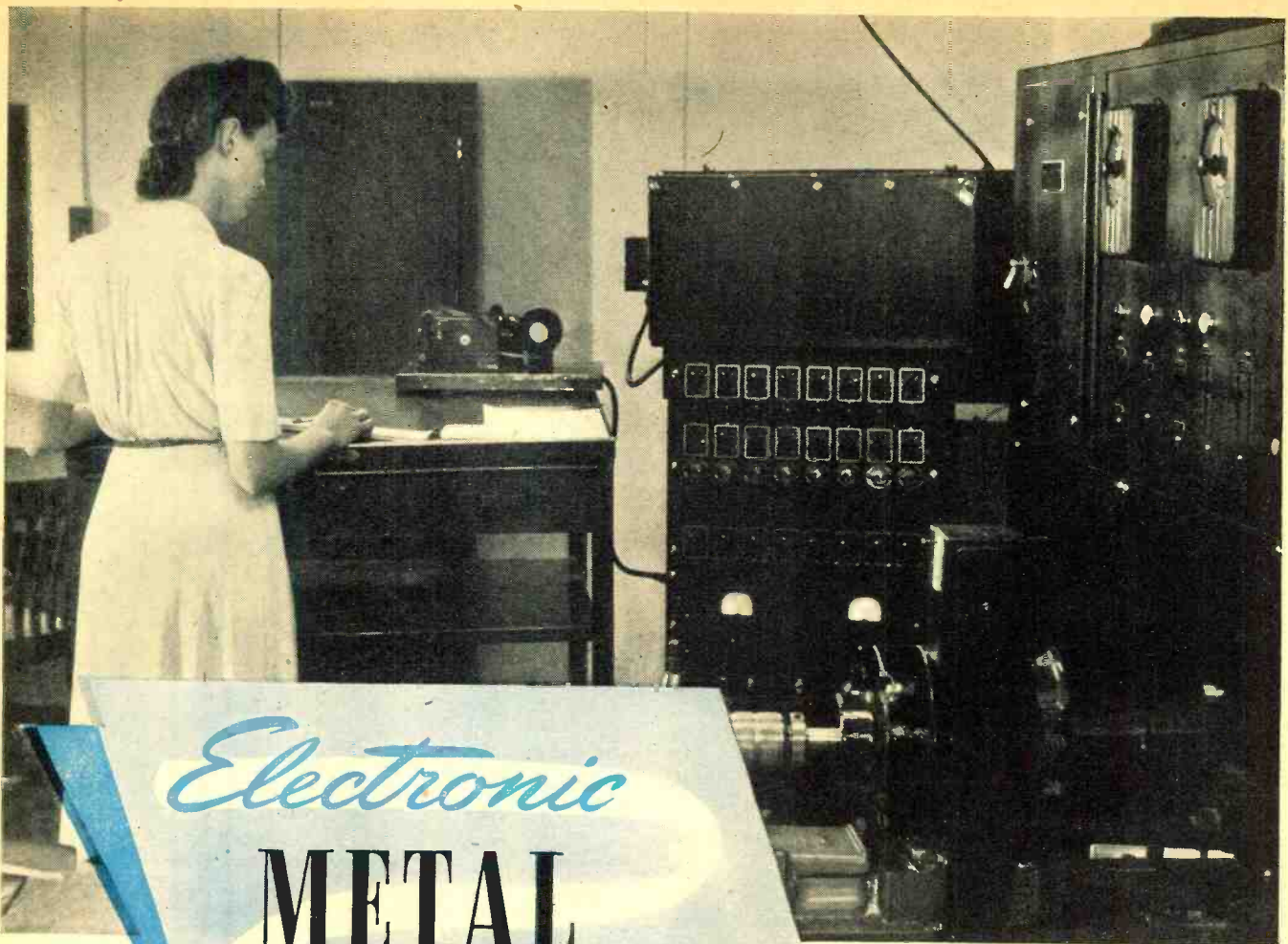

Fig. 5. Bendix MS-106 control panel in modified Beechcraft C-45.





# Electronic METAL ANALYZER

Operator notes results of final test made by using spectrometer to analyze alloys.

By  
**S. R. WINTERS**

**Newly developed direct-reading spectrometer makes possible analysis of a maximum of 14 different elements found in industrial alloys.**

**C**ONVERTING rays of light into electricity, by using an electric spark generated on a strip of metal, a new electronic apparatus critically examines steel or other metal and defines the precise percentage of each element present—a process requiring only 40 seconds. This novel spectrometer, or electronic meter, was designed by *The Dow Chemical Company* of Midland, Michigan and inasmuch as it is a direct-reading device it may render obsolete the conventional spectrograph.

Originally chemical methods were employed in metal industries to determine the exact amounts of each of several elements in an alloy; then the spectrograph displaced the chemist's test tube as a means of analysis. The latter method proved more accurate

and a greater time saver than chemical analysis. But somewhat analogous to the flippant expression of going around your elbow to get to your thumb, spectrographic analysis involved a round-about process of photographing the spectral lines on a film, developing and calibrating it, and after placing it in a microphotometer, the percentage of each element then had to be calculated. These successive steps of operation were time-consuming—the complete process requiring from 15 to 30 minutes.

The new direct-reading spectrometer is a hybrid product of a combination of recent developments in electronics and the optical science, resulting in an electronic measuring instrument which automatically records the precise concentration of each of several metals in

the form of a chart. It is capable of measuring the presence of at least 14 different elements, and the device may be so constructed as to enlarge its capacity to include an analysis of even more elements. The spectrometer, the only one of its kind, was built jointly by J. L. Saunderson, V. J. Caldecourt and E. W. Peterson of the Spectroscopy Laboratory of *The Dow Chemical Company*. Currently, determinations are being made for the following elements in the magnesium alloys: aluminum, manganese, zinc, beryllium, iron, calcium, silicon, and copper.

In the new spectrometer, as well as in the conventional spectrograph, the source of light is an arc or spark generated on the sample of metal subject to critical examination. This rainbow of light is broken up into the lines of the spectrum by use of a prism or grating. Instead of taking a photograph of the spectrum, this direct-reading spectrometer provides a slit for each element, through which the lines for that particular element are

given passage. A special photoelectric tube is situated behind each slit, an arrangement which permits of converting light into electricity and then amplifying it approximately 200,000 times. Then, this electronic energy is stored in condensers, which is the first step in the process, requiring only 20 seconds. At this juncture, the arc is stopped automatically, a paper roll begins to move, and the electric condensers are discharged slowly. Electronic amplifiers, designed especially for this purpose, determine the time element in the discharge of each condenser. The usual design of amplifier would require standardization for each sample of metal examined, but this unusual amplifier is adjusted, only once a week, by use of a "magic eye." The length of the lines for each element in the metal corresponds to the time of discharge for each condenser. Calibrated scales convert these length of lines into percentages of metal or alloy composition.

Scientists of *The Dow Chemical Company* outline the following steps in this method of analyzing metals and alloys; (a) generating a source of radiation with the unknown material as electrodes; (b) passing a beam of this radiation into a multiple-exit-slit spectrometer, which is equipped with energy collecting and amplifying instruments; (c) measuring the relative energy contained in each of several predetermined spectrum lines; (d) comparing this measured energy with the energy similarly received from standard samples; (e) and thereby determining the composition of the unknown sample.

The arc or spark between two electrodes, as the source of light, carries a current of a few amperes, at electromotive forces varying from 2000 to 27,000 volts. The slit through which this beam of light passes does not differ materially from a slit in any scientifically-built spectrograph. The slit must be sufficiently narrow to allow the beam to resolve itself logically into its various wavelengths without overlapping. Too, the slit must be long enough to admit of an appropriate quantity of energy. Ordinarily, the length and width of the slit should be comparable to the dimensions of the usual monochromator.

The beam of radiation is split into its integral wavelengths by use of a prism or, preferably, a grating. A plane grating of either the reflection or transmission design may be employed, although transmission gratings are practically obsolete. The prism or grating is in a fixed position in comparison with the rotating mounting, ordinarily employed in a monochromator. A concave reflecting diffraction grating has been found quite satisfactory. With the beam of light resolving itself into its different wavelengths, certain spectral lines may be selected, such as those which will be measured in arriving at the desired analysis. Optimum lines, for example, for each of the specific components may be se-

lected with respect to the orthodox principles of spectroscopy. In some instances, however, it will be well advised to employ the electronic energy from more than one line for a particular component. In such case, the energy will be assembled by optical methods into a single collecting and measuring unit.

The particularly novel aspect of this direct-reading electronic "analyzer" is the process of assembling and determining the energy contained in the spectrum lines for each of the components being assessed. More specifically, the energy from one or more lines of each element subject to analysis is collected in an electron multiplier photoelectric tube, of the RCA type No. 931A, sensitive to light radiation down the spectrum to about 3400 Angstroms. This design of electronic tube may be obtained, if a special order is authorized, with a particular glass envelope, capable of transmitting light radiation down to 2400 Angstroms. Nine stages of amplification are present within the tube itself; therefore, the output of current is enlarged to 230,000 times that of the input energy. Moreover, the electronic output is of sufficient magnitude to be used for some purposes without additional amplification.

Various methods are available for determining the energy from each of the photoelectric tubes (one for each element), as the means of finding out the composition of the unknown source. This current could be measured with a galvanometer, which would indicate the amount of current flowing and, thus, the quantity of energy present in a certain spectrum line. The galvanometer scale could be calibrated to afford a direct reading but, as is customary in spectroscopic work, it would be an instantaneous reading and

thus would vary appreciably from one moment to another. Therefore, we are advised that dependable results would only be obtainable by integrating such a galvanometer reading over a specified period, a sufficient time to "iron out" all these instantaneous variations.

The process for assembling and measuring the energy over a fixed period involves charging a condenser from the photoelectric tube during a definite time of exposure. The energy stored in such a condenser is the total energy received during an exposure, which is of sufficient duration to average out any slight instantaneous variations of relative intensity. A determination of the energy so "packed" into the condenser may be employed to indicate the metal composition sought.

This volume of current is determined by discharging the condenser through a fixed resistance unit of such character that the condenser will be deprived of the electric current over a measurable period, say, from 5 to 60 seconds. To vouchsafe such accuracy, the condensers must be capable of almost complete discharge. These condensers should be able to discharge nearly 100 per-cent of their stored energy in order to approximate conformity with the so-called "exponential decay law." Because, if this law is not heeded, intensity fluctuations and slight variations in time of exposure do not strictly cancel in the determination of relative intensities.

"By measuring the original charge put in a condenser which collects the energy representing a given unknown constituent of an alloy and comparing it with the charge put in a reference condenser by the spectrum line or lines used for internal control, the amount of the unknown constituent can be determined," points out *The Dow*

(Continued on page 164)

Close-up view of the recording device used in The Dow Chemical Company equipment.

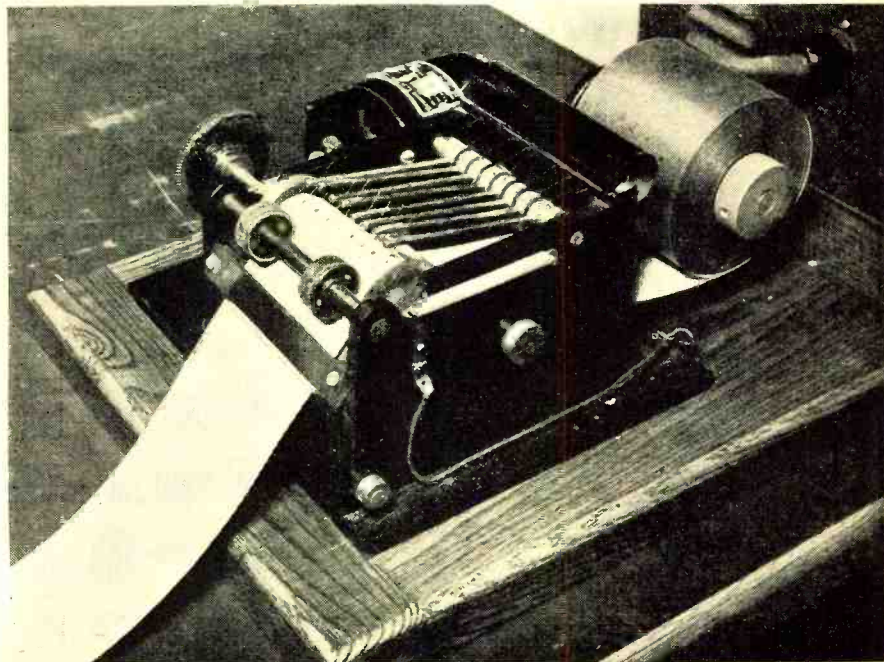

# SOUND CONDITIONING *Spurs Sales*



Fig. 1. Modern sound conditioning makes this radio store an inviting place to shop.

By

**J. J. ROWLAND**

Acoustical Dept., The Celotex Corp.

**Harsh, irritating noises in your sales rooms can lose sales for you. This article tells you easy ways to hush unpleasant sounds by use of modern acoustical treatment.**

**N**OW that production of radio receivers has reached peacetime proportions and more and more sets are appearing on the market, the wise serviceman-dealer is beginning to think in terms of competition ahead—if he has not already done so.

Manufacturers are lending vital support to their distributors and dealers in the way of promotional material, and consumer advertising. The market is ready, but whether or not the dealer is successful depends on a great number of factors. One of the important customer decisions will be "Where shall I buy my new radio?" A pleasing and restful atmosphere in the dealer store will be one of the considerations which will carry weight with prospective customers.

While hundreds of retailers have, in the past, been in contact with architects, builders and sales engineers, and have been getting set for the time when they could modernize their stores, many have neglected to even consider such a program because of

the lack of merchandise and experienced sales help which characterized the war period. It can be assumed that soon the public will settle down and be more selective in their choice of merchandise and the retail outlets.

To this end, the modern, up-to-date radio store will strive to include in its modernizing program a favorable combination of all elements, such as, floor, walls, ceiling, entrance, store proper, lighting, air conditioning, ventilation and sound conditioning.

### Sound Conditioning

Sound conditioning is the art and practice of treating rooms and the interiors of buildings so as to minimize the annoying effects of noise—"unwanted sound."

This is done by the use of sound absorbing materials. When a sound wave strikes a wall, its energy is partially reflected, partially absorbed, and partially transmitted. Any absorption at the point of reflection will tend to decrease the different com-

ponents and minimize the characteristics of direct sound. Acoustical treatment and the shape of the room must be such that reflected sound is thoroughly diffused.

Sound travels in spherical waves at a speed of 1120 feet per second, in all directions from the source. Within the store area when the sound strikes the walls, ceilings or floor, some is absorbed, the balance is reflected back into the room. The absorption coefficients of some well known materials and furnishings are as follows.

Material	Absorbs	Reflects
Plaster	.025	.975
Concrete	.015	.985
Wood	.03	.97
Glass	.027	.973
Carpet	.20	.80
Acousti-Celotex C-9	.70	.30

One can easily see from the above why noise can build up to such a volume as to be exceedingly irritating.

Materials are available today which are made especially to quiet excessive noise within all types of areas. These

are called "acoustical materials" and are made of various basic materials. All are porous in construction. They absorb more sound than they reflect. They are tested and rated for their absorption coefficients at a number of frequencies by both the Acoustical Materials Association and by the National Bureau of Standards. The efficiency of an acoustical material is expressed in simple percentage of sound absorbed at various frequencies.

### Installing Acoustical Tile

Acoustical tile for sound conditioning may be applied directly to an existing ceiling by means of adhesive, or nailed to wood strips attached to the ceiling. In order to lower an exceptionally high interior, or in the case of loose, falling plaster or scaling paint, a suspended ceiling is installed by attaching 1" x 3" wood strips 12" on center to 2" x 4" wood strips 30" on center suspended from ceiling to desired height by means of straps or hangers. Acoustical tile not only quiets sound, but insulates, decorates and provides excellent light reflection as well.

It is not at all necessary to close shop while installing acoustical tile. In fact, it is good policy to advertise same, acquaint customers with the fact the improvements are being made for their benefit. Everything done in the way of store modernizing is reflected in merchandise display and increased sales.

### Results of Sound Conditioning

Various types of store equipment, i.e., telephones, typewriters, and office machines generate as much sound in one location as another. By use of sound absorbing material the loudness is cut down because the original sound dies out faster. It is not amplified by repeated reflections from wall-to-wall and from ceiling-to-floor as in an average untreated room, but is quickly absorbed.

In a radio store, noise quieting is an essential feature. In playback or demonstration rooms sound conditioning is coupled with sound insulation in order to insure an ideal hearing condition and also to eliminate sound transmission.

A common acoustical problem in building construction is the transmission of sound through walls, floors and ceilings. In practically all types of construction, sound transmission from one room to another through the dividing wall takes place as a result of diaphragmatic vibration. The surface may be set into vibration either by direct mechanical impact, as by a footstep on a floor, or by the alternating air pressure due to sound waves incident on the surface. The former is called impact transmission and the latter is termed airborne transmission. In either case the vibrating surface generates new sound waves of reduced intensity in the room on the other side.

The transmission loss of any wall is

a physical property of that wall just as is its weight or rigidity, and depends only on the materials and method of construction used in erecting the wall and not on the loudness of the sound striking it nor on the size or acoustical properties of the room on either side of it.

The playback or demonstration room plays a very important part in the merchandising of radios and records and record playing instruments.

Fine radio-phonographs, FM, and standard broadcast sets, free from fading, static and station interference are now being built. Superb instruments in beautiful cabinets, built by master craftsmen to meet the exacting demand of the most discriminating buyer are on the way. Prospective buyers will be assured of crystal clear reproduction of every wave in the wide range of recorded sound frequencies whether it be speech, instrumental music, song or sound effect.

Among the requirements for good listening are that volume should be adequate, however, it should not be "loudness" resulting from reverberation. The components of complex sound should maintain their proper relations, and successive sounds, in fast moving speech or music, should be clear and distinct.

Sound conditioning the playback or demonstration room is particularly desirable. Musical tones seem clearer and softer, and the result is a highly effective demonstration under ideal conditions. This room should be treated with a sufficient amount of acoustical material to prevent sound energy from building up to an uncomfortably high level. In general, due to the average size and shape of listening rooms, treatment should be distributed on both wall and ceiling areas. In this type room it is often the tendency for a large part of the sound energy created therein to be reflected back and forth between the walls themselves without striking

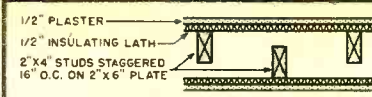
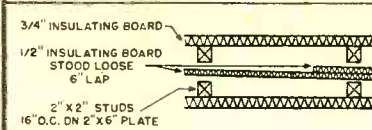
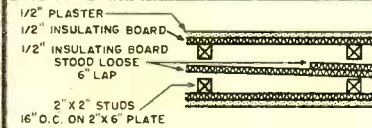
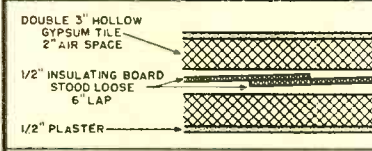
SOUND INSULATION DETAILS	WT. IN LBS. PER SQ. FT.	TRANSMISSION LOSS IN DB.	RATING
	13.0	53.7 *	EXCELLENT
	6.8	42.8 **	VERY GOOD
	12.2	52.3 **	EXCELLENT
	32.0	47.8 *	(FIREPROOF) EXCELLENT

\* \* TEST DATA BY RIVERBANK LABORATORIES  
\*\* \* TEST DATA BY INSULATING BOARD INSTITUTE

Fig. 2. Average transmission losses for different types of partitions.

the ceiling or the floor covering at all.

The acoustically correct playback room assists materially in decreasing the toughest sales resistance by contributing to the richness of tone of the instrument being demonstrated.

An acoustical treatment, properly applied, will produce a satisfactory effect in the room in which it is installed, and will, naturally, reduce the amount of sound to be transmitted, thus indirectly increasing the apparent sound insulating efficiency of the wall. However, experience has shown that considerably greater reduction in the transmitted sound is usually necessary for satisfactory results than is possible to obtain by acoustical treatment alone. Playback rooms should be free from extraneous noise and by the same token should not transmit noise to adjacent areas.

### Construction

Both from an acoustical and economical standpoint the cubical content of a playback or demonstration room should be consistent with the required end for which it is to be used.

(Continued on page 165)

Fig. 3. (A) Details of a felt or rubber gasket installation for use around door jambs. (B) Construction details for a threshold-closer for playback booth. (C) One method of constructing sound insulated windows to be used between booths or on door of playback room.

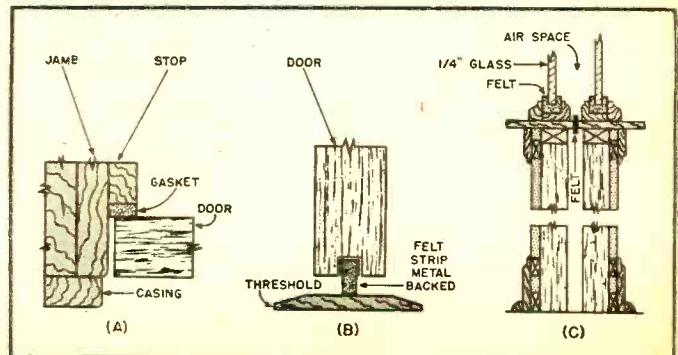

# All Wave SIGNAL GENERATOR

By

A. A. GOLDBERG, W2HKU

***This easy-to-build signal generator covers 400 kc. to 25 mc. in seven ranges.***

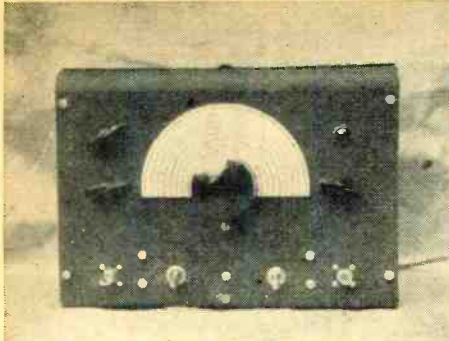

Front panel shows neat layout arrangement.

It is important that the r.f. section be well shielded. Aluminum is used in the construction of entire housing.

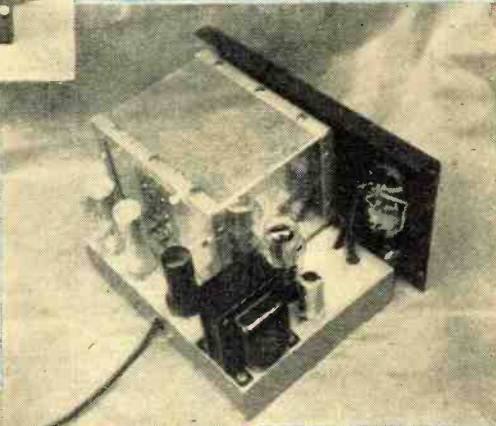

Metal housing has been removed to show details of the r.f. section. Coils of the various bands are all connected in the circuit and then selected by means of a rotary type switch.

bration. The main tuning dial in the described signal generator is a "home brew" as the aforementioned dials were too large. With mechanical modification, however, the "store bought" variety may be used.

Many signal generators are guilty of crowding in the higher frequencies. This is brought about by the use of the same tuning capacity for all bands. It is, of course, possible to design an r.f. section that will cover all frequencies with only three bands. The two lower bands are satisfactory but the highest is practically useless because of frequency crowding. A total of seven bands and three different tuning capacities cover the frequency range of 400 kc. to 25 mc.

During recent years, the trend has been toward low impedance r.f. outputs. Although it is true that high r.f. voltages are difficult to obtain with a low impedance loading, levels above 100 millivolts are rarely used. One advantage of a low impedance output is that a more efficient and smoother attenuator can be designed because of less capacity leakage. A second reason is that a low impedance coaxial cable may be used for introducing the r.f. into the apparatus being worked on. At the higher radio frequencies, there is difficulty in transferring the r.f. to the receiver without introducing resonance effects. This may be corrected by terminating the low impedance coaxial cable with a resistor equal to the cable's characteristic impedance.

Oscillator stability depends, to a large degree, upon the steadiness of the plate and screen voltages being applied. A well regulated power supply and voltage regulator tube makes for smooth, stable plate power.

Good r.f. shielding is necessary in a signal generator. If r.f. leakage exists to any degree, erratic and incor-

**S**IGNAL generators have been used since the advent of radio. When radio frequency circuits are to be aligned and peaked, a constant, calibrated source of r.f. voltage is necessary. Means must be made to alter the voltage output from zero to full voltage in a smooth and precise manner. An a.f. modulator is useful for providing modulated r.f. Most readers are familiar with this serviceable test equipment item and the uses to which it may be put.

This signal generator was designed and built while test equipment was still scarce. It is the author's contention that, for the average experimenter, a good commercial instrument is the better investment. For those who may like to "roll their own," here it is.

Certain requirements had to be met in the design of this signal generator: 1—Simplicity, 2—Dial directly calibrated in frequency, 3—Low, constant

impedance output, 4—Good band-spread, 5—Good shielding, 6—Voltage regulated power supply.

The first requirement of simplicity is met by omitting a calibrated voltage output. Voltage calibration usually cannot be relied upon over a period of time. A separate v.t.v.m. may be used for this purpose. By using iron core tuned coils, trimmer capacitors are eliminated. Several contemplated economies, such as a transformerless power supply and omission of voltage regulation were rejected since the gain far outweighed the saving.

Unlike a frequency meter, the signal generator does not require extremely accurate frequency calibration. The convenience of a directly calibrated dial rather than the calibration curve chart method can only be appreciated by those who use the instrument continuously. Dials like the *National* ACN and *Bud* No. D-1729 allow direct cali-



rect results may occur. For example, if a high gain i.f. amplifier is being checked for gain, it is important that a known voltage input to the amplifier be compared to the amplifier output voltage. If uncontrollable r.f. due to generator leakage exists in the vicinity, it is obvious that a correct measurement cannot be obtained. Another objectionable result of r.f. leakage is the limiting of the output attenuation. When 100 microvolts leakage exists, the minimum signal from the generator cannot be any less than this amount, regardless of attenuator setting.

The two points through which the r.f. leakage can occur are through the line cord and through the generator shield. A low pass filter will adequately take care of line leakage. Leakage because of defective shielding can be minimized by correct shield design. The principal considerations are:

1. Shielding be of sufficient thickness and good r.f. conductivity, such as copper or aluminum. Iron, unless copper plated, is inefficient as an r.f. shield.
2. Bring all grounds within the shield to a common point, thus minimizing shield currents.
3. Use filters on all outgoing leads such as filament, plate, etc. Good shielding is of no avail if radiating "antennas" are projecting outside.
4. Spaced, concentric shields that are connected together electrically at only one point.

A 6AK6 midget power pentode is used as the r.f. oscillator. For the sake of stability, an electron-coupled oscillator circuit is employed. With only 150 volts on the plate and screen, drift due to heating is kept at a minimum. Any lower voltage would tend to prevent an adequate r.f. voltage across the low impedance output load.

Although a straight line capacity tuning capacitor is used, much less frequency crowding at the high end of each band would occur with a straight line frequency or wavelength capacitor. By means of two extra wafers on the bandswitch, the main tuning capacity is 280  $\mu\text{f.d.}$ , 140  $\mu\text{f.d.}$ , or 70  $\mu\text{f.d.}$  In the three lowest bands, both sections of the capacitor are in parallel. For the fourth band, only one 140  $\mu\text{f.d.}$  section is used. In the three highest bands, both sections are in series, providing an effective tuning capacity of 70  $\mu\text{f.d.}$

In order to prevent the unused coils from resonating and causing dead spots, a shorting type wafer (wafer A) grounds all coils except the one in use.

The attenuator has been calculated to provide a nearly constant, low input and output impedance. With the values shown, the input impedance varies between 75 to 95 ohms, approximately. The output impedance ranges from 75 to 115 ohms.

Notice that the output coupling capacitor is only .001  $\mu\text{f.d.}$  and works into the low impedance attenuator load. This value of capacity attenuates the low frequencies where the r.f. oscil-

lator output is greater and, inversely, has less attenuation for the higher frequencies where the generated r.f. is weaker. The result is a more constant r.f. output with changes in frequency.

Radio frequency chokes do not have a constant high impedance to changing frequencies, the reason being that the choke's inductance and the capacity across it, both distributed and external, cause resonance and anti-resonance effects. The plate load r.f. choke, being no exception, would cause the r.f. output voltage to vary considerably as the dial was tuned across the band. One method of eliminating this annoying effect is to lower the "Q" of the choke with a low shunt resistance. This is taken care of automatically by the low input impedance of the attenuator.

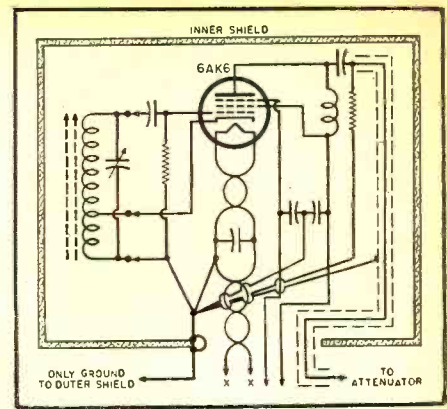

As illustrated in the diagram, the author stresses the importance of tying, at one point, all ground leads. This is considered good practice in any instrument.

Schematic diagram of signal generator. In order to simplify the drawing only one coil (L) is shown. Coils for other six ranges must be similarly wired to switch.

- $R_1, R_2$ —50,000 ohm,  $\frac{1}{2}$  w. res.
- $R_3$ —100 ohm,  $\frac{1}{2}$  w. res.
- $R_4$ —2000 ohm pot.
- $R_5, R_6, R_7, R_8, R_9, R_{10}, R_{11}, R_{12}, R_{13}$ —200 ohm,  $\frac{1}{2}$  w. res.
- $R_{14}$ —100,000 ohm,  $\frac{1}{2}$  w. res.
- $R_{15}$ —10,000 ohm,  $\frac{1}{2}$  w. res.
- $R_{16}$ —4700 ohm, 1 w. res.
- $R_{17}$ —9000 ohm, 10 w. res.
- $C_1, C_2$ —Dual 140  $\mu\text{f.d.}$  var. cond.
- $C_3$ —250  $\mu\text{f.d.}$  mica cond.
- $C_4$ —.01  $\mu\text{f.d.}$ , 200 v. cond.
- $C_5, C_{11}, C_{13}, C_{14}$ —.006  $\mu\text{f.d.}$ , 400 v. cond.
- $C_6, C_{12}, C_{15}$ —.01  $\mu\text{f.d.}$ , 400 v. cond.
- $C_7$ —.001  $\mu\text{f.d.}$ , 400 v. cond.
- $C_{10}, C_{17}$ —40  $\mu\text{f.d.}$ , 400 v. cond.
- $S_{1a}, S_{1b}, S_{1c}, S_{1d}$ —4 pole, 7 pos. sw.
- $S_2$ —S.p., 5 pos. sw.
- $S_3, S_4$ —S.p.s.t. sw.

- $RFC_1, RFC_2$ —2.5 mh., r.f. choke
- $RFC_3, RFC_4$ —100  $\mu\text{h.}$ , r.f. choke
- $CH$ —15 hy., 50 ma. filter choke
- $T_1$ —Power trans., 300-0-300 @ 50 ma., 5 v. @ 2 amp., 6.3 v. @ 1 amp.
- $T_2$ —Audio trans., 3:1 ratio
- $F_1$ —1 amp., 115 v. fuse
- 1—6AK6 tube
- 1—6C4 tube
- 1—5W4 tube
- 1—VR150 tube
- L—400-800 kc., 2.5 mh. r.f. choke;
  - 8-1.8 mc., 125 to 350 mh. iron core coil;
  - 1.5-4.2 mc., 50 to 125  $\mu\text{h.}$ , iron core coil;
  - 4-8.5 mc., 26 turns, iron core coil;
  - 8-12 mc., 17 turns, iron core coil;
  - 11.5-17.5 mc., 14 turns, iron core coil;
  - 17-25 mc., self-supporting #16 wire, 12 turns

Since the 400-800 kc. and the 17-25 mc. coils do not have iron cores, small variable ceramic trimmers are used. A 25  $\mu\text{f.d.}$  size is used across the 400-800 kc. coil while a 5  $\mu\text{f.d.}$  size is used for the 17-25 mc. coil. All coils are tapped approximately  $\frac{1}{3}$  up from ground end for cathode tap.

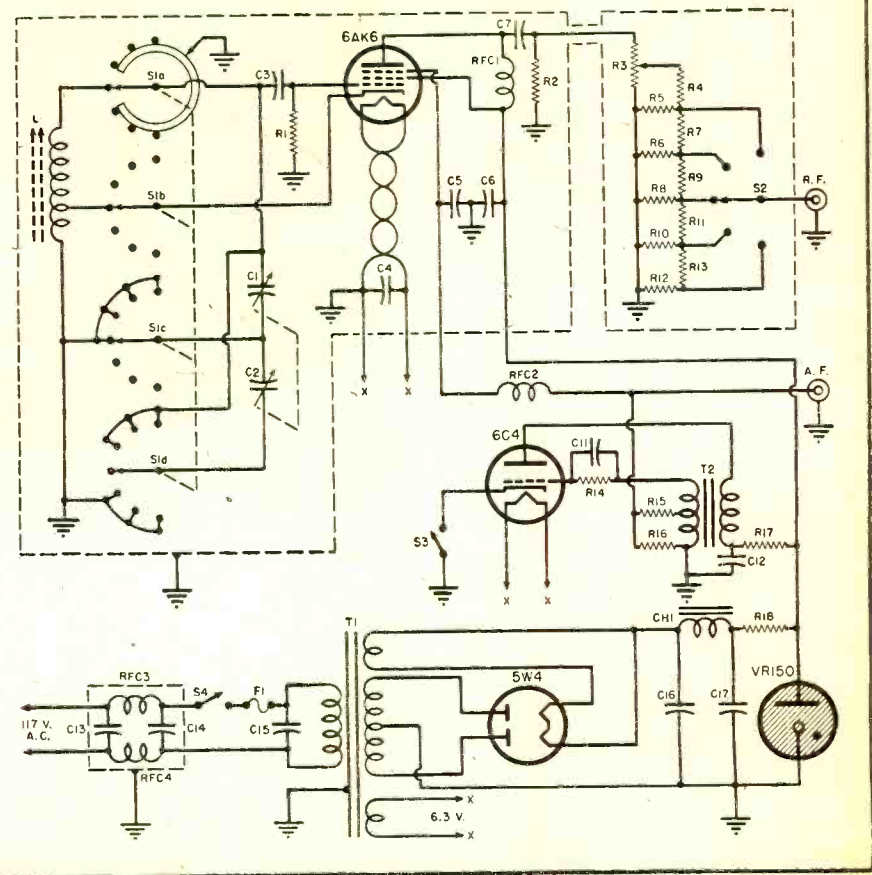

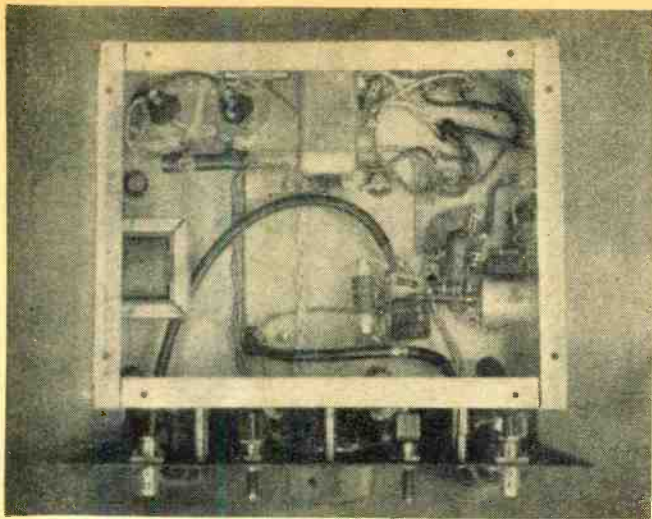

Under chassis view of completed all-wave signal generator.

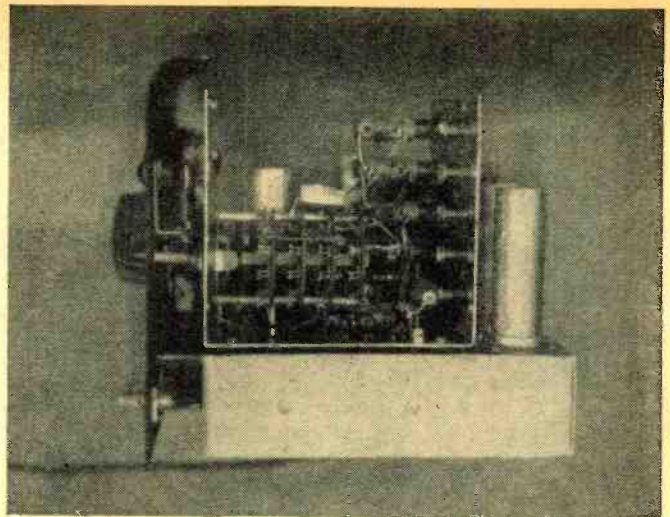

Side view shows details of the coil and switch assembly.

Suppressor grid a.f. modulation is used. The audio is applied to the suppressor through a 10:1 step-down voltage divider and through a low pass, r.f. filter being made up of a 2.5 millihenry choke and a .006  $\mu$ fd. mica capacitor. The suppressor grid is also brought out to a coaxial receptacle on the front panel. This serves two purposes: the first; to provide a means of externally modulating the r.f. oscillator, the second; to provide a handy source of fixed frequency a.f. for audio test work.

The a.c. power line is filtered through a "pi" network consisting of two 100 microhenry chokes and two .006  $\mu$ fd.

mica capacitors. Be certain that the r.f. chokes will carry the 450 ma. line current.

The signal generator, complete with power supply, is self contained in an outer metal box, (Par-Metal CA102), that measures 7 $\frac{1}{4}$ " high, 10" wide and 8" deep. In laying out the front panel, a symmetrical layout is achieved without the sacrifice of efficiency. In the center is the main dial with paper scale cemented on the metal panel. A Velvet Vernier movement was stolen from an old National Type A dial that was kicking around the junk box. This movement, with home made plastic pointer attached, is fastened to the

front panel. If care is taken to draw the various lines neatly with India ink and, as a finishing touch, color alternate frequency bands for clarity, a professional looking job results.

The 7" x 9" x 2" zinc plated chassis made for the previously mentioned cabinet is punched and drilled as shown on page 124. Make a full size template layout on heavy paper stock, indicating all hole centers. Fasten the template on the chassis with scotch tape and center punch all holes directly through the template. Following this procedure will guarantee a neat, accurate job. As a precaution, check the tube socket mounting hole centers before center punching as a slight variation exists with different sockets.

Making the aluminum shield box for the r.f. oscillator will be the most difficult mechanical task. Lay out the two "U" shaped sections by first cutting each to size, then center punching as directed for the chassis. After all the drilling is accomplished, bend each section carefully. Set two pieces of angle iron in a vise and carefully bend the aluminum by pounding with a wooden mallet. A word of caution, be sure a grade of soft aluminum is used since tempered aluminum or dural, plentiful as war surplus, will crack when sharply bent.

Although not shown in the photos, the attenuator has since been enclosed in a small shield box made of aluminum, to reduce leakage.

Install plastic grommets in the four chassis holes that will support the r.f. shield. The shield is mounted on top of the grommets by means of bolts and nuts. Before mounting the shield, however, install and wire all the oscillator circuits. It is easier to do this while the "U" shaped shield is free and unmounted.

Mount the front panel to the main chassis by means of long bolts and 1" spacers. This is necessary in order to allow enough room for the dial mechanism, coax receptacle and toggle switches.

(Continued on page 124)

Mechanical layout for oscillator shield construction. All unmarked holes should be #18. 16 gauge soft aluminum was used for the shield construction.

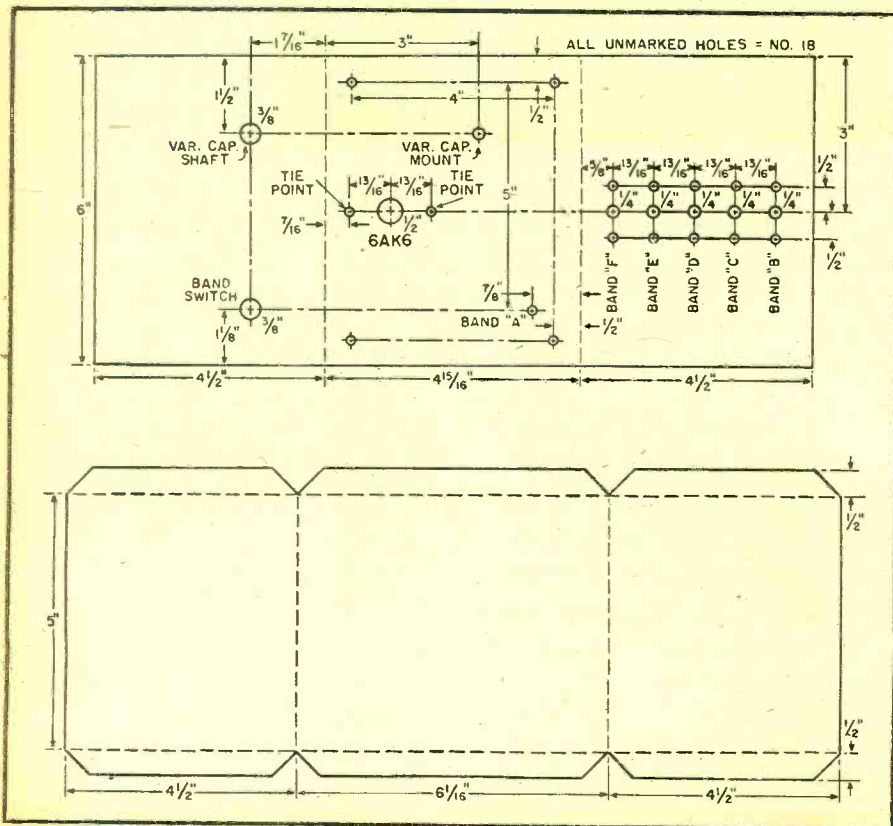

# Converting the SCR-522 TRANSMITTER

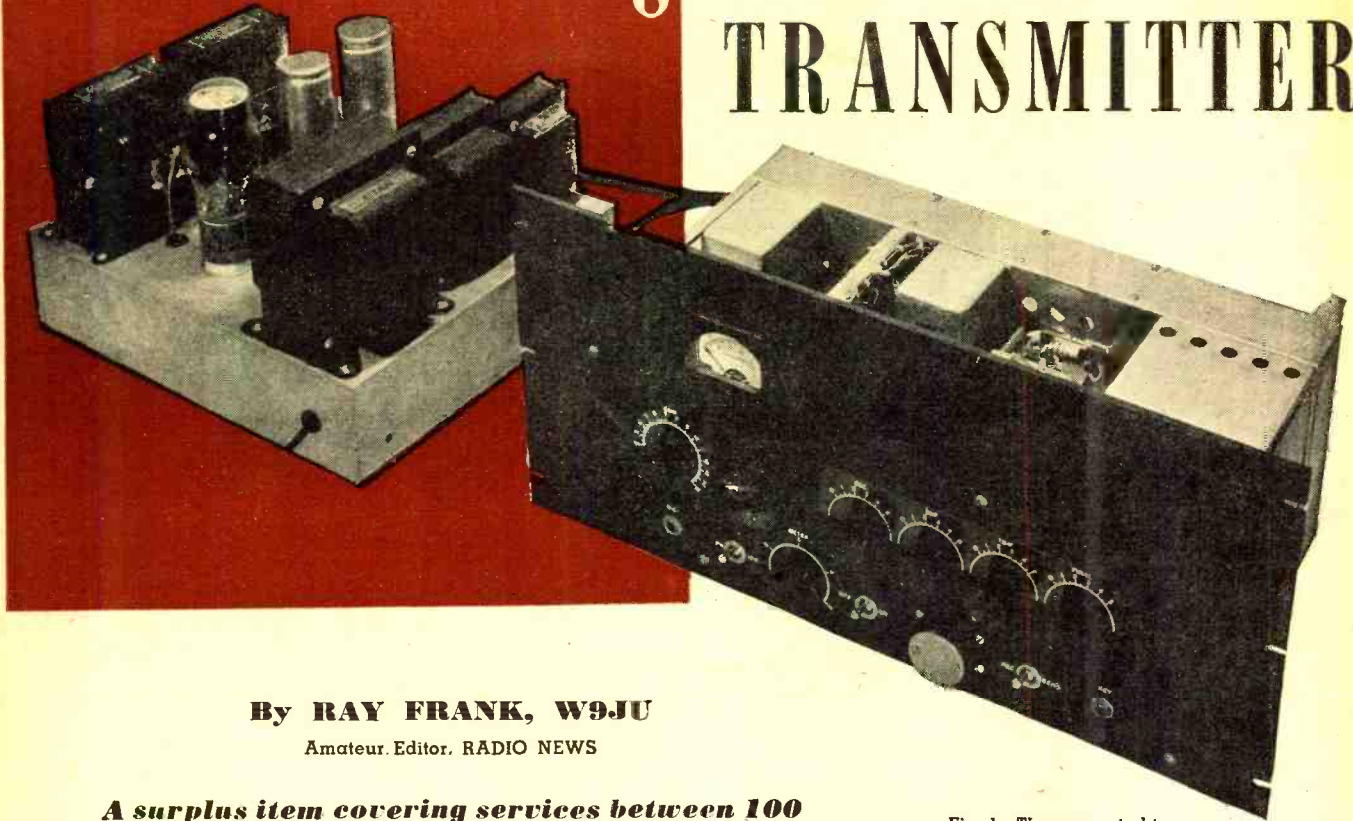

By **RAY FRANK, W9JU**

Amateur Editor, RADIO NEWS

**A surplus item covering services between 100 and 156 mc. Details for converting receiver portion were covered in last month's issue.**

Fig. 1. The converted transmitter. Power supply is built on separate chassis.

**T**HE conversion of the transmitter portion of the SCR-522 is simplicity itself, and consists almost entirely of mechanical alterations for convenience, and the addition of a suitable power supply.

Basically, the transmitter consists of a 6G6G harmonic crystal oscillator, 12A6 harmonic amplifier, 832 tripler, and 832 final. The output of the transmitter is on the 18th harmonic of the crystal used. Modulation of the transmitter is accomplished by a low impedance dynamic microphone, which feeds a 6SS7 speech amplifier, in turn driving push-pull 12A6's as modulators. A form of cascade modulation is used with the screen of the 832 tripler modulated simultaneously with the plate and screen of the final. This form of modulation has the effect of increasing the drive to the final on modulation peaks where it is likely to be needed.

For indication of r.f. output, a 6SS7 is connected as a diode, and coupled to the tank circuit of the final. The rectified current through this diode serves as an indication of the relative output, and in addition may be used as a carrier shift indicator, enabling the modulation to be monitored to prevent overmodulation.

A feedback circuit is also provided in which the plate and grid circuits of the 6SS7 speech tube may be coupled

together to allow this tube to oscillate at an audio rate of approximately 1000 cycles. This provides an easy means of tone modulating the transmitter for code operation.

The first step in the conversion is the removal of the transmitter from the case and rack. The red painted

screws holding the transmitter in place should be removed, and a *Bristol* wrench to fit the 8-32 set screws on the flexible couplings procured. When these set screws are loosened, it is possible to remove the frequency shifter slides, taking care that all the

(Continued on page 74)

Fig. 2. Schematic diagram of power supply for 117 volt operation.

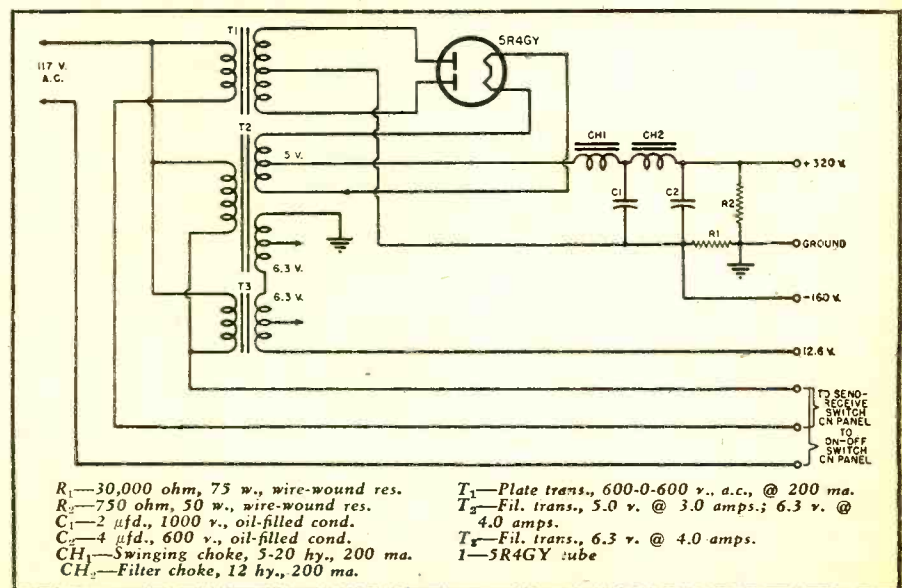

# Try this 1946 TREASURE FINDER

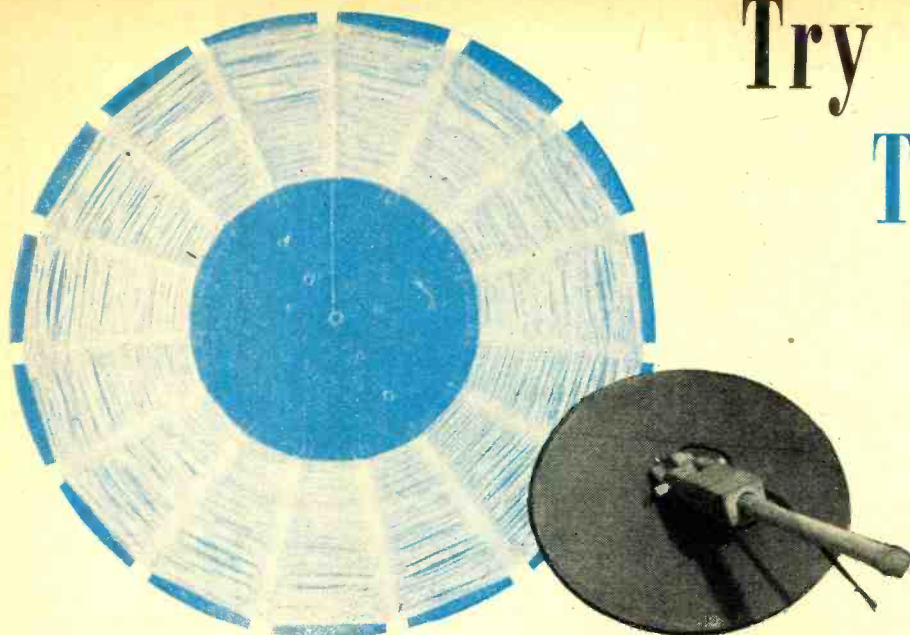

Spiderweb type loop used in search arm.

By

**W. E. OSBORNE**

Gilfillan Bros., Inc.

**This highly sensitive metal locator can spot a copper penny at a distance of three feet.**

**I**N THE design of any portable type of "treasure-finding" equipment, whether for gold or for oil, the potential prospector must always watch, in addition to sensitivity, two other most important points—weight and stability. The question of weight can be most deceiving, and while many experimenters will feel that 25 or 30 pounds is a very modest figure when first setting out, a few hours of toil in really wild country—which is nowadays the only type of country offering a fair chance of success—will usually disillusion the keenest enthusiast.

Batteries are, of course, responsible for most of the weight in the majority of locators, and it will be found preferable—even though more expensive—to use very light-duty batteries, and replace these frequently from spares kept in the camp.

Regarding stability, many factors are involved. These include frequency used, type of meter (if any) and degree of sensitivity required. A locator may be aligned in the workshop and perform very well around the front garden, but when climbing over rocky territory or uneven ground a very dif-

ferent situation arises. From the physical angle, a delicate meter will flicker uncertainly; high frequencies will provide false readings from nearby moisture or green foliage, while a highly sensitive locator, such as the beat-frequency type, needs a lot of practice, very careful handling, and constant resetting to zero beat, as every bit of conductive ore is recorded as a "find."

Since the war's end the conversion of military types of mine detectors to civilian use has proceeded rapidly. This is especially so in the case of the light and portable b.f.o. type (described below) and the more powerful radar or pulsed locators, which being heavier, are usually vehicle-mounted.

The total weight of the little unit to be described is only about 12 pounds, including antenna, and using very light-duty "A" and "B" batteries. The range, using a copper penny as a standard, is in the vicinity of three feet, while with larger pieces of metal up to ten feet has been recorded. The "pancake" type of loop antenna is employed and this is mounted on an 8-foot bamboo pole.

A beat-frequency circuit is used, consisting of two 1G4 oscillators, one fixed and one variable. The output of these is fed into the two control-grids of a pentagrid mixer which is a 1R5 miniature type. From here the difference frequency is filtered out and applied to the diode plate of a 1S5, also a miniature. After rectification and more filtering the signal is fed to the control grid of the pentode portion of this tube which normally is held at a little above cut-off point by a potentiometer. This pot, incidentally, constitutes one of the two main controls on the unit.

With the locator in a "search" condition, that is, with no other conductive material in the vicinity, the vari-

Fig. 1. Diagram of metal locator. Beat frequency oscillator principle is used.

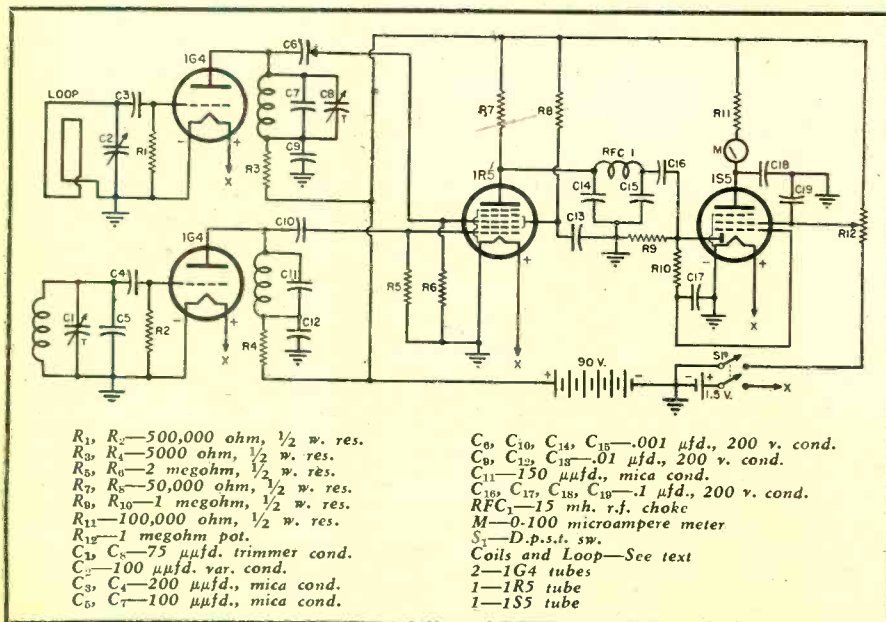

able oscillator (with the loop antenna as its grid inductance) is set at zero beat, i.e., to the exact frequency of the fixed oscillator. In this condition there will naturally be no output from the mixer tube. However, as soon as the loop approaches a metallic object, the frequency of this oscillator changes, and a difference frequency (as well as a "sum" frequency, which we disregard and filter out) appears at the mixer output. After negotiating a low-pass filter, this difference frequency is rectified negatively by the diode, and the resulting potential, being now pure d.c., brings the grid of the output tube right down to cut-off, providing meter indication at the same time.

With careful layout and wiring the difference frequency can actually be registered down to four or five cycles or less, thus providing visual pulsing of the meter needle. This condition is, of course, one of extreme sensitivity as far as the loop antenna is concerned.

Now to the actual building of the unit. A chassis of 18 or 20 gauge aluminum is required, the size being 7" x 5 1/4" x 2 1/4" high, but a larger size may, of course, be used if desired.

Complete shielding and isolation of the two oscillators is highly essential, and is quite simply accomplished by two aluminum shields, dividing the chassis into three parts as seen in the accompanying photographs. Careful wiring is, of course, necessary especially in the case of the signal leads between oscillator plates and mixer grids. These wires are shielded in flexible braid.

The signal frequency is of the order of 80 kc. and tuned-grid, tuned-plate oscillators are employed. It may be well to mention here that in comparison with the Hartley type of oscillator two extra coils were used. However, the Hartley requires three leads out to the loop antenna against the present two, and as these leads must be shielded in both cases, a lot of self-capacity trouble was avoided.

Three inductances are therefore required, of approximately 25 millihenries each. This value corresponds very nearly to that of certain standard r.f. chokes, but in case the reader possesses coil-winding facilities, 750 turns of 5/43 Litz wire, honeycomb wound on a 1/2" diameter former, will fill the bill. The coil width is 1/2", and the finished job is soaked in hot wax.

A suggested layout, as used in the original model, is shown in Fig. 2. Only one variable condenser is necessary (midget type, 75 or 100  $\mu\text{fd}$ . max.) plus two mica adjustable trimmers. In the original model one of these trimmers (plate circuit, variable oscillator) possessed a shaft instead of the usual screw-driver adjustment, so it was given a knob and mounted on the panel, but this is not absolutely necessary. The fixed oscillator trimmer (grid circuit) must never be varied after setting up for maximum oscillation.

After wiring, first test for oscilla-

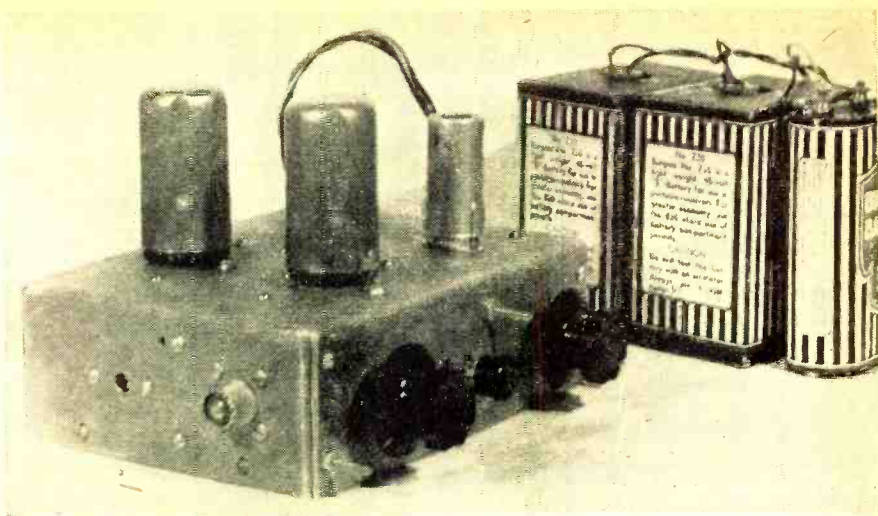

Front-side view of completed instrument. Panel has been removed to show detail.

tion with a midget neon bulb of the 991 type. There is usually enough r.f. to light the bulb simply by holding it near the r.f. coils. If not, solder a two-inch piece of wire onto one of the two bulb connections, and touch this wire on the output connections of the two oscillators in turn (or on the mixer grid terminals), at the same time adjusting the trimmers. A meter in the grid circuit of the oscillators will also serve the same purpose. As the mixer tube tends to load down the oscillators, a small fixed condenser of 5 or 10  $\mu\text{fd}$ ., connected between plate and grid of each 1G4, is often necessary to force oscillation.

The output meter, which is the sole indicator when searching for precious metals, should obviously be as sensitive as possible. However, a word of caution is necessary, as when walking over rough ground, the physical jolting will cause a 50  $\mu\text{a}$ . needle to flicker a good deal, while on the other hand, a 1 milliamperer movement, while better from the physical angle, is hardly as sensitive as could be desired.

A compromise is therefore neces-

sary, and the writer recommends a 100 or 200  $\mu\text{a}$ . meter, although if the reader has a 1/2 or 1 milliamperer unit on hand, by all means use it.

After oscillation has been established, set the meter to nearly full scale by adjustment of the output potentiometer. This controls screen and plate current almost to cut-off point. Now rotate the variable condenser very slowly and watch for meter indication back towards zero reading. If the two oscillator frequencies are approximately correct, an indication can easily be obtained either side of zero beat. However, the sensitivity here is very poor. The operator must watch for a small "kick" of the meter needle in the center of these two readings, and then "nurse" this by careful tuning to a full scale movement, or nearly so. This is zero beat, and the unit is now in a highly sensitive condition—so much so in fact, that a movement of the hand several feet from the loop will cause a deflection.

A metal cover for the bottom of the  
(Continued on page 143)

Under-chassis view of metal locator shows placement of various component parts.

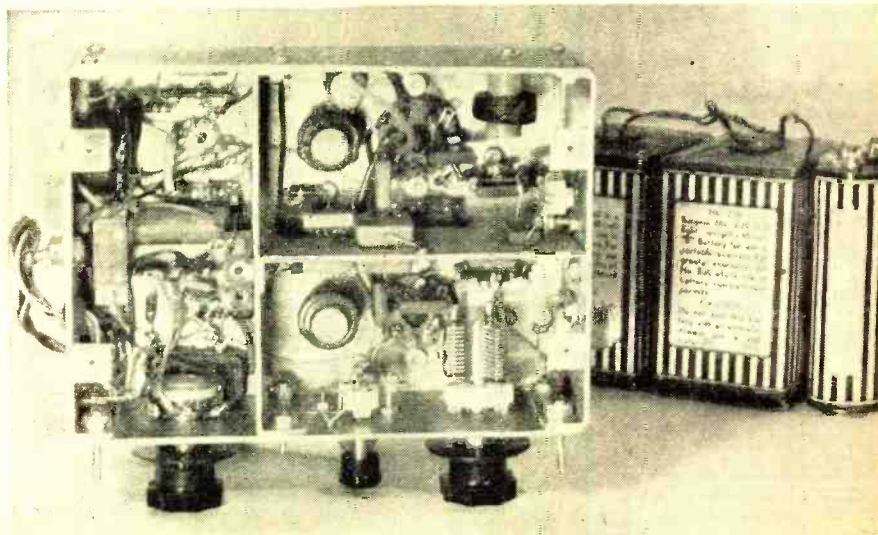

QTC

By CARL COLEMAN

**J**AMES MCKINLEY was recently assigned to a "Cape" out of the East Coast and expects to be calling back shortly. Joseph Lewinski in town recently with his Matson Line Liberty. James E. Quinn just in after a four months trip aboard his Liberty. Fred Pratt relieved aboard a "Knot" by Neal Cofer and signed aboard another "Coastal" type craft. Henry E. Young relieved of his berth aboard a Liberty in order to attend the Sheepshead Bay radar training school. . . . John D. Ayres assigned to a "Knot" at Philadelphia. . . . Fred Howe, General Secretary-Treasurer of The Radio Officers Union, sends along some information that may be of interest to many. We are still receiving inquiries from Armed Forces members seeking advice on jobs in civilian life. . . . If you are interested in a good paying job as a Flight Radio Officer, ground radio operator or radio mechanic, write or call on any of the following: Andrew R. McKelvie, Trans Ocean Airways, Oakland Airport, Oakland, Calif.; Harrison Young, American Overseas Airlines, LaGuardia Field, N. Y.; Lester Rodman of TWA at LaGuardia Field, N. Y.; American Airlines, 100 E. 42nd St., N.Y.C.; Pan American Airways, LaGuardia Field or Miami, Fla.; TWA National Airport, Washington, D. C.; Pan American Grace Airways, Chrysler Bldg., New York, N. Y.; Pan American Airways, San Francisco; Matson Lines, Oakland Airport, Oakland, Calif.; Northwest Airlines, Municipal Airport, Seattle, Wash; Pennsylvania Central Airlines, National Airport, Washington, D. C.; National Airlines, Municipal Airport, Miami, Fla.—the last named has ground jobs only. . . . Trans Ocean Airways needs, at this writ-

ing, about 150 radio operators, mostly for ground work in Alaska. They want these men now. Wages are \$475 per month. Transportation paid and return transportation will be furnished after three months if you don't like the job. American Overseas Airlines wants flight radiomen; wages run from \$275 to \$500 per month. . . . TWA wants ground radio operators. When contacting the above airlines give your age, class of license, experience, education and various other qualifications.

And speaking of airlines—the Navy has recently offered the airways a portion of Floyd Bennett Field, New York for commercial aviation in order to relieve the congestion at LaGuardia—If such an offer is taken up by the airlines the proposed new Idlewild Airport would be reduced in importance.

**H**ARRY WEISS has joined the marine service field in New York. Galfrid Summerson arrived in the Gulf recently. Ronald Bradley aboard a cargo craft again. Robert Williams



has a new, fast cargo ship. L. Hvidsten has resigned his marine service position and reportedly is engaged in the home service field. C. E. Williams still around town working as hard as ever.

**U**NDER the sponsorship of the Bureau of Ships (Navy) the Electronics Lab at San Diego has started work on a half million dollar project to study the effects of weather changes on radio transmissions in the various high-frequency bands. . . . It is expected that out of the study will come a method of extending the present day range of ultra short wave radio and radar transmissions. . . . It is believed that the range of television, for example, will be jumped up from the present one hundred fifty miles to nearly two thousand. . . . So far the fact has been disclosed that the project has advanced to a stage where atmospheric changes are detected much quicker than with meteorological instruments although no positive weather forecasting is as yet possible. . . . Stations set up at bases about twenty-five miles apart have been fitted with weather instruments for studying the effect on high-frequency transmissions.

**J**OHAN HANSON arrived recently at the big town aboard a Liberty and expects to be around town for some time. . . . Charlie Sparks in and about recently as his craft (cargo) is on the redelivery list to WSA. Ernest S. Bailey ashore from his "Knot" after it also was redelivered back to Uncle. . . . M. Meade in at the West Coast recently after traveling the Pacific for some time. . . . V. A. Smith and T. Mallonee are with HM. H. J. Mariani also another West Coast arrival with F. P. Whiting and F. E. Jones also along as second and third aboard his "Marine." . . . Harold Koch, marine serviceman at Charleston enjoying a vacation back "home" in the Mid-West.

**M**ANY operating companies, using government owned vessels which they have been running on a charter arrangement from the U. S. Maritime Commission, have been returning them since the new announcement effective the end of August which will allow the government a larger share of the profits and less to the steamship operator. . . . Formerly the arrangement was a 50-50 proposition whereby the government could claim 50 per-cent of the daily earnings of the vessels chartered out . . . under the new set-up the charter hire payable will be 50 per-cent of the average net voyage profit up to the first one hundred dollars per day which is in excess of 10 percent of the charter's capital necessarily employed in the business . . . 75 per-cent of the next \$200 per day and 90 per-cent of all net voyage profits in excess of \$300 per day. . . . This means that on a voyage that nets a vessel \$800 per day the U.S. gets \$650 and the operator \$150—the steamship operator taking  
(Continued on page 86)

# New TRANSMITTER For Amateur Radio

By

W. BRUENE, WØTTK, and N. HALE, WØJH  
Collins Radio Company

**Introducing the salient features of a new transmitter which is designed to fulfill the needs of a large part of the medium-power ham fraternity.**

**T**HE new Collins 30K has many features that are considered highly desirable in amateur radio. A large number of the more than seventy-five hams in the Collins organization had a voice in its specifications. After thorough consideration of all their suggestions, the design engineer selected the following as the features that could be included consistent with versatility and economy:

1. 500 watts input on c.w., somewhat less on phone;
2. single ended output;
3. complete neutralization on all bands;
4. low driving power;
5. bandswitching;
6. v.f.o. control, highly accurate and stable;
7. fixed bias;
8. electronic keying;
9. minimum power supplies;
10. high efficiency;
11. high level class "B" modulation;
12. speech clipper;
13. low pass audio filter;
14. single control operation;
15. accessibility for operation and maintenance.

The result is a versatile, thoroughly engineered transmitter with high performance and easy operation. A more detailed description of the circuit and components follows.

1. *Power input.* A power input of 500 watts on c.w. and 375 watts on phone was chosen because it is obtainable with low exciter power requirements, moderate tube costs, and economical power supply design. The 115 volt, 60 cycle a.c. power consumed by a transmitter of this size does not require special wiring.

2. *Single ended r.f. stage.* An Eimac 4-125A is used in the final r.f. stage. This tube is admirably suited to features 1 and 2. Using one tube in a single ended output greatly simplifies bandswitching, since only one end of each coil is switched. The 4-125A, a notable advance in beam power tetrode development, easily handles the desired power. Its high efficiency



Skillful design is combined with sturdy construction in this Collins 30K transmitter.

(75% to 80%) assures maximum power output. The grid driving power required is well below 10 watts and can be supplied from a low powered exciter setting on the operating desk.

3. *Neutralization.* The 4-125A is again suited to the purpose. It requires no neutralization, even on 10

meters. Thus the circuit is simplified and a clean signal is transmitted on all bands.

4. *Low driving power.* Discussed under the second feature.

5. *Bandswitching.* The 30K has bandswitching throughout, so that the operator can change bands quickly. (Continued on page 110)

Clipper circuit employed in transmitter.

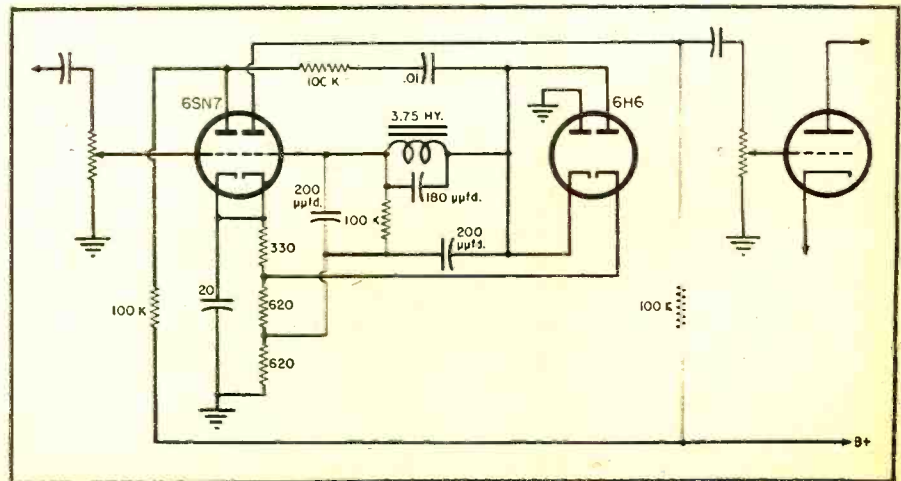

# 200 watt All-band TRANSMITTER

By  
**HARRY D. HOOTON,**  
W8KPX

**An easily constructed unit incorporating either crystal or v.f.o. control for 10, 20, 40, and 80 meter bands.**

**T**HIS 200-watt transmitter operates with full input on the four amateur bands from 80 to 10 meters. Designed especially as a flexible exciter unit for use with experimental high-power radio frequency amplifiers, it is, nevertheless, an excellent medium power rig in itself. The unit is constructed completely from standard manufactured components and uses inexpensive easy-to-get tubes. It is ideal for the fellow who wants a good, simple, foolproof transmitter that is free from "bugs" yet capable of producing a husky signal on either phone or code operation.

As the photographs and Fig. 3 show, the circuit has been reduced to bare essentials. There are no frills to run up the cost of construction or trick circuits to cause trouble. The tube lineup consists of a 6L6GA which may be used as either a first doubler or as

a crystal controlled oscillator, a 6L6GA second doubler and a pair of 809 triodes as push-pull final r.f. amplifier. The author uses a Meissner "Signal Shifter" for variable-frequency operation; the 6L6GA input tube has a tuned circuit connected between its control grid and cathode, the output from the "Signal Shifter" being connected through a low-impedance line to the grid coil link. If crystal control is desired, the connections should be made as shown in Fig. 1B. The tuning adjustments for both crystal-controlled and v.f.o. operation will be discussed in detail later in this article.

Two power supplies will be required—one capable of supplying 400 volts d.c. at 150 milliamperes for the plates and screens of the 6L6GA tubes; the other must supply 1000 volts d.c. at 250 milliamperes for the plates of the push-pull 809 power amplifier.

Table 1. Approximate dial readings for the various bands.

Band	1st doubler plate	2nd doubler plate	Final amp. plate
80 m.	not used	50	67
40 m.	not used	50	52
20 m.	24	15	30
10 m.	20	3	31

Note: The dial readings given above are approximate only. If components other than those specified are used, the dial readings may vary considerably from the values given.

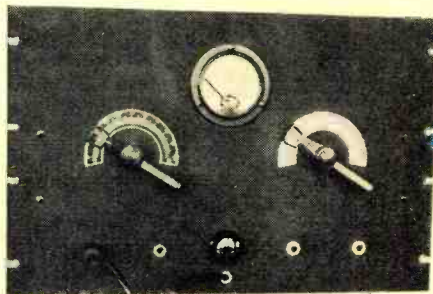
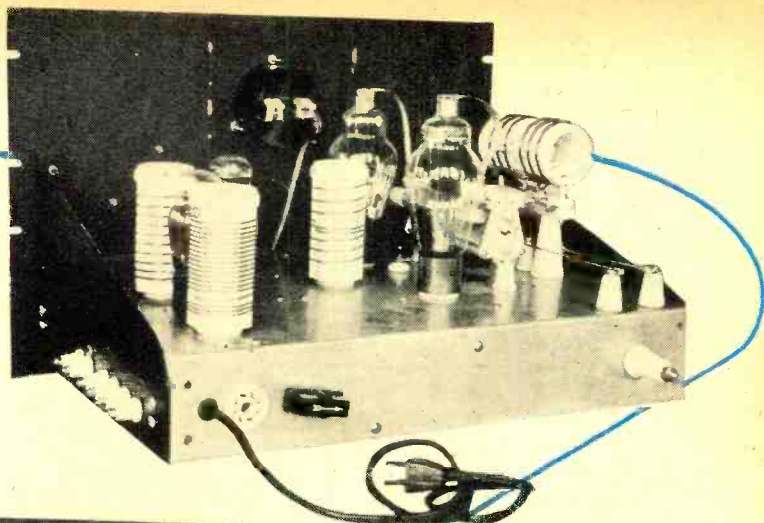

Rear view (above) and front view (left) of the r.f. portion of the transmitter.

The construction of the unit is extremely simple. As the photographs show, it is built up on a standard 13 by 17 by 3 inch cadmium-plated, heavy-duty steel chassis and a standard 12¼ by 19 by ½ inch aluminum rack panel. The aluminum panel is much easier to work than the corresponding steel type. The 6L6GA and 809 tubes, the plug-in coils, the first doubler plate tank condenser and the 809 final tank condenser are mounted on top of the chassis; the 6L6GA input tuning condenser, the second doubler plate tank condenser, the neutralizing condensers, the 809 filament transformer and the various bypass condensers, r.f. chokes and resistors are underneath the chassis. As the bottom view shows, twisted pair leads extend from the small porcelain feed-through insulators, along the end of the chassis, to the link connections of the 6L6GA input, the first doubler output, and the second doubler output coils. By attaching the v.f.o. low impedance output line to the pair of feed-through insulators nearest the rear of the chassis, excitation will be applied to the grid of the 6L6GA input or first doubler tube; a connection to the center pair of insulators will supply excitation to the grid of the 6L6GA second doubler tube; a connection to the third pair of insulators feeds excitation directly to the grid circuit of the push-pull 809s. The 6L6GA tubes are supplied with filament and plate voltage from the 400-volt power supply through an 8-prong plug and cable arrangement; the octal socket for the power connection is mounted in the back of the chassis at the extreme left. The large cone insulator at the extreme right rear of the chassis is the connection for the 1000 volt 809 plate supply lead.

The wiring between the various



parts of the transmitter must be kept short and direct. Use #14 tinned copper round bus wire for the r.f. leads. Do not make sharp bends in the plate or grid leads; keep these leads well separated and away from the chassis. The low impedance leads, such as the filament wiring and the link lines between the feed-through insulators and the links of the various coils, may be made of insulated stranded wire and twisted and dressed close to the chassis to reduce their fields. Needless to say all connections are carefully soldered with rosin-core solder and a clean, hot and well-tinned iron.

On the front of the panel, the large pointer and scale control is that of the 809 final amplifier plate tank circuit; the control at the right is that of the first doubler plate tank circuit. In order to reduce losses to the minimum, the second doubler plate tank condenser is mounted underneath the chassis close to the plug-in coil socket and the 809 grid terminals. The small round knob at the bottom of the front panel is the control for this circuit. The control knob for the tuned input circuit of the first 6L6GA is at the left rear of the chassis, near the octal power socket. It is not necessary to bring this control out to the front panel as the "Signal Shifter" supplies sufficient excitation to the 6L6GA grid on any frequency in the 80 or 40 meter bands when the input circuit is adjusted to resonance at the center of the band. The output of the first 6L6GA falls off slightly at the extreme edges of the band but still supplies over five times the amount of excitation required by the second 6L6GA. In general, no readjustment of any control is necessary for frequency changes of one-fourth the bandwidth or less. A single 0-300 d.c. milliammeter, with a length of rubber-covered microphone cable and a phone plug which may be inserted into any one of the four jacks on the front panel, enables the operator to read the various cathode currents or the plate or grid currents of the 809 tubes at will.

The tune-up and operation of the transmitter is simplicity itself. An absorption-type wavemeter, calibrated for the 40, 20 and 10 meter amateur bands, and a small neon lamp will be a great help in getting the transmitter on the air for the first time. As mentioned above, either crystal control or v.f.o. control may be used. We shall first discuss the tune-up, neutralizing and loading procedure using a "Signal Shifter" or a v.f.o. unit such as that described in the March, 1946 issue of RADIO NEWS.

To operate the transmitter on any band from 80 to 10 meters, only two sets of v.f.o. coils will be required—one set for 80 meter output and the other set for 40 meter output. For operation on 10 meters, place the 40 meter output coils in the v.f.o. and adjust the unit to a frequency which, when quadrupled to the 10 meter band, will place the transmitter output on a frequency near the center of the band. Place a 40 meter coil in the first coil

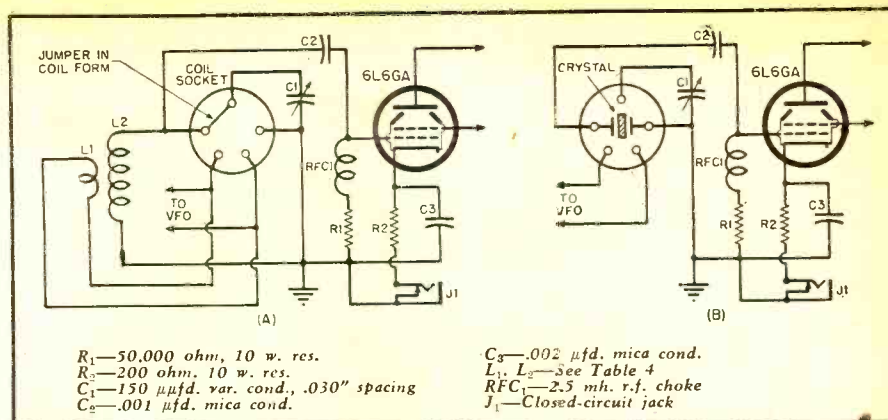

Fig. 1. Connections for (A) v.f.o. and (B) crystal operation.

Band	Xtal	1st 6L6GA plate coil	2nd 6L6GA plate coil	Final amp. plate coil
80 m.	160 m.	160 m.	80 m.	80 m.
40 m.	80 m.	80 m.	40 m.	40 m.
20 m.	40 m.	40 m.	20 m.	20 m.
10 m.	20 m.	20 m.	10 m.	10 m.

Table 2. Coil combinations for crystal controlled operation.

socket at the top rear of the chassis, place a 20 meter coil in the second coil socket and a 10 meter coil in the third coil socket between the second 6L6GA and the 809s. Place a 10 meter coil in the output tank jack bar. Insert an *open* phone plug in the 6L6GA second doubler cathode current jack. *Do not attach the high voltage lead to the 809 plate power connection.* With the 400 volt supply connected to the 6L6GA tubes and with 115 volts a.c.

applied to the 809 filament transformer primary, hold a neon lamp near the input coil and adjust the bar knob at the rear of the chassis for maximum illumination. Now, insert the milliammeter plug in the cathode current jack of the first doubler and tune its plate circuit to resonance. The grid circuit of this tube is tuned to 40 meters and its plate circuit is tuned to 20 meters; the dip in plate current will be quite pronounced.

Under-chassis view of the r.f. portion of the transmitter.

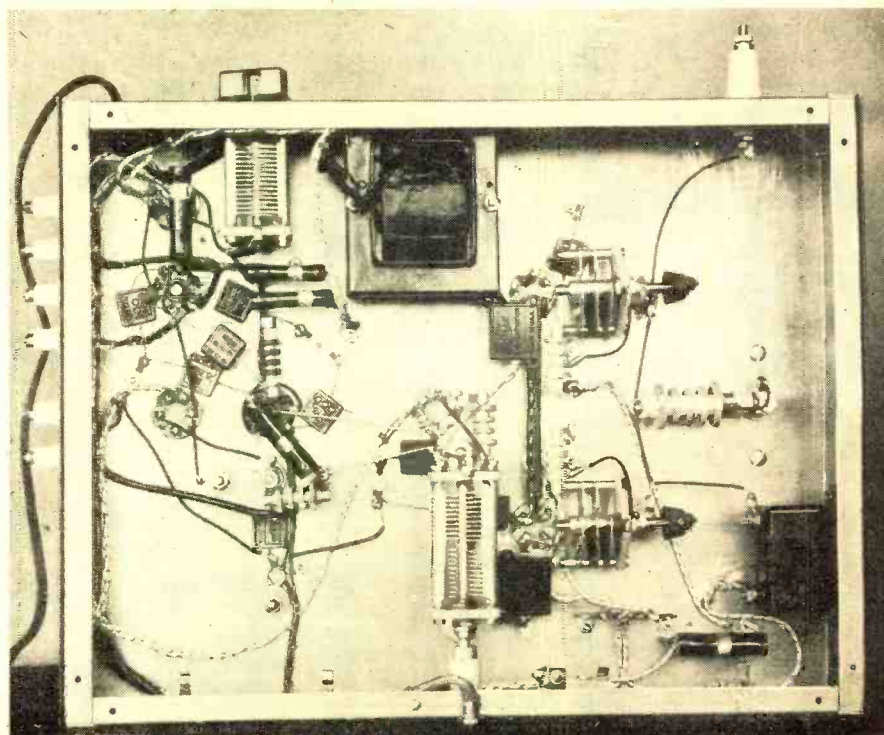



plate voltage can be applied to the 809s the final amplifier stage must be neutralized. This is a very easy operation and need be performed only once if the instructions are carefully followed. First, rotate the two neutralizing condensers to the minimum capacity position. With the 6L6GA second doubler plate circuit tuned for maximum grid current in the 809s, swing the final amplifier plate tank condenser through the point of resonance, at the same time watch the grid current milliammeter. As the tank condenser passes through the point of resonance, the needle of the grid current milliammeter. As the tank condenser passes through the point of resonance, the needle of the grid milliammeter will give a sharp flicker downward. Increase the capacity of the neutralizing condensers slowly until a point is reached where there is no change in the grid current as the plate tank condenser is rotated to any position on its 180° scale. It will be found that increasing the capacity of the neutralizing condensers past this critical point will again cause a change in grid current as the plate tank condenser is rotated through resonance. Once the setting of the neutralizing condensers is found where the plate tank condenser has no effect upon the grid current, tighten the locking nuts of the condensers and leave them alone. Apply the high voltage to the plate circuit of the 809s and tune the plate tank condenser for minimum plate current. The plate current of the 809s will run from 250 to 300 milliamperes or higher when the plate tank circuit is tuned to resonance. Without an antenna, the minimum plate current will be around 5 to 10 milliamperes or less when the amplifier is properly tuned.

Before attaching an antenna to the transmitter, check, in the same manner as described above, to insure that the output circuit is tuned to the 10 meter amateur band. It is relatively easy to mistake the 15 meter dip for the 10 meter dip in 6L6GA plate current and this is the principal reason why the use of an absorption wavemeter is recommended during the preliminary tune-up process. At the time of this writing no 15 meter band has been authorized for amateur use.

After it is ascertained that the transmitter is operating on the proper frequency band, attach the antenna coupling unit or the transmission line to the final plate tank link terminals. The Johnson 660 and 661 plate tank coils contain sufficient turns on their rotary links so that a 600 ohm line or resonant feeders of the proper length, may be connected directly to the output terminals without an output coupling device of any kind. For the preliminary loading adjustment, rotate the link coil for minimum coupling and tune the final amplifier for minimum plate current. Now, rotate the link coil to increase the coupling between the final tank circuit and the antenna; keep the final tank circuit tuned for minimum plate current. Continue to load the amplifier by in-

### COIL-SPECIFICATIONS

Type	Form	Winding Length	No. Turns	Wire Size
651	5-prong 1 3/4" dia.	2 inches	8 pl. 2 link	# 20 enam.
652	5-prong 1 3/4" dia.	2 inches	16 pl. 3 link	# 20 enam.
653	5-prong 1 3/4" dia.	2 inches	32 pl. 4 link	# 20 enam.
640	5-prong 1 3/4" dia.	2 1/4 inches	6 pl. 4 link	# 20 enam.
641	5-prong 1 3/4" dia.	2 1/4 inches	12 pl. 3 link	# 20 enam.
642	5-prong 1 3/4" dia.	2 1/4 inches	24 pl. 3 link	# 20 enam.
643	5-prong 1 3/4" dia.	2 1/4 inches	36 pl. 4 link	# 22 enam.
660	4 1/16" x 2 1/6"	3 inches	6 pl. 9 link	# 12 enam.
661	4 1/16" x 2 1/2"	3 inches	10 pl. 9 link	# 12 enam.
662	4 1/16" x 2 1/2"	3 inches	18 pl. 13 link	# 12 enam.
663	4 1/16" x 2 1/2"	3 inches	28 pl. 14 link	# 14 enam.

Coils listed above are manufactured by the E. F. Johnson Co. Coils of other materials having similar electrical characteristics may be substituted, if desired. Types 651, 652 and 653 are wound with link at bottom end of plate coil; types 640, 641, 642 and 643 are wound with a center tap and with link at center of plate coil. The types 660, 661, 662 and 663 are wound with center tap and have variable rotary-type links.

Table 4. Coil specification chart. See parts list, Fig. 3, for further details.

creasing the antenna coupling and re-tuning the tank circuit for the dip until the minimum plate current to the 809s is 200 milliamperes. With 1000 volts applied to the plate this will give an input of 200 watts to the final amplifier and should give an r.f. output of approximately 150 watts or better.

For 20 meter operation, the v.f.o. may have either 40 or 80 meter output. If 80 meter output is used the 20 meter tune-up procedure is exactly that described above except that 80,

40 and 20 meter coils are used instead of the 40, 20 and 10 meter coils specified. Check the doubler stages with the wavemeter to make sure that the transmitter is operating on an authorized amateur band. A little care may save suspension of your amateur station and operator license. If 40 meter v.f.o. output is used, connect the v.f.o. output to the center pair of feed-through insulators and place an open phone plug in the cathode current jack of the first 6L6GA tube.

(Continued on page 133)

Fig. 4. Chassis template shows correct location of major components.

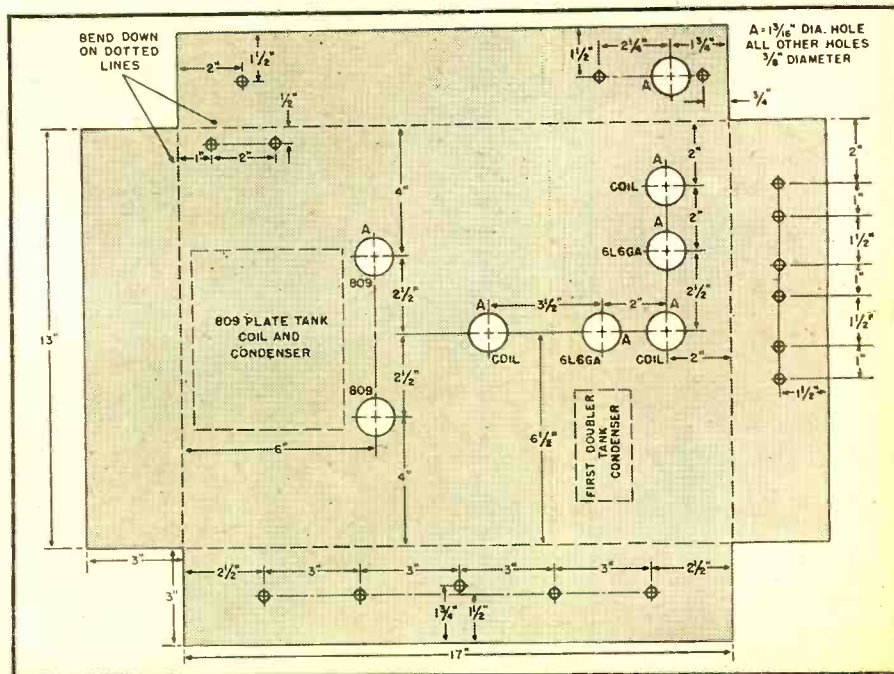



# International SHORT-WAVE

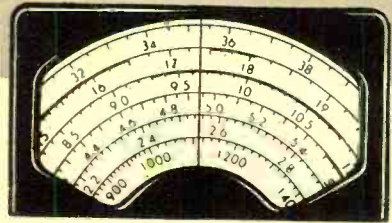

Compiled by **KENNETH R. BOORD**

**I**T IS with much pleasure that this month's International Short-Wave Department is dedicated to "Radio in Sweden." Almost every short-wave broadcaster speaks of the many listeners in this northwestern European country. *Are Swedish short-wave listeners the most active in the world?*

When we posed this question to Arne Skoog, short-wave authority in Sweden, in answer he cited these facts:

The Canadian Broadcasting Corporation writes in a printed booklet: "Reports from Sweden, England, and France rate its 50 - kilowatt beam the loudest and clearest signal from this continent. . . ." (The name of Sweden was placed first, Mr. Skoog noted.)

From *Radio Australia* comes this comment: ". . . Significantly, *Radio Australia* has many fans in Northern Europe, particularly in Sweden—a neutral country where short-wave listening was entirely free. They tell you

why they listen—because *Radio Australia* has an accurate news survey, because they're curious about the country and its peoples. To many of them it is a prospective home."

An official of KU5Q, Guam, wrote in a verification-letter: "Although KU5Q has been heard on every continent except Antarctica, more reports are received from Sweden than from the rest of the world combined."

The same testimonial comes from the Middle East Forces' Broadcasting Service, Cairo, concerning reports to JCKW, Jerusalem, Palestine, where received more than 600 letters and reports from Sweden.

You can figure it out for yourselves—but your short-wave editor would like to add that of all the countries from which we receive regular reports, Sweden leads the list with 29 monitors; this, of course, excludes the United States. Reports from Sweden are detailed and accurate, and they clearly indicate that short-wave listeners there do take their short-wave DXing quite seriously.

The population of Sweden is around 6,600,000. Of that number, the BBC concludes that almost 5,000,000 persons have heard a broadcast in Swedish on short-wave from London at one time.

It is further estimated that "*The Voice of America*" has been received in Sweden by about 100,000 listeners. There are more than 1,800,000 radio sets in the country, probably 1,000,000 of which are equipped with short-wave bands.

Mr. Skoog points out to us that the radio industry in his country was not so actively engaged in war-supply production as was the case in other countries. New receivers were sold as usual in almost every radio shop in Sweden throughout the war.

"The Swedish radio sets appear to be better for short-wave tuning than the American (broadcast) sets in general, thanks to their longer dials and wider-spread short-wave bands," Mr. Skoog explains. "They are, however, only marked by wavelengths in meters and not in frequencies (megacycles or kilocycles), which is a matter of difficulty to some listeners in tuning stations that announce only frequency.

(Continued on page 145)

## SWEDISH RADIO TO BROADCAST SPECIAL PROGRAM ON NOVEMBER 24 FOR READERS OF RADIO NEWS

On November 24, 1946, between 1600-1630 GMT (11-11:30 a.m. EST), *Radiotjänst* (The Swedish Radio) will broadcast a special DX program dedicated to readers of RADIO NEWS. Arne Skoog, short-wave authority in Sweden, who arranged the broadcast, will be at the microphone. The program will be radiated over SBT, 15.155, and SDB2, 10.780, and will immediately follow the regular North American beam, which is heard 1500-1555 GMT (10-10:55 a.m. EST). English will be the principal language used for the period. Verifications will be sent and return postage (IRC) is not required. Address, Radiotjänst (The Swedish Broadcasting Corporation), Stockholm 7, Sweden (Sverige). (Your short-wave editor would also appreciate a report from all those who tune in this broadcast, and can be addressed at 948 Stewartstown Road, Morgantown, West Virginia, U. S. A.)

256 reports were received from Sweden during the period, September 14, 1944-March 13, 1946.

Madame Angele Touchard of the Swedish section, *Radiodiffusion Française*, has received more letters from listeners than any other chef de section at the Paris Radio.

H-CJB, "The Pioneer Missionary Broadcaster" in Quito, Ecuador, has

One of the two short-wave transmitters (12 kw.) at Motala. This equipment will be used to transmit the program dedicated to Radio News and ISW on November 24th.

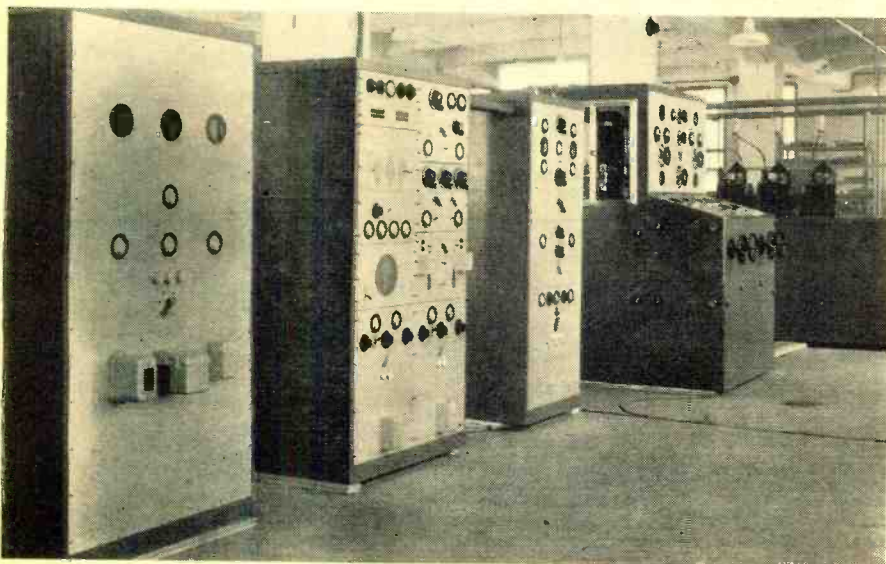

Unless otherwise indicated, all time herein is in Eastern Standard Time, 5 hours behind GMT.



**2** Chassis is withdrawn from cabinet and rectifier tube removed. Only four tools are needed for complete conversion.



**1** Typical portable receiver used to illustrate step-by-step installation of selenium rectifier.



**3** Two extension leads are soldered on the selenium rectifier lugs. Positive side is shown by red wire, negative by yellow or black.

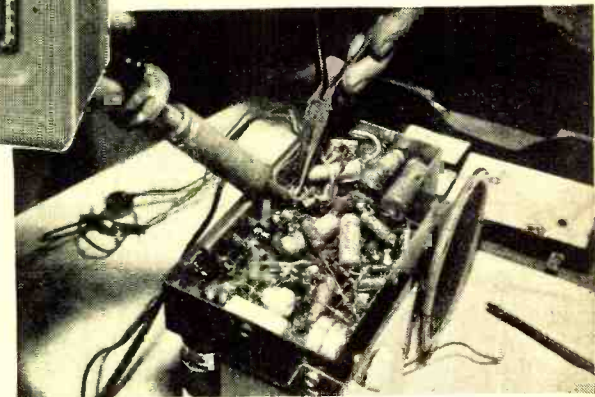

**4** Here the leads are soldered on to the appropriate pins. The red wire goes to pin 4 while yellow or black wire, whichever is used, is soldered to pin 5.



**5** Rectifier operation should now be checked by turning the receiver on. The set should operate immediately without the customary warm-up period.

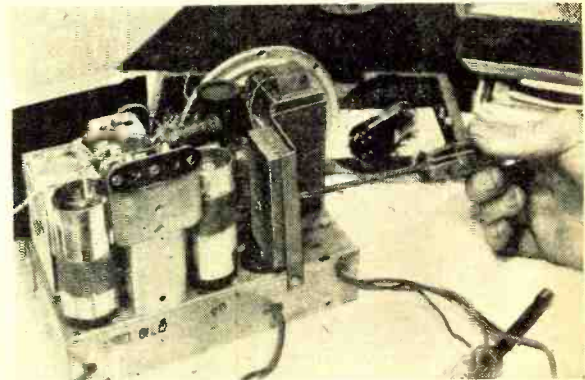

**6** Final operation consists of tightening rectifier to the chassis and placing shield over it. Chassis is then returned to the cabinet with conversion completed.

# New Selenium Rectifiers for Home Receivers

By **GEORGE EANNARINO**  
Field Eng., Federal Telephone & Radio Corporation.

**Selenium rectifiers have been designed to replace all conventional types of rectifier tubes used in home receivers.**

**M**ARKEDLY improving the performance of home receivers and completely trouble-free, the new miniature selenium rectifier stack, developed by *Federal Telephone and Radio Corporation*, Newark, N. J. means more "customer satisfaction" plus increased profits to the up-to-the-minute serviceman. One of the first advancements made in home radios since the end of the war, this stack replaces all conventional rectifier tubes, is simple to install, and is guaranteed to outlive the receiver, thereby ensuring a minimum of power supply failures.

With competition in the service field mounting, this latest development should provide a "shot in the arm" for many alert radio repairmen for it has such excellent selling points, such as instantaneous starting for both a.c. and d.c., less heat, longer battery life (in portables), improved tonal quality, trouble-free power supply operation, pilot light failures reduced to a minimum, and more audio output (in 35Z5 circuits). In every case this new type

of rectifier means customer satisfaction.

Selenium rectifiers have been used in electronic circuits for many years but due to their relatively high cost and large space factor they were not used in home receiver rectifier circuits. However, by virtue of a new process developed by *Federal*, this cost and space factor has been reduced to the point where use of the miniature selenium rectifier is entirely practical.

The rectifier stack has two distinct poles, positive and negative, corresponding to the plate and cathode of the vacuum tube and can be inserted into the circuit as such. The positive (Continued on page 131)

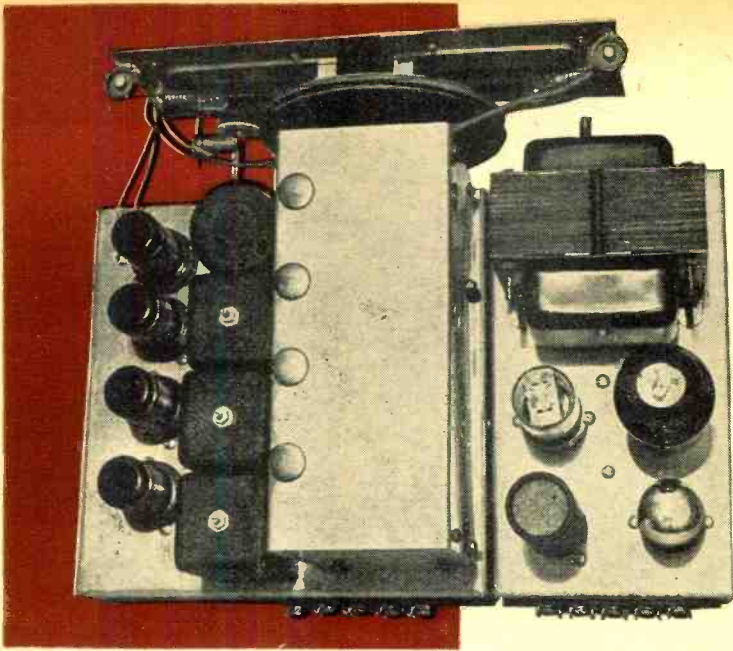

Fig. 1. Top view of the completed receiver. Note that the power supply and audio amplifier are built as separate units.

# HIGH FIDELITY RECEIVER

By  
**J. C. HOADLEY**

**Details for constructing TRF receiver which features an infinite impedance detector and high fidelity amplifier.**

**F**OR real high fidelity reception, one should put a little thought into the construction of a receiver. It is undoubtedly true that a broadband superheterodyne receiver offers a lot of advantages, such as flat bandpass over any desired range, constant sensitivity over the broadcast band, high sensitivity, and extreme selectivity on each side of the pass band, but there are also disadvantages.

The circuit of a high fidelity superheterodyne is necessarily complex, which multiplies the possibilities of oscillation, hum and noise. Because of the complexity, the cost is high. Also, at this writing, there are not any broadband i.f. transformers available. We can, however, at a reasonable cost, build a tuned radio frequency receiver which will produce fidelity comparable to the best superheterodyne and be selective enough to separate any local stations more than twenty kilocycles apart. Its effective range is about fifty miles, with a short indoor antenna. If a large outdoor antenna is used, it would, in rural areas, prove to be quite a distance getter.

Due to such troubles as QRM, QRN, fading, selective fading, etc., it is extremely difficult to realize high fidelity reception from a distant station; so, we want a receiver which has sufficient sensitivity to receive only the local stations. It is unpleasant to have to listen to several stations located on the same frequency, one in your city and one five hundred miles away.

To provide sufficient sensitivity without regeneration, we will need at least two and perhaps three r.f. amplifier stages. Each of these stages should be tuned with a ganged variable condenser. We must have a distortionless detector circuit, preferably tuned with the condenser gang, also.

If you can obtain a four-gang condenser, by all means include the third r.f. stage. The receiver can be built with a three-gang, however, with good results. In either case, care must be taken to prevent oscillation, a perverse tendency of r.f. stages.

There are several choices of tubes for the r.f. amplifier lineup. Normally, the choice would be 6SK7 tubes, but if we wish to operate our tuner on a low voltage, 6AB7 tubes can be used. The author found that maximum sensitivity could be obtained with the 6AB7s with only an 80 volt plate supply drawing about 14 milliamperes. If one were considering battery operation of the tuner in a rural location, 6AB7 tubes would be a good choice.

The detector is another item that should be carefully considered. All the usual detectors generate distortion under certain conditions. A diode is the usual choice. However, a diode has disadvantages such as distortion at low levels of modulation. One must take care not to load the detector circuit with the a.v.c. circuit, as this can generate serious distortion.

For this application, then, a cathode follower was chosen as a detector. This type of circuit is usually referred to as an infinite impedance detector. This name was chosen because a cathode follower degenerates its input capacity to a very low value, and unlike a diode, it does not constitute heavy loading during one-half of the detected cycle. This is a great advantage as it allows the detector circuit to realize a much higher selectivity.

To provide a.v.c. without using an extra tube, a new item to the radio

market, a *Germanium Crystal Diode*, manufactured by *Sylvania Electric Products Inc.*, was used. It is no larger than a one watt resistor and is provided with pigtail leads. It is soldered directly into the circuit, and according to the manufacturer, has an extremely long life. In the event that the builder wants to cut the tubes to a minimum, he may use one of these crystals as a detector.

After the radio wave is demodulated, a high quality amplifier to drive a loudspeaker must be provided. Although this amplifier is not elaborate, it has very good fidelity due to the great amount of degeneration used. The 6L6 output tube will deliver at least five watts of power to a speaker at reasonably low distortion.

So that this receiver may be of interest to a maximum of readers, it has been so designed and built as to give the reader several alternatives in its construction. The builder can construct the receiver as such. For the reader who already has an amplifier, the tuner may be constructed without the amplifier and the power supply may be made a part of the tuner or not, depending on whether the user desires to supply the tuner's power with his existing amplifier.

The circuit diagram of the tuner is shown in Fig. 6. Notice particularly the extensive bypassing and filtering. Considering the high gain of the circuit, this was found to be necessary. The r.f. coils are *Meissner* iron core slug tuned shielded models. The detector coil is an air core antenna coil. The condenser is a four-gang unit which matches the *Meissner* dial.

The chassis, for the tuner alone, measures 8 x 8 x 2 inches and was made from  $\frac{1}{16}$  inch aluminum. This aluminum was obtained from a 15 x 18 inch cookie sheet, which can be bought at most hardware stores for less than a dollar. The holes were punched with a one-inch Greenlee socket punch. The shield for the condenser was bent from the remnant of the cookie sheet. The shield's exact size will be determined by the three-or-four-gang condenser you select. Notice that the dual .1  $\mu$ fd. bypass condensers (Fig. 3) are mounted in such a manner as to shield the leads from the variable condenser to the coils. If these dual units are not readily available, one can bend up small shield strips and mount one between each pair of leads. Shielded wire is out, because it will increase the minimum capacity of the tuning condenser and will not allow the receiver to tune up to 1500 kc. Normally, this receiver would tune sharply, so we have broadened it out by putting resistors across the primary and secondary of all the coils except the first r.f. stage. In this stage, which is normally quite broad, we wish to realize all the possible selectivity that we can, to reduce cross modulation and reject any and all spurious signals which might ride through the amplifier.

The trimmers are mounted directly on the tuning condenser and holes are provided in the condenser shield so that the high frequency end of the tuning range can be aligned with the shield in place. Care should be exercised in keeping all the leads short and away from each other, to reduce the possibility of oscillation. The bypass condensers should be mounted as close to the tube sockets as possible. Mount the bias resistors directly on the tube sockets so that their leads may be short. Be sure to ground the "outside foil" end of each bypass condenser. It is well to keep the filament wiring away from the other wires and close to the chassis.

The amplifier filament and plate supply connections for the tuner are made to a terminal strip located in

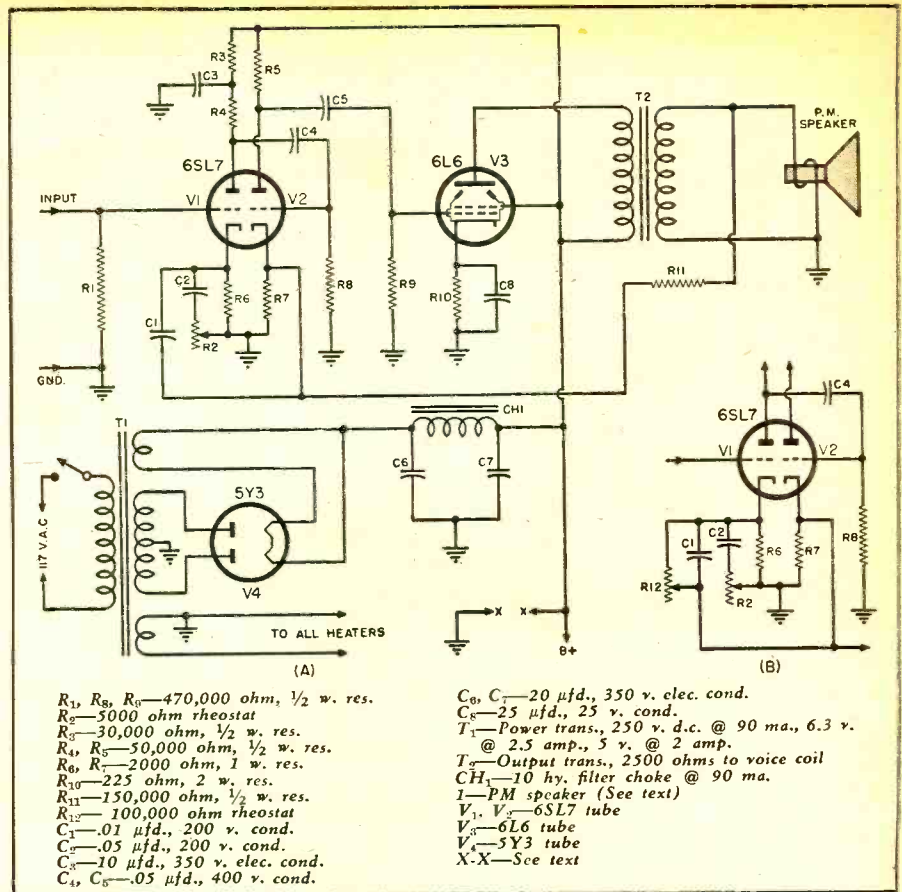

Fig. 2. Circuit diagram of the power supply and audio amplifier. A high frequency boost tone control ( $C_2, R_2$ ) is incorporated in the feedback circuit. If a low frequency boost is desired it may be added as shown in insert B, components  $C_1, R_{12}$ . Note that if audio amplifier oscillates reverse voice coil leads. Should this not eliminate the oscillation, the value of resistor  $R_{11}$  must be changed. The value of this resistor will vary with the different output transformers. To eliminate oscillation, the value of  $R_{11}$  should be increased until oscillation ceases. It is possible for the amplifier to oscillate at an inaudible frequency. This may be checked by temporarily connecting a dial light across the speaker voice coil. If the lamp lights the amplifier is oscillating.

the back of the chassis, as is the audio signal output. The amplifier and power supply (Fig. 4) are located on a separate chassis measuring  $4\frac{1}{2}$  x 8 x 2 inches, which can be bolted to the receiver chassis, located at some remote point, or used as a separate amplifier by itself.

The power transformer is a little oversize but this allows it to run

cooler, which is a desirable design feature. The amplifier and receiver do not draw over 90 milliamperes, and the transformer is rated at 120 ma. It supplies filament power for the amplifier tubes and the tuner, a total of about 2.5 amperes at 6.3 volts. The extra plate power may be made use of in case a field model speaker is used instead of the PM model, or if an

Fig. 3. Under chassis view of both the amplifier and tuner.

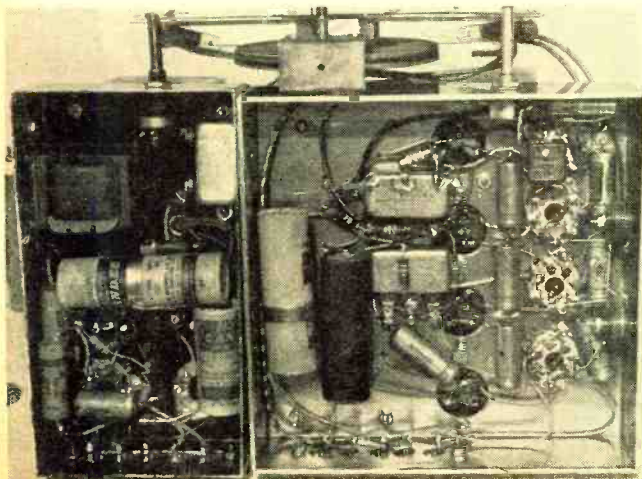
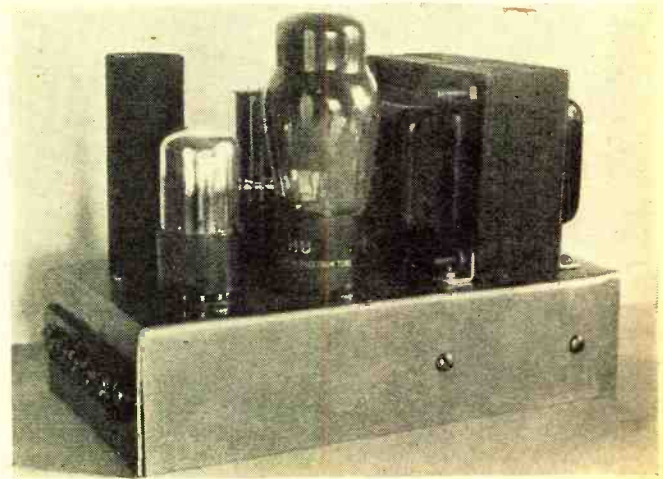

Fig. 4. Side view of power supply and audio amplifier unit.



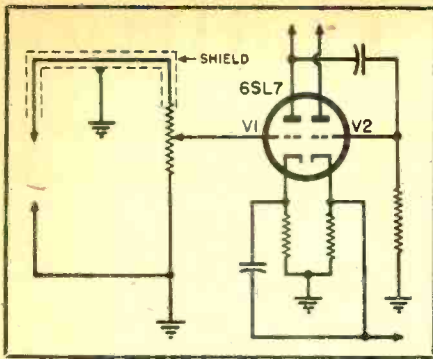

Fig. 5. Schematic diagram shows method of connecting a volume control to the input stage of the audio amplifier. This is particularly needed should the constructor want to use amplifier separate from tuner.

extra speaker is used. A 5000 ohm field or higher should be chosen and connected at the points marked X in the circuit diagram. It would be desirable to use the PM as the remote speaker, as then only two wires would have to be run to it. The voice coils may be placed in parallel. The negative feedback will compensate for the impedance mismatch.

The negative feedback network was chosen to impart a response characteristic which would compensate for the deficiencies in the speaker, output transformer, baffle, room acoustics and the human ear, at normal room volume.

This latter is quite a problem, as the response curve of the human ear is flat only when the reproduced music is as loud as the original. The more rapidly the volume is reduced, the more rapidly the ear's response to low

and high frequencies is reduced.

The high frequency boost may be varied from the panel by a control, which allows 6000 c.p.s. to be varied from flat to plus 15 db. The amplifier circuit (Fig. 2) allows the individual adjustment of the high and low frequencies, and, if it is desired to have bass response also controllable from the front panel, Fig. 2B shows how it is done. The high frequency control has the power switch ganged to it, but if the bass control is added, then, in the interest of symmetry, the power switch could be a separate control. Figs. 1, 3, and 4 show, photographically, the layout and manner of construction.

When the wiring is done, connect the two units, being sure that shielded wire is used to introduce the detector's output to the amplifier. Connect a ten foot piece of wire as an antenna. Turn on the power, and, turning the volume control up, tune in a station. If no station is received, turn the volume control to maximum and vary the trimmers and iron slugs in the coils until the noise level is at a maximum. This will tune up the receiver, roughly. Now, you should be able to tune in a station.

Pick a weak station at the low frequency end of the dial and adjust the iron cores until you obtain maximum volume. It is important that you pick a weak station so that the a.v.c. will be inoperative. If no weak station is available, reduce the antenna size.

When this is done, tune in a weak station at the high frequency end of the dial and adjust the trimmers for maximum volume. Of course, an output meter can be used for this adjust-

ment, in conjunction with a service oscillator, or a vacuum tube voltmeter may be connected to the a.v.c. bus as a maximum indicator.

If you are not able to procure adjustable iron core coils, you can align the receiver by first tuning up at the high frequency end of the band with the trimmers, and then bringing the low frequency end in line by bending the condenser plates on each gang section until maximum sensitivity is obtained. When this is accomplished, sit back and listen to your favorite musical program.

The speaker, of course, can be any size from a 5 inch on up to an 18 inch; the larger, the better. It should be properly baffled, to realize the maximum fidelity from it.

If it is desired to use the amplifier by itself, it will be necessary to mount a .5 or 1 megohm volume control on it, as shown in Fig. 5. If the amplifier is built by itself without the tuner, the volume and both tone controls may be mounted in one long side, constituting a compact 5 watt amplifier.

The combination can be mounted in a cabinet or in the wall, but it would be desirable to keep the speaker and the receiver separated, as the excellent low frequency response might cause a large speaker to vibrate the tuner excessively.

This unit, if connected to a twelve or fifteen inch speaker, will provide real high fidelity from your favorite AM station, and provide an excellent source of program material for recording. It need not cost over twenty-five dollars, including a light duty twelve-inch speaker. All of the parts are readily available.

-50-

Fig. 6. Diagram of TRF tuner. A 3-gang variable condenser may be substituted for the 4-gang unit by eliminating one r.f. stage.

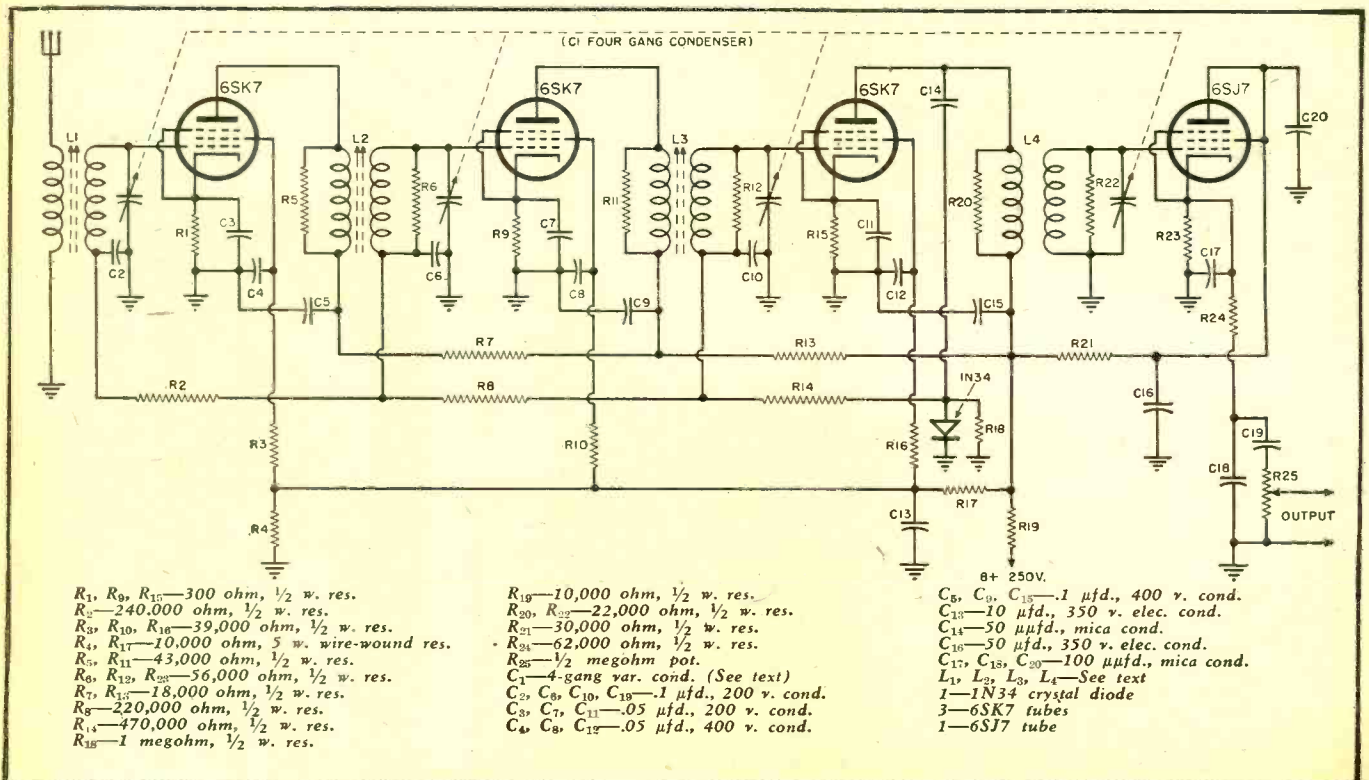



# Possibilities of Home Facsimile

*The manufacture of home facsimile equipment will open new sales opportunities for the radio dealer.*

By

**SIDNEY FELDMAN**

Radio Inventions, Inc.



Radio News cover serves as subject copy which is held in place on the scanning drum by a thin celluloid sheet. The copy is progressively scanned by submitting it to a fine beam of light from a photocell exciter lamp. This beam is reflected from the copy to the photoelectric cell, causing the current to vary as the reflected light. Before scanning is begun the operator tests the range of copy shading by means of an electric eye, and then adjusts photocell amplifier accordingly.

**F**ACSIMILE development has opened new avenues of promotion and interest for retailers, servicemen and amateurs.

As a result of technological advances the possibilities of facsimile as a new field for retail merchandising and service seem to be growing into a reality. Recently demonstrated to the technical press, the *Hogan Facsimile System* shows promise of becoming a regular service for printing by radio through FM broadcasting.

Inventor of this system is John V. L. Hogan, pioneer in radio and wire communications, who is well known as founder of high fidelity station WQXR in New York. Copy is reproduced by the *Hogan System* at the rate of 28 square inches per minute, which is somewhat better than five times prewar speeds.

In the time required for the usual 15 minute broadcast, four pages of illustrated reference copy can be transmitted by FM radio and reproduced in the home. At the same time, for example, this will permit a 15 minute newscaster on an AM station to accompany his spoken word on an associated FM station with 4000 words of printed text or four pages of maps, diagrams, photographs

in any combination of four 9½ x 12" sheets. A format can be selected to permit four-column layouts of standard newspaper size.

Through this system of instant, di-

Facsimile signals, to be reconverted from sound to printing impulses, are received by an FM receiver for staticless reception.



rect printing, copy is visible immediately as transmitted. It requires no photographic or other finishing process and occupies no more space in a radio console than that now devoted to the conventional phonograph and record-changer unit. In its present form the home recorder can be manufactured as an attachment to any FM home receiver or combined in a single unit with AM, FM and radio-phonograph.

Produced in quantity, the home unit should cost the equivalent of record changer and turntable, which makes it quite possible that the set buyer ultimately will have his choice of facsimile or phonograph, in a combination, at about the same price.

With the increase of facsimile broadcasting there would be another gadget to be sold by the radio dealer as a repeat item, facsimile paper. The *Hogan* recorder holds a 400-foot roll of paper. It is estimated this will be enough paper to last a conservative user of sustained facsimile broadcasting for a full month, and an average user, at least two weeks. At present, a roll manufactured by hand processes in the laboratory costs about \$4.00.

By quantity production methods, this may be reduced to be about \$1.00 per roll. The more ingenious the fac-

*(Continued on page 112)*

Comparison of the original copy (top photo) with the facsimile print. Reproduction of received copy is exceptionally good.



# Low Cost AUDIO OSCILLATOR

By **ROBERT W. EHRLICH**

Fig. 1. Rear view of oscillator chassis showing placement of parts.

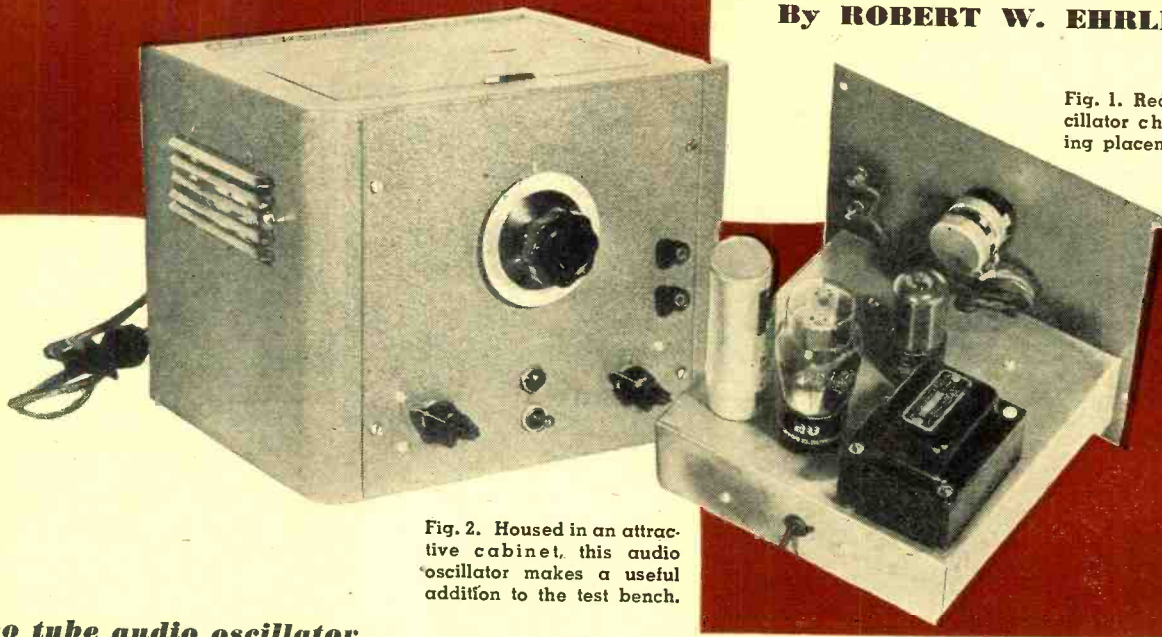
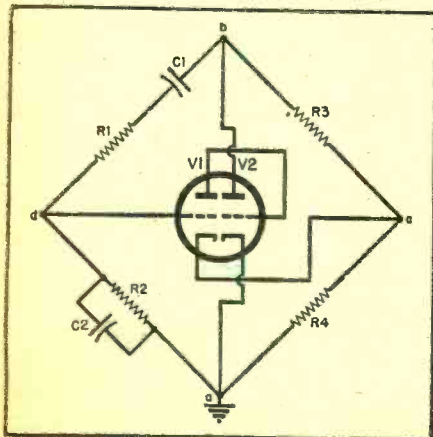

Fig. 2. Housed in an attractive cabinet, this audio oscillator makes a useful addition to the test bench.

**A two tube audio oscillator utilizing resistance tuning which may be built for \$10 at present day parts costs.**

**T**HE audio oscillator described in this article was designed with the idea of providing the experimenter with a low-cost, easily-built, foolproof test instrument that could provide a good quality audio test signal at any frequency for use in testing receivers, audio amplifiers, modulators, etc. The device fulfills these conditions admirably, at only a small sacrifice of the features that appear on more expensive commercial models.

Fig. 3. Basic Wien Bridge audio oscillator circuit. Feedback takes place from the plate circuit of tube 2 to the grid circuit of tube 1.



As the unit appears in Fig. 2, all parts can be purchased at amateur rates for about \$10. It is to be expected, however, that most of the necessary parts will be found in the junk box, thereby lessening the actual cost of construction. In fact, the oscillator lends itself quite well to junk-box production, because none of the parts, with the exception of the tuning potentiometer, are at all critical.

As for performance, the oscillator will deliver an excellent sine-wave signal at frequencies between 100 cycles and 25,000 cycles, with no band changing. The maximum r.m.s. output ranges between ten and twenty volts, with an output impedance of approximately 10,000 ohms. This impedance is low enough so that hum pickup in the output leads is minimized and conventional test prods can be used.

A standard Wien Bridge circuit is used which is basically similar to that used in many commercial audio signal generators, but it contains two important modifications that make for simplicity. One is the use of a two-gang variable potentiometer as the tuning element rather than a large variable capacitor. This not only reduces the expense considerably, but also makes possible a tremendous range of frequencies in one band (over 100 to 1). The sacrifice here is, of course, some loss of accuracy in frequency calibration; however, the majority of applications do not require extremely accurate frequency information.

The other modification is that con-

trol of the feedback necessary to sustain oscillations is brought out to the front panel. This makes it unnecessary to undertake any involved alignment procedure when the oscillator is first put into operation. Furthermore additional flexibility is introduced in that it is possible to set the feedback control to produce either a sine wave or a highly distorted pulse wave that might be required for special applications.

The basic Wien Bridge circuit used in this oscillator is shown in Fig. 3.  $R_1$ ,  $C_1$ ;  $R_2$ ,  $C_2$ ;  $R_3$ ; and  $R_4$  constitute the bridge circuit through which feedback takes place from the plate of  $V_2$  to the grid circuit of  $V_1$ . This bridge is balanced when:

$$f = \frac{1}{2\pi\sqrt{R_1 C_1 R_2 C_2}}, \text{ and}$$

$$\frac{C_2}{C_1} = \frac{R_3 - R_1}{R_4 - R_2}$$

Note that the frequency of balance depends only on values of  $R_1$ ,  $R_2$ ,  $C_1$  and  $C_2$ , and that a suitable adjustment of the ratio of  $R_3$  to  $R_4$  will bring about a balance at that frequency.

Determination of the conditions necessary for oscillation in the circuit of Fig. 3 is most easily carried out by assuming a voltage between the plate and ground of  $V_2$ , and then using vector analysis to determine whether or not the voltage between the cathode and grid of  $V_1$  will be of such a nature as to sustain the assumed voltage. Fig. 7A shows vector relationships in the bridge circuit when it is perfectly balanced. Points  $a$ ,  $b$ ,  $c$ , and  $d$  in the vector diagram correspond to similarly

lettered points in Fig. 3. Note that under these conditions, the cathode-grid voltage (*c-d*) on  $V_1$  is zero, and it cannot act to sustain the voltage (*a-b*) between the plate and ground of  $V_2$ . Therefore there will be no oscillation.

Fig. 7B shows the vector relationships when circuit values remain the same as those in Fig. 7A, but different frequencies are assumed for the applied voltage *a-b*. As the frequency changes, the junction point (*d*) between the vectors *a-d* and *d-b* moves along the dotted circle, and the cathode-grid voltage takes on the different values shown. Note that at no time is *c-d* at all in phase with the applied voltage, *a-b*. Remembering that two reversals in phase take place between the grid of  $V_1$  and the plate of  $V_2$ , it will be realized that *c-d* must have a component in phase with *a-b* to sustain oscillations. Since the feedback is out of phase, and therefore degenerative, oscillations will not take place at any frequency.

In Fig. 7C, resistor  $R_3$  is slightly smaller than the value required for balance. While there is now some feedback at the balance frequency as well as at other frequencies, it is still degenerative and no oscillations will take place.

In Fig. 7D, resistor  $R_3$  is slightly larger than the value required for balance. At frequencies close to the balance frequency (the top of the circle), the vector *c-d* swings around so that it is in phase with *a-b*. When resistor  $R_3$  is adjusted so that the voltage *c-d*, as amplified by the two tubes, is just large enough to equal voltage *a-b*, then oscillations will take place.

The preceding analysis shows two significant features of the Wien Bridge circuit. One is that for any values of  $R_1$ ,  $R_2$ ,  $C_1$  and  $C_2$ , it is possible to find a setting of  $R_3$  that will just cause the circuit to break into oscillation. The other is that oscillation is limited to frequencies very close to the balance frequency determined by  $R_1$ ,  $R_2$ ,  $C_1$  and  $C_2$ , and no harmonics thereof; from which result the inherent frequency stability and pure waveform characteristics of this circuit.

The actual circuit of the audio oscillator is shown in Fig. 4. This is the same as the circuit of Fig. 3 with the addition of a power supply and the necessary blocking capacitors for the insertion of the d.c. voltages to the tube sections. In designing the circuit, every effort was made to keep cost down. While a transformerless power supply might be used to shave expenses a little further, it was felt that an isolating transformer was necessary in order to make it possible to connect the oscillator to other apparatus that may or may not be grounded to the a.c. line.

The chassis layout and placement of parts are adequately described in the accompanying pictures and diagrams, and very little need be said. Most of the impedances were purposely kept low to avoid any problems of hum pickup that might be encountered relative to parts placement.

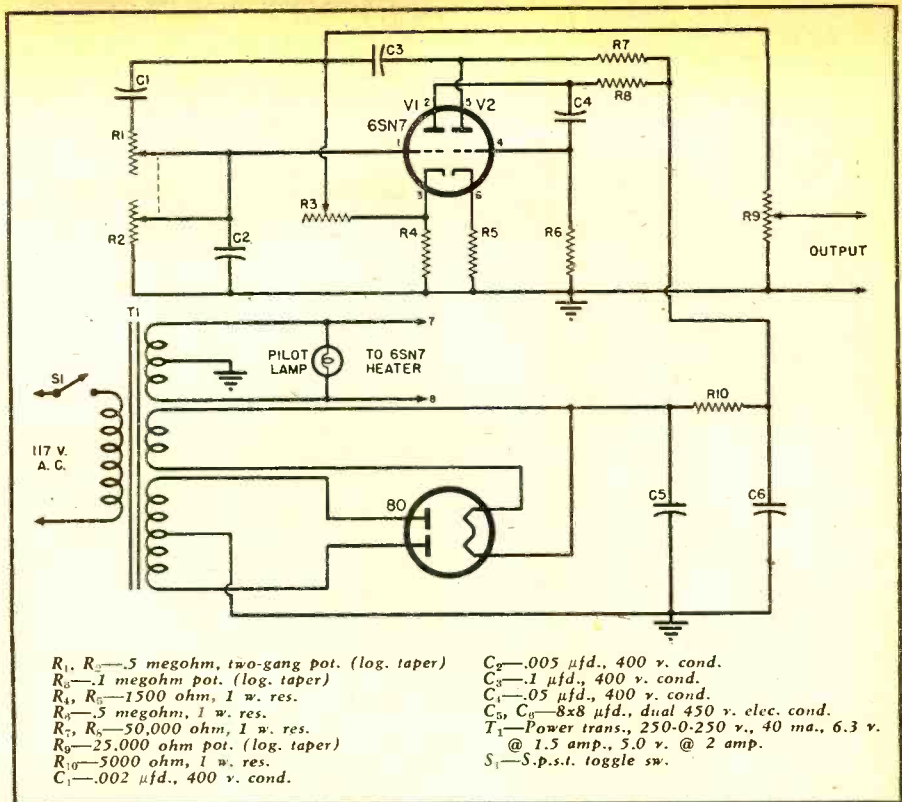

Fig. 4. Over-all circuit diagram and parts list for the audio oscillator.

Selection of parts to be used is also not very critical. It might be pointed out, however, that it is wise to use resistors and capacitors that are rated considerably higher than the wattages and voltages they will have to stand in order that stability of the unit will not be affected by overheating and breakdown of components.

In selection of potentiometers, it is important to note that they are all of the logarithmic-taper type. This taper is used in conventional volume control units, so it should not be difficult to find the correct parts. It is also important to observe the connec-

tions shown in Fig. 5 for the potentiometers. If they were connected incorrectly, calibrations on the main tuning potentiometer would be very crowded near one end, and the setting of the feedback control would be extremely critical. With correct connections, the frequency calibrations space out about equally for every octave (See Fig. 8), and adjustment of feedback can be accomplished smoothly and easily.

It is not so important to use a logarithmic taper for the output control, but it is more convenient. The total  
(Continued on page 106)

Fig. 5. Proper connections for potentiometers used in the test oscillator. All potentiometers are of the logarithmic-taper type.

Fig. 6. Bottom view of chassis.

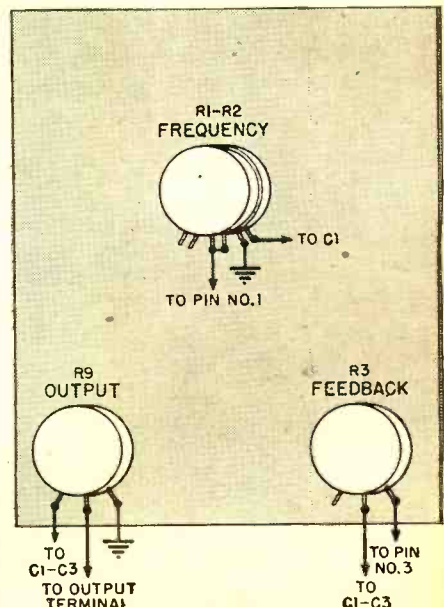
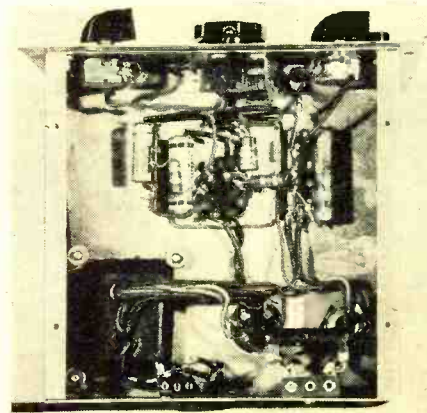

# Trouble Shooting the TELEVISION RECEIVER

By EDWARD M. NOLL

Television Tech Enterprises

**Part 16. In this, the concluding article of the series, the author covers some of the servicing problems encountered in television receivers.**

**T**ELEVISION receiver trouble-shooting and repair is no more difficult than trouble-shooting a multiband home radio. The radio serviceman must be convinced on two points if he desires to save time and do an efficient and capable service job. One, he must devote more time to studying theory and recommended procedures. Trouble-shooting, in the case of the television receiver, is really servicing by visual observation. Every receiver trouble, except sound channel failure, manifests itself in one form of malfunction of the pattern on the picture tube screen. The ability to interpret these malfunctions quickly and accurately can only come with experience and thorough knowledge of receiver theory. The second factor he must be convinced of is that hit-or-miss or revamping tactics must not be employed. Follow manufacturers' procedures and recommendations closely. When replacing defective parts, use recommended replacements, and in critical circuits, arrange wiring and parts positioning as it was originally.

Troubles can be grouped into three classifications: (1) Signal strength troubles, (2) Spurious signals, and (3) Defective parts.

Signal strength and spurious signal troubles can be corrected or reduced by the serviceman when the receiver is installed. The wise serviceman will adjust and tune each receiver in his own shop before he installs it in the customer's home. In this way, he can be reasonably certain any trouble which appears at the customer's home is an installation defect and not the fault of the receiver.

Some of the troubles he is likely to encounter are:

1. *Weak Signal.* A weak signal will usually occur at the outer extremities of the transmitter range, in congested areas hemmed in by tall buildings, and in valleys or locations isolated by mountainous terrain. The remedy, of course, is to get the antenna higher into the air, use low-loss transmission line, and a more directional antenna. Proper orientation of the antenna is extremely important in such localities. A weak signal produces a faded, noisy presentation on the picture-tube screen. Contrast control has to be ad-

vanced almost full on before any picture can be seen.

2. *Strong Signal.* Too strong a signal often occurs in the immediate vicinity of the transmitter. A strong signal gives the picture an over-exposed appearance. Some difficulties with synchronism are also experienced. It would seem logical, therefore, that all we need do is unhook the antenna. However, removing the antenna not only leaves a mismatch in the input circuits, upsetting the receiver input bandpass characteristic, but also leaves the input circuit vulnerable to stray pick-up of noises. The solution to the strong signal problem is the insertion of a resistance pad (carbon resistors between transmission line and antenna input terminals of receiver). The pad still maintains a proper match but increases the signal attenuation.

3. *Noise Pick-up.* Noise pick-up is most troublesome at the outer extremities of the transmitter range or in congested hemmed-in areas. Noise pick-up at these points not only causes an interfering pattern to appear on the screen but, in addition, sharp bursts of noise, such as might come from auto ignition interference, cause momentary high loss of synchronism. Another source of noise is diathermy installations which cause a herringbone pattern to appear on the screen. High voltage sparking from trolley cars or electric trains also interfere with picture reception at weak signal points. Here again the solution is to get the antenna high and clear, use well-shielded low-loss transmission line, and properly orient the antenna. Many times the addition of a reflector to the dipole element, which minimizes noise pick-up from the rear, will reduce the interference. The more directive the antenna is (both horizontally and low-angle vertically) the more

Fig. 1. Television receiver divided into sections for convenient trouble-shooting.

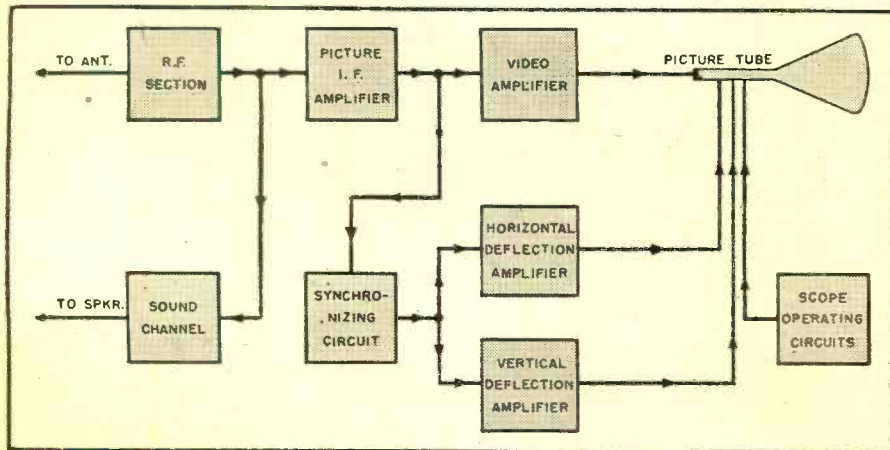

Table 1. Common television receiver faults and possible sources of their origination.

improved the signal-to-noise ratio becomes.

4. *Reflections.* Reflections or ghosts in the presentation (dual images) are caused by multi-path signals. For example, one signal may arrive at the antenna directly, while a second signal will be reflected from a large building some distance past your location. Since signal two arrives some interval after signal one but contains the same information, dual images will appear on the screen. In fact, if the transmission line is not well-shielded and is not properly matched, a signal induced into it will also cause ghosts in the presentation. Again, we have an antenna problem which can be eliminated or reduced by careful antenna planning.

- a. Horizontal directivity (uni-directional)
- b. Low-angle vertical directivity
- c. High and clear as possible
- d. Properly matched system
- e. Low-loss well-shielded transmission line
- f. Position antenna assembly where a minimum of reflections appear. Sometimes shifting the entire assembly only a few feet makes an appreciable difference.

### Receiver Troubles

The angle of attack in locating receiver troubles is to first localize the trouble to a specific section of the receiver by visual observation of the scanning raster or, preferably, with the local transmitter on the air, with a test pattern. The better equipped repair shops will possibly have their own monoscope signal generator which will couple a signal into the receiver similar in character to a transmitted signal. Output of this elaborate signal generator contains synchronizing and blanking pulses as well as a picture signal. The monoscope signal generator can also be used to demonstrate television reception to customers when the local stations are not on the air.

Thus, the first step, Fig. 1, in trouble-shooting the receiver is to localize the failure to one of the following sections; r.f. section, sound channel, picture i.f. amplifier, video amplifier, synchronizing circuits, horizontal deflection, vertical deflection, or scope operating circuits. This can be done almost immediately as follows:

1. *Scope Circuits.* If scope circuits are defective the screen will not illuminate or will be very dim with the brightness control full advanced. A breakdown in the high-voltage filter circuits will cause severe hum on the picture (continuous contraction and expansion of raster along with alternate black and white thick bars).

2. *Horizontal Deflection.* A failure in the horizontal deflection circuit is indicated when only a thin vertical line appears on the fluorescent screen or when it is impossible to cover the

(Continued on page 132)

PICTURE-TUBE CIRCUITS	
DEFECT	CHECK
1. No illumination.	a. High-voltage rectifier. b. Resistance of secondary winding of high-voltage transformer. c. Filter capacitors and resistor.
2. Some illumination. Erratic operation of centering, focus, and brightness controls.	a. High-voltage and low-voltage rectifier tubes. In the G.E. HM-171, low voltage supply is also a part of the scope operating circuit. b. Inspect, and check values of high-voltage bleeder resistors which make up the high-voltage divider.
3. Improper operation of any one scope operating control.	a. Resistance and mechanical operation of control. b. Associated bypass capacitors.
4. Improper operation of brightness control.	a. Output of low-voltage power supply. b. Brightness potentiometer and associated bypass capacitor.
5. Weak or no illumination, all other checks normal.	a. Substitute another picture tube.
6. Hum (black and white thick bars) on scanning raster. Continuous contraction and expansion of scanning raster.	a. Filter capacitors of both power supplies. b. Check for low resistance path draining excessive current from supply.
HORIZONTAL DEFLECTION	
1. Thin vertical line on picture tube. No horizontal deflection or inability to sweep entire width of raster.	a. Horizontal saw-tooth generator and horizontal sweep amplifier tubes. Substitute another saw-tooth generator tube as some tubes will not oscillate at this frequency. b. Voltage check horizontal amplifier to locate a defective part.
2. Non-linear deflection in all positions of linearity control as shown on received test chart.	a. Horizontal amplifier tubes. b. Components of linearity network and damping circuit. c. Voltage check amplifier.
3. Inability to lock-in horizontal sync. Vertical lock-in normal.	a. Horizontal saw-tooth generator tube and horizontal sync-amplifier tube, if used. Substitute another tube in saw-tooth generator. b. Check components of frequency determining network. c. Voltage check horizontal sync circuits.
4. Hum (expansion and contraction of raster horizontally).	a. Voltage circuits, looking for open or partially shorted bypass capacitors.
VERTICAL DEFLECTION	
1. Thin horizontal line on picture tube. No vertical deflection or inability to sweep entire height of raster.	a. Vertical saw-tooth generator and vertical sweep amplifier tubes. b. Voltage check vertical amplifier to locate defective part.
2. Non-linear deflection in all positions of linearity control as shown on received test chart.	a. Vertical amplifier tubes. b. Components of linearity network. c. Voltage check vertical amplifier.
3. Inability to lock-in vertical. Horizontal lock-in normal.	a. Vertical saw-tooth generator tube and vertical sync amplifier tube. b. Components of vertical sync amplifier. c. Voltage check sync circuits.
4. Hum (expansion and contraction of raster vertically).	a. Voltage circuits, looking for open or partially shorted bypass capacitor.
SYNCHRONIZING CIRCUIT	
1. Inability to synchronize vertical or horizontal sweep oscillators. Signal strength normal as indicated by wide range of intensities in random pattern appearing on screen.	a. Sync separator and amplifier tubes. b. Voltage check sync circuit.
2. Frequent loss of horizontal and vertical sync. Continuous readjusting of hold control necessary.	a. Sweep oscillator and sync tubes. b. Check component parts, sync circuits, and frequency discharge circuits. Look for overheated or intermittent parts.
R.F. SECTION	
1. No received signal. Sound and picture channels dead. Power circuits normal.	a. R.F. section tubes. Substitute a new oscillator tube. b. Voltage check r.f. section. c. Check component parts. d. Do not touch any alignment adjustments until defect has been found. Alignment in most cases will be normal after trouble has been corrected. e. As a final check, use sweep oscillator and scope to observe bandwidth and alignment.
PICTURE I.F. CHANNEL	
1. No picture signal and sync. Sound channel normal.	a. I.F. amplifier tubes. Substitute a tube known to be good, successively in each stage. b. Locate dead stage by using amplitude modulated signal generator applied stage-by-stage from video detector to converter. c. Voltage check i.f. amplifier. Check transformer windings for continuity. Do not touch alignment adjustments until trouble has been corrected. d. As a final check, use sweep oscillator and oscilloscope to observe response characteristic.
2. Loss of picture definition. Sync normal.	a. Use sweep oscillator and oscilloscope to localize loss of response in r.f., i.f. or video amplifiers. b. Substitute tube. Voltage and resistance check. Do not touch alignment until trouble has been found.
3. Interfering sound (regular pattern on picture tube which varies with sound modulation).	a. Check sound wavetraps.
4. Hum (heavy black bars moving up and down on screen).	a. Voltage and resistance check, looking for open or partially shorted bypass capacitors.

(Continued on page 132)

# SUBSCRIPTION-LEASE PLAN

*A Merchandising Success Story from Switzerland*

A Review By

**PAUL H. WENDEL**

Eastern Editor, RADIO NEWS

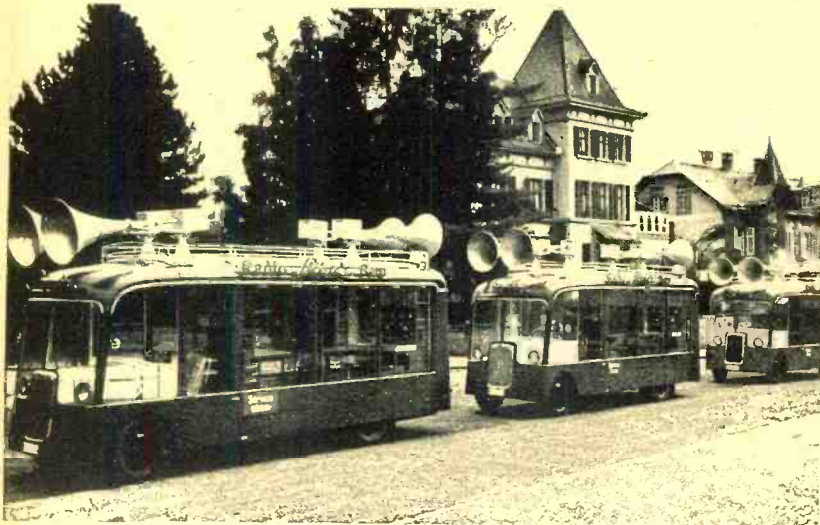

Unique glass enclosed motorized repair shops command public attention.



Customer and prospect files assure efficiency of business operation.

Large staff of skilled technicians handle repair and rehabilitation.

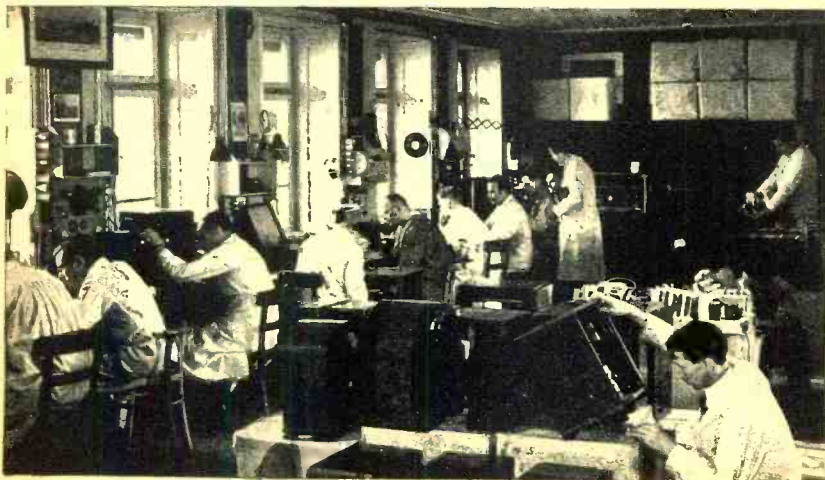

**A**NY radio retailing and service organization in these United States which could boast of more than 400 employees would indeed be considered the miracle organization of the industry, but that is the claim of Radio Steiner located in Switzerland and serving a total population of only 4.2 millions of inhabitants. Here indeed, is a success story which warrants investigation. Back in 1927 no electrically operated sets existed in Europe and people had to be satisfied with local stations which could be tuned in with battery sets and detectors. Power packs suddenly came onto the market and at that point the Steiner concern conceived the "subscription-lease" idea.

Within a year about half the owners of vacuum tube operated receivers in Switzerland had become subscribers. The plan provided these set owners with a power-pack and a rectifier for a monthly fee corresponding to the average monthly expense of operating a five-tube battery set. Provision was made so the subscriber could purchase both pieces of apparatus with 9/10 of the rental already paid at the time of decision to purchase being deducted from the sales price.

The principles of the subscription-lease program were developed during the course of years to apply to all types of receivers.

## How Subscription-Lease Works

The subscriber selects the receiver model he wants and the company delivers and installs it. Maintenance is included as a part of the original subscription-lease. For these services, a subscriber is charged a monthly rental fee, amounting to 1/48th of the list price of the set. In addition, the subscriber pays a monthly fee to cover insurance, repairs and risk, varying from 3¼ to 6 francs depending on the model involved.

For each of the first three months, the subscriber pays three times the amount of the monthly rent. From the fourth month onward, the subscriber may break his contract by giving a one-month notice. Note that the minimum proceeds of any single transaction amount to a ten months' fee which is paid in a period of four months.

At any time during the term of the subscription-lease, the subscriber may acquire the set by paying list price less rental amounts already paid, with the exception of premiums paid for repair and risk insurance. At the end of 42 months, the subscriber may declare his set purchased without further payment.

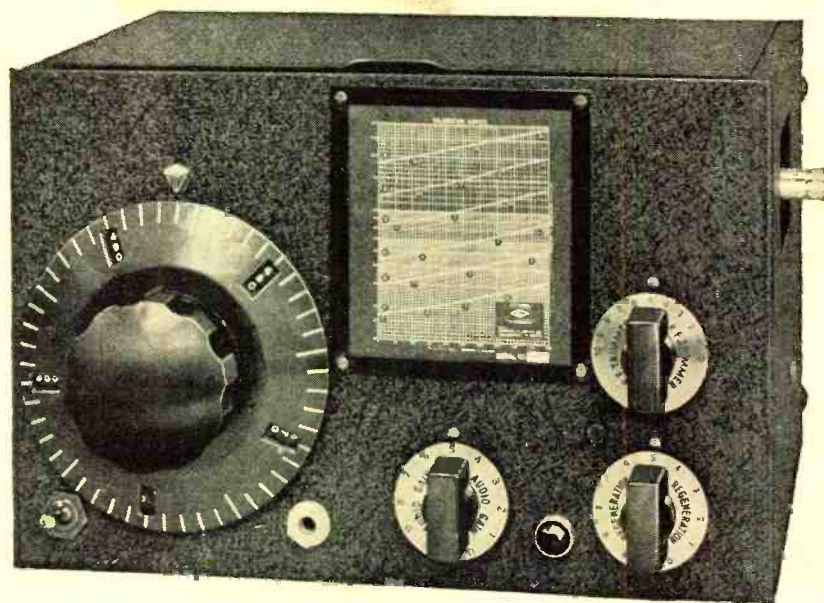

## THE 1-10A

The ONE-TEN-A is a complete redesign of the ONE-TEN, retaining all the proven design features of the older model but with improved performance and smoothness of control.

For many years the ONE-TEN has been the "standard" receiver for work in the range from one to ten meters. Although many advances in high frequency technique have been made since this little receiver was first introduced, it has easily held its place in the affections of experienced amateurs by its consistent dependability under actual operating conditions and its high usable sensitivity.

The new ONE-TEN-A inherits the fine qualities of its predecessor brought up to date by a complete restudy of circuit, mechanical arrangement and constructional details.

The ONE-TEN-A is a fine receiver.



**NATIONAL COMPANY, INC., MALDEN, MASS.**



# RADIO PARTS

SETS • AMPLIFIERS

## COMPLETE CONCORD CATALOG FREE!

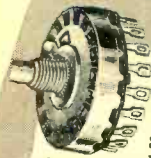

### ROTARY SWITCH

Single gang, 6 pole, 3 position, shorting switch, 1 5/16" dia. with 1/4" shaft dia. Threaded bushing 3/8" long and 3/8" shaft.  
**5B3984 . . . . . 39¢**

### ANTENNA LOOPS



For battery and midget sets or portables. Replaces antenna coil; satisfactory pickup, excellent selectivity. Inductance slightly higher than necessary, permitting removal of turns for adjustment. 4 1/4" x 8".  
**C16450 . . . . . 48¢**



### 10H 40 MA. CHOKE

Extremely compact highly efficient choke well suited for auto radio receivers and AC/DC radios. Also excellent filter chokes for other receivers and amplifiers. 1 5/16" x 1 1/4" x 1 1/2". Unshielded strap type mounting.  
**C1601 . . . . . 46¢**

### Midget Electrolytic

Midget dry electrolytic will handle any job requiring an electrolytic capacitor. Polarity clearly indicated. Bare wire leads. Easily replaces larger capacitors. Cap. Mfd 20-20. DC-WV 160. 1/2" x 2 in.  
**C3153 . . . . . 60¢**



### L PAD

8 ohms, safely rated at maximum dissipation of 2.5 watts. Has continuous range from .5 to 30 DB attenuation in 10% steps. Last 10% affords infinite attenuation. Flatted shaft extends 5/16" from standard 3/8" bushing. Dia. 1 1/2", 1 3/8" deep.  
**5B2095 . 59¢**

**CONCORD**  
**RADIO CORPORATION**  
 LAFAYETTE RADIO CORPORATION

CHICAGO 7 ATLANTA 3  
 901 W. Jackson Blvd. 265 Peachtree Street

Revised! Up-to-the minute! Listing the newest, the latest and best in RADIO PARTS, RADIO SETS, AMPLIFIERS, AMATEUR GEAR, ELECTRONIC EQUIPMENT, SUPPLIES and ACCESSORIES! Hundreds of items for every Radio and Electronic need—Condensers, Resistors, Transformers, Tubes, Test Equipment, Tools and Repair Replacement and Maintenance Parts of every kind. All standard top quality, nationally famous makes, are fully represented in the great new Concord Catalog. Complete lines including new and hard-to-get parts and equipment at latest O.P.A. prices or lower. Thousands of items—and complete stocks ready for immediate shipment from CHICAGO or ATLANTA. Your copy of the new Concord Catalog is ready now—FREE! Mail the Coupon below.

### SEE . . .

Complete showing of ham gear, equipment, supplies and accessories for amateurs, engineers, servicemen, soundmen, retailers.

### SEE . . .

the first peacetime Concord line of modern Radio Sets and Radio Phonograph Combinations—featuring a host of new, approved post-war developments...richer tone quality...super-selective tuning and reception... high fidelity...new modern design cabinets.

### SEE . . .

the thrilling new MULTIAMP Add-A-Unit Amplifiers, an entirely new revolutionary development in amplifier engineering with sensational new flexibility, power, fidelity and economy—EXCLUSIVE WITH CONCORD!

All in the new complete Concord Catalog . . . mail the coupon now.

### Mail This Coupon Now!

CONCORD RADIO CORPORATION  
 901 W. Jackson Blvd.  
 Dept. E-116, Chicago 7, Ill.

Yes, rush FREE COPY of the comprehensive new Concord Radio Catalog.

Name .....

Address .....

City.....State.....

If a set is repossessed due to dissolution of the contract, it is tested, checked, rehabilitated and made available to new subscribers at reduced rates. The repossessed sets are covered by the same guarantees as new sets.

The system provides for limitation of choice among the various sets, since no more than one model is made available for lease in each price class.

In case a subscriber desires a new or different model before the expiration of his subscription-lease contract, he may turn in his set at a rate of 10 to 15 per-cent of the price of the new model he selects. The exchange sets are subjected to thorough overhauling and some of them are placed at the disposal of the service organization for customers' service, to be used as spare sets for customers' use during repairs which cannot be handled in the customers' home.

The greatest number of these radios, however, are made available on a subscription-lease whereby the subscriber pays a fixed sum of 25 francs after delivery and installation and a monthly subscription fee of six francs. The cost of service is included in this subscription fee and the set remains the property of the company.

The subscriber may at any time break the contract at a month's notice and receive a credit note for rent paid less 50 francs, which credit may be used against the purchase of a new radio receiver. Note that in this way, the company puts out a new set and realizes 75 francs, with which sum the exchange expense can be covered.

### Tube Repair Subscription Agreement

Under the terms of this agreement the company assumes the obligation of servicing the customer's set at a monthly rate of 6 francs. The agreement contract runs for a 20 month period but thereafter may be dissolved at any time. A total sum of 50 francs for all repairs required during the entire subscription period is charged but the balance paid in may be used by the subscriber against the purchase of a new receiver.

The fact that the Steiner organization contracted to maintain, service and repair the receivers necessitated the development of an extensive service organization. Mobile workshops, sensational in design and construction, serve to merchandise the Steiner proposition. The shops are driven from place to place and provide public evidence of the capabilities of the organization. Each car carries a crew of ten men including one chief, two technicians and seven salesmen. With only three cars, in a period of two years, the company concluded contracts amounting to well over 7 million francs. The advent of the war temporarily terminated this activity.

### Merchandising and Advertising

The Steiner organization believes in extensive and colorful advertising. That they are master showmen is (Continued on page 163)



From coast to coast  
**SERVICE PROFITS  
 ARE GOING UP**

(and operating costs are going down)

thanks to

**SAMS PHOTOFACT\* FOLDERS**

Here's What Servicemen Themselves Say:

- ✓ "Your folders help give the quick service the public wants—good service, too." *Willis, Tex.*
- ✓ "They easily cut my repair work to half the original time." *Chicago, Ill.*
- ✓ "A great time saver—and cheap enough for the small shop owner" *New York City.*
- ✓ "You have what the serviceman has been waiting for all these years." *Richmond, Calif.*
- ✓ "Wouldn't swap my first set for \$100." *Ashtabula, Ohio.*
- ✓ "They make a big cut in non-productive time—especially in servicing new receivers." *Pascagoula, Miss.*



Time is the most valuable commodity you have. Cut down waste operating time and your earnings go up automatically. You, as a good business man, know that.

But maybe you don't know that Sams Radio PhotoFact Folders reduce non-productive service time by as much as 50 percent. The experience of hundreds of servicemen definitely proves that they do! PhotoFact Folders accomplish this because they give *more complete information—faster*—than any other data that has ever been available.

By means of full-page pictures, comprehensive data, voltage and resistance values, etc., they tell you everything you

want to know about radios, phonographs, intercommunication systems and power amplifiers manufactured since January 1, 1946. Released in sets of 30 to 50 folders at a time, they reach you when you need them most—just as the products described reach the market. Yet the cost, including membership in the Howard W. Sams Institute, is only \$1.50 a set. (\$1.90 a set in Canada).

Get Sams PhotoFact Folders working for you! Use the coupon below for Sets No. 5 and 6. To bring your files up to date, order the four preceding sets, too. That way your biggest expense will be behind you. Thereafter it will be an easy matter to pay as you go.

**PUBLICATION DATES:**  
 Set No. 5 . . . October 13th  
 Set No. 6 . . . October 26th

Cut This Out and Mail It to Your Distributor: If you do not know his name and address, send it directly to Howard W. Sams & Co., Inc., 2924 East Washington Street, Indianapolis 6, Indiana, and we will see that your nearest distributor gets it. (In Canada write to A. C. Simmonds & Sons, 301 King Street East, Toronto, Ontario.)

CHECK ONE OR MORE SQUARES  
 PLEASE PRINT

- Send Sets No. 5 & 6
- Send Set No. 4       Send Set No. 3
- Send Set No. 2       Send Set No. 1
- Send me a specimen folder

My (check) (money order) (cash) for Sets Nos. . . . . (at \$1.50 a set, \$1.90 in Canada) is enclosed. (If you send cash, be sure to use registered mail.)

Name \_\_\_\_\_

Address \_\_\_\_\_

Zone \_\_\_\_\_ State \_\_\_\_\_

Company Name \_\_\_\_\_

My Distributor's Name \_\_\_\_\_

City \_\_\_\_\_

**In Each PHOTOFACT  
 Folder You Get—**



1. A cabinet-view photo of the receiver to help you establish identity and control functions.
2. A top-view photo of chassis and speaker to identify component parts and alignment points.
3. A bottom-view photo of chassis and/or accessories.
4. A complete list giving keyed reference to all parts, alignment and schematic diagram.
5. A complete full page schematic diagram of the receiver with loads of new information shown in a uniform manner.
6. Stage gain measurements listed on the schematic diagram.
7. A complete voltage and resistance analysis chart for rapid check of operational values.
8. Complete alignment instructions on the receiver consistent with the keyed alignment points indicated in top- and bottom-view photos.

**HOWARD W. SAMS & CO., INC. RADIO PHOTOFACT SERVICE**

In Canada—write to A. C. SIMMONDS & SONS, 301 King Street East, Toronto, Ontario

**Attention  
GI JOE!**

Here's Your Opportunity to be First to

**Start Your Own  
RADIO SERVICE  
SHOP**

Complete Starting-in-Business  
Package Stocks of

**TEST EQUIPMENT  
TUBES, PARTS, TOOLS**

**\$350 up**

Act quickly! Meet the pent up demand for radio service. Turn your special service training into a profitable business of your own. No fuss. No worry. Here's everything you need—\$350 up. Details upon request! Write, wire or phone

**TRIPLETT 666**

"POCKET"  
VOM **\$15.25**

A.C.-D.C. Volts  
0-10-50-250-1000  
0-10-100-500 D.C. Mills  
0-300-250000 Ohms  
Size 3x6x2



**TRIPLETT 666H  
\$20.00**

Same as above plus  
5000 V. ranges

**Triplett 650SC Output Meter  
Regular \$24.50 Special .. \$16.50**

0-1.5-6-15-60-150 Volts. 4000 OHM Impedance.  
3" Meter 100 Microamp movement

**Triplett 606B . . . Regular \$16.67  
Voltage & Polarity Tester, Special \$11.95**

Ideal for plant maintenance work! Checks 115-220-440 line at a glance! Indicates AC or DC visually! Indicates DC Polarity visually!

**HALLICRAFTERS S-38**



**\$39.50**

S-40 (replaces  
S20R)

**\$79.50**

**HAMMARLUND-HQ129X \$168**  
Speaker for HQ129X \$10.50

**THE DEFIANT! \$83.95 Complete**  
25 Watt Sound System, wired, ready to use!



A reliable amplifier with 2 mke and 1 phono inputs, two 12" 20 oz. 13 watt PM speakers with 25' cables, two 12" walnut 7 ply wall baffles; one crystal microphone with table stand and 15' shielded cable.

**THE CHALLENGER! \$69.95 Complete**  
25 Watt Sound System

Same as above except includes one speaker and baffle.

**PHILCO BEAM OF LIGHT**

Selenium Cell only, no holder ..... **1.80**

20% deposit required on all C.O.D. orders. 2% transportation allowance on orders of \$25.00 or more accompanied by payment in full.

Write for  
**FREE CATALOG**

**RADIO SUPPLY &  
ENGINEERING CO., Inc.**  
129 SELDEN AVE. DETROIT 1, MICH.

# Income Tax Saving Facts For Radio Dealers

By **HAROLD J. ASHE**

Tax Counselor

**Prepare now for TAX returns. You can save money by keeping an accurate account of business transactions.**

**T**ODAY, every radio and appliance dealer in America has a silent, though exacting, partner in his business. That partner is the United States of America. Four times a year he demands his share of the profits and, on March 15, insists upon a full accounting with prompt payment of any balance due. Even if the business venture proves to be unprofitable, this silent partner insists on being shown before he relinquishes his claim on his active partner.

In spite of this novel arrangement in which the silent partner cannot lose, active partners continue to treat the casting up of accounts upon which the division of profits is based as a minor matter worthy only a few harassed last hours crowded in before final tax deadline. It is little wonder that, in all too many instances, Uncle Sam gets more profits, called taxes, than, by his own partnership agreement, he is entitled to.

It is the writer's firm conviction that if the average small merchant would hang out a sign "closed to compute income tax" for a week, he would make more money than if he continued to serve his patrons during that period. Many taxpayers too poor to give \$100 to war charities, nevertheless pony up \$200 or \$300 in overpayment of taxes because they "can't find time" to do a thorough job of making out a tax return which truly reflects their financial circumstances. Yet, such oversight on the taxpayer's part may represent as much income as he may make by hard work and careful management in four or five weeks' time.

With 1945 income taxes taking (even in the lowest tax bracket) \$23 of every \$100 in taxable income, it simply means that of every \$100 of overlooked business expense—or personal deductions—to which the taxpayer is rightfully entitled by law, he is being penalized at least \$23. Even a \$23 saving should warrant more than haphazard application in making an income tax return.

Assuming that most businessmen are now sufficiently versed in the purely mechanical problems of making income tax returns, it is not the purpose of this article to review that aspect of the subject. Rather it is

the author's intention to discuss certain of the finer shades of tax problems as they apply to small businessmen and to indicate certain tax-saving methods which, if employed, may materially reduce the income tax paid on a given income, just as such tax-saving methods have been employed for years by taxpayers in the higher tax brackets.

Partly because of labor and material shortages most businessmen throughout the war deferred making needed repairs and improvements to their business properties. In normal times such expenditures would have been made as a matter of course and the costs would have been reflected in income tax returns. Failure to make such needed improvements and repairs—as required—have cost taxpayers dearly in increased income taxes, odd as that may seem. A part of what such taxpayers thought they were saving by deferring such expenditures—because taxable income was increased by that amount—actually slipped through their fingers in the form of higher income taxes.

For example: John Jones, radio dealer, owns the property occupied by his store. Both inside and outside of the building is badly in need of painting. The building should have been painted in 1944; it is still unpainted in early 1946. His income subject to tax is \$4,500 in 1945. His tax is \$1,105. If, however, he had painted his property in 1945 at a cost of \$500, his income subject to tax would have been reduced by that amount and his income tax then would have been only \$960, or a tax saving of \$145. Note that this \$500 comes off of the third surtax bracket of 26 percent (plus 3 percent normal). Stated another way, the net cost of the paint job would have been only \$355. In addition, no doubt, he has sustained additional losses by reason of accelerated depreciation of his property due to neglect, as well as loss of trade, because his place is becoming run-down and dingy.

Or other improvements, such as additions to buildings, of course unlike painting, may not be written off in the year made, but must be written off as depreciation over the normal life of such improvements. Here, too, how-

# See This NEW Book for 7 Days FREE

## JUST OFF THE PRESS



**VALUABLE HELPS FOR RADIO ENGINEERS**



**HELPFUL DATA ON RADIO CONTROL & MAINTENANCE**



**DIAGRAMS, TABLES, CHARTS TO AID RADIO REPAIRMEN**



# RADIOMAN'S HANDBOOK

**A New, Valuable Book for Men Working in Radio, Electronics, Electricity**

No matter what work you do in radio, this handbook will prove mighty valuable since it contains exactly the information you wish, available in an instant. You can refer to it easily right on the job. I'm so sure that you wouldn't part with this book for many times its cost that I'm willing to send it to you for a 7-day FREE examination.

## USE IT DAILY ON THE JOB

You can't expect to carry all the necessary information you need on a job, in your head. But you CAN have all the information at your side with this handy book. Once you look through the pages of the Radioman's Handbook and see how the tables, charts, diagrams and data can save time and help you get ahead, you will see why this book is as valuable as your other tools.

## THOUSANDS OF FACTS — NOT A TEXTBOOK

Every subject is indexed and condensed to fit in readable space without waste. Over 300 pages packed full of valuable information that will help you in your daily work. When you are "on a spot" just turn to the quick index, look up the subject you want and you'll find that subject thoroughly explained with helpful diagrams and tables. Every diagram has been fully tested in the great *Coyne Electrical Shops*. Every table is scientifically correct.

## SEND NO MONEY. SEE IT FREE

I am not asking you to send any money—not a single penny. I am so sure this is the book you want and need that I will send it to you to examine for 7 days FREE. Then you look it over and you decide. If it isn't all I claim, then send it back and you owe nothing. If you are convinced that this book is worth many times its cost, then send \$3.25 at the end of 7 days and the book is yours. Send the coupon now, while it is before you!

## HERE'S WHAT THIS GREAT BOOK COVERS

- |                         |                               |
|-------------------------|-------------------------------|
| MATERIALS               | RADIO RESISTANCE & INSULATION |
| ABBREVIATIONS           | (WIRE TABLES, etc.)           |
| CIRCUITS                | CAPACITORS & CAPACITANCE      |
| POWER FORMULAS          | COILS & COIL WINDING          |
| RECEIVING TUBES         | RESONANCE & COUPLING          |
| TRANSFORMERS            | OSCILLATORS & ANTENNAS        |
| AMPLIFIERS              | RECEIVERS                     |
| SOUND SYSTEMS & DEVICES |                               |

## 3 OTHER COYNE BOOKS ... SEE THEM FREE



**Electrical & Radio Dictionary and Data Book**  
Contains 3,300 electrical, radio, radar, electronic and atomic energy terms in every shop and construction use. Know the meaning of the newest terms. Hand-picked data to help you on job. 300 pages, vest pocket size, 3x5". Flexible cover. Price \$1.50—sent on 7 days' FREE trial. Mail coupon today.



**Electronics for Radiomen & Electricians**  
Practical electronics for electricians, radiomen, anyone working in radio, television or other electronic fields. It includes details on shooting and installation. Full details on basic electronic principles. Hundreds of diagrams. See it free for 7 days, then return and owe nothing or pay only \$4.95. Mail coupon today.



**Electrical & Radio Trouble Shooting Manual**  
All new methods of trouble shooting on electrical, radio, refrigeration, diesel and automotive equipment. 500 wiring diagrams. 612 pages. 1 year free Consultation Service and Technical Bulletins. Only \$9.95 on terms—\$3 in 7 days and \$3 monthly. Cash price \$9.00. See it FREE for 7 days before buying. Mail coupon now.

## FREE TRIAL COUPON

B. W. Cooke, Director, COYNE ELECTRICAL SCHOOL, Dept. 86-T3  
500 S. Paulina Street, Chicago 12, Illinois

Send me the **COYNE RADIOMAN'S HANDBOOK** for 7 days' FREE examination. After 7 days I'll either return the book and owe nothing or I'll send you a check or money order for \$3.25.

*Here are other Coyne Books—I'll send any or all on same 7 day Free Examination Offer.*

- Coyne Electrical & Radio Trouble Shooting Manual**—1 Volume, \$9.00 cash—\$9.95 on time—\$3.00 after 7 days and \$3.00 monthly—1 year Technical Bulletins Free.
- Coyne Electronics for Radiomen & Electricians**—1 Volume, \$4.95 after 7 days' examination—1 year Free Technical Bulletins.
- Electrical & Radio Dictionary**—vest pocket size, \$1.50 after 7 days.

Name \_\_\_\_\_ Age \_\_\_\_\_  
Address \_\_\_\_\_  
Town \_\_\_\_\_ Zone \_\_\_\_\_ State \_\_\_\_\_

Where Employed? \_\_\_\_\_  
 Check here if you prefer to pay postman cash price indicated above when books arrive. Same 7 day examination and money-back guarantee of satisfaction.

**COYNE** Technical Book Division  
**ELECTRICAL SCHOOL**  
500 S. Paulina St., Dept. 86-T3 Chicago 12, Ill.

# HARRISON HAS IT

ALL STANDARD LINES

## RECEIVERS—

Hallicrafter — Hammarlund —  
National — Cardwell — RME —  
Collins — Pierson

## TRANSMITTERS—

Temco — Hallicrafters —  
Collins — Meck — Abbott

## TEST EQUIPMENT—

Supreme — Triplett — Weston —  
Hickok — Precision — RCA —  
Jackson — Simpson — GE —  
Dumont — RCP — etc.

## AMPLIFIERS—

Bogen — Thordarson — Masco —  
Bell — Eastern — Webster — etc.

## PARTS—

All good makes — Harrison  
has it! — Complete stock

**MORE AND MORE NEW  
MODELS ARE NOW IN  
STOCK FOR IMMEDIATE  
DELIVERY**

**Get yours sooner! Send  
your order to Harrison,  
NOW!**

### ROTARY COAXIAL COUPLING

52 ohm constant impedance slip ring coupling. Made for Signal Corps by Lapp, to feed rotary antenna. Head, 1 7/8" dia. machined from brass. Copper feed line 7/8" dia. is 51" long. Coaxial sockets at each end. HSS. **\$7.75**

### COAXIAL CABLE

RG-8/U. 52 Ohm Impedance. FB for feeding beams, etc. Handles a KW with high efficiency. New, perfect cables.

110-foot length with two PL-259 coaxial plugs. Total list price \$39.26! HSS **\$4.98**

65-foot length with one plus. List \$22.59. HSS **\$3.45**

Cut to size in one piece within -0% to +20% of length ordered. Full measure!

Type	Impedance	O. D.	1-100' and up	100'
RG-8/U	52 Ohms	.405"	9c	6c
RG-11/U	75 Ohms	.405"	10c	7c
RG-13/U	74 Ohms	.420"	14c	10c
RG-39/U	73 Ohms	.312"	11c	8c
RG-58/U	55 Ohms	.195"	8c	5c

# HARRISON HAS IT

HARRISON SELECT SURPLUS

### RECHARGABLE POWER PACK



One of the most sensational HSS values ever offered! This modern, Navy accepted pack will save space, weight, and money. Ideal for portable transmitters, receivers, test equipment, remote controls, etc.

Only 3 lb., 10 oz., complete! 1 1/2" x 3 3/4" x 6 1/2". Delivers — 135 volts at 20 ma in continuous Military duty or 30 ma, or more, in intermittent Amateur service; 67 1/2 volts at 5 to 8 ma; 1.5 filament or 6.3 heater, bias, and microphone voltages.

NON-SPILL storage battery can be recharged over and over for a penny or two.

Brand new, with fully charged battery, and instructions. Complete, ready to use. **\$5.50**

SPARE BATTERY. 6 volt. Fully charged. \$2.00

BATTERY CHARGER. Noiseless. Selenium rectifier type, to trickle charge these or any other small batteries. 110 Volt AC. **\$2.97**

### BC-406 15 TUBE UHF RECEIVERS

Been getting such FB reports from our customers about these swell Signal Corps Radar receivers that we just had to get more for you!

Six acorn tube RF circuit, tuned to 205 mc; four IF stages; Thordarson heavy-duty power transformer delivering 350 volts at 145 ma; four choke and oil condenser filters; 115 volt, 60-cycle operation; chassis 10 1/2" x 25 1/2" in metal case. Slightly used but fully guaranteed.

Complete with tubes: 5-954, 1-955, 4-6SK7, 2-6SJ7, 2-6N7, 1-5T4.

Instructions and diagrams for easy conversion to a hot 10 (also 6 and 2) meter superhet receiver are included. Parts alone are worth much more than our low HHS Price. **\$19.98**

### HSS OIL CONDENSERS

1 MFD. 5000 Volt. With standoff insulators. **\$3.95**

2 MFD. 1000 Volt. Compact round type. Mounts in 7/8" hole. FOUR for **\$2.34**

**MAIL ORDERS?** Certainly! Just list everything you want (items in this ad, or any ad, magazine, or catalog) and include remittance.

Vy 73 de  
Bil Harrison, W2AVA

ever, tax savings on a more modest scale may be made, provided such improvements are needed and are going to be made eventually in any case.

Assuming that 1946 taxable income will be the same as 1945, taxpayers who have failed to make such improvements and repairs where needed, but who will do so in 1946 are losers by about \$3 on the \$100, due to the fact that 1946 tax rates are lower by 3 percent in various brackets. It should be observed that if tax rates are again reduced in subsequent years, the longer such improvements and repairs are deferred, the less they will be worth to the taxpayer as tax-savers. The only exception to this rule is where the taxpayer in later years has taxable income in higher brackets than in the past.

Reverting to painting to illustrate. This job, which effects a tax saving in 1945 of \$145, if deferred until 1946 would save only \$130 on a \$4,500 taxable income.

New equipment and fixtures with a shorter useful life than buildings would effect relatively higher savings in taxes. This is aside from greater profits accruing to owners by reason of such installations and improvements.

As depreciation represents a very substantial part of the cost of doing business—and as many taxpayers fail to take any depreciation or forget depreciation on certain items—taxpayers should deliberately take time to prepare an inventory of every last item that is subject to depreciation, regardless of its relative value. Numerous small items will aggregate in value as much as a major item. Such inventory should show date acquired, value at time of acquisition, rate of depreciation, amount of annual depreciation. In addition to providing that all rightful depreciation will be reported in the tax return, such an inventory will prove invaluable in event of a fire involving an insurance adjustment. A duplicate copy of the inventory should be kept off the business premises.

While tax returns provide for a separation of business expenses and personal deductions, the latter may have as profound an effect on the tax computed as the former. Both business expenses and personal deductions determine the owner's take-home compensation from his business.

Thus, the question of whether to use the short form (where the taxpayer's income permits) or to use the long form and report the personal deductions, should not be dismissed without careful thought. The wrong decision costs many taxpayers dearly every year. The same holds true on the long form option of showing deductions or taking the standard deduction of \$500, where income is \$5,000 or more. If in doubt, the taxpayer should figure his return both ways and compare, using the one giving the greatest tax saving.

Even if there appears to be no dif-

**HAM  
HEADQUARTERS**  
Since 1925!



**HARRISON RADIO CORPORATION**

10 WEST BROADWAY • NEW YORK CITY 7

PHONE—BArclay 7-9854 • EXPORT DEPT.—CABLE—"HARRISORAD"

[JAMAICA BRANCH—172-31 Hillside Ave.—REpublic 9-4102]

# TEST EQUIPMENT

**In Stock—NOW!**

Weston • Hickok • Sylvania • RCA  
Triplett • Simpson • Precision • Jackson  
Dumont • Dayco • Radio City Products  
Speco • Knight • Ferret • McMurdo Silver

Tube Testers • Signal Generators  
Chanalysts • Signal Tracers  
Condenser Testers  
Vacuum Tube Instruments  
Volt-Ohm-Milliammeters

**ALSO  
FINEST STOCK OF**

CONDENSERS  
VOLUME CONTROLS  
TRANSFORMERS  
RESISTORS  
TUBES

and all Dealer Equipment and Supplies

Write us for our Periodical Bulletins  
on REAL Dealer Values

Immediate attention to all Mail & Phone Orders

**RADIO TELEVISION SUPPLY CO.**

Dept. 11

1509 S. FIGUEROA ST., LOS ANGELES 15, CALIF.  
Phone: Richmond 9131 Cable Address: RATELCO

# National Union Announces an EXCLUSIVE RADIO MERCHANDISING PLAN for Service Engineers



HERE IT IS AT LAST! The radio line thousands of service engineers have been waiting for—yes, the radio that has *everything* the service trade needs to cash-in on today's big pent-up new set demand.

And who else but National Union could provide a merchandising plan for radio sets—so perfectly fitted to the service engineer's special needs?

For over 15 years National Union products, plans and policies have been shaped for the exclusive benefit of service dealers.

And now N.U. RADIO SETS are here—for the same service men who have so long known and used other N.U. products—and have found the N.U. way of doing business a better, more profitable one for their special type of operations.

**THE LINE**—5 models, of which one 5-tube and one 6-tube model are now ready; three others available in 90 days.

**THE PRODUCT**—Top quality throughout; precision-built chassis; beautiful cabinets in modern designs.

**PERFORMANCE**—Thoroughly up-to-the-minute; N.U. sets compare with the best in their class.

**PRICES**—Competitive with established brands.

**VOLUME REQUIREMENTS**—None! N.U. sets are not sold on a franchise basis. Order whatever quantity you need.

**DISTRIBUTION**—Sold only through N.U. Distributors and Service Dealers.



**PRESENTATION MODEL No. G619.** 6 Tubes. AC-DC. Tuned R.F. Stage. Superheterodyne Circuit. Loop Aerial. Automatic Volume Control. Illuminated Slide-Rule Dial. Standard American Broadcasts. Mahogany Veneer All-Wood Table Cabinet, 13" x 8 $\frac{3}{4}$ " x 6 $\frac{1}{2}$ ".



**COMPANION MODEL No. 571.** 5 Tubes. AC-DC. Superheterodyne Circuit. Built-in Antenna. Automatic Volume Control. 2-Gang Air Condenser Tuning. Illuminated Slide-Rule Dial. Standard American Broadcasts. Walnut Veneer All-Wood Table Cabinet, 13 $\frac{3}{8}$ " x 7 $\frac{7}{8}$ " x 8 $\frac{1}{2}$ ".

#### OTHER MODELS NOW BEING PLANNED

- A 3-Way (AC-DC-Battery) Portable Model.
- A Combination Table Model Radio-Phonograph with Automatic Record Changer.
- A 6-Tube Battery-Powered Farm Radio Table Model.

Here, for the first time, is a practical post-war radio line for the service engineer to handle—a group of fine modern radio sets—but *above all* a proven merchandising plan which *fits*. Ask your N.U. Distributor for the complete facts today!

NATIONAL UNION RADIO CORPORATION, NEWARK 2, N. J.

## NATIONAL UNION RADIOS, TUBES AND PARTS

Transmitting, Cathode Ray, Receiving, Special Purpose Tubes • Condensers • Volume Controls • Phototubes  
Panel Lamps • Flashlight Bulbs • Radio Sets • Auto Vibrators • Ballasts • Batteries



"SPIRIT OF FREEDOM"  
5-GAITED CHAMPION GELDING  
MR. STANLEY JOHNSTON, OWNER

MISS SHIRLEY MOLOFAN  
WINNING MODEL  
"MISS PHOTO-FLASH OF 1946"

*Unbelievable*  
**QUALITY**

*... is the mark of a champion*

## OXFORD SPEAKERS

ARE BUILT ON THAT PRINCIPLE

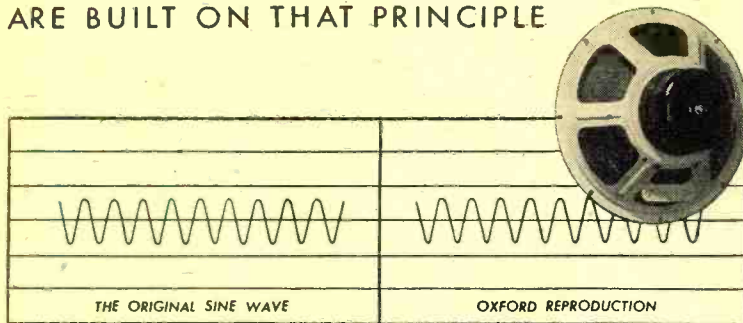

The accuracy and beauty of sound reproduction from a loudspeaker depends largely upon the excellence of the speaker design, the skill that goes into its construction, and the quality of its components. At OXFORD, none of these basic facts are overlooked. Each unit reflects the careful consideration which has gone into every step of its manufacture. Because of this, OXFORD SPEAKERS represent a precision-built instrument from which fine sound reproduction is the rule rather than the exception.

**OXFORD RADIO CORPORATION**  
3911 SOUTH MICHIGAN AVE., CHICAGO

### PRE-EXAM TESTS

For Commercial  
Radio Operator

### FCC LICENSE EXAMINATIONS



- |  |   |
|--|---|
| Rehearse the FCC license examinations                        | Check your knowledge  |
| Practice the procedure                                       | Locate your weak points                                       |
| Practice the multiple-choice examination methods used by FCC | Correct your weak points before taking the actual examination |

Prepared by Arthur R. Nilson, Famous Co-author of Nilson and Hornung's  
**RADIO QUESTIONS AND ANSWERS**  
Cleveland Institute of Radio Electronics, RN-11, Terminal Tower, Cleveland 13, Ohio

### DON'T TAKE A CHANCE

Avoid Failure on FCC Commercial Radio  
Operator License Examinations!  
USE NILSON'S COMPLETE PRE-EXAMINATION  
TESTS AND COACHING SERVICE

Enables You To

Cleveland Institute of Radio Electronics  
RN-11 Terminal Tower, Cleveland 13, Ohio  
Please send information about Pre-Exam Tests.

Name .....

Address .....

City.....Zone.....State.....

ference in income tax by use of either method, the taxpayer may still effect savings by showing his deductions, if he anticipates the situation before year-end. This situation arises where the taxpayer, as is frequently the case, owes personal bills which, if paid in the tax period reported, may be taken as personal deductions. This, of course, involves taking a snap account prior to year-end, and it is suggested that taxpayers make a memorandum on this point and keep with their tax papers where, before year-end 1946, they may be reminded of this particular tax-saver.

Let us assume that a taxpayer owes a medical bill of \$500 which he let go unpaid until 1946. However, if he had paid this bill by year-end 1945 in time to report in his current 1945 tax return (assuming that otherwise short or long form show about the same tax) he may make a tax saving ranging from \$115 upward, depending upon what tax bracket the upper layer of his taxable income is in. The same rule applies to other personal items of a deductible character, which he may elect to pay by year-end, instead of deferring, if by paying his total of personal deductions are boosted above the ten percent allowed by the short form, or by the standard deduction.

Conversely, where payment of such items may not aid him taxwise, he may elect to take the short form or standard allowance for personal deductions, and make such payments on deductible items in the ensuing year when he expects they will bulk large enough to give him a tax saving by use of the long form.

Other deductions of a personal character frequently overlooked include loss from accident, storm, hurricane, fire, flood, etc., to personal property, usually forgotten by the time the income tax is prepared. Such deductions, of course, may be taken only to the extent not covered by insurance. Losses sustained by theft, either cash or property, are also deductible, if not recovered by insurance.

Above all else, no hard and fast rules may be made that apply to all taxpayers in all circumstances. Presented with certain alternatives and choices, what a given taxpayer should do is as individual as is each taxpayer's income tax return. It has been the purpose of this article—showing by illustration—to point out that taxpayers, by becoming tax-conscious as a year-around state of mind, may be able to meet certain situations and make certain decisions with tax-saving considerations in mind and who may, without violating the tax code, effect material tax savings for themselves in the burdensome tax years ahead of us.

They should develop an inquiring mind taxwise. They should not only ask themselves: "Can I afford this?" and "Is this sound business?" but also add to these queries a new question: "How will this affect my income tax?"

**MONTH AFTER MONTH**

**ARTICLE AFTER ARTICLE**

**FACT AFTER FACT**

*...pointing your way to leadership  
in the radio servicing business*

RADIO MAINTENANCE Magazine, with its complete, up-to-date coverage of all the problems of a radio shop, can be the secret of your success. For, in each information-packed issue, you get full details about new developments in the industry . . . solutions to both everyday and unusual problems likely to confront you in the shop or on outside jobs . . . descriptions and analyses of new products and equipment . . . comprehensive discussion of various aspects of the industry by qualified authorities. So, with each issue, you move closer to the top in your work. That's why it pays to read RADIO MAINTENANCE from cover to cover when you get it and to keep your copies as a handy library of reference. You'll find that, over a period of time, your file covers everything you need and want to know on every conceivable phase of radio servicing. Yes, you'll always find RADIO MAINTENANCE a real help . . . all ways.

*regular monthly features of  
special help and interest*

Radio Service Bench—Service Kit—Electronically Speaking—Review of Trade Literature—Industry Presents (new products)—Radio Men's Opinions



**ONE ISSUE  
FREE**

**IF PAYMENT IS ENCLOSED**

November, 1946



**RADIO MAINTENANCE MAGAZINE** R. N. 11  
460 BLOOMFIELD AVE. MONTCLAIR, N. J.

Please enter my subscription as follows:

For 12 Issues   
at \$2.50

For 24 Issues   
at \$4.00

NAME \_\_\_\_\_

\*OCCUPATION \_\_\_\_\_

ADDRESS \_\_\_\_\_

CITY \_\_\_\_\_ ZONE \_\_\_\_\_

STATE \_\_\_\_\_

\*State whether Radio Serviceman, Jobber or Dealer.

**BY SUBSCRIPTION ONLY**

**Order from LAKE!  
You'll Make No Mistake!**

**RADIO CABINETS & PARTS**

**NOW AVAILABLE!  
Postwar  
2 Post  
RECORD-  
CHANGER**



With luxurious brown leatherette portable case, 15" L x 15" W, x 10" D. Latest electronic developments make this modern record-changer the finest on the market today!

**CHANGER \$19.00  
CABINET FOR SAME \$8.95**

**DE LUXE RECORD-CHANGER and  
AMPLIFIER CASE**

De luxe changer case with ample room for amplifier. Overall dimensions: 20" L. x 16" W. x 10" H. Sturdily built of 3/4" plywood, de luxe brass hardware throughout. Inside dimensions: 15 1/2" L. x 14 3/4" W. x 9 1/2" H.

**\$12.95**



**DeLuxe  
PHONO  
CABINET**

Covered in luxurious, genuine brown leatherette, has deluxe brass hardware throughout, made completely of

plywood with brown plastic handle, has padded top and bottom. Motor board 14" x 14 1/2". Overall dimensions 16" L. x 15" W. x 8" H. Your net price. **\$8.95**

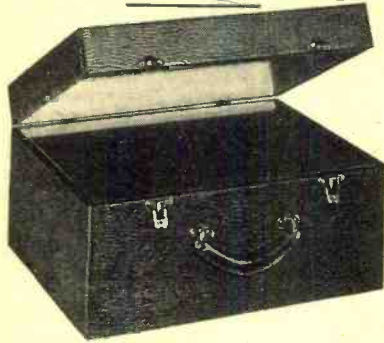

Portable Phonograph case, of sturdy, durable plywood, in handsome brown leatherette finish. Inside dimensions 10 1/2" long, 14" wide, 9 1/2" high. Has blank motor board. As illus. **\$6.95**

Also blank table cabinets of walnut veneer in the following sizes, with speaker opening on left front side: (\*Note: \*7 has center speaker grill.)

#1	8 1/4"	L x 5 1/2"	H x 4"	D \$1.95
#2	10"	L x 6 3/8"	H x 5"	D \$2.75
#3	13 1/2"	L x 7 3/8"	H x 6 1/4"	D \$3.25
#7	10 3/4"	L x 7"	H x 5 1/2"	D \$2.50

\*Speaker Opening in center of front side.

All types of radio cabinets and parts are available at LAKE's Lower prices. A large stock is listed in our catalog.

**SERVICEMEN—RETAILERS**  
Join our customer list today.  
Dept. A

Write for our NEW, 12 page, illustrated elaborate catalog!

**Lake Radio Sales Co.**  
615 W. Randolph Street  
Chicago 6, Ill.



**CIRCUIT PAGE**

(FOR PARTS LISTS SEE PAGE 70)

**RADIO NEWS, NOVEMBER, 1946 GENERAL ELECTRIC MODELS 219, 220, 221**

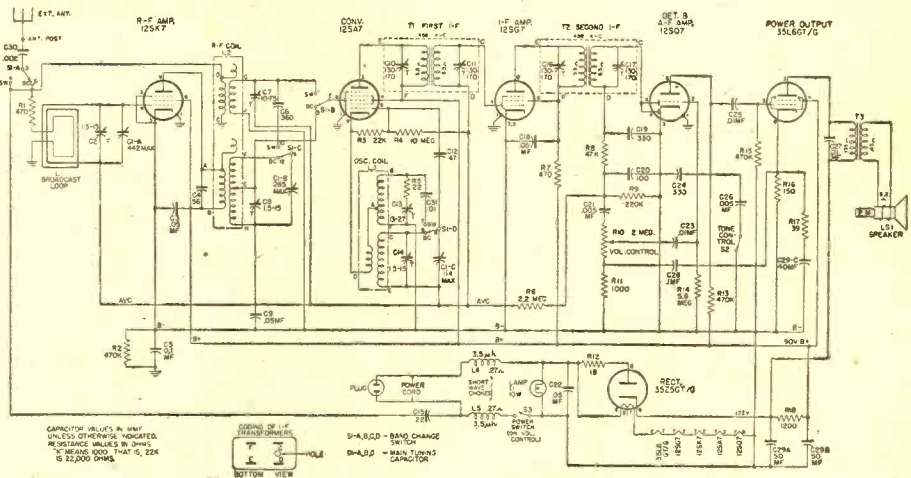

**RADIO NEWS, NOVEMBER, 1946**

**GRANTLINE MODELS 605, 606**

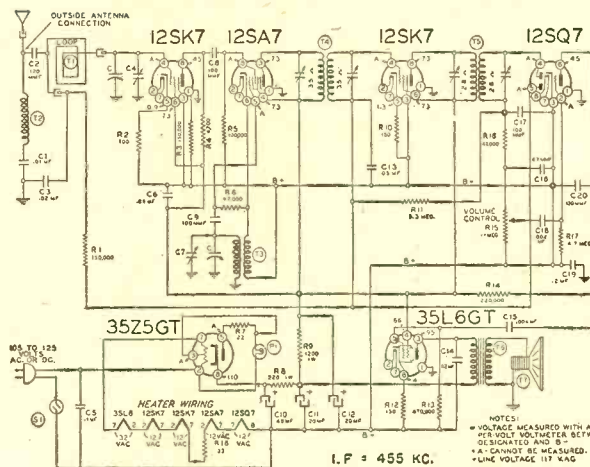

**RADIO NEWS, NOVEMBER, 1946**

**ARVIN MODELS 444, 444A**

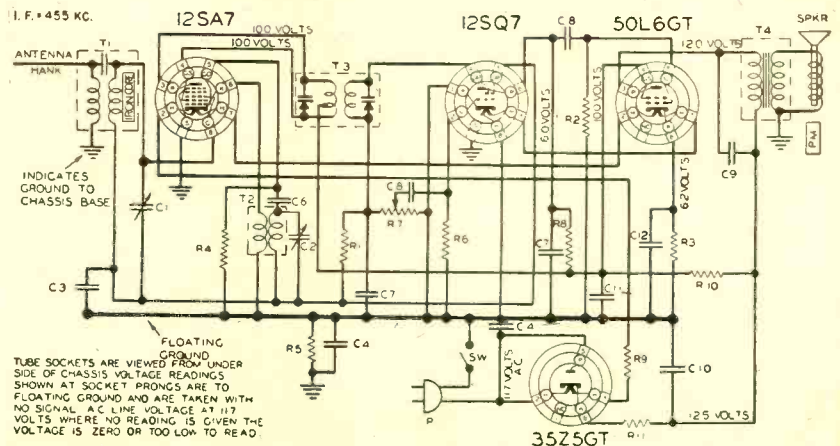



Here, and on following pages, are circuit diagrams and parts lists of many new postwar radio receivers. Radio News will bring to you other circuits as quickly as possible after we receive them from manufacturers.



To some men "radio" is a magic word. It pi ques their curiosity—fires their imagination—spurs them to action! Their every thought is devoted to mastering the complex mechanisms by which radio is controlled.

Experience has proved that such men, with radio in their blood, make the finest technicians. As they say, in measuring top talent radio programs, these men have a high "Hooper"—they're tops!

It has been our good fortune to attract as students and to develop thousands of such men from "hams" into well qualified technicians in broadcasting, communications, sound, manufacturing, sales and service.

Yes, since the inception of radio we have helped direct the destinies of thousands of aspiring men seeking an outlet for their talents. During the past four decades we have acquired an interesting insight into the motives which inspire mechanically minded men to apply their skill and training to assure maximum efficiency on the job.

For this reason we believe we can be of service to you in your personnel problem—as it applies to your technical staff.

We think you'll be interested in our observations, as they apply to YOUR personnel problems. We feel certain you'll want to clip the coupon below and send for our free booklet "Report to Industry." Whether you employ one man or hundreds, you will enjoy this factual, informative presentation. Send for it today! No obligation.

**NATIONAL SCHOOLS**

Pioneers of Technical Trade Training Since 1905  
Figueroa at Santa Barbara  
Los Angeles 37, California

Fill out and mail to  
PUBLIC RELATIONS DIRECTOR  
National Schools—Figueroa at Santa Barbara  
Los Angeles 37, California  
Please send me "Report to Industry"  
No. N-11.

Name \_\_\_\_\_  
Title \_\_\_\_\_  
Address \_\_\_\_\_  
City \_\_\_\_\_ Zone \_\_\_\_\_ State \_\_\_\_\_

RADIO NEWS, NOVEMBER, 1946

TRUETONE MODEL D2616

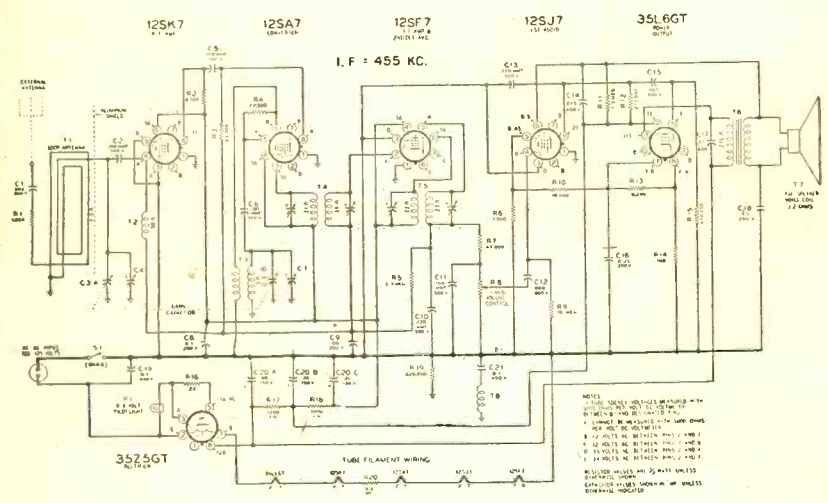

RADIO NEWS, NOVEMBER, 1946

GAROD MODEL 6AU-1

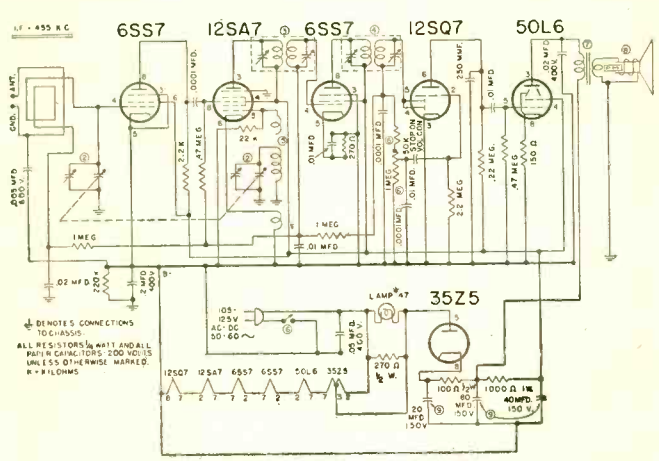

RADIO NEWS, NOVEMBER, 1946

BELMONT MODEL 5D128

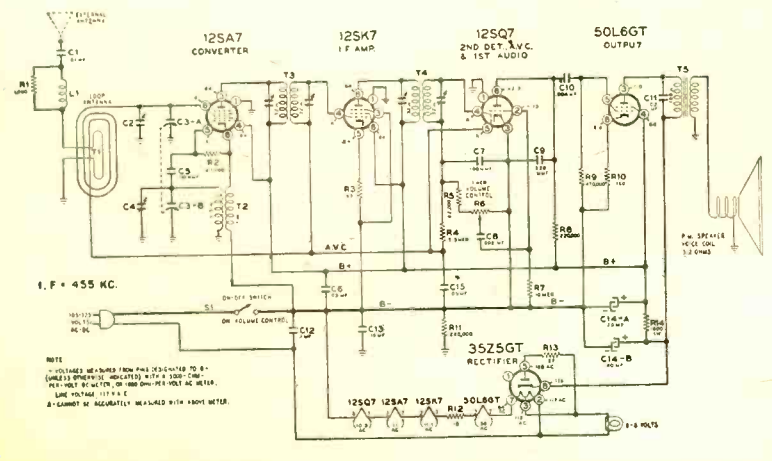

# METROPOLITAN

Guarantees Delivery From Stock!

## B-45 SIGNAL GENERATOR

for  
Servicing  
AM  
FM  
Television  
Receivers



Self-modulated Signal Generator providing a highly stable signal. Generates R.F. frequencies from 150 Kc. to 50 Mc. (150 Kc. to 12.5 Mc. on Fundamentals and from 11 Mc. to 50 Mc. on Harmonics). R.F. is obtainable separately or modulated by the Audio Frequency. Television and F.M. as well as A.M. receivers can now be speedily aligned. Modulation in the B-45 is accomplished by Grid-blocking action which has proven to be equally effective for alignment of amplitude and frequency modulation as well as for television receivers. Positive action attenuator provides effective output control at all times.

The R.F. Signal Frequency is kept completely constant at all output levels. This is accomplished by use of a special grid loaded circuit which provides a constant load on the oscillatory circuit. A grounded plate oscillator is used for additional frequency stability.

The Model B-45 is truly portable—no external source of current required. Operates on self-contained batteries. A standard "D" size 1½-Volt battery is used for the filament and a standard 45-Volt battery is used for the plate. Long battery life is assured. The filament circuit consumes only .1 Ampere and the plate circuit drain is only a few milliamperes.

Direct reading—all calibrations are etched on the front panel.

Complete with shielded test lead, self-contained batteries and instructions.

**\$2775**



### New Model 670 SUPERIOR SUPER-METER

A Combination VOLT-OHM MILLIAMMETER plus CAPACITY REACTANCE INDUCTANCE and DECIBEL MEASUREMENTS. Includes a special GOOD-

BAD scale for checking the quality of electrolytic condensers at a test potential of 150 volts. Complete with test leads and operating instructions.

**\$2840**

**FREE** Write for New 1947 Complete Catalog

**Metropolitan**  
ELECTRONIC & INSTRUMENT CO.

Dept. R, 6 MURRAY STREET  
NEW YORK 7, N. Y., U. S. A.

Phone: BArcly 7-5556

Cable Address: METRONICS

# What's New in Radio

## PORTABLE COMBINATION

One of the new combination radio-phonographs to come off the production line at Viewtone Television & Radio Corporation is a portable model



which can be carried like luggage or be used as a table model in the home.

An easy-to-operate automatic record-changer handles ten 12" or twelve 10" records and features a crystal pickup. The player turns off automatically after the last record in the stack has been played. A self-locking arm protects the unit when the machine is being carried.

The radio is a five-tube superheterodyne with a.v.c. and a built-in aero loop. The receiver comes in a sturdy, two-tone simulated leather case with lock and key.

Additional information on this combination radio phonograph is available from Charles W. Robbins, national distributor, Viewtone Television & Radio Corporation, 81 Willoughby Street, Brooklyn 1, New York.

## TUBE TESTER

Radio City Products of New York is currently offering a new tube tester, the Model 322.

A special Dynoptimum circuit permits rapid operation of the instrument with only four controls. This simplicity of operation saves time and reduces obsolescence, according to the manufacturer. Special adaptors are



incorporated in the tester for checking individual sections of multipurpose tubes. A convenient jack is provided for headphone test of noisy, swinging, or high resistance connections.

The tester is available in two types, the Model 322 is open-faced and is housed in a crackle-finish steel cabinet. The Model 322-P is supplied in a black crackle-finish welded metal portable carrying case.

Descriptive material and prices will be furnished by Radio City Products Company, Inc., 127 West 26th Street, New York 1, New York.

## POCKET SIZED TESTER

Naken Engineering & Manufacturing Co. of Chicago have recently introduced a pocket-sized continuity tester which houses in one unit all the necessary parts to perform such continuity tests.

The tester consists of a battery, bulb and buzzer with jacks provided for connections and the selection of either bulb or buzzer. The tester may be used in such a way that the self-contained battery is out of the circuit. With this mode of operation the presence of a potential can be detected.

Prices and complete data about this unit will be supplied by Naken Engineering & Manufacturing Co., 25 North Franklin Street, Chicago, Ill.

## NEW POWER TETRODE

The Tube Division of General Electric Company has announced the production of a new four-electrode transmitting tube, Type GL-5D24 for use

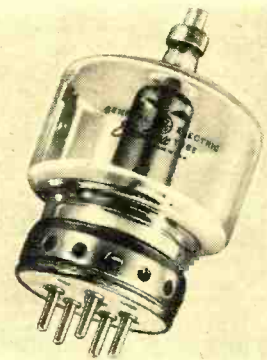

as an amplifier, oscillator or class B modulator.

This tube was designed to provide a basic power tube for FM transmitters. Because of the frequency range that includes the six-meter band, the tube is also applicable in class "C" telegraphy.

Maximum ratings of the GL-5D24 apply up to 85 megacycles. Tests made on the tube show a maximum d.c. plate voltage rating of 3500 volts, a maximum plate input rating of 600 watts and a maximum plate dissipation rating of 200 watts for continuous commercial service. Under intermittent commercial or amateur service conditions the ratings of the d.c. plate voltage, the plate input and the plate dissipation may be increased to 4000 volts, 1000 watts and 250 watts, respectively.

**RADIO NEWS**

# MAKING TUBES IS EASY...



*If*  
**YOU KNOW  
HOW!**

Hytron commercial engineer makes precision measurements of 50L6GT performance in many typical radio receivers. He then compiles weighted averages of tube characteristics selected to be correlated for functional testing.

Out of the commercial engineer's investigations grows this functional production tester. Combined functional and standardized tests are quicker. Operator can be even more accurate, and you are assured of more uniform performance.



## **FUNCTIONAL TESTING..**

You may have discovered that a tube rigidly inspected by standardized testing procedures (JAN, RMA, IRE) still may not perform satisfactorily in your equipment. Ordinary control of basic characteristics may not be enough. Functional dynamic tests—selected and correlated to simulate performance in typical equipment applications—may have to be added.

Simple analogy explains why. Testing of fundamental tube characteristics is like inspection of individual components of multi-ganged tuned circuits. When the tuner is assembled or the tube connected into a circuit, coils and condensers or tube characteristics may not combine properly. Individual variations within tolerances may be in opposition. Operational tests are the only positive checks.

Hytron commercial engineers, therefore, developed functional testers like the illustrated 50L6GT production test kit

## *Another* **HYTRON EXTRA!**

—essentially a customary equipment circuit. Whether or not a part of the standardized tests, 50L6GT characteristics related to power sensitivity and output are simultaneously checked for smooth dynamic interaction. This comprehensive functional test automatically includes additional minor tests—pertinent but usually omitted from production testing. Hum itself is also measured, because no basic characteristic test controls it adequately.

Functional testing is another Hytron extra. Based on painstakingly acquired know-how, it is often the best and easiest way to assure you of uniform, reliable tube performance in your equipment.

SPECIALISTS IN RADIO RECEIVING TUBES SINCE 1921



# **HYTRON**

**RADIO AND ELECTRONICS CORP.**



MAIN OFFICE: SALEM, MASSACHUSETTS

# NEW SOLDERING GUN

*Heats in 5 Seconds*



## SPECIAL SOLDERING GUN ADVANTAGES

TIP STAYS TINNED  
NO BURNING

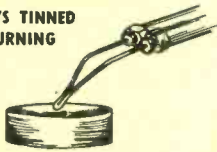

SEE WHERE  
YOU SOLDER



SOLDER AROUND  
CORNERS

Service and maintenance men can save time by the fast heating of the Soldering Gun. By use of the new induction principle, 5 second soldering heat is supplied from a light weight built-in transformer.

The loop type tip gives you other advantages that are important in soldering. Good balance with weight close to your hand makes it easier to use. The narrow tip gets in between a lot of wiring with ease. Connections can be made without burning insulation. The tip can be formed readily to work in tight places.

See your radio parts distributor for a demonstration, or write direct for descriptive bulletin.

- ★ 100 Watts 115 Volts 60 Cycles
- ★ Intermittent Operation With Trigger Switch
- ★ Can't Overheat or Burn Out
- ★ Impact Resisting Case
- ★ Handle Stays Cool
- ★ Good Balance—Weight Close To Hand

512 NORTHAMPTON ST.

**WELLER MFG. CO. Easton, Pa.**

# HOW TO PASS Commercial Radio Operators' FCC LICENSE EXAMINATIONS...

How To Pass  
FCC  
LICENSE  
EXAMINATIONS

CLEVELAND INSTITUTE  
of  
RADIO ELECTRONICS  
Terminal Tower Cleveland, Ohio

## FREE BOOKLET

Tells you the Government Requirements for all classes of commercial licenses. Saves you many hours of random, undirected study. Assures a minimum of time in getting your ticket!

Approved for Veteran Training Under  
G-1 Bill of Rights

## CLEVELAND INSTITUTE OF RADIO ELECTRONICS

Successors to Nilson Radio School, founded 1939  
Smith Practical Radio Institute, founded 1934

RN-11 TERMINAL TOWER CLEVELAND 13, OHIO

MAIL THIS COUPON

Don't Delay—  
Write Today!

CLEVELAND INSTITUTE OF RADIO ELECTRONICS  
RN-11 Terminal Tower, Cleveland 13, Ohio

Gentlemen: Please send your FREE Booklet, "How to Pass FCC License Examinations."  
(NOTE: This booklet does not cover examinations for Amateur Licenses.)

Name .....

Address .....

City ..... Zone ..... State .....

If a Veteran check here

Further information on the GL-5D24 is available on request to the Tube Division, Electronics Department, General Electric Company, Schenectady, New York.

## NEW RECORD CHANGER

The Model 70 automatic record changer has recently been added to the Webster-Chicago Corporation's line of production and replacement units.

This unit will play a 1 1/8" stack of 10 and 12 inch records intermixed. An



automatic "disengage" device relieves pressure on the rubber drive wheel when the machine is not in use. The Model 70 also includes velocity trip, automatic shut-off, improved rim drive and 4-pole shaded pole motor. The stainless steel spindle is spring cushioned to prevent center hole wear of records.

This model will be available soon through regular distribution channels. Additional data on the Model 70 will be furnished by Webster-Chicago Corporation, 5610 Bloomingdale Avenue, Chicago 39, Illinois.

## HOME RECEIVER

Hallicrafters Company of Chicago have introduced their first home receiver, the Echophone Model EC-113, a five tube (plus rectifier) a.c.-d.c. table model unit.

An innovation in the form of electric bandsread tuning has been intro-

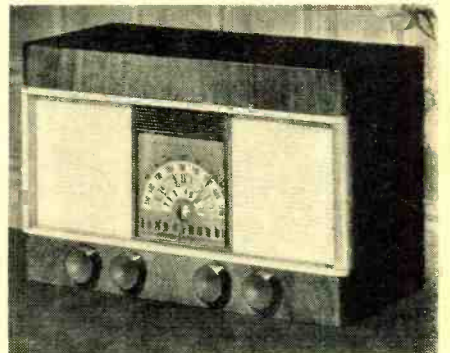

duced in this receiver. It provides, by means of a separate linear bandsread scale, wide separation of stations at all frequencies in the short-wave ranges.

The inside of the cabinet is tropicalized with special aluminum base seal coating.

Terminals have been provided for external antenna and ground for

(Continued on page 114)

# MINE DETECTORS

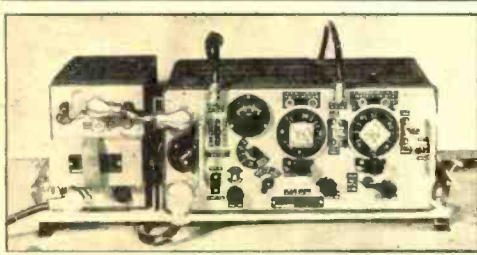

## NEW COMPLETE TRANSMITTING AND RECEIVING SETS \$68.50

No. 19—Mark I-II-III Tank, made by Zenith & Emerson, lend-lease Russia.

Trans. 6 tubes 807 final, grid mod. tel. 2 to 8 meg. cont. var. Includes 80 & 40 m. bands. Receiver 6 tube Super-Het. Also included Intercom. Sys. 3 control boxes, 3 Comb. head phones & mikes; power supply, dynamotor, 12 volts. Ideal for mobile or marine. Also includes ant., variometer. Shipping weight in crates 300 lbs. (& spare set of tubes).

# TUBES! TRANSFORMERS! CONDENSERS!



AMERTRAN PLATE TRANSFORMER! 115v-60 cycle primary 6200 volt-ct-700 mil secondary, also tapped at 2850v. Size 11" x 14" x 10"  
This buy goes for **\$39.95**



HI-VOLT TRANSFORMER 1/2 WAVE RECTIFICATION 115v-60c/3200v @ 150mils. MADE BY KENYON **\$9.95**

## NEW USN NAVY MODEL RAK-7 SHIP RECEIVER

15 kc to 600 kc. 6-tube receiver with: AVC-Band pass filter—Audio filter Noise limiter—Precision tuning with a Vernier dial— Voltage regulated power supply, with three tubes, for 60 cycle, 115 volts. Can be battery operated. Complete with spare parts box weighing 73 lbs., spare tubes and inst. book **\$73.50**



## NAVAL AIRCRAFT RADIO

NEW ARC-5 SUPERHET RECEIVERS. Tubes (included) 3-12SK7; 1-12K8; 1-12SR7; 1-12AG7. Range (specify freq. desired): 190-550 KC; 1.5-3 mc; 3-8 mc; 8-9.1 mc. Power: 24-28 VDC. Unit and Dynamotor..... **\$37.50**

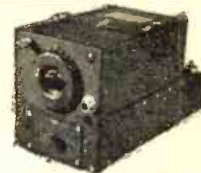

NEW ARC-5 TRANSMITTERS: 25 watts CW; 15 watts phone. Tubes (included): 2-1625; 1-1629; 1-1626; 1-6200 Kc crystal RANGE; (specify freq. desired): .5-8 mc; 8-1.3 mc; 1.3-2.1 mc; 3-4 mc; 4-5.3 mc; 5.3-7 mc; 7-9.1 mc. POWER: 24-28 VDC. MODULATOR with: **\$59.50**  
1-1625; 1VR-150; 1-12J5 28V Dynamotor Extra .....\$16.00

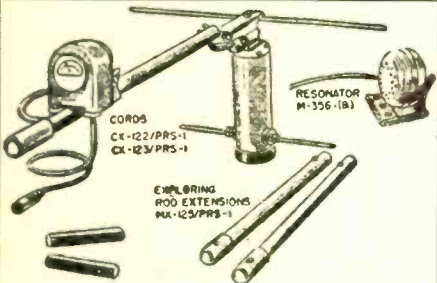

## NEW AN/PRS-1/MINE DETECTORS

—For detecting metallic and non-metallic materials by indicating either aural or visual means or both. Set consists of: Detector head, antenna and reflector, meter and housing (illus.). Amplifier assembly AM-32/PRS-1, complete (headset H8-30-B). Operates from two 45v; one 6v; one 3 volt. batteries. (Batteries not included.) Worth approximately \$175.  
Complete unit with tubes..... **\$27.50**

## NEW CATHODE RAY TUBES!!!

Made by North American Philips. These tubes are listed at five to six times our price!

Tube	Approx. List Price	Cost
3BP1	\$15.00	\$3.95
3BP1	15.00	3.95
3FP7	27.00	5.95
5BP1	20.00	4.95
5BP4	27.00	5.95
5CP1	28.00	4.95
5CP7	45.00	6.00
5FP4	32.00	4.95
5FP7	37.00	6.25
5JP1	50.00	13.50
5JP2	48.00	13.50
5LP1	41.00	8.00



Sockets for the 5CP1 and similar types ..... **\$0.95**

We have many of these tubes in quantity for manufacturers. **INQUIRE**

## U.H.F. Receiver, from SCR-268

Tunes from 201-210 mcs. Has 15 tube superhet circuit. Uses 6 acorn tubes in RF; 4 6SK7's in I-F stage designed for 20 mc, with 2 mc bandwidth. Designed for use on 115v/60c. **\$21.95**  
New low price with 15 tubes.....  
With Tuning Motor..... **\$24.95**



1-F Crystal filter for BC-312, BC-342. Resonant at 470 kc. Crystal **\$6.95** incl.



TS-13 handset with 50-ohm mike 200-ohm phone. 1 each PL-55 & PL-68. Selling brand new **\$5.95**



SPECIAL Price HURRY!!

RG-8/U... .05 per foot  
RG-9/U... .05 per foot  
RG-38/U... .05 per foot  
Minimum order \$1.50  
Limited Stock at This

## TRANSMITTING CONDENSERS

A. Cardwell type TC-300-US. 300 mmf. max. .2" spacing between plates. Ruggedly constructed. List value of \$40.50. **\$9.85**  
Our new low price.....  
B. Johnson type 500D35. Maximum cap. 500 mmf. min 35 mmf. .08" spacing, 3500v. Listed at \$11.75. **\$4.75**  
Lowered to.....



## PULSE AMPLIFIER

Signal Corps type BC409. Designed for 115 volts, AC 60 cycles. Component parts worth several times the price of this unit. Slightly used. Following are a few of the items that make up the unit.  
1-304TL (Elmco).  
3-2 mfd. 4,000 W.V. GE Pyranol condensers.  
1-3200 volt, 150 MA power transformer.  
1-Variac 5 amps, General Radio type CU 200.  
1-2 volt, 20 Amp. Al. transformer (for 304 TL).  
1-2.5 volt, 10 Amp. Al. transformer (5000 volt insulation).  
1-1 mfd. 1,000 volt, GE Pyranol. With **\$59.50**  
1-2 mfd. 1,000 volt, GE Pyranol. Tubes



**TRANSFORMERS**  
Modulation XFMR: For 211's et. A. 50 Watts 1.10  
Modulation XFMR: 811's to 813..... 5.00  
Driver: 6V6 to pair 811's..... 3.00  
CHI Trans. P.P. Mod. & Driver, 6L6's-per pair..... 3.30  
PWR: 115 v. 60c/330-0-330. 85 ma/6.3 v..... 3.95  
7.5v/8v/2v/6.3v-3..... 3.95  
PWR: 115 v. 60c/750v-110 ma/ct./6.3v-5a/5v-3a..... 5.95  
H.V. Plate: 115v/60c/2750v-750 ma oil, Navy Specs..... 35.00  
Swinging Choke: 2.5 hy @ 375 ma; 10 hy @ 75 ma..... 3.95  
**TRANSMITTER PARTS**  
GE Pyranol 23F47 2 mfd 4000 VDC (List \$30)..... 5.95  
SANGAMO G-4 Mica .004 mfd. 20,000 v (List \$110)..... 25.50  
Mica, Sangamo P3L .0005-8000 VDC (List \$20)..... 5.25

Oscilloscope Transformer. Ideal for 7 inch tubes, 9000 volts @ 10 ma. This unit, list for \$25.50 is..... **\$11.95**

Condenser Special, 4000 mfd @ 30 Listed at \$13.50 released for..... **\$ 2.40**

BX-4 Battery box used with the BC-178 Receiver-transmitter. Will hold 2-# 6 1 1/2 volt dry cells; 4-22 1/2 v. "B" batteries; 1-4 1/2 v. "C" batteries. Ideal for a portable test unit or a **\$1.95** set

SEND FOR OUR CATALOG  
All merchandise guaranteed. Mail orders promptly filled. All prices F.O.B. New York City. Send Money Order or Check. Shipping charges sent C.O.D. Send for Flyers.  
**COMMUNICATIONS EQUIPMENT CO.**  
131-A LIBERTY ST., NEW YORK 7, N. Y. TELEPHONE WH 4-7658

ALSO  
LARGE INVENTORY OF 400 CYCLE TRANSFORMERS. SEND FOR LIST.



**ARMY-NAVY**  
*Official*  
**HEAD PHONES**  
**\$2.49**

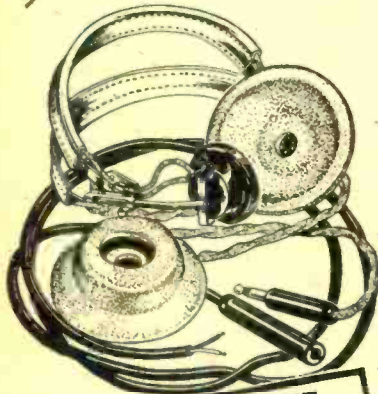

**BURSTEIN-APPLEBEE**  
*Made A Lucky Buy*

Limited quantity of these fine brand new head phones. Highly sensitive, 8000 ohms impedance. Bi-polar magnets, bakelite shell and cap. Adjustable head band, leather covered side, out of the way. Molded spring steel. Cord connects from one sponge rubber ear cushions. Our price only \$2.49 per set plus 20c postage and packing charges. Retail value \$13.50. Order Number 17A37.



**MAIL THE COUPON**  
**FREE CATALOG**

Latest developments in radio and electronic parts and devices, newest ham gear, gadgets, bargains, war surplus items... get this red hot bargain catalog FREE.

**18 YEARS**  
**IN**  
**RADIO**



**BURSTEIN-APPLEBEE CO.** Radio News  
1012 McGee St., Kansas City 6, Mo.

Send me your new FREE Catalog.  
Send me \_\_\_\_\_ pair of phones at \$2.49 per pair plus 20c pair postage. I enclose \$\_\_\_\_\_ in payment.

NAME \_\_\_\_\_  
ADDRESS \_\_\_\_\_  
TOWN \_\_\_\_\_ STATE \_\_\_\_\_

# Parts Lists

(FOR CIRCUIT DIAGRAMS APPEARING ON PAGES 64 AND 65)

**TRUETONE—MODEL D2616**

Part No. Code and Description  
C-9B1-62 R<sub>1</sub>—1000 ohm, 1/2 w. res.  
C-9B1-70 R<sub>2</sub>—4700 ohm, 1/2 w. res.  
C-9B1-80 R<sub>3</sub>—33,000 ohm, 1/2 w. res.  
C-9B1-78 R<sub>4</sub>—22,000 ohm, 1/2 w. res.  
C-9B1-34 R<sub>5</sub>—3.3 megohm, 1/2 w. res.  
C-9B1-64 R<sub>6</sub>—1500 ohm, 1/2 w. res.  
C-9B1-82 R<sub>7</sub>—47,000 ohm, 1/2 w. res.  
A-10A-10642 R<sub>8</sub>, S<sub>1</sub>—Vol. control and sw.  
C-9B1-37 R<sub>9</sub>—10 megohm, 1/2 w. res.  
C-9B1-77 R<sub>10</sub>—18,000 ohm, 1/2 w. res.  
E-9B1-32 R<sub>11</sub>—1.5 megohm, 1/2 w. res.  
C-9B1-91 R<sub>12</sub>—270,000 ohm, 1/2 w. res.  
C-9B1-73 R<sub>13</sub>—8200 ohm, 1/2 w. res.  
C-9B1-53 R<sub>14</sub>—180 ohm, 1/2 w. res.  
C-9B1-94 R<sub>15</sub>—470,000 ohm, 1/2 w. res.  
C-9B1-3 R<sub>16</sub>—22 ohm, 1/2 w. res.  
C-9B2-63 R<sub>17</sub>—1200 ohm, 1 w. res.  
C-9B2-62 R<sub>18</sub>—1000 ohm, 1 w. res.  
C-9B1-90 R<sub>19</sub>—220,000 ohm, 1/2 w. res.  
C-9B2-44 R<sub>20</sub>—33 ohm, 1 w. res.  
C-8D-10778 C<sub>21</sub>—0.02 μfd., 600 v. cond.  
C-8F3-8 C<sub>22</sub>, C<sub>23</sub>, C<sub>24</sub>, C<sub>25</sub>—100 μfd., 500 v. mica cond.  
B-8A-10827 C<sub>26</sub>, C<sub>27</sub>, C<sub>28</sub>—Two-gang cond. assembly including antenna and osc. trimmers. Range of gang: 15-452 μfd. (ant.) 10-162 μfd. (osc.)  
C-8D-10771 C<sub>29</sub>—1 μfd., 200 v. cond.  
C-8D-10770 C<sub>30</sub>—0.5 μfd., 200 v. cond.  
C-8F3-10 C<sub>31</sub>, C<sub>32</sub>—220 μfd., 500 v. mica cond.  
C-8D-10788 C<sub>33</sub>—0.04 μfd., 400 v. cond.  
C-8D-10997 C<sub>34</sub>—0.25 μfd., 400 v. cond.  
C-8D-10935 C<sub>35</sub>—0.05 μfd., 600 v. cond.  
C-8D-10775 C<sub>36</sub>—25 μfd., 200 v. cond.  
C-8D-10761 C<sub>37</sub>—0.1 μfd., 400 v. cond.  
C-8D-10760 C<sub>38</sub>, C<sub>39</sub>—1 μfd., 400 v. cond.  
C-8C-10077 C<sub>40a, b</sub>, C<sub>41</sub>—60/40/40 μfd., 150 v. elec. cond. (25 cycles)  
C-8D-10946 C<sub>42a, b</sub>, C<sub>43</sub>—40/20/20 μfd., 150 v. elec. cond. (60 cycles)  
C-201-10908 T<sub>1</sub>—Loop antenna assembly  
A-16A-12161 T<sub>2</sub>—R.f. choke coil  
A-13D-10661 T<sub>3</sub>—Osc. coil  
B-13B-10091-1 T<sub>4</sub>—Input i.f. trans.  
B-13B-10794 T<sub>5</sub>—Output i.f. trans.  
B-12C-10623 T<sub>6</sub>—Output trans. for speaker  
B-18A-10647 T<sub>7</sub>—6"x4" oval PM speaker  
A-16A-10792 T<sub>8</sub>—1-f. choke coil

**GRANTLINE—MODELS 605, 606**

Part No. Code and Description  
C-9B1-26 R<sub>1</sub> R<sub>2</sub>—150,000 ohm, 1/2 w. res.  
C-9B1-50 R<sub>3</sub>—100 ohm, 1/2 w. res.  
C-9B1-70 R<sub>4</sub>—4700 ohm, 1/2 w. res.  
C-9B1-25 R<sub>5</sub>—100,000 ohm, 1/2 w. res.  
C-9B1-82 R<sub>6</sub>—47,000 ohm, 1/2 w. res.  
C-9B1-42 R<sub>7</sub>—22 ohm, 1/2 w. res.  
C-9B2-54 R<sub>8</sub>—220 ohm, 1 w. res.  
C-9B2-63 R<sub>9</sub>—1200 ohm, 1 w. res.  
C-9B1-52 R<sub>10</sub>, R<sub>11</sub>—150 ohm, 1/2 w. res.  
C-9B1-34 R<sub>12</sub>—3.3 megohm, 1/2 w. res.  
C-9B1-29 R<sub>13</sub>—470,000 ohm, 1/2 w. res.  
C-9B1-27 R<sub>14</sub>—220,000 ohm, 1/2 w. res.  
101193 R<sub>15</sub>, S<sub>1</sub>—Vol. control and sw.  
C-9B1-23 R<sub>16</sub>—47,000 ohm, 1/2 w. res.  
C-9B1-35 R<sub>17</sub>—4.7 megohm, 1/2 w. res.  
C-9B2-44 R<sub>18</sub>—33 ohm, 1 w. res.  
B-8A-10211 C<sub>19</sub>, C<sub>20</sub>—Two-gang cond. including antenna & osc. trimmers  
C-8D-10761 C<sub>21</sub>—0.1 μfd., 400 v. cond.  
C-8F3-114 C<sub>22</sub>—120 μfd., 500 v. mica cond.  
C-8D-10774 C<sub>23</sub>, C<sub>24</sub>—0.2 μfd., 400 v. cond.  
C-8D-10760 C<sub>25</sub>—1 μfd., 200 v. cond.  
C-8D-10775 C<sub>26</sub>, C<sub>27</sub>, C<sub>28</sub>, C<sub>29</sub>—100 μfd., 500 v. mica cond.  
C-8F3-8 C<sub>30</sub>, C<sub>31</sub>, C<sub>32</sub>—40/20/20 μfd., 150 v. elec. cond. (60 cycles)  
11995 C<sub>33</sub>, C<sub>34</sub>—60/40/40 μfd., 150 v. elec. cond. (25 cycles)  
C-8D-10770 C<sub>35</sub>—0.5 μfd., 200 v. cond.  
C-8D-10788 C<sub>36</sub>—0.04 μfd., 600 v. cond.  
C-8F3-6 C<sub>37</sub>—47 μfd., 500 v. mica cond.  
C-8D-10778 C<sub>38</sub>—0.02 μfd., 400 v. cond.  
C-8D-10942 C<sub>39</sub>, C<sub>40</sub>—2 μfd., 400 v. cond.  
B-212-11062 T<sub>1</sub>—Loop antenna assembly  
A-13D-10215 T<sub>2</sub>—Osc. coil  
108140G T<sub>3</sub>—Input i.f. coil  
108145C T<sub>4</sub>—Output i.f. coil  
10595B T<sub>5</sub>—Output trans.  
114191B T<sub>6</sub>—5" PM speaker

**GENERAL ELECTRIC—MODELS 219, 220, 221**

Part No. Code and Description  
URD-041 R<sub>1</sub>, R<sub>2</sub>—470 ohm, 1/2 w. res.  
URD-113 R<sub>3</sub>, R<sub>4</sub>, R<sub>5</sub>, R<sub>6</sub>—470,000 ohm, 1/2 w. res.  
URD-081 R<sub>7</sub>—22,000 ohm, 1/2 w. res.  
URD-145 R<sub>8</sub>—10 megohm, 1/2 w. res.

URD-009 R<sub>9</sub>—22 ohm, 1/2 w. res.  
URD-129 R<sub>10</sub>—2.2 megohm, 1/2 w. res.  
URD-089 R<sub>11</sub>—47,000 ohm, 1/2 w. res.  
URD-105 R<sub>12</sub>—220,000 ohm, 1/2 w. res.  
RRC-004 R<sub>13</sub>—2 megohm vol. control  
URD-049 R<sub>14</sub>—1000 ohm, 1/2 w. res.  
URE-007 R<sub>15</sub>—18 ohm, 1 w. res.  
URD-139 R<sub>16</sub>—5.6 megohm, 1/2 w. res.  
URD-029 R<sub>17</sub>—150 ohm, 1/2 w. res.  
URD-015 R<sub>18</sub>—39 ohm, 1/2 w. res.  
URF-051 R<sub>19</sub>—1200 ohm, 2 w. res.  
RCT-004 R<sub>20</sub>, C<sub>21</sub>, C<sub>22</sub>—Main tuning capacitor assembly  
RCY-002 C<sub>23</sub>—1.5-15 μfd., trimmer cond.  
UCC-045 C<sub>24</sub>, C<sub>25</sub>, C<sub>26</sub>—0.5 μfd., 600 v. cond.  
RCU-053 C<sub>27</sub>—56 μfd., mica cond.  
RCC-046 C<sub>28</sub>, C<sub>29</sub>—1 μfd., 600 v. cond.  
RCU-164 C<sub>30</sub>—360 μfd., mica cond.  
RCU-110 C<sub>31</sub>—47 μfd., mica cond.  
RCY-003 C<sub>32</sub>—13-27 μfd., trimmer cond.  
RCU-108 C<sub>33</sub>—22 μfd., mica cond.  
RCU-115 C<sub>34</sub>—330 μfd., mica cond.  
RCC-045 C<sub>35</sub>—100 μfd., mica cond.  
RCC-040 C<sub>36</sub>—0.05 μfd., 600 v. cond.  
C<sub>37</sub>, C<sub>38</sub>, C<sub>39</sub>—0.1 μfd., 600 v. cond.  
RCC-004 C<sub>40</sub>—0.05 μfd., 600 v. cond.  
RCE-001 C<sub>41a, b</sub>, C<sub>42</sub>—50/50/40 μfd., 150/150/25 v. elec. cond.  
UCC-036 C<sub>43</sub>—0.02 μfd., 600 v. cond.  
RLL-003 L<sub>1</sub>—Loop assembly  
RLB-001 L<sub>2</sub>—R.f. coil  
RLC-003 L<sub>3</sub>—Osc. coil  
RLI-001 L<sub>4</sub>, L<sub>5</sub>—Power cord choke coil  
RTL-001 T<sub>1</sub>—First i.f. trans. assembly  
RTL-002 T<sub>2</sub>—Second i.f. trans. assembly  
RTO-003 T<sub>3</sub>—Output trans.

**GAROD—MODEL 6AU-1**

Part No. Code and Description  
1.411 1—Loop assembly  
1.259 2—Two-gang var. cond.  
1.259 3—First i.f. trans.  
1.409 4—Second i.f. trans.  
1.402-1 5—Osc. coil  
8.200 6—Vol. control & sw.  
9.200 7—Output trans.  
30.300 8—5" PM speaker  
5.400-7 9—80/40/20 μfd., elec. cond.

**BELMONT—MODEL 5D128**

Part No. Code and Description  
C-9B1-13 R<sub>1</sub>—1000 ohm, 1/2 w. res.  
C-9B1-82 R<sub>2</sub>—47,000 ohm, 1/2 w. res.  
C-9B1-46 R<sub>3</sub>—47 ohm, 1/2 w. res.  
C-9B1-34 R<sub>4</sub>—3.3 megohm, 1/2 w. res.  
C-9B1-85 R<sub>5</sub>—82,000 ohm, 1/2 w. res.  
101198 R<sub>6</sub>, S<sub>1</sub>—1 megohm vol. control & sw.  
C-9B1-37 R<sub>7</sub>—10 megohm, 1/2 w. res.  
C-9B1-27 R<sub>8</sub>, R<sub>9</sub>—220,000 ohm, 1/2 w. res.  
C-9B1-29 R<sub>10</sub>—470,000 ohm, 1/2 w. res.  
C-9B1-53 R<sub>11</sub>—180 ohm, 1/2 w. res.  
C-9B1-41 R<sub>12</sub>—18 ohm, 1/2 w. res.  
C-9B1-43 R<sub>13</sub>—27 ohm, 1/2 w. res.  
C-9B1-64 R<sub>14</sub>—1500 ohm, 1 w. res.  
C-8D-10761 C<sub>15</sub>—0.1 μfd., 400 v. cond.  
B-8A-10754 C<sub>16</sub>, C<sub>17</sub>, C<sub>18</sub>—Two-gang, including antenna and osc. trimmers. Range of gang: 11-388 μfd. (ant.) and 8.5-162 μfd. (osc.)  
C-8F3-8 C<sub>19</sub>, C<sub>20</sub>—100 μfd., mica cond.  
C-8D-10770 C<sub>21</sub>, C<sub>22</sub>—0.5 μfd., 200 v. cond.  
C-8D-10789 C<sub>23</sub>—0.02 μfd., 600 v. cond.  
C-8F3-10 C<sub>24</sub>—220 μfd., mica cond.  
C-8D-10788 C<sub>25</sub>—0.04 μfd., 600 v. cond.  
C-8D-10774 C<sub>26</sub>—0.2 μfd., 400 v. cond.  
C-8D-10760 C<sub>27</sub>—1 μfd., 400 v. cond.  
C-8D-10953 C<sub>28</sub>—15 μfd., 400 v. cond.  
11992 C<sub>29</sub>, C<sub>30</sub>—40/20 μfd., 150 v. elec. cond. (60 cycles)  
12311 C<sub>31</sub>, C<sub>32</sub>—60/40 μfd., 150 v. elec. cond. (25 cycles)  
C-212-10895 L<sub>1</sub>—Load coil  
A-13D-10748 T<sub>1</sub>—Loop ant. assembly  
B-13B-10091 T<sub>2</sub>—Osc. coil  
B-13B-10812 T<sub>3</sub>—Input i.f. transformer  
B-12C-10735 T<sub>4</sub>—Output i.f. transformer  
T<sub>5</sub>—Output transformer

**ARVIN RADIO—MODELS 444, 444A**

Part No. Code and Description  
R<sub>1</sub>—4.7 megohm, 1/4 w. res.  
R<sub>2</sub>—1 megohm, 1/4 w. res.  
R<sub>3</sub>—150 ohm, 1/4 w. res.  
R<sub>4</sub>—22,000 ohm, 1/4 w. res.  
R<sub>5</sub>—330,000 ohm, 1/4 w. res.  
R<sub>6</sub>—15 megohm, 1/4 w. res.

ONE OF OUR MOST IMPORTANT ANNOUNCEMENTS IN 19 YEARS OF PROVEN LEADERSHIP IN TRAINING PROFESSIONAL RADIO MEN!

**Here it is!** Your first practical step toward a good-paying career in TELEVISION . . . .

**CREI** Introduces a Streamlined  
Home Study Course  
in Practical

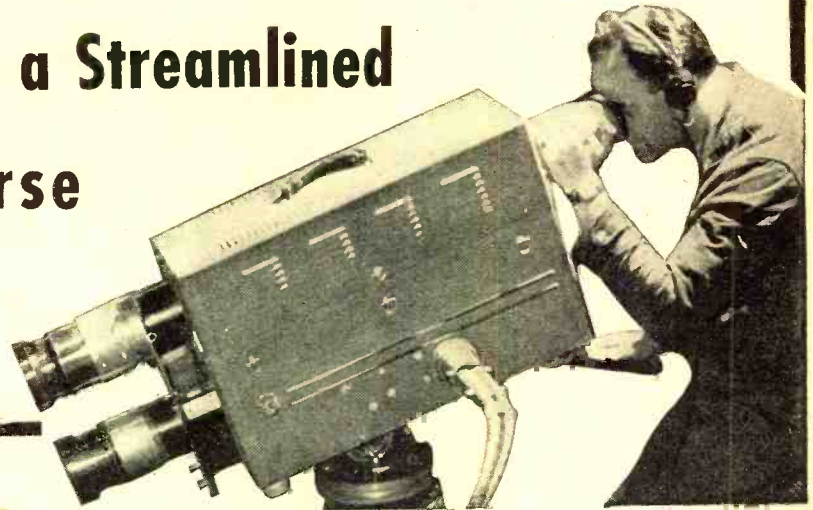

# Television

**ENGINEERING**

AVAILABLE NOW - FOR THE FIRST TIME!

Here's Your Chance to "Get in on the Ground

Floor" of Television Opportunities

Don't say, "I never had a chance!" Prepare NOW for the good paying jobs awaiting trained television engineers and technicians. Be in a position to command a "key" job in the growing TELEVISION Industry by preparing now with the type of thorough, practical TELEVISION Engineering training that the industry requires. The new CREI TELEVISION Engineering course is (1) A complete well-coordinated course of

study that covers the entire field of practical TELEVISION Engineering (2) Presented in CREI's professional and proven home study form (3) Prepared by CREI's experienced staff, based on actual experience in our own TELEVISION Studios and Laboratories, plus years of close contact with leaders in television development. Here's your opportunity to be prepared for television well ahead of competition, if you start NOW!

## CAPITOL RADIO ENGINEERING INSTITUTE

DEPT. RN-11, 16th and PARK ROAD, N. W., WASHINGTON 10, D. C.

**Just off the press! Mail Coupon  
for complete Free Details and  
Outline of the Course**

If you have had professional or amateur radio experience and want to prepare for opportunities in TELEVISION, let us prove to you we have the training you need to qualify. To help us intelligently answer your inquiry—Please STATE BRIEFLY YOUR BACKGROUND OF EXPERIENCE, EDUCATION AND PRESENT POSITION.



CAPITOL RADIO ENGINEERING INSTITUTE RN-11  
16th and Park Road, N.W., Washington, D. C.

Gentlemen: Please send me complete details describing the new CREI home study course in Practical Television Engineering. I am attaching a brief résumé of my experience, education and present position.

NAME .....

STREET .....

CITY.....ZONE..... STATE .....

OCCUPATION .....

I am entitled to training under the G. I. Bill.

Member of National Home Study Council—National Council of Technical Schools—and Television Broadcasters Association

November, 1946

71

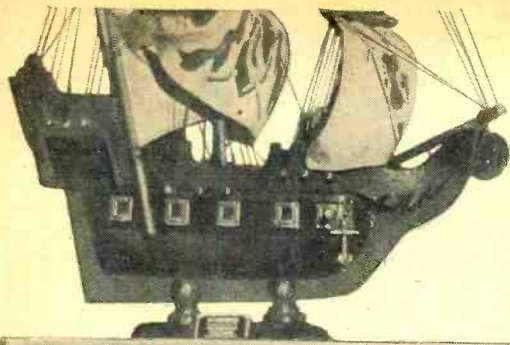

I built this television set, and Boy, what a honey it is! I get wonderful pictures and shows on it. Below, I tell you all about how I did it.

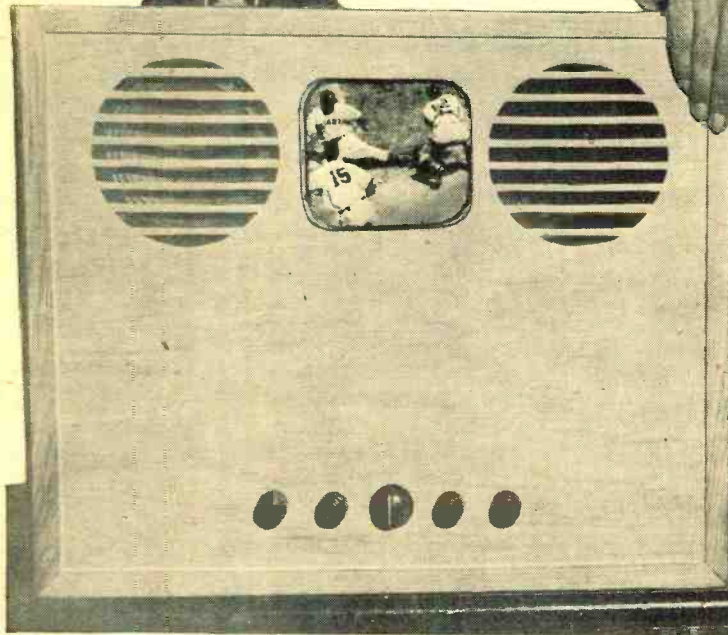

# How I Built My Own Television Receiver

By **BILL NAGEL**

**N**OT very long ago, television was a complete mystery to me. But not only did I build a complete television receiver chassis—I had a lot of fun doing it. And I've learned so much in a practical way that I'm

The two students with me here also built receivers. The picture shows us aligning our television sets.

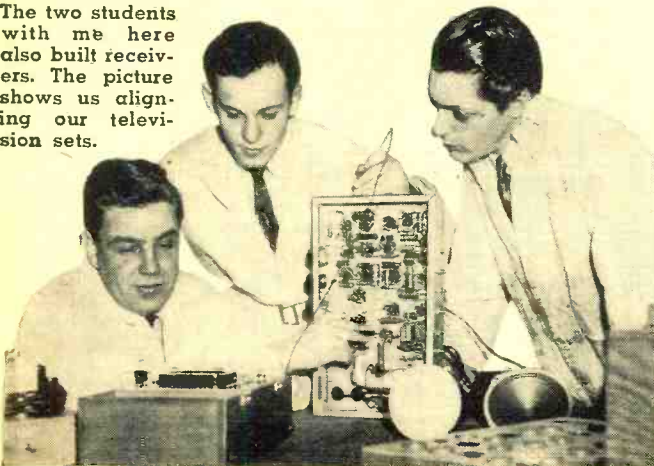

well on the road to becoming an expert. In a few years from now I'll be able to "write my own ticket."

I always had a yen to get into television, even while I was still in the service. But I didn't know just how to go about it—until I heard about the N.Y.T.I. of N.J. I went there with my discharge papers, and they did the rest. They showed me how the Veterans Administration would pay up to \$500 a year against my total educational expenses, under the G. I. Bill of Rights. This meant that I had to pay very little out of my own pocket. It's a big break for veterans like myself—especially when you get subsistence allowances in addition. And part-time jobs are easy to get so you can earn extra money. I held a job all the time I was in school. Of course, all of the students here aren't veterans.

What bothered me at first, was that my mathematics was kind of rusty. It had been some years since I had got out of high school. I soon found that the school had brush-up courses in math and even had facilities for teaching radio math from the beginning to students who had never had the advantage of a high school education. I convinced them that I was sincere and enthusiastic and that I was technically inclined, and so I became a student. Then the fun began. You know, you just



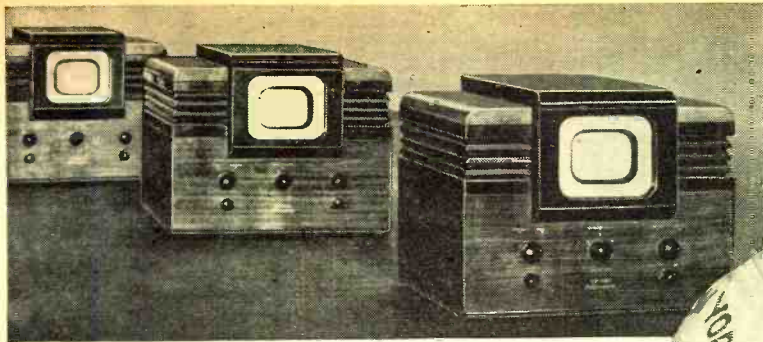

Here is a line of RCA television receivers that I and my fellow students use for comparative test purposes at N.Y.T.I. of N.J. The very latest equipment in television is ours to inspect and study at the school.

can't build a television set right off the reel. I built seven radio sets and had to go through a total of 75 practical electronic experiments, before they would even let me start on a television receiver.

Then I began work in earnest. The instructors around here have plenty on the ball, and it was amazing how fast I progressed. I can't go into all the details here, but I turned out the swell television set you see in the photo. I look mighty proud of myself, don't I? I guess I am.

Boy, school was never like this. You should see the magnificent equipment. Finest in the world! There's a swell gang here—all interested in learning—all radio bugs. They come from all over, because practical television schools are hard to find, and the N.Y.T.I. of N.J. has a wonderful rep when it comes to television. You should see the image-orthicon television camera tube they have here at the school. Imagine a little tube that costs \$795! The school cooperates in every way—I don't believe that you can find better training anywhere.

Another thing I like about the N.Y.T.I. of N.J. (which stands for the New York Technical Institute of New Jersey) is the convenient location. It's right in the heart of America's electronic industry, (Newark, N. J.), only 19 minutes from New York City. It's close to everything. Big radio, television and electronics manufacturers are nearby—like RCA, General Electric, Western Electric, DuMont, and Edison. So are the big network stations like WJZ, WEAJ, WABC, and WOR. This means that the school is always right in touch with the latest developments in radio and television.

The conditions here are really ideal. They have thousands and thousands of dollars worth of the latest types

These are my fellow class-mates (note that I am second from the left, standing) with the television receiver chassis they built at the same time I built mine. I built the cabinet

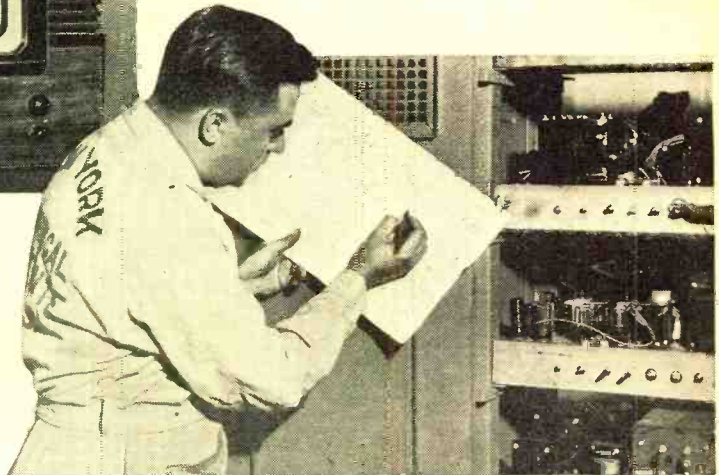

I want to learn about television transmitters also. Here you see one we have under construction. I hope to enroll for a special evening class on television transmitters.

of equipment. In fact, I estimate that each student uses \$3,500 worth of experimental and test equipment. And there is a great deal of individual instruction. Classes are small and the instructors really know their business.

I am sure there are a lot of young fellows, particularly veterans, (I was discharged because of disability), who want to get into this field. I understand there are about 120 openings for new day students in the classes beginning this November and December. If you want to get the complete dope about the school, you can have a free bulletin, which illustrates and describes its facilities and equipment; it also tells the classes that may be attended, housing conditions, costs, hours, etc. There is no charge for this bulletin. Just drop a postcard and ask for Bulletin 111. Send your postcard or letter to the New York Technical Institute of New Jersey, 158 Market Street, Newark, N. J.

at home later on. Most of the classes are small, so you are sure of a lot of individual instruction, which is very important in learning the technical side of television.



ADVERTISEMENT



R. C. (Dick) Hall  
WSEIB

## R. C. & L. F. HALL, INC.

HOUSTON: 1306 Clay Ave., Tel. C-9731  
BEAUMONT: 961 Pearl St.  
GALVESTON: 1803 Tremont St., Tel. 2-4807  
DALLAS: 2123 Cedar Springs Ave.  
Tel. C-6632

We now have four stores for your convenience. Drop in to see us. Of the new Hallcraft receiver listed, only the S-38, S-40, SX-42 will be available this year and in limited quantities. Hammarlund and RME are shipping on fairly regular schedules and we expect further shipments from National soon.



L. F. (Lillian) Hall  
WSEUG

SEND MAIL ORDERS TO HOUSTON

HALLCRAFTERS	
SX-42-540 KC to 110 MC	\$250.00*
SX-43-540 KC to 108 MC	150.00*
SX-46-540 KC to 43 MC	115.00*
S-38	79.50
S-40	79.50
HT-9 Transmitter (1500 KC to 28 MC)	250.00
S-37-FM/AM/CW (130 MC to 210 MC)	591.75
S-36A-FM/AM/CW (27.8 to 143 MC)	307.50
S-47-AM/FM (535 KC to 108 MC)	135.00

\* Speakers not included (\$15.00 UP).

HAMMARLUND	
HQ-129-X—with speaker	\$173.25
Super Pro-SP-400-X with speaker	342.00

Wire, write, or phone your order. We will ship C.O.D. with a \$5.00 deposit. We also offer easy terms and trade-in allowances for used equipment. State tax not included in above figures.

### TEST EQUIPMENT—IMMEDIATE DELIVERY

Silver Vomag, V.T.V.M. & V.O.M.	\$59.85
Silver, Model 904, Can. Res. Bridge	49.90
Superior Signal Generator	48.75
Superior 450 Tube Tester	39.50
Superior PB 400 V.T.V.M.	52.50
Speco Signal Tracer Model STAC	44.75
Speco Capohmist	16.95

Ask for other brands and models as Test Equipment is arriving in larger shipments. Also ask for complete Silver Catalogue giving a listing of all the Silver components.

### HOWARD W. SAMS PHOTO FACT SERVICE

Current information on all new models at your finger tips. Each folder includes from 30 to 50 Photo Fact Folders. These diagrams will keep you in touch with the latest sets. Price will never exceed \$1.50 per envelope. Reserve your copy today.

### A FEW OF THE MANUFACTURERS WHOSE PRODUCTS WE DISTRIBUTE

Aerovox	Claroostat	GE	Kaar	Meissner	Pioneer	Setchell-Carlson	Trim
Amphenol	Drake	Hallcrafters	Kainer	Millen	Precision	Silver	Triplett
Astaltic	Dumont	Hammarlund	Kelner	Mueller	Premax	Simpson	Turner
B&W	Echophone	Hytron	Kwikheat	National	Radel	Speed-X	Vaco
Belden	Eimac	Instructograph	Leach	Newcomb	Raytheon	Stanco	Vibroplex
Bliley	Electronics Lab.	Insuline	Leetrom	Ohmite	RCA	Supreme	Walco
Bud	Erie	Jensen	Les Logan	Panoramic	Robson-Burgess	Taylor	Ward
Centralab	Gammatron	JFD	Littelfuse	Peerless	RME	Thermador	Weller
Cinaudagraph	General Cement	Johnson	John Meck	Petersen	Sangamo	Thordarson	Weston

NATIONAL	
NC-2-40-D—(Speaker, \$16.44 extra)	\$225.00
HRO-37A-1—(1700 KC to 30 MC)	274.35
Speaker, \$10.95; Power Supply	17.70
HRO-37A-1—(Rack Model)	274.35
Speaker, \$19.85; Power Supply	33.00
NC-46—(Speaker, \$9.90)	97.50

### RME

RME-45 with crystal, meter and speaker	\$186.00
RME-84	98.70
DB-20 Presetector	68.20
VHF-152 (2, 6, & 10 Meter Converter)	86.60

ICA TOPPER ANTENNA	
The Topper is designed for mounting on the tops of fenders and cowls of the newest streamlined cars. Features a variable angle; made of rust-proof Admiralty brass; triple chrome plated; patented brass shim contacts prevent rattling and vibration.	
Order by Number 4575-3 Sections-63" Long-Open. Each	\$3.87 Net

"ACROSS THE SERVICE BENCH" is the name of our dealer bulletin. A postal card to Dept. N will bring it to you by return mail.

### HAM NEEDS FILLED IMMEDIATELY

The Ham Shack has a complete stock of all Ham components. Jot your needs down in a letter and your order will get immediate attention.

B18587

R <sub>7</sub>	—2 megohm vol. control & sw.
R <sub>8</sub>	—470,000 ohm, 1/4 w. res.
R <sub>9</sub>	—47 ohm, 1 w. res.
R <sub>10</sub>	—2200 ohm, 1 w. res.
R <sub>11</sub>	—15 ohm, 1/4 w. res.
C <sub>1</sub> , C <sub>2</sub>	—Var. cond.
C <sub>3</sub>	—.05 μfd., 200 v. cond.
C <sub>4</sub>	—.05 μfd., 400 v. cond.
C <sub>5</sub>	—.005 μfd., 400 v. cond.
C <sub>6</sub>	—.00005 μfd., 500 v. cond.
C <sub>7</sub>	—.0001 μfd., 500 v. cond.
C <sub>8</sub>	—.002 μfd., 500 v. cond.
C <sub>9</sub>	—.01 μfd., 400 v. cond.
C <sub>10</sub>	—40 μfd., 150 v. cond.
C <sub>11</sub>	—20 μfd., 150 v. cond.
C <sub>12</sub>	—20 μfd., 25 v. cond.
T <sub>1</sub>	—Antenna coil
T <sub>2</sub>	—Oscillator coil
T <sub>3</sub>	—I.f. coil
T <sub>4</sub>	—Output transformer

B17115

A19176

AC18255-1  
AC18256-1  
AC18157-1  
AC18258-1

—30—

## Converting the SCR-522

(Continued from page 35)

slides, as well as the crystal switch, are disengaged. The crystal switch is then removed by loosening the screws which hold it in place, and cutting the leads to the switch. The crystal socket is also removed.

The three relays may either be removed or left in place. In any event, it will be necessary to disconnect the relay coils as these are meant to be operated on d.c.

An 8 3/4" by 19" Masonite panel is used to remount the transmitter. Holes should be drilled to line up with the condenser shafts and the meter switch shaft.

The shafts of the tuning condensers are 5/32" in diameter. This is an awkward dimension for coupling to a standard 1/4" shaft. The couplings used were taken from some short lengths of flexible shafting, with the end that formerly held the flexible shafting drilled out to fit the condenser shafts. A felt washer was placed between each knob and the panel to furnish a slight amount of friction and prevent the tuning adjustments being disturbed.

The gain control is relocated on a line with the condenser shafts, just below and to the left of the meter. The gain control is replaced by a standard unit.

The panel is fastened to the transmitter chassis by means of 10-32 machine screws and spacers made from 1/4" copper tubing, 1 1/4" in length. These screws are fastened in the holes formerly occupied by the red painted screws, used to join the transmitter and rack.

Jacks are provided along the lower edge of the panel for microphone and key. The microphone jack is connected to terminals number 1 and 2 on plug 123-1. The keying jack, a closed-circuit type, is connected in series with the ground end of the cathode resistor of the 6SS7 speech tube.

A single-pole, double-throw toggle switch is mounted between the microphone jack and the meter switch, to permit the choice of phone or i.c.w. The leads which now go to the relay number 131 are rewired to this switch. These leads are respectively; the one to the grid of the 6SS7 through the resistor 153-4, which is rewired to the center arm of the switch, the lead

## HEXACON ELECTRIC SOLDERING IRONS

..tagged for  
the big jobs!

TYPE P-150  
(illustrated)

MINNEAPOLIS  
HONEYWELL

Westinghouse

Bendix

STROMBERG  
CARLSON

Western  
Electric

Follow the leaders—and use HEXACON! For rugged, heavy duty work or for light intricate work... here's the answer. One reason is "Balanced Heat"—dissipating excessive element-impairing heat—and minimizing element burn-outs and tip replacements. Another is their lightweight. Literature is available describing the complete HEXACON line of screw tip and plug tip irons from 40 to 700 watts, and with tip diameters ranging from 1/4" to 1 1/4".

HEXACON ELECTRIC CO.  
119 W. Clay Ave., Roselle Park, N.J.

HEXACON

HIGH-QUALITY, LONG-LASTING SOLDERING IRONS

# THE **POWER**

YOU want is

A large, stylized illustration of a hand holding a small, rectangular package. The package is open, revealing a mechanical motor inside. A black banner with white text is positioned over the package.

**in this package!**

## **POWR-PAKT MOTORS**

Alliance Powr-Pakt Motors will open and close valves, switches, operate toys and motion displays, actuate parts in business and vending machines, and can be used as component power sources in electronic control systems.

The Model 80 Phonomotor has been the outstanding favorite of manufacturers and jobbers who want a power source that's smooth, quiet, and time-tested. This is the No. 1 motor for driving turntables and record changers!

For original equipment and replacement, the leading radio manufacturers and jobbers of radio parts rely on Alliance Phonomotors and Powr-Pakt Motors to drive their turntables, record changers, recording and tuning devices.

Alliance Motors are mass produced, precision built, and low in cost. Besides Phonomotors, Alliance makes a wide range of small motors designed to meet the special demands of small loads. Write!

**WHEN YOU DESIGN—KEEP**

# **alliance**

**MOTORS IN MIND**

**ALLIANCE MANUFACTURING COMPANY**  
November, 1946

**ALLIANCE, OHIO**  
75

# REPAIR RADIOS THIS FAST, EASY WAY!

Complete, easy instructions for diagnosing and repairing common troubles in practically every home and car radio in use today

## NOT A STUDY BOOK!

You don't have to be an expert! You don't have to have a lot of costly test equipment in order to repair most radios—NOT when you have A. A. Ghirardi's famous **RADIO TROUBLESHOOTER'S HANDBOOK** at your finger tips. Bothered with "fading" on a certain model? "Noises" on another? "Poor volume"? A "dead" set or whatnot? Just look up the receiver's make and model in the 404-page Case History Section of the **HANDBOOK**. Nine times out of ten, it will tell you **EXACTLY** what the trouble is—and **EXACTLY** how to fix it. No lost time! No needless tedious testing! The **HANDBOOK** tells you—automatically!

Over 300 additional big manual-size pages contain other invaluable radio service data—Color Codes, Tube Data, Tube and Part Substitutions, I-F alignment and Transformer information and literally dozens of charts, graphs, diagrams, data and helpful hints that will help you repair any radio ever made **EASIER, BETTER and TWICE AS FAST!** Weighs over 4 lbs. Only \$5—and you actually don't risk a cent. **5-DAY MONEY-BACK GUARANTEE.**



**PAYS FOR ITSELF Pronto!**

**RADIO TROUBLESHOOTER'S HANDBOOK** will pay for itself in time saved the first time you use it! "Thanks to the **HANDBOOK**, I repaired my radio an hour after it had been returned as 'unrepairable' by a local radio shop," writes J. L. Fizzell of Kansas City. "The Case Histories take you right to the trouble and save hours of testing," says Julius Siske, Jr., of Maryland.

from the gain control, and the one from the junction of resistors 140-4 and 142. Shielded wire should be used for these connections.

Toggle switches are also provided to control the filament and plate supply. The socket for the crystals is remounted on the front panel, and the crystal oscillator rewired for only one crystal. Examination of the circuit diagram furnished with the unit will show how this is accomplished.

The antenna output connector, now in an inaccessible place behind the front panel, is replaced by a conventional coax connector mounted on the rear of the chassis. A terminal strip is also mounted on the rear of the chassis to permit the power supply to be connected.

Power requirements for this unit are 300 volts at 200 ma.; 12.6 volts at 2.35 a.; and 150 volts for bias. Normally this would require two supplies in addition to the heater requirements, but by using a single high voltage supply and grounding a point on the voltage divider, both positive voltage for the plates and negative voltage for the bias supply are available. A suitable supply is diagrammed in Fig. 2. The voltages under load with the components given are, 320 volts for the plates and 160 volts for bias. The power transformer used is one nominally rated to give 500 volts d.c. A dual filament transformer which supplied 5 volts at 3 amps. for the rectifier as well as 6.3 volts was used in conjunction with an additional 6.3 volt transformer to meet the heater requirements. Care should be taken in connecting these two transformers to insure that the 6.3 volt windings add to, and do not oppose, each other. A voltmeter will enable the proper connection to be determined with no difficulty. The entire power unit is built on a 10" by 12" by 3" metal chassis.

To enable metering of the various circuits, a metering circuit with the necessary shunts is built into the transmitter. This circuit is designed for use with a 1 ma. meter. No information is given in the instruction manual as to the internal resistance of this meter, but from the tests made, it is probably of the 100 ohm type. This meter should be connected to the two pins provided alongside the meter switch.

There are six positions provided on this meter switch with only the first five used. Position 1 indicates the plate current of the 12A6 harmonic amplifier, with the meter indicating 50 ma., full scale, in this position. Position 2 meters the plate of the 832 tripler and has a full scale range of 100 ma. Position 3 meters the plate and screen of the final as well as the screen of the tripler, with a full scale reading of 100 ma. Position 4 reads the rectified current of the r.f. diode, the full scale reading in this case being 1 ma. The fifth position measures the grid current of the final with the full scale reading being 2 ma.

The meter should be checked on one

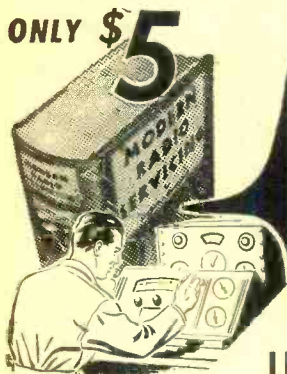

# Prepare for a Real Future in PROFESSIONAL RADIO-ELECTRONIC REPAIR WORK

## LEARN AT HOME . . . without an Instructor

Who will service the millions of new radios and complicated television, F-M and facsimile equipment to be sold within the next few years? Who will install and service the countless electronic devices now going into industry? Never before has there been such a demand for professionally-trained technicians who know their stuff—and this means training of exactly the type that A. A. Ghirardi gives you in his big 1300-page, profusely illustrated **MODERN RADIO SERVICING**. It is the ideal book for home study! Explains all types of service test instruments—how to use each one; how to make preliminary trouble checks; how to analyze circuits scientifically; how to troubleshoot; how to repair or replace parts or make substitutions; how to install equipment—and literally hundreds of additional subjects including **How to Start and Operate a Successful Service Business of Your Own**. Sold on **5-DAY MONEY BACK GUARANTEE**. You can't lose. Send coupon today!

### GET WHERE THE BIG MONEY IS!

Ghirardi's **MODERN RADIO SERVICING** is the only single, inexpensive book giving a complete course in electronic servicing by scientific professional methods. Contains over 706 clear illustrations. Quick to read—easy to understand.

### MAIL ORDER . . . Rush Coupon Now!

Murray Hill Books, Inc., Dept. RN-116  
232 Madison Ave., New York 16, N. Y.

- Enclosed find \$..... for books checked; or
- send C.O.D. (no foreign C.O.D.'s) for this amount plus postage. It is understood I may return the books for refund within 5 days if not satisfied.
- RADIO TROUBLESHOOTER'S HANDBOOK \$5** (\$5.50 foreign)
- MODERN RADIO SERVICING \$5** (\$5.50 foreign)
- MONEY-SAVING COMBINATION OFFER:** Both big books, over 2040 pages of the finest service data—only \$9.50 for the two (\$10.50 foreign).

Name .....

Address .....

City & Dist. .... State .....

### GET BOTH BOOKS AT A BARGAIN

#### SPECIAL OFFER!

Let Ghirardi's **RADIO TROUBLESHOOTER'S HANDBOOK** save you time and money on common radio service jobs—let **MODERN RADIO SERVICING** train you for complete professional, electronic service training!—Get **BOTH BIG BOOKS** at the special price of only \$9.50 for the two. Use coupon today. Check "MONEY-SAVING COMBINATION OFFER."

## 5-DAY MONEY-BACK GUARANTEE

of its ranges by means of a 0-100 ma. meter connected in series with the circuit being metered. Probably the easiest circuit to check is that of the 832 tripler plate. The connection which feeds the "B plus" to the tank circuit of this tube may be found just inside the compartment which houses the final amplifier tube. This connection should be unsoldered and the external meter placed in series with the line.

Comparison of the two readings should now be made. It is probable that the one mil meter will read high. If this is the case, resistance must be added in series with it to bring the reading down to agree with the test meter.

It is only necessary to check the meter on one position of the switch, as once adjusted to the correct reading, the shunts for other positions will be correct.

For appearances sake, nameplates were made up and placed adjacent to the various controls.

When conversion has been completed, the transmitter should be tested by picking a crystal suitable for the final frequency desired, and applying power. The meter switch should be placed in position 1, where it reads the plate current of the 12A6 harmonic amplifier. The oscillator tuning condenser should be tuned for maximum reading on the meter. With the meter switch in position 2, the operation should be repeated, this time tuning the 12A6 plate condenser. The same procedure is followed on position 3, tuning the plate condenser of the 832 tripler. The plate condenser of the 832 final should then be tuned for a dip with the meter switch in position 3.

If the tuning procedure has been properly carried out, all the tuning controls will be in approximately the same position. Any great variation in the position of these tuning controls is an indication that the wrong harmonic has probably been picked.

With the transmitter properly tuned, the antenna may be connected, and the antenna coupling adjusted for proper loading of the final amplifier. This should result in a meter reading of approximately .63 ma. with the meter switch in position 3.

-30-



A. A. Ghirardi, Radio's most famous teacher

I'll make it easy for you to

# LEARN RADIO

at home...in your spare time

## FOR BEGINNERS!

No previous training needed

I'll PROVE that my famous 972-page RADIO PHYSICS COURSE book can teach you basic Radio-Electronics quicker, easier and AT LESS COST than any other book or course. I'll PROVE it gives exactly the training you need to learn Radio-Electronics RIGHT. And I'll PROVE you'll be pleasantly surprised how quickly it helps you understand subjects that other training makes seem too difficult for beginners. Mail the coupon today. If you're not more than satisfied after reading the COURSE for 5 full days, send it back. EVERY CENT of your money will be cheerfully refunded. No questions will be asked. You cannot lose!

..and for  
**ONLY**  
**\$5<sup>00</sup>**

FOR THE COMPLETE  
TRAINING!



**9 OUT OF 10 RADIO MEN SAID:** (As proved by actual survey)  
**"Here's the Way to Learn Radio RIGHT!"**

### GHIRARDI EXPLAINS EVERY DETAIL CLEARLY AS A-B-C

EVERYTHING ABOUT RADIO, SOUND, ELECTRICITY, ELECTRONICS: Radio broadcasting Systems; Sound, Speech and Music; Electron Theory; Electric Current; Electrical Units; Ohm's Law; Resistance; Electrical Circuits; Batteries; Electro-magnetism; Electro-magnetic Induction; Inductance and Inductors; Capacitance and Condensers; Alternating Current Circuits; Electric Filters; Electrical Measuring Instruments; Electro-magnetic Radiations; Radio Transmission; The Broadcasting Station; The Receiving Station; Elementary Study of the Vacuum Tube; Vacuum Tube Detector and Amplifier Action; Tube Characteristics; Radio-Frequency Amplification; Superheterodyne Receivers; Tuning and Tuning Coils; Audio Amplification; Battery & Electric Operated Receivers; Auto-Radio; Aircraft Radio; Phonograph Pick-ups; Public Address Systems; Short-Wave Receivers; Photo-Electric Cells; Television; Testing and Servicing; Sound Motion Pictures—and dozens of other subjects.

#### NO OTHER COURSE LIKE IT

"I'd already taken a \$150 course, but since reading Ghirardi's RADIO PHYSICS COURSE book, I put the other one away," writes Gerard Champagne of Montreal. **RADIO PHYSICS COURSE is the real book you need because it teaches so clearly!**"

Ghirardi's RADIO PHYSICS COURSE book is more widely used for home study, by U. S. Signal Corps and Navy Schools and by more schools and colleges than any other book of its kind. Also, it is more widely endorsed by the very men who are engaged in radio work for a living. On an actual survey among 817 radio leaders, 724 of them—9 OUT OF 10!—picked Ghirardi's famous training as their first choice—AT ANY PRICE! And remember, these men are tops in the fields of radio-electronic servicing, aviation radio, broadcasting, engineering, designing and instructing!

No matter what phase of Radio-Electronics you plan to enter, you'll need the basic training this famous course gives you FIRST! And, this most complete training on the market comes to you all in one convenient, big, handsomely bound book. Starting with Basic Electricity, it takes you step by step through the entire field. Everything is made crystal clear. You go ahead as fast as spare reading time permits. No lessons to wait for. Many students have completed it in a few weeks—and an amazingly high percentage of them are now successful Radio-Electronic experts!

The complete cost of the book is only \$5 postpaid. Actually you don't risk a cent! Our 5-Day Money-Back Guarantee is your absolute protection.

### 5-DAY MONEY-BACK GUARANTEE

Murray Hill Books, Inc., Dept. RN-116  
232 Madison Ave., New York 16, N.Y.

Rush a copy of Ghirardi's 972-page RADIO PHYSICS COURSE BOOK on your money-back guarantee offer.  \$5 enclosed (\$5.50 foreign), or  send book C.O.D. for this amount plus postage (no foreign C.O.D.'s). It is understood I may return the book after reading it for 5 days for full refund if not more than satisfied.

Name.....  
Address.....  
City & Dist. No.....State.....

**COMPLETE BASIC RADIO-ELECTRONIC TRAINING** IN ONE BIG VOLUME

# HENRY RADIO

Most models listed below are in stock . . . ready for immediate delivery:

Hallicrafters 538 complete . . . . .	\$ 39.50
Hallicrafters 540 complete . . . . .	79.50
Hallicrafters 536A . . . . .	307.50
Hammarlund HQ-129X & speaker . . . . .	168.00
Hammarlund SP-400-X & speaker . . . . .	342.00
National NC-2-40D . . . . .	225.00
National HRO-5TA1 and HRO-5RA1 . . . . .	274.35
National NC-46 . . . . .	97.50
National T-10A with tubes and coils . . . . .	67.50
RME-45 complete . . . . .	198.70
RME-84 complete . . . . .	98.70
RME DB-20 complete . . . . .	68.20
Pierson KP-81 complete . . . . .	318.00
Panoramic panadapter complete . . . . .	99.75
Temco 75GA transmitters . . . . .	495.00
Meck 60T transmitters . . . . .	150.00
Gordon, Amphenol, Johnson rotary beams . . . . .	

All other receivers, transmitters, parts, etc. as available.

Prices subject to change.

**T**HE delivery situation is much improved. I can make immediate delivery of most receivers and other apparatus. Take advantage of the extra service and selection you get by dealing with me, based on my reputation as the world's largest distributor of short wave receivers. Send me your order now. Send five dollars and I will ship at once C.O.D. Or order on my 6% terms. I finance the terms myself to give you better service and save you money. Trade-ins accepted. Tell me what you have to trade, and let's make a deal.

Besides having all amateur receivers and transmitters, I also have a complete stock of all other amateur apparatus and parts, also test equipment, etc. I have real bargains in the really good war surplus such as SCR-211's, BC-610, BC-342, BC-348, BC-312, parts, etc. Write, phone, wire or visit either of my stores.

**BOB HENRY  
WARA**

# HENRY RADIO

BUTLER, MISSOURI AND  
LOS ANGELES 25, CALIF.

**"WORLD'S LARGEST DISTRIBUTORS  
OF SHORT WAVE RECEIVERS"**

# A LINEAR SWEEP GENERATOR

By **W. J. HAYWOOD, W2OQB**

**Construction details for a saw-tooth sweep generator covering 1 to 1,000,000 cycles.**

**I**T IS a well known fact that if a constant current is fed to a high quality condenser, the voltage waveform across the condenser will show a linear rise, while if a very heavy current is drawn from the capacitor, the voltage will drop very steeply—in addition, if the current *withdrawn* is also constant, the voltage will also decrease at a linear rate.

It is therefore possible to represent the ratio of charge to discharge time as  $I_{ch}/I_{dis}$ , and if the ratio is made very large, the charge-discharge waveform will be a very sharp saw-tooth, eminently suitable for use in saw-tooth sweep generator circuits.

In listing some of the desirable characteristics of a perfect saw-tooth sweep generator, we might look for:

1. A very high ratio of useful to non-useful waveshape (rapid fly-back);
2. Maximum attainable linearity of useful portion (linear sweep);
3. A linear fly-back waveform (although not generally considered, this may be important in order that, in observing a single wave-

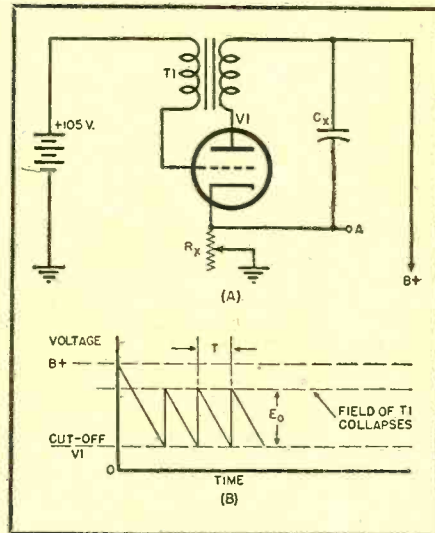
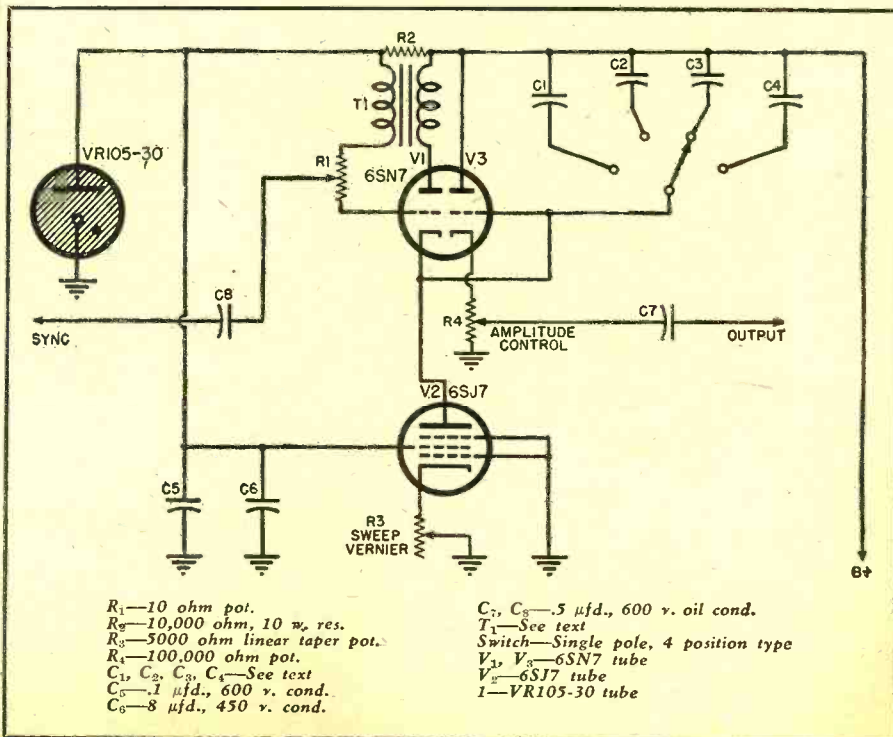

Fig. 2

form, the time lost due to flyback may not distort the leading or trailing edges of the waveform since the sweep speed may not be

Fig. 1



$R_1$ —10 ohm pot.  
 $R_2$ —10,000 ohm, 10 w. res.  
 $R_3$ —5000 ohm linear taper pot.  
 $R_4$ —100,000 ohm pot.  
 $C_1, C_2, C_3, C_4$ —See text  
 $C_5$ —1  $\mu$ f., 600 v. cond.  
 $C_6$ —8  $\mu$ f., 450 v. cond.

$C_7, C_8$ —5  $\mu$ f., 600 v. oil cond.  
 $T_1$ —See text  
Switch—Single pole, 4 position type  
 $V_1, V_2$ —6SN7 tube  
 $V_3$ —6SJ7 tube  
1—VR105-30 tube

YOU CAN GIVE BETTER, FASTER SERVICE with these

3

BALANCED  
RESISTOR  
ASSORTMENTS

STURDY, HANDSOME Resist-O-Cabinet

FREE WITH EACH ASSORTMENT

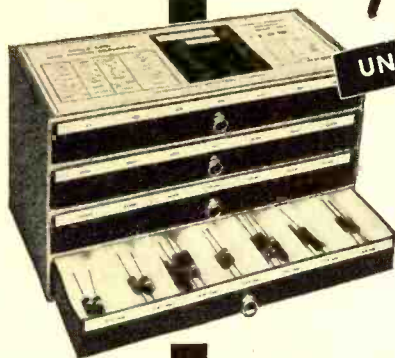

UNIVERSAL ASSORTMENT

Balanced resistor assortment. Includes 59 IRC Type BT Insulated Metallized Resistors and "universal" 10-Watt Power Wire Wound Types AB and ABA. The ABA (adjustable) type makes possible every range from a few ohms up to 10,000 ohms.



1/2 WATT ASSORTMENT

100 Type BW-1/2 and BTS Resistors. A complete assortment of most used ranges in the popular 1/2-Watt Insulated Metallized and Insulated Wire Wound Types.

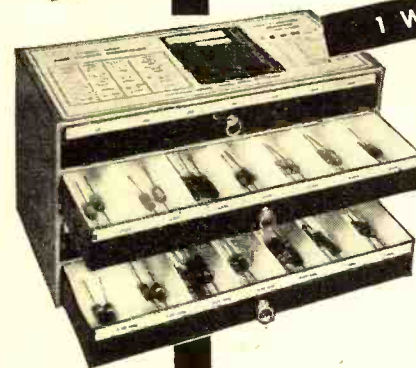

1 WATT ASSORTMENT

83 Type BW-1 and BTA Insulated Resistors. Every service engineer should have all of these top-quality 1-watt resistance ranges at his fingertips.

No one knows better than you that up-to-the-minute appearance and modern, efficient service pays off in your shop.

That's why IRC offers three Resistor Assortments to equip you for quick, easy resistor replacements on almost any job. Any one or all three IRC assortments, arranged according to type and range, are in neat, sturdy cardboard Resist-O-Cabinets that stack firmly one on top of the other. The cabinets are supplied absolutely *free* with each assortment ordered at standard resistor prices. Get in touch with your IRC distributor *today*

EASY TO STACK →

Bases of Resist-O-Cabinets are arranged for stacking so that several cabinets may be used to increase stock capacity.

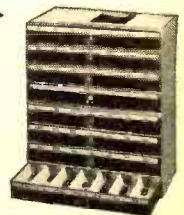

INTERNATIONAL RESISTANCE CO.

401 N. BROAD ST., PHILADELPHIA 8, PA.

Canadian Licensee: International Resistance Co., Ltd., Toronto

TIME WILL TELL!

33 Years of Experience

• THE HALLDORSON COMPANY has continuously manufactured for industry since 1913. Since inception, this firm has been and is still an individual firm . . . not a subsidiary or branch of another company.

Each and every HALLDORSON transformer is backed by 33 years of experience, research and actual field knowledge. A new and more complete line of transformers is now being developed in the HALLDORSON laboratories. Soon . . . we hope, in the very near future . . . these transformers will be available.

JOBBER: Get on our mailing list today!

THE HALLDORSON COMPANY  
SINCE 1913  
4500 Ravenswood Avenue • Chicago 40, Illinois

HALLDORSON Vacuum Sealed TRANSFORMERS



constant at the extreme edges of the scope);

4. Large amplitude waveform (at high sweep rates, 100 kc. or higher; sweep amplifiers must be linear up to the order of several megacycles making desirable a large amplitude waveform to permit the use of direct deflection);
5. Constant amplitude with change in frequency (nothing is more disconcerting to the operator than to run the sweep frequency up a bit, and have to re-set the sweep amplitude or centering controls, or both);
6. Extreme frequency range, very slow to very fast, with few controls (versatility); and
7. Simplicity and economy (no eleven tube; seven control, 565 cubic foot space heaters!).

The circuit described herein has been found to meet the above requirements to good effect.

There are several conventional constant current circuits which may be employed to charge or discharge the sweep condenser, together with numerous metastable circuits, such as multivibrators, etc., for the same purpose.

Best results were obtained with a triode blocking oscillator (to discharge the capacity) and a conventional constant current pentode circuit, combined in an unusual manner (see Fig. 1). Upon inspection, it will be seen that a simplified version would resemble Fig. 2.  $R_x$ , the variable resistance, is numerically equal to the d.c. plate resistance of  $V_2$ , the constant current pentode. Note that only the plate current of the pentode is used. For best linearity and range of control, both the suppressor and control grids are grounded.

The action is as follows:

Assume "B" plus is momentarily disconnected, and the filaments of  $V_1$  lighted. Then, the charge on  $C_x$  is zero, and no current is flowing in the circuit. If we connect "B" plus, the condenser still has zero charge at the first instant, but the cathode of  $V_1$  is at "B" plus. Since the grid is at +105 volts, the tube is cut off. Current flows through  $R_x$  to charge  $C_x$ . Since a constant current flows through  $R_x$  (due to  $E_p/I_p$  characteristics of the pentode when  $E_p$  is greater than  $E_{sp}$ ), the voltage at point A will fall at a linear rate from "B" plus to the voltage corresponding to the cut-off bias of the triode. Assume triode cut-off to be 15 volts. Then, when voltage at point A has fallen to a value equal to "B" plus minus (the grid voltage +15 v.), the triode conducts. (Note:  $E_c$ , the voltage across  $C_x$ , equals "B" plus minus the cut-off voltage of the tube—increasing "B" plus increases the voltage amplitude at the output). When the triode conducts, plate current flow causes the grid of the tube to be driven positive due to transformer action (regenerative feed-back), which causes the plate current to increase, driving the tube to saturation, provided the constants of the circuit are properly chosen.

TOROIDAL COIL FILTERS

... are the answer to any network problem

- SHARP CUT-OFF
- LOW INSERTION LOSS
- HUM PROOF
- COMPACT
- HIGH STABILITY

Toroidal Coils

Inductance—1 MHY to 3 HYS  
Frequency—300 cy. to 30,000 cy.  
"Q"—55 at 1000 cy.; 150 at 3000 cy.

Ask to be put on mailing list for complete catalogue of coils and filters.

Burnell & Co.

Designers and Manufacturers of Electronic Products

10-12 VAN CORTLANDT AVE. EAST, BRONX 58, N. Y., SEdgcwck 3-1593

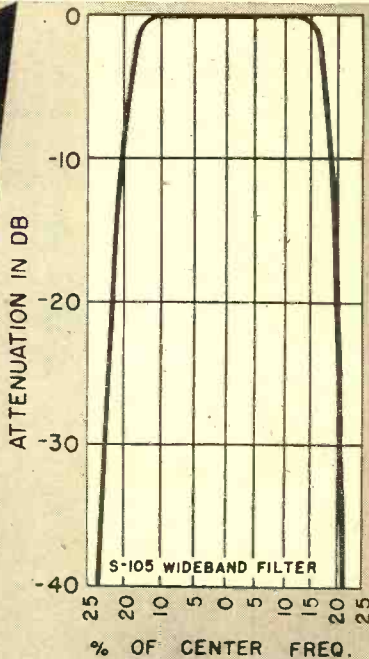

Actual measurements taken on Toroidal Coil Filter manufactured by Burnell & Co.





**YOUR FREE COPY IS READY!**

**The Complete, New  
25th Anniversary Lafayette Catalog  
of Radio and Electronic Equipment**

**SPECTACULAR RADIO VALUES!**

— HUNDREDS OF CRITICAL PARTS —

Choose the parts you want from our complete stock of over 10,000 guaranteed-quality items. Whatever your needs, supply them from this single, dependable source at money-saving prices. *Lafayette!*

**— THE LATEST IN HAM GEAR —**

Here is the greatest selection of nationally-known communications equipment: Hallicrafters, National, Hammarlund, R.C.A., Meissner. Select a "Build-It-Yourself-Kit" and build a complete radio set.

This valuable 144 page catalog offers you the latest, largest line of top-quality *radio parts, amplifiers, test equipment, ham gear, tools, radio sets, phono-radios and other types of electronic equipment and accessories.* Page after page of post-war radio developments —plus a special bargain section that lists hundreds of surplus and standard-make radio and electronic parts at slashed-price Lafayette economy. Be one of the first to receive this big, new Lafayette Catalog. It will save you time and money. Rush coupon below today for your FREE copy!

**LAFAYETTE RADIO**

**STANDARD PARTS—LEADING BRANDS**

Complete line of famous-make radio and electronic equipment of the highest quality. Included are the latest developments. All items are shipped out the same day your order is received. That's Lafayette's famous Super-Speed Service.

**RADIO WIRE TELEVISION, INC.**

100 SIXTH AVE., 110 FEDERAL STREET 24 CENTRAL AVENUE,  
NEW YORK 13, N. Y. BOSTON 10, MASS. NEWARK 2, N. J.

LAFAYETTE RADIO, Dept. RK-6  
100 Sixth Avenue, New York 13, N. Y.

Rush my FREE copy of the big, new LAFAYETTE CATALOG.

Name.....

Address.....

City.....Zone.....State.....

*Paste On Penny Postcard!*

**MAIL TODAY!**



# MONTHLY SPECIALS

## SURPLUS VALUES

**RADIO TELEPHONE HANDSETS (Army TS-13).** Compact French type unit contains sensitive 1000 ohm phone and high output 200 ohm single-button mike. Push-to-talk butterfly switch. Complete with PL-55, PL-68 and 5 1/2 ft. rubber cord. . . . \$3.45  
**Frequency Meter tech. manual (Navy).** Theory and operation. 39 illust. and schematics, 58 pp. . . . \$ .15  
**F.M. technical manual (Army).** Theory, operation, & maintenance. 86 illust., 49 diagrams, 240 pp. . . . \$ .39  
**PL-54 plug & 13" tipped double phone cord.** . . . \$ .19  
**EARPHONE (HS-23).** Replace that old worn hand now. Leather covered, adjustable forks. With PL-54 & 16" cord. . . . \$ .39

## ALNICO MAGNETS

- No. 1—Bar, 3 1/2" x 1 1/4" x 1 3/8" . . . \$ .39
- Bar in shorter lengths, per inch. . . . \$ .12
- No. 2—Face 1 1/4" x 1 3/4" x 7/8" High. . . . \$ .98
- No. 3—Heavy duty bar, 2 1/2" x 1 3/8" x 5/16" . . . \$ .98
- No. 4—Face 1 1/4" x 5/8" x 5/8" high. . . . \$ .39
- No. 5—Polished, 7/8" x 9/16" x 3/8" high. . . . \$ .35
- No. 6—Polished bar, 9/16" x 1/4" x 1/8" . . . \$1.00
- No. 7—Face 1 1/2" x 1 1/2" x 3/8" high. . . . \$ .10
- No. 8—Horseshoe, ea. pole 3/8" sq; 1 1/4" high. . . . \$ .89
- No. 9—Horseshoe, ea. pole 9/16" sq; 2" Meter Case & Housing. Complete with glass and adjust screw. 1" deep; mtg. holes 2 7/8" 1 1/2" high. . . . \$1.29

**POWER RHEOSTATS, IRC wire-wound.** All with pointer knobs & mtg. hardware: 25 watt—8, 10, 20, 50, 75, 100, 200, 375, 500, 750, or 4000 ohms. . . . \$ .69  
 50 watt—1, 15, 40, 75, 100, or 250 ohms. . . . \$ .98  
**Flexible Cased Shafts.** Permit offset control up to 90 deg. 6" long, 3/8" hub, 1/4" bore ea. end. . . . \$ .23  
**WIRE & CABLE:** 2 cond; shielded, heavy duty, outside rubber insul. Lengths of 9 1/2 ft. . . . \$ .59  
 4 cond., same as above. Lengths of 10 1/2 ft. . . . \$ .98  
**Hook-up wire.** No. 21 insulated, 100 ft. spool. . . . \$ .98  
**CO-AXIAL CABLES,** outside vinylite, 2 amphenon connectors, 3 ft. . . . \$1.19; 4 ft. . . . \$1.24; 5 ft. . . . \$1.29  
**N.B.C. RECORDINGS.** Each contains 2 complete 15 min. "Voice of the Army" dramatic programs with music. Such titles as: GI Gaghan, Philippine Return, Flight Nurse plus more than sixty others. 33 1/3 RPM. . . . \$ .29 ea.

**TUBES:** Perfect condition, but not in sealed cartons. Guaranteed for 90 days.  
 No. 26, 27, 41, 46, 56, or 6F6—29; No. 42, 59, 6A, 6C6, 6D6, 6S, 6K6, 6K7, 6V6, 6SQ7, or 6SA7—39; No. 60, 6A3 or 6A3—69

**Radiomen's Hardware Kit.** Approx. 1000 asstd. screws, nuts, lugs, washers, etc. plus handy 36 compartment kit box. . . . \$ .59  
 20mfr/200V. tubular electrolytics. . . . 6 for \$1.00

## SERVICEMEN'S KITS

- No. 1—Ten assorted R.F., antenna & oscillator coils. . . . \$2.95
- No. 2—Speaker cones; 12 asstd. 4" to 12" moulded & freeedge (magnetic incl.). Less voice coil. . . . \$2.00



- No. 3—BAKELITE MICA CONDENSERS: 50 asstd. .00001 to .2 mfd, 400-800V. Marked in figures. . . . \$2.95
- No. 4—Tubular BY-PASS CONDENSERS: 50 asstd. .0005 to .25 mfd, 200-600V. Standard brands. . . . \$2.49
- No. 5—Electrolytics: 10 asstd. including multi-section, paper & can types. . . . \$1.25
- No. 6—Dial Scales; 25 asstd. airplane & slide rule (acetate & bakelite). . . . \$2.98
- No. 7—Escutcheon Plates; 25 asstd. airplane slide rule & full-vision types. . . . \$2.95
- No. 8—Knobs; 25 asstd. wood & bakelite, including setscrew & push-on types. . . . \$1.00
- No. 9—Water Sockets; 12 asstd., 4 to 7 prong. . . . \$ .25
- No. 10—Voltage Dividers; 10 asstd. standard multitapped. High wattages included. . . . \$1.98
- No. 11—Shield Cans; 15 asstd. for coils, tubes, transformers, etc. . . . \$1.00
- No. 12—Mica Padders & Trimmers; 15 asstd. standard cap. (Incl. multiple & ceramic base types). . . . \$ .69

**SELVYN GENERATORS.** Used in pairs as transmitter & follower (rotary beam indicator) on 45V, 60 cycles, 2 1/2" x 4" per pair (ship. wt. 3 lbs.). \$4.98  
**EXPERIMENTAL TUBES.** 20 asstd sizes & base types for testing, research, etc. P.I. tested. . . . \$1.00  
**VICTOR POWER TRANSFORMERS** for models R-32, 45, 52, and 75. Unshielded. . . . \$5.95  
**PROMPT SERVICE ON ALL SPEAKER AND PHONO PICKUP REPAIRS.** Minimum order \$2.00, 20% deposit required on all orders.

WRITE DEPT. RN-11  
 PLEASE ADD SUFFICIENT POSTAGE



**LEO ONE RADIO CO.**  
 MAKERS OF CONES AND FIELD COILS  
 65-67 DEY STREET, NEW YORK 7, N.Y.  
 WORTH 2-0284-5  
 12,000 SQ FT OF RADIO PARTS

Now note that when saturated, the triode discharges the condenser at a linear rate and the current under these conditions may reach 200 to 500 milliamperes.

When  $C_x$  is discharged, the cathode of  $V_1$  will again be at, or near, "B" plus, and  $V_1$  goes to cut-off. Plate current cannot flow until  $C_x$  is charged again, a time determined by  $R_x$ . Since  $R_x$  is continuously variable, the charge rate of  $C_x$  may be varied, and the output frequency of the circuit will be varied in inverse ratio.

Inspection will show that (roughly)  $f_o$  will be  $1/R_x C_x$ , or, more exactly,  $f_o$  will be  $2I_{R_x}/CE$ , indicating that with  $CE$  constant,  $f_o$  is proportional to  $I_{R_x}$ , the charge current of  $C_x$ .

Fly-back time depends on two factors:

1. The size of  $C_x$ . Since  $Q = CE$ , where  $Q =$  coulombs, then  $T = CE/2I$ ,  $E$  being constant and approximately equal to "B" + minus  $E_{cutoff}$ ; and  $I$  being saturation current of triode;
2. The resonant frequency of  $T_1$ . The rate at which  $I_p$  of the triode increases to saturation value is a function of the inductance and distributed capacity of the windings. Since the resonant frequency of this combination may be made very high, from two to ten megacycles, this will not affect the low frequency output of the sweep circuit, but will tend to limit the upper frequency to approximately one to two megacycles with good waveforms—this is not a guess, for we have produced excellent waveforms with a ratio of  $I_{dis}/I_{ch}$  of about 15, at a frequency of one mc.

On the other hand, the low frequency output is limited by the fact that as  $C_x$  gets larger, the charge time does become in the order of 1 second or more, which is one cycle or less, but note that as  $T = CE/2I$  becomes very long,  $I_{dis}/I_{ch}$  is also very large, which means that the tube must conduct in the order of amperes or the field about the transformer will have collapsed, allowing the tube to go to cutoff before  $C_x$  is fully discharged, lowering the available sweep amplitude, although it will still be constant with any given size of  $C_x$  as  $R_x$  is varied.

With a value of 4  $\mu$ fd. at  $C_x$ , sweep waveforms of 150 volts amplitude have been obtained with a frequency of .2 cycles per second, or about 5 seconds-per-sweep.

$T_1$  must have very tight coupling (powdered iron core preferably) and small physical size. A slight step-up ratio in the plate-to-grid winding is desirable, although too much will limit high frequency because it is not easy to get a high enough resonant frequency in  $T_1$ .

In the unit constructed,  $T_1$  was a special transformer with the following specifications:

Primary: 140 turns, No. 32 enameled wire, wound on laminated iron core, 1/2" on each leg, core size 1/2" x 1/2" x 1" high.

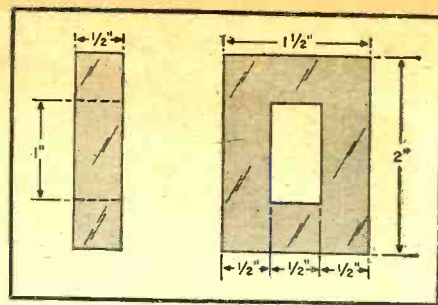

Fig. 3

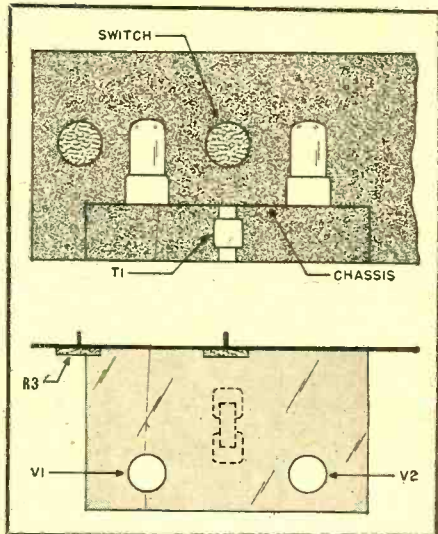

Fig. 4

Secondary: 140 turns No. 32 enameled wire, wound on laminated iron core, 1/2" on each leg on top of primary.

Core: Finest laminations that can be secured, to make 1/2" x 1/2" x 1" stack, shell type winding. (See Fig. 3.)

A transformer was also tried, wound on a conventional powdered iron, slug-type antenna coil form, consisting of:

Primary: 2 layers, total turns, 100, of No. 30 enameled wire, wound approximately 1/2" long x 3/8" diameter.

Secondary: 3 layers, total turns, 150, of No. 30 enameled wire, wound to completely cover primary.

This second transformer was successful, but did not give quite as much

Fig. 5

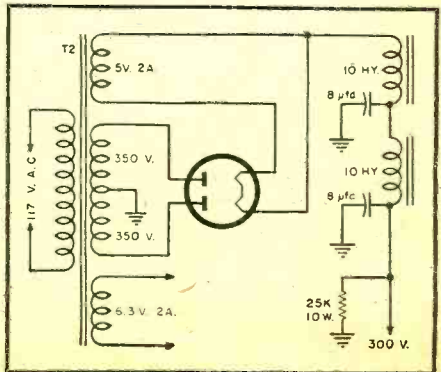

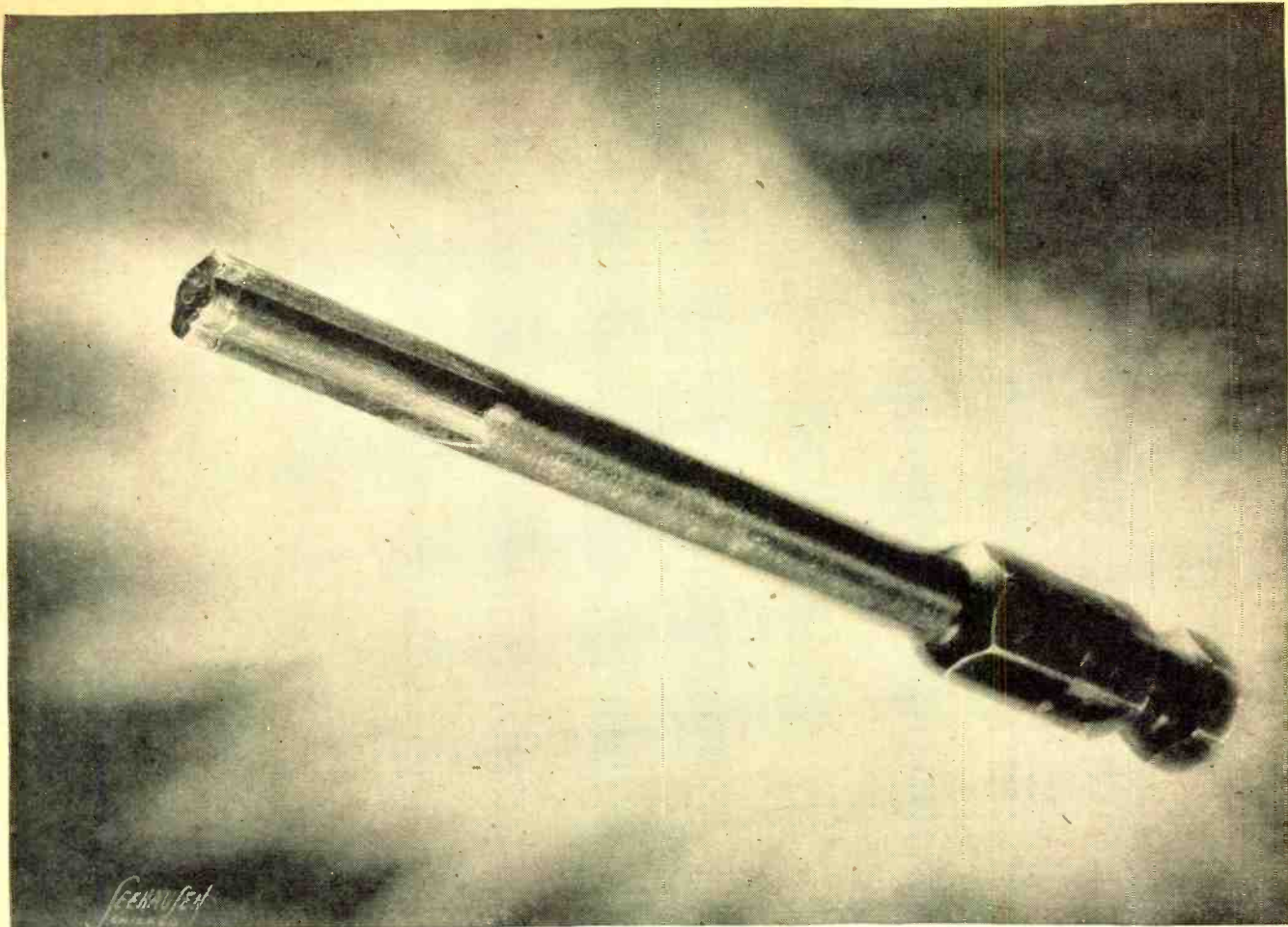

TYPE "A"  
ASSEMBLY BIT

COMMON  
SCREWDRIVER

## This Bit DROVE 214,000 SCREWS IN CONTINUOUS OPERATION

This amazing record of durability was rolled up on an assembly line of the largest automobile corporation in the world.

It is a stock bit, taken out of production shipment and was used in a power driver on  $\frac{5}{16}$ "-24x $\frac{7}{8}$ " flat CLUTCH HEAD door hinge screws . . . an operation calling for unusually high torque driving.

It is important to note that this bit served continuously on the assembly line . . . *that there was no interruption for reconditioning* during this 214,000 driving spell.

Moreover, this bit can be *repeatedly restored to its original efficiency* by a simple application of the end surface to a grinding wheel.

*Tool economy is only one of the many exclusive advantages offered by CLUTCH HEAD for faster, safer, and lower-cost assembly operation. Investigate them.*



*Check the perfect operation of this screw with an ordinary type screwdriver or any flat blade, reasonably accurate in width. Thickness of the blade is secondary.*

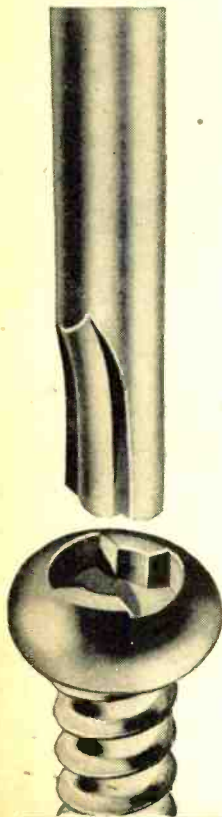

**UNITED SCREW AND BOLT CORPORATION**

CLEVELAND 2

CHICAGO 8

NEW YORK 7

# WAR SURPLUS RADIO & ELECTRONIC BARGAINS

Aerial Sections—Per Section.....	\$ .50
Bulbs—Neon ¼ Watt.....	.20
Cable Clamps—all types	
Circuit Breakers, Heinemann, Western Elec. from .01 to 100 amps.	
Coils of all types	
Condensers—large assort.—by-pass and mits; high voltage and transmitting. Variable Condensers—365 Mmf.....	1.25
Code Keys—Flameproof.....	1.75
Co-ax cable—various lengths..... ft.	.06
Chokes—Filter (all types) small 20MA.....	.45
Dials—Vernier.....	.90
Ear Phones—single with canvas strap.....	.59
Flashlights, G.I., angle type.....	.65
Fuses, all types—20 amp. screen type— 10 to box.....	.04½
Grid Caps—large transmitting tube with bracket and cable.....	.15
Head Sets, Telephone.....	1.25
Insulators, all types, small strain..... ea.	.02
Jewel Bracket Assembly—small.....	.30
Large.....	.45
Knobs—assortment at 10 for.....	.25
<b>METERS</b>	
Time Meter—Westinghouse NH35— 120V.....	7.00
0-150 MA Weston Model 506.....	3.50
0-200 MA G.E. type DW51.....	4.00
Potentiometers—all types..... ea.	.45
Phone Plugs.....	.25
Plugs, Amphenol—all types..... pr.	.75
Pilot Light Brackets and Socket, Bayonet Type.....	.04
Rheostats—large and varied assort.....	.60
Relays—DPDT—keying relay 115V AC Coil. 15 amp. contact.....	2.00
Resistors, power—large assortment. 100 watt—1000 ohm.....	1.00
Socket—above chassis—bakelite.....	.15
Socket—miniature—7-prong.....	.08
Socket—tuning eye—wired with cable and bracket.....	.20
Socket—4-prong Steatite.....	.15
Socket—Octal ceramic.....	.23
Suppressors—Auto for Spark Plugs.....	.10
Switches—Toggle 4 PDT.....	.65
Tube Shields.....	.06
Transformers—approx. 4000 or more. Kenyon Filament 110-125V input, 5V 115 amp. output.....	9.00
Terminal Strips—18 tap with mounting bracket.....	.30
<b>TUBES—Xmitting—304TL.....</b>	
250TL.....	10.00
807.....	1.10
450TH.....	25.00
6C21.....	23.00
826.....	4.95
832.....	4.95
Magnetron (damaged).....	2.00
<b>Receiving—6AC7.....</b>	
25L6.....	.80
384.....	.80
1291.....	1.00
1299.....	1.00
<b>Cathode Ray—3-in.....</b>	
5-in.....	6.00
12-in.....	9.00
24.00	
WIRE—25' No. 14 stranded insulated.....	.25

## SPECIAL

Assortment; 10 insulators various types 50 resistors, 10 condensers, 10 assorted sockets, 10 terminal strips, 5 volume controls.....	\$ 3.95
ARC/5 Receiver.....	37.50
ARC/5 Transmitter.....	32.50

Add postage to above prices.

TELL US YOUR WANTS

**THE ABELL DISTRIBUTING CO.**  
5 E. Biddle St. Baltimore 2, Md.

amplitude of sweep as the first one. Either transformer must have high losses with a high resonant frequency and tight coupling.

Since  $R_s = E_p/I_p$  of the pentode, we can control the pentode bias and thus vary  $R_s$  over wide limits. In practice, with  $R_s$  a 5000 ohm rheostat, frequency control over a range of about 50/1 may be had for any given value of  $C_s$ . This means that very few values of  $C_s$  are needed to cover the wide frequency range. Referring to Fig. 1, if  $C_1 = 50$ ,  $C_2 = 2500$ , etc., increasing 50 times in each step, then  $f_o$  will be reduced to 1/50 of its former value, which range is covered by  $R_s$ .

By this rule, only five condensers will cover a range exceeding 1 cycle to 1 megacycle.

For any given size of  $C_s$ , the output amplitude will be constant over a frequency range of about 50/1, fly-back time will be constant, and the ratio  $I_{dis}/I_{ch}$  will be the poorest at the high frequency end of each range, but can easily be 50 or more, except at the extreme high frequencies. Output amplitude will increase with "B" plus and the current capacity of  $V_1$ , the discharge tube.

The cathode follower circuit, shown in Fig. 1, will deliver between 100 and 200 volts of saw-tooth swing at a relatively low impedance, the exact

voltage will depend on "B+" and the size of the sweep condenser, being slightly less for larger condenser.

The linearity is best at high values of  $I_p$  of the pentode, but will depend on the insulation resistance of the capacitor used. Oil filled condensers should be used, the better the quality, the better the waveform at very low values of  $I_p$  of  $V_2$  (at the very low frequencies,  $R_s$ , the variable resistance represented by the d.c. plate resistance of the pentode, will be very high, on the order of ten megohms in practice, the discharge current of  $C_s$  will be in the order of microamperes).

The unit was built up as the sweep for a 2" oscilloscope, the parts layout which is not critical being shown in Fig. 4. A bakelite chassis was used to minimize stray capacity, and  $T_1$  was mounted as close as practical to  $V_1$ .

A suggested power supply is approximately 300 volts, d.c. with very low current consumption (about 12 mls). The power supply should have good regulation, and the power may be taken from a conventional scope by tapping into the supply, or a unit similar to that diagrammed in Fig. 5 may be used.

To cover the complete frequency range from one cycle to one megacycle,  $R_s$  and the four position switch are the only controls needed.

## METER TYPE TUNING INDICATOR FOR FM RECEIVERS

By FRANK SANTANGELO

FOR proper frequency modulation reception, it is necessary that the carrier frequency being received be tuned to center frequency (zero voltage). Some manufacturers have used tuning eye tubes, while others have used the zero center microammeters, usually connected (in series with a resistor to ground) in the output of the discriminator.

This latter method is generally unsatisfactory as it lowers the output of the FM tuner and, in addition, requires a very sensitive zero center meter in order to obtain good positive and negative voltage deflection.

The circuit shown eliminates the use of an expensive zero center microammeter and does not reduce the output from the FM tuner.

The circuit is essentially a high im-

pedance input vacuum tube voltmeter, adjusted by varying values of  $R_4$  to read half scale on receiver background noise (off station hiss).

By varying this value a zero center is automatically provided (point of zero voltage) therefore, when the receiver is tuned through an FM carrier, the meter will indicate both positive and negative voltage swings, the amount (assuming a reasonably sensitive meter is used, such as 0-1 or 0-5 milliammeter) depending mostly on amplification of the tube used. A glance at the circuit will show that this unit can be separately constructed and attached to any FM receiver.

By using this type of tuning indicator, it is possible to tune in an FM carrier with the greatest of ease.

—30—

Circuit diagram of meter type FM tuning indicator.

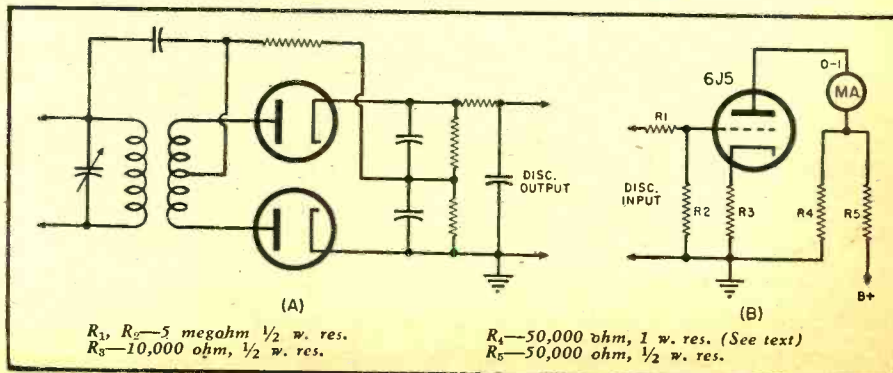



# BE A TELEVISION TECHNICIAN!

## Regularly Scheduled Programs are on the Air!

Two great broadcasting corporations have entered Television and are today producing programs. Other large organizations have applied for licenses to broadcast Television in all parts of the country! The sale of home receivers is now progressing. In other words, we believe it's the beginning of a vast and exciting new business. Regular Television broadcasting is *now* a reality!

Studio Photos Courtesy of Television Station WCBW



TELEVISION STUDIO CONTROL

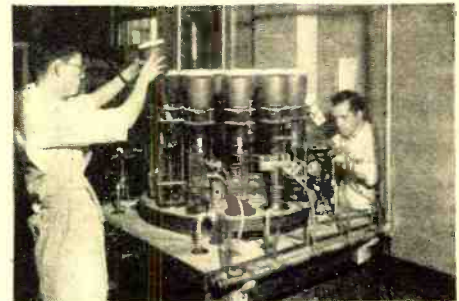

TUBE MAKING AT A.T.I.

### TELEVISION AND YOU

The opportunity in Television is far greater for the properly trained man. You owe it to yourself to investigate Television and to prepare yourself to become a valued part of a fascinating new profession.

### PREPARE THE "AMERICAN" WAY

The American Television Institute is the oldest and largest training organization exclusively for Television. "American" students are trained by top Television engineers with the latest commercial equipment. You will train under actual Television studio conditions. You will learn by doing. You can qualify for your chosen field with the necessary fundamental knowledge plus real studio experience and skill.

#### VETERANS ATTENTION!

The American Television Institute has been approved for Veteran's Training under the G.I. Bill of Rights. During the war, thousands of Signal Corps men were trained under contract with the War Department. Our training methods have been developed to a high degree and our school has up to the minute facilities in every respect. If you are a veteran, mark the coupon for the G.I. Eligibility Questionnaire.

#### WHICH PHASE OF TELEVISION?

The American Television Institute's tremendous facilities offer a complete selection of Television study—broadcast studio and control, broadcast transmitter, receiver installation and service—in fact, all departments are thoroughly covered in our laboratories.

#### WHEN DO YOU START?

The best time is right now! Immediately! New classes are forming every week. Use the coupon to get further details. Mail it today!

## American Television Institute

DIVISION OF

AMERICAN TELEVISION LABORATORIES, INC.

433 E. Erie Street

Chicago 11, Illinois

**MAIL THE COUPON TODAY**

November, 1946

#### REQUEST FOR FREE INFORMATION

AMERICAN TELEVISION INSTITUTE  
433 East Erie Street, Chicago 11, Illinois

- Please send me complete details of your Television training.
- I am a veteran.

NAME.....

ADDRESS.....

CITY & STATE.....

FOR DEPENDABLE PERFORMANCE....

# P-B' QUALITY BRAND CAPACITORS

FOR LONG LIFE



Complete line of paper and electrolytic "PB" Brand tubular capacitors now available for immediate Delivery.

Literature on Request

ATLAS Capacitors are built to the highest standards of quality in workmanship and materials. New, improved manufacturing processes and better components assure dependable performance and long life of ATLAS capacitors for all radio and electronic applications.

## ATLAS

WE INVITE INQUIRIES FROM MANUFACTURERS AND JOBBERS ONLY

ATLAS CONDENSER PRODUCTS COMPANY, Inc.  
548 Westchester Avenue • New York 55, N. Y.

Thus, we have, basically, a triode blocking oscillator whose frequency is controlled by an RC network, and a constant current tube replacing the R in the RC combination, allowing the condenser to charge at a linear rate.

We also find that we have:

1. Sweep amplitude independent of the setting of  $R_2$  for any one value of  $C_2$ ;
2. Only two controls,  $R_2$  and the four-position switch;
3. Only five high grade condensers cover 1 cycle to 1 megacycle;
4. Linear sweep with linear fly-back; and
5. High ratio usable/non-usable waveform.

QTC

(Continued from page 38)

all risk for the \$150 . . . so if your ship has recently been returned by your company to the U.S. Maritime Commission you can readily see the outfit can't afford to run too many with the losses involved for the percentage of the profits that the government allows under the new regulations . . . most marine men are of the opinion that nearly all of the present 800 odd ships built during the war and now operated on a charter basis will be returned to the government . . . many will probably be purchased, the operating company can make a more reasonable profit if they own the ship outright, and reenter service . . . others will most likely be tied up for some time.

Shipping generally has been fairly good until the present wave of returning the chartered ships back to the government. It is to be expected that it will return somewhat after the various steamship companies have returned to a more normal postwar operation. . . . As we go to press however, the general maritime strike is still under way and all shipping is tied up for the moment . . . we hope the matter will be settled shortly and that the vessels will be moving . . . it has everything tied up—only the incoming ships being permitted to dock . . . 73.

### KEEP LOOP AERIALS CLEAN

Noise or fading may result if terminals of the radio loop aerial become dirty or corroded.

The plug-in terminals may be cleaned with emery cloth as illustrated . . . H.L.

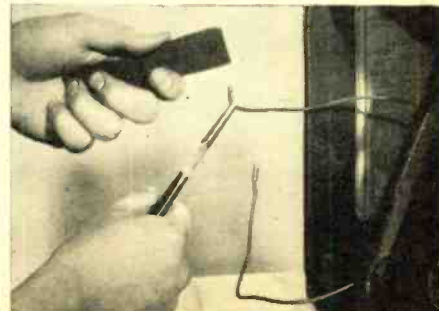

## Light & versatile FOR BETTER SOLDERING

Patterned for durability and soldering ease, this nimble pencil iron is equally at home performing large heavy duty jobs or in the hard-to-reach spots requiring pin-point accuracy.

### Check These Points!

- ★ QUICK HEATING . . . 90 SECONDS
- ★ LIGHTWEIGHT . . . 3.6 OUNCES
- ★ HANDY SIZE . . . . . 7 INCHES
- ★ SAVES ELECTRICITY . . . 20 WATTS

### ★ Perfect Balance

SEE YOUR NEAREST RADIO, HARDWARE OR HOBBY DEALER

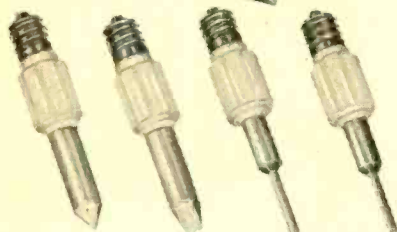

No. 536 Standard Tip, made from Hard Drawn Cap per

No. 537 Extra Hot, made from Etkaloy A

No. 538 Chisel Tip, made from Etkaloy A, Tip 1/8" dia.

No. 537 Pencil Tip, made from Etkaloy A, Tip 1/8" dia.

These 4 INTERCHANGEABLE tips give you a point for each particular job.

YNGAR Electric Tools

ROY 7151, TERMINAL AVENUE • LOS ANGELES 54, CALIF.

**NOW AVAILABLE FOR IMMEDIATE SHIPMENT!**

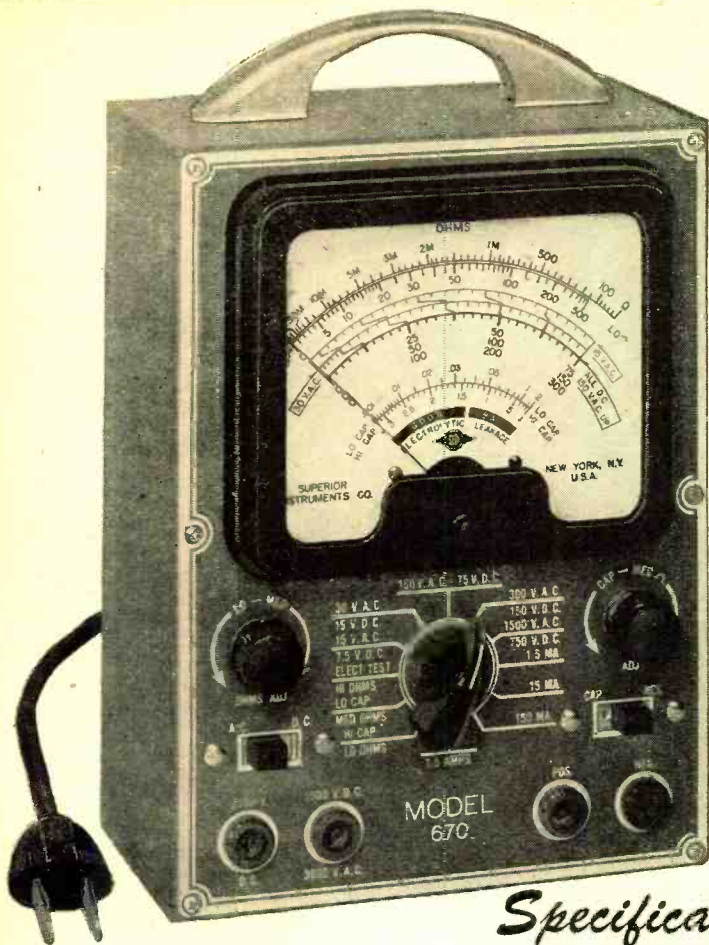

*The New Model 670*  
**SUPER-METER**

*A Combination*  
**VOLT-OHM MILLIAMMETER**  
plus **CAPACITY REACTANCE**  
**INDUCTANCE** and  
**DECIBEL MEASUREMENTS**

*Added Feature:*

The Model 670 includes a special **GOOD-BAD** scale for checking the quality of electrolytic condensers at a test potential of 150 Volts.

*Specifications:*

**D.C. VOLTS:** 0 to 7.5/15/75/150/750/1,500/7,500 Volts  
**A.C. VOLTS:** 0 to 15/30/150/300/1,500/3,000 Volts  
**OUTPUT VOLTS:** 0 to 15/30/150/300/1,500/3,000 Volts  
**D.C. CURRENT:** 0 to 1.5/15/150 Ma. 0 to 1.5 Amperes

**RESISTANCE:** 0 to 500/100,000 ohms 0 to 10 Megohms  
**CAPACITY:** .001 to .2 Mfd. .1 to 4 Mfd. (Quality test for electrolytics)  
**REACTANCE:** 700 to 27,000 Ohms 15,000 Ohms to 3 Megohms  
**INDUCTANCE:** 1.75 to 70 Henries 35 to 8,000 Henries  
**DECIBELS:** -10 to +18 +10 to +38 +30 to +58

*The Model 670 comes housed in a rugged, crackle-finished steel cabinet complete with test leads and operating instructions. Size 5 1/2" x 7 1/2" x 3".*

**\$2840**  
NET

*Model 670P*

The Model 670P is identical to the Model 670 described in detail except housed in a hand-rubbed, portable oak cabinet complete with cover.

The Model 670P comes complete with test leads and all operating instructions.

**\$35<sup>75</sup>**  
NET

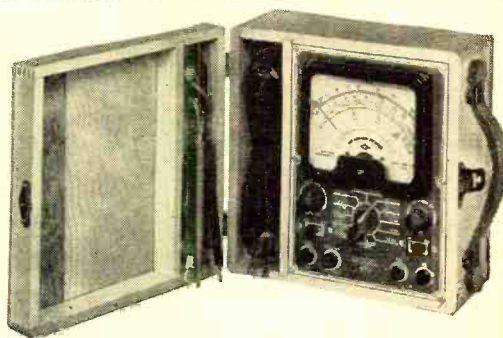

Please place your order with your regular radio parts jobber. If your local jobber cannot supply you, kindly write for a list of jobbers in your Store who do distribute our instruments or send your order directly to us.



**SUPERIOR INSTRUMENTS CO.**

**Dept. RN 227 FULTON ST., NEW YORK 7, N. Y.**

**FREE! Send for it Now!**

**ALLIED'S Catalog**  
of Everything in  
**RADIO**



**LARGEST STOCKS**  
**QUICK DELIVERY**

Send for your **FREE** copy of the handiest, most complete Buying Guide for Everything in Radio! Features thousands of radio and electronic parts, latest home radios, sound systems, amateur and builders' gear, servicemen's equipment, tools, books—world's largest and most complete quality stocks—at lowest prices! Fastest service; expert help!

**OVER 10,000 ITEMS.....**



Complete lines of all leading makes. Largest stocks of hard-to-get parts. Money-saving prices. Get everything you need from one dependable supply source.

**AMATEUR GEAR.....**



Earliest delivery on latest communications receivers. Time payment plan; trade-in accepted. Headquarters for all ham and experimenter's needs.

**HOME RADIOS.....**



Large selection of exceptional home radios and phono-radios. Handsome new styles. Wonderful performance. Today's leading set values.

**PUBLIC ADDRESS.....**

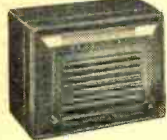

Famous Ready-to-Use Sound Systems for every P.A. requirement. Everything in amplifiers, speakers, microphones, intercom and recording.

**HANDY RADIO BOOKS.....**



Radio Formulas and Data  
Dictionary of Radio Terms  
Radio Circuit Handbook  
Radio Builder's Handbook  
Simplified Radio Servicing  
Radio Data Handbook  
ALL SIX BOOKS No. 37-799...75c  
Parallel Resistance and Series Capacitance Calculator, No. 37-960 ..... 25c  
R-F Resonance and Coil Winding Calculator, No. 37-955 ..... 25c

**ALLIED RADIO**

**ALLIED RADIO CORP.**  
833 W. Jackson Blvd., Dept. 1-L-6, Chicago 7, Ill.

- Send FREE Radio Catalog
  - Send 6 Books No. 37-799
  - Send Calculator No. 37-960
  - Send Calculator No. 37-955
- \$..... enclosed

Name.....

Address.....

City.....Zone.....State.....

# 10-METER VERTICAL COAXIAL ANTENNA

By **C. V. HAYS, W6RTP**

*Construction details for fabricating a concentric, vertical antenna for use at very-high frequencies.*

**T**HE long-awaited opening of the ten-meter amateur band found the author in need of an antenna which could be depended upon to give the maximum in performance on the following counts:

1. Ability to work DX.
2. Economy, plus ease of construction and erection.
3. Ability to work in any direction equally well.
4. Maximum efficiency in any weather.

Undoubtedly a rotary array is the logical answer to most of the above, but with materials tied up in priorities and what not, a satisfactory beam was out of the question.

After working for the past four or five years with commercial and military radio, the author was fortunately able to pick an antenna design on the basis of proven performance under practically all conditions. The design chosen was that of the coaxial, or concentric, vertical antenna, widely used in v.h.f. work.

Due to the method of feed and mount, this type of vertical antenna operates in a highly efficient manner. Briefly, the usual drawback of vertical antennas is the feed method employed. Use of an open line to the "J" type of vertical results very often in a quite serious distortion of the vertical directivity pattern, causing the major radiation lobe to assume an angle so high that optimum efficiency is virtually impossible.

The above named defect, in conjunction with the distorted pattern caused by proximity to the mounting structure, rules the "J" out. The widely used horizontal doublet was rejected because of the practically vertical radiation of a great deal of wasted power, as well as the more or less directional effect in a broadside plane. This left the "Brown ground-plane vertical" and the "vertical coax" to be considered.

The ground-plane vertical is an ex-

cellent performer but has one serious drawback to the average ham, namely, impedance matching. The resistance of this antenna is roughly 21 ohms, a value requiring more or less complicated design. The vertical coax, on the other hand, can be fed with a 70 or 50 ohm feeder directly, with about equal results.

Probably the main reason for a lack of performance in many antennas of

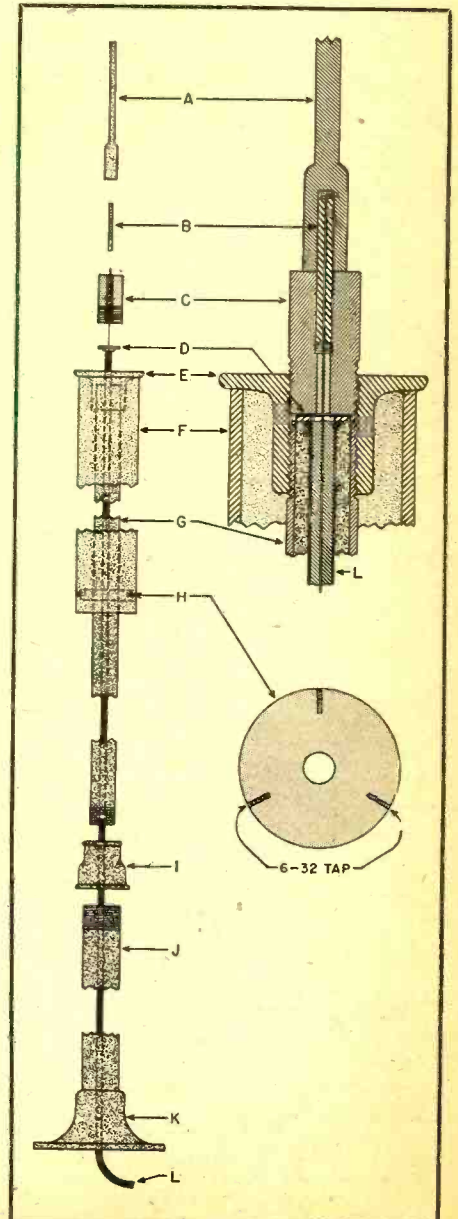

Construction details for 10-meter vertical coaxial antenna. (A) "whip" auto antenna, (B) brass stud  $\frac{1}{4}$ "-20, thread drilled lengthwise with  $\frac{1}{4}$ "-20 inside and threaded with  $\frac{3}{4}$ " pipe die on lower end, (D) brass washer, (E) brass floor flange, (F) brass tubing, (G)  $\frac{3}{4}$ " galvanized pipe, (H) doughnut insulator, (I),  $\frac{3}{4}$ "-1" bell reducer, (J) 1" galvanized pipe, (K) 4" galvanized flange for 1" pipe, (L) either 50 or 70 ohm coaxial feeder cable.



# Jensen *Speech Master* REPRODUCERS

...for clear, crisp, intelligible  
Speech\* **Reproduction**

Designed especially for speech reproduction in intercommunication and public address applications, this Speech Master family of JENSEN Reproducers, delivers clean, sharp, understandable announcements and orders. Like all JENSEN products, these Speech Masters were completely engineered to do their job efficiently and well.

**MODEL NJ-300 SPEECH MASTER** (Railroad Type).

PM design. Widely used in railroad intercommunication in locomotives, cabooses, signal towers and yards. Rugged case protects against shock and vibration; withstands dust, smoke and the elements. Voice coil impedance 12 ohms; power rating, 10 watts. Space provided inside case for 500-ohm impedance transformer. Overall height 11-3/4"; width 6-25/32"; depth 4-13/16". Holes provided in base for mounting in any position.

**MODEL AR-10 SPEECH MASTER** *ALNICO 5* design. Specially constructed reflex horn increases efficiency in mid-frequency range, giving added effectiveness and "punch" to speech quality; prevents direct access of rain and snow to speaker diaphragm. Voice coil impedance, 4 ohms and 45 ohms; power rating, 6 watts. Space provided inside for 1/2" x 1/2" transformer. Overall diameter 10"; depth 8". Complete with mounting bracket.

**MODEL AP-11 SPEECH MASTER** (Panel mounting). Similar to AP-10 but without base. Mounts in 4-27/64" cut-out; clearance eyelets for mounting screws. Depth 4 1/2" from front panel. Screws and drilling template included. Voice coil impedance 4 ohms or 45 ohms; power rating, 5 watts.

**MODEL AP-10 SPEECH MASTER** (Desk or Wall type).

PM design, desk or wall mounting. Complete with base and tilt adjustment. Double dustproofed. Rubber covered 36" cord. Internal mounting bracket for 1/2" x 1/2" transformer. Voice coil impedance 4 ohms or 45 ohms; power rating, 5 watts. Height 6-3/4"; depth 5 1/8"; diameter 5". Finish hammered gray with satin chrome trim.

**MODEL NF-300 SPEECH MASTER** (Navy Type). Developed for use as a loud speaker and microphone. Special case design over-rides wind and background noises for talk-back. Enclosed case and protective screen render this model proof against weather, dust and moisture *ALNICO 5*-PM design. Power rating, 10 watts; voice coil impedance 12 ohms. Mounts in 5 3/8" cut-out; six screw holes in rim. Overall diameter 6-7/16"; depth (from front of panel) 2-9/64". Finished in Munsel N4-5 gray enamel.

**MODEL AP-20 SPEECH MASTER** Heavy-duty unit for high-level paging and call systems in noisy industrial installations. PM design. Furnished with eyebolt for overhead suspension but available with stand for wall or table mounting. Voice coil impedance 8 ohms; power rating, 25 watts. Overall diameter 13 1/2"; depth 9"

\*For full discussion of Speech requirements, see Jensen Monograph No. 4.

**JENSEN MANUFACTURING CO.**

6617 S. LARAMIE AVENUE, CHICAGO 38, ILLINOIS, U. S. A.  
In Canada: J. R. Longstaffe, Ltd., 11 King Street, West, Toronto, Ont.



**Jensen**  
SPEAKERS  
WITH *ALNICO 5*

*Specialists in Design and Manufacture of Acoustic Equipment*

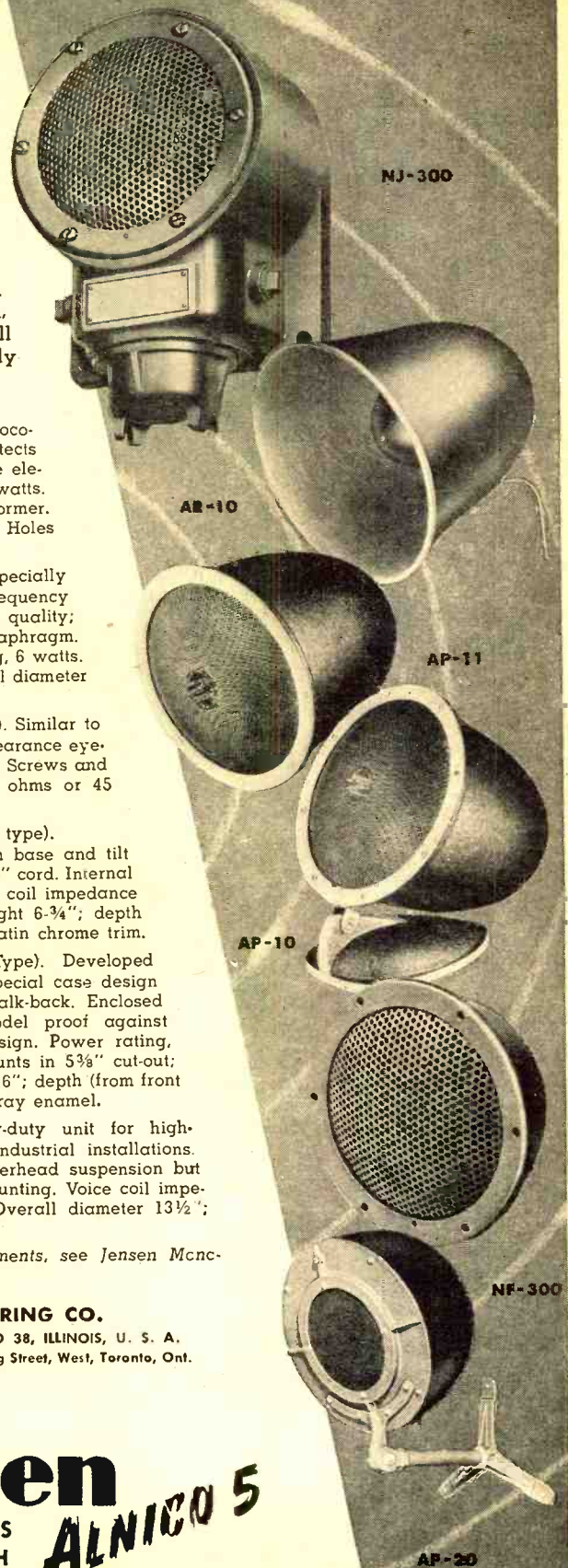

**5**

**MONOGRAPHS  
AVAILABLE**

If you haven't yet procured these five valuable technical booklets, order now—either from your dealer or direct—at 25¢ each.

1. Loud Speaker Frequency-Response Measurements
2. Impedance Matching and Power Distribution
3. Frequency Range in Music Reproduction
4. The Effective Reproduction of Speech
5. Horn Type Loud Speakers

**25¢** each



**DON'T BE A VICTIM  
OF**

**T.B.D.\***

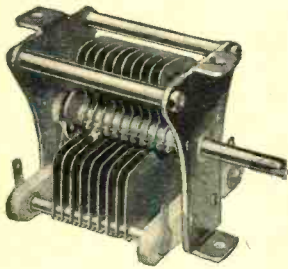

Why take chances? Use condensers that you can depend on for steady, long-range, serviceable performance. The BUD variable condenser line consists of tuning, neutralizing and padder condensers that are designed to give maximum service at moderate cost.

See your local distributor for information on the complete BUD condenser line. Ask him to show you the differences that make this line so outstanding!

\* Transmitter Break-Down

**BUD**

Can Supply All Your Needs! . . .

. . . with the latest types of equipment including: condensers — chokes — coils — insulators — plugs — jacks — switches — dials — test leads — meter lights and a complete line of ultra-modern cabinets and chassis.



**BUD RADIO, INC.**

CLEVELAND 3, OHIO

this type erected by hams is a misunderstanding of the proper element lengths, data being limited as to the proper formula for determining the element lengths. Without going into the why's and wherefore's, we will simply give the formula found most suitable for this type of antenna.

Length of upper section (the whip) equals freq. in mc. divided into 235.6

Length of lower section (the skirt) equals freq. in mc. divided into 243.3

For convenience, a list of the proper lengths for every 100 kc. in the ten-meter band is given below. Due to the high "Q," or sharpness of resonance, operation is not advisable more than 100 kc. from the optimum frequency.

Seamless brass tubing is to be preferred on several counts for the "skirt," but copper, aluminum, dural, steel tube conduit and galvanized pipe are all acceptable—results being practically the same if a good job is done in constructing the antenna.

Referring to the constructional drawing (A) is the whip; (B) is the 1/4"-20 brass screw, drilled lengthwise with a No. 40 drill; (C) is the insulator (plexiglass, bakelite, etc.); (D) is the brass washer, 1/2" i.d., 7/8" o.d.; (E) is the 2 1/2" brass floor flange, tapped for 3/4" pipe; (F) is the 2 1/2" thinwall brass tubing; (G) is a ten-foot section of 3/4" pipe; (H) is a "doughnut" insulator of plexiglass, lucite, etc.; (I) is a 3/4"-1" bell reducer; (J) is a ten-foot section of 1" pipe; (K) is a 4" galvanized floor flange, tapped for 1" pipe; (L) is 50 or 70 ohm coaxial feeder.

Vertical coaxial antenna element lengths for the ten-meter band.

- |          |                           |
|----------|---------------------------|
| 28.1 mc. | Whip equals 8' 7 7/8"     |
|          | Skirt equals 8' 4 5/8"    |
| 28.2 mc. | Whip equals 8' 7 1/2"     |
|          | Skirt equals 8' 4 1/4"    |
| 28.3 mc. | Whip equals 8' 7 3/16"    |
|          | Skirt equals 8' 3 3/8"    |
| 28.4 mc. | Whip equals 8' 6 13/16"   |
|          | Skirt equals 8' 3 9/16"   |
| 28.5 mc. | Whip equals 8' 6 7/16"    |
|          | Skirt equals 8' 3 3/16"   |
| 28.6 mc. | Whip equals 8' 6 1/16"    |
|          | Skirt equals 8' 2 13/16"  |
| 28.7 mc. | Whip equals 8' 5 3/4"     |
|          | Skirt equals 8' 2 1/2"    |
| 28.8 mc. | Whip equals 8' 5 3/8"     |
|          | Skirt equals 8' 2 3/16"   |
| 28.9 mc. | Whip equals 8' 5"         |
|          | Skirt equals 8' 1 13/16"  |
| 29. mc.  | Whip equals 8' 4 11/16"   |
|          | Skirt equals 8' 1 7/16"   |
| 29.1 mc. | Whip equals 8' 4 5/16"    |
|          | Skirt equals 8' 1 1/8"    |
| 29.2 mc. | Whip equals 8' 4"         |
|          | Skirt equals 8' 13/16"    |
| 29.3 mc. | Whip equals 8' 3 3/8"     |
|          | Skirt equals 8' 1 1/2"    |
| 29.4 mc. | Whip equals 8' 3 5/16"    |
|          | Skirt equals 8' 1 1/8"    |
| 29.5 mc. | Whip equals 8' 2 15/16"   |
|          | Skirt equals 7' 11 13/16" |
| 29.6 mc. | Whip equals 8' 2 3/8"     |
|          | Skirt equals 7' 11 1/2"   |
| 29.7 mc. | Whip equals 8' 2 5/16"    |
|          | Skirt equals 7' 11 3/16"  |

**Another Clark  
Achievement!**



This is the 20-watt member of the Clark family of carefully engineered public address amplifiers. The PA-20 is generously rated to provide plenty of faithful volume for all except the very largest auditoriums. As in the latest radio equipment, small components are terminal strip mounted for instant accessibility.

Inputs: 2 microphones, 1 phonograph.  
Frequency response: 30-15,000 flat within 2 db.  
Distortion: Less than 5% over entire range.  
Hum: At least 60 db below full output.  
Output: 20 Watts (24 watts maximum).  
Output impedance: Tapped for 4, 8, 16 and 500 ohms.

The PA-20 represents top quality engineering and performance at moderate cost. Ask your jobber or write direct for further information.

**Clark Radio Equipment Corp.**

4313 LINCOLN AVE., CHICAGO 18, ILL.

**NEW—JUST RELEASED!**

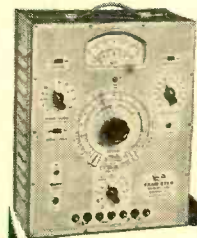

**SOLAR**

**Model CF-1-60  
EXAM-ETER**

With Exclusive Patented Solar "Quick Check" Circuit. A sturdy, reliable instrument designed to simplify and speed up electronic servicing.

- QUALITY CHECKING OF CAPACITORS UNDER ACTUAL OPERATING CONDITIONS.
- CAPACITANCE—10 mmf. to 2000 mf. mfd.
- POWER FACTOR—0 to 55 percent.
- LEAKAGE CURRENT—at voltages up to 550 volts.
- INSULATION RESISTANCE—3 to 10,000 megs.
- RESISTANCE—100 ohms to 7.5 megs.
- DC Vacuum Tube V.M. —0-550 volts.
- AC Vacuum Tube V.M. —10 to 50 volts.
- Complete with tubes and test leads, ready to operate. . . . .

**\$5970**

**RCP Model 802N  
COMBINATION  
TUBE-SET  
TESTER**



Immediate Delivery from Stock.

A complete tube tester and a complete set tester, with only 5 simple switches to operate for both tube and set tester combined.

DC VM. 0/10/50/500/1000 at 1000 ohms per v.  
AC VM. 0/10/50/500/1000.  
DC MA. 0/1/10/100/1000 DC Ammeter 0/10.  
Ohmmeter 0/500/5000/1,000,000/10,000,000. Low ohm center.

D.H. Meter—3/15/15 to 29/29 to 49/32 to 55 db.

Four range output meter—same as AC volts.  
Size: 12 3/4 x 12 5/8 inches. Weight: 11 1/2 lbs. Complete in handsome hardwood case, with test leads, self-contained batteries, ready to operate. Net. . . . .

**\$5950**

**ADSON RADIO CO.**  
221 FULTON ST., NEW YORK 7, N. Y.

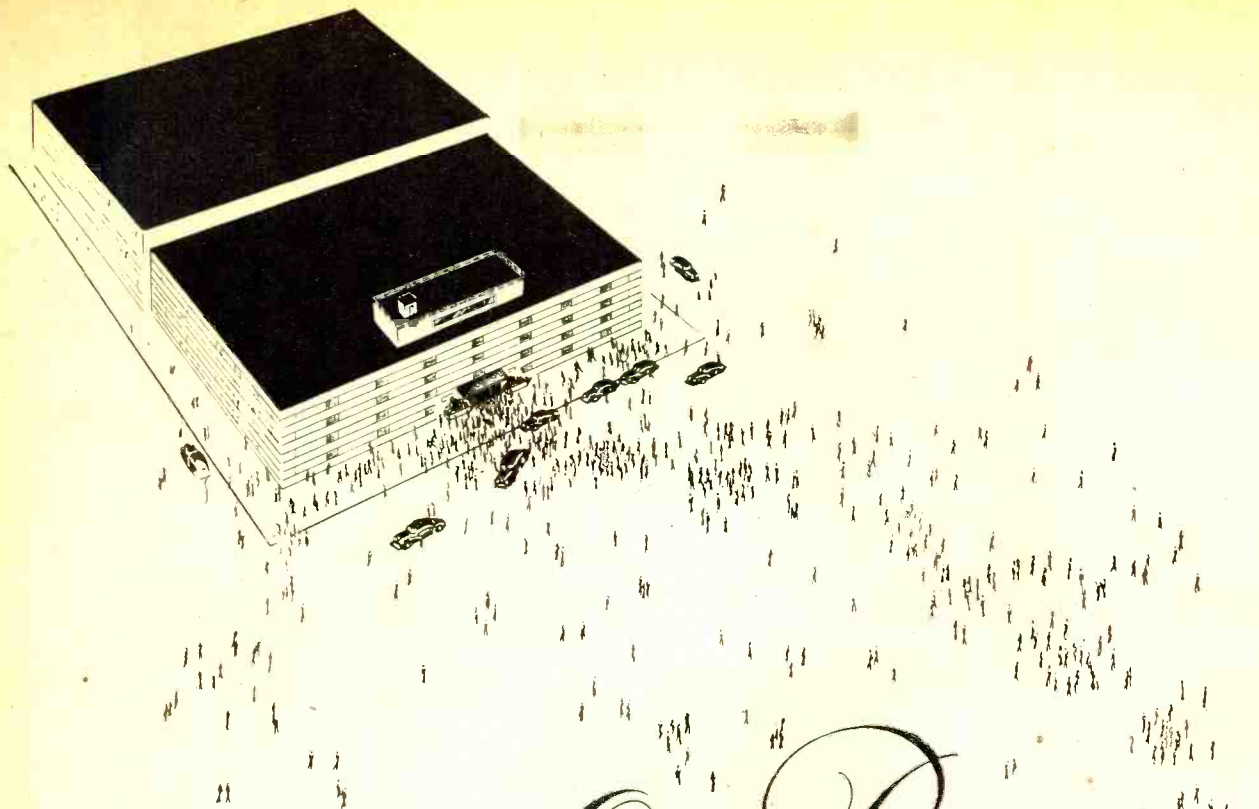

# *Our People*

For twenty-six years, since the very beginning of radio broadcasting, Air King has been steadily growing. Now over five hundred employees, trained to the high standards required by our armed services and working in modern plants with the newest and most efficient equipment can produce over three thousand sets a day.

During the war all of Air King's facilities were devoted to the making of Radar and special electronic devices. Now with all this skill and experience, Air King, the most highly integrated producer in its field, turns again to civilian production and offers a complete line of AM, FM, and Television receivers—the finest that Air King people have ever set their trained hands to make at prices indicative of high efficiency and high production.



**AIR KING**  
**RADIO**  
*Brooklyn*

*Division of* **HYTRON RADIO & ELECTRONICS Corporation**



*The Royalty of Radio Since 1920*

UTC FOR HIGH Q. In tuned circuits: filters, etc. the Q (efficiency factor) of the coils employed is a paramount performance factor. Having specialized in this field for many years, UTC has developed a number of standardized types of coils ideally suited to filter applications.



## VI-C INDUCTOR

The UTC VI-C Inductor is an exclusive item of tremendous value in filter construction. This inductor is tunable over a range of +100% -50% from the nominal value, permitting precise circuit tuning using commercial tolerance capacitors. Standard units are available in nominal inductances from 10 Mhs. to 10 Hys. These units weigh 5 ounces, measure 1 1/4" x 1-7/16" x 1-7/16"



## HQA REACTOR

These reactors are designed for audio frequency operation with high Q and excellent stability. For a typical coil, (.14 Hy.), inductance varies less than 1% from .1 to 25 volts . . . Q is 120 at 5,000 cycles . . . hum pickup is low (toroidal structure), 70 Mv. per gauss at 60 cycles . . . variation in inductance less than 1/2% from -60° C. to +85° C. . . hermetically sealed in drawn case 1-13/16" diameter x 1-13/16" high . . . weight 5 ounces Available in inductance values from 12.5 Mhs. to 2 Hys.



## HQB REACTOR

The HQB reactors are similar to the HQA series, but provide higher Q. For a typical coil, (.45 Hy.), inductance varies less than 1% with applied voltage from .1 to 50 volts . . . hum pickup twice that of HQA . . . variation of inductance less than 1/2% from -50° C. to +85° C. . . Q is 200 at 4000 cycles . . . hermetically sealed in steel case 1 1/2" x 2 1/2" x 2 1/2" high . . . 14 ounces . . . available in any inductance value from 5 Mhs. to 12 Hys.



## 3 AX EQUALIZER

The Universal equalizer for broadcast and recording service. Provides up to 25 DB adjustable equalization at 25, 50, or 100 cycles for low ends, and at 4000, 6000, 8000 or 10,000 cycles at high end. Calibrated controls read directly in DB equalization and frequency setting. The insertion loss effected is compensated for through special compensating pads so that insertion loss is constant regardless of setting. Rapid change in tone color can be obtained with negligible change in volume.

Descriptive circulars are available for each of the above products.



*United Transformer Corp.*

150 VARICK STREET NEW YORK 13, N. Y.  
EXPORT DIVISION: 13 EAST 40th STREET, NEW YORK 16, N. Y. CABLES: "ARLAB"

PY2QK—Santos, Brazil	Q5R7
KA1JB—Philippine Is.	Q5R5/8
W6SOV—Philippine Is.	"5x5"
K7FBN—Juneau, Alaska	Q5R7/8
W6PUL—Hawaiian Is.	Q5R9
VESTQ—Br. Col.	
Night short skip	Q5R6/8
VE3AIU—Ont., Can.	Q5R7/8
VE4SY—Sas., Can.	Q5R7
VE4AKI—Sas., Can.	Q5R9
W5JZQ/W6—Ariz.	
Night short skip	Q5R9plus
W6PUZ—Tinian Is.	Q5R6
W2LFE/K6—Haw. Is.	Q5R9plus
W9QMD/KE6—Johnston Is.	Q5R9plus
WIHCH/K6—Haw. Is.	Q5R9plus

Table 1. Partial list of stations worked. Practically all districts in U.S. give Q5R9 reports, with many commenting on FB signal from the 60-watt rig used at W6RTP. Many of the DX stations worked were from CQ's and reception on a homemade super with the antenna is as good as the transmitting reports.

Any garage or similar place equipped for brazing can do the job of brazing the flange (E) to the skirt (F), at small cost, after which (A) and (F) cut to the formula given, the insulator (C) is tapped and drilled for the screw (B), and threaded for an inch on one end with a 3/4" pipe die; the washer (D) is carefully soldered to the outer conductor of (L), of which some three inches of the inner conductor and insulating material have been left above the trimmed-off outer conductor. With the section of pipe (G) slipped up through the bottom of skirt (F) and screwed firmly into flange (E), the feeder (L) is slipped down through the assembly from the top, with the washer (D) coming to rest against the end of the pipe (G), a half inch or so below the surface of flange (E). Next screw the 1/4"-20 screw (B) into the insulator (C), which in turn screws into the upper half of flange (E), jamming washer (D) firmly between it and the pipe section (G), insuring a good connection for the outer conductor of feeder (L). The upper end of the inner conductor of (L) will fit nicely through the No. 40 hole previously drilled through screw (B)—trim the wire flush and solder to the screw, completing the feeder connection. Screw whip (A) onto the inch or so of the screw (B) left above the insulator (C), fit the lower section of pipe (J), with the bell reducer (I), onto the 3/4" pipe (G), fit flange (K) on the bottom of the 1" pipe, and your antenna is complete. Couple to the final tank coil with a one or two turn link and you're ready for ground wave; short skip; long skip; north, south, east and west, with an equally strong signal.

The complete cost of the antenna as built by the author was under \$8.00, including a quart of aluminum paint, and six hours of work. See Table 1 for an idea of what to expect from your vertical coaxial.

-30-

MANUFACTURERS!

DISTRIBUTORS!

# CLOSE OUT

Complete radio parts stock to be liquidated. All parts are unconditionally guaranteed to be perfect, and as represented. A 25% deposit required on all orders. References: R. G. Dunn, and Bank of America, Los Angeles, California. All items subject to prior sale.

10% DISCOUNT FROM PRICES SHOWN ON ORDERS ABOVE \$250.00

### NOTICE

No Orders Under \$50.00

RESISTORS  
ALL INSULATED AND  
COLOR CODED

Quantity on Hand

AT \$11.00 PER 1,000
12,300—3 Ohm, 1/2 Watt
2,324—500 Ohm, Flexible
33,200—2,400 Ohm, 1/2 Watt
1,725—15,000 Ohm, 1/2 Watt
13,125—30,000 Ohm, 1/2 Watt
1,600—100,000 Ohm, 1/2 Watt
19,186—220,000 Ohm, 1/2 Watt
1,016—250,000 Ohm, 1/2 Watt
3,460—250,000 Ohm, 1/2 Watt
3,849—680,000 Ohm, 1/2 Watt
AT \$10.00 PER 100
2,649—20,000 Ohm, 20 Watt
AT \$28.00 PER 100
2,403—10,000 Ohm, 100 Watt
PHONOGRAPH PICKUPS
3,000—Astatic, Straight, with L26 Cartridge, List \$4.95 . . . \$1.65
47—Astatic, with Perm. Jewel LP6 Cartridge, List \$10.00 . . . 3.50
224—Astatic, Curved, with L40 Cartridge, List \$6.50 . . . 2.25

### CONDENSERS

Quantity on Hand	Price per Hundred
37,700—00005 Mfd. Tiny Ceramic	\$2.00
58,165—0002 Mfd. Tiny Ceramic	2.00
10,900—0005 Mfd., 150V. very	2.00
Tiny Tubular	2.00
7,059—0005 Mfd. Small Mica	2.90
700—001 Mfd., 600V. Cornell	7.90
Dubilier	2.90
250—006 Mfd., 600V. Mica	6.60
Postage Stamp	
1,700—006 Mfd., 600V. Solar	7.90
Tubular	7.90
1,500—02 Mfd., 600V. Solar	7.90
Tubular	7.90
1,000—05 Mfd., 600V. Sola	9.90
Tubular	9.90
1,500—05 Mfd., 400V. Solar	7.90
Tubular	7.90

### VOLUME CONTROLS

75—5,000 Ohm with Switch	.66
147—1/2 Megohm Tapped, Less Switch	.30
105—1/2 Megohm with Switch, Short Shaft, Chromed, takes large Nut	.49
103—1/2 Megohm, Midget Centralab with Switch and Two Taps, Push Knob	.49
640—1/2 Megohm, Bradleyohm, Less Switch	.32

### MISCELLANEOUS

460—4 Prong Water Socket	\$ .04
1,150—Headphones, Army H23, Leather Headband, Rubber Earcups, with PL55 Plug, Hi-Impedance, List \$16.00	1.85
830—Phone Jack, Female, with	

Quantity on Hand	Price
Plastic Housing, for Army H23 Headset Cord	.25
68—ICA Neutralizing Tool Kit, List \$7.50	1.95
4,400—Slices Spaghetti, Asst. Sizes, Colors	.02
1,000—Slices Muroc Spaghetti, Rubberized	.03
15—Phono Cases, Luggage, for Player and Amplifier, Blue and Brown	7.95
443—Rotary Switch, 4 Pole 5 Position, Short Shaft, Surplus	.17
832—2 Prong Male and Female Plug, Radio Battery Type	.03
1,492—Flashlight Lamps, 2.3V., 2.5V. and 3.8V.	.02
730—Code Keys, Army J38, Large Plastic Base, with Shorting Key and many Adjustments, Beautiful, List \$6.50	.55
5,000—45 Volt "B" Battery, same as Burgess 230N. Packed for Overseas. Full Charge. Fully Guaranteed. Mfg. Date Aug. 1944.	.22
2,000—6 Volt Jumbo "A" Batteries, Eveready 718, fully Guaranteed. Service Date Aug. 1944	.10
2,000—90 and 3 Volt Packs, Army BACT, uses Standard 45 Volt Plug. Fully Guaranteed. Mfg. Date Sept. 1945. Dimensions 1 1/2 x 3 1/4 x 1 1/4"	.30
557—Terminal Strip with Seven Mounted Insulated Coaxial Resistors, Complete	.10

**BIGG  
RADIO STORE**

2506 W. WASHINGTON BLVD.  
LOS ANGELES 16, CALIFORNIA

WE SHIP ANYWHERE IN THE WORLD  
INTERNATIONALLY FAMOUS

# FLANAGAN

**RADIO CORPORATION**

## RADIO TUBES

SEND FOR  
COMPLETE  
LIST OF  
AVAILABLE  
RADIO TUBES  
AND PRICES



## SUPER-METER

THE NEW MODEL 670

A combination VOLT-OHM MILLIAMMETER plus CAPACITY REACTANCE, INDUCTANCE and DECIBEL MEASUREMENTS. Added Features: The Model 670 includes a special GOOD-BAD scale for checking the quality of electrolytic condensers at a test potential of 150 volts.



**\$28.40**

## CHANGERAK

Makes an ideal work and display fixture for selling new Record Changers. All new combination sets are now being made with Record Changers. Cash in on this business. Order your CHANGERAK now!

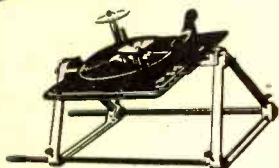

**\$11.95**

## FREE CATALOG

Send for free catalog and prices of hard-to-get Radios, Radio Tubes, Radio Parts, Pickups, Motors, Condensers, Tube Checkers, Volt and Ohm Meters, Signal Generators, Signal Tracers, etc. Please mention Radio News when writing.

## FLANAGAN'S SPECIALS

- Rayon A-C Cords ..... 15c ea.
- Phono-Motors (self-starting) ..... \$4.20 ea.  
9 in. Plush Plate included.
- Knobs (50 Assorted) ..... \$2.50 box  
Push on and screw types
- 5-Tube Punched CHASSIS ..... 39c ea.
- Rubber Zip Cord (Spools—1000 ft.) ..... \$15.50 spool
- 2-Conductor Stranded No. 20
- 100-Foot Roll Push Back Wire ..... .75c
- All Rubber, Rubber Plug A-C CORDS ..... 25c ea.
- 100 Feet Spaghetti ..... \$1.00
- 4 x 4 Dial Windows ..... 7c ea.
- AC-DC Antenna Hanks (For all radios) ..... 10c ea.
- 100-Foot Roll HOOK-UP WIRE ..... 50c
- INSULATED RESISTOR KITS (over 100) ..... \$2.00 box
- All wanted sizes—List price \$12.50
- 100 Assorted 10-Watt WIRE WOUND RESISTORS ..... \$12.50 per 100
- 10 Assorted VOLUME CONTROLS (No switches) ..... \$1.50
- Medium single output for 50L6 ..... 60c ea.
- COMPLETE JEWEL ASSEMBLY—With jewel, socket and bracket ..... 10c ea.
- LITTLE FUSES (All glass)—1¼ Amperes ..... 1c ea.
- U. S. Army THROAT MIKES ..... \$1.65 ea.  
Extension cord and switch 50c extra
- Three-tube PORTABLE RECORD PLAYERS ..... \$36.40 ea.
- Tone control—Beautiful cabinet
- ANTENNA LOOPS (For all small sets) ..... 48c ea.
- JACKSON SOLDER IRONS ..... \$1.60 ea.
- DIAL CABLE (Braided Bronze—Braided Rayon) ..... 1c ft.
- Official U. S. Army TELEGRAPH KEYS ..... 50c ea.
- CRYSTAL MICROPHONES (American Model D7TP.) ..... \$8.44 ea.
- MULTI-METER (New model PB210) ..... \$35.75 ea.
- AC-DC Portable type
- Standard SIGNAL GENERATORS, \$49.50 ea.
- CARBON RESISTORS (Box of 100 most needed sizes) ..... \$1.29 box
- INSULATED TIP JACKS (Red or Black) ..... 8c ea.
- AUTO AERIALS ..... \$1.45 ea.
- Brand New CARBON HAND MIKES ..... \$1.50 ea.

## PHONO AMPLIFIERS

An Exceptional Value!

### 3-TUBE AC-DC

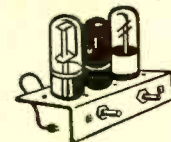

Completely Wired, with tubes and ready to operate. Uses a dynamic speaker. 450 ohm field. Complete with tubes, 50L6, 35Z5, 12SQ7, less speaker. **\$7.44**

## CRYSTAL PICKUPS



**\$2.19** each

COMPLETE WITH  
HARDWARE  
LATEST DATE OF  
MANUFACTURE

## PHONO-MOTOR

SELF-STARTING  
PLATE INCLUDED

**\$4.20** each



## TUBE TESTER

THE NEW  
MODEL 450



Speedy Operation Assured by newly designed rotary selector switch which replaces the usual snap, toggle, or lever action switches. We can give you detailed specifications. The model 450 comes complete with all operating instructions. Size 13" x 12" x 6".

**\$39.50**

# FLANAGAN

**RADIO CORPORATION**

N. E. Cor. 7th & CHESTNUT STS., Philadelphia 6, Pa., U. S. A.

# SMOOTH MUSIC

with  
*Smooth Power*



• You'll find unvarying smoothness straight across the wide line of GI motors for phonographs, recorders and record-changers. It's smoothness that flows from careful balancing, unvarying speeds, vibrationless mechanisms and painstaking workmanship. It's *Smooth Power!*

That's the kind of smoothness that makes easier selling and happier customers. So, for the sweet music that comes from this smooth selling . . .  
*Standardize on Smooth Power Motors.*

**NOTE TO INDIVIDUAL USERS:**

Smooth Power Motors are sold only through established trade channels.



DEPT. MR • ELYRIA, OHIO

# LETTERS

*from our readers*

**FAVOR REQUESTED**

**M**ANY thanks for the March, April, May editions of RADIO NEWS which you kindly sent for the only dollar I was able to obtain. Our people have now clamped down on all dollars so I suppose I've had it.

"RADIO NEWS is ideal for 'Kivvy Street' servicemen like myself. Unfortunately we have no equivalent periodical in Britain.

"Perhaps there may be some of your readers who would care to send on their used copies to a place where they would be very acceptable?"

14572057 CFN Bolton B.A.  
Telecom  
22 ARMD. BDE. w/S R.E.M.E.  
British Army of the Rhine

*Here is a chance for some of you readers to be a pal. Copies of RADIO NEWS may be addressed to Mr. Bolton at the address given above.*

**HERE'S HELP**

**I**N THE July issue of RADIO NEWS, many readers commented on the difficulty they had in attaching the parts lists for the RN Circuit Page on the back of the same 3 x 5 card that contained the diagram.

"It can be done by cementing the top edge of the parts list to the top edge of the card and then folding under the excess length of the list so that it matches the 3 x 5 inch size. This edge is left uncemented and is easily unfolded when reference is made to a particular set.

"I hope this will help to solve some of the problems attached to this department. It's a swell service and we're all for it."

C. H. Hartwell  
Chicago, Illinois

*See, it is really simple after all!*

\* \* \*

**WANTS CLASS D LICENSES**

**I**N READING the "Letters From Our Readers" column in your September issue, I noted the comments made by Mr. Roger Harris of Los Angeles and those added by you, covering the proposed issuance of class D licenses to interested persons capable of passing theory exams, but lacking the required code proficiency demanded by class A, B and C amateur licenses.

"In my opinion your comments failed to cover the proposal completely for several reasons. Among these are the following:

"First, and most important, the generosity of the FCC has provided the ham with 7 bands above the 200 mc. proposed minimum and these are, I'm certain you will agree, pitifully unmanned today. The amateur must

show some activity on these "very high" and "super high" frequencies if he hopes to retain them.

"Most of the amateurs now holding A, B and C licenses, with many exceptions, I'll agree, have pioneered the 160, 80, 40, 20, 10 and 5 meter bands and these bands are "home" to them. The "rush" to occupy the shorter wavelengths hasn't been much more than a slow crawl.

"As a radio operator instructor in the Marine Corps, I had many good operators for "phone" work who could not, in spite of intensive instruction, master those beastly dots and dashes. These men were by no means considered as persons contributing toward lowered standards of phone operation. Quite the opposite was generally true. These men worked harder to improve their operating methods and practices to make up for their lower code speeds.

"Second, the funds with which the FCC amateur section operates are provided by all citizens and the amateur is expected to provide public services either directly or indirectly. An example of indirect service is the fact that the necessary equipment for the class D licenses will provide jobs in the radio industry and thus help to raise our standard of living.

"Increased demand will necessitate improved high frequency equipment and manufacturing techniques, thereby providing an abundance of high, ultra-high and super-high frequency equipment at tremendously lowered prices. You will certainly agree that the new FM and television equipment needs just a "little" such aid! We will all benefit, class A, B, C and private citizens alike from increased demand resulting from the class D ham.

"Third, I think anyone interested in operating above 200 mc. has plenty of the experimenter in his blood.

"For the record, my license is class A."

James R. Wilburn, W3KYH/4  
Oak Ridge, Tenn.

*You have some good points there, Mr. Wilburn.*

\* \* \*

**SPEAKER PROBLEMS**

**I**HAVE about forty speakers of varying types and sizes. When requiring a speaker, however, I have found it more convenient to purchase one to fill the requirements than to "cut and try" in utilizing one on the shelf.

"This situation is caused by the total lack of information (other than stock numbers) on the speakers themselves. The field coil presents no problem, but it is the voice coil impedance that defies measurement.

# OUR LATEST SPECIALS FOR SERVICEMEN, AMATEURS, AND EXPERIMENTERS!

**POWER TRANSFORMERS**—Ideal for radio construction or replacement. Primary—110V, 60 Cycle. Filament and high-voltage windings are center-tapped. Specify whether 6.3 or 2.5 V is wanted.

For 5-6 tube sets: 650V, 45MA; 5V fl. and either 6.3 or 2.5V fl. \$1.75

For 6-7 tube sets: 675V, 50MA; 5V fl. and either 6.3 or 2.5V fl. 1.90

For 7-8 tube sets: 700V, 70MA; 5V fl. and either 6.3 or 2.5V fls. 2.35

For 9-15 tube sets: 600V, 150MA; 5V fl. and a 6.3V fl. only 2.95

Transmitting type filament transformers—5000V insulation—2.5V, 20Amps. 1.49

5V, 10Amps—\$1.98; 6.3V, 8Amps—\$1.98; 2.5V, 25Amps auto. 6.3V, 3Amps. 2.25

**AUTO-TRANSFORMERS**—May be used on 90 to 250 volts for step-up or step-down applications. Up to 300 Watt capacity. 1.95

**FILTER CHOKES**—200, 300, 400, or 500 ohms—Heavy duty—99c; Midget type—59c; 250MA, 35 ohms DC—Fully shielded in black crackle case, only—\$1.95. **AUDIO TRANSFORMERS**—Single plate to single grid 3:1—79c; Single plate to P.P. grids—79c; Heavy-duty, class "AB" or "B" P.P. inputs—\$1.49; Midget output, for AC-DC sets—69c. **UNIVERSAL OUTPUT TRANSFORMER**—tapped for various impedances—99c; **MIKE TRANSFORMER**—Single or double button—79c; High Fidelity **MIDGET MIKE** to grid transformer, similar to UTC oncuer units. \$3.00

**TUBES**—A Warehouse Full of Them!—Order all types needed, not just the critical types, and we'll do our best to supply you completely!

**SELENIUM RECTIFIERS**—Dry disc type, 1½" by 1", 1.2 Amp. maximum, suitable for converting DC relays to AC, for supplying filament source in portable radios, converting DC meters to AC applications, and also may be used in low current chargers. .99c

**TRIPLET METER RECTIFIERS**—Full wave, may be used for replacement, or in construction of all types of test equipment. \$1.25

**E-Z WIRE STRIPPERS**—Cleans insulation from solid or stranded wire swiftly, neatly, and without damaging wire. A real time saver. Standard model—\$3.95; Automatic model—Stays open after grip is relaxed until wire is removed. \$4.95

**SILVERTONE CABINETS**—Walnut finish—excellent replacement cabinets—Model 1923, 11x18x20; Model 4465, 15x10x8, and Model 4619, 9x10x16½. Each. \$1.50

**FIRESTONE PORTABLE CABINETS**—Two tone, leatherette covered carrying cases, sloping dial—Ideal for rejuvenating banged-up portable sets. \$3.95

**PHONO CABINETS**—With speaker grille—\$7.75; Without—\$8.50. Both types leatherette covered with well designed grips and hardware.

**PORTABLE AIR COMPRESSOR**—Attaches to ¼ H.P. motor. Just the thing for refinishing radios, painting cars, blowing out chassis, etc. 100 lb. gauge and siphon type gun with 12 feet of rubber hose included. Pressure adjustable to stay constant at any pressure up to 100 lbs. Net Price, \$21.60

**RECORD CHANGERS**—These are beauties—two post, with featherweight plastic and chrome pick-up, plays 10" and 12" records intermixed! Complete with hite leatherette, mahogany or walnut stained cabinet, your choice. Ready for attachment to any radio at the give-away price of only. \$24.95

**CRYSTAL PHONO PICK-UP**—Latest design. Features needle pressure compensation to reduce record wear. Excellent replacement for any record player. \$2.75

116V, 60 cycle phono motor & table. 5.95

Motor and Crystal Pickup together. 7.95

**AUTO ANTENNAS**—Cowl Type 3-section type, with triple plated chrome, complete with shielded leads—66"—\$1.50; 96" (4-section)—\$2.75; "Hooker" antenna, adjustable to any angle for rocket and torpedo bodies. 72"—\$2.75; Fender and Cowl types—adjusts from 20" to 50"—\$3.00; Underhood type—mounts on either side of regular and alligator hood—no holes to drill on body of car. 72"—\$2.50; Disappearing 50" fender type. \$3.75

**RADIO HANDBOOK**—Published by Editors and Engineers—Tenth Edition. \$1.95

All Rider's Manuals and publications at current prices

**MICROPHONES**—Bullet crystal mike—Only \$5.45; Bullet dynamic mike—\$7.45; Both are nationally advertised brands and sold elsewhere at much higher prices. **SHURE T-17** single button mike, made for Signal Corps, has press-to-talk switch in handle, and is complete with cord and plug—Only \$2.75! Midget Mike—Made for Signal Corps. Single button type, with stretched duraluminum diaphragm. Gold plated finish. This unit makes an excellent lapel mike, or concealed pick-up. Specially priced at. .95c

**CONDENSERS**—Guaranteed one year! Priced in lots of ten or more, either one type or assorted. 50mfd. 150v—53c; 25mfd. 35v—23c; 20-30mfd. 150v—46c; 20-20mfd. 150v—35c; 20mfd. 150v—23c; 10mfd. 450v—32c; 10mfd. 35v—23c; 8-8mfd. 47v—65c; 8mfd. 450v—45c; 8mfd. 200v—20c. **PAPER CONDENSERS**—600 W.V. 25mfd.—23c; 1mfd.—1c; .05mfd.—1c; .02mfd.—9c; .01mfd.—9c; .006mfd.—8c; 5mfd.—36c; 1.0mfd.—45c; Screwneck aluminum can type—16mfd.—600V.V.—85c; 16mfd.—550 P.V.—65c; Mica condensers—any size—15c or 100 Micamold assorted for. .59c

**RELAYS**—Sigma No. 4RJ—2000 ohm, SPDT—May be adjusted to operate on less than one milliamperes! Ideal for photoelectric and electronic control circuits. Regular price \$8.50, now only \$2.50; **GUARDIAN SPST RELAY**—12 to 24 bits, 11as 400 ohm, center-tapped coil for operation in balanced current circuits if desired—\$1.25; **GUARDIAN 3-make, 1-break, 12 to 24 volts—\$1.00 each, or 5 for \$3.75; SPST, normally open, works on AC or DC. Only—65c; 4-pole (3-make, 1-break), 400 ohm, AC or DC, excellent for plate circuit of tube, photo-cell amplifiers, etc. \$1.75**

**BENDIX SCR-522**—Very High Frequency Voice Transmitter-Receiver 100 to 156 MC.—Pushbutton Selection of 4 Channels—Crystal Controlled and Amplitude Modulated—15 Watt Output and 3 Microvolt Receiver Sensitivity gave good communication up to 180 miles at high altitudes. Receiver has 10 tubes and transmitter tubes, including 3 832's. Furnished complete with 17 tubes and power supply for 12 or 24 volts, also remote control boxes, cable connectors and antenna. This job was good enough for the joint command to make it standard equipment in everything that flew, even though each set cost the govt. \$2500.00. Your cost. \$75.00

## General Electric 150-Watt Transmitter; Brand New! Only \$67.50

This is the famous Liaison transmitter used in U.S. Army bombers and ground stations during the war. Its design and construction have been proved in service, under all kinds of conditions, all over the world.

The entire frequency range is covered by means of seven plug-in tuning units which are included. Each unit has its own oscillator and power amplifier coils and condensers, and antenna tuning circuits—all designed to operate at top efficiency within its particular frequency range. Transmitter and accessories are finished in black crackle, and the milliammeter, voltmeter, and RF ammeter are mounted on the front panel.

Here are the specifications: **FREQUENCY RANGE:** 200-500 Kc. and 1500-12,500 Kc. (Will operate on 10 and 20 meter band with slight modification.) **OSCILLATOR:** Self-excited, thermal compensated, and hand calibrated. **POWER AMPLIFIER:** Neutralized class "C" stage, using 211 tube, and equipped with antenna coupling circuit which matches practically any length antenna. **MODULATOR:** Class "B"—uses two 211 tubes. **POWER SUPPLY:** Supplied complete with dynamotor which furnishes 1000 volts at 350 milliamperes. Complete instructions are furnished to operate set from 110V AC. **SIZE:** 21½ x 23 x 9½ inches. Total shipping weight, 250 lbs., complete with all tubes, dynamotor power supply, seven tuning units, antenna tuning unit, and two profusely illustrated instruction books, all in the original factory packing case.

These transmitters are priced to move fast; quantities are limited! Order today, and be the proud owner of one of the finest rigs obtainable.

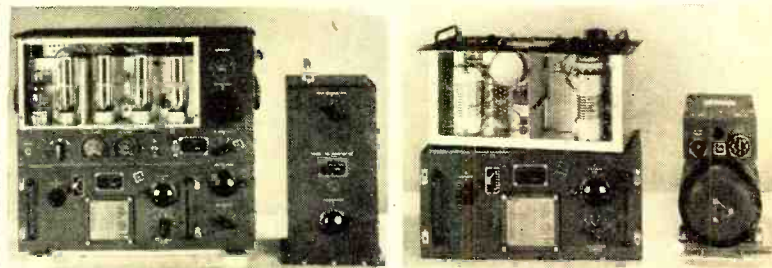

## 14-Tube UHF Superheterodyne Receiver—\$39.95

This beautifully constructed receiver was designed especially for Signal Corps communication service, and is one of the finest and most sensitive sets ever manufactured. Operating from 110V 60 cycles, this set has two tuned RF stages, tuned converter and oscillator, five IF stages, using iron-core IF's, a diode detector, tuning eye, and a two stage amplifier that will drive a speaker or phones. The frequency range is 158-210 Mcs. It is a simple matter to operate on other

bands by making a slight alteration in the tuning coils. A complete set of tubes is included with each receiver, along with a circuit diagram and parts list. The high-voltage power supply delivers 150 milliamperes, and is well filtered by a heavy-duty choke and three 7 Mfd. oil-filled condensers. This buy of a life-time cost the government about \$700. Amateurs and experimenters will never again be able to purchase fine equipment at such a tremendous saving!

**The finest in government surplus radio equipment—immediate delivery! Write for surplus sheets!**

## General Electric RT-1248

General Electric RT-1248 15 tube transmitter-receiver with TERRIFIC POWER (20 Watts) on any 2 instantly selected, easily pre-adjusted frequencies from 435 to 500 Megacycles. Transmitter uses 5 tubes including a Western Electric 316 A as final. Receiver uses 10 tubes including 2-955's as first detector and oscillator, and 3-7H7's as IF's, with 4 slug-tuned 40MC. IF transformers, plus a 7H7, 2-7E6's, and 2-7E7's. In addition unit contains 8 relays designed to operate any sort of external equipment when actuated by a received signal from a similar set elsewhere. Originally designed for 12 volt operation, power supply is not included, as it is a cinch for any amateur to connect this unit for 110V AC, using any supply capable of 400V DC at 135 MA. The ideal unit for telephone use as in a taxicab, or for any kind of remote control applications, as with drone airplanes. Supplied with 15 tubes in original factory packing. Priced at only \$29.95 10% less if ordered in quantities of two or more.

## SCR-284 Transmitter-Receiver

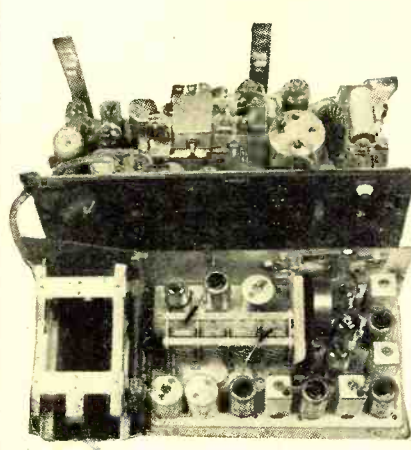

Made to be used in Army jeeps and trucks, as well as in the field, or as a headquarters set, the SCR-284 is particularly adaptable for all amateur, experimental, marine, aircraft, police, and mobile applications.

The receiver is a 7-tube superheterodyne, featuring an RF stage, four double-tuned 435 KC iron-core IF transformers, two audio stages, a beat frequency oscillator for CW reception, and is powerful enough to operate a large size speaker. The transmitter employs a calibrated crystal oscillator, a buffer amplifier, and a pair of RK-75 tubes in the final amplifier stage. The speech amplifier and modulator will operate with any ordinary mike, or for \$2.75, we can include a Signal Corps mike, complete with press-to-talk switch. A built-in antenna tuning circuit, including an RF ammeter, will match the transmitter to any length of antenna. The transmitter plates are supplied by a 500 volt, 160 MA dynamotor which operates from either a 6 or 12 volt automobile battery. The transmitter output is 25 watts, and operates on both phone and CW. The frequency range is 3760-5825 KC. Operation on other bands may be facilitated by the use of plug-in coils. Circuit diagrams and operating instructions are furnished.

These sets are specially priced at \$39.95, complete with set of 13 tubes and crystal. The dynamotor, which must be used, if it is not desired to use 110V AC, is \$15 additional. Where a compact and dependable medium power unit is desired, this set is unbeatable!

**BUFFALO RADIO SUPPLY, 219-221 Genesee St., Dept. 11N, BUFFALO 3, N.Y.**

# Harvey has record changers

Harvey is headquarters for sound equipment. In stock are record players, changers, amplifiers, speakers, mikes, complete p.a. and sound systems, etc. Take advantage of our fast efficient service... send or call in your orders!

## RECORD CHANGERS

Utah Record  
Changer

\$18<sup>26</sup>

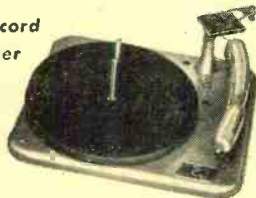

Utah Record Player—Same model, available in attractive pearl finish cabinet with amplifier, speaker, tone and volume controls. High quality phonograph reproduction in a neat small unit.....\$44.15



WEBSTER  
Model  
50-1

\$21<sup>60</sup>

WEBSTER  
Model  
56-1



\$27<sup>20</sup>

Thordarson 8-Watt Amplifier, Model 30W08—Ideal for phono or p.a. work. Has separate mike and phono controls, tone control. Finished in grey wrinkle, panel trimmed in green. Uses two 6J7, one 6L6G, one 5Y3GT.

Net price, less tubes.....\$25.98  
Kit of tubes..... 3.26

Also in stock, a complete line of permanent magnet speakers of all sizes, unmounted or in cabinets and baffles for indoor or outdoor use.

Telephone: **WRC** LOngacre 3-1800

# HARVEY RADIO COMPANY INC.

103 West 43rd St., New York 18, N. Y.

"The 400 cycle "blocked impedance" value can be obtained, but the other impedances cannot. At first, I thought that the "blocked impedance" might be approximate enough for satisfactory match, but calculations based on it alone still results in evident mismatch, even if the mechanical impedance in modern speakers has been reduced to a minimum.

"Therefore, it would be a great boon for the idle units here and elsewhere, if a method within the reach of ordinary servicing equipment could be devised whereby a reasonably accurate figure could be arrived at.

"I read your magazine thoroughly and marvel at the wealth of information it contains, but somehow seemingly small problems like the one above seldom find attention and therefore a solution."

D. W. Baird  
Ashland, Wisconsin

Have any of our readers a practical and simple solution to Mr. Baird's problem?

\* \* \*

### A RATHER BIG ORDER

"SINCE many new men, thru war service, have acquired an interest in radio recently (count me in), I would like to suggest an ambitious, helpful undertaking for you. Most of these new 'radio men' want to build (and can use the experience) radio, sound and test electronic equipment. Only having recently become acquainted with your magazine, we, then, have missed many good articles you've no doubt printed in the past.

"I would like to see reprints, in pamphlet or booklet form, of past RADIO NEWS articles collected and bound perhaps in groups such as: Broadcast Receivers, S.W. and Ham Receivers, P.A. Systems and Audio Amplifiers, Ham Transmitters, General Ham Equipment, Electronic Test Equipment and General Servicing Notes.

"Such pamphlets should sell for

about \$1 each and would be more useful in separate groups, something like the above listing rather than one large book at \$5 or more with all topics included.

"Is it too ambitious a project for you?"

Edward A. Bogusz

Paterson 3, New Jersey

Under ordinary circumstances this wouldn't be too ambitious a project for us to tackle. In fact we have wanted to offer this service to our readers for some time. Our inability to secure the necessary newsprint to put out such specialized booklets has us stopped for the time being, but it is high on our list of projects which will be undertaken when the paper is again available.

\* \* \*

### SIGNAL TRACER

"MANY thanks to you for the information on building an r.f., i.f. and a.f. signal tracer, as published in your January and April issues.

"I made mine exactly as outlined by the second article and was very well pleased with the results. I didn't have a speck of trouble. It took right off the first time that I tried it.

"I think this type of tracer is tops because it is so simple to operate."

Frederick G. Arndt

Albion, Michigan

Mr. Arndt's success with this construction can be traced, undoubtedly, to careful attention to details and meticulous care in wiring the unit.

\* \* \*

### TREASURE FINDER

"THE September, 1946 RADIO NEWS had an article by W. E. Osborne on 'Treasure Finding Modernized.' This article had more cold facts, broad coverage and common sense on the subject of detectors than I've run across in the line since entering the field during War I.

"Such articles, plus a builder's supplement for beginners are a good serv-

## CONDENSER TESTER

FROM Oscar E. Blair, Jr. of Baltimore, Maryland comes this suggestion for a simple and inexpensive condenser tester of his own design.

Essentially the unit consists simply of a "B" power-pack with a neon light in series with the positive lead.

According to the designer, the tester works exceedingly well showing up leaky or shorted condensers from any size from 10  $\mu$ fd. on up.

For use, the suspected condenser is simply connected across the two jacks. If the condenser is good, there will be a momentary flash of the neon bulb as the condenser charges. If the condenser is open this flash will not be observed. Leaky or shorted condensers will show up by a glow in the neon bulb.

Condensers of the electrolytic type should not be tested with this unit.

-30-

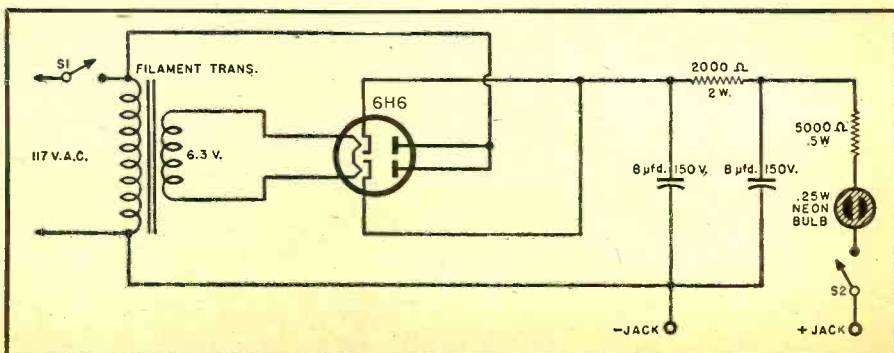



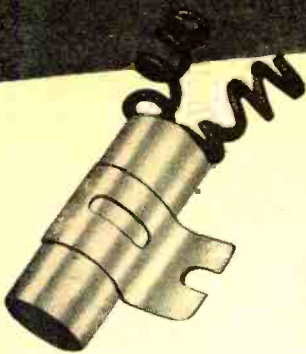

## IF-37 FILTERS

Only \$1.11 each  
NET

# IT TAKES RADIO NOISES OUT OF FLUORESCENT LAMPS

Sprague IF-37 Filters are specifically designed for fluorescent lamp interference suppression. They offer the most effective way to suppress "hard-to-stop" interference conducted down the power line to remotely located receivers. One filter is required for each auxiliary. They are installed simply by connecting them

directly to each fixture across the incoming leads.

*Note to Radio Dealers:* Install Sprague IF-37 Filters on every fluorescent light in your own store to suppress noise for better, quieter radio and television demonstrations!

## A NEW SPRAGUE ATOM

Handiest, most convenient dry electrolytic capacitor for vertical chassis mounting!

In Type LM Universal Mounting Replacements, Sprague offers a new Atom dry electrolytic which can be mounted in any position to replace inverted can, spade-lug or similar vertical-mounting capacitors. Equipped with special mounting devices to replace screw type can mounting, LM Atoms fit any chassis hole from 3/16" to 7/8" diameter. Their separate positive and separate negative leads can be connected together to get common positive or negative sections. Because they prevent section-to-section electrolysis, they are especially recommended to replace old common positive condensers. Like all Sprague Atoms, Type LM Capacitors are made with famous Sprague etched foil and are completely sealed and moisture-proofed.

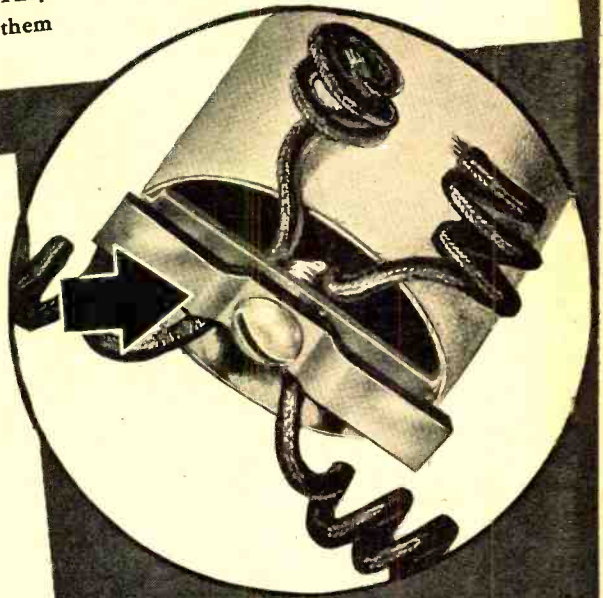

THESE ARE ALL THE MOTOR-START CAPACITOR REPLACEMENT TYPES I EVER NEED!

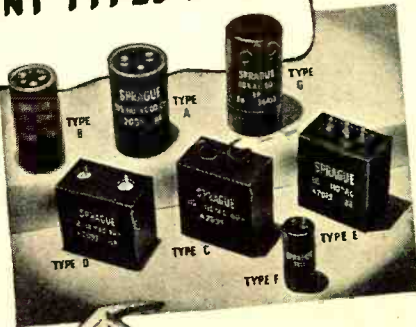

## MAKE MONEY ON REFRIGERATOR REPAIR JOBS

When you've repaired the radio . . . why not repair the refrigerator, too? Make one trip pay for two jobs! Use these Sprague Universal Motor-Start Capacitors for every motor starting need. The seven shown here are all you'll require. They're always in stock . . . quick, easy to install . . . and absolutely dependable! They always fit—the terminals are right for quick installation. For details on how to select the exact unit needed for any standard motor, write for Sprague booklet: "A NEW COMPLETE STORY ON MOTOR STARTING CONDENSERS." It's free!

WRITE for new Sprague Catalog

# SPRAGUE PRODUCTS COMPANY

NORTH ADAMS, MASSACHUSETTS

Jobbing Distributing Organization for Products of the Sprague Electric Co.

# Low Cost FEILER TS-1 Signal Tracer

## Saves Time, Money, Guesswork on Radio Repairs!

GETS TO THE HEART OF RADIO TROUBLE IN A FLASH!

Locates Causes of:

- Noisy Sets
- Parts Failure
- Mistracking
- Low Sensitivity
- Distorted Tone
- Intermittent Sets



MODEL TS-1  
ONLY  
\$9<sup>85</sup>

Complete with vacuum tube (less batteries)

### Easy to Use! Pays for Itself!

Servicemen! Experimenters! Here's an absolutely dependable Signal Tracing Analyzer at the lowest price ever quoted for such an instrument! Enables you to test any radio or amplifier just by touching the Analyzer probe to any portion of the circuit—the signal you hear in the phones permits you to isolate and locate the trouble in just minutes. Easy to use—no special skill needed. Works with any magnetic headset, 1000 ohms or higher. Requires only one 22½ v. battery and one No. 2 flashlight cell. Self-contained in compact (6¾ x 4¾ x 3¼") brown metal case; with snap-lock cover and battery compartment. Compact bakelite probe houses miniature vacuum tube and circuit components; has 3 ft. cable. Excellent instructions included. An invaluable instrument that pays for itself quickly!

### IMMEDIATE DELIVERY

Place your order for the TS-1 Signal Tracing Analyzer with your regular parts jobber. If he cannot supply you, write for name of nearest jobber stocking this instrument—or send your order directly to us.

# FEILER

## FEILER ENGINEERING CO.

803-D MILWAUKEE AVE., CHICAGO 22, ILLINOIS

# Reliability

## IS THE KEYNOTE IN ROBSON-BURGESS MULTITESTERS



MODEL MT 200

ROBSON-BURGESS has a growing line of test equipment under full scale production—equipment to match the greatest advances in radio—equipment accurately and expertly designed for efficiency and durability.

Robson-Burgess Company, specialists in test equipment manufacture, meet the need for a sturdy, low priced multitester with the new MT-200. Housed in a metal, gray crystalline finish case, it has a 3½-inch square 400 microampere D'Arsonval movement meter; self contained battery; wire wound Universal Shunt. Sensitivity: 1000 ohms per volt on AC or DC. Ranges: DC and AC Voltmeter—0/5/15/50/150/500/1500 volts; DC Milliammeter—0/10/100/500 milliamperes. Ohmmeter: 0/10 megohms in four ranges (36/360/3600/36,000 ohms center scale). Rugged, durable and accurate, it is available now at most radio equipment dealers.

# ROBSON-BURGESS CO.

## OMAHA, NEBRASKA

ice to readers of all classes in any line, as they combine results from wide experience, technical advice and a human side for 'use appeal'."

A. L. Murphy  
Trona, California

A second article, dealing with the construction of such a treasure finder, appears in this issue.

### SERVICE SHOP ITEM

YOUR RADIO NEWS is tops. I wouldn't miss a copy.

"Here is a little service shop helper that is a 'must' in every ham shack or shop. Needing a small-parts cabinet I purchased (in the dime store) several knife, fork and spoon boxes. I found the drawer pulls on the next counter. The rest of the project was simple. I built a small box to house the drawers using little slats as drawer slides. Incidentally, the drawers are used sideways as it takes less frontage on a shelf. These drawers which are 13½" x 8½" x 2" are invaluable for housing resistors, condensers and other small radio parts and hardware."

Frank H. Coxson  
Greenville, Pa.

Here is a practical idea that many of our readers might like to adopt.

### DO YOU DX CEYLON?

I RECEIVED the June issue of RADIO NEWS, I find it interesting, especially the Circuit Page, as it is a great help to amateurs and radio servicemen.

"Am an ex-serviceman from the Signal Corps, from the Instrument Mechanic Section, so have taken a keen interest in radio.

"Kandy, the town where I live, is the center of the tea plantation and

### RADIO "INSURANCE"

MANY of our readers have inquired about the "radio insurance" method of conducting a service business. Up to the present we have had few details of this type of repair plan, however, full details have been furnished us by E. R. Wright, Chief Engineer of Radio Engineering of New Haven, Conn., whose copyright plan it is.

According to Mr. Wright, the "Wright Radio Service Plan" is available to radiomen for a small fee which entitles them to yearly or lifetime participation in the plan, the amount of the fee and the number of service shops so licensed being governed by the population of the town or city.

The plan has produced a noticeable leveling off in service charges in areas where it is in operation and has succeeded in driving out the fly-by-night operator who has been operating to the disadvantage of all honest operators.

The "radio insurance," as offered, sets a flat fee for the servicing of radios for a given year. The rates for such service are not specified as local conditions will affect such charges. The advantage of the plan is that the serviceman has a guaranteed income, whether the sets under the "plan" need servicing or not. In addition, he still may collect his regular profit on replacement parts required to effect needed repairs.

*Announcing...*

*the new* **BLILEY CCO..**  
**crystal controlled oscillator**  
*for* **RADIO SERVICE TECHNICIANS**

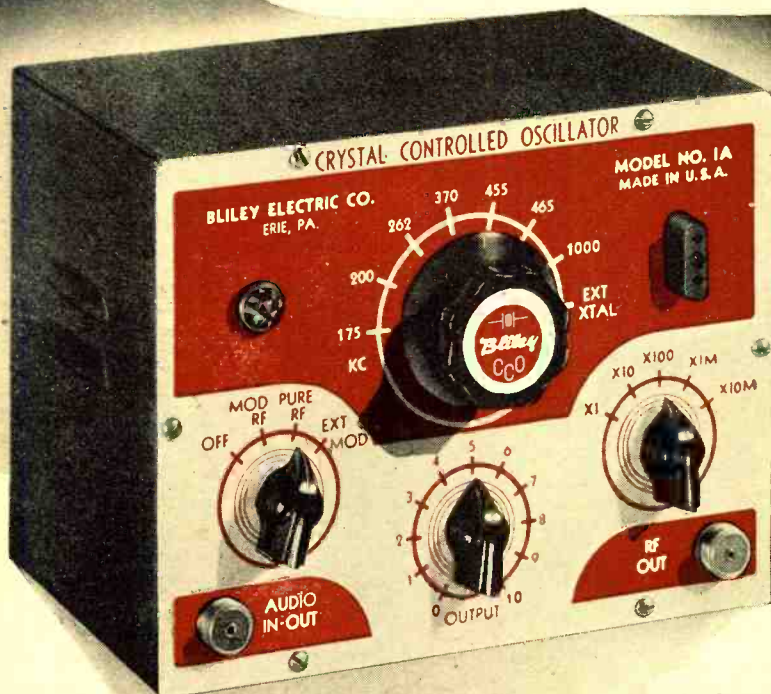

Ask your Bliley  
distributor for  
Bulletin 32

**Bliley**  
CRYSTAL CONTROLLED OSCILLATOR

With this instrument, Bliley, the pace-setter in frequency control for 15 years, sets a new standard for proficiency and accuracy in the radio service field.

In the Bliley CCO, low temperature coefficient crystals, stable to within  $\pm 0.1\%$ , provide—

- DIRECT CRYSTAL CONTROL, with instant selection of the 5 most commonly used i-f frequencies—175kc, 262kc, 370kc, 455kc and 465kc.
- DIRECT CRYSTAL CONTROL at 200kc for r-f alignment.
- DIRECT CRYSTAL CONTROL at 1000kc for short wave alignment.

There is an external socket for addition of special frequencies, a three position modulation selector and a five step attenuator with vernier output control from 0 to 15 volts.

There's no guesswork in radio service with the CCO. It's a Bliley "techniquality" product, engineered for the professional radio service technician.

the hill capitol of the island. It was also the capitol of the Sinhalese kings before the island was captured by the English in 1815. We also have a few miles away a Botanical Garden of world fame and I wish if you are only here to see the few wonders of our island.

"Am anxious to come in contact with some of your readers in America and Canada. I wonder readers in Europe and America hear our station Ceylon—on wavelengths 428-8 and on 61.2 meters and Radio SEAC, Ceylon—on wavelengths 25.46 meters, 19.84 meters and 49.38 meters.

"With best wishes and kind regards to all."

Thuan. M. W. Jamion  
69, Halloluwa Road  
Kandy, Ceylon

Here is a chance for some of you DXers to start an interesting correspondence on shortwave matters.

#### TECHNICAL DATA

JUST a word to let you know you are putting out a swell magazine, especially the Circuit Page.

"Also, I was very much interested in the article by Mr. Stevens in the August issue on Cathode Followers in amplifiers. However, Mr. Stevens expresses a need for a cathode type tube similar in characteristics to a 6A3 (2A3) or 6B4 for this application. For the benefit of anyone interested as I am, I should like to point out that the 6A5-G has been on the market for sev-

eral years and has electrical characteristics identical to the 6A3 even to the heater ratings, but having cathode-heater rather than filament."

Richard Gaines  
Stephenville, Texas

Many thanks to Mr. Gaines for passing this information along to our readers.

\* \* \*

#### AVIATION RADIO ENTHUSIAST

I AM greatly pleased to see your new circuit department and have entered my subscription for three years to RADIO NEWS. I don't want to miss any.

"Please print circuits of the light plane radios as soon as possible. And how about more dope, stories and technical data on light plane radio equipment in RADIO NEWS each month. I'm sure it would help sell more magazines."

Stanley T. Herrick  
Plaistow, New Hampshire

An article covering the installation of radio equipment in personal planes appears in this issue. We hope that it will be of help to our readers who are interested in radio equipment for light planes.

\* \* \*

#### REQUEST FOR ARTICLES

RADIO NEWS is tops and I have copies dating back ten years or more.

"There are a few things I hope you will be able to work out which I think, and probably lots of other men too,

are needed. I am referring to a system whereby you would print in bold letters at the top of the page the title under which you could file either the page, or list on cards for future reference. Also I would like to see you put ads on the back of pages carrying articles.

"How about articles on appliance repairs, service benches, business forms and methods."

Sherman's Appli. Repair Shop  
Detroit, Michigan

We are always on the lookout for good writers on the subjects you requested. When we find articles that are suitable for RADIO NEWS, we will pass them on to our readers. As for your suggestions on the make-up of the book, this is a little more difficult to do than you might expect. We are giving our readers the Circuit Page backed up by ads to facilitate filing for future reference. We would like to remind our readers that a yearly index appears each January for your convenience.

\* \* \*

#### HONORS FOR MISS SULLIVAN

I AM writing just a few lines to congratulate you for your fine work on the trans-receiver born out of your handiwork, your knowledge of radio principles and your diligent effort. The appearance is very neat and, undoubtedly, its performance will reach all expectations.

"I am enclosing a heavy wire connection that has become a symbol to our radio fraternity that comprises



# What A BUY!

Portable Voice-and Code Radio

## RECEIVER-TRANSMITTER

Self-contained 200 KC Calibrated Crystal

BC-654-A is a combined transmitter and receiver designed for portable or vehicular operation. The frequency range of both transmitter and receiver is continuous from 3700 to 5800 kilocycles; all stages gang tuned by anti-back lash worm gear dial mechanisms.

The BC-654-A is 18" wide, 14" high, and 9½" deep. Weight 44¾ pounds. Power required for Receiver—1.5, 45 and 90 volts D.C. Power required for Transmitter—1½, 6, 51, 84 volts D.C. and 500 volts D.C. at 160 ma. Operates from Dynamotor PE-103-A.

DESCRIPTIVE CIRCULAR SENT ON REQUEST

➤ One-third deposit with order, balance C. O. D., F. O. B. shipping point. When check accompanies order, we prepay shipping charges.

### D. & H. DISTRIBUTING CO., Inc.

311 S. Cameron Street  
Harrisburg, Penna.

PARTS DIVISION

31 East Lee Street  
Baltimore 2, Md.

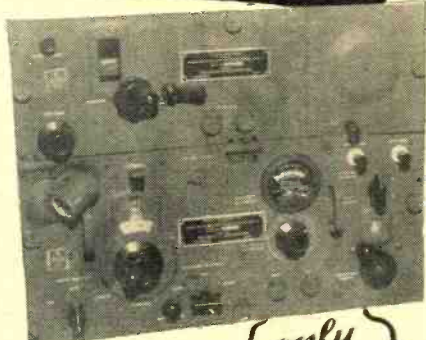

BUY IT  
to use . . .  
BUY IT  
for parts

It's the greatest  
value ever offered.

Complete with case less dynamotor

only  
**\$29.95**  
as is  
PARTS ALONE  
WORTH 20 TIMES  
THE PRICE

# PARTS

## and Radio Equipment

I.F. Transformer (456KC).....	\$ .75
R.F. Choke (2.5 Millihenry).....	.15
Resistor Kit (100 resistors).....	2.95
AC Cord with Plug (6 foot)....	.24
K2375 Test Lead.....	.75
Reiner Test Lead.....	3.60
A.C.-D.C. Antenna Hanks.....	.19
G.E. Synchronous Vibrator....	2.85
Carbon Tet. (gal. can).....	2.25
Drake "400" Soldering Iron....	2.70
Dial Belts.....	.16
Clark PA20 watt Amplifier....	51.75
Clark PA30 watt Amplifier....	108.00
RCP 461AP Volt-Ohm-Milliam-	
meter.....	39.50
Webster No. 50 Changers.Net	21.60
Ungar Soldering Pencils, handles	.78
Tips.....	.78
Kester Rosin Core Solder, 1 lb.	
spool.....	.65

Full line of RMS Radio Cabinets, Astatic mikes, xtals, pick-ups, E-L Vibrators, Clarostat controls and resistors, Rider text books, and hundreds of other parts. Ask to be put on our mailing list.

**SAME DAY SERVICE**

# SUPER PRO

Series 400



## Less QRM---Phone or CW

When the bands are active it only takes one minute to find that you need Hammarlund's patented variable crystal filter to have a successful QSO—either phone or CW.

Look to the future! When the number of Hams doubles or trebles you will need the crystal filter that weeds-out the QRM . . . If you can't hear 'em, you can't work 'em!

Price (SP-400-X)

**\$342.00**

Including Speaker



# HAMMARLUND

THE HAMMARLUND MFG. CO., INC., 460 W. 34<sup>TH</sup> ST., NEW YORK 1, N. Y.  
MANUFACTURERS OF PRECISION COMMUNICATIONS EQUIPMENT

# SPEED UP REPAIRS WITH THESE G-C AIDS!

## G-C is HEADQUARTERS for RADIO PARTS and SERVICE AIDS



All Types of Radio Cements, Chemicals, Coil Dopes, Compounds.

G-C leads the field in supplying Radio - Electronic Manufacturers and Service Men with Parts, Tools, Radio Cements, Chemicals and Compounds. Insist on Genuine G-C Quality.



Dial Cables, Dial Belts, Packaged Hardware, Cabinet Repair Kits



Speedex Wire Strippers Alignment Tools Ne-O-Lite Testers

Order from Your Jobber—Send for G-C Catalog



**GENERAL CEMENT MFG. CO.**  
ROCKFORD, ILLINOIS

the old-timers Northeastern Division of Radio Experimenters of Mexico. The story behind this wire connection is that it was made by me and sent to a newcomer into hamdom who was having trouble in making neat heavy wire connections. Eventually he sent it along to somebody else and in turn, again, it was forwarded elsewhere until finally it returned to me. Since that day we have adopted it as a symbol of our club and, if you permit me, I beg to you that you keep it as a souvenir from your friend in Old Mexico.

"At this particular time I am not on the air on my own and all my activities go through XE2JN, this city, as we all are piling our efforts toward a 0.5 kw. Club Station.

"I sincerely hope that in the near future we might be able to contact by means of Amateur Radio, till then **MORE POWER TO YOU.**"

Ing. Horacio Mattei A. Gte.  
Calle Belden No. 1510  
Nuevo Laredo, Tam.

-50-

### Spot Radio News

(Continued from page 14)

well ahead of the prewar monthly rate of 1,100,000. It goes without saying that the industry is expending every effort to impress upon OPA the significance of CPA's findings. High production should lead to decontrol. But how soon the CPA production figures will lead to free enterprise is still a moot question in Washington. . . . Incidentally, the radio industry contributed its share to the summer-end employment totals for the nation, hailed by CPA as "four million higher than the war-time level of a year ago." Civilian employment was reaching the 60,000,000 mark as Labor Day rolled round, with the increases showing most markedly in non-agricultural fields. A record large buying public seemed indicated for the holiday season.

**REGARDLESS OF OPA's ATTITUDE** on decontrol, the industry continues to push for an early decision. A recent conference was called by Radio Manufacturers Association President R. C. Cosgrove in Washington. Industry leaders met with OPA officials. RMA announced after the conference that immediate steps were under way for accumulating the required information on the radio industry's production, inventories, and sales in preparation for the filing of formal decontrol petitions. "We will exert every effort and tap all of the radio industry's resources in this fight to bring about decontrol of the industry through processes provided by Congress in the new OPA extension act," Mr. Cosgrove said, and emphasized the significance of current production records: "Radio set production, by unit volume, is already greater than it was before the war, and it will probably increase this fall

## EXTRA-SENSITIVE, NOISE-PROOF QUALITY HEADSETS



MINIATURE

Sturdy, hi-quality headsets. Designed and manufactured to meet rigorous U. S. Government specifications! Both types are extremely sensitive, and employ matching transformers for hi-impedance outputs, and to isolate any plate current from the phones proper. Also, each employs miniature phone units, with Alnico magnets, engineered for maximum efficiency. The "MINIATURES" are a lightweight, compact type with soft-rubber eartips, flexible rubber cord, rubber spring-clip, and standard phone plug.

PRICE COMPLETE \$2.95

"NOISE-PROOF" headsets employ the same hi-efficiency phone units, but in rubber-cushioned magnesium earcups that fit snugly and comfortably over each ear. Ideal for hams and commercial operators who use "cans" a lot, and for recording engineers, aircraft pilots, and others. Their superiority, for comfort and efficiency, over regular headsets is overwhelming.

PRICE COMPLETE \$5.95

Send check or money order for postpaid delivery. Dealer and Distributor inquiries invited on quantity.

**TAYBERN EQUIPMENT CO.**

120 GREENWICH ST. NEW YORK 6, N. Y.



NOISE-PROOF

## CAREERS in RADIO

**INTENSIVE COURSES**—Thorough, technical education for progressive men and women.

1. **RADIO TECHNICIAN**—The MRI General Course, Includes F.M. & Television. Prepares For FCC Broadcast Licenses.
2. **RADIO & TELEVISION SERVICING**—Prepares for employment as Repairman on Standard Broadcast, F.M. & Television Receivers.
3. **RADIO COMMUNICATIONS**—Prepares for FCC Operators' License. Leads to position as Merchant Marine or Flight Radio Officer, Commercial Operator.
4. **FUNDAMENTAL RADIO MATHEMATICS**—The MRI Preparatory Course. Required pre-training for students lacking a basic mathematical background.

**MELVILLE RADIO INSTITUTE**

45 W. 45th St., N. Y. 19, BR 9-5080

"The Radio School Managed By Radio Men"

Licensed by the State of New York

**MELVILLE RADIO INSTITUTE**

45 West 45th St., New York 19, N. Y.

GENTLEMEN:

Send me FREE Information about your school. RN

Name.....

Address.....

MAIL THIS COUPON NOW

# Tubes are... CHARACTERS!



AMATEUR



123-209



BROADCAST

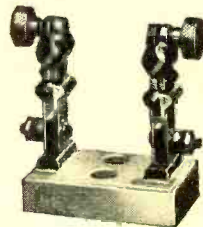

124-212



INDUSTRIAL  
ELECTRONIC

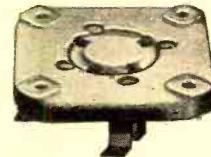

122-244

## Handle them with Johnson Sockets

SOCKET—	BASE OR TYPICAL TUBE
123-209	Med 4
123-210	Pin Bayonet
123-211	Standard Jumbo
	4 Pin
123-216	Giant 5 Pin
	Bayonet
124-212	833 A
124-213	152TL
124-214	1500th
124-215	204A
120-267	9000 series
120-277B	Miniature
121-235	Acorn
121-245	
121-265	
122-101	829
122-217	Small 7 Pin
122-224	4 Pin
122-225	5 Pin
122-226	6 Pin
122-227	7 Pin Med.
122-228	Octal
122-234	RK72
122-237	7 Pin Large
122-244	Super Jumbo
	(Industrial
	No. 412 Base
122-247	826
122-248	826
122-275	Giant 5 Pin
124-220	899R

There are many types in the tube family. Like humans they differ in appearance and performance. Each makes individual demands on its socket. A JOHNSON socket accommodates the 4-250A where provision for adequate heat dissipation is a major requirement. JOHNSON designed the first ceramic socket for miniature tubes where the socket must hold the small pins firmly and still accommodate minor variations without fracturing the envelope.

JOHNSON has achieved unusual prominence through skill in engineering both ceramics and metal to meet these demands. Experienced electronic engineers recognize and provide for tube and circuit requirements. Confidence, cooperation and assistance on the part of tube manufacturers explain the more complete line, and why JOHNSON is the only manufacturer producing some types. When you need sockets look to JOHNSON. The price is usually no more, frequently less.

For more information write Dept. Z

# JOHNSON

*a famous name in Radio*



E. F. JOHNSON CO. WASECA, MINN.

November, 1946

SAVE HOURS OF  
CATALOG EXPLORING

These 8 pages  
OF  
POWER TUBE  
INFORMATION

— give essential characteristics of more than a hundred Communication, Industrial, Rectification, Electro-Medical, Amateur and Special Purpose tubes classified by function.

— tables are keyed to output with handy type-number cross index.

— truly useful on the desk of the busy distributor, maintenance engineer, and equipment designer and manufacturer.

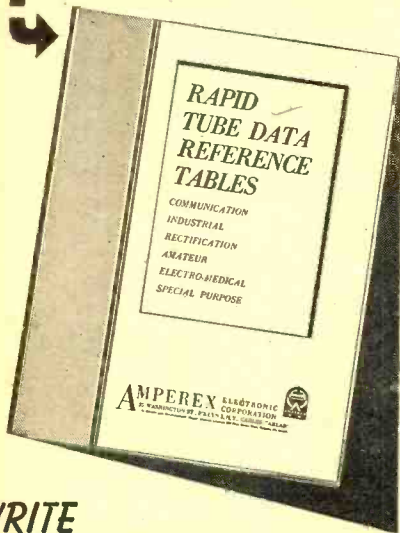

WRITE

**AMPEREX ELECTRONIC CORPORATION**

25 Washington St., Brooklyn 1, N. Y.

In Canada and Newfoundland: Rogers Majestic Limited  
622 Fleet Street West, Toronto 2B, Canada

as well as attain a better balance between the supply of consoles and table model receivers. We believe that the industry can make a strong case for decontrol at the earliest opportunity." He warned, however, that it is going to take time. "Because of the lengthy procedures and detailed data required before it can petition for decontrol and on account of the long wait periods allowed for decisions by OPA officials and the decontrol board, it is unlikely that we can obtain a decision on decontrol for several months, probably not before December."

**ONE OF THE OLDTIMERS** in radio, Zeh Bouck, passed away recently after a short illness. Formerly associated with RADIO NEWS, Mr. Bouck was well known for his many contributions on radio subjects to various technical publications.

**TWO PROMINENT FIGURES** in the radio industry, Charles Golenpaul and Walter Jablon, have been appointed directors of the 1947 Radio Parts and Electronic Equipment Trade Show Corporation. It would be difficult to find two men better suited for this important job.

**THE YEAR 1946** will be the biggest on record as far as the Federal Communications Commission is concerned, work-load figures already tabulated in Washington indicate. As an indication, 70,000 hams now have licenses. Between May and August, a total of 12,500 were processed, and the work is now current. Equally heavy is the load of applications for new AM stations—almost as many as the number of AM stations now operating. A total of 850 new applications are now pending, as compared with 977 stations already licensed. In addition, 303 construction permits have been granted. Some 65 FM stations are now on the air and 510 have either construction permits or conditional grants. This is in addition to 250 pending applications. Six licenses have been granted for television, plus 27 construction permits and 30 pending applications. And on top of all this, late summer and early fall found the Commission swamped with requests from municipalities for two-way radio systems. Almost every city in the nation wants a system installed. FCC is processing all applications as quickly as possible and looking toward 1947 with expectation of more work than this year.

**FCC ALSO REPORTS** a boom in radiotelephone service, despite wartime restrictions. Reports filed with the Commission show that the number of paid radiotelephone conversations increased from 49,493 in 1940 to 297,726 in 1945. The latter year showed a 97 per-cent increase over the previous year, while the first quarter of this year showed 120,150 calls—up 61 per-cent on an annual basis over 1945. Radiotelephone calls—if you're inter-

For Soldering in  
Tight Places...

**DRAKE**

No. 400 Soldering Iron

Smallest Industrial Iron  
Ever Designed  
60 Watts—1/4 in. Tip  
Only 9 in. long—Wt. only 8 oz.

This mighty mite is backed by DRAKE'S 25 years of soldering iron manufacturing experience. The high quality and long service of DRAKE Soldering Irons have made them outstanding favorites with all types of radio men everywhere. The DRAKE No. 400 is an outstanding value at

Only \$4.50  
list



Drake Has an Iron  
for Every Purpose  
Ask Your Radio  
Parts Jobber.

**DRAKE ELECTRIC WORKS, INC.**  
3656 LINCOLN AVE., CHICAGO 13, ILL.

**REAL VALUES  
in HAM GEAR**

Hi-Imp. Dyn. Mike with Switch	\$9.95
Bendix 28V. Inter-Comm. with 6SJ7 & 6V6 tubes	4.95
5 Ele. Beam 2-meter Ant. Complete	7.00
350 Mil. 6 henry 82 ohm choke	2.95
110V.-70 MA., 770 V. ct., 6.3V.-2.5A., 5V.-2A. Transf.	2.95
10 Mfd. 600V. Oil Cond.	1.25
.5 Mfd. 2000V. Oil Cond.	.75
10" 500 ohm field Dyn. Spkr. with P.P. out.	5.00
Mobile Bk. Crackle Cab. with 3" Lord mts. 13" x 10" x 9"	1.00
3" 1 mil. meter (0-10 scale)	3.50
2" 1mil. meter (0-100 scale)	2.50
6.3V. 3 amp. Fil. Trans.	1.60
5V. 3A. and 6.3V. 3A. Fil. Trans.	1.50
2/6.3V.-3A. and 5V.-3A. Fil. Trans.	1.95
1000V. plate Trans. at 5MA.	1.95
1500V. plate Trans. at 10 MA.	2.95
2000V. plate Trans. at 10MA.	3.95
Hi Imp. Earphones adj. Band-Cush. and Plug	1.75
5" Blk. Crackle Spkr. Cab. and Cover	.75
.00015 Mid. Variable and fluted knob	.50
Rec./Trans. BC 148, 3960 Kc.—4360 Kc.	2.95
9 foot 3 sec. threaded Ant. Rods	1.50
Telephone Type Scr. Ant. Insulator	.10
2" Ceramic Bell Insulators and 3" thread	.25
1 Mfd.-1500V. Upright Con Cond.	.50
1" fluted Knob for 1/4" Shaft	.10
2" fluted Knob for 3/8" shaft	.15
100-ft. Roll Phosphor. Bronze lead with ball	.45
J38 Key with Switch	.50
RCA 288 ohm twin lead	ft. .63
8" P.M. Speaker	2.95
PL 540 or 55 plug	.10
Ceramic Rect. caps.	.10
Ceramic Octal Socks. 1 1/2"	.10

*Standard Parts Corp.*

**AMATEUR DIVISION Dept. N**  
235 MAIN ST. HEMPSTEAD, N. Y.



# MID-AMERICA HAS EVERYTHING FROM "A" TO "Z"

## ANTENNAS

32 1/2" Collapsible Vertical.....	\$1.49
10 Mtr Collapsible Vertical.....	\$1.49
12 1/2 Foot Telescopic.....	\$1.95
Phantom A-27, 2-4.5 mc.....	\$1.49

## CABLE

Co-Axial RG8U Standard	
Amphaloid 52 ohm.....	Per ft. 8c
Per 100 ft.....	Per ft. 6c
Per 1000 ft.....	
Co-Axial RG54-A/u, 58 ohm	
Per 100 ft.....	Per ft. 7c
Per 1000 ft.....	Per ft. 5c
Eight cond. shielded, colored rubber ins. six of #20, two of #16. Rubber jacket, external tinned woven shielding. O.D. 9/16".	
Per 100 ft.....	Per ft. 10c
Per 1000 ft.....	Per ft. 7 1/2c

## COIL FORMS

Kit of 10 Ceramic transmitting coil forms..... \$1.49

## CONDENSERS

Kit of 10 Bathtub condensers..... \$1.49

## AIR PADDER CONDENSERS

Ceramic Insulation, Screwdriver Adjust.	
100 mmf.....	29c
140 mmf.....	49c
Following sizes available—5, 15, 25, 35 and 50 mmf, each.....	19c

Kit of 10 Asstd. Air Padder Condensers..... \$1.49

## G.E. PYRNOAL CONDENSERS

MFD	VDC	PRICE	MFD	VDC	PRICE
.25	1000	39c	.1	7500	\$1.95
1	500	39c	4	1500	\$2.95
1	600	49c	10	1000	\$2.95
2	600	89c	12	660	\$3.50
1	1000	98c	15	1500	\$3.95
6	600	98c	1.5	6000	\$4.95

## HEAVY DUTY OIL FILLED CONDENSERS

MFD	VDC	PRICE	MFD	VDC	PRICE
.075	16000	\$4.95	3	4000	\$4.50
1.5	6000	8.95	10	6000	24.95
Dual 1 mfd 3000 VDC.....		\$3.95			
Dual 1 mfd 7500 VDC.....		\$9.95			

## TUBULAR PAPER CONDENSERS

MFD	VDC	PRICE	MFD	VDC	PRICE
.01	600	9c	.3	200	10c
.006	1000	10c	.1	1000	15c
.05	600	10c	.004	1600	19c

## VARIABLE CONDENSERS

GANG	MMF	PRICE	GANG	MMF	PRICE
2	10	49c	1	500	\$1.29
1	50	49c	2	370	\$1.49
1	13	69c	3	75	\$1.49
2	35	98c	4	140	\$1.95

## MISCELLANEOUS CONDENSERS

Hi-voltage mica. Kit of 10 pieces, from 600-2500 volts..... \$2.95  
Hi-voltage mica. Kit of 10 pieces, from 3000-5000 volts..... \$5.95  
Mica. Kit of 25 pieces. Ass'd sizes from .00005 to .001, 300-600 v., per kit..... \$1.98

## DYNAMOTORS

Kit of 3 listed below..... \$4.95  
SIZE: 3 1/2" x 6" long, excluding shaft. R.P.M. 4000.

VDC	AMPS.	VDC	AMPS.
6-9	6.4	450	60
12	3.5	480	42
24	1.75	480	42

## MID-AMERICA SPECIALS AT-3 Antenna Tuning Unit

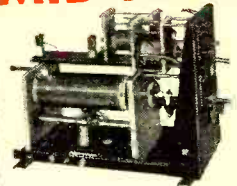

An outstanding achievement in high frequency design! Covers all frequencies between 1.5 and 18 MC without use of plug-in inductance. Tunes any single wire antenna from 15 ft. whip to long wire. Ceramic insulation constructed to withstand high r. f. voltages. Simple to operate. Black wrinkle finish case measures 10 1/4" wide, 14 1/2" high, 24" deep. Packed for shipment—wt. 56 lbs. Less 12 mmf and 50 mmf vacuum condensers.

**SPECIAL PRICE \$26.95**

## SPEAKERS



5" Alnico Speaker, 4 Ohm VC, Limited Quantity..... \$1.70  
6" PM 2.5 Alnico V..... \$2.95  
10" PM, 18 oz. slug..... \$7.95

AP-10 JENSEN Speechmaster, 5 Watt PM in metal housing less base..... \$4.95

## HEAVY DUTY LINE FILTER



Solar Elim-O-Stat Type EN106, SPECIAL \$1.79  
CS153199, 20 amps, 115 V.A.C., 600 V.D.C.

## RHEOSTATS

50 ohm, 25 watt.....	59c
70 ohm, 25 watt.....	59c
2500 ohm, 25 watt.....	79c

## SWITCHES

Antenna DPDT Hi-voltage, knife..... 39c

## MICROSWITCHES

Type C, white top, SPST, normally closed, #WZ-7RSTC..... 39c  
Type C, #BZ-R5, SPDT..... 39c  
Type C, #BZ-3RDT, SPDT..... 39c  
GE #CR1070C103-A3 momentary SPST normally closed..... 39c

## PRESS-TO-TALK

DPST, NO, with 5 ft cord, UL-68 and JK-48..... 24c

## PUSH BUTTON

10 Button, momentary contact, non-locking, right hand..... 49c  
10 button, momentary contact, non-locking, left hand..... 49c  
5 Button, pos. action, locking..... 49c  
4 Button, pos. action, locking..... 49c

## TOGGLE

Lever type, 3PDT 10 amp 250 VAC..... 59c  
Push type SPST NO, 3 amp 250 VAC..... 29c

Kit of 10 Selector Switches..... \$1.49

## TUBES

Immediate Delivery

6AC7.....	97c
6AG5.....	\$1.19
6BJ6.....	97c
6SLGT.....	79c

## TRANSFORMERS

Universe output transformer, single or push-pull tubes to any voice coil. Rate at 10 watts..... \$1.20  
Power transformer, primary 105-125 VAC 60 cps. Secondary 5 volts 190 amps..... \$14.95

## TRANSMITTER

8C-223-A, 80 meter band; phone, CW, ICW; VFO or crystal controlled; 25 watt output..... \$22.50

## Transmitter-Receiver

Portable FM Transceiver SCR-510, range 5 miles, 20 to 27.9 MC, crystal controlled with 80 crystals, complete..... \$79.50

## VOLUME Control

Kit, 10 volume and tone controls, no wipers, long shafts..... \$1.79

## WIRE

Single conductor #18 solid, rubber ins. OD 1/8", black, green only..... 69c  
Per 100 ft..... \$5.45  
Per 1000 ft.....

Two conductor, #14 stranded with external tinned woven braid, O.D. 3/8"..... Per ft. 8c/ft.  
Per 100 ft..... Per ft. 6c/ft.  
Per 1000 ft.....

## ZILLIONS

of other big-value parts, transmitters, tubes, and electronic equipment listed in MID-AMERICA'S Catalog. It's free for the asking. Just send coupon below and your FREE copy will be mailed at once.

## QUANTITY BUYERS

Dealers... Jobbers... Industrials... Schools... and other quantity buyers—write for special trade discounts on items listed as well as hundreds of others.

## HAND SET

Type TS-13 Telephone type with 200 ohm carbon mike and 2000 ohm earphone plus talk switch and cords with plugs..... \$2.95

## HEAD SET

Type HS-23 8000 ohm impedance, with cushions, 12" cord and PL-54 plug..... \$1.50

## INVERTERS

Input 27 VDC 35 amps, output 115 VAC 4000 cps..... \$4.95  
Input 24 VDC 1 amp, output 26 VAC 400 cps 6 VA..... \$1.95

## KEYS

Transmitting J-38..... 75c  
Automatic Keyer TG-10-H with oscillator and 25 watt amplifier. 110 VAC, 60 cycle operation (less tubes)..... \$39.95

## MICROPHONES

Single button carbon hand mike, with press-to-talk switch, 5 ft. cord with PL-68 three circuit plug..... \$1.75  
Single button carbon lip mike. Fastens over upper lip, attaches to headset. With short cord and PL-291 plug..... 89c  
Single button carbon mike. Attaches to headset and held in front of mouth by bracket. Aviometer type 7042..... 98c

Kit of 3 microphones, as listed above..... \$2.95

## RECEIVER

Long Wave Receiver RAK-7, 15 to 600 KC, 110 VAC operation, complete with power supply and tubes..... \$64.50

## RECTIFIER

Dry Disc Full-wave, 64 VAC input, 30.2 to 33.5 VDC output at 5.2 amps..... \$4.75

## RESISTOR KITS

20 asstd.—5, 10, 25 watt wire wound, popular sizes..... \$1.79  
10 Candohms 5 to 20 watts, IRC or equiv..... 75c

## IMPORTANT!

To assure fastest possible service and delivery, please send 25% deposit with your orders. Balance C.O.D. Send orders to store address. All prices shown are F.O.B. Chicago warehouse.

## GUARANTEED

All items shown in this ad are guaranteed as rated by nationally-advertised manufacturers and are new, unused and in perfect condition.

## Motor Speed Controls

10 ohm, 7.07 amp, 500 watt, flush mounting..... \$3.95  
12.5 ohm, 10 amp, 500 watt, bracket mounting..... \$3.95  
175 ohm, 3.7 amp, 800 watt, 125 volts, bracket mounting..... \$4.95

## POWER SUPPLIES

Portable vibrator type, input 6/12/24 VDC, output 200 VDC 120 ma..... \$1.95  
Mobile, dynamotor type, input 12 VDC 12 amps, output 275 VDC 110 ma, and 500 VDC 50 ma, complete with fuse and filters..... \$9.95

## FREE Catalog



Mid-America Co., Inc., Dept. E-116  
2412 S. Michigan, Chicago 16, Illinois

Send me at once—ABSOLUTELY FREE—your brand new catalog listing hundreds of "hard-to-get" radio parts, transmitters, and electronic equipment... ALL AT MONEY-SAVING PRICES.

NAME.....  
ADDRESS.....  
CITY..... STATE.....

## MID-AMERICA CO.

STORE  
2412 S. Michigan Ave.  
Chicago 16, Ill.  
PHONE: VICTory 5987

WAREHOUSE  
2307 S. Archer Ave.  
Chicago 16, Ill.  
PHONE: VICTory 7820

# OUTSTANDING VALUES

**RADIO • ELECTRONIC  
and COMMUNICATION SUPPLIES**

Order Today Immediate Delivery

## MODULATION TRANSFORMER



Modulation transformer perfect for inputs up to 300 watts—Class C load on primary No. 1 4000 ohms—primary No. 2 is designed for screen of Pentode or Pentode—primary will match 811, 809, T220 & T240 tubes. Complete factory specifications and circuit diagram included. . . . . \$4.95

W.E. driver transformer Class B—matches 6L6 in Push-Pull to any Class B grids. Perfect match for above transformer. . . . . \$3.95

Driver Transformer. Single 6V6 to push-pull. 811 grids. Chicago Transformer Co. . . . . \$1.50

## A HOT SPECIAL

Plate Transformer built by Kenyon. 1450 Volts C.T. @ 420 mills, 110 Volt, 60 Cy primary. . . . . \$7.95, two for \$15.00



## PLATE TRANSFORMERS

6200 Volt CT—700 Mills, 110 Volts, 60 Cycles tapped primary 2 KVA Amertran, Limited quantity . . . . . \$39.95

## CONDENSERS

Variable Condenser—E. F. Johnson split stator 150 MMF per section .175 spacing—7000 Volts. Your cost . . . . . \$8.95

Johnson edgewound coil—mycalex insulation and mounting, plated, 26 turns at 1/4" spacing—perfect for all ham bands. . . . . \$3.95

Sangamo No. G1 mica condenser—.001/6000 Volt working . . . . . \$10.95

Sangamo No. G2—.003/8000 Volts working. . . . . \$13.95

## MISCELLANEOUS

Langevin Swinging Choke—9/60 henries 400/50 mills. DC resistance 72 ohms. . . . . \$12.75

866 Filament Transformer 2 1/2 V. at 10 A. Kenyon—insulated for 10,000 Volts—Tri 110 Volts, 60 Cy. 4.25

Overload relay 10 mil 5000 ohm with 110 V. AC automatic reset coil. Protect those expensive amplifier tubes . . . . . \$3.95

Motor type time delay relay—adjustable to 1 minute. 110 Volt 60 Cy. Hayden motor. Perfect for 866 Time delay . . . . . \$5.95

Antenna change-over relay DPDT. Silver contacts—Leach 110 Volt 60. . . . . \$2.50

2 1/2 amp RF meter 3 1/2" with built in thermo couple . . . . . \$5.95

Cool That Kilowatt—Dual Blower blows 200 cubic feet per minute. Delco 110 Volt. 60 Cy. Slightly used but perfect. Completely noise free. . . . . \$15.95

1000 KC. Xtal Precision AT Cut mounted in standard holder . . . . . \$4.95

Veeder-Root Counter No. S40 reads 999.9. Your cost . . . . . \$1.50

APC Padders—screw driver adjustment from 4 to 75 mfd. A complete assortment of 6 padders. Special . . . . . \$1.49

Bleeder Resistor IRC—50,000 ohm. 100 watt. Special 89c or 2 for 1.69

**B & W Coils & Westline Xtals in stock.  
Let us know your requirements.**

All prices F.O.B. our warehouse New York City, N. Y.  
• We invite all inquiries.  
• Write for latest bulletin 9RC.

Export cable address:  
MICROWAVE—New York

**NIAGARA RADIO SUPPLY**  
160 Greenwich St., New York 6, N. Y.  
Bowling Green 9-7993

ested in making one—can be transmitted to forty-eight countries outside North America these days. Included are such far-off spots as Australia, Japan, Russia, Sweden and Switzerland.

—30—

## Audio Oscillator

(Continued from page 51)

signal voltage across this control is approximately 15 volts, while most amplifiers require an input of only 1/2 volt or 1/4 volt. A logarithmic-taper control, connected as shown in Fig. 5, spreads the low-output range over a wide arc and makes it easy to adjust for these outputs while still allowing for greater output if desired.

Placing the unit into operation is a relatively simple matter, and, wired correctly, it will work the first time it is turned on. As a rough performance check, connect a pair of high-impedance headphones to the output, set the output control to a fairly low value to avoid overloading the circuit, set the frequency dial about mid-scale, and adjust the feedback control until oscillations just take place as indicated by a tone in the headphones. Then swing the frequency dial back and forth over the entire range. Very little adjustment of feedback should be required to produce oscillations from the lowest frequency, where the dial is fully clockwise, up to a frequency which is above the range of audibility.

It will be noted that the unit will stop oscillating some distance away from the high-frequency end of the dial. This is normal, and is a result of loss in gain caused by lowered impedance of the potentiometer. Oscillations should not drop out, however, until the frequency is somewhat above the audible range. It is not advisable to try to force oscillations in this dead region at the high end of the dial through the use of the feedback control; because the audio frequency so obtained will be no higher than the upper limit observed with a normal setting of the feedback control, and a considerable adjustment of feedback will be required when returning to lower frequencies.

The over-all frequency range can be checked with the aid of an oscilloscope or a comparison oscillator whose frequency calibration is already established. If, for some reason, it is desired to shift the frequency range, this can be done by changing the values of C<sub>1</sub> and C<sub>2</sub>. Making either capacitor smaller will raise the frequencies, and vice-versa. Changing these values will not extend the over-all frequency range but will simply shift the entire range of the instrument higher or lower as desired.

Some extension of the over-all range can be obtained through the substitution of a 1 megohm double potentiometer for the .5 megohm unit specified for R<sub>1</sub> and R<sub>2</sub>, along with suitable readjustment of C<sub>1</sub> and C<sub>2</sub>. This will

# R-L PORTABLE & TABLE MODEL RECORD PLAYERS



Beautifully designed cabinet of matched birch veneer. Built-in amplifier, 5" PM speaker with Alnico #5 Magnet. Lightweight tone arm assures longer life for records. Shipping weight, 13 lbs.

**B6201 Net \$26.97**

Portable model similar to B6201, with wood case covered in smart two-tone leatherette. Shp. wt. 17 lbs.

**B5816 Net \$28.22**



Write for FREE 1946 Parts Catalog



731 West Washington Boulevard  
DEPT. N CHICAGO 6, ILLINOIS

## Sensational Transformer Values



**THORDARSON FILAMENT TRANSFORMER**, Order #T-11. 105 V. 60 cycle primary. Three Secondaries; #1, 6.3V @ 3.9 Amps; #2, 6.3V @ 4.5 Amps; #3, 9.7V @ 0.5 Amp. Here's the Transformer for the ham and builder who are satisfied with nothing but the best—at a price you can't afford to miss. Case style as illustrated, Black crackle finish. 4 3/4 x 4 1/4 x 3 3/4 . . . . . \$2.45 ea.

**THORDARSON POWER TRANSFORMER**, Order #T-32. Tapped Primary: 110, 115, 120 Volt, 60 cycle. Secondary #1, 440 V ct @ 150 ma. Secondary #2 5V @ 3 Amp. Conservatively rated. Case and dimensions as above except has blue-gray enamel finish. . . . . \$3.25 ea.

**GENERAL ELECTRIC FILTER CHOKE**, Order #T-17. All Choke with no frills. 10 Hy @ 250 ma, 120 Ohms D.C. Resistance. Not cased. Special. . . . . \$2.50

**GENERAL ELECTRIC FILTER CHOKE**, Order #T-18. Hermetically sealed case, 10 Hy, 75 ma, 330 Ohm D.C. Resistance. Size 2 1/4 x 2 1/2 x 2 3/4. . . . . \$1.15 ea.

**BUTTERFLY CONDENSER**, Order #C-8. For the UHF experimenter we have located these top quality condensers. Four rotor and two stator plates. Rotors mounted on ball bearing supported shaft. Designed for front panel mounting. Made to U. S. Navy specifications. . . . . \$1.25 ea.

**HAMMARLUND AIR TRIMMER CONDENSER**, Order #C-9 3-28 mmf. screwdriver adjustment, with locking nut, isolantite base. . . . . \$7.95 ea.

**GENERAL ELECTRIC ROTARY SWITCH**, Order #S-5. Heavy duty ceramic switch. Ideal for high voltage meter switching, etc. 5 position, single pole. Complete with Indicator Knob. . . . . \$8.95 ea.

**CATHODE RAY TUBE**, 5BP1. Not rejects, but top grade U. S. Navy inspected and accepted. Special. . . . . \$5.50 ea.

**TUBES**. All government inspected and accepted.  
2x2/879 . . . . . \$1.00 ea.  
6AC7 . . . . . \$1.00 ea.  
6H6 . . . . . \$ .75

All Merchandise Brand New and Guaranteed  
TERMS: 25% Deposit with order, Balance C.O.D.  
All prices F.O.B. New York

**WEBER RADIO LABORATORIES**  
3124 Avenue "I", Brooklyn 10, N.Y.

# How to Pin Down Production Costs!

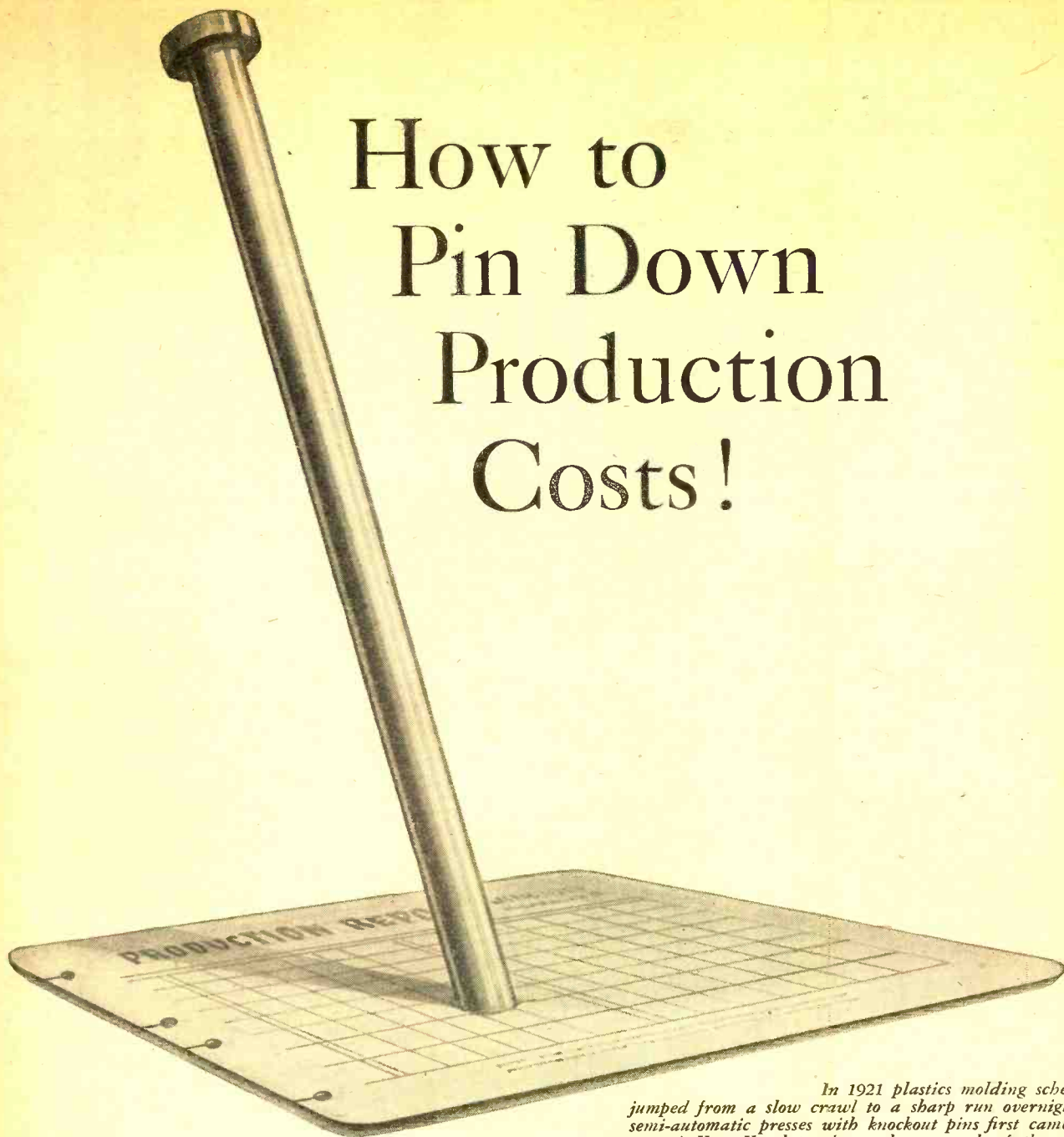

*In 1921 plastics molding schedules jumped from a slow crawl to a sharp run overnight, as semi-automatic presses with knockout pins first came into use. A Kurz-Kasch engineer shares much of the credit!*

**T**OMORROW'S improved molding practices will grow out of bright ideas simmering *today* in some progressive molding plant—paying dividends to the customers whose production will benefit before the crowd.

*New* production ideas have been an *old* Kurz-Kasch habit since the birth of the plastics industry. See how they'll benefit you—send for your free booklet, "A Businessman's Guide to the Molding of Plastics"—on your business letterhead, please.



# Kurz-Kasch

*For Over 29 Years  
Planners and Molders in Plastics*

Kurz-Kasch, Inc., 1429 S. Broadway, Dayton 1, Ohio. *Export Offices:* 89 Broad Street, New York, N. Y.  
*Branch Sales Offices:* New York • Chicago • Detroit • Los Angeles • Dallas • St. Louis • Toronto, Canada.

## THE 40-RE RECORDING AMPLIFIER

40 WATTS  
OUTPUT

•  
LOW  
INTER-  
MODULATION  
COMPONENT

•  
LESS THAN  
3% TOTAL  
HARMONIC  
DISTORTION

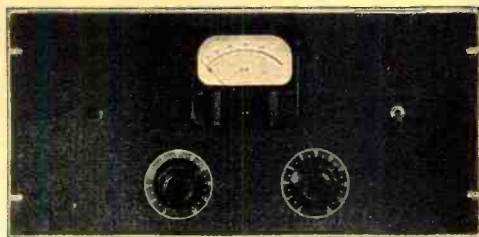

±1 DB  
30-15,000N

•  
3 RECORDING  
CHARACTER-  
ISTICS

•  
4" SQUARE  
ILLUMINATED  
V.I. METER

*Three recording characteristics at the turn of a knob: Orthacoustic, flat or special, to your specifications. Can be driven from standard preamp. levels.*

**COLLINS AUDIO PRODUCTS COMPANY**

126 PARK ST.

WESTFIELD, N.J.

*Now Available in Quantity!*

THE ELECTONE RADIO PHONO COMBINATION  
WITH AUTOMATIC CHANGER. O.P.A. LIST AT **\$78<sup>15</sup>**

Also—the new improved table model with  
planetary drive and tubeless rectifier at **\$26<sup>70</sup>**

Write for attractive discounts

**WARREN DISTRIBUTORS**

3145 WASHINGTON STREET, JAMAICA PLAINS 30, MASS.

ELECTONE DISTRIBUTORS FOR N. E.

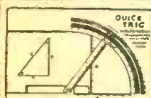

**SOLVE TRIG  
PROBLEMS QUICKLY  
WITH EASY TO USE  
QUICK TRIG**

This NEW IDEA in a slide rule enables you to solve QUICKLY, trig., radio, electricity, and carpentry problems. Simply set the slides. Right in front of you are the answers for ALL THREE sides and angles of a triangle. Gives degrees and tangents of angles. No need to figure with paper and pencil. Easy instructions included.

### SINE CIRCLE

This completes all your trig. needs. It gives trig. functions such as sine, cos., tangent, secant, etc., for the complete 360 degrees. Both for only \$1.50 postpaid, or we will send C.O.D. plus postage, by return mail.

REED MFG. CO., 124 W. 4th St., Los Angeles 13, Calif.



### NEW CATHODE-RAY TUBES

New 5CPI's in original sealed cartons, (6-lbs.)..... \$7.95  
New 3BPI's in original sealed cartons, (5-lbs.)..... \$5.95  
Sockets for above, with tube 45c; otherwise..... \$ .90  
New 5CPI Steel shields, cadmium plated (3-lbs.)..... \$ .85  
New 954, 955, 956, 957 Acorn tubes in original cartons, not rejects, postpaid in U. S. each..... \$ .89  
Westinghouse 4 1/2" dia. 0-200 D.C. microammeter..... \$6.50  
Westinghouse 4 1/2" dia. 0-150 D.C. voltmeter..... \$5.50  
Westinghouse 4 1/2" dia. 0-20 D.C. milliammeter..... \$4.95  
Miniature 1/2 wave selenium rect. 18r. 5-1ma. 5 for \$1.00  
Matched pairs selenium rect. for meters..... 2 for \$ .50  
100 feet spaghetti 1/2 HV cambric, 1/2 plastic;..... \$1.00  
12-18 gauge..... \$ .65  
12-18 .5V Carbon pile voltage regulators (3-lbs.)..... \$ .65  
115/15v & 230/30v, 50 watt, 60 cyc. hermetically sealed transformers in black crinkle case (4-lbs.)..... \$1.25  
New dynamotors 24v DC to 240v DC 30 ma (6-lbs.) \$2.75  
New dynamotors 24v DC to 270v DC 120 ma (6-lbs.) \$3.25  
New dynamotors 24v DC to 450v DC 200 ma (8-lbs.) \$4.25  
Relays 24v DC DPDT plus DT grounding, HV Insul. \$ .89  
Astatic PL-40 Phono pick-up arm with crystal..... \$2.90  
Please include sufficient shipping postage  
Write for free electronic bargain list.

**OHMEYER ENGINEERING LABS.**

Fairview Blvd. • Dept. C. • Hempstead, N. Y.

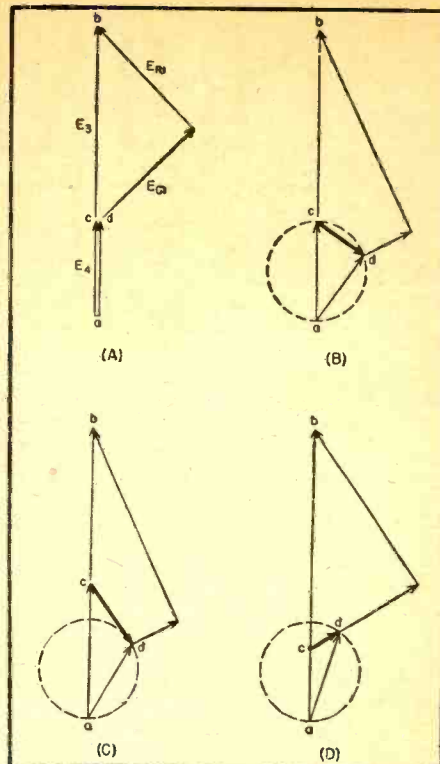
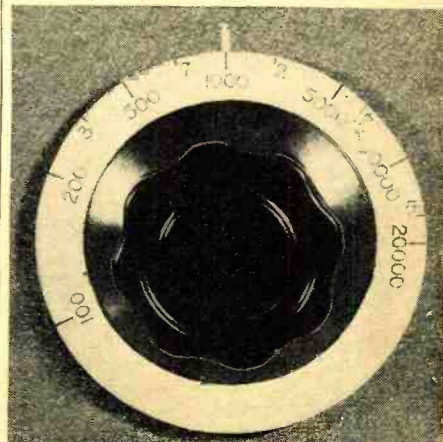

Fig. 7. Vector relationships in bridge circuit of Fig. 3. Letters on the vector diagram correspond to similarly lettered points in Fig. 3. (A) Bridge perfectly balanced. Cathode-grid voltage (c-d) on tube 1 is zero. (B) Changes in vector diagram from that of (A) where frequency changes. Vector c-d takes on various values as point d moves in a circle. (C) Same as (B) with resistor  $R_1$  smaller than the value required for balance. (D) Same as (B) with resistor  $R_2$  larger than the value required for balance. Note that vector c-d may be in phase with the voltage a-b. Under these conditions, oscillation occurs.

just about double the frequency range, but, of course, the calibrations on the dial will be more crowded.

Once the frequency range has been established as desired, the oscillator is ready for calibration by comparison with a known source. Before calibrating, it should be understood that both the setting of the feedback control and the amount of loading on the output

Fig. 8. Close-up of main tuning dial showing how frequency calibrations space out when potentiometer is correctly connected.



# CRONAME *Facilities*

FOR ELECTRONIC COMPONENTS  
AND FINE METALCRAFT

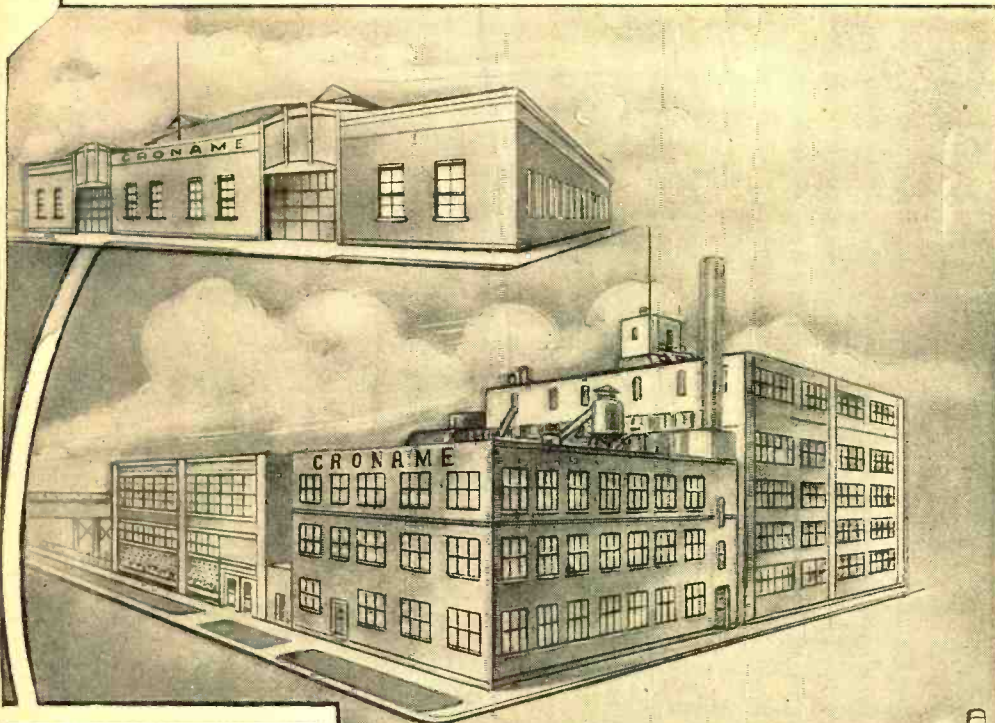

ENGINEERING  
ETCHING  
LITHOGRAPHING  
EMBOSSING  
ENGRAVING  
STAMPING  
ALUMINUM WELDING  
& HEAT TREATING  
ASSEMBLIES  
SOLDERING  
METAL FINISHING  
PLATING

ANODIZING  
PARKERIZING  
OXIDIZING  
FLUORESCENT  
PHOSPHORESCENT  
DECORATED GLASS  
GLASS DIALS  
DECORATED PLASTICS  
FORMED PLASTICS  
RADIO TUNING UNITS  
REMOTE CONTROLS

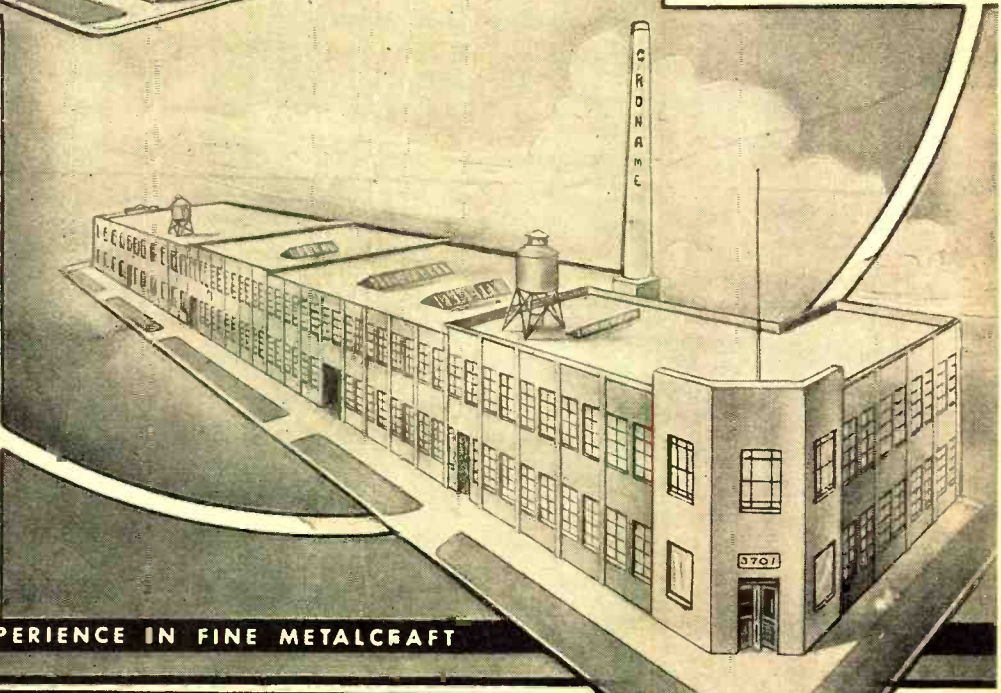

OVER 40 YEARS EXPERIENCE IN FINE METALCRAFT



**CRONAME**  
INCORPORATED

3701 RAVENSWOOD AVENUE  
CHICAGO 13, ILLINOIS

# SRI for radio and electronic SPECIALS!

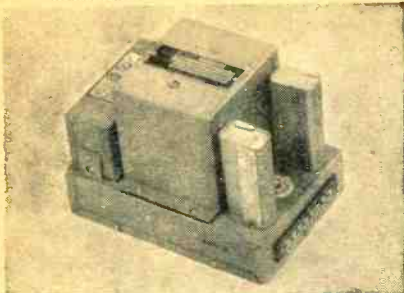

## POWER SUPPLY

110 V. DC & 110 V. AC Input.  
375 V. @ 200 MA. 6.3 V. @ 3.0 A. Output.  
ELECTRONIC LABS. Model  
S-1365 A. Complete less rect.  
tube ..... **\$15<sup>95</sup>**

TELESCOPIC ANTENNA 12'10" Extend-  
ed. Plated steel— $\frac{1}{4}$ " Base screw stud  $\frac{7}{8}$ "  
dia. base ..... **\$2.75**

DYNAMOTOR 6 and 12 V. DC Input  
500 V. DC @ 160 MA. Cont., 224 Inter-  
mittent, with filter, relays, fuses, etc. Type  
PI03A. SPECIAL ..... **\$13.75**

FREQUENCY STANDARD 100-95,000 KC  
1000-100-10 KC Check points. Multivi-  
brator and output amplifier. 110-250 V.  
AC. 25-60 cycles, complete with spare  
tubes ..... **\$29.50**

CONSTANT OUTPUT AMPLIFIER Doubles  
average modulation level and keeps it  
at 100%. Send for literature. .... **\$59.50**

MULTIPLE FILTER CONDENSER 8-8-8-8  
MF. 600 V. DC  $4\frac{1}{2}$ "x $3\frac{3}{4}$ "x $3\frac{1}{4}$ " Herm.  
sealed SPRAGUE ..... **\$2.95**

FILTER CHOKE 5-19 HY. 300 MA. Ken-  
yon type T510. .... **\$3.90**

CARBON SB HAND MIKE — PUSH  
SWITCH 4 ft. cord and 3 way plug **\$2.89**

HS-23 HEADPHONES 8000 OHMS  
IMP. Short cords—leather bands with  
extension cord ..... **\$2.59**

FOLDING ANTENNA 10'6" extended,  
brass, 17" folded, base  $\frac{1}{2}$ " threaded **\$1.95**

RCA 803 125 W. Shielded Pentode **\$12.50**

RCA 813 100 W. Beam Tetrode. . **\$9.95**

RCA 828 75 W. Shielded Pentode. . **\$8.50**

SEND 25% Deposit—Balance C.O.D. (No  
other way.) For Bulletins—Dept. RN167.

## SURPLUS RADIO, INC.

2-54 148th STREET  
WHITESTONE, N. Y.

will affect the frequency. Therefore, it is necessary to calibrate the unit with some high impedance device connected to the output, such as an oscilloscope or a high impedance amplifier input circuit. In addition, it is necessary to adjust both the feedback control and the frequency control for each frequency of calibration in such a manner that a sine wave is produced at the desired frequency. Of course, an oscilloscope is ideal for determining whether or not the unit is delivering a sine wave; but in the absence of such an instrument, the feedback control should be adjusted just slightly beyond the point where it breaks into oscillation. A good sine wave will be obtained until the feedback is advanced considerably beyond this point.

Another consideration in calibration is that most commercial two-gang potentiometers have considerable backlash. Therefore, each calibration point should be determined only after turning the main tuning dial in some certain direction, whether right or left as desired.

In using this test oscillator, it should be borne in mind that it is by no means intended as a precision instrument, and frequency calibrations can be off as much as five or ten per-cent. However, it is very stable for all its simplicity, and once set to deliver a sine wave at some frequency it will maintain a reliable signal of constant output and good waveform for long periods of test.

-50-

## New Amateur Transmitter

(Continued from page 39)

This is particularly desirable on the higher frequency bands which usually are open for a limited number of hours each day. Five separate tank coils are utilized (10 and 11 meters use the same coil), each with its own variable link. The link couples the antenna or feeders to the cold end of the plate coil. All links are mechanically coupled together and are operated by a control knob on the front panel. They feed directly into 52 ohm to 73 ohm transmission lines. For higher impedance transmission lines an external tuning circuit should be employed. Either balanced or unbalanced antennas can be used.

6. *V.f.o. control.* This was accomplished with a high degree of success. The dial is calibrated directly in frequency. The exciter unit will be discussed in detail in the latter part of this article.

7, 8, 9. *Power supplies.* Economical design dictates that the power supplies be kept to a minimum. A high voltage supply, low voltage supply, and a bias supply provide all the d.c. power required by the 30K. A single high voltage supply feeds both the r.f. power amplifier and the modulator tubes. Since the 4-125A tube requires high voltage and low current, as do the

75TH modulators, a pair of 866A rectifiers can deliver easily the required plate current for both stages. The low voltage supply provides voltage for the 4-125A screen, the speech amplifier, and the modulator driver. It also supplies bias voltage for the 4-125A and the modulator tubes. With the 4-125A biased to cut-off, keying can be accomplished in the exciter.

10. *High efficiency.* In the 30K circuit, plate efficiency of the 4-125A is between 75 and 80%. The tank and coupling circuits are designed for low loss, thus delivering maximum power to the antenna.

11, 12, 13. *Speech equipment.* Speech amplifiers and modulator equipment are on one chassis located in the transmitter cabinet. The audio input will accommodate either crystal or high impedance dynamic microphones. The amplifier is conventional, with the exception of the speech clipper and filter employed.

Prior to the development of the 30K, a considerable amount of investigation in the laboratories had proved the advantages of audio peak clipping. In congested frequencies such as amateur bands, or in adverse atmospheric conditions, peak clipping raises the effective modulation level and provides greater intelligibility at the receiving end. It also prevents over-modulation, because audio peaks and transients are clipped before reaching the modulator.

A low pass filter, following the speech clipper, attenuates all frequencies above 4000 c.p.s. This cut-off frequency is high enough to preserve the naturalness of the voice, yet eliminates excessive bandwidth. In field tests, listeners have reported that the 30K takes a comparatively narrow band width in amateur bands.

A pair of *Eimac* 75TH tubes are utilized as modulators. The modulation transformer has a separate winding for modulating the 4-125A screen.

A manually operated "phone-c.w." switch is located in the modulator unit, and is controlled by a knob on the front of the transmitter. For c.w. operation, this switch opens the filament circuit of the modulator tubes and shorts the secondary of the modulation transformer.

The audio gain in the speech amplifier is controlled by a knob on the front panel. The clipping level is adjusted manually from the rear of the cabinet, and can be set to occur at any desired percentage of modulation.

14. *Single control operation.* The transmitter plate switch and the exciter switch are connected in series. Just by leaving the transmitter switch in the "On" position, the exciter switch will have complete control of transmitting and receiving functions. The exciter switch has an extra section for use as a receiver disabling switch.

If push-to-talk operation is desired, the "push-to-talk" switch is connected in series with the plate control section of the exciter switch. Both transmitter and exciter switches are left in the

"transmit" position. An extra relay is then necessary for disabling the receiver. Calibration procedure is unchanged. Terminals are provided for operation of a receiver disabling relay, and also for an antenna change-over relay in the transmitter.

15. *Accessibility.* The cabinet is of sturdy welded steel construction. All units, tubes, and wiring are easily accessible through the full length rear door. Electrical interlocks break all high voltages when the cabinet is opened. The door may be locked with a key to prevent entrance by unauthorized persons.

All operating controls are conveniently located on the front panel. Meters are mounted on an insulated panel located behind a glass window near the top of the transmitter. Another window permits observation of the 4-125A r.f. amplifier.

#### Exciter Unit

The exciter unit for the 30K can be adapted easily to drive a variety of higher powered transmitters. All circuits are ganged together and controlled by a single tuning knob. The variable frequency oscillator is a peacetime application of a rugged and highly stable wartime development. The dial is calibrated directly in frequency, and is accurate to within 1 kc. in the 40 meter band. Accuracy on the other bands is directly proportional. The 1 kc. allowable deviation includes the frequency error due to all normal operating conditions. The v.f.o. operates in the 160 meter band.

One control bandswitches all circuits simultaneously. The exciter covers the 80, 40, 20, 15, 11, and 10 meter bands. In the "calibrate" position, the exciter can be tuned to zero beat with a received signal without turning on the transmitter.

Electronic keying provides fast, clean c.w. operation. When the key is removed from the jack, the circuit is automatically closed for phone operation. The exciter output is fed through a 73 ohm coaxial transmission line to a link on the grid coil in the transmitter.

Operation of the exciter is extremely simple—one control switch, a bandswitch, and single dial tuning. It can be used either as a transmitter or as a versatile exciter. Frequency control is rapid, accurate, and reliable.

#### Field Tests

The 30K has been given strenuous and critical tests in actual amateur operation. The ease and reliability of operation were firmly established. As was expected, the speech clipper was highly satisfactory, and effectively raised the modulation level. The signal was kept clean, and intelligibility was definitely increased. The low-pass audio filter maintained a narrow band width. It can be said truthfully that the clipper enabled the operator to obtain and maintain solid contacts that would have been lost otherwise in static and crowded frequencies.

-30-

November, 1946

# Colorful BEAUTY WITH ACCENT ON PERFORMANCE

## TURNER COLORTONE MICROPHONES

*New crystal and dynamic microphones in a choice of rich, gem-like colors*

Modern as tomorrow . . . packed with new performance features that give more accurate pick-up and higher fidelity reproduction of voice and music . . . Turner Colortone Microphones bring the beauty of matching color to microphone applications. Styled of rich, long lasting, shock resisting plastic in a choice of color finishes, they are especially adapted to orchestras, night spots, home recorders, and television studios. Green, orange, yellow and ivory models are now in production for limited delivery. Ask your dealer or write for details.



#### TURNER COLORTONE CRYSTAL

- Highest quality Metalseal, moisture proofed crystal.
- 90° tilting head. Semi or non-directional operation.
- Wind and blast proofed.
- Barometric compensator.
- Choice of color finishes.
- Turner precision diaphragm.
- 20 ft. removable cable set.
- Response: Within  $\pm 5$ db from 50 cycles to 10,000 cycles.
- Level: -52db below one volt/dyne/sq.cm.

*Crystals licensed under patents of the Brush Development Company*

#### TURNER COLORTONE DYNAMIC

- Heavy duty dynamic cartridge.
- Alnico V Magnet for increased sensitivity.
- Mu metal transformer shield eliminates possibility of extraneous pick-up.
- 90° tilting head. Semi or non-directional operation.
- Wind and blast proofed.
- Choice of color finishes.
- Turner precision diaphragm.
- 20 ft. removable cable set.
- Response: Within  $\pm 5$ db from 50 cycles to 10,000 cycles.
- Level: -54db below one volt/dyne/sq.cm.
- Impedances: 50, 250, 500 or high.

*Licensed under U. S. Patents of the American Telephone and Telegraph Company, and Western Electric Company, Incorporated.*

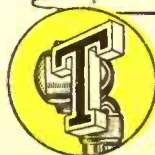

Microphones BY TURNER  
THE TURNER COMPANY

900 17th Street N. E.

Cedar Rapids, Iowa

TURN TO TURNER FOR THE FINEST IN ELECTRONIC EQUIPMENT

# MILO

Your "Q" for Quality

IMMEDIATE DELIVERY

## ABBOTT TRANS-CEIVER TR 4B New Model



144-148 Megacycles **\$50.46** not

Kit of tubes—  
HY 75-955-6V6-7F7 **\$6.96** not

### Famous QUAM NICHOLS REPLACEMENT SPEAKERS AVAILABLE NOW

- 4" PM \$2.25
- 5" PM \$2.34
- 6" PM \$3.66
- 5" 450-ohm \$2.31
- 4" 450-ohm \$2.16
- 4x6" oval \$2.52
- 6" 1000-ohm \$2.70

ALL QUAM NICHOLS SP'K'RS HAVE EXCLUSIVE ADJUST-A-CONE FEATURE.

### U.S. SIGNAL CORPS SURPLUS 3" P. M.

- NYLON-ACETATE BLAST PROOF CONE
- SPKR WEIGHS 1 LB.—HEAVY
- ALNICO MAGNET
- EXCELLENT TWEETER
- INTER-COMM. SETS
- RADIO REPLACEMENT
- EXCELLENT FOR PORTABLES
- 3 OHM V.C.

#### A Milo Special at \$1.98

Have complete stock ON HAND of Aerovox, SIMPSON, Hammarlund, I.R.C., B&W, Utah, Premax and other nationally known parts and equipment.  
If not rated, 20% with order, balance C.O.D.

# MILO

Dept. N

Radio and Electronics Corp.

200 Greenwich St., N. Y. 7, N. Y.  
BEekman 3-2980-1

Export Div.—WESTERN INTERNATIONAL  
168 Washington St., N. Y. 6, N. Y.

## Facsimile for the Home (Continued from page 49)

simile program material of popular appeal, the larger the sale of paper and the more often the customer will return to the store for refills. The paper is manufactured with a moderately high moisture content, packaged in moisture-proof cans and loaded into the home recorder in a humidior, obviating any moistening process in home or store.

There are no rapid reciprocating mechanical motions in the facsimile mechanism. The only operation necessary on the part of the user, after he had loaded his recorder, is to adjust the volume control. Finished copy unrolls to be read at the reader's convenience.

Copy is produced by tapping into the output of the FM discriminator, feeding it through a recorder amplifier to the recorder unit. The recorder amplifier not only does the conventional job of building up the signal to values necessary to mark the paper electrolytically but furnishes pure d.c. for marking the paper. It also controls framing and synchronization in the recorder.

The recorder resembles a type-writer mechanism, having feed rollers and a printer-bar. Paper passes from the storage humidior under the printer-bar and over a drum on which a wire is wound in helical form to complete the circuit from printer-bar—through the paper to the helix wire.

Both drum and helix rotate at the relatively slow speed of 360 r.p.m., the effect of the helix being a lateral contact across the paper, line by line. The degree of blackness produced electrolytically, at any moment, is proportionate to the current passing through the paper, and this in turn, is controlled by the received radio signal. After the mark is made at the helix bar, the paper moves up another 1/105 of an inch to mark the next line. It then passes over a miniature heating unit and ironing unit which drive out all moisture, and thus the paper issues clear and crisp.

The printer-bar furnishes some of the ingredients to the electrolytic process which marks the paper. It must therefore be renewed, after every two or three rolls of paper are used. But this is so easily done that service attention is unlikely. The printer-bar is a thin blade of iron 8 inches long, corresponding to the length of each printing line, and is of negligible cost. Aside from lubrication, tube replacement and occasional cleaning there is substantially no service attention required by the home recorder.

Broadcasting of facsimile newspapers and printed matter in association with AM and FM sound programs may be started in about a dozen leading cities of the country sometime next year. If it catches on, servicemen will

## RADIO CHASSIS PUNCH

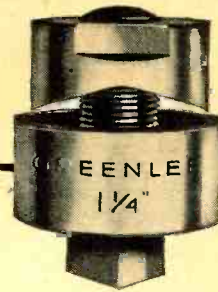

Saves hours of work cutting clean, accurate holes in radio chassis—for connectors and other receptacles. Simply insert cap screw in hole to be enlarged (drill small hole if necessary), turn with ordinary wrench to force punch through the metal. No reaming or filing—hole is smooth and clean. No distortion—die supports metal. Ten sizes from 3/4" to 2 1/4"; also up to 3 1/2" for meters. Write for free catalog 33E to Greenlee Tool Co., 1891 Columbia Ave., Rockford, Ill.

REGISTERED TOOLS  
**GREENLEE**  
FOR THE CRAFTSMAN

## "THE HOUSE OF A MILLION RADIO PARTS and TUBES"

... for the Amateur, SWL, Service and Sound Man

- Vomax Model #900 V.T.V.M. and Visual Signal Tracer.....\$59.85
- Weston #665 Type #1 Volt-OHM-Milliammeter Analyzer..... 58.50
- Superior P.B. 100 Volt-OHM-Milliammeter 6 D.C. Volt, 5 A.C. Volt, 3 D.C. Current, 3 Resistance, 5 Output Meter, 3 Decibel Ranges..... 28.40
- F. #1 Feiler Signal Tracer..... 9.85
- M. #450 Superior Tube Tester..... 39.50
- 0 to 1 Standing Wave Meter, has a 0-1 ma. movement used for field strength and feeder checking. 3 1/2"..... 4.95
- G. E. 3 1/2" O-V-M Foundation Meter (Make your own Testing Meter)..... 6.95
- 0-1 R. F. Meter 2 1/2" G. E..... 4.95
- 0-300 ma. or 0-500 ma. 3 1/2" Meters Sq. 3.95
- 100 Watt Output Transformer for two 6L6 in P. P. Taped Sec. for V. C. and Lines. Shielded upright mounting.... 3.95
- 600 Volts C.T. 100 ma. 6.3 V. amps. 5V. 2 amps. Power Transformer, upright shielded..... 3.95
- Crosley #1014—10-tube Power Transformer..... 2.95
- Servicemen's Kits of Resistances, Condensers, Filter Knobs, Speaker Cones, Wire, Tubes.

#### Special: RME #45 Radio Receiver

We have one of the largest parts and tube stocks in the country, all for immediate shipment.

Send your QSL or SWL card to W-8-E-S-N, Lee R. Kemberling, Sales Manager, for the latest HAM BARGAIN BULLETIN.

*Lifetime*  
**SOUND EQUIP. CO., Dept. 52**  
911-913 JEFFERSON AVE., TOLEDO 2, OHIO





"Imitation" is the sincerest form of flattery—so, being human, we're "flattered" that our "out front" T-LINE is the most copies-of-all transformer housings! Competitors were quick to see the superiority of T-LINE over the "horse and buggy," unpotted open-type transformers—and adopt this improved design principle.

More power to them! But, meanwhile Kenyon Designers are still ahead with these—

### KENYON T-LINE ADVANTAGES

- UNIVERSAL MOUNTINGS—die-punched in a single, simultaneous operation, so that they ALWAYS REMAIN EXACT!
- Electrically and Mechanically FOOL-PROOF LUGS—DEPENDABLE under EVERY CLIMATIC CONDITION!
- UNIFORMITY and BEAUTY of APPEARANCE assured in finely designed ONE STYLE CASE in durable, black dull satin finish enamel!
- PROVED-THROUGH-SERVICE EXCELLENCE of electrical and mechanical design that today is being produced from AVAILABLE MATERIALS at LOW COST!

### TRANSFORMER TROUBLE? CONSULT KENYON!

You are cordially invited to present your transformer problems to Kenyon Engineers. Pioneers in transformer development and design, we SPECIALIZE in "SPECIAL UNITS" for the electronics field and other commercial and industrial users. Our seasoned advice is, of course, yours—entirely without obligation.

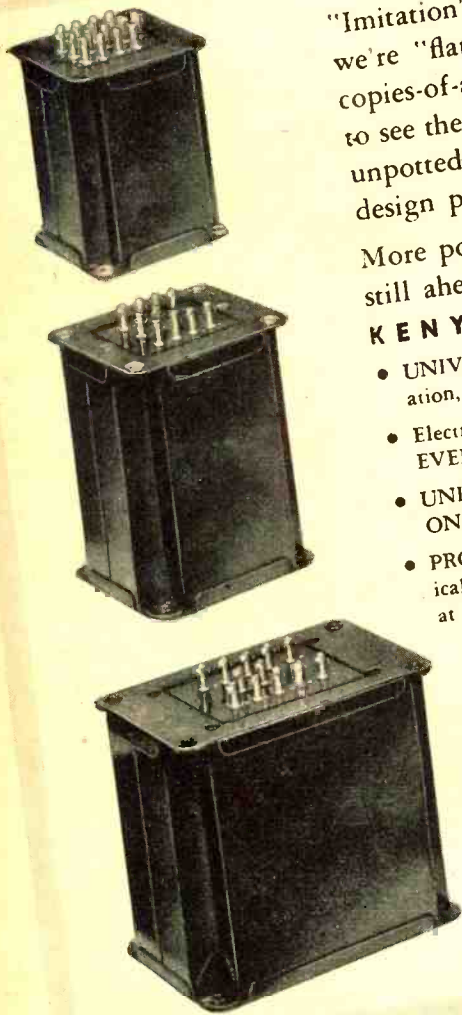

# KENYON TRANSFORMER CO., Inc.

840 BARRY STREET  
NEW YORK, U. S. A.

have to become familiar with the home recorders and be ready to service them.

Some thought has been given to how extensive this training need be. But if printed matter will not convey the necessary information to the trade, prospective manufacturers stand ready to provide for training servicemen at their plants. Whether this will be necessary is not clear as yet but it will be before quantity production receivers are available because a considerable period of experimental programming will precede presentation of any general facsimile broadcasting service. During this period, a quantity of pre-production recorders will be in the hands of typical home users to gain experience in programming and service problems.

Though the accent primarily has fallen on commercial home facsimile, an interest is being awakened in the amateur who also can get printed matter and pictures into his home by radio facsimile.

For producing a picture of about 105 line screen on a 360 r.p.m. drum, the bandwidth is about 6000 cycles. This is somewhat too much for a typical "ham" radio-telephone transmitter. But it would be no trick at all to make a special ham-type home recorder which operates at half speed, by switching the two-pole synchronous motor to four-pole operation. This would cut down copy speed to 14 square inches per minute but it would

still have plenty of speed. Using a standard typewriter with solid single space copy, it would deliver 115 words a minute, which still is moving it along.

Since amateur operators are interested in long distance communications, synchronization through power systems would be impractical, but satisfactory automatic synchronization systems are available which overcome this difficulty. They depend upon the use of pulses, transmitted between scanning lines, to govern the receiver-motor speed.

Nobody can tell when amateur facsimile will be available because, at present, attention is being focused on the BCL field. But one or two familiar makers catering to the amateur field are studying the production problem with a view to making a low-cost amateur-BCL machine and slow-speed narrow band scanner for amateur transmission.

Transmitting scanners and demonstration recorders made by the *General Electric Company* will be available to FM broadcasting stations early in 1947, and quantity production home recorders may appear late in the year. Since such things as fancy hardwood cabinets do not confuse production for the amateur market, it is more than likely that essential components or complete recorders and scanners for amateurs will be available before the public has a chance to buy facsimile recorders in quantity.

## What's New in Radio

(Continued from page 68)

ception of distant or weak stations.

The EC-113 covers three bands, 535 to 1625 kc., 2200 to 7100 kc. and 6900 to 22,000 kc.

*Hallicrafters Company*, 2611 South Indiana Avenue, Chicago, Illinois will supply additional information about their home receiver line upon request.

### POCKET TESTER

*Robson-Burgess Manufacturing Company* of Omaha, Nebraska, has recently introduced a pocket size unit which indicates shorts, leakage,



grounds and voltage for routine testing and repair work.

Known as the Meg-Lite, this unit operates on 115 volts, a.c. or d.c. Leakage resistance to 200 megohms can be checked and voltages from 90 to 500 volts, a.c. or d.c. can be indicated. The

-30-

# AMAZING RADIO OPERATES FREE

Positively needs no house current, no batteries. Has no tubes. Remarkably, requires no ground connection and no lengthy old-fashioned aerial. HAS SPECIALLY DESIGNED, RADIO IMPULSE RECEPTOR, 6½ ft. sq. Receives local standard broadcasting stations. (Exciting long distance reception at night.) Radio gives headphone operation for personal use. Has excellent tone; adequate volume, sensitivity and power of selectivity. Exceedingly simple to operate. Can be built even by teen-age youngsters using wire and only a few ordinary, readily obtainable, reasonably priced, new or used parts. This practical radio sensation may well develop into an "ATOMIC BOMB HIT" amongst hobbyists, young and old. Be the first in your neighborhood to build and enjoy this thrilling radio. For all necessary plans and illustrations send \$1 to PAUL SEMAN, Dept. 3, 1522 Fred St., Whiting, Indiana.

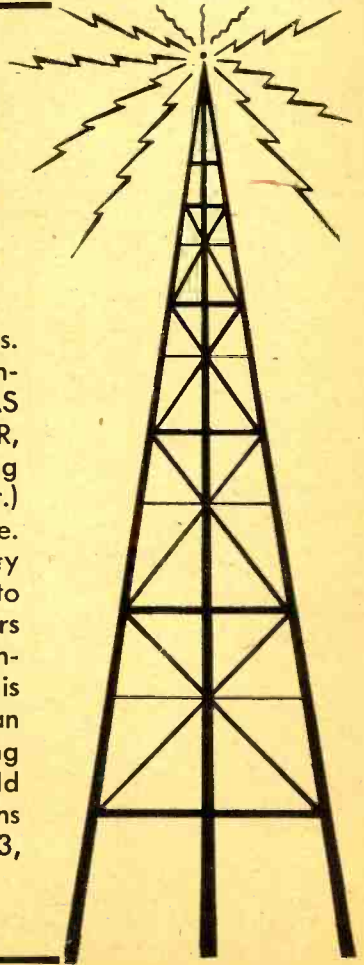
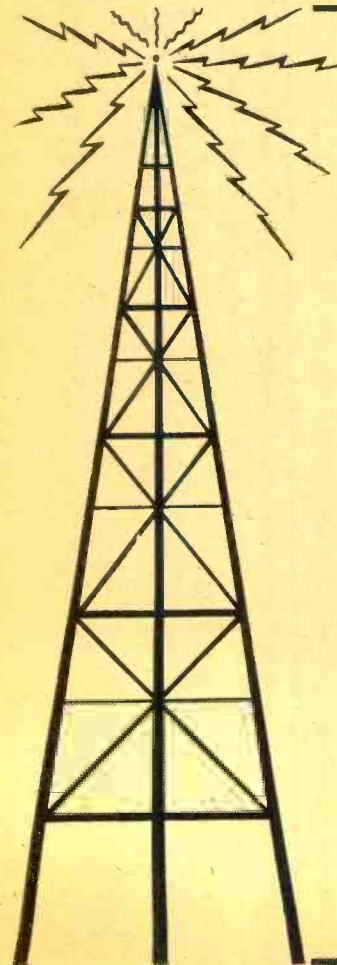



$CQ (bsmc) + ed + \frac{73c}{7s(8at)} + 4(ii) = (Tfp + eoi)(iyUHFe) *$



\* CENTRALAB Quality button silver mica capacitors + early delivery + 73 combinations made up of 7 styles with 8 available terminals + 4 individual inspections (capacitance, power factor, voltage breakdown and leakage resistance) = Trouble free performance and ease of installation in your Ultra High Frequency equipment.

Send for Bulletin 586

# Centralab

Division of GLOBE-UNION INC., Milwaukee

PRODUCERS OF



# Portable A.C. Ammeter

Surplus New  
Weston Model 528



Dual Range 0-3 Amp. and 0-15 Amp. full scale for use on any frequency from 25 to 500 cycles. The ideal instrument for all commercial, industrial, experimental, home, radio, motor and general repair shop testing. Comes complete with a genuine leather, plush-lined carrying case and a pair of test leads. A very convenient pocket sized test meter priced at less than 50% of manufacturers list.

YOUR COST **Only \$12.50**

## PANEL METERS

- Gruen, 2 1/2" 0-100 microampere movement, Black Dial Dual Scale marked from -8 to +6 D.B. and 0 to 100 microamperes @ \$3.50
- W.E., 3 1/2" 100-0-100 microampere, concentric style @ \$4.00
- W. E., 3 1/2" 0-200 microampere, concentric style @ \$4.00
- Marion, 3 1/2" 0-200 microampere, 68 ohms resistance @ \$4.95
- W. H., NX-33, 2 1/2" 0-1 M.A. mvt., Special black scale, 10 division scale, 0-200 @ \$3.00
- G. E., DW-41, 2 1/2" 0-1 M.A. mvt., Special white scale, marked 0-140 D.C. volts M.A. and 0-500 D.C. M.A. @ \$3.50
- W.H., RX-35, 3 1/2" Square case, Dual range 0-30 and 0-300 M.A. D.C. @ \$4.50
- G.E., DW-41, 2 1/2" 0-15 volt D.C. Black scale, No caption @ \$2.50
- Weston, 517, 2 1/2" 0-300 volts A.C. @ \$7.00
- Weston, 301, 3 1/2" Power Level Indicator, 625 microampere 1.2 volt A.C. mvt., self-contained rectifier, blank scale @ \$6.00
- G.E., DO-46, 3 1/2" 400 microamp, 3 volt A.C. movement, self-contained rectifier, Spec. scale @ \$5.50

### SURPLUS NEW GUARANTEED

All meters are in round bakelite cases, flush mounted, white scale unless specified otherwise.

Write for complete listings. Please add sufficient postage. Excess will be refunded.

## MARITIME SWITCHBOARD

336 Canal St., New York 13, New York

Worth 4-8217

unit can be switched to either high or low sensitivity as required for the particular circuit to be tested.

Prices and deliveries on this pocket Meg-Lite will be furnished by Robson-Burgess Manufacturing Company, Omaha, Nebraska.

### EXPORT TABLE MODELS

Two new table model receivers, designed for the export market, are currently in production at the Chicago plant of Stewart-Warner Corporation.



The Model 9013-A has three bands covering from 13 to 550 meters. This superheterodyne has selective manual tuning and a 6 inch PM dynamic speaker. The circuit features ten tuned circuits for all bands and four watts power output. Designed for a.c. operation, it has five tubes and rectifier; power transformer of 50-60 cycles with taps at 110, 125, 150, 200, 225 and 245 volts; plug-in for phonograph; external antenna connection, and completely impregnated components to withstand tropical operating conditions.

The Model 9017-A (illustrated) is housed in a dark walnut-finished plastic cabinet. This receiver is a popularly priced a.c.-d.c., three-band superheterodyne with five inch speaker and five tubes and a rectifier. It is de-

## SECURE DIAL CORD KNOT

RADIO dial cords of the type illustrated have a habit of becoming loose at the knots where the cord is attached to the spring or to the hook on the dial drum.

The application of cement of the kind used for radio speakers will keep these knots in place for a much longer time. . . . . H.L.

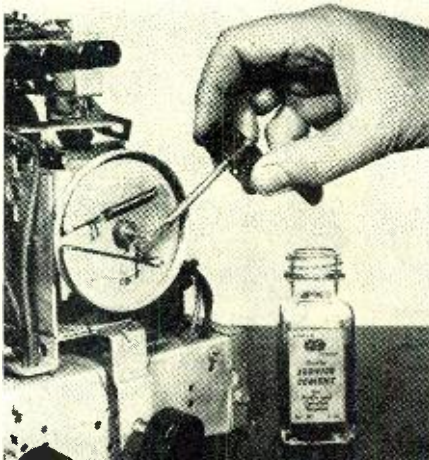

## "SINGER" TUNER!

Makes any amplifier into a 5 or 6 tube superhet radio



Completely wired and ready to operate  
**\$7.95**  
(Less Tubes)

Uses 12SA7-12SQ7-12SK7

## "SINGER" PHONO AMPLIFIER!

3 tube AC-DC—completely wired and ready to operate

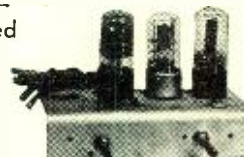

**\$2.95**  
(Less Tubes)

Uses 50L6-35Z5-12SQ7

## "SINGER" RECORD PLAYER!

INCLUDES:

- 3 tube amplifier, 5" speaker
- Tone control, fine motor
- Crystal pickup, handsome cabinet

**\$19.95**  
(Less Tubes)

Completely wired and ready to operate

### Immediate Delivery!

25% Deposit Required With Order

N. J. INDUSTRIAL CO.

11 Hill Street Newark 2, N. J.

## SCENIC . . . has "hard-to-get" TEST INSTRUMENTS



McMurdo-Silver  
"VOMAX"  
Vacuum-Tube Volt-Meter and Electronic Multimeter  
Thousands Sold!  
Only \$39.85 Net



McMurdo-Silver  
Model 904  
CAPACITANCE-RESISTANCE BRIDGE  
Measures resistance, capacitance under actual operating conditions  
Net Price \$49.90

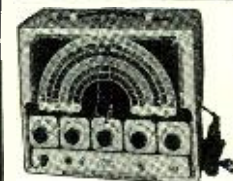

APPROVED  
Model A-200  
SIGNAL GENERATOR  
● 8 R.F. BANDS  
100 Kc.-250 Kc.,  
190 Kc.-500 Kc.,  
420 Kc.-1000 Kc.,  
1000 Kc.-3000 Kc.,  
3 Mc.-9 Mc., 9 Mc.-25 Mc., 18 Mc.-50., 27 Mc.-75 Mc.,  
Net Price \$49.50

OTHER INSTRUMENTS IN STOCK  
DUMONT 274 - 5" oscilloscope.....\$99.50  
SIMPSON 260 volt-ohm-milliammeter 38.95  
SIMPSON 240 "Hammer" ..... 26.50  
TRIPLETT 2413 tube tester ..... 49.50  
TRIPLETT 625-N volt-ohm-milliammeter ..... 45.00  
TRIPLETT 2432 signal generator ..... 88.50  
RADIO CITY 802-N tube and set tester 59.50  
WATERMAN 2" oscilloscope ..... 55.00  
MASCO 17 W. amplifier with tubes.... 30.49  
MASCO 17 W. amplifier and phono top 41.42  
MASCO 35 W. amplifier and changer top 88.85

—Send for New Catalog—  
C.O.D. orders should be accompanied by 25% deposit.  
SCENIC RADIO & ELECTRONICS CO.  
53 Park Pl. Dept. N., New York City 7



**WHATEVER YOU NEED IN RADIO OR ELECTRONICS**

**PARTS...SETS...KITS  
TESTING EQUIPMENT...TOOLS  
PUBLIC ADDRESS EQUIPMENT  
TRANSMITTERS**

**YOU CAN GET IT AT NEWARK!**



**SERVICEMEN**

Three big stores, each carrying tremendous stocks, are ready to serve you with tools, replacement parts, test equipment, sets or anything else you need. Wire, write or telephone if you can't visit one of our stores. If you can visit with us you'll find our trained staff of tremendous help to you.

**SERVICE**

Mail orders are shipped the same day they are received. You don't have to wait when you buy from Newark. On special inquiries, we give you full information, prices and delivery dates promptly. Newark will give you service that will help you serve your customers better.



**PUBLIC ADDRESS SYSTEMS FOR EVERY NEED AND PURPOSE**

No matter what your public address needs may be, Newark has the outfit that will do the job for you. All the well known, standard makes are carried in stock. Delivery is fast and dependable . . . in New York and Chicago we maintain our own delivery system . . . for out-of-town customers we ship orders the same day they are received.

All our stores are staffed by trained men who know public address needs and can help you select the outfit that will best serve your purpose. If your needs are unusual, they know how to make up special combinations to satisfy them efficiently.

If you can, visit one of our stores. If you can't come to see us, write, phone or telegraph and your inquiry will be answered promptly and fully. Newark has the stock, Newark has the 'know how', Newark can help you.



**BUILD YOUR OWN RADIO AND ELECTRONICS DEVICES AT LOW COST**

With Newark's kits and parts you can easily build radio receivers, transmitters, amplifiers, and other exciting radio and electronics devices.

• • •  
Make a good radio receiver for yourself or a fine record player with automatic changer at tremendous savings. You can construct these and many other radio and electronics devices easily. Our men know how to make them and will gladly show you if you can visit one of our stores—or will explain clearly by mail.

**FOR GOOD BUYS AND A GOOD TIME VISIT OUR BIG BARGAIN COUNTERS**

These big bargain counters in all our stores, are loaded down with special items available in quantities too small to advertise. Marvelous war-time sets, new small gadgets you can have fun with . . . all sorts of new parts and special things you'll want to see. Come in, look around and ask all the questions you wish. Come in often you'll have a wonderful time.

**WRITE FOR OUR BIG BARGAIN BULLETIN LISTING THE LATEST AVAILABLE EQUIPMENT**

Magazines are printed months before you read them, stocks change, new things are developed and made, so we give you the very latest news about the very newest things in radio and electronics in our Big Bargain Bulletin. Send for your copy today and know all about the latest equipment first. When writing address Dept. G1.

**NEW YORK**  
242 50 W. 55th St.  
New York 19, N. Y.

**NEWARK**

**CHICAGO**  
323 W. Madison St.  
Chicago 6, Ill.

**ELECTRIC COMPANY, INC.**

New York City Branches: 115-17 W. 45th St. & 212 Fulton St.

# Let us solve your Audio problem

We Are Fully Equipped to Design and Build Your Amplifier Requirements.  
**MANUFACTURERS — JOBBERS — SCHOOLS — INSTITUTIONS**

WRITE FOR DETAILS

Unit Price

**\$695**

Complete with tubes



Model 35

3 tubes AC-DC, uses 12SQ7, 50L6, 35Z5.  
 Tone and volume control with line cord.  
 Available for dynamic or PM speaker.

## PHONO AMPLIFIERS

Immediate Delivery

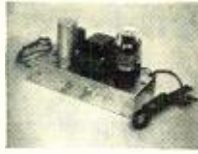

Model 80

3 tubes AC only, 4 watts output uses 6J5, 6V6, 80 tubes. Tone and volume controls.  
 Uses PM speaker. Supplied with line cord.

Unit Price

**\$1050**

Complete with tubes

Send Deposit with Order—Quantity Prices on Request  
 Write to Dept. N

## SOUND PRODUCTS COMPANY

80 Main Street

WHITE PLAINS, N. Y.



### THE NEW KP-81 COMMUNICATION RECEIVER

A real, post war receiver, planned and developed during and since the war, by Karl Pierson, one of the country's leading receiver designers. The KP-81 embodies many new circuit features never before used in a receiver generally available to the amateur. We sincerely urge those who desire the finest in receiver performance to write for descriptive literature. Or send your order for immediate delivery. Be the first in your area to own this fine receiver.

**KP-81 complete with tubes and speaker \$318.00**

— Also Available for Immediate Delivery —

HAMMARLUND Super-Pro	• •	\$340.00
HAMMARLUND HQ-129-X	• •	\$173.25
RME 45	• •	\$198.70
GON-SETT 10-11 meter converter	• •	\$39.95
PANADAPTER PCA-2T200	• •	\$99.50

Write for catalog sheet on other specials. We carry one of the largest radio parts stocks on the West Coast.

We invite your inquiries

**973-WEST BASE LINE, San Bernardino, Cal.**



signed for 117 volt operation on 50 or 60 cycles, and external adapters are provided for operation on high voltages if desired.

Details of both of these receivers will be furnished by *Stewart-Warner Corporation*, Chicago, Illinois, upon request.

### G.E. COMBINATION RADIOS

*General Electric Company* has recently previewed their line of Musaphonic home radios which feature several innovations.

The new line makes use of the *G.E.* tuning system which features the use



of silver-plated variable inductances. According to the company, this system surpasses the efficiency of gang condensers and is highly effective in the new high FM frequencies and short-wave bands.

Other improvements include a completely redesigned audio system, a single tuning indicator for both AM and FM reception, a "fool-proof" tone arm on the record player and the company's exclusive electronic reproducer.

Shown is the Model 43 of the line. This console radio-phonograph combination is available in knotty pine cabinet of contemporary design.

Details of the line will be furnished by *General Electric Company*, Electronics Department, Syracuse, New York.

### LINE VOLTAGE CONTROL

The Type V-10 Variac, designed to meet requirements for variable line voltages in various servicing applications, experimentation work and labo-



ratory testing, has been announced by *General Radio Company* of Cambridge, Massachusetts.

Their new 115-volt models are rated at 10 amperes, with a 15 ampere maximum which coincides with the capacity

## "ELECTRO-EYE" CONTROL



In Home, Office and Factory  
**THIS** type AC-1 photoelectric unit consists of 2-stage amplifier and sensitivity control. Comes in a handsome metal cabinet. Complete with tubes and instructions . . .

**\$1143**  
 Net

LIGHT SOURCE  
 Operates AC-1 "ELECTRO-EYE" at distances over 30 ft. Fixed-focus optical system . . . for 115 v. A.C. or D.C. (20% deposits on all C.O.D. orders)

**\$327**  
 Net

**RADIO DEVELOPMENT LABS**  
 362-R Atlantic Avenue BROOKLYN 2, N. Y.  
 (Dealers Write for Quantity Discounts)

## TELEVISION COMPONENTS

**MAGNETIC DEFLECTION YOKES:—**  
 No. DY-1S. For deflection angles up to 55° as required by such tubes as type 9JP1, 7CP1, 10BP4, 10EP4, etc. 2 1/4" long . . . \$14.75  
 No. DY-2L. For deflection angles up to 40° as required by such tubes as type 9AP4, 12AP4, 5TP4, etc. 3 1/4" long. \$15.75  
**Blocking Oscillator Transformers:—**  
 No. OT-101H. For 15,750 cycle horizontal oscillators . . . \$1.75  
 No. OT-102V. For 60 cycle vertical oscillators . . . \$1.75  
 Immediately available. Order direct or through your jobber.  
 Quantity inquiries invited for above type Deflection Yokes or for other types built to specifications.

**THE ELECTRON COMPANY**  
 1988 East 59th St. Cleveland 3, Ohio

# 3 Standards OF ELECTRONIC QUALITY

## THORDARSON TRANSFORMERS

A quality line...backed by 51 years of outstanding transformer manufacture. Designed for every electronic requirement, these new Thordarsons make difficult installations easy and are your assurance of top-notch performance under all conditions. Ask for them today.

## RADIART VIBRATORS

Radiart Vibrators are sealed against air and moisture, effectively preventing point oxidation and guaranteeing effective operation under conditions too tough for ordinary units. Specify Radiart today. Look for the Red Seal... your guarantee of vibrator excellence.

## MEISSNER ANALYST

The most modern and complete service instrument yet available. Tests receivers and locates faults by the signal tracing method, fastest and most reliable method to date. All controls accurately calibrated with functions clearly indicated.

Thordarson-Meissner-Radiart products listed and recommended in Photo-Fact Folders.

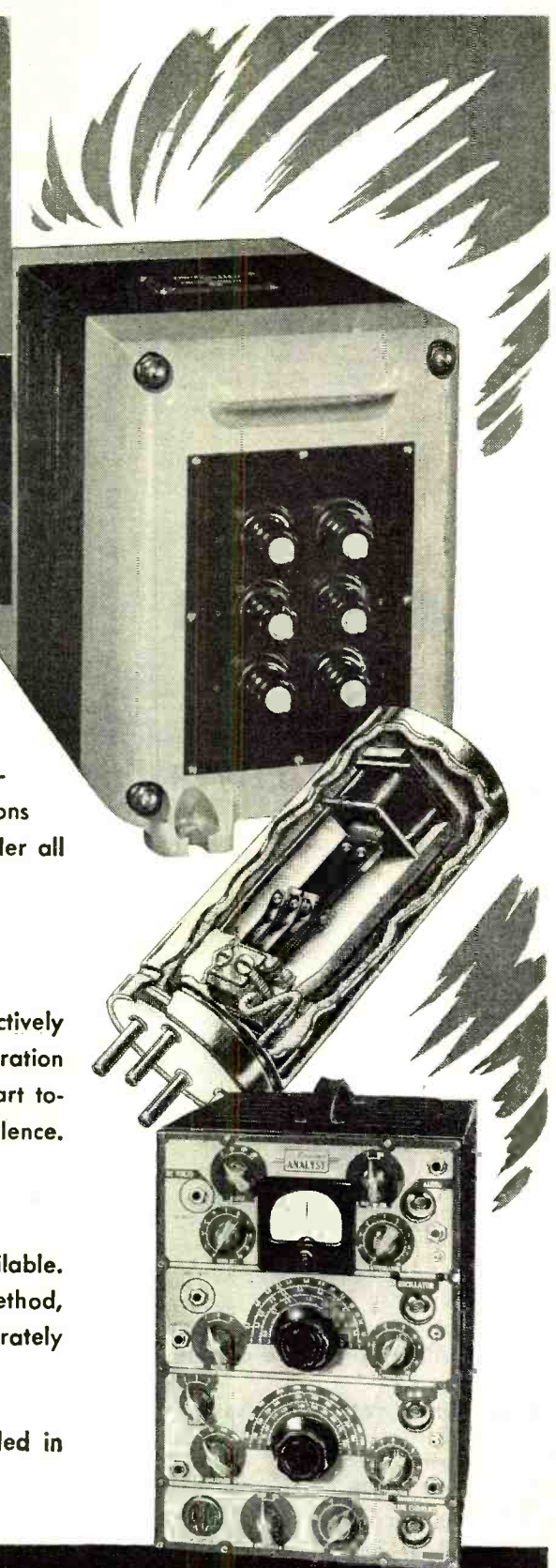

ELECTRONIC DISTRIBUTOR AND INDUSTRIAL SALES DEPARTMENT

# MAGUIRE INDUSTRIES, INCORPORATED

936 N. MICHIGAN AVENUE · CHICAGO 11, ILLINOIS

# TRANSVISION

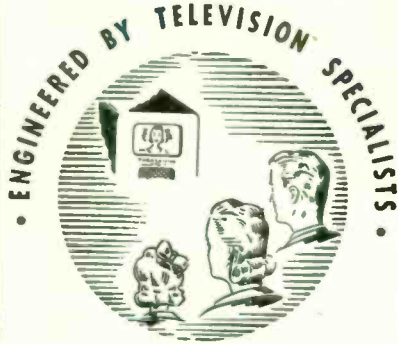

## THIS NEW TELEVISION KIT

Offers you a High Quality  
TELEVISION RECEIVER

ready for Easy,  
Rapid Assembly



*Easy-to-Assemble: No knowledge of television required. COMPLETE easy-to-follow INSTRUCTION SHEET gives you all the knowledge you need.*

This Kit INCLUDES SOUND, all component parts, and the following:—

1. Specially designed Television Antenna.
2. A \$30.00 Lectrovision seven-inch Picture Tube . . . plus ALL other tubes.
3. Pre-tuned R-F unit.
4. Finished front panel.
5. All solder and wire . . . and sixty feet of low loss lead-in cable.

Price: complete with ALL tubes, \$139.50. Shipment will be made approximately 10 weeks after receipt of order. \$25.00 deposit required on all orders, balance C.O.D.

We believe that the comparative quality of this set is superior to other available sets. For full information write to:

**TRANSVISION, INC.**

P.O. Box No. 364, New Rochelle, N. Y.

of commonly used outlets, plugs, cords, etc.

The output voltage of these new Variacs is continuously variable from zero to 17% above line voltages. The line is available in 6 models, 115 volt and 230 volt service.

Additional information will be forwarded by *General Radio Company*, 275 Massachusetts Avenue, Cambridge 39, Massachusetts, to those requesting it.

### MINIATURE RADIOHM

*Centralab* is currently in production on a new Model 1 Radiohm specifically designed as a volume attenuator for hearing aids, pocket radio receivers and miniature amplifiers.

This new type unit will be available in 500 ohms to 5 megohms in six dif-

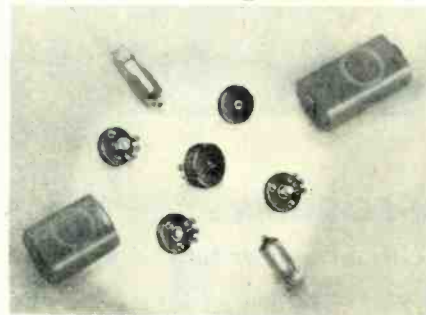

ferent tapers. Features of this new Radiohm include, dust shield to keep out foreign matter, three optional mounting locations, optional cam for external switch operation, separate assembly knob, twin resistor contact, terminals insulated and independent of mounting, and tolerance  $\pm 20\%$  standard for all values and curves.

Photos, construction drawings and

additional information are included in a temporary bulletin, Form No. 394, which is available from *Centralab*, 900 East Keefe Avenue, Milwaukee 1, Wisconsin.

### MULTIWIRE CONNECTORS

*Alden Products Company* has recently added a new series of multiwire connectors to its line of electrical components.

These connectors provide that the two elements of each combination lock together by means of a generous sized knurled locking ring that engages slots in the opposite member. When the connector is locked, a rubber gasket exerts reverse pressure on the ring to make the assembly vibration proof, at the same time sealing out moisture from the prongs.

The shielding on the cable is brought inside the metal shell and its pigtail (or wire soldered to the shield) is brought back through a hole in the shell and soldered, thus providing strain relief.

Additional details and a technical data sheet on this line of connectors will be furnished by *Alden Products Company*, 117 North Main Street, Brockton 64, Massachusetts.

### RECTIFIER PLATES

The *Seletron Division* of the *Radio Receptor Company* has recently introduced their new 5" x 5 3/4" selenium rectifier plates built on aluminum to the trade.

Developed specifically for high current capacity and especially applicable for electroplating and battery charging, although not limited to this use,

The first FM transmitter to be shipped by the Federal Telephone and Radio Corporation of Newark, New Jersey, is crated for delivery by special truck to radio station KOWH, Omaha, Nebraska, the Omaha World-Herald station. This 1 kw. equipment will use a new FM square-loop antenna, a Federal development. The transmitting station is a house which was purchased and moved to the proper location.

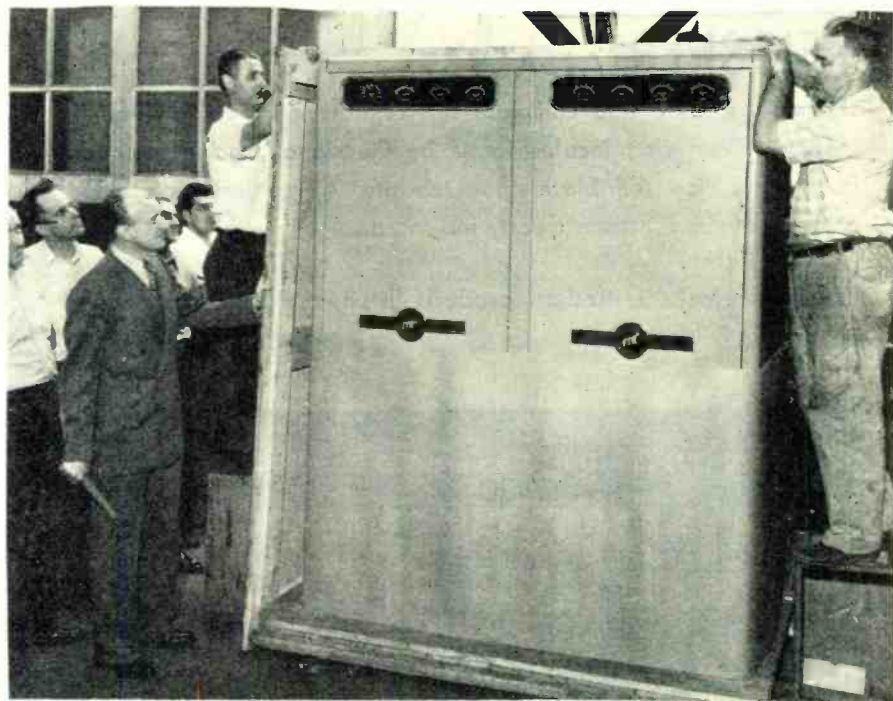



# LIBERTY — First in Radio Values

## 6-Tube "Super Het" Radio Kit

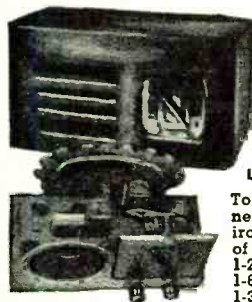

Complete including attractive Walnut cabinet. Pictorial diagram furnished. All parts mounted.

**YOUR COST \$1495**

Less Tubes, Wire, Solder

To assemble all one needs is a soldering iron and 30 minutes of your time. Uses 1-25L6 1-25Z6 1-6SQ7 1-6SK7 2-6SJ7 or 1-50L6 1-35Z5 2-12SJ7 1-12SK7

## 5-Tube "Super Het" Radio Kit



Complete including attractive Brown Bakelite cabinet. Pictorial diagram furnished. All parts mounted. App. size 9 x 5 x 6 inches. Uses one 25L6—one 25Z6—one 6SA1—one 6SQ7—one 6SK7 or one 1-50L6 1-35Z5 1-12SA7 1-12SQ7 1-12SK7

**YOUR COST \$1295**

Less Tubes, Wire, Solder

## Portable Phonograph Kit



Attractive Leather Covered cabinet. Complete with motor, pick-up, amplifier. Size 14x7 1/2 x 19 inches. Uses one 25L6—one 25Z6—one 6C5. Tone and volume controls.

**YOUR COST \$2395** Less Tubes, Wire, Solder

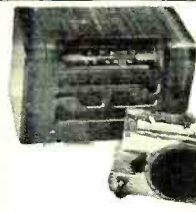

## IMMEDIATE DELIVERY Special 5-Tube "Super Het" Kit with SLIDE RULE DIAL

Plated chassis. Beautiful Walnut Cabinet. Built-in antenna. Dimensions 6 5/8 x 7 7/8 x 12 3/4 in. Uses one 12SA7—one 12SK7—one 12SQ7—one 50L6—one 35Z5. Pictorial diagram furnished.

**YOUR COST \$1995**

Less Tubes, Wire, Solder

## RADIO LINE FILTER



This radio line filter is designed to steady a choppy or rippling line—and to filter out power line noises, fluorescent light noises, elevator noises, RF noises, etc., which are super-imposed on the line by passing them into the ground.

**YOUR COST \$595**

## ATTENTION!!

### RADIO AMATEURS OIL FILLED CAPACITORS



Standard Brands Shipping wt. 1 lb. Impregnated Porcelain high tension terminals.

**YOUR COST**

2 mfd.—1000 V.	.....	\$1.60
4 mfd.—1000 V.	.....	2.20
4 mfd.—1500 V.	.....	2.80
8 mfd.—1000 V.	.....	2.80
2 mfd.—1500 V.	.....	2.20

## X-MITTING MICAS



.00075 — 600V	....	12c		
.0005 — 600V	....	12c		
.0001 — 600V	....	12c		
.00025 — 600V	....	12c	.04 — 600V	....
.02 — 600V	....	15c	.003 — 600V	....
.022 — 600V	....	15c	.001 — 1000V	....
.027 — 600V	....	15c	.01 — 1000V	....

## BRANDS

.02 — 1000V	....	20c
.01 — 1250V	....	20c
.002 — 1200C	....	20c
.0004 — 2500V	....	25c
.0051 — 2500V	....	25c
.005 — 2500V	....	25c
.0035 — 2500V	....	25c

## Record Changer

complete with motor and pick-up. Fully Guaranteed.

List \$37.50 **YOUR COST \$1950**

## VOLUME CONTROLS

	<b>YOUR COST</b>
No Switch	40M ohm 25c each
1000 ohm	50M ohm
5000 ohm	100M ohm
10M ohm	200M ohm
50 ohm	20M ohm 750M ohm
100 ohm	1 meg 800M ohm
700 ohm	25M ohm 2 meg
Duals Your Cost, 35c ea.	
100 M—100 M ohm	100 M—15 ohm

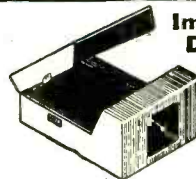

## Immediate Delivery

your cost **\$775**

Portable leatherette

Cabinet for Electronic Phonograph. Size 7x14 1/2 x 18 inches

## AN EXCEPTIONAL VALUE

3 tube A.C. D.C. Phono Amplifier Kit—less tubes, with speaker—uses 6C5—2 5 Z 6—2 5 L 6—



**YOUR COST \$495**

# LATEST MODELS SUPERIOR TEST EQUIPMENT

## The New Model 450 TUBE TESTER



Speedy operation assured by newly designed rotary selector switch which replaces the usual snap, toggle or lever action switches. Tests all tubes up to 117 volts including 4, 5, 6, 7, 7L Octals, Locals, Bantam, Junior, Peanut, Television, Magic Eye, Hearing Aid, Thyatrons, Single Ended, Floating Filament Mercury Vapor Rectifiers, etc. Also pilot lights. Tests shorts and leakage up to 3 Megohms in all tubes. Tests both plates in rectifiers. Tests individual sections such as diodes, triodes, pentodes, etc., in multi-purpose tubes. Uses a 4 1/2" square rugged meter. Works on 90 to 125 Volts 60 cycle A.C. Extra Service—The Model 450 may be used as an extremely sensitive condenser leakage checker. Housed in portable leatherette covered cabinet complete with all operating instructions. Net wt., 8 lbs.

**YOUR COST \$3950**

## The New Model 600 SET TESTER

A new combination tube tester and multi-meter. A complete testing laboratory all in one unit. Incorporates all the features of the Model 450 plus the following Multi-Meter Specifications: D.C. Volts (at 1,000 ohms per Volt) 0 to 7.5/15/75/150/750/1,500 Volts. A.C. Volts 0 to 15/30/150/300/1,500/3,000 V. D.C. Current 0 to 1.5/15/150 Ma. 0 to 1.5 Amp. Resistance 0 to 2,000/20,000/200,000 ohms 0 to 20 Meg-ohms. Decibels (based on 0 decibels equals .006 Watts into a 500 ohm line). —10 to +18DB, +10 to +38DB, +30 to +58DB Model 600 is housed in a beautiful hand rubbed cabinet complete with test leads, tube charts, and detailed operating instructions. Size 13"x12 1/2"x6".



**YOUR COST \$6250**

## The New Model 680—5000 OHMS per VOLT VOLT-OHM MILLIAMMETER



A single scale is used for all voltage (both A.C. and D.C.) and current ranges. Thus all readings are plain and obvious. Radio servicemen will be delighted with this time-saving innovation. Measures: D.C. VOLTAGES to 1500 volts; A.C. VOLTAGES to 1500 volts; RESISTANCE to 2 megohms; OUTPUT VOLTS to 1500 volts; D.C. CURRENT to 150 MA; DECIBELS to +58 D.C. Housed in hand-rubbed oak, portable cabinet. Complete with self-contained battery, test leads and instructions.

**Your Cost \$2765**

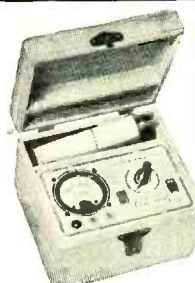

## Model CA-11 SIGNAL TRACER

\*Signal intensity readings indicated directly on meter.  
\*Only one connecting cable—No tuning controls.  
\*Highly sensitive—uses an improved vacuum tube volt-meter circuit.  
\*Tube and resistor-capacity network are built into the Detector Probe.  
\*Weights 5 lbs. Measures 5"x6"x7".  
\*Provision is made for insertion of phones.

**YOUR COST \$1875**

## The New Model 705 SIGNAL GENERATOR



**RANGES:** From 95 kc to 100 mc, continuously variable. Calibration accurate to 2% through broadcast bands, within 3% for high frequency bands. Planetary drive condenser, direct reading calibration, output modulated or unmodulated. Self-contained electronic modulation 400c sine wave available for external use. Special feature provided in having two degrees of modulation at both approx. 30% and 80%.

**YOUR COST \$4950**

**TERMS: 10% Deposit with Order—Balance C.O.D.—Minimum Order \$2.00**  
Catalog 1946-47 in preparation—Get your name on our mailing list NOW!!

# LIBERTY SALES CO., INC.

115 WEST BROADWAY  
NEW YORK 13, N. Y.  
BARclay 7-6063

these rectifier plates feature long life and minimum weight with maximum heat dissipating value when arranged in suitable combinations of series or parallel plates, according to the company.

Full details of the new selenium rec-

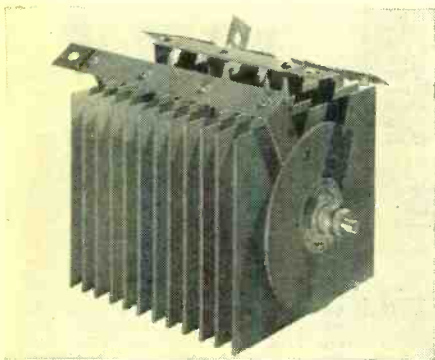

tifier plates will be furnished by the *Seletron Division of the Radio Receptor Company*, 251 West 19th Street, New York 11, New York.

### FATHOMETER

Of interest to small boat enthusiasts and servicemen who install and maintain marine equipment is the new, compact Fathometer which was recently announced by *Raytheon Manufacturing Company's Marine Division, Submarine Signal Company* of Boston, Massachusetts.

The entire system, consisting of a control unit, projectors and a vibrator power supply unit, can be quickly

and easily installed. The components of the control unit, i.e., signal generator, echo amplifier, indicator and driving mechanism, are mounted in a single spray-proof case about one foot square and four inches deep.

The unit gives accurate depth measurements within a range of 400 feet at a rate of 360 soundings per minute. These can be checked with the charts to identify underwater landmarks, and assist in determining position regardless of fog, darkness or weather conditions.

Additional data on this unit will be furnished by *Raytheon Manufacturing Company*, 60 East 42nd Street, New York 17, New York, upon request.

### PORTABLE COMBINATION RADIO

*Fada Radio and Electric Company, Inc.* are currently announcing their new Model 647 deluxe portable radio-phonograph combination with automatic record changer.

The unit is housed in a two-tone luggage type case with a genuine leather handle. The record changer is capable of handling both ten and twelve inch records with the cover closed.

The radio is a six-tube superheterodyne with untuned r.f. stage. Four controls regulate the operation of the unit, including tuning, tone, on-off volume control and phono-radio switch. A specially designed loop antenna eliminates the necessity for external connections to the radio. An illumina-



ated slide rule dial permits easy tuning.

Additional information on this model and other radios in the company's line will be furnished upon request to *Fada Radio and Electric Company, Inc.*, Long Island City, New York.

### TABLE MODEL COMBINATION

Production has recently been started on the new Model F-617 combination radio with automatic record changer, according to the announcement made by *Templetone Radio Mfg. Corp.* of New London, Conn.

The set is housed in a mahogany finish wood cabinet with a heavy solid wood front. Full view slide rule dial with a fluorescent plastic pointer and large numbers are features of this unit. The lid is mounted with a full-length piano type hinge and has a ratchet type adjustable self-support. The automatic record changer han-

...

Raytheon 866A filament transformer 115V 60c pri. 2.5Vct 11A Sec and Two new RCA 866A tubes... \$5.90  
With Millen caps and sockets... \$7.00  
Raytheon Transformer only... \$3.25

Transformer High Voltage new 115V-60 Cy. Sec 600V CT 240 MA 1540V no CT 380 MA \$4.95 Two for \$7.00

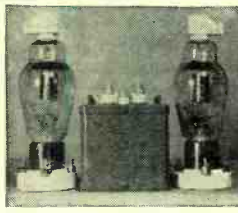

New W.E. Beachmaster Amplifier Navy parts... \$ 9.95  
W.E. Dynamic microphone D-1734B-A... \$ 3.95  
W.E. Dynamic microphone Cartridge... \$ 3.95  
W.E. Dynamic microphone Transformer Inpt... \$ 2.00  
W.E. 250watt Trumpet & Nine Drivers... \$125.00  
W.E. PP Inpt & PP Driver trans (2)... \$ 6.95  
W.E. 500 Headset with 8 ft. cord & plug... \$ 3.95  
W.E. Time delay relay 115V/5 amp cts 30 sec... \$ 1.49  
W.E. 16mf/400WVDC oil Cond's two for... \$ 2.35  
W.E. Crystal 1N21-22-23-26 Lead sealed 4 for... \$ 1.50  
Buttery UHF Cond's with 703 socket (895)... \$ 3.95  
Halfdraters M&XTAL HT-4 units 10C810 (839)... \$ 2.95  
W.E. Tnsf 115V/60cy pri 5V/26A sec 15000V ins... \$ 4.50  
Kenyon 115V/60cy pri 5V/60A sec H.V. ins... \$ 7.95  
Kenyon Pwr trans BC412 C'Ray tube fil & P 2500V... \$ 5.95  
Thornd Hi-Fi PP6LE outpt 3800 pri. tap sec... \$ 3.00  
Vitropus Resistor 17500 ohm 25W Tap at 7500; 3 for... \$ 1.00  
IRC WW Resistor 100000 ohms 40W ea. 65; 2 for... \$ 1.00  
Sockets Amphenol 88TN octal HF 25 for... \$ 1.50  
Sockets Amphenol 48SS octal Ceramic 10 for... \$ 1.00  
Socket Amphenol 49-SS11L Magnal Ceramic 3 for... \$ 1.00  
Socket Johnson 60Watt no. 211B (S1.0) 2 for... \$ 1.00  
Socket Eby Miniature HF mica B & Shield 4 for... \$ 1.00  
Socket RCA DiHeptal & Adj Ring (\$7.00).... \$ 1.15

OHMS

V

0-3 1000

0-10 10000

0-30 100 M

0-100 1 Meg.

0-300 10 Meg.

Electronic Volt-Ohmmeter brand new U. S. Army Type 1-107-F Precision Unit. "Tab" special \$24.60. Additional V.T.V.M. Loctal tube I LE 3/SP Sig C... \$1.15

# "TAB"

## That's a Buy

Transformers and Chokes New G'insp 115V/60 cy Pri.

Raytheon cased 840 VCT/110ma. 530VCT/21ma. 5V/3A, 5V/3A, 6.3V/1A, 6.3V/3A, HV ins (\$5.00).... \$ 2.50  
Two for \$4.50; Five for \$10.00, 25 for \$45.00  
GE 10hy/250ma/100ohm choke... \$ 1.65  
Thornderson 8Hy/150ma/200ohm two for... \$ 1.94  
WB 200 microamps 3 1/2" x 1 1/2" hkl case... \$ 4.95  
Simpson one ma 3 1/2" x 1 1/2" hkl case... \$ 3.00

Weston AN Indicator Two 500 microamp mv's \$ 1.78  
Westghse elapsed time Indicator 115V/60cy... \$ 4.50  
Gr Variac 200 LU new G'insp... \$13.95  
Transformer C'Ray 4000V/2ma shielded GE... \$ 3.95  
Transf C'Ray Fil. 6.3V/2A, 2.5V/1.75A GE... \$ 3.00  
Transf 1600V/2ma, 2.5V/1.75A, 6.3V/0.6A GE... \$ 2.95  
Transf Bias Sec 80, 70V/100mA GE... \$ 2.95  
Rectifier GE cu-Oxide FI 50V/5amp... \$ 2.95  
Inst Fil 6.8V&4V/10A, 6.5V/6A, 5V/3A, GE... \$ 3.95  
Tnsf P 2000VCT/250ma, 5V/3A Cased GE... \$ 6.95  
150VCT/220ma \$3.25; 300VCT/270ma... \$ 3.95  
Tnsf P&F 1300VAC/200WVDC GE... \$ 1.65  
Auto Trans 115, 160, 170, 180V/1.95-1.73 Amp... \$ 2.95  
Two 6.3V/3A, 7V/14A, 5V/6A, 5V/3A, GE... \$ 5.95

Dynamic Earphones & Microphone push to talk Complete with cord & plug new gr'd... \$ 2.95  
1 transformer to match earphones & mike... \$ 1.25  
Dynamometer new navy Insp 12 or 24 Inpt Elcor output 12V/3A, 215V/110ma... \$ 1.95  
Elcor output 500V/0.50ma... \$ 1.95  
2 Dynamometers 275&500V & Inpt filter... \$ 3.48

National XC-5 socket 5P (DP85C) 4 for... \$ 1.00  
Buss & Little fuses 3AG/250ma 48 for... \$ 1.00  
Choke (e) 10Hy/250ma/110ohms two for... \$ 2.80  
Kurman adj. 1000 cv AC source New G'I... \$ .97  
TNY Headsets & microphone with plug (S1.0) 2 for... \$ 3.95  
Cond'r oil new G'insp 16mf/400WVDC WE 2 for... \$ 2.35  
Cond'r 0.5mf/600WVDC B&H tub 5 for... \$ 1.00  
Cond'r 10mf/600WVDC (2/2.5mf&3mf) 2 for... \$ 2.50  
Cond'r 20mf/600WVDC (1/2.4-5-8mf) 2 for... \$ 5.00  
Cond'r 3mf/30VAC/1000WVDC GE 2 for... \$ 2.50  
Cond'r 2mf/2000WVDC W&C 2 for... \$ 4.25  
Cond'r 3mf/3000WVDC 2 for... \$ 5.00  
Cond'r 10mf/660VAC/2000WVDC GE (839) 2 for... \$ 2.70  
Cond'r 15mf/660VAC/2000WVDC GE (839) 3 for... \$ 3.90  
Cond'r 2mf/12500WVDC Westghse (\$210)... \$25.00

Cond'r 1mf/2500WVDC Westghse (8395) \$75.00  
Weston Df-500/600 ohm Line-104.6... \$ 3.95  
GE Interlock switch (LP \$2.25) 2 for... \$ 1.25  
Resistors Kit 1000T L&W 50 to 2 meg... \$ 2.50  
Cond'r Kit qty Silvermica 50 for... \$ 2.00  
Vol controls Kit AB-J 50 to 1 meg; 10 for... \$ 2.50  
Cord 5J Hvi-duty 16 ft ext'sion M&F plugs \$ 1.00

\$2 Min. order. FOB N.Y.C. Add Postage all orders and 25% deposit. WHITEHALL 3-3557. Send for catalog 300. Specialists in International Exports, School, College & Industrial trade. Buy thru "TAB" and save.

CRYSTALS MTD GUARD\* 2 to 10 mc's ACTIVE OSC'S LOW TEMP DRIFT EACH... \$ .85

FOUR FOR... \$3.00

DC-9 CRYSTAL 1000KC VACUUM STD'S... \$5.95

100KC CRYSTAL STD'S \$7.20

RCA 808JAN new (\$7.75) 200Watts \$2.70 @ 5.00  
2 for... \$ 7.00  
JAN 812A New S'G insp. \$3.75 @ 2 for... \$ 1.55  
GE 807 JAN new (L.P. \$2.75) each... \$ 1.35  
GE 446A/2040 RCA Lighthouse tube (\$11)... \$ 6.95  
GE 1641 Rk60 FW.H.V. Rect (\$2.75)... \$ 1.99  
RCA 6AC7 JAN new 4 for... \$ 3.00  
5CP1 & socket \$7.50; 3BP1 & socket... \$ 3.95  
WE 368AS Tube UHF 20watt to 1700 mc's new... \$ 7.95  
WE703 A Tube UHF 20watt to 1000 mc's new... \$ 5.95  
WE 717A Door Knob Tube new... \$ 1.95  
WE 307A KP. Pent. (L.P. \$13)... \$ 5.95  
WE 339A RF. Pent. (L.P. \$24)... \$ 6.95  
JAN 805/905-VT143 (L.P. \$11)... \$ 4.95  
6G5/605 Ray Tubes (1.55) .75 @ 2 for... \$ 1.00  
RCA 2V3G JAN H.V. C'Ray Rect. 16500V... \$ 1.25  
957 Acorn JAN new (L.P. \$3.00) .65 @ 2 for... \$ 1.25  
955 Acorn JAN new (L.P. \$2.85) .65 @ 2 for... \$ 1.25  
RX215 Raytheon new (L.P. \$24.30) FW 500V/15A... \$ 7.95  
VR150 JAN new (L.P. \$2.80) .75 @ 2 for... \$ 1.30  
RCA 9002 JAN new (L.P. \$2.00) .65 @ 2 for... \$ 1.25  
GE Vacuum Cond'r 50mf/1600V Z-690... \$ 3.95  
RCA 80 JAN (L.P. \$1.20) .85 @ 2 for... \$ 1.10  
RCA 1E7G JAN (L.P. \$1.80) 1.50 @ 2 for... \$ 2.50

## "TAB" Special

Navy TBY portable ultra Hi-Freq. 28 to 80 mc's transceiver Voice & CW Spot calibrated, including crystal calibrator, all tubes, a dj. ant; phones, mike, carrying case \$36.00 each. Two for... \$58.00

Additional spare parts, Vibrator supply, Trunk, Antenna, manual and other spares... \$25.00

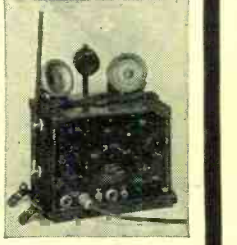

"TAB" • Dept. RNII, Six Church Street, New York 6, N.Y., U.S.A. • "TAB"

There's only

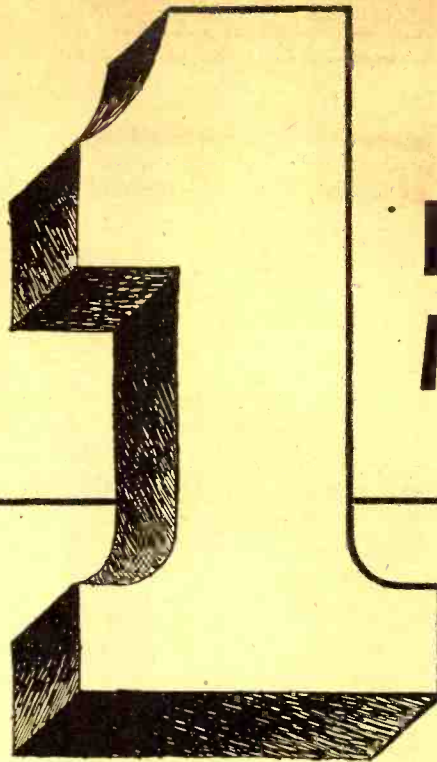

**RIDER  
MANUAL**

**BUT IT'S IN FOURTEEN VOLUMES**

Rider Manuals are the only single source upon which you can depend for authoritative servicing data on pre-war American made receivers.

Rider Manuals cover the things which our 16 years of specialized publishing have proved you want and need; supplying such vital material as receiver schematics, voltage data, resistance values, chassis layouts and wiring, and trimmer connections.

Further evidence of our continuing service to the servicing industry will be found in the forthcoming Volume XV. This new volume will contain specially prepared and highly refined servicing information available from no other source — not even from the set manufacturer. This supplementary material is information you need, offered in a form that will make it most useful to you. It will result in the saving of servicing time — an increase

in production worth many times the price of the volume!

Our advertisement next month will announce Volume XV and give important details on the revolutionary and exclusive features it will contain.

With Volume XV as with the other fourteen volumes "You're right with a Rider Manual!"

**JOHN F. RIDER PUBLISHER, INC.**

404 FOURTH AVENUE, NEW YORK 16, N. Y.

Export Division: Rocke-International Corp., 13 East 40th Street, New York. Cable ARLAB

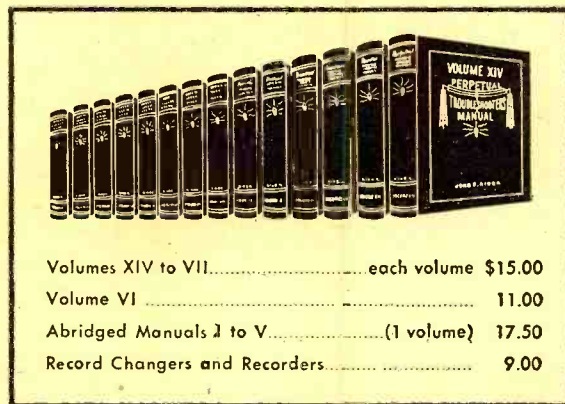

Volumes XIV to VII.....	each volume	\$15.00
Volume VI .....		11.00
Abridged Manuals I to V.....	(1 volume)	17.50
Record Changers and Recorders.....		9.00

**RIDER RADIO BOOKS KEEP YOU IN TOUCH WITH SUCCESS**



This new Rider Book, soon to be announced, will be of lasting usefulness to everyone interested in any phase of radio.

- The Cathode Ray Tube at Work**  
Accepted authority on subject . . . \$4.00
- Frequency Modulation**  
Gives principles of FM radio . . . 2.00
- Servicing by Signal Tracing**  
Basic Method of radio servicing . . . 4.00

- The Meter at Work**  
An elementary text on meters . . . \$2.00
- The Oscillator at Work**  
How to use, test and repair . . . 2.50
- Vacuum Tube Voltmeters**  
Both theory and practice . . . 2.50
- Automatic Frequency Control Systems**  
—also automatic tuning systems . . . 1.75
- A-C Calculation Charts**  
Two to five times as fast as slide rule 7.50

- Hour-A-Day-with-Rider Series—**
- On "Alternating Currents in Radio Receivers"
  - On "Resonance & Alignment"
  - On "Automatic Volume Control"
  - On "D-C Voltage Distribution" **\$1.25 each**

**RADAR — JUST OUT — \$1.00**  
*Entertaining, Revealing, even a layman can understand explanation*

**Better**  
**ATLAS SOUND**  
**Equipment**  
*Ready for YOU*



**DOUBLE REENTRANT PROJECTOR**

Many sizes. From 15 in. air column to 6 foot air column.



**360 RADIAL CHANDELIER PROJECTORS**

Double Reentrant. For driver units. 3 and 4 foot air column lengths.



**DRIVER UNITS**

Various Power Handling Capacities. Newest types of Indestructible Phenolic Diaphragms.



**MINIATURE TYPE RE-ENTRANT PROJECTORS —BOOSTER SPEAKERS**

High-efficiency. Weather-proof. Complete with Driver Unit and Universal Bracket.



**CONE TYPE PARABOLICS and CHANDELIER BAFFLES** for all size cone speakers. Wooden and Metal Cone Speaker Enclosures, Baffles, Carrying Cases, Loud speaker Support Stands and Brackets.



**MICROPHONE SUPPORT STANDS**

20 types and sizes. All Fittings, Adaptors and Accessories. Floor Stands, Desk Stands, Banquet Stands, Boom Stands.

Write for New Illustrated Catalog Sheets.

**ATLAS SOUND CORPORATION**

1447 39th St., Brooklyn 18, N. Y.

dles twelve 10" or ten 12" records. The tone arm is equipped with a permanent type needle.

Distribution of this combination will



be through Temple distributors but additional information will be supplied by Templetone Radio Mfg. Corp. of New London, Conn., upon request.

**I.F. TRANSFORMERS**

National Company, Inc. of Malden, Massachusetts, has recently introduced a line of new i.f. transformers designed for high frequency AM and FM applications. All of these transformers operate at 10.7 mc. and can be used

(Continued on page 160)

**Signal Generator**

(Continued from page 34)

The signal generator will only be useful if accurately calibrated. One may imply that it is necessary to purchase a second signal generator in order to calibrate the first. This is, of course, not essential since existing radio stations furnish accurate frequency standards. For example: broadcasting stations, accurate to 20 cycles,

can be used for calibrating the first two bands.

Frequencies between 550 and 1600 kc. are calibrated by beating the fundamental of the signal generator against the broadcasting stations in any broadcast receiver. Care must be taken not to beat images when using a superheterodyne. Remember that an image will be off by a frequency twice that of the i.f. The frequencies below 550 kc. are calibrated by beating the second harmonic of the signal generator against the broadcasting station. Be careful when approaching the intermediate frequency of the broadcast receiver as spurious beats will be heard.

Errors can be more easily discovered if the calibration is first made with curves on graph paper. Direct calibrations can later be printed on the main dial. Before calibration is attempted, mark one main dial scale from zero to one hundred.

Calibration of the higher frequencies is certainly more difficult. Radio station WWV, operating on 2.5, 5, 10 and 15 mc., is, by far the most useful frequency standard. If an all-wave receiver is not available, it is recommended that a simple regenerative receiver be constructed for picking up WWV.

Another useful item for working in conjunction with WWV is an accurate 100 kc. oscillator, either self excited or crystal controlled. As each signal generator point is recorded against WWV, the harmonics of the 100 kc. standard are used for 100 kc. check points plus or minus WWV.

Adjust the iron cores of each coil so that the various bands just overlap by a small amount.

-30-

Mechanical layout shows chassis construction for all-wave signal generator.

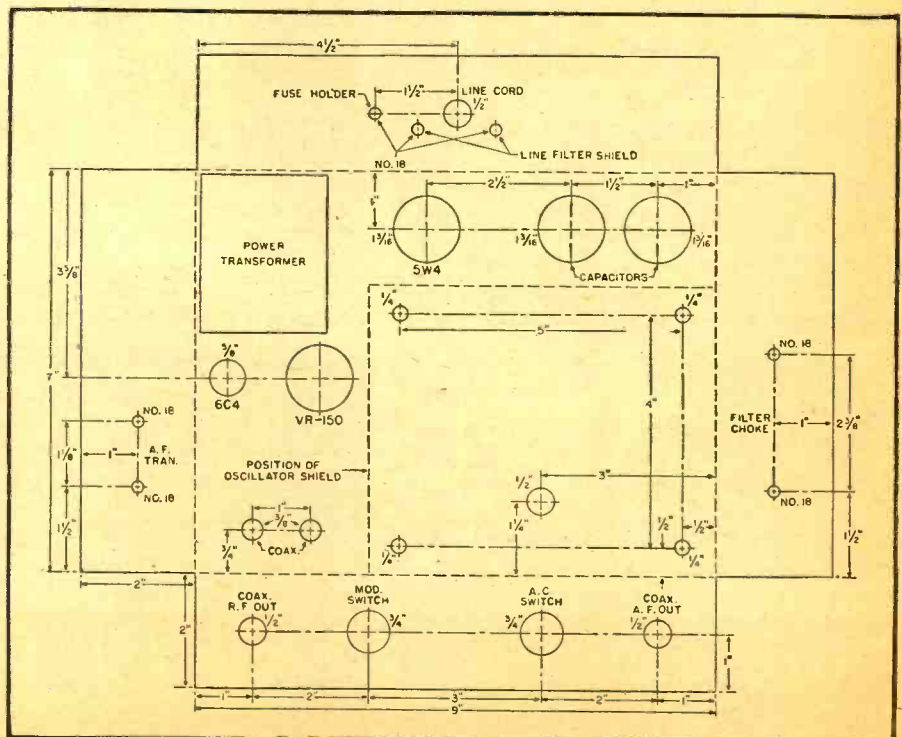

# Technical BOOKS

**"ELECTRONIC TUBES, TRANSMITTING TYPES,"** compiled by the Electronics Department, General Electric Company. Published by *General Electric Company*, Schenectady, New York. 600 pages. Price \$2.00.

Of particular interest to equipment designers, broadcast engineers, and experimenters, this 600 page book recently issued by *General Electric Company*, contains photographs, outline drawings, ratings, performance curves and application data on 94 tube types, covering the full scope of AM, television FM and communications. Also included in this book is data on the Phasitron and Lighthouse tubes.

This manual is subject to periodic revision at an annual fee of \$1.00 applicable after December 31, 1947. Until that date new and revised data will be supplied to book owners without additional charge.

The book is being distributed by the *General Electric Company*, Schenectady, New York.

**"RADIO SERVICE STANDARD RATE BOOK"** by Robert T. Oelrich. Published by *Oelrich Publications*, Chicago. 44 pages. Price \$1.00.

Many radio servicemen who have been attempting to establish fair and

equitable rates for the servicing of radios will welcome the appearance of this book.

While it may not be practical to adopt the rates in toto, this book provides a basis of comparison for the serviceman. The book is divided into six sections, covering auto radios, a.c.-d.c. battery portables, console radios, table model radios, record players and record changers. Each of these sections outlines the general servicing procedures for each type of set, and lists standard rates for various types of repair services.

Parts prices and tube prices are conveniently listed, plus suggested standard rates for labor, service calls, pickup and delivery, estimates and alignment.

Also included is a digest of crystal cartridge data and a registry of electronic manufacturers.

The book is being distributed through radio parts jobbers.

**"ELECTRIC MOTOR REPAIR"** by Robert Rosenberg. Published by *Murray Hill Books Incorporated*, New York. 570 pages. Price \$5.00.

This book has been designed as a thoroughly practical "how-to-do-it" text for the beginner, apprentice, student or mechanic. The publishers have even designed the book differently from the ordinary text in order that it might be of practical value in the service shop. The book is divided into two sections, each section spiral bound

so that the text may be used in conjunction with the correlated illustrations.

The author has concentrated on troubleshooting and repair of common a.c. and d.c. motors. Complete instructions on rewinding have also been included. In addition to discussing specific motors, the book covers motor control systems, synchronous motors, generators, synchros and electronic control of motors. Each subject discussed is followed by a quick-reference summary of troubleshooting and repair suggestions which serves as a working guide on specific jobs.

Over 900 drawings, which fully illustrate each point discussed in the text, enhance the value of the book for the student as well as the man-on-the-job.

**THE PUBLISHER** of "Radio Tube Vade Mecum, 1945," reviewed in the September, 1946, issue of *RADIO NEWS*, has advised us that in order to facilitate the handling of orders for this book, *Editors and Engineers, Ltd.*, of 1300 Kenwood Road, Santa Barbara, California, have been named distributors for the text.

It is no longer necessary for orders to be forwarded to Belgium. *Editors and Engineers, Ltd.*, have advised that the 1946 issue, mentioned as being available soon, is expected shortly. A price of \$2.50 in U.S. currency has been set.

-30-

## Sensational Radio Kit Values

**5-tube AC-DC Super Het Kit**



105-125 V  
40-60 cycles  
550-1750 KC  
All parts mounted  
LITZ IF's-  
Loop & Os-  
cillator  
Coils  
Matched

- Walnut plastic cabinet 9 1/2 x 6 x 5.
- 5" Alnico 5 PM speaker. Variable Condenser.
- Highest quality guaranteed parts supplied.
- Uses 50L6-3525-12SA7-12SQ7-12SK7.
- Diagram insures easy construction.
- YOUR COST, less Tubes, Wire, Solder..... \$11.95**

**6-Tube 2-Band Super Het Kit**



Short Wave  
•  
16-19  
25-31  
49  
meters

All Parts Mounted  
•  
**YOUR COST \$16.95**

- Walnut plastic cabinet 11 x 7 x 6.
- 5" Alnico 5 1/2 PM speaker. Variable Condenser.
- Uses 2-12SK7-12SQ7-12SA7-3525-35L6.
- Special design high gain coils assure short wave reception.
- Professional circuit easy to build.

**Phone Combination Kit**



Tubes AC

- Astatic Crystal curved arm.
- Light-weight pickup.
- Constant speed quality motor.
- 5" Alnico 5 1/2 oz. PM speaker.
- Attractive walnut grain cabinet.
- YOUR COST, Less Tubes, Wire, Solder. \$26.95**

**Phone Motor & Pickup Kit**



Special Complete **\$5.95**

- Astatic curved arm crystal pickup.
- Top quality guaranteed constant speed motor and turntable.

**IMMEDIATE DELIVERY TERMS**

**25% Deposit with Order**  
**Balance COD**

Our Export Department ships anywhere in the world.

Write—Wire: **GRECOELEC**

*Inquiries invited on special kits and parts.*  
*We carry large stocks.*

**IRC Resistor Kits**



Supply Limited  
•  
Order New

- #1 100 Ass't BTS 1/2 watt. Popular sizes.
- 5 & 10% Tolerances..... **\$1.95**
- #2 100 Ass't BTS 1/2 watt.
- 1 & 2 watt sizes RMA. Popular sizes..... **\$1.95**

# Grossman Radio & Electric Co. Wholesale Distributors

120 Cedar Street  
New York 6, N. Y.

# Variety... VALUES!



## SUPERIOR SIGNAL GENERATOR

Model 650

110-120 Volts 50 to 60 Cycles A.C. R.F. Frequencies from 100 Kc to 35 Megacycles. Harmonics from 25 to 105 Mcacycles. Audio Modulating Frequency — 400 Cycles Pure Sine Wave. Distortion less than 2%. Uses a

Hartley Excited Oscillator with a Buffer Amplifier. Complete with coaxial cable, test leads and instructions. **\$48.75**

## SUPERIOR Model 670 Super-Meter A Combination



Volt-Ohm Milliammeter plus Capacity Reactance Inductance and Decibel Measurements Complete with test leads and instructions. **\$28.40**

## 1 TUBE RADIO KIT by "EASY BUILT"



Battery operated, easy tuning, attractive wood finish cabinet. Complete with Tube, Coil, Battery, Headphone. Hardware and Base. List Price \$4.98

**Special \$3.33**

## PHONO MOTOR with TURNTABLE

60 Cycles 115 Volts \$3.95

Suitable for every phonograph instrument where low cost and dependable performance are required.

**\$3.95**



Federal Teleco Selenium Rectifier replaces Rectifier Tube..... **99¢ each**

Tremendous Saving on By Pass Condensers! By Pass Condensers and Kit contains 100 Popular assorted types..... Normal Cost \$10.95 Special \$6.75

Filter Condenser Kits—23 assorted types— Value \$12.00 Special \$8.75

Permanent Tuner assembly.....\$2.35

Dial Face Assortment.....10 for \$1.49

Universal Replacement Loops.....59c each

10 Watt Amplifier complete with tubes.....\$22.75

Neon Testers with instructions.....List Price 50c ea. Special 29c

Dial Condensers 25 ft.....29c

Dumont 5" Scope.....\$99.50

HY-Q 75 Kit—unassembled \$9.95—assembled \$11.95

Test Leads Superflex Pencil Type.....75c

with Insulated Tip.....\$1.00

High Voltage-Heavy Duty.....\$1.95

10 or more sets of any assortment deduct 10%

1 cell Bantam Handy Flashlite

Precision tooled, solid bar aluminum, small, powerful and durable.

List Price 89c Dealer's Price 54c

Fluorescent Desk Lamps. Dealer's Price \$6.95

List Price \$11.95

Write Dept. N11 for our FLYER  
20% Deposit with order required

Variety **ELECTRIC CO., Inc.**  
601 Broad St., Newark 2, N. J.

# Should agencies be used to collect delinquent accounts?

**This is a question which every serviceman-dealer must answer. Here are the pros and cons on it.**

By **J. A. HAROLD**

**A**LTHOUGH there is plenty of "easy money" around now, the day will come when delinquent accounts become a major problem of postwar businessmen. When collections become difficult businessmen are sorely tempted to resort to collection agencies as a solution to the problem of eliminating overdue accounts on their books.

Yet, before the creditor succumbs to the wiles of a solicitor and begins beating the brush for a collection agency, he might well pause and consider all the angles inherent in turning over accounts for collection. Two alternatives will probably be presented to him by the solicitor: (1) outright purchase of the accounts, or (2) collection on a commission basis.

Where accounts are purchased outright, the price offered for run-of-the-mill delinquent accounts may net the creditor as little as ten cents on the dollar. If on a commission basis, he may pay fifty per-cent for bills collected. Granted that the collection agency may, by its work, justify such fees in some instances, nevertheless the businessman may ask himself whether from his own self-interest the services of an agency are warranted, either from the standpoint of the discount or commission or from even more compelling considerations.

While the agency is acting for the creditor he is not subject to the creditor's control. The collection agent's one and only interest is to collect the debt by fair means or foul, let the bad will created by his actions be visited upon the creditor, if it must. In the mind of the debtor, let us be clear, the action of the agent is going to be the action of the creditor, and the debtor will not make any fine distinction between the two. Methods that the creditor would hesitate to use the agency will have no qualms in utilizing.

Effective in pursuing dead-beats—and they are unexcelled in this field of activity—they are no less zealous in the harassing of honest debtors who, potentially at least, represent a part of the good will that has made the creditor's success in business possible. Small town businessmen, especially, should think twice before allowing collection agents from nearby cities to come in and roust around once-valued customers. Such customers may have a wide circle of friends who, aware of the circumstances behind the non-payment (even

if the creditor is not) may adversely affect the creditor's business. Under such conditions the selling of a \$50 debt for \$5 becomes an expensive transaction for the creditor as he puzzles over certain valued accounts dropping away.

"If I can't collect a delinquent account myself with my methods I don't want a collection agency to do it," an unusually successful businessman told me. He is noted for the good will that he enjoys in his community.

"The real test of good will," he explained "is in collecting old accounts. You can't preserve that good will if you treat customers down on their luck as if they were rascals. The businessman can usually do everything to collect a bill that an agency can. The point is that the businessman has ethical considerations that stop him. These same considerations should prevent him from allowing an agent to do what he, the businessman, would not. In any event, the businessman should understand that he must accept the consequences of the acts of the agency as far as good will is concerned.

"Three of the most valued customers I have today once headed a list of bad debts that, save for second thought, I would have turned over to a collection agency. One of them, today, is my best friend, and I wince everytime I think of it. Pushing him around wouldn't have gotten him to pay up any quicker than I did by using a little common sense and sympathetic understanding."

No objection can be raised to the use of collection agents in running down dead-beats. The trouble is that creditors rarely make fine distinctions between purely old accounts and dead-beats. And, collection agencies thrive on catching honest delinquents in every batch of accounts turned over to them. These people eventually pay, have no intention of doing otherwise. The collection agency, pushing these debtors around to make their presence felt, usually do exactly what the creditor can do; sit it out until the debtor's financial circumstances take a turn for the better.

"I'd as soon hire a so-called 'business-building organization' to come into my store as to hire a collection agency," another successful businessman said. "In either case their sole interest is in the commission—not in the continuing success of the businessman whose survival in business may

be even more dependent upon good will than upon the non-payment of a scattered few debts that have accumulated in the course of business."

The methods resorted to by collection agencies are many and varied, but all are distasteful to honest debtors and the merchant should think long ere he unleashes them against once valued customers. Not only may they be depended upon to use every legal trick of their calling, not a few step over the line in their zealousness and in so doing, occasionally, run afoul of the law. Collection agencies operating as branches of private detective agencies have a penchant for using badges in an abuse of authority. Creditors should be warned that, under certain circumstances, they may be legally liable, along with the agency, for acts committed by agency employees.

If the merchant feels that he must resort to the services of a collection agent he should take sufficient time to weigh each debt before surrendering it for collection. He should consider all consequences as against the amount he may realize if collection is made. He should try to view each case objectively asking himself if the circumstances of the debtor do not warrant waiting.

Unemotionally and impersonally he should try to determine which debtors are dead-beats and which are not, separating the sheep from the goats. An honest delinquent debtor may be a great asset in the future, if efforts are made to salvage his account and at the same time preserve his good will.

The temptation is great to vent one's ire on the honest delinquent debtor out of anger at inability to effect collection from the dishonest. The creditor can't get at the dead-beat and is only too likely to take it out on the honest debtor who apologetically acknowledges his debt.

Many debtors feel as badly about their debt as does the creditor, but don't know how to convey this feeling to the creditor and so, from a sense of shame and panic, take refuge in dodging the creditor until they can pay the bill. The creditor, therefore, shouldn't be too quick in assuming that dodging is the mark of a dead-beat, at least until other evidence supports such a conclusion. If able to pay, and the debtor does not, then the creditor is certainly safe in assuming he is dealing with a dead-beat.

Unlike your honest debtor, the case-hardened dead-beat is usually glib and ready with circumstantial stories and excuses for his failure to pay. Unless he is new at the racket he knows all of the legal tricks of his nefarious trade and, after a few interviews with him, the creditor can usually identify him for what he is.

If you must use a collection agency do so only as a last resort. Good will is too hardly won to dissipate it, let alone employ someone to destroy it!

FOR TRU

SOUND REPRODUCTION

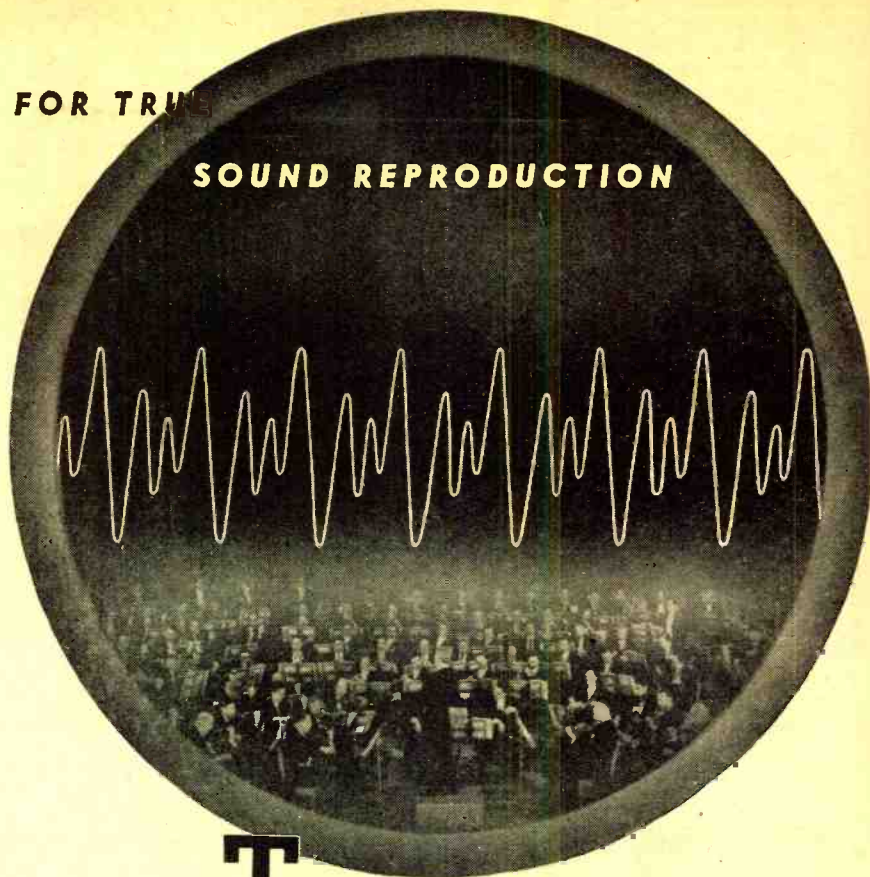





# TERMINAL

SPECIALISTS IN ALL HIGH QUALITY  
SOUND EQUIPMENT

It's results that count and that's why the **TERMINAL RADIO CORPORATION** is the leading supplier to broadcast stations, recording studios, sound engineers and other users of high quality sound equipment.

**Now Available for Immediate Delivery!**

- 
**PICKERING** Pickups, Equalizers and Preamplifiers. Pickering's is the only pickup which satisfies FCC standards for FM broadcasting. Acclaimed by top-notch sound engineers as the finest reproducer for lateral-cut phonograph records and transcriptions.
- 
**ALTEC LANSING** Speakers, Cabinets and High Fidelity Amplifiers. Chosen by leading radio stations, motion picture studios and auditoriums, Altec Lansing is now available through the Terminal Radio Corporation to studios and high fidelity enthusiasts.
- 
**RADIOTONE** Portable Transcription Two-speed 16 inch Recorders. Radiotone Hollywood's new improved portable recording equipment is probably just what you've been looking for. Now available in several models for high quality disc recording and dubbing.
- 
**AUDIO DEVICES** Audiodisc aluminum and glass base Recording Blanks. Audiodiscs are high quality, precision-made instantaneous recording blanks which have won the praise of professional and amateur recordists. Designed for all high fidelity recording applications, available in sizes up to 16 inches.

As distributors for these and other high quality audio equipment, the **TERMINAL RADIO CORPORATION** can fill your high fidelity sound requirements.

Visit our Sound Studio to see and hear the newest equipment or write us for descriptive literature and prices.

**TERMINAL RADIO CORP.**  
85 CORTLANDT STREET, NEW YORK 7, N. Y.  
PHONE WORTH 2-4415

# ATTENTION! RADIO PARTS BUYERS

Check These Specials

Place Your Order Today  
For Quick Delivery

General Motors Corp. Motor. Miniature 27.5 volts. Overall dimension 2X1X1; fixed magnet type 1/8" shaft. Powerful small motor to operate instruments, toys, etc. used in conjunction with small batteries. Cat. #101 ea. \$2.00.

Diehl Mfg. Co. Motor. A.C. Control Motor; 20 volt 60 cy. 2 phase; 5 amp. Overall dimension 2.5" x 2.5" x 3" 5/32" shaft. Cat. #103 ea. \$2.00.

Motor and Blower Assembly. Overall dimension 4 1/2" x 4 1/2" x 3"; 28 volts A.C.-D.C. useful for cooling tubes. Cat. #103 ea. \$3.00.

John Oster Mfg. Co. Shunt Motor. 27.5 volts D.C. shunt. 7 amps 5600 R.P.M. with coding device attached. Cat. #104 ea. \$2.00.

I. F. F. Transceiver Chassis. Overall dimensions 12 3/4" x 8" x 12". Complete with individual Transceiver sections; machined and ready for use. Double front panel with cutouts. Cat. #105 ea. \$1.00.

50 Asst. Porcelain standoff insulators in Kit. Cat. #106 ea. \$1.00.

15 Assorted Tube Sockets in kit 4-5-6-8 prong. Cat. #107 15 for \$1.00.

5 Rotary switches; double wafer; 10 position non-shorting. In kit. Cat. #108 5 for \$1.00.

6 Phillips screw drivers for 4/40 screws. 4" blade. Cat. #109 6 for \$1.00.

15 Bakelite knobs; set screw type. Overall dimension 1 1/2"; with pointing arrow indicator. In kit. Cat. #110 15 @ \$1.00.

Metal Tool and Parts Chest; heavy gauge steel; all welded construction, hinged top with Hasp, Handles on sides. 18" x 15" x 12" Cat. #111 ea. \$3.00.

3 Shock Mounts; for mounting radio chassis, test equipment, or other delicate equipment which needs protection from excessive vibration. Overall dimension 18 1/4" x 7 1/4" - 13 3/4" x 10 1/4" - 10 1/4" x 10". Cat. #112 3 for \$2.00.

15 Asst. Terminal Boards of many different styles; Bakelite and fiberboard. In kit. Cat. #113 15 for \$1.00.

At least 150 Resistors and Condensers mounted on terminal boards, will be worth your while to buy and strip. In prepared kit. Cat. #114 Kit @ \$2.00.

100 Motor Brush Assortment for many types of motors. In kit. Cat. #115 100 for \$2.00.

35-3 foot lengths tubing and spaghetti, transparent Vinylite, black Vinylite, Fiberglass, etc. Asst. sizes in kit. Cat. #116 35 for \$1.00.

100 Asst. Carbon Resistors, Ceramic Condensers. R. F. chokes, etc. Value \$6.00 Cat. #117 100 for \$2.00.

25 Asst. Coil Forms for Receivers, Transmitters high frequency circuits and low power stage. Cat. #118 25 for \$1.00.

5 lbs. asst. machine screws, wood screws, nuts, bolts, rivets, eyelets, washers, lugs, spacers, bushings, etc. Cat. #119 5 for \$2.00.

100 asst. Brackets, Aluminum and steel various shapes and sizes. Cat. #120 100 for \$1.00.

3 Carbon control Rheostats, 3 dual controls, 3SPST switches 3 DPDT switches, 3 asst. control assemblies. Cat. #121 15 for \$2.00.

All items listed above are subject to prior sale. TERMS: Cash with order F.O.B. Chicago, Ill. Remit only exact amount of purchase.

### SPECIAL OFFER

Buy all 21 of the above listed items for \$30.00 and save an additional \$4.00 on the entire lot.

**IRVING JOSEPH**

220 S. Halsted Street, Chicago 6, Ill.

Buyer and Distributor of Surplus Stocks

# Within the INDUSTRY

**CAPT. WILLIS E. CLEAVES**, U.S.N., has recently joined the *Collins Radio Company* of Cedar Rapids, Iowa, as aviation sales manager. Captain Cleaves has been placed on inactive status and has requested retirement after 22 years of commissioned service, most of the time in aviation radio communications.



A graduate of the U. S. Naval Academy at Annapolis in 1924, Capt. Cleaves has seen duty as communications officer on board a destroyer, as officer in charge of the Radio and Electrical Section of the Engineering Division of the Bureau of Aeronautics at Washington, D. C., and also fleet aviation communication duty.

**D. K. ROBERTS**, for the past four and one-half years associated with the Marine Division of the *Sperry Gyroscope Company*, has been added to the sales engineering staff of the *Press Wireless Manufacturing Corporation* of New York.

Before joining the *Sperry* company, Mr. Roberts served the *National Broadcasting Company* for seven years as engineer and announcer.

**SAMUEL J. McDONALD, JR.**, was recently appointed to the sales staff of

the Radio Tube Division of *Sylvania Electric*. He will serve the distributor sales division in the New York and Philadelphia territories. Mr. McDonald graduated from Brown University in 1938 and was connected with *Lever Brothers* and the *Sherwin-Williams Company* prior to his appointment as personnel supervisor for the Salem, Mass., *Sylvania* plant in 1943.



**RALPH C. POWELL**, formerly General Sales and Advertising Manager of the *Presto Recording Corporation*, has resigned to engage in business under the name *R. C. Powell & Co., Inc.* at 730 Fifth Ave., New York City. The company will handle the national distribution of a number of new electronic devices through offices located in ten cities.

Mr. Powell joined the *Presto Corporation* in 1936 where he introduced the idea of recording network radio programs for delayed broadcasting, a

procedure which is now generally used among broadcasting stations. Prior to his association with the *Presto Corporation* he was engaged in the installation and management of broadcasting stations.

**J. J. BRODERICK** has been appointed assistant manager of the Special Products Sales Division of the *Farnsworth Television & Radio Corporation*, Fort Wayne, Indiana. The Special Products Sales Division is in charge of contract sales, automatic record changers and other special products.

Mr. Broderick joined *Farnsworth* in 1940 as assistant manager of distribution services. He later became assistant to the *Farnsworth* sales manager, and then assistant purchasing agent. Prior to his present appointment he handled general administrative assignments for E. H. Vogel, vice-president in charge of sales.

**EDWARD C. BEASLEY**, formerly with *General Electric Supply Corp.*, has been appointed to the sales staff of the Koiled Kord division of *Kellogg Switchboard and Supply Co.*, Chicago. Mr. Beasley will direct sales and promotion of the Koiled Kord products in the Southwest and will maintain his headquarters in Texarkana, Arkansas.



Mr. Beasley's former positions include sales manager for the *W. B. Davis Electric Supply Company*, Memphis, Tennessee, Arkansas representative of the Little Rock branch of *General Electric Supply Company* and resident inspector for the *Chicago Signal Corps Inspection Zone*, Chicago, Illinois.

**JENSEN MANUFACTURING COMPANY** is the new name recently given the *Jensen Radio Manufacturing Company*.

To avoid any misunderstanding that might arise regarding the company's products, they have eliminated the word "Radio" from the corporate name. No change has been made in the Jensen organization and the company will continue to manufacture loudspeakers.

**A. A. JUVILER**, president of the *Hamilton Radio Corporation*, announced recently that the company name has been changed to *Olympic Radio & Televisions, Inc.*

The company produces the *Olympic*



"tru-base" radios for both the domestic and export market and therefore felt it advisable to change the name of the corporation to coincide with the name of its products.

The two acre, block square, Brewster Building at 3101-19 38th Ave., Long Island City, New York, has been leased by *Olympic*. It is estimated that this new location will bring about a fourfold increase in the company's capacity to produce radio sets.

**JOHN W. STRICKLAND**, formerly sales manager of *Globe Wireless, Ltd.*, Radiotype Division, has been named sales promotion manager of *Press Wireless Manufacturing Corporation*.



During the war, Mr. Strickland, as Major in the Army Airways Communications System, had charge of extensive installations of radar and various types of telecommunications and participated in the design and installation of communications systems for the postwar expansion program of the Air Transport Command in eighty European cities.

Prior to the war, Mr. Strickland was sales manager for the *American Network*.

**FRANK WHITAKER** has been appointed director of materials and purchasing at *Sonora Radio & Television Corporation*.

Mr. Whitaker came to *Sonora* from *Stewart-Warner Corp.*, where he was co-ordinator of the electrical division, in charge of expediting, materials, warehousing, and shipping records.

**THOMAS B. ALDRICH** succeeds R. C. Powell as general sales and advertising manager of the *Presto Recording Corporation*. Mr. Aldrich has been with the company for the past ten years in the capacity of factory sales engineer in the New York Metropolitan Area.

In 1942 he was granted leave of absence to enlist in the Army. He spent two years in the European Theater as Captain in the 9th Air Force and in the Fall of 1944 resumed his activities with *Presto*.

**JAMES S. KNOWLSON**, Chairman of the board and president of *Stewart-Warner Corporation*, was recently awarded the Medal of Merit, highest award the U. S. Armed Services can confer on a civilian. The award was made for services performed while Mr. Knowlson was a "dollar-a-year" man serving in various capacities.

**ARTHUR E. AKEROYD** has been made New England district manager for *Solar Manufacturing Corporation*. He will also serve as New England district manager, with headquarters in

**AGAIN and AGAIN  
We Hear It Said**



**"KWIKHEAT  
THERMOSTATIC  
SOLDERING IRONS  
ARE THE BEST  
AT ANY PRICE!"**

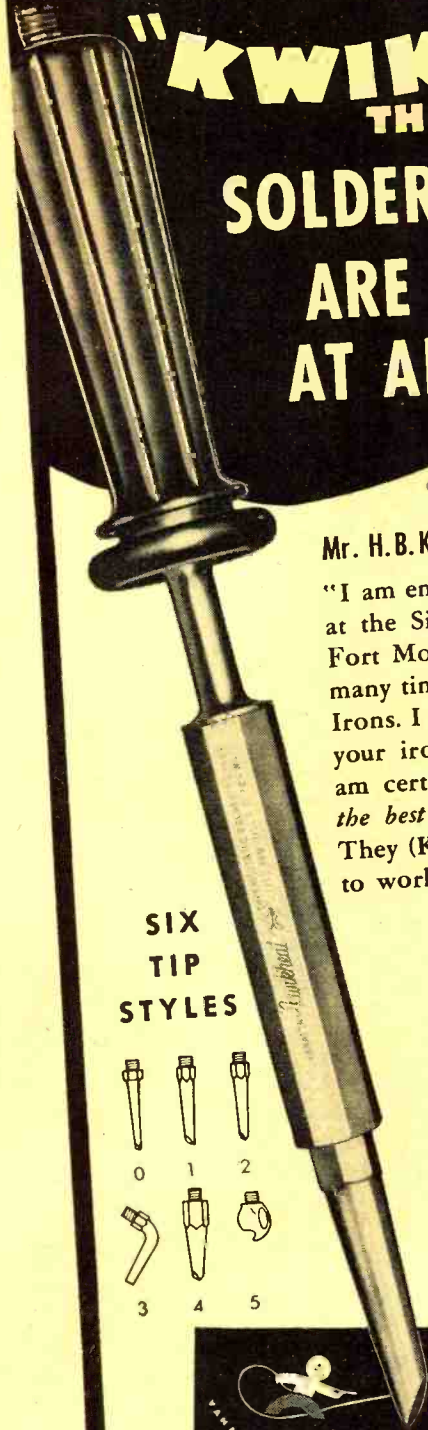

Mr. H. B. K. of Long Branch, N. J.\* says, "I am employed as a radio mechanic at the Signal Corps Laboratories at Fort Monmouth. In my work I have many times used Kwikheat Soldering Irons. I had never seen, nor heard of your irons until I came here, but I am certainly convinced that they are the best irons that can be obtained." They (Kwikheats) are a real pleasure to work with. \* Letter on file at our office

**SIX  
TIP  
STYLES**

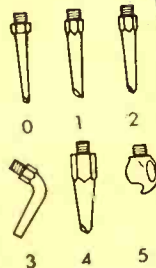

**CHECK THESE MANY  
KWIKHEAT FEATURES...**

- Thermostatic control
- Heats in 90 seconds
- Light weight (13½ oz.)
- Cool, protecting handle
- Six interchangeable tips
- Tips need less dressing
- Power cost reduced

225 - Watt List \$11.00  
450 - Watt List \$14.50

**KWIKHEAT  
THERMOSTATIC  
SOLDERING IRON**

A Division of  
Sound Equipment Corporation of California  
3903 San Fernando Rd., Glendale 4, Calif.

YOU  
NAME  
IT!



## EXACT FREQUENCY AT NO EXTRA COST

Why pay a "premium" for the exact frequency you want? PR will furnish you EXACT FREQUENCY (integral kilocycle) AT NO EXTRA COST. This offer holds good for all amateur ranges . . . 80, 40, 20 and 10 meters . . . and for all frequencies, including 11 meters! See your jobber. It's ten to one he will have the exact spot you want . . . if not, the factory is giving 24-hour service. All PR Precision CRYSTALS are low drift . . . less than 2 cycles per MC per degree centigrade. Get the new PRs for accuracy . . . maximum power output . . . activity . . . stability . . . protected from contamination and moisture . . . unconditionally guaranteed. Petersen Radio Company, 2800 West Broadway, Council Bluffs, Iowa (Telephone 2760).

10 Meters—PR Type Z-5 . . . . . \$5.00  
20 Meters—PR Type Z-3 . . . . . 3.50  
40 and 80 Meters—PR Type Z-2 . . . . . 2.65



**RADIO COURSES**

- RADIO OPERATING
- RADIO SERVICING — ELECTRONICS
- CODE
- REFRIGERATION SERVICING

Personal Counselling Services for Veterans  
Write for Latest Trade & Technical Catalog

**Y.M.C.A. TRADE & TECHNICAL SCHOOLS**  
7 W. 64th Street New York City

**CHANGER and RADIO CABINETS**

WRITE TODAY for big free catalog and price list of all the latest changer and radio cabinets including our popular radio and changer combination cabinet.

**VAUGHAN CABINET COMPANY**  
3722 North Clark Street Chicago 13, Illinois

Boston, for *Solar Capacitor Sales Corp.*, Solar subsidiary distributing the company's products to electrical and radio jobbers.

Mr. Akeroyd joins *Solar* after 14 years with the *Raytheon Manufacturing Company*, where he was manager of distributor sales.

\* \* \*

**BERNARD BENSON** was recently appointed purchasing agent in Detroit for the *Utah Radio Products Division* of *International Detrola Corporation*.

Mr. Benson was formerly assistant purchasing agent of *Utah* before that company was acquired by *Detrola*.

\* \* \*

**NORMAN H. LAWTON** has been elected to vice president in charge of sales for the two *Franklin* companies; the *A. W. Franklin Mfg. Corp.*, manufacturers of radio sockets, plugs, switches and assemblies and the *Franklin Airloop Corp.*, manufacturers of the new *Air-loop* antennas. Both companies are in New York.



\* \* \*

**ARROW SALES, INC.**, has begun business in their own new, large building at 59 West Hubbard Street in Chicago where they will stock all types of radio parts, equipment and supplies.

Rudy Weiss has dissolved *Arrow Radio Company* and become president of the *Arrow Sales, Inc.* Ralph Sackley, former sales manager for the war assets of *Belmont Radio Corp.*, is secretary-treasurer of the firm.

\* \* \*

**HOWARD J. SILBAR** is assuming the duties of Jean H. DuBuque as coordinator of advertising and public relations for *Lear, Incorporated*. Mr. DuBuque left *Lear* to become new Director of Aviation for the City of Dallas, Texas.

For five years before entering the service in 1942, Mr. Silbar worked in the advertising and public relations department of *Burroughs Adding Machine Company* in Detroit. Prior to that he was correspondent from Michigan for several national business papers.

\* \* \*

**LYNN BRENDEL** has been promoted to the post of general service manager of the *Hallicrafters Company* of Chicago. Mr. Brendel will be responsible for the servicing of all *Hallicrafters* equipment and the operation of the company's six service centers throughout the country.

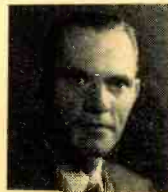

Mr. Brendel was previously associated with *United Motors Service* as a sales and service engineer, and later with the *Bendix Radio Corporation* in Detroit as a sales and research engineer, from which post he moved to the position of sales engineer in the com-

# THIS MONTH'S SPECIALS

At Greenwich Sales

## AMERTRAN REACTOR

Type W #29025  
1 Henry 800 mhs  
D.C. Resistance 7.5 Ohms  
Shipping Weight—35 lbs.  
Special At . . . . . \$4.50

## GENERAL ELECTRIC REACTOR

# K54J205 10 Henry 250 mil Potted, Uncased, 120 Ohms DC Resistance. Specs on unit. . . . \$2.00

## FOUNDATION FOR A 5" or 3" SOLE

#1 Transformer—115 V. Pri. 2000 Volt 2.2 mhs secondary . . . . . \$4.00  
#2 Tube—5BP1 and Socket . . . . . 7.75  
#3 Tube—3BP1 and Socket . . . . . 6.00  
#4 Rectifier—2X2/879 with National Ceramic Plate Cap. . . . . 1.10  
#5 6AC7/1852 . . . . . 90c Six for . . . . . 5.00  
#6 Wire Wound Posts—2000 Ohm. 5000 Ohm. 20,000 Ohm. Four for. . . . . 1.00  
5" Kit. Consists of item #1, 2, 4, 6. Special . . . . . 12.00  
3" Kit. Consists of item #1, 3, 4, 6. Special . . . . . 10.00

## A KILOWATT BOTTLE ASSEMBLY

Includes tube 304TL, filament transformer, tube socket, plate cap, filament bypass condensers, wired, ready to use; perfect. . . . . \$15.00

## EXTERNAL ANODE TRIODE

Type 801L 100 Watts at 200 Mc. Ideal for a 2 Meter Rig. Takes 1000 volts at 100 mhs. Special . . . . . \$4.50

25% deposit required on all orders.  
Prompt delivery assured.

# GREENWICH SALES CO.

59 Cortlandt St.—Whitehall 3-3052  
New York City 7, N. Y.

# POTTER'S BARGAINS

200 Micro-Amp. 3" Marion Meter, center scaled giving 100 Micro-Amps each side of center. Just the thing for a V.T.V.M. Special while they last \$4.39.

Radio tubes. Almost a complete stock at 29c, 32c, 42c, 52c, etc. Write for latest price list.

Dynamic Microphone. Our special hi-imp. Mike complete with connector and 10 ft. cable. Chrome finish \$7.95. Gun metal finish \$7.45.

We can give immediate delivery on the following test equipment:

McMurdo-Silver Vomax \$59.95  
Capacity Resistance  
Bridge . . . . . 49.90  
Dumont 3" Oscilloscope 105.00  
Waterman Pocketscope. 55.00  
R-B V-O-M Model  
MT-100 . . . . . 22.50  
R-B V-O-M Model  
MT-200 . . . . . 27.50  
R-B Meg-Lite . . . . . 4.95  
Fil-A-Tester . . . . . 5.95  
Appliance Checker . . . . . 5.90  
DC Volt-Ohmmeter . . . . . 9.95

2% Cash discount on all test equipment.  
25% deposit on all COD orders. Postage or Express charges extra.

# POTTER RADIO CO.

Dept. R-N

1312-1314 McGee St., Kansas City 6, Mo.

pany's War Assets Administration surplus disposal agency. During the war he served as a radio engineer for the Chicago Signal Corps depot.

**EMERSON RADIO AND PHONOGRAPH CORPORATION**, New York City, has announced the acquisition of 100% of the authorized and issued capital stock of *Plastimold Corp.*, Attleboro, Mass.

The *Plastimold Corporation*, for many years manufacturers of plastic radio cabinets in addition to fabricating a variety of molded plastic products, will serve as a wholly owned subsidiary of *Emerson Radio*. The corporation will continue with the present operating personnel and will maintain the same policies.

### Selenium Rectifiers

(Continued from page 45)

side, denoted by a "+" sign, is equivalent to the cathode while the negative side functions as the plate. Soldering the stack into the set in this manner constitutes the entire replacement operation unless the filament of the tube was linked to other parts of the circuit, in which case a resistor is used to replace the rectifier tube filament.

Installation of the miniature #403D2625 selenium rectifier can be made right in the customer's home as indicated in Figs. 1-6. The set shown is a typical three powered portable using a 117Z6 rectifier. As is evident

from the schematic of the power supply (Fig. 7) the filament of this tube is not interlocked with any other component in the set. Therefore it is only necessary to insert the stack into the circuit along the lines outlined in the previous paragraph. Solder the positive side to the cathode terminal on the tube socket, the negative side to the plate terminal, and the installation is over.

Only four tools are required to perform the entire 7 minute operation,—a soldering iron, screw driver, socket wrench, and a pair of long nose pliers. First the chassis is withdrawn from the cabinet and the tube is removed from the socket (Fig. 2). Extension leads are then soldered on the rectifier stack. It is recommended that the positive lead be covered with red wire so as to distinguish it from the negative lead, which is usually made yellow or black (Fig. 3).

At this point it should be noted that, whenever possible, the stack should be installed underneath the chassis. However, in this case, as is the case with many portables, though the stack is only 1 1/4" x 1 1/4" x 1 1/16", it did not fit underneath the chassis and was inserted from above in the space that was formerly occupied by the tube. In this latter case some type of protective covering must be provided.

Fig. 4 shows the leads which were drawn through center of the tube socket and soldered to the appropriate pins, the red lead to the cathode ter-

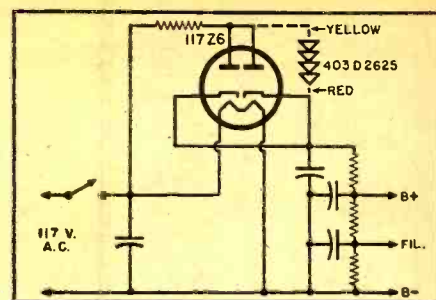

Fig. 7. Schematic diagram shows method of substituting a selenium rectifier for a conventional 117Z6 tube.

minial and the yellow one to the plate terminal. The set is then turned on and if the rectifier has been installed correctly, it should start operating immediately, (Fig. 5). Finally a protective covering, which is supplied with the stack and tightened to the chassis via a screw and nut (Fig. 6). The chassis is then put back in cabinet and the job is done.

After insulation of the rectifier, check filament voltage. If this is too high for normal tube operation, insert a 27 ohm resistor in the line just before the rectifier to bring the operating voltage of the filament back to normal.

Three operational improvements have been achieved with the installation of this rectifier. In the first place, since rectification is now immediate, the set operates as soon as it is turned

# Fahnestock Clips

## RADIO'S GREATEST CONVENIENCE

### FAHNESTOCK SPRING BINDING POST GRIPS THE WIRE BY THE ACTION OF A SPRING



No tools required to make the connection. Grips the wire with just the right pressure for good electrical contact. Simply press down, insert the wire and let go. Does not injure wire, hence connection can be made or opened as often as desired. Available in large variety of types and sizes to fit any radio purpose and any requirement as to position, space or method of attachment. You will find them in the better sets.

Positive contact; cannot jar loose. Brass or bronze—non-rusting.

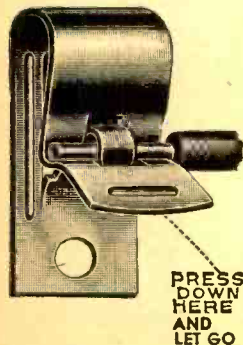

### FAHNESTOCK ELECTRIC COMPANY, Inc.

46-44 ELEVENTH STREET  
LONG ISLAND CITY 1, N. Y.

Please send us at once, Descriptive Literature, Prices and Delivery Schedule on

### FAHNESTOCK CLIPS

For .....  
Name .....  
Address .....  
City ..... State .....

Enjoy your Radio  
**MORE**



Add a **WEBSTER "55"**  
and play records through your  
radio.

### EASY TO CONNECT

Webster "55" is a table model  
automatic record changer and  
it comes equipped with neces-  
sary cords. Just plug it in to  
your radio and you still have  
your radio plus a phonograph.



SOLD IN **BETTER  
RADIO STORES**

WEBSTER "55" is com-  
pletely new. It is easy to  
connect, easy to play and  
will stand up under con-  
stant use for many years.

The choice of music lovers

**WEBSTER CHICAGO**  
5610 BLOOMINGDALE AVE.  
CHICAGO 39, ILLINOIS  
32 years of Continuous Successful Manufacturing

### LAST MINUTE SPECIALS!

Iron Cord Sets, 6 ft. fine quality, G.E. Wire with plugs	Each \$ .42
Extension Cord Sets, 7 ft. with 3-way cube tap	.41
Excello Automatic Iron, 1000 watt	7.25
1 Burner Hot Plate	2.43
Steam electric iron	8.48
Dominion electric room heater	5.90
Electric heat pads, 3-heat control	3.30

### ELECTRIC COFFEE MAKER SET

Consists of a beautiful Electric Coffee Maker Stove, 8-cup Glass Coffee Maker, Attachment for Grilling, also attachment for making Toast

(O.P.A. Retail Price \$9.98 each) **6.85**

Write for illustrated literature featuring other merchandise.

2% discount for payment with order, otherwise shipped C.O.D. net.

**SHEFFIELD RADIO & APPLIANCE CO., INC.**  
916 W. Belmont Ave. Dept. B Chicago 14, Ill.

on, in contrast to the filament warm-up period previously required. Secondly, in view of the low internal impedance and high efficiency of the stack, the ambient temperature of the set is reduced by approximately 35° F. which results in increased battery life. Finally, the long life of the selenium rectifier means that power supply troubles are reduced to a minimum.

Federal has developed replacement sheets covering every possible power supply used in home receivers, which give specific, easy-to-follow instructions, on what steps are necessary to install this rectifier. These sheets are available to all servicemen and can be obtained by writing to *Federal Telephone and Radio Corporation*, 200 Mt. Pleasant Ave., Newark, N. J.

-30-

## Television Receivers

(Continued from page 53)

screen area with the width control full advanced.

3. *Vertical Deflection.* A failure in the vertical deflection circuit is indicated when only a thin horizontal line appears on the fluorescent screen or when it is impossible to cover the screen area with the height control full advanced.

4. *R.F. Section.* A failure in the r.f. section of the receiver is indicated when the scanning raster is normal but there is no sound or picture signal. This could also be an antenna defect.

5. *Sound Channel.* A sound channel failure is indicated when there is no sound but a normal picture.

6. *Picture I.F. Channel.* A picture i.f. channel failure is generally indicated by a normal sound but no picture and no locking-in of the scanning raster. Locking-in of the scanning raster causes the dimensions of the entire raster to decrease slightly when the contrast control is advanced to the point where the sync pulses lock-in the sweep oscillators.

7. *Video Amplifier.* A failure in the video amplifier is indicated by a normal sound and a locked-in scanning raster but no picture or just a trace of one with the contrast control full advanced.

8. *Synchronizing Circuits.* A failure in the synchronizing circuits is indi-

cated by what seems to be a strong signal (abundance of blacks and whites on the picture tube screen) but general instability and inability to maintain a stationary image.

### Bench-Checking Receiver

For bench-checking the receiver, a good antenna system should be available as well as a means for grounding the chassis. Proper grounding is necessary to protect the serviceman in case of a high voltage leak between primary and secondary windings of the high-voltage transformer. The antenna system should be trouble-free so the serviceman can be certain any defect is a fault of the receiver and not the antenna system.

Inasmuch as tube failure is the most frequent trouble, the tubes of the defective section should be checked first. In fact, checking all tubes throughout the receiver is a good first step. If the defective part cannot be located by a careful mechanical inspection of the defective section, voltage measurements should be made. However, before making any tests with the receiver turned on, disconnect the high-voltage transformer. In some receivers this means unsoldering a high-voltage lead as prescribed by the manufacturer, while in others it is only necessary to remove the primary fuse from the high-voltage transformer primary. So far as defects in the high-voltage circuits are concerned, they can all be located by resistance measurements or mechanical inspection with the equipment turned off.

Inasmuch as the number of types of television receivers which will reach the market this year will be limited, it would be of great benefit to the serviceman if he would find out as much as he could about a representative model of each line and draw up a trouble chart. The trouble chart presented herewith does not cover all, or even a large percentage, of the troubles that could occur. Its value lies in the fact that it evolves a procedure and develops an understanding of the techniques which can be employed to localize trouble. The trouble chart, Table 1, lists common faults found in most types of television receivers. A typical picture channel, General Electric HM-171, was published on page 52 of the June, 1946 issue.

-30-

Table 1. This is a continuation of the table appearing on page 53.

VIDEO AMPLIFIER	
DEFECT	CHECK
1. No picture on screen. Scanning raster locked-in. Sound normal.	a. Video amplifier tubes. b. Voltage check video amplifier.
2. Loss of definition as indicated by blurring of lines on test pattern. The r.f. and i.f. response patterns are normal.	a. Substitute video amplifier tubes. b. Voltage check video amplifier. Check component parts (coupling capacitors and peaking coils).
3. Weak picture with light range reversed — whites are black; blacks, white.	a. One stage inoperative. Check plate circuits for open. Check tubes.
4. Hum (heavy black bars).	a. Voltage and resistance check for shorted plate load resistor, and open or partially shorted by-pass capacitor.

## 200 Watt Transmitter

(Continued from page 43)

Tune the plate circuit of the second 6L6GA and the plate circuit of the 809s to 20 meters in the same manner as outlined previously.

For 40 and 80 meter operation the 809s may be excited directly from the v.f.o. output. The coils used in the second doubler plate circuit and the plate circuit of the 809s should tune to the same frequency as that of the v.f.o. output. An open phone jack may be inserted in each of the 6L6GA cathode current jacks or the 400 volt power supply may be turned off; the doubler circuits are not required when the 809s are excited directly from the v.f.o.

If crystal control operation is desired, place the crystal in the 5-prong coil socket as shown in Fig. 1. Turn the plate circuit of the first 6L6GA for minimum plate current and then detune the circuit slightly on the *high-frequency* side of resonance. This improves the stability of the crystal oscillator. It must be remembered that no frequency doubling takes place in the first 6L6GA circuit when using crystal control; the plate circuit is tuned to the same frequency as that of the crystal. The second 6L6GA, however, is a doubler. For operation on 80 meters, it will be necessary to use a 160 meter crystal; for operation on 40 meters, an 80 meter crystal must be used. When using 40 and 20 meter crystals for 20 and 10 meter operation respectively, it is necessary to be very careful to make certain that doubler is tuned to *two* times the crystal frequency and not to some other harmonic. Use the wavemeter as outlined before, for checking.

The approximate dial settings and coil combinations for the four amateur bands are given in the accompanying tables. Table 3 is for v.f.o. operation. Table 2 is for crystal control operation. In making up the coil combinations for the v.f.o. table it is assumed that the v.f.o. unit will supply at least *10 watts output power* on the 80 and 40 meter amateur bands.

Rear view of completed transmitter.  
An external power supply is required.



November, 1946



Type AN3102 Receptacle Shells, sizes 8S to 48



AN3108 Plug



AN3106 Plug



AN3100 Recept.



AN3101 Recept.

Developed prior to World War II for standardization purposes, the AN (Army-Navy Specifications) Connector type series remains as one of the most versatile and widely known lines of electric multi-contact fittings. The large range of shell sizes, insert arrangements, interchangeable parts and accessory fittings make the Cannon Electric "AN" a desirable, all-purpose connector. Cannon Electric's "Quality Control" from diecasting to assembled fitting produces a dependable product used extensively not only in aircraft but also in radio, radar, instruments and countless general electrical applications.

Thousands of aircraft and radio technicians worked with these "Cannon Plugs" during the war; the same thousands are still demanding Cannon quality in peacetime because they know it served them well when the perfect operation of every electrical part of the war machine meant the protection of lives and more efficient prosecution of the offensives.



The 6th Revised Edition of the "AN" Bulletin will be mailed free upon request. Write Dept. K-228, Cannon Electric Development Co., 3209 Humboldt Street, Los Angeles 31, Calif. Prices on specific "AN" Connectors must be obtained from Cannon representatives located in principal cities or directly from factory. For those living outside the U. S. A. and in countries other than the British Empire, write Frazer & Hansen, 301 Clay Street, San Francisco 11, Calif.

**CANNON  
ELECTRIC**  
DEVELOPMENT COMPANY

3209 Humboldt St., Los Angeles 31, Calif.

IN CANADA (and British Empire export)  
CANNON ELECTRIC COMPANY, Ltd., TORONTO



SINCE 1915

# Now! Get COPIES of Anything, in a Jiffy!

... Right in your own office or plant! New, low-cost, error-proof method saves typing, drafting, checking—TIME!



Amazing New Unit—  
**The APÉCO PHOTOEXACT**

Copies anything written, typed, printed, drawn, or photographed

Photo-Copier \$55  
Copies up to 18" x 22"

Also continuous cabinet models for prints of any length, up to 42" wide.

Quickly, Easily copy  
**BLUE PRINTS, TRACINGS, WIRING DIAGRAMS, SPECIFICATIONS, DRAWINGS, GRAPHS, CHARTS, LETTERS**  
(over 100 others)

Make accurate permanent copies of anything at 1-a-minute speed—for less than the price of a phone call! No darkroom or technical knowledge needed. Anyone can operate APÉCO—“America’s Most Widely Used Photocopy Equipment.” Get full information, TODAY!

**MAIL COUPON NOW for this FREE book**



American Photocopy Equipment Co.  
2849 N. Clark St., Dept. HK116  
Chicago 14, Ill.

Send, without obligation, your 20-page illustrated book on Photocopying and its savings in time, money and labor.

NAME.....  
COMPANY.....  
TITLE.....  
ADDRESS.....  
CITY & STATE.....

## GRAB REE'S WHOLESALE RADIO

2608 Ross Ave.  
**DALLAS 1 TEXAS**

**RCA Institutes, Inc.**  
Offer thorough training courses in all technical phases of Radio and Television

WEEKLY RATES      DAYS—EVENINGS  
VETERANS: RCA institutes is approved under G. I. Bill of Rights  
For Free Catalog write Dept. RN-48  
**RCA INSTITUTES, Inc.**  
A Service of Radio Corporation of America  
75 Varick St., New York 13, N. Y.

Almost any good antenna can be used with this transmitter. The author used a pair of half-waves in-phase with 33 foot feeders on the 10 meter band. Stations on the West Coast of the U.S.A. and Europe were contacted from a location in central Pennsylvania. The ends of the 33 foot feeders were connected to the final tank link coil terminals, no coupling device whatever being used. The antenna was about 38 feet above ground.

—30—

### Aircraft Radio (Continued from page 27)

which replaces the military transmitter. (This is a fifty watt transmitter and receiver unit). This group can be seen to the left of the center of the control panel. See illustration Fig. 5, shown on page 27.

3. Tuning and audio controls for a single military range receiver having a frequency range of 195 to 550 kilocycles. These controls were removed from the military control box, and can be seen to the right of the center (Fig. 5).

4. “Audio On-Off” switches (one for each of the receivers, ADF, range receiver and communications receiver) are provided for each of the pilots. These are located along the lower edge of the control panel at each end of the panel.

5. Two hybrid transformers which provide dual audio outputs from the ADF and range receiver. (The communications receiver unit already has dual audio channels).

6. Two auto-transformers to provide impedance matching from high to low impedance as required with some models of military receivers.

It can be seen that all controls are ahead of the pilots’ line of vision and complete separation of the audio facilities have been provided. Reasonable cleanness has been gained, too. The remote crank for a trailing wire antenna reel is within easy reach of both pilots. Space for this control was made by relocating the ADF control box to the left of its original position. The military transmitter control was also removed. A comparison with the original cockpit layout can be made by referring to Fig. 2.

#### An “Unmodified” Cockpit Layout

In contrast to the modified installation as just illustrated compare the foregoing with the new control panel shown in Fig. 7. This is an engineered unit starting with a completely new set of radio gear. Nothing makeshift has been required. A single unit takes the place of the several controls required in the modification. The entire radio system was treated as a unit and engineered from that standpoint. The advantages gained are obvious, but a few should be pointed out such as; a very clean cockpit with all radio controls ahead of the pilots’ line of vision; ease of installation; complete

# “VOMAX”



#### OUTSTANDING

##### FEATURES

- D.C. Volts at 51 and 126 megohms.
- A.C. and r.f. volts at 6.6 megs.
- Resistance .2 ohms to 2,000 megs.
- D.C. current 1.2ma. through 12 amperes.
- D.B. — 10 through +50.
- PLUS visual dynamic signal tracing.

In our critical opinion these features establish “VOMAX” as standard of comparison. Early shipment at only \$59.85 net — as long as price holds.

**RADIO EQUIPMENT DISTRIBUTORS**  
709 SO. MAIN ST.  
LOS ANGELES 14, CALIF.

## HAMS, EXPERIMENTERS TRY THIS NEW TWO-METER RING-TUNER

A COMPLETE variable tuning unit having a tuning range of 140 m.c. to 160 m.c. (with 3.5 uuf tube capacity) designed for single hole mounting on receivers, wave meters, frequency meters, low power transmitters and oscillators. Manufactured expressly for use in the amateur 144 m.c. to 148 m.c. band. Compact and easy to assemble... no condensers to trim, no coils to wind, no sliding contacts. “Q” is many times greater than conventional condenser combinations. Send check or money order for a Clarkstan Ring Tuner today! Write for free technical bulletin 110-RN.

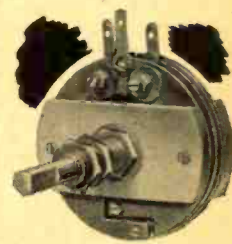

**YOUR NET PRICE \$4.80** - No C.O.D.'s  
Send Check or M.O.

**DISTRIBUTORS** — get in on this fast moving item — write for details today!

**CLARKSTAN CORPORATION**  
11927 W. Pico Blvd.  
Los Angeles 34, Cal.

use of all facilities offered by the particular units involved; saving in weight and over-all cost. The control panel illustrated provides the following:

1. Complete selection of audio outputs by either pilot with no mutual interference.

2. Audio level controls and marker receiver sensitivity control within easy reach of either pilot.

3. Individual range-voice filter selector switches for each pilot. Only the ADF or range receiver output can be filtered at one time, not both at the same time, with each filter selector switch.

4. Tuning control, tuning meter, band selector and function selector switches for an ADF having frequency range of 200 to 1750 kilocycles. All ADF controls are red.

5. Tuning control, band selector, function selector and AVC-MVC-CW switches for a range receiver having a frequency range of 150 to 1100 kilocycles and 2.0 to 10.00 megacycles. This receiver has provision for the addition of an antistatic loop antenna. Facilities for two crystal lock-in points within the frequency range are also a part of this receiver.

6. Channel selector, transmit-interphone switches, and indicator light for a ten channel crystal controlled communications unit. The channel selector switch automatically operates an antenna changeover relay on those channels on which a trailing wire is used if this type antenna is included.

7. Microphone and headset jacks located for convenient routing of the microphone and headset cords. These do away with the need for any external jack boxes.

An easily installed mounting base is used. Four captive screws are used to secure the panel to the mounting base. Mechanical tuning shafts are well routed from the controls back to the receivers. "On-Off" switches are combined with the receiver function switches, marker receiver "Hi-Lo" sensitivity switch and the communications unit channel selector switch.

#### Installation Problems

The radio system controlled by this panel approaches in completeness those carried by commercial airlines. And now that an outline of the problems to be answered has been made let us get into the problems confronting the engineer from the actual installation standpoint.

#### Transmitter Fixed Antennas

In low and high frequency transmitter work the problem of antennas will likely remain as one of the greatest stumbling blocks to good transmitter efficiency. Due to the small physical sizes of the medium weight aircraft in use a single, straight wire of even thirty feet in length is difficult to obtain without many compromises.

For example, on one of the most widely used aircraft the distance from one vertical fin to a mast located at a

# BETTER VALUES from ARROW!

## NAVAL AIRCRAFT RECEIVER

Broadcast Band from 520 to 1500 KC, tube complement. 3-12SK7, 1-12SR7, 1-12A6, 1-12K8; can be used with 24V dynamotor supplying A & B power; can be converted to AC or DC or 32 volt sets; 3 stages of IF used, uses 3 gang condenser, complete with tubes and schematic. **\$12.95**  
Each.....  
Dynamotor DM32A, each.....\$4.95

## SUPREME FOUNDATION METER

40 Micro Amps., 20,000 ohms per volt. 4 1/2" square. Manufactured by Supreme Instruments Corp. **\$8.95**  
Each.....

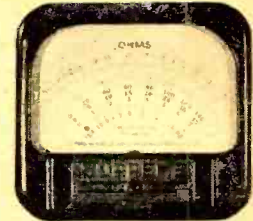

## HEADPHONES

Signal Corps, 8000 ohms and 200 ohms, ea. ....\$2.49  
Lots of 10.....\$19.50  
2000 ohms Headphones, Trimm, ea. ....\$1.79  
Lots of 10.....\$16.00

## SPEAKERS

	EACH
PM Alnico 4"	\$1.60
5"	1.65
6"	2.25
4x6"	2.15
6" extra heavy	2.85
8"	3.85
Dynamic 12"	6.95
1000 ohm field	

## SOCKETS

Molded octal sockets, ea.	7c
lots of 100	\$5.00
Ceramic sockets with metal ring, ea.	9c
lots of 100	\$7.00

## 3 1/2" G. E. AUTOMATIC TIME METER

60 cycle 110 volts. This time meter consists of a cyclometer driven by a telechron synchronous motor. Connect to an electric circuit; it will measure and indicate the number of hours, tenths of hours or minutes that the circuit is in use. Shipping wt. 6 lbs.—list \$17.00.  
Your Cost.....\$4.95

## MICA CONDENSERS

All popular sizes. 100 assorted.....\$2.95

## TRANSFORMERS

4-5-6 Tube Power Transformer, 110-120V, 6.3 V and 5V winding	\$1.89
7-8-9 Tube Power Transformer, 110-120V, 6.3V and 5V winding	2.59
10-12 Tube Power Transformer, 100 Ma., 6.3 V. and 5V winding	3.19
6L6 output transformer	1.79
Single output for 50L6, 25L6, 6V6	.55
Single pentode output for 42, 43	.55
AC-DC Chokes, 250 ohms	.45

## TUBULAR ELECTROLYTIC CONDENSERS

	EACH
2500 mfd. 3 v	.49c
250 mfd. 10 v	.29c
50 mfd. 150 v	.54c
40 mfd. 150 v	.42c
20 mfd. 150 v	.35c
10 mfd. 50 v	.29c
20-20 mfd. 150 v	.55c
30-30 mfd. 150 v	.65c
40-40 mfd. 150 v	.70c
50-30 mfd. 150 v	.75c

## KITS

Kit of 10 assorted volume controls up to 2 meg. less switch	\$1.59
Kit of 50 assorted knobs	2.85
Kit of 5 to 20-watt resistors	1.89

## PICKUP

Low pressure crystal pickup	\$2.20 each
Lots of 10	\$19.50

## PLUGS

PL55 Plugs	20c each
Lots of 100	\$15.00

## JACKS

JK 26	20c each
Lots of 100	\$15.00

## CARBON MIKE

T-17-B carbon mike, ea.	\$1.49
-------------------------	--------

Wholesalers, dealers, institutions and other quantity purchasers... write, wire, phone for quantity prices.

# ARROW SALES, INC.

59 WEST HUBBARD STREET • CHICAGO 10, ILLINOIS

Telephone: SUPERIOR 5575

**NOW—A REALLY HIGH-POWERED—  
Radio Engineering  
Library**



**NOTE:**

The Library comprises a selection of books culled from leading McGraw-Hill publications in the radio field.

- especially selected by radio specialists of McGraw-Hill publications.
- to give most complete, dependable coverage of facts needed by all whose fields are grounded on radio fundamentals.
- available at a special price and terms.

THESE books cover circuit phenomena, tube theory, networks, measurements, and other subjects—give specialized treatments of all fields of practical design and application. They are books of recognized position in the literature—books you will refer to and be referred to often. If you are a practical designer, researcher or engineer in any field based on radio, you want these books for the help they give in hundreds of problems throughout the whole field of radio engineering.

**5 VOLUMES, 3559 PAGES, 2558 ILLUSTRATIONS**

1. Eastman's FUNDAMENTALS OF VACUUM TUBES
2. Terman's RADIO ENGINEERING
3. Everitt's COMMUNICATION ENGINEERING
4. Hund's HIGH FREQUENCY MEASUREMENTS
5. Henney's RADIO ENGINEERING HANDBOOK

10 days' examination. Easy terms. Special price under this offer less than books bought separately. Add these standard works to your library now; pay small monthly installments, while you use the books.

**10 DAYS' FREE EXAMINATION—SEND COUPON**

**McGraw-Hill Book Co.**  
330 W. 42nd Street, New York 18, N. Y.

Send me Radio Engineering Library, 5 vols., for 10 days' examination on approval. In 10 days I will send \$2.50 plus few cents postage, and \$4.00 monthly till \$26.50 is paid, or return books postpaid. (We pay postage on orders accompanied by remittance of first installment.)

Name .....

Address .....

City and State .....

Company .....

Position ..... RN-11-46

**Now for EVERY WORK SHOP!  
NEW Electroplates  
by BRUSH**



**Easy to Plate CHROMIUM  
GOLD, SILVER, NICKEL, COPPER**

*For Pleasure and Profit!*

If you have a workshop—at home or in business—you need this new Warner Electroplater. At the stroke of an electrified brush, you can electroplate models and projects—you can replating worn articles, faucets, tools, fixtures, silverware, etc. with a durable, sparkling coat of metal. . . Gold, Silver, Chromium, Nickel, Copper or Cadmium. Method is easy, simple, quick. Everything furnished—equipment complete, ready for use. *By doing a bit of work for others, your machine can pay for itself within a week.* So make your shop complete by getting a Warner Electroplater right away. Send today for FREE SAMPLE and illustrated literature. ACT AT ONCE!

**WARNER ELECTRIC CO. Dept. K-101  
1512 W. Jarvis Chicago 26, Ill.**

**FREE Details & Sample!**

WARNER ELECTRIC CO., 1512 W. Jarvis Chicago 26, K-101  
Gentlemen; Send Free Sample and Details to:

Name .....

Address .....

City ..... State .....

point above the cockpit is approximately twenty-two feet. Twenty-two feet is less than one-third of a quarter wavelength for 3105 kilocycles. The angle between the legs of a "V" formed by an antenna running from each vertical fin to the mast above the cockpit is small. "Folding," and effective shortening of the forty-four foot antenna obtained in this way, results. It is desirable, too, to be able to use one fin-to-mast antenna for a range receiver without having to employ an antenna changeover relay. If the communications antenna is used for a range receiver such a relay is needed.

Unless the lead-in is made at some angle greater than sixty degrees to the straight portion of the antenna the total electrical length is effectively shortened. In this particular case a well spaced lead-in back through the fuselage to a point just ahead of the horizontal stabilizer can be installed to allow the lead-in to depart from the fuselage at close to a ninety degree angle (reducing capacity) and feed the overhead portion of the communications antenna at close to a ninety degree angle. Even though the lead-in is longer and inside the fuselage, an over-all improvement in effectiveness of the antenna can be obtained as compared with an antenna whose lead-in within the fuselage is short, but which departs from the fuselage and feeds the overhead portion of the antenna at comparatively sharp angles. Further improvement in the characteristics may be obtained by carrying the overhead portion of the communications antenna over the nose of the aircraft. A short mast, erected as far forward on the nose as possible, is used to anchor the forward end of the communications antenna. That is, of course, if the pilot's objection is not too great! By finishing such a mast in dull black the reflection becomes nil, and actual obstruction to vision is not nearly as much as would be thought.

The writer's experience has shown that an antenna such as just described "loads" almost like a standard communications antenna on a Douglas DC-3, but of course, the radiation is not nearly as good with equal power. In practice a fifty watt transmitter working into an antenna with a nose mast gave coverage of at least 75 miles on the congested itinerant frequency channel, 3105 kilocycles. "Clear channels" such as used by commercial operators extend this range by several times. (See Fig. 3.)

On most of the smaller, single engine craft it is often necessary to depart from a single wire and revert to the "clothes line" system of stringing wires from wingtips to tail, etc. With high speed aircraft (over 180 miles per hour) many serious disadvantages present themselves. It is entirely possible that mechanical resonance between the aircraft structure and the antenna might occur. Vibration of the antenna wire in the wind-stream could then cause antenna

**Radio Amateurs**

**ATTENTION**

**Prepare your  
Christmas Gift Early.**

Guaranteed to play radio kit and record player in unit housing. Including 5 tubes 12SA7, 12SQ7, 12SK7, 50L6, 35Z5

**Price \$37.50**

Also 6 station intercommunication sets with substation.

**Price \$29.50**

Record players, ready to play, volume and tone controls, with Detrola Changer, 3 tube amplifier, 6" speaker, Speaker hole metaled grill covered with grill cloth.

**Price \$39.50**

Record players ready to play with Seeburg changer, 3 tube amplifier, 6" Speaker metal grill front. Speaker hole metaled grill covered with grill cloth.

**Price \$44.50**

Separate Stands for above changers including metal grill and grill cloth to cover either in walnut or mahogany.

**Price \$9.95**

Also 3 tube amplifier with tubes, Volume & Tone Controls, Line Cord,

**Price \$9.95**

**BARCLAY ELECTRONICS**

3328 Gwynns Parkway Baltimore 16, Md.

**THE WORLD'S  
RADIO TUBES**

*U. S., British,  
French, Czeck,  
German, Italian,  
Russian, etc., etc.*

**240 pages of complete characteristics with explanations in four languages.**

ELECTRONICS says, "Here at last is the radio tube handbook radio engineers have dreamed of . . . in seven carefully prepared tables and charts."

"Probably the most complete and authoritative set of tube-data in existence," says RADIO CRAFT.

**Up to date.  
1946 edition just out.**

**BUY IT AT YOUR FAVORITE RADIO PARTS DEALER or direct by mail from us.**

**\$2.50 per copy**

Plus 7c Postage in U.S.A.

**EDITORS & ENGINEERS, LTD.**

1302 Kenwood Road, Santa Barbara, California  
(MINIMUM TRADE ORDER, 3 COPIES)



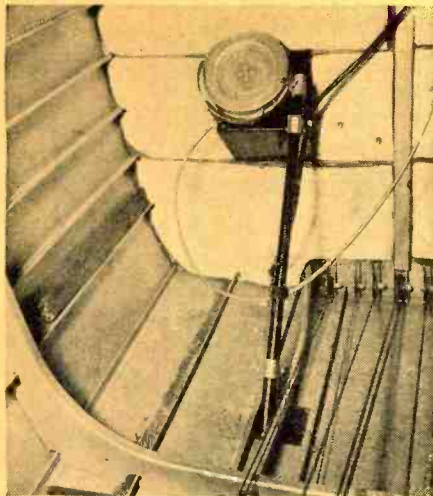

Fig. 6. Trailing-wire antenna reel.

breakage, or structural failure. It is obvious that a wire across the windstream will be more susceptible to icing than one running lengthwise to the windstream and the ice load and shape will affect the mechanical resonance point of the antenna. Angles of greater than 20° between the antenna wire and windstream should not be exceeded where the airspeed is 180 miles per hour or over. Drag (wind resistance) increases rapidly, too, as the angle increases.

The "spider web" type antenna system will certainly make possible transmitter loading, yet the radiation resistance is usually rather low. It is also possible that cancellation occurs to some degree.

The inconvenience to the loading of passengers who must thread their way through a maze of wires has to be considered. In addition, greater difficulties and hazards in hanging an aircraft having such a web of wires hanging from it are encountered. If damage is not done to another craft the antenna in question is often pulled loose, stretched or otherwise made to require some maintenance.

**Loading Units:** Unless the transmitter itself has sufficient provision for loading built into it some form of external loading unit will be required. A very effective loading coil can be constructed with little cost. Loading coils should be built of the lowest loss materials available and spaced as far away from any structure as possible. A major disadvantage of external loading is that only one frequency can be readily taken care of without resorting to a more or less complex unit.

**Antenna Icing, Precipitation and "Ground" Effects:** No completely successful simple method of combating ice and rain on antennas has been developed. Precipitation of any kind seriously changes the antenna resistance and reduces radiation, usually because of detuning. Wherever possible final tuning adjustments should be made in flight in a clear sky to prevent the effects of ground capacity and precipitation. The detuning ex-

November, 1946

# TUBE TESTERS

NEW

MODELS

Quantities in Stock Now!

Famous JACSON Model 637  
TUBE TESTER and  
ANALYZER, Price ..... \$82.00

- \* Automatic push button selector.
- \* Provisions for modernization.
- \* Test all types.
- \* Dynamic output tube test.
- \* Ballast tube tester.
- \* Test for shorted or leaky condensers.
- \* Multirange A.C. voltmeter 0-10, 0-100, 0-250, 0-500, 0-1000, 0-2500.
- \* Multirange D.C. voltmeter 0-10, 0-100, 0-250, 0-500, 0-1000, 0-2500.
- \* DB meter — 10 to 14, 10 to 34, 30 to 54 DB.
- \* Multirange D.C. milliammeter 0-1, 0-10, 0-100, 0-500 ma.
- \* A.C. amperes 0-10 amps.
- \* Triple range ohmmeter 0-3000, 0-30,000/30 meg ohms.

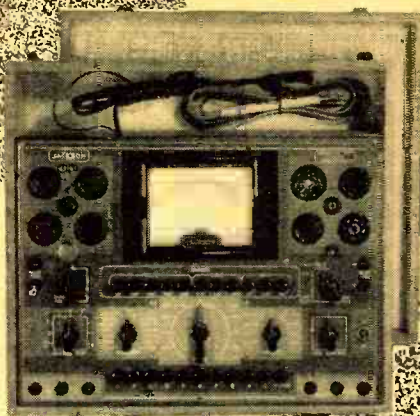

## SYLVANIA

Counter Model No. 139 ..... \$69.50

Portable Model No. 140 ..... \$69.50

- \* Short test with proper voltages.
- \* Tests performed under dynamic conditions.
- \* Special provision for easy modernization.
- \* Tests lock-in standard, acorn, miniature and other types.
- \* Sturdy rugged construction — portable carrying case of gray crackle finished steel.
- \* NOT BUILT FOR SYLVANIA BUT BUILT BY SYLVANIA to do a thorough testing job.

## Simpson Model 305 -- \$46.25

TOPS IN QUALITY AT LOW COST

- \* Checks all types.
- \* Checks pilot lamps and Christmas tree lamps.
- \* Checks ballast types.
- \* Latest improved circuit.
- \* New 3-way switching makes it possible to check any type regardless of base connections.
- \* Sockets for every receiving type
- \* Large fan shaped meter.



Dayco Model 410 -- \$50.00

- \* Flexible and easy operation.
- \* New circuit incorporates latest recommended loads and voltages.
- \* Sensitive hot short test.
- \* Ballast tube test for over 300 types.
- \* Dial light test.
- \* Ohmmeter 0-40,000 and 0-400,000
- \* Voltmeter 0-100 and 0-1000 D. C.
- \* Furnished complete with test leads in beautiful oak case.

IMMEDIATE  
DELIVERY--

Easy Terms—

Write for List  
of All Avail-  
able Test  
Equip-  
ment

# SREPCO

STANDARD RADIO & ELECTRONIC PRODUCTS CO.

135 East Second Street, Dayton 2, Ohio

MAIL ORDERS GIVEN PROMPT ATTENTION! WRITE US FOR  
INFORMATION ON ALL PARTS --- 20% DEPOSIT ON MAIL ORDERS

ALL PRICES  
ARE NET  
F. O. B.  
DAYTON, O.

# Can't Be BEAT At TWICE The Price

E. M. C. "VOLOMETER"\*  
(\* Trade Name)



**PRESENTING:** A new line of volt-ohm-milliammeters of the highest quality, and at a price that is destined to make radio history! The EMC line of VOLO.



Model 100

METERS are rugged, flexible instruments manufactured to the highest standards of quality and precision, and yet they sell for a price that can't even be approached by com-



Model 101-B

petitors unless quality is sacrificed or features are eliminated. Want proof?



**SPECIAL FEATURES:** Unusually wide resistance ranges. AC volts from 25 cycles to one megacycle with no temperature error. Battery and rectifier replaceable

**SPECIFICATIONS:** Model 100 (top left) 6 AC-DC voltage ranges, (1000 ohms per volt). 0 to 3-12-60-300-1200-6000 volts. 4 DC current ranges, and 3 resistance ranges, 1/4 ohm to 30 meg-ohms. Open face (shown) \$21.95.

**MODEL 101-B** (center) 4 1/2 inch meter. 4 resistance ranges, 1/20th ohm to 20 megohms. 5 AC-DC voltage ranges and 3 DC current ranges. Open face (shown) \$20.95. Portable model \$24.95.

**MODEL 101-A** (bottom left) Same as Model 101-B in every respect, except that this model is equipped with a 3 inch meter. Open face (shown) \$17.50.

**ELECTRONIC  
MEASUREMENTS CORP.**  
114 Liberty St., New York 6, N. Y.

perienced with the aircraft on the ground is not serious since contacts with the control tower can still be made. Final tuning adjustments to transmitter should never be made in rain or snow. Detuning due to precipitation of any kind becomes more serious in its over-all effect when the antenna resistance is small since any change resulting from this source is a greater percentage of the total. If transmitter tuning must be done in a hangar extreme care in prevention of fires must be taken. It is definitely not a good practice. Nor can the adjustments be considered final. An external primary power source should be used whenever possible in order to save the low capacity aircraft batteries carried in the ship.

**Trailing Wire Antennas:** Trailing wire antennas are very often the only answer to a highly efficient transmitter system. Unfortunately they are not only inconvenient to the crew, causing additional work for them, but present actual danger to those on the ground in case the antenna weight is lost while in flight or when the antenna is not reeled when landing (forgetfulness on the pilot's part is not always to blame!). A solid weight of any kind is unstable aerodynamically and will oscillate especially as it is being reeled in. Damage to the aircraft structure results if the weight strikes the ship. Unless the fairlead is properly located the wire may foul some part of the landing gear, controls, pitot masts, etc. A piece of one-inch open link chain weighing approximately a pound, although not good in appearance (see Fig. 6), will not whip or oscillate. A string of lead beads on a section of flexible cable is perfectly stable at all speeds. Neither of these require a swivel to prevent twisting of the antenna wire as do any of the drag cup or windsock type antenna "Drags." Rubber balls and windsocks are very popular with small aircraft, but a strong swivel must be used even at the lower speeds if it is to last very long.

The use of v.h.f. will make possible small, light and simple mast type antennas. The lead-in problem and routing will be much simplified, too.

**Antenna Changeover Relays:** When a transmitter antenna is used for a receiver antenna, a changeover switch must often be provided. The changeover relay employed must be positive and not subject to vibration. Self cleaning contacts are of primary importance and a cover of some kind should be used for protection from dirt and damage. Intermittent and noisy receiver operation is often traced to this source. Where high r.f. voltages must be handled, as is the case with a short antenna, a vacuum relay may be required, and although they are more expensive their reliability and trouble-free characteristics make them a good investment. Most transmitters have built-in changeover relays, but the type of relay and its usage should be considered nevertheless.

**Receiver Antennas:** Balanced "T"

*F. M. Listeners!*

## the new GON-SET

F. M.  
CONVERTER



Provides New FM  
Band Reception  
(88-108 MC) for Re-  
ceivers Covering  
Old FM Frequen-  
cies (42-50 MC)

"GON-SET" F. M. Converters are available in three bands, covering the following frequencies:

TYPE "A"	TYPE "B"	TYPE "C"
88 to 96 m.c.	96 to 104 m.c.	100 to 108 m.c.

In ordering, be sure you choose the correct model covering the frequencies utilized in the area where the receiver is to be used.

**\$14.95**

Manufactured by

**WATERPROOF ELECTRIC CO.**  
BURBANK, CALIFORNIA

Attention . . .

### RADIO MANUFACTURERS and WHOLESALERS

**WIRE-WOUND RESISTORS**  
1/3 to 200-WATT — Large Assortment  
**SPRAGUE—WARD LEONARD—I.R.E.  
SHALLCROSS, Etc.**

#### CONDENSERS

Aerovox	Cornell Dubilier
Sprague	Tobe Deutschman
Solar	Westinghouse
Fast	Guderen

125,000 all Capacities

Fuses	Jones Terminal Strips
Knobs	Buss Fuse Holders
Resistors	G.E. Switchettes
Micro Switches	Potted Filter Chokes

4 Contact Ceramic Sockets  
Octal Sockets—Ceramic & Mica

#### WIRE

Special 40,000 feet, single conductor, shielded, 22 gauge, gray covering  
Manufactured by Western Electric Co.

WHOLESALE ONLY

**CLARK-REISS DISTRIBUTORS**

32 Broadway

Digby 4-6891

New York City 4

antennas or balanced "V" antennas with a vertical lead-in are preferred for receivers working on the 200 to 400 kilocycle band due to more symmetrical "cone-of-silence" characteristics over the radio range stations (nondirective reception). It is not always possible to attain this due to mechanical mounting problems, etc., and fortunately, when a 75 megacycle marker receiver is used the importance of the cone-of-silence indication is of less importance. In addition better signal pickup is obtained with the same length of antenna used as an "L" type rather than a "T" or "V" type antenna. A "T" or "V" antenna should have at least eight feet on each leg for satisfactory service and be as well spaced from the fuselage as possible. An "L" type approximately ten or twelve feet long will prove adequate for most range receivers. The distortion of the cone-of-silence due to directivity, is not often so serious as to make it useless in case the marker receiver is not used.

Whip antennas have excellent characteristics, but there are two major objections to their use. The first is their small size (approximately 5½ to 6 feet) which is not great enough for adequate signal pickup under all conditions. The second is breakage. An "L" antenna for long distance work and a whip for close in radio range work has been used with very good results. However, an antenna changeover relay is required. Where possible the range receiver antenna should be located on the belly of the aircraft in order to reduce to a minimum blanketing of the signal by the aircraft and allow direct path reception. Small ground clearances and hazards to ground crews will not always make belly mounting practical.

The ADF sense antenna will work most satisfactorily if it meets the requirements as outlined above and at the same time passes directly over and in line with the loop antenna. Minor departures from such installation have been made in many cases which work perfectly. Automatic compass action is difficult to predict and ADF bearing reversals may occur where extreme unbalance of loop sense antenna location exists. An "L" antenna approximately ten feet in length passing over the loop housing with four inches or more clearance will produce very good results.

Proper operation of the marker receiver is dependent to a large degree upon the placement of the marker antenna with respect to all surrounding objects including other antennas, landing gear, etc. The antenna should be horizontal in flying position of the aircraft and the external lead-in short and vertical. A half wavelength or approximately 76 inches is used. The position of the tap must be determined by the spacing between the antenna and the aircraft structure. A fifty ohm coaxial line is used for a lead-in inside the fuselage. The coaxial cable shielding must be grounded directly at the point of entry of the external

November, 1946

# DON'T



EVERY radio engineer will tell you it is, literally, as hazardous to change to a "strange" type of Phonograph Pickup Cartridge in making replacements as it is to change horses while crossing a stream.

The cartridge used in any pickup arm originally supplied with phonograph equipment was carefully selected by set manufacturer engineers for certain characteristics contributing most to the quality of reproduction of such equipment. To switch to another type cartridge is taking unnecessary chances. The safest course is duplication of the original. That Astatic Cartridges are preferred and used by a majority of leading manufacturers of electrical phonographs and automatic record changers is convincing evidence of their expert engineering, high operating efficiency and dependable service.

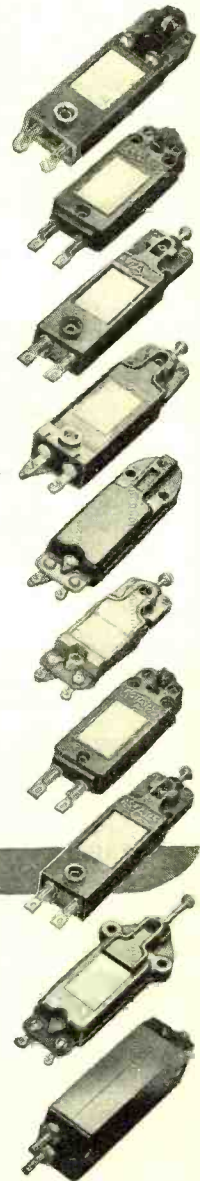

**Sigmon's - WEST VIRGINIA'S LARGEST RADIO SUPPLY HOUSE!**

**AMPLIFIER for GUITAR OR PHONO**

★ TUBES 6SJ5, 6J5, 6L6, 5Y4G  
★ 4 Tubes—Hi Gain  
★ Two Microphone or Instrument Inputs  
★ Phone Input  
★ 6½ Watts—Beam Power

★ Solid Wood Cabinet  
★ Aeroplane Cloth Covered  
★ Tone Control  
★ Heavy Duty 8" Speaker  
★ Complete with Tubes

Complete with Tubes—List \$59.50 **Your Cost \$37.00**

VMI BRUSH CONTROL MIKE—Net \$10.40  
MM TURNER CONTACT MIKE—Net \$9.45

**PHONO AMPLIFIER**  
3 Tube AC-DC  
Uses: 50L6, 35Z5, 12SR7, and 450 ohm speaker  
**Net \$5.97**

FOR LATEST CATALOG WRITE TO...

**Sigmon's**  
RADIO SUPPLY  
CHARLESTON, W. VA.

**EASY TO LEARN CODE**

It is easy to learn or increase speed with an Instructograph Code Teacher. Affords the quickest and most practical method yet developed. For beginners or advanced students. Available tapes from beginner's alphabet to typical messages on all subjects. Speed range 5 to 40 WPM. Always ready—no QRM.

**ENDORSED BY THOUSANDS!**

The Instructograph Code Teacher literally takes the place of an operator-instructor and enables anyone to learn and master code without further assistance. Thousands of successful operators have "acquired the code" with the Instructograph System. Write today for convenient rental and purchase plans.

**INSTRUCTOGRAPH COMPANY**  
4711 SHERIDAN ROAD CHICAGO 40, ILLINOIS

**LES Correspondence Courses in RADIO and ELECTRICAL ENGINEERING**

**ELECTRICAL ENGINEERING** Get good grasp of wide electrical field. Prepare yourself at Low Cost, for secure future. Modern course. So simplified anyone can understand quickly.

**RADIO ENGINEERING** Extra fine course in radio, public address, photo-electric work. Train you to be super-service man, real vacuum-tube technician. Servicemen needed badly. Diploma on completion.

Send postcard or letter for Free Copies of school catalogs. Full details, all about deferred payment plan, etc. SEND NOW!

**LOW AS \$25** Either Course

LINCOLN ENGINEERING SCHOOL, BOX 931-R95, Lincoln 2, Nebr.

**Specify SAUERISEN**  
**ACIDPROOF CEMENTS—COMPOUNDS**  
FOR  
Tanks, Sewers, Stacks, Floors  
Technical cements for all purposes.  
Send sketches or samples  
Sauereisen Cements Company • Pittsburgh 15, Penna.

lead-in. Where the antenna has approximately nine inches separation from the fuselage the tap is usually five to six inches off center to produce the correct impedance matching. Adjacent antennas and obstructions may cause severe distortion of the marker beacon patterns (due to marker antenna directivity produced) to the extent that the marker station cannot be located accurately. Audio signal will appear some time before the visual light signal. The visual light signal should be visible for a period of approximately 20 to 25 seconds when passing over a station at 3000 to 4000 feet at a speed of 120 miles per hour. Sensitivity adjustments and antenna characteristics will determine the time element and in any case the symmetry must be very good. Flight tests are the only means of determining accurately the over-all performance. Only high quality insulators should be used on the marker antenna to reduce leakage and maintain the antenna characteristics as nearly as possible to the original adjustments. A balanced "T" range receiver antenna may sometimes also be used as marker receiver antenna by employing a coupling transformer. Such a system may limit the size of the "T" antenna to a degree where the range receiver is not as effective as is desired. Careful flight testing and adjustment is needed. A half-wave dipole with the coaxial cable making connection at the center of the antenna has been tried with some success, yet the mechanical difficulties and maintenance required is almost prohibitive.

**Loop Antennas:** A preferred location for an antistatic loop is on the belly and free of obstructions. Difficulty of mounting, antenna cable length and chances of mechanical damage sometimes dictate placement on the top-side. Practical results have proven that loop antennas mounted on top give fully satisfactory results operationally. If two loops are to be mounted adjacent to each other approximately two feet of space should be allowed between them to prevent interaction or coupling. This objection is not so serious where one is a fixed position loop.

In every case where a loop antenna is to be used to take bearings on a station, calibration correction must be determined beforehand. Only in a very few instances on wood constructed aircraft has calibration correction been so small as to be negligible. On the other hand plus and minus errors of up to 20 degrees are common even where the loop antenna is unobstructed and is placed symmetrically on the aircraft. Instructions for calibration determination can be found in the manuals accompanying this type of equipment, and although involved, is not particularly difficult.

**Location of Radio Gear:** Placement of the radio units poses several requirements, each of which must be met. Four of the major considerations are as follows:

**10-Meter 3-Element BEAM ANTENNA**

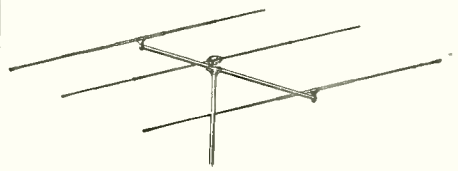

- ... After lengthy tests, our engineers have developed a highly efficient beam ...
- designed to convert the Workshop 10-meter dipole #29AD to a 3-element beam
  - adjustable telescopic elements
  - rigid construction to withstand high winds and ice
  - adjustable spacing between elements
  - simple, clean-cut design for quick assembly
  - to be used with Workshop rotating mast
  - co-axial transmission line recommended

10-Meter Beam Conversion Kit Model #29B.....\$27.50

The above kit converts the 10-meter dipole model #29AD (price, \$6.75) to a 3-element beam.



**The WORKSHOP ASSOCIATES**  
66 Needham St., Newton Highlands 61, Massachusetts

**The BUY of a LIFETIME!**

U. S. SIGNAL CORPS **only**

**5 Meter SHORT WAVE TRANSMITTERS** **\$3.49**

(72.2 Mc.) **BRAND NEW**

Complete with Tube

One 1½ volt dry cell and 67½ volts of B operates it. Just attach di-pole, key or mike, connect the batteries and it's ready to use. Signal Corps spec wired with silver wire, silver-mica condensers, and precision resistors. Highly stable circuit with Lo-Loss silver inductance. (Adjustable paddler.) Schematic supplied.

- Converts easily to walkie-talkie and Ham bands.
- Weighs less than a pound.
- Shipped by express only. No C.O.D.s. No Parcel Post
- A sacrifice at only \$3.49. Postal or express money order or certified check.

**NEWARK SURPLUS MATERIALS CO.**  
324 Plane St., Dept. N Newark 2, N. J.  
Send stamp for our giant Catalog

**Now on Sale!**

**RADIO-ELECTRONIC ENGINEERING**

November 1946 Edition

An eight page magazine with articles of interest for all radiomen.

Send **10c** (coin only)

**ZIFF-DAVIS PUBLISHING COMPANY**  
Dept. AE-2, Circulation  
185 N. Wabash Ave., Chicago 1, Ill.

1. Available space. Standardization of unit size and multiples of this size have been followed in the designs of the past few years in transport type equipment as shown in Fig. 4. Most radio rack designs will accommodate them, however this does not hold in all cases. A few aircraft are encountered in which radio racks have not been installed and which require complete structures to be added. Modification of existing racks, or addition of structure, must be approved by the Civil Aeronautics Authority.

2. Structural strength. Often too little attention is paid to this phase. Radio racks already installed have maximum load limits assigned. Where modification is necessary, or new structure, careful structural strength investigation should be made. A weight penalty results when the structure is heavier than needed and danger of structural failure is present if too light. The radio rack itself is seldom part of the primary airframe, but the tie-points are carefully chosen and reinforced in order to properly distribute the load throughout the primary airframe structure. Aircraft manufacturers go to great lengths to obtain adequate strength with light weight. The airframes are normally designed to withstand loads as high as six or more "G." Any changes or additions must be capable of withstanding similar loads and yet not cause excess stresses to appear throughout the adjacent airframe. Civil Air Regulations Bulletin No. 18 covers accepted practices and approved methods of making repairs, materials used, rivet sizes, etc.

3. Location as regards antenna lead-ins; electrical cable routing; mechanical shaft routing; accessibility for maintenance. In most cases considerable compromise must be made in this category. Locating a unit in a compartment with a fuel tank, even a well ventilated compartment, is highly dangerous since gasoline fumes are

Fig. 7. Bendix MS-117 control panel mounted in a Beechcraft Model 18.



## METROPOLITAN Guarantees Delivery from Stock!

### McMURDO SILVER INSTRUMENTS



**"SPARX" DYNAMIC SIGNAL TRACER**

Frequency range from 20 cycles to over 200 mega-cycles. Net ..... **\$39.90**



**CAPACITANCE RESISTANCE BRIDGE**

1/4 mmfd/ohm through 1,000 mfd/megohms 0-50% power factor. Net ..... **\$49.90**



**"VOMAX" VACUUM TUBE VOLTMETER**

One of the finest test instruments of its type. Net ..... **\$59.85**

### SUPERIOR INSTRUMENTS



**Model CA-11 SIGNAL TRACER**

\*Signal intensity readings indicated on meter. \*One connecting cable—no tuning controls. \*Highly sensitive—uses improved V. T. V. M. circuit. Net ..... **\$18.75**



**Model 450 TUBE TESTER**

Tests all tubes up to 117 volts. Speedy operation assured by newly designed rotary switch which replaces conventional snap, toggle or lever action switches. Net ..... **\$39.50**



**Model 650 SIGNAL GENERATOR**

Improved AC—operated—generating RF frequency from 100 Kc to 105 Mc. Audio modulating frequency is 400 cycle pure sine wave. Three-step ladder-type alternator. Net ..... **\$48.75**

### RADIO CITY PRODUCTS INSTRUMENTS



**Model 322 Dynoptimum TUBE TESTER**

Simple operation—only 4 switches used. Special noise test or tubes that otherwise test "good." Counter model. Net ..... **\$41.50**  
Portable model, 322P..... **\$45.50**



**Model 705 SIGNAL GENERATOR**

From 95 Kc to 100 Mc, continuously variable. Planetary drive condenser. Self-contained electronic modulation 400c sine wave for external use. Net ..... **\$49.50**



**Model 802N Combination TUBE & SET TESTER**

DC Voltmeter 0 to 1000 at 1000 ohms per volt. AC Voltmeter 0 to 1000 DC Milliammeter 0 to 1000. Ammeter 0 to 10. D. B. Meter—8/15/15 to 29/29 to 49/32 to 55 decibels. Net ..... **\$59.50**



**Model S-10-A Pocket Size OSCILLOSCOPE**

Complete Cathode ray oscilloscope. Net ..... **\$55.00**



**Model 689-IF WESTON Ohmmeter**

Widely used for production testing of armature and field resistances of small motors etc. List price \$25.50. Net ..... **\$14.85**



**Model 274 DUMONT Five-Inch OSCILLOSCOPE**

Professional type oscilloscope complete with tubes and operating instructions. Net ..... **\$99.50**

Supreme 543-S Multi-Tester .....	\$ 24.75	RCP 461P Sensitive Multi-Tester .....	\$ 42.63
Supreme 589 Tube and Battery Tester .....	\$ 48.95	RCP 664 Electronic Multi-Tester .....	\$ 45.00
Supreme 565 Vacuum Tube Voltmeter.....	\$ 63.50	RCP 683A V. T. "Billionaire" .....	\$ 92.61
Supreme 546 Oscilloscope .....	\$ 89.75	RCP 668 Vacuum Tube Volt-Ohm Capacity Meter .....	\$ 74.50
Superior 679 Super Meter .....	\$ 28.40	Monitor Crystalline Signal Generator .....	\$ 57.50
Superior 500 Electronic Multi-Tester .....	\$ 52.50	Shallcross 630 Wheatstone Bridge .....	\$ 75.00
Superior 600 Combination Tube & Set Tester .....	\$ 62.50	Shallcross 637 Kelvin-Wheatstone Bridge.....	\$100.00
RCP 448 Pocket Multi-Tester .....	\$ 24.50	Shallcross 638 Kelvin-Wheatstone Bridge.....	\$150.00

Write for our FREE Complete 1947 Catalog!

**Metropolitan**

**ELECTRONIC & INSTRUMENT CO.**

Dept. R, 6 MURRAY STREET  
NEW YORK 7, N. Y., U. S. A.

Cable Address: METRONICS  
Phone: BARclay 7-5556

**BUILT-IN QUALITY**  
 Made Our Famous  
**RADIO & PHONO KITS**  
 A National Success!  
 THE IDEAL KITS FOR  
 STUDENTS • SCHOOLS  
 HOSPITALS • SERVICEMEN  
 AMATEURS



Our Model S-5 uses the universally accepted super heterodyne circuit containing the following tubes: 12SA7, 12SK7, 12SQ7, 50L6, 35Z5 and tunes from 550 Kc to 1600 Kc. Model S-5 (illus.)

..... Complete Kit including tubes, Bakelite cabinet and four pages of diagrams and instructions ..... **\$17.95**

**New! Sensational!**  
**COMBINATION  
 RADIO  
 PHONO KIT**



- 5-tube superheterodyne radio
- Beautiful walnut finish cabinet
- 5" Alnico V Speaker
- Astatic L-72 Pickup

Model RP-S5, complete kit @ ..... **\$34.95**

All Kits Are Furnished Complete,  
 Less Wire & Solder

Direct Shipments to All Parts of the World!  
 25% Deposit on C.O.D. Orders

**RADIO KITS COMPANY**

Dept. K, 120 Cedar St., N. Y. 6, N. Y.

Come to the famous

**COYNE  
 TRAINING SHOPS**

where you "learn by doing"



**TRAIN FOR RADIO-  
 ELECTRONICS  
 IN A FEW WEEKS**

**Prepare For A Good Job Now With  
 A Lifetime Future!**

Trained Radio-Electronics men needed now. They will be needed too in the years to come. Don't be caught napping. Get a Radio training now and be ready. Learn by Doing. Free employment service for life after graduation. Many earn while learning. If you are short of money, ask about my Student Finance Plan. Now added Training in Industrial Electronics and Electric Refrigeration. We are also equipped to train those who qualify under G. I. Bill. We also have facilities for men with physical disabilities whether due to war or other causes. Fill in and mail coupon for details.

**SEND COUPON FOR FULL DETAILS**

H. C. LEWIS, Pres., Radio-Electronics Div.  
 COYNE ELECTRICAL SCHOOL

500 S. Paulina St., Dept. 86-1K, Chicago 12, Ill.

Send Big Free Book; also details about Coyne Part-Time Employment and Student Finance Plan

Send G. I. Bulletin  Physical Disability

NAME..... AGE.....

ADDRESS.....

CITY..... STATE.....

almost always present after fueling and normal arcing of dynamotor brushes can cause them to explode. Such installations have been made in exceptional cases but only where the fuel tank compartment was perfectly sealed off from the radio or baggage compartment in which the radio was located.

4. Weight and balance. This requirement becomes more critical as the weight of the radio equipment increases in comparison with the total gross weight of the aircraft since the percentage of change in c.g. (center of gravity) location is increased and is, therefore, more pronounced. This is a straight-forward problem in mechanics.

Each aircraft has an individual operations record which includes the empty weight of the craft, c.g. location and total empty weight moment (weight in pounds multiplied by moment arm in inches giving moment in inch-pounds).

The c.g. must lie within certain designated limits, fore and aft, (lateral c.g. is not computed) in order for the aircraft to be licensed. In computing empty c.g. expendable load such as fuel cannot be considered. However, fuel, oil, deicing fluid, baggage, passengers and their locations must all be considered in the most unfavorable, extreme positions in computing loaded weight. The c.g. must not exceed either the forward or rearward limit under any condition of loading. In some cases a "placard" is attached to the aircraft designating the allowable load, and its position. Such limitation is very undesirable for the operator and should not result from the addition of radio equipment if at all possible. In many cases a "loading schedule" is used. Greater flexibility is obtained, but computation of load and its placement must be made prior to a flight. Before an installation is begun careful investigation should be made of the effect on c.g. location and the limitations that may be placed on loading the aircraft. As was mentioned previously this becomes more critical as the weight of the aircraft decreases.

The "reference" or "datum" line of the aircraft is usually the nose of the ship in twin-engined craft; and the leading edge of the wing in single-engined craft. Location of "items" are taken from this point which gives the "arm." The weight of the item is then multiplied by the arm, resulting in the "moment." An algebraic summation of the moments is added to the original moment shown in the operations record. The total weight is added to the listed empty weight. The new c.g. can then be obtained by dividing the new moment (inch-pounds) by the new empty weight (pounds). The result is the new c.g. location (in inches) from the reference or datum line. All items removed or added are handled in this manner and must be listed on the operations record permanently. While anyone can make the computations they must be certified, and

**Immediate Delivery from STOCK!**



**New Model 670  
 SUPERIOR  
 SUPER-METER**

Combination VOLT - OHM MILLIAMMETER plus CAPACITY REACTANCE INDUCTANCE and DECIBEL MEASUREMENTS. GOOD -BAD Scale for checking quality of electrolytic condensers at test potential of 150 volts.

**Complete \$28.40**



**New Model 450  
 SUPERIOR  
 TUBE TESTER**

Speedy operation assured by newly designed rotary selector switch. Tests all tubes up to 117 volts, including 4, 5, 6, 7, 7L, Octals, Locals, Bantam Junior, Peanut, Television, Magic Eye, Hearing Aid, Thyratrons, Single Ended, Floating Filament, Mercury Vapor Rectifiers, etc., also pilot lights.

**Complete \$39.50**

Write Dept. N11 for FREE 1947 catalog.

**ATLAS ELECTRONICS COMPANY**

11 Edward M. Morgan Pl., New York 32, N. Y.

**ORDER NOW**

BC 348 and BC 312 Army Receivers	\$59.95
Signal Corps I-222A Signal Generator	
Range 8-15 MC, 150-230 MC	\$69.95
300 Ohm Amphenol Twin Lead,	
per 100 ft.	\$ 2.90
75 Ohm Amphenol Twin Lead,	
per 100 ft.	\$ 2.00
P-23 Army Head Set, 8000 Ohm	
with 5 ft. Cord and Plug	\$ 2.95
3 Gang 410 Mmfd. Per Sect. Cond.	
Excellent quality	\$ 2.95
2" PM Speaker (Bakelite Cased)	
Used in Walkie Talkie	\$ 1.95
Type 400 Advance-IKW Antenna Relay	\$ 5.40
Signal Corps Telegraph Key	\$ 1.10
VT 127 Tubes (Equivalent to 100 TL)	\$ 3.50
VT 232 Tubes (Equivalent to HY 615)	\$ .98
Jan 6 AK5 Tubes	\$ 1.95
Jan 832-A Tubes	\$ 5.95

Send for Our Special Bulletin of  
 Government Surplus Items

**DOW RADIO**

1759 E. COLORADO PASADENA 4, CALIF.  
 Pasadena Phone-Sycamore 3-1195  
 Los Angeles Phone-RYan 16683

**SCIENCE TODAY**

November 1946 Issue

**NOW AVAILABLE!**

8 pages, featuring articles  
 on popular science.

**SEND 10¢** (coin only)

**Ziff-Davis Publishing Co.**

Dept. AE-1, Circulation  
 185 N. Wabash Ave. • Chicago 1, Ill.

signed for, by a licensed aircraft mechanic.

In every case a licensed mechanic must supervise and approve all work done on the aircraft and sign for its airworthiness, etc., in the aircraft's logbook and operations record.

The quality of mechanical and electrical work done in aircraft is traditionally high as compared to some other fields. It is the soundest investment an aircraft owner can make—good work and maintenance. High standards should be expected and demanded. A well made radio installation having good electrical connections, well supported cables, etc., will continue to give trouble-free, reliable service and require little, if any, maintenance. A poorly made installation cannot be relied upon and can eventually cost more than the original cost of the best.

-30-

### Treasure Finder

(Continued from page 37)

chassis is necessary, and this should now be screwed on. Metal shields should also be provided for the four tubes. Another very useful, and almost essential, addition is a two or three foot length of metal braid attached to the chassis. This is held in one hand while operating and prevents annoying body capacity between the chassis and the operator.

The loop is wound "spider-web" fashion on a circular piece of 1/4 inch phenolic, or other insulated material. Over-all diameter is 14 inches and the diameter of the inside turn is 4 inches. About 250 turns of 26 gauge d.s.c. wire are required—that is, 125 turns on each side of the former. The 250 turns are counted at the cross-over points, or slots, which incidentally, may be any odd number between 7 and 15. A photograph of an experimental loop is shown on page 36.

After mounting a couple of solder lugs in the center, connect a suitable length of low-capacity coaxial cable (5 feet of RG62U was used by the writer) and test with the complete unit. If everything proves to be satisfactory soak the loop in hot wax, mount two other circular pieces of phenolic top and bottom as a cover, and fill the edges with plastic wood or other similar compound. Finally coat the whole loop unit with shellac for

Fig. 2. Chassis layout.

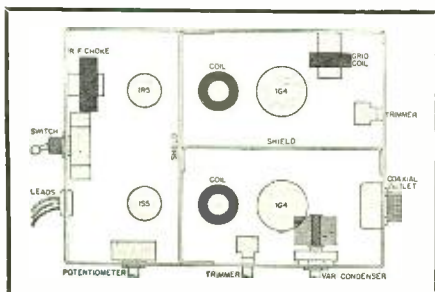

# Mr. Radioman—

## What are your Qualifications?



### EMPLOYERS ARE CHOOSEY!

#### PREPARE FOR HIGH LEVEL EMPLOYMENT WITH THESE CLEVELAND INSTITUTE HOME STUDY COURSES

1. **Mathematics for Radio and Communication Engineering.**
2. **Advanced Course in Radio Communication Engineering.**  
A college-level Radio Engineering Course.
3. **Master Course in Radio Communication.**  
Covers fundamentals of Radio and includes complete preparation for FCC Commercial License Examinations.
4. **Specialized Television Engineering.**  
Including post-war Television Techniques.

*All Courses Include*

**The Remarkable Workbooks of Instructional Aids, prepared by the instructing staff of Cleveland Institute.**

Choose the course best suited to your needs—Start with the section you are qualified to enter—Use the economical CIRE "Pay-As-You-Go Plan."

*Write for descriptive folder.*

## CLEVELAND INSTITUTE OF RADIO ELECTRONICS

Successors to

NILSON RADIO SCHOOL  
Founded 1939

SMITH PRACTICAL RADIO INSTITUTE  
Founded 1934

RN-11 TERMINAL TOWER, CLEVELAND 13, OHIO

Approved for Veteran Training Under "G-I Bill of Rights"

(MAIL THIS COUPON)

Cleveland Institute of Radio Electronics, RN-11 Terminal Tower, Cleveland 13, Ohio.  
Gentlemen: Please send information about your home study courses in Radio Electronics.

NAME ..... I desire training in .....

ADDRESS ..... I have had experience in broadcasting   
servicing  operating  mfg.  CAA   
Army-Navy  amateur  other.....

CITY ..... I am a High School Grad.  College   
Degree.....  Check here for Veteran  
Enrollment Information.

ZONE ..... STATE .....

## HAM GEAR

**In Stock—NOW!**

#### RECEIVERS—

National • Hallicrafters • Hammarlund • RME

#### TRANSMITTING TUBES—

RCA • Eimac • Gammatron • Taylor Sylvania • Amperex • Hytron • United

#### METERS—

Weston • Triplett • Simpson

## ALSO

**FINEST STOCK OF**

Transmitting Variable Condensers, Coils and Inductors, Transformers, Chokes, Insulators, Antenna Equipment, Exciters—and EVERYTHING necessary for building a Crystal Stage Transmitter.

Write us for our Periodical Ham Bulletins on REAL Ham Values.

Mail and Phone Orders Our Specialty

## RADIO TELEVISION SUPPLY CO.

Dept. 11

1509 S. FIGUEROA ST., LOS ANGELES 15, CALIF.  
Phone: Richmond 9131 Cable Address: RATELCO



**PRECISION ELECTRONIC REGULATED POWER SUPPLY**

Immediate Delivery

Type A:—Variable from 210 to 335 V.D.C. at 400 M.A.

Type B:—Variable from 535 to 915 V.D.C. at 125 M.A.

Built for the U. S. Army as part of power supply of RA-57-A, but never used.

Adapted to civilian use by mounting on 12 1/4" or 14" x 19" panel, black or grey crackle finish, & installing meters, brackets, chassis, pilot lights, switches, fuses, etc. Fits any standard 19" rack or cabinet. Complete with tubes and ready to plug in. All units checked and inspected at 150% of rated load before shipment

**Specifications:**

Input: 115 V. 50-60

Regulation: Less than 1/10 V. change in output voltage with change from 85 to 145 V.A.C. input voltage & from no load to full load (over wide latitude at center of variable range)

Ripple: Less than 5 Millivolts at all loads and voltages.

Tubes used in Type A: 2—836; 6—6L6; 2—6SF5; 1—VR150; 1—VR105.

Tubes used in Type B: 2—836; 2—6L6; 2—6SF5; 1—VR150; 1—VR105.

**Construction Features:**

Weston 301 (or equal) ammeter & voltmeter Can vary voltage by turning small knob located on front of panel.

Separate switches, pilot lights & fuses for filament volts & plate volts.

All tubes located on shockmount assemblies.

Fuses mounted on panel & easily accessible. Rigid construction. Individual components were designed to withstand the most severe military conditions & are greatly under-rated.

Some of the current users of these power supplies are:—electronic laboratories; aircraft, metallurgical & chemical research labs.; technical schools; commercial & amateur radio stations, etc.

**NET PRICE:**

Type A—\$175 F.O.B. Baltimore

Type B—\$168 F.O.B. Baltimore

Subject to change without notice

Approx. shipping weight, 100 pounds

**NATIONAL RADIO SERVICE CO.**

Reisterstown Rd. & Cold Spring Lane  
Baltimore 15, Md.

**GENERAL UTILITY CHEST**

Radio Parts - Hardware - Tools, Etc. End opening—2 drawers 2" deep x 8 1/2" x 15 1/2" 100 compartments. Every shop needs several of these well constructed plywood chests shipped express C.O.D. S/C cost \$27.50

Rush order today special price, \$5.45

**TERRY JAY**

550 Arlington Place, Chicago 14, Illinois

**RADIO ENGINEERING TELEVISION ELECTRONICS**

Courses in every phase of radio and electronics open to high school graduates. Thorough training, modern courses. Enrollments limited. Approved Veteran Training.

**VALPARAISO TECHNICAL INSTITUTE**

Dept. RS Valparaiso, Indiana

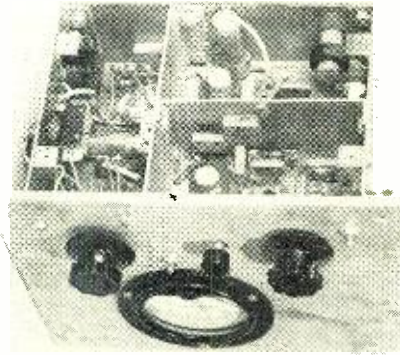

Bottom view of locator with panel in place.

waterproofing purposes, and mount it on a long bamboo pole. A wooden dowel and supports for angle adjustment, as shown, are additional refinements.

It should be borne in mind that the ultimate frequency is set by the plate inductance of the fixed oscillator. This has no variable trimmer, and therefore all other tuned circuits are resonated with this one.

The added capacity of shielded leads, such as the loop antenna cable, must be watched carefully, and it will be noted that in the original schematic the writer has deleted the fixed shunt capacitor in the grid circuit of the variable oscillator in order to balance up the loading of the antenna cable.

The complete set is mounted in a wooden (or aluminum) box with meter on the top panel. The chassis is screwed to this panel and the batteries lie in the bottom of the box. Ninety volts of light-duty "B" batteries and 1 1/2 volts "A" battery are required. At the expense of a heavier "A" battery drain, the 1G4 oscillators may be replaced by the more powerful 3A5 miniature tube (with two halves in parallel) if desired.

A strap is attached to the two sides of the box, and then slung over one shoulder. Holding the loop a few inches from the ground, the operator moves very slowly along until the meter needle dips towards zero. He then calls his wife with her pick and shovel, and the fun begins.

—30—

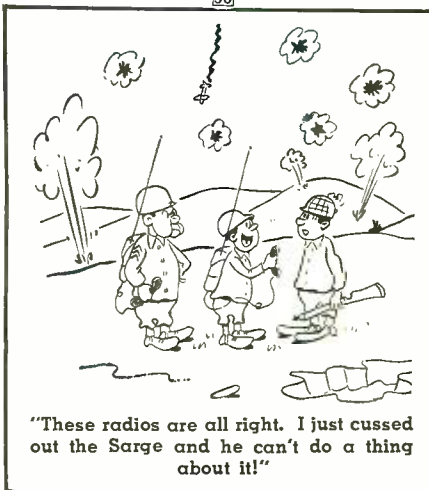

"These radios are all right. I just cussed out the Sarge and he can't do a thing about it!"

\$5.00

\$5.00

**DE LUXE RADIO ASSORTMENT**

CONTENTS INCLUDE:

THROAT MIKE

MOTOR OR DYNAMOTOR

TRANSFORMERS

SWITCH BOX

SWITCHES

KNOBS

RESISTORS

CHOKES

COIL FORMS

TUBE SOCKETS

PILOT LITE W/BULB

CONTACT POINTS

INSULATORS

FLEXIBLE SHAFTS

TERMINAL BOARDS

CONDENSERS

RELAYS

FUSE HOLDER

AND MISCL. SMALL PARTS.

Shipping Weight 20 lbs.

SEND ONLY \$5.00 for each kit wanted.

No C.O.D. ORDERS FILLED

ALL SHIPMENTS BY RAILWAY EXPRESS CHARGES COLLECT

**PRESTOLITE**

STORAGE BATTERIES

12 VOLTS 68 AMPS. 6 CELL

Dry charged or uncharged (specify which) Heavy rubber case, carrying handle, over-seas pack. Shipping weight 80 lbs.

Send only \$8.00 for each bottery wonted.

No C.O.D.

**GEORGE BROOKS & ASSOCIATES**

220 S. Holsted Street

Chicago 6, Illinois

*Special Offer to Radio Chemical Users* INTRODUCING! **O-B PRODUCTS**

<b>O-B Radio Cement (8 oz.)</b> .....	List Price \$1.60
(All Purpose)	
<b>O-B Cement Thinner (8 oz.)</b> .....	.75
<b>O-B Speaker Cone Remover (8 oz.)</b> .80	(Quick Acting Cement Solvent)
<b>O-B Carbon Tetrachloride (8 oz.)</b> .80	
<b>Your Cost for above items not \$3.95 But \$1.98</b>	

**Check Enclosed** Name.....  
Ship Prepaid Address.....

**Send C.O.D.** I will pay shipping cost City.....  
Zone State

Name of Jobber.....

**O-B LABORATORIES**  
P. O. Box 1137 Glendale 5, Calif.

**ARC-5**  
6 TUBE SUPERHETERODYNE AIRCRAFT RECEIVERS  
WAR SURPLUS BRAND NEW with DYNAMOTOR and all TUBES EACH ONLY— **\$22.50** Post Paid U.S.A.

Priced for quick sale. Quantity limited. Frequency ranges 3-6 MC or 6-91 MC. Specify frequency when ordering. Guaranteed brand new. Send check or money order. Immediate shipment. Hurry!

**GROBAN SUPPLY CO.**  
1522 S. Michigan Avenue  
CHICAGO 5, ILLINOIS

**WIRELESS PHONO OSCILLATOR**  
NO LICENSE REQUIRED  
Transmits recordings from phono pickup or voice from mike to radio without use of wires up to 500 ft. Neatly Designed.  
Complete Kit with tubes.....\$5.75  
Above Kit assembled and tested.....\$6.95  
Immediate delivery.

**CONSTANT ELECTRIC**  
112 Cornelia Street Brooklyn 21, N. Y.



## International Short-Wave (Continued from page 44)

Some new models, now in production, are expected to have both meters and megacycles on the dials. The economic situation in Sweden has been good and therefore the high prices haven't mattered a great deal."

Short-wave listening has received widespread publicity in Sweden. Short-wave stations are often introduced by the Swedish Radio, while the radio publications, "Roster i Radio" and "Kortvags-Lyssnaren," frequently feature illustrated, lengthy articles from the short-wave stations, along with instructive material. In addition, the leading newspapers—"Dagens Nyheter," "Stockholm Tidningen" and "Aftonbladet"—are introducing actual radio stations abroad to their readers. Current short-wave station lists are published regularly by "Roster i Radio," "Kortvags-Lyssnaren," and by the manufacturer of Radiola, one of the leading receivers in Sweden.

"This kind of publicity is of great

importance," comments Mr. Skoog. "And it seems likely that no other country goes so far in publicity on DXing."

A group of short-wave enthusiasts banded together early in 1944 under the name, *Sveriges Radioklubb* (The Radio Club of Sweden). Shortly, the membership reached 1500 members scattered all over the country. Meetings were arranged in Stockholm, attended by hundreds of visitors. Small affiliated local clubs were also founded in several rural cities and towns. While the parent organization has not been active for some time, many of the small local clubs are going on with their activities. Swedish short-wave fans also hold memberships in clubs in other lands, particularly the *Universal Radio DX Club* in the United States.

Broadcasts in the Swedish language from abroad form another good reason for the keen interest of short-wave listeners in Sweden. For the benefit of Swedish-speaking readers, Mr. Skoog lists some of these transmissions in Swedish (in GMT; add one hour for Swedish Time):

New York—NBC broadcasts *daily* programs at 1730-1745 over WGEA/WGEO, 15.330, and WBOS, 15.210.

London—*Daily* programs in Swedish are radiated by the BBC at 1830 on 307 meters and on short-wave frequencies of 7.150, 9.675, and 11.800.

Moscow—*Radio Centre* broadcasts two daily 30-minute programs in Swedish—at 1915-1945 and 2015-2045, respectively, on 6.100, 7.165, 9.720, and 9.780.

Paris—The *daily* program for Sweden is heard at 1945-2000 on 463 meters and on the short-wave frequency of 9.560.

Quito—With more listeners in Sweden than in any other part of the world, HCJB now transmits three regular weekly programs in Swedish—Sundays, Tuesdays, Thursdays at 2130-2200 on 9.958, 12.455, and 15.100.

Brazzaville—From French Equatorial Africa, *Radio Brazzaville* beams a 15-minute program to Sweden every fourth Wednesday (November 6, December 4, January 1 and 29 (and so on), between 2030-2045, on frequencies of 9.440 and 11.970. This program was inaugurated because of the tremendous

# RHS TELEVISION-SCOPE-POWER EQUIP'T.

## OSCILLOSCOPE KIT

5CP1 Cathode Ray Tube. Each.....	\$ 6.95
Socket for 5CP1. Each.....	1.98
Anode Button for 5CP1. Each.....	.35
Shield for 5CP1. Each.....	1.49
2X2A Rectifier Tube. Each.....	1.25
Plate Cap for 2X2A Ceramic. Each.....	.20
Socket for 2X2A Ceramic. Each.....	.25
Xformer, 1600v, 6.3v, 2.5v, 110v., 60 cycle. Each.....	7.50
Condenser, oil. .5-2000v. Each.....	2.10
Order separately or COMPLETE KIT. Special	16.95

## HEAVY DUTY CHOKE

35Hy. at 270Ma. 105-Ohm D.C. Res. 6000v  
Ins. Can deliver 400Ma.  
Special ..... **\$9.95**

## OIL CONDENSERS: G.E., AEROVOX, G.D., Etc.

2mfd 600v.....	\$.60	4mfd 2000v.....	\$3.95
4mfd 600v.....	.75	10mfd 2000v.....	4.35
8mfd 600v.....	1.10	12mfd 2000v.....	4.95
1mfd 1000v.....	.90	15mfd 2000v.....	5.95
2mfd 1000v.....	1.05	.05mfd 3000v.....	2.95
4mfd 1000v.....	1.10	.25mfd 3000v.....	3.25
8mfd 1000v.....	2.00	1mfd 3000v.....	3.50
1mfd 1000v.....	2.40	2mfd 3000v.....	3.75
15mfd 1000v.....	2.88	.05mfd 4000v.....	4.35
6mfd 1500v.....	2.56	.25mfd 4000v.....	4.60
2mfd 1500v.....	6.95	1.0mfd 4000v.....	6.85
1mfd 2000v.....	.95	2.0mfd 4000v.....	7.60
3mfd 2000v.....	2.95	1mfd 7000v.....	3.95

## WESTON MODULATION METER

Mod. No. 301—3" A.C. rectifier type 1000 ohms per volt.  
Exceptional buy at..... **\$3.95**

## FEDERAL'S NEW MIDGET SELENIUM RECTIFIER

Replaces Rectifier-Type Tubes.  
Special ..... **\$1.60**

All material is new and guaranteed unless otherwise stated.

## TUBES: NEW JAN APPROVED

6C4.....	\$.75	9002.....	\$.69
6J6.....	.85	9003.....	.69
866.....	1.19	9004.....	.79
813.....	9.95	1625.....	.79
1629.....	.75	12507GT.....	1.30
6AL5.....	.75	811.....	3.25
6AG7.....	1.25	30.....	1.89
6AE7.....	1.25	1E7G.....	1.25
125K7GT.....	1.30	957.....	.99
6AK5.....	1.60	958.....	1.10
6AC7.....	.95	959.....	1.15
257B.....	14.95	6C5.....	.75
5BP4.....	8.95	125A7.....	1.55
		50L6GT.....	1.30

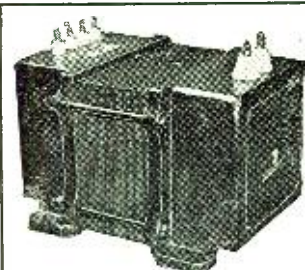

## AMERTRAN HEAVY DUTY PLATE TRANSFORMER

For your dream rig. Pri. 105-115v, 60 cycle. Sec. 3100-0-3100, full voltage across sec. 6200v at 700Ma. Rated 2KVA. **\$39.95**

Our Price .....

## SWINGING CHOKE

9/36 hy at 750/75  
MA ..... **\$19.95**

## MODULATION STAGE KIT

Driver Xformer  
Pri.-Z-600 ohms  
Sec.-Z-10000 ohms  
Mod. Xformer  
Pri.-Z-15000 ohms  
Sec.-Z-4250 ohms  
Ratio—1:13 1 KV Test at 235 ma.  
Test 5kv. Will drive pair 813's

SPECIAL FOR PAIR..... **\$6.95**

## XFORMERS, SCOPE & TELEVISION, 115v.-60cyc.

6500v at 4 ma.....	\$9.95
6000v at 2 ma.....	7.95
3950v at 4 ma., tap at 1250v—1 ma.....	7.50
3710v—10 ma.; 2.5v at 3A; 2.5v at 3A.....	9.95
2500v—10 ma.....	6.50
4000v—2 ma.....	6.50
2050v—2 ma.; 2.5v at 3A.....	8.95
1710v—7ma.; 2.5v at 3A; 6.3 at 3A.....	7.95
1600v—2 ma.; 6.3v at 1.75A.....	6.50
1600v—2 ma.; 2.5v at 3A.; 6.3v at 3A.....	7.50
1230v—tap at 630v at 150 ma.; 500v at 2 ma.; 100v at 2 ma.; 6.6 at 8A; 6.3 at 6A; 5v at 3A; 2.5 at 1.75A.....	9.95

## XFORMERS—FILAMENT 115v.-60c. HI VOLTAGE INSULATION

2.5v at 1.75a; 6.3 at 1a.....	\$ 3.95
2.5v at 10 amps.....	3.25
2.5v at 2a, 6.3v at 1a.....	3.95
6.3v at 21.5a, 2v at 2a, 4v at 1a.....	6.95
5v at 115a.....	14.95
5v at 190a.....	17.50

## FILTER CHOKES

### Hi-Voltage Insulation

1 henry—200 ma—3000v Ins.....	\$2.25
4 henry—250 ma—3000v Ins.....	3.95
10 henry—250 ma—3000v Ins.....	3.25
12 henry—170 ma—2000v Ins.....	2.95
12 henry—360 ma—6000v Ins.....	3.95
15 henry—30 ma—1500v Ins.....	1.95
20 henry—30 ma—2500v Ins.....	2.25
75 henry— 8 ma—1000v Ins.....	1.95

## POWER SUPPLY FOR MARK 1-11-111 OR OTHER EQUIPMENT

12 Amps—12v D.C. from 110v A.C. Unnecessary to tear set apart. Leave set portable. **\$32.50**  
COMPLETE READY TO PLUG IN.....

No mail orders for less than \$2.50.  
20% deposit required with all orders.

# RADIO HAM SHACK Inc., 63 Dey St., New York 7, N. Y.

EXPORT DIVISION: WESTERN INTERNATIONAL, 168 WASHINGTON ST., NEW YORK 6, N. Y.

mail response from listeners in Sweden. It was difficult to arrange this service inasmuch as there was not a Swedish-speaking announcer on the station's staff, and the station finally called upon the good will of local Swedish missionaries. Since the time of these missionaries is quite limited, it has not been possible to broadcast more than a 15-minute session in Swedish every fourth week.

### Radiotjanst

The verification card now being sent out by the Swedish Radio lists this information:

"Sveriges Radio" is the announcing call used in the Swedish radio programs. As an interval signal, an old melody from Dalarna Province is employed. The Swedish Broadcasting Corporation, *Radiotjanst*, is a semi-state institution and commenced its activities in January, 1925. In January, 1946, receiver licenses numbered 1,840,000 (the entire population of Sweden is 6,600,000). At present, Sweden has the largest number of licenses in relation to population of any country in Europe. The Swedish Radio broadcasts a common program over 33 stations, generally on Sundays and holidays from 7-22 GMT (2 a.m.-5 p.m. EST) and other days from 6.15 to 7.15 and from 11 to 22 GMT (1:15-2:15 a.m. and 6 a.m.-5 p.m. EST). There are also two 12 kw. short-wave transmitters in Motala, through which special programs for listeners abroad

are broadcast daily at 1-2 and 15-16 GMT (8-9 p.m. and 10-11 a.m. EST). Calls listed on the card are SDT-2, 15.665; SBT, 15.155; SBP, 11.705; SDB-2, 10.780; SBU, 9.535; SDT, 9.4425; SBO, 6.065; and SDB, 5.7325. (At the present time, SBT, 15.155, is the one best heard in the United States, especially at 10-10:55 a.m. daily in the North American beam.)

A letter just in from Y. Samsioe, an official of *Radiotjanst*, informs us that the Swedish short-wave services are now in the process of being completely reorganized. "As you have possibly heard," he explains, "the Government has granted us a rather large sum of money for extending out shortwave services through stronger transmitters and so on. This, however, will take some years to accomplish and during that time we shall have to go on with our old transmitters. Nevertheless, from about the beginning of November of this year, we are going to increase our transmissions by 50 per cent—and, above all, to introduce special programs for short-wave listeners all over the world.

"As you certainly understand, we have had enormous difficulties to overcome and our short-wave service has suffered by them, but now the situation has brightened considerably and we are trying to get in contact with short-wave listeners in every corner of the world.

"We promise to answer all listeners' reports promptly and to give information



Sven-Bertil Norberg, Secretary of the Foreign Relations Department. His voice is often heard from Stockholm during point-to-point short-wave contacts.

of its existence, and, as in other countries, it performs an important service in promoting popular enlightenment and in the distribution of news, as well as being a vehicle for high-quality entertainment," he continued. "In 1939, this country was able to record the highest number of licenses per 1000 inhabitants in Europe, surpassing in that respect her competitors, Denmark and Great Britain. Sweden still holds that position. The license fee amounts to 10 kronor a year. The Telegraph Commissioners assume responsibility for the technical arrangements, while the program activities are carried out by the Corporation, *Radiotjanst*, in which the Press and the leading firms of the radio industry are partners."

The principles formulated by the Swedish Government for drawing up the programs require that the transmissions be varied and entertaining; moreover, they should be of a high intellectual, cultural, and artistic standard and should be characterized by reliability, objectivity, and impartiality. Popular education and popular enlightenment should be promoted, and efforts should be made to establish and maintain as intimate cooperation as is possible with the musical and popular educational organizations which are supported by public funds. Expressions of opinion on political subjects of topical interest may be broadcast, provided it is open to different trends of opinion to expound their views.

Programs of *Radiotjanst* have undergone considerable expansion during the last few years. The transmission period at present amounts to about 4000 hours per year—an average of 11 hours a day. The organization preparing the programs has been extended and improved. The international exchange of programs—particularly between the Northern Countries—has been on a large scale since the end of the war.

## SLATE Symphonette

### PORTABLE RECORD PLAYER



**Immediate Delivery!**  
Model A-10

- 3 Tube AC-DC Amplifier with a 4 Tube Performance
- Washable Simulated Leatherette Covering
- Plays 10" or 12" Records with Lid Closed
- Separate Variable Volume and Tone Controls
- On-Off Switch
- Hi-Fidelity Crystal Pickup
- Heavy-Duty Motor

List Price **\$39.65**

Dealer's Price **\$28.00** Fed. Tax Included

### TABLE MODEL #RC401A

#### Automatic Record Changer

Complete with Amplifier and Speaker. Rich brown simulated grained leather covering. A.C. Amplifier, engineered to produce a high order of fidelity. Volume control and a full range tone control. On-off switch. 5" Alnico speaker. Single post type changer with fast change cycle. Crystal cartridge mounted in a non-resonant arm.

List Price Zone 1 \$60.45

List Price Zone 2 \$63.50

Dealer's Price **\$41.54 Tax included**  
6 or more **\$40.54 Tax included**



### MODEL 2120 VIBRATOR INVERTER, \$8.10 each

#### 6 or more, \$7.20 each

Input 115 V. DC, Output 110 V. AC, 60 Cycles, 25 Watts. Suitable to operate all popular Phono and Record Changers.

All Prices F.O.B. New York

## SLATE COMPANY

2553 Webster Ave., Dept. N

Fordham 7-1711

New York 58, N. Y.

Musical programs take up nearly half of the broadcasting time. By special agreement, *Radiotjanst* has the regular use, for orchestral music, of the largest symphony orchestra in Sweden. *Radiotjanst* has an arrangement with the Royal Opera whereby transmissions from the theatre may be made on an unlimited basis. Programs include both light entertainment music and music of a classical nature. With a view of promoting more interest in music, special programs are arranged, often in an entertaining form with musical competitions.

In its talks programs, *Radiotjanst* seeks to meet the many requirements and demands as expressed in various trends of taste and different classes of society by dividing the broadcasts into groups and subjects. Topical events are commented on in special talks and interviews as well as in regular surveys (foreign policy, new legislation, Parliamentary news, new books, and the like). There are also agricultural talks, talks for housewives, and lectures on academic subjects. Approximately 170,000 pupils in about 4000 schools listen to the School Radio Broadcasts, and to meet the needs of adult education, there are popular educational lectures on Sunday mornings, series of talks especially intended for "groups of listeners," as well as language courses and talks in foreign languages. Light is thrown on questions of the day through discussions between representatives of various shades of opinion. From its own publishing department, *Radiotjanst* issues textbooks for language courses, lecture series, school-radio handbooks, and books of other sorts.

By means of readings from works representative of various fields of literature, the radio aims—apart from giving mere diversion—to promote the people's cultural development. A large number of newly-published books are presented to listeners in this way.

One item appreciated widely is the programs concerned with religious education. The Sunday services and the devotional broadcasts are apportioned as between the State Church and the Free Church communities in consultation with the most important trends of ecclesiastical opinion.

Many of the programs are taken up with reports from the Swedish provinces and industries, as well as with interviews with typical and original representatives of different occupational and population groups. Since it is frequently possible to record these program items, a valuable and interesting body of material regarding the Swedish people's mode of living and way of talking is being preserved for the benefit of future research and for posterity.

The Swedish Radio's news service is highly developed. News is broadcast three times daily direct from the Newspapers' Telegram Bureau. Weather reports from the State Meteorological-Hydrographical Institute are heard four times a day. The Radio also al-



## Navy Panoramic Adaptors!

The Panoramic Adaptor tells you at a glance what is going on over a wide area of the band. When attached to your receiver, the adaptor will visually indicate whether there are signals present within the area covered. It will show the relative frequency of each signal, relative signal strength, the type and percentage of modulation. This Navy unit was built to rigid specifications without consideration of cost. It will allow you to locate "holes" in crowded bands, detect weak signals, and contribute generally to the improved operation of your station. The RBV-2 covers a continuous band of frequencies 100 Kc. wide. Operates on 115/230 V.A.C. 50/70 cycles. New and packed in original crates. Tropicalized.

**PRICE \$94.50**  
**ONLY \$94.50**  
F.O.B. Chicago

### Army Walkie-Talkies!

The BC-322 is a complete, portable radio communication set. It is light enough to be strapped on the back and powerful enough for dependable voice transmission over a range of 10 to 20 miles. Frequency band 52 to 65 Mc. These sets are new in original crates. The low price includes tubes, handset, telescopic antenna, batteries and battery adaptor, and carrying case. \$75.00 F.O.B. Chicago. Model BC-222 has two bands but otherwise the same as the BC-322. Frequencies from 28 to 38 Mc. and 38 to 52 Mc. These sets have been in service but have been renewed by the Government. New batteries. No carrying case.

**PRICE \$45.00**  
**ONLY \$45.00**  
F.O.B. Chicago

### Government

#### Termination Material

Condensers	Transformers
Resistors	Volume Controls
Spaghetti	Controls
Switches	Vibrators
Transmitting Tubes	B-L Selenium Rectifiers
Wire-Cable Relays	Dial Light Assemblies
Tube Sockets	Whip Antennas

**WELLS SALES, INC.**  
4717 W. Madison St.  
Chicago 44, Ill.

USE COUPON BELOW FOR COMPLETE INFORMATION

WELLS SALES, INC., 4717 West Madison Street, Chicago 44, Illinois

Please ship.....for which \$.....is enclosed.

Please mail free Amateur Radio Circular.

Please send prices and information on the following items: .....

NAME .....

ADDRESS .....

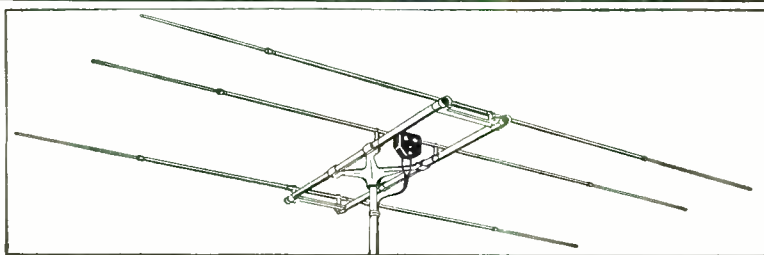

### S/C LABS ADJUSTABLE ROTARY BEAM KITS 702A, 702B, 702C

Type 702A	28.1 mc to 29.7 mc (10 meter band)	\$39.95
Type 702B	50 mc to 54 mc (6 meter band)	29.95
Type 702C	144 mc to 148 mc (2 meter band)	24.50

The new S/C LABS THREE ELEMENT BEAM presents a distinct high-gain directive antenna designed for 2, 6, and 10 meter amateur bands, adjustable in every respect and sound in mechanical design. Electrically and mechanically engineered to give the best in efficiency. The antenna is constructed of the finest grade aluminum, weight of entire beam is less than 15 lbs.

PRECISION AND ADJUSTABLE ANTENNA  
Type 701A (28-44 mc) 10-meter amateur.....\$8.95  
Type 701B (44-88 mc) Television 5 meter amateur 7.95  
Type 701C (88-148 mc) FM 2 meter amateur.....7.45  
In stock, all types of coaxial cables, transmission lines and hookup wire.  
See your local dealer or buy direct.

S/C LABORATORIES, Inc., Dept. R, 20-22 Van Wagenen St., Newark 4, N. J.

# CAPACITORS -

OIL, PAPER and  
ELECTROLYTIC



**Illinois**  
CONDENSER COMPANY

1616 N. THROOP ST.  
CHICAGO 22, ILL.

famous for

**GREAT VALUES**

**OUTSTANDING OFFERINGS  
OF NEW KITS**

**H-101 FIVE TUBE SUPERHETERODYNE KIT**—  
Small Bakelite cabinet approximate size  
9"x5"x6", complete parts except wire and  
solder for the construction of a standard super-  
heterodyne receiver using 50L6, 35Z5, 12SA7,  
12SQ7, and 12SK7.

A simplified circuit diagram included in this  
kit enables any one with a slight knowledge  
of radio to construct a highly efficient  
receiver. Price not including tubes... **\$10.75**

**H-105 AUTOMATIC RECORD CHANGER KIT**—  
consists of 1—Automatic Record changer, single  
post; 1 Portable leatherette cabinet for above;  
1 Crystal pick up. 1—5" P.M. and output trans-  
former; 1 complete kit of parts including tubes  
but excluding wire and solder, to construct a  
3-tube amplifier using 1-50L6, 1-35Z5,  
and 1-12SQ7. Price complete... **\$36.95**

All prices are F.O.B. New York City.

Write for our new catalogue showing new  
test equipment, tubes and a large  
variety of new replacement parts.  
We ship anywhere in the U.S.A.  
—promptly.

**RADIO DEALERS  
SUPPLY COMPANY**

135 LIBERTY ST., NEW YORK 6, N.Y.

lots time for broadcasting notices, at  
the request of the police, concerning  
missing persons.

Under the title, "The Day's Echo," a  
special 15-minute program presents  
comments on the news of the day.  
Topical Swedish reports from all over  
the world form a striking feature of  
this session. Since the end of the war,  
the Swedish Radio has sent its own  
news reporters to various countries  
of Europe. There is a special section  
devoted to picking up foreign broad-  
casts, and where also important  
speeches and reports are recorded.  
These recordings will no doubt prove  
of great value for research when  
events and speeches that have made  
world history have been recorded and  
catalogued.

The Radio-Theatre is a most popu-  
lar form of dramatic art in Sweden.  
As a rule, at least one major and  
several minor theatrical performances  
are given each week. The Royal Dram-  
atic Theatre in Stockholm and the  
Municipal Theatre at Gothenburg  
have undertaken by contract that  
their artists collaborate with the  
Radio-Theatre in providing a certain  
number of performances each year.  
Some of the Radio-Theatre's perform-  
ances are adapted for study circles.

A wide provincial organization—  
comprising program managers and  
radio agents in most of the major towns  
and at practically all of the local  
broadcasting stations—guarantees  
that the Swedish provinces contribute  
to an all-round National Program.  
Program managers at the larger sta-  
tions are moreover allowed to broad-  
cast local programs of a specifically  
provincial character or of special local  
interest.

For the benefit of Swedes living  
abroad, *Radiotjänst* broadcasts about  
13 hours per week a specially-compiled  
program on short-wave. These broad-  
casts include music, reports from indus-  
tries, news and short comments on  
the Riksdag (Parliament), cultural  
progress, economics and trade, and so  
on. In addition to these short-wave  
programs—intended mainly for Swedes  
living in North America—there is  
broadcast once a week the "Swedish  
*Chronicle*" for the benefit of Swedes  
living abroad on the Continent of Eu-  
rope, as well as foreign-language  
broadcasts each weekday evening.

Further, lists of the names of for-  
eigners evacuated to Sweden during  
the final phases of the war are read  
in special short-wave broadcasts. Reg-  
ular radio programs have also been  
arranged (including entertainment  
and news) in about ten different lan-  
guages for the benefit of refugees in  
Sweden.

### The Technical Side

Considerable activity has been going  
on in the technical field, too. The  
number of studios has increased. This  
year, the Corporation has at its dis-  
posal 13 studios in Stockholm, ranging  
in size from rooms with a floor space  
of a few square yards to large concert

## Specials!

Fuse Post Panel Mounting for  
3AG Fuse Black Bakelite... **\$ .29 Ea.**

50 Assorted Knobs—Fits 1/4"  
Shaft Set Screw... **\$2.95**

Single Gang—SP-11 Pos. Iso-  
lantite Ins. Switch 1" Shaft... **\$ .69 Ea.**

100' Rolls 7-Strand Bare An-  
tenna Wire, 10 for... **\$1.95**

WRITE FOR OUR REGULAR  
BULLETIN OF RADIO SPECIALS

**Massey's Radio Supply**  
Wholesale Distributors

2992 Eighth St.  
Riverside, California

### JOBBERS

#### AMATEURS AND SERVICEMEN

Klystron 723 A-B each .....\$ 6.72

B. C. 229 receiver, used, and

B. C. 230 transmitter used .....\$15.95

When purchased separately each \$10.00

0-200 micro amp. meter, 2 1/4 inches,  
each ..... \$3.65

Western Electric condensers and re-  
tard coils, 10 assorted ..... \$1.95

Five conductor cable 20 ft. lengths ... \$ .79

Tubular condenser .001-.002

(TTR) Solar 100 for ..... \$4.39

#### AMSCO NOVEMBER SPECIALS

High frequency signal corps radio trans-  
mitter B. C.—702 A and radio re-  
ceiver B. C.—701 A. Special .....\$29.95

10 lb. assorted radio parts ..... 1.69

Write for our circular featuring radio  
components at bargain prices.

#### AMERICAN SALES COMPANY

1811 West 47th Street Chicago 9, Illinois

## FILMGRAPH PAT'D Conference Recorders

UNINTERRUPTED  
Longtime (up to 12 hours) Conference  
& Telephone Recordings on Safety Film  
Models for Dictation "TALKIES"

ECONOMICAL  
PERMANENT  
INSTANTANEOUS  
PLAY-BACK

MILES REPRODUCER CO., INC. 812 BROADWAY, N.Y. 3 RN-11

### ROTA-BASE

NEW HANDY LAB. DIAL. Simply turn the movable  
dial to the tube number desired on the ROTA-BASE  
and complete, correct connections are instantly indi-  
cated on the "prong" diagram. Filament, grid, plate,  
cathode, etc., to more than 300 tube types are given.  
No more valuable time lost on lengthy reading or  
thumbing of pages. ROTA-BASE actually gives a  
"prong" picture of the connections. PRICE NOW  
ONLY \$1.00. Postage prepaid or sent C.O.D. plus  
postage. Money back if not delightfully pleased.  
**REED MFG. CO.** 124 W. 4th St.  
Los Angeles 13, Calif.

### MANUFACTURERS

Have capacity for sub-assembly work and wire  
stripping facilities.  
We have developed a unit to permit standard  
flashlight cells to be used in place of special "A"  
Batteries. Inquiries invited.  
6 volt vibrator transformer 200 volt 30 M.A.—  
\$1.50 each net.

**BANK'S MANUFACTURING CO.**  
1105 W. Lawrence Avenue, Chicago 40, Illinois

## ELECTRICAL TRAINING

Intensive 32 weeks' residence course in fundamentals of  
industrial electrical engineering, including radio, elec-  
tronics. Prepares for technician, engineering aides. Ap-  
proved for veteran training. 53rd year. Catalog.

**BLISS** ELECTRICAL SCHOOL  
7698 Takoma Ave.  
Washington 12, D. C.



**RADIO NEWS**

halls. Power lines have been reconstructed in order to improve the quality of broadcast transmissions, while the broadcasting stations have modernized or redesigned their equipment altogether. Apparatus for steel-band recording, wax-recording blanks, magnetophones, and lacquer-recording blanks, as well as other up-to-date equipment, is now available in quantity for broadcasting in Sweden. Some of this equipment is installed in the five reporting cars belonging to *Radio-tjanst*, one of them being equipped with a frequency-modulated ultra-short-wave transmitter for use in reporting work.

During 1946, work was started on the construction of a Broadcasting House in Stockholm. It will be completely modern, will contain 15 major studios, three of them concert halls with accommodations for audiences of 1000, 500, and 250, respectively. The aggregate size of the Broadcasting House will be 134,000 cubic meters. The actual building—which is expected to be completed in 1949—will cost 14,600,000 kronor; the technical equipment, 3,900,000 kronor; acoustics, 982,000 kronor; and the building site, 7,700,000 kronor.

In January, 1945, a Government Commission appointed to investigate the present and future requirements of the Swedish Radio, presented its report, which contains comprehensive recommendations for three simultaneous programs; this would be made



Arne Skoog, Swedish DX-er who will act as master of ceremonies for the November 24th broadcast dedicated to Radio News readers and ISW listeners.

possible by establishing over the entire country a high-frequency wired wireless network over telephone lines—a technical method that is best suited to a country with Sweden's geographical and demographical conditions. The Commission had previously recommended the erection of two new short-wave transmitters of 100 kw. each, and the above-mentioned Broadcasting House.

Regarding the position of the Swedish Radio in the community, the Com-

mission made this observation: The independence of those in charge of broadcasting—their relative exemption from control, both formally and actually, by authorities and official bodies—is a primary interest. The broadcasting Corporation, representing a semi-State-owned monopoly, should, as far as possible, be ensured the enjoyment of all the advantages of a private publicity undertaking without its self-evident loyalty to the State being disregarded on that account.

From this outline, it is clear that the already highly-developed Swedish Radio will continue to expand and progress.

#### Radio Publications

Among the popular radio publications in Sweden are these:

*"Roster i Radio"* (Voices in Radio)—This is the official Swedish program paper, owned by the Swedish Radio Corporation, Radiotjanst; address, *"Roster i Radio,"* Jakobsgatan 7, Stockholm 16. Current paid circulation is 120,000. Published weekly, 40 pages. Contains Swedish Radio programs in detail with illustrations, articles, and a special column for short-wave listeners. Two or three times a year, it carries a comprehensive short-wave station list compiled by Arne Skoog.

*"Popular Radio"*—A monthly illustrated magazine, primarily for radio engineers, servicemen, and amateurs. Circulation is 9,000, 24 pages. Con-

**it's RADIONIC FOR Everything ELECTRONIC**

CAT. No. 47

Parts and Accessories  
Broadcast & Tel. Tubes  
Test Instruments  
Public Address  
Intercommunicators  
Amateur Equipment  
Hardware  
Technical Books  
Recorders  
Record Changers  
Radios  
Television Components

See Index on Page 17th

Chancellor RADIO

**RADIONIC EQUIPMENT CO.**  
170 NASSAU ST. NEW YORK 7, N. Y. Phone WO. 2-0241  
Opposite CITY HALL near E. KLYN BRIDGE

# FREE! Radionic Catalog

RADIOS & PARTS

HAM GEAR

TEST EQUIPMENT

Thousands of items illustrated, described and priced in our new 1947 catalog. Hams, Servicemen, Experimenters, Engineers, Schools, Institutions, Govt. Depts., Industrial Organizations, Laboratories, etc. will find this book a great help in their search for "hard-to-find" equipment.

RADIONIC EQUIPMENT CO.  
170 Nassau St., Dept. 511, New York 7, N. Y.

Please send me a copy of your 1947 catalog.

Name.....  
Address.....  
City..... State.....

## Famous LUCY RECEIVER (KIT FORM)



This famous portable receiver designed for and used by the U. S. Secret Service, Paratroopers and the land and sea forces, is now available to you for the first time.

### 6 TUBES INCLUDED

Small, compact, ultra-efficient. No drilling or punching required. Complete wiring diagram supplied.

- Uses 6 Miniature Tubes 1R5, 1L4, 1S5, 3 1T4's in a superhet circuit
- 2 Band Covers 2-12 Megacycles
- Requires 90 Volts B & 1 1/2 Volts A Battery
- Iron core (456 K.C.) I.F. Transformers
- B.F.O. for CW reception

All Original Parts, Shipping Weight, 4 lbs. (Less Phones & Hookup Wire) **\$1995**

## CABLE TEST SET

(Manufactured by Western Electric)



Consists of a tone unit, an exploring coil, a telephone receiver and cord housed in a wooden cabinet with carrying strap. This set designed for locating faults in short lengths of non-loaded telephone cable. This test set may be used in locating grounds, shorts, crosses, split pairs and wet spots.

Complete (Less Batteries) . . . **\$1295**

WRITE FOR QUANTITY PRICES

20% Deposit with Order • Include Postage

**KELVIN ELECTRONICS**

74 Cortlandt Street, New York 7, N. Y.

CATALOG ON REQUEST

## FREE PIPE SMOKER'S BIBLE for 1947



NOTHING LIKE IT-BETTER THAN EVER

- Helpful Hints
- Hundreds of Pictures
- Full Size

RESERVE YOUR COPY NOW!

SAVES YOU MONEY—

Big Book — packed full of pipe smoker's bargains from the world over. We import direct and save you money. Limited paper supply restricts printing to 185,000 copies . . . bulk will go to regular customers. Only limited number in excess, so, if you want pipes and tobacco at Special Mail Order Prices, reserve your copy now. Meantime, we'll send PIPE LORE Magazine FREE. Mail penny postcard today for delivery in early November. ACT NOW!

READY IN NOVEMBER—SEND FOR IT NOW

**WALLY FRANK, Ltd.**

150 NASSAU ST., N. Y. 7, N. Y., Dept. 225

## RADIO

RADIO Technician and Radio Communications courses. Register now for new classes starting first MONDAY of each month. Day and Evening Classes.

**AMERICAN RADIO INSTITUTE**

101 West 63d St., New York 23, N. Y.

Approved under GI Bill of Rights.

TIME (EST)	WAVE-LENGTH	FRE-QUENCIES	PROGRAMS
Weekdays			
8-9 p.m.	25.63	11.705 kc.	Special programs for listeners abroad.
8-9 p.m.	31.46	9.535 kc.	Special programs for listeners abroad.
10-11 a.m.	19.80	15.155 kc.	Special programs for U.S.A.
12:30-12:55 p.m.	27.83	10.780 kc.	Bulletins in German, Swedish and English.
12:30-12:55 p.m.	19.80	15.155 kc.	Bulletins in German, Swedish and English.
Sundays			
8-9 p.m.	25.63	11.705 kc.	Special programs for listeners abroad.
8-9 p.m.	31.46	9.535 kc.	Special programs for listeners abroad.
10-11 a.m.	25.63	11.705 kc.	Special program for U.S.A.
10-11 a.m.	19.80	15.155 kc.	Special program for U.S.A.
4:30-5 p.m.	27.83	10.780 kc.	Special programs for listeners abroad.
4:30-5 p.m.	31.46	9.535 kc.	Special programs for listeners abroad.

### Swedish Short-Wave Schedules.

tains technical articles, construction plans, diagrams, and the like. Address, Popular Radio, Postfack 3221, Stockholm 3.

"Kortvags-Lyssnaren" (The Short-Wave Listener)—This was formerly "DX-Radio." Is an illustrated monthly. In each issue there is published one-third of a complete short-wave station list, with a time-on-the-air diagram. Foreign broadcasters are introduced to Swedish readers through attractively illustrated articles, and there are also columns for information concerning veries received, for the latest DX loggings, and so forth. Address, "Kortvags-Lyssnaren," Stockholm 29.

"QTC"—This is a new house organ for S.S.A. (Sveriges Sandare Amatör, or Swedish Sending Amateur Association). Is just getting started and will be issued monthly for distribution only to members of S.S.A. free-of-charge. Address, Editor Ingenjör Hans Eliaeson, SM5WL, Järnmalmsvägen 2, Traneberg, or S.S.A., Stockholm 8.

### Facts About Sweden

Sweden occupies the eastern and largest part of the Scandinavian peninsula in northeastern Europe. The Government is a constitutional monarchy. The Riksdag (Parliament) has

two Chambers—the first of 150 members, the second of 230 members. All persons—men and women—over 21 years of age are entitled to vote.

The King of Sweden is Gustav V, who succeeded on the death of his father, Oscar II. A Social Democratic Government rules the country; there is a Prime Minister.

Lakes and rivers are more numerous in Sweden than in any other European country except Finland. The Government's hydro-electric plant, Porjus, in Lapland many miles north of the Arctic Circle, the center of a vast iron mining section, has a capacity of 150,000 horsepower. The water power resources of the country are approximately 30,000,000,000 k.w.h.

Although of broken, mountainous topography, Sweden contains much productive land, well-watered, on which the Swedish people have attained high efficiency in agriculture. Half the people are on farms which number about 420,000, of which 120,000 are under five acres, and 270,800 are between five and 50 acres. Many trees, particularly in Lapland, are 120-160 years old. Of the vast forest area (about 58,000,000 acres), 45 per-cent is owned by farmers, 4 per-cent by large landed proprietors, 27 per-cent by companies having sawmills, pulp

"Dagens Dikt" is a daily noontime program featuring the reading of the "poem of the day." Here the program is being recorded in Studio Nine.

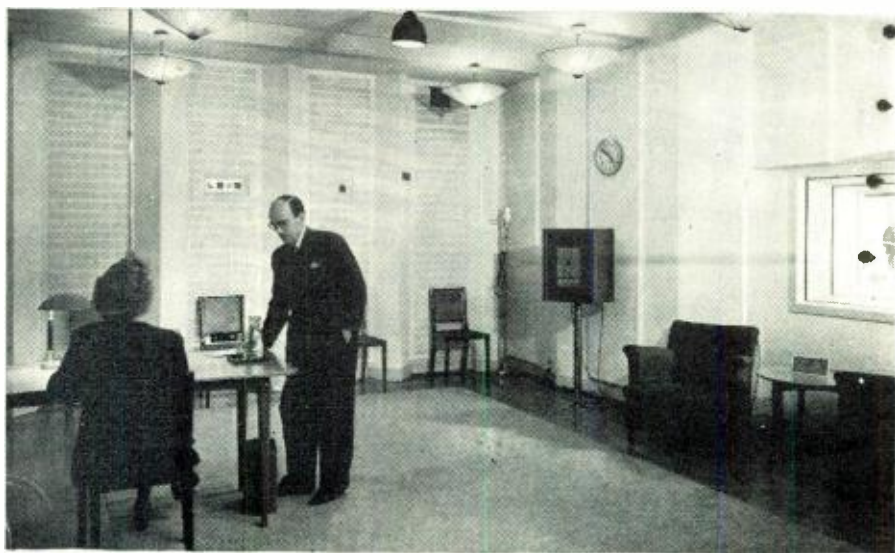

mills, and so on, and about 24 percent by the State. In forestry, lumbering, sawmills, and pulp mills, 265,000 men and women are regularly employed and 400,000 more obtain some part of their living therefrom. Fabrication of rayon and other textiles made of pulp has increased, and it has even been possible to produce cattle fodder from woodpulp.

About 10,000 people are engaged in the mining industry, which is most extensive north of the Arctic Circle. Swedish steel is of especial value in tool making. The iron and mechanical industry employs about 175,000; textiles, 80,000; and the paper industry, 60,000.

The population is very homogeneous, being entirely of the Scandinavian branch of the Aryan family, except about 20,000 Finns and 6500 Lapps. Most of the people are Lutheran Protestant, which is the State religion, but complete freedom of worship exists. Education is compulsory.

The Army has been enlarged with special attention paid to mechanization. Service is compulsory between the ages of 20 to 47. The Air Force has been increased to 16 wings. Sweden adopted a five-year defense plan in 1942 with annual cost estimated at 755,000,000 kronor. The Navy (1945) consists of four cruisers, seven coast defense craft, 21 destroyers, six torpedo-boats, 42 minesweepers, 28 submarines, 19 motor torpedo-boats, two minelayers and small craft. The personnel is approximately 10,000. The Swedish merchant marine numbered 2107 vessels of more than 20 tons (1944).

Sweden comprises 173,347 square miles and the 1944 population was listed at 6,522,827, now is approximately 6,600,000. Stockholm is the capital city.

#### Best Bets in Sweden

We are indebted to Sven Lindhe, Carl-Eric Petersson, and Lars-Olof Forsstrom for this list of "best bets" for Swedish listeners, given in Swedish time (Swedish time is 1 hour ahead of GMT, 6 hours ahead of EST):

Radio Andorra, 5.990/5, can be heard well around 1900-0000. OTC2, 9.745 (varying), Leopoldville, Belgian Congo, is best around 0115-0200. PCJ, 15.220, Hilversum, the Netherlands, heard well in Happy Station Programs, Sundays and Wednesdays, 1630-1800. FZI, 11.970, Radio Brazzaville, French Equatorial Africa, good to 0200.

CXA19, 11.835, Montevideo, Uruguay. HCJB, 12.455, Quito, Ecuador, 2200-0200. PRL7, 9.720, Rio de Janeiro, Brazil, at 2100-0300. ZYC8, 9.610, Rio de Janeiro, Brazil. ZYB8, 6.095, Sao Paulo, Brazil. LRX1, 6.120, Buenos Aires, Argentina. LRY, 9.455, Radio Belgrano, Buenos Aires, Argentina, 0000-0200. LRS, 9.315, Radio Splendid, Buenos Aires, Argentina, 2300-0000. LRX, 9.660, Buenos Aires, Argentina, 0000-0100.

CNR, 9.082, Radio Maroc, Rabat, French Morocco. TAQ, 15.195, Ankara,

# HAM SPECIALS

## From HAM Headquarters

	Net Price
Panoramic Adapter PCA-2	\$99.75 Ea.
Cabinet: 24 1/2" Wide, 29 1/2" Deep, 7 1/2" High, Gray Crackle Finish. Ideal for Transmitter	90.00 Ea.
Choke: 300 MA Swing 9-19 Henry, Smooth 11-Henry	7.50 Pr.
Choke: 2 1/2 MH. R.F.C.	.19 Ea.
Code Oscillator: Complete with Speaker; Metal Case, Bathub	9.95 Ea.
Coil Assembly: R.F. from Army Receiver BC-224M	.75 Ea.
Condenser: 1x 1x 1 Mfd. 600-Volt Tobe Metal Case, Bathub	.49 Ea.
Condenser: .5 and 2 Mfd. 600-Volt Bath-tub	.19 Ea.
Condenser: 2 Mfd. 600-Volt Solar DC Aluminum Can, Oil Filled	.89 Ea.
Condenser: 100 MMF. Midget Variable	.50 Ea.
Condenser: 2 Mfd. 1000-Volt, Oil Filled, Round Can, C.D.	1.50 Ea.
Condenser: 10 Mfd. 1400-Volt, Oil Filled, Rectangular Type	6.75 Ea.
Condenser: 10 Mfd. 1000-Volt, Oil Filled, Rectangular Type	6.75 Ea.
Condenser: 3 Mfd. 2000-Volt, Oil Filled, Rectangular Type	3.25 Ea.
Condenser: 50 MMF	.50 Ea.
Condenser: 8 Mfd. 600-Volt C.D. Oil Filled	2.75 Ea.
Condenser: .001 Mfd. 5000-Volt Mica	2.40 Ea.
Condenser: 6 Mfd. 600-Volt Oil Filled, Rectangular Type	.75 Ea.
Condenser: 3x3 Mfd. 600-Volt Oil Filled, Rectangular Type	.99 Ea.
Condenser: 4 Mfd. 600-Volt C.D. Aluminum Can, Oil Filled	1.50 Ea.
Converter: Gonsetti 4 tube supplied for either 10 or 8 meter band	39.95 Ea.
Crystals: 1N27 Sylvania Diode	.50 Ea.
Handy Talkie: Complete with Batteries, 3B85 K.C. Frequency	49.50 Ea.
Chassis: For Handy Talkie	10.00 Ea.
Insulator: 3" Feed Through	1.00 Ea.
Meter: Westinghouse 2" D.C. MA. 0-10-25-50-100-150-200-250-300-400-500	3.50 Ea.
Meter: Burlington, 2" A.C. 0-150, 2" Round	2.25 Ea.
Meter: Time Hour, 110-Volt, 60-Cycle	3.50 Ea.

	Net Price
Mike: Breast Mike	\$ 1.95 Ea.
Mike: T17B Carbon Hand Mike	2.50 Ea.
Plug: PL-55 Army Type Plug (100-Lots, \$-25 Ea.)	.35 Ea.
Receiver: EC-342 Frequency 200 to 500 K.C.—1500 KC—20 MC. As is	60.00 Ea.
Relay: D.P.D.T. 6-Volt D.C. Coil, Leach 1/4" Silver Contact	1.75 Ea.
Shield: 6C4 Tube Shield	.12 Ea.
Transformer: 5.3 M.C. I.F. Iron Core Interstage	.49 Ea.
Transformer: 5.3 M.C. I.F. Iron Core Diode	.49 Ea.
Transformer: G.E. Modulation—200 Watts. For 811s to 813	6.00 Ea.
Transformer: 2.88 M.C. I.F.	.29 Ea.
Transformer: Filament, 6.3 Volt at 1 3/5 Amps., Small Round	1.20 Ea.
Transmitter: BC-223 Frequency 2000 to 3000 K.C.	25.00 Ea.
Transmitter and Receiver: BC-1335 F.M. Ideal for 10 Meter Mobile Operation 6 or 12-Volt Input, 2 1/2 Watts Output. Dimensions 12" Long, 1 3/4" Deep, 6 1/4" High. Ready to go with Telephone Headset and (3) Crystals for 10-Meter Band	53.00 Ea.
Trimmer: Air, 15 Mmfd.	.25 Ea.
Trimmer: 3-30	.15 Ea.
Wire: Bronze Stranded Wire (250 Ft. Rolls) Heavy	3.50 Ri.

Mail Orders Promptly Filled

Amateurs to Serve You

20% Must Accompany All

C.O.D. Orders)

Write Dept. R.N.

WGSCQ—WGXUN—W6NAT—W6VHZ—

W6VIW

WRITE FOR FREE BULLETIN NO. 29

## Radio Products Sales Company

238 WEST 15TH STREET

LOS ANGELES 15, CALIFORNIA

PRospect 7471

**PRESS THE TRIGGER for HEAT in 6 SECONDS**

with the **"Flash" SOLDERING GUN**

**YOU AIM IT AT YOUR WORK with a restful, natural wrist position**

Engineered for every type of soldering, the Flash Soldering Gun gets around corners and into minute places. Heats only while pressure is on trigger—intensity of heat controlled at your finger tips. Equipped for immediate operation from our 110 V transformer, or from any standard (6-12V) storage battery in car, tractor, airplane, boat, etc. Ask about extra tips for special work, and for specifications for the heavy duty model, with its 5/8 inch tip. See your distributor, or send coupon.

**BAKER-PHILLIPS COMPANY** 3065 Lyndale Avenue So. Minneapolis 8, Minnesota

Please send circular on Flash Soldering Guns.

Name \_\_\_\_\_

Address \_\_\_\_\_

CRAFTSMAN TIPS

5/16 TIP PENCIL TIP



ENDORSED BY CHAMPIONS

Skill, speed, accuracy free of nervous tension brings big pay.

**The One and Only Candler System**

Nothing else like it. It is the course that has made code champions. Will help any sincere man gain greater speed, accuracy and skill. Learn the Candler way.

**Fast, Efficient Operators Needed**

If you need additional speed to be classed as an expert, try the Candler method. It is endorsed by champions. It has produced phenomenal results with a minimum of effort. Why not learn the faster and easier way. Get your copy of the Book of Facts for Code students. Telegraph and Radio Operators.

**CANDLER SYSTEM CO.**

P. O. Box 928, Dept. 2-M, Denver (1), Colo. and at 21 Kingsway, London, W.C.2, England

**Champion Endorses CANDLER SYSTEM**

I. R. McElroy, Official Champion Radiotelegraph Operator of the world with a speed of 75.2 w.p.m., claims his success is due to the Candler System.



**PREPARED ASSORTMENTS GUARANTEED FIRST QUALITY**

Cat. No.	Quantity	Description	Price
1001	100	1/2 Watt Resistors, All Insulated	\$2.98
1002	100	1/2 Watt Resistors, All Insulated	3.98
1003	100	1 Watt Resistors, All Insulated	4.45
1004	50	1 Watt Resistors, All Insulated	3.98
1005	10	Wire Wound Resistors Ass't'd	
		Watts	2.98
1006	50	200 Volt Paper Condensers	2.48
1007	50	400 Volt Paper Condensers	3.49
1008	50	600 Volt Paper Condensers	4.25
1009	50	Mica Condensers	2.98
1010	20	Dry Electrolytic Filter Condensers	6.75
1011	10	Resistance and Line Cords	3.98
1012	100	Water Sockets	4.50
1013	100	Plastic and Ceramic Sockets	8.50
1014	10	25 Ft. Rolls Hookup Wire—Ass't'd Colors	1.98
1015	10	50 Ft. Rolls Hookup Wire—Ass't'd Colors	3.25
1016	10	100 Ft. Rolls Hookup Wire—Ass't'd Colors	6.75
1017	10	Volume and Tone Controls—No Switches	1.98
1018	50	Large Bakelite Knobs Push On	6.50
1019	50	Large Bakelite Knobs Set Screw	7.85
1020	50	Small and Medium Knobs Push On	3.50
1021	50	Small and Medium Knobs Set Screw	3.75
1022	100	Small Bar Knobs	5.50
1023	100	Large Bar Knobs	6.75
1024	100 ft.	Spaghetti and Vinylite	.98
1025	50	Padders and Trimmers	3.45
1026	10	Coils, P. R.F. Ant. and Osc.	3.98
1027	50	Pilot Lamps	2.49
1028	20	Torgite and Slide Switches	3.98
1029	20	Water and Ceramic Band Switches	3.98
1030	20	Auto Generator Condensers	2.98
1031	20	Auto Suppressors	2.98
1032	25	Electrical Wiring Devices, Plugs, Caps, Bases, Heater Plugs, etc.	2.75
1033	50	Electrical Wiring Devices, Plugs, Caps, Bases, Heater Plugs, etc.	5.00
<b>ELECTRICAL APPLIANCES AND PARTS</b>			
		Double Burner Electric Stove Streamlined	5 6.25
		Electric Broiler Deluxe type	12.50
		Fluorescent Desk Lamp, Brown, Blue or Rust	6.25
		Fluorescent Kitchen Unit	5.35
		Electric Phonograph	29.90
		Replacement Stove Element 660 W.	.12
		Replacement Electric Iron Element 55 W.	.75
		Replacement Toaster Element	.75
		Electric Iron Cord Set, Bakelite Plug	.45
		Electric Iron Cord Set, Switch Plug	.89
		8 ft. Extension Cord with Cube Tap	.45
		6 ft. Rubber Replacement Cord	.21
<b>SEND FOR TRUTONE COMPLETE RADIO AND ELECTRICAL LIST</b>			
Terms: 25% deposit required with order. Balance C.O.D. Merchandise sent prepaid if full remittance accompanies order.			
<b>TRUTONE PRODUCTS CO.</b>			
303 West 42nd Street, Dept. N, New York (18), N. Y.			

Turkey, around 1200; TAP, 9.465, Ankara 1700-2145. CSW6, 11.035, Lisbon, Portugal, 2200-0300.

CKNC, 17.820, and CKLX, 15.090, Montreal, Quebec, Canada, 1800-2300.

In addition to the above, practically all the U.S. and the BBC stations are heard at good level in Sweden.

**The Ilse**

Through the efforts of Arne Skoog, Sweden, and Bill Howe, short-wave editor of the *Universal Radio DX Club* in the United States, the *International League of Shortwave Editors* came into being at the end of 1945. They organized an exchange of information, with members in various parts of the world. Members in addition to Messrs. Skoog and Howe include Rex Gillett, DX Editor of "Radio Call," South Australia; Arthur Cushen, a leading short-wave authority and contributor to radio publications, New Zealand; and Sr. Carlos Ramirez, short-wave editor of "Radio Guia," Havana, Cuba. Mr. Skoog is chairman.

**Polskie Radio**

From W. Pawlak, Chief, Foreign Liaison, *Polskie Radio*, Warsawa al. Stalina 31, comes this information:

"We have only one short-wave station, Warsaw III, situated at Raszyn, near Warsaw, using 7.5 kw. and scheduled, 9.5268, 9-10 a.m., and 6.1149, 1:55 p.m.-12 midnight." (Note: I believe schedule for the 6.1149 frequency is an error, for the mimeographed detailed schedules in *English* enclosed with Mr. Pawlak's letter, list the radiation as 1655-0300 Central European Time, or 9:55 a.m.-8 p.m. EST.) Details of schedules given were (converted to EST):

9:55 a.m.-1 p.m.—Transmission of the General Program. 1-1:10 p.m.—Interruption. 1:10-1:20 p.m.—Program for Yugoslavia. 1:20-1:30 p.m.—Interruption. 1:30-3 p.m.—Transmission of the General Program. 3-3:20 p.m.—News in *English*. 3:20-3:40 p.m.—News in Russian. 3:40-4 p.m.—News in French. 4-4:15 p.m. (Monday)—The UNRRA Mission in Poland (Bulletin); (Tuesday, Thursday, Saturday, Sunday)—News in Yiddish. 4-5 p.m. (Wednesday, Friday)—Transmission of the General Program. 4:15-5 p.m. (Tuesday, Thursday, Saturday, Sunday)—Transmission of the General Program. 5-8 p.m.—Press news by the Polish Press Agency PAP (at dictation speed).

Warsaw I operates on 395.8 meters (758 kcs.).

Mr. Pawlak continued, "We usually relay the General Program in Polish and as special broadcasts we give only news in *English*, French, Russian, Serbo-Croate, Yiddish. You will probably understand that in the actual conditions, it is impossible to give identifications in *English* during broadcasts in other languages. We send verifications and answer all questions put to us by listeners. An IRC is required, but even so, we always answer." *Polskie Radio* issues publica-

**A REAL SCOOP!**

**MINIATURE EXTRA-SENSITIVE HEADPHONES**



Signal Corps Type HS-30 and matching transformer plus extra ear plugs at 1/10 original cost.

**\$3.49 NET**

POST PAID IMMEDIATE DELIVERY

- Wide Frequency Response
- High or low impedance
- Featherweight-Adjustable Headband

**Electronic Supply Corp.**

40-14 Greenpoint Avenue, Long Island City 4, N. Y.

**ALMO - WHOLESALE RADIO-ELECTRONICS PARTS DISTRIBUTOR**

Immediate Delivery From Stock

R.C.P. 448	Pocket Multitester	\$24.50
R.C.P. 424A	Volt-Ohm-Milliammeter	\$29.50
R.C.P. 322	Tube Tester	\$41.50
R.C.P. 461	AP Sensitive Multitester	\$43.50
R.C.P. 664	Electronic Multimeter	\$45.00
R.C.P. 322P	Tube Tester (Portable)	\$45.50
R.C.P. 668	Vacuum Tube Volt-Ohm-Capacity Meter	\$74.50
R.C.P. 665	A.V.T. Volt-Ohmmegger Insulation Tester	\$94.50

**KIT ASSORTMENTS**

100-Ass't.—1/2 Watt Resistors—Insulated	\$1.95
100-Ass't.—1 Watt Resistors—Insulated	\$2.50
100-Ass't.—2 Watt Resistors—Insulated	\$2.95
20-Ass't.—Volume Controls	\$2.45
6-25 ft. rolls—Hookup Wire Ass't. Colors	\$1.25
20-Ass't.—Auto Radio—Suppressors	\$2.45

Mail Orders Filled Promptly

10mbar 3-6513

509 ARCH STREET, PHILADELPHIA 6, PA.

**A TOOL SHOP IN YOUR HAND**



Smooth, steady power for buffing scratched cabinets, metals, corroded tube and socket pins; removing burrs, sanding, etc. Grinds, drills, saws, engraves, etc. 25,000 r.p.m. AC or DC. Wt. 12 oz. In steel case with 45 accessories, \$27.50. Handee, with 7 accessories, \$20.50.

**THE RIGHT ACCESSORIES**

Choose them from the complete line—over 300 made right in the Handee plant.

**CHICAGO WHEEL & MFG. CO.**

1101 W. Monroe St. Dept. RE, Chicago 7, Ill.

FREE 64 PAGE CATALOG

**HANDEE - TOOL OF 1001 USES**

**RADIO TUBES**

Most Critical Types in Stock 50L6, 1A7, 35Z5, etc. Brand New, in Sealed Cartons 100% Guaranteed

Repairmen and Dealers, Write For List at Trade Discounts  
**RADIO-EXPERTS**  
178 E. 33rd Street Paterson 4, N. J.



tions in *English*, Mr. Pawlak concluded. (Several nice photos of the installation at Raszyn, 17 km. from Warsaw, were forwarded; we hope to use them soon in ISW.)

**More Sunspot Activity**

Renewed disturbance of ionosphere conditions, due to sunspot activity, played havoc with international short-wave reception the last week in July. Reports from all parts of the U. S. and Canada indicate that the severe magnetic storm all but blotted out s.w. reception for about four days. WWV, Bureau of Standards station in Washington, D.C., was inaudible much of the time, even at short distances.

As pointed out to me by Clyde P. Brockett, Department of Chemical Engineering, University of Toronto, "it is interesting to note that the BBC doesn't miss a trick. As usual, at the beginning of this period of disturbance, they announced the probability of poor radio reception 'for some time' because of 'disturbed ionosphere conditions.'" Mr. Brockett comments that "this is the sort of thing I should like to see radio stations do more of, especially since there must be plenty of reliable information these days in various quarters on disturbances of this nature from continuously-recording instruments."

**The Anti-Franco Radio**

Carl Beck, New York, reports an "anti-Franco, anti-Phalangist Radio," 14,900, signing off at 5:33 p.m.; Spanish only.

**Club Notes**

Australia—From H. J. Clark, secretary, V.R.I. Wireless Club (V.K.3RI), Victorian Railways Institute, Flinders Street Station Building, Melbourne, Cl, Victoria, comes this data:

"The Victorian Railways Institute Wireless Club was formed in July, 1926, by railwaymen in Victoria who were interested in the amateur side of radio broadcasting. A transmitting license was granted to the Club in November of that year under the call-sign, V.K.3RI, the letters 'R.I.' being applied for by the Club as designating 'Railways Institute.' Broadcasting began on the 200-meter band immediately, and regular transmissions were made on week nights and on Saturday afternoons and Sunday mornings and afternoons, the programs being publicized at that time in the local weekly radio magazine, 'Listener In.' Subsequently, the commercial broadcasting stations opened up the 200-meter band for commercial broadcasting, and in common with other amateurs, our Club was restricted in its hours on the air, and the only regular transmissions then carried on were on Sunday afternoons and at night, with irregular transmissions at other times. Concurrent with these restrictions, however, transmissions were conducted on the 20-, 40-, and 80-meter bands and later on 56 megs. (5-meter band). When the war commenced, all amateur broadcasting in Australia ceased and

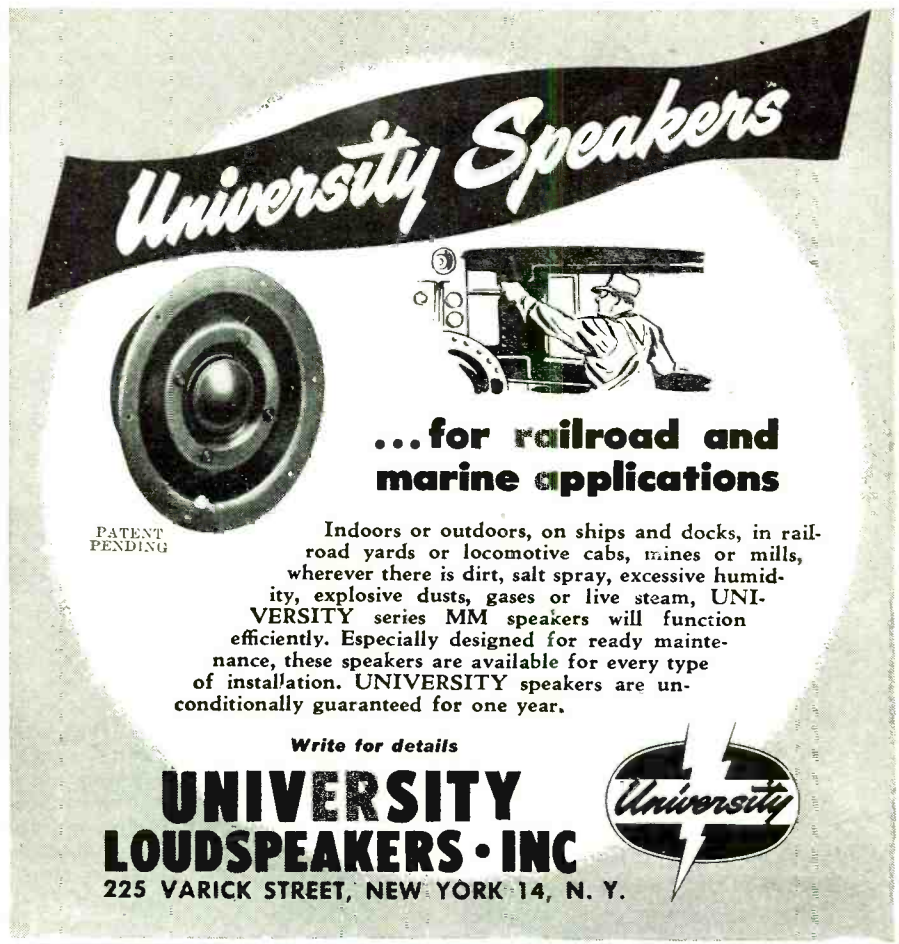

**University Speakers**

**...for railroad and marine applications**

Indoors or outdoors, on ships and docks, in railroad yards or locomotive cabs, mines or mills, wherever there is dirt, salt spray, excessive humidity, explosive dusts, gases or live steam, UNIVERSITY series MM speakers will function efficiently. Especially designed for ready maintenance, these speakers are available for every type of installation. UNIVERSITY speakers are unconditionally guaranteed for one year.

Write for details

**UNIVERSITY LOUDSPEAKERS • INC**

225 VARICK STREET, NEW YORK 14, N. Y.

PATENT PENDING

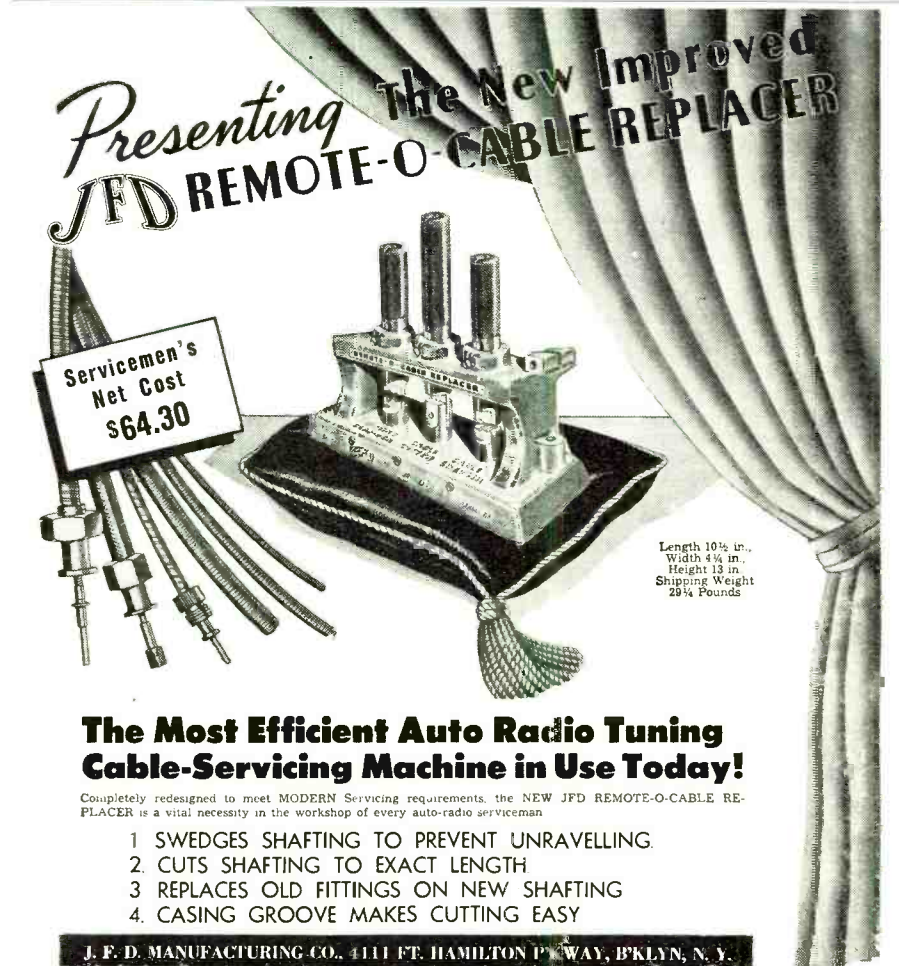

**Presenting The New Improved JFD REMOTE-O-CABLE REPLACER**

**Service Men's Net Cost \$64.30**

Length 10 1/2 in.  
Width 4 1/4 in.  
Height 13 in.  
Shipping Weight 29 1/4 Pounds

**The Most Efficient Auto Radio Tuning Cable-Servicing Machine in Use Today!**

Completely redesigned to meet MODERN Servicing requirements, the NEW JFD REMOTE-O-CABLE REPLACER is a vital necessity in the workshop of every auto-radio serviceman

- 1 SWEDGES SHAFTING TO PREVENT UNRAVELLING.
- 2 CUTS SHAFTING TO EXACT LENGTH
- 3 REPLACES OLD FITTINGS ON NEW SHAFTING
- 4 CASING GROOVE MAKES CUTTING EASY

J. F. D. MANUFACTURING CO., 4111 FT. HAMILTON P. WAY, B'KLYN, N. Y.

# Alsam's NEW TU-TONED CASES

Contrasting two-toned leatherette finish



Model  
P-305

Portable  
Phonograph Case

Dimensions: 15 1/2" L. x 14 1/4" W. x 8" H.



Model  
RC-275

Portable  
Automatic Phonograph  
Record-Changer Case

Dimensions:  
18" L. x 16" W. x 10 1/2" H.

The brand new Alsam "Tu-Toned" Cases enhance the beauty. Write for our new illustrated literature. Prices furnished upon request.

ORDER FROM YOUR JOBBER!

**ALSAM PRODUCTS COMPANY**  
805 MILWAUKEE AVENUE  
CHICAGO 22, ILL.

## THE STAR TESTER

MODEL M II



All instruments shipped complete with batteries, test leads, and instructions for use. Net Price

**26.95**

**PROMPT  
DELIVERY  
ACT NOW!**

### FEATURING

A large 4 1/2", 400 microampere meter for accuracy of readings on all ranges.

27 separate ranges for measurements.  
10,000 ohm per volt sensitivity AC and DC.

A metal crackle finish cabinet for ruggedness of use under all working conditions.

### DESIGN DATA

- 5 AC Voltage Ranges  
0 to 10/50/250/500/1000 Volts
- 5 DC Voltage Ranges  
0 to 10/50/250/1000 Volts
- 5 Output Meter Ranges  
0 to 10/50/250/500/1000 Volts
- 1 DC Current Ranges  
0 to 1/10/100/1000 MA
- 3 Resistance Ranges  
0 to 5,000/500,000 ohms  
0 to 5 Megohms
- 5 Decibel Ranges  
-10 to +14, +4 to +28, +18 to +42,  
+24 to +48, +30 to +54 DB

If your dealer cannot supply, send check or M.O. (50% deposit on C.O.D. orders)

## STAR MEASUREMENTS CO.

442 E. 166th Street New York 56, N. Y.

up until May 28 of this year we have only had the 6-meter and 10-meter bands restored—although we are hoping to have all other bands restored in the near future.

"Originally composed solely of railwaymen, the Club altered its Constitution in 1930 to admit non-railwaymen as 'associate' members in the proportion of one associate member to every two railwaymen.

"Annual subscription to the club is 5/- and in order to raise funds for our activities, dances are held during the year—and for these we have a very good social committee.

"Although the club did at one stage conduct classes in radio for tuition, no classes are held at present for class tuition, but individual tuition is given to new members desirous of same from the other members who are qualified to teach. The Club is affiliated with the Wireless Institute of Australia, which is the governing body for amateurs in Australia, and is also a member of the American Radio Relay League.

"Present officers are: President, T. Ramsey; vice-presidents, W. Brennan and H. McBain; secretary, H. Clark; assistant secretary, R. Duncan; and treasurer, W. I. May. These officeholders are elected at the annual meeting held in July each year and are eligible for reelection. A Management Committee of 8 members is also chosen at the annual session. Officers of the Club are ex-officio members of that committee. The Club, of course, is an affiliate of the Victorian Railways Institute and operates under the Constitution of that Institute."

\* \* \*

### All-Continent Tips Given

DXers in the Eastern United States who are anxious to verify *all-continents*, will be pleased to learn that this is possible at this time in about 2 hours of *evening* listening and by sending out correct reception reports. I suggest:

Africa—OTC-2, 9.738 (varying), 8:10 p.m. when *English* news is given from Leopoldville; address, The Belgian National Broadcasting Service, Leopoldville, Belgian Congo (Africa).

Asia—*All-India Radio*, 15.160 or 15.190, Delhi, 9:30 p.m. when *English* news is given with frequent announcements; address, All-India Radio, Delhi, India.

Australia—Tune *Radio Australia* on VLC9, 17.840, or VLA9, 21.60, at 8 p.m. when *English* news is featured; address, Radio Australia, Melbourne.

Europe—Here you can have your choice: Paris on 9.550 is excellent at 9 p.m. in *English* news period; Bern, 9.539, Switzerland, is also at fine level during its entire North American nightbeam, 8:30-10 p.m.; address for Paris is Radio Nationale Francais, Paris; for Switzerland, The Swiss Broadcasting Corporation, Berne.

North America—Tune to 25-, 19-, or 16-meter band at 8 p.m. when the West Coast transmitters are coming through "full tilt!" *English* is used

## RESISTORS is our Business

which means that your orders for

**1/2-, 1-, 2-WATT**

**CARBON & WIRE-WOUND  
RESISTORS**

will be filled from stock

the same day we receive them

*That's a fact!*

## LEGRI S COMPANY

846 Amsterdam Avenue

New York 25, N. Y.

ACademy 2-0018

## DEFECTIVE TESTING OR MEASURING EQUIPMENT AND RADIOS REPAIRED

with Laboratory precision equipment. Tube Checkers—Signal Generators—Ohm Meters—Oscilloscopes—Signal Tracers—Combination Instruments—Communication Receivers—Standard Radios any make or model. Send that instrument in for prompt repairs and calibration. Send no money—Pack carefully—Give complaint. We will immediately repair and ship. However, if cost is over \$10.00 we will estimate repairs and mail estimate of cost of repair for your approval. Remember we guarantee to restore that instrument to perfect operating condition.

Established 1932

## FOHT RADIO COMPANY

153 EAST TWELFTH STREET, ERIE, PA.

Howard J. Foht W8VJC

**NEW TINY POCKET SIZE RADIO!**

Slips in your pocket or purse—Wt. only 3 ozs.! Complete READY TO PLAY as shown with self-contained phone for personal use. Beautiful black plastic case. Has patented fixed Crystal-Slide Tuning Dial! NO TUBES, BATTERIES, OR ELECTRIC PLUG-IN REQUIRED. USUALLY RECEIVES LOCAL BROADCASTS without outside aerial wires.

**GUARANTEED TO WORK**  
when connected and used according to instructions. Can be used in homes, offices, hotels, cabins, in bed after hours, etc.

**SEND ONLY \$1.00** (cash, money order, check) and pay postman \$2.99 plus delivery fees on arrival or send \$3.99 for postpaid delivery. IDEAL GIFT FOR CHILDREN OR ADULTS ALIKE! Get your PA-KETTE RADIO NOW for real enjoyment. (All Foreign Orders \$5.00 U.S. Cash.)

PA-KETTE ELECTRIC CO., Dept. RN-11, Kearney, Nebr.

**SERVICEMEN!!**

IN STOCK

**TUBES—PARTS—TEST EQUIPMENT**

Triplet—RCA—Simpson—Hickok—Supreme  
Tube Checkers—VTVM—Sig. Generators

**CHIEF ELECTRONICS**

Wholesale Only

104R Main St. Poughkeepsie, N. Y.

**PEN-OSCIL-LITE**

Extremely convenient test oscillator for all radio servicing; alignment • Small as a pen • Self powered • Range from 700 cycles audio to over 600 megacycles u.h.f. • Output from zero to 125 v. • Used by Signal Corps • Write for information.

**GENERAL TEST EQUIPMENT CO.**

38 Argyle Buffalo 9, N. Y.

and announcements are frequent. Address of the United Network transmitters is Fairmont Hotel, San Francisco, California.

South America—Tune the old standby, HCJB, 12.455 or 9.958, Quito, Ecuador, at any time between 8-10 p.m., usually has *English* program around 9 p.m.; address is simply, HCJB, Quito, Ecuador.

Morning "best bets" for all-continents include:

Africa—OTC5, 17.770, Leopoldville, Belgian Congo, *English* news at 8:30 and 11:30 a.m.; address given above.

Asia—Radio SEAC, 15.12, Colombo, Ceylon, best around 6-8 a.m.; *English* news at 6 and 7:30 a.m.; address, 191 Turret Road, Colombo, Ceylon.

Europe—London in the 25-, 19-, and 16-meter bands is "all over the place." Now verifies. Send 10 cents in unused postage stamps with your report to Bryan Hayes, Local BBC Representative, 8 Althorpe Crescent, New Bradwell, Bletchley, Bucks, England. Another European regularly beamed to North America is SBT, 15.155, Stockholm, Sweden, 10-11, a.m., usually with *English* news around 10:05 a.m.; some days has not been audible here lately, but reception from this quarter should improve as autumn advances. Sends out verie card now for first time. Address, Swedish Radio, or Radiotjanst, Stockholm, Sweden (Sverige).

North America—CKNC, 17.820, Sackville, N.B. (studios in Montreal,

Quebec), usually heard well all morning; address, International Service, CBC, Montreal, Quebec, Canada.

South America—HCJB, 12.455 or 9.958, Quito, Ecuador, is your "best bet" here, too, mornings. Heard around 6-8 a.m. with fine level; address given above.

\* \* \*

#### Verifications

So much interest is being shown in s.w. verifications these days, I am devoting some space to it each month.

Grady Ferguson, North Carolina, has received verification by airmail letter on NIGF, 9.065 and 18.530, Atom Bomb Expedition: "NIGF, the Army Communications Ship, 'Spindle Eye,' is the successor to the old 'Apache.' The call, WVLC, is now held by the 'Spindle Eye' but has been temporarily set aside for this operation. We are modulating dually, an RCA 7.5 kw. high-frequency voice transmitter, and 96C Wilcox 2.5 kw. Thanks for your interesting report of our signal. The 'Spindle Eye' is taking up a new position for test 'Baker' and will act as a relay to NICO and NCLG, U.S.S. *Mt. McKinley* and *Appalachian*, respectively." Ferguson reports he heard NIGF, 8.530, with this relay from 6:15 p.m. to their going off the air at 10:08 p.m., July 24, with only fair signal at beginning but improvement until it was good, with swings up to R6 toward the last. He did not give address for verification, but I will have the address by the time you read this; in case

you're still interested, drop me a line.

Address for verification from JODK, 2.510, Seoul, Korea, is: Radio Department, Bureau of Public Information, Headquarters USAMGIK, A.P.O. No. 235, c/o Postmaster, San Francisco, California; letter verification received in New Zealand was signed by James W. Browitt, assistant director. (Cushen)

Verification from the British Forces Network which operates from Hamburg, Germany, on 7.290, is Maj. J. F. Bassett, RA, No. 2 Field Broadcasting Unit, British Forces Network, British Army of the Rhine.

Mail address for KU5Q, Guam, is Box 10, Com-Marianas, c/o Postmaster, San Francisco, California. A Texas correspondent, Buddy Giles, reports KU5Q is now using a form letter for verification.

Address of the new DTYC, 5.3025, Munich, Germany, is A.P.O. No. 170; has asked for reports; tests, 8-8:30 a.m.

Verifications are being sent out promptly by PCJ, Holland; reports are requested and will be acknowledged over the air in Eddie Startz's "Happy Station" programs. Address is PCJ, Postbus 150, Hilversum, Holland (The Netherlands).

The *Sharq-el-Adna* station (6.135, 6.710, 6.790) verifies from Jaffa, Palestine, with nice verification card.

Address of HP5H, 6.122, Panama, is Apartado 1045, Panama City, Republic of Panama.

**HAMS**  
WHILE THEY LAST

Another McGEE Scoop **WAR SURPLUS**

**BRAND NEW** *in original carton!*  
**NAVY MODEL Portable Short Wave**  
**RADIO RECEIVING SET**

● Here's **BRAND NEW** listening fun for amateurs, hobbyists. No license required to operate set. Weighs only 5¼ lbs. Includes 5 standard Tubes:—Two—1T4; One—1R5; One—1S5; One—1L4 and includes set of high impedance headphones. Sufficient power to drive a small speaker. Uses two flashlight batteries and one—67½ Volt battery.

● **Set** covers frequencies from 5 to 13 megacycles which includes American and foreign short wave broadcast bands on 25, 31 and 49 meters; as well as some commercial aircraft stations. You will be able to hear South American, European and American short wave broadcast stations.



Instruction Manual

**PERMABILITY TUNING**  
Can be easily converted as Standard Broadcast Receiver!

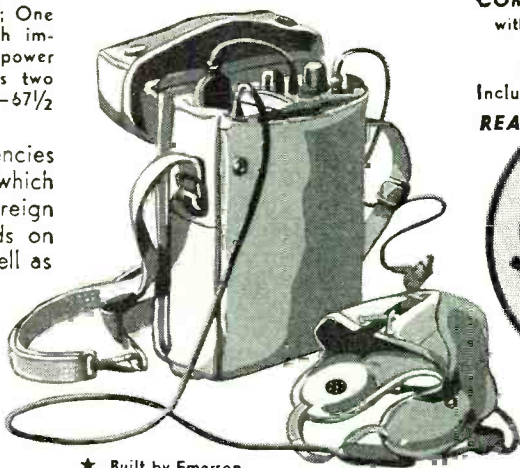

★ Built by Emerson.

5 to 13 megacycles  
**FREQUENCY RANGE**

**COMPLETE** ----  
with **EVER READY** Batteries,  
Head Phones,  
Canvas Carrying Holder.  
Includes 5 standard Tubes:—  
**READY TO OPERATE—**

**ONLY!**  
**\$14.95**  
complete  
with batteries,

**GET YOUR ORDER IN TODAY**  
First come—First served.

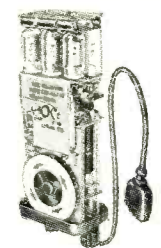

Streamlined Chassis



Battery Power Unit Pack Section

**McGEE RADIO & ELECTRIC COMPANY**  
**1225 McGEE STREET**  
**KANSAS CITY 6, MO.**

## Sensational Value!

T-17B HAND MIKE (NEW)  
ARMY SURPLUS



These Signal Corps inspected and approved microphones were constructed for the Army. Sales price was more than double your low purchase price. Made of durable plastic. Complete with 5 ft. rubber coated cord and plug PL-68. Press-to-talk button. 200 ohms. Ideal as standard equipment in planes, radio transmitters, mobile P.A. call systems, etc. Can be adapted to most radio sets as home broadcaster mike for entertainment by using mike transformer with dry cell battery.

**SUPPLY IS LIMITED  
ACT QUICKLY**  
to take advantage of this exceptionally low offer. We are confident that you cannot beat this price anywhere.

**WHILE THEY LAST**  
plus 2% Sales Tax  
in Illinois

**ONLY \$1.95**

### MAIL THIS COUPON

SHURE APPLIANCE & RADIO, Dept. N  
120 N. Green Street, Chicago 7, Illinois

Send me.....Signal Corps inspected and approved T-17B Microphones at \$1.95 ea.

Money Order or Check enclosed.

I will pay Mailman on arrival \$1.95 ea. plus postage and C.O.D. charges.

NAME.....

ADDRESS.....

CITY.....STATE.....

PLUS 2% SALES TAX IN ILLINOIS

## TYPICAL RESCO VALUES!

### HANDSET

(H 22 A U) Like new type telephone handset. Standard single button carbon microphone; 1000 ohm D.C. resistance receiver (hi-impedance). With 5-ft. rubber cord, ending in PL 55 and PL 58 phone plugs.



**4.95**

### CODE PRACTICE OSCILLATOR

For large groups. Universal power supply.

**39.95**

### BC 620 FM TRANSMITTER & RECEIVER

Complete with battery case, vibrator power supply, telescopic antenna, sectional antenna and spring mount... handset... all tubes and -80 crystals.

**79.50**

### CHASSIS

Solid and punched, in stock. For special sizes give our Metal Dept. just 48 hours to make them up.



### PUNCHED CHASSIS IN STOCK

18 x 8 1/4 x 2—59c	6 x 4 1/2 x 2 1/2—29c
12 1/4 x 5 x 2—59c	6 x 6 x 2 1/2—39c
10 x 4 x 1 3/4—49c	10 x 8 x 2—29c

## JUST OFF THE PRESS!

SPECIAL BULLETIN OF VALUES ON RADIO PARTS AND EQUIPMENT

Send for Yours Today!

# Radio Electric

SERVICE CO. OF PENNA., INC.

7TH AND ARCH STREETS, PHILA. 6, PENNA.  
Branches at 5133 Market St. and 3145 N. Broad St., Phila. Also in Wilmington, Del., Easton, Pa., Allentown, Pa.

156

OAX4H, 6.365, Lima, Peru, "Radio Mundial," verifies from Apartado 1098.

Address of ZEA, 7.600, is G.P.O., Box 792, Salisbury, Southern Rhodesia.

Reports to *Radio Belgrad* should be addressed to Kneza Milosa 16/V, Belgrade, Yugoslavia.

The Klofta short-wave station in Norway answers reports from Klofta Kortboljerkringkaster, Oslo, Norway (Norge).

Although DXers in the U.S. (including myself) have been unable to get a verification from *Radio Eirrean*, Dublin, this reply has recently come to K. G. Frick, Sweden: "It is desired to thank you for your communication relative to reception of the Irish Short-Wave Br. Station on May 6th, 1946, and to confirm your reception reports. The Irish Short-Wave Br. Station, 1.5 kw., transmits daily 12:40-1 p.m. on 16.82 meters (17.84), and from 4:10 to 5:30 p.m. on 31.27 meters (9.595). We shall be glad at all times to receive reception reports from you." (Reports of mine addressed merely *Radio Eirrean*, Dublin, Eire, have not been returned, so it is presumed that address is sufficient. I did receive a reply to one letter, however, stating that their station would not be on the air for some time yet, but they did not verify my reception of reported 17.84. It is assumed they referred to a new station probably now under construction.)

Reception reports for *Radio Noumea* should be addressed in care of Le Chef de Cabinet du Gouverneur, Directeur du Service de l'Information, Noumea, New Caledonia (Nouvelle-Caledonie).

Bern, Switzerland, is now verifying with a nice card, not with a letter as formerly. (Legge, VRC) Merely address The Swiss Broadcasting Corporation, Berne, Switzerland.

Reports for verification by *All-India Radio* in Bombay, Calcutta, Madras, or Delhi, should be addressed to All-India Radio, Delhi, India.

"I have received a letter verification from *Radio Rangoon*, Burma. They seemed surprised to get a report of such excellent reception strength in Canada. They use a Marconi 7.5 kw. xmtr, with a Franklin Master Oscillator. The aerial is a center-fed dipole. Have also heard from Calcutta; they use a Phillips 10 kw. transmitter; the Calcutta engineer stated that the Delhi transmitters 'go as high as 100 kw.'" (Bromley)

Miss Eileen Reis, Program Director, "The Voice of America in North Africa," Algiers, reports: "Letter verifications are sent when correct reception reports are received, and an International Reply Coupon is appreciated. Reports should specify the frequency of the station heard, the time in GMT, the date, and as much program information as possible (*particularly the language in which the program is presented*) over as long a period of time as possible." (NOTE: These comments are good standard

# STREAMLINE

## YOUR SERVICE DEPARTMENT

with  
**4-in-1**

Job Cards - Shop Cards - Postal Notices - Storage Signals



**NOW!**  
4-in-1  
offers  
**JOB CARD STYLING**

"CUSTOM TAILORED" SERVICE RECORDS STYLED TO ORDER

SAMPLES AND PRICES ON REQUEST **Radio Press** MORGANTOWN WEST VIRGINIA

# RECORDS

## LATEST & HARD-TO-GET BACK NUMBERS

Some slightly used and some brand new—Victor, Bluebird, Columbia, Okeh, Decca, Capitol, etc. Such artists as Glenn Miller, Benny Goodman, Harry James, Bing Crosby, Frank Sinatra, Gene Autry, Duke Ellington, Fats Waller, Guy Lombardo, Andrews Sisters, Kate Smith, Ink Spots, Mills Bros., etc.

**BIG PROFITS** Your opportunity to cash in on this new field that is sweeping the country. Specify the type of music that sells best in your territory such as Swing, Sweet Music, Cow-boy, Hill-billy, Polkas, Blues, etc. Your price \$13.90 per 100 records, f.o.b. Chicago, 2% off for cash with order. All shipments made within 48 hours.

CHAS. HOODWIN CO.

4419 Broadway, R-15, Chicago 40, Illinois  
World's Largest Dealers in Used Records

## BUFFALO'S LEADING SUPPLY HOUSE

In the BUFFALO Area  
see **DYMAC INC.** for your  
radio and electronic parts and  
equipment

# Dymac INC.

2329-31 Main Street, Buffalo 14, N. Y.

## SOUND RECORDING SCHOOL

A practical 9 months' course in Sound Fundamentals, Recording, and Sound Transmission measurements; in a laboratory containing transmission sets, oscillators, square wave generator and intermodulation analyzer, and other equipment.

Two complete recording studios assimilating broadcast, motion picture and commercial sound recording, under the direction of H. M. Tremaine.

Approved for Veterans

DON MARTIN SCHOOL OF RADIO ARTS  
1655 Cherokee St., Hollywood, Calif.

## LEARN RADIO REPAIR

Millions of radios repaired yearly. Get into this profitable business: and OPERATE YOUR OWN RADIO SHOP. Our specialized Radio-Television Servicing Course prepares you for this business opportunity. Practical laboratory training, engineer-instructors. Enroll now. Free booklet. APPROVED FOR VETERANS

Western Radio Communications Institute  
631 West Ninth Street, Dept. G, Los Angeles 15, Calif.

RADIO NEWS



# Electronic Voltmeter Ohmmeter

Gives you constant accuracy and guaranteed performance. A stable bridge circuit type vacuum tube meter for measuring AC-DC voltages and ohms. Actual tests establish its superiority. Simple to operate. Hand calibration and hand calibrated multiplier resistors assure constant accuracy and stability.

Measures DC volts up to 600 with constant input resistance of 11 megohms. Resistor in the DC probe permits readings in signal-carrying circuits. Positive or negative indications through a reversal switch. Net price, \$75.00.

Meter Ranges: DC 0-3; 0-30; 0-150; 0-300; 0-600. Multiply by 4 with external probe. AC 0-3; 0-30; 0-150; 0-300. Ohms 0-1000; 0-10M; 0-100M; 0-1 Meg.; 0-100 Meg.

**ELECTRONIC MANUFACTURING CO.**  
714 RACE STREET HARRISBURG, PA.

## RADIO PARTS SOUND SYSTEMS ELECTRONIC APPARATUS

# Depend on RADOLEK

Radolek's big Free Profit Guide Catalog and Profit Bulletin supplements keep you abreast of the rapidly changing radio situation. Buying from Radolek means greater values, better service and more profits. Make Radolek your buying headquarters.



**FREE CATALOG**



**Large Stocks  
Fast Service**

**SEND TODAY!**

RADOLEK CO., Dept. B-120  
601 W. Randolph St., Chicago 6, Ill.  
Please send your FREE Profit Guide Catalog.

Name.....  
Address.....

**SAVE AT RADOLEK**

practice for sending reports asking verification by *any* station.)

For newcomers, address of *Radio Milan* is repeated this month: Radio Italiana, Via Arsenale 21, Torino, Italy.

"Recently I received a nice verie postcard from HI2T, Monsenor Nouel, Dominican Republic; report was sent May 9 by regular mail and the card was received July 17; it is yellow and white, signed by a 'director.' Address is simply La Voz del Yuna, Monsenor Nouel, Dominican Republic; frequency was listed as 6.480. I also have received a nice card from *Radio Andorra*. My veries now total 50, not too bad for only 6 months of DXing." (Gauvreau)

COBC, 9.365, Havana, Cuba, heard nightly to 11 p.m., verifies with a letter and a tiny verie the size and shape of a U.S. airmail stamp, with perforation, *et al.* Address is Apartado 132. (Moss)

### Acknowledgments

\*\*\*

AUSTRALIA—Gillett, *Radio Call*, Radio Australia, DXSA, Addis. CALIFORNIA—Balbi, Dilg, Curtiss, McCarthy (at sea); Norton, URDXC; West Dyke, Gould. CAMEROUN—Le Chef Du Service Radioelectrique. COLORADO—Woolley. CONNECTICUT—Georges. CZECHOSLOVAKIA—Halas. DENMARK—Friis. DISTRICT OF COLUMBIA—*West Indian Radio Newspaper*. EGYPT—Cairo Calling, *Forces' Radio Times*. ENGLAND—Hayes, BSWL, Harrison; Bear, International Short Wave Club. FLORIDA—Rowland. HOLLAND—Koelmans; Startz, PCJ. INDIA—All India Radio, *Indian Listener*. INDIANA—Hart, Green; Jacobs, Grand National SWL Club; Brimelow. ITALY—Radio Italiana. KANSAS—Seckler. KOREA—Ware. LOUISIANA—Smith, Miller, Brennecke, Crandall. MARYLAND—Weyrich. MASSACHUSETTS—Harris, Simonian, Kernan, French. MISSOURI—Kierski, International Round Table. NEW JERSEY—Wooley, Williams, De Brier, *Newark News Radio Club*. NEW YORK—Legge, Australian News & Information Bureau, BBC, Wohl, Beck, Taylor, Yates, Bill Dugan. NEW ZEALAND—Cushen, Watson, Milne. NORTH CAROLINA—Ferguson. OHIO—Sutton; The Crosley Corporation. ONTARIO—Bromley, MacKay, Brook. PENNSYLVANIA—Cooley, Callahan, Jones, Gonder, Black; Hankins, VRC. QUEBEC—CBC; Gauvreau. ROUMANIA—Theodor. SOUTH AFRICA—Laubscher. SWEDEN—Skog, Radiotjanst, Ekblom, Skogslund, Bergstrom, Narosky, Carl-Eric Petersson, Frick, A. B. Standard Radiofabrik, Ulvsunda, Edberg, Svensson, Erik Petersson, Sten Andersson, Lindberg, Gilbert Anderson, and others. TEXAS—Thompson, Giles. VIRGINIA—Howe, URDXC; Norris, Mayo. WEST VIRGINIA—Rupert, Reese.

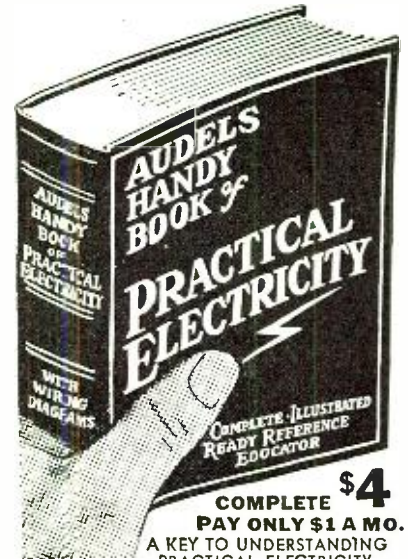

**COMPLETE \$4  
PAY ONLY \$1 A MO.**  
A KEY TO UNDERSTANDING PRACTICAL ELECTRICITY

Audels Handy Book of Practical Electricity for Maintenance Engineers, Electricians and All Electrical Workers—1440 Pages, 2600 Illustrations. A quick, simplified, ready reference book, giving complete instruction and practical information on the rules and laws of electricity—maintenance of electrical machinery—A.C. and D.C. motors—armature winding and repair—wiring diagrams—house lighting—power wiring—cable splicing—meters—batteries—transformers—elevators—electric cranes—railways—bells—sign flashers—telephone—ignition—radio principles—refrigeration—air conditioning—oil burners—air compressors—welding and many modern applications explained so you can understand. All indexed for ready reference. Step up your own skill with the facts and figures of your trade. Audels Mechanics Guides contain Practical Esale's Trade Information in a handy form. Fully illustrated and Easy to Understand. Highly Endorsed. Check the book you want for 7 days' Free Examination.

Send No Money. Nothing to pay postman.

## CUT HERE MAIL ORDER

AUDEL, Publishers, 49 W. 23 St., NEW YORK 10, N. Y.

Please send me postpaid for FREE EXAMINATION books marked (x) below. If I decide to keep them I agree to mail \$1 in 7 days on each book ordered and further mail \$1 monthly on each book until I have paid price. Otherwise, I will return them.

- HANDY BOOK OF ELECTRICITY, 1440 Pages \$4.
- AUTOMOBILE GUIDE, 1700 Pages . . . 4.
- REFRIGERATION & Air Conditioning, 1280 Pgs. 4.
- OIL BURNER GUIDE, 384 Pages . . . 1.
- POWER PLANT ENGINEERS Guide, 1500 Pages. 4.
- PUMPS, Hydraulics & Air Compressors, 1658 Pgs: 4.
- WELDERS GUIDE, 400 Pages . . . . . 1.
- BLUE PRINT READING, 416 Pages . . . . . 2.
- SHEET METAL WORKERS Handy Book, 388 Pgs. 1.
- SHEET METAL PATTERN LAYOUTS, 1100 Pgs. 4.
- AIRCRAFT WORKER, 240 Pages . . . . . 1.
- MATHEMATICS & CALCULATIONS, 700 Pgs. . . . 2.
- MACHINISTS Handy Book, 1600 Pages . . . . . 4.
- MECHANICAL Dictionary, 968 Pages . . . . . 4.
- DIESEL ENGINE MANUAL, 400 Pages . . . . . 2.
- MARINE ENGINEERS Handy Book, 1280 Pages 4.
- SHIPFITTERS Handy Book, 272 Pages . . . . . 1.
- MECHANICAL DRAWING COURSE, 160 Pages . . . 1.
- MECHANICAL DRAWING & DESIGN, 480 Pgs. 2.
- MILLWRIGHTS & Mechanics Guide, 1200 Pgs: 4.
- CARPENTERS & Builders Guides (4 vols.) . . . 6.
- PLUMBERS & Steamfitters Guides (4 vols.) . . 6.
- MASON'S & Builders Guides (4 vols.) . . . . . 6.
- MASTER PAINTER & DECORATOR, 320 Pgs. 2.
- GARDENERS & GROWERS GUIDES (4 vols.) 6.
- ENGINEERS and Mechanics Guides  
Nos. 1, 2, 3, 4, 5, 6, 7 and 8 complete . . . 12.
- Answers on Practical ENGINEERING . . . . . 1.
- ENGINEERS & FIREMANS EXAMINATIONS . . . 1.
- ELECTRICIANS EXAMINATIONS, 250 Pages . . . 1.
- WIRING DIAGRAMS, 210 Pages . . . . . 1.
- ELECTRICAL DICTIONARY, 3000 Terms . . . . . 2.
- ELECTRICAL POWER CALCULATIONS, 425 Pgs. 2.
- RADIOMAN'S GUIDE, 914 Pages . . . . . 4.
- ELECTRONIC DEVICES, 216 Pages . . . . . 2.
- ELECTRIC LIBRARY, 12 vol., 7000 Pgs., \$1.50 vol.

Name.....  
Address.....  
Occupation.....  
Employed by..... RN

# TOWARD NEW HORIZONS

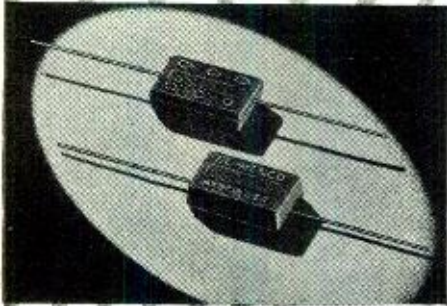

Tested and proved in every important theatre of war, El-Menco Capacitors are now serving with equal merit in the products of peace. Insure the correctness of this important part of your product by specifying El-Menco Capacitors.

Write on your firm letterhead for our catalog. Foreign Radio and Electronic Manufacturers communicate direct with our export department, at Willimantic, Connecticut for information.

**THE ELECTRO MOTIVE Mfg. Co., Inc.**  
Willimantic, Connecticut

- SPEAKERS
- AMPLIFIERS
- RECORDING MACHINES
- PUBLIC ADDRESS SYSTEMS
- MICROPHONES (GUITAR)
- VOLUME CONTROL (FOOT PEDAL)

Complete facilities for manufacturing all types of Radio, Sound, Recording, Directional Finding and associated equipment. Our public address systems and theatre speakers are known all over the world. Write for literature on the above mentioned lines.

Many products formerly manufactured under the trade names of Fox and De Armond are now combined with Rowe Industries. 15 years' experience at your command.

Submit your problems. Address  
Dept. RN1146  
**ELECTRONICS DIVISION**

**ROWE Industries**

3120 MONROE ST., TOLEDO 6, OHIO

# Manufacturers' Literature

Readers are asked to write directly to the manufacturer for the literature. By mentioning RADIO NEWS, the issue and page, and enclosing the proper amount, when indicated, delay will be prevented.

## MELLON REPRINT

*Mellon Institute of Industrial Research* is currently offering a 32-page reprint entitled "From the Research Laboratory to the Armed Forces."

Although the reprint covers several diverse fields there is one article which should be of interest to the readers of RADIO NEWS, i.e. "Research Improves Resistors for Radio and Radar" by Edward E. Marbaker.

Copies of this reprint are being distributed free of charge upon request to *Mellon Institute of Industrial Research*, University of Pittsburgh, Pittsburgh 13, Pa.

## C-D CATALOGUE

A new and revised catalogue which contains a listing of all electrolytic, paper and mica capacitors, in addition to capacitor test instruments and interference filters manufactured by the company, has been issued by *Cornell-Dubilier Electric Corporation*.

This 24-page catalogue, No. 195A, gives design and engineering information, dimensional sketches, physical properties and installation instructions for the capacitors described in the text.

A copy of this catalogue may be obtained from local jobbers or direct from *Cornell-Dubilier Electric Corporation*, South Plainfield, New Jersey.

## MALLORY CATALOGUE

The new 37-page catalogue issued by *P. R. Mallory & Co., Inc.* contains listings of hundreds of the company's products which are of particular interest to the radio serviceman.

Included in the listing are such items as dry electrolytic condensers, paper dielectrics, tone controls, vitreous enamel fixed and variable resistors, switches, jacks and plugs, vibrators, rectifiers, battery chargers, power supplies and miscellaneous hardware items.

Known as Catalogue No. 467, this publication will be furnished upon request to *P. R. Mallory & Co., Inc.*, Indianapolis 6, Indiana.

## TUBE SELECTION BOOKLET

Of interest to broadcast engineers and industrial designers is the new 8-page booklet, ETX-10, prepared by the Tube Division of *General Electric Company's* Electronics Department.

Included in the booklet are characteristics, ratings, prices and warranties of *G.E.* transmitting and industrial electron tubes.

Tube types are arranged alphabetically in thirteen sections and listed numerically by type number.

Description and rating publication numbers are included in the chart of key information concerning each tube type.

Copies of booklet ETX-10 are available at *G.E.* tube distributors or on request to the Tube Division, Electronic Department, *General Electric Company*, Schenectady, New York.

## PARTS BULLETIN

An 8-page supplement to the company's complete catalogue is now available according to *Concord Radio Corporation*.

This supplement features new merchandise which is currently available for shipment, and includes standard and hard-to-find radio and electronic parts.

A copy of the new bulletin may be obtained by writing *Concord Radio Corporation*, 901 West Jackson Boulevard, Chicago 7, Illinois.

## WATERPROOF CONNECTORS

Bulletin No. W-146, covering the new type "W" waterproof connectors, has just been released by *Cannon Electric Development Company*.

Designed specifically for sub-marine geophysical explorations, these connectors are also suitable for use in swamps, lakes, rivers, docks, with underground cable, or in any outdoor application where moisture conditions make a sealed fitting necessary.

Engineering and mechanical specifications for the Type "W" connectors are given in this bulletin which will be forwarded by *Cannon Electric Development Company*, 3209 Humboldt Street, Los Angeles 31, California to those requesting it.

## AMPLIFIER DATA

A data sheet covering the *Pan American Electric Company's* Monitor Amplifier is now available, according to a recent announcement by the company.

Covering the PAB-1500 Monitor Amplifier, the data sheet lists applications in broadcast and recording work, electrical and mechanical characteristics, and a schematic diagram of the unit.

A copy of this data sheet will be furnished upon request to *Pan American Electric Company, Inc.*, 132 Front Street, New York 5, New York.

## ELECTRO-VOICE CATALOGUE

*Electro-Voice, Inc.* has recently issued a complete new catalogue and selections guide which is currently available upon request.

This illustrated catalogue gives complete data and information on the

company's line of cardioid, dynamic, crystal, velocity, differential and carbon microphones. One of the features of the catalogue is the selection chart which makes it easy to select the correct microphone for specific applications.

A copy of the catalogue may be secured from any authorized *Electro-Voice* distributor or by writing the company, *Electro-Voice, Inc.*, 1239 South Bend Avenue, South Bend 24, Indiana.

### COLOR CODE GUIDE

*Allied Radio Corporation* has recently released their new RMA-JAN Color Code Guide for radio and electronic type resistors.

This pocket-sized guide is easy to operate, consisting of three rotary discs which are equipped with code colors and corresponding resistance values. Upon setting the color value, the correct numerical value appears at corresponding windows at the bottom of the guide. The guide also includes data covering resistance tolerance and a complete listing of RMA-JAN 10% resistor stock values.

These guides are available at a nominal charge of ten cents. Make your request direct to *Allied Radio Corporation*, 833 West Jackson Blvd., Chicago 7, Illinois.

### NATIONAL SCHOOLS CATALOGUE

A fully illustrated, 34 page catalogue entitled "Your Future in Radio, Television and Electronics" is currently being offered to prospective students by *National Schools* of Los Angeles.

Included in the catalogue is a resumé of the courses offered by the school, biographies of the faculty and pictures of the equipment and training facilities which are available to students.

A copy of this booklet may be obtained from R. B. Murray, Mail Sales Advertising, *National Schools*, 4000 South Figueroa Street, Los Angeles 37, California.

-30-

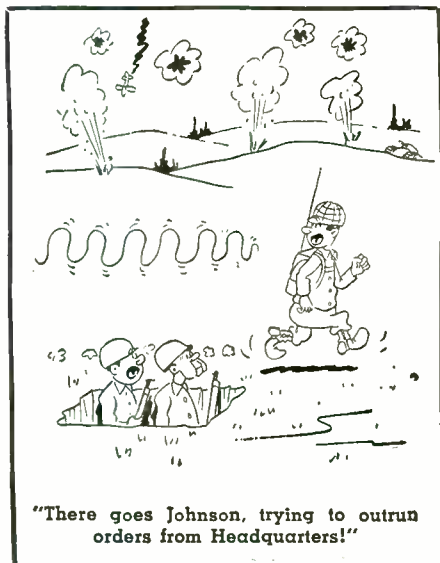

November, 1946

## Flash! IT'S A SIMPSON TESTER Model 260

High sensitivity set tester for television and radio servicing  
For bench work or as a portable unit.

### RANGES

At 20,000 ohms per volt D.C. or 1,000 ohms per volt A.C.  
2.5-10-50-250-1000-5000

Milliamperes D.C.

10-100-500

Microamperes

100

Ohms

0-1,000 (12 ohms center)

0-100,000 (1200 ohms center)

0-10 Megohms (120,000 ohms center)

(5 Decibel ranges: -10 to +52 DB) Complete with leads

ONLY \$3895

Immediate Delivery



### Crowe Modern Slide Rule Dials



Escutcheon with Crow-glass Crystal antique bronze finish Complete with pilot light sockets.

Overall Dim.

Model 341-\$3.60 ea. .... 3 1/8 x 8 1/8

Model 339- 3.18 ea. .... 3 1/8 x 6 7/8

Model 534- 1.47 ea. .... 2 7/8 x 4 7/8

Model 535-\$1.74 ea. .... 1 1/2 x 5 1/8

### CABINET SPECIAL

Walnut, Mahogany or Blond

High finish, of sturdy construction. Blanks with speaker grill.

10 x 6 1/2 x 6 Blond ..... \$2.95

10 x 6 1/2 x 6 Walnut Mahogany ..... \$2.65

14 x 7 1/2 x 7 Walnut Mahogany ..... \$3.75

WE HAVE IN STOCK A COMPLETE LINE OF RADIO TUBES FOR IMMEDIATE DELIVERY. QUANTITY LIMITED. ALL ORDERS ACCEPTED SUBJECT TO PRIOR SALE

Write for our new, post-war catalog

## RADIO PARTS COMPANY

614 W. RANDOLPH  
Dept. N  
CHICAGO 6, ILL.

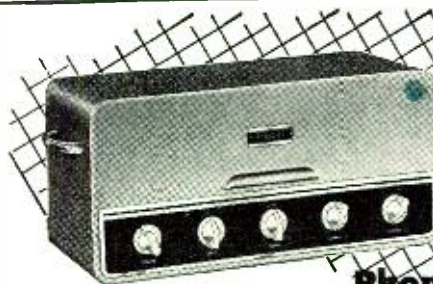

### ANOTHER NEW MODEL

by Newcomb

### The KXP-30

### Phonograph or Monitoring Amplifier

Again leading the field in the production of quality sound equipment ...

Newcomb announces a NEW MODEL 30-Watt phonograph amplifier, the KXP-30 ... Its truly remarkable performance, its unusual flexibility of application make the KXP-30 the perfect answer to the amplifier needs of the most critical ... For wired music reproduction; as a monitoring or playback amplifier for broadcast or recording studio, the KXP-30 is unequalled ... In the home, as a deluxe phonograph amplifier, its full quality treble and bass tones at even lowest volume levels make this outstanding contri-

bution by Newcomb the newest answer to the postwar demand for quality in the sound reproduction field ... Freedom from hum; dual-acting, distortion free individual tone controls; extended flat frequency response from 20 to 20,000 cycles ... these and many other features combine to make the KXP-30, as all Newcomb products, the logical choice of the quality-minded buyer ... Not Merely as Good as the Others, but Better than All Others! Send for details of our complete line of sound equipment.

THE SOUND OF QUALITY

Newcomb

AUDIO PRODUCTS CO.

MANUFACTURERS

DEPT. F 2815 S. HILL STREET, LOS ANGELES 7, CALIFORNIA

# AMATEURS AND RADIO REPAIRMEN

We appreciate your bearing with us on the delay in deliveries, but hope you remember we accepted no orders for material we could not deliver.

Parts are coming in more freely now so the percentage of 100% filled orders is increasing. Thanks again.

**EXCLUSIVE DISTRIBUTORS  
FOR STROMBERG-CARLSON  
AMPLIFIERS**

*Stanton Radio Supply*

W9PSP                      W9JKE  
521 State St.,              11AMMOND, INDIANA  
Phone 2314



## MULTI-RANGE TEST EQUIPMENT FEATHERWEIGHT—12 OUNCES

MINIATURE—3 1/8" x 2 1/4" x 2"

- VOLT-OHM-MILLIAMMETER MODEL 450A**  
Volts DC: 0-5/10/50/500/1000, sensitivity 1000 ohms per volt. Milliampere DC: 0-1. Ohms Full Scale: 5000/50,000/500,000. Ohms Center Scale 30/300/3000. NET \$9.75
- AC-DC VOLT-OHM-OUTPUT-METER MODEL 451-A**  
Volts AC-DC: 0-10/50/100/500/1000, sensitivity 1000 ohms per volt. Ohms Full Scale: 500,000. Ohms Center Scale: 7200. NET \$13.65  
Model 451B Special: 2500 ohms per volt on DC ranges, \$1.50 additional
- HIGH SENSITIVITY VOLT-OHMMETER MODEL 452A**  
10,000 Ohms Per Volt. Volts DC: 0-10/50/100/500/1000. Ohms Full Scale: 2000/20,000/200,000/2,000,000. Ohms Center Scale: 30/300/3000/30,000. NET \$13.65

**CHICAGO INDUSTRIAL INSTRUMENT CO.  
CHICAGO 10, ILLINOIS**

## What's New in Radio

(Continued from page 124)

without change on the new FM band. Insulation is polystyrene for low losses. The transformer is 1 1/2" square and stands 3 1/2" above the chassis. The units are available for immediate delivery. Additional information may be secured by writing *National Company, Inc.*, Malden, Massachusetts.

### CRYSTAL HOLDER ADAPTER

A new service is offered to radio amateurs in the use of the new Crystal Holder Adapter announced recently by *Carl E. Mosley*, Overland 14, Mo.

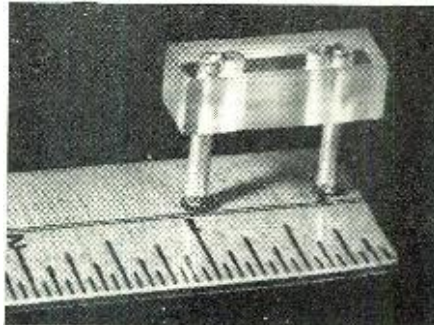

It provides a convenient, low cost means by which a new type crystal holder with a pin spacing of 1/2 inch can be used in existing sockets which have a spacing of 3/4 inch such as in the usual 5 or 6 prong tube sockets or any of the special 3/4 inch crystal sockets.

These adapters are being distributed through radio suppliers who stock amateur parts. Additional information will be furnished upon request by writing *Carl E. Mosley*, 2125 Lackland Road, Overland 14, Missouri.

### TELEVISION CAPACITORS

A new line of hermetically-sealed, high-voltage capacitors, especially designed for use in rectified r.f. type power supplies for television receivers and other cathode-ray tube applications have been announced by *Solar Manufacturing Corporation* of New York.

These capacitors are available in voltage ratings up to 30,000 volts, d.c. and in capacitances up to 500 μfd.



The units are housed in solder-sealed glass bushings with a choice of either ferrule terminals for mounting in standard fuse clips, or screw terminals for more rigid means of support and connection. The ferrule terminal types have been designated the *Solar* Type

## RADIO COURSES

SERVICING, BROADCAST ENGINEERING,  
COMMERCIAL OPERATING, TELEVISION  
Individual Laboratory Work! — Learn  
By Doing!

Day and Evening Classes

Approved by the Maryland State Department of  
Education and the Veterans Administration

Free to Vets — Textbooks, Tools, Test Set

Write for Bulletin

### Baltimore Technical Institute

1425 Eutaw Place — Dept. R  
BALTIMORE 17, MARYLAND

## ELECTRONIC VOLT-OHMMETER

\$1185 110 VOLTS AC 20 RANGES  
0.5/10/50/100/500/1000 5000 volts  
DC and AC. 0-1,000,000.000 ohms  
in six overlapping ranges. Sensitivity:  
over MILLION OHMS per VOLT on 5  
volt range.

POSTPAID Complete kit includes all component parts, tubes, punched and drilled chassis and beautifully enameled panel. Easily assembled and wired. Special slideback circuit developed during war by scientist at the California Institute of Technology gives amazing sensitivity and flexibility while completely eliminating necessity of batteries and expensive meter. Each instrument is individually calibrated. Dial scale over nine inches long!

In addition to performing the usual volt-ohm functions, this instrument easily measures these voltages: SUPERHERC OSCILLATOR, AVC, AFC, TRUE GRID BIAS AT THE GRID, BIAS CELLS without affecting the circuit. Measures the exact leakage resistance of INSULATION, TUBES, CONDENSERS. It can be used with a signal generator for SIGNAL TRACING.

### STERLING ELECTRONIC COMPANY

Dept. 3  
166 N. Sierra Bonita Ave., Pasadena 4, California

## PAPER and MICA CONDENSERS

50 paper and mica condensers \$1.00. Brand new, fine assortment, popular sizes. Wt. app. 1 lb. f.o.b. Cash, check or M. O.

Kensington, P.O. Box 91, Bklyn. 18, N. Y.

### POCKET VOLT OHM METER

Bakelite Case

Range—  
0-1000/10,000/100,000/1,000,000 ohms  
0-3 30/300/600 volt D.C.  
1,000 ohm per volt  
100 micro-amp movement  
Complete with batteries and test leads...\$14.95  
C.O.D. or prepaid if remittance accompanies order  
TERRY JAY  
550 Arlington Place Chicago 14, Illinois

## ANY BOOK IN PRINT



Delivered at your door. We pay postage. Standard authors, new books, popular editions, fiction, reference, medical, mechanical, children's books, etc. Guaranteed savings. Send for Clarkson's 1947 catalog.

FREE Write for our great illustrated book catalog. A short course in literature. The buying guide of 800,000 book lovers. The answer to your Christmas gift problem. Free if you write now—today!

CLARKSON PUBLISHING COMPANY

Dept. R6, 1257 So. Wabash Ave., Chicago, Ill.

## NOW AVAILABLE PORTABLE RADIO BATTERIES

For 3-Way Portable Sets \$5.00 fully activated for immediate use.

Shipped - All Charges Prepaid - upon receipt of check or Money Order - No Stamps or Cash.

STARTER BATTERIES, Inc.  
1665 SIXTY-THIRD STREET  
BROOKLYN 4, N. Y.

## RADIO ENGINEERING!

EX-SERVICE MEN can complete work here in shortest possible time. Courses also in Civil, Electrical, Mechanical, Chemical, Aeronautical Engineering; Business Administration, Accounting, Secretarial, Science, 63rd year. Enter Jan., Mar., June, Sept. School now filled to capacity. No applications can be accepted until further notice.  
TRI-STATE COLLEGE 15115 College Ave., ANGOLA, INDIANA  
DEGREE IN 27 MONTHS

RADIO NEWS



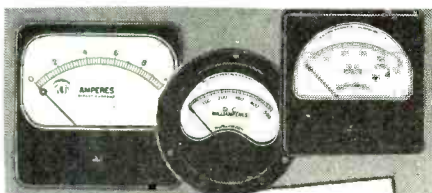

... PRECISION IS BASIC

WITH **Burlington INSTRUMENTS**

These are the features that make Burlington Instruments your logical choice — Alnico Magnets used in all DC moving parts—Perfectly aligned Jewel Supports—Phosphor bronze control springs — Ceramic pointer stops—non-shifting balance weights.

All ranges AC or DC available in 2½", 3½", 4½" sizes, rectangular and round.

Inquiries solicited

**BURLINGTON INSTRUMENT CO.**  
910 Fourth Street,  
BURLINGTON, IOWA



**BIG SAVINGS**

Hundreds of specials for RADIO SERVICEMEN

- CATHODE RAY TUBES
- POWER & TRANSMITTING TUBES
- HEADPHONES, etc.
- HARD-TO-FIND TEST METERS



**7 LB. EXPERIMENTERS RADIO PARTS ASST.**  
A "gold mine" for the experimenter, radio serviceman, handyman and repairman. Hundreds of valuable radio, radar and electronic parts, screw machine parts, bushings, sub assemblies, etc. More than your money's worth every time. An amazing value. Money-back guarantee.

**K130R—FULL 7 POUNDS ONLY \$1.79**

War Surplus Bargain Book  
Page after page of war surplus and other bargains for the radio serviceman; a list of specials for home, shop and outdoors.  
**IT'S FREE! WRITE TO-DAY**

**FREE CATALOG**

**STARK'S** Dept. 509 So. STATE STREET  
RNI246 CHICAGO 5, ILLINOIS

November, 1946

QTMF and the screw terminals Type QTMH.

Especially selected low power-factor paper is mineral oil impregnated under extra high vacuum in making these capacitors in order to assure satisfactory performance under high operating temperatures, according to the manufacturer.

Additional details of these high-voltage capacitors will be furnished by *Solar Manufacturing Corporation*, 285 Madison Avenue, New York 17, New York.

**R.F. PROBE**

Manufacture of a new r.f. probe for functional testing of high-frequency power circuits is under way at the Boonton, New Jersey plant of *Radio Frequency Laboratories, Inc.*

In operation, when the probe tip is subjected to an r.f. field, a proportionate r.f. current is capacitively induced, rectified and indicated on a *Weston 506 meter*.



Among the uses for this probe are the quick detection of standing waves, shielding power leaks, r.f. choke efficiency, and circuit tracing for r.f. in all radio-frequency equipment and associated components.

The unit may also be used for checking AM, FM and television transmitters up to 1500 mc., electronic heating and soldering equipment, antennas and transmission lines, diathermy apparatus and other r.f. units.

Additional data will be supplied by *Radio Frequency Laboratories, Inc.*, Boonton, New Jersey, upon request.

**THREE-ELECTRODE TUBE**

The Tube Division of *General Electric Company* has recently introduced a new three-electrode transmitting tube, Type GL-5C24 which was designed and tested for service as class A and class AB1 audio-frequency amplifier and modulator.

The tube is particularly adapted for high power AM transmitter applications where very low distortion levels are required.

Typical operation as a class A amplifier and modulator include: a d.c. plate voltage rating of 1500 volts; peak a.f. grid voltage of 150 volts; power output of 55 watts. At maximum ratings of 1750 volts, the plate input is 250 watts. The mu of the tube is 8.

When used as a class AB1 amplifier and modulator the d.c. plate voltage is 1750 volts. The maximum signal plate input is 300 watts.

Further technical information on

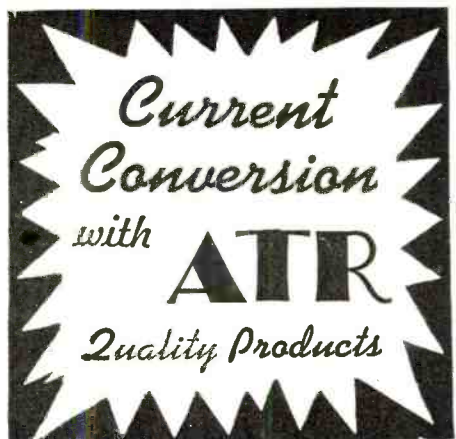

**ATR "A"**

**BATTERY ELIMINATORS**

FOR CONVERTING A.C. TO D.C.  
New Models . . . designed for testing D.C. electrical apparatus on regular A.C. lines. Equipped with full-wave dry disc type rectifier, assuring noiseless, interference-free operation and extreme long life and reliability.

- Eliminates Storage Batteries and Battery Chargers.
- Operates the Equipment at Maximum Efficiency at All Times.
- Fully Automatic and Fool-Proof.

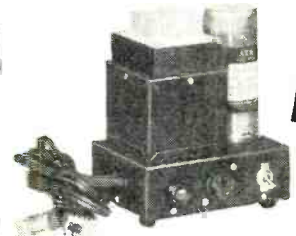

**ATR**

**LOW POWER INVERTERS**

FOR INVERTING D.C. TO A.C.  
Another New ATR Model . . . designed for operating small A.C. motors, electric razors, and a host of other small A.C. devices from D.C. voltages sources.



**ATR**

**STANDARD AND HEAVY DUTY INVERTERS**

FOR INVERTING D.C. TO A.C.  
Specially designed for operating A.C. radios, television sets, amplifiers, address systems, and radio test equipment from D.C. voltages in vehicles, ships, trains, planes, and in D.C. districts.

WRITE FOR NEW CATALOG—  
JUST OFF THE PRESS!

**AMERICAN TELEVISION & RADIO CO.**  
Quality Products Since 1931  
ST. PAUL 1, MINN. U. S. A.



### THE ELECTRON TRACER

COMPLETE ELECTRONIC VOLTMETER-OHMMETER and audible signal tracer — ALL IN ONE UNIT. STABLE, ACCURATE, TIMESAVING. Now in full production. For the first time an instrument is available which can isolate trouble in any radio circuit. Audible signals are traced quickly in any stage, (20 cycles to 100 megacycles). Uses transmitted signal as test signal, which in many cases eliminates the need for a Signal Generator.

A PATENTED STABLE BRIDGE-TYPE VACUUM tube meter for measuring AC-DC voltages from .1 to 1000 volts, and 2 ohms to 1000 megohms. Measures DC volts up to 1000, with constant input resistance of 26 megohms. PRICE—\$69.50

INTERESTED?  
WRITE FOR FULL DETAILS!!!

**EICO**

ELECTRONIC  
INSTRUMENT CO.

926 Clarkson Avenue Brooklyn N. Y.

## RISCO SPECIALS Immediate Delivery

### HERE AT LAST! Kitchen Fluorescents

No extra wiring. Easily adaptable to your present fixtures. Underwriters approved parts. Uses 2-15 or 2-20 watt lamps. Specify sizes when ordering. Lamps 80c each.

ONLY  
**\$4.50**



### PHONO AMPLIFIER

3-Tube A.C.-D.C.  
Volume and tone controls.  
Completely wired ..... **\$3.50**  
25 @ ..... **\$2.95**

PHONO AMP KIT  
With 3 tubes and 5" speaker ..... \$7.95  
Less tubes or speaker. 5.95  
Uses 12SQ7-35Z5-50L6

### RADIO TUBES!

All Hard-To-Get  
No. In Stock  
Astatic L-70 Crystal Pickup  
Shure Gilder Crystal Pickup

\$2.15 ea.  
10 @ \$1.95

Sig. Corps J-38-keys.....49c  
T-17B Microphone.....1.75  
CODE PRACTICE SET  
In Sept. issue Compl.  
approx. ....\$11.00

Write for Details  
Rush Name  
FREE BIG CATALOG  
25% on C.O.D. Orders

**RISCO SALES CO.**

WHOLESALE RADIO DISTRIBUTORS  
414 2nd Ave. at 23rd, N. Y. 10, N. Y.

the GL-5C24 is available from Tube Division, Electronic Department, General Electric Company, Schenectady, N. Y.

### FARM RADIO

The Echophone Division of Hallcrafters Company of Chicago has recently placed on the market its Model EC-600, four-tube, battery-operated home receiver for use in farm homes,

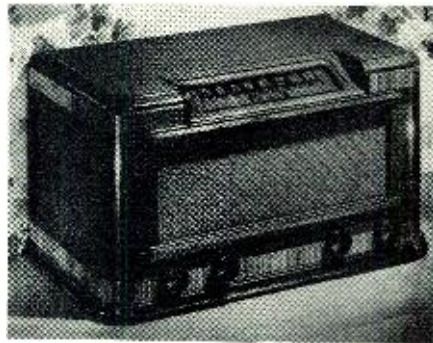

summer cottages and other locations where power line service is not available.

This receiver covers the entire broadcast band from 535 to 1750 kc. and is designed to operate from a single battery unit which provides 1000 hours service under normal use.

The speaker and audio system feature a powerful 6½ inch PM speaker, driven by a beam-power amplifier.

The unit is housed in a walnut veneer cabinet with oriental walnut banding and harmonizing center panel of richly textured grille cloth. A beveled slide rule dial is made up with large numbers for easy and accurate tuning.

Details of this Model EC-600 will be furnished by *Hallcrafters Company*, 2611 South Indiana Avenue, Chicago, Illinois.

### TELEVISO V.T.V.M.

A direct reading instrument featuring a full-scale sensitivity of .5 volt for use at radio and audio frequencies has been introduced by *Televiso Products Company* of Chicago.

This new vacuum tube voltmeter, the Series 200A, provides accurate readings as low as 100.000 microvolts,

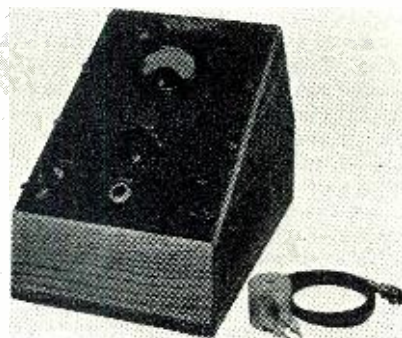

according to the manufacturer. Several new features in both circuit and housing design have been incorporated in this unit, including a rear storage compartment which contains a source of calibration voltage equal to 5 r.m.s. volts ± 2%; precision wire-wound re-

- Insulated Carbon Resistors—¼, ½, & 1 watt 5 ohms to 20 Meg per 100 assorted....\$2.98
- Plastic Cabinets. 97/8x6x5, Black or Brown, painted white \$1.00 extra. \$2.48
- Unimeter, G.E. UM-3. Complete with batteries .....\$33.97
- Loop Antennas, List \$1.00.....\$ .38
- Power Transformer. High Voltage 750 C.T. 5V., 6.3V., B mount 50 Mil.....\$2.17
- Oscillator Coil .....\$ .27
- I.F. cans 450 to 465.....\$ .59
- 6AG7 Tube—While they last.....\$ .98

All prices listed are net.

All items are subject to prior sales.  
Send for special bulletin.  
10% required for C.O.D.

**G. F. BEARD**

242 W. Brookdale Fullerton, Calif.

## WAR SURPLUS EXTRA SPECIAL

SPRAGUE metal-encased, oil impregnated, tubular condensers, 600 VDC. .1 mfd. 10 for.....\$1.39  
CRYSTALS—Sylvania type IN21, high frequency, plug-in type receiving crystal (make a fine meter rectifier). 2 for \$1.75  
JACKS—Signal corps type JK34A, short phone jack. 10 for.....\$1.49  
MICA MOLDS, .01 mfd., 400 Volt, molded-in-bakelite. 10 for 79c—25 for.....\$1.79  
IRC RESISTORS, 10,000 Ohm 10 Watt, Type A B. 10 for.....\$1.49  
Write for circular listing many other outstanding values. SPECIAL Prices on lots of 1000 or more of any item. Shipping extra.  
Erie Supply Co. 88 Exchange St. Rochester, N. Y.

## ELECTRONICS

Electronic Technician Training Course. Qualify for Radio Communication (Commercial Government License); Radio Repair Service; or be an Industrial Electronic Technician. Register now for new classes starting every four weeks. Approved under G. I. Bill of Rights. Residence day and evening school. Write to

**ELECTRONICS INSTITUTE, INC.**  
21 HENRY, DETROIT, MICH.

INVENTORS — if you consider your invention to be something of importance, you may take steps to protect it with a U. S.

## PATENT PROTECTION

Patent which gives you the right to exclude others from making, using and selling the invention as claimed. Detailed information and steps to take to secure Patent Protection will be mailed to you promptly without obligation. Victor J. Evans & Co., Merlin M. Evans, Registered Patent Attorney, 182-M Merlin Bldg., Washington 6, D. C.

## IMMEDIATE DELIVERY

### SPECIAL VALUES

COND. KIT #1655 CONSISTING OF:  
5-20-20 Mfd. 150 V. & 25 Ass'd By Pass. \$2.99  
BY PASS COND. KIT—17 Ass'd 400 & 600 V. .99  
RESISTOR KIT—50 Ass'd ½ to 1 Watt. .99  
DIAL CORD KIT—60 Pk. Ass'd & Springs. .99  
LOOP ANTENNA—5" x 8"..... .45  
ANT. & OSCIL. or ANT. & RF. COIL SETS ..... .69  
SELENIUM RECTIFIER—Replaces 11Z6, 50Y6, etc. .... .99  
CRYSTAL PICKUPS—1¼ Oz. .... 2.79  
Write Today for Bargain Bulletin  
**RADIO DISTRIBUTING CO., Pasadena 18, Cal.**

SUPREME QUALITY  
**Vasco**

TRADE-MARK REG. U. S. PAT. OFF.  
**ELECTRIC SOLDERING IRONS**  
4116 AVALON BLVD., LOS ANGELES 11, CALIF.

In the Rocky Mountain Region It's  
**RADIO & TELEVISION SUPPLY CO.**

ELECTRONIC EQUIPMENT

152 Hobson Avenue, Pueblo, Colo.  
P.O. Box #892

"If we don't have it, we'll get it—  
or it can't be had! Phone 5729"

# WANTED!

## Articles by Radio Amateurs

2000 to 2500 words

Covering any material of genuine interest to radio amateurs, such as:

- Transmitters
- Receivers
- Antennas
- Test Equipment

Articles should be typewritten (double spaced) and accompanied by suitable diagrams, photos, and parts lists. Liberal payment will be made upon acceptance.

Address all communications to

Box 419

## RADIO NEWS

185 North Wabash Avenue  
Chicago 1, Illinois

## ELECTRICIANS! RADIOMEN!

Here's the answer  
Book to Bigger Pay!

ELECTRICAL & RADIO

# TROUBLE SHOOTING MANUAL

Yours for 10 Days FREE

EARN MORE

A BIG Book with more than 500 large, 8½" x 11" Electrical and Radio Shop Prints!

by quickly spotting troubles! This great book tells you where to look—how to find—what to do! 612 pages—8½" x 11"—really 4 books in one: (1) New Step-by-Step Trouble Shooting. (2) 500 Shop Prints. (3) Electrical and Radio Dictionary. (4) Spare Time "Fillin'" Jobs. Take it with you on every job—it will take you into the higher money bracket—put you in demand as a "doctor" for troubles. Written by the Coyne staff and backed by 47 years experience. Coyne wants you to see for yourself how others have increased their earnings through this book. Read our FREE TRIAL OFFER below, and RUSH THE COUPON TODAY.

TECHNICAL DIV. COYNE ELECTRICAL SCHOOL, Dept. 86-T4  
500 SOUTH PAULINA STREET, CHICAGO 12, ILLINOIS

COYNE ELECTRICAL SCHOOL, Dept. 86-T4  
Technical Book Division, 500 S. Paulina St., Chicago 12, Ill.

Send postage prepaid, your new Coyne Electrical and Radio Trouble Shooting Manual. After 10 days' trial, I'll either return it, or send \$3, then \$3 monthly until \$9.95 is paid; or pay \$9 cash.

NAME \_\_\_\_\_  
ADDRESS \_\_\_\_\_  
CITY \_\_\_\_\_ ZONE \_\_\_\_\_ STATE \_\_\_\_\_

Check here if you want Manual sent C.O.D.—You pay postman \$9.00 when delivered. Same 10 day free examination and money back guarantee.

November, 1946

sisters; copper lined cabinet which prevents extraneous r.f. fields from affecting operation accuracy; and unique mechanical construction.

Full details on the Series 200A will be furnished by *Televiso Products Company*, 7466 Irving Park Road, Chicago 34, Illinois.

-30-

## Subscription-Lease Plan

(Continued from page 56)

graphically demonstrated by their mobile workshop technique. The company also uses publication advertising, elaborate and richly colored literature and catalogues which during the course of years have been sent to every citizen of Switzerland.

A lottery idea which would probably be illegal in the United States was also used to supplement their sales promotion. In the Steiner lottery plan, the customer writes the address of a possible prospect on his premium card. Should the contract be closed with the prospect, the subscriber receives ten francs. He also has the right to check four numbers from the numbers 1-20 on his registration card. Every month, four numbers are drawn by lot and if the subscriber has picked the winning number, he receives an additional ten francs, two winning numbers, 25 francs; three winning numbers, 100 francs; four winning numbers, 500 francs. During the course of three years the company states they have paid out 500,000 francs but against this have earned a supplementary turnover of more than 10 million francs.

This alert and aggressive Swiss organization is extending its plan for the future with broad vision to include television and magnetic recording, but is clinging to the subscription idea as the main foundation of its business operation.

-30-

## EMERGENCY EARPHONES

THE UNIT described and illustrated There may be used as a substitute earphone on the reception of c.w. signals, according to F. Harris of Chicago, Illinois, who designed it.

The earphone consists of two sheets of metal such as copper or aluminum separated by a sheet of insulating material, varnished or high grade writing

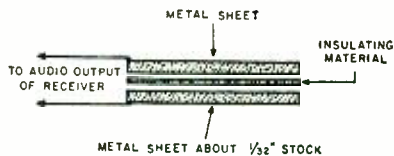

paper may be used. An audio signal of approximately 1000 cycles will excite this condenser earphone sufficiently to give good output on c.w. signals.

The area of the metal sheets need not be very great, according to Mr. Harris, two pieces, 4 x 4 inches, will serve nicely.

-30-

## AMATEURS! LOOK!

Leo, W0GFQ Now Offers

# IMMEDIATE DELIVERY!

On His New, Exclusive, Low Priced

## WRL GLOBE TROTTER TRANSMITTER KIT



## Users Acclaim Its Superior Performance!

Actual field reports of amateurs using the Globe Trotter testify to its excellent performance. It's the hottest ham equipment on the market today. The WRL Globe Trotter is capable of 40 watts input on C.W. and 25 watts input on phone on all bands from 1500 KC through 28 Megacycles. Incorporates the Tritet Oscillator using a 40 meter Xtal; Heising choke modulation; three bands, all pretuned; 10, 20, and 80 meters; two power supplies, one for 807 final and modulator tubes, one for speech amplifier and oscillator stage.

40 WATT INPUT  
Cat. No. 70-300 ..... \$69.95

Complete including all parts, chassis panel streamlined cabinet, less tubes, coils, and meter.

No. 70-312 same as above, wired by our engineers ..... \$79.50

1 Set of Coils, Meter, Tubes \$15.15 Extra

For Fast Delivery order your receiver now from World Radio. Easy pay plan available.

RME 45 ..... \$186.50

RME 84 ..... \$98.70

Hammarlund HQ129X ..... \$173.25

Hammarlund SPC-400-SX ..... \$323.25

Hallicrafters S-38 ..... \$39.50

★ NEW LOW PRICE ★

## 15 TUBE TRANSCEIVER

Complete Transmitting and Receiving Set, 3 SETS IN ONE—6 Tube Receivers for 80 and 40 meter bands; 235 Meg. transmitter; Interphone system. Complete with dynamotor. OK for portable work. Includes parts Kit worth about \$400 itself. \$69.00  
Cat. No. 70-298



## New Type PHONO OSCILLATOR

Wired less tubes. Cat. No. 16-191 \$4.95

No aerial required Utilizes high quality loop both as part of oscillator circuit, and radiating medium. Trimmer provided to adjust frequency to any portion of broadcast band between 1250 KC and 1700 KC Uses 35L6 and 35Z5 tubes

## FREE! Our Latest Flyer

Packed with real buys in radio, electronic, and general merchandise.

Giant Radio Map

(Size 3½ ft. x 4½ ft.) ..... 15c

Handy Tube-Base Calculator ..... 25c

Tube and Circuit Book ..... 10c

\* Prices quoted are domestic. Write for export prices.



Formerly Wholesale Radio Laboratories  
Address Dept. RN-11 Council Bluffs, Iowa,

163



## Clippard

### ELECTRONIC VOLT-OHMMETER, MODEL 406

**Immediate Delivery!**

We invite comparison of this instrument with any at any price for appearance, ruggedness, accuracy, stability, 0-1 to 1,000 volts U.H.F., A.C., D.C. 0-1,000 megohms. Pen-type dual-diode A.C. probe. No extras to buy. Send for details or order today.

**\$89.50**  
NET

From Jobber or F.O.B. Cinti.

**CLIPPARD INSTRUMENT LAB., INC.**  
1125 Bank St., Dept. 1, Cincinnati 14, Ohio

## HOPP Plastic RADIO DIALS

DIAL WINDOWS, NAME PLATES, GAUGES, CALCULATORS, SCALES, CHARTS, ETC.



PLASTIC RADIO DIALS have endless possibilities in design, size, shape and color combination. Attractive and durable, our radio dials, windows and scales are preferred by many leading Radio manufacturers.

Not only for dials, but for numerous other electronic and electrical applications, Laminated Plastics are preferable.

Consult with our artists and engineers regarding applications for your particular purpose. Or . . . send us your blue prints or samples for quotation.

**THE HOPP PRESS, INC.**  
460 W. 34th STREET, NEW YORK 1, N. Y.  
ESTABLISHED 1893

## Metal Analyzer

(Continued from page 29)

Chemical Company. "Such a determination," the company continues, "is made by the well-known method of plotting the log of the relative intensities against composition, using known standards in plotting the original or calibration curve. This method is used in the usual spectrographic technique. In analyzing magnesium alloys, there are several good magnesium spectrum lines, each of which is stronger than the lines of any of the constituents. One or more of these spectrum lines is, therefore, used as the internal control or the reference line. The intensity of such a line is equal to the original charge in a condenser multiplied by a constant.

"It is unnecessary (as well as impractical) to completely discharge the condensers, or to determine their original charge. It is suitable to time the discharge of all condensers down to a given low voltage, such as 1.0 volts, supplied by a standard cell. This discharge is made through a resistance unit such that the *RC* constant of the circuit is about 5 seconds, which means that a condenser loses 63 per-cent of its initial charge in 5 seconds or, for the current involved in our method, a condenser is discharged in an easily measurable period of about 10 seconds. A range of *RC*, 3 to 6, is suitable as long as exactly similar *RC* constants are used for all condensers.

"It is very simple and effective to start the discharge of all condensers at the same instant and record on a multi-point recorder the time required to discharge each condenser down to the given standard voltage. By measuring the *difference* between the time required to discharge each condenser and the time required to discharge the reference condenser (that one charged by the magnesium spectrum line used for internal control), and by then comparing these differences with similar differences in time produced from alloys of known composition, the composition of an unknown sample may be read directly with calibrated scales.

"Various magnesium base alloys are made by melting together suitable amounts of various alloying elements. The final composition of such alloys must fall within rather narrow limits. The alloying metals of chief interest are aluminum calcium, manganese, zinc, iron. Others may be of interest in certain circumstances and provision may be made for the simultaneous determination of such metals in place of, or in addition to, those mentioned above.

"A spark source and facilities for preparing electrodes are provided, as for any spectrographic method, with special attention given to the need for speed in completing the analysis.

"A special monochromator is provided having a fixed exit slit for one or more lines of predetermined wave-

length from each of the metals magnesium, aluminum, manganese, zinc, iron and/or any others. Behind each of these slits is mounted an electron multiplier tube, such as the *RCA* No. 931A, previously described. The output of each tube is wired to a condenser such as previously described which, in turn, is connected in series through a switch with a resistance. Between the terminals of the condenser is placed an electronic timing circuit so arranged that a signal is given at the instant at which the condenser voltage drops to exactly 1.0 volts, for example.

"In practice, a sample of molten metal is ladled from the pot in which it has been alloyed. The sample is poured into a mold in which a portion of it freezes in a shape approximating the shape of the electrodes used as the source of energy. As soon as the metal has solidified, it is removed from the mold and dressed down to standard size as a pair of electrodes. The electrodes are clamped in position and the power is turned on. After a suitable pre-arcing period, in which the arc can establish itself between the electrodes, the shutter over the monochromator is opened for a time exposure of several seconds.

"During this exposure, the energy in each of the predetermined lines is picked up by a multiplier electronic tube, which amplifies the energy and charges a condenser. After the exposure, the power source is cut off and the electrodes removed. The switches which discharge the condensers are all closed at the same instant and a signal indicating the starting of this discharge is sent to a multi-point recorder in which the record paper is moving at a carefully controlled and constant rate past the row of marking pens, one of which is connected to each condenser circuit. The discharge of the reference condenser takes place in about 10 seconds, a longer period of time than is required for the discharge of any of the other condensers. During these 10 seconds, all the other condensers discharge to the common level of 1 volt in varying times.

"The time of complete discharge to this voltage is indicated on the recorder paper. The distances between these indications and the mark showing discharge of the reference condenser are compared with similar distances derived from alloys of known compositions to indicate the unknown composition. When the discharge characteristics of known compositions are determined a transparent plate may be prepared in which various percentages of each component are scribed along lines corresponding to the lines of the several components scribed on the recorder. In this way, the master plate (which may be somewhat different for each type of magnesium alloy) can be placed directly over the record as soon as the reference condenser is discharged and the marks representing the discharge of each condenser will fall under a scale marking calibrated

**RADIO NEWS**

to read directly the percentage of the unknown component which was responsible for this particular discharge."

The only unit of this new spectrometer yet built, the one in the magnesium alloying plant of *The Dow Chemical Company* at Midland, is the electronic "sentinel" on guard in scientifically controlling the composition of fresh metal, as 15,000 pounds of it are being poured into the furnace every five minutes. However, one instrument company is planning to manufacture at least one hundred of these spectrometers annually. A high school graduate can operate the device, which, in the final analysis, means that electronics is "reading" the ultimate mixture of various metals before melting them into ingots or castings. No longer is it necessary for a human operator to hold a pot molten for thirty minutes.

-50-

### Sound Conditioning

(Continued from page 31)

In this respect a suitable size would be approximately 8' wide, 8' long and 8' high, inside measurements. Observation windows should be constructed of double panes of glass set in felt or soft rubber.

To overcome sound transmission special attention should be paid to wall construction. As a general rule, weight, thickness, density and rigidity determine the "sound proofness" of any wall. Where weight and extreme thickness is impractical special techniques have been worked out to make use of various combinations of free air spaces between independent walls. Sound absorbing materials are used extensively in these combinations.

A few partitions and their average transmission losses are shown in Fig. 2.

All cracks or openings which may exist around doors should be sealed by providing felt or rubber gaskets on the door stops at the head and jambs, and installing a special metal-bound, felt strip threshold-closer, as illustrated in Fig. 3.

Efficient sound insulation in windows is required when windows are used for observation. These should be constructed with double panes of heavy glass with each pane isolated completely from the frame by gaskets of felt or rubber around all four edges. It is advisable to have the panes of slightly different thickness, to avoid resonance effects. Details of this construction are clearly illustrated in Fig. 3.

In the case of machine vibration the simplest method of reducing this type of sound transmission is to provide a resilient mounting for the machine which will tend to cushion and absorb the vibration rather than transmit it directly to the building structure. Rubber, cork, or spring mountings are designed to carry any load limit. Pads

**IMMEDIATE DELIVERY!**

### Model 5015

#### Clinton Walnut Automatic Radio Phonograph Combination

Beautiful walnut cabinet with hand rubbed piano finish, lid of seasoned walnut with core 13/16" thick, guaranteed against warping, 18 3/4"D x 10 1/2"H x 16"W.

5-tube radio, 6" dynamic speaker with Alnico five magnet, heavy duty power transformer, complete with tubes (6SA7, 6SR7, 6C5, 6V6, equi. 6x5) takes 12-10" or 10-12" records, automatic Crescent changer, dual volume \$56.00 and separate tone controls.



### Model R5515

#### Clinton Electrolu Automatic Radio Phonograph Combination

Expensive luxurious leatherette, brass hardware throughout with saddle stitched leather handle, 15"D x 9 1/2"H x 21"W.

5-tube radio, 6" dynamic speaker with Alnico five magnet, heavy duty power transformer, complete with tubes (6SA7, 6SR7, 6C5, 6V6, equi. 6x5) takes 12-10" or 10-12" records, automatic Crescent changer, dual volume \$49.50 and separate tone controls.

20% deposit required on all orders  
Write for our new illustrated catalog;  
it's FREE!

Dept. A

**UNION Radio Corporation**

328 S. Paulina • Chicago 12, Ill.

You Can Now SIGNAL TRACE with a "Pencil"\*

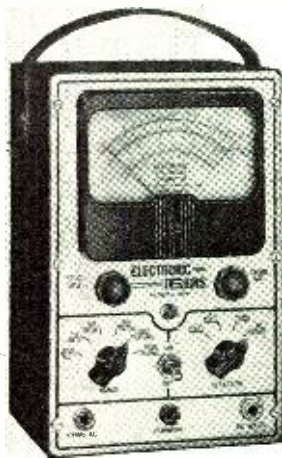

**PROVAC**

featuring **EDIPROBE**  
\*Pencil-thin RF probe

The PROVAC electronic vacuum tube volt-ohmmeter permits the laboratory engineer and radio service technician to measure every voltage required in the design laboratory and radio servicing.

Measure R.F. with the same ease as measuring D.C. with the latest development in R.F. probes. It is no longer necessary to guess at which point the signal stops.

DC Ranges: 0 to 3-10-30-100-300 and 1,000 volts. All ranges have a constant input resistance of 11,000,000 ohms. Accuracy 3% ±

AC Ranges: 0 to 10-30-100-300 and 1,000 volts. Sensitivity: 1,000 ohms per volt. Accuracy 3% ±

Electronic Ohmmeter Ranges: 0-1,000 ohms, 0-10,000 ohms, 0-100,000 ohms, 0-1 megohm, 0-10 megohms, and 0-1,000 megohms.

R.F. Voltage ranges 0/3-10-30-50 Volts to be measured on 100 Volt range.

Bridge Amplifier Circuit Meter individually calibrated for use with set of test leads, signal tracer probe and batteries.

#### Features of the EDIPROBE

- Smallest R.F. probe made.
- Frequency range 60 Cycles to over 100 Megacycles.
- Effective circuit loading: 3 mmf. and 1 megohm.
- Can be used as an output meter.
- Can be used for measuring decibels.
- Checks condensers for open circuit.
- Works with any standard V.T.V.M.

PROVAC Model ED 100 \$59.50 (with EDIPROBE)... VTYM Model 100 (without probe)... EDIPROBE (RF Probe)... \$9.85

Jobbers and dealers write for exclusive Territory Distribution. Orders addressed to us will be credited to your nearest dealer.

Write Dept. N K for FREE Technical Manual

**ELECTRONIC DESIGNS, Inc.**

IRVINGTON, NEW YORK



EDIPROBE \$9.85

# Problems?

## If you need help . . .

in development or design of new electronic apparatus using high performance crystals—call on VALPEY.

## NEW EQUIPMENT FOR —

- Crystal control in UHF ranges.
- Advanced supersonic devices.
- Precision temperature control to measure exact frequencies.

**CALL VALPEY** for custom designed crystals—for the solution to any frequency control problem.

For friendly, expert assistance—

**Invariably it's VALPEY**



Craftsmanship in Crystals Since 1931  
HOLLISTON, MASSACHUSETTS

## MORE SMASH BUYS at National Radio Distributors

### IMMEDIATE DELIVERY

The Famous National Radio Kits

**ALL PARTS MOUNTED**

**Ready for easy wiring**

New and improved A.C./D.C. Superhet, featuring latest Post-War engineering, including beautiful modern design brown plastic cabinet, built-in loop antenna and Alnico speaker. Uses 12SA7, 12SK7, 12SQ7, 50L6, and 35Z5 tubes. Price (complete with cabinet) . . . . . **11.95**

Lots of 50 or more (complete with cabinet) . . . . . **10.95**

Kit of 5 matched tubes for above . . . . . **4.25**

4 Tube A.C./D.C. T.R.F., built-in loop antenna and Alnico speaker. Price (complete with cabinet) . . . . . **10.95**

Lots of 50 or more (complete with cabinet) . . . . . **10.25**

Kit of 4 matched tubes for above (12SK7, 12SJ7, and 50L6, and 35Z5) . . . . . **3.50**

### GLO-IRON

The safe, cordless plastic toy that actually GLOWS in Sparkling Red through its translucent body.

Features smooth-steel ironing base and On-Off switch. Complete with battery and bulb.

Absolutely brand new and different, will delight the youngsters heart.

Individually and attractively boxed.

List Price \$1.29 Your Net (in dozen lots) Each **.78**

Please enclose at least 25% with C.O.D. orders  
Write for New Catalog It's Free



**National Radio Distributors**

**1029 E. 163 St., New York 59, N.Y.**

of cork, rubber or fiberboard and other compliant materials may also be used.

Not to be overlooked in the process of construction is the ventilating system. The air ducts should be about 6" x 12" in size and should be about 20' long. In case of fan or air noises conducted by the ducts it will be necessary to line the duct with an absorbent material. This will prevent the duct from acting as a speaking tube in transmitting the sound into the room. This is also true of ducts leading to adjacent rooms.

If the best reception is to be enjoyed from radios and record transcriptions, sound conditioning is an absolute must.

Broadcasting companies spend thousands of dollars on program arrangement, engineering, studios, and the consequent heightened standards of broadcast quality in order to transmit the finest possible productions.

The radio industry is incorporating many developments obtained from wartime research, into models now coming off production lines. A dealer should be in a position to take advantage of these by presenting his merchandise in the most skillful manner possible.

Acoustical treatment is now, more than ever, being included in construction specifications. Leading acoustical products manufacturers have franchised distributors thoroughly experienced in all phases of sound conditioning.

The benefit of their experience is available without obligation. A little time spent with a sound conditioning engineer will yield an excellent return to the serviceman-dealer.

—50—

# Classified

Rate 20c per word. Minimum 10 words

## RADIO ENGINEERING

RADIO Engineering Broadcasting, Aviation and Police Radio, Servicing, Marine Operating and Electronics taught thoroughly. Expenses low. Write for catalog. Valparaiso Technical Institute. Dept. N. Valparaiso, Ind.

## FOR SALE

SELENIUM Rectifiers, full wave, 5 ampere, \$1.85; 1 ampere, \$2.50. Half wave 5 amperes, \$4.50; 2.2 amperes, \$2.25; 1.5 ampere, \$1.85. Bulletin. Bursma Radio, Route 5, Grand Rapids, Mich.

RADIO tubes, parts, wholesale. Bulletin, 3c. Henshaw, 3313 Delavan, Kansas City, Kansas.

WEST Prices. Radio Tubes, parts. Bargain lists 3c. Potter, 1314 McGee, Kansas City 6, Mo.

WIRELESS phono-osc. transmits voice, recordings up to 500 ft. without wires; Kit with tubes, \$5.75. Kit wired with tubes, \$6.95. Constant Electric, 112 Cornelia St., Brooklyn 21, N. Y.

SELL—National communication receiver, 100 ASP, McElroy Recorder RRD, \$9.00. C. Horn, 325 E. 163 St., New York 56, N. Y.

5SDG SELSYNS, \$1.75; RCA 2050 Thyatron, 75c; Luminous Paint Kit, \$2.50; C-1 Autopilot Amplifier, as is, with 6 plate relays and 7 tubes, \$5.75, less tubes, \$3.75; "principles of Radio Engineering," Glasgow (McGraw-Hill), \$2.50; SCR-522, new and complete, \$97.50; AN/APN-1 Radio Altimeter, new and complete, \$95.00; also APT-5A, SCR211, BC406, BC375, BC348, BC224, SCR-274, SCR284A, new and used. Free Descriptive List. Engineering Associates, Far Hills Branch Box 26, Dayton, Ohio

SPECIAL BUYS—Pan Oscillo Receiver 3" oscilloscope, panoramic adapter, synchroscope, receiver (when used with converter). Ideal General and Television service work, laboratory. 110v 60 cycle. New original cartons originally \$1750, your cost \$97.50. Send 60c for 80 page technical manual. BC 406 15 tube superheterodyne 205mc receiver 110V 60 cycle. Easily converted 2-10 meters or FM. Instructions furnished. Clearance price \$21.45. New meters W. E. Output—4 to +6DB—3" \$3.95. Frequency 48-62 cycles 3" \$2.95. Triplett 2" 0-150ma pair \$6.35. 5G Selsyn generators, perfect antenna direction indicator. 110V 60 cycle \$12.00 pair. Transmitting tubes new G. E. 814 \$11.45 pair. RCA8012. UHF to 500mc \$8.95 pair. Eimac 304th \$17.90 pair. Convert BC 312 to 110V 60 cycle exact replacement army power pack, new, \$14.85. Signal Generators Measurements Corporation Type 65 B-75kc-30mc. Slightly Used but perfect \$475.00. High Power Modulators. Two 500 audio units in one channel rack 110V 60 cycle less eleven tubes new \$325.00. Westchester Electronic Products, 29 Milburn Street, Bronxville, New York.

HICKOK TUBE Tester Model 530 Excellent Condition—Best offer takes. Kurth's Sound Equipment, Citizens Bank Building, Hutchinson, Minnesota.

CLOUGH Brengle Signal Generator. Just Factory Calibrated Model OCX. Best offer takes. Kurth's Sound Equipment, Citizens Bank Building, Hutchinson, Minnesota.

PR-16 Communications Receiver with Jensen baffle and 12" speaker. F. Knapp, 6508 Montgomery Rd., Cincinnati, Ohio.

DIAGRAM, Case Histories for Every Receiver, 35c. Lopes, 780 E. 214, New York, N. Y.

SELSYN Transmitters and Repeaters. Diameter, 4"; weight, 10 lbs. Write to J. A. Weber, 150 Maple, Hershey, Pa.

6' NEON Radio Service sign. Details, Best Vibrator Co., Box 5802, Cleveland 1, Ohio.

400 CYCLE Dynamotors. 28VDC input, 115VAC output, 485VA. Shaft extension, black crackle, \$12.50. Amplidyne Motorgenerators 28VDC to 60VDC 530W, \$10.50. Generators, 30VDC 300 Amperes, \$22.50. New. Postpaid. Free list Aircraft, Electrical, Radio Parts. Erecoc, 1006 Hewitt, Everett, Wash.

HRO NOISE limiters, 2 tubes, variable control, easily installed. Drill one hole only. Complete with instructions, \$15.95. Radio Electronic Sales, 46 Chandler St., Worcester 2, Mass.

VOICOID stops that rub. \$1.25 bottle. Pat. pending. Rounds out warped coil cores. Trial size 25c. Restore that radio speaker cone for \$1.00 with "New Tone" harmonic solution. Stops cracking, rattles, blasting. Gives ear-ease, simulates 5th dimension, FM and out of doors reception. Lasts for years. Tested and approved by American Research Laboratories. Pat. pending. Trial size 25c. Radio Research Products, W. Malloy, Mgr., 1528 E. 64th St., Chicago, Ill.

PRESELECTORS, 10 to 20 meters, self contained power supplies, \$19.95; 2 meter super-regen receivers, \$22.50; write for details. Constant Electric, 112 Cornelia St., Brooklyn 21, N.Y.

INDUSTRIAL Instruments. Model RN-I Wheatstone Bridge, \$90.00. Model DR-52 Resistance Decade, \$100.00. Model 652 Jackson Audio Oscillator, \$90.00. Model 546 Supreme Oscilloscope, \$70.00. AC Variable Voltage Adjuster with Voltmeter, \$25.00. 20 New Panel Meters, all ranges. For radio service and amateurs' parts. Send for complete list. L. Dye, 150 Sunset Ave., Dayton, Ohio.

HAMMARLUND HQ 129X Vomag VTVM, BC221 frequency meter, TBY7 & power supply. S. Mayo, 372 E. 16th St., Brooklyn 26, N. Y.

## WANTED

SURPLUS Radio Supplies, Tubes, Manuals, Test Equipment. Give complete information, prices, quantity. Bursma, R.R. 5, Grand Rapids 4, Mich.

WANTED—Rider Manuals I, II, III. A. R. Villedanne, R.F.D. No. 1, Claremont, N. H.

WANTED—Dual speed transcription phonomotor with turntable, for sixteen-inch recordings, 110 volts AC. C. C. Bonsell, 20 Race Road, Fairfield, Ohio.

WANTED—Springfield 1903 Service rifle in perfect condition, high serial number (as issued) and other rifles. Exchange for high grade semi-professional recorder, amplifier, mikes, etc. Value over \$300.00. Write giving full particulars. Box 437, % Radio News.

WANTED—Army Tech. School Radio Workbooks. Chris Carey, Fair Haven, Vermont.

## CORRESPONDENCE COURSES

CORRESPONDENCE Courses and self-instruction books, slightly used. Sold. Rented. Exchanged. All subjects. Satisfaction guaranteed. Cash paid for used courses. Complete information and 100-page illustrated bargain catalog FREE! Write Nelson Company, Dept. 2-59, Chicago 5.

**RADIO NEWS**

USED Correspondence Courses and Educational Books sold or rented. Inexpensive. Money-back guarantee. Write for Free Catalog listing 4000 bargains.—(Courses Bought.)—Lee Mountain, Pisgah, Ala.

AMATEUR radio licenses. Complete code and theory preparation for passing amateur radio examinations. Home study and resident courses. American Radio Institute, 101 West 63rd Street, New York City.

USED Educational and Technical Books on all Subjects Bought, Sold, Rented; Catalog Free. Educational Exchange, Henagar, Ala.

RADIOTELEPHONE first class sample tests, \$10.00. We correct. New correspondence course. Box 1298, Hollywood, Calif.

**PATENT ATTORNEYS**

PATENTS—U.S. and Foreign Patents Secured. Trade-marks and Copyrights registered. Searches made to determine Patentability and Validity. Patent, Trade-mark and Unfair Competition Causes. Lancaster, Allwine & Rommel, Registered Patent Attorneys, Suite 414, 815 15th St., N.W., Washington 5, D. C.

INVENTORS—Steps to be taken in obtaining patent protection available upon request. Victor J. Evans & Co., 148-M Merlin Bldg., Washington 6, D. C.

**HELP WANTED**

RADIO Instructors. Receiver servicing experience. College Degree preferred. \$3600 a year to start. \$4200 after four months. Work in the heart of the Radio Industry. Write Raleigh G. Dougherty, 158 Market Street, Newark 2, New Jersey, % New York Technical Institute of New Jersey.

INSTRUCTORS in Electronics and Radio. Prefer former Navy Radio Technician instructors willing to locate in the Detroit, Mich., area. Write to Box 431, % Radio News.

**FOR EXPORT**

FIVE and Six tube all metal cabinet superhets available in beautiful cabinet. All voltage ranges. Fulton Distributors, 3349 Fulton Road, Cleveland 9, Ohio. Tel. SH. 1916.

**MISCELLANEOUS**

BUILD your own radio 5 tube super het kit complete with all tubes and walnut cabinet using 50L6, 35Z5, 12SA7, 12SK7, 12SQ7. All major parts assembled. Easy to wire. Your cost, \$16.95. McGee Radio Co., 1330 Broadway, Denver, Colo.

RADIO wholesale repairs. Just send us the radio prepaid, we repair and return C.O.D. You add markup and deliver. Complete stock. We fix them all. 48 hrs. service. Our low prices mean more markup profits for you. Ship to Elkins Radio, Elkins, W. Va.

TRADE—Recorder for Model 1903 Springfield Service rifle in perfect condition with serial number over 1,350,000 (as issued) and other rifles. Write giving full particulars. Box 438, % Radio News.

ELECTRIC Meter Laboratory. Electrical Instruments, Tube Checkers and Analyzers repaired. War surplus meters converted for civilian use. Hazelton Instrument Co., 140 Liberty St., New York, N. Y. Tel. Barclay 7-4239.

**BARGAINS**

- 2" PM Speaker with Output . . . . . \$ 1.58
- Label Mike Cable . . . . . .066 ft.
- Generator Condensers
- Solar 1—25 or 5 MFD . . . . . \$ .24
- Solar 30 MFD 450 Con. . . . .
- Plugs into Octal Socket . . . . . \$ .78
- Signal Generator—All Wave . . . . . \$49.95
- Tube Checker—Latest Portable . . . . . \$39.50
- 67½V Minimax B Surplus . . . . . \$ .79
- Superior Call Signal Tracer . . . . . \$18.75
- Record Changer . . . . . \$18.95 ea.—2 for \$35.00

Send For Latest Bulletin

**MAC'S RADIO SUPPLY**  
 8320-22 LONG BEACH BLVD.  
 SOUTH GATE, CALIF.  
 Telephones — KIMBALL 4111-4112

GET ON SUN'S MAILING LIST!  
  
 122-124 DUANE ST. NEW YORK 7, N. Y. Barclay 7-1840

November, 1946

**For the Record**

(Continued from page 8)

The signal picked up and used most effectively was a reflection from a nearby building.

The reproductions were excellent. The image appearing at the rate of 20 frames per second, scanned 525 lines per frame for each of the basic colors—red, yellow and blue—was pleasant to observe and in the short program, seemed to develop no eye-strain.

But, here again at CBS we were shown laboratory models operated by top flight engineers. The receivers, although housed in attractive cabinets, were all carefully built by expert workmen.

This brings up a question. Shall we scrap black and white television now and concentrate all of our planning and research on color television?

Black and white television is today a reality. Most of the technical problems of production have been solved and we are assured of a large volume of quality home receivers at prices within reach of the average purse, once labor and material difficulties have been successfully resolved.

But color television is still in the laboratory. Those of us who have sweated through the laborious process of making engineers' successes in the laboratory commercially successful and production line assembly usable, dependable products in the hands of the layman, can see months and perhaps years of work ahead to make color television commercially feasible.

It is the opinion of your editor that the future of television can best be insured by proceeding rapidly with the techniques already learned and make black and white television a reality to the bulk of the country as soon as possible. Television in color will be a natural development and it will fall quickly into its place in the radio pattern when adjustments have been effected that will make those laboratory successes commercially possible.

**T**HE new series of articles on Recording—scheduled for this issue—has been delayed due to last-minute revisions. We'll try to start the series in our next issue. . . . . O. R.

**ERRATUM**

The formula for calculating the length of a quarter-wave matching transformer shown on page 66 of the September, 1946 issue of Radio News should have been 246/fVD. All lengths specified in the various formulas in the article are in feet.

**Photo Credits**

- Pages
- 25, 26 . . . . . Beech Aircraft Corp. Credit
- 27 (left) . . . . . Dallas Aero Service
- 27 (right), 137, 141 . . . . . Bendix Radio Division
- 28, 29 . . . . . Dow Chemical Company
- 30 . . . . . The Celotex Corporation
- 35 . . . . . Arthur Haug, Staff Photographer
- 39 . . . . . Collins Radio Co.
- 45 . . . . . Federal Telephone & Radio Corp.
- 49 . . . . . Walter Steinhard, Staff Photographer
- 54 . . . . . Steiner Company, Bern, Switzerland
- 146 . . . . . Foto Soren, Sweden
- 150 . . . . . Foto Daniels, Sweden

**CONVERT Your BC 312 Receiver To AC Operation**

The RA—20 POWERPACK fits right into the dynamotor compartment

Five minutes is all it takes to make the change. No fuss with batteries, or make-shift messy power supplies. The RA-20 can be used to power many other types of similar equipment designed for dynamotor or battery operation.

- Primary 110-120 VAC 60 cycles
- Deliceries 250 VDC @ 95 mils
- 12 V @ .3 amps
- 12 V CT @ 2. amps
- RA-20 price \$14.95

**FEDERATED Specials**

UHF Acorn tubes 954, 955, 956, 957, VR 59, 69c each. All new, unconditionally guaranteed.

Type 902 CR 2" regular \$9.75  
 Special \$3.95

**IMMEDIATE DELIVERY ON THESE ITEMS**

**The NEW ABBOT TR4B \$52.00**

The New compact single unit 60 watt MECK TRANSMITTER complete with tubes built in modulator, power supply and antenna changeover relay. Measures only 15 x 11 x 9". A complete rig \$150.00.

**The HAMMARLUND SUPERPRO receiver \$310.05**

DUMONT'S NEW 5-INCH OSCILLOGRAPH—type 274—The biggest oscillograph value ever offered only \$99.50.

The new PAN ADAPTER—adaptable to any communications receiver. Model PCA-2 (one year guarantee) \$99.75.

The new McMurdo Silver model No. 904 CAPACITANCE & RESISTANCE BRIDGE made by the maker of "VOMAX" resistance from ¼ ohm to a thousand megohms capacity measurements from ¼ mmfd to 1,000 mfd. Adjustable internal potential from 0 to 500 volts for testing electrolytic capacitors. Power factor measurements calibrated in percentage. Complete with tubes and test leads 105/125 volt AC operation. \$49.90.

**Federated Purchaser**  
 INCORPORATED  
 distributors of RADIO - ELECTRONIC and SOUND EQUIPMENT  
 80-RN PARK PLACE, N. Y. 7  
 Phone: WH 4-2080

# INDEX OF ADVERTISERS

November  
1946

<p>Abell Distributing Co., The <i>Brodx Advertising Agency</i>..... 84</p> <p>Adson Radio Co. <i>Bass &amp; Weber Company, Inc.</i>..... 90</p> <p>Air King Radio <i>Henry A. Loudon Advertising</i>..... 91</p> <p>Alliance Manufacturing Company <i>Foster &amp; Davies, Inc.</i>..... 75</p> <p>Allied Radio Corporation <i>George Brodsky, Advertising</i>..... 9,88</p> <p>Almo Radio Company <i>E. L. Brown, Advertising</i>..... 152</p> <p>Alsam Products <i>Sander Rodkin Advertising Agency</i>..... 154</p> <p>American Phenolic Corporation <i>Burton Browne Advertising</i>..... 21</p> <p>American Photocopy Equipment Co. <i>Arthur Meyerhoff Advertising</i>..... 134</p> <p>American Radio Institute <i>Sternfield-Godley, Inc.</i>..... 150</p> <p>American Sales Company..... 148</p> <p>American Television Institute <i>Turner Advertising Agency</i>..... 85</p> <p>American Television &amp; Radio Co. <i>Firestone-Goodman Advertising Agency</i>..... 161</p> <p>Ampere Electronic Corp. <i>Frank H. Kaufman</i>..... 104</p> <p>Arrow Sales Inc..... 135</p> <p>As'atic Corp. <i>Wearstler Advertising, Inc.</i>..... 139</p> <p>Atlas Condenser Products Co., Inc. <i>Beregan-Jarret Advertising</i>..... 86</p> <p>Atlas Electronics Company <i>Bass &amp; Weber Company, Inc.</i>..... 142</p> <p>Atlas Sound Corporation <i>Burke &amp; Wayburn, Inc.</i>..... 124</p> <p>Audak Co. <i>Hart Lehman Advertising</i>..... 8</p> <p>Audel Publishers <i>Gran' &amp; Wadsworth Co.</i>..... 157</p> <p>Baker-Phillips Company <i>Foulke Agency</i>..... 151</p> <p>Baltimore Technical Institute..... 160</p> <p>Banks Mfg. Co..... 148</p> <p>Barclay Electronics..... 136</p> <p>Beard, George F..... 162</p> <p>Bell Telephone Laboratories <i>N. W. Ayer &amp; Son</i>..... 24</p> <p>Bigg Radio Store..... 92</p> <p>Bliley Electric Company <i>Hardy Advertising Agency</i>..... 99</p> <p>Bliss Electrical School <i>N. W. Ayer &amp; Son</i>..... 148</p> <p>Brooks, Geo. &amp; Associates..... 144</p> <p>Bud Radio, Inc. <i>Allied Advertising Agency</i>..... 90</p> <p>Buffalo Radio Supply <i>International Advertising Agency</i>..... 95</p> <p>Burlington Instrument Company <i>Weston-Barnett, Inc.</i>..... 161</p> <p>Burnell Company <i>Mitchell Advertising Agency</i>..... 80</p> <p>Burstien-Applebee Company <i>Frank R. Whalen Advertising</i>..... 70</p> <p>California Radio &amp; Electronics Co. <i>Bass &amp; Weber Company, Inc.</i>..... 11</p> <p>Candler System Co. <i>Rand-Ries, Inc.</i>..... 152</p> <p>Cannon Electric Development Co. <i>Dana Jones Company</i>..... 133</p> <p>Capitol Radio Engineering Institute <i>Henry J. Kaufman Advertising</i>..... 71</p> <p>Centralab <i>Gustav Marx, Advertising</i>..... 115</p> <p>Chicago Industrial Instrument Co..... 160</p> <p>Chicago Wheel &amp; Mfg. Co. <i>Weston-Barnett, Inc.</i>..... 152</p> <p>Chief Electronics..... 154</p> <p>Clark Radio Equipment Corp. <i>Turner Advertising Agency</i>..... 90</p> <p>Clark Reiss Distributors <i>Bass &amp; Weber Company, Inc.</i>..... 138</p> <p>Clarkson Publishing Co. <i>Smith, Benson &amp; McClure, Inc.</i>..... 160</p> <p>Clarkston Corporation <i>Stellar, Miller &amp; Ebberts</i>..... 134</p> <p>Cleveland Institute of Radio Electronics <i>Kenneth H. Kolpien</i>..... 62,68,143</p> <p>Clippard Instrument Laboratory <i>Savage &amp; Talley, Inc.</i>..... 164</p> <p>Collins Audio Products Co. <i>Collins Radio Company</i>..... 22</p> <p>McCann-Erickson, Inc. <i>Communications Equipment Company</i>..... 69</p> <p>Borough Advertising Agency..... 69</p> <p>Concord Radio Corporation <i>E. H. Brown, Advertising</i>..... 56</p> <p>Constant Electric Company..... 144</p> <p>Coyne Electrical School <i>Phil Gordon Agency</i>..... 59,162</p> <p>Coyne Electrical School <i>McJunkin Advertising Agency</i>..... 142</p> <p>Crabree's Wholesale Radio <i>Croname, Inc.</i>..... 109</p> <p>D &amp; H. Distributing Co. <i>Business Service Agency</i>..... 100</p> <p>DeForest's Training, Inc. <i>MacDonald-Cook Company</i>..... 15</p> <p>Dow Radio..... 142</p>	<p>Drake Electric Work, Inc. <i>William Hoffman &amp; Associates</i>..... 104</p> <p>Dymac, Inc. <i>Harold Warner Company</i>..... 156</p> <p>Editors &amp; Engineers..... 10,136</p> <p>Electronic Designs, Inc. <i>Bass &amp; Weber Company, Inc.</i>..... 165</p> <p>Electronic Equipment Distributors..... 118</p> <p>Electronic Institutes, Inc..... 162</p> <p>Electronic Instrument Company <i>Purnies &amp; Associates</i>..... 162</p> <p>Electronic Manufacturing Co. <i>Business Service Company</i>..... 157</p> <p>Electronics Measurements <i>Purnies &amp; Associates</i>..... 138</p> <p>Electronic Supply Corp. <i>Regent Advertising Agency</i>..... 152</p> <p>Electro-Motive Mfg. Co., Inc. <i>Cory Snow, Inc.</i>..... 158</p> <p>Erie Supply Company..... 162</p> <p>Esse Radio Company <i>George S. Diener Company</i>..... 20</p> <p>Evans, Victory J. &amp; Company <i>Emery Advertising Co., Inc.</i>..... 162</p> <p>Fada Radio &amp; Electric Company, Inc. <i>Sternfield-Godley, Inc.</i>..... 6</p> <p>Fahnestock Electric Company, Inc..... 131</p> <p>Federated Purchaser, Inc. <i>Altomari Advertising Agency</i>..... 167</p> <p>Feiler Engineering Co. <i>George Brodsky Advertising</i>..... 98</p> <p>Flanagan Radio Corporation <i>Stewart-Jordan Corp.</i>..... 93</p> <p>Foht Radio Company..... 154</p> <p>Frank Wally, Ltd. <i>Dundes &amp; Frank, Inc.</i>..... 150</p> <p>General Cement Mfg. Co. <i>Turner Advertising Agency</i>..... 102</p> <p>General Industries Co., Th <i>Fuller &amp; Smith &amp; Ross, Inc.</i>..... 94</p> <p>General Test Equipment Co. <i>Suzanne B. Hayman, Advertising</i>..... 154</p> <p>Greenlee Tool Company <i>Howard T. Monk &amp; Associates</i>..... 112</p> <p>Greenwich Sales Co. <i>Bass &amp; Weber Company, Inc.</i>..... 130</p> <p>Groban Supply Company <i>A. L. Addison Advertising</i>..... 144</p> <p>Grossman Radio &amp; Electric Co. <i>Arnold Coban Corporation</i>..... 125</p> <p>Guardian Electric <i>Kennedy &amp; Company</i>..... SECOND COVER</p> <p>Hall, R. C. &amp; L. F., Inc..... 74</p> <p>Haldorson Company, The <i>Sander Rodkin Advertising Agency</i>..... 80</p> <p>Hallcrafters Company, The <i>Burton Browne Advertising</i>..... 5</p> <p>Hammarlund Mfg. Co., Inc., The <i>Roeding &amp; Arnold, Inc.</i>..... 101</p> <p>Harrison Radio Corporation <i>Altomari Advertising Agency</i>..... 60</p> <p>Harvey Radio Company, Inc. <i>Shappe-Wilkes, Inc.</i>..... 96</p> <p>Henry Radio <i>Burton Browne Advertising</i>..... 78</p> <p>Hexacon Electric Co. <i>George Homer Martin</i>..... 74</p> <p>Hoodwin, Chas. Co..... 156</p> <p>Hopp Press, Inc <i>Gallard Advertising Agency</i>..... 164</p> <p>Hytron Radio &amp; Electric Corp. <i>Henry A. Loudon Advertising</i>..... 67</p> <p>Illinois Condenser Company <i>Sander Rodkin Advertising Agency</i>..... 148</p> <p>Instructograph Company <i>Turner Advertising Agency</i>..... 140</p> <p>International Resistance Corp. <i>John Falkner Arndt &amp; Co.</i>..... 79</p> <p>J. F. D. Mfg. Company <i>Bergman-Jarret Company</i>..... 153</p> <p>Jensen Radio Manufacturing Co. <i>Burton Browne Advertising</i>..... 89</p> <p>Johnson, E. F. Company <i>David, Inc.</i>..... 103</p> <p>Joseph, Irving Associates..... 128</p> <p>Kelvin Electronics <i>Sternfield-Godley, Inc.</i>..... 150</p> <p>Kenyon Transformer Corp. <i>Jasper, Lynch &amp; Fishel, Inc.</i>..... 113</p> <p>Kurz-Kasch, Inc. <i>Kircher, Helton &amp; Collett</i>..... 107</p> <p>Kwikheat <i>West-Marquis, Inc.</i>..... 129</p> <p>Lake Radio Sales Company <i>Sander Rodkin Advertising Agency</i>..... 64</p> <p>Legri S Company <i>Cromwell Advertising Agency, Inc.</i>..... 154</p> <p>Leotone Radio Co. <i>Altomari Advertising Agency</i>..... 82</p> <p>Liberty Sales Co., Inc. <i>Sternfield-Godley, Inc.</i>..... 121</p> <p>Lifetime Sound Equipment <i>Miller Agency Co.</i>..... 112</p> <p>Lincoln Engineering School <i>Buchanan Thomas Advertising Agency</i>..... 140</p>	<p>Moc's Radio Supply..... 167</p> <p>Maquire Industries, Inc. <i>City Advertising Agency</i>..... 119</p> <p>Mallory, P. R. &amp; Co., Inc. <i>Aitkin-Kynett Co.</i>..... THIRD COVER</p> <p>Maritime Switchboard..... 116</p> <p>Martin, Don Scool of Radio Arts..... 156</p> <p>Massey's Radio Supply..... 148</p> <p>Melville Radio Institute <i>Seidel Advertising Agency</i>..... 102</p> <p>Metrooltan Electronic &amp; Instrument Co. <i>Bass &amp; Weber Company, Inc.</i>..... 66,141</p> <p>Mid-American <i>E. H. Brown, Advertising</i>..... 105</p> <p>Miles Reproducer Co., Inc. <i>Altomari Advertising Agency</i>..... 143</p> <p>Millen, James Mfg. Co., Inc. <i>James Millen, Inc.</i>..... 12</p> <p>Milo Radio Electronics Corp. <i>Burke &amp; Wayburn, Inc.</i>..... 112</p> <p>Murray Hill Books, Inc. <i>Harry P. Bridge Advertising</i>..... 76,77</p> <p>McGee Radio Company <i>Edgar Walter Fischer</i>..... 155</p> <p>McGraw-Hill Book Co., Inc..... 136</p> <p>McMurdo Silver Company <i>Edward Owen Company</i>..... 16</p> <p>N. J. Industrial Agency..... 116</p> <p>National Acoustic Products <i>Paul Basinger Studio</i>..... 163</p> <p>National Company, Inc. <i>Graydon Smith Advertising</i>..... 55</p> <p>National Radio Distributors <i>Burke &amp; Wayburn, Inc.</i>..... 166</p> <p>National Radio Institute <i>Van Sant, Dugdale &amp; Company</i>..... 3</p> <p>National Radio Service..... 144</p> <p>National Schools <i>Stodel Advertising Agency</i>..... 65</p> <p>National Schools <i>Mayers Company, Advertising</i>..... 23</p> <p>National Union Radio Corp. <i>Hutchins Advertising Agency</i>..... 61</p> <p>Newark Electric Company <i>Charles Brunelle Company</i>..... 117</p> <p>Newark Surplus Materials Co. <i>William N. Scheer</i>..... 140</p> <p>Newcomb Audio Products Co. <i>Stevens-Hall Advertising</i>..... 159</p> <p>New York Technical Institute of New Jersey <i>Schwab &amp; Beatty, Inc.</i>..... 72,73</p> <p>Niagara Radio Supply <i>Burke &amp; Wayburn, Inc.</i>..... 106</p> <p>O &amp; B Laboratories..... 144</p> <p>Ohmeyer Engineering Labs..... 108</p> <p>Olson Radio Warehouse <i>Jessop Advertising Agency</i>..... 169</p> <p>Oxford Radio Corp. <i>Signet Company</i>..... 62</p> <p>Pa-Kette Radio Company <i>Arrow Advertising Agency</i>..... 154</p> <p>Petersen Radio Company <i>Bozell &amp; Jacobs</i>..... 130</p> <p>Potter Radio Company..... 130</p> <p>RCA Institutes, Inc..... 134</p> <p>R. L. Electronics Corp. <i>R. S. Wittenberg Advertising</i>..... 106</p> <p>Radio City Products <i>Reiss Advertising Agency</i>..... 18</p> <p>Radio Corporation of America <i>J. Walter Thompson Advertising</i>..... 170</p> <p>Radio Dealer Supply <i>H. J. Gold Advertising</i>..... 148</p> <p>Radio Development Labs <i>Altomari Advertising Agency</i>..... 118</p> <p>Radio Distributing Co..... 162</p> <p>Radio Electric Service Co. <i>David Zibman Advertising</i>..... 156</p> <p>Radio Equipment Distributors <i>Ross, Gardner &amp; White Advertising</i>..... 134</p> <p>Radio-Experts..... 152</p> <p>Radio Ham Shack <i>J. R. Kupsick Advertising Agency, Inc.</i>..... 145</p> <p>Radio Kits <i>Hamburger Advertising Agency</i>..... 142</p> <p>Radio Maintenance Magazine <i>Shappe-Wilkes, Inc.</i>..... 63</p> <p>Radio Parts Company <i>Sidney S. Lovitt Advertising</i>..... 159</p> <p>Radio Press..... 156</p> <p>Radio Products Sales Company <i>Barton A. Stebbins</i>..... 151</p> <p>Radio Supply &amp; Engineering Co. <i>Karl G. Behr Advertising</i>..... 58</p> <p>Radio &amp; Television Supply <i>Thomas H. Stevenson</i>..... 162</p> <p>Radio &amp; Television Supply Co..... 60,143</p> <p>Radionic Equipment Co. <i>Bass &amp; Weber Company, Inc.</i>..... 149</p> <p>Radio Wire Television, Inc. <i>Reiss Advertising Agency</i>..... 81</p> <p>Radolek Co. <i>Turner Advertising Agency</i>..... 157</p> <p>Reed Manufacturing Co. <i>Borg Advertising Agency</i>..... 108,148</p> <p>Rider, John F., Publishers <i>Lansford F. King Advertising</i>..... 123</p> <p>Risco Sales <i>Diener &amp; Dorskind</i>..... 162</p>
--	---	---



Robson-Burgess Co. Pfeiffer Advertising Agency.....	98
Rowe Industries Miller Agency Co.....	158
S/C Labs Gallard Advertising Agency.....	147
Sams, Howard Company, Inc. Atkin-Kynett Company.....	57
Sauereisen Cements Co. McCarty Co.....	140
Scenic Radio & Electronics Co. Buss & Weber Company, Inc.....	116
Seman, Paul A. N. Baker Advertising Agency.....	114
Sheffield Radio & Appliances Co. Sander Rodkin Advertising Agency.....	132
Shure Appliances Paul Basinger Studio.....	156
Sigmon's Radio Supply Advertising, Inc.....	140
Slate & Co. Buss & Weber Company, Inc.....	146
Sound Products Company Buss & Weber Company, Inc.....	118
Sprague Products Harry P. Bridge Advertising.....	97
Sprayberry Academy of Radio Harry P. Bridge Advertising.....	7
Standard Parts Buss & Weber Company, Inc.....	104
Standard Radio & Electronic Products Mount Printing Company.....	137
Stanton Supply Company.....	160
Star Measurements Company Altomari Advertising Agency.....	154
Stark's A. L. Addison, Advertising.....	161
Starter Batteries, Inc.....	160
Sterling Electronics Company.....	160
Stevens Walden, Inc. Howard Wesson Co.....	14
Sun Radio & Electronics Co. Buss & Weber Company, Inc.....	167
Sun Radio of Washington, D. C. Kal-Ehrlich & Merrick.....	17
Superior Instrument Corp. Buss & Weber Company, Inc.....	87
Supreme Publications Henry H. Teplitz Advertising.....	13
Surplus Radio, Inc. Buss & Weber Company, Inc.....	110
Sylvania Electric Products, Inc. Newell-Emmett Company.....	FOURTH COVER
T A B	
Buss & Weber Company, Inc.....	122
Taybern Equipment Co. Buss & Weber Company, Inc.....	102
Telectron Company, The.....	118
Terminal Radio Corporation Regent Advertising Agency.....	127
Terry Jay.....	144-160
Transvision, Inc. H. J. Gold Advertising.....	120
Triplett Electrical Instrument Co. Western Advertising Agency.....	19
Tri-State College Clem J. Steigmeyer Advertising.....	160
Trulone Products Co. Terrill Belknap Marsch.....	152
Turner Company, The W. D. Lyon Company.....	111
Ungar Electric Tools, Inc. Walter C. Davison.....	86
Union Radio Corp. Sander Rodkin Advertising Agency.....	165
United Screw & Bolt Corp. Fred Mellis Advertising.....	83
United Transformer Corp. Shapp-Wilkes, Inc.....	92
University Loudspeakers, Inc. George Homer Martin.....	153
Valparaiso Technical Institute Smith, Benson & McClure, Inc.....	144
Valpey Crystals Cory Snow, Inc.....	166
Variety Electronics Company Buss & Weber Company, Inc.....	126
Vasco.....	162
Vaughan Cabinet Company.....	130
Warner Electric Company Mason Warner Company.....	136
Warren Distributors.....	108
Waterproof Electric Company.....	138
Weber Radio Labs. Buss & Weber Company, Inc.....	106
Webster-Chicago Corporation William Hoffman & Associates.....	132
Weller Manufacturing Co. Beaumont, Heller & Sperling, Inc.....	68
Wells Sales, Inc. Turner Advertising Agency.....	147
Western Radio Communications Institute.....	156
Western Sound & Elec. Labs., Inc. Morrison Advertising Agency.....	169
World Radio Laboratories, Inc. Pfeiffer Advertising Agency.....	163
Workshop Associates Larcom Randall.....	140
YMCA Trade & Technical Schools Cecil & Presbrey, Inc.....	130



### Western Model WE-100 AW

Housed in a rich 18th century mahogany finish cabinet, this model plays up to 12 records automatically. Has complete tone and volume controls. Amplifier has automatic base compensation for full tones at low volume levels. Convenient inside light — 8-inch speaker — plays with doors closed.

### Western Model WE-100

Single Play, Portable, in modern luggage type case, with 3-tube amplifier, 5" speaker.

### Western Model WE-100 AP

#### AUTOMATIC RECORD PLAYER

Completely self-contained, automatic, with 8" speaker and 3-tube amplifier. Plays 10" or 12" records. Easily portable, in its attractive luggage type case. WESTERN Model WE100.

**WESTERN SOUND & ELECTRIC LABORATORIES, Inc.**  
MILWAUKEE, WISCONSIN

You Should Have An **OLSON**

# PANEL LAMP TOOL

for easy installation and removal of all size panel lamps

No C.O.D.'s

The slickest tool yet offered to the Radio Service Man. Made of live rubber, with two size openings so that any bulb will fit. No more fumbling to get at a burned-out lamp. No more squirming to install a new one. Put a couple in your kit!

New Fall Catalog is off the press.

Write for your free copy

**MAIL TODAY** **OLSON RADIO WAREHOUSE**

**73 E. MILL ST., DEPT. 49, AKRON, OHIO**

Send me \_\_\_\_\_ Panel Lamp Tools at 25c ea.  
I enclose \$ \_\_\_\_\_.

NAME \_\_\_\_\_

ADDRESS \_\_\_\_\_

CITY \_\_\_\_\_ STATE \_\_\_\_\_

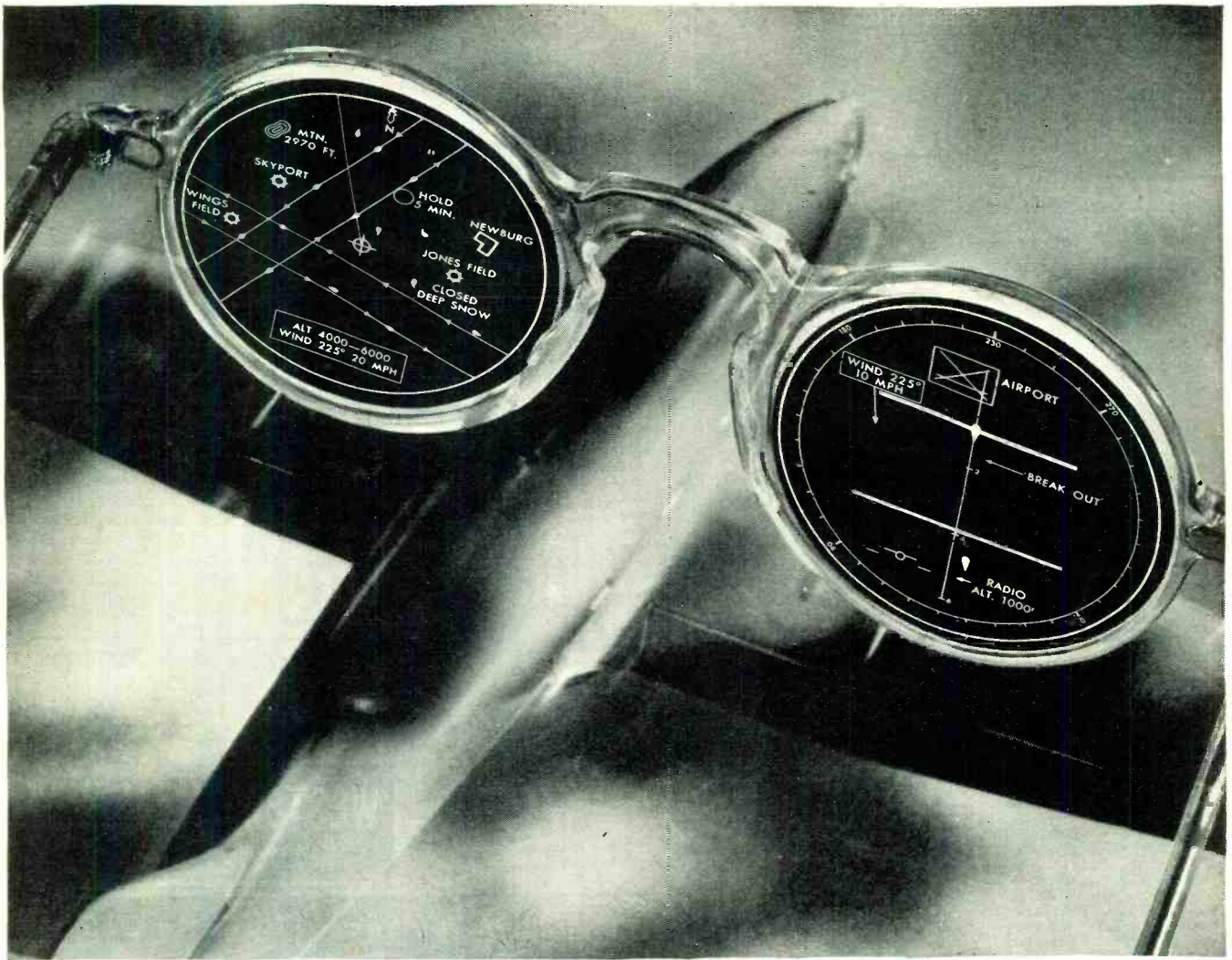

Teleran pictures—air traffic control by radar plus television.

## Teleran—"radio eyes" for blind flying!

It's a television "information please" between airplane and airport—with the pilot's questions given split-second answers on a television screen mounted in the cockpit.

Teleran (a contraction of TELEvision—Radar Air Navigation) collects all of the necessary information on the ground by radar, and then instantly transmits a television picture of the assembled data to the pilot aloft in the airplane.

On his receiver the pilot sees a picture showing the position of his airplane and the position of all other aircraft near his altitude, superimposed upon a terrain map complete with route markings, weather conditions and unmistakable visual instruc-

tions. The complex problem of air traffic control is well handled by Teleran.

Teleran—another achievement of RCA—is being developed with Army Air Forces co-operation by RCA Laboratories and RCA Victor, endless sources of history-making developments in radio and electronics. They are also your assurance that any product bearing the RCA or RCA Victor monogram, is one of the finest instruments of its kind science has yet achieved.

Radio Corporation of America, RCA Building, Radio City, New York 20 . . . Listen to The RCA Victor Show, Sundays, 2:00 P. M., Eastern Standard Time, over the NBC Network.

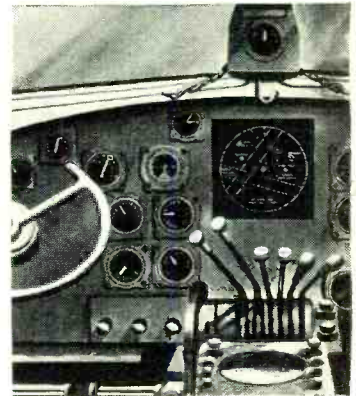

**Instrument Panel of the Future.** The Teleran indicator, mounted in a cockpit, simplifies the pilot's job by showing his position relative to the airport and to other planes in the vicinity. It promises to become one of the most useful developments in the history of aviation.



**RADIO CORPORATION of AMERICA**

PRINTED IN U. S. A.



# You'll find a Mallory Vibrator in 8 auto radios out of 10



**WANT A COPY?** A complete list of replacements for all pre-war auto radios. Valuable service information too! Ask your Mallory distributor.

**Y**ES, Mallory Vibrators are the most widely preferred and the most widely used of all vibrators made today. There must be good reasons why this year, as for many years past, 80% of all automobile radios have been equipped with Mallory Vibrators. There *are* good reasons.

Mallory is the largest producer of vibrators in the business. It has the most extensive manufacturing "know-how"—the most active staff of research experts. Every Mallory Vibrator that reaches the market is checked and double-checked against tough specifications.

These are some of the reasons why Mallory manufactures 80% of all vibrators used in original equipment. They are the same reasons why Mallory Vibrators are your best bet for replacements, too. See your Mallory distributor. He has a complete line of 6, 12 and 32 volt Mallory Vibrators.

**P. R. MALLORY & CO., Inc.**  
**MALLORY**

VIBRATORS... VIBRAPACKS\*... CAPACITORS... VOLUME CONTROLS  
 ... SWITCHES ... RESISTORS ... FILTERS ... RECTIFIERS ...  
 POWER SUPPLIES. ALSO MALLORY TROPICAL\* DRY BATTERIES,  
 ORIGINALLY DEVELOPED BY MALLORY FOR THE U. S. ARMY.  
 \*Reg. U. S. Pat. Off.

**APPROVED PRECISION PRODUCTS**

**P. R. MALLORY & CO., Inc., INDIANAPOLIS 6, INDIANA**

# YOUR NEXT RADIO NEEDS "LOCK-IN!"

"PROVED IN RADAR!  
BEST FOR YOUR SET!"



LOOK FOR LOCK-IN TUBES BEFORE  
YOU BUY A RADIO!

Why? Because more than any other tubes,  
Lock-ins are in step with the trend in modern  
radio — a trend toward higher and higher  
frequencies.

Proved in Radar and secret radio equipment  
— Lock-ins are perfect for FM and Television.  
Be sure your next radio is truly up-to-date!  
Look for Lock-ins!

"PERFECT FOR  
EVERY TYPE  
OF RADIO!"



"TOPS FOR FM  
AND TELEVISION!"



"DEFIES JARRING  
— STAYS PUT!"



© 1945  
Sylvania Electric  
Products Inc.

# SYLVANIA ELECTRIC



Executive Offices: 500 Fifth Ave., New York 18, N. Y.

Makers of Radio Tubes; Fluorescent Lamps, Fixtures, Wiring Devices; Electric Light Bulbs; Electronic Devices