

# RADIO NEWS



APRIL  
1944  
25c



**TOO GOOD**



**JUST RIGHT**



**NOT SO GOOD**



Admit it. Like any enlightened gentleman, you too are a connoisseur when it comes to women. You can pick 'em; and no fooling. Feminine desirability we leave to you, but we do pride ourselves upon fashioning tubes "just right" for your electronic equipment.

As you know, ideal production would yield only tubes with the exact characteristics required. In practice, Hytron sets close tolerances for all characteristics, and then painstakingly controls production to hit uniformly the centers of those tolerances.

Does it seem strange that Hytron rejects not only tubes "not so good" but also "too good"? Consider a simple example. Mutual conductance is a figure of merit normally desired high. Once your circuit constants have been fixed for a standard tube, however, too great transconductance may give unstable performance.

Hytron strives, therefore, to produce for you tubes which are standardized; uniform tubes which — as originals or spares — will always be *just right* for the war-time radio and electronic applications you design.



OLDEST EXCLUSIVE MANUFACTURER OF RADIO RECEIVING TUBES

**HYTRON**  
CORPORATION

ELECTRONIC AND  
RADIO TUBES

SALEM AND NEWBURYPORT, MASS.



**BUY  
ANOTHER  
WAR BOND**

**Men NOW in Radio  
who Don't Think  
they know it ALL  
Read This**

If you're a Radio Serviceman you want to keep up with latest Radio developments, be ready to service the FM receivers, Television sets, and understand Electronic devices. You DON'T want to lose out because you lack TECHNICAL knowledge. . . . If you're an operator you don't want to be baffled by new Radio circuits, equipment. You want the EXTRA knowledge that wins promotions, extra pay. Read my message below—then MAIL COUPON!

**If You're NOT  
Working in Radio Now  
Read This**

You should begin cashing in on your interest in Radio QUICKLY—ACT NOW! The Radio repair business, a busy field because no new home and auto Radios are being made, offers more opportunities than ever to make \$50 a week in full time jobs or your own business—or to make \$5 to \$10 a week EXTRA fixing Radios in spare time. Practically all branches of Radio need Technicians or Operators or both. Find out how I train you at home—how I give you practical experience. Read my message below—then MAIL COUPON.



J. E. SMITH, President  
National Radio Institute  
30th Year of Training Men for Success in Radio

**FREE RADIO LESSON**

I will send you a FREE Lesson, "Getting Acquainted with Receiver Servicing," to show you how practical it is to train at home. It's a valuable lesson. Study it—keep it—USE it—without obligation! Tells how "Superhet" Circuits work, gives hints on Receiver Servicing, Locating Defects, Loudspeaker Repair, Gang Tuning Condenser, etc. 31 illustrations. Mail Coupon NOW for your FREE copy!

**Make Me Prove I Can Train You at Home  
to Be a RADIO TECHNICIAN or OPERATOR**

**YOU BUILD THESE AND MANY  
OTHER RADIO CIRCUITS  
WITH KITS I SUPPLY**

By the time you've conducted 60 sets of Experiments with Radio Parts I supply—have made hundreds of measurements and adjustments—you'll have had valuable PRACTICAL experience.



You build this SUPERHETERODYNE CIRCUIT containing a pre-selector, oscillator-mixer-first detector, i.f. stage, diode detector-a.v.c. stage and audio stage. It will bring in local and distant stations. Get the thrill of learning at home evenings in spare time while you put the set through fascinating tests!

You build this MEASURING INSTRUMENT yourself early in the Course, useful for practical Radio work on neighborhood Radios to pick up EXTRA spare time money. It is a vacuum tube multimeter, measures A.C., D.C. and R.F. volts, D.C. currents, resistance, receiver output.



Building this A.M. SIGNAL GENERATOR will give you valuable experience. Provides amplitude-modulated signals for test and experimental purposes.

Whether you're a beginner, or already in Radio—whether you want your own Radio business or a good Radio job—mail the Coupon for a FREE Lesson from my Radio Course. I want you to see for yourself how clear my Course is—see how it's planned to help you become a successful Radio Technician or Operator. And with this sample lesson I'll send my 64-page illustrated book, "Win Rich Rewards in Radio." It describes the many fascinating jobs Radio offers; explains my unique training method.

My method has helped many men already in Radio. Edward M. Schimke, 425 S. 21st St., Irvington, N. J., wrote: "I found I was losing both time and money in my Radio business, then I applied the knowledge gained from your Course and my business grew from a small room to an up-to-date store." It has helped hundreds of beginners, too. Here is what James E. Ryan, 119 Pebble Court, Fall River, Mass., writes: "I was working in a garage when I enrolled with N.R.I. I am now Radio Service Manager of 4 stores. My FREE book contains more than 100 letters like these from men I trained. They show that N.R.I. gives real help!"

**More Radio Technicians and Operators  
Now Make \$50 a Week Than Ever Before**

There's a big shortage of capable Radio Technicians and Operators because so many have joined the Army and Navy. Fixing Radios pays better now than for years. With new Radios out of production, fixing old sets, which were formerly traded in, adds greatly to the normal number of servicing jobs.

**Many Beginners Soon Make \$5, \$10  
a Week EXTRA in Spare Time**

The moment you enroll for my Course I start sending you EXTRA MONEY JOB SHEETS that show how to earn EXTRA money fixing Radios. Many make

\$5, \$10 a week EXTRA in spare time while still learning. I send you SIX big kits of real Radio parts. You LEARN Radio fundamentals from my lessons—PRACTICE what you learn by building typical circuits like those illustrated on this page—PROVE what you learn by interesting tests on the circuits you build.

**Extra Pay in Army, Navy, Too**

Men likely to go into military service, soldiers, sailors, marines, should mail the Coupon now! Learning Radio helps get extra rank, extra prestige, more interesting duties, HIGHER PAY. Also prepares for good Radio jobs after service ends. Over 1700 Service men now enrolled.



**Be Ready to Cash in on Good Pay Jobs  
Coming in Television, Electronics**

Broadcasting Stations, Aviation and Police Radio, and other Radio branches are scrambling for Operators and Technicians. Radio Manufacturers, now working on Government orders for Radio equipment, employ trained men. The Government too needs competent Civilian and enlisted Radio men and women. And, think of the NEW jobs that Television, Electronics and other Radio developments will open after the war.

**Mail Coupon for Free Lesson and Book**

The opportunity the war has given beginners to get started in Radio may never be repeated. So take the first step at once. Get my FREE Lesson and 64-page, illustrated book. No obligation—no salesman will call. Just mail coupon in an envelope or paste it on a penny postal.—J. E. SMITH, President, Dept. 4DR, National Radio Institute, Washington 9, D. C.

**GOOD FOR BOTH 64 PAGE BOOK FREE  
SAMPLE LESSON FREE**

J. E. SMITH, President, Dept. 4DR  
National Radio Institute, Washington 9, D. C.

Dear Mr. Smith: Mail me FREE without obligation, your Sample Lesson and 64-page book, "Win Rich Rewards in Radio," which tells about Radio's spare time and full time opportunities and tells how you train men at home to be Radio Technicians. (No salesman will call.)

I AM doing Radio Work.  I am NOT doing Radio Work.

Name..... Age.....  
Address.....  
City..... State..... 4PR



# CONTENTS

### FEATURES

Weather Maps for Radio Broadcast.....	<i>Dr. F. W. Reichelderfer</i>	21
Fundamental Optics.....	<i>Albert A. Shurkus</i>	24
Automatic Radio Compass.....	<i>Myron F. Eddy</i>	27
Wired Radio—Circuit Designs.....	<i>Rufus P. Turner</i>	29
The American Forces Network.....	<i>Kenneth R. Porter</i>	32
Loud Speaker Response Measurements.....		35
2½ Meter Transceiver for WERS....	<i>Howard A. Bowman, W6QIR</i>	38
Japan's Wireless War.....	<i>Alexander Kiralfy</i>	40
Inductive and Reactive Effects in Straight Leads....	<i>Clark Jackson</i>	42
Pentode Amplification Chart.....		45
Theory and Application of U.H.F. ....	<i>Milton S. Kiver</i>	46
Britain's Commando Communications.....	<i>H. W. Barnard</i>	48
Standard Frequency Broadcast Service.....		50
Practical Radio Course.....	<i>Alfred A. Ghirardi</i>	51
You Will Never See an Atom.....	<i>John D. Goodell</i>	53
The Saga of the Vacuum Tube.....	<i>Gerald F. J. Tyne</i>	54



COVER PHOTO  
BY RUDY ARNOLD

Combat troops operating latest type walkie-talkie. Note additional antenna sections protruding from pouch for use when greater distances of communications are required.

### DEPARTMENTS

For the Record.....		8
Spot Radio News.....	<i>Lewis Winner</i>	10
Technical Book & Bulletin Review.....		44
QTC.....	<i>Carl Coleman</i>	44
What's New in Radio.....		58
Manufacturers' Literature.....		70

WILLIAM B. ZIFF  
Publisher

B. G. DAVIS                      C. R. TIGHE  
Editor                              Ass't to Publisher

OLIVER READ, W9ETI  
Managing Editor

WM. A. STOCKLIN              R. A. WHITEMAN  
Associate Editor              Technical Editor

JOE MARTY, JR.                J. M. ECKERT  
Field Editor                      Assistant Editor

R. B. FRANK, W9JU            E. H. SEHNERT  
(on leave)                        Chief Draftsman

K. R. PORTER                    W. E. SMITH  
War Correspondent            War Photographer

S. L. CAHN                        GEORGE BERNER  
Advertising Mgr.                Advertising Director

HERMAN R. BOLLIN            H. G. STRONG  
Art Director                      Circulation Director

Copyright, 1944  
ZIFF-DAVIS PUBLISHING COMPANY  
Editorial Offices: 540 N. Michigan Ave., Chicago 11, Ill.  
Member of the Audit Bureau of Circulations

RADIO NEWS is published monthly by the Ziff-Davis Publishing Company at 540 N. Michigan Ave., Chicago, Ill. New York Office, 270 Madison Ave. Washington, D. C., Office, Earle Bldg. Special Washington Representative, Col. Harold E. Hartney, Occidental Hotel. London Editorial Representative, A. Spenser Allberry. Subscription Rates: In U. S. \$3.00 (12 issues), single copies, 25 cents; in South and Central America and U. S. Possessions, \$3.00 (12 issues); in Canada \$3.50 (12 issues), single copies 30 cents; in British Empire, \$4.00 (12 issues); all other foreign countries \$6.00 (12 issues). Subscribers should allow at least 2 weeks for change of address. All communications about subscriptions should be addressed to: Director of Circulation, 540 N. Michigan Ave., Chicago, 11, Ill. Entered as second class matter March 9, 1938, at the Post Office, Chicago, Illinois, under the Act of March 3, 1879. Entered as second class matter at the Post Office Department, Ottawa, Canada. Contributors should retain a copy of contributions. All submitted material must contain return postage. Contributions will be handled with reasonable care, but this magazine assumes no responsibility for their safety. Accepted material is subject to whatever adaptations, and revisions, including "by-line" changes, necessary to meet requirements. Payment covers all authors, contributors or contestants rights, title, and interest in and to the material accepted and will be made at our current rates upon acceptance. All photos and drawings will be considered as part of material purchased.



**WHERE SHALL I DISPOSE OF THIS, SIR?  
 — I FOUND IT TRYING TO STEAL  
 THE PLANS OF MY ECHOPHONE EC-1!**



**Echophone Model EC-1**

(Illustrated) a compact communications receiver with every necessary feature for good reception. Covers from 550 kc. to 30 mc. on three bands. Electrical band-spread on all bands. Beat frequency oscillator. Six tubes. Self-contained speaker. Operates on 115-125 volts AC or DC.



**ECHOPHONE RADIO CO., 540 N. MICHIGAN AVE., CHICAGO 11, ILL.**

# SYMBOLS OF QUALITY

**HAMILTON**  
*The Watch of Railroad Accuracy*

THE  
WALDORF  
ASTORIA

**COLT** **GOOD YEAR**

*Marshall Field & Company*

 **ALCOA**

  
**STETSON**

**NEW YORK  
CENTRAL  
SYSTEM**

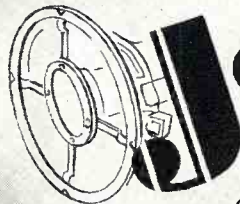
 **Jensen**

*Manufacturers and Designers of Fine Acoustic Equipment*

JENSEN RADIO MANUFACTURING COMPANY, 6601 S. LARAMIE AVE., CHICAGO 38, U. S. A.

*Serving*  
THE WORLD'S GREATEST  
AIRLINE —

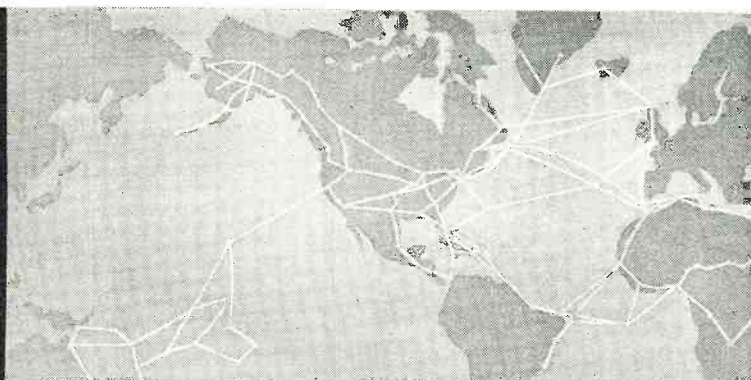

*Routes of the World's Largest Airline . . . the Army Air Forces Airways*



*Signal Corps Photo*

*Airdrome Traffic Control Tower somewhere along the lines of the Army Air Forces. Operated by the Army Airways Communications System Wing. Maintains two-way communication between airfield and aircraft.*

*Transmitter for Airport Traffic Control. ▶ Output rating 50 watts, Frequency range 116 to 126.25 megacycles.*

**Our Proudest Achievement** — A gigantic network of air routes—more than 100,000 miles of communications, landing fields and supply depots—*that's the Army Air Forces Airways.* RADIO RECEPTOR'S contribution to the equipment of the radio life-line of these airways is its proudest achievement. Developed in pre-war days . . . refined and simplified in the crucible of conflict, RADIO RECEPTOR airway and airdrome equipment will be ready, when victory comes, to doff its war paint and resume civilian dress.

**Plan Now for Victory** — Although our entire production now goes to the Army Air Forces, the Signal Corps and other war agencies, our engineers will be glad to confer with you on your plans for peace. The 6,000 new airports, estimated by the CAA as needed by the country, will require virtually the same type of equipment which is being supplied to the military services. To the thousands of municipalities planning the expansion of existing airports, or the construction of new ones, we offer our experience.

Write for our interesting, non-technical booklet, "Highways of the Air", which explains the importance of radio to aviation. Desk RN-4.

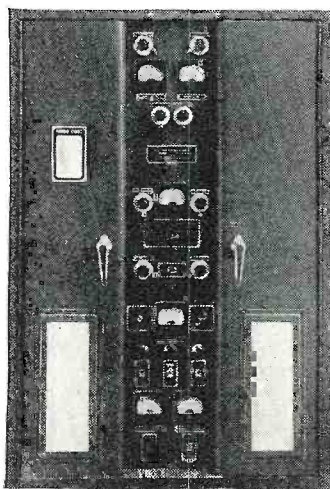

*Control Cabinet Assembly. Consists of ▶ transmitter remote control unit, loud speaker and two fixed frequency airport receivers.*



*Awarded for Meritorious Service on the Production Front.*

**SPEED THE DAY OF VICTORY  
BUY MORE WAR BONDS**

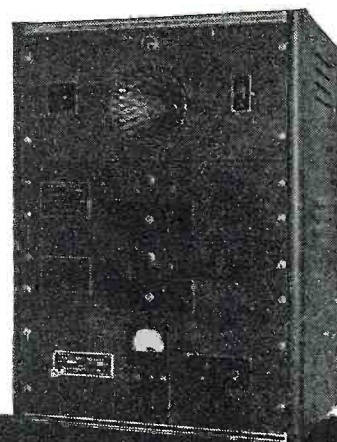

**RADIO RECEPTOR CO., INC.**

Engineers and Manufacturers of Airway and Airport Radio Equipment

251 WEST 19th STREET  
NEW YORK 11, N. Y.

S I N C E 1 9 2 2 I N R A D I O A N D E L E C T R O N I C S

RADIO CIRCUIT HINTS

# SYLVANIA SERVICEMAN SERVICE

by  
**FRANK FAX**



HERE is the third in the new Sylvania "Hints" series. "Radio Circuit Hints," now ready for distribution, is a handy reference book to consult in connection with your every-day work.

You know the importance of understanding radio circuits. The information in this 69-page book will help make your job easier.

Check the table of contents, reproduced below.

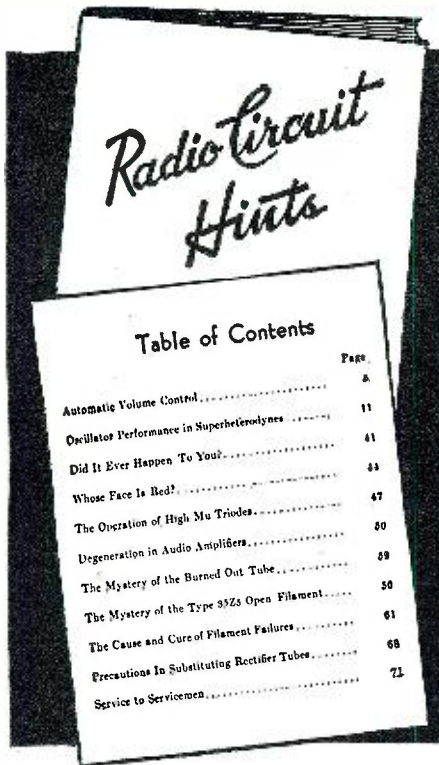

This is the third of the new Sylvania "Hints" series.

"Hints" books are FREE. If your jobber does not have copies in stock, write to: FRANK FAX, SYLVANIA, EMPORIUM, PA.

**SYLVANIA**  
ELECTRIC PRODUCTS INC.  
RADIO DIVISION • EMPORIUM, PA.

# For the Record

BY THE EDITOR

THERE is considerable undue concern on the part of many radio amateurs, manufacturers and others as to whether or not the government will see fit to restore prewar amateur channels after the conclusion of the present war. We have discussed the problem at great length with many hams, prominent manufacturers, government officials and members of the Army Signal Corps. The consensus of opinion is that proper steps have already been taken to insure sufficient channels for the present license holders and thousands of new amateurs who will join the ranks when it is again possible to resume the pursuit of the amateur radio hobby.

The Signal Corps, for example, recognizes the amateur for his true worth and is cognizant of the fact that without the backlog of thousands of these men it would not have been possible to set up a highly efficient communications system practically overnight. They realize, too, that the development of new equipment and ideas by the amateur has been of tremendous value to the war effort. Many peacetime amateurs, perhaps a physician, have contributed outstanding ideas which have developed into major improvements in military transmitting and receiving equipment. Knowing this, the Signal Corps set up laboratories where these men could continue their experiments with military cooperation. They were supplied with the necessary tools and instruments and, in many cases, were given laboratory jobs where they could work hand-in-hand with engineers on the development of new Signal Corps equipment.

Specialized training has been given to thousands of men in ultra-high-frequency technique. Many radar schools were set up and many hams have now received a very worthwhile technical background on the subject. After the war these men will be vitally interested in building transmitters and receivers for operation on the ultra-highs. Most of them will be better equipped than prewar amateurs who relied entirely upon basic circuits to guide them in the design of UHF gear. With many radio frequency channels still untapped it seems reasonable to expect that there will be considerable activity on UHF channels and that many postwar amateurs will be entirely satisfied with local "rag chews."

The FCC fully appreciates the value of the radio amateur and it is expected that they will continue to give proper consideration to amateur problems in cooperation with the ARRL. As far as

we can determine, there appears to be no cause for alarm as far as the FCC is concerned. Even though this agency is now flooded with requests for specific frequencies and channels for television, facsimile, aviation and other services, we are confident that a solution will be found whereby channels can be used to greater advantage and all services will be allotted sufficient space.

The Navy, too, has been augmented by men who have come into the Service with an amateur radio background. Many a ham holds a key job in Naval radio communications. We have talked to many of these men in Washington and at various bases and training centers and have discussed the problem at great length. In analyzing the Navy's viewpoint on the subject, there appears to be no doubt that they have already expressed their feelings that steps should be taken not only to protect *present* amateur channels but to *provide additional space* when servicemen from overseas are able to return to the air. It is no secret that our Navy has won several important sea battles with the use of radio devices. When the full story can be told, we will discover that Joe Doaks, radio operator from Podunk, Iowa, was at the controls of one of these electronic units. Hams who have become radar operators are performing a vital job in clearing the sea-lanes for the forthcoming invasion of the Japanese empire. The government certainly is aware that former hams have given the Navy a valuable adjunct to their communications system. We can't believe these men will "let the ham down."

The American radio industry, which is producing military radio equipment, includes thousands of prewar hams. They are to be found in practically every important laboratory in the country. Peacetime receivers and transmitters originally designed by them have been adapted for military use and they have contributed many improvements which have given the United States the finest radio equipment in all the world. Many of these manufacturers, recognizing the important contribution of the ham, are now demanding that full recognition be given to these "scientific wizards" as being the backbone of the communications structure.

We of RADIO NEWS are confident that Washington is fully aware of the problem and that a favorable solution will be forthcoming after V-Day. . . O.R.



# INSPECTION

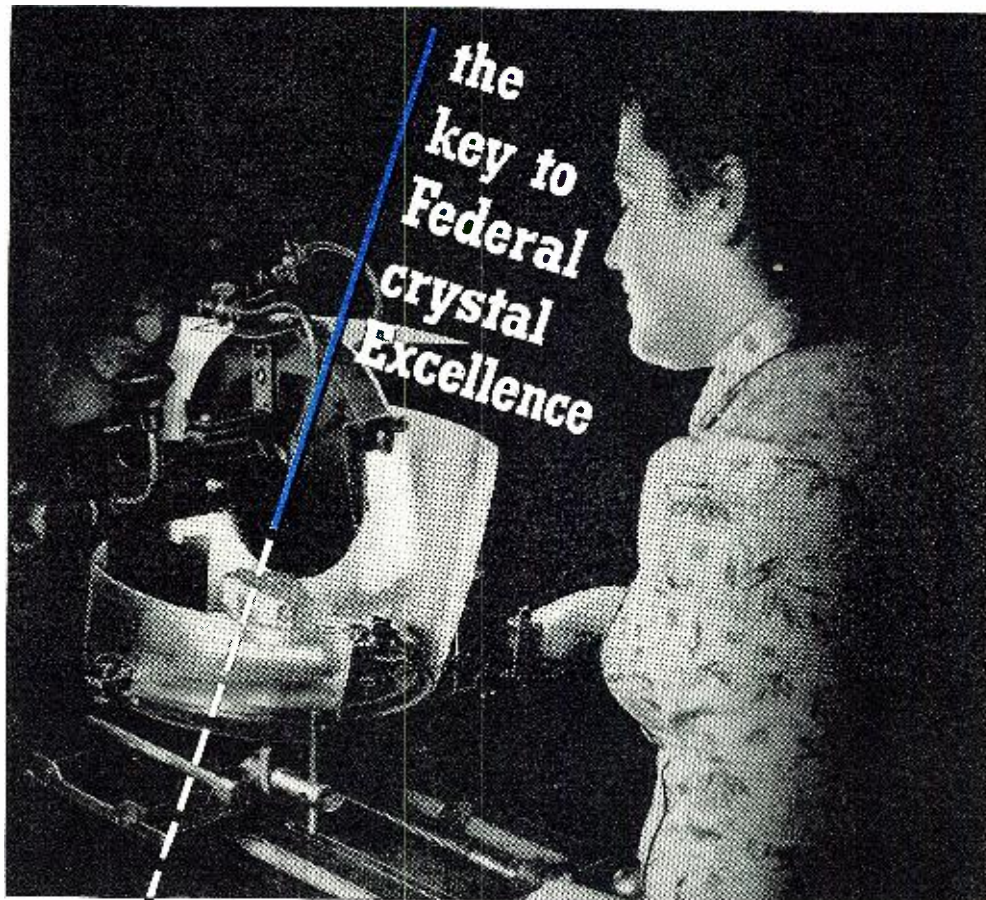

*Federal is a leading manufacturer of aerial navigation, broadcast and general communications equipment. Its outstanding contributions through the years have made the name Federal synonymous with radio development and progress.*

Key to the excellence of Federal Crystals is intensive, step-by-step inspection, geared to strict production tolerances.

And behind this painstaking process are world famous engineers, skilled technicians, highly developed precision machinery.

As a result, Federal has earned a reputation for crystals of the highest standard — crystals which are today filling a vital role in wartime radio.

Remember, Federal's comprehensive facilities can fill any crystal need . . . from the lowest frequency bar to the highest oscillator plate.

And with every crystal goes the Federal stamp of approval, an assurance of uniform performance under the most difficult operational conditions.

When it's crystals you want—call Federal.

*Federal Telephone and Radio Corporation*



Newark, N. J.

Designed for



Application

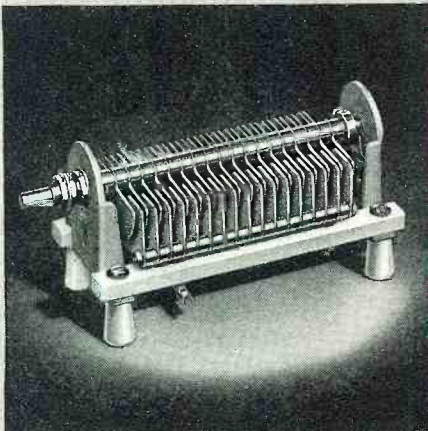

### 12000 Series

#### Transmitting Condensers

Rigid heavy channeled aluminum end-plates. Isolantite insulation, polished or plain plate edges. One piece rotor contact spring and connection lug. Compact, easy to mount with connector lugs in convenient locations "Designed for Application."

Available in standard peak voltage ratings of 3000 and 6000. Single and split stator types. Capacities up to 150 mmfd at 3000 volts.

**JAMES MILLEN  
MFG. CO., INC.**

MAIN OFFICE AND FACTORY  
**MALDEN  
MASSACHUSETTS**



By **LEWIS WINNER**

RADIO NEWS Washington Correspondent

*Presenting latest information on the Radio Industry.*

**ELECTRONIC AND RADIO EQUIPMENT** were on the plus side of the production ledger in the eighteenth monthly report of Donald M. Nelson, WPB chairman. Specifically, production on this equipment was up 4 per cent. The only other item in the increased production column was aircraft. This variation, or lack of increase for some of the projects, reflects the fact that, in the main, the war production program for some of the material has reached high gear and is settling down for a long pull, while radio and aircraft production activities are still being expanded.

According to this report, 1944 will present new problems to the expanding programs of the radio and electronic industries. The report also goes on to say that during December, signal equipment showed a 4 per cent over-all increase in output over November. The 1943 production of radio equipment jumped more than 110 per cent over 1942. Production in 1943 emphasized airborne equipment. And in 1944 this emphasis will increase, as a 35 per cent increase in production is being scheduled for the signal equipment program.

Radio's role in the war effort was also stressed in Secretary of the Interior Harold L. Ickes' annual report to President Roosevelt. The report showed that millions of radio insulators were processed in a departmental laboratory to speed the manufacture of communications equipment. Other specialized work of this nature was also a consideration of the department. In commenting on this extended policy, Mr. Ickes said, "We are not remote from the working and fighting fronts of this world. Our key men are on the scene of action in all the fields into which our jurisdiction extends. . . . Some of our scientists go directly to the front in the course of this work."

**THE FREQUENCY MODULATION BROADCASTERS** held their annual meeting in New York, in a two-day session which preceded the IRE meeting. And here, too, the attendance broke records, for over six-hundred registered.

The guest of honor, Major Edwin H. Armstrong, inventor of the wide-swing FM system, presided at an afternoon session discussing the birth of frequency modulation and its evolution to its present format. He emphasized the need for FM band expansion, cit-

ing that another thirty channels are required.

FCC Chairman James Lawrence Fly discussed the virtues of FM during a luncheon session, pointing out that frequency modulation is of age and it will have a place of ever increasing importance in American broadcasting.

One of the highlights of the meeting was a surprise message from President Roosevelt. The message read, "Please convey my good wishes to all the broadcasters who are assembled to plan the future of frequency modulation broadcasting in this country. . . . The development of frequency modulation to the point where it affords the basis for a broader and improved broadcasting service to the people of this country represents another forward stride in the development of the highly useful art of radio. So long as our competent scientists in the radio industry are on the job, we can rest assured that this Nation will continue to lead in the advance of this science which is so vital to the country and to the world at large. . . . It is my fervent and confident hope that the broadcasters of this country will keep step with the advancing science and will continue to lift radio broadcasting to ever higher planes of public service."

Representatives of leading FM manufacturers also appeared, discussing their postwar FM receiver and transmitter plans. Speaking for General Electric, I. R. David said that his company anticipates manufacture of five-million FM receivers during the first full year of postwar production to help meet an estimated national need of approximately twenty-five million receivers of all types. F. R. Lack, who was head of ANEPA and has now returned to Western Electric, cited that Western Electric has thus far manufactured over \$129,000,000 worth of FM equipment for the Armed Forces.

At a round table session presided over by Philip G. Loucks, FMBI counsel; E. K. Jett, FCC chief engineer; George Adair, FCC assistant chief engineer; C. M. Jansky, Jr., FMBI technical advisor; Walter J. Damm, FMBI president; Major Edwin H. Armstrong; John Shepard, 3rd, president of FM's American Network; and Commander Paul A. DeMars, U.S.N., formerly chief engineer of the Yankee Network, dozens of questions from prospective FM users were answered. The questions ranged from the technical qualities of FM transmission to

**RADIO NEWS**

# SOLAR CAPACITORS ADD

*Quality Above All*

## TO WAR EQUIPMENT

The collage features five overlapping pages from the Solar Capacitors Catalog 12:

- Top Left:** A photograph of a large capacitor with two terminals. Below it is the heading "TYPE XJ HIGH VOLTAGE FILTER CAPACITORS" and a technical description.
- Top Center:** A page titled "PAPER CAPACITORS RECTANGULAR METAL CONTAINERS" with a table of specifications for "TYPE XJ" capacitors.
- Top Right:** A page titled "DRY ELECTROLYTIC CAPACITORS ROUND METAL CONTAINERS" with a table of specifications for "TYPE DI" capacitors.
- Bottom Left:** A photograph of a cylindrical capacitor. Below it is the heading "TYPE XP SERIES" and a technical description.
- Bottom Center:** A page titled "MICA CAPACITORS TRANSMITTING TYPE XZ" with a table of specifications for various capacitor models.

**160 PAGE CATALOG  
FREE**

*A request on your letterhead will bring you Catalog 12 showing the full line of Solar Capacitors.*



**MANUFACTURING CORPORATION**  
285 MADISON AVENUE • NEW YORK 17, N. Y.

CAPACITORS and RADIO NOISE-SUPPRESSION FILTERS

Ⓜ 5218

April, 1944

11

**GOOD  
MECHANICS  
LIKE  
WALDEN  
WORCESTER  
TOOLS**

*Ask Your Jobber*  
*Send for Catalog*

**STEVENS WALDEN, INC.**  
465 SHREWSBURY STREET  
WORCESTER, MASSACHUSETTS

its economic properties. In a question on FM transmitter costs, C. M. Jansky, Jr., pointed out that a one-kilowatt transmitter would cost around \$20,000, while a fifty-kilowatt unit might cost around \$120,000. FM transmitters having up to five-kilowatts power were a bit more expensive than AM transmitters, he said. Above that, however, he explained, FM transmitters are cheaper.

Many of the interesting engineering facts presented by C. M. Jansky, Jr., earlier in the session were reviewed at this round table discussion. For instance, Mr. Jansky pointed out that the AM allocation structure consists of one-hundred and six channels, while the FM allocation structure consists of but forty channels. He said also that around fifty-thousand kilocycles, in which the FM band was included, waves travel outward in all directions to distances two or three times line of sight, that is 20, 50, 100 miles, and sometimes further. He emphasized the point that FM stations have substantially the same coverage areas day and night, which is in contrast to the wave propagation characteristics in the 550 to 1600 kc. AM band. He also analyzed the power required for both types of transmission. He said that it takes approximately 2500 times as much power at an AM station to deliver clear reception at a given receiving point, as it would for an FM station operating on the same frequency at the same place. In discussing the noise and interference problem, he said that a one-fifth kilowatt FM station is the equivalent of five-hundred kilowatts on an AM station on the same channel!

**LUDWIG ARNSON**, pioneer radio engineer, has received the Marconi Memorial Medal of Achievement. The award reflects forty years of undivided service to the cause of radio communications development.



In as typical a success story as anywhere in the American saga, Arnson pioneered the development of much present-day equipment, and associated himself with such stalwarts of the industry as Guglielmo Marconi and David Sarnoff.

**THAT VITAL PIECE OF RADIO LEGISLATION**, the White-Wheeler Bill, is still (at this writing) in the rewriting stage, with the Senate Interstate Commerce Committee staff in charge of the rewriting. The Committee has studied the voluminous testimony offered, and expects to include many of the changes proposed.

During the last hearings on this bill, E. K. Jett, the new FCC commissioner, provided some "food for thought." He said that there are fifty distinct branches of communications to be considered in the act. This presents

a tremendous problem, particularly in the postwar era when the demand for frequencies will be intense. He said that there may be many problems facing the Communications Commission which might perhaps require fundamental determination of policy by Congress. He cited also the FM and television problems, that were analyzed in his paper before the AIRE group. He pointed out the interference problems that exist in broadcasting which must be considered. The problem of multi-path signals that appear as ghosts on a television screen is a problem of frequency allocation that requires study, he said.

In commenting on the proposed legislation, co-author Senator Wheeler stated that when the bill is finally a law, there should be no doubts as to interpretation of the terms . . . public interest, convenience and necessity. He said that he was fully aware of the peculiarities of the problems of the broadcast industry. "No two broadcasters think alike," he said. He based this opinion on the fact that the industry is composed of all kinds of business men . . . showmen, industrialists, administrators, and so on. "Notwithstanding these vagaries," he said, "the American system of broadcasting will come out on top."

Among the measure's changes that are being considered are those providing for a rotation of the chairmanship annually, provision of a system of fining (\$500 a day, proposed fine) covering violations of regulations which might not warrant revocation proceedings, and an expansion of the limitations imposed on FCC's over-all jurisdiction.

The original form of the bill proposed separation of the Commission into two divisions; one for common carrier and one for broadcasting and affiliated services, with a chairman for each division. The chairman of the FCC would be executive officer over both divisions with, however, no assigned duties for either division.

It is expected that Congress will probably act upon the new bill shortly after this column appears.

**TWO PROPOSED RULINGS BY THE FCC** covering network recordings and the publicizing of broadcast station business records, have not been accepted too cordially by many broadcasters or legislators. The new recording ruling, which is officially identified as Section 3.409, would require that every radio program broadcast over a regional or national network be recorded by the station at which the program originates, unless the program is itself a transcription. And under this rule, the originating station would be required to retain the transcription for one year. This proposed rule does not require stations to record local or non-network programs.

Network officials have indicated that during peacetime they always recorded all programs, but due to the shortage of equipment, material and manpower, it was necessary to dis-

# HERE'S YOUR SUCCESS CHANCE

BE A

# RADIO-ELECTRONIC TECHNICIAN!

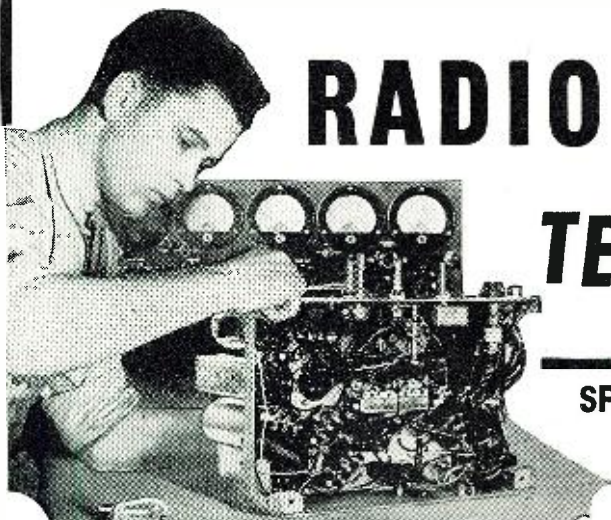

**SPRAYBERRY TRAINS YOU  
QUICKLY FOR WAR  
AND PEACETIME WORK**

**IF YOU REMAIN A  
CIVILIAN OR ENTER  
MILITARY SERVICE . . .**

**Radio Training Will  
Enhance Your Future!**

**•READ THESE LETTERS.**

**One Job Nets About \$26.00**

"Since last week I fixed 7 radios, all good-paying jobs and right now I am working on an amplifier system. This job alone will net me about \$26.00. As long as my work keeps coming in this way, I have only one word to say and that is 'Thanks to my Sprayberry training' and I am not afraid to boast about it."—ADRIEN BENJAMIN, North Grosvenordale, Conn.

**Sprayberry Graduate Wins  
Out in Army Test**

"Since I completed your elegant Course in Radio I have been drafted into the Army and put into the Signal Corps. I had to compete to get the job I now hold and as a result of my training with you, I made the best grade and got the job. The point I am driving at is if it hadn't been for your thorough course in Radio I would probably be peeling potatoes now. I recommend your training to all because it is written in language that the average layman can understand."—ARCH PLUMMER, JR., Fort Meade, Md.

**Student Makes \$15.00 to \$20.00  
A Week in Spare Time**

"After starting your Course I began doing minor radio service jobs and I want to say that I have been flooded with work. So much so that I have had to neglect my lessons. I want to say your training has done a great deal for me. I am making \$15.00 to \$20.00 a week in spare time. Even so, I'm going to go back to my studies and finish the Course."—SANFORD J. CHICOINE, Whitler, Ontario, Canada.

**You Do Practice-Giving Experiments  
with Real Equipment**

The offer I make you here is the opportunity of a lifetime. It's your big chance to get ready for a wonderful future in the swiftly expanding field of Radio-Electronics INCLUDING Radio, Television, Frequency Modulation, and Industrial Electronics. Be wise! NOW is the time to start. No previous experience is necessary. The Sprayberry course is short, intensive, and interesting. It starts right at the beginning of Radio. You can't get lost. It gets the various subjects across in such a clear, simple way that you understand and remember.

**You Get a Dual-Purpose  
Radio Set**

I supply you with Radio Parts which you use to gain pre-experience in Repair work. These same Parts are used for testing and for Signal Tracing, etc. I make it easy for you to learn Radio Set Repair and Installation Work . . . by practical, proved, time tested methods. I teach you how to install and repair Electronic Equipment. Your success is my full responsibility.



**Prepares You for a Business of Your Own . . . or  
Good Radio Jobs**

My training will give you the broad fundamental principles so necessary as a background no matter what branch of Radio you wish to specialize in. Soon you'll be qualified for a good paying job in one of the nation's Radio plants doing war work OR a business of your own. If you enter the Army, Navy, or Marines, my training will help you win higher rating and better pay. Let me prove what Sprayberry training can do for you.

**EASY TO START . . .**

Remember it is not necessary for a Sprayberry student to have any previous experience in the field of Radio. You can master the Course in your spare time. It will not interfere in any way with your present duties. Along with your Training, you will receive my famous Business Builders which can bring you in a nice profit shortly after you begin my Course.

**DON'T  
PUT  
IT OFF!**

**GET FREE BOOK**



Get the facts about my training—now! Take the first important step toward the money-making of your dreams. All features are fully explained in my big, illustrated free book. Write for it at once.

SPRAYBERRY ACADEMY OF RADIO  
F. L. Sprayberry, Pres.  
Box 500WD  
Pueblo, Colorado.

Please rush my FREE copy of "HOW TO MAKE MONEY IN RADIO, ELECTRONICS and TELEVISION."

Name . . . . . Age . . . . .

Address . . . . .

City . . . . . State . . . . .

Tear off this coupon, mail in envelope or paste on penny postcard.

**NOW! BECOME A MONEY-MAKING RADIO SPECIALIST**

# Are You Letting Others By-Pass You



**to a Better Job, Greater Pay  
and a Secure Peace-Time Future  
in Radio-Electronics?**

**Others Are Training Now with  
CREI to Prepare for Secure  
Engineering Jobs in  
Radio-Electronics After the War!**

In December and January, CREI received from students the greatest number of lessons for grading in the history of the school.

### What does this mean to you?

It means that more men than ever before realize the great opportunities that await technically-trained men. It means that they are investing a small portion of their present-day earnings in training for post-war job security.

### Competition will be keen!

JOBS THAT PROVIDE SECURITY—jobs that will mean something long after "tomorrow" has come and gone—must be won and HELD on ability. The men who will RETAIN the important radio engineering positions after the war is over are those men whose positions are essential—whose ABILITIES are specialized.

**CREI HOME-STUDY COURSES** in Practical Radio Engineering have been studied by more than 8,000 professional radiomen. Today, hundreds of ambitious men, just like yourself, are taking our specialized spare-time training to give them the technical skill to supplement their present ability . . . to earn a better living . . . and to create a secure place for themselves in the great post-war world of radio-electronics.

**DON'T SAY YOU HAVEN'T THE TIME.** CREI courses are designed to be studied in the most crowded schedules. You can study a few hours a week without interfering with your present work. So, write for all the facts now—for this is the time to make sure that your preparation for post-war success shall not be "too little, too late!"

### • WRITE FOR FREE 32-PAGE BOOKLET

If you have had professional or amateur radio experience and want to make more money—let us prove to you we have something you need to qualify for a better radio job. To help us intelligently answer your inquiry—PLEASE STATE BRIEFLY YOUR BACKGROUND OF EXPERIENCE, EDUCATION AND PRESENT POSITION.



## CAPITOL RADIO ENGINEERING INSTITUTE

Home Study Courses in Practical Radio  
Engineering for Professional Self-Improvement

Dept. RN-4, 3224—16th Street, N. W.  
WASHINGTON 10, D. C.

Contractors to U. S. Navy—U. S. Coast Guard—  
Canadian Broadcasting Corp.—Producers of Well-  
trained Technical Radiomen for Industry

pense with this practice. This war-time procedure was approved by government officials. Speeches of most commentators and public speakers are, however, still being recorded, they said. Many of these officials say that they are therefore a bit puzzled about this new proposal.

The FCC implies that it is necessary to have a permanent record of network broadcasts for reference purposes.

The second ruling, FCC Order No. 118, provides for an inspection of all broadcasting business transactions except, of course, station financial affairs. This order is an amendment to the FCC Rules of Practice and Procedure relating to inspection of records, and is said to be based on the decision made in the recent Supreme Court ruling of Justice Frankfurter.

Both proposed rulings were argued before the FCC at special sessions. In a few weeks the decisions should be known.

**TWENTY THOUSAND EMPLOYEES AND EXECUTIVES** of Chicago's half a hundred radio and radar manufacturing plants saw Miss Dorothy Crisp, solderer on the assembly line of American Phenolic Corporation, crowned the Chicago Radio-Radar Queen, at a huge rally last month in the Chicago Stadium.

This ceremony was the high spot in the drive of the industry for more women employes. The attendance was big in spite of the final blasts of a twenty-four hour blizzard and near-zero temperature.

For the background of the main event of the evening, the choosing and crowning of the queen, the industry's committee had a program of entertainment by a group of headline radio, stage and screen stars.

**THE RADIO CLUB OF AMERICA, INC.**, founded in 1909, has announced its newly-elected officers for 1944, as follows:

President, F. L. Klingenschmitt, Amy, Aceves & King, Inc.; Vice President, O. James Morelock, Weston Electrical Instrument Corp.; Treasurer, J. J. Stanley, Continental Sales Company; Corresponding Secretary, M. B. Sleeper, FM Radio-Electronics Magazine; and Recording Secretary, J. H. Bose, Engineer connected with Major E. H. Armstrong at Columbia University.

The new president stated: "It is interesting to note that even though the stress of the times is keeping everyone in the radio industry actively engaged, the prospects of future technical papers to be given before the club looks very good."

**THE SECOND WAR CONFERENCE** of the National Electric Wholesalers Association will be held at the Stevens Hotel, Chicago, Illinois, April 19th through April 22nd, 1944. This will be the Association's Thirty-sixth Annual Meeting.

The War Conference will include a complete review of the membership's participation in the many phases of the war program served by their numerous houses. The present status of Government regulations and orders affecting electrical wholesaling will be considered, as well as the probable changes in prospect.

Postwar plans for electrical wholesalers and appliance distributors will be featured in the report of the Postwar Planning Committee. That Committee, headed by Mr. Herbert Metz, General Lamp and Lighting Sales Manager of Graybar Electric Co., Inc., New York City, has conducted several outstanding forum meetings since its appointment at Buffalo, New York, last May. Its report at Chicago will be a noteworthy one.

By the time the Conference opens, many developments will probably have occurred which will have some direct bearing on reconversion plans. The War Conference will give that subject ample attention from the standpoint of distribution.

The Program Committee is arranging for the appearance of outstanding business leaders to address the Conference.

Attendance at N.E.W.A. Conferences is always large and from practically every important marketing center of the country. In view of the extremely important times ahead, it is expected that all previous attendance records will be exceeded at the Chicago Conference.

**MEMBERS OF THE ARMED SERVICES**, particularly those in the Signal Corps, will be interested in a cash prize contest now being conducted by The Hallicrafters Company, 2611 South Indiana Avenue, Chicago, Illinois, to get firsthand information on the performance of the SCR 299 mobile radio units. Many of the hundreds of letters received have enabled the manufacturer to further improve upon the operating efficiency of this versatile communications unit. First prize of \$100 is offered each month for the best letter received giving performance data and constructive criticisms. Improvements in later models now being used on all fighting fronts have been made possible by some of the suggestions contained in letters received when the contest first opened. All servicemen are invited to participate. Complete details and rules may

(Continued on page 120)



# Designed for *urgent* **PRODUCTION SCHEDULES**

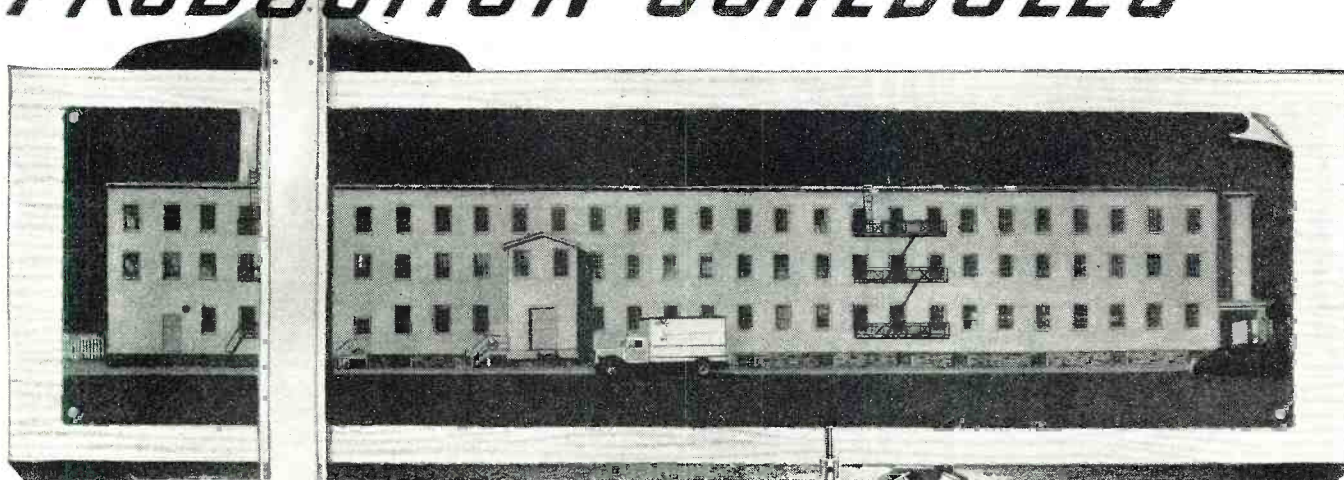

## THIS

is the new ARHCO plant. Incorporating more than 60,000 square feet of space, it was planned and designed for today's urgent production schedules. Marking another milestone in our successful 21-year growth, it provides even better facilities for research, engineering, manufacturing and delivery.

Out of this new ARHCO plant come over two thousand individual components . . . each one doing a big job in radionic and industrial applications. Moreover, we are equipped to produce special parts from your blueprints. Quotations and advice furnished upon request.

***Put more dollars to work . . . tell the Boys  
 you mean it by buying more War Bonds today***

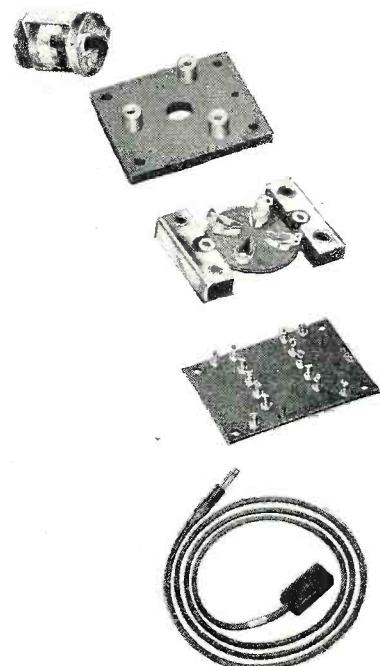

*American Radio Hardware Co., Inc.*  
 152 MACQUESTEN PARKWAY SOUTH • MT. VERNON, NEW YORK  
 MANUFACTURERS OF SHORT WAVE • TELEVISION • RADIO • SOUND EQUIPMENT

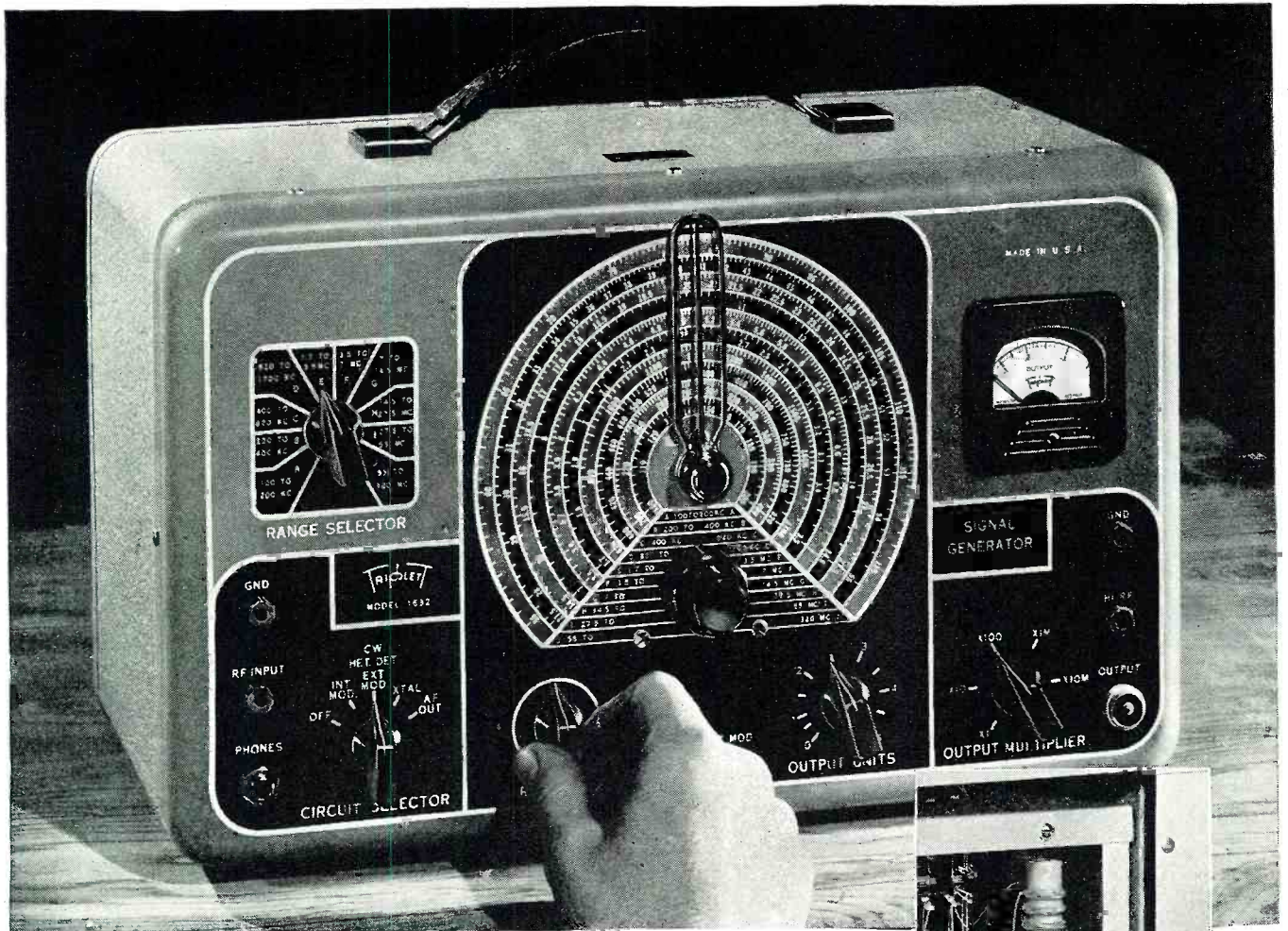

MODEL NO. 1632

# Signal Generator

CONTINUOUS COVERAGE—100 KC. TO 120 MC. • ALL FREQUENCIES FUNDAMENTALS

A complete wide-range Signal Generator in keeping with the broader requirements of today's testing. Model 1632 offers accuracy and stability, beyond anything heretofore demanded in the test field, plus the new high frequencies for frequency modulated and television receivers, required for post-war servicing. Top-quality engineering and construction throughout in keeping with the pledge of satisfaction represented by the familiar Triplet trademark.

Of course today's production of this and other models go for war needs, but you will find the complete Triplet line the answer to your problems when you add to your post-war equipment.

# Triplet

ELECTRICAL  
BLUFFTON



INSTRUMENT CO.  
OHIO \*\*\*

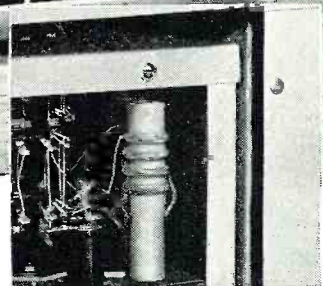

- Triple shielding throughout, Steel outer case, steel inner case, plus copper plating.

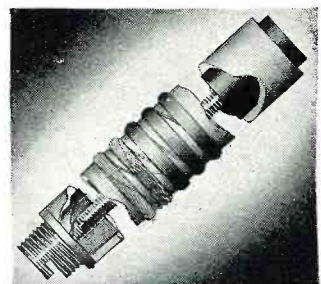

- All coils permeability tuned. Litz wire wound impregnated against humidity with "high-Q" cement.

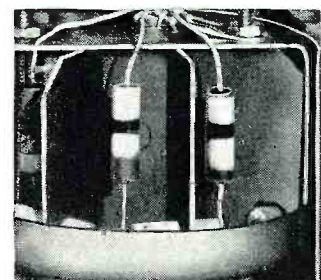

- Note sections individually shielded with pure copper. Entire unit encased in aluminum shield.





*Goin' Places!—*

## THANKS TO RADIO

This is one sneak raid that backfired—that ended where the only "good" Japs are found—because *radio* gave a warning . . . *radio* guided our interceptors . . . *radio* played its usual major part in the engagement. That's *radio* today. Tomorrow, this wartime "know how" will be applied to the creation and production of new FADA Radios with undreamed-of standards of beauty, faithfulness, performance and durability.

PLACE YOUR FAITH IN THE

**FADA**  
*Radio*

OF THE FUTURE

*Famous Since Broadcasting Began!*

**FADA RADIO AND ELECTRIC COMPANY, INC., LONG ISLAND CITY, N. Y.**

# Does Your Product Require . . . **MORE COMPACT RESISTORS?**



The war has proven the importance of compactness in radio, electronic and electrical equipment. Unquestionably the dimensions of many post-war products will reflect the studies that have been made to conserve space. More compact components developed for the war will find great demand for peace-time users.

The Ward Leonard Strip Type Resistor is a typical example. Its flat section permits installation in places where there is not room for a round section resistor of the same value. Other regular Ward Leonard Resistors are available for special purposes.

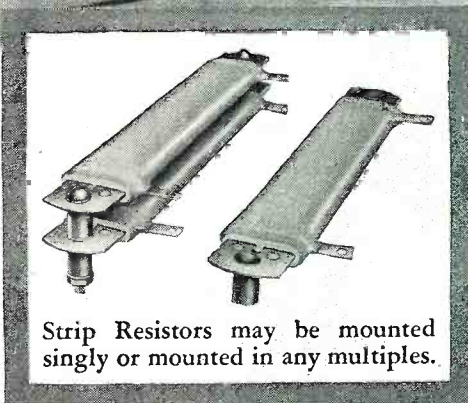

Strip Resistors may be mounted singly or mounted in any multiples.

*The Ward Leonard Resistor Catalog shows resistors of various types, terminals, mountings, enclosures, and resistance values. Send for it.*

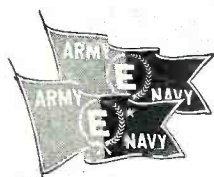

## **WARD LEONARD**

### **RELAYS • RESISTORS • RHEOSTATS**

Electric control  devices since 1892.

**WARD LEONARD ELECTRIC COMPANY, 32 SOUTH STREET, MOUNT VERNON, N. Y.**

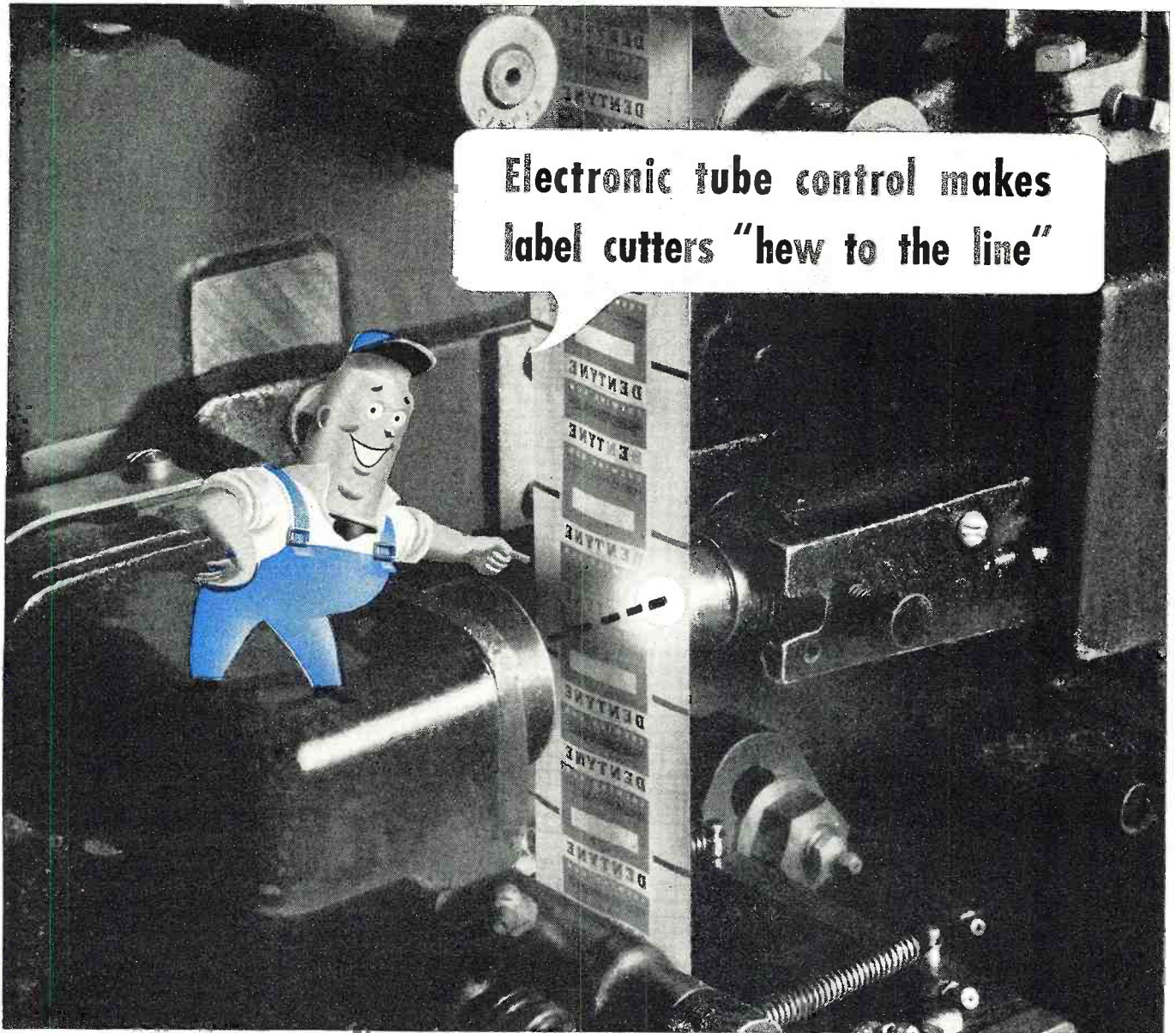

Electronic tube control makes label cutters "hew to the line"



The G-E phototube and G-E thyratron are the electronic tubes used in synchronizing the operation of this packaging machine.

Here the G-E phototube is being used in a photo-electric relay control—to eliminate cumulative errors in label-cutting register caused by slippage, shrinkage or stretching of paper. It makes possible the use of a continuous web of paper (instead of individual pre-cut sheets) with complete accuracy.

As the web rolls through the processing machine, the phototube scans the margin for the register marks, and—in co-operation with the thyratron tube—

gives the command to "CUT" at precisely the right instant. (Subsequent operations of the machine wrap and package the individual sticks of gum.)

The G-E phototube is exceptionally versatile. It can operate with transmitted or reflected light; on transparent, opaque, dull, glossy, shiny, or colored material. . . . Its applications in counting, sorting, and inspection jobs are unlimited.

The phototube is only one of a complete line of G-E electronic tubes now

working for industry on innumerable jobs and many kinds of machinery. It is the purpose of G-E electronic tube engineers to aid any manufacturer of electronic devices in the application of tubes. Through its nation-wide distributing system, General Electric is also prepared to supply users of electronic devices with replacement tubes.

**"HOW ELECTRONIC TUBES WORK"**

This booklet will be mailed to you *without charge*. Its 24 pages are interestingly illustrated and written in easily understood language. Shows typical electronic tubes and their applications. Address *Electronics Department, General Electric, Schenectady, N. Y.*

• Tune in "The World Today" and hear the news direct from the men who see it happen, every evening except Sunday at 6:45 E.W.T. over CBS. On Sunday listen to the G-E "All Girl Orchestra" at 10 P.M. E.W.T. over NBC.

G.E. HAS MADE MORE BASIC ELECTRONIC TUBE DEVELOPMENTS THAN ANY OTHER MANUFACTURER

**GENERAL  ELECTRIC**

162-C3

# SEARCH <sup>AND</sup> RE-SEARCH

Years of engineering research are responsible for

the many well known Hammarlund marine type

variable condensers, which are now playing such

a vital role in the search for

enemy ships over the seven seas.

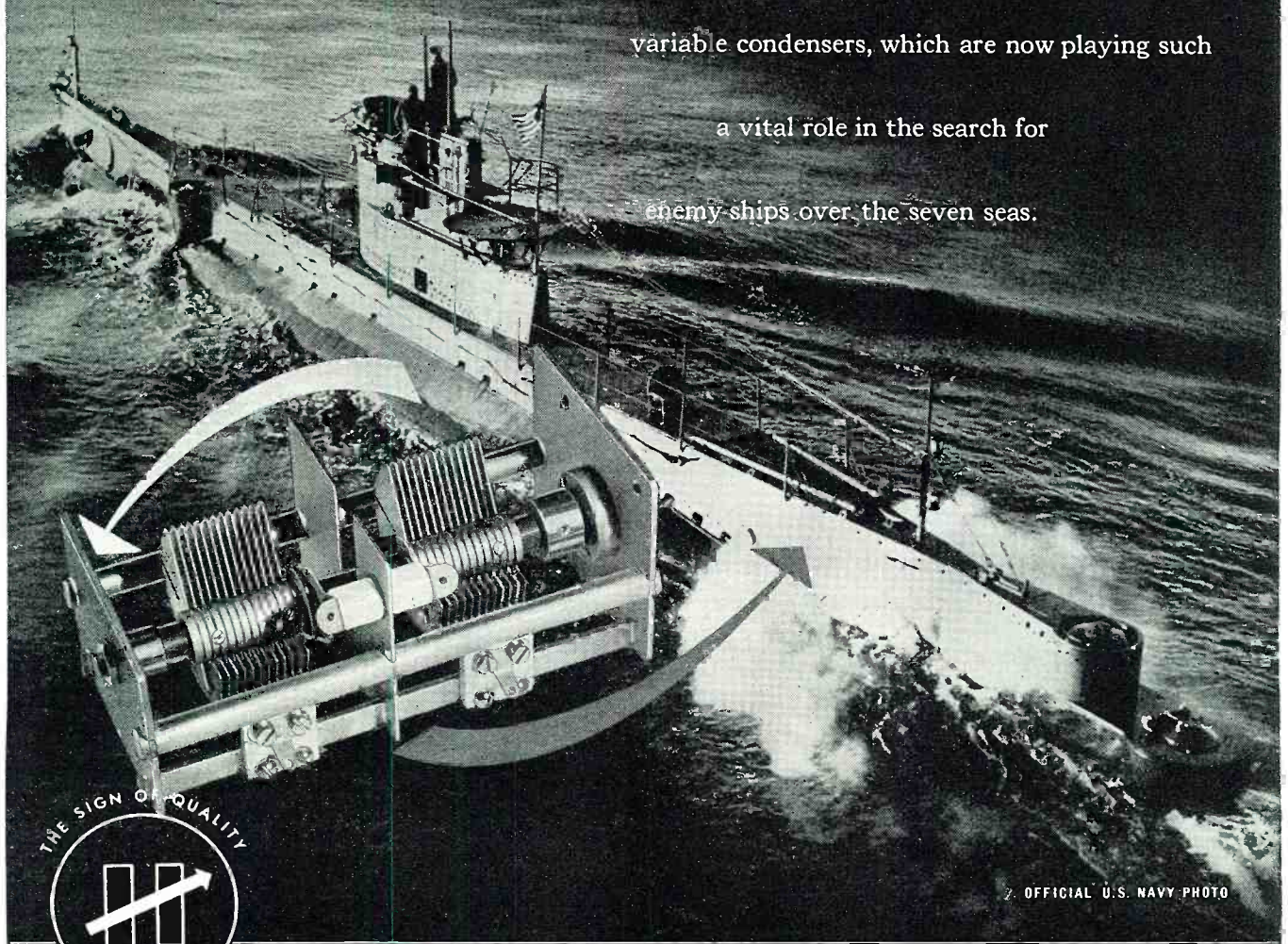

2. OFFICIAL U.S. NAVY PHOTO

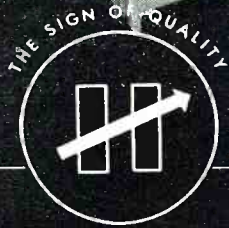

ESTABLISHED 1910

**THE HAMMARLUND MFG. CO., INC., 460 W. 34<sup>TH</sup> ST., N.Y.C.**  
MANUFACTURERS OF PRECISION COMMUNICATIONS EQUIPMENT

# WEATHER MAPS FOR RADIO BROADCAST

By **Dr. F. W. REICHELDERFER**

Chief, U. S. Weather Bureau

**Developments in weather mapping for broadcasting up-to-the-minute weather reports to postwar public.**

*EDITOR'S NOTE: The Chief of the Weather Bureau and his assistants in the Synoptic Reports and Forecasts Division describe some extraordinary weather-mapping developments of the war. Communications are the life-blood of meteorology and weather forecasting. Twenty years ago, simple weather maps were transmitted by radio and recorded on shipboard. Modern weather maps are far more accurate and detailed; they include a great deal of information as to what is going on in the atmosphere far above the earth's surface. These latter reports are secured by means of radiosonde equipment, which record and transmit the weather back to the ground station. Twice a day these units are carried aloft on small, free balloons from about 45 places in the United States. All of this information is quickly analyzed, charted and included in the "canned weather map" described herein.*

▶ **TUNING** in the morning weather map on one's own radio set at home or in the office may be an every-day occurrence for hundreds of thousands of people throughout the country after the war, when already existing facilities can be made available to the public. Specialists of the United States Weather Bureau, one step ahead of developments in communications, are prepared for the day when a complete and accurate weather map will be a regular part of the "Radio Print" broadcast which will be featured by all radio networks. Meteorologists and technicians have cooperated in the effort to develop this new public service. The Weather Bureau's part of the job is completed; the mapping system is ready and the maps can be made ready to go as soon as the communications problems are solved.

Before the war a small and very simple weather map, specially prepared by the Weather Bureau for wirephoto distribution, was carried by many of the larger daily newspapers.

These little maps were studied by hundreds of thousands of newspaper readers in the United States every day as a guide by which to form some sort of judgment of their own, with the aid of the Bureau's forecast in the paper. Maps of the future can be far more detailed than those pre-war charts, and may be recorded along with news bulletins, cartoons, and illustrated advertisements on a radio receiver, which, under mass production, is expected to sell for a price within the reach of anyone now able to buy an inexpensive radio set.

One of the marvelous technical achievements of the war, which is no longer buried with military secrets, is the Weather Bureau's central map system. Shortly after Pearl Harbor, weather was recognized as a factor of

→  
Inflated balloon of radiosonde, carrying parachute, instrument box, and trailing antenna. Small box contains instruments for recording temperature, pressure, and humidity. Automatic radio equipment sends information to a ground receiver.



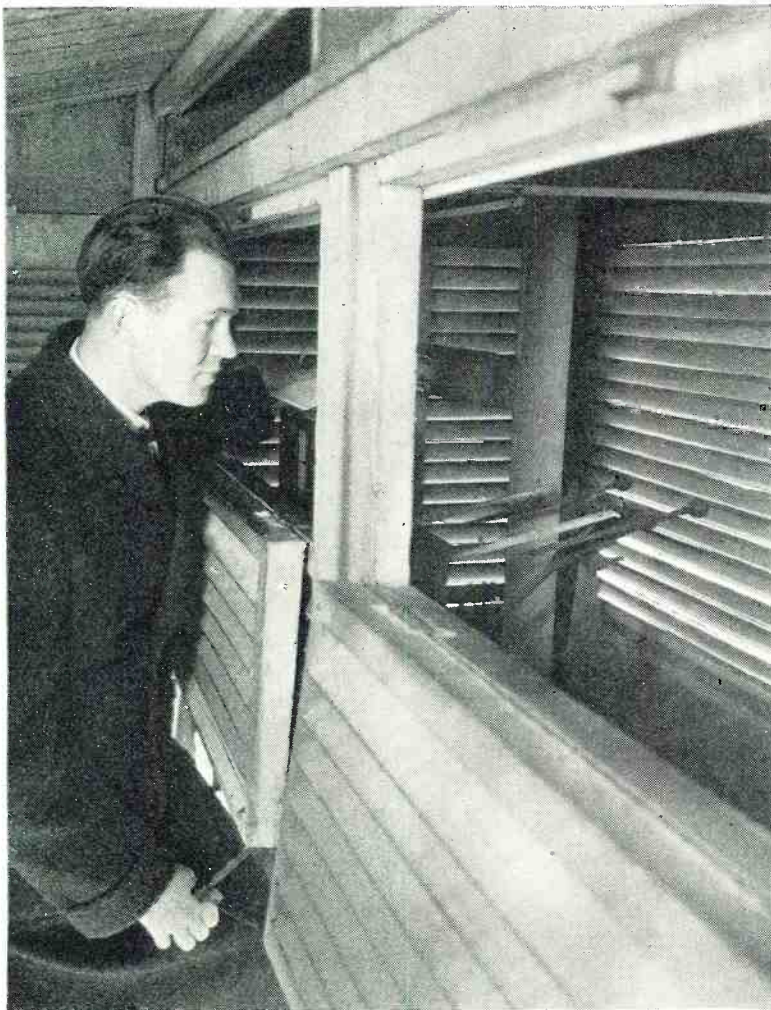

Weather observer reading instruments at one of 800 reporting stations.



Plotting coded surface and upper air reports.

extreme importance in the war, and there was a demand from our Armed Forces for the fastest possible weather map service. Maps far more detailed and technical than those of past years were required and speed was the essence in preparation and distribution. The technicians of the Bureau, aided by special funds provided by Congress, developed this map service to meet these requirements, and had the system organized in time to go into operation in February, 1942.

At the present time this master map service operates on schedule four times a day over 26,000 miles of teletype circuits in the United States, including the primary circuit operated by the Civil Aeronautics Administration and numerous connecting lines to Army and Navy base weather stations and Weather Bureau offices.

This is the fastest weather map service in the world. The records of transmission time will give some idea of the amazing speed attained by this service. Prior to the war, the weather of the United States was analyzed, and the master map was completed and transmitted on the teletype circuits approximately 4½ hours after the time the weather observations were taken at various points over the United States. By the new system a more extensive, more detailed, and

more accurate map goes on the teletype circuits approximately one hour and a half after the observations are taken.

This reduction in time was accomplished by rearranging the weather-collecting circuits and by the organization of a unique office in Washington made up of specialists, including a selection of the Bureau's most expert weather analysts. In this unit, a complete weather map of the United States is prepared every three hours. At the end of each 6 hours, a master weather map of the United States is prepared in five sections. A separate small group of specialists works on each of these sections. When they are finished, the five parts of the map are pushed together like the parts of a jigsaw puzzle, the master analyst gives it the finishing touches, and the map is ready for distribution.

It was at this stage that the Weather Bureau had planned to photograph the map and send it over the radio by facsimile, or some other radiophoto or wirephoto process. However, the required telephoto facilities were not available. When it became necessary in February, 1942, to distribute this map over the United States to Weather Bureau offices and Army and Navy bases and stations, the technicians in the Weather Bu-

reau had to devise another system for distributing the map. The Bureau's code experts solved the problem. They devised a method of transmitting the map in a numeral code. This system proved to be highly satisfactory and is being used today.

As the master analyst puts the finishing touches on the nation-wide weather map which has been assembled from the five individually prepared sections, a coder transposes the lines and points on the chart into a numeral system. At the same time a checker decodes these figures and plots the data on a blank chart as rapidly as the work progresses. In twenty minutes the map has been completely transposed to numerals and the master analyst has a check map in front of him to show that every office in the United States receiving these numerals will be able to transpose the message, already recorded on their teletype receivers, into a correct picture of the weather over the United States. This message in numeral form is commonly known as a "canned map."

Each map is made up of reports from more than 500 airway stations, and more than 300 reports from regular weather observing stations in the United States.

Many of these stations observe and

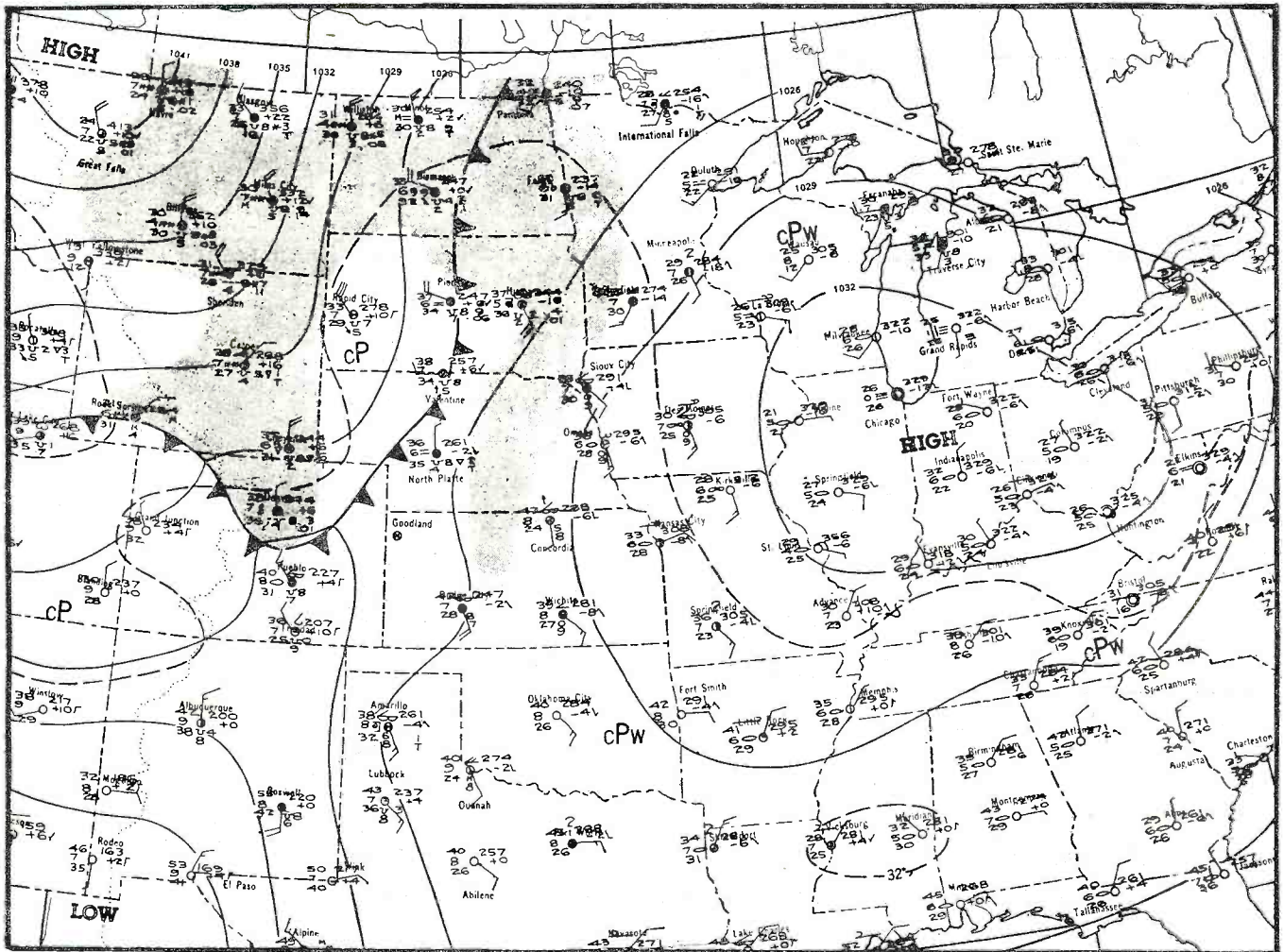

Section of the daily weather map. The original map is cut into five sections which are completed simultaneously.

report wind directions and velocities at 1000-ft. intervals above sea level, determined by charting the progress of small gas-filled balloons as they rise upward and are carried along by the various layers of moving air through which they ascend. These reports are supplemented by numerous soundings of the upper atmosphere by means of radiosondes, or miniature radio transmitters, which often travel more than fifteen miles above the surface. They are lifted by helium-filled balloons which burst in the reduced pressure of the upper reaches of the atmosphere, permitting the delicate instruments to drift back to earth suspended from tiny parachutes. These little 2-lb. transmitters are released twice daily by over forty stations throughout the country.

While the present "canned map" system is highly efficient, greater detail could be shown in the same distribution system by use of a facsimile or television process. The Weather Bureau system is now producing on regular schedule the master maps that could be used in a nation-wide radio distribution system, but we will have to wait until these new techniques of communications can be applied to peacetime public service.

### TIME SCHEDULES FOR FASTEST WEATHER MAP SERVICE IN THE WORLD



Local weather observations are completed at hundreds of points throughout the United States.



Coded reports are received by teletype at relay stations and automatically punched out on tape and fed into other machines for transmission over various circuits.



Work under way. Chart cut into five pieces. Each plotter charts data from a separate sequence of reports.



The five separate pieces are assembled and the analysis—a picture of the weather one hour ago at more than 800 spots throughout the country—is coded for transmission over the teletype. With facsimile transmission the coding operation will be eliminated.



Detailed nation-wide weather analysis goes out for distribution over teletype circuits which carry it to teleprinters in Army, Navy, and Weather Bureau offices over the country. This fast service provides a complete analysis in approximately one hour and a half.

# FUNDAMENTAL OPTICS

Fig. 1. Chromatic aberration—the failure of a lens to image all colors at the same image point.

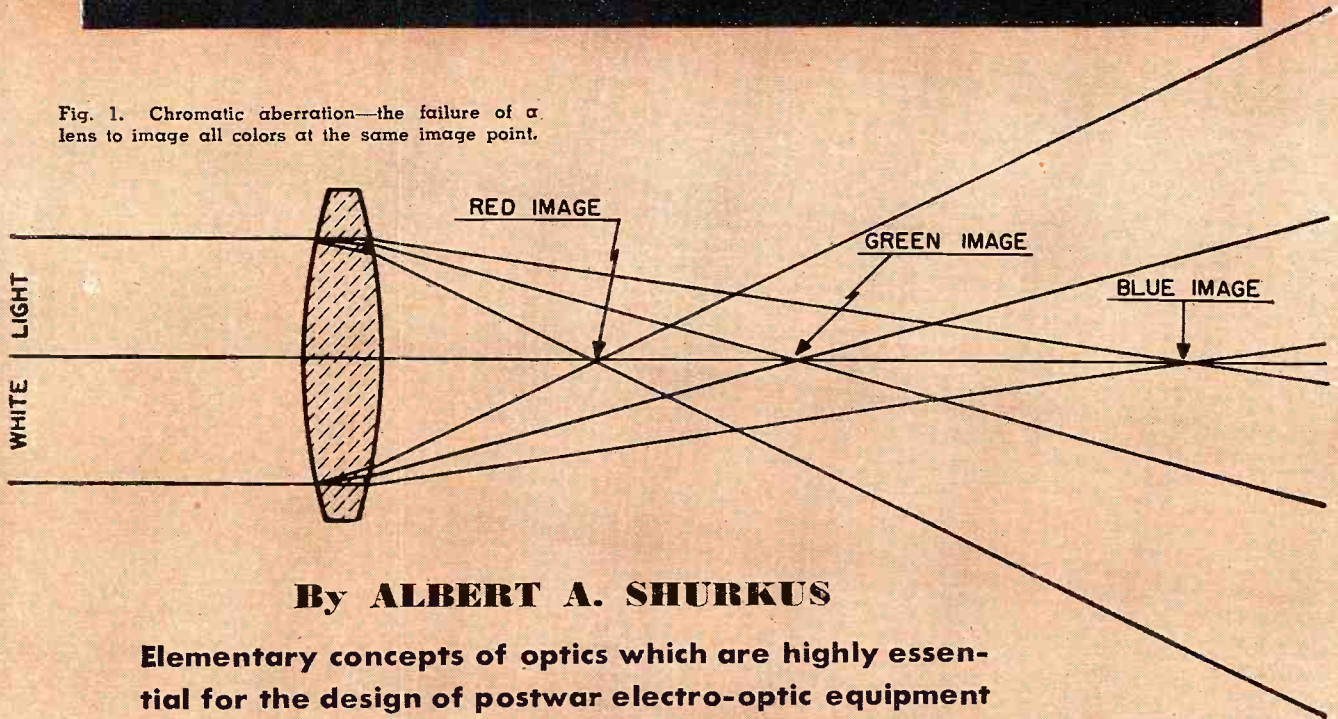

By **ALBERT A. SHURKUS**

**Elementary concepts of optics which are highly essential for the design of postwar electro-optic equipment**

URING the closing years of the seventeenth century, two apparently antagonistic theories upon the propagation of light held sway. Each theory had its adherents, and in the vanguard of each group were two of the fathers of the science of optics, Sir Isaac Newton and Jan Christian Huygens. One theory, dating back to the ancient Greeks, assumed that light consisted of a stream of corpuscles or discrete particles originating at the object being seen. This was the theory followed by Newton. The contradictory theory, that

light was a longitudinal wave, like sound, was advanced by Huygens. The sheer weight of Newton's opinion, however, kept this theory relegated to the background until about the nineteenth century by which time overwhelming evidence had been accumulated, forcing its acceptance.

In more recent years, discoveries in the fields of X-rays and photoelectricity have seemingly complicated matters again by requiring a new theory for their explanation. This new theory, the quantum theory, is similar to the old corpuscular theory in that it, too, assumes that the energy in a beam of light is concentrated in distinct points. The quantum theory, however, does not nullify the usefulness of Huygens' wave front concepts. Indeed, there is good reason to believe that both theories are but special cases of a more general principle yet to be advanced.

### Wave Fronts

Assuming light to be a wave motion, Huygens demonstrated that its progress through a three-dimensional medium is similar to the manner in which ripples move out upon the surface of a still pool of water when a stone has been cast into it. Consider for the moment a point source of light. If the velocity of propagation of light is the same in all directions

from that point, then the locus of any given phase of the disturbance is a sphere. The manner in which this

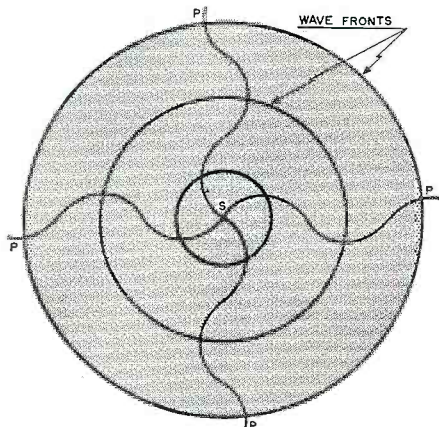

Fig. 2. Wave fronts of point source light.

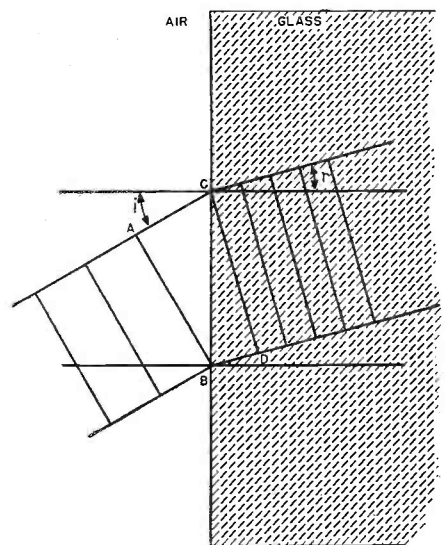

Fig. 3. The incident and refraction angles.

comes about can be seen from Fig. 2. The point source is *S* and light waves radiate in all directions from it. After any given time, the locus of the point *P* upon each wave, as shown, is a sphere. Huygens also showed that the wave front at any future time can



be determined by assuming every point upon the given wave front as a new source of light. If the medium is not isotropic, that is, if the velocity of propagation is different in different directions, as it is in many crystals, then the wave fronts are ellipsoidal.

It becomes mathematically difficult, and in some cases impossible, to describe the shape of a wave front unless it is either plane or spherical. Because of this, new concepts proved to be necessary. The physical non-identity, the ray, was therefore created. A ray is defined as a line originating at the source and drawn perpendicular to the wave fronts. Since all wave fronts about a given point source in a particular medium are concentric, it is said that light rays travel in straight lines. A bundle of rays originating at a single point is known as a pencil. All practical light sources have a finite area, however, each point of which emits a pencil, and the group of pencils is called a beam. The entire science of geometrical optics is based upon the concept of rays and that it has proved workable is evidenced by the number of excellent lenses and optical systems available today.

#### Reflection and Transmission

When light falls upon a surface, it is a commonly observed phenomenon that at least part of the incident light is returned by the surface. The acute ratio of the incident light returned,  $I_r$ , to the total light intensity incident,  $I_o$ , is defined as the reflectance, or reflectivity, of the surface; that is

$$R = I_r / I_o$$

where  $R$  is the reflectivity. No surface obtainable reflects all the light falling upon it. Freshly polished silver has a reflectivity of about 91%, aluminum about 71%, chromium 55%,

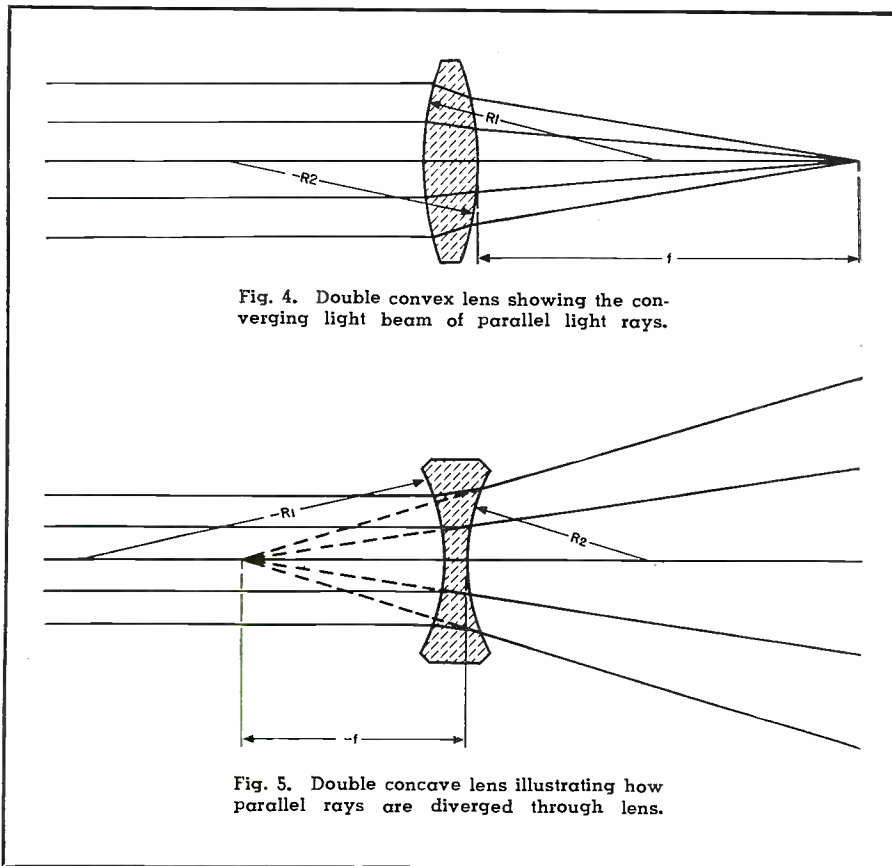

Fig. 4. Double convex lens showing the converging light beam of parallel light rays.

Fig. 5. Double concave lens illustrating how parallel rays are diverged through lens.

and carbon about 23%. Of course, the nature of the surface is an important factor in its reflectivity. Corroded and rough surfaces will naturally reflect less than highly polished, uncorroded surfaces. If the reflectivity is independent of wavelength it is said to be non-selective, while if there is a dependency, the reflectance is termed as selective. The appearance of the reflectivity curves

for several common substances is shown in Fig. 6. As a general rule, most materials are selectively reflective and possess at least a tint of color when viewed by the light reflected from them.

Besides being termed as either selective or non-selective, a reflection is said to be either specular or diffuse. Should a plane wave front be returned as an unbroken wave front, the reflec-

Fig. 6. Reflectivity curves of several common substances.

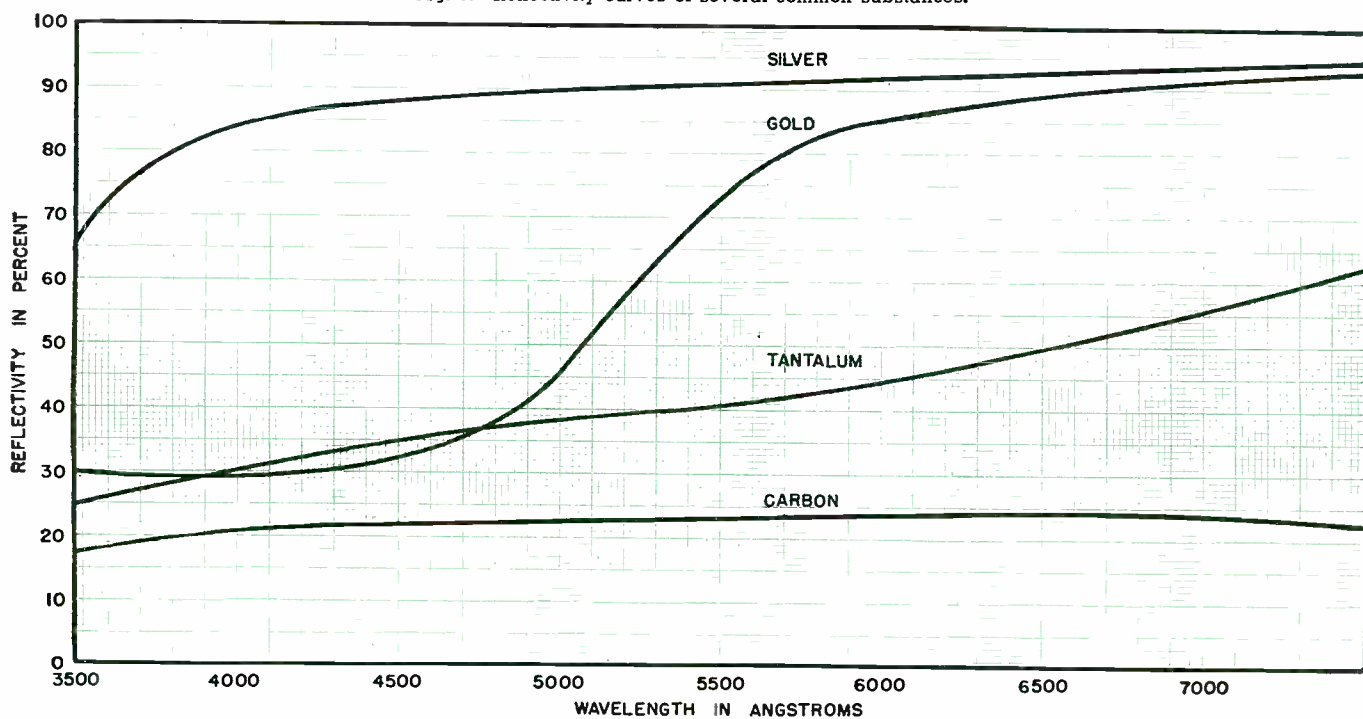

LIGHT OF ONE COLOR

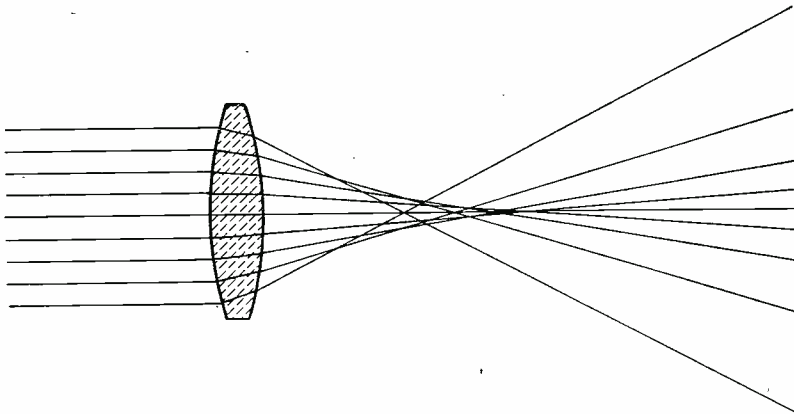

Fig. 7. Spherical aberration—the failure of the lens to image the light passing through its various zones at the same image point.

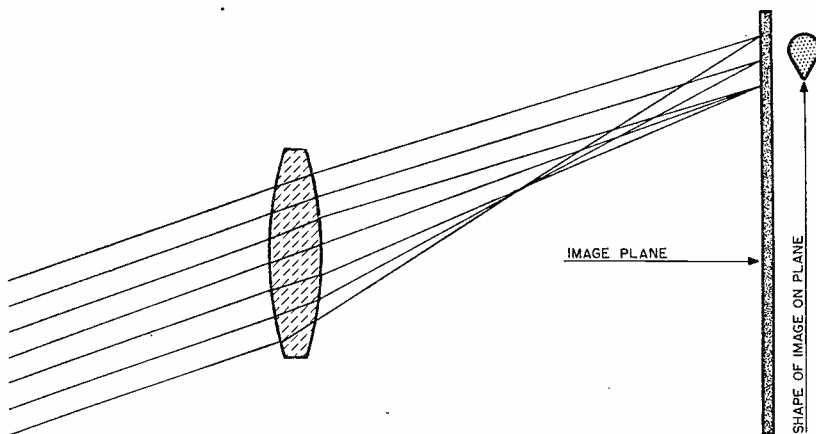

Fig. 8. Coma aberration, resulting from zonal variations in lens magnification, is closely associated with spherical aberration.

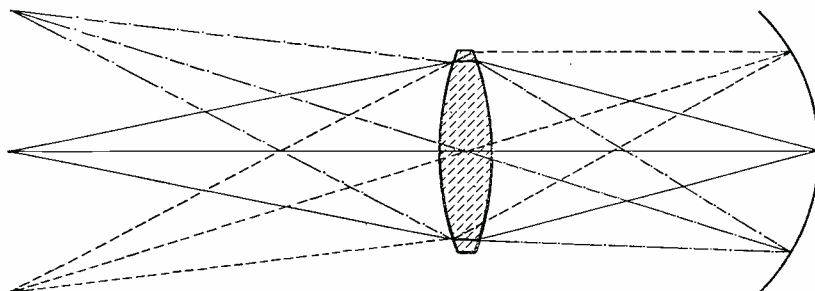

Fig. 9. Curvature of the field is a variation of image distance with obliquity and results in a curved image plane.

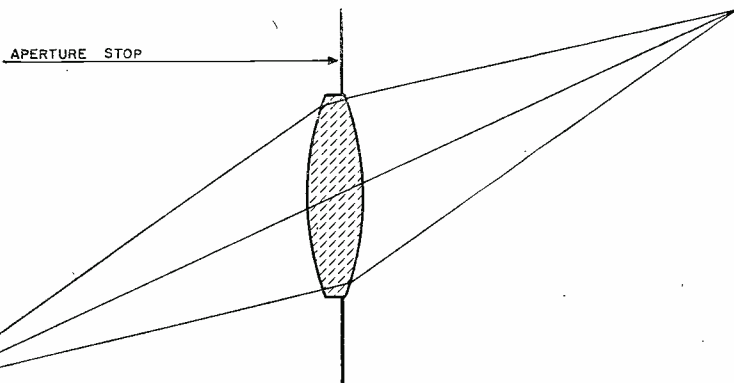

Fig. 10. The rim of the lens is the aperture stop of the system as only the light passing through the lens will appear in the image.

tion is said to be specular. A polished mirror acts in this manner. If, however, the surface is sufficiently rough or irregular, a plane incident wave front is broken into many wavelets scattered in all directions. Such a reflection is referred to as diffuse. Chalk is a diffuse reflector.

If the material is transparent and light is able to penetrate into it, some of the light, indeed a small fraction of the total, will be reflected by the surfaces, some of the light will be absorbed, while the remainder will pass through. The transmission of a material is defined as the ratio of the intensity of the transmitted light,  $I$ , to the total light intensity incident,  $I_0$ , that is

$$T = I/I_0$$

The absorption, similarly, is the ratio of the intensity of the absorbed light to that incident, or

$$A = \frac{I_0 - I}{I_0} \text{ (assuming no surface reflection)}$$

If no other losses occur, then it is evident that the sum of the percentage of light transmitted and the percentage absorbed is 100. This is true only if no scattering or surface reflections occur. Of recent years a technique has been developed whereby the losses due to surface reflections can be minimized by coating the glass surfaces with "anti-reflection" films, that is, films of materials possessing very low reflectivities.

The opacity of a material is defined as the reciprocal of its transmission, and the optical density is the logarithm of the opacity.

$$D = \log_{10} O = \log_{10} \frac{1}{T} = 10 - \log_{10} T$$

In materials that are homogeneous, such as glass or clear liquids, the absorption depends upon the thickness of the material and is proportional to it. It is also dependent upon the absorption of the material per unit thickness of that material. This is known as Beer's law and is the foundation of the science of colorimetry. Beer's law, however, holds only when monochromatic light is used and when the material exhibits no scattering. Surface reflection losses, too, must not be included in the over-all absorption.

Curves of either spectral transmission or reflectance can be obtained for any material by the simple expedient of allowing monochromatic light to be incident upon the material in question and then measuring either the transmission or reflectance as the wavelength of the light is changed. The degree of the monochromaticity of the light used in this determination will affect the ability to locate small differences in the spectral transmission or reflectance. The more truly monochromatic is the light used, the better will small differences be detected. Many electronic devices have been built to accomplish this measure-

(Continued on page 98)

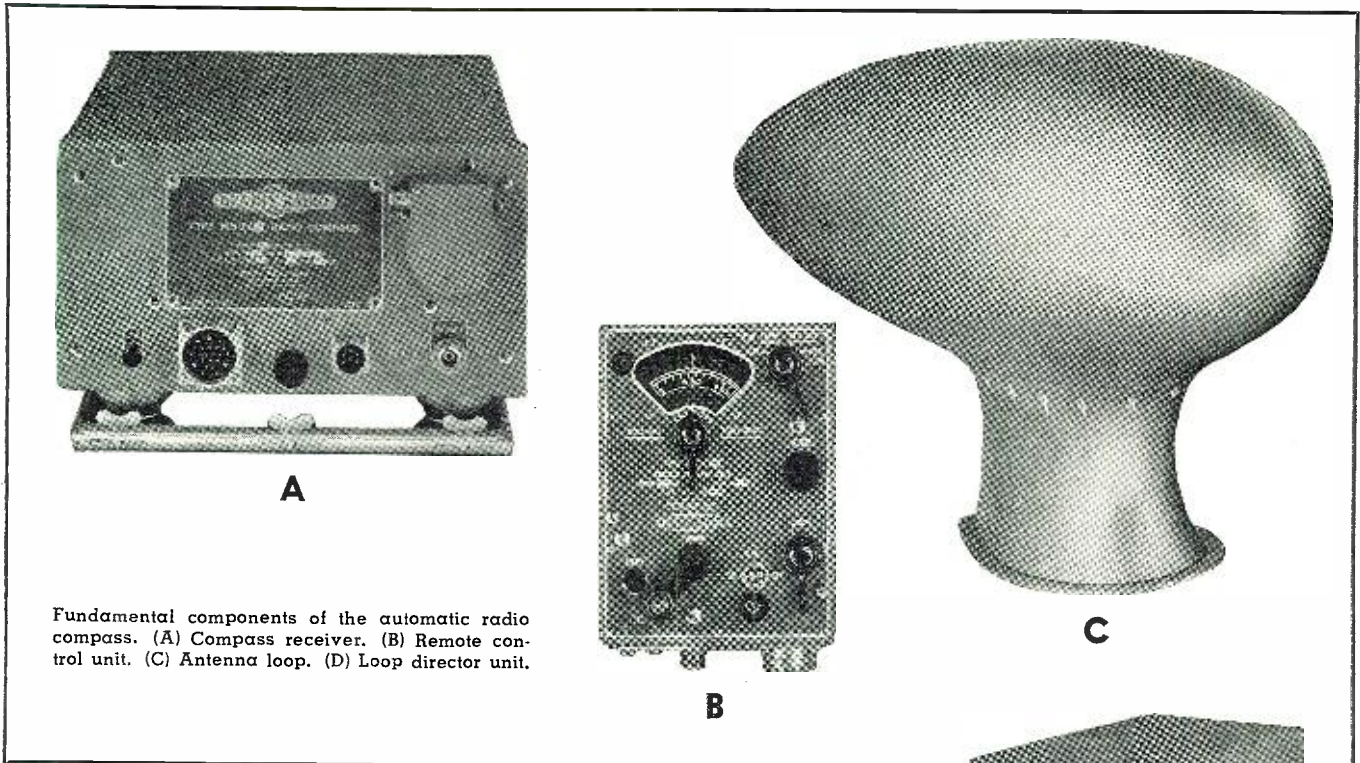

Fundamental components of the automatic radio compass. (A) Compass receiver. (B) Remote control unit. (C) Antenna loop. (D) Loop director unit.

# Automatic Radio Compass

By **MYRON F. EDDY**

Lieutenant, USN, (Retired)

*The operation, design, and basic principles of the automatic radio compass used for instrument flights.*

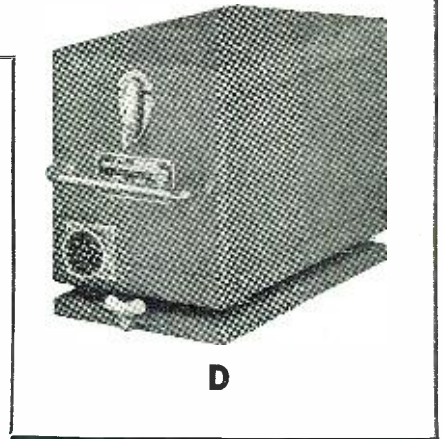

AT THE beginning, when radio was first adapted to the airplane, it was quite an insignificant instrument. As time progressed, it became the mouth and ears of the airliner itself and later, it was applied to navigation. Radio became a partner to the pilot who could listen to it and trust in it. Aircraft radio equipment has expanded to the point where the automatic radio compass now points out the way for the pilot. It points independently of the radio range beacon and it outpoints the ordinary radio compass.

The radio beacon reported whether or not the plane was to the right, left, or definitely on course, and it was satisfactory as long as the pilot could stay on the laid-out airways.

As to the original manual-type radio compass, it was possible to tell whether or not the airship was heading for home. It could even tell the pilot that "Chicago is over there—north"; and "Kansas City is behind you—southwest."

The more recently-designed automatic radio compass, however, does all these things. It does not need the

Fig. 1. Block diagram of the complete assembly. The streamlined loop unit is mechanically operated by reduction gear train (A) and the low inertia loop drive motor (B).

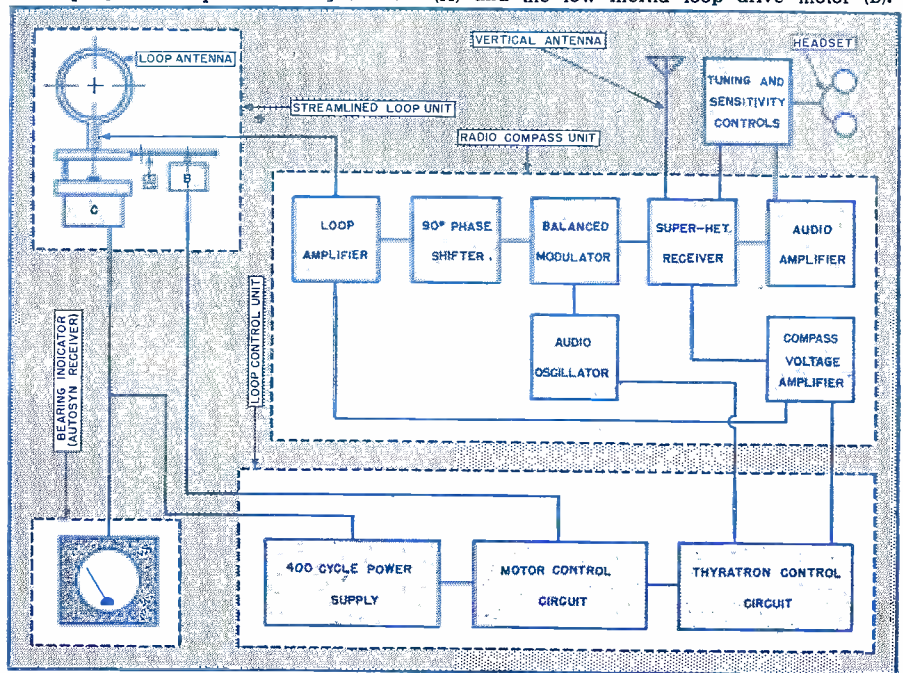

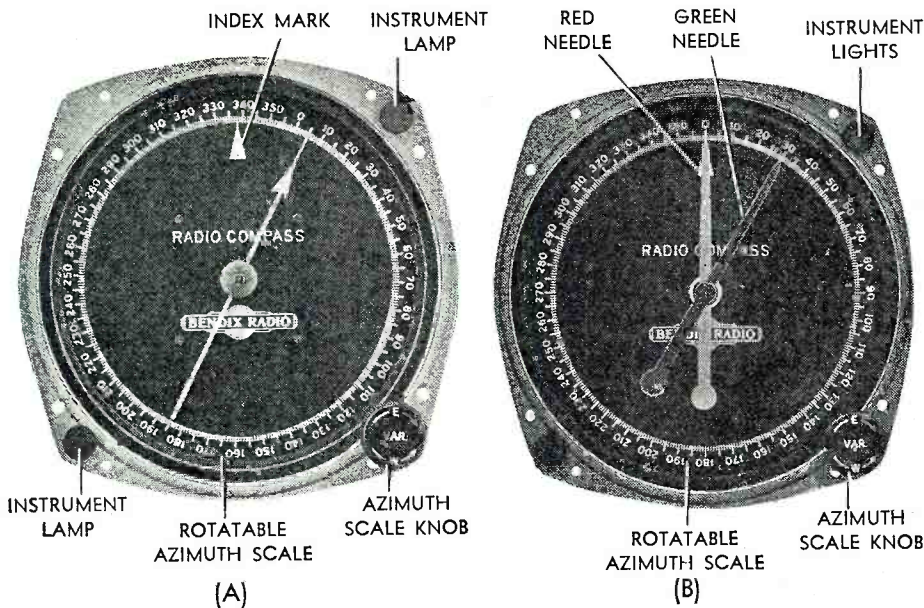

Fig. 2. (A) Zero center type meter indicator. (B) More modern type remote azimuth indicator used with compass loop antenna, which automatically seeks its correct position.

radio range and the pilot does not have to rudder towards a ground transmitter or rotate a loop antenna.

This unit is a logical engineering development of the early null type radio compass. This basic type radio compass employs a directional loop type antenna. Originally, if the loop was

rigidly fixed in place on the plane it was called a direction finder and if it could be rotated so as to take bearings without changing the flight course, it was called a radio compass. The terms radio compass and radio direction finder are now considered synonymous.

These instruments are still in use.

In both cases the loop is connected to a receiver. When the loop (or airplane) is moved so that the loop points at the transmitter, receiver volume is maximum. The trouble is, audibility is high over a large arc and it is hard to decide as to the direction of the transmitter within  $10^\circ$ .

When the loop is given a quarter turn your radio compass receiver will have minimum audibility. This is the null method. It is used at ground radio compass stations but it is not so good when engine noises must be combatted.

Besides the disadvantages of both the "maximum" and "null" methods, there is another: the  $180^\circ$  ambiguity error. This simply means that the pilot can be exactly  $180^\circ$  wrong as to direction.

A flyer left Miami for New York in a land plane in stormy weather. The first radio compass bearing he could get was identified, by its call letters, as Jacksonville. The bearing was  $270^\circ$ , due west from him at the time he took his bearing. Figuring he was over water, he quickly ruddered west, straight toward Jacksonville and land. But the signals quickly faded out instead of building up. That was the tip-off. He flew east again, reversed his compass loop, picked up Jacksonville strongly, and landed there much later, dangerously low on gas.

In order to eliminate this possible error, a non-directional antenna (in this case called a "sense" antenna) can be switched in on the radio compass receiver in addition to the loop, and the loop rotated slightly; there then will be either an increase or decrease in volume and if the operator can be sure which is occurring he will know whether or not to correct the bearing secured by adding  $180^\circ$ .

The next type developed to eliminate ambiguity—called the right-left type—is tied in with the engineering of the Bendix unit. It combines the output voltages from a directional loop antenna and a non-directional sense antenna similar to the method employed in the aural null equipment. However, the switching operation in this set is performed continuously and at a predetermined rate by electrical circuits within the radio compass unit. A zero-center type meter indicator, Fig. 2a, is connected to the radio compass output so that the operator gets a visual indication. To get a radio bearing the pilot rotates the loop antenna by hand until the pointer of the meter assumes the zero or "on course" position. The radio bearing is then read from an azimuth scale which is mechanically attached to the shaft of the loop antenna. The  $180^\circ$  ambiguity in direction is eliminated by following a definite right-left procedure in rotating the loop antenna to bring the indicator to the "on course" position.

This right-left radio compass is a marked improvement over the original aural null type equipment in that a visual bearing indication is obtained

(Continued on page 86)

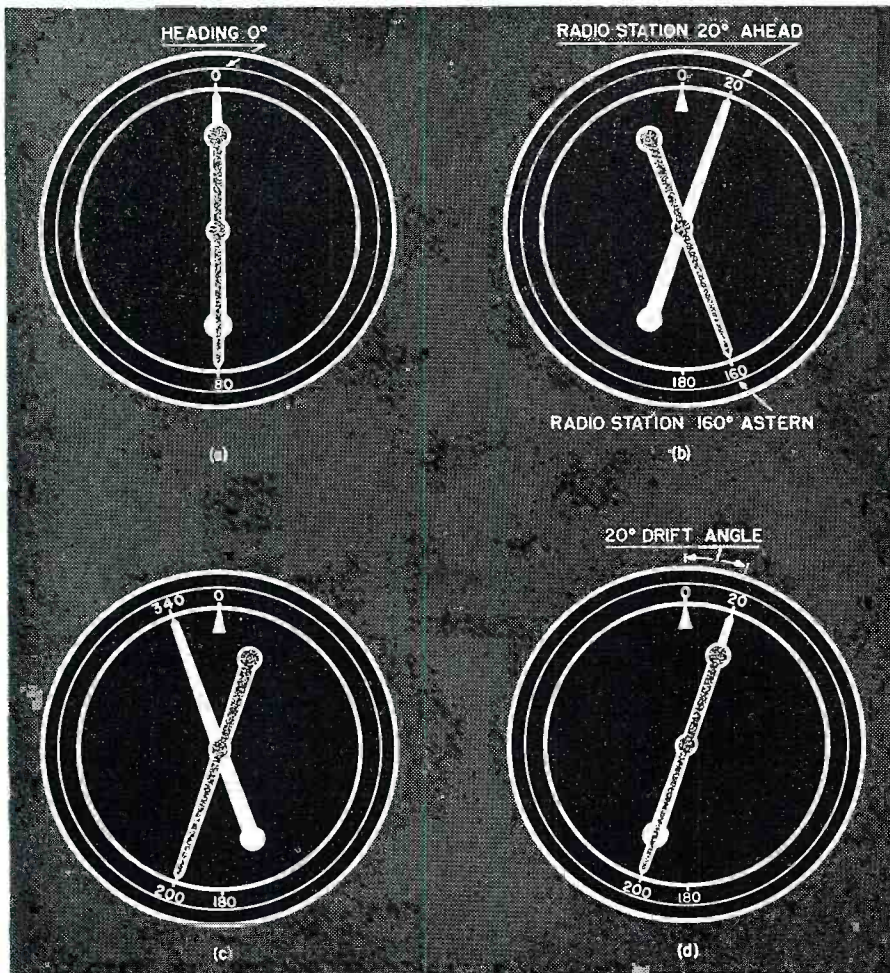

Fig. 3. Azimuth indicator showing position of plane in flight. (A) Plane on course. (B) Plane left of its course. (C) Plane drifted to right. (D) Plane held on course,  $20^\circ$  drift angle.

# WIRED RADIO—CIRCUIT DESIGNS

By **RUFUS P. TURNER**

Consulting Eng. RADIO NEWS

**Description of many practical circuits, of interest to amateurs and experimenters, on carrier-current communications using power lines.**

**W**IRED radio has come to be known by many experimenters since the shutdown of amateur transmitters. But this does not mean that transmitting and receiving radio signals over wires is a new art. Electric power companies have been using wired radio for years, under the name *carrier currents*, for voice communication over their regular lines, operating remote relays, and reading distant meters. Practicability of the system has long since been proven in the field.

Experimental use of wired radio is not necessarily restricted to communications. Signals may be sent over the electric light lines to control motors, lights, alarms, and the like on a hobby basis, to tune radios; and in general to perform any operation which may be initiated by a relay. Communications or control may be carried on between points in a single building or, when conditions permit, across town.

A particular advantage of wired radio over ordinary wire-connected electrical systems is that special lines are not required; the existing electric wiring will serve. The same line that supplies power to the sending and receiving equipment will also convey the radio signals.

A few communities have adopted wired radio for Civilian Defense emergency communications as an adjunct to regular ultra-high-frequency radio, and have reported considerable success. In many other localities, amateurs are employing carrier currents for voice or code communication up to distances of five or more miles. A few intercommunicator outfits operate on the wired-radio principle, offering the economic advantage that inserting the power plug at any point completes *all* connections. This is a lush field for experimentation.

At present, no radio license is required for carrier-current systems as long as the field strength of any actual *radiation* from the conducting lines does not exceed 15 microvolts per meter at a distance (in feet) equal to 157,000 divided by the signal frequency (in kilocycles). The graph of Fig. 1 gives the maximum permissible distances for this allowable signal strength at various frequencies between 100 and 1300 kc. By means of this curve, the experimenter may tell at a glance what his legal radiation distance is.

Wired radio is open for unrestricted

use, except in certain critical localities in which the military authorities have forbidden the use of any form of private communications equipment. These areas have been designated from time to time in standard news bulletins and are at present proclaimed by notices posted in post offices and other government buildings in the critical communities.

To many of our readers, wired radio is doubtless still a "foreign" subject. For their benefit, we aim to review in this article the circuits and systems which are available and to outline the features of each. In this way, we hope to shed light on a subject which is destined to grow in importance in postwar electronics.

Wired radio is similar in principle

to normal radio communication, except that in the former system the waves are guided by wires instead of being radiated into space. In order to minimize radiation, low radio frequencies are employed universally in all carrier-current work. From the graph of Fig. 1, it may be seen that greater leeway in radiation is possible at the lower frequencies.

Any pair of wires might be employed to convey the carrier currents, although it is customary to use the power lines. Experimenters should not use the telephone lines under any circumstances. Any private wire line, lawfully strung between any two buildings, might be employed for carrier-current purposes.

The functional block diagram of

Fig. 1. Maximum permissible distances for allowable signal strength at freq. of 100 to 1300 kc.

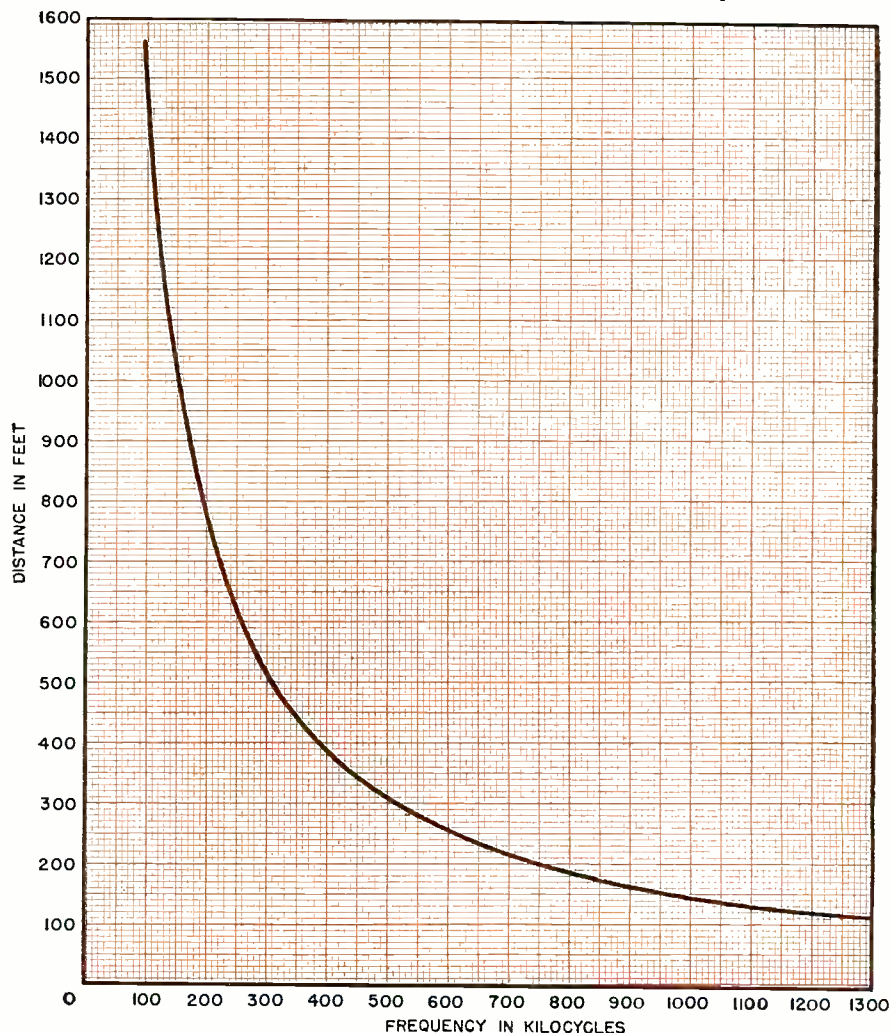

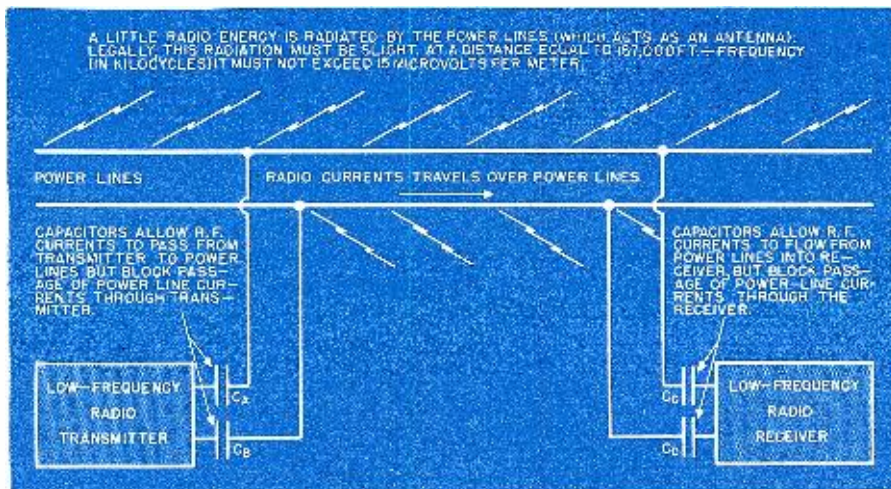

Fig. 2. Functional block diagram illustrating the principles of wired-radio communications.

Fig. 2 illustrates the wired-radio principle. Note that both transmitter and receiver derive their operating power from the same line into which they communicate. The transmitter delivers radio-frequency currents to the line through the coupling capacitors  $C_A$  and  $C_B$ , and the receiver picks up the carrier currents through a similar pair of capacitors,  $C_C$  and  $C_D$ . These capacitances are so chosen in value as to offer high reactance at the line frequency and low reactance at the signal frequency. They are rated to withstand the peak line voltage plus the signal voltage and must have low leakage.

If only low r-f power levels are to be handled, the transmitter may be a simple oscillator, and the receiver a detector stage with or without an amplifier. Where a sensitive relay is to be controlled by carrier currents, the receiver may be comprised entirely of the control-tube circuit. If higher power levels are to be handled, the transmitter circuit must be capable of developing a reasonable r-f power level across the very low impedance of the power-line circuit. In general, for voice or code communication between nearby points, such as those within a

single building, a low-powered transmitter unit will be entirely adequate.

In commercial carrier-current systems, transmitting and receiving equipment are capacitively coupled directly to the high-voltage feeders. But private experimental systems do not have access to the high-voltage side of service transformers and must operate on the low-impedance secondary side of these transformers. This means that private signals which are to be transmitted over a distance must be forced through the lighting transformers (frequently on both ends of the communication circuit) and will undergo considerable attenuation as a result. The impedance of power lines on the "house" side of service transformers is of the order of 10 ohms or so at the low radio frequencies commonly employed in experimental carrier-current communication, the line being shunted by lamps, motors, and appliances in parallel.

The best frequencies for private experimental wired radio are in the range 175-500 kc., with the lower frequencies in this band the most desirable. A number of electric light and power companies employ frequencies below 150 kc. for their own communications, re-

mote switching, and telemetering, and interference will be occasioned in these services by amateur use of frequencies below 150 kc. Frequencies higher than 500 kc. will be liable to cause broadcast interference, both by direct pickup and by entry of signals through receiver power transformers, and are in general more readily radiated by overhead power lines. However, the higher frequencies may be employed (and small broadcast receivers utilized for reception) if the transmitted power is maintained so low that no interference is created in neighboring receivers not coupled to the lines. It is recommended, however, that high-frequency operation be restricted to a single building and that the transmitter power be reduced always to the level just sufficient to communicate with the most distant receiver in the building.

In wired-radio systems, the transmitter may be a simple modulated oscillator; or for better frequency stability, a modulated oscillator-amplifier arrangement. In private experimental work, high selectivity is not usually required. As a result, the receiver or detector may be broadly tuned and crystal control of the transmitter, while desirable, will not be a must.

In some localities, electrical machinery and power system faults might produce a high line noise level. Where this is the case, reception may be improved by employing FM. Some experimenters have already reported that the rudimentary frequency modulation obtained by slightly overmodulating a self-excited oscillator and using a superregenerative receiver has overcome line noise sufficiently for practical purposes, although voice quality is considerably impaired.

#### Low-Powered Transmitter

A low-powered, low-frequency oscillator circuit, suitable for short-distance wired radio is shown in Fig. 3. This is a series-fed Hartley with a continuous tuning range from 150 to 1500 kc. The unit is operated on a.c. or d.c. Direct-current plate power is delivered by V2 which may be any line-operated rectifier, such as types 12Z3, 25Z5, 25Z6, 35Z5, 50Y6, etc.

The oscillator tube, V1, may be any of the small 6.3-volt triodes, such as types 37, 76, 6C5, 6J5, 6P5, etc. Filaments are wired in series and voltage for the string obtained from the line through the series dropping resistor, R2, the value of which is given in the schematic for one 6.3 and one 25-volt tube in series (each drawing 0.3 ampere). This value may be altered somewhat by other heater combinations.

The tank coil, L1, is wound on a 3-inch-diameter form and consists of 110 turns of No. 18 d.c.c. wire close-wound. Its inductance is approximately 400 microhenries. The tap on coil L1, for V1 cathode connection, should be made at approximately 20 turns. The tuning condenser shunting inductor L1 has a maximum capacitance of

Fig. 3. Low-powered, low-frequency oscillator circuit suitable for short-distance wired radio.

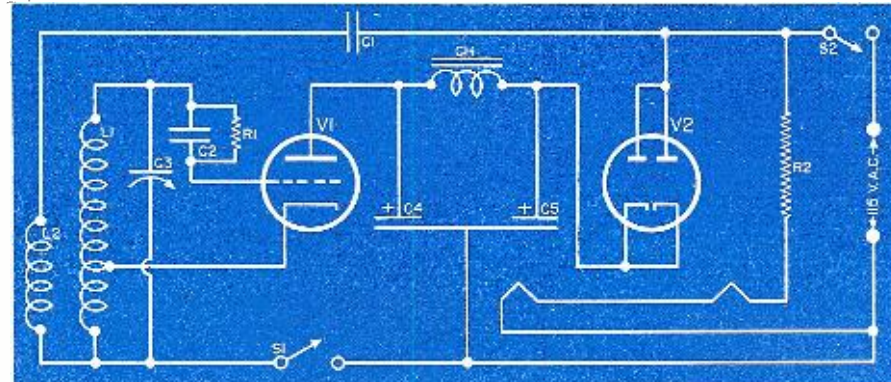

$C_1$ —.05- $\mu$ f.d., 600-volt tub. cond.—Aerovox  
 $C_2$ —.0001- $\mu$ f.d. mica cond.—Aerovox  
 $C_3$ —1000- $\mu$ f.d. variable cond.—Cardwell XR-500-PD (with sections in parallel)  
 $C_4$ ,  $C_5$ —Dual 8- $\mu$ f.d., 450-volt elect. cond.—Aerovox PRS  
 $CH$ —Midget 10-20-henry filter choke—U.T.C.

$L_1$ ,  $L_2$ —See text  
 $R_1$ —50,000-ohm, 1/2-watt resistor—Aerovox  
 $R_2$ —279-ohm, 50-watt resistor—Ohmite  
 $S_1$ ,  $S_2$ —S.p.s.t. toggle switch—Arrow  
 $V_1$ —37, 76, 6C5, 6J5, or 6P5  
 $V_2$ —25Z5, 25Z6, or similar high-voltage-heater rectifier

1000  $\mu\text{fd.}$ , and may be a three-section 350 or 365  $\mu\text{fd.}$ -per-section broadcast tuning condenser with the sections connected in parallel. L2, the line coupling coil, consists of ten turns of No. 18 d.c.c. wire closewound upon a strip of varnished paper, empire cloth, or other high-grade insulating tape wound snugly about the center of L1.

R-F output of the oscillator is capacitively coupled to the power line through C1 (.05  $\mu\text{fd.}$ , 600 volts) and through direct connection of the lower end of L2 to the other side of the line through the a.c.-d.c. power supply.

S2 is the on-off power switch, while S1 interrupts operation of the oscillator without opening the filament circuit. A contactor, telegraph key, or other signalling device may be connected in place of this switch. For voice modulation, switch S1 may be replaced by the secondary of an audio transformer terminating the modulator circuit (see Fig. 4). This transformer may be a common interstage replacement unit and the modulator tube may be of the same type as that employed in the oscillator. A transformer-coupled carbon microphone may be operated directly into the grid circuit of this simple modulator, while microphones of higher quality will require intermediate amplification.

### Companion Receiver

Since the oscillator shown in Fig. 3 tunes through the standard broadcast band, any broadcast receiver might be employed to pick up its signals from

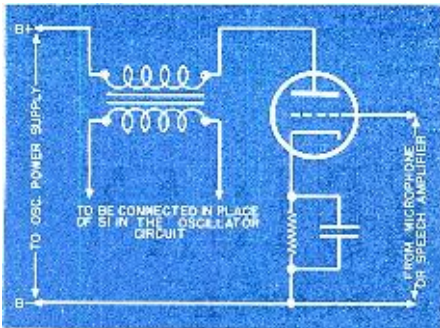

Fig. 4. Voice modulator for use with Fig. 3.

the line by simple connection as shown in Fig. 5. Note that both ANT and GND terminals of the receiver are capacitance-coupled to the power line through C1 and C2, .1- $\mu\text{fd.}$ , 400-volt tubular units. If best operation is not obtained when transmitter and receiver are tuned inside the broadcast band, the line plug of the receiver should be reversed in the receptacle. A simple, but effective communicator system may be made up of the oscillator, modulator, and midget broadcast receiver.

### Simple Low-Frequency Receiver

The broadcast receiver will not be satisfactory when the wired-radio transmitter is operated at frequencies below 550 kc. A special receiver circuit for the low frequencies is shown in Fig. 6. This is a simple three-tube, fixed-tune autodyne with a pentode

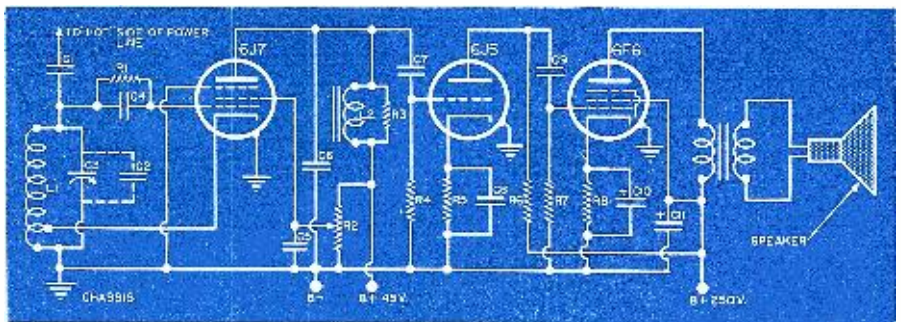

Fig. 6. Special receiver circuit for low frequencies, using fixed-tuned autodyne and detector.

C<sub>1</sub>—.001 to .002- $\mu\text{fd.}$  mica cond.—Aerovox  
C<sub>2</sub>—See text  
C<sub>3</sub>—Trimmer in BFO can (See text)  
C<sub>4</sub>—.0001- $\mu\text{fd.}$  mica cond.—Aerovox  
C<sub>5</sub>—.25  $\mu\text{fd.}$  400-volt tub. cond.—Aerovox  
C<sub>6</sub>—.00025- $\mu\text{fd.}$  mica cond.—Aerovox  
C<sub>7</sub>—.01- $\mu\text{fd.}$ , 200-volt tub. cond.—Aerovox  
C<sub>8</sub>—10- $\mu\text{fd.}$ , 25 d.c.w.v. elect. cond.—Aerovox PRS  
C<sub>9</sub>—.1- $\mu\text{fd.}$ , 400-volt tub. cond.—Aerovox  
C<sub>10</sub>—10- $\mu\text{fd.}$ , 50 d.c.w.v. elect. cond.—Aerovox PRS

C<sub>11</sub>—8- $\mu\text{fd.}$ , 450 d.c.w.v. elect. cond.—Aerovox  
L<sub>1</sub>—Superhet BFO coil (See text)  
L<sub>2</sub>—300-henry, 5-ma. iron-core choke—Kenyon P-500  
R<sub>1</sub>—30,000-ohm, 1/2-watt resistor—Aerovox  
R<sub>2</sub>—30,000-ohm wirewound pot.—Clarostat  
R<sub>3</sub>, R<sub>4</sub>—25-megohm, 1-watt resistor—Aerovox  
R<sub>5</sub>—5-megohm, 1/2-watt resistor—Aerovox  
R<sub>6</sub>—2500-ohm, 1-watt resistor—Aerovox  
R<sub>7</sub>—1-megohm, 1-watt resistor—Aerovox  
R<sub>8</sub>—600-ohm, 10-watt resistor—Ohmite

detector. Coupling to the a.c. line is through capacitor C1.

Tuning is accomplished in this receiver by means of a superhet beat-oscillator coil-condenser combination, L1-C3. These coils are available with variable condensers, in shield cans, for 175-, 455-, 456-, 465-, and 500-kc. operation. Many experimenters have one or more among their spare parts. The single frequency is set by screwdriver adjustment of C3 and may be changed whenever the transmitter frequency is shifted. A tuning range of 50 to 100 kc. is provided by the internal condensers of these units. Lower frequencies than those afforded by the L1-C3 combination may be reached by connecting a suitable capacitance, C2, in parallel with C3.

The detector is impedance-coupled to the first audio stage by means of the plate choke, L2, and the .01- $\mu\text{fd.}$  capacitor, C7. The choke is iron cored and should have an inductance rating of 300 henries or higher at 5 milliamperes d.c. If headset operation is sufficient, the final audio stage may be dispensed with, the headset being connected in the 6J5 plate circuit in place of the plate load resistor.

The entire receiver may, if desired, be operated from a simple a.c.-d.c. power supply by substituting a 25L6, 50L6, or similar high-voltage-heater output tube for the 6F6 and making corresponding changes in cathode and grid resistors in the output stage. There is no objection to making the line-operated power supply a voltage doubler.

In operation, it may be necessary to alter the capacitance value of C1 to suit individual installations. Variations in signal strength, line impedance, distances to be covered, and similar factors will influence the size of the coupling capacitor.

### Higher-Powered Transmitter

The receivers just described are capable of operation at some distance from the transmitter. The simple

oscillator-type transmitter, on the other hand, will not send a wired-radio signal very far "down the line," and in general will be most suitable only for communication in the same building in which it is located. When longer distances are to be covered by wired radio, the transmitter output must be high enough to counteract the high line losses.

Transmitter circuits for longer-distance communication are shown in Figs. 7 and 8. The arrangement in Fig. 7 is a simple self-excited shunt-fed Hartley oscillator employing a triode-connected 6V6-G. In this circuit, the large tank capacitance of .003  $\mu\text{fd.}$  is supplied by a 2500-volt mica unit, tuning adjustments being made by means of clips supplied to taps along L1.

L1 consists of 100 turns of No. 18 d.c.c. wire closewound on a 3-inch-diameter form. This tank will reach as low as 140 kc. by means of "clip tuning." Every fifth turn of L1 is tapped. Coupling to the a.c. line is provided by the pickup coil, L2, and the two .05- $\mu\text{fd.}$  coupling capacitors. L2 is 15 turns of No. 18 d.c.c. wire closewound around the center of L1, and protected from the latter coil by a winding of empire cloth, transparent Cellophane tape, or other insulating binder. The .05- $\mu\text{fd.}$  capacitors must be of good quality and rated to with-

(Continued on page 62)

Fig. 5. Converted standard receiver for use with carrier-current transmitter.

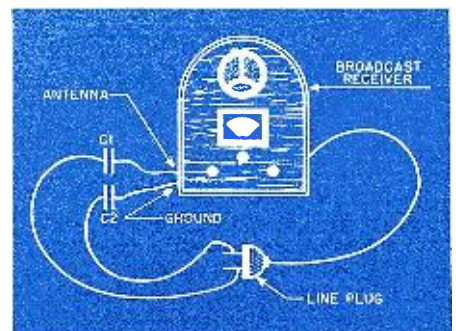



Broadcast being held in Studio "A." Note two Presto transcription tables in foreground and BBC record table in background.

AMERICAN soldiers in the European Theatre of Operations have their own private radio network now—thanks to the British Broadcasting Corporation and the U. S. Army Signal Corps.

The Yanks can tune in on Bob Hope and Jack Benny and all their other favorite radio stars almost as they did in the good old days of civilian clothes and unpowdered eggs. It's not quite like the living room at home; the programs come to them over G.I. olive drab radio sets, and listeners usually are sprawled on G.I. cots in G.I. Nissen Huts. But the programs are possibly their closest link to home, and that's important when home is some thousands of miles away.

Briefly, the network comprises a series of low-power transmitters situated near United States Army installations. These transmitters are linked by telephone lines to the main studio, which receives transcriptions of the leading programs broadcast by the National, Blue, Columbia and Mutual Broadcasting Systems each week. These are augmented by recordings, news programs, BBC originations, and special G.I. shows to complete the well-rounded schedule broadcast daily

# THE AMERICAN

By **KENNETH R. PORTER**

RADIO NEWS War Correspondent

*With the cooperation of the BBC, the Yanks in the E. T. O. now have their own private network.*

by the American Forces Network.

All this, of course, would not have been possible without the generous and friendly cooperation of the BBC, which waived its monopolistic rights on radio broadcasting in Great Britain and offered many of its own facilities so that the Yanks could enjoy American programs on what the soldiers call the "G.I. Network."

And the "G.I. Network" is just that. Officers and enlisted men of the Signal Corps are responsible for maintaining the enterprise—getting the programs through to their fellow men in khaki. To many of the Signalmen it is merely an application of their peacetime pursuits, for many of them

were radio installation and maintenance men in civil life.

The program end of the network is handled by a staff of administrators, writers, directors and announcers whose Army classification cards show they made their mark in radio long before Hitler started turning the world upside down. Now they're G.I.'s who consider themselves darned lucky to be able to make such good use of their civilian experience.

No mere words can describe the planning, work, and improvisation that built the American Forces Network into the leading—and in some cases the only—form of recreation for American soldiers in this Theater.



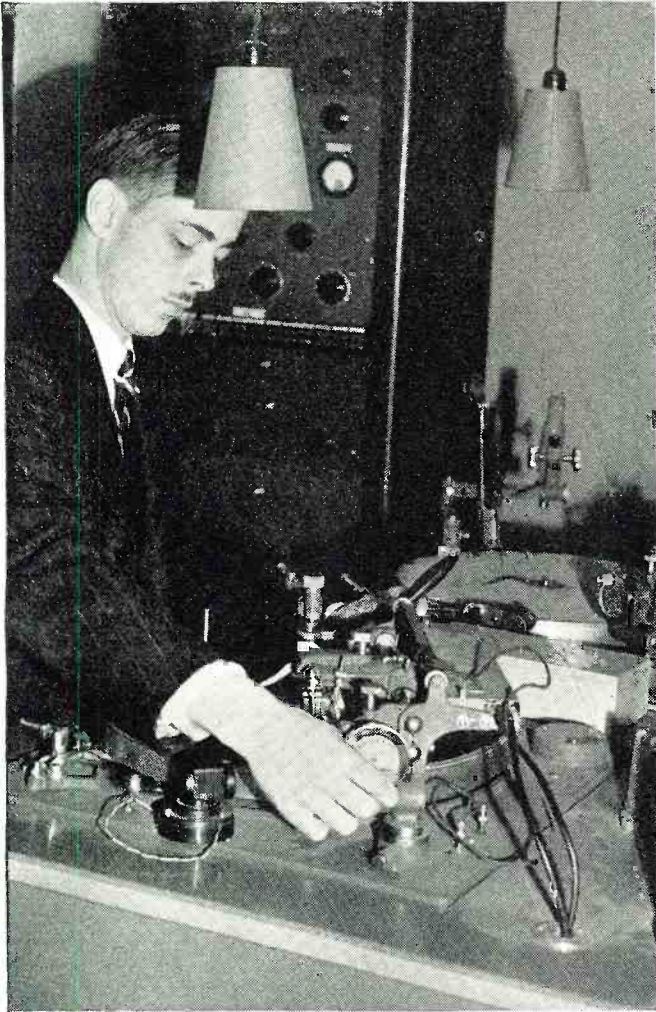

News broadcast cutting being made in recording and cutting room.

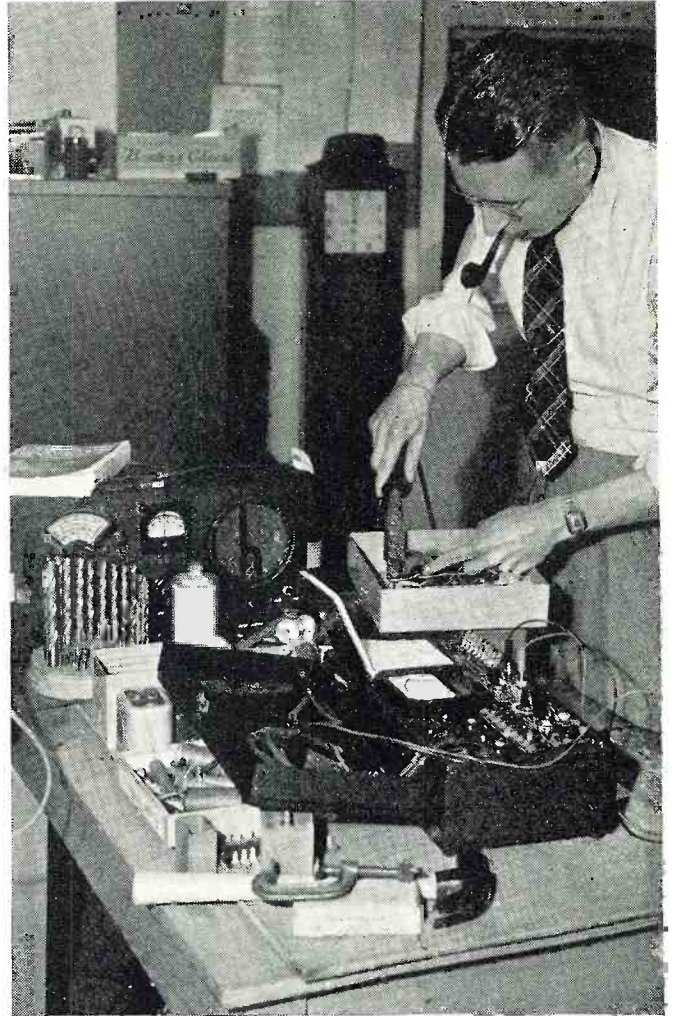

Civilian technicians are employed for radio repair and maintenance.

# FORCES NETWORK

The equipment finally selected, and the way that equipment has been utilized, certainly is of interest not only to radio enthusiasts, but to everyone who has a relative or friend serving with the Army in Great Britain.

Much of the political and technical work encountered in establishing a network so novel in its use and so large in scope, was handled by Mr. Brewster Morgan, chief of the OWI Radio Division and Mr. Richard Condon, chief engineer for OWI in London. These men are responsible for arrangements with BBC which permit use of the British Network's lines and of its outstanding news and entertainment features. When the Wireless Telegraphy Board, governing body of radio communication in the United Kingdom, gave its blessing, the Network's future was assured.

Keystone of the entire American Forces Network is the central studio—a former BBC emergency studio from which news broadcasts were made during the blitz period. The OWI and BBC studio engineers revamped the existing facilities, doing considerable rewiring and remodeling to equip the studio for its new job. New amplifier bays and control positions were installed along with two

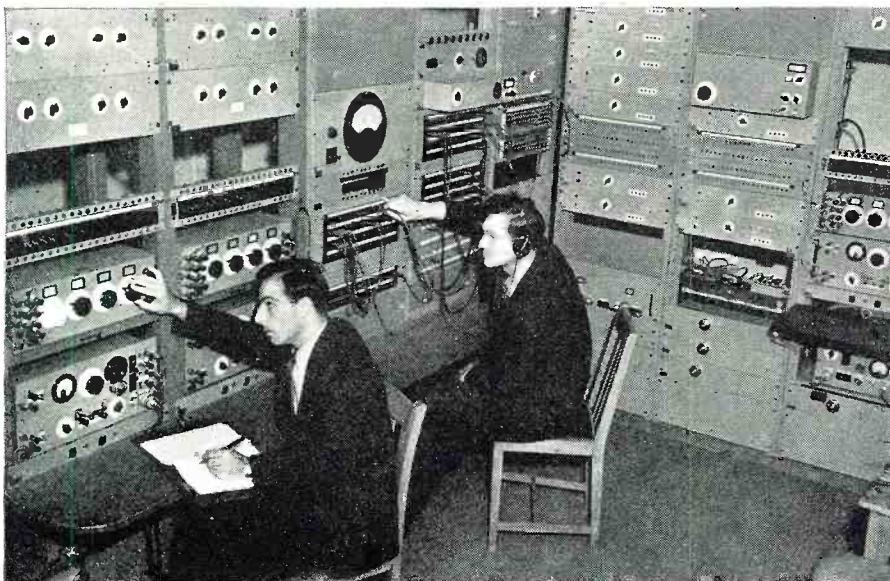

Civilian technicians, formerly with the RAF, at their posts in the control room.



Newsroom is typical of that operated by any large radio network.



News cast being broadcast from a secondary studio over the network.

recording channels and a teleprinter news service. Inter-bay wiring was rerouted and several additional telephone cable inputs were run into the control room.

Since the entire system used by the Network is based upon its unique transmission facilities, a thorough description of the control room must be preceded by a few words about the series of transmitters installed throughout the British Isles by the Signal Corps.

Captain L. C. Sigmon, former chief engineer at KMPC in Hollywood, was in charge of installing the 50-watt transmitters and connecting them to BBC equalized lines. He was assisted in his work, especially in the adjusting phase, by Mr. T. J. Chadek of San Diego, California and Technical Sergeant Claude Fulk, both highly experienced radio men.

The transmitters are completely portable, taking up no more space than an ordinary kitchen table. They comprise a high gain speech amplifier, two-channel mixer, speech amplifier power supply and a high and low voltage power supply for the R-F section and modulation. All transmitters operate on 1402 and 1420 kilocycles. They are crystal controlled, and the Terman Woodward system of efficiency modulation is used in the two 814 tube lineup along with the 807 crystal oscillator and 807 buffer tubes. The input is approximately 250 watts.

Antenna structures and sites were selected on the basis of expediency. Most of the antenna supporting masts are of the readily demountable type which can be erected in half an hour. These are 72 feet high and support a  $\frac{1}{4}$  wave "L" type antenna. Since it

is desirable to keep the range of the transmitters short—a maximum of seven miles—no special ground systems were employed. A matching network incorporated in the transmitter allows power to be run into any type antenna less than  $\frac{1}{4}$  wave in length.

All transmissions operate from the central studio and no facilities are provided for local announcements. Two G.I. operators, however, are assigned to maintain each transmitter station. In addition there is a permanent staff of officers and enlisted men whose job is to select sites for additional installations and to order supplies and perform the necessary clerical work. Since the number of transmitters is being increased from day to day, these Signalmen are among the busiest soldiers in the European Theater.

Besides the transmitters, which already are numerous enough to provide extensive coverage for even the most isolated outposts of Americans in Great Britain, speakers wired directly to the studio have been placed in barracks, Red Cross clubs and other places where soldiers congregate in the London area. There is no need, therefore, for a transmitter in London.

The control studio is under the direction of the Special Services Division. The radio chief is Lieutenant Colonel Charles H. Gurney, former owner of WNAX, Yankton, South Dakota, who, with Captain John S. Hayes, formerly of Mutual Broadcasting Company in New York, supervises the soldiers and civilians who make up the American Forces Network staff.

The control room and studio engi-

neering staff is composed of former radio station and "ham" operators. These include Don V. R. Drenner, KGGF, Coffeyville, Kansas; F. Lewis, WTAR, Norfolk, Virginia; J. L. Boor, KFJI-KGIR, Great Falls, Montana; Robert L. Ellis, W6CA, Los Angeles, California; and Harold O. Wright, W9UYA, Peoria, Illinois.

Their headquarters control room which uses chiefly British apparatus, consists of ten standard rack-and-panel bays, which hold all the necessary equipment for the operation of the studios for monitoring, signaling, and transmission. A series of line amplifiers feeding a "ring main" to provide programs to the recording channels, and for monitoring to various offices also is available.

Four operating positions are maintained, only one of which is in use normally. The others are stand-by and recording feed positions. A tone source for lining-up, a limiter which feeds the normal line to the transmitter network, and various jack fields and equalizer panels are included on the bays.

A talk-back circuit is provided to Studio A, and loudspeaker monitoring is fed to Studio A, C, and the news room. Studio A is the normal feed to the network. This studio has mike channels and two Presto transcription tables, as well as a BBC TD/7 type two-position record table. Studio B also has a TD/7 (turntable desk) announcer control of the mike, signaling circuits, and phone and monitoring circuits.

Considerable difference exists in nomenclature and methods of operation between the American and the BBC networks. The American Forces

*(Continued on page 78)*

# LOUD SPEAKER RESPONSE MEASUREMENTS

Prepared by the **TECHNICAL SERVICE DEPT.**  
Jensen Radio Manufacturing Co.

## **Technicalities of acoustical laboratory measurements and the possible misinterpretations of frequency response curves.**

THE present high level of technical achievement in the field of electroacoustics is largely due to improvements in measurements technique. Today it is possible to measure accurately the frequency response characteristic of a loud speaker and such data provides the means by which experienced electroacoustic engineers determine how the speaker will sound to the listener in the final application. But despite the great usefulness and evident advantages of such a procedure, it is important to recognize that the frequency response of a loud speaker, as observed by listening tests or visualized from a measured response curve, is a product of the particular acoustic environment under which it is obtained. Evidently, then, a measured response characteristic will not indicate the results to be expected in the final application unless the listener will hear the loud speaker under exactly the same conditions as those under which the measurements were made.

Our purpose here is to show how frequency response measurements are made and used by engineers in the designing of loud speakers, to indicate suitable measuring methods, to show the possibilities for misinterpretation in the use of response curves, and the extent to which response curves indicate final performance in the ultimate application.

### **The Human Ear**

It seems worthwhile here to review some of the things that have been learned about the behavior of the human hearing mechanism. Despite the fact that the ear is a rather inexact and unsatisfactory acoustical instrument in the engineering sense, a loud speaker must ultimately stand or fall on its performance as appraised by the ear. It is for this all-important reason that laboratory response curves are always checked by exhaustive listening tests.

The range of auditory sensation is described by the group of equal loudness curves in Fig. 1. Each curve shows the intensity level required at various frequencies to produce a sound judged by the listener to be as loud as the 1,000-cycle reference intensity level. The lower curve defines the "threshold of audibility"—the

point where sound is as barely audible as a faint whisper. The uppermost curve is known as the "threshold of feeling," for at this intensity level sound becomes painfully loud and is not only heard but felt.

These curves are, in effect, *inverted*

**EDITOR'S NOTE:** *The average purchaser of loud speakers is not an engineer and naturally is unfamiliar with the many technicalities of acoustical measurements as they are made in the laboratory of the speaker manufacturer and recorded as "response curves." This material has been prepared primarily to acquaint those workers with sound, whose interests and experience are outside the laboratory, with the general problems of loud speaker measurements and the practical significance of frequency response curves.*

response curves of the ear, since the sound intensity level is varied as the frequency is changed to keep the observed loudness constant, and they lead to the following conclusions:

1. The ear frequency response depends on the intensity level of the sound.
2. The relative low-frequency re-

sponse is poorest at very low intensity levels and improves as the intensity level is increased. This means that at low levels, the low frequency response of a loud speaker will appear to be poor compared to that at higher levels on listening tests.

3. The extreme high frequency response also appears to improve with increase of intensity although to a smaller degree.

4. The ear is most sensitive for pure tones in the 3000- to 4000-cycle region at all intensity levels.

As is well known, hearing ability varies widely between individuals and marked impairment or deafness is rather common. Beasley has shown<sup>1</sup> that only 1% of the population have thresholds as low as shown, and that 50% of the population have thresholds more than 15 db higher than that of the group illustrated.

Individual hearing ability progressively deteriorates with age. Not only is there likely to be a general loss of acuity over the entire frequency range, but the ability to hear high-

<sup>1</sup> The National Health Survey, Hearing Studies Series, Bulletin No. 2, The United States Public Health Service, Washington; 1938.

Fig. 1. Loudness level contours. Each curve shows the sound intensity required at any freq. to produce a loudness equal to that resulting from the 1000 cycle intensity indicated.

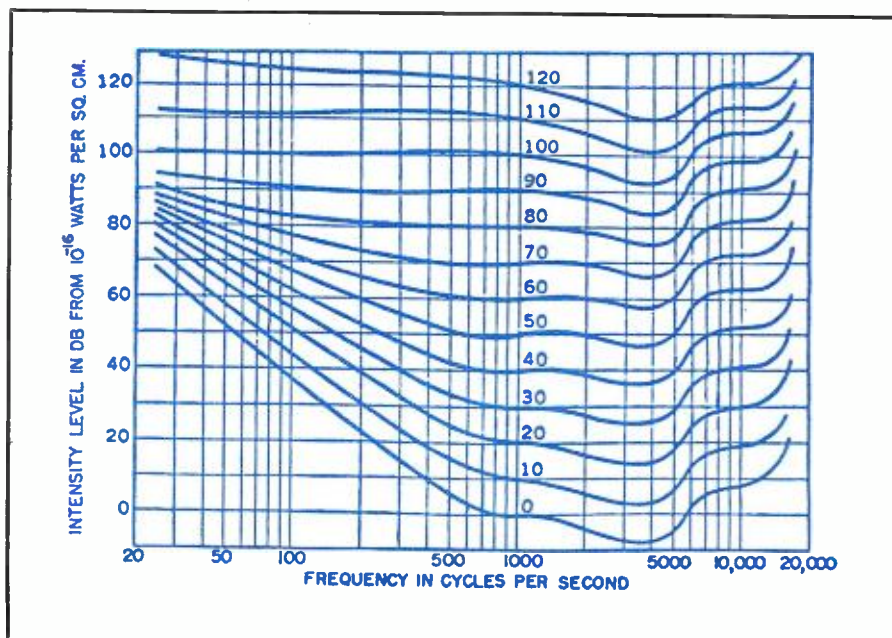

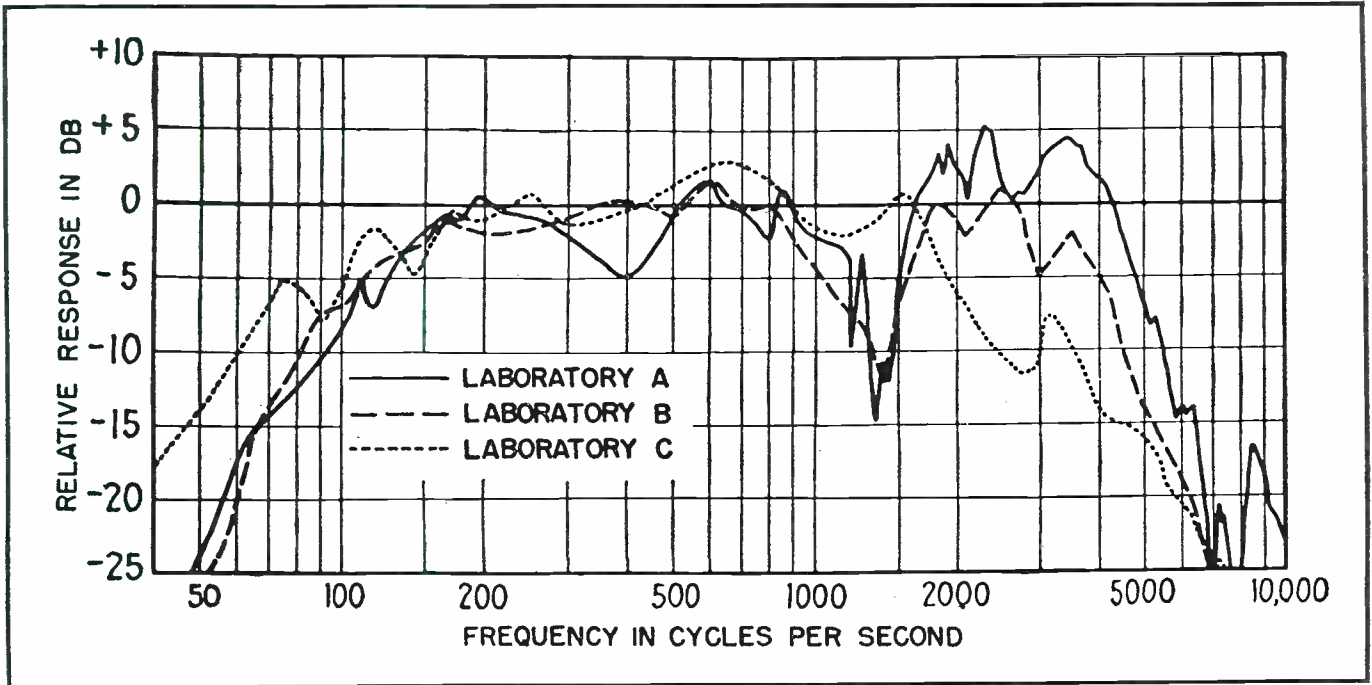

Fig. 2. Response curves of the same speaker as reported by three different laboratories, indicating need for complete familiarity with test conditions in evaluating response data from different sources. Curves have been graphically smoothed to facilitate comparison. Data showing in detail the effect of test conditions on measured results is given at length later in this article.

frequency sounds continuously decreases as age advances. For example, representative values of the falling-off in ear sensitivity with age, at 4,000 cycles (compared to age 25), are: age 35, 10 db; age 45, 12 db; age 55, 24 db.

In addition to the individual differences and trends with age, the hearing ability of a given individual may vary considerably over a short period of time due to auditory fatigue produced by prolonged exposure to loud sounds. Illness may also cause temporary impairment of hearing.

All of these factors must be kept in mind in conducting listening tests, for the judgment of listeners can be no better than their ability to perceive the thing to be appraised. In the laboratory it is, therefore, an evident advantage to be able to eliminate ear

judgments during the engineering design and development process, later utilizing listening tests to supplement and confirm data provided by response measurements.

#### Response of the Ear

The ear is a pressure-actuated device. The observed loudness of a sound depends on the acoustic pressure exerted on the ear drum. In telephone receiver listening, the sound is delivered directly to the ear canal, but in the case of loud speakers, the sound arrives at the listener by wave motion in the intervening space. Outdoors in free space, the sound waves move directly from the source to the listener.

Indoors, however, the situation becomes highly complicated. Here sound not only reaches the listener

direct from the source, but is reflected from walls, ceiling and floor. Each reflecting point becomes in effect a loud speaker, with the reflected sound tempered by the position and nature of the reflecting surface. What the listener hears is the resultant of the sound waves reaching him from many different positions and with different phases and amplitudes. The sound which the listener hears is further altered, at least in interpretation, because two ears (binaural effect) make possible an approximate localization of the source just as two eyes give depth and position to a view. The listener is thus enabled to exercise some subjective discrimination in favor of the direct sound over that which arrives from other directions.

In loud speaker response measurements, what is determined is the net resultant sound pressure at a specified point, or the average of the pressures over a specified area, according to the method used. While this yields some indication of what a listener would hear were he present, yet for the reasons outlined above, it must be remembered that the result is still fundamentally a measurement of the sound field produced by the speaker and not a determination of its effect on an observer.

To sum up briefly, then, it is known that the frequency response of the ear varies with the intensity level of the sound, and is most uniform at high intensities. Hearing ability varies widely in the population and impairment is common. Hearing ability deteriorates with age, especially at the high frequencies.

Loud speaker response measurements cannot indicate *exactly* what a listener will perceive, even if all these

Fig. 3. Theoretical polar characteristic of a 12-inch speaker represented by an equivalent vibrating piston in an infinite baffle. At low frequencies the radiation is non-directional, but at high frequencies is increasingly concentrated on the axis of the speaker, falling off rapidly as the azimuth angle is increased. Characteristics are for free space at infinite distance and only major lobes are shown.

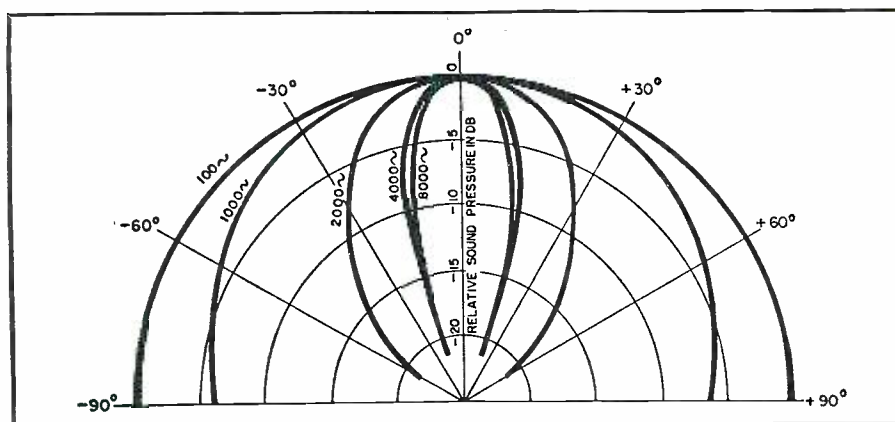

factors are taken into consideration, because (1), a given measuring microphone indicates the resultant pressure at a point in the sound field, whereas the pressure at the listener's ear located at the same point would be different due to diffraction around the head; (2), binaural (two-ear) localization of the position of the speaker by the listener tends to bias him somewhat in favor of the direct sound, while a given microphone (a single electroacoustic "ear" with smaller and different diffraction effects) is unable to discriminate in this manner, and indicates the resultant of all the pressure components from all directions at the measuring point.

#### Curves from Different Sources

To illustrate and repeat the caution frequently voiced by loud speaker engineers against the tacit acceptance of response curves without regard to conditions of measurement, let us refer to Fig. 2. Three prominent laboratories with long experience in acoustic measurements were asked to measure the response-frequency characteristic of the same identical loud speaker. The curve requested was that which the laboratory would normally publish as representative of the speaker. The resulting individual curves are quite different over important parts of the frequency range and would certainly lead to different judgments of merit by the reader. The accuracy of individual measurements is unquestioned. The differences in the results of the individual laboratories were due to the use of different methods, all of which were quite valid and descriptive of the speaker if properly interpreted in the light of experience.

It is common practice in loud speaker design work to make a number of different kinds of response measurements. Some of the methods give results which, while they tell only a part of the complete performance story, indicate immediately what changes the designer may have to make. Long experience in interpreting response curves and instinctive allowance for unmeasured but well-understood effects inherent in the general design, permits this "short-story" technique within the laboratory. However, when the results are passed on to engineers who are not daily workers in the field of electroacoustics, it is a matter of practical experience that misunderstandings and misinterpretations are more the rule than the exception.

#### Factors Influencing Measurement Techniques

The response-frequency characteristic of a loud speaker involves a determination of the sound pressure in the acoustic field resulting from constant input to the amplifier driving the loud speaker, the frequency being varied over the range of interest. The sound pressure is measured by means of a calibrated microphone and associated amplifiers.

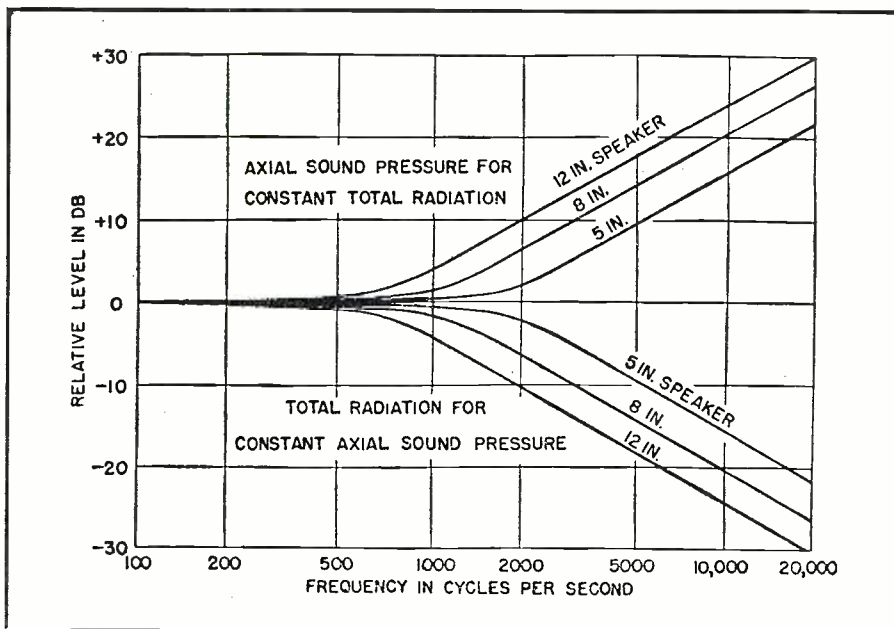

Fig. 4. Theoretical sound pressure on axis required to maintain constant total radiation, and total radiation resulting from constant axial pressure for speakers of various sizes. The speaker is assumed to be replaced by an equivalent piston, vibrating in an infinite baffle in free space.

By far the most important factor in loud speaker measurements is the purely acoustical portion of the system. The space surrounding and linking the speaker and microphone not only provides a transmission system of a highly complex nature between the transducers, but also reacts upon the speaker and determines the acoustic impedance which the radiating system "sees." Stated in another way, the efficiency of the speaker and the total power radiated by it, depend on whether it is radiating into (1) *free space outdoors*, or (2) *into a room or bounded space*. For the room case, there are general differences depending on location of the speaker with respect to the boundaries. As will be shown later in typical curves for a representative direct radiator speaker, the indoor efficiency in the frequency range below about 800 cycles is highest when the speaker is located on the floor (or ceiling) at the corner intersection of two walls, less when located on the floor (or ceiling) against a wall near its center, and least when mounted on a wall midway between floor and ceiling. These effects are due to the progressively greater solid angles<sup>2</sup> into which the speaker radiates in the respective positions described.

Another important feature of the room is its behavior as a complex acoustical resonator. In a rectangular room there are a large number of resonant frequencies or normal modes of vibration whose location in the frequency spectrum is dependent on the height, length and width of the room. These modes, as they are ex-

cited from the loud speaker, produce wide fluctuations in response at any given point in the room. In moderate to small rooms, the low-frequency modes are relatively widely spaced in frequency, thus making it difficult to obtain truly satisfactory low-frequency reproduction compared to that observed in larger rooms. At high frequencies, the modes are very closely spaced, even in small rooms. On this account also, then, it is essential to consider the room as a vital part of the acoustical system and no study of loud speaker performance (for types intended for indoor use) is complete without measurements of the response-frequency characteristic in a typical listening room.

While outdoor measurements at great heights simplify the acoustic surroundings and eliminate room effects, the accompanying disadvantages of interfering weather, wind and temperature conditions make it necessary to perform the majority of routine development measurements indoors, even on speakers designed for outdoor applications. The exact performance in any particular application, for reasons just discussed, can only be determined from measurements taken on location after the speaker has been installed.

For many years it has been customary to make indoor "dead-room" measurements, in which room resonances are partially damped out by the use of highly absorbing wall treatment. This, combined with close placement of the microphone, serves to produce fairly smooth response curves which are convenient in development work and demonstrate the result of design changes in a particular type of speaker. Such curves, of course,

(Continued on page 106)

<sup>2</sup> A solid angle is the three dimensional angle enclosed by a set of boundaries intersecting at a common point. These boundaries often reduce to some simple form such as, for example, an infinite baffle which restricts the sound radiation to a hemisphere.

★

# 2 1/2 Meter Transceiver For WERS

By  
**HOWARD A.  
BOWMAN, W6QIR**

*Constructional details for building a highly efficient 2 1/2 meter WERS transmitter and receiver unit.*

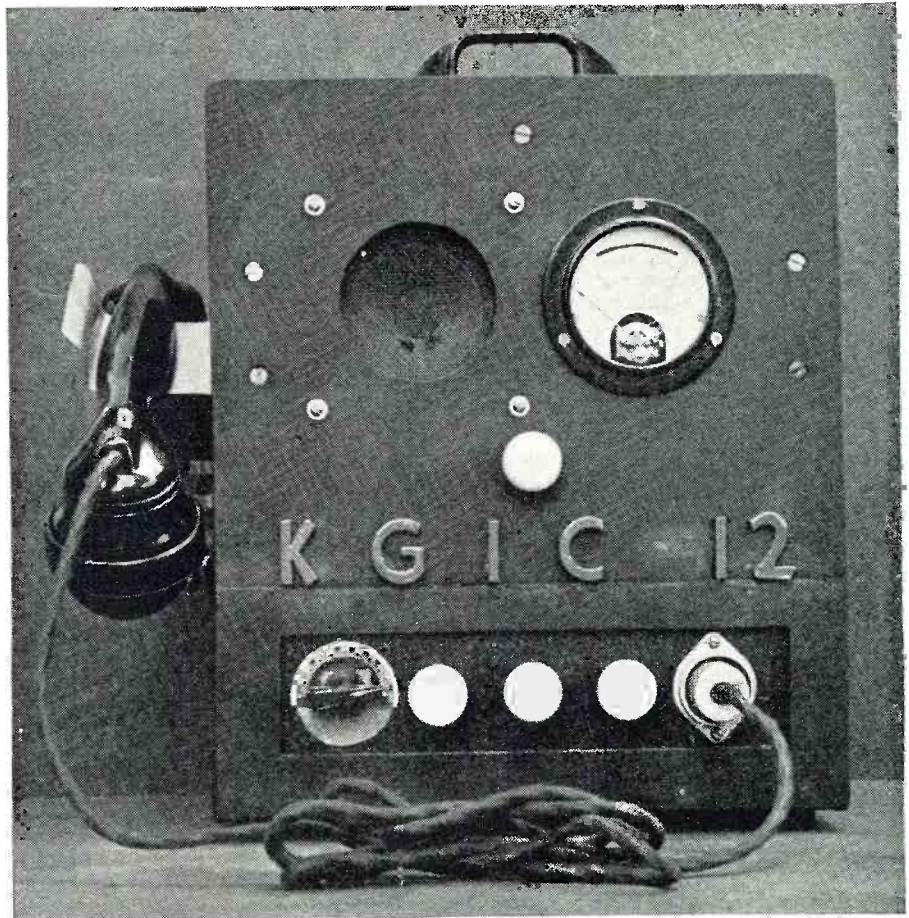

Front panel view. Along the chassis, controls are: receiver tuning, regeneration, send-receive switch, audio gain (R<sub>2</sub>), and the socket for the handset. The modulation control (R<sub>1</sub>) is located above call letters.

THE 2 1/2 meter (112-120 megacycles) transmitter-receiver illustrated and described herein was built in response to a need for additional units in the War Emergency Radio Service network (WERS). The construction of this unit is not difficult, all the parts being obtainable from one source or another. Neither

the 1/4" plastic sheet stock used for insulation nor the copper tubing used for the transmitter plate tank, can now be purchased. Both of these items, however, are needed in rather small quantities and a sufficient amount may be found in junk boxes. The r-f portion of the transmitter incorporates push-pull 7A4 tubes, us-

ing 1/4" copper tubing as a tuned plate circuit. The grid circuit, made up of coil L3, is untuned. If 7A4 tubes cannot be had, any of the other 6.3-volt triodes would be suitable. A slight loss in efficiency will be encountered, however. The modulator is made up of the 6J5GT voltage amplifier and a 6V6GT power output tube. These two tubes are similarly used for the receiver portion of the unit.

The sockets for the 7A4 tubes should be of some high-grade bakelite composition; polystyrene would be ideal, if it is available. These sockets are mounted side by side towards the front of the chassis and at the right-hand corner. Before mounting the sockets, remove all prongs which will not be used. Locate the sockets with the plate prongs mounted toward the rear of the chassis so that the plate leads are made as short and direct as possible.

The tuned plate circuit is made up of two pieces of copper tubing, each 1/4" in diameter and approximately 16" in length. They are, when assembled, to be spaced 1 3/32" center to center. To maintain this proper spacing, cut two pieces of 1/4" plastic, 5/8" wide and about 1 1/4" long. Locate and drill two 1/4" holes in each piece to provide a means of mounting the two copper tubes. Then, from one edge of the plastic, drill a hole at right angles to each 1/4" hole and tap for a 6-32 machine screw. In final assembly, 6-32

Wiring diagram of complete unit. If handset is used the receiver section should be of a high impedance. If low impedance unit only is available, connection must be made to secondary of output transformer.

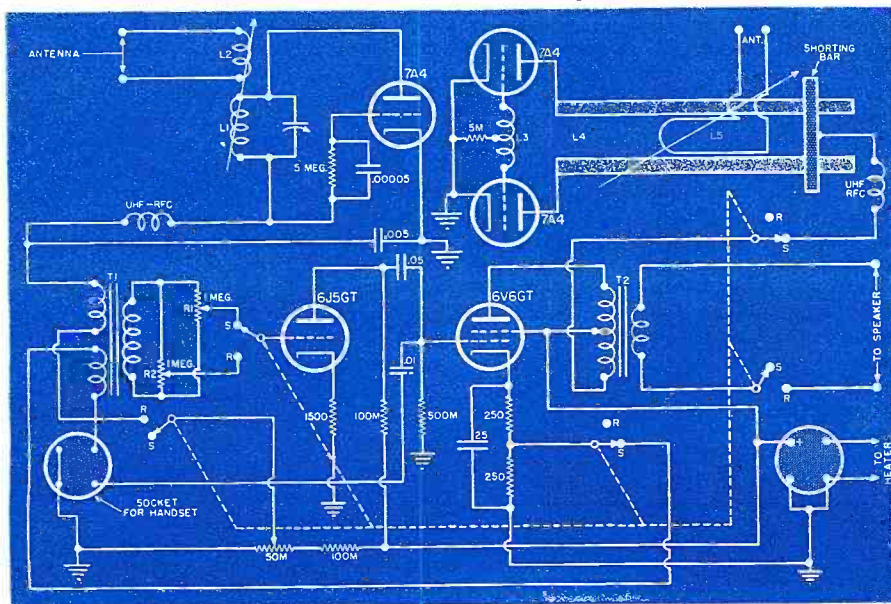

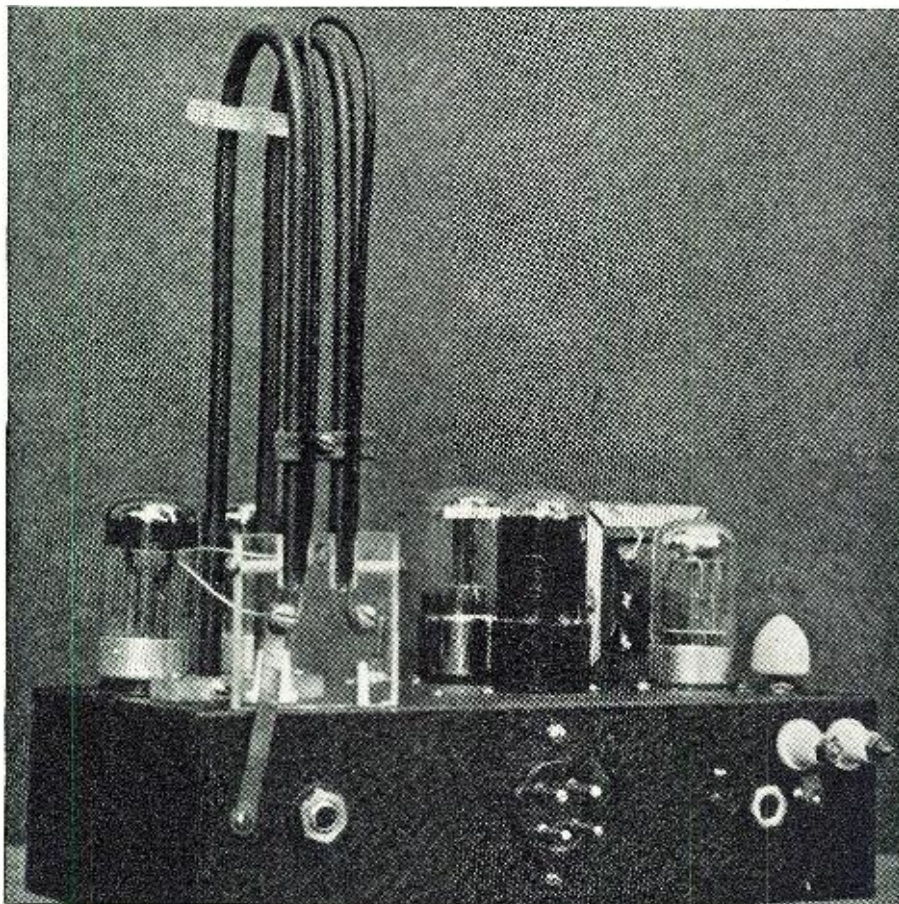

Rear view of chassis. The plate rods and their mounting plate are visible in corner. The copper grounding straps may be seen from one side of transmitter hairpin and from one receiver antenna feedthrough. The knob at the right is for receiver antenna tuning.

set screws are used to mount the plate rods securely.

To the rear of the two 7A4 r-f tube sockets, drill two  $\frac{3}{8}$ " holes. These holes should be spaced the same distance as are the rods and should be midway between the two plate prongs of the sockets so that the leads from the rods to the plate prongs will be of the same length and as short as possible.

Each rod is then flattened by squeezing in a vise about  $\frac{1}{8}$ " back from one end. Insert a piece of copper strapping about  $\frac{1}{4}$ " wide, cut from an old shield can, into the flattened end of each rod and solder securely. These copper straps will serve as the connections to the plate prongs of the tube sockets.

Bending the rod may be done over any round form of approximately 3" in diameter. Allow the rods to project about  $\frac{1}{2}$ " below the chassis at the plate end. At the power supply end the rods should come down vertically just inside of the back of the chassis and to about  $1\frac{1}{2}$ " above the chassis.

The two spacers may now be installed. One of them must first be drilled to take a couple of small bolts which will fasten it to the chassis directly over the two  $\frac{3}{8}$ " holes drilled near the plate prongs of the r-f tube sockets. This spacer will then automatically center the two plate rods passing through the chassis and when bolted and screwed tightly, will ef-

fectively prevent motion of the rods. The other spacer holds the rods at the plate end towards the upper bend.

Another piece of plastic is used to separate the rods at the rear of the chassis. It is made as shown in the rear-view photograph and also affords a convenient way of attaching the antenna-coupling hairpin.

The shorting bar used to set the rods to frequency is made of two pieces of scrap copper tubing cut from the rods. Each piece is about  $1\frac{1}{8}$ " long and is flattened with a hammer. A hole big enough to pass a 6-32 screw is drilled through the center point of each piece. One piece is left flat; the other has both ends bent over so that it forms a shallow, flat-bottomed "U."

The ends of the "U" shaped piece fit loosely around the outer edges of the rods. The UHF r-f choke should be of the type having lugs instead of wire leads. To one lug is soldered a 6-32 brass nut. A 6-32 brass screw may then be run through the "U" shaped piece, between the rods, through the flat piece, and screwed into the nut on the choke. Tightened, the whole assembly grips the rods firmly. The choke should extend downward toward the chassis, and from its other end a piece of flexible wire goes to a soldering lug on top of the feed-through insulator which brings plate voltage through the chassis.

Beneath the chassis the pieces of copper strap from the rods are bent in an easy curve and soldered to the plate prongs of the sockets. The grid coil (L3) is wound with No. 14 enameled wire. It has five turns spaced out so the coil is about  $\frac{5}{8}$ " long, and the ends are soldered directly to the grid prongs. The grid bias resistor goes from the midpoint on the coil to the chassis ground point between the sockets. To this point are brought the ground leads from both sockets.

### The Receiver

The receiver is built at the other end of the chassis. The tube socket is mounted on the chassis deck itself, but all other components are beneath the chassis. The tuning condenser is mounted on a rectangular piece of  $\frac{1}{4}$ " plastic. The piece measures about  $1\frac{1}{2}$ " x  $2\frac{1}{2}$ ". One long edge is drilled and tapped for two 6-32 screws and one short edge is drilled and tapped for one 6-32 screw. This piece is then mounted in the chassis about  $1\frac{1}{4}$ " from the front edge of the chassis. Three holes are drilled in the chassis, two in the top and one in one end, and 6-32 screws used to mount the piece of plastic securely to the chassis. The condenser is mounted so that the shaft comes about  $1\frac{1}{2}$ " from the end of the chassis and midway between top and bottom.

The ends of the coil (L1) are soldered directly to the condenser lugs and connections then made to the socket.

The coil (L1) has four turns No. 14 enameled wire wound on  $\frac{1}{2}$ " diameter form and spaced out  $\frac{1}{2}$ ". The condenser is driven by an insulated coupling and a short length of shafting. The grid leak-condenser leads should be as short as possible, as should the plate lead. The UHF r-f choke should have its lead clipped off so that it mounts very close to the coil, and the bypass condenser on the plate voltage supply should have its grounded end run to the common ground point near the detector socket.

### Audio Section

The balance of the chassis, below and above deck, is given over to the audio section. A transceiver transformer (T1) is used as an audio transformer on receive and as a mike transformer on transmit. If one is not available a mike primary of 50 or 60 turns of No. 28 or 30 wire may be wound on an audio transformer. Failing this, a microphone transformer may be used and the audio output of the detector capacity coupled into the grid circuit of the 6J5.

Handset transmitter voltage is obtained from the junction of the two resistors in the cathode circuit of the 6V6GT output tube. It is conveniently obtained and proper voltage is thereby had. The 6J5 amplifier tube is left unbypassed so that degeneration is obtained. This degeneration will result in a reduction of gain. However, there is sufficient gain to drive

(Continued on page 72)

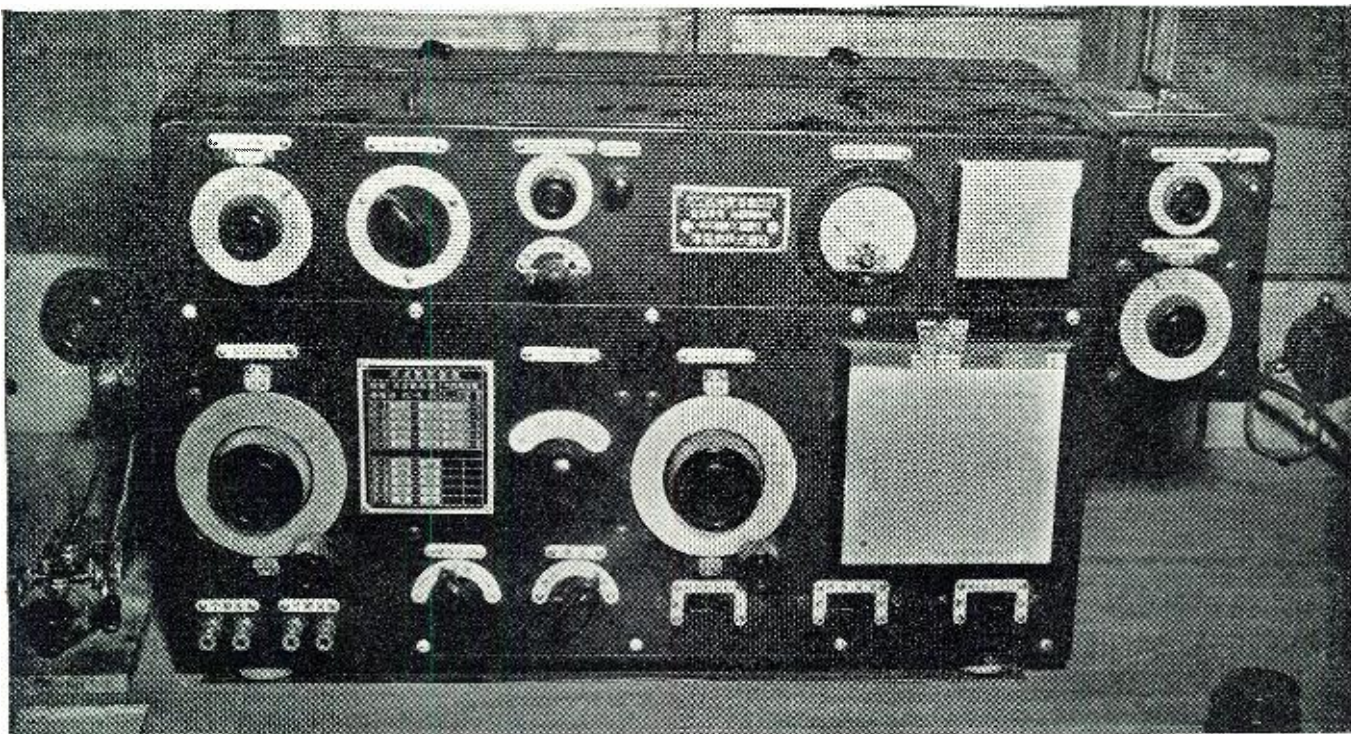

Japanese radio set captured in good condition, when the Leathernecks surprised the Japs on Guadalcanal.

# JAPAN'S WIRELESS WAR

By **ALEXANDER KIRALFY**

*An unusual episode that took place during World War I and which may have significance in today's warfare.*

THIRTY years ago an historic incident occurred which gives us a new insight into the curious workings of Japan's mind. It shows a strange Nipponese employment of the air waves absolutely at variance with the boasted courage of the samurai. And last, but not least, it directs our attention to some phases of "electronic" warfare which are apt to be overlooked. Let us consider these first. . . .

There are few if any fields of war effort receiving greater scientific attention than that dominated by the radio tube. Were our sending and receiving equipment to cease functioning, the consequences might well be disastrous. It follows that every improvement we achieve in this vital field, and every advantage we gain over the Axis powers in this respect has a significance which it would be difficult to exaggerate. These improvements belong, not only to the physical realm of apparatus, but also to the mental realm of operational invention and resourcefulness. In the immense Pacific Theater of war, in

particular, much depends upon adequate methods of communication and of misleading the enemy.

What *extraordinary* methods we may be pursuing in this regard must naturally remain a closed book for the duration.

In the Pacific the keynote of Allied strategy has been surprise. In this vast area we have landed where we are the least expected, bombed Japanese airfields when they were most heavily stocked with planes, and we are endeavoring to bring important parts of Tojo's fleet into action.

An electronic strategem has been to switch call-names of stations ashore and afloat. In World War I the signal of the German flagship was transferred to a shore station with the result that the British Grand Fleet came upon the Kaiser's flagship and accompanying squadrons far at sea when the German flagship was supposedly busy "chattering" back home at its base. In 1914 the Japanese drove German sea power out of the Pacific by means of an "electronic" fleet.

When World War I broke out, the Japanese delayed their entrance into the struggle. Though they were then Britain's ally they were thinking, as usual, of themselves alone. Strange as it may seem, the Japanese were not interested in destroying the German Pacific Squadron of armored and light cruisers. They decided to let the British lose ships in that task. As the German High Command later and correctly concluded, Tokyo even then was husbanding its naval resources against a day when it would fight the United States. So far as the German warships of Admiral Graf von Spee were concerned, Japanese eyes became suddenly myopic. They could not see nearby Teutonic fighting ships because of the powerful vessels which swung at anchor at Mare Island and San Diego on our own West Coast. Was Tokyo, back in 1914, already thinking of the future, and of an Axis?

Be that as it may, the fact remains that the Japanese made no effort to track down and fight the German cruisers in the Pacific. Only once did they catch sight of a German



auxiliary cruiser at sea, and then turned their attention obligingly in the opposite direction. Tokyo had decided to fight, not with guns, but with aerials. Though none of the contestants—British and French, Japanese and German—was then over-careful in observing wireless silence, Japanese lapses in this regard were so numerous and flagrant as to warrant the conclusion that they constituted a “system.” This also explains why Tokyo procrastinated at the beginning. Japanese officials unquestionably wanted to know first just where the German squadron was located and whither it was heading. Then, without running the slightest risk, they wanted to herd it out of the islands which were to become their mandate, and drive von Spee out of the North Pacific into the Atlantic.

The location of the German cruiser squadron, which steamed out into the Pacific before the outbreak of the war in Europe, could be gleaned by tapping Japanese telephones and cables used by German officials in that country and attempting to break their wireless messages. These services were under government control or supervision by virtue of the Telegraph Act of Japan of 1900. In view of the extent and “intensity” of the Japanese espionage system at home and abroad and this people’s “super-inquisitiveness” that has astonished foreigners for centuries, there can be little question but that the Japanese spared no pains to exhaust all intelligence possibilities before entering into the status of belligerency.

Tokyo’s first act of “belligerency” was to broadcast to the world through the Nagasaki wireless station that her warships had been dispatched to take

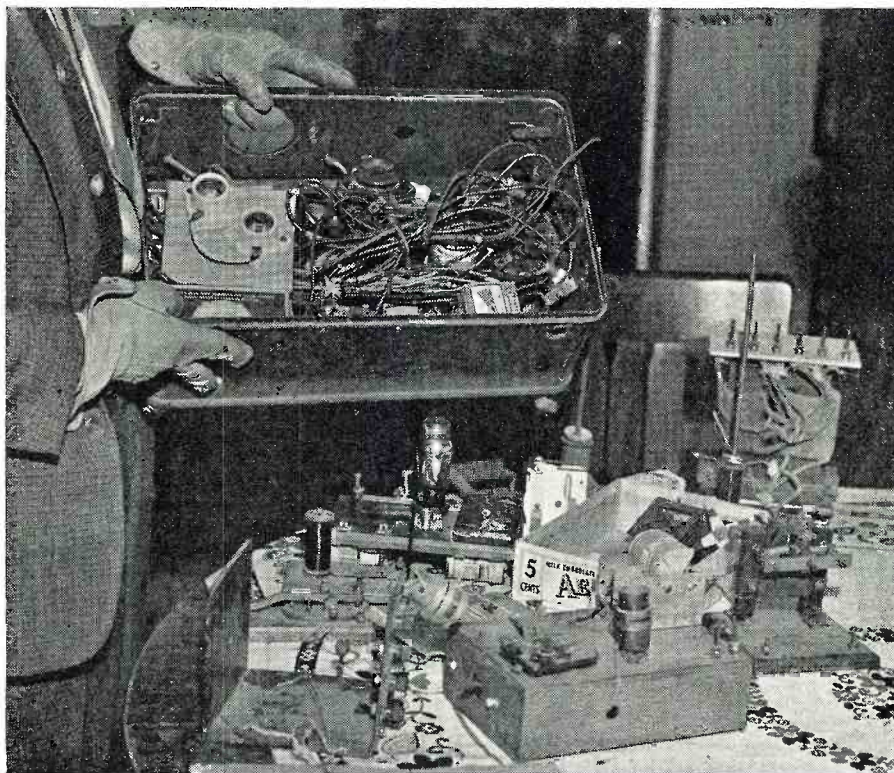

Radio parts seized when C-men and deputy sheriffs raided 40 Japanese-owned farms on the rugged Palos Verdes coast, south of Los Angeles.

over the German islands in the Pacific—where von Spee was in hiding. This was an inexcusable disclosure of military intentions on the part of a nation as well known for its secrecy as for its inquisitiveness—until, of course, we note the method in the madness. The Nagasaki news item alerted the German ships and thereafter, though with no undue haste, they slipped along the Japanese wireless beam towards Cape Horn.

Strategically posted before hostilities began, Japanese warships cautiously fanned through the Pacific islands figuratively sweeping the Germans towards the southwest with a wireless broom. They helped von Spee go precisely where he wanted to go himself—into the Atlantic. During the very first night of war between Japan and Germany, Nipponese troops landed in Palau and set signal fires  
(Continued on page 74)

Communications Post of “nerve center” of a Marine Corps regiment on Tarawa. The equipment was set up soon after Yanks landed on the Jap-held island in the face of strong opposition and tough natural barriers.



# INDUCTIVE AND REACTIVE EFFECTS IN STRAIGHT LEADS

By CLARK JACKSON

*An analysis of the inductive and reactive effects of straight wire conductors essential in determining high-frequency circuit designs.*

THE inductance of a short, straight piece of heavy wire is low enough to render the reactance of such a conductor immaterial at the lower communication and power-line frequencies. A rule-of-thumb procedure accordingly has long been observed: To employ straight-running conductors of heavy wire for electronic circuit connections.

An inductance which introduces a negligible amount of reactance at the lower frequencies may cause considerable concern at the very high frequencies encountered in modern electronic practice. A good bus connector at one frequency then becomes a reactive circuit element at a higher frequency and must be considered by the circuit designer. A straight 2-inch length of No. 12 wire, for example, has an inductance of only 0.039 microhenries and would be considered an efficient conductor at 60 cycles, where its reactance is 0.000147 ohms, and it is tolerable even at 1000 kc. where its

reactance is about  $\frac{1}{4}$  ohm. But this same lead shows a reactance of  $12\frac{1}{4}$  ohms at 50 mc., neglecting skin effect, and its characteristics demand attention in circuits operating at that frequency.

The effect of the reactance of a 2-inch straight length of No. 12 wire would thus have to be considered if this connector were employed within the attenuator of a 50-mc. signal generator. Coupling leads of this size likewise might be expected to introduce appreciable attenuation in ultra-high-frequency low-voltage r-f circuits, because of these reactive effects.

The magnitude of lead inductance and reactance varies directly with frequency. The effect at super-high frequencies might correctly be expected to mount at such a rate that conductor length becomes as much a matter of circuit design as does the characteristics of lumped-characteristic components. In addition to reactance, the effective r-f resistance of a lead,

which also is a function of frequency, must be taken into consideration, since this parameter combines vectorially with reactance to determine the total impedance offered by the lead. For the present, however, we shall concentrate upon reactance.

Since our circuit components must be provided with leads, however short and straight, the additional circuit reactance introduced by these connectors is of moment in more than occasional instances. One example involves the total inductance of fixed-capacitor leads which act with the capacitance of the unit to set up a series-resonant circuit: Consider a capacitor of .01  $\mu$ fd. with two  $\frac{1}{2}$ -inch No. 20 wire leads connecting into the external circuit. The total inductance in this case (.02  $\mu$ h, neglecting inductance of the capacitor section itself) will establish with the .01- $\mu$ fd. capacitance a series circuit, resonant at approximately 11 mc. Resonant current will reach a high level in this "sub-circuit"; and if 11-mc. operation is planned, the designer must be certain that it will not exceed the safe current-rating of the capacitor.

The importance of lead inductance and reactance at high frequencies naturally introduces some curiosity as to the nature of these parameters and the methods whereby they may be calculated. It is the purpose of this article to present a simplified picture of straight-wire inductance and list simple formulas for its calculation.

## Inductance and Reactance

The following formulas for determining inductance and reactance of straight round wires are based upon the inductance equations given by *Circular 74* of the National Bureau of Standards. The author's formulas have been written to show dimensions in inches, rather than in centimeters, however, since the former units are usually more convenient to a number of electronic workers.

Where length ( $l$ ) and diameter ( $d$ ) are measured in inches, the inductance of a straight round wire is equal to:

$$L_o = .00508 l \left[ \log_e \frac{4l}{d} - 1 + \frac{\mu}{4} \right]$$

microhenries.....(1)

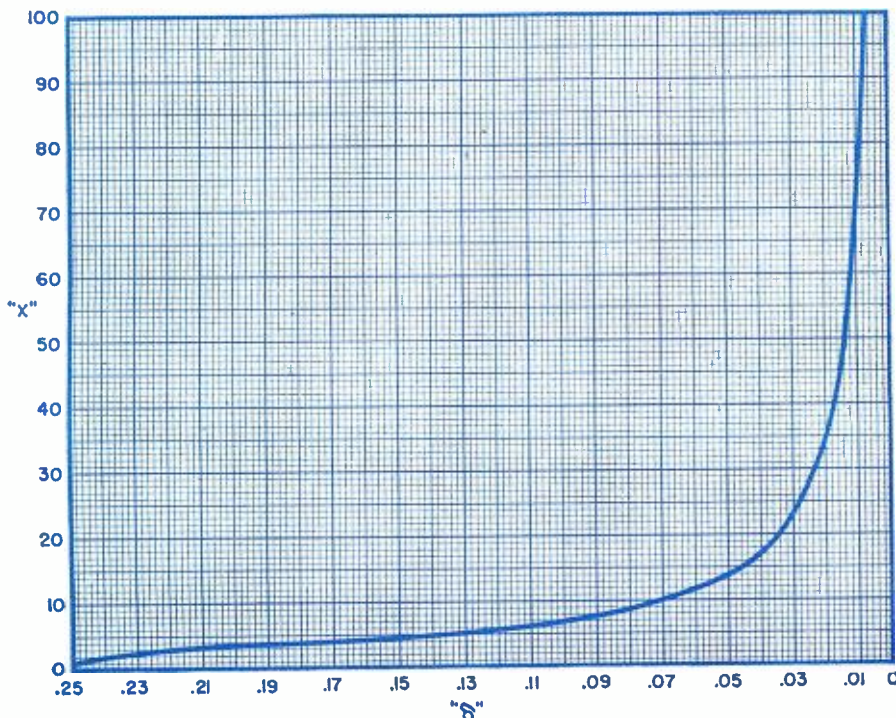

Fig. 1. Curve used to obtain value  $\delta$  needed in calculating inductance of straight wire at any frequency. Argument "x" is obtained from equation  $.3569d \sqrt{\mu l/p}$ .

$\mu$  is the permeability of the conductor material, being 1 in most cases, since that figure applies to copper which is commonly employed for leads.

In terms of the common logarithm, the expression for inductance becomes:

$$L_o = .00508l \left[ 2.303 \log_{10} \frac{4l}{d} - 1 + \frac{\mu}{4} \right] \text{ microhenries} \dots (2)$$

Non-ferrous materials are generally employed as high-frequency conductors, a fact which acts to simplify the right-hand end of the expression within the brackets to give the following formula which is used in most calculations:

$$L_o = .00508l \left[ 2.303 \log_{10} \frac{4l}{d} - .75 \right] \text{ microhenries} \dots (3)$$

The inductance of the straight round wire decreases somewhat as the operating frequency increases, reaching at infinite frequency a value equal to:

$$L_{\infty} = .00508l \left[ 2.303 \log_{10} \frac{4l}{d} - 1 \right] \text{ microhenries} \dots (4)$$

A general formula for the inductance of a straight round wire at any frequency is:

$$L = .00508l \left[ 2.303 \log_{10} \frac{4l}{d} - 1 + \mu\delta \right] \text{ microhenries} \dots (5)$$

Where:

- $\mu$  is the permeability of the wire material (equal to 1 for copper),
- $\delta$  is obtained from the graph of Fig. 1 in terms of "x". The argument

$$\text{"x" is equal to } .3569 d \sqrt{\frac{\mu l}{p}}$$

Where:

- f is in cycles per second, and p is the volume resistivity of the wire material in microhm centimeters; equal to 1.724 for annealed copper wire, and to 1.771 for hard-drawn copper. "x" for copper wire at 20° C. is equal to  $.272 d \sqrt{f}$

Formula (5) usually is not employed and preference is given to the general formula (3), the resultant error increases with frequency (e. g., becoming approximately 8 per cent at 25 mc.) and will be of moment in some close calculations, particularly at the super-high frequencies.

The expressions for reactance of a straight round wire (based upon the relationship  $X_L = 2\pi fL$ ) are:

General Formula:

$$X_L = .0319 \times 10^{-6} fl \left[ 2.303 \log_{10} \frac{4l}{d} - 0.75 \right] \text{ ohms} \dots (6)$$

For any Frequency:

$$X_L = .0319 \times 10^{-6} fl \left[ 2.303 \log_{10} \frac{4l}{d} - 1 + \mu\delta \right] \text{ ohms} \dots (7)$$

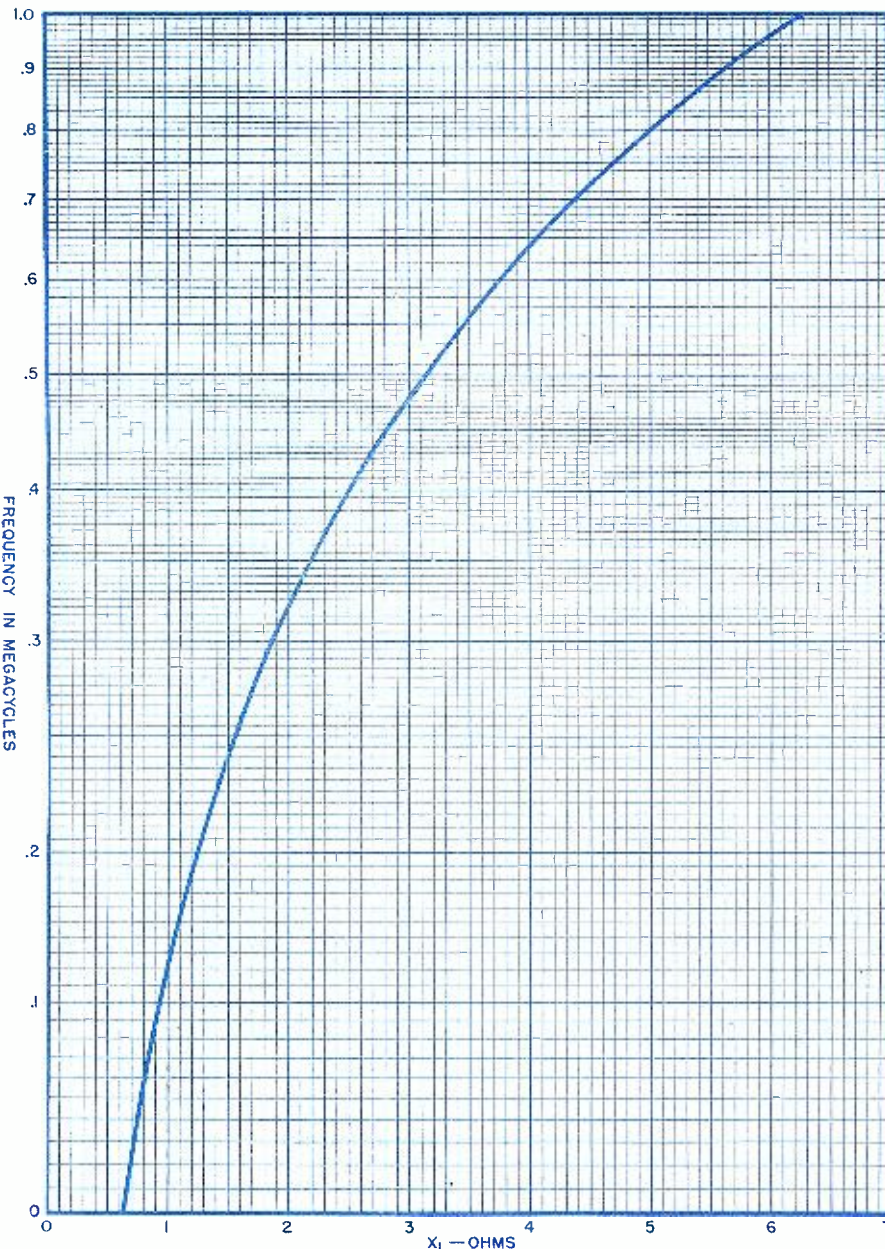

Fig. 2. Variation of inductive reactance of a 1 microhenry inductor between .1 and 1 megacycles. The curve may be extended to other frequencies as explained in text.

Where:

- f in each case is in cycles per second, both in the above formulas and in the expression for "x" from which  $\delta$  is derived (see Formula 5).

#### Universal Reactance Curve

For convenience in calculations and in estimates, the graph of Fig. 2 shows variation of inductive reactance for a 1-microhenry inductor between .1 and 1.0 megacycle. The utility of the curve may be extended to show the reactance of any inductor at any frequency in the following manner:

- $L_s = 1 \mu h$  (curve basis),
- fs = frequency on graph,
- $L_x =$  "test" inductance,
- fx = "test" frequency.

A.  $L_x = L_s$ , frequency between .1 and 1.0 mc. Use all graph values directly.

B.  $L_x$  larger or smaller than  $L_s$ , fre-

quency between .1 and 1.0 mc. Locate

$X_{L_s}$  for  $L_s$  on the curve and multiply  $X_{L_s}$  thus obtained by  $L_x/L_s$ .

C.  $L_x = L_s$ , frequency higher or lower than graph values. Move decimal point in frequency figure (fs) on graph to right or left to yield the test frequency value (fx), locate  $X_{L_s}$  for  $L_s$  on the curve, and multiply  $X_{L_s}$  thus obtained by  $fx/fs$ .

D.  $L_x$  larger or smaller than  $L_s$ , frequency higher or lower than graph values. Move decimal point in frequency figure (fs) to right or left to yield the test frequency value (fx), locate  $X_{L_s}$  for  $L_s$  on the curve, and multiply  $X_{L_s}$  thus obtained by  $\frac{L_x(fx)}{L_s(fs)}$

In each of the preceding examples, L is in microhenries and f in megacycles.

**"MAINTENANCE AND SERVICING OF ELECTRICAL INSTRUMENTS,"** by James Spencer. Published by *The Instruments Publishing Company, Inc.*, Pittsburgh, Penna. 256 pages. Price \$2.00.

This book is intended to give practical information on the maintenance and service of electrical indicating instruments. At first, much of the material was written as a guide for teaching the subject in industrial electrical schools, and for training personnel for instrument manufacture. Because of the present emergency, however, and the many new applications for electrical indicating instruments, the guide information was amplified and put into book form.

The subject of maintenance and servicing of electrical instruments has never previously been covered in book form. Here, it is written in a lucid style. Each general type of instrument in common use is first covered with a simple explanation of the underlying principle of operation, and then followed by detailed instructions on maintenance and repair. It covers the construction, testing, applications, principles of operation and maintenance of all kinds of electrical instruments.

This book should be useful to all instrument users, switchboard attendants, testing engineers, and instrument servicemen, as the accuracy and efficient life of instruments depend to a large extent on intelligent handling.

**"THE RADIO AMATEUR'S HANDBOOK,"** 1944 Edition, by the Headquarters Staff of the American Radio Relay League. Published by *The American Radio Relay League, Inc.*, West Hartford, Conn. 664 pages. Price \$1.00 in U. S. A.; \$1.50 elsewhere.

Although all amateur radio operations were halted at the advent of the war, this book has been called on to serve in most branches of both military and civilian radio training. The book, which is an institution with a background extending back over more than two decades, presents technical radio instruction so understandably that amateurs are able to absorb the essentials rapidly, due to the fact that the material is presented so that learning radio is made easy.

The 1944 edition is designed to perform that function more effectively. It differs from previous editions mainly in the expansion and revision of the "theory" part of the book—the chapters on fundamental principles and design. Explanations of certain principles have been amplified.

The "construction and data" section of the book closely follows the recent editions, except that a new chapter on Carrier-Current Communication has

*(Continued on page 110)*



**By CARL COLEMAN**

**T**HE Institute of Radio Engineers held a display of radio equipment at the Hotel Commodore in New York City in late January which attracted radiomen from all branches of the industry. The display, held in conjunction with the annual winter technical meeting of the institute, included captured enemy radio equipment and communications equipment standards for the Army, Navy and Air Corps. The entire meeting was, as usual, packed with interesting addresses by the top-notch men of radio who really "know how."

Hubert M. Turner, associate Professor of Electrical Engineering at Yale University was elected president of the Institute for 1944. Lynde P. Wheeler, Chief of the Engineering Department's Information Division of the Federal Communications Commission was the retiring president.

**R.** ANDRESEN is now out as a Navy brass pounder. J. F. Palmer has taken out a Liberty assignment from an East Coast port. Liberty assignments also included K. Da-

vidson. I. J. Gaffney had his Liberty in the yard for overhaul recently. Robert Lacey took out a new C-3 assignment after his last tanker job. Bob is dickering with OWI for a job in foreign parts, although with his past experiences, most anything will seem mild now. A. C. Vahtrok has been assigned to one of the ships that were taken over at the start of the war, originally operated by an occupied country. O. Andersen is still with the same old cargo job out of the East Coast. John W. Scott is on a Liberty job now. Ernest MacDowell has resigned his shore berth and plans to return to the briny deep where he has been a brass pounder for many years. H. D. Baker and J. D. Williams were in town recently; both are on cargo ship assignments.

**A**NNUAL meeting and banquet of the Veteran Wireless Operator's Association was held February 12th, Lincoln's birthday, at the Hotel Astor in New York City. Bill McGonigle, president of the association, introduced a very distinguished list of speakers, including representatives from the various United Nations. Speakers from our own Military and Maritime services were also on the impressive program as they were at the previous meeting a year ago. Men with over ten years of radio operating experience are eligible for membership in this organization—contact Mr. W. C. Simon, at Pier 7, North River, New York, N. Y., for information concerning membership.

**A**LTHOUGH over half a million radio receiving tubes were released for domestic use by the Radio and Radar Division of the WPB recently, many local

*(Continued on page 82)*



## Pentode Amplification Chart

**G**IVEN the load resistance in ohms and the transconductance in micromhos, place a straightedge across the chart through these values. Obtain the effective amplification of the stage at the point of intersection of the straightedge and the left vertical axis.

### EXAMPLE:

$G_m = 2200$  mhos  
 $R_L = 30,000$  ohms  
 From the chart  $A = 66$

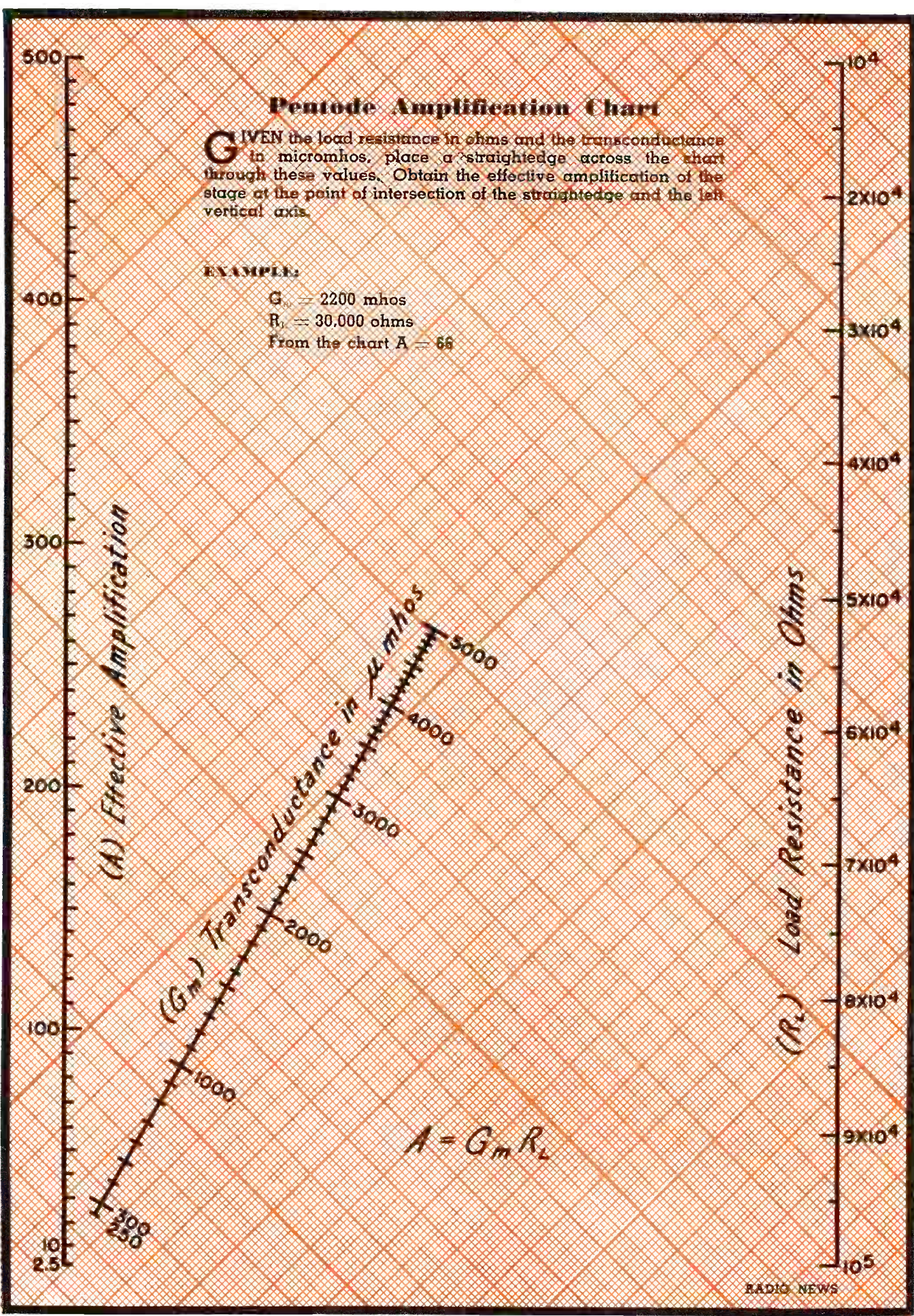

RADIO NEWS

# THEORY AND APPLICATION OF J. E. F.

By MILTON S. KIVER

## Part 4. An introduction to the theory of transmission lines, covering their many important properties at broadcast frequencies.

**W**HILE transmission lines, at low frequencies, find their most extensive use as coupling systems between the transmitter and its antenna, at ultra-high frequencies their use becomes more universal. Not only are they used, as mentioned above, for low frequencies, but they also find application as interstage coupling devices, tuning circuits, in-

electric. In this case, the dielectric is composed of the air between the conductors and the insulation, if any, wrapped around the conducting wires. And since the condenser action is not perfect, it is shown schematically by placing a resistance across the condenser, thus denoting leakage. The presence of inductive reactance, however, is not so easily explained. We

of the two parallel conductors.  
 $r =$  radius of one wire.

It does not make any difference what units  $d$  and  $r$  are measured in so long as they are both the same. For the concentric cable, the inductance is given by

$$L = .741 \log_{10} \frac{b}{a} \text{ mh./mile}$$

where

$b =$  radius of outer conductor.  
 $a =$  radius of inner conductor.

To represent the above inductance, capacitance and resistance in schematic form for analytical purposes, a diagram such as shown in Fig. 1 is often used in engineering books on transmission lines. Although the various components are shown separate and distinct from each other, they are really distributed evenly along the line. It is only because of our inability to show these components as they really are that forces us to resort to the above method.

It might be advisable to point out at this time that any expression given for resistance and inductance should take into account the fact that both these quantities vary with frequency. The resistance must be corrected because as the frequency increases the current tends more and more to flow near the surface of the conductor and thus increase the effective resistance. This, of course, is the well-known skin effect and is a function proportional to frequency. As for the inductance, it is found to change slightly, due mostly to the fact that because most of the current at high frequencies flows at the surface of the conductor, there are less internal flux-linkages and hence, the change in the self-inductance. The percentage change for the inductance is far less than the corresponding change in resistance with change in frequency.

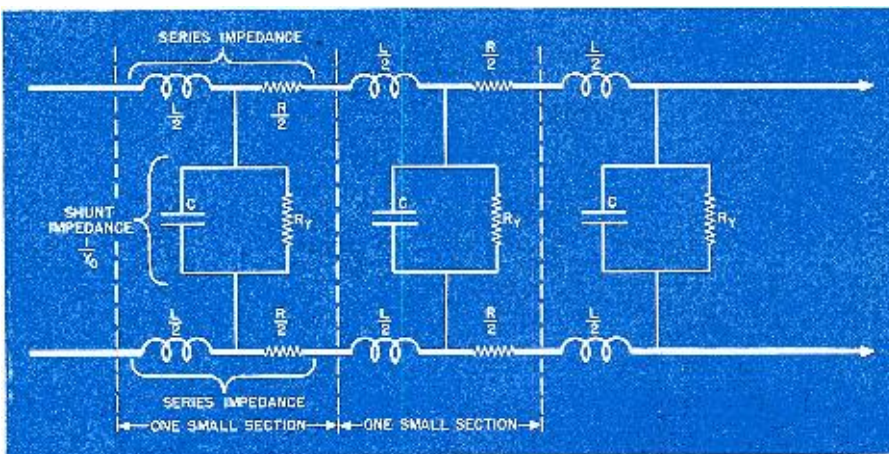

Fig. 1. Distributed properties of transmission line in terms of lumped circuit constants.

ductances, capacitances and even as high or low pass filters. All this comes about by the simple expediency of varying the length and end construction of any ordinary transmission line.

It is the purpose of this chapter to delve into the mysteries of transmission lines operated at the broadcast frequencies and to cover many of their most important properties.

It would perhaps be best to begin with ordinary inductance, capacitance, and resistance, the type that can be bought in any radio shop. These inductances, capacitances or resistances, as the case may be, are said to be lumped because each is complete and distinct from the others. We are, of course, neglecting the resistance inherent in the wires of the reactors.

Now, if we were to take two wires and string them close together, using one to conduct the current away from an a.c. generator while the other one conducts the current back, it would be found that this two-wire system contains more than just resistance. Inductance and capacitance could also be measured, although physically none of these could be seen. The capacitance can perhaps more easily be explained when the definition is recalled—namely—two conductors separated by a di-

must go back to the concept of magnetic lines of force and attack the problem from this angle. Inductance may be defined as proportional to the total flux lines per unit current that encircle the wire. By starting with this concept, the inductance per unit length of any wire or system of wires can be developed. It will be found that the inductance of a pair of parallel conductors is given by

$$L = 1.482 \log_{10} \frac{d-r}{r} \times 10^{-3} \text{ henries/mile}$$

where

$d =$  the distance between the centers

Fig. 2. Current and voltage components resulting from transmission line losses.

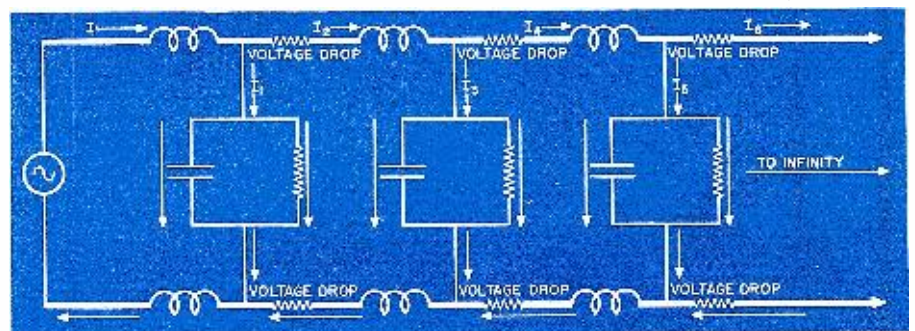

Any differences in the capacitances at the various frequencies are usually ignored, since the error introduced this way is negligible.

Since the transmission line has these various impedances distributed along its length, there must be some definite value of impedance that a generator, or other electrical circuit, will see as it "looks" into one end of this line. Of course, it is assumed above that there is some sort of circuit connected to the opposite end so as to form a complete path. If the circuit or impedance at the end of the transmission line is correctly matched to the transmission line, all the power from this line will be absorbed by the load and none will be reflected. But if there is a mismatch of impedances, some power will be reflected, some absorbed. Naturally, the case where all the power is not absorbed does not represent the maximum power transfer and hence, results in a loss in efficiency. This reflected energy results in standing waves of voltage and current along the transmission line—a condition that may or may not be desirable, depending upon the requirements of the particular case.

Associated with the transmission line are three other constants that will be defined in order to make this discussion complete. The first of these additional constants is called the characteristic impedance of the transmission line and is denoted by the symbol  $Z_k$ . To understand this constant, imagine a transmission line which is infinitely long and has a generator connected to one end. The impedance that this generator will see is termed the characteristic or surge impedance and will have one definite value, dependent, of course, on the resistance, inductance and capacitance per unit length of the particular cable. Cutting out a portion of the line will have no effect on the input impedance, since we will still be left with an infinite line. The equation for the characteristic impedance is quite simply developed in any communication engineering text and turns out to be

$$Z_k = \sqrt{Z_i / y_0}$$

where

$Z_i$  = the series resistance and inductance per unit length of line as shown in Fig. 1.

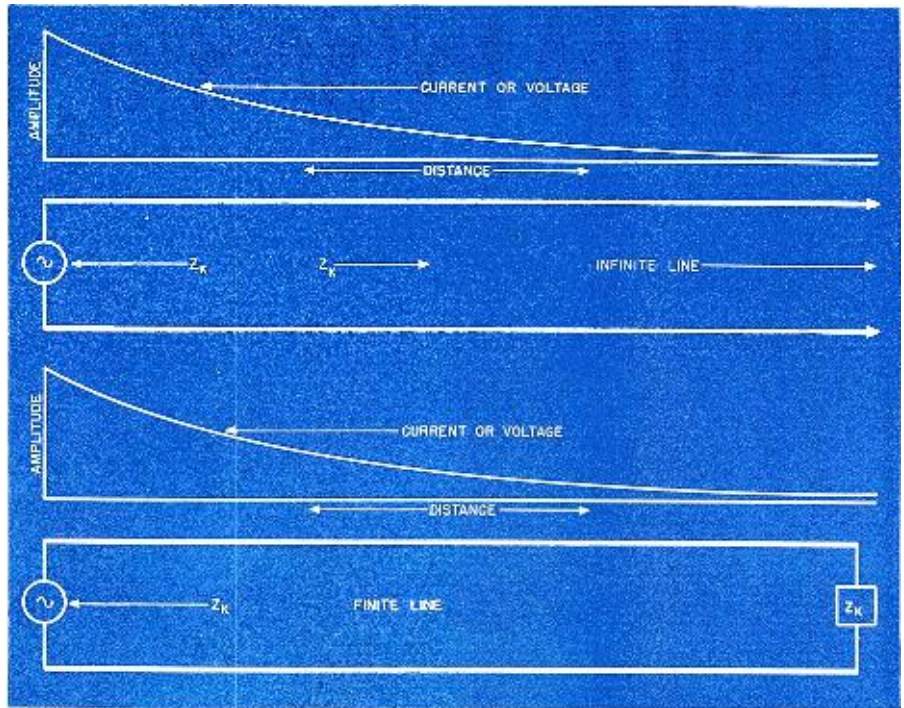

Fig. 4. Illustrating the similar effects between an infinite line and a finite line terminating in its characteristic impedance  $Z_k$ .

$y_0$  = the reciprocal of the shunt impedance across the line as represented by the condenser (C) and resistor  $R_y$  in parallel.

It should be remembered in all this discussion that a uniform transmission line is assumed so that any section may be taken as representative of the whole line.

Now let us follow the current and voltage values as we proceed down the line and see the reason for the various changes. The type of measuring instrument used is of little consequence at this point and will be taken up in great detail in a subsequent chapter. In Fig. 2, let the current that leaves the generator be labeled  $I$ . As this current is sent down the line, part of it ( $I_1$ ) is diverted through the leakage resistance and condenser and so the current left ( $I_2$ ) is equal to  $I$  less the amount diverted ( $I_1$ ). Further on, the same process takes place again resulting in the smaller current  $I_3$  and as we continue it can be seen that eventually the resultant current will be reduced to zero. At no point was

the process broken and so the diminution of current was gradual, as pictured in Fig. 3.

Investigating the voltage distribution along the line we find the same sort of diminishing effect, due, of course, to the various voltage drops across the series resistances in the transmission line. These are also pointed out very clearly in Fig. 2 and from here it can likewise be seen that the voltage across the line at any point will be less and less the further we are from the source.

While all of the preceding discussion may be very enlightening, some readers may wonder as to its practicability since infinite lines are not encountered in actual practice. However, the same effect as an infinite line may be obtained by taking any length of line and terminating it in an impedance equal to its characteristic impedance, since by doing this we simulate an infinite line as far as any generator connected to the input of the circuit is concerned. All power transmitted down the line will be absorbed without reflection by the load just as it is likewise done with an actual infinite transmission line. Fig. 3 shows this process pictorially and may be of further help in visualizing this action.

When a transmission line is to be used for communication purposes, the ideas just developed with regard to terminating the line in  $Z_k$  is usually observed as closely as possible since then very little reflection will take place and the distortion will be kept to a minimum. However, if the characteristic of the line should suddenly change—as for example terminating the line in an impedance other than  $Z_k$  then the current and voltage distribution will no longer be gradual but will,

(Continued on page 90)

Fig. 3. Current and voltage amplitude along an infinite transmission line.

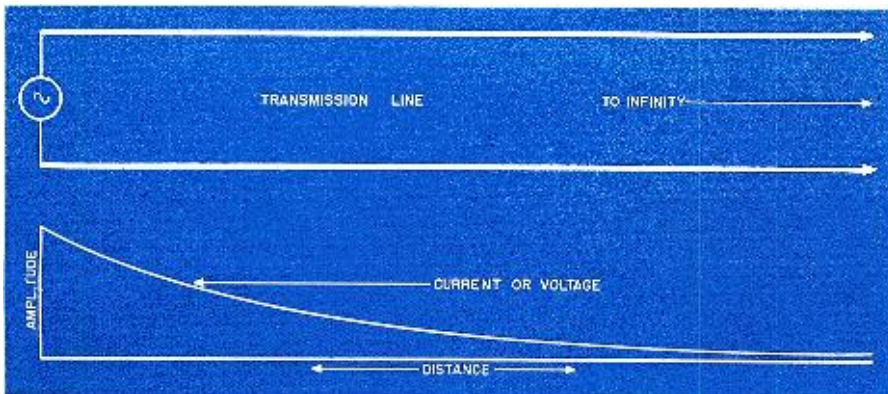

# BRITAIN'S COMMAND



Men of battalion headquarters with wireless transmitter and receiving set, moving forward with troops.

**By H. W. BARNARD**

"Wireless World," London

## ***Communications equipment and techniques that will be used by Allied sea, land, and air forces in forthcoming European invasion***

COMBINED Operations by Britain's sea, land and air forces and those of her Allies are playing an increasingly important part as the attack on Hitler's so-called European Fortress grows. An essential feature of these operations, which vary in size from small raids on enemy or enemy-occupied coasts to the large-scale landings in Algeria, Tunis, Sicily, and Italy, is communications.

The provision of communications between individual landing parties, between landing parties and their headquarters, and between troops ashore and ships and assault craft off-shore in Britain's Combined Operations is a complicated affair involving naval as well as military and R.A.F. personnel. The Commando signals sec-

tion plays an important role. It should, perhaps, be explained that a Commando is a highly offensive unit of Britain's Army comparable in size to a small battalion.

Recently I took part in an exercise which showed the task of the signals branch in maintaining communications during actual operations. The practice "scheme" involved landing on an open beach on the south coast of England. Two small Commando parties, each having a separate objective some miles inland, were engaged.

The two forces embarked onto the landing craft from the headquarters ship before daybreak on an autumn morning. Once under way the course was set by the Pole star. During the passage complete silence—radio and

otherwise—was maintained; any communications passing between the craft and headquarters might have disclosed our presence to the "enemy."

As we approached the beach, which was backed by high cliffs, dim lights, placed there by a beach marking party, guided us to our landing place. On touching down, we leapt ashore with our radios, the smallest of which were carried by the signallers in the operating position on their chests, while the larger types were transported in waterproof carrying cases.

The large sets were taken from their cases, and fastened to the backs of the signallers. Ropes were lowered over the cliff by the advance units and the signallers, with the apparatus on their backs, scaled the 100 ft. cliff. This was no small feat



# COMMUNICATIONS . . .

of strength and agility, for the lightest set, with accessories, weighs about 30 lbs.

Slight opposition having been overcome, the operator of the lightweight set with each force made contact with the headquarters ship, after which the two forces advanced toward their respective objectives. Throughout the advance progress reports were dictated to the operator of the small set by the leader of each force so that headquarters was provided with a complete picture of the operation, including details of the casualties sustained, prisoners taken and positions gained.

On being advised that the landing had been successful, the advance headquarters embarked and proceeded to the beach. Having landed and taken up their position about two hundred yards inland, the transmitter-receivers, which are of a much heavier type than either of those used by the advancing forces, were opened up.

The operators then made contact with the two forces which were halted so that the larger sets they were carrying could be adjusted and brought into operation. It was now the task of the operator of the larger set with each force to maintain contact with the advance headquarters, leaving the small sets to concentrate on communications between the two forces.

The more bulky type of apparatus employed by headquarters necessitated the erection of a rope railway from beach to cliff-top. The apparatus was successfully transported in this way and in spite of the rough usage functioned perfectly—proof indeed of the quality of workmanship put into the apparatus.

Damage is, of course, sometimes sustained, and to meet such contingencies each operational section includes an Instrument Mechanic whose job it is to maintain the gear in use and to set the apparatus to the wavelengths selected for the operation in hand. His equipment includes spanners, screwdrivers, soldering kit (a small blow lamp is used for heating) and test meter.

An important feature of all Commando operations is the duplication of each channel of communication, which, in addition to radio, may include line telephony and visual signalling.

It will be seen from this brief description of the exercise, which was typical of the continuous training undertaken by Commando signallers, that the apparatus required must be capable of being set up quickly, of withstanding shocks, simple in operation and, as far as possible, waterproof.

Before describing some of the spe-

cial radio transmitters and receivers used by Commando signallers, it is worth considering the men who are in this newest radio branch of Britain's Services.

Most of the officers and men in Commando Signals have volunteered from the Royal Corps of Signals for this hazardous, but far from humdrum, work. As well as the badge of Royal Signals on their green berets, they wear on their sleeves the Combined Operations badge, above which are the words "Commando Signals."

In addition to being a first-class operator, a Commando signaller must be a fully trained Commando soldier, for not only has he to carry out his signal duties under the extremely difficult and often arduous conditions of Combined Operations, but also must be able—and equipped—to take a hand in fighting if the need arises.

Great importance is attached to physical fitness and ability to march fast while carrying additional weight, as it is highly probable signallers will have to keep pace with Commando assault troops who are not encumbered with wireless gear. It is obvious, therefore, that all equipment used by Commando signallers must be capable of being carried by the operators, if need be for some days.

One of the most interesting sets used by the signallers is a small combined transmitter-receiver, which, designed especially for Combined Operations, is carried on the chest next to the respirator. So that the operator's hands are free a special type of microphone is strapped to the throat.

The operating panel is on the top of this set, which employs an eight-foot sectional rod aerial.

A feature of this combined trans-

*(Continued on page 80)*

Radio operator and equipment of the British Eighth Army in the midst of Tunisian offensive.



# STANDARD FREQUENCY BROADCAST SERVICE

*Frequency standards that are broadcast daily by the National Bureau of Standards for use in accurately calibrating all types of radio equipment.*

TABLE I. TRANSMITTED RADIO FREQUENCIES.

2.5 megacycles (= 2500 kilocycles = 2,500,000 cycles) per second, broadcast from 7:00 P.M. to 9:00 A.M., EWT (2300 to 1300 GMT).  
 5 megacycles (= 5000 kilocycles = 5,000,000 cycles) per second, broadcast continuously day and night.  
 10 megacycles (= 10,000 kilocycles = 10,000,000 cycles) per second, broadcast continuously day and night.  
 15 megacycles (= 15,000 kilocycles = 15,000,000 cycles) per second, broadcast from 7:00 A.M. to 7:00 P.M., EWT (1100 to 2300 GMT).

Two changes beginning Feb. 1, 1944, are announced in the standard frequency broadcast service of the National Bureau of Standards. One is the addition of a new radio frequency, 2500 kilocycles per second, at night. The other is omission of the pulse on the 59th second of every minute. The entire service is described here. It comprises the broadcasting of standard frequencies and standard time intervals from the Bureau's radio station WWV near Washington, D.C. The service is continuous at all times day and night, from 10-kilowatt radio transmitters. The services include: (1) standard radio frequencies; (2) standard time intervals accurately synchronized with basic time signals; (3) standard audio frequencies; (4) standard musical pitch, 440 cycles per

second, corresponding to A above middle C.

The standard frequency broadcast service makes widely available the national standard of frequency, which is of value in scientific and other measurements requiring an accurate frequency. Any desired frequency may be measured in terms of any one of the standard frequencies, either audio or radio. This may be done by the aid of harmonics and beats, with one or more auxiliary oscillators.

At least three radio carrier frequencies are on the air at all times, to insure reliable coverage of the United States and other parts of the world. The radio frequencies that are transmitted are shown in Table I.

Two standard audio frequencies, 440 cycles per second and 4000 cycles per

second, are broadcast on the radio carrier frequencies of 5, 10, and 15 megacycles. The audio frequency 440 cycles only is broadcast on 2.5 megacycles. The 440 cycles per second is the standard musical pitch, A above middle C; the 4000 cycles per second is a useful standard audio frequency for laboratory measurements.

In addition there is on all carrier frequencies a pulse of 0.005-second duration which occurs periodically at intervals of precisely one second. The pulse consists of five cycles, each of 0.001-second duration, and is heard as a faint tick when listening to the broadcast; it provides a useful standard of time interval, for purposes of physical measurements, and may be used as an accurate time signal. On the 59th second of every minute the pulse is omitted.

The two audio frequencies are interrupted precisely on the hour and each five minutes thereafter; after an interval of precisely one minute they are resumed. This one-minute interval is provided in order to give the station announcement and to afford an interval for the checking of radio-frequency measurements free from the presence of the audio frequencies. The announcement is the station call letters (WWV) in telegraphic code (dots and dashes), except at the hour and half hour when a detailed announcement is given by voice.

The accuracy of all the frequencies, radio and audio, as transmitted, is better than a part in 10,000,000. Transmission effects in the medium (Doppler effect, etc.) may result in slight fluctuations in the audio frequencies as received at a particular place; the average frequency received is however as accurate as that transmitted. The time interval marked by the pulse every second is accurate to 0.000 01 second. The 1-minute, 4-minute, and 5-minute intervals, synchronized with the seconds pulses and marked by the beginning or ending of the periods when the audio frequencies are off, are accurate to a part in 10,000,000.

The beginnings of the periods when the audio frequencies are off are so synchronized with the basic time service of the U. S. Naval Observatory that they mark accurately the hour and the successive 5-minute periods.

Of the radio frequencies on the air at a given time, the lowest provides service to short distances, and the highest to great distances. Reliable reception is in general possible at all times throughout the United States and the North Atlantic Ocean, and fair reception throughout the world.

Information on how to receive and utilize the service is given in the Bureau's Letter Circular, "Methods of using standard frequencies broadcast by radio," obtainable on request. The Bureau welcomes reports of difficulties, methods of use, or special applications of the service. Correspondence should be addressed National Bureau of Standards, Washington, D. C.

-30-

Transmitting station, typical of many that are calibrated by means of frequency standards.

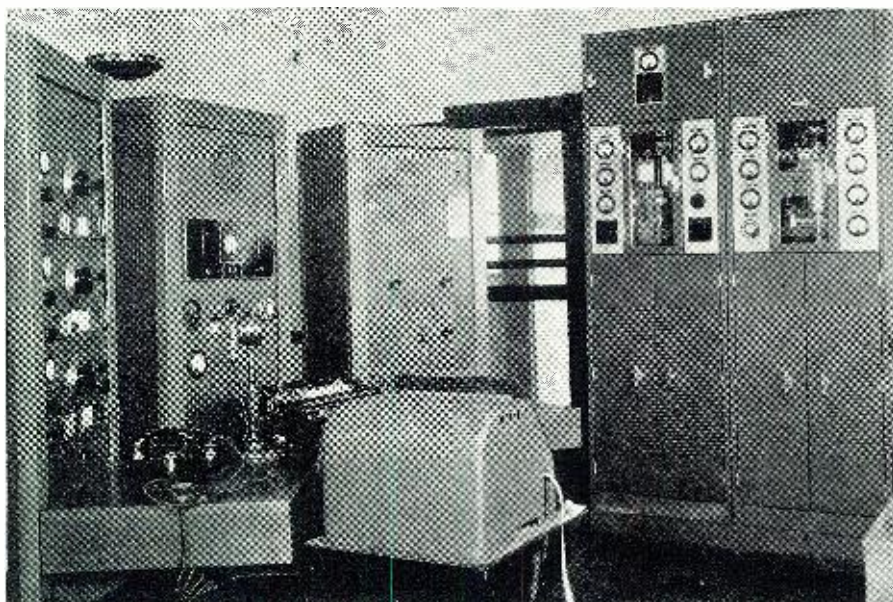

# PRACTICAL RADIO COURSE

by ALFRED A. GHIRARDI

## Part 22. Inverse feedback—covering the effects of phase-shift and tone-control operation by means of selective degeneration.

IN OUR previous discussions of inverse feedback action it was assumed that the feedback voltage *always* arrived at the grid input circuit exactly 180 degrees out of phase with the input signal, as illustrated at (a) of Fig. 1. In practice, this is never the case. This exactness of opposition at all signal frequencies is the most difficult condition to fulfill in practical amplifiers. In all actual amplifiers there is a tendency, due to ca-

ly, the nature of many feedback networks used is such that the phase of the feedback voltage varies somewhat with the signal frequency so that the relative phase of feedback and input signal voltages is exactly 180 degrees at only one or two frequencies; at other frequencies it gradually shifts around to almost an in-phase condition. However, in general it is tacitly understood that the phase somewhere near the center of the useful fre-

shift, each stage has another phase shift which is due to reactances in the coupling units and the capacitance of the tubes. This shift varies with the signal frequency, and is never more than 90 degrees for one stage. The amplification and phase shift characteristics of a feedback amplifier are, therefore, of fundamental importance in determining whether or not that amplifier will be stable.

A certain amount of phase shift takes place in each stage of both transformer-coupled and resistance or impedance-coupled amplifiers, but the degree of shift is much less in the latter. In the upper portion of (a) in Fig. 2\* is shown the typical amplification-vs-frequency characteristic of an ordinary single-stage transformer-coupled amplifier. Immediately below it is a graph showing the phase shift that occurs in it. The phase shift is measured from that of a normal mid-range audio frequency. At this normal mid-range audio frequency there is, of course, the usual phase shift of 180° between the grid and plate circuit of the amplifier, but in Fig. 2 we are interested only in the amount that the phase of the output varies from the normal figure. Hence, the normal phase shift of 180° is shown as *zero* in the phase-shift graphs.

In (b) of Fig. 2 are shown the corresponding graphs for a typical single-stage impedance or resistance-coupled amplifier. It is seen that the maximum phase shift with either type of coupling takes place at the extreme low and high ends of the frequency range, with the shift at the high end

\*After F. E. Terman.

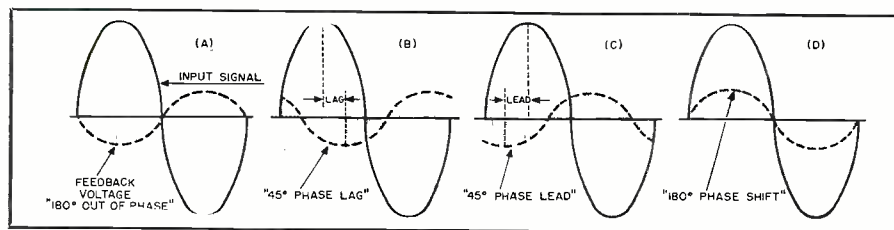

Fig. 1. Possible phase shifts that effect the operation of inverse feedback.

pacities and inductance in the circuits, for a phase shift to take place within the feedback loop, so that the condition which exists is somewhat like that illustrated in Fig. 1 where the feedback voltage either *lags* behind exact opposition as shown at (b), or *leads* it as shown at (c), by some value.

Furthermore, as we shall see presently, the amount of this lag or lead from exact opposition usually varies with the signal frequency. Aside from the fact that this causes the effective amount of feedback (and therefore its compensating effects) to be different at different signal frequencies, one must be careful to see that the lag or lead never amounts to 180 degrees (d), for the feedback then becomes *positive*, which is liable to result in amplifier instability and even oscillation.

In certain feedback amplifiers, those where the voltage is fed back over 2 or more stages, or where the feedback network itself adds an appreciable shift to that of a single stage, this may happen. Of course, the gain of the amplifier can purposely be reduced at the frequencies where oscillation takes place to a value which makes  $A\beta$  less than 1. Doing this, however, limits the total amount of feedback which can be used under such conditions and, therefore, correspondingly limits the maximum amount of reduction in distortion, hum and noise that can be secured through its use.

Actually, it is not necessary that the feedback voltage be wholly out of phase (180°) with the input signal voltage for some degeneration to occur. In fact, as we shall see present-

quency range of the amplifier is the one referred to, even though it may be quite different at other frequencies. So long as the feedback voltage has a component in phase with the input voltage, some regeneration will occur, and vice versa.

### Phase Shift in Amplifiers

Because of its importance, it is desirable to examine this matter of phase shift in amplifiers more closely. It was explained in a previous lesson that the phase of the signal voltage is reversed in each amplifier stage (and this is taken into consideration when determining the proper polarity of the feedback voltage during the design of the feedback amplifier). In addition to this 180 degree-per-stage

Fig. 2. Typical amplification and phase characteristics of single-stage amplifier. (A) Transformer-coupled. (B) Resistance or impedance-coupled.

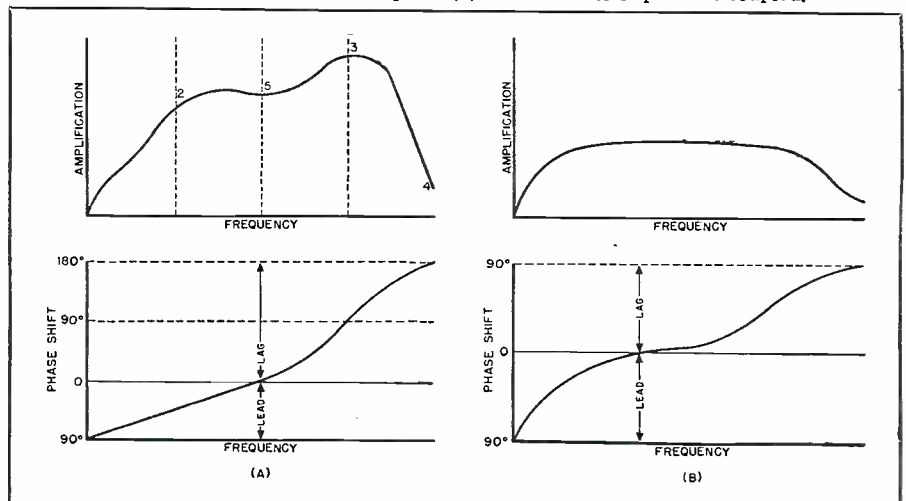

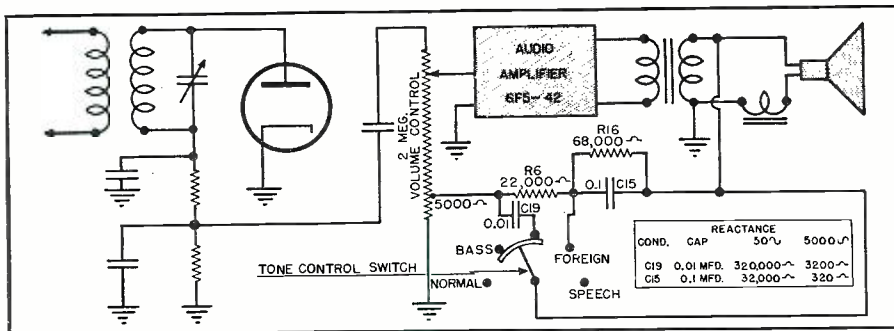

Fig. 4. Selective inverse feedback tone-control circuit used in G.E. F-75 receiver.

usually causing the most difficulty. In the case of transformer coupling the amplification-frequency characteristic reveals a poor low-frequency response below point 2, a resonant peak at point 3, then a falling off rapidly toward point 4. Now, the coupling transformer is in effect a complicated network of mutual inductance, leakage reactance, shunting capacitances on both primary and secondary, etc. The relative magnitudes and effects of these so vary with the signal frequency that the typical phase-shift characteristic illustrated at the lower portion of (a) results. At the mid-frequencies (around point 5) there is little phase shift through the transformer; therefore the feedback voltage will be 180 degrees out of phase with the input signal voltage, and the degenerative action will be 100 per cent effective if we neglect to consider any other possible shifts in phase in the amplifier circuit or feedback network. But at the low and high ends of the frequency range there will be a shift in phase through the transformer as shown, with the result that the feedback voltage at these frequencies will not be exactly 180 degrees out of phase with the input signal voltage and therefore the effectiveness of the degeneration will vary accordingly. So long as the total phase shift is less than 180°, the feedback remains *negative*, as required for stable operation. However, at the higher frequencies, the phase shift may approach 180 degrees (lag), so the feedback voltage will be substantially or completely *in phase* with the input voltage, in which case the gain of the amplifier will be appreciably increased, due to *regeneration*. If the shift is large, then the amplifier may be thrown into violent

oscillation and the output tubes may be seriously damaged by the heavy plate currents that will flow. At any rate this regenerative action will tend to boost the amplifier characteristic in this range, causing undue and unwanted emphasis of the higher audio frequencies. For this reason, inverse feedback over an amplifier stage whose input as well as output is transformer-coupled is usually impracticable unless special design precautions are exercised.

The undesirable effects of phase

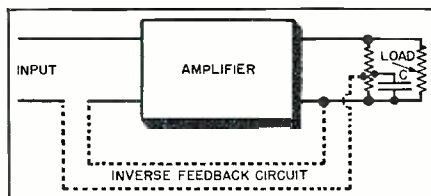

Fig. 3. Providing treble boost by shunting condenser across feedback circuit.

shift in transformer-coupled amplifiers are sometimes reduced somewhat by loading the primary of the output transformer with a shunting resistor. This tends to dampen the effect of the series-resonant circuit presented by the primary winding.

Inspection of the lower portion of (b) in Fig. 2 reveals that phase shift is not as great in a resistance or impedance-coupled amplifier stage as it is in a transformer-coupled stage. A *leading* phase shift, approaching 90° at the low audio frequencies occurs, while at the higher frequencies the phase shift is actually as great as 90°. (The reason the phase shifts with frequency in a resistance or impedance-coupled amplifier may be readily understood by drawing the equivalent circuit of the

amplifier and considering the value of the reactances and resistances in the circuit at the low, mid-range, and high frequencies.)

### Tone Control by Means of Selective Inverse Feedback

Increase feedback designed in a special way is often employed to accomplish still another purpose. Up to the present we have assumed that the feedback circuit itself is free from any form of distortion. Since it contains no tubes or transformers there is generally no question of amplitude distortion. But, if condensers or inductances—circuit elements that vary in impedance according to the signal frequency—are included, the amount of feedback will vary with the signal frequency; that is, it will be "*selective*." For example, suppose a condenser, *C*, is shunted across the part of a potentiometer that taps off the feedback voltage, as illustrated in Fig. 3. At low frequencies the condenser may make negligible difference since its reactance is large compared with the resistance it shunts. However, at the high-frequencies its reactance decreases to such a low value that its shunting effect across the resistance will materially *reduce* the percentage of output voltage fed back. The result is to give a boost to the treble end of the frequency characteristic. By using suitable components and proper design of the feedback network the amplifier may be made to have almost any desired frequency response. This makes possible a very flexible sort of tone control. In general, if it is desired to have the amplification vary with frequency in some particular way, this can be accomplished by designing the feedback network so it has the same transmission *loss* characteristic (or frequency characteristic) as the desired *gain* characteristic.

### Practical Radio Receiver Tone Control by Inverse Feedback

In many amplifier applications it is desirable to be able to alter at will the frequency characteristic of the amplifier to meet the particular circumstances. For example, in a radio receiver or a P. A. amplifier it is often desirable to *decrease* the amount of high-frequency audio response when listening to signals having a high noise background. Study of the inverse feedback circuit arrangement used to accomplish such variable-frequency response in receivers such as the General Electric F-74, F-75 and F-77 will serve to illustrate practical tone control circuits of this type, and will prove generally instructive at this point. One of the advantages of this type of tone control is that it permits separate control over the bass and the treble amplification of an amplifier.

Fig. 4 illustrates the simplified schematic block diagram of the audio portion of the F-75 receiver and is typical of the tone-control circuits used in other G. E. receivers of this series. Notice that the voice coil signal volt-

(Continued on page 66)

Fig. 5. Audio-response characteristics for various tone-control switch positions of Fig. 4.

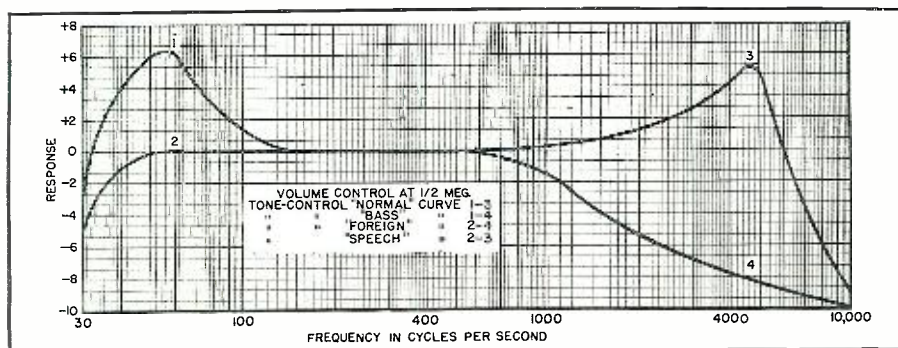

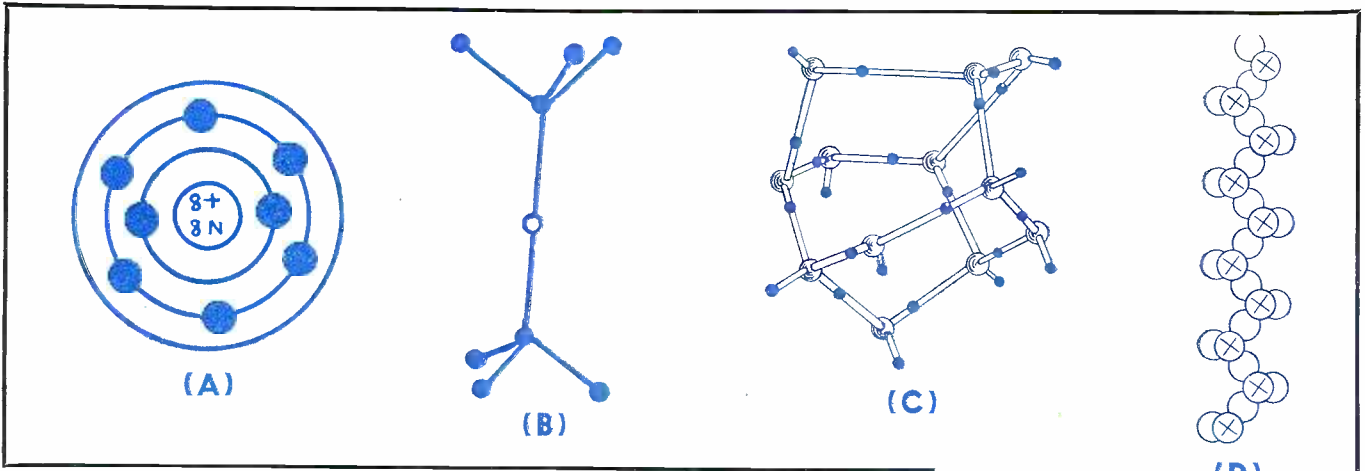

# YOU WILL NEVER SEE AN ATOM

By JOHN D. GOODELL

*Emphasizing the dangers of symbol-reality confusions regarding sub-microscopic structures and their clarification.*

EVERYONE likes to speculate about the ultimate mysteries of sub-microscopic structures. Engineers, physicists and scientific workers of all kinds are interested in atomic theory; in gaining a better understanding of the electrons, positrons, protons, neutrons and all the other arbitrary symbols for the "building blocks" of the universe. Unfortunately, there are few men who can spare the time necessary to follow the details of current thought on these subjects or to develop a satisfactory understanding of the specific mathematical language used to express the theories and experimental results obtained.

In order to think intelligently on these subjects, it is not necessary to understand the detailed equations with which a theory is deduced or proven. Forsaking the language of mathematics means only that we must accept the conclusions stated by competent mathematicians, and think in terms of the "thing" instead of its symbols. There are certain advantages in this view, and many of our most important realizations have originated with such reasoning, later to be expressed with greater accuracy in mathematical symbols and demonstrated by operational observation.

From time to time articles are pub-

lished for purposes of reviewing the recently attained concepts of sub-microscopic structures. These papers are a valuable and important contribution to the dissemination of knowledge, but connected with them is a grave danger of semantic confusion. It is the purpose of this article to point out some of the hazards and to clarify the thinking processes necessary to the attainment of understanding.

When we think of something as being "real" we generally associate it with observations made by our nervous systems. We think of seeing, feeling, hearing or some other physical reaction. In some instances we accept the reality of a force because we see the results of its operation. Magnetism is not evident to our senses except as we observe its effect on objects we *can* sense; when a magnet is separated from any matter on which it has an action observably by our nervous systems, we find it difficult to realize that a force is present. This is analogous to the ancient question as to the existence of sound when no observer hears it. The answer, of course, is that the existence of sound energy is in no way dependent on the presence of an observing mechanism. If this seems obvious, let us remember the difficulty we had in reaching the field

(Continued on page 110)



(E)

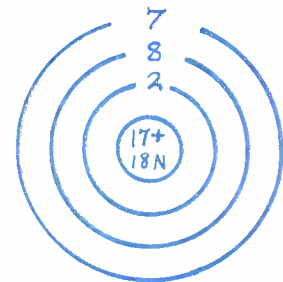

(F)

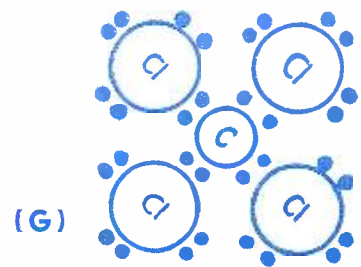

(G)



(H)

Typical symbols of several atomic and molecular structures. (A) Oxygen atom. (B) Si<sub>2</sub>O<sub>3</sub>. (C) Arrangement of water molecules in ice. (D) SiO<sub>2</sub>, silicon oxygen single chain. (E) Packing drawing of GeS. (F) Chlorine atom. (G) Carbon tetrachloride. (H) Packing drawing of NH<sub>4</sub>Br.

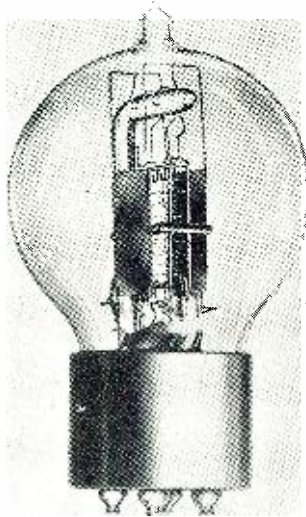

Fig. 113.

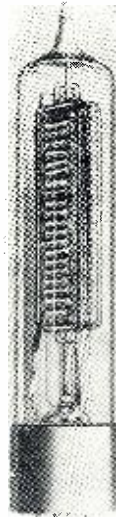

Fig. 114.

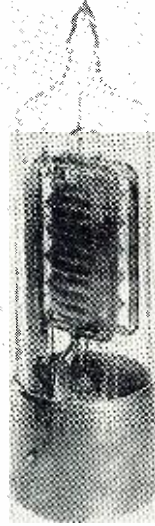

Fig. 115.

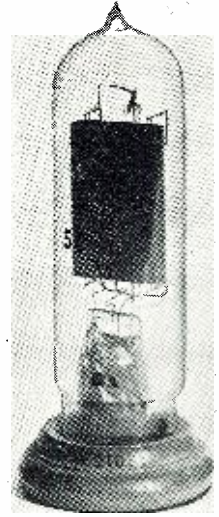

Fig. 116.

# THE SAGA OF THE VACUUM TUBE

By **GERALD F. J. TYNE**

Research Engineer, N. Y.

**Part II. Covering a number of the unusual earlier constructed tubes that are of particular interest to many old timers.**

UP TO now we have discussed Western Electric vacuum tubes of the telephone repeater type and a few made for the Army and Navy during World War I. There were a number of other early tubes however, and some of these may fall into the hands of the tube collector. Some will bear few marks of identification but may be recognized from their descriptions and photographs, which follow. First let us consider the power tubes.

The low power output tube for telephone applications, type "O," has already been described as well as the so-called "5-watt" tube, type "E."

The type "E" was preceded by another tube known as the type "K," which is shown in Fig. 113. This was originally intended for application in government equipment as a transmitter tube for aircraft use. It operated at a plate voltage of about 500 volts. This voltage was considered to be a source of serious danger to the oper-

ator and the type "K" was abandoned in favor of the type "E" which operated at 300 volts plate. The type "K," to which was assigned the Western Electric code designation "202A" had a machined brass base similar to that used on the early telephone repeater tubes, but of larger size.

Prior to this time the only extensive use of power tubes by the Western Electric Company had been in the famous transatlantic telephone tests conducted in 1915. These were one-way transmissions, the transmitter being at Arlington, Virginia. A bank of some 550 tubes operating in parallel was used in the final amplifier. To fully appreciate such a feat as this and realize the difficulties which had to be overcome by these pioneers, one should hear the stories told by the men who did the job. Problems of division of load, intertube wiring, parasitic oscillations, cooling, and a host of others, which can be fully appreciated only by one who has tried to operate more



Fig. 117.

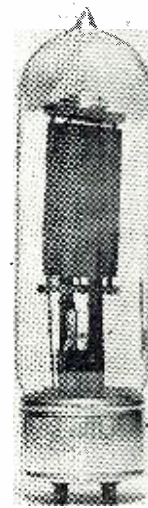

Fig. 118.



Fig. 119.

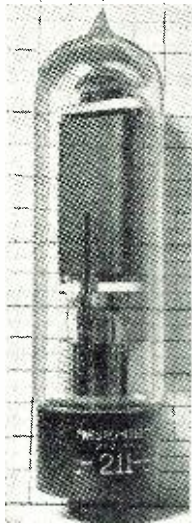

Fig. 120.

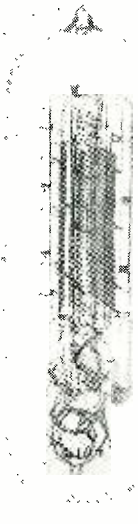

Fig. 121.



Fig. 122.



Fig. 123.

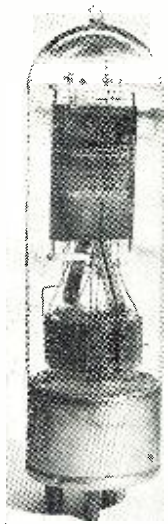

Fig. 124.

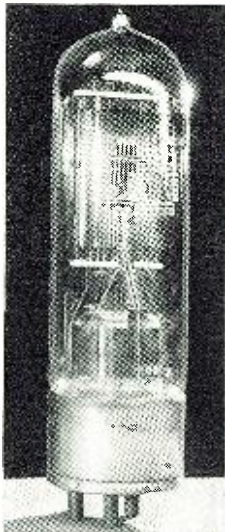

Fig. 125.

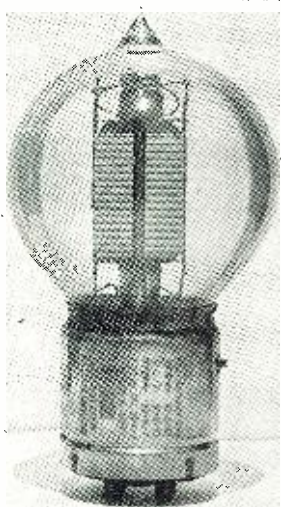

Fig. 126.

than two tubes in parallel, had to be solved. That this was accomplished in a short time is another instance of the results of cooperative effort in an industrial laboratory.

The tubes used in this amplifier were known as type "W" and the official designation was "204B Vacuum Tube." The type "W" operated with a filament current of 4 to 4.5 amperes, plate voltage of 600 volts, and plate current of 150 to 200 milliamperes. Most of the type "W" tubes used at Arlington were unbased although some based tubes, similar to that shown in Fig. 114, were also used.

The most noticeable feature of the type "W" was the plate. Since a solid sheet metal plate of the requisite size would contain much occluded gas which would have been difficult to remove with the evacuation technique of that day, the construction shown in the photograph was adopted. The plate was made from a strip of metal tape bent back and forth as shown. The material used was a high resistance alloy and leads were brought out from both ends of the strip. The tape could thus be heated by the passage of current from an external source, during the evacuation process, and the occluded gases thus expelled.

Another similarly constructed tube, used chiefly as a modulator in the long distance tests preceding the transatlantic tests, was known as the type "S" and had the code designation "204A." This tube is illustrated in Fig. 115. Although this tube was smaller in size, the similarity in construction to the type "W" will be noted. It was the experience and knowledge gained in the development of these tubes which enabled the Western Electric Company to produce the other types of power tubes urgently requested by the U. S. Government for radio communication in World War I.

After the war there grew up a de-

mand for higher powered tubes for radio transmitters and public address systems. This need motivated the development of two series of tubes which are familiar to those acquainted with the early days of broadcasting. One was known during its development as the type "G" and the other as the type "I."

The type "G" was one variety of the size which later became commonly known as the "50-watt" and was the progenitor of the Western Electric 211A and others of the 211 series. As in all such developments, problems were encountered in the process and various structures were tried before one suitable for commercial service was attained. Figs. 116 and 117 show some of the element assemblies tried out during this process. The construction finally adopted, which was given the code designation "211A Vacuum Tube" is shown in Fig. 118.

This tube operated with a filament current of 3.4 amperes at 9 to 10 volts. The plate voltage was usually about 750 and plate current 40 to 80 milliamperes. The amplification factor was about 12 and the internal plate impedance 3000 to 4000 ohms. The operating life was about 300 hours. The base was the same size as that originally brought out by the Western Electric engineers for the type "K" tube, and eventually adopted as standard for all 50-watters, by other manufacturers as well.

The 211 type tubes were intended for operation at a fixed value of filament current, and the value of filament voltage was determined by the filament resistance. They were usually operated, however, from a constant voltage source. Hence, they were classified at the time of manufacture into five groups, and the classification was indicated by a letter etched on the bulb at the end of the serial number. The letters used were A, B, C, D, and E.



Fig. 127.

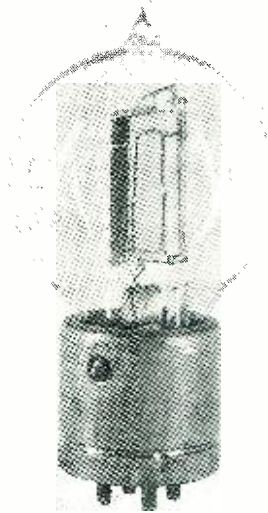

Fig. 128.

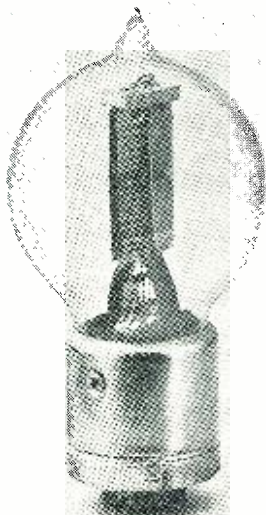

Fig. 129.

This was done so that when two or more were required to operate with their filaments in parallel from the same source, tubes suitable for operation at the same filament voltage could be selected.

The 211A Vacuum Tube was replaced, about the middle of 1924, by the 211D which used a different filament. The characteristics of this new filament were sufficiently controllable so that the classification of tubes in accordance with their filament resistance was no longer necessary to their successful operation in parallel. Hence, no classification letter was needed. A photograph of one of the earlier 211D vacuum tubes is shown in Fig. 119.

In 1926 the 211E was introduced. It differed from the 211D in that it was intended primarily for use as an audio amplifier, and had small spirals incorporated in the grid and plate leads, which may be seen in Fig. 120. The effect of these small radio frequency chokes was to discourage the tendency to set up high-frequency parasitic oscillations in the circuit in which such tubes were operated in parallel.

The code and patent markings were at first placed on the metal base of the 211 types in depressed characters, but later were applied to the bulb by the use of baked enamel lettering. Still later tubes used molded plastic bases. The 211 series of tubes have not been made since 1938, having been replaced by later designs.

The type "I" tube was the forerunner of the 212 series of Western Electric tubes, and was rated at 250 watts. Figs. 121 and 122 show two of the experimental tubes of this type and Fig. 123 shows the early commercial type which carried the code designation "212A." This tube had an over-all height of about 13 3/8 inches and a diameter of 3 3/8 inches. It was intended for both oscillator and modulator use.

The filament current was 6.25 amperes at 12.5 to 14 volts. The nominal plate voltage was 1500 and the plate current 100 to 150 milliamperes. The amplification factor was about 16 and the internal plate impedance about 2000 ohms. The code and patent markings were on the base, as will be seen from the photograph.

Like the 211A, the 212A vacuum tubes bore a letter designation following the serial number, to indicate filament resistance. In addition they bore a 1/2 inch high numeral (1, 2, 3, or 4) stamped on the bulb a short distance above the base. This numeral was determined by the plate impedance of the particular tube. The classification was such that satisfactory operation in parallel could be obtained with two tubes whose classification numbers did not differ by more than one. That is, a class 1 tube would operate satisfactorily in parallel with another class 1 or a class 2, but not with class 3 or 4. A class 2 tube would operate satisfactorily in parallel with either class 1, 2, or 3, but not with class 4, and so on.

The 212A Vacuum Tube was replaced in 1924 by the 212D, photographs of which are given in Figs. 124 and 125, and somewhat later the 212E was brought out. The 212D tubes were classified in accordance with plate impedance in the same way as the 212A, but because of a new filament did not require classification in accordance with filament resistance.

In addition to the power tubes described, the Western Electric Company also made a number of small tubes during this time for non-telephone applications. Since, for the most part, these were similar in structure to some of the telephone tubes they will be mentioned only briefly.

The 208A and 209A were the same as the 101B and 102A except for the  
(Continued on page 92)



Fig. 130.

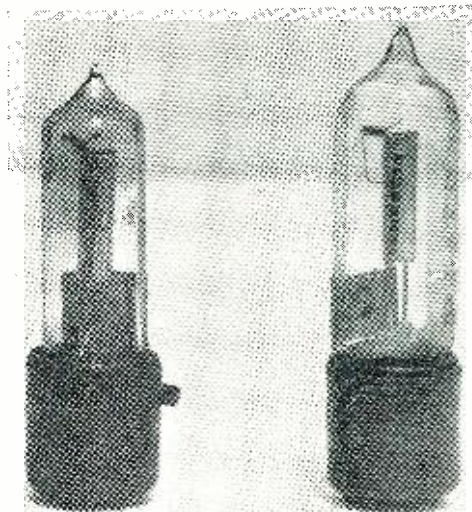

Fig. 131.



# OHMITE

RHEOSTATS and RESISTORS

*in the Fight*

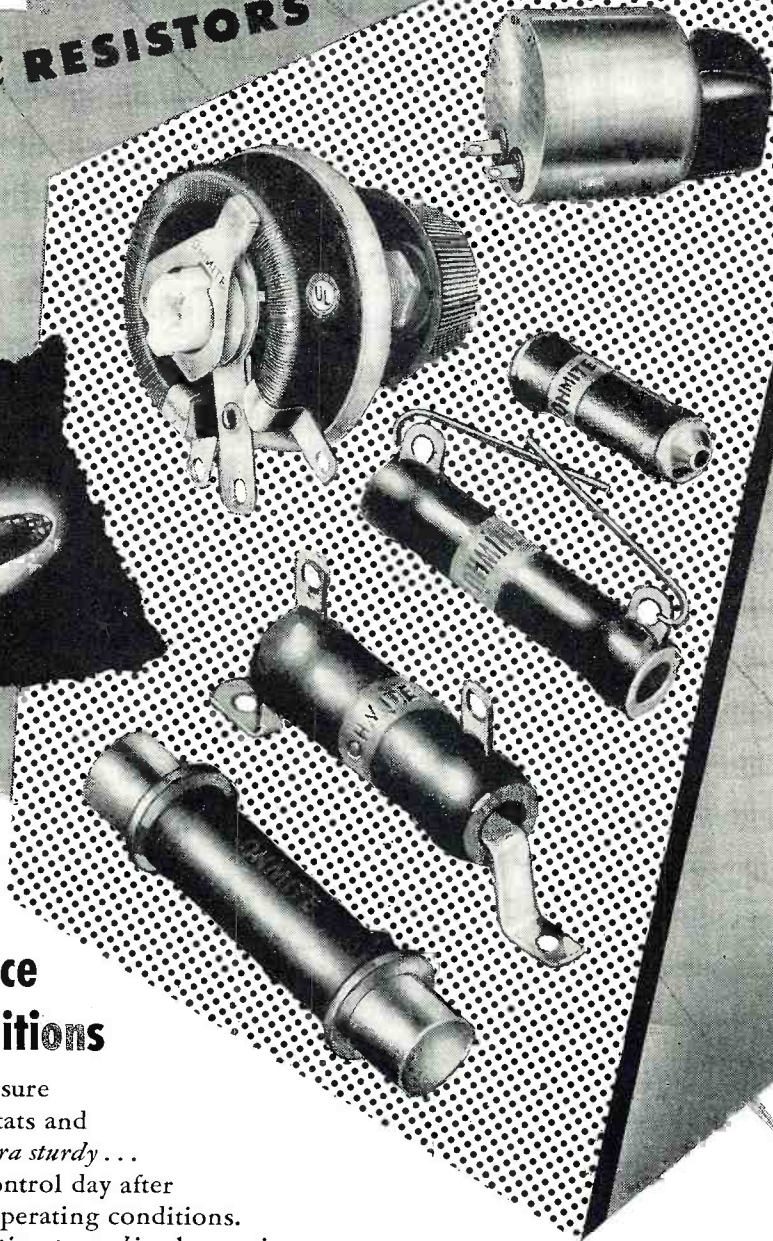
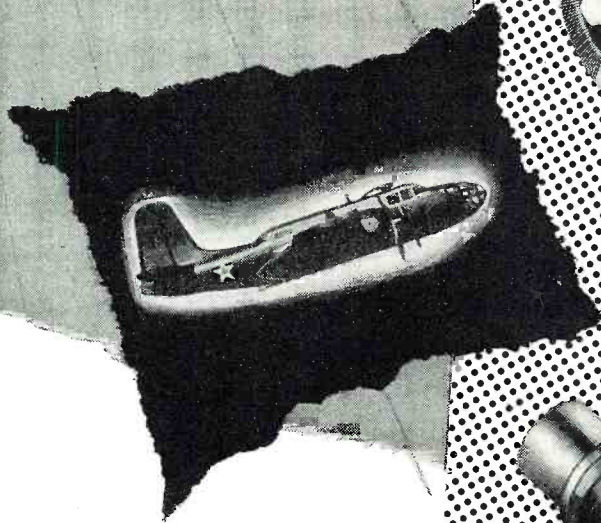

## Maximum Performance Under ALL Conditions

You can always expect the fullest measure of performance from Ohmite Rheostats and Resistors. *Because, they're made extra sturdy . . .* to provide accurate resistance-control day after day under the most critical operating conditions.

This dependability has been *time-proved* in electronic and electrical equipment on land, sea and in the air . . . in every phase of communications. Ohmite Engineers are glad to assist you on any resistance problem.

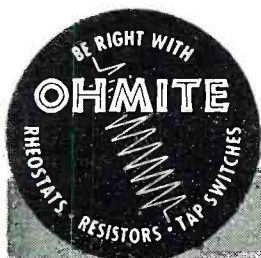

Send for Quick-Reference Catalog 18

*Gives helpful information on Ohmite stock resistors, rheostats, chokes, and tap switches . . . for all types of applications.*



**OHMITE MANUFACTURING CO.**

4883 FLOURNOY STREET—CHICAGO 44, U. S. A.  
*Foremost Manufacturers of Rheostats — Resistors — Tap Switches*

# WHAT'S NEW IN RADIO

## OIL TYPE CAPACITRONS

The new "EC" oil type Capacitrons are designed as standard components to replace many similar types of special capacitors used in the production of war equipment. They are being manufactured in several capacity ranges with DC working voltage ratings from 600 to 1,500 to meet U. S. Signal Corps and Navy Specifications.



The new units are locked on the chassis by means of a solid nut and lockwasher through a single hole to clear the  $\frac{3}{4}$ " x 16" threaded bakelite neck. The bakelite neck is lock-spun into the extruded, insulated metal container, making possible a 100% hermetic seal. Grounding of either insulated terminal is readily accomplished

with a special ground-lug. Dimensions of the 3  $\mu$ fd. and 4  $\mu$ fd. size units are 1 $\frac{1}{2}$ " in diameter by 4 $\frac{1}{2}$ " in height.

The new "EC" oil type Capacitrons are being manufactured on a standardized, concentrated production basis for a number of users. Further information is available by writing to *Capacitrons, Inc.*, 318 West Schiller Street, Chicago 10, Illinois.

## COILS FOR ELECTRONIC HEATING

A broad assortment of standard coils for electronic heating applications, plus specialized facilities for the production of non-standard types, is offered by *Barker & Williamson*, 235 Fairfield Ave., Upper Darby, Pa.

Standard B & W heavy duty coils meet many electronic heating applications up to 1 kw. Of the B & W "Air Wound" design (no solid winding form), these coils are light in weight,

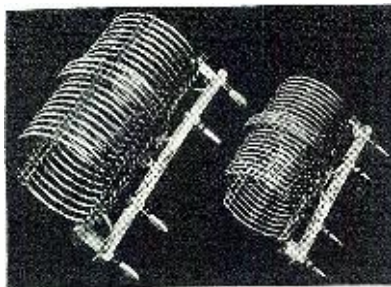

adaptable to numerous mounting arrangements, are exceptionally sturdy, and have low dielectric loss. Equally important, they are wound to uniform pitch, offer utmost design adapt-

ability, and lend themselves readily to mechanical and electrical revisions in circuits that must be adjusted, or which are still in the experimental stage. Many special coils are also being produced regularly for electronic heating uses.

Catalog will be sent upon request, or samples submitted to specifications.

## TUBE VOLTMETER PROBE

A new probe designed for greater convenience and efficiency, especially at high frequencies, such as those encountered in frequency modulation and television design and test work, is

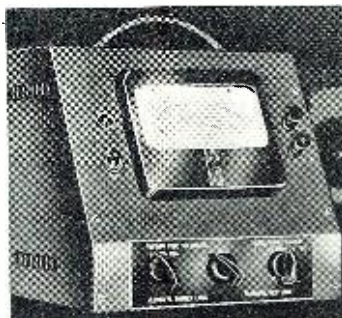

being supplied by *Alfred W. Barber Laboratories*, 34-02 Francis Lewis Blvd., Flushing, N. Y., as a unit of their Wide Range Vacuum Tube Voltmeter. This probe is cone shaped with the "high" terminal in its nose. This permits extremely close connection to be made to the circuit under test which is very important at high frequencies. The probe is molded from low-loss material thereby reducing loading on the circuit under test to a minimum.

Vacuum Tube Voltmeter Model VM-27E is shown. The probe being attached to a four foot cable permits the voltmeter proper to be placed in the most convenient position on the test bench. The large meter may be easily read even at a distance. Simplified controls and stable operation make the Model VM-27E Vacuum Tube Voltmeter an extremely useful instrument even in the hands of inexperienced operators.

The Model VM-27E Vacuum Tube Voltmeter measures voltages from 0.1 to 100 volts at d.c., a.c. and r.f. frequencies to over 100 megacycles. Descriptive bulletin available from the maker.

## TRANSMISSION LINE CALCULATOR

A calculator for solving radio transmission line problems has been placed on the market by *The Emeloid Co., Inc.*, Arlington, N. J.

It is fundamentally a special kind of impedance coordinate system mechan-

ically arranged with respect to a set of movable scales to portray the relationship of impedance at any point along a uniform open wire or coaxial transmission line to the impedance at any other point as well as to the several other electrical parameters.

These other parameters are plotted as scales along a radial arm and around the rim of the calculator, both of which are arranged to be independently adjustable with respect to the main impedance coordinates.

All of the parameters are related to one another and specific solutions to a given problem are obtainable through the use of an adjustable cross-hair index.

The more important parameters which are plotted on the calculator include (a) Impedance and reflection coefficient at any point along the line, (b) Length of line between any two points in wave lengths, (c) Attenuation between any two points in decimals and (d) Voltage or current standing wave ratio.

This calculator, which is 9" in diameter, is simple to use and is made by the *Emeloid Tempered Fabrication Methods*.

## LANGEVIN TYPE 101-A

The *Langevin Company, Inc.*, of 37 West 65th Street, New York, has announced a new amplifier known as Langevin Type 101-A. Its outstanding virtue is low-frequency wave form at high output levels. Volume range is excellent, inherent noise level being 68 db unweighted below full output of plus 47 VU at 2% RMS harmonic distortion. With the input impedance of 600 ohms, the gain is 60 db. Using bridging input, the gain is 46 db. Output impedance is adjustable 1 to 1000

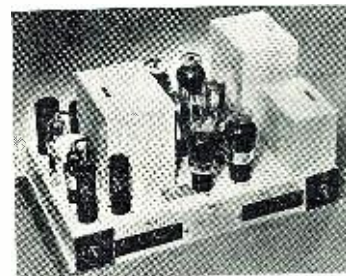

ohms. Gain vs. Frequency and Power Output vs. Frequency characteristics of the amplifier are available upon request.

## HALF-FREQUENCY GENERATORS

To fill a need in industry and laboratories for a wide range calibrated Signal Generator which is dependable on the Ultra-High Frequencies, the *Haines Manufacturing Company*, 248-274 McKibbin Street, Brooklyn, New

# UNDER ANY TRYING CONDITION

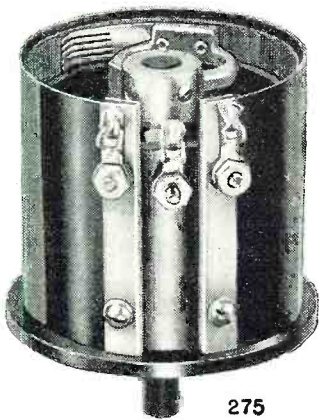
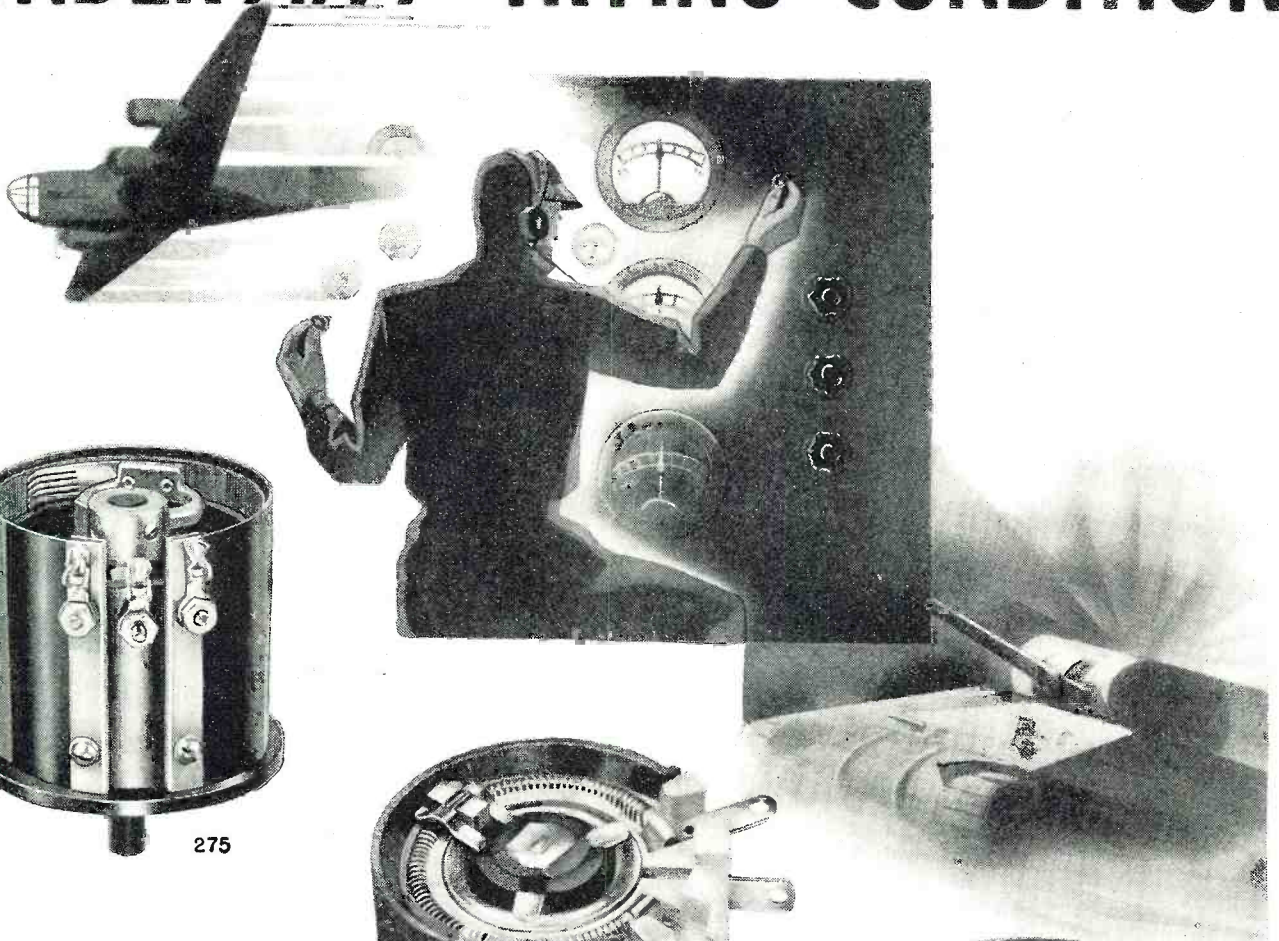

275

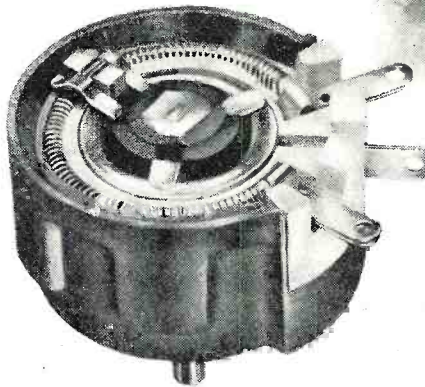

SPECIAL 25 AND 50 WATT

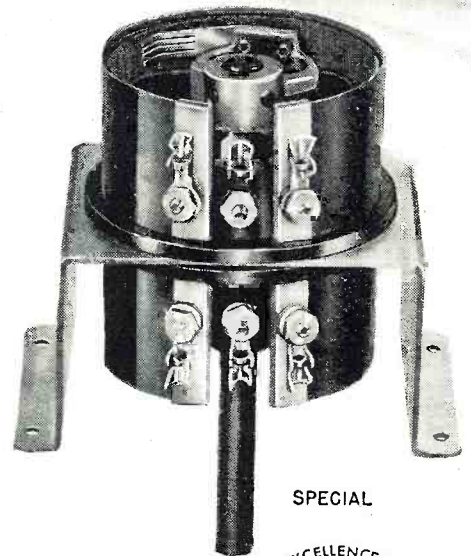

SPECIAL

UP A MOUNTAIN IN A TANK  
HURLING THROUGH SPACE  
IN A FORTRESS . . . . .

WITHSTANDING THE GRUELLING PACE OF A WAR PLANT . . .

DeJur wire-wound potentiometers, in any assignment, fulfill their tasks capably and satisfactorily. The new line of these potentiometers covers a wide range of applications, for present and future use. Write for your copy of our "Special Bulletin", just off the press.

HELP SHORTEN  
THE WAR . . .  
BUY MORE  
WAR BONDS

## DeJur-Amsco Corporation

MANUFACTURERS OF DeJUR METERS, RHEOSTATS, POTENTIOMETERS AND OTHER PRECISION ELECTRONIC COMPONENTS  
SHELTON, CONNECTICUT



NEW YORK PLANT: 99 Hudson Street, New York 13, N.Y. • CANADIAN SALES OFFICE: 560 King Street West, Toronto

April, 1944

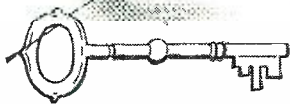
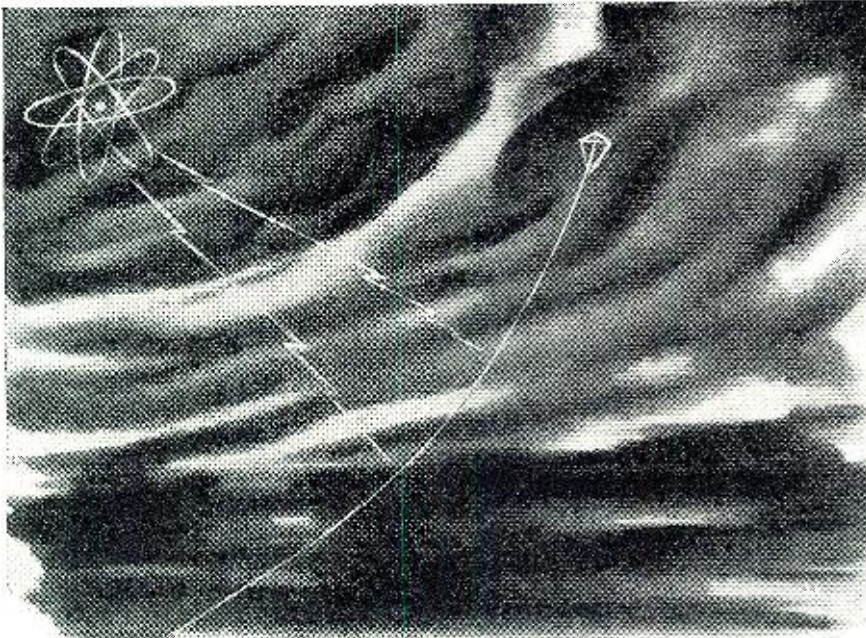

## A SCIENCE...born in a THUNDERSTORM

**B**EN FRANKLIN dared to prove the relation between lightning and static electricity with a kite, key and string, during a thunderstorm. With luck he lived to give impetus to the new science of electricity... This same adventurous experimental spirit has been shown throughout the history of electrical science in America.

In Stancor laboratories interest centers upon the *transformer*: the master coordinator of electronic energy. While Stancor Transformers now are being used for control systems in war, military challenge has produced important new developments for use in peace-time industry... For tomorrow, Stancor—is a name to remember.

SPECIFY



# STANCOR

★ Transformers ★

STANDARD TRANSFORMER CORPORATION  
1500 NORTH HALSTED STREET - CHICAGO

*Manufacturers of quality transformers, reactors, rectifiers, power packs and allied products for the electronic industries.*

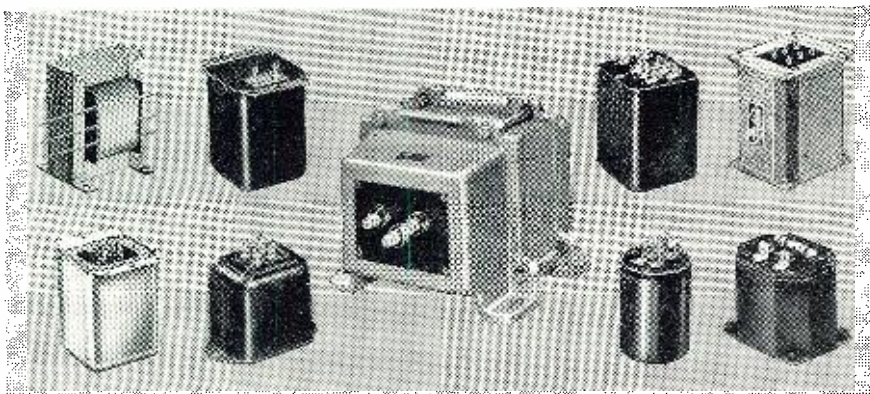

York, announces a new line of High-Frequency Generators. The HF73 is a new rugged portable model. It is continuously variable from 200 megacycles to 800 megacycles. It is hand calibrated and frequency is read in both megacycles and centimeters directly on a large, easily read scale. The HF73, complete with power supply, is housed in a steel cabinet 15" x 7" x 7½". Engineering details and specifications will be sent to any engineering laboratory upon request. The HF73 is ready for immediate shipment.

### AIRCRAFT TYPE DC MOTOR

A new design of Aircraft type direct-current series motor is now being produced by the *Alliance Mfg. Company*.

Primarily designed to operate blowers for cooling purposes in Aircraft equipment, the unit operates on 28-volt DC source at 0.75 amperes delivering a full 1/80 H.P. at 8000 R.P.M. The motor is of the latest approved Aircraft design of light weight and high efficiency, consistent with sturdy, totally enclosed, ball bearing construc-



tion. It measures over-all, less the ¼" diameter shaft extension, 3" in length by 1⅞" diameter and weighs 17 ounces. Low temperature rise permits operation under high ambient temperatures.

This basic design can readily be modified to meet other volume applications with either shunt or series winding for desired voltage, current drain and horsepower output up to 1/50 consistent with speed and duty cycle.

Descriptive literature and further information may be obtained upon request from the *Alliance Mfg. Company*, Lake Park Boulevard, Alliance, Ohio.

### PRECISION POTENTIOMETERS

Precision potentiometers which can operate for 2,500,000 revolutions at 360° continuous rotation in both directions, for 24 hours a day are among the types brought forth by the *DeJur-Amsco Corporation* of Shelton, Conn., in its 1944 listing of units designed for a variety of electronic and industrial techniques.

Among the ten-odd models are Types 260, 275, 261, 260T, and 291. Outstanding feature of this group is the fact that extremely close tolerances are used, which require winding equipment built especially for DeJur.

These special machines space-wind the resistance wire on a strip of fabric base bakelite. The strips are then coated with a bonding agent which

*(Continued on page 118)*

# SPRAGUE TRADING POST



## A FREE Buy-Exchange-Sell Service for Radio Men

### IMPORTANT NOTICE!

We discourage offers to buy or sell anything beyond the O.P.A. ceiling prices, and will not knowingly accept such ads for the Sprague Trading Post. Buyers and sellers please cooperate by reporting infringements.

**EQUIPMENT FOR SALE**—One No. 1175 Triplett multi-purpose all-wave tester incl. an all-wave signal generator; also precision No. 500 tube checker, counter model, fully modernized with charts and factory data. A. Witlin, 1711 Ocean Parkway, Brooklyn, N.Y.

**FOR SALE**—75 Burgess 45-volt portable B batteries in orig. cartons, dated June 1944. Will sell all or part at cost. Want RCA voltohmmyst. Ed's Radio Ray, Spencer, Iowa.

**FOR SALE OR TRADE**—20 brand new Philco 4-prong universal vibrators. Irving P. Horowitz, Sutter Radio Service, 118 Sutter Ave., Brooklyn, N.Y.

**FOR SALE**—Supreme 560 Vedolyzer, used three months; Clough-Brengle all-wave signal generator, model OCA; one 2-color neon sign reading "EXPERT RADIO REPAIRS," 10" letters; model SX-211 Hallicrafters receiver with separate speakers; Rider's manuals 1 to 7 incl.; RCA service notes, 1932 to 1936. Cpl. M. Bailowitz, 32978813, 1124 Sig. Serv. Gp., Robins Field, Warner Robins, Ga.

**FOR SALE OR TRADE**—Several selective crystal kits, also superhet kits. Need tubes: 1A7G; 3Z5; 50L6; 6K8; 6SA7; 6SK7; 6SQ7; 12SA7; 12SK7; 12SQ7; 1C5G; 1H5G; 1N5G, etc. Have several tubes for sale. Morton Thurman, 897 Bryant Ave., Box 59, New York, N.Y.

**FOR SALE OR TRADE**—Abbott DK-3 2 1/2 mtr. transceiver. Need National CRM scope, 15-25 watt c.w. transmitter, or will take cash. Dick Moore, 215 Ridgewood Ave., West View, Pittsburgh 2, Pa.

**FOR SALE**—One V-2 Electro-Voice velocity high imp. mike, completely rebuilt at factory, with 14' cable. \$20. Leroy S. Hackmann, 1208 Lee St., Jefferson City, Mo.

**FOR SALE OR TRADE**—Hammarlund Pro communication receiver; Motorola Golden Voice car radio; Clough-Brengle OCA DC all-wave signal generator; Triplett-Readrite 430 tube tester; Readrite 710-A Analyzer; Rider's Manual No. 5; courses, books, etc. Excellent condition. Glenn Watt, Chanute, Kans.

**WANTED**—R.M.E. or Hallicrafters receiver in good operating condition. Cpl. R. E. Peterson, A.S.N. 15359108, Hq. & Hq. Btry., 589th AAA AW Bn. (S.P.), Camp Stewart, Ga.

**TUBES TO SWAP OR SELL**—34—RCA 30; 9—01A, G-E; 5—57 Tungsol (all in sealed cartons). Also two 802 RCA and one 807 used tubes. Want Sprague De-Luxe Telohmike. Vincent Siclari, Electronic Eng. Co., 7414 13th Ave., Brooklyn 19, N.Y.

**WANTED**—Test equipment and parts of all kinds for new shop. Cash on the line. Describe fully. Rush! Joe A. Cora, Service Elec. Co., 167 Webster St., Monterey, Cal.

**FOR SALE**—Two type 954 and two 956 acorn tubes, \$5 ea. C.O.D. Frank Dane, 3852 Eagle St., San Diego 3, Cal.

**FOR SALE**—Model 557 all-wave direct reading signal generator (Readrite Ranger) with batteries, \$10. Paul Grauer, Wilson, Kans.

**FOR SALE**—New Bogen E-14 amplifier, 14-watts, hi-fidelity, 2 mike inputs, phono input & tone control. D. Jarden, 7149 Ardleigh Ave., Philadelphia 19, Pa.

**TUBE CHECKER FOR SALE**—Jewell tube checker 538R, 9" round meter with 2 1/2" AC voltmeter in A-1 condition, complete with tube charts. \$38. Can be modernized to incl. V-O-M. Garrison Elec. & Radio Service, 124 Dover St., Hot Springs, Ark.

**WANTED**—A good capacitor analyzer for cash. George Keefe, 4937 Chancellor St., Philadelphia 39, Pa.

**WANTED**—A good DC V-O-M, also a tube tester. Will consider any type and age if in usable condition. W. S. Girten, Fist Radio Shop, 1702 Highly St., St. Joseph, Mo.

**WANTED FOR CASH**—Good test oscillator or signal generator, preferably Supreme 561. Chas. L. Kramer, 112 Government Ave., Norfolk 3, Va.

**FOR SALE**—Northern Electric input unit R-2522-4. One channel low imp. mike, and two channels low imp. mike or line, all to grid. S. B. Cassidy, 390 Queen St., Fredericton, N.B., Canada.

**WANTED**—A6G tubes, also Rider chanalyst and voltohmmyst, Jr. (RCA). Doerr Radio Service, 1165 Breedlove, Memphis, Tenn.

**FOR SALE**—One Rider's Manual No. 4, \$5. Supreme 400B diagnetometer (has 3 meters, AC volts; DC ma., DC volts—1 meter needs repairs) \$40. Want Rider's Manuals Nos. 7, 8, 9, 10, 11. Botbyl Radio Shop, 1009 Sophia St., Muskegon 25, Mich.

**WANTED FOR CASH**—Modern tube tester and signal generator in good cond. Wallace Radio Shop, 517 Bank St., Wallace, Idaho.

**WANTED FOR CASH**—Rider chanalyst, condenser tester, RCA voltohmmyst, good oscillator, and late tube checker. Describe fully. J. M. Winchester, 1414 3/4 So. Elm St., Alhambra, Cal.

**WANTED**—Elec. and Radio books and magazines. Must be cheap and in good condition. State edition, title, author. John A. Seaman, Gentry, Ark.

**FOR SALE**—Never used; ultra-high freq. RCA tubes: 10—832, \$17 ea.; 20—9003, \$2.50 ea.; 4—9002, \$2. ea.;

1—T-20 @ \$2.25; Weston No. 507 0-3 R.F. ammeter. Donald A. Brienen, 970 School Pl., Green Bay, Wisc.

**FOR SALE**—Weston AC and output meter, No. 571, AC scale 1.5-6-15-60-150 volts, \$20. R. E. Wright, C-68, R.A.A.F., Roswell, N. M.

**FOR SALE**—Jackson 640 sig. generator, \$25; Jackson 660 sig. analyzer, \$73; 910MCP Precision tube checker, \$25; Supreme 592 meter (less case) \$38; Solar CB-60 condenser tester, \$15; Webster-Chicago W-929 30-watt comb. 6 & 110 AC amplifier with tubes, \$105; 2 Jensen PM-12B P.M. speakers, \$14.50 ea.; 2 Kainer all steel projectors, \$7.50 ea.; one Shure Unidyne mike with 25' cord, \$19. All perfect—used only 3 mos. Owner in army 3 years. Henry L. Feltes, Arcadia, Wisc.

**WANTED FOR CASH**—Philco console radio with automatic remote tuning unit mfg. in 1939. Prefer shop-worn model. Tech-Sgt. Roman W. Feltes, 20645020, A.P.O. 32, 32nd Signal Co., %P.M., San Francisco, Calif.

**FOR SALE**—235 new sealed RCA-Sylvania-Emerson tubes incl. many hard-to-get types such as 50L6's, 12SA7's, etc. Also Rider's No. 1 and 2 at \$2.50 ea.; Perpetual Rider's @ \$7.50; new Pioneer enc-motor; 6 new crystal pickups (Astatic crystals) \$4.50 ea.; good 10-station intercom. master and one remote, \$20; 50 good used tubes incl. many 12, 25, 35, and 50 volt tubes. Write for list. Baldwin Radio, 13 Fulton Ave., Jersey City 5, N. J.

**WANTED**—Tube tester, also V-O-M in good condition. Have No. 339 Supreme analyzer to swap or sell. G. T. Harrison, 18 Franklin St., Petersburg, Va.

**TUBES FOR SALE**—6F8; 6J5; 6L6; 1612; 6L7; 6SF5; 6N7; 5V4; 205D; 6C5; 2A6; 220; 6A7; 6K7; 6A4; 6B7; 12A5; 17; 26; 31; 30; 35; 38; 48; 49; 50; 55; 56; 79; 81; 83; 41; 6V6; 85; 12SA7; 35Z5; 50L6; 25Z5. Fred Cronin, 533 W. 112 St., New York 25, N.Y.

**WANTED**—by serviceman starting back in business: Signal generator; V-T-V-M and other test eqpt., also parts, tubes, etc. Herbert T. Lear, 932 South Avenue, Westfield, N. J.

**TUBES WANTED**—Urgently need 1A7 1N5; 1H5; 1B7. Cash for good, tested tubes. G. G. Hairston, R.F.D. No. 1, Box 45, Martinsville, Va.

**FOR SALE**—852 RCA tube, almost new. Make offer. General Radio Service, 1203 Eckhart St., Fort Wayne 5, Ind.

**BOOKS FOR SALE**—Radio Service Course book, 1943 ed. (Supreme Publ.); Understanding Radio by Watson-Welch-Eby; Fundamentals of Radio by W. L. Everett. Want to buy late ed. Modern Radio Servicing by

### "NOT A FAILURE IN A MILLION"

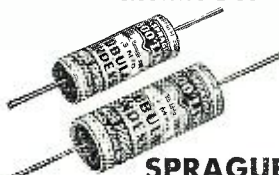

### SPRAGUE TC TUBULARS

When there's a by-pass capacitor job to do, do it with famous Sprague TC Tubulars — and forget it. They will not let you down! We'll appreciate it if you ask for them by name.

Ghirardi; Servicing by Signal Tracing by Rider. W. L. Keeling, 1609 West Broadway, Muskogee, Okla.

**FOR SALE**—Superior 1130 signal generator, 100 kc.—105 mc., in A-1 condition. Also have 300-watt Janette converter, 110 DC to 110 AC. Guilford Radio & Sound Service, 3400 Greenmount Ave., Baltimore 18, Md.

**EQUIPMENT FOR SALE**—Supreme 333 de-luxe analyzer; Supreme 89 de-luxe tube and condenser tester; Clough-Brengle OCA signal generator; Weston 301 0-1 milliammeter; Electro-Voice 610 dynamic mike; Chrome combination mike stand; 15-watt amplifier; 10" Cinaudagraph P-M speaker (no baffle); Lafayette-Garrard portable record player; 40 new tubes (all saleable types); and 40 used tubes. William Chappell, 824 Wauceada Ave., Benton Harbor, Mich.

**FOR SALE**—Weston DB meter No. 301, square face, —10 to +6 db. on 500 ohm line, \$17. Astatic D104 crystal mike on table std. with 25' cable and plug, perfect, \$17. Brush crystal cutting head RC20, \$10. Charles Wallace, 78-15 68 Road, Middle Village, N.Y.

**WANTED**—Hickok 510X tube tester, also sig. gen. and Rider's manuals. Goutrief Steckert, Chilton, Wisc.

**WANTED**—Two speed 78 and 33 1/4 r.p.m. 6V DC flyer governor controlled motor compl. with 10" turntable; some 6V phonographs with 6V amplifier, has Astatic crystal pickup, dual speed turntable. Want Rimco model 701 dynalyzer or Hickok 155 Tracometer and 188X sig. generator. Edward Schuh, Ed's Radio Service, Avon, S. D.

**WANTED FOR CASH**—An AC-DC V-O-M or similar multimeter in good condition. Riverside Radio Service, Route 1, Box 79, Maribel, Wisc.

### YOUR AD RUN FREE

Send us your Sprague Trading Post advertisement today. We'll be glad to run it free as a part of our special wartime advertising service to the radio profession. "Equipment for Sale" and "Wanted" advertisements of an emergency nature will receive first attention. Different Trading Post ads appear regularly in *Radio Retailing*.

Today, *Radio Service-Dealer*, *Service*, *Radio News*, and *Radio-Craft*. Please do not specify any particular magazine for your ad. We'll run it in the first available issue that is going to press. Sprague, of course, reserves the right to reject ads which, in our opinion, do not fit in with the spirit of this service.

Dept. RN-44, SPRAGUE PRODUCTS CO., North Adams, Mass.

# SPRAGUE CONDENSERS KOOLOHM RESISTORS

Obviously, Sprague cannot assume any responsibility, or guarantee goods, services, etc., which might be exchanged through the above advertisements

## Wired Radio

(Continued from page 31)

stand 600 volts. It is recommended that, whenever possible, these units each consist of five .01- $\mu$ fd. mica units connected in parallel.

The oscillator may be powered by any good 400-volt, 150-ma. d.c. supply and may be modulated by a 10 to 20-watt audio amplifier with a suitable coupling transformer to match the oscillator plate impedance (EP/Ip). Keying or any similar signal control of the unmodulated carrier may be accomplished by breaking either the B plus or B minus line.

Fig. 8 shows an oscillator-amplifier unit, employing an I-F crystal of the receiver-filter type. Use of the Pierce circuit around the 6C5 (or 6J5) triode, circuit around the 6C5 (or 6J5) triode,

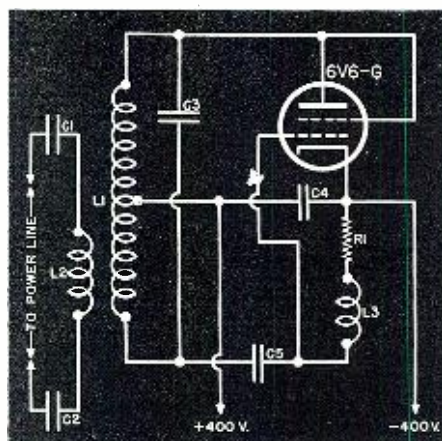

Fig. 7. Shunt-fed Hartley oscillator.

$C_1, C_2$ —.05- $\mu$ fd. (See text)  
 $C_3$ —.003- $\mu$ fd. mica cond.—Aerovox  
 $C_4$ —.01- $\mu$ fd. mica cond.—Aerovox  
 $C_5$ —.00025- $\mu$ fd. mica cond.—Aerovox  
 $R_1$ —50,000-ohm, 10-watt w.w. resistor—Ohmite  
 $L_1, L_2$ —See text  
 $L_3$ —85-mh. r.f. choke

eliminates low-frequency tuning in the oscillator. I-F crystals are available on 455, 456, 465, and 500 kc.; and in addition, crystals intended for standard frequency use are ground to 100 and 1000 kc. In some quarters, 175-kc. crystals also are to be found.

The amplifier stage of this transmitter is built around a tetrode-connected 6V6-G. The amplifier tank,

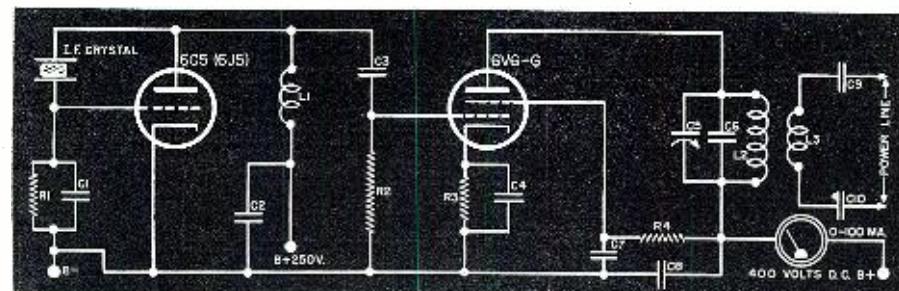

Fig. 8. Pierce oscillator-amplifier unit used for long-distance communications.

$C_1$ —.00025- $\mu$ fd. mica cond.—Aerovox  
 $C_2, C_3, C_4$ —.01- $\mu$ fd. mica cond.—Aerovox  
 $C_5$ —.01- $\mu$ fd., 600-volt tub. cond.—Aerovox  
 $C_6$ —.100- $\mu$ fd. double-spaced variable cond.—National TMC  
 $C_7$ —.0035- $\mu$ fd. mica cond.—Aerovox  
 $C_8, C_9, C_{10}$ —.05- $\mu$ fd. cond. (See text)

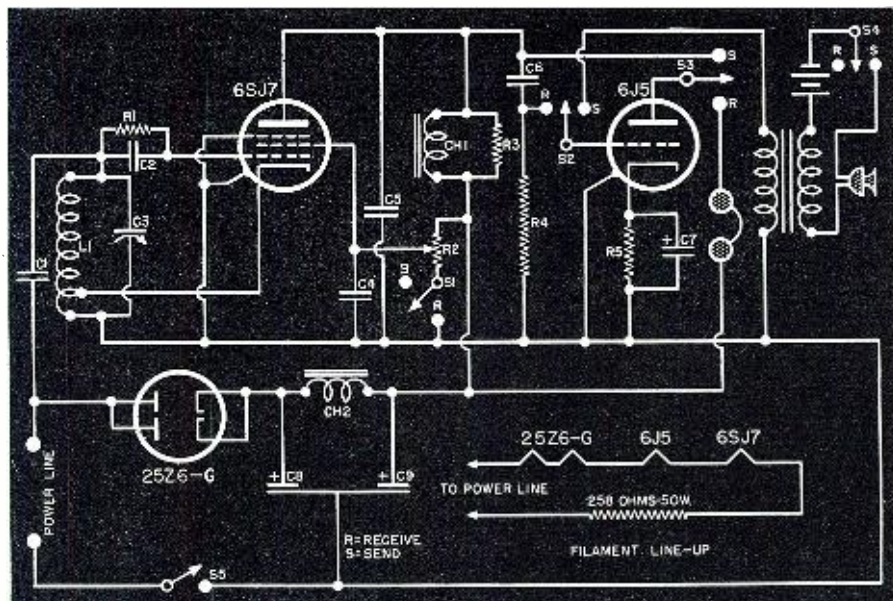

Fig. 9. Low-powered, low-frequency transceiver may be used over a 1000-ft. power line.

$C_1$ —.001 to .002- $\mu$ fd. mica cond.—Aerovox  
 $C_2$ —.0001- $\mu$ fd. mica cond.—Aerovox  
 $C_3$ —Trimmer in oscillator can  
 $C_4, C_5$ —.01- $\mu$ fd. mica cond.—Aerovox  
 $C_6, C_7$ —.00025- $\mu$ fd. mica cond.—Aerovox  
 $C_8$ —10- $\mu$ fd., 25 d.c.w.v. elect. cond.—Aerovox PRS  
 $C_9, C_{10}$ —Dual 8- $\mu$ fd., 450 d.c.w.v. elect. cond.—Aerovox PRS  
 $CH_1$ —300-hy., 5-ma. iron-cored audio choke—Kenyon P-500  
 $CH_2$ —10-20-hy. midget b.c.-type filter choke—U. T. C.  
 $R_1$ —50,000 ohm, 1/2-watt res.—Aerovox  
 $R_2$ —50,000-ohm wirewound pot.—Clarostat  
 $R_3$ —.25 megohm, 1-watt res.—Aerovox  
 $R_4$ —.05 megohm, 1/2-watt res.—Aerovox  
 $R_5$ —2500 ohm, 1-watt res.—Aerovox  
 $S_1, S_2, S_3, S_4$ —Elements of a 4 p.d.t. anti-capacity switch—Federal  
 $S_5$ —S.p.s.t. toggle switch—Arrow

L2-C6, is tuned to the crystal frequency. L2 is closewound on a 3-inch diameter form with No. 18 d.c.c. wire, and C6 is a 5000-volt mica unit. For 450-500-kc. response, L2 will consist of 60 turns, C6 will be .0035  $\mu$ fd., and the tuning section—C5—a 100- $\mu$ fd., double-spaced variable condenser.

The crystal-controlled unit, like the 6V6-G oscillator, may be voice- or tone-modulated by any good 10 to 20-watt audio amplifier provided with an output transformer for matching the plate impedance of the 6V6-G (approximately 4000 ohms). Keying or other intermittent signalling may be accomplished by interrupting either the cathode or B-plus lead in the amplifier stage.

R-F coupling to the a.c. line is provided by the pickup coil, L3 and the two coupling capacitors, C9 and C10. L3 is ten turns of No. 18 d.c.c. wire closewound around the plate-half of L2 and insulated from L2 by means

of empire cloth, several windings of transparent Cellophane tape, or similar protective binder. The coupling capacitors are each .05- $\mu$ fd. units rated to withstand at least 600 volts d.c. Wherever possible, these units should each be made of five .01- $\mu$ fd. mica units connected in parallel.

The crystal-controlled unit of Fig. 8 offers the advantage of high stability along with increased power. It may be operated by any good 400-volt, 150-ma. d.c. power supply which has a 250-volt tap, and is capable of communication over distances up to five miles in congested areas and up to ten miles in open country where power lines are overhead.

### Wired-Radio Transceiver

Fig. 9 shows the circuit of a low-powered, low-frequency transceiver for carrier-current communication. This unit employs only three tubes, including the rectifier, and is entirely satisfactory as a fixed-frequency intercommunicator. Two units of the same type might be employed over at least 1000 feet of power line with good results. Although an a.c.-d.c. half-wave line-type rectifier is shown in the schematic, a transformer type of power supply is entirely permissible if the builder wishes complete isolation of the d.c. circuits and chassis from the power line. Likewise, the 25Z6-G (or comparable rectifier tube) may be wired as a voltage doubler to give increased signal strength when transmitting and somewhat louder signals when receiving.

Tuning to the low carrier frequency is accomplished by means of the tank L1-C3 which comprises a regular su-

# YOUR MONEY BACK IN 5 DAYS

**IF** Ghirardi's big 972 page **RADIO PHYSICS COURSE** doesn't teach you **RADIO-ELECTRONIC** fundamentals **FASTER** and at **LESS COST** than any other book or course!



**A. A. GHIRARDI**  
Radio's most widely read Author

**THE MOST WIDELY USED TRAINING BOOK OF ITS KIND IN THE WORLD**

Here, in a single, big 972-page volume, is a miracle of modern Radio-Electronic Training—sold at a small fraction of the price you might expect to pay—and backed with a **5-DAY MONEY BACK**

**GUARANTEE** that makes you the sole judge of whether or not you want to keep it. *You cannot lose!*

**NO PREVIOUS TRAINING REQUIRED**

Everything that can be done to make learning Radio easy for you at home has been done in Ghirardi's **RADIO PHYSICS COURSE**. No previous training is required. All you need is a little spare reading time—and a desire to get started **RIGHT** for a profitable, interesting future in any of Radio's many branches, from Radio and Electronic servicing, to Aviation, Military, Broadcasting, Manufacturing, Public Address, and many others. There is no guesswork when you buy Ghirardi's famous **RADIO PHYSICS COURSE**. You **KNOW** you'll get complete, time-tested Radio-Electronic training and get it right **BECAUSE:**

1. *This same inexpensive book has given more people their basic training than any other ever published.*

- 2. *It is more widely endorsed and recommended by men already in Radio.*
- 3. *It is more universally used for home study, and more widely used in more U.S. Army Signal Corps, Navy, and civilian schools and colleges than any other.*

**Would you want any better proof?**

What other books and courses skim over, **RADIO PHYSICS COURSE** painstakingly explains in detail so that you cannot fail to understand clearly. It even contains over 300 pages devoted to the all-essential foundation knowledge of Electricity without which no Radio Training could possibly be complete or understandable.

**MORE TRAINING FOR YOUR MONEY**

Such features are highly important. They explain why thousands of civilians and men in the armed forces report that **RADIO PHYSICS COURSE** makes the study of Radio-Electronics easier, more interesting, and more genuinely helpful to them than any other book or course they've ever seen.

Actually, this famous volume gives you the scope of 36 different courses in one—packed into an easy-to-follow 972-page book with 508 clear illustrations, and 556 self-testing review questions—all for the price of only \$5 complete (\$5.50 foreign). Send for it today!

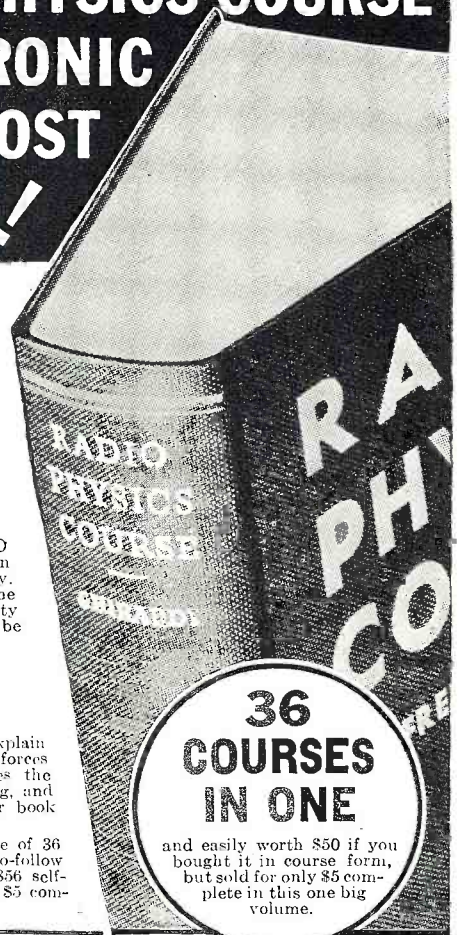

**36 COURSES IN ONE**

and easily worth \$50 if you bought it in course form, but sold for only \$5 complete in this one big volume.

## NEW! Ghirardi's Wartime Guide for **DIAGNOSING, LOCATING, AND REPAIRING RADIO RECEIVER TROUBLES** (RADIO TROUBLESHOOTERS HANDBOOK—Now in its 3rd Revised Edition)

Stop guessing on radio service jobs—stop wasting time **THAT ACTUALLY COSTS YOU MONEY!** . . . Here is the most important book any repair shop or individual can own during these war shortage days! Enables you to cut corners on jobs—cut troubleshooting and repair time **IN HALF!**—train new helpers—repair cheap sets at a real profit—substitute available tubes and parts properly—handle tough

jobs in half the usual time—and much more.

**COVERS 75 VITAL SUBJECTS**

This new 3rd, Special Wartime Edition of Ghirardi's popular **RADIO TROUBLESHOOTERS' MANUAL** has been completely revised, greatly enlarged, and contains nine entirely new and additional sections of vital new material—including the finest, most up-to-the-minute tube chart you've ever seen. Its 404-page Case History Compilation

gives common trouble symptoms (their Causes and Remedies), for over 4,800 models of the 202 most popular makes of receivers—and that is just the beginning of the book's usefulness. 74 other big subjects include all the various kinds of information you need to help you repair more radios in less time and at better profit to you.

Sold for only \$5 complete (\$5.50 foreign) on a **5-DAY MONEY-BACK GUARANTEE**. Folder free.

**JUST OUT!**

### GHIRARDI'S FAMOUS **MODERN RADIO SERVICING**

Another indispensable volume by Radio's best known technical author is Ghirardi's **MODERN RADIO SERVICING**—the only single text book covering modern radio testing instruments, troubleshooting, and repair procedure **COMPLETELY**. Actually it is a 1300-page homestudy course on the entire art of Radio repair, complete with 706 illustrations, and 720 self-testing review questions. Sold for only \$5 complete (\$5.50 foreign).



See Money-Saving Combination Offer in Coupon!

## THE 3 GREATEST VALUES IN MODERN RADIO TRAINING

Radio & Technical Publishing Co., Dept. RN-44  
45 Astor Place, New York (3), N. Y.

- Enclosed find \$..... in payment for books checked below; or
- Send C.O.D. for this amount plus postage. In either case, if I am not fully satisfied, I may return the books at the end of 5 days and **RECEIVE MY MONEY BACK**

**MONEY-SAVING COMBINATION OFFER**

- Ghirardi's **RADIO PHYSICS COURSE** \$5.00 (\$5.50 foreign)
  - NEW 3rd Revised Edition of RADIO TROUBLESHOOTERS' MANUAL** \$5.00 (\$5.50 foreign)
  - MODERN RADIO SERVICING** \$5.00 (\$5.50 foreign)
- Troubleshooters' Handbook and Modern Radio Servicing at a special price of only \$9.50. **FOR THE TWO** (\$10.50 foreign).

Name.....  
Address.....  
City..... State.....

# REPAIR ANY MAKE OF RADIO EQUIPMENT!

Prepare Now for a Good-Paying Job in the Radio-Electronic Field

# SMALL and MEDIUM TRANSFORMERS for QUICK delivery

If you have the proper priority rating, Consolidated Radio can now make deliveries in a few weeks instead of many months!

Consolidated Radio Products Company has recently greatly expanded its production facilities on a wide range of small and medium transformers including Pulse Transformers, Solenoid Coils, Search Coils. Other products include Range Filters, Headsets.

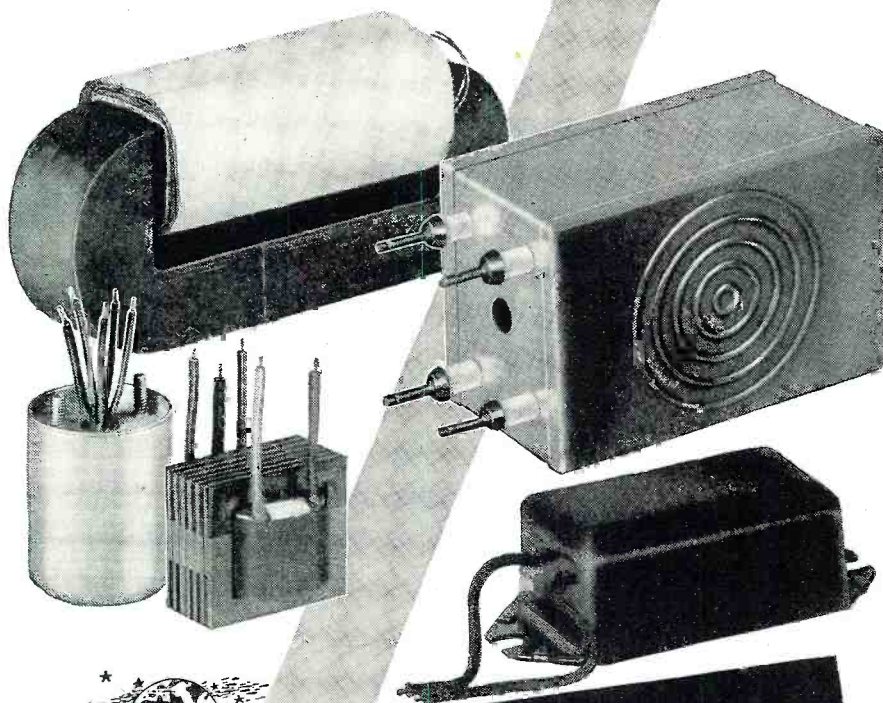

perhet beat-frequency oscillator can assembly. The frequency is set by screwdriver adjustment of the trimmer C3, and may be shifted over a narrow band at will. These oscillator "coils" are manufactured in small sizes and do not require much chassis space.

Shifting from transmitting to receiving is accomplished by a single flip of a four-pole, double-throw switch, the sections of which are designated S1, S2, S3, and S4. In the receiving position, the following connections are completed: R2 is connected to ground (B-minus) as a voltage divider and serves as the regeneration control, the grid of the 6J5 audio tube is connected to the detector output and grid resistor R4, the headphones are placed in series with the audio plate and B-plus, and the microphone battery-transformer circuit is opened. The following connections are made in the sending position of the changeover switch: R2 is opened, thereby permitting the 6SJ7 tube to oscillate at full strength; the 6J5 grid is connected to the microphone transformer secondary; the 6J5 plate is connected to the oscillator plate for Heising modulation; and the microphone circuit is closed.

A standard handset may be employed with this transceiver, if an output transformer is provided in the 6J5 plate circuit for impedance matching between the audio plate and the low-impedance headphone of the hand-

Pi-Wound R-F Chokes			
Kc.	1 mh.	2.5 mh.	
150	1100	450	$\mu\mu\text{fd.}$
200	650	250	$\mu\mu\text{fd.}$
250	400	170	$\mu\mu\text{fd.}$
300	281	120	$\mu\mu\text{fd.}$
350	210	85	$\mu\mu\text{fd.}$
400	160	65	$\mu\mu\text{fd.}$
450	130	52	$\mu\mu\text{fd.}$
500	105	43	$\mu\mu\text{fd.}$

Chart I. Parallel resonance capacitance for 1 and 2½-millihenry chokes.

set. The impedance ratio required will be approximately 9000-to-75 ohms if the a.c.-d.c. power supply is employed as shown in the schematic, and approximately 27,000-to-75 ohms if a 250-volt power supply is used.

Coupling between the detector and audio stages is provided by choke CH<sub>1</sub> and capacitor C6. C6 is removed from the circuit by the changeover switch when the latter is in the transmit position, but the choke remains to serve as a modulation reactor. This choke must be iron-cored and should be rated at 300 henries (5 milliamperes). Such reactors are not easily obtained at this time, and the builder may be inclined to experiment with whatever reactors he has on hand. Fair results are obtained with midget filter chokes of 20 henries or more inductance.

Coupling of r.f. to the line (as well as coupling of the receiver to the line) is accomplished by C1, which should be a mica capacitor rated at

(Continued on page 135)



The world  
may be  
shrinking—

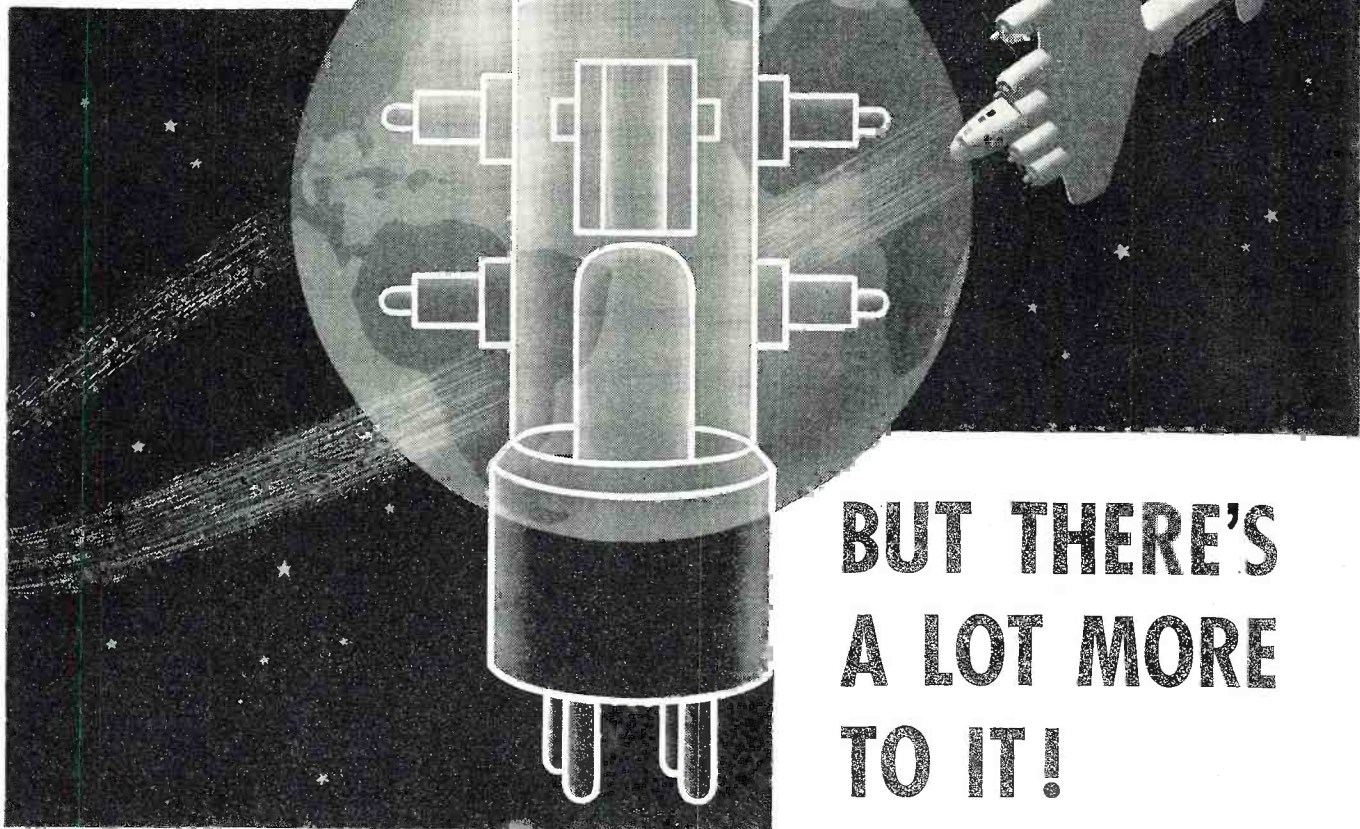

**BUT THERE'S  
A LOT MORE  
TO IT!**

Right now, in action on ships and planes and vehicles, there are radio and electronic applications that were vague dreams a few short years ago. They were built for war, but their principles promise new products and refinements to enrich the peace that follows.

It has been Delco Radio's privilege to work closely with Army and Navy engineers in exploring the possibilities of radio and electronic equipment. Many problems of design have been solved through cooperative research—many problems of production overcome by Delco Radio's experience as a large manufacturer of precision radio instruments. From laboratory to drawing board to production line, Delco Radio has been in on the job of making electronics

practical for mobile artillery, tanks, aircraft, ships and field units.

This accumulated experience is a reservoir of technical knowledge that will add a lot to the world of tomorrow.

***Put your dollars "in action"***  
**BUY MORE WAR BONDS**

**Delco Radio**  
DIVISION OF  
**GENERAL MOTORS**

age is coupled back through a resistance-capacitor network (comprising the tone-control circuit) to a 5,000-ohm tap on the 2-megohm volume control. Later, more will be said about the reason for this tap arrangement.

To understand the operation of the tone control circuit, it will be helpful first to view the results accomplished by the tone control. It has been found that under normal conditions the most desirable reproduction is had when the audio characteristics are as shown in the response curve labeled 1-3 of Fig. 5. Under certain conditions it is often desirable to accentuate the bass, and this is done by decreasing the high frequency response as shown in curve 1-4. When receiving weak or foreign signals, which are often times accompanied by a relatively high noise level, it has been found that the signal-to-noise ratio is usually increased if the bass as well as the high-frequency audio response is decreased as shown in response curve 2-4. In speech, the intelligibility is for the most part carried in the higher frequencies; hence, response characteristic 2-3 is desirable for speech reproduction.

To fully visualize the operation of the tone control circuit would require a knowledge of the phase shift in the amplifier and tone control circuit as well as the impedance-vs-frequency characteristic of the tone-control circuit. As the phase shift in the amplifier is somewhat involved, the impedance-vs-frequency characteristic of the tone control circuit only will be considered. This characteristic alone will give an accurate understanding of the tone control operation.

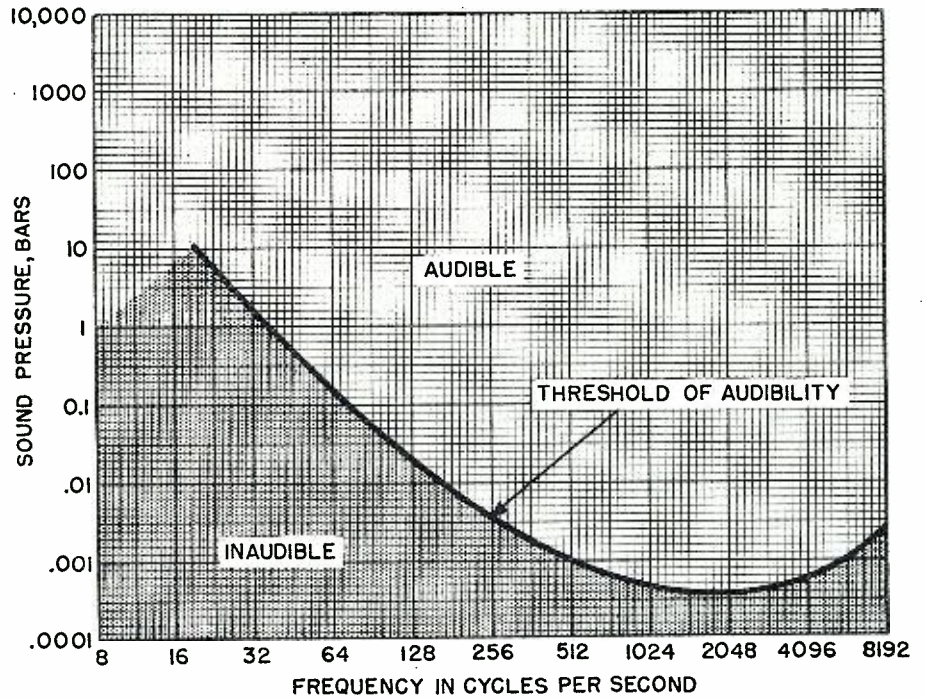

Fig. 6. Minimum sound pressure, audible to the average ear at various frequencies.

With the tone control in the *Normal* position, voice coil signal voltage is fed back through the resistance-capacitor network *R16*, *C15*, and *R6* of the tone control circuit to the tap on the volume control. The effect of this resistor-capacitor network is to provide *more* inverse feedback at the mid-range and higher audio frequencies than at the low frequencies. Since the greater the inverse feedback the less the gain of the amplifier, the amplifier will therefore provide a *lower* amount of amplification for the mid-range and higher frequencies. The mid-range and higher frequency output will therefore be *less* than at the

low frequencies (see response curve 1-3 in Fig. 5). The result of this selective audio feedback is an improvement in "tone quality" and an extended range of the low frequencies. The amplifier circuit is designed to produce the peak at point 3 thus giving the two peaks in curve (1-3).

Upon moving the tone control to the *Bass* position a 0.01- $\mu$ f. capacitor *C19* is shunted across the 22,000-ohm resistor as well as the 68,000-ohm resistor and 0.1- $\mu$ f. capacitor. As shown in the box in Fig. 4, this capacitor has a reactance of 320,000 ohms at 50 cycles. This high reactance, of course, is large compared to the 22,000-ohm

Fig. 7. Frequency characteristics of audio amplifier (Fig. 4) at various volume-control settings.

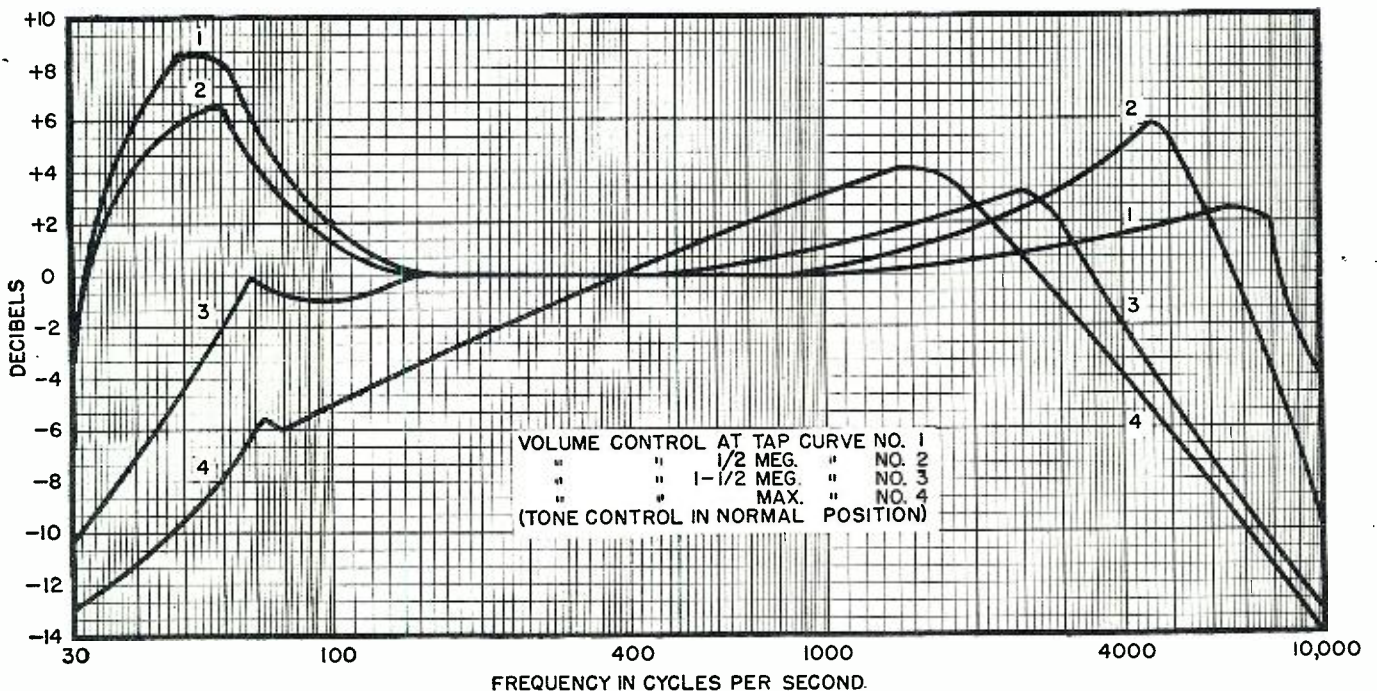



Where Office Machines can't be coddled  
**Underwood's the choice...**



—From Remote African Base Pan American World Airways reports Hardihood of Underwood Equipment.

No Casualties Permitted—Unlike the AOST cities where service facilities are, even in wartime such rem

vacations, they have required remarkably little special attention.

**THIS GOES FOR  
 RADIO RECEIVERS,  
 TOO**

It's an old tradition for National equipment to do the tough jobs at inaccessible outposts. Long before the war, National receivers had already become the first choice of expeditions to the far corners of the earth.

Pan American has long used National equipment, and many years of experience with the ruggedness and dependability of National receivers were back of Pan American's choice in the picture shown above.

**NATIONAL COMPANY, INC., MALDEN, MASS.**



# MURDOCK Radio Phones Have Passed the Battle Test!

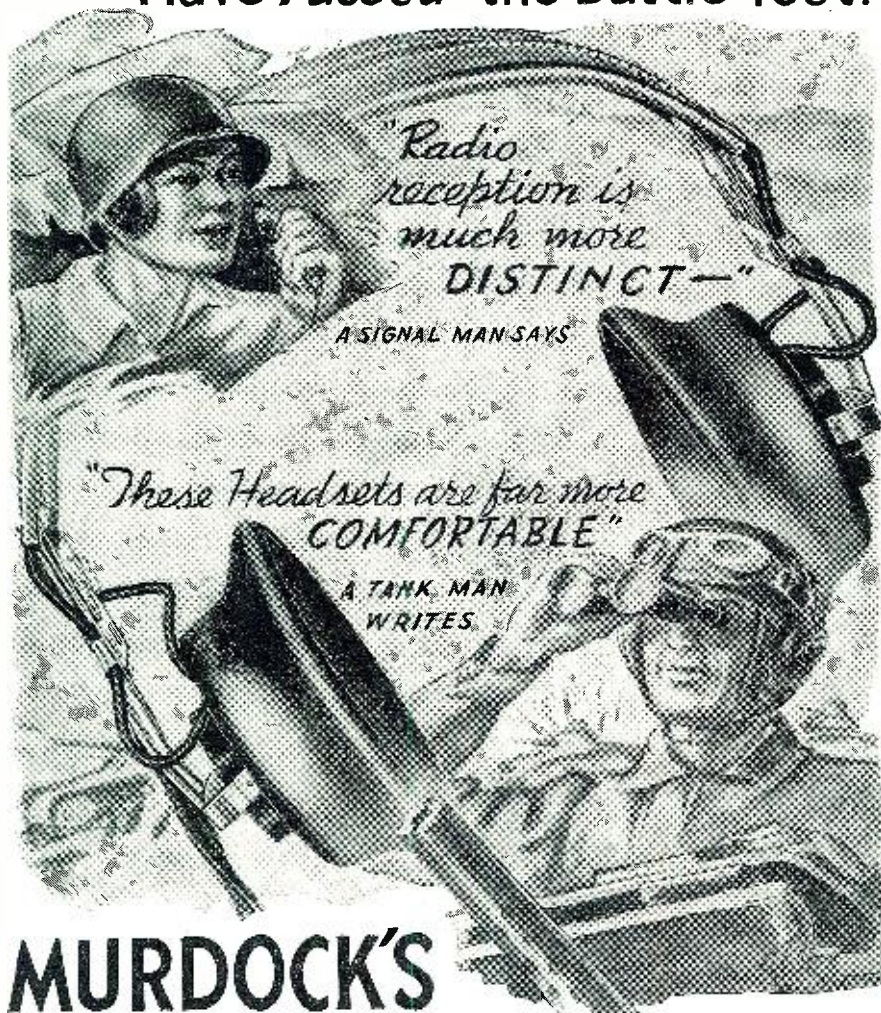

"Radio reception is much more **DISTINCT**—"

A SIGNAL MAN SAYS

"These Headsets are far more **COMFORTABLE**"

A TANK MAN WRITES

## MURDOCK'S the Choice when Peace Comes!

### We Invite Sub-Contract Orders

Our busy plant still has facilities for making more Radio Phones and related parts on a sub-contract basis. If we can help you in this field, please write us!

**I**n lurching tank and shell-swept fox-hole MURDOCK Radio Phones have met and stood the acid test of war. Their surprisingly clear and sensitive reception has never failed to bring a message through without distortion.

Tried and perfected in the heat of battle, MURDOCK will give you when peace returns all the advantages of the world's keenest radio ears!

*Write for Catalogue!*

**WM. J. MURDOCK CO.**  
125 Carter St., Chelsea 50, Mass.

and 68,000-ohm resistor and accordingly, the low-frequency voltage coupled back is unaffected by the addition of the 0.01 capacitor in the circuit. On the other hand, at 5,000 cycles the reactance is but 3,200 ohms and accordingly, the high-frequency feedback will be materially increased by the voltage coupled through the capacitor. This increased feedback at the high frequencies will result in a decreased gain at the high frequencies, while the lows will be unaffected as the feedback was unchanged for this range of frequencies. Response curve 1-4 in Fig. 5 then, is the characteristic for the amplifier with the tone control in the Bass position.

When the tone control is moved to the Foreign position, the 0.01- $\mu$ fd. capacitor *C19* which increased the high-frequency feedback is still in the circuit, but in addition, the 0.1- $\mu$ fd. capacitor *C15* is now "shorted" out. This capacitor had a reactance of 32,000 ohms at 50 cycles and 320 ohms at 5,000 cycles. With the capacitor in the circuit, the 320 ohms at 5,000 cycles is effectively a "short" as compared to the other resistances in the circuit. On the other hand, the 32,000 ohms at 50 cycles is comparable to the other resistances in the circuit. As a result, shorting out the 0.1 capacitor *C15* has small effect on the high-frequency feedback but materially increases the low-frequency feedback, with a consequential decrease in gain at the low audio frequencies as shown in response curve 2-4 of Fig. 5. Hence we now have more degeneration of both the high and the low frequencies than of the middle range.

In the Speech position, the 0.01- $\mu$ fd. capacitor *C19* that increased the high-frequency feedback is disconnected from the circuit, while the 0.1- $\mu$ fd. capacitor *C15* and resistor *R16* are "shorted" by the switch. Consequently, resistor *R6* alone is in the feedback circuit between the voice coil and the tap on the volume control. When feedback is obtained through a resistive network  $\beta$  is independent of frequency, and the relative phase shift and dependence of gain upon frequency can be made negligible, accordingly, this allows equal degeneration of all frequencies, resulting in the amplifier response curve 2-3 in Fig. 5.

From this, it is seen that selective degeneration affords a very simple means of changing an amplifier's frequency response characteristics to meet various conditions.

### Bass Compensation

With the feedback voltage coupled to the input of the amplifier in the manner illustrated in the circuit of Fig. 4, it is apparent that the ratio of the feedback voltage to signal voltage applied to the amplifier is variable, depending upon the setting of the 2-meg. volume control. When the movable arm is on the 5,000-ohm tap, the ratio of feedback voltage to the audio signal voltage is maximum, while with the movable arm of the volume control in the "MAX. VOL." (2-megohm) posi-

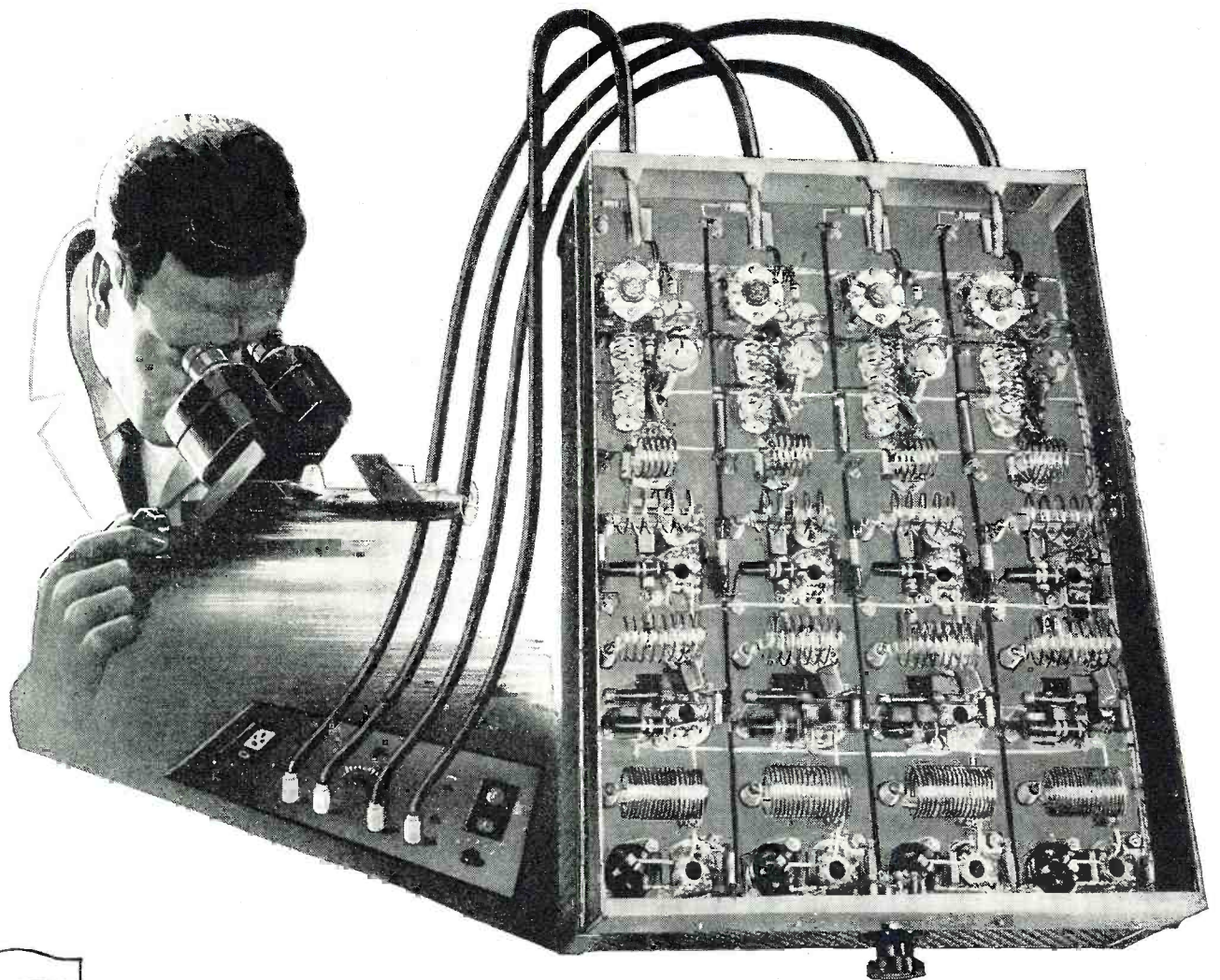

**TO EXACTING laboratory standards**

The reason for our successful interpretation of specialized production problems is an open secret. ECA has an invaluable supplement to sound experience and versatile facilities. This is the competitive spirit in our ranks fostered by both management and labor. Such a challenge to individual effort results in greater efficiency, greater economy, and a deeper insight into the assignment at hand.

The ECA Laboratory Frequency Standard is an excellent example of our work. This unit is used in our production department for testing and calibrating equipment. It is a frequency standard providing checking of ultra-high frequencies with an accuracy of one hundredth of one percent. It is composed of crystals and a series of frequency multipliers which multiply each crystal frequency 64 times. This unit was built in the ECA laboratory since there is no commercial equipment available that will guarantee the required accuracy at certain ultra-high frequencies. It has made possible the delivery of specially needed equipment for the war agencies.

100%  
IN WAR WORK  
OCCASIONALLY,  
HOWEVER,  
PRODUCTION  
SCHEDULES  
PERMIT US  
TO ACCEPT  
ADDITIONAL  
ASSIGNMENTS

*FIGHT HARD WITH WAR BONDS . . . BUY ALL YOU CAN, AND MORE*



**ELECTRONIC CORP. OF AMERICA**

45 WEST 18th STREET • NEW YORK 11, N. Y. • WATKINS 9-1870

tion, the feedback voltage will be unchanged but the audio signal applied to the amplifier will be greater; hence the ratio between the two will be a *minimum*. This variable ratio between feedback and input signal voltages serves the very useful purpose of varying the audio characteristics as the volume level is changed. It is important that the audio characteristics of the amplifier vary with the volume level in a manner based upon the characteristics of the ear.

In Fig. 6 is shown the auditory sensation of an average ear. The curve, marked *Threshold of Audibility*, indicates the *minimum* sound pressure audible to the average ear at the various frequencies throughout the speech and music spectrum of the audio range. Study of this important graph shows that as the volume is *decreased* in an amplifier having a linear characteristic, the bass frequencies will become inaudible much sooner than the mid-range frequencies because the ear is less sensitive in the bass-frequency range than in the middle range and, consequently, requires more sound pressure for audible perception in the bass range. Experience has shown that at the relatively low sound levels often most desired in the home, the bass frequencies are inaudible unless compensation is used to raise the level of the bass frequency sound pressure. But, unless this compensation varies properly with the setting of the volume control, the output will appear to have too much bass at the higher volume settings, or else no bass at the lower levels. This latter condition of little audible bass at low volume settings is extremely common and, undoubtedly, has been noticed by most listeners using receivers having uncompensated volume controls.

Several types of bass-compensated volume control circuits have been used on the more recent receivers. One of the simplest and most satisfactory is the type (Fig. 4) having the feedback brought back to a properly located tap on the volume control. Fig. 7 shows the frequency characteristics of the G. E. F-75 audio amplifier which employs this circuit, at different settings of the volume control. (This response curve is for the audio amplifier alone. The over-all fidelity curve would show a somewhat lesser amount of high frequency response because of the I.F. amplifier selectivity.) It will be noted that at low volume settings the amplifier has a rising bass characteristic which compensates for the relatively low sensitivity of the ear at the bass frequencies. The fact that the frequency characteristic of the amplifier is dependent upon the volume control setting is the result of the varying proportion of feedback-to-signal which results at different volume control settings. The feedback circuit is designed to give a rising bass characteristic, but as the volume is increased the per cent of feedback *decreases*, as does the amount of bass emphasis.

(To be continued)

## Manufacturers' Literature

Readers are asked to write directly to the manufacturer for the literature. By mentioning RADIO NEWS, the issue and page, and enclosing the proper amount, when indicated, delay will be prevented.

### APPROVED PRECISION PRODUCTS

The new 1944 *Mallory* catalog of Approved Precision Products recently has been released.

This catalog includes the complete line of *Mallory* radio, electrical and electronic parts, with sizes, dimensions and rated capacities, together with list prices. It is profusely illustrated with drawings of the units, and has many diagrams showing curves of the units themselves.

The catalog is available through *Mallory* distributors or by writing directly to *P. R. Mallory & Co., Inc.*, 3029 East Washington Street, Indianapolis 6, Indiana.

### STORY OF DRY BATTERIES

A 48-page booklet entitled "The Inside Story of Dry Batteries—A Guide for Students," has recently been released by the *National Carbon Company, Inc.*

The booklet states that the dry battery is one of the common articles of everyday use, supplying the need for packaged electricity to many devices. Most of us are familiar with at least two of these: the flashlight and the portable radio.

Due to the fact that although the use of dry battery powered devices is widespread, information is not readily available and a considerable misunderstanding exists as to how they operate and how they are built, this booklet was prepared to supply this information in clear, concise form. It gives a description of certain features of improved construction which provide longer life or the same service in smaller size and weight.

The booklet starts with the history of the dry battery, gives the fundamental principles of electricity applied to these batteries, and progresses to their characteristics, operation and construction, and finally describes the "Eveready" battery developments which have been made.

Copies of the booklet are available upon request to the *National Carbon Company, Inc.*, New York, New York.

### ELECTRONIC COMPONENTS CATALOG

The new 36-page *Stackpole* Electronic Components Catalog giving full details on Fixed and Variable Resistors, inexpensive Switches, and Iron Cores for a wide variety of electric, radio, and other electronic applications, has recently been released. Also included, are engineering information and data of interest to those dealing with items of this sort.

Particular interest attaches to the listing of standard and high-frequency iron cores, this catalog representing

the first assembling of complete information on these popular items. In addition to complete listings on the various types of *Stackpole* insulated and non-insulated cores, etc., the catalog contains helpful reactance charts as well as time constant charts for series circuits.

Other features include detailed listings, dimension diagrams, etc., of the line of slide, line, and rotary-action switches; 1/2-, 1/2- and 1-watt fixed resistors, as well as variable resistors in standard and midget sizes for practically any radio, hearing device, or similar application.

A copy of the catalog will be sent on request to *The Stackpole Carbon Company*, Electronic Components Division, St. Marys, Pa. Ask for Catalog RC6.

### HIGHWAYS OF THE AIR

Radio's important contribution to the safety of human life and property in air transport is forcefully brought out in a new booklet "Highways of the Air," just published by the *Radio Receptor Company*, makers of airline and airport radio navigational and traffic control equipment.

To quote from the foreword of the brochure, "The importance of radio navigational aids and airport traffic equipment in the successful operation of the airways is too little understood by the layman." In simple non-technical language, "Highways of the Air" outlines the function of their equipment and with the aid of numerous diagrams and illustrations, just what the "beam" is, how it is generated, and how it is sent to the pilot for his guidance in plying the skyways.

Among other topics explained is the airport traffic control system, as installed at LaGuardia Airport in New York, the new National Airport at Washington, D. C., and other modern air terminals. Various components including radio ranges and the several different types of markers are described and their uses discussed.

Written for the layman, its non-technical contents are highlighted by many photographs, maps, and charts. "Highways of the Air" is available free upon request to the *Radio Receptor Company, Inc.*, 251 West 19th Street, New York 11, N. Y.

### CERAMIC CAPACITORS

To supplement bulletin No. 630 on Ceramic Capacitors, *Centralab*, Division of *Globe-Union, Inc.* has just released a new 4-page folder . . . No. 721. It contains condensed information on special types of capacitors now in production.

Types illustrated and described are  
(Continued on page 114)

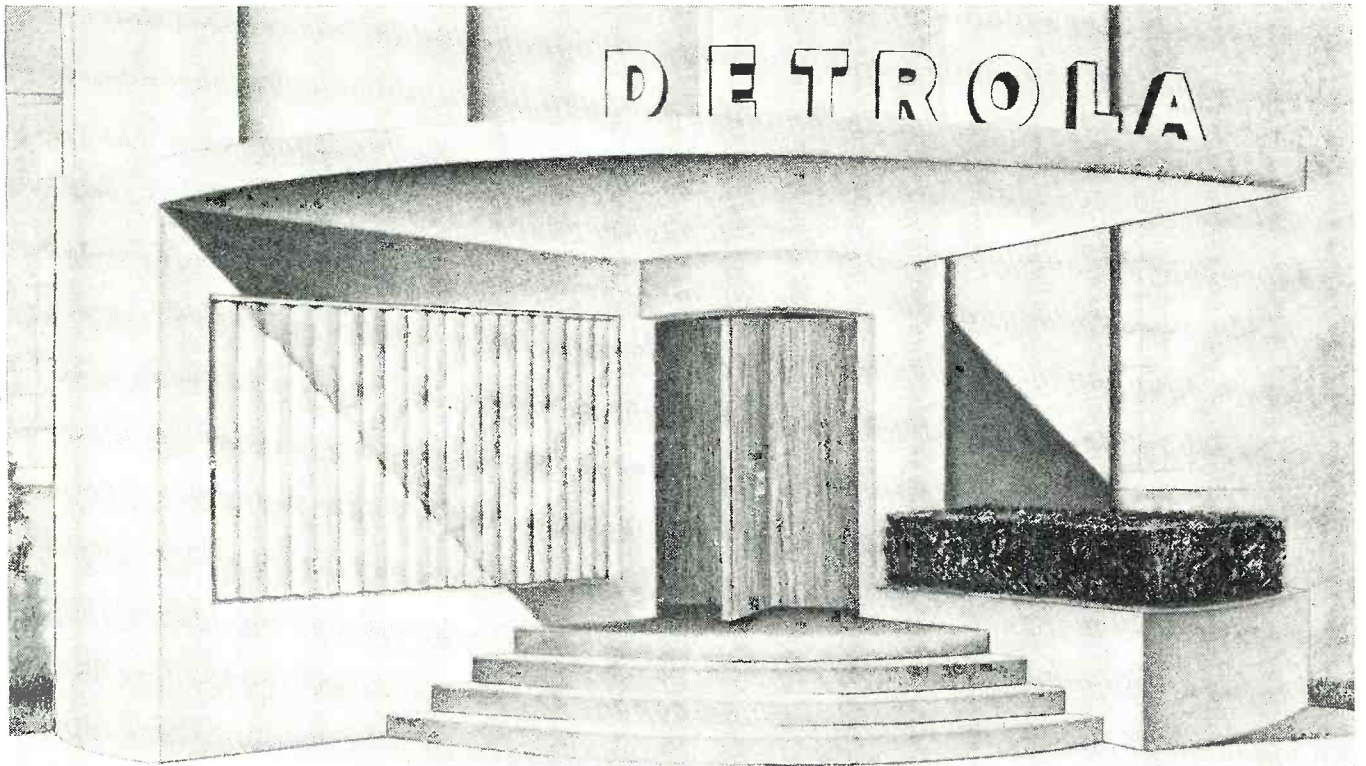

## PORTAL to PRECISION for War and Peace

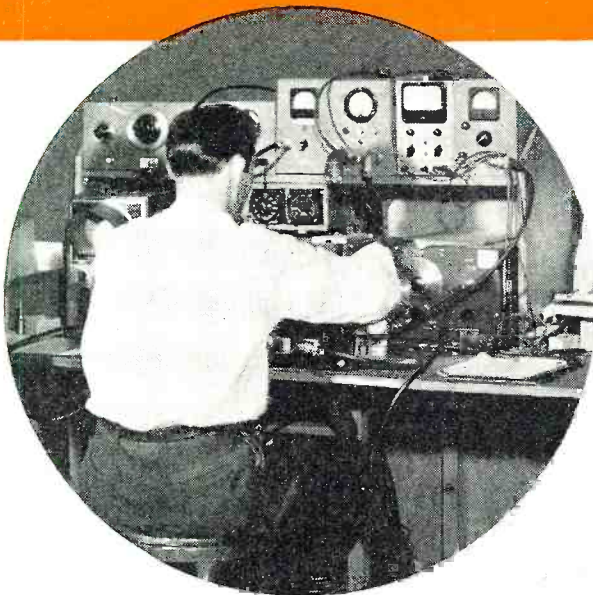

Shown here is the proposed new doorway to Detrola's offices and laboratories. It will soon be a part of the building—to serve not only as a practical and functionally beautiful entrance-way, but to stand as an outward symbol of the many changes that have brought the NEW DETROLA into being. Today this great radio-electronic plant is streamlined throughout—with new research and engineering talent, new production facilities and hundreds of highly trained workers. All of these are dedicated, now, to the manufacture of highest quality war equipment. After Victory, in combination with the experience gained in war, they will be dedicated to the production of highest quality electronic products for civilian use. *Help Secure Victory and Make Victory Secure—Buy War Bonds.*

# DETROLA RADIO

DIVISION OF INTERNATIONAL DETROLA CORPORATION • BEARD AT CHATFIELD, DETROIT 9, MICH.

C. RUSSELL FELDMANN



PRESIDENT



# UNIONAIR



*A New*  
**RECOGNITION  
LIGHT SWITCH BOX  
SMALLER—STURDIER  
EASY TO INSTALL  
EASY TO REPLACE**

Constant production of Electrical Junction Box Assemblies to aircraft manufacturers' specifications has developed an awareness in our Engineering Department of opportunities to improve standard units. This results in the design and development of units such as the one pictured.

This unit takes its place with our steadily growing schedule of production of Junction Box and Wiring Assemblies for Aircraft, all made by Unionair under our Single Responsibility.

## UNIONAIR

*Junction Box Assemblies — Hydraulic Fittings  
Conduit Fittings — Junction Boxes*

UNION AIRCRAFT PRODUCTS CORP., NEW YORK

### WERS Transceiver

(Continued from page 39)

the output tube to full power output.

There are two gain controls, R1 and R2, incorporated in the grid circuit of the 6J5 amplifier tube. Control R1 permits accurate setting of the modulation level so that during transmission the operator will always return automatically to the same level. After this control is once adjusted for proper modulation voltage output, it might be well to remove the knob on the control to offset the tendency of the operator to turn the wrong knob. It may be advisable to mount this control other than on the front panel.

The control R2 is used to adjust the volume output of the receiver.

This unit has been designed to utilize a standard handset. Sufficient output is provided from the grid terminal of the 6V6 output tube to produce a strong signal in the handset. The transmitter is connected to one of the windings of the T1 transformer. A plug connector has been incorporated in order that the handset can be connected conveniently. If, however, the microphone only is used, an ordinary open circuit jack may be employed instead of the socket connector shown.

A push-pull pentode to voice coil transformer is used as combination modulation and speaker transformer. The speaker is mounted in the cabinet, and to permit pulling out the chassis without demounting the speaker, a compact connector of the type used for auto-radio antenna leads, is soldered to the top of the chassis and connections made to the speaker. If necessary, the speaker may be disconnected, the rig pulled from the cabinet and operated, using the handset receiver in place of the speaker.

#### Tuning and Operating

The antenna link (L5) for the transmitter is a hairpin loop mounted by the two 8-32 screws on the rear mount for the plate rods. It consists of No. 12 wire and is covered with spaghetti. It extends very nearly to the top of the bend in the rods, and loading is adjusted by moving the hairpin closer to or away from the rods. The meter comes in handy in this operation but is not really necessary otherwise, except that the normal plate currents for the modulator and output r-f stages must be entered on the request for the FCC license to use the transmitter.

The transmitter frequency may be set by varying the shorting bar position and making measurements on lecher wires. The grid coil may then be squeezed or expanded to get maximum output. When these are adjusted the antenna link may be set to give 50 ma. plate current.

The receiver is set to cover the band by squeezing or expanding the coil



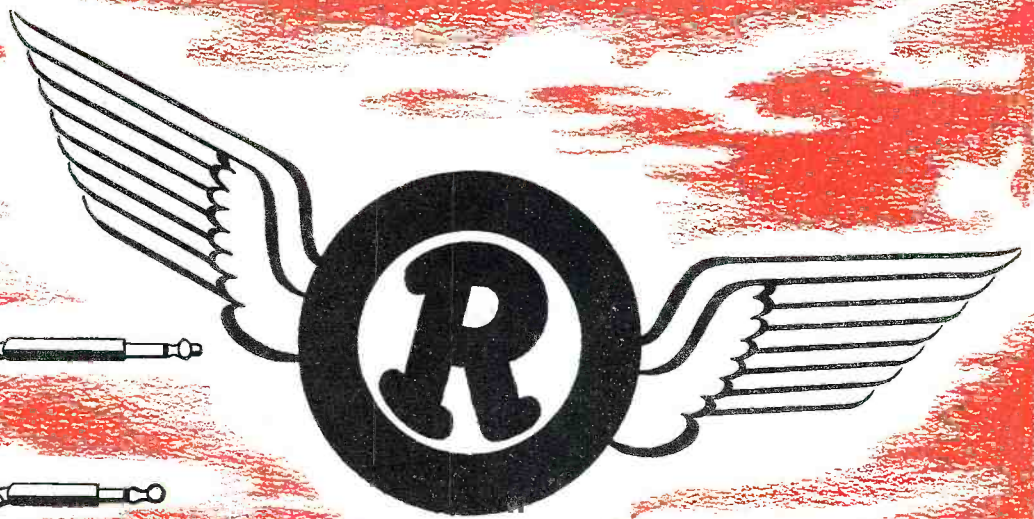

**WIRES** *are* **WINGS**

**THAT SPEED COMMUNICATIONS  
... ON THE WAR FRONT!  
... ON THE HOME FRONT!**

**Runzel**  
**CORDS · WIRES · CABLES**  
Are "Standard Equipment" Everywhere

**RUNZEL CORD & WIRE CO.**  
4723 - 31 MONTROSE AVENUE • CHICAGO

(L1). The antenna coil (L2) is a two-turn link the same diameter as the coil mounted on a piece of ¼" fiber rod which projects downward from the top of the chassis and is held firmly by a 'phone jack. A knob permits varying it. This control for varying the antenna coupling should have been mounted on the front panel, however lack of space prevented its installation.

The antenna switch is not shown on the diagram. It is mounted on the outside of the cabinet and is a single pole—double throw knife switch rebuilt on a base of ¼" plastic stock. The leads from the two sections of the unit were originally run through parallel rubber covered wire, however the high capacity between the wires prevented normal operation. Now the leads are well separated and performance is greatly improved. One side of each antenna link is grounded through a piece of ¼" copper strap run to the chassis and held by a 6-32 screw.

#### Construction Notes

The chassis is a standard 5" x 9½" x 2" black crackle job, and the cabinet is 6" x 10½" x 12". The cabinet is made of ¾" plywood and the panel is ½" tempered masonite. Four rubber feet keep the bottom of the cabinet from marring furniture, and a plastic handle obtained in the dime store provides easy carrying. A homemade bracket of thin sheet metal forms a

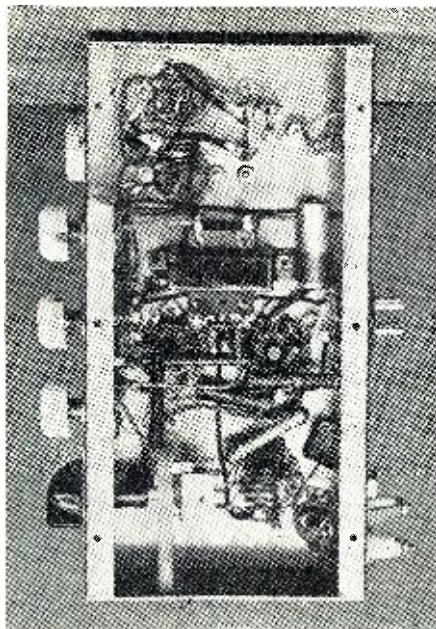

Under-chassis view. With control knobs kept to the left, the transmitter section will be at the top of the picture and the receiver at the bottom. The plastic plate for mounting the receiver-tuning unit is visible in the lower left-hand corner.

convenient rest for the handset unit.

Some device should be employed to hold the chassis rigidly in the cabinet. The unit shown uses two sheet metal clamps, each of which bears against the back drop and one end of the chas-

sis, and is screwed to the bottom of the cabinet.

Obviously it will be nearly impossible to duplicate the unit exactly, even if that were desirable. The builder's junk box and ingenuity will determine the type of construction in most cases. KGIC-12 is an example of how such a unit may be built, not how it must be built.

#### Caution

In final assembly the transmitter should be adjusted accurately with a UHF wave meter or other similar equipment. For WERS work, operators are assigned specified frequencies and deviation from set frequency is not permitted. The ARRL has already recommended certain frequencies to be used in various parts of the country.

Do not attempt to operate this transmitter unless you are a participant in the local WERS networks, having a special license for operation. Do not attempt to tune the transmitter with the antenna connected, as it will produce a very strong signal which may lead to serious consequences.

-30-

### Japan's Wireless War

(Continued from page 41)

blazing. At the time, a German gunboat and a merchantman were at anchor in this island group. The latter, seeing the tell-tale flames, wirelessed the gunboat which immediately scampered off. Though the Japanese must have detected this nearby signal they made no attempt to chase either ship.

Soon afterwards two big German auxiliary cruisers, steaming northwards to the Marshall Islands, ran into strong signals from seven Japanese warships, which thus disclosed their position among the Caroline Islands. The Germans promptly about-faced and made for Rabaul to the south. Five weeks later one of these vessels made another dash to the north for Yap, but only to fall into the wireless "beam" of eight Nipponese warships. Short of coal, the ship reached Guam and was interned.

These frequent Japanese signals had not been primarily directed at German auxiliary cruisers, gunboats and merchantmen. They were really intended for the aeriels of von Spee's big cruisers. On September 1st, while steaming on a westerly course, the German flagship ran into a veritable storm of Japanese wireless signals originating in the region of Hawaii, presumably from a large fleet. One of the messages was not even coded. It informed the Japanese consul in Honolulu that the transmitter of the message, openly designated as the battle cruiser *Kongo*, was bound for Hawaii. In later years the first officer of one of the two German armored cruisers expressed his thankfulness for this Japanese assistance. Oddly enough, there

## Products of "MERIT" means Fine Radio Parts

... PARTS manufactured exactly to the most precise specifications.

Long manufacturers of component radio parts, MERIT entered the war program as a complete, co-ordinated manufacturing unit of skilled radio engineers, experienced precision workmen and skilled operators with the most modern equipment.

MERIT quickly established its ability to understand difficult requirements, quote intelligently and produce in quantity to the most exacting specifications.

Transformers—Coils—Reactors—Electrical Windings of All Types for the Radio and Radar Trade and other Electronic Applications.



**MERIT COIL & TRANSFORMER CORP.**  
311 North Desplaines St. • CHICAGO 6, ILL.



## ***PUT YOURSELF IN HIS SHOES***

*What would YOU expect of the folks back home?*

It has been a long time since these feet touched the soil of the U. S. A. It may be still longer before they are turned toward home again. They are on a bitter road that must be followed to an unknown end.

And above these feet, in their muddy shoes, is a man who loves life, its comforts and its pleasures as much as you and I. But he is willing to sacrifice all for us.

What are we giving up for him? We cannot share his hardships.

We cannot share his danger. But we can back him up with the finest equipment. And we also can make sure that he won't have to face the evils of inflation when he comes back home.

We can do all this simply by digging deep into our pay for more War Bonds—more than we think we can afford to buy. And after we have bought them, we can hold on to them by sacrificing some of our luxuries and comforts.

That's no more than our plain, clear duty to our fighting men, to our country, and to ourselves. *Let's show the world we know how to do it!* Belmont Radio Corporation, 5929 West Dickens Avenue, Chicago 39, Illinois.



**Belmont Radio**  
TELEVISION \* FM \* ELECTRONICS

★ ***LET'S ALL BACK THE ATTACK WITH WAR BONDS*** ★



## Universal Microphones get around

UNIVERSAL microphones really get around. They actually go places and do things. Built sturdy and rugged, they withstand climatic changes and operate equally as well in extreme hot and cold climates. They represent the latest in scientific achievement and engineering design. Complete microphones, together with jacks, cords, plugs, switches, and other integral parts are made at the new UNIVERSAL plants in Inglewood, California. Today, of course, their production is devoted solely to military items for prime and subcontractors, but, when tomorrow comes, and with it a new standard of living in which voice communication via radio and electronics will play an extremely important part these same instruments, and many new models as well, will once more be available through the usual radio trade channels to a public made even more voice communications conscious than in pre-war days.

*Available from stock, 1700U series microphone. Single button carbon type, push-to-talk switch, etc. For trainers, inter-communication and general transmitter service.*



**UNIVERSAL MICROPHONE CO. LTD.**  
**INGLEWOOD, CALIFORNIA**

FOREIGN DIVISION, 301 CLAY STREET, SAN FRANCISCO 11, CALIFORNIA  
CANADIAN DIVISION, 560 KING STREET W., TORONTO 2, ONTARIO, CANADA

is no evidence that the big *Kongo* was in this part of the ocean. When the German gunboat previously referred to reached Honolulu six weeks later—without seeing a trace of Japanese ships, the proximity of the *Kongo* was still in the rumor stage. An old Japanese battle ship, salvaged from the Russian fleet defeated in 1904-5, did put in an appearance, and this vessel or some other may have been using the name of the *Kongo* in order to scare away the German admiral, for he would not have dared to meet such a formidable opponent as the new battle cruiser whose name had been used.

How many Nipponese warships chased Graf von Spee by remote control? How many were large and new, fit to meet him, and how many too old and small to risk an encounter with the Gneisenau and Scharnhorst? How many, with their extraordinarily high masts, saw the Germans, but yet remained unseen? When signals from seven or eight Japanese warships were taken in, were there actually that many Nipponese craft broadcasting, or were two or three using the name-signals of a greater number? Were dreadnaughts whispering through low-power "sets" and destroyers screaming through specially powerful "lungs?" These questions we may find answered in the archives in Tokyo.

Guided by these nudges from the ether, von Spee successfully crossed the Pacific without having set eyes upon anything Japanese. Off the coast of Chile he encountered a much weaker British squadron which was as anxious to fight an enemy of superior strength as the Japanese had been anxious to avoid meeting vastly inferior forces. Though victorious at the ensuing Battle of Coronel the German admiral met his doom in the southwest Atlantic at the hands of a British squadron at the Battle of the Falkland Islands. When the news of the annihilating defeat reached Berlin, German newspapers echoed a Tokyo story alleging that the Japanese navy had destroyed von Spee at the Falklands, assisted, "incidentally," by some British ships. To their cunning way of thinking the Japanese *had* scored a victory, but not one of the type found in the textbooks. Their heroism was of the remote-control type, and their shot and shell were dots and dashes. Without a ship or man getting scratched Tokyo's "electronic" navy had cleared the Pacific of German forces.

Great as is the part out electronics is playing in the present war, it is a vital means to an end, and not an end in itself. Instead of being dissipated in the ether, the emissions of our aerials in the Pacific are translated into terms of bursting bombs, exploding shells, whizzing bullets, rumbling tanks and the flash of the bayonet. The Japanese ships and lives saved by wireless in 1914 are not faring so well against weapons directed by America's Army and Navy.

-50-

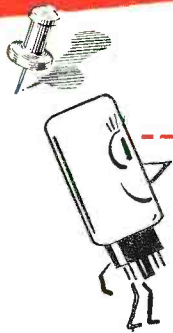

# Keep an electric eye on your radio future

by don herold

The present has plenty of irritations for any radio service man.

There are such pains in the neck as shortages of help, shortages of parts, shortages of things to sell ... and a surplus of impatient customers.

But no business in America has a brighter future than radio.

Just try to keep your electric eye on the future.

There may not be the miracles that some folks expect in radio. Some people think radio will bring them pretty girls on toast for breakfast every morning, robots to do all the housework, and electronic relief for hangovers. Well, radio's future is not that bright—but it is bright.



Even now, the radio industry has enough practical advancements on tap to make most families want new receiving sets when peace arrives. Television is pretty sure to come down to within reach of millions of pocketbooks. And there'll be

important doctoring to do even on the old sets that live on.

Why not begin now to build lists of prospective customers in your territory? When you do a job, write down names of customers and makes and condition of sets they own. And reach out for other names. Be ready to spring when Victory comes and, with it, Opportunity.



## Make a note of it

Include International Resistance units in your plans. As a radio user, I'll say that it bucks up my confidence in a service shop to know that it uses top parts in servicing my sets.

No. 2 in a series of special messages prepared by America's famous business writer, humorist and cartoonist, Don Herold. ... In sponsoring these Don Herold "broadcasts," IRC pays tribute to the thousands of Radio Service Men who, whenever possible, specify and use IRC resistance units in their work.



# INTERNATIONAL RESISTANCE CO.

401 N. Broad St. • Philadelphia 8, Pa.

IRC makes more types of resistance units, in more shapes, for more applications than any other manufacturer in the world.



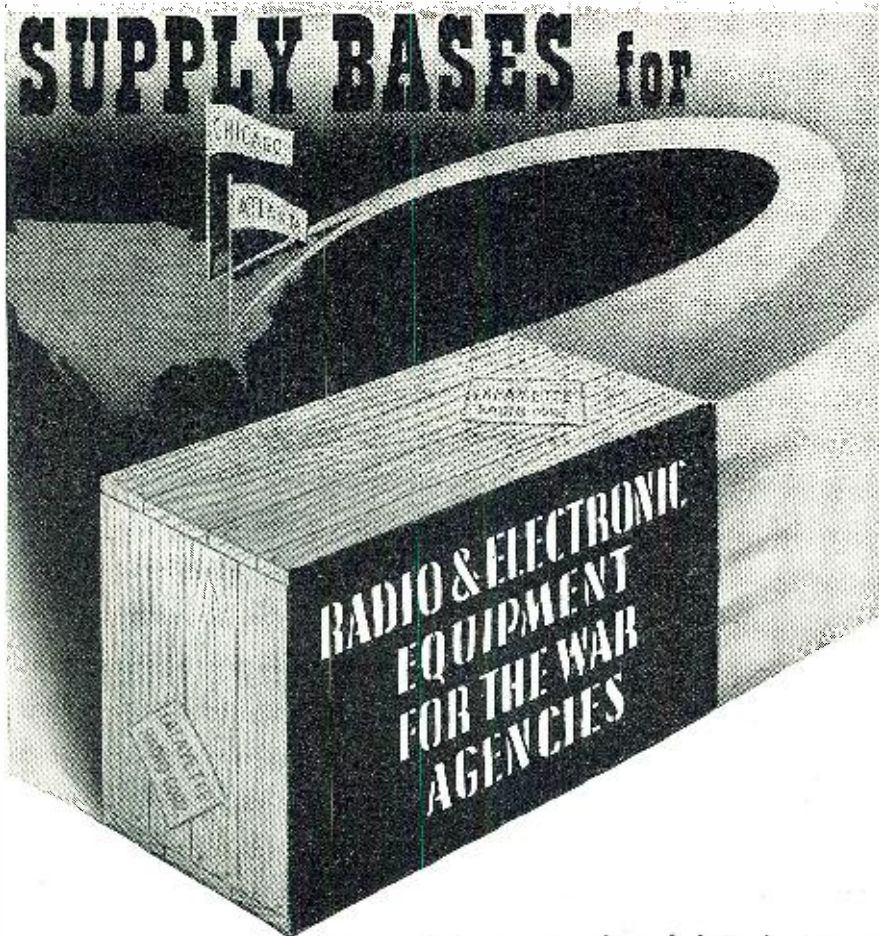

If you need the newest radio and electronic parts and equipment, etc., your requirements can be adequately met by Lafayette Radio Corporation. Our "supply bases" in Chicago and Atlanta are on 24-hour call. We make every effort to provide same-day service. A separate super-speed division is devoted to wartime industry and the Armed Forces. One of our most desirable specialties is the procurement of equipment for laboratory and experimental projects.

For non-critical consumer applications, Lafayette Radio Corporation carries a supply of all standard radio replacement parts plus a wide variety of useful parts and equipment.



**Free! AMERICA'S NO. 1 CATALOG** RADIO AND ELECTRONIC COMPONENTS AND EQUIPMENT.

Recently published. A powerful volume, filled from cover-to-cover with listings and descriptions of thousands of needed items... plus valuable information concerning delivery and priority problems. MAIL COUPON TODAY!

**LAFAYETTE RADIO CORP.**  
 901 W. Jackson Blvd., Chicago 7, Ill., Dept. E-4  
 Please send me a free copy of the new Lafayette Radio Corporation Catalog No. 94.

NAME.....  
 ADDRESS.....  
 CITY..... STATE.....

**YOUR BLOOD IS NEEDED ON THE BATTLEFIELD... GIVE TODAY!**

**Lafayette Radio Corp.**  
 901 W. Jackson Blvd., Chicago 7, Illinois ★ 265 Peachtree Street, Atlanta 3, Georgia

**American Forces Network**

(Continued from page 34)

Network uses both. Visual and signal light types of cueing are used. Equipment is referred to by American terms usually, but both terminologies exist among the engineers.

A large number of telephone cables carry programs to the control room from the BBC services and provide control lines, normal music lines, and remote lines for the Network. Mr. A. W. Leach, OWI lines engineer, working with Mr. H. B. Rantzen, head of the BBC lines department, has provided these, as well as several additional circuits for a "wired net" to various Army headquarters. The normal lines, except the "wired net" lines, are equalized and fully reversible.

All control room equipment is brought to high-level jack-fields, and inter-amplifier patching, inter-line patching, or substitution is possible through a system of "inners-to-outers" jack wiring and listening jacks. Normal lines to outlying points are BBC lines leased by OWI. Most remotes are engineered by the Outside Broadcasting Department of BBC, which provides lines for special pick-ups.

The normal control amplifier used for studio work is of considerable interest. Known as OB/A/8, it is a BBC remote amplifier, a two-stage affair with 90 DB. gain and an ingenious vi, called a PPM (peak program meter). These amplifiers now are used almost exclusively by BBC, and in conjunction with a mixer, a line amplifier, and the usual adjuncts, provide flexible and high quality studio control. A standard control position, comparable to a studio console, (such as the WE 23-A OR C) as used at the American Forces Network consists of an OB/A/8, mixer, line patching jack field, (high and low level), a D amplifier, (for cueing and monitoring), and a line amplifier which has four output channels. Each line is therefore isolated by a small no-gain amplifier stage, called by BBC, a trap valve. High-frequency pentodes are used throughout in the OB/A/8, the D amplifier, and the trap valve amplifier. This has resulted in a standardization of tube types, a most important factor in wartime.

Although an emergency Diesel-powered a.c. unit is maintained, the OB type amplifiers may be operated from batteries in event they are used on remotes, or power fails.

The limiting amplifier is used, contrary to normal practice, to feed the entire net. This is because it is impractical and uneconomical in war time to install a limiter at each transmitter location. The over-all level transmitted to line is plus 4 db. With a depth of approximately 16 db. giving a satisfactory dynamic range. Reference level is 1 milliwatt across 600 ohms.

# Ready

## LATEST...MOST COMPLETE DATA ON INERTEEN CAPACITORS FOR D-C CIRCUITS IN ELECTRONIC EQUIPMENT

Every engineer, designer and technical man concerned with developing high-performance electronic equipment for war or postwar use should have this booklet handy. It's packed with fresh facts and data on Westinghouse D-C Inerteen Capacitors and their application. Essentially, it is a guide to the selection and use of capacitors for any D-C applications in communications, electronics or related fields.

It will bring you up to date on capacitor advancements, and provide dimension data for designing of equipment.

Includes ratings from 400 volts to 250,000 volts D-C.

To make sure that a copy reaches your desk without delay, use the coupon to reserve your copy. Westinghouse Electric & Manufacturing Co., East Pittsburgh, Pa., Dept. 7-N.

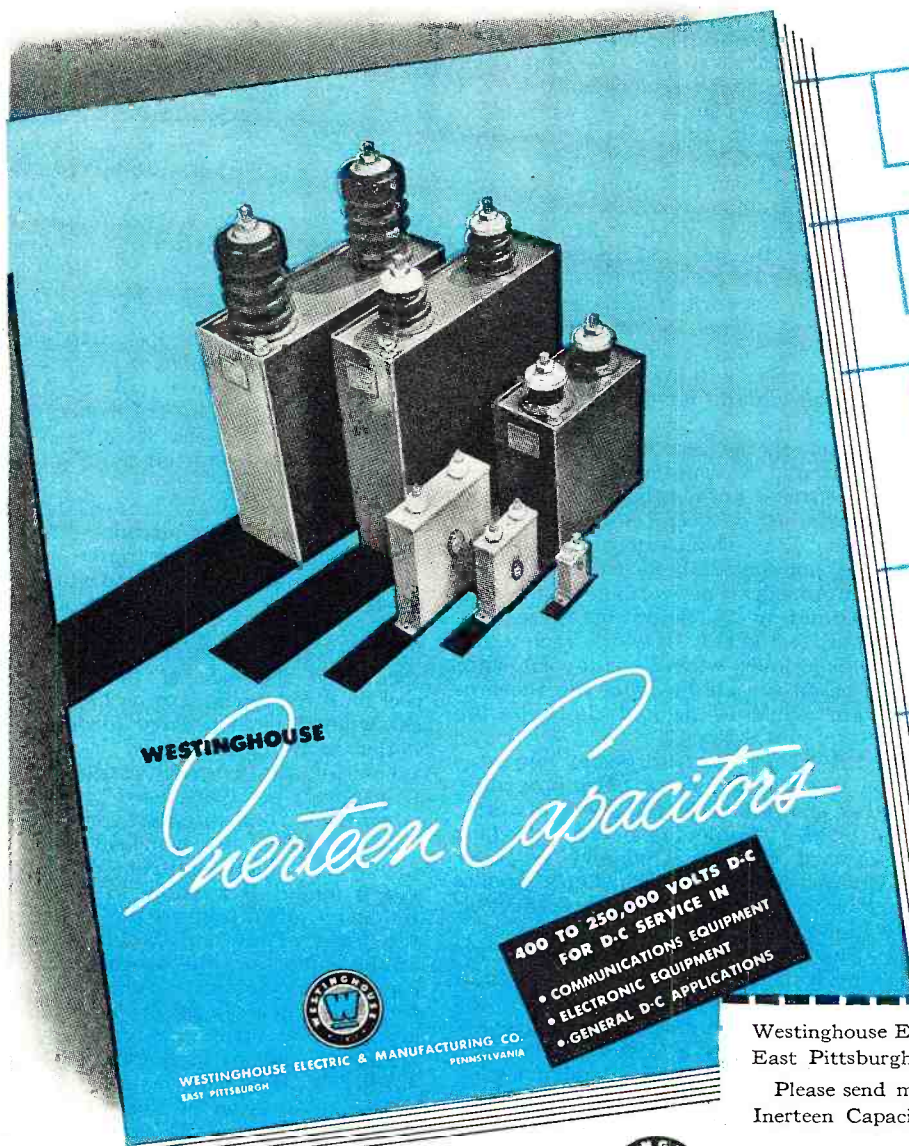

CAPACITOR CONSTRUCTION—its effect on performance.

FEATURES that improve performance and reliability.

SPECIFICATION DATA—covers working temperature ranges, capacitance and voltage tolerances on both intermittent and continuous service.

DATA on dimensions, weights, and capacities.

APPLICATION DATA for each type of Inerteen Capacitor.

CHECK LIST for application data.

**ASK FOR A COPY...NOW**

Westinghouse Electric & Mfg. Co.,  
East Pittsburgh, Pa., Dept. 7-N.

Please send me a copy of your new book on  
Inerteen Capacitors.

Name \_\_\_\_\_  
Position \_\_\_\_\_  
Company \_\_\_\_\_  
Address \_\_\_\_\_  
City \_\_\_\_\_ State \_\_\_\_\_

# Westinghouse

PLANTS IN 25 CITIES . . . OFFICES EVERYWHERE

## INERTEEN CAPACITORS

April, 1944

J-60542

79

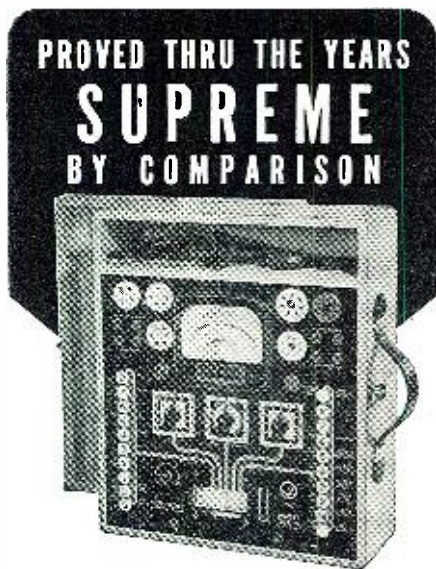

**Model 504-A**  
Tube and Set Tester

Right now Supreme is 100% in war production. After Victory, you again can count on Supreme Testing Equipment for dependability, durability and ACCURACY . . . the same Supreme qualities which today are helping keep vital communications open on the battle fronts of the world.



**Model 542**  
Pocket Multimeter

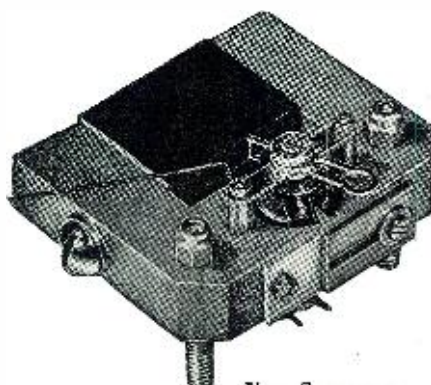

**New Supreme**  
"Hairline Accuracy"  
Meter



Microphones in use at the present time are Turner dynamics, although BBC type "A" ribbons are available when bi-directional properties are needed.

Although original plans called for two recording channels only one has been installed and is in operation. Recording work is normally handled by Mr. Fred Lewis and Mr. Robert Ellis, but all OWI engineers work flexibly enough to permit rush recording in the event a regular recording man is not available. The equipment is a standard Presto bay with dual turntables. Some modification has been made in the slope controls and this has been set at world characteristics with a rather more than usual high-frequency emphasis.

Playback facilities have been wired so that programs can originate from the recording bays to the Network. All BBC programs are fed to the recording room via the D amplifiers in the control room, and any of the four control positions, working from any of the three studios may be fed there for recording. Short-wave pickups, or monitoring from the BBC facilities also are routed to the "ring main" and recording room. Glass base 16" and steel base 12" discs are normally used for record cutting.

So that the greatest amount of coverage may be obtained from this very complete network installation, efforts are being made to have a radio in every G.I. day room where broadcasts come within range. Several hundred small receivers have been shipped here by the Special Service Section of the Army and have been distributed to isolated posts.

Programs are obtained from several sources. The Special Service Division of the War Department records the most popular daily broadcasts of the four American networks and ships approximately 25 hours of these programs to the G.I. Network each week. Soldiers know when their favorites are to be on the air by following the program schedule printed daily in the "Stars and Stripes."

BBC shows, with special emphasis on BBC's crackerjack news programs, also are available for the Network's schedule. Yanks have come to look forward just as anxiously as their British cousins, to Big Ben's nine-o'clock chimes and the newscast that follows.

Supplementing the BBC news, the American Forces Network maintains its own battery of news teletypes and radio news processors who prepare newscasts with a distinct American angle for their soldier audiences.

During the World Series the short-wave broadcasts from New York and St. Louis were recorded in the central studio and rebroadcast to cheering soldier audiences a few minutes after the games ended. When short-wave reception permits, the leading football game of the week is recorded for re-broadcast on Sunday afternoon. The G.I.'s "eat it up."

A well-catalogued library of more than five thousand recordings ranging from Beethoven to Benny Goodman, form the basis of several excellent record programs which feature, of course, numbers requested by the listeners. Live talent programs are difficult to plan because most soldiers are busily engaged in less pleasant pastimes. However, despite the obstacles encountered, more and more talented soldiers are appearing before live mikes in the G.I. Network's studios.

There is no adequate method of measuring the morale-boosting effect of the Soldier Network. However, the volume of fan mail certainly reflects wholesale appreciation on the part of the G.I. listeners and great credit upon the Signal Corps men who are largely responsible for the Network's success.

-30-

### Commando Communications

(Continued from page 49)

mitter-receiver is that it is fix-tuned to three wavelengths, any one of which can be employed by the turn of a switch. The water-proofing of the set is completed by a rubber sheath passing over the plug and socket on the panel connecting the set to the batteries, which are carried in a separate container on the operator's back.

The over-all dimensions of this set, which is used for telephony only, are approximately 12x8x4 inches. The change-over from sending to receiving is done by a press-button switch on the operating panel.

The heavier pack transmitter-receiver carried by the advancing forces has considerably longer range and is used for telegraphy (Morse) as well as telephony. It is carried on the back of one signaller and is operated by another. By means of a rotatable socket on the side of the case the sectional rod aerial can be kept vertical when it is necessary for the signaller to lie down.

One of the heavier transportable transmitter-receivers, used by the advance H. Q. and intended for stationary operation, is provided with a means of remote control. This provision makes it possible to erect the set in an advantageous position from the point of view of radiation while at the same time the operator can be concealed a short distance away. This set, which derives its power from an accumulator through a vibrator, operates on 'phones in the 19 to 31 and 4.2 to 7.5 megacycles bands.

This description of Commando signallers, and some of the apparatus they operate and maintain, proves that the normally conflicting qualities required in the fighting soldier and in the technician have been successfully combined in Commando Signals—one of the newest branches of Britain's Forces.

-30-



# UHF OPERATION?

Yes—and Power, Performance, and Low Price, too, with RCA-815

HERE'S a natural for that u-h-f transmitter you've been planning — the RCA-815. Handles 75 watts input (ICAS) at 150 Mc with less than 0.5 watt driving power! And it's priced at only \$4.50. RCA-815 is a favorite for u-h-f work—FM or AM—for 9 good reasons:

1. **Small Size:** Glass-button stem structure provides short leads and compactness. Less than 5 inches high.
2. **Two Tubes—One Envelope:** Combining two tubes in one envelope eliminates one socket; saves space; simplifies electrical problems.
3. **Low Driving Power:** At full input, the 815 needs less than 0.5 watt grid drive. That means simplified construction of low-power stages.
4. **No Neutralization:** The 815's beam-power construction ordinarily makes neutralization unnecessary. Circuit stability is thus improved.
5. **Low Heater Power:** The 815 takes only 1.6 amps at 6.3 volts or 0.8 amps at 12.6 volts.
6. **Low Plate Volts:** You can get full CCS input (60 watts, class C telegraph) with 400 volts on the plates; full ICAS input (75 watts) with 500.
7. **High Output:** Only a small package, but 815 will give you plenty of wallop right up to 150 Mc; and at reduced ratings it will operate up to 225 Mc.
8. **Price:** For all these features, the amateur net price is just \$4.50.
9. **Performance:** Only one thing need be said about the performance of the RCA-815: To meet war demands, we increased production of this tube type to 46 times the 1941 level. Isn't that fact alone *proof* of performance?



## MAXIMUM RATINGS

Class C Telegraph Service (All values are for both units)

	CCS	ICAS
Plate Volts	400	500
Screen Volts	225	225
Plate Current, Ma.	150	150
Grid Current, Ma.	7	7
Plate input, watts	60	75
Screen input, watts	4.5	4.5
Plate dis., watts	20	25
	Units in Series	Units in Parallel
Heater Volts	12.6	6.3
Heater Amperes	0.8	1.6



Get your copy—35¢

RCA, 600 So. Fifth St., Harrison, N. J.  
Please send me the newly revised 72-page RCA Transmitting Tube Guide. Enclosed is 35¢.

Name \_\_\_\_\_  
Call \_\_\_\_\_  
Address \_\_\_\_\_  
City \_\_\_\_\_ State \_\_\_\_\_



RADIO CORPORATION  
OF AMERICA



You save time and work . . . you get all your needs faster . . . by dealing with this one central source. Here, under one roof, are concentrated the largest and most complete stocks of radio and electronic equipment . . . over 10,000 items . . . all leading makes. This means rush delivery on tubes, parts, kits, test equipment, public address . . . for training, research, engineering, production and maintenance.

Our close contact with all leading manufacturers assures latest supply data. Our veteran staffs help you with technical problems. This complete service simplifies procurement and expedites delivery of many diversified needs. The result is more efficient service to the Armed Forces, Government Agencies, Laboratories and War Industries. *Save time . . . Call Allied First.*

Write, Wire, or Phone Haymarket 6800

**ALLIED RADIO CORPORATION**

833 W. JACKSON BLVD., DEPT. 1-D-4, CHICAGO 7, ILLINOIS



**REPAIR AND REPLACEMENT PARTS AVAILABLE WITHOUT PRIORITY**

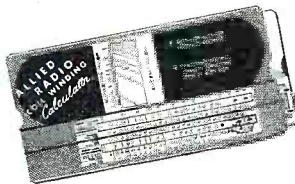

**NEW Rapid R-F Resonance and Coil Winding Calculator**

New, dual-purpose Calculator devised by Allied for fast and accurate determination of resonance factors and coil winding data. Simple, easy to use. Send for it now. No. 37-955. Price net, only . . . . . 25c

**6 VALUABLE RADIO BOOKS FOR 75c**

*Specially prepared by technical experts for radio training and for helpful reference. Priced only to cover cost of preparation and mailing.*



**RADIO BUILDERS' HANDBOOK.** Simplified theory and projects. No. 37-750 . . . 10c

**RADIO-FORMULAS & DATA BOOK.** Handy, pocket-size manual. No. 37-752 . . . 10c

**SIMPLIFIED RADIO SERVICING.** Short cuts in troubleshooting. No. 37-755 . . . 10c

**DICTIONARY OF RADIO TERMS.** Easy-to-understand definitions. No. 37-751 . 10c

**RADIO CIRCUIT HANDBOOK.** Schematics and Pictorials. No. 37-753 . . . . 10c

**RADIO DATA HANDBOOK** Formulas — Tables — Charts No. 37-754 . . . . . 25c

ALL SIX BOOKS No. 37-799 . . . . . 75c  
*Write for Quantity Quotations*

ALLIED RADIO CORP., Dept. 1-D-4  
833 W. Jackson Blvd., Chicago 7, Illinois

Please send the following items (\$\_\_\_\_\_ enclosed)

- 37-750       37-752       37-754
- 37-751       37-753       37-755
- All 6 Radio Books    Free Catalog    Calculator

Name \_\_\_\_\_  
Address \_\_\_\_\_  
City \_\_\_\_\_ State \_\_\_\_\_



radio servicemen still report that there is a shortage of some of the more common types used in the average broadcast receiver. Some servicemen have even reported many sets in for repair not being returned to customers because they cannot obtain the necessary tubes for replacement use. All of these men also report the usual shortage of help in shops where many of the employees have been called for service with the Armed Forces. This last has even affected some of the smaller broadcasting stations with some willing to take part-time operators for fill-in jobs. The serious shortage of batteries did not develop, although the demand is still well beyond the supply.

**A** GOOD many men have developed new equipment during the present war. Many of these ideas have already been put into use by the Armed Forces or merchant marine and will materially aid in shortening the war or in helping to save lives, while other items can be used on the home front to help boost civilian morale. If you have any invention or idea which might save lives or shorten the war in any way, communicate with the Smaller War Plants Corporation, Technical Development Section, 226 W. Jackson Blvd., Chicago, Illinois.

**J**ACK MENICK is now out at a West Coast air base school after having transferred from the Signal Corps over to the Air Corps. Jack holds a high speed ticket from the Signal Corps; he says it's a long time since he saw Cooperstown, the 'ole home town. H. Roberts was in for a short vacation recently after a trip on his latest cargo job. R. MacTaggart was also in for a short vacation after his tanker assignment. Harry Adams is now aboard a Liberty. Lawson Egley has taken an assignment on one of the 'production' vessels of the last war—one of the old Hog Islanders. Karl Evensgood was in a while ago on his latest freighter. Elmer Merrow has taken out another Liberty. Harry Weinstein, another old timer in marine brass pounding, still keeps up with the goings on in the world via radio school where he studies the latest wrinkles in FM. Harry has recently been engaged in getting a new broadcast rig going over in Jersey City. J. McCall is out on a new cargo assignment from the East Coast.

**T**HE Signal Corps reported a total of 280,000 enlisted men and 28,000 officers a short while ago—that's double the entire regular army total in the days before the war. Fifty military and over two hundred and sixty civilian schools took part in the training of this army of radio operators and technicians for our of-

# How to Use P. R. MALLORY & CO. Inc. **MALLORY** Victory Electrolytic Capacitors In High Surge Applications



Mallory Victory Electrolytics have the same surge voltage ratings as other Mallory units of the same working voltage.

When replacing electrolytic capacitors where a high surge voltage condition is suspected, the following information will be helpful:

1. The surge condition exists from the time the switch is closed until the tubes heat up establishing normal load.
2. While the electrolytics draw current during the warming-up period, this load is temporary and may be of no safety value after a period of continuous operation.
3. High line conditions should be considered.

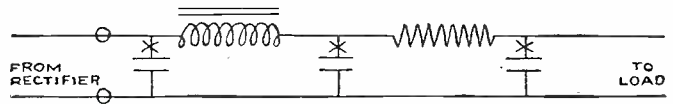

**The best way to determine actual surge possibilities:**

- a. Disconnect all electrolytics (except cathode by-pass).
- b. Connect a 2 to 4 mfd. paper condenser (600 V.) across voltmeter terminals and read voltage at output of rectifier during warm-up period.
- c. Note line voltage and mathematically compute (by ratio) surge voltage at 130 volt line for safety.

**Use following table** in making replacement. Bear in mind that where series connection is necessary the capacity is one-half of one of the units (two 8 mfd. in series equal 4 mfd.). No equalizing resistors are necessary with electrolytics in series.

Working Volts of Unit	Maximum Surge Volts Allowable
150	200
250	300
450	525
two 250 V units in series	600
two 450 V units in series	1050

**NOTE:** Where heater type rectifiers are used, there is little likelihood of unusual surge conditions, and replacement may be made without this procedure.

The *working* voltage rating of capacitor should be equal to or higher than measured *working* voltage at high line, regardless of surge requirements.



Buy More War Bonds

## Mallory Helps for the Service Engineer



**MYE TECHNICAL MANUAL**  
 —408 pages of complete data on capacitors, noise suppression, receiving tubes, loud speakers, vibrators, phono-radios, automatic tuning and other valuable information. Available from your Mallory distributor...Price, \$2.00.

**4TH EDITION RADIO SERVICE ENCYCLOPEDIA** . . .  
 Complete information on repairing any make or model of receiver. Circuit references, original part numbers and recommended replacements. Available from your Mallory distributor . . . Price, 95 cents.

P. R. MALLORY & CO., Inc.  
 INDIANAPOLIS 6, INDIANA



**"Built-in Fight"**

**Characterizes a**

**TURNER MIKE**

**MODEL 22D**

**TIME TO TURN TO TURNER PIONEERS IN THE COMMUNICATIONS FIELD**

**BUILT** to stand up and deliver under the roughest, toughest treatment, Turner Microphones are rugged instruments which give clear, crisp, sharp performance under any and all acoustic and climatic conditions, — indoors or out, — on the ground or in the air.

For the Paul Reveres of today — the men who must get the message thru and cannot afford garbled communications, Turner Microphones are high favorites for sound engineering.

But rugged dependability and intelligibility are not the only virtues of Turner Microphones. Distinctly styled, their streamlined beauty gives them top billing for P. A. systems where handsome appearance must be considered. Broadcasting studios rely on their efficient performance and prestige-building lines.

For a mike that combines outstanding performance characteristics — a mike with "built-in fight" PLUS eye-catching appeal, choose a Turner such as 22D Dynamic, pictured above.

Crystals Licensed Under Patents of The Brush Development Co.

**FREE** -- We've a Turner Microphone Catalog Here for YOU -- Write for your free copy today. Just Address --

**The TURNER CO., Cedar Rapids, Iowa**

fensive action against the Axis. That sure is going to be one big crowd of men looking for new positions in radio after the war. Naturally, all of these men will not engage in radio as their life work but rather, will return to previous positions outside of radio. However a good many will want to continue in the work which they have received training in.

**I**F INTEREST to those engaged in design and construction of various types of electronic and radio equipment will be the new vacuum capacitors for use in circuits with peak voltages between 7500 and 16,000 which were recently announced by the General Electric Company of Schenectady, N. Y. They also have started production of four types of vacuum switches which are relatively free from arcing, corrosion, dirt and oxidation, the contacts being completely sealed in a vacuum construction.

The Westinghouse Lamp Division held an interesting exhibit in New York during the winter which demonstrated the possibilities of power transmission by means of radio. The exhibit also dealt with the part that the phosphors play in wartime, such as chemically treated cloth strip and the miniature fluorescent tube lights, which are familiar to the men in the Armed Forces and merchant marine. New developments such as these are being brought into use daily and with those which must be kept secret for the present should assist in making radio and its allied fields most interesting after the present war.

**J**AMES HASTIE has resigned from his tanker assignment at an east coast port, we hear, and wants a new job with a different run. Jimmie says the old run was so popular the sea was getting full of ruts. A. Hiduarfen has taken an assignment on an ex-passenger vessel. P. A. Barker has taken out a freight vessel assignment. A. H. Garhett was in recently with his cargo ship for repairs at an East Coast shipyard, the usual annual overhaul. Hugh Turnbull ex-FCC in the big city has been transferred to an "in charge" job in the "I know everything that goes on department—but you can't find me section—nice work, if you can get it—and a raise at that." Some of the boys sure have landed some nice jobs, and are doing good work in them during the present conflict.

H. A. Munro, who is still with the Coast Guard, has a 2nd class rating and is on his way to a first now. Jimmy Wood, RMIC, also of the CG, is looking for word from some of his old gang from the Canal Zone. Bob Small has been transferred from his shore berth on the west coast to sea again. W. Holden is trying to make a break into the Bell Labs. W. Glazar has taken a job with MRT in New York. C. Amato is being called for induction. Congratulations are in order for Eddie Sittler who became a papa recently.



wherever a tube is used...

*For example—*

### Resistance Welding

Thyratron tubes, working with other thyratron or ignitron tubes and usually a relay, control the current for spot, projection, seam and other types of resistance welding for lower maintenance and better welds.

THERE'S A JOB FOR

## *Relays* BY GUARDIAN

Your post-war product must stand the competition of price as well as quality. And manufacturers who use electron tubes to boost production, cut material costs, and increase product performance, have the edge on competitors. Electronic control of resistance welding is one cost-saver to consider.

In this, as in most other tube applications, the use of a relay increases efficiency. The Series 175 DC and Series 170 AC Relays by Guardian, when used in the output of the tube circuit, control external loads in accordance with the tube operating cycle. These relays have binding post terminals in place of solder lugs. Bakelite bases, molded to reduce surface leakage, give a higher breakdown factor. Contact capacity: 12½ amps., at 110 volts, 60 cycles, non-inductive. Information on contact combinations, coil voltages, and further data is yours for the asking.

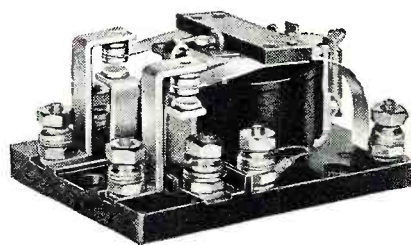

Consult Guardian wherever a tube is used. However, Relays by Guardian are NOT limited to tube applications but may be used wherever automatic control is desired for making, breaking, or changing the characteristics of electrical circuits.

**GUARDIAN**  **ELECTRIC**  
1630-D W. WALNUT STREET CHICAGO 12, ILLINOIS

A COMPLETE LINE OF RELAYS SERVING AMERICAN WAR INDUSTRY

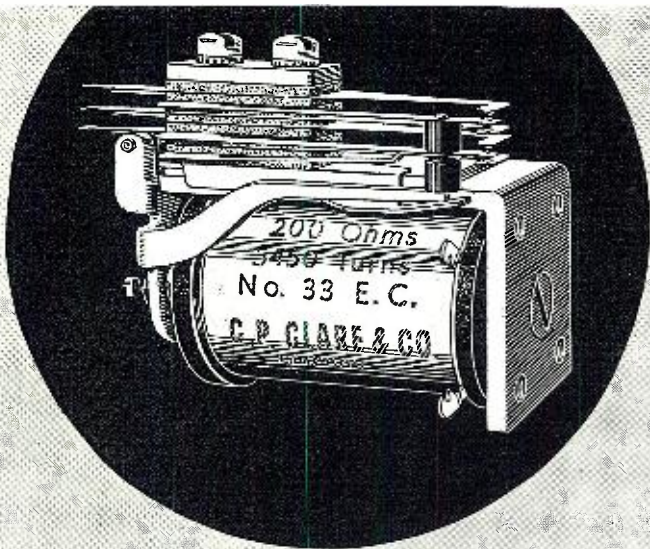

**SHOCK? EXPOSURE? VIBRATION?**  
**THIS CLARE TYPE G RELAY**  
**WITHSTANDS THEM ALL**

This Clare Type "G" Relay has come through the rigorous tests of war with flying colors. Its many applications where shock and vibration are factors, include radio and radar equipment, walkie-talkies, compasses and aircraft controls.

Exposed metal is plated to withstand a 200 hour salt spray test. Special insulators of heat treated Bakelite reduce moisture absorption, providing minimum cold flow. Type "G" can be provided with 12 different types and sizes of contacts which are welded to the nickel silver springs by a special process. This provides for effective dissipation of heat.

Every Clare Relay is built of the finest materials and under precise manufacturing conditions. Each is "custom-built" to the exact specifications your design calls for. Put your relay problem up to our engineers. Send for the Clare catalog and data book. C. P. Clare & Co., 4719 Sunnyside Avenue, Chicago (30), Illinois. Sales engineers in all principal cities. Cable address: CLARELAY.

# CLARE RELAYS

"CUSTOM-BUILT" Multiple Contact Relays for Electrical, Electronic and Industrial Use

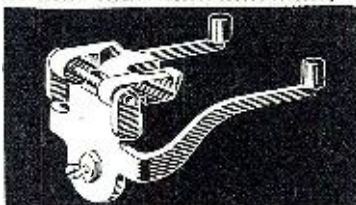

Double arm armature assembly of stainless steel shaft operating in a marine brass yoke. Heelpiece, core and armature assembly of magnetic metal.



Contacts are welded to nickel silver springs by special process. May be of precious metals or alloys in 12 different standard, or special, types and sizes.



High voltage spring pile-up insulators of special heat treated Bakelite. Has minimum cold flow properties, low moisture absorption content and permits punching without cracks or checks.

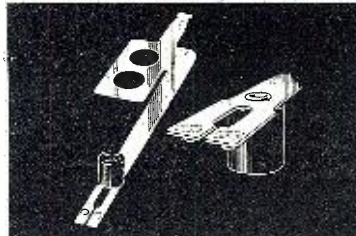

Spring bushing insulators are made of Bakelite rod under patented process. Resist vibration and withstand heavy duty service.

## Automatic Radio Compass

(Continued from page 28)

in a shorter time. In addition, the right-left type radio compass is designed so that a minimum headset output does not result while a radio bearing is being taken. This means that the pilot may receive intelligence from the radio station while in the process of obtaining a radio bearing. Probably the most popular use of the right-left type of radio compass is as a visual "homing" indicator while flying directly toward a given radio station. The loop is rotated and set so that an "on course" indicator reading is obtained when the radio station is directly ahead of the aircraft.

A deviation of the aircraft from the "on course" direction is shown by movement of the indicator needle to either side of the zero position. If the aircraft is turned to the left from an "on course" heading, the indicator needle moves to the right of the zero position, indicating that the aircraft must be turned to the right to regain the "on course" heading.

The automatic radio compass is null seeking and a refined modification of the right-left types. Automatic rotation of the loop antenna is provided; it is unnecessary for the pilot to manually rotate the loop antenna to obtain a radio bearing. The compass loop automatically seeks the correct position and gives the pilot an immediate bearing indication on the remote azimuth indicator, shown in Fig. 2b. No adjustments, other than tuning-in the proper radio signal, is made by the pilot to obtain a radio bearing. This helps a lot in a fast plane when the pilot is in a hurry to establish a position "fix" by radio bearings.

The automatic compass has another practical advantage. Any radio compass bearing is apt to "swing" when flying over mountainous country and during the hours of sunset and sunrise. This is due to radio waves being reflected. When this happens the pointer of the automatic compass literally swings also and warns the pilot to wait until it settles down before plotting any cross bearings.

The various components employed in an automatic radio compass installation are shown in the simplified block diagram, Fig. 1. The present design consists of five items: the automatic loop unit, the radio compass unit, the loop director unit, the bearing indicator, and the remote control unit.

A detailed description of the complete operation of this equipment would be out of order here but there are two flight cases that should be presented as practical performance examples.

Two complete sets of automatic radio compass equipment are installed in an aircraft. The azimuth positions of the two loop antennas are indicated on a dual bearing indicator, as shown in Fig. 3. The pointers are mounted

# Connecticut Telephone and Electric Division,

M E R I D E N



C O N N E C T I C U T



*Today:* Field telephones, military switchboards, electronic devices, aircraft ignition systems—produced to Army-Navy "E" standards by a group of men and women putting an average of 15% of their incomes into war bonds and proud of one of the lowest percentages of absenteeism in the nation.



*Tomorrow:* Civilian communications equipment, industrial control instruments, hospital communicating and signalling equipment, and precision electrical products — produced by men and women who are demonstrating their ability to get things done and done right—earning the right to be remembered.

© 1944 Great American Industries, Inc., Meriden, Conn.



... and waiting for you

FOR THE ARMY AND NAVY, the David Bogen Company is intensifying production of vital intercommunication, detection and specialized sound distribution equipment.

For Bogen distributors, we're working steadily to catch up with the demand for Bogen catalog equipment. It's equipment that's doing a mighty important war job, too. Delivery dates are being kept more regularly. What's more, they are going to be better.

We illustrate the Bogen Model E75, unquestionably one of the finest High Power Amplifiers ever manufactured to commercial specifications. Under wraps, and waiting for Victory, are D.B. plans for great new postwar equipment. This will be channeled through Bogen distributors for your profit and prestige . . . and the common good of a world at peace.

BUY MORE WAR BONDS AND STAMPS

**David Bogen Co. Inc.**

663 BROADWAY NEW YORK 12, N. Y.



THE STANDARD OF PERFORMANCE



Bogen Sound Systems

• Commung-Phones

• Amplifiers

• Electronic Equipment

concentrically on a common azimuth scale, so that the bearings of the two radio stations are continuously shown on the same indicator. The control knobs of one automatic radio compass and the corresponding indicator pointer are colored green in comparison to red for the controls and pointer of the second automatic radio compass.

*Case 1:* Flying a straight line between two given radio stations without the aid of other navigational instruments.

First, the pilot tunes in two stations, one on each automatic radio compass and flies the aircraft to keep the two pointers diametrically opposite, as shown in Fig. 3a. The pointers have the appearance of a double ended pointer when they are exactly opposite. A simple indication of the position of the aircraft relative to the lines between the two stations is provided by visualizing the center of the pointers as the position of the aircraft, and the ends of the pointers as the two radio stations. As long as the center of the pointer is on a straight line between the pointer ends, the aircraft is on a straight line between the two stations.

If the pointers assume a position resembling that shown in Fig. 3b, so that the center is to the left of the ends of two pointers, the aircraft is to the left of the line joining the two stations.

A condition similar to that shown in Fig. 3c, would immediately indicate that the aircraft is to the right of the desired course.

For cross-wind conditions, a heading of the aircraft is established by trial until the two pointers remain exactly opposite, as shown in Fig. 3d. The crab angle necessary to hold the aircraft on the straight line course is then read directly by noting the angular distance from the zero index to the pointer representing the station ahead of the aircraft. The red needle is generally used to indicate the forward station.

*Case 2.* To fly along the extension of a straight line between two radio stations. In this case if the two stations were being approached along the extension of their common line, and the red needle represented the second station, only the green needle would appear. Upon passing over the first station, the green needle reverses to the 180 degree position and remains opposite the red pointer. After the second station is passed over, the red needle swings to the position of the green needle. The two pointers stay in coincidence until the aircraft deviates from the extended line, or until the pilot retunes the equipment associated with the red needle to a third station.

Other cases will develop in military flying where the mission of the flight is to reach an objective during a radio silence in enemy territory. In these cases a series of radio fixes from friendly stations using secret call letters will do the trick.



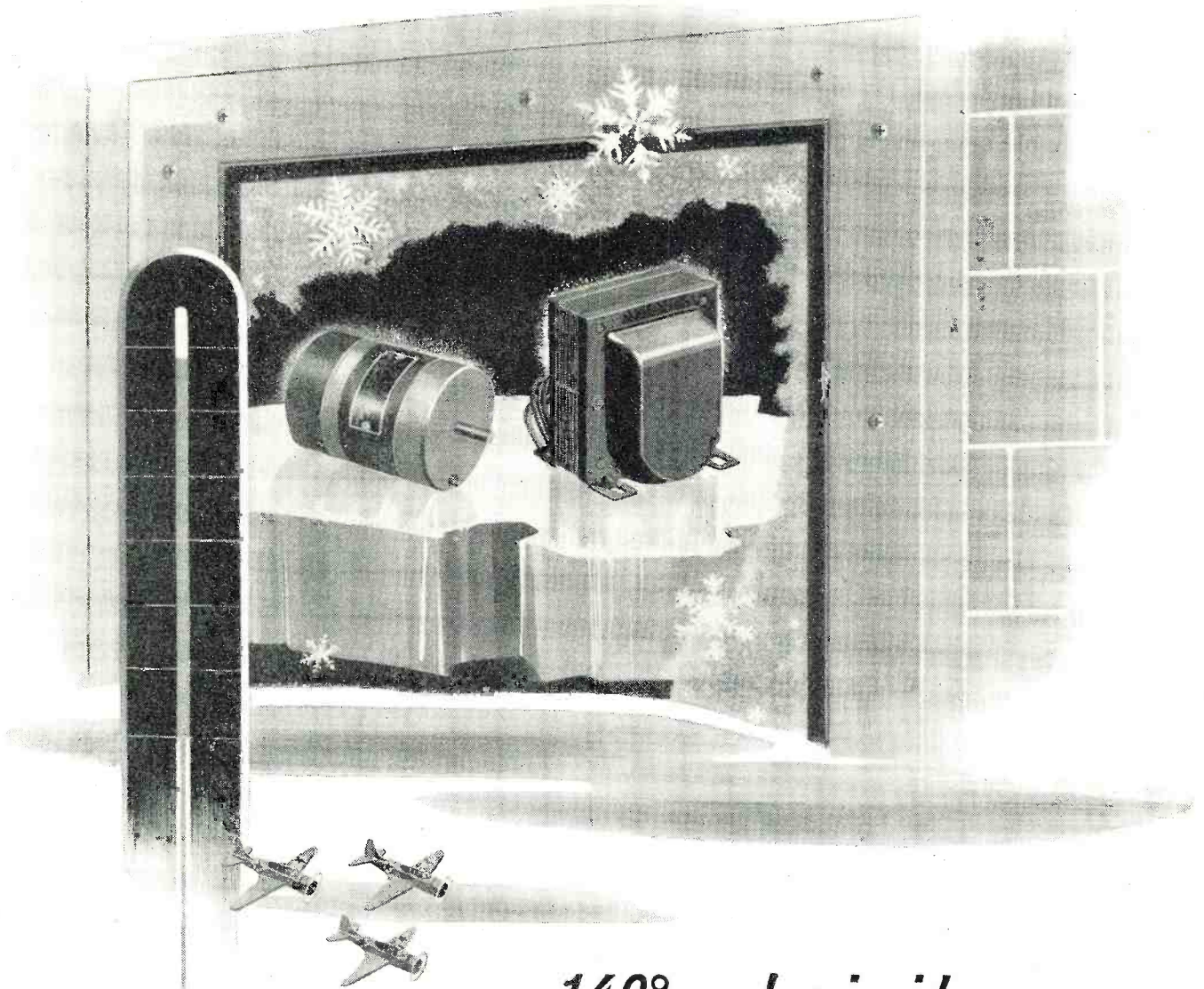

## 140° cooler inside

There is a piece of the stratosphere just beyond that glass door. The air pressure is less than one-fourth of normal air pressure. And the temperature is 70 degrees below zero.

The Utah parts being tested are proving that their performance will be "as specified," whether they are to operate on the ground or high in the air.

This and other tests which parts undergo in the *complete* Utah laboratory are particularly important in adapting the new electronic and radio developments—in making them militarily and commercially usable—now, and tomorrow!

★ ★ ★

**Every Product Made for the Trade, by Utah, Is Thoroughly Tested and Approved**

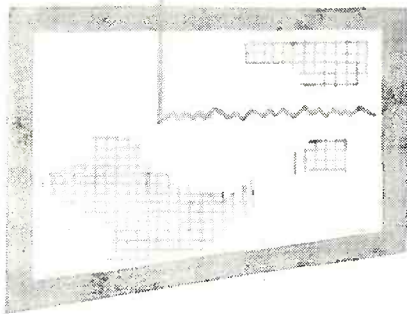

# Utah

Radio Products Company,

824 Orleans Street, Chicago 10, Illinois



Keyed to "tomorrow's" demands:  
Utah transformers, speakers, vibrators,  
vitreous enamel resistors, wirewound controls,  
plugs, jacks, switches and small electric motors.

## U. H. F. Course

(Continued from page 47)

in general, tend to vary sharply from point to point. While this may prove unwise when intelligence is to be transmitted, yet it may be very desirable if the transmission line is to be used for some other purposes—perhaps a tuned resonant circuit or even an inductance or capacitance. This will be taken up very shortly and is mentioned here to point out that at the ultra-high frequencies transmission lines are not always used as such but may assume various forms and in order to arrive at these other applications we must re-

sort to different terminations of the transmission lines. But do not forget that at any frequency, if the transmission line is terminated in the appropriate  $Z_k$  (that is, appropriate for that frequency since  $Z_k$  changes with frequency) all power transmitted will be absorbed and will not be reflected.

When radio waves are sent down a transmission line, it is very important that they all arrive at the receiving end with the same relative voltages and phase angles ( $\beta$ ), else distortion of the signal will result. This distortion can be divided into two parts, one part is called attenuation and is concerned with the relative magnitudes of the various frequencies, and the other part is called phase distortion or phase de-

lay. Both are proportional to frequency and, unless proper precautions are taken, can become excessive on long lengths of transmission lines. The reason for the change of attenuation and phase constant becomes obvious when the elements of a transmission line shown in Fig. 1 are examined. Since capacitive and inductive reactances change with frequency and since both constants are proportional to these impedances, they will also change with frequency, hence producing the above mentioned distortion.

There are two widely used methods that are used to minimize this distortion. One method, extensively used in telephone transmission lines, is to insert networks at various points in the line that tend to accentuate the frequencies that have been most attenuated by the transmission line. In other words, these units have properties that are just opposite to the properties of the line and are sometimes referred to as compensators. The other method is usually more expensive and involves the use of specially constructed cable. This cable is so built that the attenuation constant (usually designated by the symbol  $\alpha$ ) is not dependent on frequency and the phase constant is made linearly proportional to frequency. With these two changes very little distortion of the signal will result. At the ultra-high frequencies there is some simplification that takes place in the formula for characteristic impedance as given above. The simplification comes about because at these high frequencies the inductive reactance is usually very much larger than the resistance in series with it (the line resistance) and the parallel conductance of the line is much less than the shunt capacitance. With these simplifications, the characteristic impedance,  $Z_k$ , reduces to

$$Z_k = \frac{L}{C} \text{ (a pure resistance)}$$

where  $L$  is in henries per unit length and  $C$  is in farads per unit length. The impedance acts as a pure resistance because the equation contains no reactive components (imaginary terms). Since we are primarily interested in the ultra-high frequencies, only this case will be of interest to us.

The three last-mentioned constants namely— $Z_k$ ,  $\alpha$  and  $\beta$  are not separate and distinct from the really fundamental units of the line—resistance, inductance and capacitance. They were only introduced to simplify the various characteristics of the line and can always be expressed in terms of the really fundamental units mentioned above.

The above facts have been presented so as to serve as a background for what will be covered next month—namely—the use of the transmission line at the ultra-high frequencies. It is always best to show the connection between the apparatus encountered at the upper frequencies with those in common use today, else the basic underlying principles (which are the same for both) will be lost.

(To be continued)

# SOUND PROJECTS CONTRIBUTION TO hallicrafters BUILT SCR-299

The SCR-299 successfully adapts itself to the "Blitz" type of warfare. It stands up under severe abuse and transmits successfully under the most difficult conditions. To our troops fighting on all fronts it is a familiar sight . . . it helped pave the way for the Allies in Africa, Sicily, and Italy. . . In maintaining a constant flow of power for the SCR-299, Sound Projects Company battery chargers are doing an all-important job in helping to "Win the Battle of Communications."

**SOUND PROJECTS CO.**  
CHICAGO (22) ILLINOIS



# CROWNE

## *Finished Cabinets*

for ELECTRONIC UNITS  
RADIO RECEIVERS  
INSTRUMENT HOUSINGS  
AND CLOCKS



---

CROWE NAME PLATE AND MANUFACTURING CO.  
3701 RAVENSWOOD AVENUE CHICAGO 13, ILLINOIS  
40 YEARS EXPERIENCE IN FINE METALCRAFT

---

## Saga of Vacuum Tube

(Continued from page 56)

code and property markings. The 210A was similar to the 104A. The marking "Property of the American Tel. & Tel. Company" was omitted and the marking "Western Electric Company" was applied instead. The 223A was similar to the 104D except that a heavier filament was used.

Probably one of the best known of the Western Electric small tubes of this period was the 216A, which was intended for use in the amplifiers of small public address systems and similar low power applications. It was somewhat similar in characteristics to the 101D but with a plate structure resembling that of the VT1. Figs. 126 and 127 show several variants of this tube.

There were also a series of rectifier tubes using the same general construction as the corresponding amplifier tubes. The 214A and 217A shown in Figs. 128 to 130, were similar to the 211A and 216A respectively, with the grid omitted. The 219A and 219D were the rectifier counterparts of the 212A and 212D.

In the low filament power field there were the 230D and 231 D. These were used in the same applications as the well known RCA UV199 and UX199 types. The 221D and 235D were general purpose tubes similar to the RCA UV201A.

The only other early Western Electric tube which the collector is likely to acquire is the 215A, also known as the Signal Corps VT5, and the Navy CW-1344. It was first known as the type "N" vacuum tube. This is the

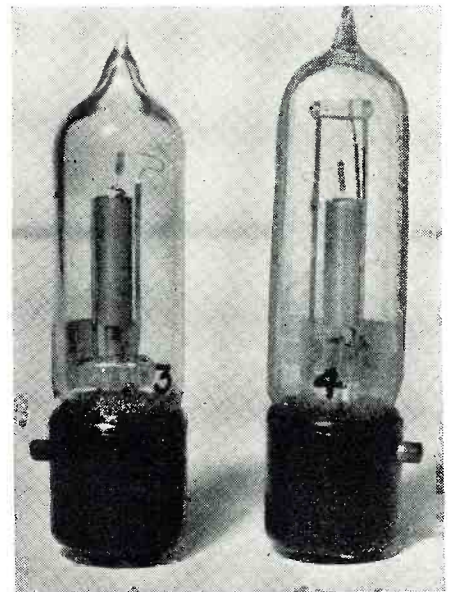

Fig. 132.

original "peanut" tube, so called because of its size. It was the only early Western Electric tube to utilize a concentric element assembly.

The filament was a single strand mounted vertically, the grid a spiral

## From the Thunder of War—

When speech transmission was called upon to take over the communication requirements of modern war, an era of close co-operation developed between the Army, Navy and the entire Radio Industry, far surpassing anything in history. Like a tidal wave, came designs for practical new types of equipment based upon the research of America's engineers in peace.

Permoflux met the challenge with the application of the Dynamic principle to produce better headphones and speakers—amazing new types of flat response instruments which provide superior intelligibility to the voices of America's Fighting Men.

**BUY WAR BONDS FOR VICTORY!**

TRADE MARK  
**PERMOFLUX**  
PERMOFLUX CORPORATION  
4916-22 W. Grand Ave., Chicago 39, Ill.

PIONEER MANUFACTURERS  
OF PERMANENT MAGNET  
DYNAMIC TRANSDUCERS

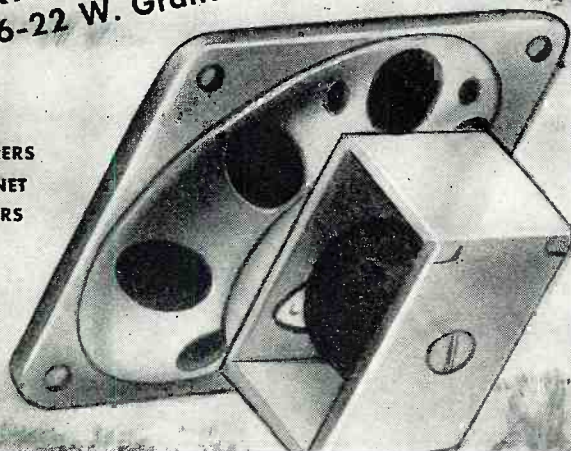

**EVERY** *Electro-Voice* **Microphone is**



One outstanding Electro-Voice achievement is the Model 7-A, a desk mounting type communication microphone. Designed for and approved by the CAA, this microphone is extensively used for airport landing control in addition to a number of other sound pick-up applications. The smooth frequency curve, rising with frequency, gives extremely high intelligibility even under the most difficult conditions.

Another . . . the now-famous Model T-45 "Lip Mike" . . . a noise-cancelling Differential Microphone . . . was designed by Electro-Voice in close collaboration with the Fort Monmouth Signal Corps.

**Every Dynamic, Carbon and Velocity Microphone in our complete line is DESIGNED by ELECTRO-VOICE.**

*We maintain a network of distributors throughout the country. If your limited quantity needs can be filled by any of our Standard Model Microphones, with or without minor modifications, we suggest that you contact your nearest radio parts distributor.*



**ELECTRO-VOICE MANUFACTURING CO., INC.**  
1239 South Bend Ave. • South Bend 24, Indiana  
EXPORT DIVISION: 13 EAST 40th ST., NEW YORK 16, N. Y.—U. S. A. CABLES: ARLAR

wire, and the plate a cylinder. Fig. 131 shows two of the early variants of this tube, the difference being chiefly in the bulb size. The tube shown at the left in Fig. 132 is the next variant, in which the spirally coiled filament tension spring has been replaced by a single bent wire. These early "N" tubes were very sensitive to mechanical disturbances. This was to some extent overcome by modification of the element structure to include a glass re-enforcing bead as shown in the tube at the right in Fig. 132. All of these earlier "N" tubes had metal bayonet locking pins inserted in the molded plastic base. Subsequently, a new base with a molded bayonet pin was developed and may be seen on the tube

whose element structure is shown at the right in Fig. 133. This variant, in which the glass re-enforcing bead has been increased in size, utilized magnesium flashing and was the final development of the 215A.

Somewhat later, for applications which required less sensitivity to microphonic disturbances, and yet low filament power and approximately the same electrical characteristics as the 215A the tube shown in Fig. 134 was developed. This was designated 239A. Earlier tubes of this code had tips but the later ones were of the tipless variety.

With this we bring to a close our consideration of the earlier Western Electric tubes. Very little informa-

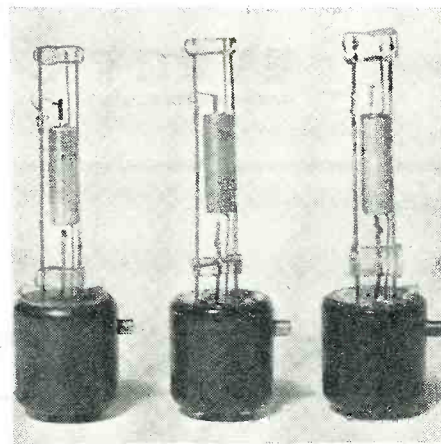

Fig. 133.

tion has been published concerning the contributions to tube development made by this organization. For this reason these tubes have been treated in as much detail as space will permit. In our next article we shall return to the consideration of this work as carried on by de Forest and his co-workers, with the aid of funds received from the sale of rights to the Audion.

#### CAPTIONS FOR ILLUSTRATIONS

Figure 113. Western Electric Type "K" or 202A Vacuum Tube. The machined brass base is the size of that used by the Western Electric Company, and later by others, for the "50-watt" type tubes. Photograph courtesy Bell Telephone Laboratories.

Figure 114. Western Electric Type "W" or 204B Vacuum Tube. This is a based tube of the type used in the Arlington-Paris tests of 1915. Both based and unbased tubes were used in the transmitter. Photograph courtesy Bell Telephone Laboratories.

Figure 115. Western Electric Type "S" or 204A Vacuum Tube. This is a based tube of the type used as a modulator in the tests which preceded the Arlington-Paris transmissions. Photograph courtesy Bell Telephone Laboratories.

Figure 116. Western Electric Type "G"—second embodiment of the 50-watt type tube. Made in 1919. Photograph courtesy Bell Telephone Laboratories.

Figure 117. Western Electric Type "G"—final version—coded 211A Vacuum Tube—1919. Photograph courtesy Bell Telephone Laboratories.

Figure 118. Western Electric 211A Vacuum Tube—commercial version of the Western Electric Type "G."

Figure 119. Western Electric 211D Vacuum Tube.—Replaced 211A Vacuum Tube. This tube has an improved filament and has the code and patent marking on the bulb in baked enamel lettering. Photograph courtesy Bell Telephone Laboratories.

Figure 120. Western Electric 211E Vacuum Tube—similar to the 211D except for the inclusion of spiral coils in the grid and plate leads.

**CRYSTALS**  
*Any Cut • Any Frequency*

Meck skill and precision are performance-proved. Meck experience is proved by our completely diversified selection of crystals in a wide range of types—silver-plated, too. Our Special Crystal Service Division is today prepared to meet exacting requirements to any specifications on short notice.

*For your urgent needs, either large or small, phone*  
**PLYMOUTH (INDIANA) 33**

**JOHN MECK INDUSTRIES**  
PLYMOUTH, INDIANA

EXCELLENCE IN  
MUSIC AND VOICE  
RECORDING INSTRUMENTS

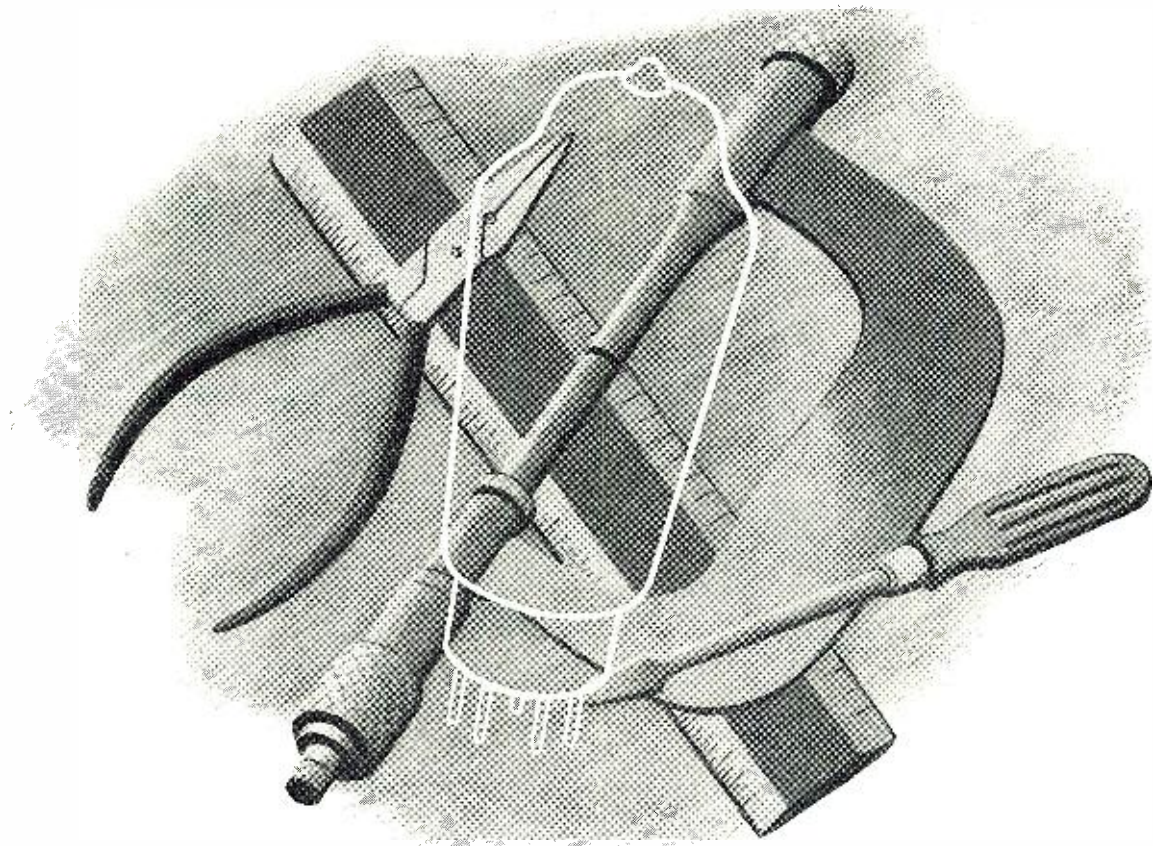

## SEQUEL TO "KNOW-HOW"... *"Can Do"*

The manufacture of delicate electronic equipment is not just a post-war dream with I. C. E.! Every day, carefully packed boxes leave the I. C. E. plant... bound for action. Obviously, just *where* and *how* this equipment is being used cannot be told. But we can tell you this: After the war when you're ready to put electronics to work in your plant... I. C. E. will be ready to work for you. Ready not only with the "know-how," but with the equipment and manpower necessary to produce what you want... when you want it!

*Electronics*

... the promise of great things to come



**INDUSTRIAL & COMMERCIAL ELECTRONICS**  
BELMONT, CALIFORNIA

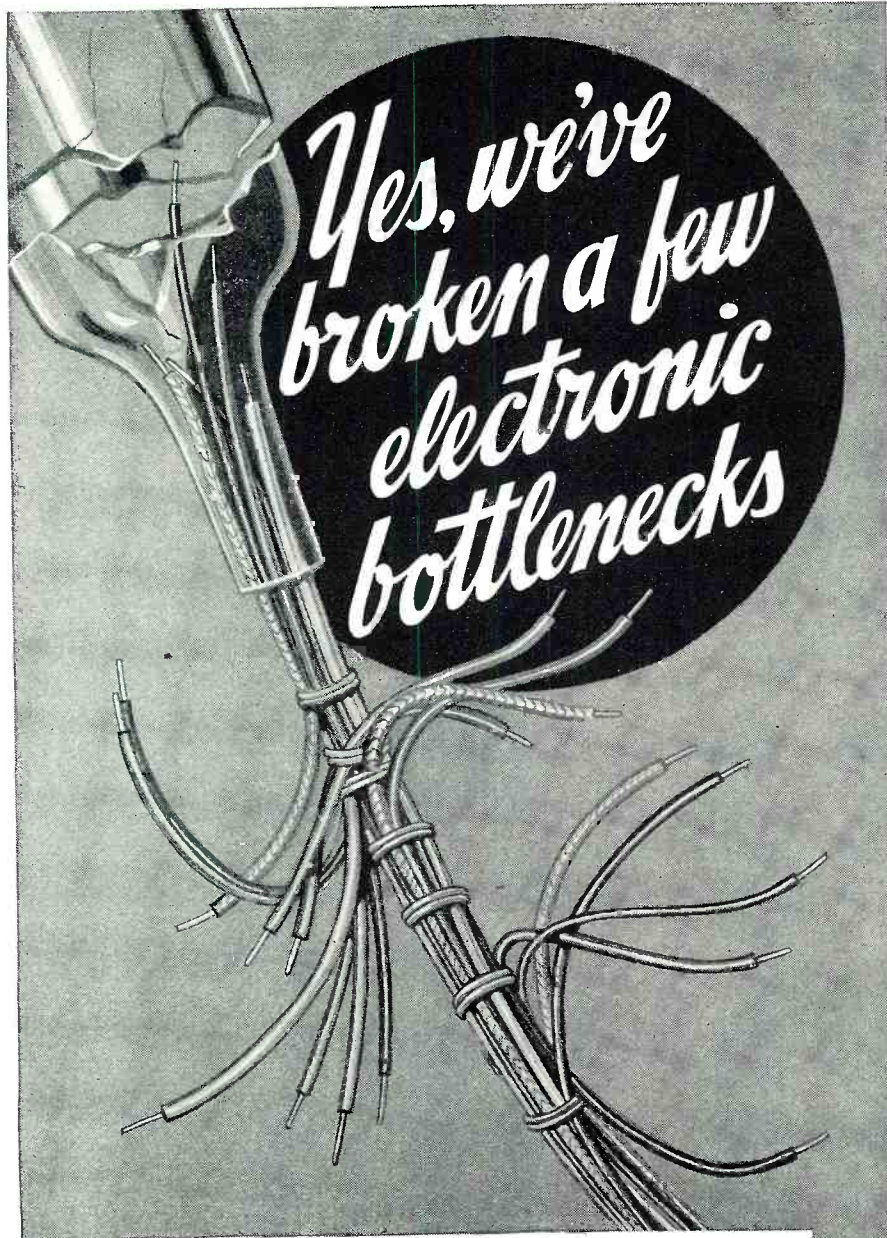

*Yes, we've  
broken a few  
electronic  
bottlenecks*

Harnesses — made to your toughest “specs” — that’s one of our big dishes. Several internationally known radio manufacturers can tell you that Wallace methods help them get the production they want. Of course, it’s all in winning the war but it’s fine training for competitive peacetime operation, too. Perhaps we can use this experience to help you get the jump on competition once peace is declared.



**Wm. T. WALLACE MFG. CO.**  
 General Offices: PERU, INDIANA  
 Cable Assembly Division: ROCHESTER, INDIANA

Figure 121. Western Electric Type “P” Power Tube—first attempt at 250 watt air cooled tube and forerunner of the 212 series of tubes. Made in 1919. Photograph courtesy Bell Telephone Laboratories.

Figure 122. Western Electric Type “P” Power Tube—second version. Made in 1919. Photograph courtesy Bell Telephone Laboratories.

Figure 123. Western Electric 212A Vacuum Tube—sample of the early commercial tubes of this series.

Figure 124. Western Electric 212D Vacuum Tube—improved 250 watt tube which replaced the 212A—front lighted to show construction.

Figure 125. Western Electric 212D Vacuum Tube—same tube as Figure 124 except back lighted.

Figure 126. Western Electric 216A Vacuum Tube—early model. The base has been made from that of the 208A

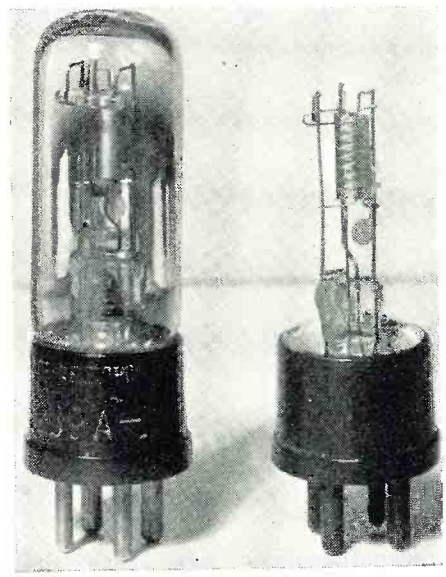

Fig. 134.

by cancelling the former code marking and those of the patent markings which did not apply to the 216A. The new code number and license notice are carried on a paper band around the neck of the tube.

Figure 127. Western Electric 216A Vacuum Tube—later version than that shown in Figure 126. The code and correct patent marking are on the base but the license notice is still carried on the paper band around the neck of the tube.

Figure 128. Western Electric 217A Vacuum Tube—early form—rectifier with structure based on that of the 101D. Photograph courtesy Bell Telephone Laboratories.

Figure 129. Western Electric 217A Vacuum Tube—later type—rectifier version of the 216A. Photograph courtesy Bell Telephone Laboratories.

Figure 130. Western Electric 217A Vacuum Tube—still later version in pear shaped bulb. Photograph courtesy Bell Telephone Laboratories.

Figure 131. Left—Early model of Western Electric Type “N” tube.

Right—later model using larger bulb diameter.



# Du MONT Oscillography

... from **A** to **X**, **Y** and **Z**

➔ The new DuMont Type 241 oscillograph is literally an enlarged version of the 3-inch Type 224 already meeting the more critical requirements of oscillograph users.

The 5-inch tube means larger oscillograms for more detailed studies. The added Z-axis amplifier for beam modulation permits use of timing signals or blanking impulses for further applications.

Both instruments—Type 224 (3-inch) and the new Type 241 (5-inch) set new standards for commercial-grade oscillographs. Wide-band Y-axis amplifiers permit study of sig-

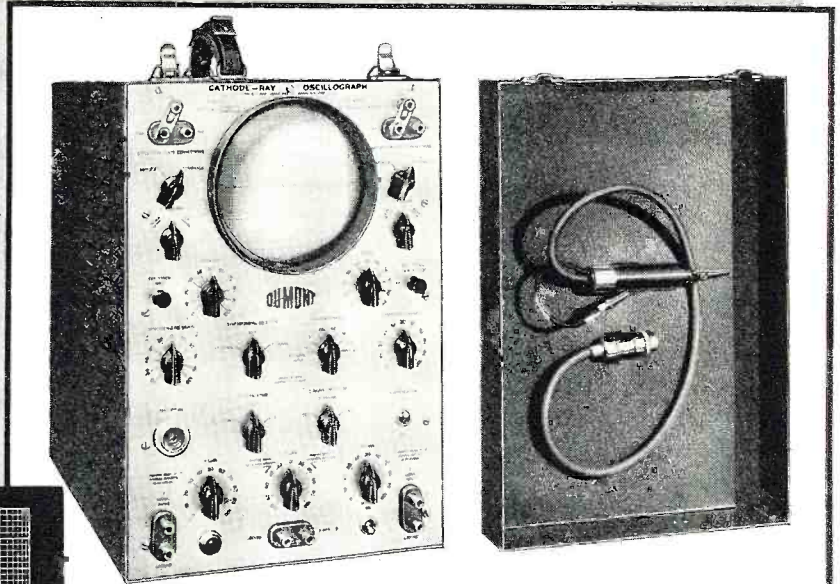

## FEATURES

Du Mont Type 5JP1 intensifier-type cathode-ray tube for brilliant, easy-reading oscillograms.

Y-axis or vertical deflection response uniform from 20 c.p.s. to 2 mc. Comparable faithful square and sinusoidal wave response.

X-axis or horizontal deflection amplifier with uniform response to 100 kc.

Both amplifiers have input attenuators and distortionless gain controls.

Y-amplifier has input connection for test probe and shielded cable supplied with instrument, reducing input capacitance and eliminating usual stray pickup.

Z-axis amplifier modulates intensity of electron beam with signal applied to input terminal post, or with return trace-blanking pulse produced by linear-time-base generator.

All high-voltage electrolytic capacitors eliminated from circuit.

17½" high; 10¾" wide; 21" deep. 65 lbs.

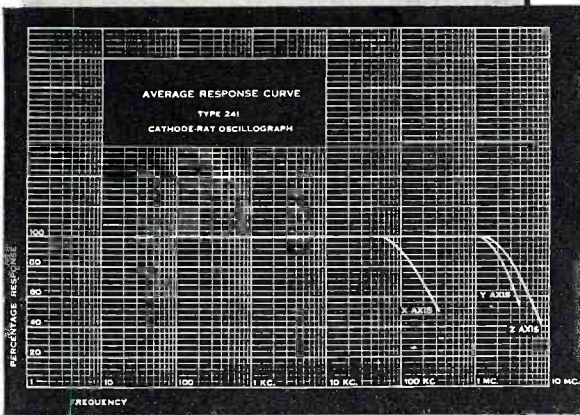

nals of frequencies far beyond the range of usual instruments. Both have a comparably wide-band square and sinusoidal wave response. Both permit a wide choice of panel connections for extreme flexibility in applying signals to the cathode-ray tube. Both are ruggedly housed and supplied with removable front cover for added protection in transit or when not in actual use.

These two expanded-range-expanded-versatility DuMont Oscillographs, along with other DuMont types, round out an outstanding choice of instruments for your particular kind of oscillography.

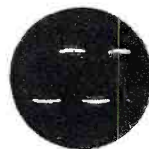

50 c.p.s.



500 c.p.s.



25 KC.

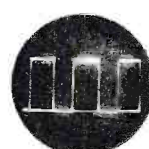

100 KC.

# DUMONT

**ALLEN B. DU MONT  
LABORATORIES, Inc.**

Passaic • New Jersey  
Cable Address: Wespexlin, New York

➔ Write for literature

Figure 132. Left—Western Electric Type "N" Vacuum Tube—redesign showing new filament tension spring.

Right—Later model with small diameter glass beads for stiffening element assembly and reducing response to mechanical shock.

Figure 133. Western Electric 215A Vacuum Tube—commercial production of type "N"—element assemblies. The one at the right with the heavier glass reinforcing beads is the later construction.

Figure 134. Western Electric 239A Vacuum Tube.

Left—Complete tube of late type. Earlier tubes had the code marking on the glass.

Right—Element assembly of this tube with plate opened up to show spiral grid and axial filament.

(To be continued)

### Fundamental Optics

(Continued from page 26)

ment automatically. Probably the most widely publicized of these is the Hardy color analyzer. This instrument will accomplish in minutes what formerly took a trained technician hours.

#### Refraction

As far back as the tenth century

the Arab Alhazen demonstrated the true behavior of light as it passes from one medium into another. It remained for Willebrord Snell, over six centuries later, however, to determine the mathematical law relating the angles of incidence and refraction. Snell's law, the law of refraction, states that the sines of the angles of incidence and refraction are in a constant ratio to each other for any given medium. Its proof, based upon the concept of wave fronts, is relatively simple.

Consider, as shown in Fig. 3, the boundary between two materials, one less dense than the other, like air and glass. The plane wave fronts incident upon this surface are brought closer together after entering the denser medium because the velocity of the propagation of light is directly proportional to the density of the material in which it is traveling. If, too, the wave fronts are incident upon this boundary at an angle ABC, as shown, then the wave fronts will suffer a turning action because part of the wave will be slowed down sooner than the remainder. The wave fronts will then leave the boundary at an angle BCD. It can be seen, also, that in the time that point A takes to travel to point C, point B would have traveled to point D. The distances AC and BD, therefore, are proportional to the velocities of the light in the two mediums, or

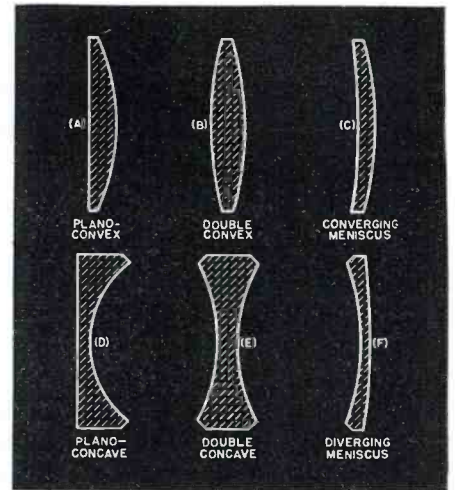

Fig. 11. A number of common lenses having spherical surfaces.

$$\frac{AC}{BD} = \frac{\text{velocity of light in air}}{\text{velocity of light in glass}} = \frac{V_a}{V_g}$$

Mathematically, we can divide both numerator and denominator of a fraction by the same quantity without changing that fraction, hence

$$\frac{AC/CB}{BD/CB} = \frac{V_a}{V_g}$$

But it is soon evident that  
 $AC/CB = \text{sine } \angle ABC$   
 $BD/CB = \text{sine } \angle BCD$

## The Business End OF THE SCR-299

Many weapons of war team up with Onan Electric Plants for the power that makes them effective. One of the most famous of these teams is the Army's SCR-299 Mobile Radio Station, powered by Onan PE-95 10 KW Electric Plant. Onan builds a complete line of Electric Plants ranging in sizes from 350 to 35,000 watts, 50 to 800 cycles, 100 to 660 volts, A.C.; 6 to 4000 volts, D.C.; and Dual A.C.-D.C. output types.

Descriptive literature sent promptly on request.



Army-Navy E awarded to each of the four Onan Manufacturing Plants.

# BUILT BY ONAN



## ONAN

## D. W. ONAN & SONS

1889 ROYALSTON AVENUE, MINNEAPOLIS, MINNESOTA



# DYNAMIC DEMONSTRATOR

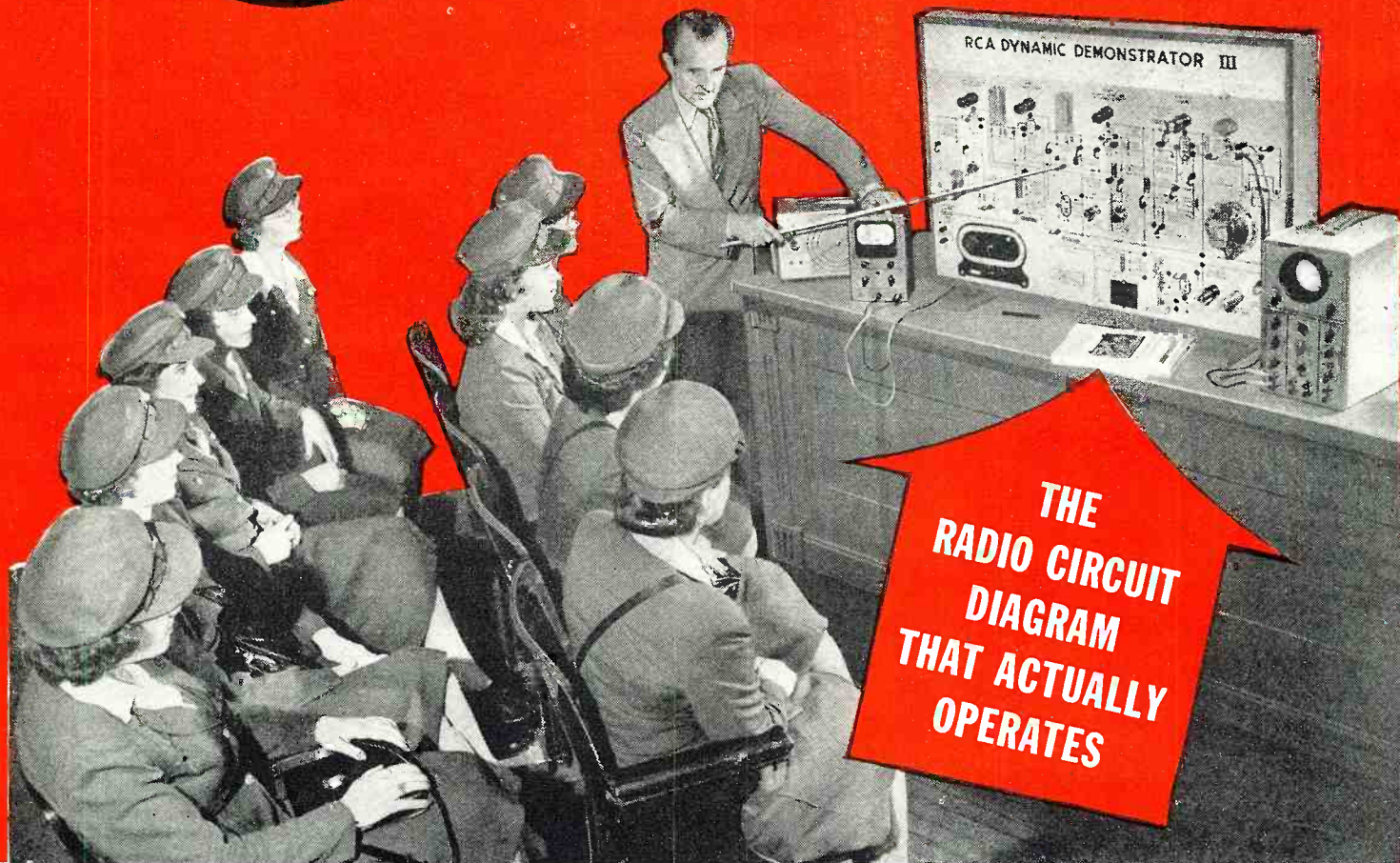

BUY MORE WAR BONDS

UNIVERSALLY accepted for practical laboratory and vocational instruction in radio.

Consists of the working parts of a six-tube radio receiver, mounted in proper functional position on a large schematic diagram suitable for use in visual instruction. Jacks are provided for interruption and test of the various circuits. When used with modern radio test instruments, facilitates both qualitative and quantitative analysis of radio circuit conditions—an ideal setup for rapid radio instruction. RCA Dynamic Demonstrators, like the one shown above, are in very extensive use today in practical laboratory and vocational radio training schools. For audio demon-

strations—for service adjustments—for signal tracing technique—for all manner of measuring, checking, testing, analyzing. (NOTE: Currently, deliveries can be made from stock, subject to prior sale, on a priority of A-1-a or higher.) Please address inquiries to Test and Measuring Equipment Section, RADIO CORPORATION OF AMERICA, Camden, New Jersey.

**RCA Test and Measuring Equipment**  
**RADIO CORPORATION OF AMERICA**

Can YOU use this



# VARIABLE INDUCTOR

Culminating a number of years of research, the UTC Variable inductor is an ideal tunable device for peaked amplifiers, filters, etc. This sealed unit measures 1 1/4" x 1 7/16" x 1 7/16". Available in inductance value from 10 Mhy. to 10 Hys.

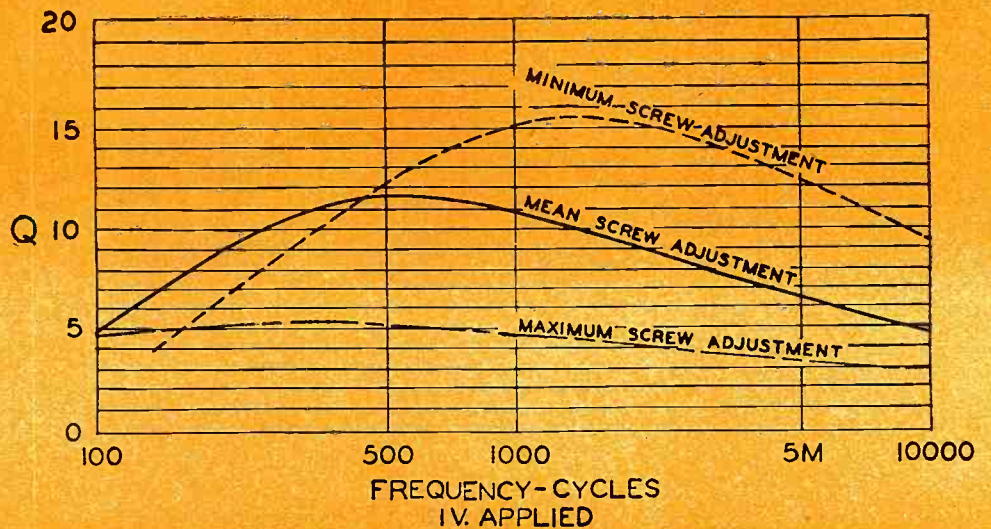
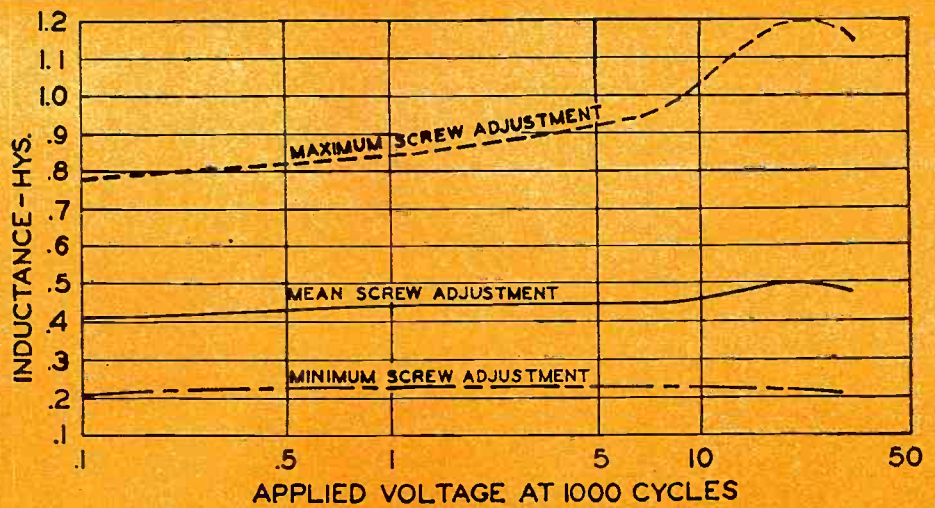
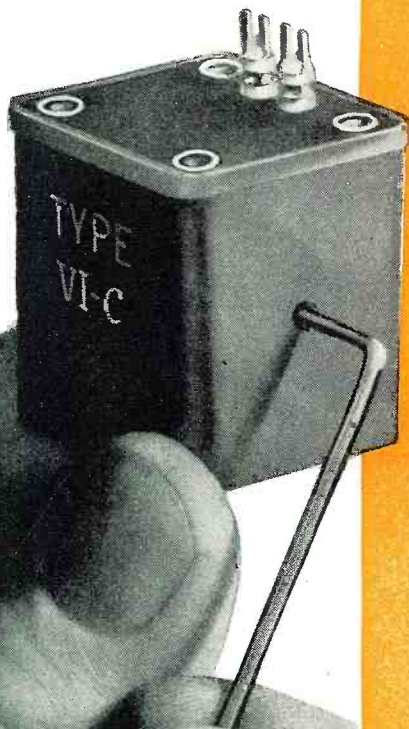

*United Transformer Co.*  
 150 VARICK STREET • NEW YORK 13, N. Y.

EXPORT DIVISION: 13 EAST 40th STREET, NEW YORK 16, N. Y., CABLES: "ARLAB"

Thus 
$$\frac{\text{Sine } \angle ABC}{\text{Sine } \angle BCD} = \frac{Va}{Vg}$$

Since the refractive index of a material is defined as being proportional to the velocity of the light in that material, then

$$n = kVa \quad n' = kV'g$$

$$\frac{n}{n'} = \frac{Va}{V'g}$$

The refractive index of air is very nearly 1.0, therefore,

$$n' \text{ sine } \angle ABC = 1.0 \text{ sine } \angle BCD$$

In the section upon wave fronts it was stated, however, that a ray is defined as that line perpendicular to the wave fronts. It can be seen, then, that the angle the incident ray makes with the normal to the surface is equal to  $\angle ABC$  and, likewise, the angle that the refracted ray makes with the normal is equal to  $\angle BCD$ . The normal, by the way, is that line drawn perpendicular to the surface at the point the incident ray enters the surface. We can now write Snell's law of refraction in its most common and most workable form, that is

$$n' \text{ sine } i = n \text{ sine } r$$

With the law of refraction as one of his most fundamental rules, the geometrical optician has evolved a complete method for the design of lenses and lens systems. Some of the simpler relationships will be given below.

### Lenses and Lens Systems

A lens, in its simplest form, is a piece of transparent material bounded by two regular surfaces. These surfaces may be either plane or curved. Usually the curved surfaces are spherical, although it is entirely possible to make them parabolic, elliptical, or any other regular curve. The transparent material may be glass, either inorganic or "organic." The inorganic glasses may be crystals like quartz or rock salt or they may be made by the fusion of silica and alkali with, in some cases, other materials added to give some desired characteristic. "Organic" glasses are the various transparent plastics of which there are many.

A perfect lens is one that will form a reproduction of an object true to scale in all three dimensions without blurring or distortion. No practical lens is perfect in this sense, although in a great many cases perfection is closely approximated.

In the development of formulas for the action of lenses it is usual to assume the so-called "thin lens" convention; that is, it is usual to consider lenses of no thickness. This results in a great simplification of the formulas and the approximate results so obtained are sufficiently accurate to be useful. Naturally, in precise optical design the lens thicknesses must be considered and the formulas used are decidedly more complex. We shall limit our discussion to the *thin lens formulas*.

A beam of parallel light originating at a very distant object will emerge

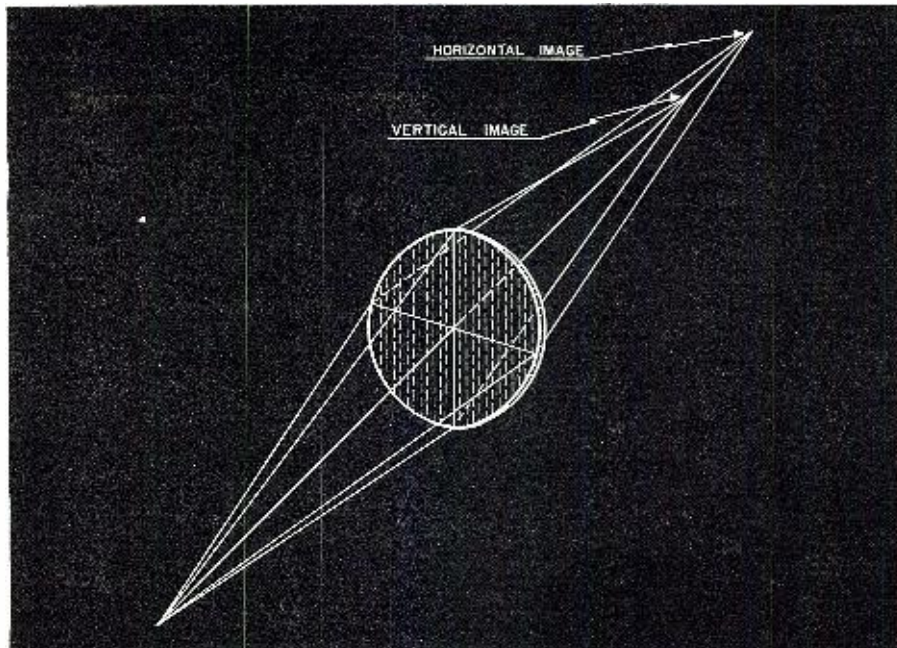

Fig. 12. A pictorial representation of the formation of an astigmatic image.

from a lens as either a converging or diverging beam, dependent upon the form of the lens. Lenses thicker through their centers than through their edges will cause the light rays to converge, those thicker at their edges, on the other hand, will cause the rays to diverge. This action is illustrated in Figs. 4 and 5. There are six varieties of lenses with spherical surfaces, viz., (a) plano-convex, (b) double convex or bi-convex, (c) converging meniscus, (d) plano-concave, (e) double concave or bi-concave, and (f) diverging meniscus (Fig. 11).

The line joining the centers of curvature of the lens surfaces is called the optic axis of the lens. When parallel light is incident upon a lens, the crossing point of the emergent rays with the optic axis is called the focal point. There are two such points for every lens, one for parallel light entering the lens each way. For thin lenses the two focal points will be equidistant from the lens. This is not so for "thick" lenses.

The most important constant of lenses is their focal length. It is ap-

proximately that distance from the back face of the lens to its focal point. It can be determined experimentally by using the sun as a source or by using light rendered parallel by another lens. Or it can be calculated by use of the following formula:

$$\frac{1}{f'} = -\frac{1}{f} = (n-1) \left( \frac{1}{R_1} - \frac{1}{R_2} \right)$$

in which the notation is that shown in Figs. 4 and 5 ( $n$  being the refractive index of the lens). Study of this formula will reveal that since it is conventional in optics to call all distances and surfaces with their centers of curvature to the left of the lens negative and those to the right positive, it is entirely possible to have lenses of a negative as well as of a positive focal length. It so happens that this sign convention makes all lenses that diverge parallel rays negative in focal length and those that converge parallel rays positive. Accordingly, the former are called negative, or minus, lenses, while the latter are called positive, or plus.

For every position that an object

Fig. 13. Diaphragm placed before the lens with its edge acting as an aperture stop.

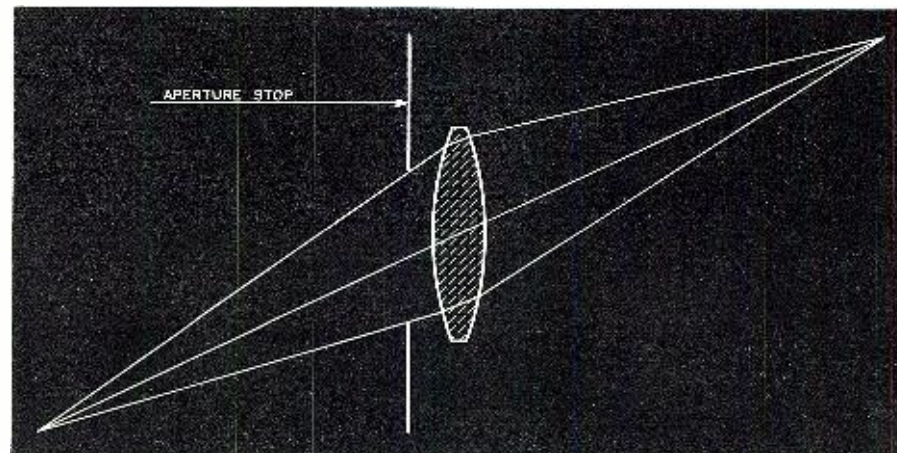

# Leadership in the Production of

## CONNECTORS · CABLES and PLASTICS for ELECTRONICS

• Wide experience in the field...close collaboration with the industry's leading engineers...adequate production facilities...explain Amphenol's leadership in the manufacture of Army-Navy Type Connectors, Conduit, and Conduit Fittings, Low-Loss Cable and Connectors, and Plastics for electronic applications. Amphenol A-N products are precision engineered to give lasting dependable operation. The greatly increased production facilities at the Amphenol plant expedite the handling of orders quickly and efficiently. Depend upon Amphenol quality, workmanship, and service!



Low-Loss Coax and Twinax Cables and Connectors built to latest Army - Navy specifications.

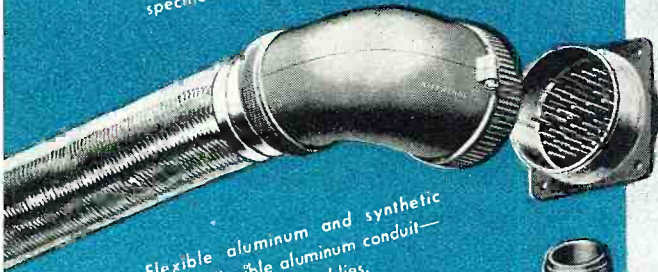

Flexible aluminum and synthetic covered flexible aluminum conduit—complete conduit assemblies.



A-N Approved Conduit and Conduit Fittings for conduit and A-N connector assembly.



A-N Connectors, Plugs, and Receptacles — all required sizes, styles, and insert arrangements.

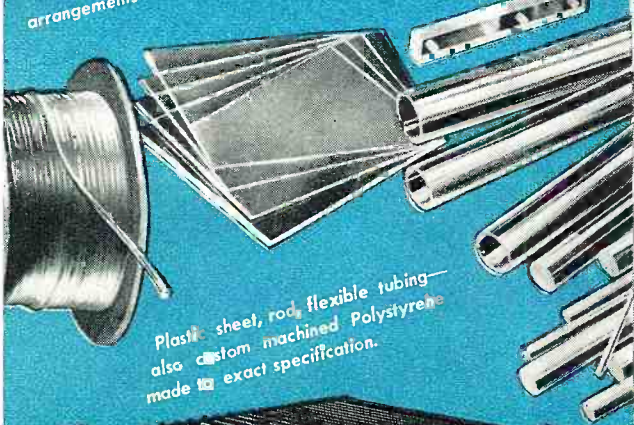

Plastic sheet, rod, flexible tubing—also custom machined Polystyrene made to exact specification.

### THE LEADERSHIP CATALOG OF THE INDUSTRY



With complete specifications of all Amphenol Products, technical data, charts, and helpful information—a guide book of electrical equipment used in aircraft, radio, shipbuilding industries. Send your request on company letterhead.



AMERICAN PHENOLIC CORPORATION · CHICAGO (50) ILLINOIS  
IN CANADA · AMPHENOL LIMITED · TORONTO

may occupy with respect to a lens, there is a corresponding position for the image. Since the object and image distances are so coupled, they are usually referred to as conjugate distances. The mathematical correlation existing between these conjugate distances is

$$\frac{1}{f'} - \frac{1}{s'} - \frac{1}{s}$$

where  $s$  is the object distance and  $s'$  the image distance. This expression is useful to determine, for example, where the image of a lamp filament will lie when using a given lens.

The magnification, too, can be determined from these same conjugate distances, since

$$m = \frac{s'}{s} \text{ (for a lens in air).}$$

Knowing the magnification of a lens, one can determine the size of image to be expected.

Many times it is desirable to use more than one lens. This may be necessary, for example, when the magnification of a single lens is less than that desired. All high-power microscope objectives are compound lenses. If  $f_a$  and  $f_b$  represent the focal lengths of two thin lenses separated by the distance  $d$ , then the focal length of the combination is

$$\frac{1}{f'} = -\frac{1}{f} = \frac{1}{f_a} + \frac{1}{f_b} - \frac{d}{f_a f_b}$$

And the over-all magnification is

$$m = \left(\frac{s'}{s}\right)_a \left(\frac{s'}{s}\right)_b$$

where the subscripts indicate that the conjugate distances are for the two lenses  $a$  and  $b$ .

### Lens Aberrations

As has already been mentioned, there is no such thing as a truly perfect lens, even though the ideal is oftentimes approached. The principal lens aberrations are chromatic aberration, spherical aberration, coma, astigmatism, curvature of field, and distortion. The best manner to describe them is by means of diagrams.

Chromatic aberration is a failure of the lens to image all colors at the same image point, as shown in Fig. 1. Thus, for a point source at infinity there will be found various colored images along the optic axis. It is, in all probability, the most objectionable of all aberrations. It is overcome by the so-called achromatic systems, the simplest of which consists of two lens elements, one positive, and the other negative. Each lens element is designed to have the reverse chromatic aberration of the other.

Spherical aberration is pictured in Fig. 7. It is the failure of the lens to image the light passing through its various zones at the same image point. It is evidenced by the inability to form a truly "sharp" image, rather the entire image appears to be bathed in diffuse light. Occasionally photographers purposely introduce spherical

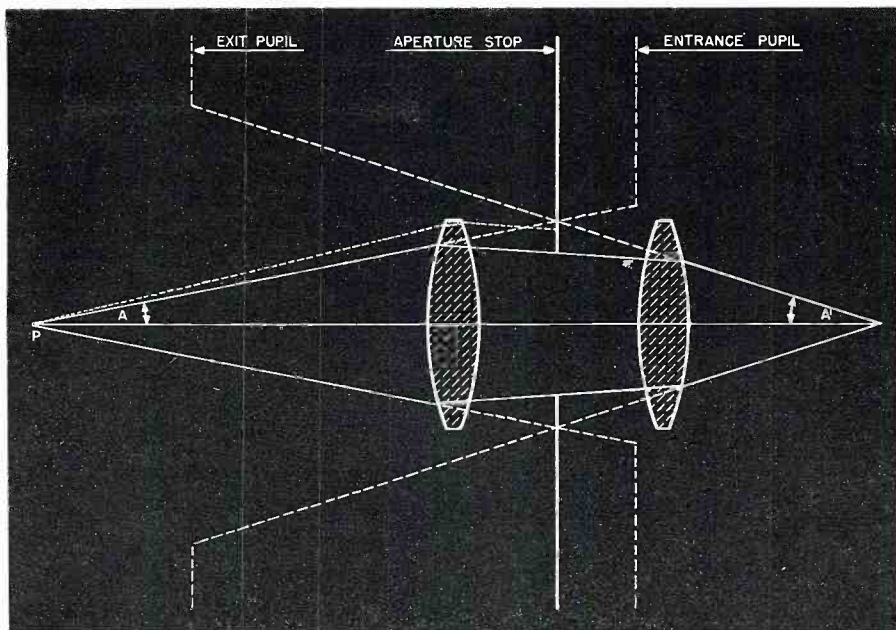

Fig. 14. The effect of an aperture stop between two lenses on passing light rays.

aberration into their lenses for portraiture since the aberration tends to conceal minor blemishes upon the subject. This aberration can be minimized by giving the lens the proper form. Parabolic surfaces, too, have proven to be useful in this regard, but these surfaces cannot be made regular enough, as yet, upon a commercial scale to be acceptable.

Coma is an aberration that is difficult to portray in purely non-technical terms. It arises because of a zonal difference in magnification and is closely associated with spherical aberration. The reduction of spherical aberration will, as a rule, reduce coma. The manner in which a comatic image is formed is shown in Fig. 8.

Astigmatism is a term widely known

**PRODUCING FOR VICTORY**  
... and for **PEACE TOO!**

Halldorson Transformers are playing a vital role on many battle fronts throughout the world, helping to "get the message through" for our own forces and our allies. Known for ruggedness, dependability of performance, and efficiency they're doing a he-man's job wherever they serve, whenever they're needed.

We've also found time to produce for the home front. A full line of Victory Type transformers are being manufactured in our plant. Quantity limited, of course! But built to Halldorson standards like their brothers-in-arms, bringing new life to civilian sets in many of America's homes.

**THE HALLDORSON COMPANY, 4500 Ravenswood Avenue, Chicago 40, Illinois**

**JOBBER:** We'll be glad to send you complete information regarding Halldorson Victory Type Transformers upon request.

**HALLDORSON**  
*Vacuum Sealed*  
**TRANSFORMERS**

# ELECTRONICS BOOK HEADQUARTERS FOR THE WEST • Mail Orders Handled Anywhere

We stock nearly all leading radio and electronics books for immediate shipment, and can furnish any other currently-published electronics book on short notice. Send stamp for catalog. Especially popular books at present are those listed below.

**THE RADIO HANDBOOK**, by Editors and Engineers. Radio's outstanding practical text for war-training and regular purposes. Basic electrical and radio theory in the simplest possible language for those without mathematical or technical training, backed up with how-to-build-it descriptions of dozens of types of transmitting, receiving, and test equipment. Illustrated with hundreds of diagrams and large photographs.

Enlarged and revised chapters for war-training purposes, includes expanded basic principles, more test equipment which can be home- or field-built, and mathematics for solving simple radio problems.

Over 600 pages, durably clothbound, gold-stamped. From your favorite dealer or direct from us, postpaid, for \$2.00 in U.S.A. (plus 2½% tax in Calif.); elsewhere, \$2.25.

**PRACTICAL RADIO COMMUNICATION**, by A. R. Nilson and J. L. Howard. Covers the entire spectrum of radio waves including operators' license requirements; combines theoretical principles and practical radio operating; intended both for home study and radio schools. Covers transmitting, receiving, and power equipment for all types of stations including marine, broadcasting, and ultra-shortwave. 927 pages. \$6.00.\*

**PRINCIPLES OF RADIO**, by Keith Henney. Combines both theory and practice—begins with the fundamental principles of electricity, and develops the subject of radio in a clear, logical manner. One of the most popular basic texts, selected (among others) for government-sponsored radio training courses. \$3.50.\*

**MATHEMATICS FOR ELECTRICIANS AND RADIOMEN**, by N. M. Cooke. Algebra through quadratic equations, logarithms, trigonometry, plane vectors, elementary vector algebra, and other mathematics needed to solve everyday radio and electrical problems, with emphasis on direct applications. 604 pages. \$4.00.\*

**RADIO PHYSICS COURSE**, by A. A. Ghirardi. Basic fundamentals of electricity, radio, television and sound especially adapted to home instruction; a minimum of mathematics; contains many self-review questions. Covers every branch of radio including broadcasting, servicing, aviation, marine, police, military, public address, and electronics applications. 972 pages. \$5.00.\*

**RADIO ENGINEERING HANDBOOK**, by Keith Henney and 23 collaborators. The leading handbook of the radio engineering profession. A large amount of reference material in concise form with emphasis on design data and many tables, charts, equations, formulas, and diagrams, pertaining to all phases of radio. 945 pages. \$5.00.\*

**MICROWAVE TRANSMISSION**, by J. C. Slater. A thorough exposition of the characteristics of microwaves with emphasis on the use of Maxwell's equations.

\*Add 4% for domestic postage (including A.P.O.s); foreign, 10%. In California, add 2½% tax.

EDITORS AND ENGINEERS, 1420 N. Highland Ave., Los Angeles 28

tions as a means of handling transmission line design problems; hollow pipes and coaxial lines are treated extensively. 310 pages. \$3.50.\*

**RADIO ENGINEERS' HANDBOOK**, by F. E. Terman. This book is a unique combination of the tabular data type of handbook plus concise extracts of the explanatory type of material, such as features the author's Radio Engineering. Its thirteen sections concentrate on tubes, circuits, transmitters, power supplies, antennas, fundamentals, formulas, design data, tables, and diagrams; a considerable amount of data is included which is not readily found in other texts. 1019 pages. \$6.00.\*

**SERVICING BY SIGNAL TRACING**, by John F. Rider. Covers thoroughly the only method of locating difficulties applicable to all types of electrical communication systems both of audio and radio frequencies. 360 pages. \$3.00.\*

**SERVICING SUPERHETERODYNES**, by John F. Rider. A complete treatment for practical use. 307 pages. \$1.00.\*

**CATHODE-RAY TUBE AT WORK**, by John F. Rider. Practical construction, understanding, and use of this most valuable tool; many actual c.r. "patterns" are shown. 338 pages. \$3.00.\*

**FREQUENCY MODULATION**, by John F. Rider. General description of system plus details of f.m. receiver operation and maintenance. 136 pages. \$1.50.\*

**THE RADIO MANUAL**, by G. E. Sterling. A comprehensive and practical handbook written especially for commercial and broadcast operation. Covers not only principles and methods but also a wide variety of apparatus. 1120 pages. \$6.00.\*

**RADIO ENGINEERING**, by F. E. Terman. A comprehensive treatment of all phases of radio communication written from the engineering viewpoint; both qualitative and quantitative analyses are included. \$13 pages. \$5.00.\*

**MEASUREMENTS IN RADIO ENGINEERING**, by F. E. Terman. A comprehensive discussion of measurement problems commonly encountered by radio engineers. Complete and practical with emphasis on the design of laboratory equipment and upon those methods requiring the least equipment. 400 pages. \$4.00.\*

**THEORY AND APPLICATION OF ELECTRON TUBES**, by H. J. Reich. A thorough ground work in tube and circuit theory. Emphasis both on fundamental principles and applications to communication and industrial engineering. 670 pages. \$5.00.\*

**PRINCIPLES OF ELECTRON TUBES**, by H. J. Reich. An abridgement of "Theory and Application of Electron Tubes" with less emphasis on communication problems. 397 pages. \$3.50.\*

**ELECTRONICS**, by J. Millman and S. Seely. Basic electronic principles and applications to problems in electrical engineering and physics; theory of operation of electronic devices, both gas filled and vacuum. 721 pages. \$5.00.\*

because of the popularity of anastigmatic lenses. The term itself is derived from the Greek word *stigma* meaning point and the Greek prefix *a* meaning no. It is the inability of a lens to image a point as such. An anastigmatic lens is one that has no astigmatism; that is, it can image a point properly. This aberration arises because the lens images light passing through it horizontally at a different point than light passing through vertically. A pictorial representation of the formation of an astigmatic image is shown in Fig. 12.

Curvature of field is the variation of image distance with obliquity (Fig. 9). It is evidenced by the fact that the image plane must be curved if the entire image is to be sharply defined upon it. It can be shown that the astigmatism and curvature of field of a thin lens are independent of the shape of the lens. Neither of these aberrations can be corrected by using a negative and a positive element in contact, like chromatic aberration, or by changing the form of the lens, like spherical aberration. They can be corrected, however, by adjusting the separation of the elements.

Distortion, a truly descriptive term, is the variation of magnification with obliquity and exists in two forms. These forms, taking their names from the appearance of the shape of the image of a square object, are pincushion and barrel distortion.

From even this simple treatment of aberrations it should be evident that the work of the optical designer is beset with many difficulties.

## Theory of Stops

In optical electronics virtually all of the receptors used are responsive to changes in light intensity. Through use of the theory of stops this fact enables the designer to overlook any consideration of lens aberrations for the most part. Occasionally, however, some aberration will become especially obnoxious and will force its correction.

Even the most cursory examination of Fig. 10 will reveal that if a point source is placed before a lens, only those rays passing through the lens will be in the final image. The rim of the lens is, therefore, called the aperture stop of the system. Consider, now, Fig. 13. In the system shown, a diaphragm has been placed before the lens. The new aperture stop is the edge of this diaphragm. It can be also described as the front stop in contradistinction from stops appearing later in a system.

A still more general case will reveal more upon this theory of stops. For that reason consider the combination of lenses shown in Fig. 14. The steepest ray that can travel through the system is that shown starting at an angle A. Any ray starting at an angle greater than A will be stopped by the diaphragm. In this case the between-the-lens diaphragm is the aperture stop for the complete system. But it must not be forgotten that as far as



Still your best bet for replacements

Centralab VOLUME CONTROLS



\*Old Man Centralab "Old Man" is right . . . for he is a real "old timer". There is no substitute for experience, and the "Old Man" now, as in the past twenty-two years, is still your best bet.

Centralab

Division of GLOBE-UNION INC., Milwaukee





**BLOOD DONATIONS** by the hundreds have been made by Breeze workers to the Red Cross Blood Bank,

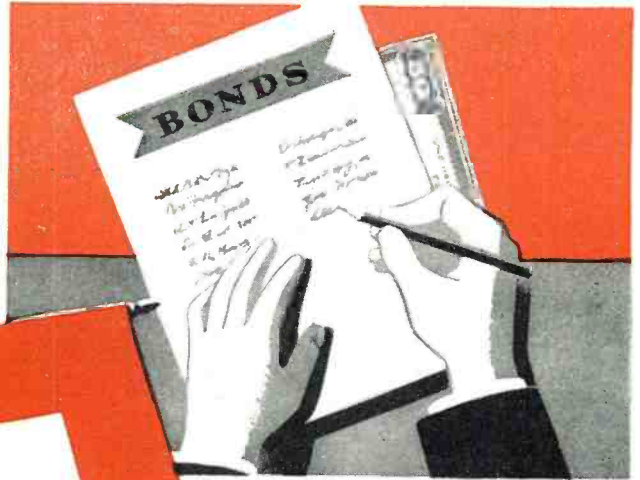

**WAR BOND DRIVES** have been enthusiastically supported in addition to payroll deduction purchases.

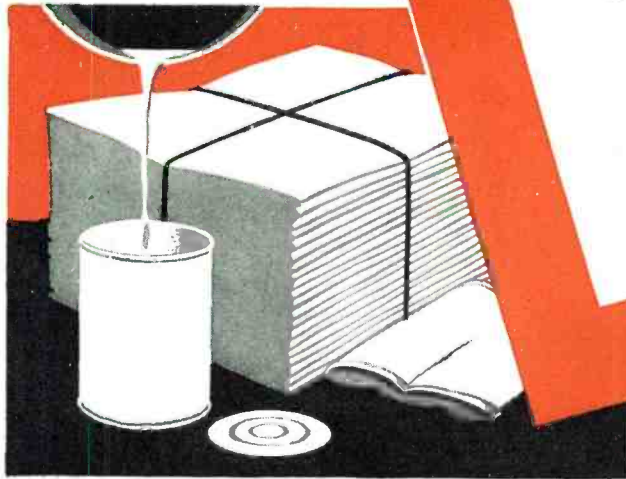

**SALVAGE CAMPAIGNS** both at home and at their work are aided by the efforts of Breeze men and women.

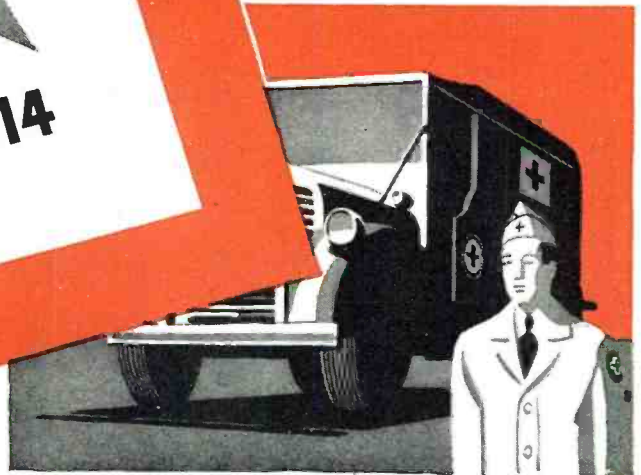

**RED CROSS** ambulance, station wagon and special car donated by management of Breeze to Motor Corps.



# Our Third Front

**VICTORY DEPENDS ON WHAT WE DO AT HOME AS WELL.**

THERE IS a Third Front, here at home, on which the men and women of Breeze are fighting. Putting 10% and more of their pay in war bonds, giving blood regularly to the Red Cross Blood Bank, cooperating to the fullest extent in civilian defense activities and government war campaigns, Breeze workers are a part of the great team that is backing up the boys at the front.

Without this teamwork, the efforts of our fighting men might well be wasted.

And in addition to their outside work, the men and women of Breeze are on the job day and night, turning out in tremendous quantities the well-known Breeze products which are serving America today on fighting fronts the world over.

**Breeze**   
**CORPORATIONS, INC.**  
 NEWARK, NEW JERSEY

**PRODUCTION FOR VICTORY • PRODUCTS FOR PEACE**

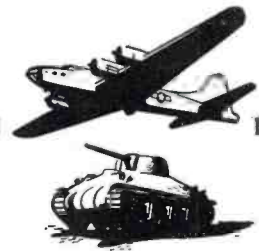

**A Few of the Many Breeze Products in the Nation's Service**

- Radio Ignition and Auxiliary Shielding • Multiple Circuit Electrical Connectors • Flexible Shielding Conduit and Fittings • Cartridge Engine Starters • Internal Tie Rods • Elevator and Rudder Tab Controls • Flexible Shaft and Case Assemblies • Aircraft Armor Plate

the lens system is concerned, this diaphragm is but another object and each lens in the system will form an image of it. The image of the aperture stop formed by the first lens of the system is known as the entrance pupil, that formed by the last lens is the exit pupil. The position and size of either of these pupils can be readily determined by application of the lens formulas given in a foregoing section.

Since the angle A subtended at the object point, P, by the entrance pupil determines the amount of light traversing the system, that angle can be used to express the light gathering ability of the system. For finite object distances this light gathering ability is expressed as the numerical aperture, or N.A., where the defining equation is

$$\text{N.A.} = n \sin A$$

in which n is the index of refraction of the object space. For photographic or telescopic lens where the object distance is for all practical purposes infinite, the light gathering ability is called speed or f/number. Speed is defined as the ratio of the focal length of the objective to the diameter of the entrance pupil. For single lenses, or lenses in contact with each other, the entrance pupil can be considered to be the rim of the lens acting as the aperture stop.

$$\text{speed} = f/\text{number} = \frac{\text{focal length}}{\text{lens diameter}}$$

Since the manufacturers of phototubes list the sensitivity of their prod-

ucts in terms of microamperes per lumen, it is oftentimes desirable to be able to calculate the light flux in the image. This can be done by use of the following equation:

$$E' = k\pi B \sin^2 A'$$

where E' is the illumination of the image (in lumens/area), B is the brightness of the source (in candles/area), and A' is the angle subtended at the image by the exit pupil. For single lenses, or lenses in contact, the exit pupil can be considered as the rim of the lens. The quantity k is the transmission factor of the optical system. If the number of glass to air surfaces present in the system is known, this transmission factor can be calculated (approximately) from

$$k = \frac{0.96}{1 + 0.04(N - 1)}$$

where N is the number of glass to air surfaces.

When the object is at infinity, an expression that is also useful for determining the illumination of the image is

$$E' = k \frac{\pi B}{4} \cdot \frac{1}{(f/\text{number})^2}$$

This expression is particularly easy to use since the speed and transmission factor are all that need be known about a lens.

Having found the illumination of the image, the flux can be determined by multiplying the illumination by the area of the image.

-30-

## Speaker Measurements

(Continued from page 37)

show neither outdoor performance, nor indoor performance under representative listening conditions; their main justification is one of convenience to the development engineer.

The new trend in sound room construction for precision acoustical measurements is the so-called free-space room. Here the wall absorption is especially designed to reduce reflections by providing a closer acoustical impedance match between the air and the absorbing system at the inner surface of the boundary. Experience justifies the rather heavy expense of free-space sound rooms for organizations carrying on extensive research programs, although an approach to true free-field conditions has been only approximated at frequencies above a limiting value in the general region of 100 cycles per second.

In considering measuring techniques and evaluating response curves, it is essential to keep in mind the importance of *directivity*, for most conventional speakers are non-directional at low frequencies and highly directional at the higher frequencies. If we represent a conventional cone-type direct radiator speaker by means of a vibrating piston and compute the theoretical directivity characteristic shown in Fig. 3, we obtain the familiar polar pattern for this type of speaker with its characteristic pro-

## ENGINEERS • TECHNICIANS • AUTHORS

THE BOOK DIVISION OF THE ZIFF-DAVIS PUBLISHING COMPANY PRESENTS AN OPPORTUNITY FOR YOU TO CONTRIBUTE TO A SERIES OF POST-WAR MANUALS, TEXTBOOKS AND GENERAL WORKS TREATING ALL PHASES OF SCIENCE, ENGINEERING, BUSINESS AND INDUSTRY.

### SUBJECT MATTER IS TO INCLUDE THE FOLLOWING:

- 1 Textbooks in Electrical Engineering for Engineering Schools and Colleges.
- 2 Textbooks giving training in the fundamentals of Radio Electronics, and Electricity to prepare technicians in any branch of these industries.
- 3 Manuals and handbooks for students, technicians or teachers of Radio or Electronics.
- 4 General works treating new developments in all branches of Electricity.



ZIFF-DAVIS PUBLISHING COMPANY • Chicago • New York

PLEASE SEND MANUSCRIPTS TO: 270 MADISON AVENUE, NEW YORK 16, N. Y.

# Crystals

FOR THE CRITICAL

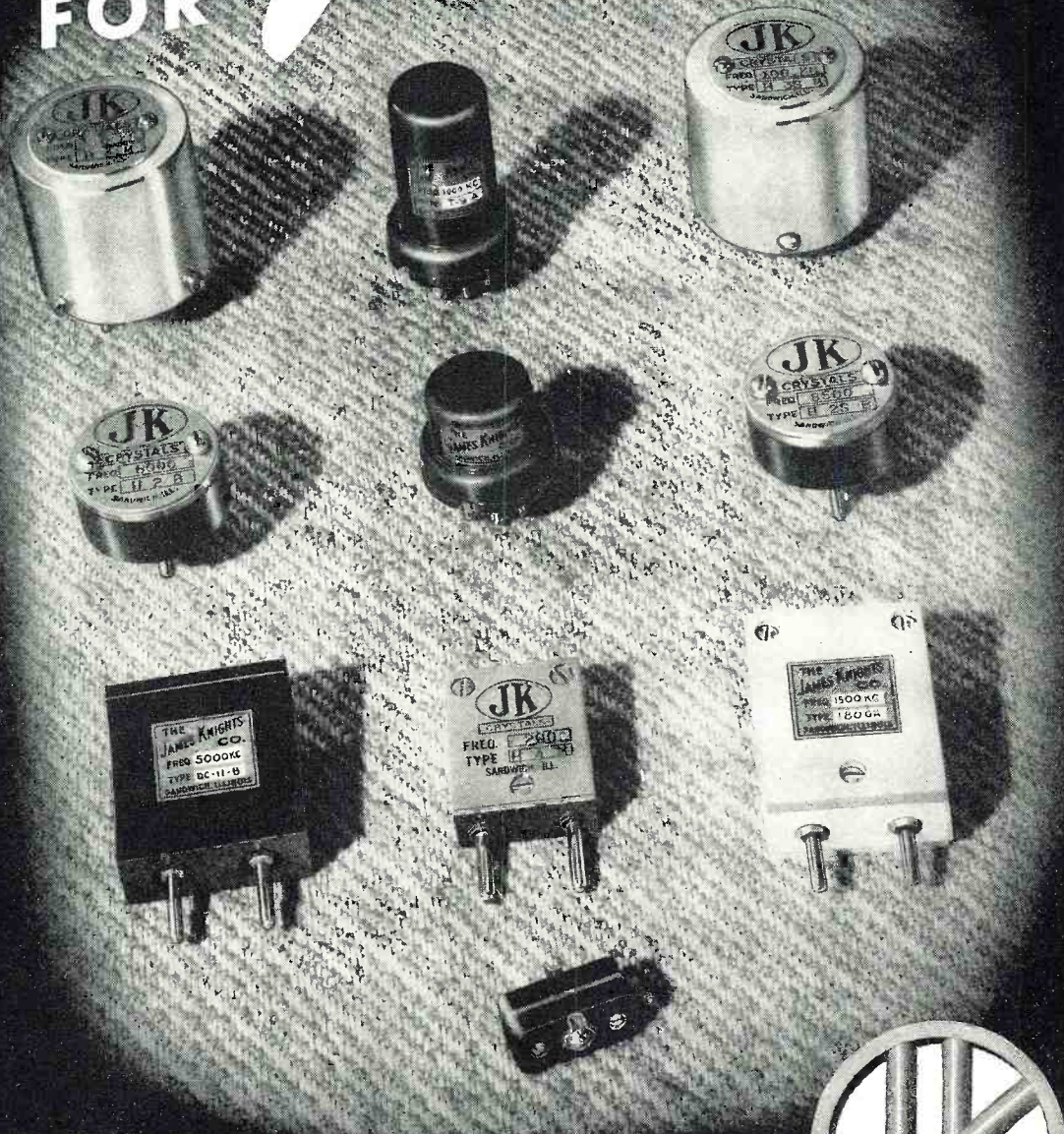

The **JAMES KNIGHTS** Co.  
SANDWICH, ILLINOIS



# RECENT WILEY BOOKS IN COMMUNICATIONS—ELECTRONICS

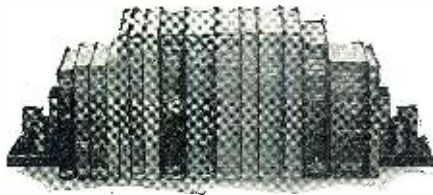

Post-war plans in your field are being made now. This, then, is the time, to step up your knowledge. Be ready for new duties. Look over the important titles listed below. Make your selection and order from the coupon today.

## HOW TO PASS RADIO LICENSE EXAMINATIONS—Second Edition

By Charles E. Drew

320 Pages \$3.00

Newly revised and brought up to date, this well-known book, in question-and-answer form, offers much helpful material to amateur radio operators, radiotelephone and telegraph operators, whether interested in broadcasting, marine, aeronautical, or any other field of radio transmission and reception.

\* \* \*

## RADIO RECEIVER DESIGN—Part I

By K. R. Sturley

435 Pages \$4.50

Communications engineers will want to own this book, which covers radio frequency amplification and detection. A detailed study, stage by stage, beginning with the aerial and going as far as the detector.

\* \* \*

## TIME BASES—In Scanning Generators

By O. S. Puckle

204 Pages \$2.75

Covers the subject from both the design and the development points of view; assembles more time bases circuits than have heretofore been available in one volume.

\* \* \*

## THE TECHNIQUE OF RADIO DESIGN

By E. E. Zepler

312 Pages \$3.50

Deals with the day-to-day problems of the radio engineer, both in the development and in the testing of radio receiving apparatus of all types. Thoroughly practical.

\* \* \*

## FUNDAMENTALS OF VIBRATION STUDY

By R. G. Manley

128 Pages \$2.75

For the engineer and designer, an introduction, logically developed, to basic vibration theory. Does not require previous knowledge of advanced mathematics.

\* \* \*

## COMMUNICATION CIRCUITS—Second Edition

By Laurence A. Ware and Henry R. Reed

330 Pages \$3.50

An expansion of an eminently successful book to include new material on physical aspects of wave guide transmission, impedance matching, solution of circuits, and the theory of rectangular and cylindrical wave guides.

## HYPER AND ULTRA-HIGH FREQUENCY ENGINEERING

By Robert I. Sarbacher and William A. Edson

644 Pages \$5.50

A practical treatment of an important new branch of communications engineering, requiring no special advanced knowledge. Of value to the beginner, as well as those having some familiarity with the subject.

\* \* \*

## GUIDE TO CATHODE RAY PATTERNS

By Merwyn Bly

30 Pages \$1.50

Important for technicians and laboratory workers. This book summarizes briefly by means of sketches and captions the cathode-ray pattern types encountered in the usual course of laboratory and test bench work.

\* \* \*

## FUNDAMENTAL RADIO EXPERIMENTS

By Robert C. Higgy

96 Pages \$1.50

Thirty-two basic experiments in electricity, electronics and radio, with a full explanation of the principles involved as well as laboratory procedure.

\* \* \*

## BASIC ELECTRICITY FOR COMMUNICATIONS

By William H. Timbie

603 Pages \$3.50

A simple, clear presentation of the fundamentals of electricity and their application in the problems of communications and radio. The first twelve chapters illustrate the principles by simple application to communications appliances. The remainder of the book covers the appliances and their operation.

\* \* \*

## ENGINEERS' DICTIONARY Spanish-English and English-Spanish

Compiled by Louis A. Robb

423 Pages Flexible Binding \$6.00

A practical, up-to-the-minute dictionary of engineering and construction terms, expressly prepared for Pan-American use. Uses the Spanish of Central and South America.

### —ON APPROVAL COUPON—

JOHN WILEY & SONS, INC.

440 Fourth Avenue, New York 16, N. Y.

Please send me on ten days' approval the books I have checked in this advertisement (or I am attaching to this coupon a separate list of the books desired). At the end of that time, if I decide to keep the books, I will remit indicated price plus postage; otherwise I will return the books postpaid.

Name.....

Address.....

City and State.....

Employed By.....RN-4-44

gressive concentration of radiation on the axis as the frequency is increased. This confirms our practical experience, namely, that a listener on the axis of the speaker observes the maximum high-frequency response, and that the high-frequency response drops off as the listening position is shifted away from the axis. There is no such effect at low frequencies as indicated by the circular non-directional pattern in the illustration. Directional characteristics are nearly always taken out of doors or under free field conditions to eliminate the interfering effects of reflections. For speakers intended for outdoor use, a group of response curves taken at various angles to the axis will indicate the relative response at different positions in the audience. Outdoor data of this type cannot be used to predict indoor performance at different listening positions because in small rooms reflected sound and normal modes introduce wide fluctuations in response from position to position, even at the same azimuth angle of the speaker. At moderate distances from the speaker, the total sound energy from all directions (in a fairly large listening room) arriving at the reference position is likely to be many times that of direct sound from the loud speaker.

Further consideration of the influence of directivity leads to two important conclusions: (1), that significant measurements representative of performance in live rooms require a determination of the *total-radiation-frequency* characteristic (as contrasted with the simple axial pressure response-frequency characteristic); (2), a *flat* axial response frequency characteristic in a conventional direct radiator speaker means that the total radiation is *falling off at the high frequency end* because of the limited angle throughout which sound is radiated due to directivity. The converse is also true—a constant total radiation frequency characteristic demands that the axial pressure rise as the frequency increases; the more directional the speaker, the greater the required axial pressure rise at high frequencies to maintain constant total radiation.

The second point above is illustrated by the computed curves in Fig. 4 in which the loud speaker has been assumed to be a rigid piston of equivalent size. It will be seen that for constant axial pressure, the total radiation of a 12-inch speaker falls off approximately 18 db at 5,000 cycles. If constant radiation is desired, the axial pressure must rise 18 db over the low frequency value at 5,000 cycles. With smaller speakers the effect is less because they are not as directional at high frequencies. However, the effect of directivity is still pronounced even for 5-inch speakers. In an actual speaker, the concentration of radiation is somewhat less than that indicated due to cone flexing. It should be mentioned here that while the principle of a rising axial response to maintain total radiation at the

*McElroy... and nobody else*

Whenever you see the McElroy name on a piece of equipment... that's McElroy and nobody else. We never imitate... never copy. We create... design... build... and deliver. One of our most notable achievements is the *new XTR-442 BM Automatic Transmitter*—an essential where transmission must be regulated to a given number of words per minute. The new XTR-442 BM comprises two units.



**Keying Unit** which consists of the McElroy keying head coupled to a newly designed drive. The speed of the keying head is instantly adjustable at any rate from 10 to 200 words per minute. At any given setting, the rate cannot vary because of the constant speed motor.



**Electronic Unit** which responds to the keying head to produce either tone for keying a radiotelegraph transmitter, or to key a transmitter with a heavy-duty pivottless relay. The tone can be impressed on a radiofrequency carrier current, sent to a remote transmitting station, filtered and used to operate a transmitter without requiring relay action. The heavy-duty relay in this unit may also be used to break the actuating current to a relay in a radiotelegraph transmitter.

BLOOD IS AMMUNITION , . . GIVE A PINT TO THE RED CROSS TODAY

IF YOU HAVE A PROBLEM IN RADIO TELEGRAPHY OR AN APPLICATION INCORPORATING PRESENT OR FUTURE ELECTRONIC DESIGN, WE WOULD LIKE TO WORK WITH YOU

**McElroy**



**MANUFACTURING CORP.**  
82 BROOKLINE AVE. BOSTON, MASS.

WORLD'S LARGEST MANUFACTURER OF AUTOMATIC RADIO TELEGRAPH APPARATUS

# RED HOT VALUES in RADIO PARTS!



## Combination Table Cabinet

Modern table type phono cabinet; highly finished walnut. Dimensions: 14" front to back, 16" side to side, 5½" bottom of table panel to top, height over all, 13". In original cartons—while they last ..... **\$7.95**



## AUTO SET SPECIALS To Boost Your SPRING SALES!

We have a limited quantity of nationally known makes of auto radios available now. Latest models . . . all brand new and in original cartons. Write for description and price list.



**67½ V. B. BATTERY**  
4" L. x 1¼" D. x 2½"  
W. to replace Min-  
Max of same size.  
**\$1.85 each**



**71½ V. C. BATTERY**  
4" W. x 2¾" H. x ¾"  
D.



39c each  
10 for **\$3.50**

**2 CELL 1½" V. A.  
BATTERY**

Heavy Duty  
3¾" H. x 1" D. x  
1¾" W.  
**35c each. 10 for \$3.00**



### THE YEAR'S BIGGEST OFFER!

A 10-pound assortment of various usable radio parts. Every serviceman should have one of these kits. Only..... **\$2.95**

**FREE:** Servicemen write today for free catalog listing thousands of replacement parts.

**10% Minimum Deposit Required with Order**

## RANDOLPH RADIO

609 WEST RANDOLPH ST., CHICAGO 6, ILL.

"Millions of Parts for Millions of Radios"

higher frequencies has been applied to improved single-unit direct radiator speakers in recent years, the highest performance specifications for wide-range reproducing systems have thus far been met only with reproducer designs in which the low and high frequency ranges are divided and separately reproduced by units designed for best performance in their respective ranges. The best practice involves the use of diaphragm-type driver units working into subdivided cellular or other special horns for wide-angle radiation at the higher frequencies.

(To be concluded in the next issue)

### Book Review

(Continued from page 44)

been added. This is the alternative field which amateur experimenters have found most interesting and fruitful under wartime restrictions on normal radio communication.

Several chapters dealing with apparatus designs of various kinds have been organized with especial regard for the reader's convenience. The classified vacuum-tube data tables have been revised to include some fifty new tubes on which data was released during the year, and a supplementary cross-index by type numbers has been added to facilitate locating tubes whose classifications are not known.

The book contains numerous illustrations, which are serially numbered, and an extensive index for easy reference for the reader.

**"ROGER WILCO" A B C OF RADIO FOR FLYERS,** by Lieut. Adras P. LaBorde, A. C. Published by *Military Service Publishing Co.*, Harrisburg, Pennsylvania. 124 pages. Price \$2.00.

This book covers the basic radio procedure for pilots and other airmen, and for students, that will enable them not only to absorb the fundamentals of the use of wireless itself, but equip them with the knowledge and knack requisite to the most efficient employment of their plane radio equipment.

The idea of the author was to talk in type. Otherwise, to get across what he had to teach, as an instructor, in just about the language and style that he uses in his classroom. Straight out from the shoulder, idiomatic, free-and-easy, without any involved expression that many technical writers are prone to employ when they take pen in hand. He has included the vernacular with the necessary information, which makes this book simple for all students to understand.

Within the covers of the book are the symbols of the International Morse Code and many other commonly used operating signals, as an easy reference for the reader. The book itself includes such subjects as an explanation of the pilot's radio equipment, using the radiotelephone and radiotelegraph, radio air-traffic control, radio

in emergencies and air navigation, practical radio navigation problems, and message by radio. The Appendix gives frequencies; repeats the commonly used operating signals, which are printed on the cover; phraseology for expressing numbers; position report and radio flight plan, correct sequence; emergency signals and U. S. broadcast stations, 50,000 watts.

**"PRACTICAL RADIO AND ELECTRONICS COURSE FOR HOME-STUDY,"** prepared under the direction of M. N. Beitman. Published by *Supreme Publications*, Chicago, Illinois. Three volumes, totaling 367 pages. Price for complete set \$3.95.

This set of books deals with every phase of radio and electronics. Among the 53 lessons is material on television, U.H.F., facsimile, ignitron, X-rays, FM, radio servicing, welding, radio transmitters, and every other topic related to electronics.

The books are intended for home-study. The material is arranged in two columns. The wider column contains the text material, while the narrower column contains special comments to explain the difficult parts, offer suggestions, give references, and in general take the place of a teacher.

Volume One includes material on the fundamentals of radio and electronics; Volume Two covers receivers, transmitters, and test equipment; and Volume Three covers applied electronics and radio servicing. The material is well illustrated and is clearly written. It is stated that when the course has been completed, the student will be ready to accept work as a radio and electronic equipment serviceman, laboratory assistant, factory inspector, or any other similar position.

-30-

### You'll Never See An Atom

(Continued from page 53)

conceptions that have recently had such far-reaching implications in the progress of scientific thought. It is still difficult for many of us to conceive the presence of field strengths when we have no mechanism for observing them. How rarely are we conscious of living in the presence of innumerable radio frequency fields!

Perhaps the most important contribution of Albert Einstein has been to release us from psycho-illogical blocks to our thought processes. The relativistic viewpoint connotes an entirely new mental attitude, and one which our children will find easier to accept than we because they do not "know any better." It is a common proverbial expression that states, "He accomplished this because he didn't 'know' that it was impossible." In a field of such active growth as the electron arts, it is important to maintain a flexible mental attitude with regard to the things we "know."

In many instances phenomena may be explainable by several theoretical structures. Increased accuracy of ob-

*Here's Proof  
Majestic will give people what they want!*



**MAJESTIC  
RADIO NEWS**  
with Standings of the Stars

**Fibber McGee Tops  
How the Stars Rate  
FM — Postwar Reality**

*Ratings*

Fibber McGee is currently the nation's first choice in radio programs. Hooperatings, the "face" form the basis of these semi-monthly ratings.

A comprehensive analysis of radio listening habits is made on a continuous schedule. In 34 cities from coast to coast, Hooper investigators make 2500 telephone calls per hour from 8:00 AM to 10:30 PM. This huge listening sample reveals what America listens to and gives a clear indication of the relative popularity of various radio shows. Principal listings will be those of the 15 most popular night-time shows, but periodically ratings of daytime shows will also be published.

Majestic Radio News No. 1  
January 30, 1944

**THE STANDINGS  
OF THE STARS**  
National Program Ratings of your  
15 Best-Liked Shows from  
Hooper Radio Reports

PROGRAM	When	How	1st	2nd
Fibber McGee & Molly	Tue.		1	2
Bob Hope	Tue.		2	1
Charlie McCarthy	Sun.		3	3
Jack Benny	Sun.		4	4
Aldrich Family	Thur.		5	4
Joan Davis & Jack Haley	Thur.		6	5
Abbott & Costello	Thur.		7	11
Mr. District Attorney	Wed.		8	10
Frank Morgan & Fanny Brice	Thur.		9	9
Walter Winchell	Sun.		10	14
Bing Crosby Music Hall	Thur.		11	7
Kay Kyser	Wed.		12	15
Take It or Leave It	Sun.		13	13
Fred Allen	Sun.		14	19
Your Hit Parade	Sat.		15	16

Note: Red Skelton leads all programs broadcast after 10:30 PM E.W.T. Ratings are based on 2500 telephone calls per hour made from 8 PM to 10:30 PM in 34 cities. Thus, several leading programs heard after 10:30 E.W.T. are not rated.

**FM — Radio's Next Step**

Practically every radio manufacturer is planning now to make FM available in most postwar models. The clarity of signal, greatly improved fidelity, reduced noise and greater realism in tone seems sure to make FM more popular, more

pleasing to hear. To give the vast majority of listeners the same type of program service they now enjoy, new FM broadcasting equipment will have to be installed, new techniques will have to be worked out to make FM available on a country-wide basis. FM requires a different type of network hookup than the present



# Majestic's 1944 Advertising Features Majestic Radio News

(THE STANDINGS OF THE STARS)

**All the Evidence is Clear** as to the kind of operation Majestic will set up for building and selling radios.

**The Controlled Distribution Plan** assures dealers of the kind of selling practices that the radio business has needed for a long time.

**The Controlled Production Plan** makes it clear that before a radio is started down the production line, there is definite knowledge that it can be sold, and sold quickly, at a profit to you and to us.

**And now Majestic's Opening Gun in Advertising** is further proof that Majestic is direct, and has its feet on the ground. It's further proof that Majestic is ready, willing and able to assume its place among the leaders in the radio business.

**ON RADIO PAGES!**

Majestic believes the best time to talk radio is when the consumer is thinking of radio. So the Majestic Radio News appears on the radio pages of leading newspapers . . . one of the best read pages of any newspaper . . . any day!

**MERCHANDISING POWER!**

There's tangible usable power in the Majestic Radio News—vast potential merchandising power adequate to stimulate interest in your store . . . powerful enough to establish any Majestic outlet as official radio headquarters!

**NO GUFF! NO FLUFF!**

This is all about radio . . . the standings of the stars, news of favorite pro-

grams, news of radio interest, news about Majestic. No big talk on vague subjects, no boasting, no hard-to-keep promises!

**EXCLUSIVE!**

Majestic has been given the exclusive right by C. E. Hooper, Inc., to publish the Top Hooperatings in consumer publications. The Hooper Radio Reports on which the standings are based are the nation's most widely used radio survey statistics and are generally recognized as the official index of radio program "box office."

**TWICE A MONTH!**

The Official Hooperatings are tabulated at the middle and end of each month. Majestic gets and publishes the figures immediately.

**Majestic Means Business . . .  
and lots of it!**



MIGHTY MONARCH OF THE AIR

MAJESTIC RADIO & TELEVISION CORPORATION  
2600 West 50th Street • Chicago 32, Illinois

100,000,000 radio fans listen, talk, think and argue about radio! And Majestic will talk to your future customers about radio in terms they understand.

# VICTORY...in the Making

Here, at Doolittle, we are coordinating every effort and skill to help provide the communications equipment so essential for Victory. This will mean better peace-time communications after our battles are won.



To Assure Victory  
Buy More U. S. War  
Bonds and Stamps

*Doolittle*  
**RADIO, INC.**  
*Builders of Precision Radio Communications Equipment*  
7421 S. Loomis Blvd., Chicago, U. S. A.

servation often requires adjustment of old theories, and even, in many cases, complete rejection of previous beliefs and the development of a new perspective. We are safe if we use theories as we understand them to apply at a particular date—we are in grave danger if we erect mental barriers by accepting *any* theory as absolute and final. Theory, and even apparent operational proof, should always be accompanied by a mental footnote, "Subject to change without notice."

The conceptions of omnipresent field strengths are relatively easy as compared with the thinking process necessary for sub-microscopic understanding. Here we are dealing with entities which may not exist at all in the same terms as the "realities" ordinarily observed by our nervous systems. An electron cannot be properly visualized, and probably no amount of magnification with any type of visual aid would permit our eyes to see an atom. Most graphic representations of atomic structure lead us to think of electrons and other basic units as corresponding to tiny billiard balls with definite boundaries. This is a mistaken conception likely to lead us into all sorts of fallacious reasonings.

It is all right for us to use these graphic models so long as we remember that they are strictly symbolic in the same sense as numbers or words, and are in no way a "photographic" literal presentation.

Contemporary beliefs concerning the characteristics of atomic structures are conceived on as firm a foundation of theoretical and empiric knowledge as any statement in physics. An atom may be considered as a charge structure in which a complex pattern of electrical relationships is undergoing continuous re-orientation with enormous rapidity. It is worthwhile to contemplate some of the motions that are believed to be going on simultaneously in an atomic structure:

1. The electrons and the nucleus are moving around a common electrical center.
2. The electrons and the nucleus are spinning on their own axis.
3. The electrons are moving from inner to outer shells and back again.

When it is borne in mind that the velocities involved are of the order of 5,000 miles per second and greater, it is evident that no static sketch can be an adequate literal representation. If it is deemed necessary to attempt a literal visual translation of atomic structures, a Walt Disney motion picture would probably be the only satisfactory medium.

The electron may be thought of as a point charge existing in time and space and traveling with high velocity. A safer conception, less likely to result in "billiard ball" visualization, is to think of an electron as a field distributed with spherical symmetry in space and time, traveling continuously with high velocity, the density of the field bearing an inverse exponential ratio to the distance from the center

## Remember THE ISOSO-LOOP?



This was the highest "Q" loop known. It went into vast numbers of pre-war receivers. For the present, all of our efforts are devoted to making DX Xtals but when Peace comes, we hope to be, once again, the World's Largest Loop-Aerial Manufacturers.

*May we help you with your post war plans?*

**DX CRYSTAL CO.**  
GENERAL OFFICES: 1841 W. CARROLL AVE., CHICAGO, ILL., U.S.A.

**DX**  
**XTALS**  
the heart of a good transmitter



# Dependable Power..

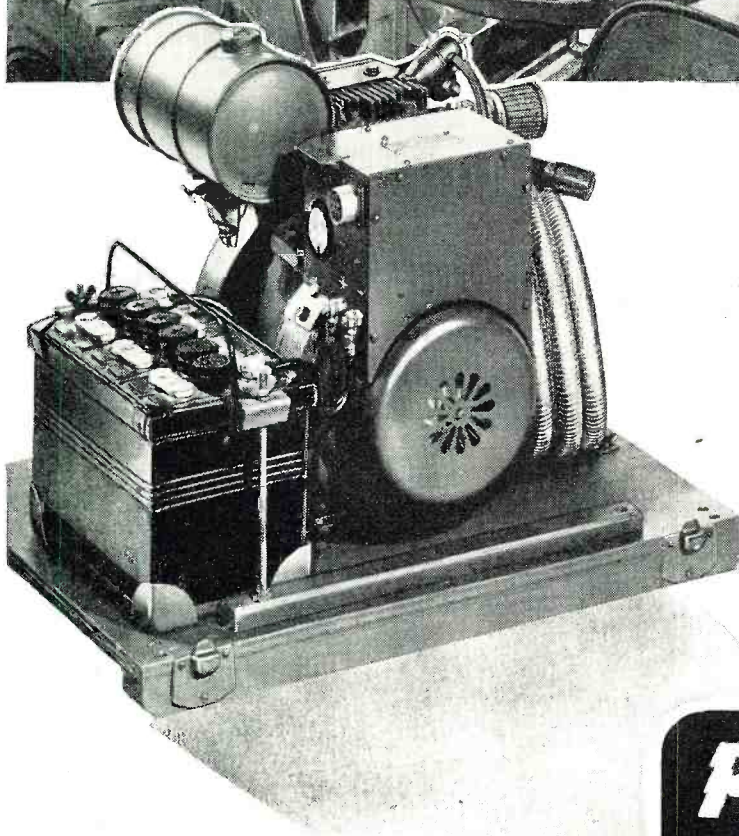

PIONEER GEN-E-MOTOR • 5841 West Dickens Avenue  
Chicago 39, Ill. • Export Address: 25 Warren St., New York 7, U.S.A.

Probably the most important single factor in modern warfare is complete, dependable communications. Dependable communications require a dependable power supply. Pincor is proud of its part in furnishing portable gasoline-driven and other electrical power supply units to the fighting front as well as to the home front.

Look to Pincor for your post war needs in power plants, motors, converters and battery chargers.

DYNAMOTORS • CONVERTERS  
GENERATORS • D C MOTORS • POWER PLANTS  
GEN-E-MOTORS



Cable Address: SIMON-  
TRICE • NEW YORK

BUY WAR BONDS

(point charge). An electron, then, has a specific center but no definite boundary. Its radius is theoretically infinite and can be defined only in terms of distances from other entities.

To further complicate our present thinking, we are forced to regard our fundamental structures on the basis of different theories to explain various behaviors. Wave mechanics and classical mechanics are applicable to various sets of data with respect to particles; wave optics and ray optics express overlapping explanations of the characteristics of light. Electro-magnetic theory appears to extend upward through and beyond the frequency spectrum of visible light phenomena. Mass and energy are demonstrably interchangeable, and matter may be

considered as a dense grouping of the centers of fields.

A particle may be thought of as an area of space in which at a particular time a group of waves, oscillating with random symmetry, coincide in phase relationships so as to reinforce each other and produce sufficient density to be characterized as substance. Currently applied equations express probabilities with respect to the "immediate future" existence of aggregations of particle (wave group) fields in time and space relationships—not an assumed repetitive oscillation of specific "billiard ball" identities.

When we discuss the problems of thinking on macroscopic, microscopic and sub-microscopic levels, it is important not to consider the necessary

mental readjustments as being purely concerned with relative *size* dimensions. Extreme differences in *size* levels, combined with wide variations in the order of common velocities, imply such totally different structure laws as to make simple direct comparisons impossible. An atom enlarged to the macroscopic level would no longer *be* an atom and it would function in an entirely new way. It becomes evident that sub-microscopic structures cannot be visualized or literally modeled on the macroscopic level.

It is a healthy mental process to attempt an understanding of these things because it exercises our faculties in adapting new perspectives and tolerant viewpoints. On the other hand, if we form the habit of confusing symbolic sketches with actual atomic structures, we achieve a state of helpless insanity akin to the unfortunate man who tries to build a radio receiver out of parts designed to correspond physically with the symbols in schematic diagrams. If a student insisted on visualizing the earth today in terms of a flat map, we would deplore his insanity. The parallel is obvious.

We are living on the threshold of an era during which the primary mysteries of sub-microscopic structures may be explained. Furthermore, the discoveries of individual workers are disseminated more rapidly to a broader group of professional scientists than ever before. It is of utmost importance that the total thinking of the human race be guided into channels of clear conceptions, and that the psychological "blocks" to understanding be eliminated. Consider the difficulties of thought we have encountered because of the original assumption regarding the direction of current flow and the resultant term, "positive" and "negative."

—30—

**Mrs. Lit.**

(Continued from page 70)

the No. 840, No. 841, No. 851, No. 850, No. 852 and No. 814-078.

A free copy may be obtained by writing to *Centralab*, Division of *Globe-Union Inc.*, 900 East Keefe Avenue, Milwaukee, Wisconsin.

#### IGNITRON MERCURY-ARC RECTIFIERS

Ignitron mercury-arc rectifiers for 501-kw and higher ratings, 250 to 900 volts, are featured in an attractive, new 36-page bulletin recently issued by the *General Electric Company*.

Fully illustrated, the publication lists the many advantages of these rectifiers for converting alternating current to direct current in mines, railways, steel mills, electro-chemical, and other industrial plants where d.c. is required for general use. In addition, some of these advantages—easy installation, quick starting, quiet op-

## "THE HELP SITUATION" by Larlar



Tired of competing with war industries for the services of experienced radio men? Tired of training help and then losing them to war plants that can afford to outbid you?

Here is help you can afford; help that is trained, help that can be depended upon to stick with you and work as long and as hard as you.

**RIDER MANUALS** reduce to a minimum, the time required to trace troubles in faulty receivers. **RIDER BOOKS** tell how to speed servicing work by means of modern, short-cut techniques. In making it possible for fewer men to produce more work they are contributing to the solution of the "help" problem for servicemen all over the world.

When you need help, competent, dependable help, remember **Rider Manuals** and **Rider Books**. They can provide the extra help you need; The Extra Hand you must have if you are to meet your patriotic duty to "keep 'em playing."

## HERE'S HELP YOU CAN AFFORD

#### RIDER MANUALS (13 VOLUMES)

Volumes XIII to VII.....\$11.00 each volume  
 Volumes VI to III..... 8.25 each volume  
 Abridged Manuals I to V [1 volume]...\$12.50  
 Automatic Record Changers and Recorders 6.00

#### OTHER RIDER BOOKS YOU NEED

The Cathode Ray Tube at Work  
 Accepted authority on subject..... \$3.00  
 Frequency Modulation  
 Gives principles of FM radio..... 1.50  
 Servicing by Signal Tracing  
 Basic Method of radio servicing..... 3.00  
 The Meter at Work  
 An elementary text on meters..... 1.50  
 The Oscillator at Work  
 How to use, test and repair..... 2.00  
 Vacuum Tube Voltmeters  
 Both theory and practice..... 2.00  
 Automatic Frequency Control Systems  
 — also automatic tuning systems..... 1.25  
 A-C Calculation Charts  
 Two to five times as fast as slide rule..... 7.50  
 Hour-A-Day-with-Rider Series—  
 On "Alternating Currents in Radio Receivers"—  
 On "Resonance & Alignment"—  
 On "Automatic Volume Control"—  
 On "D-C Voltage Distribution"—..... 90c each

#### JOHN F. RIDER PUBLISHER, INC.

404 Fourth Avenue, New York 16, N. Y.  
 Export Division: Rocke-International Electric Corp.  
 13 E. 40th Street, New York City      Cable: ARLAB

# RIDER MANUALS

GIVE YOU THE HELP YOU NEED!



# RADIO-ELECTRONICS

## HOME-STUDY COURSE

IN **3** BIG MANUALS

8½ x 11 in.  
**50 LARGE LESSONS**  
*New 1944 Edition*



M. N. Beitman, teacher and author of many books, directed this preparation. Instructions to help you study at home included in the narrow column on each page.



**ONLY \$3.95**  
**COMPLETE 3 VOLUMES**  
**50 Lessons**

### NEW AMAZING OFFER

New Radio-Electronic Course of 50 large, fact-packed lessons; covers every topic of radio and modern electronics; bound in **three** big manuals and sold **complete** at the unbelievable bargain price of only \$3.95, nothing else to pay. Now is your chance to take advantage of this amazing money-saving offer. Let this home-study course guide you quickly to an essential high-pay job in a radio plant, or in electronic War industry, or help you open your own radio service shop, or aid you in getting higher rank in the Army. Learn radio and electronics to earn more money now; prepare for the coming after-the-war opportunities in Electronics.

### THREE COURSES IN ONE

You will find this complete training of 50 large lessons is really **three** distinct courses covering (1) *Practical Radio*, (2) *Applied Electronics*, and (3) *Radio Servicing*. The lessons are clear, practical, interesting, easy to master and use. No special education or previous experience is needed. Notice in the illustration of the manuals, at the left, how the helpful explanations and remarks in the narrow column on each page serve as the teacher. These comments guide you over the hard parts, stress the more important points, show you how to perform many educational experiments using any home-radio. There are hundreds of review self-testing questions, 427 drawings, pictures, diagrams, and service hints. These newly prepared lessons will teach you all about basic radio, transmitters, test equipment, radio servicing, and every topic of Electronics — photo-cells, X-ray, metal locators, airplane beacons, FM, recording, facsimile, welding controls, television, etc.

### GREATEST BARGAIN IN RADIO-ELECTRONIC TRAINING

Get a complete course of training in practical radio and electronics for less than the cost of a single book. The fifty large lessons, making up the complete course in 3 volumes, are simple to follow, easy to master and apply. Many drawings, examples, diagrams, and instructor's suggestions (in the side column, on each page) help you move along quickly and find learning interesting fun. Review questions at the end of each lesson permit you to check your progress. You enjoy learning important radio and electronic facts. In a surprisingly short time, you are ready to do highly skilled radio repairing, building of electronic equipment, or hundreds of other War-winning tasks in the growing Electronic and Radio industries.

### MANY LESSONS ON RADIO REPAIRING

Volume 3, of the course, includes lessons, service hints, case histories, and troubleshooting charts which will show you how to repair all radio sets quickly and easily. This material alone is worth many times the low price of \$3.95 for the complete 3-Volume course. Send *no-risk* order coupon today. Look over and use these lessons for 10 days without obligation. You have everything to gain—and nothing to lose.

### These Lessons Will Tell You All About

- Meters, Power Supplies
- Circuits, Microphones
- Test Equipment, FM, Tubes
- Oscillators, Amplifiers
- Photo-cells, Circuits, X-ray
- Facsimile, Television
- Recording, Superhets
- Alignment, Motor Control
- Radio Servicing, Gages
- Electronics in Industry
- Radio Circuits, Hints
- Testing Radio Parts
- Transmitters, Operating
- Detectors, Metal Locators
- Welding Controls, Beacons
- High-frequency Heating
- Frequency Standards, P.A.
- Analyzers, Tube Testers
- and hundreds of other topics

### LESSONS ON ALL PHASES OF ELECTRONICS AND RADIO

Let this authoritative, easy-to-understand, practical course pave your way into Electronics—the money-making field of the future. Prepare now. Use this training in your spare time to get ahead in a good War-job. Be ready to grab the opportunities in post-war Electronic developments. Let these lessons train you, serve as your teacher and guide, and give you the needed practical time-saving hints on the job. All topics completely indexed—all subjects easy to find.

### LIMITED QUANTITY

All three volumes of the *Practical Radio and Electronics Course* have just been printed. Although a large quantity of courses is on hand now, our bargain price will create a tremendous demand. Government (WPB Order L-243) paper limitation policies may prevent reprinting. Better order immediately for examination—no obligation to buy.

**SEND TRIAL COUPON TODAY**

### BE A RADIO-ELECTRONIC EXPERT

Train quickly, in your spare time and in your own home, for a well-paying interesting job in the expanding two-billion dollar radio-electronic industry. You begin with elementary principles and quickly progress to practical explanations of radio building, servicing, and all branches of Electronics. In these well written 50 lessons, experts from every field of Electronics tell you important facts and knowledge which they gained during years of practical experience. These easy-to-follow, well illustrated lessons will give you the useful "know-how" needed to obtain and get ahead on the job. Send "no-risk" coupon today and examine all three volumes in your own home, without obligation.

### POST-WAR OPPORTUNITIES IN ELECTRONICS

Electronic applications, devices, and accomplishments, not even imagined a few years ago, are now helping us win the War. Improved and unique new civilian uses of electronics and radio will result immediately after the War. The peace-time advancement in the radio-electronic industry will compare with the rise of the auto industry after the last war. Plan and prepare to be in the midst of this money-making opportunity. Let this lowest priced, home-study course give you the needed training.

### SENT ON TRIAL FOR 10 DAYS

Take advantage of our no-risk examination offer. Send trial order coupon. You will receive the complete **3-Volume Course** for 10 days' use. Begin your radio-electronic study without cost or obligation. If you are pleased, the complete course of 50 lessons, in three large manuals, is yours to keep for only \$3.95, full price, otherwise it costs you nothing for the examination. No risk on your part.

### Money-Back Guarantee

You must be entirely satisfied or your money will be immediately refunded. You are permitted to make full use of the course for 10 days, on a trial basis. *Supreme Publications.*

### NO RISK TRIAL ORDER COUPON

### SUPREME PUBLICATIONS

328 S. Jefferson St. Chicago 6, Illinois

Ship the complete 3-Volume **Practical Radio and Electronics Course** for 10 days' examination. I must be satisfied or you will refund my money in full.

- I am enclosing \$3.95, full price, send postpaid.
- Send C. O. D. I am enclosing \$..... deposit.

Name: .....

Address: .....

City: ..... State: .....

# Supreme Publications

PUBLISHERS OF RADIO BOOKS, MANUALS, AND DIAGRAMS

328 South Jefferson Street

Chicago, Illinois



**"HERMETIC SEALING"**  
Sprang from the ideas of Hermes,  
fabled Greek author of books  
devoted to Astrology and Alchemy

Drawn from  
the Statue  
of Hermes  
by Praxiteles.

**THE LATEST IDEA in true Hermetic Sealing is a Thordarson Development**  
**" TRANSFORMER TERMINALS IN GLASS "**



The above types are suitable for use anywhere  
in the world, regardless of climatic conditions.



**THORDARSON**

TRANSFORMER DIVISION  
THORDARSON ELECTRIC MFG. CO.  
500 WEST HURON STREET, CHICAGO, ILL.

*Transformer Specialists Since 1895*  
**ORIGINATORS OF TRU-FIDELITY AMPLIFIERS**

eration, and low operating and maintenance costs—are described in considerable detail.

The major portion of the publication is devoted to an interesting description of the design and mechanical construction of these rectifiers, their operation, and the successive steps involved in their manufacture and assembly. A number of schematic diagrams effectively illustrate this part of the publication.

Copies of this bulletin may be obtained by writing directly to the *General Electric Company*, Schenectady, New York, and asking for Bulletin GEA-3706.

**TRANSFORMERS**

New 36-page illustrated catalog describes various types and sizes of stock transformers manufactured by *Standard Transformer Corp.*, together with complete and detailed specifications.

This is a complete catalog which lists not only transformers for most electronic applications but many stock converters as well for the conversion of a.c. to d.c. Valuable charts are provided to quickly identify the correct units to be used in various applications. Sent free upon request to the *Standard Transformer Corp.*, 1500 N. Halsted Street, Chicago, Ill. Ask for catalog 140-F.

**FLUORESCENT ACCESSORIES CATALOG**

A new 16-page catalog on all *General Electric* fluorescent accessories, with full data on the new *G-E* Watch Dog (Registered U. S. Pat. Off.) starters, has been published by the Appliance and Merchandise Department and is available upon request to the *General Electric Company*, Bridgeport 2, Conn.

The booklet points out that "proper functioning of a fluorescent lamp depends largely on three auxiliary devices—the lampholder, the starter and the ballast," and then goes on to supply technical information regarding fluorescent lamps, ballasts and starters in order to emphasize the extreme importance of fluorescent accessories in supplying quality lighting.

Four pages of the catalog are devoted to the operation of the Watch Dog starter. The precision starting of lamps by Watch Dogs and their ability to end the blinking of a "dead" lamp are explained. In addition to calibration adjustment, dead lamp lookout and lamp lighting tests are illustrated and described. The advantage of Watch Dog starters for war plants are listed and illustrated with diagrams.

A detailed description is given in the catalog on how the starters, starter sockets and lampholders operate, why they are necessary and how they contribute to fluorescent lighting. Tests made of the starters are described in detail regarding starting, performance and timing. Diagrams giving mounting dimensions of *G-E* fluorescent lampholders are shown.

-30-

**RUGGED**

Accuracy and dependability are built into every Bliley Crystal Unit. Specify **BLILEY** for assured performance.

**BLILEY ELECTRIC COMPANY**  
ERIE, PENNSYLVANIA

*Bliley Crystals*

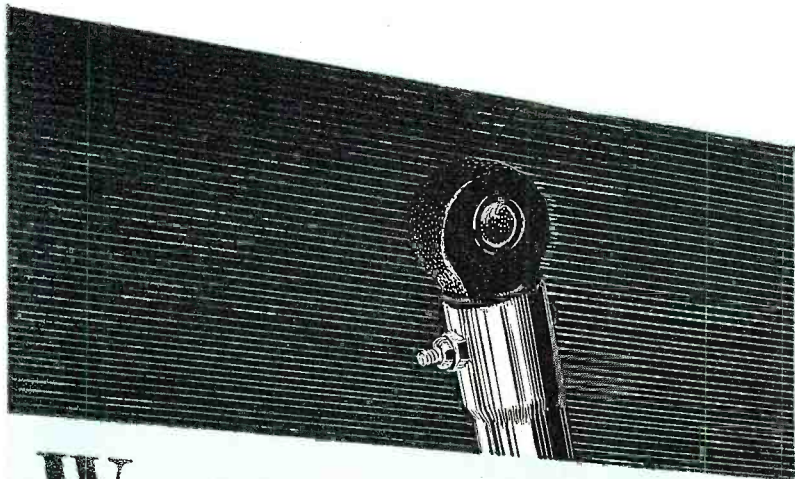

# Want to move 35 Tons?

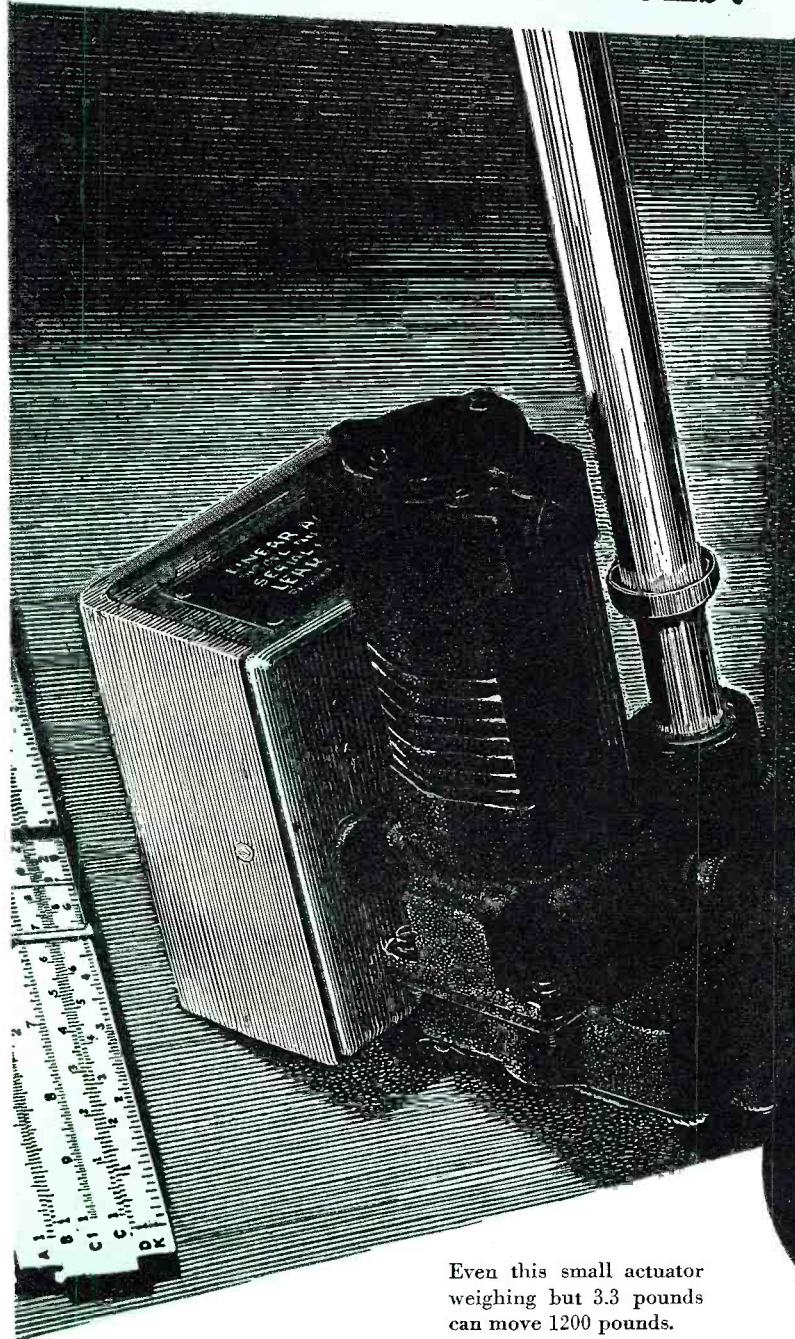

Even this small actuator weighing but 3.3 pounds can move 1200 pounds.

**WE** wouldn't tell you how fast America's fighting planes go. That's a military secret.

But we've all read it's well over 300 miles an hour. We've read too how they hit 700 or 800 miles an hour in dives. And how paint was peeled by the air pressure. Did you ever stop to think that the plane's flaps and controls have to work surely, smoothly and dependably against pressures like that?

It's done by such mechanisms as you see in the picture.

They are called Lear Actuators.

They are powerful. Some can push up to 75,000 pounds.

They are light. That's a "must" in aircraft.

They are small. They have to fit in available space.

A good many preconceived notions had to go by the board to meet all these requirements. For example, the little electric motor that runs them is full of revolutionary engineering refinements.

Every man and every minute we have now can't make all the motors and actuators that we would like to deliver for Uncle Sam's aircraft.

But the day is coming when they will have different jobs to do. New jobs on peacetime products—perhaps like steering ocean liners, or parking cars, or things we've never thought of.

That is one reason for this advertisement. We want to know who can use an actuator or a motor like these.

Another reason is, we want you to know that there is available the kind of thinking and engineering which have produced these and some 250 other Lear products,





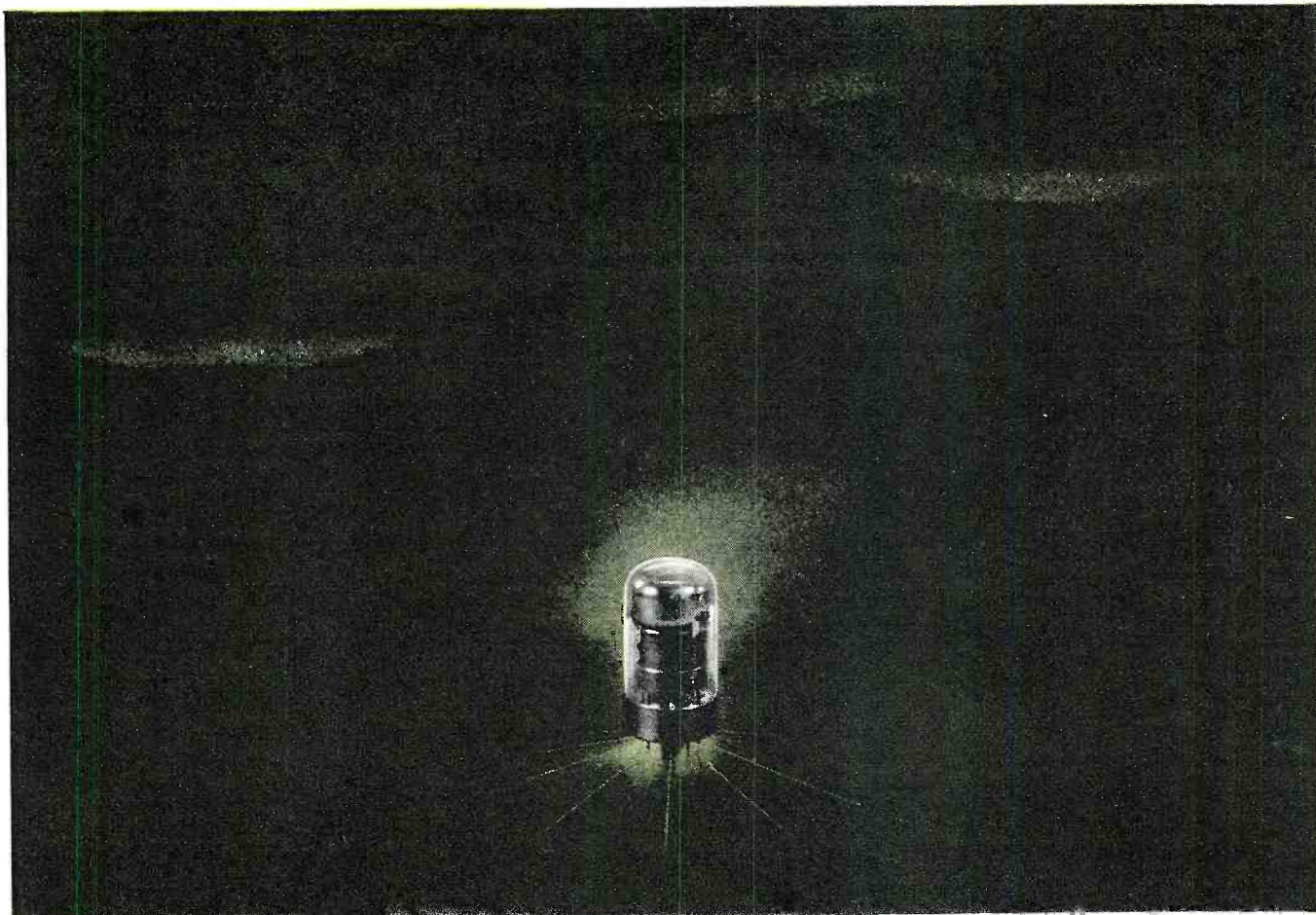

## ART AND SCIENCE... BOTH

 Little wonder that tube making is often referred to as an *art*. For much of the work is by hand. To fashion these complex assemblies of filaments, grids, plates and wires; to position the parts within such close space limitations—parts, mind you, that often are so fragile, flimsy and elusive, *tweezers* are required to handle them—calls for a high degree of skill, a steady hand and an eye for accuracy. Art is right!

Yet, today, guiding every move of every N. U. production worker's hands is the "know how" of many scientists and engineers. Here are

chemists, physicists, metallurgists, and men high in the sciences of electronics and mechanics—all teamed up in a scientific tube development and production program recognized as a model throughout this industry.

It takes a lot of *both* science and art to make the advanced-design, high performance N. U. tubes now being produced for combat service. Today they are being battle-tested for the greatly expanded post-war needs of service engineers. *Count on* National Union.

**NATIONAL UNION RADIO CORPORATION, NEWARK, N. J.**  
*Factories: Newark and Maplewood, N. J., Lansdale and Robeson, Pa.*



# NATIONAL UNION

## RADIO AND ELECTRONIC TUBES

*Transmitting, Cathode Ray, Receiving, Special Purpose Tubes • Condensers • Volume Controls • Photo Electric Cells • Panel Lamps • Flashlight Bulbs*

**AMCON**

## CAPACITORS IN PLASTIC

American has pioneered in the application of plastics to electrolytic and by-pass capacitors. Engineered to precision standards in jar-proof design, with finer electrical characteristics. They improve the appearance of any radio or electronic assembly—and they boast a time-tested record for dependability.

DATA  
SHEETS  
ON  
REQUEST

**AMERICAN CONDENSER CO.**  
2508 So. Michigan Ave. Chicago, Ill.

one part per million per degree Centigrade drift, has unusual activity, and has been made to vibrate both on the low and high modes so that dual-frequency crystals of this particular cut can be readily produced.

By contour grinding the crystals can be lowered and raised in frequency, and consequently, the exact adjustment of frequency is easily accomplished. The crystal can be used in either air-gap mountings or can be plated and clamped at the nodal point. Frequencies as low as 10 kilocycles and as high as 300 kilocycles have been produced with good results.

For further details write to the James Knights Company, Sandwich, Illinois.

-30-

### Spot News

(Continued from page 14)

be obtained by dropping a line to The Hallicrafters Company, 2611 South Indiana Avenue, Chicago, Illinois, U. S. A.

**CITED FOR HIS** "theoretical and experimental investigation of ultra-high frequency propagation in wave guides and radiation from horns, and the application of these principles to engineering practice," Dr. W. L. Barrow, director of fire control research at the Research Laboratories of the Sperry Gyroscope Co., was presented with the Morris N. Liebmann Memorial Prize at an Institute of Radio Engineers' banquet held in the Hotel Commodore.

Professor H. M. Turner, president of the Institute and associate professor of Electrical Engineering at Yale, presented the award, which consists of the income from a grant set aside through the generosity of E. J. Simon, Fellow of the Institute, to perpetuate the memory of the late Lt. Col. Morris N. Liebmann, vice-president and chief engineer of Foote-Pierson and Co., Inc., who was killed in action during World War I.



Before joining the Sperry Company in October, 1943, Dr. Barrow was for many years a consultant of the company while carrying on his professional duties as associate professor of Electrical Communications and director of the Harbor Building School at the Massachusetts Institute of Technology.

**THAT KENTUCKIAN RADIO INVENTOR . . .** Nathan B. Stubblefield . . . whose inventions we described several months ago in these columns, has now been honored by the Kentucky House of Representatives. A resolution was adopted providing public recognition of the late Mr. Stubblefield as the true inventor of the radio.

## RMS Cabinets

Complete line to accommodate all standard sets. Solid wood construction in Walnut or Leatherette Finish.

Model  
PA-10  
Portable  
Phono &  
Amplifier

COMBINATION RADIO ..  
PHONO ..  
SPEAKER-BAFFLE  
RECORD-CHANGER

Write for Complete Price List and Specifications to Department RN

**RADIO MERCHANDISE SALES** 730 E. 149th Street  
NEW YORK 55, N. Y.

## RADIO SERVICEMEN!

Write for our new catalog of bargains and many hard-to-get items. Immediate delivery—No waiting.

**SIGMON RADIO SUPPLY**  
708-10 Bigley Ave. Charleston 2, W. Va.

## RADIO ENGINEERING DEGREE IN 27 MONTHS

Intensive, specialized course, including strong basis in mathematics and electrical engineering, advanced Radio Theory and Design. Modern laboratory. Low tuition. Self-help opportunities. Also 27-month courses in Aeronautical, Chemical, Civil, Electrical and Mechanical Engineering. Enter Mar., June, Sept. & Dec. Catalog.

**INDIANA TECHNICAL COLLEGE**  
744 E. Washington Blvd., Fort Wayne 2, Ind.



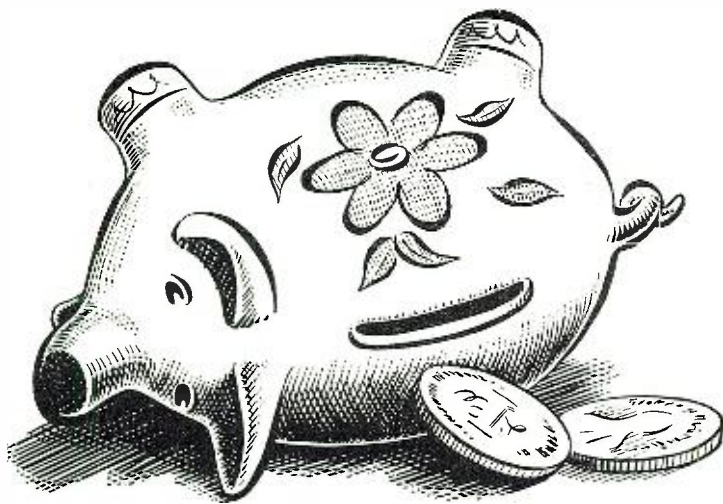

# READY WHEN THAT RAINY DAY CAME

WHEN today's big emergency came along, one of America's greatest resources was the know-how and productive skill stored up by industry. Accumulated through the years, this practical experience made possible the building of the world's mightiest war machine.

Simpson Instruments offer an example. Into their making has gone all that 30 years of experience can contribute to the design and manufacture of electrical instruments and testing equipment. From this long specialization has come a noteworthy advance in instrument design — a basic movement of a type long recognized for its greater accuracy and stamina, and which now for the first time has been made a matter of rapid mass production.

Fortunately, this patented Simpson movement was ready and waiting when today's emergency brought a tremendous demand for electrical instruments. It enables Simpson to build them fast, and build them well.

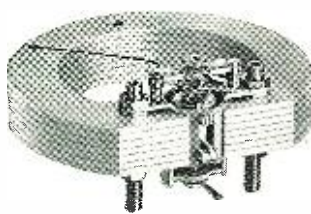

**The Simpson Movement** is a full bridge type with soft iron pole pieces. It refines this basically better movement to its finest expression, and eliminates the slow, costly construction which before now limited its application. Today this production speed is all-important. Tomorrow, the economies of mass production will mean far greater dollar value, in instruments that stay accurate.

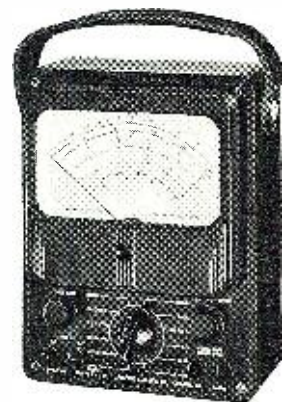
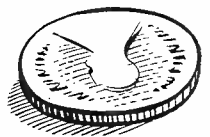
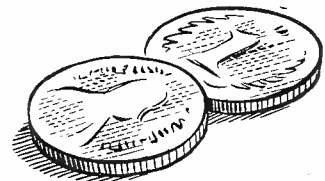
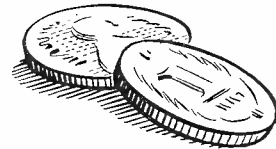

**SIMPSON ELECTRIC COMPANY**  
5200-5218 W. Kinzie St., Chicago 44, Illinois

# Simpson

INSTRUMENTS THAT STAY ACCURATE

Buy War Bonds and Stamps for Victory

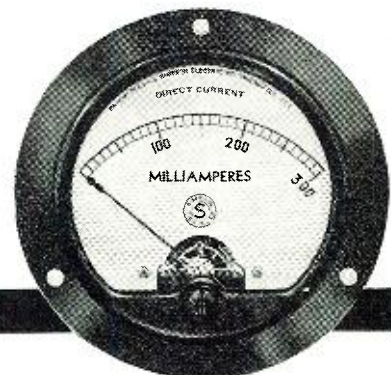

# Over 100 Different Numbers in RADIO TUBES!

We have "HARD-TO-GET" and "HARD-TO-FIND" Tubes available and coming in every day. Over 100 different tube numbers. Join our list of preferred customers by writing for those tubes you've been trying to obtain. Tubes for Ray Guns, Phonographs, and all types of coin-operated machines.

**ONLY CONSUMER BUSINESS ACCEPTED!**

WRITE FOR OUR PRICE LIST!

All Shipments Express C.O.D.

Do Not Send Check or Money Order!

**ONLY MAIL ORDER BUSINESS!**

**CHICAGO NOVELTY COMPANY, Inc.**

1348 Newport Avenue

## Sign This!

### CONSUMER'S CERTIFICATE

I hereby certify that the part (s) specified on this order are essential for presently needed repair of electronic equipment which I own or operate.

Name .....

Address .....

Date .....

WPB Limitation Order No. L-265.  
Makes "Consumer's Certificate" mandatory with each order!

The resolution was introduced by W. B. Moser, Representative of Murray County, in which Mr. Stubblefield was born. Mr. Moser pointed out that Mr. Stubblefield has been recognized by historians, scientific authorities, and *Who's Who* as radio's inventor.

This resolution is the first step in creating a park at Stubblefield's birthplace in his honor.

**"TUBES AVAILABLE FOR IMMEDIATE DELIVERY . . . as long as they last" . . .** read an advertisement in a Canadian trade journal recently. The tubes advertised for sale were 6AB5, 1H5G, 88M, 37, 2A3, 01A, 77M, 85M, 83, 36, 38, 6F8G, 6J5G, 6B7M, 6R7G, 6B7S, 6AF5G, 46, 6AC5GT, 6SF5GT, 6SF5, 6A5G, 6C5G, 31, 1E7G, 2E5, 1J5G, 6A4, 6B5, 6L5G, 6K8G, 6SA7, 6V6GT, 6V7G, 15, 12SF5, 12J5GT, 12C8, 12A5, 89, 6R7M, 1R5, 1S4, 1S5, 6F7, 7G7, 7V7, 7E6, 14C7, 7H7, 6Q6G, 6AD7G, and UX120 . . . believe it or not!

**THE WHITE STAR FOR CONTINUED** meritorious production has been added to the Army-Navy "E" Flag of Shure Brothers, designers and manufacturers of Microphones and Acoustic Devices, Chicago. The White Star Award was presented by Lt. Colonel Nathan Boruszak to the men and women of Shure Brothers on December 15, 1943, at an impressive and stirring factory meeting.

S. N. Shure, General Manager, led the workers in a pledge, in accepting the Army-Navy "E" pin and Ensign Alice Connely, U.S.N.R., presented the "E" pins to the two oldest employees, who accepted them in behalf of the workers.

**NEARLY TWO THOUSAND ENGINEERS** attended the annual Winter Conference of the IRE in New York City to listen to one of the finest groups of engineering, industrial and military papers that has been presented in many years. Government representatives who spoke included Commanders J. J. Raby and A. B. Chamberlain of the Navy, and Lieutenant C. W. Martel, of the Army, as well as E. K. Jett, G. P. Adair, W. N. Krebs, and P. F. Siling, all of the FCC.

In a talk on radio's part in the war effort, Commander Raby pointed out that radio has progressed to such an extent in the last ten or twelve years that those of us who were flying then can hardly believe the change. He pointed out that in 1932, when he was a radio officer of a single-seater flying squadron, the job was quite simple because he had no radio. Soon after, he said, they were issued six two-way voice sets which were installed in the planes of the section leaders. From that time on, he explained, his loafing days were over.

The import of communications was further emphasized in his report on the first attacks on Morocco. His job

## 110-VOLTS AC from DIRECT CURRENT

with KATO KONVERTERS. Furnish standard 110-volt AC from 32, 110, or 220-volts DC. Good deliveries on sizes 350 through 1500 watts.

PIONEERS IN THE BUILDING  
OF SMALL ROTARY CONVERTERS



Katolight Rotary Konverter, 225 Watt

Good deliveries on 5, 7½, 15 and 25 KW AC generators. Mfr.'s DC generators, motor generators, frequency changers, high frequency generators.

Kato's entire production at present must be confined to orders with high priorities.

KATO ENGINEERING CO.  
112 Rock Street, Mankato, Minnesota

## VICTORY CONDENSERS

Here it is! . . . the Government approved Victory Condenser that we are producing for immediate delivery on L265 ratings or better. Write for complete list of Victory items and prices.

For VICTORY Buy  
United States War  
Bonds and Stamps

## POLYMET CONDENSER CO.

699 E. 135th ST., NEW YORK 54, N. Y.

## RADIO TECHNOLOGY

**RCA** Institute offers an intensive two-year course of high standard embracing all phases of Radio and Television. Practical training with modern equipment. Also shorter specialized courses in Commercial Radio Operating, Radio and Television Servicing, and Aviation Communications. For Free Catalog write Dept. RN-44.

**RCA INSTITUTES, Inc.**  
A Radio Corporation of America Service  
75 Varlick St., New York 13, N. Y.

LES Correspondence Courses in  
**RADIO and ELECTRICAL ENGINEERING**

**ELECTRICAL ENGINEERING** Get good grasp of wide electrical field. Prepare yourself at Low Cost, for secure future. Modern course. So simplified anyone can understand quickly.

**RADIO ENGINEERING** Extra fine course in radio, public address, photo-electric work. Trains you to be super-service man, real vacuum-tube technician. Services are needed badly. Diploma on completion.

Send postcard or letter for Free Copies of school catalogs, full details, all about deferred payment plan, etc. **SEND NOW!**

**WRITE** **LOW \$25** Either Course **AS**

**LINCOLN ENGINEERING SCHOOL, Franklin Stn., Box 61-R64**  
(Formerly at Lincoln, Neb.) WASHINGTON, D. C.

# STUPAKOFF

FOUNDED IN 1897

*Ceramics for the World of Electronics*

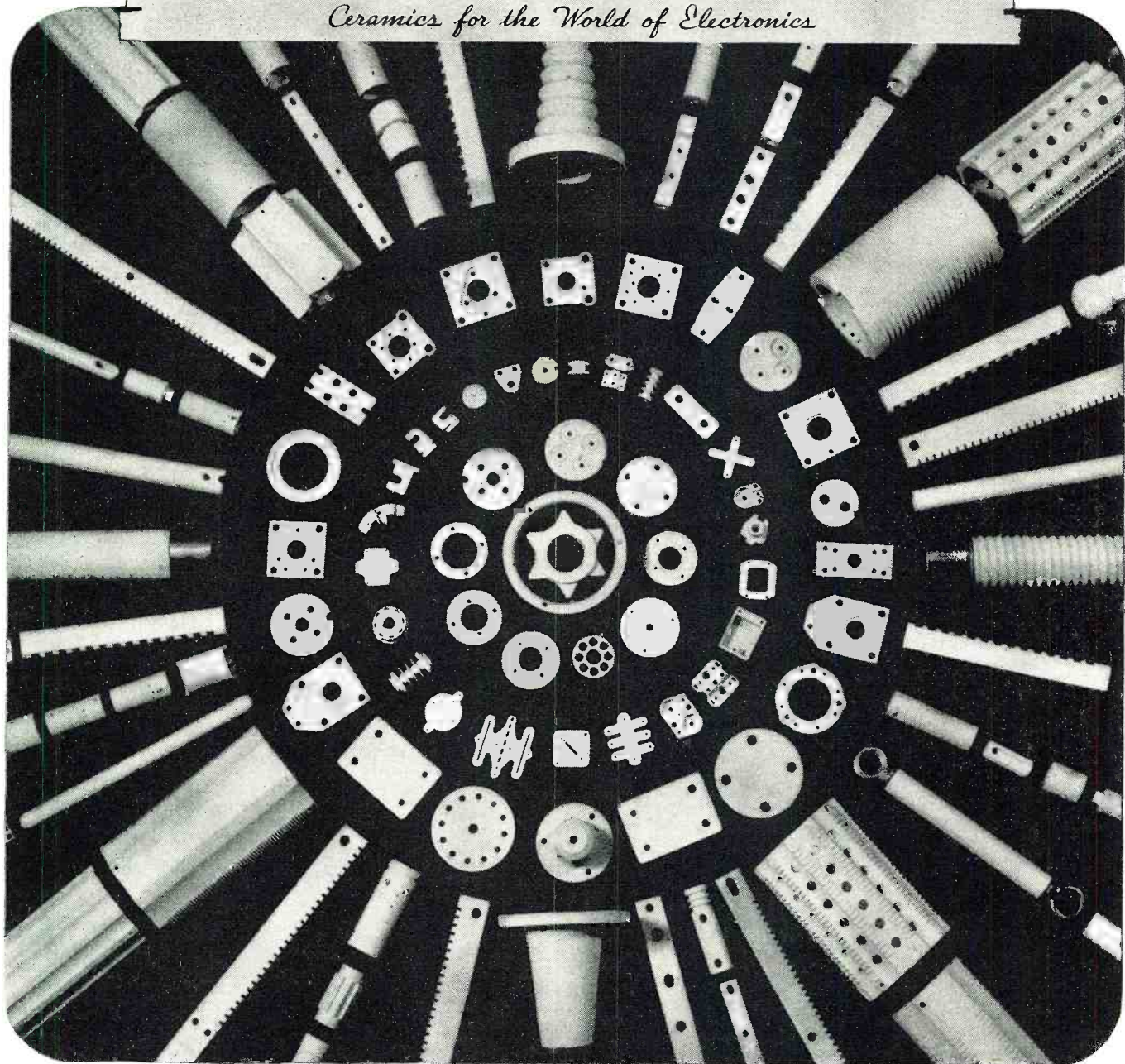

## NSULATORS

*Engineered with the proper material  
for your particular application*

- POST
- TUBULAR—SINGLE OR MULTIPLE HOLE
- LEAD-IN
- SPACER
- ANTENNA
- ELECTRONIC TUBE
- SPREADER
- ENTRANCE
- COIL FORM
- SPECIAL



Buy War Bonds

**STUPAKOFF CERAMIC AND MANUFACTURING CO., LATROBE, PA.**

## Inter-Communication System

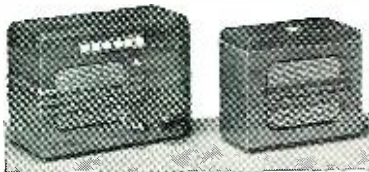

### SAVE TIME—EFFORT—MONEY

Ideal for Radio Servicemen, Factories, Hospitals, Army Camps or Service Centers. Easy to install, operates on AC or DC current.

This unit provides two-way conversation between Master Station and up to 5 Remote Stations. From Master Station you can carry on a separate conversation with any one Remote Station. Remote Stations can call and communicate with the Master Unit.

Model No. 908A—Including: One Master Station, One Remote Station, 50 Feet wire cable.

**\$34.95**

Model No. 909—Extra remote station.

**\$7.50**

Price .....

Additional wire per 100 feet.

**\$2.75**

Price .....

Notice: PRIORITY RATED ORDERS with rating of AA-5 or higher receive immediate shipment. Orders without priority rating acceptable, subject to WPB authorization.

### SPECIALS

No. 14D—Dynamic speaker, 14", 800 ohms. Regular list price \$13.20. Only.

**\$4.95**

No. 12 UPM—Heavy duty 12" permanent magnet speaker. Only.....

**\$14.95**

Write today for our new bulletin of radio component parts, cabinets, complete console radios and de luxe phonograph recorders.

**Mutual Radio Products Company**  
2926 Shakespeare Avenue Chicago 47, Illinois

## CUT HOLES FAST



### in radio chassis

No tedious drilling... no reaming... no filing! Saves hours of work. Cuts clean, accurate holes for sockets, plugs, other receptacles. Tool has three parts: punch cuts through chassis, die supports metal and prevents distortion, cap screw is turned with wrench to cut hole. Sizes for holes 3/4" to 3 1/2". For complete information write Greenlee Tool Company, 1884 Columbia Ave., Rockford, Illinois.

WRITE FOR FREE FOLDER S-119 →



then, he said, was to effect close cooperation between a carrier-based fighter squadron of Grumman Wildcats with the Army amphibious force landing in the Casablanca, Fedela, Port Lyautey area. Since no landing fields were available, the carrier-based aircraft were quite important in this project. Thus, radio became a very essential factor. Commander Raby said that landing with the troops at each beachhead was a naval aviator who acted as a liaison with the senior Army officer. This man was equipped with a portable radio providing two-way contact with not only the aircraft carriers but with the planes in the air.

"This officer would call the Wildcat fighters by radio, and direct them to the place of enemy attack. With this formidable plan, enemy planes were soon on the run," said Commander Raby.

The radio range beacons were also praised by Commander Raby. He said, "I can assure you gentlemen that there is no finer feeling than to hear the beacon, after you have been flying for some time over seemingly endless wastes of water in a land plane."

Commander Raby also told of his adventures with the new radio-equipped Grumman Hellcat fighters. "These new planes and their new equipment were excellent," he said. "They had more channels and greater range. And," he said, "upon our arrival at one of the large bases we augmented our radio equipment with some of these new sets which operated on high frequencies. They proved outstandingly invaluable in the operations that came later on, which included the raids on Marcus Island and Wake Island."

In his concluding remarks Commander Raby said, "I believe that the advances made by you gentlemen in electronics for combat use will have a far reaching effect on the world of flight and of safety at sea after the war is won."

Standardization of service equipment was analyzed by Lieutenant C. W. Martel. He pointed out that last November, the Signal Corps standards agency, which was established in January, 1943, was succeeded by ANESA, or The Army-Navy Electronics Standards Agency. In discussing the procedure which is followed by ANESA, he said that the Army or Navy first chooses the component to be standardized on the basis of the tangible advantages which will result. Then the Signal Corps coordinates requirements for all the branches of the Army. The Bureau of Ships follows the same procedure for the various Naval bureaus. After this material has been collected, the Army and Navy representatives meet and discuss any differences that may exist. After this session, a preliminary spec sheet is drawn up and submitted to industry for study. The War Production Board is, of course, also consulted during this process. At the conclusion of this combined study period, a report is pub-

lished by ANESA as a joint Signal Corps Tentative Bureau of Ships Ad Interim specification. Upon publication, these specifications become effective even though final approval has not been secured. Accordingly, design engineers and manufacturers must meet the requirements provided for in this tentative specification, until the final specification is issued. Of course, there are provisions for adjusting these standards if necessary. To do so, a waiver is required.

The next step in this standardization procedure involves the independent processing of the specification by the Signal Corps and the Bureau of Ships to the joint Army-Navy specification board for approval. After it has been approved, WPB receives it. It is also sent for consideration to the War Committee on Radio and the American Standards Association. In addition the Armed Forces review and give careful consideration to recommendations submitted by these agencies. At the conclusion of these discussions, the specification is published as one of the JAN—Joint Army-Navy Series.

At the present time there are about eighty different items on the standardization program. Up for study are dynamotors, vibrators, fixed molded paper dielectric capacitors, resistors, etc.

Lieutenant Martel also discussed some of the standards already developed as a result of these coordinated efforts. One of these JAN projects covers an improved type of audio and power circuit cable for use in aircraft installations. In its present form, this cable uses plastic insulating material instead of rubber. According to Lieutenant Martel, this plastic has a number of advantages in that it exerts no corrosive action on copper. Thus, the shielding braid does not have to be tinned. Accordingly, tin and rubber which are two critical materials, are conserved. In addition, he pointed out, the plastic can be made in various brilliant and permanent colors. Thus, color coatings can be applied directly instead of by the use of cotton strands. Lieutenant Martel explained that this step expedited both installation and manufacture. He also discussed a new dielectric material that has resulted from the studies of the standardization group. This is known as polyethylene, and does not deform because of high temperature or nitrogen gas pressure.

"Tubes, of course, have also been a major source of study by the standardization group," he said. "Standardized types known as the JAN-1 were put into force in March, 1943. A modified version, the JAN-1A, is now in effect. Incidentally," he said, "the Canadian services are also following these tube specifications."

He also pointed out that the standardization program has also afforded interchangeability of equipment. "Thus," he said, "the Marine Corps now uses some Army apparatus."

TAKE A TICKET TO—

A YEAR OF  
PROGRESS  
1944

TICKETS

12 MONTHS OF **AIR  
COMMERCE**  
EDITION OF **FLYING**

12 MONTHS OF  
**FLYING**

The coming year will witness some of the greatest developments in the history of man—most of them in the air. This progress will be faithfully followed and skillfully interpreted in **FLYING**, and **FLYING** Air Commerce Edition during the next 12 months.

That's why a subscription to either of these editions is a ticket to air progress. For no matter what your interest in aviation may be, one of these editions is *exactly* tailored to fit your requirements for news, information and data on all up-to-the-minute aviation developments—

**FLYING**

**FLYING**, the world's most widely read aviation magazine, contains newsy stories and timely articles covering *every* phase of aviation—all written with the balanced objective of authoritative information in readable form.

**Flying AIR COMMERCE Edition**

Bound within a limited number of copies of the regular edition of **FLYING**, this section of full magazine dimensions contains special articles on air-borne traffic, of interest only to airline, air transport, state, municipal and national airport executives, and to heads of large organizations that regularly use common carriers to transport their merchandise.

*Obtainable only by subscription, The Air Commerce edition is available ONLY to the groups described.*

*Subscribe to Your Edition Today* ➔

**ZIFF-DAVIS PUBLISHING COMPANY**

540 North Michigan Avenue, Chicago 11, Illinois

New York      Washington      Los Angeles      London, Toronto

Please enter my subscription to **FLYING**—\$4.00: (Air Commerce Edition—\$4.50 for 1 year).

Name.....

Address.....

City..... State.....

Firm Name.....

Type of Business..... Your Title.....

Start with..... issue

Remittance enclosed       Bill me later

"Please send check or money order. We cannot be responsible for currency".

## ILLINOIS CONDENSERS

.....WORTH REMEMBERING!

NEXT time you purchase capacitors let the satisfactory experiences of our many users be your guide—choose from the "ILLINI" line of electrolytic and paper types. They're known for reliability, durability and consistent quality. Manufactured by condenser specialists for eight years who produce nothing but condensers.



### ILLINOIS CONDENSER COMPANY

1160 NORTH HOWE STREET  
CHICAGO, ILLINOIS

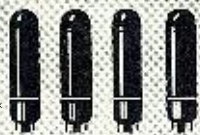

#### 4 STANDARD TYPES

of Amperite Regulators replace over 400 types of AC-DC Ballast Tubes now in use.

Amperites are real REGULATORS... have patented Automatic Starting Resistor which prevents initial surge and saves pilot lights.  
Ask Your Jobber

# AMPERITE

THE *Simplest*  
WAY TO REPLACE

## BALLASTS

WRITE FOR REPLACEMENT CHART

AMPERITE Co. 541 BROADWAY, NEW YORK, N. Y.

In an analysis of the operations of the engineering division of the FCC, chief engineer Jett who, incidentally, is now also an FCC Commissioner, projected a study of frequencies above 300 mc. He said that when we consider the vast number of channels that will be required for a half-million airplanes by 1950, a four-ocean Navy, a huge Army communication system, a greatly enlarged police radio and harbor radio system, FM, facsimile, and so on, the apparent roominess in the channels above 300 mc. ceases to look so encouraging. This point is further aggravated when we consider the demands of television which require a channel at least 6000 kilocycles wide, or wide enough for a hundred or more standard width communication channels, he explained. The problem is particularly puzzling for FM and television.

"The present eighteen channels and the standards governing this service are inadequate for an efficient nationwide competitive system of television broadcasting," he explained.

He said that we should have at least twice this number of channels. And in FM broadcasting, which at present operates in the 42 to 50 mc. band, there is only room at present for five non-commercial educational broadcast channels and thirty-five commercial channels.

"Here, too," he said, "we need twice as many channels."

Relay channels for network programs were also discussed by Mr. Jett. In analyzing this phase of study he said, "We know, for example, that these relay stations will be installed on towers which will be spaced from thirty to fifty miles apart. The transmitter for each channel of communication will be of very low power, perhaps only a fraction of one watt. Interference will be minimized and efficiency increased through the use of directional beams with the result that the same frequency may be utilized in many sections of the country. There is no reason why this nationwide network should not also carry network programs for standard broadcasting, FM, facsimile, and private telegraph and telephone circuits for the press, stockbrokers, and agencies that usually lease private wire facilities. Who should be granted the privilege of operating this system? Should it be competitive with the telephone and telegraph services, which now operate as monopolies in their respective fields? Should there be competitive radio networks, thereby necessitating a forest of towers along the same route? Should the company or companies operating the radio network also be permitted to operate terminal facilities at the subscribers' offices? Should the chain broadcasting companies be permitted to own and operate their own radio networks? These are but a few of the questions which will confront the Commission when, as, and if materials and manpower again become available for the

production of civilian equipment."

One of the treats at this meeting was the appearance of the world famous scientist, Dr. E. S. W. Alexanderson of General Electric, who, for the first time in more than a decade, presented a paper. His contribution, prepared in collaboration with M. A. Edwards and K. K. Bowman, discussed the amplidyne. This unusual device, according to Dr. Alexanderson, is a two stage amplifier used for power control. Accordingly, it has a variety of versatile application possibilities.

Some of the problems encountered in tube design were discussed in a few of the papers. Dr. Dwight O. North of RCA, for instance, reviewed the results of the behavior of noise after passage through a square law detector and a linear detector. He discussed an arrangement whereby the ordinary diode detector can supplant the conventional thermocouple in noise measurement work.

Lloyd P. Smith of Cornell University, who is now temporarily with RCA as a consultant, discussed the quantum theory and its limitations imposed on resonator control of electrons. He pointed out that when an electron interacts with a high frequency electromagnetic field, it does not exchange energy with this field in a continuous manner. He said that the quantum theory requires that the energy change must occur in discrete energy steps of one quantum each where the energy quantum is  $h\nu$ .

"These energy steps become very small indeed when the frequency is not high," he explained. "However, the energy exchange takes place by a great number of small successive steps so that it would appear to take place continuously. Where the frequency becomes large, this stepwise exchange of energy leads to results which differ from those one would expect from the classical electro-dynamics." For at thirty-thousand megacycles," he said, "the quantum is one-hundred and twenty-three microvolts. Accordingly, the electron volt energy of an electron would have to change in steps of this amount."

In his concluding remarks he pointed out that this phase of study and its application in the control of electron beams in high-frequency velocity modulation tubes is of considerable importance.

The Don Lee Broadcasting System's director of television, H. R. Lubcke, spoke about orthicon cameras in television studio work, at the conference. He pointed out that the orthicon cameras allow a reduction of incident light on the stage to 250-foot candles, from the previous value of a thousand-foot candles for the iconoscope. He explained that a brightness of 130 foot-lamberts is sufficient, with a fifty per cent reflection factor as from the face. This corresponds to a Weston reading of fifteen, he showed. A greater depth of focus is realized since there is an allowable decrease in lens aperture from f2.7 to f6.3. He also pointed out

**THE  
SIMPLE  
A-B-C  
DeFOREST  
WAY!**

# Learn RADIO ELECTRONICS quickly • easily AT HOME



The famous Dr. Lee DeForest supervised the preparation of DeForest's Training

## You GET **A** LOOSE-LEAF LESSONS

DeFOREST'S TRAINING includes 90 loose-leaf lessons, prepared under the supervision of one of the world's foremost Radio authorities, Dr. Lee DeForest—inventor of the audion tube which has helped make modern radio possible... holder of over 300 radio patents... and often called "Father of Radio."

## FOR A BETTER OPPORTUNITY TODAY — PLUS A BETTER POST-WAR FUTURE

Get into Radio and Electronics—a billion dollar OPPORTUNITY FIELD OF TODAY that promises such a THRILLING POST-WAR FUTURE. See how you may get ready for a GOOD JOB or a BUSINESS OF YOUR OWN... BETTER PAY and HIGHER RATING in military service. Read how DeFOREST'S prepares you for your start in Radio-Electronics quickly, easily, in your spare-time at home—the simple "A-B-C" DeFOREST'S Way. You'll find all these answers, and more, in DeFOREST'S big, illustrated book, "VICTORY FOR YOU!" Write for it today. It's FREE.

## You Get This Exclusive 3-WAY Combination of Radio Training Advantages

You READ... you SEE... you DO! (A) You get well-illustrated lessons prepared the modern loose-leaf way to help keep your training up-to-date. (B) You get real, practical RADIO EXPERIENCE from eight big kits of standard Radio parts and assemblies. (C) You get the use of a 16 mm. MOVIE PROJECTOR AND 12 TRAINING FILMS. You S-E-E "hidden actions" of Radio circuits from fascinating, easy-to-learn-from ACTION MOVIES. You get what we think are the major Radio training aids—AT HOME!

## You Get EMPLOYMENT SERVICE

DeFOREST'S Training includes an effective EMPLOYMENT SERVICE that has long-established contacts with many companies employing trained Radio men. You enjoy this valuable assistance once you are trained. DeFOREST'S is affiliated with the DeVRY CORPORATION—well known manufacturer of Motion Picture Sound Equipment.



**YOU CAN BUILD 133 FASCINATING EXPERIMENTS WITH THIS EQUIPMENT**

## You SHOW **C** MOVIES AT HOME

You get the use of a genuine DeVry 16 mm. motion picture projector and films which provide the easy to understand, highly effective modern visual training—a method used today to train better and faster in war plants and military service. Radio principles come to life!

... you see electricity in action, electronics made CLEAR the EASIER DeForest way. Get DeForest's BIG FREE BOOK, "VICTORY FOR YOU"—a key to a good pay job in the electronics industry, to a business of your own or to better military rating and pay. Act now. Mail the coupon today!

**SEND FOR FREE BOOK!**



## **B** You WORK AT HOME WITH PRACTICAL EQUIPMENT

You enjoy a "Home Laboratory." You get valuable Radio experience by building modern Radio circuits that operate; also, "Electric Eye" devices, Light Beam Transmitter, Public Address System, Wireless Microphone, etc. 133 fascinating experiments in all—in spare time, at home.

# DeFOREST'S TRAINING INC., Chicago, Ill

DeFOREST'S TRAINING, INC.  
2535-41 N. Ashland Ave., Dept. R-5,  
Chicago 14, Illinois, U. S. A.

Please send me—FREE and WITHOUT OBLIGATION—illustrated book, "VICTORY FOR YOU," showing how I can prepare for Radio with your Home Movies and Laboratory Kits.

Name ..... Age.....

Address.....

City ..... State.....

(Please help our country save paper. Do not reply unless you are 17 or over).



# LOSE YOUR SHIRT?



## HERE IS THE BOOK THAT SHARPENS YOUR WITS AGAINST SHARPERS . . . .

Mickey MacDougall, ace gambling detective, exposes the neat and vicious tricks and devices used by sharpers at cards, dice, roulette, at race tracks and other sucker "come-ons." This is his own pungent story of exciting adventures and private investigations.

If you must gamble, read **DANGER IN THE CARDS** first, Michael MacDougall has worked with the police and exposed sharpers, cheats, swindlers, and race-track manipulators.

**DANGER IN THE CARDS** rolls up the sleeves of the most expert "gamblers" . . . uncovers the hidden ace, the loaded dice, the magnetized spinner.

**READ IT AND PROFIT . . . TAKE THE 'CHEAT' OUT OF CHANCE**

**AT YOUR LOCAL BOOK STORE OR**

**PLACE YOUR ORDER DIRECT**

**\$2.50**

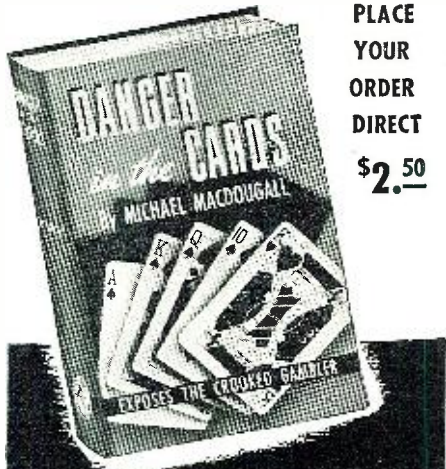

Ziff-Davis Publishing Company  
540 North Michigan Avenue  
Chicago 11, Ill.

that the lighting and makeup technique with the orthicon is no different than the usual television or motion picture procedure.

The interesting subject of oscillators was covered by W. A. Edson of Bell Telephone Laboratories. He analyzed the three functions of oscillators.

"The first of these," he said, "is gain. A filter, which will produce a change of phase shift with a change of frequency, is the second requisite of an oscillator," he said. "And the third," he pointed out, "is an amplitude-limiting device." This particular feature was stressed by Mr. Edson, for, he pointed out, this function is often left to the tube itself. "All useful oscillators," he said, "show considerable excess gain if measured at a low enough level. This excess gain must be accounted for," he explained. "A limiter, so that a finite constant output can be reached, should be used to account for this gain."

Mr. Edson analyzed many oscillator circuits, including the Hartley and Meacham. He also discussed limiters, classifying them into four groups. In these groups are, according to Mr. Edson, thermal devices such as carbon and tungsten lamps; varistors such as copper oxide thyrite and some electronic diodes; tubes which reduce their gain with simple overload with an increase of current through them; and tubes which reduce their gain by virtue of a bias developed as a result of oscillation.

Chairmen of the thirteen panels of the Radio Technical Planning Board also appeared at the conference and reviewed briefly their programs (this data was presented by your correspondent in these columns during the early part of the year).

**THE SHELLAC SITUATION** has improved so much that WPB has granted an additional 50 per cent allotment to record manufacturers. This brings the total permitted for use to the 1941 level. Last year record makers were limited to 20 per cent of their 1941 level. And at the beginning of the present quarter, this was increased to 50 per cent. However, 30 per cent of this allotment covered the use of those grades which had an OPA ceiling of 41.1 cents or more per pound. According to WPB officials, the same grading will be followed in the new allotment schedule.

It appears that there are now two other bottlenecks in record-making. These are paper and manpower. Paper, of course, does not constitute an actual record-producing problem, but rather a packaging and shipping difficulty.

Paging package experts!

**A REORGANIZATION, LOOKING TOWARD** greater efficiency in war production, has recently taken place in the Engineering Department of the Hallicrafters Company.

The post of Chief Engineer held by R. E. Samuelson is to be a staff posi-

tion as part of management instead of a line position reporting to management. F. W. Schor becomes Chief Engineer in Charge of Development and Irving Glerum becomes Chief Engineer in Charge of Production.



Messrs. Glerum, Samuelson and Schor are shown examining one of the Hallicrafters receivers, the Model SX-28.

It is expected that this reorganization of responsibilities will be conducive to increased efficiency in all departments. The Hallicrafters Company has already been awarded the Army-Navy "E" on three occasions for excellence in production.

**ENGINEERS, EXECUTIVES AND ADMINISTRATORS** were quite jubilant over the confirmation of E. K. Jett as FCC Commissioner to succeed George H. Payne. Mr. Jett, who was sworn in on February 15th, will remain as Commissioner until June 30th.

**PREPARE for a GOOD Peace-Time Job**

**12 WEEKS SHOP TRAINING IN ELECTRICITY**  
*That is ESSENTIAL NOW!*

**LOOK AHEAD!** Why take a narrow, no-future job? Do vital war work while preparing for the big job competition after the war.

**UNLIMITED OPPORTUNITIES**  
Trained electricians are urgently needed NOW. And when Victory comes, amazing new opportunities will be open in Electronics, House Wiring, Air Conditioning, Power Plants, etc. You learn them all at Coyne, America's greatest "Learn by Doing" Electrical School! Now! Industrial Electronics Training included at no extra cost.

**MENT! WHETHER YOU ARE 16 OR UP TO 50, GET MY BOOK!**  
Coyne training is EASY, PRACTICAL. Train on real electrical equipment, not by correspondence. Covers every branch of Electricity. Don't let age, lack of education or experience hold you back. You don't need much money—start now, pay tuition after graduation. I'll even help you get part-time work to help with living expenses. Lifetime Job Service. Also have facilities for men with physical disabilities. Write for details.

**H. C. LEWIS, President**  
**COYNE ELECTRICAL SCHOOL**  
500 S. Paulina St., Dept. 44-83, Chicago 12, Ill.

Send FREE Coyne Book. Tell me about your "Pay after Graduation" plan and Special INDUSTRIAL ELECTRONICS Training included at no extra charge.

NAME.....

ADDRESS.....

CITY..... STATE.....



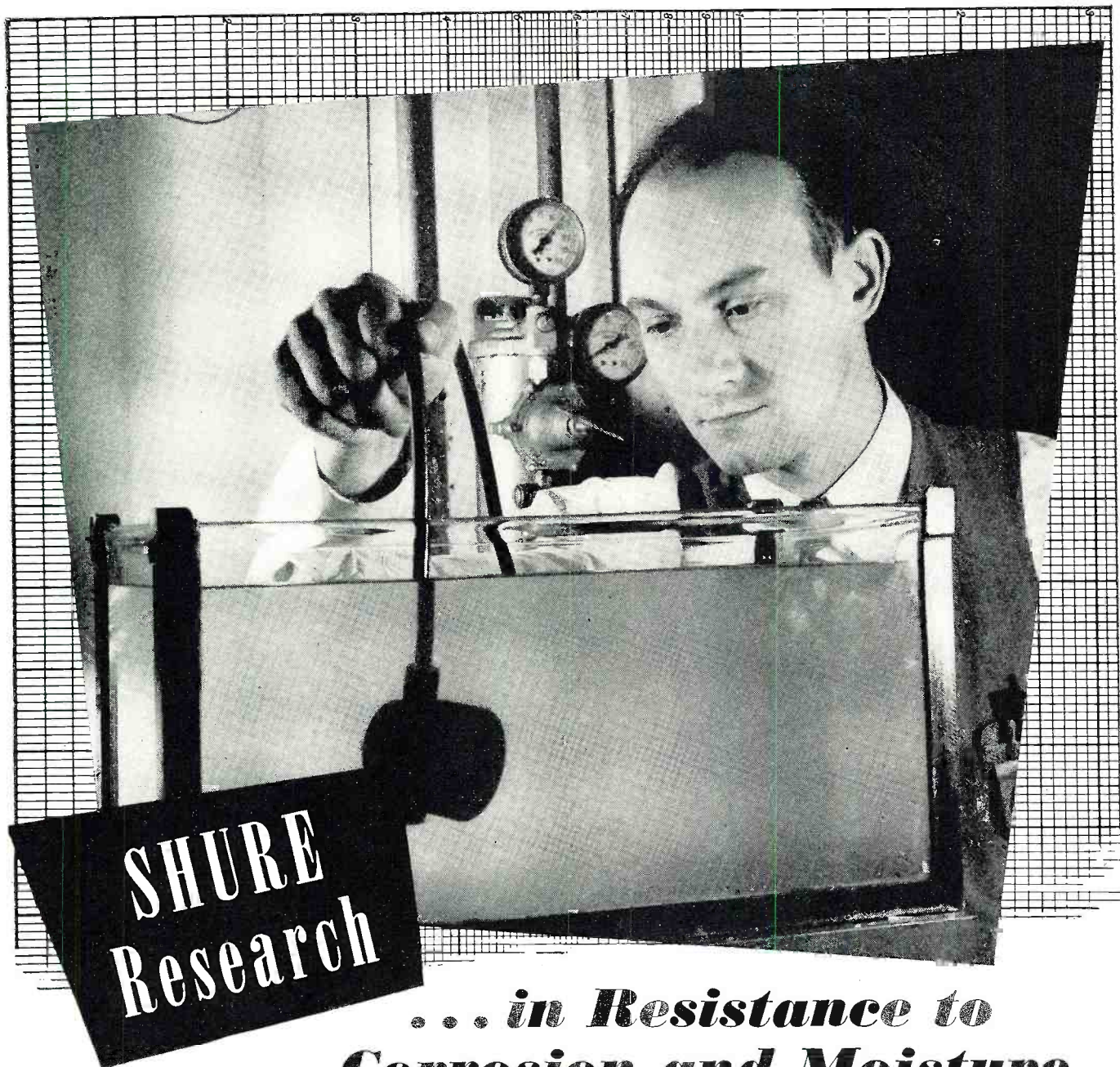

*... in Resistance to  
Corrosion and Moisture*

This is a standard test at Shure Brothers. The microphone is connected to the air pressure line and submerged. No bubbles—its “insides” are protected against rain and ocean spray. More than that, Shure engineers have successfully defeated corrosion of iron, steel, brass and aluminum microphone parts—and they were the first to moisture-proof, successfully, Rochelle Salt Crystal Microphones. You may well look to Shure engineers to provide you with better microphones and headphones.

**SHURE BROTHERS, 225 West Huron Street, Chicago**  
*Designers and Manufacturers of Microphones and Acoustic Devices*



## What "VACO VERSATILITY" Means to the radio man

It means that there is always available just the right tool to fit the right job. We have always specialized in producing screw drivers and tools especially for radio needs. Display below illustrates versatility of Vaco developments.



Over 173 Standard types in our catalog. Write for further information.

**VACO PRODUCTS CO.**

319 E. Ontario St., CHICAGO 11, ILL.

Canadian Branch Warehouse:

560 King St. W., Toronto 2, Ont.

## 7 Days

## Free Examination

# PRACTICAL RADIO INFORMATION

Including Frequency Modulation—Television, etc.



Inside Radio Information for all Servicemen—Aircraft Pilots, Students. AUDELS RADIO-MAN'S GUIDE contains 772 Pages, 400 Diagrams & Photos is complete—gives Authentic Principles & Practices in Construction, Operation, Service & Repairs. Covers clearly and concisely Radio fundamentals—Ohm's Law—Physics of sound as related to radio science—Measuring instruments—Power supply—Resistors—Inductors—Condensers—Transformers and examples—Broadcasting stations—Radio Telephony—Receivers—Diagrams—Construction—Control systems—Loud speakers—Antenna systems—Auto Radio—Phonograph pickups—Public Address Systems—Aircraft & Marine Radio—Radio Compass—Beacons—Automatic Radio Alarms—Short Wave—Coil Calculations—Testing—Cathode ray oscillographs—Static Elimination—Trouble Pointers—Underwriter's standards—Units and tables—Frequency Modulation—REVIEW QUESTIONS & ANSWERS. Ready Reference Index.

**\$4 COMPLETE • PAY ONLY \$1 A MO.** Get this practical information in handy form for yourself—Fill in and MAIL COUPON TODAY—

**AUDEL Publishers, 49 W. 23rd St., N.Y.** Mail AUDELS NEW RADIO-MAN'S GUIDE for free examination. If O. K., I will send you \$1 in 7 days; then remit \$1 monthly until \$4 is paid. Otherwise I will return it.

Name \_\_\_\_\_  
Address \_\_\_\_\_  
Occupation \_\_\_\_\_  
Reference \_\_\_\_\_ RN

1950. Succeeding him as chief engineer is George P. Adair, who was formerly assistant chief engineer in charge of broadcasting. Philip F. Siling, chief of the international division, has been assigned to Mr. Adair's post, and Marion W. Woodward has been advanced from assistant chief to chief of the international division.

Mr. Jett's political faith, identified by him as "Independent," was accepted. And accordingly, the FCC is now composed of four Democrats . . . Fly, Craven, Walker and Durr . . . two Republicans . . . Case and Wakefield . . . and Mr. Jett, who is an Independent.

In announcing his approval for confirmation, Senator White said that he knew Mr. Jett to be a man of ability, integrity and character.

The promotion of Mr. Adair is on a permanent basis. However, the other two assignments are for the duration only, since Lieutenant Commander Gerald C. Gross is on leave as assistant chief engineer in charge of broadcasting.

Congratulations, Commissioner Jett, Chief Engineer Adair, Assistant Chief Engineer Siling, and International Division Chief Woodward!

**THE RECENT DISMISSAL OF THE FCC RULING** affecting newspaper ownership of stations has turned the green light on for newspaper station buyers. In the East the New York Times announced that it had purchased John V. L. Hogan's high fidelity station WQXR and its FM affiliate, WQXQ. Mr. Hogan and Elliott Sanger, president and executive vice-president respectively of the Interstate Broadcasting Company which operated these stations, have been retained as chief executives of the new operating unit under five-year contracts.

In the middle West the Indianapolis News announced purchase of Station WIBC, Indianapolis. This station is but six years old. It now operates on a clear channel of 1070 kilocycles. WQXR operates on a channel of 1560 kc.

Both sales still have to be approved by the FCC. However, it appears that undoubtedly permission for the sales will be granted in both instances. And it appears as if within the next few months many other newspapers throughout the country will announce purchases of radio stations.

**TELEVISION CELEBRATED A MAJOR EVENT** a few weeks ago with the forming of an official Television Broadcasters Association. President of this new association is Allen B. DuMont, noted cathode-ray tube manufacturer. Lewis Allen Weiss of the Don Lee Network was elected vice-president. On the board of directors are F. J. Bingley, Philco; Robert L. Gibson, General Electric; O. B. Hanson, NBC; C. W. Mason, Earle C. Anthony Inc.; E. A. Hayes, Hughes Tool Co.; Worthington Miner, CBS; and

(Continued on page 134)

## MASTER DRAFTING MACHINE

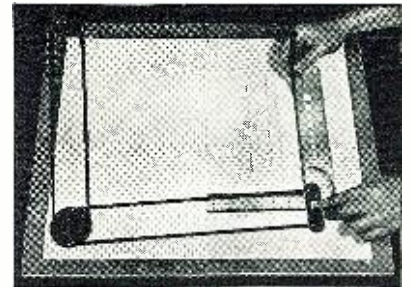

• **Biggest time-saver for dimensioned sketches, lettering and layouts ever sold at this low price. Size, 20"x24". Limited only \$3.95 supply.** While they last

Order Today!

**RANDOLPH RADIO**

609 W. RANDOLPH ST., CHICAGO 6, ILLINOIS

## MASCOT SLIDE RULE

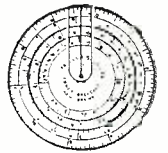

Fits the pocket. Quickly solves any problem in multiplication, division, proportion. Gives the square, the square root, logarithm and reciprocals of all numbers. Trig scales give sines and tangents of numbers. Fine black graduations on white celluloid. Price in fabricoid case \$1.00, in leather case \$1.25. Money back if not satisfied. Special offer to agents and dealers.

MONITOR SLIDE RULE—6" Dia. Made in white Vinylite. Same scales as Mascot Slide Rule. Without case, \$2.95. Leatherette case, 75c additional.

TAVELLA SALES CO.

25-SD West Broadway, New York 7, N. Y.

Whether you require a  
**DIMOUT**  
or  
**TOTAL BLACKOUT**  
PILOT LIGHT

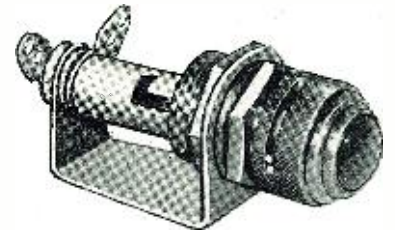

**Gothard**  
VIBRATION RESISTING  
SHUTTER TYPE LIGHT

is  
**AVAILABLE BOTHWAYS!**

Complete gradation of light within 90° rotation of shutter. Also available with polarized lens. Faceted or plain Jewels. Colors: red, green, amber, blue or opal. Write for complete information.

**Gothard . . .**  
MANUFACTURING COMPANY  
1350 N. NINTH ST., SPRINGFIELD, ILL.

# GET INTO RADIO

## ELECTRONICS TELEVISION *Now!*



Checking performance of a radio-telephone transmitter with an oscilloscope. National trained Radio Technicians, in Broadcasting Stations, in Industrial Plants and in business for themselves are well paid specialists. Their services are in urgent demand.

Shortages in trained, skilled men run into the hundreds of thousands. Wartime demands for Radio men are tremendous and will continue UNABATED after the war. The developments in all branches of electronics point to an unlimited future. That's important to you. You want training in a field that will continue to advance. National Schools offers you a time-tested method of Home Training which has helped thousands of men to more pay, and unlimited opportunity in a vigorous and expanding industry.

# Shop Method Home Training by a Long Established Resident School

Here is your opportunity to get the sound, practical up-to-date knowledge in Electronics, Television, Frequency Modulation and other latest developments in Radio. This is not just instruction in theory. It is a real, down-to-earth course based on the shop training that has been developed and improved by National Schools' methods since 1905.

### EASY TO LEARN THE NATIONAL WAY

Now, right at home, you can prepare quickly to be of greatest service to your country and yourself. Yes, right at home in your spare time. National's time-tested plan of Home Training will definitely establish you. In a short time, you can hold a good job in this fascinating field. Furthermore, you become equipped for an ever bigger career in the years of reconstruction after the war.



### RADIO EQUIPMENT INCLUDED

You work with real radio equipment and materials which we furnish. During your National course you build experimental units, check circuits—get real practice with tools and parts. You learn by doing and in a short time you are ready for your first job in radio. Take the important step now. Fill out and mail the coupon at once.

### FREE LESSON

#### and Opportunity Book

To prove that you can easily learn radio at home by National's famous "Shop Method" home training, we will send you this sample LESSON without cost or obligation. With it, we will send you a big, 36 page book, "Your Future in Radio, Television and Electronics."



### TRAIN DURING MILITARY SERVICE



Prepare for Radio Service in Army and Navy. In U. S. Gov't. service you install, operate and maintain most technical equipment such as secret ultra-high frequency apparatus to locate airplanes, submarines, etc. Get promotion in rank and increased pay almost from the start

### START EARNING EARLY

Many beginners start earning extra money even before they have finished their National training. They are needed for radio repair work in plants and factories, in part-time work in broadcasting studios. No previous experience is needed to start. National training is so simple and practical that every step of the way seems natural. You get ahead fast and in a very short time you have a sound grasp of technical terms, tools, parts and equipment.

### GREAT POSTWAR DEMAND

Radio is only one of the courses you receive when you become a National Student. Electronics is brand new and open to every trained radio man. After this war it will produce new marvels that will be needed and used in every home. General Electric, Westinghouse and all great manufacturers have many new electronic inventions ready to market. National men, because of their knowledge and training, will be among the first to cash in. Television is a *big new opportunity*. National men will have the "know how" to merit jobs in this great industry.

### COMMAND ANY OF THESE JOBS

Radio Expert  
Electronics Engineer  
Radio Broadcasting  
Studio Technician  
Television Technician  
Aviation Radio  
Ship & Harbor Radio  
Business of Your Own  
Industrial Sound

137 Different Types of Jobs to Choose From

### NATIONAL GRADUATES WIN GOOD JOBS



"I have been in the broadcasting field since graduating from National. Am with Station W1BX. I recommend your School."—Fred Hoffman, Utica, N. Y.



and tell them of my good luck National has brought to me."—Chas. Plunkett, Danbury, Conn.

### WITH BIG FIRM

"Am employed at General Electric plant in Bridgeport as inspector on Radio for Army and Navy. I owe a great deal of my success to National Training. Wish I could see your instructors and tell them of my good luck National has brought to me."—Chas. Plunkett, Danbury, Conn.

## NATIONAL SCHOOLS

LOS ANGELES 37, CALIFORNIA  
EST. 1905



### MAIL OPPORTUNITY COUPON FOR QUICK ACTION

National Schools, Dept. 4-RNR  
4000 S. Figueroa Street  
Los Angeles 37, Calif.

Mail in envelope  
or paste on penny postal

Please rush me, FREE and without any obligation on my part, Sample Lesson in Radio, Television and Electronics and full details of your "Shop Method" of home training. No salesman will call.

Name..... Age.....

Address.....

City..... State.....

Include your zone number to assure promptness.

# SOME ENGINEERS WE DON'T WANT AT NATIONAL UNION



Let's make it plain. There are a lot of engineers WE DON'T WANT. We have an outstanding group of engineering specialists who are GOING PLACES. They're thinkers, doers, practical dreamers. We're proud of them. WE DO WANT more engineers to join them but they have to be fellows who measure up. If you're not just trying to hit a high spot today. If you want to get into the exciting war work we're doing now and ride along on our great peace time electronic tube band wagon — THIS IS YOUR BIG OPPORTUNITY. We are adding to our staff engineers who specialize in

ELECTRONIC TUBES  
PRODUCTION  
DEVELOPMENT  
MEASUREMENTS  
PHYSICS  
ELECTRICITY  
TRANSMITTING TUBES.

Our laboratories in Newark, N. J., offer ideal working conditions. We prefer that you have a degree in electrical engineering, physics, chemistry or mathematics—your experience, however, may be sufficient.

Why don't you find out whether you're one of the engineers National Union DOES WANT. Write and tell us about yourself or Phone HUmboldt 2-5252, Ext. 72, for appointment.



**NATIONAL UNION RADIO  
CORPORATION**  
50 Spring Street, Newark, 2, N. J.

# ★ INDUSTRIAL ★ MAN-POWER BUREAU

## WESTERN ELECTRIC CO.

In PEACE

Source of supply for the  
Bell System

In WAR

Arsenal of communication  
equipment

wants

## RADIO ENGINEERS

For Design of  
Radio Test Sets

also

## TESTERS

To do inspection and testing of  
Radio Equipment

RELEASE STATEMENT AND U.S.E.S.  
CONSENT NEEDED

Write or apply in person to:

C. R. L.

EMPLOYMENT DEPARTMENT

100 Central Ave.  
Kearny, N. J.

Work Now in the Industry  
of the Future



## RADIO ENGINEERS ASSISTANT ENGINEERS LAYOUT DRAFTSMEN

Immediate Openings in Develop-  
ment, Specifications, Production  
Engineering and Test Equipment.

100% WAR PRODUCTION

Post War Future

Good Wages

Semi-Annual Bonus

Free Life Insurance

Weekly Sick Benefits

Surgical and Hospital Care

Paid Vacations

We also need Lab Assistants, Qual-  
ity Testers, Analyzers, Phasers.

# Motorola

GALVIN MFG. CORPORATION  
4545 Augusta Blvd. \* Chicago

## ELECTRONIC ENGINEER or ELECTRICAL ENGINEER with HIGH FREQUENCY EXPERIENCE

Preferably with some background in  
mechanical engineering. Position with  
well established company of known rep-  
utation in the Middle-West with post-war  
possibilities in the manufacture of in-  
dustrial electronic equipment. State  
education, experience, salary expected,  
marital and draft status.

Box 337, % RADIO NEWS.

## PERMANENCY

EXPANSION of largest Marketing Research company  
(employing over 700 salaried individuals) has created  
several openings in its Radio Research field staff.  
Technical training or knowledge of radio necessary.  
Our Radio Research is applied to essential industry,  
and our Company offers unusual possibilities both  
during and after the war.  
Starting salary \$172.50 per month with opportunity  
to increase earnings substantially in supervisory and  
management work. These positions mean some travel  
and location in Middle West or East. Complete mov-  
ing expenses borne by our Company. Car is essential  
with full allowance for operation. All travel expenses.  
Ability to organize, handle details and meet all types  
of people is important (although our work does not  
entail selling). Please give us your business experi-  
ence, education, age, religion and draft status for a  
personal interview. Desirable ages 25 to 40.  
The several successful applicants will be sent to our  
own training school at full salary. These positions  
mean long hours and hard work, but offer advance-  
ment on both merit and length of service, and asso-  
ciation with an outstanding national organization.

RADIO NEWS, BOX 308  
540 North Michigan Avenue Chicago, Ill.

## WANTED VARIABLE CONDENSER ENGINEERS

FOR

Mechanical Design

Electrical Design

Development Work

Tool Design

Manufacturing Procedures

If you are experienced in one or more  
of the above, and are not now using  
your highest skill in war work, we are  
interested in hearing from you. Give  
full details of your experience and qual-  
ifications. These are permanent posi-  
tions and salary will be commensurate  
with ability.

E. F. JOHNSON COMPANY  
WASECA, MINNESOTA

"This section is designed to help the radio industry obtain trained, experienced, technical men to facilitate vital war production. Before applying for any of these positions consult your local United States Employment Service office to determine War Manpower Commission regulations concerning the changing of jobs. If you are already employed in war work at your highest skill, stick to your present job."

## POSITIONS OPEN

*Design Engineers  
Field Installation  
and  
Maintenance Engineers  
at*

## WESTINGHOUSE

For Field Service Work  
with  
Micro-Wave Equipment

Opportunity for Service  
Outside the United States  
If Desired.

Radio Engineers and Electrical Engineers acceptable for brief training course prior to field assignments.

No one employed at his highest skill in essential industry should apply.

Applicants living outside the Baltimore area must obtain a "Statement of Availability" from their nearest United States Employment Service office.

*Apply in Person or by Letter to*

**RADIO DIVISION  
WESTINGHOUSE ELECTRIC &  
MANUFACTURING COMPANY  
2519 Wilkins Avenue  
Baltimore, Maryland**

## ENGINEERS

Junior, Semi-Senior and Senior

Wanted for production developmental work. Must have some experience as technician and background in theory. Interesting work. Good living conditions. Salary in keeping with experience and background. Write stating qualifications in full. Interview arranged promptly.

*Write to: Personnel Department*

**SPRAGUE SPECIALTIES CO.**

NORTH ADAMS, MASS.

Applicants will be engaged only in strict compliance with regulations of the War Manpower Commission.

## RADIO

- . . . engineers
- . . . draftsmen
- . . . laboratory assistants
- . . . mechanical engineers
- . . . production men

A TOP-FLIGHT RADIO MANUFACTURER who is NOT in a manpower emergency wants to establish contact with top-flight radio men who, today, are NOT in a job hunting emergency.

WE ARE LOOKING AHEAD to the postwar day when we can turn from the vital war work we now are doing and begin on the constantly growing bank of civilian production which is on our books.

LOOKING AHEAD, we want to add capable men as rapidly as they are freed from essential wartime work so they can fit themselves into our organization and be ready for responsible jobs when we get the "go" signal on major peacetime projects.

OR—IN CASES OF MEN WHO MUST REMAIN on essential war jobs for the duration—we want to establish contact and be acquainted to save time when a move can be made.

GOOD INCOME PLAN, wide-open opportunity, a sound future, pleasant surroundings in midwest location.

PLEASE SUPPLY FULL DETAILS in letter, including address and telephone number so our representative can get in touch with you for personal interview soon. Write Box 336, % Radio News.

## RADIO-ELECTRONIC ENGINEERS TESTERS TECHNICIANS

**EXCELLENT OPPORTUNITIES  
IN A MAJOR POST WAR FIELD**

Openings available at our Research Laboratories and Electronic manufacturing unit. Leaders in the design and development of vital electronic equipment for the armed forces.

Essential workers need release statement.

Write, stating experience, education, draft status, salary requirements or apply to

## SPERRY

**GYROSCOPE CO., INC.  
RESEARCH LABS. & ELECTRONIC  
PLANT  
STEWART AVE. & CLINTON RD.  
GARDEN CITY, NEW YORK**

## PRESS WIRELESS, Inc.

Has openings for persons with radio communication and manufacturing experience.

## RADIO ENGINEERS TECHNICIANS OPERATORS

*Apply: Personnel Division*

230 West 41st St., New York, N. Y.

or

435 No. Michigan Ave., Chicago, Ill.

## RADIO ENGINEERS

At least two years' design and development experience with Radio Communications Equipment manufacturer on items subsequently satisfactorily produced in quantity. Knowledge and experience in two-way mobile equipment, low power transmitters, receivers, and controlled equipment essential. Permanent position. West Coast Manufacturer. Will pay expenses to coast for interview if qualifications satisfactory. Write giving complete past experience, employment record, salary received, and technical references.

**BOX NO. 338**

c/o RADIO NEWS

## TECHNICAL WRITERS WANTED! Spare Time

Engineers, amateurs, servicemen, instructors, and physicists who have had experience in writing technical manuscripts for publication.

Manuscripts to cover theory, application, or construction of electronic equipment, including:

AM RADIO  
FM RADIO  
FACSIMILE  
TELEVISION  
BROADCASTING  
TRANSMITTERS  
TRANCEIVERS  
ELECTRONIC CONTROL  
ULTRA-HIGH FREQUENCY  
HAM EQUIPMENT  
SERVICE EQUIPMENT

Reply Box 310, c/o Radio News, 540 N. Michigan Avenue, Chicago 11, Illinois.

**IF YOUR SPEED IS LESS THAN 50 W.P.M. SEND TODAY FOR THIS 52 PAGE FREE BOOK - FOR AMATEURS AND COMMERCIAL RADIO OPERATORS**

It shows that "crack" operators rely on something besides practice to develop their high speed and proficiency; it explains the "knack" of sound-sense and sound-consciousness—the secret of speedy sending and receiving. Once you acquire these mental processes, reading code becomes almost second nature to you, just as the rhythm of a dance band becomes automatic to musician and dancer.

Champions endorse the Candler System. It is used in training Commercial Operators, Amateurs, and Radiotelegraph Specialists in Signal Corps, Marines, Navy, Coast Guard, Airlines, Broadcast Studios, Police Inter-City Communications. Wherever the fastest, most efficient operators are found, there you will find Candler trained men.

If you want s-p-e-e-d, if you have any difficulties in operating technique, if 40-50, and more, wpm seem fantastic speeds to you—send for this revealing 52 page Book now. It's yours without cost or obligation. Simply send your name and address to—

**CANDLER SYSTEM COMPANY**  
Dept. 2D Box 928, DENVER, COLO., U.S.A.  
And at 121 Kingsway, London, W. C. 2, England

**NOW—A REALLY HIGH-POWERED—  
Radio Engineering  
Library**

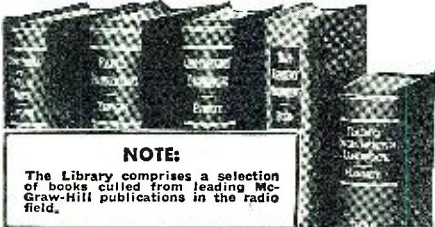

**NOTE:**

The Library comprises a selection of books culled from leading McGraw-Hill publications in the radio field.

- especially selected by radio specialists of McGraw-Hill publications
- to give most complete, dependable coverage of facts needed by all whose fields are grounded on radio fundamentals
- available at a special price and terms

THESE books cover circuit phenomena, tube theory, networks, measurements, and other subjects—give specialized treatments of all fields of practical design and application. They are books of recognized position in the literature—books you will refer to and be referred to often. If you are a practical designer, researcher or engineer in any field based on radio, you want these books for the help they give in hundreds of problems throughout the whole field of radio engineering.

**5 VOLUMES, 3319 PAGES, 2289 ILLUSTRATIONS**

1. Eastman's FUNDAMENTALS OF VACUUM TUBES
2. Terman's RADIO ENGINEERING
3. Everitt's COMMUNICATION ENGINEERING
4. Hund's HIGH FREQUENCY MEASUREMENTS
5. Henney's RADIO ENGINEERING HANDBOOK

10 days' examination. Easy terms. Special price under this offer less than books bought separately. Add these standard works to your library now; pay small monthly installments, while you use the books.

**10 DAYS' FREE EXAMINATION—SEND COUPON**

**McGRAW-HILL BOOK CO.,  
330 W. 42nd Street, New York 18, N. Y.**

Send me Radio Engineering Library, 5 vols., for 10 days' examination on approval. In 10 days I will send \$3.00 plus few cents postage, and \$3.00 monthly till \$24.00 is paid, or return books postpaid. (We pay postage on orders accompanied by remittance of first installment.)

Name .....

Address .....

City and State .....

Position .....

Company .....

(Continued from page 130)

Paul Raibourn, Television Productions Inc.; as well as Mr. Weiss and Mr. DuMont.

In the Association at the present are nineteen members. These are . . . Allen B. DuMont Laboratories, Inc., Balaban and Katz Corp., Columbia Broadcasting System, Don Lee Broadcasting System, Earle C. Anthony, Inc., General Electric Co., General Television Corp., Hughes Tool Co., Intermountain Detrola Corp., Milwaukee Journal, K F R E Fresno, Midland Broadcasting Co., N. W. Ayer & Son, Inc., National Broadcasting Co., Philco Corp., Television Productions, Inc., WGN, Inc., and WOR.

The Association has already voted to become a contributing sponsor to the Radio Technical Planning Board. Incidentally, Panel Six of this board, devoted to television, has met several times to discuss allocation and other transmission problems. In a recent meeting members of this panel discussed the relative merits of AM and FM as the sound channel for television. In this respect the cooperation of Panel Five, devoted to Very High Frequency broadcasting, has been requested.

Multipath distortion, which appears to increase as the higher frequencies are used, is also being studied by members of Panel Five. This is particularly important since television broadcasting may be directed into higher frequency channels.

Interviews with several of the executive engineers of television systems indicate that the technical aspects of television are sufficiently advanced to provide practical use today. Efforts are now being directed towards the development of more sensitive cameras, and larger receiving screens. Since motion picture companies are allied with television activities on many fronts, complete harmony is expected between the two mediums of entertainment, in a showmanship and a technical way. Incidentally, the problem of producing and staging television shows seems to be one of the most difficult to solve at the present time. New York and Hollywood specialists are striving to effect a practical solution.

Hollywood, it appears, may become the television center. This was emphasized by Sidney N. Strotz, vice-president in charge of the western division, NBC, Hollywood, California, in his paper in the current issue of "Radio Age," the RCA house organ. Mr. Strotz said, "Hollywood is an ideal spot for television production, because it is the only place in America that has so many competent technicians who are familiar with both motion picture and radio production. I have no doubt that film will be used extensively in the technique of television. I don't think there is enough talent in the world to supply the demand that would have to be met if all television entertainment were put on a live

basis. Rehearsal hours, memorizing lines and staging live productions, to say nothing of the mechanical factors like sets and scenery, would make it a formidable, if not impossible problem. I believe that television production will have to embody both live shows, such as special broadcasts of news and sporting events, and entertainment previously put on film, as the motion picture studios are doing today. Anyway we look at it, Hollywood is bound to increase in importance as a center of both radio and television."

**Personals . . .**

**W. P. Hilliard** is now general manager of the radio division of Bendix Aviation, succeeding **Hugh Benet**. Mr. Hilliard was formerly director of sales and engineering. In 1936 Bendix purchased Mr. Hilliard's company, merging it with the radio division. . . . Many CBS executives are now serving in the Armed Forces: **Lt. Comm. Melford R. Runyon**, USNR, CBS vice-president and director; **Lt. Col. Lawrence W. Lowman**, Army, CBS vice-president in charge of operations; **Comm. Harry C. Butcher**, USNR, aide to Gen. Eisenhower, CBS vice-president in charge of Washington operations; **Comm. A. B. Chamberlain**, USNR, CBS chief engineer; **Lieut. (j.g.) J. Dunham Gilbert**, USN, supervisor of WABC technicians, and **Capt. Nelson Smith**, Army, also a supervisor of WABC technicians. . . . **Major Gen. Follett Bradley**, former commander of the 1st Air Force at Mitchell Field, is now assistant to the president of Sperry Gyroscope. . . . **John Harold Ryan**, assistant director of censorship in charge of radio, has been elected president of the National Association of Broadcasters. . . . A test instrument industry advisory committee has just been announced by WPB. Members of the committee are **A. H. Hotopp, Jr.**, Technical Device Corp.; **David Newman**, The Daven Co.; **Paul Jackson**, The Jackson Electrical Instrument Corp.; **E. G. Perkins**, Supreme Instrument; **V. E. Jenkins**, Weston Electrical Instrument Corp.; **Milton Reiner**, Radio City Products Co.; **J. J. McCarthy**, Triumph Manufacturing Co., and **A. J. Lush**, Rawson Electrical Instrument Co. . . . **Lt. Col. Dee Berry**, a Signal Officer in the Northwest Service Command, who has played an important role in the Alcan

**PHOTO CREDITS**

Page Numbers	Credits
27 (top), 28	
(top) . . . . .	Bendix Radio
32, 33, 34 . . . . .	Bureau of Pub. Relations, War Dept.
40 . . . . .	U. S. Marine Corps
41 (top) . . . . .	Acme
41 (bottom) . . . . .	Official Marine Corps photo from Acme
48, 49 . . . . .	British Official Photo
50 . . . . .	Eastern Airlines

# LEARN CODE

the way you'll be using it

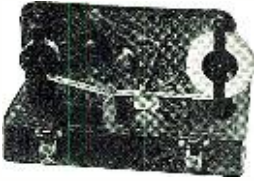

by SOUND

The best way to learn to read code is by listening to code. The best way to learn to send code is by hearing your own

sending repeated back to you. With the new All-Electric Master Teleplex Code Teaching Machine, you learn code the natural, easy, fascinating way. Only instrument ever produced which records your sending in visible dots and dashes—then SENDS BACK your own key work at any speed you desire. There are NO PERFORATIONS—NO INK. Far superior to anything ever developed... a marvel of simplicity. *That's why practically every school teaching code uses MASTER TELEPLEX.* We furnish complete course, including the All-Electric Master Teleplex, give you personal instruction with a MONEY-BACK GUARANTEE—All at a surprisingly low cost. Write today for FREE catalog RN-6. No obligation

TELEPLEX CO., 107 HUDSON ST., JERSEY CITY, N. J.



**"The Inductance Authority"**  
by Edward M. Shiepe  
B.S., M.E.E.

The only book of its kind in the world. Listed by the Government among the recommended technical books. 36 full page 9x12 charts and ten pages author's instructions on how to figure all types of solenoid coils. Saves ten times its cost in tedious and time consuming calculations. Check your work Postpd. with the charts and avoid costly errors.

**\$2.50**

GOLD SHIELD PRODUCTS (Dept. RN4)  
350 Greenwich St., New York 13, N. Y.

**RADIO AND ELECTRONIC DEVICES**



**BURSTEIN-APPLEBEE CO.**  
1012-14 McGee St. Kansas City, Mo.

**Specify SAUERISEN**

**ACIDPROOF CEMENTS—COMPOUNDS FOR**

Tanks, Sewers, Stacks, Floors  
Technical cements for all purposes.  
*Send sketches or samples*  
Sauerisen Cements Company · Pittsburgh 15, Penna.

**COMMERCIAL RADIO INSTITUTE**

A radio Training center for over twenty-three years.

**RESIDENT COURSES ONLY.**

Pre-induction, Broadcast, Marine Telegraphy, Aeronautical, Television, Service.  
Classes now forming for April 10th. Literature upon request.

Dept. D., 38 W. Biddle St.  
Baltimore 1, Md.

Communications System project, is now executive officer of the Central Signal Corps School at Camp Crowder, Missouri.

—50—

**Wired Radio**  
(Continued from page 64)

.001 to .002  $\mu$ fd. For best results in a given locality, some experimentation might be necessary as far as the actual capacitance of this unit is concerned.

If a.c.-d.c. operation is employed, as indicated in Fig. 9, it is strongly urged that the chassis be insulated from the metal panel and cabinet in order to prevent shock to the operator. B-minus, it will be observed, returns directly to one side of the line and will thus expose the operator unless precautions are taken.

### Emergency Tank Coils

Aside from the specially-wound, large-diameter coils for low-frequency carriers, superhet beat-frequency oscillator cans, superhet high-frequency oscillator coils, and pi-wound r-f chokes may be utilized with suitable capacitances to tune to the low frequencies.

The superhet beat-oscillator coils include one or two trimmer condensers which are generally adjusted by means of a screwdriver and these units will accordingly require no external shunt capacitance unless it is desired to reduce their normal operating frequency. Superhet high-frequency oscillator coils, on the other hand, are designed for tuning in the broadcast band (500-1600 kc.) with a 365- $\mu$ fd. variable condenser. The amount of parallel capacitance required with these to reach desired low frequencies will depend upon the inductance value of the coil and the frequency to be reached. Pi-wound chokes are available commonly in two values—1 millihenry and 2.5 millihenries. Many amateur operators have these items in their spare-parts boxes. A listing is made in Chart I of the parallel capacitances required to reach certain common low-frequency values with 1- and 2.5-mh. chokes. For operation in oscillator circuits such as those of Figs. 3, 6, and 9, the cathode tap is taken from the connection between the 2nd and 3rd pi's in the 2.5-mh. choke or between the 1st and 2nd in the 1-mh. job. These chokes do not exhibit a good Q at radio frequencies and therefore are not recommended except for low power use, as in receivers and transceivers. Under no circumstances, should they be employed as tank coils in higher-powered transmitter circuits where circulating tank current will reach a level of several amperes r-f.

*A succeeding article will deal with control systems operated by carrier currents, and with a practical carrier-current intercommunicator system.*

—50—

Order From

# RADOLEK

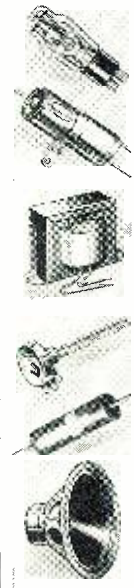

**RADIO PARTS  
ELECTRONIC  
APPARATUS  
SOUND SYSTEMS**

Make Radolek your dependable buying source for everything in radio, sound and electronics. We can supply essential merchandise to repair any radio—tubes, condensers, resistors, controls, transformers, etc.—all at lowest prices.

**Large Stocks:** Radolek's large stocks assure the finest and most complete selections of all available items. Thousands of servicemen rely on Radolek for their entire requirements.

**Fast Service:** Streamlined handling of every order simplifies procurement problems and gives you fastest possible delivery. Whatever your need—for industry, the Armed Forces or civilian replacement—ordering from Radolek saves time, effort and expense.

Get This Free  
Buying Guide



SEND TODAY!

RADOLEK CO., Dept. B-89,  
601 W. Randolph St., Chicago, Ill.  
Please send your FREE Buying Guide.

Name .....

Address .....

DEALER     SERVICEMAN     SOUND ENG.

SAVE AT RADOLEK

**Guaranteed Rebuilt  
VIBRATORS—\$1.00 ea.**

Send old vibrator. For very prompt delivery, enclose remittance and return postage. We rebuild any make or kind of vibrator or relay. Send your old vibrator to  
**BEST VIBRATOR CO., Box 5802**  
Cleveland 1, Ohio

*Learn* **RADIO-ELECTRONICS**

**12 WEEKS TRAINING IN  
COYNE SHOPS ON REAL  
RADIO - ELECTRONIC  
EQUIPMENT! FOR MEN 16  
UP TO 50**



Prepare for a great Peace time future *H. C. Coyne* and a good job in Radio and Electronics now. Coyne "LEARN BY DOING" training covers latest developments in this field. Prepare quickly, easily. Fascinating well paid work in maintenance, installation and servicing Radio and Electronic equipment.

**I'LL FINANCE YOUR TRAINING!**

Start now—pay tuition after graduation. My plan has helped thousands. I assist you in getting part-time work while at COYNE to help pay living expenses. Job Service when trained. Also have facilities for men with physical disabilities. Write!

**ELECTRONICS AND TELEVISION**

Tremendous expansion in Radio, Electronics, Frequency Modulation and Television predicted after the war—a world of new opportunities. Get ready for a Peace time future and a good job NOW with practical Coyne Radio Training.

**FREE BOOK!** Whether you're 16 or up to 50 get facts, Special Industrial Electronics training included at no extra cost now. Mail coupon today.

H. C. LEWIS, Pres., RADIO DIV., COYNE ELEC. SCHOOL  
500 S. Paulina St., Dept. 44-14, Chicago 12, Illinois

Send me FREE BOOK, "Your Future in Radio", and details of Industrial Electronics training included at no extra charge and easy "Pay-After-Graduation" plan.

NAME.....AGE.....

ADDRESS.....

CITY.....STATE.....

COMPANY	AGENCY	PAGE NO.	COMPANY	AGENCY	PAGE NO.
Aerovox Corp.	Austin C. Lescarboursa & Staff.	137	McElroy Mfg. Corporation	Shappe-Wilkes, Inc.	109
Allied Radio Corp.	Henry H. Teplitz	82, 136	McGraw Hill Book Co.	Triangle Adv. Agcy.	134
American Condenser Corp.	C. Wendel Muench & Co.	120	Majestic Radio & Television Corp.	Aithin-Kynet Co.	111
American Phenolic Corp.	Evans Associates, Inc.	102	Mallory, J. R. & Co., Inc.	Western Adv. Agcy., Inc.	94
American Radio Hardware Co. Inc.	Shappe-Wilkes, Inc.	15	Meck, John, Industries	Ross Llewellyn, Inc.	74
Amperite Co.	H. J. Gold & Co.	126	Merit Coil & Transformer Corp.	James Millen, Inc.	10
Audel, Theo., & Co.	Grant & Wadsworth	130	Millen, James, Mfg. Co., Inc.	John A. Smith & Staff.	68
Belmont Radio Corp.	Beaumont & Hohman, Inc.	75	Murdock, Wm. J. Co.	Mutual Radio Products Co.	124
Best Vibrator Company		135	National Company, Inc.	Graydon Smith, Adv.	67
Bliley Electric Co.	W. S. Hill Co.	116	National Radio Institute	Van Sant, Dugdale & Co.	3
Bogen, David, Co., Inc.	Shappe-Wilkes	88	National Schools	The Mayers Co.	131
Breeze Corps., Inc.	Burke Dowling Adams	105	National Union Radio Corp.	Sayre M. Ramsdell Assoc.	119, 132
Burstein-Applebee Co.	Frank E. Whalen Adv. Co.	135	Nelson Co.	A. N. Baker Co.	118
Candler System Co.	Galen E. Eroyles Co.	134	Ohmite Mfg. Co.	Henry H. Teplitz	57
Capitol Radio Engineering Institute	Henry J. Kaufman Adv.	14	Onan, D. W. & Sons	Burton Browne, Adv.	98
Centralab	Gustav Marx Adv. Agcy.	104	Permoflux Corp.	Turner Adv. Agcy.	92
Chicago Novelty Co., Inc.	Sandler Rodkin Adv.	122	Pioneer Gen-E-Motor	Burton Browne, Adv.	113
Clare, C. P. & Co.	J. R. Hamilton Adv. Agcy.	86	Polymet Condenser	Sternfield-Godley, Inc.	122
Commercial Radio Institute		135	Press Wireless, Inc.		133
Connecticut Telephone & Electric Div.	Wilson & Haight, Inc.	87	Radio Merchandise Sales		120
Consolidated Radio Products	Burton Browne, Adv.	64	Radio Receptor Co., Inc.	Shappe-Wilkes, Inc.	7
Coyne Electrical School	Mc Junkin Adv. Co.	128, 135	Radio & Tech. Div. of Murray Hill Books	Harry P. Bridge Co.	63
Crowe Name Plate & Mfg. Co.		91	Radolek Co.	Turner Adv. Agcy.	135
DeForest's Training, Inc.	MacDonald-Cook Co.	127	Randolph Radio		110, 130
DeJur Amso Corp.	Shappe-Wilkes, Inc.	59	RCA Engineering Products	Kenyon & Eckhardt, Inc.	99
Detrola Corporation	Zimmer-Keller, Inc.	71	RCA Institutes, Inc.	Kenyon & Eckhardt, Inc.	122
Doolittle Radio, Inc.	Henry H. Teplitz	112	RCA Victor Division	Lansford F. King, Adv.	114
DuMont, Allen B. Laboratories, Inc.	Austin C. Lescarboursa & Staff.	97	Rider, John F. Publisher, Inc.	Duane Wanamaker, Adv.	73
DX Crystal Company	Michael E. Mayger	112	Runzel Cord & Wire Co.		135
Echophone Radio Co.	Burton Browne, Adv.	5	Sauereisen Cements Co.	Henry H. Teplitz	129
Editors & Engineers		104	Shure Brothers		120
Electro-Voice Mfg.	Shappe-Wilkes, Inc.	93	Sigmon Radio Supply	Kreicker & Meloan, Inc.	121
Electronic Corporation of America	Shappe-Wilkes, Inc.	69	Simpson Electric Co.	O. S. Tyson & Co.	11
Fada Radio & Electric Co., Inc.	Sternfield Godley, Inc.	17	Solar Mfg. Company	Burton Browne, Adv.	90
Federal Telephone & Radio Corp.	Marschalk & Pratt Co., Inc.	9	Sound Projects Co.	Equity Advertising Agcy.	133
Galvin Mfg. Corporation	Gourfain-Cobb Adv. Agcy.	132	Sperry Gyroscope Co.	Harry P. Bridge Co.	61, 133
General Electric Co.	N. W. Ayer & Son, Inc.	19	Sprague Products Co.	Harry P. Bridge Co.	13
General Motors Corp., Delco Div.	Campbell-Ewald Co.	65	Sprayberry Academy of Radio	Burnet-Kuhn Adv. Co.	60
Gold Shield Products	Sternfield Godley, Inc.	135	Standard Transformer Corp.	Howard-Wesson Co.	12
Gothard Mfg. Company	Merchandising Advertisers	130	Stevens Walden, Inc.	W. S. Hill Co., Adv.	123
Greenlee Tool Co.	Howard H. Monk & Assoc.	124	Stupakoff Ceramic & Mfg. Co.	O'Callaghan Adv. Agcy., Inc.	80
Guardian Electric Mfg. Co.	Kennedy & Co.	85	Supreme Instruments Corp.	Henry H. Teplitz	115
Haldorson Co., The		103	Supreme Publications	Arthur Kudner, Inc.	8
Hallcrafters	Burton Browne, Adv.	Back Cover	Tavella Sales Co.	Reuben Barkow, Adv.	130
Hammarlund Mfg. Co., Inc.	Roeding & Arnold	20	Teleplex Co.	Terrill Belknap Marsch Assoc.	135
Hytron Corp.	Henry A. Ludon, Adv.	2nd Cover	Thordarson Electric Mfg. Co.	Duane Wanamaker, Adv.	116
Illinois Condenser Co.		126	Tobe Deutschmann Corp.	Franklin Bruck Corp.	138
Indiana Technical College	N. W. Ayer & Son, Inc.	120	Triplet Electrical Instrument Co.	Western Adv. Agcy.	16
Industrial & Commercial Electronics	Garfield & Guild	95	Turner Co., The	W. D. Lyon Co.	84
International Resistance Co.	The Lavenson Bureau	77	Union Aircraft Products	Maxon, Inc. Adv.	72
Jensen Radio Mfg. Co.	Burton Browne, Adv.	6	United Transformer Corp.	Shappe-Wilkes, Inc.	100
Johnson, E. F., Co.	David, Inc. Adv.	132, Third Cover	Universal Microphones Co., Ltd.	Ralph L. Power	76
Kato Engineering Co.	Turner Adv. Agcy.	107	Utah Radio Products Co.	The Buchen Co.	89
Knights, James Co.		107	Vaco Products Co.	Duane Wanamaker, Adv.	130
Lafayette Radio Corp.	Shappe-Wilkes, Inc.	78	Wallace, Wm. T.	Michael F. Mayger	96
Lake Radio Sales Co.		118	Ward Leonard Electric Co.	E. M. Freystadt Assoc.	132
Lear Avia, Inc.	Arthur Kudner, Inc.	117	Western Electric Co.	Deutsch & Shea Adv. Agcy.	132
Lincoln Engineering School	Buchanan-Thomas Adv. Agcy.	122	Westinghouse Electric & Mfg. Co.	Fuller & Smith & Ross, Inc.	79, 133
			Wiley, John & Sons, Inc.	S. Duane Lyon	108

**Classified**

Rate 15c per word. Minimum, 10 words

**CORRESPONDENCE COURSES**

RADIO Communications courses qualifying for all Federal licenses. Home study and resident courses. American Radio Institute, 44 East 23rd St., New York, N. Y.

USED Correspondence Courses and Educational Books sold or rented. Inexpensive. Money-back guarantee. Write for Free Catalog listing 4000 bargains.—(Courses Bought).—Lee Mountain, Pisgah, Ala.

CORRESPONDENCE Courses and self-instruction books, slightly used. Sold. Rented. Exchanged. All subjects. Satisfaction guaranteed. Cash paid for used courses. Complete details and 84-page illustrated bargain catalog free. Write Nelson Company, 237. Chicago.

LEARN Radio Code, Phonograph record, two sides, easy learning. \$1.00. Howerdel's, 102 Hancock Ave., Jersey City, N. J.

**PATENT ATTORNEYS**

INVENTORS—Before disclosing your invention to any one send for Form "Evidence of Conception";

"Schedule of Government and Attorneys' Fees" and instructions. Sent free. Lancaster, Allwine & Rommel, 414 Bowen Building, Washington, D. C.

**RADIO ENGINEERING**

RADIO Engineering, Broadcasting, Aviation and Police Radio, Servicing, Marine Operating and Electronics taught thoroughly. Expenses low. Write for catalog. Valparaiso Technical Institute, Dept. N, Valparaiso, Ind.

**WANTED**

I WANT to buy a set of Rider's service manuals (second hand). N. U. Ahmed, 838 N. Dupont St., Wilmington, Del.

WANTED: Complete circuit and values of Resistors and condensers for 1932 Norden-Hauck Admiralty Super 10-Receiver. C. E. Simpson, 210 Bland St., Bluefield, W. Va.

WANTED: Tube tester: AC-DC VOM of 1000 ohms per volt sensitivity, signal generator. Carl A. Covington, 1918 N. 16 St., Arlington, Va.

**FOR SALE**

WIRE-WOUND potentiometers and resistors: Potentiometers—9 watt 12000 ohms; 50 watt 8.8

ohms, 11, 2.5, and 3; 300 watt 103 ohms; 150 watt 300 ohms; 40 watt 225 ohms. Resistors: 200 watt, fixed. 50 ohms, 3, 5, 15, 2.5, and 10; 25 watt 500, 1460, 1500, 2200, 2290, 2500; 2 watt 12000 and 500. War essential given preference. Hatry and Young, Hartford, Conn.

COMPLETE Victory line of filter and by-pass condensers. Miller coils. 1.P.s., etc. 4", 5", 8" PM speakers. Send for list. Huntress Radio Co., 418 W. Spring, Freeport, Ill.

**NEW! ALLIED'S Rapid R-F RESONANCE & COIL WINDING CALCULATOR**

only 25¢

Simple! Easy to use! For fast accurate determination of resonance factors and coil winding data. Only 25¢ postpaid. No. 37-955.

**ALLIED RADIO CORP.**  
833 W. Jackson, Dept. C1-D-4, Chicago 7

**ALLIED RADIO**



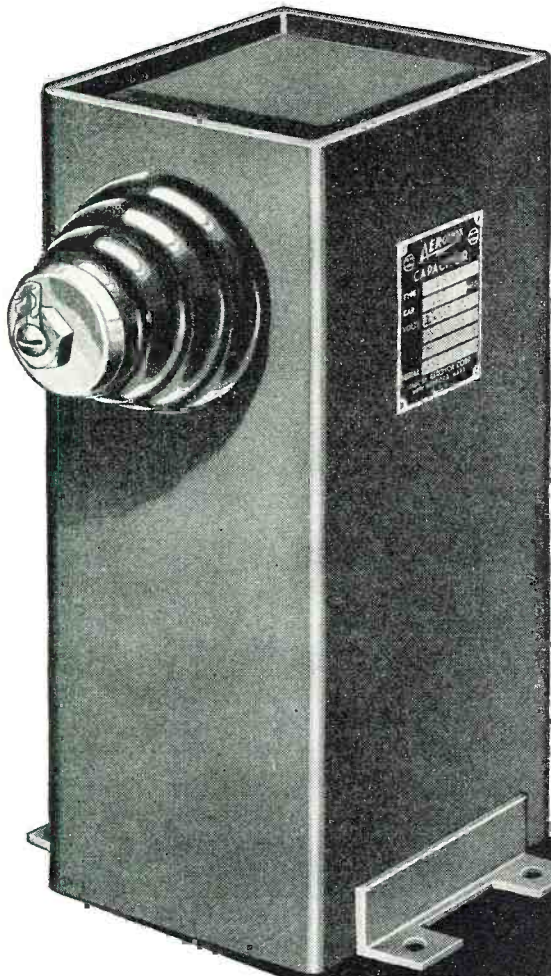

Aerovox oil-filled capacitors for war and for peace—a giant 15,000 volt unit with side terminal and grounded case, to reduce head room; a small "bathtub" unit for use in better-grade radio and electronic assemblies.

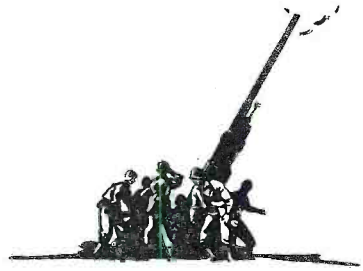
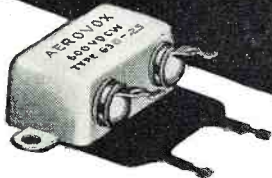

**TODAY...**

**Aerovox Capacitors Go to War**

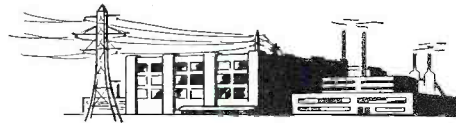

**TOMORROW...**

**Aerovox Capacitors Help Build  
Peacetime Progress**

● In countless ways Aerovox capacitors are speeding up the winning of the war. Thousands of skilled workers, carrying out the designs and specifications of engineers long specializing in capacitors, are meeting a large portion of the wartime requirements.

Indeed, Aerovox personnel has expanded threefold since Pearl Harbor. Close to half a million square feet, in two plants, are now devoted exclusively to capacitor production.

Today Aerovox is all-out for the war effort. Winning the war comes first. But tomorrow, when

victory shall have been achieved, Aerovox once more will be ready as never before to rebuild for peacetime progress—to meet the requirements of the expanding radio industry and the booming electronic era. Special types of yesterday shall be the commonplace types of tomorrow. New standards of life and performance for your assemblies can be taken for granted.

Let us help you now with your wartime needs. And it isn't too early now to be discussing your post-war plans and problems. Submit your capacitance problems or needs.



*Capacitors*

**INDIVIDUALLY TESTED**

**AEROVOX CORPORATION, NEW BEDFORD, MASS., U. S. A.**

**SALES OFFICES IN ALL PRINCIPAL CITIES**

**Export: 13 E. 40 ST., NEW YORK 16, N. Y. • Cable: 'ARLAB' • In Canada: AEROVOX CANADA LTD., HAMILTON, ONT.**

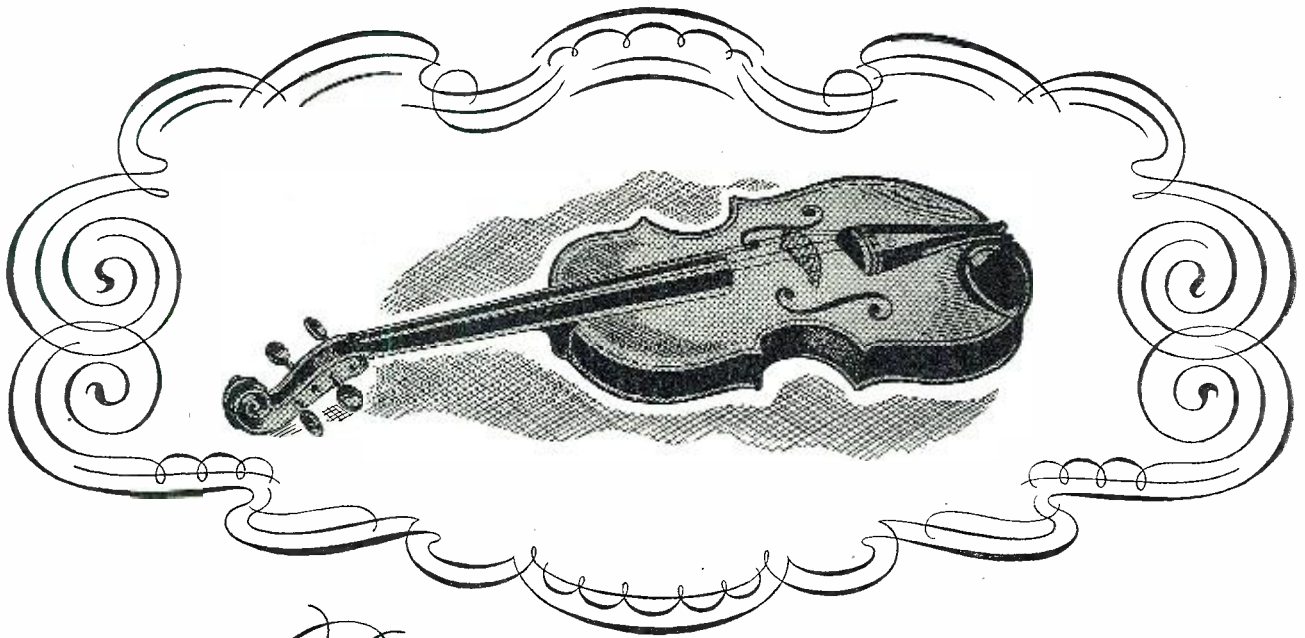

# Proved true by time

Time alone can prove how good capacitors are. The enviable reputation of Tobe Capacitors for *long life* rests on an almost complete absence of "returns". Such things don't "just happen". Back of Tobe Capacitors are constant research, specialized manufacturing experience and rigid inspections. Ratings are always on the conservative side.

Whatever your condenser problems, we invite you to put them up to our engineers. You will receive prompt service and close co-operation.

## LONG LIFE ASSURED

**TRS 605.**  
5 mfd. 600 volts

**SIZE—**  
Overall height 5"

**CONTAINER—**  
1 1/16" x 2 1/2" x 4"

Dimensions of other TRS models on request.

**SPECIFICATIONS FOR TRS CAPACITORS**

<b>CAPACITY—</b> .1 to 50.0 mfd.	<b>RESISTANCE Terminal to Case—</b> 10,000 megohms minimum.
<b>WORKING VOLTAGE—</b> 600 volts DC to 6,000 volts DC.	<b>POWER FACTOR—</b> .002 to .003
<b>SHUNT RESISTANCE—</b> 15,000 megohms per mfd.	<b>VOLTAGE TEST Terminal to Case—</b> 2,500 VDC for 600 volt condensers.

Capacitor unit tested at 2 1/2 times rated voltage.

Universal (wrap around) L or foot type and screw Spudo-lug mounting brackets can be supplied.

*A small part in Victory today . . . A BIG PART IN INDUSTRY TOMORROW*

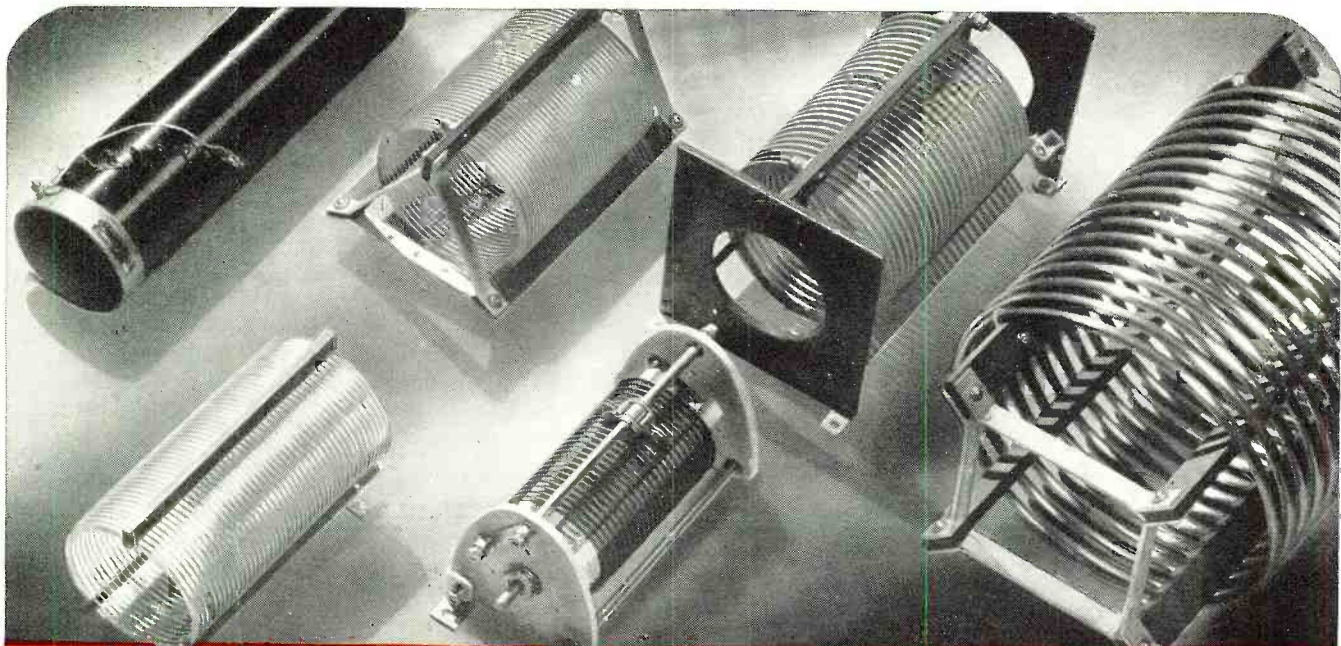

## *Inductors - to specifications*

From the small 100 watt tube socket types to the large 100KW types using copper tubing, Johnson inductors are designed to rigid specifications. They are more than coils. Into each of Johnson's inductors go more than 20 years of "know how"—familiarity with materials—skill in mechanical design—knowledge of circuits—and experience in electrical design for greatest efficiency in the particular application. Tapped inductors, fixed and variable coupling coils, variable inductors, and clips are all features Johnson can furnish. Copper tubing, wire, edgewise wound copper strip, or flat copper strip are available. Insulation materials used are steatite, Mycalex, Bakelite, and porcelain. Write for suggestions on YOUR inductor problem. Quotations furnished on the basis of either mechanical specifications or performance specifications.

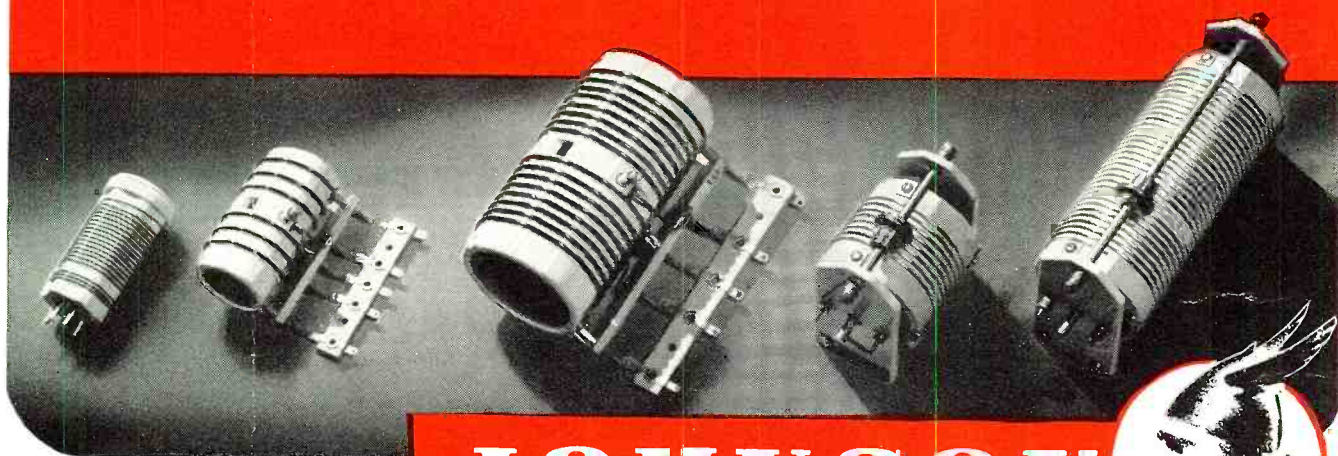

*Write for New*  
JOHNSON CATALOG  
968Z

# JOHNSON

*a famous name in Radio*



E. F. JOHNSON COMPANY • WASECA • MINNESOTA



## MEET YOUR NEW NEIGHBOR . . .

Radio's role in the post-war world will be a major one . . . one that will contribute to the shaping of a better world for *all* peoples . . . bringing about a better understanding between nations.

Hallicrafters equipment met the demands of war at its outbreak—**BUT** war's incentive drove Hallicrafters *forward* to produce *even greater* communications equipment—weapons that are "Winning the Battle of Communications!"

The results of more than fifty million dollars worth of war research and developments in Radio will go into *your* Hallicrafters equipment when the war is won . . . greater transmitters and receivers for *you* because of the great job being done now by Hallicrafters.

**LOOK TO HALLICRAFTERS** for *your* post-war receiver!

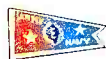

# hallicrafters RADIO

**BUY  
MORE  
BONDS!**

For ten years Hallicrafters has been the radioman's radio. Ask any electronic technician anywhere in the world . . . yes, particularly ask an enemy radio expert . . . which receiver brings the world together.

THE HALLICRAFTERS CO., MANUFACTURERS OF RADIO AND ELECTRONIC EQUIPMENT, CHICAGO 16, U. S. A.