

March

SHORT
WAVE
TIME
TABLE

RADIO NEWS

AND

SHORT WAVE RADIO

Special Features:

- **Eliminating Ignition Noise.**
- **Successful Servicing**
- **Two New Receivers**
- **Television Explained**

The Automatic Tuner



25c
U. S. and
Canada



Click! Here's Your Station!

HERE IT IS

The Instruction Book
That Thousands of
Radio News Readers
Asked Us To Publish

Over 130 Illustrations

Covers the
Fundamentals
of Radio

Given To You
FREE
If You Subscribe
For 5 Issues Of
Radio News At A
Special Low Rate

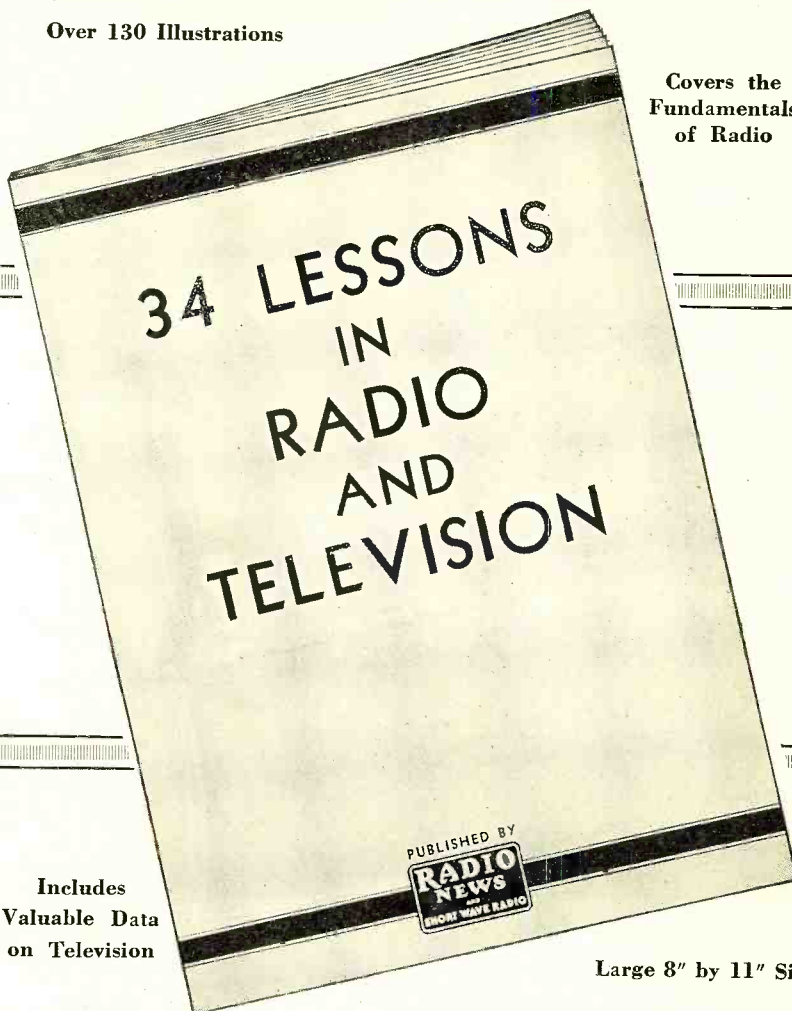

"34 Lessons in Radio and Television" will guide you, step by step, in clear, easy-to-understand language, from the elementary theories of radio and electricity to the intricate problems involved in constructing modern radio receivers. You learn how to build carefully designed, high-efficiency receivers—and understand how and why they work! You find out how vacuum tubes operate—what radio frequency, audio frequency, regeneration and automatic volume control mean and what they accomplish—how to become a radio amateur—and all of the other information you have always sought. In addition, this book gives you the necessary background data so that you will be able to build television receivers and understand how and why they work!

List of Contents

"34 Lessons in Radio and Television" includes reprints of all installments of "The Radio Beginner" which appeared in RADIO NEWS from May, 1936, to June, 1937. Here is the complete list of contents: Fundamentals of Electricity—Vacuum Tubes—Reception of Radio Waves—Radio Symbols and Circuits—A Simple Diode (or Crystal) Receiver—Operation of Vacuum Tubes—Building a Simple Triode V. T. Receiver—Radio and Audio Frequency Amplification—A One-Stage Audio Amplifier—and How a Power Supply Works.

Includes
Valuable Data
on Television

Also, Operation of an Audio Amplifier—Fidelity of Amplifiers—Building an Amplifier-Power Unit—Regeneration—Building a Two-Tube Regenerative Tuner—Operation of Pentode Tubes—Advantages of Pentodes—Simple Tuned R. F. Receiver—Discussion of T. R. F. and Superhets—A High-Quality Broadcast Receiver—Automatic Volume Control—Oscillators and Mixers—Facts About Antennas—Photocells—Breaking Into the Amateur Game—and Code Practice Oscillators.

Vital Data on Television

And, of particular interest to every radio man: History of Television—Television with Kerr Cells—Scanning Disk Television—Cathode-Ray Tubes—The Sweep Circuit and Power Supply—Cathode-Ray Tubes in Television—Television Receiver Design—Present-Day Television in the U. S.—and Television Progress Abroad. You get *all* these

Large 8" by 11" Size

valuable lessons, written in clear, easy-to-understand language, profusely illustrated with over 130 helpful photographs, diagrams and charts, *absolutely free* in connection with our special offer!

HERE IS OUR OFFER:

You can get a copy of "34 Lessons in Radio and Television" *absolutely free* by placing your subscription today for 5 issues of RADIO NEWS at only \$1. (Canada and Foreign \$1.25.) Act now! Our supply of these books is diminishing rapidly! Present subscribers may obtain the free book by accepting this special offer and having their subscriptions extended for five months.

Mail the Coupon Now!

Radio News, Dept. 383
608 So. Dearborn St.
Chicago, Illinois

Enclosed find \$1. Enter my subscription for 5 issues of RADIO NEWS and send me a free copy of "34 Lessons in Radio and Television." (Canada & Foreign \$1.25.)

Name.....

Address.....

City..... State.....

If you are a serviceman, check here

RADIO NEWS

608 So. Dearborn St.

Chicago, Illinois



J. E. SMITH
President
National Radio
Institute
Established 1914
The man who has
directed the
home study training
of more men
for the Radio In-
dustry than any
other man in
America.

I WILL TRAIN YOU TO START A SPARE TIME OR FULL TIME RADIO SERVICE BUSINESS WITHOUT CAPITAL

**HERE ARE A FEW EXAMPLES
OF THE KIND OF MONEY
I TRAIN MY MEN TO MAKE**



**\$200 TO \$300 A MONTH
IN OWN BUSINESS**
"For the last 18 months I have been in business for myself, making between \$200 and \$300 a month. I have N.R.I. to thank for my start in this field."—ARLITZ J. PROEHNELL, 224 W. Texas Ave., Goose Creek, Texas.

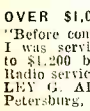

OVER \$1,000 BEFORE GRADUATING
"Before completing half the N.R.I. Course I was servicing sets, and I made \$1,000 to \$1,200 before graduating. I am doing radio service work for myself now."—ASHLEY G. ALDRIDGE, 1228 Shepherd St., Petersburg, Va.



**CHIEF OPERATOR BROADCASTING
STATION**
"When I completed 20 lessons, I obtained my Radio Broadcast Operator's license and immediately joined Station WJMC, where I am now Chief Operator."—HOLLIS F. HAYES, 85 Madison St., Lapeer, Mich.



**EARNINGS TRIPLED BY N. R. I.
TRAINING**
"I have been doing nicely, thanks to N. R. I. Training. My present earnings are about three times what they were before I took the Course. I consider N. R. I. Training the finest in the world."—BERN-NARD COSTA, 201 Kent St., Brooklyn, N. Y.

Do you want to make more money? The world-wide use of Radio has made many opportunities for you to have a spare time or full time Radio service business of your own. Three out of every four homes in the United States have Radio sets which regularly require repairs, servicing, new tubes, etc. Servicemen can earn good commissions selling new sets to owners of old models. I will train you at home in your spare time to sell, install, service, all types of Radio sets to start your own Radio business and build it up on money you make in your spare time while learning. Mail coupon for my 64-page book. It's Free—it shows what I have done for others—what I am ready to do for you.

**Many Make \$5, \$10, \$15 a Week Extra
In Spare Time While Learning**

Almost every neighborhood needs a good spare time serviceman. The day you enroll I start sending you Extra Money Job Sheets. They show you how to do Radio repair jobs, how to cash in quickly. Throughout your training I send you plans and ideas that have made good spare time money—from \$200 to \$500 a year—for hundreds of fellows. I send you special Radio equipment and show you how to conduct experiments and build circuits which illustrate important Radio principles. My training gives you PRACTICAL EXPERIENCE while learning.

**There's a Real Future in Radio
For Well Trained Men**

Radio already gives jobs to more than 300,000 people. And in 1936, Radio enjoyed one of its most prosperous years. More than \$500,000,000 worth of sets, tubes and parts were sold—an increase of more than 60% over 1935. Over a million Auto Radios were sold, a big increase over 1935. 24,000,000 homes now have one or more Radio sets, and more than 4,000,000 autos are Radio equipped. Every year millions of these sets go out of date and are replaced with newer models. More millions need servicing, new tubes, repairs, etc. A few hundred \$30, \$50, \$75 a week jobs have grown to thousands in 20 years. And Radio is still a new industry—growing fast!

**Get Ready Now for Your Own Radio Business
and for Jobs Like These**

Radio broadcasting stations employ engineers, operators, station managers and pay up to \$5,000 a year. Spare time Radio set servicing pays as much as \$200 to \$500 a year—full time jobs with Radio jobbers, manufacturers and dealers, as much as \$30, \$50, \$75 a week. Many Radio Experts own and operate their own full time or part time Radio sales and service businesses. Radio manufacturers and jobbers employ testers, in-

spectors, foremen, engineers, servicemen, paying up to \$6,000 a year. Radio operators on ships get good pay, see the world besides. Automobile, police, aviation, commercial Radio, loud speaker systems are newer fields offering good opportunities. Television promises to open many good jobs soon. Men I trained are holding good jobs in these branches of Radio. Read their statements in my 64-page book. Mail the coupon.

**I GIVE YOU
A PROFESSIONAL
SERVICING
INSTRUMENT**

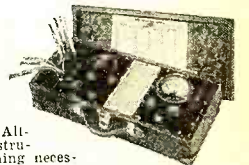

Here is the instrument every Radio expert needs and wants—an All-Wave, All-Purpose, Set Servicing Instrument. It contains everything necessary to measure A.C. and D.C. voltages and current; test tubes, resistance; adjust and align any set, old or new. It satisfies your needs for professional servicing after you graduate—can help you make extra money servicing sets while training.

**Save Money—Learn At Home
Money Back Agreement Protects You**

I am sure I can train you at home successfully. I will agree in writing to refund every penny you pay me if you are not satisfied with my Lessons and Instruction Service when you finish my Course. I'll send you a copy of this agreement with my Book.

**Find Out What Radio Offers You
Get My 64 Page Book Free Now**

Act Today. Mail the coupon now for my Free Lesson and my book, "Rich Rewards in Radio." Both are free to anyone over 16 years old. My book points out Radio's spare time and full time opportunities and those coming in Television; tells about my Training in Radio and Television; shows you letters from men I have trained, telling what they are doing and earning. Find out what Radio offers YOU! MAIL THE COUPON in an envelope, or paste it on a penny post card—NOW!

**J. E. SMITH, President
National Radio Institute,
Dept. 8CR
Washington, D. C.**

**GET MY LESSON ON
SUPERHETERODYNE
PRINCIPLES FREE**



I will send you my 38-page Lesson "Broadcast, All-Wave and Television Superheterodyne Receiver Principles" absolutely Free, to prove to you that my Course is practical, helpful, complete. This fascinating

lesson contains an analysis of the superiority of the superheterodyne over other circuits; separate sections which cover the action of preselectors, oscillators, mixer and detector circuits, pentagrid converter circuits, tracking, shielding, padding, all-wave receivers, I. F. amplifiers, special broadcast I. F. channels for Television reception, etc. You can get this Lesson absolutely free simply by mailing the Coupon now.

**The Tested Way
to BETTER PAY**

**GOOD FOR BOTH 64 PAGE BOOK FREE
SAMPLE LESSON FREE**

J. E. SMITH, President, National Radio Institute, Dept. 8CR, Washington, D. C.

Without obligating me, send your Lesson "Broadcast, All-Wave and Television Superheterodyne Receiver Principles" and free book about spare time and full time Radio opportunities and how I can train for them at home in my spare time—about the N.R.I. Set Servicing Instrument you give me. I am particularly interested in the branch of Radio checked below.

- Radio Service Business of My Own
- Spare Time Radio Service Work
- Retail Sales of Radio Sets and Equipment
- Service Expert for Retail Stores
- Broadcasting Station Operator
- Aviation Radio Operator
- Ship Radio Operator
- Loud Speaker Systems, Installations and Service
- Auto Radio Installation and Service
- Television Station Operator
- Service Expert with Radio Factory
- Commercial Radio Station Operator
- All-around Servicing Expert

(If you have not decided which branch you prefer—mail coupon now, for information to help you decide.)

NAME AGE
ADDRESS 23 FR-2





Edited by LAURENCE MARSHAM COCKADAY

S. GORDON TAYLOR
Managing Editor

WILLIAM C. DORF
Associate Editor

JOHN H. POTTS
Technical Editor

BILL EVERETT
Art Editor

SAMUEL KAUFMAN
Broadcast Editor

Vol. XIX, March, 1938, No. 9

Reading Guide to this Issue—

- AMATEURS—3, 4, 7, 11, 12, 13, 14, 15, 16, 17, 23, 24, 25, 27
- BROADCAST FANS—5, 6, 9, 11, 12, 16, 18, 20, 21, 24
- DEALERS—1, 2, 5, 8, 10, 12, 15, 17, 24
- DESIGNERS—3, 7, 17, 23, 24
- DX FANS—9, 11, 12, 16, 18, 24, 26, 27
- ENGINEERS—3, 7, 12, 23, 24
- EXPERIMENTERS—3, 4, 5, 7, 8, 12, 16, 17, 19, 23, 24, 27
- MANUFACTURERS—2, 3
- OPERATORS—3, 6, 12, 19, 23
- SERVICEMEN—1, 3, 4, 5, 7, 8, 10, 12, 17, 23, 24, 27
- SET BUILDERS—5, 7, 8, 12, 15, 16, 17, 23, 24, 27
- SHORT WAVE FANS—4, 9, 11, 12, 16, 20, 21, 24, 25
- STUDENTS—1, 3, 4, 5, 6, 7, 8, 10, 12, 16, 17, 22, 23, 24, 27
- TECHNICIANS—3, 7, 8, 10, 12, 23, 24

1	Serviceman's Diary.....	Anonymous	516
2	Frontispiece.....	Arthur Moss	518
3	Fighting "Snow Static".....	Thos. Calvert McClary	519
4	Killing Auto QRM.....	W2JCR	521
5	High-Fidelity "Compak" Tuner.....	Gerard J. Kelley	522
6	Bringing Back Voices From the Past.....	Laurence M. Cockaday	524
7	Alignment Chart.....	John M. Borst	524
8	Practical Lessons in Television (Lesson 3).....	F. L. Sprayberry	526
9	Scott All-Wave "Sixteen".....	Cockaday and Taylor	529
10	Service—Sales.....	John H. Potts	530
11	Air Test of All-Wave "15-17".....	Taylor and Cockaday	532
12	At Your Dealers.....	The Associate Editor	533
13	The "Ham" Shack.....	Everett M. Walker	534
14	The New 809 Transmitting Tube.....	Donald Mellor	535
15	The Radio News Transmitter (Part 4).....	Watzel and Bohlen	536
16	ABC's of Antenna Design (Part 4).....	I. Queen	538
17	The Radio News A. C. Preamplifier.....	A. J. Haynes	540
18	Station List (U. S. by Frequency).....	William C. Dorf	542
19	Obstacle Detector.....	Perry M. Jones	543
20	The DX Corner for Short Waves.....	Laurence M. Cockaday	544
21	World Short-Wave Time-Table.....	The Editor	546
22	Students' Radio Physics Course.....	Alfred A. Ghirardi	552
23	The Technical Review.....	The Technical Editor	554
24	Free Booklet Service.....	The Service Editor	555
25	The Amateur Observer.....	W2JCR	556
26	The DX Corner for the Broadcast Band.....	S. Gordon Taylor	558
27	The Radio Workshop.....	Wm. C. Dorf	564

Do You Really Read Radio News?

EVERY issue of Radio News presents material of direct interest and help to everyone interested in any branch of radio. Do you as a reader take full advantage of all it has to offer? We suggest that you try a stunt this month: First read the articles which appeal to you most. Then glance through The Reading Guide being careful not to overlook any portion of an article or department which will add to your store of knowledge. Spend an evening at it, or two or three, and we believe you will be surprised how much you have been missing.

Published Monthly by Ziff-Davis Publishing Company, Washington and South Avenues, Dunellen, N. J.

Editorial and Executive Offices

608 S. Dearborn St.,
Chicago, Ill.

381 Fourth Ave.,
New York, N. Y.

Entered as second class matter at the Post Office at Dunellen, N. J., under the act of March 3, 1879. Copyright, 1938, by Teck Publications, Inc., in U. S. and Canada. All rights reserved. Registration of title of this publication as a trade mark applied for in the United States Patent Office. Printed in the United States of America. The contents of this magazine must not be reproduced without permission. We cannot be responsible for lost manuscripts, although every care is taken for their safety.

25c a copy. Subscriptions, \$2.50 a year, \$4.00 for two years; in Canada and Foreign Countries \$3.00 a year, \$5.00 for two years. Subscribers are notified that change of address must reach us five weeks in advance of the next date of issue.

A New Principle in Electronic MUSIC

(The "Electone" Piano)

By John Strong

DURING the past decade much research has been devoted to the problem of making a small piano comparable in volume and richness of tone with the larger concert grand. Laboratory studies of the wave forms of the concert grand tones have indicated that electrical amplification of the vibrations of the strings in small pianos would enable such results to be achieved and, in addition, permit of other musical effects beyond the capabilities of any non-electrical piano.

The apparatus illustrated is the new "Electone" piano manufactured by Krakauer Brothers and is an outstanding example of the modern development of this new art. The young lady is seated at the miniature piano and the modernistic speaker stands alongside.

Figure 2 is a photograph of the sound pick-up system. The strings for each note on the piano are stretched over small wood screws which are set in an insulating board. Each of these wood screws is connected to a source of high voltage and acts as a miniature condenser microphone. The piano strings are close to each screw but do not touch it. The vibration of the strings, when struck by the hammer, causes variations in the electrostatic

FIGURE 2



charge on the wood screw. These variations are amplified by a pre-amplifier followed by a high-gain 30-watt amplifier to which a large loudspeaker is connected. The pre-amplifier and controls are shown in the photograph below.

In addition to the usual damper and sustaining pedals, the Krakauer Electone has a "swell" pedal which enables the player to build up a tone or chord from a whisper to full vol-

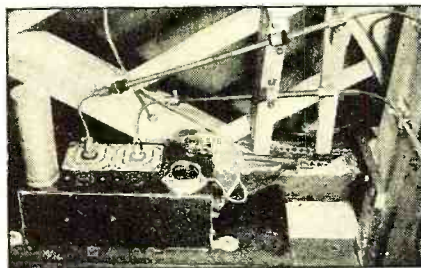

ume without again striking the keys, thus duplicating an effect formerly attained only by the organ.

The instrument has a standard keyboard and action and therefore has a standard piano touch. It is an outstanding development in electronic pianos and offers the musician a means of producing new and more beautiful piano music. (*This description is based on data supplied by Mr. M. K. Bretzfelder of Krakauer Brothers.*)

A Good Report on American Radio

Washington, D. C.—Commissioner T. A. M. Craven of the Federal Communications Commission, who has just returned from Havana, Cuba, where he represented the United States in the capacity of Chairman of its delegation to the Inter-Amer-

ican Radio Conference, issued the following statement today:

"The accomplishments of the Inter-American Radio Conference in Havana have greater significance in the interest of the public of the United States than is generally realized or than originally contemplated. This was the first conference of its kind ever held on this continent. However, there was successfully concluded a series of agreements concerning the application of radio to Inter-American communications including aviation, police, broadcasting, fixed services, shipping, and other services for which radio is useful. Of great significance is the fact that for the first time in history a decision was made to undertake cooperative action with respect to the radio needs of the Americas."

Transit Control by Radio

New York, N. Y.—Transportation despatching and supervising may soon be done by radio. The Brooklyn and Queens Transit Company is reported to be considering the installation of an experimental two-way system utilizing a fleet of automobiles equipped with ultra-high-frequency transmitters and receivers, if approval can be obtained from the Federal Communications Commission. Wide adoption of such service by public utility companies will create a large number of new jobs for trained radiomen.

Growing Interest in Language Study

Columbus, Ohio—Growing popularity of radio programs from abroad has brought with it an increased public demand for knowledge of modern foreign languages, reports W. E. Meiden, of the Ohio State University, who conducts an advanced French class over WSOU, the university station.

Pages From A Serviceman's DIARY

TUESDAY. Arrived early and started in on shop work while waiting for more calls. Jerry finished making out statements and drifted into the shop.

"A good serviceman ought to be able to fix anything," he remarked, watching me struggle with an intermittent "fader" which refused to fade.

"So what?" I asked him. (I should have known better. He was just looking for an opening to make a dirty crack.)

"Oh, nothing," he replied. "Only I was just thinking that you always talk about the jobs you fix and never mention the ones you fall down on. For instance, windmill radios."

"That was last summer," I reminded him. "And, after all, I didn't work on that set. Why bring that up now anyhow?"

"I was over to see Howie last night," Jerry answered, "and found him talking to the owner of the windmill job. He's still raving about the swell job Howie did and gave him two bottles of Scotch as a Christmas present."

Jerry Rubs It In!

Jerry likes to rub it in. Perhaps I should have taken that job but the fellow sounded like a "phoney" when he called up so I didn't want to risk a 20-mile trip on what seemed a wild-goose chase. Here are the facts and you can judge for yourself.

On a very hot day last August, I picked up the phone and listened to a bird complain about a "windmill" radio which he said ran all right for a few weeks and now wouldn't work at all. It was one made in Chicago and really was a swell job. He had seen it while on a trip and had it shipped to him, making his own installation. He was very proud of it. Unfortunately, he had neglected to consider that a windmill requires wind or it won't run. With his location down in the valley and on the side instead of the top of the house, it would take a hurricane to make it even budge!

All this I gathered from his story. I told him the windmill wouldn't start charging the battery unless it was installed in the clear and even

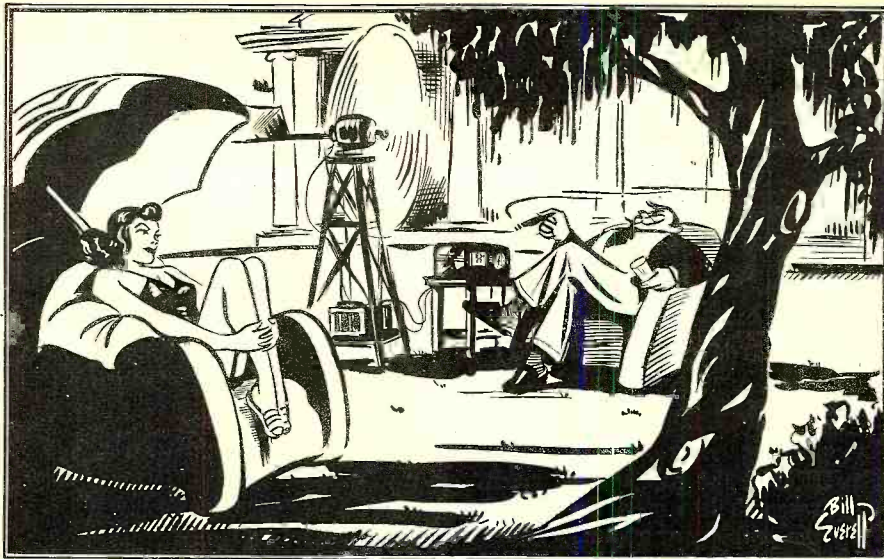

A SATISFIED CUSTOMER IS A "SATISFIED" CUSTOMER
Our serviceman turns down what seems to him a foolish request on the part of one of his clients but another serviceman, much to Our Hero's chagrin, takes on the job and receives a good sizable spot of cash. What would you have done?

then an 8-mile-an-hour breeze was required (which doesn't occur so often in his particular neighborhood). I could relocate the windmill for him, of course, so it could operate efficiently.

Don Quixote?

No, that was not what he wanted! The windmill, if moved at all, would have to be brought closer to the ground and the house and not put away up where he couldn't enjoy it. What he did want, I discovered, was to listen to the sweet whirr of the wheel as the breeze spun it around, forming a pleasant background for the music. And, likewise, he felt it would be nice to sit out on the porch on hot afternoons and let the windmill act as a fan to cool him off. The neighbors, he admitted, were beginning to razz him about the whole idea.

Whistle for a Breeze

I tried to explain to him that, if there was sufficient breeze to operate the windmill, he might just as well catch it directly instead of taking it second-hand from the windmill. He could take a fan, of course, and wave it in front of the windmill to get it

THESSE records from an anonymous serviceman's diary should be of decided interest to veteran servicemen, as well as to those whose experience in the service field is more limited. Written by a man who "knows his stuff," and shot with an occasional outcropping of humor, these items provide many hints not found in text books. More of these pages will appear from time to time.

going but that would be a rather tiresome procedure, particularly in such warm weather. He hung up the phone!

Jerry had been listening and kept trying to butt in. But he usually has such dumb suggestions that I refused to be interrupted. Now he jumped on me for not trying to sell the bird a Tungar battery-charger.

"Oh, yeah," I yelled. "Don't you know that these windmill affairs are made especially for charging batteries? And also, you've got to have a line supply to operate a Tungar charger. If this bird had electric light, why would he have bought a windmill radio? You're a lot of help, you are."

Nasty Jibes!

Next day Howie came strolling in, looking particularly happy.

"You fellows must be rolling in wealth," he remarked, "when you can afford to pass up thirty-five dollar jobs."

"As, for instance?" I asked him.

"You got a call yesterday from a bird upstate who wanted his windmill radio put in proper operating condition and you passed it up."

"And he paid you thirty-five dollars for what?" I wanted to know.

He repeated the whole story as the customer had told it to me, adding that the man had been somewhat peeved because I hadn't helped him. Howie simply inquired whether a.c. line supply was available. Learning that it was, he dug up a Tungar charger and beat it right out to the customer's place.

"I didn't argue with him," Howie said. "Whatever he wanted I told

(Turn to page 567)

STEP INTO A GOOD PAYING JOB I'll Train You At Home to Make

**\$35 to
\$75 per Week**

IN RADIO

**CASH IN ON THE MOST SENSATIONAL
TRAINING PLAN IN RADIO'S HISTORY**



Unlimited money-making opportunities exist for live, wide-awake fellows in the great Radio industry. Good-paying jobs await properly trained go-getters in all of Radio's fascinating branches. Right now is the time to prepare yourself for one of these fine opportunities. The unusual Sprayberry method of training will make you a Radio expert within a short space of time . . . at low cost. It will set you up in a business that will assure you of a good, steady income and complete security in the future.

I ACTUALLY SET YOU UP FOR A PROFITABLE BUSINESS

Here, at last, is a new and different type of Radio training. It not only teaches you all phases of Radio . . . it equips you for an actual start in business . . . full or spare time. Sprayberry Training has been conscientiously designed to fit you for a truly worthwhile place in Radio . . . for a position well above the average. Of singular importance is the fact that the lessons which comprise the Sprayberry Course are written in an exceptionally understandable and simple manner. They are intensely interesting . . . carry through from the very basic fundamentals of Radio in clear, logical sequence right up to the theory and practice of the more advanced technique. All twelve branches of Radio are covered thoroughly. Nothing is left out.

MAKE MONEY WHILE YOU'RE LEARNING

Remember: with the Sprayberry Course of Training you are equipped to set up a handy home laboratory. From the very beginning you are shown how to get profitable spare-time Radio service work. Moreover, you are shown how to do these jobs. Thus you gain practical experience, not to be gotten in any other way. Besides, you add tidy sums of cash to your bank account while you're learning.

NO EXPERIENCE REQUIRED

Makes no difference what sort of work you are now doing . . . the Sprayberry Course is written so that anyone can understand it. The lessons can be studied in spare time. Absolutely no previous experience or background in the field of Radio is required.

BIG PROFESSIONAL OUTFIT GIVEN

The finest equipment offered with any Radio Course is available to Sprayberry students. You get an all-wave, all-purpose analyzer, Rider Manuals (7076 pages), Tool Kit, Electric Eye outfit and Experimental Apparatus.



QUIT DREAMING Get Busy . . . Make a Future for Yourself

Actually getting started seems to be the hardest part of any undertaking. It is easy enough to sit idly by and envy those fellows who have good paying jobs and who are building toward splendid incomes and real security in the future. But these fellows are no smarter than you are. The essential difference is that they have taken the initiative to pull themselves up by their own boot straps. You can do the same thing! Be your own boss! Don't just "wish" for more money. . . . Start training for it . . . RIGHT NOW. Your decision to act immediately in behalf of your own interests will probably prove later to be the turning point in your life. I can't urge you too strongly to get started in RADIO.

THESE FELLOWS MADE GOOD . . . SO CAN YOU

Farm Boy Makes \$100 Per Month In Spare Time

"I am well satisfied with your Course. Explanations are clear and complete. I am working into full time servicing and will be able to make a great deal more than that \$100 per month I made in my spare time. A large battery and electric company has asked me to locate my shop at their place of business. Other men, without your training, wanted to locate there, but the owner of the business did not think that they knew enough about Radio." Merlyn Hansen, Iowa.

Claywood Owns Big Service Business!

"I can truthfully say your Course has helped me to the success I now enjoy. Two men and a stenographer comprise my staff. I expect to hire another man soon to take care of my sound truck rentals and public address work. My men have also taken your Course and we all believe that you should be commended for its thorough coverage. We are definitely making money at Radio service work." Henry J. Claywood, N. H.

THE MOST IMPORTANT COUPON YOU'LL EVER CLIP!

Remember: The Sprayberry Course Is Sold Under An Iron-Clad, Money Back Agreement.

SPECIAL

SERVICEMAN'S COURSE

. . . of an advanced nature for men already in Radio work. Explains newest methods, circuits and short cuts. Terms low as \$3.00 per month. All courses, features, etc. described fully in big, 48-page FREE BOOK. You owe it to yourself to investigate Sprayberry Training before signing up for any course.

Get My Free Book!

Mail Coupon Now

SPRAYBERRY ACADEMY OF RADIO
F. L. Sprayberry, Pres.
125-C University Place, N. W.
Washington, D. C.

Please send me free copy of "More Money in Radio".

Name..... Age.....

Address

City..... State.....

Mail in envelope or paste on postcard. If interested in Service Course only check here ().





A PROGRESSIVE POLICY FOR SERVICEMEN AND DEALERS
"RADIO NEWS, one of the oldest magazines in the industry, is co-ordinating merchandising with servicing, so that the serviceman, who is technically inclined, is now being helped to use his technical ability from a sales point of view, thus increasing his earning capacity. We, as manufacturers in the radio parts industry, endorse this progressive policy on the part of RADIO NEWS."

Arthur Moss

Secretary and Sales Manager
SOLAR MANUFACTURING CORPORATION

Radio News

Volume XIX

March, 1938

Number 9

Fighting "SNOW STATIC"

(The Enemy of Aviation Radio)

THE chief immediate aeronautical radio problem today is "snow static". This static is peculiar to aviation in that it is usually experienced on aircraft travelling above 100 mph. Identical effects are caused by a plane flying through surrounding areas of ice, snow, rain, hail, dust, damp and strong electric disturbance. It is not the same static as that caused by intermittent lightning crashes. It affects and at times completely blankets out aircraft reception. It is caused by the aircraft itself. It has nothing to do with ignition static resulting from unshielded engines, batteries, wiring, etc. and shield leaks. During Dick Merrill's flight across the Atlantic through extremely "soupy" weather, snow static caused complete loss of reception on the 6590 kc band during several hours. During the same period, transmission on the same band from the plane was clearly received on both sides of the Atlantic. Until snow static can be eliminated, more powerful ground transmission will not solve the problems of blind flying, the main technique of transport aviation.

High Voltage

It is estimated that the total voltage along a straight line between the earth's surface and the outermost atmosphere is around 1,000,000 volts. The charge near the earth is normally about 35 volts per altitude foot. This thins off with altitude until at 20,000 feet the charge is about 15 volts per altitude foot. A

HERE is outlined a series of researches conducted for the purpose of discovering the true source of "snow static," that insidious interference which occasionally blots out signals from a radio beacon station and renders a plane's direction-finding apparatus inoperative.

By

Thos. Calvert McClary

plane at normal climb to 20,000 feet will build up an electrical charge of about 300,000 volts in relation to the earth's surface. But in relation to the surrounding atmosphere at 20,000 feet, the plane is charged at zero.

Once collected, the plane's charge is permanent until discharged or further charged. But flying at level altitude, the plane passes through areas of lower or higher charge. If

the charge is the same as the aircraft's, nothing happens. But if the charge is counter, there is a discharge either from plane to atmosphere, or atmosphere to plane. Snow static is the result.

The effect of sun-spots on our atmosphere is not yet understood, but the simpler effects of the sun are. Sun rays heat portions of the atmosphere unequally causing warmer portions to rise. The electro-static field normally retains an equilibrium, but the rising air brings up moisture which condenses to fog and clouds.

If fog forms rapidly, condensed droplets are churned about. The electro-static charge remaining on the droplets is also churned about resulting in unstable electro-static area. Theoretically, the area within a cloud should be composed of sections of positive and negative charge. Actually drops are in constant motion and positive and negative charged drops are inter-mixed.

There are two general types of static-forming clouds. One is the thundercloud formed by rising moisture. The other is the result of air masses of different temperatures meeting and forming a "layer". The thundercloud type usually reaches maximum early in the afternoon and subsides as the sun goes down. The static from such clouds usually disappears before midnight. In any case, local storms can be flown around or above.

Static Areas

The layer type of clouds show static areas

ONE SOURCE OF THE "SNOW STATIC" TERROR

Here is a giant transport plane about to descend through a cloud bank layer. The operator relies on getting his bearings from the direction finder. Ahead is a narrow pass in the mountains. Will the electric charges from droplets in the clouds gather on the plane's metal fuselage and interfere with radio-beacon reception?



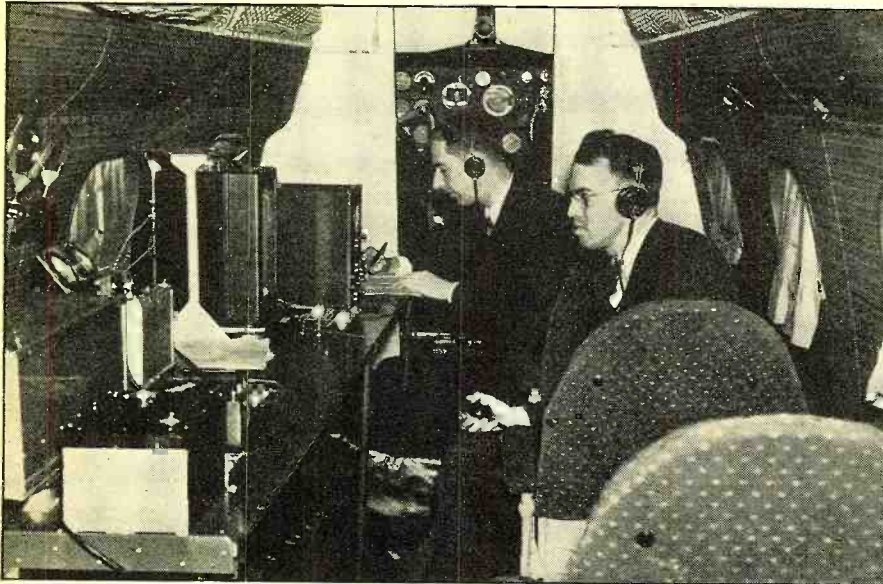

A FLYING LABORATORY
Scientific equipment, installed in the cabin of the United Air Lines laboratory ship, tests out anti-static radio antennas.

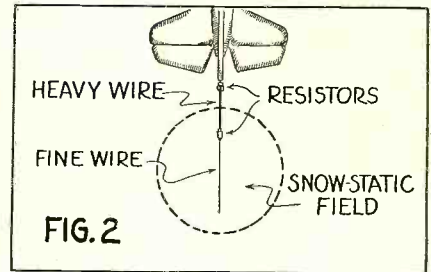
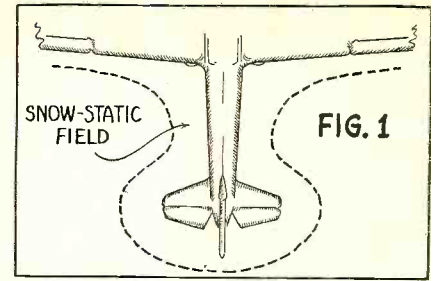

at practically any time of day or night and may extend hundreds of miles long. When the line of flight is at right angles to the layer, the static areas are quickly passed. But when the layer is parallel to line of flight, the static continues for the length of the front. As these masses lie over the earth like a slice of cake, it is often possible to avoid static areas by change of altitude. The two difficulties are, that other layers may exist there too; and that air currents, temperatures, or winds at levels free of electric disturbance may be unfavorable to highest aircraft efficiency.

It was to find a solution to the problem of snow static that United Air Lines began a study of conditions in November, 1936. Tests were under the direction of H. M. Hucke, UAL Superintendent of Communications Laboratory. Purdue University,

Reed College, Oregon State College, Bell Telephone Labs, and Bendix Radio, also took part in tests along with UAL engineers. No other air lines were officially represented. Yet the tests may be said to be representative of the aviation industry as work was talked of quite openly,

STATIC-PROOF PLANES?

The men shown below are technicians working on "snow-static" problems. At left, H. M. Hucke, chief of the aerial static expedition, examines a number of anti-static devices preparatory to a test flight. At right, Pilot Bert Ball and Mr. Hucke examine other types of projecting discharge devices.

engineers of other lines watched closely and occasionally noted their own problems or suggestions. Results of the research to date were given recently before the Institute of Aeronautical Sciences at Denver.

Several planes were used during tests for field work, but the chief testing was done within a laboratory hangar with a standard 10-passenger, twin-motored, all-metal Boeing transport, fully equipped with electrometers, oscillograph, recording meters and special radio sets and antennas. After sufficient data was gathered under artificially induced atmospheric conditions to warrant a conclusion, field tests were made under similar conditions to check results. Results were strikingly parallel.

The first experiment proved that there was such a thing as snow static. Both ascending and descending through fog (Turn to page 572)

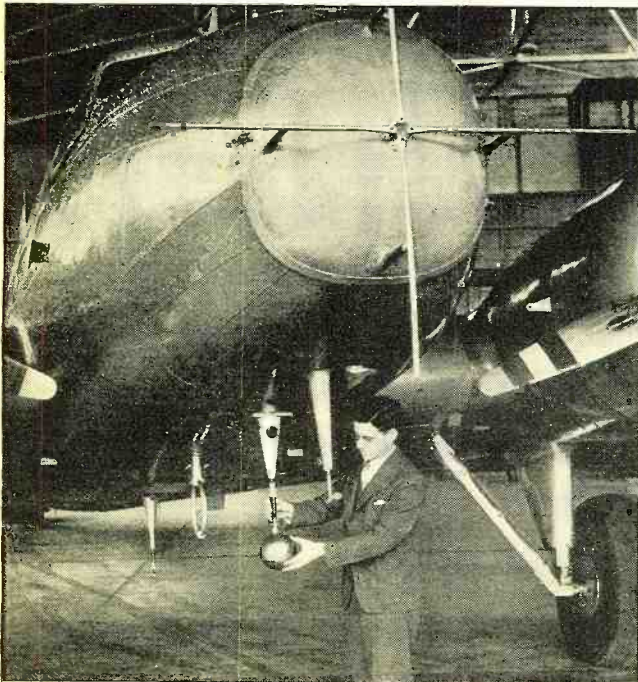

Killing AUTO QRM in Your Receiver

By W2JCR

WITH broadcasting being extended to lower and lower wavelengths, and with the growing popularity of the 5-meter and 10-meter amateur bands, automobile ignition noise is becoming an increasingly troublesome factor for the listener. Some of the newer receivers include noise-silencer circuits in recognition of this fact, but the great majority of receivers now in use, capable of tuning down to 10 meters, do not provide this refinement. To see what, if anything, could be done about it some experimental work was recently carried on at W2JCR with results which were distinctly worth while.

The object of this experimentation was to find some form of simple noise suppressor or noise limiter system which could be readily installed in a typical modern receiver to really provide relief from this form of interference. This location, at the intersection of two heavily travelled streets, is one where 10-meter operation is well nigh impossible due to the high level of ignition noise. All through the day, and a good part of the night, every change of the traffic light results in a barrage of anywhere from ten to fifty cars grinding ahead in low, shifting to second and finally getting away in high. Then a steady drone as cars continue with the green light. Another change in the light and this whole process is repeated as the cross traffic gets under way.

Spoils Reception

This situation is such that during the day on Sunday, at which time the 10-meter band DX is at its best, the ignition noise alone will hold the "R" meter practically constant at R7 to R9. Obviously this leaves little opportunity for intelligible reception of anything much less than an R9-plus signal.

This, then, was the location where the experiments were conducted, and

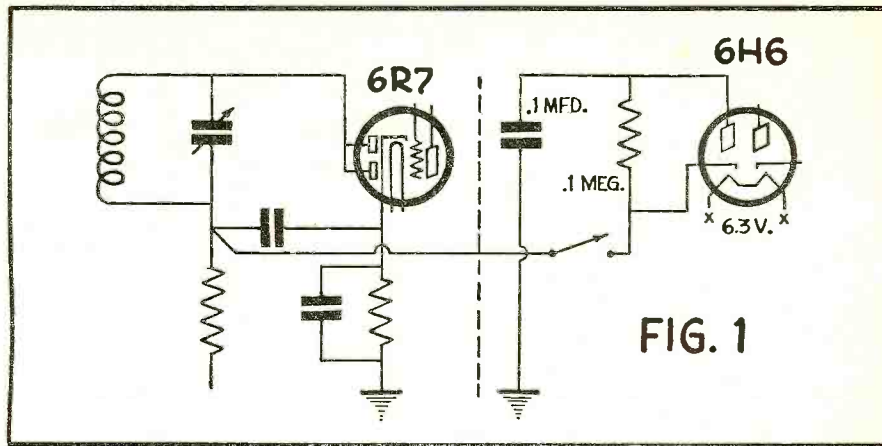

FIG. 1

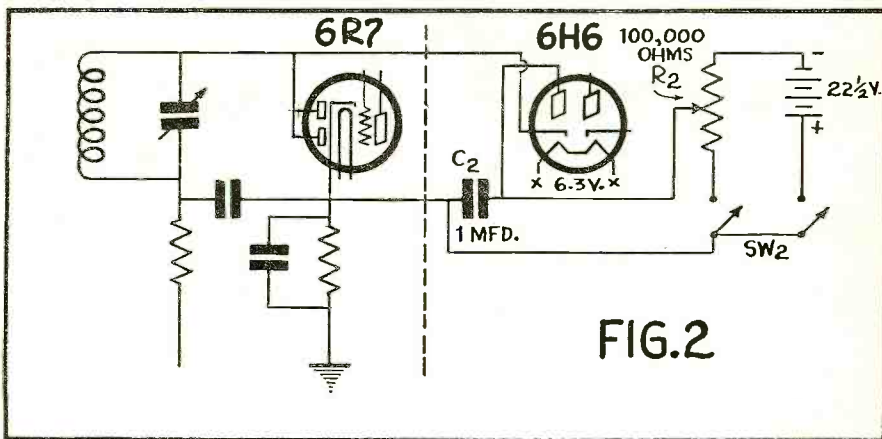

FIG. 2

TRY THESE CIRCUITS ON YOUR OWN RECEIVER

Figures 1 and 2 show two optional circuits, as added to a 1938 Super-Skyrider. The detector circuit of this receiver is shown at the left of the broken lines; the simple, added noise-reducing circuits at the right.

a 1938 Super-skyrider (SX-16) was the "guinea pig."

The first system tried was one suggested by W2AMJ. This is shown in Figure 1. To the left of the broken line is the second detector circuit of this receiver and no changes are necessary in this. The added equipment, shown to the right of the broken line constitutes the noise limiter system. This consists of a 6H6 diode tube (only one diode sec-

these leads support the socket and tube. The resistor is supported by its own leads right at the tube socket terminals and the condenser is grounded to any nearby point on the chassis.

This system is more or less automatic and is apparently highly satisfactory in some locations. At W2JCR it proved to be better than nothing but still left much to be desired, possibly due to the unusually high noise level. In some locations where the ignition noise level is lower it is doing a good job, notably at W2AMJ and W2JQX.

Effective System

The second system, and the one which was the most effective of the simple systems, is shown in Figure 2. 6H6 and socket are installed as described above. The by-pass condenser (C2) is wired in right at this socket. The 22½ volt biasing battery, the potentiometer and its switch are mounted outside of the receiver (although they can be mounted inside with the potentiometer knob located on the front panel if desired). In our case a small hole was drilled through the rear of the chassis and
(Turn to page 562)

WHEN we get down below 20 meters in wavelength our fun really begins, as far as automobile ignition interference is concerned. It is then that many experimenters, amateurs and short-wave fans realize for the first time how popular their immediate vicinity is with automobile drivers.

tion of which is used) and socket, a 1-megohm, half-watt resistor and a .1 mfd paper condenser. A switch S1 was also included to cut the limiter in and out.

The 6H6 tube socket is mounted under the chassis, below the socket of the second detector. The filament terminals are connected directly to any convenient point of the 6.3 volt filament wiring of the receiver. This is done by means of heavy wire as

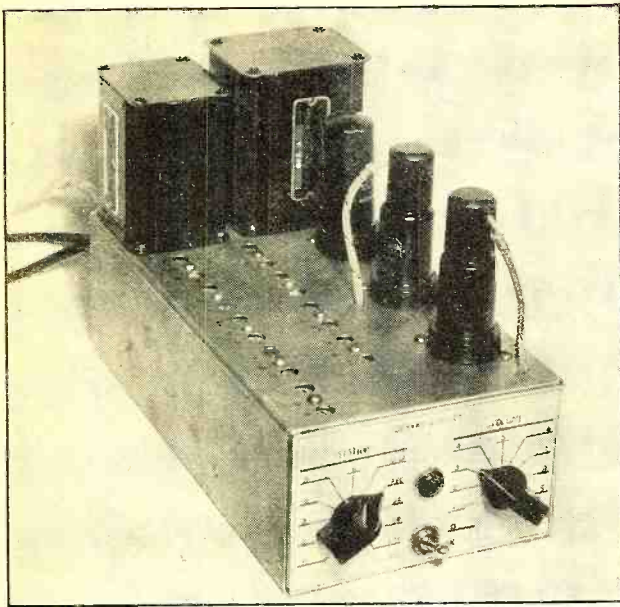

CLOSE-UP OF THE TUNER

Pretuned by means of the trimmers to six desired local stations, each is instantly tuned in thereafter by a flip of the station selector switch. This unit is bound to be popular with servicemen, home set-builders and experimenters who wish to become acquainted with automatic tuning, first hand.

VARIOUS forms of fixed tuned receivers have been designed and used for some time by the author and have proved most convenient and enjoyable. So many desire to build a similar type of receiver that this compact 6-station tuner was designed especially for RADIO NEWS readers. This self-powered unit may be employed to feed a high-quality audio amplifier or as a new tuner in conjunction with a good broadcast receiver audio system. It may also serve as a complete low-volume receiver when used with a permanent-magnet dynamic speaker or headphones.

As a complete receiver, it is ideal for children's use. It may be adjusted to limit the reception to those stations presenting children's programs and its low volume under such conditions will not disturb the rest of the family. Each station is exactly tuned, a flip of the switch selecting any one of six stations. It is also handy for news programs late at night or early in the morning. The low volume level is ideal for single-room reception. The tuner may also be used for arm-chair operation so that programs may be chosen with the utmost ease. The amplifier and speaker, if used, may be installed at any desired location remote from the tuner.

Design Features

The design of this six-station tuner is based upon the premise that most enjoyable reception can only be secured from those stations which deliver a signal more than 30 db. above

the local noise level. Also, as tuning must be broad for high-fidelity reception, the sensitivity of the receiver must be kept fairly low in order to prevent out-of-town stations from causing interference. Since most good programs are chain broadcasts, sensitivity adequate for local stations only, has been incorporated in the design.

A good antenna system is a necessity for high-quality reception. In the author's case this is a Taco No. 301 Master antenna system. This was chosen because it is of the noise-reducing type and, with the No. 302 receiver coupler, more than one set may be operated efficiently from the same aerial. This latter feature is important as it does away with one switching operation. By having a high signal-level and a high signal-to-noise ratio, such as good antennas give, the design of the tuner is greatly simplified.

HIGH QUALITY RECEIVER

Below: At the right is shown the 6-station tuner and at the left a high-fidelity, home-built amplifier which was described in the August and September, 1936, issues. The two units may be separated a distance up to 30 feet if desired.

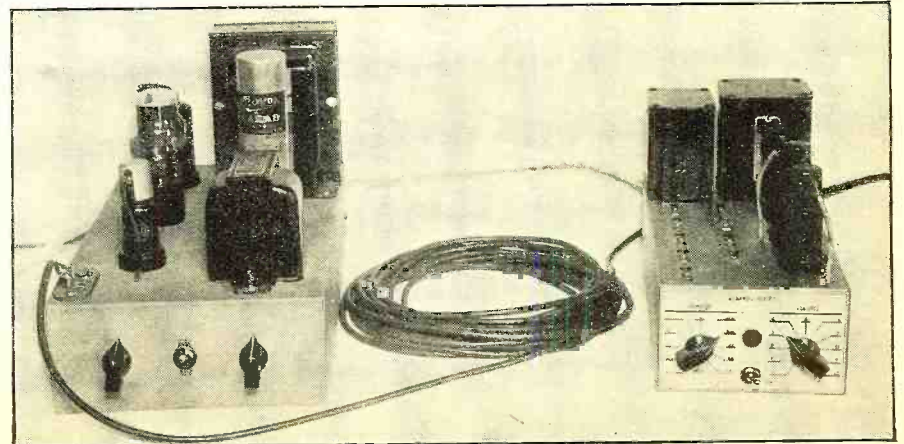

Build This Completely "COMPAK"

*(Tunes in
By Gerard*

A single stage of r.f. amplification gives sufficient sensitivity and fewer tuned circuits are required. The problem of broad band-pass is also less difficult with a minimum number of tuned circuits. By employing a low-impedance primary antenna transformer with a capacity-coupled band-pass circuit, satisfactory selectivity can be secured with a single high-impedance interstage r.f. transformer. As this r.f. transformer secondary is loaded by the diode section of the 6R7 the circuit is broad enough for high-quality. To allow change of stations without readjusting the volume control level, individual values of cathode bias resistance for the 6K7 are used for each station, eliminating the need for a.v.c.

Remote Control

As used by the author the output circuit works into the .5 megohm volume control of the direct-coupled amplifier described in the December, 1937, issue of RADIO NEWS. This amplifier is located 30 feet away and connected to the tuner by a two-conductor shielded cable. The second conductor and shield are used for a

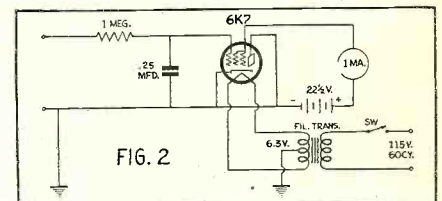

Automatic High-Fidelity TUNER

(6 Stations)

J. Kelley

relay circuit to operate the power supply of the amplifier. This relay may be a Leeds type LDS if the tuner power supply is capable of furnishing 40 ma. Or an old Yaxley battery relay may be made to operate on 10 ma by replacing the present winding with $\frac{1}{4}$ lb. of 38 or 40 enameled wire. The price of either type of relay is so reasonable that rewinding is worth while.

High Fidelity

The output load resistance for the 6R7 is low enough so that the attenuation of high frequencies is minimized when used with a cable of this length. For longer runs or to work into a line-to-grid transformer a Kenyon type T101 plate-to-line transformer is used by the author.

Due to the compact size of the tuner, it is necessary in wiring the unit to connect long leads to all points mounted directly on the chassis before mounting the under chassis parts. Each circuit should be wired as completely as possible be-

fore the next part is mounted. After the sockets, trimmers, choke and power transformer are mounted the aluminum strip carrying the three r.f. coils and shields is mounted. This has one end cut away to allow the power toggle switch to be easily removed so that the pilot lamp may be changed if necessary. The pilot lamp is a miniature Christmas tree lamp rated at 15 volts. At 6.3 volts it furnished just the right amount of light and has a very long life.

Easy Assembly

After the r.f. transformers are connected, the Yaxley selector switch is mounted. This switch, which is of the six-gang type, should be reassembled so that the diode circuit gang is next to the mounting plate and then, after two spacers, the 6K7 bias selector gang is mounted. Next, after one spacer, the band-pass selector gang and finally, after two spacers, the antenna selector gang are assembled. After the selector switch has been installed by means of angles soldered to the chassis, the 6R7 plate resistor and coupling condenser are wired to the Amphenol chassis connector by means of a shielded lead.

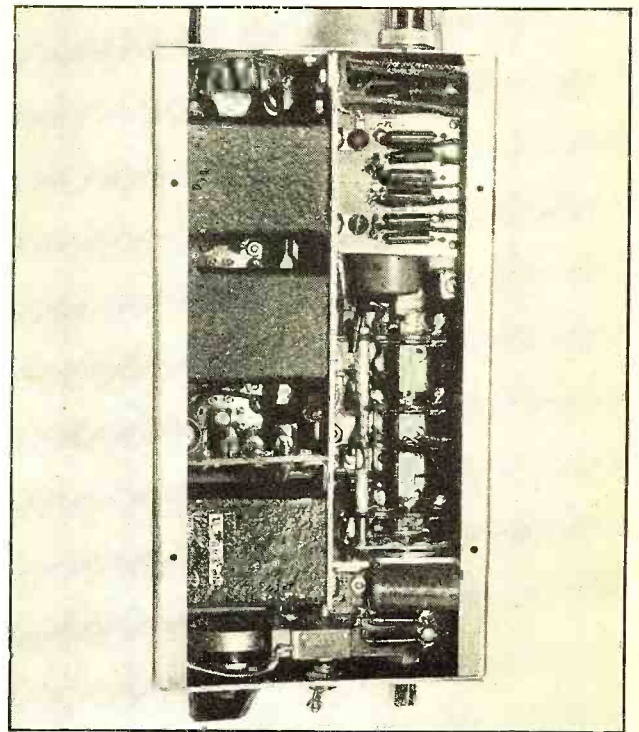

The tuner should be tested to find the necessary size of 6K7 cathode bias resistors required for each station and the proper value permanently installed.

For extremely strong stations it may be necessary to place a resistance in series with one of the tuned circuits to prevent distortion in the 6R7 due to overload. This resistance, which may be between 2 and 50 ohms, should be placed in series with the proper trimmer condenser of the coil feeding the 6R7 diode section.

For adjusting the trimmers it is best to connect a v.t. voltmeter across the diode load resistance. A suitable circuit is shown in Figure 2. This simple v.t. voltmeter reads the d.c. voltage change across the diode load resistor and is not affected by modulation. To use this means of lining up, the tube voltmeter is connected to the tap point of the 50,000 and 500,000 resistors and the cathode of the 6R7 tube. Each trimmer is adjusted until maximum reading is obtained on the meter.

Other Features

While the tuner as described here is ordinarily to be used in conjunction with a separate amplifier it readily can be seen that a complete unit with its own audio amplifier system can be easily made. It is interesting to note in connection with the complete receiver that, at first, a prospective customer will generally worry about the stations he is going to miss, but, after realizing that it is possible to have, if necessary, from 1 to 11 different stations, depending upon cost, as the Yaxley switch allows such a
(Continued on page 568)

THE SCHEMATIC CIRCUIT

Figure 1. The circuit of the tuner and circuits for remote control of amplifier by means of a relay. (A) shows circuit for controlling a.c. supply to a separate amplifier; (B) is a circuit which utilizes the amplifier of a radio set, automatically disconnecting the receiver from its amplifier and connecting the tuner when the latter is turned on.

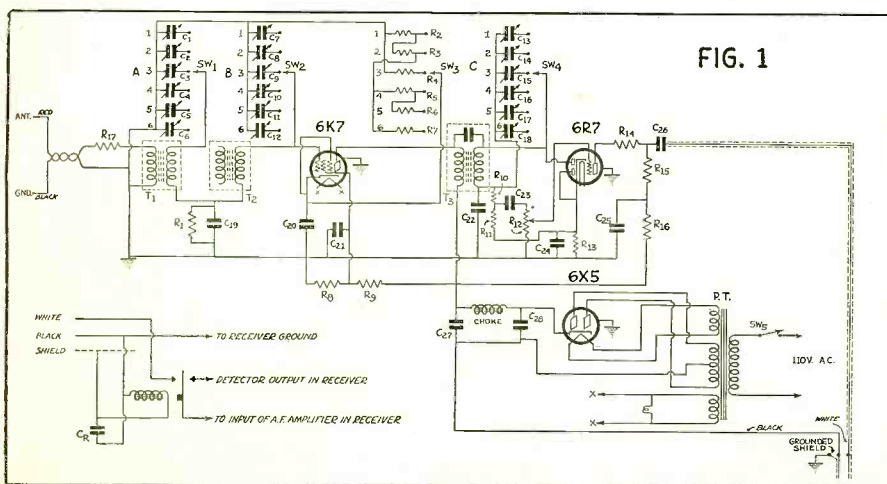

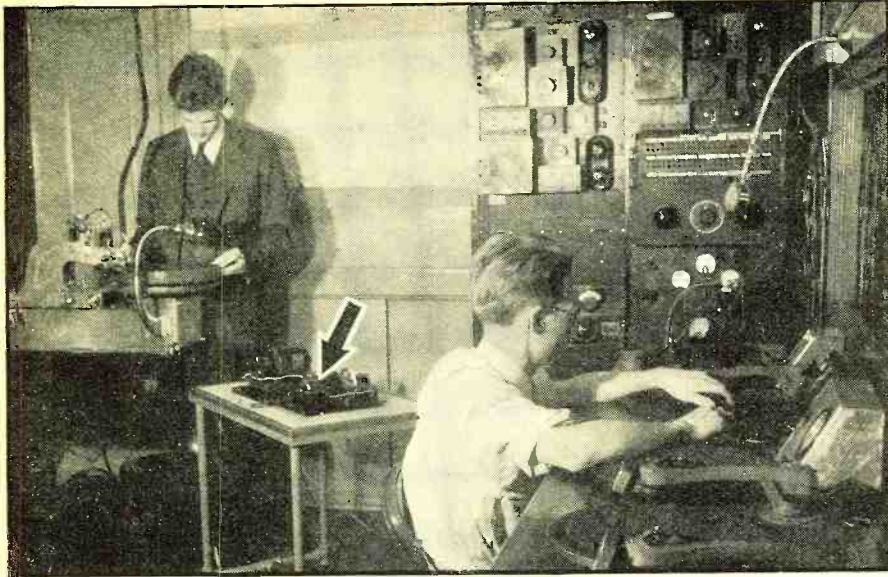

Bringing Back VOICES From the Past

By L. M. Cockaday

ON a very fair Thursday evening, not so very long ago radio listeners from coast to coast could hear, over the Mutual Network, the voice of the late Theodore Roosevelt in an address he made to a boys' club 25 years ago. The broadcast was made through the medium of a phonograph record. This old type cylinder record was amplified and electrically transcribed onto a disk for the broadcast and the story of how the old record came to be made almost a quarter of a century ago, was told by Robert Vincent at whose request Colonel Roosevelt made the speech. Vincent was being interviewed by Jerry Danzig of the WOR Press Section.

"Teddy" Speaks Again

Since then, letters and cards have been pouring in from all sections of the country stating how much the audiences enjoyed that program and asking for more features of that nature. Many friends of Theodore Roosevelt said that the voice of this greatly beloved American, as heard by them on the radio, was unmistakable and characteristic.

The electrical reproduction of T. R.'s voice was made at the Reeves Sound Studios, 1600 Broadway, New York. Accordingly our news reporter and photographer proceeded to these studios; to bring you pictures of the equipment used in the transcription of this record. Mr. H. E. Reeves

HOW TEDDY ROOSEVELT'S VOICE WAS REJUVENATED
Scene in the Reeves Sound Studios, where the 25-year-old cylinder record is being reproduced with its tones revitalized on a wax disc. The device for replaying the old record (indicated by arrow) is shown on the small centrally located table. The operator in the foreground is monitoring the feeble sounds produced by the old record. The amplifier in the background is strengthening these tones, while the second operator watches the delicate cutting of the new disc.

stated that his company is now working on many similar ventures and that the Edison Laboratories in New Jersey are co-operating with him in this respect. "Kipling wrote in his latest book 'Gramophone records of good men would be more helpful to education than bushels of printed books.' That expresses our sentiments exactly," said Mr. Reeves. He continued: "We will shortly be able to release for a special series of radio broadcasts and for use in schools and homes, records of the actual voices of such past leaders of American Life and American Culture as William McKinley, Garrett A. Hobart, William Jennings Bryan, Phineas T. Barnum, Woodrow Wilson, John Wanamaker, Thomas A. Edison, William Howard Taft and scores of others. Also the present leaders of current thought in all fields, we hope, will make recordings for us, so that their voices may be preserved for posterity. Permanent copies of all these records will be kept in the archives of the Library of Harvard University."

Useful Educational Project

This is an interesting and most useful project and will not only be entertaining but may do much for educational purposes. One will be able to sit by one's own fireside and hear Bryan give a discourse on Im-

Alignment CHART

*Shows Relation between
Capacity, Inductance
and Frequency*

By John M. Borst

THE chart on the opposite page permits instant determination of the capacity and inductance required to tune to a desired frequency. The values of C, L and the corresponding frequency are on a straight line, thus by using a ruler any one of the three quantities can be found if the other two are known. Example: A condenser of 350 microfarads will tune to 550 kc. with an inductance of 240 microhenries (see dotted line). In this case all the B scales are read.

In order to make the range of the chart large, there are two sets of figures on the frequency scale and the inductance scale. The user should always employ all A scales or all B scales for any single problem.

The range of the chart can be further extended by multiplying all values of C and L by a convenient factor (10, 100, etc.) and dividing all values of F by the same factor.

By popular request the range of the chart now extends into the ultra-high-frequency region. One should remember that values of C and L for these frequencies are so low that the wiring itself may constitute a large part of it.

mortality or Taft suggest a solution to the difficult Labor Question. Classes in science will be able to listen to Thomas A. Edison himself tell about the marvels of electricity and history students can actually hear Calvin Coolidge welcome home that intrepid flyer who succeeded alone in a single motored plane in completing the first non-stop flight from New York to Paris. Also that flyer's story of his reception in Europe spoken by himself is one of the records in this series. Surely, this is a step in the right direction and it is not surprising that one of the late Thomas A. Edison's closest associates recently said: "Reeves has done a wonderful work in these transcriptions. He is doing his share for the technical advancement of the heritage left us by Mr. Edison."

(Turn to page 576)

THIS CHART WILL DO YOUR CALCULATING

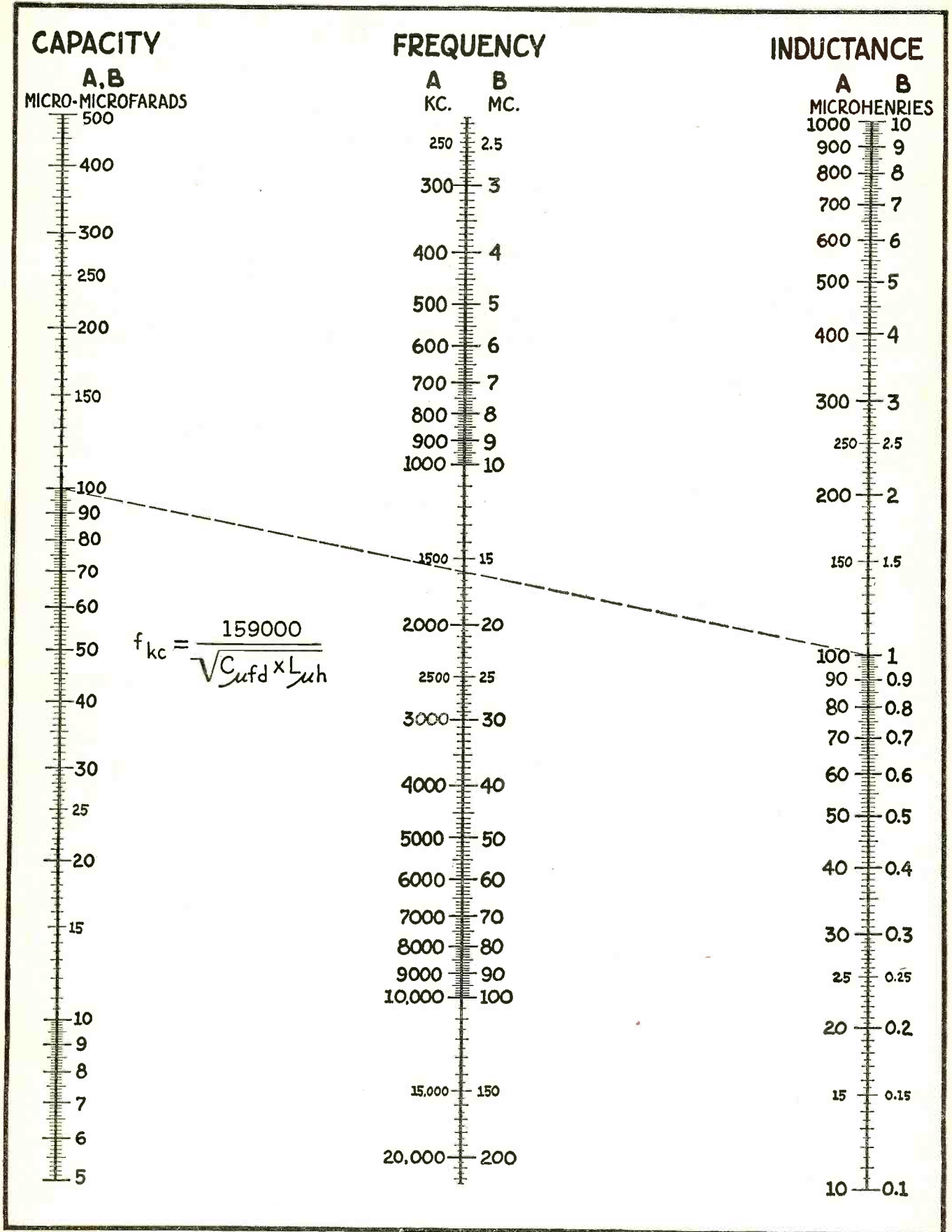

Figure 1. When any two of the quantities F, L, or C are known the third can be found by drawing a straight line. Example: 100 mmfd. and 100 microhenries tune to 1590 kc. (reading all A scales) or 100 mmfd. and 1 microhenry resonates at 15.9 mc. (reading all B scales).

Practical Lessons in TELEVISION

(Lesson Three: The Flying Disc)

By F. L. Sprayberry

TO reproduce a picture by the scanning disc method we must have an antenna for receiving the television signals that were generated as outlined in Lesson Two. By means of a special wide-band tuned r.f. or superheterodyne receiver the signal is picked up and demodulated just as any other signal and the video component is fed to a capacity-coupled amplifier. We now have the complete electrical equivalent of the original picture in rapid succession, one line at a time, at the receiver output. We can now see how these impulses are reconstructed into a moving picture.

Just as we needed an amplifier which would handle up to 54,000 cycles for transmission, so we must also have such an amplifier at the receiver because the signal, as you may easily realize, is of very low intensity at the receiving antenna.

The Neon Tube

At the receiver we must produce quantities of light at the right points on each picture area, exactly corresponding to those scanned at the transmitter pick-up system, or they all must have the same time separation regardless of the time of transmission. This is accomplished at the receiving end by means of a neon tube and a flying disc similar to the one used for transmission. We will first be concerned with the operation of the neon lamp and then with how it functions in the reconstruction of a moving picture.

The neon tube is the device which serves to convert the series of video impulses into equivalent light values or quantities of illumination. Note this is just the reverse process of the photo-cell. No attempt is made with this type of neon lamp to determine any position of the light but to follow simply the variations of the video wave accurately.

Neon is an inert gas making up a minute part of the gases of the atmosphere. It will not chemically combine with any other substance, and for this reason is highly adaptable for the problem. The gas is put in a tube having two rectangular

THIS lesson describes some of the early disc methods for receiving television pictures. A good solid understanding of these gives the reader a background upon which he can build an experienced viewpoint on modern practice. Lesson two, last month, showed how a picture was "sent" by the scanning disc and explained the method. Future lessons follow each month. Don't wait—start now!

parallel plates about $1\frac{1}{2}$ to $1\frac{3}{4}$ inches square and about $\frac{1}{8}$ inch apart. The tube is then partially evacuated, leaving in it neon gas at a low pressure.

With the plates or electrodes spaced a given amount and at a predetermined pressure, a definite voltage will produce a definite illumination of the remaining gas. This is due to ionization of the gas resulting from bombardment of free electrons with atoms with sufficient impact to free others. The energy given up by the electrons as they recombine with atoms is liberated in the form of light. In the case of neon, this light is of a red-orange color as determined by the atomic structure of the gas or its specific nature. Being chemically inert the neon does not combine with the molybdenum or tungsten electrodes and does not become absorbed by these electrodes to any appreciable extent.

An electron will travel along electrostatic lines of force when it is free

to move and having nothing to interfere with its motion will accelerate indefinitely. If allowed sufficient free space, the electron will soon gain enough energy of momentum to liberate one or more electrons from atoms with which it collides. The voltage, pressure and energy of ionization all determine just when ionization will take place.

Ionizing Voltage

In neon tubes the voltage required for ionization is around 100 to 150 volts or more. Above this voltage a sufficient amount of light will be liberated to account for a good percentage of power being absorbed by the device. If at 150 volts the radiation is just becoming visible it may reach maximum illumination at say 220 volts. Beyond this point, known as the optimum point, the light would not increase in proportion to the instantaneously applied signal impulses. For almost any increase in voltage above this point there would be no increase in light. Between this point of saturation of illumination and the "ignition point" as it is called where illumination begins, the light is proportional to the voltage applied and thus if we apply an amplified voltage equivalent of the original signal, the video frequency, to this neon tube it can be made to follow the original picture light variations.

The design of the neon tube is such that the entire plate will glow with as nearly a uniform glow as possible over its surface.

The diagram of a practical television receiver designed for disc scanning and reconstruction of pictures is shown in Figure 22. The similarity of this circuit to ordinary broadcast receiver circuits is at once apparent. In many high-fidelity circuits there will be resistors such as R1, R2 and R3. They tend to broaden out the selectivity of the i.f. amplifier, allowing the passage of a wider band of frequencies. While for high fidelity it may only be necessary to include a band of frequencies 15,000 cycles wide, for disc television, as we have just learned, we

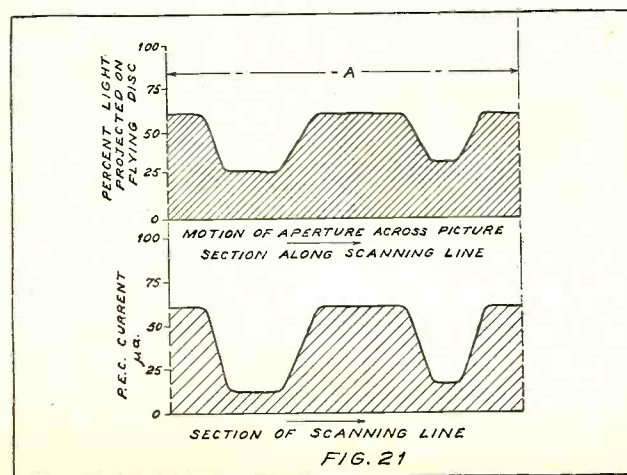

RADIO NEWS FOR MARCH, 1938

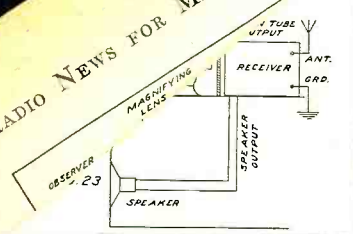

must pass at least 54,000 cycles.

The selectivity of the i.f. circuits must in this case be made very broad in tuning (108 kc. in this case). The shorting switches are provided so that the circuit may be used either for selective audio reception or television reception.

Although a capacity-coupled circuit with resistance plate and grid loads as shown here is admittedly better from the audio viewpoint, it is absolutely essential in the case of television. No satisfactory transformer would give an equivalent linear response from about 20 to 54,000 cycles. At the output we have a selection between a regular dynamic speaker and simply a neon lamp and resistor used as a load for the tube. The resistor is simply a protective agent for the neon lamp to limit its maximum current.

Small Time Lag

Obviously we could not use a filament type lamp in this way as the filament could neither heat nor cool as rapidly as would be required for this work. On the other hand, the gas can be illuminated to full brilliancy and can go completely "out" as many as 100,000 times per second. Hence in $1/54,000$ of a second it may attain any degree of illumination over its entire surface.

Our problem now becomes one simply of distributing the light over the surface of the plate within the neon tube so as to form the original succession of pictures. This distribution is not done on the neon tube itself, but rather the aperture through which the plate is viewed is moved in the same manner that it is moved for transmission and by the same means.

Mounting the Disc

A Nipkow disc identical to the one used for transmission is used for reception. The disc is mounted in a similar way with the neon tube directly behind it so that the total area covered by the pin holes is covered in back of the disc by the rectangular plate of the neon tube. Very often a large magnifying (convex) lens is used in front of the disc as in Figure 23 to increase the size of the pictures reproduced, but this does not increase

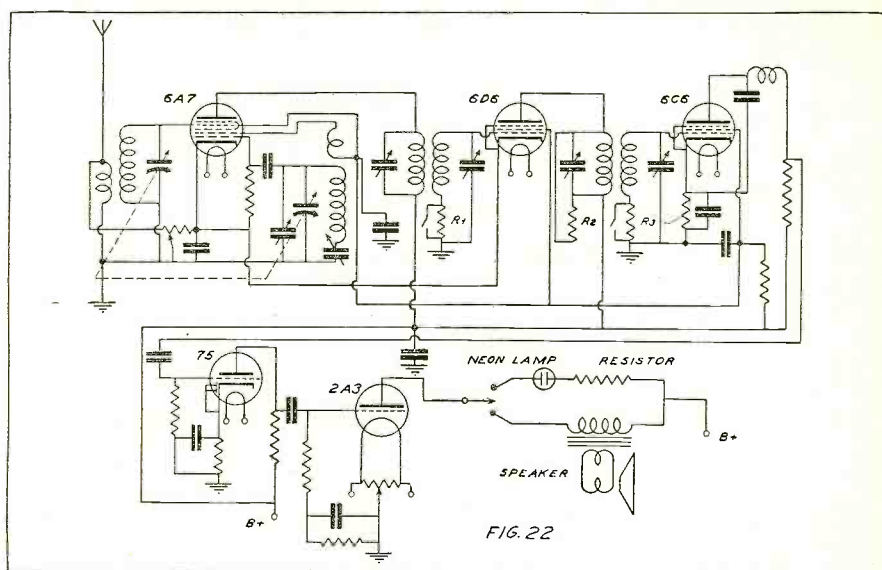

the detail. The picture detail is entirely a matter of the number of elementary areas which it contains. Magnification increases the size of each area and the size of the entire "frame" but the number of areas of the frame remains constant.

As the first aperture of the receiver disc passes across the topmost section of the neon tube plate, called the "target", the amount of light falling on the photo-cell for an equivalent time of transmission makes the neon lamp vary in brilliance in the same manner. Therefore, the top line will be a luminous reproduction of the light content of the top line of the picture being transmitted. The same is true for each line, and if the discs are driven at precisely the same speed, each successive picture will be reconstructed.

How it Operates

While the entire area of the target is varying in illumination, only one small area is viewed at a time, yet the entire surface is made visible, point at a time, 15 times per second. Because of the retaining power of the human eye, the entire surface is apparently seen instead of a series of "twinkling" areas which are actually

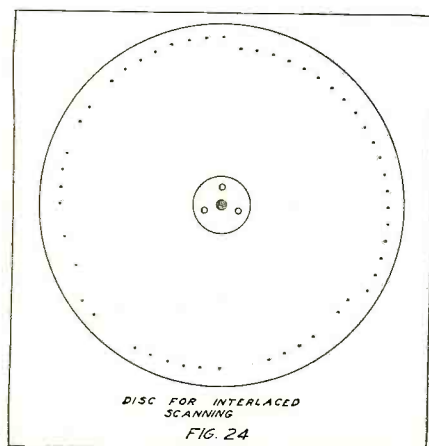

exposed. In this way the transmission of moving pictures is possible.

We have purposely confined our studies of television so far to the essence of the idea only, omitting certain details which, of course, are necessary to the practical operation of the system. As these mechanical systems are now obsolete in view of more recent developments in the electronic field, these details are of little importance. Our studies thus far have served to show how pictures were first transmitted, and having shown how it is possible to rapidly "integrate" any picture into small areas, producing an electrical equivalent of the relative light of these areas, transmitting and receiving these equivalents as individual impulses, again producing luminous equivalents from these impulses and "reconstructing" a mosaic picture with these luminous impulses. In substance this is the theory of all television. No other method of acquiring these results has yet come to light. Whether this is done mechanically or electronically does not alter the case. There is apparently no way to get around the problem of transmitting only a single series of impulses bearing one continuous and sequential piece of information or intelligence.

Other Systems

It might be well to investigate briefly the general construction of other mechanical systems which will be very instructive in presenting the problems and shortcomings of all mechanical systems. It is indeed remarkable how man's ingenuity has overcome many of the difficult problems involved in the art of television. Developments have followed in rapid succession, improving the picture size, the picture detail, the light intensity used, the number of frames per second and the accuracy of synchroniza-

tion of transmitter and receiver—al-
badly needed improvements.

One of the first improvements
made was that of driving the disc at
20 or 24 revolutions per second to
produce this many pictures per sec-
ond respectively. The disc was en-
larged and more holes were used (75
and 90 holes were commonly used)
thus increasing the number of lines
per frame. With a larger and heavier
disc, more power was required for
operation and its speed control re-
quired more apparatus. The higher
speed produced more noise which, of
course, is objectionable. It was be-
lieved by some investigators that a
disc having three spirals instead of
one, with the successive holes off-set
to scan every third line, produced a
more satisfactory picture which un-
doubtedly has some basis of fact. It
would scan lines 1, 4, 7, 10, 13, etc.,
in its first 120 degrees of rotation
then start with lines 2, 5, 8, 11, etc.
in its second 120 degrees rotation,
finally finishing its revolution with
lines 3, 6, 9, 12, 15, 18, etc. thus
covering them all in one revolution
as before. Such a disc appeared as
in Figure 24. The instantaneous mo-
tion at the top and bottom of the
picture were thus better "merged"
into one picture there being some-
what less displacement of the object
than in the single spiral type. This
is, of course, equivalent to three times
as many pictures, but each of a more
incomplete character. A certain
amount of "flicker" was thus elimi-
nated.

The Drum Scanner

For a given disc an increase in
the number of holes correspondingly
reduced the width of the picture as
this would be dependent on the dis-
tance between centers of the holes.
A "drum scanner" (Figure 25A) ap-
peared in the developments consist-
ing of a cylinder about 6 inches in
diameter—hollow, with apertures
drilled in its surface, forming a 4 or
6 turn "helix" on the cylindrical sur-
face, such as a pipe thread with a
very broad pitch. It was used prin-
cipally for reconstruction in a "tele-
visor", as it did not apply particu-
larly well for pick-up purposes.

As for many of the later discs,
the holes in the drum were cut square
to let through some 27% more light
without reducing the picture detail.
For the one with six helical turns of
apertures, the drum was driven six
revolutions for each picture, and for
fifteen pictures per second, this neces-
sitated a speed of 6x15 or 90 R.P.S.
On the axis of the drum was
mounted a 6 target neon lamp—see
Figure 25B. There was a separate
lead for each target and a commu-
tator attached to the motor shaft so

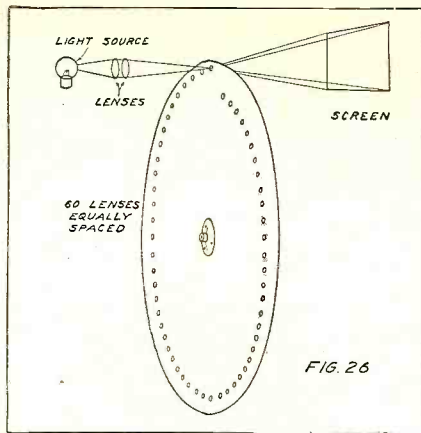

that one target would be used only
for one revolution of the drum. This
would handle the first 6th of the
frame and the other targets would
take up the balance of the picture
in succession. When first used, the
drum was fitted with fused quartz
spokes, one for each aperture, extend-
ing to the collar surrounding the neon
tube in the hub. They met at the
center collar in six rings so that each
passed directly in front of the neon
target and carried the light diffusing
it at the outer end. It was later
found that these were not necessary
and were discarded.

Mounting the Drum

In many cases the drum was
mounted vertically with its axis, cor-
responding with the side to side
scanning pattern of the transmitting
disc. If mounted horizontally, of
course, the picture was reconstructed
from top to bottom, and to be trans-
mitted in like manner from a side of
the transmitting disc instead of from
the top.

Many lens discs made their ap-
pearance in the development of me-

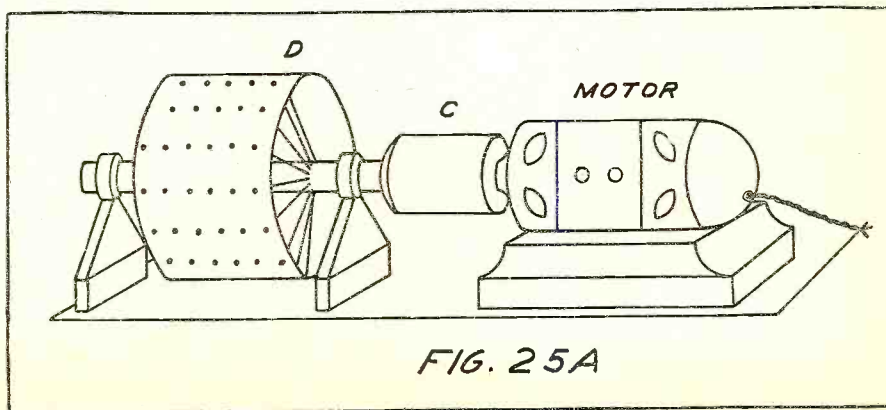
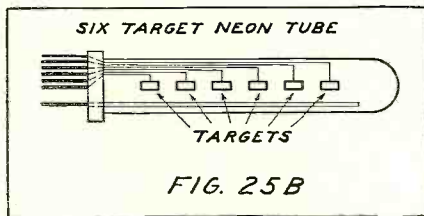

RADIO NEWS FOR MARCH, 1938
Instead of simple complete transmitter and receiver obtained intense spots of light on individually adjusted so would project the light a rect points across the picture

Introduces First Mobile Television Station

New York, N. Y.—The National
Broadcasting Co. announces Ameri-
ca's first mobile television station to
be used in experimental television
pickups of outdoor news events. The
new unit, consisting of two large mo-
tor vans, contains television control
apparatus and a micro-wave trans-
mitter. The new mobile unit is oper-
ated by a crew of ten engineers. In
the Metropolitan area, where the
steel framework of many skyscrapers
impedes ultra-high frequency trans-
mission, the normal working range
of the new unit is expected to be
about twenty-five miles.

New Method of Recording and Reproducing Sound

Berlin, Germany—A new invention
recently placed on the market here
under the name of "Teliphon" is a
device about the same size as a por-
table radio set with attached electric
cables, microphone, and separate
loudspeaker. The essence of the de-
vice makes use of a band of some
hard material similar to a pyroxylin
plastic in the shape of a film of the
usual 35 mm. size and with the usual
perforations. Sound is recorded on
this moving band by a cutting device
which cuts a groove in it. One hun-
dred parallel grooves can be cut. The
"Teliphon" can record a long speech
or conversation in a very small area
and will produce it immediately.

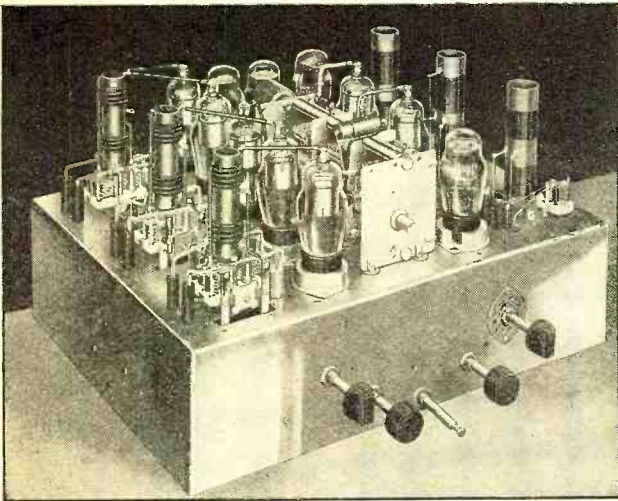

TO SHOW QUALITY OF "INNER" WORKMANSHIP
This view of the receiver is one taken with the shields and front dial removed so that the coil arrangements and the working details are laid bare to inquisitive eyes. Very often beautifully finished and polished shield "cans" hide poor workmanship, but in this case it is really a shame that the operator cannot see the well-made tuning units.

HERE is a receiver for the most hard-to-please readers of RADIO NEWS, whether they are experienced short-wave listeners, amateurs, or broadcast listeners with a trained ear for good music. There is so much that is "new" technically, as well as good laboratory practice in the design of this set, that it is felt by our editors that an article along technical lines will be appreciated.

BRIEFLY, the new Scott "16" receiver employs, as the name would suggest, 16 tubes to cover all frequencies from 550 kc. to 22 mc., in four bands. It incorporates an r.f. system with the proper kind of selectivity and a remarkable value of useful sensitivity for DX work. Looking at the diagram, which is printed herewith, one can see that the circuit includes one

high-gain r.f. system, three stages of intermediate-frequency amplification, diode detection, and three stages of audio-frequency amplification, two of which are push-pull. The audio amplifier employs phase-

THE POWER PACK AND OUTPUT AMPLIFIER

This unit is as well made as the receiver. It is a high-power stage, capable of a maximum of 16 watts of audio and a full 13½ watts without distortion.

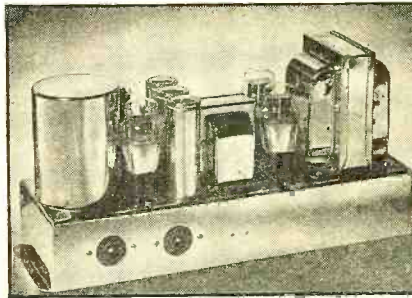

DX Fading Reduced by DUAL A.G.C.

in New 16-Tube Super (Scott Model "Sixteen")
 By Laurence M. Cockaday and S. Gordon Taylor

inversion as well as negative feedback for high-fidelity reproduction from 30 to 7500 cycles. The set is capable of 13½ watts undistorted audio output.

The loudspeaker is a double-cone model for covering the entire range. The local oscillator is electron-coupled.

Two separate automatic volume-control systems are employed, one for the r.f. stage and one to control the i.f. stages to prevent any possibilities of overloading.

The novel supershield antenna-coupling system provides effective noise reduction on the important short-wave bands, using an automatic switching arrangement for the broadcasts and adjacent channels.

A further amplification of certain features of the receiver will be interesting to the strictly technical person. Looking at the antenna-switching arrangement, it will be seen that when the receiver operates on the two short-wave bands, the signal is picked up on (Turn to page 569)

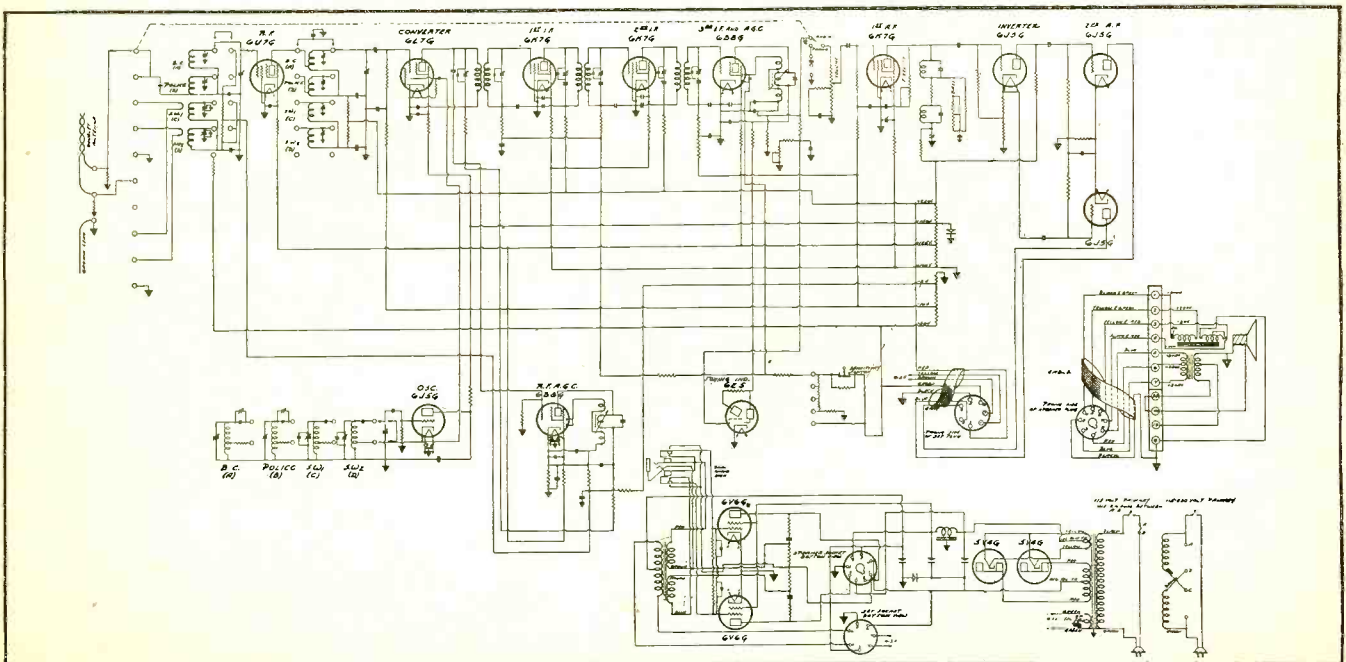



AN UNUSUALLY WELL-EQUIPPED SHOP
 Figure 1: Shannon Radio Service has a Service Bench which any serviceman would be proud to own. Note the symmetrical layout and variety of good equipment.

THIS MONTH'S "SUCCESS" INTERVIEW

LOCATED in the heart of Westchester County, Shannon Radio Service is an outstanding example of an ideal radio service shop. The owner, Howard A. Shannon, is shown at his desk in Figure 2. In the business since the start of broadcasting, Shannon has built up a reputation for competent servicing which extends even to adjoining States. He has resisted the temptation to expand, however, preferring to keep personal contact with his customers and to improve his present shop rather than to open new ones. Strictly a service business, he sells no sets or appliances. However, Shannon's salesmanship is distinctly in evidence as he goes in for many radio side lines, such as Public Address and sound-on-film apparatus, which add profits from year to year.

Your Service Editor visited Shannon this month to look over his layout and dig up information regarding his business and technical methods. As shown in Figure 1, Shannon has an unusually well-equipped Service Bench. The bench itself is 13 feet long and the test panel above measures 4 by 9 feet. The panel is of one-inch wood and can be removed as a unit when changes are required. Since Shannon keeps pace with newer developments in test equipment and methods, the shop equipment is constantly being improved and increased.

In the center of the test panel is a meter board incorporating large single-range voltmeters and milliammeters. The meter in the center of

this group is used for checking intermittent "faders". It is cut into the main "B" line of the power pack and indicates, when the set fades, whether the trouble causes an appreciable change in the plate current.

At the upper left, a Philco Universal test speaker is installed behind the attractive grille. Directly opposite a similar speaker grille is shown, but there is no speaker behind it. Instead a colored light, operated by a relay connects to an ohmmeter. In bench checking, the serviceman can keep his eyes on his test prods while checking a set for shorts, a light flashing when the short is located.

Beneath the speaker grilles are two standard Weston and Jewell test panels and in the lower center is a Clough-Brengle type OC signal gen-

erator which has been converted into a crystal oscillator. Four crystals are employed, two for standard intermediate frequencies of 175 and 465 kc. and two for the standard broadcast band.

On the test bench, from left to right are a Simpson Roto-Ranger, a Tobe condenser analyzer, Weston analyzer. At the far end are a condenser decade box for substitution test purposes, a large Clough-Brengle model OMA Signal Generator and frequency modulator and the model CRA oscillograph by the same manufacturer.

Accessory Equipment

The air compressor beneath the bench proves a most valuable addition to the shop equipment. It is a specially-built affair of a type similar to that employed for spraying auto bodies. It is fitted with a pipe nozzle which gives a powerful concentrated jet of air. This enables any chassis to be thoroughly and completely cleaned in a moment.

Both a.c. and d.c. are available, a

Service

This Month:

How Shannon succeeds . . . "Dummy" Tubes . . .
 Knight's Service Shop . . . Adopting Tiny Tots
 . . . Service Hints . . . New Auto Antennas . . .
 Telechron Clocks

erator which has been converted into a crystal oscillator. Four crystals are employed, two for standard intermediate frequencies of 175 and 465 kc. and two for the standard broadcast band.

On the test bench, from left to right are a Simpson Roto-Ranger, a Tobe condenser analyzer, Weston analyzer. At the far end are a condenser decade box for substitution test purposes, a large Clough-Brengle model OMA Signal Generator and frequency modulator and the model CRA oscillograph by the same manufacturer.

At the upper left, a Philco Universal test speaker is installed behind the attractive grille. Directly opposite a similar speaker grille is shown, but there is no speaker behind it. Instead a colored light, operated by a relay connects to an ohmmeter. In bench checking, the serviceman can keep his eyes on his test prods while checking a set for shorts, a light flashing when the short is located.

Beneath the speaker grilles are two standard Weston and Jewell test panels and in the lower center is a Clough-Brengle type OC signal gen-

HOWARD A. SHANNON AT HIS DESK

Figure 2. Usually he's hard at work at the bench, which accounts for the white smock which he is wearing. Here he checks over each bill personally to make certain each charge is correctly entered.



Sales

By John H. Potts
Service Editor

bank of 4 mercury-vapor rectifiers supplying up to 2 amps., d.c., at 110 volts.

The method of mounting the cathode-ray oscillograph is novel and convenient. It is installed on a sturdy platform which is fastened to an iron pipe so arranged that it can be revolved to any desired position. The pipe fits into a broad base which gives the stand a solid foundation. The hood over the cathode-ray tubes was constructed by Shannon and helps to keep out extraneous light and reduce eye-strain.

Of special note is the convenient and efficient means of handling Rider's Manuals. These are stored in a typewriter display cabinet, one end of which is shown at the extreme left in Figure I. The glass front may be swung up and slid back into the cabinet. A sliding shelf in the cabinet, when pulled out, provides a support for the manuals.

Additional test apparatus (not shown) includes an RTL counter tube checker and a Taco Resonance Indicator.

Handle Any Type Job

With this elaborate array, Shannon is able to handle practically any type of radio job. He is the authorized service stations for Scott radios in his locality, of which there are many since Westchester County has the highest per capita wealth in the United States.

Shannon is very frank with his customers. "When a man drops in and asks to talk to the radio engineer, I tell him that we are only service-men. We employ no radio engineers, since servicing requires a different type of knowledge and the ability to work fast, so an engineer without practical experience in servicing would not be efficient at our work."

"What about advertising?" I asked him.

"Now and then I take display space in the local newspaper," Shannon told me, "but it really doesn't pay out directly. A lot of people will

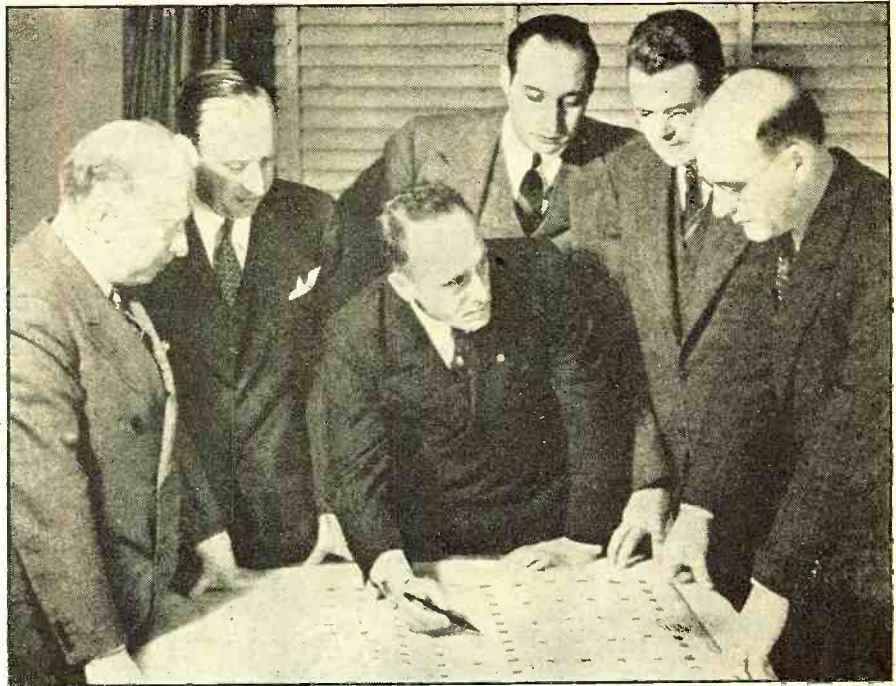

GETTING READY FOR THE 1938 NATIONAL TRADE SHOW
Figure 3. The Board of Directors of the Radio Part Manufacturers National Trade Show express their approval of the layout of the Exhibition Hall for the 1938 National Parts Show. Grouped around the table, left to right, are Arthur Berard (Ward-Leonard) Vice President; Arthur Moss (Solar) Secretary-Treasurer; K. C. Prince, Legal Counsel; H. E. Osmun (Centralab); and S. N. Shure (Shure Brothers) President. Ken Hathaway (pencil in hand) Managing Director, has just explained to Mr. Shure how he arranged for straight 8-ft. backwalls for practically all booths.

call up and ask what it will cost to fix their radios and when they find out we make a charge for diagnosis, they hang up the phone. My business has been built up by personal recommendation from satisfied customers, though I suppose advertising helps indirectly in getting things started. Our two outside servicemen use ordinary cars with no advertising signs on them, not because it wouldn't be a good thing to keep the name before the public, but because they are fast drivers and I'm afraid they might some day have an accident which would give my business a black eye. To reduce overhead, I rent rather than own a truck which is used largely for aerial jobs requiring ladders. You see, we have no consoles

to deliver and don't really require a truck every day."

"I have three employees, two outside men and one in the shop. And, of course, I keep busy at repair work myself. All work on straight salary and one man has been with me since I started in business, back in 1924."

"We stick pretty closely to straight radio servicing and the test equipment on hand enables us to handle a surprisingly large volume of business. Though our hourly rate at the shop is \$2.50, the equipment and our experience enable us to turn out a given job at the same price to the customer as others doing good work, regardless of their hourly rate. We charge only \$.75 for pickup and delivery and the shop charge for a bench test is likewise \$.75. I encourage customers to bring in their sets, since the equipment helps a great deal in corralling the job."

Public Address Work

"We do quite a little public-address work, selling installations outright as well as renting apparatus. We now have seven 60-watt and two 30-watt amplifiers, on hand, all Websters, with Racon and Cinaudagraph speakers and crystal mikes."

"Electric stethophones provide another good side-line. These we make up by assembling a Brush special stethophone mike, an 8-watt Webster

(Turn to page 550)

Servicemen! Dealers!

HAVE you a well-equipped shop, neatly and efficiently laid out? Or an attractive and effective Window Display, Sales Counter, Demonstration Room, or Service Bench? If so, send in a photo, with a short description, for publication. After using it, you can have the cut, free of charge.

Here is a chance to obtain an expensive cut, gratis, suitable for any literature or newspaper advertising you have in mind.

Send photos and captions to the Service Editor, RADIO NEWS, 381 Fourth Avenue, New York City.

Operating Test Report on the ALL-WAVE "15-17"

By S. Gordon Taylor
and Laurence M. Cockaday

LAST month McMurdo Silver described his newest receiver—the "15-17" all-wave super-heterodyne. One has been in operation for some weeks in one of the RADIO NEWS proving stations in New York City and this article presents a report of these operating tests.

Outstanding Features

It is usually the practice in such reports to list a long string of stations heard. The result is that little space is left to describe other operating features. While the great majority of readers are interested in the DX capabilities of a receiver, almost everyone is equally interested in other features such as tone quality, ease of tuning and operation, effectiveness of the a.v.c. system, etc. Considering this, an attempt will be made to cover the various features of the receiver without over-emphasis on the sensitivity.

This is not to imply that the "15-17" lacks sensitivity, because actually it rates extremely high in this respect. In many instances distance stations were brought in better on this receiver than on others with which it was compared—and all of the others were above-average receivers. The test location was a rather poor one because of its high noise level, for which reason the sensitivity tests were based partly on this comparison with other receivers of known quality. In this location it is seldom possible to hear the trans-pacific short-wave stations, for instance. But on every occasion when a try was made for them, they were brought in by the "15-17," the signals ranging from poor to good, depending on conditions, but at all times were intelligible. European, South American and others up to five or six thousand miles distant were regular fare, in many instances vying with local broadcast stations in quality and general excellence of signal strength and clarity of reproduction.

On the broadcast band, in which

range the local noise level is much lower, the receiver did a fine job, providing early evening reception from all over the country and good reception from a number of west-coast stations later in the evening, in spite of the fact that west-coast reception has been notoriously poor in this vicinity this season.

So much for the sensitivity. So far as it was possible to judge it fully confirmed the measured rating mentioned by Mr. Silver in his descriptive article.

Variable Selectivity

The selectivity, and provision for varying it, both proved highly effective. In the 3 kilocycle position it was found possible in some cases to bring in a station understandably with interfering stations so close as to cause a violent heterodyne whistle when set for medium or wide-band operation. In this selective position sidebands are cut quite appreciably, of course, but still leave speech entirely understandable. In the medium, or 8-kilocycle, position, the selectivity is still above that of the average receiver. Here the quality is improved and music, while not "high-fidelity" is at least entirely acceptable and above average. The seeming inconsistency in these last two statements is undoubtedly accounted for by the steep sides of the selectivity characteristic engineered into this receiver.

THE "15-17" offers an excellent example of the trend toward universal utility in receivers of the better class. It not only performs ideally as a home receiver, but also includes many of the features so important in amateur communication service—such as good band-spreading, super selectivity, beat oscillator for c.w. code reception and a "log-able" tuning arrangement; all of these with the minimum of complexity in operation.

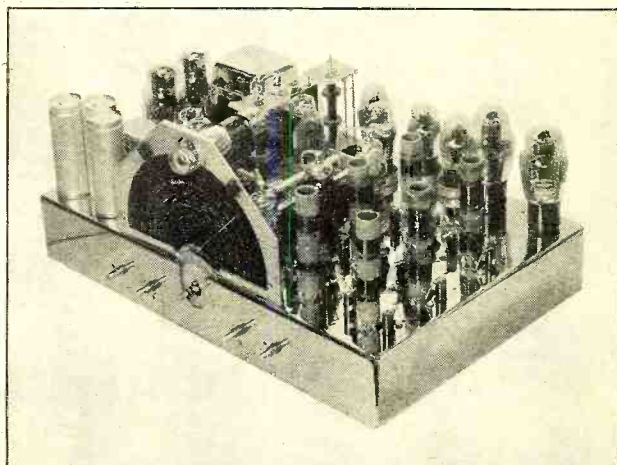

THE "STRIPPED" CHASSIS

Here the "15-17" is shown with all shield cans removed, disclosing the clean-cut workmanship even in places which are normally concealed from view.

In the broad-band position (16 kilocycles) really high quality is provided. It is in this range that musical pitches up to 8000 cycles are included. The sensitivity falls off in this position but that is of no importance because it is used only for reception of good local broadcast stations anyway.

Control of Tone

Complete range of tone is provided by the band-width (selectivity) and bass control knobs. As the former knob is swung from the 16-kilocycle to the 8-kc. and then the 3-kc. positions the high notes are progressively attenuated and therefore under complete control in three steps. The bass-control knob does the same thing for the bass register; attenuating the lows at its lowest setting and boosting them at the other extreme of its range. As a result the rumble of the organ can be reproduced in all its majesty, and can even be emphasized if desired. The combination of the two controls allow any degree of shading desired to suit individual taste.

In addition to the selectivity and bass control knobs just mentioned, the other controls are the conventional ones; tuning, volume and band selector. They are, however, conventional in name only. The tuning control, for instance, is the same as used on the "Masterpiece VI". It provides a 12 to 1 tuning ratio but at each reversal jumps to an 80 to 1 ratio for 1 revolution of the large knob, after which it again assumes the 12 to 1 ratio. This makes tuning the critical short-wave ranges a pleasure.

In addition to the large, fully calibrated dial there is a small secondary dial, the full circumference of which constitutes a scale marked off into 200 divisions. Short-wave stations can be (Continued on page 576)

See Them AT YOUR DEALER'S (New Radio Products)

Pie-Wound Precision Resistors

The Ohmite Mfg. Co. announces the Riteohm "81", a vacuum impregnated, non-inductively pie-wound precision resistor of 1 percent accuracy and 1 watt rating. This unit extends the line of Ohmite precision resistances to values not reached by the Riteohm type 71 resistor. The new unit is ideally suited for use in voltmeter multipliers, laboratory equipment, etc.

A Pillow-Speaker

The Brush Development Company recently announced a new crystal-operated radio set accessory known as the "Hushatone" (pillow-speaker). The unit is an ideal accessory for midget radio receivers as well as for the typical home radio. Persons enjoying a "Hushatone" do so by placing it under a pillow and reclining in a chair, on a couch, or in bed. A sickbed in the home or hospital is an ideal application for the "Hushatone."

Portable Phono-Player and Amplifier

The outstanding features of this new Allied portable a. c.-d. c. transcription reproducer and record player include: a built-in amplifier unit with 4 watts output, dual-speed universal phono-motor with 12 inch turntable, 12 inch crystal pick-up, built-in scratch filter, tone control, and 8 inch permanent magnet dynamic speaker. All 8, 10, or 12-inch recordings, as well as 16-inch transcriptions, may be reproduced with unusual fidelity. Both 33½ and 78 r.p.m. recordings are accommodated. The entire unit is housed in a portable leatherette case measuring only 19½ by 11¼ by 14 inches.

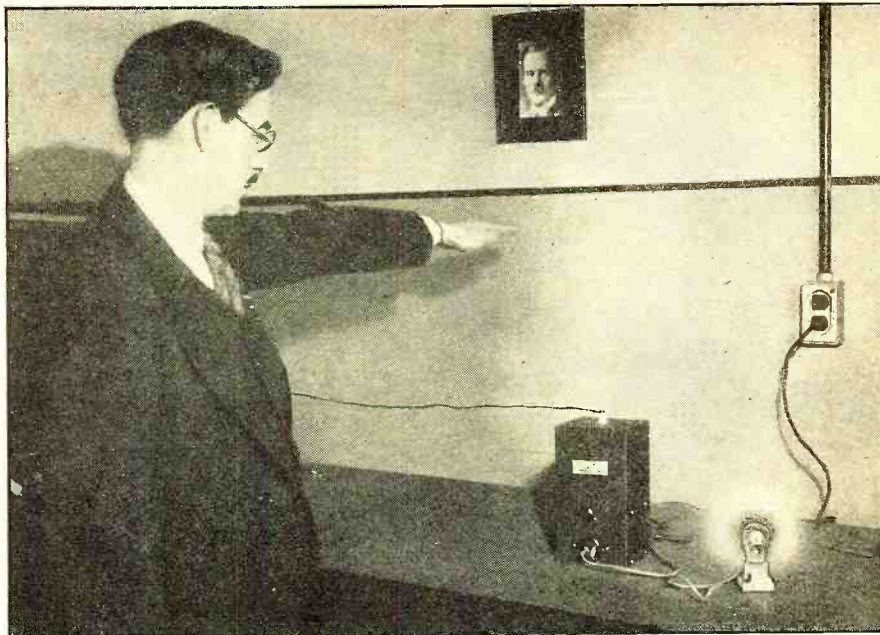

A WAVE OF THE HAND AND "CLICK"; IT WORKS!
No one can walk near this new device without the lamp lighting. No, it isn't Magic! It's a capacity relay which will turn on an alarm or other machinery as well as lighting the light shown in the photograph. It's name is "Sensitrol".

New Capacity Relay

A new device operating on the capacity relay principle has just been introduced by the Sensitrol Company. This instrument, shown in operation in the photograph, will switch on a light, ring an alarm or

operate advertising display when a person approaches a wire connecting to the apparatus. This capacity relay is unusually low in price, yet sensitive and fool-proof in operation. It is small and may be easily adjusted by an inexperienced user.

Low Cost Dynamic Mike

This is the latest Transducer "Bullet" dynamic type microphone. The model MK20, as it is known, is housed in a black metal case 3 inches overall length and 2 inches in diameter. It can be had in low imped-

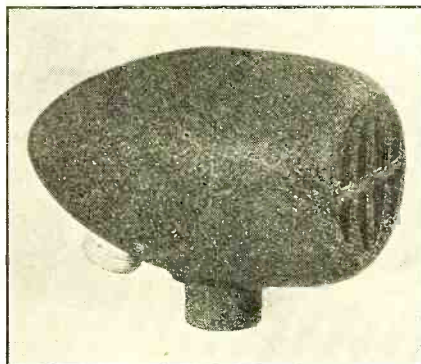

ance 200 ohms, or high impedance. The specifications show sensitivity minus 55 d.b. and frequency response, 90 to 9000 cycles.

Well-Designed Call Systems

This is the master unit of the new RCA Victor-Phone wired intercommunicating call system. By rotating the selector switch on the right, conversation between the master unit and any one of five remote units can be carried on. The knob on the left is a volume control and the switch in the

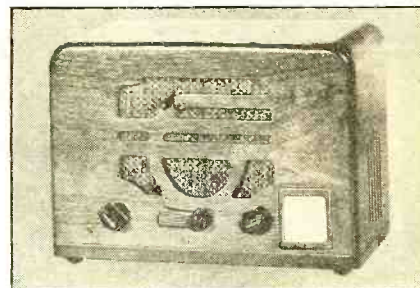

center is pressed for talking. The remote units can be used to call the master unit and carry on a two-way conversation. It is not necessary to hold open the talking switch (shown) after contact has been established. This company also makes a wireless call system which operates on the carrier frequency principle. Three systems can be operated in close proximity to each other without interference.

New Set Tester

The type 4800S set tester recently introduced by the Hickok Electrical Instrument Company features d.c. voltage ranges of 10, 50 and 250 volts at substantially infinite ohms-per-volt, in addition to the usual 5 a.c. and d.c. ranges at 1000 ohms-per-volt. A 0-500 microampere and 3 milliampere ranges are provided. The ohmmeter portion covers from .05
(Turn to page 570)

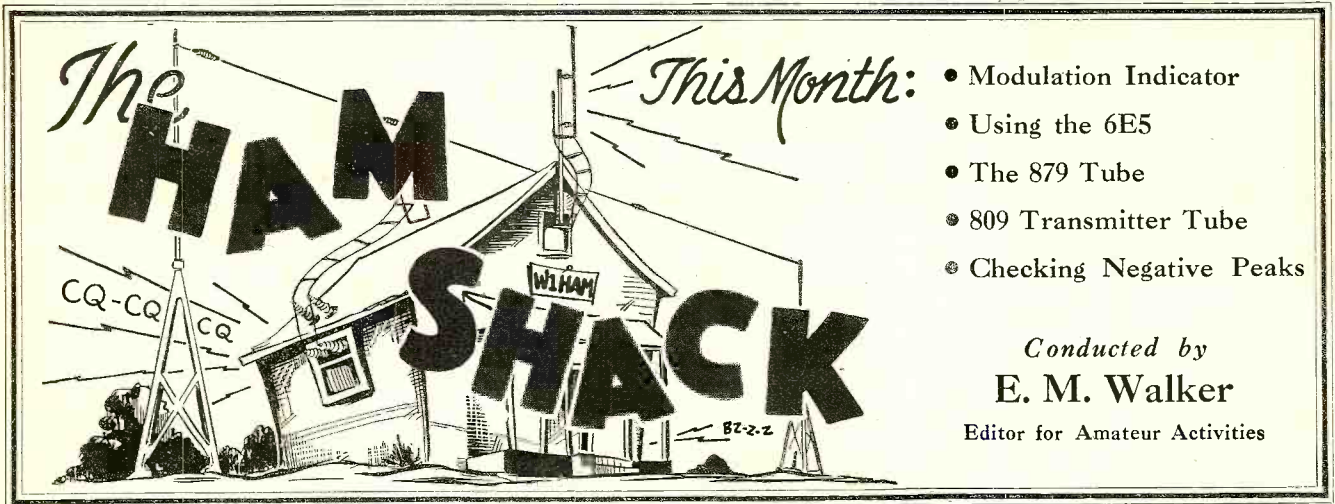

- Modulation Indicator
- Using the 6E5
- The 879 Tube
- 809 Transmitter Tube
- Checking Negative Peaks

Conducted by
E. M. Walker

Editor for Amateur Activities

JUDGING from the number of ragged signals heard on amateur phone bands recently, the tendency toward over-modulation seems to be increasing. Recently while listening on the 10-meter band carrier shift was detected on seven stations heard in slightly less than one hour.

FEDERAL regulations require that all phone stations be equipped with a means of monitoring modulation. In view of the crowded conditions on amateur bands today, if (despite the contrary) there was no other reason for watching over-modulation than the spirit of fair play, every operator should make an effort to guard against it. It is signals of this type that are responsible for a large percentage of the interference on the amateur phone bands. If every signal was cleanly modulated and within the legal limit, there would be much less interference.

Overmodulation!

This subject of over-modulation has been discussed before in this department, so we will not dwell too long on its effects. There are numerous devices available to the phone operator for checking modulation. Several meter manufacturers are making direct-reading, carrier-shift and modulation-percentage indicators. There are nearly a dozen types of oscilloscopes available on the market. And in addition there are simple carrier-shift indicators that may be constructed by the station owner at small cost.

Recently a unit that meets phone station requirements was brought to our attention and tried at the writer's station. It was designed by L. C. Waller, of the RCA Radiotron Division of the RCA Manufacturing Company. In addition to being an extremely accurate and sensitive device, it is inexpensive to construct. It is built around the 6E5 "electric eye" tube and may be mounted in a small cabinet that may be placed on the operating table behind the mi-

crophone where it is constantly before the operator's eye.

The 6E5 is more familiarly known to amateurs as a visual tuning-indicator tube. It consists of a high-mu triode mounted in the same envelope with a cone-shaped fluorescent screen or "target" whereon is attached a blade-like ray control electrode. To understand the application of the 6E5 as a negative-peak modulation indicator, it might be pointed out that the pattern on the "target" has a shadow sector of about 100 degrees when no bias is applied to the triode. This shadow appears because the so-called ray-control electrode is at negative potential with respect to the "target." If negative bias is applied to the triode, the triode plate-current decreases along with the voltage across the "target" and triode plate. At the same time the electrode becomes less negative with respect to the "target," and the shadow area diminishes. The shadow area is reduced to a narrow black line when about 7 volts of negative bias is applied on the triode grid. Because of this function the 6E5 is an excellent voltage-indicating device, and hence when used in conjunction with a high-voltage, half-wave rectifier tube, offers an excellent negative-peak over-modulation indicator for amateur use.

This negative-peak over-modulation indicator may be constructed for a few dollars, and, save for tubes, most of the components probably are available in the average station. In addition to the 6E5, an 879-type tube is used as a high-voltage rectifier. In the unit constructed at the writer's station the 879 rectifier and its components were mounted on the same chassis with the high-powered modulated amplifier, and the 6E5 indicator and its small power supply was mounted in a 5 by 9 by 6-inch metal cabinet which may be placed on the operating table. The two units are linked together by means of a twisted pair of the type used for doublet antenna lead-in purposes.

Indicator Cabinet

The unit that mounts on the chassis of the modulated amplifier consists of the rectifier tube, its filament transformer, the condenser "C," which may be from .05 to .5 mfd., and a 500,000-ohm variable resistor or potentiometer. The indicator cabinet contains, in addition to the 6E5, a 1-megohm resistor connected across the "target" and the ray-control electrode, and the small power supply which consists of a midget transformer and small filter. The latter is capable of delivering about 200 volts. It will be noted that both

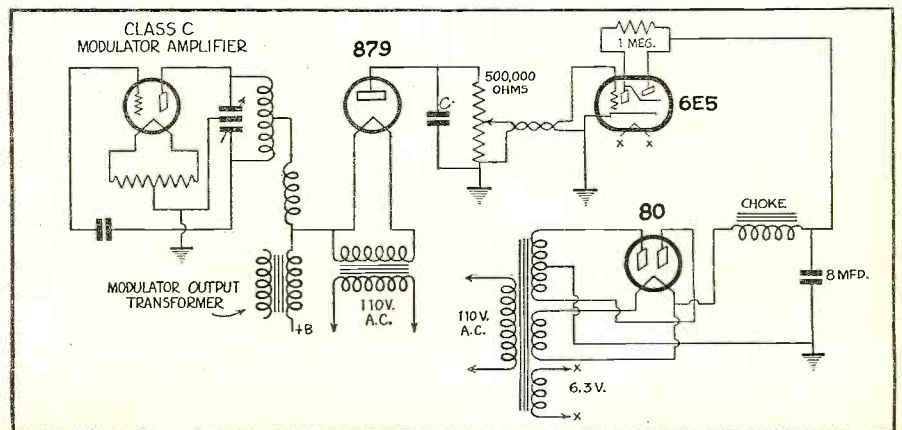

A Department for the amateur operator to help him keep up-to-date

units are grounded and in each case the twisted pair connects the two. Therefore, it is necessary that the twisted-pair wires be marked so that the same wire is grounded at both points.

It will be noted from the schematic diagram the filament circuit of the 879 rectifier is connected to the plate lead of the modulated amplifier. This should be at a point after the plate voltage passes through the modulating transformer but on the "cold" side of the radio-frequency choke coil in the plate circuit of the r.f. amplifier.

How It Works

It is obvious from the explanation of the operation of the 6E5 that when the modulated alternating current is positive, no current will pass through the rectifier tube because its filament is at positive potential with respect to its plate. This is also true as long as the negative side of the modulated a.c. voltage is less than the direct-current voltage applied to the plate of the modulated amplifier. But when the negative a.c. voltage exceeds the positive d.c. voltage applied to the modulator plate, the carrier will cut off and the filament of the rectifier (the 879) becomes negative with respect to the rectifier plate. This allows it to rectify and pass a rectified d.c. through the 500,000-ohm variable resistor which serves as a load resistor. This current causes a bias to be applied to the triode section of the 6C5. As previously explained, with a bias applied negatively to the triode section of the "electric eye" tube, the "target" pattern is caused to swing closed. Thus, it will swing closed every time the negative audio peak voltage is in excess of the d.c. plate voltage or when carrier cut-off takes place.

Very Sensitive

As a negative-peak over-modulation indicator the 6E5 when used in such a circuit is extremely sensitive. As pointed out before, the eye of the 6E5 may be completely closed when a bias of only 7 volts is applied to its triode section.

The 500,000-ohm variable resistor, which is connected from ground to the plate of the rectifier tube, provides a means of controlling the sen- (Turn to page 567)

New
"809"

Transmitting Tube
By Donald Mellor

THE RCA-809 is a three-electrode transmitting tube of the high-mu type for use as a radio-frequency amplifier, oscillator, or Class B modulator and audio-frequency amplifier. Because of its high perveance, the 809 can be operated at high plate efficiency with low driving power. The plate connection is brought out through a separate seal at the top of the bulb to provide high insulation. The internal structure of the 809 permits operation of the maximum ratings at frequencies as high as 60 megacycles. The maximum plate dissipation is 25 watts for Class C telegraph and Class B services. RCA-809 is equipped with a ceramic base.

Tentative Characteristics and Ratings

Filament Voltage (a.c. or d.c.)...6.3 volts
 Filament Current.....2.5 amperes
 Amplification Factor.....50
 Direct Interelectrode Capacitances:
 Grid-Plate.....6.7 mmfd.
 Grid-Filament.....5.7 mmfd.
 Plate-Filament.....0.9 mmfd.

Maximum Ratings and Typical Operating Conditions

As A.F. Power Amplifier and Modulator—Class B
 D-C Plate Voltage.....750 max. volts
 Max. Signal D-C Plate Current.....100 max. ma.
 Max. Signal Plate Input...75 max. watts
 Plate Dissipation*.....25 max. watts

Typical Operation
Unless otherwise specified, values are for two tubes.
 D.C. Plate Voltage.....500 750 volts
 D.C. Grid Voltage.....0 -5 volts
 Peak a.f. Grid-to-Grid Voltage.....135 140 volts
 Zero-Sig. d.c. Plate Current...40 35 ma.
 Max.-Sig. d.c. Plate Current...200 200 ma.
 Load Resistance (Per Tube).....1300 2100 ohms
 Effective Load Resistance (Plate-to-plate).....5200 8400 ohms
 Max.-Sig. Driving Power (Approx.).....2.4 2.5 watts
 Max.-Sig. Power Output (Approx.).....60 100 watts

*Averaged over any audio-frequency cycle of sine-wave form.

† Grid voltages are given with respect to the mid-point of filament operated on a.c. If d.c. is used, each stated value of grid voltage should be decreased by 4.5 volts and the circuit returns made to the negative end of the filament.

As R.F. Power Amplifier—Class B Telephony
Carrier conditions per tube for use with a max. modulation factor of 1.0
 D.C. plate voltage 750 max. volt

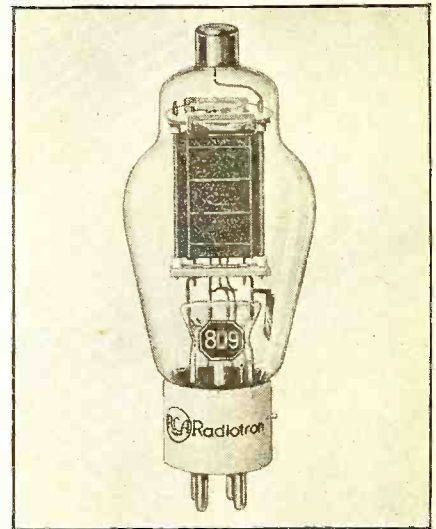

D.C. plate current 50 max. ma.
 Plate input 37.5 max. ma.
 Plate dissipation 25 max. wts.
Typical operation
 D.C. plate voltage 500 750 volt
 D.C. grid voltage † -5 -10 volt
 Peak R.F. grid voltage 35 40 volt
 D.C. plate current 50 50 ma.
 D.C. Grid cur. (ap.) 6 5 ma.
 Driving power (ap.) 1.4 1.5 wts.
 Power output (ap.) 7.5 12.5 wts.

As Plate-Modulated R.F. Power Amplifier—Class C Telephony
Carrier conditions per tube for use with a max. modulation factor of 1.0

D.C. plate voltage 600 max. volt
 D.C. grid voltage -200 max. volt
 D.C. plate current 83 max. ma.
 D.C. grid current 35 max. ma.
 Plate input 50 max. wts.
 Plate dissipation 17.5 max. wts.

Typical operation:
 D.C. plate voltage 500 600 volt
 D.C. grid voltage -160 -160 volt
 Peak R.F. grid voltage 250 250 volt
 D.C. plate current 83 83 ma.
 D.C. grid cur. (ap.) 32 32 ma.
 Driving power (ap) 7.2 7.2 wts.
 Power output (ap.) 30 38 wts.

As R.F. Power Amplifier and Oscillator—Class C Telephony
Key-down conditions per tube without modulation †

D.C. plate voltage 750 max. volt
 D.C. grid voltage -200 max. volt
 D.C. plate current 100 max. ma.
 D.C. grid current 35 max. ma.
 Plate input 75 max. wts.
 Plate dissipation 25 max. wts.

Typical operation:
 D.C. plate voltage 500 750 volt
 D.C. grid voltage -50 -60 volt
 Peak R.F. grid voltage 135 140 volt
 D.C. plate current 100 100 ma.
 D.C. grid cur. (ap.) 20 20 ma.
 Driving power (ap.) 2.5 2.5 wts.
 Power output (ap.) 35 55 wts.

† Grid voltages are given with respect to the mid-point of filament operated on a.c. If d.c. is used, each stated value of grid voltage should be decreased by 4.5 volts and the circuit returns made to the negative end of the filament. The above data were supplied by R.C.A. engineers.

WIXK Begins New Foreign Programs

Boston, Mass.—A new broadcast program is being transmitted over the Westinghouse station WIXK, 9570 kc., on Mondays at 4:00 p. m. E.S.T. The new program is international in aspect and is called "Radio Round The Clock."

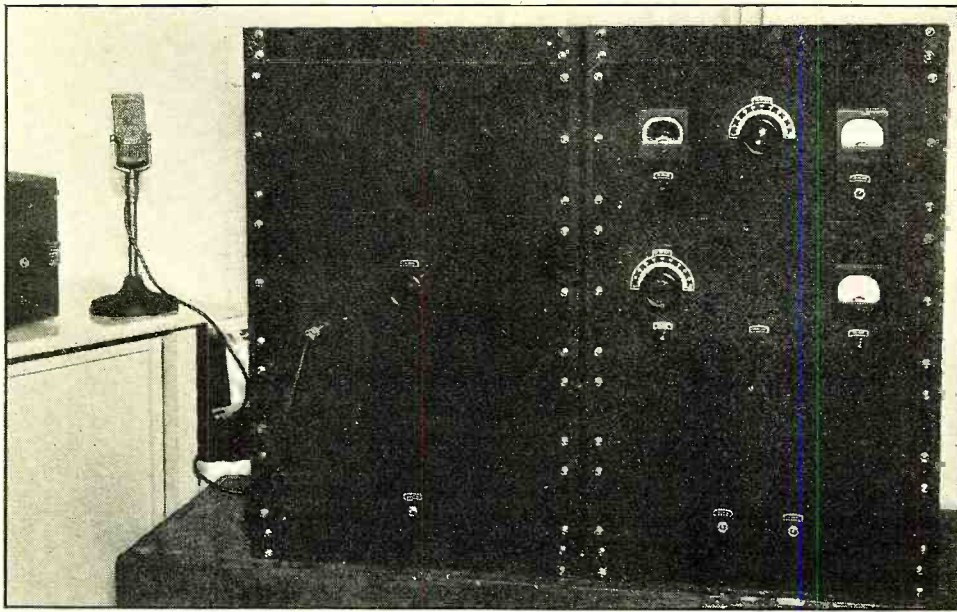

THE "10-80" TRANSMITTER SET UP FOR TEST
 At right, top to bottom, are the 112-watt r.f. final, the exciter, and the dual r.f. power supply. The modulator rack at the left has the speech amplifier and 60-watt modulator in the center, its power supply at bottom. The top panel is blank, affording space for antenna tuning equipment, oscillograph, or other equipment which the constructor may wish to add later.

The Radio News

"10-80" X'MITTER

for "Progressive" Construction

THE design of this complete transmitter is such that no rebuilding of the earlier units is required as the later ones are added—and no parts are discarded. The object of this design was to enable the amateur who wants a really high-class transmitter, but who cannot afford to buy the parts all at one time, to build as his pocketbook allows and yet be on the air from the day the first step is completed. Thus far the construction of Units A, B, C, D and E have been described.

The final step is the slight alteration of the modulator to provide 60 watts of audio, and the construction of an additional power supply (Unit F). Then the entire equipment is mounted on the two 32-inch Par-Metal table-type racks, as shown in the accompanying photographs, and the constructor finds himself possessed of a rig which will do him proud.

In step 2, the low-power phone, the 250 ma. available from Unit B was suf-

THE present is the fourth article of this series describing a "progressive" type of transmitter construction. The transmitter started in the December issue as a simple 25-watt c.w. rig to which units have been added each month until now it winds up as an excellent 112-watt phone transmitter.

**By Chester Watzel
 and Willard Bohlen**

(Part Four)

ficient for both Units A and C, each unit taking approximately half of this current. The low current drain of the modulator Unit C was due to the use of only two 6L6's in the power stage for low-power phone operation. With the use of all four 6L6's for full modulator output, however, practically 250 ma. are required for Unit C alone. Thus another power supply, Unit F, is necessary. No further data on the additional Unit F is required outside of that given in the diagram and parts list, as it is a duplicate of Unit B except for a slightly different arrangement of parts due to its having a whole chassis to itself.

Certain minor changes are necessary in the modulator Unit C when changing from two to four 6L6's so as to produce the full 60 watts of audio. Referring to the diagram of this unit on page 411 of the January issue, only one change is necessary in the connections to the output transformer, T1.

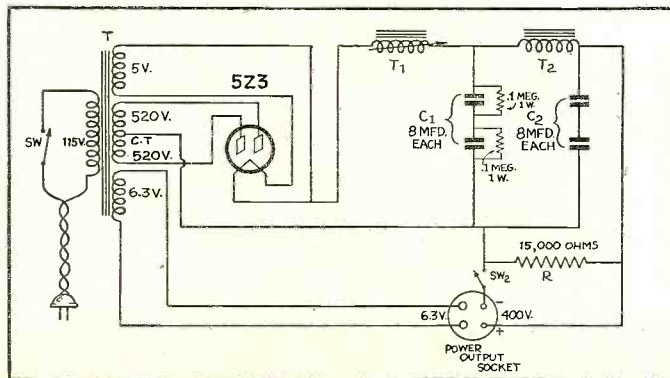

The plates of the 6L6's still run to terminals 1 and 6, with the B-plus to 2 and 5. On the secondary side of the transformer one connection is still left on Terminal A. The other connection, which went to C for operation with only two 6L6's now runs to D. This is the only change.

Modulator Matching

It is noteworthy that only one connection need be changed on T1 for any type of operation with this particular transmitter. This is the above-mentioned secondary lead which runs to either B, C or D. The B connection is made when a light bulb is connected across the output for an approximate check of the output watts, whether two or four 6L6's are in the sockets. While a 30-watt bulb should be used to check the output on low power, a 60-watt bulb should be used for a high-power check.

Resistor Adjustments

The full 200 ohms of cathode resistor R6 were used to bias the pair of 6L6's. It should now be adjusted to 100 ohms for use with four tubes. In order that the full heat dissipation rating of the resistor may be retained, one connection should go to the slider set at the mid-position, with the other connection going to both ends simultaneously. This will, in effect, parallel both halves of the resistor.

The resistance of R7 should be adjusted so that, with all five tubes in their sockets, the voltage to the 6N7 plates and 6L6 screens is dropped to 300 volts. This can be quickly checked with a voltmeter.

It will be noticed that the r.f. rack arrangement is the same as shown last month. No changes are necessary in this except, of course, to connect two wires between the pairs of "modulator" connection insulators on Units C and E. The excitation and antenna coupling to the push-pull T20's should be adjusted so that, with the tubes drawing 150 ma. plate current the grid current will be 34 ma. (for two tubes). With the 220's properly tuned and neutralized and drawing these amounts of grid and plate currents, the final stage is in proper condition to be modulated. The connections to the modulation transformer T1 previously detailed will provide a

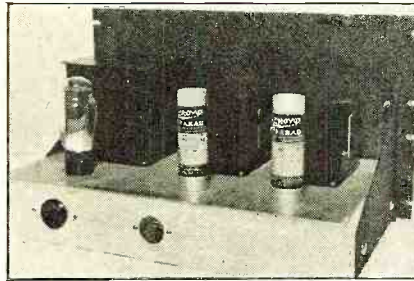

THE MODULATOR SUPPLY
This unit provides all power for the modulator system, including the push-pull-parallel 6L6's which provide up to 60 watts of audio in straight Class AB1.

proper match between the two units with both running at full output. Further details on the proper tuning and adjustment of the r.f. Units A and E will be found in last month's article.

(The completed transmitter was tried out at the old QRA of W2JCR with such satisfactory results that it is now being permanently installed in the new location. It is hoped that it will be on the air in time to include a description of the installation and the results obtained in the next issue.—
THE EDITORS.)

Parts List for Unit F

- C1—Aerovox type GL5 dual 8-8 mfd. electrolytic (with 2 sections in series)
- C2—Aerovox type GL5 dual 8-8 mfd. electrolytic (with 2 sections in series)
- R—Ohmite type 0416 15,000 ohm 50-watt bleeder resistor
- SW—single-pole single-throw toggle switch
- SW2—Cutler-Hammer toggle switch, 250 v., 10 amp. (this switch was a later addition and is not shown in photo)

PLUG-IN CONNECTORS

All d.c. and 110-volt line connections are made by means of cables and plugs. In making initial tuning adjustments the cathode circuits of either the T20's or the 807 buffer can be opened by inserting open phone plugs in their respective keying jacks. The plate circuit of the T20's can also be opened by disconnecting the cable to the modulator. This permits the final grid meter to serve as an indicator in tuning the preceding stages.

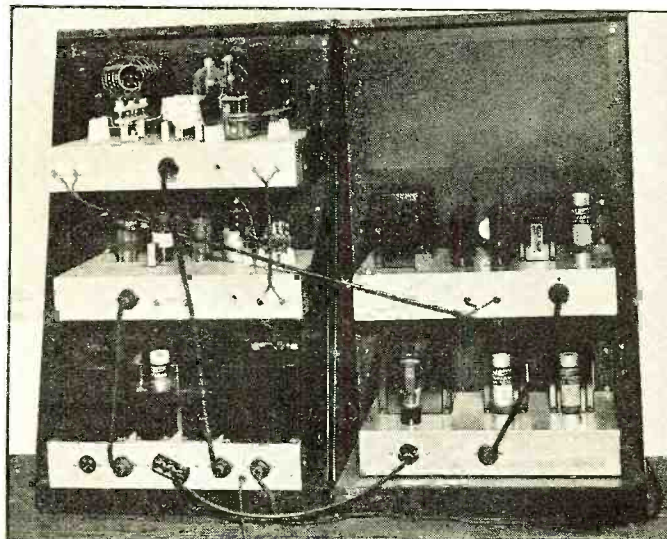

T—Kenyon type T-216 power transformer, 520-85-0-520 v. at 250 ma., 5 v. at 3a, 2.5 v. 3a, 6.3 v. at 3a, c.t.; 6.3 v. at 3 a, c.t.

- T1—Kenyon type T-501 swinging choke
- T2—Kenyon type T-151 smoothing choke
- 1 A.C. flush receptacle for 115-volt line input
- 2 Wafer sockets, 4-prong
- 1 Coto type CI-47 indicator plate, "Plate Voltage"
- 1 Par-Metal type 3605 black crackle finished panel, 19 by 10½ inches
- 1 Par-Metal type 15312 heavy-duty cadmium chassis, 17 by 13 by 3 inches
- 1 Par-Metal type SB-713 brackets
- 1 RCA type 5Z3 rectifier tube

Optional Equipment

- 1 Par-Metal type TR-3220 rack, 32 inches high
- 1 Par-Metal blank panel, type 3604 (black Steel) or type 3679 (black aluminum)

10 Meter Tests

Since the above was written more tests have been conducted using the rig on 10 meters. The permanent installation, complete with remote control switching, relay antenna switching, etc., is rapidly nearing completion and will be described in an article next month.

The 10-meter tests have shown the "10-80" to be exceptionally smooth in operation, both on phone and c.w. No spectacular distances have been covered with it for the reason that this band has been relatively "dead" during the test period. Stations which a month or so ago were working all continents are now lucky to get out a thousand miles. However, various measurements and observations show a high degree of efficiency for this new transmitter and all it needs is normally favorable conditions to start doing its stuff.

In the rear view photographs at the left it will be noted that a wire (actually it's a pair of wires) is shown coming out through a grommet in the rear of the main power chassis. These leads terminate in a small 2-connector female plug to provide connections for an antenna relay. Inside the chassis the leads are connected across the primary of the 750 volt transformer which supplies the final plates. Thus the antenna is automatically thrown to the transmit position when the plate supply is thrown on the final. The relay employed is a Ward Leonard type 507-531 double-pole, double-throw radio frequency unit for
(Turn to page 568)

The A, B, C's of ANTENNA DESIGN (Radiation Patterns)

AN antenna system is simply a tuned circuit containing inductance, resistance and capacity. Contrary to the usual closed circuit, however, these components are distributed over a wide area. An open antenna system is found to have a higher resistance than a closed circuit of the same electrical dimensions. This latter loss results from the fact that radiation through space takes place.

Figures 1A and 1B show the conditions about an oscillating antenna. We note in Figure 1A that circular lines of magnetism are present due to the moving electrons and the lines of electro-static energy in Figure 1B are due to the accumulations of electrons at the ends of the radiators. These two forces are always present and are at right angles to each other and to the direction of propagation. The waves are radiated from the wire with the speed of light (186,000 miles, or 300,000,000 meters, per second).

The Ionosphere

The first radio waves which were made use of commercially were of very low frequency, since it was difficult at the time to generate adequate power at higher frequencies. These longer waves were found to pass easily around objects and to follow the curvature of the earth. Great distances could be covered only by the use of very high power. The power in a receiving aerial, under average conditions, depended upon the distance, the height above the earth and the transmitting power.

As higher frequencies were developed, it was assumed that their use would be limited to local communica-

By I. Queen
(Part Four)

A KNOWLEDGE of antennas, the way in which they radiate, and the manner in which radio waves travel is one which every radioman should have, but one which is usually neglected. Every serviceman, experimenter, and amateur among our readers should read and carefully study this series. It is, in the editor's opinion, one of the clearest explanations written in ordinary language that has ever been printed. Read it yourself and tell your friends about it.

tion. It was shown that they would be unable to follow the earth's curvature. In time, however, it was found that unbelievable distances could be easily covered at times with the expenditure of but slight power.

This was discovered to be due to the reflection from layers of "clouds of ions" suspended in the atmosphere, at heights of several hundred miles. This ionosphere is known as the Heaviside Layer after one of its investigators. This layer is lower in daytime than at night and its average height varies with different seasons.

This reflection characteristic applies to a wide spectrum of short-wavelengths down to about 7 or 8 meters. Below this the energy waves possess characteristics somewhat similar to those of light. They travel mostly in straight lines and bend around obstacles with difficulty.

Skip Distance

This reflection property of the ions in the upper atmosphere accounts for the extreme distances sometimes attained by short-waves. This also explains the fading which takes place at times. Reflection may take place several times and one wave may strike a receiving antenna out of phase with another which arrives by a shorter path. It also accounts for the difficulty experienced with "skip distance". It may be impossible to receive a certain station at a distance of 100 miles while this same station may be coming in with great volume at a distance of 700 miles. This occurs when the Heaviside Layer reflects a strong signal down to earth at this great distance while the ground wave becomes imperceptibly weak. It is then impossible to receive the station until it is reflected from above.

Figures 2A and 2B show the state of affairs when the Heaviside Layer height is at a minimum (due to great

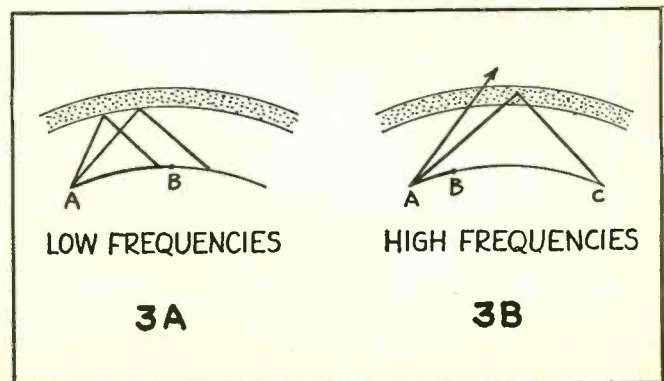
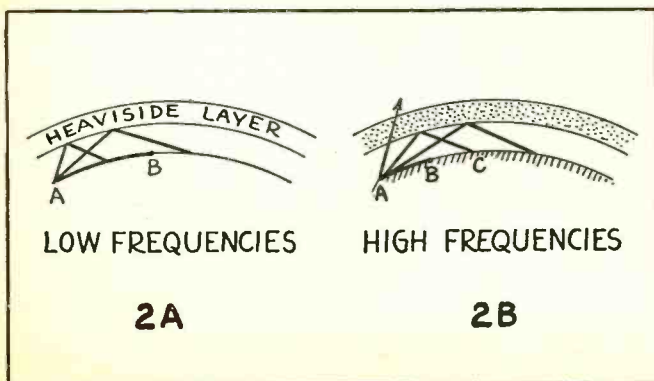
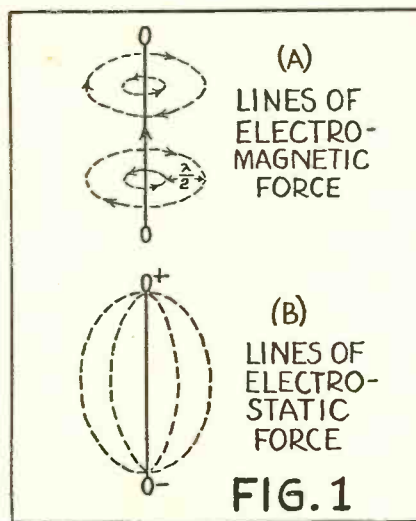

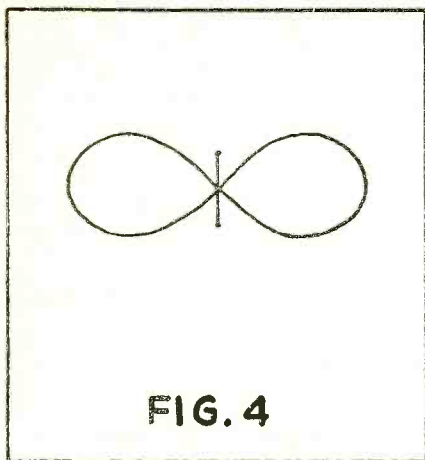

FIG. 4

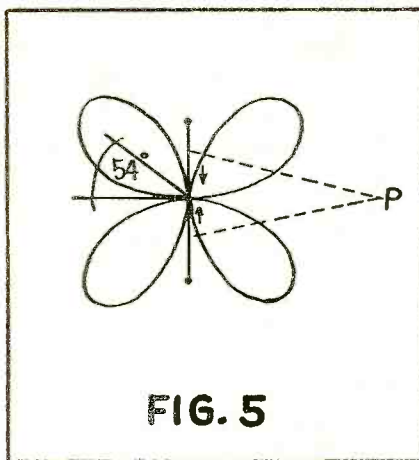

FIG. 5

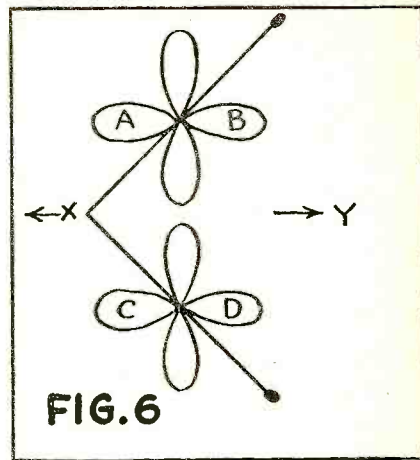

FIG. 6

ultra-violet activity of the sun). This occurs about the middle of the day and especially in Summer. The ground wave covers only the short distance AB. Beyond this we have skip distance until the first reflection comes to earth at C in Figure 2B. Since the earth is also a good conductor of electricity, it is entirely possible for the wave to be reflected upward again, and so on. We note that the higher frequencies, due to their greater penetrating power, pass through the ionosphere as their direction approaches the vertical. We see that we cannot expect much distance from the broadcasting frequencies, in the Summer during the day. The higher frequencies, on the contrary, penetrate deeper into the ionized area before finally being reflected. Thus they travel greater distances and reappear much further on, although the ground wave will be dissipated more rapidly. Figures 3A and 3B illustrate the conditions when the Heaviside Layer is at a greater average height. The shorter waves may be reflected such great distances as to escape the earth altogether.

Radiation Patterns

The foregoing paragraphs show us the need of knowing how to control the direction in which wave propagation is taking place. Then, if we were able to direct the energy we have available in the desired direction, maximum effects could be expected. If we are using a half-wave Hertz doublet we find by field measurements that the radiation is of a pattern similar to that in Figure 4. The shape of the loops shows the positions at which we can expect to receive a given amount of energy. As indicated, most of the energy will be sent out in a direction perpendicular to the center of the antenna, where the r.f. current is greatest. The loops, of course, are merely cross-sections of the field. If the loops were imagined to revolve with the wire as their center of revolution, the volume generated would represent the

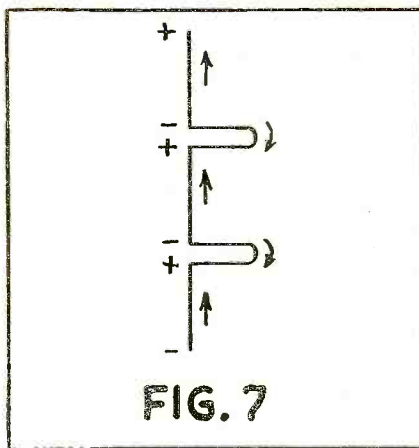

FIG. 7

field strength surrounding it.

In a vertical antenna the radiation would be non-directional in the horizontal plane. In a horizontal antenna maximum energy would be received in the vertical perpendicular plane passing through the center of the wire.

It should be remembered that when a given antenna at a certain frequency radiates best in a given direction, it will also receive best from the same direction at the same frequency.

Full-wave Aerials

If for the same aerial, we now double the frequency, it becomes a full-wave antenna in which the two half-waves are out of phase. The same field pattern will then not apply. Instead there will be a distortion and two additional loops will appear as in Figure 5. This is due to interference from the two half-waves which are oscillating in different directions. At a point (P) perpendicular to the center of the radiator we can expect to receive energy in one phase and at the same instant we would pick up an equal amount of energy in the opposite phase and no signal would result. This accounts for the null points in this area. Also, at all points which may be considered to be half a wavelength more distant from the center

of one half-wave than the other half-wave we can expect a reinforcement of energy and this is the case. Similarly, we can expect two additional loops for each half-wave oscillating on the antenna. The size of these loops will depend upon the length of the wire.

Broadcasting stations are of course more interested in the ground wave than in any Heaviside Layer reflection. Because of their higher wavelengths, Marconi systems are used. It is desired that radiation be non-directional in the horizontal plane, of course. A maximum coverage is found for heights of about one-half wavelength, for a vertical wire.

The "V" Antenna

We have seen that in a full-wave, wire radiation takes place mainly along two planes passing through the center of the wire. By superimposing the energy contained in loops from different aerials in the same phase, it is possible to increase energy propagation in a given direction. This principle is taken advantage of in the "V" antenna (Figure 6). Two full-wave wires are connected together at one end at a given angle. We see from the illustration that loops A, B, C, D produce radiation in the same direction. Furthermore, since the centers of the two wires are a full-wave distant from each other (measured along the wire) radiation from the two wires is *in phase*. A station situated at any point in the arrow direction either X or Y receives a signal simultaneously from both wires in phase resulting in maximum level.

If we increased the length of the aerial we would find that since each half-wave of wire is oscillating out of phase with the adjacent ones distortion of the field pattern would result. Instead of increasing the length of the radiation loop to one large one, we would simply have several smaller ones. Null points would appear in any area equally distant between two out-of-phase sections. By

(Continued on page 575)

The Radio News

A.C. Preamplifier

(and Remote Control)

A truly humless, a.c. powered preamplifier which provides 60 db. "hop," is easy to build, requires little space on the operating table and includes a switch for remotely controlling the transmitter, receiver, amplifier or other equipment with which it may be used.

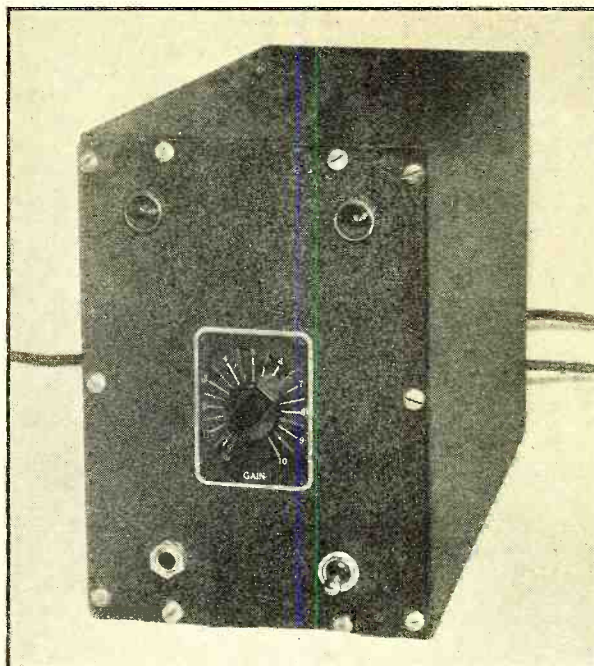

FOR P.A. OR AMATEUR USE

Requiring table space only 5 inches wide by 10 inches deep, this unit provides 60 db. gain of highest quality and includes a switch for standby control of the entire station.

THE preamplifier described here was designed primarily for amateur use but may, of course, be used in P. A. work as well. It is entirely self-contained with its own power supply which also provides current for the pilot lights and relays.

As lateral space is always at a premium on the operating table, the cabinet width has been held down to only 5 inches. Such a design is also desirable from an electrical standpoint as it permits a logical tube sequence and keeps the power and output leads at the rear out of the way. The microphone input is fed in at the front, passes straight through the amplifier and out the back, and the power supply is well-separated from the output.

Completely Filtered

A unique feature is the resistance filter used in the power supply circuit. This type saves both money and space but a more important advantage is that it provides extremely effective filtering where power demands are small, as they are in this amplifier. This type of filter also confines the source of stray magnetic fields to the power transformer alone, which is isolated by placing it at the extreme rear of the chassis. The "proof of the pudding" is that with crystal microphone plugged in and the gain full on there is not the slightest trace of line hum audible in a sensitive pair of headphones across the output.

In addition to the resistance-capacity network, comprising the low-frequency filter, both the input and

high-voltage output of the power transformer are bypassed to ground. This is a refinement which is well worth the slight cost, particularly if the amplifier is to be used in connection with a transmitter where r.f. feedback and pickup in the line must always be guarded against.

Flat Frequency Response

The circuit, Figure 1, is a straightforward resistance-coupled amplifier with the coupling values chosen conservatively to provide faithful overall amplification rather than maximum possible voltage gain.

An output transformer is not required unless the length of the line between the two amplifiers is unusually great. A shielded line such as a microphone cable should be used, the shield itself providing the

By A. J. Haynes

THERE has been a recent tendency to overlook the advantages and purpose of the separate preamplifier and to build the complete, high-gain audio system on a single chassis. In the case of P.A. equipment, there is an excuse for this, as it results in a more compact and portable job. The amateur, however, has no such excuse! The extra cost of building such a unit, separate from the rest of the modulator, is quite negligible and certainly well worth while when we consider that its use helps materially to avoid the headaches of r.f. feedback, hum pickup, microphonic howling, etc.

ground lead, and any length up to 75 or 100 feet can be used without fear of too much attenuation of the high audio frequencies.

In spite of the .1 mfd. plate-coupling condenser in the output of the preamplifier, it is good practice to use a second condenser of this size in series with it in the grid input of the power amplifier so that the grid leak will be conductively isolated from the connecting cable.

The only shielding necessary in the whole circuit is that on the grid leads of the tubes. One of the new Sylvania 1221 non-microphonic input pentodes is shown as an input tube although a 6C6 may be substituted if desired. Two Mallory grid-bias cells are used to maintain the proper voltage on the input grid. They are small, convenient, inexpensive and do not wear out with age, but there is one precaution which must be observed in their use: if a velocity, dynamic or other type of microphone is used which provides a conductive circuit from the input grid to ground a condenser must be inserted in the grid lead between the grid leak and the input to prevent the cells from being short-circuited. Even the slightest drain will ruin these cells, so don't try to measure their voltage with a voltmeter.

Remote Control

The d.p.d.t. toggle switch (SW2), located at the lower right-hand corner of the panel, serves as the station stand-by switch by actuating relays on the receiver, transmitter, antenna,

etc. It likewise controls the red pilot light which is so connected as to light when this switch is thrown to the "transmit" position. This entire switching circuit is shown at the lower right-hand corner of Figure 1. Other relay arrangements may be used if desired. In fact, this circuit is so flexible that it will accommodate any desired arrangement of relay switching—or of direct switching. In this latter case, the type of switch and plug employed will depend on the amount of power to be handled.

With the circuit as shown, the a.c. supply to the relays is taken from points Z-Z' at the a.c. input to the preamplifier unit. Thus, when the main "on-off" switch is thrown to the "off" position, it opens the a.c. lead to the relays. The green pilot is always lighted when the preamplifier is in operation. The red pilot light, however, is lighted only when the "stand-by" switch is in the "transmit" position.

If a double-throw relay is employed, one of the two control circuits can be eliminated and a d.p.s.t. switch employed at SW2.

Cable Connectors

In this model the audio output of the preamplifier terminates in a small plug-socket and plug similar to the one employed in the relay switching circuit. If constructors follow the same practice, it is suggested that the unused prong of the output plug be cut off and the unused hole of its sockets be plugged up with a match stick. This will avoid the possibility of plugging the cables into the wrong outlets.

The photographs show the arrangements of parts. No special precautions are necessary in wiring although it is recommended that it follow the usual rules of keeping leads short

COMPLETELY HUM FREE

Although a.c. operated, the unusually effective filter and the isolation of the power transformer, as shown in the view at the right, absolutely avoid hum.

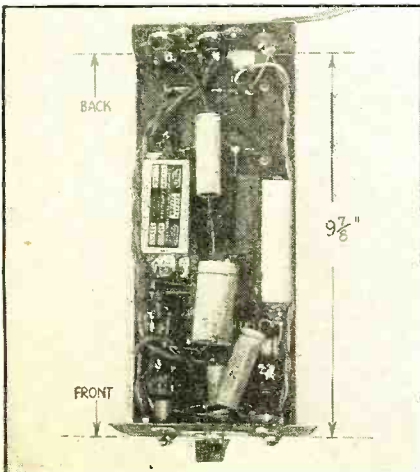

THE CIRCUIT

Resistance coupling is employed throughout with values selected to provide excellent quality. This also contributes materially to the complete absence of hum, even when employed ahead of a high-power modulator or P.A. amplifier.

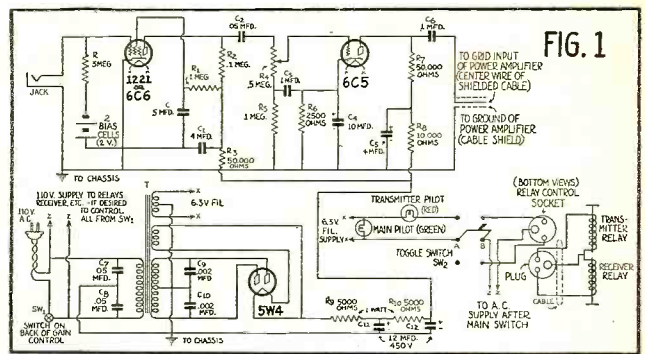

and running all long leads close to the chassis. Use spaghetti over "hot" resistor and condenser pigtails.

On the model illustrated all of the electrolytic condensers, with one exception, are placed below the chassis. It would perhaps be better to put them in the same relative position above the chassis, thus leaving more room below for the smaller parts and making the wiring a bit easier.

For practical purposes this amplifier is as perfect as a battery-operated job. It introduces *no audible hum* into the power amplifier, even with the gain wide open. It has a voltage amplification of 1000, or approximately 60 db., which is more than sufficient for any conceivable amateur or P.A. work.

Parts List

- C—Solar type S-0263 electrolytic, .5 mfd., 400 v.
- C1, C5—Solar type LG5-44 electrolytic, 4-4 mfd., 450 v.
- C2, C7, C8—Solar type S-0230 paper tubular, .05 mfd., 600 v.
- C3, C6—Solar type S-0240 paper tubular, .1 mfd., 600 v.
- C4—Solar type DT879 electrolytic, 10 mfd., 35 v.
- C9, C10—Solar mica, .002 mfd., 800 v., a.c.
- C11, C12—Solar type LG5-12 electrolytic, 12 mfd., 450 v.
- J—Yaxley type A-1 midget jack

- R—IRC, 3 megohms, 1/2 watt
- R1—IRC, 1 megohm, 1/2 watt
- R2, R5—IRC, .1 megohm, 1/2 watt
- R3, R7—IRC, 50,000 ohms, 1/2 watt
- R4—Yaxley volume control potentiometer, .5 megohm, with switch
- R6—IRC, 2,500 ohms, 1/2 watt
- R8—IRC, 10,000 ohms, 1/2 watt
- R9, R10—IRC, 5,000 ohms, 1 watt
- SW1—(See R4)
- SW2—H & H, toggle switch, d.p.d.t.
- T—Kenyon, type K-40MY, power transformer; 640 v., C.T., 40 ma.; 6.3 v., C.T., 2.1 a.; 5 v., 2a.
- 1 Sylvania 1221 non-microphonic pentode
- 1 Sylvania 6C5
- 1 Sylvania 5W4 rectifier
- 2 Mallory bias cells with dual holder
- 2 octal wafer sockets
- 1 6-prong wafer socket
- 1 Yaxley, type 310R, pilot light bracket, red jewel
- 1 Yaxley, type 310G, pilot light bracket, green jewel
- 2 Na-ald, midget shielded outlet plugs and sockets, 3-prong
- 1 Yaxley, type 75A, shielded microphone plug
- 1 line cord and plug
- 1 Korrol special cabinet and chassis, completely punched and drilled

New Radio Course

Columbus, Ohio—A short course on broadcast engineering is announced by Ohio State University for the Spring. The purpose is to bring together leaders in the industry and practicing engineers from all parts of the U. S. and Canada.

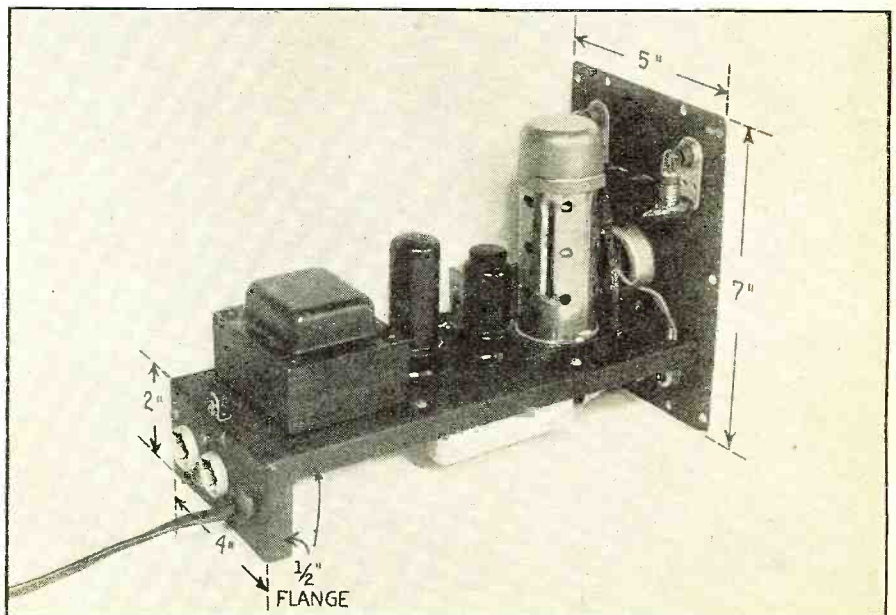

BROADCAST STATIONS IN THE U. S.

(Arranged by Frequency, Wavelength and Call Letters)

Compiled by William C. Dorf

- 550 kc., 545.5 m.
KFUO, KFYR, KOAC, KSD,
K TSA, WDEV, WGR, WKRC,
WSVA.
- 560 kc., 535.7 m.
KFDM, KLZ, KSFO, KWTO,
**WFIL, WIND, WIS, WQAM.
- 570 kc., 526.3 m.
KGKO, KVI, WKBN, WMCA,
WNAX, WOSU, WSYR, WSYU,
WWNC.
- 580 kc., 517.2 m.
KMJ, KSAC, WCHS, *WDBO,
WIBW, WILL, WTAG.
- 590 kc., 508.5 m.
KHQ, KMTR, WEEL, *WKZO,
WOW.
- 600 kc., 500.0 m.
KFSD, WCAO, WICC, WMT,
WREC.
- 610 kc., 491.8 m.
KFRC, WCLE, WDAF, WIP.
- 620 kc., 583.9 m.
KGW, K TAR, WFLA, WHJB,
WLBZ, WSUN, WTMJ.
- 630 kc., 476.2 m.
KFRU, KGFX, WGBF, WMAL,
WPRO.
- 640 kc., 468.7 m.
KFI, WGAN, WHKC, WOI.
- 650 kc., 461.5 m.
**KIRO, WSM.
- 660 kc., 454.6 m.
WAAW, WEAF.
- 670 kc., 447.8 m.
WMAQ.
- 680 kc., 441.2 m.
KFEQ, KPO, WLAW, WPTF.
- 690 kc., 434.8 m.
(Reserved for Canadian stations.)
- 700 kc., 428.6 m.
**WLW.
- 710 kc., 422.5 m.
**KIRO, KMPC, WOR.
- 720 kc., 416.7 m.
WGN.
- 730 kc., 411.0 m.
(Reserved for Canadian stations.)
- 740 kc., 405.4 m.
KMMJ, KTRB, WHEB, WSB.
- 750 kc., 400.0 m.
KGU, WJR.
- 760 kc., 394.7 m.
KXA, WEW, WJZ.
- 770 kc., 389.6 m.
KFAB, WBBM.
- 780 kc., 384.6 m.
KEAT, KFDY, KFQD, KGHL,
KWLK, WEAN, WMC, WTAR.
- 790 kc., 379.7 m.
KGO, KOAM, WGY.
- 800 kc., 375.0 m.
WBAP, WFAA, WTBO.
- 810 kc., 370.4 m.
WCCO, WNYC.
- 820 kc., 365.9 m.
WHAS.
- 830 kc., 361.4 m.
KOA, WEEU, WHDH, WRUF.
- 840 kc., 357.1 m.
(Reserved for Canadian stations.)
- 850 kc., 352.9 m.
KIEV, **KWKH, WKAR, WWL.
- 860 kc., 348.8 m.
WABC, WBOQ, WHB.
- 870 kc., 344.8 m.
WENR, WLS.
- 880 kc., 340.9 m.
KFKA, KLX, KPOF, *WCOC,
WGBI, WPHR, WQAN, WSUI.
- 890 kc., 337.1 m.
KARK, KFNF, KFPY, KUSD,
WBAA, WGST, WJAR, WMMN.
- 900 kc., 333.3 m.
*KGBU, KHJ, KSEI, WBEN,
WELI, WFMD, WJAX, WKY,
WLBL, WTAD.
- 910 kc., 329.7 m.
(Reserved for Canadian stations.)
- 920 kc., 326.1 m.
KFEL, KOMO, KPRC, KVOD,
WAAF, WORL, **WPEN, WRAX,
WSPA, **WWJ.
- 930 kc., 322.6 m.
KMA, KROW, *WBRC, WDBJ.
- 940 kc., 319.2 m.
KOIN, WAAT, WAVE, WCSH,
WDAY, WHA, *WICA.
- 950 kc., 315.8 m.
KFWB, KMBC, WHAL, *WRC.
- 960 kc., 312.5 m.
(Reserved for Canadian stations.)
- 970 kc., 309.3 m.
KJR, WCFL, WIBG.
- 980 kc., 306.1 m.
KDKA.
- 990 kc., 303.0 m.
WBZ, WBZA.
- 1000 kc., 300.0 m.
KFVD, **WHO.
- 1010 kc., 297.0 m.
KFUS, KGGF, KQW, WHN,
WNAD, WNOX.
- 1020 kc., 294.1 m.
KYW, WDW.
- 1030 kc., 291.3 m.
(Reserved for Canadian stations.)
- 1040 kc., 288.5 m.
KRLD, **KTHS, KYOS, **WESG,
**WTIC.
- 1050 kc., 285.7 m.
KFBI, KNX, WEAU, WGVA.
- 1060 kc., 283.0 m.
**KTHS, **KWJJ, **WBAL,
WJAG, **WTIC.
- 1070 kc., 280.4 m.
KJBS, WCAZ, WTAM.
- 1080 kc., 277.8 m.
WBT, WCB, WMBI.
- 1090 kc., 275.2 m.
KMOX.
- 1100 kc., 272.7 m.
*KGDM, WBLL, WPG.
- 1110 kc., 270.3 m.
KSOO, WRVA.
- 1120 kc., 267.9 m.
KFIO, KFSG, KRKD, KRSC,
KTVC, WCOP, WDEL, WISN,
WJBO, WTAW.
- 1130 kc., 265.5 m.
KSL, WJJD, WOV.
- 1140 kc., 263.2 m.
KVOO, WAPI, WSPR.
- 1150 kc., 260.9 m.
WHAM.
- 1160 kc., 258.6 m.
WOWO, WWVA.
- 1170 kc., 256.4 m.
WCAU.
- 1180 kc., 254.2 m.
KEX, KOB, WDG, WINS,
WMAZ.
- 1190 kc., 252.1 m.
KTKC, *WATR, WOAI, WSAZ.
- 1200 kc., 250.0 m.
KADA, KBTM, KDNC, KELO,
KFJB, KFXD, KFXJ, KGCI,
KGDE, KGEK, KGFJ, KGHJ,
KGV, KMLB, KOOS, KSUN,
KVCV, KVEC, KVO, KWG,
- KWNO, WABI, WAIM, WAYX,
WBBZ, WBHP, WBNO, WCAT,
WCAX, WCLO, WCPO, WDSM,
WEST, WFAM, WFTC, *WHBC,
WHBY, WIBX, WIL, WJBC,
WJBL, WJBW, WJNO, WJRD,
WKBO, WLVA, WMFR, WMP, C,
WOLS, WRBL, WSAL, WTHT,
WTOL, WVAE.
- 1210 kc., 247.9 m.
*KALB, KANS, KASA, KDLR,
KDON, KFJI, KFOR, KFPW,
KFUS, KFXM, KGLO, KGY,
KHBG, KIUL, KLAH, KOCA,
KPFA, KPPC, KROY, KVS, O,
KWTN, WALR, WBAX, WBB, L,
WBLY, WRBR, WCOL, WCRW,
WEBQ, WEDC, WFAS, WFOY,
WGBB, WGCM, WGN, Y, WGRM,
WHBF, WHBU, WJBU, WJBY,
WJEJ, WJIM, WJTN, WJW,
WKOK, WLMU, WMFG, W, OMT,
WPAX, WSAY, WSBC, *WSIX,
WSNJ, WSOC, WTAX.
- 1220 kc., 245.9 m.
KFKU, KATMC, KTW, KWSC,
WCAD, WCAE, WDAE, WREN.
- 1230 kc., 243.9 m.
KGBX, KGGM, KYA, WFBM,
WNAC.
- 1240 kc., 241.9 m.
KGC, U, *KLLPM, KTAT, **KTFI,
WKAQ, WXYZ.
- 1250 kc., 240.0 m.
*KFOX, KXOK, WAIR, *WCAL,
WDSU, WHBI, *WLB, WNEW,
WTCN.
- 1260 kc., 238.1 m.
KGVO, KHSL, KOIL, KPAC,
KRGV, KUOA, KVOA, WHIO,
**WNBX, *WTOC.
- 1270 kc., 236.2 m.
KGCA, KOL, KVOR, KWLC,
WASH, WFBR, *WJDX, WOOD.
- 1280 kc., 234.4 m.
KFBB, KLS, WCAM, WCAP,
WDOD, WIBA, WORC, WRR,
WTNJ.
- 1290 kc., 232.6 m.
*KDYL, KLCN, KTRH, WEBC,
WJAS, WNBZ, WNEL.
- 1300 kc., 230.8 m.
KALE, KFAC, KFH, WBBR,
WEVD, WFAB, WFEC, WHAZ,
WHBL, **WIOD—WMBF.
- 1310 kc., 229.0 m.
KAND, KARM, KCKN, *KCRJ,
KFPL, KFRR, KFYO, KGEZ,
KGF, W, KHUB, *KINY, *KIT,
KPDN, KRBA, KRMD, KROC,
KROA, KRRV, KSRO, KSUB,
KTSM, KVOL, KVOX, KWOS,
KXRO, WAML, WBEO, WBOW,
WBRE, WBRK, WCLS, WCMI,
WDAH, WEBR, WEMP, WEXL,
WFBG, WFDF, **WGH, WGT, M,
WHAT, WJAC, WLAK, WLBC,
WLNH, *WMBO, WMFF, WNBH,
*WOL, WRAW, WROL, WSAJ,
WSGN, WSJS, *WTAL, WTEL,
WTJS, WTRC.
- 1320 kc., 227.2 m.
KGHF, KGMB, *KID, KRNT,
WADC, WORK, *WSMB.
- 1330 kc., 225.6 m.
KGB, KMO, KRIS, KSCJ, WDRC,
WSAI, WTAQ.
- 1340 kc., 223.9 m.
KDTH, KGDY, KGIR, KGNO,

- *WCOA, WFEA, WSPD.
- 1350 kc., 222.2 m.
*KIDO, KWK, WAWZ, WBNX, WMBG.
- 1360 kc., 220.6 m.
KCRC, KGER, WCSC, WFBL, WGES, WQBC, WSBT.
- 1370 kc., 219.0 m.
KAST, KCMO, KEEN, KELD, KERN, KFGQ, KFJC, KFRO, KGAR, KGFL, KGKL, KICA, KIUB, KLUF, KMAC, KOBH, KOKO, KONO, KRE, KRKO, KRMC, KSLM, KTEM, KTOK, KUJ, KVGB, KVRG, KWYO, *WABY, WAGF, WATL, WBLK, WBNY, WBTM, WCBM, WDAS, WDWS, WEOA, WFOR, *WGL, WGRC, WHBO, WHDF, WHLB, WIBM, WLLH, WMBR, WMFD, WMFO, WMIN, WOC, WPAY, WPR, WRAK, WRDO, WRJN, WSAU, WSVS.
- 1380 kc., 217.4 m.
KOH, KOV, WALA, WKBH, *WNBC, WSMK.
- 1390 kc., 215.8 m.
KLRA, KOY, KRLC, WHK, WQDM.
- 1400 kc., 214.3 m.
KHBC, KLO, KTUL, WARD, WBBZ, WHDL, WIRE, WLTH, WVFW.
- 1410 kc., 212.8 m.
KFJM, KGNC, KMED, WAAB, WBCM, WHIS, WROK, WSFA.
- 1420 kc., 211.3 m.
KABC, KABR, KATE, KBPS, KCMC, KEUB, KFAM, KFIZ, KGFF, *KGGC, KGIW, KIDW, KIUN, KLBM, KNET, KORE, KRBC, KRLH, KTRI, KUMA, KWBG, KXL, WACO, WAGM, WAPO, WAZL, *WCBS, WCHB, WEED, WELL, WGPC, WHFC, WILM, WJBR, WJMS, WLAP, WLEU, WMAS, WMBC, WMBH, WMBC, WMFJ, WMSD, WPAD, WPAR, WPRP.
- 1430 kc., 209.8 m.
KECA, KGNF, KSO, WBNS, WHEC, WHP, WMPS, WNBR, WOKO.
- 1440 kc., 208.3 m.
KDFN, KELA, KXYZ, WBIG, WCB, WMBD, WSAN.
- 1450 kc., 206.9 m.
*KGCX, KIEM, KTBS, WAGA, WGAR, WHOM, WSAR.
- 1460 kc., 205.5 m.
KSTP, WJSV.
- 1470 kc., 204.1 m.
KGA, WLAC.
- 1480 kc., 202.7 m.
KOMA, WHIP, WKBW.
- 1490 kc., 201.3 m.
*KFBK, WCKY.
- 1500 kc., 200.0 m.
KAWM, KBIX, KBST, KDAL, KDB, KGFI, KGKB, KGKY, KNEL, KNOW, KOTN, *KOV, KPLC, KPLT, KPQ, KRNR, KROD, KSAL, KUTA, KVOE, KXO, WCNW, WDNC, WGAL, WHBB, WHEF, WJBK, WKAT, WKBB, WKBV, WKBZ, WKEU, WMBQ, WMEX, WNB, WNL, WOMI, WOPI, WRDW, WRGA, WRTD, WSYB, WTMV, WWRL, WWSW.
- 1530 kc., 196.1 m.
KNBY, WBRV.
- 1550 kc., 193.6 m.
KPMC, WQXR.

*Construction permit.
**By special authorization.

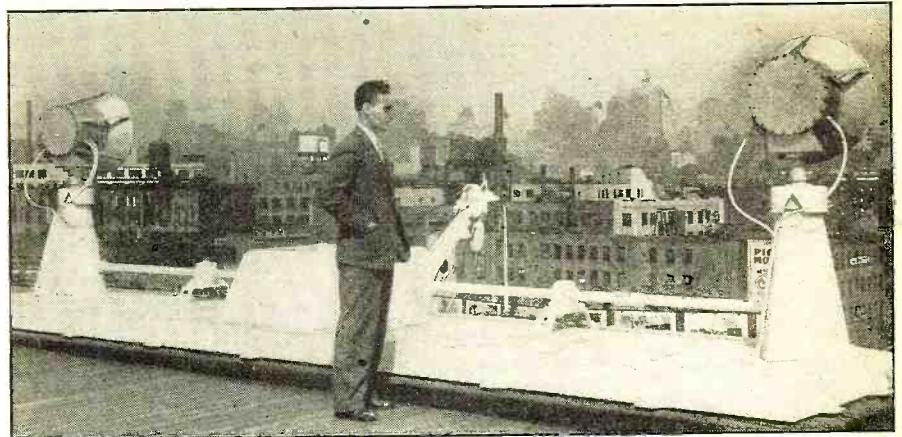

Testing Out An Obstacle Detector for Marine Use By Perry M. Jones

HIGH atop the S.S. *Normandie* there are two huge klaxon-shaped instruments pointed toward the bow. The two units, almost identical in appearance, are located on the roof of the ship's bridge and, taking into consideration the fact that this French liner vies with the S.S. *Queen Mary* for the distinction of being the "world's biggest ship," you'll realize that this spot is even higher than many New York rooftops.

At a perfunctory glance, you might guess that the instruments are searchlights or warning sirens. But they're not. Or rather, they are an electronic approximation of both! Using ultrashort waves instead of light, the device designed by the Société Française Radio-Électrique is said to detect obstacles in the ship's path and sound a warning to the bridge.

Here is an invention that may bring new laurels to radio as a preserver of lives at sea. Much is still secret about the new device's application and results. French Line officials assert that the new installation is being used experimentally on this season's crossings. When the writer visited the liner, the ship's officers permitted an inspection of the equipment but refused to answer questions about it aside from admitting that the system employed micro-waves. However, they declared that the new system was operating along the same lines as the earlier SFR equipment tested previously. And available data

MICRO-WAVE "EARS" FOR FOG-BOUND SHIPS

The new experimental obstacle detector being tested out on the S. S. Normandie. In the two "klaxon"-shaped objects are a directive micro-wave transmitter and a directive micro-wave receiving set. One of these "klaxons" sends out a wave which reflects from an object in the path of the ship and is picked up again by the receiver in the other "klaxon." A study of triangles is supposed to give the obstacle's location.

on the previous year's experiments yield an outline of the present principles.

The peculiarity of micro-waves, in that they are reflected by solid objects, makes the device at least theoretically workable. This is especially invaluable to a radio "feeling" device as the tiny waves are reflected by any objects—whether or not they're partly insulators or conductors.

Hence, one of the klaxon-shaped instruments is a micro-wave transmitter; the other a receiver. The transmitter sends out a directional signal and, if there is no obstacle in its path, there is no reflection and, of course, no reception on the bridge deck. Like the transmitter, the receiver too is directional. The units are far enough apart to eliminate any direct reception; only reflected signals will reach the special receiver.

By using a wave in the neighborhood of 16 centimeters, a sufficiently narrow beam is provided which is designed to "feel out" an obstacle in the liner's path and permit the ship's officers to mathematically compute its exact location ahead.

After determining the angle at which strongest reflected signals are received, the line between the receiver and transmitter is regarded as a base in forming a triangle, the point of which corresponds to the distance of the obstacle from the liner.

The received signals are carried through amplifiers to a telephone headset or a visual indicator on the bridge. It is interesting to note the robot properties of the system which dispenses with human attention until

(Turn to page 563)

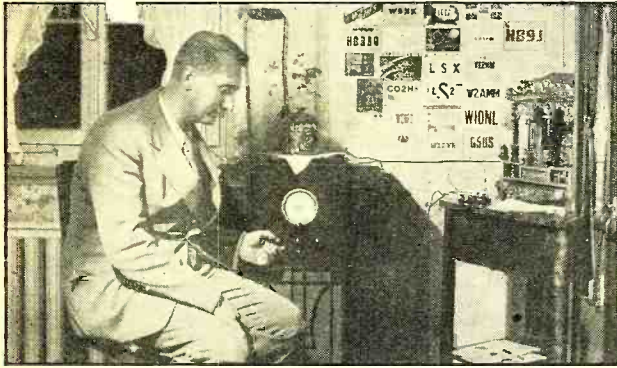

DX CORNER OF FAMOUS "SWISS" LISTENER
Hugo W. Richter, RADIO NEWS observer, at Zurich.

The DX for SHORT

Conducted by

THE Sixtieth installment of the DX Corner for Short-Wave contains the World Short-Wave Time-Table for 24-hour use all over the world and Official Observers' reports of stations heard this month. Consult these two items regularly and make your all-wave set pay big dividends!

Credit Where It Is Due

THE "star" list of Short-Wave Listening Post Observers this month includes Observers Alfred, Honda, Kiser, Myers, Croston, Ruiz, Fleming and Catchim. Their work in logging new stations and clearing up the mystery of proper call letters, exact operating frequencies of some of the stations first heard last month, is excellent and we congratulate them for their mighty fine reports.

Kind of Data Needed

IN making up your listener reports, it is recommended that the Observer keep the following facts in mind. What is required is, essentially, the call letters of the station, the city and country, the exact frequency of operation, the exact operating schedule of the station in Eastern Standard Time, the station's spoken slogan, if any, and any other identifying signal such as chimes, animal or bird calls, bells, etc., and the address of the station for verification purposes.

Especially are we interested in data on changes of frequency or schedule or changes in call letters for any station. Another point of extreme interest is data on new stations just coming on the air, this data to be prepared as recommended above.

Listening Post Photos

Also, we would like to have new photographs of Listening Posts, preferably with the owner in the picture. Verification cards sent in to RADIO NEWS are always welcome and some of these are reproduced with credit to the sender. Don't forget, this is your DX Corner and you can do much to make it better and more helpful to every Short-Wave Listener.

Reports of Listening Post Observers and Other Short-Wave Readers of the DX Corner

LISTED in the following columns is this month's consolidated reports of short-wave stations heard by our wide-world listening posts. Each item is credited with the Observer's surname. This allows our readers to note who obtained the information. If any of our readers can supply Actual Time Schedules, Correct Wavelengths, Correct Frequencies and any other Important Information (in paragraphs as recommended), the DX Editor, as well as our readers, will be grateful for the information. On the other hand, readers seeing these reports can try their skill in pulling in the stations logged and in trying to get complete information on these transmissions. The report for this month, containing the best information available to date, follows:

Europe

GSC, Daventry, England, 9580 kc., Sunday 7 p.m. (Kiser); Saturday 5:45 p.m. (Myers); 11 p.m. (Nowak, Whyte, Wollenschlager); daily 6:20-8:45 p.m. (Dressler, McNeill).

LA VOZ DE GUATEMALA
Two listeners, Douglas S. Catchim and Charles S. Werdig, sent in this "veri." of TGW for publication. It is printed in three colors and very attractive.

Radiofutura Nacional
TGW
La Voz de Guatemala
Centro América

TGW:
1210 kw. - 1 kilovatio.

TGWA:
9665, 11760, 15170, 17300 kw. 10 kilovatios.

Tenemos el gusto de acusar recibo de su reporte por nuestra transmisión del 11-12 de octubre de 1937 de "10 DITS" C.

La presente sirve como VERIFICACION puesto que sus datos se encuentran de acuerdo con la hora y programa de ese día en 11,760 kw.

Quedamos de Ud. muy agradecidos.

Dirección
Guatemala, 2 de diciembre de 1937

GSD, Daventry, England, 11,750 kc., daily 6-8 and 9-11 p.m. (Myers, Nowak, Lindner, Redmond, Whyte, Hernday, Wollenschlager); 11,770 kc. (Catchim, Dressler, Black, Coover, McNeill, L. F. Gallagher).

GSF, Daventry, England, 15,140 kc. (Whyte); Thursdays 4:30 p.m. (Jaffe); 4-6 p.m. (L. F. Gallagher).

GSL, Daventry, England, 6110 kc., 9-11 p.m. (Pinkerton); daily 6:20-8:45 p.m. (Dressler, Coover, Catchim).

DJL, Zeesen, Germany, 15,110 kc., daily 4:50-10:45 p.m. (Alfred, Lander, Wollenschlager, L. F. Gallagher).

DJN, Zeesen, Germany, 9540 kc., daily 4:50-10:45 p.m. and 12-5 a.m. (Alfred, Lander, Hernday, Jaffe, Dressler, Sprague, McNeill).

DZE, Zeesen, Germany, 12,130 kc., Fridays 4:08 p.m. (Jaffe, Pairman).

DZC, Zeesen, Germany, 10,290 kc., 6 p.m. and 10:45 p.m. (G. C. Gallagher, Pairman).

DJO, Zeesen, Germany, 11,790 kc., 9 p.m. (L. F. Gallagher).

DZA, Zeesen, Germany, 9675, 9680 kc., irregularly. (Sprague).

DJP, Zeesen, Germany, 11,855 kc., daily 4:50-10:45 p.m. and 12-3 a.m. (Alfred, Honda).

I2RO3, Rome, Italy, 9635 kc., Mondays, Wednesdays, Fridays and Sundays 6-7:30 p.m. (from veri) (Myers); from December 1 American hour daily 7:30-9 p.m. (Scala, Whyte, Atherton, Wollenschlager); daily 6:30-9 p.m. (Fleming); 9660 kc. (Catchim, Adkins, Unger, Dressler); daily 11:40 a.m.-5:30 p.m. (Sprague, L. F. Gallagher). Address: 5 Via Montello, Rome.

RK1, Moscow, U. S. S. R., 7520 kc., daily 7-9:15 p.m. (Alfred, Espenschild); 7540 kc., reports requested (McKenzie, Yoshimura, Unger, L. F. Gallagher). Slo-

Corner the WAVES

L. M. Cockaday

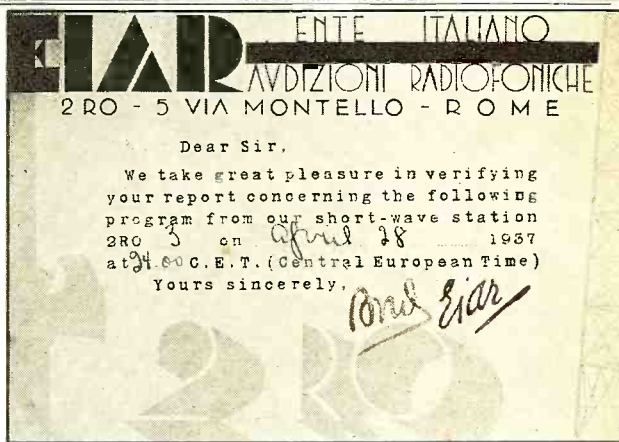

gan: "This Is Moscow Calling".

RAN, Moscow, U. S. S. R., 9600 kc., daily 7-9:15 p.m. (Alfred, Lander, Whyte, Jaffe); reports requested (McKenzie, Unger, Catchim, L. F. Gallagher). Address: Solianka 13, Radio Centre.

RNE, Moscow, U. S. S. R., 12,000 kc., daily 10-11:30 p.m., Sundays and Wednesdays 3-4 p.m. (Alfred); 12,060 kc. (Crosston, Lander, Jaffe); Sundays 6-12 a.m., 2-6 p.m., daily 3-6 p.m., reports requested. (McKenzie, Yoshimura). Address: Radio Centre, Moscow.

RWJ, Alwa Ata, U. S. S. R., 12,180 kc., 11 p.m. with program similar to RNE. (G. C. Gallagher).

CS2WA (CT1AA), Lisbon, Portugal, 9650 kc., Tuesdays, Thursdays and Saturdays 4-6 p.m. (Alfred, Myers, McKenzie, Yoshimura, Unger, Betances, Harris, Catchim). Slogan: "Radio Colonial". Address: Av. Antonio Augusto d'Aguiar, 144, Lisbon.

CSW, Lisbon, Portugal, 9940 kc., 6-8 p.m. (Alfred); off the air (Jaffe); 11,840 kc. and 11,040 kc. (from veri) (Lindner); daily 5:30-8 p.m. (Dressler). Slogan: "Emissora Nacional". Address: Rue do Quelbas.

TPA4, Pontoise, France, 11,715 kc., irregularly 5:15-12 p.m. (Sprague). Slogan: "Radio Colonial".

"Radio Bilbao", Spain, 7200 kc., Spanish Nationalist station (Ruiz); 7240 kc., 4 p.m. (Betances).

"Radio Sevillas", Spain, 7150 kc., Spanish Nationalist station. (Ruiz).

"Radio Requette", Madrid, Spain, 7210 kc., daily 4:30 p.m. (Betances).

"Radio Salamanca", Salamanca, Spain, 10,370 kc., 6-8 p.m. (Alfred); Fridays 9-10 p.m., signs

THE VATICAN'S RADIO STATION
Looking from the cloisters in Vatican City toward the towers of radio station HVJ. Photo furnished by Observer R. Brossa, of Chieri, Italy.

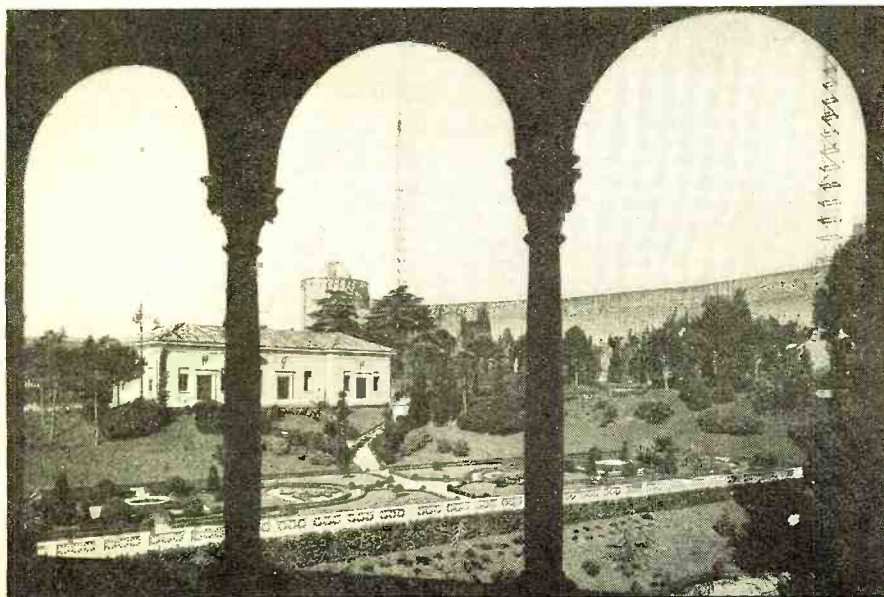

ITALIAN "HEARD" CARD
Mr. Burnell Unger, of Hanover, Pa., received this verification from the Rome short-wave station 12RO.

with "Franco, Franco, Franco!" (Myers, Ruiz); daily 9-10 p.m. (Scala, Betances, Jaffe, Catchim, Blanchard, Dressler); cuckoo and bugle calls (N. C. Smith, Lindner, Coover, Nutkis, Espenschild, L. F. Gallagher, Schrock). Slogan: "Radio International".

EAR, Madrid, Spain, 9480 kc., irregularly 7-9 p.m. (Alfred); daily 7:30-10 p.m. (Catchim). Slogan: "This is the Voice of Republican Spain". Address: Foreign Broadcast, Medeiroceli, Madrid.

ERGU, Barcelona, Spain, 7155 kc., 5 p.m. (McKenzie).

HAT4, Budapest, Hungary, 9125 kc., Wednesdays and Sundays 7-8 p.m., Saturdays 6-7 p.m. (Alfred); reports requested (Myers, Espenschild, Catchim, Dressler).

HAS3, Budapest, Hungary, 15,370 kc., Sundays 9-10 a.m., requests reports (from veri) (McKenzie, Espenschild). Address: Radio Labor, Budapest.

SPW, Warsaw, Poland, 13,635 kc., daily 6-7 p.m. (Alfred); 11,540 kc., 6-8 p.m. on holidays. (Unger, Mott, Whyte, Jaffe, Espenschild; McKenzie, Yoshimura, Sprague, L. F. Gallagher). Address: 5 Mazowiec Street.

SPD, Warsaw, Poland, 11,530 kc., daily 6-7 p.m. (Alfred); relays SPW. (McKenzie).

PHI, Hilversum, Holland, 11,730 kc., Sundays 8-9:30 p.m. (Alfred, Ruiz); 17,775 kc., daily except Wednesday 7-8:30 a.m. (Sprague); daily except Wednesdays to 10 a.m. (Honda).

PCJ, Hilversum, Holland, 9590 kc., Sunday 8-9 p.m. and Wednesdays and Thursdays 7-10:30 p.m. (Alfred, Kiser); Sundays 7-8 p.m. (Nowak, Jaffe, Whyte, Yoshi-
(Turn to page 548)

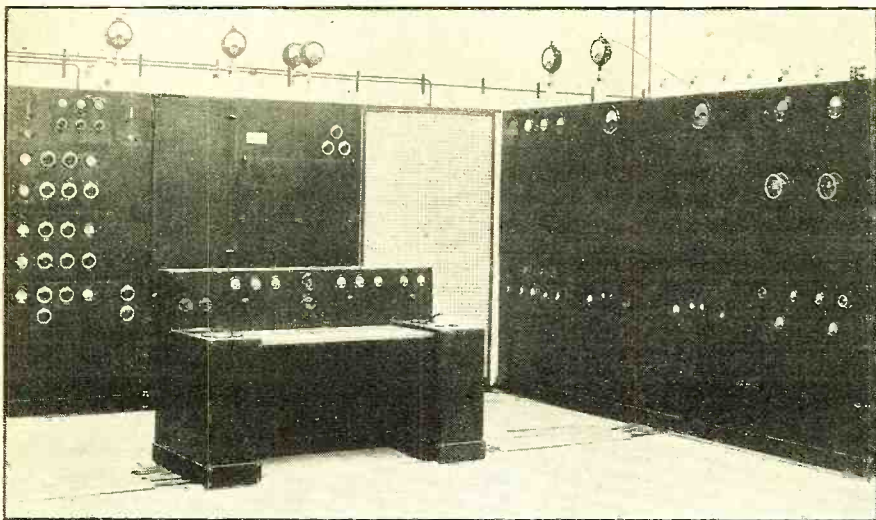

The DX Corner (Short Waves)

(Continued from page 545)

mura); 15,220 kc. (Jensen, Wolenschlager, Black, Sibbin); Wednesdays 8-11 a.m. (Honda, L. F. Gallagher). Slogan: "Philips Radio".

TFJ, Reykjavik, Iceland, 12,235 kc., Sundays 1:40-2:30 p.m. (Alfred, Croston, Jaffe).

SM5SX, Stockholm, Sweden, 15,155 kc., Tuesdays 5 p.m. (Jaffe); daily 11 a.m.-5 p.m., Sundays 9 a.m.-5 p.m. (McKenzie, Yoshimura).

OZF, Skamlebaek, Denmark, 9520 kc., 4-6:40 p.m. (Unger); daily 2-6:40 p.m., reports requested. (McKenzie, Betances).

OLR2B, Prague, Czechoslovakia, 6015 kc., testing (Betances); 6030 kc. and 9550 kc., desires reports on which frequency is best. Schedule: Fridays and Wednesdays 8-10 p.m. (9550 kc.) and 10 p.m. on, on 6030 kc. (Catchim).

OLR3A, Prague, Czechoslovakia, 9550 kc., Mondays, Thursdays and Fridays 8-10 p.m. (Catchim); daily 2:30-4:25 p.m., reports requested. (McKenzie, Pairman, Schrock).

ORK, Ruyssede, Belgium, 10,330 kc. (Yoshimura); daily 1:30-3 p.m. (from veri). (Fleming, Sprague).

HBO, Geneva, Switzerland, 11,402 kc., Fridays 2-2:15 p.m., Saturdays 6:45-8 p.m. (Kure).

HBL, Geneva, Switzerland, 9345, Fridays 2:30-2:45 p.m. and 7:30-7:45 p.m. and 8-8:15 p.m. (Kure, Wollenschlager, Coover, McNeill).

Africa

EA9AH, Tetuan, Spanish Morocco, 14,030 kc., 4:45-9:30 p.m.

TANDJONG PRIOK, JAVA

This is the transmitter and control desk of the Dutch Guiana station whose signals are considered a "prize catch" here in America

(Alfred, Betances, Jaffe); Thursday 6 p.m., Friday 5 p.m., 1:25 p.m. on Wednesday (Blanchard, Fleming).

EAJ43, Tenerife, Canary Islands, 10,370 kc., 3-4:30 p.m. (Alfred); requests reports, daily 2:45-4:15 p.m., 5:45-7:45 p.m. and 8:15-9:45 p.m. (McKenzie, Chambers, Yoshimura, Honda, Fleming).

ZUD, Roberts Heights, Africa, 8700 kc., 5-7 a.m. and 10-12 a.m. (31 meters) and 12:15-4 p.m. (50 meters) (Umstead, Westman).

"Radio Guardia Civil", Tetuan, Spanish Morocco, 6500 kc., 4-5 p.m. (Betances).

ZTJ, Johannesburg, Transvaal Protectorate, South Africa, 9610 kc., daily except Sunday, 11:45 p.m.-12:45 a.m. (Alfred, Nowak, Unger); bugle sounds reveille call (Chambers, Espenschild); bugle call used (Jaffe); chimes at midnight (Williams, Frost, Black, Dressler, Kentzel, G. C. Gallagher, Hands).

ZSS, Klipheuveld Capetown, South Africa, 31.23 meters, 4:30-11 a.m. 49 meters, daily 11 a.m.-4 p.m. (Westman).

ZTD, Durban, Natal, 48.87 meters, same schedule as ZTJ (Westman).

ZNF, Hansa, Mafeking, Bechuanaland, South Africa, 50.48 meters (Westman). Slogan: "A New Courier".

ZNB, Mafeking, Union of South Africa, 50.84 meters, daily except Saturday 1-2:30 p.m. (Westman).

CR6AA, Lobito, Angola, West Africa, 7177 kc., Wednesday, Friday and Saturday, 2:45-4:45 p.m. (Westman); 9666 kc. (Frost).

ELM, Africa, 5000 kc., daily at 12 noon and 4 p.m. (Jacks).

Oceania

VPD2, Suva, Fiji Islands, 9540 kc., Signed Thursday, 7:04 a.m. (Jaffe).

FK8AA, New Caledonia, 49 meters, Tuesday and Saturday 2-5 a.m. (Sibbin). Slogan: "Radio Noumea". Address: Charles Gaveau, 44 Rue de L'Alma.

KZRM, Manila, Philippine Islands, 9570 kc., daily 3:30-6 p.m. and 5-10 a.m. (Yoshimura, Fleming, Schrock).

VK3LR, Lyndhurst, Australia, 9580 kc., daily 5-7 a.m. (Alfred, Lindner, Williams, Yoshimura, Lander).

VK3ME, Melbourne, Australia, 9510 kc., daily 5-7 a.m. (Alfred, Lindner, Williams, Yoshimura, Lander).

VK6ME, Perth, West Australia, 9590 kc., irregularly 6-7 a.m. (Alfred, Yoshimura, Lander).

Asia

JZI, Nazaki, Japan, 9535 kc., daily 4:30-5:30 p.m. (Alfred, Kashimoto); 9610 kc., daily 8-9 a.m. (Fleming); heard 3-4 p.m. (Harris, Honda).

JZJ, Nazaki, Japan, 11,800 kc., daily 8-9 a.m., 4:30-5:30 p.m. and 12:30-1:30 a.m. (Alfred, Myers, Jaffe, Yoshimura, Whyte, Kashimoto, Gertenbach, Black, Fleming, Blanchard, Dressler, Wollenschlager, Harris, F. Gallagher,

GREETINGS TO SHORT-WAVE LISTENERS

Observer Harold E. Schrock, of Pontiac, Illinois, sends Best Wishes and "Lots of DX" to RADIO NEWS short-wave listeners the world over.



Honda, Messmer). Slogan: "Voice of Japan."

JZK, Nazaki, Japan, 15,160 kc., daily 4:30-5:30 p.m. and 12:30-1:30 a.m. (Alfred). Signed with gong (Jaffe, Yoshimura, Whyte, Redmond). Not in use any more (Honda).

JIB, Taiwan, Japan, 10,530 kc., 8:30-9 a.m. (Alfred, Mott); daily 5-10 a.m. (Yoshimura) and 8650 kc. and 19,820 kc., relays JFAK (Fleming).

JDY, Dairen, Kuantung, Manchukuo, 9925 kc., daily 7:10-8 a.m. (Alfred, Myers, Crasten, Frost, Kentzel).

JFAK, Taihoku, Japan, 9630 kc., signed 10 a.m. (Mott, Yoshimura), daily 5-10 a.m. (Yoshimura, Gertenbach).

ZBW, Hong Kong, China, 9525 kc., irregularly, 6-7 a.m. (Alfred). Signed 9:30 p.m. (Mott, Yoshimura, Poll).

XGOX, Nanking, China, 9800 kc., heard 7:30 a.m. with news (Craston); 9700 kc. (Honda).

PLP, Bandoeng, Java, 11,000 kc., 5:30-7 a.m. (Alfred, Ruiz), heard 8 a.m. (Sibbin). Slogan: "Batavia."

PMN, Bandoeng, Java, 10,260 kc., irregularly 5:30-7 a.m. (Alfred, Myers, Yoshimura); heard 11-11:30 a.m. and 6:25 p.m. (N. C. Smith).

RV15, Khabarovsk, Siberia, 4250 kc. (Yoshimura, Lander); daily 12-9 a.m. (Sprague).

North America

W2XE, New York, N. Y., 15,270 kc., heard 2:30-6 p.m. (Kiser, Nowak, Redmond); 11,830 kc. (Catchim).

W1XK, Boston, Mass., 9570 kc., heard 7 a.m.-1 a.m. (Kiser, Nowak); 8665 kc. (Catchim, Sibbin).

W2XAD, Schenectady, New York, 15,330 kc., heard 11 a.m.-9 p.m. (Kiser). Signed 4 p.m. (Nowak, Redmond, Whyte, Sprague, Sibbin, L. F. Gallagher).

W8XK, Pittsburgh, Pa., 6140 kc., heard Sunday 3 p.m. (Kiser, Redmond); heard 5 p.m. (N. C. Smith); 15,210 kc., daily 10 a.m.-7 p.m. (6140 kc. heard 6 p.m.-1 a.m.) (Jensen) (6140 kc., daily 10-12 p.m.) (Fleming, Catchim). Reports requested (Harris, Honda, L. F. Gallagher).

W8XAL, Cincinnati, Ohio, 6060 kc., 6:30 a.m.-8 p.m., 11 p.m.-2 a.m. (Kiser, Lindner, Redmond, Catchim).

W2XGB, Hicksville, New York, 17,310 kc. (Craston); 12,865.5 kc. Reports requested (Beyer, Black); 12,900 kc. (Jensen, Catchim); 8655 kc., heard (Turn to page 560)

MORE FAMOUS RADIO ENGINEERS Acclaim SUPREME INSTRUMENTS!



"I am particularly glad to see SUPREME introduce so efficient and reliable an instrument as the Model 541 Set Tester—and so extremely efficient for all types of service work."

Karl W. Miles
Chief Engineer
THE HALLICRAFTERS, INC.



"I was really amazed at the excellence and flexibility of Model 551 Analyzer, considering its very low price. A serviceman entering a home with it should certainly present all the earmarks of competence and ability."

McMurdo Silver
President
McMURDO SILVER CORP.



"I have found Model 570 Signal Generator meets all requirements to an excellent degree, and I can well recommend it to those contemplating the purchase of such an instrument."

W. L. Murphy
Directing Engineer
RADIO TRAINING ASS'N. OF AMERICA



SOME of America's finest radio engineers . . . men who work daily with test instruments costing thousands of dollars . . . certainly *know* fine instruments. They recognize superiority in accuracy . . . in quality. That's why these same men who use the best laboratory instruments available acclaim Supreme instruments—the instruments for your service laboratory.

Too, Supreme instruments are easy to own. Your parts jobbers sell them for only a few dollars down—balance in monthly payments—on S. I. C. terms, *the world's easiest installment terms!*

JUST OFF THE PRESS!
FREE Illustrated 1938 Catalog. Write for it!

FREE "Adequately Equipped Shop" Certificate
Send for the free booklet explaining how you can qualify for a Supreme "Adequately Equipped Shop" Certificate.

SUPREME INSTRUMENTS CORP.

GREENWOOD, MISSISSIPPI · U. S. A.

Export Dept.: Associated Exporters Co., 145 W. 45th St., New York City Cable Address: LOPREN, New York

TELEVISION FANS!
Make sure you get every installment of "Practical Lessons in Television" by subscribing for RADIO NEWS today!

Leadership

TRIMM
Presents the
TRIMM COMMERCIAL HEADSET

Like its companion, Trimm Featherweight, the Trimm Commercial is destined to become the standard by which other headsets are compared.

Especially suited to the discriminating amateur—built to more exacting requirements—provides a new high in sensitivity, service, and clarity of sound.

Write today for catalog R-2

TRIMM RADIO MANUFACTURING COMPANY
1770 W. Berneau Ave. Chicago, Illinois

RADIO ENGINEERING

TRI-STATE COLLEGE
DEGREE IN 2 YEARS.

Complete Radio Engineering Course in 96 weeks. Bachelor of Science Degree. Radio (television, talking pictures and the vast electronic field) offers unusual opportunities for trained radio engineers. Courses also in Civil, Electrical, Mechanical, Chemical, Aeronautical Engineering; Business Administration and Accounting. Low tuition, low living costs. World famous for technical two-year courses. Those who lack high school may make up work. Students from all parts of the world. Enter September, January, March, June. Write for catalog. 1638 College Ave., Angola, Ind.

**POCKET SIZE...
YET Precise!**

**WESTON
Model 697
VOLT-OHM-
MILLIAMMETER**



**ONLY
\$28⁸⁰**

NET IN U. S. A.

Here's a convenient, pocket-size radio test instrument . . . but one that is made to the same standards of accuracy and dependability as the larger WESTON instruments. Nothing has been sacrificed to achieve this small size. The ranges provided, too, are complete for radio servicing:

Voltage Ranges: AC and DC—0-7.5; 0-15; 0-150; 0-750

Current Ranges: DC only 0-7.5 and 0-75 milliamperes

Resistance Ranges: 5000-500,000 ohms full scale; 35-3500 ohms center scale

Size: 5 1/8" x 3 3/4" x 3 1/8"

Model 697 is a most convenient tester to carry on service calls . . . a cinch to handle on the bench or around the shop . . . yet it is extremely low-priced for a sturdy, dependable WESTON instrument. Model 697 and other pocket-size WESTON testers should be included in every serviceman's kit. Be sure you have full information. Return the coupon today.

**WESTON
Instruments**

Weston Electrical Instrument Corporation
615 Frelinghuysen Ave., Newark, N. J.
Send complete information on Pocket Size Testers.

Name _____
Address _____
City _____ State _____

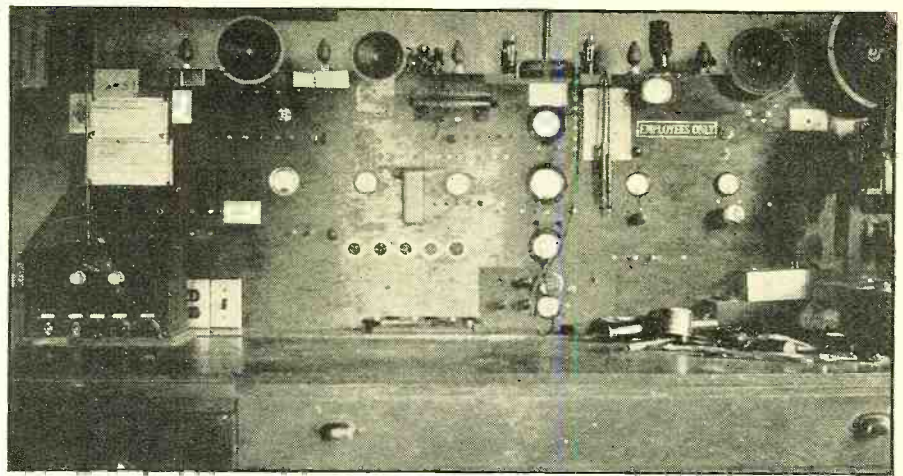

A SERVICE BENCH FOR EFFICIENT WORK
Figure 4. This is a view of part of R. C. Knight's service shop in Woodland, Wash. Prompt service is his aim and this arrangement enables him to give it.

SERVICE—SALES

(Continued from page 531)
amplifier and a Jensen 8-inch p.m. speaker. This stethophone mike, by the way, worked out nicely in an underwater p.a. job with the mike installed in a diver's suit, the mike pressing against his chest."

"Sound-on-film projectors of the 16 mm. variety are rather common around here and we get quite a number to service."

I noticed his smock which he wears while at work. Shannon is neat in every respect, as the shop shows. If he has to run out on calls, he often takes along a smock and white gloves to handle the chassis, so he can present himself with clean hands and clothes to each customer. But he is no "sissy." Most service customers are women and by creating an impression of super-cleanliness, Shannon brings silently yet forcefully to their attention the filthy appearance of the chassis. The need for servicing is thus emphasized in a manner which any good housewife can understand. It pays.

And in the Summer, he spends week-ends at his country home, far away from white smocks and white gloves. There he can get good and dirty without hurting business.

TUBE OR NOT TUBE?

THE war on dummy and fake tubes, which has resulted in action by the Radio Manufacturers Association and the Federal Trade Commission, has now reached the stage where a definition of what constitutes a dummy tube is being given consideration.

To this writer, this matter of definitions has no bearing on the subject. The important point is the contribution to receiver performance or con-

sumer satisfaction which the tube or similar device provides. Tubes which are tubes by any definition have been employed by unscrupulous manufacturers in receivers with only the filament or heater wired in. In such a case, the purpose is obviously to mislead purchasers and is fraud.

On the other hand, it might be contended that a set employing 4 output tubes in push-pull parallel could produce the same results by using a pair of tubes giving power output equal to the four tubes. Or that a single multi-purpose tube be used instead of two single-purpose tubes. There are sound reasons why a conscientious designer might insist, in some cases, on using two tubes when one would do the trick insofar as a narrow definition of performance is concerned. It may be desirable to have the heat developed to be dissipated over a wider area to avoid injury to other parts or the cabinet, the wiring and location of controls may be simplified by using two tubes in place of one, and in some instances, longer trouble-free performance may result. These are points which should be taken into consideration before any hard-and-fast regulations are set up.

Primarily, of course, most of the trouble has resulted from abuses in merchandising receivers containing an inexcusable number of glass-enclosed resistors which are represented to be tubes. This practice cannot be too strongly condemned. Yet it should not result in a blanket condemnation of all receivers employing ballast regulators. A properly-designed ballast regulator has distinct advantages over a line-cord resistor. It reduces fire and shock hazard, simplifies receiver design and prolongs the life of tubes and pilot light under widely-

varying voltages. The latter point is by no means insignificant to the consumer, as the constant replacement of pilot lamps is an unmitigated nuisance. To these should be added that the ballast regulator is manifestly simpler to replace than a line-cord resistor.

Unfortunately, one great drawback to the ballast regulator is the enormous number of types in use. The dealer finds it impractical to carry a complete stock of over 300 types, so it is difficult for a customer to get immediate replacements. There has been a definite trend toward reducing the number of types by making one regulator serve as replacement for several types.

A more enlightened attitude toward such regulators, by both manufacturers and dealers, will be of profit to the radio business and the public.

THIS MONTH'S SERVICE BENCH

R. C. KNIGHT of Woodland, Washington sent us the photograph (Figure 4) of his efficient service bench. The test panel is nicely laid out, impressive in appearance and convenient to use. A vacuum tube voltmeter is installed in the center of the panel, flanked on the left by a Clough-Brengle signal generator and on the right by a Solar condenser tester. A Supreme tube tester and Hickok oscillograph are also included in the shop equipment. The husky test prods draped over the test panel are fitted with heavy, flexible wire which will stand hard usage without developing internal breaks. A test speaker with a universal field coil saves dragging in the customer's speaker when only the chassis requires shop repair.

Mr. Knight has a clever and eco-
(Turn to page 565)

STORING SMALL PARTS

Figure 5. A novel and inexpensive way of keeping condensers, resistors, etc., in sight and where they belong.

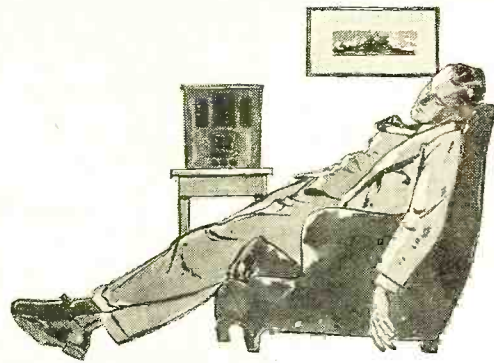

Radio Tubes are a lot like you!

WHEN you've done a hard day's work you're pretty tired—but you get a chance to rest up. Like you, radio tubes get tired, too. But—a rest does them no good.

And so, your radio set's performance goes haywire.

If you haven't changed your radio tubes for a year or more, it will pay you—in the form of better reception, better tone, better volume—to replace tired tubes with a new set of RCA Radiotrons.

Remember—300,000,000 RCA Radio Tubes have been bought by radio users—*proof* that they're the world's finest. No wonder—they're made by the world's foremost radio organization—the only company engaged in every phase of the radio industry.

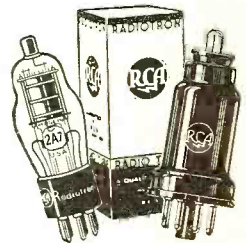

RCA presents the Magic Key every Sunday, 2 to 3 P. M., E. S. T., on the NBC Blue Network.



Radio Tubes

RCA Manufacturing Co., Inc., Camden, N. J. • A Service of the Radio Corporation of America

1938 RADIO DATA BOOK GIVEN FREE! (See 3rd cover)

PRICES REDUCED

on two Brush micro-phones—BR2S and B-1. If your jobber can't supply you, write us.

THE BRUSH DEVELOPMENT CO.
3311 PERKINS AVE., CLEVELAND, OHIO

TRAIN FOR ELECTRICITY IN 12 WEEKS

"Learn by Doing"
I'LL FINANCE YOUR TRAINING!
My Big Free Book tells you how we train you in 12 weeks—to start in the growing field of Electricity, by actual shopwork on real electrical machinery—not by books or correspondence. Amazing plan enables many to get training first... then take 18 Months to pay in small monthly payments starting 5 Months from date you start school. Experience or advanced education not needed. Many Earn While Learning. Free lifetime employment service. Diesel Engines, Radio, Electric Refrigeration and Air Conditioning instruction included. MAIL COUPON for FREE BOOK and all Facts.

H. C. LEWIS, President, COYNE ELECTRICAL SCHOOL
500 S. Paulina St., Dept. 38-81, Chicago, Ill.

Send Big Free Book with facts on Coyne training and tell me about your "Pay-Tuition-After-Graduation" Plan.

NAME _____
ADDRESS _____
CITY _____ STATE _____

a \$50.00
Radio Course

for only \$4-

RADIO PHYSICS COURSE
A. GHIRARDI

Ghirardi's Great 972 page
RADIO PHYSICS COURSE

What a bargain! What a chance for you to really learn radio the easy way. Here's the whole famous Ghirardi RADIO PHYSICS COURSE condensed into one great big 972-page volume—easy to read, easy to understand. This complete instruction course will teach you RADIO, ELECTRICITY, SOUND—and even TELEVISION—while sitting right at home in your own easy chair. Yes, it's all here, all you need to learn is thoroughly explained painstakingly and simply, so you can really understand it at once. Nothing is left out!

What You Will Learn From This Book!

- Sound, Speech and Music . . .
- Electrons . . .
- Electric Current . . .
- Electric Units and Circuits . . .
- Resistance . . .
- Ohm's Law . . .
- Batteries . . .
- Magnetism . . .
- Electromagnetism . . .
- Transformers . . .
- Inductance . . .
- Condensers . . .
- Alternating Current Circuits . . .
- Filters . . .
- Electrical Measuring Instruments . . .
- Radio Waves and Radiations . . .
- Broadcast Stations . . .
- Receiving Equipment . . .
- Vacuum Tubes . . .
- Radio and Audio Frequency Amplification . . .
- Superheterodynes . . .
- Loud Speakers . . .
- Battery Operated Receivers . . .
- Power Supply Units . . .
- Electric Receivers . . .
- Automobile and Aircraft Receivers . . .
- Phonograph Pickups . . .
- P. A. Systems . . .
- Short-wave Receivers . . .
- Photoelectric Cells . . .
- Television . . .
- Antennas and Grounds . . .
- Testing and Servicing Receivers . . .
- Sound Motion Pictures . . .
- Appendixes . . .
- 856 Review Questions for Self-Study . . .
- LOTS MORE!

Get The Complete Ghirardi Course Now!
Ghirardi's marvelous style, freedom from unnecessary mathematics, and more than 500 clear illustrations make everything so clear and simple that you need no previous training to understand it. That's why more radio schools and students use it than any other radio book in the world. All radio instructors recommend it. They say it's the best there is—at any price! You get it at the amazingly low price of only \$4. Where could you do better than this? YOU CAN'T! So order your copy right now. Remember—every penny of your money back if not fully satisfied!

TEAR OFF — FILL OUT — AND MAIL

RADIO & TECHNICAL PUBLISHING CO.,
45 Astor Place, New York, Dept. RN-38.

Enclosed find \$4. Send my RADIO PHYSICS COURSE at once, postpaid. (Foreign \$4.50.)

Send me a free circular describing this book.

Name

St.

City & State

MONEY-BACK GUARANTEE

MILLION ALL-WAVE OSCILLATOR

A. C. D. C.
6 BANDS—100-25,000 K.C.
SEPARATE AUDIO
LINE FILTERS

19.95
NET

Write for literature on our complete line of test instruments.

MILLION RADIO AND TELEVISION LABORATORIES
577 N. UNION ST., CHICAGO, ILL.

RADIO PHYSICS COURSE

ALFRED A. GHIRARDI

Lesson 71—Voltmeters

A VOLTMETER is used to measure the difference of electric pressure between two points in an electric circuit. This difference of electric pressure or potential is commonly called "voltage" or "voltage drop." Voltmeters are used extensively in all kinds of electrical work, and are always connected "across," or "in parallel with," the source of voltage.

If a milliammeter were connected directly across the line, the e.m.f. would send a strong current through the fine wire, low resistance, moving coil and burn it out. To prevent this, a *high fixed resistance* is connected in series with the moving coil, as shown at (A) of Figure 1. The milliammeter

when 1 milliampere flows through the coil. Let us assume this is to be built in the form of a voltmeter having a range of 150 volts. Then enough resistance R, must be connected in series with the coil so that when the voltage across the terminals of the meter is 150, exactly 1 milliampere will be flowing through the resistor and coil, and the pointer will be deflected to the end of the scale.

By Ohm's law: $E = I \times R$.

1 milliampere equals .001 ampere; therefore since $E = I \times R$, $150 = .001 \times R$

$$150$$

from which $R = \frac{150}{.001} = 150,000$ ohms.

$$.001$$

The symbol R_m is usually employed

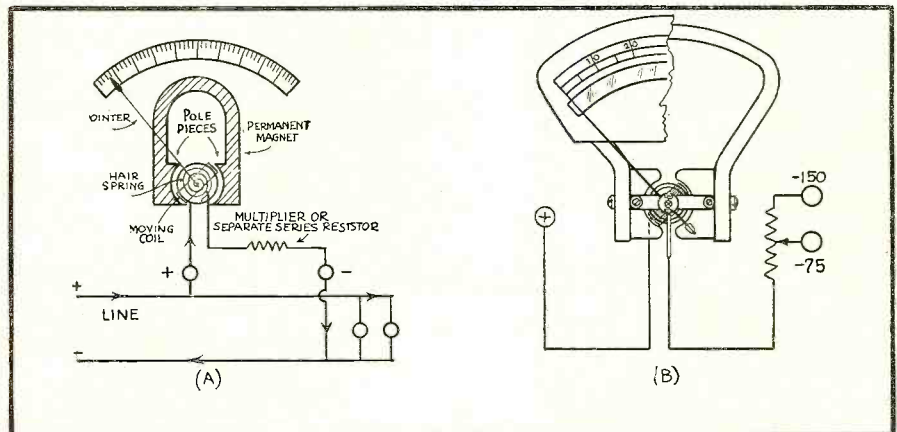

Figure 1. The general arrangement of a d.c. voltmeter. In addition to the basic moving coil assembly there is a resistor connected in series with the coil. This "multiplier" resistor determines the range of the meter. At (B) is shown the use of a tapped multiplier resistor to obtain a voltmeter having two ranges, 75 and 150 volts.

movement can then be connected across the line in series with this resistance and be used to measure voltage, since the current flowing through the coil, and therefore the turning force at any instant, is proportional to the voltage applied across the terminals of the instrument, ($I = \frac{E}{R}$).

A voltmeter is simply a galvanometer or milliammeter movement connected this way and having its scale graduated in volts instead of milliamperes. Whenever space is available the series resistor is contained within the case of the instrument. The series resistor is considered to be part of the voltmeter. Most voltmeters have a relatively high resistance, so they take a very small current from the line.

Suppose the galvanometer movement in the voltmeter of (A) in Figure 1 is so constructed that its pointer deflects over the full scale

to designate the total resistance of the meter, but since the resistance of the moving coil is very small compared to the series resistance R, R_m is taken as being the same as the series resistance in most practical problems. The scale of the above instrument would be graduated uniformly in volts, with the maximum at 150 volts.

The high resistance is usually placed inside the voltmeter case, and connected in series with the coil. It is called a *multiplier resistance*. When space is not available, external resistors or "multipliers" are used.

D'Arsonval voltmeters sometimes cause trouble due to open circuits in the multiplier or series resistor. These resistors are wound of the thinnest resistance wire to be had, and are easily damaged by mechanical abuse or by allowing the multiplier to get wet. If the multiplier is made up of sections and becomes open-circuited, the open section can usually be located and bridged, without the neces-

sity of sending the instrument back to the manufacturer.

It is common to build voltmeters so they have more than one range. This is done by simply tapping the series resistor at suitable points for the low voltage ranges. Thus in the voltmeter considered above, the total series resistor is 150,000 ohms. If a tap were made at the center of this and brought out as shown at (B) of Figure 1, a voltage of only 75 volts applied between the common terminal and the tap at this 75,000 ohm section, would send a current of

$$I = \frac{E}{R} = \frac{75}{75,000} = .001 \text{ ampere}$$

through it, and would produce full-scale deflection. Thus, this would provide a 75-volt range for the instrument in addition to the 150-volt range. Three binding posts would be arranged on the instrument as shown. In order to have the current flow through the coil in the proper direction, the binding post marked (+) is connected to the positive wire of the line, and either of the other posts are connected to the (-) side of the line. A small push-button switch is often provided in portable instruments so that the voltmeter circuit may be closed only when the measurement is being taken.

When using a double-range voltmeter or ammeter, care should be taken not to accidentally apply too much voltage or current to the low-scale terminals, since burn-out of the moving coil may result. If the voltage or current in the circuit are not known, the high-reading range should always be tried first. Then if the reading is less than the highest value of the lower reading range, that range should be used for the final test.

Radio Telephone for Freight Trains

Philadelphia, Pa.—Radio short-wave sending and receiving equipment was recently installed on a Pennsylvania 30-car freight train so that the trainmen could communicate between the caboose and the engine cab. The apparatus is operated in a similar manner to the telephone, but of course, without connecting wires.

Daily News Report

Schenectady, N. Y.—Americans, regardless of what far corner of the world they may be in, can now tune in for the daily news report from home. This new short-wave program feature, to be known as the American radio news tower, will be broadcast at 5 o'clock E.S.T. each afternoon, except Saturdays and Sundays over the two powerful General Electric international stations, W2XAD, 19.56 meters; and W2XAF, 31.48 meters.

Still "Years Ahead"

RADIO BY McMURDO SILVER

STARTLING radio engineering achievements have characterized the work of McMurdo Silver for a quarter of a century. Year after year his radio receivers have won the acclaim of technical schools, engineering laboratories, radio distance receiving champions, leaders of scientific expeditions, and internationally famous musicians... have made widely accessible results previously considered unobtainable outside of a laboratory. This leadership in radio engineering is strikingly demonstrated by current models. It is no exaggeration to say that no real conception of what radio offers today is possible until you have tested the 1938 masterpieces of this master engineer. Here is radio which, with uncanny "reach" goes to the earth's four corners to snare unique and unusual programs... music, sports, news, ships' messages. Thirty-six distinctive technical features are responsible for the "Years Ahead" performance of tomorrow's radio by McMurdo Silver. Send for details.

The 15-17—Advanced 15 tube super-heterodyne circuit delivering functional efficiency of 17 tubes... Every coil and circuit is individually tested and chassis chrome plated throughout.



The Masterpiece VI—New t. r. f. super-heterodyne and exclusive Multi-Band Circuit, chromium plated steel cabinet.

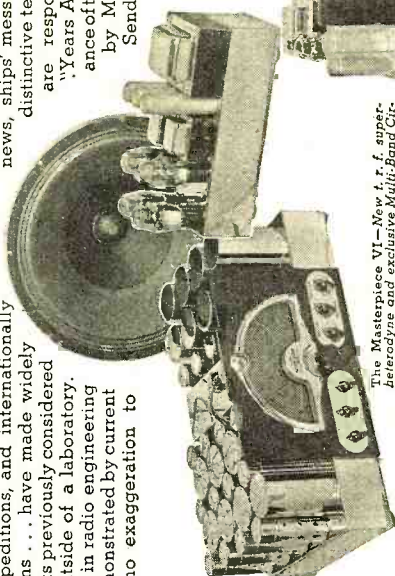

The 14-15—Super-sharp communication receiver of 14 tubes (15 with larger speaker) with tuned and stabilized regenerative r. f. wave bands.

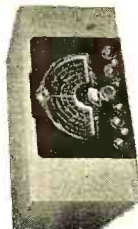

McMURDO SILVER
2900 A SOUTH MICHIGAN AVENUE, CHICAGO, ILLINOIS

Ask your **JOBBER**
for the **NEW**

STANCOR

"HAMANUAL"
New Tubes . . . New Circuits
16 NEW TRANSMITTERS
5 WATTS TO 1000 WATTS

STANDARD TRANSFORMER CORPORATION
850 BLACKHAWK STREET, CHICAGO

LEARN CODE
the way you'll be using it—by **SOUND**

There is only one way to learn to read code and that is by listening to code. There is only one way to learn to send code and that is by hearing your own sending repeated back to you. With the new all electric Master Teleplex Code Teaching Machine you learn code the natural, easy, fascinating way. Only instrument ever produced which records your sending in visible dots and dashes—then **SENDS BACK** your own key work at any speed you desire. We furnish complete course, lend you the All Electric Master Teleplex, give you personal instruction with a **MONEY BACK GUARANTEE**—all at a surprisingly low cost per month. Write today for **FREE** catalog R.N. 3. No obligation.

TELEPLEX CO. 72-76 Cortlandt St., New York City

Bill - the
 This is the
 RADIO SERVICE INC.
 2024 MAIN STREET
 CINCINNATI, OHIO
 I spoke to you at home
 It's a honey
 JAMES SMITH
 PH. 1
 RAD.

- 1% Accuracy to 3,000 K.C.
- 2% for Higher Frequencies
- Range 110 to 20,000 K.C.

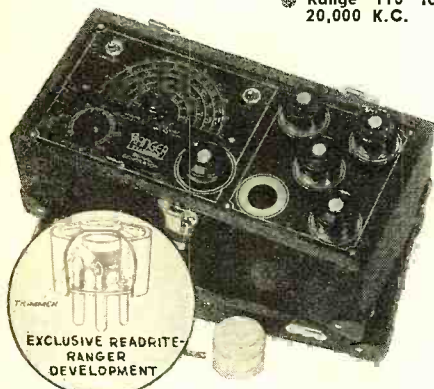

Model 557 Complete
 DEALER PRICE
 Only \$18.90

ACCURACY
 Guaranteed in This Low
 Price Signal Generator

★ Wherever you go you will hear praise for Model 557 Direct Reading Signal Generator. Continuous use day in and day out has clearly demonstrated its remarkable accuracy and reliability.

Model 557 Direct Reading Signal Generator uses plug-in type coils. Five frequency bands are covered from 110 to 20,000 K.C., all fundamentals. Completely shielded for static and magnetic fields. Attenuation and stability are outstanding features. Strong signals both modulated and unmodulated are furnished.

Each individual coil is separately calibrated by an exclusive method of peaking with trimmer condensers. Furnished complete with batteries and accessories.

Readrite
 TESTERS **RANGER** METERS

READRITE METER WORKS
 315 College Ave., Bluffton, Ohio

Please send me more information on Model 557.

Name.....
 Address.....
 City..... State.....



THE TECHNICAL REVIEW

CONDUCTED BY THE TECHNICAL EDITOR

Fundamentals of Engineering Electronics, by William G. Dow. Published by John Wiley and Sons. The tendency of many textbooks on this subject has been to skim over superficially the essentials of electron physics and to give proportionately greater attention to circuit analysis. This new book by Professor Dow is different. Its aim is to furnish the student once and for all a solid foundation upon which he may build his knowledge of the intricacies of electronics. The result is an excellent book on a most difficult subject.

The subject matter has been treated with a minimum of mathematical pyrotechnics, which makes for greater clarity and smooths the way for the student. Not that it is easy to grasp—to fix physical concepts firmly in the mind calls for hard study—but it is well worth while.

Part I deals with electrons. In Chapter 2 there is a comprehensive discussion of the electrostatic field of a triode. This is followed by chapters on electron ballistics, cathode rays, space-charge flow, and others largely devoted to electron tube physics. This part ends with chapters on amplifiers and oscillators. Part II covers mainly atomic energies, photoelectric emission, photosensitive devices and rectifier circuits.

The bibliography is extensive and the subject matter of this book, as indicated in the foregoing, fills in many of the dead spots encountered in other books on the subject.

The Low-Voltage Cathode-Ray Tube and Its Applications, by G. Parr. Obtainable in the U. S. from Allen B. Dumont. This new book, which is published in England, deals with the engineering aspects of cathode-ray tube design, performance and applications. Chapter 1 covers construction and operation; Chapter 2, focusing and performance. Other

chapters describe the design of linear and other time bases, and its application in radio, industrial and television engineering. The appendix gives information on photographing images. A comprehensive bibliography adds to the values of this book.

There has been a definite need for just such a book as this. It is concisely and clearly written and its 176 pages contain a surprising amount of information for the designer and user of cathode-ray tubes. The inclusion of circuit constants for schematic diagrams is an additional advantage.

Questions and Answers Handbook, by L. O. Gorder, Allied Radio Corporation. Here is a book which every serviceman should have. In concise form, it covers the needed theory and practical points which are required for successful servicing. This handbook was originally compiled for the IRSM and was formerly available only to members at high cost. A total of 3499 questions and their answers are given. These are divided in groups such as basic theory, superheterodynes, speakers, antenna systems, modulators, and oscillators, auto-radio, test equipment, interference elimination, and many others. Many valuable pointers will be picked up by a study of this book.

Review of the Proceedings of the Institute of Radio Engineers for December, 1937

Minimum Noise Levels Obtained on Short-Wave Radio Receiving Systems, by Karl G. Jansky. The various sources of noise in a radio receiving system are considered and the theoretical minimum is compared with the limit actually measured on different antennas over a limited portion of the short-wave spectrum. Data are given on the extent and intensity of man-made interference. Diathermy machines are the greatest offenders during daylight.

Experiments with an Underground Ultra-High-Frequency Antenna for Airplane Landing Beam, by H. Diamond and F. W. Dunmore. The report on work done for the purpose of locating the landing beam in the center of an airport. The effect of the proximity of the ground to the transmitting antennas is discussed.

Note on Large Signal Diode Detection, by S. Bennon. The author discusses distortion in diode circuits caused by "non-tracking".

Review of Contemporary Literature

Transmission Line Structures as High-Frequency Networks, by W. P. Mason, Bell Laboratories Record, December, 1937. A discussion of the application of coaxial transmission line structures to filter networks for ultra-high frequencies. They appear to have many advantages over the ordinary coil and condenser filter at such frequencies.

Limiting Amplifiers, by John P. Taylor, Communications, December, 1937. The author describes various means employed to secure volume compression.

Background Noise Corrections in the Measurement of Machine Noise, by L. E. Packard, General Radio Experimenter, December, 1937. The problem of making satisfactory sound measurements under adverse conditions is considered and a graph for background noise correction in the final result is given.

Recording Resistance-Welder Secondary Current, by H. W. Lord, Electronics, December, 1937. The advantages of a "pick-up" coil method of oscillographic recording of the high currents delivered by resistance welders are pointed out by the author.

Scientific Research Applied to the Telephone Transmitter and Receiver, by Edwin H. Colpitts, Electrical Engineering, December, 1937. A discussion of factors influencing the design of telephone transmitters and receivers. The characteristics of the human voice and ear are considered.

Radio Receiver Power Supplies, Aerovox Research Worker. This subject is covered in two parts, Part I appearing in the August-September and Part II in the October-November issues of this informative house organ. Various types of rectifier circuits are discussed in Part I and curves showing output voltages and ripple percentage with varying circuit constants are presented. Part II describes a test set-up employed to secure experimental data and includes a number of curves showing measured values of ripple and d.c. output voltage for standard filter circuits.

FREE BULLETINS

Helpful Folder on Microphones

The Universal Microphone Company recently published a new catalog folder on their complete line of ribbon and carbon mikes. The pamphlet also lists their hearing aids, and accessories. For your free copy send requests to RADIO NEWS, 461 Eighth Avenue, New York City.

Latest Parts Catalog

Through the courtesy of the Radolek Company,—RADIO NEWS is able to offer the readers a free copy of the new 1938 Radolek catalog. It is a large 164-page book with descriptions and illustrations on radio receivers, testing instruments, P. A. systems, and thousands of different radio products. Send requests to RADIO NEWS, 461 Eighth Avenue, New York City.

Special Catalog

The Cornell-Dubilier Electric Corporation just announced a special 4-page catalog "Flyer," No. 151A; containing complete specifications on their condenser line. Free copies are available to all readers. Address RADIO NEWS, 461 Eighth Avenue, New York City.

Speaker Replacement Catalog

Servicemen and experimenters have been waiting for this new Carron Mfg. Company's catalog. It specializes in speaker coil and cone replacements, and in addition, lists r.f. transformers and other parts including call systems, headphones, etc. Copies of this book can be ordered free of charge from RADIO NEWS, 461 Eighth Avenue, New York City.

Special! For Radio Amateurs

The Harvey Radio Laboratories have just sent out notices announcing their latest catalog No. 52 for amateur and commercial services. It describes the standard line of Harvey transmitters; and all amateur and broadcast engineers will be interested in securing a copy. Address requests to RADIO NEWS, 461 Eighth Avenue, New York City.

RADIO NEWS Booklet Offers Repeated

FOR the benefit of our readers, we are repeating a list of valuable, FREE technical booklets and manufacturers' catalog offers, which were described in detail in the November, December, 1937, and January, February, 1938, issues. The majority of these booklets are still available to all readers. Simply ask for them by their code designations and send your request to RADIO NEWS, 381 (Turn to page 563)

ALLIED offers RADIO'S GREATEST VALUES

NEWEST SETS

OVER 12,000 PARTS

DOZENS OF KITS!

SOUND EQUIPMENT!

TEST EQUIPMENT!

**FOR DEALERS • SERVICEMEN
SOUND MEN AMATEURS SET BUILDERS**

Everything in Radio
AT LOWEST PRICES!

What's your interest in Radio? Do you sell sets? Build? Service? Whatever you need, ALLIED has it and can save you money. Our big 164-page book shows over 12,000 radio parts; Sound Systems for every need, 8-60 watts, portable, mobile, permanent; Intercom Systems; all types of testers, analyzers, tube-checkers, set-testers, meters, signal generators; Amateur receivers, transmitters, transceivers; Build-Your-Own Kits; books, tools, etc.—and 61 great "Knight" Radios offering newest features, Push-Button Tuning, etc., at amazingly low prices. Radio men everywhere say, "ALLIED's catalog's the place to shop; it saves you time and money!" Get this big Book of Values now—it's Free—just send coupon.

FREE! BUILDER'S PARTS LISTS

We supply Free Parts Lists of matched kits for building any circuit described in this or in any other magazine. Just specify where seen.

Free CATALOG

ALLIED RADIO CORP.
Dept. I-C-8
833 Jackson Blvd., Chicago, Ill.



Send your 1938 Catalog Free

Name.....

Address.....

City.....State.....

ALADDIN

Announces a Perfected
AUTOMATIC
Push-Button TUNER

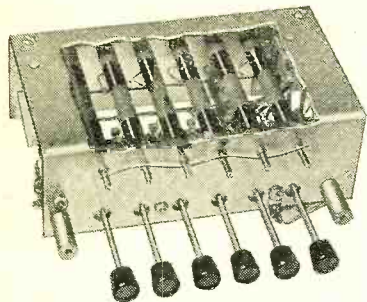

Designed For STABILITY, and Elimination of Frequency Drift

The simplicity of operation and excellent performance of this ALADDIN Automatic Tuner can be attributed to the following combination of features:

EASE OF ADJUSTMENT—Only ONE adjustment per station is required and it is easily made from the FRONT of the panel. Note illustration shows these adjustments are located exactly above the push-buttons, allowing simple, speedy access for station selection, even by the layman.

STABILITY OF OPERATION—Inductance tuning is used throughout in combination with stabilized fixed condensers. This provides a greater degree of tuning stability, elimination of frequency drift, and better uniformity of operation on any band. A new type coil-switch assembly insures accurate tracking in all positions.

PRECISION WORKMANSHIP AND QUALITY MATERIALS—Great care, engineering skill and quality materials, comparable to those used in the fabrication of fine precision instruments, are used in the making of this ALADDIN tuning mechanism.

MANUFACTURERS—For increased sales specify ALADDIN Automatic Tuning in your 1938 designs.

DEALERS—Insist upon ALADDIN Automatic Tuning in your new receiver lines. Its simplicity of operation enables your customer to make station changes himself.

For complete details, WRITE, TELE-GRAPH or CABLE

ALADDIN RADIO INDUSTRIES, INC.
466n W. Superior Street, Chicago, Ill. U.S.A.

Licensees of Johnson Laboratories, Inc.

These devices manufactured under one or more of the following U. S. Letters Patents 1,877,830 1,910, 228 1,975,593 1,978,569 1,978,600 1,982,989 1,982,990 1,991,428 2,002,000 2,082,690 2,005,308 2,018,620 2,028,651 2,032,360 2,032,912 2,035,439 2,051,012 2,059,595 2,082,587 2,093,959 2,082,985 2,094,189 2,095,420. Other patents pending.

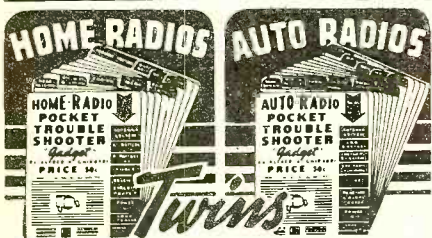

Ghirardi's "TROUBLE SHOOTERS"

DO THE WORK—BUT YOU GET THE MONEY

SPEND YOUR SERVICE WORK by using Ghirardi's amazing new "TWIN" pocket-size radio "TROUBLE-SHOOTERS" that instantly tell you exactly where to find the trouble in a receiver by the "Trouble Symptom" method. They'll point the way directly to over 800 DIFFERENT RECEIVER TROUBLES—and their REMEDIES—in a jiffy! **HOW THEY WORK:** Easy as pie—you take up your Gadget; pick out the eyeletted card marked for the particular Trouble Symptom you find in the "TWIN" receiver; flip the card around, and there you'll see all the possible Causes for the particular trouble, the exact Tests to make, and the Remedies to apply. Work quick as a flash—almost like magic!

One 9-card Gadget for HOME RADIOS—one with 12-cards for Auto Radios, only \$1 a pair (\$1.20 for foreign). **MAIL LAR TO THIS AD,** write your name and address in the margin, and mail it NOW for both Gadgets. You don't risk a penny! Sent postpaid anywhere on 5-day trial!
Radio & Technical Pub. Co.
Dept. RN-38
45 Astor Pl., New York **NOW!**

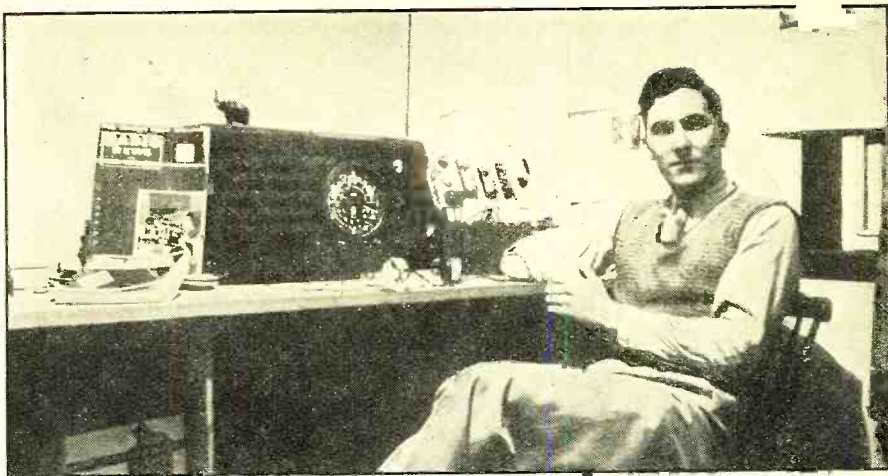

THE AMATEUR OBSERVER

Conducted by W2JCR

THIS is just another suggestion to observers that their "Calls Heard" lists be limited to DX stations. Many reports received from the first district, for instance, list 20-meter phone stations only a few hundred miles distant. This does not represent DX by any stretch of the imagination and neither station owners nor other DX'ers profit from such reports. We suggest 3000 miles as the minimum for 10, 20 and 40-meter DX; 2000 miles for 75-meter DX; 1500 miles for 160-meter DX and 30 miles for 5-meter DX. If you—and you—and you use these figures as a standard, it will save you time in making your reports and it saves time in editing them.

THE following observers would like to correspond or exchange S.W.L. cards with others:

James R. Wood, 212½ Sixth Avenue, Madison, Minn., wants to exchange cards.

Homer Bohlender, RR No. 2, Brookville, Ohio, will answer all S.W.L. cards or will exchange scenic postcards.

William W. Oglesby, Jr., Harrisburg, North Carolina, will send his card to all S.W.L.'s requesting it.

Zane Sprague, E. Liberty Street, Covington, Indiana, wants to exchange cards or letters with foreign listeners.

Calls Heard

By L. P. Mathieu, Box 429
Port Elizabeth, South Africa

20 meter phone and c.w.: W1AA-7, 11FG-8, 1G1X-5, 1GR-6, 2HUO-8, 2DLD-7, 2AKV-7, 2AZ-8, 2HF-7, 2HAD-8, 3FSD-6, 3AHS-6, 3LN-7, 3IR-6, 3ABM-8, 4DHZ-7, 4HX-8, 4DSY-6, 4DKY-6, 5DNV-5, 5GAR-6, 5EEN-4, 6NNR-6, 6MLG-8, 6TT-5, 6JNB-6, 6NKP-5, 6FCU-5, 6CUU-7, 6HOE-6, 6LEN-7, 6NXX-7, 6COE-6, 6FCL-7, 6UAZ-8, 6BHO-5, 6BBU-5, 6VXZ-6, 6MDF-5, 6ELL-7, 6FUF-6, 6E3EO-7, 3NB-6, 3FB-5, 4FI-4, 5BO-5, 5E2AH-6, 4KDDH-6, 6CO2OY-5, NY2AE-7, PY2BX-5, 2KE-6, LUSDH-5, 5BZ-5, 5CZ-8, 7AC-7, 0A4AL-5, CE1AO-6, 3AC-5, 3CO-7, YV5AB-4, CX2BK-5, 3BL-5, K6QOE-6, KAIME-9, 1YL-6, 1BH-8, VK2HF-7, 2AG-5, 2NY-5, 2AB-5, 3LA-6, 3ZZ-6, 6MW-6, PK1ZZ-7, 1ME-9, 1MF-8, 1RI-8, 1MO-8, 2WL-8, 2JN-6, 4DG-5, FISAC-7, VS6AB-5, YU2AE-5, 2LL-5, 2CO-5, VS7GI-5, ON4BK-5, 4FS-4, 4GK-4, F8XP-8, 8MG-7, G8NI-8, 5JO-5, 5MO-8, 6RH-6.

By VE3ALG, Eric Adams, 509½ Yonge Street, Toronto, Ont., Canada

40 meter c.w.: W5YH, 6FIG, 6NWI, 6PDN, 6MPY, 6LBB, 6GIX, 6AWY, 6PCX, 6OWR, 6NHK, 6LQM, 7DC, 7COT, 7ASG, 7BC, XE2IN, VE4OM, 5ABB, YV5AO, K6QNF.

NEW OBSERVERS

(Appointed during December)

United States

California: Jack Allen, William Harri-man
Illinois: Harold E. Schrock
Indiana: Zane Sprague
Massachusetts: Alton L. Caldwell, Jr.
New York: George L. Krausse, Byron H. Kretzman, Abraham S. Nutkis
Ohio: J. Weiss
Wisconsin: Raymond Hernday

Foreign

Canada: Ken King
South Africa: L. P. Mathieu

By Richard C. Eaton, 394 Tremont Street, North Tonawanda, N. Y.

10 meters: EI2L-7, G5BM-6, 5JA-5, 5ML-8, 5SA-7, 6BW-8, 6HL-6, GM6RG-8, K6MUV-9, 6NDV-6, 6OQE-8, ZU3G-7.

20 meters: EA9AH-8, EI2L-9, G5KH-7, 5ML-8, 5NI-9, 5TP-6, 6VX-6, 6XR-7, HC1JB-5, HH2B-6, 5PA-8, HK1DG-8, 3JA-8, ON2OY-8, TI2AV-7, 2FG-7, VO6JO-8, 6L-4, VP9R-9, YV5ABF-8, 5AD-5, 5AE-9, ZUGP-5.

160 meters: W1ERF-9, 1GIT-8, 1HGP-5, 1IQC-8, 1ITM-8, 1ITX-9, 1IZJ-8, 3AKX-8, 3EFB-7, 3FDY-8, 3GFB-7, 3GZS-7, 4EGH-5, 4EJK-5, 4ERH-7, 9ARN-9, 9BFP-9, 9LLX-9, 9MIT-9, 9ROQ-7, 9SVL-7, 9TKO-8, 9TLQ-9, 9TLZ-7, 9UBD-8, 9UFW-8, 9UWL-8, 9VRV-7, 9WCN-7, 9WYO-7, 9YCF-7, 9ZBD-9.
William Dean Noeys, 5112 North 22nd Street, Omaha, Neb.

10 meter phone: G5JO-7, 6BH-8, 6BW-8, VK2GU-9, K6MUV-7, 6OQE-9, VP6BY-9, LU7AG-8, XE1K-8.

20 meter phone: VK2ABD-8, 2OG-7, 2VA-7, 2VV-7, 2XQ-7, 3AL-9, 3WD-5, 3WV-7, 3XI-8, 3ZL-7, 4IU-6, ZT6AL-8, ZU6P-8, G2AK-9, 2PU-6, 5RV-8, 5ZJ-8, 6ML-5, F3OO-7, YV4AB-5, 5AD-8, 5JKJ-8, VO6D-9, LU4BH-8, NY2AE-9, VP5AG-8.

By D. S. Catchim, Quarters 1102, MB, Quantico, Va.

20 meters: CE3DW, F3KH, 3LN, 3MC, 3EX, 3NF, 3DC, 3NN, 3LN, F3SAB, 3AF, FT4AN, G3KA, 5RV, 6LK, 6DL, 6XR, HC1JB, HH2B, 2LD, 5PA, HK1EP, 1OG, 3JA, 3JA, HR5C, 5Z, K6KMC, LU5AN, 7AC, 9BP, 0A4C, 4AL, ON4SS, ON2OY, SV1AK, TI2AV, 2FG, VO6D, 6T, VP3BG, 6YB, YV5ABF, 5AM, 5AK, 5AD, ZS5M, ZT5Z, GIL, ZU5Z, 6P.

By Harry Honda, 429 North Fremont Avenue, Los Angeles, Calif.

20 meter phone: VK2ADE, 2ADT, 2AFO, 2AP, 2BK, 2DT, 2HQ, 2HS, 2OB, 2OI, 2RI, 2UC, 2VV, 2XQ, 3AL, 3BZ, 3MX, 3LA, 3NP, 3PL, 3OZ, 3WG, 3XJ, 3ZZ, 4ADF, 4RI, 4VD, KA1BH-8, 1ME-8, KZ1L-7, J2MI-6, VS6AB-7, PK1GL-7, F3HM-6, 3OO-7, GSKL-6, 8SB-5, ZS5M-7, F3SAB-5, LU1EJ-8, IUA-8, 1DJ-8, 2EE-7, 5AM-8, 5CZ-9, SAP-7, 9PA-7, CE2AR-7, 3AA-7, 3AV-6, 0A4C-4, 4L-7, 4AL-7, HK1F-7, PY2AK-5, YV4AV-5, 5AK-7, HC1FG-7, 2BG-6.

By Garland Haas, 807 South Garvin Street, Evansville, Ind.

20 meter c.w.: VK2TF-9, 2RA-9, 2AH-9,

HEARS THEM IN SO. AFRICA

Observer Mathieu, Port Elizabeth, South Africa, hears plenty of W's and VE's, as attested by his list, the first of this month's Calls Heard.

2NY-7, E2O-9, 3GP-6, 7AB-5, LU5AN-9, ZL1LM-7, 11I-9, 11I-9, HK3ER-6, K5AA-9, 5AG-9, 7GDK-9, CNSAR-3.

20 meter phone: HC11B, GM6RC, YV5ABF, 5AP, HK1JN, HH2B, 5PA, CT1PY, K7FST, LU4BI, HR2A.
By Bill Sloan, 4926 San Jacinto Street, Dallas, Texas.

20 meter phone: HH2B-8, 2G-8, 5PA-9, HK1AA-7, 1JN-7, 3JA-9, 4AG-9, HC1FG-8, CE1AO-7, OA1C-8, 4AL-7, NY2AE-8, 2RC-9, 2AV-8, 2KP-8, YV5AA-9, 5AM-7, 5ABF-9, 5AD-6, 5AK-7, LU4BH-7, 5AN-7, 8AB-8, K6OQE-9, 6NZO-9, 6BNR-9, 6BAZ-9, 6GAS-8, V06B-8, V13BG-7, 3BH-6, 6TR-9, VK2XO-7, 3GO-5, OQ5AA-6, ZU6P-7, ZTAL-6, ZS2N-6.
By Raymond J. Roehl, 778 Edmund Street, St. Paul, Minn.

20 meters: CNSAJ-3, SAN-4, E12L-3, F3OO-4, SDV-3, SPU-4, G2PU-4, 5KH-3, 5JO-3, 6LK-4, GM5NW-3, HS1BJ-5, HH2B-9, 5TA-5, 5K-6, HH5TA-5, LU5CO-4, ON2OY-7, VP3THE-4, VK4JU-2, VYIAM-5, 5AE-6, ZU6P-4, 6PN-3, 6T-3, ZT5S-3, ZS2N-4, ZL2Z-3.
By H. Francis Shea, Box 4 East Machias, Maine.

10 meter phone: OK3VA-7, ZE1JR-6, VK2ND-3.

20 meter phone: CT1PA-5, CNSAI-4, SAJ-5, SMB-3, SAM-7, EASAE-5, 9AH-7, E12I-7, FA3HC-4, 3QV-5, FT4AN-5, FB8AB-2, F3HZ-6, 8UE-7, 8KW-6, 3OO-5, 3NF-4, SPU-4, 8ZM-3, 8AM-5, SDR-7, C2AK-7, 2AI-6, 2MF-4, 2XV-5, 5PT-5, 5VD-7, 5KH-7, 5JE-6, 6NR-3, 6DO-6, 6WU-2, 6OS-6, 6WT-4, 6BW-6, 8MG-4, 8MA-4, 8CS-4, GM5ST-5, 5NW-6, 6RG-5, GW2UI-5, LU7AB-7, LA1G-3, 4P-3, OA4C-5, 4N-5, 4PA-4, 4VK-5, ON2OY-5, PAOFB-5, OIOW-5, SUIKG-3, 1CH-4, VK3GQ-5, 3BT-4, 3ZZ-5, 3BZ-4, ZSLAL-3, 2N-5, 5M-6, 5X-5, 6A1-4, 6AL-5, 6AU-4, ZT5S-3, 5L-4, 6AL-5, ZU5I-4, 6P-7, 6AF-5, 6L-5, OQ5AA-4.
By Richard A. Rush, 241 West 112th Street, Los Angeles, Calif.

10 meters: VPGYI-6, LU2EL-8, 7AZ-7, 7AG-3, ZL2BI-9, 2FY-9, 3DK-6, 3DJ-4, 3KZ-9, 4AS-7, 4FW-7, VK2GH-9, 2UZZ-7, 3YP-7, HI7G-9, ZU6P-5, YV5AK-8, 5AA-7, TI2FG-8, E12L-6.

20 meters: LU4BH-9, 4EL-9, 8AB-9, YV5ABF-9, HH2B-6, 5PA-8, VK2QI-4, 2AP-9, 2ADE-6, ZS2N-3, ZU6P-7, VP3THE-9, OA4C-8.

By E. H. Walker, 23 Burlington Road, Chiswick, W4, London, England.

20 meter phone: W1JG-5, 1CNX-6, 1WE-4, 1ADM-8, 1APA-4, 2BRI-6, 2IUV-9, 2BZ-6, 2ICE-7, 2BBI-5, 2IVQ-4, 2AD-4, 3GBP-5, 3EFS-5, 3CHE-6, 3GS-3, 4BYK-7, 4EF-5, 4BPD-6, 4APK-5, 4CYU-5, 4DCR-4, 4DSY-5, 4AHH-4, 8AU-5, 8HEQ-4, 8HUL-4, 8QDU-5, VK2XU-6, 2VR-4, K4ENY-8, NY2AE-5, XE1GK-5, HC1FG-4, CE3CO-5, OA4E-8, HK3IA-4, CO2JJ-4, 2RA-8, CNSMT-9, 8AM-9.
By G2BERM, M. J. Bright, Lampitts House, Woodlands, W. Southampton, England.

10 meter phone: W1NN, 1COO, 1GVZ, 1JIL, 1KPP, 1BMM, 1KII, 1HON, 1IDA, 1IFG, 1IAF, 1AIK, 1EBE, 1ILB, 1CYO, 1HFO, 1EZW, 1KCK, 1INX, 1PT, 1AFP, 1NB, 1DGP, 2DB, 2ETU, 2HDM, 2KSR, 2ICV, 2HPZ, 2DOY, 2HN, 2GFH, 2HYU, 2ATC, 2AMS, 2HGU, 2AOG, 2HDK, 2ION, 3BZ, 3JVS, 3AKX, 3FKK, 3DMG, 3EUA, 3GSV, 3BW, 3BFL, 3EWN, 3CKT, 3GCL, 3DUK, 4ECF, 4GB, 4EBM, 4FT, 4CYU, 5FES, 5GGX, 5SPB, 6NMF, 7EMP, 7FBL, 7GGG, 8HHZ, 8BVP, 8KPH, 8KYY, 8OTK, 8CHB, 8BTO, 8HSP, 8ERS, 8IWG, 8MYI, 8IHI, 8IFC, 8BCH, 8IHR, 8OUL, 9TTB, 9CTP, 9DKU, 9LBB, 9CCD, 9OSO, 9ZHB, 9BQQ, 9LQT, 9TII, 9YV, 9EKD, 9CSI, 9CTC.

10 meter c.w.: ZE1H, VU2CO, ZS1C.
20 meter phone: W1BO, 1IFG, 2HDK, 2ZC, 3EWN, 3EEN, 3HXX, 4DLH, 4IW, 6GCT, 8NSE, 9IFG, 9WII, YV5AA, NY2AE, CNSAM, VK4KO, TI2FG, KAIME.
By H. L. Hirschberg, 38 Marney Road, London, S.W.11, England.

20 meter phone: W1ADM-8, 1APA-5, 1ANA-6, 1BLO-9, 1DET-7, 1FH-7, 1G00-6, 1IFG-7, 1IED-6, 1FFK-6, 1IUG-7, 1JZA-9, 1JZL-4, 1LI-5, 1ZD-8, 2AZ-6, 2BEI-5, 2BX-6, 2RZ-7, 2DH-8, 2DX-8, 2DXY-5, 2DZ-9, 2GC-3, 2GJZ-8, 2COQ-6, 2IUQ-7, 2IT-5, 2OCL-6, 2VC-5, 2ZC, 3ADN-8, 3AIR-7, 3AMH-5, 3APO-7, 3ASG-5, 3RAM-6, 3BB-5, 3BEI-7, 3BMA-7, 3BVU-8, 3CTS-7, 3CYS-8, 3CZS-6, 3FC-5, 3FGY-6, 3FII-7, 3GBP-5, 3NC-6, 4BYY-7, 4CYU-8, 4DLH-9, 4DNP-6, 4EEE-8, 4EF-7, 4MS-6, 4NM-4, 5AMX-6, 5BAT-8, 5FHT-5, 6AH-8, 6GCT-9, 7FCO-5, 7HS-5, 8AU-8, 8BYF-8, 8CTD-8, 8EVE-8, 8HEQ-5, 8HFU-9, 8JOE-9, 8JNU-7, 8KBL-8, 8KML-6, 8MTX-6, 8OAR-9, 8WA-7, VE1IN-6, 2KX-5, 3AL-7, 3CE-6, VOIC-8, VK2XU-6, 6MW-6, CO2RA-5.
(Turn to page 576)



Overloads don't worry me

IN fact, "I can take it" whether it is heat, cold, or the ceaseless humidity of the tropics... all the headaches that confront the set builder. In this particular field I answer this problem of resistance with a fixed resistor whose characteristics are so constant that they oftentimes form the standard by which all others are judged.

Which is why so many set builders and service men turn to Centralab for the satisfactory answer.



DIVISION OF GLOBE UNION, INC. MILWAUKEE, WIS.

British Centralab, Ltd. Canterbury Rd., Kilburn London N. W. 6, England

French Centralab Co., 118 Avenue Ledru-Rollin, Paris XI, France

CANDLER Maker of Champions CAN MAKE YOU A CODE EXPERT



LEARN AT HOME

To Read Code Like You Read Print

If you've practiced and practiced, but can't get over the "hump" that seems to be your limit—don't be discouraged. Thousands of skilled operators have had the same experience. Some of them thought they weren't smart, others thought they weren't cut out for radio operators. But you should see those fellows today! They can send beautiful code, and copy the fast stuff 6 or 7 words behind without effort. Those fellows have Automatic Sound Consciousness—and they got it from Candler!

It's true that Candler Training has produced the champions. But what's more important is that Candler takes average fellows, hams who are almost ready to give up, AND TURNS THEM INTO EXPERT OPERATORS!

PRACTICE ALONE WON'T DO IT

Write McElroy in Boston. He's the World's Champion. Ask any skilled operator. Here's what they'll tell you. "You can't get code alone—with any kind of practice set. Let Candler show you HOW to practice. He can make an expert out of any man or boy!" After only two months of Candler training, Jean Hudson, only 9 yrs. old, copied 30 wpm for the Class E. Championship.

NEW FREE CODE BOOK

Today might easily be the turning point in your radio career—IF YOU DO ONE THING! Address a penny card to Candler. Ask him for his new FREE Book, "How Code Champions Are Made." Whether you are a beginner or amateur, do yourself this favor now. It's so human to forget. Be sure of this opportunity. Write TODAY!

CANDLER SYSTEM CO.

Department N-3 Asheville, North Carolina, U. S. A.

1938 RADIO DATA BOOK GIVEN FREE! (See 3rd cover)



Everything SOLD ON TIME PAYMENTS

Have the latest and finest radio equipment NOW and pay for it on convenient monthly terms! Send for your copy of Wards 1938 Radio Catalog—the finest ever printed. Lists everything for the Service Man, Amateur and Experimenter at rock-bottom prices. See how much you can save and how easily you can buy the radio equipment you need. Mail the coupon NOW for your FREE copy.

MONTGOMERY WARD

MONTGOMERY WARD, DEPT. SW-4, CHICAGO, ILL. Please send me my FREE copy of Wards 1938 Radio Catalog. I am particularly interested in the equipment I have checked at left.

SOUND SYSTEMS AND EQUIPMENT
INTER-COMMUNICATION SYSTEMS
"HAM" TRANSMITTERS AND PARTS
"HAM" RECEIVERS AND SUPPLIES
TESTING INSTRUMENTS AND BOOKS
REPLACEMENT SUPPLIES AND PARTS

NAME _____
 ADDRESS _____
 CITY _____ STATE _____

MIDWEST... SAVES YOU 50% DIRECT FROM FACTORY

20 TUBES

6 WAVE BANDS

30 DAYS FREE TRIAL

JUST TOUCH ONE BUTTON—NO NEED TO TURN CONTROLS ON THIS MOTORIZED MIDWEST

Only 49.95 LESS TUBES NEW LOW BASE PRICE CHASSIS

ONLY Midwest gives you a combination of Mystic Movie Dial, Traveling Coloray Eye, and Motorized Tuning! Just touch a button on top of radio and FLASH!... your station comes in perfectly tuned, in 1/2 second. World-wide reception up to 12,000 miles brings in weak distant stations, like locals, and assure glorious, crystal-clear realism. Famous Midwest Factory-To-You plan enables you to buy at wholesale price... to save up to 50%... to enjoy 30 days' FREE home trial... pay as little as 50 cents a week. **Send for FREE 1938 Catalog MIDWEST RADIO CORPORATION Dept. NN-11 Cincinnati, Ohio**

TERMS AS LOW AS 50¢ A WEEK

SAVE COUPON ON 1¢ POSTCARD... OR WRITE TODAY!

MIDWEST RADIO CORPORATION
Dept. NN-11, Cincinnati, O. Name _____
Send me your new Price, catalog and complete details of _____ Address _____
your liberal 30-day Free trial offer. _____ Town _____ State _____
(Special offer and prices prevail only when dealing direct with factory by mail.) User-Agents Make Easy Extra Money. Check Here for details with 1938 BATTERY catalog.

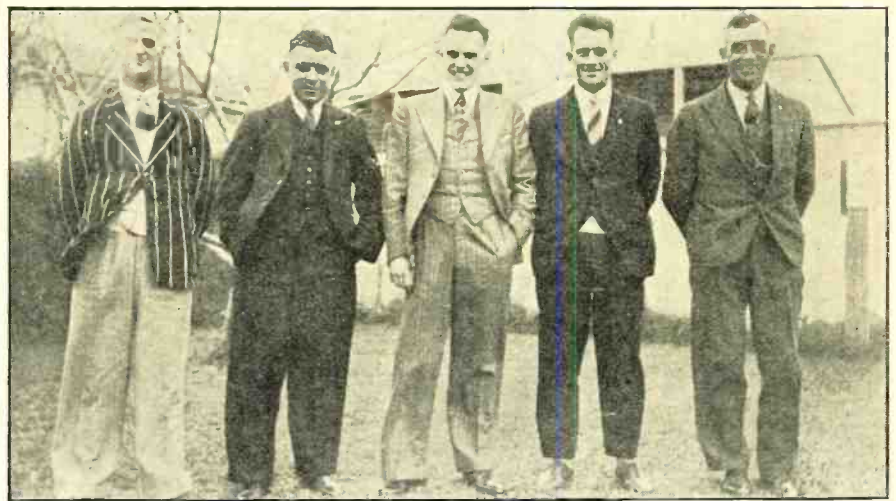

ALL HAIL THE ZEDDERS!

We hear much about the New Zealand DX Club. Here are the men who guide its destinies, members of the Advisory Board. They are, left to right: J. P. Coswlinshaw, 1st V. President; A. Cox, President; K. P. Murphy, Secretary; R. Roycroft, 2nd V. President; L. W. Mathie, 4th V. President.

THE DX CORNER

(For Broadcast Waves)

S. GORDON TAYLOR

DX CALENDAR

BELOW are given lists of special DX broadcasts. The initials following an item indicate the organization to which the program is dedicated and where a RADIO NEWS special has been arranged for by an Observer, his name is given in the schedule.

Don't fail to tune in the RADIO NEWS specials on this list and as many others as possible—and above all, don't fail to report to each station tuned in, giving them as much information as you can concerning their signal strength, fading, quality, etc. Where verifications are desired it is always desirable to enclose return postage.

Hours shown are Eastern Standard Time and are all a. m. unless otherwise indicated.

Day	Hour	Kc.	Call	State	Kw.	Club
1	4-4-30	1370	WPAY	Ohio	.1	NRC
1	6-6-15	1420	WMBS	Pa.	.25	R. News, Sahlbach
6	2-4	1120	WJBO	La.	.5	R. News, Golson
6	3-4	1370	KWYO	Wyo.	.1	IDA
8	2:30-2:50	1310	WPBG	Pa.	.1	NRC
8	3:10-3:30	1370	WBTM	Va.	.1	NRC
8	3:30-3:50	1010	WNAD	Okla.	1.	NRC
8	3:30-3:50	1370	WRAC	Pa.	.1	NRC
8	3:40-4	1210	KFVS	Mo.	.1	NRC
8	4:20-4:40	1310	KRMD	La.	.1	NRC
8	4:30-4:50	610	WCLE	Ohio	.5	NRC
8	4:50-5:10	1260	RGVO	Mont.	1.	NRC
8	5:10-5:30	1370	KAST	Ore.	.1	NRC
8	5:20-5:40	1370	KOMO	Mo.	.1	NRC
8	5:30-5:50	1420	KIDW	Colo.	.1	NRC
8	5:30-5:50	1450	WGAR	Ohio	.5	NRC
8	5:40-6	1200	WCAT	S. Dak.	.1	R. News, Sahlbach
8	5:50-6:10	1210	KLAH	N. Mex.	.1	NRC
8	6-6:20	1200	KOOS	Ore.	.1	NRC
9	3:40-4	1310	KAND	Texas	.1	R. News Sahlbach
9	4:20-4:40	1430	KSO	Iowa	.5	R. News, Sahlbach
9	5:20-5:40	1370	KELD	Ark.	.1	R. News, Sahlbach
9	5:40-6	1420	KRBC	Texas	.1	R. News, Sahlbach
10	2:30-2:50	1210	WJTN	N. York	.1	NRC
10	2:50-3:10	1410	WHIS	W. Va.	.5	NRC
10	3:20-3:40	1370	WBLK	W. Va.	.1	R. News, Sahlbach
10	3:40-4	1200	WJBC	Ill.	.25	R. News, Sahlbach
10	4:10-4:30	1500	KAWM	N. Mex.	.1	R. News, Sahlbach
10	4:10-4:30	610	WMBS	Fla.	1.	NRC
10	4:40-5	1500	WTMV	Ill.	.1	NRC
10	5-5:20	570	KGKO	Texas	.25	NRC
10	5-5:20	1310	WTRC	Ind.	.1	NRC
10	5:10-5:30	1500	KGPI	Texas	.1	NRC
10	5:10-5:30	740	KTRB	Calif.	.25	R. News, Sahlbach
10	5:20-5:40	1310	KFYO	Texas	.1	NRC
10	5:20-5:40	1070	KJBS	Calif.	.5	NRC
10	5:20-5:40	1370	WIBM	Mich.	.1	NRC
10	5:40-6	1260	KHSL	Calif.	.25	NRC
10	5:40-6	1370	WDWS	Ill.	.1	NRC
10	5:50-6:10	1500	KGKB	Texas	.1	NRC
10	5:50-6:10	1410	WBCM	Mich.	.5	NRC
10	6:10-6:30	1420	KGIW	Colo.	.1	NRC
11	5-5:20	1420	KIUN	Texas	.1	R. News, Sahlbach
12	3:40-4	1370	WFOR	Miss.	.1	NRC
12	4:20-4:40	1390	KRLC	Idaho	.1	R. News, Sahlbach
12	4:20-4:40	1310	KTSM	Texas	.25	R. News, Sahlbach
12	4:40-5	1420	KCMC	Texas	.25	R. News, Sahlbach
12	5-5:20	1420	KGFF	Okla.	.25	R. News, Sahlbach
12	5:20-5:40	1370	KFRO	Texas	.25	R. News, Sahlbach
13	2-3	1160	CMHJ	Cuba	.175	
14	3:40-4	1320	WSMB	La.	1.	R. News, Sahlbach
14	4-4:20	1280	WCAP	N. Jersey	.5	R. News, Sahlbach
14	4-5:20	1210	WFOY	Fla.	.25	R. News, Sahlbach
15	6-6:30	1310	KGJV	Nebr.	.1	R. News, Sahlbach
19	4:30-5:30	1320	KGMB	T. H.	1.	UDXC
27	2-4	1120	WJBO	La.	.5	R. News, Golson
27	3:30-4	750	KGU	Hawaii	2.5	IDA
March						
1	4-4:30	1370	WPAY	Ohio	.1	R. News Sahlbach
3	1-2	1450	WAGA	Ga.	5.	R. News, Sahlbach
5	4:10-4:30	1280	WTNJ	N. Jersey	.5	R. News, Sahlbach

HANDEE
Tool of 1001 Uses

A Whole Shop Full of Tools in One

Grinds, polishes, routs, drills, cuts, carves, sands, saws, sharpens, engraves. Uses 200 accessories. For home, shop or take to job. Plugs in any socket AC or DC 110V, 13,000 r.p.m.

Get A Demonstration
at Hardware, Dept. Stores, Tool Dealers or order on 10 Day Money-Back Trial. \$10.75 and up postpaid, 3 Accessories Free. De Luxe Model \$18.50, with 6 Accessories. Catalog Free.

CHICAGO WHEEL & MFG. CO., 1101 W. Monroe St. Dept. AB, Chicago

For Faster Better Jobs

New CRAFTSMAN Project Book
Pleasure and Profit with a Hand-
dec. Easy working plans for making many interesting and unusual projects 25c, stamps or coin.

ELECTRICAL ENGINEERING

For those who can't afford the time and expense of a 4-year college course, Bliss offers a condensed ONE YEAR residence training, combining essential Theory and Practice. 45th year. CATALOG ON REQUEST!

BLISS ELECTRICAL SCHOOL
1473 Takoma Ave., Washington, D. C.

6 2-4	1120	WJBO	La.	.5	R. News, Golson
8 5:20-5:40	1210	KFJI	Ore.	.1	R. News, Sahlbach
8 5:30-5:50	1420	KIDW	Colo.	.1	R. News, Sahlbach
8 5:50-6:10	1420	KORE	Ore.	.1	R. News, Sahlbach
10 2-6	1160	CMHJ	Cuba	.175	R. News, Sahlbach
10 3:30-3:50	1310	WSAJ	Pa.	.1	R. News, Sahlbach
10 5-5:20	1310	WTRC	Ind.	.1	R. News, Adkins
10 5:10-5:30	1200	WWAE	Ind.	.1	R. News, Sahlbach
11 4:20-4:40	1210	WMFG	Minn.	.1	R. News, Sahlbach
11 5-5:20	1210	WEBQ	Ill.	.1	R. News, Sahlbach
12 3:10-3:30	1370	KWYO	Wyo.	.1	R. News, Sahlbach
12 3:40-4	1370	WFOR	Miss.	.1	R. News, Sahlbach
12 4:30-4:50	1370	KUJ	Wash.	.1	R. News, Sahlbach
12 4:40-5	1310	WGTM	N. Car.	.1	R. News, Sahlbach
12 5-5:20	1250	KIT	Wash.	.5	R. News, Sahlbach
13 3-4	1490	WCKY	Ky.	.5	IDA
14 4-4:20	1370	WAGF	Ala.	.1	R. News, Sahlbach
14 4:50-5:10	1310	WLAK	Fla.	.1	R. News, Sahlbach
14 5:40-6	1320	KGMB	T. H.	1	R. News, Sahlbach
27 2-4	1120	WJBO	La.	.5	R. News, Golson
27 3-4	1210	KFOR	Nebr.	.1	IDA

Periodic

Mondays—
9:15-9:30 p.m., 690 kc., CJCJ, Calgary, Alta., Canada, .1 kw. (tips).

Wednesdays—
12:30 a.m., 1390 kc., KOY, Phoenix, Ariz., 1 kw. (tips).
1:45-2 p.m., 780 kc., WTAR, Norfolk, Va., 1 kw. (URDNC) (tips).

Saturdays—
1-1:10 a.m., 1390 kc., KIRA, Little Rock, Ark., 1 kw.
10:30 a.m., 830 kc., WEEU, Reading, Pa., 1 kw. (tips).

Sundays—
12:45-1 a.m., 1280 kc., KLS, Oakland, Calif., .25 kw. (URDNC) (tips).
2:45-3 a.m., 1010 kc., CKWN, Vancouver, B. C., Canada, .1 kw.
3-3:30 a.m., 1410 kc., CKMO, Vancouver, B. C., Canada, .1 kw.
3:30-3:45 a.m., 570 kc., KMTR, Los Angeles, Calif., 1 kw. (tips).

Monthly—
1st day of each month, 3-4 a.m., 1260 kc., WTOG, Savannah, Ga., 1 kw.
1st Sunday of each month, 4-4:30 a.m., 1340 kc., KGDY, Huron, S. Dak., .25 kw.
2nd Tuesday of each month, 3-5:30 a.m., 1370 kc., KRMC, Jamestown, N. Dak., .1 kw.

General Franco's Stations

OBSERVER Touvenin, of France, submits the following list of Spanish stations controlled by General Franco. This list he obtained direct from the Department of Printing and Propaganda of the Spanish Nationalists:

Call	Location	Kc.	Kw.	Closing (p.m. EST)
EAJ55	Algiciras	1500	.2	6:45
EAJ26	Anteguera	1500	.2	7:00
FET2	Avila	1214	.2	7:00
Radio Espana	Bilbao	1492	.2	7:00
EAJ52	Badajoz	1492	.2	7:00
EAJ27	Burgos	1258	6.0	7:00
EAJ59	Cadiz	1500	.2	7:00
EAJ46	Ceuta, Maroc	1492	.2	6:30
EA124	Cordoba	1492	.2	7:00
EAJ41	Coruna	1429	.25	7:00
EAJ16	Granada	1492	.18	7:00
Radio Huelva	Huelva	1492	.175	7:00
EAJ58	Frontora	1467	.25	7:00
EAJ50	Las Palmas	1363	.2	7:00
EAJ63	Leon	1445	.2	7:00
EA138	Logrono	1500	.15	7:00
EAJ68	Lugo	1500	.2	7:00
EA19	Malaga	1492	.2	7:00
EAJ21	Meillia	1500	.19	5:30
EAJ57	Orense	1350	.02	7:30
EAJ13	Palma de Mallorca	1492	.2	7:00
FET4	Palencia	1365	.015	7:00
EAJ6	Pamplona	1320	.45	7:00
EAJ40	Pontevedra	1500	.2	7:00
Radio Nacional	Salamanca	1095	20.0	8:00
EAJ56	Salamanca	1500	.2	9:00

Radio Espana	San Sebastian	1258	1.0	7:00
EAJ4	Santiago	1492	.3	7:00
EAJ64	Segovia	1320	.14	7:00
R. News, EAJ5	Sevilla	731	5.0	7:00
EAJ43	Tenerife	1492	.2	9:00
EAJ49	Toledo	1500	.2	7:00
EAJ47	Valledoled	1492	.2	7:00
EAJ48	Vigo	1492	.2	7:00
EAJ62	Vitoria	1421	.16	7:00
Radio Zamora	Zamora	1430	.2	7:00
EAJ10	Larageza	1210	.2	7:00

In addition to their regular programs, a number of these stations relay programs from "Radio Nacional," Salamanca, from 9:30 to 10:00 a. m. and 6:15 to 7:15 p. m., and talks by General Queipo de Llano from 5:30 to 6:15 p.m. These stations are: EAJ55, 26, 52, 27, 59, 24, 41, 16, 58, 50, 63, 38, 68, 9, 57, 13, 6, 40, 4, 64, 5, 43, 49, 47, 48, 62, 10; FET2, FET4, Radio Bilbao, Radio Huelva, San Sebastian and Radio Zamora.

AUSTRALIAN LIST

THE following up-to-date list has been received from Observer Watson of Christchurch, N.Z.

National Broadcasting Service Network

Call	Kc.	Kw.
1YA	650	10
2YA	570	60
3YA	720	10
4YA	790	10

N. B. S. Auxiliary Stations

Call	Kc.	Kw.
1YN	880	.15
2YB	760	.1
2YC	840	.5
2YD	990	.2
3YL	1200	.5
4YO	1140	.15
4YN	680	.5

National Commercial Broadcasting Service Network

Call	Kc.	Kw.
1ZB	1070	1
2ZB	1120	1
3ZB	1430	1
4ZB	1220	1

Private Stations

(Subsidized, No Advertisements)

Call	Kc.	Kw.
1ZM	1250	.25
1ZJ	1310	.1
2ZHI	820	.1
2ZP	900	.25
2ZR	920	.02
3ZR	940	.4
2ZJ	980	.075
4ZD	1010	.05
4ZM	1010	.06
2ZM	1150	.08
2ZL	1240	.035

NOTES FROM READERS

OBSERVER TOMLINSON, Port Chester, N. Y.: "Have heard a new British station on 1122 kc. Don't know who it is but it's not Newcastle. There's also a new S.A. on 1310 kc. This is LS11 but he's pretty hard to separate from the mad mob on 1310 kc. On the long waves the German on 160 kc. is usually good beginning 4:30 p.m.; Moscow No. 1—172 kc., Paris PTT—182 kc. and Droitwich—200 kc. also good after 4:30 p.m. Lhati, 166 kc., heard twice. They leave the air at 5 p.m. At midnight Berlin, 191 kc., starts transmissions and at 12:30 a.m. I've heard Brasov, Rumania several times. A new South American on 882 kc. is YV5RV I be-

(Turn to page 568)

MEN WANTED TO QUALIFY AS Television Engineers

If you can Qualify you get this Practical Professional TELEVISION EQUIPMENT

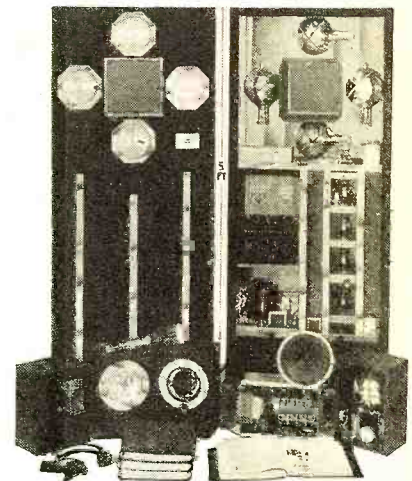

at NO EXTRA COST!

This opportunity is presented to men who can meet our entrance requirements. The American Television Institute is now training the greatest number of men for the television engineering profession in America. Television is already commercial in England but we cannot go forward in America without many trained television engineers. We are now looking for the best men we can obtain to give America the split-second television service it will soon have on a national scale. We believe that among the readers of "Radio News" there are technically inclined men who will make high grade Television Engineers if given the proper training; men who fully appreciate the great professional and financial possibilities in this new industry. If you can qualify, you will receive IN ADDITION to your complete Television and Radio Engineering Training, this complete professional television transmitter and receiver 5 ft. high, cathode ray tube with large 7 in. screen, sweep circuits, photo electric cells, gas arcs, 50 watt radio transmitter, superheterodyne receiver, Hi-gain transmission amplifier, projector, Mazda's, lenses, loud speaker, meters, phones, and complete RCA tubes. Complete text books and technical manuals. This equipment is sent to you at home and is yours to keep. This is not a training for which everyone can qualify, but if you have ability and desire a real future in this new industry, we will be pleased to send you our examination and all particulars entirely free of charge. No obligation. For your convenience we have enclosed this mailing blank below. Mail it NOW!



AMERICAN TELEVISION INSTITUTE
433 E. Erie St., Dept. RN 338, Chicago, Ill.
Send Free book, Examination, and complete details describing A.T.I. Television Equipment and Training. No cost or obligation.

Name..... Age.....
Street.....
City..... State.....

New HETRO "Automatic Tuner"
That Can Be Installed On ANY Radio

This new Hetro development is truly one of the most outstanding contributions you've been offered in a long time. Quickly converts any Superheterodyne to an AUTOMATIC TUNER in a few minutes. Anyone can install it. No special tools needed. No fuss . . . no bother! Simplifies tuning. Just push a button set wave selector. Push another button set wave selector. Push a third button set wave selector. Push a fourth button set wave selector. Push a fifth button set wave selector. Push a sixth button set wave selector. Push a seventh button set wave selector. Push an eighth button set wave selector. Push a ninth button set wave selector. Push a tenth button set wave selector. Push an eleventh button set wave selector. Push a twelfth button set wave selector. Push a thirteenth button set wave selector. Push a fourteenth button set wave selector. Push a fifteenth button set wave selector. Push a sixteenth button set wave selector. Push a seventeenth button set wave selector. Push an eighteenth button set wave selector. Push a nineteenth button set wave selector. Push a twentieth button set wave selector. Push a twenty-first button set wave selector. Push a twenty-second button set wave selector. Push a twenty-third button set wave selector. Push a twenty-fourth button set wave selector. Push a twenty-fifth button set wave selector. Push a twenty-sixth button set wave selector. Push a twenty-seventh button set wave selector. Push a twenty-eighth button set wave selector. Push a twenty-ninth button set wave selector. Push a thirtieth button set wave selector. Push a thirty-first button set wave selector. Push a thirty-second button set wave selector. Push a thirty-third button set wave selector. Push a thirty-fourth button set wave selector. Push a thirty-fifth button set wave selector. Push a thirty-sixth button set wave selector. Push a thirty-seventh button set wave selector. Push a thirty-eighth button set wave selector. Push a thirty-ninth button set wave selector. Push a fortieth button set wave selector. Push a forty-first button set wave selector. Push a forty-second button set wave selector. Push a forty-third button set wave selector. Push a forty-fourth button set wave selector. Push a forty-fifth button set wave selector. Push a forty-sixth button set wave selector. Push a forty-seventh button set wave selector. Push a forty-eighth button set wave selector. Push a forty-ninth button set wave selector. Push a fiftieth button set wave selector. Push a fifty-first button set wave selector. Push a fifty-second button set wave selector. Push a fifty-third button set wave selector. Push a fifty-fourth button set wave selector. Push a fifty-fifth button set wave selector. Push a fifty-sixth button set wave selector. Push a fifty-seventh button set wave selector. Push a fifty-eighth button set wave selector. Push a fifty-ninth button set wave selector. Push a sixtieth button set wave selector. Push a sixty-first button set wave selector. Push a sixty-second button set wave selector. Push a sixty-third button set wave selector. Push a sixty-fourth button set wave selector. Push a sixty-fifth button set wave selector. Push a sixty-sixth button set wave selector. Push a sixty-seventh button set wave selector. Push a sixty-eighth button set wave selector. Push a sixty-ninth button set wave selector. Push a seventieth button set wave selector. Push a seventy-first button set wave selector. Push a seventy-second button set wave selector. Push a seventy-third button set wave selector. Push a seventy-fourth button set wave selector. Push a seventy-fifth button set wave selector. Push a seventy-sixth button set wave selector. Push a seventy-seventh button set wave selector. Push a seventy-eighth button set wave selector. Push a seventy-ninth button set wave selector. Push an eightieth button set wave selector. Push an eighty-first button set wave selector. Push an eighty-second button set wave selector. Push an eighty-third button set wave selector. Push an eighty-fourth button set wave selector. Push an eighty-fifth button set wave selector. Push an eighty-sixth button set wave selector. Push an eighty-seventh button set wave selector. Push an eighty-eighth button set wave selector. Push an eighty-ninth button set wave selector. Push a ninetieth button set wave selector. Push a ninety-first button set wave selector. Push a ninety-second button set wave selector. Push a ninety-third button set wave selector. Push a ninety-fourth button set wave selector. Push a ninety-fifth button set wave selector. Push a ninety-sixth button set wave selector. Push a ninety-seventh button set wave selector. Push a ninety-eighth button set wave selector. Push a ninety-ninth button set wave selector. Push a hundredth button set wave selector.

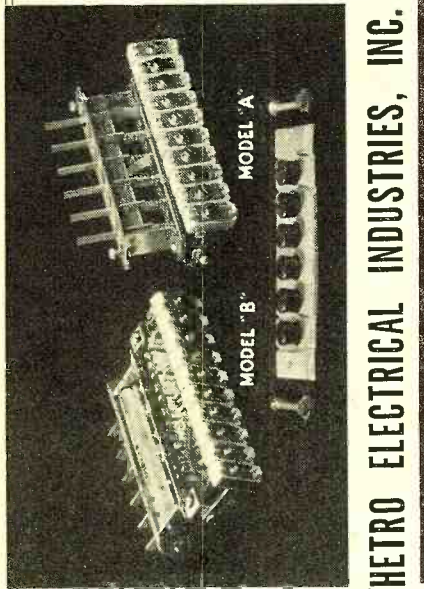

HETRO ELECTRICAL INDUSTRIES, INC.

MICROPHONE COMPARISON CHART FREE!



The New "Bullet" microphones challenge comparison. Each microphone in the new "Bullet" line is definitely superior to any other microphone in its price class. Every model is engineered and made to exacting quality standards comparable only to rugged telephone equipment. "Bullet" microphones are technically superior, acoustically correct; they are streamlined for sound reasons. Write for a copy of the free microphone comparison chart with complete data on the new "Bullet" line . . . now!

Priced from \$19.50 to \$90

"BULLET" MICROPHONES
 Made Only by
TRANSDUCER CORPORATION
 30 Rockefeller Plaza, New York, N. Y.

QUALITY recommends

Condensers by **SOLAR**

WET . . . DRY
 PAPER
 MICA . . . TRIMMER

Please Write for Details
SOLAR MFG. CORP. 599-601 Broadway
 New York City

RADIO ENGINEERING,
 broadcasting, aviation and police radio, servicing, marine radio telegraphy and telephony. Morse telegraphy and railway accounting taught thoroughly. Engineering course of nine months' duration equivalent to three years of college radio work. School established 1874. All expenses low. Catalog free.
Dodge's Institute, Oak St., Valparaiso, Indiana

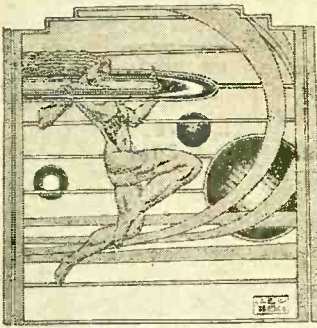

P. O. Box 2294
 Cable: "VOZAIRE"
 Phones: F-2316
 F-4019

LA VOZ DEL AIRE, S. A.

25 y G. - Vedado
 Havana, Cuba

Thanks for your valuable information of _____ regarding our performance and programs. The data submitted by you is correct and in accordance with the station's log.
 Please accept this card as OFFICIAL VERIFICATION OF RECEPTION.
 LA VOZ DEL AIRE S. A.
 Very truly yours,
 J. BENITEZ, Manager.

Havana, Cuba, _____ de _____ 1938

The DX Corner (Short Waves)

(Continued from page 549)

9-9:30 a.m. Request reports (L. F. Gallagher).
KKQ, Bolinas, Calif., 11,950 kc., heard 8-9 p.m. (Alfred).
W2XAF, Schenectady, New York, 6150 kc. (Ruiz); 9530 kc., 4 p.m.-1 a.m. (Kiser, Espenschild, Whyte, Hernday, Catchim).
W3XAU, Philadelphia, Pa., 6060 kc. (Ruiz); daily to 7 p.m. (Nowak, Redmond); 9590 kc., heard Sunday 1 p.m. (Catchim).
W1XAL, Boston, Mass., 11,790 kc., heard 4:45-6:30 p.m. (Crastron); 6090 kc., Monday 7:30-9:30 p.m. Code practice after 8:30 p.m. (Myers); "University Club" (Kiser); Friday 9-10:35 p.m. (Atherton, Nowak), 11,790 kc.; Saturday 4-7 p.m. (15,250 kc., Sunday 10-12 a.m.); 21,460 kc. irregularly. Daily except Saturday and Sunday, 4-7 p.m. (McCue); daily 7-12 p.m. (Fleming, Catchim, Honda, L. F. Gallagher).
W9XJL, Superior, Wis., 26,100 kc. (from veri); (Mott) daily 11 a.m.-6 p.m. (Harris), relays **WEBC**, **WMFG**, **WHLB** and **W9XUX** (from veri) (Honda).
CJRX, Winnipeg, Canada, 6000 kc., heard Sunday 5-11 p.m. Relays **CJCB** (Crastron); 11,730 kc. (Kiser, Redmond, Hernday, Espenschild, Wollenschlager).
CFRX, Toronto, Canada, 6070 kc., The Rogers S. W. Station (from veri) (Mott, McCue). Relays **CFRB** irregularly (Sprague).
XEWB, Guadalajara, Mexico, 11,710 kc., Tuesday 4:30 p.m. (Myers); signs 11 p.m. (Honda). Slogan: "Radio Emisora Cultural."

THAT CUBAN STATION
This is the verification card of COGD, as received by Charles S Werdig, of Washington, D. C. It is printed in orange, blue, silver and black, and is a fine addition to the short-wave listener's collection.

XEWW, Mexico City, D. F. Mexico, 9500 kc. (Wollenschlager), daily 7-12 p.m. (Blanchard); 15,165 kc. (Fleming); 9480 kc. (Lindner), daily 5:30-1 a.m. (Dressler); relays **XEW** (Sibbin, Honda).
Emisora Del Partido Nacional Revolucionario, Guadalajara, 7100 kc. (Betances, Honda); heard 9 a.m. daily 'til 11 p.m. (Schrock). Address: San Madera Avenue, No. 210, Jalisco.
W10XEF, Reindeer Point, Greenland, 13,000 kc., heard with program (Jensen).
OX2QY (Commercial Call is **W10XAB**), Reindeer Point, Greenland, 14,310 kc. (McGregor Expedition), heard 9-11:30 p.m. (Frost); 14,370 kc., heard irregularly, 6-7 p.m. (Blanchard); 14,350 kc. (Black, Harris, Kentzel, Espenschild); 17,300 kc. (Honda).
West Indies
COCM, Havana, Cuba, 9800 kc., daily 7 a.m.-midnight, (Kiser), 9820 kc., relays **CMCM**, (Myers), 9840 kc., (Alfred, Ruiz, Williams), 9860 kc., (Blanchard, Adkins, Black, Coover, G. C. Gallagher, Honda). Slogan: "Transradio Colombia." Address: P. O. Box 33.
COCQ, Havana, Cuba, 9740 kc., daily 6:55 a.m.-1 a.m., (Kiser), 9090 kc., and 9700 kc., (Alfred), 9100 kc., and 9690 kc., (Betances, Adkins, Espenschild, Hernday, Lander, Whyte, Gertenbach, Herzog, Coover, G. C. Gallagher, Sprague, Schrock, Honda). Slogan: "R.C.A. Vic-

tor." Address: 25 No. 445 Vedado.

COCX, Havana, Cuba, 11,500 kc., daily 6:55-1 a.m., (Kiser), 11,435 kc., five chimes at ann., (Myers, Alfred, Espenschild, Wollenschlager), 11,435 kc., (L. F. Gallagher), heard 9-10 p.m., (Honda). Address: P. O. Box 32.

COBZ, Havana, Cuba, 9000 kc., daily 7:30 p.m.-1 a.m., (Kiser), 9030 kc., (Alfred, Lindner, Wollenschlager), 9200 kc., (N. C. Smith). Slogan: "Radio Solas." Address: P. O. Box 866.

COGF, Matanzas, Cuba, 11,800 kc., daily 8-10:30 p.m., (Alfred, Wollenschlager), Monday, Wednesday and Friday 9-10 p.m., (Catchim), heard 6-7 p.m., (N. C. Smith, Black).

COBX, Havana, Cuba, 9200 kc., daily 6-11 p.m., (Alfred, Black), 9150 kc., (L. F. Gallagher), 9220 kc. (G. C. Gallagher) (from veri.), (Honda). Address: San Miguel 194.

COJK (CO9JZ), Camaguey, Cuba, 8665 kc., daily 7-10:30 p.m., (Alfred, Catchim, Dressler, L. F. Gallagher).

COKG, Santiago, Cuba, 8900 kc., heard 6-8 p.m., (Craston), 8980 kc., (Betances), 8920 kc., (Adkins), daily 5-6 p.m., 9:30-10:30 p.m., except Sunday, (Atherton, Beyer, Espenschild), 8800 kc., (L. F. Gallagher, Honda).

HI8J, La Vega, Dominican Republic, 6383 kc., daily 10:40 a.m.-11:40 a.m., 5:40-7:40 p.m. (Betances).

HI8Q, Trujillo City, Dominican Republic, 6200 kc., signed 10 p.m., (Atherton), heard 8 p.m., (Honda).

HIN, Trujillo City, Dominican Republic, 11,280 kc., (Lindner), 12,600 kc., Monday 7-9:30 p.m., (Catchim, Coover).

FZF6, "Radio Martinique", Fort-de-France, Martinique, 9685 kc., daily 6:30-7:45 or 7:55 p.m., sign off with "La Marseillaise." (Noyes), 9700 kc., (Blanchard, Coover, Catchim, Honda). Address: P. O. Box 56.

HH2S, Port-au-Prince, Haiti, 5915 kc., daily 7-8:30 p.m., (Fleming), daily except Sunday 7-10 p.m., (from ann.), signs with chimes playing "taps". (Catchim).

Central America

TIEP, San Jose, Costa Rica, 6710 kc., daily 7-10 p.m., (Kiser), 6690 kc., (Alfred, Hernday). Slogan: "La Vos del Tropico," "La Voz de Los Isthmus." Address: P. O. Box 257.

TIEP, San Jose, Costa Rica, 6410 kc., (Alfred), signs around 10 or 11 p.m., (Atherton), daily

7-9:30 a.m., 12-2 p.m., 4-11:30 p.m., (Hernday, Catchim, Fleming, Dressler, Honda). Slogan: "La Voz de La Victor." Address: P. O. Box 224.

TGWA, Guatemala City, Guatemala, 15,300 kc., Sunday 1:45 p.m., 11,750 kc., Sunday 7:30 p.m., (Kiser), Sunday 8-12 p.m., (latter freq.) (Myers), 11,760 kc., 12-2 a.m., 9-12 p.m.; 9685 kc., 9-12 p.m., and irreg.; 15,170 kc., 1-3 p.m., (Alfred, Nowak, Betances, Scala), 15,170 kc., daily 11 a.m.-11 p.m., (Jensen, Wollenschlager, Blanchard, Fleming, Lindner, Coover, Sibbin, Catchim, Schrock, Honda). Slogan: "Ministre de Fomento", "The Voice of Guatemala", "Radiodifusora Nacional."

ZIK2, Belize, British Honduras, 10,600 kc., Monday, Thursday and Saturday 7:30 p.m., (Alfred), Tuesday, Thursday, and Saturday, 7:30-7:45 p.m., (Harris), 10,550 kc. (Fleming, Catchim, Kentzel, Honda).

YSD, San Salvador, El Salvador, 7894 kc., daily 5-8 p.m., (Schrock). Slogan: "Radio Nacionales."

HP5K, Colon, Panama, 6005 kc., heard 7-9:30 p.m., (Alfred), daily 11:30 a.m.-1 p.m., and 6-11 p.m., and 7-9 a.m., (Magnuson, Fleming, Catchim). Slogan: "La Voz de la Victor." Address: P. O. Box 33.

HP5A, Panama City, Panama, 11,700 kc., daily 6-10:30 p.m., (Alfred), heard 10 a.m.-10 p.m., (Kiser), 11,100 kc., (Lindner, Adkins, Dressler), weekdays 5-10 p.m., Sunday 6-10 p.m., (Harris), signs with "Anvil Chorus." (Honda, Catchim). Address: P. O. Box 954.

HP5J, Panama City, Panama, 9590 kc., irreg. 7-9 p.m., (Alfred, Coover). Slogan: "La Voz de Panama."

South America

HKV, Bogota, Colombia, 8740 kc., Tuesday and Friday 7-7:15 p.m. with news, (Craston).

HJ1ABP, Cartagena, Colombia, 9620 kc., heard Sunday 7:35 p.m., (Kiser), daily 5-11 p.m. (Myers, Espenschild, Wollenschlager, Black). Address: P. O. Box 47.

HJ1ABB, Barranquilla, Colombia, 4807 kc., heard 6-11 p.m., (Harris, Coover, Pairman).

HJ1ABJ, Santa Marta, Colombia, 6025 kc., formerly HJ2ABJ, signed 10 p.m., (Honda).

HJ3ABX, Bogota, Colombia, 6122 kc., signed 11:45 p.m., (Alfred). Slogan: "La Voz de Colombia."

Servicemen depend on the Technical Manual because it covers—not just a few items—but almost every phase of the radio tube field. It lists over 200 tube types . . . gives full information on glass, metal, "G" type and Sylvania "Ballast" tubes, as well as those for Majestic receivers. Includes typical circuit diagrams, bias resistor charts, and a wealth of other valuable information.

This "servicemen's friend" should be part of your tool-kit. Send the coupon and 25c . . . today!

SYLVANIA
Set-Tested Radio Tubes

HYGRADE SYLVANIA CORP. RN-38 Emporium, Pa.

Here is 25c. Send me my copy of the new Sylvania Technical Manual.

Name

Address

City State

SERVICEMAN EXPERIMENTER
 DEALER AMATEUR

LET ME TRAIN YOU *at home*
FOR A GOOD RADIO JOB



Get in Line for Big Money!

Radio is growing fast. Modern receivers require thoroughly trained experts for service and maintenance. You can become such an expert... right at home... through R.T.A. methods and begin earning money almost from the start of your course. In a very short time you will

Be the ONE Man in 1,000

who understands everything there is to know in order to give quick "sure-fire" service to all kinds of receivers. You can be the one man who can take the service business away from the old-time radio "tinker."

No Experience Needed

Even though you know nothing about Radio now, you can quickly qualify the R.T.A. way to step right into a well paying position—or start your own profitable business. Use your spare time and

LEARN AT HOME

Most R.T.A. members start making money right from the beginning. The special servicing equipment which is supplied without extra cost makes this possible. Don't wait—get started now. Write today for our Interesting Radio Book FREE.

INCLUDED WITH OUR TRAINING



This efficient time-saving, trouble-finding Circuit Analyzer and Resistance Tester helps you to make money without delay.

Don't Put It Off—Send Coupon Now

RADIO TRAINING ASSOCIATION OF AMERICA
 4325 Ravenswood Ave., Dept. RN-38, Chicago, Ill.

RADIO TRAINING ASSN. of AMERICA
 Dept. RN-38, 4325 Ravenswood Ave., Chicago, Ill.
 Gentlemen: Send me details of your Enrollment Plan and information on how to learn to make real money in radio quick.

Name.....
 Address.....
 City..... State.....

A great buy.....
Elgin Test Instruments

Model 808 Volt-Ohm Mill Meter

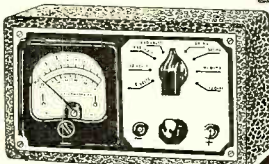

Every range and scale available from one switch. Confusing terminals are entirely eliminated. Compactly designed only 6 1/2" x 2 3/4" x 3 1/2". 2% guaranteed accurate D'Arsonval meter used. Readings available:

- 0/5/50/500/1000 Volts D.C.
- 0/5/50/500 D.C. Milliampere.
- 0/500/500000 ohms Resistance.
- Servicemen's Net Price..... **\$8.95**

Model 950 All-Purpose Unit

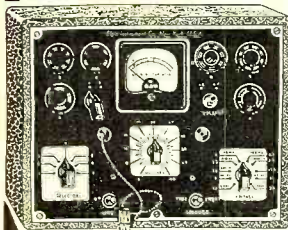

Probably the greatest value ever offered in test equipment.

Offers a complete and accurate value test of all tubes re-

leased to date, plus volt-ohm and milliampere tests.

Servicemen who are looking for this type of instrument cannot afford to pass up this wonderful buy. Tube Tester Highlights: Neon short test; Separate section tests: "Good"—"Bad" Test. A.C. and D.C. readings similar to Model 801A described above.

Servicemen's Net Price..... **\$19.95**
 Send for General Catalog

TRY-MO RADIO COMPANY, INC.
 85 Cortlandt St. New York City, N. Y.
 "This Is Our Only Outlet"

The DX Corner
 (Short Waves)

(Continued from page 561)

HJ3ABD, Bogota, Colombia, 4836 kc., heard 7-11 p.m., (Harris).

HJ4AB, Manizales, Colombia, 6108 kc., heard 7-10 p.m., (Alfred). Slogan: "Radio Manizales."

HJ4ABC, Ibaque, Colombia, 6090 kc., heard 7-12 p.m., (Unger).

HJ4BA, Medellin, Colombia, 11,690 kc., heard Saturday 9:15 p.m., (Hernday).

YV5RJ, Caracas, Venezuela, 6250 kc., daily 11 a.m.-10:30 p.m., (Unger), relays YV5RI, (Magnuson, Schrock). Slogan: "La Voz de la Esfera." Address: Suetart & Cia., P. O. Box 1908.

YV4RD, Maracay, Venezuela, 6300 kc., heard Wednesday 8:15-8:45 p.m., (Catchim).

YV1RH, Maracaibo, Venezuela, 6360 kc., daily 5-11 p.m., (Fleming, Dressler, Lindner). Slogan: "Ondas del Lago."

YV5RP, Caracas, Venezuela, 6270 kc., heard irreg., (Lindner), relays YV5RQ, (from veri.), (Honda). Slogan: "Radio Caracas", "La Voz de la Philco."

PSH, Marapicu, Brazil, 10,220 kc., daily 7-9 p.m., anxious for reports, (Noyes), relays PRF4, (Alfred, Kiser, Mott, Harris, Catchim, Pairman, Bishop, Fleming, Markuson, Betances, Black, Geigand, Atherton, Kentzel, Coover, G. C. Gallagher, Nutkins, Honda, Herzog). Address: Radio Internacional do Brazil; P. O. Box 709.

PPQ, Sepetiba, Brazil, 11,670 kc., heard 6:30-10 p.m., relays PRA2, (Alfred). Slogan: "Radio Brazil."

PRF5, Rio de Janeiro, Brazil, 9501 kc., daily 4:45-5:45 p.m., (Alfred, Ruiz, Yoshimura), signed 9 p.m., Wednesday and Friday, (Blanchard).

CXA8, Montevideo, Uruguay, 9640 kc., daily around 6 p.m., relays LR3, (Alfred), daily 7-12 p.m., (Atherton, Honda, Schrock). Slogan: "Radio Belgrano." Address: Radio Belgrano, Buenos Aires.

CXA2, Montevideo, Uruguay, 6010 kc., heard 5:45 a.m., reports requested, (Ruiz, Betances). Slogan: "Compania Continental de Publicidad." Address: 1431 Juan Carlos Gomez, Montevideo.

OAX4Z, Lima, Peru, 6092 kc., signed 12 midnight, relays

OAX4A, (Alfred). Slogan: "Radio Nacional."

OAX5C, Ica, Peru, 9580 kc., heard 8-12 p.m., (Craston), 9620 kc., (G. C. Gallagher).

PRADO, Riobamba, Ecuador, 6620 kc., Thursday 9-11:30 p.m., (Alfred).

HC2RL, Guayaquil, Ecuador, 6650 kc., Tuesday 9-11 p.m., (Unger, Espenschild), Sunday 5:30-8 p.m., (Dressler).

CB1170, Santiago, Chile, 11,700 kc., heard irreg., 6-10 p.m., old call CB615, (Alfred), relays CB89, 10 a.m.-2 p.m., (Craston, Ruiz), requests reports, (McKenzie, Honda). Slogan: "Radio Service."

CB1190, Valdina City, Chile, 11,900 kc., heard daily 6-11:10 p.m., request reports, announces in English at end of broadcast, (Alfred, G. C. Gallagher). Address: Box 642.

VP3THE, British Guiana, 13,780 kc., daily 6:30-6:55 p.m., (Alfred), also on 20 meters, (Terry Holden Expedition), (Atherton, Chambers), 13,750 kc., (Fleming, Frost, Black, Adkins, Herzog, Dressler, Kentzel, Honda, Schrock, Catchim).

VP3BG, Georgetown, British Guiana, 6130 kc., daily 11:30 a.m.-12:30 p.m. and 4:15-9:15 p.m., (Jaffe, N. C. Smith), Sunday 5-7 p.m., (Harris). Address: 1 Wellington St., Georgetown.

Auto QRM.

(Continued from page 521)

the two leads twisted and brought out through it.

This system has the advantage that it can be closely adjusted to provide the necessary amount of limiter action. The adjustment required in the case of a weak signal would block the receiver if a strong signal were tuned in. On the other hand, when adjusted to reduce the noise on a strong signal the limiting action on a weak signal would be insufficient. Thus by varying the control in accordance with the signal strength and the noise level, maximum effectiveness is obtained.

The switch is desirable primarily because in the case of some extremely strong local signals the receiver will block unless the biasing battery is increased to 45 volts. On such strong signals noise doesn't bother anyway so the limiter is switched out of the circuit. The switch is also opened when the receiver is not in use, to prevent unnecessary drain on the bias battery, which is one of the midget type "B" blocks. This is not

important, however, as the current drain through the potentiometer is so low that the battery will last for months even if it is never turned off.

It is well to try retuning the last i.f. transformer after the limiter has been installed as the added wiring may tend to slightly detune this circuit.

Since installing the limiter circuit shown in Figure 2, reception on 10 meters has improved tremendously. Many signals which are 100 percent understandable with the limiter are unintelligible speech swamped in a background of noise when the limiter is switched off.

While the 1938 Super-skyrider was used as the subject of these experiments, the same system can undoubtedly be employed with other receivers using diode detection. In fact this same system was employed in the Radio News "Quartet", 5 and 10-meter receiver described in the March, 1937, issue, and was found to be tremendously effective on both these bands. The only difference there was that the system was built into the receiver during its design and the biasing voltage was obtained from the power supply instead of resorting to the use of a B battery. To accomplish this it is necessary to isolate the negative output of the power supply from the receiver chassis and this is difficult to do in a ready-built receiver.

In locations where there are few cars passing at any one time the ignition can be eliminated almost 100 percent. Where other types of noises are present at levels higher than that of the signal they can be reduced. If they are regular recurrent pulses similar to ignition, they can be substantially eliminated.

In closing it might be mentioned that this system works at all wavelengths. However, its utility, so far as ignition noise is concerned, lies mainly in the ranges above 15 megacycles because it is here that this form of disturbance is the most troublesome.

Obstacle Detector

(Continued from page 543)

an alarm of "obstacle ahead!" may be sounded. The parabolic transmitter and receiver automatically turn from side to side covering an arc that well represents the ship's lane. When a signal is returned by an obstacle ahead, the beams stop moving and the fixed angles permit the essential mathematical calculating to determine the obstacle's position.

Here's a device that shows tremendous possibilities for added safety

at sea. If it proves practical, it undoubtedly will be applied to other vessels as soon as the experimental findings are complete.

The Technical Review

(Continued from page 555)

Fourth Avenue, New York, N. Y. The literature marked with an asterisk is available only to bona fide servicemen, dealers and engineers. In applying for these folders it is necessary to send in your request on your card or letterhead. If you are an amateur give call letters. The list follows:

- N1—Parts Catalog. Wholesale Radio Service Co.
- N3—Catalog on Radio Accessories, Cabinets, etc. Bud Radio, Inc.*
- N4—Allied Radio Corp. Parts Catalog.
- D1—Supreme Instrument Catalog.
- D2—R.M.A. Color Code Chart. Free. Cornell-Dubilier Corp.
- D3—Condenser and Resistor Catalog. Aerovox Corp.
- D4—Technical Pamphlets on Intercommunications Systems. Wright-DeCoster, Inc.
- D5—Transmitter Manual. Standard Transformer Corp.*
- D6—"Skyrider" Receiver Booklet. Hallicrafters, Inc.
- D7—The Muter Ballast Tube Catalog.
- D8—Centralab's Volume Control and Accessory Catalog.
- Ja1—Modell's Radio Receiver Catalog.*
- Ja2—Tube Chart. Raytheon Production Corp.
- Ja4—Catalog on I.F. Transformers. Aladdin Radio Industries, Inc.
- F1—Stromberg-Carlson Tel. Mfg. Company's Folder on Microphones.
- F2—Parts Catalog. Hammarlund Mfg. Company.
- F3—Catalog on Radio Accessories, Sets, Etc. Trymo Radio Company.
- F4—Condenser and Tube Folder. National Union Radio Corp.
- F5—Solar's Catalog on Transmitting Capacitors.*
- F6—Drake Mfg. Company's Dial Light Assemblies.
- F7—Aerovox Booklet on Noise Suppression.

RMA Assists Servicemen

Washington, D. C.—Assistance in organization of the new Radio Servicemen's Association into a national, representative and effective trade body will be given by RMA. The new national organization of servicemen succeeds the former Institute of Radio Service Men and is a combination of a number of local service organizations in the principal cities of the country. T. P. Robinson of Dallas, Texas, is the new president of the RSA which held its first Board meeting in Chicago on October 11. Ingvar Paulsen of Boston is secretary, and Lee Taylor of Chicago is treasurer.

LENNON

made extra money this *Easy* way



**"IT HAS STARTED
ME OFF ON A
BUSINESS THAT
HAS SHOWN A
STEADY INCREASE"**

Mr. P. T. LENNON
Hartford, Conn.—SAYS—
My orders have been getting "Special Attention"—Sales are easy because I always have what the customer wants. Let me thank you for the splendid service, also for your many sales helps.

YOU SAVE UP TO 40%

The latest 1938 Spring & Summer edition of our new large Radio catalog is an encyclopedia on Standard Radio Sets. You will find illustrated and described, all the newest 1938 models in home electric sets — farm battery sets and auto and boat sets. Sets made by Stromberg Carlson—RCA—Zenith—Philco—GE—Grunov—Emerson—Fada—Garod—Motorola—Kadette—Delco and many others.

**Get This New
1938 Catalog FREE**

also our plan on how you may make big weekly commissions in spare or full time. Experience is not necessary as our catalog describes fully each set and the instructions we furnish will help you make sales easily. The discounts our salesmen make are as high as 40% off the list price and every set is shipped in a factory sealed carton with a 3 year written guarantee.

SPECIAL INDUCEMENT
You may purchase a radio for yourself and take advantage of the salesman's discount and use it in your own home for demonstration purposes for future orders.

MODELL'S is the only Radio organization in the U. S. selling Standard Make Nationally Known Radio Sets in every hamlet, town, farm.

Many other men have written us, telling how easy and simple it is to sell Standard Make, Nationally Advertised Radios. You always have what the customer wants, because we carry over 400 different models of Radio Sets, ranging in price from \$7.95 to \$1,500. We have been in business for almost 50 years and have been selling radios for about 20 years, so you see you are doing business with a concern of responsibility and reputation.

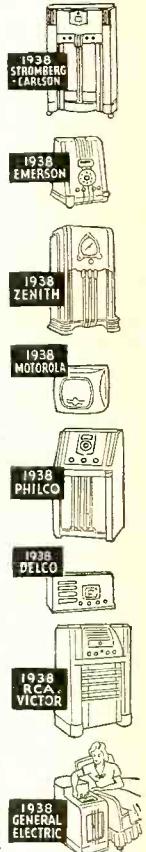

and over
400
other models

Modell's

Since 1889

- NEW YORK, N. Y.
58 Cortlandt St.
- CHICAGO, ILL.
56 W. Washington St.
- ATLANTA, GA.
57 Forsyth St.



MODELL'S, Dept. G-11,
58 Cortlandt St., New York City, N. Y.

Send me your New Spring and Summer 1938 catalog
 How may I increase my income
 I wish to purchase a Radio for myself.

NAME

ADDRESS

CITY STATE

PASTE COUPON ON PENNY POSTCARD

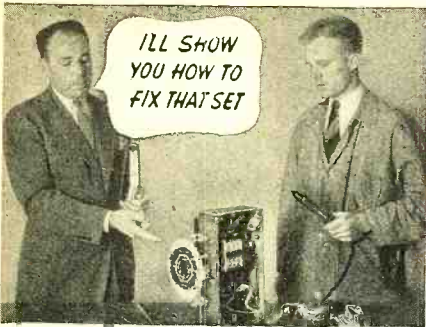

All Service Jobs made EASY - if you use "Ghirardi"

HERE'S WHAT HE'LL DO FOR YOU!

- **TEST INSTRUMENTS**
He'll explain everything about the construction and operation of all types of servicing instruments, with diagrams, construction data, etc.—even how to build your own!
- **TROUBLE-SHOOTING**
He'll give you latest testing and trouble-shooting short-cuts, explain the servicing of AVC and QAVC Circuits, etc.
- **REPAIR METHODS**
He'll show you latest repair methods for parts and sets, how to align superhets, eliminate electrical interference, etc.
- **SPECIALIZED SERVICING**
He'll throw in a whole course on Auto-Radio installation and servicing from A to Z, servicing All-Wave sets, High-Fidelity sets, etc.
- **CASE HISTORIES, Etc.**
He'll give you the "Case Histories" of over 1300 receivers, I. F.'s of over 6,000 superhets, and over 25 invaluable tables and charts to speed up your service work—and keep more coming to you regularly in his "Supplement Sheet Service."

Let A. A. Ghirardi come into your shop and help you with your radio service work! Just like having constantly at your elbow one of the greatest radio servicing authorities in the world—when you get Ghirardi's 2 great servicing books and start using them in your work. They're so practical and to the point—so well illustrated, clear and easy to understand—that they'll make every one of your repair jobs easier, quicker, more profitable to handle.

The whole science of radio servicing clearly explained in his **MODERN RADIO SERVICING** book. Ghirardi gives you the most complete accumulated knowledge available on present-day servicing methods and practices—test instruments, trouble-shooting, repairing, etc. It explains exactly **WHAT TO DO** and **HOW**.

Handy DATA BOOK, too! The loose-leaf **RADIO FIELD SERVICE DATA** book is full of just the kind of receiver data you're always needing in a hurry on every service job—in the shop and out. A regular Supplement Sheet Service keeps it always up to date. Time saved means more money, so save your money by ordering today these 2 "extra hands" for your shop. Mail the coupon right now! You don't risk a single penny!

MODERN RADIO SERVICING & RADIO FIELD SERVICE DATA BOOK
7800 PAGES 813 ILLUS.
(TOTAL)

Both Books for \$6
Sent Postpaid Anywhere!

TO: Radio & Technical Pub. Co., Dept. RN-38, 445 Astor Place, New York

Here's \$6 for my copies of **MODERN RADIO SERVICING** and **RADIO FIELD SERVICE DATA** (including the Jan. and June '37 Supplements to the Data Book) postpaid (\$6.50 foreign). Send free descriptive literature about these 2 servicing books.

NAME _____
STREET _____
CITY _____ STATE _____

ORDER NOW! MONEY-BACK GUARANTEE!

110 VOLTS A.C.

Fan belt generator for sound trucks. Produces constant voltage at various engine speeds. Cannot be burned out. Also good for operating flood lights, car heating, electric drills, neon signs. Sizes: 250 to 1000 Watts. Prices from \$25.00 net. Write for literature.

LEJAY MFG. COMPANY
154 Lejay Bldg., Minneapolis, Minn.

LES Correspondence Courses in RADIO and ELECTRICAL ENGINEERING

ELECTRICAL ENGINEERING Get a good grasp of wide electrical field. Prepare yourself, at Low Cost, for secure future. Modern course. So simplified anyone can understand quickly.

RADIO ENGINEERING Extra fine course in radio, public address, photoelectric work. Trains you to be super-service man, rent vacuum tube technician. Experimental kits furnished. Diploma on completion. Tuition ONLY \$25, either course. Deferred payment plan available.

FREE! Send name quick for free copies of school catalogs, student magazines, complete details. **SEND NOW!**

LINCOLN ENGINEERING SCHOOL, Box 931-69, Lincoln, Nebr.

The RADIO WORKSHOP

Items of interest for beginners, experimenters and radio constructors.
Conducted by William C. Dorf

Modernizing Silver Marshall 726 S. W. Receiver

Owners of old Silver Marshall model 726 SW receivers will be interested in the following improvements made in this set by H. C. Smith, a fellow experimenter of Bridgeport, Connecticut. Although this model is over six years old, reports seem to indicate that there are a surprising number still in active operation.

Readers possessing this set are no doubt familiar with the circuit and know that it is a double superheterodyne using two intermediate frequencies. The changes involved in the improvements, concern the main i. f. 175 kc. amplifier and there should be no difficulty in following the revisions as they have been marked on the original and corrected circuits.

formers T1 and T3 with the new Aladdin Polyiron transformers; substitution of the type 58 tube in place of the four 35s and the use of a 2A6 in place of the old 27 to provide diode detection, automatic volume control and additional audio gain. The portion of the circuit showing the changes appear in Figure 2.

In making the changes, the first job is to remove the first i.f. input transformer (T1) and the output i.f. transformer (T3). Next, cut a piece of sheet aluminum about 3 inches square, drill a hole in each corner to take 1/8-inch machine screws to fasten it to the chassis. Then drill mounting holes for the Aladdin type A175 and A275 transformers and a hole about 3/8 of an inch to pass the connecting leads. The 5-prong wafer sockets for the r.f. first detector, the two i.f. and the second de-

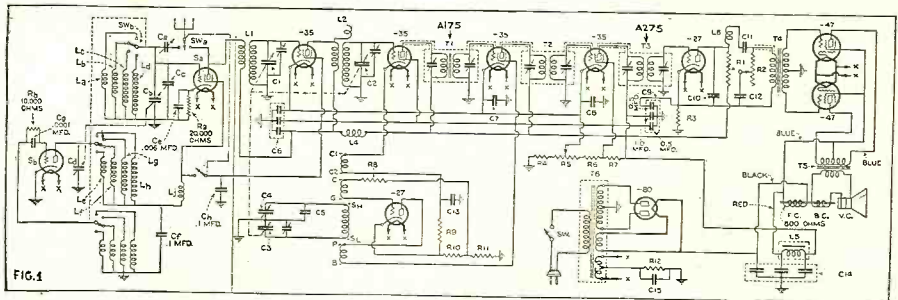

Mr. Smith advises that he is at the present time incorporating these improvements in a third S.W. 726 set and he has very kindly offered his services to any reader who may require additional information in making the changes.

The major revisions in the set, responsible for the improved sensitivity and selectivity are: the replacement of the old i.f. trans-

detector stages are removed and 6 prong type sockets installed to accommodate the type 58 and 2A6 tubes.

In making these changes it will not be necessary to move any of the other parts above or below the chassis. You will find plenty of surplus space for mounting the additional resistors and condensers for the automatic volume control circuit.

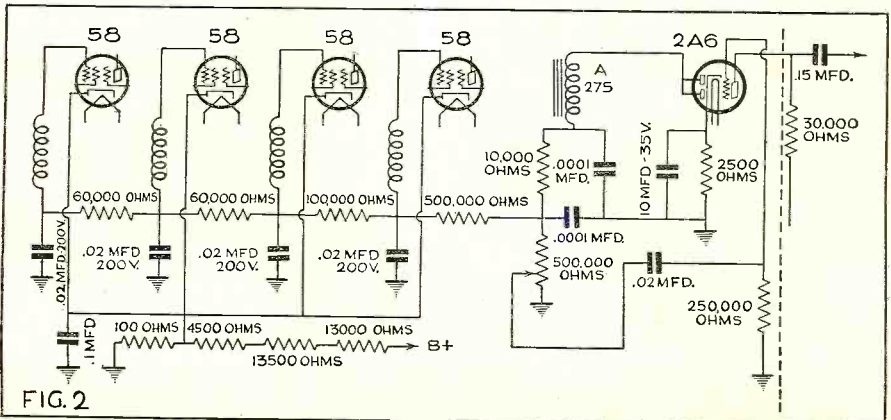

After making the changes, Mr. Smith reports that a big improvement was noted on the broadcast bands, as an example, in his location it was possible to tune in WKBW, Buffalo, 1480 kc.; WCKY, Covington, 1490 kc.; and WWRL, Woodside, 1500 kc.; without objectionable interference from the adjoining station and with plenty of volume to spare. Short-wave reception was improved on all bands. The approximate cost for the replacement parts did not exceed \$15.00.

Inexpensive Output Meter

Here is a simple constructional kink that solves the problem of an output meter for the experimenter or serviceman of limited means. The transformer can be any old power or filament unit, capable of furnishing five volts for the filament of the 80

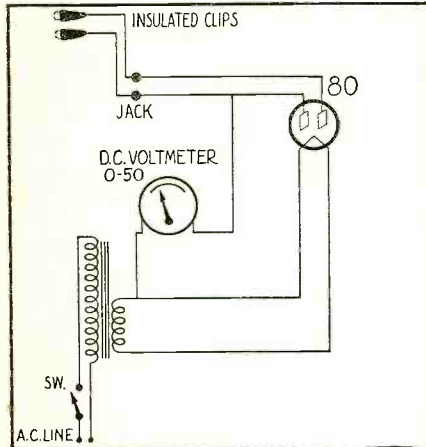

type tube. To connect the device to your receiver, simply connect the clip of the connecting leads to the output stage—ahead of the speaker transformer.

The 80 type tube is used to rectify the audio component without upsetting the balance of the set. The d.c. meter will show the slightest change in the receiver output.

LOUIS G. PATTERSON,
New Ulm, Minn.

No Cost for This One

Here is the No. 999 tip for a soldering iron holder. It is practical, easy to make, and works out very successfully. The accompanying drawing outlines the simple details for its construction. The articles required consist of a piece of corrugated metal eave spout about 3 inches in diameter by 6 to 8 inches in length and a piece of asbestos board 1/4 inch thick. This holder is an improvement over the light wire-type stands which are so easily tipped over and, of course, being under the bench, it means more available space on top for other equipment.

R. S. HOWARD,
Milton, Wis.

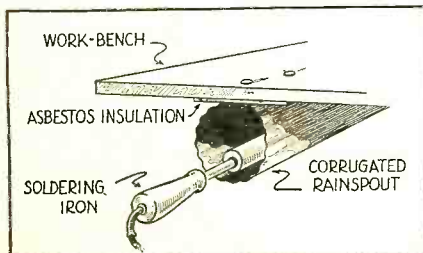

Service—Sales

(Continued from page 551)

nomical stunt for storing his stock of resistors and other small parts. As illustrated in Figure 5, they are distributed according to size in glass fruit jars so that the stock is always in full view. The tall array of shelves is shallow—each jar has a front row position. The upper row of jars in each compartment is kept in perfect order by fastening the caps permanently in place along the upper ledge of each shelf. When any particular resistor is required, a twist of the wrist removes the jar containing same from its position. The cap cannot be mislaid; it remains to bear silent witness that the jar is missing and must be restored to its proper place.

Beneath the bench a supply of big Edison cell batteries duplicate operating conditions when battery-type receivers have to be serviced. A B eliminator serves the same purpose for radios which are partly line-operated. A pickup and turntable enables phono combinations to be properly taken care of and do double duty when required for p. a. work.

A complete set of Rider's Manuals, a full line of Sylvania tubes, Mallory volume controls, Solar condensers as well as an assortment of transformers and other components combined with Mr. Knight's excellent equipment make rapid and efficient service the order of the day at Knight Radio.

ADOPTING "TINY TOTS"

OUR friend Nate Silverman, who operates the Ace Radio Laboratories in Lorain, Ohio, has developed a nice sideline to his service business by supplying local garages with Tiny Tots. In case you overlooked it, the Tiny Tot is the compact, simple and extremely sensitive superregenerative receiver described by A. J. Haynes in the September, 1937 issue of RADIO NEWS. In Lorain, the police department has recently installed a two-way radio system operating on 37.1 megacycles. Equipped with Tiny Tots, local garage owners pick up reports of auto wrecks and shoot out to the scene of the accident, often arriving before the police car. Silverman's first customer pulled in 38 wrecks within a few weeks after he got the receiver. Other garage owners learned the secret and clamored for similar equipment.

Silverman builds the Tiny Tot in a standard midget cabinet, and revises the circuit by increasing the coil turns to 20, tapping at the 3rd turn for the aerial. Type 56 tubes with a 2A5 for output and an 80 rectifier allow the use of low-priced

**WHEREVER TUBES
PLAY A VITAL PART
YOU'LL FIND
RAYTHEON
ON THE JOB!**

It is just as important for you to use top quality tubes as it is for the United States Navy. They use Raytheon because it is the tube that can be depended upon to work smoothly in any circuit... and stand up under the roughest usage and thundering vibration of a battleship under fire. The Navy can't stop in the middle of a battle to find which tube has blown!

Leading licensed set manufacturers, too, prefer Raytheon because of their sturdiness and uniformity. And when you make a replacement in a receiver you must be just as confident. That is why thousands of Servicemen depend upon Raytheon.

Order Raytheon for greater permanent tube profits.

**"WORLD'S LARGEST
EXCLUSIVE RADIO
TUBE MANUFACTURERS"**

RAYTHEON
CHICAGO • NEW YORK • SAN FRANCISCO
ATLANTA • NEWTON, MASS.

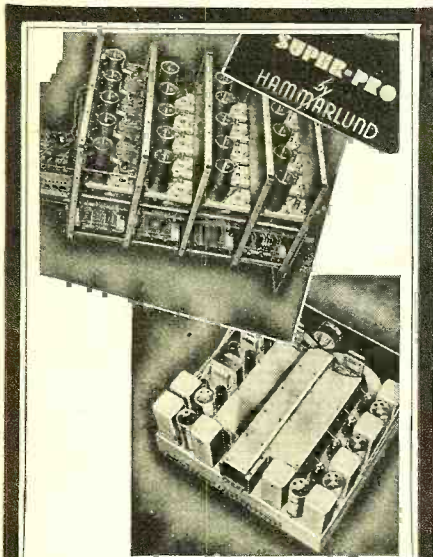

FOR TOUGH JOBS!

"The 'Super-Pro' has certainly proved itself a gem on my toughest expedition assignments. It is a grand set and I wouldn't be without it at any time," says Len Hammond, Fox Movietone News. Mail coupon below for complete details!

HAMMARLUND MFG. CO., INC. RN 3-38
424-438 W. 33rd St., N. Y. C.

Please send me "3S" catalog.

Name.....

Address.....

City..... State.....



Canadian Address: 41 West Ave., North, Hamilton, Ontario

QUICK, EASY WAY TO TRAIN FOR RADIO in 12 WEEKS

H. C. Lewis

I'LL FINANCE YOUR TRAINING

Mail the Coupon TODAY and I'll not only tell you about my quick, easy way to train for a good pay job in Radio, Television and Sound, BUT, I'll also tell you how you can get it and pay for it, in Easy monthly payments starting 60 days after your 12 weeks' training period.

LEARN BY DOING

On Real Equipment in Coyne Shops
Simple, easy method of Practical Training. You don't need previous experience or a lot of book learning. You work on real equipment in the Coyne Shops at Chicago. Electric Refrigeration training at no extra cost.

Earn While Learning, Job Help After Graduation

We help you get part time work to help with living expenses and then give you employment service after graduation.



H. C. LEWIS, President,
Radio Division, Coyne Electrical School,
500 S. Paulina St., Dept 38-3K, Chicago, Ill.

Dear Mr. Lewis:
Please send me your Big FREE Book, and details of your PAY-AFTER-GRADUATION-PLAN.

NAME.....

ADDRESS.....

CITY..... STATE.....

KLOGRAPH Pencil Painted Fountain Pen
Point perfect for any style of writing. Excellent for carbon, ruling, and rapid work. 14K Solid Gold Point. Fully guaranteed. Only \$1.00 postage paid.
SEVAN CO., Dept. 18, 7 E. 42 St., New York City

power transformers designed for 2.5 volt tubes. Tuning is fixed once and for all at 37.1 megacycles by employing a trimmer condenser concealed beneath the chassis. This keeps inquisitive garage employees from attempting to explore the ultra-short waves when they should be on the lookout for police alarms.

The same stunt is also being pushed by a "ham" serviceman in Yonkers, N. Y. with equally satisfying results. So don't pass over the articles on amateur apparatus. They have dollars-and-cents value to live-wire dealers and servicemen.

THE DAY'S WORK

Often there are simple remedies which apply to troubles in a wide variety of receivers. For instance,

Tunable Hum

afflicts many types of receivers when open power-line wiring is prevalent; particularly in rural districts. Any plug-in line filter usually cures the trouble; or two 0.1 mfd., 600 v. condensers connected in series across the outlet, with the center tap grounded will be equally effective. And take the case of,

Noisy Tuning

which is encountered in Philco 60, RCA-48, etc. This is often caused by the plating flaking off the gang condenser and forming small burrs. Removing all leads and applying high voltage between rotor and stators will burn off these burrs. Of course, if we have

Noisy Tuning with Oscillation such as occurs frequently in Stromberg 642, 846, 14 and other makes using a fork grounding tab on each gang condenser rotor, the cure is simply to remove the high-resistance contact which corrosion has caused. This may be done by cleaning and bending the forks to increase the tension.

Unnecessary service calls on new sales are a pain-in-the-neck to all dealers and servicemen. For instance, on the new type 813 K—RCA Overseas model if the

Automatic Tuning Mechanism Drags

and sticks, tell the customer to make sure the change-over switch is turned all the way to the "Electric" tuning position. New owners are inclined to handle the switch a little too gingerly and, if positive contact is not made, this trouble results.

NEW AUTO ANTENNAS

A COMPLETE new line of auto antennas embodying the latest trends in both technical efficiency and styling has been announced by the Parts Division of the RCA Manufacturing Company and is shown in Figure 6.

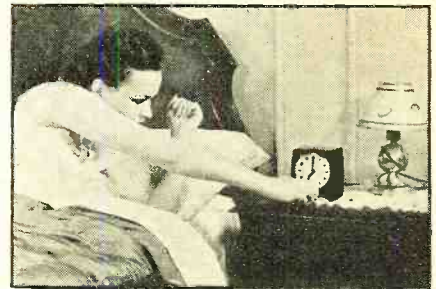

WAKE UP!

Figure 7. The Telechron does its stuff accurately and dependably.

A completely new "monogram" antenna with an unusual style note provides a car top antenna of outstanding appearance and efficiency. With this antenna no holes need be drilled through the car top; it has an adjustable telescopic cowl bar which will fit any type car. A weather-proof connection is made at the cowl.

The antenna itself has a high gloss satin finish that is guaranteed rust-proof. It is provided with a streamlined Bakelite insulator equipped with a special rubber suction cup providing easy installation. The antenna extends telescopically from 21 to 35½ inches in length.

The new Cowltenna is the latest vertical type auto antenna and is permanently installed at the side of the cowl. The streamlined insulator includes a rubber pad to insure a perfect seal. Guaranteed to be rust and corrosion-proof, this antenna extends telescopically from 28¾ to 49½ inches and requires no soldering.

The RCA Rodtenna is most easily installed, requiring only five minutes to complete the job. To put it on, the door hinge-pin is removed, the Rodtenna attached and the pin replaced. That is all there is to it. There is no drilling, soldering or cementing. The Rodtenna has high signal pick-up, reduces wheel static and is made of high carbon vanadium steel, triple chromium plated. A weather-proof moulded rubber insulator and a spe-

AUTO ANTENNAS

Figure 6. A variety of new designs in auto antennas is illustrated below. They are easy to install and look well.



cial 10½ inch flat connection lead is included.

The RCA Telescopic Rodenna is similar to No. 9793 except that it is adjustable in height, fastening to the door hinge in the same way. It extends from 29½ to 50½ inches in height and is made of a new non-rusting metal having excellent pickup qualities.

For under-car installations there is the RCA Dipole Antenna, which is simple in design, efficient in operation and easily installed on any car. Because of its construction and location, ignition interference is reduced to a minimum. Adjustable brackets provide a wide variety of installation locations and allow for adjustments for road clearances.

THEATER SOUND FILM ADVERTISING FOR TELECHRON CLOCK DEALERS

The Warren Telechron Company has announced the first of a series of Theater Advertising Sound Film "Shorts" to aid the dealer in publicizing his own store in conjunction with Telechron Self-Starting Electric Clocks, shown in action in Figure 7.

This new sales film, produced by the Modern Display Film Company of Chicago, is available to dealers handling Telechron Clocks and can be run at small cost in local movie houses. Information about the new Telechron Sales Film can be obtained from the Warren Telechron Company at Ashland, Mass.

The "Ham" Shack

(Continued from page 535)

sitivity. Actually it regulates the amount of excess modulating voltage applied to the "electric eye" tube. When adjusting this resistor for bias it should be done in gradual steps. If high voltage is used in the transmitter and the resistor is near the high-voltage circuits, the transmitter should be turned off each time an adjustment is made. The simplest method of doing this is first to set the resistor so that about one-quarter of its resistance is across the twisted-pair line. Then turn on the transmitter and advance the audio level while speaking into the microphone until the 6E5 shadow jumps closed. This point indicates over-modulation. If the shadow closes too much, less resistance is required across the twisted-pair line; if not enough, more resistance should be cut in, but preferably when the plate power is turned off the transmitter. Once the point is found when the "eye" closes on over-modulation peaks, it need not be adjusted again unless the power input to the modulated

stage is changed (i.e., by varying the plate voltage). However, even then it probably will not be necessary to readjust the potentiometer, because, as pointed out before, only 7 volts of negative bias is needed to close the shadow of the 6E5.

The condenser "C", which is connected across the loading resistor or potentiometer, determines the time-lag of the "electric eye." The larger the capacity, the slower it will close, due, of course, to the voltage it stores up. Necessarily this condenser should have a minimum capacity of .05 mfd. If a smaller capacity were to be used, the shadow would close and open so rapidly that over-modulation peaks might be missed. It was found that .1 mfd. is a good compromise.

Tests made at the writer's station showed this over-modulation indicator to be extremely sensitive, the "eye" winking with the slightest trace of over-modulation. Its operation compared favorably with more expensive over-modulation devices. It should provide the amateur who has a lean pocketbook with an excellent means of checking and preventing the disturbance he might cause on the phone bands.

List of Parts

- 1 cabinet 5 by 9 by 6 (Bud)
- 1 chassis to fit above cabinet
- 1 filament transformer for 879, 10,000-volt insulation (United)
- 1 500,000-ohm variable resistor (Yaxley)
- 1 1-megohm, 1-watt resistor (Ohmite)
- 2 four-prong sockets (Hammarlund)
- 1 five-prong socket (Hammarlund)
- 1 8 mfd. filter condenser (Aerovox)
- 1 small power transformer with 6.3 and 5 volt filament windings (Thordarson T7078)
- 1 small filter choke 10 henrys, 40-m.a. Thordarson

Serviceman's Diary

(Continued from page 516)

him I'd do—but how I did it was my business, not his. First thing, I put his battery on charge. While it was picking up some pep, I looked over the situation. The windmill had been fastened near a second-story window, completely cut off from any breeze from the West—and that's about the only direction you can get a real wind from in his section. He wanted it where he could see it, so I took it down and set it up in the front yard. It was really a beautiful thing, all painted up in bright colors. But it moved so lazily.

"Next, I looked over the generator, which was geared to the windmill. Found I could change it over to act as a motor and did so, cutting out the charging relay. Then I reconnected the battery across both the motor and the radio and cut in a switch at the porch. When everything was all set, I let the charger



EVERYTHING... Just as You Want it!

Before assembling Volume VIII we asked servicemen WHAT they wanted and HOW they wanted that information arranged.

RIDER MANUAL VOLUME VIII

JUST OFF THE PRESS

gives you the servicing data you need—simplified and standardized.

more complicated 1938 receivers. This is in addition to the complete information on the sets of over 100 manufacturers—1650 pages of indispensable facts—and the price is the same as last year.

Included with Volume VIII is a special EXTRA section entitled, "How It Works." Covering operations peculiar to the

MARCH *ahead* OF TIME WITH THESE NEW RIDER BOOKS

AUTOMATIC FREQUENCY CONTROL SYSTEMS

With Automatic Frequency Control Circuits in most new higher-priced models, knowledge of "AFC" means money in your pocket! Learn the practical facts, from these easy-to-understand explanations. Get your copy today. Cash in on profitable "AFC" work. Hard covers. 144 pp. \$1.00.

SERVICING SUPERHETERODYNES

Changes, changes, changes! That has been the history of the superheterodyne circuit. Make repairs quickly by analyzing the different parts of the circuit quickly. Rider shows you how in this revised edition which has 288 profusely illustrated pages. \$1.00

THE CATHODE-RAY TUBE

Written especially so you can understand the subject. With introduction of new, cheaper Cathode-Ray Tubes, this book is even more indispensable for its complete practical information on Oscillographs, etc. 336 pp. 450 illustrations. \$2.50

"AN HOUR A DAY WITH RIDER" BOOKS —60¢ each

ON AUTOMATIC VOLUME CONTROL will speed up your AVC work. 96 pp. 65 illus.
ON RESONANCE & ALIGNMENT. You need this! 96 pp. 48 illus.
ON D-C VOLTAGE DISTRIBUTION IN RADIO RECEIVERS. How d-c voltages are led to tube elements, etc. 96 pp. 69 illus.
ON ALTERNATING CURRENTS IN RADIO RECEIVERS—with drawings and diagrams.

ORDER TODAY

JOHN F. RIDER, PUBLISHER
1440 Broadway, New York City

YOU NEED ALL 8
Rider
MANUALS

GET READY TO CASH IN ON 1938 RADIO SERVICE BUSINESS . . . the easy National Union Way!

Get the equipment you need FREE with purchases of National Union radio tubes and condensers

What do you need to make yours the "finest radio service lab in town"? Whatever it is, National Union is ready to give it to you. Thousands of service engineers are cashing in on the National Union free equipment plan. They're building their reputation . . . they're growing, making more money.

Now, with National Union condensers it's twice as easy as ever before because condenser purchases and N.U. tubes all help to earn the things you need. Get in on the N. U. proposition for 1938. Get in on it now! Ask for name of nearest N. U. distributor.

QUALITY! NATIONAL UNION'S BYWORD

The N. U. research staff is your assurance that National Union Products will never let you down.

National Union Radio Corporation RN-338
570 Lexington Ave., New York City

Who's the nearest N. U. Distributor?

Name

Address

City State

DO YOU LIKE

RADIO

TELEVISION

INTEREST YOU?



Send for your free copy

You men anxious to make good in radio and related industries want the true facts,—you want to know about employment opportunities and requirements. National Schools,—a million-dollar trade school,—will supply you with a sincerely honest statement of facts on what you should do to get into the profitable radio industry. No exaggerations,—no mis-statements. Mail coupon today. ¶ Send for your free copy. Real facts on radio employment requirements. ¶ You need real experience. National offers complete training with modern equipment.

NATIONAL SCHOOLS
Los Angeles

Request for FREE BOOK of DETAILS

NATIONAL SCHOOLS,
 Dept. RN-3, 4000 S. Figueroa St., Los Angeles, Calif.

NAME Age

ADDRESS

CITY STATE

DON'T BUY TEST EQUIPMENT until you've investigated Radio City products. See your jobber. Write to Dept. N for catalog.

RADIO CITY PRODUCTS CO.

88 PARK PLACE NEW YORK CITY

float across the battery temporarily, switched on the juice and was he happy! The windmill revolved, the radio played and he got his breeze. The bill wouldn't have amounted to more than twenty-five bucks but he insisted on handing me an extra ten. And now he wants me to add a lot of attachments to his electric train, which runs all over the basement. What a customer!"

"You're lucky you caught him when his keeper was away," I told Howie.

But Jerry sat by and heard the whole story. And I've been hearing it ever since. Such is radio!

Compak Tuner

(Continued from page 523)

variation, he soon changes his mind. This is especially true if it is possible to let him try one out before he has decided on a model and allow him to compare its entertainment value with his present radio. The reaction regarding the stations being missed is: "Oh, I can get them on the old set, but why bother?"

In closing it should be remembered that this tuner can be made small enough to be placed in any form of cabinet or even between the books in a bookcase as shown on this month's cover and is so flexible that any possible combination of stations or conditions can easily be designed for, thereby allowing each customer to have the tuner adapted to his particular needs.

List of Parts

- C1, C2, C7, C8, C13, C14—Hammarlund trimmer condensers, 20-100 mmfd., Type QTD—100.
- C4, C9, C10, C15, C16—Hammarlund trimmer condensers, 55-250 mmfd., Type QTD—250.
- C5, C6, C11, C12, C17, C18—Hammarlund trimmer condensers, 100-450 mmfd. Type QTD—450.
- C19—Aerovox mica condenser, .003 mfd., Type 1467
- C20, C21, C23, C26—Mallory tubular condenser, Type TP-428, 0.1 mfd., 400 v.
- C22—Aerovox mica condenser, Type 1468, .00005 mfd.
- C24—Mallory electrolytic condenser, Type TS-101, 10 mfd., 25 v.
- C25—Mallory electrolytic condenser, Type CS-123, 8 mfd., 250 v.
- C27—Mallory electrolytic condenser, Type CN-152, 8-8 mfd., 250 v.
- Ch—Kenyon filter choke, 30 henries, 25 ma., Type T157
- R1, R10—I.R.C. carbon resistor, 50,000 ohms, ½ watt
- R2—I.R.C. carbon resistor, 300 ohms, ½ watt
- R3, R7—I.R.C. carbon resistor, 100 ohms, ½ watt
- R4—I.R.C. carbon resistor, 2000 ohms, ½ watt
- R5, R6—I.R.C. carbon resistor, 1000 ohms, ½ watt

- R8, R9—I.R.C. carbon resistor, 50,000 ohms, 1 watt
- R11—I.R.C. carbon resistor, 500,000 ohms, ½ watt
- R12—I.R.C. 500,000 ohms, Type 13-133 volume control
- R13—I.R.C. carbon resistor, 800 ohms, ½ watt
- R14, R15—I.R.C. carbon resistor, 5,000 ohms, ½ watt
- R16—I.R.C. carbon resistor, 10,000 ohms, 1 watt
- R17—I.R.C. carbon resistor, 50 ohms, ½ watt
- P.T.—Kenyon power transformer, Type T-249, 470 v., c.t., at 20 ma., 6.3 v., c.t., 0.6 a., 6.3 v., c.t., 0.9 a.
- S1, S2, S3, S4—Yaxley selector switch, type 1361-L
- S5—H & H toggle switch, s.p.s.t.
- T1—Meissner Ferrocart antenna coil, type 7411
- T2—Meissner Ferrocart interstage coil, type 7860
- T3—Meissner r.f. coil, type 1497
- 1 Amphenol PC—3F chassis connector
- 1 Amphenol MC—3M cable-type connector
- 1 Yaxley pilot light assembly, type 310-G
- 2 Yaxley ¼-inch black bar knobs, type 366
- 1 Crowe gain-control plate, type 436
- 2 Metal-tube shield caps
- 1 I.C.A. chassis, 9½ by 5 by 3 inches
- 1 Sylvania 6x5 tube
- 1 Sylvania 6K7 tube
- 1 Sylvania 6R7 tube
- 3 small strips bakelite
- 1 strip aluminum
- 3 8-prong sockets
- 2 Octal-tube grid caps
- 1 pilot lamp (see text)
- 6 ft. 110-volt connector cord and plug
- 30 ft. Leeds three-wire connecting cable

"10-80" X'mitter

(Continued from page 537)

110-volt a.c. operation. This is just one of the refinements being provided in the permanent installation to be described next month, an installation which is being planned to serve as an ideal set-up for an apartment where efficiency, compactness and convenience are all given due consideration.

DX Corner—B.B.

(Continued from page 559)

lieve. Argentine stations are fair to good after 7 p.m. with LR5 on 830 kc. the best."

Enrique Hidalgo, Cienfuegos, Cuba: "Due to my absence from Cienfuegos, I have been unable to give any series of DX specials this year from CMHJ. My absence has been due to my activities as track and field coach of the 1938 Cuban Olympic team. There will be two specials from CMHJ (see DX Calendar—Ed.) The one on March 10 will be under my direction and beautiful veri cards will be given as rewards to listeners reporting this 4-hour program."

Observer Law, Edmonton, Alberta, Canada: "As a result of the regional conference held in Cuba last fall, Canada has been assigned 15 high-power channels, seven of which are for unlimited power. These are: 540, 690, 740, 860, 990, 1010 and 1580 kc. The channels of 940, 1070, 1130 and 1550 will be limited to 50 kw. The 800, 900, 1060 and 1080 channels will be for Class 2 stations."

Observer Hunt, Leucadia, Calif.: "Twenty JO's were heard here between September 10 and November 8. This is as many as were heard during the entire 1936-37 season."

Observer Routzahn, York, Pa.: "Am using a Patterson PR15 this season and it's the best set I have owned to date. No TP reception to speak of during December. European reception fair but hope for improvement during January. PP, Bordeaux and Normandie are the "Best Bets" from Europe so far. The S.A.'s are coming in very well."

Observer Roman, Chicago, Ill.: Have heard two steamships operating on 1630 kc.—the S.S. Weyburn at Middle Island, Lake Huron and the S.S. Canadian at Port Stanley. Have also heard WNYF (New York City Fire Dept.) on this same frequency calling experimental stations W2XNA, W2XND, etc. Can anyone provide information on the Canadian stations which give weather reports for the Great Lakes between 10:45 and 11 p.m., C.S.T. on 1630 kc.?

Observer Woytan, Syracuse, N. Y.: CBO and CBW are the new calls for CRCO and CRCW. Would like to know what station operated on 1000 kc. on November 7 at 4 a.m.

Observer Watson, Christchurch, N. Z. reports that 1ZB, 1090 kc., Auckland; 2ZB, 1120 kc., Wellington; 3ZB, Christchurch and 4ZB, Dunedin which constitute the New Zealand national network have already developed a firm hold on the radio public due to their brighter programs, ultra-modern equipment and high-fidelity recordings. The whole service is on a sound commercial basis similar to that in Australia. All four of these stations operate with 1 kw. in the antenna.

Merlin Olmstead, Washington, D. C. reports reception of a new station at Nassau, a British island of the Bahamas. He hears it from 8:30 to 9:30 p.m., E.S.T. on a frequency of 540 kc. The call is ZNS.

Observer De Laet, Dayton, Ohio: Australian 4QN has shifted frequency from 600 to 630 kc.

Observer Routzahn, York, Pa.: Trans-Pacific reception not so good this season. The stations just heard were 2BL and 2NR of Australia and 2YA, 3YA and 4YA of New Zealand. Hawaiian stations are well received with KHBC, 1400 kc. and KGU, 750 kc. the best.

Observer Coales, Hampshire, England: United States reception generally poor although on November 16, 17 and 18 a number of United States stations were heard with tolerable loudspeaker volume. South Americans have been audible a number of nights but mostly very weak indeed. They were quite good on the three dates mentioned above and also on November 9. I heard a South American on 1440 kc. and am sure I heard the announcer say "Radio Provincial, La Plata". I logged the program and sent in a report. I notice a Massachusetts listener reports the La Plata station LS11 on 1310 kc. Now I am wondering whether I mistook the call heard on 1440 kc. These Spanish announcers are very difficult to understand when their signals are weak, especially with large slices of static chucked in.

Harry Honda, Los Angeles, Calif.: KMTR, Hollywood, 570 kc. conducts a "ham fest" from 3 to 3:30 a.m. every Sunday morning. The programs are conducted by Jim Guest, W6HCN and Don Draper, W6GXM. They interview the wives and prospective wives of hams to obtain their idea of ham radio, etc. These broadcasts are specials by the Los Angeles Chapter of the ARRL. Also, short-wave tips are given every morning at 3 a.m. over KMTR.

Dual A. G. C.

(Continued from page 529)

both halves of the doublet, but when changing to the other two higher-wave bands the input is coupled through a capacity to separate secondary coils. The band-switch short-circuits the coil which is next lowest in frequency to that being used. The 6U7G tube used in the first stage provides exceptionally high sensitivity in this circuit.

One of the new 6L7G converter tubes is used for frequency conversion. The r.f. signal is applied to the control grid while the oscillator output from the G6G5 is coupled to grid No. 3 so that both modulate the cathode emission with a signal of 465 kc. This is then applied to the i.f.

(Turn to page 571)

FOR THOSE WHO WANT The Best

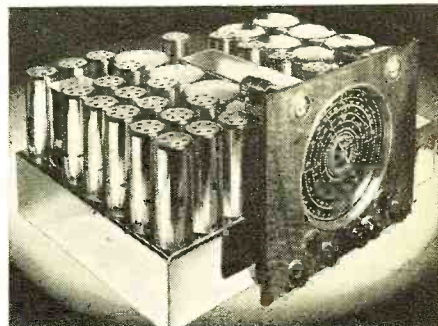

**WORLD'S
Finest
RADIO**

Only a custom, laboratory-built SCOTT radio can give such sensational performance! Features currently new in many factory mass-produced receivers were offered in a SCOTT years ago! So far advanced in design, and so perfect are the materials and hand craftsmanship in a SCOTT that it is guaranteed for 5 years!

AMAZING PERFORMANCE

Distance? . . . The SCOTT holds 6 official World's Records. Tone? . . . Finer than the costliest motion picture sound system. Sensitivity? . . . The World's most powerful radio. Fidelity? . . . 50% higher than the average high priced radio. Quiet? . . . Four static reducing systems (electrical and atmospheric). Handling capacity? . . . Up to 300% more than ordinary receivers. Selectivity? Continuously variable from 2 to 16 kc. You will be amazed at the spectacular ability and moderate cost of this hand made, precision instrument.

30 DAY FREE HOME TRIAL

Own the guaranteed finest in Radio . . . A SCOTT! 30-day free trial in your own home, and Budget Plan, anywhere in U.S.A. Laboratory built on order only. NOT SOLD THRU STORES. Send the coupon for all the facts. ACT NOW.

FOR A SHORT TIME ONLY MAIL COUPON FOR SPECIAL OFFER!

E. H. SCOTT RADIO LABORATORIES, INC.
4440 Ravenswood Ave., Dept. 568,
Chicago, Ill.

Send all the facts, order blank, and Special Offer. No obligation.

Name.....

Address.....

City & State.....

**STUDIOS: NEW YORK, CHICAGO,
LOS ANGELES, LONDON**

HAM SPECIAL!



Western Electric
211E TUBE

ONLY \$4.50

High Power Amp. or Osc. (on 40 to 160 meter bands). 65 watt continuous plate dissipation; 100 watts intermittent. Four pin 50 watt base. Replaces 211A and 211D. Limited quantity. All brand new in factory sealed cartons.

SEND YOUR ORDER IN TODAY
Complete Sections on 'ham' equipment, parts, tools, etc. Lists 70 brilliant 1938 Lafayette Receivers. **Don't delay! Clip Coupon for FREE catalog.**

WHOLESALE RADIO SERVICE CO., Inc.
NEW YORK, N.Y. • CHICAGO, ILL. • ATLANTA, GA.
100 SIXTH AVENUE • 901 W. JACKSON BLVD. • 205 PEACHTREE STREET
BOSTON, MASS. • BRONX, N.Y. • NEWARK, N.J. • JAMAICA, L.I.
100 N. BROADWAY • 140 E. FORDHAM RD. • 116 CENTRAL AVENUE • 4000 144th STREET

WHOLESALE RADIO SERVICE CO., Inc.
901 W. JACKSON BLVD., CHICAGO, ILL.
Rush FREE 1938 Catalog No. 69-2C8

Name _____
Street _____
City _____ State _____

PASTE COUPON ON PENNY POST CARD

NOW!
BIG PROFITS INSTALLING PUSH BUTTON TUNING

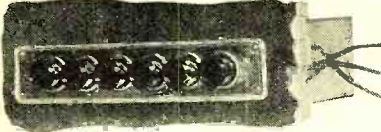

Fits any radio, only three wires to connect. Is completely shielded in black DURO-LAC finished metal container 5 1/4" wide 2 1/2" deep 1 1/2" high.

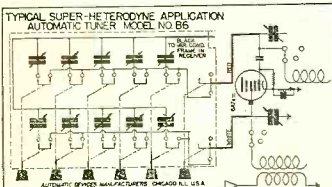

Model B6 (as described above) sent postpaid to any part of the United States on orders accompanied with money orders. Nothing more to buy..... **3.95** NET

WRITE FOR FREE LITERATURE
AUTOMATIC DEVICES MANUFACTURERS
Dept. 3A, 4243 W. Ogden Ave., Chicago, Ill.

RADIO ENGINEERING

RCA Institutes offer an intensive course of high standard embracing all phases of Radio and Television. Practical training with modern equipment at New York and Chicago schools. Also specialized courses and Home Study Courses under "No obligation" plan. Catalog Dept. RN-38.

RCA INSTITUTES, Inc.
A Radio Corporation of America Service
75 Varick St., New York 1154 Merchandise Mart, Chicago

AT YOUR DEALER'S

NEW RADIO PRODUCTS

(Continued from page 533)
ohms to 10 megs. in 5 ranges and a 5 range capacity meter is included. Further provision is made for db. and inductance measurements. The instrument is battery-operated except for the highest ohmmeter range and for

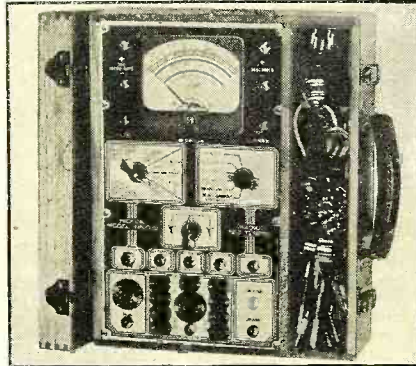

the capacity meter. For these ranges, the built-in power supply is employed. The walnut case measures 5 by 10 by 12 3/4 inches and a satin-etched metal panel adds to its attractive appearance.

Triple-Tuned

The important specification features of the new Aladdin type N-200 triple-tuned i.f. transformers include easy alignment; all tuning condensers adjustable from the top of the shield can; compact size measuring only

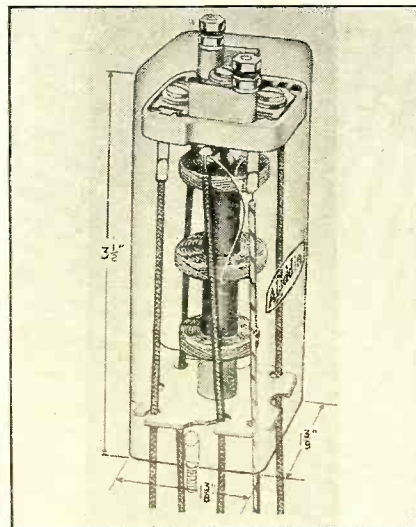

1 3/8 inches square by 3 1/2 inches long; high adjacent channel rejection—about 30 kilocycles wide, 20 times down; and a broad flat top approximately 8 kilocycles wide. This new transformer is tuned to 465 kilocycles.

Full Line of Transmitting Condensers

The E. F. Johnson Company, spe-

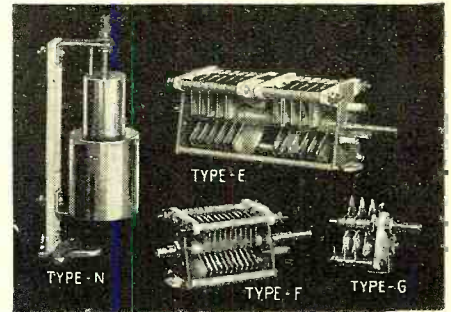

cialists in the production of all types of variable transmitting condensers, announce the new type "N" concentric condenser designed for neutralization of the new low C tubes. They are available in a wide range of capacities and the manufacturer points out that there is no change in voltage rating from minimum to maximum. The types E and F, small size, lightweight condensers can be used for either chassis or panel mounting. The single section unit can be had in maximum capacities from 49 to 254 mmfd., and the dual section units from 49 to 201 mmfd. The type G condenser is designed for neutralization and suitable for receiver construction. All condensers feature "Alsimag" 196 insulation.

Announcing New Speaker System

This new Lansing "Iconic" speaker system includes a new high-frequency unit designed for constant efficiency up to 10,000 cycles or above, a new multi-cellular horn which gives uniform coverage over an angle of 80 degrees, and a new low-frequency unit with very low distortion. Though it is smaller in size,

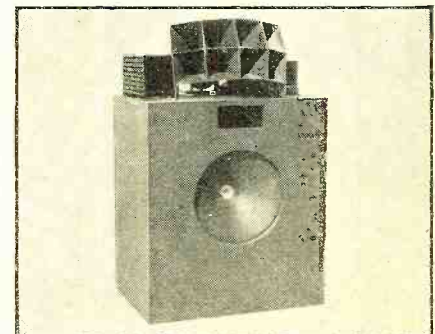

the "Iconic" is somewhat similar in design and performance characteristics to the Lansing-Shearer theater horn systems. Flexible in operation, it can be altered in size and shape within wide limits to suit particular installation conditions.

Complete P. A. Systems

The new 1938 line of Lafayette

"Co-ordinated" sound systems offered by the Wholesale Radio Service Co. are designed to meet every professional and industrial use to which sound amplification equipment can be put. They are available in all power ranges from 5 to 90 watts.

The Lafayette 15-20 watt sound system illustrated is inclosed in an

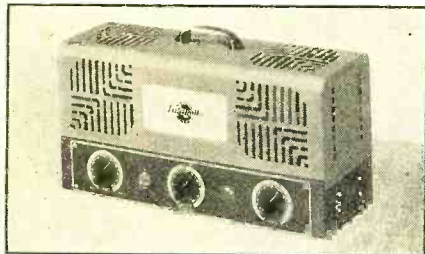

attractive "Streamlined" decorative steel cover finished in platinum grey with dark grey chassis. Among its many advanced features are: 6 all-metal tubes, mixing and fading controls, variable output impedances, etc.

Wide Application for New Midget Condensers

Three gang midget condensers are now made available by Bud Radio, Inc. Rotor and stator plates are made of brass and securely soldered to their respective shafts. Mounted

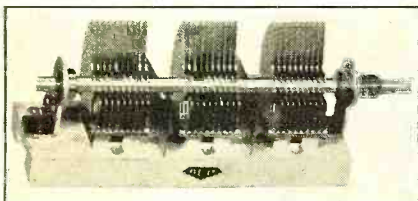

on ceramic bases 1 3/4 inches wide by 5 3/4 inches long, these units are supplied in several popular capacity sizes, and should find many uses in transmitters, receivers and test equipment by amateurs and engineers. The manufacturer lists the new gang condensers of 20, 35, 100, and 140 mmfd. capacity per section.

Modernize Your Receiver with Automatic Tuning

The Hetro 5-station automatic push-button tuner system is designed for quick and easy installation on any superheterodyne receiver which is without benefit of touch-button tuning. The master control is of the double-pole double-throw switch type and can be connected directly to the
(Turn to page 576)

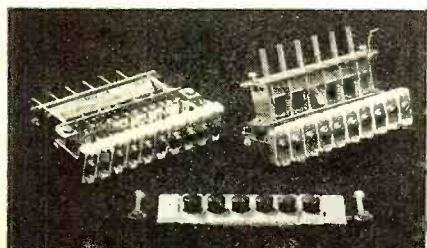

Dual A. G. C.

(Continued from page 569)

tuning stages.

Now a word about the two automatic-gain-control systems. In the r.f. circuit the control grid of the 6B8G tube is coupled through a capacity to the plate of the converter tube. The 6B8G tube both amplifies and rectifies the signal and applies the rectified energy to the grid circuit of the 6U7G, effectively preventing overloading when tuning to powerful local stations.

In the second a.g.c. circuit, the 6B8G tube serves as an extra i.f. amplifier and diode detector, supply-

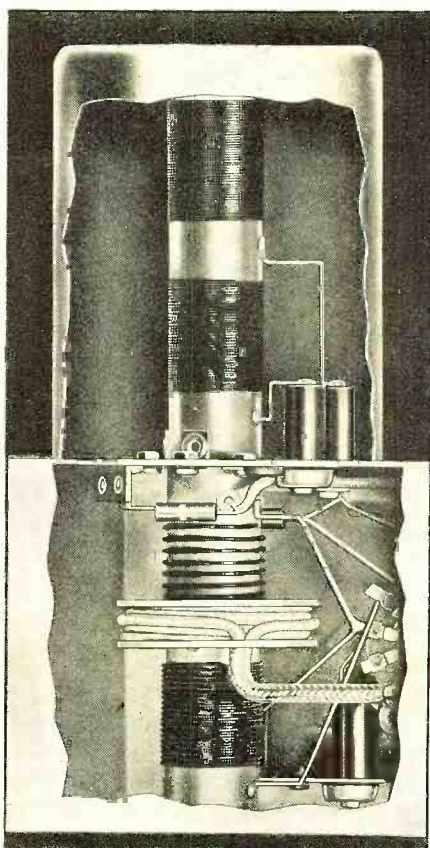

ing voltage for controlling the first and second i.f. tube stages and preventing distortion in this part of the circuit. The sensitivity switch (which may be seen near the 6G5 tube in the diagram) may be pulled out when tuning for signals and in such a position the bias is changed on the i.f. tubes to about 30 volts which provides silent tuning between stations. The tuning eye (6E5) indicates when a station is properly tuned "on the nose."

Some other features of the receiver include the following: input circuit for playing phonograph records; full bass tone compensation; a separate heavy-duty power supply, using two of the new heater-type 5V4G tubes; provisions for connecting external

25,000 OHMS PER VOLT

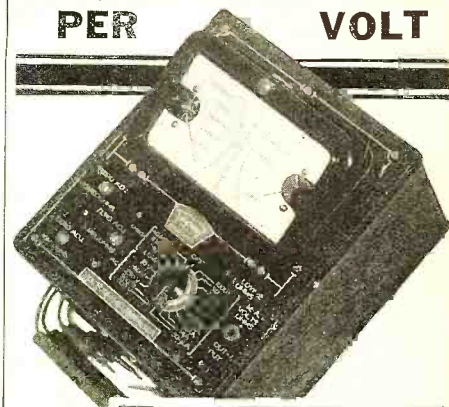

Dealer Price \$31.17

*Model 1200-E
Volt-Ohm-Milliammeter*

- Resistance Readings to 40 Megohms
- Separate A.C. and D.C. Instruments in Tilting Twin Case; Accuracy of Each Within 2%
- For All Radio Measurements Not Requiring a No Current Draw Vacuum Tube Voltmeter

Triplet Master Volt-Ohm-Milliammeter Is Easily Identified by the Exclusive Tilting Twin Instrument. By All Odds the Overwhelming Favorite . . . Because It Is the Most Practical.

Model 1200-E offers a new order of precision testing with 25,000 Ohms per Volt. Modern Radio sets that require delicate balancing can be easily and quickly adjusted. READINGS: D.C. Volts 10-50-250-500-1000 at 25,000 Ohms per Volt. A.C. Volts 10-50-250-500-1000. 50 D.C. Microamperes, 1-10-50-250 Milliamperes; Resistance 1/4-1000 Low Ohms; Backup Circuit; 0-40,000 Ohms; 4 and 40 Megohms.

A TRIPLET MASTER UNIT . . . one of a series of co-related single unit testers made in standard sizes, the most economical method yet devised for completely equipping the all-around radio service shop with high quality instruments. Catalog gives complete information regarding other Triplet Volt-Ohm-Milliammeters.

New LABORATORY TEST BENCH PANEL

As Shown Contains:

- I210-A Tube Tester
- I232 Signal Generator
- I209-A A.C. Voltmeter
- I209-D D.C. Volt-Ohm-Milliammeter

Model 1404
Dealer Price \$95.50
(complete less lamp)

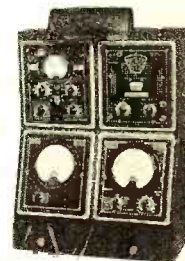

OTHER LABORATORY MODELS

Model 1402 with compartments for any two DeLuxe Testers.

Model 1403 with accommodations for any two Master Units and one DeLuxe Tester.

TRIPLET Precision ELECTRICAL INSTRUMENTS

THE TRIPLET ELECTRICAL INSTRUMENT CO.
153 Harmon Dr., Bluffton, Ohio.

Please send me more information on Triplet Model 1200-E _____; Model 1404 _____

Name _____

Address _____

City _____ State _____



**SKILL
did it**

Into this famous unit have been packed years of research and engineering skill. The result—a transformer that gives clear, natural, dependable amplification under all circumstances, whose good reputation is universal with amateurs and professionals alike. Frequency characteristics are exceptionally uniform; filter types give full inductance with rated d.c. flowing; power units have better than 10% regulation. Consult our Bulletin 1002 for complete details. Write:

AMERICAN TRANSFORMER CO.
178 Emmet Street Newark, N. J.



**OUR 1938
RADIO PARTS
CATALOG**
CONTAINS ITEMS
OF INTEREST TO
RADIO AMATEURS,
BEGINNERS AND
SERVICEMEN

Write for your
free copy now

CAMERADIO
963 LIBERTY AVE. PITTSBURGH, PA. 30 TWELFTH ST. WHEELING, W. VA.
Established 1919

Radio Digest
Sensation OF THE RADIO FIELD!

- It's the ONLY magazine with the best from ALL branches of radio (except business and entertainment).
- Digests, extracts, reprints from QST, Radio, All Wave Radio, Radio News, Electronics, Service, Communications, Bell System and R.C. All paper, house organs, over seas journals.
- Twelve issues for \$2.50 in U.S.A., Canada, and Pan-American countries. Elsewhere, \$3.00 or 12s. 6d. Sample copy, 25c.

RADIO DIGEST
7460 Beverly Blvd., Los Angeles

CODE—TAPES FOR EVERY NEED

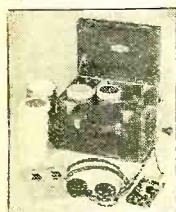

You can easily learn or improve your Radio or Morse Code—typical messages are sent you by the INSTRUCTOGRAPH P.M. at any speed. Senior model with 10 tapes and Book of Instructions—\$20.25. (Rented at low cost.) Junior model with 5 tapes and Book of Instructions—\$12.00 (Not rented). Complete oscillator equipment, less battery, \$6.50. Send for full information today to:

INSTRUCTOGRAPH CO., Dept. NR-3, 912 Lakeside Pl., Chicago, Ill. Representatives for Canada: Radio College of Canada, 863 Bay St., Toronto.

Buy on Cash or Terms—**HALLICRAFTER and R.M.E. SHORT WAVE RECEIVERS—SPEED-X and VIBROPLEXES.**

38-ohm speaker; a special "dual" phone jack that allows phone-and-loudspeaker reception when the phone plug is inserted part way, and phone "alone" when the plug is pushed all the way in. The receiver also may be obtained with two additional tubes in a scratch-filter circuit which takes out all noise when playing records.

An idea of the excellent mechanical workmanship on this receiver can be obtained from an examination of the photograph at the head of this article which shows the receiver with a dial and the shield can removed. Cut-away photographs of the i.f. tuning units, and the oscillator unit show the careful shielding and beautiful coil and coupling workmanship inside the chromium-plated "cans."

The chassis dimensions are 15 1/4 inches wide, 12 3/8 inches deep and 10 inches high. The output amplifier and power unit is 16 inches long, 5 3/8 inches deep and 8 inches high.

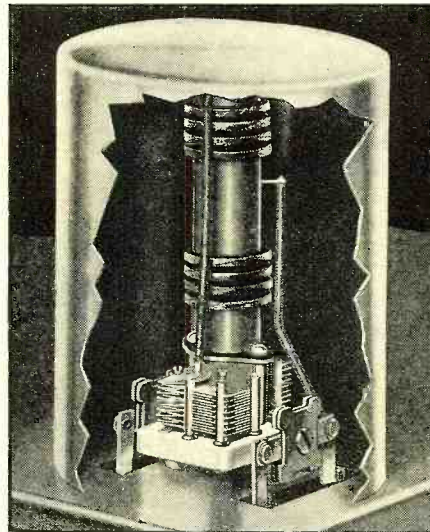

The controls on the receiver, looking at the front of the panel, include the main tuning dial with its control knob centered below it; the volume-control knob, at the extreme left; the bass control, next on the left; center, the silent-control button; next on the right, the fidelity control; and on the extreme right, the wave-change switch which has four radio positions and one marked "P" for playing records. From standpoints of design, workmanship, and operation, the receiver recommends itself immediately for both distance and local reception. It is easy to tune and should give long and satisfactory service.

If further technical details are required by interested readers, it can be obtained by writing to the E. H. Scott Company, in care of RADIO NEWS, and the added information will be supplied free of charge.

In the next issue a result of our Laboratory and Listening Post tests on the "16" will be published.

Snow Static

(Continued from page 520)

particles, no static was heard as long as the charge on the plane did not exceed a certain potential. As soon as the discharge from a 2-ft. steel point on the tail of the plane, or from the antenna, exceeded the potential in equilibrium with the surrounding charged atmosphere, then snow static sounds were heard on the plane's receiver.

A series of metal points were installed on the plane to learn the distribution of this discharge. These were arranged on the nose, tail, each wing, behind exhaust outlet, behind props and at four points along the plane's belly. A number of group systems connected to vacuum tube electrometers. Electrometers were connected to paper recorders.

A grouping of points suggested by Professor E. C. Starr of Oregon State College gave best results. Two-foot rods were distributed from the plane in the disturbed air at the tail and the undisturbed air forward of the nose. A plate on the nose recorded impacting water particles. Data collected gave conclusions that: (1) the plane may be either positive or negative with respect to surrounding atmosphere; (2) at any instant one swing may be in positive cloud particles while the other is in negative; (3) at any instant the nose of the plane may be in positive particles while the tail is in negative or vice versa.

During one field flight through a thundercloud the plane's magnetic compass moved 10 degrees with respect to the gyro compass, for several minutes. This could have been caused by a strong magnetic field in the cloud or by a cross flow of current in the plane structure. Ground tests required a wing flow of about 45 d.c. amperes to produce the same deviation. A nose-to-tail flow of 125 amperes was required for the same effect, varying with the plane's position with respect to the earth's magnetic field.

It is known that propeller action in cutting up water particles at 800 feet per second will produce an electric charge. It was concluded that a plane wing moving at 260 feet per second would do likewise. It was found that a negatively charged point will produce a corona about 50 percent more readily than a positive. From these facts six variables influencing snow static were concluded. Most interesting was that foreign matter in water particles is of considerable importance. Portland, Ore., tapwater split by a rotating prop

gives a positive charge, while Cheyenne, Wyo., tapwater gives a negative.

Static noise in these tests began with the plane charge as low as 30,000 volts, depending upon local humidity and the proximity of corona points on plane to the receiver and antennas. The "crying" sound of snow static began about 55,000 volts and occurred most readily when the plane was positive with respect to ground. The sound was easily traced to the corona discharge of some point or projection on the plane. It was concluded that the space charge in the ionized air around the point breaks down at an audio-frequency rate varying with humidity and voltage gradient at the point.

A study of the plane structure indicated that antenna masts, rivet heads, cotter keys, aileron hinges, tail, wheels, antennas, and any sharp point on projection on the plane are the focal points of corona discharges and consequently the source of snow static. Insulating these points will quiet the discharges only until the plane has built up to a higher potential when other points start corona discharges.

A study of the snow static shows that it has a short wavelength and that its attenuation with distance is rapid. The field pattern caused by a point in the corona at the rear of the plane is shown in Figure 1. Note that the area of interference production is parallel with the trailing edges of the plane. When a resistor was added in series with the point, interference in the plane was considerably reduced by moving the field area to the rear of the airplane, comparatively isolating it. One-hundred-thousand-ohm resistors and in cases up to 10 megohms are necessary. Moving the center of interference away from the plane takes advantage of the field's rapid attenuation.

Under similar conditions it is obvious that a trailing discharge point located some distance behind the plane with two suppressor resistors (see Figure 2) would help to discharge the plane. With a single trailing wire, up to 1-milliamper, 100,000-volt discharges at 50 feet could be made without disturbance in receivers hooked up to regular antennas. When the suppressors were removed, a 25-micro-ampere discharge two feet from the plane prevented radio reception.

TWA are now carrying on extensive research with a trailing wire and resistors. However, trailing gear has the disadvantage of coming in contact with the ground on landing and may cast loose, leaving any equipment dependent upon its presence deficient until reinstallation. Trying

to get around the mechanical handicap, UAL tried seventeen 3-foot, 3/1000-inch diameter wires, with a 5-megohm resistor in each, attached to wing and tail surfaces. Results compared with the single trailing wire were very inferior. Neither method made possible a rate of discharge fast enough when the plane entered areas where water particles had too high a potential.

Tests showed clearly that snow static interference is considerably greater at the tail of the plane than at the nose. With snow static of average strength present, the two loops located in the tear-drop housing and on the plane belly were both rotated and showed the source of maximum disturbance toward the rear of the plane. With extreme static, rotating loops showed static in all directions, indicating that corona had started on wing tips and propellers also.

In mild snow static, when beacon reception on the "V" antenna was normal, the two rear beacon antennas were so noisy no reception was possible. Although the 40-foot top antenna was superior to the "V" for signal pick-up, during snow static discharge the "V" could pick up 5000 kc. short-wave stations 1000 miles distant when the signals were obliterated on the top antenna.

Up to this point in research, UAL had not tested a trailing-wire antenna, but concluded it would be the worst type of antenna for reception during snow static. However, the type has decided advantages over existing systems for distance reception on the lower frequencies during clear local conditions.

A 150-foot trailing discharge wire of No. 14 B. & S. stranded aircraft cable, with no resistance suppressors in it, neither increased nor decreased snow static on the beacon frequencies. The short-wave receiver, however, was tuned to a 60-meter wavelength, hence the 150 feet of cable plus the 65 feet plane length was more than one wavelength long. Reeling the cable in and out gave two nodes of maximum and two nodes of minimum snow static, but the minimum was not sufficiently low to aid reception.

There had been some theories due to the presence of snow static at speeds above 100 m.p.h (also occasional interference at ground stations when the wind was above 100-mile velocity), that snow static was caused by particles striking the antenna. To check this, single-wire antennas were housed in both bakelite and aluminum 1-inch tubes, the antennas thoroughly insulated and with lead-ins completely enclosed in metal. With this protection no particles could

Use
YAXLEY
APPROVED RADIO
PRECISION PRODUCTS

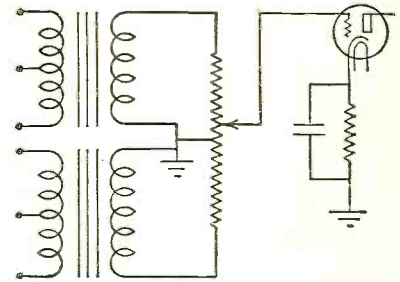
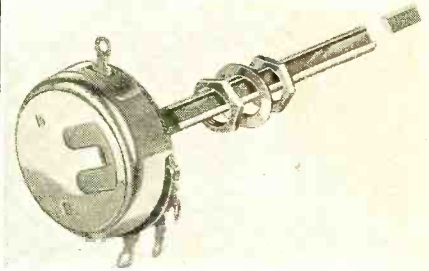

Fader Control for Electronic Mixers

The Yaxley TRP 609 control, a special one megohm center-tapped potentiometer with a combination right and left-hand taper has won well-deserved popularity as a means of fading two high impedance circuits into the grid of a following tube.

This control embodies the new Yaxley SILENT features of construction and is well-adapted for use in high gain amplifiers because of its noise-free characteristics.

The price is \$1.50 list, less knob. You can procure this part from your Mallory-Yaxley Distributor.

P. R. MALLORY & CO., Inc.
INDIANAPOLIS INDIANA

Cable Address—PELMALLO

Use
MALLORY
P. R. MALLORY & CO. Inc.
APPROVED RADIO
PRECISION PRODUCTS



E. H. RIETZKE

PRES. OF CREI

IF

You are an experienced radioman;
You are ambitious to get ahead rapidly in radio;
You realize the necessity of a directed training in the engineering principles of radio but are unable to take advantage of college training.—

Then--

Mail coupon for our new illustrated book "A Tested Plan." It will give you complete details of an advanced home study course in Practical Radio Engineering written for the experienced radioman.

CAPITOL RADIO ENGINEERING INSTITUTE

Dept. RN-3

Washington, D. C.—14th & Park Rd.
New York City—29 Broadway

MAIL THIS COUPON TODAY!

Please send me complete details and illustrated 48-page booklet—"A Tested Plan for a Future in PRACTICAL RADIO ENGINEERING."

Name.....

Address.....

City..... R.N.3

BOY! THIS MAKES RADIO REPAIRING A CINCH

RADIO KINK-AIDS

ONLY \$1.95

Complete with Metal Cabinet

Practical Repairs for 3,000 RECEIVERS
Over 3,000 filed and indexed service kinks to repair those hard-to-fix home and auto radios. Just pull out the card corresponding to the name and model of the set you are repairing, and there you have listed the service troubles found in that radio and how to fix them.

FREE WRITE FOR BULLETIN RN 3 AND SAMPLE CARDS

AKRAD PRODUCTS CO.
362 Wooster Ave. Akron, O.

Tear out this ad, write your Name and Address in the margin, mail \$1.95 and we will send out at once.



Automatic Tuning
Priced as low as \$11.95

Buy from us and save up to 50%. One year written guarantee. No-risk home trial—money back if not absolutely satisfied.

1938 CATALOG FREE
50 beautiful models, 5 to 15 tubes, for FARMS, HOMES and AUTOS
ONE YEAR GUARANTEE

SEND POSTCARD NOW!
SILVER MFG. CO., Inc., 2868 Elston Ave., Dept. 110, Chicago

RADIO COURSES

RADIO OPERATING: Prepare for Gov't License Exam
RADIO SERVICING Including Short Wave
AMATEUR CODE
ELECTRONICS • **TELEVISION**

Day and Evening Classes—Booklet Upon Request
NEW YORK Y.M.C.A. SCHOOLS
7 W. 63rd Street, New York City

strike antennas. Good reception resulted, but no better than reception over the regular No. 14 bare copper wire antennas exposed to weather.

In conditions where the plane becomes highly charged to the point where corona appears as St. Elmo's fire, No. 14 antennas must also go into corona. Since the wires have a small diameter, they might discharge to the atmosphere sooner than other points on the plane. The standard "V" antenna was replaced with wires of a diameter from 3/1000 inch up to 1-inch tubing. With the increase in diameter, reception improved. Outgoing corona current decreased, but not to the point to make a change of antenna wire diameter of practicable importance.

A pair of horizontal and vertical dipole antennas was tried with 100,000-volt charges. Tuned and coupled to the receiver by an electrostatically shielded antenna transformer they gave a definite improvement over corona static as compared to a single bare wire, but their signal pick-up was too poor for practical aircraft use. Resonating the aluminum tube antenna gave some gain against corona static, but not enough to warrant use. A receiver having a high-impedance antenna coupling system was compared with one having low impedance. Corona static in ratio-to-signal pick-up was nearly identical on both receivers.

On a trip in a Pacific tropical marine warm air mass no reception was possible after the metal-covered anti-static loops were used for a period of 25 minutes. This, of course, rendered them inoperative.

The advantage of metallicly shielded loops lies in their metal covering and the streamlining of the covering. An experimental wood nose covered with copper foil was installed on the plane. The foil was cut to form a Faraday shield. An unshielded loop in this nose gave practically the same results as the loops with metal immediately surrounding the wires. The loop in the tear-drop housing gave the same results as the nose ring or metallicly covered loop on the plane's belly. The nose-ring loop was about 5 percent better than the loop on the plane belly. The conclusion was that it was because it was farther forward.

A low-impedance metallic loop with an impedance-matched network gave the same results as a high impedance of the same metallicly covered construction. The wooden nose without copper foil was painted with a mixture of dope and graphite to give a resistance of 20,000 ohms to the plane structure. Signal pick-up dropped about 15 percent for loops inside this nose. No change in snow static interference occurred. An unshielded loop in this nose suffered from snow static while a metallicly covered loop in the same place gave its usual advantages.

Any insulated surface such as windshield, de-icers, non-metallic loop housings, etc., can charge up with respect to the plane. When the charge becomes high and the plane flies into higher or lower charged areas, the insulated surfaces will spark to the plane structure.

Painting the loop housing with dope and graphite stops this source

INDEX TO ADVERTISERS

Akrad Products Co.....	574	Models.....	563
Aladdin Radio Industries Inc.....	536	Montgomery Ward.....	557
Allied Radio Corp.....	555	National Radio Institute.....	513
American Television Inst.....	559	National Schools.....	568
American Transformer Co.....	572	National Union Radio Corp.....	568
Arrow Sales Co.....	576	New York Y.M.C.A. Schools.....	574
Automatic Device Mfrs.....	570	RCA Institutes, Inc.....	570
Bliss Electrical School.....	558	RCA Manufacturing Co.....	551
Brush Development Co., The.....	551	Radio City Products Co.....	568
Burstein-Applebee Co.....	575	Radio Digest.....	572
Cameradio Co.....	572	Radio & Technical Publishing Co.....	552, 556, 564
Candler System Co., The.....	537	Radio Training Association of America.....	562
Capitol Radio Engineering Inst.....	574	Radolek Co., The.....	575
Central Radio Laboratories.....	557	Raytheon Production Corp.....	565
Chicago Wheel & Mfg. Co.....	558	Readrite Meter Works.....	554
Classified.....	575	Rider, John F.....	567
Coyne Electrical School.....	551, 566	Scott Radio Labs, Inc., E. H.....	569
Dodges Institute.....	560	Sevan Co.....	566
Goldentone Radio Co.....	575	Silver Corp., McMurdo.....	553
Hallicrafter's Inc.....	Back Cover	Silver Mfg. Co., Inc.....	574
Hannarlund Mfg. Co., Inc.....	566	Solar Mfg. Co.....	560
Hetro Electrical Industries, Inc.....	560	Sprayberry Academy of Radio.....	517
Hygrade Sylvania Corp.....	561	Standard Transformer Corp.....	553
Instructograph Co.....	572	Supreme Instruments Corp.....	549
International Correspondence Schools.....	576	Teleplex Co.....	553
LeJay Mfg. Co.....	564	Transducer Corp.....	560
Lincoln Engineering School.....	564	Triad Mfg. Co., Inc.....	575
Mallory & Co., Inc., P.R.....	573	Trimm Radio Mfg. Co.....	549
Midland Television, Inc.....	575	Triplet Electrical Instrument Co.....	571
Midwest Radio Corp.....	558	Tri-State College.....	549
Million Radio & Television Lab.....	552	Try-Mo Radio Co., Inc.....	562
		Weston Electrical Instruments Corp.....	550
		Wholesale Radio Service Co.....	570
		Wright DeCoster, Inc.....	575
		Zephyr Radio Co.....	576

LEARN RADIO TELEVISION
MIDLAND'S

Color-Coded Extension Training fits you for better radio jobs—prepares for future television opportunities. Backed by 5000-watt Columbia music network broadcasting station, KMBC. Graduates qualified to take Government operator's license exams. Lifetime employment service. All necessary equipment for "home laboratory" experiments furnished. 90 illustrated lessons. 10 laboratory manuals. After "home training," bus tickets to Kansas City for 4 weeks' intensive training in laboratories. Get facts—write for free catalog. MIDLAND TELEVISION, Inc., Power & Light Bldg., 110-C W. 14th St., Kansas City, Mo.

RADIOS..SAVE UP TO 50%

DEAL DIRECT...FACTORY PRICES! Many models to select from: AC-DC, All-Wave, armchair models; automatic tuning; car radios; Farm sets that operate like city radios! Send postcard for NEW Bargain Catalog FREE, 30-DAY TRIAL plan and agent-user proposition! GOLDSTONE RADIO CO., DEPT. A3, DEARBORN, MICHIGAN

Free Catalog

30 DAY TRIAL \$6.98 UP

TRIAD Radio Tubes
Triple Checked for Quality

TRIAD MFG. CO., INC.
Pawtucket, R. I.
The Quality Name in Radio

RADIO IN IT'S ENTIRETY!

"B-A" serves the trade with every need in radio—complete 160-page catalog of nationally known radio receivers, public address, parts, supplies and equipment. Orders shipped same day received.

COMPLETE CATALOG AVAILABLE

BURSTEIN-APPLEBEE CO. 1812-14th MCGEE ST. KANSAS CITY, MO.

Read Classified Advertising—It Pays

Advertisements in this section sixteen cents a word for each insertion. Name and address must be included at the above rate. Cash should accompany all classified advertisements unless placed by an accredited advertising agency. No advertisements for less than 10 words accepted. Objectionable or misleading advertisements not accepted. Advertisements for these columns should reach us not later than 3rd of 2nd month preceding issue.

TECH PUBLICATIONS, INC.
461 Eighth Ave. New York, N. Y.

Correspondence Courses

USED Correspondence Courses and Educational Books sold or rented. Inexpensive. Money-back guarantee. Write for Free Catalog listing 4000 Bargains. (Courses bought.) Lee Mountain, Pisgah, Alabama.

Detectives

DETECTIVES—Make Secret Investigations. Write George Wanger, 2640-R, Broadway, New York.

Patent Attorneys

PATENTS. Instruction "How to Establish Your Rights" and form. "Evidence of Conception" sent Free! Lancaster, Allvine & Rommel, 414 Bowen Building, Washington, D. C.

PATENTS—Advice and booklet free. Highest references. Best results. Promptness assured. Watson E. Coleman, Patent Lawyer, 724 9th Street, Washington, D. C.

Patents and Inventions Wanted

INVENTIONS COMMERCIALIZED. Patented or unpatented. Write Adam Fisher Company, 278 Enright, St. Louis, Missouri.

Personal

WANTED original poems, songs, for immediate consideration. Send poems to Columbian Music Publishers, Ltd., Dept. 293, Toronto, Can.

Phonograph Records

EXTRA—Musicians, Music Writers, Amplifier Men—You can get slightly used phonograph records of late swing bands, 100 for \$4.00. No two alike. Send \$2.00 deposit. Balance C.O.D. Novelty Records Co., 614 Spring Garden St., Philadelphia, Pa.

Radio

RADIO Engineering, broadcasting, aviation and police radio, servicing, marine and Morse telegraphy taught thoroughly. All expenses low. Catalog free. Dodge's Institute, Elm St., Valparaiso, Ind.

RADIO R.T.I. Course, slightly used, \$5.00. Postcard brings details. Supreme, 3727 West 13th, Chicago.

QSL'S—New designs, 300 for \$1.75. Samples, Wilbur Printers, Sec. 3, 732 Federal St., Chicago, Ill.

Salesmen Wanted

WANTED COUNTY DISTRIBUTORS. Excellent opportunity for earnings. Nationally advertised product. Large company. Dept. 256 Fyr-Flyer Company, Dayton, Ohio.

of noise. If, however, the plane passes through an icing area, an ice cap will form on top of graphite paint. This ice cap is an insulator and may charge up and spark over in the same manner. Thus in ice, the paint does not accomplish its purpose. The answer is streamline loop housing so that ice does not form.

For some time bakelite stubs instead of the egg-type insulators have been used on transmitting antennas to avoid ice troubles. These stubs have been designed according to usual streamline form with a blunt forward edge. As a result of the loop housing and icing research, new stubs are being designed with a sharp front edge. This should finally solve the antenna icing problem which has been the cause of many not quite understandable (at the time) airplane crashes.

During the course of one flight the bonding on one of the ring cowls broke. This is not a particularly unusual event. The ring cowl, resting on leather pads, charged up in snow static and sparked over at regular signal intervals. In average charged clouds the sparking sounded in the headphones like pebbles falling in a metal pail. Any other exposed metal parts which are not bonded would cause similar static. First steps toward improving plane reception should include thorough, regular inspection of all bondings.

Definite results of the tests established that: (1) the advantage of metal-shielded loops over bare wires varies with the intensity of the corona discharge; (2) in mild snow static the advantage as measured by r.m.s static output of the receiver may be 20 or 30 to 1; (3) in heavy snow static the advantage drops to 5 or 10 to 1; (4) in very heavy snow static no reception can be heard on any loop antenna even when flying within 2 or 3 miles of the range station. But further research on this problem must be continued if a complete solution is to be found. And a solution must be found if planes are to be able to use radio when it is most needed.

Antenna Design

(Continued from page 539)

canceling radiation from alternate sections energy will be radiated in phase the full length of the wire, (Figure 7). No radiation can take place from the wires folded over each other since the field of one cancels that of the other. For a vertical wire we thus have maximum energy in the horizontal plane through the center of the wire.

TECHNICIANS

ability to furnish custom built inter-communication systems when using Talk-Bak* Units is one reason for their great popularity.

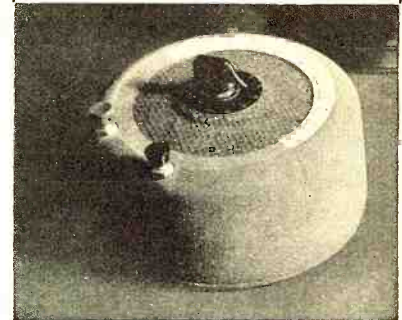

Attractive Model T.B.U. 1700 Size 6 1/2" diameter 3" high
FREE New Technical and Sales Pamphlet

gives complete information regarding all known inter-communication systems. Method of connecting different Talk-Bak* Units and full detailed information on what they will accomplish. Write for it and be sure to include your distributors' name.

Wright-DeCoster Distributors are always anxious to cooperate.

WRIGHT-DeCOSTER, Inc.

2255 University Ave., St. Paul, Minn.
Export Dept.: M. Simons & Son Co., New York

Cable Address: "Simontrice"

Canadian Representatives:
Wm. F. Kelly Co., 1207 Bay St., Toronto, Ont.,
Taylor & Pearson, Ltd., Edmonton, Alberta
*Copyrighted



Everything you need in radio. It's all in this new RADOLEK RADIO PROFIT GUIDE. Every repair part for every receiver. Newest radio receivers. New 1938 model public address amplifiers, outputs for 5 to 100 watts. New model public address speakers. Test instruments. Technical books. Special equipment. Leading standard brands. Every item guaranteed. It must be right or we make it right.

And everything under one roof. You get what you want promptly, and exactly what you want. Radolek's immense stock plus Radolek's efficient organization insures you fastest service. 25,000 service men depend on this service and benefit by Radolek's lowest prices. Send now for your copy of Radolek's Radio Profit Guide. It will help you make more money.

RADOLEK

601 W. Randolph, Chicago, Dept. B-15

Send me the 1938 Radolek Radio Profit Guide FREE.

Name.....
Address.....
Serviceman? Dealer? Experimenter?

RADIO

holds great rewards for trained men



The big opportunities in Radio will be enjoyed by trained men. The International Correspondence Schools Radio Course, prepared by leading authorities and constantly revised, will help make you a trained man! A fascinating book - FREE.

ELECTRICAL ENGINEERING

—A Great Industry with a Great Future

The new I. C. S. Course in Electrical Engineering covers this fascinating field thoroughly. If you are just starting or are on the way to a real paying position in this industry, this course brings the knowledge necessary for advancement.

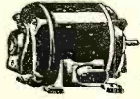

MECHANICAL ENGINEERING

—A Field with a Future

This I. C. S. Course has meant advancement to hundreds of ambitious mechanics, draftsmen, blacksmiths, foundrymen, patternmakers, apprentices, and mechanical engineers. You, too, will find that enrolling for an I. C. S. Course is an investment in a Bigger Future. Use the coupon!



AUTOMOBILE EXPERTS are always in demand

The rapid progress in manufacture and service of the modern automobile brings new opportunities to thousands of ambitious and forward-looking men. There's always a demand for trained men. The new I. C. S. Automobile Course will make you a trained man! The time to act is now. Use the coupon.



INTERNATIONAL CORRESPONDENCE SCHOOLS

BOX 8282-T, SCRANTON, PENNA.

Without obligation, send me full information on subject checked below:

- RADIO AUTOMOBILE COURSE
 ELECTRICAL ENGINEERING
 MECHANICAL ENGINEERING

- | | | |
|--|--|---|
| <input type="checkbox"/> Architecture | <input type="checkbox"/> Drafting | <input type="checkbox"/> Accounting |
| <input type="checkbox"/> Concrete Construction | <input type="checkbox"/> Good English | <input type="checkbox"/> Salesmanship |
| <input type="checkbox"/> Reading Shop Blueprints | <input type="checkbox"/> Advertising | <input type="checkbox"/> Show Card Lettering |
| <input type="checkbox"/> Civil Engineering | <input type="checkbox"/> Diesel Engines | <input type="checkbox"/> Civil Service |
| <input type="checkbox"/> Gas Engine Operating | <input type="checkbox"/> Refrigeration | <input type="checkbox"/> High School Subjects |
| <input type="checkbox"/> Chemistry | <input type="checkbox"/> Highway Engineering | <input type="checkbox"/> Air Conditioning |
| <input type="checkbox"/> Poultry Farming | <input type="checkbox"/> Inventing and Patenting | <input type="checkbox"/> Aviation Engines |

Name _____ Age _____
 Address _____

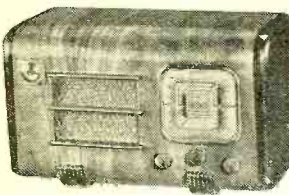

SAVE

UP TO 50%
 1938 Models
 Latest Features
 MONEY BACK
 GUARANTEE
 Free Catalog
 Zephyr Radio Co.
 13137 Hamilton
 Blvd.
 Detroit, Michigan

6-VOLT UNIVERSAL POWER PACK

At Less Than Price 6-Prong Synchronous Vibrator Alone!
 LISTS \$15.00 Operates 2 volt set from 6 volt storage battery, also operates 6 Volt house sets, auto sets, S.W. transmitters and receivers. Output, 180 Volts at 50 M.A. On 4 Volt cell supplies 120 Volts at 30 M.A. Housed in case 3"x4"x6 3/4". Shipping Wt. 6 lbs.



ONLY \$3.95 NET
 ARROW SALES COMPANY
 Chicago, Ill.

27 S. Jefferson St.

All-Wave "15-17"

(Continued from page 532)

logged on this dial by making a notation of the frequency shown by the large dial and the division reading on the small one. In this manner a very acceptable degree of band-spreading is obtained, even on the lower-wave range. The 20-meter amateur band, for instance, spreads out over a range of 35 degrees on this secondary dial, the 10-meter band over 70 degrees, etc.

The calibration of the main dial was checked at several points in each range and the maximum error found to be 3 kilocycles in the broadcast band; in the other ranges it did not exceed 1/3 of 1 per cent which is very good indeed for an all-wave receiver, as this percentage represents an error of only 3 kilocycles per 1000 kilocycles.

Extensive tests were made on the various amateur bands, with results that were little short of surprising. The high tuning ratio coupled with the secondary dial system provides satisfactory band-spread; the sensitivity meets all requirements; the high signal-to-noise ratio permits good weak-signal reception and the selectivity in the 3 kc. position is better than that of the average communication receiver. A beat-frequency oscillator, and a very stable one, is included for c. w. reception and a very fair degree of single-signal operation is actually obtainable in this type of reception.

Unusual though it may be for an all-wave broadcast receiver, reception on the low wavelengths including the 10-meter amateur band is really good, with plenty of DX from 10-meter "hams" all over the world.

As a musical instrument, little is left to be desired. There are numerous adjectives that could be used in describing it but we will content ourselves by saying that the quality of reproduction is nothing less than beautiful, conveying to the listener the full thrill and enjoyment of fine music, with full value to the instruments which are lost in the average receiver. In the tests even musicians were impressed with the fidelity of reproduction—and when musicians are impressed the receiver must be good!

Thus the brief description of the findings of this listening post test are concluded except to add that the receiver was found to be one worthy of an excellent rating whether for use primarily as a musical instrument, DX getter, world-wide short-wave rover or a combination of all of these in the hands of a serious minded listener.

At Your Dealer's

(Continued from page 571)

tuning condenser, to the wave-band switch, or it can be connected into and out of the circuit in place of the tuning condenser. It is supplied complete with five connecting leads an escutcheon, list of broadcast stations, mounting screws, drilling template, and all necessary operating instructions. The trimmers are specially designed for minimum "drift" and are not affected by climatic changes. It is supplied in two types that can be mounted on the top, side or front of the cabinet, and may be adjusted after being completely installed, without having to remove the chassis or the tuner from the cabinet.

Voices from the Past

(Continued from page 524)

A graduate Mechanical Engineer of Georgia Tech and Brooklyn Polytechnic, Hazard E. Reeves became research engineer for the Columbia Phonograph Co. and later recording engineer for the Stanley Recording Co. He has been consulting engineer for many well-known firms and Director of Recording for the Harvard University Film Foundation. He is now president of his own Laboratory and technical adviser to the Omnixox Company.

The Amateur Observer

(Continued from page 557)

- 6AM-7, ZS6AG-6, HC1FG-S, FT4A1-7, ST4AN-9, T12FG-S, YV5AA-7, LU1KA-6, By Denver Edward Whyte, P. O. Box 441, Beira, Portuguese East Africa
 20 to 40 meters: W1BS, 11SY, 1CES, 1BES, 1SH, 1TW, 1GR, 1FH, 2IKV, 2MB, 2EDW, 2DLT, 2JKO, 3NBY, 3FSG, 3AMP, 4HX, 4UZO, 4IKU, 4OSS, 4EF, 4BB, 5TC, 5FDE, 5EFG, 5VXH, 5AV, 5FIY, 5AGP, 5BDB, 5AWE, 6KM, 6CNA, 6LMO, 6NNR, 6LR, 6BKY, 6TG, 6LWE, 6QN, 6NTT, 6NWT, 6NWO, 6WTF, 6DDN, 6NMO, 6ALJ, 6MBE, 6DDA, 6FD, 6OGI, 6NKP, 6MPV, 6AL, 6OK, 6FGW, 6ANW, 6OAS, 6ABF, 6CFI, 6FD, 6KY, 6TK, 6BIB, 6EOY, 6LLO, 6SI, 6ASH, 6DYE, 6ABF, 6FTU, 6BKY, 7BBC, 7SAMO, 7EAY, 9GTE, 9FT, 9HOI, 9NLT, 9GEG, 9CDO, 9ODQ, 9BDV, 9XFI, 9LFX, 9LG, 9RK, 9ARL, 9AEV, 9GIC, 9PHO, 9PKMX, 1ZZ, 1RL, 2AW, 2WL, 3DB, 3GD, 3ER2L, 3KATME, 1DT, 1HS, 1YL, 1DBIOR, 1PYJR, 1KOOE, 1GOQ, 1TNG, 1VSIK, 1AD, 2AK, 5AG, 5PYAQ, 5KAW, 6VY, 6FS, 6LUIQ, 1AL, 2AF, 3EJ, 5CZ, 7AG, 8FN, 9BV, 9CTIC, 9FQA, 9Q7LO, 9AL, 9E1LR, 2UO, 2MF, 2ABD, 3KL, 3SH, 4VJ, 4WJ, 2LT, 2MI, 4QV, 6TV, 6VU2CQ, 2HQ, 6VK2JU, 6MW.

"Hi-Fi"

In the February issue we presented a constructional article on a receiver which was titled the "Hi-Fi '9'". This name was selected without knowledge that the Standard Transformer Company of Chicago holds a copyright on the name "Hi-Fi" and we regret any possible confusion that might result.

IT'S FREE!

With a Subscription For Radio News

EVEN a casual glance at the list of contents given below will prove, beyond a doubt, that the 1938 RADIO DATA BOOK is one of the most useful radio volumes ever published. It supplies the hard-to-get information that is invaluable for reference work in every line of radio. YOU need a copy—no matter what your connection with radio. And, you can obtain this great book *absolutely free of charge!* Simply return the coupon below with your remittance of \$1. (Canada & Foreign \$1.25) for a 5-month subscription for RADIO NEWS and we will rush a copy of the 1938 RADIO DATA BOOK to you without any additional cost! If you are already a subscriber and want this book, mail the order blank with your remittance and your present subscription will be extended. Act now and avoid disappointment—our supply of these valuable books is limited!

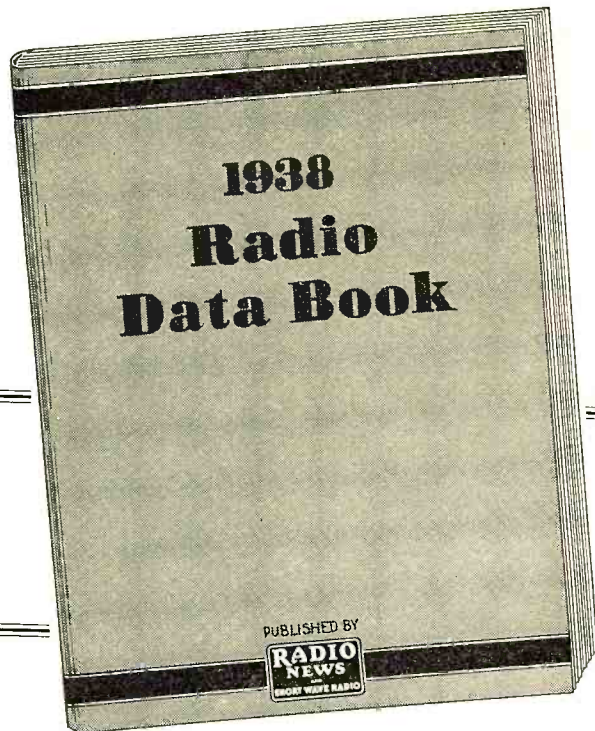

Complete List of Contents

TELEVISION

The Present Status of Television
RCA, Philco, Farnsworth and Don Lee Systems
Building a Don Lee Television Receiver

RADIO RECEIVERS

Tiny One-Tube Pocket Set
Easy-to-Build 4-Tube S. W. Set
Low-Cost High-Fidelity Receiver
5-550 Meter R-S-R Receiver

SERVICE AND LABORATORY APPARATUS

Simple Test Oscillator
Radio News "Capatron" Signal Generator
Multi-Range Tube Voltmeter
Midget Cathode-Ray Oscilloscope

PUBLIC ADDRESS SYSTEMS

Three-Channel Pre-Amplifier
Mobile 10-Watt Amplifier
Inverse Feedback 60-Watt Amplifier
Direct-Coupled High-Fidelity Amplifier
Figuring Decibel Ratings

SERVICE HINTS

Vibrator Trouble-Shooting
Installing a Mobile P. A. System
Oscillation and Noise in Supers
Noise in 6-Volt Farm Sets
Curing Noisy Volume Control
1937 Ford Auto Radios
The Majestic Series 90

SERVICE HINTS (Continued)

Replacing Knob Wedges
How Much to Charge for Service Work
An Improvised Scriber

EXPERIMENTAL RADIO DATA

A Closet-Door Work Bench
Home-Built Photo-Electric Device
Midget Instrument Power Supply
Instrument Amplifier
New Kink for Increased Selectivity
Useful Earphone Circuits
Car Aerial from Old Music Stand
Rewinding Old Transformers for 6-Volt Tubes
Handy Connecting Leads
Output Meter Using 6H6 Tube
6H6 Oscillator
Improved Condenser Tester
Removing Chassis Smudges
Rack for Radio Manuals
Home-Made Bridge Analyzer
Antenna Kink for Motor Car Radios
A Decibel Meter
Handy Container for Nuts and Bolts
Work Bench for the Small Shop
Handy Tuning Knob
Combination Power Supply and Audio Amplifier
Home-Made Stand for Single-Button Mikes

AMATEUR AIDS

Learning the Code
Curing BCL Troubles
Transmitting Tube Charts

AMATEUR RECEIVERS AND TRANSMITTERS

"Quartet" Receiver for 5 and 10 Meters
10-Meter Converter
X'tal Control 5-10-20-Meter Transmitter
2-Tube M.O.P.A. Transmitter

RECEIVING TUBE CHARTS

Detector and Amplifier Tubes
Series Filament Power Output Tubes
Rectifiers
Cathode-Ray Tuning Indicators
Socket Connections

STATION LISTS

World Short-Wave Station List

Mail Coupon Now!

RADIO NEWS, Dept. 383A
608 So. Dearborn St., Chicago, Ill.

Enclosed find \$1. (Canada & Foreign \$1.25). Enter my subscription for 5 issues of RADIO NEWS and send me a free copy of the 1938 RADIO DATA BOOK. If renewal, check here ().

Name.....

Address.....

City..... State.....

*Announcing
the*

SKY CHALLENGER II

*With the New Hallcrafters Infinite Image Receptor**

We are proud to announce the Sky Challenger II, not as just another new receiver, but as a definite contribution to amateur radio. With the Sky Challenger II, we offer another new and far-reaching Hallcrafters development—the Infinite Image Receptor.

With this new circuit, equivalent in operation to several expensive pre-selector's and an integral part of the New Sky Challenger II, annoying image interference is completely eliminated. But this is not all. It has the same famous 1000° Spiral Band Spread System used in the Super Skyrider, and a host of other quality features that make it an outstanding value at its new low price. See it! Operate it! Compare it! Write for full information today.



- ★ 9 Tubes
- ★ Infinite Image Receptor
- ★ 1000° Spiral Band Spread
- ★ New Recessed Main Tuning Dial
- ★ Full Coverage 38 MC to 540 KC (7.9 to 545 meters)
- ★ Beat Frequency Oscillator
- ★ Tone Control
- ★ "S" Meter Terminals
- ★ Crystal Filter Circuit
- ★ Iron Core I.F.'s
- ★ AVC Switch
- ★ Better Sensitivity and Selectivity

the hallcrafters inc. 2603 Indiana Ave., Chicago, U.S.A. • Cable Address: "HALLCRAFT," Chicago

"WORLD'S LARGEST BUILDERS OF AMATEUR COMMUNICATIONS RECEIVERS"

*Patent Applied For