

ELIMINATING INTERFERENCE

RADIO NEWS

**January
25 cents**

**The
"Electric Ear"
of Radio**



**Filter design
Direct-coupled Amplifiers
Beat-frequency Oscillator**



—“I HAVEN'T MISSED A SINGLE BROADCAST

OF LOUDSPEAKER RECEPTION, WITH ABSOLUTELY EVERY WORD AUDIBLE SINCE THE FOURTH DAY OF LAST APRIL, OF STATION VK3ME (MELBOURNE, AUSTRALIA), EVERY PROGRAM LOGGED IN MY LOG BOOK”

... writes a Lincoln owner in the mountains of Tennessee. (Name and address on request.) He continues: “This not only applies to Melbourne, but

I HAVE NOT MISSED A SINGLE TEST

of JIAA, Kemukawa, Japan since May 1st, as my records indicate. Other stations the world over are received on their schedules as regular as clockwork. Even the little 1½ KW station of Ponzon, Poland is received on its wave of 31.35M regularly every Tuesday and Thursday.”

“Even with all the thrill that short waves possess, a new one comes when foreigners are logged on the broadcast band. Last week when I received Sydney, Honolulu, and Osaka (Japan), all in one morning, it makes a feeling come that almost takes away the thought of the prevailing period of depression. It is almost weird to turn on the set in the mid-day and log over thirty stations from seventy-five to twenty-five hundred miles distant, but, I add that the day it occurred was the best day of reception that I have had on broadcast in many months.”

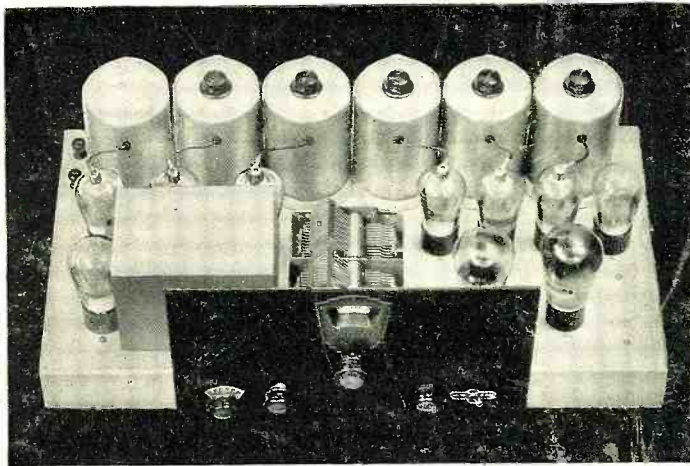

Super Power Means Super Performance IN YOUR HOME

**15 to 550
METERS**

**NO
PLUG-IN
COILS**

**GLOBE-
CIRCLING
POWER**

**LABORATORY
CONSTRUCTED
BY COMPETENT
ENGINEERS**

A SLIGHT touch of a switch puts the tremendous power of a Lincoln DeLuxe to work for you. POWER that pulls in programs from the four corners of the earth, that spans the seven seas to bring fascinating programs from foreign lands into your own home! POWER that enables Lincoln owners to enjoy enviable records of almost unbelievable performance! However, sheer power alone could not effect such remarkable results. The overwhelming success of Lincoln receivers is due to precise and positive control of the exceptionally high amplification derived from four tuned I. F. stages.

Globe Circling Power Applied to Short Waves

The Lincoln short wave feature is not to be confused with hastily improvised “converters,” “adapters” or other accessory units that are being used in some receivers. Lincoln engineers have succeeded in designing the DeLuxe to accommodate short waves in precisely the same manner as the reception of broadcast stations. This feature is inherent in the receiver itself, and has no external parts or connections. Each band of short wave frequencies is tuned through its permanently placed coils and is passed through the high-gain, screen-grid I. F. stages exactly the same as broadcast frequencies, thereby utilizing the entire resources of the famous Lincoln circuit.

A small no-capacity selector switch on the front panel gives instant access to any of the four bands of short waves or the broadcast band.

DeLuxe DC-SW-10 Battery Model is a Marvel of Crystal-Clear World-Wide Performance

From its first public appearance the Lincoln DeLuxe DC-SW-10 has achieved universal success. Retaining the identical engineering features that has placed Lincoln A. C. equipment far ahead of the field, the DC-SW-10 battery model offers extremely quiet, crystal-clear reception of both broadcast and short wave programs.

Availing themselves of the new low drain tubes, Lincoln engineers were completely successful in duplicating the mighty power, hair-line selectivity and famous Lincoln tone quality of the A. C. models. In addition, the DeLuxe DC-SW-10 is astonishingly quiet in operation and possesses a richness of tone that is truly phenomenal. Although primarily designed for rural and unelectrified sections, the DeLuxe DC-SW-10, because of its freedom from line-noise and its marvelous tone quality is finding increasing favor in urban homes.

COUPON

Clip and mail the coupon for complete information about the Lincoln DeLuxe SW-32 (110V-60 cycle A. C.) and the DeLuxe DC-SW-10 (battery model) receivers.

LINCOLN RADIO CORPORATION

Dept. N-1, 329 S. Wood St., CHICAGO, ILL.

Name.....

Street.....

City..... State.....

Train *with* R.T.A. *for* Radio Service Work

Important and far-reaching developments in Radio creates sudden demand for specially equipped and specially trained Radio Service Men.



*This excellent
set analyzer
and trouble
shooter included
with our course
of training*

MANY skilled Radio Service Men are needed now to service all-electric sets. By becoming a certified R. T. A. Service Man, you can make big money, full time or spare time, and fit yourself for the big-pay opportunities that Radio offers.

We will quickly give you the training you need to qualify as a Radio service man . . . certify you . . . furnish you with a marvelous Radio Set Analyzer. This wonder instrument, together with our training, will enable you to compete successfully with experts who have been in the radio business for years. With its help you can quickly diagnose any ailing Radio set. The training we give you will enable you to make necessary analysis and repairs.

Serving as a "radio doctor" with this Radio Set Analyzer is but one of the many easy ways by which we help you make money out of Radio. Wiring rooms for Radio, installing and servicing sets for dealers, building and installing automobile Radio sets, constructing and installing short wave receivers . . . those are a few of the other ways in which our members are cashing in on Radio.

As a member of the Radio Training Association, you receive personal instruction from skilled Radio Engineers. Upon completion of the training, they will advise you personally on any problems which arise in your work. The Association will help you make money in your spare time, increase your pay, or start you in business. The easiest, quickest, best-paying way for you to get into Radio is by joining the Radio Training Association.

This amazing Radio Set Analyzer plus the instructions given you by the Association will transform you into an expert quickly. With it, you can locate troubles in all types of sets, test circuits, measure resistance and condenser capacities, detect defective tubes. Knowing how to make repairs is easy; knowing what the trouble is requires expert knowledge and a Radio Set Analyzer. With this Radio Set Analyzer, you will be able to give expert service and make big money. Possessing this set analyzer and knowing how to use it will be but one of the benefits that will be yours as a member of the R. T. A.

Write for No-Cost Membership Plan

We have worked out a plan whereby a membership enrollment need not cost you a cent. Our thorough training and the valuable Radio set analyzer can be yours. Write at once and find out: how easily both of these can be earned.

Now is the time to prepare to be a Radio Service Man. Greater opportunities are opening up right along. For the sake of extra money in your spare time, bigger pay, a business of your own, a position with a future, get in touch with the Radio Training Association of America now.

Send for this No-Cost Membership Plan and Free Radio Handbook that will open your eyes as to what Radio has in store for the ambitious man. Don't wait. Do it now.

RADIO TRAINING ASSOCIATION OF AMERICA

Dept. RNA-1 4513 Ravenswood Ave. Chicago, Ill.

Fill Out and Mail Today!

RADIO TRAINING ASSOCIATION OF AMERICA
Dept. RNA-1, 4513 Ravenswood Ave., Chicago, Ill.
Gentlemen: Send me details of your No-Cost Membership Enrollment Plan and information on how to learn to make real money in radio quick.

Name.....

Address.....

City..... State.....

S. GORDON TAYLOR
Technical Editor
WILLIAM C. DORF
Associate Editor



RAYMOND J. KELLY
Associate Editor
JOS. F. ODENBACH
Art Editor

Edited by LAURENCE M. COCKADAY

VOLUME XIII

January, 1932

NUMBER 7

CONTENTS

(Cover Design by Morey)

- | | |
|---|---|
| Thirty-seven Years of Radio Progress
By <i>Senatore Guglielmo Marconi</i>PAGE 553 | The March of Electrons
By <i>Raymond Francis Yates</i>PAGE 573 |
| The Microphone—Radio's Electric Ear
By <i>Thomas Elway</i>PAGE 555 | Electric Filter Design
By <i>C. A. Johnson</i>PAGE 574 |
| "Wireless" Centralized Radio
By <i>D. E. Replogle</i>PAGE 558 | The Radio News Ear Aid
By <i>S. Gordon Taylor</i>PAGE 575 |
| Are You Responsible for Interference?
By <i>Tobe Deutschmann</i>PAGE 560 | A New "Super" for Circuit Experimenters
By <i>Chesley H. Johnson</i>PAGE 578 |
| The Latest Example of Tuned R.F. Design
By <i>Glenn H. Browning</i>PAGE 562 | How to Build a Beat Frequency Oscillator
By <i>Donald Lewis</i>PAGE 580 |
| Electrical Transcription for Broadcasting
By <i>Thomas Calvert McClary</i>PAGE 564 | Rack-and-Panel Design for P. A. Systems
By <i>McMurdo Silver</i>PAGE 583 |
| The Future of Radio in Broadcasting
By <i>Zeh Bouck</i>PAGE 566 | Using Graphs and Charts in Modern Radio
By <i>John M. Borst</i>PAGE 585 |
| Reducing Noise in Talking Picture Film
By <i>Barton Kreuzer</i>PAGE 569 | Commercial Applications of the Direct
Coupled Amplifier
By <i>George E. Fleming</i>PAGE 587 |
| Power Supply for the R. N. Transmitter
By <i>Nat Pomeranz</i>PAGE 571 | Mathematics in Radio
By <i>J. E. Smith</i>PAGE 589 |

DEPARTMENTS

- | | |
|----------------------------------|----------|
| The Service Bench..... | PAGE 590 |
| Service Data for Servicemen..... | PAGE 593 |
| Radio Physics Course..... | PAGE 594 |
| With the Experimenters..... | PAGE 596 |
| Radio Science Abstracts..... | PAGE 599 |
| Latest Radio Patents..... | PAGE 601 |
| Backstage in Broadcasting..... | PAGE 603 |
| What's New in Radio..... | PAGE 604 |
| News and Comment..... | PAGE 606 |

Published Monthly by Teck Publishing Corporation, Washington and South Avenues, Dunellen, N. J.

OFFICERS

Lee Ellmaker, *President*
Warren P. Jeffery } *Vice Presidents*
Huston D. Crippen }
William Thompson, *Treasurer*
Wesley F. Pape, *Secretary*

EDITORIAL AND EXECUTIVE OFFICES

350 HUDSON STREET, NEW YORK CITY, N. Y.

Entered as second class matter at the Post Office at Dunellen, N. J., under the act of March 3, 1879. Copyright, 1931, by Teck Publishing Corporation. All rights reserved. Title Registered at the U. S. Patent Office. Printed in the United States of America. The contents of this magazine must not be reproduced without permission. We cannot be responsible for lost manuscripts, although every care is taken for their safety.

25c a Copy, \$2.50 a year,
\$3.50 in Canada, \$3.50 in
Foreign Countries. Sub-
scribers are notified that
change of address must reach
us five weeks in advance of
the next day of issue.

I Will Show You Too

How to Start a Spare Time or Full Time Radio Business of Your Own Without Capital



J. E. SMITH, President
National Radio Institute

The man who has directed the Home-Study Training of more men for the Radio industry than any other man in America.

Here are a few examples of the kind of money I train "my boys" to make

Started with \$5 Now has Own Business



that is play."—Howard Houston, Route No. 2, Box 454-E, Tucson, Ariz.

"I started in Radio with \$5, purchased a few necessary tools, circulated the business cards you gave me and business picked up to the point where my spare time earnings were my largest income. Now I am in business for myself. I have made a very profitable living in work

\$700 in 5 Months Spare Time

"Although I have had little time to devote to Radio my spare time earnings for five months after graduation were approximately \$700 on Radio, sales, service and repairs. I owe this extra money to your help during the time I studied and since graduation."—Charles W. Linsey, 537 Elati St., Denver, Colo.



\$7396 Business in 2 1/2 Months

"I have opened an exclusive Radio sales and repair shop. My receipts for September were \$2,332.16, for October \$2,887.77 and for the first half of November, \$2,176.32. My gross receipts for the two and one-half months I have been in business have been \$7,396.25. If I can net about 20% this will mean a profit of about \$1,500 to me."—John F. Kirk, Kirk Sales and Service, Union Block, Spencer, Iowa.

My Free book gives you many more letters of N. R. I. men who are making good in spare time or full time businesses of their own

THE world-wide use of receiving sets for home entertainment, and the lack of well-trained men to sell, install and service them have opened many splendid chances for spare time and full time businesses. You have already seen how the men and young men who got into the automobile, motion picture and other industries when they were young had the first chance at the key jobs—and are now the \$5,000, \$10,000 and \$15,000 a year men. Radio offers you the same chance that made men rich in those businesses. Its growth is opening hundreds of fine jobs every year, also opportunities almost everywhere for a profitable spare time or full time Radio business. "Rich Rewards in Radio" gives detailed information on these opportunities. It's FREE.

So many opportunities many make \$10 to \$25 a week extra while learning

Many of the ten million sets now in use are only 25% to 40% efficient. The day you enroll I will show you how to do 28 jobs common in most every neighborhood for extra money in your spare time. I will show you the plans and ideas that are making as high as \$200 to \$1,000 for others while taking my course. G. W. Page, 2210 Eighth Avenue, S., Nashville, Tenn., writes: "I made \$935 in my spare time while taking your course."

Many \$50, \$60 and \$75 a week jobs opening in Radio every year

Broadcasting stations use engineers, operators, station managers, and pay \$1,200 to \$5,000 a year. Radio manufacturers use testers, inspectors, foremen, engineers, service men and inspectors for jobs paying up to \$7,500 a year. Radio Operators on ships enjoy life, see the world, with board and lodging free, and get good pay besides. Radio dealers and jobbers are continually on the lookout for good service men, salesmen, buyers, managers, and pay \$30 to \$100 a week. Talking Movies pay as much as \$75 to \$200 a week to the right men with Radio training. My book tells you of other opportunities in Television, Aircraft Radio and other fields.

I will train you at home in your spare time

Hold your job until you are ready for another. Give me only part of your spare time. You don't have to be a high school or college graduate. Hundreds have won bigger success. J. A. Vaughn jumped from \$35 to \$100 a week. E. E. Winborne seldom makes under \$100 a week now. The National Radio Institute is the Pioneer and World's Largest organization devoted exclusively to training men and young men, by correspondence for good jobs in the Radio industry.

You Must Be Satisfied

I will give you an agreement to refund every penny of your money if you are not satisfied with my Lessons and Instruction Service when you complete my course. And I'll not only give you thorough training in Radio principles, practical experience in building and servicing sets, but also Advanced Training in any one of five leading branches of Radio opportunities.

My 64-Page Book Gives the Facts

Clip and mail the coupon now for "Rich Rewards in Radio." It points out the money-making opportunities the growth of Radio has made for you. It tells of the opportunities for a spare time or full time Radio business of your own, the special training I give you that has made hundreds of other men successful; and also explains the many fine jobs for which my course trains you. Send the coupon to me today. You won't be obligated in the least.

Get my new book It points out what Radio Offers You



You Get Extensive Practical Experience With the Outfits I Give You

Shown here is one of the many circuits you can build with the eight big home experimental outfits I give you. These outfits are real Radio parts and the 100 experiments you make with them explain clearly the basic principles of whatever branch of Radio you choose—and give you practical experience in servicing practically every type of receiving set made.

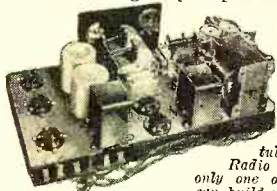

Back view of seven tube screen grid tuned Radio frequency receiver—one only one of many circuits you can build with my outfits.

Special Free Offer
"The Principles of Television"

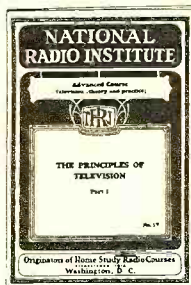

For the first time this authoritative book on Television is made available to the general public. Until now only my students could have it. Act promptly, and I'll send you a copy FREE, in addition to my big free book "Rich Rewards in Radio." This book on Television gives you the fundamental facts about Television, its status, a comparison of sound and visual communication, and describes in detail the typical devices used in the six fundamental steps of Television. Get the facts about this coming field of great opportunity. Mail the coupon NOW.

J. E. SMITH, President
Dept. 2AR
National Radio Institute
Washington, D. C.

THIS COUPON IS GOOD FOR ONE FREE COPY OF MY NEW BOOK

mail it TODAY

J. E. SMITH, President,
National Radio Institute, Dept. 2AR
Washington, D. C.

I want to take advantage of your special offer. Send me your two books "The Principles of Television" and "Rich Rewards in Radio." I understand this does not obligate me and that no salesman will call.

Name.....
Address.....
City..... State.....

Get the facts on my Lifetime Employment Service to all Graduates

The Editor—to You

INDUCTIVE interference is unquestionably the greatest ill that mars and spoils radio reception in the large cities in America—and probably for that matter over the whole earth. In the temperate zones "old man static" has been virtually conquered by high-powered broadcasting stations and by the more selective input circuits of the modern receiver.

Inductive interference, more popularly termed "man-made static", is largely a product of the city. It is due, indirectly, to the higher standard of living now prevalent in the cities and, directly, to some of the electric household devices now commonly found in our homes, as well as to the great electric power lines that serve our communities with electric light and power for various purposes.

The electric refrigerators, heating pads, sewing machines, vacuum sweepers, and other small-motor devices in our homes, as well as electric elevators in the larger apartments, either automatic or operator controlled, and our telephone and telegraph systems all add to the ether din some form of wave vibration that is transmittable directly to our receiving sets over short distances. Power lines themselves sometimes contain defective insulation and cause leakage producing radio noises over a whole neighborhood.

* * *

CAN this interference be cured?

* * *

UNDoubtedly many listeners have become discouraged on account of this interference and have lost interest in radio listening-in. Likewise, many prospective buyers of radio receiving apparatus are deterred from purchasing sets, and enjoying radio reception, by the fear of bad reception due to these disturbances.

* * *

ONLY a short time ago an *executive* of a large business in New York City stopped at our offices and asked whether or not there was a cure for this type of interference. It seems that he had retained in his home, for a number of years, a small battery-operated receiver of an early type. During his conversation with the Editor he mentioned that he had had two different radio dealers try to install for him a modern electric set and also try to eliminate the terrible noise in his reception. Both attempts failed, and he had gone back to his old battery set, which, on account of being very insensitive, did not receive the interference loud enough to bother him. An investigation of his location traced the trouble to an automatic elevator and also to an electrical device in his own apartment. Finally a modern radio installation was made for him, with interference eliminators placed on the offending apparatus, and his troubles were solved once and for all.

* * *

HERE is a great opportunity for thousands of servicemen, and service departments of dealers, to rectify the trouble

of radio interference, obtaining more satisfaction from the sets for radio users and at the same time increasing the sale of modern receivers.

* * *

ON PAGE 560 of this issue will be found an article on this subject of interference describing some of the causes, the effects and the apparatus used in eliminating the trouble.

THE recent passing of the eminent electrical wizard, Thomas A. Edison, ended a career of service and beneficence to all mankind. Everyone knows of his genius in devising and developing the incandescent electric lamp, the phonograph, the modern type of electric microphone and many other now more or less familiar devices in everyday life. Few laymen, however, appreciate what Edison has done for radio. Many years ago he discovered the "Edison" effect. This phenomenon is the basis upon which our modern vacuum tubes work. He dis-



covered that a stream of electric particles were shot from a heated filament in a vacuum. This is the phenomenon now used in all vacuum tubes in which the filament, heated by electricity, like Edison's first incandescent lamp, shoots out a stream of electrons to be caught by a plate in the modern tube. Edison himself had built many such tubes with both filaments and plates and had been able early to measure the resulting currents generated thereby. The pioneer inventor also took out many early patents on radio transmission and reception schemes, some of them radically different than those we use today. His mind was ever active, even up to the last moments, with problems in physics and chemistry, his last work being that on synthetic rubber from goldenrod.

Radio men, along with the rest of humanity, mourn his passing and honor his memory. His example will always be an encouragement and will therefore add impetus to the strivings of other inventors.

RADIO NEWS contains this month an outline of radio progress, during the

last thirty-seven years, by another genius, Senatore Guglielmo Marconi, who is still experimenting and adding to the world's wealth of knowledge and comfort. Read his interesting words that foretell added understanding and co-operation between the nations of the earth.

* * *

Do you know what a microphone is?

* * *

THOMAS ELWAY describes the various types of microphones that have been developed and tells of possible future progress in the "electric ear" that makes all radio broadcasting possible.

* * *

C. A. JOHNSON starts his important series on Electric Wave Filters, describing the various types for both radio and audio frequencies and giving the mathematics for their design and construction.

* * *

PERSONS who are hard-of-hearing will find on page 576 the RADIO NEWS "Ear Aid," a device to rectify poor hearing and re-establish the afflicted on a normal physical basis. Servicemen can build this device economically and service them perhaps better than any other kind of technician. If you are hard-of-hearing, you can go to your neighborhood serviceman who keeps your radio set in good repair. He will be glad to accommodate you and help you remedy your trouble.

* * *

Two new receiving sets are presented to the public, as well as a short-wave transmitter, a beat-frequency oscillator for servicemen and service laboratories, in this issue.

* * *

OUR readers write in constantly that they are enjoying the articles and information in the past issues of RADIO NEWS. Here are excerpts from typical letters coming in to the editor's desk.

"I would like to extend through you my most sincere appreciation of the departments conducted by Mr. S. G. Taylor and Mr. Howard Rhodes. It is with interest that I have watched RADIO NEWS change through the cycles of radio progress. I wish to point out that the two departments mentioned give numerous people, like myself, plenty of food for thought plus interesting experiments to be tried out in the laboratory."

JAMES F. DONNELLY,
Wellington, New Zealand.

* * *

"**Y**OUR magazine is too good to be true and I only hope that you continue it forever. I enjoyed the recent article on the home-built set analyzer and have built one with slight modifications to suit my particular needs."

GUY F. FOSTER, Guthrie, Okla.

* * *

Stewart Lockaday

Big Pay Jobs for Trained RADIO Men

5000

Service Men Needed



ACTUAL PHOTOGRAPH OF STUDENTS WORKING IN SERVICE DEPT. OF COYNE RADIO SHOPS

LEARN RADIO~TELEVISION TALKING PICTURES AT COYNE

TEN WEEKS of SHOP TRAINING on RADIO EQUIPMENT

Dissatisfied with your job? Not making enough money? Then let me show you how to prepare for a real job and how to make real money, in RADIO—one of the fastest growing, biggest money-making trades on earth.

JOBS LEADING TO BIG PAY

Scores of jobs are open—jobs as Designer, Inspector and Tester—as Radio Salesman and in Service and Installation work—as Operator or Manager of a Broadcasting Station—as Wireless Operator on a Ship or Airplane—with Talking Picture Theatres and Manufacturers of Sound Equipment—with Television Laboratories and Studios—fascinating jobs, offering unlimited opportunities to the Trained Man.

PRACTICAL Shop Training

Come to Chicago and prepare for these jobs the QUICK and PRACTICAL way—BY ACTUAL SHOP WORK on ACTUAL RADIO EQUIPMENT. Some students finish the entire course in 8 weeks. The average time is only 10 weeks. But you can stay as long as you please, at no extra cost to you. No previous experience necessary.

Broadcasting — Television Sound Equipment

In addition to the most modern Radio equipment, we have installed in our Shops a complete model Broadcasting Station, with sound proof Studio and modern Transmitter with 1,000 watt tubes—the Jenkins Television Transmitter with dozens of home-type Television receiving sets—and a complete Talking Picture installation for both "sound on film" and "sound on disk." We have spared no expense in our effort to make your training as COMPLETE and PRACTICAL as possible. Mail the coupon for full particulars!

Free Employment Service TO STUDENTS

After you have finished the course, we will do all we can to help you find the job you want. We employ three men on a full time basis whose sole job is to help our students in finding positions. And should you be a little short of funds, we'll gladly help you in finding part-time work while at school. Some of our students pay a large part of their living expenses in this way. Get all the facts!

COYNE IS 32 YEARS OLD

Coyne has been located right here in Chicago since 1899. Coyne Training is tested—proven by hundreds of successful graduates. You can get all the facts absolutely free. JUST MAIL THE COUPON FOR A FREE COPY OF OUR BIG RADIO AND TELEVISION BOOK.

H. C. Lewis, Pres. **Radio Division** Founded 1899
COYNE ELECTRICAL SCHOOL
500 S. Paulina Street Dept. 12-8C Chicago, Illinois

H. C. LEWIS, President
Radio Division, Coyne Electrical School
500 S. Paulina St., Dept. 12-8C, Chicago, Ill.

Send me your Big Free Radio, Television and Talking Picture Book. This does not obligate me in any way.

Name.....
Address.....
City....., State.....

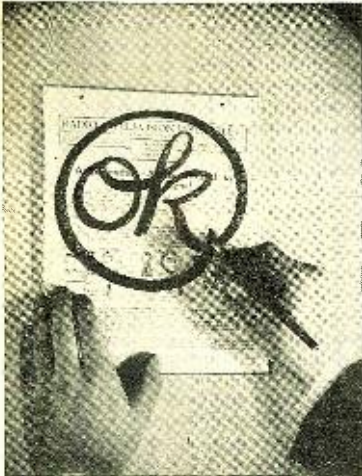

... say these
Leading Radio Manufacturers

Millions of people have learned that the names below stand for the very highest possible quality in Radio design, manufacture and performance. Now, after a thorough examination and investigation by their engineers, these great companies have put their stamp of approval on R.T.I. Training. They have endorsed this training and recommend it to all men who want to make good in Radio. This is the only home training in Radio to receive the endorsement of this group.

- BOSCH—United American Bosch Co.
 - BRUNSWICK—Brunswick Radio Corporation
 - BALKEIT—Balkeit Radio Corporation
 - CROSLY—Crosley Radio Corporation
 - CLARION—Transformer Corporation of America
 - DEFOREST—DeForest Radio Co.
 - FADA—F. A. D. Andrea, Inc.
 - HOWARD—Howard Radio Co.
 - KENNEDY—Colin B. Kennedy Co.
 - MAJESTIC—Grigsby-Grunow Co.
 - PHILCO—Philadelphia Storage Battery Co.
 - SILVER-MARSHALL—Silver-Marshall, Inc.
 - STROMBERG-CARLSON—Stromberg-Carlson Telephone Mfg. Co.
 - SENTINEL—United Air Cleaner Corporation
 - ZENITH—Zenith Radio Corporation
- R. T. I. Training is also endorsed by these Radio Trades Associations:
RADIO TRADES ASSOCIATION—St. Louis, Mo.
RADIO SERVICE MANAGER'S ASSOCIATION—New York
MUSIC AND RADIO TRADES ASSOCIATION—Salt Lake City, Utah

An OPPORTUNITY TOO GOOD TO MISS

Ambitious \$20 to \$40 a week men who want to earn \$50 to \$75 a week and more, will be interested in this message.

The great Radio Industry, because of its amazingly rapid growth, is today very much in need of TRAINED men to fill its more responsible jobs. These are the better-paying jobs in Radio... those which give steady work at good pay, as a starter, and early advancement to still better-paying jobs, as a future.

But to qualify for these better jobs men must know Radio as they know their 'A B C's'. They must know the theory of Radio, as well as the practical side, and be able to teach other men some of the things they know. The day of the tinkerer or amateur mechanic in Radio is gone... and gone forever. What the Industry wants today... what it is demanding... is TRAINED men. And men now doing Radio work will either have to get their training at once or make way for TRAINED men from the outside.

The Radio Industry urges men to get the training they need, but it has no time or facilities to train them itself. So with the cooperation of leading Radio manufacturers and Trade Associations, the Radio and Television Institute was organized to train them at home... no matter where they live... in their spare time... easily and quickly... and at a cost of only a few cents a day.

The Institute's Course of home-training was planned, written and is actually supervised by an Advisory Board, made up of prominent and highly paid Radio Engineers and Executives, each actively connected with some large Radio concern. That means R.T.I. Trained Men are trained right, because the members of this board, through their Radio connections, know exactly what the Industry needs in the way of trained men, and they are pledged to see that every R. T. I. student is trained to meet that need.

Radio service and installation work is just the starting point in R.T.I. Training. It prepares men for the more important positions in Radio and the Sound Picture field, and gets them ready for the new positions being created, or to be created, through new uses of Radio



- Offered in the World's Fastest Growing Business

principles in the amazing new field of Electronics. This feature alone makes R.T.I. the one outstanding home training.

Because it is so practical... so helpful... so thorough and complete... many of the largest and best known Radio Manufacturers... whose names are listed to the left...

... have unqualifiedly endorsed R.T.I. Training and are recommending it not only to their own men, but to all men who want to make good in Radio.

So if you are ambitious... if you are not progressing as fast as you would like... if you want to get into work where the future is certain... learn what Radio and its sister industries has to offer. Find out more about this amazingly easy course of home training, and more about the wonderful opportunities for TRAINED men in this... the world's fastest growing industry. Everything is fully explained in the

RADIO BOOK OF FACTS AND OPPORTUNITIES

Send today for your copy. The book is free.

The Electronic Field
 "Radio"... as most folks know it today... is only one part of a tremendous and amazing new field called "Electronics". The R. T. I. book of facts tells all about it. Industrial Radio... Television... Talking Pictures... and all the new uses for vacuum tubes and photo-electric cells are included and are fully explained.

RADIO and TELEVISION INSTITUTE, Dept. 841, 2130 Lawrence Ave., Chicago

Without obligation of any kind please send me a copy of the "Radio Book of Facts and Opportunities." I am interested in your home-training and the opportunities you say exist in the great field of Radio, for "trained" men.

NAME.....

ADDRESS.....



Technical Advance at Your Fingertips

The average radio listener today knows little of the real enjoyment and interest to be had out of the latest developments in radio. This is especially true of those listeners who have old models or the ordinary types of receivers. For those, listening is confined mostly to local stations. There are now, however, thousands of listeners who are experiencing a real thrill from their modern receivers, for these sets are capable of picking up programs of unusual interest from all over the world on both the short and long waves. It surprises many to learn that the modern receiver will actually bring in, consistently, stations in foreign countries with greater volume and finer tone than the listener with an ordinary set is able to secure from stations a few hundred miles distant.

RADIO NEWS readers are fortunate in having at their fingertips every month the very latest news of technical advances in the many fields of radio development, described and written by men who are recognized leaders in the radio world, and who know what is going on in radio.

President,
E. H. Scott Radio Laboratories, Inc.



Seat of a Famous 1901 Wireless Experiment

It was in this tower that the first wireless signals (the letter "S" in quick succession) were received across the Atlantic. Photograph, posed just after the completion of the test, shows Marconi, standing on the steps of the tower with his two assistants, Messrs. Paget and Kemp; tower keeper at lower right

Radio News

VOLUME XIII

January, 1932

NUMBER 7

Thirty-Seven Years of Radio Progress

The development of wireless telegraphy and telephony, from its inception as a revolutionary theory to the perfection of present-day radio broadcasting; an important and historical outline of radio progress from the lips of—

Senatore Guglielmo Marconi

IT can truly be said that the seed from which wireless has sprung was the discovery made by Michael Faraday, 100 years ago, that it was not necessary for two electrical circuits to be in actual physical contact in order that electrical energy might pass across the small space between them. This great discovery was followed by the magnetic theory of Clark Maxwell, published in 1865, in which he visualized the existence of electrical waves in space, of which experimental proof was given by Heinrich Hertz in 1888.

In 1895 I commenced my own researches, with the express intention of utilizing electric waves for telegraphing across considerable distances and succeeded at that early date in transmitting and receiving intelligible telegraphic signals, across space, over distances of about one and three-quarter miles.

These first tests were soon followed by more important improvements and by new discoveries such as that of the enormous distance over which these waves traveled and were detected, notwithstanding the intervening curvature of the earth, which discovery enabled scientific investigators subsequently to learn something new about the constitution and condition of the atmosphere at great heights, thus opening up vast and fertile fields of useful research which have lately allowed us to scrutinize still more effectively some of the mysteries left up in the strata which surrounds the earth.

The beginnings of tel-

ephony, as we know, whether operated by line or radio waves, naturally date from the invention of the electro-magnetic telephone receiver and the carbon microphone. This takes us back to the days before Hertz, actually to the time of Maxwell, for it was in 1861 that Philip Reiss, of Germany, using a primitive form of electro-magnetic receiver, with an imperfect electric contact, obtained, by means of instruments connected together by wires, the first experimental result that was ever recorded.

From 1871 to 1874 Elisha Gray, among others, took out patents for the apparatus which was built to transmit speech, though not very perfectly. But it was Alexander Graham Bell, in 1876, who evolved the first practical form of telephony.

This was later modified for commercial use, employing a magnetic speech cone on one end and an iron diaphragm which was given the well-known bell shape associated with his name. Many of the present-day desk telephone receivers retain this shape but a horseshoe magnet is used instead of a bar magnet.

For the microphone, which was invented two years later, we are indebted to Professor Howes and Thomas A. Edison, for their discoveries in this field made public in the same year, that is, in 1878. From that time the telephone commenced its conquests of communication and later speech was transmitted by submarine cables across narrow channels. But there, for the time being, developments stopped.

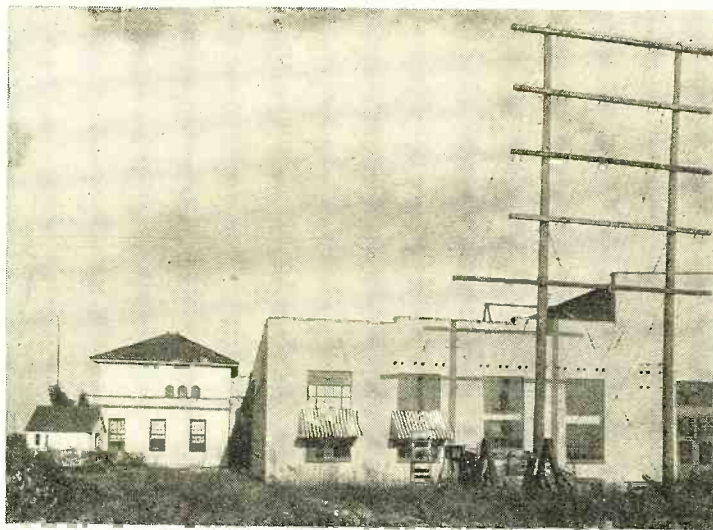

R. C. A. Photo

THIRTY YEARS AGO—AND TODAY

The little shed at the left is the first commercial wireless station built by Marconi in the United States. It is now completely overshadowed by the new buildings and antennas of the modern transatlantic station at Rocky Point, L. I.



MARCONI AND BRAIN-CHILD

An early photograph of the inventor of wireless and one of his first receivers set up for the long-distance test

That was the position in 1900 when Professor Fessenden made a first attempt to transmit speech through space by electric waves and was able to effect some sort of communication over a distance of one mile. As is well known, the speech currents are formed and superimposed on a high-frequency wave which must be unbroken. Transmission by the induction coil and interrupter of that day, although quite practical in radio for telegraph work, was impossible with the telephone because the dead intervals between sparks was quite unsuitable for telephony. To approach the required condition of carrier current, Professor Fessenden endeavored to make the waves more continuous and overlapping by increasing the number of sparks to 10,000 per second, and he obtained some measure of success.

By the year 1902, a distance of twenty miles had been covered, and then in 1906 Professor Fessenden made a real advance by employing for the first time the high-frequency alternator which gave him a useful carrier wave of 20,000 cycles per second. This enabled him in the following year to transmit speech a distance of about two hundred miles.

First Transatlantic Wireless

It is interesting to note here the development of wireless telegraphy during this period. In December, 1901, I was able for the first time, by means of stations especially constructed for that purpose, to transmit and receive telegraphic signals across the Atlantic Ocean to St. John's, Newfoundland, a distance of about 1800 miles, thus discovering that really big distances were possible because the electrical waves follow the earth's curvature around the globe.

Early in 1902, during a voyage on an American liner going to New York, I was able to receive, from Poldhu, signals at nighttime, although during the day the transmission range fell to 700 miles. I was therefore enabled to discover the now well-known fact that signals transmitted by wavelengths of a few hundred meters can be received over much greater distances by night than during the hours of daylight.

On my subsequent voyage to the United States on the *S. S. Laconia*, during the following year, news messages were received by wireless daily. This is worthy of note because the results were so successful that a number of other ships were fitted with long-distance receiving apparatus and a wireless broadcast news service was officially

Senatore and Lady Marconi on their private yacht Electra when they inspected "beam stations"



"ON BOARD"

opened in 1904. This telegraphic news service has continued without a break up to the present time. The broadcasts during the War were, of course, of an official nature only, but the news broadcasts were resumed immediately after the war. Poldhu continued to send out news until May, 1922, when the telegraphic broadcasts were taken over by Clifton.

It was about 1906 that my company put up a proposal to the British Post Office that they should be allowed to broadcast news to all newspapers in the country. However, this was not agreed to at the time.

While I was personally very much occupied in improving my transatlantic stations at Clifton and Glace Bay, Captain A. H. Round, one of my associates, had a small transmitter working near the Battery in New York City, from which speech and phonograph records were transmitted to the Times Building and liners in their docks.

There were, of course, at that time, no amplifying tubes and the rectifier was connected to the aerial circuit. In order to utilize the power in the aerial, microphones were re-

quired. Among the best of these were the liquid microphones. With these transmitters, in 1908, messages were transmitted from Rome to Sicily, a distance of 300 miles, and finally in 1912 communication was made from Rome to Tripoli, a distance of 600 miles.

The invention of the Fleming tube in 1904 and the three-electrode tube of Lee De Forest in 1907 enabled the disability, which had delayed the commercial development of wireless telephony, to be removed. As was to be expected with a new system, the early results were obtained working over short distances.

It was in June, 1913, that Dr. Meisner employed the oscillating tube as a carrier wave generator for transmitting speech a distance of 23 miles. My first tests (*Continued on page 608*)

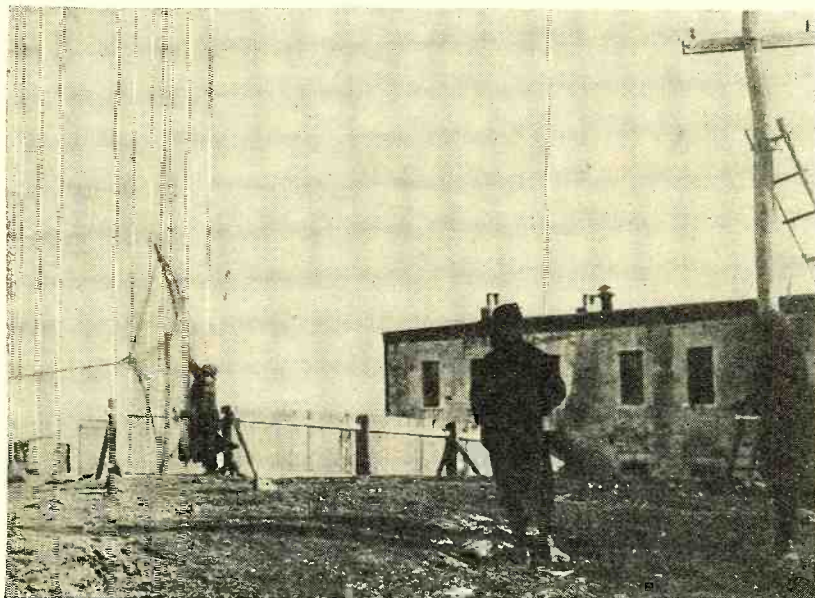

THE KITE THAT PICKED UP EUROPE

One of Marconi's assistants at St. John's, Newfoundland, releasing the kite that carried the receiving antenna used to receive the "S" signals across the Atlantic from Poldhu. Marconi is seen in the foreground

The Microphone— RADIO'S ELECTRIC EAR

The development of the microphone, without which neither broadcasting nor ordinary line telephony would be possible, has been going on for 100 years or more. The history of development, descriptions of the various kinds of microphones and future possible developments are outlined here

IT has been said that a man is no better than his senses, and certainly radio is no better than its electric ear. What the microphone will not pick up, no radio transmitter can broadcast. If the microphone makes mistakes, as human ears sometimes do when listening to an unfamiliar language, those mistakes will be broadcast by radio or perpetuated in sound records, no matter what engineers may try to do to prevent it. The faults of microphones not only mark a serious low point in sound recording but are the chief difficulty confronting the newest branches of acoustic science, such as noise analysis, which depend on accurate measurement of sounds.

Radio engineers and acoustic experts naturally dream of new microphones; new ways to convert sound waves into electric oscillations, improvements in present principles which might avoid some of the difficulties. Among the most promising of recent developments are the two new directional microphones, the ribbon microphone and the microphone equipped with a parabolic reflector to catch and focus the sound waves, the latter perfected by Mr. C. W. Horn, Mr. O. B. Hanson and their associates in the National Broadcasting Company.

The purpose of these devices is to keep the microphone from hearing too much. The human ear has a remarkable

By Thomas Elway

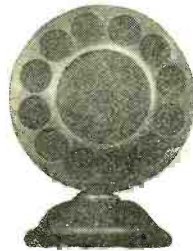

ability, which no microphone yet has been trained to have, of sorting out desired sounds from unwanted ones. A forest, for example, is full of sounds from rustling leaves, sounds of the wind, faint cries of animals or noises of insects, the more continuous sounds of waterfalls or streams. Yet let a small stick snap under an intruder's foot hundreds of yards away and every experienced woodsman will hear it instantly.

Sometimes it is said that city people have ears too insensitive for such feats, but this is not true. There is no general difference, tests have shown, between the sensitivity of city ears and that of country ones. The difference is merely in the sounds to which one listens. Go to any noisy city street and drop a half dollar on the pavement. Everybody for scores of feet around will turn and look. It is not that city people are more mercenary than others. The difference is that snapped sticks are important to woodsmen and not to city folk, while small metallic tinkles like that of a coin on the pavement are important sounds in a machine-filled city but not in the woods.

We hear, all experiments show, very much what we need to hear or wish to hear. Sounds which mean nothing to us we ignore. Fabulous fortunes await an inventor who can give a microphone this same ability; who can make it listen, for

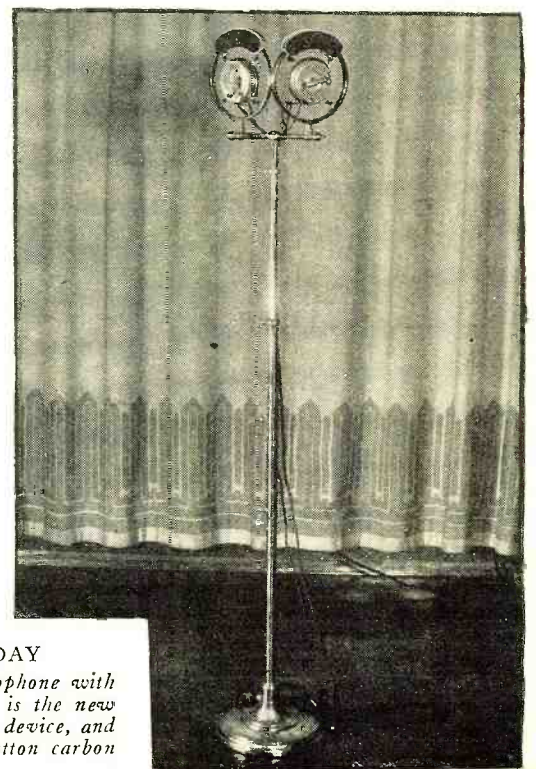
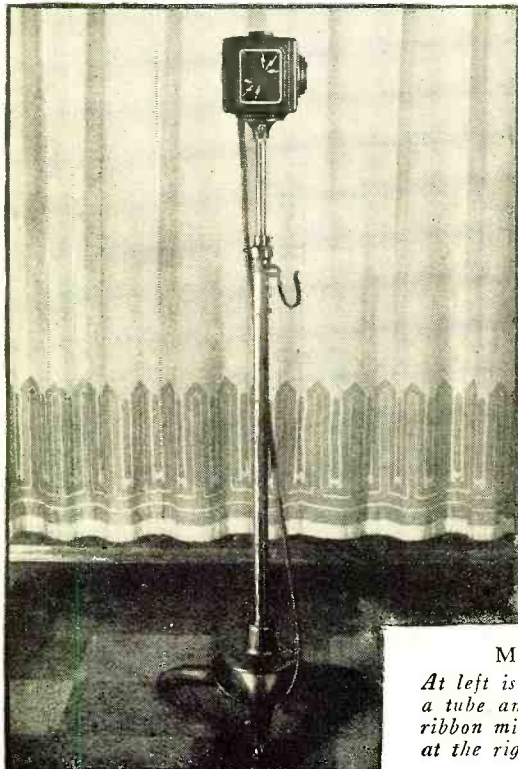

MICROPHONES IN USE TODAY

At left is the popular condenser microphone with a tube amplifier in the head. Center is the new ribbon microphone, actually a dynamic device, and at the right is the standard double button carbon microphone

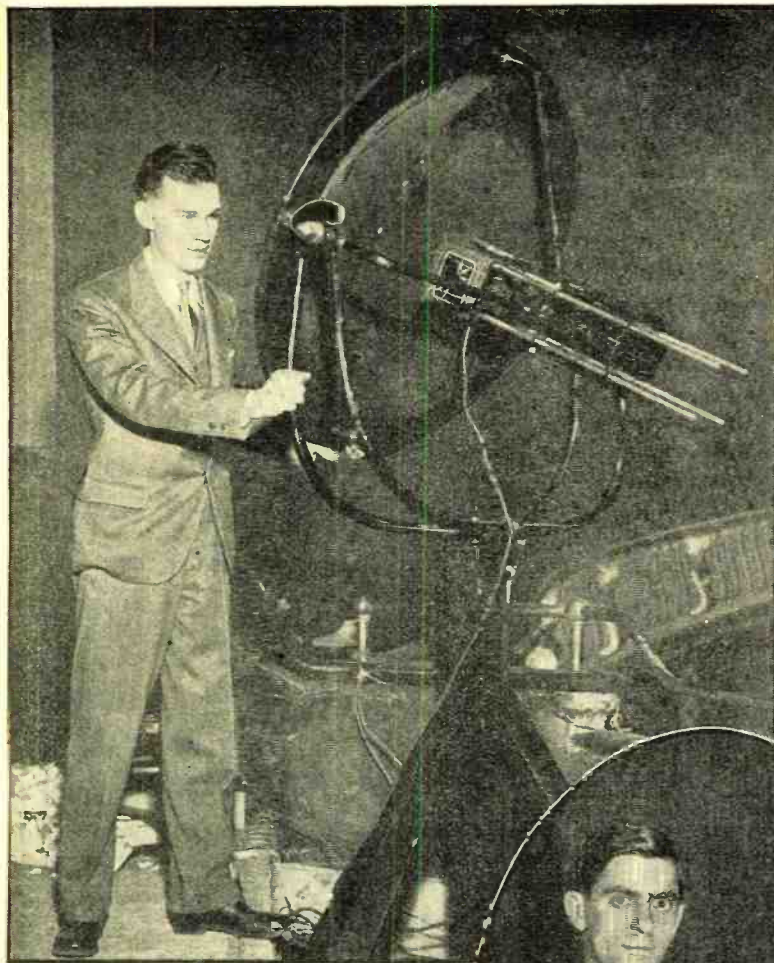

FOCUSING THE ELECTRIC EAR

This is the new parabolic microphone which may be focused on the performer from a distance. This is particularly applicable for pick-up work in theatres and sound studios

example, to the voices of the cast in a talking motion picture can fail together to record the incautious sneeze of some visitor to the set.

Microphones Indiscriminate

Once I made a phonograph record. A half dozen people were listening carefully, including, so far as was possible for the speaker, myself. No one heard anything amiss. After the record was cut, pressed and completed, everybody heard, when it was played, a dog bark in the middle of it. Undoubtedly the dog barked somewhere on the street outside the recording room while the record was being made. Nobody on the "set" heard him. Every ear was too intent on what it was trying to hear. The microphone, having no intentions or consciousness to sway it, heard the faint "woof woof" just as it heard everything else.

To hope for a microphone which will select sounds in accordance with their meanings is probably as hopeless as the famous order of a government official to his radio engineers to provide a loudspeaker which would translate Spanish into English. Yet some approach can be made to this. The reflector microphones, for example, pick up sounds from one direction more completely than from another, so that the sounds from a stage, for example, can be recorded or broadcast in spite of a considerable amount of noise from other directions. Another possibility is the ribbon microphone, described recently in RADIO NEWS and by Mr. H. F. Olson of the R. C. A. Photophone, Incorporated, before the Society of Motion Picture Engineers.

The principle of the reflector microphone is the well-known one of the concentration of sounds by parabolic mirrors; the familiar principle of the whispering gallery. Sound waves

in the air behave somewhat like light waves in space. Just as light can be concentrated by a curved mirror, like the mirrors of gigantic telescopes, so faint sound waves can be concentrated by suitable curved surfaces and focused on the one spot where the sensitive diaphragm of the microphone is placed.

Parabolic mirrors have the property of making conversions of waves, either light waves or sound waves, between a straight line and a point. In a searchlight the parabolic mirror concentrates the light from a point source into a parallel beam. In the parabolic microphone the mirror concentrates the sound of a parallel wave beam upon the microphonic point.

Directional Properties Useful

The practical result is that such a mirror may be trained on a stage or on any part of a stage or even on a single actor or singer and will concentrate on the sensitive microphone itself the waves from that single direction much more intensely than waves from any other direction. The sensitivity of the microphone then may be set to pick up these intenser waves, but to miss almost altogether the feebler waves from other directions. Thus a cough in the studio or the noise from an audience in a theatre is largely kept out of the microphone and its amplifier circuits.

The ribbon microphone attains the same end by a somewhat different principle. Its sensitive element is a tiny metallic ribbon vibrating in an electromagnetic field. The ribbon responds, it is easy to see, chiefly to sounds which strike against its flat side. Sounds approaching it sidewise encounter only the edge of the ribbon and are less likely to move it effectively. This, of course, is not a complete theory of the instrument. Were everything as simple as that, all micro-



DYNAMIC MICROPHONES

In oval Eddie Cantor as he appeared years ago before one of the early type dynamic microphones. At right, the inner construction of the magnetic microphone, showing at the bottom the ribbon vibrator suspended between the poles of the electro-magnet. The transformers and other devices above are housed in the casing as shown on the preceding page

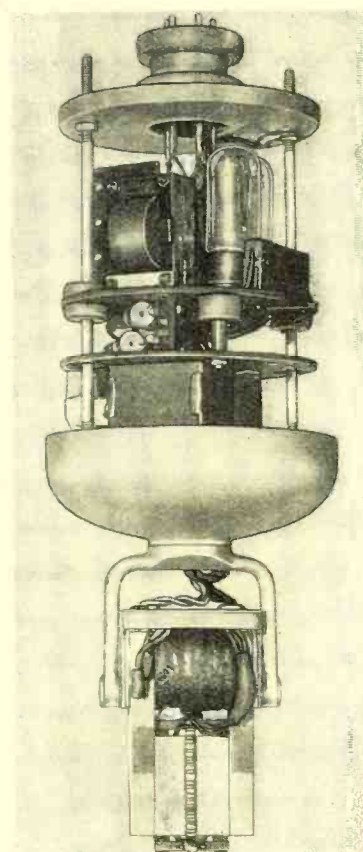

phone difficulties would have vanished long ago. This does indicate, however, the chief essential of the device.

By these two developments, or more likely by some combination of both of them, it is probable that microphones soon may be made almost perfectly directional, so that interference by noises off-stage or from other directions in a studio will be reduced to a minimum. Meanwhile, improvements are needed and are promised in other characteristics of microphones, especially in obtaining particular responses to sounds of different frequency, uniform or selective as each set of circumstances may require.

Three Main Types

Microphones now in use or prominently under study fall, in the main, into three general and significantly different types. One type includes the carbon microphones, more accurately called the loose-contact microphones, still largely used in telephone work and in many smaller broadcasting stations. Another type is the condenser microphone, now the preferred device in radio broadcasting and in the making of talking motion pictures. Third is the so-called dynamic microphone, recently coming into use and more promising for the future than either of the others. Closely related to these dynamic microphones are the so-called magnetic or electro-magnetic ones; now including some of the cheapest and poorest microphones on the market but by no means without possibilities of turning out, like Cinderella, the final belles of the ball.

As usually happens in scientific matters of real importance, the beginnings of all three of these modern

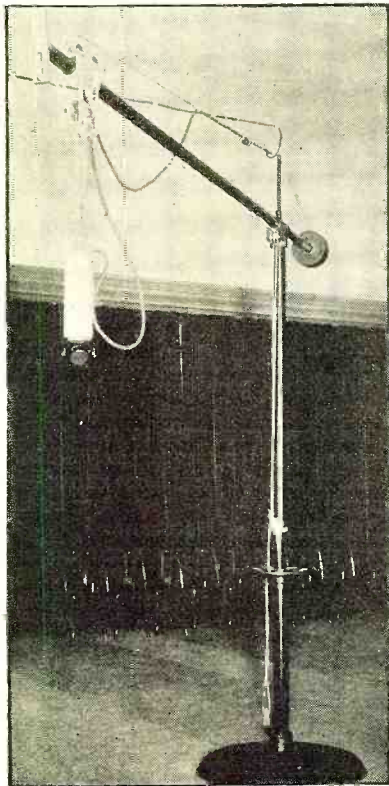

NOVEL SUSPENSION

A new microphone stand adjustable to the performer's stature

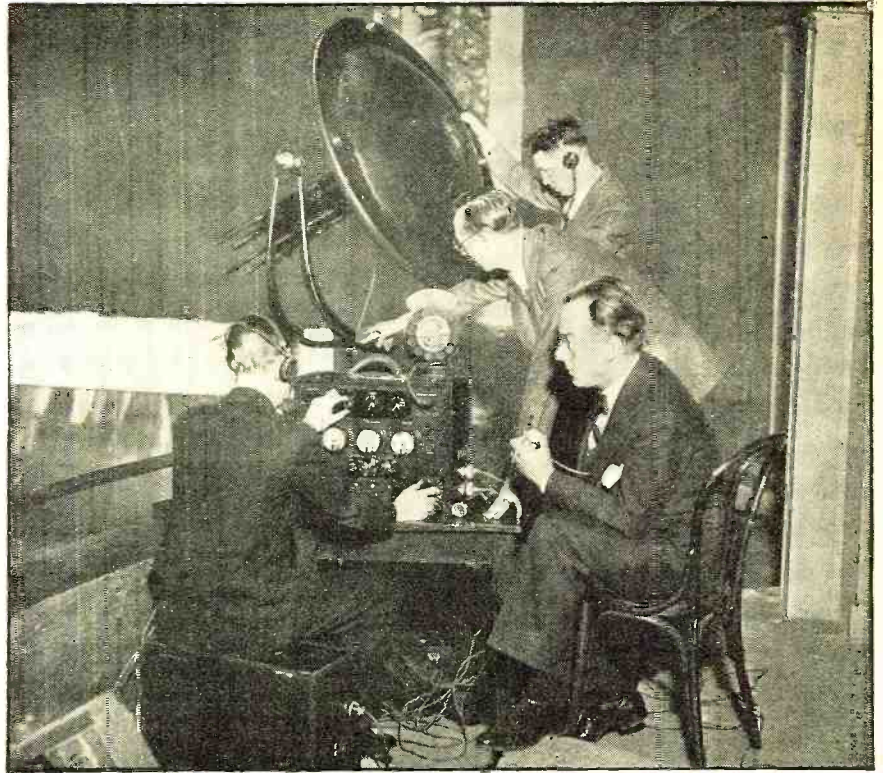

COMPLETE SET-UP FOR THEATRE BROADCASTS

N. B. C. engineers and operators preparing to broadcast a musical feature from the stage. The control unit is shown below the parabolic microphone and a carbon microphone is set in place for announcements

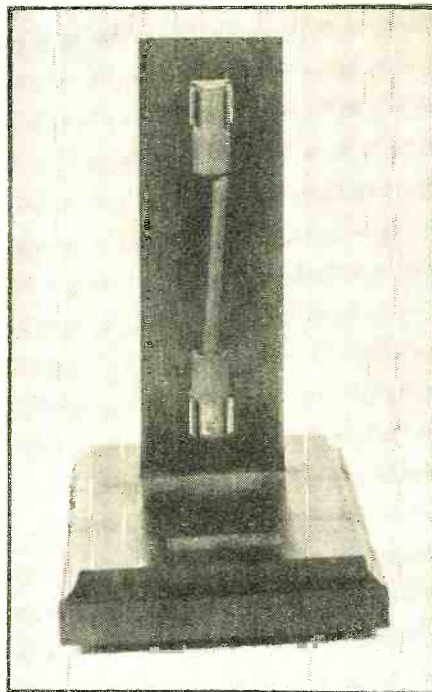

DADDY OF THEM ALL

An early Hughes microphone which consists of a carbon rod supported between two carbon cups. It is sensitive enough to pick up the sound of a fly walking, a watch ticking or a heart beating

sound waves alter greatly the resistance of the carbon contacts so that the current that flows is greater or less in accordance with the vibrations.

This device was the first true "microphone," and still is almost the only one, for that word ought to mean something that magnifies sound, not merely something that picks it up electrically. The Hughes microphone can be used (Continued on page 612)

microphone types can be traced back many years, even before the invention of the telephone. The Reis transmitter of 1861, for example, was essentially a loose-contact microphone between metal terminals. Bell's tuned-reed transmitter of 1875, two years before the famous liquid transmitter said "Mr. Watson, come here, I want you," was a forerunner of the modern magnetic and dynamic types. Probably the condenser type of microphone is the oldest of all, for this principle is reported to have been used in one of the crude transmitters of du Moncel five years before the Reis experiments and twenty years before Bell. Much of this early history of the microphone recently was summarized admirably by Mr. H. A. Frederick of the Bell Telephone Laboratories in a paper before the Acoustical Society of America.

Early Developments

The simplest type of loose-contact microphone, anticipating all the faults and most of the merits of the most recent carbon devices, was developed as long ago as 1878 by the famous English-American inventor, Mr. D. E. Hughes. Three iron nails, one laid loosely across the other two, are enough to make a Hughes microphone, but the usual and best form of the device is a pointed rod of carbon held loosely between two hollowed-out carbon supports. A small direct current is sent through the loose contacts between the three pieces of carbon. Slight vibrations of the central carbon piece set up by

"Wireless" Centralized Radio

A Boon to Hotels and Schools

The tremendous cost of wiring for "Radio in Every Room," particularly in larger hotels, is almost entirely eliminated in the new system of "Guided Radio" as installed in the Lincoln Hotel, New York, and described here

By D. E. Replogle*

THE wiring required to distribute a choice of radio and recorded programs throughout a large hotel looms big in the cost of a centralized radio installation. And if the building happens to be standing, so that the wiring must be "fished" through walls and floors, the cost becomes almost prohibitive. Hence the attractiveness of a centralized radio system in which radio and recorded programs are distributed via the steel framework and existing wiring system to every part of the building, dispensing with costly special wiring. Such an installation, making use of the so-called "guided radio" technique, has just been completed in the Lincoln Hotel in New York City, constituting the theme of the remarks that follow.

In dispensing with the usual special wiring required by the audio system of centralized radio, the guided radio method utilizes one or more radio transmitters, depending on the number of channels desired. The signals put out by these transmitters are propagated along the steel framework and normal wiring system of the building, instead of through space, from which fact the system derives its name of guided radio. The system is the invention of Dr. Francis LeRoy Satterlee and has been developed by Radio Systems, Inc. The Lincoln Hotel installation described below has been handled throughout by the De Forest Radio Company.

Four-Channel System

The equipment for the guided radio installation of the Lincoln Hotel is on the twenty-eighth floor, close to the antenna on the roof. It comprises four receivers for picking up the desired radio programs, a phonograph turntable for handling recorded programs, the master control unit from which the entire operation is controlled, and four transmitters, one for each channel. The operator can tune in the desired radio programs or supply any desired recorded programs. A monitor receiver permits of checking up on the program in any given radio-frequency channel, while a volume indicator that may be connected to any circuit furnishes the operator with a visual check on the volume level which may be set at any value. Short patch cords permit of making any desired connections. The monitor loudspeaker may be rapidly switched from one circuit to another. The interconnecting board provides a remarkable flexibility in program arrangement, since any of the transmitters may be modulated by any of the receivers, by the

*In charge of Engineering, De Forest Radio Company.

phonograph or by a microphone. All the transmitters may be modulated simultaneously with the same program. Additional amplifiers, mixers, attenuators and other equipment may be introduced in any circuit in obtaining the desired results.

The transmitters are designed particularly for guided radio work. They are of the master oscillator, power amplifier type. The modulator circuits are designed with utmost care so as to provide the highest quality transmission. The oscillator and intermediate amplifier have a separate power supply, so as to insure frequency stability. The transmitters are capable of modulation up to 100 percent, being of the most modern design.

A special receiving antenna, located on the roof and connected to the receivers through a new type of transmission line, serves to eliminate motor noises and other electrical disturbances, making for quiet, clean-cut reception. The intercepted programs are re-converted into modulated radio frequencies and distributed over the framework and normal wiring.

In the typical building, the power mains enter the basement and terminate in the panel board. In order to distribute the power and lighting load evenly and to avoid the use of excessively large wires, the lighting wiring is ordinarily split up into a number of risers. Each riser feeds five to ten floors in a given section of the building. From small panel boxes on each floor, branch lines run to the various rooms. The neutral of the three-wire system is connected to the ground in the basement.

The "Guided" Principle

The risers have practically no resistance to the power current, but present a considerable impedance to high-frequency currents such as are employed in guided radio transmission. The structural framework of the building, on the other hand, because of its large cross-section, offers a low-impedance path to the ground even at the high frequencies. Therefore, if a radio-frequency current is passed through the circuit formed by riser, ground and framework, a potential is established between the end of the riser and the ground. Because of the distribution of the impedances, practically the full voltage of the transmitter can be established. By coupling the extreme ends of all the risers to the transmitters, through special feeders, uniform distribution is attained throughout the building. A radio-frequency voltage is thus established between the lighting circuit and the radiator in any room, and it is this voltage which is utilized for the operation of a simple radio receiver in the individual rooms.



A "GUIDED" RECEIVER

One type of receiver used in the individual rooms is mounted in a telephone table. It consists of a single tube, a single tuning control to select programs from any one of the four channels, a volume control knob and a dynamic loudspeaker

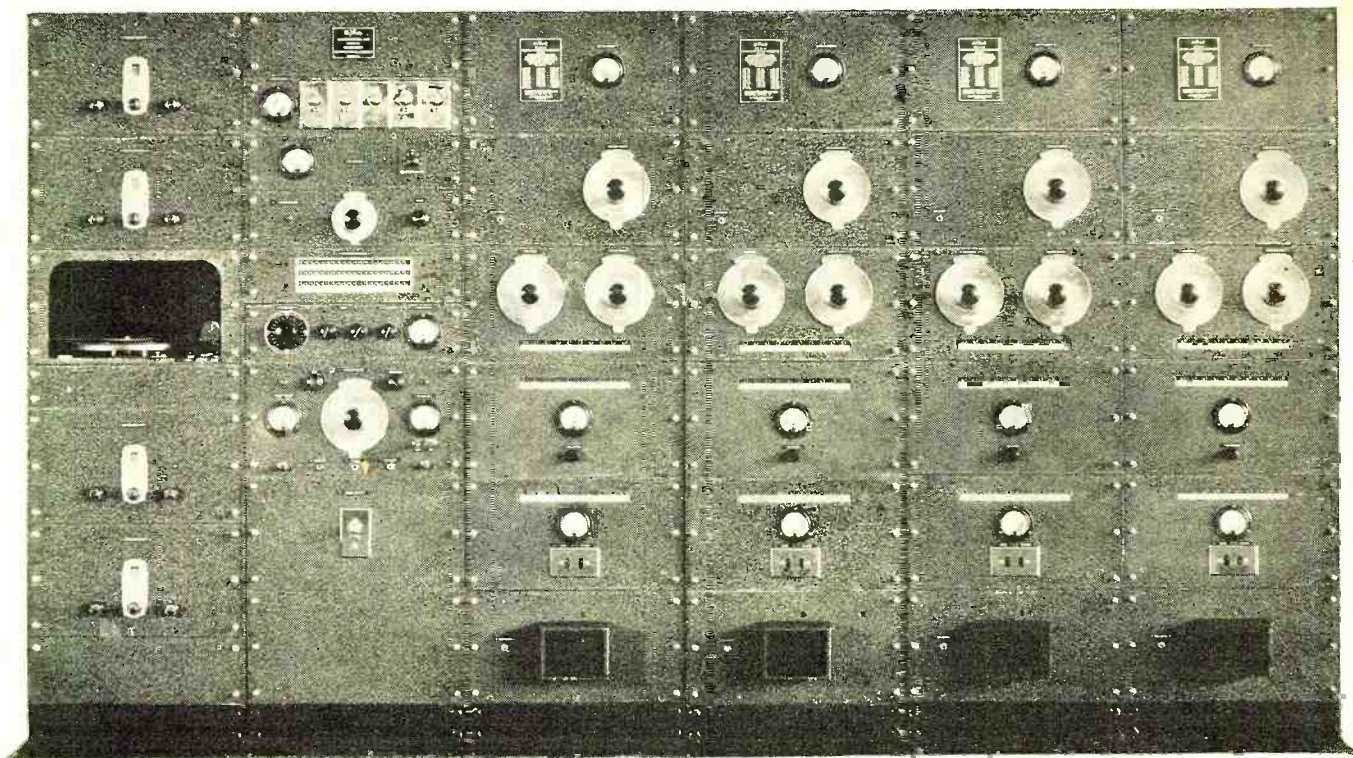

THE CENTRAL EQUIPMENT IN THE LINCOLN HOTEL

A four-channel installation. The four-channel transmitters are mounted on the four panels at the right. The left-hand panel contains the four broadcast receivers and phonograph. Next to it is the control panel

The risers in modern buildings are found in shaftways and ducts. They terminate in panel boards on each floor. The special feeder lines can be run through the same shaftways to the panel boards on each riser. Indeed, the building is hardly disturbed in installing the guided radio system. In the Lincoln Hotel, containing 1400 rooms, only 2500 feet of wire were necessary for the entire radio installation.

The individual receivers in the rooms are in the form of small bed tables. Each receiver comprises a simple tuner, a single tube operating as a power detector, a dynamic loud-speaker and a volume control. Because of these simple elements, the servicing is reduced to a negligible minimum. The receiver plugs into a base receptacle and is provided with a ground lead connected with the radiator. Volume is ample for the average hotel room.

Constant Volume

The main consideration in any centralized radio installation is a choice of programs. A minimum of four simultaneous programs is considered necessary for satisfactory entertainment catering to the wide range of tastes found in the average hotel. An equally important consideration is freedom from cross-talk, since the programs are rendered useless if they overlap. In the case of the guided radio installation, cross-talk is eliminated by the choice of frequencies employed for the transmitters. These frequencies may be adjusted for any degree of separation that may be desired.

The maintenance of a correct volume level is another important consideration in the centralized radio installation. In the usual audio system the volume level is largely determined by the output of the centralized audio amplifier, as well as the

load of loudspeakers which it is feeding. As the number of listeners-in varies throughout the day, the load changes accordingly, and the volume level necessarily varies unless an operator is on duty to correct for the varying load or automatic load compensation is provided. The quality also suffers as the result of the varying load.

In marked contrast, the guided radio system experiences no change in volume with a varying number of listeners-in. The additional energy for greater volume is derived from the tube in each individual receiver, together with the adjustment of the volume control of that receiver. The principle is exactly the same as with the ordinary radio receiver, the volume of which is quite unaffected whether no other receivers or a million other receivers are tuned to the same program.

Extraneous noises, generally a serious problem in centralized radio installations, play little part in the guided radio system. The reason is that the sensitivity of the individual receiver is exceedingly low, while the signal level is quite high, making for a minimum of background noises. Nevertheless, by means of a special antenna and transmission line, as well as other precautions, all parasitic disturbances are kept at a minimum.

Low Cost

In the original installation, the guided radio system is by all odds the simplest and least expensive in any sizable building. In addition, the system has a delightful flexibility, since any part of the building can be reached by the programs without special wiring or alterations. If the building is to be added to, the system is immediately ready to serve the added space. If more program channels are desired, additional transmitter units can be (Continued on page 615)

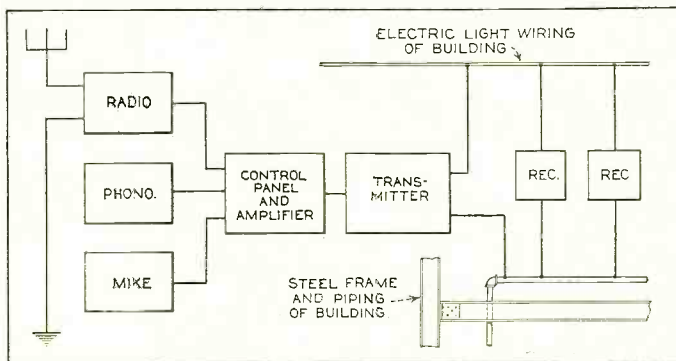

HOW THE SYSTEM WORKS

In the control room radio programs, phonograph or microphone are used to modulate the transmitters and the output of the latter is carried along the electric wiring and pipe lines, from which simple receivers in individual rooms receive the programs

Are You Responsible for Radio Interference?

Much radio interference for which we blame the power, lighting and railroad companies actually originates in our own homes. This article points out some methods of checking up on—and eliminating—this type of interference

ONE of the first questions which is brought up in any discussion of radio interference is: "Who is responsible for overcoming radio interference?" Often an interference discussion never gets beyond this one question. Undoubtedly this responsibility is divided among a number of groups, no one of which should be expected to bear the entire or even a major part of the cost of improving radio receiving conditions.

To the layman it sometimes appears that the radio dealer and radio manufacturer should be responsible for clearing the ether of radio disturbances which interfere with radio reception. The receiver purchaser usually reasons that the dealer and manufacturer are making a profit from the sale of radio products and they should contribute largely to the elimination of interference so that the use of their products will be increased. There is slight justification for this expectation. Nevertheless, in most cases radio dealers and manufacturers are doing everything within their power to improve radio reception. It is hardly fair, however, to expect too much from this source. It is just as reasonable to expect that automobile dealers and manufacturers should provide for maintenance of roads, as it is to expect that radio dealers should undertake the elimination of radio interference for all purchasers of radio equipment.

Are Power Companies Guilty?

It is undoubtedly true that power companies are responsible for some radio interference. Electrical equipment which is subjected to extremes of temperature and moisture is bound to develop irregularities of contact which are likely to cause radio interferences. However, in many cases these circuit irregularities are likely to affect the transmission of power and consequently any defects in public utility equipment are usually located and remedied before the interference becomes serious. Undoubtedly, power companies have a considerable interest in the elimination of radio interference, since they benefit materially from the use of radio equipment. Not only is the radio load well worth considering, but whenever radio is used the use of current for lighting and often for appliances is increased. It is, therefore, to the advantage of the power company to do everything possible to improve

By Tobe Deutschmann*

radio reception and thus stimulate the use of radio. Practically all power companies maintain crews equipped with the most modern instruments for locating interference. These crews not only investigate complaints received from radio listeners, but they also patrol the power distribution lines to make sure that disturbances are located as soon as they appear.

After the responsibility of the radio dealers and power companies has been discussed someone is sure to advance the idea that "There ought to be a law." Before enacting any legislation, however, municipal authorities have a definite responsibility.

In many cases electrical apparatus owned and operated by the municipality is causing radio interference. Traffic controlled apparatus, flashing beacons, signal equipment and battery-charging equipment are among the most common offenders. It is, therefore, advisable that municipal authorities attend to the elimination of interference from this apparatus before enacting any legislation intended to compel the filtering of privately owned apparatus.

Trees as Trouble Makers

One case was found a short time ago in which the greater part of the interference in a city was due to tree grounds on power wiring, and also on fire-alarm circuits. The Park Commission had for a long time opposed any trimming of trees to eliminate these grounds, and it was necessary, before taking any other steps to improve radio reception in that city, to remove the chairman of the Park Commission and to arrange for the necessary trimming of trees.

But even after the power companies, radio interests and municipal authorities have done all in their power to overcome radio interference there still remains a great deal of interference which is outside the field of any of these three groups. The last class of interference is clearly the responsibility of the individual.

One of the best illustrations of the individual's responsibility was found in a case encountered in a mid-western city. In the course of his tracing an interference complaint the investigator for the power company checked the service entrance of an apartment building. He found 28 plug type fuses which had blown and had been backed with pennies instead of being replaced by new fuses. Several of the fuses had

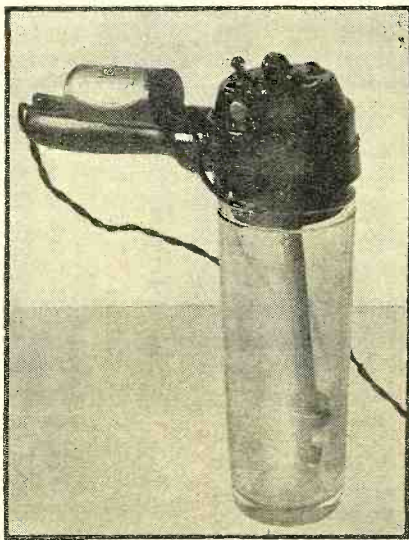

HOME-MADE "STATIC"

This tiny mixer approached a thunder storm in its effectiveness as a static maker, until the small filter was installed on its handle

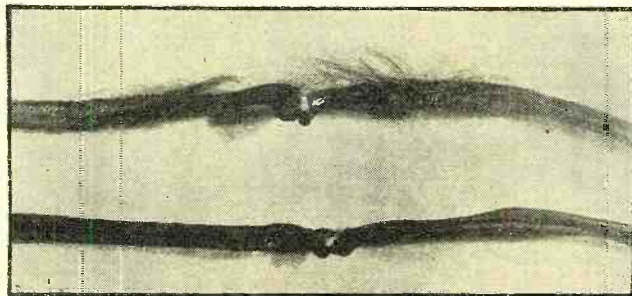

UNSUSPECTED TROUBLE-MAKERS

These two worn lamp cords were found to be causing interference in nearby radio sets, due to kinks which broke the insulation, allowing a partial leakage of current at times

*Tobe Deutschmann Corp.

not been set in place tightly enough to make firm contact, with the result that considerable interference was originating in the fuse blocks. Further investigation showed that some of the circuits whose fuses had been substituted were connected to lamps and electrical appliances having attachment cords in extremely bad condition. In many cases the original blowing of the fuse was caused by a short-circuit in the appliance cord. This short burned clear when the fuse was replaced with a coin, but there still remained a considerable possibility that this partial short-circuit would cause radio interference.

Home-Made Interference

It is probable that amateur electricians, whose knowledge of electrical circuits stops with the understanding that it is possible to place a coin behind a plug fuse, are responsible for a large proportion of radio interference. Lamp and appliance manufacturers may also contribute to this interference by using sub-standard material, particularly attachment cords. These cords do not have the individual conductors properly protected, with the result that, after the appliance has been in use for some time, a broken strand in one conductor may easily puncture the insulation of that conductor and also the insulation of the conductor on the opposite side of the line, thus causing a short-circuit which may result in a great deal of interference before a firm enough contact is made to cause the fuse to blow.

The first step to be taken by any individual who finds radio interference in his home is to investigate the fuses in the main and branch circuits. If he finds any fuses shorted out, they should be replaced at once with good fuses of the correct capacity for use in the circuit. It is important that this be done not only from a radio interference standpoint, but also to prevent any possibility of fire due to short circuits. After the fuses have been replaced and any contacts which may be loose have been tightened, both service and branch switches should be inspected for possible loose connections.

The next step to be taken in this systematic check-up is an inspection of all electrical appliances and lamps in the building. This inspection should cover: attachment plugs, cords, circuits and lamps. Also, unless armored cable, conduit, boxes, cabinets and fittings are grounded in accordance with Code requirements, there is a possibility that charges accumulated on these metal parts will gradually leak off to ground or to other metallic objects, with consequent radio interference. It is, therefore, advisable to make as careful a check as possible to be sure that they are bonded together and are properly grounded.

Checking Home Appliances

After all the building wiring has been checked and the necessary repairs made, the various electrical appliances in the building should be operated one at a time while the receiver is in operation in order that the amount of interference created by each appliance may be determined. Most household electrical appliances cause some radio interference, since they are generally operated by universal motors which are inherent sources of radio interference.

The interference created by household appliances is fed

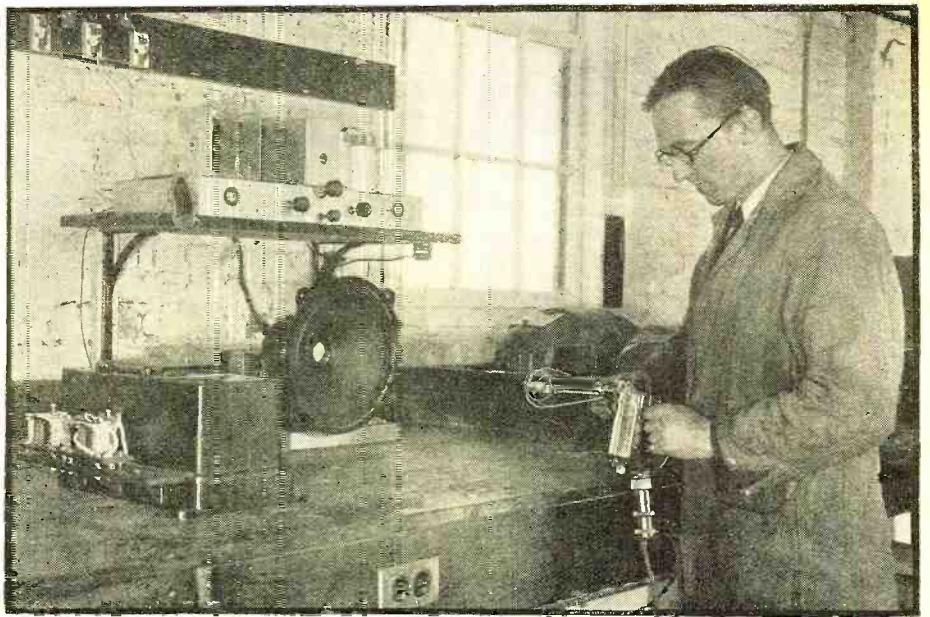

USE OF ELIMINATORS

Filters used on household devices should be mounted directly on the device, as in the case of this electric egg beater, where the filter is in the attachment cord

back from the point at which the making and breaking contact occurs, and is radiated from all wiring associated with the appliance. This interference not only affects receivers supplied with current from the circuit to which the appliance is connected, but may also be fed back into the service wiring and thus carried to nearby buildings. In some instances the interference from a single appliance may cover several blocks.

There is only one satisfactory way of overcoming radio interference, and that is by application of suitable filters at the points at which the interference originates. There is a mistaken idea that a great deal of interference enters the receiver through its power connection and that the use of a filter at the power connection to the receiver is all that is necessary to overcome interference. It is a very simple matter to check this theory. All that is necessary is to disconnect the antenna and ground wires from the receiver and to connect together the antenna and ground terminals of the receiver. In practically every case this procedure will be found to prevent any interference pick-up and also any pick-up of broadcast signals. It is, therefore, obvious that the interference is entering the receiver through the antenna and ground connections and that if good reception is to be obtained, some method must be found to prevent the radiation of the interference.

Filters at Sources

This is best accomplished by providing a filter to keep the interference from being impressed on building wiring and thus prevent radiation. The type and location of the filter required will depend to a considerable extent upon local conditions, but there are a few fundamental rules which should be followed in overcoming the interference. One, for instance, is to locate the filter as close as possible to the point at which

the interference originates. It is often found that locating a filter at the end of an appliance cord fails to provide elimination of interference, because enough interference is radiated from the cord to nullify any benefit that would be obtained from the use of the filter.

In determining the procedure to be followed in suppressing the interference from any piece of (Continued on page 626)

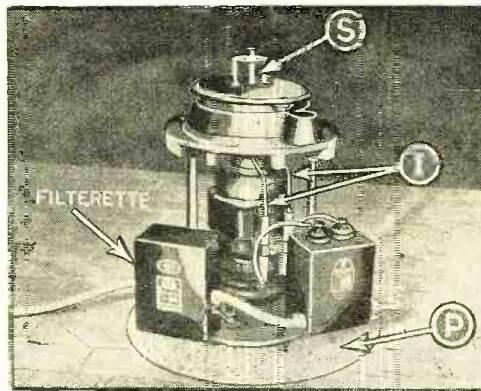

OIL BURNER INTERFERENCE

Certain types of oil burners cause considerable radio trouble, due to a high-frequency spark employed. Filtering is accomplished in the line, aided by adequate shielding of high-tension circuits, which include points marked S and I

The Latest Example of Tuned R. F. Design

In his article last month, Mr. Browning discussed a new r.f. design, particularly the solution of the problem of obtaining uniform sensitivity with high gain. This month he discusses the problems of obtaining adequate selectivity and life-like tone reproduction

By Glenn H. Browning
Part Two

THE use of two band-pass selectors in the MB-32 receiver solved two problems at the same time. First was the question of selectivity, for it was desired to have the same degree of selectiveness on both high and low frequencies, and such is not the case utilizing exclusively tuned-radio-frequency transformers. That tuned-radio transformers are more selective on the low frequencies may easily be shown from the following analysis. Consider the r.f. transformer shown in Figure 2A, last month. The fact that the primary is present adds resistance to the secondary circuit so that instead of the secondary having a resistance R_2 it has an apparent resistance R'_2 , which may be shown to be:*

$$R'_2 = R_2 + \frac{M^2\omega^2}{R_p^2 + L_1^2\omega^2} R_p \quad (1)$$

The apparent selectivity of the circuit will be inversely proportional to

$$\frac{R'_2}{L_2\omega}$$

Let this value be called η'_2 . Then from previous notation Equation 1 becomes

$$\eta'_2 = \eta_2 + \frac{\tau R_p}{L_1\omega} \left(\frac{R_p}{L_1\omega} + 1 \right) \quad (2)$$

In the case of the screen-grid tube

$$\frac{R_p}{L_1\omega} \gg 1$$

consequently we have

$$\eta'_2 = \eta_2 + \frac{\tau L_1\omega}{R_p}$$

Now all values are constant in Equation 3 except ω . Thus the greater its value, the greater the value of η'_2 and the poorer the selectivity of the transformer.

It is also a well-known fact that two tuned circuits, coupled together, have the characteristic of giving either a single or double-peak resonant curve. Consider the circuit shown in Figure 7A. If the mutual inductance or coupling between the two coils is too small, a resonant curve such as shown in Figure 8A will be obtained, where there is only one peak to the curve and the voltage at its maximum value is less than it would be if the coupling was increased. As the coupling between the two circuits is increased, this peak will get higher and higher, up to a certain point. Further increasing the coupling spreads out the resonant curve into two peaks, each one having maximum voltage which is obtainable from the two circuits with a given input (see Figure 8C). Thus, two coupled, tuned circuits may act as an approximate band-selector, passing a range of frequencies determined by the coupling between them.

Choice of Coupling

However, if these circuits, which are to be tuned over a considerable range of frequencies, act as

*See "Electric Oscillations and Electric Waves," by G. W. Pierce. Page 159, equation 24.

band selectors, it is necessary to choose the type of coupling with care. It may be readily shown that the frequency range between the two peaks must therefore be:

$$f_o = \frac{1}{2\pi} \sqrt{\frac{Z_m^2 - R^2}{L^2}} \quad (1)$$

Where R represents the resistance in either of the two tuned circuits, L the inductance in either circuit, and Z_m the mutual inductance between them.

If the two are magnetically coupled, as in Figure 7A, then $Z_m = M\omega$ where M is the mutual inductance and ω is 2π times the incoming frequency. Therefore, by previous notation:

$$f_o = \frac{\omega}{2\pi} \sqrt{\tau^2 - \tau_1^2} \quad (2)$$

As τ and τ_1 are practically constant, this equation shows that if the coupling is set so that a band-pass effect of 5 kc. is obtained at 545 kc, the band has increased to 13.8 kc. at 1500 kc. Thus, this type of coupling would make a broad tuning set at the higher frequencies.

Capacity Coupling

But the two tuned circuits may have a coupling due to a capacity as shown by

Figure 7B. In this case $Z_m = \frac{1}{C_o\omega}$ and the separation between peaks is

$$f_o = \frac{\sqrt{1 + C_o^2\omega^2 R}}{2\pi C_o\omega L} \quad (3)$$

The only variable quantity, with frequency, in the right side of this equation is ω , and it may be seen that the band-pass effect, or separation between the two tuning peaks, is almost constantly widening slightly narrower as the frequency

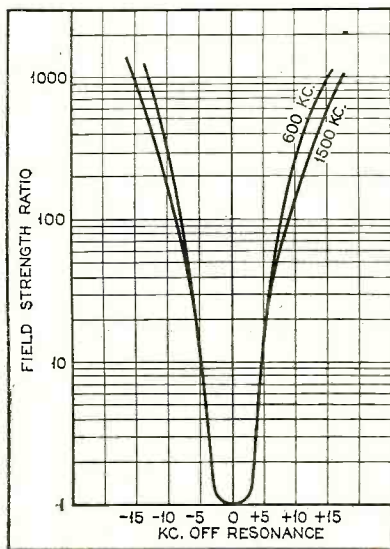

UNIFORM SELECTIVITY

Figure 9. These curves, taken with the new receiver at the extremes of the broadcast band, are almost identical

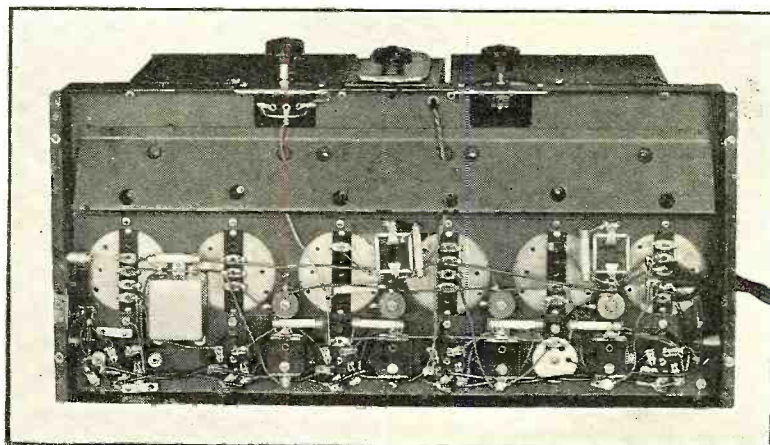

UNDER THE CHASSIS

A straight-line layout is employed, both for tubes and coils, keeping wiring to a minimum and widely separating the output from the input

increases. Thus, this type of a circuit has a somewhat narrower band, or tunes sharper on the high frequencies.

An Effective Combination

It will be remembered that a tuned r.f. transformer is broader as the frequency is increased, so that the combination of two tuned transformers and two band-selector circuits gives a selectivity curve almost identical over the broadcast range, provided, of course, that the value of the coupling condenser is correctly chosen. Fig. 9A shows the selectivity of the MB-32. It will be noted that the curves for 1500 and 600 kc. are so closely alike as to almost fall on top of one another.

The second problem solved by the band-selector circuits was that of fidelity or audio tone quality. There has been of late a great deal of discussion about side bands and whether a too sharply tuned circuit diminishes the intensity of the high audio frequencies. Rather than enter into a lengthy mathematical discussion of the question, the writer will endeavor to give a physical explanation of what actually occurs within a tuned circuit which is being excited by an amplitude-modulated carrier. First, however, it should be appreciated that a sharply tuned circuit responds more slowly than a dull circuit to any influence tending to increase or decrease the current within it. Consequently, if the sharply tuned circuit is being excited by a carrier modulated by various audio frequencies, the current set up will increase or decrease with the low frequencies in a creditable manner, whereas the high audio frequencies do not allow sufficient time between their maximum and minimum values for the current in the tuned circuit to follow faithfully. Consequently, the high frequencies will not be passed on with as great an amplitude as was present in the incoming signal. Consequently special "compensating" audio systems then become essential in order to obtain satisfactory tone quality.

Utilizing two band-pass circuits should and does materially aid in preserving the high audio tones in their correct proportion and thus permits the use of a "flat-gain" audio system.

Volume Control

Control of volume on a radio set always seems to be one of the last design problems considered, probably because it appears easy. However, considerable time and thought were given this question of the MB-32. The new variable-mu tubes should make the problem easier, and, in fact, they do. There are at least two logical means of controlling volume. One is to vary the voltage on the screen grids while the other is to vary the bias on the control grids. Experiment, however, shows that varying the bias on the control grid makes the receiver considerably more selective. Consequently, the volume control was placed so as to vary the tube's bias and at the same

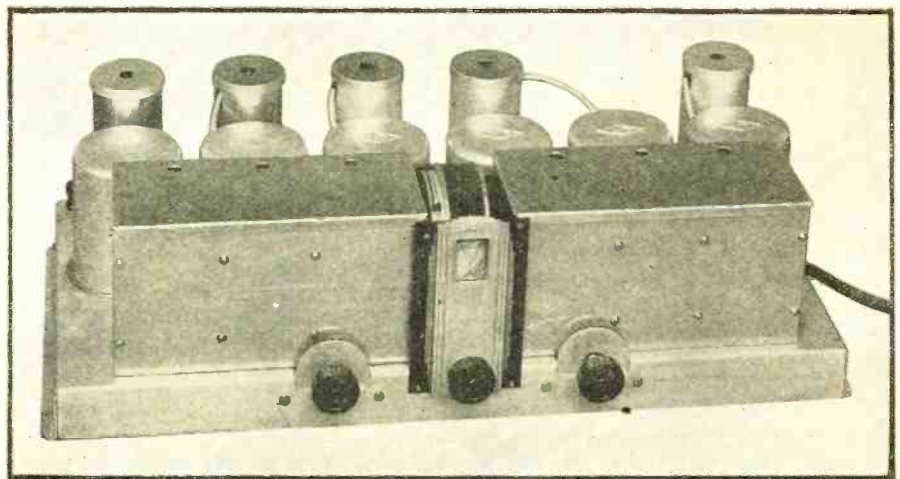

THE TUNER CHASSIS

The tuning condenser gangs, coils and tubes are all separately shielded to insure absolute stability at all frequencies

time so tapered that every degree rotation decreased or increased, logarithmically, the amount of signal necessary to give a standard output as indicated in by Figure 10. This means that the sound intensity from the speaker as determined by the ear would increase or decrease evenly, as the volume control is tuned. In many cases this detail, which is a great convenience to those operating the receiver, has been somewhat neglected, and as a consequence ordinary volume controls are turned a considerable distance before any apparent change in volume is obtained.

Consideration of detector circuits and tubes, together with experimental data, indicated that the type -27 tube, with power or linear detection, gave the best results as regard quality and its ability to handle strong signals with the least amount of distortion. This circuit was shown in Figure 1, last month. A filter circuit is used in the plate, consisting of two by-pass condensers and a radio-frequency choke. This confines all r.f. current to the prescribed paths and adds materially to the stabilization of the tuner.

Shielding the variable condensers was found necessary in order that the set, whose sensitivity is as great as can be utilized at almost any time of year, would be absolutely stable at all frequencies with the volume control "on full."

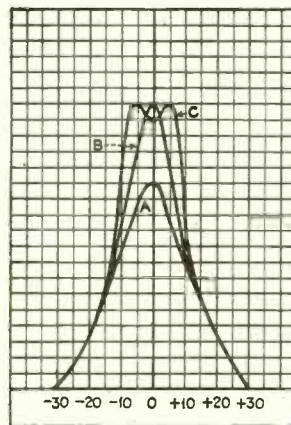

BAND-PASS EFFECT

Figure 8. Two tuned circuits, coupled together, will provide a band-pass circuit only when the proper degree of coupling exists, as at C. The two curves, A and B, show the effect of too loose coupling

The Audio End

So much space has been taken up in the design of the radio-frequency tuner that very little detail will be given on the amplifier-speaker combination. It suffices to say that a push-pull audio transformer with a special high-permeability core is used, in conjunction with one stage of resistance coupling. As tone quality was considered paramount at all times during the design of the receiver, two type -45 power tubes are employed in preference to pentodes as outputs, and are capable of delivering approximately 4 watts of undistorted power to the loudspeaker. This output is sufficient for small halls or theatres. The frequency response, as shown in Figure 11, extends as low as 25 cycles with a slight peak at 5000 cycles. This type of response, when used with a tuner such as described, is almost ideal, for even using band-pass circuits the high frequencies are slightly less in amplitude than they were in the carrier, and this is somewhat offset by the rising characteristic of the amplifier.

The power supply, for both the amplifier and the tuner, is incorporated in the speaker-amplifier, so that all that is necessary is to plug the two units together to have a (Continued on page 618)

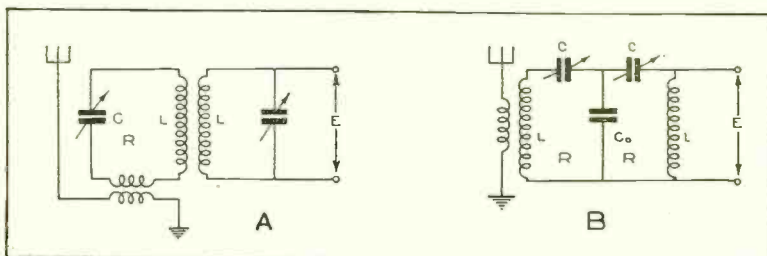

PRE-SELECTOR CIRCUITS

Figure 7. (a) A typical pre-selector circuit. (b) The improved circuit which employs capacity coupling to provide a more nearly uniform band-pass effect

Electrical Transcription

For Broadcast Purposes

This new art has been developed to a point where only an expert can distinguish between an electrically transcribed broadcast and a studio program. The author discusses this field and explains how the near perfection of today is achieved

By Thomas Calvert McClary

IN December, 1928, electrical transcription broadcasts made their entrance bow to the vast radio audiences of this continent. There had been broadcasts from phonograph records since the days of '21 and '22, of course, but the new type of recorded broadcast offered a tremendous advance over the old.

To the layman "electrical transcription" was merely a high-fat phrase for phonograph records. Recalling the pandemonium of noise received during the early days of radio when a great deal of the musical entertainment was limited to the broadcast of ordinary records, fans whose musical senses had, during the interval, grown accustomed to the best of programs, raised a howl of protest at the introduction of electrically transcribed programs that almost strangled at birth one of radio's greatest innovations—an innovation that alone has made it possible for the unseen audiences, particularly those in isolated sections, to receive as fine program material from local stations as from chain hook-ups. When it is considered that forty per cent. of the population of this country lives in rural districts, the true significance of good recorded programs is seen. Recorded programs, therefore, fill a recognized need.

Luckily for the public's enjoyment, responsible institutions and business interested themselves in electrical transcription and with the announcement that Bell Laboratories was working on its development, a doubting public, in whose breast is buried a deep respect and faith in this institution, none too graciously granted the new type of broadcast a fair trial.

The public's attitude remained sceptical, however, and every defect and fault in the programs brought forth much derogative hooting of the "I told you so" species. It took well over a year and a half to win their approval, and it was not until last winter that national surveys proved conclusively that electrical transcription had definitely been accepted by radio owners.

However, difficulties could not seriously hinder a type of broadcast which had grown out of three very definite needs: the necessity for the advertiser to reach all sections of the country at the same chosen hour in each community in spite of the three-hour time difference from coast to coast; the necessity for the advertiser to reach isolated communities through small local stations and yet maintain the high type of program the product, public and general reaction to the company demanded; and the necessity for small stations to be able to broadcast sustaining programs equal in merit to the

programs from chain hook-ups. Obviously, the latter problem was serious. Chain broadcasts of good programs to such an extent that local stations, unable either to arrange or afford programs of comparative quality, were finding it increasingly difficult to furnish sustaining or local programs which would hold the listener interest.

The pioneers in electrical transcription broadcasting faced many technical difficulties which had to be overcome by extensive research and experimentation. While electrical transcription and ordinary phonograph records seem closely allied to the casual observer, it was found that their respective broadcast values were widely divergent. Records produced by the old methods sound well enough on a phonograph, but standing up under tremendous amplification is a different matter.

Among many things causing even the best records made under the old methods to be inferior for broadcasting is the fact that it was not possible to transcribe the higher frequencies and there was a decided emphasis on the low. This prevents true reproduction and leaves the flat, muffled

tone with the accompanying boom in the bass notes so often heard in inferior work. Only by recording the full range of frequencies can the character and personality of a program be faithfully reproduced, and research by the Bell Laboratories can be thanked for making this possible.

One of the first and foremost companies to interest itself exclusively in the arranging and manufacturing of recorded programs for broadcast purposes was the Sound Studios of New York, Inc. They are important in any discussion of the matter, for they took the lead at the start, and what they have accomplished is largely the history of this part of the industry. Through licenses which enable them to avail themselves of years of research and experimentation in the radio broadcast, telephone, phonograph and talk-

ing movie fields, and through the efforts of a field staff of over six hundred engineers, they have made possible much of the beauty and trueness of recorded programs as we know them today.

Some of the unlimited research necessary for perfection and progress in the field of electrical transcription may be guessed at by a glance into one of the Sound Studios during a performance. Instead of being solidly insulated with sound deadeners, as would be expected, the walls are covered only at



MAKING THE RECORDS FOR BROADCASTING

The first recording for electrical transcription is made on relatively soft wax, and from this is transferred to a "master" disc, from the "master" to a "pressing" and a "mother," from the "mother" to a "stamper" and, finally, from the "stamper" any number of final discs may be made. In one process a pressure of seventy-eight tons is provided by the press on the left

certain strategic points. The result is that, standing in one corner of the room, a person's voice from another quarter may be heard as a mere whisper, but by moving only a few feet it is heard loudly and distinctly. This planned variation is taken advantage of in the placing of microphones and for the placing of instruments and vocal talent. It took acoustical engineers twenty-six weeks to chart out, experiment and construct these studios. Since then, many changes have been made, and the results have proven so satisfactory that radio stations are beginning to adopt this type of studio.

The Recording Process

When recordings are being made, several microphones may be used to pick up the program. The "mixing" or balancing, as it is termed (that is, causing the pickups of the various microphones to assume proper proportion to their place in the program), is done in the control room, after which the program passes through properly equalized circuits and is cut into the large 16-inch, 33 1/3 r.p.m. discs on the double synchronizing turntables. This "mixing" makes for better tone value and eliminates the necessity for sections of the orchestra or vocal group to tone down during any part of the performance in order to accentuate or emphasize another section. Sometimes the voice which you eventually hear standing out clear and full against the soft background of the orchestra can barely be heard in the studio during the actual recording of the piece.

Immediately after the recording is finished one of the wax discs is played back to the assembled group of artists, technicians, directors, producers, sponsors of the program, engineers, harmonic experts and others interested in the utmost perfection of the program, for their okay. If any flaw is detected from the standpoint of any one of the group, the recording is discarded and another made immediately. If it receives the okay of all involved, however, the duplicate disc which was cut at the same time is taken to the galvanic baths, where the cut side is electroplated as it swishes back and forth on the end of a long rod. From this is taken the resulting reversed plate called a "master."

The master is then taken to the pressing room, where two pressings are made. These are composed of earth-shellac material identical with the final discs. The material is first heated and then placed in the press with the master. Here, under seventy-eight tons pressure, it is again heated and baked.

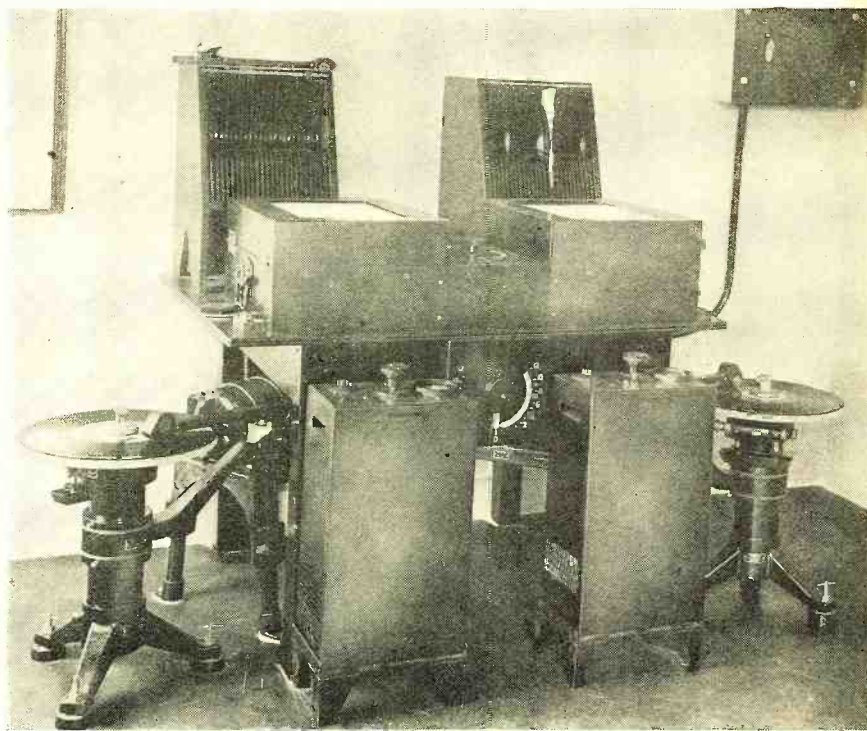

EQUIPMENT AT STATION WOR

Equipment employed in reproducing electrical transcriptions is a far cry from the primitive phonograph used in studios a few years back. Today's equipment must be of the highest precision in order to maintain the high quality of reproduction made possible by modern methods of recording.

Once again the group of experts interested in the perfection of the program assembles to approve or disapprove of the recording. If all is satisfactory, the master is in turn electroplated and a "mother" taken from it. The master is then filed away for safe keeping in the event something disastrous happens to the mother.

The mother plate now has indented lines (having been made from the master, which was the reverse of the wax). It is necessary to make another reverse for pressing the final discs. So it too is electroplated and the resultant "stamper" taken therefrom is used for the final pressings. If anything happens to the stamper, the master is brought forth and the process repeated.

The large 16-inch 33 1/3 r.p.m. discs grew out of the regular 12-inch 78 r.p.m. records which were found to be unsatisfactory for broadcast or talking movies. At 78 revolutions there are variations detrimental to the program, and it was found that the high speed crowded frequencies and limited the efficiency of recording to full audio scale.

"Editing" Recordings

Recordings need not be made in sequence, as are studio programs, but may be made in sections, split up and correctly re-recorded at a later date, in much the same way movies are made. For instance, if three symphony selections, several vocal, a talk, announcements, etc., are to be incorporated into the complete program, each separate group of recordings may be made at different times or in different studios at the same time. The symphony selections can all be played and recorded in one studio while perhaps the announcer is going through his duties in another and the vocal selections are being made in a third. When each section of the program has been approved the recordings may be "dubbed" onto another disc in their correct order, and the complete program is ready.

This type of broadcast has decided advantages inasmuch as events happening miles away may (Continued on page 619)

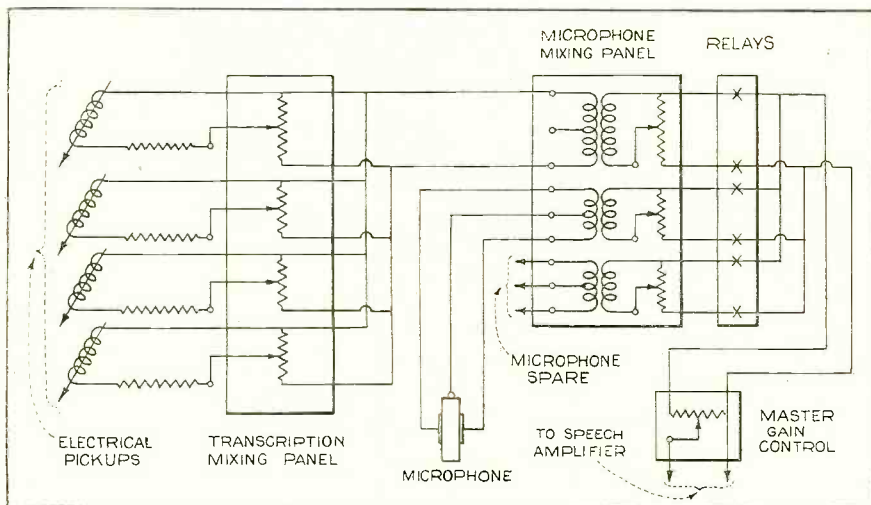

A TYPICAL OPERATING SCHEMATIC DIAGRAM

Schematic diagram of the special equipment employed at the broadcast station to permit the use of high-grade electrical transcriptions

The Future of Radio

As Foretold by

Prophets have been prolific in their future. Their prognostications, often have brought small honor to their author endeavors to paint a truthful its development, comparing



BROADCASTING ROOM OF YESTERDAY

Photo shows the combination control and transmitting room of old WOR. These two functions are divided in present broadcasting layouts

TO the old-time radio operator QRD is a simple interrogation of destination—radio for “Quo vadis?”—whither are we bound? And the old-timer, by the way, is best able to answer as to radio’s future. He has seen it develop from its infancy, when its squawking voice was limited to the crackle of dots and dashes. He has faith in its science, but at the same time he has no illusions as to the rapidity with which it may advance, and his prognostications regarding its future are based on sober probability, not on the fantastic guesses that made Jules Verne an intriguing story-teller.

Quality in Program Material

Progress in radio evolves simultaneously along two paths—the technique of transmission and reception, and the program. We have already pointed out that this latter phase of radio is perhaps the more important, for therein lies the impetus, the stimulation to further technical perfection. Radio’s engineering status today must give credit to the program. The frequency bands covered in the modern receiver and transmitter are merely the answer to a demand to receive the frequencies actually existent in any orchestra. And though from a technical point of view radio has approached close to practical perfection, the importance of the program is by no means lessened, because the patronage of radio facilities and the ultimate fate of the industry still depend upon the pleasure which the listener derives from his set. Should programs, in their own way, approach as close to perfection as radio’s technical advance, the dollar will buy a better radio value, and the social, esthetic and political aspects of civilization will be materially benefited. The possible perfection of the radio program is therefore a matter of prime importance. As we pointed out in our preceding article, the radio program of today is little better than the typical presentation of four years ago, and many of the criticisms voiced against the programs of yesterday apply now.

The advent of the sponsored

By Zeh

program, about eight years back, opened the way to the utilization of genuine talent by providing a logical and simple means of recompense. Before that time, aside from phonograph records and piano rolls, radio presentations were dependent upon free talent, and, like most things obtained for nothing, it was worth exactly what it cost. Unfortunately, like Pandora’s box, the sponsored program brought with it an evil almost the equal of its blessing—the fact that the sponsor insisted upon receiving credit for the money he was spending. This, in itself, was fair enough, but he soon took advantage of the helpless predicament of

the radio listener to describe the merits of the product he was manufacturing, in all conceivable degrees of directness and subterfuge, which were equally nauseating and unpalatable. The head of a large advertising agency once said to me: “No advertisement can succeed if the advertising urge or the advertising effort is apparent. The test of a good advertisement is that the person should be unconscious of sales intent in reading the advertisement or listening to the sales argument.” An active movement is under way to regulate and reduce the advertising content of radio programs. This is the continuation of a consistent effort that has been acting in this direction for the last seven years.

Concerning Sponsored Programs

An editorial in the May, 1929, issue of *Radio* devoted some space and considerable intelligence to the problem:

“Who would erect a billboard in his back yard so that his family might have the pleasure of seeing the pretty picture of a girl smoking a cigarette or a bull standing behind a fence? Yet that is practically what the purchaser of a radio set is asked to do today. Is it any wonder that the people who have invested billions of dollars in receiving sets are critical

of the kind of programs that are sent into their homes? The marvel is that more people have not thrown away their sets in disgust.

“The blame rests squarely on the shoulders of the broadcasters who do not censor the length and character of the advertising which is interlarded in their programs.



UP-TO-DATE TRANSMITTERS

Above, the transmitting room for station W.E.A.F., located in Bellmore, New York, and, below, the transmitting room of W.J.Z., located at Bound Brook, New Jersey. Studios for both of these great stations are located in the heart of New York City



in Broadcasting

Past Development

guesses as to radio broadcasting's made with little scientific background, apostles. In this second article the picture of radio's future, by studying the present with its history

Bouck

Formerly there was a great deal of justifiable talk about the debt that radio manufacturers and dealers owed the broadcaster. Without broadcasting, no radios could be sold. But now there should be just as much talk about the debt that the broadcasters owe the manufacturers and dealers. Without radios, no programs could be sold. . . . Broadcasters have frequently taken business that any reputable newspaper or magazine would refuse.

"It is to be hoped that the broadcasters and offending advertisers will realize these truths before it is too late. Radio advertising, to be effective, should be palatable and non-obtrusive. Anyone will remember and commend a good program and those who made it possible, while they will condemn the attempts that are being made to cram long-winded talks into their ears. Radio is just as effective a builder of ill will as it is of good will. This is an evil that deserves the attention of the radio industry whose business is threatened if the evil is not stopped.

Classifying Advertising Programs

Publicity or sponsored programs may be roughly split into five classes, according to the manner in which the publicity is introduced:

1. The simple mention of the sponsor.
2. Programs incorporating a few unobtrusive words concerning the sponsor or his product. Such programs are rarely objectionable.
3. The theme song type. The publicity is generally incorporated in the theme song. The publicity is seldom half as objectionable as the silliness of the songs.
4. Programs accompanied with a long harangue about the

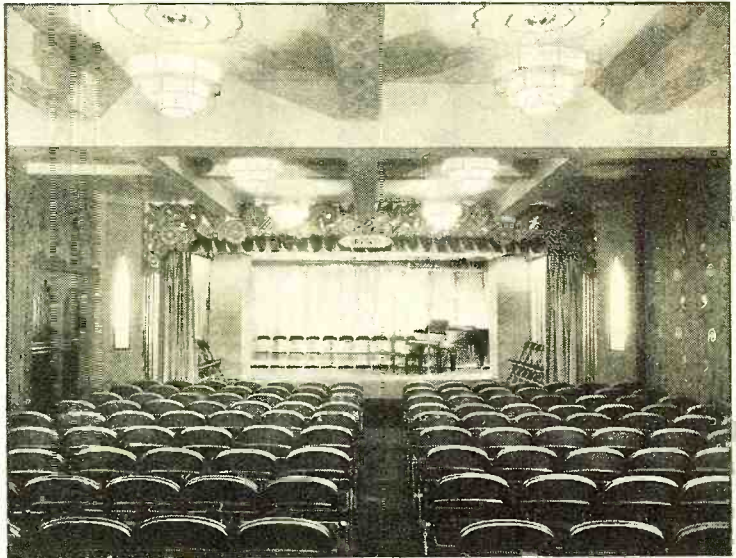

TODAY'S STUDIO THEATRE

A completely modern touch in the development of the studio is that of Station WMCA in New York. Comfortable chairs are provided for visitors, who may watch the artists as they perform

generally mythological merits of the product. These are certainly objectionable.

5. Programs in which the product is mentioned repeatedly throughout the hour, and often worked into the program itself. Household programs are perhaps the most flagrant offenders in this way.

We have so far considered the esthetic development of radio broadcasting. While the possibilities for program progress were almost limitless during the last half of the first decade of broadcasting, we have observed that little has been made of the potentialities. The inclusion of a nauseating amount of advertising in the sponsored programs has not abated in the least. A few changes have been made, anatomically and in trade-marks, but the plugging, like the complacent little brook, goes on forever. What was once good for a slim waist is now recommended for the Adam's apple. True, the programs themselves are a little better, as radio technique has developed, and as the sponsors gained enough faith in the new medium to justify large appropriations for finer talent.

Technical advance, though limited in its possibilities, has progressed definitely, narrowing the distance between its past attainments and the theoretical limitations of perfection. The main goal of engineering development, simple to define, is to reproduce in the home the sound impinging on the microphone in the studio. Radio, in this respect, was perhaps seventy-five percent perfect in 1926. A secondary aim of engineering perfection is to increase the number of homes in which this reproduction can be effected. As this last consideration depends somewhat upon economic factors, the degree of attainment as an engineering accomplishment cannot so readily be expressed numerically.

Technical Developments

It is possible today, within the service area of a modern broadcasting station, to reproduce a studio program in the home with a degree of perfection that is practically above criticism. In this respect it may be said that radio-telephone development has achieved its ultimate aim.

The progress, since 1922, has been convergent from several points of attack. We have first of all the microphone, the earliest type being an all-too-rapid adaptation of the regular telephone transmitter of dubious frequency characteristics. This was placed in a tin can, the cavity resonance of which contributed to

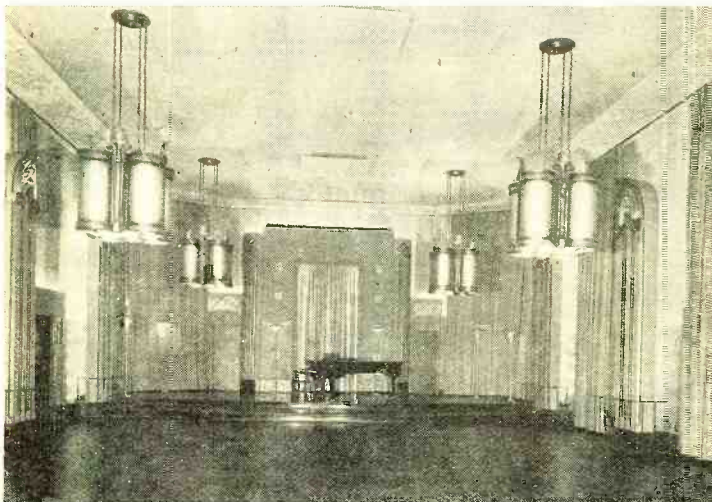

A STUDIO WITH A COLOR SCHEME

In this modern broadcasting room, in one of the N. B. C. studios, colored lights of changing qualities, to fit the moods of the broadcasting, are projected from the modernistic candelabra

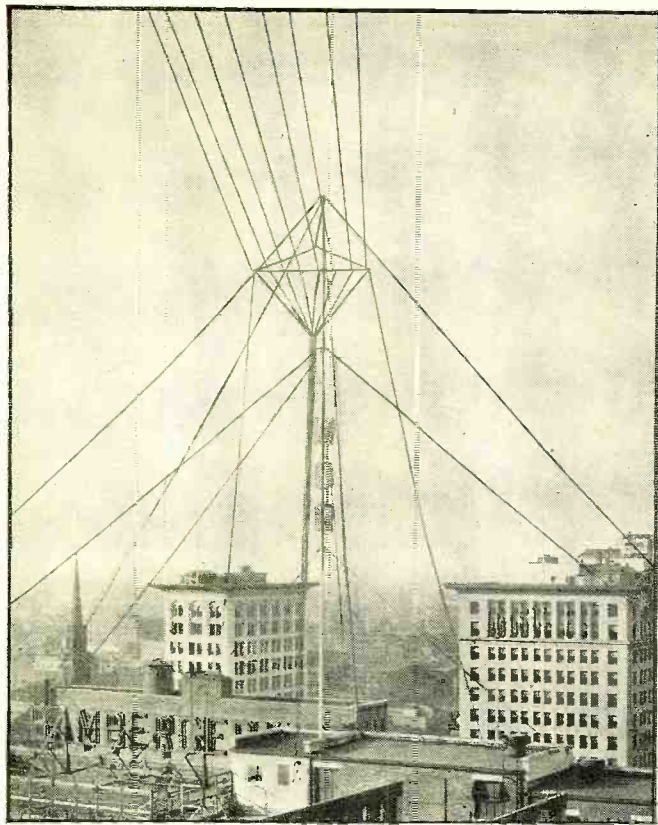

THE OLD ORDER OF ANTENNAS—

When transmitters existed in cities, the antennas were put up on wood or tubular steel masts, such as this one of eight years ago on top of the Bamberger station in Newark

the background hiss of overloaded and frying carbon. The induction microphone was rediscovered simultaneously with the introduction of the two-button mike. The former was little more than a loudspeaker worked backwards, the vibrations picked up by the diaphragm or cone causing a dynamo action in the windings corresponding to the sound. The frequency characteristics of the induction mike were, for a short time, a trifle better than those of the direct-current types. From 1926 to 1930 the standard two-button mike, with its familiar gauze-opening can, did an excellent transmitting job—and is still widely used. Its characteristics fall short only of the condenser type which is very close to acoustic perfection.

Audio channels, already quite good in 1925, benefited by almost infinitesimal improvements, which, in accumulation, are definite and noticeable. Both the radio and audio-frequency characteristics of the transmitters have been improved by developments in the radio-frequency circuits and by the use of crystal-controlled oscillators. Carriers rarely wander more than fifty cycles off the frequency authorized by the Federal Radio Commission or the copyright owner, and this stability has made possible increased modulation without distortion, accompanied with a more powerful signal.

Science Applied to Studio Design

The acoustic properties of the studio have been subjected to engineering analysis, and the psychological environment of the artist has received similarly scientific investigation. Studio pick-up today is an exact science, with microphone placement and acoustic damping arranged to a nicety. Colored lights play in subtle diffusion, engendering in the performer a mood compatible with his emotional efforts. Some studios have been designed as miniature theatres, catering to the artistic temperament that demands a visible audience for its finest expression. And the technique of the outside or nemo pick-ups has been improved with simultaneous consistency.

The commercial radio receiver has been constant, although it has lagged a year or so behind the perfection of the transmitter. The customary economics of manufacturing were partly responsible for this. The makers of radios, automobiles or clocks invariably refuse to incorporate new improvements

until the consumer has been stuck with a hundred thousand or so antiquated models which the manufacturers necessarily have on hand.

The secondary goal of radio perfection—the wider dissemination of broadcast programs—has made remarkable strides in the past five years through the continued perfection of receivers, the use of super-power, short-wave transmission and station synchronization. While the manufacturers, through a process of economic mayhem, succeeded in keeping the screen-grid tubes and the pentode in the background for a time, receivers incorporating these latest principles are at last available. Such receivers, in superheterodyne designs, and incorporating variable-mu tubes with automatic volume control, contribute much to the reception of distant stations. And the use of these new tubes, regardless of circuit, results in better receivers for the money than it has heretofore been possible to buy, with a naturally resulting expansion in receiving facilities.

Super-Power Broadcasting

Super-power is today a *fait accompli*—an accepted fact. Any attempt to reduce the power of our 50-kw. stations would probably face a protest equal to that which organized in 1925 to prevent broadcasting on power exceeding 1000 watts! Believe it or not, the "Citizens' Radio Committee"—composed of radio listeners, engineers and of course a couple of Congressmen—fought the increase of power with all the arguments and fallacies with which fanatics impede progress. The secretary of the Committee wrote to me in March of that year:

"Super-power cannot prevail or endure. It is diametrically opposed to the best interests of the art. It tends to foster a condition that will result in chaos and corruption. . . . The efficiency of stations would be destroyed if super-power went into effect. . . . Super-power? Why the need? Super-power will be attacked unmercifully by the theatrical interests, the church, the school and the public on account of the destroying influence! Super-power is the fog of broadcasting. It blankets the interest of the listener-in. Finally the mercenary intent and purpose of super-power will react against the sponsors."

Short-wave transmission has contributed much to the expansion of national and world-wide (Continued on page 615)

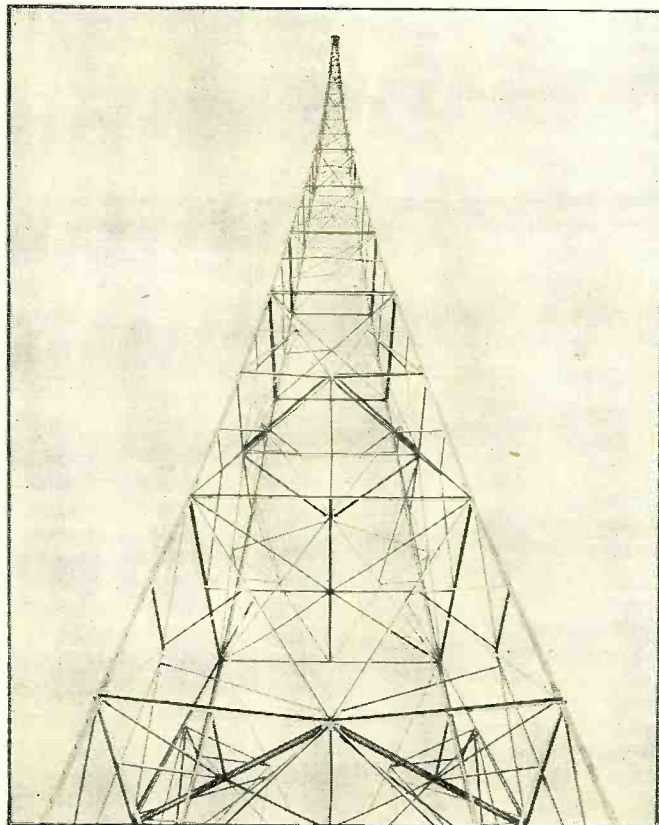

—AND THE MODERN STEEL GIANT

This is one of the gigantic towers that support the mighty antennas of station WEAJ, located some thirty miles out of New York on Long Island

REDUCING NOISE in Talking Picture Film

The author continues his description of the latest method for solving the problem of film noise in the talkies. He gives the technical details of the ingenious unit for "masking" the photo-cell while it is idle

By Barton Kreuzer
Part Two

THE function of the circuit controlling the shutter described last month is to make the "unmasking" action as rapid as is consistent with quiet operation and the "masking" or closing of the track after the cessation of the sound sufficiently slow so that no secondary modulation can occur at the lowest frequency to be recorded. The latter part of this statement means, of course, that a true ripple-free d.c. must be delivered to the shutter down to the lowest frequency to be recorded.

In simplified form the circuit used to accomplish this is shown in Figure 6. The voltage across "R₂" varies the grid bias of a pair of vacuum tubes which in turn control the shutter. The input admittance of the tubes is negligible so no account is taken of them in the following analysis:

- E = voltage impressed
- R₁ = resistance of source (a rectifier)
- R₂ = bias resistor
- C = capacitor
- E' = voltage across C
- i₁, i₂, i₃ = current in respective arms of the circuit

$$i_1 = C \frac{dE'}{dt} \quad (4)$$

$$i_2 = \frac{E - i_3 R_1}{R_2} \quad (5)$$

$$i_3 = i_2 + i_1 \quad (6)$$

From these simple network equations an expres-

sion for "i₂" may be found to be

$$i_2 = \frac{E - E\epsilon^{-\frac{t}{R'C}}}{R_1 + R_2}$$

Where $R' = \frac{R_1 R_2}{R_1 + R_2}$

When $t = \infty$, $i_2 = \frac{E}{R_1 + R_2}$

Solving for "t" when i₂ = 0.9 of this value

$$t = 2.3 \frac{R_1 R_2}{R_1 + R_2} C \quad (7)$$

This expression deals with the time necessary for the growth of the rectified current. Now, since the voltage has been supplied from a rectifier (which has been assumed to present d.c. to the circuit), there is no appreciable reverse current flow through "R₁." The current at discharge may be written in the conventional form:

$$i'_2 = -\epsilon^{-\frac{t}{R_2 C}}$$

Allowing for a decrease in current of ten to one the time necessary is:

$$t' = 2.3 R_2 C \quad (8)$$

Equations (7) and (8) determine the operating time of the current in the

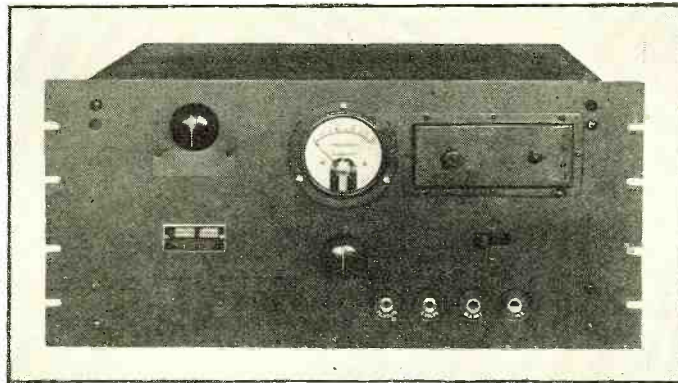

FRONT VIEW
Figure 12. Here is the control panel, showing the meter, jacks and potentiometer controls

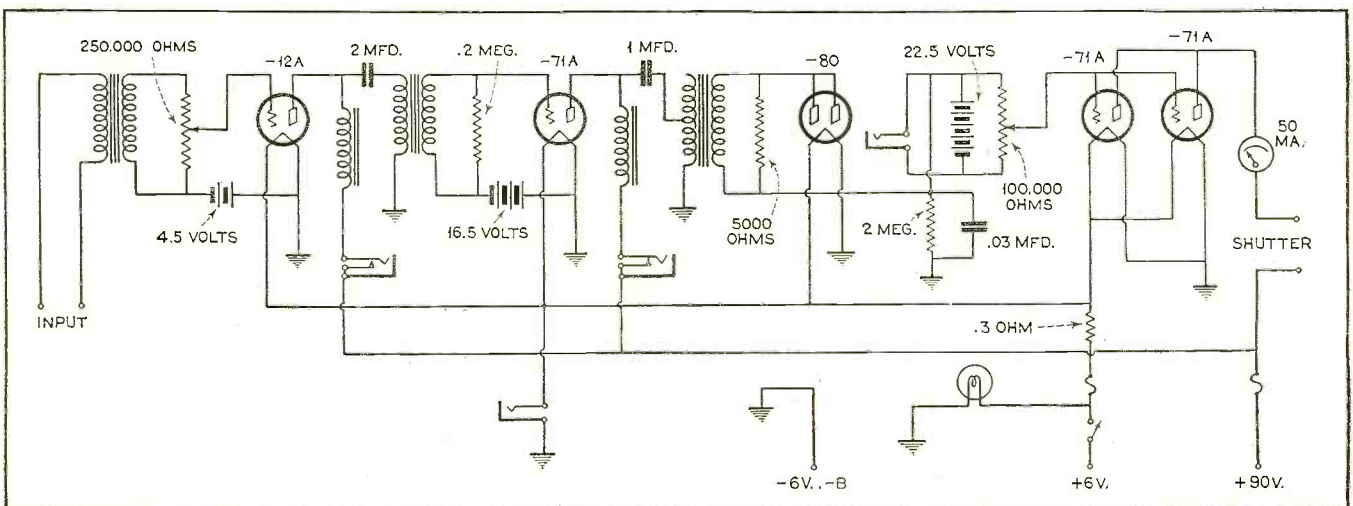

ACTUAL CIRCUIT EMPLOYED

Figure 7. Circuit diagram of the control circuit, including both a.c. and d.c. amplifiers and rectifier

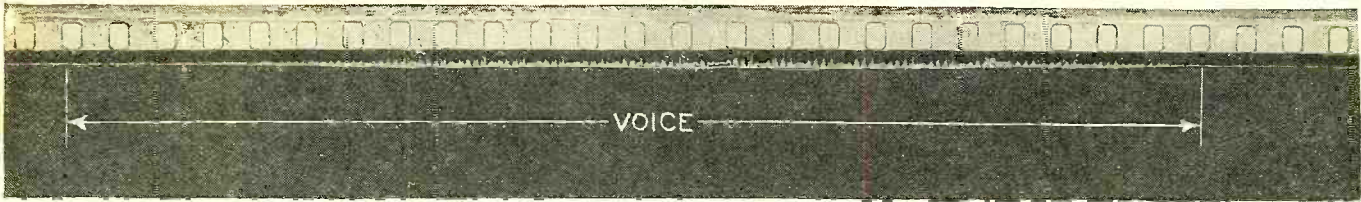

CORRECT RATE OF MASKING

Figure 13. Photograph of a sound track obtained for an actual speech syllable with the masking shutter working at correct speeds

shutter circuit. Actual shutter operation is further influenced by the inertia of the shutter mechanism and a certain amount of inductance inherent in the e.m.f. source.

After careful consideration of the factors involved, a choice has been made which provides satisfactory operation with circuit elements which can be quite easily used in commercial apparatus. The time actually required for complete "unmasking" of the track is from .005 to .007 second and the time necessary for complete "masking" is .11 second. The circuit diagram of the shutter control circuit embodying an amplifier and rectifier is shown in Figure 7.

As shown in Figure 2e (see Part One), the input to the amplifier is bridged across the low-impedance line to the galvanometer. The load imposed on this line by the amplifier is a negligible one.

Since equations (7) and (8) deal with the operating times (opening and closing) of the shutter current, the variables in these equations must be carefully considered in designing the shutter control circuit. After the length of time necessary for closing the shutter has been decided upon, the factors in equation (8) may be fixed. These elements, "R" and "C," are chosen so that construction of commercial apparatus will not be difficult; i.e., the value of "R₂" is not sufficiently great to require special precautions to guard against leakage, nor is the magnitude of "C" such that the capacitor will be bulky. Consideration is also given to equation (7) so that its solution will result in resistance values which may be commercially realized. With the resistance and capacitance values of equation (8) satisfied, equation (7) has only one variable which must be determined, for any one value of opening time. This is the value of "R₁."

In Figure 7 the elements "R₂" and "C" are quite obvious, being respec-

tively two megohms and 0.03 microfarads. "R₁," however, is somewhat more complex. It is composed of the diode resistance, the transformer resistance referred to the diode side and the preceding amplifier tube plate resistance referred to the diode side of the transformer. It should be apparent that the choice of the preceding vacuum tube and the ratio of transformation as well as the diode resistance all play an important part in determining the value of "R₁."

Tubes in Parallel

Two suitable vacuum tubes in parallel are employed in the output stage on low voltage to insure extreme stability and long life. The variable bias supplied to these tubes is polarized to cause a decrease in their plate current as the signal voltage to the vibrator increases. This means that the moving vane draws away as the current through the shutter windings diminishes.

Use is made of the curvature of the grid voltage vs. plate current characteristic of these vacuum tubes to provide a type of operation of the shutter that precludes the possibility of distortion occurring due to the "overshooting" of high amplitude sounds of short duration. Therefore at low modulation values the shutter "unmasks" the track to a degree more than directly proportional to the modulation. This insures adequate track width for the recording of the high-amplitude, high-frequency sound components which occur so often in recording and allows a factor of safety in recording which protects against "overshooting" of the sound track.

Figure 8 shows the overall input vs. output characteristic of the amplifier and rectifier. Figure 9 shows the amplifier frequency characteristic. The control circuit has been built into the RCA Photophone standard (Cont'd on page 610)

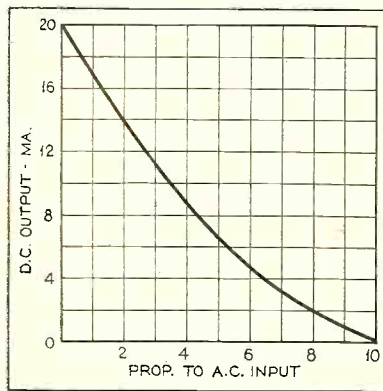

CONTROL CIRCUIT CURVE

Figure 8. Showing how the output varies in respect to the input

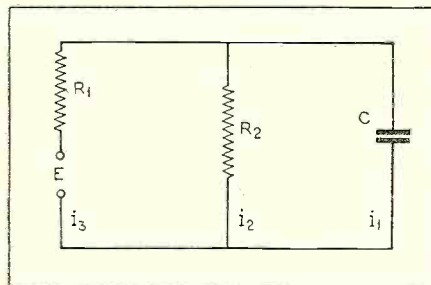

SIMPLIFIED CIRCUIT

Figure 6. Diagrammatic outline of shutter control circuit

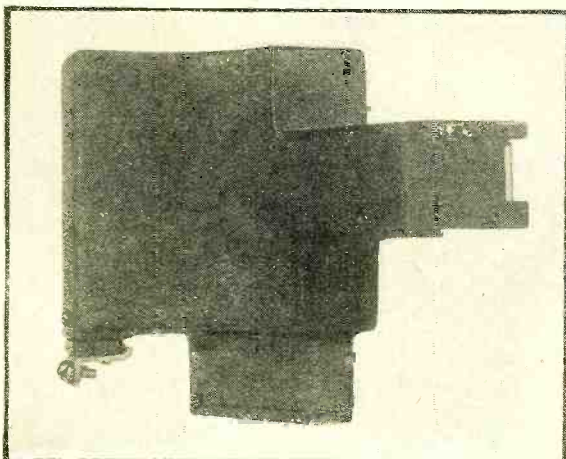

THE SHUTTER AS USED

Figure 10. This gives a view of the magnetically controlled shutter unit with its case attached

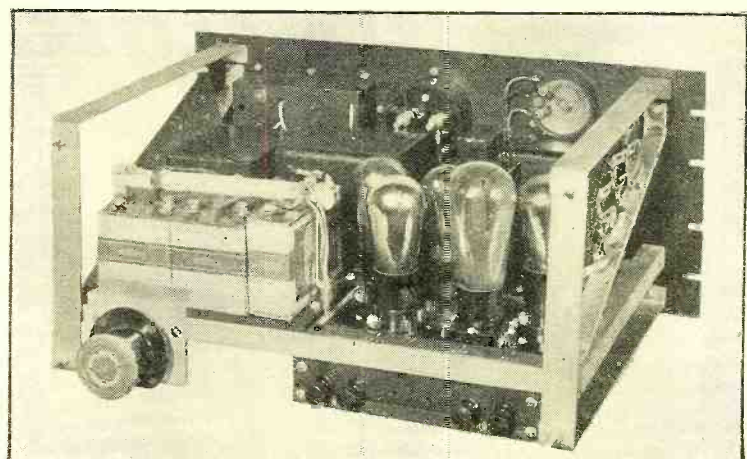

INSIDE VIEW OF CONTROL UNIT

Figure 11. Here is the control unit seen without its metal cabinet, showing arrangement of the component parts and tubes

Power Supply for the *Radio News* Transmitter

The power supply, for the one-tube transmitter described last month, is covered in detail in this article. The advantages of the type 566 mercury vapor rectifier are discussed. Some transmitter operating hints are also included

By Nat Pomeranz*
Part Two

approximately seven-tenths of the peak voltage.)

The tube is of the slow heater type and takes about 30 seconds to heat up.

WITH our self-excited oscillator using the -52 type tube constructed as described in last month's issue of RADIO NEWS, we are now ready for the construction of the power supply unit to be built on the bottom shelf of the frame.

There is nothing complicated or out of the ordinary in the power supply. Full-wave rectification is employed. The output from the rectifier tubes is fed into a brute-force filter which provides the pure direct current necessary for the satisfactory operation of a really good code or phone transmitter.

This constructional article specifies the use of the type -66 mercury vapor half-wave rectifier, although this type of tube is not used in the power supply of the transmitter in the RADIO NEWS Laboratories for reasons which will be explained further.

The type -66 rectifier is the ideal tube for use in amateur transmitters under most conditions. It requires a filament voltage of 2.5 at 5 amperes. It will stand a peak voltage of 7500 volts. This means that the tube will safely handle an a.c. input of 5250 volts as measured on a regular a.c. voltmeter. (The ordinary a.c. high-voltage meter will show

Because of this it is necessary to keep the filaments of the two rectifier tubes in operation throughout the operating time. Otherwise a delay of 30 seconds in answering a fellow amateur during a two-way chat will often make it difficult to maintain contact unless the fellow at the other end has an unusual amount of patience.

A filament transformer to light the two -66 tubes must deliver a total of 10 amperes for the two tubes and must have high-voltage insulation. A voltage insulation of 10,000 (as our

transformer manufacturers rate them) is essential, according to the manufacturers of these tubes.

Once placed in operation, the type -66 rectifier offers an outstanding feature in its almost unlimited life, if it is not mistreated. One of our larger transmitting tube manufacturers, in an effort to determine the life of the tube, placed a number of them in operation many months ago, when the tube was first introduced to the public. They have been in continuous operation ever since and show very little sign of wear.

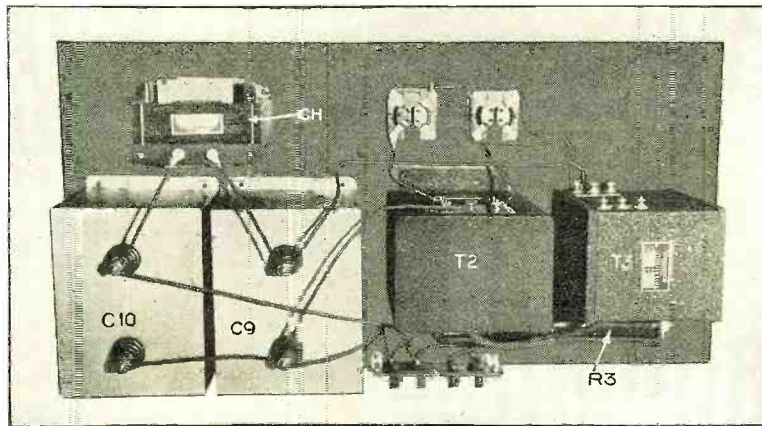

THE PLAN VIEW

The location of parts is clearly shown. At the extreme right is the Type 210 Power Compact, which is being used temporarily to light the filaments of the -81's

*U. S. N. R., W2WK-W2APD.

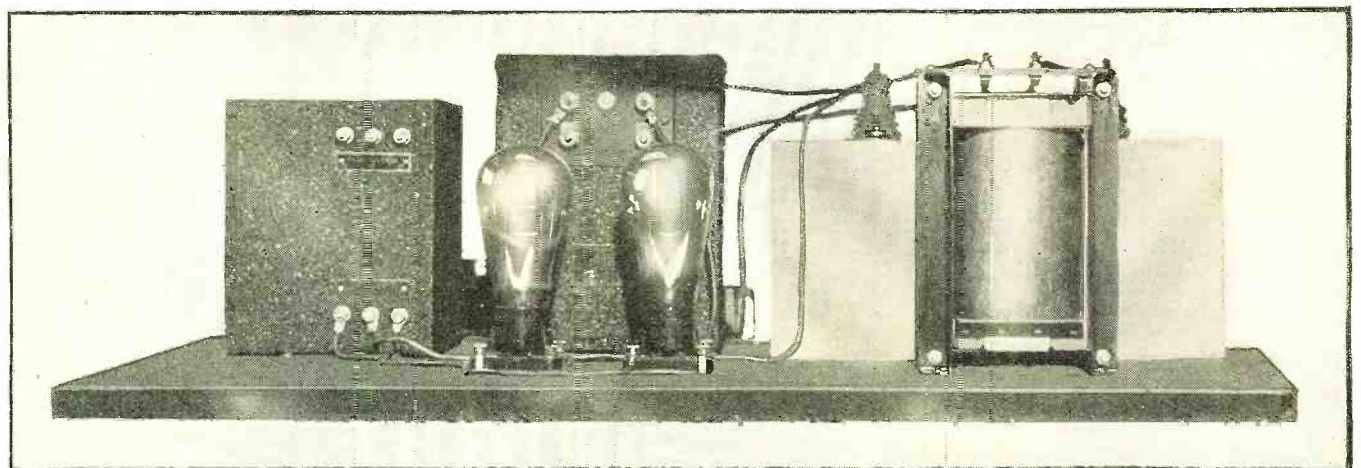

THE POWER SUPPLY SHELF

The complete power supply as it looks from the front. While mercury vapor rectifier tubes are recommended, the type -81's shown here are being used temporarily, for reasons explained in the text

Due to the fact that at the present time 110-volt alternating current service is not available in the RADIO NEWS Laboratory, an alternating-current generator is used and the -81 type rectifier is temporarily substituted for the -66. The generator, while running, creates interference in the short-wave receiver and it is, therefore, essential to stop the generator while receiving. The -81, which passes current as soon as the filament is lighted, makes a very good substitute. However, we are not able to use more than 1000 volts on the plates without the danger of breakdown. At 1000 volts the tubes run quite cool, since no more than 90 milliamperes is ever drawn through them. They are rated to deliver 110 milliamperes each.

In the constructional model we used a Thordarson 210 Power Compact which delivers, among other voltages, 7.5 volts for two -81 tubes. Only this winding is used on the transformer. It is not a practical method of use, but since a 210 Compact will later be used for plate and filament supply for our crystal-controlled stages, we have placed this transformer in temporary use.

If, in place of the -66 type rectifier tube, readers who construct this outfit prefer to use -81 rectifiers, the only change necessary is from the 2.5-volt filament transformer specified in the parts list to one delivering 7.5 volts. With the -81 tubes, the filament transformer need not have high-voltage insulation but can be of the ordinary type such as is used in receiver power-pack construction.

Selection of Parts

Still another type of rectifier tube can be used. Some companies are manufacturing a half-wave mercury vapor tube which somewhat resembles the -66 but requires a filament voltage of 7.5 volts. This tube is therefore interchangeable with the -81.

The plate power transformer is a Thordarson Type T-2387, which delivers a total of 3000 volts. On either side of the center-tap it is tapped at 1500 volts and 1000 volts. These taps are brought to a terminal strip on the transformer. In wiring to this transformer, the connections are made to large soldering lugs which are provided with the transformer.

The brute-force filter consists of eight microfarads of filter condensers and a Thordarson Type T-2027 filter choke. The latter is a 30-henry choke and is rated at 300 milliamperes, maximum.

In selecting the filter condensers, ones having a rating of 2000 volts d.c. were adopted. These condensers are also rated at 1600 volts rectified a.c. An error is often made by the

building amateur in the proper choice of condensers so far as ratings go. Most condensers manufactured have just one rating placed upon them, which is the d.c. working voltage. If we would have d.c. to feed into these condensers, they would not be necessary for filtering. Our voltage rating must therefore be figured on rectified a.c. and not on d.c.

The common error in a case of this kind is to use condensers having a voltage rating of 1500 volts (d.c.). This rating is the equivalent to a rating of around 1300 volts rectified a.c. and would be too low for safe use. Our supply utilizes two Flechtheim Type TH-400, each having a capacity of 4 microfarads.

An Electrad 100,000-ohm, 100-watt "bleeder" resistor is used to provide a slight load on the rectifier tubes when the transmitting key is up and no current is being drawn from the power supply and also to discharge the filter condensers when the power is shut off. A charged filter condenser will produce some queer reactions upon the human body when applied properly.

The "bleeder" resistor is an absolute necessity when -66 tubes are used unless two tubes can be perfectly matched to each other. The total drain upon these tubes is so small to what the tubes can really handle when the voltage is applied to the oscillator tube, that, often, just one of the two rectifier tubes goes into operation, leaving the other in the circuit but not passing any current. The result is a plate voltage which is only half-wave rectified and therefore not as pure d.c. as wanted. One can tell when the rectifier tube is operating by a bluish glow near the inside top of the tube when the key is pressed. The "bleeder" resistor keeps both tubes passing some current continuously after the key is pressed for the first time and they are therefore more stable in operation.

Optional Use of R.F. Chokes

For wiring the power supply unit, a Number 14 rubber-covered wire is used. This insures adequate insulation in the wiring as well as flexibility while working.

A binding post strip having four binding posts, two for a.c. input and two for d.c. output, completes the apparatus needed.

In some cases, radio-frequency currents flow back into the wiring of the power pack when the transmitter is in operation. This deficiency tends to introduce a ripple in the note produced by the oscillator. In this event, radio-frequency choke coils can be placed at the points marked X on the diagram.

With both the tuned-grid-tuned-plate oscillator and power pack completed, the transmitter is now ready to be placed in operation.

A permanent transmitting antenna (*Continued on page 621*)

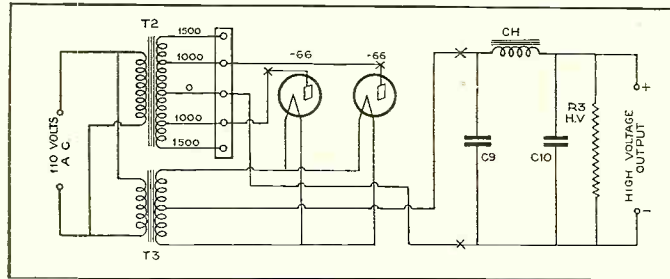

THE POWER SUPPLY CIRCUIT

There is nothing unusual in the circuit employed. In fact, simplicity is one of its features

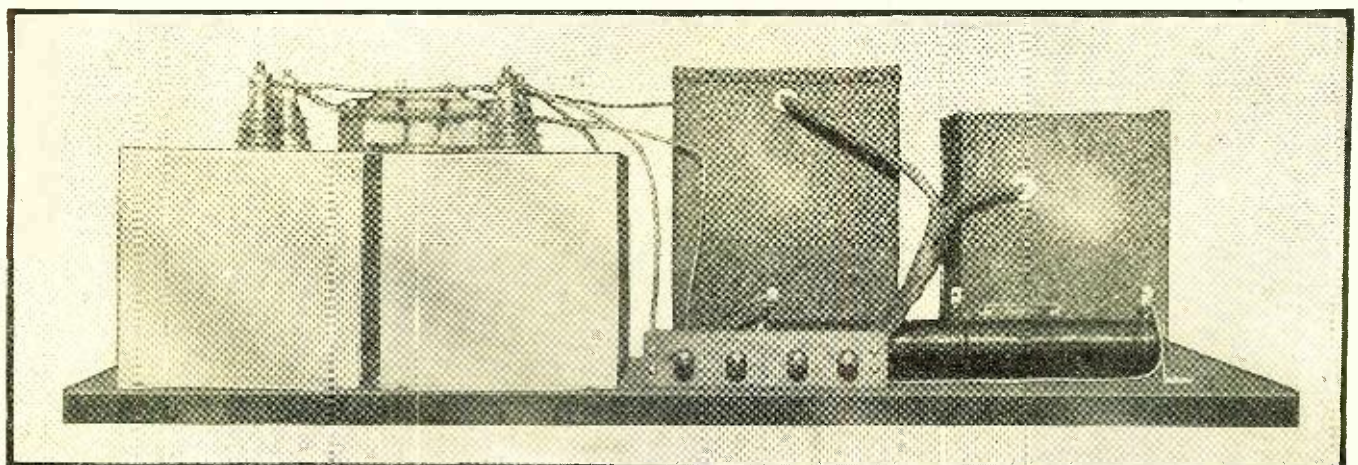

THE REAR VIEW

The only external connections are for the a.c. line and the high-voltage output. These are made at the terminal strip in the foreground

The March of Electrons

New applications for radio and electronic devices in commercial and scientific fields are developing daily. Recent applications, as described here, give some indication of the tremendous potentialities of this relatively new science

By Raymond Francis Yates

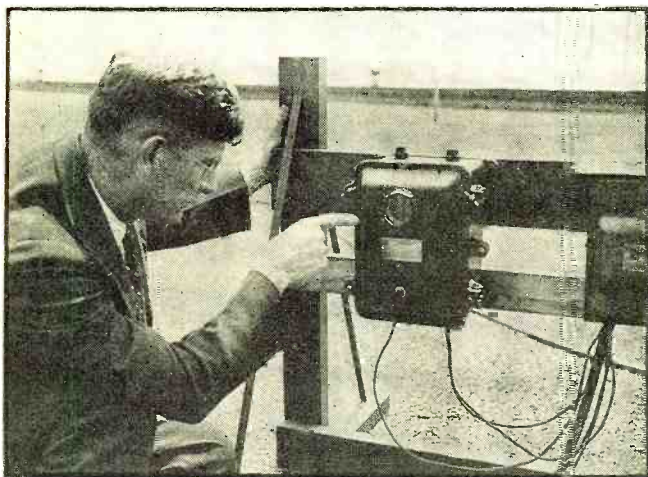

THE MODERN "LAMP-LIGHTER"

Street lighting systems are effectively controlled by photo-cells, which are actuated by the waning and return of daylight

IN the larger centers of population, cement is no longer mixed "on the job," but rather in a central plant, and it is carried from this point by special trucks with slowly revolving tank bodies.

The photoelectric cell has recently been used in such plants with amazing success. Once more the human element has been removed and once more the photo-cell demonstrates how beautifully it can replace the human eye. In this case it accurately measures out the materials entering into the mix, stopping the flow at precisely the correct moment. This it does by being so attached to a scales that the pointer of the scales interrupts a beam of light and causes the cells, working through a series of relays, to cut off the flow of materials by means of motor-operated devices.

V. T.'s in the Printing Industry

It has been suggested that photo-electric cells be used to automatically regulate the flow of ink on large printing presses. Today such operations are done by hand, but if experiments now under way prove successful this will no longer be necessary.

The cell, or series of cells, is mounted so as to intercept light from the printed pages as they come from the press. If the ink distribution becomes too lean, the vacuum photo-cell operates a relay and the relay in turn operates small motors that regulate the flow of ink. These devices would permit one press attendant to care for a larger number of presses—always providing, of course, that the pressmen's union would permit such a thing.

Polarized Fluorescence and the Photo-Cell

D. R. Morey of Cornell University has succeeded in measuring polarized fluorescence by means of a photo-electric cell, a nicol prism and a vacuum-tube amplifier. It always has been a rather difficult matter to measure the percentage of plane polarized light in weak radiations by means of purely visual devices. Morey has overcome this by placing a high quality nicol, with ends perpendicular to the length, on a photo-electric cell. The device used in conjunction with vacuum-tube amplifiers may then be employed to measure radiations far too weak for visual instruments. This is just another example of how the photo-cell, the vacuum tube and the grid-glow tube are being applied to the problems of pure science,

not only in the physical laboratory but the chemical and biological laboratory as well.

Electronic Lighting

Those who are putting a great deal of faith in recent researches concerning gas-filled illuminating tubes, are of the opinion that the filament electric light is doomed. Constant improvement is being made upon the spectrum of these newer illuminants that are claimed to be much more efficient and economical than are ordinary lights. Some of this enthusiasm appears justified when one considers the inroads made on lighting by ordinary means by the appearance of gas-filled illuminants for advertising purposes. Here the electronic discharge through gases gives not only greater efficiency but greater brilliancy and range of vision as well. Much is claimed for the newer lamps for home illumination.

Measuring Moisture with Electrons

Not a day goes by, it seems, that some new use for electronic devices is not found. It is rather surprising to know that over two hundred uses for vacuum tubes have been found outside of radio. Now the Bureau of Standards measures the moisture in lumber and other materials by the use of electronic instruments.

Automatic Headlight Dimmer

Night travel on the two-lane roads at high speed has been made dangerous by glaring headlights and not a few very serious accidents have been due to drivers being momentarily blinded. A Buffalo radio experimenter has recently perfected a photo-electric dimmer that operates automatically. It is placed on the front of the car in a position where it will intercept the light from the approaching car. Operating through one amplifier, it trips a special relay that automatically throws on the dim lights and brings the bright ones back again after the passing car has gone on. The device is simple, inexpensive, and positive in its action. Perhaps it shall some day be a law to have each automobile equipped with its automatic electronic light dimmer.

It has been a problem for the manufacturers of collapsible metal tubes, such as those used to hold tooth-paste, to find defective articles—that is, tubes with holes in them, by rapid inspection. By whirling these tubes (Continued on page 617)

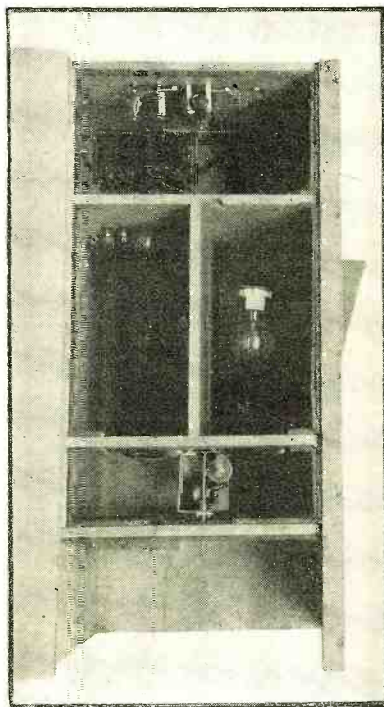

SMOKE DETECTION IN HOLLAND TUNNEL

Ventilation control is of the utmost importance in this vehicular tunnel. Excessive smoke, from any cause, is at once indicated by this equipment which employs a photo-electric cell and amplifier

Electric Filter Design

The importance of electric wave-filters in radio communication both for transmitter and receiver designs cannot be overestimated. The following article, the first of a comprehensive series, introduces the subject and defines the units and terms employed in filter work

By C. A. Johnson*

IF world-wide radio development program is to continue to expand by increasing the number of new stations, by the use of higher and higher power and by the use of new wavelengths, it is apparent that the radio apparatus used at both the sending and receiving ends must be constantly improved. Because of the commercial importance of this expansion program and in view of the fact that the quality of the electric-wave-filters used in radio receivers and transmitters determines, in a large measure, the fidelity with which speech and music may be reproduced, the radio engineer is always on the look-out for improvements in his circuits. It is true that the proper selection of tubes, the maintenance of proper voltages at all points in the circuit and the care used in shielding, are all essential in the design of a high quality radio system, but it remains for electric-wave-filters to insure the engineer that only the program to which he is listening will come through and that it will be heard very nearly as the artists are producing it.

It will, therefore, be the purpose of this series to explain the design of electric-wave-filters and to illustrate their many uses in radio communication systems. It is well known that the design of fairly complicated circuits can often be accomplished by those who are well informed in the use of certain charts and who can use a slide rule to advantage. These papers are being prepared with the hope that the presentation of such knowledge to that great body of appreciative engineers who are not specialists in transmission networks will make for a more rapid progress of the radio art.

Utility of Design Charts to Be Featured

One of the objectives of these articles is to instruct the reader in the use of design charts so that the most of his electrical design work may be done by the use of these two simple devices.

The problem of filter design will be approached from what may be called an "impedance viewpoint." This is the logical

*New York University.

method of approach, and is definitely responsible for the great strides which have been made in the practical application of transmission networks to modern electrical communication systems.

If we distinguish the circuits of a complete radio telephone system (as illustrated in Figure 1) on the basis of the frequency of the electric waves in that circuit, they may be designated as: (1) the antenna circuit, (2) the radio frequency circuit, (3) the intermediate frequency circuit (in double detection or superheterodyne sets²), (4) the audio frequency circuit and (5) the power supply circuit. We find that filters must be used in each of these circuits if the overall performance characteristic of the set is to approach the ideal.

The Use of Filters in Radio Communication Systems

The ideal antenna coupling circuit has at least two distinct functions: (1) to pass on to the radio-frequency circuit a wide band of frequencies covering the broadcast band over which reception is desired, and to suppress frequencies outside this band, (2) to give more suppression to high-power stations in a given geographical area than to other less powerful stations in the same area. These two things can be accomplished by means of a fixed wide-band filter and one or a number of adjustable-band elimination filters. In many radio sets, it often happens that the first of these functions is partly taken care of in an untuned radio-frequency transformer and the second is either entirely neglected or else "wave traps" are inserted; but for the best results, these devices cannot be substituted for correctly-designed filters. The band-filter for a radio-broadcast set would be designed to allow frequencies from 550 to 1500 kc. to pass freely while frequencies outside this band were attenuated. The band elimination filters would be designed to give a definite amount of attenuation to all radio voltages received from each of the particularly high-level stations; this would prevent them from coming in "all over the dial." Un-

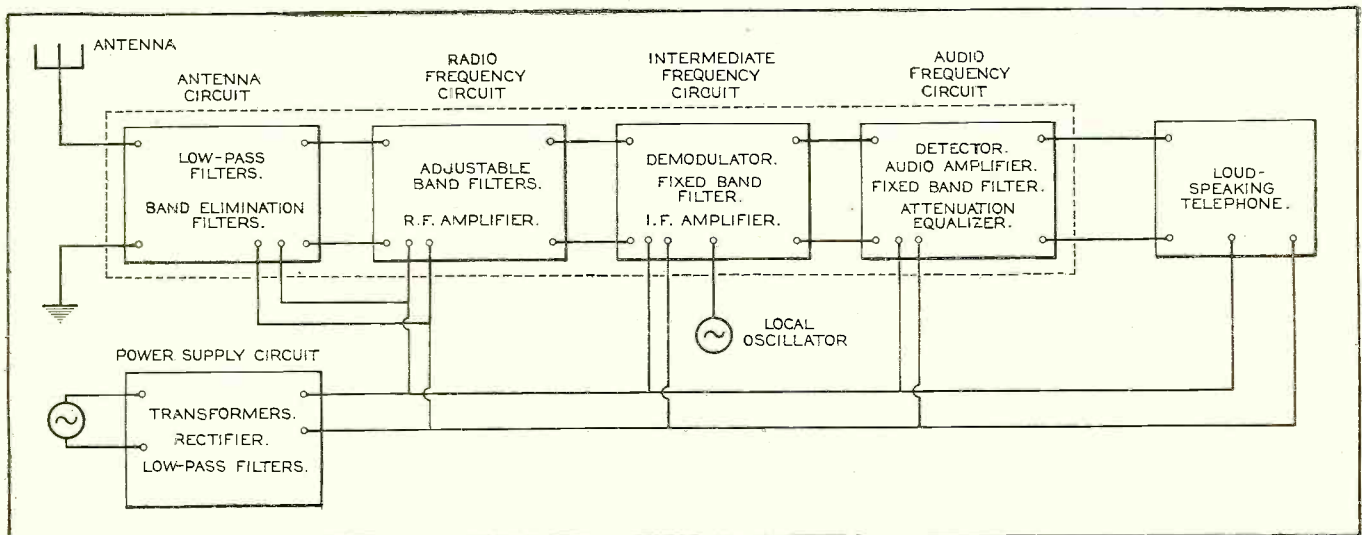

ELECTRIC WAVE-FILTERS IN A HIGH QUALITY RECEIVER

Figure 1. Schematic diagram illustrating the use of various types of filters in a radio broadcast receiver of excellent design. The author will describe these separately in future articles

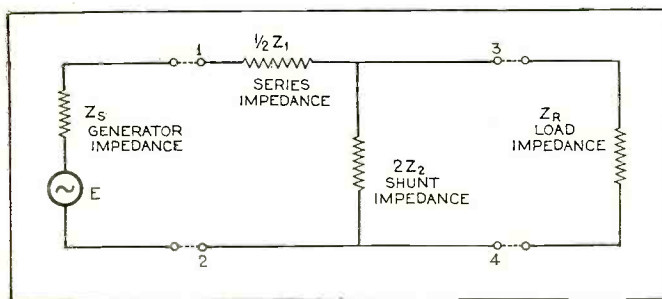

A HALF-SECTION FILTER

Figure 3. Shows a simple half-section filter connected in a transmission line between a generator and an output load. The common designations used in filter work for the various connections are shown

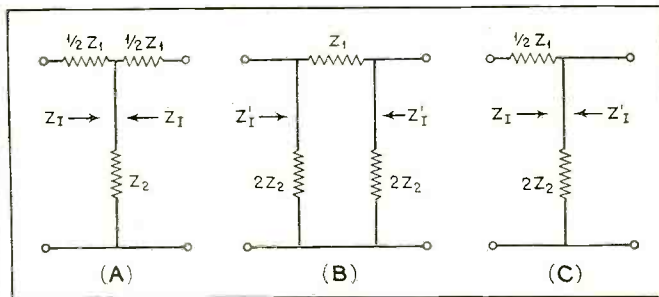

THREE COMMON FILTER CIRCUITS

Figure 4. A filter may be terminated (a) mid-series on both ends, (b) mid-shunt on both ends, or (c) mid-series on one end and mid-shunt on the other end

less these filters are included in the antenna circuit, the discrimination required in the radio frequency circuit for a high quality radio set is difficult to obtain.

The radio-frequency circuit must contain selective band-pass filters so that a particular station may be singled out from the others. These filters must be adjustable, usually with a single control, and their characteristics should be such that all radio-frequency voltages received from any single station are attenuated equally and by only a small amount.

In case the set is one which uses demodulators (or modulators for the transmission set), the radio voltages are changed to intermediate-frequency voltages, and filters are required so that only the desired band of demodulated frequencies will be passed on to the detector. Usually the fixed band-filters required for this part of the circuit must give high suppression to frequencies very close to the desired band (especially to the "carrier" or local oscillator frequency) because many other modulation products will fall near to the one selected for reception. The transmission quality is also more difficult to obtain in a filter at the lower frequencies because the percentage band width is much larger. Just why this is true will be explained later when the design of band filters is taken up.

The voice frequency circuit must deliver electrical energy to the loudspeaker which in turn must change this energy into sound waves that are identical to those entering the microphone at a distant transmitting station. In order to do this, the circuit must do two things (1) reject all frequencies except those being produced at the transmitter (2) put in attenuation to all those frequencies which have not been attenuated proportional to other frequencies by any of the circuits and by the speaker itself. These things can be done by a band-pass filter and an attenuation equalizer. Usually delay correction (to insure that all frequencies are delayed by an equal amount) is not necessary except in extremely high-quality radio sets such as the long-wave transatlantic radio telephone systems. (See footnote 2.)

Considerable hum and other interference is often experienced when power is supplied to radio sets from alternating-current power lines through a rectifier. A large part of this interference can be overcome by inserting properly designed low-pass filters in the power supply circuit. Such a filter is also an effective suppressor of interference due to sudden changes in power-line voltages occasioned, for example, by switching electric lights on and off.

Definition of Units and Terms Used in Filter Work

In order to explain the action of electric-wave-filters it will be necessary to define a few and state the symbols used in standard practice. A transmission line provides for electric currents to travel from a generator to a load and also one for their return. The path to the load or receiver is usually called the "high side" of the line and the return path is often called the "ground." When any impedance is inserted in the high side of the line it is called a "series impedance arm," and is designated by the symbol Z_1 . This may be a resistance,

a coil, a condenser or any combination of them. A few of the simplest impedance arms together with the mathematical expression for their impedance and an idea of how the impedance varies with frequency is given in Figure 2. If the impedance arm is connected across the line so that part of the current flows back to the generator before reaching the load it is called a "shunt arm" and is referred to by the symbol Z_2 .

A filter may be represented by one or more series impedances

SOME OF THE SIMPLEST IMPEDANCE ARMS WHICH ARE REPRESENTED BY Z_1 OR Z_2	MATHEMATICAL EXPRESSION FOR IMPEDANCE	SYMBOLIC REPRESENTATION OF IMPEDANCE VARIATION WITH FREQUENCY
	$Z = R$	
	$Z = j\omega L$	
	$Z = \frac{1}{j\omega C}$	
	$Z = R_{eff} + jX = \frac{\omega L}{Q} + j\omega L \left[1 - \left(\frac{f}{f_r} \right)^2 \right]$	
	$Z = R_{eff} + jX = \frac{\omega L Q}{\left(\frac{f}{f_r} \right)^4 + Q^2 \left[\left(\frac{f}{f_r} \right)^2 - 1 \right]^2} = j \frac{\omega L}{\left(\frac{f}{f_r} \right)^2 - 1}$	

NOTES: $\omega = 2\pi f$, $Q = \frac{\text{REACTANCE}}{\text{EFFECTIVE RESISTANCE}} = \frac{\omega L}{R}$, $f_r = \text{RESONANT FREQUENCY}$

SYMBOLS USED IN FILTER WORK

Figure 2. Above are the symbols for various simple impedances with their mathematical expressions and the symbolic representations of their variation of impedance with frequency

and shunt impedances connected in a transmission line. This is illustrated by a half-section filter in Figure 3.

Since we shall restrict the use of the symbols Z_1 and Z_2 to refer to full "series" and full "shunt" arm impedances of a filter section, the half-section filter shown in Figure 3 consists of $\frac{1}{2} Z_1$ in series with the line and $2 Z_2$ in shunt with the line. This is done because when we add two impedances of the value $\frac{1}{2} Z_1$ in series we get a full series arm impedance Z_1 , and when we add two impedances of (Continued on page 625)

NOTE 1—For an excellent discussion on filters for such radio set read, "Production of Single Side Band for Transatlantic Telephony," by R. A. Heising, in the Bell System Technical Journal, June, 1925.

NOTE 2—For example, if we wish to pass a 10 kc. band at 1000 kc. the percentage band width is $10/1000 = 1$ per cent.; however, if this band is demodulated down to 100 kc., the percentage band width is 10 per cent.

Q A really effective hearing aid not only brings the joy of living into the otherwise drab existence of those afflicted with deafness, but also enables them to earn a livelihood in vocations which would otherwise be closed to them



The Radio News Ear Aid

The complete directions for building a device which constitutes a powerful hearing aid for the deaf, or may be used as an auxiliary amplifier to greatly increase the effectiveness of any type of electrical hearing aid

AMONG the many thousands of readers of RADIO NEWS the majority have had some experience in radio construction, and there are probably several thousand who are themselves hard-of-hearing or who have relatives or friends who are so afflicted. Many have considered applying their radio knowledge in the construction of vacuum-tube hearing-aid equipment but have been prevented by a lack of suitable circuits and designs, or by inability to obtain suitable parts.

The author set out, some time ago, to make a thorough study of the hearing-aid field in order to determine the requirements for such equipment; then to design a device which would meet these requirements, at the same time arranging so that all the necessary parts would be made available in order that anyone could duplicate the equipment.

The fruit of this endeavor is presented here in the form of the RADIO NEWS "Ear Aid," on which complete constructional data is given. The design of the Ear Aid is based on the principle that a hearing aid should provide such a close approach to normal hearing that persons conversing with the deaf user of the device should not find it necessary to raise their voices. In other words, the device should permit the user to take a normal part in conversation, thus overcoming

By S. Gordon Taylor

a tremendous handicap under which he or she would otherwise labor.

The great majority of hearing devices now on the market do not attain this result except in the cases of relatively slight hearing impairment. Almost invariably it is necessary to raise one's voice in talking to a user of the average hearing device; the user is under a constant strain in an effort to understand what is being said. Now, if the user of an electrical hearing device

were provided with a compact vacuum-tube amplifier, to which he could connect the microphone of his present hearing device, in listening to the output of the amplifier he would obtain substantially the same quality of reproduction as before—but at a considerably higher volume level. Thus he would hear better, with less strain on himself and on persons talking to him.

The RADIO NEWS "Ear Aid" provides such an amplifier. It consists of a one-stage, vacuum-tube amplifier which includes an input transformer of suitable impedance value to work with any of the types of microphones employed in hearing-aid work. A special headphone is employed, the impedance of which is suitable to work directly from the plate circuit of a vacuum tube, without a transformer. The equipment is arranged, in extremely compact form, in a case which provides space for the amplifier

Money for Dealers and Servicemen

THE RADIO NEWS Ear Aid offers dealers and servicemen a unique opportunity to expand into a new field for which their knowledge of amplifiers and acoustics makes them particularly well fitted. Every community offers its share of hard-of-hearing prospects—and every sale of an Ear Aid represents a neat profit. It will cost the dealer little to make a model for demonstration. So far as prospect lists are concerned, the storekeepers, churches, doctors and school heads in any neighborhood can provide names of deaf persons, and in most cases will willingly do so.—The Editors.

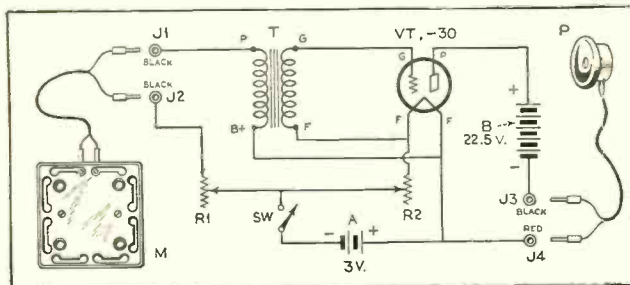

FIGURE 1. THE CIRCUIT DIAGRAM

equipment, batteries and microphone, as well as for the headphone, when not in use.

The unit has been designed to work with any type of hearing-aid microphone. For those who do not already possess an electric hearing aid, a special microphone is specified in the list of parts at the end of this article. This microphone is one of the few microphones on the market designed for this type of work and has given excellent results in our tests.

The headphones which are included in regular commercial hearing aids cannot be used with the Ear Aid because their impedance value is too low to approximate the output impedance of the vacuum tube. To include an impedance-matching transformer in the tube output would involve adding considerably to both the weight and the size of the Ear Aid. The special transformer required would probably cost as much as the new headphone. Nothing would be gained by using the old headphone.

In the photographs are shown several views of the Ear Aid, with the special De Forest microphone. In the design of the case, room has been provided for this microphone and a cutout in the front of the case permits the Aid to be used without removing the microphone from the case. For readers who build this equipment and wish to buy the case it will be a simple matter to adapt their present microphones to this space, by mounting it on a small square baffle to fit the cut-out in the case. The De Forest microphone is equipped with a suitable extension cord which permits it to be removed from the case when using the apparatus when sitting at the table or in a theatre. It is often more convenient to place the amplifier out of the way on the floor. In adapting any other type of microphone for use with the Aid it is only necessary to cut the microphone wires and solder phone tips on the ends. These can then be plugged into the tip jacks in the Aid. If the same microphone is at times to be used without the Aid, a pair of jacks can be fastened to the ends of the wire which formerly connected to the microphone in the old hearing device. A pair of tip jacks mounted on a small bakelite block, such as are used for the loudspeaker connections of some radio sets, will serve this purpose nicely.

Whether the microphone specified in the parts list or another type is used, the construction and operation of the Ear Aid is the same, and the microphone current is supplied from the flashlight cells in the Aid. But before going into the con-

structional details, the reader will naturally be interested in the subject of cost. The parts for the complete Aid cost around \$47.50 at list prices. This is far cheaper than any commercial hearing device of anywhere near comparable power. In fact, it is less than half the price of such devices. Without the microphone, the cost of all other parts is less than \$30, list. If one has already invested anywhere from \$35 to \$100 or more in a commercial hearing device, the additional expenditure of \$30 to make it doubly effective certainly seems justified.

The Parts

All of the parts specified are now on the market. Some of them are obtainable at local radio stores, while others have less widespread distribution. All are available as a kit from certain dealers who are specializing in these parts; or the special parts, such as the microphone, case, fittings and headphone may be purchased direct from the manufacturers. It is suggested that readers who are interested consult the advertising section of this issue for the names of these dealers.

The Circuit

The circuit of the Ear Aid, Figure 1, is really very simple. The microphone, M, works through a microphone transformer, T, into the grid circuit of a type -30 vacuum tube. In the output of this tube a single headphone, P, is connected in series with the 22½-volt B battery. A single pair of flashlight cells, A, provides both the microphone current and the tube-filament current. There are separate rheostats (R1 and R2) in each of these circuits, as mentioned before.

Constructional Data

The chassis type of construction is employed, with everything except the rheostats, headphone and microphone mounted on an aluminum sub-base. All parts are mounted and the wiring is completed before this chassis is dropped into place in the case. After putting it in place, the rheostat shafts are slipped through the proper holes in the front of the case, the mounting nuts tightened and the knobs attached.

Those who buy the parts ready for assembly need only follow the photos in assembling them, as (*Continued on page 628*)



PACKED FOR CARRYING

The Ear Aid is completely self-contained, provision being made for the headphone and headband, as shown, when not in use. The drop door in the front permits sound to reach the microphone freely while in position in the case

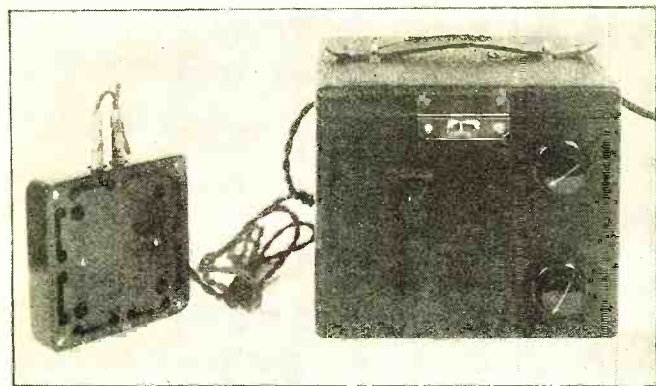

REMOVABLE MICROPHONE A FEATURE

The microphone may be left inside the case while in use, or it may be removed and placed on desk or table, with the case in a drawer or on the floor, out of the way

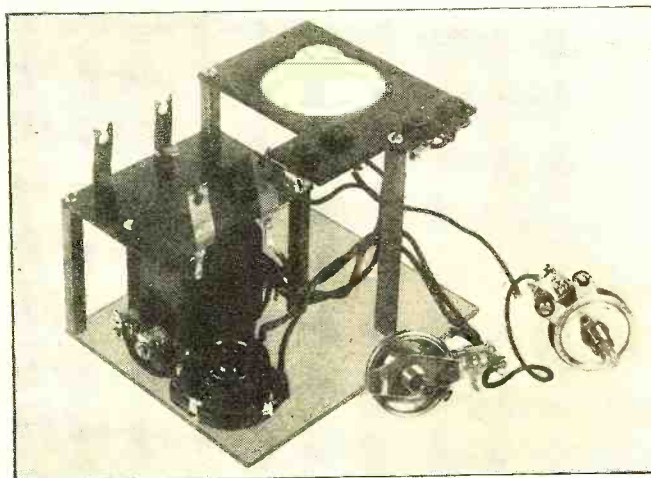

THE CHASSIS

This view shows the chassis before installing in the case. This, together with Figure 2, will provide all information on the location of parts

A New "SUPER" for Circuit Experimenters

Many requests have been received from readers for a receiver design which offers more than simply a kit assembly job. The answer is given here in a description of the JSW-4, an "all-wave" set using home-made coils and offering considerable flexibility so far as many other parts are concerned

By Chesley H. Johnson
Part One

THERE are numerous arrangements possible for the reception of short-wave signals, and, with patience and care, results may be achieved with very simple, inexpensive equipment. However, experience with various types of receivers leads the writer to the conclusion that, if a dependable receiver is desired for short-wave work, one is forced to use some form of the superheterodyne. But one of the complications of the usual form, at wavelengths much under thirty meters, is the difficulty of designing a suitable pick-up coil between oscillator and first detector or modulator. The locking effect between these circuits is very troublesome, due to the necessity of tuning both circuits to nearly the same frequency. The second harmonic type might suggest itself as a solution, but the difficulty of adjustment and calibration is in the way.

Using an autodyne detector, there is obviously but a slight loss in sensitivity, due to the detector being but slightly off resonance (tuned to the incoming signal) and full modulation is achieved without the trouble in designing a suitable form of pick-up coil. The autodyne also makes it possible to dispense with one tuned circuit. However, since one tube is a small factor in the cost of a complex set such as a superheterodyne, and selectivity is sacrificed with the loss of this tuned circuit, it follows that the circuit may be replaced by an r.f. amplifier stage. This amplifier furnishes a considerable increase in sensitivity and sharpens up the tuning quite noticeably with no more controls and equipment than were at hand in the first place. The difficulty lies in coupling this amplifier to the autodyne detector.

R.F. Coupling

Considerable experimenting shows that the use of the shunt feed choke method is satisfactory using a high-gain screen-grid tube. With a good choke, a high-impedance load is

placed in the plate circuit without instability and a high radio-frequency voltage is fed to the autodyne tube through very loose coupling.

The use of alternating-current tubes is quite desirable both from the standpoint of efficiency and convenience. These tubes are far superior from the standpoint of not being microphonic, as may be determined by operating battery type tubes below 20 meters. No trouble with hum may be anticipated, if heater type tubes are used, using almost any type of power pack.

Referring to the schematic diagram, Figure 1, the antenna is coupled by a very small variable condenser to the first coil L1, in the grid circuit of the pentode tube r.f. amplifier which is tuned by C2. A small coil, L2, in series with the screen-grid circuit of this tube produces stability in this cir-

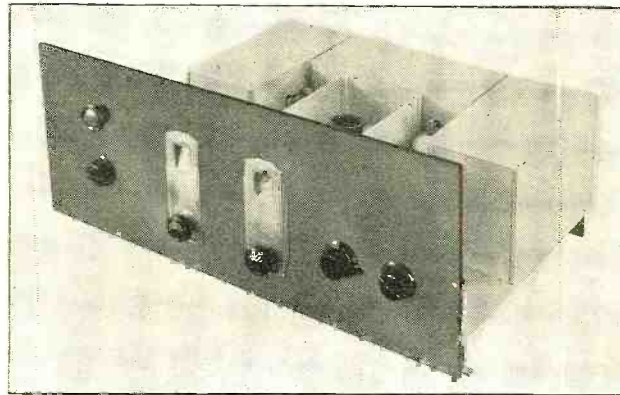

THE FINISHED RECEIVER

At the extreme left are the antenna series condenser control (above) and the heterodyne oscillator control. In the center are the r.f. and autodyne detector tuning controls. To the right of these is the i.f. amplifier regeneration control and at the extreme right is the volume control

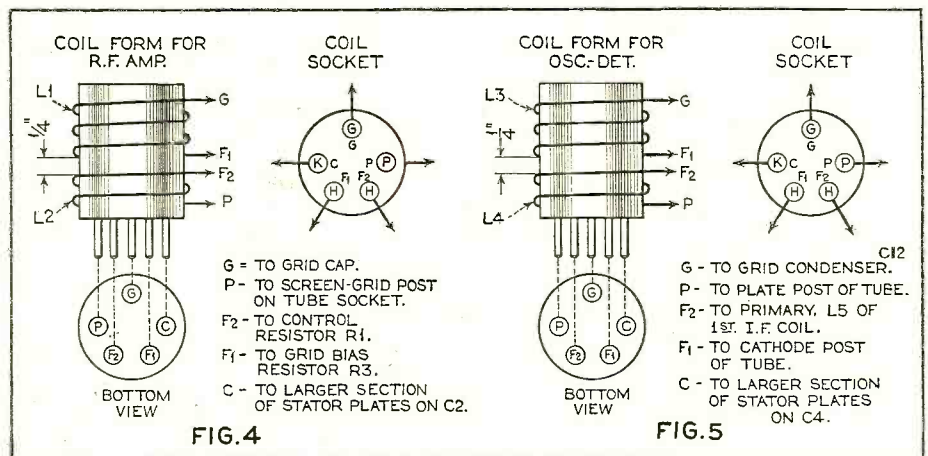

COIL DESIGN DATA

Figures 4 and 5. If Silver-Marshall coil forms are used, the tickler is wound in the slot at bottom of form with number 30 D.S.C. wire, in all cases. For the broadcast band and somewhat below use six turns on L2, arranged to cause regeneration, but for very short waves use one turn arranged to cause negative feedback, i.e., with terminals reversed or so as to oppose oscillation and produce stability of the r.f. stage. Use number 30 D.S.C. wire for all secondaries having over 40 turns. Use number 22 D.S.C. wire for all other secondary coils. Before soldering connect together the G and C prongs of coil forms for the broadcast range (200-550 meters). C is left unconnected on all other forms. All coils are wound in one direction and the grid end is taken as the top of the coil

cuit by feeding back a negative voltage, adjustable by R1. Where this neutralizing device is found unnecessary it may be left out or short-circuited by a wire. Or, at the longer wavelengths, this coil may be reversed to produce regeneration in the r.f. amplifier. This gives quite a gain, especially on the broadcast range. A small coupling condenser C11 feeds the output of the pentode to the grid of the autodyne detector. The plate circuit of the autodyne detector is coupled back to the grid coil L3 by the tickler coil L4 to produce oscillation and give the beat frequency or heterodyne. The degree of this oscillation may be controlled by R3. The plate circuit includes the coil L5, which feeds the signal to the i.f. amplifier. A condenser by-pass, C13, controls the intensity and somewhat tunes the input to the amplifier.

Regenerative Second Detector

The i.f. amplifier, as it uses screen-grid tubes, is impedance coupled for a high gain. It consists of two stages and feeds into a regenerative second detector. The second detector has a tickler coil L9 in the plate circuit to provide additional sensitivity and to permit c.w. signals to be received. The feedback is controlled by R11. An r.f. filter is provided by the two condensers, C23 and C27, and the choke RFC2. The pure audio signal is then fed through a transformer-coupled amplifier to the loud speaker.

Analyzing the circuit, it will be observed that several interesting features are incorporated. So far as the writer is aware, they are new and never before used in this particular manner. There is a pentode tube to give r.f. amplification before detection and the tube is arranged for positive and negative feedback something similar to the oldtime Superdyne; also, a novel scheme to couple an r.f. stage to an autodyne detector and yet prevent the interlocking or "sticking" which is common to such a circuit. Double regeneration is available through the two detectors. Oscillation in the i.f. amplifier is controlled through R4, which regulates the voltage on the screen grids.

There are a large number of high-capacity condensers used, which, in conjunction with the variable type high resistors,

TOP VIEW WITH SHIELDS REMOVED

All tuned circuits, including the i.f. coils and condensers are enclosed in box shields, with the single exception of the r.f. stage, which is unshielded

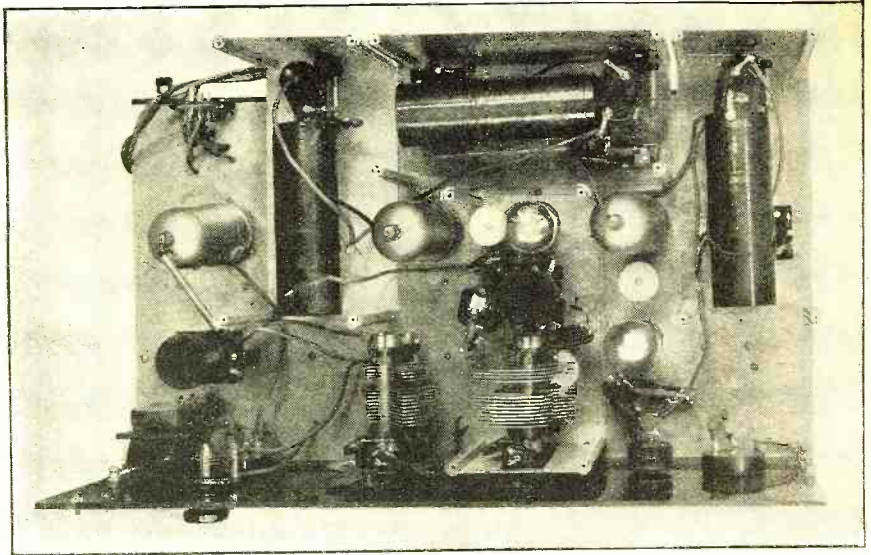

serve to stabilize, filter and isolate the various circuits involved in the hook-up. These resistors serve both as a block to coupling currents and also to adjust the voltages to the best operating values. Although these resistors may also serve as volume controls, they should never be entirely cut out for the foregoing reason.

Coil Data

The building of this set may be gathered from a close examination of the various sketches and the accompanying tables. The tables in this article give all the necessary data concerning the coils, while the sketches next month will show the wiring and the layout of the parts. It is not essential that the exact arrangement given be followed. One may have his own ideas of this.

An aluminum baseboard or chassis, beneath which are to be mounted all miscellaneous condensers and resistances, acts as a support for the shields and associated (Continued on page 623)

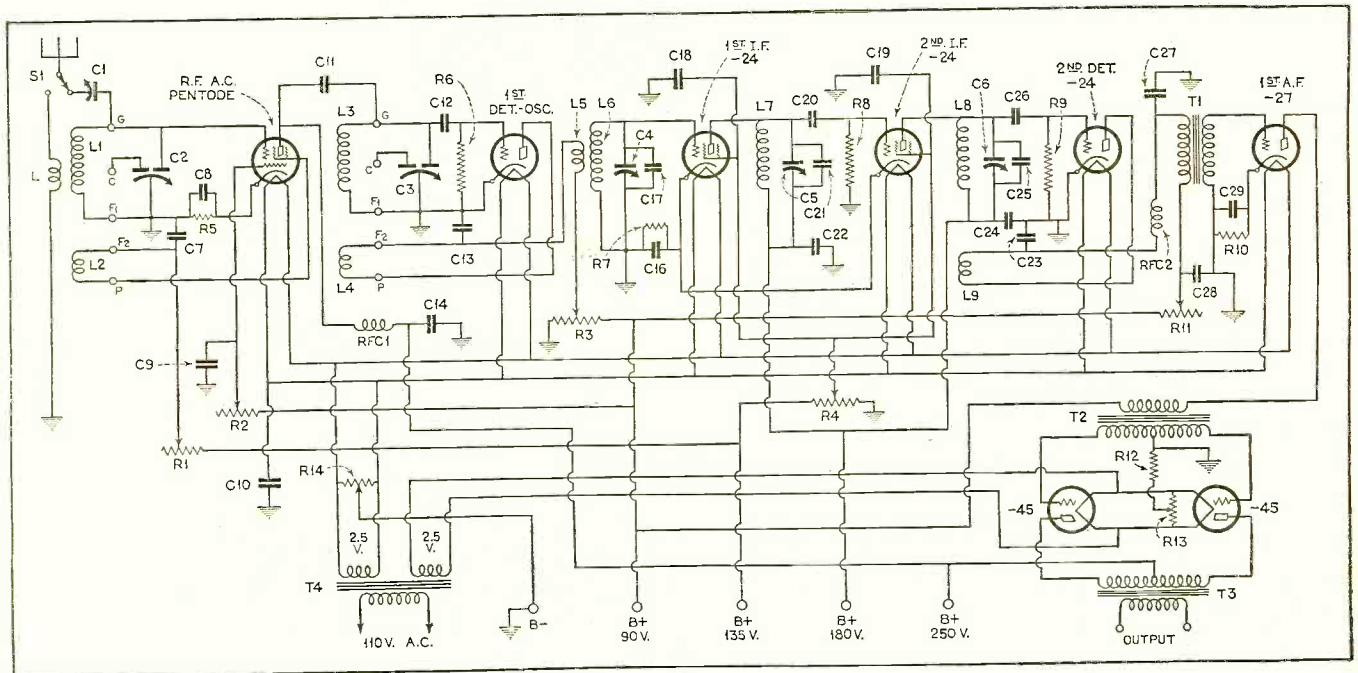

THE CIRCUIT DIAGRAM OF THE RECEIVER

Figure 1. This diagram includes the audio amplifier, in addition to the five-tube tuner circuit. The audio end, however, is not included in the chassis shown in the photos. The r.f. pentode tube is available (see list of parts), but for readers who prefer multi-mu tubes a modification of the circuit will be shown next month

How to Build Your Own Beat-Frequency Oscillator

At last experimenters are offered complete design data on a really dependable beat-frequency oscillator, the accuracy and constancy of which compare most favorably with the best commercial instruments, at only a fraction of the cost

By Donald Lewis*

WHETHER a radio laboratory has only a small amount of equipment, such as we might find in a reasonably well equipped service shop, or a very complete range of laboratory instruments, such as we would find in the engineering department of a radio manufacturer, there are certain instruments that play almost indispensable rôles. Into this class most certainly fall, for example, the vacuum-tube voltmeter, the audio-frequency oscillator and the radio-frequency oscillator. This article describes one of these essential units—a beat-frequency audio oscillator of rather unusual characteristics. Because of these characteristics, which are explained in detail below, the audio frequency generated by the oscillator is unusually constant and the oscillator is easily set in operation and calibrated.

The beat-frequency oscillator, because it is capable of producing any audio frequency from about 30 cycles up to about 10,000, proves invaluable in testing all types of audio-frequency apparatus. Audio-amplifier characteristics can be measured quickly and accurately. If the oscillator is used to supply a loudspeaker, the frequencies at which various parts of the loudspeaker resonate can easily be determined, whereas their determination by any other method would be exceedingly difficult. A beat-frequency oscillator can be used to modulate a radio-frequency oscillator, and if the modulated radio-frequency current is then supplied to a receiver an approximate determination of the amount of side-band cutting is possible.

If a beat-frequency oscillator is to prove most useful, it is essential that it have certain characteristics. In the first place, the frequency of the output must maintain itself at the proper value. For all ordinary work the frequency should certainly be stable within about 1 per cent.

Constancy of Output

A second characteristic which an oscillator of this type should possess, if it is to reach its maximum usefulness, is constancy of output voltage as the frequency is varied from the lower to the upper limit. If more voltage output is obtained at certain frequencies than at others we must continually readjust the output voltage control to maintain constant output.

Furthermore, it is essential that means be provided to readily check the calibration of the oscillator. Check-

ing the calibration against some fundamental source of audio frequency cannot always be accomplished rapidly and easily. For this reason it is preferable that some device which permits ready checking of the calibration be built into the oscillator. It is also essential that the audio-frequency output be reasonably free of harmonics, for it is only with fairly pure tones that accurate checking of audio-frequency apparatus is possible.

Obviously, the oscillator can be supplied with power from either batteries or a rectifier and filter system. Batteries are preferable for greatest accuracy, but the rectifier-filter system of power supply is preferable from the standpoint of convenience and permanence.

The oscillator to be described in this article uses the 110-volt, 60-cycle line as a source of supply, the line being connected through an automatic voltage regulator to prevent variations in line voltage from affecting the frequency of the oscillator.

The Beat Generator

Audio frequencies can be produced in a number of ways, but where it is desirable that a great many different frequencies be available the vacuum tube affords the simplest means of producing

them. The vacuum tube can be used to produce these frequencies directly, *i.e.*, it can be made to oscillate at the desired frequency, or we can use a beat-frequency method of obtaining the audio-frequency tones.

In a beat-frequency audio oscillator we find two tubes oscillating at comparatively high frequencies and the output of these two oscillators is coupled to a detector tube. The detector tube is followed by an audio-frequency amplifier to

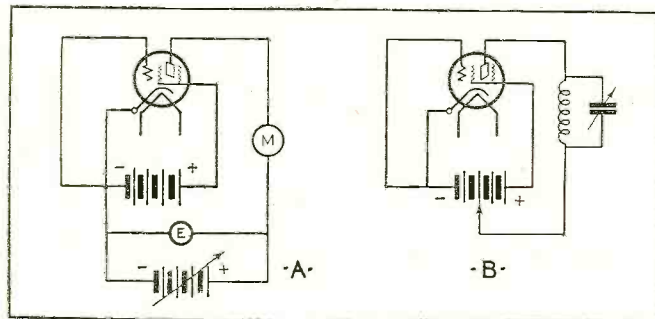

THE DYNATRON PRINCIPLE IS USED

Figure 2. (a) Circuit for determining the negative resistance characteristic of four-element tubes. (b) The basic dynatron circuit

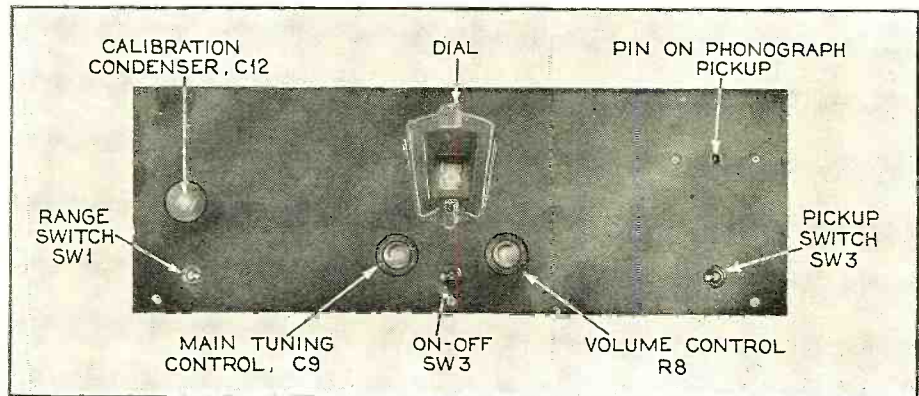

THE SIMPLE PANEL ARRANGEMENT

All controls are mounted on the front panel. The detailed purpose of each is explained in the text

*Hammarlund Mfg. Co.

provide the desired value of power output. The frequency of one of the oscillators is fixed while the frequency of the other is made variable over a small range. In the output of the detector will be obtained a frequency equal to the difference in the frequencies of the two oscillators.

Frequency Difference

Since audio frequencies are desired in a beat-frequency oscillator, we find the two oscillators always differ in frequency by an amount equal to the frequency of the desired audio tone. If, for example, we desire to generate an audio frequency of 1000 cycles, with one oscillator fixed at 50 kc., then the frequency of the other oscillator would be adjusted to either 49 kc. or 51 kc. The difference in frequency of 1 kc. (1000 cycles) would give us the desired audio tone. It can be readily seen, therefore, that in a practical unit the highest audio frequency desired determines the extent to which the frequency of the adjustable oscillator must be varied. If, as is usually the case, the highest desired tone is 10,000 cycles and the fixed oscillator generates 50 kc., then the control on the variable oscillator must be capable of adjusting its frequency from a value exactly the same as that of the fixed oscillator (under which conditions a zero frequency output would be obtained) to a value either 10,000 cycles higher or 10,000 cycles lower than 50 kc.

Since the audio tone is determined by the difference in frequency between the two oscillators, it follows that the accuracy with which the desired tone is maintained will depend entirely upon the stability of the oscillators. A given change in the frequency of either oscillator is more serious, the lower the audio tone being produced. If the difference frequency is adjusted to obtain an audio tone of 50 cycles and the fre-

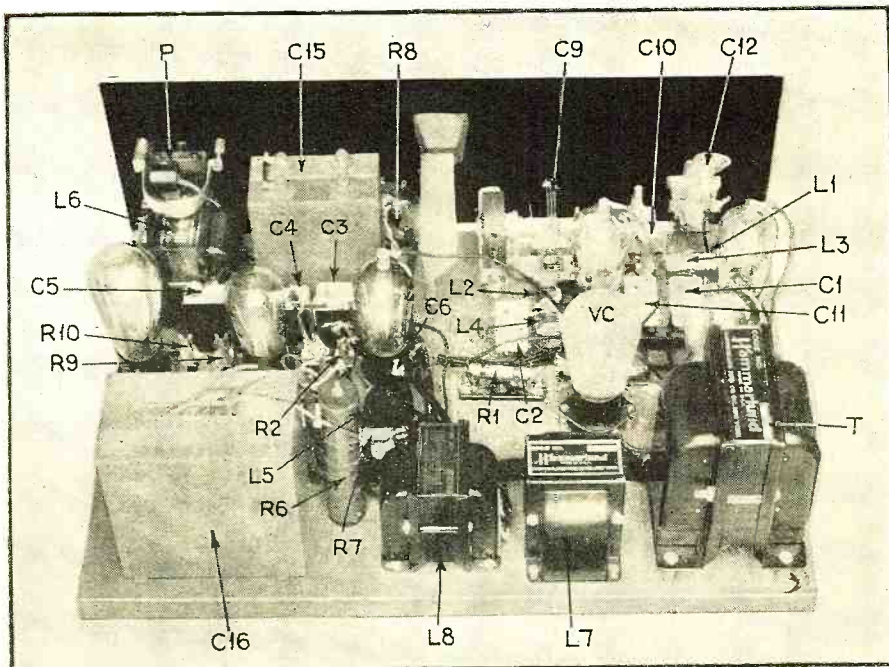

THE LAYOUT OF PARTS

The symbols correspond with those of the circuit diagram, Figure 1

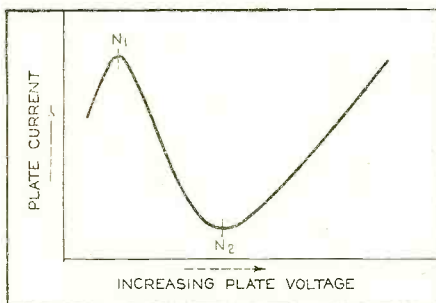

THE "DYNATRON REGION"

Figure 3. Over a portion of the curve (N1 to N2) the plate current decreases as the plate voltage increases. This is where the tube functions as a dynatron oscillator

quency of one oscillator should increase by 10 cycles, then the audio tone will change from 50 to either 40 or 60, representing a change of 20 percent from the desired tone of 50 cycles. If, on the other hand, the two oscillators differed by 10,000 cycles, thereby giving an audio tone of this frequency, and one oscillator then changed its frequency by 10 cycles, the audio tone would be altered from 10,000 cycles to either 9,990 or 10,010, which represents a change of only one-tenth of one percent. It follows, therefore, in determining the degree to which the oscillator frequencies must be maintained constant, that it is necessary to consider the percentage variation which a given change in oscillator frequency will produce when the lowest desired audio tone is being generated. If the oscillator frequencies are maintained sufficiently constant to hold the lowest desired frequency within one or two percent of its correct value, then the higher frequencies will remain constant to a much greater degree. This matter is complicated, of course, by the fact that both oscillators may vary in the same direction; the variations then tend to neutralize each other; it is for this reason that we sometimes find that stabilizing the frequency of one oscillator to a high degree may actually tend to decrease the constancy of the audio tone.

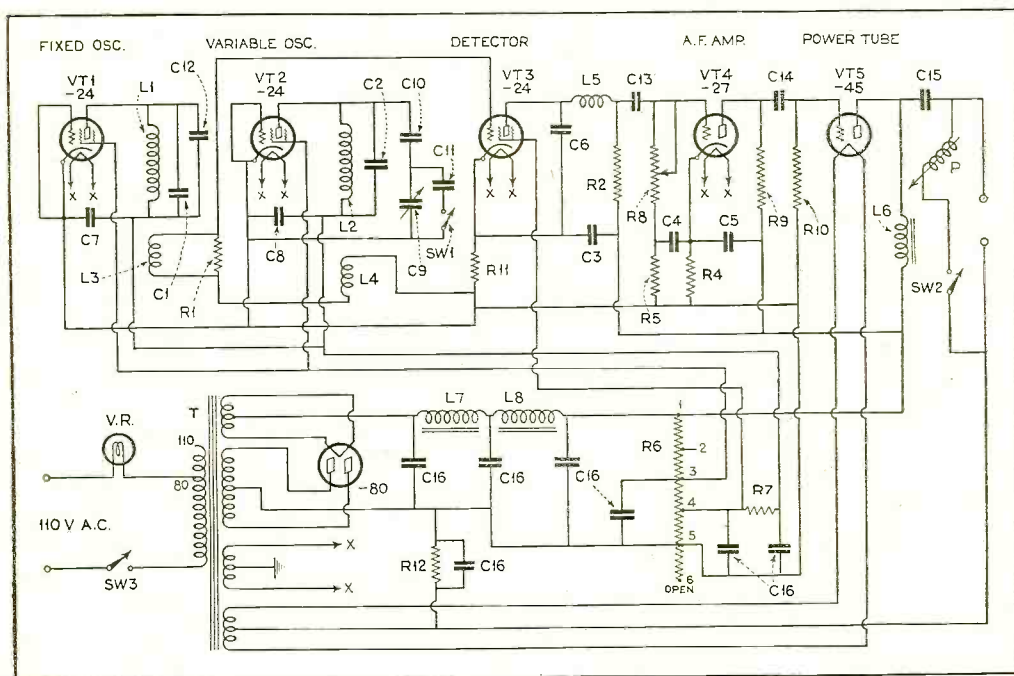

THE COMPLETE CIRCUIT

Figure 1. A detailed discussion of each portion of the circuit is presented in the text

Circuit Design

With these facts in mind let us examine the circuit of the beat-frequency

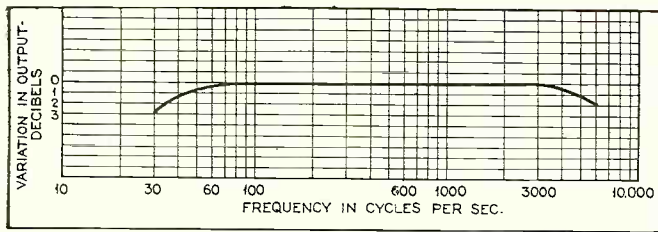

CONSTANT POWER OUTPUT A FEATURE

Figure 4. As indicated by this curve, the audio power output is maintained at a constant value for frequencies between 50 and 4,000 cycles, and from 30 cycles to about 8,000 cycles the variation does not exceed 3 db

oscillator shown in Figure 1. As the discussion progresses we will be able to bring out the various interesting features of the device. We would like to say, however, that this oscillator is presented not so much as a final product or the best that can be built, but rather as a type of beat-frequency audio oscillator that has certain definite advantages. In building up the unit illustrated in this article the idea was to construct a unit that would be generally applicable in ordinary laboratory tests and service work, and the experience the author has had with the instrument in the laboratory has proven that it well fulfills these purposes.

The tubes VT1 and VT2 are the oscillators operating at frequencies around 50 kc.; the exact frequency at which they operate is not important, it simply being necessary that the frequencies of the two oscillators be the same when the frequency control dial is turned to zero. VT1 is the fixed frequency oscillator, the oscillatory circuit consisting of the coil L1 and the condenser C1. VT2 is the variable frequency oscillator. The main oscillatory circuit is L2 and C2, but shunted across C2 is a group of three condensers, one of which is controlled by the main dial in the center of the panel so that by adjusting this condenser the frequency generated by the tube can be varied to produce the desired audio frequency. If the circuits of these two oscillators are examined it will be noted that screen-grid tubes are used, and furthermore, that only one coil is required in the oscillator circuit, this coil in parallel with the condenser being connected in the plate circuit of the screen-grid tube. This type of oscillatory circuit, in which a single tuned circuit is used, is known as the "dynatron" and it utilizes the negative resistance characteristic obtained from a screen-grid tube when the plate voltage is lower than the screen-grid voltage. If a screen-grid tube is set up in a simple test circuit as shown in Figure 2A and the plate current at various plate voltages is plotted, we will obtain a curve similar in form to that shown in Figure 3. Here we note the interesting condition that an increase in plate voltage produces a decrease in plate current. It is over this region of the characteristic that the tube is said to have a negative resistance characteristic. If the tube is operated at such voltages as to give a negative resistance characteristic, it is found that oscillations are produced simply by connecting a tuned circuit in series with the plate as shown in Figure 2B. Since the ordinary three-element tube when used as an oscillator requires the use of a feedback coil in addition to the main oscillatory circuit, the dynatron certainly has the advantage of simplicity. Also, whereas we find that the ordinary three-element tube when used as an oscillator has quite poor frequency stability, the dynatron has remarkably good frequency stability.

Since it is essential that the oscillators in a

beat-frequency circuit maintain a constant frequency, it was decided to use the dynatron circuit in this unit, with the thought that the resulting audio-frequency output might be subject to much less variation with slight changes in plate, grid, or filament voltages; experience has proven that such is actually the case. In order to obtain best results it was found, however, that the two tubes used as oscillators must show essentially the same variation of plate current with plate voltages. It is therefore advisable in picking tubes for use as oscillators to set up the circuit shown in Figure 2 and plot the dynatron characteristics (see Figure 3) on a number of tubes, finally choosing for the oscillators two tubes which show nearly identical characteristics.

It is necessary that the output of the two oscillators be coupled to the grid of the detector tube, VT3. This is accomplished by means of the coils L3 and L4 which are connected in series across the grid-cathode circuit of the screen grid detector. Coil L3 is coupled to the fixed oscillator and coil L4 to the variable oscillator and hence, when they are both connected in series, voltages from both oscillators are impressed on the grid of the detector tube. We have found that ordinary intermediate-frequency transformers containing a primary and secondary are very well adapted for use in a beat-frequency oscillator. This is a fortunate circumstance since many experimenters will probably have a pair of transformers that can be used for this purpose. The secondary of one transformer can be used for L1 and the primary of the same transformer for L3. The secondary of the other transformer is used for L2 and the primary for L4. For the coils in this particular unit use was made of a pair of unmounted coils designed for use in intermediate-frequency amplifiers.

If both oscillators feed the same amount of r.f. voltage to the grid of the detector tube the percentage modulation will in effect be one hundred percent, but to minimize the distortion produced by the detector tube it is desirable that the percentage modulation be quite low and we therefore find that L3 is shunted by resistance R1 so as to reduce the voltage applied to the detector tube from the fixed frequency oscillator. This resistance is shunted across the coil coupled to the fixed frequency oscillator because the audio frequency output voltage must be (Continued on page 627)

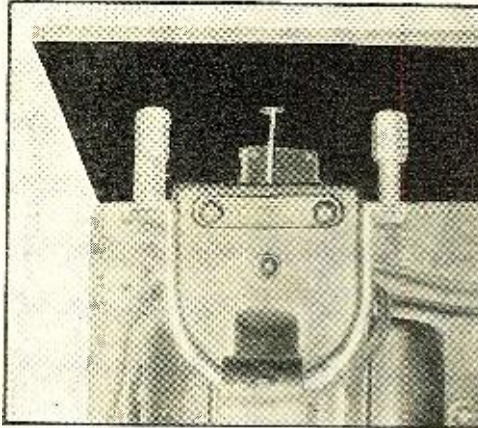

PICK-UP CHECKS CALIBRATION

The pick-up unit, with pin in chuck, is mounted with pin projecting through panel. This novel scheme provides an instantaneous check on calibration accuracy, as explained in the article

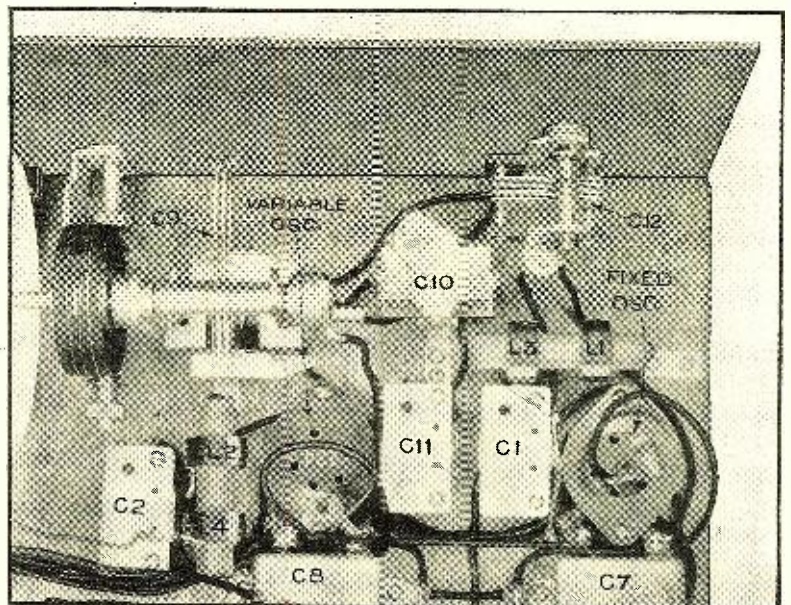

DETAILED VIEW OF OSCILLATOR COMPONENTS

The exact placement of the coupling coils and condensers is indicated

Rack-and-Panel Design for Public Address Systems

The use of amplifiers, pick-ups, and control circuits with matched input and output constants, and with the separate units mounted on individual panels, afford a flexibility of design for public address or school broadcast work that can be easily adapted for local conditions

SOUND systems for public address work consist, fundamentally, of a pick-up device, an amplifier and loudspeakers. But sound systems which are composed of these basic elements and nothing more can render only a limited type of service. Where flexibility is essential and a number of service conditions exist, the element of *control* becomes increasingly important. In the line of development to be described below it is only natural that considerable attention has been paid to those control facilities which permit the widest possible use of the basic equipment.

All units are constructed on panels for rack mounting. It is thus possible to start out with a few units and expand the system from time to time at a minimum of cost. Added advantages of this type of equipment are accessibility for repairs, convenience in operation and small floor space requirements.

Rack Assembly for Flexibility

A rack installation design suitable for radio, record or voice coverage of large indoor or outdoor audiences is illustrated in Figure 1. Progressing from top to bottom, the units are PA-12A meter panel, PA-60B volume indicator, PA-72A superheterodyne tuner, PA-54A mixing panel, PA-45A reproducer, PA-80A output-control panel and the PA-22A 50-watt amplifier.

With the panel designs described in this article a large number of different combinations can be assembled to meet the conditions of many installations and to cover even out-of-door assemblies. Racks of specialized designs can be assembled with power units of from 15 to 100 watts or more.

Referring to Figure 1, the top panel carries two Weston milliammeters. The meter at the left has a normal range of 200 ma. and is used for checking the plate current of power tubes. The other meter has an indicated range of 1.5 ma., but a shunt is normally connected across the terminals, increasing the range to 15 ma. The low range is made available by depressing a push-button switch which disconnects the meter shunt. The low range allows measurements of plate current on low power or voltage amplifier tubes, while the high range is useful when adjusting microphone current. Particularly

By McMurdo Silver*

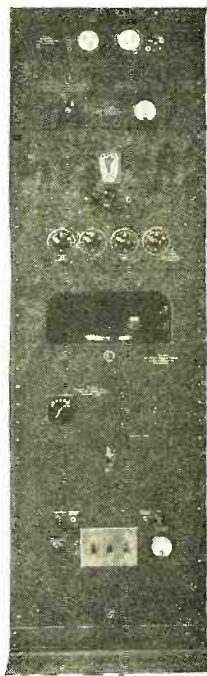

FRONT VIEW OF PANEL

Figure 1. Shows the general purpose public address rack, with the various panels set up and connected at the rear

convenient is the fact that the meters terminate on jacks at the panel, and connections to the various circuits where current is to be measured are made by means of patch cords (two-conductor cords with standard telephone plugs on both ends). This eliminates unsightly leads permanently attached to the panel, for the patch cords may be removed when not in use. The panel size is 4 inches by 21 inches for S-M racks, but can be supplied 5 1/4 inches by 19 inches for standard relay racks.

The superheterodyne tuner embodies the S-M-716 tuner with integral power supply. The output circuit is of low impedance as required for feeding the mixing panel or the input control unit. A monitoring jack makes it possible to adjust the tuner to the desired program while the rest of the system is in use on another pick-up. This avoids breaks in the reproduction and the audience is not compelled to listen to the tuning-in process. An auxiliary switch opens the output circuit when the tuner is not supplying input to the amplifier. The panel size is 10 inches by 21 inches.

The Mixing Panel

All pick-ups feed into the mixing panel for main switching and volume control operations. Fundamentally, this unit is a three-channel, series-type mixer including a master volume control, but a number of unusual features characterize the design. Figure 2 shows a wiring diagram of the instrument. It will be noticed that "cam" switches make it possible to throw either of two pick-up circuits on each of the three mixing channels. Six input circuits can thus be accommodated, three of which can be fed to the amplifier simultaneously, their respective outputs proportioned in any desired manner. The

master volume-control enables regulation without altering the relative levels of the individual channels. Fading between two channels is accomplished by running the volume control down on one channel and up on another simultaneously.

Constant-impedance, T-type volume controls are used throughout. Volume control on any channel is thus independent of the volume on all other channels. This complete independence of volume control settings is preserved even when certain channels are not in use due to a compensating arrangement which simulates the pick-up when a cam switch is in the "off"

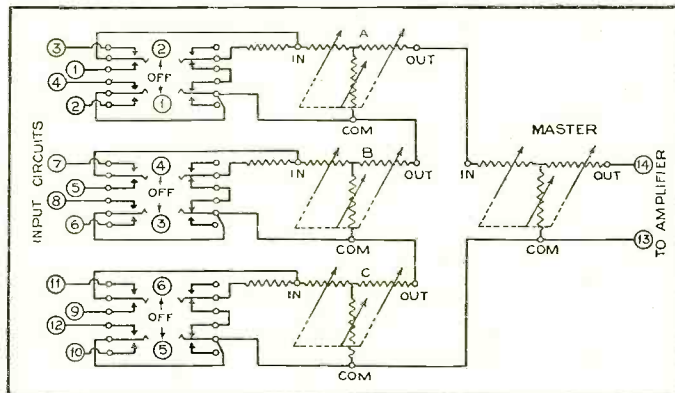

SCHEMATIC OF THE MIXING PANEL

Figure 2. Connections for the master volume control and the three mixing controls are shown, together with the input and output jacks used in the system

*President, Silver-Marshall, Inc.

position. An important advantage of constant-impedance volume controls is apparent when they are used with "inductive" sources such as a phonograph pick-up. Ordinary potentiometers alter the transmission-frequency characteristic for each setting of the volume control, resulting in an evident difference in quality at low and high volumes. No such change in quality is possible with constant-impedance volume controls.

Mixing transformers are not supplied with the panel, since these transformers would be of different designs for different applications of the mixing panel. Since the impedance of the individual channel volume controls is 200 ohms, no transformer is required for a pick-up having this value of internal impedance.

There are many applications of this mixing panel. Panel dimensions are 6 inches by 21 inches, with a 5 1/4-inch by 19-inch size available for relay rack mounting. A removable, black-enameled dust cover protects the apparatus. Attractive 20-division dial plates, finished in nickel and black, make it relatively easy to duplicate volume control settings.

Recorded selections are reproduced by means of the record reproducer panel, which includes a synchronous, motor-driven turntable and a high-quality electromagnetic pick-up. The motor maintains constant speed regardless of the pick-up load or a.c. line voltage, eliminating wavering of pitch and bothersome speed readjust-

ments. Both 10 and 12-inch records may be played. The motorboard is placed in a recess behind the panel and is accessible through a cut-out in front. Ample room is provided for changing records and needles. This compartment is also enclosed by a metal dust cover. Panel dimensions for the unit are 10 inches by 21 inches as regularly supplied, or 10 1/2 by 19 inches for relay rack mounting.

The volume indicator is a power level indicating instrument for quantitative monitoring of audio-frequency circuits. In the rack illustrated in Figure 1 the volume indicator measures the output level of the 50-watt amplifier, but the instrument has many other applications.

The panel contains a rectifier type meter, calibrated from -8 to +8 db., and a tapped L network which extends the range 40 db. in 4 db. steps. The total range covered thus extends from powers slightly less than 1 milliwatt to nearly 400 watts. Calibration is based on a reference level of 6 milliwatts and a load impedance of 500 ohms. The instrument itself is high impedance and therefore does not appreciably load the low-impedance circuit across which it is connected. Figure 3 shows its schematic wiring diagram. When used on other than 500-ohm circuits, a constant

and correctable error is introduced. The proper correction in db. is readily obtained from a chart furnished with the instrument. Where relative readings only (Continued on page 637)

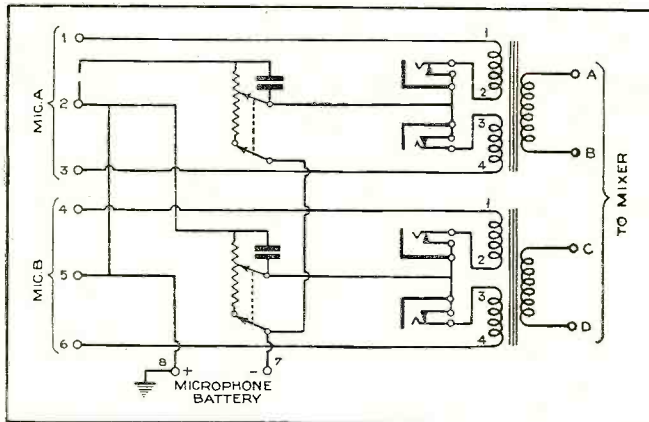
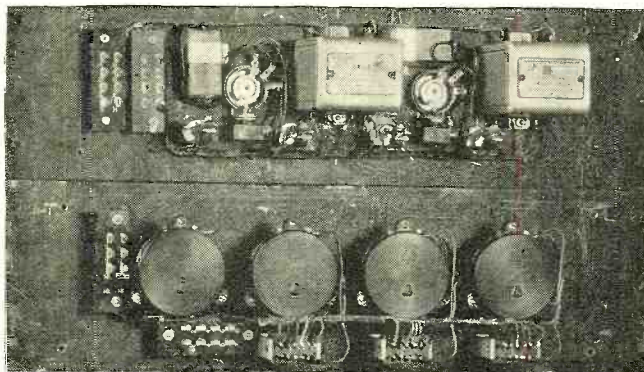

DIAGRAM OF MICROPHONE-CONTROL PANEL

Figure 5. Shows connections to the two double button microphones, the microphone battery and the two lines extending to the mixer. The jacks when not in use automatically cut in a balancing circuit which prevents disturbing the balance of either line



REAR VIEW OF CONTROL PANELS

Figure 6. The appearance of the apparatus behind the microphone control panel at top, and the mixing panel below

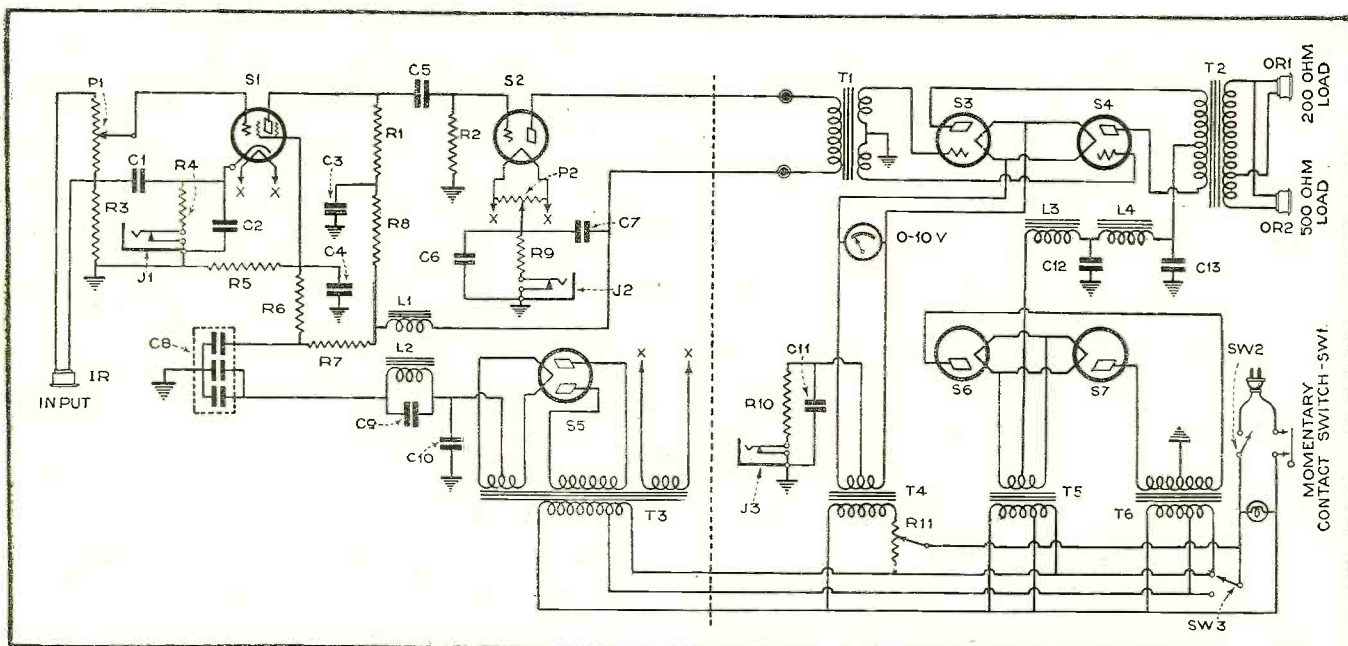

HOOK-UP OF THE THREE-STAGE 50-WATT AMPLIFIER

Figure 4. Shows schematic wiring diagram of the unit, using a -24 type tube in the first stage, a type -45 tube in the second stage and two type -845 tubes in the push-pull output stage

Using Graphs *and* Charts in Modern Radio Practice

So much useful information is presented graphically in radio publications that much value is lost unless the reader has at least a basic understanding of curves and charts. This article should help to provide some working knowledge of the subject

CURVES and graphs are the engineer's most useful aids; they enable him to pick out points of maximum efficiency, showing the constants needed to obtain such efficiencies. Without a curve, or differential calculus, it would take a lot of cutting and trying, with the resultant loss of time, to arrive at the same result.

A curve, or rather the locus of an equation, once drawn, shows at a glance all possible pairs of values of the variables which satisfy the equation of that curve. If one of these variables is the unknown, the curve gives all the possible solutions and the equation has been solved once and for all.

By selecting the proper scales, it is possible to simplify the curve so that it becomes a straight line. Since a straight line needs only two points to determine it, only two-point computations are necessary to enable us to draw this line; an obvious saving in time and labor.

Graphs Save Time

There are numerous other examples where graphs will simplify the task of the engineer as well as of the business man.

At present many of our readers may not understand completely how curves and graphs can save them labor and how to interpret them; it is for those that his article explains their fundamental principles and their applications. In future issues of RADIO NEWS this article will be followed by a series of logarithmic alignment charts.

The theory of curves leads us into the branches of higher mathematics: analytic geometry and differential calculus. It is not to be expected that the entire subject can be covered thoroughly, but we can give the elementary theory of coordinate systems and the uses of curves. If the reader is desirous of further study in this subject, he can refer to standard textbooks on mathematics.

By John M. Borst
Part One

THIS article introduces a complete series which will provide a wealth of worth-while material for engineers and experimenters. This first article will aid the uninitiated to a better understanding of the purpose and utility of graphic presentation. Later articles will carry the subject further and will provide a number of logarithmic alignment charts which will have real practical value to the engineer, designer and experimenter.

It all started when René Descartes originated the idea of the rectangular coordinate system. You have been using this system already without knowing it. The location of a city on the surface of the earth by means of latitude and longitude, and the location of a building by means of street and number, are examples. In the latter case we extend it into three dimensions when we also indicate on what floor an apartment or office is located.

In this discussion we shall restrict ourselves to plane geometry, but it is obvious that these principles can easily be extended to three dimensions.

In Figure 1 we show two lines perpendicular to each other, intersecting at the point O, the origin. These lines, XX_1 and YY_1 , divide the plane into four parts called "quadrants." The quadrants are numbered, starting from OX_1 and going around anti-clockwise (see Figure 2). Drawing PQ and PR , in Figure 1, parallel to YY_1 and XX_1 respectively, and measuring the distances from O to Q and from O to R, it is clear that these distances completely define the point; for, knowing these, we can again locate it.

Basic Rules

In this, the "cartesian" coordinate system, XX_1 is called the x-axis and all distances along it are called "abscissae." It has been universally agreed upon that distances measured from O toward the right shall be counted positive; distances from O toward the left shall be counted negative.

The line YY_1 is called the y-axis; distances along it are called "ordinates." The distances measured from O upwards are positive and downwards, negative.

These few rules take care that there shall be no duplications; that is, no two points can have the same pair of coordinates.

Figure 2 illustrates this principle. Here we have plotted one

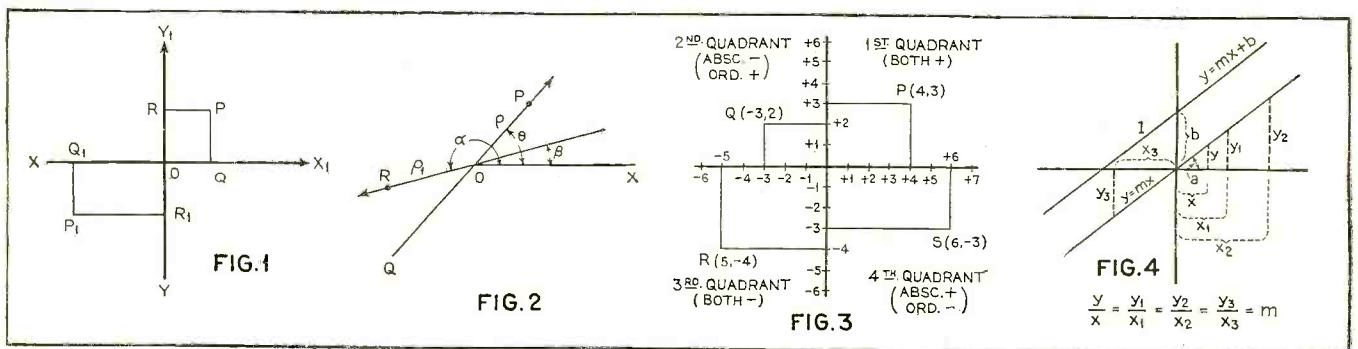

THE COORDINATE SYSTEM

Figures 1, 2, 3 and 4 illustrate the principles explained in the text

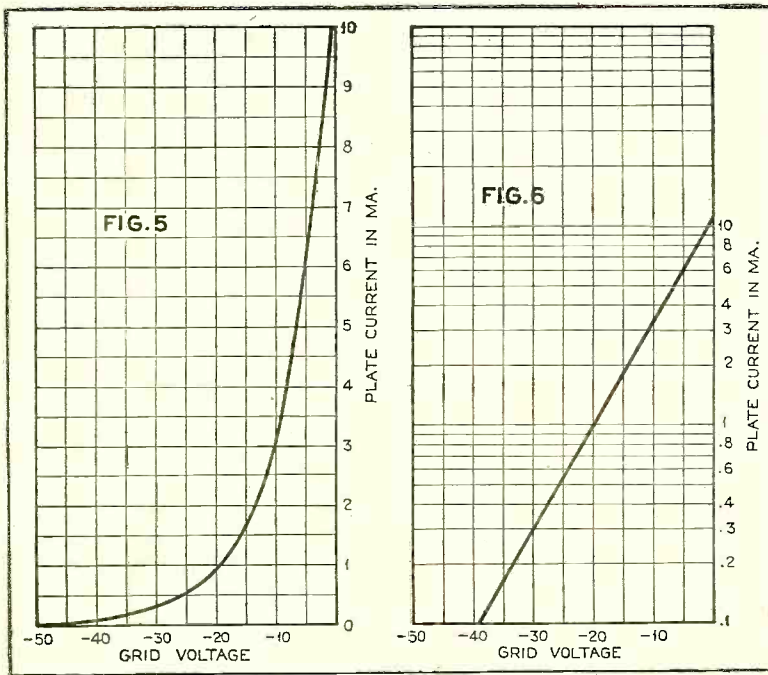

TUBE CHARACTERISTICS CURVES

Figure 5. Static characteristic of type -35 tube, plotted in normal form.
Figure 6, the same, but with ordinates in logarithmic proportions

point in each of the four quadrants. Note how the signs vary; in the first quadrant abscissa and ordinate are both positive; in the second quadrant the abscissa is negative and the ordinate positive. In the third quadrant both coordinates are negative and in the fourth quadrant the ordinate is negative but the abscissa is positive.

Generally, when letters are used, the abscissa is denoted by x and the ordinate by y . The usual notation for a point with abscissa x and ordinate y is $P(x, y)$.

Any point in the plane can be represented by two real numbers and conversely, any two real numbers may be taken to represent a point.

The polar coordinate system defines a point by an angle and the distance of the point from a fixed point, the pole of the system. This is illustrated in Figure 2. Here O is the pole and OX is the line from which we start measuring the angle—in an anti-clockwise direction. The point P is determined when we know the distance from O to P and the angle XOP in degrees or radians.

The line OX is called the polar axis. The line OP is called the radius vector and the angle θ the vectorial angle. The latter, when measured in an anti-clockwise direction is consid-

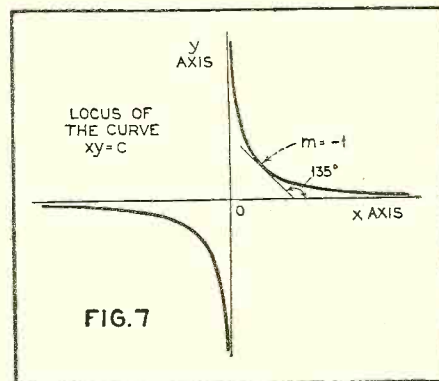

ered positive, in a clockwise direction, negative. Distances along the vector radius are counted positive in the direction which makes the angle θ with OX . For instance, in Figure 2, the distance OP or ρ is positive, for this direction makes an angle θ with OX . Distances in the other direction, from O towards Q , are negative.

Such lines, on which a positive direction has been accepted, are called directed lines and the direction is generally indicated with an arrow. For convenience it has been agreed upon that with the angle between two directed lines is meant the angle between their positive directions. This agrees with the rules, given above, for the signs of the vector radius and the vectorial angle. So, for instance, the coordinates of the point R in Figure 2 are α and ρ_1 . The same point can also be represented by β and $-\rho_1$. In the case of polar coordinates, a point can be represented in more than one way, but two coordinates define only one point.

Other Systems

There are still other coordinate systems; for instance, the oblique system. This resembles the rectangular system, with the difference that the coordinate axes intersect at an oblique angle. The representation of points is the same as with the rectangular system; remembering that RP and QP must be drawn parallel to the axes.

There are various transformation formulas which enable the engineer to change from one system to another when that seems desirable, but we cannot go into that.

Let us return to the cartesian coordinates.

A point can be represented by a pair of real numbers; let us now see how we can represent a straight line. Beginning with a simple case, see Figure 4, a line has been drawn through the origin. It is now easy to see that the ratio of the ordinate to the abscissa of each and every point on the line is the same; they are the corresponding sides of similar triangles.

Instead of defining this line by the coordinates of many points, we define it by this ratio, which is the same for all points. The ratio completely defines the line for any point, of which the coordinates have that ratio, is on our line. There are no other points in the

plane which satisfy this requirement. We need to plot only two points in order to draw the line; in our particular case one point is sufficient; the origin is the other.

This line can be represented algebraically by the equation $y/x = m$. In this formula "m" is a constant. Looking again at Figure 4, it may be seen that the angle "a" of the line with the x-axis, the inclination, is defined by this ratio. y/x is the tangent of the angle of inclination and is known as the slope.

Often a line is drawn as an illustration of two variables which are dependent on one another. (Continued on page 632)

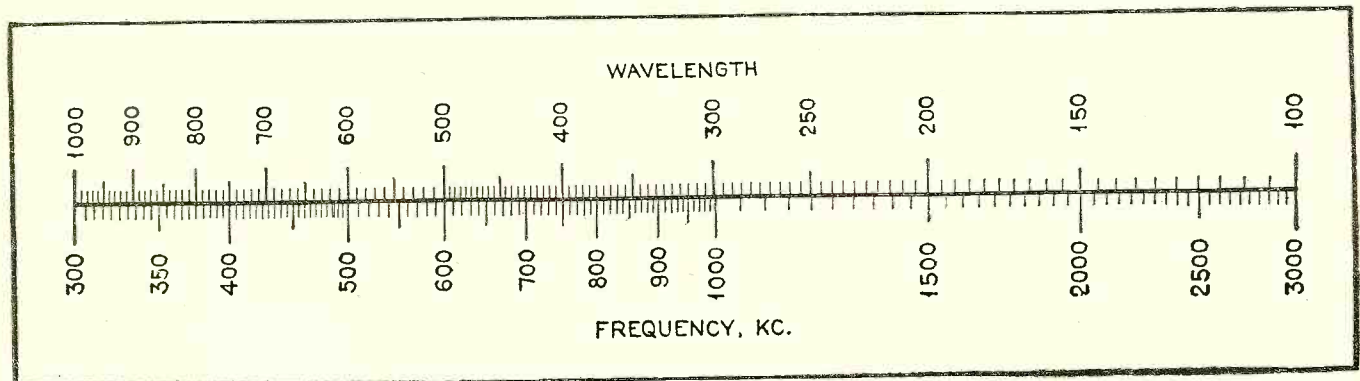

WAVELENGTH-FREQUENCY CHART

Figure 8. A simple form of chart which permits instant conversion of frequency to wavelength and vice versa.

Commercial Applications of the Direct Coupled AMPLIFIER

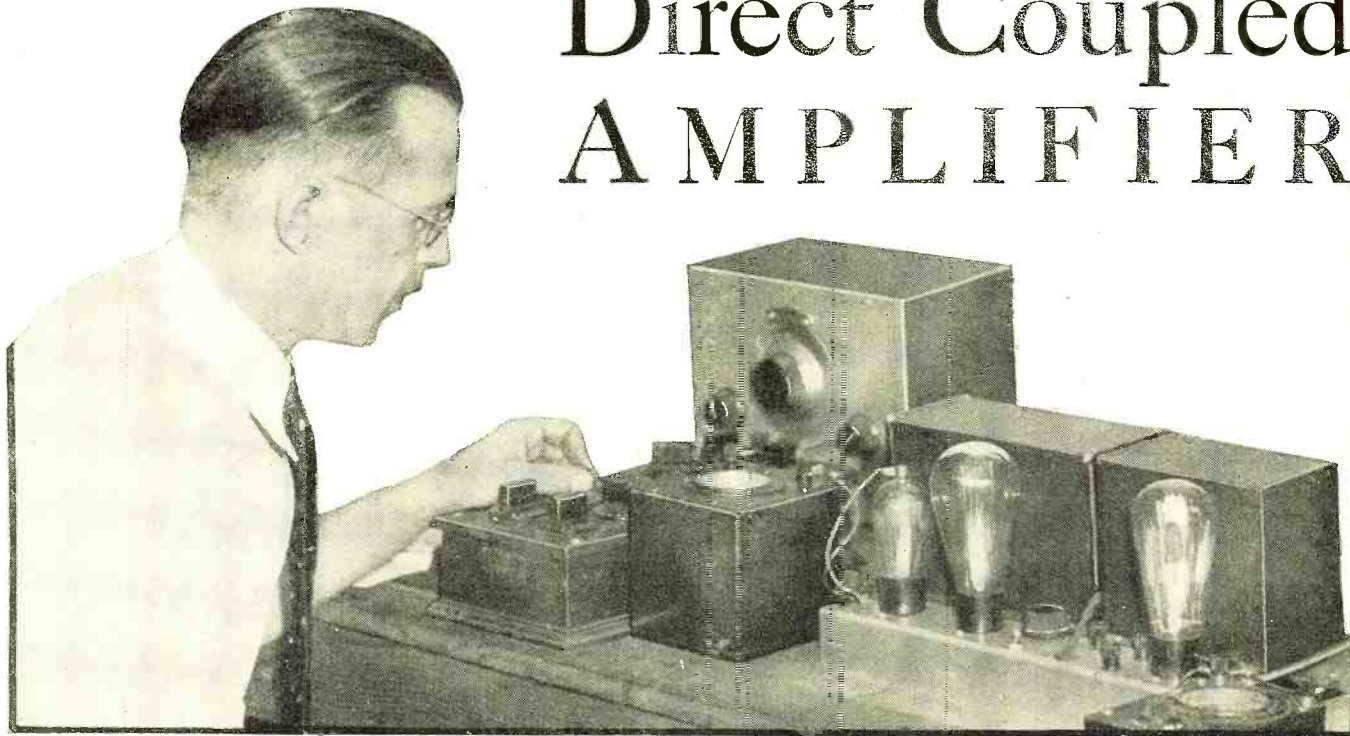

WORKING ON THE NEW AMPLIFIER DESIGN

The author making fidelity measurements on one of the models described in this article

The introduction of direct-coupled audio amplifiers created a furore in radio circles about two years ago; presenting outstanding advantages—and numerous brain-teasing problems as well. How the problems have been eliminated—but the advantages retained—is explained in this article

IT is rarely, if ever, the case that any outstanding development leaves a design laboratory in such condition that it is immediately applicable to commercial purposes. This is particularly true of an outstanding development such as the direct-coupled amplifier.

For nearly eighteen years such eminent scientists as Dr. Pierce and Mr. Arnold had realized the obvious advantages of this circuit and had devoted a good portion of their time to its development. However, it was only recently that the circuit was brought to the state of perfection that even laboratory models would work consistently with sufficient stability to render them practical.

The direct-coupled circuit was offered to the public some time back and met with instant and tremendous success, even though it still had to face the embryonic growth as a commercial practicability. Many wrinkles appeared and each one in turn had to be ironed out before the circuit reached its present state of perfection.

Hum Elimination

The research engineer, having given the public this circuit, naturally left it to commercial enterprise to find its applications and to refine its principles. The success that has been met with in accomplishing this end is attested in the many satisfactory installations of

By George E. Fleming*

direct-coupled amplifiers, both here and abroad. Before this perfection was reached, many changes were of necessity made, and it would be interesting to compare the basic circuit and the present-day circuit of the -45 amplifier. Figure 1 gives the laboratory constants, while Figure 2 illustrates the refinements that are to be found in the commercial amplifiers.

It will be found in Figure 1 that a hum-bucking device (P) is used. This device was highly satisfactory from a standpoint of hum elimination, but added a control to the amplifier that was of necessity readjusted for each change in operating conditions encountered. Before the advent of inexpensive electrolytic condensers such a device was necessary unless one desired to use an expensive two-stage filter. However, with electrolytic condensers now available, it is possible to reduce the hum to highly satisfactory limits without having to use such a device. The complete filtration of the screen-grid circuit, as shown in Figure 2, further assisted in reducing the hum.



A COMPACT LOW-POWER UNIT

This direct-coupled amplifier with built-in power supply provides two stages, the second a power stage employing a type -45 tube

Further Refinements

It will also be noticed that the grid return of the input tube is brought to a value more positive than ground in the original circuit. This was not an objection when a phonograph pick-up or such generating device was used, but became distinctly objectionable when one attempted to resistance couple any

*Electrad, Inc.

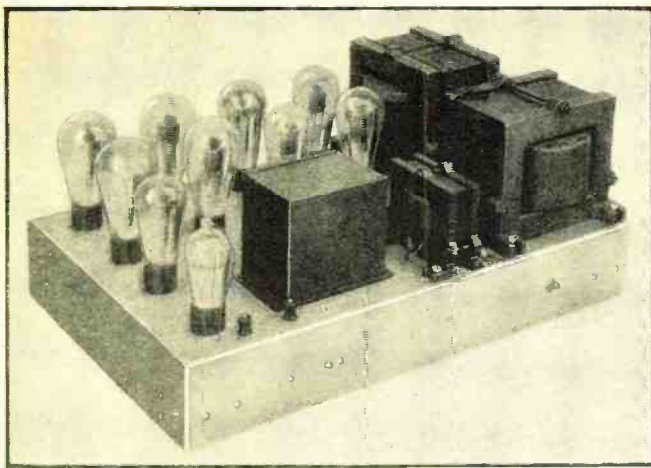

A REAL "POWER" AMPLIFIER

This unit includes four type -50 tubes in a push-pull parallel arrangement, following a -24 and a -45. It provides an undistorted output of 24 watts

device such as a preceding tube or a photoelectric cell into the amplifier. The grid return in the present models is to ground. Hence one experiences no difficulty in any conventional type of coupling.

Other refinements, such as a higher gain, make the present -45 circuit highly applicable when used as a voltage amplifier, preceding a power output stage. The excellent frequency characteristics that are obtainable from this circuit are a great advantage when one desires to use additional amplification.

The ruggedness of the amplifier has also been improved to

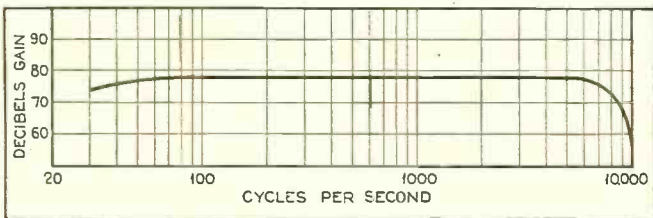

THE FIDELITY CURVE

Figure 5. This curve shows an absolutely flat gain of 78 db, from 70 to 5,000 cycles, for the type D-250 amplifier. The fidelity of reproduction, using such an amplifier, is limited only by the characteristics of the loudspeakers and inputs employed with it

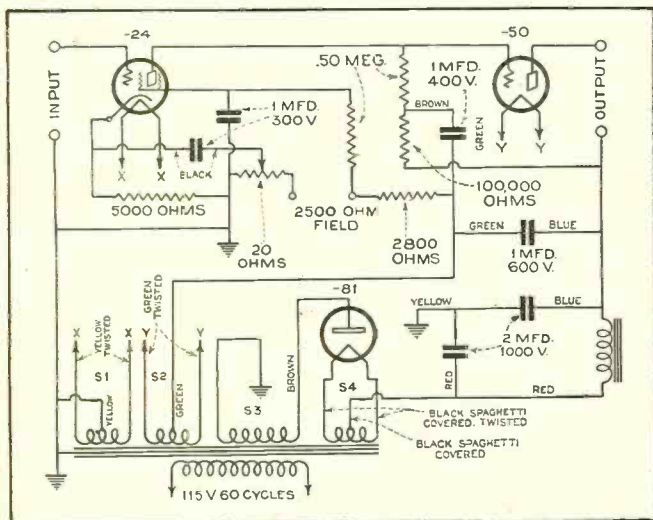

A MODERATE-POWER AMPLIFIER

Figure 3. A direct-coupled amplifier, using a single type -50 tube in the output. The use of an improved "hum-bucking" system permits half-wave rectification so that the high voltage required can be obtained with a single type -81 tube

such an extent that one need have no hesitation in using it for continuous duty. Highly perfected resistors and liberal safety factors contribute their share to this ruggedness.

For an amplifier of moderate power output built as an integral unit, the Electrad A-250 amplifier, the wiring diagram of which is shown in Figure 3, was designed. Since no full-wave rectifier tube is available to handle the voltage necessary for the operation of this amplifier, we have two choices in design. Either we may use two type -81 tubes in a full-wave circuit or we may use one type -81 tube in a half-wave circuit. The latter plan was adopted. Here again, however, we run into the condition where electrolytic condensers are not applicable, and if we desire to use the half-wave circuit, hum-bucking of some modified form becomes a necessity. With the new constants we may use here a very low resistance potentiometer and thus get a very close adjustment of our hum-bucking which, combined with the screen-grid filtration, results in a hum level of less than 1/4 volt.

For High Power Output

The power output from this A-250 amplifier is sufficient to operate several dynamic speakers and its gain is such that the input from an ordinary phonograph pick-up is sufficient to overload the power tube. The frequency characteristics are excellent, being fully equal to those of the smaller type B-245 amplifier.

As we get into higher power outputs it becomes logical to use a push-pull arrangement of the output tubes in preference to the use of high-power individual tubes with their attendant high voltage and current conditions. (Continued on page 616)

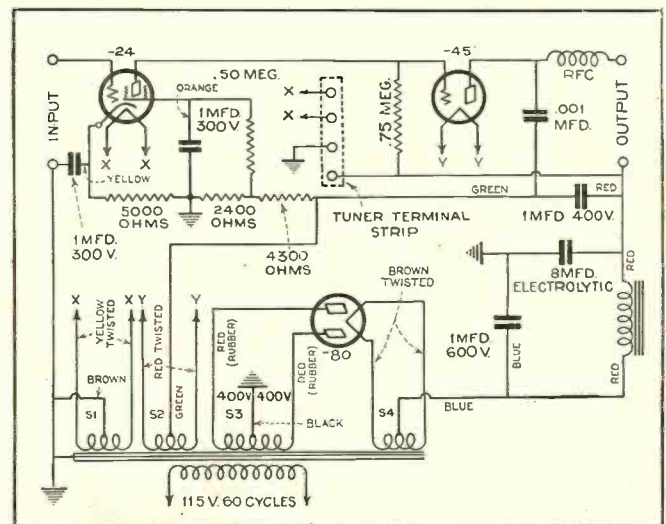
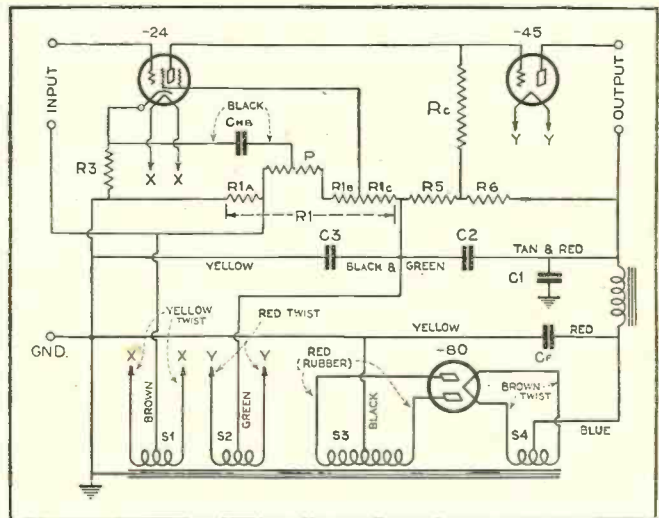

DIRECT-COUPLED CIRCUIT DEVELOPMENT

Figure 1 (top). The standard Loftin-White circuit commonly employed by experimenters. Figure 2. A modern commercial adaptation of the direct-coupled circuit, in which the formerly rather tricky "hum-bucking" resistor is eliminated

Mathematics in Radio

Trigonometry and Its Application in Radio

By J. E. Smith*

Part Thirteen

THE unit of electric current is the *ampere*. Let us recall the theoretical definition of an ampere, which is defined as that steady rate of flow of current which will deposit a certain definite amount of silver from a certain solution in one hour. An alternating current is not a steady current and it will not deposit any silver from a solution, since whatever it deposits in one-half a cycle it takes off when it is flowing in the opposite direction.

In order to compare an alternating current with a direct current, it is defined that the effective value of an alternating current is that value which will produce the same heating effect in a circuit as a direct current of the same amount. Alternating current voltmeters, ammeters and wattmeters usually indicate effective values.

Trigonometry gives us an interesting proof that the effective voltage of an alternating e.m.f. is equal to .707 times the maximum e.m.f. and in like manner the following expression for the effective alternating current is true:

$$I_{\text{effective}} = .707 I_{\text{maximum}}$$

Now, if a direct current flows through the wire of Figure 13 (a) which has a resistance R, we know that the wire becomes heated and the power developed in the resistance is:

$$P = I^2 R$$

expressed as the power in watts. If an alternating current, such as that indicated in Figure 13 (b) is now sent through the resistance R, the instantaneous heating effect is proportional to the square of the current at that instant.

Let us refer to the circular diagram of Figure 14 and let $R_1 B$ represent the instantaneous value of the voltage (or current) at an angle x. The angle is shown at approximately 45°.

In the right triangle, $OR_1 B$, it is noticed that $\sin x = \frac{R_1 B}{h}$ and since the hypotenuse h can be taken equal to 1, $\sin x = \frac{R_1 B}{OB}$.

Also, the length "a" is $\cos x = \frac{OB}{h} = OB$. From the right triangle, $h^2 = o^2 + a^2$ and since $h = 1$, h^2 must be equal to 1 and therefore $o^2 + a^2 = 1$.

As the vector moves in a counter-clockwise direction, the sine of the angle x takes on values from 0 to 1 while the cosine of the angle x takes on values from 1 to 0. In either case, the average of the squares of the sine and cosine must

be the same. If, as just shown above $\sin^2 x + \cos^2 x = 1$

then

$$(I) \text{ average } \sin^2 x + \text{average } \cos^2 x = 1$$

The above conclusion may not be quite clear, but let us take a similar set of equations in actual numbers and the relation will be a little better understood. We know that

$$(a) 10^2 + 10^2 = 200 \text{ since } 100 + 100 = 200$$

Let us multiply each part of (a) by the factor .7 and we have:

$$.7 \times 10^2 + .7 \times 10^2 = 7 \times 200, \text{ which becomes } 70 + 70 = 140, \text{ a proof}$$

Now the same method has been used in the above set of equations, and we have the average $\sin^2 x + \text{average } \cos^2 x = \text{average } 1$, and since the average of 1 is 1, the above formula has been proven.

Continuing, we note that the average of the squares of the sines must equal the average of the squares of the cosines, therefore, we are at liberty to substitute in the above equation (I) average $\sin^2 x$ in place of average $\cos^2 x$. Thus (I) becomes

$$\text{average } \sin^2 x + \text{average } \sin^2 x = 1 \text{ or}$$

$$2 \text{ average } \sin^2 x = 1$$

$$(II) \text{ Therefore, average } \sin^2 x = \frac{1}{2}$$

Taking the square root of both sides of this equation

$$\sqrt{\text{average } \sin^2 x} = \frac{1}{\sqrt{2}}$$

Now, we have shown that $e = E_m \sin x$, and squaring both sides of this equation, $e^2 = E_m^2 \sin^2 x$. Taking the average of both sides of the latter equation, we have:

$$(III) \text{ average } e^2 = \text{average } E_m^2 \sin^2 x$$

But from equation (II) above, average $\sin^2 x = \frac{1}{2}$, so substituting this value in (III), we have:

$$\text{average } e^2 = E_m^2 \times \frac{1}{2} = \frac{E_m^2}{2}$$

Taking the square root of both sides of this equation—

$$(IV) \sqrt{\text{average } e^2} = \frac{E_m}{\sqrt{2}} = \frac{E_m}{1.414} = .707 E_m$$

The effective value, E_{eff} , of the voltage will be the square root of the average of the squares of the instantaneous values, thus $E_{\text{eff}} = \sqrt{\text{average } e^2}$ and (IV) becomes (Cont'd on page 631)

HEREWITH is presented the thirteenth of a series of instruction articles on mathematics, emphasizing especially its application to radio. The articles which have appeared thus far are:

WHAT HAS GONE BEFORE

Arithmetic.....	Page 542	Dec., '30
The Slide Rule.....	630	Jan., '31
Algebra in Radio.....	722	Feb., '31
Algebra in Radio.....	826	Mar., '31
Algebra in Radio.....	920	Apr., '31
Algebra in Radio.....	1004	May, '31
Geometry in Radio...	1088	June, '31
Geometry in Radio...	63	July, '31
Geometry in Radio...	230	Sept., '31
Trigonometry in Radio	288	Oct., '31
Trigonometry in Radio	292	Nov., '31
Trigonometry in Radio	491	Dec., '31

*President, National Radio Institute.

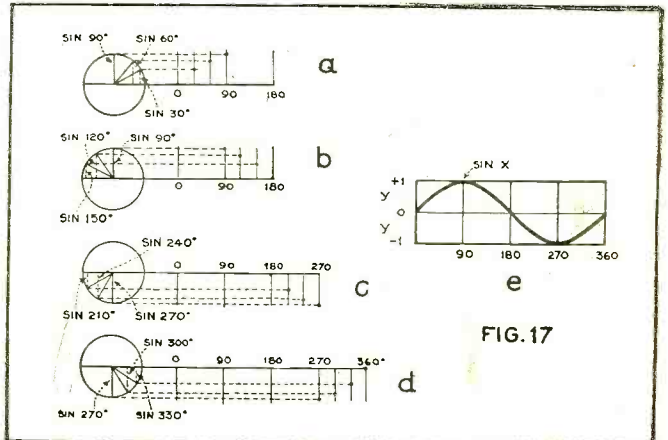
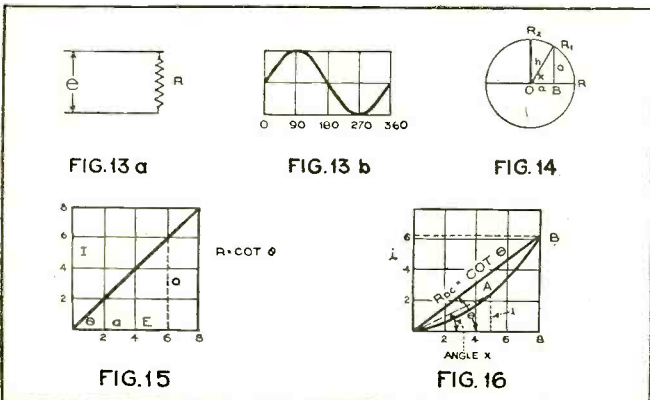

The Service Bench

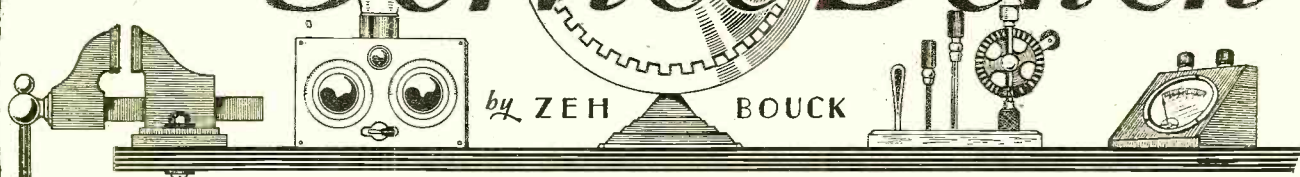

by ZEH BOUCK

New Lines for the Serviceman—Pepping Up Performance and Profits—
Service Shops—Teaching the Customer—Portable P-A Jobs—Service Kinks
—Radiolas—General Motors—Service Notes

Pepping Up Performance and Profits

AS the design for the radio receiver approaches theoretical perfection, its rate of development, like that of anything approaching a limit, becomes slower. A 1930 model receiver was a lot better than a 1920 design, but the improvement of the 1932 receiver over its predecessor of two years before is less marked. During the first decade of radio broadcasting, receivers quickly became antiquated. Today it is not necessary for the average person to buy a new receiver every year. Yet "the world does move," and the opportunities for the serviceman to modernize reasonably satisfactory equipment in the light of consistent development are many and profitable.

James A. Robinson, "Old Reader" and "pro bono publico" of *The Service Bench*, sends along the following detailed data on increasing performance with the Radiola 44, 46 and the Graybar 52CL, in the servicing of which he has specialized.

Concerning these receivers Mr. Robinson writes: "Sometimes one receiver outperforms another of the same make and model. There apparently is no good reason for this—some of these models are simply better performers. It is for the benefit of the serviceman, whose business it is to make a set 'do its stuff,' particularly upon the models mentioned, that the notes which follow are written.

"No set will perform its best without good tubes, and before operating with screwdriver and pliers it is desirable to test the receiver under perfect conditions. Tubes may be new, test well, and yet not perform. Proper combination is essential, particularly in a superheterodyne. Install good tubes, properly combined—no one is better able to do this for a customer than the serviceman.

Circuit Changes

"Before attempting the circuit changes herein recommended, release the socket-power unit (hereafter referred to as the s-p-u) and examine its hook-up—particularly the parts directly affected by the following circuit changes. (See Figure

1.) Check back to the circuit given, as this is our starting point. (Some of the early models of the Radiola 44 and 46

THE serviceman is like the barber of old. His task is many sided because there are multitudinous things no one else can do as well as he. Aids for hearing are directly in his line—they are by-products of radio development. No one is better fitted than the radio serviceman to install and maintain such equipment. And the confidence and respect of his clients has gained him an entry into millions of homes. There is opportunity here for a humanitarian and profitable effort that should not be overlooked.

and the Graybar 520L show slight variations from this circuit.)

"Remove the 15,000-ohm resistor (light

gray) from the condenser block and place it in the same position as the 3300-ohm resistor (green and red), removing and discarding the latter resistor. The 2000-ohm resistor (red and black) will now be in series with the 15,000-ohm resistor, as indicated by the dotted lines on the diagram, in place of the 2000-ohm one and the 3300-ohm resistors which were in series with lug 3 on R₂ (lugs counted from right to left) and lug 6 on the terminal strip (counted in the same direction). Lugs 1 and 2 on the terminal strip are the heater connections. (Heater wires are black with a yellow tracer.) Be careful to replace the pieces of paper under the small resistors, the same being essential for insulation purposes.

"A 250,000-ohm resistor will be found connected to lug 4 on R₂. This resistor is brown and blue and should be removed and discarded, at the customer's option, as it has an effect on the tone quality, emphasizing the bass.

"Procure a 40,000-ohm resistor and wire it across the lugs on the condenser

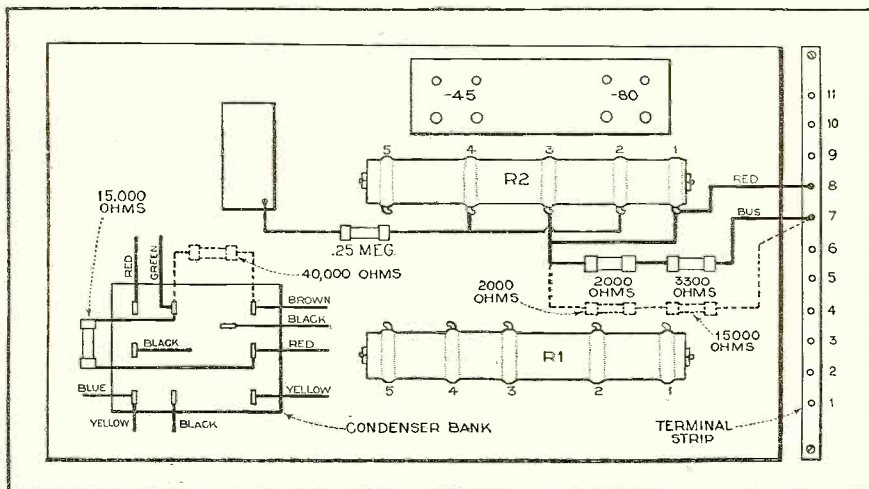

DIAGRAM OF CIRCUIT CHANGES

Figure 1. Socket power unit, Radiola 45 and Graybar 520L. Dotted lines show circuit changes as described in text

block to which are soldered a green lead and a brown lead. Replace the s-p-u, and make the following adjustments with care and precision:

"The lead connecting the antenna to the local-distance switch is shielded, the shield being grounded through a yellow wire. Remove this yellow wire.

"Connect the s-p-u and place the receiver in operation—noting the improvement already effected. Turn the local-distance switch on *distance*, and proceed:

"Loosen the chassis from the shelf or cabinet. If it is the table model, remove both the chassis and the s-p-u. If it is the console type, tip the chassis back toward you so that the three trimming condenser screws may be readily adjusted. With the assistance of a modulated oscillator or a reasonably steady broadcast signal, line up the three trimmers for maximum response, beginning with the detector stage (which is first from the left to right, facing the rear of the chassis). The expert can do a fair job using his ear, providing more definite instruments are not available. If the trimming is done by ear, turn down the volume control to the minimum audible response and trim each stage for loudest volume on that adjustment. If convenient, use an 0-5 milliammeter in the plate circuit of the detector. This may be readily done by removing the wire from lug number 5 on the s-p-u terminal strip (counting the black with yellow tracer as the wire on lug number 1), connecting the meter between the lug and the wire. A meter may also be connected by shunting it across the voice coil of the dynamic speaker.

"Adjust the trimmers first on a signal of 1400 kc. or thereabouts, and repeat the process at about 600 kc., returning and rechecking both adjustments. If maximum adjustment results in oscillation, while tuning, remove the shields over tubes numbers 2 and 3 and clean the shield bases with sandpaper. All shields must make perfect contact with the chassis or troublesome oscillation will occur.

"The most marked improvement will be on sensitivity. The writer changed over a Radiola 46, pepping up the 'local' response to the point where it compared favorably with the former operation of the 'distance' adjustment—and without loss in tone quality."

The principles involved in the changes recommended by Mr. Robinson on the Radiola and Graybar models may, of course, be applied to other receivers. Rejuvenating alterations generally consist of resistor changes, applying high plate voltages on the tubes. Such changes, however, must be effected with discretion, as the game is not worth the candle if tube life is materially shortened, or if the set is unstable as a result of increased regeneration. Clean shields, or additional shielding, with r.f. filtering by means of chokes and condensers, will often make it possible to take advantage of increased sensitivity without instability or tonal deficiency.

Trimming is a process that should be a part of practically every service call—and certainly where tubes are changed. The greatest discrepancy will generally be found in the oscillator section of superheterodynes.

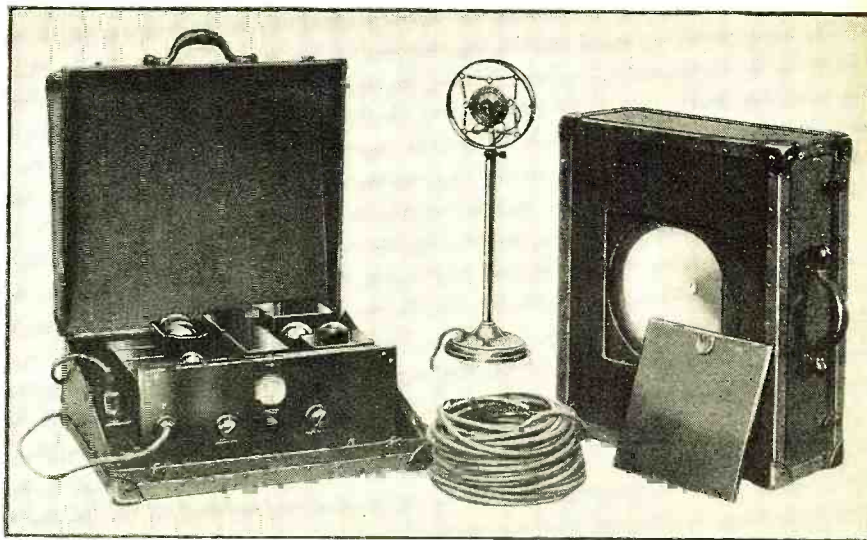

PORTABLE P. A. EQUIPMENT

Figure 2. Such equipment offers a real source of income for servicemen

The serviceman in the small city or town is finding portable public-address system apparatus a highly profitable adjunct to his usual stock-in-trade. Picnics, church socials, commencement exercises, political gatherings and general meetings all offer money-making oppor-

tunities to the serviceman so equipped. Figure 2 shows an excellent portable arrangement manufactured by the Webster Company, 850 Blackhawk Street, Chicago, Ill. This consists of the microphone, portable amplifier and power supply and the portable, self-baffled speaker.

A few years back, an essential operation in the modernization of a receiver was the installation of good audio-frequency transformers and the provision for power tubes. Good transformers, however, have been placed in receivers, listing for over \$100 in price, since 1928.

tion common to both tubes—providing an ideal center-tapped return.

Some receivers of even fairly recent vintage suffer considerably from hum. Occasionally this can be subdued by brute force treatment with one of the new electrolytic condensers.



SERVICEMAN AND SPORT
Albert J. Herda, of the Herda Electric Company, Baltimore, occasionally shoots duck instead of trouble

But there are still a goodly number of receivers employing -71 tubes in push-pull that could be improved by the substitution of -45's. H. D. Hatch suggests a simple way of making this change without buying a special filament transformer to take care of the 2.5-volt requirement. By connecting the filaments in series, they may be lighted from the 5.5-volt winding that originally supplied the -71's. The 750-ohm grid-bias resistor is connected between ground and the filament connec-

All in a Day's Work

The day's work can be speeded on its way by a service bench provided with good instruments, the right tools and plenty of wide-open spaces. A reasonable amount of the correct equipment is probably the best answer to the problem of efficient servicing. There is no necessity for the service laboratory to look like the control room of a 50,000-watt broadcasting station, however. An excellent layout is reproduced in the photograph of the service shop operated by Harry Cochran in Brownwood, Texas. His essential equipment includes: turntable and magnetic pick-up for a.f. testing—modulated r.f. oscillator—i.f. oscillator for supers—and the usual meters arranged for convenient use, through clips, prongs, jacks and plugs. All of the equipment has been built by Mr. Cochran, who services for Dublin and Cannon, of Brownwood, dealers in Atwater Kent, R.C.A. and Victor. Mr. Cochran writes:

"A minimum charge of 75 cents is made on all service calls. This includes an inspection of the antenna system, tubes, batteries and the receiver. If the trouble is located in the receiver, the chassis is removed from the cabinet and taken to the shop for repair. The set is then tested on broadcast reception for a period of thirty minutes or more, and returned to the customer. A non-technical explanation concerning the cause of the trouble

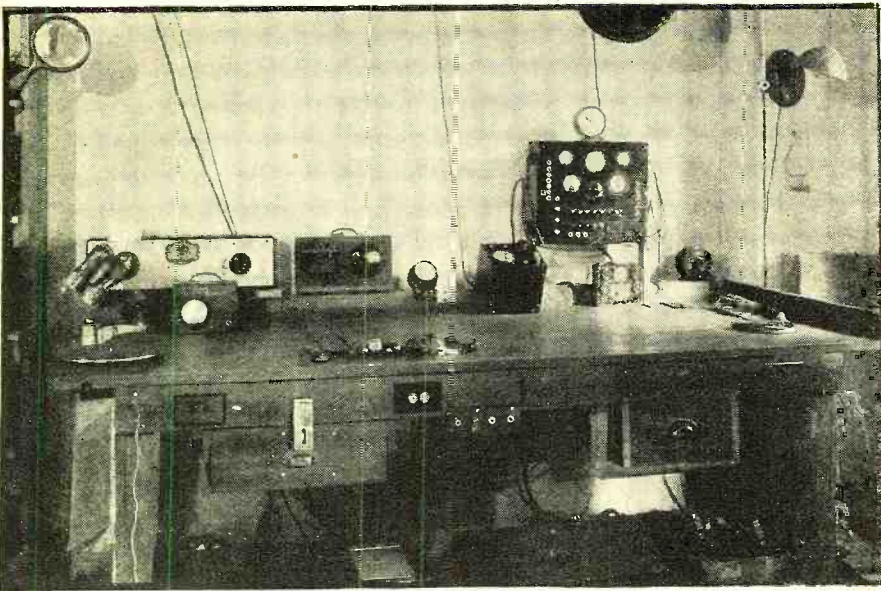

A TEXAS WORKSHOP

The service shop of Harry Cochran, Brownwood, Texas, is a good example of essential equipment plus plenty of elbow room for work

and the remedy is given if such information is requested."

Screen-Grid Leads

"While servicing several screen-grid receivers I have found it necessary to replace the wire which leads to the grid or cap on the top of the tube. This lead is usually encased in screen or armor, and in several cases it had broken off. Instead of trying to repair or replace the exact wire, which would have entailed the delay of procuring the part from an authorized dealer, I have found it satisfactory to substitute the ordinary armored cable such as is sold at automobile accessory stores and is used to wire up tail lights, etc. This is covered with armor which is satisfactory as a shield, and it is easily grounded in the usual way.

WILLIAM C. DUER,
Denver, Colo."

In making such substitutions for shielded wire in the grid leads it is important to consider the possible capacity difference between the substitute and original leads. An increase of a few micro-microfarads here will limit the tuning range of the receiver. In changing one lead the receiver will almost invariably have to be retrimmed. The same holds even when all leads are changed if the original dial settings, for stations, is to be retained.

Simplified Radio Instruction

The idea of Mr. Cochran of telling the customer something about his radio is an excellent one. A reasonable amount of education in this respect should be interesting rather than burdensome and should result in more intelligent—and therefore more pleasurable—operation of the receiver. Ray E. Everly, who installs Scott radios for the good folks in Newton, Ill., has the same idea:

"The average radio dealer apparently figures that his customer will learn all that is necessary about his radio from the printed card tacked on the console cover.

He does not appear to realize that fifteen to thirty minutes of simplified instruction would result in a more satisfied customer and the elimination of many unnecessary and unprofitable service calls.

"Turn on the power switch, and explain what it does by analogy with an electric light, toaster or vacuum cleaner. Tell your customer that you are allowing time for the tubes to heat properly. Show him how to advance the volume control, making slight readjustments in the tuning if necessary, so as to secure the best possible tone. Explain that while the set is capable of excessive volume, it is not good for the apparatus and eventually will be harmful. Show him that slightly better quality will always be had at moderate volumes. Explain to him the significance of the dial readings and the manner in which stations can be logged. Tell him a few simple facts about radio in general, and encourage him to ask questions, which should be answered intelligently in an A B C style. If you can make him understand a few things that heretofore have been mysterious to him, he will be completely sold on your ability. If you are servicing a receiver for the first time—one that has been sold by another—take the first opportunity to start the owner in the kindergarten class."

A Service Tip on the Radiola 66

"A large percentage of the Radiola Model 66 superheterodyne receivers, after being in use a short time, develop a mushy and distorted reproduction, evidenced by a sort of bubbling sound in the output. This is noticeable especially at low volume levels. After considerable difficulty the writer traced this trouble to the volume control. The volume controls are tight and apparently make good contact, as there is an absence of crackling when the volume is adjusted. The trouble is due to the grease placed in the volume control bearing at the factory. This gradually softens and works into the movable arm contact plate. In an ordi-

nary volume control system this minute variation of electrical contact would cause little or no trouble, but in the Radiola 66 circuit the volume control adjusts the grid bias of the tuned radio-frequency and first intermediate-frequency stage which is followed by a high-gain amplifier. The remedy is to remove the volume control (note carefully the position of the soldered leads), take it apart and remove all traces of grease. Do not attempt to tighten the adjustment by bending the contact arm—do it by bending the feet on the contact arm or the bronze washer between the contact plate and bearing. Much time and temper can be saved if the two hex nuts are secured with wads of tissue paper before the volume control is put back in position. It is then an easy matter to start the mounting screws and remove the tissue paper with long-nose pliers."

Record Pick-ups on the 60, 62 and 64

"The general method of inputting for phonograph pick-up, i.e., connecting into the detector plate lead, will not work on these receivers due to the fact that only one stage of audio-frequency amplification is employed. The best procedure is to make an audio amplifier out of the second detector tube by changing the grid bias. This can be accomplished by opening the grid lead, and running a wire from the grid to the pick-up transformer and a "C" battery. The remaining terminal from the secondary of the pick-up transformer should be connected to terminal number 7 (black with green tracer) on the terminal strip. A 2000-ohm resistor will work in place of the "C" battery, but will admit more hum in the circuit. A single pole double throw switch can be permanently installed to change from radio to phonograph."

FRANK M. COATES,
Coates Radio Co., Sioux City, Iowa.

Noise in the General Motors Series

And concluding a busy day's work, we have Herman Lemons, of Panhandle, Texas, shooting trouble on a General Motors receiver. Writes Mr. Lemons:

"The most common trouble encountered by the writer in servicing the new G.M. receiver has been intermittent reception with the set going into oscillation on the higher frequencies. The cause of this has always been found in faulty connections to the rotor plates of the variable tuning condensers. A wiping contact is used, and since the receiver is set so near the oscillation point, when a poor contact is made the set suddenly goes into oscillation at the higher frequencies. I have remedied this by cleaning the wiping contacts of the condensers and coating them with a thin coat of graphite oil. Sometimes it is necessary to solder a wire to the shaft of the condensers, in the extra compartment left for a condenser, and then ground it to the can. This will always bring about the desired results if the shields over the t.r.f. coils are well

(Continued on page 622)

Service Data for Servicemen

Compiled by Nat. Feiner*

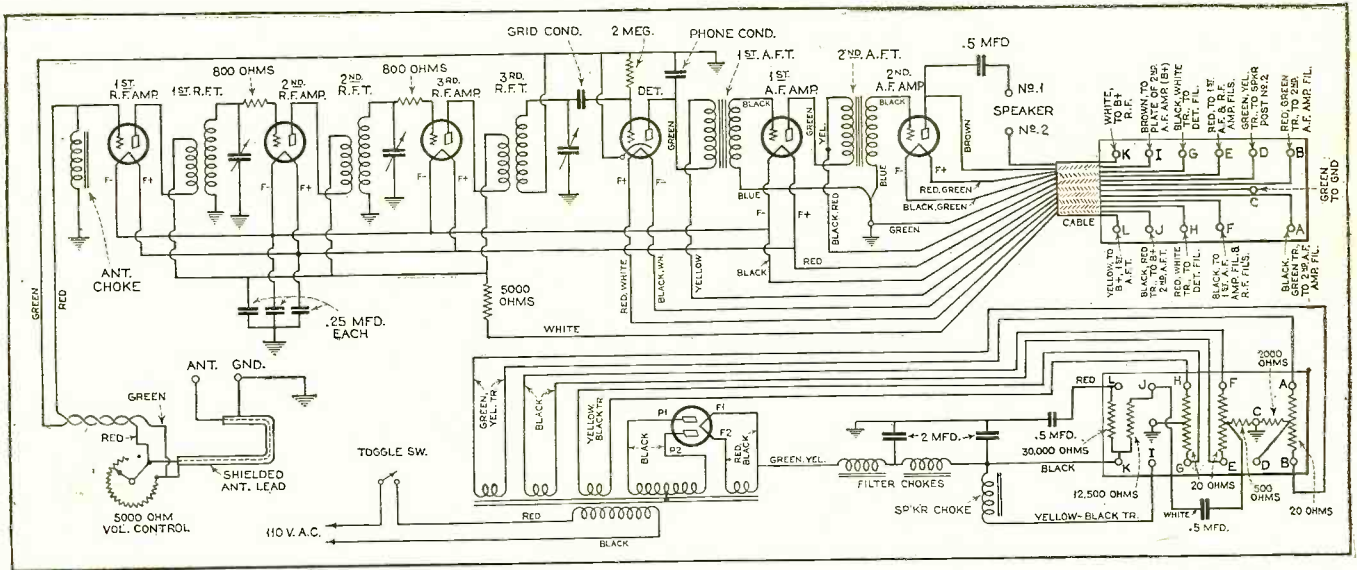

ATWATER KENT, MODEL 37

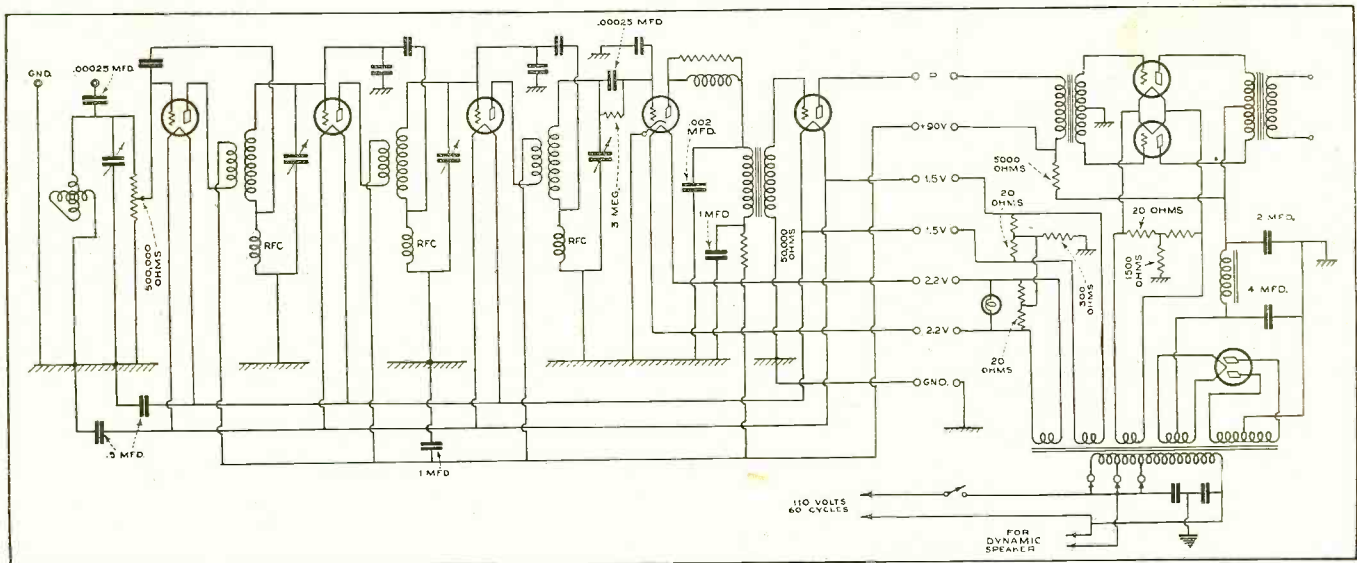

BOSCH, MODEL 156

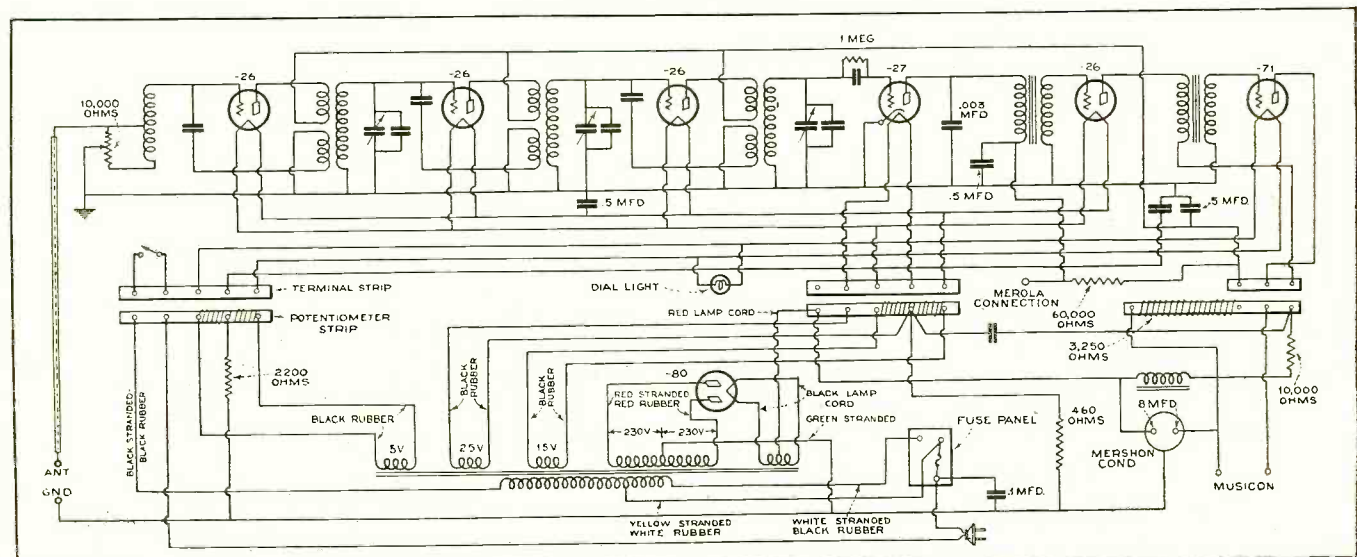

CROSLY, MODEL 704-A

*Chief Engineer, Federated Purchaser.

Radio Physics Course

This series deals with the study of the physical aspects of radio phenomena. It contains information of particular value to physics teachers and students in high schools and colleges. The Question Box aids teachers in laying out current class assignments

MATERIALS in which the atoms hold on to their electrons very strongly so that it is difficult to free any electrons and make them flow along in a definite direction, are known as *non-conductors* or *insulators*. There is no sharp distinction between conductors and insulators. Substances that for some cases would be regarded as fair insulators would in other cases be regarded as fair conductors.

For instance, the grid-leak resistance employed with the ordinary detector tube in a radio receiver usually has a resistance of 2 million ohms. In radio work this is considered as offering a conducting path for the charges on the grid of the tube to leak off slowly, so it is a conducting path. In ordinary electrical work a body having a resistance of two million ohms would be considered a good insulator.

Some substances which are good insulators at one temperature become fairly good conductors when their temperature is raised. Glass acts like this. The resistance of carbon also decreases as the temperature is increased. We do not know of any perfect insulator. All practical insulators will allow some electrons to flow through them (conduct some current) if e.m.f. is applied to them. The actual rate of current flow through a body having a given resistance and given e.m.f. applied to it can be calculated. This will be studied later. Thus a piece of bakelite of certain dimensions, having a resistance of say ten million ohms, will have flowing steadily through it a small current of .00001 (one-hundred-thousandth) ampere if an e.m.f. of 100 volts is applied to it. As this current is very small, we can say that a piece of bakelite is a good insulator, since a medium amount of e.m.f. cannot make many electrons move through it. However, if 1,000,000 volts is applied to this same piece of bakelite (provided it does not break down) a current of 0.1 ampere would flow through

By Alfred A. Ghirardi*

it and if we were particularly interested in employing this as an insulator to prevent leakage of current at this voltage, it might not be considered a very good insulator under these conditions.

It is fortunate that certain substances do not conduct electricity freely and may therefore be used as insulators, for if this were not so, we would find it impossible to conduct electricity from one place to another through metallic conductors. If we did not have insulators, we would not be able to isolate one electric circuit from another and short-circuits would occur. Figure 1 shows several examples of the use of insulating materials in radio equipment.

The ohmic resistance which an insulating material offers to current flow or leakage through it is called the *resistivity* or *insulation resistance*. It is measured in ohms and is usually expressed as the resistance of a cube of the material measuring 1 centimeter on each side, at a certain temperature. Table 1 shows the volume resistance of dielectric materials, from tests made by the Bureau of Standards.

Lesson Six
(Continued from Lesson Five)

The Electron Theory, Generation of Electric Energy Conductors and Insulators

Insulation Breakdown

If a sufficiently high e.m.f. is applied to an insulating material, the electric forces acting on the free electrons in the material become very great. Under these forces the free electrons are speeded up to very high velocities, proportional to the forces acting on them. As this velocity becomes very high, the velocities acquired by the electrons in the short paths between collisions with molecules becomes greater and greater, and finally at a voltage intensity which is fairly definite for any particular insulating material, the few free electrons acquire

NOTE: The surface resistivity of any material is lowered by humidity, and by the presence of moisture. For example, the surface resistivity of hard rubber which is 10^{18} ohms at a relative humidity of zero drops only to 10^{15} at a humidity of 60; but it then drops to 10^{12} at humidity of 80 and to 10^9 at a humidity of 90.

*Radio Technical Pub. Co., Publishers, Radio Physics Course.

RESISTIVITY OF SOLID DIELECTRIC MATERIALS	
RESISTIVITY OF A CENTIMETER CUBE AT 22° CENT. OR 71.6° FAHRENHEIT IN BILLIONS OF OHMS (1,000,000,000 OR 10^9)	
Bakelite	India, slight stains.....50,000,000
No. 1.....200	moulded.....1,000,000
No. 150.....4,000	Porcelain, unglazed.....300,000
No. 190.....100	Quartz, fused.....5,000,000,000
No. L-558.....20,000,000	Rosin.....50,000,000
micarta.....50	Rubber, hard.....1,000,000,000
Celluloid, white.....20	Shellac.....10,000,000
Condensite.....40	Sulphur.....100,000,000
Fibre, hard.....20	Waxes
red.....5	beeswax, yellow.....2,000,000
Glass, ordinary.....90,000	" white.....6,000,000
plate.....20,000	ceresin (over).....5,000,000,000
Lavite.....20	halowax No. 1001.....20,000
Marble	" No. 5055 B.....20,000,000
Italian.....100	paraffin.....50,000,000
Tennessee.....5	parowax.....10,000,000
Vermont.....1	sealing.....8,000,000
Mica	Woods, paraffined
African, spotted black.....40,000	mahogany.....40,000
" brown clear.....2,000,000	maple.....30
colorless.....200,000,000	poplar.....500
India ruby, stained.....50,000	walnut.....10

TABLE 1

TABLE OF BREAKDOWN VOLTAGES	
MATERIAL	DIELECTRIC STRENGTH OR BREAKDOWN VOLTAGE IN VOLTS PER .001" THICKNESS OF MATERIAL
Cotton (single covering).....	260 - 340
Cotton (double covering).....	210 - 240
Silk (single covering).....	350 - 565
Silk (double covering).....	320 - 420
Mica.....	2000 - 8000
Micanite (cloth).....	175 - 310
Micanite (paper).....	280 - 390
Paraffined paper.....	800 - 1000
Asbestos.....	60 - 100
Glass.....	150 - 300
Dry process porcelain.....	1000
Dry Manilla paper.....	110 - 320
Press Board.....	200 - 330
Untreated pure para rubber.....	300 - 500
Air (dry).....	50

TABLE 2

such high velocities that upon colliding with neutral molecular or atomic structures they tear away the more easily detached electrons, giving rise to a greatly increased number of free electrons. This destructive process rapidly increases the supply of free electrons and thus a conducting channel or path is formed through the insulating materials. The intense destructive bombardment results in *failure, breakdown or puncture* of the insulating medium, during which con-

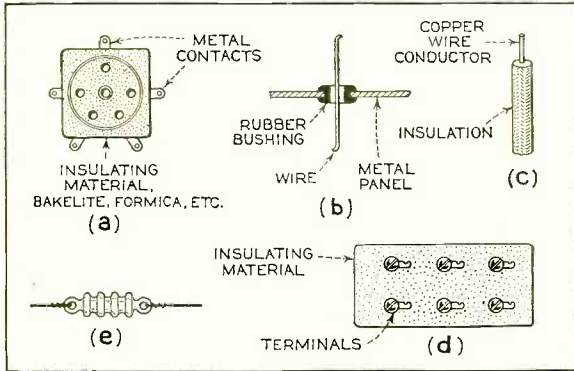

INSULATION TYPES USED IN RADIO

Figure 1. (a) A vacuum tube socket; (b) bushing in metal panels; (c) covering on wires; (d) terminal strips; (e) antenna

dition the material fails to insulate. This breakdown is indicated by the formation of a brush discharge or by the actual passage of an electric spark. Upon breakdown, sufficient heat is produced to char a path through such insulating materials as wood, silk, cotton, tape, bakelite, etc. Materials like porcelain or glass will be cracked open or a small channel will be melted through them due to the concentration of the energy.

This is what happens when the insulation on wires or the waxed paper or mica dielectric between the tinfoil sheets of fixed condensers used in radio sets breaks down. Practically the same action takes place when a high voltage is applied between the spark gap points in an automobile spark plug, or when a lightning discharge takes place between two electrically charged clouds or between a cloud and the earth, as shown in Figure 2. The *breaking down* of insulating material should be distinguished from the simple current flow or *leakage* through it discussed in the previous article. The breakdown action makes the insulation worthless, thereafter, unless the insulating property can be healed

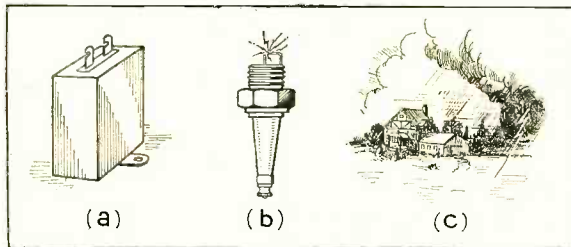

ELECTRICAL BREAKDOWN

Figure 2. (a) In condensers, due to breakdown of waxed paper insulation; (b) in a spark gap (here it is intentional) due to breakdown of air insulation between points; (c) lightning, due to breakdown of air insulation between clouds and the earth

or restored upon removal of the high e.m.f. as in the case of the air path in the spark plug, or between clouds, in the oxide films formed in electrolytic condensers, etc. In these cases the insulation is not permanently damaged.

The electric intensity at which an insulating material fails or breaks down is called the *dielectric strength* or *breakdown voltage* of the material. It is expressed in volts per centimeter length of conducting path in the insulator, or sometimes in "volts per inch." The breakdown voltages of a few of (Continued on page 618)

Question Box

PHYSICS and science instructors will find these review questions and the "quiz" questions below useful as reading assignments for their classes. For other readers the questions provide an interesting pastime and permit a check on the reader's grasp of the material presented in the various articles in this issue.

The "Review Questions" cover material in this month's installment of the Radio Physics Course. The "General Quiz" questions are based on other articles in this issue as follows: How to Build Your Own Beat Frequency Oscillator, The March of Electrons, Using Graphs and Charts in Modern Radio Practice, Commercial Applications of the Direct-Coupled Amplifier, Thirty-seven Years of Radio Progress, "Wireless" Centralized Radio, The Microphone—Radio's Electric Ear.

Review Questions

1. Explain why copper is a good conductor, and Bakelite is a very poor conductor of electricity.
2. Distinguish between (a) the resistance of an insulating material to current leakage through it and (b) voltage breakdown of this material.
3. Arrange the five following materials in the order of their resistivity: glass, unglazed porcelain, hard rubber, Italian marble, beeswax.
4. Explain why the resistivity of a material such as hard rubber varies with humidity.
5. Just what electronic action takes place when a condenser breaks down from overloading?
6. What unit of volume is usually understood in expressing the insulation resistance of any material?
7. If equal thicknesses of the five following materials were simultaneously subjected to a gradually increasing voltage, in what order would they be likely to break down: rubber, air, paraffined paper, glass, porcelain?

General Quiz on This Issue

1. What are the two essential requirements for a really good beat frequency oscillator?
2. In what year was the Atlantic first spanned by "Wireless" signals?
3. Why is it considered desirable, in high-power amplifier systems, to use two or more type -50 output stages rather than a single stage using super-power tubes?
4. Why is it inadvisable to have the two oscillators provide equal voltages in a beat frequency oscillator?
5. What are the distinctive advantages and shortcomings of the condenser microphone? The carbon microphone? The dynamic microphone?
6. For what two prime purposes are graphs used in radio?
7. Where might a parabolic microphone be used to advantage?
8. Name five distinct industrial or commercial applications of photo-electric cells.
9. What would be the characteristics for an ideal microphone?
10. In plotting a wavelength-frequency conversion chart, why is it most practical to use a logarithmic scale?
11. In the new "Guided Radio" system for hotels, what method is used to carry the programs to the individual rooms?

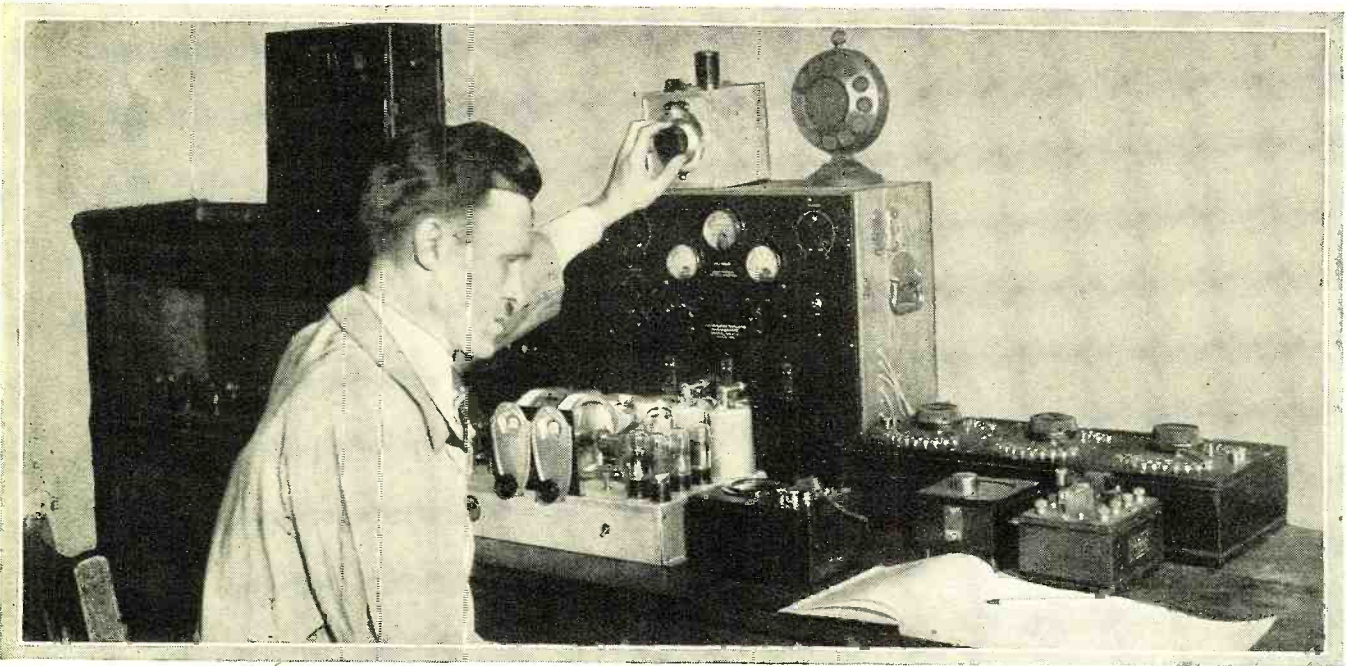

With the Experimenters

A \$15.00 Auto Radio; Home-Made Phonograph Pick-up; Pentode Adapter; Crystal Receiver; Static Reduction; Increasing Neutrodyne Sensitivity; A.C. Voltmeter Multipliers; Low Reading Ohmmeter; Rejuvenating Phono Pick-ups

An Automobile Radio for \$15.00

There are many good automobile radio outfits on the market, but the principal drawback to their popularity is in the price. Most sets sell for more than \$50.00 complete with radio tubes and batteries. The outfit I describe can be rigged up for \$15.00 or less and will offer as much entertainment as the more expensive ones.

I bought an old Atwater Kent Model No. 35 radio set from one of our local radio dealers. This is a one-dial controlled, six-tube set using a -71-A type

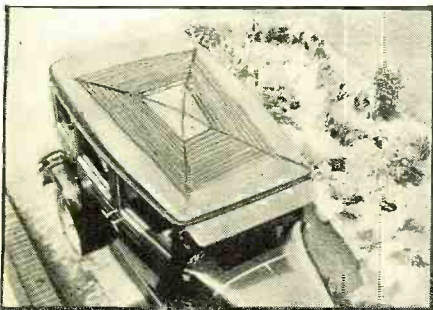

A simple type of automobile radio antenna

power amplifier tube. These can be bought at a reasonable price, as radio dealers are glad to get rid of battery sets since there is no demand for them. The one I bought cost \$3.50, complete with tubes.

Conducted by S. Gordon Taylor

The set was mounted directly underneath the front seat of my Chevrolet sedan. It was, of course, necessary to take the set out of the cabinet to mount the radio chassis on the front part of the seat rest, which served as the control panel. The controls from the chassis were then extended through the seat rest, and tuning is done from the outside without having to lift up the seat when the set is operated.

The loudspeaker was mounted directly under the dashboard on a piece of celotex. This acts both as a baffleboard and a mounting for the speaker. I used a Bosch unmounted loudspeaker, but any other make of speaker will work equally as well.

The B and C batteries were placed not far from the set, underneath the seat. A running-board tool box was placed on the running board to the left of the driver, to house the tools of the car which were formerly under the seat.

The A supply for the set is obtained from the car battery.

After several experiments it was found that the most suitable aerial is a loop constructed on the roof of the car. Strips of bakelite, about 12 inches x 3/8 inch x 3/16 inch were placed on the roof, one on each corner of the car, pointing

towards the center. Grooves were cut in the strips into which bell wire was strung, thus forming a loop aerial. Another way to make the aerial is to place copper screening between the roof and the cloth ceiling of the interior of the car. This is a more complicated method but makes a neater job.

Since the A minus of the radio set is grounded, and the A minus of the car, the frame of the car served as a ground. After installing the complete radio set it was found to work very well without the

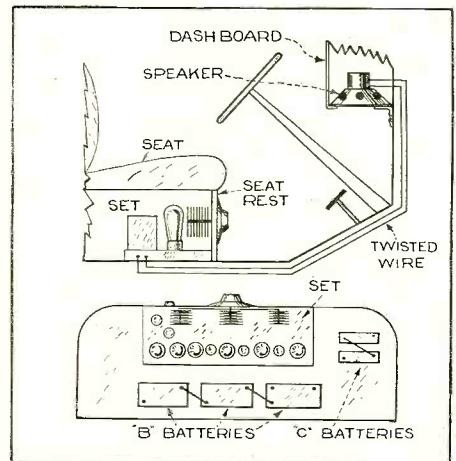

The schematic layout of the auto radio installation

aid of suppressors for the spark plugs. Noises from the ignition were slight and caused no annoyance. It operated as well when the car was running as when idle.

The cost of the complete outfit was as follows:

- 1 Atwater Kent No. 35 one-dial-controlled set \$ 3.50
- 3 B batteries @ \$1.50 each 4.50
- 1 unmounted loud speaker 4.00
- 2 C batteries @ 35c each70
- 1 roll bell wire25
- 4 strips bakelite75
- 1 celotex, 12 inches x 12 inches x 1 inch25

Total \$13.95

A. HARVEY,
Passaic, N. J.

A Home-Made Phonograph Pick-up

An easy and inexpensive way to make a magnetic pick-up for a phonograph is shown in Figure 1.

Remove the diaphragm from one telephone receiver and solder a phonograph needle to its edge. The needle should be one of the kind which may be used several hundred times before being discarded. However, even an ordinary needle will run 50 to 100 times before a change of tone is noticed. A hole is drilled, or it may be burnt through the edge of the cap with a hot wire. The needle protrudes through this hole. The phonograph reproducer should be removed and the telephone receiver put in its place and held there by elastic bands. The hole in the cap of the telephone receiver should be facing

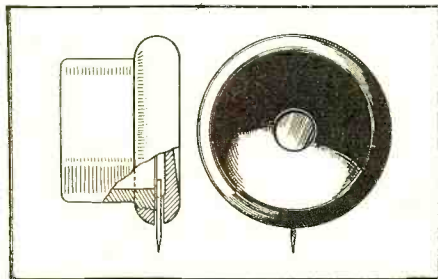

Figure 1

out from the tone arm opening.

The leads from the receiver may be connected to the radio in the same manner as any other pick-up unit, and the phonograph can then be run as usual. Another diaphragm can be used instead of the original and then the headphone is in no way injured for its original use.

When used with a good radio, the all-round results are excellent. One is now in use in the writer's home.

H. L. NICOLL,
Battleford, Sask., Canada.

A Home-Made Pentode Adapter

In a set using a four-prong output tube, a pentode may be used by means of an adapter. This adapter is made by using the base of a four-prong tube and a five-prong subpanel type socket which fits within (or may be rested on top of) the base. The base of the tube is removed by applying a hot soldering iron to each of the prongs in turn and flicking the

solder from the prongs; the glass bulb may then be removed by twisting.

Five wires are attached to the screws of the socket, the cathode wire being drawn through a hole drilled through the side of the base. The other wires are skinned and placed in the corresponding prong of the tube base. These wires are then pulled taut and soldered. The ends are then cut off in such a way as not to project beyond the side of the prong, as this will prevent the prong from entering the amplifier tube socket opening.

The cathode wire is connected to the B+ side of the output transformer.

WILLIAM WAGNER,
Cincinnati, Ohio.

1250 Miles with a Crystal Detector

Here is the layout of my crystal receiver (Figure 2), which I believe beats Mr. Lawrence Fesler's receiver, which was described in the September issue of RADIO NEWS.

My set cost only 90c for parts, but that it is capable of good results is shown by the following list of 13 stations re-

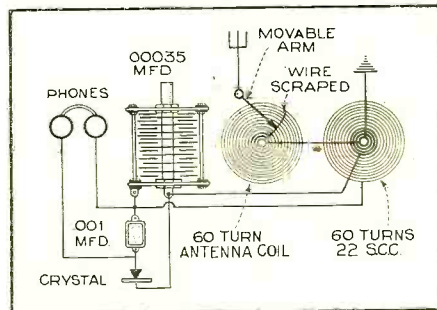

Figure 2

ceived, as compared with the 13 stations received by Mr. Fesler.

Mr. Fesler's Log

		Miles
Sioux City	KSCJ	6
Omaha	WOW	95
Cincinnati	WLW	650
St. Louis	KMOX	410
Cleveland	WTAM	745
Chicago	WMAQ	435
Minneapolis	WCCO	280
Vermilion	KUSD	10
Yankton	WNAX	20
Omaha	WAAW	95
Chicago	WFNR	435
Dallas	WFAA	675
Chicago	WENR	435

Average mileage 330

My Log

		Miles
Bismarck	KFYR	6
Mandan	KGCU	6
St. Paul	KSTP	470
Denver	KOA	525
Minneapolis	WCCO	460
Dallas	WFAA	1000
Chicago	WENR	715
Cincinnati	WLW	975
Cleveland	WTAM	1000
St. Louis	KMOX	775
Chicago	WBBM	715
Superior	WEBC	400
Los Angeles	KFI	1250

Average mileage 638

The coils I use are of the spider web type, wound on forms having 13 prongs. As indicated in the diagram, one of them is an antenna loading coil. This is equipped with a slider. The other coil is the antenna-coupling coil, consisting of primary and secondary windings. The secondary is tuned by means of a .00035 variable condenser. The number of turns for each coil is shown in the diagram.

On our local station, KFVYR, this set makes the programs audible on a loud-speaker.

HOWARD BYRNE,
Bismarck, North Dakota.

Simple Static Reducer

In searching for a way to get through the tremendous static disturbances that hamper radio reception in the tropics, I found that grounding the free end of a

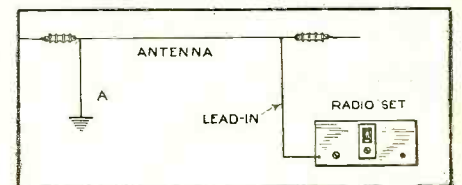

Figure 3

receiving antenna, as shown at A, Figure 3, eliminates considerable static while strength and steadiness of reception are notably increased.

Where formerly a good conventionally insulated antenna was required to get any decent reception, now a comparatively small indoor aerial under a sheet-iron roof brings in stations much better with less disturbances. This class of aerial eliminates the need of a lightning arrester and an antenna insulator which in these hard times amounts to something in itself.

Let's hear results from other radio enthusiasts who try this stunt.

CHARLES UNTERBERG,
Cristobal, Canal Zone.

Increasing Sensitivity of Neutrodyne

Here (Figure 4) is a simple and effective method of utilizing regeneration in a neutralized set. It is easily applied to any such radio, as the only connection to be changed is the lead from the by-pass condenser to the cathode of the detector tube.

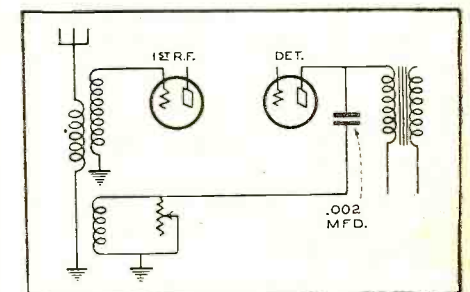

Figure 4

Obtain a cardboard tube a trifle smaller than the antenna coil of the set, some No. 28 or 30 wire, and a rheostat 0-1500 ohms. Wind 5-10 turns on the tube in the same direction as the antenna coil and bring out two long leads. Slip the coil into the filament end of the antenna

coil. Connect the inner lead to the wire from the condenser, following the diagram, and the lower end to the cathode or grounded shield. The rheostat is shunted across the coil.

For success the set should steam at low frequencies with the rheostat all in, and at high frequencies with the rheostat shorted out. This condition can be achieved by varying the number of turns and the degree of coupling. It is necessary that the coupling be as loose as possible in order to minimize the detuning effect of the added coil. If the detuning effect is large, the sensitivity will be diminished.

The position of the rheostat is not critical nor is its adjustment. The volume control knob may be removed and the rheostat substituted. An external volume control may be substituted.

SAMUEL EIDENSOHN,
Bronx, New York City.

Multipliers for A.C. Voltmeters

Multipliers for a.c. meters seem to puzzle many of our readers if one may judge by the number of inquiries on the subject.

An a.c. voltmeter may have its range extended by placing a resistance in series with it just as with a d.c. voltmeter. The resistance however must be non-inductive. The difference in resistance due to skin effect is so small at 60 cycles that it can be neglected.

For a small extension of the scale of a 60 cycle a.c. meter the resistance method is best, but if one wants to multiply the scale by ten or more it is more economical to do it with condensers. For a.c. frequencies over 60 cycles the condenser method is used exclusively.

A condenser offers a reactance to an alternating current of $1/2\pi fC$ ohms. It is our problem to figure out how large a condenser we need to make the total impedance of the circuit n times as large as that of the meter alone when n is the desired scale multiplication factor. The only difficulty is that the capacitive reactance and the meter resistance cannot be added arithmetically, but must be added vectorially because the current in the condenser is 90 degrees out of phase with that in the meter itself.

Take as an example the Jewell voltmeter pattern 78 of 0-5 volts. We should like to extend this meter to 150 volts. The multiplication factor, n , is then 30. In the Jewell catalog we find the meter resistance is approximately 50 ohms. The total impedance wanted in this circuit is 1500 ohms.

$$Z = \sqrt{r^2 + X_c^2}$$

$$1500 = \sqrt{2500 + X_c^2}$$

Solving for X_c :

$$X_c = \sqrt{2,250,000 - 2500} = \sqrt{2247500} = 1499 \text{ ohms.}$$

In these expressions Z is the total impedance of the meter circuit; X_c is the reactance of the condenser and r is the resistance of the voltmeter.

The required capacity for the condenser can now be obtained from the formula given above. It will be found to be 1.73 mfd.

In most cases the capacity will be found an odd value. The thing to do is to take the nearest capacity value available, in this case 1.75 mfd.

As a check we shall now calculate the value of this capacity as a multiplier. The condenser of 1.75 mfd. has a reactance of 1515 ohms at sixty cycles; adding to this the meter resistance, *vectorially*, we find the impedance to be 1516 ohms. Dividing by the meter resistance the multiplication factor is found to be 30.3.

J. VAN LIENDEN,
New York City.

More Data on the Low-Reading Ohmmeter

In this department last month a method was described by the author for the accurate relative measurement of low resistances. We shall now show how this hook-up can be calibrated without the needs of standards of any kind.

In the circuit of Figure 5 (a) is shown a milliammeter in series with a rheostat R and a dry cell. When we adjust this

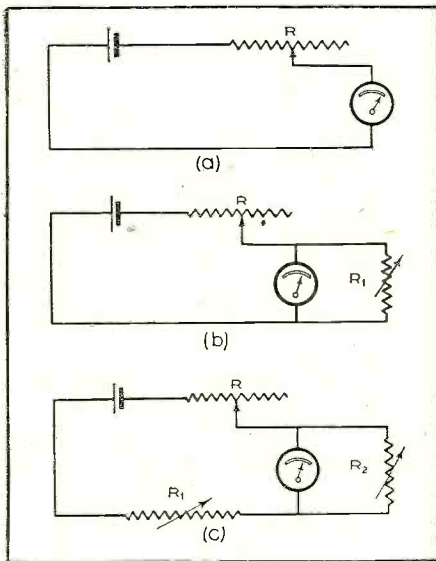

Figure 5

rheostat until the meter shows full-scale deflection, which means then that there is one ma. flowing in the circuit, and we have measured the voltage of the cell, the total resistance can be figured out with Ohm's Law. This is the resistance of the rheostat, the meter and the cell combined.

The circuit is now broken and an unknown resistance is inserted, in series. The current is read and the total resistance can again be calculated with Ohm's Law. The difference between this value and the one found before is equal to the unknown resistance. This one has now become one of our standards.

After the value of this unknown resistance has been so obtained, we take it out and the milliammeter will again show full deflection. Now, if this resistor is connected across the meter the current will come down. The current can now be noted and, knowing the value of the resistor, gives us the first point of the calibration curve. Other resistances can then be taken and their values determined as in the case of this one, giving us additional calibration points.

In practice it is really necessary to obtain only one value, and that is the resistance of the meter. When we once have that, the entire curve can be calculated.

In order to measure the meter resistance it is shunted with a variable resistance, R_1 , Figure 5 (b), which is adjusted until the meter shows half the current it gave when it was not shunted. This means that the current divides equally between the two paths and therefore the resistance must be the same.

The resistance of R_1 should now be determined by placing it in series with the meter in the way described above. It will, however, be found that the difference in current is so small that it can hardly be observed. The way to overcome this difficulty is to temporarily make our 0-1 ma. meter an 0-10 ma. meter.

To do this the resistance R_1 is taken away—but do not change the setting of it—and replaced by a third rheostat R_2 . The latter is adjusted until the meter reads one-tenth of the original current. The rheostat R_2 is now the temporary multiplier shunt. The rheostat, R , is again adjusted for full-scale deflection, making the total current in the circuit 10 milliamperes. The total resistance is then $E/.010$ ohms, where E is the battery voltage.

Breaking this circuit and putting R_1 in it [as in Figure 5 (c)] gives us another current value. The total resistance is then obtained by Ohm's Law and the difference between this and $E/.010$ is the meter resistance.

Changing the hook-up again to that in (a), the value of any unknown resistor across the meter is equal to

$$\frac{r}{I - i}$$

ohms

where r is the meter resistance
 I is the current at full deflection
 i is the current observed when r shunts the meter

In this case, resistances down to 1/10 the meter resistance can be accurately measured.

For lower ranges, R_2 can be put across the meter, as mentioned before, and the unknown be put across the combination. Then, if R_2 multiplies the readings by 10, this combination now has 1/10 of the meter resistance and this is the value to be substituted for r in the above formula. With this shunt it is possible to measure resistances down to 1/100 of the meter resistance, or even lower.

One word about accuracy. The assumption that when we shunt the meter the total current remains the same has been used here. This is not exactly true. For shunting a resistor with another makes the total resistance smaller and consequently the current becomes greater. However, the maximum error so introduced is only 2 percent. This error will be reduced to 2/3 percent if we use a 4½-volt battery and a rheostat, R , of 5000 ohms.

JOHN M. BORST,
New York City.

Rejuvenating Phonograph Pick-Ups

Like the deterioration of tubes, the symptoms of the disease were very gradual and insidious, but finally it was indubitably apparent that although the radio (tuner), the amplifier and the speaker were working as usual, the phonograph records were weak, the bass notes espe-

(Continued on page 633)



Radio Science Abstracts

Radio engineers, laboratory and research workers will find this department helpful in reviewing important current radio literature, technical books and Institute and Club proceedings

Radio Frequency Electrical Measurements, by Hugh A. Brown. Published by McGraw-Hill Book Company, Inc. This is an example of a book that fills a definite and essential need. For a long time there has been required a book that would cover quite completely all types of radio-frequency measurements, that would bring together the wealth of material on the subject which has been published, and correlate and organize it so that an engineer desiring to make some particular measurement could readily find ways of doing it.

The author follows the same general treatment throughout the text. First the theory and principles are derived and explained. Then follows a brief description of the necessary steps in the laboratory procedure, and finally there is given a discussion of the precision obtainable, precautions, and general merits of the method. The book is divided into ten chapters and an appendix. The chapter headings, which are as follows, give a good idea of the scope of the text: Measurement of Capacity; Measurement of Inductance; Measurement of Resistance; Measurement of Frequency; Antenna Measurements; Electromagnetic Wave Measurements; Thermionic Tube Coefficients; Electromotive Force, Current, Power; Measurement of Wave Form; Transmitter, Receiver and Piezo Electric Measurements. In all cases the number of different methods are described together with their advantages and disadvantages.

This is a book which we feel will prove a useful addition to the library of any engineer or student. It contains information gleaned from many periodicals both here and abroad and undoubtedly contains much measurement data which might otherwise not come to the attention of the engineer.

Television, by Edgar H. Felix. Published by McGraw-Hill Book Company, Inc. Here we have a book on television which aims to set down, without ballyhoo, its existing status and future possibilities. The book is commendable because of its frankness since all too many books on this subject have contained an over-abundance of optimism. The author states in the preface that he feels a conservative attitude is particularly helpful

Conducted by Howard Rhodes

at this time because television has been treated to an excess of premature and unwarrantedly hopeful publicity.

The text of the book deals in considerable detail with the various television systems, methods of scanning, light sensitive elements, transmission and reception, synchronization, and other problems that must be brought to a satisfactory conclusion before television can hope to become commercially practical. The latter chapters of the book consider television from a program angle, its commercial possibilities and factors which must be considered in establishing a television entertainment service.

We feel this book to be a sincere effort to describe the existing status of the art and the improvements which must be made before it will have any real program value. It should do much to bring television "down to earth."

Review of Articles appearing in the November, 1931, issue of the Proceedings of the Institute of Radio Engineers

Development of a Circuit for Measuring the Negative Resistance of Pliodiatrons, by Edward N. Dingley, Jr. The author describes a simplified test circuit, an adaptation of the Wheatstone bridge, which can be used to measure the negative resistance of a dynatron. The method gives accurate results and eliminates the laborious task of plotting Ep-Ip curves and calculating the negative slope over the operating range.

The Use of Rochelle Salt Crystals for Electrical Reproducers and Microphones, by C. Baldwin Sawyer. It has been known for a long time that rochelle salt crystals exhibited marked piezo-electric effects which made it possible, theoretically at least, to utilize them in loudspeakers and microphones. This article describes practical methods of producing such crystals and gives actual data on their use. The authors list their advan-

tages as: cheapness and simplicity, long life and freedom from fatigue, flexibility, the ability to generate large voltages for given acoustic pressures, a large force of vibrational displacement permitting the use of heavy cones and diaphragms, freedom from the necessity of exciting current, permanent magnets or polarizing voltage.

The Adjustment of the Multivibrator for Frequency Division, by Victor J. Andrew. In a multivibrator controlled by a voltage of another frequency bearing a harmonic relationship to the multivibrator frequency, the effect of varying the control voltage is analyzed, and a method for determining the best value of this voltage is described. Methods of coupling the control voltage are shown in which frequency division by an odd integer will occur more readily than by an even integer, and vice versa.

Methods for Measuring Interfering Noises, by Lloyd Espenschied. A number of different methods for measuring interference are described. Some of the methods apply to the measurement of static and other types of radio interference and other methods apply to measurements of ordinary acoustical disturbances. This article simply gives a resume of the various methods without going into detail regarding the characteristics of any particular unit.

The Broadcasting Installations in the New "House of Radio", by Gunther Lubzynski and Kurt Hoffman. This article is a description of the broadcasting equipment installed in the new "House of Radio" at Berlin-Charlottenburg, Masurenallee. The article includes photographs of the various studios and control rooms together with circuit diagrams of the amplifiers, wire line systems, etc.

Vacuum Tubes as High-Frequency Oscillators, by E. D. McArthur and E. E. Spitzer. The problem of tubes for generating power at wavelengths below five meters is discussed. The theory of the triode and split-anode magnetron is considered with particular reference to the limitations imposed by opera-

tion at short wavelengths. Essential data are given for examples of each type of tube, showing the power that can be obtained at various wavelengths.

Review of Contemporary Periodical Literature

Radio Frequencies—Their Characteristics. Electronics, September, 1931. A page chart in color covering the frequency spectrum from 10 to 4,000,000 kilocycles and indicating the type of service to which the various frequency bands are being placed. The part of the chart dealing with the extremely high frequencies is especially interesting since it records the experimental work being carried out between 100 and 400 megacycles in which range the transmissions exhibit altogether different characteristics than they do at other frequencies.

Interference from Shared-Frequency Broadcasting, by C. B. Aiken. Electronics, September, 1931. An excellent discussion of the effects which occur when two transmitting stations operate simultaneously on the same frequency assignment, but whose carriers actually differ by a few cycles. The author points out that the receiver tuned to the transmission will receive both carriers and their sidebands and as a result there will be interaction between the two carriers and the four groups of sidebands. The strongest interference generated is due to the beating of the two carriers. Due to the modulation between the desired carrier and the undesired sidebands there will be produced sounds highly distorted and extremely displeasing. The author concludes that shared-frequency broadcasting should be restricted to widely separated stations.

The Calibration of Microphones, by Harry F. Olson and Stanford Goldman. Electronics, September, 1931. This article deals with the problems of calibrating condenser microphones over the range of 40 to 10,000 cycles. In such calibrations the desired data is the volts output of the microphone for a given sound pressure in free space at the microphone. The Rayleigh disc affords a method of determining the sound intensity, but has the disadvantage that when the disc is used in a free space the accuracy is impaired due to the sensitivity of the disc to small air currents. For low frequencies even a well damped room is objectionable because of standing waves. The authors have overcome these problems by designing an acoustic transmission system which is equivalent to an infinite non-dissipated line. The diagram of this acoustic system is shown in Figure 1. As indicated, one end of the tube termi-

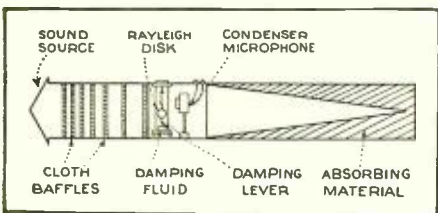

nates in the sound source. The sound is propagated through several cloth baffles and finally reaches the Rayleigh disk and after it the condenser microphone under test. After the sound passes the microphone it is gradually absorbed without reflection by increasing thicknesses of felt. Having once obtained the absolute calibration of a microphone and its associated amplifier the absolute calibration of others may be obtained by comparison with it.

Ghost Images, by U. A. Sanabria. Radio Industries, September, 1931. The author recounts a number of his experiences in connection with the transmission and reception

of television images on various frequencies and at various distances from the transmitter. Due to reflections of the transmitted wave, the receiver frequently shows not one but several images, the extraneous images being referred to usually as "Ghost images".

Acoustics of a Flexible Space Theatre, by Carl W. Meyers. Motion Picture Projectionist, September, 1931. This article by the staff acoustical engineer of the Johns-Manville Corporation describes a series of acoustical analyses to determine the nature and extent of the acoustical treatment which will be required in the proposed Ukrainian National Theatre. The method used was to take a light source and place it at the point where the sound source would normally be and then take photographs of various sections of the theatre to record the manner in which the light is reflected or concentrated at various points. This method is based on the work of R. F. Norris of the Burgess Laboratories, who has determined that light and sound follow essentially the same characteristics.

On Interference, by Professor Absalon Larson. Elektrotechnik und Maschinenbau, Vienna, August 23, 1931. Translated by John M. Borst.

This is the publication of a paper, presented before the International Consultative Committee for Radio-Electrical Communications at Copenhagen.

The author traces the cause of interference of the "man-made static" type to sparks in electrical machinery. These cause an irregular wave to be propagated along the power line and it passes to the receiving set through the capacity between the power line and the lead-in. This is borne out by experiments.

He discusses circuits for the elimination of this effect and shows the applications to different types of apparatus. The general procedure is to enclose the offending appliance in a shield. Then, to insert induction coils of .0001 h. in each lead passing through the shield and connect condensers of .1 to 1 mfd. between each of these wires and the shield, where they pass through the latter. The connected wires are kept as short as possible.

The author further offers a series of experiments and the theory of shielded rooms with constructional details of one.

His theory shows that in order for the cage to be effective it will have to satisfy these three conditions: (1) All parts must be electrically connected together; (2) no holes large enough to allow lines of force to pass through and terminate on a metal object outside can be tolerated; (3) all conductors passing through the screen, including telephone, steampipe, lighting wires, etc., must be filtered as discussed above.

Research of the Apparent Electromotive Force of a Microphone Transmitter, by P. Massaut. L'Onde Electrique, Paris, July, 1931. Translated by John M. Borst.

In books on telephone transmission the microphone is treated as a generator of constant impedance, developing an electromotive force, independent of the conditions of the external circuit. The author derives a mathematical expression for this apparent electromotive force and finds that it contains a variable which depends on the impedance of the circuit wherein the microphone is connected.

This means that the generated e.m.f. will not be the same for the same microphone in different circuits, even if the direct current through it remains the same.

It follows that the different factors which govern the magnitude of the apparent e.m.f. have varying importance for different types of microphones. It is therefore not possible to compare the efficiency of two different types by putting them in the same circuit under the same conditions.

The author applies his expression to a simple case and discusses the results. Ways to reduce the distortion are: (1) reducing the volume of the voice; (2) increasing the external resistance; or (3) reducing the cross-section of the carbon charge (taking out some of the carbon). All these methods reduce the power.

The best method to increase the power without affecting the articulation is not by raising the voice, nor by coming closer to the microphone, but by increasing the direct current through it, within certain limits.

Audible Frequency Ranges of Music, Speech and Noise, by W. B. Snow. The Journal of the Acoustical Society of America, July, 1931. A thorough investigation into the frequency characteristics of musical instruments, voices and common noises. The results of the measurements are given in table form which is reproduced in Figure 2.

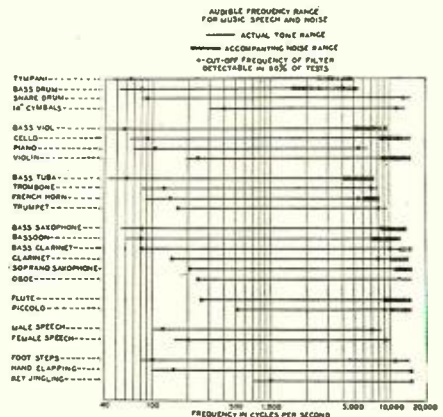

The data needs but little explanation. For example, the Tympani is shown to have a tone range from about 47 cycles up to 2400 plus an accompanying noise range that extends to 5000 cycles. The other curves can be similarly interpreted. To determine the importance of the various frequencies, low and high pass filters were employed and the two circles on each curve indicate the points at which eighty percent of the observers could detect a change in quality. From this chart many interesting conclusions can be drawn. For example, there are only three circles below 80 cycles so that a very slight change in quality would result if a reproduction system passed no frequency below 80 cycles. At the high frequency end there are many circles beyond the 9000 cycle point which indicates that for really good reproduction these high frequencies must be reproduced.

A Method of Calculating the Performance of Vacuum-tube Circuits Used for the Plate Detection of Radio Signals, by J. P. Woods. The University of Texas Bulletin No. 3114. This bulletin analyzes mathematically rather than experimentally the performance of detector tubes. It considers ideal detector circuits, large signal detection, and analyzes the detection characteristics of one tube of the type O1A. This tube is analyzed with respect to its sensitivity and distortion with various input voltages and various degrees of modulation. This type of tube is, of course, not used in modern sets as a detector, but the method of analysis can be applied equally well to other types of tubes.

The Wireless Alarm, by Dr. A. Ristow. Funkmagazin, Berlin, August, 1931. Translated by John M. Borst.

The author discusses the requirements for automatic alarm systems, both for collective and for individual calls.

One difficulty is in the first relay, employed in the plate circuit of a rectifier tube. The current needed to hold the relay closed is (Continued on page 635)

Latest Radio Patents

A description of the outstanding patented inventions on radio, television, acoustics and electronics as they are granted by the United States Patent Office. This information will be found a handy radio reference for inventors, engineers, set designers and production men in establishing the dates of record, as well as describing the important radio inventions

1,820,396. **ELECTRODE STRUCTURE.** FREDERICK S. McCULLOUGH, Edgewood, Pa., assignor to Stupakoff Laboratories, Inc., Pittsburgh, Pa., a Corporation. Filed Jan. 5, 1926. Serial No. 79,350. 8 Claims.

1. A cathode structure comprising a cylindrical metal shell open at at least one end having a plurality of spaced apart refractory discs therein in contact with the inner walls thereof and a heater wire in the form of a reentrant loop within the shell supported by the refractory discs out of contact with the metal shell, the terminals of the loop projecting from the open end of the cylinder.

1,820,137. **MAXIMUM RANGE RADIO LOUD SPEAKER.** WYLIE JAY HANNA, Bayside, N. Y. Filed Nov. 9, 1928. Serial No. 318,172. 32 Claims.

1. A device of the character described, including a speaker unit, a primary sounding medium of a light material operated by said unit to reproduce high notes and a secondary sounding medium of a heavier material connected to the primary sounding medium for reproduction of bass notes, said secondary sounding medium being divided into a plurality of areas, and means being provided to slightly deaden one of the said areas with respect to the other, for reproduction of the lowest notes.

1,819,469. **RADIO SYSTEM.** WILHELM KUMMERER, Berlin, Germany, assignor to Gesellschaft für Drahtlose Telegraphie m. b. H., Berlin, Germany, a Corporation of Germany. Filed Feb. 1, 1926. Serial No. 85,083, and in Germany Apr. 20, 1925. 3 Claims.

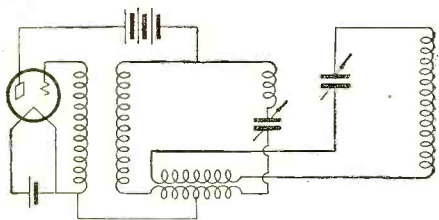

1. In a radio frequency system, a source of oscillations having a fundamental and harmonics existing therein, said source including a circuit tuned to the fundamental frequency having inductive and capacitive branches connected in parallel and connected to said source of oscillations, said inductive branch consisting of a coil and a portion of a coupling inductance connected in series, said capacitive branch consisting of a coil, a condenser and a second portion of a coupling inductance connected in series and a load circuit coupled to each of said coupling portions whereby the introduction of harmonic frequencies in said load circuit is substantially suppressed.

*Patent Attorney, National Press Building, Washington, D. C.

Conducted by Ben J. Chromy*

1,820,836. **ELECTRON DISCHARGE DEVICE** SALVATORE SCOGNAMILLO and PAUL ARNDT, New York, N. Y. Filed June 25, 1928. Serial No. 288,172. Renewed July 3, 1931. 4 Claims

1. An electron discharge device, including a cathode comprising a pair of metallic plates each having a channel in one of its faces adjacent to each of its ends and secured together face-to-face with their channels disposed opposite to one another and forming a pair of parallel chambers, and a filament having a pair of parallel portions extending, respectively, through said chambers.

1,821,032. **WAVE-SIGNALING SYSTEM.** JAMES ROBINSON, London, England. Filed Nov. 21, 1929, Serial No. 408,889, and in Great Britain Sept. 9, 1929. 33 Claims.

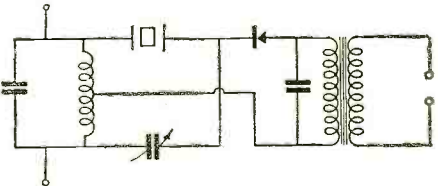

1. A wave signaling system including a transmitting station for transmitting a carrier wave modulated by a wanted signal, and a receiving station provided with selective receiving means, the selectivity of said means being such that there is no response to interfering signals whereof the carrier frequency of such interfering signals lies outside the resonance curve of said means, but differs from the frequency of the wanted carrier wave by an amount less than the highest modulation frequency of the wanted signal, whereby the relative amplitude of different modulation frequencies is altered, yet modulations of the carrier wave of the wanted signal corresponding to the whole of the required modulation range may be reproduced, and means at one of said stations for altering the relative amplitude of different modulation frequencies in the opposite sense.

1,825,232. **RADIO RECEIVING LOUD-SPEAKER.** WALTER H. HUTH and BYRON B. MINNTUM, Chicago, Ill., assignors to Story & Clark Radio Corp., Chicago, Ill., a Corporation of Delaware. Original application filed Oct. 9, 1928, Serial No. 311,399. Divided and this application filed Sept. 15, 1930. Serial No. 481,862. 6 Claims.

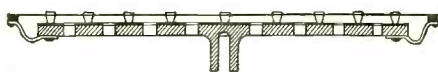

1. An electrostatic reproducer comprising a stationary member and a vibratory member disposed a distance apart, with a plurality of

yielding and resilient supports interposed between the two members, distributed over the opposing surfaces thereof, said members being adapted to be included in series in a reproducing circuit to cause audible action thereof by the vibration of said vibratory member.

1,821,442. **APPARATUS FOR PRODUCING LIGHT WAVES.** ORAN T. McILVAINE, East Cleveland, Ohio, assignor to McIlvaine Patent Corporation, St. Charles, Ill., a Corporation of Delaware. Filed Feb. 23, 1928. Serial No. 256,234. 9 Claims.

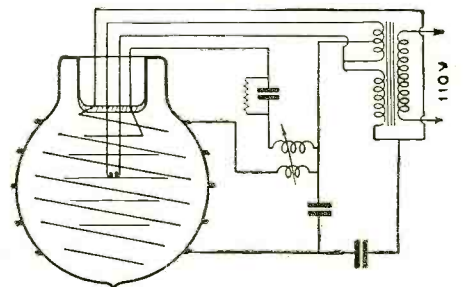

1. A source of light rays comprising a globe having therein an ionizable gas under low pressure, a filament, an anode and a control electrode surrounding said filament and made of a pattern to facilitate the emission of light rays, a source of current for said filament, high-frequency oscillating circuits including said filament and said anode and controlling electrode and connections establishing an external circuit between said filament and anode, said external circuit containing a source of e.m.f.

1,821,402. **ANTENNA.** HAROLD O. PETERSON, Riverhead, N. Y., assignor to Radio Corporation of America, a Corporation of Delaware. Filed Nov. 8, 1927. Serial No. 231,804. 17 Claims.

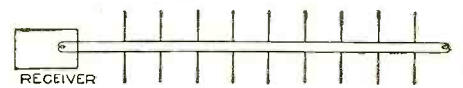

1. A directive receiving antenna for short waves comprising a pair of feeder members and a plurality of transverse pick-up wires coupled to the feeder members, said pick-up wires being substantially smaller than a half wave in length in order to detune them and to limit their effect on the velocity of energy transfer on the feeder members.

1,823,327. **SHIELDING FOR RADIO-FREQUENCY AMPLIFIERS.** WILLIAM A. MacDONALD, Little Neck, and FRED E. JOHNSTON, Flushing, N. Y., assignors to Hazeltine Corporation, Jersey City, N. J., a Corporation of Delaware. Filed Dec. 24, 1927. Serial No. 242,844. 16 Claims.

1. In an amplifier, a plurality of stages of radio-frequency amplification, each stage including a coupling coil, and an open-ended fixed tubular metallic shield encircling said

coil and effective to restrict the magnetic field thereof.

1,821,380. TRANSMITTING OR RECEIVING AERIAL SYSTEM FOR WIRELESS TELEGRAPHY OR TELEPHONY. CHARLES SAMUEL FRANKLIN, Buckhurst Hill, England, assignor to Radio Corporation of America, a Corporation of Delaware. Filed Feb. 17, 1926. Serial No. 88,761, and in Great Britain Feb. 24, 1925. Renewed Jan. 31, 1931. 17 Claims.

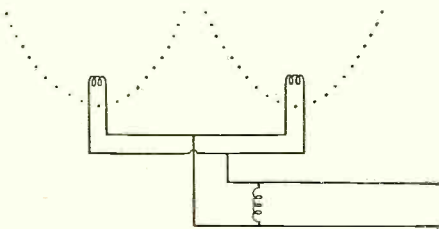

2. A directive aerial system comprising a plurality of parabolic reflectors arranged side by side, an aerial at the focus of each reflector, all of the focal aerials being maintained in the same phase so that the concentration of energy radiated is substantially proportional to the sum of the apertures of the reflectors.

1,821,698. LIGHT INDICATING SYSTEM AND METHOD. GERHARD R. FISHER, Palo Alto, Calif., assignor to Federal Telegraph Company, San Francisco, Calif., a Corporation of California. Filed July 13, 1927. Serial No. 205,343. 5 Claims.

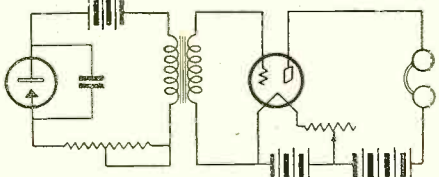

1. A method of operating a gas discharge tube having cold electrodes in order to detect variations in light intensity, the method being characterized by the use of an energizing circuit for the tube including a source of direct current, and a relatively high resistance in series with said source, said method comprising adjusting the values of the circuit so that substantially no oscillatory current flow occurs for a given light intensity falling on the tube, but so that oscillatory current flow occurs for a slightly decreased light intensity.

1,822,996. ELECTRICAL BALANCE CIRCUIT. CARLOS B. MIRICK, Washington, D. C., assignor, by mesne assignments, to Federal Telegraph Company, a Corporation of California. Filed Dec. 3, 1927. Serial No. 237,577. 7 Claims.

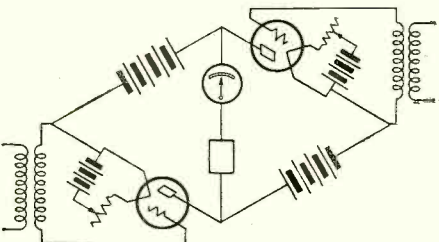

1. In a balanced circuit, the combination of a pair of vacuum tubes having filament-heating circuits, grid-filament and plate-filament circuits, an input coil disposed within each of the grid-filament circuits, the plate-filament portion of each vacuum tube forming a leg of a bridge circuit, a source of plate current power for each of said vacuum

tubes, each of said sources forming a leg of said bridge circuit and an indicating device connected between the plate electrodes of said vacuum tubes, said indicating device consisting of a relay.

1,821,496. RADIO AND SOUND REPRODUCING AND RECORDING DEVICE. DAVID G. COHEN, Brooklyn, N. Y. Filed Feb. 18, 1931. Serial No. 516,557. 3 Claims.

1. A device of the class described consisting of means for receiving radio broadcast sounds, an audio amplifier connected to said radio receiving means, a microphone also connected to said amplifier, and a recording device and a loudspeaker connected to the output of the amplifier.

1,824,777. PIEZO ELECTRIC CRYSTAL SYSTEM. JAMISON R. HARRISON, Pittsburgh, Pa., assigned to Wired Radio, Inc., New York, N. Y., a Corporation of Delaware. Filed Oct. 15, 1929. Serial No. 399,738. 7 Claims.

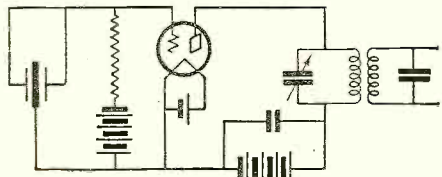

2. In a piezo electric crystal system, a source of electrical potentials, a piezo electric crystal element cut to have two faces, the planes of which are parallel to the X axis and perpendicular to the Y axis of said element, and means for utilizing potentials from said source to produce fields of like sign on both of the faces of said element and of like sign simultaneously on all of the sides of said element, the latter fields being of different sign from the fields produced on the faces of said crystals.

1,822,057. METHOD FOR RECORDING PHOTOGRAPHIC SOUND RECORDS. FREEMAN H. OWENS, New York, N. Y. Filed Sept. 17, 1928. Serial No. 306,496. 8 Claims.

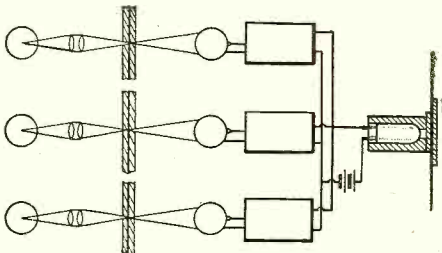

1. The method of making a composite photographic sound record comprising the steps of synchronously converting a plurality of photographic sound records into electric impulses, combining said impulses, modulating the intensity of a single recording lamp by said combined impulses, and photographing the modulated light rays from said lamp on a sensitized film.

1,823,794. WIRELESS TRANSMISSION SYSTEM. ABRAHAM ESAU, Jena, Germany. Filed Oct. 25, 1927, Serial No. 228,528, and in Germany Oct. 29, 1926. 4 Claims.



1. The method of transmitting and receiving radio signals which consists in simulta-

neously transmitting separate signals by differently polarized waves of substantially horizontal polarization and separately receiving and coordinating such waves.

1,821,780. LOCAL-DISTANT SWITCH FOR SUPERHETERODYNE RECEIVERS. HORACE C. ALLEN, Merchantville, N. J., assignor to General Electric Company, a Corporation of New York. Filed Oct. 7, 1930. Serial No. 487,049. 8 Claims.

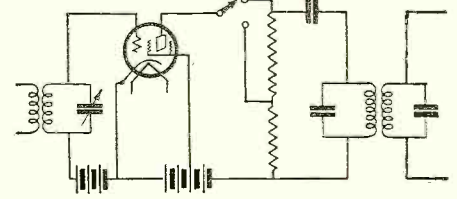

1. In a superheterodyne receiving apparatus, the combination of a signal detector having an output circuit, an amplifier coupling device connected with said output circuit, said coupling device having a predetermined frequency response characteristic, switching means connected between said output circuit and the coupling device for changing the energy transfer from said output circuit to said device, and means arranged to be connected in circuit with said coupling device and said output circuit by said switching means for preventing a change in the frequency response characteristic of said coupling device when said switching means is operated.

1,824,819. ELECTRICAL FILTER. HARRY W. HOUCK, Mount Vernon, N. Y., assignor to Dubilier Condenser Corporation, New York, N. Y., a Corporation of Delaware. Filed May 17, 1926. Serial No. 109,500. 3 Claims.

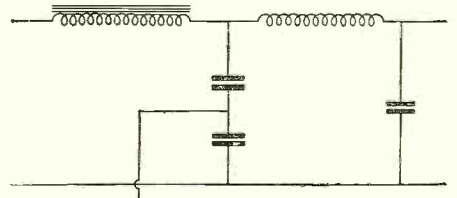

1. An interference eliminator for connection between radio receiving apparatus and a source of power supply, comprising a series-connected choke coil for suppressing low-frequency disturbances, a series-connected high-frequency choke coil, and condensers connected in circuit with the high-frequency choke to form an oscillatory circuit for preventing the passing of radio-frequency disturbances.

1,821,906. ART OF RADIO SIGNALING. LOUIS COHEN, Washington, D. C. Filed Feb. 27, 1930. Serial No. 431,929. 20 Claims.

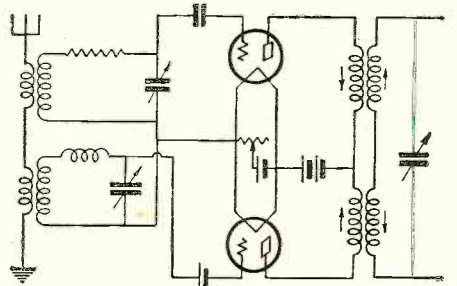

1. The method of selective signaling which comprises impressing the signal energy on (Continued on page 620)

Backstage in Broadcasting

Chatty bits of news on what is happening before the microphone. Personal interviews with broadcast artists and executives. Trends and developments in studio technique

EDDIE CANTOR, wide-eyed singing comedian of the stage and screen who from time to time was heard on the air as a guest artist, recently joined the ranks of full-fledged radio stars when he was co-featured with Rubinoff, noted violinist, on the weekly Chase and Sanborn hour of the NBC. Eddie brought a unique type of microphone personality into the studio and immediately won the favor of all studio folk. Before each program goes on the air, Eddie cuts comic capers in the studio for the edification of the assembled visitors and musicians. Before the microphone, his gestures and

ocular mannerisms make it difficult for studio visitors to refrain from prohibited laughter. Between turns, he hoots all about the studio and one doesn't know what he'll do next. In all, Eddie has won the hearts of the studio folk as well as listeners.



Eddie Cantor

THE National Advisory Council on Radio in Education, following the lines of development discussed at its convention in New York last spring, is sponsoring a series of radio lectures on economics and psychology Saturday evenings over a coast-to-coast NBC hook-up. The University of Chicago Press is publishing supplementary material to aid radio listeners. At the completion of thirty lectures in each subject, complete transcriptions may be offered to the public in book form. The earlier weeks of the series brought to the chain's microphones such well-known educators as James R. Angell, president of Yale University; Edward S. Robinson, professor of psychology, Yale University; Gardner Murphy, professor of psychology, Columbia University, and Leta S. Hollingworth, professor of education, Teachers College, Columbia University. Levering Tyson, director of the advisory council, and John W. Elwood, NBC vice-president, are supervising the presentations.

IN past years NBC engineers were forced to cope with the problem of multiple microphone placement at the broadcasts of the Chicago Civic Opera Company. The Chicago company claims to be the first organization of its kind to broadcast direct from a theatre stage, the first



By
Samuel Kaufman

program going on the air six years ago. Fifteen separate microphones were utilized to pick up the first season's programs. The following year eighteen microphones were used. This season's offerings from the huge Civic Opera Theatre are picked up by but two or three parabolic reflector microphones. Each of the directional pick-up devices is situated in the balcony and is focused on the singers and musicians. The world-famed troupe's roster includes Charles Hackett, Richard Bonelli, Rosa Raisa, Tito Schipa and numerous others long experienced in radio broadcasting.

THE Columbia Broadcasting System for three years in a row has won the distinction of having one of its fair artists awarded the title of "most beautiful radio artist in America." Harriet Lee, the tall, blonde songster of WABC, emerged as the successful artist in the 1931 contest. In 1929, Olive Shea, of WABC, captured the award, while in 1930 the victor was Bernadine Hayes, of WBBM, a Chicago CBS outlet. Harriet hails from Chicago, where she worked in a music shop by day and attended the



Chas. Hackett



Harriet Lee

Chicago College of Music at night. An audition brought her many radio engagements in the mid-West. She soon came

to New York and her deep contralto voice soon won her a berth on the CBS staff. Since winning the title of "Miss Radio, 1931," Harriet has entered the talkies, being starred in musical shorts.

DESPITE the great distances covered by Phillips H. Lord ("Seth Parker") and his cast of NBC actors on the ten weeks' tour of the nation which ended in December, they were heard regularly each week on their Sunday night program.

The personal appearance tour carried them to twenty-three states and two Canadian provinces. The Sunday night gatherings of Seth Parker and his neighbors were picked up from associated network stations in Cleveland, Chicago and Los Angeles. Effie Palmer, Agnes Moorehead, Bennett Kilpack, Raymond Hunter, Carlton Bowman, Norman Price, Ruth Bodell, James Black and Gertrude Forster were the cast members accompanying Lord on his tour.



Phillips H. Lord

THINGS have certainly been breaking for the Boswell Sisters since they arrived in New York less than a year ago. The trio of New Orleans belles gained a wide following on the NBC which they retained when they switched to the CBS. Their radio success brought a long vaudeville contract, and they continued broadcasting from whatever town theatrical contracts carried them to. The peak of their careers was reached last Fall when they were co-starred at the Palace Theatre in New York with Morton Downey and simultaneously launched the thrice-weekly Baker Chocolate Company periods on the CBS.

COLUMBIA Broadcasting System Engineers have been conducting extensive experiments on scenic backgrounds for the television presentations of W2XAB, the chain's experimental visual transmitter in New York. It was planned to have twenty-four miniature stage sets mounted in a wooden box a foot long and four inches deep. Each setting would be two inches high. Life images coming from the scanner would then be superimposed

(Continued on page 636)

What's New in Radio

A department devoted to the description of the latest developments in radio equipment. Radio servicemen, experimenters, dealers and set builders will find these items of service in conducting their work

Midget Receiver

Description—A seven-tube midget superheterodyne receiver employing two -24 type tubes, one -27 type tube, two -35 type tubes, one -47 pentode type tube and one -80 rectifier tube. The receiver chassis and a mid-



get super dynamic speaker are housed in a matched butt walnut cabinet.

Makers—All-American Mohawk Corp., North Tonawanda, N. Y.

Combination Volume Control and Power Switch

Description—A new type of wire wound volume-control with a built-in power line switch, which is approved by the Underwriters' Laboratory for 1 ampere at 250 volts or 3 amperes at 125 volts. This compact dual control is especially adapted for use in midget and automobile receivers and for sets

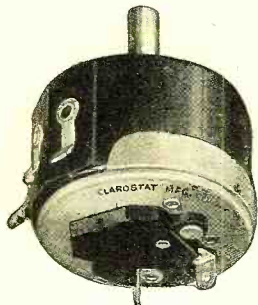

where space is at a premium. They are enclosed in a bakelite casing with metal end caps and are made for one hole mounting. The outside diameter measures 1 5/8 inch and the depth is 1 1/8 inch. The volume control is obtainable in any resistance combination.

Makers—The Clarostat Manufacturing Co., Inc., 285 No. Sixth Street, Brooklyn, N. Y.

Compact Relay

Description—This midget relay, measuring only 2 3/4 inches by 1 7/8 inches, is adapted to many industrial purposes, such as instrument devices and signal systems, and for

Conducted by The Technical Staff

radio receivers employing remote control and automatic tuning. This relay is made in eight different contact arrangements. The

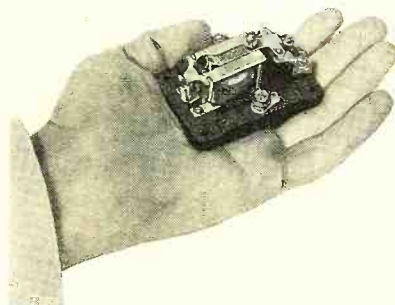

constructional features of the relay are: Form-wound, moisture-proof coils; renewable silver contacts and a moulded base. The contacts are capable of handling up to 5 amperes of current and the coils are available for voltages from 6 to 120 volts, 60 cycles a.c. or 24 volts d.c.

Makers—Struthers Dunn, Inc., 139 No. Juniper St., Philadelphia, Pa.

Tube Tester

Description—A tube tester of sturdy construction measuring twenty-eight inches long by thirty inches high, provided with sockets

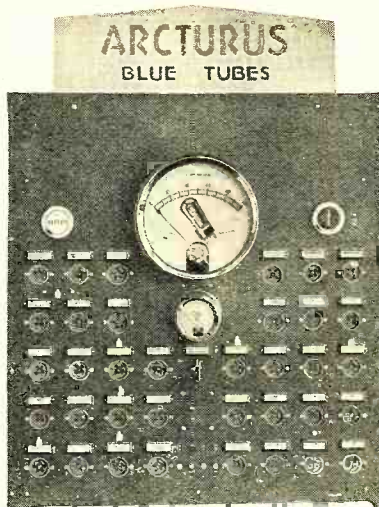

to take practically every standard type tube. All measurement readings are made on a single large meter with a nine-inch face, which is readable from a distance of ten feet. Cards above each tube socket indicate correct reading limits for the tube under test. Spare sockets are included and may be wired in for new type vacuum tubes that may appear in the future. This instrument can test for open circuits, short circuits, plate current and emission.

Makers—Arcturus Radio Tube Company, 255 Sherman Ave., Newark, N. J.

Midget Receiver

Description—A superheterodyne mantel type set featuring automatic volume control, tone blender and spotlight dialing. The following tubes are employed: Two -35 type, two -24 type, one -27 type, one -47 pentode



type and one -80 type rectifying tube. The cabinet dimensions are 17 3/8 inches high by 16 inches wide by 11 1/4 inches deep. The model 7A is designed to operate from 110 volt 60 cycle a.c., and the model 7AX from 110 volt 25 cycle a.c.

Makers—United States Radio & Television Corp., 360 N. Michigan Ave., Chicago, Ill.

Pentode Output Transformers

Description—A new series of three audio-amplifying output transformers, with center tapped primary, designed to match the impedance of two -47 pentode type tubes to various loads. The secondary impedance values for type numbers 6150, 6152 and 6200 are respectively: 500 ohms (line), 4000 ohms



(magnetic speaker) and 15 ohms (electrodynamic speaker).

Maker—American Transformer Company, 178 Emmet Street, Newark, N. J.

Tuning Dials

Description—The new line of DeJur-Amsco tuning accessories, comprising dials, dial lights and escutcheon plates include approximately 100 different types of dials, thereby meeting practically every radio receiver tuning dial requirement. The six general designs are as follows: Full vision, as shown in the accompanying illustration, sector vision, sector vision bevel, direct drive, direct drive bevel and large direct drive. The dials

are available in either one hundred divisions or kilocycle graduations and in tan or white scales. The escutcheon plates can be sup-

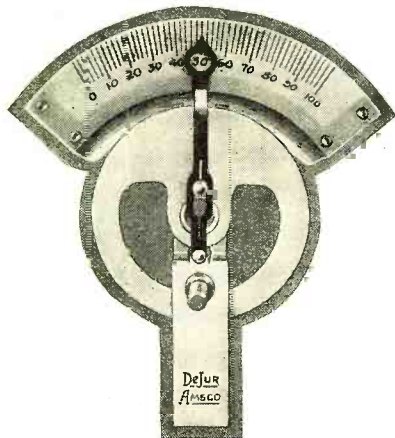

plied in a wide variety of patterns.
Maker—DeJur-Amsco Corp., 95 Morton Street, New York City.

Set Analyzer

Description—A compact portable set tester, featuring non-shatterable meter glasses, triple range ohmmeter, triple range rectifier type output meter, 24 measuring ranges available at quick connection pin-jacks for use with outside test leads and an 0-4-8 ampere a.c. meter range for servicing electric refrigerators and other electric home appliances.



This instrument performs all service tests on radio receivers, including sets employing the multi-mu and pentode type tubes.

Maker—Jewell Electrical Instrument Co., 1462 N. Walnut St., Chicago, Ill.

Tube Sockets for Transmitters

Description—The model 131A tube socket

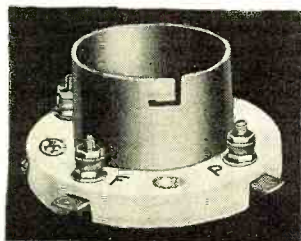

is designed to fit the standard 50 watt transmitter tube base such as type -03A, -11, -45 and -72. The mounting base is heavy glazed Isolantite, and the metal parts are nickel plated. The phosphor bronze contact springs

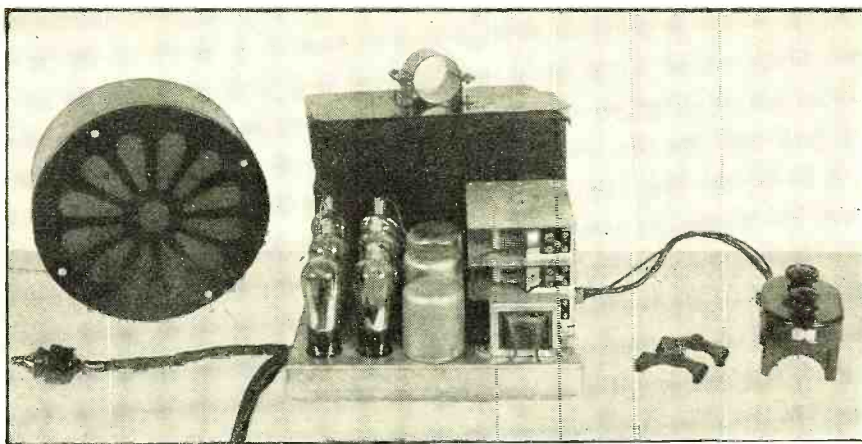

Automobile Radio Receiver

Description—The Marquette automobile receiver employs the newly developed automobile tubes, three -36 screen grid type tubes, one -37 type tube and two -38 pentode type tubes. This is a complete outfit including suppression resistors and condensers, Magnavox dynamic speaker, remote control and antenna equipment. The receiver and the remote control are clamped to the

steering column. The clamping arrangement of the receiver box is so designed that it is adaptable to any make of car. Three holes are only required for the installation, two holes for the antenna device and one hole for mounting the speaker.

Maker—Marquette Radio, Inc., 110 West 18th St., New York City.

are made in one piece and provide both a sidewise and bottom contact. The base diameter of the socket is 3 3/8 inches.

Makers—Radio Engineering Laboratories, Inc., Long Island City, N. Y.

Light-Sensitive Cell

Description—The "Light-O-Stat" light-sensitive unit can be adapted to many industrial applications such as counting moving objects, safety devices and burglar or fire alarm systems. These units fit a standard 4-prong tube socket. Depending upon the requirements of the circuit and intensity of illumination, the potential may be as low as 1.5 volts or as high as 45 volts. These light-sensitive units are available in six different resistance ranges and are produced in two sizes, type "A," 1/2 inch by 1/2 inch sensitive area, diameter 1 3/16 inches, height 1 7/16 inches; type "B," 3/4 inch by 3/4 inch sensitive area, diameter 1 7/16 inches, height 1 3/4 inches.

Maker—Photo-Electric Laboratories, Lansing, Michigan.

Mutual Conductance Meter

Description—A direct reading instrument for the measurement of the mutual conductance of all types of vacuum tubes having an amplification factor between 3.5 and



42, and of all screen-grid type tubes. This instrument is of the copper oxide rectifier

type and the 7 1/4 inch diameter case is designed for flush mounting. An external compensator mounted in a box measuring 7 inches by 3 1/2 inches is supplied with the meter.

Makers—Weston Electrical Instrument Corporation, Newark, N. J.

Tube Tester

Description—A direct reading tube tester especially designed so the prospective cus-



tomers can read with complete understanding the condition of his vacuum tubes. The instrument is a.c. operated and a separate tube socket is provided for each type of tube. The large meter scale is divided in the following three sections: good, weak and poor. Tests are made for quality, shorts and opens. The cabinet measures 17 inches by 9 inches and the back panel is twelve inches high.

Makers—The Radio Products Company, Dayton, Ohio.

Home Demonstration Aerial

Description—The "Quick-Set" aerial is designed for the serviceman or radio salesman
(Continued on page 639)

News and Comment

A page for the news of the whole radio industry, including important trade developments, new patent situations, comments by leading radio executives, notes, rumors and opinions

Unique Film Contract

NEW YORK—Having agreed to recognize the sound track of their names as transcribed upon a strip of film as legal signatures to a contract, Eddie Cantor, the noted comedian, and Samuel Goldwyn, the producer of Cantor's pictures, were parties to what was perhaps the most unique contractual arrangement ever consummated when they participated in a discussion over long-distance telephone from the Electrical Radio Show in New York City to Goldwyn's office in Hollywood, California.

Through the medium of RCA Photophone portable sound-recording apparatus which had been set up in New York, a sound and picture record was made of Cantor from the time he placed the long-distance call to the Goldwyn studios until the conversation had been completed: At the same time and perhaps for the first time in the history of contractual agreements, a connection having been made between the recording apparatus and the long-distance wire leading to the telephone used by Cantor, a complete and authentic sound record of the conversation between Cantor and Goldwyn was registered upon the film.

I. C. A. Expands

NEW YORK—To meet an increasing demand for television equipment, radio receivers and accessories, a new holding company has been formed for the Insuline Corporation of America, according to an announcement by S. J. Spector, president. The new company, which is to take care of the financing and expansion of business development, is to be known as the Standard Television and Electric Corporation.

The Insuline Corporation will continue intact as heretofore, buying, selling, advertising and merchandising, under the ICA brand. Mr. Spector will continue as president of the Insuline Company while Mr. A. G. Heller remains as treasurer.

The officers of the Standard Television and Electric Corp. are Mr. S. J. Spector, president; Mr. A. G. Heller, vice-president, and Mr. J. S. Barshay as secretary. An able board of directors will assist the officers in governing the policies of the corporation. The board of directors include: Brig. General Brice P. Disque, director, Anthracite Institute; J. N. S. Brewster, president, Brewster Badeau & Co., insurance; Elwood Horton, secretary and treasurer, Miller, Franklin & Company, Inc., engineers and accountants; S. J. Spector; Chas. E. Stuart, president, Stuart, James & Cooke, Inc.; Alex. G. Heller, J. S. Barshay, attorney-at-law.

New Film Laboratory

HUDSON HEIGHTS, N. J.—Continuing with his plan to place 16 mm. movies on a big business basis, Rudolf Mayer, president of International 16 mm. Pictures, Inc., and brother of Louis B. Mayer, of Metro-Goldwyn-Mayer, announced that his organization had acquired the U. S. Laboratories at Hudson Heights, N. J. This is the second laboratory purchase made by Mr. Mayer, and it is his intention to merge both into a huge organization which will have a weekly capacity of more than 4,000,000 feet of 16 mm. film. The new organization will be known as the Union Film Laboratories.

Reported by
Ray Kelly

RMA Trade Show at Chicago Next May

NEW YORK—Chicago will again be host to the largest industrial gathering of the United States, the Seventh Annual Convention and Trade Show of the Radio Manufacturers' Association, which attracted over 22,000 persons last June.

According to announcement by B. G. Erskine of Emporium, Pa., chairman of the show committee of the Radio Manufacturers' Association, the big annual radio conclave at Chicago will be held during the week of May 23, 1932, with headquarters at Chicago hotels to be selected later, subject to approval expected later by the RMA Board of Directors. The show committee met at New York and decided unanimously upon Chicago and the week of May 23rd for the 1932 industry events. Several other cities, Pittsburgh, Detroit, St. Louis, Atlantic City and Toronto also presented invitations.

Mexican Station Threat

WASHINGTON, D. C.—Serious international complications that involve the radio administrations of the three largest nations of North America are developing from the fact that Dr. John R. Brinkley, deposed Kansas medico-broadcaster and candidate last year for the governorship of Kansas, has made good his threat to build a powerful radio station in Mexico in order to reach his old American audience.

American and Canadian government agents have been watching with keen interest the erection of the new 75,000-watt station at Della Acuna, Province of Coahuila, Mexico, just across the Rio Grande from Del Rio, Texas. The station has been testing on 735 kilocycles with the call letters XER. With 75,000 watts, it is destined to be the most powerful station in the western hemisphere, the next most powerful being the several 50,000 watters in this country.

Though it is admitted that the station has been built with Brinkley capital, its erection has been authorized by the Mexican government and licensed to a Mexican corporation. This despite the fact that an official of the Mexican embassy was informed, when he made personal inquiries at the Federal Radio Commission some months ago, that Dr. Brinkley's radio license had been revoked by the Commission, later sustained by the courts, for carrying medical advice regarded as inimical to public health and contrary to public interest.

Reports Brisk Business

PHILADELPHIA, PA.—That there is no sign of a business depression about the offices and plants of the International Resistance Company is evident from the statement of Harry Kalker, sales manager, regarding present activities. "This month happened to be the peak month in our history," states Mr. Kalker. "We shipped out well in excess of 1,000,000 units, plus a large amount of filament from our Philadelphia plant to our licensees."

Tube Litigation Settled

NEW YORK—To promote immediate stabilization of the radio industry, C. H. Braselton, president of Arcturus Radio Tube Company of Newark, N. J., recently announced that his company, together with a number of other radio tube manufacturers, reached an amicable settlement of its litigation with the Radio Corporation of America.

C. G. Munn, president of the De Forest Radio Company, announced that its triple damage suit against Radio Corporation of America has been settled by the payment to De Forest of \$1,000,000 in cash, and that cross license agreements on tube patents only have been entered into by both companies.

Samuel E. Darby, Jr., of the firm of Darby and Darby, today announced that an understanding has been reached for the settlement of all of the anti-trust law suits instituted against the Radio Corporation by radio vacuum tube manufacturers who were not operating under license of the patents of the Radio Corporation of America. This understanding is with reference to actions brought against the Radio Corporation for alleged violation of the Clayton Act, by reason of the so-called "Clause 9" license agreement between the Radio Corporation of America and radio receiving set manufacturers.

The companies who joined in the understanding with the Radio Corporation are: De Forest Radio Company, Mellotron Tube Company, Vesta Battery Company, the Van Horne Company, Schickerling Products Corporation, Gold Seal Electrical Company, Universal Electric Lamp Company, Republic Radio Tube Company, Mutual Electric Lamp Company, Continental Corporation, the Sunlight Lamp Company, Marvin Radio Tube Corporation, Radex Corporation, Globe Electric Company, Arcturus Radio Tube Company, Duratron Radio Tube Corporation, Gold Seal Manufacturing Company, Supertron Manufacturing Company, Cleartron Vacuum Tube Company, Diamond Radio Tube Company, and Poughkeepsie Gold Seal Company.

David Sarnoff, president of the Radio Corporation of America, made the following statement:

"An amicable understanding has been reached for the adjustment of the Clause 9 litigation pending between the Radio Corporation of America and a number of manufacturing companies in the radio tube field and the cases will be discontinued.

"In a number of instances patent infringement suits brought by the Radio Corporation of America have been pending against companies seeking damages in the Clause 9 cases. The active manufacturing companies that are parties to the settlement have recognized patent rights of RCA by acquiring licenses under its patents, and these patent infringement suits will be dropped. The Radio Corporation of America has also obtained rights both by itself and its tube licensees under radio tube patents owned by the De Forest Radio Company."

World Radio Center

NEW YORK—This country is rapidly becoming the world's recognized center for radio equipment of every kind, declares M. (Continued on page 640)

'Round the World Reception Every day, in all seasons

21 weeks, constant reception record from VK3ME proves SCOTT ALL-WAVE capable of tuning in clear 'round the earth regularly—every day, summer and winter.

FOR 21 weeks, a Scott All-Wave Receiver, located in Chicago has brought in, and recorded on disc, every broadcast from VK3ME, Melbourne, Australia. Each broadcast was received with perfect clarity and full volume—as the disc records decisively prove. Think of it! VK3ME, half way 'round the earth! Not just once in a while. Not just a freak happenstance. As this book goes to press, VK3ME is still being received with perfect regularity, and recorded. With a Scott All-Wave, you could get VK3ME and dozens of other foreign phone stations whenever you choose.

When the distance between Melbourne and Chicago is used as a radius, a circle drawn from Chicago as the center, includes practically the entire world. This establishes the range of the Scott All-Wave Receiver, and steady reception from all points north, south, east and west, at the extremes of the circle, PROVE the world-wide range of this remarkable instrument.

The reason for the greater range of the Scott All-Wave is the far greater amplification obtained in its intermediate stages. A new type of transformer, in which the primary is shielded from its secondary, provides such an enormous increase in gain per stage that the sensitivity of the receiver is more than adequate for world-wide reception, with the tubes operated below the noise level. Short Wave reception that is ordinarily attended with terrific interference, comes in clearly on the Scott All-Wave—and with beautiful, full, round, natural tone. Reception from VK3ME, from G5SW, Chelmsford, England, from 12RO, Rome and other

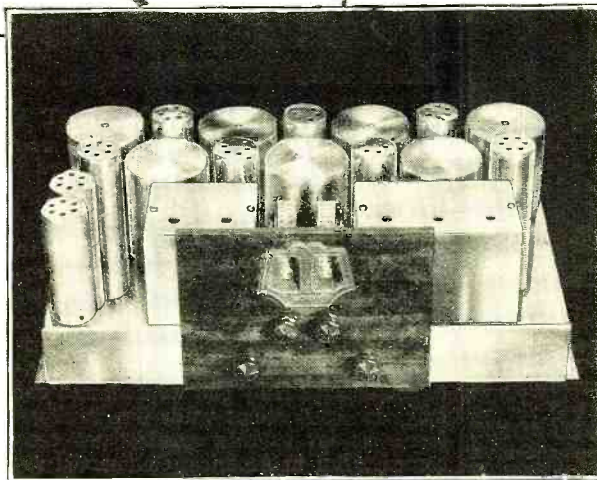
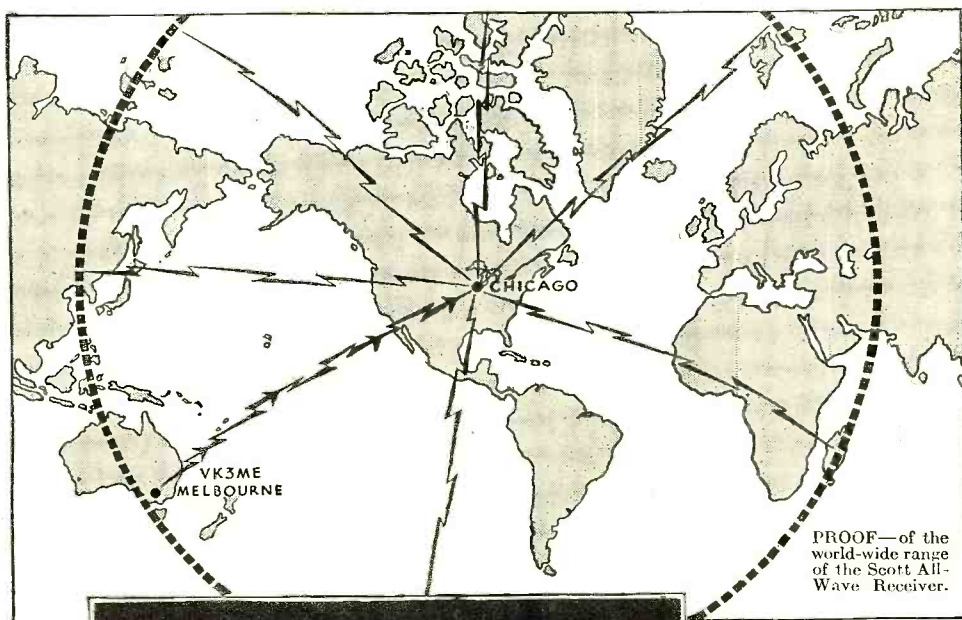

The Beautiful Chrome Plated Scott All-Wave Chassis

far off points, invariably has the quality and volume of a local station! Actually, in all truth, the Scott All-Wave gives 'round the world reception every day, in all seasons—between 15 and 550 meters.

FIVE YEAR GUARANTEE

The Scott All-Wave is not a factory product. Rather, it is built in the laboratory, by laboratory experts and to laboratory standards. For that reason, we can make the most unusual guarantee ever made on a radio receiver. The Scott All-Wave is guaranteed for full five years against defective material or workmanship. Any part that fails within that time will be replaced FREE OF CHARGE.

Mail Coupon Today

Full particulars of the Scott All-Wave will be of immense interest to you. Get them now. Read all about the receiver that challenges the whole realm of radio to any kind of competitive test. The coupon below will bring them. Clip it—fill it in—mail it today.

THE E. H. SCOTT RADIO LABORATORIES, Inc.
(Formerly Scott Transformer Co.)
4450 Ravenswood Avenue - Dept. N1, - Chicago, Ill.

CLIP—MAIL NOW

THE E. H. SCOTT RADIO LABORATORIES, Inc.
4450 Ravenswood Ave., Dept. N1, Chicago, Ill.

Send me full details of the Scott All-Wave Receiver.

Name.....

Street.....

Town..... State.....

The SCOTT ALL-WAVE

15-550 METER

SUPERHETERODYNE

'' NOW
You can afford
LIGHT SENSITIVE CELL
Experiments

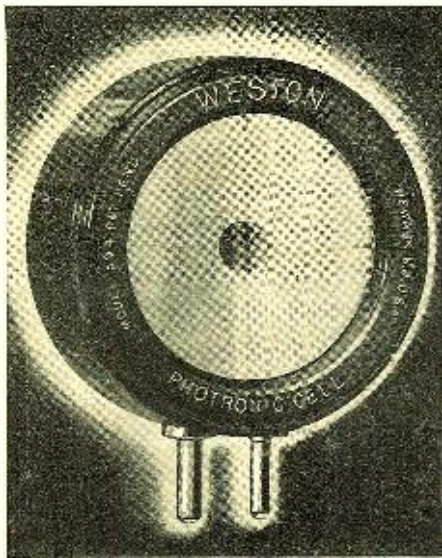

Now, for a fraction of previous costs, you can make a beam of light open doors, control lights, operate alarms, count objects . . . hundreds of practical, interesting and amazing uses in homes and factories.

With the new Weston PHOTRONIC CELL, light sensitive cell equipment costs less to buy and use. The PHOTRONIC CELL—the most advanced type on the market—is radically different, amazingly simple . . . and low in cost.

Highly sensitive, its current output is several milliamperes in direct sunlight. No dark current. No drifting. Constant characteristics. Unlimited life.

The Weston PHOTRONIC CELL operates relays directly. It uses no batteries, no amplifiers. Nothing to wear out or replace. Not easily damaged. No extras.

Made by an organization known to every radio experimenter, the Weston PHOTRONIC CELL advances light sensitive cell applications to a new simplicity—eliminating costly auxiliary equipment—bringing them within reach of every experimenter.

Write for FREE CIRCULAR YY

WESTON
ELECTRICAL INSTRUMENT CORP.
 615 Frelinghuysen Avenue, Newark, N. J.

Thirty-Seven Years of Radio Progress

(Continued from page 554)

of the tube generator were made in the following year. In March, 1914, I had the apparatus installed on an Italian warship, in Sicily, and speech was received on a second vessel. The two ships steamed off the Sicilian coast and consistently perfect reception was registered over a distance of 35 kilometers, a distance subsequently increased to 70 kilometers, with a very limited power. Communication was constantly maintained throughout a period of twelve hours. The experiments were entirely satisfactory when signals were transmitted entirely over the sea, and also when land intervened. One com-

In the same year, my assistant, Mr. Franklin, carried out a short-wave telephony beam test on very short wavelengths, a wavelength of 15 meters, across the English Sea, a distance of 80 miles. Work on this wavelength was carried in 1921 when two-way telephone communication was established between Hampden and Birmingham, a distance of 97 miles, in which case, however, a series of projectors were used.

Then, in 1921, following the successful tests of telephony on 100-meter waves between Chelmsford and Southend, stations were erected using only 1 kilowatt of energy in the aerial circuit. In Norway,

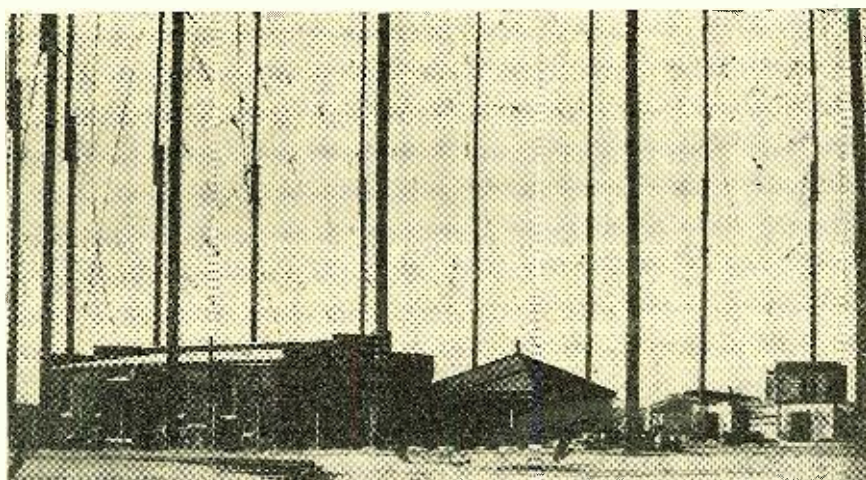

ANTENNAS OF FIRST TRANSATLANTIC STATION

The complicated system of wood masts and the station buildings of the Poldhu transmitter, heard by Marconi in America

plete wireless installation was sent to New York and communication was established between New York and Philadelphia by telephone, working both ways.

At the outbreak of the War, experiments in wireless telephony were discontinued commercially and were carried out only in connection with the military forces as far as this country was concerned. But in America, commercial research continued and in 1915 the American Telephone and Telegraph Company, working in conjunction with the Western Electric Company, succeeded, when conditions were favorable, in transmitting speech from the United States Naval Station at Arlington to the Eiffel Tower station in Paris, a distance of 3800 miles. On this occasion over 300 valves (or tubes) were used in the oscillator and modulator circuits.

At the conclusion of the war it became possible for European countries to resume their tests and in March, 1919, with the object of demonstrating that transatlantic telephone could be achieved, and using comparatively small power, one-way communication was established and satisfactorily maintained for ten days with Lewisburg in Canada, from my station in Ireland, using a tube transmitter with only two and a half kilowatts output from the generator, a wavelength of 2800 meters and an aerial 500 feet in height.

good quality telephony was received from these stations both at night and during the day. At Oslo, a distance of 700 miles, very loud and constant signals were received all night, but the day reception was variable and uncertain.

The year 1920 is memorable for a number of important wireless-telephone transmissions which had both news and entertainment value and that had the same characteristics that broadcasting has today. To encourage public interest, demonstrations were given to show that no special skill was required to talk into the telephone and that musical programs could be transmitted and satisfactorily received with ease. But in the summer of 1920 a program of vocal and instrumental music for two half-hour periods each day, for a fortnight, was broadcast from the Chelmsford station, using about five kilowatts in the aerial and the same wavelength of 2800 meters, which was the same wavelength being employed by Poldhu for the news flashes. This was in order to test the range of the transmitter. Amateurs and shipping companies were advised to send in reports. World-wide interest was aroused by this program of broadcast concerts and good reception was reported as far away as Persia and Canada.

In November, 1920, the Westinghouse
 (Continued on page 610)

Never Before a SENSATIONAL VALUE

Like
this!

Save
UP TO
50%

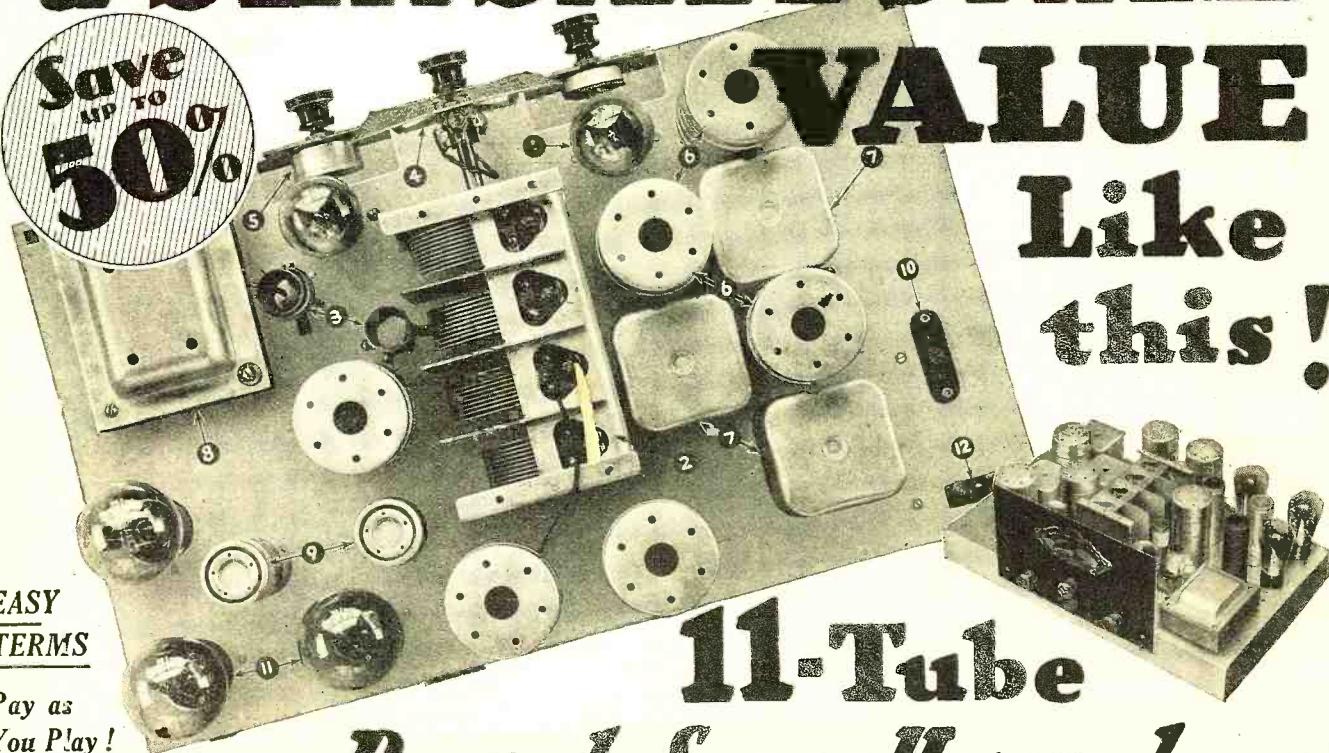

**EASY
TERMS**

Pay as
You Play!

11-Tube

Pentode Super-Heterodyne!

With Real Automatic Volume Control

More value for your money. Better quality. Greater clarity. Amazing selectivity. Perfect control of volume. Great distance range. You get all of these and many more outstanding advantages—plus a saving of more than 50%—when you buy this sensational new high-power superhet direct from the Midwest Factory. Furthermore, you are guaranteed absolute satisfaction or your money back, and 30 days' FREE TRIAL in your own home.

Compare These Midwest Features
Before You Buy!

You save more than half, and get all these great features as shown by the numbers on the photograph above:

- | | |
|---------------------------------|-------------------------------|
| 1. Automatic Volume Control | 7. Two-Stage Balanced I.F. |
| 2. Pre-Selector | 8. Oversize Power Transformer |
| 3. Litz Wound Coils | 9. Electrolytic Condensers |
| 4. Full-Vision Dial | 10. Phonograph Jacks |
| 5. Tone Control | 11. Pentodes in Push Pull |
| 6. Variable-Mu and Screen Grids | 12. Built-in Antenna |

A Host of Other Features

Police short wave arrangement—Great distance range—Better than 10KC selectivity—Built-in extra light socket—Six screen grids—Low current consumption—Auto body steel chassis—Coast to coast reception—every feature anyone could ask for in a radio. The big FREE Midwest catalog gives you all the facts. Just clip and mail the coupon—Now!

only
\$37.50
COMpletely
ASSEMBLED
With Specially
Matched Large
DYNAMIC SPEAKER

**30
DAYS
FREE
TRIAL**

**TERMS
as low as
\$5.00
DOWN**

Complete Line of Consoles
The big FREE catalog illustrates the complete line of gorgeous Midwest Consoles. Deluxe, Highboy and Lowboy models. Mail the coupon now. Compare the sensational Midwest values before you buy.

Deal Direct with Factory
Save Up to 50%

Direct-to-customer selling makes the surprisingly low Midwest prices possible. Know what it means to have one of the latest and most powerful radios on the market—with all the new 1932 improvements in tone, clarity, selectivity—at about half what you would pay in retail stores. Absolute guarantee of satisfaction protects you and eliminates all risk. And don't forget—you try any set you select for 30 full days. ABSOLUTELY FREE. You must be delighted! Mail coupon for beautiful new FREE catalog and complete details of FREE TRIAL, easy payment plan. You'll be amazed.

MIDWEST RADIO CORP.

Dept. 26 Cincinnati, Ohio

**Mail this Coupon for Complete
Details and Big FREE Catalog!**

Midwest Radio Corp.
Dept. 26
Cincinnati, Ohio

Without obligation on my part send me your new 1932 catalog, and complete details of your liberal 30-day free trial offer. This is NOT an order.

Name

Address

Town State

Send me SPECIAL USER AGENTS PROPOSITION

USER AGENTS
We pay you BIG MONEY just for showing your radio to friends and neighbors. Easy EXTRA MONEY! Check coupon for details.

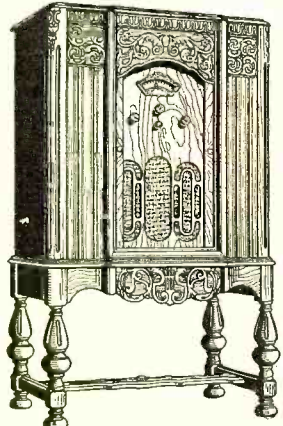

SUPREME INSTRUMENTS CORPORATION
 422 Supreme Building,
 Greenwood, Mississippi.

Please send me full particulars on

(Here indicate instrument or instruments interested in)

Name

Address

City State

Name of Jobber

City State

Be a Coupon Clipper

This one can bring real dividends from better service. Sign and mail it.



Prepare yourself for the challenge of 1932—the call for modern, perfect service—“Supreme” service. Let this coupon bring complete details on Supreme 1932 Testing Equipment, including the instrument that has set the whole service world agog. Complete . . . handy . . . versatile . . . positive . . . almost beyond belief—

SUPREME DIAGNOMETER AAA 1

5 ultra modern testing instruments in 1 at the price of **1**

Dealers' net price, f. o. b. **\$147.50**
 Greenwood, Miss.

- Model 90 Supreme Set Analyzer **\$78.50**
- Model 60 Supreme Oscillator **\$30.00**
- Model 70 Supreme Oscillator **\$49.75**
- Model 40 Supreme Tube Tester **\$30.00**

Each a "gilt-edge" investment for more service dividends. Clip coupon—mail, after indicating instrument on which data is desired.

Ask your Jobbers to demonstrate

Distributors in All Principal Cities
 Foreign Division, 130 West 42nd St., New York City
 Cable Address LOPREH New York

Thirty-Seven Years of Radio Progress

(Continued from page 608)

Company of America, having given due notice beforehand, broadcast the returns of President Harding's election from their Pittsburg station. Many thousands of people were ready with radio receivers when the results came through. They were thus enabled to anticipate the newspapers and this caused a great sensation.

During the year 1921 amateur and commercial interests in the United States erected broadcast stations in considerable numbers and the public demand for receivers grew at an extremely rapid rate, resulting later in the enormous development of broadcasting in the United States.

At one time it was a stock argument against the use of wireless that messages sent by this means could be picked up in all directions. This characteristic, however, has made it an ideal method for communication with moving objects, such as ships at sea or airplanes in flight. With the advent of broadcasting, this radiation has become a most valuable feature. There are, however, many services for which a more confined channel has distinct advantages and this requirement, I am able to say, is effectively met by the beam system, by means of which signals can be concentrated and directed in any desired direction and the power necessary reduced to a minimum. Directional or beam wireless transmission has made world-wide telephony possible and today we can speak to our friends at the ends

of the earth, on ships at sea or wherever they may be and recognize the pleasure of personal contact with the familiar intonations of their voice.

On May 30, 1925, I was able to speak direct, from here to Sydney, thus conveying intelligible speech from England to Australia for the first time, and last year, when aboard my yacht, *Electra*, in the Mediterranean (you can imagine one of our small ships with its wireless-telephone installation), whenever I wished to do so. I could talk to friends in Australia, over a distance of 9000 miles. I also spoke to others in London, Buenos Aires, Ric, New York, Montreal and Capetown, a range covering practically the whole world.

The great need of the present day is for a better understanding between men and nations, and this understanding can be fostered and helped by improvements in our communications. The most direct and satisfying means of communication between men is the spoken word, and in this respect broadcast telephony occupies a unique position as being the most potent means that the world has ever known.

I am happy if by any efforts of mine I have been able to make some contribution toward international sympathy and understanding.

Note: From a talk by Senatore Marconi, in London, during the Faraday Centennial exercises, transmitted to America by the British Broadcasting Co. and rebroadcast by the Columbia and National Broadcasting Co. systems.

Reducing Noise in Talking Pictures

(Continued from page 570)

form which allows it to be used either as a portable unit or to be incorporated into standard recording channel racks. The external supply voltages necessary are 6 and 90 volts.

may be obtained in practice. With a smaller width of track and an increased density this figure may be made larger if desired.

Figure 13 shows an actual speech syl-

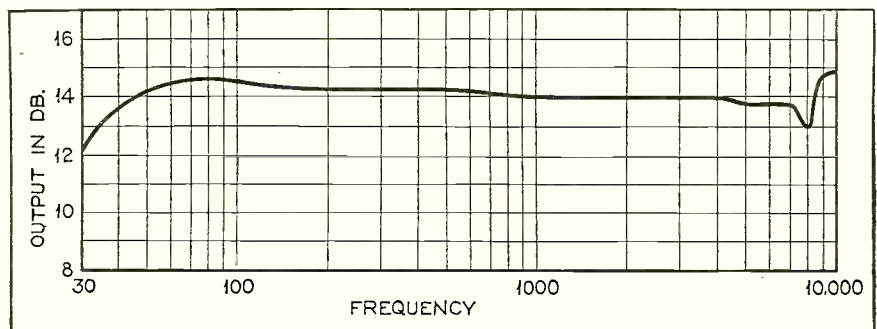

Figure 9. Frequency response curve of the amplifier in db. up to 10,000 cycles

Figure 10 shows the shutter as it is used with the cover in place. A rear view of the shutter control unit with the dust cover removed is shown in Figure 11. Figure 12 shows the unit as it is used when mounted on a rack.

With a "zero modulation" track width of 5 mils. on a print of the usual density an actual reduction in "noise" of 12 db.

lable recorded with "noise reduction" equipment of this type. Note the narrow width of clear portion before the sound starts (at the left) the widening of this portion during the period of maximum amplitude of the sound, and the slow closing of the track as the sound intensity decreases until the clear portion is once more a 5 mil. strip, as at the start.



PROOF

Over 25,000 Men have been trained under my supervision for the Better Jobs in RADIO

R. L. DUNCAN, *President*
Radio Training Schools



As a graduate and a student under your supervision, I have only the highest praise and satisfaction to offer. Any man of ordinary intelligence wanting to learn Radio could not help but master it by your method of training.

GEORGE A. KRESS,
2987 Montclair Ave., Detroit, Michigan



I am a Projectionist in charge at the Andelus theatre, recently completed. You may quote me at any time or place; refer to me, if you wish, anyone who may be interested in this vast virgin field of all that pertains to Radio and its many allied industries, and I shall be delighted to champion honestly without any reservation, your courses.

A. H. STRONG,
3005 Woodburn Ave., Cincinnati, Ohio.



To study Radio under R. L. Duncan is to learn it properly and in a way that is pleasant and fascinating. Once again thank you for your kind assistance and helpfulness.

F. E. PRICE,
361 Coleau St., W.,
Moose Jaw, Sask., Canada.



Although it has not yet been a year since I enrolled for a course under your excellent supervision, I have opened a Radio Service Shop that is effective, successful and profitable. People come for my services from everywhere.

RUSSELL PEARCE,
936-18th Street, Des Moines, Iowa.

IN hundreds of Broadcasting Stations . . . in Radio Manufacturing Plants throughout the country . . . in Radio Laboratories . . . in Wholesale and Retail Radio Stores . . . in Radio Servicing . . . in Sound Motion Picture activities . . . on hundreds of ships that sail the Seven Seas . . . and even in the latest Television developments—you will find ambitious men who have been trained under my direct supervision.

I have devoted the last twelve years exclusively to the training of men for all branches of Radio. Employers in the Radio field recognize my methods of qualifying men and young men. I have geared my training to the rapid growth and development of the Radio industry. My courses, text books, methods and equipment are based on years of practical experience.

And now, with the organization of my own independent Radio Training Schools, Inc., I am better prepared to help you than ever before, in training for the opportunities which the future of the ever-growing Radio industry will have to offer.

You too can train for Future Success in Radio

The next few years will offer more prospects than ever before. The past several months offer positive proof that the trained man has the best chance. You still can get that training which will qualify you to gain a foothold in Radio. Study at home, in spare time, at minimum expense. Earn while you learn. Capitalize your idle and spare time and reap the benefits of a trained man in a progressive industry—Radio.

Make your Idle and Spare Time Profitable

My courses include everything needed for thorough training. There are no "extras" or "specials" to cost you extra money. The lessons, text books, methods, correcting, grading and returning of examinations, all the extra help and personal consultation you need . . . everything is provided until you complete your training.

RADIO TRAINING SCHOOLS, INC.
326 Broadway New York City

And in addition you are assured *practical* as well as theoretical training.

Pick Your Branch of Radio

I am offering four distinct Radio training courses:

1. Talking Motion Pictures—Sound
2. Radio and Broadcast Operating
3. Practical Radio Engineering
4. Radio Service and Mechanics

Each course is complete. Each starts out with simple principles well within your grasp. Each is right up to date, including latest developments such as Television. Each prepares you for a good paying position. Each leads to a Certificate of Graduation.

Advanced Training for Radio Men

My Practical Radio Engineering Course is an advanced course intended for Radio men who want to go still higher. It provides that necessary engineering background which, combined with practical experience, qualifies the man for the topmost job.

Ask for Facts—Write Now!

Let me sit down with you for an hour or two at your convenience. Let's go over the possibilities in Radio. This we can best do by means of the book I have just prepared. It covers the many branches of Radio and the kind of training required. Be sure to get your copy . . . it is free.

**GET THESE
FACTS
TO-DAY**

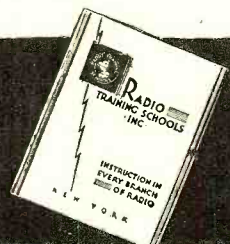

Mr. R. L. DUNCAN, *President* R.N. 1
Radio Training Schools, Inc.
326 Broadway, New York City

Without incurring the slightest obligation on my part, please send me a copy of your latest book, "Facts About Radio."

Name -----
Address -----
City ----- State -----

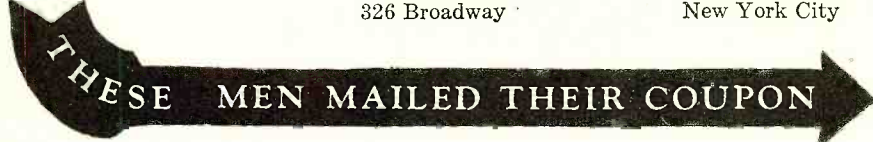

The Microphone—Radio's Electric Ear

(Continued from page 557)

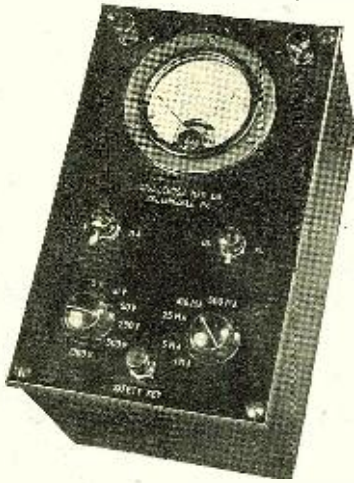

Combination Multi-Range Voltmeter and Milliammeter A. C. and D. C.

employing the new Weston A. C. and D. C. Type 301 Universal Meter and

SHALLCROSS Super Akra-Ohm

Wire  Wound

RESISTORS

The voltage range is from 5 to 1000 volts, 1000 ohms per volt, and the current range is from 1 to 500 Milliampers A. C. and D. C.

A complete diagram and full information on the construction of this circuit are contained in our Bulletin 150-D, which also contains very useful information on the application of Akra-Ohm Resistors to multi-range voltmeters, ohm meters, etc.

Our new Bulletin 150-D will be sent upon receipt of 4 cents in stamps



SHALLCROSS Mfg. Company
ELECTRICAL SPECIALTIES
120 MARKEE AVENUE
Collingdale, Pa.



GET THIS

Free new No 23, Edition of our greatly enlarged **RADIO SERVICE TREATISE**. Every radio man must have it. Contains some 75 new hook-ups, circuit diagrams, over 350 illustrations. **POSITIVELY THE GREATEST BOOK EVER FIT OUT BY ANYONE.** Editorial contents: **VACUUM TUBE TREATISE**, with many illustrations; Vacuum Tube Average Characteristics Chart; How to Take Care of Your Tubes. How to Connect Phonograph Pick-ups. Improving Tone Quality of Old Sets; Connecting Additional Loud Speakers; all fully illustrated with diagrams. Other articles: Modernizing Old Radio Sets; Low Amplifiers; Replacing Audio Transformers; Phone Attachments; How to Choose Power Transformers; Voltage Dividers; Warnings of Power Transformers; Selecting and Installing Replacement Parts in Radio Sets; Filter Condensers; Repairing Sliminators, etc.

WRITE TODAY. Enclose 2 cents for postage. Treatise sent by return mail.

RADIO TRADING CO.
27 West Broadway New York City

THERE'S NO SUBSTITUTE FOR KNOWLEDGE!

You've got to know the engineering fundamentals of radio if you want to succeed in it. We can teach you. Our Radio and Television Courses are specially written for men with at least 2 years' radio experience who want to fit themselves for the better jobs. No beginners. Write for full particulars.

CAPITAL RADIO ENGINEERING INSTITUTE, Inc.

Dept. A-11

14th St. and Park Rd., N. W. Washington, D. C.

to hear the "thundering" footsteps of a fly walking across a board or to make the drop of a pin audible throughout a theatre or for many similar spectacular experiments which Tyndall and other popular lecturers of the past generation used to astonish their audiences. Even today the possibilities of the extremely simple Hughes microphone for scientific researches and demonstrations have by no means been exhausted.

Out of this device there developed almost immediately the various types of carbon-button and carbon-grain microphones with which the names of Berliner, Blake and Edison are associated and which still do most of the sound-collecting work for the telephone art. In precise sound recording or broadcasting, however, these carbon devices are far from satisfactory. Radio has been compelled largely to discard them and sound measurement work has relinquished them entirely. The chief trouble is their inconsistency.

In the familiar carbon microphone used, until recently, as the chief instrument for broadcasting purposes, the sound waves strike first on a thin, stretched metal diaphragm. The vibrations of this diaphragm alternately compress and loosen a small collection of angular grains of hard carbon, held in one or two small metal cups. This alternation of pressure changes the electrical resistance of the loose carbon mass so that more current passes or less. Electric vibrations thus are created corresponding to the sounds.

As might be expected, these responses depend not only on the intensity and character of the sound waves but upon the condition of the carbon grains, the exact pressure exerted by the metal cups and many other matters which it is extremely difficult to control. Modern microphones should be able to respond to sound frequencies up to at least 8000 cycles a second, preferably to 10,000 cycles. This means that the change in electric resistance of the carbon mass should be complete in less than 1/20,000 of a second.

It is difficult, if not impossible, to make any loose-contact microphone work as rapidly as this. Worse still, the response in change of resistance for the same intensity and character of sound may vary notably within intervals of a few minutes, depending upon what happens to such things as the degree that the carbon grains cling together or fall apart. For quantitative purposes like the measurement of noise or for precise recording for talking pictures, these faults of carbon microphones have proved insuperable and the device is virtually abandoned.

The condenser microphone, although of ancestry quite as ancient as the loose-contact one, owes its present development chiefly to an engineer of the telephone industry of today, Dr. E. C. Wente of the Bell Telephone Laboratories. Like the carbon microphone, its principle is simple. The thin metal diaphragm merely serves as one plate of an electric condenser. If this plate moves back and

forth with reference to the other plate, all other conditions remaining the same, the electric capacity of the condenser changes in accordance with the familiar formula in which the distance between the two plates of the condenser is one item of the equation. Rhythmic alterations of the condenser capacity thus are created by sound, are picked up electrically, amplified and constitute the output of the microphone.

This condenser microphone has been a truly invaluable device, not only in broadcasting and sound recording during the past few years, but in the development of the art of acoustic measurement. Until very recent months microphones of this type have been the only ones constant enough in efficiency and other characteristics to be used at all for precise measurements. With nothing better than carbon microphones, no modern noise meter could have been developed.

By possible, although difficult, precautions concerning mechanical dimensions and the like, condenser microphones may be made to respond to sounds as high in pitch as 10,000 cycles and to have virtually the same response ratio between sound energy and electric energy over the entire frequency range between 40 cycles and 10,000 cycles. This is what is meant by a microphone the response characteristic of which is flat.

Not every condenser microphone, even of responsible manufacturers, has this much-desired flat characteristic, but the best types can be made to have it by perfect design and adjustment, avoiding the peaks or hollows of response at specific frequencies due to mechanical resonances in metal parts or in inclosed air spaces. What is even more important practically, the response characteristic of a condenser microphone, whether flat or not, commonly remains the same over long periods unless the instrument is actually taken apart or damaged.

All condenser microphones suffer, however, from a serious defect which apparently is incurable and which seems to me sufficient to destroy any chance of this type of instrument becoming the perfect microphone of the future. This defect is the necessity of placing the actual microphone diaphragm, the so-called button, within a few inches of the first vacuum tube of the amplification system. Usually this first tube is placed in the case containing the microphone, which makes that case bulkier than is desirable and also requires the supply to it of battery or other voltages for the tube.

This necessity, any radio engineer will perceive immediately, springs from the fact that the thing which this microphone really detects is a minute change of electric capacity. The capacity of the wires leading from the two condenser plates in the microphone to the terminals of the first amplifier tube naturally becomes a part of the total capacity which is being varied by the sound. If these leads are more than a few inches long their invariable capacity becomes too large a part of the whole capacity which operates the instrument and the microphone will not

EVERYTHING on the Air with ONE RECEIVER

THE entire theatre of the air is yours with this powerful, eight-tube world-girdling Hammarlund Super-Heterodyne. By merely slipping in and out the five pairs of plug-in coils, all wave bands from 14 to 550 meters, at home and abroad, are brought to your loudspeaker, crisp and clear.

Uses the new Variable Mu tubes. Highly selective. Marvelous, controlled tone from resistance-coupled amplifier with Pentode output. Long-wave oscillator for pure code note.

The perfected product of Hammarlund's more-than-30-years of precision engineering. Handsome console cabinet, with hinged top, dynamic speaker and all tubes—complete \$175.00

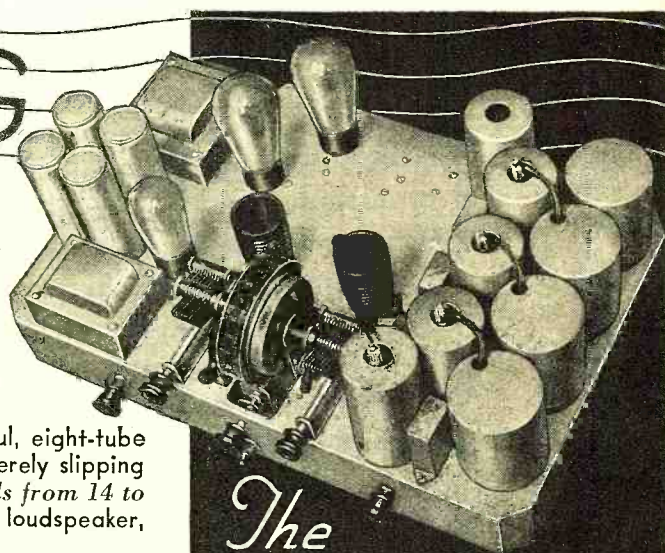

The
**HAMMARLUND
"COMET"
All-Wave RADIO**



HAMMARLUND-ROBERTS, Inc.
424-438 W33rd Street, New York.

Write Dept. RN-1 for
DETAILED DESCRIPTION.

SPECIAL CHRISTMAS and HOLIDAY SEASON OFFERS



Radio News lists below twenty-five special offers, as suggestions for Christmas Gifts. Here is your answer to the gift problem for this year. Every offer saves you money. And—don't forget your own subscription in making up your list. We will send a gift notification card to each subscriber without extra charge. New or renewal subscriptions accepted.

SAVE MONEY ON THESE SPECIAL SUBSCRIPTION-BOOK COMBINATIONS

Offer No.	Subscription	Price	Saving
1	Radio News for 2 years with "23 Lessons in Radio"....	\$4.00	\$2.00*
2	Radio News for 11 months with Radio Amateur's Handbook	2.00	1.25*
3	Radio News for 11 months with 1001 Radio Questions and Answers	2.00	1.25*
4	Radio News for 11 months with Short Wave Manual... ..	2.00	1.25*
5	Radio News for 18 months with Short Waves by LEUTZ (384 pages, red cloth binding).....	5.00	1.75
6	Radio News for 5 months with Radio Trouble Finder..	1.00	.50*
7	Radio News for 5 months with 101 Radio Hook-Ups... ..	1.00	.50*

RADIO BOOKS

Offer No.	Radio Book	Price
8	Short Wave Manual	\$.50
9	1001 Radio Questions and Answers50
10	Radio Amateur's Handbook.....	.50
11	Short Waves, by C. R. Leutz and R. B. Cable	3.00
12	101 Radio Hook-Ups25
13	Radio Trouble Finder25
14	How to Make It—Instructions for making things25

LOW PRICED MAGAZINE CLUBBING OFFERS

Offer No.	Magazine	Price	Saving
15	RADIO NEWS with Amazing Stories	\$3.50	\$1.50*
16	RADIO NEWS with Complete Detective Novel	3.50	2.00
17	RADIO NEWS with Complete Wild West Novel	3.50	2.00
18	RADIO NEWS with Popular Mechanics	4.50	1.50*
19	RADIO NEWS with American Magazine	4.75	1.25*
20	RADIO NEWS with Good Housekeeping	4.75	1.25*
21	RADIO NEWS with Cosmopolitan	4.50	1.50*
22	RADIO NEWS with Saturday Evening Post	4.50	1.10*
23	RADIO NEWS with Boy's Life	4.00	1.40*
24	RADIO NEWS with True Story Magazine	4.50	1.50*
25	RADIO NEWS with Amazing Stories and Wild West Novel	4.50	4.50*

*Over Newsstand Price.

RADIO NEWS, Dept. R-1, 350 Hudson St., New York, N. Y.

Enclosed find remittance amounting to \$..... covering following order:

Send Offer No. () TO:

Add.

Send Offer No. () TO:

Add.

Send Offer No. () TO:

Add.

Remitted by

Add.

If you want us to mail gift notification cards check here ()
Radio News Foreign or Canadian subscriptions \$1.00 per year extra

SERVICE-MEN RADIO

NEW LIVE ITEMS THAT SELL!

Service men—Save money. Make money! We offer everything for the service man at lowest wholesale prices. New, live items that will make money for you. Also A COMPLETE STOCK OF REPLACE-MENT PARTS FOR ALL SETS. What you need when you need it. Buy with confidence from the largest institution of its kind in the country!

BIG IT'S FREE!

New 1932
CATALOG



WRITE FOR YOUR COPY!

Send for a copy of our new Tenth Anniversary Catalog—the finest radio book ever issued. 144 pages crammed full of everything new in radio. Lowest prices in our history. Complete REPLACE-MENT PARTS SECTION. Write for your copy today. IT'S ABSOLUTELY FREE. Address

WHOLESALE RADIO SERVICE CO., INC.

38 Vesey St. Dept. A-12 New York

"CHI-RAD"

NEW NATIONAL AC-SW-3

3 TUBE THRILL BOX

for amateur short-wave and all other reception.
Tuner only \$32.34
National A.C. Power Pack..... \$20.30

Prices subject to change

BUT WE WILL NOT BE UNDERSOLD

REPLACEMENT PARTS

Complete line of Condenser Blocks, Trans-formers, Volume Controls and Rheostats.

SHORT-WAVE KITS

sets, transmitter parts, supplies for power packs, high voltage condensers—low prices.

**SEND 10 CENTS FOR
LATEST CATALOG**

CHICAGO RADIO APPARATUS CO.

415 S. Dearborn St. Dept. RN-1 Chicago, Ill.

GET STARTED IN RADIO

Write for free booklet telling about this growing and most promising industry. The radio operator is an officer aboard ship. His work is light, pleasant and interesting. He has many opportunities to travel to all parts of the world.

**Announcing a new course in
TELEVISION**
starting immediately. Full
information on request.

West Side YMCA Radio Institute

Established 1910

17 West 63rd Street, New York, N. Y.

perform satisfactorily. It is hard to see how this limitation of condenser micro-phones can be escaped any more than carbon microphones can escape the handicap of variation in the behavior of its loose contacts.

These serious defects of both other types provided the opportunity of the newest microphone to be perfected, the so-called dynamic or electrodynamic type. Again the principle is old and familiar; it is merely the interaction between an electric current and a magnetic field, responsible for the electric motor, the telegraph, the galvanometer, the modern dynamic loudspeaker and literally hundreds of other devices. In the kind of dynamic microphone which seems to me the most promising a small coil is attached to a diaphragm which is vibrated by the sound waves so that the coil vibrates in a fixed magnetic field. This is the reverse of a dynamic loudspeaker, the microphone coil corresponding to the voice coil. Vibration of the diaphragm causes small corresponding currents in this coil.

A reversed variant of this sometimes is called the magnetic microphone. In this type a small magnet or bit of iron is attached to the diaphragm and vibrates in the neighborhood of a coil of wire, thus generating corresponding currents in the coil. This is the reverse of the magnetic loudspeaker. Both types are closely related, it is obvious, to corresponding types of phonograph pick-up.

The great practical advantage of these microphones is that the electric impulse delivered is a small current rather than a minute change of capacity. No battery is required. The leads from the microphone to the amplifier may be of any reasonable length; probably up to several hundred feet. Tests that have been made on modern forms of this dynamic instrument indicate that its constancy and its freedom from disturbance are as great as those of the condenser microphone, if not greater. The only difficulties now left to confront the dynamic microphone seem to be mechanical ones inherent in the diaphragm and its accessories, not electric ones. The energy output, while less than that of the carbon microphone, may be made equal or superior to that of the condenser device.

It is not difficult to write the specifications of an ideal microphone. The trouble is to meet them, for several involve physical impossibilities. One requirement, for example, is that the mechanical parts which vibrate in response to the sound waves should have no inertia. If they have, the response to high frequencies is lessened, since the vibrating mass does not have time to start before the sound wave reverses in direction and the vibration is ready to start back. This means a diaphragm with no mass at all, which probably is impossible.

Only two vibrating units now known to science are virtually massless: a stream of electrons like those in a cathode-ray tube and a beam of light. Both have been tried for microphones and perhaps one or both can be perfected, but nothing really successful has been accomplished as yet. Even the dynamic microphone, therefore, seems destined to be handicapped for a few years at least by a diaphragm which has mass. This means that there will continue to be an upper limit of

frequency beyond which the microphone will not respond, although this limit certainly is above 10,000 cycles per second and probably can be made higher.

Another characteristic of an ideal microphone would be that neither the mechanical parts of the device such as the diaphragm nor the attached electric circuit have any resonance of its own, to build up the signal at some special frequency or frequency range and produce a peak of response not present in the original sound. This is a present-day fault of almost every type of condenser or dynamic microphone, especially of the cheap ones for which there is so great demand. The remedy is careful design of the purely mechanical features, for it is chiefly the mechanical resonances that are troublesome rather than electric ones.

A third requirement of the ideal microphone is that it should not itself interfere with, or limit, the electric circuits to which it is attached, as present condenser microphones do by requiring short leads to the first tube of the amplifier. This requirement the new dynamic microphones promise to meet satisfactorily.

Finally, the ideal microphone should not itself interfere with the sound wave which it is detecting; another virtual impossibility, since this would necessitate, in physical theory, either that the microphone should occupy no space or should allow the sound waves to pass through it exactly as they would do through empty air. The closest practical possibility is to make the microphone as small as possible, another item in favor of the dynamic type of instrument, since these probably can be made much smaller than now, although probably not so small as a carbon microphone. The Bell Telephone Laboratories recently have developed, however, an exceptionally small condenser microphone, the so-called "fountain pen microphone," which is said to be small enough to make its physical interference with the sound wave almost negligible.

Many other types of microphone are conceivable; some, perhaps, based on principles not hitherto tried, others as revivals and improvements of principles once tested and discarded. One of the latter is the hot-wire microphone, responding to the changes of air temperature created by the passing sound waves. Another is the liquid resistance microphone like one of the first successful ones of Alexander Graham Bell. The effect of sound waves on a high-voltage, glow-discharge maintained between two metal points in air, was used a few years ago for microphone purposes by Dr. Philip Thomas of the Westinghouse Electric and Manufacturing Company and proved to be the only microphone, which I know of, capable of responding to sounds well above 10,000 cycles per second in frequency. The device proved to be too unstable for the majority of practical uses, but it embodied a near approach to the idea of a vibrating unit, like a stream of electrons, which would have no inertia.

But even if nothing better appears than the present and promised forms of dynamic microphones there is every assurance that radio's electric ear will keep pace with the rest of the radio engineer's equipment, to say nothing of the directional characteristics of the new reflector and ribbon instruments.

Future Broadcasting

(Continued from page 568)

radio—both directly, through short-wave receivers in the home, and through the medium of retransmission on broadcast wavelengths. Trans-oceanic broadcasts, however, are by no means of recent vintage. WJZ was in the habit of putting on such programs back in 1925, and under "What Are the Air Waves Saying," in the New York *Sun* for April the 11th of that year we wrote:

"On three occasions London has been picked up at the R.C.A. laboratory in Maine, retransmitted to New York on 102 meters and then transferred to the broadcasting wave of WJZ. This certainly is interesting. At last we New Yorkers are getting our English only third-hand, which must surely result in the betterment of speech."

Such retransmission has been made more direct and reliable in the last five years through the use of greater power and higher, selective frequencies. The time when one or more wavelengths between 15 and 40 meters is not effective for trans-oceanic transmission is the exception.

Experiments with the program synchronization of several distant transmitters on the same frequency is a relatively new endeavor, and to date it has been highly successful. The progress in antenna design, with definite variations for local and distant coverage has also contributed to the consistency of widespread reception.

As a delegate to the National Radio Conference in Washington, 1924, it was our pleasure to lend an attentive ear to C. Francis Jenkins, who told Secretary of Commerce, Herbert Hoover, and the conference at large, that television was "just around the corner," and that within six months the radio listener in his home would be able to see as well as hear the performer in the studio. Just one year later it was yet around the corner.

While progress has certainly been made in television engineering during the last few years—such as the projection of large images by means of the Kerr cell modulated arc, and the crater neon tube—the actual reproduceable detail, the criterion of television success has not been increased materially.

All in all, I should say that, while television today can contribute somewhat in entertainment value to the average home, it is still "just around the corner."

Centralized Radio

(Continued on page 559)

installed without changes in the balance of the installation.

All in all, the idea of utilizing the framework and the normal wiring of a building for the distribution of radio and recorded programs is a furtherance of the broadcasting idea which is certain to grow in popularity. The Lincoln Hotel installation serves as a practical demonstration of the efficiency and practicability of an ingenious system of bringing greater radio entertainment to the people.

NEW LOW PRICES

—EFFECTIVE AT ONCE—

IRC TYPE "K"

Metallized

RESISTORS

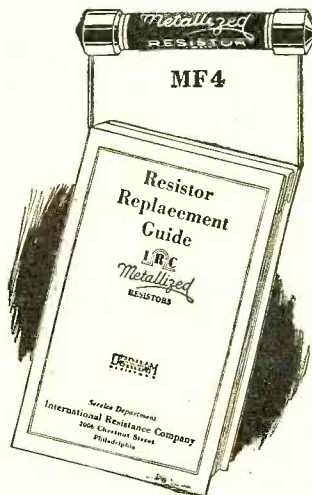

**I. R. C.
RESISTOR GUIDE
PRICE—\$1.**

Given free with purchase of 10 Metallized Resistors.

For the first time in International Resistance Company's long and successful history, *Metallized Resistors* are now in the "low-price range".

Our rapidly increasing volume has made this possible. The 1931 demand for the new Type "K" *Metallized* units went far beyond our sales of any previous year. We met this demand. We have increased our production facilities accordingly—and now, for 1932, are giving every purchaser the benefit in these substantial price reductions:

	Former Price	Now
½ Watt Resistors ...	50c List	30c
1 Watt Resistors ...	50c "	30c
2 Watt Resistors ...	75c "	40c
3 Watt Resistors ...	80c "	50c

The well-known I. R. C. standards in both materials and craftsmanship will be absolutely maintained as heretofore.

I. R. C. units will be built to the same rigid and exclusive specifications that have made Type "K" the most widely used resistor in the radio field.

The new prices are in effect at once. See your favorite wholesaler—and look for the I. R. C. *Metallized* label on every resistor. That is the mark of the genuine.

Remember—with any assortment of 10 *Metallized Resistors*, you get free of charge our I. R. C. Resistor Replacement Guide. It gives all the resistor data you need about any popular receiver—the types and values to use in each set. Ask your jobber. Other I. R. C. service helps will be supplied as heretofore.

INTERNATIONAL RESISTANCE COMPANY
Philadelphia Toronto

INTERNATIONAL RESISTANCE CO., 2006 Chestnut St., Philadelphia.

N-1

Gentlemen:

I enclose \$1.00, for which please send I. R. C. Resistor Replacement Guide.

Please send complete information on *Metallized Resistors*. I wish to purchase assortment of ten, entitling me to Resistor Guide Free.

Name

Address

City..... State.....



The Mighty Midget That Gets Great Distance!

This marvelous aerial—no bigger than a vest-pocket dictionary—is giving thorough satisfaction to thousands of enthusiastic users all over the world. No longer is it necessary to string up unsightly inside or outside aerials. Just hook up a WELLSTON GOLD TEST AERIAL and you will be amazed at the big improvement in your reception. It reduces static and hum. Gives greater selectivity without distortion. Helps eliminate overlapping. Minimizes noise and eliminates AC aerial hum because it does not connect to light socket. Although small and compactly built, it has the capacity equivalent to 62 feet of best grade aerial wire strung 50 feet high. It is of the filtered type endorsed by leading radio engineers. Get one from your dealer today. If he can not supply you, order direct. Built for electric sets only.

PRICE \$2.50

GOLD TEST REPLACEMENT PARTS

Send for our new and enlarged Catalog No. 21 listing Gold Test Replacement Condensers, Transformers and Resistances. All Gold Test Replacement units are designed with a large margin of safety and are individually tested at factory.

Dealers! Stock Wellston Gold Test Improved Aerial and Replacement Parts. Cash in on BIG DEMAND. Write for information and discounts.

WELLSTON RADIO CORP.

Dept. 202

St. Louis, Mo.

Direct Coupled Amplifier

(Continued from page 588)

The logical method of accomplishing this end seems to be to take a basic circuit, such as the type B-245 amplifier, and couple it by conventional means to the grids of the power output tubes. This was a method followed in the design of the D-250 amplifier, the circuit of which

-50 and -81 tubes is lower than if larger tubes were used in smaller number. The push-pull-parallel arrangement is an ideal one for this circuit, as it permits of a power output of approximately 24 watts of sound energy, undistorted. The frequency characteristic of this amplifier is

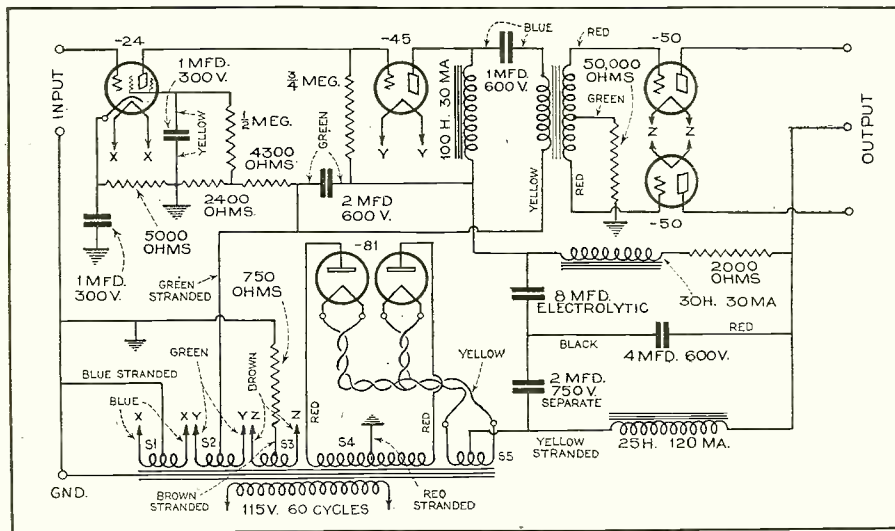

CIRCUIT DIAGRAM OF THE 12-WATT AMPLIFIER

Figure 4. This type D-250, direct-coupled unit is capable of operating several dynamic speakers at maximum volume

appears in Figure 4, shown above.

The constants of the voltage amplifier stages remain identical with those of the B-245 amplifier and the voltages are furnished both the voltage amplifier and the power amplifier stage from one common power transformer. The choice of the constants used in the choke, condenser and transformer coupling unit is such that the overall frequency characteristics of the combination are substantially flat, so that the excellent frequency characteristics of the B-245 amplifier are reflected in the output from the type -50 push-pull tubes.

Logically, the addition of another stage will give higher gain. This gain, however, does not in any way tend toward instability and the amplifier may be used in conventional manner with no fear of oscillation. The frequency response curve is given in Figure 5.

It will be noticed that the amplifier is not peaked at any point in its range and gives high gain, about 78 decibels, without sacrificing either the low frequencies which give body to the reproduction or the high frequencies which lend brilliance. The power output from this amplifier is 12.2 watts of undistorted sound energy.

A still larger unit, the E-250 amplifier, is simply another step forward in the march of power. This unit employs four type -50 tubes in the output and four type -81's for the rectifier. Again a design choice was presented to the engineers in the use of tubes. The ready availability of such tubes as the type -50 and type -81 dictated the decision where larger output tubes and rectifiers would have reduced the actual number of tubes used. The actual cost of using the types

identical with the D-250, the curve of which is shown in Figure 4, the only difference being in the power output.

Where higher power than 24 watts is desired it is of course possible to design amplifiers using larger tubes than does the E-250. However, if flexibility is taken into consideration, where extremely high power is desired, it is certainly more feasible to use a multiplicity of channels, utilizing amplifiers of the E-250 type rather than to obtain all the required power from one channel.

Availability of replacement tubes as well as the flexibility of using the separate channels on separate programs are advantages. Also, in the case of breakdown, only a portion of the speakers would be incapacitated, while the remainder would continue to operate. Where it is necessary to conserve both weight and space, it might be desirable to go to higher powered tubes, although, as explained above, both utility and expense would dictate the use of two or more amplifiers of the E-250 type.

Although power amplification as applied to sound is comparatively a new field, so much has been written on the various phases of the subject that it hardly seems necessary to go into the various uses here. The market has so broadened that no longer does the sound engineer have to seek an outlet for his energies, but rather does the market look to him for better and better equipment. In fulfilling this demand the manufacturers have rendered a real service to the public. Combined in such amplifiers as have been described in this article will be found outstandingly natural reproduction from standard recordings.

DEALERS and SERVICEMEN SEND FOR OUR NEW 64-PAGE TABLOID CATALOG



that every radio dealer and serviceman should have.

Chock full of bargains and helpful service data, this book is yours for the asking.

It will save you up to 50% on your replacement parts purchases.

Send for It Today



25 Park Place, Dept. A. New York City

GET INTO ELECTRICITY! REAL JOBS OPEN FOR YOU ELECTRICITY, easily learned in 12 weeks, offers permanent, big-pay jobs to men who know their stuff. Learn Electricity the McSweeney Shop Plan way. No books! No lessons! Not a correspondence course. You learn by DOING; by actual work with real tools on real electrical equipment. Write today for Big Free Book completely describing the 12 weeks course; also R. R. Fare and New LOW Tuition Offers.
McSWEENEY ELECTRICAL SCHOOL
E-20-1 Cleveland, Ohio

The March of Electrons

(Continued from page 573)

in front of a photo-cell, it is now possible to examine them at a high rate of speed and the defective articles are very quickly found and rejected. This is still another example of how the photo-cell is replacing the human eye in factory inspection. Paper boxes, cigars, wrappers, peas, beans and a number of other items are now inspected by the alert and swift eye of the photo-cell.

It is curious to note the many and varied places in which the photo-cell bobs up to do its ever-increasing bit. Now the reforestation service has found a new and valuable job for it to do. When used to measure the intensity of sunlight, a chore that it does beautifully, a formula is evolved which shows how closely trees may be planted in various localities and climates.

It has long since been known that nerve impulses are essentially electrical in their nature. Not only our feeling, but our sight and hearing is made known to the brain by a series of electric currents passing over the delicate nervous network. It has already been shown that the human eye functions in the same manner as a photo-electric cell and that various amounts of current are produced by light of different colors. Now two experimenters of the Psychology Department of Princeton University have amplified the delicate currents passing along the nerves running from the ear. The experiments were made with an anesthetized cat. The currents passing along the nervous system were led to a very powerful vacuum tube amplifier and were clearly heard on a loudspeaker.

Research workers in television have long realized that the neon tube, with its red spectrum, cannot be a part of the television receiver of the future. The light it emits is hard on the eyes and produces poor delineation. Experiments are now being made on tubes containing other gases and combinations of gases. It is hoped eventually to find a gas or combination of gases that will produce a light very close to daylight. This would be a very desirable thing and would put television development ahead a number of years.

Although the technique of photo-cell construction has been vastly improved during the past five years, there is still much to be desired. A German experimenter, Lange, has produced a cell in which the cathode is a thin metal film separated from the anode by a very thin semi-conducting layer very similar to that used in the copper-oxide rectifier. The metal film of the cathode is so thin as to be transparent, and the anode film is also very thin so as to reduce its electrical resistance. Most any metal may be used.

Measurements with the new cell have shown it to possess remarkable sensitivity over practically the entire spectrum, although it appears to be especially sensitive to infra-red. The inventor of the cell claims that it is ten times more sensitive than ordinary photo-cells and that it can be made very cheaply. Very important news for the electronics art, if true.

"WORKS PERFECTLY and Surely brings in the DX"



So Says One Admirer of the
**NATIONAL
SW-5
THRILL-BOX**
(Range 9-2000 Meters)

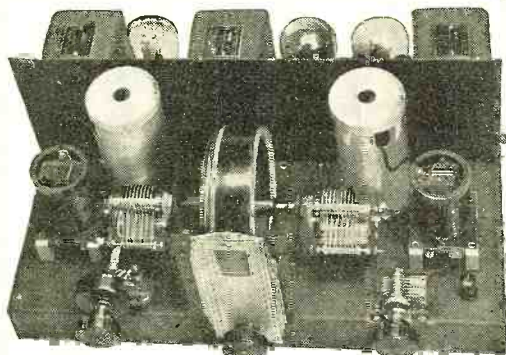

One Reason Why the THRILL-BOX Has Become an Outstanding Short-Wave Receiver

The THRILL-BOX now employs the new 235 Variable-Mu tubes. By employing a new and heretofore unused principle of these tubes with the THRILL-BOX circuit, the point of greatest sensitivity is approached along an inverse exponential curve. For this reason the same smoothness of control and the same sensitivity is available on all signals regardless of frequency, and without critical setting of the controls.

HIGH-LIGHTS on the SW-5

Range 9-2000 meters. Extremely high signal to noise ratio. True single-knob tuning. Set and forget the antenna trimmer. Easy to log with NATIONAL projector Dial, type H, no parallax. Special 270° Type S. E. Tuning Condenser with insulated main-bearing and constant-impedance pigtail makes gang-tuning possible on the short waves. Equipped with standard set of 4 pairs of R.F. Transformers covering range of 15 to 115 Meters, wound on forms of genuine NATIONAL R-39. Uses the new UX-235 Variable-Mu tubes.

giving improved sensitivity and less critical operation. Humless A.C. Power Supply with special filter section. R.F. Filter on Rectifier Tube, and Electrostatic Shield. R.C.A. Licensed.

Battery Model

Made also in Low-Drain Battery Model using new air-cell battery and 2-volt tubes.

Special Broadcast Model

Model now available using 245's in Push-Pull for Audio output, for greater volume.

Fill in Coupon below and mail Today for complete information

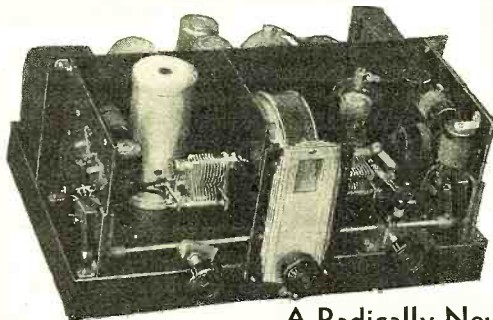

**NATIONAL
NC-5
Short-Wave Converter**
(Range 15-185 Meters)

A Radically New Type of short-wave instrument. For use with any Radio Set.

Unlike the ordinary converter, the NC-5 has two additional stages:—a high frequency pre-amplifier input tube and a high gain R.F. amplifier output tube, giving additional voltage gain of 100 and forming low-impedance coupling to radio set.

HIGHLIGHTS of the NATIONAL NC-5 Converter.

Easy to tune and log. Single Control Tuning with perfect "tracking"; high signal to noise ratio. Special HARMONIC TUNED INPUT CIRCUIT possible only with 235 tubes. Peaking on different short-wave broadcast bands. New coupling arrangement from cathode return circuits resulting in minimum background noise.

NO COILS TO CHANGE

But really effective, silent coil-switching arrangement made practicable through R-39, super-efficient low-loss insulation material developed by R.F. Laboratories specially for NATIONAL Company. Different s.w. broadcast bands fall on approximately same settings on dial.

COLOR OF DIAL-LIGHT Indicates Frequency Range

As the coil-changing switch is turned, color of dial-light changes to show which coils are in circuit.

ATTRACTIVE—COMPACT

Size, 8" x 17½" x 12"
Made in standard model with metal cabinet and special de luxe model in inlaid solid mahogany cabinet.

Send in this Coupon today.

COUPON

NATIONAL CO., Inc.
61 Sherman Street, Malden, Mass.
Gentlemen:

- (Check which)
- Please send me complete information and prices on your new NATIONAL NC-5 Converter.
 - Please send catalog sheets on the improved SW-5 THRILL-BOX.
 - I enclose 50c (stamps or coin) for your 64-page Handbook of Short-Wave Radio, describing in full the latest and best short-wave receiving circuits, adapters, converters, meters, etc.

Name
Address RN-132

SHORT WAVE

Reception with Your
BROADCAST RECEIVER

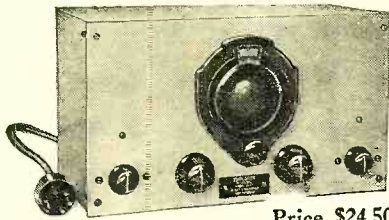

Price \$24.50

THE "EXPLORER" PLUGLESS POWER CONVERTER

Efficiency—Convenience—Economy

Obtain real short wave reception, efficiently and economically, by using an EXPLORER with your broadcast receiver. Attached to your present receiver, the performance of the EXPLORER equals that of any expensive short wave receiver. Many EXPLORER enthusiasts report consistent reception of stations such as G5SW, England; I2RO, Italy; and VK2ME, Australia, with real loud-speaker volume.

No PLUG-IN COILS. Automatic Band Selector changes wave-length bands in less than a second by turning a knob—an original EXPLORER achievement.

Power Amplifier in converter gives ample loud-speaker reception of distant stations. Special wide-spread vernier, genuine single dial tuning, and numerous other exclusive features.

Price \$24.50. Each EXPLORER air-tested at factory and ready for use. New 1932 models now ready, designed for every broadcast receiver, including the new Superheterodynes. Order now! Sent C. O. D. on receipt of \$2 or prepaid on receipt of price in full. Foreign price \$25.50, remit in full, shipment prepaid. State make and model number of broadcast receiver.

Send Now for Free Literature

RIM RADIO MFG. CO.

695 Grand St. Brooklyn, N. Y., U. S. A.

A NEW BOOK

SERVICING SUPERHETERODYNES

By John F. Rider

A NEW book offered to the radio service man. Here is the superheterodyne service information you have been awaiting for a long time. Everything you want to know and need to know about servicing superheterodynes at a profit.

Principles of operation—Explanation of the different commercial circuits—Breakdown of the superheterodyne receiver sections—Troubles in superheterodynes—Servicing superhets—Application of set analyzers—oscillators—adjustment of trimmer and tuning condensers—Facilities in superhets—Design of IF and RF oscillators. . . . Sold with Money Back Guarantee.

Price \$1.00 Postpaid

PERPETUAL TROUBLE SHOOTERS' MANUAL

By John F. Rider



the only reference book for the service men. . . . In this loose leaf service library every service man will find the receiver data he requires for PROFITABLE service work. . . . Special attention has been paid to electrical values—color coding—voltage data—GUARANTEED TO BE UP TO DATE. . . . Examine it at your local dealer.

Price \$5.00 Postpaid

Send for Descriptive Literature Describing both of these excellent books. . . . It will be the most profitable investment you ever made. . . . GET A TROUBLE-FINDING DIAL FREE.

RADIO TREATISE CO., INC.

1440 Broadway New York City

Dealers, Distributors WANTED

UNIVERSAL AUTO RADIO CORP.

1227 S. Michigan Ave. Chicago

Radio Physics Course

(Continued from page 595)

the common insulating materials are listed in Table 2. The voltages are expressed as the number of volts required to pierce a given thickness of the material (.001 inch).

The breakdown voltages are difficult to measure exactly, for they vary greatly with the particular samples tested and the conditions of test. The upper and lower limits of breakdown voltage which may be reasonably expected for the particular materials are given in the table above.

Dry air is a fairly good insulator, but its dielectric strength is not exactly proportional to the thickness of the layer. The values given in the table above are useful in determining approximately how thick a certain insulating material must be made in order to safely stand a given voltage without breaking down, remembering that the thicker the insulator is, the higher is the voltage required to break it down. Thus if a piece of mica .001 inch thick can stand 2000 volts, a piece .003 inch thick can stand approximately 60000 volts. Of course a factor of safety must be allowed to take care of possible

weak spots in the insulator, etc. Also, the properties of most insulating materials are very different when subjected to low-frequency alternating current voltages than when subjected to high frequencies. A piece of insulating material capable of withstanding 100,000 volts at 60 cycles (commercial electric light frequency) may deteriorate and become conductive very rapidly when subjected to only 20,000 volts at 150,000 cycles per second (radio-frequency current).

In radio transmitting and receiving equipment, porcelain, pyrex glass, and dry treated wood are used as insulators in the antenna system. In the station equipment bakelite, formica, hard rubber, mica, paraffin wax, beeswax, cotton, silk, glass and treated papers and cloths are used extensively as insulators. Each one has its own particular properties, such as hardness, flexibility, adaptability to molding, cheapness, thinness, etc., which make it best suited for use in a certain part of the equipment (see Figure 1).

The common conducting materials used are copper, aluminum, brass, tungsten, tin foil, etc.

Tuned R. F. Design

(Continued from page 563)

complete radio chassis.

The foregoing analysis gives only a few of the problems encountered and their solutions, in an endeavor to put out a radio chassis which would have the highest degree of sensitivity that could be used, adequate and even selectivity all over the broadcast spectrum, and at the same time lifelike quality—a virtue that some designers seem to have forgotten during the past year in their attempts to make tremendous cuts in manufacturing costs.

UNIFORM VOLUME VARIATION

Figure 10. (Right) The volume control is so tapered as to provide sound intensity which varies directly with the volume control setting, so far as the ear can detect

AUDIO RESPONSE CURVE

Figure 11. The unavoidable but slight attenuation of the higher frequencies in the tuner is compensated in the audio amplifier by a moderate peak which reaches its high point at 5,000 cycles

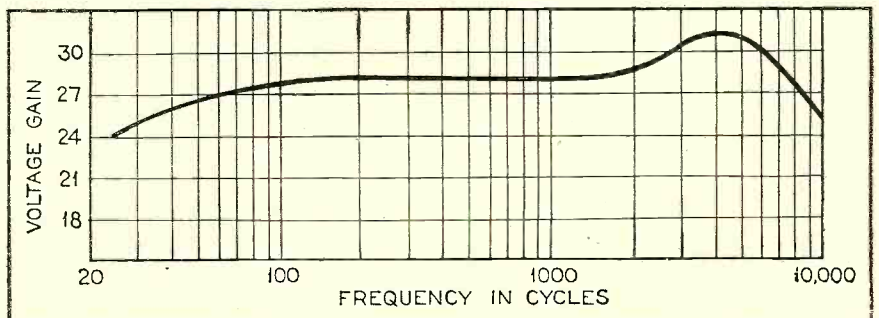
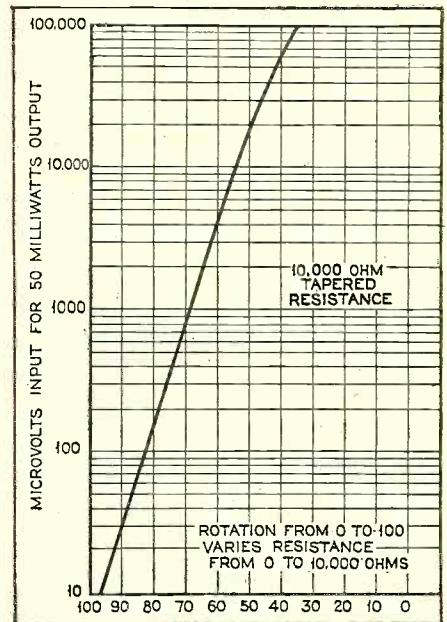

Electrical Transcription

(Continued from page 565)

be incorporated in one program and collections of talent otherwise impossible are brought together. Thus if it is desired to have the whistle of a train, the crash of thunder, the roar of waterfalls, or any number of sounds not possible to reproduce accurately in a regular broadcast, these sounds may be recorded at the source and dubbed into the program at a later date.

From the broadcast station standpoint electrical transcription broadcasts offer both advantages and disadvantages. The advantages are that the desired type of program may be put on the air at any desired time, and listeners may be offered programs comparable with the best chain broadcasts. On the other hand, record bootleggers with the ancient cry of "just as good at half the price" have misled many advertisers into releasing recorded broadcasts of inferior quality. The result is shown in the fact that many stations absolutely refuse to broadcast electrical transcriptions excepting at their own option, and many more have an additional charge of from ten to forty per cent. for recorded broadcasts unless such meet with their approval, when the charge is dropped.

Their troubles do not stop there. Broadcast equipment must be of the proper type, with the same frequency response as the sound system used in the original recording to get maximum efficiency from the programs. The best equipment is expensive—beyond the reach of many stations. Ordinary phonograph pick-ups are out of the question, as they are unable to take the load, and the result is the same as an overloaded studio broadcast.

Station equipment is similar to the sound system at the recording studios. The most up-to-date uses double synchronizing turntables on one of which the electrical transcriptions are placed, revolving at 33 1/3 r.p.m. if they are the large discs. The impulses are picked up, carried through the modulator and amplifier systems, and put on the air exactly the same as a studio broadcast.

The 16-inch discs play for approximately ten minutes, allowing ample time for the changing of discs. At the end of the first section of the performance the other synchronizing turntable is started and as the last notes of one disc are heard the operator switches the broadcast onto the other disc, which is turning at exactly the same speed, by use of a "fader." This eliminates any break whatsoever in the program other than the called for in toning down at the end of each disc and beginning of the next.

Gustave Haenschen and Frank Black, vice-presidents of Sound Studios, high priests of the broadcast program and creators of such outstanding achievements as the Palmolive, General Motors, Chase & Sanborn Choral Orchestra, Happy Wonder Bakers, Armstrong Quakers, Peters' Parade, Gold Medal, Chevrolet and many other famous national broadcasts, are credited with having been

(Continued on page 620)

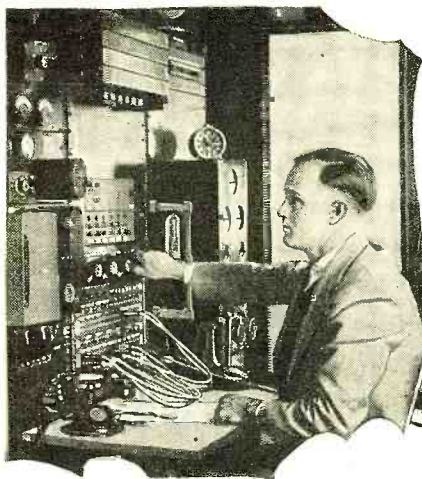

FREE RADIO BOOK~ describes many opportunities to make BIG MONEY in Radio-Talking Movies (Television also Included)

Here's a famous book that has shown many a man the way to "cash in" on the big-pay opportunities in Radio. I'm not asking \$5 or \$6 for it—it's FREE. If you're earning a penny less than \$50 a week, mail the coupon below and get a copy of this free Radio book. It will be a revelation to you!

Many Make \$50 to \$100 a Week

Radio—the NEW, uncrowded, growing, live-wire profession—needs many trained men for its good jobs every year. Television, Talking Movies, Aircraft Radio, Radio Servicing and Merchandising, trans-Atlantic Radio Telephony and many other opportunities are thoroughly covered by N. R. I. training. Each one means more big-money opportunities for a trained Radio man. My book gives the facts about these Radio opportunities. And more—it tells how you can get all the training you need, quickly and easily in your spare hours at home, by my new and practical methods. In a short time, through my training, you will be prepared to take advantage of these big-money Radio opportunities. My Free Book will give you all the facts and proof of what I have done for hundreds of other men.

Extra Dollars for You Almost at Once

Think of making \$15, \$20, \$30 extra each week "on the side," without interfering with your regular job! I'll show you how to do that, too, by using spare time that you're wasting now. I'll show you how to turn what I'm teaching you into cash almost at once, when you and I get started together. My Free Book tells you all about it. If you send for the book today, and if you have the average man's ability, it's possible for you to be making extra money in less than thirty days from now. And you can be ready for a good full-time Radio position after eight to twelve months of spare-time training.

I'll Send You This Big NEW 64-Page Book FREE

My book is filled with photos and facts—the pay-raising facts you want to read. If you're interested in Radio, or if you're interested in making more money, you owe it to yourself to read this book. The book absolutely won't cost you a cent, and you place yourself under no obligation by sending for it. No previous Radio experience needed to take advantage of this offer. No special schooling required. Fill in and mail the coupon NOW!

Address J. E. SMITH, President
National Radio Institute, Dept. 2ARA, Washington, D. C.

Hundreds of Men Have Won Success This Way

The National Radio Institute is the pioneer home-study Radio school. It has prepared hundreds of men for the Radio profession—some of them now holding leading positions in this industry. You'll find N. R. I. trained men in practically every Radio organization of any importance throughout the country. The same practical tested training that enabled these men to get ahead is now open to you. And this training has been improved, enlarged, greatly to keep up with the constant expansion of Radio opportunities.

Has Made \$10,000 More in Radio



"I can safely say that I have made \$10,000 more in Radio than I would have made if I had continued at the old job. When I enrolled with you I didn't know a volt from an ampere. I advise all ambitious young men to get into Radio. There is no greater opportunity."—Victor L. Osgood, St. Cloud Ave., West Orange, N. J.

Over \$400 Monthly



"I had 15 years as traveling salesman and was making good money, but could see the opportunities in Radio. Believe me I have made more money than I ever did before. I have made more than \$400 each month. I can't say too much for your school."—J. G. Dahlstead, Radio Station KYA, San Francisco, Cal.

Mail
coupon
Today!

J. E. SMITH, President,
National Radio Institute,
Dept. 2ARA, Washington, D. C.

Dear Mr. Smith: Kindly send me a free copy of your famous 64-page Radio book, which tells all about the big-pay opportunities in Radio, Talking Movies, Aircraft Radio, Servicing and Merchandising, and those coming in Television, and how you can train me at home to take advantage of them. I understand this places me under no obligation and that no salesman will call.

Name.....
Address.....
Town.....



FOX Units not only command attention for their output volume and tone value—they offer definite, exclusive coil and diaphragm features that insure continuous and trouble free service. The Fox Electro-Dynamic Unit and the Fox Rams Horn is a combination that outdemonstrates anything on the market.

Improve your present equipment with a Fox Unit. Complete sound engineering service. Estimates free for special work.



Engineering Co.
388-392 Dorrr St.,
Toledo, Ohio,
U. S. A.

DIRECT FROM MANUFACTURER TO CONSUMER
NEW POLO MIDGET \$16.50
COMPLETE WITH ARCTURUS TUBES



Full five tube set with 8-in. power dynamic speaker using the latest type **BEVTOLE MULT-MU TUBES**. This Midget performs on distance and has the tone quality of a large expensive set. **WONDERFUL SELECTIVITY. FULL VISION DIAL. BEAUTIFUL WALNUT CABINET. COMPLETELY NO WAITING. IMMEDIATE DELIVERY.** Complete with set of 5 **ARCTURUS TUBES**, cat. P. J. R. N. \$16.50.

OUR UNQUALIFIED GUARANTEE

We guarantee that the Polo Junior Midget is leader in its class, with unequalled sensitivity, thrilling tone and real selectivity. Buy one try it for five days, if you can find as good a set at twice the price, or we will promptly refund the purchase price. **NO OTHER MANUFACTURER THINKS THAT MUCH OF HIS SET.**

OTHER PRODUCTS WE MANUFACTURE

- The **POLO** de luxe midget receiver complete with full set of **ARCTURUS TUBES**, cat. P. M. R. N. \$23.00
- With same guarantee as cat. P. J. R. N.
- POLO ALL-WAVE RECEIVER**, cat. P. A. R. N. 37.50
- POLO ALL-WAVE CONVERTER**, cat. P. C. R. N. 35.00
- Full line of **POLO TRANSFORMERS**

Polo Engineering Laboratories
125 West 45th Street New York City
Phone—BRyant 9-6516

GEARS

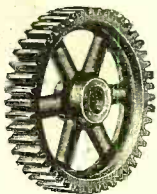

In stock—immediate delivery
Gears, speed reducers, sprockets, thrust bearings, flexible couplings, pulleys, etc. A complete line is carried in our Chicago stock. Can also quote on special gears of any kind. Send us your blue-prints and inquiries.

Write for Catalog No. 49
CHICAGO GEAR WORKS
769-773 W. Jackson Blvd., Chicago, Ill.

2 Years **RADIO NEWS** \$4.00 with **FREE** Copy of "23 Lessons in Radio"
See Page 638

RADIO BUILDERS' TUBES

- 233-247 Pentodes.....\$3.00
- 230-231-232 Two-Volt Tubes......75
- 236-237-233 Auto Tubes.....1.00
- 227 Detector......35
- 226-224-245's......50
- 210 Fifteen-Watt Oscillator......50
- 231, 250's......1.50
- 222 D.C. Screen Grid.....1.00
- 201A, 112A, 171A......55
- Carbon Pigtail Resistors, each......10

All Merchandise Guaranteed
Send for Special Supply Catalog

UNITED RADIO BUILDERS
1234-36 Springfield Ave., Dept. T, Irvington, N. J.

Latest Radio Patents

(Continued from page 602)

two oscillatory circuits of the same periodicity but each of the circuits having a different ratio of inductance to capacity; opposing the electrical effects produced in the two circuits against each other in their actions on a third circuit; and transmitting the resultant electrical effect produced in the third circuit to a detector and amplifier.

1,822,061. **METHOD AND MEANS FOR MEASURING LIGHT INTENSITIES.**
WALTER VAN BRAAM ROBERTS, Princeton, N. J., assignor to Radio Corporation of America, a Corporation of Delaware. Filed Apr. 6, 1929. Serial No. 353,036. 12 Claims.

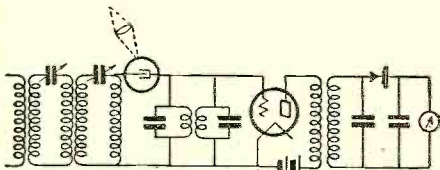

8. A system for measuring light intensity which includes a light-sensitive element which passes current in other than direct proportion to applied voltage in the presence of constant illumination, means for applying a frequency of predetermined value thereto, means for subjecting said light-sensitive element to light of unknown intensity, thereby producing currents of a frequency other than that originally impressed, means for amplifying the currents of the frequency produced by said element, and means for indicating the light intensity reaching said element from said amplified currents.

1,822,653. **PHONOGRAPH COUPLING FOR RADIO RECEIVERS.** ALFRED H. GREBE, Hollis, and PERCIVAL D. LOWELL, Jamaica, N. Y., assignors to A. H. Grebe & Co., Inc., Richmond Hill, N. Y., a Corporation of New York. Filed June 28, 1930. Serial No. 464,584. 4 Claims.

1. In a radio receiver having tuning means, a vacuum tube detector, a transformer arranged for excitation from a phonograph

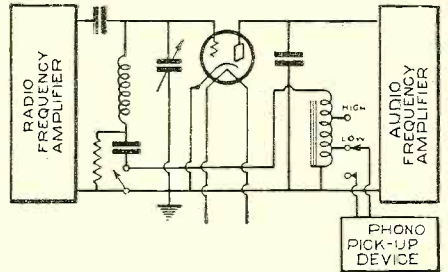

pick-up, and means automatically operated by the adjustment of said tuning means to utilize said detector tube as an amplifier of the signals generated by said phonograph pick-up.

1,823,703. **LIGHT CONTROL DEVICE.** EMIL RUPP, Berlin-Frohnau, Germany, assignor to General Electric Company, a Corporation of New York. Filed Dec. 26, 1929. Serial No. 416,732, and in Germany Feb. 22, 1929. 5 Claims.

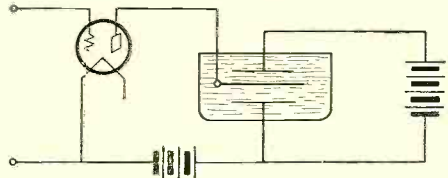

1. A light control device including a doubly refracting liquid affected by an electrostatic field, a cathode and an anode mounted in said liquid, and a control electrode arranged between the cathode and anode to control the position of the cathode drop in said liquid.

Electrical Transcription

(Continued from page 619)

largely responsible for the high quality of art in the better electrical transcription field. One of their major contributions has been the organization of a sound library estimated at over half a million dollars value.

Out of the six hundred and eleven stations in the United States, ninety-five per cent. use electrical transcription or record broadcasts at some time during the day. Of this number 126 are equipped with the most modern sound systems for the use of transcriptions, and more are installing it as time goes on. Many have partially up-to-the-minute systems. While the best results can be broadcast only by the use of both the best sound system and the best transcriptions, even stations without a thoroughly modern system are now able to offer sustaining programs of merit.

There are many advantages in electrical transcription. More time and thoroughness can be given to the making of the program, eliminating mistakes and de-

fects prior to broadcast. Programs can be gathered from widely separated points or over periods of months and incorporated into one. Otherwise impossible combinations of talent can be arranged, sound effects are real, and small stations have the best of the world's musical library within their reach.

During the past month decided progress has been made in the transcribing of programs, the major one being the elimination of almost all of the record "scratch." Glancing into the future, we see the day when television programs will be broadcast from records, and, in the home, a record attachment for the television receiver by means of which you will save the outstanding programs, building up your own library to play back at any desired time.

No longer can stations give inferior entertainment and use the excuse that better could not be arranged. Good programs, even outstanding ones, can be had—by air mail, if necessary.

RADIO NEWS Transmitter

(Continued from page 572)

has not as yet been erected for operation with the RADIO NEWS transmitter. Upon the completion of two iron pipe masts, experiments will be made to obtain a perfect "zeppelin" type antenna. Different lengths of antenna will be tried. The theory that feed wires but one-quarter of the length of the top stretch of the antenna reduces the efficiency of the system will be tested.

At present an antenna-ground system is being used with fair results. The total length of the antenna for operation in the middle of the 3.5 megacycle band is 175 feet, including the lead-in. The ground is made to a steam-pipe close by the transmitter. When using this system, one should be positive that a good ground is used. Cold-water pipes will be found to work best in most cases.

The antenna system finally adopted for use at W2RM will be described in a forthcoming issue of this magazine.

With the antenna disconnected from its circuit, the grid tank condenser should be set at approximately 65 percent of its total capacity with the 3.5 megacycle coils in the circuit. The back plate tank condenser should be placed at 50 percent of its capacity. With the keying circuit closed and with the plate supply transformer delivering 1000 volts on either side of the center-tap, the front plate tank condenser should be slowly rotated until a sudden dip is obtained on the plate milliammeter. The ma. reading should drop down to approximately 25 or 30. If the plate meter shows 100 or 110 ma. and does not respond to the turning of the plate tank condenser, it is a sign that the tube is not oscillating.

The plate condenser should be left at the point where approximately 40 mils. are drawn. Wiggle the key up and down to see if the circuit stays in oscillation.

The frequency should then be obtained by the use of a good frequency meter. Amateurs should be very cautious that their operating frequencies are in the prescribed bands. The Federal Government recently suspended the license of an amateur, subjected him to a large monetary fine and is taking action to place the party behind the bars for violating the Federal laws on frequency.

The antenna coils should be loosely coupled to the plate tank coil and the antenna lead proper connected to the lead going to the variable antenna condenser. The auxiliary feed wire should be connected to the far side of the antenna coil. Rotating the antenna condenser, the plate meter will rise as well as the antenna radiation meter. If, by turning the antenna condenser past a certain point the tube goes out of oscillation, the coupling between the antenna and plate tank coils should be further loosened. The ideal setting is where the antenna condenser, when turned to a certain point, will show maximum radiation with the tube remaining in oscillation if the condenser is turned past that point.

The antenna radiation with the antenna mentioned in this article was between .8 to 1 ampere, with a plate current of 80 milliamperes.

(Continued on page 622)

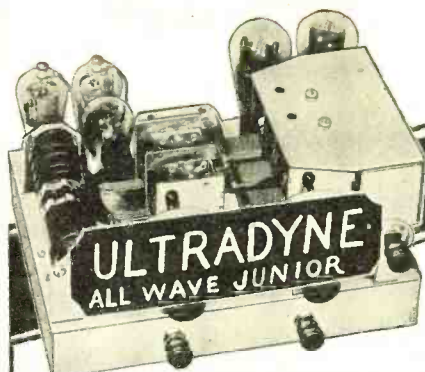

NOW READY!

The WORLD'S
GREATEST All-Wave
SCREEN GRID SUPER

ULTRADYNE

The set you have long waited for

The Ultradyne L-33 Junior is now ready, completely wired and assembled at the factory for you. This is the only set of its type that covers the entire wavelength from 15 meters up to 600 meters.

The Ultradyne is a shielded 8-tube chassis and is particularly adapted to the American broadcast, European short wave, police calls, trans-oceanic telephones, ships at sea, aeroplane and airport stations, experimental stations, long-distance reception; in fact, it includes every kind of a need that is possible in the reception of either speech or code signals.

The Ultradyne Junior is not a makeshift chassis nor is it a converter. This is truly a complete long and short-wave set from 15 to 600 meters all made in one chassis.

This circuit uses 8 tubes of the following types: two 235s, three 224s, one 227, one 280, one 247.

Two tuning dials, illuminated escutcheon plates, full range volume control and special switch for short-wave or the regular broadcast band.

This set comes equipped with a dynamic speaker.

List Price, Chassis and Speaker..... \$79.50
List Price, Complete with Tubes..... \$1.50

THE ULTRADYNE L-32 SENIOR

We like nothing better than to induce a hard-to-convince buyer. For we know after he has made a real test with this set it will mean more recommended sales for us. If you are hard to convince, all we ask is to send 25¢ for a booklet which tells you how to construct and operate the Ultradyne Model L-32 Receiver. This booklet also contains life-size picture diagrams and layouts of the entire set; also, life-size wiring diagram of the entire circuit, showing every wire location and connection.

The model L-32 Ultradyne, with the Dynatron oscillator, works equally as well on short waves as it does on the broadcast band.

ULTRADYNE KIT The kit contains 3 specially tested and matched Ultraformers with double compensating condensers in aluminum-sealed cans, 1 special steel chassis drilled and pierced as per specifications, all ready for mounting, 3 rubber grommets and 4 coil mounting pillars and INSTRUCTION BOOKLET. NOW ONLY..... **\$32.50**

When ordering send 25% with order. Balance C. O. D.

TRAUL RADIO CO., 1074 Atlantic Ave., Brooklyn, N. Y.

Study RADIO in CANADA



GEORGE MCCOLLUM

A. L. Norris, president, Norris Radio Co., writes: "My service manager, George McCollum, is one of your graduates. His excellent training has been largely responsible for the success of our Service Department."

DAY, EVENING AND HOME STUDY Classes

Complete, new Radio Course approved by leading manufacturers in U. S. A. and Canada. Our free Employment Service definitely assists you to start in a radio business of your own, or get employment as engineer, inspector, tester, service representative, salesman, etc. Write for free booklet.

RADIO COLLEGE of CANADA

310-A Yonge St. Toronto

ALUMINUM BOX SHIELDS

Genuine "ALCOA" stock, silver-plate finish. 5x9x6 \$1.89
Corner size \$4.65. 10x6x7 Monitor size \$3.25. 5x5x5
Coil Shield like picture on the right \$1.00. Any size to order.

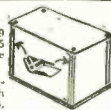

"BUDDY" Test Prod. Always sharp pointed, using phonograph needles, 4-ft. wires, splice or phone tips. Colored nipples identify each lead. \$1.50 pair.



We can furnish all parts for the Set Tester De Luxe described in October Radio News.

Parts for International Six Yaxley 7-Wire Connector. Male and Female, for 89c

We specialize in parts exclusively. We can furnish everything described in this magazine. Give us a trial. Please include postage.

BLAN, the Radio Man, Inc., 89 Cortlandt St., Box 21, New York City

F. & H. CAPACITY AERIAL



Price \$1.00 Complete postpaid

Every Instrument Tested on Actual 1127 Mile Reception

A LARGE NUMBER ARE IN USE BY GOVERNMENT, IN NAVY HOSPITAL

The F. & H. Capacity Aerial Eliminator has the capacity of the average 75-foot aerial. 50 feet high. It increases selectivity and full reception on both local and long distance stations is absolutely guaranteed. It eliminates the outdoor aerial along with the unsightly poles, guy wires, mutilation of woodwork, lightning hazards, etc. It does not connect to the light socket and requires no current for operation. Installed by anyone in a minute's time and is fully concealed within the set. Enables the radio to be moved into different rooms, or houses, as easily as a piece of furniture. 8,000 dealers handle our line. Dealers! Over 80 leading jobbers carry our line or order sample direct. Write for proposition.

---SEND COUPON, IT PROTECTS YOU---

Name

Address

City State

Send one F. & H. Capacity Aerial with privilege of returning after 3-day trial if not satisfactory, for which enclosed find check M. O. or dollar bill, or send C. O. D. Send Literature. Dealer's proposition.

F. & H. RADIO LABORATORIES
 Fargo, N. Dak. Dept. 19

BIG Reduction

in List Prices of

LYNCH

METALLIZED RESISTORS

Now it will pay dealers and servicemen to STANDARDIZE on LYNCH Metallized Resistors.

Write for details of RMA Color Code Chart and catalog showing new low list prices.



1, 2 and 3 Watts

Lynch Mfg. Co., Inc., Dept. N, 1775 B'way, N. Y.

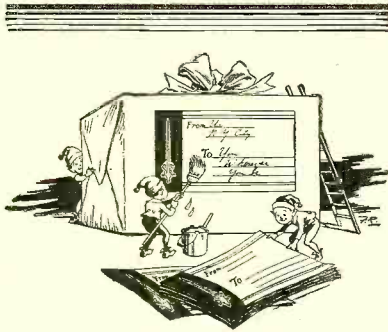

Do not open until Christmas

Let's Help Santa Claus

—Let's do our part in a worthy cause

WE are fighting for the control of cancer, which is yearly taking a greater toll of valuable lives.

To help this worthy cause, we are asking you to buy these Christmas labels, all gummed, ten to a package, price one dollar—and they make useful gifts to send to your friends, too.

For free information about cancer write to

NEW YORK CITY CANCER COMMITTEE

American Society for the Control of Cancer

34 East 75th Street New York City

Residents outside of New York City, write to American Society for the Control of Cancer, 25 West 43d Street, New York City

Universal Microphones
Proved Value—Superior Performance

Unparalleled values at rock-bottom prices. Enthusiastically endorsed for every sound use. Exclusive design features. Super-careful workmanship. Tested performance.

Complete line of microphones, stands, cables, etc. . . . at challenging prices. Unconditionally guaranteed. Consider carefully the UNIVERSAL line before you buy. For sale by dealers everywhere.

2-Button Handi-Mike
List Price \$15

BABY MIKE
List Price \$7.50

Universal Microphone Co., Ltd.
1163 Hyde Park Blvd.
Inglewood, Calif., U. S. A.

The Service Bench

(Continued from page 592)

grounded. When the set was first put on the market the manufacturer put out a small resistor to be inserted in the positive screen-grid circuit, thus cutting down the screen-grid voltage and bringing about the desired results in one way, but lowering the efficiency of the set. This idea was later found unsatisfactory, and they issued a bulletin informing their servicemen to stop this practice.

"Some of the receivers will become noisy after being operated for a while. This is caused by the pitch in the power transformer becoming warm and running out and down on the speaker plug. All that is necessary is to clean the plug, as the transformer is not injured.

"In one or two instances, the phonograph switch, which is automatically operated from the main tuning dial, became bad and caused noisy reception.

"Never connect one of these receivers with the antenna and ground reversed. This reversal will burn out the volume control, as the can is about 30 volts high.

"Balancing of this circuit is very hard without the use of a good oscillator and grip dip meter, and should not be attempted in the customer's home."

Fish-Lines and Button-Hooks

"I find a spool of fish-line and a button-hook a worth-while addition to the service kit. The fish-line is not used for DX fishing, as might be supposed, but to rethread the cable-driven drum dials. The button-hook is used to 'fish' the line through tight places. I believe this will

be of interest to the independent serviceman who repairs many different makes of receivers."

E. E. YOUNGKIN,
Altoona, Pa.

Service News

Among the most interesting and useful books prepared for the serviceman is the "Resistor Replacement Guide," published by the International Resistance Company at 2006 Chestnut Street, Philadelphia, Pa. Charts on practically all the popular radio receivers tabulate the following information regarding all resistors in each receiver: Indication of Faulty Resistor—Purpose of Resistor—Resistor Connection, From and To—Color Code of Original—Resistance Value—Recommended Metallized Resistor.

A new organization, known as the Institute of Radio Servicemen, has been formed with headquarters at 400 West Madison Street, Chicago, Ill. The new organization will in many respects be patterned after the Institute of Radio Engineers. It will be divided into sections, hold meetings and publish papers. It is probable that ultimately the new consolidation will bear influence upon the standardization of radio service fees. The Service Bench urges all servicemen readers to investigate the possibilities of the Institute of Radio Servicemen by writing to headquarters and requesting literature.

Radio News Transmitter

(Continued from page 621)

The tone of the signal produced should next be checked, either by use of a monitor or by using the receiver tuned to twice the transmitter wavelength and with the receiving antenna disconnected.

If the signals have a tendency to swing, it may be due to the long length of the antenna. This can be overcome by using an insulated wire in the approximate center of the aerial, broken up every few feet by insulators and fastened down to some solid object. This system will stop the antenna from swinging and thereby steady the outgoing signals. . . .

A word of caution on results. Give the transmitter a fair trial. Do not be discouraged by immediate failure on its performance. The writer's best transmitter did not produce the desired results until after two weeks of experimenting. It then went on to "work" almost everything heard on the receiver. On the other hand, one of the writer's transmitters effected communication with Capetown in South Africa only five minutes after it was hooked up—but failed to do anything noteworthy thereafter. This freak work can only be attributed to favorable or unfavorable conditions, something we have to accustom ourselves to.

The Parts for the Power Supply

- T2—Thordarson plate supply transformer, model T-2387
- T3—Thordarson filament supply transformer, model T-4585 (for use with type -66 tubes. See text for data on transformer used with type -81 rectifier tubes.)
- CH—Thordarson filter choke, model T-2027
- C9, C10—Flechtheim filter condenser, type TH-400, 4 mfd., 2000 volts d.c.
- R3—Electrad 100,000-ohm, 100-watt "bleeder" resistor
- 2 Airgap sockets
- 2 De Forest type 566 half-wave rectifying tubes
- 1 binding post strip

The next step in the development of the transmitter equipment will be made the subject of next month's article. Just which phase of the development this may be has not as yet been determined, as this depends on the progress made along the lines of crystal control, antenna design and voice modulation, all of which are in the experimental stage now.—THE EDITORS.

"Super" for Experimenters

(Continued from page 579)

parts. The variable tuning controls and variable resistors are mounted on the front panel. All wiring, whenever possible, is run beneath the baseboard. The heater wires are twisted and of large carrying capacity. The other wiring should be heavily insulated fine wire and bushings should be used where wiring passes through the aluminum panel or partitions of the shields while "hot" are kept above the panel. The various ground connections that are shown in Figure 1 are made by short, direct wiring to the cathode post, or resistor connected to it, for each tube concerned. This is to avoid radio-frequency currents circulating in unwanted paths in the aluminum base. The plug-in coil sockets are mounted on brass brackets somewhat above the sub-panel for two reasons; namely, to keep down eddy currents from the coils and to make readier access in changing the plug-in coils. These coils are made as directed in Figures 4 and 5 and the notes that are given with the table of coil specifications.

The layout will be given in Figure 6, next month. This will be found of great value in determining just which parts are to be located inside and outside of the shields. It is better to mount only the bases of these shields and fit them together after the wiring is nearly completed.

Keep all "hot" parts of circuits as far from the shields as possible to reduce eddy current losses. The wiring that goes above the panel will be shown next month and the remainder can be gleaned from Figure 1. This was done for the sake of clarity. It is suggested that each item when completed be checked on the diagram, so as to avoid leaving out important elements. Unless this is done it may easily happen that several very important by-pass condensers may be omitted, as there are so many that are of the same size and similarly connected. Although there are only two major controls (C2 and C4), there are four other controls that are shown as mounted on the front panels. These need only occasional adjustment and lend that additional flexibility to the set that is so desirable in very short-wave work.

In Figures 2 and 3 (next month) will be shown the main parts with their detailed dimensions and location.

It is suggested that the intermediate amplifier be wired before the rest. After construction it should, preferably, be tuned by a suitable oscillator to some frequency around 300 kc. to make sure they are matched. If the coils are correctly wound, i.e., occupy the same length of winding for the same number of turns and size, there is not any real need to do this. With all three stages alike, it is easy to adjust all three condensers as in any ordinary tuned radio-frequency set. This may be done later. It is necessary to mount the midget variable condenser, C4, C5 and C6 on a proper support with the last two insulated "above ground." The knob is removed from the condenser shafts and a saw-cut is made across the ends of the shafts to permit adjustment

ALWAYS AHEAD WITH PRICES THAT "PROVE OUR LEADERSHIP" AND HERE WE OFFER "PROOF"



STRATFORD'S NEW 5 MIGHTY 1932 TUBE MIDGET

VARIO-MU PENTODE
3-GANG CONDENSER
DYNAMIC SPEAKER
ILLUMINATED DIAL
DISTANCE SELECTIVITY
VOLUME TONE

A carefully designed circuit utilizing two vario-mu (235's), in the R.F. stages, seven grid detector (224), Pentode Power Output audio stage (247) and a full wave rectifier (280).

This triple screen grid receiver with Pentode output performs with great selectivity and sensitivity. Employs a 3-gang condenser, matched R.F. coils—Dynamic Speaker properly coupled to handle with maximum efficiency the volume from this remarkable receiver.

The cabinet is of outstanding design, finished in American Walnut.

Real Value is offered by this history making mantel radio.

Size 10 inches wide by 12 1/4 inches high by 7 3/4 inches deep. For 110-120 volts, 50-60 cycles

Price **\$13.35**

No. R-239 Less Tubes

Complete Kit of Stratford Licensed Guaranteed Tubes.

No. R-660—Price \$3.67



ATWATER KENT SHIELDED REPLACEMENT AUDIO TRANSFORMER

A compact efficient audio transformer. Size 1.6-8 inches diameter by 3.1-8 inches high. Color coated flexible leads.

No. R-1244 Price **\$1.25** 3 for \$3.50



BAL-RAD 600 VOLT UNCASED CONDENSERS

"For General Repair and Power Pack Work" 100% Guaranteed

Small—compact—inpromated in ditch. Provided with long flexible push back wire leads. Will withstand all weather conditions. Absolutely water proof.

Mtd. Cap.	No.	Each	Dozen
1.	R-2296	\$.25	\$2.75
2.	R-2297	.35	3.80
4.	R-2298	.50	5.50

"GUARANTEED 100%"

A 10-inch super-powered chassis utilizing a 280 rectifier. Can be used with any set—operates from 110 volts, 50-60 cycles. Furnished complete, with push-pull output transformer.

No. R-1807 Price (Complete with Tube) **\$5.95** Same as above with Pentode output transformer.

No. R-1828 Price **50c Additional**



FREE CATALOGUE—"MORE PROFIT"—These are but a few of the many thousand nationally known items listed in our Big New 132-Page Free Catalog—a surprise is in store for you—write for it now. "No orders accepted for less than \$3.00."

Order from this page
DEALERS
SERVICE MEN
AGENTS
SET BUILDERS
Send for our newest catalogue

BALTIMORE
RADIO CORPORATION
N-725 Broadway, New York, N. Y.

Order from this page
Terms:
20% with order, balance C. O. D. 2% discount allowed for full remittance with order only.

TRUVOLT RESISTORS



FEWER resistors required in stock—and fewer sizes in the serviceman's kit. That's the happy situation when you use TRUVOLTS.

And think how easily repairs are made with TRUVOLTS—and the valuable time you save yourself and your customers.

The exclusive TRUVOLT Adjustable Clips may be added, removed or set at any point for exact voltage values.

Patented, open-air winding keeps TRUVOLTS cool. All standard sizes.

Mail Coupon for Catalog

175 Varick St., New York, N.Y.
ELECTRAD
INC.

Please send me complete 36-page catalog and special replacement volume control guide.
Name.....
Address.....
RN-1

YOU GET THERE!



with RCA INSTITUTES radio training

NO matter what you want to learn in practical radio... whether you desire elementary or advanced knowledge... RCA Institutes is fully prepared to give you the trainings.

RCA Institutes... America's oldest radio training school, founded 22 years ago... is associated with the largest, most complete research laboratory in radio. Large variety of courses. Enter the one fitted to your needs. Modern equipment. Instructors with practical experience. Four resident schools—New York, Chicago, Boston, Philadelphia. Enroll any time. Courses start every six weeks. Free university scholarships offered. Also extension courses for home study. Free resident school scholarships for outstanding graduates. Tuitions moderate. Use coupon today.



A Radio Corporation of America Subsidiary

RCA Institutes, Inc., Dept EX-1, 75 Varick Street, N. Y. Gentlemen: Please send me your General Catalog. I am checking below the phase of radio in which I am particularly interested.

Aircraft Radio Disc and Film Recording
 Broadcast Station or Studio Talking Pictures
 Talking Pictures Servicing Home Entertainment Equipment
 Television

Name _____
 Address _____
 Occupation _____ Age _____

12 TUBE SUPER

CONSOLE MODEL COMPLETE with TUBES

\$67.50

The Roosevelt 12-Tube Super Master is a brand new, precision built receiver, years ahead in circuit design and efficiency. Uses two Pentode and five Variable Mu tubes. Automatic volume control prevents "blasting" the locals and fading on the distant signals. Actual 7 1/2 K.C. selectivity. Tremendous power and perfect tone. And think! Only \$67.50 for set, beautiful high grade console, full 12-inch dynamic speaker, all tubes and aerial. Made to sell for \$165.00. All ready to operate. Order direct from this announcement. Money back if you're not satisfied. Dealers, write for the most interesting radio deal ever offered.



COMMONWEALTH RADIO MFG. CO. 845 W. Harrison St. Chicago, Ill.



TRIMM FEATHERWEIGHT HEADSET FREE TRIAL OFFER

We have such confidence in the performance of our FEATHERWEIGHT that we unhesitatingly recommend it as the outstanding phone on the market, and to further prove our faith we will permit any FEATHERWEIGHT to be returned within 10 days for full cash refund if not satisfied.

Write today for full information

TRIMM QUALITY Fones for all purposes. Special attention given "The Hard of Hearing." TRIMM RADIO MFG. CO., 1528 ARMITAGE AVE., CHICAGO

by a small insulated-handle screw-driver. Make small holes in the shield sides, just opposite the shafts so that they may be tuned by inserting the screw-driver while the shields are in place.

Table of Coil Specifications

Turns		Tuning Range Meters	Turns	
L3	L4		L1	L2
2 1/2	2	14-16	4 1/2	1
3 1/2	3	15-18	5 1/2	1
5 1/2	4	17-23	7 1/2	1
6 1/2	5	20-28	8 1/2	1
8 1/2	6	25-35	10 1/2	1
10 1/2	7	32-45	12 1/2	1
13	8	40-52	18 1/2	1
16 1/2	9	50-60	22 1/2	1*
21 1/2	11	58-78	25 1/2	2*
29	12	75-130	34	3*
58	18	200-550	85	6*

* Connected for regeneration.

The above winding data are only approximate, as the tube characteristics as well as the individual features incident to the arrangement of parts quite appreciably affect the tuning range on the very short waves. All coils L1 and L3 are single layer, close wound. Spacing turns and larger size wire have some advantages on very short waves.

Intermediate-Frequency Coils

Coils L6, L7 and L8 are alike and consist of 300 turns of No. 30 d.s.c. wire wound single layer on bakelite tubing, outside diameter 2 inches.

The primary coil L5 has 110 turns and is mounted at the filament return end of coil L6. It is a single layer or a bunch-wound coil of No. 32 d.s.c. wire and may be wound on varnished cambric or a slightly spaced piece of bakelite tubing slipped over the form for L6.

The tickler feedback coil L9 has from 15 to 25 turns and requires considerable experimentation before being satisfactory. Use 25 turns and cut if regeneration is excessive. It is wound with No. 32 d.s.c. wire on a narrow piece of bakelite tubing that will just slip over the form for L8, or may be wound on varnished cambric laid over the winding L8. The winding is placed over the filament return end of the larger coil.

If a coil winding rig is not available, it is advisable to use a block of wood with a large wood screw driven into one end. Filing off the head and centering this piece in a chuck, it is a simple matter to wind the various coils. The block should be tapered slightly and the form for L6 slipped over it and fastened into place. Five holes, located by using the prongs of an SM form as a template, may be drilled into the end of the wood piece. These holes serve as a support to mount the form while winding coils L1, L2, L3 and L4.

The design of the i.f. amplifier is such that it forms an approximate "one-spot super" on the broadcast waves. For example:

The i.f. amplifier being adjusted to a frequency of 300 kc., it is necessary that the oscillator tune between 167 meters and 353 meters for the broadcast range. This follows from 550 kc. + 300 kc. = 850 kc. or 353 m. and 1500 + 300 kc. = 1800 kc. or 167 meters. For this reason only stations above 1150 kc. will have repeat points, assuming harmonics to be negligible. This follows from 1150 kc. - 300 kc. = 850 kc., the top value. The 1150 kc. station being received at 1150 kc. + 300 kc. = 1450 kc. and 1150 kc. - 300 kc. = 850 kc.

It is interesting to note the great advantage of a small condenser for C3 on the short waves. For example, to receive 75 m. (4000 kc.) the oscillator may be adjusted for either 69.9 m. (43000 kc.) or 81 m. (3700 kc.). Only one of these will probably appear on the scale. At 40 m. (7500 kc.) the two points are 38.5 m. (7800 kc.) and 41.75 m. (7200 kc.). In this case both points appear on the oscillator dial. These points continue to draw closer together the further down the scale in wavelength one goes. However, at 20 meters they are far enough apart to cause no trouble and serve as additional means of locating stations.

Another article next month will continue the constructional details and will also cover the detailed operating suggestions. In it will be included the panel, base and wiring layouts. The list of parts is included in the present article so that readers who desire to build the set may start preparations now.

List of Parts

- C1—Variable air condenser, Pilot J-5 (cap. 15 mmfd.)
- C2, C3—Variable air condenser, National Special ET-27 (cap. .00035 mmfd.)
- C4, C5, C6—Variable air condenser, Pilot J-23 (cap. 100 mmfd.)
- C7, C8, C9, C10, C14, C15, C16, C18, C19, C22, C24, C28, C29—Fixed paper condensers, 200 volts (cap. 1 mfd.)
- C11—Fixed mica condenser, Sangamo (cap. 70 mmfd.)
- C12, C17, C21, C25—Fixed mica condensers, Sangamo (cap. 100 mmfd.)
- C13—Fixed mica condenser, Sangamo (cap. 250 mmfd.)
- C20, C23, C26, C27—Fixed mica condensers, Sangamo (cap. 100 mmfd.)
- R1, R2, R11—Variable high resistors, Pilot Volumgrad No. 940 (0-50,000 ohms)
- R3—Variable high resistor, Pilot Volumgrad No. 941 (0-100,000 ohms)
- R4—Variable high resistor, Pilot Volumgrad (0-25,000 ohms)
- R5—Fixed resistor, 300 ohms (Electrad)
- R6, R8—Grid leaks, 3 meg. (International Resistance Company)
- R7—Fixed resistor, 250 ohms (Electrad)
- R9—Grid leak, 0.5 meg. (International Resistance Company)
- R10—Fixed resistor, 2200 ohms (Electrad)
- R12—Fixed resistor, 750 ohms (Electrad)
- R13, R14—Fixed resistors, 20 ohms (center-tapped), Pilot
- RFC1, RFC2—Choke coils, 85 mh., polarized (Hammarlund Mfg. Co.)
- S1—Single-pole, double-throw switch
- T1—Transformer, audio, 1st stage, Silver-Marshall type 225
- T2—Transformer, audio, push-pull input, Silver-Marshall type 227

(Continued on page 625)

Electric Filter Design

(Continued from page 575)

value $2 Z_2$ in parallel, we get the full shunt arm impedance Z_2 . As shown in the diagram it is common practice to designate the input and output terminals to be connected in the high side of the line by the numbers 1 and 2, respectively, and to number the terminals to be connected in the low side of the line 3 and 4, respectively. The impedance of the generator and of the load are represented by the symbols Z_S and Z_R , respectively.

A concept which greatly facilitates filter design is that of "image impedance." If any generator delivers electric energy to a load impedance so that none of the energy is reflected back to the generator it is said to be working into its image impedance. If a filter is inserted between this generator and load (or in a transmission line) so that there is no reflection of electric waves at any point, the filter is said to be working "between its image impedances." If the filter section is terminated as shown in Figure 4 (A) it is said to be "mid-series terminated" and has a mid-series image impedance Z_i . It may be terminated as shown in Figure 4 (B), then it is mid-shunt terminated and has a mid-shunt image impedance Z_i . If the filter section

(Continued on page 626)

"Super" for Experimenters

(Continued from page 624)

- T3—Transformer, audio, push-pull output, Silver-Marshall type 229
- T4—Transformer, filament, Aero 2.5-volt and 2.5 volt
- 1 panel, bakelite, 9 inches by 22½ inches by 3/16 inch
- 1 subpanel, aluminum, 12 inches by 22½ inches (preferably 14 inches by 22½ inches)
- 4 shields, aluminum, 4¼ inches by 8¾ inches by 5½ inches high
- 22 coil forms, Silver-Marshall 130-P or UY tube bases
- 2 dials, vernier type, National projection disc type
- 3 caps for screen-grid tubes (Remler)
- 3 shields for screen-grid tubes (Remler)
- 6 sockets, UY, Eby strip type for sub-panel
- 2 sockets, UX, Eby strip type for sub-panel
- 2 sockets, UY, Eby ordinary base
- 2 vacuum tubes, type -24
- 3 vacuum tubes, type -27
- 2 vacuum tubes, type -45
- 1 pentode r.f. vacuum tube, CeCo type P5 (This tube is available direct from the CeCo Company, Providence, R. I., if not obtainable from local dealers.)
- Power unit capable of supplying 80 ma. at 300 volts maximum
- 3 pieces 1/32 inch bakelite tubing 2 inches o.d. by 6 inches in length, 1/32 thickness
- 1 pound wire, No. 30 d.s.c. spool
- ½ pound wire, No. 32 d.s.c. spool
- 1 pound wire, No. 22 d.s.c. spool
- Miscellaneous hardware

—RELIABLE JR.—

1932 RADIO WITH EVERY NEW FEATURE 5-TUBE MULTI-MU PENTODE

Using the new Multi-Mu tubes in conjunction with the Pentode for the utmost in selectivity, quality and sensitivity.

NO AERIAL NEEDED—Built-in aerial eliminates the need of any antenna. Only a ground connection needed. Set up anywhere in a few minutes.

ROLA DYNAMIC—A Pentode Rola Dynamic in conjunction with a high quality amplifier gives tone comparable to any receiver.

FULL VISION TUNING—A full vision dial definitely marks the Reliable, a 1932 receiver.

Selectivity and quality of the highest degree. Perfect tone quality and selectivity ample for the most congested sections.

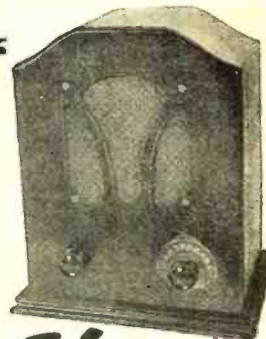

\$16.75

Complete with R.C.A. Licensed Tubes

MULTI-MU

You cannot afford to be without a copy of our new 64-page catalog. Over 2,000 items of interest listed. A post-card brings your copy to you.



RADIO SURPLUS CORP., 56 N. Vesey St., N. Y. C.

Radio Dealers: Radio Service Men!

NEW LOW PRICES
 Guaranteed Replacement Condenser Blocks and Transformers Net

Atwater-Kent 37 Cond. Block with chokes	\$3.95
Atwater-Kent 37 Power Transformer	2.95
Atwater-Kent 40 Pack Complete	6.50
Zenith ZE9, Stewart-Warner, Mohawk Blocks	3.45
Majestic "B" Eliminator Cond. Block	2.95
Electrolytic Condenser, 2 Anode	2.10
Electrolytic Condenser, 3 Anode	2.75

Hard-to-get parts—We have them
 Send us your repair work for estimate
 Write for our **FREE CATALOGUE**

Grant Radio Laboratories
 6523 South Halsted St., Chicago, Ill.

RACON USERS WILL TELL YOU . . .

There is nothing finer than a Racon

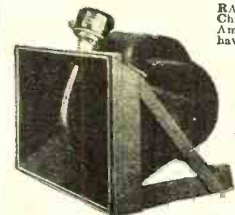

RACON HORNS for Schools—Churches—Theatres—Hotels—Amusement Parks—Air-Ports, etc. have proven to be ideal.

RACON NEW HORN No. 2115 (illustrated). Particularly adapted for small theatres, portable "Talkie" equipment and public address systems. Bell 18 in. x 24 in. x 23½ in. in depth. Air column 7½ feet. Weighs 23½ pounds, including frame.

RACON HORNS & UNITS ARE COVERED BY U. S. PATENTS NOS. 1,507,711; 1,501,032; 1,577,370; 73,217; 73,218; 1,722,448; 1,711,514; 1,751,489.

Write for Catalog Containing Complete Line
RACON ELECTRIC CO., INC.
 18 WASHINGTON PLACE, NEW YORK
 England and Canada

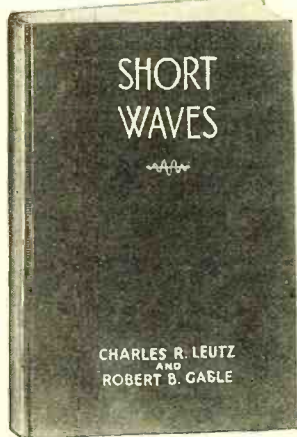

"SHORT WAVES"

with 18 months' subscription for **RADIO NEWS**
 Saving of **\$1.75**

384 Pages (6½ x 9½)

This is the most complete book on short waves yet issued, published by Charles R. Leutz and Robert B. Gasle. Price of book \$3.00.

The chapters on the propagation of short waves and directional antennas with their applications to the transatlantic radio links are the most complete of any yet available in book form. Skip distance, useful range and how they are affected by day, night or season, are exhaustively treated. Amateur and broadcast equipment, airplane radio, television and medical applications are among the other subjects covered. All the latest systems for the guiding of airplanes in fog, American and European television systems, the bloodless electric knife and many other late developments have here been brought together for the first time in a single volume.

Through a special arrangement with the publishers, we are able to offer you this book in combination with an 18 months' subscription to Radio News for \$5.00—a saving of \$1.75. Send coupon below.

TECK PUBLISHING CORPORATION
 350 Hudson Street, New York, N. Y.

R-1

Enclosed is \$5.00. Send me "Short Waves" and enter my subscription for Radio News for 18 months.

Name

Address

City

State

FILTERMATIC PRODUCTS

Help you to get the **BEST** possible reception from your **RADIO** set.



SUPER-TONE CONTROL

Will make your old Radio (battery or electrical) equal in tone to the most modern set.

Installed in one minute's time, no tools required.

Will tune out much of your noise and so-called static.

Will tune your set to suit your ears.

Positively cannot harm the finest radio in any way.

Price \$2.50 postpaid. Satisfaction guaranteed or money refunded.

SUPER-FILTERMATIC

The Modern Aerial

Thousands of satisfied users, praised by radio experts. Replaces all other aerials, reduces static and noise. Especially good on distance reception. Helps to separate stations, does not connect in light socket (therefore eliminating hum and line noise). It is very compact, measuring only 1¼ x 2 inches, is absolutely non-corrosive and non-directional. Installed in one minute, no tools needed. Will never wear out. Eliminates trouble and expense of listening-rooster.

Price only \$2.00 postpaid.

Satisfaction guaranteed or money refunded.



ALL PROGRAMS

Are Good with a **FILTERMATIC**. For all radios only \$1.00 postpaid.

Entirely automatic—no bothersome tuning. Improves tone, reduces static, brings in distance, increases volume, separates stations.

Installed in one minute, no tools required, in series with your aerial or across your aerial and ground. Satisfaction guaranteed or money refunded.

Send check or money order. C. O. D. 25% with order. (No foreign C. O. D.) Money back guaranteed after 5-day trial. Service Men and Dealers Write for Particulars. Also information about Free local newspaper advertising.

FILTERMATIC MFG. CO.

(Dept. B-10) 4458 Frankford Ave., Philadelphia, Pa.

Are You Responsible for Radio Interference?

(Continued from page 561)

Wait for this book

FREE!

You cannot possibly afford to be without this valuable book. It is not just another CATALOG—it is indeed a VERITABLE ENCYCLOPEDIA of the RADIO INDUSTRY.

WHOLESALE PRICES TO ALL

Super-Heterodyne Short-Wave Coils and Automatic Wave-Length Switch
No coils to plug in! Build your own Super-Heterodyne Short-Wave Converter. Ranges indicated by 4 position NO-LOSS bakelite shaft switch: 10 to 20, 20-40, 40-80, and 80 to 200 meters. Remarkably compact. Your cost (order from this advertisement) \$7.12
3 Gang Miniature Hammarlund .000145 Mfd. Variable Condenser. \$2.95

Here is One of the Up-to-Date Items We Are Featuring

10 to 200 Meters

COAST-TO-COAST RADIO CORPORATION

123 N West 17th St., New York N.Y.

CONDENSERS

**B
A
R
G
A
I
N
S**

We have a quantity of items to close out. Particularly suitable for the needs of radio amateurs and experimenters, they include

Mica Receiving Condensers
Mica Transmitting Condensers
Filter Blocks
Impregnated Sections, etc.

Write for special price list No. 500, descriptive of these inventory clearance bargains.

Dubilier Condenser Corp.
4377 Bronx Boulevard
New York City

NOW

Catalog 31-B
September 14, 1931

DAVALL
Radio Service Instruments

TUBE TESTERS
SET ANALYZERS
TEST OSCILLATORS
TEST PANEL
TEST ACCESSORIES

Get your FREE copy
FROM THE RADIO PRODUCTS CO.
14 HORNWOOD AVE. DAYTON OHIO

RADIO SERVICE INSTRUMENTS

Massachusetts Radio and Telegraph School

18 Boylston Street, Boston

Send for Catalogue

Tel. Hancock 8184 Established 1905

Figures Are Easy to Handle

Learn mathematics quickly! The expert in your line knows how to handle figures. Why not you? Algebra, geometry, trigonometry, and calculus are simple if you have this book to guide you!

MATHEMATICS FOR THE PRACTICAL MAN

by George Howe, M. E. All mathematical problems clearly explained. Send no money. Pay the postman \$1.50 plus a few cents postage. Money back if not satisfied.

D. VAN NOSTRAND CO., 250-N. 4th Avenue, New York City

electrical apparatus it is first necessary to analyze the circuit of the appliance from both an electrical and a radio standpoint. The electrical characteristics to be considered are:

1. Is the apparatus connected to the power line by means of a standard attachment cord and plug, or is it wired directly to the distribution system with conduit or BX? In other words, is the apparatus portable or is it designed for permanent installation?
2. How many amperes does the apparatus draw when operated at full load?
3. At what voltage does the apparatus operate?
4. Is the apparatus normally used on a.c., d.c. or may it be used on either a.c. or d.c.?
5. Does the apparatus contain a number of different circuits, some of which may draw relatively heavy current, while in no way affecting the interference (this applies particularly to hair driers)?
6. Is the frame of the apparatus normally grounded?

All of these characteristics bear on the mechanical and electrical design of the filter required. Obviously filters must be capable of operating at the voltage and current rating of the apparatus, and must be designed so that they may be installed in accordance with the best recognized standards of wiring practice. Under no conditions should a filter designed for plug-in service be connected to apparatus which is wired directly to the building circuits.

The characteristics of the apparatus which must be considered from a radio standpoint are:

1. Has the apparatus making and breaking contacts? (Commutator, centrifugal governors, automatic switches and flasher switches are the most common form of breaking contact.)
2. Is a spark gap used in any part of the apparatus?
3. Does the contact break an inductive or a non-inductive circuit?
4. At what speed does the breaking contact operate?
5. Are other circuits of the apparatus coupled in any way to the circuit in which the breaking contact is located?

All of this information is necessary in

Electric Filter Design

(Continued from page 625)

is terminated as shown in Figure 4 (C) it is terminated mid-series on the 1-2 end and mid-shunt on the 3-4 end. It is said to have a "mid-series" image impedance looking into the "input" end of the filter and a "mid-shunt" image impedance looking into the "drop" end of the filter.

NOTE 3—Electric energy may be conceived of as being reflected back towards its source when it flows past a point in an electrical circuit where the impedance looking both ways from that point is not the same. This is analogous to the reflection of light or sound energy when it goes from one media to another media of different density.

order to determine the design of the filter from a radio standpoint and the manner in which the filter must be installed for maximum efficiency.

After all of the necessary facts have been ascertained the correct filter for overcoming the interference may be chosen, and the best method of installing it may be determined. As has been stated, the most effective procedure for suppressing interference requires that the filter be located as close as possible to the point at which the interference originates. In the case of an appliance in which the interference is created by a small motor, a thermostat or a single circuit contactor, it is generally easy to locate the filter within a few inches of the interference source. In the case of apparatus causing interference due to a high-tension or high-frequency spark it may not be advisable to locate the filter at the exact point of origin of the interference.

Oil-burner ignition systems and electro-medical apparatus are outstanding examples of interference-creating apparatus in the above classification. In the case of an oil-burner ignition system the interference originates in the high-voltage circuit. As the cost of constructing a filter for use at the high voltages (10,000-15,000 volts) at which an oil-burner ignition system is operated would be exorbitant, the filter is usually installed in the low-voltage side of the system. The result of this practice is that interference may be radiated from the high-voltage wiring. It is therefore necessary, in order to overcome all of the interference, to provide shielding for the high-tension circuit. This shielding must be so installed as to leave no part of the high-tension circuit exposed. Experience has shown that enough interference may be radiated from as little as one-half inch of unshielded electrode lead to minimize the value of all filters and shielding used.

In the case of some electro-medical apparatus the frequency used is in the neighborhood of 1000 kilocycles. It is obvious that any filtering device which would confine this interfering frequency to the circuit in which it originates would prevent the high-frequency currents from reaching the patient. Consequently, the filter must be located in the primary circuit to prevent the feed-back of interference to the line. Since the 1000 kc. current flows from the diathermy machine through long leads to the patient, it is easily seen that a considerable length of radiating antenna is provided for the interference and that, if the interference is to be confined to its source, the apparatus, the connecting leads, the operator and the patient must be contained in a shielded room or booth.

With the increasing knowledge of radio interference and with the cooperation of radio manufacturers, appliance manufacturers, public utilities, municipalities, radio dealers and broadcast listeners, the present radio season should witness many improvements in radio reception and the elimination of much annoying radio interference.

Beat Frequency Oscillator

(Continued from page 582)

the same over the entire range of audio frequencies. Constant output voltage might not be obtained if the resistance was shunted across the variable frequency oscillator. This comes about because the audio-frequency voltage output from the detector, when a large and a small r.f. voltage are applied to the input, is directly a function of the *smaller* voltage. Even though the amplitude of a larger voltage varies somewhat the audio output will be the same, provided the amplitude of the smaller voltage remains constant. Under such conditions any variations in the amplitude of the r.f. voltage that may occur as the variable condenser is turned will not cause any change in audio-frequency output voltage.

With the coils used in the particular unit illustrated in this article it was found that a value of about 5,000 ohms for R1 gave best results. In determining the value of resistance to use with other types of coils the following method should be followed. The resistor R2 in the plate circuit of the detector is removed and in its place an 0-5 or 0-10 millimeter is connected. With both L3 and L4 short circuited the current should be noted. Then the short circuit across L4 should be removed and the current increase noted. L4 should then again be short-circuited and the current increase noted when the short-circuit across L3 is removed. Without any resistance both oscillators will probably cause about equal changes in plate current. Various resistances should then be connected across L3 until the change in current which it produces is only about one-fifth as great as the change in current produced by L4. The value of resistance which gives this condition should then permanently be connected across L3.

If constant audio output voltage is to be obtained it is essential that the audio amplifier have a flat frequency characteristic. The audio amplifier in this unit, which uses resistance coupling, has such a characteristic and the curve of Figure 4 shows the actual change in audio output voltage at various frequencies between 30 and 8,000 cycles. It will be noted that the maximum variation is in the order of 2 db. which is so slight as to be negligible. To obtain such a characteristic it is not only essential that the resistance-coupled circuits themselves have the proper constants, but that filtering be used to prevent degenerative or regenerative effects. In this unit the plate circuit of the detector is filtered by R3 and C3, the grid circuit of VT4 is filtered by R5 and C4 and the plate circuit by C5. To prevent audio-frequency currents in the power tube circuit from flowing through the B supply unit choke-condenser coupling is used with the low side of the output connected directly to the center tap on the filament winding supplying VT5. Radio-frequency currents in the output circuit of the detector are prevented from passing into the audio amplifier by means of the r.f. choke, L5 and the condenser C6 connected between the plate of the detector and the cathode of this tube. To prevent coupling between the oscillator circuits it will be noted that both plate

return leads are by-passed directly to the cathodes by C7 and C8.

The power supply circuit for the oscillator is the conventional rectifier and two stage filter system, the various voltages being obtained across a voltage dividing resistance connected across the output of the filter system. The screens of the two oscillators are supplied with about 90 volts from tap 3 and the screen of the detector tube is supplied with about 50 volts from tap 4. The voltage from tap 4 is reduced by means of a resistance, R7, to give about 30 volts for the plates of the two oscillators. If a different type of voltage divider resistance is used from which this voltage is directly available the reducing resistance, R7, will of course not be required. In the primary circuit of the power transformer there is connected an Amperite type 7-20 automatic line voltage control to reduce the effect of line voltage fluctuations. The use of such a voltage control is quite desirable and necessitates that the transformer primary be tapped for 80 volts as indicated in the schematic diagram. The rectifier tube is a type -80.

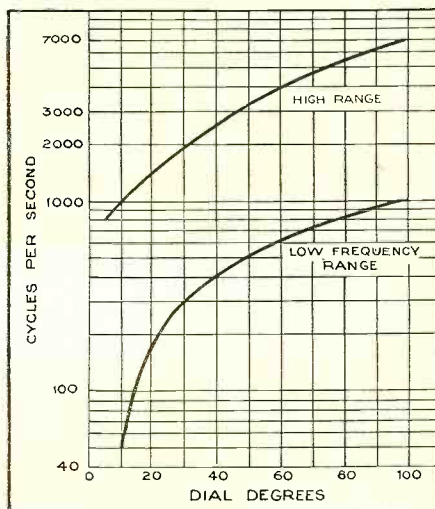

The main control for the oscillator is the variable condenser, C9, connected in series with C10 across the variable frequency oscillator. Since it is desirable that the frequency range be divided into two parts to permit ease of adjustment, the main tuning condenser, C9, is shunted by a condenser, C11, in series with a range control switch, SW1. With this switch closed the main tuning condenser has a smaller effect on the total tuning capacity and hence the frequency range is restricted. All of these condensers are of the adjustable type so that the user can adjust them so that a frequency range from about zero up to about 1,000 cycles is obtained with SW1 closed and a range from about 1,000 up to about 8,000 cycles with SW1 open. In making these adjustments the following procedure will be found most satisfactory.

With the dial controlling C9 turned to zero (condenser plates all in) and both C10 and C11 adjusted to a medium value the condenser C2 is varied until the audio

(Continued on page 629)

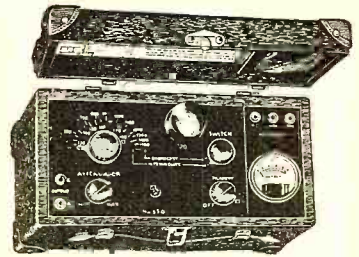

Readrite

No. 550

OSCILLATOR

Licensed by A. T. & T. Co.

\$18 Net to dealer
\$30 list

\$21 Net to dealer
with output meter

If not at your Jobbers we will ship direct when remittance accompanies order.

A sturdy modulated instrument carefully made. Completely shielded with separate battery compartment. Furnished with 22½-v. and 3-v. batteries and one '30 tube. Direct reading broadcast band (550-1500 kc.) and intermediate band (120-185 kc.). Sharp 2d and 3d harmonics for 260 and 475 kc. Operating instructions attached in case cover with shielded wire leads. Very compact. In leatherette case, 6x11½x5½ in. Weighs but 8 pounds. Built to high standards. Every serviceman should have the No. 550 oscillator to align r.f. gang condensers, locate defective r.f. transformers, adjust i.f. transformers, check oscillator stage and determine sensitivity of a receiver. A necessary instrument. Get yours today. Write for catalog of servicing instruments.

Readrite Meter Works
20 College Ave.
Bluffton, Ohio

Please send all information about Readrite Oscillator and other service instruments.

Name
Address
City State

Readrite Meter Works

Established 1904

20 College Ave., Bluffton, Ohio

The Radio News Ear Aid

(Continued from page 577)

the sub-base, shelves and fittings are drilled ready for use. Those who prefer to make their own fittings may follow the specifications in Figure 3.

The first step in the assembly is to mount the transformer, T, on the sub-base with its terminals in the position shown in Figure 2. The rear mounting lug will have to be filed slightly so it will not project beyond the rear edge of the sub-base. Next, the three posts which support the battery shelf are attached to the base, and the shelf, after attaching the battery clips, is mounted on them.

The tube socket is mounted next. Washers should be inserted beneath it to raise it off the base sufficiently to bridge the front mounting lug of the transformer. The position of its terminals is shown in Figure 2. Make sure that the connection lugs are not touching the metal sub-base. They should be bent up, at right angles, against the outside of the socket.

The long metal post which supports the front of the top shelf may now be mounted in position. The short post at the rear is mounted by removing the screw from the rear right post of the small shelf and replacing it with a one-inch screw with the head cut off. This will project up through the small shelf and the short post is screwed down tight on this projecting portion. The four tip-jacks are now mounted on the large shelf with their lower parts in the positions indicated in Figure 2. This finishes the assembly, the actual mounting of the top shelf being left until the wiring is completed.

The Wiring

The picture-wiring diagram, Figure 2, shows all necessary connections. Flexible wire with push-back insulation is to be preferred. Needless to say, all connections, except those to the B battery, should be firmly soldered, using soldering lugs where necessary. It is advisable to use a red-covered wire for the connection from the "P" terminal of the tube socket to the "+22½" terminal of the B bat-

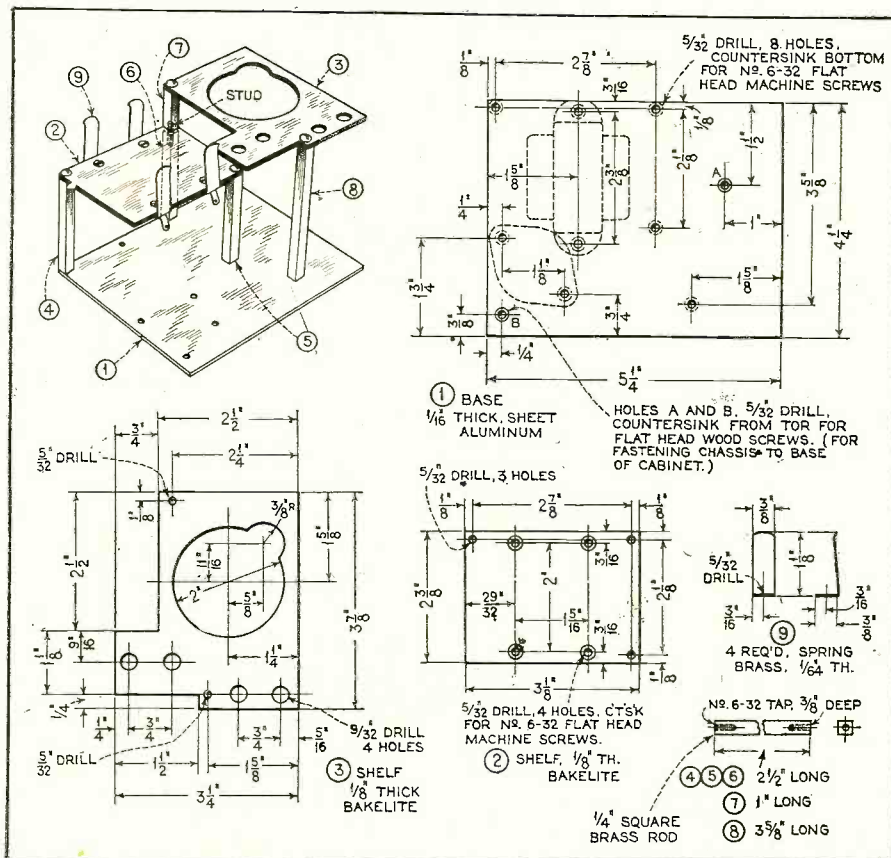

FIGURE 3. COMPLETE DETAILS OF CHASSIS AND FITTINGS

tery. This is done in order that there will be no confusion of wires later when it becomes necessary to replace the B battery. In wiring the rheostats and switch, make each wire an inch longer than necessary and make the wires to the tip jacks at least two inches oversize. This will facilitate installing the rheostats and will permit the shelf to be lifted out when replacing the B battery.

With the wiring completed the chassis may be put into the case and fastened in

place with a single ¼-inch wood screw through the hole provided in the sub-base, under the B battery. The rheostat shafts should then be slipped through the holes in the front of the case and the nuts securely tightened. Then the B battery is put in place with its negative (—) terminal toward the front, and the two wires connected to it. Finally the top shelf is fastened in place and the job is completed except for inserting the tips of the microphone and headphone cords in their respective jacks and snapping the flashlight cells into place. Be sure that the brass center caps of both cells are toward the front. The headphone jacks are the two at the right. The tip of the wire having the red tracer (or the longer end) is inserted in the red jack. All references to the "case" are made with the case specified in the list of parts in mind. This has been specially designed and marketed for the Ear Aid. Readers who prefer to construct their own cases can use the finished chassis to determine the inside dimensions, making due allowances for the microphone, headphone and headband.

Operation

To put the Ear Aid in operation, turn the lower rheostat "on" about ¼ inch. This closes the switch. After a second or two (which is required for the filament to heat up) sounds picked up by the microphone will be heard in the headphone. When the flashlight cells are new, the tube will operate effectively at this setting of the rheostat. Turning the rheo-

(Continued on page 630)

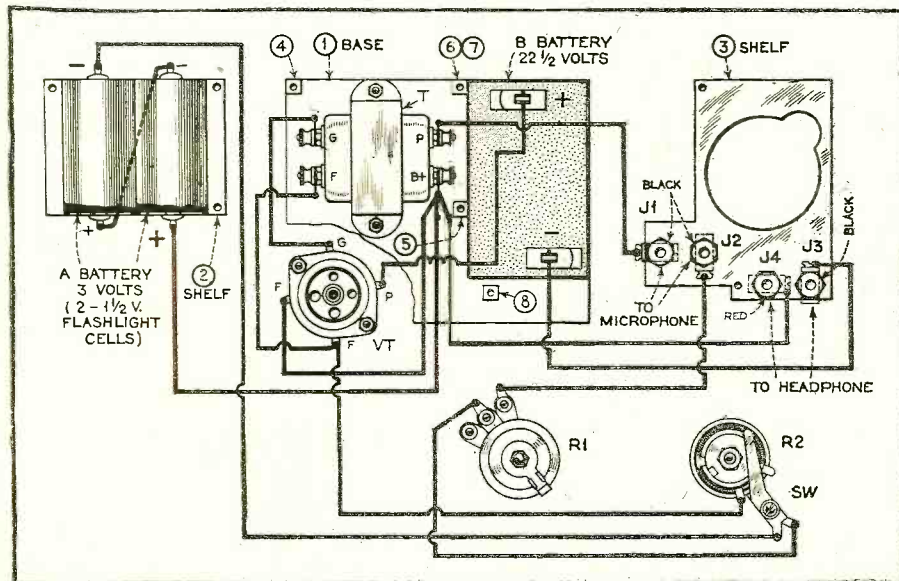

FIGURE 2. PICTURE-WIRING DIAGRAM

Beat Frequency Oscillator

(Continued from page 627)

tone, as heard in a loud speaker connected in the output, comes to zero. Then, with the range switch SW1 closed, the dial is turned to 100 and the increase in frequency noted. If the frequency goes much above 1,000 cycles the capacity of C11 can be increased and this adjustment carried out until turning the dial from zero to 100 gives a change in frequency from about zero to 1,000. Then with the range switch open the high tones up to 8,000 cycles can be checked. If 8,000 cycles cannot be obtained C10 should be reduced in capacity; if the range in frequency is too great C10 should be increased.

When the adjustments have been completed curves can be plotted indicating the dial reading and frequency and these calibration curves then used to obtain any desired tone. Sample calibration curves are given in Figure 5. In making these curves the frequency produced was checked against the standard audio-frequency oscillator. If a standard audio oscillator is not available a very good calibration can be made using a piano together with a chart showing the frequencies produced by the various keys on the piano. (Such a chart was given on page 314 of the October, 1931, issue of RADIO NEWS.) It is then simply necessary to strike a certain key and adjust the oscillator to give the same tone, and then refer to the frequency chart of the piano keyboard to determine the frequency of the tone.

Calibration Quickly Checked

Means have also been provided in the instrument to permit one to make a simple but rapid and accurate check of the calibration so that if the instrument is put in use after having been idle for some time it is possible to quickly check the calibration without going through a complete calibration procedure. Referring to the photographs and the circuit diagram it will be noted that a phonograph pick-up unit (with the tone arm removed) is connected in series with SW2 across the output. A detail photograph shows the pick-up unit and the small bit of spring brass fastened in the needle holder. Now if this unit is connected across the output of the oscillator it will be found that at a certain frequency (quite sharply defined) the brass pin will vibrate very strongly, the frequency at which it vibrates will depend on its weight, length, and other factors. It is best that various pins be tried until one is found that vibrates around 100 cycles, although the exact frequency is not important. This unit, which as the pictures show is mounted at the right of the panel, is used for checking calibration by the following method: Immediately after the initial calibration is completed the switch SW2 is closed and the main dial is then varied until the frequency is reached at which the pin vibrates, the dial setting being then carefully noted. Now whenever it is necessary to recheck the calibration it is simply necessary to bring the main dial to this same setting, turn on the unit and note if

the pin vibrates. If it does you can be sure the calibration is correct; if it does not vibrate then the dial controlling the calibration condenser C12 should be adjusted to make the pin vibrate. When this is done the recheck on the calibration is complete and the user can be quite certain that the original calibration curve will accurately indicate the frequencies being generated.

Indispensable in Shop

The various photographs have all been marked to indicate the various parts shown in the circuit diagram and the constants of these various parts can be determined from the accompanying list of parts. If the units are mounted in about the same position the experienced constructor should not have much difficulty in wiring the unit. If carefully constructed we are quite sure the unit will prove almost indispensable in many tests in the home laboratory or the service shop.

List of Parts

- R1, R7—Hammarlund type MF-412 resistors, 11,000 ohms
- R2—0.25 megohm resistor
- R3, R5—Hammarlund type MF-413 resistors, 50,000 ohms
- R4—Hammarlund type Mf-413 resistor, 2500 ohms
- R6—Hammarlund type RHQ-31 voltage divider
- R8—Centralab 500,000 ohm potentiometer
- R9—0.1 megohm resistor
- R10—0.5 megohm resistor
- R11—25,000 ohm resistor
- R12—1700 ohm resistor
- L1, L3 and L2, L4—Special oscillator coils (see text)
- L5—Hammarlund choke type RFC 85, 85 mfd.
- L6, L7, L8—Hammarlund type C-40 choke coils, 40 henries
- C1, C6—0.0002 mfd. fixed condenser
- C1, C2—Hammarlund type ICS-220 adjustable condensers, 220 mmfd.
- C3—Hammarlund type BP-12 by-pass condenser, 12 mfd., electrolytic
- C4, C5, C7, C8—Hammarlund condensers type BP-1, 1 mfd.
- C9—Hammarlund variable condenser type ML-0.0001 mfd.
- C10—Hammarlund type MCM-100 mmfd. condenser
- C11—Hammarlund type ICS-140 condenser, 140 mmfd.
- C12—Hammarlund type MCM 50 mmfd. condenser
- C13, C14—Hammarlund by-pass condenser, type BP-100, 0.1 mfd.
- C15—Two fixed condensers. 2 mfd. each, 400 volt rating
- C16—Hammarlund filter condenser block, type CHQ-31
- SW1, SW2, SW3—Toggle switches
- P—Phonograph pick-up
- Dial—Hammarlund, type SDW
- Four single grid leak mounts
- 7 x 20 x 3/16 inch panel
- Necessary hardware, baseboard, etc.



**Read
why these
Centralab
Fixed Resistors
are Different**

Yours for the Asking!

We have prepared a very interesting, illustrated, booklet describing the process of manufacture of the DIFFERENT Centralab Fixed Resistors.

There is no charge for this booklet—it is yours for the asking.

Send for it—now! Use the coupon below.

Centralab

MAIL COUPON TODAY

CENTRAL RADIO LAB.
929 E. Keefe Ave., Milwaukee, Wis.
Please send me your FREE booklet,
"Baptism of Fire."

Name

Address

City State

Radio News

ACROCYCLE OSCILLATOR

115 to 1680 kc. All frequencies accurately calibrated on dial. A dependable, high-grade instrument. Indispensable for aligning Super-Heterodyne receivers. Self contained, fully shielded. List \$30.00.

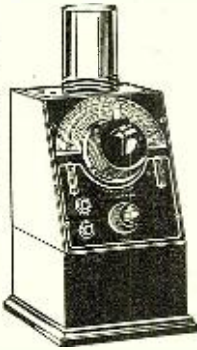

DEALERS' NET PRICE
\$17.50

Handsome leatherette carrying case, net \$2.00.

If your jobber does not carry, order direct from

J-M-P MFG. CO., INC.
3421 Fond du Lac Ave.
Milwaukee, Wisconsin

Made by the manufacturers of the pioneer short wave adapter the S. MARINER, now \$12.50.

New LONG SHORT WAVE RADIO



COMPLETE WITH CABINET
9 TUBES
DYNAMIC SPEAKER

only **\$79.50**

Radio listeners are no longer satisfied with local reception. Short wave's the thing. They demand the thrills that come with distance—ships at sea, Australia, Germany, South America. Here is the newest thing in radio. One unit, broadcast band and short wave, in amazingly beautiful cabinet. No coils to change. Four-way switch regulates all. Guaranteed to bring in any station anywhere that can be brought in by any other radio regardless of cost and operated under same conditions. Everything complete for only \$79.50.

Agents Wanted This amazing radio sensation will make money for you fast at any price. Get busy if you want to make Big Money! Exclusive territory to those who qualify. My company the largest of its kind. Write quick.

P. H. WILCOX, Secretary
Surrey Court & Fullerton
Dept. 3, Chicago

MAKE MONEY FAST

Sell an auto radio that everyone wants

Perfection Autofone

is a complete—efficient—auto radio at a sensational low price. Uses 6 new pentode, screen-grid and vari-mu auto tubes: large dynamic speaker. Easily installed.

Be our exclusive agent in your town. Special agents' price

\$33.75

Complete with tubes and batteries

Make 40% or more cash profit. Get started now—send 20% deposit—sample set and literature will be sent at once—pay balance on arrival.

Motorphone Radio Corp. of America
136 Liberty Street New York City

Wireless (Radio)

and Morse telegraphy taught thoroughly. School, oldest and largest; endorsed by Telegraph, Radio, Railway and Government officials. Unusual opportunities. Expenses low—can earn part. Catalog free. **DODGE INSTITUTE, Oak St., Valparaiso, Indiana.**

Radio News Ear Aid

We are featuring all parts for the Radio News Ear Aid including the special carrying case and fittings, the De Forest microphone and both the Trimm and Western Electric head phones.

Radio for the Deaf

We also carry the complete specified parts for the ear phone attachment described on page 492 of December Radio News. Easily attached to any radio receiver without changes in wiring. It provides separate volume control for the head phones. Write for prices. Special discount to bonafide dealers and service men.

Wm. H. Broderick
40 East 49th St., New York, N. Y.

The Radio News Ear Aid

(Continued from page 628)

stat further does not increase the amplification but does waste current. As the flashlight cells age the rheostat will have to be advanced, but should always be kept as far "off" as possible and should be turned completely off at all times when the Aid is not in use.

The upper rheostat serves for the regulation of sensitivity and volume. For maximum volume it may be turned as far as possible in a clockwise direction; for minimum, as far as possible in the reverse direction. There is no danger in



NEAT IN APPEARANCE

When closed the equipment gives no external evidence of its purpose. In appearance it has all the earmarks of a commercial product

turning this all the way up, even when the flashlight cells are new. When the lower rheostat knob is turned to the "off" position, opening the switch, it cuts off all battery current, regardless of the setting of the upper rheostat.

The only parts which are subject to wear are the batteries and the vacuum tube. The particular make of tube specified has been selected because of its especially rugged construction. It should easily last a year or more before replacement becomes necessary. The 22½-volt B battery should also last close to a year.

The pair of flashlight batteries will last anywhere from one to six weeks, depending on the amount of use. Tests indicate that where the Ear Aid is used on an average of four hours daily, these flashlight cells will last well over a week. When they do wear out, a new pair can be purchased at hardware, electrical or radio stores for 20c.

This elimination of special batteries offers a decided advantage which will be appreciated by anyone who has used a commercial hearing aid, the majority of which use special batteries which are available only from the manufacturers of these devices.

The List of Parts

It is essential, if the specifications for the chassis and fittings are to be followed, that the parts specified here (except the microphone) be employed. There is no superfluous space provided in the layout and all parts specified here are the smallest that could be found to serve their va-

rious purposes. Parts of other makes would probably not fit in the spaces allowed and would therefore constitute a needless source of trouble. The headphone offers some choice. The Western Electric unit is the best available so far as effectiveness is concerned, both in clarity and sensitivity, for this particular service. It is rather heavy, however, and for those who are willing to make some sacrifice in effectiveness in order to gain lighter weight and more compact size, an alternate "featherweight" headphone is also specified. This is the most effective one that has been found for its size and weight. For those who prefer, a "pair" of phones may be used, but the single type is most commonly used with hearing devices.

- A—Two Eveready flashlight batteries, type No. 950
- B—Eveready type No. 763 midget B battery, 22½ volts
- J1, J2, J3, J4—Yaxley insulated tip-jacks, type 422, 3 black, 1 red
- M—De Forest type US special pick-up microphone with sound-correction chamber, with special 36-inch flexible extension cord.
- P—Headphone, either Western Electric type 509W, 1100 ohms, single, or Trimm "Featherweight," 1000 ohms, single. The latter is equipped with headband and cord. The former is without headband or cord. Requires special headband and cord (see items X and Y below)
- R1—Carter 400-ohm "Imp" potentiometer, type IR-400, with small knob
- R2—Carter 50-ohm "midget" rheostat, with switch, type M-50-S, with small knob
- T—Thordarson microphone transformer, type T-2357
- VT—Eveready type 230 vacuum tube and Pilot sub-panel mounting socket No. 216
- SW—(See R2, above)
- Case—Broderick special carrying case, as illustrated
- Fittings—Broderick kit of fittings, including aluminum sub-base, bakelite shelves, brass mounting posts, battery clips and miscellaneous nuts, screws, wire, etc.
- X—Special light-weight metal headband for headphone
- Y—Special cord for headphone, 46-inch

Other Uses for the Ear Aid

The Ear Aid was designed primarily for use by individuals but will also provide excellent results for group service. It is sufficiently powerful to operate several headphones, as in church, for instance, where it may be desired to provide facilities to enable several hard-of-hearing persons to listen in. When used in this manner the Aid should be placed within a few feet of the speaker, with an extension cord of the required length to reach the seats where the headphones are to be located. There should be an individual volume control for each headphone, so arranged that varying the volume at one headphone will have little effect on the others. If more information is desired concerning this type of service it can be

(Continued on page 631)

Mathematics in Radio

(Continued from page 589)

$$E_{eff} = .707 E_m$$

Thus, the effective value of an alternating e.m.f. is equal to .707 times its maximum value E_m .

Resistance of a Tube

Trigonometry is used very often in vacuum tube theory to show the various relations concerning the constants of the tube. Let us study a few of these relations. In a circuit consisting of resistance only, Ohm's law states that the resistance is equal to the quotient of the voltage and current. When the current is plotted for various values of voltages, as in Figure 15, a straight line results. For this graph the resistance R was taken equal to 1 ohm. This graph shows that the resistance is equal to cotangent θ , and remembering that the cotangent of an angle is equal to the side adjacent "a" to the side opposite " θ ," we can readily see by reference to the figure that the resistance R is equal to

$$\frac{E}{I} = \frac{a}{o} = \cot \theta$$

RADIO NEWS Ear Aid

(Continued from page 630)

obtained by addressing the author, in care of RADIO NEWS.

The Ear Aid also makes an excellent "detective-phone." The microphone may be placed in one room, with an extension cord leading to another room where the amplifier and headphones are located. Conversation in the first room will then be clearly audible at the headphones.

Another highly practical use for the Ear Aid is found in homes where the baby's room is remote from the parents'. The Ear Aid, with a loudspeaker plugged in instead of the headphone, is placed in the parents' room. The microphone, connected to the Ear Aid by a long extension cord, is then placed in the baby's room, within a few feet of the crib. Then, should the baby cry at night the sound will be distinctly audible in the parents' room.

To some this use of the Ear Aid may seem slightly far fetched, but actually a real demand for equipment to serve this purpose is widened by frequent letters received from readers asking for suitable circuits.

Next month this series of articles on hearing aids will be continued with constructional data on a simple device to aid those who have difficulty in hearing over the telephone. This may be connected to the telephone in such a way as not to interfere in any way with the normal use of the 'phone by other members of the family, and yet provides greatly increased loudness for anyone listening through the headphone included in the new device. This will prove a boon, not only to persons who are hard-of-hearing, but also to those of normal hearing when using a 'phone in a location where external noise makes hearing difficult.

In a tube circuit, however, the current is not a straight line relation with the impressed voltage, but follows more nearly a square relation which is expressed as $i = a E^2$.

The coefficient "a" is a function of the construction of the elements of the tube and for the graph shown in Figure 16 it has been given a value equal to .1. In considering the d.c. resistance of the tube it is only necessary to take the quotient of the applied voltage over the resultant current. Thus, for the applied voltage equal to 8, the resistance will be equal to 8 divided by 6. But by joining a line from point B to the origin it is also seen that the value of the d.c. resistance is equal to the cotangent of θ . It will be noticed that in the case of a tube, the $R_{d.c.}$ changes for various values of the impressed voltage E , for in taking the point A we find that $R_{d.c.} = \cos x$, which will have a different value.

Examples in Trigonometry

In alternating current theory we have occasion to study the wave forms of double, triple and higher frequencies of various functions. We have seen that a graph of the function of the sine of an angle is a symmetrical wave above and below the reference line, the abscissa.

1. Plot on graph paper the function $y = \sin x$ for all values of "x" from 0 to 360 degrees.

In order to indicate the method of plotting the graphs as an aid to the following examples, it is well to draw the angles and tabulate the resultant sines. Thus, with reference to Figure 17 (a), the sines for the angles 0, 30, 60 and 90° are shown. It will be noticed that the circle was drawn with a radius of 10 divisions, and taking this radius equal to 1, each division will then be equal to .1. Tabulating the results for the first quadrant, we have the following sines:

- For $x = 0$; $\sin x = 0$
- For $x = 30$; $\sin x = + .5$
- For $x = 60$; $\sin x = + .866$
- For $x = 90$; $\sin x = + 1.00$

In order to determine the values of the sine for the angles 90, 120, 150 and 180°, draw the circle diagram of Figure 17 (b). Thus, tabulating the results for the second quadrant, we have:

- For $x = 90$; $\sin x = + 1.00$
- For $x = 120$; $\sin x = + .866$
- For $x = 150$; $\sin x = + .5$
- For $x = 180$; $\sin x = 0$

As shown in Figure 17 (c), the values of the sines in the third quadrant are as follows:

- For $x = 180$; $\sin x = 0$
- For $x = 210$; $\sin x = - .5$
- For $x = 240$; $\sin x = - .866$
- For $x = 270$; $\sin x = - 1.00$

Again, in Figure 17 (d), the values of the sines in the fourth quadrant are as follows:

- For $x = 270$; $\sin x = - 1.00$
- For $x = 300$; $\sin x = - .866$
- For $x = 330$; $\sin x = - .5$
- For $x = 360$; $\sin x = 0$

We have completed locating the points of the various angles from 0 — 360 de-

(Continued on page 636)

LONG LIFE

and Efficiency in Filter Circuits

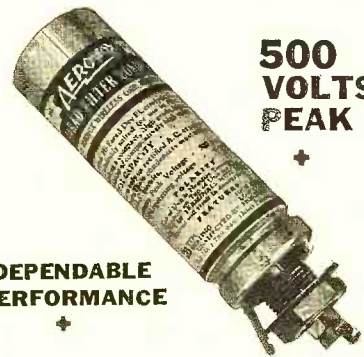

500 VOLTS PEAK

DEPENDABLE PERFORMANCE

HI-FARAD DRY ELECTROLYTIC CONDENSERS

Provide long life and high filtering efficiency, due to their design and inherent operating characteristics. They are compact, light in weight, low in cost per microfarad rating, low in leakage, stable in operation, and operate over wide ranges in temperature.



AN AEROVOX CONDENSER OR RESISTOR FOR EVERY PURPOSE

The Aerovox line includes the most complete variety of fixed condensers and resistors for every radio requirement.

Send for Catalog

Complete specifications of all Aerovox units, including insulation specifications of condensers, current-carrying capacities of resistors, and all physical dimensions, electrical characteristics, and list prices of condensers and resistors, are contained in our 40-page catalog which will gladly be sent on request.



The Aerovox Research Worker is a free monthly publication issued to keep radio engineers, experimenters and servicemen abreast of the latest developments in receiver and power supply design, and especially with the proper use of condensers and resistors. A request on the coupon below will place your name on the mailing list.

AEROVOX WIRELESS CORP.

78 Washington St., Brooklyn, N. Y.

Check and Mail This Coupon

AEROVOX WIRELESS CORP. Radio News
78 Washington Street Brooklyn, N. Y. Jan., 1932

Gentlemen:
Please send me without charge or obligation:
() Your 40-page Condenser and Resistor Manual and Catalog.
() The Research Worker.

Name.....
Street.....
City..... State.....

The New Radio Physics Course

By Alfred A. Ghirardi, E.E.

Greatly Enlarged
Second Edition

NOW READY

Contains 990 pages. More than 500 illustrations. The Radio Physics Course, which is now running in Radio News, complete in one book!

The Greatest Radio Book Ever Written

Send for free circular

Radio Technical Publishing Co. **\$3.50**
Dept. H, 22 West 21st Street, New York City

Enclosed please find cash, check or money order for _____ copies of Radio Physics Course at \$3.50 each.

Name
(Please Print)
Address



Graphs and Charts in Modern Radio Practice

(Continued from page 586)

The dependence is then expressed by the equation of the line.

When we think of x varying continuously from minus infinity to plus infinity, then we would like to know how the quantity y varies. In our example, the rate of change of y with respect to x is "m," a constant. This is the same as saying that we are dealing with a straight line or that it makes the same angle with x everywhere.

In the line shown in the figure, m equals 1; the inclination is 45 degrees, and when x varies with one unit, y varies with one unit.

When the inclination differs from 45 degrees, x and y vary at different speeds but their ratio remains constant as long as we deal with a straight line.

It should now be clear that any straight line through O can be represented with a simple equation in two variables of the general form $y = mx$.

By varying m from minus infinity to plus infinity all angles can be had. Conversely, any equation in the variables x and y of the form shown, has a locus which is a straight line.

When we are not so fortunate as to have the line pass through the origin, the line might be like l in Figure 4. This line has the same inclination or slope as the previous one, but each point is situated at a distance, b , above its corresponding point on the line $y = mx$. Consequently, the equation $y = mx + b$ will be the equation expressing the interdependence of the two variables x and y in this case.

This formula, $y = mx + b$, is the general equation for a straight line. Any equation of the first degree can be reduced to this form; therefore, any equation of the first degree has a locus which is a straight line.

We have gotten into the habit of drawing a line—the locus of an equation—in order to illustrate some law or phenomenon in physics and engineering, even though this had nothing to do with geometry.

When an equation is of a higher degree, but has only two variables, it expresses a somewhat more complicated law in physics and the locus will not be a straight line. We can give successive values to x and calculate the corresponding values for y , and plot each point. Often there will be more than one possible value of y with one value of x and so more than one point will be plotted. When a sufficient number of values have been computed and their points plotted, it will be possible to draw a smooth curve through all these points which is then the locus of the equation.

If the job has been done correctly, all points on the curve must have coordinates which are roots of the equation and all possible roots of the equation which are real numbers are the coordinates of some point on the curve. While plotting the curve we have taken it for granted that the curve had no sudden turns or loops between two points calculated. In reality we can never be sure of this and in analytic geometry it is explained how we can inspect the equation and determine from

its form what kind of a curve we are going to get. Then, when we know in advance what the curve will look like, there is no risk of making such an error.

In Figure 5 is shown a curve which was obtained from electrical measurements on a vacuum tube. When we vary the grid bias of a tube in small steps and read the plate current for each different grid bias, we can plot pairs of numbers and draw a smooth curve through the plotted points. This curve is called the static characteristic of the tube. It is supposed that the filament and plate voltage have been kept constant while making the measurements.

What can we do with this curve? In the first place it is possible to see at a glance what plate current will flow with a given grid voltage, but with a tube we are mainly interested in the rate of change of plate current with respect to the grid voltage. In other words, we would like to know how much the plate current will vary with a certain small variation of grid voltage.

This ratio, as we saw before, is expressed by the slope. But the slope of a curve—that is, the steepness of it—is of course different at every point. At any point of the curve the slope is the same as the slope of the tangent to the curve at that point.

In the case of a tube, the steeper the tangent, the greater the change of plate current for a given change in grid voltage and therefore the greater the amplification.

This ratio is called the mutual conductance of the tube if it is a three-electrode tube and transconductance when it is a screen-grid or pentode tube.

The slope can be obtained graphically by drawing the tangent to the curve at the required point, but it can also be obtained algebraically without drawing the curve. The slope so obtained is called the derivative, for it is an equation "derived" from the equation of the curve by a process called differentiation. The derivative is another equation in x and sometimes also in y which gives the slope of the curve at any point. By substituting the correct value of x , we obtain the slope at the required point of the curve.

The curve of Figure 5 is the static characteristic of a multi- μ tube. Such a tube is also called an exponential tube, for its characteristic is the locus of an exponential equation of the general form

$$y = Ce^{kx}$$

where e is 2.71828 and C and k are constants.

The curve in Figure 5 was determined experimentally, but if it ever is necessary to plot it when only the equation is given, it is easier to plot it as a straight line first.

Taking the logarithm of both sides of the equation

$$\log y = kx \log e + \log C$$

The common logarithm of e is .434, therefore

$$\log y = .434 kx + \log C$$

This formula is of the same form as

$$y = mx + b$$

if we plot y on a logarithmic scale.

In Figure 6 we show this straight line, which is the same as the curve in Figure

HEARING DEVICES

The New Universal

DE FOREST AUDIPHONE

With Miniature Earpiece Is

Dr. Lee De Forest's Latest Invention

Simple—Compact—Efficient—Low Priced

Send for Our Free Trial Offer

SERVICE MEN—NOTE!

Send for Our Special Circular on
De Forest Hearing Device Parts

HEARING DEVICES CO., Inc.

2433 Times Bldg.—Times Square, New York

MAKING A BIG HIT!

With Service Men and Dealers Everywhere



MORRILL CONDENSERS

Eliminate comebacks, stand the gaff, are compact and insure you real customer satisfaction. Especially convenient for stacking. They are setting a new engineering standard for condenser performance.

Write today for Bulletin X-2

MORRILL & MORRILL

30 Church St., New York City

Sole U. S. A. Distributors of SIEMENS & HALSKE
Condensers, Resistors, Microphones, Interference
Eliminators and Locators

You Can Become a Fast
Capable RADIO OPERATOR at HOME



By **CANDLER**
Scientific Method

In less than the usual time. Amazing results. Thousands fast. Radio operators taught by **CANDLER**. FREE advice if you're "stuck."

All questions answered personally. No obligation. If Radio operator, ask about **ADVANCED COURSE** for **SPEED** and **Copying** Behind, and "MILL" Course. **FREE BROCHURE** will save you time and money. Tune in on **Candler Short Wave Station!**

Walter H. Candler,
World's Only Code
Specialist

THE CANDLER SYSTEM CO., Dept. N-12
6343 So. Kedzie Ave., Chicago, Ill.

MILLION PARTS

QRS Portable Electric Phonograph in leatherette case, works with dry cells (Storage battery), can be used for pickups..... \$12.95
Amplifier base 8x18x4 1/2 with baffle holders..... 2.75
Freshman base 6x17 1/4 x 2 3/4 for 6 tubes..... .50
Farrand Inductor Dynamic Unit for 171 or 245..... 1.59

Experimenters' Radio Shop

129 West St. New York, N. Y.

5, but, with a different scale along the y-axis. When it is necessary to plot the locus of an exponential equation, it saves time to plot only two points on semi-logarithmic paper by making two calculations. A straight line can then be drawn between the points.

As many points as necessary can now be transferred from the logarithmic to the ordinary paper and the curve drawn. If we did not do that we would have to solve the equation for each point—and that is some job.

The reader may convince himself that the two curves are the same except for the logarithmic scale of the y-axis.

Curves of the exponential form are common in physics and engineering. Its formula was called by Lord Kelvin the "compound-interest" law; it is also known as the law of bacterial growth.

As we need to use graphs for calculation purposes, we shall conclude this discussion with a chart for the conversion of frequency to wavelength and vice versa. The relation between these quantities is

$$\lambda f = 300,000$$

where λ is in meters and f in kilocycles.

We could plot wavelength against kilocycles in the regular way, but we had better take a closer look at the resulting curve.

The locus of this equation is a rectangular hyperbola which has the shape of the curve in Figure 7. It is plain that we only can get a reasonable accuracy in the middle of the curve, where the slope is -1 . The useful portion of the curve is too short for our purpose.

We could plot $1/f$ on one of the axes, but that makes the reading difficult. There is a much easier way which needs no calculation.

Taking logarithms of both sides of the equation $\log \lambda + \log f = \log 300,000$, all we have to do is to make two logarithmic scales, invert one of them and lay them along each other so that one meter coincides with 300,000 kc. or 100 meters coincides with 3000 kc. and then all values opposite each other will have the same product and therefore satisfy the equation. The result is shown in Figure 8. The reader will see that by measuring off λ and f from opposite ends of the line, their sum is always the same.

In order to make the chart as large as possible, only a part of it is shown; it covers wavelengths from 100 to 1000 meters. For wavelengths from 10 to 100 meters, multiply the kilocycles side by ten and divide the wavelength side by ten. For longer waves the reverse may be done.

With the Experimenters

(Continued from page 598)

cially being noticeably lacking in volume. The thirty feet or so of line connecting the pick-up to the input together with its connecting plug might be faulty. These were tested, but a check-up made it plain that the trouble resided in the pick-up itself, but the prospect of investigating the true inwardness of this delicate piece of mechanism was not one to arouse one's enthusiasm.

After some reflection it was suddenly recalled that the heart and soul of a phonograph pick-up is a permanent magnet of the familiar "U" type, and it is characteristic of a permanent magnet that

application of a strong exterior permanent magnetic field, an increase in volume should be noted. Accordingly a permanent horseshoe magnet was unearthed which had been purchased many years ago. Fortunately its power had been excellently conserved by a pole piece and it was in fine condition. It weighed $\frac{1}{4}$ lb., was $5\frac{1}{8}$ " long, $2\frac{9}{16}$ " wide at the widest point, $1\frac{9}{16}$ " wide at the poles and made of bar steel $\frac{5}{8}$ " wide and $\frac{1}{4}$ " thick. In order that the strength of the pick-up magnet should be reinforced, it was necessary to know the polarity of its magnet. This was quickly determined with a magnetic compass, whose north pole pointed to the south pole of the pick-up. Accordingly, the horseshoe magnet was carefully laid down on the flat side of the pick-up with unlike poles superposed, the polar gap being placed close to the lower end and fastened in place by two rubber bands. As a matter of fact and experiment it was subsequently found that if like poles were superposed, no improvement whatever occurred. From the standpoint of the system of parallel magnet reinforcement employed in the multiple magnets of magnetos, this is the opposite of what might be expected. If, however, the pick-up magnet is regarded as functioning merely as a pole piece to the more powerful magnet, the phenomenon becomes understandable.

A record was then placed on the turntable, the amplifier turned on and the pick-up needle dropped into position. The effect was nothing short of miraculous. The volume was prodigiously enhanced, being even more than when the pick-up was new, and the lower frequencies registered with a sonority and

(Continued on page 634)

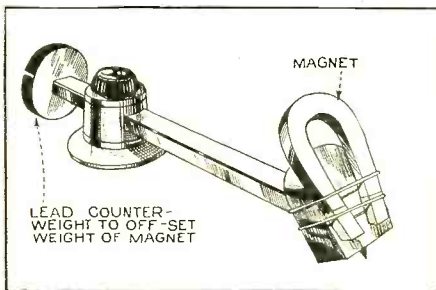

it gradually loses its magnetism, although more slowly when an armature or pole piece is allowed to remain in place to complete the magnetic circuit. In the case of pick-ups, as with electromagnetic speaker units, an armature constitutes part of the actuating mechanism, but the magnetic flow is never quite complete because of the polar gaps necessary to allow free motion. It followed, then, that if the loss of volume was due to a gradual loss of magnetic field strength, and this could be in any measure restored by the

4 Big Radio Bargains



Aero World Wide

Short Wave Receiver \$6.45

Span the World with this Set 14 to 550 Meters

A new radio thrill for you! Listen in DIRECT to London, Paris, Berlin, Buenos Aires and other broadcasting stations throughout the world via short waves. Enjoy unique foreign programs from strange lands. Your ordinary receiver cannot tune in these low wave stations.

Aero Short Wave Super-Heterodyne Converter. Converts your radio set into a short wave Super-Heterodyne.

A C Model \$12.50

D C Model \$11.50

New Aero Midget

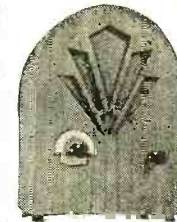

Using the Latest Type Pentode and Multi-Mu Tubes

Price - - - \$16.50

We Guarantee Coast to Coast Reception

Wonderful tone quality and selectivity. Full dynamic speaker. Full vision dial. Beautiful walnut cabinet. 5 Tube Set \$16.50, Less tubes, complete set of 5 matched tubes \$4.50.

Astounding Auto Radio Bargains



\$20.00

At last! The perfect Auto Radio. We guarantee 1000 mile radius. A masterpiece of radio engineering. Built by pioneer in the construction of Auto Radio. Latest model 6 Tube Aero Pentode Auto Radio. Price of set only \$20.00. Set complete with tubes, batteries, dynamic speaker, antenna equipment and noise suppressors. \$39.50.

Send for Latest Complete Catalog
CHAS. HOODWIN CO.

Dept. N3, 4240 Lincoln Ave., Chicago, Ill.

Now Ready
New 1932 Catalog
ICA Products
RADIO-TELEVISION
SHORT WAVE
Receivers - Parts and Accessories
FREE Write for your copy now. *Quantity limited*
Insuline Corp. of America
25 Park Place New York
Subsidiary of
Standard Television & Electric Corp.

Voltage Regulation!

For receivers employing 110 volt transformers, use the CLAROSTAT AUTOMATIC LINE VOLTAGE REGULATOR which plugs in between the receiver cord and the wall outlet. Made in 5 sizes, from 50 to 250 watts.
List price \$1.75

For receivers with built-in protection (85 volt transformer) use the CLAROSTAT REPLACEMENT LINE BALLAST. A special model for every receiver. FREE CHART on request. List price \$2.50

Clarostat Mfg. Co., Inc.
285 N. 6th St.
Brooklyn, N. Y.

RADIO BOOKS

NOW SOLD
AT
MAGAZINE PRICES
OR
FREE with *Radio News*
at a big saving!

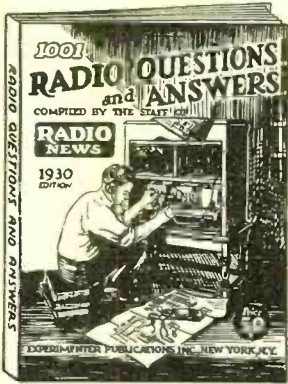

If you own a radio, you need this book. Everything you want to know about radio is in it, from "How to Kill Outside Radio Noises," to a clear description of the newest tubes and how to use them. If you have a question on radio, here is your answer and a thousand more. **96** illustrated pages. Large, 9 by 12 inch size. Beautiful colored cover. Shipped prepaid **50c** to your home for only.....



Sometimes called the Radio Amateurs' Bible. 30 profusely illustrated chapters bring you 10 How-to-Build articles, with complete instructions and diagrams; new radio wrinkles, DX hints, data on the new tubes, answers to AC problems, and helpful, money-saving ideas for the radio serviceman. Shipped prepaid to your home for **50c** only.....

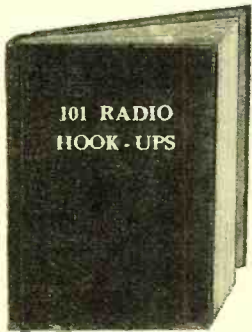

Here's a big, newly cloth bound edition of the book that every man interested in radio has been eagerly looking for! As its name implies this book contains complete diagrams and descriptions of the most popular types of receivers, short wave transmitters, test apparatus and amplifiers or units thereof used in virtually every field of radio activity. **50c**

----- Cut and Mail Today -----

Teck Publishing Corp.
Dept. R-1, 350 Hudson St., New York, N. Y.
Gentlemen: Please ship me postpaid the Radio Books I have checked below. Remittance is enclosed.
 1001 Radio Questions and Answers
 Radio Amateurs' Handbook
 101 Radio Hook-Ups

Name.....
Address.....
City and State.....

FREE!

You may have any one of the above Radio Books ENTIRELY FREE with RADIO NEWS at a reduced price. To accept this offer check square below.
 Ship me ENTIRELY FREE the Radio Book I have checked above and enter my subscription for the next eleven big issues of RADIO NEWS at the special price of only \$2, which I enclose. (Regular newsstand price of RADIO NEWS, \$2.75.)

With the Experimenters

(Continued from page 633)

clarity which was a delight to the ears. It remained only to make a final adjustment to insure a proper distribution of the added weight of the magnet. The pick-up is normally balanced or weighted so that the optimum pressure will be brought to bear on the needle—if too much, excessive wear on the record results; if too little, there is a tendency to "jump the track," causing repeating and stuttering, particularly towards the end of the record track. Only a few minutes' experimenting was necessary to determine the best position, however, and then the magnet was securely fastened by two narrow strips of adhesive tape and the rubber bands discarded. With certain types of pick-ups it will be necessary to counterbalance the arm to compensate for the added weight of the magnet.

The volume gained by the artifice described above is considerably greater than that obtained by the one-tube "booster" commonly used for power detector sets to secure sufficient amplification for operating phonograph pick-ups with satisfactory volume, and is to be recommended because of its cheapness and simplicity of attachment. Incidentally, it leaves an odd impression on the experimenter of having for once secured "something for nothing" inasmuch as no energy is consumed over that employed originally.

O. IVAN LEE, B.S.,
Jersey City, N. J.

Safeguarding Condensers

Most experimenters trying new circuits have had occasion to use condensers in series from time to time in order to obtain some definite value of voltage rating with the apparatus at hand. In such cases the experimenter may have wondered why some condensers in such circuits would "break down" or "puncture." He may have been further puzzled by the fact that this would occur principally in direct-current circuits.

The explanation for such condenser failures depends upon the fact that the impedance of a condenser connected in a direct-current circuit is equivalent to the leakage resistance of the condenser. In general two condensers of quite the same construction and capacitance may have widely separated values of leakage resistance. When two such condensers are connected in series the current in each will be the same, and since the voltage drop across each condenser is equal to the product of current times leakage resistance, the two voltage drops will be as widely separated as the leakage resistances.

An example of incorrect operation is shown in Figure 1. In this figure A and B are two 1.0 mfd. condensers rated at 500 volts. One condenser, however, has a leakage resistance of 9 megohms while the other has only 1 megohm. When the two condensers are operated in series on a 1000-volt circuit, the voltage drop across each is directly proportional to its leakage resistance. One condenser, therefore, has 900 volts across it while the other has only 100 volts. If the 500-volt condenser is not most conservatively de-

signed it will soon "fail," and when it does, 1000 volts will be impressed across the remaining condenser, bringing about its failure as well.

In Figure 2 is shown a simple remedy for this condition. Each condenser is shunted by a high resistance similar to

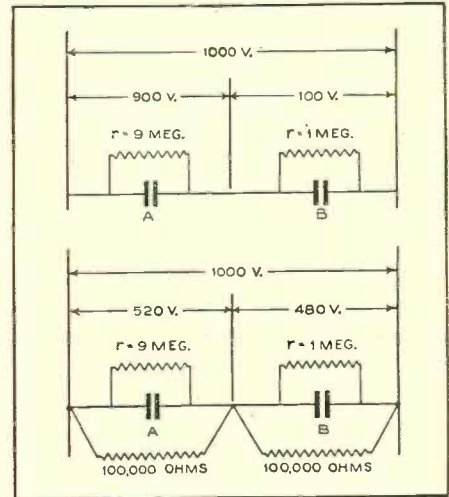

Figure 1 (top). Wrong operation
Figure 2. Simple correction

a 100,000-ohm grid leak. The resistance of these two leaks is in parallel with the leakage resistance of the condensers, giving a total resistance across the condensers of 99,009 ohms and 90,909 ohms respectively. Since the voltage will divide in approximately the same ratio, the impressed voltage on the condenser will be 480 and 520, which will probably be entirely satisfactory. There seldom occur circumstances in which the 100,000-ohm resistors introduce any undesirable effects.

Little help can be obtained with a voltmeter, because the internal resistance of most such instruments is so low as to give considerable errors when paralleling the high resistance leakage path of a condenser. Protective resistances of as low a value as possible should be chosen if no means is available for measuring the leakage resistance of the condensers.

All of the preceding remarks have to do with condensers connected into direct-current circuits. When two condensers are connected in series in an alternating-current circuit the conditions are quite different from those just described. The impedance of a condenser that is charged and discharged from an alternating-current circuit is dependent upon both capacitive reactance and leakage resistance. As a general rule, however, the capacitive reactance of a condenser is quite small compared to its leakage resistance. The voltage across two condensers in series will divide approximately in proportion

to their capacitive reactances $\left(\frac{1}{2\pi fC}\right)$ or in inverse proportion to their capacities.

CARL W. EVANS,
San Antonio, Texas.

Radio Science Abstracts

(Continued from page 600)

only about one-third of the current needed to close it. When a signal has closed the relay, any interfering signal of only one-third the strength will be able to keep it closed after the signal ends and thus prevent proper functioning.

This may be overcome by introducing a Wagnerian hammer into the circuit and so disturbing the current that it takes the full amount to hold the armature.

The alarm system at present used on ships works on the principles of timed relays. It requires dashes of a certain minimum length to close the relays and the maximum length of dash and pause together is also limited. This leaves some tolerance in the length of the dashes and pauses which will actuate the alarm.

For the individual call system, where one transmitter must be able to call any one of a number of stations, this system might be used, but it becomes too complicated. A simpler hookup is shown in an accompanying

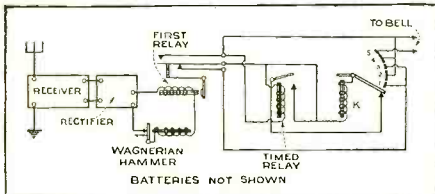

illustration, which is reproduced here (Figure 3).

The contact-arm starts moving after a preliminary dash. From then on it moves with uniform velocity over a row of contacts which have the same characteristic as the call signal. These contacts are so connected that the odd numbered ones keep the circuit closed if there is a pause and the even ones when a dash is coming in. When the incoming signal has its dashes start and stop at the right time, the circuit of relay K will always be closed, keeping the arm moving and finally ringing the bell. But if the incoming call is the least bit different the circuit will be broken which returns all relays to the rest position.

The Mechanics of Modulation, by Paul R. Huntsinger. QST, October, 1931. A semi-technical article on modulation which discusses methods of modulating waves and of rating transmitters in terms of their modulation capability. The author describes a method of measuring modulation which consists of connecting a current-square galvanometer across a coil coupled to the oscillator under test. The modulation is obtained by noting the reading of the meter when the carrier is modulated and when the carrier is not modulated. Substituting these values in the following simple expression gives the modulation.

$$M = \sqrt{2} \left[\frac{D_m}{D_c} - 1 \right]$$

where D_m is the deflection when the carrier is modulated and D_c is the deflection when the carrier is not modulated.

Moving-Coil Telephone Receivers and Microphones, by E. C. Wente and A. L. Thuras. The Journal of the Acoustical Society of America, July, 1931. A fundamental analysis of considerations affecting the characteristics of moving-coil units is given in this article. The units are analyzed in terms of their effective mass, stiffness, mechanical resistance of the diaphragm and the alternating force acting on the diaphragm. Response characteristics and brief descriptions of commercial units are given.

Mass-controlled Electro-dynamic Microphones: the Ribbon Microphone, by Harry F. Olson. The Journal of the Acoustical Society of America, July, 1931. The ribbon microphone consists of a light corrugated metallic ribbon suspended in a magnetic field and freely accessible to air vibrations from both sides; the ribbon is driven from its equilibrium position by the difference in pressure existing between the two sides. This type of microphone is highly directional, an advantage which assumes considerable importance in many instances. The author analyzes the operation of such a microphone and gives curves showing experimental and calculated characteristics.

Pamphlets, Etc.

Official Refrigeration Service Manual, by L. K. Wright. Gernsback Publication, Inc. A review of an electric refrigerator service manual may seem out of place here, but it really isn't. A large number of radio dealers now handle electric refrigerators and it is quite possible that the radio service man may find it necessary to service such units. Most of us can probably name not more than a half a dozen different makes of refrigerators, but this book lists many times that number. Besides being a service manual in that it gives complete details of each unit including the type of drive, compressor, condenser, refrigerant and control system, the book contains an excellent discussion of the fundamentals of refrigeration. It is really a text book on refrigeration as well as a service manual.

The book is divided into ten chapters. The first part deals with the fundamentals of refrigeration and refrigerants. The following chapters discuss service tools, shop equipment and trouble shooting. Unit parts, such as valves, automatic thermostats, motors, etc., are described in the latter part of the book. Complete lists are given of manufacturers together with specifications on their units. A number of useful tables including the properties of various refrigerants, comparison of thermometer scales, properties of ammonia and saturated steam, etc., are included in the appendix.

Stenode Blueprints and Data Books, published by The Stenode Corporation of America. This material relates to the Stenode receiver, the principles of which have been described quite completely in past issues of RADIO NEWS. The "Engineering Data Book" discusses in detail the technical characteristics of the receiver, with reference to its selectivity, fidelity, sensitivity, and elimination of background noise. It contains the fundamental circuit arrangements of the various parts of the Stenode circuit, including data on the compensated amplifier which forms an essential part of the receiver.

The second booklet contains complete instructions for building the Stenode receiver and with this booklet go eight blueprints giving complete dimensions, placement of parts and other information needed to build the set. The booklet itself contains the necessary lists of parts and photographs of various types of receivers, while the text describes exactly how the various units should be wired together. The latter part of the book discusses trouble shooting.

The experimenter, who has been intrigued by the Stenode circuit, will find in these booklets and blueprints all the data he requires to construct such a set. The material is quite complete and little difficulty should be experienced in putting the units together and obtaining proper performance.

THE SWING FOR TRAINED MEN IS TO ELECTRIC REFRIGERATION

Read the Story of Lewis L. Mews of New York



"I had tried my hand at radio servicing, at selling and a dozen other things. Not one of them held out when the depression came along. I heard of the demand which had arisen for trained service men in the electric refrigeration field—I found my experience in radio was a big help—in seven weeks I had completed my training—then came a good job—work—as long as you wish—field's not crowded—no doubt of a big future."

You, too, can have a job like Mews. Right at home you can study the "easy-to-learn" instructions—and in less than two months you will be ready for a good, steady job.

Men Formerly Out of Work

Men who were laid off in their old line of work, learned today's new trade—electric refrigeration, installation and servicing work—thru our practical method of training and are now enjoying steady employment with good pay. This is Electric Refrigeration's Biggest Year and NOW is a good time to learn this new trade.

We'll train you, too, like we have many others from many states. Send for descriptive folder and full information how you may prepare yourself for a job as an Installation and Service man in a short time.

Refrigeration Training School & Shops, Inc.
104 Boulevard of the Allies
Pittsburgh, Pa.

Kindly send me without obligation your folder, "More Jobs—More Money."

Name

Street and No.

City and State

SERVICE MEN

Send for this Book FREE!

RADOLEK

THE RADOLEK COMPANY, INC.

YOU NEED IT!

Everything for your business from the finest mike to the smallest screw is in this book.

GUARANTEED QUALITY GOODS

PRICES LOWEST EVER QUOTED

Fresh new dependable Merchandise at Bargain Prices!

Leading Manufacturers Lines Complete

Send For Your Copy Now!

SAMPLE BUYS FROM THIS BOOK

4 Tube A.C. Radio Quality and Value.

Walnut Cabinet \$14.65 less tubes

Dry Electrolytic Condenser 500 V. 8 mfd. Guaranteed 69c

6 Tube Replacement Transformer Brand New \$1.98

and Three Thousand Other Bargains

HEADQUARTERS

for **SERVICE MEN'S SUPPLIES**

RADOLEK CO.

623 W. Randolph St.

CHICAGO

Illinois

USE THIS CONVENIENT COUPON

Radolek Co., 623 West Randolph St., Chicago, Ill.

Please send me without obligation your Service Man's Supply Book.

Name

Address

City

State

Read Classified Advertising—It Pays

Advertisements in this section twenty-six cents a word for each insertion. Name and address must be included at the above rate. Cash should accompany all classified advertisements unless placed by an accredited advertising agency. No advertisements for less than 10 words accepted. Objectionable or misleading advertisements not accepted. Advertisements for these columns should reach us not later than 1st of 2nd month preceding issue.

TECK PUBLISHING CORP.
350 Hudson St. New York, N. Y.

Chemistry

CHEMICAL STUNTS! 84 fascinating experiments, 50c. J. Penn, Florence, Ky.

Correspondence Courses

Used correspondence school courses sold on repurchase basis. Also rented and exchanged. Money-back guarantee. Catalog free. (Courses bought.) Lee Mountain, Pisgah, Alabama.

CORRESPONDENCE COURSES—Sold, Bought, Exchanged, Rented, Bargain Catalogue Free. Hanfing, C-799 Broadway, New York.

Detectives

DETECTIVES. Work home or travel. Experience unnecessary. Particulars free. Write George Wagoner, 2190-A Broadway, N. Y.

For Inventors

INVENTIONS. patented or unpatented, now in demand. Write Chartered Institute American Inventors, 1106 Barrister Building, Washington, D. C.

Instruction

WANTED—Names of men desiring steady outdoor jobs: \$1700-\$2400 year; vacation. Patrol parks; protect game. Write immediately. Delmar Institute, A-54, Denver, Colo.

Inventions

INVENTIONS COMMERCIALIZED. Patented or unpatented. Write Adam Fisher Mfg. Co., 278 Enright, St. Louis, Mo.

Patent Attorneys

PATENTS—Write for Free Information, HOW TO OBTAIN A PATENT and RECORD OF INVENTION—or send Drawing or Model for Examination. Miller & Miller, Patent Attorneys (former Patent Office Examiners), 1006-D Woolworth Building, New York; 675 Earle Building, Washington, D. C.

PATENTS, TRADE MARKS—All cases submitted given personal attention by a member of the firm. Information and booklet free. Lancaster, Allwine & Rommel, Suite 414, 815 15th St., N. W., Washington, D. C.

Inventors—Should write for our Guide Book, "How to Obtain a Patent," and Record of Invention Blank, sent Free. Send model or sketch of inventions for our inspection and instructions free. Radio, Electrical, Chemical, Mechanical and Trademark Experts. Terms Reasonable. Victor J. Evans & Co., 616-A, 922 Ninth, Washington, D. C.

PATENTS—Advice and booklet free. Highest references. Best results. Promptness assured. Watson E. Coleman, Patent Lawyer, 724 9th Street, Washington, D. C.

PATENTS. Time counts in applying for patents. Send sketch or model for instructions or write for free book, "How to Obtain a Patent," and "Record of Invention" form. No charge for information on how to proceed. Clarence A. O'Brien, Registered Patent Attorney, 309 1/2 Security Savings & Commercial Bank Building (directly opposite U. S. Patent Office), Washington, D. C.

Photography

HAVE YOU A CAMERA? Write for free sample of our big magazine showing how to make better pictures and earn money. American Photography, 3105 Camera House, Boston, Mass.

Songwriters

COMPOSERS—VERSE OR MUSIC. Brilliant opportunity. Write at once. Van Buren, 2570 McClurg Bldg., Chicago.

Telegraphy

LEARN Wireless (Radio) and Morse telegraphy. School, oldest, largest, endorsed by telegraph, radio and government officials. Expenses low—can earn part. Catalog free. Dodge's Institute, Cour Street, Valparaiso, Ind.

Mathematics in Radio

(Continued from page 631)

greens, and by drawing a smooth curve through these points the sine curve of Figure 17 (e) will be obtained.

2. Plot on graph paper the function $y = \sin 2x$.

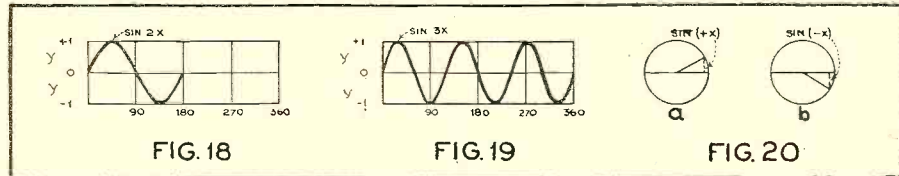

These functions of multiple angles are very important, and frequent use of them is made in the theory of radio circuits.

Tabulate the results as follows:

For $x = 0$; $2x = 0$; $\sin 2x = 0$
 For $x = 15$; $2x = 30$; $\sin 2x = +.5$
 For $x = 30$; $2x = 60$; $\sin 2x = +.866$
 For $x = 45$; $2x = 90$; $\sin 2x = +1.00$

Note: Tabulate the values of x to 360 degrees and complete the graph of Figure 18. It will be noticed that a sine wave will be shown from $0-360^\circ$ which will be twice the frequency of that shown in

to that shown in Figure 19. It is noticed that this curve has a frequency three times that of Figure 17 (e).

From the last two examples it can be easily surmised that any function $y =$

$\sin nx$ will have a frequency "nx" times the fundamental. Thus, $y = \sin 5x$, $y = \sin 7x$ and $y = \sin 9x$ will have frequencies of 5, 7 and 9 times the fundamental frequency.

4. Plot on graph paper the following function:

$$(I) y = \frac{EI}{2} (1 - \cos 2x)$$

Let $E = 20$ and $I = 10$.

This appears to be a complicated expression, but it can be treated in rather

For $x = 0$; $2x = 0$; $\cos 2x = +1$; $100 \cos 2x = 100$	Thus $y = 100 - 100 \cos 2x = 0$
For $x = 15$; $2x = 30$; $\cos 2x = +.866$; $100 \cos 2x = 86.6$	Thus $y = 100 - 100 \cos 2x = 13.4$
For $x = 30$; $2x = 60$; $\cos 2x = +.50$; $100 \cos 2x = 50$	Thus $y = 100 - 100 \cos 2x = 50$
For $x = 45$; $2x = 90$; $\cos 2x = 0$; $100 \cos 2x = 0$	Thus $y = 100 - 100 \cos 2x = 100$
For $x = 60$; $2x = 120$; $\cos 2x = -.50$; $100 \cos 2x = -50$	Thus $y = 100 - 100 \cos 2x = 50$
For $x = 75$; $2x = 150$; $\cos 2x = -.866$; $100 \cos 2x = -86.6$	Thus $y = 100 - 100 \cos 2x = 13.4$

TABLE A

Figure 17 (e).

3. Plot on graph paper the function $y = \sin 3x$.

Note: Tabulate the results as follows:

For $x = 0$; $3x = 0$; $\sin 3x = 0$
 For $x = 10$; $3x = 30$; $\sin 3x = +.5$
 For $x = 20$; $3x = 60$; $\sin 3x = +.866$
 For $x = 30$; $3x = 90$; $\sin 3x = +1.00$

Tabulate the values of x to 360 degrees and plot the curve. It should correspond

a simple way.

The equation (I) can be resolved as follows:

$$(II) y = \frac{EI}{2} - \frac{EI \cos 2x}{2}$$

for $E = 20$ and $I = 10$ (II) becomes $y = 100 - 100 \cos 2x$.

Proceeding as in the above examples, let us tabulate as in Table A.

For $a = 0$; $\sin(a - b) = \sin -30$; thus $y = -.5*$
For $a = 30$; $\sin(a - b) = \sin 0$; thus $y = 0$
For $a = 60$; $\sin(a - b) = \sin 30$; thus $y = +.5$
For $a = 90$; $\sin(a - b) = \sin 60$; thus $y = +.866$
For $a = 120$; $\sin(a - b) = \sin 90$; thus $y = +1.00$
For $a = 150$; $\sin(a - b) = \sin 120$; thus $y = +.866$

Tabulate the rest of the values to 360° and plot the curve.

*It is interesting to note the relations of the functions of a negative angle.

TABLE B

Tabulate the rest of the values to 360° and plot the curve.

5. Plot a graph of the following function: $y = \sin(a - b)$ Let the angle $(b) = 30$ degrees.

Tabulate the values of $(a - b)$ as in Table B.

It is remembered that the sine of an angle in the first and second quadrants is positive because it is above the reference line "00," shown in Figure 20 (a). The sine of an angle in the third and fourth quadrants is negative. Referring to Figure 20 (b), it is obvious that the sine of a negative angle can have the same value as the sine of a positive angle, but will be opposite in sign. Thus the sine of a negative angle of 30 degrees will have a numerical value equal to .5 (the same value as the positive angle of 30 degrees), but will have the opposite sign, thus being numerically equal to $-.5$.

Backstage in Broadcasting

(Continued from page 603)

on the tiny settings on glass and thus the transmitted picture would have picturesque backgrounds according to Columbia engineers' expectations. During the recent football season, William A. Schudt, Jr., acting television director of the chain, introduced the use of a miniature football gridiron on which the various plays were denoted by the movement of a small white football on the field which was laid out in solid black. All marking lines and numbers were in white, chain engineers claiming that white on black reproduces better than the reverse.

Public Address Systems

(Continued from page 584)

are required, this correction may be disregarded. On the other hand, if the load impedance is taken into account, a reliable indication of the audio-frequency power is afforded at the measuring point.

The volume indicator is especially useful in all types of public address installations where the speakers are located some distance away from the control operator. The operator simply observes the reading of the volume indicator which results in satisfactory covering and then regulates mixing or volume controls to maintain this level.

Panel dimensions of the volume indicator are 4 inches by 21 inches, a 5¼-inch by 19-inch size is available for mounting on racks designed for such

panels. A removable, black-enameled dust cover is furnished.

The out-put control panel functions as a coupling and switching unit between the amplifier output and from two to six 15-ohm voice coil lines. Individual "on-off" tumbler switches are provided in each line. An impedance-adjusting tap switch insures maximum transfer of power from the amplifier to the load whether 2, 3, 4, 5 or 6 loudspeakers are in service.

An output panel of this sort is useful where the number of speakers in operation varies from time to time. The switches make it a simple matter to cut out the unused lines. This panel measures 8 inches by 21 inches, with a 7-inch

(Continued on page 638)

RADIO NEWS Export Service

AS a service to our readers in locations outside the United States of America, either commercial, professional or private individuals, RADIO NEWS will arrange to provide contact with leading American manufacturers of radio supplies and receiving equipment.

To utilize this service, clip and fill out coupon below and send it attached to your letter on which you list the types of apparatus you are interested in.

Our Export Service Department will refer your inquiries direct to the proper manufacturers, asking them to send you full particulars, catalogues, prices, etc.

* * *

ALS einen Dienst für unsere Leser, entweder Kaufleute oder Privatpersonen ausserhalb der Vereinigten Staaten von Amerika, kann RADIO NEWS mit den führenden Amerikanischen Fabrikanten von Radio Apparaten Kontakt herstellen.

Für den Gebrauch dieses Dienstes schneide man die Kupon hierunter aus und sende ihn mit einer Liste von Apparaten ein der für Sie von Interesse sind.

Unsere Export Abteilung wird Ihr Schreiben umgehend an die betreffende Fabrikanten weiter befördern, mit der Bitte Ihnen Auskünfte, Preise und Katalog zu senden.

* * *

COMME un service à nos lecteurs demeurant hors des Etats-Unis d'Amérique, soit établissements commerciaux, soit personnes privées, RADIO NEWS arrangera de procurer le "contact" avec les usines les plus importantes des appareils de T. S. F. en Amérique.

Pour utiliser ce service, coupez, signez, etc., le coupon sur cette page et envoyez le attaché à votre lettre en énumérant les types des appareils qui vous intéressent.

Notre Département d'Exportation fera suivre vos requêtes aux manufacturiers directement en les priant de vous envoyer toutes informations, catalogues, prix, etc.

* * *

COMO un servicio especial a nuestros lectores que se encuentran fuera de los Estados Unidos de America, ya sean comerciantes, profesionales o personas privadas, RADIO NEWS tendra a bien ponerlas en contacto con los principales centros manufactureros de radio, de aparatos receptores y accesorios.

Para beneficiarse de tal servicio, sirvase recortar el coupón de esta página, enumere los tipos de aparatos que le interesen, y envíenlos conjuntamente con su carta.

Nuestro Departamento de Exportación se encargará de ponerse en contacto directo con dichos centros, pidiéndoles le envíen una información complete, catalogos, precios, etc.

* * *

RADIO NEWS Export Service Department

Kindly put me in contact with American firms manufacturing the class of radio apparatus noted on attached sheets.

Name

Address

Business

NEWARK ELECTRIC Short-Wave Converter

New In Design: 15 to 200 Meters. World Wide Reception; Unlimited Range. Model 440, 4 Tubes \$34.50. Model 400, 3 Tubes \$29.50.

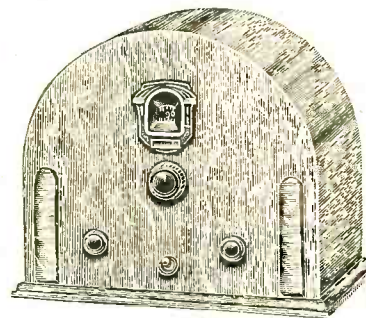

The N. E. short-wave converter operates with any make of radio. It merely connects to the antenna post of your receiver. Has self-contained power pack, no other connection, can be left connected permanently, has change-over switch for either short-wave or broadcast reception. Model 400 three-tube for extremely sensitive receivers. Model 440 four-tube with R.F. stage for any type receiver.

Sent prepaid if check accompanies order; or C. O. D. with one dollar deposit.

We carry a complete line of Replacement Condenser Blocks and Power Transformers guaranteed to be manufactured from new materials. Duplicates of the original as to external size and hookup.

In sending your order just mention the name and model of set, include a deposit of one dollar and the balance C. O. D.

When sending your order on your Letter Head, we will allow the usual discount.

NEWARK ELECTRIC CO.

A Radio Service Institution

231 West Madison St., Chicago, Illinois

You Should START THE NEW YEAR CORRECTLY

USE FLECHTHEIM SUPERIOR CONDENSERS

Catalogs Nos. 23 and 24 gratis

A. M. Flechthelm & Co., Inc.

138 Liberty St., New York, N. Y.

Make a PROFIT

Service men make \$90 per month installing AMPERITE. Send \$1.62 to Dept. RN-1, for complete sample and sales helps.



AMPERITE Corporation
561 BROADWAY, NEW YORK

AMPERITE
Self-Adjusting
LINE VOLTAGE CONTROL

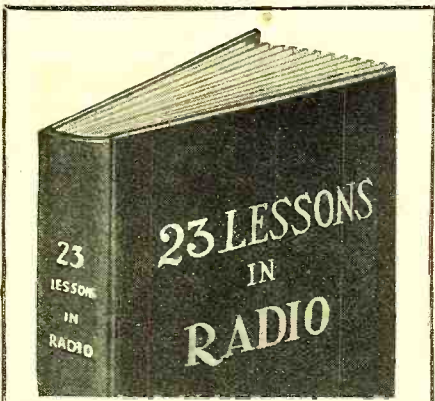

FREE

With this New Money-Saving Offer From RADIO NEWS

SO many requests have come into this office asking us for a book covering the Junior Radio Guild lessons, that we have at last, with considerable time and effort, compiled this material (along with some other information) into a great new book!

"23 LESSONS IN RADIO" is not for sale anywhere! But by subscribing through this special offer, you receive not only this great book FREE, but you also receive two whole years of RADIO NEWS for only \$4, a saving of \$2 over the single copy price. Besides, you do not need to pay the entire amount now! Simply fill out the coupon below and send it to us with \$1! We will immediately mail your "23 LESSONS IN RADIO" and your first issue of RADIO NEWS. Then you may pay the balance later as we bill you, in easy installments of \$1 a month for 3 months. Renewal or extension of current subscriptions accepted on this offer, but payment must be made now, as specified above, not when subscription expires.

A Few of the Subjects Covered:

- Elementary Radio Theory
- How the Detector Tube Works
- Construction of a two-stage audio-frequency amplifier
- How the Radio-Frequency Amplifier Works
- How To Build a "Converter" which changes your 5-tube broadcast receiver into a Short-Wave receiver
- Principles of transmitting and receiving
- Complete Chart of Standard Radio Symbols
- How To Build R F Tuner
- How To Build a 3-stage resistance coupled audio-frequency amplifier
- The How and Why of B-Power Units
- Breaking into the Amateur Game
- How to build a code test outfit
- Circuit, constructional and operating details of a Low-Power Transmitter
- How the Vacuum Tube Works
- Battery construction details
- How to Analyze Receiver Circuits

RADIO NEWS, Dept. R-1
350 Hudson Street, New York, N. Y.

Enter my subscription for two years of RADIO NEWS, and send me the book "23 LESSONS IN RADIO"—all for only \$4.00. I am enclosing \$1.00 herewith, and will pay the balance, \$1.00 a month, for the next three months. (One extra issue—25 months in all—if you send the full amount with your order.)

Name
 Address
 City State
 If renewal check here Engineer Dealer
 Are you a Serviceman Experimentor Radio Technician
 Canadian and Foreign Price, \$6.00

Public Address Systems

(Continued on page 637)

by 19-inch size also available. The input impedance is 200 ohms and the impedance-adjusting transformer is capable of handling 50 watts continuously.

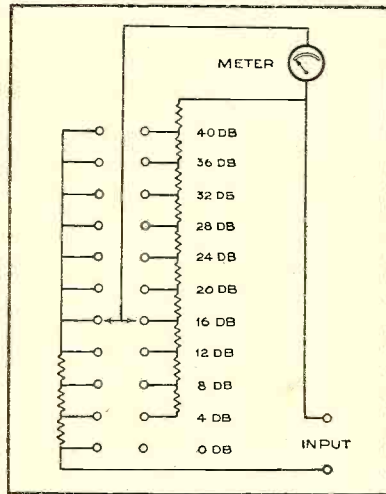

VOLUME INDICATOR CIRCUIT
 Figure 3. Schematic wiring diagram

Figure 4 shows a schematic wiring diagram of the PA-22A amplifier. The unit has three stages, consisting of a -24 followed by a -45 and two 845 tubes in push-pull, thus delivering an undistorted output of 50 watts. The input circuit has an impedance of 100,000 ohms. Low-impedance sources, such as the outputs of the mixing panel or input-control panel, are therefore fed to the amplifier through a line-to-tube transformer such as the S-M 10111. The output of the amplifier is brought out at impedance levels of 200 and 500 ohms. The 200-ohm outlet feeds the output-control panel. The 500-ohm outlet is convenient for connecting the volume indicator, although naturally either outlet may be used to feed a loud-speaker load. The panel measures 20 inches by 21 inches.

A unit designated as a microphone-control panel contains complete facilities for operating two carbon microphones. A schematic wiring diagram is shown in Figure 5. It was designed particularly to operate in connection with the mixing panel, but many other uses of the panel will suggest themselves. Individual microphone transformers, button-current control potentiometers, and microphone current-measuring jacks are provided for each microphone channel. The transformers accommodate standard 200 ohm-speaker-button microphones and a special feature consisting of an interlocked current control and switch makes it impossible to damage the microphone by interrupting the circuit when current is flowing. The impedance at the secondary terminals of the microphone transformers is 200 ohms, which is the correct value for the volume control used in the mixing panel. It should be noted that either microphone channel can be used singly or in combination with the other. A back-of-panel view of the microphone control panel in combination with the mixing panel is shown in Figure 6. The control panel measures 6 inches by 21 inches in size.

INDEX TO ADVERTISERS

	PAGE
A	
Aerovox Wireless Corp.	631
Amperite Corp.	637
B	
Baltimore Radio Corp.	623
Blan the Radio Man, Inc.	621
Broderick, Wm. H.	630
C	
Candler System Co., The	632
Capitol Radio Engineering Institute	612
Central Radio Laboratories	629
Chicago Radio Apparatus Co.	614
Clarostat Mfg. Co., Inc.	633
Coast to Coast Radio Corp.	626
Commonwealth Radio Co.	624
Coyne Electrical School	549
Classified Advertising	636
D	
Dodge's Institute	630
Dubilier Condenser Corp.	626
E	
Eastern Rabbitry	539
Electrad, Inc.	623
Experimenters' Radio Shop	532
F	
F. & H. Radio Laboratories	621
Federated Purchaser	616
Filtermatic Mfg. Co.	625
Fleethelm & Co., Inc., A. M.	637
Fox Engineering Co.	620
G	
Grant Radio Laboratories	625
H	
Hammarlund-Roberts, Inc.	613
Hearing Devices Co., Inc.	632
Hoodwin Co., Chas.	633
I	
Insuline Corp. of America	633
International Correspondence Schools	640
International Resistance Co.	615
J	
J.M.P. Mfg. Co.	630
L	
Lincoln Radio Corp.	Second Cover
Lynch Mfg. Co., Inc.	621
Mc	
McGraw Hill Book Co.	629
McSweeney Electrical School	616
M	
Massachusetts Radio & Telegraph School	626
Mid-West Radio Corp.	609
Morrill & Morrill	632
Motorphone Radio Corp. of America	630
N	
National Co., Inc.	617
National Radio Inst.	547, 619
Newark Electric Co.	637
N. Y. City Cancer Committee	622
P	
Polo Engineering Labs.	620
R	
Racon Electric Co., Inc.	625
Radio College of Canada, Ltd.	621
Radio Products Co., The	626
Radio Surplus Corp.	625
Radio Technical Pub. Co.	632
Radio-Television Inst.	550
Radio Trading Co.	612
Radio Training Association of America	545
Radio Training School, Inc.	611
Radio Treatise Co., Inc.	618
RCA Institutes, Inc.	624
Radolek Co.	635
RCA Victor Co., Inc.	Third Cover
Readrite Meter Works	627
Refrigeration Training School & Shops, Inc.	635
Rim Radio Mfg. Co.	618
S	
Scott Radio Labs., Inc., E. H.	607
Shallcross Mfg. Co.	612
Silver-Marshall, Inc.	Fourth Cover
Supreme Instruments Corp.	610
T	
Teleplex Co.	639
Trail Radio Co.	621
Trimm Radio Mfg. Co.	624
U	
Universal Auto Radio Corp.	618
Universal Microphone Co.	622
United Radio Builders	620
V	
Van Nostrand Co., D.	626
W	
Western Radio Mfg. Co.	649
Weston Electrical Instruments Corp.	608
Wellston Radio Corp.	616
West Side Y.M.C.A. Radio Inst.	614
Wholesale Radio Service	614
Wilcox, P. H.	630
Wilson Ear Drum Co., Inc.	639

What's New in Radio

(Continued from page 605)

for a quickly and easily erected temporary radio antenna installation. The mast consists of three sections of treated durable wood and when extended is 12 feet high, folded it measures 4½ feet in length. It weighs 6 pounds. The nickeled steel ball fastened on the top section houses a reel of 40 feet of

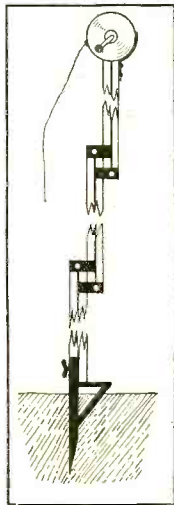

insulated stranded copper wire for the antenna. The strong channel iron spike at the bottom is easily pushed in the ground for holding the mast in erect position.

Maker—Quick-Set Aerial Company, Maryville, Missouri.

A Compact Pentode Receiver

Description—A five-tube midget receiver utilizing one type -35 multi-mu tube, one type -24 screen-grid tube, one type -27 tube, one type -47 pentode tube and one -80 type rectifying tube. The set is provided



with a new Rola model F electro-dynamic reproducer. The dimensions of the cabinet are 14½ inches high by 11¾ inches wide by 7¼ inches deep.

Maker—Radio Surplus Corp., 56 Vesey St., New York City.

Auto-Radio Receiver

Description—The accompanying illustration shows the three main parts of the new Universal six-tube automobile set—the receiver itself, which is enclosed in a metal

dust-proof case; a super-dynamic speaker and a remote control. The receiver is complete with tubes, battery box, and a kit of suppression resistors and condensers. The tubes utilized are as follows: two type -51

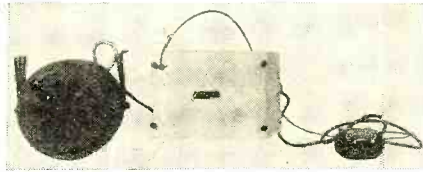

multi-mu tubes, one type -24 screen-grid tube, one type -37 tube and two type -38 pentode tubes.

Maker—Universal Auto-Radio Corp., 1223 S. Michigan Ave., Chicago, Ill.

Battery-Operated Superheterodyne Receiver

Description—The new model R-43 eight-tube superheterodyne receiver is designed for un electrified areas and direct-current districts. This set operates from the new "air cell" "A" battery and four heavy-duty "B" batteries. It is equipped with a tone control



and a permanent-magnet dynamic speaker. The receiver utilizes the following two-volt tubes, five type -30 tubes, and three type -32 tubes. The dimensions of the console cabinet are as follows: 41 inches high by 25¾ inches wide by 13¾ inches deep.

Maker—RCA-Victor Co., Inc., 155 E. 24th St., New York City.

Test Probe

Description—A vest-pocket size test prod for the serviceman, radio experimenter or dealer. It is adaptable to numerous tests for continuity, detects defective by-pass condensers and makes a real handy radio or automobile trouble light. A standard flashlight lamp is housed on top of the red and black polished composition probe handle. An 18-inch connecting cord terminating in a test clip and complete instructions are furnished with the instrument. The probe measures 7 inches by 7/16 inches.

Maker—Electrical Manufacturing Corp., 10 High St., Boston, Mass.

LEARN RADIO

this easy, practical way

WRITTEN by two widely known radio engineers, these three books cover every phase of building, repairing and "trouble-shooting" on modern receiving sets.

The books include complete instructions for building short-wave and TELEVISION receivers.

Radio Construction Library [1931 Edition]

Including Television Receivers

This practical Library includes: PRACTICAL RADIO—The fundamental principles of radio, presented in an understandable manner. Illustrated with working diagrams. RADIO CONSTRUCTION AND REPAIR—Methods of locating trouble and reception faults and making workmanlike repairs. RADIO RECEIVING TUBES—Principles underlying the operation of all vacuum tubes and their use in reception, remote control and precision measurements. The Library is up-to-the-minute in every respect and is based on the latest 1931 developments in the design and manufacture of equipment.

Three Volumes,
6 x 9—1037 pages,
605 illustrations.

See this
Library
FREE!

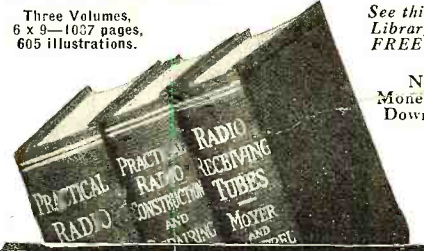

No
Money
Down

FREE EXAMINATION COUPON

McGraw-Hill Book Company, Inc.
330 West 42nd St., New York

Send me the new 1931 RADIO CONSTRUCTION LIBRARY, three volumes, for 10 days' free examination. If satisfactory I will send \$1.50 in ten days, and \$2.00 a month until \$7.50 has been paid. If not wanted I will return the books.

Name

Home Address

City and State

Position

Name of CompanyRN-1-32

MAKE \$10,000

A year raising rabbits for us. We pay up to \$12.00 each for all you raise. Send 25c for full information and contract, everything explained. Send at once and find out about this big proposition we have to offer you.

THE EASTERN RABBITRY
Route 1, Box 236 New Freedom, Pa.

Deaf 20 Years



But now I hear and will tell any deaf person FREE, who writes me, how I got back my hearing, and relieved head noises by a simple, invisible, inexpensive method which I myself discovered. Geo. H. Wilson, President Wilson Ear Drum Company, Inc. 1094 Todd Bldg., Louisville, Ky.

The HAND That Encircles The WORLD

There's ROMANCE IN TELEGRAPHY.

The man who knows code is in touch with the world. Become an expert operator. Make big money. Learn IN YOUR OWN HOME—easily, quickly with TELEPLEX—the Master Teacher. Entirely new code course in 12 rolls of tape. During last ten years TELEPLEX has trained more operators than all other methods combined.

Write for Folder "E-1"

TELEPLEX CO.
76 Cortland St.
New York



new 1932 CATALOG **BIG SAVINGS ON SUPERHETS, MIDGETS, AUTO RADIOS**

Lowest wholesale prices on the finest and the latest in radio. America's oldest mail-order radio house offers you now Varioc-Mix, Pentode Superheterodynes at big savings. Also Midgets, Auto Radios, Short Wave Receivers, Radio Phonograph Combinations, etc. Be sure to send for new 1932 catalog now.

Western Radio Mfg. Co.
126 W. Lake St., Chicago

WESTERN RADIO

WHAT YOU NEED TO SUCCEED IN RADIO



RADIO is a highly specialized business. As it develops it is becoming more exacting in its demands. But radio is the modern field of opportunity for those who keep step with its progress!

There is a great demand for *trained men* in the radio industry. There is no place for *untrained men*. Experience must be accompanied by technical knowledge.

A pioneer in radio instruction, the International Correspondence Schools have kept pace with the times and offer courses which give practical instruction in fundamentals and latest developments alike. The courses were prepared and are constantly revised by the Who's Who of Radio!

Composed of 24 basic divisions, the Complete Radio Course covers the whole field of radio. The I. C. S. Radio Servicing Course was prepared specially for men who wish to become service experts, and win over competition. The I. C. S. Radio Operating Course is vital to mastery of operating and transmitting.

We will be pleased to send you details of any or all of these subjects. Just mark and mail the coupon—the information will be forwarded at once. Do it today—*now!*

INTERNATIONAL CORRESPONDENCE SCHOOLS
Box 8280-L, Scranton, Pa.

Without cost or obligation, please tell me all about the NEW RADIO COURSE

Name _____ Age _____
Street Address _____
City _____ State _____

If you reside in Canada, send this coupon to the International Correspondence Schools Canadian, Ltd., Montreal, Canada

News and Comment

(Continued from page 606)

F. Burns, vice-president and general sales manager of E. T. Cunningham, Inc., radio tube company.

In connection with the foregoing, Mr. Burns points to the steadily growing radio export trade of this country, now amounting to over a million and a half dollars annually, as a factor likely to develop into one of considerable importance in the future trade balance sheet of American foreign commerce.

Houck Joins Kolster Radio

NEW YORK—After a ten-year association with the Dubilier Condenser Corporation and predecessor, Harry W. Houck has resigned as chief engineer in order to join Kolster Radio.

Although best known for his engineering work in the condenser field, Houck has contributed unsparingly to the development of radio reception. He was associated with the development of the original superheterodyne circuit at the Research and Inspection Division laboratories of the U. S. Signal Corps in Paris during the World War. He has been granted numerous patents on radio inventions. His radio career dates back to 1910 as a wireless amateur. He operated one of the first licensed stations in Central Pennsylvania in 1912. He has been active in the I.R.E. and Radio Club of America.

Houck has joined the Kolster Radio organization as assistant chief engineer and is stationed at the engineering laboratories in Newark, N. J.

Radio News Technical Information Service

The Technical Information Service has been carried on for many years by the technical staff of RADIO NEWS. Its primary purpose is to give helpful information to those readers who run across technical problems in their work or hobby which they are not able to solve without assistance. The service has grown to such large proportions that it is now advisable to outline and regulate activities so that information desired may come to our readers accurately, adequately and promptly.

Long, rambling letters containing requests that are vague or on a subject that is unanswerable take up so large a portion of the staff's working time that legitimate questions may pile up in such quantities as to cause a delay that seriously hinders the promptness of reply. To eliminate this waste of time and the period of waiting, that sometimes occurs to our readers as a consequence, the following list of simple rules *must* be observed in making requests for information. Readers will help themselves by abiding by these rules.

Preparation of Requests

1. Limit each request for information to a single subject.
2. In a request for information, include any data that will aid us in assisting in answering. If the request relates to apparatus described in RADIO NEWS, state the issue, page number, title of article and the name of the device or apparatus.
3. Write only on one side of your paper.
4. Pin the coupon to your request.

The service is directed specifically at the problems of the radio serviceman, engineer, mechanic, experimenter, set builder, student and amateur, but is open to all classes of readers as well.

All questions from subscribers to RADIO NEWS will be answered free of charge, provided they comply with the regulations here set forth. All questions will be answered by mail and not through

the editorial columns of the magazine, or by telephone. When possible, requests for information will be answered by referring to articles in past issues of the magazine that contain the desired information. For this reason it is advisable to keep RADIO NEWS as a radio reference.

Complete information about sets described in other publications cannot be given, although readers will be referred to other sources of information whenever possible. The staff cannot undertake to design special circuits, receivers, equipment or installations. The staff cannot service receivers or test any radio apparatus. Wiring diagrams of commercial receivers cannot be supplied, but where we have published them in RADIO NEWS, a reference will be given to past issues. Comparisons between various kinds of receivers or manufactured apparatus cannot be made.

Only those requests will be given consideration that are accompanied by the current month's coupon below, accurately filled out.

JANUARY, 1932

Technical Information Coupon
RADIO NEWS Laboratory
350 Hudson Street
New York, N. Y.

Gentlemen:

Kindly supply me with complete information on the attached question:

- I am a regular subscriber to RADIO NEWS and I understand this information will be sent me free of charge.
- I am not yet a subscriber to RADIO NEWS.
- I wish to become a subscriber to RADIO NEWS and enclose \$2.50 to receive the magazine regularly for one year, and to receive this valuable technical information service free of charge.

Name

Address

THE CENTRALIZED RADIO SECTION
of the

RCA VICTOR CO., Inc.

Wants to make connections with well established live wire Radio SERVICE ORGANIZATIONS located throughout the United States to HANDLE the

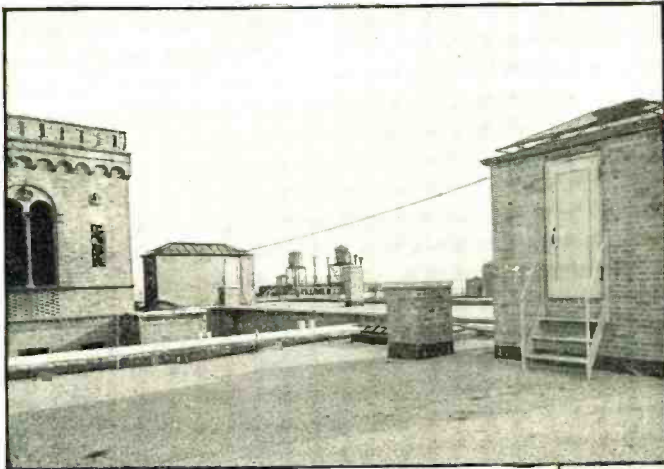

**RCA
ANTENAPLEX
SYSTEM**

Compare the above illustration showing the orderly arrangement of the RCA Antenaplex System on the roof with the hopeless tangle of aerial wires shown in the picture at the right, which is typical of the average apartment house roof. The RCA Antenaplex System provides every tenant with clear radio reception from one centrally located antenna free from interference and interaction. The illustration below will give you a fair idea of some of the equipment used in the installation of this system.

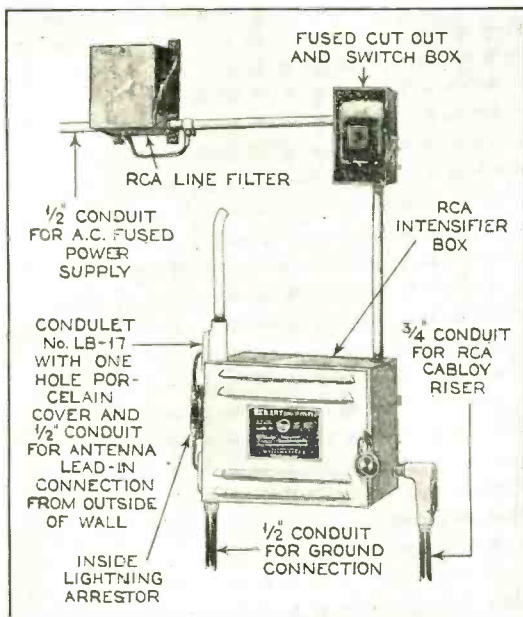
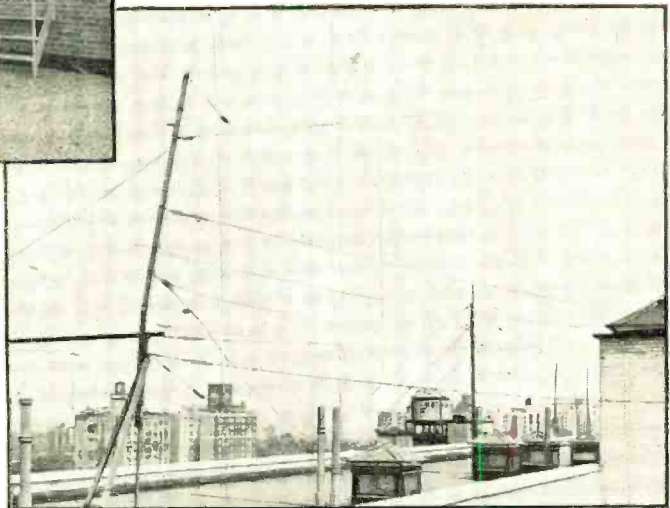

AN attractive proposition awaits Radio Service Organizations or Servicemen doing a fair volume of business who are equipped to handle this type of work. If you have contacts with Electrical and Building Contractors or are in a position to closely contact apartment house owners, write us for further information.

CENTRALIZED RADIO SECTION



RCA Victor Co., Inc.

Camden New Jersey
A Radio Corporation of America Subsidiary
"RADIO HEADQUARTERS"

SM

The
SILVER-MARSHALL
All-Wave
726 SW
Brings them in!



"This is the first time I have ever written to a radio company regarding the marvelous performance of a radio receiver. Words cannot express the thrill I get when I operate my 726 SW. It is the greatest short wave receiver I have ever tried, and believe me, I have tried most of them.

"Only had the set ten days and have logged England, Holland, Rome, South American Stations, Cuba, and most of the Short Wave American Broadcast stations.

"Outside of the foreign stations I get a kick out of listening to Ship to Shore telephone messages, airport to airport, and plane to ground. Also most of the Police stations in the U. S. and Canada.

"The set is unbelievably sharp in tuning yet the tone is great."

Yours very truly,
BANK'S RADIO COMPANY
1247 South Kedvale Avenue
Chicago, Illinois

This is just one of hundreds of letters Silver-Marshall has received from enthusiastic owners of the 726 SW.

Tubes required: 2—'24s, 3—'27s, 3—'51s, 2—'47s, 1—'80.

726 SW All-Wave Superheterodyne, complete, as described above, wired, tested, licensed, including S-M 855 electro-dynamic speaker unit. Size 20½" long, 12" deep, 8½" high. To be used on 110-120 volt, 50-60 cycle AC power. Price \$139.50 List.

SILVER-MARSHALL, Inc.

6405 West 65th Street • Chicago, U. S. A.

Canadian Division: SILVER-MARSHALL of CANADA, Ltd.

75 Sherbourne Street, Toronto

Export Office: 41 Water Street

New York City, U. S. A.

In the All-Wave 726 SW

Eleven-tube Short-Wave Super

Nine-tube Broadcast Super

No Plug-in Coils

Pentodes in Push-Pull

Sensitivity between .45 and .7
microvolts per meter

10½" Electro-Dynamic Speaker

SILVER-MARSHALL, Inc.
6405 W. 65th Street, Chicago, U. S. A.

Please send me full details on the S-M 726SW (enclosed you will find 2c).

Please send me FREE your new November General Parts Catalog.

Name

Address