

RADIO NEWS

JANUARY
25 CENTS

ASHVILLE OHIO
W. F. BOWEN
JULY 30 9500-RDF

Herbert Hoover, Jr.

Dr. Lee de Forest

Loftin & White

Wunderlich & Diehl

D. E. Replogle

C. W. Horn

E. N. Pickerill

*and Other Leaders
in Radio*





DON'T TAKE CHANCES

● **WHEN YOU ARE BUYING RADIO TUBES**

Lady Luck or Old Man Chance have never produced a consistent winner! Nowhere does that truth apply more strongly than in the buying or selling of radio tubes. Too much reliance on false quality claims has inevitably resulted in disappointment for the purchaser — and in actual loss for the dealer. TRIAD Insurance has at last definitely eliminated all guesswork in tube buying. The printed certificate accompany-



ing every TRIAD Tube guarantees a minimum of six months' perfect service. It stands as positive protection for dealer and purchaser alike — an unconditional guarantee that is winning thousands of friends daily. TRIAD MFG. CO., INC., PAWTUCKET, R. I.

Tune in on the Triadors—Friday evenings—
8 to 8:30—Eastern Standard Time—over
WJZ and associated NBC stations.

**TRIAD
INSURED
RADIO TUBES**

▼ **TRIAD—THE WORLD'S ONLY INSURED RADIO TUBE!** ▼

4 of the 40 Easy Ways to Make \$3.00 an Hour

In Your Spare Time

in RADIO

Below

are a few of the reports from those now cashing in on the "40 Easy Ways"

THE four plans shown are but a sample of the many ways in which our members are making \$3.00 an hour upwards, spare time and full time, from the day they join the Association. If you want to get into Radio, have a business of your own, make \$50 to \$75 weekly in your spare time, investigate the opportunities offered the inexperienced, ambitious man by the Association.

Our Members Earning Thousands of Dollars Every Week

The Association assists men to cash in on Radio. It makes past experience unnecessary. As a member of the Association you are trained in a quick, easy, practical way to install, service, repair, build and rebuild sets—given sure-fire money-making plans developed by us—helped to secure a position by our Employment Department. You earn while you learn, while you prepare yourself for a big-pay Radio position.

The Association will enable you to buy parts at wholesale, start in business without capital, help you get your share of the \$600,000,000 spent annually for Radio. As a result of the Association, men all over the country are opening stores, increasing their pay, passing licensed operator examinations, landing big-pay positions with Radio makers.



Mail Coupon Today for the FREE HANDBOOK

It is not only chock-full of absorbing information about Radio, but it shows you how easily you can increase your income in your spare time. Mailing the coupon can mean \$50 to \$75 a week more for you.

Radio Training Association of America
4513 Ravenswood Avenue Dept. RN-1, Chicago, Illinois



Clears \$3,000.00 Frank J. Deutch, Pa.—“Since joining the Association I have cleared nearly \$3,000.00. It is almost impossible for a young fellow to fail, no matter how little education he has, if he will follow your easy ways of making money.”

\$1,100.00 in 6 Weeks J. R. Allen, Calif.—“Have done over \$1,100.00 worth of business in the last 6 weeks. Next month I am going to open up a store of my own. I never knew that money could come so fast and easy.”

\$25.00 a Week Spare Time N. J. Friedrich, N. Y.—“I have averaged \$25.00 a week for the last 7 months even though I am not a graduate but just learning.”

Training Lands Him Job R. C. Kirk, N. C.—“Your training has been very valuable to me. I landed a job with the big department store out here a few weeks ago because I had my membership card with me. There were a large bunch of applications ahead of me.”

ACT NOW If You Wish NO-COST Membership

For a limited time we will give to the ambitious man a No-Cost Membership which need not—should not—cost you a cent. For the sake of making more money now, and having a better position in the future, mail coupon below now. You'll always be glad you did.

Radio Training Association of America
Dept. RN-1, 4513 Ravenswood Ave., Chicago, Ill.

Gentlemen: Please send me by return mail full details of your Special No-Cost Membership Plan, and also a copy of your Radio Handbook.

Name _____

Address _____

City _____ State _____

Radio News

Vol. XI

CONTENTS FOR JANUARY, 1930

No. 7

JOHN B. BRENNAN, JR.
Technical Editor

ARTHUR H. LYNCH, Editorial Director
STUART C. MAHANAY
Managing Editor

EDWARD W. WILBY
Associate Editor

In Radio News Next Month

Benjamin F. Miessner begins a series of articles describing his inventions which have enabled manufacturers of a.c. radio receivers to realize savings aggregating more than a million dollars annually.

Commander Edward H. Loftin and *S. Young White*, in the second article of their series, give more details and the circuit constants of their direct-coupled audio amplifier, which has many new and interesting features.

Carl Dreher, Director of the Sound Department at the R.K.O. Studios, Los Angeles, comments upon some interesting details of talking movie recording, together with obstacles encountered, and how they have been overcome.

Austin C. Lescarboursa will tell about the demand far exceeding the supply for trained radio men. He is making a survey of leading executives and manufacturers, and will outline the results in a number of forthcoming articles in RADIO NEWS, starting in February.

	PAGE
Cover—From a Painting by Sydney La Verne	590
Frontispiece: Evolution of the Radio Receiver.....	590
Editorial: Resolutions for the New Year.....	594
Radio—A Real Aid to Air Navigation.....	596
<small>HERBERT HOOVER, JR., tells how radio contributes to the safety of aviation.</small>	
A Broadcast Receiver for Use in Automobiles.....	599
<small>By PAUL O. FARNHAM.</small>	
The Smallest, Cheapest Loud Speaker Receiver Makes Its Bow.....	600
<small>COMMANDER EDWARD H. LOFTIN and S. YOUNG WHITE begin a series of articles describing their direct-coupled audio amplifier.</small>	
He Saves the Radio Industry a Million Dollars a Year.....	602
<small>Announcement of a series of articles by BENJAMIN F. MIESSNER.</small>	
Radio Takes to the Open Road.....	603
<small>ARTHUR H. LYNCH outlines the development of broadcast receivers for automobiles.</small>	
The Audion Conquers New Fields.....	604
<small>DR. LEE DE FOREST describes many applications of the vacuum tube.</small>	
The Latest in Flying Laboratories.....	607
Is International Broadcasting Just Around the Corner?.....	608
<small>C. W. HORN discusses the developmental work involved in the rebroadcasting of foreign programs.</small>	
And Now We Have the Straight Resistance-Coupled Audio Amplifier	610
<small>By JOSEPH MORGAN.</small>	
What Do You Know About Audio-Frequency Amplifiers?.....	612
<small>By JAMES MARTIN.</small>	
Laboratory Tests in High-Speed Production.....	614
<small>NORMAN WUNDERLICH and W. F. DIEHL tell how rigid laboratory inspection is applied to the production line.</small>	
The Community Antenna.....	616
<small>By ELMORE B. LYFORD.</small>	
Hitting the High Spots With the A.C. Super-Wasp.....	618
<small>By ROBERT HERTZBERG.</small>	
Radio's Flying Salesroom.....	621
<small>A. HENRY tells about the use of radio in aviation.</small>	
Trapped by Radio!.....	622
<small>LLOYD JACQUET relates how radio proved the undoing of a band of rum-runners.</small>	
Take Your Choice of Remote Controls.....	624
<small>Some of the newest automatic tuning devices.</small>	
Analyzing the "Hi-Q" 30.....	626
<small>By D. K. ORAM.</small>	
Where Television Is Today.....	629
<small>D. E. REPLOGLE describes a commercial television receiver for home use.</small>	
How to Get the Most From Your Short-Wave Transmitter.....	632
<small>By WILLIAM H. WENSTROM.</small>	
Simplifying Your Service Problems.....	636
<small>By JOHN B. BRENNAN, JR.</small>	
Sound Amplifiers Provide More Parks With Music.....	638
<small>By S. GORDON TAYLOR.</small>	
The Radio News-Elco Boat Receiver.....	640
Improving the "250" Power Pack With Electrolytic Condensers.....	641
<small>By R. U. CLARK, 3RD.</small>	
The Spangenberg 200-Watt Short-Wave Transmitter.....	642
<small>LESTER SPANGENBERG gives further constructional details with pictures and diagram.</small>	
The Junior Radio Guild.....	644
<small>The fundamentals of radio.</small>	
The Trade Announces.....	646
<small>New equipment and manufacturing trends.</small>	
The Radio Forum.....	648
<small>A meeting place for the experimenter, serviceman and short-wave enthusiast.</small>	

Published Monthly by the Experimenter Publications, Inc., at 184-10 Jamaica Ave., Jamaica, N. Y.

Member: Audit Bureau of Circulations

B. A. MACKINNON, President

H. K. FLY, Vice-President and Treasurer

Entered as Second-Class Matter at Jamaica, N. Y., under Act of March 3, 1879.

Executive and Editorial Offices, 381 Fourth Ave., New York, N. Y.

RADIO NEWS is published monthly on the tenth day of each month preceding that of date. Entered as second-class matter at the postoffice, Jamaica, N. Y., under the act of March 3, 1879. Copyrighted 1929 by Experimenter Publications, Inc.; title

registered U. S. Patent Office. Subscription price \$2.50 a year; \$3.00 in Canada and foreign countries. Single copies, 25 cents each. The contents of RADIO NEWS are indexed in the Industrial Arts Index.



The Old Way

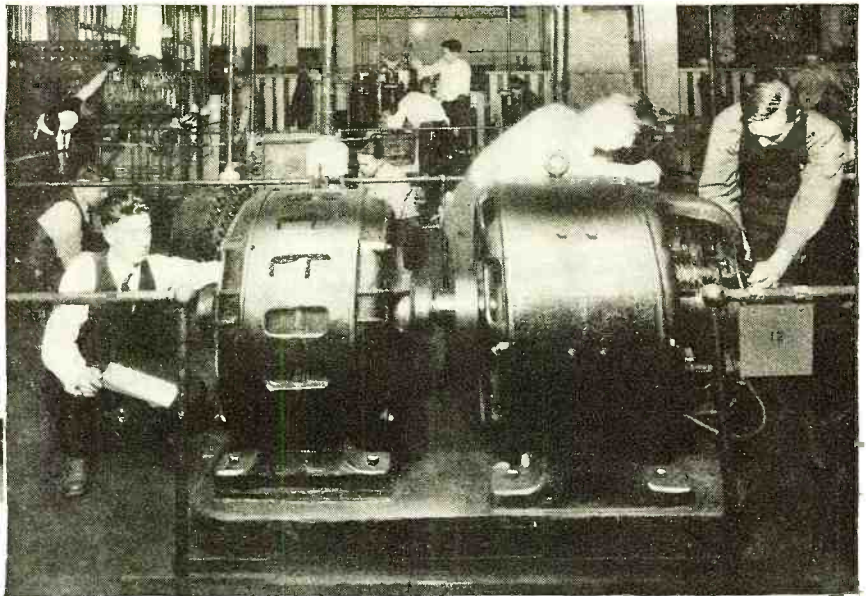

ELECTRICITY Becomes Amazingly Easy When Taught Without Books or Lessons ^{IN 90} DAYS

Why work at dull, uninteresting jobs that will never pay you more than \$35, \$40 or perhaps \$50 a week? Make up your mind NOW and become a master of electricity! Train in 12 easy weeks to hold down the kind of a job that pays \$60 and up a week, and which creates a constant demand for your services nearly any place in the world!

No Books -- No Classes

Electricity, as taught in the Great Shops of Coyne, is surprisingly easy to grasp. That's because we use no books. You learn by doing actual, practical experimenting on big, electrical machinery—finest outlay in the country. You learn by doing—and you learn from the ground up.

Not a CORRESPONDENCE SCHOOL

Experts work right along with you every step of the way. You get personal attention—you are trained not by books but on actual electrical machinery. The COYNE WAY gives you real, sound knowledge that fits you to do practical electrical work in all its branches. **Now in Our**

NO EXPERIENCE or Advanced Education Necessary

You don't need one days' previous electrical experience or advanced education to master electricity the Coyne way. Some of our most successful graduates never went farther than the 8th grade.

INCLUDED

If You Act Now!

- 1 **R. R. FARE** will be refunded upon enrollment from any point in the U. S. to Chicago.
 - 2 **AVIATION** my big new Aviation Electrical course included at no extra charge.
 - 3 **RADIO** course included absolutely without any extra charge.
 - 4 **AUTO** course, covering truck and tractor electricity.
- SEE COUPON!

Earn While You Learn

By special arrangement, our employment department helps students locate part-time work, if they want to earn while they learn. And after graduation we give them the benefit of our FREE EMPLOYMENT Service for Life. Every week we secure many positions for Coyne men.

Get FREE BOOK

Write today for my big book on Electricity with over 150 photographs. Learn what great opportunity Coyne Training opens up for you. Also get full details of my Big 3-Special Offer. No obligation. Mail the coupon now.

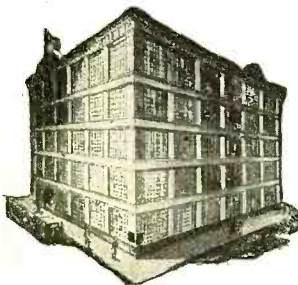

NEW HOME --

This is our new, fireproof, modern home wherein is installed thousands of dollars' worth of the newest and most modern Electrical Equipment of all kinds. We have now the largest amount of floor space devoted to the exclusive teaching of practical electricity in the world. Every comfort and convenience has been arranged to make you happy and contented during your training.

FREE BOOK Coupon

H. C. LEWIS, President
COYNE ELECTRICAL SCHOOL, Dept. 10-27
500 S. Paulina Street, Chicago, Ill.

Please send me your free catalog on Electricity and details of your railroad fare allowance and extra courses. No obligation on my part.

Name

Address

City..... State.....

COYNE ELECTRICAL SCHOOL
H. C. LEWIS, Pres., Est. 1899
500 S. Paulina St., Dept. 10-27, Chicago, Ill.

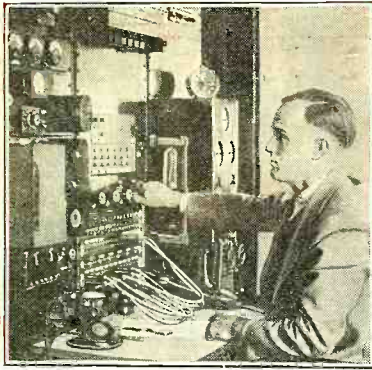

Broadcasting Stations offer fascinating jobs paying from \$1,800 to \$5,000 a year.



Operating on board ship gives you world-wide travel without expense and a salary of \$85 to \$200 a month besides.

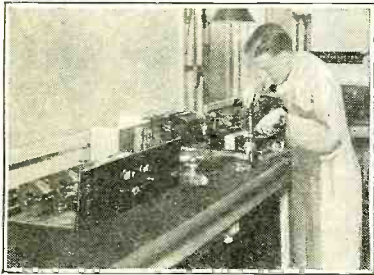

Spare time set servicing is paying N. R. I. men \$200 to \$1,000 a year for their spare time. Earnings begin almost at once after enrolling.



Commercial Land Stations are being opened very rapidly in our leading cities. Trans-Oceanic telephony offers many attractive jobs.

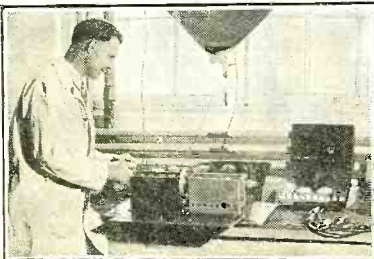

Radio factories employ thousands. Salaries for well trained men range from \$1,800 to \$5,000 a year.

You're Wanted

Many \$5,000, \$10,000 and picked from those who

You have seen how the men and young men who got into the automobile, motion picture and other industries when they were started had the first chance at the key jobs—are now the \$5,000, \$10,000 and \$15,000 a year men. Radio offers you the same chance that made men rich in those businesses. Its growth has already made many men independent and will make many more wealthy in the future. Its amazing growth can put you ahead fast too. Don't pass up this opportunity for a good job and future financial independence.

Hundreds of \$50 to \$100 a week jobs Opening Every Year

Radio needs more trained men badly. Why slave your life away for \$25 to \$40 a week in a no-future job when you can get ready in a short time for Radio where the good jobs pay \$50, \$60, \$75 and \$100 a week? And many of these jobs can quickly lead to \$150 to \$200 a week. Hundreds of fine jobs are opening every year for men with the right training—the kind of training I'll give you.

I Am Doubling and Tripling Salaries

Where you find big growth you always find many big opportunities. I am doubling and tripling the salaries of many men every year. After training with me only a short time they are able to make \$1,000 to \$3,000 a year more than they were getting before. Figure out

for yourself what an increase like this would mean to you—the many things that mean so much in happiness and comfort that you could buy with an additional \$1,000 to \$3,000 a year.

Many Make \$5 to \$25 a week Extra Almost at Once

The day you start I'll show you how to do ten jobs common in most every neighborhood that you can do in your spare time. I'll show you how to repair and service all makes of sets and do many other jobs all through my course. I'll give you the plans and ideas while they are taking my course. G. W. Page, 107 Raleigh Apts., Nashville, Tenn., writes: "I made \$935 in my spare time while taking your course."

You Have Many Jobs to Choose From

Broadcasting stations use engineers, operators, station managers. Radio manufacturers continually need testers, inspectors, foremen, engineers, service men, buyers and managers. Shipping companies use hundreds of operators and give them world-wide travel with practically no expense and a good salary besides. There are hundreds of opportunities for you to have a spare time or full time Radio business of your own. I'll show you how to start one with practically no capital. My book tells you of other opportunities. Be sure to get it at once.



\$400 a Month

"I spent fifteen years as traveling salesman and was making good money but could see the opportunities in Radio. Believe me I am not sorry, for I have made more money than ever before. I have made more than \$400 each month and it really was your course that brought me to this. I can't say too much for your school."

J. G. Dahlstead,
1484 South 15th St.,
Salt Lake City, Utah.



\$800 in Spare Time

"Money could not pay for what I got out of your course. I did not know a single thing about Radio before I enrolled, but I have made \$800 in my spare time although my work keeps me away from home from 6:00 A. M. to 7:00 P. M. Every word I ever read about your course I have found true."

Milton I. Leiby, Jr.,
Topton, Pa.



Seldom Under \$100 a week

"My earnings in Radio are many times greater than I ever expected them to be. In November I made \$577, December \$645, January \$465. My earnings seldom fall under \$100 a week. I'll say the N. R. I. course is thorough and complete. You give a man more for his money than anybody else."

E. E. Winborne,
1414 W. 48th St., Norfolk, Va.

for a **Big Pay** Radio Job

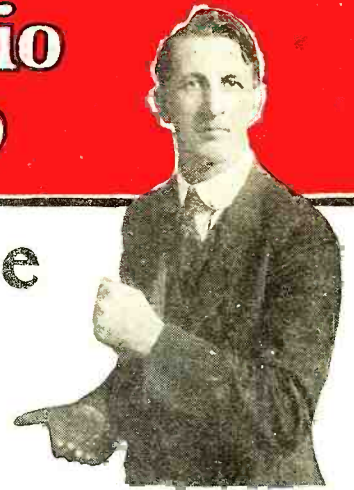

\$15,000 a year Men will be get into Radio *Now*

I Will Train you at Home in Your Spare Time to be a Radio Expert

Hold your job. There is no need for you to leave home. I will train you quickly and inexpensively during your spare time. You don't have to be a high school or college graduate. My course is written in a clear, interesting style that most anyone can grasp. I'll give you practical experience under my 50-50 method of training—one-half from lesson books and one-half from practical experiments. When you graduate you won't have to take any kind of a job to get experience—you will be trained and experienced ready to take your place beside men who have been in the field for years.

My Course is Complete and Up-to-Date

I'll give you all you need to know to hold a good job, not in one branch of Radio, but all of them. Television, Radio's use in Aviation, A. C. and screen grid sets, and many other of the latest improvements and inventions are thoroughly covered. You won't be a "one job" man when you finish my course. You will be trained for many jobs. In this way I increase your opportunities for employment and success in Radio.

Lifetime Employment Service to All Graduates

When you finish my course you won't be turned loose to shift for



Salary Three Times Larger

"Before I completed your course I went to work for a Radio dealer. Now I am assistant Service Manager of the Sparks-Withington Company. My salary is three times what it was before taking your course. I could not have obtained this position without it. I owe my success to N. R. I. training."

H. A. Wilmoth,
Sparks-Withington Co.,
Jackson, Mich.

yourself. Then is when I will step in and help you find a job through my Employment Department. This Employment Service is free of extra charge both to you and the employer. My Employment Department is getting three times as many calls for graduates this year as last year.

Your Money Back if Not Satisfied

You do not risk a penny when you enroll with me. I will give you an agreement in writing, legal and binding upon the institute, to refund every penny of your money upon completing my course if you are not satisfied with my Lessons and Instruction Service. The resources of the N. R. I., Pioneer and World's Largest Home-Study Radio training organization, stand back of this agreement.

Find Out What Radio Offers You-Get My Book at Once

One copy of my valuable book "Rich Rewards in Radio" is free to anyone interested in making more money. It tells you where the good jobs are, what they pay, how you can quickly and easily fit yourself to get one. The coupon below will bring you a copy. Send it at once. Your request does not obligate you in any way. Act NOW.

**J. E. SMITH, President
Dept. OASS
National Radio Institute
Washington, D. C.**

I give You 8 Big Outfits of Radio parts for a home Experimental Laboratory

You can build over 100 circuits with the outfits I give you. You learn from actual experience about A.C. Screen Grid Circuits, push-pull amplification and the other features in modern sets. You work out with your hands the principles, diagrams and circuits you learn from my lesson books. You get as much practical experience under this unequalled method of home training, in a few months, as the average fellow gets in two to four years in the field.

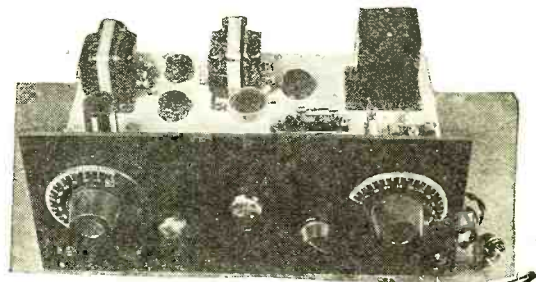

Clip and mail NOW for FREE INFORMATION

**J. E. SMITH, President
National Radio Institute, Dept. OASS
16th & U Streets, N. W., Washington, D. C.**

Dear Mr. Smith:—Send me "Rich Rewards in Radio." Tell me more about Radio's opportunities for good jobs and quick promotion; also about your practical method of Home training. I understand this request does not obligate me and that no agent will call on me.

Name

Address

City State

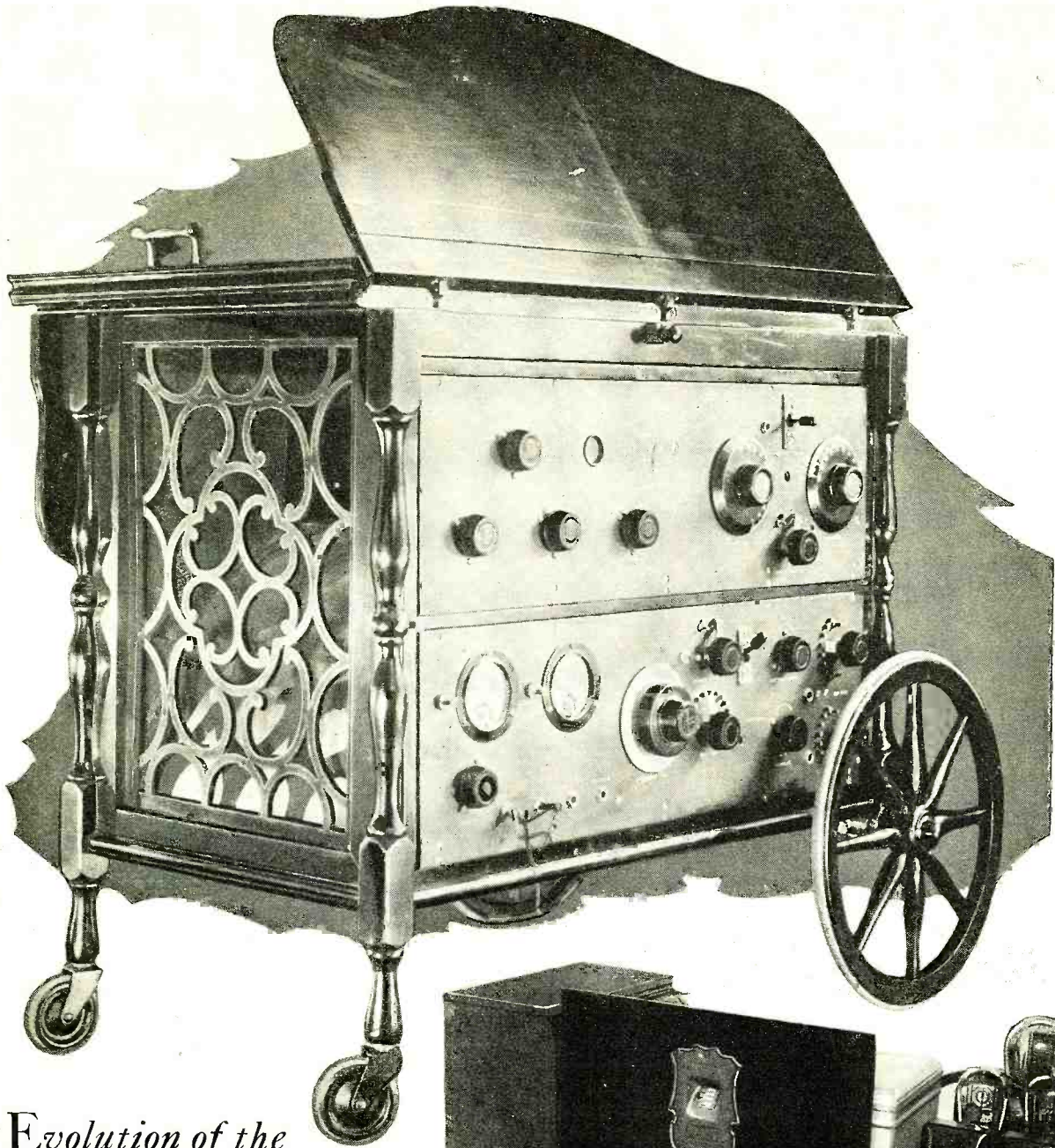

Evolution of the Radio Receiver:

SELF-CONTAINED "tea-cart" model (above) of seven years ago, complete with loop and all necessary batteries. The modern batteryless socket-powered chassis (center) is less elaborate; but the newest Loftin-White (below) is the essence of compactness, being entirely contained within the can that formerly housed only a tuning unit.

Although not yet in commercial form this new development has many interesting features: It amplifies all frequencies up to 35,000, is extremely sensitive and is very selective. It is engineering achievements such as these that are reflected in the downward trend of radio receiver prices. From the earliest days of manufactured outfits in

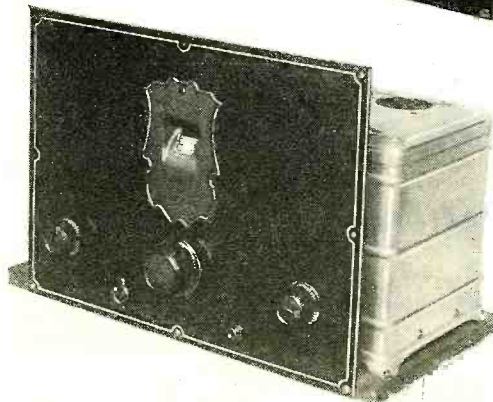
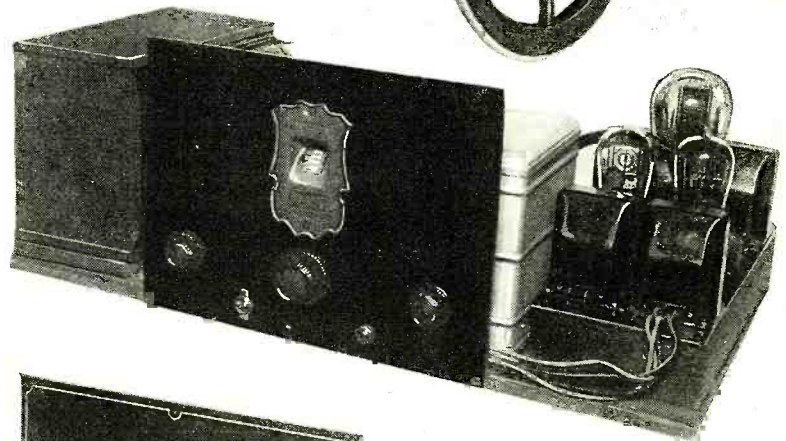

quantity production there has been a gradual lowering of the list prices with constantly increasing efficiency and improved tone quality. Further details will be found on page 600 and more articles are to follow in future issues of RADIO NEWS.

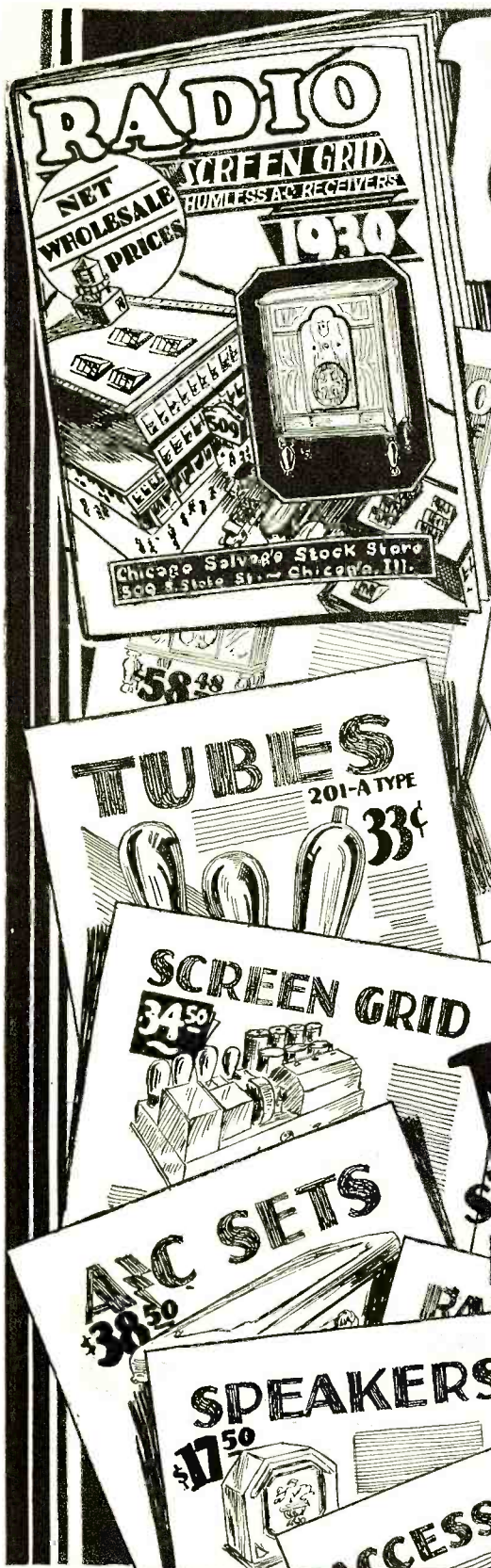

148 PAGES *of outstanding* RADIO VALUES

On every page of this big catalog for 1930 you will find radio merchandise of unusual interest—priced at the lowest wholesale quotations. No radio enthusiast or dealer can afford to be without it.

The latest radio devices and improvements are illustrated—sets, accessories, parts and kits—at price-saving reductions that spell the buyer's opportunity. Astounding offerings in new, humless, Screen Grid A. C. all-electric and battery operated sets; beautiful and artistic consoles; dynamic speakers of great volume and rich tone; and everything considered standard in accessories, parts and kits.

The startling values listed in this Catalog are made possible by our tremendous buying power, low cost of operation and willingness to take a conservative profit. Quick service, expert cooperation and unusual satisfaction are assured to every customer.

Don't fail to get this FREE wonder book. It will save you big money. Mail the Coupon Today!

New!
SCREEN GRID MODELS

FREE!
CATALOG
COUPON

Chicago Salvage Stock Store
Dept. 127
509 So. State St., Chicago, Ill.

Kindly send me (free of charge and postpaid) your new 148-page Book of Radio Bargains.

Name.....
Address.....
City..... State.....

CHICAGO SALVAGE STOCK STORE
WORLD'S LARGEST RADIO STORE
509 So. State St. Dept. 127 Chicago, Ill..



PAM music in Peruvian park

In the Zoological Gardens at Lima, Peru (pictured above), and all over the world, you will find PAM Amplified entertainment enhancing the beauties of nature.

PAM'S crystal clear voice can be suited to blend with forest sounds or increased to be easily heard above the roar of motors at air meets.

All around you are opportunities of a similar nature.

These opportunities are found in hotels, clubs, excursion steamers, schools, hospitals, parks, theatres, auditoriums, dance halls, skating rinks and swimming pools, air ports, athletic fields, boat races, outdoor services, etc.

To the pioneer dealer who first sees and grasps this opportunity in his locality comes the greater volume and profit.

A new 16-page bulletin, giving mechanical and electrical characteristics, representative installations, and many new PAM Amplifiers, will be sent upon receipt of 10 cents in stamps to cover postage. When writing ask for Bulletin No. RN6.

Samson Electric Co.

MEMBER
RMA

Manufacturers Since 1882

Main Office:
Canton, Mass.

Factories: Canton
and Watertown, Mass.



You'll note the difference from the start

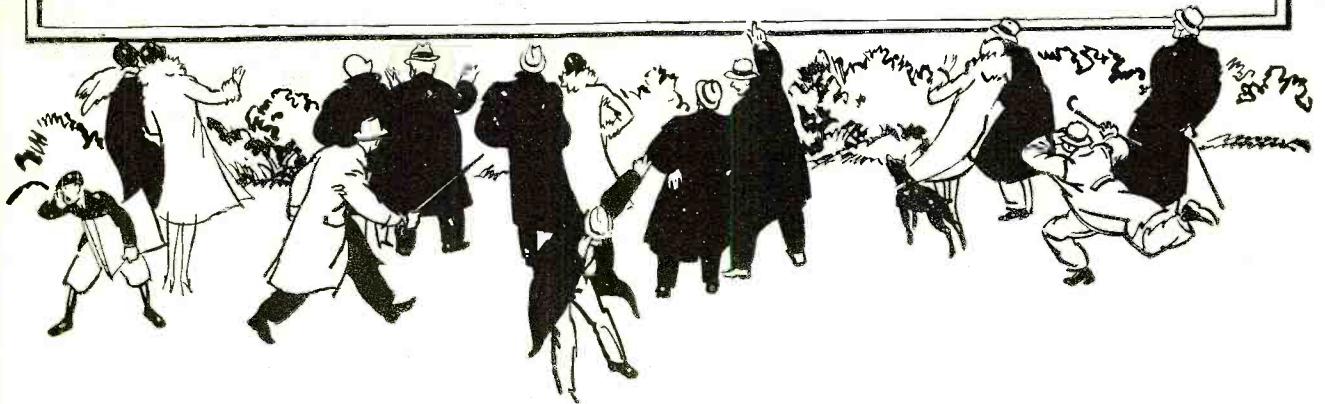

Let these Posters work for YOU . . .

Every customer visiting your store has seen De Forest Audion billboards. There were over 4,200 of them located in every important city and trading center in the United States. Radio owners already know the value of "high vacuum" De Forest Audions, made under the direction of Dr. Lee De Forest, the inventor of the first radio tube.

Let them know that your store is headquarters for these remarkable radio tubes that have set the world's standard for 23 years. Install a set of De Forest Audions in one

of your demonstrating sets. Let your customers hear them in action, and the sale is made.

Write to our nearest branch today for full details of our dealer proposition and let your cash register tell you the story of radio tube advertising that is making history.

de Forest AUDIONS

Branch Offices Located in

- | | |
|--------------|-------------|
| Boston | St. Louis |
| New York | Kansas City |
| Philadelphia | Denver |
| Atlanta | Los Angeles |
| Pittsburgh | Seattle |
| Chicago | Detroit |
| Minneapolis | Dallas |
| | Cleveland |



DE FOREST RADIO COMPANY, JERSEY CITY, N. J.

Resolutions *for the* New Year

FROM cover to cover, inside and out, we offer you an entirely new RADIO NEWS. We believe you will like it.

Our job with a magazine in the radio field is not easy. Some folks have said it is impossible. Anything that's too easy ceases to be interesting. There is no lack of interest for us. There is an ever-increasing interest in radio itself.

With 1930 bursting in upon us, suppose we look over happenings in the radio business for the past year. Marvelous progress has been made. Fewer and fewer people are buying kits which are to be used in "home-built" receivers. It is no longer possible to build a broadcast receiver *cheaper* than you can buy it. There are a few exceptions to this statement, but in general it is a fact. It is still possible, in spite of the marvelous strides radio has made, to build a *better* receiver than you can buy. This is particularly true in the short-wave field.

Increasingly Greater Values

But we were to look the whole field over. Perfectly delightful receivers in beautiful pieces of furniture are now available at almost unbelievably low prices. The quality of radio apparatus, the design and the performance of these remarkable units, enable you to purchase better receivers for about one-half the former prices.

The tone quality, sensitivity, selectivity and durability of such units as the Victor, Majestic, and Brunswick combination radio and phonographs, all priced at about \$300, are better than could be had at any price two years ago. Such progress in the portion of the radio business, best known to most of us, causes some to imagine that we are approaching the saturation point. There has been much talk about it.

But the progress made in broadcast receiver design, manufacture and distribution, is but an index of what is happening in other fields, where radio engineering is applied.

None of these new activities is as important or as far-reaching in scope as the talking movies. Applying what radio engineering has brought into being has changed the complexion of the entire theatrical world in less than a year. More changes and greater improvements will come with the new year. Can it be that any art which so intimately affects the lives of nearly all of us is not interesting? We doubt it. In order to keep our readers informed of this work we have been fortunate in having one of the best trained engineers the country has produced cover the progress being made in this important field.

Talking Movie Developments

Mr. Carl Dreher, whose articles on the radio engineering behind the talkies has been appearing in RADIO NEWS, knows what he is writing about and knows how to express it in understandable language. As former Chief Broadcast Engineer of both the Radio Corporation and the N. B. C. he takes a wealth of knowledge into his new work with RKO, at Hollywood.

Perhaps the next most obvious application of radio engineering is observed by the "man-in-the-street" when the loud-speaker tells him of a train wreck, the play-by-play progress of a football game going on a thousand miles away or an invisible orchestra supplies dinner music in his favorite restaurant, all this without the listener having to leave the peace and quiet of his home. Pupils in our public schools may now hear musical appreciation lectures by such leaders of musical thought as Walter Damrosch, without leaving their

seats. They may learn politics and economics from the greatest teachers the world has produced and they may learn of plans for international peace directly from the Ramsay MacDonalds and Owen Youngs, who are fostering them, through the medium of the public address system. Central power stations for public address systems with feeder lines running to the desired outlets are now becoming important necessities in railroad stations, hotels, schools, amusement parks, flying fields, public buildings, hospitals, and even factories. Is it possible that there is not any interest in this rapidly expanding application of radio? Again, we believe not! We have been featuring a series of articles on the practical application of sound engineering principles in the public address field by an author eminently suited by both technical and writing ability to pass the latest developments to you in a practical and interesting fashion. Mr. S. Gordon Taylor has done a great deal of research work in this field and has advised many schools and hotels in the matter of selecting and installing suitable apparatus. Before embarking upon this very intriguing work Mr. Taylor was on the Technical Staff of Popular Radio Magazine.

And then we have short waves! Not as familiar to most of us as the two examples of radio's entry into other fields, but equally if not more important. To begin to point out the applications we are at present making of short-wave radio requires more space than we can allow Mr. Wenstrom for his very informative articles which have been appearing each month, so that an attempt to outline the newer and ever-increasing applications is entirely impossible in the limited space there is here.

Short-Wave Possibilities Unlimited

However, there is much of interest going on, on the short waves. They are the playground for those serious-minded men and young men among the transmitting amateurs, who have blazed the trail in following a hazy notion to a successful conclusion and practical commercial application. They are known among themselves as "hams." They are, unbeknown to most of us, building up an international understanding by maintaining intimate radio contact with other "hams" in all quarters of the globe.

Commander Byrd has a "ham" with him at the southern end of the earth. The ham is using a lot of radio apparatus conceived by hams to let a lot of us less adventurous folks know of the progress Byrd is making.

A new corporation, called the Universal Wireless Communication Company, is now in direct competition with the regular line telegraph companies. All the operations are carried on on short waves and much of the equipment and the personnel is of "ham" origin.

Can any science which so intrigues our young men and which has such great commercial worth be uninteresting?

Can the following of an airplane in its flight between San Francisco and Australia by short-wave radio lack interest?

Our answer is no—a thousand times no—and it is our aim to have RADIO NEWS keep you informed of this great progress.

Arthur H. Lynch

R. T. I.

R. T. I. QUALIFIES YOU TO MAKE MONEY AND ITS SERVICE KEEPS YOU UP-TO-THE-MINUTE ON THE NEWEST DEVELOPMENTS IN RADIO, TELEVISION, AND TALKING PICTURES

R. T. I.



RADIO CALLS FOR MORE TRAINED MEN

Big Money quick—the chance to more than double your salary—is offered to you now. RADIO has leaped from the experimental stage to a gigantic industry, employing many, many thousands and loudly calling for MORE TRAINED MEN to fill the Big-Pay jobs.

TALKING PICTURES have taken the larger cities by storm and will sweep the entire country, opening up many new good jobs everywhere. TELEVISION now comes with even greater promise of a large number of good paying jobs and big profits for those who are prepared.

Big Money Now! More to Come

Here is an entirely new field of profitable employment—Big-Money Jobs—\$2500—\$3500—\$5000 and up, right now—lots of money easily made in spare time—increasing pay for you and more and more money as this new industry grows bigger and bigger.

Answer the Call—Get Into This Money-Making Industry Now!

The "R. T. I." famous "3 in 1" Home Training in Radio, Television and Talking Pictures makes it easy for men, young men and boys to get into this new field quickly. R. T. I. home training is practical and easy to understand. It trains your head and hands at the same time. Your opportunities for money-making are unlimited. Your age, amount of education, or experience make no difference. If you are interested and ambitious you can succeed. Are you willing to use a little spare time at home? That is all you need to quickly start making money with R. T. I. material and home training. You will be ready for a good job or profitable business of your own, even before you finish the training. Remember—you learn at home in your spare time on actual equipment included in fine, big outfits sent you by R. T. I. R. T. I. with all its connections in the industry, keeps you up-to-date and pushing forward all the time.

R. T. I. Wonderful Free Book Nothing Like It Ever Published

No one can fully realize the amazing size and future growth of the Radio, Television, and Talking Picture industries unless they know all the facts revealed in this R. T. I. book. No exaggeration is necessary—the plain truth is astounding. It will open your eyes to the dawn of the greatest development in the history of the world—the vast number of new money-making jobs—enormous spare-time profits—all within easy reach of ambitious men. Send for your copy before this edition is exhausted.

Big R. T. I. Book Free—While They Last



Let F. H. Schnell and R. T. I. Advisory Board Help You

Mr. Schnell, Chief of the R. T. I. Staff, is one of the ablest and best known radio men in America. He has twenty years of Radio experience. First to establish two way amateur communication with Europe. Former Traffic Manager of American Radio Relay League. Lieutenant Commander of the U. S. N. R. Inventor and designer of Radio apparatus. Consultant Engineer to large Radio manufacturers. Assisting him is the R. T. I. Advisory Board, composed of men prominent in the Radio industry.



Is Now Radio Engineer Through R. T. I. Training

Today I am able to class myself as a Radio Engineer along with the leaders, and this is all due to the help of R. T. I. I have been able to handle efficiently every radio problem with which I have come in contact. I cannot say too much in praise of R. T. I., and any man desiring to improve himself can do nothing better than find out what this Institution has to offer, and get started with their training.—H. E. SATTENFIELD, Chief Radio Engineer, Western Air Express, Amarillo, Texas.

**RADIO & TELEVISION INSTITUTE
Dept. 841, 4806 St. Anthony Ct., Chicago**

\$500 in 2 Months Hasn't Finished the Course
Your radio course enabled me to earn over \$500 in two months spare time work.—
J. Nofsinger, R. I. Box 37, Greenville, Ky.

\$80 a Week—Through R. T. I. Training
I am earning \$80 per week and another \$20 a week in spare time Radio Work.
Your Course was the best investment I ever made.—W. W. Mead, 915 W. 28th St., Indianapolis, Ind.

STEP UP QUICK TO A BIG MONEY JOB THROUGH R. T. I. training in Broadcasting, Sales, Service, Manufacturing, Repairing, Ship and Station Operating, Installing, in business for yourself.

R. T. I. R. T. I. TRAINS YOU AT HOME FOR A GOOD JOB OR A PROFITABLE PART TIME OR FULL TIME BUSINESS OF YOUR OWN

RADIO & TELEVISION INSTITUTE
Dept. 841, 4806 St. Anthony Court, Chicago

Send me Free and prepaid your BIG BOOK "Tune In On Big Pay" and full details of your three-in-one Home Training (without obligating me in any way).

Name.....
Address.....
City..... State.....



Herbert Hoover, Jr., at the transmitter of his own amateur station, 6XH

IT is scarcely five years since commercial aviation emerged from the experimental stage. Before that it was a hopeful development for air mail and a thriller for the curious. Today it is becoming a definite part of our transport system both for light freight such as mail and express and for passengers. Already over 5,000 planes are daily in the air on commercial business. But before there can be commercial success there must be two certainties, safety and regularity of service. The radio now assures us a large measure of both. To be able to fly with certainty by night, to pilot through or avoid fog and storm can in large measure be made certainties if constant communication can be maintained between the ground and the plane—and radio provides the missing link for just that communication. In fact, the development of radio applied to aviation assures just that margin of safety and regularity which gives the plane a definite position as a regular and safe means of transportation. It thus makes commercial application of aviation a certainty. Prior to the application of radio communication with the planes, there was no certainty of regular service; there was great danger from hazards of storm, fog and snow.

There are, generally speaking, two sorts of flying going on today—one is for pleasure and sport, while the other is commercial transportation. Pleasure flying, like picnicking, can be put off if it is a bad day, but the regular scheduled operations of the air transport companies must go on day in and day out. Both kinds of flying will be aided by radio, but it is commercial transportation that is becoming vitally dependent upon it.



Photos by International Newsreel

The pilot of a regularly scheduled plane must know two things. First, he must be able to keep track of constantly changing weather conditions that are beyond his range of vision, and second, he must be able to locate his exact position, even though the ground may not be visible. Furthermore, he must be able to get this information or any other aid he may need at any moment he may desire it.

This, briefly, is the job that radio must perform in aviation. If the pilot is to receive weather information and be able to talk with those on the ground, there must be a series of radio stations along the airways, and if these stations are to be useful they must have a complete weather observing system to draw upon. It is not, therefore, merely a matter of putting a radio set on each plane, but a large and complicated organization of ground radio stations, weather observers, and airports must be tied together with some quick and dependable method of communication and made to function together smoothly as a unit.

Radio- to AIR

An outline of what radio can of aviation. Commercial becoming vitally dependent airports for weather and

By Herbert

Situated along the principal airways of the United States are a series of 2 KW broadcasting stations furnishing the pilots of the planes with accurate weather and flying data. Here is C. W. Larson at the Oakland, California, station telephoning weather reports to planes in flight

Much of this information and service should be available to all fliers, whether they are private individuals or large transport companies. The government has undertaken to provide this service, and it has been a tremendous help to all branches of aviation. A series of 2,000-watt broadcasting stations using wavelengths of about 1,000 meters have been erected along the principal airways, each located two or three hundred miles apart. Once an hour, or oftener, they send out weather reports collected along the route, together with landing conditions at each of the airports in their vicinity. This service is free for anyone who cares to tune in for it, and although intended primarily for aviation, many other people will undoubtedly make use of it.

A Real Aid NAVIGATION

*do for the rapid development
aerial transportation is
upon communication with
other important reports*

Hoover, Jr.

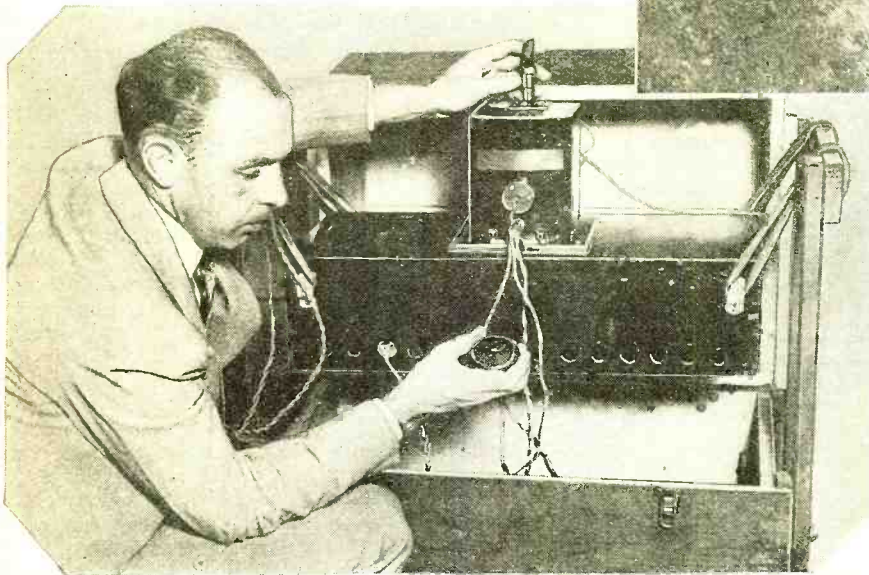

Above: This device supplements the altimeter and indicates the plane's height above the ground. Upper right: The tri-motored type of plane operated by the Western Air Express, Inc. These planes are equipped with radio to communicate with each other and the ground stations

The large transport companies who maintain daily schedules over their routes must be able to carry on two-way conversations with their planes wherever they are in flight. Obviously the government stations which broadcast weather reports cannot be expected to keep in contact with the large number of commercial planes that will soon be flying near them. The transport operators have therefore found it necessary to establish their own ground stations, along the particular routes which they fly. By pooling their equipment at places where they overlap, and placing as many routes as possible on the same channel, the best possible use will be made of the limited number of wavelengths available.

We can confidently expect to see, within the next year, a majority of the commercial planes equipped with two-way radio telephones. Every few minutes they will call their own stations on the ground,

and reassure them as to their position, probable time of arrival at the next stop, gasoline supply, or to inquire for special weather reports or other information when necessary. In an emergency the passengers may be able to talk with any part of the country by a combination of radio and land telephone wires. The pilots will be able to pass on to each other the latest information regarding the weather they are flying through and thereby check and supplement the observations from the ground.

This fulfills the pilot's first requirement in regard to the weather information. To meet the second need and enable the pilot to locate himself, still another radio device has been perfected. This is the radio beacon. These stations are located about two or three hundred miles apart, and are located at the principal airports along the route. They send out a directional beam in such a way that the pilot, using the

HERBERT HOOVER, Jr., is 26 years old and is vice-president, in charge of communications, of the Western Air Express, Inc.

He has been interested in radio for fourteen of his twenty-six years. It was his amateur radio activities which secured sympathetic consideration of amateurs from his father, when he was Secretary of Commerce, and in charge of radio in the United States. Much of his time is spent at the Vail Field, Los Angeles radio station, although he also maintains an experimental laboratory at the California Institute of Technology, in Pasadena. With an associate, he takes a great interest in experimental radio station 6XH, used for instruction purposes at Leland Stanford University. Last September he was Chairman of the Communication Committee of the First Air Traffic Conference, held at Kansas City.

He is a Lieutenant, Specialist Reserve, of the U. S. Army. For a short time he was connected with the radio laboratory of the U. S. Bureau of Standards.

same receiver with which he picks up the weather broadcasts, can tell whether he is exactly on his course, or to the right or left of it. On the right of the course the transmitter sends out a certain repetition of dots and dashes, while on the left it sends out a different combination. If an airplane is exactly on its course the two signals blend into one long dash, and the pilot knows that he is still on his route, although he may be able to see nothing. As soon as he gets slightly to one side or the other, the signal tells him which way to turn.

At important points along the airways small marker beacons have been installed. With a range of only about 5 miles. They tell the pilot how far he has progressed along his course. They are like invisible bell buoys leading into a harbor.

As an example, let me take you on a trip from Chicago to Los Angeles, and describe the way that the radio soon will be working. This is the route that my own company flies, and therefore I am most familiar with it, but the same story will shortly hold true on any of the other large lines in the country.

You step on an evening train in Chicago, and the next morning change to an airplane at Kansas City. That night—24 hours after you left Chicago—you are keeping a dinner engagement in Los Angeles.

Long before the pullman porter calls you in the morning the organization along the airway has started functioning to safeguard your trip later in the day. Weather reports have been collected and analyzed, showing the winds that may be expected at various altitudes, and the movements of rough weather areas. This requires a large network of communication—sometimes telephone, telegraph, or radio, depending on the type of country that the airway goes through. The important factors here are speed and reliability of the communication channel between all of the airports and weather stations. It is the nerve system of the air transport company.

The pilot of your plane is thoroughly aware of all general weather conditions along the route before you reach the field, but a moment before you take off he receives a second and more detailed report covering the first jump.

You settle down comfortably in your seat, and glance around at your fellow passengers. There are eight. Some, perhaps like yourself, are wondering what the next few hours are to be like. Others who have made the trip before are casually reading their morning papers. Fly-

ing holds no uncertainties for them. It is hard to believe that you are in an airplane and not a pullman car. Then the motors roar, and you are off.

It is a clear day, and you marvel at the regularity of plowed fields, the criss-crossed highways and railroads far below.

In the pilot's cockpit all is activity. Soon after leaving the ground the assistant pilot has tuned in the receiver for the hourly government weather report.

At the conclusion of the broadcast the pilot switches to short waves, and placing the microphone close to his lips, calls Kansas City. The operator there picks up his voice, and for several minutes they talk back and forth. The pilot gives his position and tells of certain weather conditions which may be useful to others flying along later, and in return receives the latest reports of conditions ahead.

As your plane approaches Wichita the pilot informs the field of his time of arrival, so that the runways may be kept clear for the least delay on landing and taking off. Two news passengers come aboard—the representatives of a large oil company with headquarters in the west. They fly back and forth regularly, taking much less flying time to travel a round trip by air than it formerly took them to go one way by train.

And so you move across Kansas, Texas, New Mexico and Arizona. As the pilot talks with first one ground station and then another, his course is guarded very much like railroads are regulated by block signals.

At the airport in Los Angeles is located a control tower where almost 5,000 miles of airway can be controlled as accurately as in the signal tower of a railroad. There are located the headquarters for the weather and communication networks and, as your plane moves along the route the ground staff keeps constant watch over it.

Not long after you have entered Arizona the control tower gets word of local thunder storms over the route ahead. Instantly the message goes out directing the



The Lighthouse Service of the Department of Commerce maintains the airways radio service posts, one of which is shown here. It was formerly under the direction of Herbert Hoover, Jr.'s illustrious father when he was Secretary of Commerce

plane to fly further to the north along the rim of the Grand Canyon. A few minutes later it is relayed to the pilot, and he advises them that he has changed his course accordingly.

Back in the cabin of the ship you are probably unaware that anything has happened; a few dark clouds on the horizon may not even catch your attention.

At the last stop before Los Angeles, two hundred miles away, the pilot learns that the weather is good all the way to the terminal field, and he starts off. As he approaches the high wall of mountains that surround the city, he sees that a fog bank is pouring over the ridges and spread out towards him. From experience he knows that these fogs roll in from the sea and that probably all of the country beyond the mountains is beneath a solid blanket. If he did not have a radio he would either turn back or else fly through one of the narrow canyons and come out underneath the clouds on the other side. With passengers he would go back and wait, but if he was flying the mail and had a parachute he would try to go through. One means delay for people who are in a hurry, and the other means risk.

With radio he has been talking with the weather man in Los Angeles for all
(Continued on page 654)

An air mail plane with its load of mail ready to take off at night from a brightly lighted airport

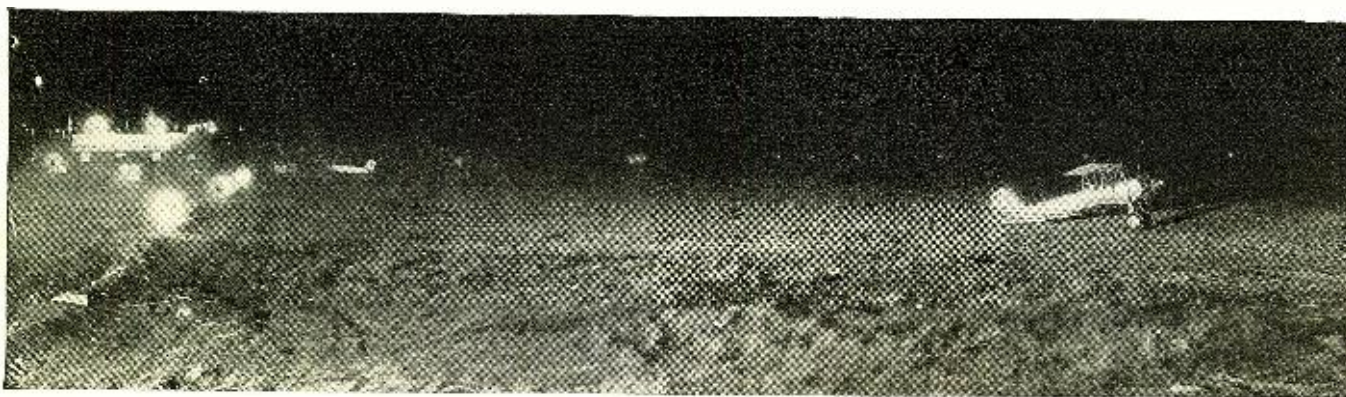

A Broadcast Receiver for Use In AUTOMOBILES*

By Paul O. Farnham

SINCE the design of a broadcast receiver for use in automobiles presents problems not encountered in the ordinary broadcast receiver for entertainment purposes, an outline of these problems and their solution may be of interest. As a starting point let us consider the limitations imposed by the type of collector suited for use on an automobile and by the interference produced by the ignition system.

Type of Collector

Of the two types of collector which might be used on an automobile, the capacity antenna is better suited for the reception of broadcast stations than is the loop antenna by reason of the directional effects and physical size of the latter. The capacity antenna will not, however, have a large effective height, due to the fact that the collector wires are preferably not extended vertically higher than the car roof for the sake of appearance and clearance. Such a collector will thus require a sensitive receiver, which will again require a rather high degree of ignition shielding. The effective height of the antenna as installed on a car is of the order of 1 meter. In order to obtain standard signal output for field intensities of 100 μ v per meter the receiver sensitivity must therefore be at least

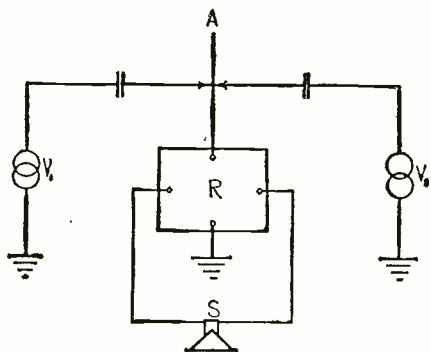

Fig. 1.—Pertaining to ignition interference. V_1 = modulated carrier station voltage, V_2 = ignition interference voltage, A = capacity antenna, R = receiver, S = loud speaker

100 μ v. Let us now consider the question of ignition interference.

Ignition Shielding

Referring to Fig. 1 we shall designate V_1 as the modulated carrier voltage received on the antenna useful in producing the desired signal, and V_2 as the voltage

In publishing this interesting article by P. O. Farnham, we feel that we may be of assistance to those radio and auto manufacturers who contemplate getting into this new and very attractive field. General Motors, Chrysler and Dodge already have started the ball rolling.

We call particular attention to the fact that the problems encountered and the manner in which they have been solved by both the Radio Frequency Laboratories, Inc., and RADIO NEWS Laboratory are very similar.

In all likelihood many others are spending much time and money along similar lines of research. We will be glad to assist manufacturers in getting under way with the least delay and the pages of RADIO NEWS will carry to our readers the story of the progress we make. —THE EDITORS.

received on the antenna from the ignition system effective in producing noise. In order that the noise from the ignition voltage V_2 shall not interfere with the received signal V_1 we may write the relation $V_1 > kV_2$.

The voltage V_2 produced by the ignition is in reality a spectrum of voltages of various frequencies so that in Fig. 2 the effective V_2 for the various frequencies to which the receiver may be tuned is shown as the bottom curve increasing with frequency. The height of this curve depends upon the effective height of the antenna and upon the degree of ignition shielding.

Above this curve and with the same slope is drawn kV_2 . This represents a limit below which the received effective station voltage V_1 must not fall if the ignition interference is to be just inaudible. The ideal sensitivity characteristic of the receiver in the presence of such ignition disturbance may now be drawn as V_1' , which represents the microvolts input-re-

*From a paper delivered before the Rochester Convention of the I.R.E., by Paul O. Farnham of the Radio Frequency Laboratories, Inc., Boonton, New Jersey.

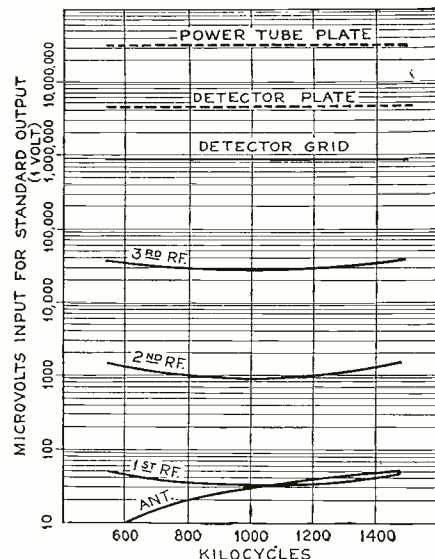

Fig. 3. Analysis of sensitivity in automobile receiver

quired at various frequencies to give a satisfactory volume level from the loud speaker. If the actual receiver sensitivity characteristic, say V_1 , falls below V_1' , at any frequency the volume control of the receiver must be operated so as to make the receiver less sensitive to the extent indicated by the cross-hatched region. The ideal sensitivity characteristic for such a receiver is thus seen to have a position slope with respect to frequency equal to the slope of the ignition interference characteristic. The actual useful sensitivity of the receiver will then depend directly upon the degree of ignition shielding.

An experimental shielding of the igni-

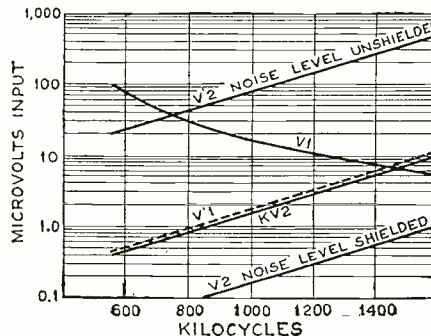

Fig. 2. The relation between useful receiver sensitivity and ignition interference level. V_2 = microvolts input for nearly complete shielding, V_2' = microvolts input for no shielding, V_1' = common sensitivity characteristic of a receiver

tion system of an Essex sedan was tried, employing copper shields over the high-tension leads, the high-tension coil, the distributor, spark plugs, and the low-tension leads. The shielding of the low-tension leads running up to the instrument board was found to be particularly important. With this rather complete shielding the ignition interference was reduced to such a level that the receiver could be operated at 10- μ v sensitivity at 1500 kc with the ignition noise just inaudible.

The improvement brought about by this type of shielding is illustrated by a com-

(Continued on page 651)



Biography of Edward H. Loftin

Edward H. Loftin was born in Montgomery, Alabama, in 1885. Following his graduation from Annapolis, he entered the navy. As a Lieutenant Commander he began special work in electrical communication. In 1915, following further studies at Annapolis, he was assigned to pioneer development of radio for aircraft for the Navy. During the World War he served in France as radio and communication officer, and was a member of the Inter-Allied Radio Technical Committee. At the end of the War he continued his investigations and research in the United States. Today he is recognized as a patent expert—in which capacity he materially aided B. F. Miessner—and a constant contributor and worker in the field of radio research. Most of his work is now carried on in the Loftin-White Laboratory.



Biography of S. Young White

S. Young White was born in New York City in 1901. When he was sixteen years old he entered the Electrical Research Development field in the test department of the General Electric Company. There followed several years of varied and helpful experience in electrical and radio operations and practice, with this and other companies. In 1924 he became associated with Edward H. Loftin in the Loftin-White Laboratory of New York. Here he experimented with electrical communication research and development. He is particularly well-known for his work in connection with the Loftin-White systems of non-reactive plate circuit for preventing oscillations in tuning radio frequency amplifiers and constant coupling. His work on direct-coupled amplifiers and detector-amplifiers has for some time created great interest among technical men.

The Smallest, Cheapest LOUD SPEAKER RECEIVER Makes its Bow

*First of a Series of Articles Describing a
Radically New Circuit Which Gives
Astonishing Results*

By Edward H. Loftin and S. Young White

Amplification of audio frequencies has heretofore been accomplished either by the transformer or by resistance coupled methods. This article is the first of a series describing another system which, although also of an early origin, has been lying dormant.

The system referred to is the direct-coupled type in which the plate of one tube is directly connected to the grid of an adjacent tube, with no transformer or condenser between, thus providing a system capable of both amplification and detection-amplification.

It has long been recognized as the soundest system of the three theoretically, but as possessing certain drawbacks which had to be overcome before it could be brought into general use. In spite of this, however, laboratory use has been made of this system in cases where amplification with minimum of distortion was so necessary as to justify the extreme inconvenience of operating the system.

Some of these difficulties of operation we described at length in a paper delivered before the Institute of Radio Engineers and published in its Proceedings for

March, 1928. We called particular attention to a tendency toward what might be termed "drifting," and described automatic methods for controlling this drift. We also discussed operation of the tubes at very high plate impedances, and very low plate currents, and consequent advantages.

Our direct-coupled system adapted to battery operation was described and discussed in the August, 1928, issue of RADIO NEWS (p. 146).

Some time before the delivery of the Institute paper, development work had been undertaken to make the system entirely a.c. operative, and it is our purpose to describe in a series of articles to follow in RADIO NEWS the difficulties we met and how they were overcome.

The first difficulty encountered was the lack of commercial hi-mu a.c. tubes, thus necessitating the carrying on of work with experimental tubes designed to our specifications. Both the heater type and the filament type, some of the latter operating with as low as $\frac{1}{4}$ volt on the filaments, were used.

Since the amplification of the system was as high at 60 cycles as at other fre-

Some of the
Loftin-White
Laboratory
equipment

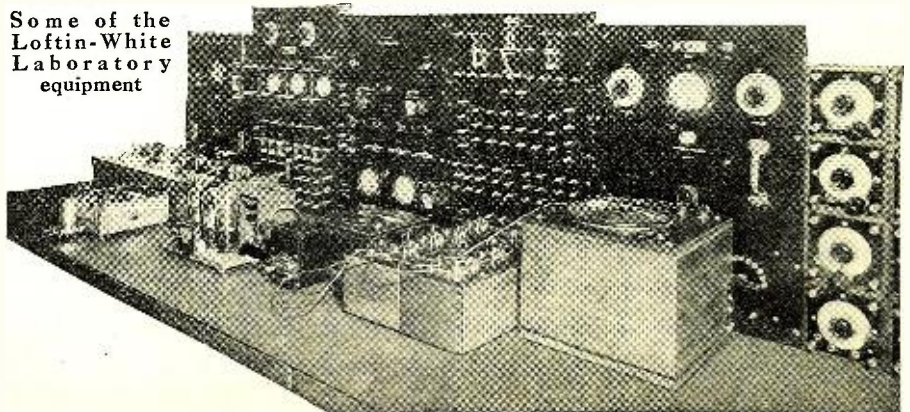

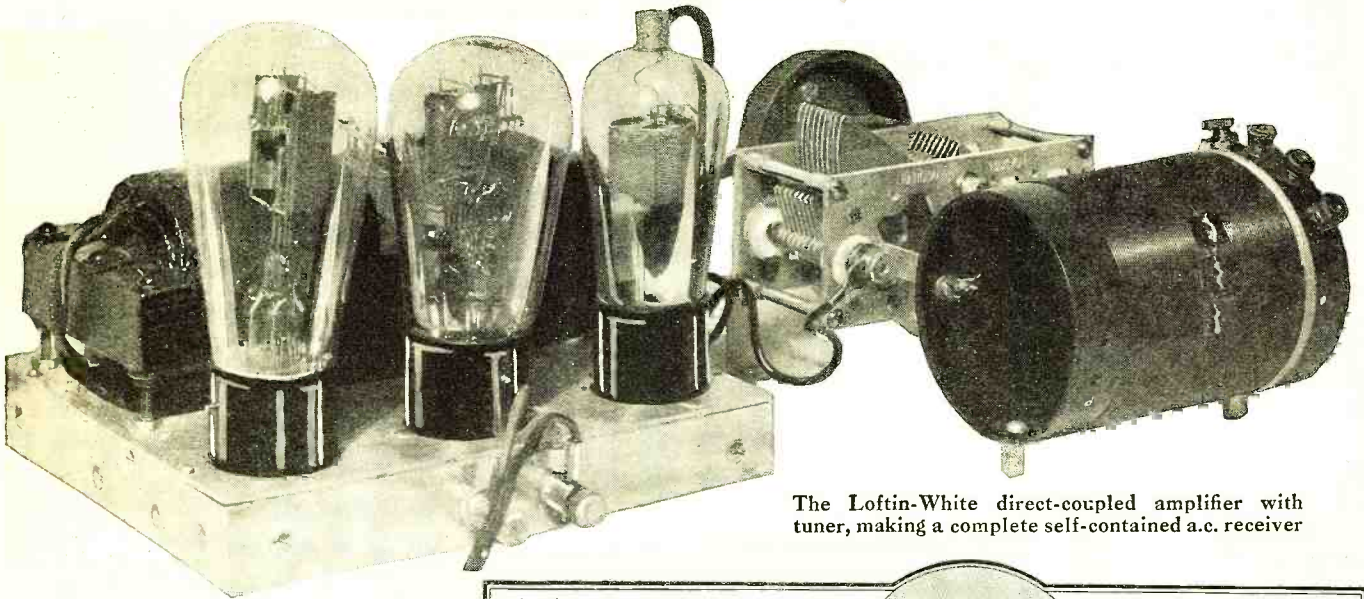

The Loftin-White direct-coupled amplifier with tuner, making a complete self-contained a.c. receiver

quencies, it was anticipated that considerable hum difficulties would arise in a.c. operation. Not only did these difficulties materialize, but in addition various incidental hums, usually obscured when the tubes are operated at normal impedances, proved noticeably annoying when operating at the very high impedances and very low plate currents which we used.

An entirely new series of automatic drift control arrangements particularly suitable for a.c. operation was developed.

Another difficulty was a motor-boating tendency, emphasized by improperly designed drift correctors, and which we had to overcome without resorting to the large condensers usually relied upon for such work.

There is also a form of blocking peculiar to direct coupling and known as trigger action. This effect, while fatal to the use of direct coupling as an amplifier, was ingeniously employed by Minorsky to form a supersensitive circuit breaker.

In seeking solutions for the above difficulties, a primary limitation was necessary in order to keep material cost at a minimum. The accompanying photo-

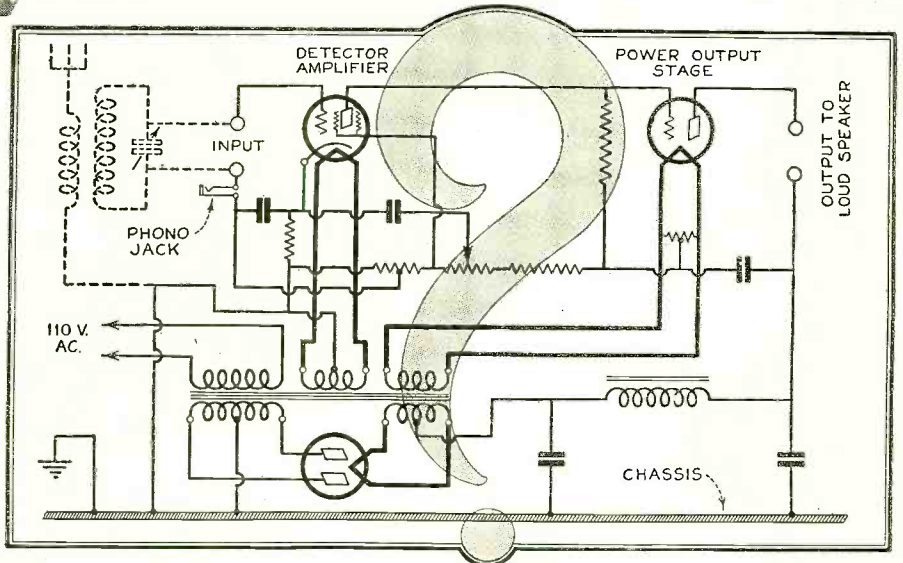

graphs, showing the extremely small size of completely a.c. operated amplifiers and detector-amplifiers, clearly show how successfully this was accomplished.

We were able to discount these difficulties from the

Can you figure out the constants of this new circuit? They will be given in the February number

Another view of the amplifier. At the left is the screen-grid detector. Center: 245 amplifier. Right: full-wave rectifier

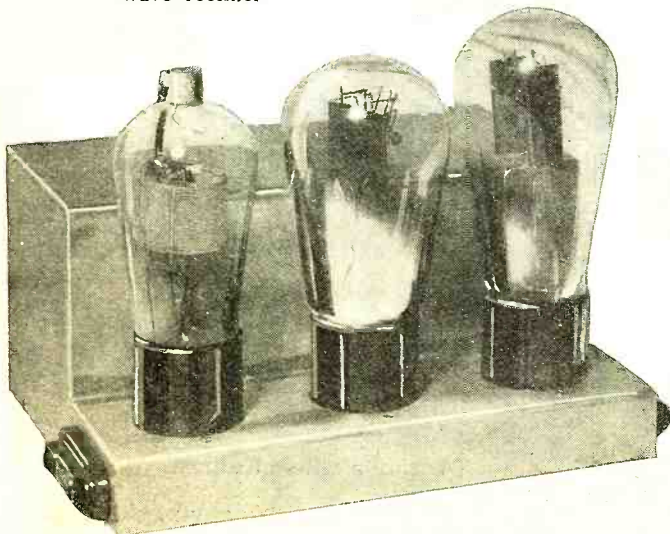

THE authors of the accompanying article are men who have devoted most of their lives to radio research. Commander Loftin was appointed to the U. S. Naval Academy from the State of Florida, in 1904, and was graduated in 1908. He began specializing in electrical communication in 1910, and since that time has held many important posts, some of which include: Radio Officer of the U. S. Naval Aviation Forces in France during the war, with headquarters in Paris; Technical Representative of the Navy Department in the negotiation and arrangements for the construction of the Navy's tremendous transmitting station near Bordeaux. He has been in charge of the U. S. Naval Radio and Sound Signalling Research and Development in the Bureau of Engineering at Washington.

Mr. S. Young White, the co-author of this article, began his radio research work in 1917 when he entered the Electrical Research and Test Department of the General Electric Company at the age of 16. At that time he assisted the famous Mr. Hoxie in the development of various types of sound reporting and sound reproducing equipment. Since then he has developed, with Commander Loftin, a group of radio circuits which have been patented. Some of these patents were recently sold to the Radio Corporation of America.

The latest development from the Loftin-White Laboratory receives its introduction to the world in general in the accompanying article. We have witnessed radio demonstration of all kinds, but we feel free to admit that the demonstrations of equipment which we have seen at the Loftin-White Laboratory are completely revolutionary in character, and we feel that our readers also will be pleased to know that a complete description of the various applications of the circuits developed by Loftin and White will appear in a series of exclusive articles in forthcoming issues of RADIO NEWS.

beginning, because we saw some very promising advantages. Chief among these was our ability to balance out, through "hum-bucking," not only the fundamental hum currents, but also all harmonics, an impossible accomplishment in any system employing either phase distortion or wave form distortion.

The frequency range of amplification is astonishingly large when screen-grid tubes are used, running with gradual attenuation from a few cycles, depending on the time-constant of the particular drift-corrector, to a point where amplification ceases—at about three million (3,000,000) cycles. The high frequency end is extended to this astonishing limit by the screen-grid tube, which does not allow the capacitatively reactive plate circuit to cause degeneration through the tube capacity.

Very high amplification per tube is obtained, averaging about 100 per stage. Due to the absence of iron in the system, we have to shield only electrostatically against hum and stray pick-up, so that we can make the apparatus extremely compact with no hum pick-up.

When the system is used as a detector-amplifier, it automatically alters from an extremely sensitive condition when no carrier wave, or very weak one, is impressed thereon to a heavily biased

(10 to 20 times initial) power handling condition for strong signals. This biasing is automatically regulated by, and in conformity with, the strength of the carrier wave itself.

In detector operation the shield grid tube prevents reverse feed-back of the radio frequency from the plate circuit, so that its load on the tuned input circuit is very small. This permits a much higher resonant voltage rise than with the normal detector and a consequent increase in sensitivity and selectivity, as viewed from

the plate circuit of the preceding radio-frequency tube or antenna circuit. The system, comprising but two tubes and operated from either an antenna or a preceding radio-frequency tube or tubes, has the same order of sensitivity as the grid leak detector and two-stage transformer, coupling three tube systems without the detector overloading features of the latter.

We shall cover more or less specifically, in our succeeding articles, applications with numerous special and beneficial features, such as detector-amplifiers for radio receivers; a very high gain, distortionless amplifier suitable for photo-electric cell

operation; a phonograph amplifier; a broad-band amplifier for television; and an amplifier for modulation amplification for transmitting. In connection with transmitter modulation, we can overload a quarter kilowatt tube from an ordinary 224 screen-grid tube. Many other uses will of course be suggested or become apparent.

The photographs shown in connection with this article give some idea of the small amount of apparatus required, especially for high gain operation. Further, they illustrate the compactness which will undoubtedly characterize receivers not of the coming season alone, but of the future.

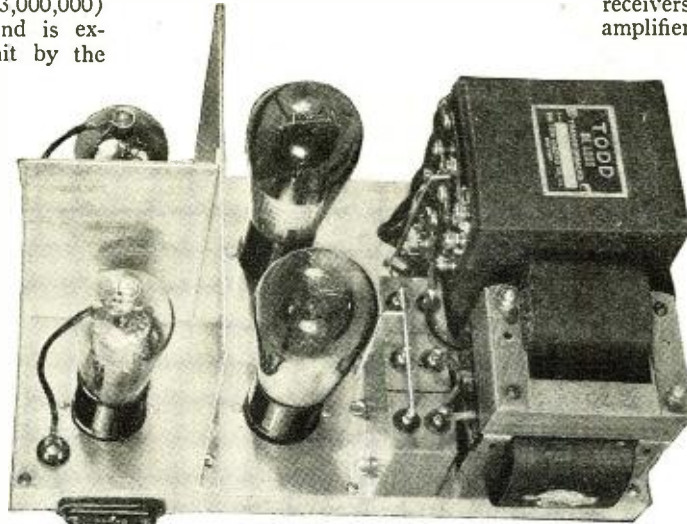

The Loftin-White three-stage direct-coupled audio amplifier and power supply, including full-wave rectifier



Benjamin F. Miessner

He SAVES *the* Radio Industry More Than \$1,000,000 *a Year*

equipment necessary to operate radio receivers from the light socket.

It is our good fortune to have known Mr. Miessner for a period of years, and to have assisted him in bringing his ideas to the attention of some of the more important radio manufacturers. In spite of the fact that, up to the present time, the manufacturers who are operating under license agreements entitling them to the use of ideas which Mr. Miessner has patented, and for which he has patents applied for, represent some of the most important in the country, there are still a few who continue to function along rather old-fashioned and much more costly lines.

In this connection it is generally found that the stumbling block lies in the engineering departments of manufacturing organizations of this character. It seems to us that the really alert chief engineer is the man who will recognize the value of sound engineering ideas, whether they

emanate from his own laboratory or not. For instance: the engineer who has vision enough to call to the attention of his company the fact that, by utilizing ideas such as Mr. Miessner has developed, it would be possible for the company to save between \$3.00 and \$5.00 in the original cost of each receiver made, and to reduce the over-all shipping weight by from 3 to 18 pounds, is an exceedingly valuable man, regardless of what he happens to be paid.

This is but one of the high spots in the highly revolutionary system which Mr. Miessner has developed, and it is with considerable pleasure that we announce a series of extremely informative articles from Mr. Miessner's pen beginning with our February number.

ONE of the most romantic tales of radio achievement is centered in the personality of Benjamin F. Miessner. Mr. Miessner maintains a well-equipped laboratory at his home in Short Hills, N. J., where he spends a great deal of his time delving into the intricacies and the vagaries of circuits, which enable manufacturers to reduce materially the cost of the power



The Recent Radio News Survey Indicates Tremendous Possibilities in This Field, Which Manufacturers and the Radio Public Have Been Quick to Recognize

By Arthur H. Lynch

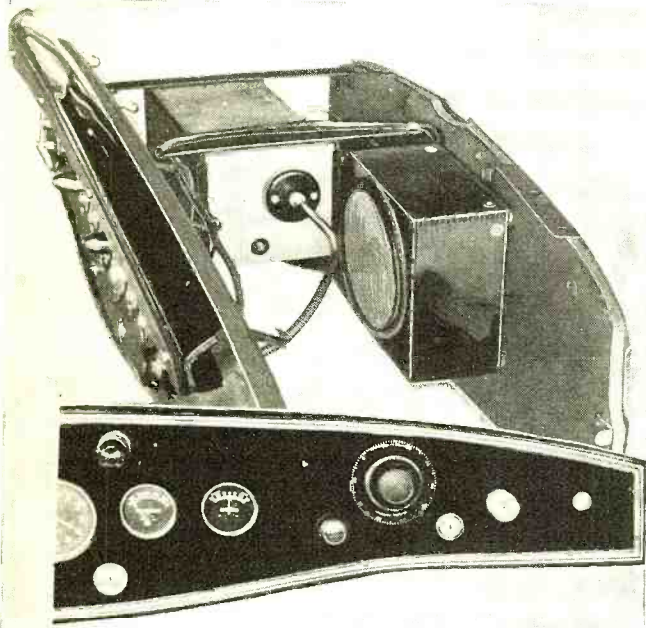

Above: Tuning in a Transitone Auto-Radio receiver. At the left: assembly details and the dashboard layout of a Delco-Remy Cadillac installation. The loud speaker is mounted behind the dash, near the receiver

WE have been operating radio receivers in motor cars for a number of years. In fact, during the Presidential Conventions five years ago we had a receiver in a touring car parked outside Madison Square Garden, where a large overflow crowd was enabled to hear the proceedings inside. In those days the receiving was done with a superheterodyne and a loop installed in a convenient portion of the tonneau. At other times similar installations were made in coupes and sedans, and occasionally we treated Broadway crowds to radio concerts and fought our way through the traffic jams during

the theatre hours. Since that time some people have come to realize that a radio receiver on an automobile is a desirable thing.

We find also that the Delco-Remy Company, a manufacturing subsidiary of the General Motors Corporation, is offering complete radio receivers for sale through Cadillac and La Salle dealers.

Some time ago the Radio Frequency Laboratories of Boonton, New Jersey, designed a remote control receiver for use in airplanes, which has proved so successful that they have now turned their attention to broadcast receivers for motor cars.

The automobile models follow the same general design as those made for airplanes, and this company is in a position to cooperate with automobile manufacturers in fitting receivers to any make of car.

The dimensions of one model of the RFL receiver are eleven inches long, seven inches high, and six inches deep. With tubes, cable, and volume control the weight is ten pounds, two ounces. The volume control knob appears on the instrument board and varies the control grid bias on the radio amplifier tubes.

One of the first concerns to enter the auto-radio field was the Automobile Radio Corporation, 37 Queens Boulevard, Long Island City, New York, makers of the "Transitone" receiver. Branches of this organization in all principal cities of the United States are prepared to install radio equipment in every make of automobile. This six-tube outfit consists of three stages of tuned radio-frequency, a detector, and two stages of audio-frequency amplification. A power tube is used in the last stage, and the entire receiver is enclosed in a copper box which serves as the necessary shield.

After several conferences with some of the most important manufacturers in the country, we find that there is a constantly

(Continued on page 675)

Greater Fields To Conquer

TO most of us who think of the vacuum tube, there arise pictures of its uses in radio. It has entered many other almost equally important fields. We find vacuum tubes playing increasingly important functions in long-distance telephone service, in medical diagnosis, in the talking movies, in television and in many of our more prosaic pursuits.

Who is better qualified to discuss this interesting subject than the inventor of the modern Aladdin's Lamp? We are pleased to present this informative article by Dr. Lee De Forest himself.

THE EDITORS

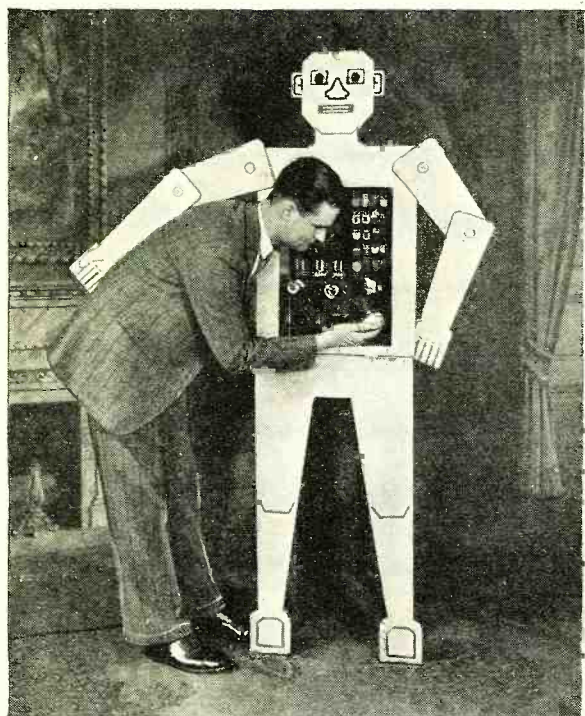

Indicating the vacuum tube, a mechanical essential of a mechanical gentleman, Mr. Televox

THE possibilities of the audion or vacuum tube far exceed the wildest flights of fancy. Many of us who marveled as children over the adventures of Aladdin and his wonderful lamp, do not fully appreciate that in the simple evacuated glass bulb, with filament, grid and plate, we have at our command a genie, Electricity, far more powerful, far more obliging, and far more useful than that grotesque giant who served our childhood here so faithfully. However, it is for us to decide upon the tasks which our electrical genie will perform at the bidding of the modern Aladdin's lamp which each of us can possess, and thereby hangs the following dissertation.

An Electrical Trigger of Untold Possibilities

First of all, let this dissertation be quite aside from radio, since it is well to assume that the readers of a radio journal are quite familiar with the many applications of the audion or vacuum tube to radio communication. Also, we shall assume that the principle and the general functions of a vacuum tube are understood,

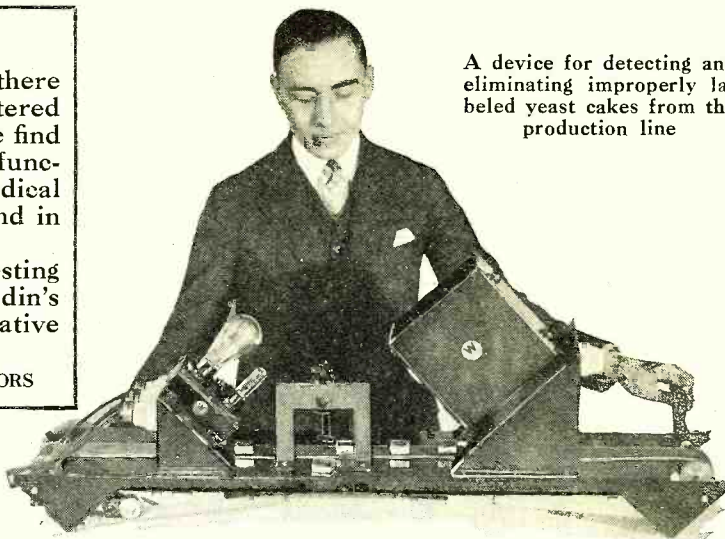

A device for detecting and eliminating improperly labeled yeast cakes from the production line

The AUDION NEW

so that we may plunge directly into our subject without wasting time on the purely encyclopaedic side.

I believe the foremost application of the audion or vacuum tube lies in its trigger possibilities. Just as a child can pull the lanyard of an 18-inch gun and fire a shell weighing $1\frac{1}{2}$ tons to a distance of perhaps 25 miles, so can a minute electrical charge—say one flea power or less—be made to actuate no end of things through the trigger action of the vacuum tube. This electric trigger action is the basis for our present amplifying and modulating systems, since a weak impulse is made to control a more powerful electrical impulse, and, what is more, the stronger carries an exact impress of the weaker. Nothing is lost in the remarkable trigger action. We go from one step or stage to the next, as many times as necessary, until we are controlling the necessary amount of power. And so we have the singer in New York heard by radio network throughout the United States, or the public speaker before the microphone heard by hundreds of thousands gathered outdoors, over the public address system.

In the Realm of Queer Noises

Using the electric trigger principle of the vacuum tube,

The Verigraph, which measures and records variations in uniformity of paper, rubber, etc., passing through a machine

or call it amplification if you prefer, I demonstrated such odd things as hearing a fly walking on a piece of cardboard, the ticking of an ordinary watch, and a pencil writing on a piece of paper, back in 1915 when working on the audion amplifier in my Highbridge Laboratory. At the time I was convinced that a very important field of application for my audion amplifier would be in making strange noises audible. I had in mind the study of countless commonplace things which in no other manner could be made audible for necessary study. Thus the footsteps of no end of insects, the song of those insects, the scratching of lead pencil on paper and so on, could be made audible. Trivial? Not at all. These things are interesting subjects for extensive research, not only leading perhaps to important contributions to our purely academic sciences, but also resulting in many practical developments.

I believe much can be done with the audion amplifier and improved forms of pick-up. Typical of what I have in mind is the work of Dr. Thomas of the West-

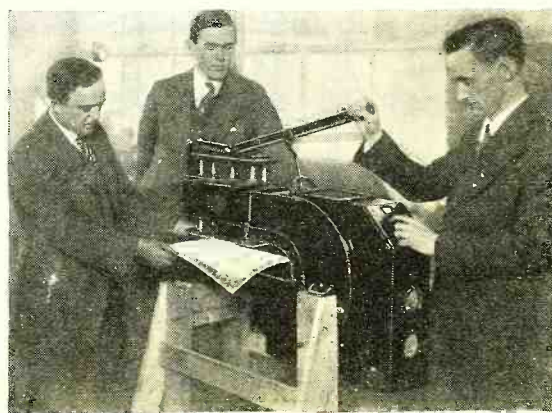

D. D. Knowles, inventor of the grid-glow tube, demonstrates the sensitive device

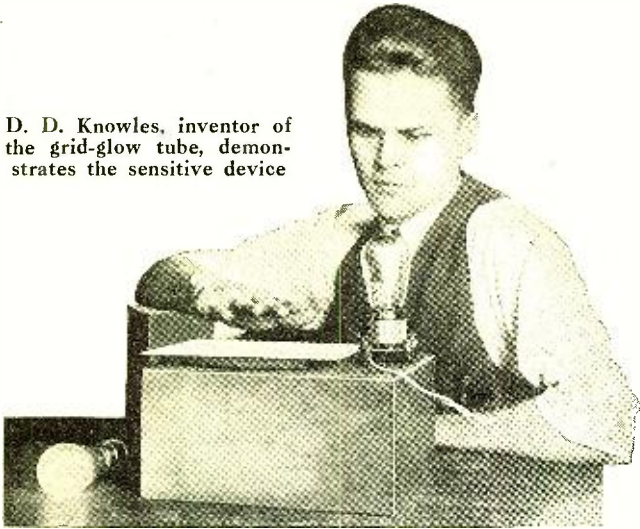

Demonstrating a miniature model of a traffic control system which has been installed in Pittsburgh

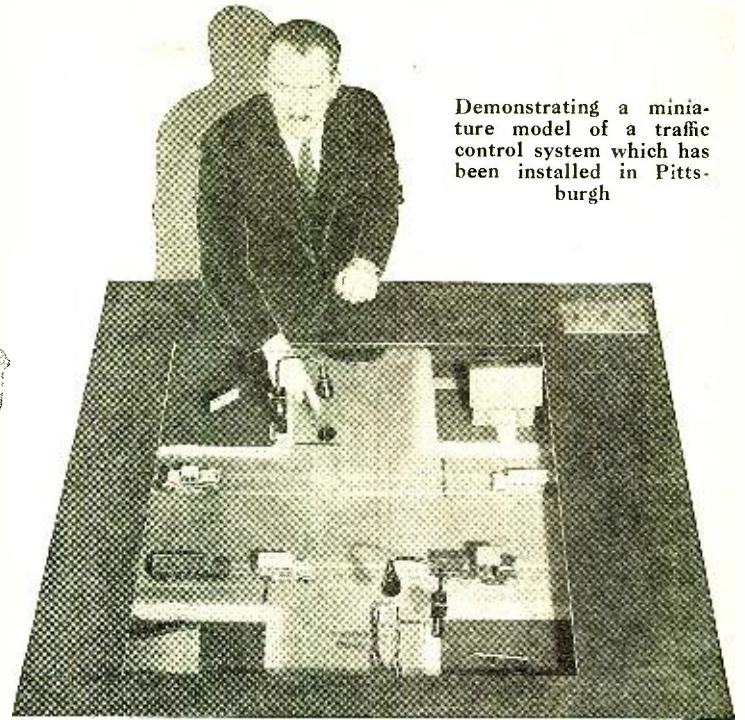

Conquers FIELDS

By LEE DE FOREST

inghouse organization, with his flame type microphone. Dr. Thomas has been able to pick up certain sound effects which are quite overlooked by the usual carbon and condenser types of microphone. He has found many concealed shades in music, which require not only a device capable of picking them up, but also an amplifier that can make them audible to our ears.

The sounds built up by the amplifier can be recorded on films or disks for subsequent reproduction and study. I have often wondered just why some of our present-day savants who delve in psychic phenomena do not make use of delicate microphones, amplifiers and recording devices in bringing to us the ghostly voices and sounds of the seance room. It seems to me that the world could have definite proof of spirit personalities once and for all, if the savants were successful in entrapping the astral sounds. At any rate we would be satisfied once and for all as to whether their observations are truly *objective*—really taking place in our

materialistic world—or simply *subjective*—taking place only in their minds. Ghost stories could be sustained or abandoned, once and for all.

Measurements of Millionths of an Inch

From sound we can well turn to measurements, where the audion is again ready to be of considerable service if properly applied. I recall reading about six years ago of the experiments of an eminent English professor who, by means of a vacuum tube circuit, was able to demonstrate the bending of a one-inch diameter bar of steel when a fly alighted on same. Imagine such ultra-delicate measurements, if you will, and you have the basis for the most accurate means of calibration we have today. The audion can function either as an oscillator, with some method of indicating what changes take place in its operating conditions, or again as a trigger device in which minute differences are impressed on its grid circuit and made out as greatly amplified or magnified differences for ready observation in the plate circuit.

At a meeting of the British Association for the Advancement of Science, held several years ago, one Professor John J. Dowling, M. A., of University College, Dublin, demonstrated what he termed the ultramicrometer. This consisted of a simple oscillating

circuit with a galvanometer in the plate circuit as the indicating means. In measuring to within one millionth of an inch with this device, it is essential that the equipment be screened. Aside from measuring thicknesses of materials, exact sizes and other matters of length, breadth and thickness, the same idea has been applied to the measurement of minute strains, displacements, expansions and the like, carried out with a degree of refinement altogether out of proportion with the simplicity and reliability of the apparatus. Weighing devices of this character have also been developed. Seismometers, or devices for measuring earth tremors, have also been developed with this vacuum tube oscillator principle.

All in all, we have in the vacuum tube a marvelous precision device which will permit our scientists and our industries to go far ahead in their measurements and checks both in the laboratory and in everyday production routine.

Electrical Eyes for Vacuum Tube Brains

Within the past few years, remarkable progress has been scored in light-sensitive cells, or devices that translate the light that falls upon them into equivalent electrical values. Most of these light-sensitive cells are exceedingly delicate, and their current variations are so weak that vacuum tube amplifiers are essential in building up the variations to the point where they can be applied for practical work.

The talking picture systems of today that record both sound and picture on one film, as originally worked out by me in my phonofilm process, depend upon this application of the light-sensitive cell

Siren which "hears" approaching airplanes and automatically turns on the airport floodlights

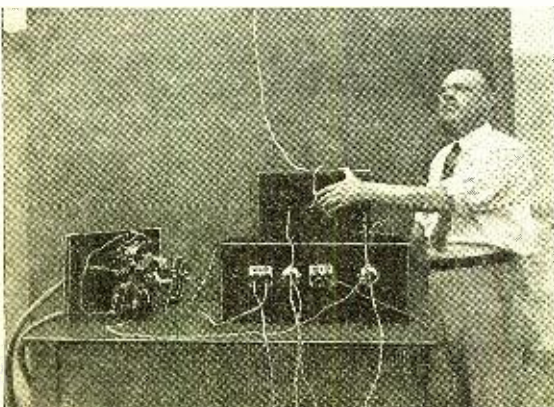

and vacuum tube amplifier. Talking pictures, having come into general use today, require no great amount of explanation.

There is a sound recording process, known as the light ray process, employed by the Brunswick organization in making its records, that is highly ingenious and serves as an example of what I should like to encourage in the way of novel vacuum tube applications. In this process the usual carbon button or the condenser types of microphones are replaced by a tiny aluminum cone not more than $\frac{3}{8}$ inch in diameter, which is capable of responding to the most delicate sound waves of the recording studio. The cone is connected by a delicate rod with a rocking mirror. A beam of light is thrown on the mirror, and is reflected to narrow slits behind which is placed a photo-electric cell. In actual practice, several parallel rays are cast on to the several slits, so that the rays are more or less shown through the slits. A vacuum tube amplifier builds up the electrical variations of the photo-electric cell, and operates the sound-recording mechanism. Thus we have a most delicate system depending on light rays rather than the movement of comparatively large and heavy diaphragms as in our usual microphones.

No end of wonderful applications are possible with the electrical eyes now at our disposal. I am told that photo-electric cells already have a vast industrial application. Such cells are employed in sorting fruit according to shade and size; in counting packages as they flash by on a conveyor belt; in making delicate shade comparisons; in separating printed sheets from unprinted sheets, and so on.

The turning on and off of lights by means of a light-sensitive cell, and the flashing of a burglar alarm as a light falls on a photo-electric cell, have been sug-

gested ever since the properties of selenium first became known. Yet today, thanks to far more sensitive and reliable light-sensitive cells, we can do far more than ever before. Also, we have the audion amplifier as compared to the old days when we had to operate a sensitive polarized relay directly from the output of the light-sensitive cell.

Before dismissing this phase of vacuum tube possibilities, I venture to predict that photographic sound recording will be the ultimate choice not only in theatres but also in the home. I predict that in the not distant future we shall have talking movies in the home, with the sound and picture on the same film. Also, our future home phonographs will make use of the film record, which is more realistic, easier to handle, plays longer, is devoid of surface noises, and, all in all, more desirable than the disk phonograph record. I dare say that some inventive mind will work out a better dictating system than we have today, whereby the sounds will be recorded on film, and reproduced by means of photo-electric cells. Perhaps the localized magnetism on steel disks and steel wires, as originally proposed by that great Danish electrical and wireless pioneer, Vladimir Poulsen, and called by him the telegraphone, may be resuscitated some day and made into a dictating machine on the one hand, and a home entertainment machine on the other. I rather incline towards the recording of sound on film, photographically, which I believe is far in advance of any other system we have yet discovered or invented.

High Frequency Possibilities

The vacuum tube is an ideal alternator or producer of alternating currents of a wide range of frequencies. Particularly in the higher frequencies does it come into its own in many new fields of application. Taking direct current as its input, the vacuum tube oscillator, or oscillion, as I originally named my oscillating tube which became the practical basis of present-day broadcasting and vacuum tube radio telegraphy, turns out alternating current of the desired frequency.

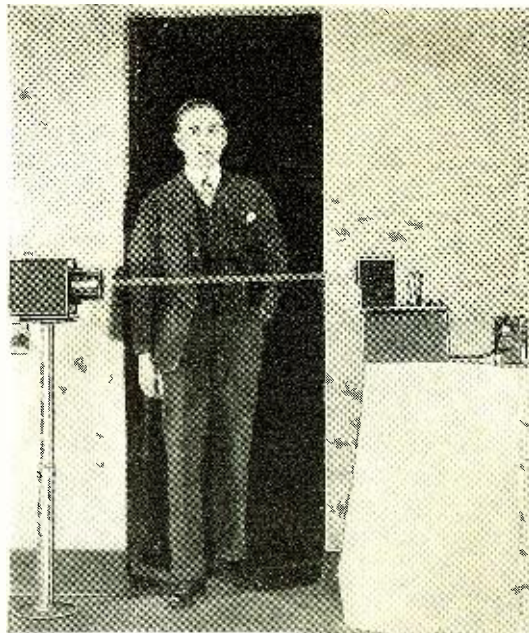
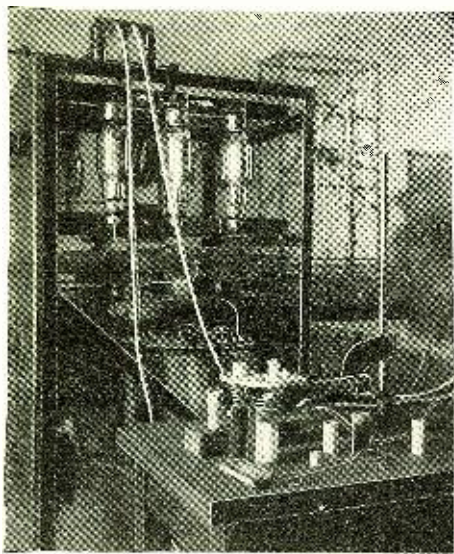

Photo-electric tube device for counting persons passing through a doorway

Of course we have not begun to make use of the oscillating vacuum tube, outside of radio communication, for any real tasks. I sometimes like to dream of a future and even more practical age when vast vacuum tubes, properly water-cooled, will be employed in our power generating and transmitting systems for the more economical handling of electricity. Imagine, if you will, a power house with a battery of huge vacuum tubes converting direct current into alternating current for long-distance transmission at the most economical frequency, whatever that may be, and imagine sub-stations along the transmission line, also with vacuum tubes but this time working as rectifiers, converting that high-frequency alternating current back into direct current of any desired voltage. That, to my mind, is the real future of the vacuum tube. Today, we have electrified railroads employing alternating current directly on the motors. We know that direct current motors are in many ways desirable. Yet we cannot conveniently convert the alternating current on the trolley wire into direct current within the locomotive cab. Again, we must employ alternating current on the trolley wire in order to reduce costly transmission lines and frequent sub-stations, when direct current is used on the trolley wire or third rail. Now if we could employ a battery of vacuum tube rectifiers in the locomotive cab, we might take the alternating current of any voltage from the trolley, pass it through step-down transformers, and then rectify it into direct current.

The idea is by no means fantastic. Vacuum tubes capable of handling hundreds of kilowatts have already been developed. Perhaps gaseous rectifiers, which are first cousins to vacuum tubes, may be employed to better advantage, where heavy current, rather than high voltage, is to be rectified. The helium rectifier has enormous possibilities in the power transmitting field, although its sponsors

(Continued on page 654)



A high-frequency induction furnace operated by vacuum tubes, and used for melting metals

View of X-ray Laboratory, showing vacuum tubes used to rectify high-voltage alternating current for the operation of X-ray tubes

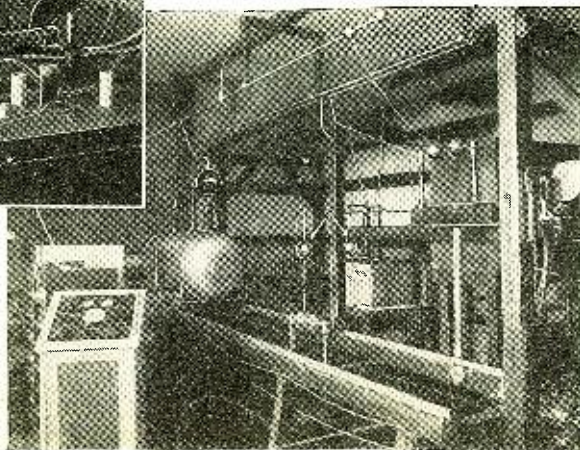



The new Ford tri-motored, all-metal plane of the Bell Telephone Laboratories is designed to be the largest and most complete flying laboratory in the world. The men who will conduct the experimental tests are, reading from left to right: F. S. Bernhard, E. L. Nelson, R. S. Blair, F. W. Woodworth, T. Durfee, R. L. Jones, D. A. Quarles, F. M. Ryan, O. M. Glunt and A. R. Brooks, pilot

The LATEST in Flying Laboratories

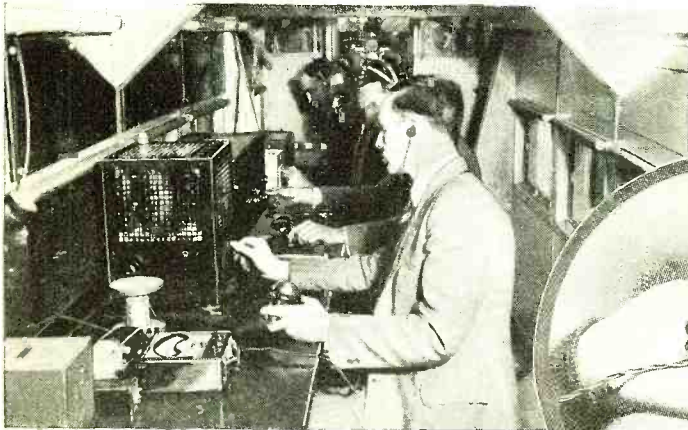

An interior view of the flying laboratory, where four engineers are working simultaneously, making tests and operating the transmitter and receiver

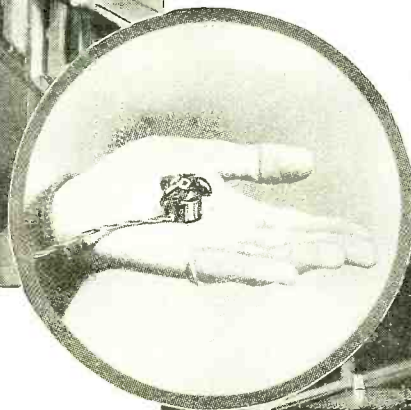

The smallest radio head telephone in the world, built to actually fit into the channel of the human ear (left)



Engineers at the small one-control five-tube screen-grid receiver, on the right of which is the fifty-watt radio telephone transmitter. Both can be operated by remote control. The operator in the foreground may be seen wearing the midget headphone

Photos by Underwood & Underwood

“Is International Broadcasting” “Just Around the

*Much experimental work remains to be
be assured of regular program*

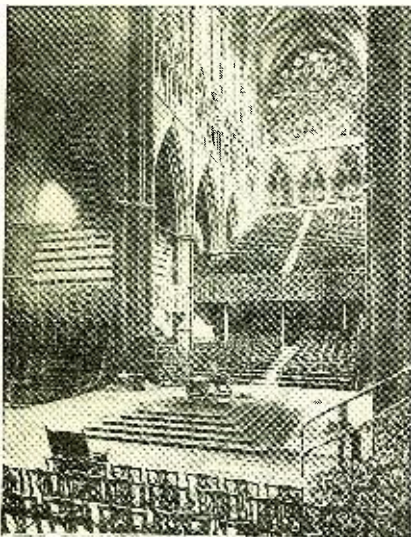

One of the best examples of international programs which have been rebroadcast in this country was the Thanksgiving services held in Westminster Abbey to celebrate the recovery of King George V

RADIO engineers who are working to develop the dream of world-wide interchange of radio programs into an actual fact today are the adventurers of broadcasting. The results of their efforts are felt all through Europe, in far-away Australia, in South America and in South Africa. The American radio listener gets occasional glimpses of the fruits of their experiments when a program originating in a foreign studio is picked up and rebroadcast by an American transmitter on a National Broadcasting Company network.

In considering what has been going on in the development of international exchange of radio programs it is well to bear in mind that attempts are not being made to link the average receiving sets in American homes directly with foreign transmitters. Instead, foreign studios are being considered as outside pick-up points for outstanding events, just as programs originate in an opera house or a convention hall in this country. Instead of using the conventional wire line to bring the program into the studio for monitoring and distribution to network stations, short waves must be employed for bringing the entertainment across the ocean.

Experiments in the use of short waves

for the exchange of programs between nations have been going on since 1923. With the organization of the National Broadcasting Company three years ago, it was considered logical to bring this new organization directly into the picture. Thus we find the present plan makes use of the Radio Corporation of America's mammoth experimental receiving station at Riverhead, L. I.; the highly developed short-wave receivers of the General Electric Company at Schenectady and Sacandage, N. Y., and the Westinghouse receiving plants in East Pittsburgh. All these receivers are connected with the NBC headquarters in New York, where much of the actual monitoring is done and where data is checked and co-ordinated. Then the data obtained by American radio engineers is checked and co-ordinated with that received from engineers abroad who are co-operating fully with the American experimenters.

The job that the engineers have tackled is a big one. It is not for an amateur nor for an organization lacking extensive financial resources. It has called for and will continue to demand infinite patience, for much experimental work must be done before American listeners can be assured of regular, reliable, uninterrupted

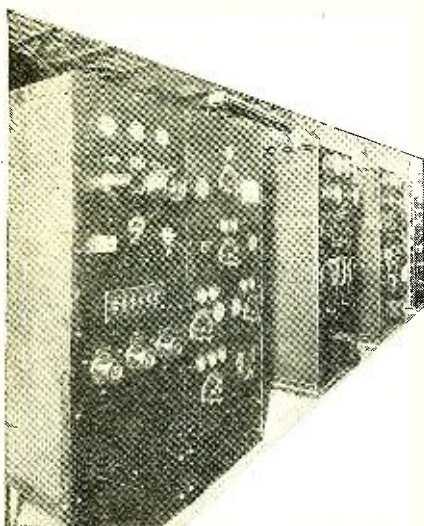

A view of short-wave transmitting equipment at Rocky Point, L. I.

Aerial network at the Rocky Point station which forms an important link in international short-wave communication

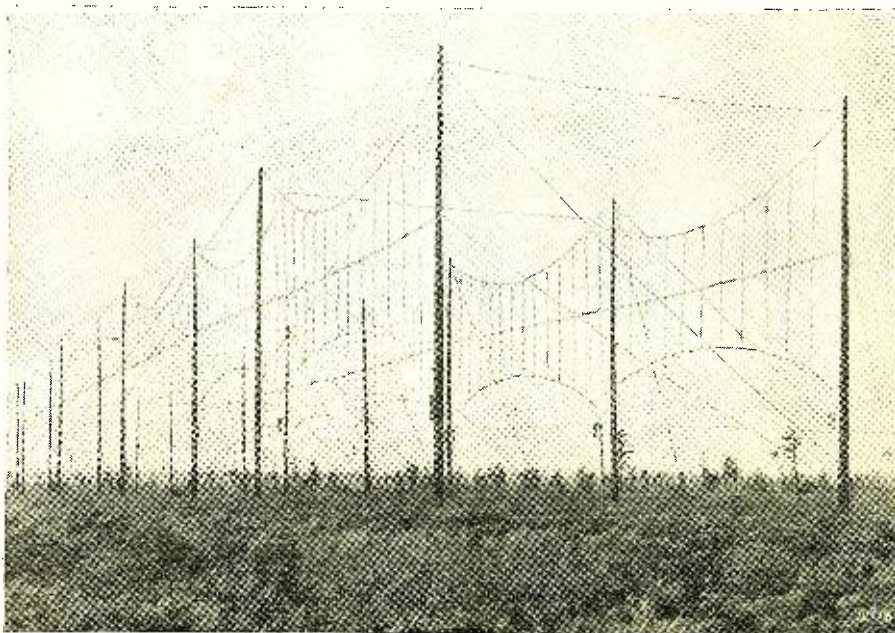

Asks C. W. Horn

Corner?

done before American listeners can reception from abroad.

reception of programs from abroad.

The chief difficulties encountered in short-wave transoceanic reception are static, irregular and erratic fading and distortion.

It is apparent that these difficulties are all natural ones. Therefore the experiments have resolved themselves into a battle between man and nature, with man pitting all his technical and engineering knowledge against natural factors that cannot be eliminated but must be circumvented.

There will always be static. It cannot be eliminated any more than sunshine and rain. However, solution of the problem will only come after untiring research, experiment and development.

Fading and resultant distortion also are caused by natural phenomena and again it is a matter of developing equipment that will bring in the desired program through these barriers.

At the present time the demand for short-wave bands exceeds the supply. The solution of this problem is to continue to narrow the bands so that the number in the whole spectrum is increased. But this is much more difficult than it sounds.

Americans have become accustomed to thinking of radio transmitters as consisting of two tall towers with wires strung between them and a small building nestled somewhere near the base. Likewise, radio receivers as small pieces of furniture, many of them not as large as a phonograph.

In order to transmit and receive powerful short-wave signals, many acres of ground are needed. Some aerials in use resemble gigantic spider webs with wires running in every direction. The transmitting equipment itself is vastly more complicated than ordinary equipment for use on the regular broadcasting waves and is many times more expensive. A large city might be built on the acreage required for the antennæ at Riverhead, Schenectady, Sacandage or East Pittsburgh.

Thus it is obvious that effective transoceanic short-wave reception cannot be accomplished through an ordinary aerial system, as some interests would have you believe. It is one of the biggest broadcasting jobs in existence and the fact that some of the world's largest experimental laboratories are working almost as a unit on the problem is merely indicative of the immensity of the task.

The work goes on at every hour of the day. Engineers often are in the laboratories and at transmitters and receivers at three o'clock in the morning. Somewhere there's always a program on the air and in most cases that program is going out on short waves in order that experimenters in other sections of the world may have the use of it for their tests.

Just what has been accomplished in international exchange of programs is a frequent question. Several excellent examples have been offered to the American listeners through the NBC system. Among them may be recalled the first English program to be put on an American network, a symphony concert from Queen's Hall, London. Another epochal rebroadcast from abroad was the Thanksgiving service in Westminster Abbey on the occasion of the recovery of King George V. That same morning radio listeners heard the voice of an announcer in Sydney, Australia. The Schneider Cup race description from England was heard by American network listeners and the rebroadcast of Gloria Swanson's voice was another. Still more recently the rebroadcast from Germany of Einstein's remarks



C. W. Horn

FOR many years Charles W. Horn, general engineer for the National Broadcasting Company, has been associated with radio in one phase or another.

He established radio communication systems in many South American countries for the United Fruit Company. He also installed the first radio compasses used by the United States Navy. In 1920 he joined the Westinghouse Electric and Manufacturing Company, where, as superintendent of radio operations, he was in charge of broadcasting and telegraph transmission. In 1927, in conjunction with the Melbourne *Herald*, he perfected transmission to Australia.

In particular he is known for his experimental work in connection with international broadcasting at KDKA. During the world war, Horn, a lieutenant in the Navy, served as a radio expert, assistant to the chief of the Third Naval District, with headquarters in New York.

He was born in New York and educated in the public schools there. He is a member of the Institute of Radio Engineers, a Fellow of the Radio Club of America, the Army and Navy Club, the Society of American Military Engineers and the Edgewood Country Club of Pittsburgh.

and the program from Huizen, Holland, may be remembered.

The quality of these programs was good. In several instances the quality was comparable to the best received dj-
(Continued on page 676)

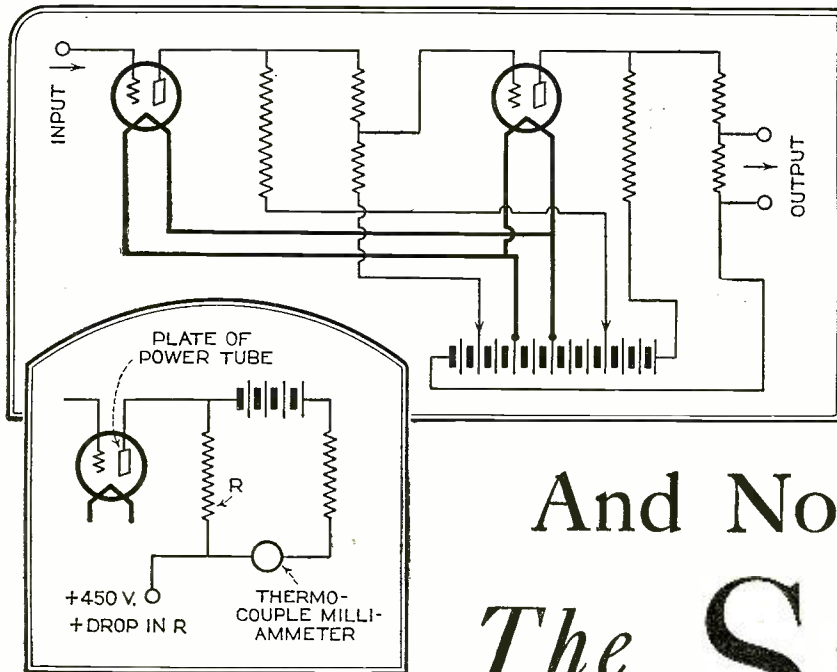

Fig. 1 (top) shows the fundamental circuit which was chosen as the most practical for straight resistance coupling. Fig. 2, below, shows the balancing-out system employed to gain a wide frequency response of from 0 to 20,000 cycles per second

MR. JOSEPH MORGAN, the author of the accompanying article, describing the results he has been able to obtain after a long series of experiments, is the Chief Engineer of the International Resistance Company. The circuits shown here are the practical embodiment of a whole group of laboratory tests and enable you to go right to the job of building—all the "bugs" have been taken out for you.

THE EDITORS

And Now We Have The Straight RESISTANCE - COUPLED

A Precision Amplifier for

By Joseph

CONSIDERATION of any specific problem must be accompanied by a knowledge and an appreciation of the associated problems. In radio the physics of sound transmission, the methods of production of voice sounds, the tonal characteristics of musical instruments, the theories of transformation of sound vibrations into sensations—these necessary elements merely indicate the complexity of the field. To these important scientific considerations there is added the artistic incentive—the desire to bring to the listener the vibrant, lifelike songs of the vocalist and the inspiring music of the orchestra.

The audio-frequency amplifier plays a very important part in the reproducing system. The inherent disadvantages of the transformer or impedance-coupled amplifier, and the resistance-condenser-coupled amplifier make these systems impracticable for magnifying, *without distortion*, the electrical input current of frequencies

between 10 and 10,000 cycles per second.

The Circuit of the Amplifier

A "straight" resistance-coupled amplifier offers few, if any, of the disadvantages of the above-mentioned systems. The difference between a "straight" resistance-coupled amplifier and the more commonly known resistance amplifier is apparent from the circuits accompanying. Some difficulty arises from an attempt to provide stable plate voltage and grid bias supply, and to arrange reasonable construction costs. As a result of considerable laboratory research the circuit shown in Fig. 1 was chosen as the most practicable for straight resistance coupling.

By using a resistor and balancing battery in the output circuit, as in Fig. 2, uniform amplification, within ± 1 decibel, is obtained from 0 cycles per second to 20,000 cycles per second. Feedback troubles, like microphonic howling, have been non-existent in all models of this amplifier.

During preliminary investigation of the possibilities of this circuit two three-stage amplifiers were constructed. These models were designed and effectively used to

Fig. 3—This is the actual circuit, showing values of parts employed, which was used in the construction of the amplifier illustrated in the upper right corner of the following page

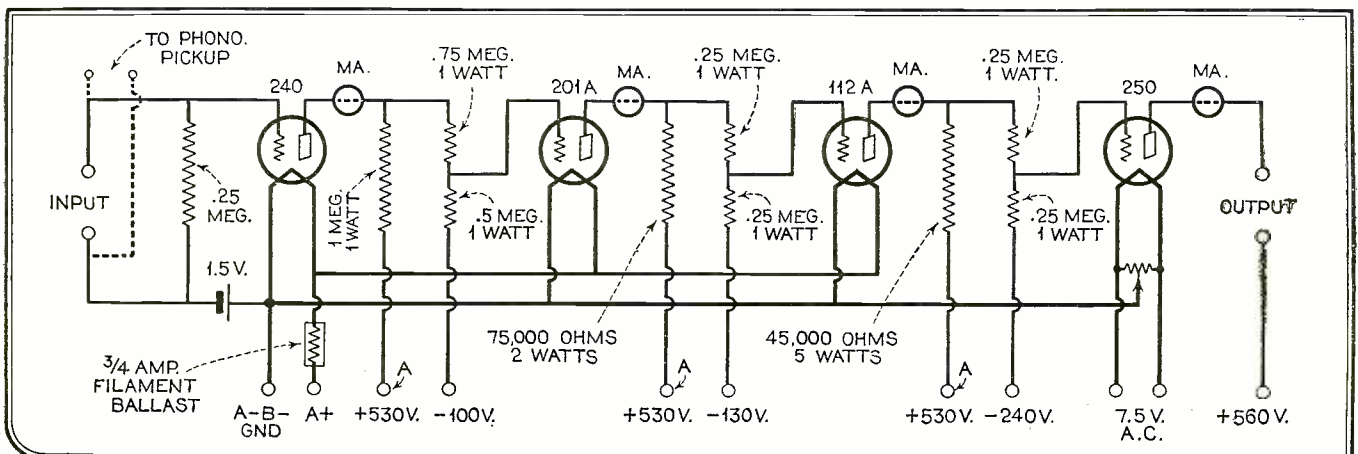

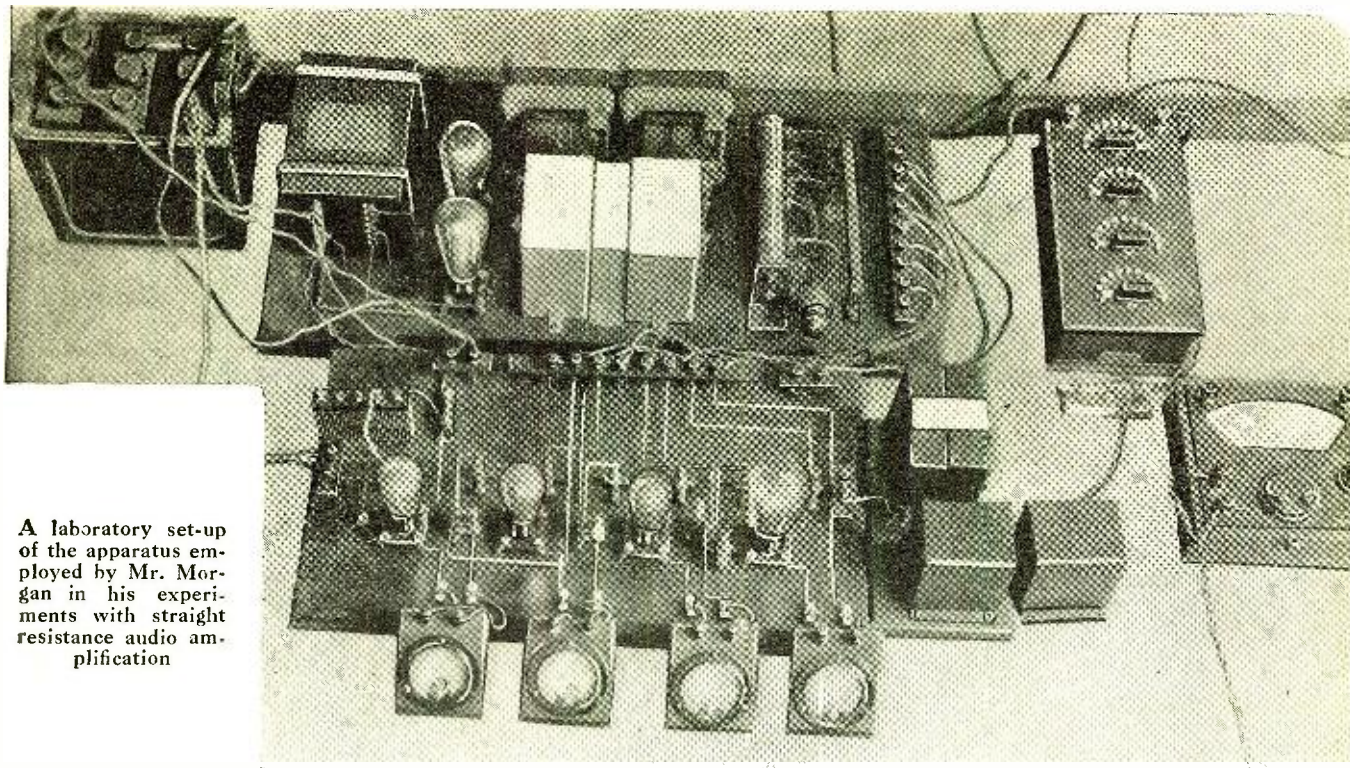

A laboratory set-up of the apparatus employed by Mr. Morgan in his experiments with straight resistance audio amplification

AUDIO AMPLIFIER

Radio and Television

Morgan

measure small differences of potential between 0 and 30,000 cycles per second.

The apparatus described below has been developed with a two-fold object: 1—To obtain an amplifier for use with phonograph pick-up or radio set, providing a gain of approximately 55 decibels, and a power output of $4\frac{1}{2}$ watts over a band of 30 to 10,000 cycles per second. 2—To use the same amplifier with modified input and output circuits for making laboratory measurements.

Radiotrons UX240 (high- μ), UX201A, UX112A and UX250 are used in successive stages. The necessary details of the circuit and its constants are given in Fig. 3.

The amplifier has been mounted "bread-board" fashion. Sponge rubber strips are attached to the end cleats to minimize vibration. At the ends of the board binding posts for input and output are arranged on hard rubber strips. Supply voltages are brought to a binding post strip at the back of the board. Along the front of the mounting board eight Fahnestock clips are mounted. These are connected to four milliammeters for reading plate current values during preliminary adjustment of the supply voltages. A busbar jumper is inserted in each of

the four pairs of clips after the initial adjustment.

Insulated filament supply wires are placed underneath the mounting board. Filaments of the first three tubes are heated by a 6-volt storage battery. A $7\frac{1}{2}$ -volt winding of the power transformer, described below, supplies the filament of the UX250.

A 2-watt resistance unit is used in the plate circuit of the UX201A. Two 2-watt units in parallel are used in the plate circuit of the UX112A. The remaining units are of 1-watt rating.

Only resistances of the highest quality may be employed. Noise, excessive resistance change with load and change of

resistance with weather conditions cannot be tolerated.

(Continued on page 660)

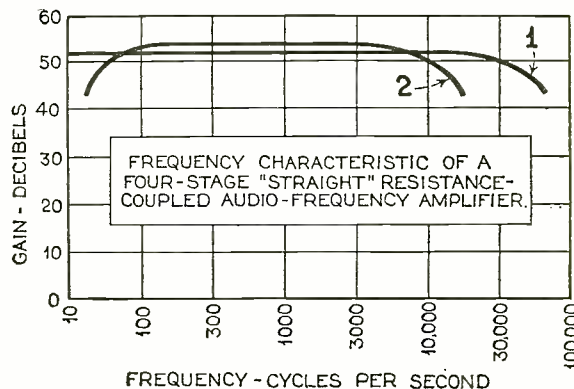

FREQUENCY CHARACTERISTIC OF A FOUR-STAGE "STRAIGHT" RESISTANCE-COUPLED AUDIO-FREQUENCY AMPLIFIER.

Fig. 5—The curve 1 shows the frequency characteristic obtained when an output resistance and balancing battery are employed in the amplifier circuit (as in Fig. 2). Curve 2 shows the frequency characteristic of the amplifier when a choke coil and condenser couples the loud speaker to the amplifier

Fig. 4—The circuit of the power supply device which provides the necessary "B" and "C" voltage for the operation of the amplifier described by Mr. Morgan

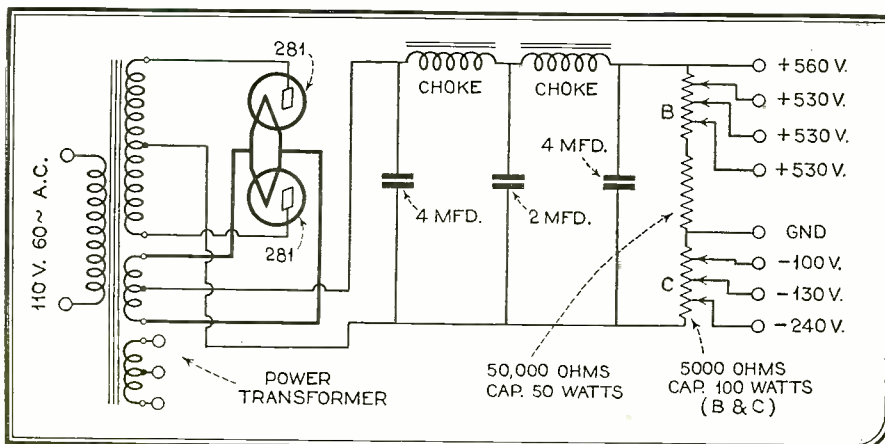

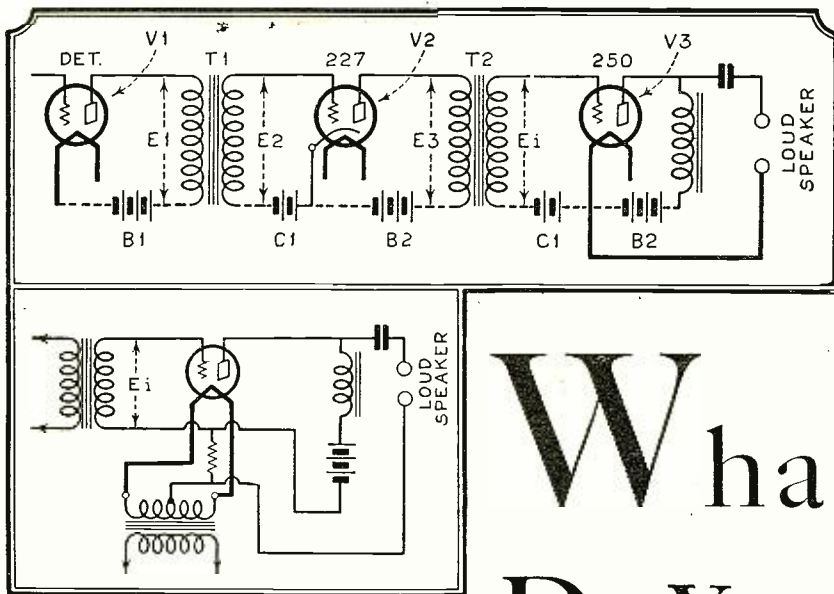

Fig. 3. Above. The circuit of a typical two-stage audio amplifier. In the text this circuit is analyzed to determine the voltage output of the detector to satisfactorily work the 250 in the final audio stage

Fig. 1. A standard power amplifier circuit whose function is explained by analysis in the text

What

Do You Know About

By James Martin

Do you know how many stages of audio amplification you require for a particular output?
 Do you know how to figure the overall gain of an audio amplifier?
 Do you know what kind of tubes to use in the power output stage?
 Do you know whether your amplifier can supply the required signal voltage to the push-pull power stage?
 All these questions, and more, are clearly answered by Mr. Martin.

IN the articles by the writer which have been published in the past issues of RADIO NEWS, an endeavor has been made to help the serious experimenter towards a better knowledge of the fundamentals of radio. Here in this article we again have the same aim—this time in connection with audio amplifiers.

Audio amplifiers? "Oh," you say, "that's old stuff." They are either transformer, resistance or impedance-coupled, the first type generally using two stages and the latter two types three stages. "Oh, yes, I know all about them."

Maybe you do. But if you do you ought to be able to answer these questions.

1. Suppose you have a power amplifier with two 250 tubes in push-pull. How much gain ought the amplifier to have in order to get full power from the 250's and only require a reasonable voltage from a grid leak and condenser type detector?

2. Suppose you want to build a set for operation on batteries. From the standpoint of comparative gain, power output and plate current consumption, what type of power tube would you use and what type of power tube in the last stage? Should the power stage be a single tube or two tubes in push-pull?

3. Can you determine without going to a lot of testing how much "C" bias is required on a particular tube in an amplifier to prevent that tube from overloading?

4. Suppose you had a two-stage transformer-coupled amplifier, could you determine how much a.c. voltage was required across the input to produce, say, 20 volts across the output?

Do you know the answers? If you do you know your amplifier theory pretty well. But if you can't answer them, read on.

In analyzing an audio amplifier from almost any angle, the place to start is at the output, working back towards the input of the amplifier. We generally know how much power output we want, or what type of power tubes we are going to use. On either of these points we can design the remainder of our amplifier.

First let us look at the power stage. Power tubes have certain definite output ratings; for example, the 171A is rated at 700 milliwatts, which is the same as 0.7 watts, the 250 is rated at 4.65 watts, etc. Now this doesn't mean that if we use a single 250 we just naturally get 4.65 watts. The rating of 4.65 watts is simply an indication of the maximum power which the 250 can supply and the actual power output may be anything from 4.65 watts down to zero, depending upon the amount of a.c. voltage we supply to the grid of the tube. This is the important fact. So let us first find out how the power output from various tubes varies with the amount of a.c. voltage supplied to the grid.

In Fig. 1 is a diagram of a single tube power amplifier stage. To analyze this circuit with regard to a.c. input voltage and a.c. output power the important characteristics are: the a.c. input voltage, the amplification constant of the tube, the

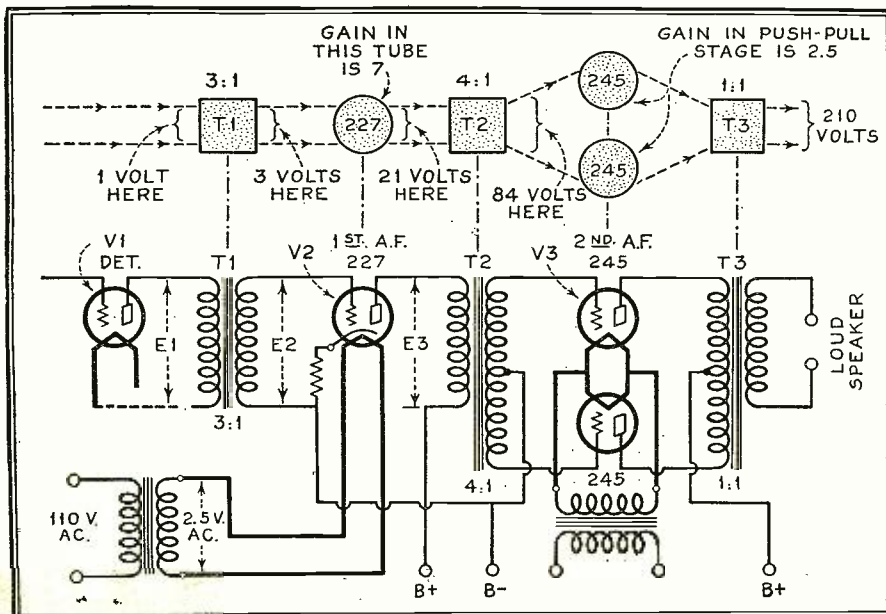
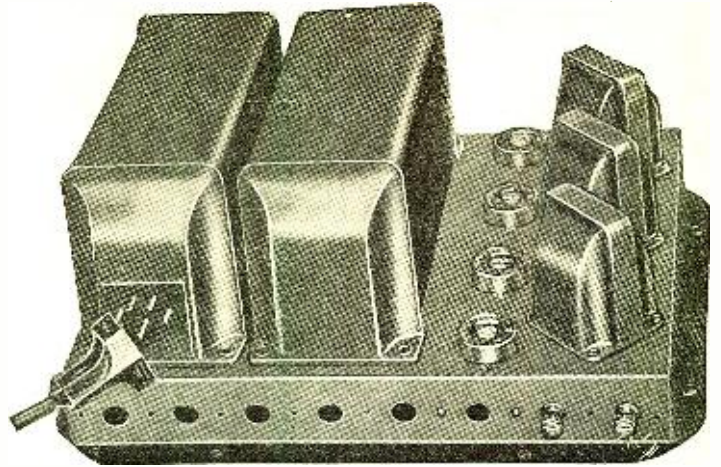
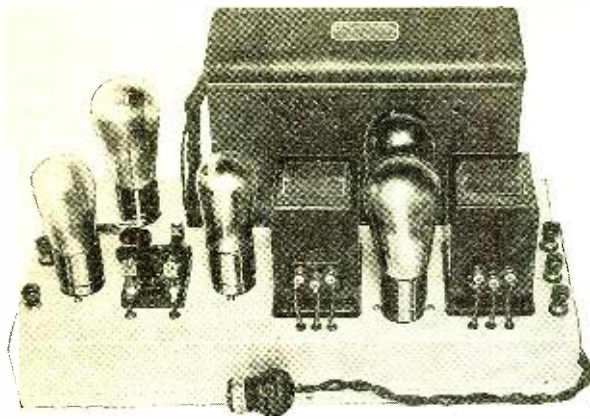

Fig. 4. Computing the gain in an audio channel is purely a function of multiplying input and output voltages by the turns ratio of transformer or the mu of the tubes



Above, the Samson PAM 45 power amplifier and, to its left, the Pilot 45 power amplifier, two types of excellent manufactured amplifier units

Audio-Frequency AMPLIFIERS?

Choice of Tubes, Amplifier Systems, Detector Output Voltages, Power Tube Grid Voltage Requirements, Are Only Some of the Problems Discussed Here

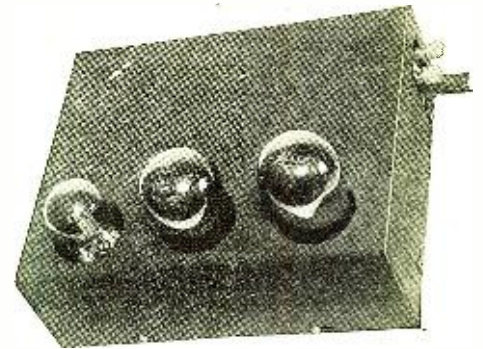

The Amertran two-stage audio amplifier employs 227 in the first stage and a pair of 210 tubes arranged in push-pull in the output stage

plate resistance of the tube, the impedance of the load in the plate circuit and finally the d.c. grid and plate potentials.

If E_i is the a.c. input voltage, then the a.c. voltage E_p developed in the plate circuit of the tube will be

$$(1) \quad E_p = \mu E_i$$

where μ is the amplification constant of the tube.

This a.c. voltage in the plate circuit will force an a.c. current I_p through the plate resistance of the tube and the load resistance. The a.c. plate current will therefore be

$$(2) \quad I_p = \frac{\mu E_i}{R_p + R_o}$$

where R_p is the plate resistance of the tube and

R_o is the load resistance

Now the power output ratings of all power tubes are based on the assumption that the tube is working into a load resistance equal to twice the plate resistance of the tube, under which conditions the tube can supply the maximum amount of undistorted power.

That is

$$(3) \quad R_o = 2R_p$$

Substituting this value in the above formula, we have

$$(4) \quad I_p = \frac{\mu E_i}{\frac{R_p + 2R_p}{\mu E_i}} = \frac{2\mu E_i}{3R_p}$$

Now the power developed in a resistance is equal to the resistance times the current squared. Therefore the power, P , delivered by the tube will be equal to

$$(5) \quad P = I_p^2 R_o$$

(Continued on page 662)

Fig. 2. This chart will show at a glance what power tube or combination of tubes may be employed to furnish a desired output

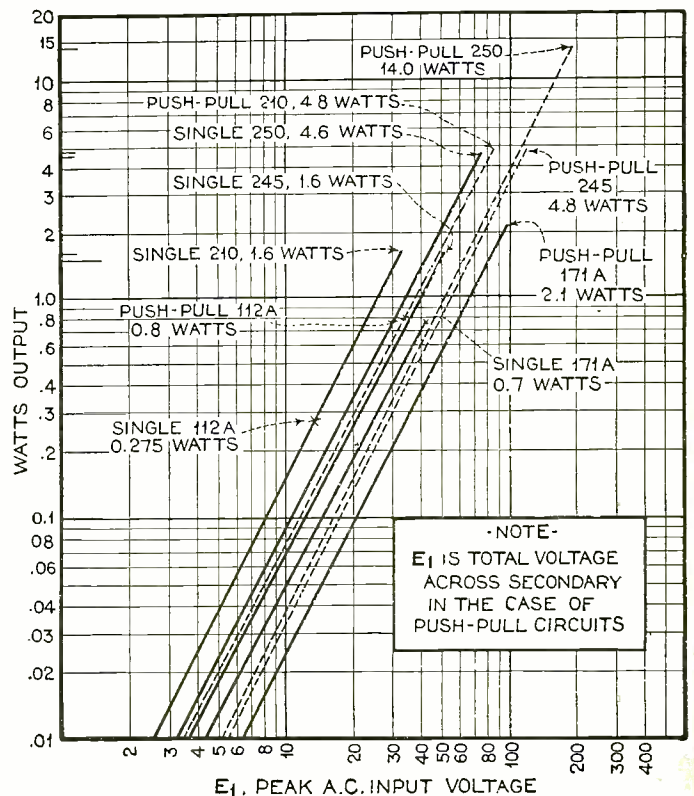

LABORATORY

High-Speed

Radio-Victor Receivers, Turned Out Seconds, Are Subjected to Preci

By Norman E. Wunderlich



**Norman
E. Wunderlich**

NORMAN E. WUNDERLICH was born in Chicago, Illinois, in 1899. He has had a great variety of radio experience, having been employed by the Marconi Company in 1917, the United Manufacturing Company of Chicago, Neutrowound Radio Manufacturing Company, the Carter Radio Company, the Victor Talking Machine Company, and the Audio Vision Appliance Company. In 1918 he was an instructor in the United States Naval Communication Service. For two years he was editor of the *Radio Topics Magazine*. He organized the Victor engineering staff and laboratories, and is now chief engineer, Audio Vision Appliance Company, laboratory of the Radio-Victor Corporation. He is a member of the Institute of Radio Engineers, the American Institute of Electrical Engineers, and the Radio Club of America.

FROM bare floors to the production of more than 5,000 precision-tested radio receivers per day by 13,000 employees is in truth an accomplishment, but when it is done in the brief span of twelve weeks it establishes what is believed to be a new record for the radio manufacturing world. Who can say that such an achievement lacks thrills throughout every step of the transition?

Less than a year ago thousands of square feet of floor space were occupied by machinery for the manufacture of Orthophonic phonographs. Many months of intensive research activity had preceded the final design of the radio receiver. The task of getting production started was approached in a manner very different from the usual procedure. Thorough and complete engineering analyses were made of every kind of material that was to go into the finished product, for it was to be the finest that human ingenuity could produce in order to be a worthy successor to a long line of musical instru-

ments. These reports, covering the sources of raw materials, were exhaustive, analytical and comparative. The manufacturers themselves were investigated to determine their ability to produce sup-

Every receiver tested at five different frequencies

Fifteen engineers check test equipment accuracy

plies of the required standard. When orders were finally placed, a representative of the Radio-Victor Corporation was stationed at each factory to keep a careful check on production.

Over two hundred of these reports were prepared by the engineering department during 1929. The Victor engineering department's original design considerations include all of the technical data and production specifications going back as far as the chemical analysis of raw materials, and leading step by step through the details of fabrication to the final check of performance characteristics. Detailed specifications covering all materials, component parts and completed instruments, were compiled and published from the preliminary engineering work. These specifications contained the fewest restrictions and widest possible tolerance, both mechanical and electrical, consistent with obtaining a high standard product.

It was necessary to design new tools for the production of the 11,000 individual parts going into this new set. Rows of 250-ton punch presses and many other types of machines were installed, and among them were threaded conveyor belts and overhead carriers, operating between elevators.

Within forty-five days production of completed units reached the 2,000 mark. Six weeks later the peak of 5,000 per day was attained.

Other manufacturers have achieved quantity production, but we believe that our organization excels in the thorough and exhaustive tests to which all Radio-Victor receivers are subjected before their final preparation for shipment. Every

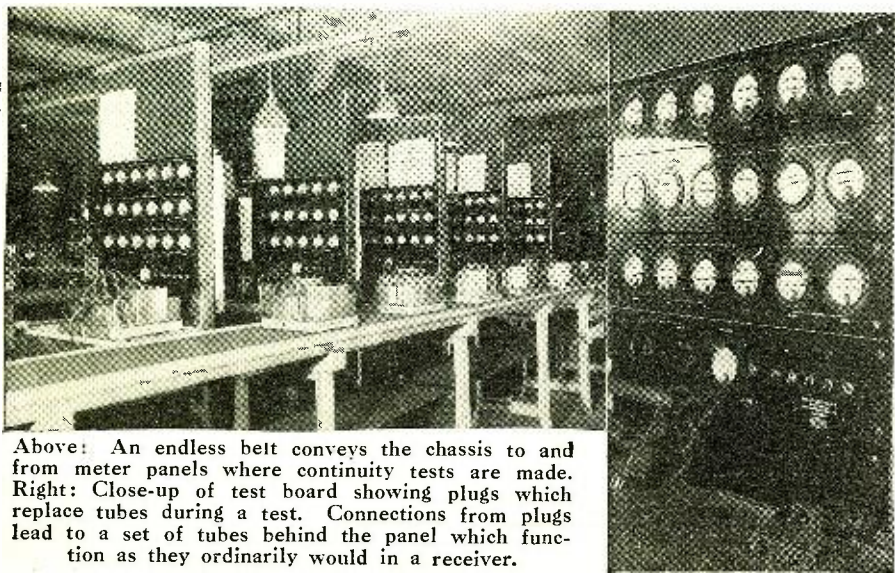

Above: An endless belt conveys the chassis to and from meter panels where continuity tests are made. Right: Close-up of test board showing plugs which replace tubes during a test. Connections from plugs lead to a set of tubes behind the panel which function as they ordinarily would in a receiver.

TESTS *in* Production

*at the Rate of One Every Eight
sion Tests and Rigid Inspection*

and William F. Diehl



William F. Diehl

Laboratory equip-
ment costing \$250,000
is used

5,000 specially tested
receivers produced
daily

receiver is meas-
ured for sensitivity
at five different
carrier frequencies
(553, 711, 948,
1264 and 1501 kilo-
cycles). The re-
sponse runs from
one to seven mi-
crovolts per meter.
Test equipment,

costing a quarter of a million dollars, has proved to be a splendid investment, bringing consistency in the product, reducing waste, and making for a trouble-proof instrument.

Shortly after production had got under way the engineering department established and maintained a radio school for foremen in the factory, the course given lasted over a period of six weeks, and in some classes there were 200 students. The training stepped up production and brought about a marked decrease in rejects. An arrangement was perfected which would permit the testing of 5,000 receivers a day at five different carrier frequencies. Ten crystal-controlled oscillators—five together with auxiliaries—were installed in a double-shielded room. Copper tubing shielded the driver leads between generator and the testing benches. Measurement is made by visual indication of the entire frequency response and audio gain characteristic of every individual audio transformer and the over-all response of the complete amplifier unit.

The testing equipment is inspected twice daily by a group of fifteen testing engineers who devote their entire time to observing test equipment and maintaining it at the highest standard.

Very interesting experiments were conducted involving the installation of loud speakers in sufficient numbers throughout the manufacturing division to make reproduction of phonograph records audible above the noise of machinery. It was found that lively tunes increased production, and slow music had the opposite effect. In the summer these loud speakers conveyed the World Series baseball

scores to the workers. Lemonade was served in the afternoons, and a cafeteria has been provided for the convenience of the employees.

Accompanying this article are some views of the standard test equipment, signal generators, and apparatus for complete analysis and measurement of both radio and audio-frequency amplifiers. Bungalow atop the engineering building houses an acoustic laboratory.

Engineering is by no means confined to the laboratory, for groups are continually in the field making performance tests of new models, working out problems of the merchandising organization, and keeping in touch with the activities and methods of other factories. Within this scope comes everything from the writing of initial specifications to the checking up on proper performance and satisfaction in the field. The executive policies which gave wide authority and liberal financial support to the engineering phase of this project left no uncertainty as to the results which were desired and expected.

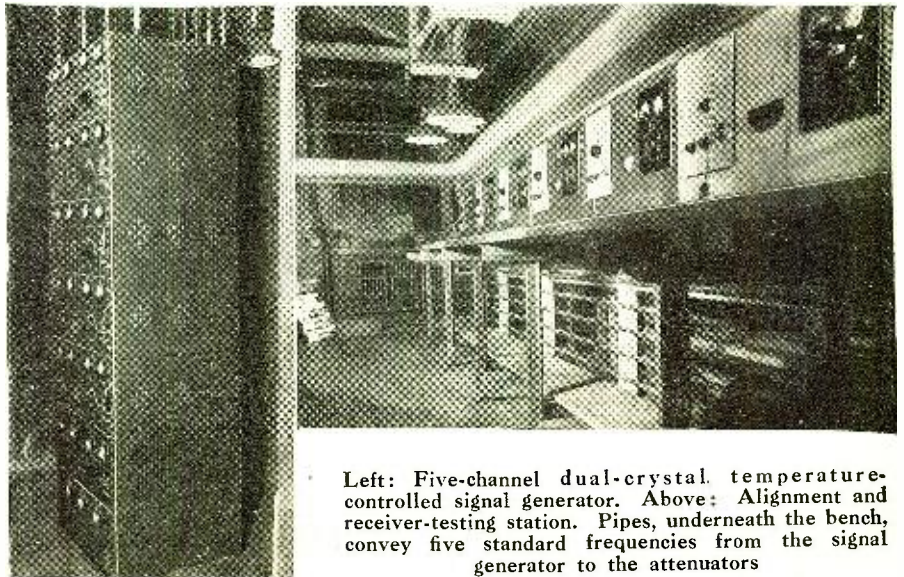

Left: Five-channel dual-crystal, temperature-controlled signal generator. Above: Alignment and receiver-testing station. Pipes, underneath the bench, convey five standard frequencies from the signal generator to the attenuators

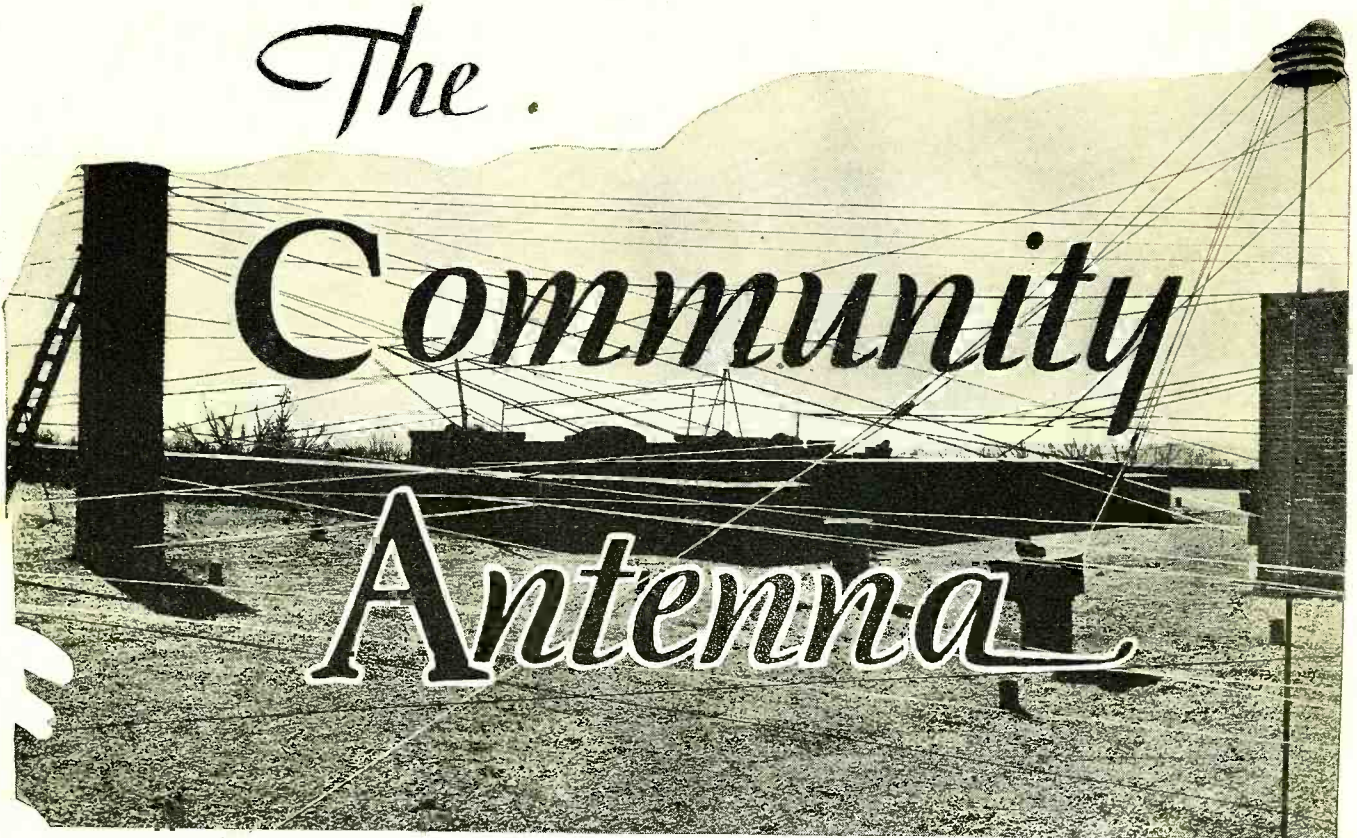

Two New Systems for Solving the Apartment House Radio Problem

By Elmore B. Lyford

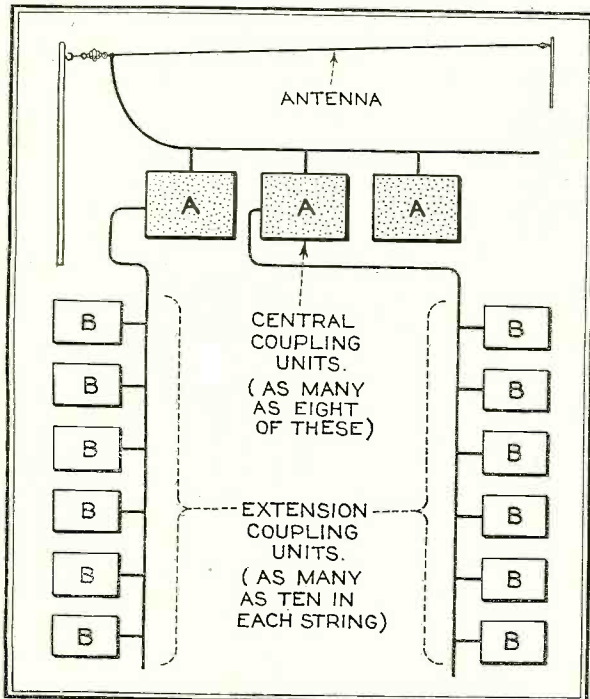

Fig. 1—As many as eight central coupling units may be fed from one antenna. These coupling units, in turn, will supply as many as ten extension coupling units, making a total of eighty outlets available from one antenna installation

EVER since the inception of the radio art, the necessity of providing some sort of antenna from which to operate the receiving set has presented a difficult and sometimes expensive problem. This has been further complicated, in cities, the great centers of population, by the presence of large apartment houses in which dwell as many as two hundred families, each of which may conceivably wish to operate a radio receiver. The result has been, in many cases, a wild tangle of antennæ, of which the scene shown above is typical. It goes without saying that such a jungle of wire disfigures the building

upon which it is, but unsightliness is only one of its disadvantages.

With such close grouping, we have just the right conditions for each one to have a maximum detrimental effect on all the others. When a receiver attached to one such antenna is tuned to some other wavelength, it often causes the partial detun-

ing of a dozen others. If it happens to be a regenerative receiver, and goes into oscillation, it may and often does spoil the reception of a score of its neighbors. What chance, too, has any but the highest and longest wire of the mass to escape a "screening" effect as a result of being hemmed in by all the others? No antenna could be expected to feed a receiver with even a semblance of a respectable signal from such a tangle of wires.

With such an obvious problem, it is only natural that some attempts should have been made to solve it. Loops, light-socket antennæ, and other forms of indoor pick-up devices have all been promoted, but in modern steel-construction buildings, they have quite uniformly fallen down on the job. Some sort of out-door antenna seemed necessary, and it remained for modern radio engineering to provide the solution.

Two Solutions to One Problem

It would be more correct to say that it remained for modern radio engineering to provide two solutions, for two separate and quite different systems have made their appearance, each of which solves the problem very satisfactorily. Both systems are being installed in a great number of apartment buildings, for apartment owners are beginning to realize that adequate

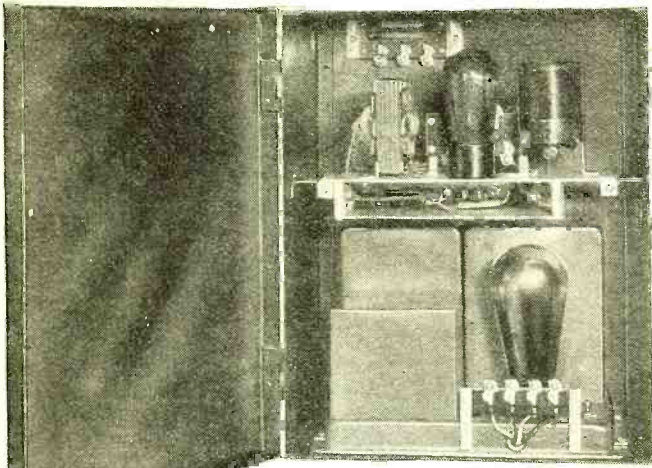

Fig. 2—The central coupling unit in its metal box. In the lower section is housed the B supply

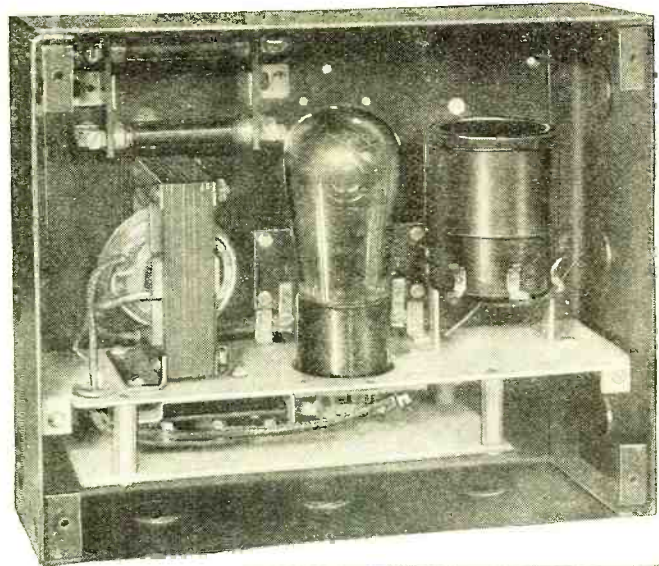

Fig. 3—An "inside" view of the extension coupling unit

radio facilities offer a strong talking point when it comes to renting their apartments.

The first of these two systems to make its appearance was that developed by the Radio-Victor Corporation, and the sketch of Fig. 1 illustrates in general how it works. Instead of a separate antenna for every receiver in the building, just one large and efficient antenna is erected, and this is connected to one or more central coupling units—as many as are found necessary. These central coupling units are marked "A" on the sketch, and are generally mounted on the roof of the building, so that they may be connected to the antenna by a short, and therefore efficient, lead-in.

From each of these central coupling units a down-lead runs to a string of extension coupling units, one on each floor, marked "B." Each of these units is designed to be the antenna connection to a receiver at that point, and as many as ten such units may be supplied from each central unit. Since as many as eight central units can be supplied from one antenna, a total of eighty receivers can be thus served. If there are more than eighty receivers in the building, a second system must be set up, duplicating the first one, and the total number of receivers divided between them.

Each of these coupling units makes use of a UX226 tube as the coupling device, its filament being supplied by the electric supply of the apartment in which it is. Each central coupling unit supplies its own "B" supply, and the "B" supply for all the extension units connected to it. In Fig. 2, which shows one of these central coupling units, the "B" power pack may be seen in the lower compartment. Fig. 3 shows the extension coupling unit, which is very similar except that there is no power supply unit.

The installation of this system is very similar to the electric wiring system in a building. The leads are run through the same sort of conduit, and the coupling units are housed in iron boxes much like the outlet boxes used in electric wiring. The antenna and ground connections, as well as the switch to control the local coupling tube, are brought to a flush wall plate similar to any other.

"Loaded Line" Principle of Second System

The second multiple antenna system which has been developed is quite different from the one described above, but it produces essentially the same results. It is a development of Amy, Aceves and King, Inc., consulting radio engineers of New York City, and is an application of the principle of the loaded line, long known and used by commercial telephone and telegraph companies. The radio application of this principle is new, however, and is meeting with considerable favor.

This system, called by its originators the Multi-Coupler Antenna System, is quite simple and inexpensive to install. It will not serve as many receivers from a single antenna as will the Radio-Victor system, but this is usually not a serious draw-back.

With the multi-coupler system, as with the others, use is made of a common antenna which in this case can be used to feed a maximum of about twenty receivers. Another main antenna must be erected for each additional bank of twenty (Continued on page 666)

Fig. 4—Circuit details of the multi-coupler system of antenna installation. One antenna will feed as many as twenty receivers

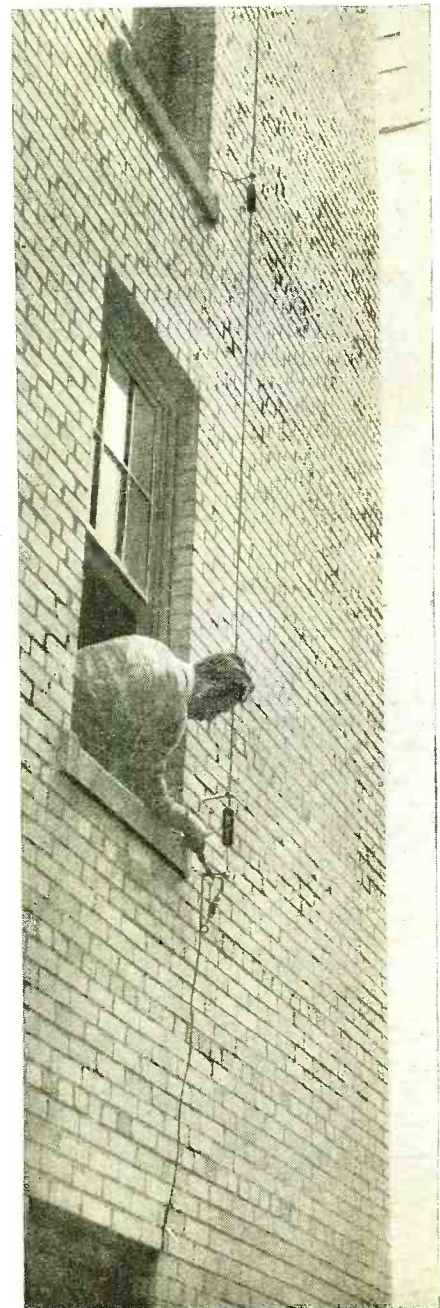
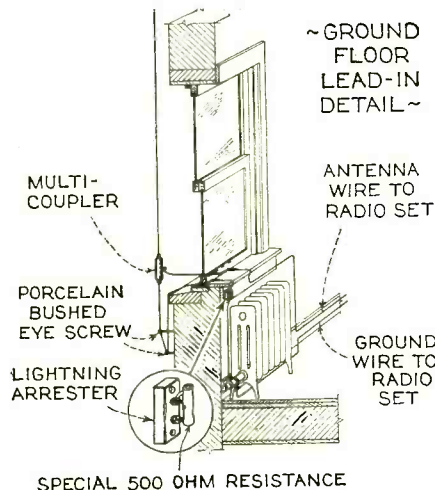
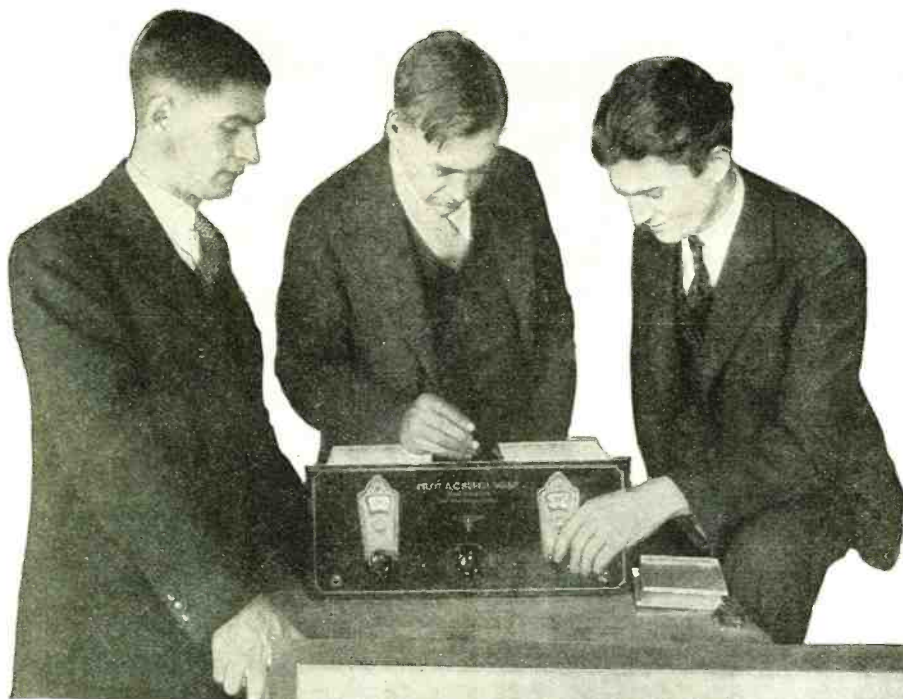

Fig. 5—The multi-coupler solves the apartment house antenna problem. The photograph shows one being installed

Hitting the A.C.

By
Robert
Hertzberg

Robert Hertzberg, the author, David Grimes and John Geloso, pilot engineers who helped develop the A.C. Super-Wasp



THE one feature of short-wave operation that in the past has deterred many radio fans from plunging into the fascinating short-wave game has been the necessity for batteries as the source of filament and plate current. Short-wave broadcasting (as distinctly distinguished from short-wave amateur telegraphy) started to develop just at the time the all-electric broadcast set achieved commercial practicability. Hitherto it was necessary to consider short-wave receivers purely in terms of battery operation. The present generation of radio fans who think twice about making another battery set, read about the extraordinary DX work being done on the short-waves and become duly aroused over it, but comparatively few of them have cared to go to the trouble of buying batteries. They have inquired:

"Why can't the short-wave set be operated from the lamp socket, just as all broadcast receivers are?"

Ever since the first few short-wave broadcast "hounds" picked up G5SW in Chelmsford, England, and PCJJ (now PCJ) in Eindhoven, Holland, the kit and set manufacturers have realized that the short-wave DX "hound" would be an even more rabid canine than his predecessor, the regular broadcast-band DX-er, but they would have to supply him with the conveniences he has grown accustomed to with broadcast sets.

Battery-operated short-wave sets

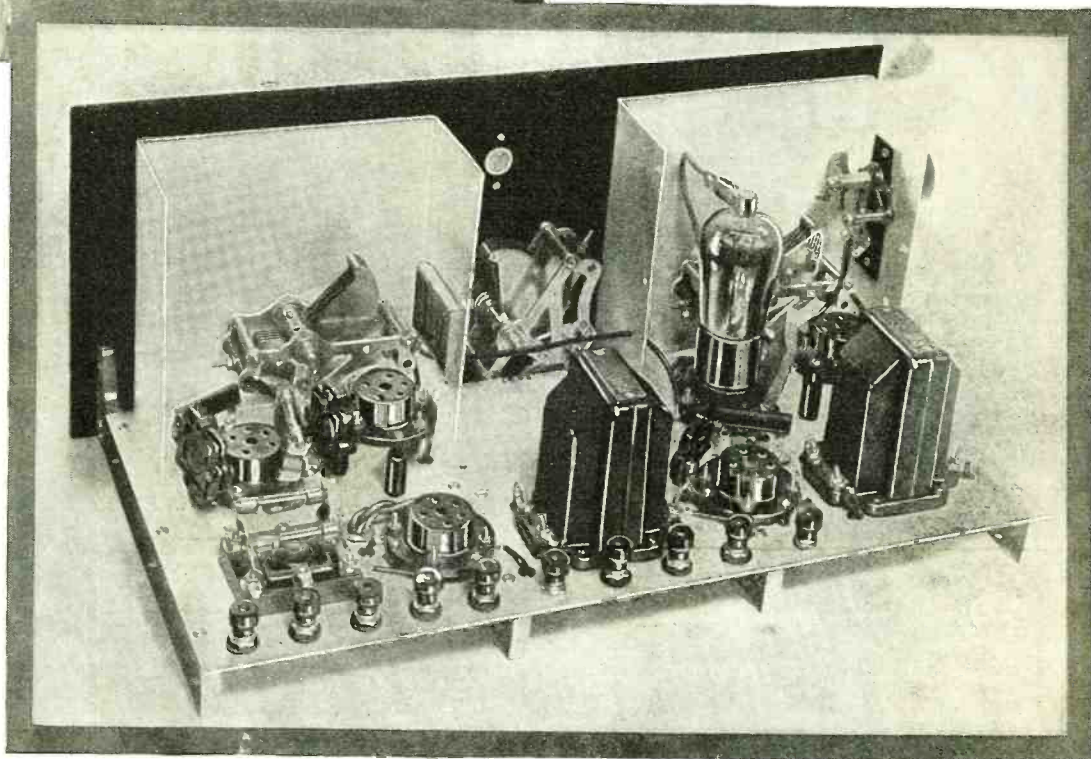

A back view of a completed four-tube A.C. Super-Wasp with the back halves of the shield cans removed to show the parts mounted inside. The audio channel is situated along the rear edge of the sub-base

brought out by a number of companies catering to the experimenters have enjoyed considerable success, but the market has hardly been scratched. The fact that so many owners of short-wave sets enjoy consistent loud-signal programs from stations in distant corners of the earth is proof that the game is not quite as uncertain as it was several years ago, when the tuned screen-grid short-wave r.f. amplifier was unheard of and when a movement of the operator's eyebrows threw the set out of tune and made the signals disappear.

Among the firms whose engineers had been growing gray hairs over the a.c.

short-wave problem is the Pilot Radio & Tube Corporation, whose battery-operated "Super-Wasp" (described in the April, 1929 issue of RADIO NEWS) has been eagerly gobbled up by radio fans anxious to hear Europe and Africa—and who have heard them quite satisfactorily. It has been the endeavor of these engineers to convert this outfit into an a.c. receptor, and until a short time ago the invariable result of their efforts was a loud, buzzing noise somewhat resembling the disturbance created by a dull buzz saw going through knotted pine. Finally, through the combined ingenuity of David Grimes, John Geloso and Robert S. Kruse, this noise was eliminated, and out of the Pilot laboratory has emerged an a.c. short-wave receiver that slides into oscillation as smoothly and gently as any battery set, with nothing but a very weak residual 60-cycle hum to indicate the nature of the power supply.

High Spots With the SUPER-WASP

All the Thrills of Short-Wave Operation Plus All the Conveniences of Full Lamp-Socket Operation With This Compact Four-Tube Receiver

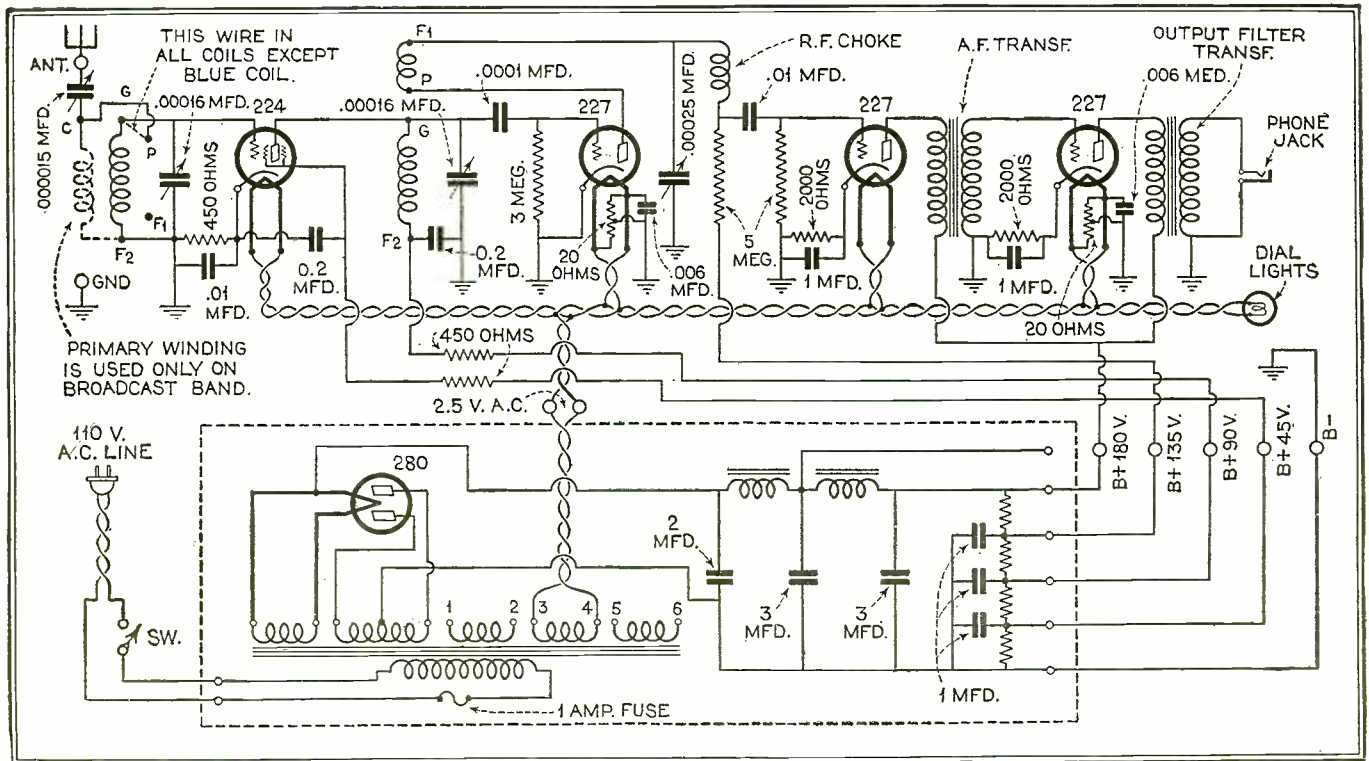

At this writing (middle of October, 1929) the "A.C. Super-Wasp," as the new set has been named, has been on the market about a month, and the enthusiastic reports voluntarily submitted by their delighted owners prove conclusively that the receiver is a reliable, commercial product, not merely an experiment at the expense of the public.

Like the original battery-model Super-Wasp, the a.c. version uses a stage of tuned screen-grid r.f. amplification, and a regenerative detector. The audio system differing slightly in that it comprises one resistance stage and one transformer coupled stage, with an output transformer to protect the earphones or loud speaker. The fact should be emphasized that the A.C. Super Wasp is so quiet it may be used for long stretches with earphones; with a loud speaker the slight hum does not appear at all.

The components of the radio-frequency and detector stages, respectively, are enclosed within aluminum shield cans, additional protection against the detuning effect of the operator's body being supplied by a metal front panel.

The set is marketed in kit form, everything down to the last washer and soldering lug being supplied. No power pack is furnished with the kit, as any standard

IN the June, 1929, issue of RADIO NEWS Mr. Hertzberg brought the battery-operated Super-Wasp to the attention of short-wave enthusiasts. It is a four-tube short-wave receiver of very fine design, for those days.

Meeting with almost instantaneous popularity, it was a foregone conclusion that this very efficient short-wave receiver for a.c. operation would be the next forward step.

Mr. Hertzberg's article describes in detail the obstacles which had to be surmounted before this ideal could be realized.

171A pack of adequate filament capacity may be used. However, the set is intended to work particularly with the Pilot No. K-111 pack, which delivers exactly the right voltages.

The receiver tunes from 14 to 500 meters, five pairs of plug-in coils being included with the kit. These are the

The complete circuit diagram of the four-tube A.C. Super-Wasp receiver and its associated power supply unit. The complete set of parts for this receiver are supplied in kit form by pilot, and are accompanied by complete instructions on how to build the receiver

well-known Pilot coils which fit into standard UY five-prong tube sockets. The importance of providing a general-purpose short-wave receiver with this wide wavelength range was brought out by the company's experience with the battery set, but it served to complicate the a.c. problem considerably.

In the investigational and laboratory work which led up to the final satisfactory development of the A.C. Super-Wasp much data was unearthed which, aside from indicating the various problems which arose in connection with this job, are of inestimable value because they apply to the problem in general, of eliminating the sources of hum in radio receivers.

The first experiments conducted with standard a.c. tubes (224 in the r.f. stage, 227's in the detector and audio positions) disclosed two general classes of "hums." The first class was what we termed "residual hum" because it could be heard

in the earphones at all positions of the tuning dials. It was arising from the audio circuit. The second class we called "tunable hums," which were very numerous and could be brought in on several places on each set of coils. They appeared to have definite wavelengths, and could readily be tuned out by manipulation of the tuning dials.

It was fairly easy to trace the residual hum right down to the detector tube, it being a question of 60-cycle induction caused by the construction of the tube itself. It was also present in the two audio stages, but the succeeding amplification was not as great as the total following the detector. Hence it was not as noticeable as that from the latter source. A study of the design of the 227 tube was started, and meanwhile a redesign of the entire audio circuit was undertaken. It was obvious that too much audio amplification was undesirable for reasons other than a.c. hum amplification, so we incorporated a system of one resistance coupled stage following the detector, and one transformer coupled stage after that. Pilot tubes with the electrical characteristics of the standard 227-type are used in all three positions, with a 224, of course, in the screen-grid stage. Other features of the Pilot 227's are entirely different, as will be shown.

The use of the first resistance coupled stage reduced the residual hum much more than the reduction of audio amplification explained. The resistance units did not act like a.c. pick-up coils, as did the transformer windings in the same location.

You may wonder why a power tube is not employed in the last stage, and why a 227 is deliberately retained. The answer is that power tubes operate on raw a.c. This is quite all right for loud speaker sets, but if you want to learn how much hum there is really present with such a tube (either the 171A or 245 type), just listen to the output of any standard broadcast receiver with a pair of earphones. The use of an output transformer allows an acceptable compromise between the tube impedance and the im-

A view of the under side of the sub-base of the A.C. Super-Wasp. Note that, so as to reduce hum to a minimum, the filament wires are twisted

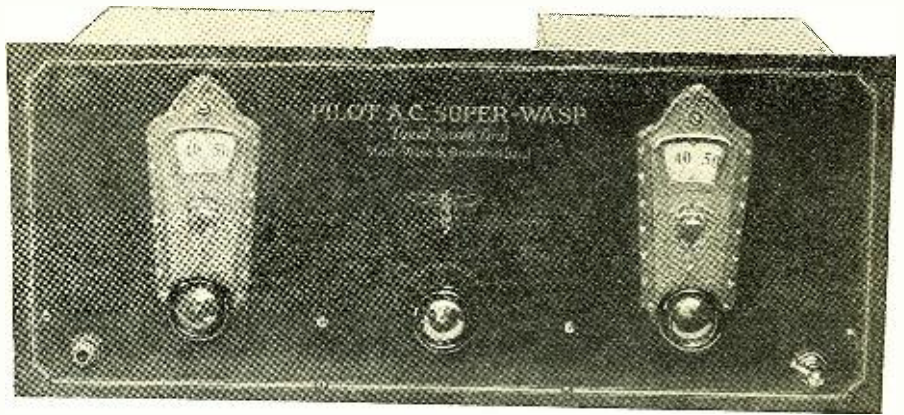
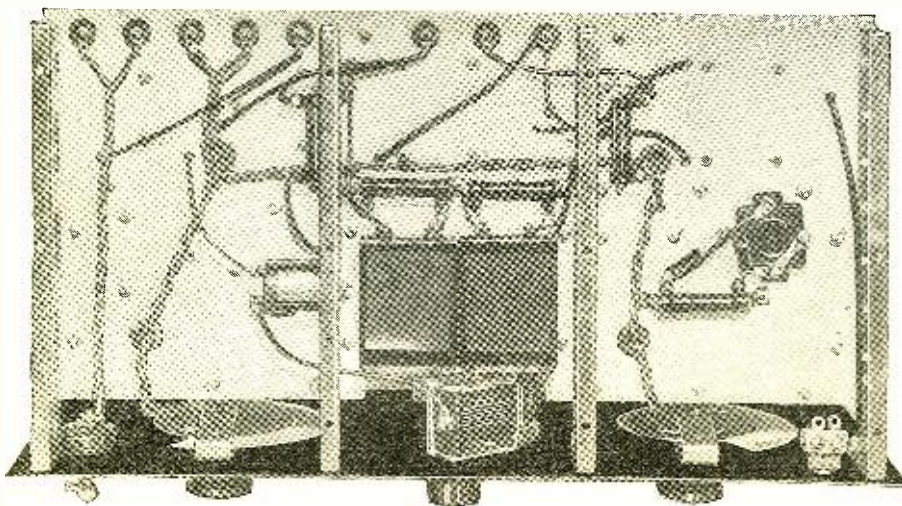

The front panel view of the A.C. Super-Wasp. Tuning is accomplished by the two main tuning dials, while the center knob controls regeneration

pedance of a loud speaker, so that the tonal quality of the set on broadcast signals is not particularly ruined, as one might suspect.

It was found that a great deal of hum was caused by an unbalanced field created by the filament of the 227 tube. The standard 227 has a straight filament running through the center of the heated cathode. It is apparent that at one instant the bottom of the filament will be positive while the top is negative, shortly followed by a reversal of this condition. The electron field within the cathode is thus rapidly twisted back and forth during each alternation of the heating current, and a noticeable a.c. hum results.

To avoid this trouble, a special 227 tube was designed in which the filament is doubled back on itself within the cathode cylinder, in the fashion of a hair-pin. In this arrangement the electronic field is neutralized at every point and no disturbing upheavals take place on the reversals of the heating current.

The above precautions killed the a.c. residual hum or, at least, reduced it to a negligible minimum. The tunable hums next came under surveillance and these were the most exasperating puzzles. We studied the hums with the antenna entirely disconnected from the set. This removed some of the disturbances which were coming in from the ether. This class of disturbance, and sometimes hum, is beyond our power to solve. Such effects would be as noticeable on any other type of set.

By far the greater number of our hums continued to persist, even after we had removed the antenna. These obviously existed in the receiver itself, and, as such,

fell under the curable classification. Those on the red and orange coils, within the wavelength bands of 14 to 50 meters, were the strongest. They must have arisen from some high-frequency oscillation in the set modulated by the 60-cycle current. Some combination of inductance and capacity was acting as a transmitting circuit. This was finally found to be actually true. The capacity of the oscillating system is the internal capacity of the cathode-heater combination. The inductance is that of the leads combined with that of the center-tapped resistance connected across the filament. This resistance unit actually has enough inductance to be troublesome at the very short waves. The cure consists in merely adding a capacity across one side of this center-tapped "inductance" so as to kill the resonant combination. A casual glance at the audio circuit of the A.C. Super-Wasp will reveal these .006 mfd. by-passing condensers across the mid-tap resistors in both the detector and last audio circuits.

With these two culprits put away, there still remained other hums, occurring on the higher wavelength coils up in the green and blue range (100-500 meters). These were obviously caused by similar circuits except with higher inductances and capacities, so that the wavelengths were longer. As a further clue to their cause, they did not occur until the plate and grid connections were made for the screen-grid tube. They existed in these leads and were obviated by the insertion of the .2 mfd. by-passing condensers and the small chokes. The chokes are commercial, cylindrically wound resistors; but their main function in the plate and screen-grid leads is a choking one. They are indicated on the sketches as 450-ohm resistors.

There is one other point of special mention that should not be overlooked. Many of you are already familiar with the "squawking" of the ordinary regenerative receiver at the very point of oscillation. It is most annoying, not only because of the racket, but because that particular point is the one at which signals are most likely to be heard. This was given considerable attention in the a.c. design and, as a result, it has been completely subdued. The high resistance in the plate circuit of the detector accounts for this. There appears to be a highly critical condition existing in the

(Continued on page 666)



The Super-Universal Fokker monoplane of the R. C. A. equipped with radio for communication work, and piloted by E. N. Pickerill, formerly chief radio operator of the S.S. *Leviathan*

RADIO'S FLYING SALESROOM

An Aerial Survey Shows That Aircraft Radio Facilities Are Very Badly Needed at Most Airports

By A. Henry

MANY old-timers will recognize the name of E. N. Pickerill as one of the oldest of old-timers in the radio operating field. Few, however, know that in addition to his service as chief radio officer of the *Leviathan* he was a flying lieutenant during the war. At the present time he has charge of a Super-Universal Fokker, owned by the Radio Corporation of America, and used as a "flying salesroom." Some of the standard equipment installed on this plane includes a 100-watt combination telephone and continuous-wave transmitter designed by the Radio Corporation of America for aircraft use, and a beacon receiver, operated by a remote control from the pilot's cockpit. This remote control feature is also incorporated in the transmitter. There are, in addition, other receivers designed for inter-plane communication while in flight, and between the plane and the ground.

Pickerill has just returned from his first trip in the new plane. He made stops at Roosevelt Field, L. I., the Cleveland Municipal Airport, the municipal airports at Terre Haute, St. Louis, Tulsa, Fort Worth, Houston, New Orleans, Mobile, Montgomery, Atlanta, Greensboro and Philadelphia. The survey revealed that radio facilities for communication with aircraft were totally lacking at most of these fields. At Meacham Field, Fort

Worth, he found an experimental radio station operated by the Southern Air Transport, and a similar station at Houston, Texas. The Department of Commerce station at Greensboro, N. C., provided him with all kinds of weather information, but in order to get these data he had to visit the radio station, since he was unable to get them while in flight. At the Pitcairn Air Field in Philadelphia, which is one of the important links in the air mail chain, Mr. Pickerill found that there were no radio communication facilities. In fact, on his return flight from Atlanta to Roosevelt Field, he ran into hazy weather in Philadelphia, and, wanting to procure information concerning the weather in New York, had to drop in at the Pitcairn Field and telephone to Roosevelt Field!

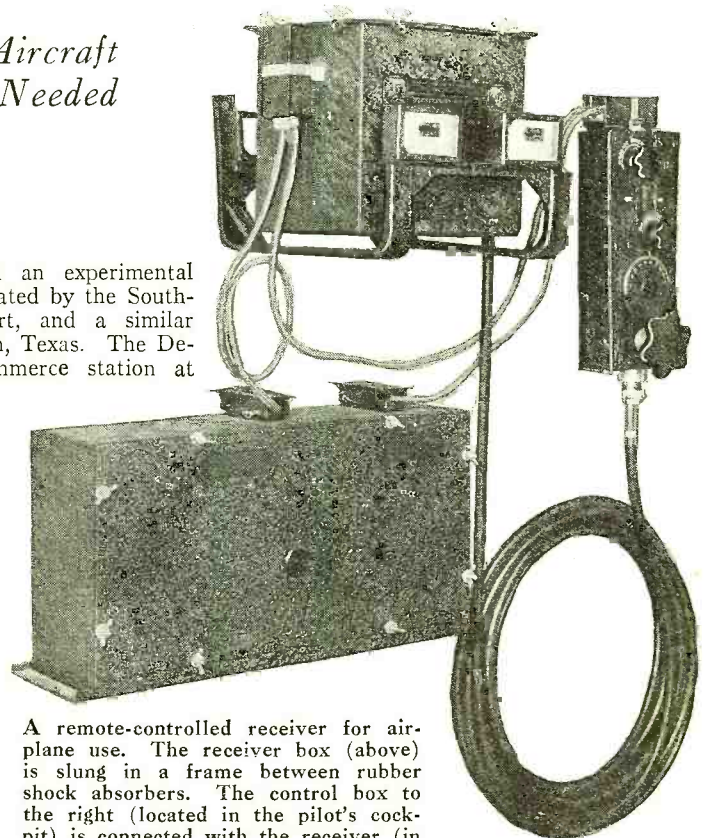

A remote-controlled receiver for airplane use. The receiver box (above) is slung in a frame between rubber shock absorbers. The control box to the right (located in the pilot's cockpit) is connected with the receiver (in the plane's tail) by a long, flexible shaft. The battery box is below

At the Cleveland Air Races, Pickerill took up Harold True, the chief announcer of WTAM, who gave a running account of the flight of the *Los Angeles* over the Cleveland Municipal Airport. It was transmitted from the plane on 109
(Continued on page 667)

TRAPPED

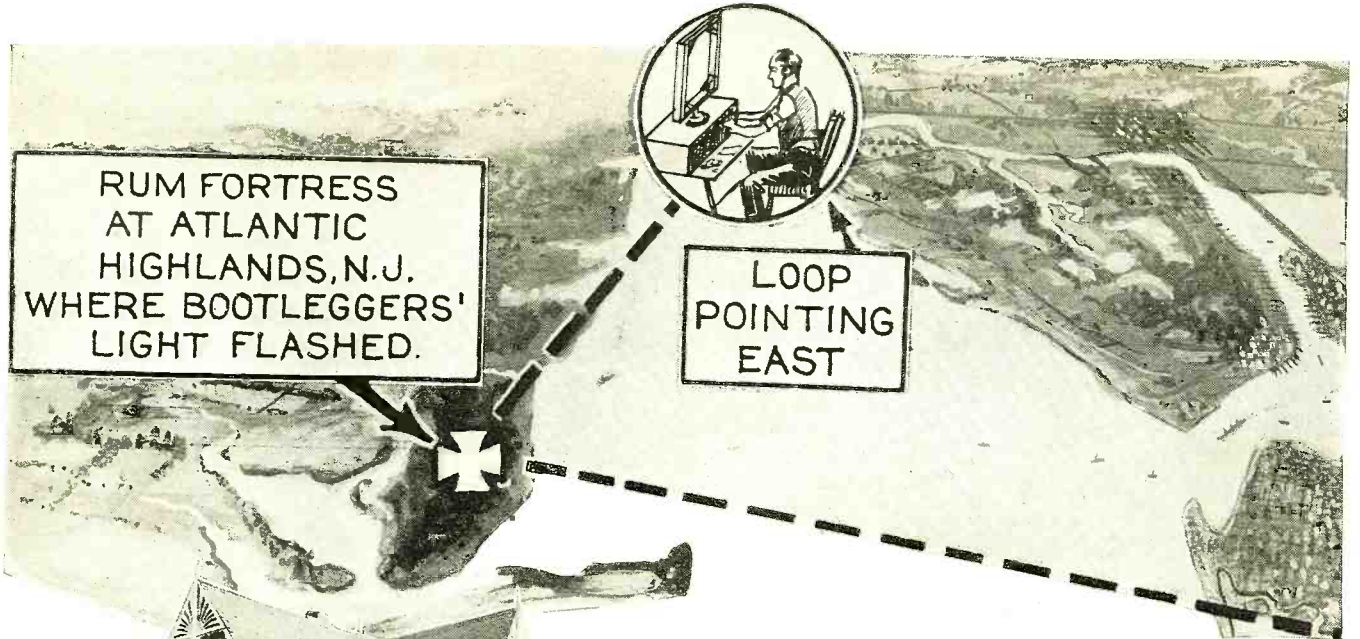

Bootleggers' Use of Unlicensed Short-Wave Transmitter Proved Their Undoing When Traced by Means of Direction-Finding Receivers

The lawbreakers' headquarters. Former home of Oscar Hammerstein

Some of the paraphernalia discovered by officers

A "PIRATICAL" stronghold heavily armed and nestled high on a promontory overlooking the sea—smugglers running in their burdons under cover of night—speedboats loading up in the fog, and hastily returning to their bases before dawn—heavily laden ships meeting by previous arrangement in sheltered coves—then, suddenly, the long-planned raid, with its simultaneous assaults on widely separated smugglers' retreats scattered along miles of coast-line. Brigands under arrest!

Then, the discovery that radio had trapped them!

It sounds like a page out of Stevenson!

Smugglers, guns, hidden caves, forbidden bounty, night watches, running chases, revolvers and old swords . . . all the scenic accessories for a sequel to "Treasure Island."

But this is no story out of fiction. It is an actual happening, a thrilling narrative of modern piracy, with the cunning law evader outwitted by the modern use of radio.

This episode has all the dramatic suddenness and the fanciful variations of a Stevensonian adventure, brought up to date by the introduction of high-speed boats, machine guns with concrete defenses, and radio. It was enacted only a short time ago along the Atlantic Coast within a few miles of the busy metropolis of New York.

At thirty-five different points along the shore, from Atlantic City to the eastern

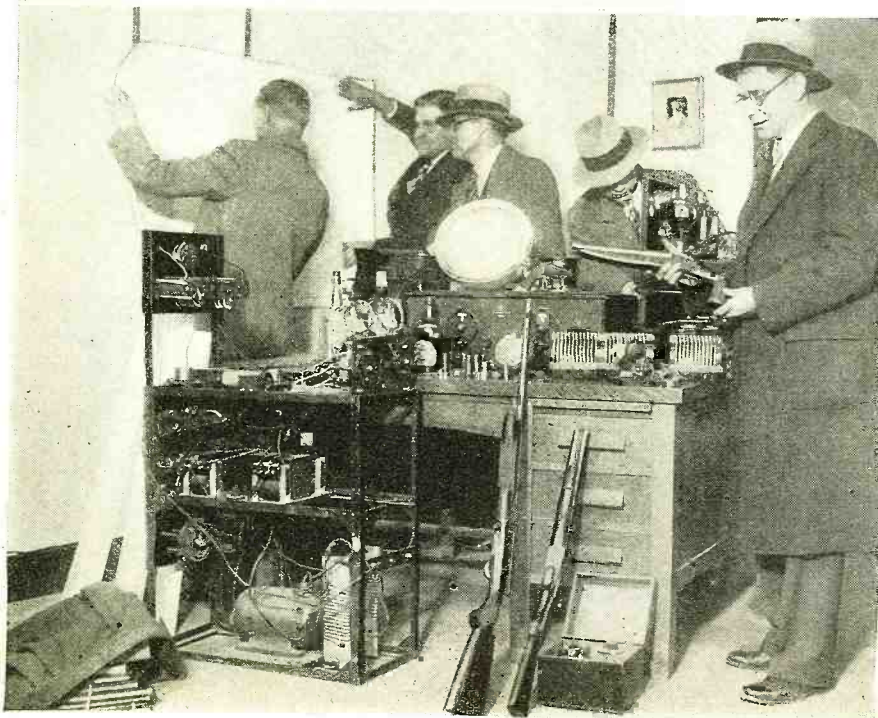

by RADIO!

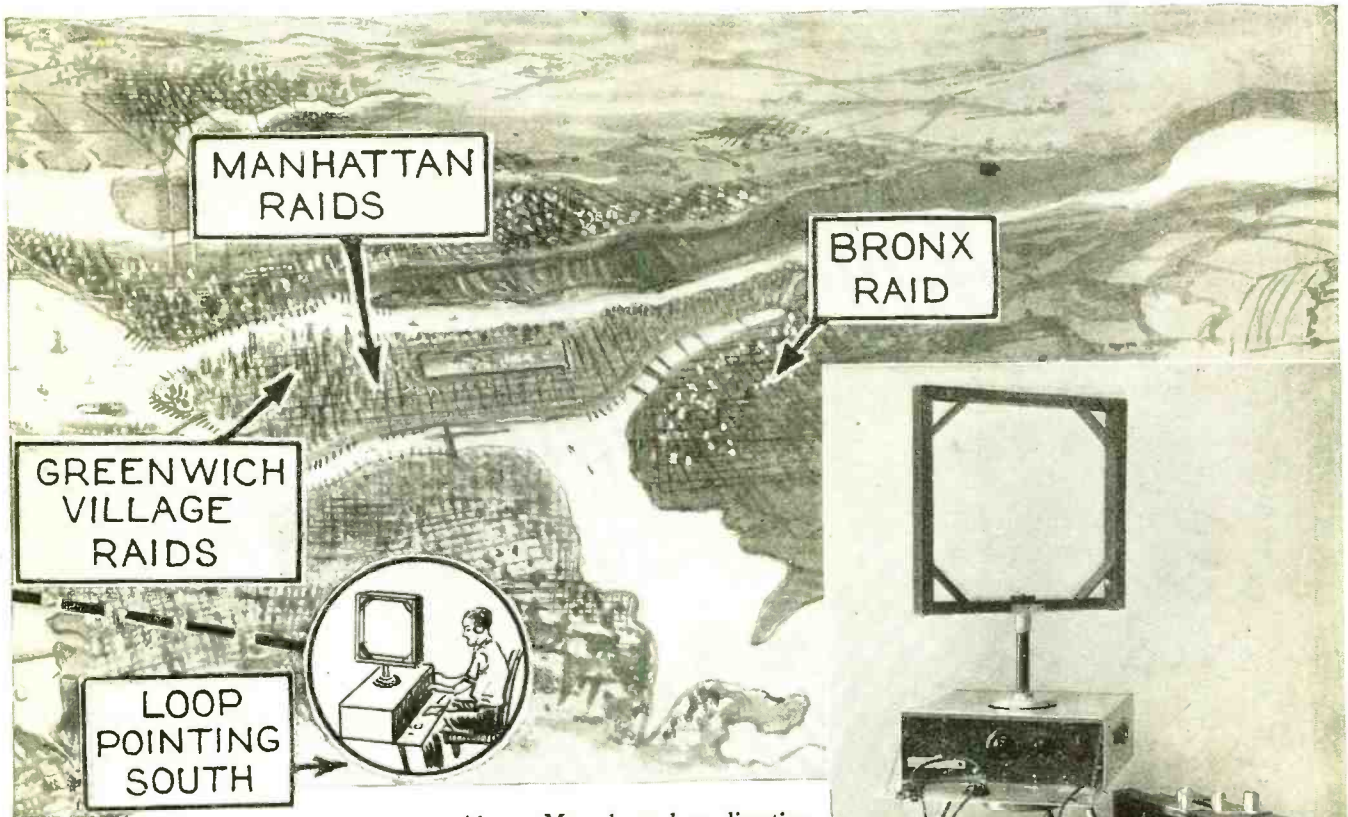

end of Long Island, probably old haunts of the smugglers of yore, the government agents swooped down at the "zero hour" of four-thirty p.m. to surprise the law-breakers. By six o'clock that same evening, the job was done, and thirty-two alleged bootleggers were in the hands of the law.

Among their booty prohibition officers found cases of liquor, pistols, guns, magazines, automobiles, records, books, boats and a real "stronghold." But most interesting was the wireless equipment discovered in the mansion of the "million dollar outfit" that operated six boats, a fleet of speedboats, and a trucking system for transporting the liquid goods. Among the prisoners was the radio operator of the alleged bootleggers' station that directed this fleet for the master-mind of the rum ring . . .

As the details of the sensational raid were disclosed, it became evident that radio had played a big part in the location of the various rum quarters, revealed its operations, and finally helped to close-in on them. It is probably the first time that radio has been used on such a big scale, both by the bootleggers, for their alleged criminal practices, and by the Government for their location and apprehension.

Atop Beacon Hill stands the "mansion." It was there that the radio station, with the operator at the key, was found. The three-storied house contains twenty rooms,

(Continued on page 667)

Above: Map shows how direction finders located outlaws' base, from which they flashed radio and light signals to ships at sea

At right: Loop receiver used by government agents

Below: Typical installation in Coast Guard radio room

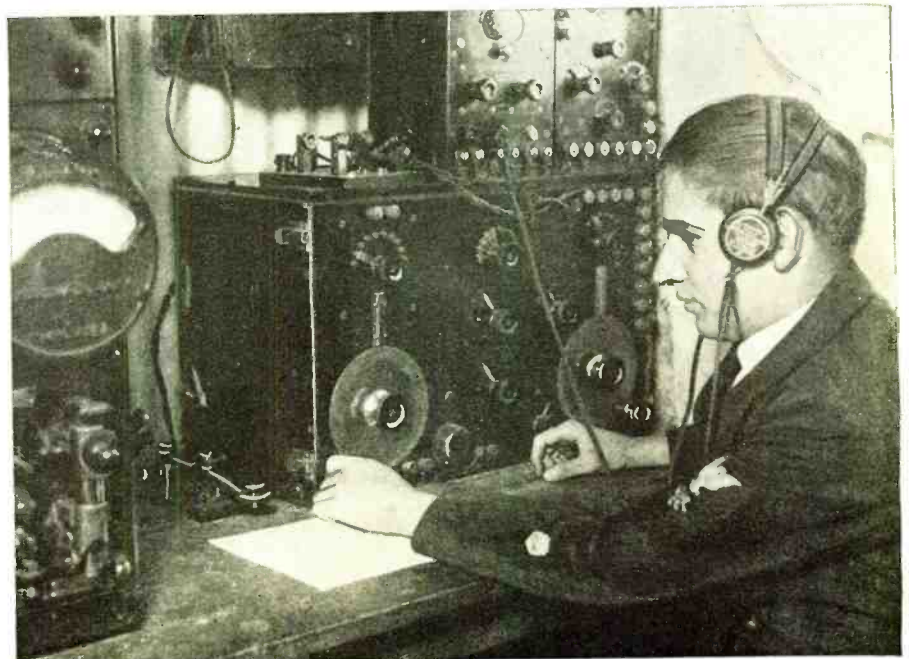
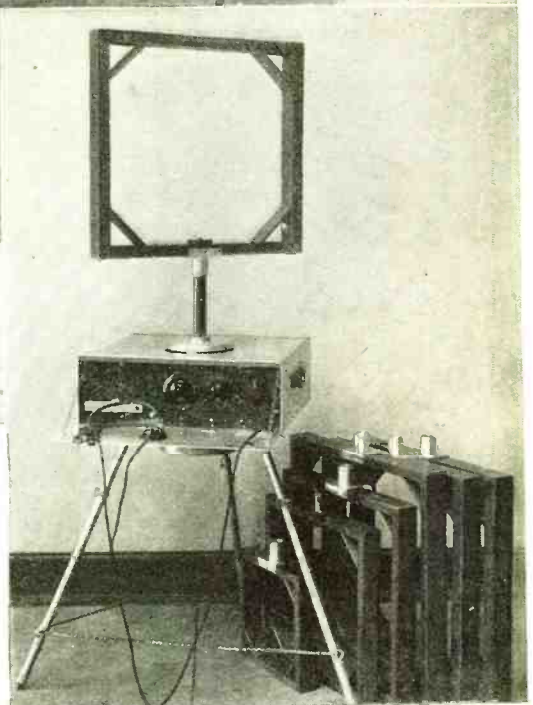

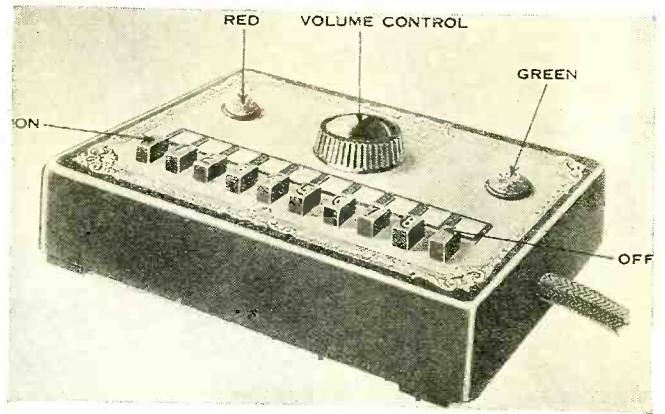
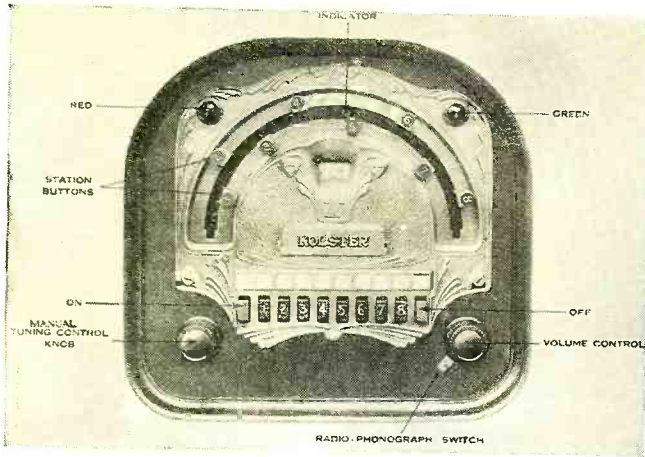

Take Your Choice of Remote

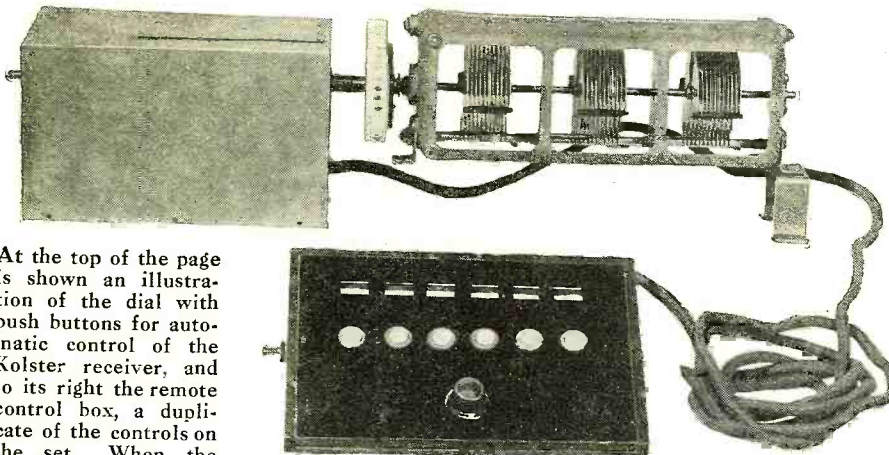

Some of the Automatic Manufacturers Are

At the top of the page is shown an illustration of the dial with push buttons for automatic control of the Kolster receiver, and to its right the remote control box, a duplicate of the controls on the set. When the "on" button is pushed the green light is illuminated, indicating that the set is functioning. When automatically tuning from one station to the other the red light functions

MUCH water has passed over the dam since the days when an up-to-date radio receiver had sometimes as many as eight or ten controls, each one playing an important part in satisfactorily tuning in a set to

To the left, the Motormatic remote and automatic tuning device. The box at the extreme left houses a motor which turns the condenser shaft. By pressing the buttons on the remote control box, rotation of the shaft may be stopped at prearranged points corresponding to positions of the condenser rotor plates where stations are tuned in

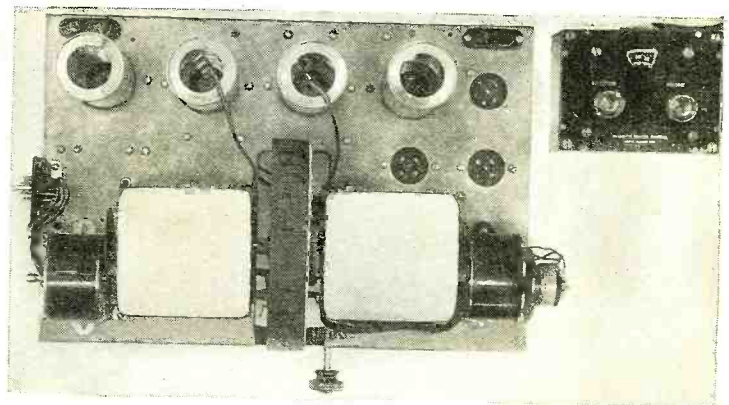

Above, the Sleeper Kineomatic automatic tuning unit applied to a receiver. By turning the knobs on the control box, shown at upper right, small motors attached to the condenser shaft and volume control are made to operate, rotating in 1/2 degree jumps

To the left, the Zenith receiver with automatic tuning device, and, in the insert, an illustration of the remote control box

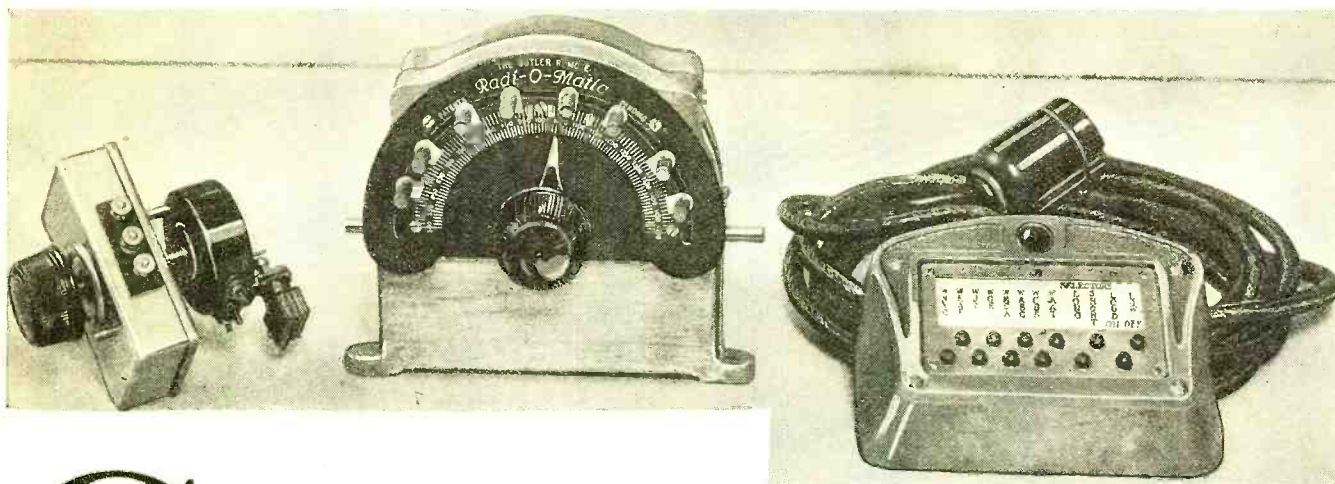

Controls

Tuning Devices Which Presenting This Season

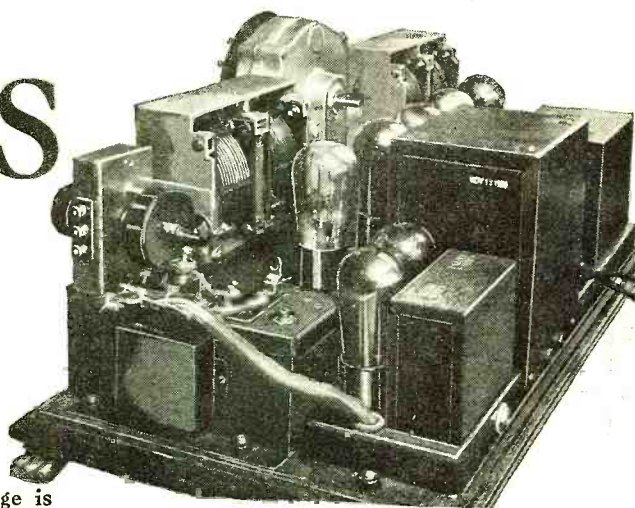

a desired program. There were separate controls for tuning each circuit, separate rheostats for each tube, antenna switch taps, volume control, battery switches, jacks and so on.

In the rapid strides which have been made in the direction of simplifying radio receivers, the picture has changed considerably. Today, we usually have one dial for single control tuning and one knob which serves the dual purpose of turning the receiver on or off and regulating volume. Yet, even that doesn't seem to completely fill the bill. In proof whereof we present some of the new automatic and remote controls which are being offered to the public this season.

By their use it is possible, without leaving your armchair or otherwise bothering yourself to get up and walk over to the radio set, to push a button or turn a knob, and presto, the set is turned on, tuned to the desired station and the volume adjusted to the correct amount. In truth, a lazy man's paradise.

In general all of the systems, with few exceptions, depend for operation on the action of a small motor geared down to a very slow speed to turn the condenser shafts or volume controls. These motors can be started or stopped by merely pressing the correct button. Stops are provided which, after the receiver is installed, are permanently set for the favored stations. They will then automatically stop the rotation of the condenser shaft at a point where the signals from a desired station are brought in when its corresponding button is depressed.

At the top of this page is shown the Butler Radiomatic motor with stops on the dial (center) and (right) the remote control box with its push buttons and indicator light. At the extreme left is the volume control line switch motor

The Butler Radiomatic system of automatic tuning makes use of a special slow-speed motor, having no momentum of its own, so that it stops exactly at the point desired. Separate motors are used for the tuning condensers' unit and for the volume control

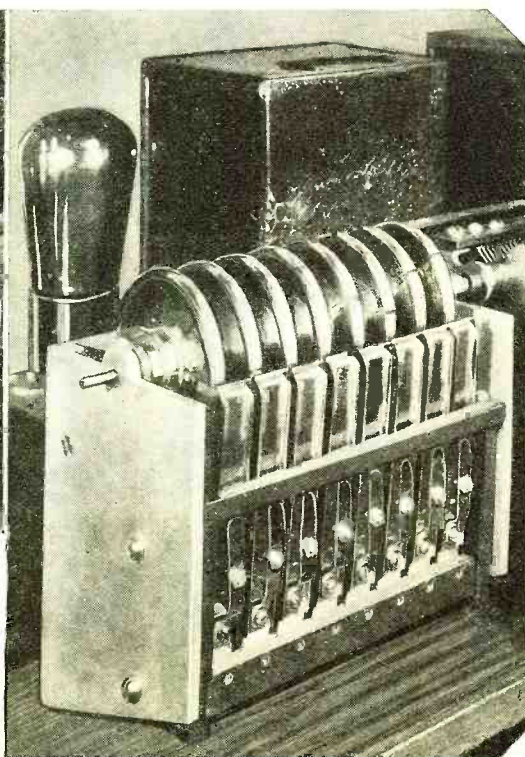
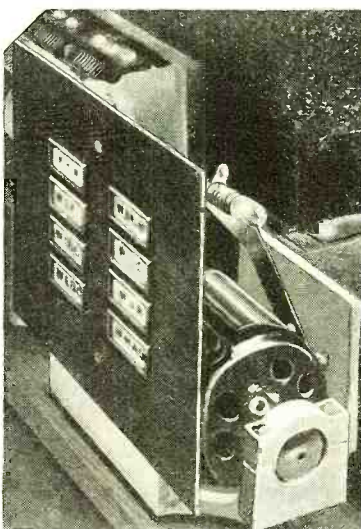

Above and to the right are shown the rectangular push buttons, motor and selector switches of the Carter system of automatic tuning. Pressing the button causes the motor to rotate the condenser shaft to a stopping point determined by the cam and switch (at the right), which is connected to the button pressed

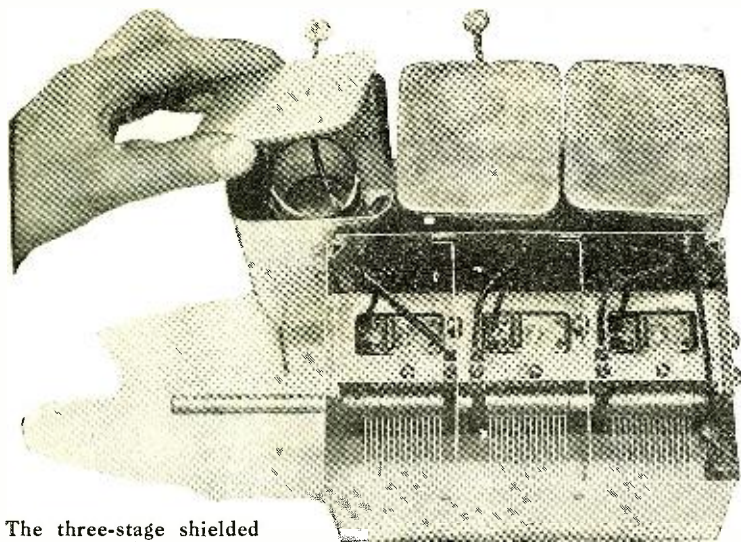

Analyzing the The Band Selector and Three-Stage Screen- Grid Amplifier is the "Heart" of this New Kit Receiver

The three-stage shielded tuned radio-frequency amplifier unit of the Hi-Q 30

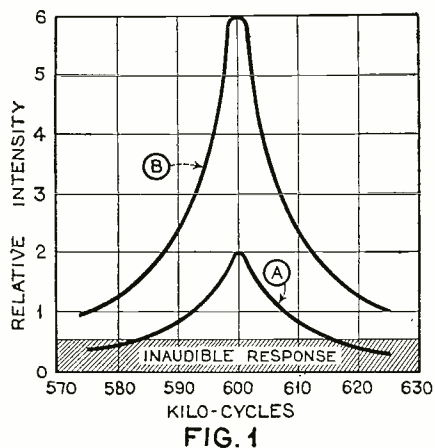

THE outstanding feature of the Hi-Q 30 broadcast receiver is its novel frequency-selecting or tuning system which affords almost unbelievable selectivity with consequent freedom from interference. This quality is instantly apparent even when the receiver is operated in locations where the most adverse receiving conditions exist. Therefore it is felt that a rather complete explanation of the principles involved in the design of the selecting system will prove of interest to the constructor.

An analysis of the selectivity required of a modern high gain receiver indicates the desirability of separating it into two classifications. For want of better terms one of these classifications will be called "wide" selectivity and the other "narrow" selectivity. "Wide" selectivity may be defined as that kind of selectivity which enables the receiver to be satisfactorily operated only a few blocks away from a super-power broadcast transmitter without having the signals from that station pop in at unexpected dial settings and without hearing the nearby station's program as a background while listening to other stations several broadcast channels above or below its frequency. Good "narrow" selectivity enables the operator to tune in a weak distant signal without interference from a relatively much more powerful station operating on a frequency only one channel above or below that of

the desired station. Many good receivers possessing a high degree of "narrow" selectivity are woefully deficient in the matter of "wide" selectivity. Many superheterodynes especially, having knife-like selectivity of the "narrow" type, prove totally unsatisfactory when operated in close proximity to one or more high-powered transmitters. In view of the present trend toward higher transmitting power and high-percentage modulation, it is quite evident that a good "wide" selectivity characteristic is becoming increasingly important. In addition, the "narrow" selectivity requirements have also been increased by the gradual shift to higher gain radio-frequency amplifiers. While this connection may not be evident at the first glance, it is nevertheless a fact that the selectivity (both "wide" and "narrow") must be increased as the amplification is made greater if the receiver is not to appear unselective. While the actual selectivity of a receiver can be definitely determined in the laboratory without regard to its sensitivity (amplifying power), the receiver owner or experimenter judges it entirely by its apparent selectivity. As an illustration let us consider two receivers, one of which has, say, three times as much amplification as the other. However, let both have the same actual selectivity. The response characteristics of these two receivers are shown by curves A and B of Fig. 1. Let both receivers be accurately tuned to 600 kc. with their volume controls turned to maximum. Assuming that no stations are on the air except one 580 kc. station, no sound will be heard from the less sensitive set because it has not sufficient amplification to magnify the signal from the 580 kc. station to the point where it becomes audible. On the other hand, the signals will be heard with the more sensitive receiver, and inasmuch as it is bringing in a 580 kc. station while the dials are tuned to 600 kc. it will invariably be declared the less selective receiver of the two, even though laboratory

measurements show the selectivity of both to be identical. Since the "gain" or sensitivity of the Hi-Q 30 is of a very high order, extreme measures have been taken to insure a degree of selectivity commensurate with the enormous amplification.

Selectivity Depends on Many Factors

In general, it can be said that the selectivity of a receiver depends on the kind and number (and to a certain extent on the arrangement) of its tuned circuits. Also that the amount of its radio-frequency amplification depends on the kind and number of stages of r.f. amplification employed. In practice, of course, these two statements do not hold absolutely true, because the tube constants have an effect on the tuned circuits and the type of tuned circuit used has a marked effect

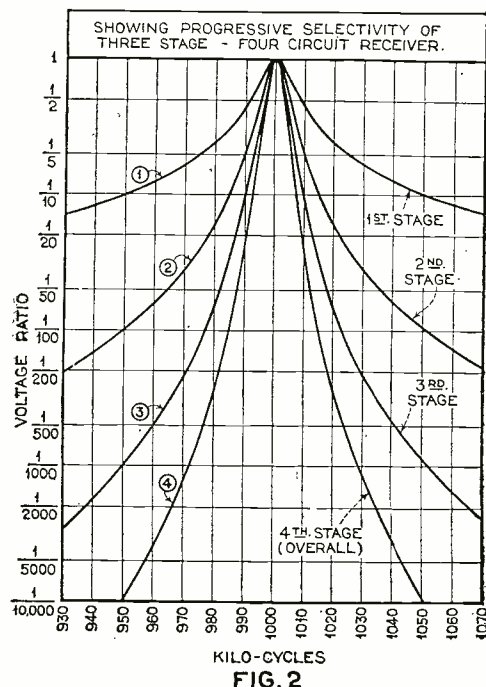

By D. K. Oram

“Hi-Q” 30

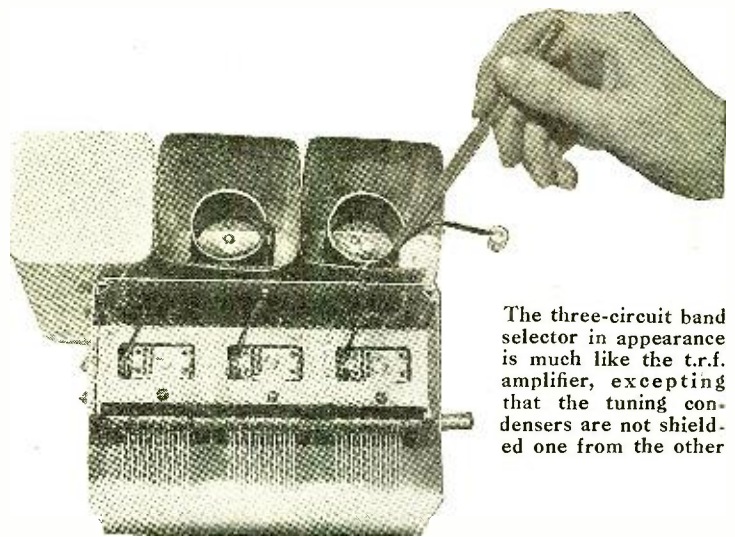

The three-circuit band selector in appearance is much like the t.r.f. amplifier, excepting that the tuning condensers are not shielded one from the other

MR. ORAM is Chief Engineer of the Hammarlund Manufacturing Company and is largely responsible for the development of the Hi-Q line of receivers.

In this, the second, article dealing with the Hi-Q 30, he presents, in a most interesting way, the theory, borne out by actual test and proved by practical operation, upon which the Hi-Q 30 was developed to its present high state of perfection.

Step by step Mr. Oram explains to you the solution of all the engineering problems which confronted him, culminating finally in the production of the 1930 Hi-Q.

on the amount of amplification secured from a given tube. In the following illustration, however, it will be assumed that these modifying factors have been taken into account.

In the conventional radio receiver having three stages of radio-frequency amplification there are four tuned circuits. These consist of a tuned input circuit—often referred to as an antenna coupler—and three tuned interstage radio-frequency transformers. Since these four circuits are arranged in cascade, if they are all tuned to the same frequency, their selectivity is cumulative, and may be of a very high order if the individual circuits are of good design. For example, let us assume that the four circuits are substantially alike and each has a selectivity factor of ten for a five per cent difference in frequency. This means that if one of the circuits

is tuned to resonance with a 1000 kc. signal, an interfering 950 kc. signal, of equal intensity, will only produce one-tenth as much voltage in the tuned circuit as the 1000 kc. desired signal.

The response characteristic for such a circuit is shown by curve No. 1 of Fig. 2. Let us assume such a four-circuit receiver to be tuned to 1000 kc. and that there are two signals of equal intensity induced in the antenna, one at a frequency of 1000 kc. and the other at 950 kc. After passing through the first tuned circuit, the interfering 950 kc. signal will be only 1/10 as strong as the desired 1000 kc. signal. After passing through the second circuit it will be only 1/100 as strong; after the third 1/1000, and after the fourth circuit only 1/10,000 as strong and consequently negligible.

This cumulative selecting process is illustrated graphically in Fig. 2, where curve No. 1 represents the output of the first tuned circuit; curve No. 2 the output of the second circuit, etc. Curve No. 4 represents

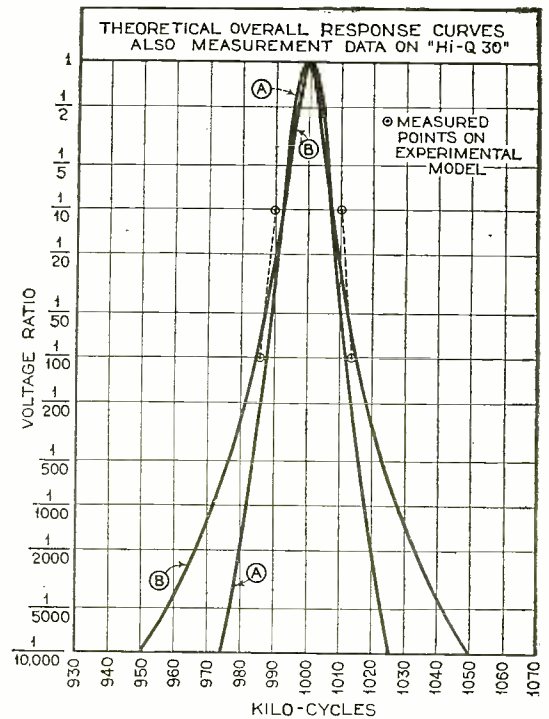

FIG. 4

the output of the fourth and last tuned circuit and consequently indicates the theoretical overall selectivity of the receiver. However, if the 950 kc. interfering signal were ten times as strong as the 1000 kc. signal to begin with, the final ratio would be 1/1000 instead of 1/10,000. If the 950 kc. signal should be from a very powerful and nearby station it might quite easily induce a voltage in the receiving antenna one hundred times as great as that from the 1000 kc. station to which the receiver is tuned. On the above basis, then, only 1/100 of the output of the fourth tuned circuit should be from the interfering station.

Although it would depend on the relative modulation, type of program, etc., being transmitted, we will assume that this amount of interference would be just insufficient to be noticeable in the loud speaker output. It is interesting to note, however, the distinct difference between

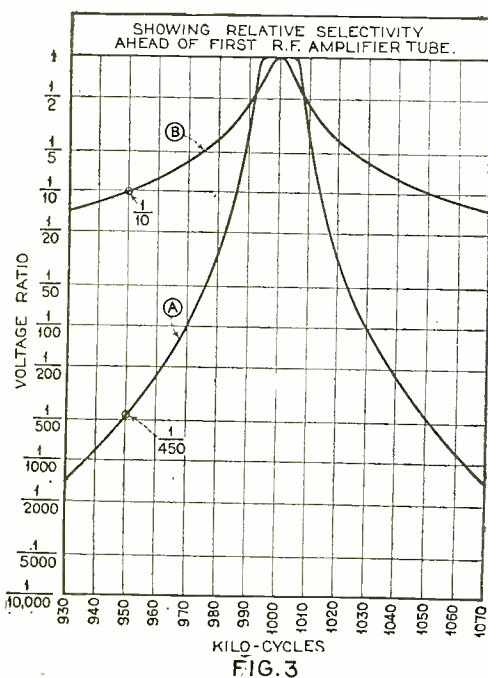

FIG. 3

the case of equal signals in the antenna and the last mentioned case where the interfering signal is 100 times as strong in the antenna. In the case of equal antenna intensities the unwanted or interfering signal was always weaker than the 1000 kc. signal as they were applied to the grid of each succeeding radio-frequency amplifier tube. In the latter case the interfering 950 kc. signal being 100 times as strong in the antenna is 10 times as strong on the grid of the first r.f. tube, equal at the grid of the second r.f. tube, and not until both signals have passed through the third tuned circuit and reached the grid of the third r.f. amplifier tube has the intensity of the interfering signal been reduced to 1/10 that of the desired 1000 kc. signal. As stated previously, the fourth tuned circuit and the detector *should* further attenuate the interference to the point where it would not be noticed, but unfortunately such is not always the case, and the interfering signal comes through with disconcerting audibility, especially during pauses in the program of the desired station. That this is not a simple case of broad tuning or lack of selectivity is easily demonstrated.

If the receiver is left tuned to the 1000 kc. station until it signs off it will be found that the interference from the 950 kc. station disappears instantly when the carrier of the 1000 kc. station goes off the air. Also it is often quite possible to tune the receiver to say 980 kc. (when there is no station operating on that frequency) without hearing a trace of the offending 950 kc. station. In addition, very careful laboratory measurements made with the conventional artificial signal generator will indicate a degree of selectivity more than adequate to separate the two stations.

This particular kind of interference is often referred to as "riding in" or "cross-talk" and often occurs with sensitive and otherwise selective receivers. It can undoubtedly be explained by the fact that no vacuum tube is a perfect amplifier. That is to say, all amplifier tubes have a slight rectifying action as well as amplifying action even when the grid, filament and plate voltages are exactly as specified by the manufacturer. This rectification,

or more properly distortion, increases rapidly as the amplitude of the signal voltage impressed on the grid increases. In the case of a powerful nearby station the single tuned circuit preceding the first r.f. amplifier tube, even though tuned to a different station, permits a large voltage from the nearby station to reach the grid of the tube, along with the signal to which the receiver is tuned. Due to the slight distorting action of the first amplifier tube the weaker signal is slightly modulated by the stronger or interfering signal and the damage is done. No matter how great the number and selectivity of the remaining tuned circuits, the interference will persist right through to the loudspeaker. On the other hand, if the selectivity of the first tuned circuit were sufficient to reduce the signal from the unwanted station to a relatively low value this modulation effect could not take place and the succeeding tuned circuits would then be able to further reduce the interference to the vanishing point.

It is practically impossible to design a single tuned circuit possessing such a degree of selectivity. Even neglecting the damping effect of the antenna-ground circuit, a coil having a "Q" of 200, that

ωL
is, $\frac{\omega L}{R} = 200$, which represents a very

low loss coil indeed, would only have a selectivity factor of 20, and the nearby 950 kc. signal, above referred to, would still be five times as strong on the grid of the first amplifier tube as the 1000 kc. signal to which the circuit is tuned.

Three-circuit Antenna Stage Cuts Interference to Minimum

Inasmuch as the *overall* selectivity of the hypothetical four-circuit receiver under discussion is quite high when no question of superimposed modulation is involved it is quite obvious that if all four tuned circuits were placed in cascade

ahead of the first r.f. amplifier tube, the interfering 950 kc. signal would be so reduced that "riding in" would be impossible. This amounts to separating the functions of selectivity and amplification—all the selecting is done first and then the desired signal (free from interference) is amplified to the desired degree and fed to the detector and so on to the loud speaker. This is in marked contrast to the more common practice of selecting and amplifying simultaneously. The need for revising

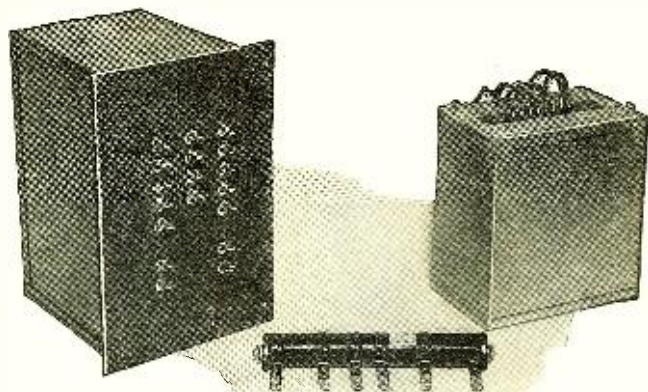

The power supply, like all the other components of the receiver, is composed of separate units easily wired to form a complete receiver

the old standards of receiver design is quite apparent, in view of the changed conditions now prevalent in the field of radio broadcast reception. One important change is the widespread use of screen-grid tubes as radio-frequency amplifiers. Their tremendous amplifying power alone necessitates more careful receiver design if full advantage is to be taken of their possibilities, without running into new difficulties. Another important change is that of "high percentage" modulation. This, together with super power, undoubtedly aggravates any tendency a receiver may have toward superimposing the modulation of such a station on the carrier of a distant station or weak local station to which the receiver is tuned.

In view of the foregoing it is obviously desirable to place a large part of the frequency selecting apparatus ahead of the radio-frequency amplifier of a modern receiver.

The Hi-Q 30 has a total of six tuned circuits, divided into two groups of three each. The first group of three circuits constitutes a filter or pre-selecting unit which insures a remarkable degree of "wide" selectivity besides providing considerable "narrow" selectivity. This unit is located between the antenna and the grid of the first radio-frequency amplifier tube. The second group of three tuned circuits consists of three interstage radio-frequency transformers. This second unit forms the radio-frequency amplifier and at the same time increases the "narrow" selectivity enormously. A further advantage possessed by Hi-Q 30 frequency selecting system lies in the band-pass characteristic of the three circuit pre-selecting unit. Instead of having an overall response characteristic like curve No. 3 in Fig. 2, as might at first be supposed (assuming similar circuits) it has in reality a broad-topped, steep-sided characteristic more like curve A of Fig. 3. This is due to the peculiar behavior of tuned coupled circuits.

Side-Band Cutting an Unknown Quantity in Hi-Q 30

When such circuits are suitably coupled, and each circuit is tuned to the same frequency, they react on each other in such a manner as to produce several dis-

(Continued on page 671)

The audio channel of the Hi-Q 30 is compactly located along the right and rear edges of the chassis

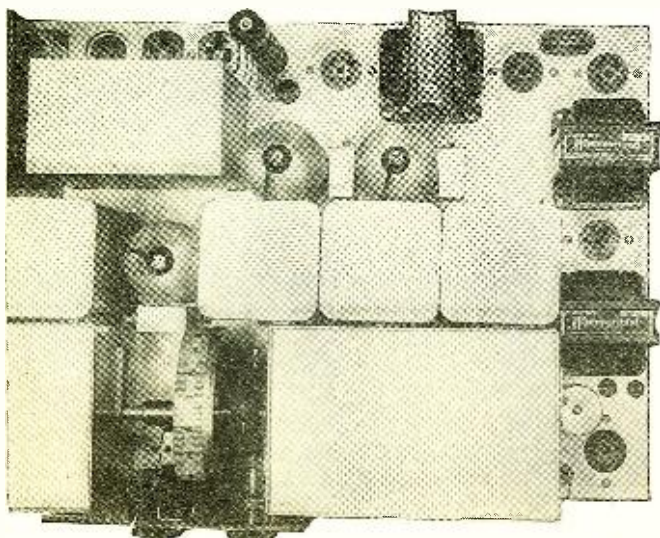

Film pick-up transmitting apparatus recording pictures by translation of light values into electrical values

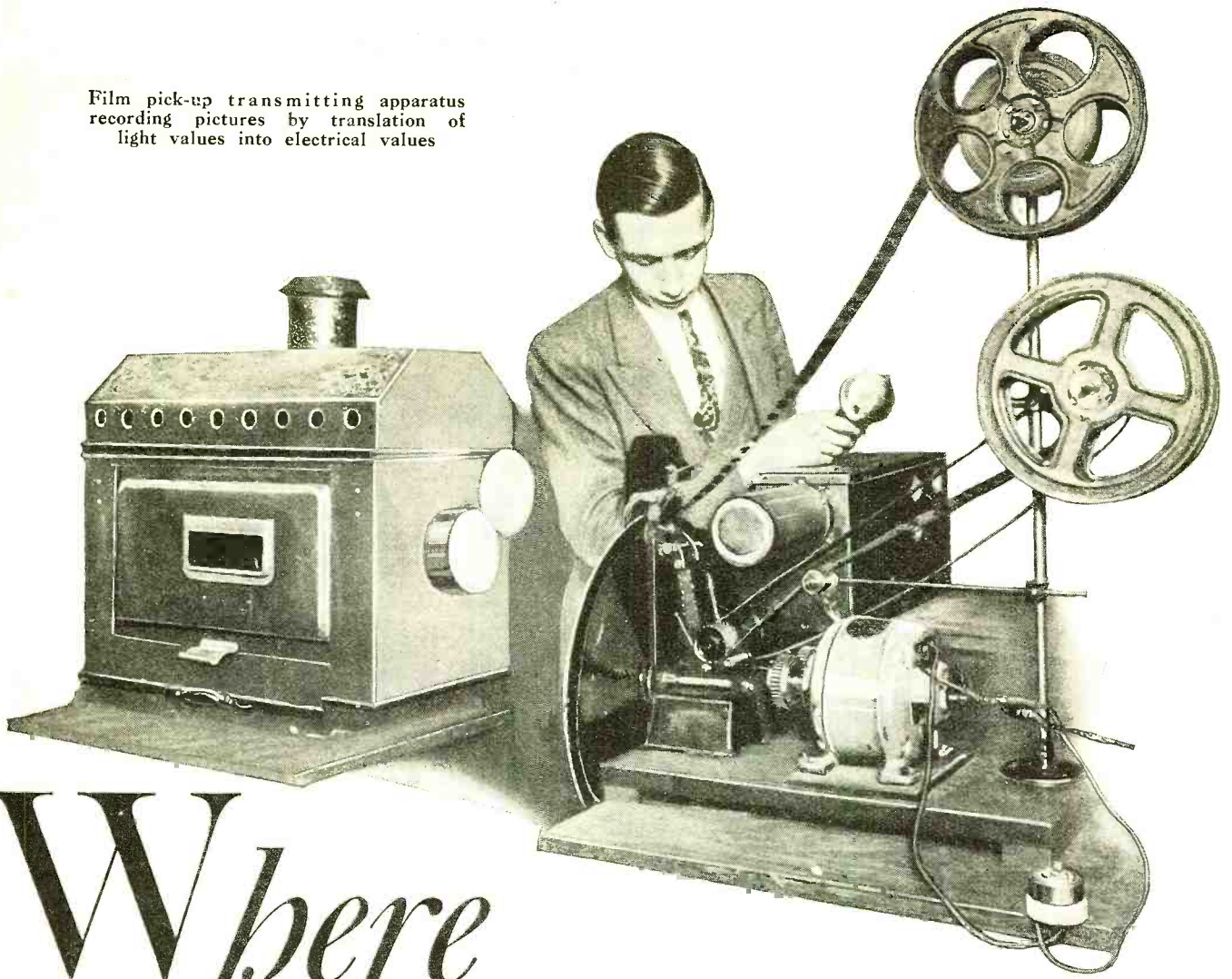

Where TELEVISION is TO-DAY

The commercial television receiver begins to take form

By D. E. Replogle

TELEVISION is pretty much the same story as the "House that Jack Built." Most of us recall that one feature of Jack's House led to another and still another, in an endless chain. In television development, the situation is much the same; the solution of one feature leads to a new problem, the solution of which uncovers still another problem, and so on. Nevertheless, with the application of intensive research and specialized engineering effort, many problems of practical television have already been solved, and we are now on the eve of commercialized sight broadcasting.

For a correct appraisal of practical home television, it is well at the start of any discussion to differentiate between the ideal and the practical. Thus, there



Mr. Replogle has been identified with radio since 1912. After being graduated from the Massachusetts Institute of Technology he became associated with the Raytheon Manufacturing Company, where he was responsible for the design of the "Kino-Lamp" used in television. He is now Assistant to the President of the Jenkins Television Corporation.

are two broad schools of television thought today, both correct in their own way, and both working toward the future of the art. The first school seeks ultimate perfection and is quite unhampered by considerations of time, effort and money. Even at this early date this school is endeavoring to demonstrate a highly refined form of television including excel-

lent detail and even natural colors. The demonstrations of the Bell System engineers are most representative of this school, for no time, effort nor money is being spared to achieve the desired end. With an eye to a future important use of long-lines telephone service, the telephone engineers are pioneering in television just as they did in radio broadcasting.

The splendid development of broadcasting possibilities through experimental station WEAF and the original Red Network, finally bringing about the most profitable use of wire networks yet uncovered, is now being repeated in the case of television. However, it should be noted that these efforts have to do solely with the most elaborate form of television, using as many telephone wire chan-

nels as may be necessary, the most elaborate kind of equipment and no end of engineering talent for the setting up and operation of the system.

But what about simple, inexpensive, feasible home television? To answer that question, we turn to the second school of television thought, which concerns itself with the prompt development of a satisfactory television system for home use. In this school the paramount consideration is to bring about a compromise between the ideal and the practical. Engineers are fully aware of the limitations of the existing technique of scanning or dissecting the image into a number of lines. They have come to accept the relatively narrow radio channels placed at their disposal as the connecting links between transmitter and receiver. They fully realize the need for simple and inexpensive equipment. Hence their development efforts are predicated on definite limitations at the very start. It is a matter of striving for the best possible results, under the existing circumstances. Above all, it is imperative that at least a start be made.

To the average individual, it is the second school of thought that merits discussion. The first school is interesting, of course, and such achievements as excellent detail and natural colors are to be admired. However, immediate interest focuses on a system for home use, just as the average individual is more interested in a home movie outfit than in the elaborate and costly talking picture system for the palatial picture theatre.

All of which leads to the modest results obtainable with a really practical television system. While the enthusiastic novelist and the dreamy inventor may have sold the public the idea of viewing a Broadway revue or a football game in vivid form on the television screen, the fact remains that such achievements are still in the dim future. For the present, we are in the babyhood of the television art, and must be contented first of all to master our ABC pictures. And so we are down to the brass tacks of practical home television. Let us see, then, what has taken place in this specific field.

Television experimentation began in earnest in July, 1925, when C. Francis Jenkins of Washington, D. C., a noted inventor in the fields of motion picture projection, ultra-speed cinematography and facsimile communication, inaugurated a radio television or sight broadcasting service from his experimental station, W3XK, at Washington, D. C. De-

¶ The enthusiastic novelist and the dreamy inventor may have sold the public the idea of viewing a Broadway revue or a football game in vivid form on the television screen, but the fact remains that such achievements are still in the dim future.

¶ Our greatest problem at present is one of coverage. We are making field-strength measurements, and hope to know shortly precisely what to expect by way of a dependable television area.

¶ Sound broadcasting—a far simpler technique—required almost a decade for development into satisfactory merchandise. With sight broadcasting, we may well expect to take the same time to attain satisfactory equipment for general use.

spite the limited power of 50 watts, this station soon had a following of television experimenters extending from coast to coast and border to border. Mr. Jenkins sought the co-operation of radio amateurs and experimenters and received it in ample measure. To further television interest, he even supplied television kits at cost. While the "lookers-in" had to build their own equipment, they have grown in numbers to something like 20,000 at the beginning of this year.

In November, 1928, a group of capitalists and business men, having decided that the Jenkins television experiments had attained a practical stage ready for commercial exploitation, formed a company based on the patents, laboratories and experiences of Mr. Jenkins. The noted pioneer was made Vice-President in Charge of Research,

with headquarters in his laboratories at Washington. Meanwhile, the commercialization of the Jenkins television system was centered in the main offices and engineering laboratories at Jersey City, so as not to hamper the functions of pure research by the urgent demand for immediate results.

More than a year has elapsed since the formation of the television organization. The engineering development during the past thirteen months has been concentrated mainly on the evolution of a practical home televisor or device for converting television signals into animated pictures, together with a satisfactory sight broadcasting service.

At first, the engineering development centered about the home televisor model of Mr. Jenkins, comprising a horizontally mounted motor, scanning drum and revolving switch, contained in a cabinet with an inclined mirror and magnifying lens on top. The scanning drum was provided with a four-target neon lamp and light-conducting rods leading from light source to holes in the drum. The revolving switch served to flash the targets in proper rotation. Several drawbacks were soon uncovered in the practical development of this device.

The next step was to mount the motor and drum vertically, so that the luminous dots of the drum might be viewed directly through shadow-box and magnifying lens, entirely housed in an attractive cabinet. This arrangement, while a decided improvement over the model with exposed mirror and magnifying lense, still made use of the four-target neon lamp, light-conducting rods, and revolving switch.

The Jenkins scanning drum makes for a compact home televisor, in contrast with the usual bulky scanning disc.

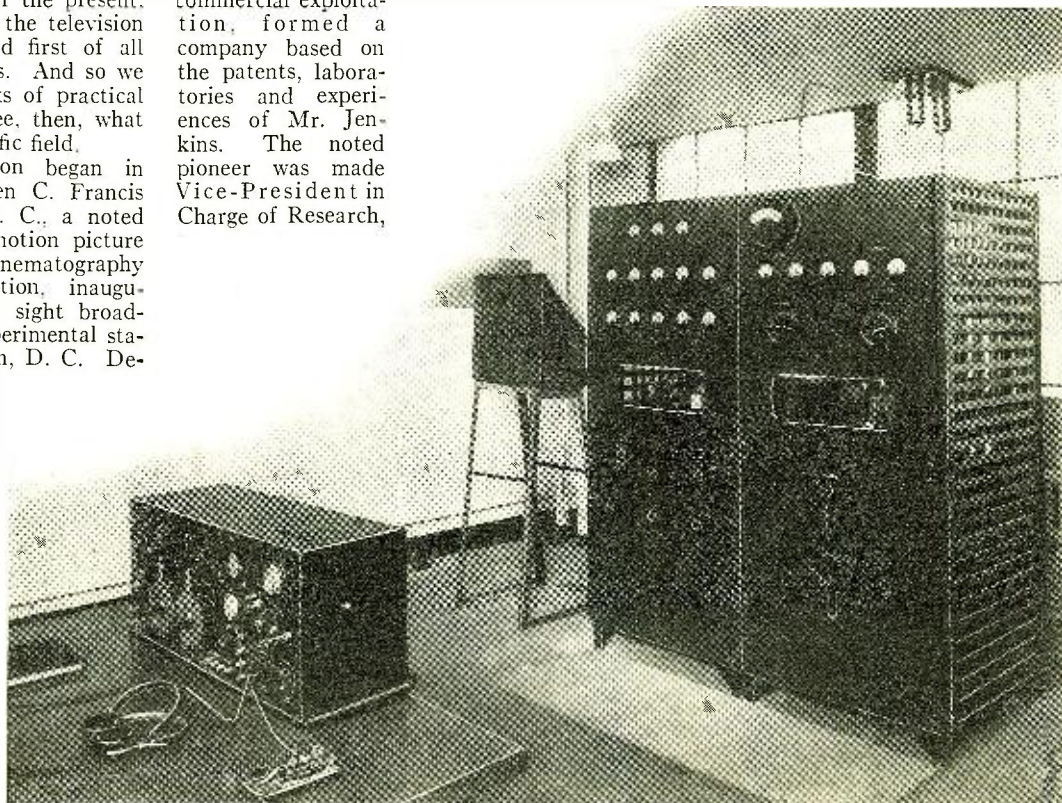

Transmitting room of television broadcasting Station W2XCR, showing transmitter, television monitor, and code receiver

While the latter requires only one revolution for the scanning or assembly of each picture by means of its 48 holes through which the glowing plate of the neon lamp is seen, the former illuminates only one-quarter of its holes, or 12, with each revolution, so that four revolutions are required to assemble one picture. The basic feature of the scanning drum had to be retained in any subsequent refinement, because of its inherent advantages over the usual disc.

The design which has been finally worked out possesses the original compactness plus remarkable simplicity, low cost and improved detail. Briefly, the refined televisor comprises a vertically mounted driving motor and scanning drum, a selector shutter with four curved slots, and a single plate neon lamp. The scanning drum requires four revolutions for each complete picture of 48 holes. The selector shutter, with curved slots, serves to mask all but the twelve holes of that particular revolution and is driven at one-quarter the speed of the drum, by means of reduction gearing. The revol-

motor switch one or more times, until proper framing is obtained. The horizontal framing is accomplished by a simple adjustment of the motor frame.

It should be noted that the televisor is simply the "unscrambler" or device which translates audio signals into pictures, just as the loudspeaker translates audio signals into sounds. Therefore, the televisor must be employed in combination with a short-wave radio set, a suitable amplifier and a satisfactory radio power unit. The usual type of regenerative short-wave receiver is by no means ideal for good television reception. Regeneration introduces distortion. Also the usual short-wave receiver cuts off at about 3,000 cycles, which, while no handicap in audible reproduction, is fatal to pictorial detail.

Therefore, the Jenkins engineering staff has found it necessary to develop a satisfactory short-wave set, without regeneration, with an audio range up to at least 20,000 cycles, in order to improve pictorial detail. Likewise with the audio amplifier: transformer coupling being unsatisfactory for good detail, suitable resistance-coupled amplifiers have been developed. Television workers have found that their efforts only began with the evolution of a practical televisor, since a suitable radio set and amplifier had to be developed as companion equipment.

With a full appreciation of the limitations of lay operation, the televisor has been made as simple as possible. The amplifier output is led to the televisor. Also, a loud-speaker is connected with the televisor. To tune in a television signal, the first toggle switch is thrown to the "Loud-speaker" position and the receiver is tuned until the characteristic buzz-saw note is heard loudest. Then the switch is thrown to the "Picture" position, and the motor switch is thrown to start the motor. Looking into the shadowbox, the "looker-in" sees a series of horizontal luminous streaks or bands, weaving a pattern of pink and black figures. If the portions of two frames or pictures are seen at one time, one above the other, the motor switch is flipped one or more times to obtain proper framing. That is all there is to television reception—so far as the "looker-in" is concerned.

Meanwhile, however, the television workers must provide satisfactory signals—suitable pictures to be snatched out of space. The transmitting end has presented many problems due to the wider range of frequencies handled. Special amplifiers have had to be developed, with many stages of special resistance-coupled amplification. Extraordinary precautions have had to be taken in shielding the components and conductors.

During the past year, the development engineers have designed and constructed two powerful television transmitters, one about five miles north of Washington,

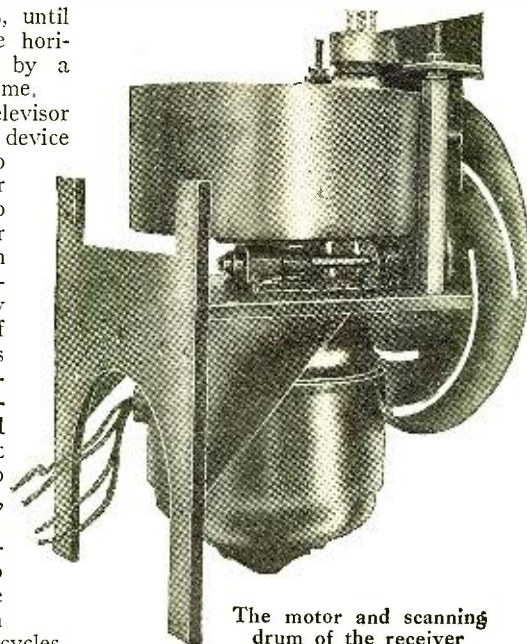

The motor and scanning drum of the receiver



The Jenkins Televisor, which converts television signals into pictures for home entertainment

ing switch has been dispensed with, as well as the light-conducting rods. The apparatus can be made comparatively silent.

The refined Jenkins Televisor is now in production and samples are being shipped to various points for extensive and exhaustive tests under actual home conditions. The commercial model is in the form of an attractive cabinet measuring approximately 18 to 18 by 24 inches. At the front end is a recessed opening or shadowbox, through which the pictures are viewed. A magnifying lens set back in the shadowbox, serves to enlarge the pictures sufficiently to be viewed by four to eight "lookers-in" at a time. The shadowbox permits of viewing the pictures in subdued light, as contrasted with the absolute darkness formerly required.

Directly below the shadowbox is the control panel, with two toggle switches. The top switch can be thrown to "Loud-speaker" or "Picture" position, while the lower switch serves to start, accelerate and stop the driving motor. The vertical framing is accomplished by snapping the

with the historic call letters W3XK, originally employed by Mr. Jenkins in his pioneer sight broadcasting, and the other at Jersey City, with the call letters W2XCR. Both stations have been operating on regular schedule, practically every day, with voice announcements, half-tone pictures and animated shadowgraphs. Many problems have had to be solved in the development of these stations and even now there is still much to be done before entirely satisfactory television service is established in the two territories to be covered by these stations. Our greatest problem at present is one of coverage. We have fitted up a truck with a receiving set for making signal strength measurements and shortly hope to check up on our service range, so as to know precisely what to expect by way of a dependable television area.

Aside from the technical phase of television broadcasting, another consideration has been that of the subject matter. With the present 48-line picture, the amount of detail that can be handled is quite limited. For the sake of comparison, let us take a square inch of the usual half-tone engraving in the newspapers, which represents about the equivalent of a 65-line television picture. If we mark off a section $\frac{1}{4}$ inch square, we have
(Continued on page 677)

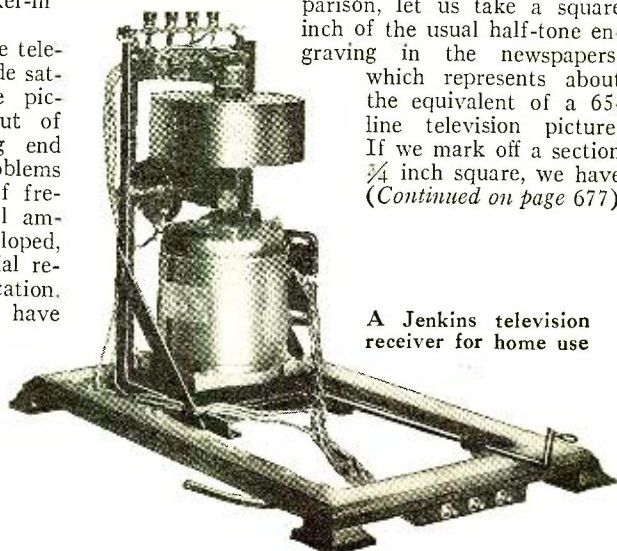

A Jenkins television receiver for home use

Lieutenant Wenstrom measuring the voltage nodes of his antenna with a neon pencil

To the right, log book in which he keeps a record of his station's activities



Time for the Week Ending

Date	Time	Call	in	NAME	IND	STAS	NOTE	ASS	GRM	WX	Remarks
TEST				Utica, N.Y. - War	clp	and	RA	mid	quad.		
Apr. 22	8:00P	EL-LAW		Pedersen, Notleden, Norway	wrk	5	DC	mid	sum	rising	2nd Europe Dk
23	9:00P	EF-BHS		Sorty, France	wrk	5	DC	mid	sum	clay	3rd Europe Dk
24	9:00P	RMK		Cattus Valley, N.Y.	wrk	7	5	mid	sum	clv	42.2 mts (75)
R-1	26	7:30A	7:40D	Chicago, Ill.	wrk	6	8	slct	sum	clv	
28	6:50A	ca-10U		Canberra, Australia	wrk	3	2	DC	slct	clv	1st Europe
29	7:40A	SJF		Huntsville, Ala.	wrk	6	4	DC	slct	clv	
30	7:30P	SBCC		Springdale, Pa.	wrk	7	5	DC	slct	clv	
TEST				with new 20 ft. ctone right under	ant		no dit.	RS	with both old		and new ctone.
3	8:00P	SBCC		Owego, N.Y.	wrk	3	1	RAC	mid	clv	
4	7:20P	7ELN		Chicago, Ill.	wrk	7	5	RAC	mid	clv	NEW CTONE.
5	8:00P	SBCC		Springdale, Pa.	wrk	7	5	DC	mid	clv	
6	8:00P	SBCC		Springdale, Pa.	wrk	5	6	RAC	mid	clv	
7	8:00P	SBCC		Springdale, Pa.	wrk	6	5	RAC	mid	clv	
8	8:00P	SBCC		Springdale, Pa.	wrk	7	6	RAC	mid	clv	
9	8:00P	SBCC		Springdale, Pa.	wrk	5	5	RAC	mid	clv	
10	8:00P	SBCC		Springdale, Pa.	wrk	5	7	RAC	mid	clv	
11	8:00P	SBCC		Springdale, Pa.	wrk	5	5	RAC	mid	clv	
12	8:00P	SBCC		Springdale, Pa.	wrk	7	6	RAC	mid	clv	
13	8:00P	SBCC		Springdale, Pa.	wrk	7	6	RAC	mid	clv	
14	8:00P	SBCC		Springdale, Pa.	wrk	7	6	RAC	mid	clv	
15	8:00P	SBCC		Springdale, Pa.	wrk	7	6	RAC	mid	clv	
16	8:00P	SBCC		Springdale, Pa.	wrk	7	6	RAC	mid	clv	
17	8:00P	SBCC		Springdale, Pa.	wrk	7	6	RAC	mid	clv	
18	8:00P	SBCC		Springdale, Pa.	wrk	7	6	RAC	mid	clv	
19	8:00P	SBCC		Springdale, Pa.	wrk	7	6	RAC	mid	clv	
20	8:00P	SBCC		Springdale, Pa.	wrk	7	6	RAC	mid	clv	
21	8:00P	SBCC		Springdale, Pa.	wrk	7	6	RAC	mid	clv	
22	8:00P	SBCC		Springdale, Pa.	wrk	7	6	RAC	mid	clv	
23	8:00P	SBCC		Springdale, Pa.	wrk	7	6	RAC	mid	clv	
24	8:00P	SBCC		Springdale, Pa.	wrk	7	6	RAC	mid	clv	
25	8:00P	SBCC		Springdale, Pa.	wrk	7	6	RAC	mid	clv	
26	8:00P	SBCC		Springdale, Pa.	wrk	7	6	RAC	mid	clv	
27	8:00P	SBCC		Springdale, Pa.	wrk	7	6	RAC	mid	clv	
28	8:00P	SBCC		Springdale, Pa.	wrk	7	6	RAC	mid	clv	
29	8:00P	SBCC		Springdale, Pa.	wrk	7	6	RAC	mid	clv	
30	8:00P	SBCC		Springdale, Pa.	wrk	7	6	RAC	mid	clv	
1	8:00P	SBCC		Springdale, Pa.	wrk	7	6	RAC	mid	clv	
2	8:00P	SBCC		Springdale, Pa.	wrk	7	6	RAC	mid	clv	
3	8:00P	SBCC		Springdale, Pa.	wrk	7	6	RAC	mid	clv	
4	8:00P	SBCC		Springdale, Pa.	wrk	7	6	RAC	mid	clv	
5	8:00P	SBCC		Springdale, Pa.	wrk	7	6	RAC	mid	clv	
6	8:00P	SBCC		Springdale, Pa.	wrk	7	6	RAC	mid	clv	
7	8:00P	SBCC		Springdale, Pa.	wrk	7	6	RAC	mid	clv	
8	8:00P	SBCC		Springdale, Pa.	wrk	7	6	RAC	mid	clv	
9	8:00P	SBCC		Springdale, Pa.	wrk	7	6	RAC	mid	clv	
10	8:00P	SBCC		Springdale, Pa.	wrk	7	6	RAC	mid	clv	
11	8:00P	SBCC		Springdale, Pa.	wrk	7	6	RAC	mid	clv	
12	8:00P	SBCC		Springdale, Pa.	wrk	7	6	RAC	mid	clv	
13	8:00P	SBCC		Springdale, Pa.	wrk	7	6	RAC	mid	clv	
14	8:00P	SBCC		Springdale, Pa.	wrk	7	6	RAC	mid	clv	
15	8:00P	SBCC		Springdale, Pa.	wrk	7	6	RAC	mid	clv	
16	8:00P	SBCC		Springdale, Pa.	wrk	7	6	RAC	mid	clv	
17	8:00P	SBCC		Springdale, Pa.	wrk	7	6	RAC	mid	clv	
18	8:00P	SBCC		Springdale, Pa.	wrk	7	6	RAC	mid	clv	
19	8:00P	SBCC		Springdale, Pa.	wrk	7	6	RAC	mid	clv	
20	8:00P	SBCC		Springdale, Pa.	wrk	7	6	RAC	mid	clv	
21	8:00P	SBCC		Springdale, Pa.	wrk	7	6	RAC	mid	clv	
22	8:00P	SBCC		Springdale, Pa.	wrk	7	6	RAC	mid	clv	
23	8:00P	SBCC		Springdale, Pa.	wrk	7	6	RAC	mid	clv	
24	8:00P	SBCC		Springdale, Pa.	wrk	7	6	RAC	mid	clv	
25	8:00P	SBCC		Springdale, Pa.	wrk	7	6	RAC	mid	clv	
26	8:00P	SBCC		Springdale, Pa.	wrk	7	6	RAC	mid	clv	
27	8:00P	SBCC		Springdale, Pa.	wrk	7	6	RAC	mid	clv	
28	8:00P	SBCC		Springdale, Pa.	wrk	7	6	RAC	mid	clv	
29	8:00P	SBCC		Springdale, Pa.	wrk	7	6	RAC	mid	clv	
30	8:00P	SBCC		Springdale, Pa.	wrk	7	6	RAC	mid	clv	
1	8:00P	SBCC		Springdale, Pa.	wrk	7	6	RAC	mid	clv	
2	8:00P	SBCC		Springdale, Pa.	wrk	7	6	RAC	mid	clv	
3	8:00P	SBCC		Springdale, Pa.	wrk	7	6	RAC	mid	clv	
4	8:00P	SBCC		Springdale, Pa.	wrk	7	6	RAC	mid	clv	
5	8:00P	SBCC		Springdale, Pa.	wrk	7	6	RAC	mid	clv	
6	8:00P	SBCC		Springdale, Pa.	wrk	7	6	RAC	mid	clv	
7	8:00P	SBCC		Springdale, Pa.	wrk	7	6	RAC	mid	clv	
8	8:00P	SBCC		Springdale, Pa.	wrk	7	6	RAC	mid	clv	
9	8:00P	SBCC		Springdale, Pa.	wrk	7	6	RAC	mid	clv	
10	8:00P	SBCC		Springdale, Pa.	wrk	7	6	RAC	mid	clv	
11	8:00P	SBCC		Springdale, Pa.	wrk	7	6	RAC	mid	clv	
12	8:00P	SBCC		Springdale, Pa.	wrk	7	6	RAC	mid	clv	
13	8:00P	SBCC		Springdale, Pa.	wrk	7	6	RAC	mid	clv	
14	8:00P	SBCC		Springdale, Pa.	wrk	7	6	RAC	mid	clv	
15	8:00P	SBCC		Springdale, Pa.	wrk	7	6	RAC	mid	clv	
16	8:00P	SBCC		Springdale, Pa.	wrk	7	6	RAC	mid	clv	
17	8:00P	SBCC		Springdale, Pa.	wrk	7	6	RAC	mid	clv	
18	8:00P	SBCC		Springdale, Pa.	wrk	7	6	RAC	mid	clv	
19	8:00P	SBCC		Springdale, Pa.	wrk	7	6	RAC	mid	clv	
20	8:00P	SBCC		Springdale, Pa.	wrk	7	6	RAC	mid	clv	
21	8:00P	SBCC		Springdale, Pa.	wrk	7	6	RAC	mid	clv	
22	8:00P	SBCC		Springdale, Pa.	wrk	7	6	RAC	mid	clv	
23	8:00P	SBCC		Springdale, Pa.	wrk	7	6	RAC	mid	clv	
24	8:00P	SBCC		Springdale, Pa.	wrk	7	6	RAC	mid	clv	
25	8:00P	SBCC		Springdale, Pa.	wrk	7	6	RAC	mid	clv	
26	8:00P	SBCC		Springdale, Pa.	wrk	7	6	RAC	mid	clv	
27	8:00P	SBCC		Springdale, Pa.	wrk	7	6	RAC	mid	clv	
28	8:00P	SBCC		Springdale, Pa.	wrk	7	6	RAC	mid	clv	
29	8:00P	SBCC		Springdale, Pa.	wrk	7	6	RAC	mid	clv	
30	8:00P	SBCC		Springdale, Pa.	wrk	7	6	RAC	mid	clv	
1	8:00P	SBCC		Springdale, Pa.	wrk	7	6	RAC	mid	clv	
2	8:00P	SBCC		Springdale, Pa.	wrk	7	6	RAC	mid	clv	
3	8:00P	SBCC		Springdale, Pa.	wrk	7	6	RAC	mid	clv	
4	8:00P	SBCC		Springdale, Pa.	wrk	7	6	RAC	mid	clv	
5	8:00P	SBCC		Springdale, Pa.	wrk	7	6	RAC	mid	clv	
6	8:00P	SBCC		Springdale, Pa.	wrk	7	6	RAC	mid	clv	
7	8:00P	SBCC		Springdale, Pa.	wrk	7	6	RAC	mid	clv	
8	8:00P	SBCC		Springdale, Pa.	wrk	7	6	RAC	mid	clv	
9	8:00P	SBCC		Springdale, Pa.	wrk	7	6	RAC	mid	clv	
10	8:00P	SBCC		Springdale, Pa.	wrk	7	6	RAC	mid	clv	
11	8:00P	SBCC		Springdale, Pa.	wrk	7	6	RAC	mid	clv	
12	8:00P	SBCC		Springdale, Pa.	wrk	7	6	RAC	mid	clv	
13	8:00P	SBCC		Springdale, Pa.	wrk	7	6	RAC	mid	clv	
14	8:00P	SBCC		Springdale, Pa.	wrk	7	6	RAC	mid	clv	
15	8:00P	SBCC		Springdale, Pa.	wrk	7	6	RAC	mid	clv	
16	8:00P	SBCC		Springdale, Pa.	wrk	7	6	RAC	mid	clv	
17	8:00P	SBCC		Springdale, Pa.	wrk	7	6	RAC	mid	clv	
18	8:00P	SBCC		Springdale, Pa.	wrk	7	6	RAC	mid	clv	
19	8:00P	SBCC		Springdale, Pa.	wrk	7	6	RAC	mid	clv	
20	8:00P	SBCC		Springdale, Pa.	wrk	7	6	RAC	mid	clv	
21	8:00P	SBCC		Springdale, Pa.	wrk	7	6	RAC	mid	clv	
22	8:00P	SBCC		Springdale, Pa.	wrk	7	6	RAC	mid	clv	
23	8:00P	SBCC		Springdale, Pa.	wrk	7	6	RAC	mid	clv	
24	8:00P	SBCC		Springdale, Pa.	wrk	7	6	RAC	mid	clv	
25	8:00P	SBCC		Springdale, Pa.	wrk	7	6	RAC	mid	clv	
26	8:00P	SBCC		Springdale, Pa.	wrk	7	6	RAC	mid	clv	
27	8:00P	SB									

Every amateur is interested in receiving confirmation of communication with far distant stations. These cards are only a few of those received by Lieut. Wenstrom, shown below, at his transmitter



message. If the entire message is received correctly, the receiving operator sends "NR7 R"; or he may call for repeats by sending "?WA" (word after), "?WB" (word before), "?AA" (all after), "?AB" (all before). "RPT NR7" or "RPT MSG" would call for a total repetition.

An Amusing Instance

Once there was an amateur traveling on a commercial liner, and checking with a short-wave receiver the signals of an amateur friend ashore. Wishing at the least possible expense to let the shore friend know that all his transmissions had been received well, the sea passenger filed a commercial radiogram of which the text was simply "R." The ship operator obligingly fired the message at a commercial shore station, which promptly came back "RPT TEXT." The ship sent "R." "R URSELF," replied the shore station. "HW ABT THE TEXT?" "TEXT R," said the ship. "NO TEXT NOT R," from the shore station. And so, as Briggs would say, far into the night.

Telephone operation closely parallels code operation, with a few exceptions, such as "come in, please," for the code "K." The procedure is not as standardized as code, and varies a good deal with the individual. The procedure, here given, while not exhaustive, is enough to start with. Other details will be learned that many amateurs operate incorrectly, and as in any other group activity, success depends largely on teamwork. For full information about traffic handling, see the American Radio Relay League's pamphlet, "Rules and Regulations of the Communications Department."

Foreign Countries

In the example calls above we used W as the beginning letter, signifying that the stations were within the continental limits of the United States. The beginning letter for our territories and colonies is K. Similarly, the amateur calls of each nation begin with definite letters, listed in Table 1. With this it is possible to determine at once the particular foreign country from which a received signal is coming. For the last four countries the old intermediates are given, as the new amateur call letters are not yet known.

"QSL" cards are simply postcards on which are printed some details of one's station. Seven typical foreign cards are shown in the photograph. As a rule, cards should be exchanged with a foreign station actually worked. Answering cards from foreign receiving stations or domestic stations is something for the individual to decide, but few operators feel that it is necessary.

Further Tests

The Home Transmitter tests reported

last month were all conducted with plate voltages around 200. In some further tests we added a 100-volt booster unit to the plate supply. It consists of four 24-volt storage "B" batteries, mounted on a board with the charging bulb and switch. This practically doubles the output, and brings the performance, detailed in Table 2, up to that of an a.c. power supply installation. The 12-volt antenna indicating bulb is replaced by one rated at 6 volts, 3 c.p.; this has a normal current

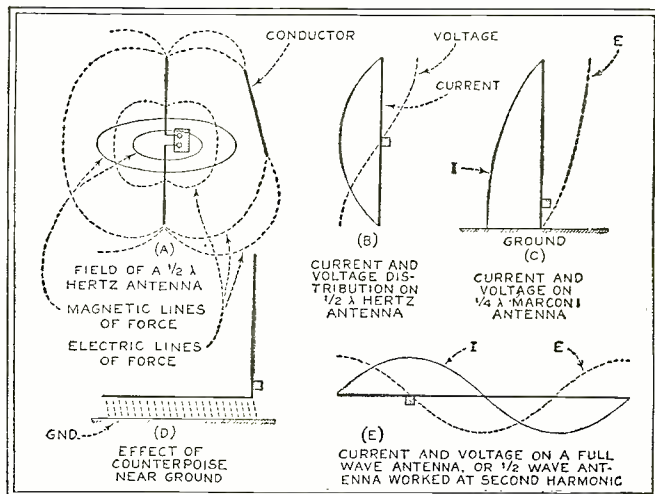

Fig. 1—At A is shown a $\frac{1}{2}\lambda$ Hertz antenna, with the absorption effect of a nearby conductor indicator. B shows the voltage and current distribution of this type of antenna, while in C the same is indicated for a $\frac{1}{4}\lambda$ Marconi antenna. With the latter a counterpoise, as shown in D, may be used. E shows the voltage and current distribution of a full-wave antenna worked at its second harmonic

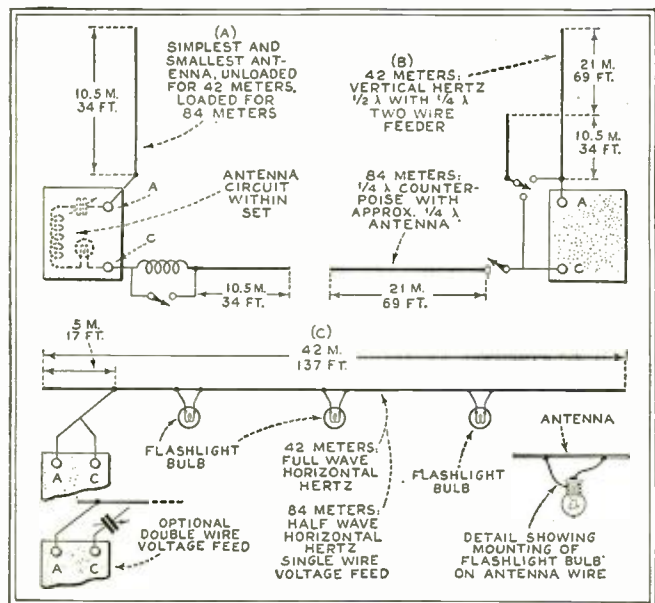

Fig. 2—These diagrams illustrate the various systems of r.f. transmission or "feeder" lines which are in general use in short-wave transmission work

Transmitter should not eclipse the performance here recorded and get 40-meter distance up to 2,000 or 3,000 miles in late night or early morning, particularly later on in the fall and winter. International communication on the 40-meter band has lately been almost at a standstill for several reasons. The one narrow

of .6 amps, a cold resistance of 1.7 ohms, and a white-hot resistance of 10 ohms. We also use a grid leak of 10,000 to 15,000 ohms.

On the first test with the voltage booster we heard VE3BO sending out a CQ, and called him on 41.2 meters. He came back immediately, and reported our signals R5 and QSA3, pure d.c. tone and steady. His location was Toronto, Ontario, about 300 miles away. This was an excellent contact, without interference or repeats—a rather rare occurrence in the crowded 40-meter band. We next raised W3UX at Berwyn, Pa., about 150 miles away. This station was using "break-in," so that we could talk rapidly back and forth despite a good deal of interference. Our signal was R5 QSA5, and steady in frequency.

In another test soon after midnight we tuned the transmitter to 77 meters. The static at W2CX was very bad, and the other stations reported it heavy also. We first raised W3ADX at Allentown, Pa., not far for that time of night. The next contact was better—W9ANQ at Waukegan, Ill., 700 miles out. Considering the output power of about 5 watts, we should not expect much greater distance than this in the 80-meter band. The third contact was W8DMS at Detroit, Mich., distant 500 miles. Each of the QSO's lasted about half an hour, and each new station was raised with surprising promptness for a low-power set.

Some further tests were made with the 40-meter coil. At about 8 a.m. we raised W9GCO of Angola, Ind., 600 miles out, who reported "pure d.c. and QSA3." The next morning W4ADF at Moultrie, Ga., 900 miles to the south, reported "pure d.c. QSA3 steady." One or two other uncertain contacts were made, but the signal had become unsteady due to the varied wobbles of the obsolete 240-volt d.c. lighting circuit, now in its last gasp before conversion to a modern a.c. system. This is a local fault, however, and not a general one; when tested with all battery power, the transmitter sounded like crystal control, as did the same circuit at W2BEI with a.c. supply. There is no reason why builders of the Home

band for all nations has greatly increased the difficulties, particularly for low-power sets; English amateurs report some difficulty in raising even the Continent. Many foreign nations have been slow in licensing their amateurs under the international agreement which went into effect last January. The transmission conditions for 40-meter work have been very unfavorable throughout the summer. The last two difficulties, of course, should clear up by the middle of this winter.

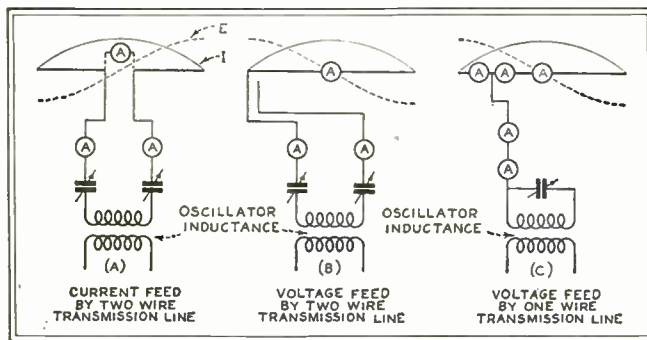

Fig. 3—Three types of short-wave transmitting antenna which will work satisfactorily on 42 meters or from 83 to 85 meters. A is a $\frac{1}{4} \lambda$ antenna, B a vertical antenna with 2-wire feed, and C a horizontal Hertz, $\frac{1}{2} \lambda$, for 84-85 meters or full-wave for 42 meters

Antenna Design

Circuit designers are prone to claim superior results for their sets. We hear statements such as "this transmitter covers extreme ranges with a small input," or "in this location the Colpitts circuit has been found much better than the Hartley, which will not work at all." The truth is that the efficiency of most properly designed oscillator circuits is about the same regardless of type; for a given input they all deliver about the same radio-frequency power to the antenna. Granted an oscillator of average efficiency, then the greatest element in transmitting success is the antenna. Of course, things like location and weather have a great deal to do with it, but over these things we have no control. Within certain limits of space, cost and trouble, we can arrange our antenna to suit ourselves.

From the standpoint of electrical effi-

ciency only, the simplest and most efficient arrangement would be to hang a single wire $\frac{1}{2}$ wavelength (λ) long from a balloon several miles above the earth's surface, and to cut in our transmitter at the center of it. Our receiver, our power supply wiring, even ourselves, would all have to be absent from this picture of electrical efficiency—a limitation which makes it somewhat impractical of attainment. Such a system, shown in Fig. 1A, is called a $\frac{1}{2} \lambda$ Hertz antenna, because Hertz used it to radiate electric oscillations long before radio had any practical significance. In order to construct transmitting antennas it is necessary to know something of the principles which govern them. The writer could simply say "cut this wire a certain length, and stretch it thus." But this is not the way to approach transmitting; one must have some idea of what it is all about. If we look at the antenna of Fig. 1A for a very small instant of time, we shall find that the center oscillator is charging the top wire to one polarity and the opposite wire to the opposite polarity. As in the case of a condenser, therefore, an electric strain exists between the two halves of the antenna; or it creates an electric field, shown by the dotted lines. Within the limits of the frequency and the antenna capacity a momentary current actually flows vertically in the wires and this of course sets up a magnetic field, represented by the horizontal circles. The two fields should not be thought of as separate entities, but as components of the electric field as a whole. At each change of current caused by the oscillator this

field builds up, and with the next current change part of it collapses into the antenna again. But part of it does not have time to collapse before the next current change forces it outward again, and this part, spreading ever outward into infinite space at the enormous speed of light, is called the radiation field—the only useful field for communication purposes.

Absorption Effects

Now let us assume that a conductor is brought near an antenna; we can see from the figure that, coming within the electric field and having currents induced within it, it will seriously distort the field and absorb a great deal of energy. That is why we projected the ideal balloon-hung antenna above—to get it away from absorbers of energy. In actual practice, of course, we fall far short of the ideal—note the W2CX antenna in the photograph, surrounded by other wires.

Antenna Currents and Voltages

We have said that under the urging of the oscillator, potentials and currents momentarily exist in the antenna; let us see how these elements are distributed. Fig. 1B shows the same $\frac{1}{2}\lambda$ Hertz antenna, and the distance away from it of the solid and dotted curves at any point gives an idea of the relative amplitude of current and voltage at that point. The current (solid line) is maximum at the center, and tapers off towards the ends. The voltage (dotted line) is minimum at the center and maximum at both ends. That means, for instance, that it is more important to keep the ends away from absorbers than the middle, for the high voltage at the ends may cause losses. It also means that if we wish to measure the antenna current, we should insert the meter at the center.

Fig. 1C shows a so-called Marconi antenna, in which the antenna proper is $\frac{1}{4}$ wavelength long (or loaded by a coil if less), and the ground (or water) takes the place of the bottom wire of the Hertz system. Where the ground conduction is good, this system is efficient; not so in the case of a high resistance ground, as on a dry desert. This very simple type of antenna was suggested last month as a starting point in transmission tests—the ground being a convenient water pipe or steam radiator. In the Marconi system we do not need to use a conductive ground; we can use a counterpoise (capacitative ground) instead. Such an arrangement is shown in Fig. 1D. It is readily seen that the system is equivalent to that of 1C with a condenser in the ground lead; it offers the advantage of low resistance by reaching directly a large ground surface. Either the antenna or the counterpoise, or both, may be bent instead of straight. The usual transmitting antenna is in effect a compromise between the two systems.

The nearer it approaches the ground, the more it becomes a Marconi antenna; the higher up we get it, the more it approaches the ideal Hertz form. If the reader is interested in pursuing further the general theory of antennas, we suggest Morecroft's "Principles of Radio Communication," Chap. IX; or Lindblad and Brown: "Main Considerations in Antenna Design," Proc. I. R. E. June, 1926.

Harmonic Operation

Going back to the antenna of 1B, we might liken it to a violin string which is plucked at the center. The string will then vibrate as shown by the solid current curve. By plucking the

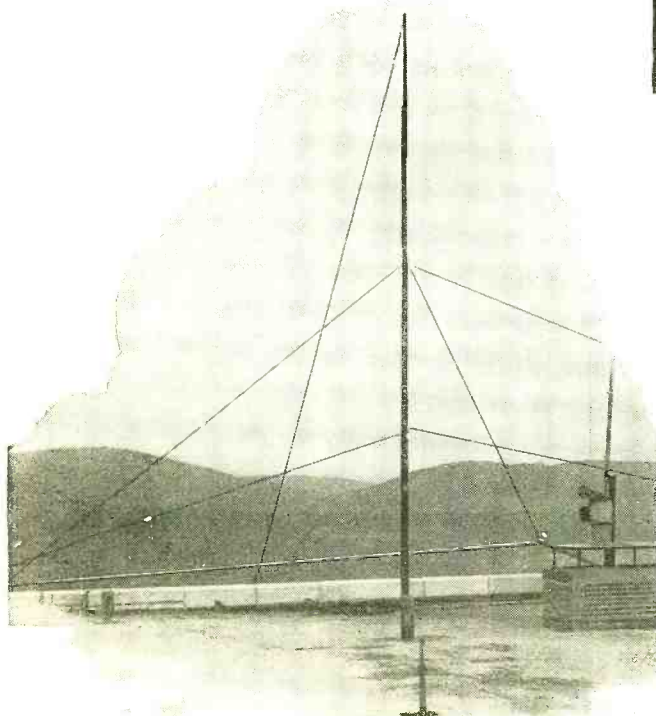
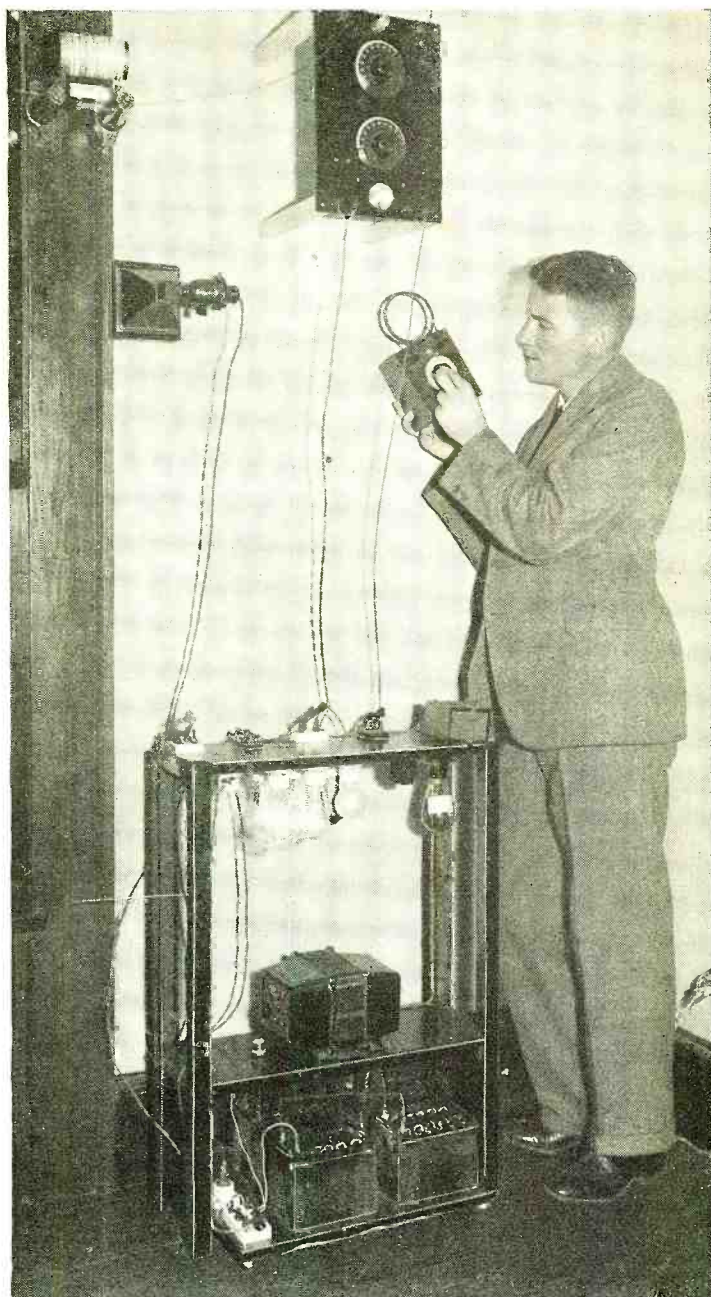

Checking the wavelength adjustment of your transmitter frequently insures efficient operation. The wavemeter tells you whether the transmitter is adjusted to work correctly with the antenna you have provided

Mast guy wires should be broken in electrical lengths by the use of insulators so as not to resonate with the antenna. Otherwise these guys will absorb some of the radiated energy

string in a certain manner, however, we can make it vibrate not as a whole, but in two halves, like the solid current curve of 1 E. (The truth is that it vibrates both as a whole and in parts, but let us neglect this.) The as-a-whole vibration is said to be its fundamental note; the half-and-half vibration is said to be its second harmonic. Similarly, we can have a full-wave Hertz antenna equivalent to two $\frac{1}{2}\lambda$ ones placed end to end. Call it a full-wave 40-meter antenna working at 40 meters, or a half-wave 80-meter antenna working at its second harmonic (40 meters); two ways of saying the same thing.

R.F. Transmission Lines

We have said that we wish if possible to get the antenna up in the air away from absorbers. It may be either vertical, slanting, or horizontal; the last position keeps both ends well away from the
(Continued on page 651)

The panel tester in RAO News Laboratory used to determine the working conditions in the first radio-frequency stage of a manufactured receiver

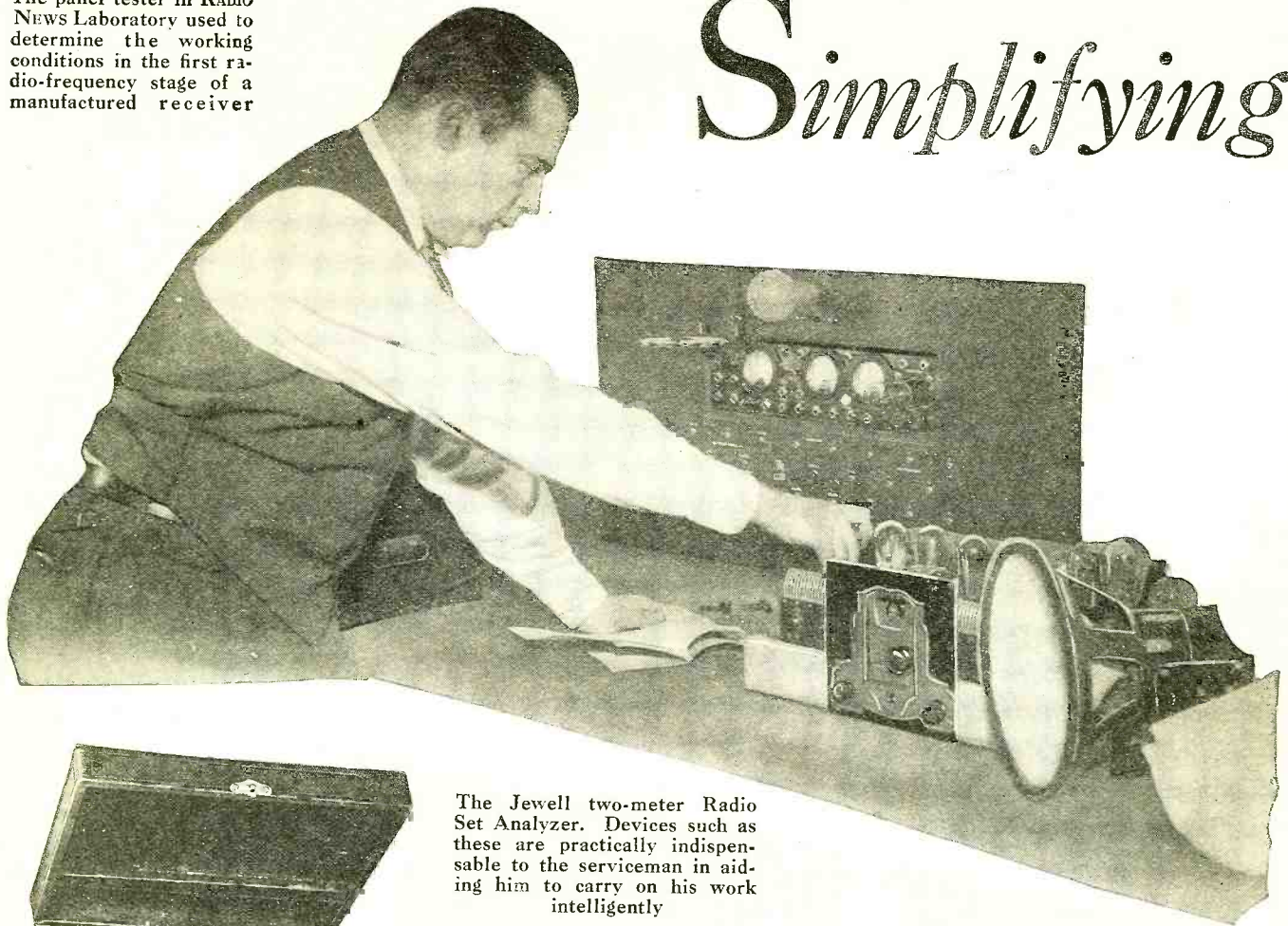

Simplifying

The Jewell two-meter Radio Set Analyzer. Devices such as these are practically indispensable to the serviceman in aiding him to carry on his work intelligently

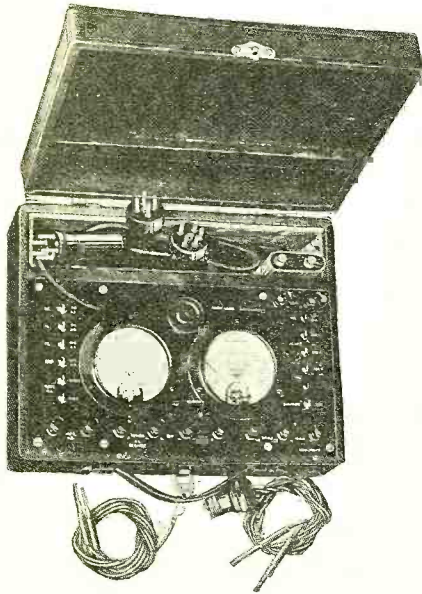

NOT so very long ago, servicing the radio receiver was very much of a "hit-or-miss" proposition. When trouble occurred, the serviceman usually spent hours trying to locate the cause. If by good fortune he happened to ascertain what was wrong with the set, and if he were able to remedy the fault, he generally finished his work by switching the tubes around until the set played loudest. He then considered his job well performed.

Through the use of carefully designed set testers, of which there are a number now available, radio servicing has been put upon a scientific basis. With these instruments it is possible for the radio service-

man to locate any trouble, no matter how intricate or complicated the radio set. He is able to do this in the set-owner's home without moving the receiver, since practically all of these instruments are conveniently portable. Moreover, he is able to test every tube, regardless of its make or type, by an accurate but simple and rapid analysis, which tells him the exact condition of the tube. In one particular unit, the Supreme Diagonometer, if any of the tubes (which have thoriated filaments) happen to be paralyzed, these can be reactivated at once, since the instrument contains a means of rejuvenating tubes. In fact, the tubes may be rejuvenated without removing them from the set. It would be impossible, in an article of this scope, to describe the innumerable tests which can be made with these com-

IN testing a receiver for faulty operation, do you tackle the problem in a hit-or-miss fashion or do you approach it with a definite line of attack in mind?

Successful servicemen who dispatch the job in the shortest time possible, or at least without wasting time in an unsystematic search for the trouble, have found it increasingly important to make use of accepted types of set testers and analyzers in their diagnosis work.

The instruments described here, while only representative of the many which are now available, show the trend in simplifying test procedure, which in the long run amounts to more dollars saved and more customers pleased.

A word to the wise is sufficient.

THE EDITORS

Removing the diagonometer tray from the test panel for placement in the carrying case is a job of but a few minutes



Your SERVICE Problems

Here Are Some Up-to-Date Test Instruments for the Experimenter and Serviceman

All set up and ready for business. The diagnometer is mounted in the recess provided for it in the laboratory test panel, the pin jacks on the panel making access easy to any instrument in the diagnometer

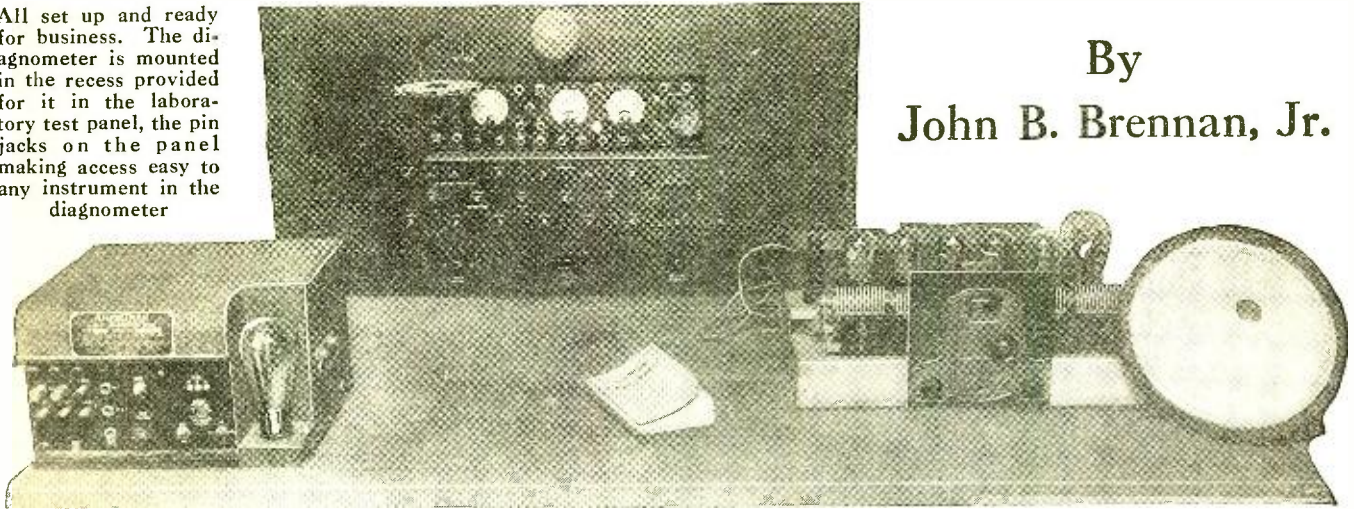

By
John B. Brennan, Jr.

mercial testers. However, a general description of several of the more prominent types of testers will be given.

General Description of the Diagnometer

The diagnometer utilizes three precision meters. These include a four-scale direct current voltmeter, a four-scale alternating current voltmeter and a three-scale milliammeter. A self-contained power plant is built into the instrument. This consists of a step-down transformer with a tapped secondary for using ordinary house-lighting alternating current to provide the different voltages required. The tapped secondary can furnish voltages of 1.5, 2.5, 3.3, 5.0, 7.5, 10.3 and 15 volts. There is a selective switching arrangement for connecting any one

The Supreme Diagnometer mounted in its carrying case for portable use. Racks, as shown, are provided for carrying tested tubes, while the lid of the case contains adapters, clip heads, pin plug leads and spare parts for repair work



of these voltages to the filament circuits of the tube-testing sockets, as desired. By the use of the selector switches, the plate and oscillating circuits are automatically closed, at the same time disconnecting the power plant from other parts of the instrument. A master plunger is provided, by means of which line voltage readings may be taken at any time during the tests. All meters and other delicate parts of the diagnometer are made practically accident and fool-proof, by means of protective resistances and other protective devices.

The diagnometer is equipped with a universal analyzer plug, making possible all analyses with the use of only one adapter. In addition to provision for standard UX and UY type tube sockets, there is a vertical tip projection for the attachment of the control grid of screen-grid tubes and two horizontal contact plugs for attaching the trolley connections of overhead heater-type tubes. All connections are brought into the instrument through the same cable.

An important feature of the Supreme Diagnometer is the oscillator. This is capable of providing oscillation tests on practically all types of tubes, as well as of furnishing modulated radio-frequency signals for the synchronizing and calibration of tuning condensers, neutralizing of radio-frequency circuits and for checking

up the performance of a radio receiver under actual receiving conditions.

The major features of the diagnometer can be summed up under eight headings. These are: (1) Tube Tester; (2) Modulated Radiator; (3) Resonance Indicator; (4) Neutralizer; (5) Analyzer; (6) Continuity Tester; (7) Rejuvenator; (8) External Use of Meters.

However, this instrument can be put to hundreds of other uses. Various fixed condensers are available from .001 mfd. to 2 mfd. There is a 30-ohm rheostat and also a 500,000-ohm variable resistance and even an audio transformer. All these components are ready for instant substitution in a radio receiver.

(Continued on page 672)

The Weston Model 547 Radio Set Tester. Three meters of the multi-range type, together with tester plug and exploring leads, make this a very compact portable unit

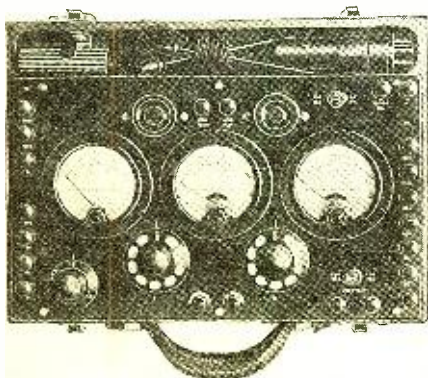

Sound Amplifiers Provide MORE PARKS with MUSIC

By
S. Gordon
Taylor

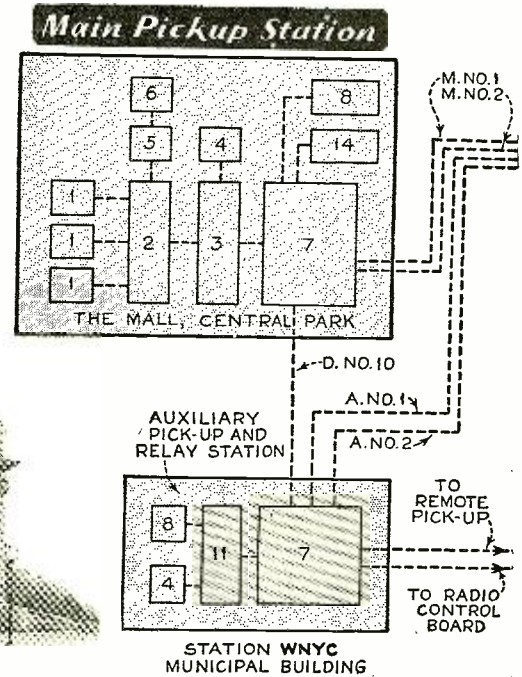
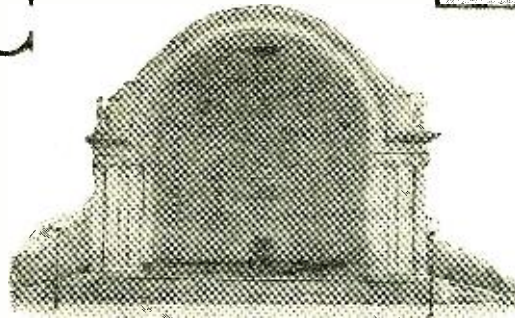

Fig. 1—The famous bandstand on the Mall in Central Park, where concerts originate that are reproduced in other parks throughout the city

THE previous article of this series described in detail the extensive and highly modern sound amplifier system installed in the new high school at Great Neck, Long Island. This month takes up a description of the New York City centralized parks installation.

In the earlier articles of this series consideration was given to many of the technical details involved in installation work, covering installations both small and large. This present article and the one preceding are intended to provide a broader understanding of the almost limitless applications of sound amplifiers. It should be realized that the average installation man or radio man just entering the sound amplifier field can scarcely hope to handle such extensive jobs. Even if the design of such installations lies within his ability, the financial end offers difficulties because of the comparatively large sums of money involved. Nevertheless, these descriptions of outstanding installations will provide many ideas which are directly applicable to correspondingly smaller installations in other communities, and are therefore of direct value to installation men.

Succeeding articles in this series will outline details for making small installations. These will include descriptions of a number of typical small installation projects, and an effort will be made to include detailed circuits and specifications.

The New York City parks installation is of special interest to professional radio and sound amplifier men because it involves some fundamental ideas which are bound to grow in popularity with municipal governments, thus opening new opportunities for those concerned in the equipment and installation fields. In order to bring out these ideas it is necessary to go back several years.

For a number of years concerts have been provided nightly throughout the summer season in New York City by world-famous bands. These concerts are given in Central Park or the City College Stadium and originally had the drawback that only a very small proportion of the music lovers of the city were able to crowd within hearing range. Later the municipal broadcast station, WNYC, and one of the national broadcast chains undertook to broadcast these programs, thus making them available to millions of listeners all over the country, but there were still many residents who, lacking radio receivers, could not enjoy the concerts.

When Mr. Albert Goldman became Commissioner of Plant and Structures for the City of New York he recognized this deficiency and conceived the idea of installing amplifiers and loud speakers in other parks throughout the city so that the concert programs from Central Park or the Stadium could be reproduced in all sections. Thus a resident in any part of the city could enjoy the concerts simply by going to a neighborhood park.

Under the supervision of Mr. Goldman, plans were drawn and designs were made by Mr. Isaac Brimberg, engineer in charge of the radio division of the Department of Plant and Structures. The planning of such a comprehensive installation was greatly complicated by the fact that New York City includes an area of approximately 298 square miles and has a total of 230 parks distributed throughout this area. Many of these parks are not much more than public squares and not sufficiently large to justify the installation of

amplifiers and reproducers. Some of the larger parks are so close together that individual installations were scarcely justified. After careful consideration it was decided to start by equipping 25 parks and gradually increasing this number in succeeding years until the ultimate total of 80 had been equipped.

As soon as plans could be drawn and specifications made up bids were called for and the contract was awarded to the Natural Sound Amplifying System, Inc. Work was started almost immediately on the actual installation, with the result that it was in operation before the end of the summer.

Details of System

In general the complete installation consists of a pick-up station at the Mall in Central Park, with provision for auxiliary pick-ups from the studios of the municipal broadcast station, WNYC, or through WNYC from other remote points, such as the Lewisohn Stadium at City College and the bandstand in Prospect Park, Brooklyn. From these various sources concert programs are available every evening and also Sunday afternoon. In addition other programs of special interest are available through WNYC. With this arrangement there is never a lack of material of the highest calibre.

From the pick-up station at the Mall in Central Park, or its auxiliaries, the programs are fed into the main distribution station located in Central Park near the Mall. At this station the programs are distributed to the eight Manhattan parks and also to four sub-distribution stations located in the four boroughs outside of Manhattan. At each of these sub-distribution stations the programs are amplified again to compensate for line losses, and from each sub-distribution station the

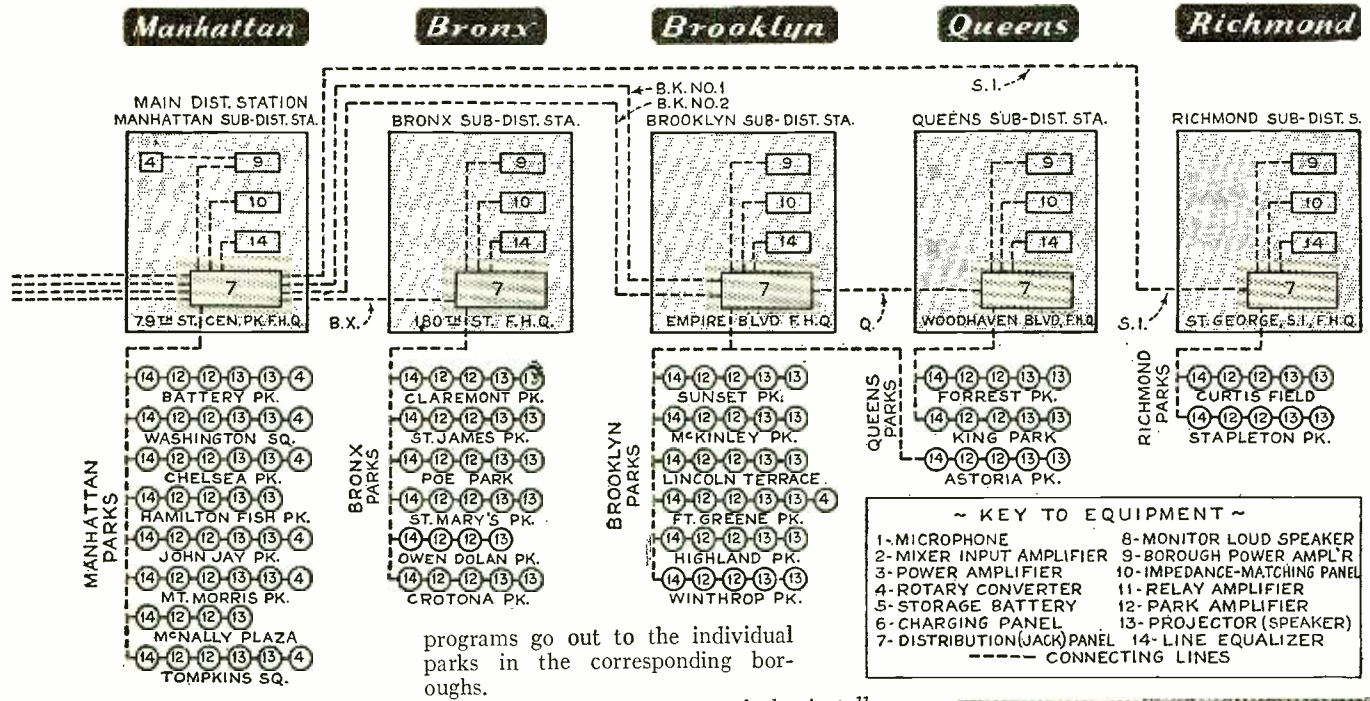

Fig. 2—Some idea of the problem of distributing the concerts from a central point to the other city parks may be obtained from the diagram above

programs go out to the individual parks in the corresponding boroughs.

The general arrangement of the installation is graphically shown in Fig. 2. The main pick-up station on the Mall is shown in the upper left and below it the auxiliary pick-up and relay station at the studios of WNYC. The outputs of these are fed into the main distribution station and from there to the sub-district stations and to the individual parks.

The installation man will naturally be interested in the equipment employed in the various portions of this installation. An accompanying illustration, Fig. 1, shows the huge bandstand erected on the Mall in Central Park. In this three portable microphones are employed and their outputs are carried through individual lead-sheathed cables to the operating room in the basement of the bandstand. Fig. 3 shows a view of the rack installed in this operating room. In this illustration the markings indicate the functions of the various parts quite distinctly. The top panel is the volume indicator, which has a vacuum tube voltmeter arrangement providing direct meter readings indicating volume level. The larger panel immediately below this contains the mixer and speech amplifier equipment. The mixer employs three tubes, one for each microphone. These are the three shown at the extreme left. The milliammeter directly above them provides a plate current reading on these tubes. The (Continued on page 652)

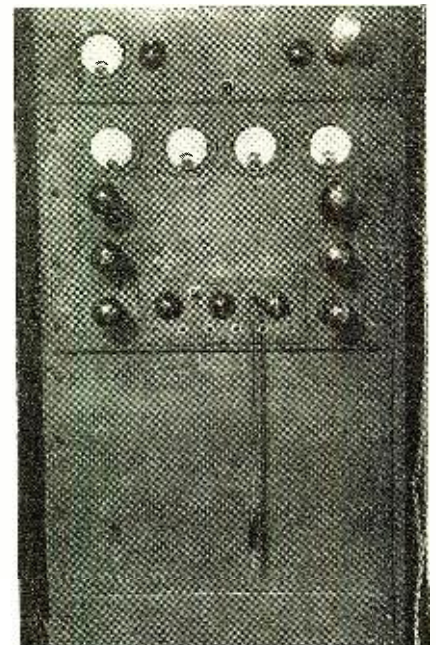
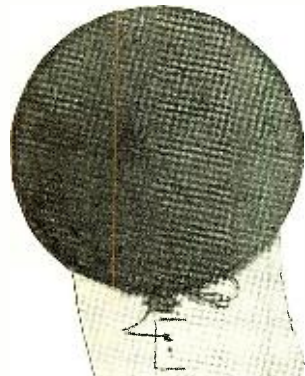
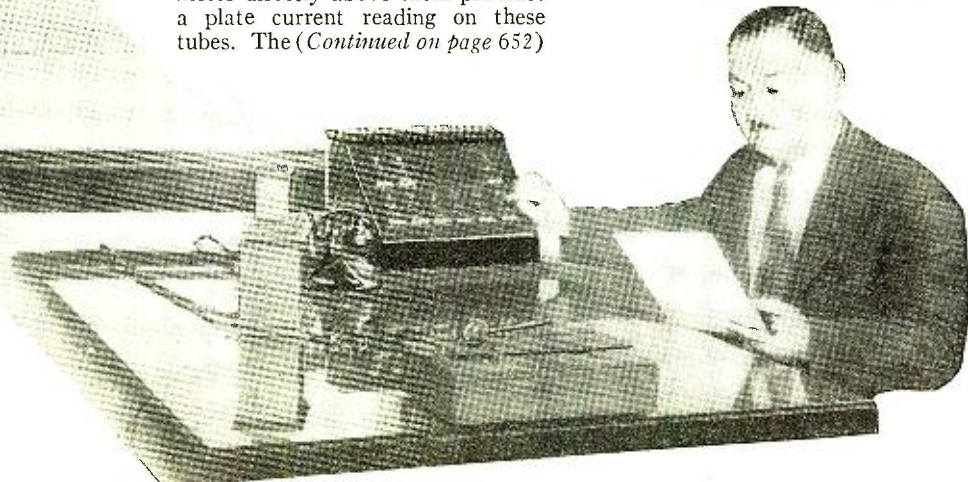

Fig. 3—The Samson amplifier rack located in the basement under the bandstand. Here the concerts are monitored and amplified before being sent to the other parks

Fig. 1—Isaac Brimberg, engineer in charge of the Radio Division of the Department of Plant and Structures of New York City, who designed the centralized parks amplifier system described in this article



The Radio News-Elco Boat Receiver

Constructional Details for Building a Broadcast Outfit which also may be used for Direction-Finding

IN all our experiments with receivers suitable for use on motor boats there have been two major problems to solve—two conditions to be met and overcome.

First, interference created by the ignition system, comprising the spark coil, distributor, wiring and spark plugs, had to be eliminated. This was accomplished by the use of shielded spark plugs and a complete system of shielded wiring. For this purpose we used the Hahn spark plugs and shielded ignition wire.

Second, microphonic noises, set up by the vibration of the boat while under way, was first solved by the use of a.c. type of tubes powered from a d.c. source. The circuit featured in the receiver employing this type of tube was described on page 413 of RADIO NEWS for November. Recently that receiver has been modified so as to make a more presentable appearance and also its circuit has been changed so as to adapt it for use on boats having a 12-volt storage battery.

In the d.c. model boat receiver, illustrated in the December issue, the bugbear of microphonic noise was eliminated by the use, in a d.c. circuit, of heavy tube ballast shields which prevented each tube as a whole from responding to these vibrations. Both the d.c.-operated a.c. tube model and the d.c. model with shield ballasts have satisfactorily performed without the slightest trace of modulation due to vibration effects.

The circuit of the d.c. model RADIO NEWS-Elco Boat Receiver is shown in Fig. 1, values for the parts employed noted thereon.

On the set's panel are five knobs, one

THE family who used to find recreation in its automobile now finds more labor than rest in a motor trip. Congested traffic, an ever-increasing problem, is forcing America to take to the water. The quiet beauty and serenity of our coastal waters, our rivers and lakes, are rapidly usurping the place of the paved road as a field for rest and recreation.

With this thought in mind, the importance of the experiments now under way by RADIO NEWS and the Elco Boat Works takes on a new significance. Within my memory the yachtsman was considered a financial plutocrat; he belonged to a favored class. But today "the butcher, the baker, and the candlestick maker" have their cruisers. American ingenuity and production methods have brought yachts, like automobiles, within the reach of the average American family. That may surprise you, but it is nevertheless true. A motor cruiser costs no more than a good automobile.

Satisfactory radio reception aboard these thousands of small yachts is thus an important step forward for hundreds of thousands of people. Motor cruising will be made safer and pleasanter. Music and entertainment will be always available, while in fogs the yachtsman will be able to make port with a minimum of danger and inconvenience. Weather forecasts and storm warnings, broadcast at frequent intervals, will also be at his command.

Motor cruising has already been made as safe as, or safer than, automobiling. This new safety factor, made possible by the persevering effort of RADIO NEWS co-operating with us, coincides with the introduction of four-wheel brakes on the motor car. It is an added margin of protection which, like many things, may not be needed often, but on certain occasions becomes indispensable.—Henry R. Sutphen, President, National Association of Engine and Boat Manufacturers; Vice-President, Electric Boat Company.

meter and one switch. The meter is placed permanently in the tickler circuit of the detector stage and is useful, when the set is operated with a loop for direction finding purposes, in indicating minimum or maximum signal strength. Its exact use will be described later. Directly below the meter is a double-pole single-throw jack switch which opens up the filament and "B" battery circuits, entirely disconnecting the receiver from the batteries. To

the right of the meter is the resistance regeneration control, while to the left is the resistance screen-grid voltage control, used more or less as a volume control. In the lower center part of the panel is the knob which controls the drum dial and which in turn controls both two-gang tuning condenser units. On the left is the trimmer condenser for the antenna stage and to its right, the trimmer for the detector stage.

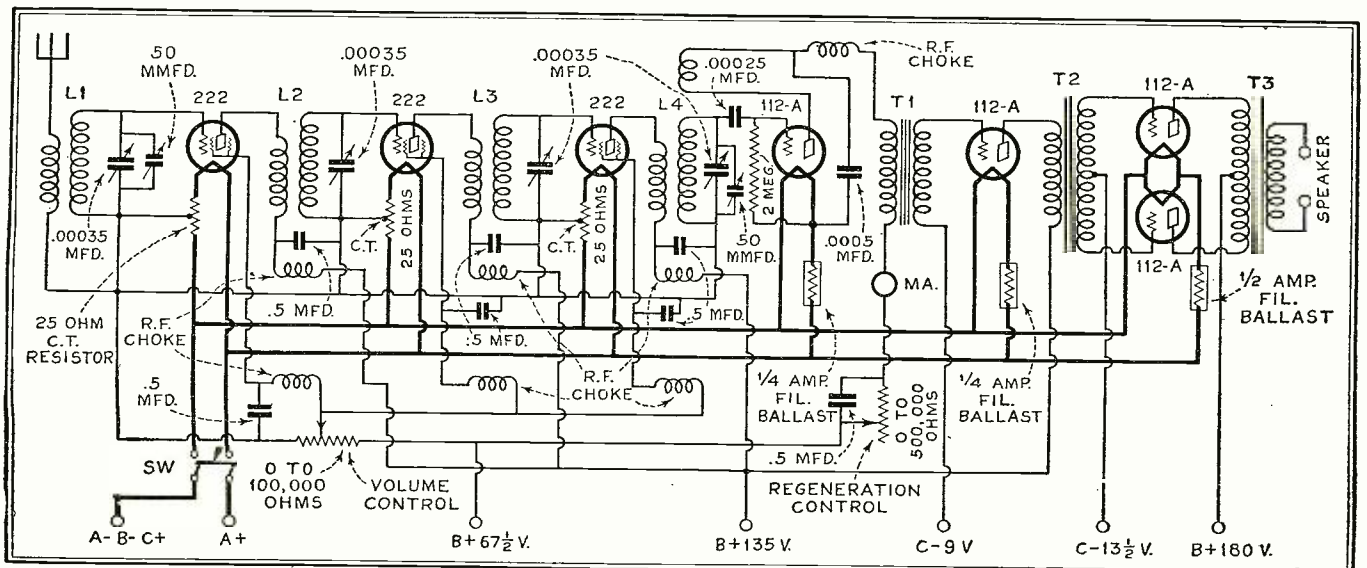
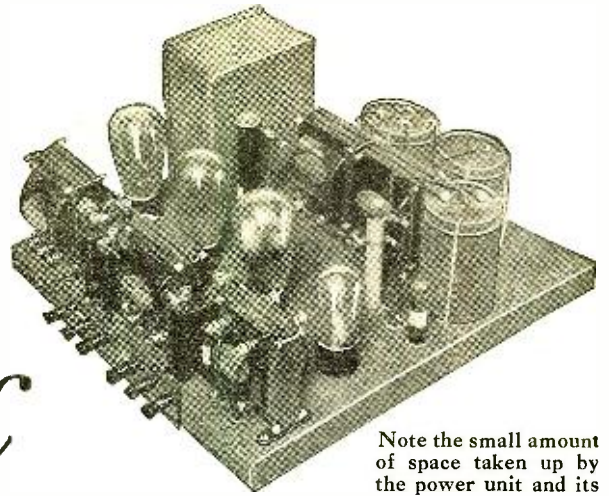

Fig. 1. This is the complete circuit of the d.c. model Radio News-Elco Boat Receiver. The coils used are standard Remler broadcast coils, No. 562 and 564, the latter being used in the detector circuit. All the other parts employed have their values indicated on the diagram

Improving the "250" Power Pack with Electrolytic Condensers



Note the small amount of space taken up by the power unit and its electrolytic filter condensers. A total of fifty-eight microfarads is provided for the filter section

By R. U. Clark, 3rd

MANY attempts have been made to produce a long-lived electrolytic condenser of the aluminum and borax type that will stand a d.c. peak voltage in excess of the present rather critical value of 400 volts (about 340 working volts maximum). So far no real lasting success has crowned such efforts; however, experimental progress points to eventual success.

It has been shown in previous articles that the wet electrolytic condenser will operate safely at a working voltage which is 85% of the peak rating. This is due to the electrical leakage characteristics of the condenser. This feature accounts for the widespread success of the electrolytic unit in the "245" type of power pack.

Although single blocks of electrolytic condensers are not suitable in their pres-

ent form for direct connection to high-voltage filter networks such as supply voltage to accommodate the 210 or 250 tubes, such condensers can be, and are being, used commercially in series, and singly in special circuits to filter high-voltage rectifier outputs.

The use of electrolytics in a series circuit to filter high voltages is not new, but such use involves a point for argument among engineers, viz: unless the series units are equal as to capacity and leakage current the voltage filtered will divide unequally across the condensers, overworking one and under-working the other. This is not true, however, of units at the voltage divider where the potentials at the condensers are held constant by the proper arrangement of condenser connections to the voltage divider.

In the case of a series arrangement of condensers at the rectifier, however, if the leakage current or capacity is unequal the insulating films assume new voltage breakdown levels in the course of time. This, in turn, will automatically vary the capacity of the individual units, and thus will also act to unbalance the filter. If well-matched condenser units

are employed in the construction of the power pack no difficulty will be experienced in their use, unless one condenser happens to contain more impurities in solution than its mate and the filter is used only intermittently. In such a case the poor unit should show a high leakage current after a few weeks' use. Then, of course, it should be replaced.

Condenser units which show a high leakage current, if used at fairly frequent intervals, say every day or so, will have but little adverse effect upon the filter unless the units are overloaded or heating occurs.

In the high-voltage power pack shown in Fig. 1 the circuit is so arranged that even if poorly matched condensers are used they will always be kept in good working order, due to the use of small resistors which connect directly to a point of sufficient potential on the voltage divider to cause the voltage to divide nearly equally across the units. These stabilizing resistors must be of at least 5000 ohms resistance if a low hum-level is desired.

The filter shown is suitable for use in a power unit for supplying either a single 250 tube or a push-pull 250 audio amplifier.

In the event that the filter is to be used with a phonograph amplifier the resistance of the lower section of the voltage divider should be reduced from 16,000 to about 10,000 ohms. The divider in all cases should be capable of handling at least 10 watts safely.

It will be noted that three different sized electrolytic condensers are used in the hookup shown; a single 8 mfd., a double 8 mfd. and one triple unit consisting of one 18 mfd. section and two 8 mfd. sections. When connected in this manner the effective main filter capacity in the power tube is 4 and 4 mfd., and in the voltage divider 4 and 8 mfd., making a total of 20 mfd.

The variations in transformer secondary voltages and choke inductance rating are to allow for different load conditions, the

(Continued on page 665)

Fig. 1
The "power supply" circuit, featuring the electrolytic condensers in the filter section. All values of parts used are indicated

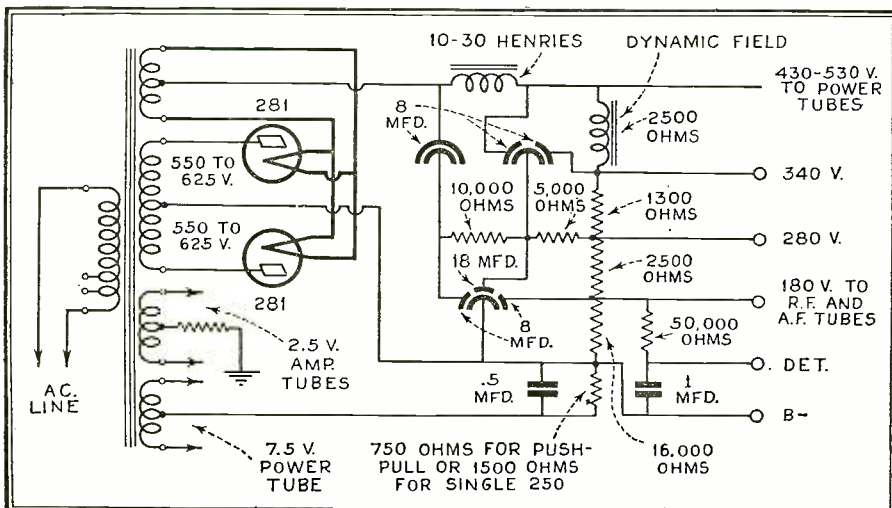

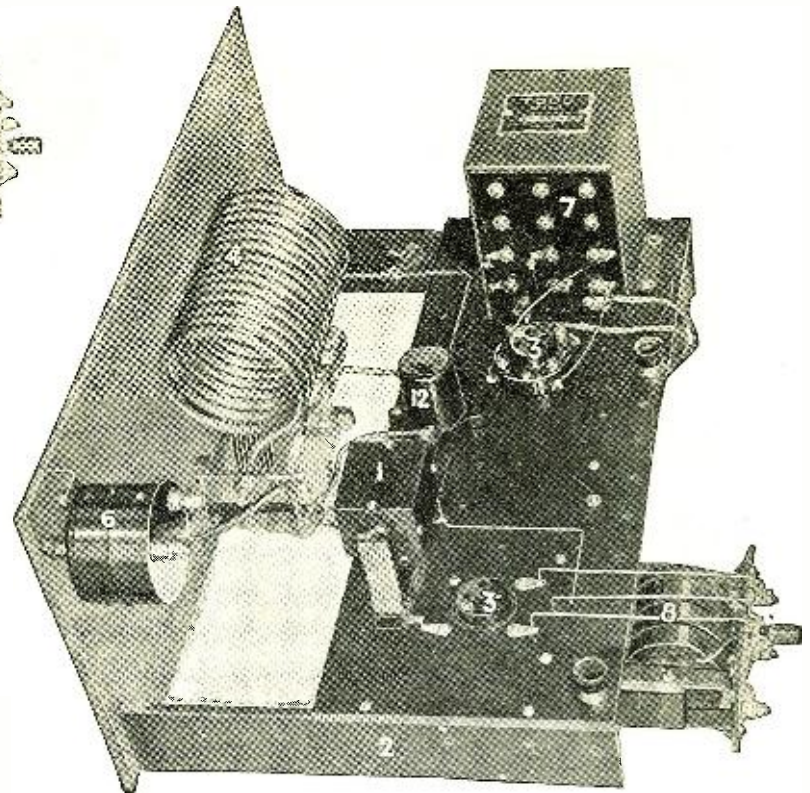
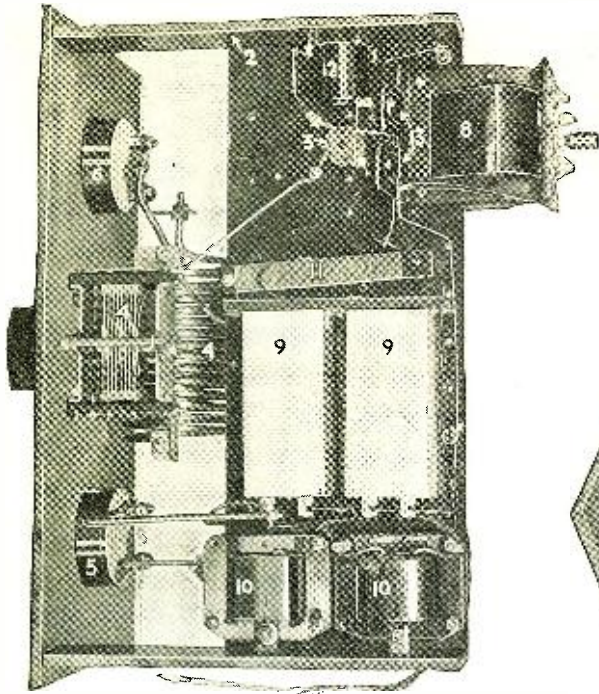

Further Constructional Details of the

Spangenberg

200 WATT

Parts List for Crystal Oscillator Panel

- 1 3,500 kc. crystal and holder (1)
- 1 complete frame (2)
- 2 UX tube sockets (3)
- 1 Cardwell .00035 mfd. condenser and dial with coil attached (15 turns) (4)
- 1 0 to 100 milliammeter (5)
- 1 0 to 2 Weston thermo-couple r.f. meter (6)
- 1 Todd type T80-275 power transformers, 350 volts (with filament supply for UX280) (7)
- 1 Todd type F-7.5 filament transformer, 7½ volts (8)
- 2 Flechthem 6 mfd. filter condenser (600 volts) (9)
- 2 10-henry chokes (10)
- 1 15-ohm fixed rheostat for filament transformer (11)
- 2 General Radio 8-henry chokes (12)
- 3 Sangamo .002 mfd. condensers (13)
- 1 UX210 tube (14)
- 1 UX280 rectifying tube (15)

Parts List for Frequency Doublers

- 1 complete frame (1)
- 1 Cardwell .00035 mfd. condenser and dial with coil attached (10 turns) (2)
- 1 Cardwell .00025 mfd. double spaced condenser and dial with coil attached (5½ turns) (3)
- 1 UX tube socket (4)
- 1 RCA tube socket and mounting for UX203A (5)
- 1 Sangamo .002 mfd. condenser (6)
- 3 Sangamo .002 mfd. condenser (5,000-volt test) (7)
- 1 Jewell a.c. voltmeter, 0-15 volts (8)
- 1 Jewell milliammeter, 0-200 mills (9)
- 1 r.f. choke, ½" diameter, 400 turns No. 28 d.c.c. wire (10)
- 1 r.f. choke, 1" diameter, 350 turns No. 30 d.c.c. wire (11)
- 1 Ward Leonard vitrohms resistor, 10,000 ohm, type 507-8 (12)
- 1 key relay shunted with a 5,000-ohm resistor in series with ½ mfd. (1,80 volts) condenser (13)
- 1 UX210 tube (14)
- 1 UX203A tube (15)
- 1 high-voltage condenser, .002 mfd. (16)
- 2 200-volt condensers, .002 mfd. (17)
- 1 Faradon high-voltage condenser, .002 mfd. (18)
- 1 r.f. choke, 1¼" diameter, 300 turns No. 28 d.c.c. wire (18)

THIS month we take up the construction details of two of the sections of the Spangenberg 200-watt short-wave transmitter, the Home Set DeLuxe, described on pages 398 and 399 of the November issue of RADIO NEWS.

In that issue the photographs showed quite plainly the general scheme which was employed in assembling into a complete whole the four units which comprised the transmitter.

The illustrations accompanying show the layout employed in the crystal oscillator and the frequency doubler, the first two units to be described separately.

Above, to the left, is shown the underside view of the crystal controlled oscillator panel, while directly to its right is shown the constructional and assembly details of the top side of this unit.

Second from the right is shown the underside of the frequency doubler unit. The placement and layout of the various parts which comprise this unit are clearly indicated.

The photograph to its right shows the top view of the frequency doubler as seen from the back.

Each of the parts in both units is numbered to conform with the numbered part in the parts list. Also, the circuit diagram, shown at the right, is similarly numbered so as to indicate the position and use of the part in the circuit.

With the aid of the photographs, which indicate the general layout and mode of assembly and the numbered parts which in addition have their respective values noted also, it should prove comparatively simple to prepare, assemble and wire the parts into a complete whole.

In a following issue will be presented photographically the layout of the power amplifier unit, the assembly of the transmitter as a whole, and the general information concerning its construction.

This 200-watt crystal controlled station has been on the air for six months and is widely known for its steady, clear signal.

With it Mr. Spangenberg has contacted amateurs in most every part of the globe, particularly New Zealand, South Africa, India and many points in Europe.

The transmitter is operated under the call letters W2MB.

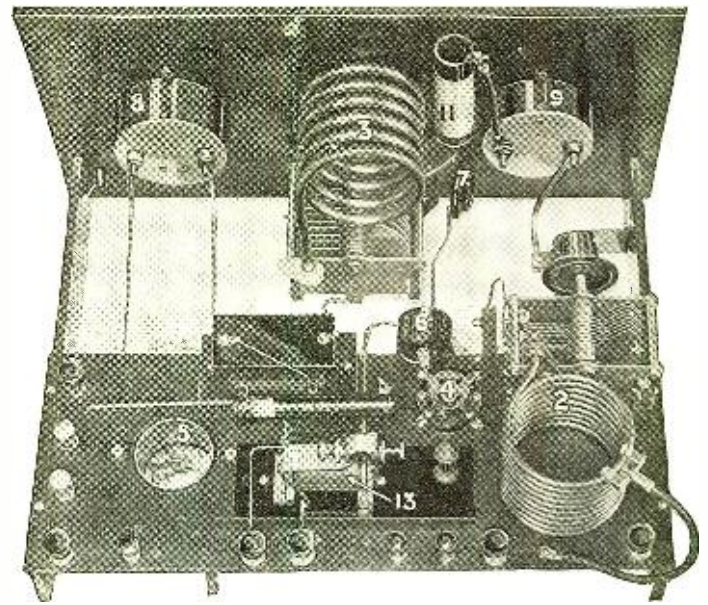
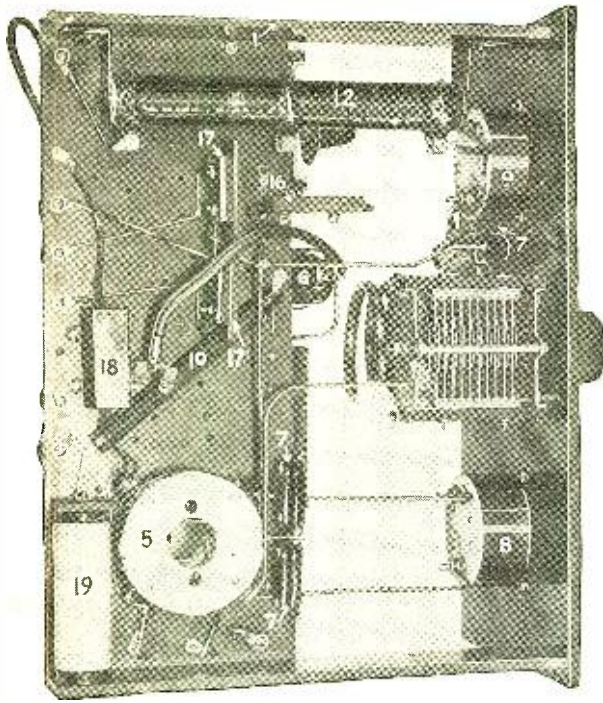

In Pictures and Diagram

SHORT WAVE TRANSMITTER

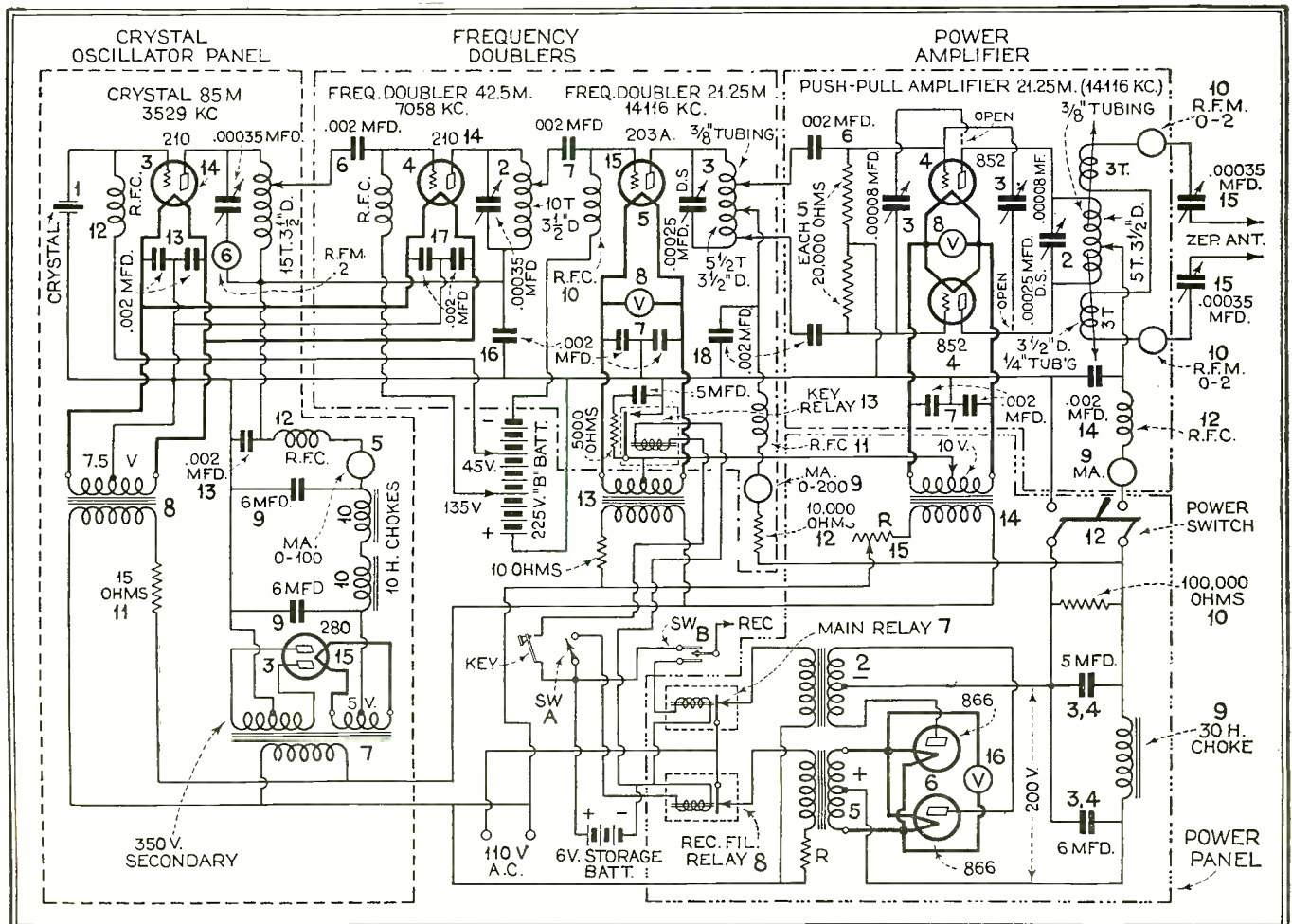

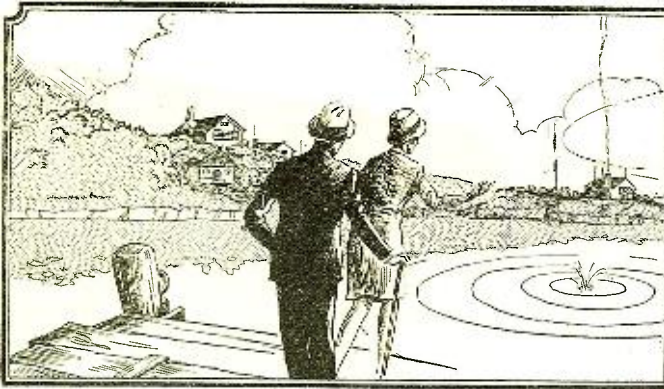

A stone, thrown in the water, causes waves to radiate in ever-widening circles

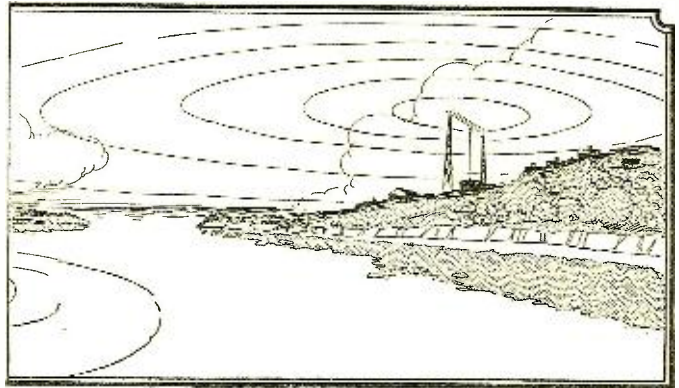

The waves from the antenna of a radio station, while not visible, are radiated in much the same manner



The Junior RADIO Guild



LESSON NUMBER SIX

The Fundamentals of Radio

ONE of the first questions which the beginner in radio is apt to ask is "how does a radio station send out its signals?" To answer this so that you will get a clear idea of the action involved, suppose we make use of an analogy for an example. Time and again this simple analogy has been employed and will serve again here. Supposing you throw a stone into a body of water, say, a lake. You will notice that as the stone strikes the water, waves of a circular form are set up and slowly expand in radius until perhaps the force of the impact is totally expended. (See the picture above, to the left).

In general, this is what happens when a signal is sent out from the antenna of a radio station. That is, the waves, carrying the signal, radiate into space, only the speed with which they travel is very rapid—186,000 miles per second.

Now, going back to our lake, supposing at some distance from where the stone struck there was a bit of wood floating quite serenely. When the waves radiated by the stone reached the wood it would bob up and down on the waves. In other words, the waves set up by the throwing of the stone have imparted a motion to the bit of wood.

Similarly, if we can have an antenna erected on our roof, then the waves set up by the broadcasting station's antenna will strike it and a portion of the wave will be absorbed and passed along to whatever receiving apparatus is attached to it.

If there are many pieces of wood in our lake, all within range of the waves set up by the stone, each one will be affected and will bob up and down. Similarly if there are many antennas within range of the waves broadcast by the antenna of the radio station, then each one will absorb a minute

THE Junior Radio Guild is an organization whose membership is composed of boys who are interested in learning more about radio.

This organization, under the direction of the Technical Staff of RADIO NEWS, has prepared a series of lessons for beginners. The lesson printed here deals with the fundamentals of radio.

Future lessons will show you how to build another type of radio receiver.

If you wish to join the Junior Radio Guild, fill out and send to us the coupon on page 672.

portion of the wave and will affect the receivers attached to them.

This, of course, will explain only roughly the general way in which broadcasting stations and receivers affect each other. There are many ramifications which enter into the rather complicated system of radio transmission, but for the purpose of drawing a simple parallel here it will not be necessary to go into the technical details involved.

At the Other End of the Receiving Antenna

The radio signals which are absorbed by the receiving antenna are of such a nature as to be inaudible to the human ear. They are composed of vibrations which occur so rapidly that, without the proper kind of apparatus, we cannot hear them directly. Therefore, what this apparatus does is to convert these rapid vibrations into sounds that are intelligible to us. This apparatus we call our receiving set, and during all the years of progress in the radio art these receiving sets have grown from simple crystal sets to the rather complicated multi-tube receivers we have with us today.

To the beginner, however, the crystal receiver, so called because it makes use of a piece of galena or silicon crystal to convert or rectify the transmitted signals so that we can hear them, still commands a great deal of interest because it is simple to build, easy to operate and requires no batteries to make it function.

The wave which is transmitted from the antenna of the broadcasting station is what is called a carrier wave. That is, it carries the voice or music vibrations, which are superimposed upon it, from the microphone which is in the broadcasting studio. The carrier

Fig. 1

The circuit of a simple crystal receiver. S1 and S2 are contact switches; L is a coil wound as described in the text; C1 is a variable condenser of .00035 mfd.; R is a crystal detector; C2 is a .002 mfd. fixed condenser, and P a pair of headphones

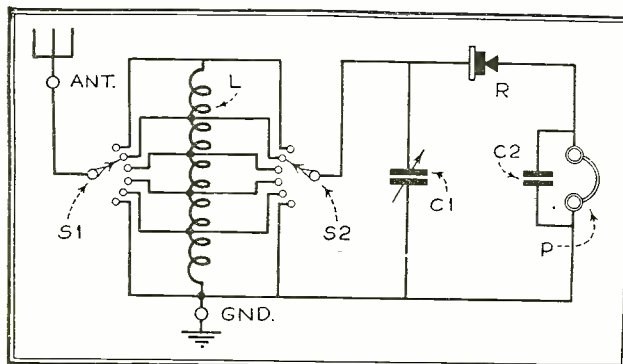

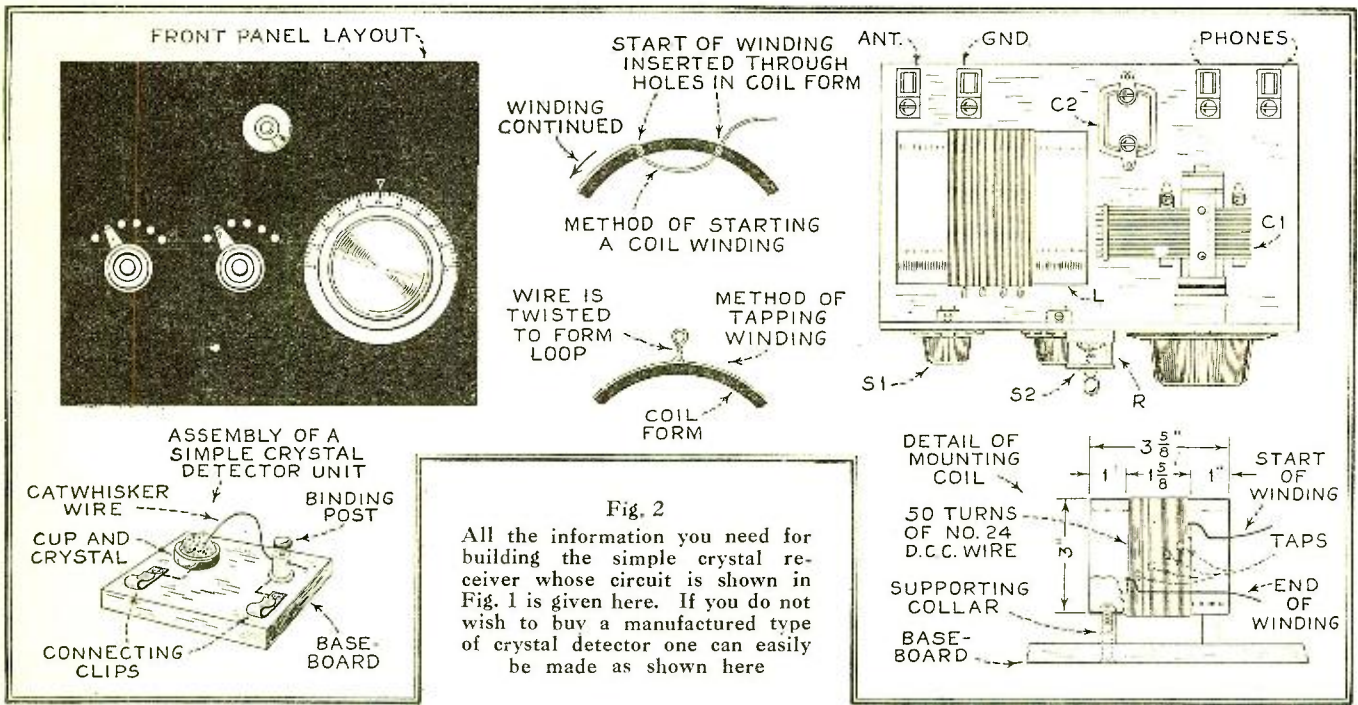

wave form is shown in A, Fig. 3. Note that the amplitude, or in other words, the strength of one vibration, is as strong or equal to the others. However, when the voice currents from the microphone are passed along to it through the various amplifiers which are employed in the studio control room then the shape is varied as shown in B. Here the minute variations of current, or vibrations of different amplitude, change the shape so that there are various heights of hill and valley, so to speak, on either side of the center line.

These rapid vibrations, occurring at such a speed as to be inaudible to the human ear, are radiated from the antenna of the station and, as explained previously, are radiated into space.

When they reach a receiving antenna where the receiving apparatus, that is, the coils and condensers, have been adjusted to tune to those particular signals, they are absorbed and passed on to the crystal detector. Here, they are caused to operate the crystal detector so that, while it does not register the minute changes of each vibration, it does register the difference between vibrations, or in other words, only passes on to the phones that current which may be indicated by the envelope-shaped curve in C of Fig. 3.

The amount of signal which is heard in the phones depends largely upon first, the tuning qualities of the coil and condenser to tune only to the desired signal, and secondly, upon the sensitivity of the crystal detector. Through practice, a sensitive contact can be found on the crystal which will give the maximum amount of signal.

How to Build a Crystal Receiver

One of the simplest of these crystal receivers is described here and is repre-

sented diagrammatically in Fig. 1. Here we have a coil, L, consisting of 50 turns of No. 24 d.c.c. wire on a cylinder 3 inches in diameter by 3 5/8 inches long. The actual winding space occupies 1 5/8 inches, leaving a margin at each end of 1 inch.

The coil is tapped at every fifth turn, the tap being brought out to a double set of switch taps, indicated by S1 and S2. To the end of the coil and S2 is connected a variable condenser C1 which, with the two switches, tunes the receiver to the desired signal. The tuned-in signal is then rectified by the crystal R and fed to the headphone P. Across the headphones is connected a fixed condenser so as to make the signals of stronger intensity in the headphones.

All of the apparatus can be mounted on a board about 9 inches square and arranged as shown in Fig. 2.

end of the wire through the holes to fasten it and then begin winding.

At every fifth turn, as the winding of the wire advances, the wire is twisted in a loop as shown, until all fifty turns are completed.

Connection of the various pieces of apparatus is shown quite clearly in the accompanying sketches.

To operate the receiver some random adjustment of the switch S1 will have to be made until you become acquainted with the manner of operating the set. Set switch S2 at the top of first tap and then slowly rotate the knob of the variable condenser until a signal is heard. If you have a manufactured type of crystal detector, then all that will be necessary to obtain a clear signal is to touch the fine pointed wire to various spots on the surface of the crystal until the most sensi-

tive one has been found. The drawing shows how a home-made one can be made.

Next month the Junior Radio Guild Lesson No. 7 will describe radio symbols as used in the preparation and reading of circuit diagrams and will outline the first unit of a vacuum tube receiver which will be described in future lessons.

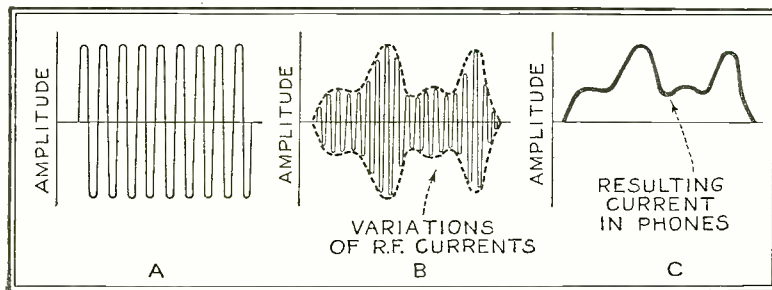

Fig. 3

At A we show the continuous wave or carrier waves set up by the oscillators at the transmitter; in B the microphone current has changed the form of this wave to conform with the variations in the speech or music which is being broadcast; at C is shown the form of the current variation which operates the diaphragm of the headphones attached to the crystal set

The coil for this simple receiver is wound as follows:

Punch two holes close together about 1 inch from the edge of the tube, pass an

YOU or your friends may join the Junior Radio Guild merely by sending us the membership coupon (properly filled out) which is printed on page 672 of this issue. There is no age limit, nor do we require that you have any previous training in or knowledge of radio. Of course, if you are familiar with radio, know how to read circuit diagrams or build a set, so much the better. The lessons will then help you to review what you already know.

The Trade Announces:

New Equipment and Manufacturing Trends

An Audio Oscillator

For the radio laboratory and experimenter the Wireless Egert Eng., Inc., has designed a new audio oscillator under type No. A01. The announcement for the precision instrument is that the oscillator is intended for use with any apparatus

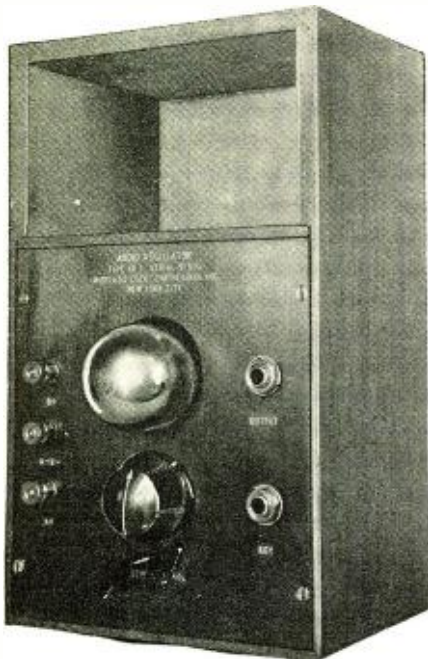

Fig. 1—A compact audio oscillator

which requires a steady audible note over the frequency band of 200 or 4,000 cycles. Provision is made by a pair of plugs for a speaker in the output circuit and the note to be interrupted by a key, allowing the oscillator to be used for code work among its many other uses such as the

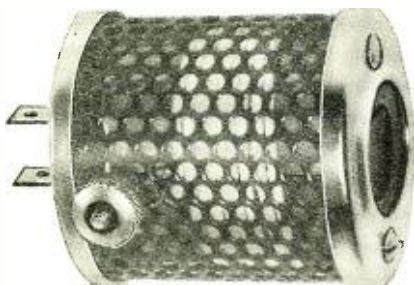

Fig. 2—Antenna and voltage controller combination

modulation of CW transmitters, testing loud speakers and amplifiers. A compartment is furnished in the solid walnut carrying case for earphones when the apparatus is used as a portable unit. Fig. 1 shows the oscillator with the top removed.

Antennavolt by Insuline

The announcement of a combination socket antenna and voltage controller is made by the Insuline Corporation of America, the new antennavolt. This device has all the advantages of a socket antenna and at the same time preventing a.c. tubes and set wiring from damage or burn out by overloading. A binding post is provided on perforated Japanned metal body for the antenna connection. Two models are obtainable, in the light duty for operation of sets requiring up to 125 watts and heavy duty with a safety factor up to 250 watts, Fig. 2.

Miles' Dynamic

New heights of reproducing power and realism based on years of extensive research and development is the result claimed by the Miles Mfg. Co. for their new Miles' electrodynamic air-column unit, Fig. 3. This unit consists of an entirely new diaphragm construction, voice coil, perforated sound chamber and adjustable mechanism. An undistorted power of 30 watts is obtainable in both

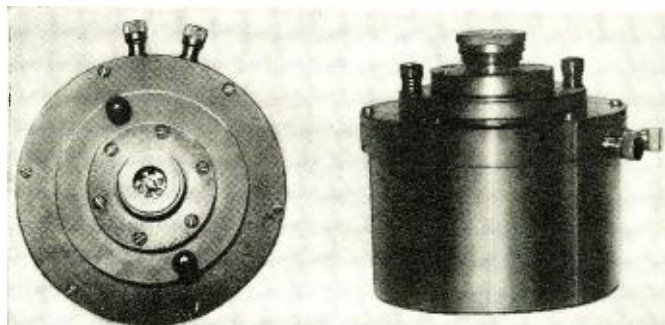

Fig. 3—Left, dynamic unit and (below) air-column horn, suitable for theatre or outdoor sound amplifying systems

the a.c. and d.c. models. To operate in conjunction with the electrodynamic unit are a series of air-column horns, ranging from 3½ feet to 10 feet with a maximum bell opening of 42 inches square. Such a combination permits a frequency range of from 50 to well over 5,000 cycles, and is suitable for theatres or auditoriums seating 1,200 persons.

Mueller's New Ground Clamp

In the Mueller Electric Company's new ground clamp provision has been made eliminating the cleaning of the water pipe for making good connection. This clamp in Fig. 4 is provided with two pointed fingers on one side and set screw on the opposite side of its frame for tightening. A screw binding post permits the making of a permanent connection of the ground wire.

"Radio Convenience Outlets" is the title of the Yaxley Mfg. Company's new booklet, listing every conceivable type of radio outlet, jacks and plugs which they

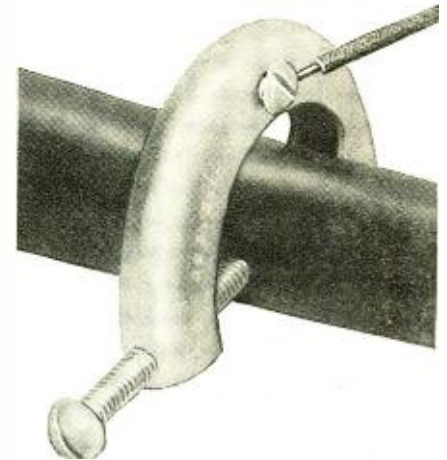
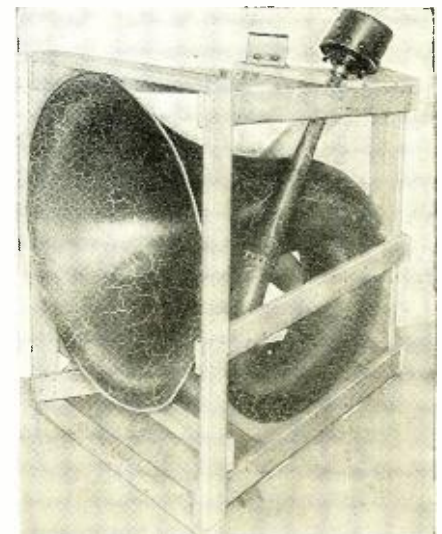

Fig. 4—Speedy connection ground clamp

manufacture. This booklet is published by the Yaxley Manufacturing Company of 1528 West Adams Street, Chicago, Ill.



Jefferson's Replacement Transformer

Of special interest to the serviceman and the home experimenter is the new replacement audio transformer by Jefferson Elec. Mfg. Company. The transformer, according to its manufacturer, is of exceptionally husky construction, although small in size. The frame is so constructed forming mounting legs, permitting a mounting of the transformer at any position or angle. The frequency curve is comparable with the leading audio transformers on the market.

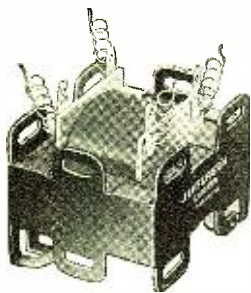

* * *

"The Fundamental Principles of Power Supply Unit Design" is the latest publication by the Engineering Department, Aerovox Wireless Corp., 70 Washington Street, Brooklyn, N. Y.

This treatise is a simple technical outline of the why and wherefore of the various power supply units, including the voltage dividers, bypass and filter condensers as well as a discussion of hum elimination. The booklet is of interest to both the beginner and the technical radio reader.

A Line of Bath-tub Condensers

From the DeJur-Amsco Corp. of New York City comes the announcement of a new line of bath-tub type condensers in gangs of from 1 to 8 either with or without dial. Each of the condensers in the gang type are provided with com-

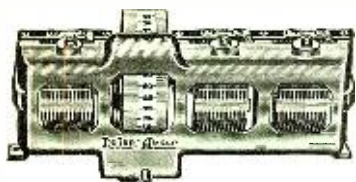

Fig. 5—Bath-tub condenser with drum dial

pensators providing adjustment up to 35 mmfd., the adjustment nut being grounded to the frame and rotor plates, thus eliminating the use of a special insulating adjustment field, hand capacity and



Fig. 6—Non-inductive filter condenser

speeding up the adjustment of multiple circuits. The bath-tub type condenser is supported at three points as are also the stator plates and the bearing shaft. Constant tension is maintained on the rotor

shaft by the use of a special Thackeray spring at the center bearing, resulting in a smooth tuning action. A standard spacing between the rotor and stator plates of .035 inch allows a minimum capacity of each section of the gang condenser of 17.5 mmfd. with the compensating variable set at minimum. These condensers are manufactured in the usual .0003, .00035 and .0005 mfd., Fig. 5.

Flechtheim's New Products

To operate in conjunction with the filter circuit for the new type 250 power tube, A. M. Flechtheim & Company, Inc., have produced a bank unit of high tension condensers rated at 1,000 volts a.c. This unit TC244 is of the non-inductively wound type, permitting an exceptionally small outer protecting case for the three condensers in bank of 2, 4, 4 mfd. The 250 tube requires a capacity of 2, 4, 4 mfd. in the circuit of a two-stage filter,



Fig. 7—Universal voltmeter

according to this manufacturer, and this condenser has been designed to meet the requirement, Fig. 6.

For testing the B voltage on such a pack, the A. M. Flechtheim & Co., Inc., have also produced an a.c. and d.c. universal 600-volt meter, utilizing the electrodynamic principle. This voltmeter has the advantage of being used on either alternating or direct current without changing or modifying connections in any way. Reversing the polarity of the meter terminals will not effect its reading. On full scale deflection, the total current consumption is only 10 mils., Fig. 7.

* * *

Mr. Sylvan Harris, formerly of the editorial staff of RADIO NEWS, has been recently appointed to the engineering staff of Fada Radio Co. by F. A. D. Andrea, Inc., manufacturers of the Fada radio receiver.

Sensitive Laboratory Equipment

For the research worker and those interested in making super-sensitive measurements comes the announcement from the Sensitive Research Instrument Corp. of a new Microammeter with single, double and triple d.c. readings. This new model J Microammeter, Fig. 8, employs the standard sized single pivot fused coil movement similar to that used in the larger sized former models. The movement is damped so that the pointer just passes its final position before coming to rest. A range as low as 3 microamperes with a full scale reading over a hand-calibrated three and one-quarter inch scale

is obtainable, all within one-half of one per cent accuracy. The instrument is mounted in a polished moulded bakelite panel enclosed in a dustproof walnut case. A zero set knob corrects the pointer which is also protected for portable use by a locking key.

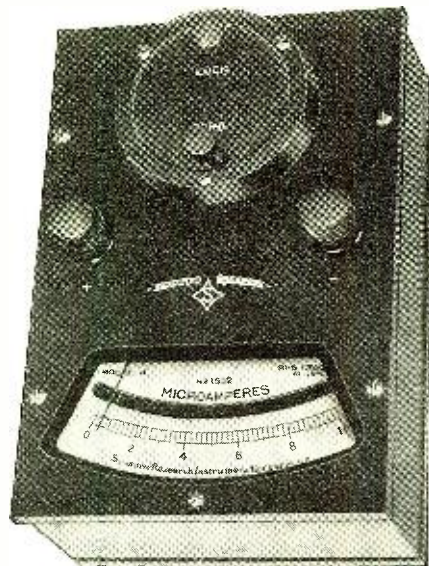

Fig. 8—Supersensitive ammeter

A second new model is offered in the ultra-sensitive strictly portable "SS" type, manufactured for use with d.c. in microammeters, millivoltmeter and high resistance voltmeter, and for radio frequency in microammeters, milliammeters, millivoltmeters and voltmeters. This instrument is an improvement over the former model "S" in that the usual restoring spring has been replaced by a special heat-treated rectangular suspension strip, so adjusted that the moving coil pivot is just

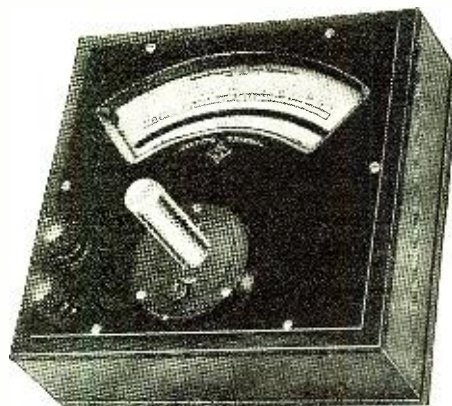

Fig. 9—A portable microammeter

guided by a highly polished sapphire jewel, reducing the pivot friction to a minimum. Such construction, according to the manufacturer, in conjunction with a special designed magnetic circuit results in sensitivity and constancy of calibration, heretofore unheard of. The model "SS" is hand calibrated and guaranteed to be within 1/2 per cent. on direct current and two per cent. of alternating or radio frequency currents in percentage of full scale value. It is strictly portable and can be used immediately without any set-up whatever, eliminating levelling or special handling. Fig. 9.

The Radio Forum

*A Meeting Place for Experimenter, Serviceman
and Short-Wave Enthusiast*

The Experimenter

A Wheatstone Bridge

For the experimenter, Mr. Clyde A. Randon, of Oakland, Cal., outlines the construction and operation of a simple Wheatstone bridge. A Wheatstone bridge is essential for any resistance measurements at high or low frequencies, as high-frequency resistance units are calibrated at low frequencies or with direct current. Such a useful instrument may easily be constructed on a meter stick from brass strip and a small milliammeter. The complete instrument as well as the circuit is shown in Fig. 1 and may be constructed mainly from material in the junk box.

The brass strip and meter stick are mounted on a spruce board with binding posts. A length of No. 28 nichrome resistance wire is then stretched on the meter stick, the ends being made fast to pushpins at points A and E. The slider S is a length of brass of which a portion of one end is ground to a knife edge. To secure a proper balance the knife edge is moved along a slide wire and the deflection is returned to its initial value (with no battery connections). The correct position can be located quite accurately. If desired, the bridge may be provided with mercury cups for connecting the resistors Rx. Small cups such as found on crystal detector holders are ideally suited for this purpose. The balance indicator is a 1-milliamper meter. To allow the instrument to read in both directions, the needle is shifted off the zero position three divisions by means of the zero corrector. This also makes the operation very simple and the position of the pointer is more easily read. To operate, the switch SW is closed and the slider is moved along the wire until the pointer of the meter returns to its initial reading. When this

condition is obtained, the drop in voltage (according to Ohm's law) along AB equals the voltage difference between A and D; hence, $I_s R_s = I_w R_w$. The drop along the paths Be and De, since no current then flows through the meter, must also be equal, so that $I_s R_s$ is $(100 - R_w) I_w$. Since the resistance of the slide wire is directly proportional to its length, another application of Ohm's law, equals simply being substituted for equals. By use of a little algebra, the relations can be combined to give the following formula:

$$R_x = \frac{R_s (100 - R_w)}{R_w}$$

The experimenter will notice that this formula depends

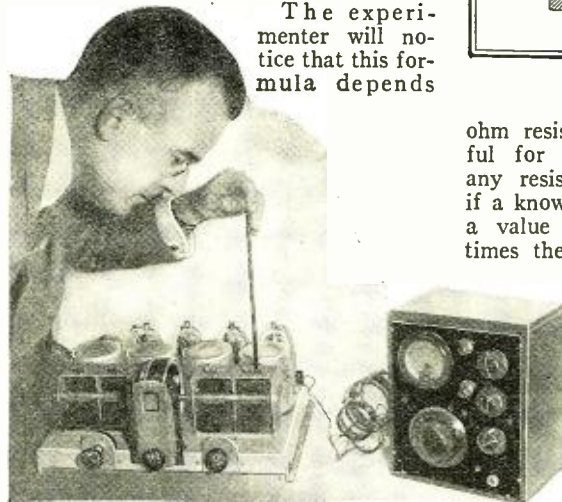

The lining up of gang condensers is extremely simple, when using a modulated oscillator. One must remember, however, to use a long-handled insulated screw-driver in making any adjustments, so as to eliminate hand capacity effects

for its deviation only on Ohm's law. When balance is secured, position of the meter stick R_w is read, and by substituting the above relation, the unknown resistor is found. One-ohm and three-

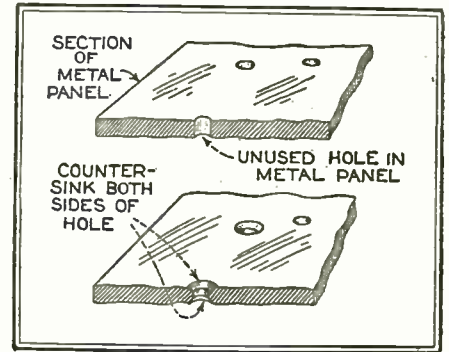

Fig. 2

ohm resistance units will be found useful for the experimenter's laboratory; any resistance values can be measured if a known resistance is available, having a value between one-fourth and four times the unknown.

When using a one-milliamper meter, a 1,000-ohm resistance should be inserted in series with the three dry cells which are used to furnish the current, otherwise the current may damage the meter. From the following list of parts, the experimenter will realize how easily this test unit can be constructed.

- 1 piece brass strip 1/8 in. by 1/2 in. by 5 feet
- No. 28 nichrome resistance wire
- 1 1,000-ohm resistor
- 1 one-ohm resistance standard
- 1 three-ohm resistance standard
- 1 one-milliamper d.c. meter
- 7 binding posts
- 3 dry cells
- Crystal detector cups
- Meter stick and spruce board about 1/2 in. by 10 in. by 42 in.

A Kink for the Experimenter

An excellent idea comes from Mr. H. G. Williams of Seattle, Wash., for making use of old metal panels which have a number of holes that need to be plugged. Take a drill and countersink both sides of the panel. Now lay the panel on the board and sweat some solder into the hole. After the solder is cool, file down so that the surface is even with that of the panel.

Fig. 1

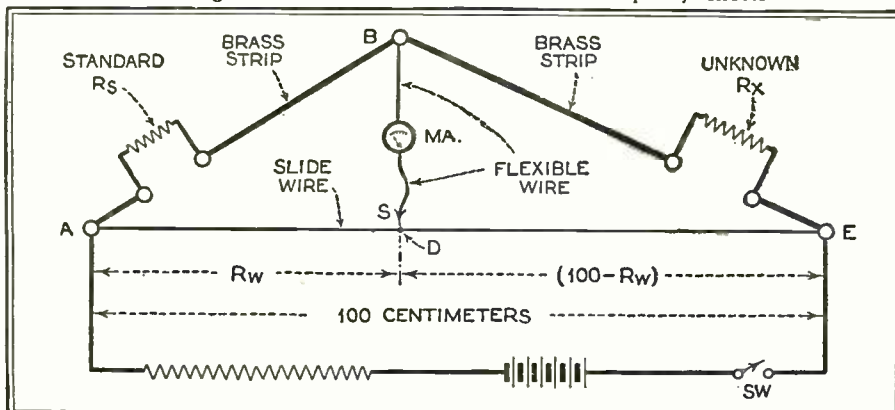

The Serviceman

Testing Condensers

EDITOR, SERVICEMAN:

In previous correspondence with your office, I mentioned a method of measuring resistance with a voltmeter of known resistance. Although I learned that method

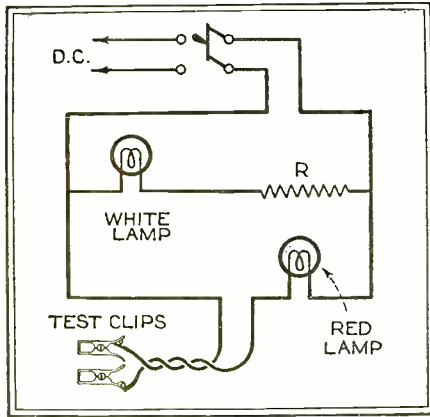

Fig. 1

as much as 15 years ago, it had not appeared in any radio publication to my knowledge. However, very shortly after sending the item to you, it appeared in a current issue of a manufacturer's booklet. Merely a coincidence, I assure you. With the above off my chest, may I offer the following circuit for testing short condensers.

This idea has not appeared in print, to the best of my knowledge. I have used it to test telephone condensers as long ago as 17 years. The resistance R, Fig. 1, is just high enough so that the white lamp does not light when the red lamp does. The d.c. can be taken from the "B" circuit taps. The test clips are snapped on the condensers to be tested and the switch closed. If the red lamp lights, the condenser is shorted. If the white lamp lights, the condenser is not shorted (this does not mean, however, the condenser is O. K., it could be open). Of course, all set connections must be off the condenser when under test. A red lamp could be placed between the common connection on the filter block and "B" minus, to light in case of a short in any of the condensers forming the block.

Hoping the above may be of some help to other servicemen, I am

Yours very truly,

L. S. Dow.

A Practical Coil Winder

Many servicemen have often gone to the trouble of rewinding defective coils by hand and have as often wished they had some sort of a coil winder. Mr. Herminio L. Alvarez, of Manila, P. I., had the same wish, but has gone a step farther in that he has designed and built a coil winder, of which constructional details follow.

The most expensive unit of the winder

is the tool grinder, but as the majority of servicemen have such a grinder in their shop, this expense is eliminated. Let us continue.

First, obtain a brass rod, 12½ inches by ½ by ½ inch. Then at one end divide it into two equal portions, two inches long, Fig. 2. Make the cut with a hacksaw and bend the two halves at right angles to the rod, drilling two ¼-inch holes 1½ inches from the center of the square rod, as shown. Then, from the grinder remove the front plate holder, drilling two ¼-inch holes through the face plate 1½ inches out from the center of the driving shaft of the grinder and 180 degrees apart. The two cones were obtained from a carpenter shop (with the holes already drilled), and the 1-inch wooden discs attached) for 10 cents each. The fixed or headcone is then bolted together with the brass shaft to the face plate of the grinder by means of carriage bolts. The movable or adjustable cone has a square hole which fits snugly on the brass rod, and the wooden disc has a key-way through which a wedge is tapped, in order to keep it from drawing back in use. Fig. 2 shows the completed winding with the

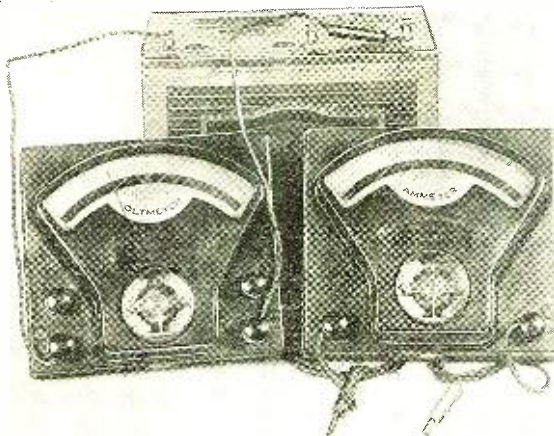

To determine the value of a "B" battery a voltmeter is required, not an ammeter. The latter may be used to test dry "A" batteries

tube form in place. The preparing of the

winder for use is simple. The adjustable cone and disc are slid off the shaft and the tube in which the coil is to be wound inserted. Then the cone and disc are replaced and wedged tightly to the shaft, holding the assembly firm. The crank on the winder is turned with the right hand clockwise or counterclockwise, and with the left hand the wire is easily fed on the coil form.

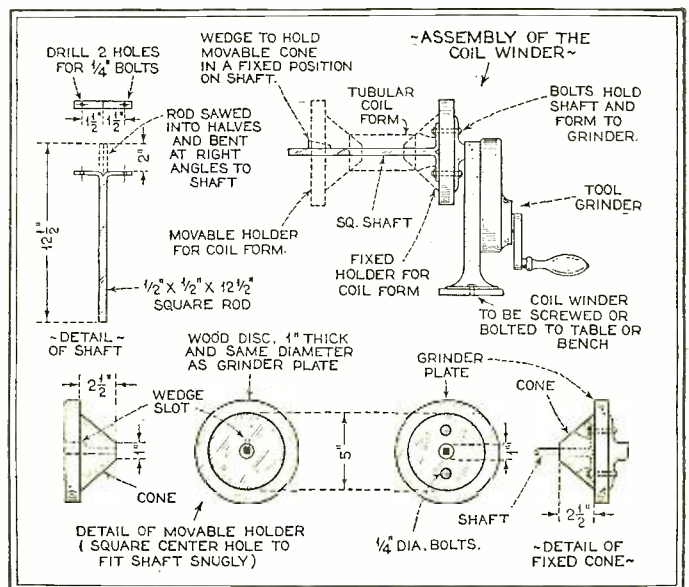

Fig. 2

On Short Waves

Another Plug-in Coil

"Some experimenters and short-wave enthusiasts may not be lucky, or might I say unlucky enough," writes Charles W. Ford, "to have sufficient old 201A tube bases for making plug-in coils for the short-wave Junk Box receiver." He can

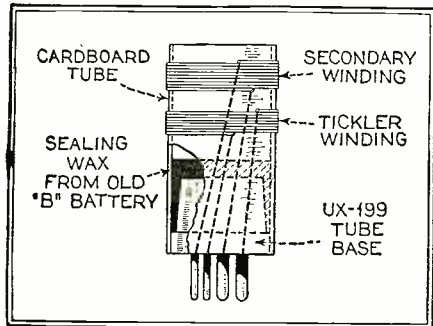

Fig. 1

readily use UX199 type bases by breaking the glass of the tube and of course cleaning out the base. The next procedure is to obtain some cardboard mailing tubes, 1 1/8 inches inside diameter, cutting into lengths about 2 inches each. On each length of mailing tube is wound a secondary and tickler for use on the regular short-wave bands. Make sure, however, to leave generous leads for soldering to the tube base prongs. The tube with the coil already wound is slipped over the tube base and the coil ends soldered to the proper prongs, after which sealing wax from the top of a "B" battery is melted and poured between the tube base and the coil tubing, as shown in Fig. 1. A set of water colors and camel hair brush may be used in tinting the coil form, designating coils for various wave bands.

Stepping Out with an S.W. Adaptor

Editor Short Wave:
I have been reading your RADIO NEWS for over a year and I enjoy it very much, especially the Short Wave section. During this time I have read many reports of short-wave reception, but it all seems to have been accomplished with a regular short-wave set. I do not recall having read any reports of short-wave signals using just a short-wave adaptor.

I have been using a Flewelling adaptor on a seven-tube superheterodyne receiver, with an "A" and "B" power unit, for about a year and have had very good results.

I have verifications from G5SW at Chelmsford, England, PCJ at Eindhoven, Holland, and from KGO at Oakland, Cal., this last reception being at noon. I also have received several short-wave stations but I have never bothered to write for verification. These stations which I get right along are those of KDKA, Pittsburgh; WGY, Schenectady; WABC, New York; WLW, Cincinnati, and CJRX, Winnipeg.

There are a few others, but as I do not get them regularly I am not putting them down. This reception is all on the loud speaker and I have had G5SW about 40 times since the first of April.

All this with an adaptor up here in what we call a very poor radio locality and where daytime reception is practically unknown.

Needless to say I receive lots of code, but as I do not understand it I do not know where it is coming from.

Probably this reception with an adaptor is being duplicated all over the country, but most of the short-wave fans seem to have short-wave sets.

Yours truly,
EARL C. RICHARDSON,
Marquette, Mich.

S.W. Rebroadcast

A real thrill was experienced recently by Mr. Donald F. Wright of San Pedro, Cal., in that he was able to pick up with sufficient volume on his short-wave receiver KIXR, Philippine Islands, and PHI, Hausen, Holland, and relay them over 30 miles of land line to KNX, the broadcast of these two short-wave stations with their announcements for a period of 30 minutes. From Mr. Wright's location, KIXR is nearly 8,000 miles to



By careful adjustment of the antenna coil of the short-wave receiver signal pick-up is increased and dead spots in tuning eliminated, allowing regeneration over the full scale of the tuning dial

the west and PHI is approximately the same to the east, really a very notable achievement.

EDITOR, SHORT WAVE:

I have finally been able to get PHI at Huizen, Holland, on 16.88 meters. I heard PHI Sept. 9, 11, 13, 14 (Mon., Wed., Fri., Sat.). I presume PHI is on the air these days every week. I heard this station from about 8:30-11 A. M. (E. S. T.) on each of these days. I have not had a schedule from PHI as yet, but expect one later and will inform you of it if it is different than the above. I find that PCJ at Eindhoven is operating on the same schedule as it has been for the past few months. I received a card from PCJ today and here is the schedule. Someone may find it useful.

SCHEDULE OF PCJ
Wavelength 31.3 meters
9.59 x 10

Thursday—18-20 and 23-0.

Friday—0-3 and 18-20, all G. M. T.
Saturday—0-6.

I have found also that KGO (W6XNO) on 23.35 meters has also changed its schedule. I heard KGO Sept. 9, 12, 14 (Mon., Thurs. and Sat.) nights and also Sept. 10, 11, 13 (Tues., Wed. and Fri.) afternoons. KGO is on after 8 P. M. (E. S. T.) nights and after 12:30 P. M. afternoons.

CJRX is on the air about every night and comes in here with good volume generally. G5SW at Chelmsford has not been coming in as well as it used to. Signals are very weak.

I have not heard DHC from Nauen, Germany, for several weeks, but at that time I heard them several nights a week at 8 P. M. (E. S. T.) for 5 or 10 minutes. Without doubt DHC came in louder here than any station I have ever heard on the short waves. It was so loud that a loud speaker could be operated with one stage of audio amplification and without any antenna. In a previous letter I mentioned I was using a fan antenna with better results than with a single wire. I find this is still true with wavelengths above 50-60 meters. With waves below 50 meters, I use a 15-foot single wire inside antenna, the end being directly connected to the grid of a screen-grid tube in a National Short Wave set. Another thing is to connect a variable condenser (.00025 mfd.) across a section of the antenna and tune this approximately to the station desired and considerable more volume can be obtained.

Respectfully yours,
ROBT. N. VANDERWARKER,
Taunton, Mass.

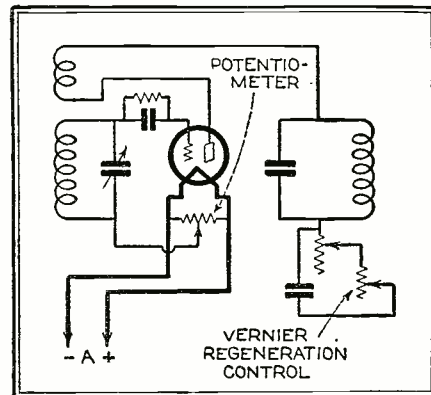

Fig. 2

"On Short Waves" is your department. If you have any ideas which you have put into practice and found useful, let the other fellow know about them too. Not only do we want you to read what the other fellow is doing, but also let him know what you are doing.

Send your contributions to the Editor of the Radio Forum, typewriting, if possible, on one side of the page. Sign your name and address legibly and draw diagrams on separate sheets of paper.

A Broadcast Receiver for Use in Automobiles

(Continued from page 599)

parison between the curve V_2 , which represents the noise level with complete shielding as described above, and the curve V_2' , which represents the noise level in the absence of shielding.

Electrical Characteristics of Receiver

Having decided upon the degree of ignition shielding which will be economically possible from actual ignition interference measurements and from the desired receiver sensitivity, the design of the actual receiver may be undertaken.

The division of amplification in the receiver may be considered as a first step. Since the receiver will be subjected to rather severe shocks in use it appears desirable to use a rather low order of audio-frequency amplification so that microphonic noise may be minimized. The necessary high radio gain may be advantageously secured by the use of the shielded tetrode so that by supplying the detector tube with a rather high radio input voltage the detector may be made to operate directly into the output tube. Battery tubes such as the UX-222 appear to be undesirable since the filament structure is not sturdy enough to withstand the severe shocks.

In Fig. 3 is shown an amplification analysis of an early model of the RFL automobile receiver. The radio amplifier comprises an untuned input circuit, three UY-224 tubes with three condenser-tuned circuits feeding a UY-224 detector. The detector and output tube are connected by resistance coupling. A moving-armature speaker having an impedance approximately equal to the output impedance of the power tube is used. The radio-frequency amplification from the grid of the first tube to the grid of the detector is approximately 45,000 at 1,000 kc. The voltage detection factor (plate

rectification) for 30 per cent modulation is about 6. By proper design of the input circuit the overall sensitivity characteristic of the receiver is given a positive slope with respect to frequency in order to obtain as closely as possible the ideal characteristic V_1' , shown in Fig. 2.

Since the interior of the usual automobile constitutes a sound chamber with relatively high attenuation of the higher audio frequencies due to the reflection characteristics of the upholstery, it will be advantageous to use a loud speaker giving considerable greater response at the high frequencies than at the low.

Physical Structure

Limitations on the space available for installing the receiver in the car made it desirable to keep the dimension from front to back rather short. This permits the receiver to be placed below and behind the instrument board of the car. The short dimension was obtained by placing the three tuning condensers with their shafts parallel to each other and perpendicular to the face of the receiver, rather than arranging them on the same shaft, as is the usual practice. The three shafts carry pulleys with wire belts and are driven from a direct tuning control mechanism acting on the central shaft. Some consideration was given to the use of a three-gang variometer for tuning the circuits, but the principal objections to its use lie in the difficulty of matching the inductance of the molded type, which would be necessary to cover the frequency range, and the poor selectivity of the circuits at the high frequencies.

Shielding between the radio amplifier tubes is obtained by mounting the by-pass condensers associated with each tube in a rather long thin metal box, and placing this condenser unit between the tubes as an electrostatic shield.

Power Supply

The heater supply for the tubes is obtained from the 6-volt storage battery in the automobile. The four UY-224 heaters are wired in series-parallel with the 5-volt filament of the 112-A output tube bridged across them giving a total current consumption of 3.75 amperes. Plate and screen voltage supply is obtained from a 180-volt B battery and a C battery is used to bias the output tube.

Results of Road Tests

The original model of this receiver was installed on an Essex sedan at Boonton, N. J. Observations were taken during a daylight trip to Springfield, Mass. on three broadcast stations, WJZ, WOR, and WEA. The location of the car, the time, and the character of the surrounding country were noted, and the type of reception noted at various points along the route. Most noticeable was the effect of travel through hilly country in reducing the general level of the output which could be obtained from the receiver and the rapid fluctuations of the signal as the car progressed. Strong reception, as indicated by overloading of the output tube before full receiver sensitivity was used, was obtained up to distances of between 50 and 100 miles from the three stations previously mentioned.

The problem of signal fluctuation seems serious enough to warrant the use on this type of receiver of the automatic volume control developed here and now employed in other RFL broadcast receivers.

It is desired to acknowledge the contribution of W. D. Loughlin embodied in the design of the receiver, and the assistance of F. H. Drake in connection with the experimental work on the ignition shielding.

How to Get the Most From Your Short-Wave Transmitter

(Continued from page 635)

ground, and is to be preferred. Now, bearing in mind the current and voltage distribution on the antenna, let us put it within reason where we want it and get the excitation to it by a transmission line, or "feeder," just as the electric power company feeds our home lights over a line. One system of doing this is shown in Fig. 2A. The antenna is the same as that of Fig. 1B, with the set removed some distance and connected to it by a two-wire line. The system is called "current feed," because the line meets the antenna at a current maximum. Theoretically the current should be equal throughout the line—no standing waves, as shown by nodes of current and voltage, should exist on it. If these conditions are attained (by complicated tuning arrangements) the line may be of any length.

But such perfection is beyond average amateur practice, and most of us can be content with a simpler method of getting practical results—making the line an even number of quarter-wavelengths long. This

makes the standing waves "come out even," and as the two wires neutralize, they do not radiate. The great difficulty with all feeder systems is that the feeder refuses to be content with mere feeding, and tries to join the antenna in its function of radiation. The whole system may operate as a Marconi antenna, possibly on some harmonic of the fundamental frequency, with the filament transformer making a convenient ground. For this reason in all feeder experiments the filament circuit should be grounded, preferably through a thermoammeter of ample rating. If the ammeter shows current, something is wrong.

In Fig. 2B we have exactly the same antenna, this time "voltage fed." In other words, the line joins the antenna at a point of high voltage—the end. This

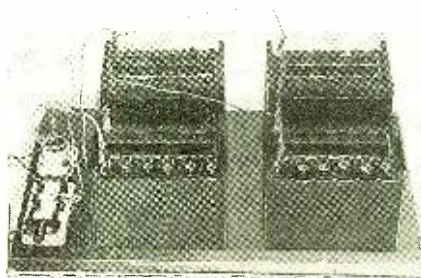

These storage "B's" boost the d.c. line voltage to about 350 volts

has one advantage over the previous system—the antenna can be worked at harmonics without changing the type of feed—can be used, say, for both 80 and 40 meters. For the same reasons given above, the length of the feeder should be an odd number of quarter wavelengths. But as convenience and space usually limit it to less than $\frac{1}{4}\lambda$, this is not a serious handicap.

Two-wire lines have their advantages, but they are difficult to construct. In addition, due to the comparatively large surface and weight of spacing insulators, they are unwieldy in bad weather. Fig. 2C shows another voltage feed system, using only one wire. One side of the resonant secondary circuit at the set is connected directly to a high-voltage point on the antenna—it could be the end, but moving the feeder in a little way makes it less likely to radiate. The feeder could also be connected directly to the oscillator circuit, but the intermediate tuned circuit provides smoother coupling control and causes less nearby interference. This system is easy to build, but hard to adjust, as the feeder has a strong tendency to become part of the radiating system. With the system in perfect adjustment, the feeder current should be equal throughout its length, the antenna current should be maximum at center and equal on the immediate opposite sides of the feeder connection. The adjustment difficulties are minimized by using a feeder less than $\frac{1}{4}\lambda$ in length. For further practical information on antenna systems and feeders the reader should see R. S. Kruse: "Feeding the Antenna," *QST*, July, 1926; and other articles in the same magazine for January and September, 1929.

84-42 Meter Antennas

Now that we have labored rather heavily through some of the principles and details of antenna design, let us apply them to our own problem. We wish to operate in both the 80-meter band and the 40-meter band. If we use two separate antennas, we may choose any of the types described above; if only one, our choice is more limited. Fig. 3 shows three antennas that will work from 83 to 85 meters, and also at 42 meters. By far the simplest is Antenna A— $\frac{1}{4}\lambda$ antenna and $\frac{1}{4}\lambda$ counterpoise a 42 meters. With

the loading coil (25 turns of spaced No. 16 wire on 2½-inch form) in, the antenna tunes through the whole 80-meter band. The actual A type antenna of W2CX is shown in the photograph, along with some of the nearby receiving antennas which

TABLE 1
International Amateur Call Letters
Commonly Heard in the
United States

CM	Cuba	SM	Sweden
CT	Portugal	SP	Poland
CV	Roumania	UO	Austria
CW	Uruguay	VE	Canada
D	Germany	VK	Australia
EAR	Spain	VO	Newfoundland
F	France	W	United States of America
G	Great Britain	X	Mexico
HC	Ecuador	ZL	New Zealand
K	U. S. Colonies	ZS	Union of South Africa
LA	Norway	AC	China
OH	Finland	AJ	Japan
ON	Belgium	SC	Chile
OZ	Denmark	EU	Italy
PA	Netherlands	EU	Russia
PY	Brazil		
RX	Panama		
	SA		Argentine

The last six countries are listed with their old intermediates; their new amateur call letters are not yet known.

* * * * *

do not help its efficiency. This design has the utmost simplicity and compactness, and is the best solution where one can only use a restricted portion of the roof. It is quite efficient on the 40-meter band, but less so on the 80-meter band.

Strictly speaking, the antenna and counterpoise lead-ins should come into the house through pyrex bowls, or through the center of a window pane. But this raises the old question—who is living in the house, you or the transmitter? The W2CX lead-ins, shown in the photograph are a compromise between electrical efficiency and convenience.

Antenna B calls for an overall height (or slanting length) of 100 feet, and of course something to support the high end. By changing two switches it is converted from a Marconi type with counterpoise for the 80-meter band to an elevated vertical Hertz, two-wire voltage fed,

for the 40-meter band. This antenna has shown good results at W2WP. For those who have the facilities for installation, it will perform well. Due to the heavy current in the closed secondary circuit, the indicating bulb should be shorted out.

Antenna C is a horizontal Hertz, half-wave for 84-85 meters, and full-wave for 42 meters. Either single-wire or two-wire feed may be used. At the half and quarter points are flashlight bulbs, shunted around a few inches of the antenna wire, the drop across which at high current points will be sufficient to light the bulbs. When transmitting on 84 meters the center bulb should light brighter than the others; when the wave is 42 meters the two outer bulbs should brighten up equally and the center bulb should go out. This may seem rather mysterious—to be lighting bulbs on a single dead-ended wire, but the reasons appear in Fig. 1.

The transmitting story is a long one. That is what makes it interesting—one can never say "I have built this and that, and I am through." We can only mention the ranges to be expected of the Home Transmitter. In the daytime we

TABLE 2
Home Transmitter Performance

Code or Phone	Wave-length Meters	Plate Volts	Osc. Plate Mils.	Input Watts	Antenna Amps.
CODE	85	330	55	18	.4
mod. choke shorted.	77	330	55	18	.4
mod. plate disconnected	42	330	60	20	.3
PHONE mod. choke and plate in circuit	85	310	50	16	.3

Modulator grid bias -44 v.; plate current 50 mls.

should do around a hundred miles in the 80-meter band and a few hundred on 42 meters. At night the 80-meter range spreads out to a thousand miles or so, while the 40-meter signals may on occasion travel several thousand. The reasons for these differences, one of the latest chapters in the radio art, are an interesting story which must be held over to next month. Here we are now, after a very respectable number of pages, scarcely beyond the end of the antenna. In the next article we shall journey out into space, to study the far-flung courses of the radio waves themselves.

More Music for City Parks

(Continued from page 639)

small insert panel at the bottom contains the mixer controls for the three microphones with jacks which permit the six button currents to be read by means of the plug and cord shown suspended from this panel and connected to the right-hand meter. The three tubes at the right of this main panel represent the two-stage speech amplifier into which the mixer feeds. The first stage of this amplifier employs a single tube, at the lower right. The second and third tubes constitute a push-pull stage for the speech amplifier output. Two of the meters are employed to check plate currents on these tubes.

An amplifier located on the lower half of the rack is a standard PAM 19 and

represents a single push-pull stage, using 250 type tubes. The output of the speech amplifier feeds into this and its output in turn is fed into the output terminal-switching panel, from which the programs go to the distribution station and WNYC.

The mixer tubes and speech amplifier tubes are battery operated to keep the hum level down. The high output amplifier is operated from a rotary converter not shown in the illustration. This arrangement is made necessary by the fact that this section of New York City is supplied with direct current.

It will be noticed from the diagram in Fig. 2 that the equipment is identical in the main distribution and sub-distribution

stations, except for the inclusion of a rotary converter to provide the a.c. supply for the amplifiers in the main distribution station in Central Park, a d.c. district. As indicated in the diagram, this equipment consists of a power amplifier, an impedance-matching panel, a line equalizer and a distribution panel. The power amplifiers here were at first omitted, but experience showed them to be necessary to obtain maximum flexibility and best control of the system. The distribution panel is somewhat similar to a telephone switchboard and is so arranged that the various output lines can be cut in or out as desired.

(Continued on page 678)

LET RCA INSTITUTES START YOU ON THE ROAD TO . . . SUCCESS IN RADIO

Radio needs you . . . That's why the entire Radio industry is calling for trained men . . . That's why thousands of men who answered these advertisements are now earning from \$2,000 and up a year. Radio is thrilling work . . . easy hours, too, vacations with pay and a chance to see the world. Manufacturers and broadcasting stations are now eagerly seeking trained RCA men . . . Aviation and radio in the movies also provide innumerable opportunities . . . Millions of sets need servicing . . . thousands of ships require experienced operators . . . Never before was there an opportunity like this.



Radio Mechanic and Inspector \$1800 to \$4000 a Year.



Broadcast Station Mechanic and Inspector \$1800 to \$3600 a Year.



Land Station Operator \$1800 to \$4000 a Year.



Broadcast Operators \$1800 to \$4800 a Year.

This is the Only Course Sponsored by Radio Corporation of America

RCA sets the standards for the entire Radio industry . . . The RCA Institutes' Home Laboratory Training Course enables you to quickly learn all the secrets of Radio . . . In your spare time, in only an hour or so a day, you can obtain a thorough, practical education in Radio . . . You get the inside information, too, because you study right at the source of all the latest, up-to-the-minute developments. RCA, the world's oldest Radio organization sponsors every single detail in this course.

You learn Radio by actual experience with the remarkable outlay of apparatus given to every student. You learn the "How" as well as the "Why" of every Radio problem, such as repairing, installing and servicing fine sets. That's why every graduate of RCA Institutes has the experience, the ability and the confidence to hold a big-money Radio job.

For the added convenience of students who prefer a Resident Study Course, RCA Institutes, Inc., has established Resident Schools in the following cities:

- New York 326 Broadway
- Boston, Mass. 899 Boylston St.
- Philadelphia, Pa. 1211 Chestnut St.
- Baltimore, Md. 1215 North Charles St.
- Newark, N. J. 560 Broad St.

Graduates of both the Home Laboratory Training Course and the Resident Schools receive exactly the same training and enjoy the same privileges so far as jobs and salaries are concerned. And every Home Study graduate may also attend any one of our resident schools for post-graduate instruction at no extra charge.

Graduates of RCA Institutes Find It Easier to Get Good Jobs

They are closest to the source of Radio's greatest achievements because the progress of Radio is measured by the accomplishments of the great engineers in the huge research laboratories of the Radio Corporation of America.

Students of RCA Institutes get first-hand knowledge, get it quickly and get it complete. Success in Radio depends upon training and that's the training you get with RCA Institutes. That's why every graduate who desired a position has been able to get one . . . That's why graduates are always in big demand.

Study Radio at the Oldest and Largest Commercial Training Organization in the World

Send for our Free Book. . . or step in at one of our resident schools and see how thousands of men are already on the road to success in Radio. Remember that you, too, can be successful . . . can speed up your earning capacity . . . can earn more money in Radio than you ever earned before. The man who trains to-day will hold down the big-money Radio job of the future. Come in and get our free book or send for it by mail. Everything you want to know about Radio. 40 fascinating pages, packed with pictures and descriptions of the brilliant opportunities in this gigantic, world-wide money-making profession.

See for yourself why graduates of RCA Institutes now occupy thousands of well-paid positions. These positions are usually available in from 3 to 10 days after graduation for men who can qualify. RCA Institutes' will back you up to the limit. Our catalogue is yours free . . . SEND FOR IT TODAY!

Clip this Coupon NOW!

RCA INSTITUTES, Inc.
Dept. EX-1, 326 Broadway, New York, N. Y.

Gentlemen: Please send me your FREE 40-page-book which illustrates the brilliant opportunities in Radio and describes your laboratory-method of instruction at home!

Name.....

Address.....

SPONSORED BY

RCA INSTITUTES, INC.

Formerly Radio Institute of America





CORWICO
VULCAN
LIGHTNING ARRESTER

**Also Ejects Static Charges
Improving Reception**

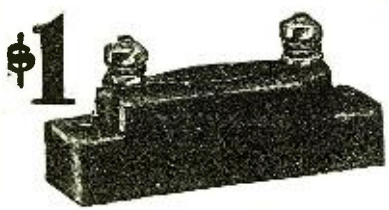

\$1

The Corwico Vulcan Lightning Arrester is manufactured in accordance with a new engineering principle that protects your radio against damage from lightning and also dissipates accumulated static charges. Buy one today for lightning protection and better reception.

At Your Dealer's or Direct
Upon Receipt of Price.

CORNISH WIRE CO.
24 Church St. New York City

MAKERS OF THE FAMOUS

BRAIDITE HOOK-UP WIRE

DON'T FORGET

There are plenty of thrills left in Radio reception when you're working on Short Waves.

THE
Short Wave 4
(as described in August issue)

will give you the best Short Wave reception obtainable.

FREE an August copy of *Radio News* describing the Short Wave 4 in detail is yours upon request.

Price on Complete Parts for Short Wave 4.....**\$62.50**

A Short Wave Calibrated WAVEMETER designed to check your Short Wave stations in a finished Walnut Cabinet**\$12.50**

Special Instruments and Laboratory Apparatus constructed or designed to order.

Watch for something real good in our next advertisement.

Order on this Coupon

WIRELESS EGERT ENGINEERING, INC.
179 Greenwich St., New York

Enclosed please find money order for which you will kindly send at once (check one desired).

Parts for Short Wave "4".....\$62.50

Short Wave Wavemeter.....12.50

Thank you very much

Name

St. and No

City and State

Radio—A Real Aid to Air Navigation

(Continued from page 598)

most an hour and is aware of the fog long before he could see it. As he nears the mountains he begins to climb, and before long is high above the clouds. Nothing can be seen ahead but a billowy sea of fog. No landmarks are visible. He turns on the beacon receiver and tunes in the long dashes that indicate that he is directly on his course. Occasionally he changes his direction slightly when he begins to hear one set of signals louder than the other, but otherwise he keeps straight ahead. Every few minutes he talks to the weather office again and learns the height of the fog above the ground, the wind velocity and the conditions he can expect on the field when he lands. As he leaves the mountain peaks behind and moves on over the clouds, the sun drops over the horizon and dusk sets in. Suddenly he throttles down the motors and glides into the fog bank. He has picked up the marker beacon over San Bernardino. There are a few minutes that resemble the inside of a package of cotton, but the pilot, with his eyes glued to the instruments, and his ears tuned to the dashes of the beacon, pays no attention. Then in a flash the fog is gone, and a thousand feet below twinkle the lights on the outskirts of the city. A few miles ahead a beacon light on the airport flashes

a welcome, and the pilot changes his course slightly in order to come in against the wind. He switches off the beacon receiver, and calls the dispatcher at the airport. In a moment the floodlights outline the field and a siren shrieks as the plane gently floats in to a perfect landing.

To many people this may seem fantastic, but to those in the aviation business it is an assured fact. There are undoubtedly other developments yet to come. I believe that within a short time the government will require radio on commercial airplanes just as it now requires all ocean liners to be equipped before they can leave port. In fact, radio will be even more important in aviation than it is in shipping, because a boat, rarely traveling at over twenty miles an hour, can ride out a storm or anchor off port almost indefinitely, while an airplane must travel at over a hundred miles an hour, and must find its airport immediately.

It is just 25 years since the Wright brothers made their first air flight, and at this same time Marconi was transmitting his first feeble signals across the Atlantic by radio. Few people would have imagined that a combination of these two great discoveries would give to us a great arm of commercial transportation—aviation.

The Audion Conquers New Fields

(Continued from page 606)

so far seem contented with just the rectification of a. c. socket power into suitable direct current supply for radio sets, which is child's play compared with power applications.

We know that high-frequency currents travel on the surface of conductors. We know also that the higher the voltage, the less the current for a given amount of electrical energy, since wattage, which is volts times amperes, is the measure of electrical energy. We know that up to a certain point, insulation, rather than a conductor, is more economical in electrical transmitting lines. I therefore venture to prophesy the application of vacuum tubes at some future time for the generation of high-frequency, high-voltage current which will be sent over transmission lines made up of metal tubing with very thin walls, due to the surface conduction of high-frequency currents. The high voltage will permit of tremendous energy with reasonable current flow. There may be some measures taken to confine the high-frequency energy to the conductors and not have such lines act as huge antennae to interfere with radio services. The transmission towers may be several hundred feet high, because of the long strings of insulators. However, it seems to me that the day will come when we shall make our coffee in an electric percolator and our toast in an electric toaster supplied with current from a hydro-electric power plant a thousand miles away. It is possible. It is feasible. It must come. And the oscillating audion will play an important

part in that field, just as it now plays in the limited power field of radio communication.

The High-Frequency Furnace

Today we are just beginning to apply the high-frequency possibilities of the oscillating vacuum tube. In many vacuum tube production plants there are to be seen oscillating vacuum tubes employed as bombardiers. The purpose of the bombardier is to heat the metal parts of a vacuum tube, as it is being evacuated, to incandescence, thereby driving out all the gases imbedded in the metal, and also to flash the "getter" or chemical which sweeps out the residual gases in the bulb. The bombardier simply passes high-frequency energy through one or more coils of wire, each coil having just a few turns of heavy copper tubing, as a rule, perhaps water-cooled, and the coil or coils or dropped over each glass bulb as it comes in position for bombardment.

Remarkable things can be done with the enormous amount of high-frequency energy available from oscillating vacuum tubes. For instance, there is the vacuum furnace, in which metals, very much subject to contamination from the air, are placed in a vacuum and then subjected to intense heat by means of high-frequency currents in a nearby coil. It will be noted that the high-frequency currents set up a high-frequency field, and any mass of metal in that field becomes heated to incandescence due to the in-

(Continued on page 658)

For There's a Reason
ELECTRAD Superiority

Licensed by Techni-
dyne Corp., U. S.
Pats. 1034103-1034104
and Pats. Pend.

Built for **RELIABILITY**
Famed for **PERFORMANCE**

YOU can always rely on getting what you pay for in **ELECTRAD** Radio Resistances and Voltage Controls. Manufacturers and Custom-Radio designers use them because they *must have quality* when their own reputations are at stake. Ably supervised manufacture, *coupled with the will to work continuously for IMPROVEMENT*—that's why Electrad superiority is definite and real—that's why the name "Electrad" is respected the world over by men who **KNOW** radio values.

TRUVOLT
All-Wire Resistances

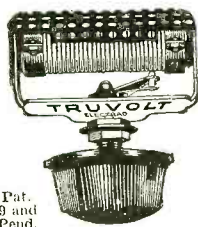

U. S. Pat.
1676869 and
Pats. Pend.

TRUVOLTS are the experienced constructor's choice for eliminators and power packs because of their patented air-cooled winding, which gives more stable operation and longer life.

Variable TRUVOLTS (*illustrated*) have metal shield and knob control. Ideal for experimental power supply banks where quick, fine variation is desired. Last longer owing to *end-wise* travel of contact over wire. 22 stock sizes, \$2.50.

Fixed models have an adjustable sliding clip for accurate setting at exact value desired. No other resistance has this feature. All usual sizes.

PHASATROL
The Universal R. F.
Balancer

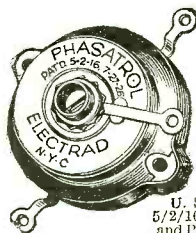

U. S. Pats.
5/2/16, 7/27/26
and Pats. Pend.

The PHASATROL offers a simple, yet thoroughly effective means of eliminating oscillation and distortion in radio frequency amplifying circuits—either tuned or untuned. Can be quickly installed without experience. One PHASATROL for each R. F. stage is required.

Handsome, totally enclosed bakelite case can be mounted anywhere. Complete instructions for installing in various popular receivers is packed with each unit.

List Price \$2.00 each.

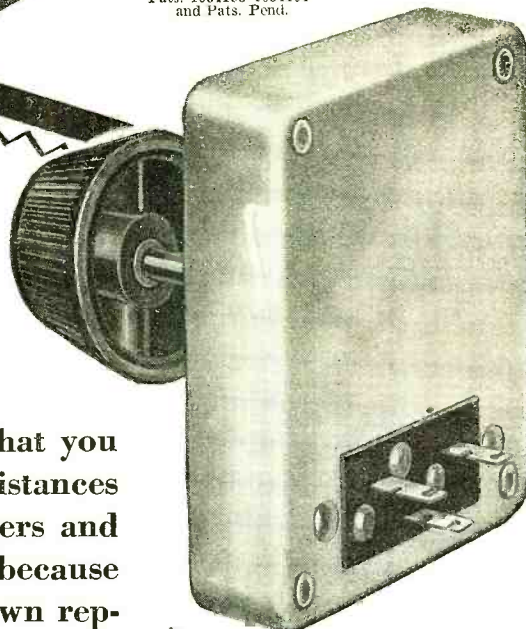

Super-TONATROL
The **ELECTRAD** Heavy
Duty Volume Control

This new **ELECTRAD** volume control is the first device of its kind that offers builders of modern power receivers a smooth, accurate control of high voltages *combined with unusually long life*. Easily dissipates 5 watts.

Its new type resistance element is *permanently* fused to an enameled metal plate. A pure silver *multiple* contact gives stepless variation that is revolutionary. Practically all-metal construction, with riveted cover. Bakelite insulation. Handy, slotted soldering lugs.

Made in seven types, with resistance values and curves for all usual volume control purposes, including output from electrical phonograph pickups. List price \$2.40 and \$3.50.

Mail
Coupon for
Descriptive
Circular

175 Varick Street

New York, N. Y.

ELECTRAD
INC.

ELECTRAD, Inc., Dept. RN-1, 175 Varick Street, New York, N. Y.
Please send data on products checked.
 Super-TONATROL TRUVOLTS PHASATROL All Products
Name.....
Address.....

HAMMARLUND'S Rich Experience Has Gone Into the Parts Used in the Superb, New "Hi-Q-30" RECEIVER

EIGHTEEN years of designing and producing precision telegraphic, telephonic and radio instruments is the insurance of quality which you get in every Hammarlund product.

Whether you purchase the complete parts for the astounding new "Hi-Q-30" Receiver—or merely a single condenser, choke coil, or transformer, remember that there never has been but one standard of Hammarlund manufacture—and that is to make the best possible in the light of current knowledge.

Write Dept. RN-1 for Folder Describing Many New Hammarlund Products

HAMMARLUND MANUFACTURING CO.
424-438 W. 33rd ST., NEW YORK, N. Y.



Complete KITS of all the Popular Circuits including the new **Hi-Q-30**

5m 712 Band Selector
H. F. L. Master Tone
Universal Meter

Mail Orders Filled Promptly
30 Years Efficient Service

Write to **M. & H.** New Catalog Ready
SPORTING GOODS CO.
512 Market St., Phila., Pa.

24 Hour Service On Your Hi-Q-30 Order

Get the Best Where There's the Best Service West of the Rockies

We Have a Complete Stock of All Receivers and Parts

SETBUILDERS: Write for wholesale catalog.

WEDEL COMPANY

Established 1888
520 SECOND AVE., SEATTLE, WASH.

Hammarlund Hi-Q-30 Screen Grid Receiver

Buy your complete Hammarlund Hi-Q-30 Kit—EXACTLY AS SPECIFIED—at our low special price. Only \$95.55 complete! Individual parts at the same low prices listed in the big 1930 Wholesale Catalog.

List Price \$162.50
SPECIAL PRICE

Other special bargains shown in our Big Catalog

Send for your FREE copy of the new 1930 Wholesale Catalog TO-DAY—the bargain book of the radio field.

WHOLESALE RADIO SERVICE CO., INC.
36 Vesey Street, Dept. HR, New York City



A Complete Line of Condensers and Resistors

In the Aerovox Wireless Corporation, radio manufacturers, jobbers and retailers have found a dependable source of supply for all types of condensers and resistors. This complete line includes:

Condensers

- Filter Condensers
- High Voltage Condensers
- Transmitting Condensers
- Bypass Condensers
- Filter Blocks
- Bypass Blocks
- Buffer Blocks
- Bakelite Case Units
- "A" Condensers
- Mica Condensers

Pyrohm Resistors

These are vitreous enameled resistors which are available in all resistance values and watt ratings, in fixed and tapped combinations.

Non-Inductive Resistors

- Lavite Units
- Grid Leak Type Units

Resistor Mountings

A wide variety of mountings for all types of resistors.

Wire Wound Resistors

- Grid Suppressors
- Center-tapped Units

A complete catalog containing detailed descriptions and illustrations will be sent on request.



By an Amperite for every tube. Dr. Radio Engineer

The Prescription for Better Radio Reception

AMPERITE automatically maintains the most efficient tube voltage. Improves tone, sensitivity, volume. For every tube. \$1.10 with mounting (in U.S.A.). At all dealers.

AMPERITE Corporation
561 BROADWAY, NEW YORK
FREE—"Amperite Tube Chart." Write Dept. R.N.-1

AMPERITE
REG. U.S. PAT. OFF.
The "SELF-ADJUSTING" Rheostat

This symbol in a radio diagram means—

HI-Q

HEADQUARTERS

FOR THE TRI-STATE SECTION
Pennsylvania-Ohio-West Virginia

A COMPLETE STOCK OF
HAMMARLUND PARTS

ALWAYS ON HAND

★ SEND FOR CATALOG ★

CAMERADIO
430 WOOD ST.
at Diamond St.
PITTSBURGH PA.

Tuned BAND-FILTER

Flat-Top, Straight-Side
10-Kilocycle Selectivity

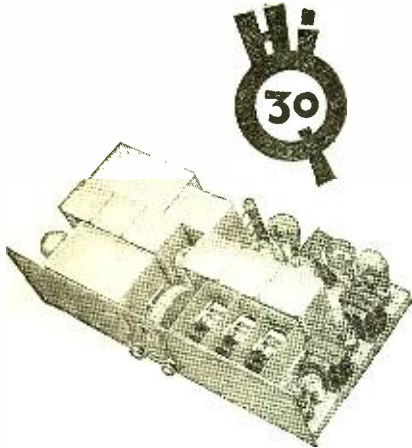

A famous feature exclusive with Hammarlund Receivers for two years.

Gives perfect 10-kilocycle tuning, without cutting sidebands.

Reduces background noises. Improves tone.

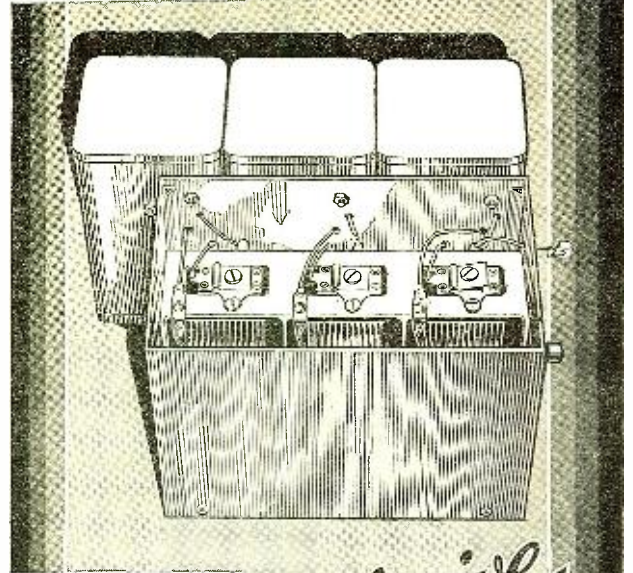

NEVER before, outside of special laboratory models, has there been available to radio constructors such a receiver as the new "HiQ-30."

Its extraordinary features are so far in advance of even previous "HiQ" Models that the loyal army of Hammarlund enthusiasts throughout the world will welcome the "HiQ-30" with nothing short of amazement.

A masterpiece mechanically and electrically, with extraordinary beauty as well. No miscellaneous collection of parts—but *each component specially built* for the characteristics of the circuit and everything to the last screw supplied by the factory.

Perfect selectivity—range limited only by atmospheric conditions—deafening power under velvet control—tone that thrills the music critic—one-dial operation—uses any length antenna—push-pull '45 audio amplifier—permanent phonograph connection—choice of speakers and cabinets, including phono-radio combinations.

Build the "HiQ-30" yourself or we'll recommend a local custom-radio builder to assemble it for you.

Get the "HiQ-30" story *Now*. Mail coupon for 48-page Manual—a wonderful guide book for constructors of modern receivers.

HAMMARLUND-ROBERTS, INC.
424-438 W. 33rd St., New York

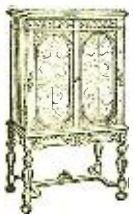

BLACKSTONE
One of nine magnificent "HiQ-30" Special Consoles available from the factory.



WINDSOR
A radio-phonograph combination of rare excellence and distinctive beauty.

Hammarlund Custom-Built RADIO

Exclusive

**Completely Wired
Factory-Built Units**

Including Three-Stage Tuned Band Filter—Three-Stage Tuned Screen-Grid Amplifier—Special Power Pack—Six Tuned Circuits—individually and collectively shielded.

The most flexible—the most scientifically accurate—the greatest performing radio of all time.



MANUAL
424-438 W. 33rd St.
New York

Mail Coupon and 25c for "HiQ-30"
HAMMARLUND-ROBERTS, INC., Dept. RN1,
Enclosed 25c (stamps or coin) for 48-page
"HiQ-30" Manual.

Name.....

Address.....

RACON

Electro-Dynamic Type Horn Unit For Radio



Here you'll find those full, rich tones of the dynamic type.

Here you'll find clearness and distinctiveness, minus distortion of the horn type.

No. 1315
Air Column 104 in.
Bell 18 in. by 24 in.
Depth 13 in.



Racon Junior Electro-Dynamic Type Horn Unit
Patented May 7, 1929

This revolutionary change in the type speaker for radio use is but slightly higher priced than the ordinary speaker, but marvelously better. Tests prove it.

RACON ELECTRIC CO., INC.

FACTORIES:

18 Washington Place, New York
Slough, Bucks, England, and 3 Mutual Street, Toronto, Canada

The Audion Conquers New Fields

(Continued from page 654)

tense current generated within the metal. Years ago, we had electrical wizards who came out on the vaudeville stage and fried eggs in a frying pan placed on a cake of ice. A high-frequency coil, concealed beneath the cake of ice, served as the source of heat. In a more sophisticated age, such wonders receive scant consideration.

High-frequency current has also been applied to a limited extent in surgery, in the form of the so-called "radio knife." This is simply a high-frequency generator connected with a piece of platinum wire and to the patient's body. As the platinum wire comes in contact with the flesh, intense heat is generated and the platinum wire sears its way along, cauterizing as it goes so that the wound is absolutely clean and ready to heal rapidly. I believe this thing is only in its infancy, and that great things can be expected of high-frequency current in surgery.

Vacuum Tubes and Your Health

Perhaps human life is largely electrical in its nature. Such medical savants as Dr. George W. Crile of Cleveland, Ohio, have spent many years in propounding certain bio-electrical theories, while many fakery from coast to coast have spent as many weeks getting various "electronic" machines in shape for treating gullible patients. In fact, electricity, particularly anything involving vacuum tubes or approaching radio technique, has been so maligned by fake doctors that one almost dreads to mention the possibility of vacuum tubes in medicine for fear of giving ammunition to unworthy workers. It may be recalled how one Dr. Albert Abrams of San Francisco, some five years ago, had thousands of followers for his new medical cult—yes, it was almost a religion—of electronic reactions and vibrations. Just about the time Dr. Abrams died, in 1924, his theories and principles were being fully exposed as the worst form of quackery.

Nevertheless, there is some subtle, little known, but worth while investigating basis for the electrical nature of life. It may be that some day, the high-frequency energy developed by oscillating vacuum tubes will be applied here to good effect. It may be that we shall develop diagnostic equipment involving the super-sensitive qualities of the vacuum tube. However, when such advances are scored in medicine, the apparatus will consist of something more than a glorified receiving set with a collection of variegated lamps which, according to present "radio doctors," serve to indicate whether you have sore eyes or bunions, lumbago or ingrown nails, blood poisoning or cold sweats, or what have you. There is much the vacuum tube specialist can do for the medical profession, if sincere men get to work on the possibilities of high-frequency currents on the one hand, and the delicate detection properties of vacuum tubes on the other.

Robots Without End

The vacuum tube, with its marvelous trigger action, should develop into no

end of robots. Already we have mechanisms that do certain tasks far better than human operators, and which depend on the marvelous trigger action of the vacuum tube. In matters of delicate measurements, differentiating between good and bad products, picking out sizes, shades, patterns and so on, we have many robots already at work, but only the surface has been scratched in putting electrical brains and muscles to task in our factories.

I sometimes like to dream of electrical robots on the farm, because I originally came from Council Bluffs, Iowa, where big farms of waving corn are uppermost in mind. I like to think of the future farmer, standing or sitting in an observation tower, operating one or more electrical tractors by means of remote radio control. Why not? It is quite feasible, even now. Not only can the farmer flash his commands to the distant tractor, but he can receive a signal back from the tractor informing him as to its every move, just as the signalman in the railway electric switch tower receives a signal back from the distant switch, confirming the receipt of the original order and the fact that it has been carried out.

During the World War, the Germans had crewless boats operating off the Belgian shore, with which they attempted to attack British monitors. While the attempts may have failed, the ingenuity of the Germans was nevertheless commendable. Our own John Hays Hammond, Jr., whose laboratory is located at Gloucester, Mass., a long while ago demonstrated his crewless boats which sail in and out of shipping on Gloucester Bay, without difficulty, under the guidance of the skipper on shore. It takes no keen imagination to foresee a future war, if such should be visited upon suffering humanity, with crewless airplanes loaded with torpedoes and enormous air bombs, guided towards their objectives from a distant and safe point, by means of radio control.

And So On And So On

One might go on almost forever, thinking up new possibilities for the vacuum tube. To me, who has been privileged to see my idea grow from just an experiment on gaseous detection of radio signals, to the basis of the entire radio industry, the long-distance telephone lines, the talking motion picture industry, the huge broadcasting establishment, the revived phonograph industry, and many other tangible things, it seems natural to expect almost anything of my brain child in the future. Let us note that with progress guided by organized research and engineering development, practically anything is possible. I have, at my command, a remarkable engineering and research staff today at our DeForest plant in Jersey City—an organization which converts problems into solutions, ideas into workable models, and laboratory findings into production items, in days as contrasted with years in the old days of chance discovery and invention. And with my contact with this new order of things, I make bold in my predictions.

Stop A.C. Noise!
Improve Selectivity!

To eliminate "static" from motors, street cars, telephones and electrical appliances, plug in a Falck Claroceptor between wall socket and radio set. This new improvement by a pioneer manufacturer grounds and thus blocks out line interference noise and radio frequency disturbances. Also improves selectivity and distance. Requires no changes in set. Measures just 3½ x 5½ x 2½ inches. Thousands all over America now use the Claroceptor for clearer A.C. reception. Get one right away—at radio parts dealers. Write for descriptive folder.

\$7.50
with cord and plug



Falck CLAROCEPTOR

Manufactured by ADVANCE ELECTRIC CO.
1260 W. Second Street Los Angeles, Cal.
JOBBER AND DEALERS, GET OUR PROPOSITION

SM

One Mile from WSM— 400 from WMAQ—and the 712 Cuts 20 kc.!

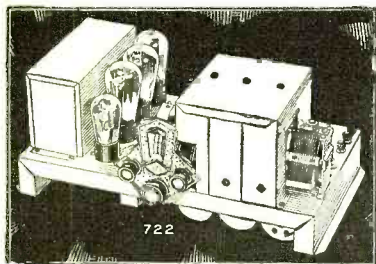

722 Band Selector Seven

Providing practically all 1930 features found in most new \$200 receivers, the S-M 722 is priced absurdly low in comparison. 3 screen-grid tubes (including detector), band filter, 245 push-pull stage—these help make the 722 the outstanding buy of the year at \$74.75 net, completely wired, less tubes and cabinet. Component parts total \$52.90. Tubes required: 3—'24, 1—'27, 2—'45, 1—'80.

Beautiful Cabinets

The handsome new 707 table model shielding cabinet, finished in rich crystalline brown and gold, suitable for 722, 735, or 735DC, is only \$7.75. Special arrangements have been made whereby these receivers may be housed in magnificent consoles especially adapted to them. Be sure to send for the new Fall S-M General Parts Catalog, for details of these cabinets.

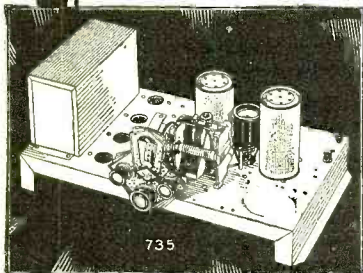

Keep up-to-date on Silver-Marshall progress; don't be without THE RADIOBUILDER. New products appear in it in advance of public announcements. The October 15th issue, for example, described a new amplifier design for television reception, as well as hints on installing the wonderful 712 as the radio tuner unit in rack-and-panel installations. If you're not getting THE RADIOBUILDER regularly—use the coupon!

Big Opportunities This Year for S-M Service Stations

Custom-builders using S-M parts have profited tremendously through the Authorized S-M Service Station franchises. Silver-Marshall works hand-in-glove with the more than 3000 professional and semi-professional builders who display this famous insignia. If you build professionally, let us tell you all about it—write at once!

SILVER-MARSHALL, Inc.

6405 West 65th St., Chicago, U. S. A.

W. W. DILLON & CO.
Realtors, Nashville, Tennessee

"Silver-Marshall, Inc., Chicago:

"I have had your 712 tuner for about ten days now . . . over a hundred stations have been received . . . I live within a mile of the towers of WSM (650 kc.) but am able to bring in WMAQ (Chicago, 670 kc.) and KPO (Oakland, Calif., 680 kc.) . . . I find I get results on a short indoor aerial which you claim only when using a longer outdoor antenna . . . I am using 30 feet of rubber-covered wire tacked up in the attic . . . Some night I may put up a decent aerial, connect it as you direct and bring in China."

—M. G. Horkins

The custom-built S-M 712 used by Mr. Horkins is a straight one-dial all-electric tuner, as easy to operate as the cheapest radio. Whether it's a world-beating set for your own home, or a custom design to build for "fastidious listeners"—the S-M 712 so far overshadows competition that comparison becomes ludicrous.

And if You Prefer a Still Lower Cost—

"Silver-Marshall, Inc., Chicago:

"I received my 722 . . . That receiver is certainly the best for the money—KDKA or WBZ without any heterodyning at blasting volume, or WRVA and WPG, or WJZ and WBBM, or WEAF and WMAQ. (All four are 10 kc. separations.) WJZ, WGY, KDKA and CKAC, 400 to 600 miles away, are regular daylight features . . . I will keep on boosting Silver-Marshall sets like I have been doing since four years ago."—Gleason Belzile, Rimouski, Quebec, Canada.

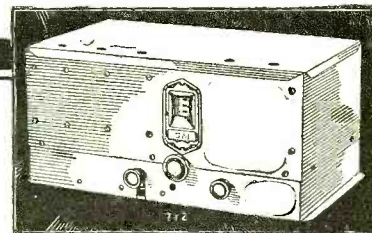

The New "Boss of the Air"—S-M 712

Far more selective and sensitive even than the Sargent-Rayment 710, the new all electric single control 712, with band-filter and power detector, stands far beyond competition regardless of price. Feeds perfectly into any audio amplifier, the S-M 677 being especially suitable and convenient. The 712 can be easily mounted for use as radio tuner in a rack-and-panel amplifier installation; the superlative quality of its reception makes it ideal for this purpose, while the low-impedance power detector works perfectly into any type of power amplifier. Tubes required: 3—'24, 1—'27. Price, only \$64.90, less tubes, in shielding cabinet. Component parts total \$40.90.

677 Amplifier

Superb push-pull amplification is here available for only \$58.50, less tubes. Ideal for the 712, since it furnishes all required power (180 volts B, 2½ volts A.C.). Tubes required: 2—'45, 1—'27, 1—'80. Component parts total \$43.40.

Short Wave Reception Without Batteries

A screen-grid r.f. stage, new plug-in coils covering the bands from 17 to 204 meters, regenerative detector, a typical S-M audio amplifier, all help to make this first a. c. short-wave set first also in performance. Price, wired complete with built-in power unit, less cabinet and tubes, only \$64.90. Component parts total \$44.90. Tubes required: 1—'24, 2—'27, 2—'45, 1—'80. Two extra coils, 131P and 131Q, cover the broadcast band at an extra cost of \$1.65.

Adapted for battery use (735DC) price, \$44.80, less cabinet and tubes. Component parts total \$26.80. Tubes required: 1—'22, 4—'12A. All prices net.

Silver-Marshall, Inc.
6405 West 65th Street, Chicago, U. S. A.

Please send me; free, the new Fall S-M Catalog; also sample copy of The Radiobuilder.

For enclosed.....in stamps, send me the following:
..... 50c Next 12 issues of The Radiobuilder
..... \$1.00 Next 25 issues of The Radiobuilder.

S-M DATA SHEETS as follows, at 2c each:

-No. 3. 730, 731, 732 Short-Wave Sets
-No. 4. 255, 256, etc., Audio Transformers
-No. 5. 720 Screen Grid Six Receiver
-No. 6. 740 "Coast-to-Coast" Screen Grid Four
-No. 7. 675ABC High-Voltage Power Supply
-No. 8. 710 Sargent-Rayment Seven
-No. 9. 678PD Phonograph-Radio Amplifier
-No. 12. 669 Power Unit
-No. 14. 722 Band-Selector Seven
-No. 15. 735 Round-the-World Six
-No. 16. 712 Tuner (Development from the Sargent-Rayment)
-No. 17. 677 Power Amplifier for use with 712

Name.....

Address.....

ELECTRICAL ENGINEERING

BOOKS SENT FREE

New Edition Containing 100 Pages on
A-C RADIO!

8 FLEXIBLE MAROON VOLUMES

4300 pages, 5200 illustrations, deluxe gold stamped binding, index in each book, general index in Vol. 8. Covers every subject in Electricity—Light, Power, Transmission, Generators, Motors, Switchboards, Radio, Telephone House Wiring, Railways, etc.

We're glad to send a set to your home to examine and use as your own for 15 days—to show you that here is the most up-to-date and complete work on Electricity ever published. Written by CROCKER of Columbia U.—MILLIKAN of Calif. "Tech."—HARRISON of General Electric and 26 other noted Electrical Engineers. Starts off with elementary Electricity in simple, non-technical language for the beginner and includes every Engineering branch for use of experts on the job.

Complete Electrical Reading Course

Electricity, the biggest industry in the world, continues to grow the most rapidly. And it offers better jobs, bigger salaries and a brighter future than any other field. Every dollar, every hour invested in learning Electricity will come back to you a thousand-fold. Learn in spare time with these books at one-fifth the cost of trade courses. Outline for organized study, quiz-questions and a year's free consulting membership in the American Technical Society included without extra cost, if you mail coupon immediately.

Look it up!

Thousands of these sets are used as R E F E R E N C E books by men employed in electrical, building construction and allied lines. The JIFFY INDEX puts the answers to 20,000 questions right at your finger tips.

AMERICAN TECHNICAL SOCIETY
Dept. E-125
Drexel Ave. & 58th St., Chicago

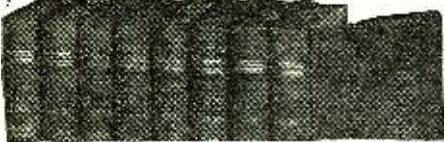

American Technical Society
Dept. E-125 Drexel Ave. & 58th St., Chicago

Please send for 15 days' free trial 8-volume set of Electrical Engineering just off the press, subject to return if I wish to. (I pay the few cents express charges on receipt of books, you pay express if returned.) If I decide to keep them, I will pay \$2.00 after 15 days trial, then \$3.00 a month until \$4.80. Special advertising price is paid, after which books become my property. Year's Consulting Membership to be included free.

Name.....
Address.....
Employed by.....
Employer's Address.....

Choice of 1200 Newest RADIO VALUES

SEND for our wholesale 1930 catalog. Filled with amazing values in screen grid radios, 245 push-pull audio, radio consoles, kits, parts. Guaranteed merchandise at wholesale prices.



WESTERN RADIO MFG. CO.
128 W. LAKE ST. CHICAGO ILL.

Patents Trade-Marks
EDWARD C. SASNETT
Attorney at Law and Registered Patent Attorney
Ex-Principal Examiner and Examiner in Electrical Division, U. S. Patent Office
542 MCGILL BLDG., WASHINGTON, D. C.
Personal Service

And Now We Have The Straight Resistance-Coupled Audio Amplifier

(Continued from page 611)

Resistances have been apportioned to provide that the potential of the supply sides of the plate resistors (marked "A," Fig. 3) shall be the same. For maximum flexibility, however, separate leads have been brought to the binding post strip.

It will be noted that the amplifier is a self-contained, non-adjustable unit.

The Power Supply

A power supply of 800 volts at approximately 75 milliamperes is needed for "B" and "C" voltages for the amplifier. The design considerations therefore differ slightly from those of the more common 450-volt supply.

The power transformer is equipped with three center-tap secondaries—two 7½-volt windings and a 1,500-volt winding. A pair of UX281 rectifier tubes have given excellent results in spite of months of strenuous service in the laboratory. Low-resistance chokes have been connected in a condenser-input-filter circuit to provide as high a terminal voltage as possible.

Across the power supply a resistance bank of 60,000 ohms is connected for obtaining variable supply voltages. To each terminal of the supply is connected a 5,000-ohm, 100-watt wire-wound unit with four variable taps. A bridging resistor of 50,000 ohms connects the ends of the adjuster units to maintain stability. A binding post strip corresponding to the strip on the amplifier is provided at one end of the heavy oak mounting board.

Fig. 4 indicates the wiring diagram of the power supply. Taps on resistor "B" provide variable plate voltages. Changes in grid bias are made by changing taps on resistor "C." Since taps for "B" voltages may be kept constant, the adjustment of the amplifier consists in arranging the taps of "C" to give proper plate current, plate voltage and grid bias.

For preliminary set-up approximate voltages are indicated on the two diagrams, Fig. 3 and Fig. 4. Readjustments are then easily made to take care of slight variations in tubes and other equipment.

By using a resistor and balancing bat-

tery in the output circuit, the gain will be constant within ± 1 decibel from 0 cycles per second to some higher frequency at which the shunting capacity of tube electrodes and wiring becomes appreciable. Fig. 5 shows the amplification for two systems: 1—with output resistance and balancing battery as shown in Fig. 2; 2—with choke coil and condenser output for use with loud speaker in the reproduction of speech and music.

This amplifier and associated power supply have been extensively used in making oscillographic studies of the output of a beat frequency oscillator. The equipment proved very effective for amplifying the original current of small amplitude to obtain sufficient power to operate the usual vibrator oscillograph.

A photograph of the amplifier and power supply connected for laboratory measurements is shown.

Parts Employed

- 1 Miller power transformer; 110-volt, 60-cycle primary; 2 7.5-volt secondaries; 1 1,500-volt secondary.
- 2 Amertran 15-henry, 200-milliamperere filter chokes.
- 2 Radio Appliance Co., 4-mfd., 1,300-volt (a.c.) filter condensers.
- 1 Radio Appliance Co. 2-mfd., 1,300-volt (a.c.) filter condenser.
- 1 Ward-Leonard 50,000-ohm resistor.
- 2 Rubicon Co. 5,000-ohm, 100-watt, tapped wire-wound resistors.
- 6 Benjamin sockets, No. 9040.
- 3 Durham 2-watt metallized powerohms.
- 9 Durham 1-watt metallized powerohms.
- 12 Durham grid leak mountings.
- 2 UX281 tubes.
- 1 UX240 tube.
- 1 UX112A tube.
- 1 UX201A tube.
- 1 UX250 tube.

The reproduction of recorded and broadcast speech and music, using this amplifying system with effective associated apparatus, is truly remarkable.

Many other interesting uses for the apparatus will no doubt come to the mind of the experimenter.

Book Review

"Radio Telegraphy and Telephony." By Rudolph L. Duncan and Charles E. Drew. John Wiley and Sons, Inc., New York. 950 pp. Illustrated. \$7.50.

This is one of the best technical textbooks which has come to the editor's desk in many months. The word "technical" does not do it full justice, however. It is not written in a heavy, highly abstruse style, but rather in a simple, easy manner, presenting involved technical dissertations in a way that even the uninitiated can readily comprehend.

Any attempt to outline, even generally, the contents of the book falls far short of its mark. The information presented is complete, concise and easily assimilated. Beginning with a simple explanation of the laws governing magnetism, such subjects are covered as: Motor-

generators and starters, storage batteries and charging circuits, meters, principles of alternating current, vacuum tubes, receiving circuits, a.c.-operated receivers and tubes, commercial receivers, rectifiers, antenna design and construction, commercial broadcast transmitters, short-wave transmission, short-wave transmitters and receivers, arc transmission, radio direction finders, and broadcast equipment.

The text is amply illustrated with drawings and photographs. Excellent circuit diagrams, both schematic and pictorial, are given. An unusually complete appendix is devoted to formulæ, tables and other useful data.

It is our opinion that the authors have done an excellent and constructive piece of work, and we are glad to recommend "Radio Telegraphy and Telephony" to our readers.

Thousands of Positions Open Right Now for Motion Picture Sound Engineers

Due to the fact that radio and sound are so closely allied, men with radio experience are the most adaptable

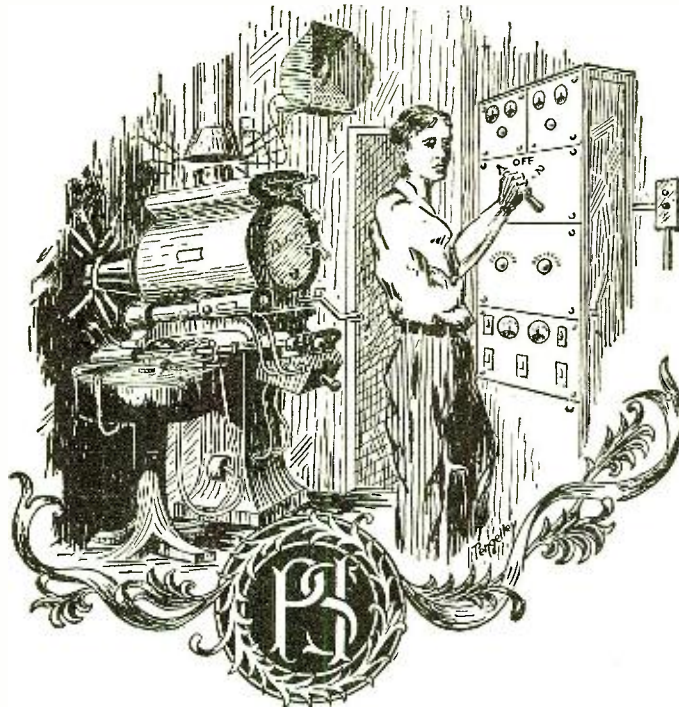

Salaries
Ranging
UP to
\$200.00
per
WEEK

WE are in contact with chain theatres and manufacturers of Sound equipment who desire the services of competent sound men as engineers, projectionists, installation and service men. Our employment department will assist you in making a profitable connection free of charge.

GUARANTEE

Our guarantee insures you that if you enroll as one of our students and take advantage of the many opportunities that your membership entitles you to, your increased income will pay the tuition of the course many times. We unconditionally guarantee that if for

any reason you are dissatisfied (you being the judge) we will refund every cent you have paid.

POLICY

Our course on Sound Projection which is prepared by the most eminent authorities on Electrical Acoustics will qualify you for a Profession whose place in the engineering world is second to none. All of the available knowledge of the art and the underlying fundamental principles of sound are given to you in an every-day, plain-talk language, as well as two weeks' practical training in the operation, servicing and installation of Sound Equipment.

DEMAND

In the 20,000 theatres throughout the United States and Canada, which now employ approximately 50,000 projectionists, it is estimated that a very small per cent of this number are qualified to fill the position as sound operators. Many thousands of new men will have to be taken into this field as fast as the many thousand unwired theatres are wired for sound as the additions of sound doubles the number of operators required. This condition will create many thousands of positions at salaries up to \$200.00 per week. The tuition for these courses is very reasonable and is payable in easy installments as you study. Also you have the added convenience of studying at home in your spare time. Fill out and mail the coupon below today for special scholarship proposition.

Mail Coupon for Free Information

PROJECTIONIST SOUND INSTITUTE

F. A. JEWELL, Gen. Mgr.

P. O. Box No. 28, Easton, Pa.

PROJECTIONIST SOUND INSTITUTE,
P. O. Box No. 28, Easton, Pa.

R. N.-1

Gentlemen:

Please send me, by return mail, full details of your Special Scholarship Proposition on Sound Projection.

Name.....

Address.....

City.....State.....

EXCELLO Radio Consoles



Model R61

A beautiful Walnut Cabinet with sliding doors of matched Butt Walnut and selected Japanese Ash sidepanel overlays. Accommodates Buckingham, Crosley, Atwater Kent, Fada, Sparton and all standard receivers. Ample space for Receiver, Speaker, etc.

Write today for Free illustrated folder of all new styles, including Phono-Radio Combination Consoles.

EXCELLO PRODUCTS CORPORATION
4832 West 16th St., Cicero, Illinois

'Dependable 'B' Battery Power'

Non-Destructive, Re-chargeable, Edison Element Batteries for Long and Short Wave Receivers. 100 volt, \$12.00; 140, \$17.00; 180, \$24.00. Prices include dry TRICKLE CHARGER. All batteries shipped dry with solution. Send no money, pay expressman. Also "B" and "A" Battery Outfits operating from 32-volt systems.

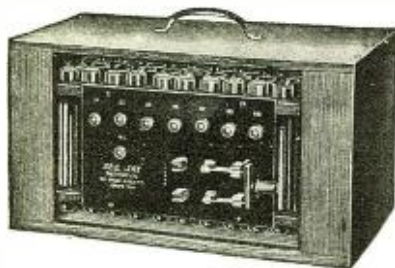

Write for our interesting booklet. See Jay Battery Co., 911 Brook Ave., N. Y. C.

See the Craters in the MOON!

Astronomical and Terrestrial TELESCOPE

Magnifies 30 Times

Own a genuine Astronomer's Telescope. See thousands of miles away. Make Sun, Moon Planets, Stars your next door neighbors. Moon, Craters, Sun Spots, Eclipses, Comets enlarged 30 times. Splendid thrill!

Hours of fun looking at scenery, games, bathing beauties. Great for trips and voyages. Made like telescopes used in observatories. Gerding wrote: "Moon seemed 10 yards away!"

See Landscapes, Games, Ocean Scenes, Enlarged 30 Times!

Diameter 2 inches. Special friction adjustment for focusing. Adjustable bracket and clamp can be fastened to chair, fence, branch, etc. Finest materials. Will last a lifetime.

Five Days' Free Trial

Rush only \$1.00 now. Pay balance (\$1.95 plus postage) when postman delivers. Keep 3 days. If not delighted, return telescope and money will be refunded.

Price Only \$2.95

EARN \$10 A DAY
Charge 25c to look at the moon

R. B. SPECIALTY CO.,
Dept. A-335
220 E. 3rd St., Cincinnati, O.

What Do You Know About Audio-Frequency Amplifiers?

(Continued from page 613)

and substituting the value of I_p given in equation (4) we have

$$(6) P = \left(\frac{\mu E_i}{3R_p} \right)^2 R_o = \frac{\mu^2 E_i^2}{9R_p^2} R_o$$

Since $R_o = 2R_p$, the formula can be simplified to

$$(7) P = \frac{\mu^2 E_i^2}{9R_p^2} 2R_p = \frac{2\mu^2 E_i^2}{9R_p}$$

Now the maximum amount of power a tube can deliver is ordinarily limited by the grid bias on the tube, for the peak value of the input a.c. voltage must not exceed the d.c. grid bias. If we revise the preceding formula so that it is in terms of peak a.c. input voltage, we have

$$(8) P = \frac{\mu^2 E_i^2}{9R_p}$$

where

E_i = peak a.c. volts applied to grid of tube

μ = amplification constant of tube

R_p = plate resistance of tube

This formula can be simplified for any given type of power tube by substituting in the formula the proper values of plate resistance and amplification factor. For example, for the 245 tube $R_p = 1,900$ ohms and $\mu = 3.5$, therefore

$$P = \frac{3.5^2 \times E_i^2}{9 \times 1900} = \frac{.67 E_i^2}{1000}$$

This formula gives the power in watts. Since we frequently rate tubes in terms of milliwatts, we can multiply the formula by 1,000 to get power in milliwatts. That is

$$P_{mw} = 0.67 E_i^2$$

which is a very simple formula to work with. These simplified formulas have been worked out for all types of power tubes, both singly and in push-pull. They are given in Table I.

We can check the accuracy of these formulas by an example, for the maximum value of E_i can be taken as equal to the d.c. bias on the tube. The 171A requires a bias of 40 volts; therefore

$$P = \frac{40^2}{1000} = \frac{1600}{1000} = 1.6 = 1.6 \text{ milliwatts}$$

and the tube is rated at 700—so our formula is accurate within about 4 per cent., more than sufficiently accurate for practically all purposes.

Now, knowing our formulas are correct, we are ready to determine how the output of any tube varies with the a.c. input voltage. To do this we need simply to substitute for E_i various values from zero up to a value equal to the rated "C" bias on the tube. This has been done and the results of all these calculations on the various tubes are summarized in the curves of Fig. 2. I do not recall having seen such curves published previously. They are very useful, especially in connection with our study of audio amplifiers. We will return to a consideration of them several times in connection with the following discussion. For the present let these curves serve simply to indicate that the rated power output of any power tube is not obtained unless the tube is supplied with the maximum allowable a.c. input voltage. Take, for example, the curve for a single 171A. With 40 volts peak on the grid, rated output (700 milliwatts) is obtained—if, however, the grid excitation is only 20 volts peak, the power output is 190 milliwatts.

TABLE I

Type of Power Tube	Plate Resistance	Amplification Constant	Final Formula Power in Milliwatts
112	5,000	8	$1.5 E_i^2$
171A	2,000	3	$\frac{E_i^2}{2.1}$
245	1,900	3.5	$0.67 E_i^2$
250	2,000	3.8	$0.75 E_i^2$
210	5,000	8	$1.5 E_i^2$
112 P-P	10,000	8	$0.75 E_i^2$
171A P-P	4,000	3	$\frac{E_i^2}{4.2}$
245 P-P	3,800	3.5	$0.34 E_i^2$
250 P-P	4,000	3.8	$0.37 E_i^2$
210 P-P	10,000	8	$0.75 E_i^2$

Since this is the case, we must be sure that in designing audio amplifiers we base the design on this fact—the maximum a.c. voltage required on the grid of the power tube. It certainly would be foolish to use a type 250 tube with an audio amplifier circuit which couldn't supply sufficient voltage to the 250 grid to load it up.

Let us suppose that a type 250 tube is to be used as the output stage of a two-stage transformer-coupled audio amplifier. The two transformers have turns ratios of

(Continued on page 664)

RADIO WORLD BOOK SERVICE

AS the first and only national radio weekly, now in its eighth year, RADIO WORLD publishes the most timely, up-to-date news of radio circuits and events in the set-building and broadcasting fields. Technical accuracy second to none. Get a copy at your news-stand today, 15c. RADIO WORLD advises impartially on all radio topics, including what text-books to buy, and helps you to read the books properly. Every book advertised on this page is essential to your radio library.

Five New Volumes Offer Short-Cut to Knowledge!

MORECROFT

"Elements of Radio Communication"



The latest book by Prof. John H. Morecroft, of the Engineering Department of Columbia University, and past president of the Institute of Radio Engineers, is his "Elements of Radio Communication," a book for the novice to enjoy. We regard this as the best elementary book to inform you authoritatively on the technical phases of radio in plain language, without requirement of mathematical knowledge. The book is a complete course on the elements of radio, containing much material never before published. It has 226 pages, 170 illustrations and a complete index. Just out, it is the book of the year in radio. Cloth bound. Order Cat. ME @\$3.00

By the same author: "Principles of Radio Communication," second (new) edition. This book is for advanced students. It is the standard of excellence in its field. It covers much the same ground as the later book, only much more fully and more technically. (Contains 1,001 pages, 831 illustrations. Cloth bound. Order Cat. MI' @ \$7.50

covers much the same ground as the later book, only much more fully and more technically. (Contains 1,001 pages, 831 illustrations. Cloth bound. Order Cat. MI' @ \$7.50

MOYER and WOSTREL

"Radio Receiving Tubes"

The need for an elementary book on radio tubes that answers all the important questions has been filled by James A. Moyer, Director of University Extension, Massachusetts Department of Education, and John F. Wostrel, Instructor in Radio Engineering, Division of University Extension, Massachusetts Department of Education.

This new book is a complete discussion of tube principles, functions and uses, thoroughly up-to-date. In this book the essential principles underlying the operation of vacuum tubes are explained in as non-technical a manner as is consistent with accuracy. The book covers the construction, action, reactivation, testing and use of vacuum tubes as well as specifications for vacuum tubes and applications for distant control of industrial processes and precision measurements. 297 pages, cloth bound. Order Cat. MWT @\$2.50

By the same authors: "Practical Radio," including the testing of radio receiving sets, 378 pages, 223 illustrations. Cloth bound. Order Cat. MWPR @\$2.50

"Practical Radio Construction and Repairing," 319 pages, a companion volume. Order Cat. MWPRC @\$2.00 [Note: The standard look on tubes for advanced students is "The Thermionic Vacuum Tube," by Hendrik Van der Bijl. Order Cat. VDB @\$5.00]

ANDERSON and BERNARD

"Audio Power Amplifiers"

Here is the first book to be published on "Audio Power Amplifiers." Now printing, it is certain to fill a void in radio literature. The whole subject is fully covered in a masterful theoretical discussion of audio amplifiers and power supplies, supplemented by constructional chapters, with complete wiring diagrams and specification of parts. Learn while you build! J. E. Anderson, M. A., technical editor of RADIO WORLD, and Herman Bernard, L. L. B., managing editor of RADIO WORLD, both of the Institute of Radio Engineers, have explained fully the phenomena of power amplifiers. Learn all about motorboating and its cures, push-pull theory and practice, grid bias methods and effects, vacuum tubes in audio circuits, AC and battery type AF amplifiers, phase relationships, common impedance, filter systems, by-pass condenser effects, necessities for tone quality, values of coupling constants, and a host of other topics associated with power amplification, including speech amplifiers and "talkie" installations.

More than 200 pages and more than 100 illustrations are devoted to an analysis of this outstanding radio subject. "Power Amplifiers" is authoritative, original and comprehensive. It is free from the traditional errors that have crept into this subject. The theoretical part of the book can be understood by most novices, while the constructional part, that capitalizes the previously imparted knowledge, is thoroughly understandable by anybody. There is virtually no mathematics in the book. Cloth bound. Order Cat. PAM @\$3.50

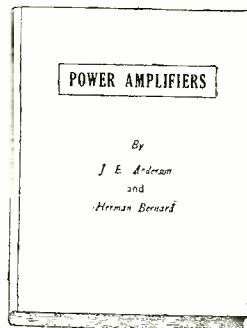

RIDER

"Service Man's Manual"

Two new books by John F. Rider, R. E. Member, Institute of Radio Engineers, constitute the series grouped by him under the heading "Service Man's Manual." Part I is "Mathematics of Radio," Part II is "Trouble Shooter's Manual."

The value of one of these books is more than doubled by the possession of the other.

"The Mathematics of Radio," 128 pages, 8 1/2 x 11", 119 illustrations, bridges the gap between the novice and the college professor. It gives a theoretical background so necessary for a proper understanding of radio and audio circuits and their servicing. Flexible cover. Order Cat. MOLT @\$2.00

The first comprehensive volume devoted exclusively to the topic uppermost in every service man's mind is "Trouble Shooter's Manual," just published. It is not only a treatise for service men, telling them how to overcome their most serious problems, and fully diagramming the solutions, but it is a course in how to become a service man. It gives all the details of servicing as they have never been given before. Finding the right mode of attack, applying the remedy promptly and obtaining the actual factory-drawn diagrams of receivers always have been a big load on the service man's chest. But no more. Rider, expert on trouble shooting, has produced the outstanding volume on servicing, and has taken the load off the service man's chest!

This book is worth hundreds of dollars to any one who shoots trouble in receivers—whether they be factory-made, custom-built or home-made receivers. The home experimenter, the radio engineer, the custom set-builder, the teacher, the student—all will find this new book immensely informative and absolutely authoritative.

MORE THAN 100 WIRING DIAGRAMS OF RECEIVERS MADE BY MORE THAN FORTY DIFFERENT SET MANUFACTURERS ARE PUBLISHED IN THIS BOOK, INCLUDING OLD MODELS AND LATEST MODELS! RCA, ATWATER KENT, CROSLY, MAJESTIC, ZENITH, STROMBERG CARLSON, KOLSTER, FEDERAL, FADA, Etc. 240 pages, size 8 1/2 x 11"; 200 illustrations. Imitation leather cover. Order Cat. TSM @\$3.50

FREE! Read Radio World Every Week



RADIO WORLD will help you in your radio work, so you will be able to use meters most valuably. Keep abreast of new circuits, intimate details on perfecting existing sets, get inside track on sensitivity, distance reception, tonal quality, and news of radio, technical and non-technical. Enjoy the writings of McQuirde Stiver, J. E. Anderson, Herman Bernard, John F. Rider and a host of other radio engineers in RADIO WORLD. You can find no magazine that better caters to your needs than RADIO WORLD. Short waves? RADIO WORLD will tell you all about them. Extremely sensitive broadcast receivers? Their construction and operation are fully discussed with confident regularity. Power supplies—push-pull or otherwise? AC receivers? Screen grid tubes? Large receivers that give a super-abundance of performance—small, economical receivers that give performance out of all comparison to their size? Are you interested in these? Then you're interested in RADIO WORLD.

See the list of nine meters at left. Obtain one or more of these meters free, by sending in \$1 for 8-weeks' subscription, entitling you to one meter; \$2 for 16 weeks, entitling you to two meters; \$3 for 26 weeks, entitling you to three meters; \$4 for 35 weeks, entitling you to four meters; \$5 for 41 weeks, entitling you to 5 meters; \$6 for 52 weeks, entitling you to six meters.

Present RADIO WORLD mail subscribers may renew their subscription under this remarkably generous offer. Put a cross in square. □

- 0-6 Voltmeter D.C. Cat. 326
- 0-50 Voltmeter D.C. Cat. 337
- 6-Volt Charge Tester D.C. Cat. 23
- 0-10 Amperes D.C. Cat. 338
- 0-25 Milliamperes D.C. Cat. 325
- 0-50 Milliamperes D.C. Cat. 350
- 0-100 Milliamperes D.C. Cat. 390
- 0-300 Milliamperes D.C. Cat. 399
- 0-400 Milliamperes D.C. Cat. 394

RADIO WORLD

145 W. 45th St., N. Y. City—Published Weekly.
All Newsstands, 15c per copy—\$3, six months—\$6 a year

Gentlemen: Enclosed find \$..... for which please send items checked on coupon. (RNJ)

<input type="checkbox"/> CAT. ME @ \$3.00 <input type="checkbox"/> CAT. MP @ \$7.50 <input type="checkbox"/> CAT. PAM @ \$3.50 <input type="checkbox"/> CAT. MWT @ \$2.50 <input type="checkbox"/> CAT. MWPR @ \$2.00 <input type="checkbox"/> CAT. MOR @ \$2.00 <input type="checkbox"/> CAT. TSM @ \$3.50 <input type="checkbox"/> CAT. VDB @ \$5.00	<input type="checkbox"/> CAT. 326 Name <input type="checkbox"/> CAT. 337 <input type="checkbox"/> CAT. 23 <input type="checkbox"/> CAT. 338 <input type="checkbox"/> CAT. 325 <input type="checkbox"/> CAT. 350 <input type="checkbox"/> CAT. 390 <input type="checkbox"/> CAT. 399 <input type="checkbox"/> CAT. 394 City State
---	---

WHEN CONTROL IS EVERYTHING---

Storm, sleet, fog, darkness . . . the airplane pilot must "carry on."

At such time Control is everything.

Your radio must "carry on" whenever you snap the switch.

Your control (volume control) must function smoothly . . . easily . . . consistently if you would be rewarded with clear-sounding entertainment. Your radio will do just that if it is CENTRALAB equipped.

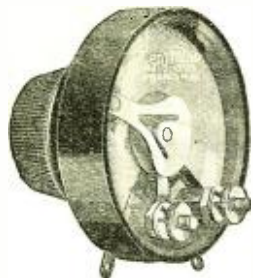

Write for free booklet, "Volume Controls, Voltage Controls, Their Uses."

Centralab

CENTRAL RADIO LABORATORIES
20 Keefe Avenue Milwaukee, Wis.

BE A REGISTERED RADIO TECHNICIAN IN 90 DAYS

This great electrical school from which Broadcasting Station WISN is operated, is training men to fill the enormous demand for radio technicians. The thorough, practical and complete course covers all branches of radio, including the latest developments in the field of television.



Operating Room of Broadcasting Station WISN at School of Engineering

EARN WHILE YOU LEARN



Brilliant future awaits men in this big money-making field. Our course is endorsed by the Federated Radio Trade Association. Our graduates are "registered" and can easily qualify as competent service men at good pay. Co-operation with large Milwaukee industries enables us to help place students at part time jobs. You earn while learning. Low tuition. School orchestra. Fraternities. Write for catalog today!

Founded 1903 Dept. B.N.-130, 1229 Milwaukee, Wis.

SCHOOL of ENGINEERING of Milwaukee

SEND FOR THIS FREE BOOK OF SELF HELPS

New practical working methods for Aviators, Radio Men, Inventors, Engineers, Mechanics, Automobile and Battery Men, Electricians, Contractors, Carpenters, Painters, Decorators, Artists, Advertisers and other technical men. Over 200 books covering practically all kinds of mechanical work. Write for your free copy today.

FREDERICK J. DRAKE & CO., Publishers
510-179 No. Michigan Blvd., Chicago

Audio-Frequency Amplifiers

(Continued from page 662)

3 to 1. We want to determine how much "C" bias is required on the first audio amplifier tube and we want to know how much voltage the detector must supply to the input of the amplifier to get maximum power from the 250 tube. The fundamental circuit of the amplifier is given in Fig. 3.

The 250 tube requires a peak voltage E_i of 84 on its grid to supply maximum output. This peak voltage of 84 volts must be obtained from the transformer T2. The voltage across its primary must therefore be

$$E_3, \text{ voltage across primary} = \frac{\text{Voltage across secondary}}{\text{Turns ratio}} = \frac{E_i}{T_2}$$

$$= \frac{84}{3}$$

$E_3 = 28$ volts

Therefore the tube V2 must supply 28 volts to the transformer in its plate circuit. This a.c. voltage in the plate circuit is equal to the a.c. voltage E_2 on the grid of the tube multiplied by the amplification constant of the circuit. The tube is a 227 with an amplification constant of 8, but in transformer-coupled amplifier circuits it is only possible to realize about 90 per cent. of the actual μ of the tube. Therefore $8 \times .90 = 7$, approximately. Therefore the voltage E_2 must be

$$E_2 = \frac{\text{Voltage in plate circuit}}{\text{Effective } \mu \text{ of the tube}}$$

$$= \frac{28}{7}$$

$$= 4 \text{ volts peak a.c. on the grid of V2}$$

Since, as pointed out previously, the peak a.c. applied to the grid of a tube must never be greater than the "C" bias voltage, it follows that the bias E_2 required on the grid of V2 must be 4 volts or more—4.5 volts would be quite satisfactory.

The voltage E_1 which must be supplied by the detector is equal to the a.c. voltage E_2 across the secondary of T1 divided by the turns ratio 3. Therefore E_1 , the a.c. voltage across the primary of T1, is

$$E_1 = \frac{\text{Voltage across T1 secondary}}{\text{Turns ratio of T1}} = \frac{E_2}{3}$$

$$= \frac{4}{3}$$

$E_1 = 1.33$ volts, which is the voltage the detector must supply.

The undistorted output of ordinary grid leak and condenser detectors is limited to about 0.2 or 0.3 volts, and so this amplifier could not be supplied from such a detector. A "C" bias detector with a plate voltage of 45 and a "C" bias of 4.5 volts could, however, be used.

The voltage gain of the entire amplifier can be determined by multiplying to-

gether the various factors we have separately considered.

$$\text{Total gain } G = T_1 \times V_2 \times T_2$$

$$= 3 \times 7 \times 3$$

$$= 63$$

Suppose such an amplifier is operated from a grid leak and condenser detector from which only 0.3 volts can be obtained without serious distortion. The voltage E_i applied to the grid of the 250 will then be

$$E_i = 63 \times 0.3$$

$$= 18.9 \text{ volts}$$

and with this a.c. voltage on the grid, the power output (as observed from Fig. 2) will be only 0.29 watts! It is useless to use power tubes unless one is sure that the preceding tubes are capable of supplying the required a.c. voltages without distortion. It is quite possible that when a new amplifier is built which doesn't sound as good as a previous amplifier the trouble is due to overloading of some sort in one or more of the stages preceding the power stage. The result will be that the quality will only be good at low volume and as soon as the volume is increased to the limit of the output stage the quality goes sour. One might naturally consider that the new power stage was at fault, since the other parts of the amplifier have good results with a smaller power tube. The important point is that the entire audio amplifier is a single unit and it must be so designed. If we make any changes in one part of the circuit we must be sure to consider the effect of this change on the remainder of the amplifier.

Many of us prefer to use resistance or impedance-coupled amplifiers. Suppose we had a single 250 tube and wanted to supply it from an impedance-coupled amplifier. From the detector circuit we can get 0.3 volts. Therefore the gain of the amplifier must be

$$\text{Gain of amplifier, } G = \frac{\text{Peak voltage required by 250}}{\text{Peak voltage from detector circuit}}$$

$$= \frac{0.3}{280}$$

Now in an impedance-coupled amplifier there are no step-up transformers, the only gain being due to the tubes. Suppose we were to use type 227 tubes. Their amplification constant is 8, and assuming we get 90 per cent., the actual gain per stage will be about 7. Therefore, the total number of stages required will be

$$\text{No. of stages} = \frac{\text{Total required gain}}{\text{Gain per stage}}$$

$$= \frac{280}{7}$$

$$= 40 \text{ stages required!}$$

Think of it! But I'll bet there are some fans operating a 250 tube from an impedance-coupled amplifier, with a grid leak and condenser detector.

If one has a special liking for impedance-coupled amplifiers with a.c. tubes,

high-mu tubes must be used. From these tubes a stage gain of about 20 can be obtained, so the number of stages required will be

$$\begin{array}{r} 280 \\ \hline 15 \\ \hline = 19 \text{ stages} \end{array}$$

Rather excessive, we all agree. Let us approach the problem from another angle. Ordinarily an impedance amplifier uses three coupling units and two tubes (between the detector and power tube) and therefore the gain due to the two tubes will be 15×2 or 30. The voltage required from the detector tube will be

$$\begin{array}{r} \text{A.C. voltage from detector} \\ \hline \text{Voltage required by 250} \\ \hline \hline \text{Gain of amplifier} \\ \hline 84 \\ \hline = \text{---} \\ \hline 30 \\ \hline = 2.8 \text{ volts from detector} \end{array}$$

This is, of course, a much greater voltage than we ordinarily take from a detector, but it can be readily obtained from a "C" bias detector, operating with some 90 volts on the plate and say a 10-volt "C" bias, the r.f. input to the detector being increased so that the higher a.c. output voltage can be obtained from the plate circuit.

An amplifier in common use today is a two-stage transformer-coupled affair with two type 245 tubes in push-pull. Let's analyze it. The fundamental diagram of such an amplifier is given in Fig. 4. The a.c. voltage E_t across the secondary of the push-pull transformer can be obtained from the curves of Fig. 2 by noting that the curve for 245 tubes in push-pull ends at approximately 120 volts, which is the peak a.c. voltage E_t . Since the transformer T2 has a turn ratio of 4:1, the a.c. voltage E_3 required from the preceding tube is

$$\frac{120}{4} \text{ or } 30 \text{ volts.}$$

The gain in the tube V2 is 7, so the peak a.c. signal on the grid of this tube will be 30 divided by 7 or 4.3 volts. Therefore for safety the grid bias should be about

(Continued on page 673)

Improving the "250" Power Pack

(Continued from page 641)

greater the load the higher the transformer voltage and greater the choke inductance necessary.

The filter shown here will give a fairly low hum level even with a three-stage amplifier, provided stray pickup is kept low. The layout as shown when used with a very high grade radio set gave a hum response which measured less than twenty-five hundredths of a volt. This represents a very low level for a high-voltage pack using the 250 power tube.

Parts recommended: Thordarson and Amertran transformers and chokes, National chokes, Electrad adjustable resistors, Mershon condensers.

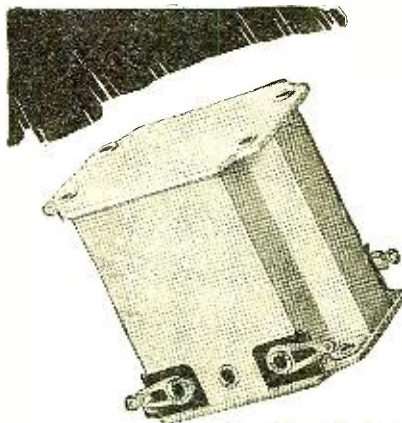

AmerTran De Luxe Audio Transformer—List Price \$10.00. Type 151—Between one input and two output tubes—List Price \$15.00



Type AF-8 Audio Transformer—Either 1st or 2nd stage audio—Turn ratio 3½—List Price \$6.00



Type 710 Audio Transformer—Between two input and two output tubes—List Price \$20.00

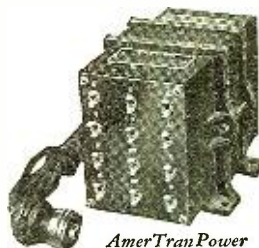

AmerTran Power Transformer—Type PF-245A—List Price \$22.00



Bring the Studio to your Home

There is no excuse for imperfect radio reception. But even today, receiving sets fail to reproduce music and the speaking voice in true tone identical with the range of pitch and the rich fulness of sound quality as broadcast in the studio.

The weak point in most receiving sets is in the audio system.

AmerTran Audio Transformers and Power Transformers shown here perfect the audio system and bring the programs into your home exactly as they go over the air through the microphone. For further descriptions of these and thirty-odd products in the field of radio reproduction that have attained the perfection necessary to AmerTran Standard of Excellence, write for Bulletin 1065.

The facilities of our engineering department are at the service of everyone interested in better radio reproduction.

AMERTRAN

TRADE MARK REG. U.S. PAT. OFF.

QUALITY RADIO PRODUCTS
 AMERICAN TRANSFORMER COMPANY
Transformer builders for over 29 years
 178 EMMET STREET, NEWARK, N. J.

AMERICAN TRANSFORMER CO.
 178 Emmet St., Newark, N. J.
 Please send me Bulletin 1065 containing complete information on AmerTran Transformers, for better radio reception.

Name

Address

HN-1-30

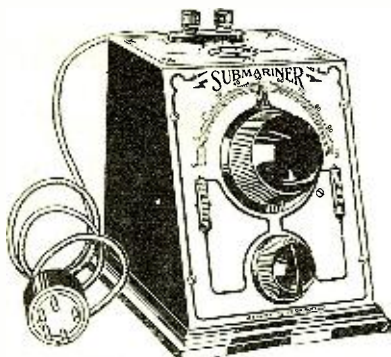

SHORT WAVES

THE SUBMARINER

will convert your receiver into a short wave receiver without any changes.

Enthusiastic owners have written us from all parts of the world. Stations broadcasting music 8000 miles away have been received. Very little static on short waves. Latest improvements—shielded—vernier dial 64 to 1 ratio—a quality product—on the market over three years.

MANY MODELS

16-32 meters, AC or DC, \$17.50. Interchangeable coil, 12-160 meters, AC or DC, \$22.50. "J" model gives five times volume of other adapters, price, 16-32 meters, \$22.50. Interchangeable coil "J" model, \$27.50. Sent postpaid upon receipt of price or C. O. D. if \$1.00 accompanies order. Give name of set and tubes used, when ordering.

J-M-P MFG. CO., INC.

3415 Fond du Lac Ave., Milwaukee, Wisconsin



When You Come to
Boston
Massachusetts

Plan to Stay at the
**MAYFLOWER
HOTEL**

Home of Broadcasting
STATION WLOE
Moderate rates.



GEARS

In stock—immediate delivery
Gears, speed reducers, sprockets,
thrust bearings, flexible couplings,
pulleys, etc. A complete line is
carried in our Chicago stock. Can
also quote on special gears of any
kind. Send us your blue-prints and
inquiries.

Write for Catalog No. 40
Chicago Stock Gear Works
769-773 W. Jackson Blvd., Chicago, Ill.

FREE Wholesale Radio Catalog

SEND FOR IT TODAY

Send for our new illustrated catalog of nationally known AC sets, kits, parts, accessories, consoles, etc. All lines at Lowest Wholesale Prices. Write for your FREE copy today.

SHURE BROS. CO.
Dept. 318 335 W. Madison St. CHICAGO, ILL.

No matter what your resistance problem may be—whether an unknown high resistance value for a critical receiving circuit or a heavy duty low resistance value for grid-biasing the largest audio power tube or even transmitting tube—

Remember there's a **CLAROSTAT** for Every Purpose

Clarostat Mfg. Co., 281 N. 6th St., Bklyn., N. Y.

Community Antennas

(Continued from page 617)

receivers, but this means only two or three antennae in all for most installations.

From each antenna, a down-lead goes to a series of multi-couplers, one after the other, and at the end this lead is grounded through a resistance of the proper value. This arrangement makes for equal voltage distribution over the entire line—the receiver in the basement gets just as good a signal as the one in the penthouse.

Within each multi-coupler is a network of coils and condensers, from the center

of which is taken off the antenna supply for the receiver at that point. The values of these coils and condensers are so chosen that the string of multi-couplers acts as a low-pass filter, passing mainly the broadcast frequencies, and shutting off much of the interference on other wavelengths. In series with each receiver lead, if necessary, is inserted a small resistance which effectually cuts down the interference which any oscillating receiver can cause in others, but which does not appreciably reduce the signal strength to the receiver.

The down-leads from the antenna, in which the multi-couplers are inserted, are run down either the outside or the inside of the building. If on the outside, they run down the side or back, while if on the inside they run down an airshaft or inner court, so that they are not in evidence to detract from the appearance of the building.

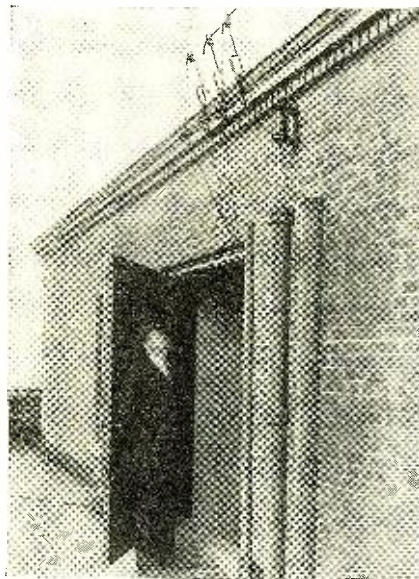

Fig. 5 shows an installation man completing the mounting of the last multi-coupler of a line, right outside the window of an apartment, in a court of the building. This installation also shows how relatively inconspicuous the multi-couplers are, even when mounted on the outside of a building, due to their small size (they are only six inches long and an inch and a half in diameter).

With these two systems of centralized antennae in the field, we may yet hope to see the time when every apartment roof will not be an eyesore because of its bent poles and ragged loops of wire, and when every courtyard will not be filled with a tangle of wires running in all directions.

Hitting the High Spots With the A. C. Super Wasp

(Continued from page 620)

grid circuit at the starting point of oscillation. Just as the grid tends to change from the slight positive bias, which it normally has, to the negative value which the rectification gives it, it undergoes an oscillatory condition which causes a bad "squawk" when the plate voltage is fed through a transformer. But when the plate potential is supplied through a high resistance, such as .5 megohm, the effective plate voltage drops when this condition occurs and this decline immediately stops the oscillation or "squawk." The result is that the new A.C. Super-Wasp goes into r.f. oscillation in a very smooth manner, permitting perfect regeneration on even the weakest stations.

As the A.C. Super-Wasp is supplied in kit form, along with a full-size blue-print and detailed assembly directions, there is no necessity for giving instructions here.

In actual operation the A.C. Super-Wasp is slightly more sensitive than the now famous battery model, which has earned a marvelous reputation. While it would be foolish for anyone to say that reception of foreign stations is easy, it is safe to say that it is not difficult with the Super-Wasp, because the tuned r.f. stage actually amplifies, and obviates the necessity for critical regeneration control. The set, in New York, has brought in short-wave broadcast stations in England, Holland, Germany, Spain, Canada, Australia and British East Africa, with varying degrees of strength. Stations G5SW, PCJ and W6XN come through on the loud speaker, sometimes exceptionally loud, sometimes so weak that the phones barely register. The set produces a million dollars' worth of thrills, and as a thrill maker it is presented to radio fans.

Men and More Men for Radio

THERE is a crying need for trained men in the radio industry, and the demand within the next year will be even greater. Radio schools, pressed constantly for graduates, are establishing branches throughout the country in cities where radio instruction has not heretofore been available. Teaching staffs are being augmented, and there is an increasing demand for correspondence courses.

In view of this situation, RADIO NEWS has commissioned Austin C. Lescarboura formerly editor of *The Scientific American*, to make a survey of the field in order to get the facts and details from leaders in the industry, and from manufacturers, dealers, and schools devoted to teaching radio. The results of the survey will be outlined in a forthcoming series of articles.

Radio's Flying Salesroom

(Continued from page 621)

meters. True's story was rebroadcast by WTAM so that many listeners in the vicinity of Cleveland were able to hear their first program originating from the air.

While traveling from Houston to New Orleans, a series of tests was conducted with the Galveston and Port Arthur stations. During this flight one of the broadcasting stations at New Orleans picked up KHRC, the call letters of Pickerill's plane, and rebroadcast everything that was spoken into the flying microphone. J. A. Pohl, superintendent of the gulf division of the Radio Corporation, was on board the plane. He had no idea, however, that his conversation was being broadcast by one of the New Orleans stations, and he was greatly surprised on landing at Menafee Field to find a group of his friends who had heard his dissertation and motored out to meet him.

On the route between St. Louis and Tulsa weather reports were picked up from the Department of Commerce stations at St. Louis, Kansas City, Omaha, and Wichita. All of these stations were heard over the entire route, and Pickerill believes that this weather service is almost perfect.

We have printed this article hoping that our readers and particularly the young men will realize the remarkable field for development presented by aircraft radio. It is from them especially—those who are interested in radio—that further progress will probably be made. Here is an almost unlimited opportunity for advancement, presenting possibilities which are today beyond our perception. It is this great future which we must endeavor, by experiment, by labor, and by invention, to bring about.

Trapped by Radio

(Continued from page 623)

and is built in the American rococo style of the 80's. This emphasizes its brazenness, perched as it is on the hilltop, with a view commanding not only the hilly south shore of Staten Island and the wide banks of the Shrewsbury River, but also, to the right, Sandy Hook Bay and the great ocean. It is plainly visible from the open road that approaches it.

To the average person it is an ugly, lone house, left unoccupied for the last 15 years, and certainly too unlovely for its former owner, Oscar Hammerstein. That single wire, coming out of a window and running to a thirty-foot pole on the estate, might have been anything, including an aerial to pick up broadcast programs. When the government sleuths got right up to it, and watched the operator at the key, they knew, from the information provided by the Radio Service of the Department of Commerce, that this was a transmitting station.

What they found, when they finally reached the radio room, so quietly that even the operator on watch was undisturbed, was a typical station of the amateur type.

Months of patient listening-in on the station that turned out to be an illicit
(Continued on page 669)

The NEW H-F-L Mastertone Laboratory Made Receiver

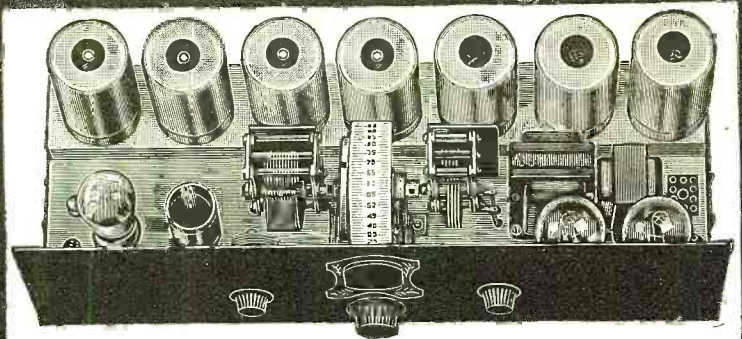

Completely Built and Assembled by H-F-L Engineers—Shipped ready to Operate

All metal completely shielded chassis: 7" x 21" x 7 1/2". Fits nearly all consoles. 11 tubes operating at peak efficiency [5-224; 3-227; 2-245; 1-280.] Single dial positive one-spot tuning; Humless AC Operation; Uses 5 Screen-Grid tubes, 5 Tuned R. F. Circuits; High Power Screen-Grid detector, with 175 volts impressed on plate; Automatic line voltage control inbuilt holds voltage against fluctuating; 100-Volt DC Dynamic field supply incorporated; 3 stage Phonographic amplifier; Finest quality precision made parts.

Amazing Power

Startling realism! Unfailing accuracy! Its great power and sweet tone awe and thrill, setting new standards of performance achieved by H. F. L. engineers after two years of tireless research and tests under all conditions.

Keenest Sensitivity

Unlike any ever known! Gets distant stations clearly, sharply, distinctly with only wire screen or metal plate aerial built in cabinet.

Highly Developed Circuit

Intermediate employs 4 screen-grid tubes with 5 tuned filter circuits, easily adjustable to peak of tuned frequency. Positive 10 Kilocycle selectivity. Most highly engineered receiver ever built.

The New Audio System

Uniform amplification over entire musical scale. Operates with dynamic, magnetic or horn speakers without a bit of hum.

The H-F-L Power Master

Not an ordinary power pack, but a specially developed unit of the Mastertone, built separately to simplify installation. Has oversized transformer, full wave type 280 rectifier tube.

Built by Hand—Yet Low in Price—

Quality—not quantity—the H-F-L Mastertone standard. One demonstration will convince you that its the master receiver of all times. Fully guaranteed.

Write today for complete description and price.

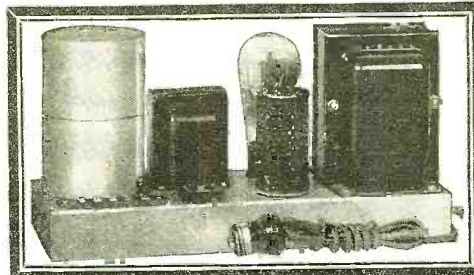

HIGH FREQUENCY LABORATORIES
28 North Sheldon St. Dept. 23 Chicago, Ill.

SET BUILDERS and DEALERS

Send for ROYAL-EASTERN'S NEW 124-page 1930 General Wholesale Catalogue

It is free. No obligation to buy

Every worth-while radio, electrical and sporting goods item is featured at lowest wholesale prices. Being the largest Radio and Electrical Mail Order House in the East, we can serve you best. We buy no seconds. We have no job lots. Only fresh and clean products in original factory cartons.

32 YEARS OF SERVICE TO THE TRADE—THREE BRANCHES—BEST CREDIT RATING—WE CARRY LARGEST STOCK IN THE EAST

Our Banking Affiliations and Depositories
The National City Bank of New York, N. Y.
Living Trust Company, New York
Brooklyn National Bank, Brooklyn, N. Y.
Bank of Manhattan, Long Island City, N. Y.
Huguenot Trust Co., New Rochelle, N. Y.

Royal-Eastern Electrical Supply Company

Send for Catalogue Today. It's free

14-B West 22nd Street

New York, N. Y.



GIVE THEM THEIR FAVORITE MAGAZINE

Why allow yourself to be pushed about in crowded shops at the last minute trying to find just the right present? The gift of the appropriate magazine happily solves these problems. You are sure of giving those friends on your Christmas list a most welcome present that comes not once, but *every month* throughout the year.

Sitting comfortably at your own desk, you can do most of your Christmas shopping by returning the coupon below. For in keeping with the holiday spirit we have prepared some unusual gift bargains. Just give us the names and addresses on your Christmas list, with the title of the magazine that is to go to each. We'll even send them an attractive announcement card in your name, to arrive in their Christmas mail.

HOLIDAY BARGAIN PRICES

The special holiday prices here listed are effective only if your Christmas order is for two or more subscriptions.

Screen Book

Each month it brings its readers the best movie novel of the month in complete book-length form, with illustrations taken direct from the movie itself (worth at least \$2.00 in any bookstore). Movie reviews, screen gossip, movie news; full-size gravure portraits of the stars, and several shorter stories are also included in each issue. Regular price \$2.50 per year; special holiday price \$2.00.

Science and Invention

For the wide-awake family that wants to keep up with the latest developments in science and exploration. Written in non-technical language, it brings its readers a liberal education in the fields of radio, electricity, aviation, carpentry, automotive mechanics, television, photography, chemistry, etc. Hundreds of illustrations. Regular price \$2.50 per year; special holiday price \$2.00.

Aero Mechanics

Full of valuable information for everyone interested in aviation. Within its pages the reader will learn: how a pilot controls his airplane; how the propeller works; what one has to do to become a flier; how to build model air craft; how to build a glider; and dozens of other practical, helpful bits of information every aviation enthusiast should know. Regular price \$2.50 per year; special holiday price \$2.00.

Radio News

The world's greatest radio magazine. Every new development, idea or invention that affects radio is here illustrated and described. The inside stories of the big broadcasting stations, how to tell a good loudspeaker from a bad one, how to save money in servicing your set, all about the new sets that are coming out, are some of the features covered within its pages. Regular price \$2.50 per year; special holiday price \$2.00.

Plain Talk

For the intelligent person who isn't afraid to call a spade a spade. It prints the truth about vital topics from Birth Control to Prohibition; from Psycho-Analysis to Public Morals; from Art and Science to Metaphysics and Politics. Shaw, Durant, Darrow, Ludwig and Bromfield and other equally famous men are among the contributors. Regular price \$1.00 per year; special holiday price \$3.00.

SIMPLY RETURN THIS COUPON... LEAVE THE REST TO US

MACKINNON-FLY PUBLICATIONS, Dept. 2401d
381 Fourth Avenue, New York

Gentlemen:

Please enter Christmas Gift Subscriptions as follows and send each of these named below your Gift Announcement Card. I enclose remittance for \$..... (Special holiday prices effective only if two or more subscriptions are ordered).

MAGAZINE
NAME
ADDRESS

MAGAZINE
NAME
ADDRESS

MAGAZINE
NAME
ADDRESS

MAGAZINE
NAME
ADDRESS

YOUR NAME

ADDRESS

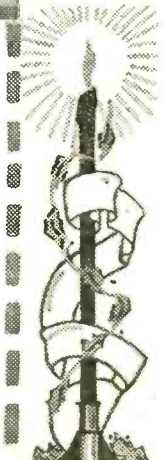

Trapped by Radio

(Continued from page 667)

one, enabled the expert to pick up the thread of the code message, and continue the radio conversation with the ship at sea. It was nearly decoyed into the net of waiting Coast Guard ships specially detailed to watch the landing spot, to which the rum runner was directed by the Government's radio expert!

It was a short-wave set that was doing the damage—probably costing not more than a thousand dollars to build. The transmitter, of the conventional design, was panel-mounted and of fairly neat construction. Together with this working transmitter, the raiders seized another set in the course of being assembled. Receiving apparatus, together with a wave-meter and code books, were taken also. Even a copy of the Coast Guard's secret code book was found on the operator's desk.

It is not exactly certain at this time what the frequencies were on which the signals were sent, over the rum runner's radio network. Frequency changes, however, were often made, and the code they employed frequently altered besides.

Undoubtedly the bootleggers' own cleverness defeated them. Radio is not commonly used by smugglers, and any signals of suspicious character are usually reported by amateurs who are listening in on practically every wave length below the broadcast bands. It is not surprising, then, that amateurs in the Second and Third Radio Districts should have promptly noticed and reported to the government radio inspector strange signals transmitted within their wave bands.

Though it was impossible for these amateurs to locate them definitely, the strange tactics of a station which they believed to be of an amateur ownership suggested to them questionable use of a device that they respected greatly. Complaints were lodged, and a search was then made by the government department which has charge of policing the air—the Radio Division of the Department of Commerce.

For months, a young radio engineer member of the staff of the Second District listened to the signals. The call letters used corresponded to no known amateur's station that was lawfully operating at the time. The fact that the station would send for hours at a stretch, at one time being "on" for a full eighteen hours, aroused further suspicion.

It was possible to train compass direction finders on the emanations, but due to the frequency variations and the short waves that this station used, instruments designed for lower frequencies did not operate accurately.

After weeks of work, instruments were brought to within a mile or so of the suspected station. It wasn't realized even then that the station was engaged in assisting the unlawful traffic of liquor, but the department was convinced that the operator was a violator of the law which requires stations and operators to be licensed. It was therefore its business to locate the station and silence it.

Radio Inspector Redfern was "loaned" to the Treasury Department to superintend further investigation, once it was clearly established that there was some

Televocal

Quality Tubes

No. A-C
224
Screen
Grid

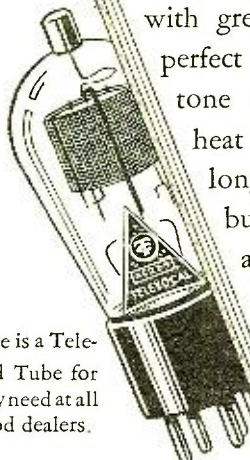

There is a Tele-
vocal Tube for
every need at all
good dealers.

Are Go-Getters. Developing extreme sensitivity and hair-line selectivity they will bring in stations heretofore strangers to your set, clearly and without hum, with greater volume and perfect reproduction of tone quality. They heat rapidly, are long-lived and built to stand any strain.

No. A-C
227
Quick
Heating



They cost no
more, giving
longer service
and are liberally
guaranteed.

**NATIONAL UNION
RADIO CORPORATION**

Televocal Division, Dept. A-1
400 Madison Ave. New York City



Pat. Applied for Serial No. 375,581

A Sensational New Aerial

You can bring in any station that you get on your outside aerial. Take down your outside wires and put in

The Wellston Gold Test Aerial

New filtered type containing gold-plated wire. Gets clearer reception. Cuts down noises. No A. C. noise or hum.

Does not plug into a lamp socket. You can attach it in one minute and place it anywhere. Equal to 54 feet of outside aerial.

Install it and forget it—always fully efficient. "It's the Aerial of Tomorrow."

Only \$2.50

If your dealer cannot supply you, we will mail it to you upon receipt of price.

Wellston Radio Corpn.

Dept. M. O.

St. Louis, Mo.

MAKE GOOD RECEPTION EASY



Thousands of users marvel at the difference in reception with a Townsend "B" Power Unit. Full, sweet tone, clarity, volume and greater distance are among the many advantages reported daily.



TOWNSEND "B" POWER UNIT

Hooked up in a few minutes; just plug into the light socket and forget it. Delivers up to 100 volts on any set—D.C. or A.C.—any cycle.

Approved and passed by the rigid laboratory tests of "Popular Radio" and "Radio News."

Over 150,000 Now in Use!

There's no longer any reason for putting up with the expense and undependable performance of "B" Batteries—when you can own a good "B" Power Unit for \$6.85. Over 150,000 Townsend "B" Power Units now in use—a substantial proof of satisfaction.

Send Only \$1.00

Send name and address with only \$1.00. On arrival of Townsend Power Unit pay postman \$5.85 plus postage. Try out ten days, then, if it fails to do everything we say, return it and money paid us will be refunded. Make a REAL receiver of your set.

TOWNSEND LABORATORIES
125 Townsend St. Chicago, Ill.

Beats 135 Volts of "B" Batteries

Your Eliminator is very satisfactory. I had been using three 45-volt "B" batteries with my set, but I get better results from your 90-volt Eliminator than I got from the 135 volts of "B" batteries.

Joseph Mallen,
Providence, R. I.

Wouldn't You Like to Get Into Amateur Radio?

Imagine the thrill of building and operating your own private short-wave transmitter and receiver, and talking with other amateurs all over the world!

Talk with the Byrd Expedition at the South Pole! Chat with other expeditions in the far corners of the earth! Gossip with Frenchmen, South Africans, Chinese, Australians, or fellow-Americans thousands of miles away. Or, if you wish, listen in on concerts direct from London, Holland and Australia! You can do it for less than the price of your broadcast receiver and

Here Is a Book That Tells You How!

The Radio Amateur's HANDBOOK

It explains everything about amateur radio and short-wave work from A to Z. Tells you how to build short-wave receivers from the simplest to the most complicated, that will bring you signals from all over the world: how to learn the code; how to get your licenses; how to build simple transmitters; how to build better transmitters; how to adjust and operate your set.

232 pages 6½ x 9½ 188 illustrations
Over 60,000 copies in use

Sent postpaid anywhere in the world for

\$1

American Radio Relay League
Hartford, Connecticut, U.S.A.

A Radio Parts Guide THE NEW YAXLEY Catalog



Send for it today for complete listings of Radio Convenience Outlets, Connector Plugs, Rheostats, Fixed and Grid Resistances, Jacks, Jack Switches, Phone Plugs, etc.

YAXLEY MFG. CO.
Dept. N, 1528 W. Adams St., Chicago, Ill.

definite relation between the station's signals and the shipments of liquor. It seemed strange, for instance, that the set was constantly working when trans-Atlantic traffic was busiest. Redfern intercepted many messages, and though they were difficult to copy, the first transcripts were sent down to Washington for decoding by the army experts.

It was an amazingly clever code, the main secret of which was the use of long words instead of short ones, and vice versa. Three of the code books were found during the raid, together with the copy of the Coast Guard smuggled in from a spy "planted" in the Government service. Thus, it was an easy matter for the operator at Highlands to intercept messages sent by unsuspecting Treasury officials to the Coast Guard ships and bases and to turn them over to the bootlegger chiefs. Thus informed, arrangements for the shipment and distribution of liquors could be made without interference.

The indictment, faced by the rum-runners' wireless operator, Malcolm MacMasters, charges that the station was established by the bootleggers on March 30, 1929, at 33 Shrewsbury Avenue, Highlands, N. J. MacMasters is held in \$30,000 bail, not only for violation of the Volstead Act, but also for transmission without either a station or an operator's license. It is said that this is the first time that the Radio Act penalties will be applied to such an offender.

With the discovery of the main transmitter of the radio rum ring, the prohibition forces have crippled the communication system built up at great cost by the bootleggers. It is said that the message warning the sea-going boats filled with liquor to turn back because of the raid was flashed by another secret installation which has not as yet been found.

In their fleet of six ships clearing from St. Pierre to Bermuda, but allegedly making side trips to within the harbor lights of New York, and a swarm of ten speed boats to do the unloading and fast ferry-work between the "mother ships" and shore, the bootleggers had a very comprehensive radio network, the extent of which probably will never be learned by the authorities. It is thought that all the ships, including the speed boats, were equipped with radio, and were directed in their moves by the main station located in the house captured on the Highland hill top . . .

This apprehension of rum-runners in the unusual manner just related is only one of the jobs for which the Radio Division of the Department of Commerce is equipped. Its great duty is the policing of the air. Its personnel and instruments to do this apparently hopeless job are relatively small. Yet it keeps a watch on the 650-odd broadcasting stations, the 16,000 licensed amateur transmitters, and the thousands of commercial stations.

Its main function is to keep the transmitters on the frequency or wavelength assigned them by the Federal Radio Commission. In hunting down frequency changes and variations, it often discovers lawbreakers and unlicensed stations. Then enters the engineer with his direction-finding equipment . . . And a lawbreaker is caught!

How to Get the Most Out of MARRIAGE MEN! Daringly Different

from any other publication; our big intimate Magazine is strictly for you! Can't be described—must be read! No Fake, no Fads, no Fiction, no Foolishness—but surprisingly original, courageous, and 100% valuable to you. Devoted seriously to intimate subjects in which NORMAL MEN everywhere are individually interested—such as Physical Fitness, Personal Hygiene and Prevention, Virile Manhood, Masculinity, Social and Married Life, etc. Thousands of men would not sell their copies for money. You will know WHY when you see it. If you are married or ever expect to be, both you and wife will benefit—for IT DOES NOT DUPLICATE ANY OTHER MAGAZINE but actually deals with vital subjects heretofore not generally discussed in print. Endorsed by men's physicians. And edited to meet a long-felt need.

Are You Normal?
If so, our big 100% HUMAN MAGAZINE is just what you need! Act now!

No book can possibly be as satisfactory. **CUT THIS OUT**, send with \$1 now for 6 mo. trial sub. with 6 big bar numbers besides. (10 copies in all.) **SAMPLE COPY 25c.** (None free.) Satisfaction guaranteed or money promptly refunded. No chance to lose!

Locoma Pub. Co.
Dept. 30, Battle Creek, Mich.

YOUNG MEN interested in themselves must not miss the above offer.

Choice of 1200 Newest RADIO VALUES

SEND for our wholesale 1930 catalog. Filled with amazing values in screen grid radios, 245 push-pull audio radio consoles, kits, parts. Guaranteed merchandise at wholesale prices.

FREE

WESTERN RADIO MFG. CO.
1225 W. LAKE ST. CHICAGO ILL.

RADIO BARGAINS!

Brand new 7 tube A. C. chassis, guaranteed. . . . \$29.75
Short Wave 1 tube sets 4.75
Used 5 tube radios as low as 9.90
Power Transformers and Condenser Blocks at extremely low prices. Send for bargain list of sets, accessories and parts.

CHAS. HOODWIN CO.
4240 Lincoln Ave. Dept. A-3, Chicago
DEALERS IN BANKRUPT RADIO STOCKS

MASON, FENWICK & LAWRENCE PATENT LAWYERS

600 F St., N. W., Washington, D. C.
Estb. over sixty years. Send sketches. Electrical, Aeronautical and Chemical Inventions carefully handled. Practice before the U. S. Courts and the Patent Office. Prompt and careful service. Write us. Protect your inventions.

TRADE MARKS REGISTERED

32 volt RADIO ADAPTER

NO LOST CURRENT NO ACID
NO CHARGING NO UPKEEP

ELIMINATES "A" BATTERY

Thousands of country homes are operating direct on farm light outfits with this simple, inexpensive King Gole Adapter. Screws into any 32-volt light socket. Fully guaranteed. Send for circular.

ANYLITE ELECTRIC COMPANY
1434 Wall Street Fort Wayne, Ind.

"The Junk Box Short-Wave Receiver"

Blue Print No. 58

is no longer out of stock. We have a complete new supply of the blueprint for this popular home constructed short-wave receiver; 25c is the price postpaid.

RADIO NEWS
381 Fourth Ave., N. Y. City.

Analyzing the Hi-Q 30

(Continued from page 628)

tinct peaks or voltage maxima. When the amount of coupling between circuits is of the correct amount and the effective resistance of the tuned circuits is of the proper order, these peaks merge or blend together to form a substantially flat top as illustrated in curve A, Fig. 3. The sides of the curve, however, are not materially affected and remain as steep as in curve No. 3 of Fig. 2. This results in a marked improvement in the fidelity of the loud speaker output with no loss of selectivity. The exact shape of the top of such a curve depends on the coupling between the individual circuits, the effective resistance of the circuits, and the frequency to which the unit is tuned. Fortunately, however, its exact shape is of no material importance; it may be hollow in the middle, higher on one side than on the other, or very much rounded. So long as it has substantial *width*, the most critical listener will not be able to detect the irregularity, while even the most casual listener will detect the improvement over the sharply peaked tuning characteristic.

Some of the advantages of the Hi-Q 30 frequency selecting system are illustrated in Figs. 3 and 4 where comparisons are drawn with the conventional four-circuit receiver previously described. The immense improvement in "wide" selectivity is clearly shown in Fig. 3 where curve A represents the selecting effect of the Hi-Q pre-selecting unit and curve B represents that of the first circuit of the four-circuit receiver. In the case of the Hi-Q 30 an interfering signal of 950 kc. would have to be 450 times as strong in the antenna in order to reach the grid of the first r.f. amplifier tube at the same amplitude as a 1000 kc. signal, whereas in the four-circuit receiver it would only have to be 10 times as strong. As a more practical way of looking at it a 950 kc. interfering signal of 450 times the intensity of the desired 1000 kc. signal would be attenuated by the Hi-Q 30 pre-selecting unit to a one to one ratio by the time both had reached the grid of the first r.f. amplifier tube. After that, it is a simple matter for the three remaining circuits to further attenuate it to a negligible value. In the other case, however, the interfering signal would still be 45 times as strong as the desired signal at the grid of the first tube. This condition would undoubtedly prove ideal for rectification and its resulting modulation, and even though the remaining selectivity were theoretically sufficient (which in this case it is not) the interference would undoubtedly be present in the output from the loud speaker. This brings us to a consideration of Fig. 4 which represents the overall selectivity of both receivers; curve A is that of the Hi-Q 30, while curve B is that of the four-circuit receiver. Curve A of Fig. 4 is made by combining the selectivity of the pre-selecting unit as shown in curve A of Fig. 3 with curve 3 of Fig. 2, since the last three circuits of both receivers are assumed to be identical. Curve B of Fig. 4 is merely a reproduction of curve 4 of Fig. 2. The superiority of curve A is quite apparent as would be expected in view of the fact that one receiver has six tuned circuits whereas the

THREE T... IS the POWER with the Lincoln

PERFECTLY CONTROLLED 8-40

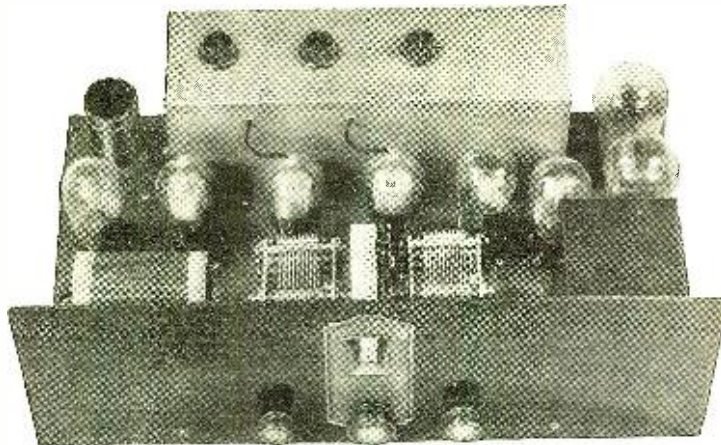

EVERY DEGREE ON THE DIAL REGISTERS a station with local volume. Not a squeal or a howl. Stations explode in at a slight movement of dial. The super design of this radically new receiver, coupled with the fact that every receiver is actually built by competent engineers in our laboratory, makes possible this marvelous performance.

A NEW [24 TYPE SCREEN GRID AMPLIFIER utilizing for the first time the specified tube voltages produces a heretofore unknown amplification perfectly controlled without oscillation.

800 MILES DAYLIGHT RECEPTION from a steel building in the heart of Chicago.

LINCOLN ENGINEERS have the reputation of building the most powerful long distance equipment known. Hundreds of old time super builders state the LINCOLN super outperforms every competitive equipment they have ever handled.

HIGH GAIN PER STAGE brings in a distant low-powered station like a local. Our laboratory has tested on stations hundreds of miles away consistently all day long throughout the summer.



LINCOLN 78-40-B

SET BUILDERS and DISTRIBUTORS you can tune into real business without interference from net price catalogs. All sales will be handled direct from our offices with our full co-operation. Write for details covering qualified distributors and special discounts.

WESTERN REPRESENTATIVE: Lincoln Radio Sales Agency, 200 Davis St., San Francisco, Calif.

LINCOLN RADIO CORPORATION

Dept. N

329 So. Wood St.

Chicago, Ill.

BE A RADIO DOCTOR



Radio servicing offers the biggest opportunity for the man interested in radio. About 10,000,000 receivers need service some time or other, many are naturally inefficient and can be improved on.

The Radio Doctors, Inc., is the only institution teaching exclusively radio repairs, having specialized on this phase of radio for a number of years.

\$3,000 to \$5,000 per year

The professional "Radio Doctor" receives \$2.00 or \$3.00 per visit and is welcomed in the best of homes—may I tell you more about this new, fascinating and extremely profitable business? Write now for free booklet, "Why the Radio Doctor." (Early inquiries will receive a blueprint of a recent well-known manufactured superheterodyne.)



E. W. PARKER, Pres. RADIO DOCTORS, INC., Dept. N9, 131 Essex Street, Salem, Mass.



High School Course in 2 Years

This simplified, complete High School Course—specially prepared for home study by leading professors—meets all requirements for entrance to college, business, and leading professions.

20 Other Courses

Over 200 noted Engineers, Business Men, and Educators helped prepare the special instruction which you need for success. No matter what your inclinations may be, you can't hope to succeed without specialized training. Let us give you the practical training you need.

American School
Drexel Ave., 58th Street
Dept. H-153 Chicago

Money Back When You Finish If Not Satisfied

AMERICAN SCHOOL, Dept. H-153
Drexel Avenue and 58th St., Chicago

Send me full information on the subject checked and how you will help me win success in that line.

- | | |
|-------------------------|--------------------------|
|Architect |Electrical Engineer |
|Building Contractor |General Education |
|Automobile Engineer |Lawyer |
|Civil Engineer |Mach. Shop Practice |
|Structural Engineer |Mechanical Engineer |
|Business Manager |Steam Engineer |
|C. P. A. & Auditor |Draftsman & Designer |
|Bookkeeper |High School Graduate |

Name.....Age.....
St. and No.....
Town.....State.....

\$75 to \$125 Weekly

Charging Batteries Starts You

Let me show you how to make big money right from the start. I've prepared a FREE book explaining all details. First week's profit pays for all equipment. You can get all the battery charging business in your community with my Service Station Charger—it's years ahead of ordinary chargers—handles 50% to 70% more batteries. I explain everything—start you in a business of your own and put you on the way to big money. Write for FREE BOOK.

C. F. HOLMES, Chief Engineer, Dept. L
Independent Electric Works
4912 North Clark St. Chicago, Ill.

FREE BOOK—Just Out

★ ★ ★

TRI-STATE HEADQUARTERS
Pennsylvania—Ohio—West Va.

WHOLESALE RADIO

To DEALERS and SET BUILDERS we offer the most prompt and efficient service. We handle only the best merchandise and give MAXIMUM DISCOUNTS.

★ GET OUR CATALOG ★

CAMERADIO

430 WOOD ST.
at Diamond St.
PITTSBURGH PA.

LEARN TELEGRAPHY WITH TELEPLEX

Be an expert Morse or Continental code operator! BIG PAY—TRAVEL—FUN—ADVENTURE. After a few short weeks of practical study with Teleplex you will be an expert operator. This amazing instrument teaches you right in your own home. Works like a phonograph. No knowledge needed—beginners learn at once! NOT A SCHOOL. Free 10 days' trial. Write for FREE booklet N-11.

TELEPLEX CO., 72 Cortlandt Street, New York City



To be sure of getting your copy each month, subscribe to RADIO NEWS, \$2.50 a year. Experimenter Publications, Inc., 381 Fourth Avenue, New York City.

other has but four. What is not quite so apparent, however, is the improvement in the shape of the top of curve A, over that of curve B. It will be noticed that from unity ratio down to 1/10, curve B is entirely inside curve A. From this it follows that the attenuation of the higher audio-frequency modulation (popularly known as side-band cutting) will be greater in the case of curve B than of curve A. Consequently the audio fidelity of receiver A will be better than that of receiver B. Below the 1/10 ratio curve A is inside of curve B and this indicates an increasing degree of selectivity. To illustrate let us assume both sets tuned to a distant 1000 kc. station having a field strength of ten microvolts per meter. Then an interfering signal at a frequency of 980 kc. would have to be 1800 times as strong or 18,000 microvolts per meter, in order to produce a one to one interference ratio in the loud speaker of receiver A, while it would only have to be 270 times as strong or 2700 microvolts per meter to produce an equal amount of interference in receiver B. When these voltage ratios are converted into power ratios they become simply amazing; in the case of receiver A the power of the interfering 980 kc. signal must be over 3,000,000 times as great; in receiver B it must be 73,000 times as great.

While the above has been largely a theoretical discussion of the selecting effect of various arrangements of tuned circuits, it is interesting to note the rather close agreement of the measured points plotted on Fig. 4. These four points were obtained in the course of some sensitivity measurements of one of the Hi-Q 30 models and represent the interfering effect of 10 times input and 100 times input. These measured points show a slightly wider band than the theoretical curve, but the slope of its sides is even steeper than predicted, indicating better audio fidelity (less side-band cutting) and about equal selectivity.

Simplifying Your Service Problems

(Continued from page 637)

Through the pin jacks, conveniently located on the back of the instrument tray, access may be had, for external use, to all the meters and apparatus therein. With the Supreme Diagonometer open transformers can be bridged, condensers can be tested for breakdowns and leakage, and countless other combinations and tests are possible, meeting every need that can be encountered in the servicing of radio apparatus.

Diagonometer Serves Dual Purpose

A new test panel has recently been developed by Supreme which permits the diagonometer to serve a dual purpose. The various instruments, circuits and other parts are housed in a substantial hardwood tray, measuring 17 3/8 inches by 5 1/2 inches by 4 1/4 inches. When the diagonometer is used as a portable laboratory, this instrument tray is carried in the neat and compact black leather-finished carrying case, which weighs but twenty pounds completely equipped.



Become a Member of the JUNIOR RADIO GUILD

and Receive Your Introductory Lesson FREE!

In just a few short weeks you can build your own radio set, make sets for your friends at a big profit, and become an authority on radio for your whole neighborhood.

It's lots of fun, too, when you learn through the Junior Radio Guild, because you actually build sets as you learn. And there is practically no hard study, because we tell you all about radio in simple, easy words that even a baby could understand.

Over 12,000 boys are already members of this great organization sponsored by RADIO NEWS, and they have told so many of their friends about what wonders it has done for them, that membership is increasing rapidly.

BIG MONEY If You Learn Now!

All you have to do to become a member of the Junior Radio Guild, absolutely FREE, is to mail us the coupon below. The 25c we ask for is merely to cover the cost of the beautiful bronze membership pin and your membership card. You receive your introductory lesson absolutely FREE!



Mail the Coupon Today!

JUNIOR RADIO GUILD, Dept. 2401u
381 Fourth Avenue, New York, N. Y.

Gentlemen:

Please enroll me as a member of the JUNIOR RADIO GUILD. I enclose 25c (coin or stamps) to cover the cost of my membership pin and membership card. I also understand that I will get the introductory lesson in Radio Instruction for Boys FREE by return mail.

Name.....

Address.....

City.....State.....

Through the use of the new test panel, the diagnetometer can be converted almost instantaneously into a permanent laboratory, completely equipped to handle any kind of a radio testing job, on the serviceman's own test bench.

The test panel, which is shown in one of the accompanying illustrations, is attractive in appearance and substantial in construction. It can be fastened at the rear of the bench, so as to allow the maximum room for working on the set to be tested. When the serviceman arrives at his shop with his portable laboratory, he lifts the instrument tray from the carrying case and sets it up in the test panel, so that the meters, etc., appear to be an integral part of the panel. The instrument tray is put into place from the rear of the panel, being held securely on strong wrought-iron brackets. These, in turn, are fastened to the panel itself.

A socket outlet is provided on the vertical center line of the test panel, near the top, so that the special lamp cord provided with the diagnetometer may be connected readily to the outlet in the hardwood tray. Hence, the 100-watt limiting lamp is always in plain view above the meters, ready to give visible notice if a short-circuited tube happens to be placed on test.

Directly below the outlet, there is a toggle switch, by means of which the house-lighting current may be switched "on" or "off" the socket outlet. Below the space occupied by the panel of the instrument tray there are twenty-three pin jacks, corresponding to the twenty-three jacks on the rear of the instrument tray. Flexible leads are soldered at the rear of the panel to each pin jack. Each lead is carefully marked and terminates in a small plug, which can be plugged into its corresponding jack on the back of the instrument tray, after the latter has been put into place on the panel.

At the bottom of the panel, on the vertical center line, a 23-plate variable condenser is mounted. This is wired to two pin jacks located in the test panel, directly above the position occupied by the oscillator coil, when this is plugged into place. By connecting two small flexible leads between the jacks on the coil base and the two jacks on the panel, the variable condenser is available for tuning the oscillator coil.

The serviceman will find this test panel to be the last word in convenience, utility and economy.

What Do You Know About Audio Frequency Amplifiers?

(Continued from page 665)

5 volts, which means that the plate voltage ought to be about 100. The a.c. voltage E1 required from the detector is 1.4 volts, since T1 has a ratio of 3 and 4.3, the voltage on the secondary, divided by 3, gives 1.4 as the primary voltage E1. If the detector was only able to supply 1.0 volt without serious distortion the voltage Et supplied to the two power tubes would be

$1.0 \times 3 \times 7 \times 4 = 84$ volts
and from Fig. 2 the power output with 84 volts will be about 3 watts.

SCORE 1 $2\frac{1}{2}$ miles of wire—primary inductance of 175 henries with 1 mill D. C.

SCORE 2 Flat Curve—25 to 8000 cycles; no pronounced resonant peaks at any frequency.

SCORE 7 for FERRANTI

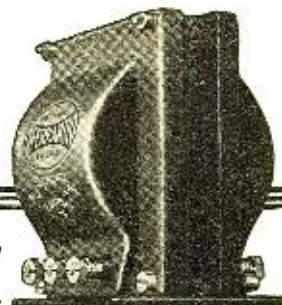

High Amplification—3% to 1 Ratio (A.F.5) With Curve flat within 1 db. between 25 and 8,000 cycles.

when used with tubes having approximately 8000 to 10,000 ohms impedance.

THE ability of a transformer to maintain high amplification is dependent upon the primary inductance. In FERRANTI Audio Frequency Transformers the primary inductance is made large by using a great number of primary turns, a core of large cross section and a short mean core path, but not so short as to make the D. C. saturation appreciable.

Ferranti Transformer superiority is proved by scientific tests and emphasized by unchallenged performance.

27 different types... one for every audio need. Write for correct type for your requirements.

Do you know that Ferranti Transformers have removable feet... that they may be mounted in any desired position (top, bottom or side) in a radio receiver or power amplifier?

Out NOW!
New 1930 FERRANTI Amplifier Book

Contains much hitherto unpublished information on Power Amplifiers as developed in Ferranti laboratories by Ferranti engineers. Needed by everyone interested in Power Amplifiers. Send 15c. coin, to help pay production and mailing cost.



130 W. 42nd St. Desk 51
New York, N. Y.

Smashing Radio BARGAINS!

WHOLESALE PRICES

Shown in NEW 1930 Catalog!

LARGE DISCOUNTS

The 1930 Lafayette Screen-Grid All Electric Radio Receiver is made for people who want the finest in radio... 245 Pins Pull Amplification, Illuminated single dial control, 9 tubes, and every modern feature. Over 30 cabinet models. Liberal discounts and tremendous values.

30 Days Free Trial

Try the new Lafayette right in your own home for 30 days without any cost to you. Convince yourself that the Lafayette will out-perform any receiver on the market. Write at once for full particulars of our sensational 30 days free trial offer.

Here Is Your Chance

to buy nationally famous radio equipment at WHOLESALE PRICES. Brand new GUARANTEED merchandise at BIG DISCOUNTS. Every single item in the Wholesale Radio Service Catalog is a RADIO BARGAIN. You save money when you buy from WHOLESALE.

Sent Free on Request

Write today for a FREE COPY of the NEW 1930 WHOLESALE catalog. The bargain book of the radio field! Big values, low prices, and personal service. SATISFACTION OR YOUR MONEY BACK on every purchase.

Rush Coupon at Once

Clip the coupon and mail it TODAY for your free catalog! We pay all charges.

32 Gorgeous Consoles

SCREEN GRID LAFAYETTE

all Electric A-C 9 TUBES

Wholesale Radio Service Co., Dept. C-15,
36 Vesey Street, New York, N. Y.

Send me ABSOLUTELY FREE the new 1930 Wholesale Catalog.

Name.....

Address.....

Town..... State.....

A RADICAL NEW DEVELOPMENT
IN PUBLISHING NOW BRINGS
YOU THE BEST NEW DETECTIVE
NOVELS COMPLETE FOR 25¢



The VAN NORTON MURDERS

THERE have been so many detective novels published in the past few years that to find one both exceedingly well written and startlingly different is a distinct surprise.

"The Van Norton Murders," by Charles Reed Jones, combines both these qualities in a swift-moving and refreshing pace. The author, you may recall, also wrote "The King Murder," Dutton's Book of the Month for April, which called forth columns of praise from the nation's critics, because of its novel reasoning and unusual plot development.

In "The Van Norton Murders" the plot evolves around a wealthy Long Island family which is rapidly being killed off in spite of all the police can do. It seems evident that it isn't an outside job, yet no trace of suspicion can be pinned on anyone in the whole household.

One of the detectives in the story, however, tells you that he knows the murderer, and that you can figure it all out yourself if you have read the story carefully up to this point (and you actually can). You'll probably find that from the moment you turn the first page you will be so completely enveloped in the problem before you that the wee early hours of the morning will still find you gripping the arms of your chair in tensed fascination.

AND THE COMPLETE PRICE IS ACTUALLY ONLY 25c

Moreover, the publishers have gone and brought the novel within reach of everybody by enabling you to buy it complete for only 25c at all newsstands.

Simply ask your newsdealer for the January Complete Detective Novel. (There will be a new one at your newsstand every month.) If he is already sold out, send 25c in stamps or coin to

THE MACKINNON-FLY PUBLICATIONS, INC.
381 FOURTH AVENUE, NEW YORK, N. Y.

"I know damn well he didn't shoot himself, because I never heard of a guy shooting himself in the back, but the door was locked."



ASK FOR THIS MONTH'S COMPLETE
DETECTIVE NOVEL ... AT ALL
NEWSSTANDS FOR ONLY 25¢

Radio Takes to the Open Road

(Continued from page 603)

growing demand for information regarding the various types of receivers designed for automobile use, and the various systems for eliminating some of the defects encountered where these installations are made. Among the service men and operators of garages and filling stations there is a rapidly growing demand for automobile receiver kits. RADIO NEWS has already spent thousands of dollars in investigating the field for the application of automobile receivers as well as the technical requirements which the use of these receivers involves. This introductory article indicates the line along which we are working, and in succeeding articles we shall provide our readers with definite technical information from which they may duplicate the results we have obtained.

The Circuit

From sad experience we have found that ordinary radio receivers will not function satisfactorily when bounced around in an automobile. Furthermore it is necessary in choosing a circuit to give serious consideration to the size of the automobile battery, the charging rate of the generator on the car, the number of tubes it will be necessary to use, and the character of reception we are going to demand. For ordinary purposes we recommend the use of not more than two stages of tuned radio-frequency with some suitable audio amplifying system. Our own experience indicates that, for a number of reasons, resistance coupling is desirable. In the development of a circuit of this character it is necessary, in order to receive from local stations, to provide very much greater sensitivity in the radio-frequency circuit than is required with the ordinary broadcast receiver, where it is possible to use a good sized antenna and a satisfactory ground. In order to obtain this result we have used a screen-grid blocking tube in the antenna circuit, 2 screen-grid radio-frequency stages feeding into a hi-mu tube operating as a detector and feeding into a screen-grid resistance-coupled audio tube having as a second stage a standard 112 output tube. Some output filter device should be used to prevent the high voltage from the B batteries passing through the leads to the loud speaker.

In choosing tubes for a receiver of this character, best results can be obtained if the heater type a.c. tubes are employed in a series parallel connection. There are three reasons for using tubes of this character: First, they are not as fragile as battery-operated screen-grid tubes; secondly, they are less microphonic and thirdly, the amplification per stage is greater when they are used. There is one serious drawback, however, which results from the increased filament consumption of tubes of this nature. This is particularly bad when the car is equipped with a small battery and you are operating a receiver with a heavy filament drain during the winter months. This is especially noticeable when you make a number of short runs and are frequently starting and stopping. The combined drain occasioned by this starting and the use of the radio

receiver means that your battery will run down faster than it can be charged by the generator. If an attempt is made to compensate for this deficiency by increasing the charging rate of the generator, you run the risk of burning out the winding. Therefore, in some of the receivers with which we have been experimenting, a compromise has been effected by using the ordinary type of battery-operated tube.

Receiver Suspension

We have attempted to get the maximum gain out of our radio-frequency and audio-frequency circuits. We also have tried to overcome the shortcomings of filament fragility, as well as possible microphonic noises, by suspending both the socket supporting panel and the entire receiver on springs.

We believe that the ideal radio receiver for automobile use should have the following qualifications: It should be compact, light, completely self-contained, sensitive, comparatively selective, capable of producing good tone quality, and both water and dust-proof. The system found to be most satisfactory is that of building a good circuit into a metallic housing, with all of the seams of this housing made both water and dust-proof by the application of parafine-soaked felt inside the seams. Such a receiver has been built into a brass case measuring 7x7x14 inches. The entire assemblage may be mounted in any part of a car, such as under the back seat, under the front dashboard, directly to the baffle plate which supports the motor section from the inside of the tonneau; or, for that matter, it may be mounted on brackets under the hood and directly above the motor, as is done with some of the cars made by General Motors. A switch, volume control and dial are mounted on the dashboard or in any other convenient part of the car, and the receiver itself is operated by a remote control.

An ideal way to mount the receiver is to make two brackets out of wrought iron and hang them from the chassis, so as to provide an anchorage similar to those used for carrying the storage battery on most cars. Precaution should be taken, however, to make these brackets large enough to provide either spring or cushioned rubber suspension for the receiver itself. The proper type of shock-absorbing suspension will take up most of the road shocks, and will result in better reception as well as increased tube life.

Remote Control

In connection with the remote controls we find that flexible shafting, such as is used in dental drilling machinery, is ideal when it is combined with reduction gears. We have been able to secure suitable cable from the S. S. White Dental Company, and the Boston Gear Works has provided us with the various worm and pinion gears having a reduction ratio of 20 to 1. One set of gears is used between the dial shaft and the dental cable, and the other set forms the connection between the flexible shaft and variable

(Continued on page 676)

Here's the Answer

to every question about the principles, methods, or apparatus of radio transmitting and receiving. A complete course in radio operation in a single volume.

THE RADIO MANUAL

A New Edition

Complete new chapters on aircraft radio equipment; Practical Television and Radiomovies with instructions for building a complete outfit; radio interference; 100% modulation; latest equipment of the Western Electric Co.; the Marconi Auto-Alarm System; and many other developments of the past year. All this information is added in the new edition and, besides, the entire book has been brought right up to date with much new material. *The Radio Manual* continues to be the one complete and up-to-the-minute handbook covering the entire radio field.

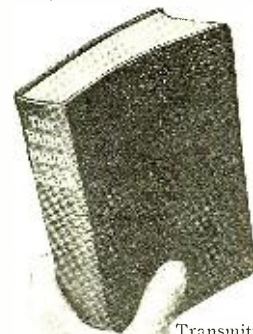

A Handbook for Students Operators Inspectors

20 big chapters cover: Elementary Electricity and Magnetism; Motors and Generators; Storage Batteries and Charging Circuits; The Vacuum Tube; Circuits Employed in Vacuum Tube

Transmitters; Modulating Systems and 100% Modulation; Wave-meters; Piezo-Electric Oscillators; Wave Traps; Marine Vacuum Tube Transmitters; Radio Broadcasting Equipment; Arc Transmitters; Spark Transmitters; Commercial Radio Receivers; Marconi Auto-Alarm; Radio Beacons and Direction Finders; Aircraft Radio Equipment; Practical Television and Radiomovies; Eliminating Radio Interference; Radio Laws and Regulations; Handling and Abstracting Traffic.

An immense amount of information never before available including detailed descriptions of standard equipment is presented.

Prepared by Official Examining Officer

The author, **G. E. Sterling**, is Radio Inspector and Examining Officer, Radio Division, U. S. Dept. of Commerce. The book has been edited in detail by **Robert S. Kruse**, for five years Technical Editor of QST, the Magazine of the American Radio Relay League. Many other experts assisted them.

Free Examination

The new edition of "The Radio Manual" has just been published. Nearly 900 pages, 369 illustrations. Bound in Flexible Fabrikoil. The coupon brings the volume for free examination. If you do not agree that it is the best Radio book you have seen, return it and owe nothing. If you keep it, send the price of \$6.00 within ten days.

Order on This Coupon

D. Van Nostrand Co., Inc.,
250 Fourth Ave., New York

Send me the Revised edition of THE RADIO MANUAL for examination. Within ten days after receipt I will either return the volume or send you \$6.00, the price in full. Radio News 1-30

Name

St. & No.

City and State

Is International Broadcasting Just Around the Corner?

(Continued from page 609)

rect from American transmitters. While listeners declared themselves satisfied with these programs, engineers know that it would be impracticable at the present time to announce a regular schedule of programs originating in foreign studios. That time is coming, but just how near it is we cannot now predict.

Engineers hesitate to give any guarantee because they receive none from Mother Nature herself that magnetic storms or other of her whimsical playthings will not interfere with their plans.

While listeners in this country await

foreign programs, those in England, France and Germany are regularly enjoying entertainment originating in the New York NBC. Programs which these foreign listeners tune in from their own local broadcasting stations received from the United States by short waves. Likewise American programs have been heard through networks in Australia, and an experimental station in Johannesburg, South Africa, receives them regularly.

Few of us have ever met these engineers in the remote parts of the world, yet a strange friendship has grown up

between American radio engineers and the men who are devoting their entire time to the interchange of programs with foreign countries.

It is not hard to believe that this friendship and feeling of fraternity will spread to the millions of radio listeners themselves when these programs begin to come to them regularly from studios throughout the world. Many of us are idealistic enough to think that the work we are doing will contribute much to the dreamed of World Peace.

Radio Takes to the Open Road

(Continued from page 675)

Ignition Noise

Noise caused by the ignition system can be picked up by the receiver in many ways, but for the purpose of this article it will suffice to outline the methods of elimination without delving too deeply into the cause. Thanks to the inventive genius of a young engineer named Hahn we have been able to locate a new type of spark plug which, in addition to numerous valuable ignition features, provides complete shielding for the ignition system. By the use of these plugs and armored cable in the entire ignition system we have found it possible to eliminate all ignition noise. Another system developed by the Transitone Radio Corporation includes the insertion of a 20,000 ohm resistor in series with each of the spark plugs, and another in series with the lead which enters the center of the distributor head. Special shielded

condenser. No fittings suitable for use with these gears are available at present, and they must be made by hand. This is a comparatively delicate undertaking and requires more than ordinary skill with tools.

A forthcoming issue of RADIO NEWS will contain complete details for making an assemblage of this character.

Shielding

In connection with the remote control of the receiver we have found that a great deal of the noise caused by the ignition system used on the motor can be eliminated by properly shielding the wires leading from the receiver itself to the control panel, and to the B batteries. In order to bring about this result we have used No. 14 paired armored cable, and we have run the group of wires used in the B battery circuit through a metallic sleeve.

wire for use with Hahn Spark Plugs is now available from the Packard Electric Co. as well as the Rome Cable Company. We believe that other cable manufacturers will soon be ready to provide similar wiring facilities. Battery cables designed to connect the A and B supply for the receiver are now being made by the Runzell-Lenz Company in Chicago, and this company will make cables of this character with any number of leads and in specified length.

In connection with this automobile radio activity RADIO NEWS believes that it is opening an entirely new field of experiment and research. Within the next few months automobile radio reception probably will be one of the most important developments in this field. More specific information concerning the actual design of a receiver suitable for automobile use will appear in our February number.

INDEX TO ADVERTISERS

PAGE	PAGE	PAGE	PAGE
A	F	N	S
Advance Electric Co..... 658	Ferranti, Inc..... 673	National Co., Inc..... 677	Samson Electric Co., Inc..... 592
Aerovox Wireless Corp..... 656		National Radio Institute..... 588-589	Sasnett, Edward C..... 660
Allied Radio Corp.	H	National School of Visual Edu- cation 679	School of Engineering of Mil- waukee 664
Inside Back Cover	Hammarlund Mfg. Co..... 656		See Jay Battery Co..... 662
American Radio Relay League.. 670	Hammarlund-Roberts, Inc..... 657	O	Shure Bros. Co..... 666
American Sales Co..... 677	High Frequency Labs..... 667	Omnigraph Mfg. Co..... 677	Silver-Marshall, Inc..... 659
American School..... 672	Hoodwin Co., Chas..... 670		Supreme Instruments Corp.
American Technical Society.... 660		P	Back Cover
American Transformer Co..... 665	I	Pilot Radio & Tube Corp..... 680	T
Amperite Corp..... 656	Independent Electric Works.... 672	Projectionist Sound Institute.. 661	Teleplex Co..... 672
Anylite Electric Co..... 670			Televoal Corp..... 669
C	J		Thorla Radio Products..... 679
Cameradio Co..... 656-672	Jeffries Transformer Co..... 679		Townsend Labs..... 669
Central Radio Labs..... 664	J-M-P Mfg. Co., Inc..... 666	R	Triad Mfg. Co., Inc.
Chicago Radio Apparatus Co.... 679		Racon Electric Co..... 658	Inside Front Cover
Chicago Salvage Stock Store... 591	L	Radio Doctors, Inc..... 671	V
Chicago Stock Gear Works..... 666	Lincoln Radio Corp..... 671	Radio Institute of America.... 653	Van Nostrand Co., D..... 675
Clarostat Mfg. Co., Inc..... 666	Locoma Publishing Co..... 670	Radio & Television..... 595	W
Conn Musical Instruments.... 679		Radio Training Association of America 585	Wedel Co..... 656
Cornish Wire Co..... 654	M	Radio World..... 663	Wellston Radio Corp..... 669
Coyne Electrical School..... 587	Mason, Fenwick & Lawrence... 670	R. B. Specialty Co..... 662	Western Radio Mfg. Co..... 660-670
D	McLain Orthopedic Sanitarium. 679	Royal Eastern Electric Supply Co..... 667	Wholesale Radio Service Co. 656-673
DeForest Radio Co..... 593	McSweeney Electrical School.. 677		Wilson, George..... 678
Drake, Frederick J., & Co..... 664	Mayflower Hotel..... 666		Wireless Egert Engineering, Inc..... 654
E	Metal Cast Products Co..... 679		Y
Electrad, Inc..... 655	M. & H. Sporting Goods Co.... 656		Yaxley Mfg. Co..... 670
Excellio Products Corp..... 662			

While every precaution is taken to insure accuracy, we cannot guarantee against the possibility of an occasional change or omission in the preparation of this index.

Where Is Television Today

(Continued from page 631)

about the equivalent of our present 48-line television picture. Our subject matter is limited to simple close-ups, such as the human face, hands, or simple objects with minimum detail, when working with half-tone or full gradation of tones. With the Jenkins transmitters and televisions, half-tone pictures can be handled with just as much detail as is possible in 48-line interpretation. However, due to the space limitations—the necessity of concentrating on close-ups—we have preferred to concentrate on shadowgraphs, or plain black-and-white pictures, whereby the detail is interpreted in broader terms, permitting of handling correspondingly larger figures, such as full-length human beings, together with some background.

Black-and-White Images

These shadowgraph pictures, often called radiomovies, permit of telling a story in an altogether novel and attractive manner, just as the animated cartoon on the motion picture screen is a charming variation from the minute pictorial detail of the usual photoplay. As still another problem of television development, the services of expert scenario writers and picture directors have been enlisted, to the end of evolving interesting stories for the television audience. It is fully realized that while the scientific interest in television may have justified such subjects as a child jumping rope or playing with a ball, in shadowgraph form, the "lookers-in" are already beginning to take interest in the subject matter, which simply spells programs.

All in all, we are on the eve of commercial home television. There are many problems still to be solved, but it seems best to seek the solution of these problems in the everyday use of television. Just as the automobile manufacturer must learn the weak points of his new model in actual usage, so in television we may be pardoned for enlisting the public in our future experimentation.

Future Sight Broadcasting

Furthermore, it is only by having the public take part in this pioneering that we can secure the necessary encouragement and support for the vast amount of development work that still lies ahead of us.

Sound broadcasting—a far simpler technique—required a half dozen years for development into practical merchandise and almost a decade to become satisfactory merchandise. With sight broadcasting, we may well expect to take at least five years and most likely a decade to attain satisfactory equipment for general use. Meanwhile, however, there is plenty of thrill in television. There are many potential pioneers, ready to take part in the everyday development of the young art. And so, with all the cards on the table, we are now ready to welcome television into the home, without unreasonable expectations on the one hand or unwarranted promises on the other.

Add the Highest Quality of Radio To Your Present Amplifier

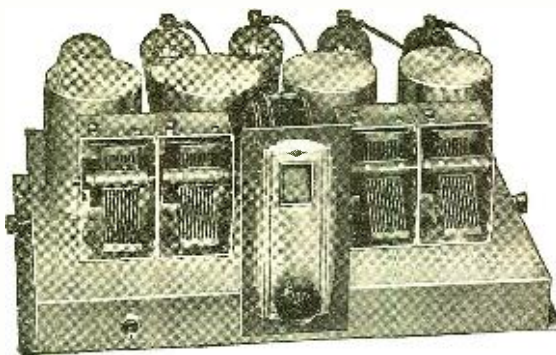

If you wish to add the most modern type of Radio Reception to your—

Electric Phonograph Auditorium Amplifier Public Address System Power Amplifier

the NATIONAL Screen Grid MB-29 Tuner is especially adapted for such use.

Equipped with 4 Screen Grid A. C. tubes, it will give satisfactory reception on indoor antenna even in steel frame buildings. Has every modern feature, including power detection, Band Pass tuning, and heavy aluminum chassis.

Write today for full technical information mentioning Radio News.

NATIONAL CO., Inc. Malden, Mass.
Est. 1914

NATIONAL SCREEN-GRID—MB-29



LEARN CODE AT HOME RADIO AND TELEGRAPHY
WITH AUTOMATIC TRANSMITTERS
Has Helped Thousands To Better Positions
U. S. Govt. Depts., Colleges, Scientists, and Schools use it
Be an operator, broadcaster, experimenter, etc. Read telegraph and short wave codes by aid of the Omnigraph easily and quickly. World's hobby. Models \$17-\$40. Catalog free.
OMNIGRAPH MFG. CO., 810 E. 39th St., C6, Brooklyn, N. Y.

LEARN ELECTRICITY in 12 Weeks and Make \$50 to \$150 Weekly

You can do it easily if you will come to my famous school where in 12 weeks you can step into a highly paid electrical job paying \$50 to \$150 a week and make good.

LEARN ON REAL EQUIPMENT—NO BOOKS
You work with expert instructors on full size motors, generators, batteries, switchboards, armatures, and house wiring.

NO EXPERIENCE OR EDUCATION NEEDED
It is easy to learn Electricity in my practical work shop. No books to read. No dry lessons to learn. You learn by doing. No matter how strange Electricity is to you, I guarantee that, when you graduate you'll know electricity from "A to Z" and if you find you cannot fill a big pay job, I'll refund every penny. **MAIL COUPON FOR FREE BOOK AND SPECIAL LOW TUITION OFFER.**

J. H. McSweeney, Pres.

McSweeney Electrical Schools

Dept. E-17-R
1815 E. 24th St., Cleveland, O.,
or 263 Madison St., Memphis,
Tenn.

(Address school nearest you)

J. H. McSweeney, Pres.

McSweeney Electrical Schools

Dept. E-17-R, 1815 E. 24th St.
Cleveland, O., or 263 Madison St.
Memphis, Tenn.



Dear Mac: Send me a copy of your big free book on ELECTRICITY; also details of remarkable tuition offer, and radio course.

NAME

ADDRESS

TOWN STATE.....

\$175.00 KOLSTER DYNAMIC REPRODUCER



Height 42"
Width 25 1/2"
Depth 19"

Model K-5

Combined with 210 Power Amplifier and "B" Supply Unit

\$49.50 (without tubes)

This famous genuine Kolster K-5, AC Electro-Dynamic Reproducer is complete with a 210 Power Amplifier and "B" Supply Unit all self-contained on a steel frame. This real fine matched rugged Unit weighs 45 lbs. without the Cabinet. The Cabinet itself is Pencil-Striped Walnut, beautifully designed with Cathedral grille.

If desired, the 210 Power Amplifier will also supply 22.67 and 90 volts "B" current, sufficient for any set using up to 8 tubes. An automatic voltage regulator tube, UX-874, maintains the "B" voltage silent and steady.

This Electro-Dynamic Reproducer can be used with any battery or AC set, replacing the last audio stage, or be used with all tubes of the set. Wherever used it will bring out every shading and range of tone; every note is reproduced with utmost faithfulness, pure and undistorted. It will modernize any radio receiver.

Uses 1—UX-210, 2—UX-281 and 1—UX-874 tubes. A 20-ft. cable is included with each instrument. Operates direct from 50-60 cycle, 110-120 volt AC current.

Brand new in original factory cases and guaranteed. Every Reproducer is serial-numbered and has factory guarantee tag enclosed.

AMERICAN SALES COMPANY
19-21 Warren St. New York City

Read Classified Advertising—It Pays!!!

Advertisements in this section twenty-six cents a word for each insertion. Name and address must be included at the above rate. Cash should accompany all classified advertisements unless placed by an accredited advertising agency. No advertisements for less than 10 words accepted. Objectionable or misleading advertisements not accepted. Advertisements for these columns should reach us not later than 1st of 2nd month preceding issue.

Classified Advertising Manager—Experimenter Publications, Inc., 381 Fourth Avenue, New York City

Agents Wanted

Guaranteed Genuine Gold Leaf Letters anyone can put on store windows. Large profits, enormous demand. Free samples. Metallic Letter Co., 422 N. Clark, Chicago.

Aluminum

1/16-INCH ALUMINUM 52¢ per square foot. Any size and thickness proportionately. Drilling, Tapping, IRLE SPECIALTY, 1737 East 4th, Brooklyn, N. Y.

Business Opportunities

Unusual Opportunities in the Neon Tube sign Business! New industry. Large profits. Big salaries. Reliable, authentic information. \$1.00. Neon Laboratories, Box 203, Houston, Texas.

Free Book. Start Little Mail Order business. Hadwil, 5A-74 Cortlandt Street, N. Y.

Amateur Cartoonists: Sell your cartoons, new plan. Smith's Service, EX1194, Wematche, Wash.

Inventions Commercialized. Patented or unpatented. Write, Adam Fisher Mfg. Co., 278 Enright, St. Louis, Mo.

Correspondence Courses

Used correspondence school courses sold on repurchase basis. Also rented and exchanged. Money-back guarantee. Catalog free. (Courses bought.) Lee Mountain, Pisgah, Alabama.

Detectives

Detectives. Work home or travel. Experience unnecessary. Particulars free. Write George Wagner, 2190 Broadway, N. Y.

For Inventors

Inventions Commercialized. Patented or unpatented. Write, Adam Fisher Mfg. Co., 278 Enright, St. Louis, Mo.

For Sale

Western Electric Type 1-A 500 Watt Transmitter; Western Electric Type 1-B Power Panel; Western Electric Type 8-A Speech Amplifier; Western Electric Motor Generator System to supply 1-A Transmitter including antenna equipment and Tower. Fleetwood Hotel, Miami Beach, Fla.

Help Wanted—Instruction

Be a Detective—Biggest paying work; everything. Write National Headquarters, 189 East 83rd, New York.

Wanted Immediately. Eligible Men—Women. 18-55. qualify at once for permanent Government positions. \$165-\$280 month. Gov't experience unnecessary; paid vacations. Common education; thousands needed yearly. Write, Instruction Bureau, 251, St. Louis, Mo. Quickly.

Miscellaneous

Gigantic Mail: send me 25¢ (coin or stamps) for one pound of mail. Ted Armour, 136 East 28th St., New York.

Learn Code at Home with our famous Code machine. Write Codegraph Mfg. Co., Winchendon, Mass.

Inventions Commercialized. Patented or unpatented. Write, Adam Fisher Mfg. Co., 278 Enright, St. Louis, Mo.

Patent Attorneys

Patents—Advice and booklet free. Highest references. Best results. Promptness assured. Watson E. Coleman, Patent Lawyer, 724 9th Street, Washington, D. C.

Inventors—Should write for our Guide Book, "How to Obtain a Patent," and Record of Invention Blank, sent Free. Send model or sketch of inventions for our inspection and instructions free. Radio, Electrical, Chemical, Mechanical and Trademark Experts. Terms Reasonable. Victor J. Evans & Co., 922 Ninth, Washington, D. C.

Patents—Write for Free Instructions. Send Drawing or Model for Examination. Carl Miller, Registered Patent Attorney (former Patent Office Examiner), 262 McGill Building, Washington, D. C.

Patents

Inventions Commercialized. Patented or unpatented. Write, Adam Fisher Mfg. Co., 278 Enright, St. Louis, Mo.

Printing, Engraving, Multigraphing

Multigraphing, two dollars thousand. Miscellaneous Printings. Mayer Ray Corporation, Monmouth, Illinois.

Radio

Bargains. Used Radios. Guaranteed perfect working order. \$6.85 and up. Bargain list on request. Bright Bros., Dept. D, 5698 Milwaukee Ave., Chicago.

Wanted: Men to work with National Radio Service organization. No selling scheme. Radio Doctors, Inc., Dept. N., Essex St., Salem, Mass.

The Wonder Book of the Age—Hoff's—RADIO trouble finder. For explanation send for Free Circular. Joseph Mezland, Dist. Mgr., 429 Bush St., San Francisco, California.

Radio Towers

For Sale—Two 125-foot steel radio towers in excellent condition. Formerly used by WMAQ when located on the Hotel La Salle. Towers disassembled and available on short notice. Price \$650 at Chicago warehouse. Address Engineer WMAQ, The Chicago Daily News.

Salesmen

Sell \$1,500 Insurance Policy \$1.00 Yearly. Every man, woman prospect. Big profits. Established life income. United States Realty, Townsend and Superior, Desk 25, Chicago.

Song Writers

Song Poem Writers: "Real" Proposition. Hibbler, 1191, 2104N, Keystone, Chicago.

Telegraphy

Learn Morse and wireless telegraphy. Big salaries. Tremendous demand. Expenses low, can earn part. Catalog free. Dodge's Institute, Cour Street, Valparaiso, Indiana.

(Continued from page 652)

For the most part the equipment at the individual parks is identical. The main exception comes in some of the Manhattan parks, where it is necessary to include a rotary converter because of the d.c. supply. Also there are two of the parks which have a single reproducer instead of two.

There are two identical PAM 19 amplifiers on the rack, one connected to each of the projectors on the roof. The noticed that there are few adjustments which provides ample coverage, holding the other in reserve for use in case of trouble in the first channel. It will be fieri and projectors can be operated at arrangement is such that the two amplifiers the same time, but the more usual plan is to operate only one amplifier and speaker central panel is the on-off switch with pilot light and the volume control knob. Below this on the small strip is a special line equalizer.

Novel Distribution System Used

In view of the wide distribution of the city parks, the wiring for the amplifier system presented quite a problem. This will be better appreciated when it is noted that the area covered is approximately thirty miles long. The problem was simplified by the fact that this entire area is covered with a network of wiring of the fire alarm system. Investigation proved the feasibility of using these wires to carry the programs from the main distribution station to the sub-distribution stations and from these to the individual parks. This main distribution station is located at the fire signal headquarters in Central Park and the sub-distribution stations are located in the fire headquarters of the various boroughs.

The use of these lines involved certain problems taken care of partly by the equalizers installed in each of the parks and distribution stations.

When in operation this entire concert distribution system requires the attention of only ten men. One operator is stationed at each of the sub-distribution stations and two at the main distribution station. These operators go from park to park in their districts to turn the amplifiers on in preparation for the evening's program. Then they return to their borough headquarters, where they are on constant call should trouble develop in any of the individual park installations. Upon completion of the evening's program they make the rounds once more to turn off the power in the individual parks. In addition to the six men thus employed there are also men stationed at the main pick-up station, where they handle the details of microphone placement, volume control, etc.

Entire Installation Cost \$35,000

Some of the financial considerations involved in an extensive installation such as this will be of interest. The entire installation, including equipment, material, labor, supervision and design, cost the city approximately \$35,000. This includes also the operating cost for the portion of the past summer in which the installation was in service. Additional parks can probably be added to this chain at a cost of approximately \$1,000 each.

Who Wants a Sedan FREE?

STUDEBAKER—BUICK—NASH! TAKE YOUR CHOICE!
or \$2000.00 Cash

Thousands of dollars in new autos and grand prizes will positively be given free to advertise and make new friends for my firm. Choice of Studebaker or Buick or Nash new 4-door sedan delivered free, or \$2000.00 cash. Also Oldsmobile, Pontiac, Chevrolet, Fords, diamonds, other fine prizes and cash will be given free. No problems to do. No fine writing required. No words to make. No figures to add. Bank guarantees all prizes.

PICK YOUR LUCKY STAR!

All the stars in the circle are exactly alike except one. That star is different to all the others and it may be a lucky star for you. Can you pick it out? If you can, mark the different star and send the circle to me at once along with your name and address. A prompt answer can start you on the way to win the great \$2000.00 free prize.

BE PROMPT—WIN \$650.00 EXTRA

Someone like you who will write me at once can get \$650.00 cash just for being prompt, so you may thank your lucky stars if you send your answer right off. No risk. Nothing to buy. Nothing hard to do. Over \$7000.00 in valuable prizes will be given free of cost. Send today and I will show you just how you can get your free choice of these splendid new sedans or \$2000.00 cash, without cost or obligation of any kind. All win plan! A reward for everybody. SEND NO MONEY. Answer AT ONCE.

GEO. WILSON, DEPT. 11, AUGUSTA, MAINE

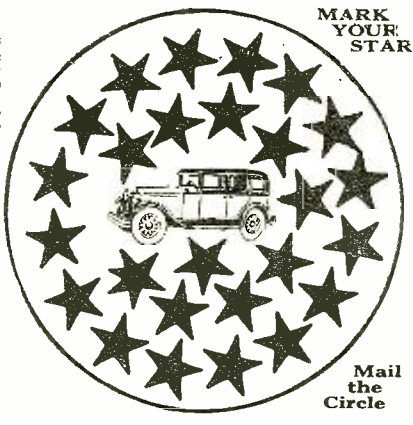

Since Early Childhood

Infantile Paralysis

After 4 months at McLain Sanitarium, William Peacock, 18, walked flat on his sole for the first time in years. See photos and letter:

As long as I can remember I walked on the toes of my left foot. I had always dreamed of the time when I would walk flat on my sole and McLain Sanitarium made that dream a reality. I will always speak a good word for McLain's.

WILLIAM D. PEACOCK
R. R. No. 2, Ashburn, Georgia
McLain Sanitarium (established 1898; is a private institution devoted to the treatment of



crippled, deformed and paralyzed conditions generally. No surgical operation requiring chloroform or general anesthetics. Plaster Paris not used. Patients received without delay. Parents retain full charge of children if desired.

WRITE FOR FREE BOOKS

"Deformities and Paralysis," and "References," which show and tell of McLain Sanitarium's facilities for treating Club Feet, Infantile Paralysis, Spinal Diseases, and Deformities, Hip and Knee Disease, Wry Neck, etc. Also illustrated magazine, "Sanitarium News," mailed free every 60 days.

McLain ORTHOPEDIC SANITARIUM

869 Aubert Ave., St. Louis, Missouri, U.S.A.



Chi-Rad's New 1930 RADIO CATALOG

Sent FREE to Set Builders

Now ready—Chi-Rad's latest money-saving catalog. All the latest parts, accessories, kits and sets such as: New Wasp AC Shield-grid Short Wave Receiver Complete with Power Pack; New National Shield-grid Short Wave Receiver, kit \$33.00, or completely constructed \$39.00; 3,000-volt new type R3 Rectobulbs \$10.00.

Send today for your free copy

CHICAGO RADIO APPARATUS CO.,
415 S. Dearborn St., Dept. RN.,
Chicago, Ill.

WANTED — MEN

TO MANUFACTURE METAL TOYS AND NOVELTIES

Big demand for 5 and 10c store Novelties, Ashtrays, Toy Soldiers, Animals, Auto Radiator Ornaments, etc. We co-operate in selling goods you make; also buy these from you. Small investment needed to start and we help you build up. WE FURNISH COMPLETE OUTFITS and start you in well-paying business. Absolutely NO EXPERIENCE and no special place needed. A chance of a lifetime for man with small capital. Write AT ONCE if you mean strictly business and want to handle 1930 wholesale orders now being placed.

METAL CAST PRODUCTS COMPANY,
Dept. 12, 1596 Boston Road - - - New York City

TRANSFORMERS FOR RADIO POWER SUPPLY

A-B-C Power for all receivers. Primary 105 to 115 volts 50 or 60 cycles Secondaries—2½ volts, 9 amperes—2½ volts, 3 amperes—5 volts center-tapped, 4 amperes—300 volts each side of center-tap, 125 milliamperes. All lugs mounted on bakelite, concealed inside case, completely shielded. Mounting for sub-panel or regular. Price \$11.90. Write for our literature. Dealers get in now.

JEFFRIES TRANSFORMER CO.
7427 Alameda Blvd. Los Angeles, California

At first glance the cost of \$35,000 would seem to be rather high, but when it is remembered that this installation is capable of entertaining a quarter million people or more at one time this cost seems most reasonable. From now on the operating cost will be the only expense, and this will amount to only a few thousand dollars a year. For this expenditure public entertainment is available every evening and Sunday afternoon. This cost would be justified for its entertainment value alone, but in addition to this it provides the means for musical education and musical appreciation available through no other source, so far as the poorer classes in the city are concerned.

There are countless towns and smaller cities throughout the United States that could advantageously adopt a similar scheme for the entertainment of their residents. It is true, of course, that most cities and towns do not have the advantage of the high grade municipal concerts enjoyed in the City of New York, but, on the other hand, the same concerts could be put on the air in other towns and cities after being picked up by radio through the chain systems that regularly broadcast the New York concerts. In this connection there is the consideration that summer radio reception is sometimes marred by static, but if the signal level of local broadcast stations is high there are comparatively few evenings during the summer that static will be troublesome. If it is not considered advisable to depend upon radio pick-up there is nothing to stand in the way of employing phonograph selections. The world's finest music of all types has been recorded and this provides a simple means of obtaining excellent and varied program material.

In many cases the cost of the necessary installation would, in the long run, be lower than the cost of hiring mediocre bands. In addition better music can be provided and it could be distributed over a wider area for the entertainment of more people. More and more municipal governments are realizing the opportunities provided in this field. Many cities are at the present time planning installations similar to that in New York City and many others are considering some such plan. This provides an excellent opportunity for the wide-awake installation man who is looking for profitable contracts. Almost no town is too small or too large to be a prospect for such a job.

The selection of suitable equipment is obviously a most important factor in the success of an extensive sound amplifier installation. Theoretically cost should not be a primary consideration, but unfortunately it usually is a very important one, and therefore it must be carefully considered by the installation man in planning or in bidding on a job.

Tone quality is always an important consideration and in public installations, such as that described in this article, equipment that is foolproof and will stand up in service is of the utmost importance. No apparatus that is not entirely trustworthy should be considered for a minute and in addition to this it is by all means advisable to have adequate reserve equipment, such as the duplicate amplifier installations in the parks in New York.

LIFE-TIME DX AERIAL

Guaranteed Double Volume and Sharper Tuning

Description of Lifetime DX Aerial

No. 30—LENGTH 30 FEET:
Assembled ready to string up. Brings in volume of 150-ft. aerial but retains the selectivity of a 30-ft. aerial. Rings are heavy gauge solid zinc. Duplicates in design and non-corrosive materials the aerials used by most of largest Broadcasting Stations. Design permits using this powerful aerial in 30-ft. space (preferably outside). Sharpens tuning of any receiving set because of short length but has enormous pick-up because 150 ft. of No. 12 enamelled wire is used. Made for owners of fine radio sets who want great volume on distance without destroying sharp tuning. (Also used by many owners of short-wave outfits.) "Makes a good radio set better."

PRICE, \$10.00

No. 60—LENGTH 60 FEET:
Assembled—ready to string up. "Big Boy" size. (Same description as above except that 300 ft. of wire is used, making this the most efficient and powerful aerial possible to manufacture.)

PRICE, \$12.50

Manufactured by
THOROLA RADIO PRODUCTS,
1014 So. Michigan Avenue Chicago, Illinois

Popular

LEARN saxophone, cornet, trombone—any band instrument. Be popular—make more money. It's easy. Play tunes first day. Ready for band or orchestra in 30 to 90 days. The world's greatest band leaders and soloists endorse Conns. Easiest blowing qualities; speediest action. Yet these superior instruments cost no more. Write for Free Book and full details of FREE TRIAL and Easy Payment offers. Mention instrument; C. G. Conn, Ltd., 1042-Z Conn Bldg. Elkhart, Ind.

CONN
WORLD'S LARGEST MANUFACTURERS OF BAND INSTRUMENTS

JOSEPH FALK
At 100 Mass. earned \$8,000 playing a Conn saxophone while in college. Appeared in 6 countries; plays 23 instruments; nearly all Conns.

BIG-PAY JOBS in ELECTRICITY

\$60⁰⁰ to \$150⁰⁰ WEEKLY

Amazing new method. Trains you quicker and better. Motion Pictures in your own home make every point clear. Genuine DeVry motion picture projector at no extra cost. Thousands of feet of film furnished. We pledge to give you training and employment service necessary to secure a better job at bigger pay or refund money. Get full facts. No obligation. Write quick while offer lasts.

Motion Pictures Train You QUICK

National School of Visual Education, Dept. I-NA
537 S. Dearborn St., Chicago, Ill.

Send book, "The Film Way to Bigger Pay," with facts about this new, easier way to master electricity

Name.....Age.....
St. or R. F. D.....
City.....
State.....

MAIL THIS COUPON NOW!

GREAT NEWS

IN RADIO!



A.C. SHORT-WAVE RADIO PILOT SUPER-WASP

WITH this short-wave outfit you pick up programs 10,000 miles away! You listen to the biggest thrills in radio—entertainment broadcast from foreign countries—new, different, exciting airventures! Available in easy-to-assemble kit form, in A.C. or battery types. Designed by 3 famous short-wave engineers—David Grimes, John Geloso and Robt. S. Kruse.



Kit K-115 (A.C. Operated)

\$34⁵⁰

POWER PACK EXTRA
(Pilot K-111 recommended)

Kit K-110 (Battery operated) **\$29⁵⁰**

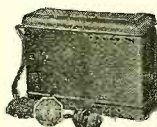

Pilot Power Packs

K-111 for 171-A Tubes

Thorough filtration makes hum inaudible. Very compact. Output 220 volts. Recommended for A.C. Super-Wasp. Complete—**\$16⁵⁰** ly assembled and wired

K-112 for 245 Tubes

Easily handles two 245's in push-pull plus five or six 227 and 224 types. Output 300 volts. Ultra-compact. Completely **\$19⁵⁰** assembled and wired

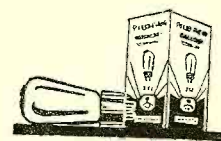

PILOTRONS

Endorsed by Professionals

When radio engineers, professional set-builders, and advanced experimenters demanded a tube of vastly superior qualities, Pilot responded with Pilotrons. Their enthusiastic reception by radio's fussiest folks proves that here at last is a line of tubes made to professional standards. For example, Pilotron 227 was especially developed by Pilot engineers for both regular broadcast sets and for the A.C. Super-Wasp Short Wave receiver—and is the only A.C. Tube suitable for short-wave detection.

DO YOU BELONG?

The Radio International Guild invites you to join its international organization of radio enthusiasts. Return the coupon now with 50c and receive membership pin, certificate and current issue "Radio Design." You will also receive 3 additional quarterly issues of "Radio Design"—the Guild's Official Organ.

RADIO INTERNATIONAL GUILD, 103 Broadway, Brooklyn, N. Y.

Enclosed please find 50c for which kindly enroll me as a regular member Radio International Guild which includes four quarterly issues of Radio Design, membership pin, certificate and identification card.

Name _____ (Please write or print plainly)

Address _____

City _____ State _____

PILOT RADIO & TUBE CORP.

WORLD'S LARGEST RADIO PARTS PLANT—ESTABLISHED 1908

323 BERRY STREET

Prices quoted are for Custom Set-Builders in U. S. A.



TRADE MARK

BROOKLYN, N.Y., U.S.A.

Get Latest Catalog from nearest Authorized Dealer or Direct from Factory.

\$34.50

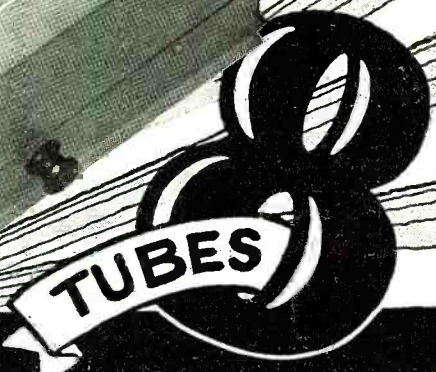

SCREEN GRID TUBES

SCREEN GRID CHASSIS



POWERFUL super-sensitive A. C. receiver establishing a new standard of perfection in radio design. Incorporating such advanced features as screen grid R. F., power detector, "245" push-pull power audio, dynamic tone quality plus practical scientifically shielded construction. Its super power assures unusual distance range—its ultra-selectivity adapts it for use in the most congested broadcasting districts. Available in a wide range of beautiful consoles—dynamic speaker equipped.

Write Today for this new 196-page catalog full of all the latest in radio showing the new, humless, Screen Grid A. C. all-electric and battery operated sets. Beautiful consoles, dynamic speakers, accessories, parts, kits; everything in radio and all at rock-bottom wholesale prices. Hundreds of real radio bargains from a Radio House backed by over \$3,000,000 in resources. Send for it now before you buy anything more in radio supplies! *USE THE COUPON.*

FREE RADIO CATALOG!

ALLIED RADIO CORPORATION

711 W. Lake St. Dept. B-4 Chicago, Ill.

Allied Radio Corporation,
Dept. B-4
711 W. Lake Street, Chicago, Ill.

Please send me your new 1930—196-page radio catalog — which we understand is to be absolutely free.

Name.....
Address.....
City..... State.....



Modulated radiator for testing, synchronizing, neutralizing

Self-contained power plant

Screen grid socket analysis without oscillation.

External connections for all apparatus

Tests both plates both type rectifiers

All tubes tested under actual operating conditions

750 Volt 4 scale A.C. and D. C. meters, 3 scale milliammeter.

Universal analyzer plug

All continuity tests without batteries

THE SUPREME DIAGNOMETER is universally recognized as the most thorough and efficient testing equipment in the radio field. Thousands of enthusiastic, satisfied users attest to its earning power in Service Work. So far in advance of other devices as to be beyond comparison. Get the facts!

AHANDSOME test panel for laboratory or shop use, in connection with the DIAGNOMETER, can be had at slight extra cost. DIAGNOMETER can be instantly disconnected for portable use. In keeping with SUPREME standards . . . the most complete, practical and convenient laboratory test panel ever designed.

WRITE NOW FOR THE AMAZING FACTS

Supreme Instruments Corporation
347 Supreme Building
Greenwood, Miss.

“Set Testers” prove only 29% to 40% efficient in comparison with the SUPREME DIAGNOMETER