

THE

Radio Masters

MONTHLY

DEVOTED EXCLUSIVELY TO THE

INTERESTS OF THE RADIO SERVICEMAN

APRIL - MAY

1940

F I F T E E N C E N T S T H E C O P Y

The "INSIDE" Story



TUBE TEST AND AC SEALED CALIBRATION CONTROLS

2 visible, 2 not seen . . . Each instrument individually calibrated and controls set and sealed against elaborate laboratory standards . . . affording maximum accuracy and duplicate performance characteristics of each and every PRECISION instrument.



WIRE SHUNTS, HAND WOUND

to 1% accuracy on impregnated moisture-proof bobbins. Metallized multipliers matched to 1% accuracy plus closely tracked and individually calibrated meters, provide guaranteed 2% D.C. and 3% A.C. readings on all ranges.



INDIVIDUALLY HAND CALIBRATED BOBBINS

insure maximum meter accuracy for tube test and multi-meter functions. Correct ONLY for the meter in each particular instrument . . . Provides duplicate quality performance of all PRECISION units.



FULL-SIZE, HEAVY CORE POWER TRANSFORMER . . .

Rated far in excess of maximum load requirements, as are all components of PRECISION test equipment . . . providing guaranteed service and an unmatched high in performance. . . .



HEAVY DUTY RUGGED SELECTOR SWITCHES

Positive snap-in action with low resistance, silver plated contacts . . . Assure long lasting, trouble-free operation.



TELEPHONE CABLED WIRING

employed throughout . . . providing uniform, color-coded, systematic wiring of all instruments. Only finest grade heavily insulated wire used.

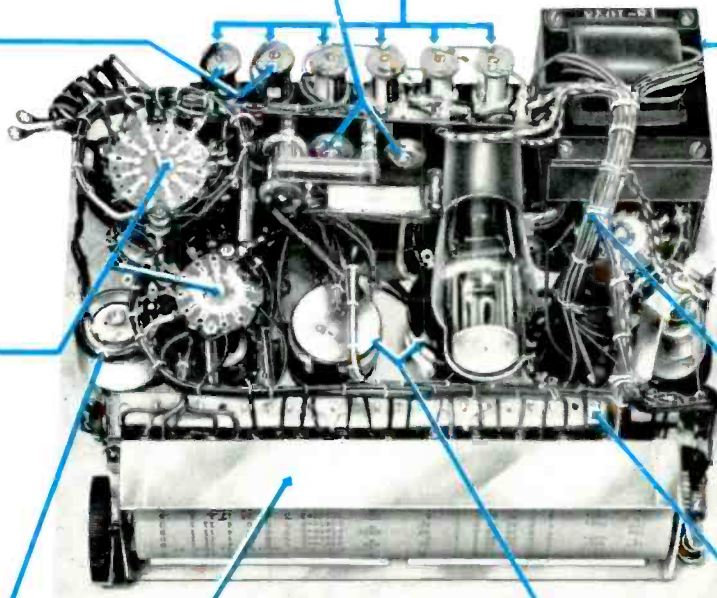

MICRO-LINE ADJUSTMENT provided by use of continuously variable, high wattage line voltage control. No arbitrarily tapped transformer employed.



BUILT-IN DOUBLE WINDOW ROLLER TUBE CHART provides speedy, easy reading tube references . . . Rugged and foolproof in operation . . . New Spring friction lock eliminates annoying back lash.



FULL-SIZE WIRE WOUND CONTROLS employed throughout . . . Held to very close tolerances . . . High wattage rating . . . Assures fullest accuracy and long performance.



AUTOMATIC PUSH-BUTTON SYSTEM

12 dual sets of double wiping silver plated contacts and phosphor bronze locking springs provide the heart of the PRECISION free point, anti-obsolescence Dynamic Mutual Conductance tube test circuit.

920 P

844 L

852 P

870

830

E 200

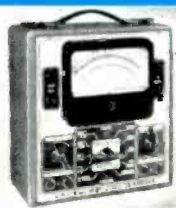

More than 40 models in the PRECISION 1940 LINE . . . 15 Mutual Conductance Tube Tester and Set Tester models ranging in price from as low as \$29.95 . . . 16 Multi-Range Tester models from as low as \$10.95 . . . Signal Generators from \$24.95 . . . etc. . . . See them at your local distributor . . . Ask for the PRECISION TEST EQUIPMENT 1940 CATALOG.



PRECISION TEST EQUIPMENT

Standard of Accuracy

SEE THEM AT YOUR JOBBER

PRECISION APPARATUS COMPANY

647 KENT AVENUE

BROOKLYN, NEW YORK

Export Division: 458 BROADWAY, NEW YORK CITY, U.S.A.

Cable Address: MORHANEX

ADVISORY BOARD

Lieut (jg) Perce B. Collison, USNR
*Commander of the 5 meter
 NCR net, 3rd Naval District*

Sven. T. Aberg
L. M. Ericsson Tel. Co.

Frixo Stathopoulos
*Chief Engineer . . . Electronics
 Division . . . EpiPhone*

Fred Norman
*Instructor In Charge of Radio &
 Television Servicing, RCA Institutes*

James L. A. McLaughlin
Consulting Engineer

Arthur E. Rhine
Radio Engineering Service

LEWIS WINNER

Editor

THE Radio Masters MONTHLY



DEVOTED EXCLUSIVELY TO THE INTERESTS OF THE RADIO SERVICEMAN



VOLUME 1 APRIL-MAY, 1940 NUMBER 2

A limiter circuit for Frequency Modulation that operates at the lowest input ever known, makes its bow. (Page 6)

The original inventor of radio broadcasting, known only to his home folks, receives a vote of honor for the first time. (Page 8)

Electrons and neutrons popularized. (Page 13)

Choosing the correct power output for the occasion simplified by unique chart. (Page 21)

Code classes go on the air. (Page 22)

Amateur Radio.....	22
All In A Day's Work	
The Little Man Who Wasn't There.....	8
Wired Broadcasts Within an Apartment House.....	8
The Original Inventor of Radio Broadcasting.....	9
Case Histories.....	14, 15, 17, 19
Current Information.....	25
New Equipment and Material.....	23
News and Views.....	4
Service Highlights	
A New Frequency Modulation Limiter Circuit.....	6
Analyzing the Degeneration Circuit.....	7
The Dumont Television System.....	20
High Frequency Noise Balancing System.....	21
Stepping Up These Sales.....	16
Your Page of Knowledge	
Frequency Modulation.....	10
Radio Test Equipment.....	11
Television.....	12
Fundamentals In Radio.....	13

EDITORIAL STAFF

Associate Editors

Adolph Suchy, *Instructor of Radio
 at Brooklyn High School for Specialty Trades*

Max Spitalny, *Former Instructor of
 Radio at Stuyvesant Evening Trade School*

Stanley Rich (W2DIW), *Radio Engineer,
 United States Navy*

Werner Mueller, *Consultant, Universal
 Electronic Labs.*

Henry H. Hesse, W2ERY
Chief Draftsman: Charles F. Detjen

15c
 THE
 ISSUE

Published Monthly and Copyrighted 1940 by

THE RADIO MASTERS

53 Rumsey Road, Yonkers, New York

\$1
 A
 YEAR

Jack Grand, Publisher..... Lewis Winner, Editor

Editorial and Advertising Offices, 116 Broad Street, New York City. Telephone: BOWling Green 9-9838.

Address all business and subscription communications to 53 Rumsey Road, Yonkers, New York, and editorial and advertising communications to 116 Broad Street, New York City.

news and views

STATE licensing of servicemen, one of the many interesting subjects that have been discussed around the table during the RADIO MASTERS broadcasts, has stirred up many camps of thought. Many have written in stating that state licensing would create havoc in the business of the serviceman, and many have said that, for the first time, real order and improved business would be the order of the day.

During one of the broadcasts, Fred Herman said, "Licensing would tend to rather perpetuate the incompetent, than eliminate him . . . You just can't successfully introduce a law that will regiment a group of people and permit good and bad to thus be placed in a single classification of service, nor can you separate the good from the bad and allow the better to have greater advantages. Therefore the competent and the incompetent both would have to be licensed. You would have to grant the incompetent a license just as much as the competent, because he too, is in business, and probably has been in busi-

What do you think about licensing? Send in your views to Editor. And in the next issue, a complete consensus will be published . . . a consensus that

should establish an accurate trend of thought on this very important topic. . . . better than ever before. Of course there are those who

NOTICE

This issue of The RADIO MASTERS Monthly has been dated APRIL-MAY to permit distribution during the early part of the month, instead of the latter part. All issues, hereafter, will be out during the first week of the month.

refuse to heed this warning, but they will fall to the wayside, unless they perk up!"



AT A BROADCAST WITH THE RADIO MASTERS. Left to right: Jack Grand, Emil Leavitt of Carl Fisher, the Northenaires quartette, Tord Benner and Lewis Winner.

SPECIAL lecture tours by engineers of many of the companies are becoming more and more popular. Servicemen are thus receiving information which is invaluable to them.

At the recent meeting of the Philadelphia Radio Servicemen's Association, Leon Podolsky, chief engineer of the Sprague Products Company, spoke about interference elimination to over a hundred servicemen. Emphasizing the increasing importance of interference elimination, as a result of the present trend to the higher frequency spectrum, Mr. Podolsky classified radio noises into three types. The first two, natural disturbances, and "monkey-chatter" between stations have largely been eliminated by improved broadcasting. However the third, man-made radio noises, have now become even more of a factor than ever before. By using a newly developed interference eliminator, Mr. Podolsky showed how it was possible to track down any noise source. Then with an interference analyzer, the exact chokes or filter condenser necessary to eliminate the noise, could be found, and quickly installed, without any guesswork.

The importance of working with the serviceman's local public utility company was emphasized. Although not in a position to do interference work outside what may be created by their own power lines or equipment, most utilities will lean over backward to help the serviceman, who specializes in interference elimination.

Several instances were given, showing exactly how certain servicemen had found a profitable new field of business in this work. One man living in a town of 5000 population, went over the entire community including the traffic lights and retail store equipment and made it a model of noise-free reception.

Tubes present another interesting

topic covered by engineer-lecturers. Walter Jones, commercial engineer for Hygrade Sylvania, returned last week from a tour in the central south. He spoke to groups in New Orleans, Birmingham, Nashville, Chattanooga and Knoxville. Mr. Jones found a particularly lively interest among servicemen in oscillator circuits and battery receivers.

VOLUME controls, probably one of the most important components in a radio receiver, are also one of the most interesting. The thoroughness of their design and production, are most essential to the general efficiency of a receiver.

"In the volume controls of today," said J. Edward Trefz, of Clarostat, at a RADIO MASTERS broadcast, "special composition elements afford a smoother . . . more even distribution of control.

"Many wonder why wire controls are not as popular today. Wire wound controls can be supplied only up to

100,000 ohms, and it is impossible to go any higher, economically. In addition, wire controls cannot be tapered as readily as the composition controls. And thus there has been this decided swing to these composition controls.

"Because the control is manually rotated every time the radio receiver is placed into operation, and because of its electrical position in the circuit, it is highly important that the volume control be both mechanically and electrically smooth and quiet in operation. Otherwise, the noisy condition is apparent.

"It must be remembered, though, that any resistor, whether it be wire wound or carbon composition, variable or fixed, generates noise when current is passed through it. If sufficient amplification were to follow any fixed resistor, in its own circuit, and the amplified output applied to a loud speaker or earphones, we would hear a crackling sound. This crackling sound is what is termed . . . "thermal noise" . . . and is of thermic origin. That is, all resistors are thermogenous, or affected by the heat due to the wattage dissipated. Fortunately, radio receivers do not have sufficient amplification to make these thermal noise audible. However, I mentioned this type of noise, to prove that no matter what is done to remedy noise, there will be noise present. But, replacement of the defective control will eliminate the noise as far as the ear is concerned. The human ear has an amplifying characteristic, just like the tubes in the receiver. And because of this trait, the controls have to be tapered. The ear requires approximately ten to twelve times the original intensity to double a given volume of sound. A tapered control of specific graduation of the resistance will afford the proper result."

Listen In

TO THE

UNUSUAL PROGRAM

OF

THE RADIO MASTERS

Every Sunday

9:15 to 9:30 P.M.

on

STATION W B N X

1 3 5 0 K . C .

all in a days work

Unusual True Stories from The Radio Serviceman

IN the early part of April, Felix Storm received a phone call from the superintendent of a large apartment house, asking him to drop over and see the tenants regarding the installation of loud speakers in each apartment.

"Now," writes Felix Storm, "I had heard of speakers in hotel rooms and apartment-hotel rooms, but never in a plain apartment house. And so it was with a great deal of wonderment and enthusiasm that I raced over on this unusual assignment. When I arrived at the apartment house, I found a moderate size building, tenanting about 30 families. Naturally I was all the more puzzled, for I couldn't imagine why loud speakers should be wanted in such a comparatively small building. Well, I went up to the superintendent, told him who I was, and was taken across the alley to a storage room, that had been transformed into an attractive

studio. I learned that concerts were held here every week, and that due to the tremendous interest in these musicals, the director of the programs suggested that an amplifying system be incorporated, so that the music could be fed to the apartments of everyone. Each and phonograph as its nucleus. Tenants of the tenants had chipped in for payment for this service, that would give them all the exclusive music they want, with no noise . . . no static.

"It seems as if the orchestra leader was quite a radio bug, who was very fluent with the technicalities. He installed the amplifier, and was unable to install the speakers, because of a special series of assignments he had just received. So it was my good fortune to have been called in on this interesting job. I used the antenna and ground leads that ran through the building to connect up the speakers to the amplifying

system. Thus I had no internal wiring to worry about.

"I have learned that several other musicians have followed this same idea, in supplying music to their good friends and tenants of the houses in which they live. Les Paul of the Les Paul trio, appearing with the Fred Waring band, installed a similar system in the apartment house in which he lives in Astoria. Assisting Mr. Paul was Ernie Newton, another member of the Fred Waring band. The studio here had its origin in the living room of Mr. Paul's apartment, with a microphone of the house became so enthusiastic that enlargement of the studio was imperative, and into the basement they went to build this improved studio. Among the famous musicians who have appeared on this system are . . . Ray Baudac and his drums, and Matty Matlock and his clarinet . . . both members of Bob Crosby's Bobcats."

TALK about strange experiences," says Otto Pascal, "I struck a most unusual one a short time ago. It's about the little man who wasn't there.

"I was given a service call to a certain address, and was warned to knock quite huskily on the door when I got there, for the customer was a little hard of hearing. So off I went with my analyzer and tubes to this man's home. I rang the bell, and rang about a dozen times, with no response. Then I started to knock. And boy, did I rap on that door, but still not an answer. 'I guess I'll have to barge in,' I said to myself. So with a heave ho, I opened the door and in I went.

"Seeing a light in the living room, I entered the hall leading to it, shouting . . . radioman . . . radioman is here. I yelled until I was blue in the face, but still no reaction. I finally collected enough verve to enter the living room, and found my customer reading the paper. He lifted his head in surprise, stabbed me with a piercing look and yelled . . . 'What do you mean busting into my house this way. Can't you ring the bell?'"

"Well, I gulped and nearly dropped my analyzer, but managed somehow to control my reflexes, and went to work. The trouble was small, and was I glad, for I couldn't duck out quickly enough."

IN March 20, 1938, the folks of the little city of Murray, Kentucky dedicated a modest marker on the campus of Murray State Teachers College. And on this simple marker were inscribed three words . . . "INVENTOR OF RADIO".

"I doubt if few folks outside of Murray knew about this dedication," writes Charles Donning.

"None of the great networks were on hand with portable transmitting

units to broadcast the event, for the man's name meant nothing to the millions of Americans who listen in every day. You who are reading this, undoubtedly never even heard of him. His name was Nathan Stubblefield.

"Although everyone knows that credit for having first transmitted sound waves without the aid of wires goes to Marconi, who invented wireless telegraphy, Nathan Stubblefield, was really the first to invent, discover and manufacture equipment for the wireless transmission of sound, music and the human voice. Yes, it was to Nathan Stubblefield, that the United States granted the first improved wireless patent . . . No. 887,357.

"In 1892, Mr. Stubblefield began broadcasting and his first words over the air were . . . 'Hello Rainey'. They were heard by Dr. Rainey T. Wells, a young attorney, who lived across a swamp in Kentucky. Today that swamp is the magnificent campus of Murray State Teacher's College.

"Stubblefield's equipment at that time consisted of what might be called a 'crazy box', some telephone equipment, two rods, and some coils of wire. What that box contained, only he and his attorney knew. On Decoration day, 1902, he proved to a critical audience of inventors, statesmen, business men and newspaper reporters, that his voice could be heard by wireless a mile distant from the transmitter. The successful demonstration was made in Philadelphia, between the Belmont Mansion and Fairmont Park. In later demonstrations, his voice was transmitted 27 miles. During that same year, he both broadcasted and received messages from shore on board the steamer, Bartholdi, on the Potomac River.

"Patents were granted to him by England and the Dominion of Canada in

1908. He even anticipated the installation of radios in automobiles, for his British patent contains a drawing of a horseless carriage, with a radio, that he called a radio.

"From his patent, it is apparent that he discovered the fundamental principles of sound broadcasting, and receiving that have made modern radio possible. Although he revealed to no one, except perhaps his son, the contents of the box he used, the diagrams accompanying his patent disclose the basis of his invention.

"Why then, was this man so unknown . . . why did he fail to attain the fame for which he had worked so hard? Did someone steal his invention? Was he insane? The answer, oddly enough, was an emphatic—no. Although Nathan Stubblefield wanted fame and wealth . . . in fact he wrote to his cousin, Vernon . . . 'You and I will yet add luster to the Stubblefield name' . . . he lacked executive ability. He was so suspicious of every investigator that he would not sign a contract for the commercializing of his invention, fearing that he would be cheated. But he was a true genius . . . an erratic stubborn genius, who housed the secret of his invention in a small box and repulsed visitors with a shotgun. Once he was offered \$40,000 for a part interest in the invention. Later was offered a half million, and still he refused.

"Poor Nathan Stubblefield, suspicious of everyone, finally renounced his wife, children and friends. In 1928, a two line notice ran in a Kentucky paper, reading . . . 'Nathan Stubblefield was found dead today, in his two room shanty, on the other side of town.'"

"Even the radio, which he invented, failed to make mention of his death."

your page of knowledge

Frequency Modulation . . Television . . Fundamentals in Radio . . Test Instruments

FREQUENCY modulation is being heralded as the form of transmission that will eliminate all noise, interference and fading. It is called the most practical carrier of high fidelity sound. In fact so many claims, some wild, most true, are being made, that, a cool understanding is essential at this time.

One of the most fundamental differences between the methods of reception of frequency modulation and amplitude modulation is the means whereby audio voltage is developed. In amplitude modulation a linear rectifier causes any change in electrical amplitude to pass through for reproduction by the audio system. In frequency modulation, means are provided, in the discriminator and limiter, whereby voltage develops proportional to frequency only. That is, the discriminator or detector characteristic is such that for signals of fixed amplitude but varying frequency, a voltage will be developed according to deviation from a central frequency. The curve, "detector characteristic" FIG. 1, illustrates this point. As can be seen, any signal of frequency F_0 will de-

FREQUENCY MODULATION

By STANLEY RICH

Part 1

velop zero output voltage from the discriminator. If the signal is of some other frequency, still within the limits F_1 and F_2 , it will develop a positive or negative voltage dependent upon its position on the characteristic curve.

It is quite evident, that although the discriminator is sensitive to frequency variation it also will respond to ampli-

tude variation. That is, if two signals at a particular frequency are compared, the larger will develop higher output voltage. However, if some means were available to limit all signals to the same level, amplitude variation would be removed and then detection would take place only on the basis of frequency difference. Thus, amplitude modulation, or the variation in intensity of a signal would be wiped out. Such a steamroller is the limiter stage of Fig. 2.

In this limiter, a pentode operating at very low plate and screen voltages, all amplitude variations are washed out providing the signal at the input is greater than six volts. It does this by grid rectification. That is, any signal, say, of 50 volts, is rectified on its positive swing by the grid of the tube. A negative voltage builds up across the grid leak almost equal to the peak amplitude of the signal. The grid condenser, thus charged, maintains the voltage almost constant during the presence of signal. The tube, thus biased by grid rectification too far beyond cutoff, will amplify only on the very peaks of signal. Therefore, all

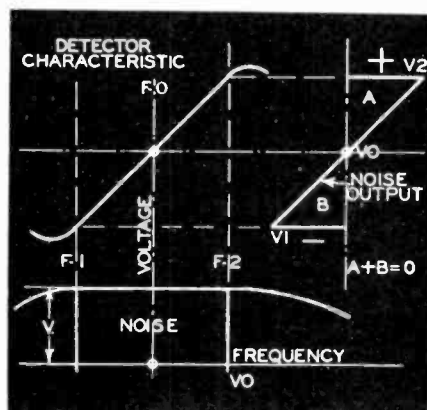

FIG. 1

signals of smaller value than carrier will not be amplified. All larger signals will level themselves by the limiting action of the grid condenser — resistor combination of the limiter stage.

The effectiveness of noise reduction lies in both the limiter and discriminator circuits. However, most noises are eliminated in the limiter. It is this stage which determines the least practicable signal to noise ratio at which signal will over-ride the background. The grid leak type limiter just discussed will allow a signal to noise ratio of roughly, six to one. The suppressor type limiter discussed elsewhere in this issue will allow even smaller ratios.

However, certain noises are eliminated in the discriminator circuit itself. These are of the white or spectrum type of disturbances such as atmospheric crashes and discharges. A noise such as a lightning crash is shown in Fig. 3, at A. It covers all frequencies uniformly, tapering off toward higher frequencies. This is much like the white light of an incandescent source. No particular frequencies are emphasized but general coverage is effected. To make a homely comparison, lightning crashes are received uniformly whether tuned to WMCA or WQXR.

The discriminator eliminates this type of noise as is shown by Fig. 1. At the lower left hand corner, a typical spectral noise is shown. It extends throughout the range of discriminator detection as can be seen by its place beneath the detection characteristic. The limits F1 and F2 are symmetrical about F0, the central operating frequency of the detector.

Now, frequency F2 is rectified as the positive voltage V2. The frequency F1

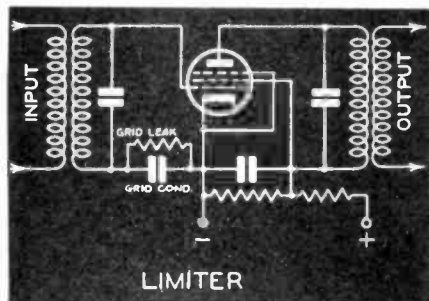

FIG. 2

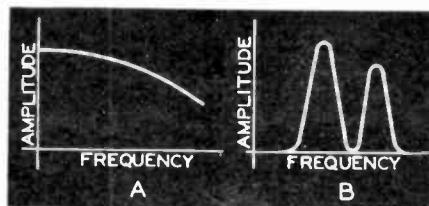

FIG. 3

is rectified as the equal, but opposite voltage V1. All voltages in between, appear on the straight line curve from V1 to V2, or the noise output curve. It is evident that if every item is symmetrical, each positive point will theoretically be matched by a negative one. Hence, area A equals area B, and the noise can produce no output, since A equals B and A-B equals 0. Thus, most atmospheric noise, such as lightning noises are eliminated by the very nature of the detection scheme.

Another way to view the entire frequency modulation scene is put forth excellently by Major E. H. Armstrong, the great inventor and pioneer in frequency modulation. He states that the transmitter gives to the transmitted signal a characteristic which is singularly not possessed by all unwanted signals and noise. The method of detection is then made such that signals having only this peculiar characteristic can be received. All others are therefore rejected.

CAN YOU ANSWER THESE QUESTIONS?

1. How do the principles used in the detection of amplitude modulation differs from those of the frequency modulation detector?
2. Why cannot a linear detector demodulate frequency modulation?
3. What prevents the discriminator from responding to changes in amplitude?
4. How can the limiter circuit aid in the suppression of interfering noise?
5. Does the discriminator reduce interfering noise? What kind?
6. How is this reduction affected?
7. Does atmospheric noise affect frequency modulation?
8. Why can't amplitude modulation be used to transmit, wide range sound, in the presence of severe noise?

In the event corrections of your answers are desirable, THE RADIO MASTERS MONTHLY will be glad to lend a hand through their special answer department. Simply send your answers to "Page of Knowledge" department, and include a self addressed stamped envelope plus ten cents in stamps or coin to cover cost of handling. Mark your request . . . for Part 1 . . . Frequency Modulation.

It can be said that a changing frequency is the only key to the lock of the receiver and since noise and unwanted signals represent amplitude modulated fixed-frequency signals, they go undetected.

Frequency modulation is capable of the greatest fidelity, since there is no side band cutting in the receiver. Even if there were, the limiter would restore all changes in amplitude. Therefore, the highest quality of transmission can be broadcast without trouble. Another point of comparison worthy of note at this time, is that, in amplitude modulation the wider the band, or the higher the fidelity, the greater the level of noise. This is not true in frequency modulation. As a matter of fact, the wider the transmitted band of frequencies the greater will be the relative attenuation of noise.

(To be Continued)

RADIO TEST EQUIPMENT

By ADOLPH SUCHY

Part 2

IN last month's discussion we spoke of the basic instrument — the d'Arsonval type meter. This basic instrument may be used as either an ammeter or voltmeter according to how it is connected in the circuit. Also, we can measure resistance by using it in conjunction with a battery and resistor. With this meter, a few resistances, a battery and a rectifier, we can cover all of the operations necessary in making a voltage — current analysis or a point to point analysis. This leaves only the newest method of analysis, signal tracing which cannot be accomplished by its use. It must be emphasized that while each method of analysis is important to know it is dependent on the other two. In other words in order to do a complete and efficient job in radio servicing the ser-

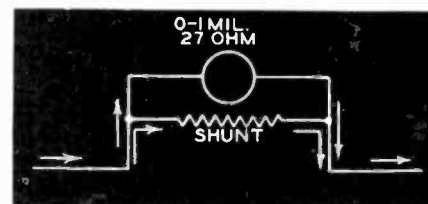

FIG. 2

vice man must know voltage — current analysis, point-to-point testing and signal tracing. One is useless without the other two. Therefore, this important phase of instrument application will now be analyzed.

First, let us take a look at voltage — current analysis. When radio servicing was in swaddling clothes the set analyzer was the most popular form of servicing equipment. This instrument plugged into the tube sockets of the receiver and extended the circuits to the meter which was switched into various parts of the circuit. With the introduction of multi-element tubes, adaptors became necessary and the instrument became unwieldy, because of the many arrangements of pins in the basing of the tubes. Lately this method is coming back to its own. By actual switching this method has become popular again. In Fig. 1 we see just how the analyzer places the meter in the different circuits.

By placing the meter with a suitable shunt in series with the plate circuit, we can measure the plate current. This shunt may be calibrated very easily. By knowing the resistance of the meter we have on hand, we can make it read anything we desire. Let us suppose we have on hand an 0-1 milliammeter. If we wanted to make this read 0-10 milliamperes we must add a shunt as in Fig. 2. Part of the current would have to flow through the shunt and part of the current through the meter. But we already know that the meter will only stand one milliamperes of current. Therefore, nine milliamperes must flow through the shunt. If nine mils flows through the shunt, then the shunt carries nine times as much current as the meter. We already know, through ohm's law, that the higher the current the less the resistance. This is proportional. So, we can say that there would be nine times as much resistance in the meter as in the shunt. Therefore the resistance of the shunt would be one ninth that of the meter. Suppose the meter resistance was 27 ohms, then the shunt for 10 mils would be three ohms. The resistance of any shunt may thus be calculated.

By switching various values of shunts into the circuit, we can increase the utility of the meter many times. As a matter of fact we can have as many instruments as we have shunts, but care must be taken when switching arrangements are used. The switch must have positive contact with negligible resistance. If one contact of the switch were open, the meter would only have the

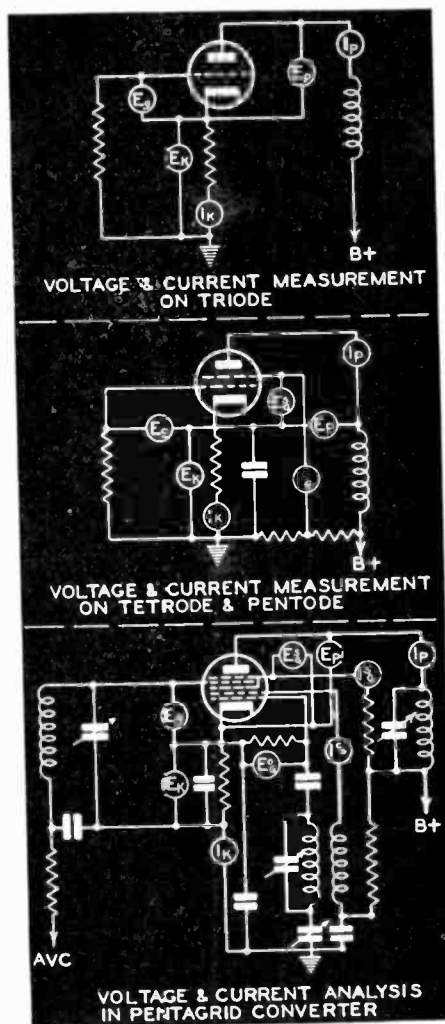

FIG. 1

CAN YOU ANSWER THESE QUESTIONS?

1. Why must a service man know all methods of analysis?
2. Of what material is a shunt made? How is it used?
3. How is a milliammeter always in the circuit?
4. An 0-1 mil meter, having a resistance of 50 ohms, has its range increased 50 mils. Calculate the shunt resistance necessary.
5. Draw a diagram of a multirange milliammeter, using a switch to change the shunts.
6. What kind of a switch would you use for the meter in the question above? Why?
7. Why is it necessary to know the resistance of the leads going from the switch to the meter in your circuit?
8. Why did set analyzers go out of the picture for a while, and how is it that they are being used again?

In the event corrections of your answers are desirable, THE RADIO MASTERS MONTHLY will be glad to lend a hand through their special answer department. Simply send your answers to "Page of Knowledge" department, and include a self addressed stamped envelope plus ten cents in stamps or coin to cover cost of handling. Mark your request . . . Part 2 . . . Radio Test Equipment.

0 - 1 mil range on that switch stop, and if the service man were to measure on that stop, thinking that the shunt was in the circuit, the meter would be seriously damaged. Also, when calibrating shunts, the service man must take into consideration the resistance of the leads going from the switch to the meter. Suppose we had a shunt with a resistance of .029 ohms and the leads from the meter to the switch measured .01 ohm, this would make the total resistance .039 ohms and the calibration would be incorrect. In next month's discussion we will discuss voltage measurement and show how the present instruments can be made more useful in measuring high voltages.

(To be Continued)

TELEVISION By HENRY HESSE Part 1

THE band of six megacycles, allotted to a television station is a fixed maximum. Experiments are constantly being conducted endeavoring to increase the detail that can be transmitted over this channel. Out of one of these experiments evolved the system of vestigial sideband transmission. Vestigial sideband transmission broadcasts the carrier with the complete upper sideband but only a vestige of the lower sideband as shown in Fig. 1 (B). Conventional double sideband transmission is shown in Fig. 1 (A). A comparison between these two forms of transmission shows an increased transmission band from 2.5 mc. to 4.0 mc. with a 60% improvement in picture detail by the use of vestigial sideband transmission.

In order that the picture and accompanying sound could be tuned in by a single control on the receiver, a standard was established placing the sound carrier 4.5 mc. higher in frequency than the picture carrier [Fig. 1 (B)]. As an example let us suppose we tuned in the NBC television transmitter W2XBS, broadcasting a picture carrier on 45.25 mc. and a sound carrier on 49.75 mc., on a single control receiver. The picture and accompanying sound are independently transmitted from separate antennae atop the Empire State Building in New York City. Both picture and sound signals are picked up by the same receiving dipole antenna. Both signals pass thru the broadly tuned r.f. amplifier and first detector circuits together. The difference between a local oscillator operating on a frequency of 58 mc., mixed with the two signals in the first detector pro-

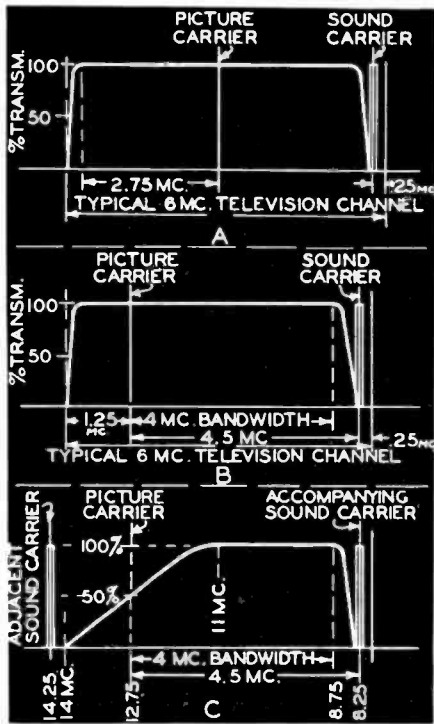

FIG. 1

duces two separate intermediate frequencies of 12.75 mc. for the picture and 8.25 mc. for the sound.

The sound i.f. (Sif) has a broad

bandwidth, up to 100 kc., to prevent audio distortion if the receiver is slightly detuned. The Sif usually consists of two stages to compensate for the reduced gain of broadband transformers. The remainder of the sound channel, usually hi-fidelity, is entirely conventional.

The picture i.f. (Pif) circuits are very broadly tuned to pass a band between 2.5 mc. and 4.0 mc. wide. There may be as many as five Pif stages in some of the large television receivers. The Pif transformers are a complex arrangement of coils, condensers and resistors to obtain the broad band and special response characteristic, required in vestigial sideband reception, Fig. 1 (C). The Pif response must be cut off at 8.25 mc. which is the accompanying sound i.f., and also at 14.25 mc., the adjacent sound i.f. channels, to prevent sound modulation of the picture, which would produce alternate light and dark horizontal bands in the picture. The Pif response must rise rapidly from 8.25 mc. to 8.75 mc. and remain flat to about 11. mc. The response should then slope gradually downward to 50% response at 12.75 mc., which is the picture carrier frequency, continuing the gradual downward slope to zero at 14.25 mc. This Pif response characteristic is required to prevent picture distortion when using vestigial sideband transmission. Therefore Pif amplifier adjustments are elaborate and complicated, requiring special equipment. It is therefore important that the manufacturer's service instructions be read carefully and understand them thoroughly before attempting any adjustments.

(To be Continued)

CAN YOU ANSWER THESE QUESTIONS?

1. What is interlaced scanning?
2. Why is it used?
3. What bandwidth is assigned to a television station?
4. What is vestigial sideband transmission?
5. How much better is it than the conventional double sideband transmission?
6. What standard was established to permit the picture and sound to be tuned in on a single control receiver?
7. What picture intermediate frequency is used?
8. What sound intermediate frequency is used?
9. If a television station broadcasts a picture on 51.25 mc., what is its accompanying sound carrier frequency?
10. What must the local oscillator frequency be to produce the intermediate frequencies, asked for in questions 7 and 8?
11. What is the sound IF bandwidth?
12. Why is it used?
13. What frequencies must be cut off in the picture IF?
14. What happens if the frequencies in question 13, are not eliminated from the picture IF?

In the event corrections of your answers are desirable, THE RADIO MASTERS MONTHLY will be glad to lend a hand through their special answer department. Simply send your answers to "Page of Knowledge" department, and include a self addressed stamped envelope plus ten cents in stamps or coin to cover cost of handling. Mark your request . . . For Part I . . . Television.

FUNDAMENTALS IN RADIO

By MAX SPITALNY

Part 2

A KNOWLEDGE of electrostatic charges and the laws governing them is very important in radio work. This is particularly true in the study of electronics (vacuum tubes, photo electric cells, etc.), the functioning of radio parts (particularly condensers) and the proper shielding for various units in the receiver.

The electron theory has been able to explain all phases of electrical phenomena. This theory is based on the belief that the atom, the smallest division of matter, is composed of two

things; positive electrical charges called protons, and negative electrical charges called electrons. Atoms of different elements differ from each other only in the number and arrangement of the protons and electrons.

Each atom consists of an inner nucleus composed of protons and some electrons, and an outer shell of electrons. These electrons in the outer shell revolve about the central nucleus in orbits somewhat similar to our solar system, and it is their number and arrangement that determines the properties of the atom.

Normally the atom or the matter composed of atoms is electrically neutral. However, under certain conditions, such as rubbing two substances together, electrons may be transferred from one substance to another. This produces an excess of electrons on one substance and a shortage of electrons on the other. An excess of electrons forms a negative electrical charge; a shortage of electrons forms a positive charge.

The terms positive and negative charge are conventional terms that were fixed long before the electron theory had been formulated. The scientists of that day believed that something moved when two electrical charges were established, but whatever it was, was so small that it could not be measured. To distinguish the two charges, one was called positive and the other negative. Positive means more and negative means less. The scientists

(Continued on page 29)

CAN YOU ANSWER THESE QUESTIONS?

1. What is the electron theory?
2. Why does a body become electrically charged when rubbed?
3. What are the laws for charged bodies?
4. What is an electro-static field?
5. Why do we consider the electron as a negative electrical charge?
6. What is a condenser?
7. How can we apply the laws of charge bodies to a charged condenser?
8. How can we apply these laws to the action of a radio tube?
9. Explain the action of the various grids in a pentode?
10. How can you explain the use of shielding in radio work?

In the event corrections of your answers are desirable, THE RADIO MASTERS MONTHLY will be glad to lend a hand through their special answer department. Simply send your answers to "Page of Knowledge" department, and include a self addressed stamped envelope plus ten cents in stamps or coin to cover cost of handling. Mark your request . . . for Part I . . . Fundamentals of Radio.

CASE histories

Compiled by **ARTHUR E. RHINE**

SPECIAL NOTICE: Your case histories can earn you quick cash. Send them to the Editor of The RADIO MASTERS Monthly. For everyone published, you receive \$1.00.

PHILCO MODEL 89 or 19

PROBLEM

Lack of response over low frequency half of the band.

SOLUTION

The 36 tube will stop operating because of excessive bias. Remove the cathode resistor and replace with one of 5000 to 7500 ohms (no higher). Examine the oscillator condenser stator for defective or loose contacts. Check up on the oscillator coil connections to the coil lugs, too. Some of these receivers were found to have poorly tinned oscillator coil terminals. Thus on general principles, it is wise to clean off and re-tin all connections to lugs.

Submitted by Leonard T. Falk

FADA OLD MODELS

PROBLEM

Identifying color coding of resistors before adoption of RMA standards.

SOLUTION

Follow the color code table shown below.

Submitted by Cbas. Kelcey

OHMS	COLOR	OHMS	COLOR
125	GRAY-YELLOW END	7500	YELLOW-BLUE END
250	LIGHT BROWN	10000	BLUE-YELLOW END
500	BROWN-BLUE END	13000	WHITE-BLUE END
750	GREEN	15000	BLUE-RED END
1000	GREEN-YELLOW END	20000	GREEN
1200	DARK GREEN	25000	YELLOW-GREEN END
1500	GREEN-RED END	50000	BLUE
2000	BLACK	70000	VIOLET
2500	RED-YELLOW END	125000	GRAY
3000	WHITE	.25MEG	YELLOW
4000	WHITE-ORANGE END	.5 MEG	BROWN
5000	ORANGE	2 MEG	RED
6700	BLUE-WHITE END		

RCA MODEL VA-20

PROBLEM

Distortion when volume control is well advanced.

SOLUTION

Remove condenser C4 and resistor R2 from the cathode of the 6A8 oscillator modulator. Connect cathode and shell (SH) or chassis. Install a 10 megohm resistor between modulator grid and cathode of 6A8. Open green lead from the volume control to the modulator grid of 6A8 and install a .0025 mfd. condenser in series. Add a 120,000 ohm resistor across terminals 1 and 3 of volume control.

Submitted by Gury Hardy

GENERAL ELECTRIC MODELS A-70 and A-75

PROBLEM

Lack of sensitivity.

SOLUTION

Diode plate lead must be dressed as far as possible to the front of the chassis. This green wire is attached to a lug on the 2nd IF transformer. Feedback from this wire to the plate R9 1000 ohm resistor mounted between the first and second IF transformer, will kill sensitivity. Keep them as far apart as possible.

Submitted by A. E. Rhine

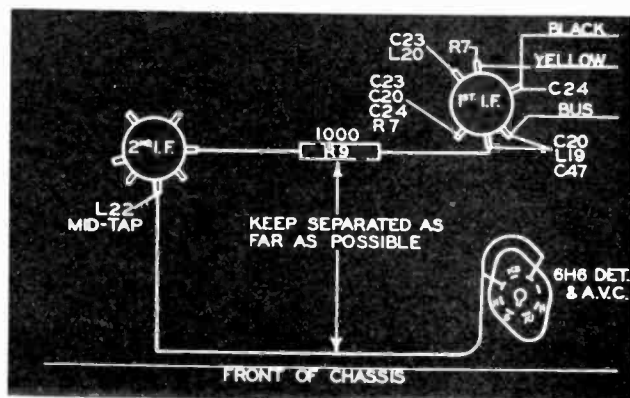

PHILCO

MODEL 70

PROBLEM

Howl, due to condenser plate vibration.

SOLUTION

Replace condenser gang rubber mounting washers with new live rubber washers, and dead under-chassis rubbers with new live rubber washers, too.

Submitted by Carl Posen

VARIOUS MAKES

VARIOUS MODELS

PROBLEM

Noisy volume controls . . . new controls also noisy.

SOLUTION

New controls often apparently noisy, are replaced unnecessarily. Excessive DC grid current flowing in volume control and first audio stage will cause this puzzling situation. Test of all tubes associated with volume control will reveal excessive grid current conditions. Make this test, before changing a noisy control which otherwise tests perfectly.

Submitted by Thomas Franklyn

STEWART WARNER

MODEL R-149

PROBLEM

Hum between stations, or residual hum.

SOLUTION

Attach blue wire from power transformer to grounded terminal of 6K7 RF socket. Remove remaining portion of this wire from front 6L6 socket filament. Make a twisted pair of two colors, long enough to dress close to chassis front and to reach heater lugs of 6L6's, as shown in the diagram below. Remove blue and wire connecting speaker socket to heater lug of 5V4G rectifier socket. Re-install the same wire to same terminals, but dress the wire as high as possible. Make provision for anchoring this wire in final position. Remove front screw holding input transformer. Turn this transformer, until mounting screw of output transformer is in position to hold both output and input. Dress all transformer leads as far from tube sockets as possible. Tighten all power transformer bolts. Carefully check 6L6's. Replace tubes if they do not match. Check rectifier tube for equal rectification of each plate.

Submitted by Ronald Quale

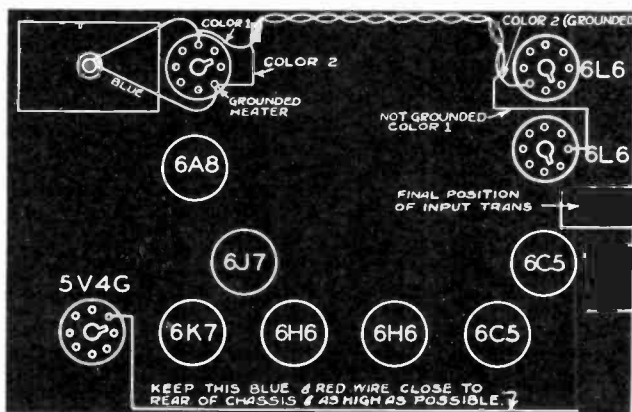

EMERSON

MODELS 108/10, etc. (Chassis U5A)

PROBLEM

Excessive hum.

SOLUTION

R-10 pilot light will be found shorted to chassis. It should be replaced with a 10 watt wire wound 25 ohm type. Replace carefully, so as to prevent danger of future shorts.

Submitted by Walter Roth

GENERAL ELECTRIC

MODEL A-82

PROBLEM

Low rumbling volume or rumbling noises or whistles.

SOLUTION

Open can of the second intermediate frequency transformer, and re-solder all connecting leads to both the primary and secondary windings.

Submitted by Bart Hoplarson

RCA

MODEL 106 SPEAKER

PROBLEM

Replacing disc rectifiers with tube rectification.

SOLUTION

Build a voltage doubler rectifier circuit, employing a 25Z5 tube. Support tube socket on the speaker frame, using brackets remaining after removal of disc rectifiers. In the output of doubler positive line, place a 700 ohm, 80/100 watt resistor. A line ballast of 319 ohms (or within 2½% of this value plus or minus) will be necessary in series with 25Z5 filament. Two 8 mfd., 300/400 volt condensers are the only other essentials required.

Submitted by Rudy Oltor

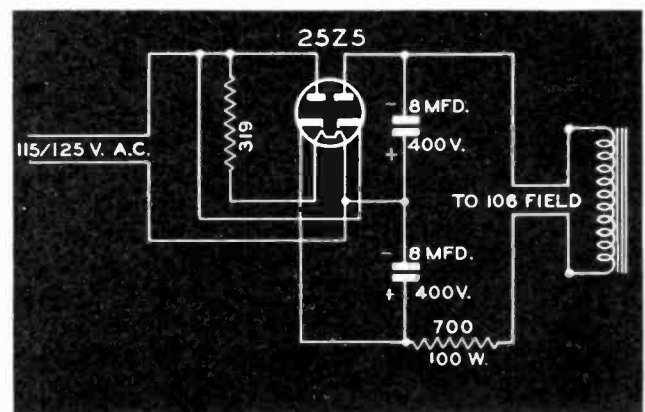

stepping up those sales

With Bruce Burlingame . . . Eli Lurie . . . Boyd Zinman

IN this busy world of ours, we so often overlook those means of increasing business that are truly closest to us. For instance, though every one has at one time or another recognized the fact that antenna installation is quite a formidable means of making the wheels go round, few today are capitalizing on this very important phase of the business, according to Eli Lurie of American Communications.

"With the economical multiple antenna system now available the serviceman is afforded an excellent opportunity to increase sales," says Mr. Lurie.

"About 75% of all the apartment houses in New York have antenna wire, more commonly called . . . spinach . . . strung all over the roof", continues Mr. Lurie. "Nine times out of ten, each tenant feels that any antenna on the roof is his legitimate property and as a result, it is common practice for a large group of antennas to connect to the best antenna on the roof. Thus you have high impedance inputs . . . double inputs . . . and low impedance inputs . . . all connected together on the same antenna, with little, if any satisfactory reception for anyone. The wiring on the roof constitutes somewhat of a

menace, since many of the antennas of the antennas hang quite low, and thus obstruct passage. In addition, the appearance of the building gives one the idea that it might have been built, more or less, as a support for these antennas. The fantastic, wierd jumble of wire on top of the roof, plus the irregular wires running up and down the building, certainly injures the appearance too . . . an appearance of which the building owner might be proud. Yet, this owner has never been able to do anything about this condition, because he realizes that his tenants must have radio reception, regardless of how a building may be affected.

"Now, there are two methods that can be followed to solve this problem and at the same time, promote business. The first method consists of selling the owner of a building the idea of installing a good antenna system . . . an antenna system that really works . . . and have him pay outright for such an installation. The second method is one which has all the earmarks of a good sbuiness set-up behind it. With this latter method, the installation does not cost he landlord a penny. The serviceman takes upon himself to install a complete multiple antenna system which

terminates in each apartment. The landlord specifically agrees that all radio service work in his particular building will be turned over to the serviceman. And the superintendent of the building is also informed of this agreement. The tenant is then approached and told that in order to be able to use the new outside antenna system that has just been insalled, there will be a small charge of anywhere from \$2.00 to \$5.00, depending on the arrangements made. Now this money will be returned to the tenant, if at any time, he might have trouble with his radio provided the charges for the repair are equal to or greater than the charge made for the antenna connection. In other words, the antenna system is used as an inducement to have the tenant repair his radio, when such repairs are needed, and the premium that he is offered, is the use of the outside antenna.

"Of course, the landlord, must take it upon himself to guarantee the radio serviceman that no additional outside antenna will be installed on the roof. This he will usually be willing to, because in addition to being able to advertise the feature of antenna outlets in every apt., he will also be able to feature an attractive building without the
(Continued on page 18)

RCA MODEL 94BP4

PROBLEM

Audio oscillation or howl.

SOLUTION

Green lead to number 8 pin of IC5-G socket must be kept as far separated from the blue lead (connected to same socket) as possible. Green lead connecting loop antenna to tuning condenser must be dressed so as to lay between the IH5G and IC5G tubes.

Submitted by Daniel Smafter

ALL MAKES ALL MODELS

PROBLEM

Interference from Neon signs.

SOLUTION

Interference from Neon signs is caused solely by direct radiation. No radiation occurs from the AC line. Exceptions to the rule are negligible. The entire unit including frames, metal casings, etc., radiates as a unit, although the actual field strength usually is negligible at a distance of over 6 feet. Dirty tubing, connections, and insulators all contribute to radiate interfering signals. Do not attempt to use RF chokes or condensers in the high voltage circuit, because this will serve to increase interference. Clean tubes and ground these from a central point, by winding a small sheet of foil around tube, and connecting it to the frame. Only extremely dirty or worn out tubes can cause interference by way of the AC lines. A filter will suffice to cure the condition. Antennas adjacent to interfering neons should be replaced with a noise reducing type of antenna, using a vertical rod pickup. This should be placed as far as possible from the interfering sign. The length of the transmission lead will make no difference, when using such an antenna system.

Submitted by A. E. Rhine

SOME MAKES AC/DC MODELS

PROBLEM

Hum.

SOLUTION

Remove audio grid resistor, usually about 5000 ohms to ground. Substitute two 2500 ohm resistors in series, or two resistors, each one-half the value of the original. From point where the two resistors are joined, by-pass to ground, with a .1 mfd. 400 volt condenser.

Submitted by Carl Thomas

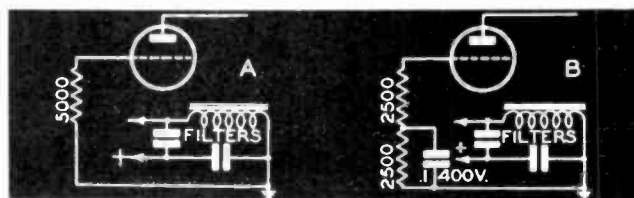

ANY MAKE ANY MODEL

PROBLEM

What is the cause of a crystal pickup burning out?

SOLUTION

Cathode internal short, or low resistance condition between the elements of the heated tube, to which the lead from the pickup is attached.

Submitted by Emil Lapiano

RCA MODEL R 6

PROBLEM

Unstable operation.

SOLUTION

Locate screen plate bleeder 16,000 ohm resistor, which is in series with an 8000 ohm cathode resistor. Gradual disintegration and value alteration of either of these two resistors seriously affects the other, thus creating a highly unstable condition. Avoid repetition of this trouble by installing a 10 watt wire wound 16,000 plate-screen resistor and a 3 watt 8000 ohm cathode resistor. Be sure that the 16,000 ohm resistor tests above 15,000 or under 16,500 ohms (about 3% plus or minus). The 8000 ohm resistor may test anywhere from 7000 to 9000 ohms, but it is advisable to keep within a 3% tolerance in this case, too, since the total extreme value differences at a 10% tolerance is 4800 ohms, or 20% of total 24,000 ohm bleeder circuit.

Submitted by A. E. Rhine

GENERAL ELECTRIC MODEL A-75

PROBLEM

IF amplifier 1000 ohm, 6K7 plate resistor R9, burns up.

SOLUTION

The C-37 .1 mfd. 400 volt, IF plate by-pass condenser is shorted. Replace with .01 mfd. 600 volt condenser. Replace resistor R9 with 1/2 or 1 watt, 1000 ohms.

Submitted by Leonard Scan

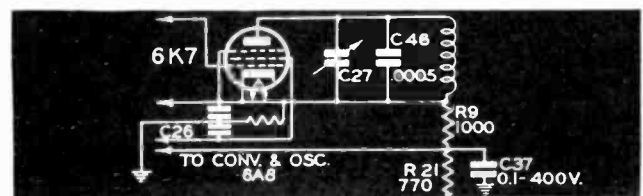

unsightly antenna wires strung all over the roofs. Now when you consider that an apartment house of sixty to seventy apartments may have as many as one hundred to one hundred fifty radios, which would require an average servicing of at least once a year, you can readily see that if this business is assigned to just one radio serviceman, increased revenue will certainly result.

"There is one more step in this new antenna business . . . an important step that should prove quite profitable to the serviceman. This opportunity exists in the installation of radio antennas in the new small homes which are being built all over the city, and in New Jersey, Westchester and Long Island. These small homes are ideal for the selling of this idea, for radio outlets are necessary in each of the rooms. Then the building could be sold on the same basis that modern apartments are rented . . . and the tenants or owners could have noiseless, clean reception in any room of the house."

REAL success in radio servicing is based on a sensible balance between selling and business ability and technical ability," says Bruce Burlingame of Supreme Instruments.

"Any successful business, personal or otherwise, consists of two distinct elements," continues Mr. Burlingame. "First there is the problem of selling your product, which in this instance, is honest radio service. The second step or problem consists of performing this service at a profit to the serviceman and to the complete satisfaction of the customer. Now to analyze further, the price or fee agreed upon between the customer and the serviceman, before the work is started, represents all of the money that the job is going to produce. From that point on, every moment spent, every error made in lo-

cating and correcting the trouble is overhead expense. Add to these items the cost of parts that require replacing, and rent, light, heat, telephone, automobile expense and other incidentals, in addition to the cost of the tools and test equipment. Now, subtract these expense items from the agreed cost of the job, and you have the profit that is finally made. Careful analysis quickly shows that the only variable over which the serviceman has any control, is the time he spends on the bench with a defective radio. It therefore stands to reason that if he can service each job perfectly, in less time, he has more time to go out selling his business and developing the trade of more clients. This is the only way he can increase his gross income. Selling is therefore the most important and primary job in the success story of any radio service man."

THE photo-cell today presents unlimited possibilities to the serviceman. A simple demonstration of the value of this device will quickly convince anyone of the tremendous importance and usefulness of them, according to Boyd Zinman of Teletouch.

"Two factors . . . high price and instability . . . were foes of the photo cell for quite a while. But now, there are electric eye units on the market, ranging in price from \$7.50 to \$750.00. Experience of tube manufacturers has solved the other problem.

"An entire floor of a store or a home can be protected by this amazing device, today, at a ridiculously small cost. And there is no comparison in the efficiency between the new photo-cell and the standard burglar alarm system. The standard system consists of tin foil around the windows, in association with a network of wires around the walls, which when broken by an intruder, actuates a signal or gong. How-

ever it is entirely possible for an intruder to avoid this network of wires, and thus break in without fear of the signal going off. Incidentally this type of protection has never been accepted by the public for their homes, in view of the ugly wires that have to be connected up with such a system.

"There are many other applications of the photo cell. For instance, the tiny gold plated screws that are used in a watch are today counted by a photo-cell. Formerly they were weighed. This process always resulted in variations . . . a variation that was quite costly.

"The photo-cell unit has also been installed in public announcement systems. For instance at the American Foundation For The Blind, an installation has been made to announce to the blind who may be looking for this building. As they pass, a beam of light is interrupted and they hear . . ." This is the American Foundation For The Blind Building."

"Still another interesting use of photo-cell is in factories for checking smoke density. Particularly is this pertinent in those cities where they have smoke ordinances.

"On the ramps of garages, the photo cells also find themselves in great favor. Here they offer double protection . . . protection against thieves, who walk up to the ramp and pilfer from the cars, or even steal the car itself. The other protection afforded means a saving of lives. For the eye across the ramp will prevent serious accidents. An auto coming out will automatically sound an alarm . . . warning anyone who might be on the ramp or crossing it. I realize that folks can use their horn to warn, too, but unfortunately, too many do not use their horns and as a result, we have needless death."

RCA MODEL U-125

PROBLEM

Eliminating a too-low frequency response.

SOLUTION

Too low a frequency may be remedied by connecting a 1/2 megohm, 1/2 watt resistor across crystal cartridge terminals, under head of pickup, or across any part of pickup circuit.

Submitted by Gerald Dominick

ALL MAKES ALL MODELS

PROBLEM

Interference from electric fans.

SOLUTION

Always by-pass as close to the brushes as possible. Interference is caused by sparks or arcs drawn by segments of fan motor commutators from the carbon brushes. A .1 mfd. 400 volt condenser, attached directly to each brush with the outer foil end of each condenser grounded directly to the motor frame will always cure this trouble, although it is sometimes necessary to run a wire from the motor frame to ground for complete success. This simple cure applies to all small motors, such as dentist drills, etc. Very large motors, especially with dirty segments or badly undercut commutator mica or worn brushes, draw a healthy array of interfering arcs or sparks and will therefore require capacities up to .5 mfd., 600 volt for success. Powerful motors of great horsepower are kept in such a new state of repair, that they rarely arc or radiate interference.

Submitted by A. E. Rbine

STEWART WARNER MODEL R-149

PROBLEM

Hum modulates station signals, not always evident in shop.

SOLUTION

Remove the 110,000 ohm resistor and .01 mfd. condenser from the 6K7 IF screen. Connect this 6K7 IF screen grid directly to 6J7 screen grid. One side of AC line is connected to a buffer condenser. Install a .1 mfd. condenser from remaining side of line to chassis.

Submitted by H. T. Iony



GRUNOW MODEL 821 (CHASSIS 8B)

PROBLEM

Volume cannot be reduced.

SOLUTION

Defective bias condenser on 2nd detector cathode is the cause of the trouble. Replace, using low voltage, 35 volt, 8 to 10 mfd. condenser.

Submitted by George Rohmer

PHILCO-FORD 1937 MODELS

PROBLEM

Interference from ignition.

SOLUTION

Remove antenna lead in from riveted lug and locate antenna coupling transformer behind "header board". Solder antenna lead-in directly to coupling transformer can. Poorly riveted lug is sufficient to cause this interference.

Submitted by Stevens Palenson

EMERSON MODELS USING 6A8GT and 6Q7GT TUBES

PROBLEM

Fading.

SOLUTION

Resolder grid leads to grid caps.

Submitted by Harry R. Troetel

MIDWEST MODELS 16 to 34

PROBLEM

How to interpret RMA resistor value colors.

SOLUTION

The pointed color represents the "dot". The center color represents the "tip". The remaining color represents the "body". Reverse the above and you have, 1st—"body"; center—"tip" and pointed color—"dot".

Submitted by William Olphenbeim

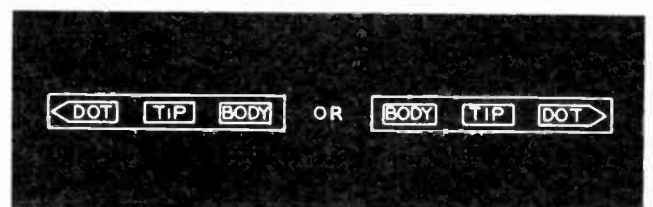

the area to be covered, the total acoustic power can then be computed. Knowing the acoustic power required, the electric power is then found by multiplying the total acoustic power by 4. The resultant will be the electric power required. We multiply by 4, since only about 25% of the electrical audio power can be delivered or applied to the voice coil of a well designed dynamic speaker. The following chart will be of help in approximately estimating power requirements.

APPROXIMATE POWER REQUIREMENTS		
(Low Background Noise)		
Area	Electric Power from Amplifier (Directional Speaker, 25% E.F.F.)	Acoustic Power (Directional Speaker, 25% E.F.F.)
1,000 Sq. ft.	4 Watts	1 Watt
2,000 Sq. ft.	8 Watts	2 Watts
3,000 Sq. ft.	12 Watts	3 Watts
5,000 Sq. ft.	20 Watts	5 Watts
8,000 Sq. ft.	32 Watts	8 Watts
10,000 Sq. ft.	40 Watts	10 Watts
20,000 Sq. ft.	80 Watts	20 Watts
25,000 Sq. ft.	100 Watts	25 Watts
50,000 Sq. ft.	200 Watts	50 Watts
100,000 Sq. ft.	400 Watts	100 Watts

For coverage of those areas not given, the acoustic power can be found by multiplying the area in square feet by .001. The electrical amplifier power is then found by multiplying by 4.

Thus far a rough outline has been given on the relationship of speaker efficiency versus electric audio power, to receive acoustic power. Of course, the foregoing is not a cure-all, but it is a great help since it is a fair average. The variations encountered in the field are various, and usually it is better to be well prepared. That is, to have reserve power is better than not to have enough. You can always cut your gain, but woe unto you, when you have to raise the level, and there isn't any more!

The data supplied above applies chiefly to outdoor use. For indoor P. A. installations the acoustic power required is a little less. Of course, the figures are based on standard equipment such as R.C.A.; W.E.; Thordarson, etc.

Now to return to the acoustic power levels. The sound man's chief problem is acoustic levels. He must know their relationships and ratings. Since the human ear has a logarithmic response curve to variations in sound intensity, any base that is used for a unit figure, must also vary on a logarithmic scale. The unit accepted as standard is the "decibel". The syllable "deci" means one-tenth, while "bel" was derived from Graham Bell, noted telephone inventor. The abbreviation used commonly is "db". In Audio Frequency work, the decibel is used to express the logarithmic ratios of powers, voltages or currents. In defining the gain of amplifiers and their associate circuits such as attenuating resistors, etc., or in comparing equipment with standards, the "decibel" is used. As it is, only a trained person could notice a change in sound intensity of a single note, when this intensity is varied 1 db. Changes of less than 1 db cannot be noticed by the ear. The average person can only notice a change, when the level or intensity is varied over 3 db.

As the basis of the decibel is logarithmic, it can thus readily be used in comparison of sound levels as heard by the ear.

To determine the db. value, this formula should be followed:

$$\text{db (decibel)} = 10 \times \log \frac{\text{Power Output}}{\text{Power Input}}$$

Suppose therefore we are delivering a 10 Watt signal into an amplifier and are getting a 100 Watts of audio power out of same. The ratio is then 100 to 10 or simply equal to 10. Now as the logarithm of 10 is 1, the overall gain in signal level in db is 10x1 or 10db.

Try and remember this example, as it may help in a pinch. Each increase of 10 times the original power compares

with an increase of 10db. Another easy fact to remember is, that if you double the output of the amplifier the gain is increased by 3db. This is so, since the log of 2 is .301 and 10 x .301 is 3.01 or about 3.

This covers the application of the "decibel" to increases in power. The next important use is for "power level". Of course the term "power level" implies that we have an established standard "zero level." We must keep this in mind, so that when we use "power level" we use the corresponding "zero level". To cite an example: if 12.5 milliwatts represents the "zero level", then the output of a 12.5 Watt amplifier delivering 12.5 Watts will be

$$\begin{aligned} \text{db level} &= 10 \times \log \frac{\text{Power Output Level}}{\text{Zero Power Level}} \\ &= 10 \times \log \frac{12.5 \text{ Watts}}{.0125 \text{ Watts (12.5 Milliwatts)}} \\ &= 10 \times \log 1000 \end{aligned}$$

$$\text{db level} = 10 \times 3 = 30 \text{ decibels.}$$

This 12.5 milliwatts represents "zero level", the same level as used by R.C.A. who rate their equipment on this basis. The "zero level" used by the A.T.T. is 6 milliwatts. The navy uses 1 milliwatt "zero level". Note that not all "zero levels" are the same! Remember these standards. They will help you in your sound work.

—Werner Mueller

TELEVISION EQUIPMENT

AFTER a long series of experiments the Dumont Labs recently demonstrated a new television system, that has been proposed for adoption as standard by the industry. The proposed system would permit pictures of greater detail to be transmitted without exceeding the present six megacycle station allotment. Receivers built to operate under the present system would

LAST month, mention was made of a simple receiver with which to practice the receiving of code or C. W. signals. In Fig. 1, that receiver is shown, in the form of a two tube circuit with a regenerative detector and one audio stage. The detector is the familiar electron-coupled grid-leak type, using a 6J7-G pentode. Regeneration control is affected by controlling the screen grid voltage. The 100,000 ohm potentiometer in the screen circuit performs this function. The audio stage, a 6C5-G, is coupled by an impedance resistance coupler, as shown, and operates a pair of headphones in its plate circuit. This receiver has been used by the writer for many years as an auxiliary unit to a larger set and has always afforded very gratifying results.

In order to insure proper operation of the unit on all frequencies, several precautions must be observed. First, secure a good, low loss socket for the plug-in coils. Second, use ceramic-insulated midget tuning condensers. Third, be certain to use connecting leads that are as short as possible. To insure this, mount the detector tube socket no more than 3 inches from the coil socket and the condensers no further than 3 inches from either.

The tuning coils for the various bands may be wound as follows. Use isolantite or some other low loss ceramic 4-prong plug in forms so that a regular tube socket may be used. The caution on the use of quality insulation socket applies even more strongly here. For the 10 and 20 meter amateur bands, wind coils with No. 14 enameled wire . . . three and one half turns, tapped one and one quarter up from the



By STANLEY RICH, W2DIW

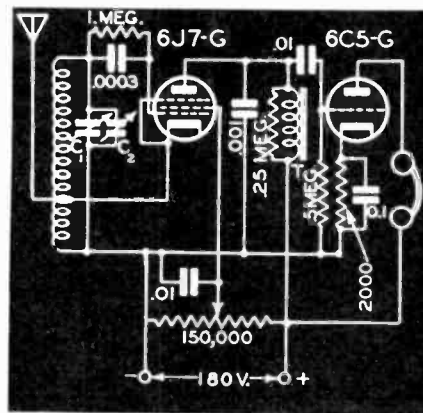

FIG. 1

ground end for the 10 meter band . . . seven turns, taped two and one half turns from ground for the 20 meter band. For the 40 meter band, wind 12 turns, using No. 18 wire, and tap 4 turns from ground. On the 80 meter coil, wind 25 turns of No. 24 wire,

running a tap 8 turns from the ground. The 160 meter coil should be wound with 50 turns of No. 30 wire; tapped 15 turns from the ground.

Of course, a good, hum-free power supply should be used, in addition to a reasonably sensitive set of headphones.

Analyzing Communication Receiver Circuits of the Day

Modern communication receivers present an excellent opportunity to study many unusual engineering developments of great value to all interested in amateur radio.

One of the more important of these circuits is the crystal I.F. filter, using a quartz crystal to narrow the received band of frequencies to a section of only fractions of a kilocycle. This is done in the reception of C. W. or code signals where interference may be severe and maximum rejection of noise or other signals is desired. Also, by proper manipulation of the filter circuit, the crystal filtering action may be broadened to permit the reception of phone signals in crowded channels.

The property of the quartz crystal which is the basis of this filter action is its piezo-electric sensitivity. That is, when a voltage is applied to the active faces of a quartz crystal, a physical expansion or contraction takes place in the quartz. If the voltage is an alternating one, such as an I.F. frequency signal, the quartz will respond by both contracting and expanding, that is, vibrating at the applied frequency. Now, if the crystal is ground so that it is

(Continued on page 30)

CODE PRACTICE SCHEDULE

As promised, a special series of code practice schedules have been planned to afford everyone an opportunity to learn the code. The schedule, shown below, becomes effective May 10th, and will be in force without interruption, until further notice.

Mon. 7-7:30 P.M. W2DIW 1893 KC
 Fri. 7:30-8:30 P.M. W2MGX 7185 KC
 Fri. 8:30-9:30 P.M. W2MCA 28050 KC

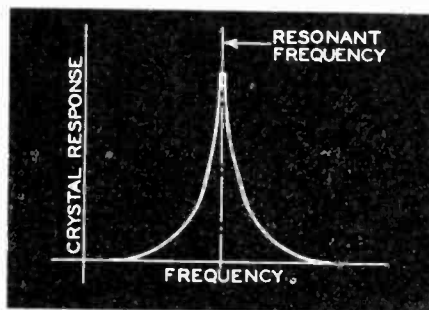

FIG. 2

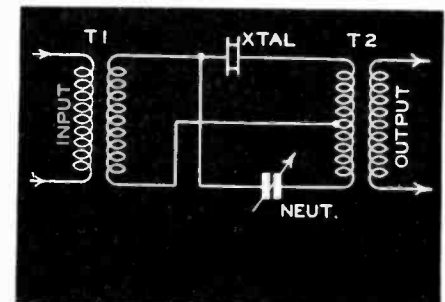

FIG. 3

WIRE STRIPPER—A new handy pocket size tool by UNIVERSAL DRESSER that strips BX cable in one operation. It takes any cable with two or three wire No. 12 or 14.

* * *

ANTENNA RELAY—This new antenna switching relay by MEISSNER affords automatic transfer of the antenna from the transmitter to the receiver in amateur station operation. It can also be used for other high frequency switching. Contacts are unusually large, wide opening and designed to handle heavy loads. A 1KW transmitter may be switched without danger of arcing or burning. Alsimag 196 insulation is used.

* * *

SOCKETS—For simple broadcast receiver and elaborate amateur transmitter, MILLEN has produced a line of utility sockets. All types have important features, necessary for critical performances.

* * *

COMBINATION TESTER—An effective new instrument by RADIO CITY that is equipped for testing the new miniature tubes. Has a medium ohmmeter range, powered by a self contained battery. High ranges are powered by self contained plug in line supply. Meter is protected by a meter fuse. Instrument protected by double line fuses. Unique AC voltage measurements have linear scales to coincide with DC. Has provision for decibel measurements and condenser leakage tests, and many other unusual features.

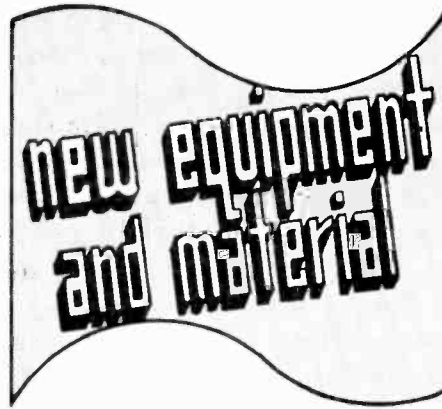

CONTROL AID—To repair noisy carbon controls, GENERAL CEMENT has produced a preparation that can just be applied to the defective spot, to eliminate the trouble.



MULTIPLE RANGE AMMETER—In this interesting device by SIMPSON a current transformer and an indicating instrument have been combined in a small AC multi range ammeter, and is a member of the "Micro-Tester" series of instruments. It is pocket size and weighs but 20 ounces. Readings in any of five different ranges, from fractions of an ampere to 25 amperes are available.



MICROPHONE STAND—Made of die cast metal to which a highly polished chromium finish has been applied without the medium of a metal shell that is usually applied over the casting, this new stand by EASTERN MIKE-STAND, eliminates metallic vibration. The edge of the base is fitted with a rubber ring, which acts as a base guard and shock absorber.

* * *

PLUG IN CONDENSERS—Handling with the ease and speed of a radio tube, these new AEROVOX condensers with the plug-in feature permits an electrolytic condenser to be instantly removed without tools or trouble. Uses a special Octal base with nickel plated brass prongs. Electrolytic section is hermetically sealed in aluminum can. Available with either etched foil or plain foil, in two can diameters, 1 3/8" and 1 5/32".

* * *

SOUND TUBES—Thirteen types of tubes, specially designed for Sound work, have been developed by NATIONAL UNION. They can be substituted in all cases for the like type of tube in the regular line. Emission limits are very high to insure exceptional uniformity, long life, and adequate power handling capacity. Gas and grid current are held to low limits for minimum distortion.

* * *

QUICK CHECKER—A capacitor analyzer by SOLAR that actually checks up on condensers while they are at work in the circuit. Two models are available. Model BQC, checks condensers for opens, shorts, intermittents, RF impedance, power factor and separate capacity measurements from .00001 to 70 mfd., with the aid of a built in Wien bridge. Model QC has all of the BQC features, except that it does not include the bridge-circuit.

(Continued on page 24)



NEW EQUIPMENT

(Continued from page 23)

CRYSTAL MICROPHONE — Offering a new high output, with slightly rising frequency characteristics, this new unit by UNIVERSAL will find itself quite useful in many sound installations. Output level is 48 db below one volt per bar and the frequency range is from 50

* * *

POWER PROTECTOR — To afford complete protection to motors, magnets, vibrators, and other control circuits, where the frequent cycles of operation would soon crystalize and break a simple fuse element, LITTLE-FUSE, has developed a slo-blo fuse with a high time lag. A special spring action in the fuse prevents crystalization on repeated heating and cooling of the fuse link.



PRESELECTOR — A completely self-contained 2 stage high gain preamplifier with a tuning range of from 540 KC to 43 MC. is now available from HOWARD RADIO. It may be used to feed any type receiver or other radio apparatus. Input for standard antenna or rotating loops. Four loops are furnished for different frequencies. Compass scale at base of loop indicates direction of loop for direction finding.

* * *

FREQUENCY MODULATION — A strikingly designed vertical collapsible red antenna for the ultra highs used in FM, is now available from EX-STAT. It incorporates an unusual antenna transformer with an RF iron core and symmetrically wound coils, completely sealed in a porcelain base, that can be rotated and placed in any position.

(Continued on page 26)

THE ONLY MAGAZINE THAT OFFERS COMPLETE RADIO REVIEW COURSES ON TELEVISION..INSTRUMENTS FREQUENCY MODULATION RADIO FUNDAMENTALS PLUS 4 PAGES OF CASE HISTORIES PLUS TIMELY DATA ON AMATEUR RADIO SALES HELPS CIRCUIT ANALYSES ALL FOR ONLY \$1 A YEAR With The First Two Issues FREE! MAIL IN SUBSCRIPTION CARD TODAY! THE RADIO MASTERS MONTHLY 53 Rumsey Road, Yonkers, N. Y.

\$ 50,000 ISN'T TIN!

WHEN DOLLARS WERE MIGHTY SCARCE IN 1936

DALE - SYLVANIA DEALERS MADE

TEN CENTS EXTRA EVERY TIME THEY SOLD SYLVANIA AND EARNED MORE THAN \$50,000 — JUST IN EXTRA DIMES THEY'LL DO IT AGAIN — EASILY — IN 1940

It Will Pay You — To Investigate

THE DALE-SYLVANIA TUBE CONSIGNMENT PLAN

EXCLUSIVELY DISTRIBUTED BY

THE DALE RADIO COMPANY, Inc.

1780 BROADWAY
New York City

Telephone
COLUMBUS 5-2666

SEND FOR THIS!



Sylvania technical material to help you service the oldest as well as the newest radio sets in use. Write for the New Sylvania Technical Manual, 264 pages of complete tube data on over 344 types of tubes, also circuit diagrams. Price 35c.

A NEW 10 Pt. SERVICE by EX-STAT

- 1—Complete Neighborhood Service!
- 2—Complete Replacement Parts Service!
You get the part you want when you want it!
- 3—Every Product Made With The Utmost of Precision, with Highest Quality Material!
- 4—Complete Technical Assistance!
- 5—Bonus-Dividends With Your Purchases!
More from your dollar than ever before.
- 6—Double Guarantee on Every Product!
- 7—Price Right!
- 8—Complete Advertising Assistance!
- 9—Beautiful Gifts For Your Customers!
- 10—New exclusive Products!

You Can Now Buy Ex-Stat Products from

THE RADIO PARTS CO.
156 W. 230th St., N. Y. C.
106 E. 181st St., N. Y. C.

• • •

PARK RADIO & ELECTRIC CO.
127 E. Park Ave., Long Beach, L. I.

• • •

MINEOLA RADIO SHOP
167 2d Street, Mineola, L. I.

• • •

H. W. LEDERHAUS & CO.
91-05 37th Avenue, Jackson Heights, N. Y.

SEE THEM TODAY!

All questions will be cheerfully answered.
Phone or write today!

TILTON ELECTRIC CORP.
15 EAST 26th STREET, NEW YORK CITY
Tel.: CAledonia 5-1330

CONDENSERS . . . RESISTORS . . . BALLASTS
VOLUME CONTROLS . . . TRANSFORMERS
SUPPRESSORS . . . ANTENNAS . . . WIRE

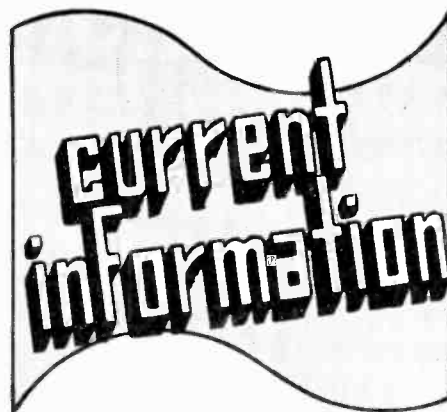

(For Copies of the Following, Use the
Special Mailing Card)

1—PORTABLE BATTERIES—The development of the 1.4 volt radio tubes has brought a new conception of convenience and enjoyment to everyone. The remarkable efficiency of these tubes make possible the use of small, compact battery units to fit inside of tiny cubicles in cabinets. The many types of batteries available for this service are described in the latest Ray-O-Vac catalog. * * *

2—FULL RANGE REPRODUCTION—A complete interesting discussion of an assortment of reproducers for every purpose, appears in the new J brochure. Included are a host of informative diagrams and illustrations. * * *

3—RADIO WIRE—The numerous antenna systems available today for many forms of reception are described in the Belden loose-leaflet style catalog. All types of wire, useable for a wide variety of purposes, are also discussed in a complete manner. * * *

4—SCREWDRIVERS—Square blade, round blade, screw holding and other styles of screwdrivers are described in the Park Metalware catalog sheets. These screwdrivers employ shockproof, transparent handles, and real alloy steel blades. * * *

5—SOUND CONTROL—The fascinating study of noise quieting, vibration isolation and acoustical correction, has been treated with a striking degree of care and accuracy by Johns Mansville in their new attractive booklet. * * *

5A—ROD ANTENNAS—A new rod antenna that offers 95% noise reduction, tremendous increase in signal and unusual 240° flexibility of mounting, is described in the latest EX-STAT technical, just released.

(Continued on page 27)

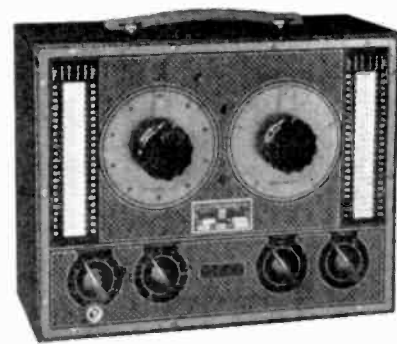

PRIDE OF OWNERSHIP

Engineers, servicemen, amateurs, everywhere are proud of their Clough-Brengle instruments. They know that the C-B name represents advanced design, careful construction and accurate calibration. They accept C-B instruments as the best in their field.

Ask for data sheets on the OCX Signal Generator (above), the No. 225 Tube Tester (below), and the other important Clough-Brengle instruments. All are reasonably priced.



We recommend and stock
C-B instruments

SUN RADIO COMPANY

212 Fulton Street New York, N. Y.
Telephone: BArelay 7-7647

New York's Oldest Complete Radio
Organization

**They are all ready to
Serve You!!**

**SPRAGUE CONDENSERS
KOOLOHM RESISTORS
TEST EQUIPMENT**

— **DISTRIBUTORS** —

NEW YORK CITY

Fischer Distributing Co.
222 Fulton St.

Radio Wire Television, Inc.
100 6th Av.

BRONX

Radio Wire Television, Inc.
542 E. Fordham Road

BROOKLYN

Shupack Radio Distributing Co.
482 Sutter Av.

JAMAICA

Radio Wire Television, Inc.
90-08 166th Street

NEWARK

Krich-Redisco, Inc.
422 Elizabeth Av.

Radio Wire Television, Inc.
24 Central Av.

PATERSON

Advance Radio Co.
309 Park Av.

Metropolitan Representative
Wm. Rutt — 12 W. 46th St., N. Y. C.

SPRAGUE
PRODUCTS CO.
NORTH ADAMS, MASS.

**RADIO PANELS
MACHINE ENGRAVING
ON ALL
PLASTICS AND METALS
SPRAYED ALUMINUM AND
STEEL PANELS**

**SPECIAL DIALS AND
NAME PLATES TO ORDER**

A TRIAL WILL CONVINC

W. W. ACKERMAN
37 BARCLAY ST., N. Y. C.
Telephone: BARclay 7-1378

SERVICE HIGHLIGHTS

(Continued from page 21)

resultant audio voltage would be zero, if the bridge was balanced by manipulating R5. This is true, but in operation to prevent the cancellation of the desired audio signals applied to the first AF tube, a DC biasing voltage is applied to diode P2K2. This prevents rectification of one side of the bridge. It also prevents the appearance of audio components across R5, for all values of the IF signal, less than the biasing voltage. This DC biasing voltage is obtained from the tube acting as an AVC control tube. That is, a separate tube, in this case a duplex diode, supplies the AVC voltage for the receiver. This voltage is through a suitable filter, R7 and C8 (Fig. 1 B), applied between R3 and R5.

The amount of DC bias applied, is controlled by the AVC voltage developed, which, of course, depends on the strength of the signal received. Thus no manual control is necessary for adjusting the diode bias bridge voltage that is unbalanced, since the action is entirely automatic. R7 and C8 have enough time delay to prevent an increase of bridge-bias voltage, prompted by incidental noise impulses of short duration, that are impressed on the diodes of the AVC tube.

Balancing is accomplished by turning the arm of R5, until the minimum noise level is heard. This circuit, as earlier mentioned, can be easily adopted to existing receivers. For short wave work, it is very valuable. For broadcast use, it is not recommended, since it has the tendency to block strong carriers.

—Werner Muller

**GARRARD
RECORD
CHANGERS
CAN BE A
BIG NEW
SOURCE
OF PROFIT**

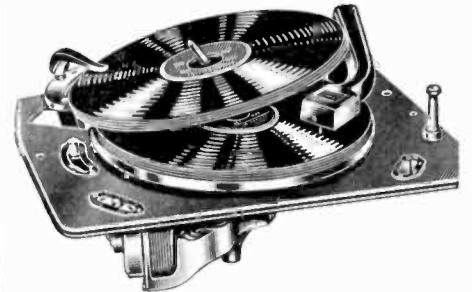

Call at Your Parts Distributor, or Write
Direct for Free Catalog.

GARRARD
SALES CORPORATION
296 BROADWAY • NEW YORK

**C-D ENGINEERS TO APPEAR AT I.R.E.
ASSOCIATION MEETING IN JERSEY CITY**

William F. Bailey, chief engineer of Cornell-Dubilier, and a group of C-D engineers will appear at the May 7 meeting of the Independent Radio Engineers Association, to be held at 22 Liberty Avenue, Jersey City, New Jersey. The topic to be discussed will be . . . How to cure noise caused by fluorescent lights, neon lights, street cars, etc.

The meeting will begin at 8:30 P.M. Everyone is invited.

Martin Seel is president of the IRE Association.

FUNDAMENTALS IN RADIO

(Continued from page 13)

had guessed wrong and that is why we consider the electron today as having a negative electrical charge.

These electrical charges obey simple laws:

1. Like charges, whether positive or negative, repel each other.
2. Unlike charges . . . a positive and a negative charge . . . attract each other.
3. The effect is directly proportional to the magnitude of the charges. The greater the charges, the greater will be the attraction or the repulsion.
4. The effect is inversely proportional to the square of the distance between the charges. Doubling the distance between two unlike charges divides their attraction by four.

A simple illustration of electrostatic charges is found in a condenser. A condenser consists of two metallic plates that are close together but separated from each other by an insulating material. If we connect a condenser to a source of direct current, electrons accumulate on one plate of the condenser and are removed from the other. The condenser is charged; one plate being negative and the other positive. The unlike charges on the plates will attract each other. The larger the area of the plates, the greater will be the attractive force or the capacity of the condenser. By decreasing the distance between the plates, the attractive force or capacity is increased according to the laws of the inverse square of the distance.

The action of a radio tube is dependent upon the effect of electrostatic charges. Electrons are emitted from the cathode within the evacuated tube. These are tiny negative electrical charges that are free to move. A positive charge will attract them. A negative charge will repel them or retard their motion. Therefore, within the tube, these electrons emitted from the cathode are attracted by the positive charge on the plate of the tube, and their motion is regulated by the charge on the grid which is placed in their path. If the grid charge is more positive, the electron flow is increased. If it is more negative it is decreased. If the grid charge is sufficiently negative, the electron flow can be stopped or cut off.

The addition of other elements in the

SERVICEMEN AMATEURS!

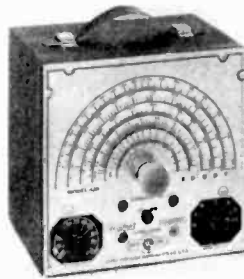

Webster Crystal Pickups	\$249
Webster Magnetic Pickups	\$189
Self-Starting AC Phono. Motor Complete with Turntable	\$219
Phileo 12" Dynamic Speakers	\$125
Tubular Cond. .0001 to .1 (400 W.V.)	5¢
5" Dynamic Speakers with 3000 ohm field output	95¢
Zenith Doublet Antenna Kits	89¢
R.C.A. Tubes Reduced to 68% off List Price	

WRITE IN FOR LATEST FREE DIAGRAMS AND CATALOG
EAGLE RADIO • 84 Cortlandt St., N. Y. C.

tube also follow electrostatic laws. Thus in a pentode, grid one is the control grid. It has a negative electrical charge and regulates the electron flow. Grid two is the screen grid. This has a positive electrical charge and neutralizes the negative space charge of the electrons within the tube. Since the screen grid is positive it will increase the electron flow. Grid three is the suppressor grid and has a negative charge. Electrons moving at a rapid rate strike the plate with sufficient force to cause secondary emission of electrons from the plate.

These secondary emission electrons which might interfere with the proper action of the tube, are repelled by the negative charge of the suppressor grid, and are attracted right back to the plate.

A strip of metal placed about a charged body, can screen or shield that body from neighboring electrical charges. Such shields are placed between critical elements in a receiver, around tubes (particularly detector and oscillator tubes), and even around the receiver itself, to prevent interaction of neighboring electrostatic and also electromagnetic fields.

(To be Continued)

The Buy of a Lifetime A PRECISION SIGNAL GENERATOR

- Direct Reading 100 K.C. to 66 M.C. (3000 to 4.5 meters)
- A.F. and R.F. Outputs
- Modulated or Unmodulated R.F.
- Condenser tests
- Pure Sine Wave Audio Output
- Operates on 110 Volts A.C. and D.C.

Complete as Described with Tubes, **\$9⁹⁵**
Cabinet, Instructions.

VOLT-OHM-MIL TESTER

- 3" 1 Ma Meter
1000 ohms per Volt
- D.C. Volts 0/2.5
/10/50/250/500
/2500
- A.C. Volts 0/15
/150/1500
- Ohms 0/2500/
25000/250000
- D.C.M.A. 0/1/10
/100/1000
- Decibels
-10+53
- Output 0/15/50
/150/1500

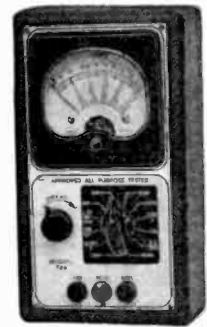

Model 720 A.C.+D.C.	\$785
Volt—Ohm—Mil	
Model 710 D.C.	\$585
Volt—Ohm—Mil	

INCREASE YOUR INCOME A HOBBY DEPARTMENT PAYS BIG DIVIDENDS . . . AN ALL YEAR ROUND PROFITABLE BUSINESS

FOR THE SMALL INVEST-
MENT OF \$25.00 YOU CAN
START WITH A TREMEND-
OUS STOCK

TRYMO CARRIES A COM-
PLETE LINE OF MODEL
RAILROADS, AEROPLANES,
RACING CARS AND BOATS

*See Our Model Railroad
in Action!*

**DEALERS — GET OUR
SPECIAL PROPOSITION**

**TRYMO HOBBY CRAFT
& SUPPLY CO.**

85 CORTLANDT ST., N. Y. C.

Telephone: BARELAY 7-6395

THE **LAST** WORD

IN
SERVICE

Everything

IN
**RADIO
TELEVISION
SOUND**

TUBES
PARTS
AMPLIFIERS
TEST INSTRUMENTS
AMATEUR RADIO EQUIPMENT

**LARGEST STOCKS
IN THE CITY**

ALL LEADING ADVERTISED BRANDS
 ALPHA R. C. A. STANCOR
 AMPHENOL JENSEN SUPREME
 ASTATIC KENYON SYLVANIA
 BLILEY MEISSNER TAYLOR
 CENTRALAB NATIONAL THORDARSON
 CLAROSTAT I. R. C. TRIPLETT
 CORNELL-DUBILIER RIDER U. T. C.
 HALLICRAFTERS WESTON HAMMARLUND
 and many others

COME IN and SEE US TODAY!
 CONVENIENTLY LOCATED IN THE
 HEART OF DOWNTOWN NEW YORK

TIME PAYMENTS ARRANGED

**SUN RADIO
COMPANY**
 212 FULTON STREET
 NEW YORK CITY
 Telephone: BARCLAY 7-7647

INDEX TO ADVERTISERS

Ackerman, W. W..... 28

Approved Tech. Appliance Co..... 26

Clough-Brengle..... 25

Dale Radio Co., Inc..... 24

Eagle Radio Co..... 29

Garrard Sales Corp..... 28

Meissner Mfg. Co..... 27

National Union Radio Corp..... 27

Precision Apparatus Co..... 2

Radio City Products Co..... 32

Recoton Corp..... 26

Supreme Instrument Corp..... 31

Sprague Products Co..... 28

Sun Radio Co..... 25, 30

Terminal Radio Corp..... 26

Tilton Electric Corp..... 25

Trymo Hobbycraft & Supply Co..... 29

AMATEUR RADIO

(Continued from page 22)

resonant to a certain specific frequency, when a signal of that frequency is applied, it will vibrate violently in comparison with its response to all other frequencies. The crystal is, then, highly selective as we can see from Fig. 2. It obviously is a good filter since its response to certain frequencies passing through it will be much greater than others which, for all purposes, can be considered rejected by the crystal.

A physical explanation would use the theory of sound for a basis. Briefly, when voltage is applied to a crystal face, a physical or sound wave of compression or rarefaction starts from that face at the speed of sound in quartz. It moves through the crystal, is reflected at the opposite face and returns, much as acoustic waves in an organ pipe. It is evident that if the distance between faces is exactly correct, the reflected wave will reinforce the original signal, causing the crystal to resonate at this particular frequency. The total effective response is therefore quite substantial.

In practice, the circuit shown in Fig. 3 is most popular. The crystal is placed in series with the I.F. line between two transformers, and passes a narrow band of frequencies from the input to the output. The neutralizing condenser or phasing condenser, as it is sometimes called, will cancel out the portion of the input passed, without filtering by the capacity of the crystal holder and wiring. It is this condenser, which, if not exactly set to neutralization, allows a broadening of the band of frequencies passed by the filter.

Other types of mechanical resonant filters have been tried or used, with less success than with quartz crystals. Magnetostrictive elements, and metal bars driven by non-resonant crystals have seen the public light but have bowed to the crystal. In almost all sets in use today, the crystal filter is the most likely to be found.

FOR COMPLETE DYNAMIC *Signal Tracing*

USE MODEL 560 VEDOLYZER WITH MODEL 561 COMBI- NATION OSCILLATOR

THE MODEL 561 is radio's most complete oscillator—a combination of 4 essential instruments which every well equipped serviceman should have. It provides (1) A.F. oscillator, 15 to 15,000 cycles. (2) R.F. oscillator. Variable amplitude or frequency modulated. (3) Carrier and modulation monitor. Vacuum tube circuit. A.F. and R.F. oscillators may be used separately or the variable audio oscillator used to modulate the R.F. Percentage of modulation read directly on meter. (4) Frequency modulator. Double image, positive self-synchronizing.

THE MODEL 560 is a basically different dynamic test instrument using a high frequency 3" scope; 3 stage, wide range, high gain, television, video, vertical amplifiers; multi-range, multi-function, push button controlled, vacuum tube A.C., D.C., ohm and megohmmeter; super-sensitive R.F. voltmeter; broadcast, I.F. and oscillator variable tuning section; push button controlled multi-probe input circuit. The Model 560 Vedolyzer used with the 561 Oscillator is radio's finest and most complete signal tracing set-up.



OR USE MODEL 562 AUDOLYZER WITH MODEL 561 COMBINATION OSCILLATOR

THE MODEL 562 is the simplest and most logical signal tracing and dynamic tester available. Servicemen everywhere are recommending its use because it will start "paying off" an hour after it reaches your shop. It is not necessary to "take out" a few days and learn

to operate your new instrument. One hour with the AUDOLYZER, a test oscillator, and a receiver and you can learn into those repair jobs you have pushed aside to rest for a while. The AUDOLYZER contains a five inch dynamic speaker for its primary indicating device; a meter to monitor RF, IF, AF, AVC, AFC, and D.C. voltages; a two stage tuned amplifier to check frequencies from 95 KC to 14.5 MC; a vernier and step attenuator to control signal level reaching speaker; a vacuum-tube voltmeter to check D.C. volts from 0 to 1000 volts in seven ranges; a single probe to be used in any type circuit; dual probes for intermittents.



CHOOSE EITHER
COMBINATION—
YOU CAN'T
GO WRONG!



SUPREME

504 TUBE AND SET TESTER

GET YOUR BENCH PLANS FREE

We do not make or offer for sale any panels or test benches. But it is a definite part of our policy to help all service men. Therefore, we have prepared a large 4-page booklet in which we discuss service benches in general, give valuable cost data, actual designs with detailed instructions for building, and our suggestions for necessary accessories. Sent free.



MODEL 504 is SUPREME's finest combination tube tester, set tester and condenser tester. All tubes correctly tested regardless of base terminations or filament voltages. 31 multimeter and resistance ranges available on fast push button switches. Condenser settings included on roller chart for every capacity and working voltage. The Model 504 plus your signal tracing instruments and you have everything that a modern shop requires.

SUPREME INSTRUMENTS CORP.
GREENWOOD, MISS., U. S. A.

Export Dept., Associated Exporters Co., 145 W. 45th St., New York City



Engineer's Report

EXPRESSING ENTHUSIASM FOR

RCP TEST EQUIPMENT AND SERVICE

"One of the most complete and speediest pieces of equipment I have ever used," writes J. C. Fisher, Engineer with Radio Stations WQIZ and WRHT, Nashville, Tenn., about model 801 Combination Tube and Set Tester. "And after my experience with your service I am completely sold on your products. So much so that I took the liberty to show our correspondence to two of the largest distributors here. . . . They were astonished at the quick service I received."

Engineer Fisher's experience with Radio City Products and service is typical of what thousands of RCP users everywhere are enjoying. RCP has demonstrated that dependable, quality test equipment can be designed and delivered at moderate cost . . . that test equipment value — rests on how much you get for your money . . . and finally, that service speaks louder than words.

More servicemen are turning to RCP for Test Equipment now than ever before. Because it's engineered ahead, and because it's all quality. You can rely on your RCP instrument for years of top-notch, trouble-free service. Dependability is built into every line of it by skillful workmen who know the answers to your test instrument needs . . . know even how to outmaneuver obsolescence. Join the enjoyers of RCP reliability . . . RCP performance . . . RCP value in test equipment today.

MULTITESTER MODEL 445



Even in appearance, this quality test instrument is in a class with testers costing twice the low RCP price. Check the features—compare AC-DC Multitester Model 445 with any other test equipment in its range. Discover for yourself how much MORE for your money RCP gives you.

Five range DC voltmeter 0/5/50/250/500/2500—Four range DC milliammeter 0/1/10/100/1000—DC Ammeter 0/10 — Four range AC voltmeter 0/10/100/500/1000 — Three range ohmmeter 0/500/100,000/1 Meg. — Four decibel ranges —8 to —15/12 to 35/26 to 49/32 to 55 — Four output ranges—same as AC volts.

A great value at \$9.95

TOPS IN PERFORMANCE • ROCK BOTTOM IN PRICES
HERE ARE A FEW TYPICAL RCP VALUES

MODEL 308
FAMOUS
DYNOPTIMUM
CIRCUIT



Tests new miniature tubes — Checks pilot lights, headlights, ballast tubes. Noise and hum tests for tubes showing "good". Spare sockets.

\$1695

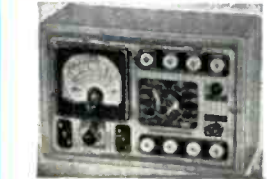

SUPERTESTER MODEL 411
5 stage AC-DC voltage ranges to 5000 volts. 3 stage, AC-DC current range to 25 amps. 3" square meter 200 micro-amperes or 5000 ohms per volt. DC MA. 0/10/100. DC Microamps 0-200.

\$1625



SIGNAL GENERATOR
Wide all-wave coverage from 95 Kc. to 100 Mc. Direct reading. 30% modulation at 400 cycles sine wave. Attenuation in approximate microvolts by 5 step ladder attenuator. 1 to 500,000. AC operated.

\$2295



Trouble Shooter Model 432
Lowest priced "legitimate" tester on the market. DC volts 0.5/0.50/0.500/0.1000 at 1000 ohms per volt. DC MA 0.1/0.10. Ohms 0.500/50.000/500.000.

\$595

RADIO CITY
PRODUCTS CO., INC.
88 PARK PLACE, N. Y. C.

"FREE—Characteristics Chart for more than 240 of the latest tubes including NEW MINIATURE TUBES. Contains tube Characteristics, base terminal diagram with socket connections for every tube. Send coupon for free catalog and free tube chart."

RADIO CITY PROD. CO., INC. 5-40RM
88 PARK PLACE
NEW YORK CITY, N. Y.
SEND IMMEDIATELY FREE R.C.P. CAT. NO. 122 AND TUBE CHART.
NAME _____
ADDRESS _____
CITY _____ STATE _____