

FEBRUARY 1948

35 CENTS

**EVERYTHING IN TELEVISION · RADIO · ELECTRONICS
FOR THE RADIO SERVICE - TECHNICIAN**

RADIO

MAINTENANCE

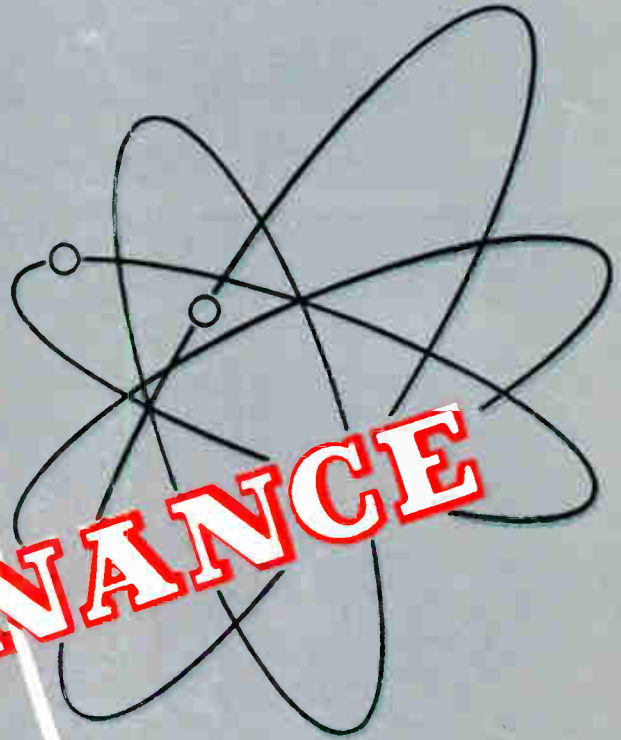

LET'S WORK TOGETHER

**HOW TO USE SWEEP
GENERATORS**

**VOLTAGE
REGULATORS**

YEARLY SUBSCRIPTION \$3.00

BOLAND & BOYCE INC., PUBLISHERS

MONTCLAIR, N. J.

World Radio History

Sustained CAPACITY

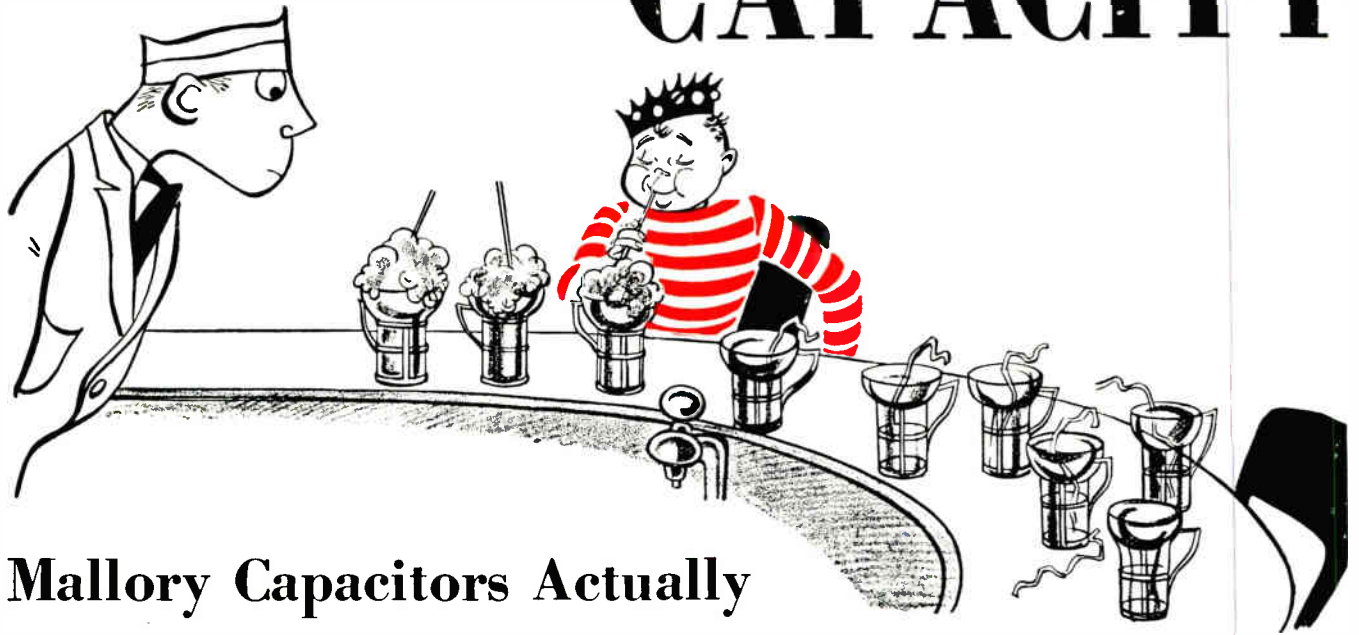

Mallory Capacitors Actually Increase in Capacity After 2,000* Hours

Install Mallory FP Capacitors with the knowledge that they will last in a "hot set" with temperatures up around 185° F.—they will last on the shelf or in an inactive set without needing reaging—and they will last without loss of capacity.

Their RF impedance—their ability to withstand ripple current, are other plus values that make Mallory capacitors popular with radio service men, as well as with manufacturers of radio equipment.

THE MALLORY "GOOD SERVICE FOR GOOD BUSINESS" PLAN

will increase business and profits in your shop.

A unique follow-up file makes it easy to keep customers.

You tie in with Mallory acceptance to develop new business—ask your distributor about it.

Mallory is never satisfied to produce parts that just get by. In all Mallory Parts you will find a generous margin in your favor. Mallory capacitors will operate at 185° F.—that's 35° hotter than R. M. A. requirements.

*2,000 HOURS OF OPERATION

An actual test of Mallory capacitors operated in an oven at 185°F. and 450 volts DC, plus 10 volts of 120 cycle ripple, showed them still going strong and with increased capacity at the end of 2,000 hours. Typical results:

At Start of Test		After 2,000 Hours	
Capacity	Resistance	Capacity	Resistance
20.9 mmf	6.16 ohms	23.5 mmf	6.5 ohms
20.1 mmf	6.5 ohms	23.4 mmf	6.55 ohms

BUY MALLORY ASSURED QUALITY AT REGULAR PRICE LEVELS

P. R. MALLORY & CO. Inc.
MALLORY

CAPACITORS . . . CONTROLS . . . VIBRATORS . . .
SWITCHES . . . RESISTORS . . . RECTIFIERS . . .
VIBRAPACK® POWER SUPPLIES . . . FILTERS

*Reg. U.S. Pat. Off.

APPROVED PRECISION PRODUCTS

P. R. MALLORY & CO., Inc., INDIANAPOLIS 6, INDIANA

A Sign of Successful Servicing



NELSON HAS ALL 16 RIDER MANUALS

(and Volume XVII on order)



**"There's Nothing
More Essential!"**

"Rider Manuals are a must, for an efficient radio servicing business. Of all the equipment we have, there is nothing more essential, more free from obsolescence, more everlastingly profitable than our complete set of Rider Manuals."

Says

DON. D. NELSON
Don. D. Nelson Radio
Seattle, Wash.

VOL. XVII
to be published
IN MARCH
1600 pages

This volume, taking up where Vol. XVI leaves off, will contain authorized* servicing data on the products of over 100 manufacturers. In it will be found not only single band but also multi-band receivers with their Rider-exclusive "clarified-schematics." Record players and wire recorders used with receivers are covered. Also with each receiver are covered. Also with each Vol. XVII will be the separate "How It Works" book and a cumulative index covering Volumes XVI and XVII.

Watch for publication date of separate manual on Television exclusively.

In towns and cities from one end of the country to the other you will find all 16 Rider Manuals over the benches of profit-making shops. This, because they earned that fingertip position of prominence. They are there, not for display, but for use — not an occasion, but for practically every job that comes to rest on the bench.

Nowhere else, nowhere else but in Rider Manuals can be

* Rider Manual data is OFFICIAL, AUTHORIZED, right from the service departments of the set manufacturers. They know best, the proper servicing procedures for their own products.

24 HOUR DATA SERVICE

For 10c (stamps are OK) you receive photostats of schematic, voltage data, parts list (and everything else that will fit on two 8 x 11 inch sheets) on any newly issued, or old, receiver. (Additional necessary sheets same rate.) Send 20c with order; adjustment will be made. Here is a way to get whatever service data you need between Rider Manual publication dates.

found the wealth of authoritative* radio servicing data needed to quickly diagnose the troubles in ailing American-made receivers issued since 1920. Volume XVII to be published in March will contain material that is time-savingly-valuable to you right now.

Order it today — give your shop the Sign of Successful Servicing, a complete set of Rider Manuals.

Volume XVI	\$ 8.40
Volume XV	18.00
Volumes XIV to VII (ea. vol.)	15.00
Volume VI	11.00
Abridged Manuals I to V (one vol.)	17.50
Record Changers and Recorders	9.00
Master Index, covering Manuals, Vols. I to XV	1.50

NOTE: Individual Volumes VI, VII and VIII will be replaced after this year by a single Abridged Manual Vol. VI to VIII.

JOHN F. RIDER PUBLISHER, Inc., 404 Fourth Avenue, N. Y. 16
Export Agent: Rocke International Corp., 13 E. 40th St., N.Y.C. Cable ARLAB

RIDER MANUALS

MEAN SUCCESSFUL SERVICING

LETTERS

Dear Sir:

. . . . I am surprised that you do not run more service notes than you do. I for one have been collecting these for years from numerous books, magazines, etc. and have information on thousands of receivers. Undoubtedly many other servicemen have followed suit and would welcome such notes.

I know that this type of material must come from the servicemen themselves, so I am including a few which I have come across in my work. You will note that most of these are late models.

I would certainly appreciate knowing what you think of these.

Very truly yours
John W. Findarle

Dear Sir:

How about printing some service notes about actual receiver models? I often run across types of sets which have troubles you seem to find over and over again. A summary of what happened in particular sets and how they were fixed sure would help me a lot and probably other servicemen.

Yours truly,
James E. Parker

(A new department of case histories will start in an early issue—Ed.)

Gentlemen:

. . . I have a suggestion that may or may not be of use to you. When an advertisement describes a bulletin or something of a similar nature that may be obtained by clipping a coupon and mailing it, place the coupon in such a manner that it can be clipped without defacing a portion of an article that may be on the other side of the sheet. In this manner, the coupon may be clipped and the article may be retained in its entirety for future reference. I realize that this may not be practicable in all cases. Perhaps an extra sheet could be inserted containing necessary coupons for such advertisements with a note included in each advertisement referring the reader to the page of coupons.

Very truly yours,
William A. Bentley

(We do this whenever possible—space doesn't always allow—Ed.)



New!
**MERIT
HELP
FOR
REPAIR
MEN**

Compact Replacement Kit containing 8 MERIT Quality Transformers for wide range of requirements. The MERIT Kit takes the place of so-called "universal replacement transformers", and brings much greater convenience to repair men. Each transformer is designed for its particular use, and individually labeled on frame with its number and data. Each kit is packed in handsome display box. For further information see your jobber, or write us.

Kit No.	List Price	OUTPUT TRANSFORMERS
Kit No. 1	\$11.75	(2-ea.) A-2928, (1-ea.) A-2930, A-2931, A-2932, A-2934, A-2936, A-2937
Kit No. 2	12.20	(2-ea.) A-2928, A-2937, (1-ea.) A-2930, A-2931, A-2934, A-2936
Kit No. 3	11.80	(1-ea.) A-2928, A-2930, A-2931, A-2932, A-2933, A-2934, A-2937, A-2938
Kit No. 4	12.90	(2-ea.) A-2928, A-2931, A-2936, A-2937



MERIT COIL & TRANSFORMER CORP.

TELEPHONE

4427 North Clark St. Long Beach 6311 CHICAGO 40 ILL.

Yes

APPLICATION ENGINEERED Circuit Testers by "PRECISION" To meet your individual instrument needs



THE NEW SERIES "80"

1000 OHMS PER VOLT D.C.
1000 OHMS PER VOLT A.C.

34 Ranges to 6000 volts A.C. and D.C.... 12 Amperes D.C.... + 70 DB... 10 Megohms (all self-contained).

Designed to meet the same high calibre performance standards as the Series 85 (at right) but is specifically intended for use wherein greater resistance to electrical and physical overload is of more importance than extremely high sensitivity.

"Application Engineered" for general purpose industrial and radio service-maintenance-test requirements.

VOLTAGE RANGES: 0-6-12-60-300-1200-6000 volts

CURRENT RANGES: 0-.6-6-60-300 MA. 0-1.2-12 Amps.

RESISTANCE RANGES: 0-1000 ohms (8 Ω at center scale)
0-100K-1 Meg - 10 Megohms

DECIBEL RANGES: From -20 to +70 DB

Complete with batteries and test leads **\$32.70**

THE NEW SERIES "85"

20,000 OHMS PER VOLT D.C.
1000 OHMS PER VOLT A.C.

34 Ranges to 6000 volts A.C. and D.C.... 120 microamperes D.C.... 12 Amperes D.C.... + 70 DB... 60 Megohms (all self-contained).

Physically and electrically engineered as a compact, yet full-bodied, laboratory styled high sensitivity test set.

Ideally "Application Engineered" for production, test, laboratory, school and service-maintenance phases of modern radio-electronics-communications: A.M., F.M., T.V.

VOLTAGE RANGES: 0-3-12-60-300-1200-6000 volts

CURRENT RANGES: 0-120 microamps. 0-1.2-12-120 MA. 0-1.2-12 Amperes.

RESISTANCE RANGES: 0-6000 ohms (35 Ω at center scale)
0-600K-6 Meg - 60 Megohms.

DECIBEL RANGES: From -26 to +70 DB

Complete with batteries and test leads **\$38.75**

PLUS these superior physical features common to both the new Series 80 and 85:

- ★ 4 1/8" rectangular, wide angle, bakelite cased meters.
- ★ Heavy duty molded bakelite instrument case size 5 1/2 x 7 1/8 x 3".
- ★ Sweatproof plastic carrying handle.
- ★ Heavy gauge, anodized aluminum panel, resistant to moisture and abrasion.
- ★ Full Rotary Range and Function Selectors.
- ★ Recessed 6000 volt safety jacks.
- ★ Only two pin jacks for all standard ranges and functions.
- ★ Price includes ohmmeter batteries, test leads and operating instructions manual.

Ask to see these and other "Precision" Application Engineered instruments, now on display at all leading radio parts distributors. Write to factory for new, complete 1948 catalog, including full details of the Precision *Electronic* tube performance testing circuit.

PRECISION
TEST EQUIPMENT
Standard of Accuracy

PRECISION
APPARATUS COMPANY INC.
92-27 HORACE HARDING BOULEVARD
ELMHURST 5, NEW YORK

Export Division: 458 BROADWAY, NEW YORK CITY, U. S. A. • Cables: MORHANEX

McMurdo
SILVER

NEW!



FM & TELEVISION SWEEP SIGNAL GENERATOR

Here's what you and thousands of research and service technicians have demanded . . . a frequency-modulated FM and TV sweep signal generator. With this new McMurdo Silver MODEL 909 and your oscilloscope you can visually align FM and TV receivers . . . quickly and perfectly . . . for it comes with simple but complete instructions to put you at the head of the parade in FM and TV service.

Quality and completeness are as high as price is low . . . the regular "trademark" of Silver LCETI . . . Laboratory Caliber Electronic Test Instruments at prices you can afford.

CENTER-FREQUENCY RANGE 2/226 mc. — 5" vernier-driven calibrated dial. A new Silver development covers 2/77, 70/154 and 151/226 mc. in 3 bands without band-switching!

STABILITY is extraordinary. New u.h.f. tubes give stability such that FM and TV 'scope pictures once set up will "stay put" for hours on end.

SIZE AND STYLE match "VOMAX" and all Silver LCETI. Power required is 105/125V., 50/60 a.c. at 35 watts. Size 12 $\frac{3}{4}$ " x 7 $\frac{3}{4}$ " x 6" overall.

CO-AXIAL OUTPUT CABLES. 3 ft., d.c. isolated, 5/125 Ω impedance for r.f.; separate horizontal synchronizing cable. Both with clips for direct connection to receiver circuits.

SWEEP FREQUENCY is panel-knob variable 0/9 mc. . . . to set correct sweep for FM and TV i.f. and r.f. alignment. True electronic, not distorting and troublesome mechanical sweep.

SYNCHRONIZATION is either power line sine wave, or sawtooth to 'scope from 909. R.F. OUTPUT is panel-knob controllable 0/500,000 micravolts maximum. More than ample for all visual alignment with any good oscilloscope.

MODEL 909 FM & TV SWEEP SIGNAL GENERATOR makes you master, not victim, of today's most profitable service fields . . . at a price which is already the amazement of the industry!

Model 909 Only \$48.50 Net

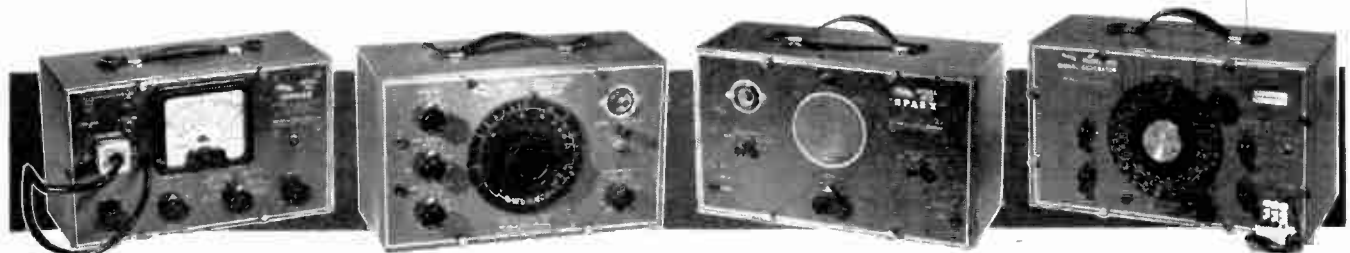

900 "VOMAX" 51 ranges; d.c., a.c., a.f., i.f., r.f., 20 Ω /500 mc. 0/3000 V. d.c.; 0/1200 V. a.c., current 0/12 A. ; resistance 0/2000 meg Ω ; db.—10/+50. The overwhelming choice of wise research and service technicians.
Only \$59.85 Net

904 CONDENSER/RESISTOR TESTER. $\frac{1}{4}$ mmfd./1000 mfd.; $\frac{1}{4}$ Ω /1000 meg Ω ; variable d.c. polarizing voltage leakage current; 0/50% power factor. Laboratory accuracy of $\pm 3\%$. Measures all condensers with 0/500 V. rated d.c. volts applied.
Only \$49.90 Net

905 "SPARX" DYNAMIC SIGNAL TRACER/TEST SPEAKER. Traces a.f., i.f., r.f. signals thru any receiver, tests pick ups, mikes, PA amplifiers. 20 Ω /200 mc. Saves time in receiver repairs as does no other single instrument
Only \$39.90 Net

906 FM/AM SIGNAL GENERATOR. 8 ranges, $\pm 1\%$ accurate, 90 kc./210 mc. 0/100% AM, 0/1000 kc. FM modulation. Less than 1 microvolt to over 1 volt metered output. The outstanding signal generator buy.
Only \$99.50 Net

SEND FOR COMPLETE CATALOG. See these and Silver communication transmitters, receivers, "Micromatch", Xtal-controlled VFO, pretuned freq. multiplier at your jobber.

OVER 36 YEARS OF RADIO ENGINEERING ACHIEVEMENT

McMurdo Silver Co., Inc.

EXECUTIVE OFFICES: 1240 MAIN ST., HARTFORD 3, CONN.
FACTORY OFFICE: 1249 MAIN ST., HARTFORD 3, CONN.

RADIO

MAINTENANCE

INCLUDING
ELECTRONIC
MAINTENANCE

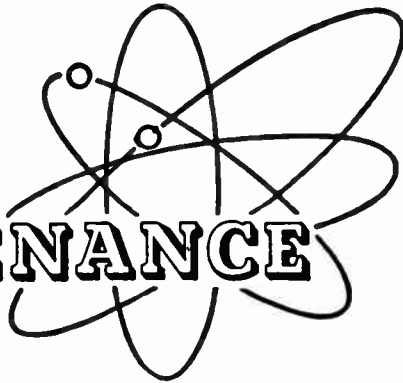

Volume 4

FEBRUARY 1948

Number 2

CONTENTS

Using Sweep Generators for FM Alignment	McMurdo Silver	6
Practical information for FM servicing		
Let's Work Together	John T. Frye	10
Your jobber can help you		
Voltage Regulator Operation	Irving Dlugatch	12
VR tubes are coming into greater use		
The Organizations		18
News about servicemen's groups		
Time Savers	Harry Leeper	20
A new department of photo hints		
Industry Presents		26
New products		
Electronically Speaking		28
What's new in the trade		
Over the Bench	John T. Frye	35
A Serviceman's Opinion		
Review of Trade Literature		37
Catalogs, books, etc.		
The Notebook		39
Practical suggestions from readers		

WILLIAM F. BOYCE
Publisher

JOSEPH J. ROCHE
Editor

THOMAS A. BYRNES
Director of Field Services
and Quality Control

HOWARD SHONTING
Advertising

J. RICHARD JOHNSON
Managing Editor

AL JOHNSTON
Circulation Manager

STUART J. OSTEN
Midwestern Advertising

VICTOR M. TURNER
Art Director

EASTERN OFFICE
460 Bloomfield Ave.,
Montclair, N. J.
Tel.: Montclair 2-7101

PAUL WENDEL
Sectional Advertising

MORTON SCHERAGA
Contributing Editor

MIDWESTERN OFFICE
228 No. La Salle St.
Chicago, Ill.
Tel.: Dearborn 3507

Copyright 1947, Boland & Boyce, Inc.

Radio Maintenance is published monthly by Boland & Boyce, Inc., at 34 No. Crystal St., East Stroudsburg, Pa., U.S.A.; Executive and Editorial Office, 460 Bloomfield Ave., Montclair, N. J. Subscription Rates: In U. S., Mexico, South and Central America, and U. S. possessions, \$3.00 for 1 year, \$5.00 for two years, single copies 35 cents; in Canada, \$3.50 for 1 year, \$6.00 for 2 years, single copies 40 cents; in British Empire, \$4.00 for 1 year, \$7.00 for 2 years, single copies 50 cents; all other foreign countries, \$5.00 for 1 year.

Change of address: Four weeks' notice required for change of address. When ordering a change, please furnish an address stencil impression from a recent issue if you can. Address changes cannot be made without the old stencil as well as the new one.



**Sound-System
CONTROLS**

★ When it comes to controlling individual loud-speakers without upsetting that multiple-speaker network and introducing distortion, your best bet is the Clarostat CIB Attenuator, because . . .

This compact, inexpensive, constant-impedance output attenuator dissipates 10 watts at any setting.

Operates noiselessly, without distortion. Linear attenuation in 3 db steps up to 30 db and then final step to infinity. Zero insertion loss.

Highly recommended as individual speaker control in multi-speaker P-A systems. Also as output level control for power amplifiers.

8, 15, 50, 200, 250 and 500 ohm impedances.

2" dia. x 2 3/4" long. One-hole mounting. 1/4" bar knob standard equipment.



Ask our jobber to show you this item. Also L- and T-pods. Ask for catalog.

Controls and Resistors

CLAROSTAT MFG. CO., Inc. • 285-7 N. 6th St., Brooklyn, N. Y.

In Canada: CANADIAN MARCONI CO., Ltd.
Montreal, P.Q. and branches

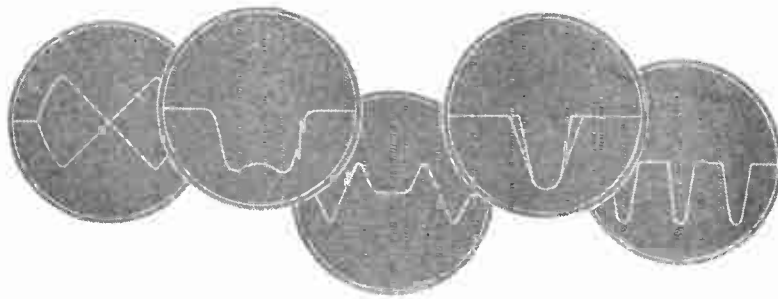

USING SWEEP GENERATORS FOR FM ALIGNMENT

By McMurdo Silver

This practical information on FM receiver alignment is something you'll be able to put to work right away on those new FM sets.

DURING the past decade many excellent articles have appeared explaining FM receiver IF, discriminator and RF alignment. No one has been the final word upon the subject because of a progressive change in manufacturer-recommended and service-possible methods. Many service technicians passed over such articles, saving them for study at the time when FM service became a real problem in their areas. Many are unable to find them when they are needed.

That time is here, FM broadcast stations pretty well blanket the country today. FM receivers today sell at well below \$100; low-priced FM converters at \$15 to \$30. The technician who expects to profit from today's FM service demands, who does not wish his competitors to put him in the background by taking his customers away, must master the techniques of FM service here and now.

These articles describe certain essential theory together with simple, practical methods of assuring quick mastery of FM. They represent the application of considerable experience in FM to derive simple and effective procedures.

AM-FM Receiver Differences

In an FM receiver the limiter and the discriminator (or ratio detector) circuits replace the second detector and AVC of the conven-

It is with pleasure that we present a two article series on FM alignment by such a well known authority as Mr. Silver. The material has been presented in lecture form to the Lehigh Valley Radio Servicemen's Association (Bethlehem, Pa.) Philadelphia Radio Servicemen's Association, and the Del-Mar-Va Radio Servicemen's Association (Salisbury, Md.). At these radio technicians' meetings the information was received with well-deserved enthusiasm. The presentation is in two parts to ensure that none of the details need be omitted.

tional AM superheterodyne. The only other difference between the two is that the FM receiver is more broadly tuned. Each type of receiver has RF amplifiers and mixer-converters which pass both FM and AM signals. The FM IF amplifier differs from its AM brother only in operating at a higher frequency and in passing a much wider band of frequencies—usually 150 to 200 kc wide as compared to 10 to 20 kc wide for AM IF amplifiers. The audio amplifiers are also the same in both receivers. This is evidenced by their use for both AM and FM in combination sets.

Recognition of the above facts indicates that AM servicing techniques are equally applicable to FM RF, converter, IF and AF circuits. The real difference in servicing the two types boils down to IF align-

ment—which includes those other two elements, limiter and discriminator, found only in FM receivers.

FM Signal Tracing

Since there are no AM broadcast signals to test upon within the RF tuning range of the usual FM set, an amplitude modulated signal generator is used for signal tracing. AM signal tracing is directly employable with such a tracer as the Silver Model 905 "SPARX" to locate troubles lying between antenna input and FM limiter grid resistor. This method becomes theoretically unavailing from first limiter plate circuit through the discriminator—until the discriminator load resistors are reached. From that circuit point through the audio circuits to the speaker voice coil, AM signal tracing once more takes over.

The similarity of test and service procedure in terms of circuit continuity, tube operating voltages, etc., etc. likewise applies to both FM and AM receivers.

Alignment Procedure

Digestion of the foregoing paragraphs can serve to take most of the "mystery" out of FM service and eliminate the fears with which many service technicians seem to regard FM. It becomes apparent that the only unusual process in servicing FM receivers is alignment

—and to make this simply understandable, simply “do-able” without pain and trouble is the purpose of this article.

In early FM receivers the IF amplifier center-frequency (mid-point of the 150 kc band to be amplified) was usually 4300 kc. It has progressively been moved upward to minimize image interference. Today the standard IF among most manufacturers is 10.7 mc. In any super-heterodyne image interference can occur only for a signal spaced twice the IF away from a desired signal. Since the FM broadcast band of 88/108 mc is only 20 mc wide, and $2 \times 10.7 = 21.4$ mc, it follows that this 10.7 mc intermediate frequency puts images outside the FM band.

Early methods of alignment were quite involved. A complete response curve was plotted by taking output readings at many frequencies through the pass band of the receiver. This process had to be repeated each time a further adjustment was made on the trimmers. This laborious procedure was often replaced by a simple “center-frequency” alignment which of course, gives no check on the symmetry of the pass band. Without this symmetry, quality of reception is impaired.

Equipment Required

Visual alignment of broad-band IF and discriminator or ratio detector circuits is mandatory if the job is to be done correctly. Two instruments are essential—a cathode-ray oscilloscope and an FM signal generator operating on intermediate frequencies as well as the

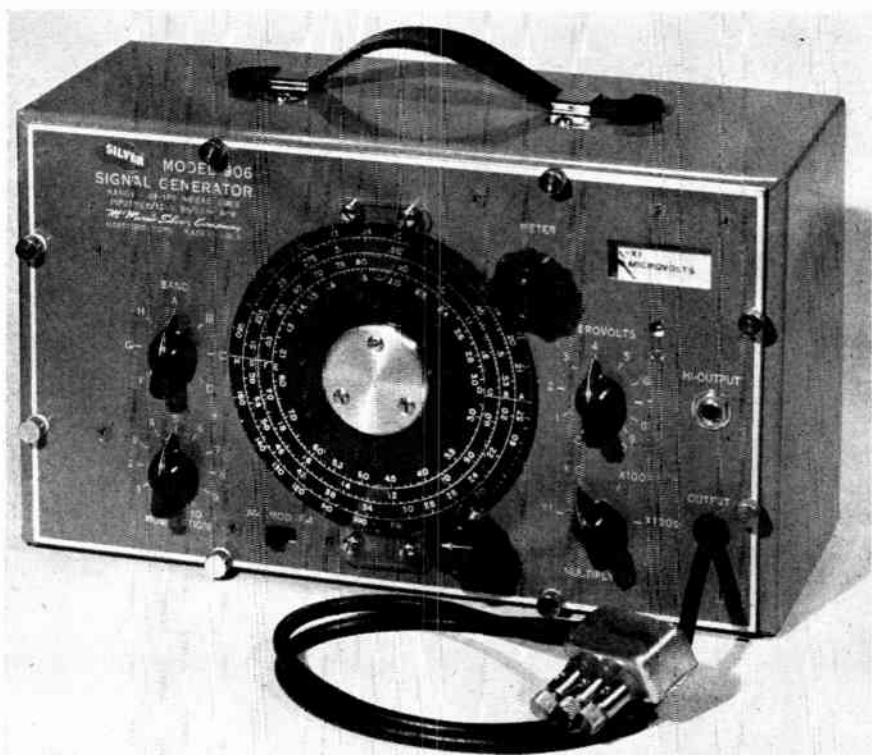

Fig. 1 The type 906 FM-AM signal generator. This generator provides a fixed sweep oscillator in addition to the usual AM signal output.

88/108 mc RF tuning range of FM receivers. Such a signal generator is illustrated in Fig. 1, and provides complete AM as well as FM coverage. Or it may be the new Silver 909 FM Sweep Generator—if the user already has a good AM signal generator. For FM, it is necessary that, once a desired frequency has been set up on the generator dial, this frequency may be rapidly varied over a 1000 kc total range. This frequency-modulated, or “sweep” signal, must be adjustable to traverse a little more than the normal FM receiver band width.

By use of such a signal generator and an oscilloscope, we can obtain “pictures” of the actual receiver selectivity curves. By watching these pictures exact alignment is effected. This method also shows up regeneration or oscillation “in a flash,” and does the whole job in a matter of minutes rather than in hours or days.

The unmodulated AM carrier of the Silver 906 combination FM-AM signal generator allows alignment at proper center-frequency. It also allows actual pass-band width of receiver circuits to be checked

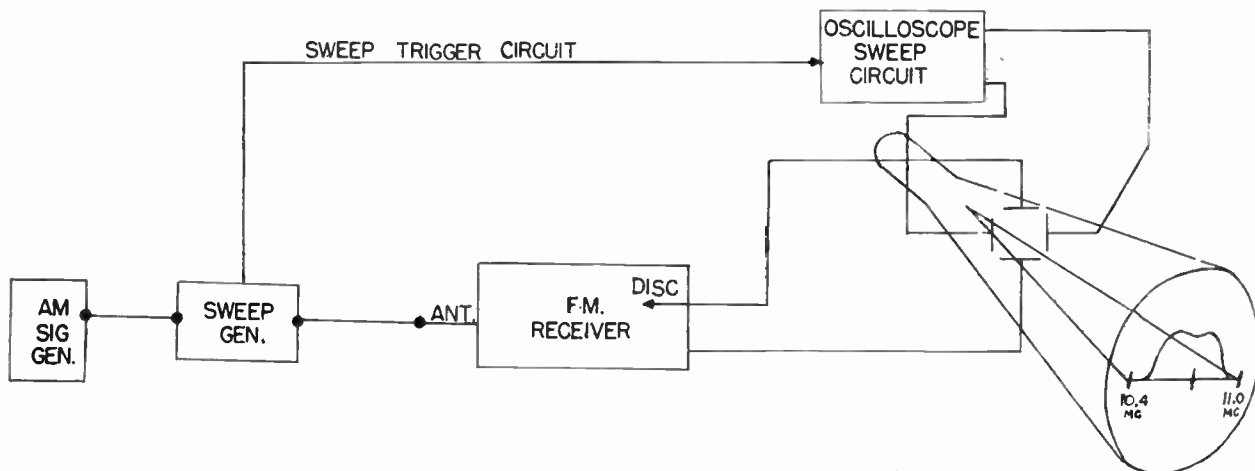

Fig. 2 This diagram shows the equipment is arranged to produce oscilloscope patterns of the response curve of an FM receiver.

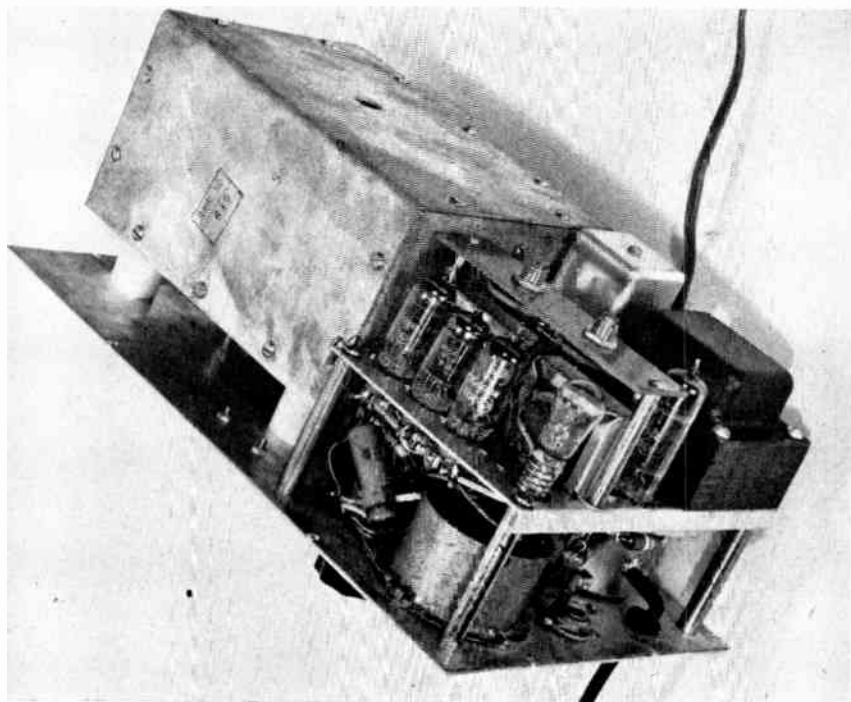

Fig. 3 Internal view of the type 906 signal generator.

and sensitivity to be measured. For this purpose any ordinary AM signal generator may be used, once its calibration has been checked for accuracy at required frequencies. This fact permits the technician already having a good AM signal generator to avoid the \$99.50 to \$225.00 cost of the combination FM/AM generator by acquiring only an FM and television sweep alignment signal generator such as is now available at less than \$50. (Silver 909)

Selectivity Patterns

An understanding of how the oscilloscope is able to trace out on its screen the pictures of Figs. 4 and 5, of the selectivity curves (pass-band) of receiver IF and discriminator circuits will help in mastering visual alignment. A representative setup for FM alignment is shown in Fig. 2. The output of the signal generator fed to the receiver is frequency-modulated (swept) over the required range of approximately 300 kc above and below fundamental frequency. A reactance modulator acts on one of two RF oscillators in the signal generator to provide this sweep.

Sweep is accomplished in the generator by means of a reactance modulator. A voltage at line fre-

quency is applied to the grid of the reactance tube, which changes the frequency of the oscillator in the generator. One complete cycle causes a sweep from 300 kc below center frequency through the center frequency to 300 kc above resonance—then back again.

Suppose we now feed this sweep signal into an FM receiver and use the following procedure:

1. Connect oscilloscope vertical plates across the limiter grid resistor.
2. Adjust the generator to the intermediate frequency.
3. Adjust oscilloscope sweep to the power line frequency.

Two pictures of the selectivity curve will result. One is the exact reverse of the other (left to right). The beam traces twice through the pass-band, once in each direction, while moving horizontally across the screen.

More useful pictures are obtained by using a horizontal scope sweep rate less than the sweep rate of the generator. For instance, Fig. 4 shows the image obtained when the ratio is 2/3. In other words, with a power frequency of 60 cycles, the scope sweep would be set at 40 cycles.

Fig. 4 is a most useful picture, since it allows slight readjustment

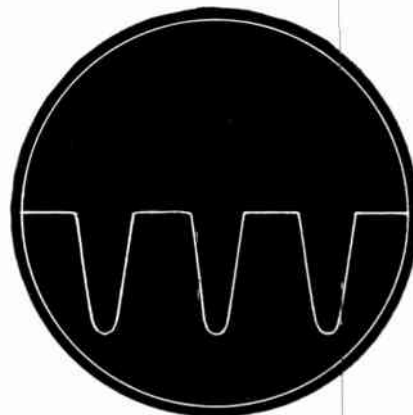

Fig. 4 Oscilloscope pattern obtained when the ratio of the oscilloscope sweep frequency to the sweep frequency of the generator is 2/3.

of the frequency-modulated signal generator frequency to exactly the frequency initially set up by the main-dial controlled and unmodulated VFO (or by the external AM signal generator where an FM sweep generator such as Silver 909 only is used) for initial center-frequency alignment. This readjustment of the combination signal generator output frequency after frequency modulation is applied is made just sufficient so that the two horizontal lines connecting the three curves of Fig. 4 are of equal length.

If the oscilloscope sweep frequency is set to double the mains frequency, then the electron beam will trace once across the screen during the time the signal generator is being swept upward through the pass-band, when at the end of this sweep the saw-tooth oscillator of the oscilloscope will snap the electron beam back to start a second trace of the beam across the screen. During this second interval in time the signal generator will be sweeping downward (in opposite direction) through the receiver pass-band. This is what causes the two super-imposed (but reversed in direction, hence called "mirror image") traces of Fig. 5 to appear. These are the most useful pictures for effecting correct alignment.

A little thought upon the above statements will indicate that the lower the rate of oscilloscope horizontal sweep, the more times per oscilloscope-beam sweep the signal generator frequency may trace upward, then downward, across the receiver pass-band; and so the greater the number of cycles, or se-

lectivity curve traces, which will simultaneously appear on the scope screen. It is to be remembered that each trace, left to right, is the reverse, or mirror image, of the preceding trace, and that signal generator and oscilloscope horizontal sweep voltage frequencies must be in harmonic relation to "stop" a picture upon the oscilloscope screen.

The IF amplifier of the FM receiver must be correctly aligned first. The RF and converter circuits may then be aligned without changing connections between set and oscilloscope. The discriminator, or ratio detector, as the case may be, should be aligned last, as it requires a change of 'scope connections. After considerable experience it may be found convenient to align the detector before the RF and converter sections. It is simpler to feed the generator signal into the mixer grid, then align all IF transformers, rather than to align stage-by-stage—since the overall IF response must be checked anyhow.

Signal Generator Limitations

Before actual alignment procedure is described, it is necessary that we understand why it is desirable first to align the IF circuits to center-frequency using an unmodulated RF signal, before making a visual check on the response curve. We "sweep" a fixed frequency oscillator, then beat this FM output with a variable frequency oscillator. Thus we derive the frequency modulated output signal. This output signal has either the sum or the difference frequency of the two oscillators, as in Fig. 6. (In the new Silver Model 909 FM and TV sweep generator, both sum and difference frequencies are used to provide three output ranges without band switching. It is believed that this is the first instrument to take advantage of this characteristic of beating oscillators, with the resultant stability and simplicity it provides.)

In order to obtain a frequency "sweep" of 1000 kc (and of 6 to 10 mc for TV) by an electronic reactance modulator, the oscillator to be swept must be operated at somewhere around 40 to 115 mc. If it is stable to 1% in output frequency, then it should not be relied upon to closer than 400 kc (1.15 mc in the 909 FM and TV generator)—

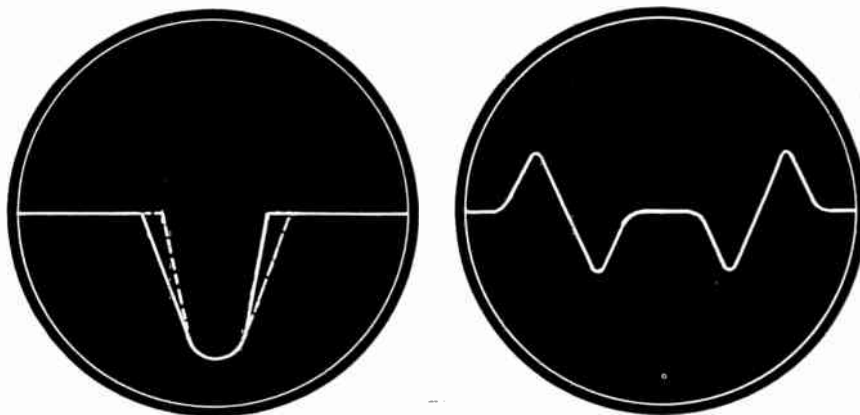

Fig. 5 Left: Double trace obtained when the oscilloscope sweep is set to twice the power frequency. Right: Discriminator trace obtained with sweep adjusted for the power frequency.

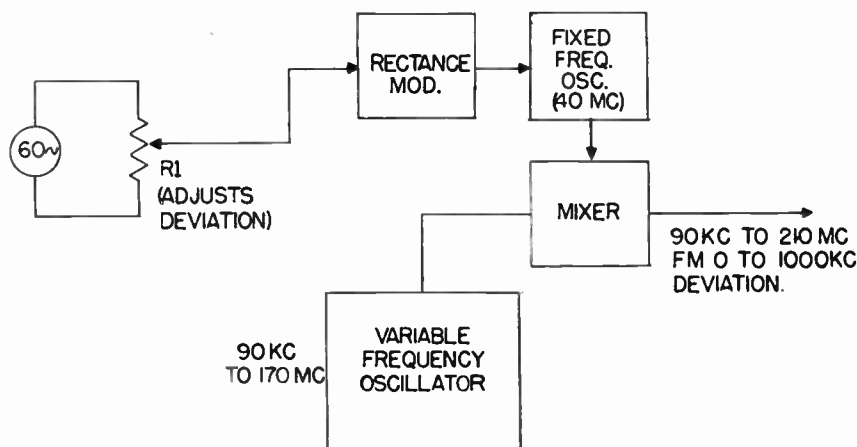

Fig. 6 How the FM wave is produced by beating a fixed frequency swept oscillator with a variable frequency oscillator.

a sizable percentage of 10.7 mc IFs, for example. The 40 mc "sweep" oscillator of the instrument illustrated beats with its VFO set at either 29.3 or 50.7 mc in order that the output frequency may be the desired 10.7 mc for IF alignment. Obviously some hundreds of kilocycles of error may creep into alignment by this method.

Fortunately this error is easily obviated. If the unmodulated output of the 906 (or AM signal generator) is set to 10.7 mc, for example, and the IF amplifier is then center-frequency aligned using a VTVM across limiter grid resistor as output meter, the error in frequency will be only 1% at most. This is negligible. By so aligning the IF circuits before shifting to visual alignment, the operator can be certain of correct center frequency alignment. In shifting over to oscilloscope in place of meter, and

frequency modulated instead of unmodulated test signal, he can adjust the signal generator dial to bring its FM output exactly in step with the IF amplifier previously correctly aligned on the unmodulated (single-oscillator) frequency of high accuracy.

The three foregoing paragraphs bring out a point important indeed in the use of any and all makes of FM "sweep" generators. The error involved is not, in any good signal generator such as that illustrated, a function of drift. It is only of the order of initial dial calibration accuracy.

So far we have discussed the differences between FM and AM receiver alignment, how selectivity patterns are obtained, and some of the important characteristics and limitations of signal generators. In next month's article, we'll discuss actual alignment procedures.

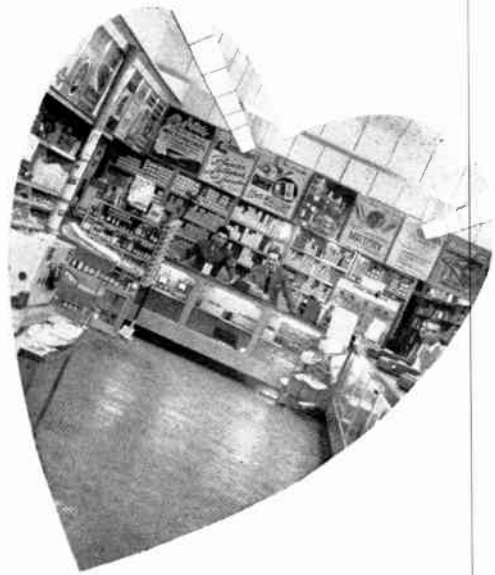

by John T. Frye

The serviceman has much to gain from good relations with his jobber.

THE "first" of anything is usually a pretty crude, improvised, and inefficient affair. Take the first gasoline engine, for example. Its bumping, loose-fitting bearings wasted as much power as they transmitted. We have come to realize that machining down to the thousandth part of an inch is necessary in the various working parts of an engine if power is to be smoothly transferred from one part to another with maximum efficiency.

Did you ever stop to consider that what is true in mechanics is equally true in the world of business? The whole mammoth, mushroom business of radio equipment maintenance is like a huge machine. Radio servicing came into being so rapidly that this machine has been literally thrown together, and the articulation of its various parts—the serviceman, the jobber, the manufacturer—has not been too good; yet, unless each of these parts works in close and frictionless contact with the other, there is a tremendous loss of time, money, effort, and efficiency.

As far as the serviceman is concerned, the relations between himself and his jobber are of the most immediate interest. He has no difficulty in seeing the advantages accruing to the jobber out of an improvement in these relations. Increased sales, increased profit, and more rapid turnover of stock is

bound to accompany any improvement along this line. Moreover, since the distributor will be in a better position to know what his customers actually want, he can buy more intelligently and profitably, placing proper emphasis on the high-demand, fast-moving lines. Furthermore, he can expand his business with confidence according to its needs when he is sure of a loyal following of customers.

With human frailty, the serviceman is not always so quick to perceive his own advantages from closer cooperation with his jobber; yet these advantages are greater—at least in number—than those falling to the lot of the distributor.

Availability of Parts

The most important thing the jobber does for the serviceman is to provide him with the parts where he wants them and when he wants them; but to take full advantage of this most important service, the repairman must be thoroughly familiar with the distributor's stock. What is more, he must let the jobber know what materials he expects to use so that these things may be purchased in advance and kept ready for him.

The jobber also makes it possible for the serviceman actually to see and examine new pieces of service and test equipment prior to purchase. This removal of the buying-a-pig-in-

a-poke factor from equipment is especially important to the serviceman in the outlying districts. What is more the jobber "endorses" the equipment he sells to the extent that his reputation as well as that of the manufacturer is pledged to satisfying the purchaser.

The jobber also provides a fine service in the distribution of various service aids, such as tube manuals, "tips," descriptive literature on new equipment, etc. The manufacturer sends this material to the jobber in huge lots and depends upon him to distribute it to the various servicemen in his area. Obviously, he will give such material to the repairmen who patronize him regularly.

Finally, if any further proof is needed of the importance of working closely with the jobber, all you have to do is to remember what happened during the war to the tube situation. When the tube situation got really tight, the fellow who had not bothered to establish close contact with a particular jobber was just out of luck. Each jobber—and who can blame him?—took care of his own and diverted what tubes reached him into the hands of the customers who had given him their business back when this business was really appreciated. It is great fun to be a bargain hunter and to play the field when everything is going your way; but when you really need a

friend, you naturally turn to your regular jobber.

There is a growing awareness of the need for improved cooperation between servicemen and jobbers springing up all over the country, and RADIO MAINTENANCE has selected three representative jobbers who are pioneering in improving jobber-serviceman relations. These companies are: Almo Radio Company, 509 Arch Street, Philadelphia 6, Pa.; Commercial Sound & Radio, 528 East Colfax, South Bend 17, Indiana; and Ebinger Radio & Supply Company, 2211 Gravois Ave., St. Louis 4, Mo.

Each of these progressive, forward-looking companies has made a slightly different approach toward the problem of drawing servicemen and jobbers closer together for their mutual benefit; so let us examine one at a time the methods employed:

Almo publishes and distributes free of charge a house organ called "The Almo Broadcaster." This little magazine, a monthly, contains a wealth of material interest to the serviceman. Service hints, "ham" news, description of new equipment complete with pictures, advice from outstanding men in the service field—these are but a few of the subjects covered in this compact but surprisingly information-packed little publication.

In addition, the company sponsored a meeting at Town Hall in Philadelphia, on January 21st, 1947. At this meeting Mr. W. K. Burlingame, Chief Technician of the Dumont Laboratories, Television Receiver Division, gave a lecture on television that was attended by over one thousand servicemen, dealers, engineers, and broadcast station operators.

Mr. Green, President of Almo, writes of this meeting: "We feel that television is breaking too fast for the average serviceman to keep abreast of it without help, and this Dumont meeting was planned so that he could be brought up to date on what television servicing would demand of him in the way of knowledge, service equipment, skilled help, etc.

"It is surprising how amazed some of the boys were to find out how unprepared they were for television. It brought them to the realization that they had to prepare themselves for bigger and better jobs. Of course, the benefits to us

as a jobber were realized through the sales of equipment to these prospective customers."

Another meeting is planned for the fall or early winter in cooperation with the Philadelphia Radio Servicemen's Association on television antennas. Mr. Green goes on to say to other jobbers:

"We feel it is the obligation of all parts jobbers to help in these educational programs. I say 'edu-

cational' with no reflection on the serviceman but merely because it serves as a link between the manufacturer and the serviceman. The jobber, since he knows both intimately, is particularly in a position to bring the two together."

Mr. Green states flatly:

"The policy of our company is to create and hold the good-will of the dealers and servicemen in this vicin-

→ To Page 16



A group of servicemen who heard a lecture about oscilloscopes by Professor Quigley of Notre Dame. The meeting was sponsored by Commercial Sound and Radio Co. of South Bend Indiana. Professor Quigley is at the right, standing.

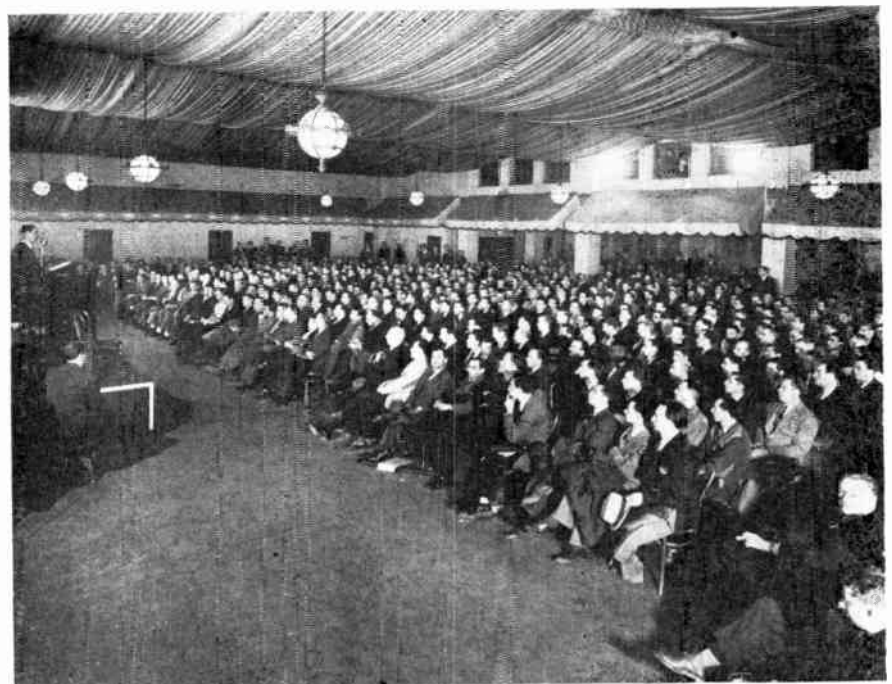

Over a thousand servicemen attended a lecture given by W. K. Burlingame of Dumont Laboratories. The meeting was sponsored by Almo Radio and was held in Town Hall in Philadelphia in January 1947.

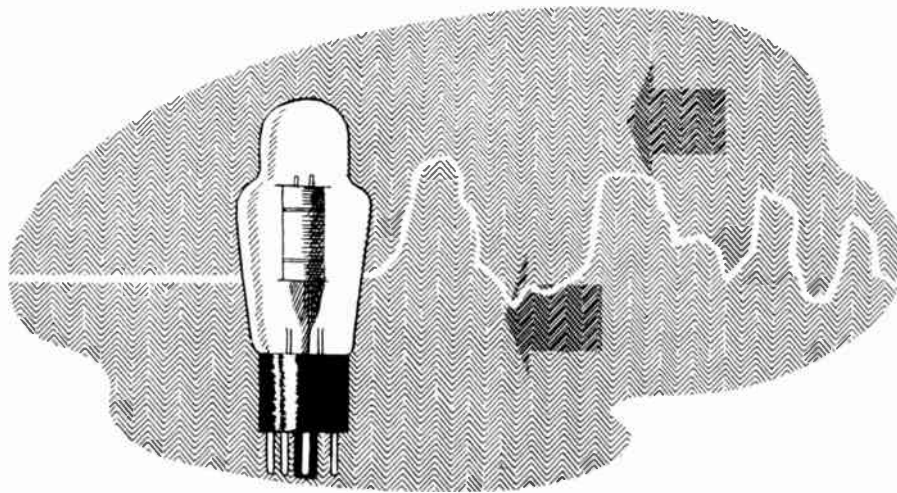

VOLTAGE REGULATOR OPERATION

by Irving Dlugatch

Many modern receivers use VR Tubes

VOLTAGE regulators are an important part of many new television and FM receivers. Better grades of AM sets and PA systems also employ some control to keep certain plate voltages constant. High frequency oscillators used in receivers in the 50 to 200 mc range would be too unstable without good plate and screen supply regulation. Until recently, the serviceman seldom encountered voltage regulator circuits, so the following discussion should be helpful in handling new receivers containing these circuits.

The equivalent circuit for any power supply delivering current to a load is shown in Fig. 1. R1 is the load resistor. R2 is the internal resistance of the power supply. In a battery, R1 would be the resistance of the electrolyte. In a generator, it would be the resistance of the armature winding. In radio receivers, it is more complex. Here it includes filter chokes and rectifier tube resistance, the construction of the power transformer, and even the nature of the AC power source.

In Fig. 1, E is known as the "generated voltage." This is the voltage our supply would give if we didn't have to worry about transformer losses, filter choke resistance, etc. and is about equal to the "no

load" voltage of the supply. (Neglecting the effect of a bleeding resistor, if there is one.) When we apply a load, it's the same as lowering the value of R2; more current flows. As a result, a voltage drop develops across R1. V, the useful output voltage, is thus lowered. Should R2 be removed from the circuit, leaving it open, there will be no drop across R1. The value of the terminal voltage under this condition is called

the no-load voltage. The extent to which V changes from full load to no load is referred to as the regulation of the system. A power supply that has good regulation will change its terminal voltage only slightly with varying load.

Good regulation is important in many electronic circuits. Changing the potentials at any of a tube's elements including the heater will affect its plate resistance. This is because any variation in the number of electrons that reach the plate can happen only if the plate resistance changes. Whether the tube is used as an oscillator or amplifier, the output is dependent on the plate resistance. The ear may not detect any difference in the loudness of the signal when regulation is poor. However, it will notice the distortion produced. Also, the change in plate and screen voltage will detune oscillators and RF amplifiers by altering interelectrode capacities. This is serious at the high frequencies used in FM and television. It takes but a few micromicrofarads of capacity to shift a television oscillator's frequency several megacycles. This may mean a badly distorted picture and loss of the sound.

Theoretically we shouldn't need voltage regulators. As soon as the

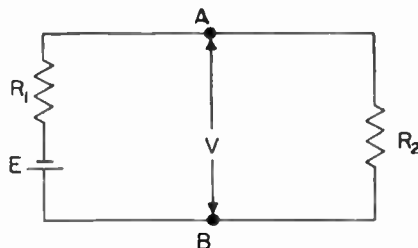

Fig. 1 Equivalent circuit for a power supply and load arrangement.

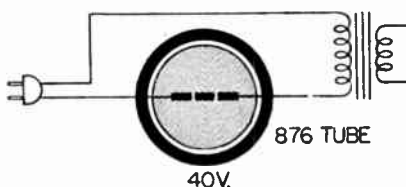

Fig. 2 Diagram showing the use of a type 876 primary voltage regulator.

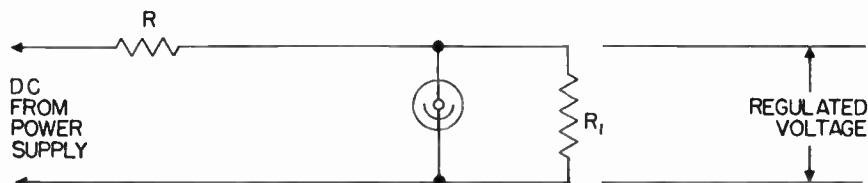

Fig. 3 Equivalent circuit of a power supply using a voltage regulator tube.

receiver heaters warm up, everything should reach an "equilibrium" condition. What, then, are the causes of voltage variations? First, power line AC voltage is not perfectly constant. In spite of the efforts of power companies to eliminate variations, some always occur because the load on the lines is going through many changes and the voltage cannot be completely stabilized. In rural districts, line voltages may sometimes vary by as much as 20%.

The second source of voltage variations is in the receiver itself. Temperature changes cause resistance changes in the components. The control circuits (AVC and others) used are such as to cause plate current fluctuations when signals tuned and detuned and when signals of different strengths are received. Strong noise pulses and other interference effects also contribute to instability in voltages.

Protection against upswings in line voltage can be provided by increasing the normal internal resistance of the AC supply. Ballast resistors called current regulators are designed for this purpose. These include the familiar filament dropping resistors built into line cords or constructed to plug into a tube socket. They are usually made by winding nichrome wire around a heat resistant insulating material. Considerable heat is developed by the resistor. This means that plenty of ventilation has to be provided.

An older form of the ballast resistor was used as in Fig. 2 in series with the primary of the power transformer. As can be seen, the primary must be designed to operate at a much lower than normal voltage. That is why such a regulator cannot be shorted out without damaging the transformer. The resistance is sometimes made of iron and enclosed in a glass bulb containing hydrogen gas. The gas lengthens the life of the regulator. The 876 tube is an example of a current regulator. It has a mogul base and is listed as requiring

1.7 amperes with a voltage drop of 40 to 60 volts. The chief disadvantage of all ballast resistors is that they dissipate a good deal of power. The most efficient, least expensive, and most used kind of regulator is the cold cathode glow discharge type known as "VR" tubes.

These tubes contain a plate and a cathode. Their bulbs hold a gas at low pressure which is not active chemically. If a high DC voltage is applied between the electrodes, the gas atoms break down forming positively charged ions and negative electrons. The electrons are attracted to the positively charged plate. The ions go to the negative cathode where they receive new electrons. As the electrons enter the ions, energy is given off in the form of light. We see it as a bluish glow.

Once this process has begun, the presence of the positive ions lowers the potential difference between the electrodes and keeps it constant at a low value. Any increase in applied voltage increases the ionization releasing more electrons. This amounts to a decrease in resistance. A decrease in voltage has the opposite effect. It is as though the tube were automatically adjusting its resistance to maintain a constant voltage drop.

Because of the tube's low opposition to current flow, it cannot be used without a series resistor to limit the current. Fig. 3 shows the circuit for the use of VR tubes. When R_1 increases, additional current is carried by the tube. When R_1 decreases, the tube current falls. The voltage across the regulator tube will be constant only when its current stays within the limits given in the characteristics chart. The last column in the table indicates how much the tube voltage will vary. These figures are correct if the tube current does not fall below the minimum value or rise above the maximum. Also, the load current should not vary more than 20 to 35 milliamperes. When the tube is operating properly, a faint glow should be seen. A very bright



The OA2 miniature type regulates at 150 volts.



The standard VR type of regulator tube is pictured above.

glow means excessive current. This shows that the power supply voltage needs to be reduced. No glow means too little current and is due to low power supply voltage or excessive load current.

It must be remembered that a high voltage is needed to start the tube. The lowest possible voltage needed

Thousands of Servicemen asked us:
"Why Don't You Publish a Tube Placement Guide?"



NOTHING LIKE IT!

Practical—like all SAMS Manuals! *Complete*—the only single source for tube placement data on almost 4500 models. *Accurate*—correct information on every model. You get 192 pages of invaluable data in a handy, sturdily-bound pocket-size book. Say goodbye to tube placement identification problems—save time—get more work done faster! Now at your local job-ber for ONLY.....\$1.25

SO WE DID!
AND HERE IT IS:
THE NEW PRACTICAL HOWARD W. SAMS
"RADIO RECEIVER
TUBE PLACEMENT GUIDE"

It's the book you'll use every single day—in the handy pocket-size you like—that shows you exactly where to replace each tube in almost 4500 models! Covers receivers from 1938 to 1947. Each tube layout is illustrated by a clear, accurate diagram, with tubes identified by large, easy-to-read type numbers. Saves you valuable time identifying tube placement, especially where the customer has removed the tubes from the set. Eliminates irritating hit-and-miss methods and risky guessing—helps you work faster, more profitably. Completely indexed for quick, accurate reference. Handy on service calls—a big help on every job—outside or in the shop. You'll want several copies for bench and outside calls. They'll pay for themselves over and over again. Order today!

The World's Most Practical Radio Service Manuals!



PHOTOFACT Volume 3 is ready for you—brings your post-war service data right up to January, 1948! Companion to Volumes 1 and 2—the most *practical, accurate and complete* Radio Data ever compiled. Here is everything you need for fast, efficient, profitable servicing of all post-war models—bound in easy-to-use volumes. Order your PHOTOFACT Volumes now—the Radio Service Data with the *exclusive* features that meets all your actual needs!

Volume 1. All post-war models up to January 1, 1947.

Volume 2. Models from January 1, 1947, to July 1, 1947.

Volume 3. Models from July 1, 1947, to January 1, 1948.

Your Price, Each Volume, in Easy-to-Use Deluxe Binder.....\$18.39

SPECIAL OFFER: If you haven't a complete file of all PHOTOFACT Folders to date, you can trade in the individual Sets you now own for complete volumes at amazingly low cost. Write today for special offer, stating what Sets of Folders you now own (use coupon at right).

Howard W. Sams' 1947 Automatic Record Changer Manual. Only book of its kind—complete service data on all current Changers and Recorders. 400 pages. ONLY.....\$4.95



Howard W. Sams' Dial Cord Stringing Guide. No other manual like it—shows the *right* way to string the dial cords of models produced from 1938 through 1946. It's a "must" for Servicemen. ONLY.....75c

BOOST YOUR EARNING POWER!

Mail This Order Form

to HOWARD W. SAMS & CO., INC.
 2924 E. Washington St., Indianapolis 6, Indiana.

My (check) (money order) for \$..... enclosed.

- Send SAMS' TUBE PLACEMENT GUIDE(S) at \$1.25 per copy.
- Send PHOTOFACT Volume 3 (including Sets Nos. 21 through 30) in DeLuxe Binder, \$18.39.
- Send Volume 2. Send Volume 1 (\$18.39 each).
- Send SAMS' 1947 AUTOMATIC RECORD CHANGER MANUAL(S) at \$4.95 each.
- Send SAMS' DIAL CORD STRINGING GUIDE(S) at \$0.75 per copy.
- Send FREE PHOTOFACT Cumulative Index.
- Send details of your Special Trade-In Offer.

Name.....
 Address.....
 City..... State.....

HOWARD W. SAMS & CO., INC.
 INDIANAPOLIS 6, INDIANA

Export—Ad. Auriema—89 Broad St., New York 4, N. Y.—U. S. of America
 Canada—A. C. Simmonds & Sens, 301 King St., East—Toronto, Ontario

PHOTOFACT SERVICE

"The Service that pays for itself over and over again"

Let's Work Together

→ From Page 11

ity. We feel we can better do this through close cooperation with them in helping to sponsor these meetings that are timely and interesting to them. We feel these meetings are essential and that the men are getting first-hand information from people who are considered 'tops' in the industry and are well versed in the subject on which they lecture."

Commercial Sound & Radio Company of South Bend also has featured lectures in its jobber-serviceman cooperation program. The lectures were in the form of a series given by Professor Quigley of Notre Dame University on the various phases of the theory and operation of the oscilloscope. The lectures, given at night during the winter and early spring, were held to one hour, and refreshments were served after each meeting. Each lecture pertained to a specific topic relating to the oscilloscope.

Mr. A. E. Kester, President of Commercial Sound & Radio, says:

"The reaction of the servicemen was more than we anticipated. They are asking for more of this type of meeting, and we are planning, starting in October, a regular school on various types of test equipment, such as Oscillators, Vacuumtube Voltmeters, Television, Alignment of FM Receivers, etc. Also we hope to get enough fellows interested in making trips to various manufacturing plants. So far, we have had three offers on these trips on a share the cost plan; that is, the cost would be divided between the distributor, manufacturer, and person attending."

He points out that a lot of the fellows stayed long after the meetings, which gave the personnel of C. S. & R. an opportunity to get their reaction on the meeting and on business in general. The company had an opportunity to come in contact with a number of new accounts and to get to know personally many new and potential customers. More concrete results were found in the sale of fifteen oscilloscopes.

In summarizing, Mr. Kester says: "The purposes of these meetings have been more than three-fold. The most important part, it gave the servicemen an opportunity to know each other, and this was an important fac-



The Ebinger Radio Co. sponsored this meeting at Lymmer Hotel, Herrin, Ill., a few months ago.

tor during the war. For instance, when merchandise was very scarce, the fellows helped each other out on various parts and tubes the distributor and manufacturer were unable to secure for them. Second purpose: it showed the servicemen that they were no longer 'Screwdriver Mechanics' but are engaged in a highly-trained profession and deserve credit and recognition as such. They need take a back seat for no one. Third purpose: it created a lot of good will for us and showed the serviceman that we were back of him 100% and that his problems were our problems."

Consistent with this desire to have the servicemen "get together," Commercial Sound & Radio has also given purely social parties from time to time. Refreshments were always served at these parties and diverting entertainment was provided.

Ebinger Radio and Supply Company of St. Louis also has great confidence in meetings of servicemen with a lecture on a pertinent subject sponsored by their company. One difference lies in the fact that they take the meeting to the serviceman, at least as nearly as they can. The territory covered by this company is estimated as having a radius of roughly a hundred miles, with St. Louis as the center. The lectures are given at various key towns in this huge area, with servicemen from twenty or thirty neighboring towns being invited to attend. To round out the program, several large meet-

ings are arranged for St. Louis itself.

Mr. John Devereux of the Sales and Advertising Department of Ebinger's sums up the aims of these meetings as follows:

"First and foremost, they give the servicemen an opportunity to secure more information so that they will be better technicians and better business men. We like the idea of factory men for speakers because they have the broad general knowledge and the practical experience about their own products which enable them to answer any question which the average serviceman is likely to shoot at them. Knowing in advance that he is to address a group composed only of servicemen, the speaker can slant his talk to meet their requirements.

"The second purpose developed accidentally. It is the promotion of good fellowship and better understanding between individual servicemen. It has worked out particularly well in our regional meetings. Servicemen, from perhaps adjacent towns, who know each other only by reputation, find out over a glass of beer or two that the cheap chiseler they have been cussing a lot is really not such a bad guy after all.

"When we have accomplished the first two purposes, we automatically take care of the third. That, of course, is the promotion of good will for the Ebinger Radio & Supply Company."

Mr. Devereux admits frankly that

→ To Page 24

Here's how
hundreds of men
working in Radio
**WIN PROMOTIONS,
EXTRA PAY**

I TRAINED THESE MEN AT HOME



Sixteen Years Previous Experience
"Before I enrolled with N.R.I., I had 16 years of actual Radio experience, but found many helps in your Course. I am now Administrative Assistant to the Officer in Charge of a U.S. Army Applied Electronics School."—Wallace G. Baptist, 1907 Willow Spring Road, Dundalk, Md.



Seven Years Previous Experience, Now Department Head
"I did not start as a beginner, but had seven years experience as a commercial Radio operator. Last April I came to work for the Gates Rubber Company to set up, train and install a complete industrial equipment department."—Norman B. Hood, Denver, Col.

Ten Years Previous Experience, Doubles Earnings

"I had been servicing Radios for ten years. I found it necessary to get the technical knowledge I lacked, so I enrolled with N.R.I. I believe my earnings have more than doubled since taking the N.R.I. Course."—I. L. Hankey, Jr., 278 W. 5th St., Frederick, Md.



N.R.I. Training Helps Operator Win Advance

"Before taking the N.R.I. Course I felt I was a phoney holding a job as Assistant Communications Operator. I feel now worthy of the job and future advancement. I have advanced to Assistant Aircraft Communicator."—John Keller, S. Market St., Martinsburg, Pa.



**NOW LET THIS WORLD-FAMOUS
N.R.I. COURSE HELP YOU STEP AHEAD**

MAKE MORE MONEY IN RADIO!

My Course Teaches Timesaving Service Methods, Techniques, Television, FM, Electronics

Here are just a few of the topics covered:
Photoelectric Control Circuits with Relays
Peak and Band-Pass R.F. Tuning Circuits
Broadcast, All-Wave and Television Superhet Receiver Principles
Light-Sensitive Cells for Control Circuits
The Vacuum Tube as an A.C. Generator in Radio-Television Circuits
Current, Voltage and Resistance Measurements
Vacuum Tube Voltmeters,
Cathode Ray Oscilloscopes

Frequency Modulated Signals, the F-M Receiver
Automatic Tuning Control Systems
Professional Radio Servicing Techniques
How to Isolate Defective Section and Stage
How to Isolate Defective Circuit and Part
Tuning Circuit Troubles
Field and Bench Testing of Radio Parts
Uses for Optics in Electronics and Television
Practical Electronic Equipment
Essentials of Outdoor and Indoor Public Address Systems

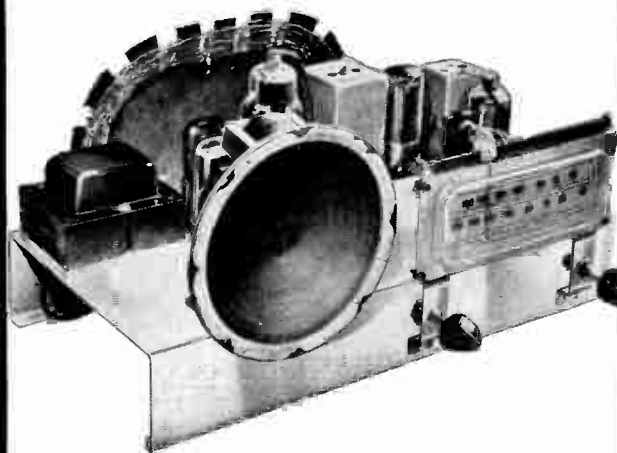

You Build This Complete Receiver with Standard Radio Parts I Supply

You get valuable experience testing and repairing this and many other circuits you build from N.R.I. Kits. These kits are not loaned to you, but become your property. Mail coupon for full details!

THE way to EARN more money in Radio is to handle MORE service jobs in LESS time! And the N.R.I. Course is designed to help you do just that! With N.R.I. training, you KNOW the short-cuts and time-savers that speed up routine repair jobs. You KNOW how to locate trouble *fast* on the tough jobs as well as the easier ones. And you KNOW up-to-date servicing methods needed on FM, Television, and Electronics.

Find Out What N.R.I. Can Do For YOU

Read the letters at top of this page. They are from just a few of many men who were working in Radio before they took my training. I helped them get ahead, and I can help you. Mail the coupon for my 64-page book, "How to be a Success in Radio, Television, Electronics," FREE. See how I train you at home, how I give you UP-TO-DATE, PRACTICAL knowledge . . . how you get professional experience building, testing, repairing real Radio circuits with kits I send.

SAMPLE LESSON FREE

I'll send you a Sample Lesson FREE to show you how quickly you learn from my illustrated, easy-to-understand lessons. No obligation. Get Sample Lesson and Book by mailing coupon. Just mail Coupon NOW in envelope or paste on penny postal.
J. E. Smith, President, Dept. 8BY3, The National Radio Institute, Pioneer Home Study Radio School, Washington 9, D. C.



J. E. Smith, President,
National Radio Institute

**VETERANS
APPROVED
UNDER
G. I. BILL**

Good for Both—FREE

Mr. J. E. SMITH, President,
Dept. 8BY3,
National Radio Institute,
Washington 9, D. C.

Mail me FREE, Sample Lesson and 64-page book.
(No salesman will call. Please write plainly.)

Name
Address
City State
(Please include Post Office Zone Number)



HYTRON

Handy TUBE TAPPER
Much-needed TOOL
Locates Intermittents

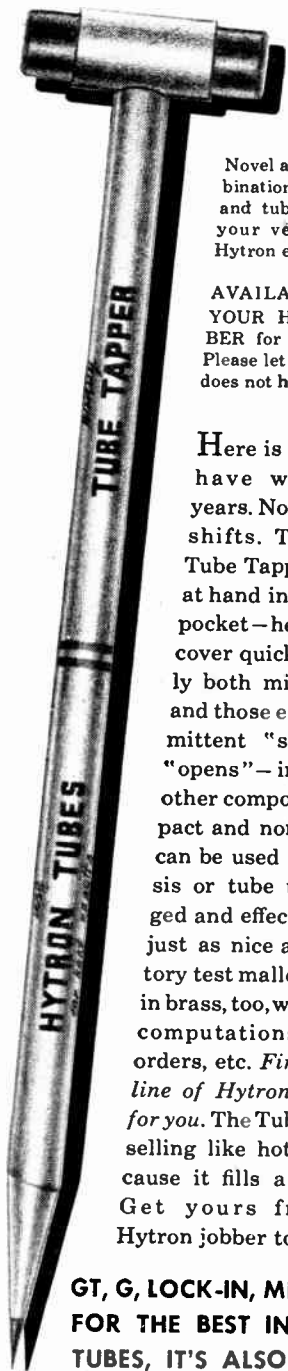

Novel and useful combination pencil, eraser, and tube tapper. Fits your vest pocket. A Hytron exclusive.

AVAILABLE FROM YOUR HYTRON JOBBER for only a nickel. Please let us know, if he does not have it in stock.

Here is the tool you have wanted for years. No more make-shifts. The Hytron Tube Tapper—always at hand in your breast pocket—helps you discover quickly and easily both microphonism and those elusive intermittent “shorts” and “opens”—in tubes or other components. Compact and nonmetallic, it can be used on set chassis or tube tester. Rugged and effective, it does just as nice a job as factory test mallets. Doubles in brass, too, when making computations, writing orders, etc. *First of a new line of Hytron tube tools for you.* The Tube Tapper is selling like hot cakes, because it fills a real need. Get yours from your Hytron jobber today.

GT, G, LOCK-IN, MINIATURE—
FOR THE BEST IN RECEIVING
TUBES, IT'S ALSO HYTRON.

HYTRON

RADIO AND ELECTRONICS CORP.
Salem, Massachusetts

Of the Organizations

Reports from all over United States and Canada are making it clear that the Radio Service Technician is finding membership in an organization of great benefit. Radio Maintenance has kept you informed by starting this column many months ago, and we have watched group activity grow. If you are an organization member, let's hear from you about your group activities.

Walter Koop, Chairman of the publicity committee of the Philadelphia Radio Servicemen's Association, recently sent us some interesting information about the Association's code of ethics enforcement. Certain rules of ethics are generally followed by members and violations are carefully investigated. The manner in which investigation are carried out is as follows (we quote from Mr. Koop's letter):

“All complaints are referred to our Board of Governors and a committee is appointed by them to handle these complaints as they are received. This has been our procedure for several years and has worked very satisfactorily.

“The investigating committee calls on the complaining customer and examines the radio equipment which was repaired. They also examine the bill if one was given the customer, and proceed to contact the serviceman or company which performed the work. If the committee finds the serviceman is at fault, he is given three days in which to correct the trouble. If he

does not make the correction in three days, the equipment is taken to the shop of a member for proper repairs and then returned to the customer.

“The original serviceman is then billed for this work. If he does not pay the bill and give complete assurance of mending his ways, he is dropped from the membership of PRSMA and notice of this action is published in PRSMA News. We have found cases where the customer has been unreasonable or of questionable honesty. In cases of this type, we point out his unreasonableness and make every effort to absolve the unjustly accused serviceman.”

Mr. Koop mentions that 85 per cent of complaints received concern non-members, in which case, unfavorable publicity exposing their unethical methods is used, after a thorough investigation has conclusively proved them to be at fault.

One of the largest meetings of the Hudson Valley Radio Servicemen's Association was held October 14th at the famous Smith Brothers' Restaurant in Poughkeepsie, N. Y.

Speakers at the meeting were Messrs. Irving Einhorn of the Tung-Sol Lamp Works, Newark, N. J.; Ken Burkaw, Sales Manager, Jobber Division, Cornell-Dubilier Electric Corp., Plainfield, N. J.; and Hy Steinberg of Blair-Steinberg, manufacturers' representatives of New York City. This meeting which was attended by servicemen from a radius of over forty miles is the forerunner of a active winter season.

Mr. Einhorn showed a special motion picture describing the man-

→ To Page 36



"It's the one that REALLY WORKS"
Reports Pilzer Twigg

You all remember Pilzer from way back before the war. He repairs radios at the Acme Radio Emporium. After field-testing advance samples of the new Sprague TM, Mr. Twigg reports:

"Up to now I couldn't keep a tubular in the auto radio in my Model T long enough to bother with puttin' one in. Now motoring is fun again. The radio coos like a baby. Sprague TM's are the only ones that really work!"

The first truly practical all-purpose HIGH-TEMPERATURE MOLDED paper tubulars—New type TM

- Highly heat resistant
- Moisture resistant
- Non-inflammable
- Conservatively rated
- Small in size
- Mechanically rugged
- Completely insulated

After more than four years of intensive research, plus one of the largest retooling programs in its history, Sprague announces a complete line of high-temperature molded paper tubular capacitors that offer far-reaching advantages for a long list of products ranging from home or auto radios and electrical appliances to military equipment. These new molded types will be known as "TM" units. Basically, because of its completely new method of construction, this Sprague TM unit is so far ahead of anything now available, it should

have the same effect on the paper tubular capacitor business that bakelite molded resistors had in the resistor field years ago.

The unique high-temperature molded construction of these new capacitors assures maximum dependability even under extremes of heat, humidity, and physical stress. Thus the new TM types have virtually universal application in modern equipment. **YOU CAN STOCK ONE BRAND FOR ALL REQUIREMENTS—SPRAGUE TM'S!**

Reach for a Sprague and know you're right!

CAPACITORS

SPRAGUE

*KOOLOHM RESISTORS

• T.M. Reg. U.S. Pat. Off.

SPRAGUE PRODUCTS COMPANY, North Adams, Mass.

(JOBGING AND DISTRIBUTING ORGANIZATION FOR THE PRODUCTS OF THE SPRAGUE ELECTRIC COMPANY)

TIME SAVERS

by Harry Leeper

Each month Mr. Leeper will describe two suggestions helpful in radio service work and illustrate them with photographs. This is a new, regular, feature, in addition to "The Notebook" which features suggestions from readers.



DIAL POINTER MOVEMENT

Radios which use a sliding type of pointer or indicator often have uneven dialing due to the pointer mechanism catching on the metal frame.

A light application of vaseline will usually correct this condition. Care should be used to avoid placing any of the vaseline on the dial cord.



ELIMINATING VIBRATION NOISE

The dial face of radios of some types makes a loose contact with the cabinet which results in vibrating noise at certain volume or tones.

Moleskin adhesive is available which has a soft covering and when applied as shown acts as a cushion between the dial face and the cabinet.

More than one layer of the adhesive may be used where necessary.

DESIGNED FOR THE BETTER SERVICE SHOP...



RCA'S NEW FM SWEEP GENERATOR
... third unit of a
revolutionary new line

Provides every signal you need for fast, accurate FM alignment

THE WR-53A removes the last element of doubt from FM receiver alignment... regardless of band-width requirements. You bring the recognized advantages of the sweep method of alignment to every FM job—speed, accuracy, and reliability that add up to a perfect job every time, in less time.

It's packed with features to make your work easier. Here's a quick check list:

- ... i-f center frequency, 8.3 to 10.7 mc
- ... adjustable i-f sweep width ... internal and external frequency modulation ...
- r-f range continuously variable from 85 to 110 mc ... provides AM or c-w signals
- ... includes step and fine attenuators ...
- a scope phase control permits centering of sweep patterns.

With the i-f sweep section, you can align i-f stages by the variable-frequency or visual method. When used with an oscilloscope or VoltOhmyst, you can quickly adjust an FM discriminator circuit by either the visual or single-frequency method. Alignment of r-f, local-oscillator, ratio-detector, and mixer circuits all become simple, routine jobs.

Here's an instrument that's comparable in performance yet half the price of similar laboratory-type equipment. It's a "natural" for the receiver manufacturer's laboratory as well as the radio service shop.

A new bulletin is yours for the asking. *Keep in touch* with your RCA Test Equipment Distributor.

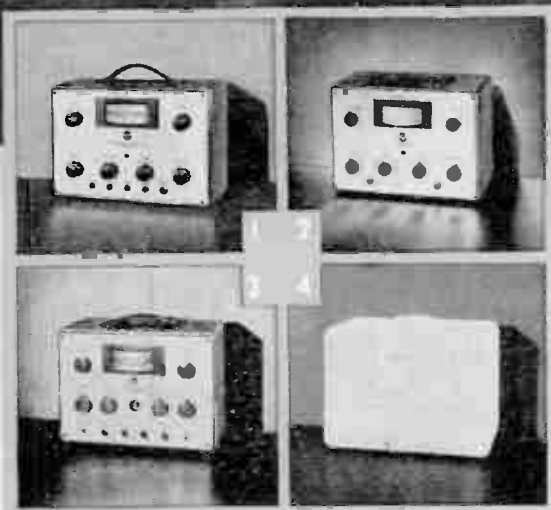

ON THE WAY—a superior line of test equipment that puts time-consuming service jobs on a profitable, production-line basis... that anticipates all FM and television needs. Matched styling of all instruments permits attractive, convenient grouping. Watch for announcements of the other units in this new line.



TEST AND MEASURING EQUIPMENT
RADIO CORPORATION of AMERICA
ENGINEERING PRODUCTS DEPARTMENT, CAMDEN, N. J.

In Canada: RCA VICTOR Company Limited, Montreal

RESISTANCE and WATTAGE

marked on every unit!

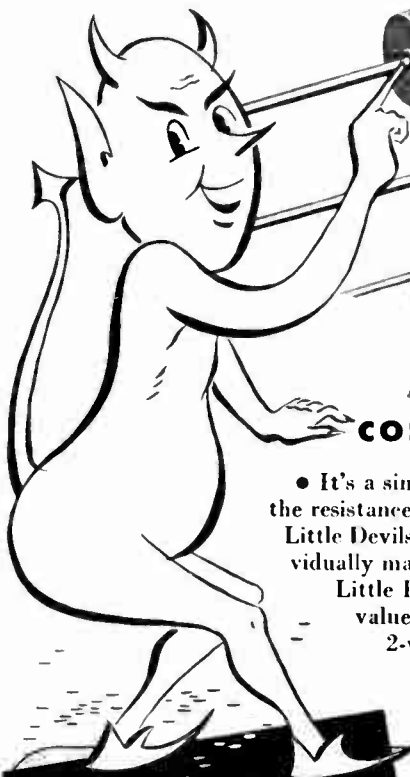

OHMITE *Little Devil* composition resistors

• It's a simple matter, now, to make sure you're getting the resistance and wattage you want. Just ask for Ohmite Little Devils. Every unit is not only color-coded but individually marked for quick positive identification. Ohmite Little Devil resistors are available in standard RMA values from 10 ohms to 22 Megohms, in 1/2, 1, and 2-watt sizes. Tol. $\pm 10\%$. Also $\pm 5\%$ in 1/2 and 1-watt sizes.

Available Only Through Ohmite Distributors

Other
OHMITE
ITEMS...

TYPE AB POTENTIOMETER

New high quality 2-watt molded composition unit with good safety margin
Sold only by Ohmite distributors.



BROWN DEVIL RESISTORS



Rugged, dependable, wire-wound, vitreous-enameled. Easily mounted by tinned wire leads. Tol. $\pm 10\%$. Five, 10, 20-w sizes.

DIVIDOHM ADJUSTABLE RESISTORS

Used as multi-tap resistors or voltage dividers. Provides odd resistance values quickly. Vitreous-enameled.



NEW OHM'S LAW CALCULATOR

Solves any Ohm's Law problem with one setting of slide. Send now—25¢.



WRITE FOR CATALOG 19

Provides useful data on selection, application, of rheostats, resistors, tap switches, chokes, etc.



OHMITE MANUFACTURING CO.

4912 Flournoy Street, Chicago 44, Ill.

Be Right with

OHMITE

RHEOSTATS * RESISTORS * TAP SWITCHES

Voltage Regulator Operation

— From Page 14

90 volts and operate at 60 volts.

Electronic voltage regulation is used where higher voltages are involved and, also, where the output voltage is not going to be fixed. One version giving excellent regulation is that of Fig. 7. If the output voltage goes up, the current through R_3 , R_4 and R_5 will increase. This will make E_g rise. The bias on the grid of the 6J7 is the difference between E_g and the voltage fixed by the VR tube in series with the cathode. E_g places a positive potential on the grid. The cathode voltage supplies a negative potential. If E_g increases, the grid becomes more positive. This permits more plate current to flow in the 6J7. The larger plate current makes point A more negative with respect to point B because the current flows from A to B. Therefore, the grid of the 2A3 is made more negative. The 2A3 plate current is then reduced which means less current is supplied to the load. As a result, the output voltage decreases.

Should the output voltage fall, then E_g drops. This decreases the 6J7 plate current and finally makes the 2A3 grid more positive. The increased 2A3 current, boosts the output voltage.

The available regulated voltage can be varied by changing E_{gk} . That is why R_4 is made adjustable. If more load current than a 2A3 can carry is desired, additional 2A3s can be put in parallel as indicated by the dotted lines.

In general, the VR tubes and the electronic regulator compensate for line voltage variations as well as for load changes. In addition, maintaining constant voltage essentially reduces the internal resistance of the power supply. Therefore, regeneration and degeneration voltages are less likely to build up in the power supply. This might occur with many stages of amplification such as video IF amplifiers. It also results in reduced hum and less chance of "motorboating." However, defective VR tubes may be a source of noise. The best test for this trouble is replacement with another tube.



Says the service expert who values his good reputation and the repeat business that goes with it—

**"I SELL
KEN-RAD
RADIO
TUBES
BECAUSE
THEY'RE
BUILT
RIGHT"**

**"...AND
BECAUSE
THEY
PLAY
RIGHT
I BUY
THEM!"**



—asserts the tone-conscious radio owner who appreciates the superior quality of Ken-Rad tubes.

KEN-RAD DOUBLE ACCEPTANCE

puts profits in the repairman's pocket

● You're glad to install Ken-Rad tubes because their reputation stands high with you, as well as with other service experts. And Ken-Rad tubes reward this enthusiasm by helping you secure a bigger repeat business—based on clients' faith in your standards of work as shown by the quality tubes and parts you use.

DOUBLY ACCEPTED . . . by you and your customers! That's why Ken-Rad tubes hold a coast-to-coast margin of popularity. Radio owners endorse their finer tone, their long-

playing life. *You* prefer to sell Ken-Rad tubes—*customers* want to buy them! It's a favorable meeting of minds, creating more sales and greater profits.

NOW is the time to impress your name and high-grade repair facilities on your neighborhood! Radio-set production is large; owners' service needs will grow. Ken-Rad tubes can help you gain wider, friendlier local recognition, with the increased business "take" that will result. Install and sell Ken-Rad *doubly-accepted* radio tubes!

● "ESSENTIAL CHARACTERISTICS" Ken-Rad's Booklet ETR-16— is a "must" for the dealer or service man who wants a convenient, concise, and comprehensive guide to the selection of radio tube types. Your free copy will be mailed you promptly on request. Write for it today!

178-GA3-8880

KEN-RAD *Radio Tubes*

PRODUCT OF GENERAL ELECTRIC COMPANY

Schenectady 5, New York

ESPEY

The Custom Built Chassis



Notice those
lines!
That compact—
well-proportioned
—design!
Really a beaut!

Yessir! In producing the **ESPEY** line of custom-built chassis we have kept in mind the physical dimensions necessary for chassis units which could be easily adapted to custom-built work, or as replacements for existing inferior units. Carefully engineered and manufactured to give absolute satisfaction in any type of installation. The Model 7-B can serve as an ideal replacement for AM sets housed in highly thought-of cabinets.

The **ESPEY Model 7-B** is an AM/FM superheterodyne receiver with 10 tubes plus a rectifier tube, operating on 105/125 volts AC, 50/60 cycle. Wired for phono operation, this superbly engineered receiver is supplied, ready to operate, with 10" speaker with Alnico #5 magnet, antennas, and all necessary hardware.

For further details about this—and the rest of the **ESPEY** line—write to Department F today.

ESPEY MANUFACTURING COMPANY, INC.
528 EAST 72ND STREET-NEW YORK 21, N. Y.

man."

As an example of the nature and attendance of the St. Louis meetings, four hundred radio servicemen for the Metropolitan St. Louis area heard Myron F. Melvin, Field Engineer for P. R. Mallory, Inc., of Indianapolis discuss the latest developments in television and FM Broadcasting at a meeting on April 7th at the St. Louis House. Service techniques developed for the eleven components manufactured by P. R. Mallory were discussed and demonstrated.

Jobbers Take Initiative

So there, viewed from three different angles and in three different parts of the country, we have a glimpse of the new spirit of cooperation that is springing up between jobbers and servicemen. While there are minor differences in method of attacking the problem, there are much more striking similarities:

Jobbers are agreed that the responsibility for leadership in this move rests squarely upon their own shoulders. Standing as they do between the manufacturer and the serviceman, they are a "natural" for bringing the two together—to the advantage of all three.

Meetings of radio servicemen, with a lecture on a timely subject by a factory representative or an outstanding figure in the radio field is the most popular vehicle for furthering this cooperation. In such meetings, both the educational and the social aspects should be stressed.

These get-togethers are receiving a most enthusiastic welcome from the servicemen, who are pleading for more of the same.

The jobbers sponsoring the meetings are well pleased with the benefits that they themselves are receiving from them. Not only do they emphatically and unanimously state this, but the fact that they are planning more and larger meetings is even stronger evidence that this is so.

Manufacturers Assist

Manufacturers are more than willing to contribute lecturers, for they realize that this is splendid advertising for their products placed exactly where it will do the most good.

It is not hard to read the meaning of these straws in the wind. Those

→ To Page 40

Let's Work Together

→ From Page 16

they have not had much luck in arranging lectures to aid the servicemen in becoming better businessmen. As he explains:

"It seems to be too much of an individual problem to handle in a general way. The best answer we have so far is Mike Ebinger. If a man goes into an interview with Mike with an open mind, he will come out a better radio business

S.S.S.

"Servicing by Signal Substitution"

Learn about this modern dynamic approach to radio servicing with ONLY BASIC TEST EQUIPMENT.

... Fully described in a 120 page book available from your Precision Distributor or factory at 40c.

... Schools are invited to inquire regarding quantity orders from our Educational Division.

PRECISION
APPARATUS COMPANY, INC.
ELMHURST 2, N. Y.

Manufacturers of Fine Test Equipment
RADIO • TELEVISION • ELECTRICAL • LABORATORY

Here's that NEW F.M.—A.M. *Sig. Gen.*



Model 3433 Signal Generator

F.M. SWEEP FROM 0 TO 300 K.C. MODULATION FREQUENCY 60 OR 400 CYCLES PER SECOND.

Stable frequency modulated signals give undistorted wave form. This permits easy and more precise alignment over all frequency ranges thus insuring maximum performance in a radio set that can in every way be comparable with original factory adjustments.

Other features include: constant deviation by using a fixed frequency reactance oscillator, 110 Volt A.C. line filter to prevent leakage thru power supply, horizontal synchronized sweep voltage available thru jack on front panel.

Be sure to see this new Triplet F.M.—A.M. Signal Generator at your Parts Distributor.

For complete technical description write Dept. W-28

Frequency Ranges: Fundamentals—from 100 K.C. to 120 M.C. in ten bands. Added Frequency—(provided by built-in fixed 50 M.C. oscillator) from 120 M.C. to 170 M.C. Second harmonics can also be used to double the A.M. fundamental ranges.

Precision first...to Last



TRIPLET ELECTRICAL INSTRUMENT COMPANY • BLUFFTON, OHIO
Representatives in Principal U. S. and Canadian Cities.

SMASH Values from MID-AMERICA

Look at these sensational buys in brand-new, unused, top-quality radio parts and electronic equipment. You've never seen big buys like these before! And that's only the beginning. These values are but a few of the hundreds and hundreds of items Mid-America has in stock right now. Write for free catalog. You'll save money!

New Standard Brand TUBES at World's Lowest Prices!

1A5GT.....47c	12AT6.....47c	9002.....41c
1H5GT.....47c	12C8.....49c	9003.....31c
1N5GT.....59c	12SA7GT.....47c	9006.....41c
1R5.....59c	12SG7.....49c	1E36.....19c
2-2 8/9.....59c	12SR7.....47c	1M20.....19c
304.....72c	12SQ7.....47c	2C26.....49c
3Q5GT.....69c	12S97GT.....47c	3BP1.....\$1.00
5Y3GT.....43c	12SR7.....69c	5CP1.....\$1.75
6AG5.....69c	2B07.....79c	3D21A.....\$1.00
6H6.....49c	35L6GT.....47c	15E.....\$1.95
6J6.....59c	35W4.....45c	15R.....\$1.95
6SA7.....47c	50A5.....65c	RK34 2C34.....79c
6SA7GT.....47c	50B5.....47c	HY114B.....79c
6SH7.....34c	117Z3.....79c	HY615.....79c
6SK7GT.....47c	954.....39c	801A.....99c
6SQ7.....45c	955.....39c	803.....\$3.75
6V6GT G.....47c	1613.....25c	807.....90c
6X5GT.....45c	1619.....13c	830B.....\$1.95
7C4.....59c	1624.....25c	1005.....49c
7E5.....59c	1625.....25c	1960.....\$1.00
7Y4.....59c	1632.....25c	V990.....79c
7Z4.....59c	1633.....25c	VR150.....79c



DACO Tube Tester

Tests performance, leakage and shorts in ALL receiving tubes, even sub-miniature and acorn. PLUS provision for tubes that may be invented. Durable construction is fully shielded; dust-proof case, high-visibility meter, illuminated chart; no books or charts to be misplaced. Simple, fast operation with positive contact slide-switches; tests EVERY tube element. 110 volt AC. 16 1/2" x 14 1/2". MA-2193.....\$29.50

PORTABLE DACO TUBE TESTER

Same construction and operating features as counter model. Enclosed in sturdy case with durable black leatherette covering. 12 1/2" x 12 1/2". MA-2194.....\$32.50

PHONO AMP and RECORD CHANGER



Inexpensive phono amplifier and record changer with "big set" features. Positive-action Crescent changer handles 10" and 12" records without jamming; finger-tip reject button. Lightweight counter-balanced pickup arm with Shure crystal and lifetime floating sapphire needle. 78 RPM constant-speed motor. 5" PM speaker and high-quality amplifier complete with tubes. Base measures 15 1/2" x 12 1/2" x 6". MA21 Base with motor, turntable and record changer. MA-2192.....\$14.95



15" HIGH-FIDELITY DYNAMIC SPEAKER

Husky 25-watt dynamic speaker for use where perfect reproduction is desired. Ideal for both indoor and outdoor installations. 12,500 ohm field. 16 ohm voice coil. Regular \$40.00. MA-2190.....\$18.95

FM and HAM ANTENNA



AN-104-B. 1/2-wave at 100-156 MC; formerly used with SCR-522, 274-N. ARG-5. A pair make an excellent broad-band dipole for FM reception. Coaxial connector in base. Very sturdy; use anywhere. MA-2153.....39c

FREE CATALOG

Order now—right from this ad! Send 25% deposit—we ship C.O.D. for balance plus postage. Write, too, for Mid-America's big, complete catalog that lists hundreds and hundreds of hard-to-get items—ALL AT UNBEATABLE LOW PRICES! Mail orders and catalog requests to store address—Dept. RM-28

MID-AMERICA CO. Inc.

STORE: 2412 S. MICHIGAN AVE. CHICAGO 16 ILL. WAREHOUSE: 2307 S. ARCHER AVE. CHICAGO 16 ILL.

THE INDUSTRY PRESENTS



ELECTROLYTIC CONDENSERS

Aerovox midget-can electrolytic condensers, known as "Dandees," are now available in voltage ratings of 500, 600, and 700 volts DC working in addition to lower ratings previously released. Capacitance values are 8, 10, 12, and 16 ufd. Further details may be obtained from Aerovox Corporation, New Bedford, Mass.

available. Further information can be obtained from Kay Electric Co., 34 Marshall St., Newark, N. J.

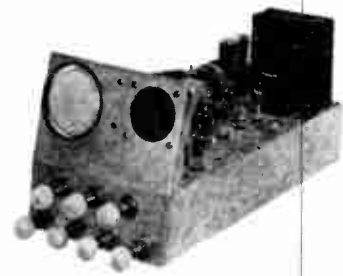

TELEVISION KIT

A television kit intended for self-instruction purposes has been introduced by the Espey Manufacturing Company, Inc. There is a large demand from servicemen and amateurs for a low-cost simplified television kit which instructs the individual in the basic concepts of television. This kit is a television tool for technical schools which are primarily interested in the instruction value of the mechanism rather than its commercial aspects. In using a three-inch picture tube, Espey was primarily concerned with the development of a training kit; and, therefore, felt that the size of the screen was of secondary importance. The fact that the high voltage is only 1000 volts makes it safer for experiments in trainee hands.

The kit uses miniature tubes, making the size of the unit only about 50 per cent greater than that of the familiar 5 tube AC/DC broadcast receiver. This provides the utility of a personal television set as well as aid in self instruction. For further information, write to Espey Mfg. Co., Inc., 528 East 72 Street, New York 21, N. Y.

SILVER SOLDER KIT

The American Products Corporation's silver soldering outfit produces non-corrosive, leak-proof joints stronger than the metal itself. It includes all necessary equipment and materials for brazing and compares favorably with acetylene torch brazing on metals up to 1/4" thickness. The outfit includes an alcohol torch, fuel, heat-retaining chamber, accessories, instructions for use, and a silver solder supply kit including a

→ To Page 36



MARKER OSCILLATOR

The Kay Mega-Marker is a precision variable marker oscillator which covers the range of 19 to 29 megacycles for the television IF band. A crystal oscillator supplies a 10.7 mc signal for FM receivers, and 12 inches of calibrated scale length provide an accuracy of 0.02 mc. Harmonic check points from the crystal controlled oscillator are

FOR FASTER SOLDERING
2 NEW WELLER
SOLDERING GUNS
 with

Solderlite



The new Weller Soldering Guns with Solderlite plus the fast 5 second heating help make service work more profitable for radio, television and appliance service men, electrical maintenance men, electric motor rewinding and repair shops automotive electrical service.

A useful and time-saving tool for laboratory workers, experimenters, hobbyists, telephone installation and maintenance men. S107 100 watts single heat, D207 100/135 watts dual heat.

See your radio parts distributor or write for bulletin direct.

WELLER
MANUFACTURING CO.
 812 Packer St., Easton, Pa.

ELECTRONICALLY SPEAKING

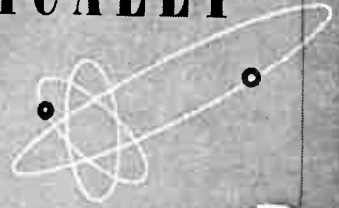

ENGINEERS in the Tube Division of General Electric recently released a story about a radio tube which fell 10,000 feet from a Flying Fortress and not only survived but is now in use in a transmitter. The tube's descent took place after an attack by the Luftwaffe on a formation of Flying Fortresses in 1943.

In the course of the ensuing battle several planes exploded, and it was observed that a small package fell to the earth. A standard transmitting tube, the G1-211, was found in the package. Neither the filament nor any of the other elements were injured. A. A. Blik, of Enschede, Netherlands, reported in a letter recently that the tube is at present in operation in the transmitter of a Netherlands amateur radio group.

A fall from this height without injury to the filament is particularly remarkable in view of the fact that the filament of the tube is made of thoriated tungsten, which is even more brittle than the glass envelope in which it is enclosed.

Interesting data on the propagation of television signals over great distances were recently gathered by Dr. Thomas T. Goldsmith and his DuMont engineers. These data were taken during about 4000 miles of air travel made possible by the cooperation of the U. S. Army Air Corps and the Signal Corps, who supplied the plane, some of the equipment, and part of the personnel. Observations were made of the telecast transmissions of stations WABD in New York and WTTG in Washington. The plane flew between New York and Washington in observing the signals of both stations, and between New York and Boston for further data on WABD alone.

Results indicated adequate sig-

nal strength for line of sight reception even up to a distance of 250 miles, although pitching and turning of the plane caused considerable variations.

Another interesting result of the flight was the study made of the effects of interference. The fact that WABD and WTTG operate on the same channel made this possible. With the airborne receiver about midway between the transmitters, the beat frequency pattern completely obliterated the video component.

It seems that New York City is going to be a center for development of television in the motion picture industry in the East. The Radio Corporation of America and the 20th Century Fox Film Corporation recently signed a contract for a joint program of research on large screen television. The project will be centered in the film company's Movietone Newsreel studios in Manhattan. An identical contract was recently signed between RCA and Warner Brothers.

A demonstration of the practicality of facsimile was recently given to strollers along the boardwalk near the municipal auditorium in Atlantic City. Radio Inventions, Inc., of New York City, with cooperation from General Electric, arranged the demonstration as a feature of the National Association of Broadcasters convention. News transmitted from the headquarters booth was delivered to various display points along the boardwalk by electronic means.

Howard W. Sams, publisher of the Photofact Radio Data Service, recently announced the development by his organization of a new, uniform style of schematic diagram

→ To Page 30



Quick Starting

Like the split second dash of a startled deer in the snow-capped northlands, the Radiart VIBRATOR has no equal in quick starting! This is true even under the most adverse conditions occasioned by frigid temperatures. The low battery voltage that accompanies cold weather holds no threat to Radiart VIBRATORS, they start, and start quickly even with a minimum of voltage . . . even less than 5 volts . . . yet easily withstand high voltages. This unique quality is a tribute to the special design and engineering skill behind Radiart VIBRATORS. Just another reason why Radiart leads the field . . . and is preferred by servicemen who want their customers to be supplied with the best.

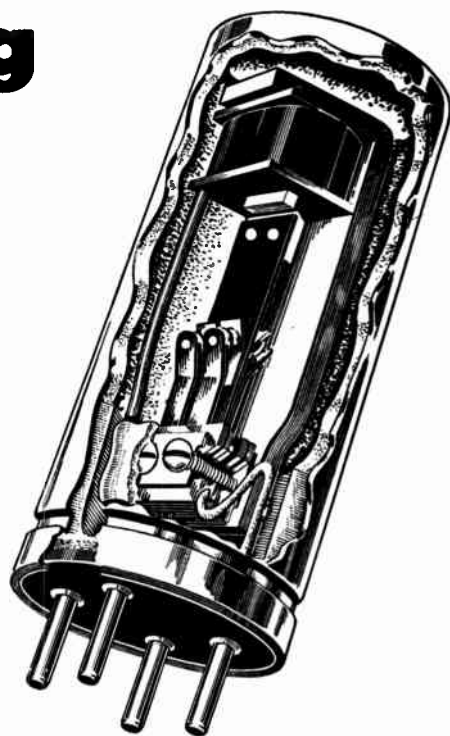

The Radiart Corp.

CLEVELAND 2, OHIO

Electronically Speaking

→ From Page 28

representation. The "Standard Notation" schematics feature a basic set of uniform standards to which every diagram is drawn. This standardization eliminates the difficulties of varying symbols and different styles. Since a single form is used for all circuits, savings in service time are made possible. Radio Maintenance readers were given the opportunity to participate in a poll taken among thousands of service technicians by the Sams' organization in cooperation with the Radio Manufacturers' Association. The results of this poll determined the standards which were decided upon.

According to Dan Halpin, RCA Victor Television Receiver sales manager, television today broadcasts to regions with a combined population of nearly 25,000,000 people in eight metropolitan sections. He estimates that by 1948, 10,000,000 more potential listeners will be added, and mid-1949 will see 15 additional cities being served.

Mr. Halpin described the importance of establishing economical network facilities for broadcasters as soon as possible. An example of this is the way WBKB, Chicago, is broadcasting the Notre Dame football games from South Bend to the Chicago viewing audience. Notre Dame welcomes this arrangement because every seat in their 55,000 seat stadium is already allocated, and there are tremendous demands for more.

The lighthouse keeper, who keeps his light burning at all costs for the safety of ships, will be assisted by a new electronic development announced by General Electric Company here.

The new unit is a small radar beacon for lighthouses whose op-

→ To Page 32

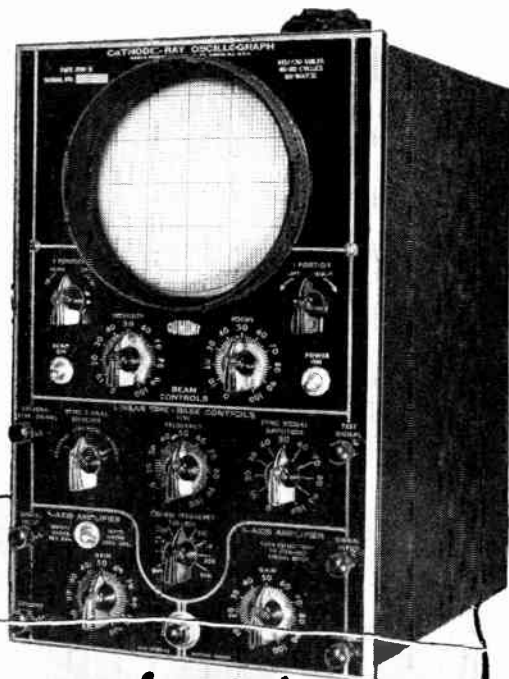

Comparison
is the true test!

- ★ High deflection sensitivity—0.01 v/in!
- ★ Wide-frequency response—flat from 2 to 100,000 cps
- Etc. Etc. Etc.

DU MONT Type 208-B CATHODE-RAY OSCILLOGRAPH

◆ You be the judge. Compare the Du Mont Type 208-B Cathode-ray Oscilloscope with any other instrument claimed to be its equivalent.

Compare deflection sensitivity (0.01 v/in for the 208-B); frequency response (2 to 100,000 cps for the 208-B); degree of distortion for any setting of gain control (no discernible distortion over entire range of gain control with the 208-B).

Meanwhile, don't be misled by "paper" specifications. Ask your jobber to demonstrate any other instrument alongside the 208-B. Compare

© ALLEN B. DU MONT LABORATORIES, INC.

linearity and range of sweeps. Look inside the instruments. Notice the fine electrical and mechanical craftsmanship in the 208-B.

You'll soon be convinced that the 208-B is the *quality instrument* for that *quality servicing* that pays the real money. Definitely, you won't be satisfied with less.

Your 208-B is well within reach of your pocketbook. At \$270 it's the best investment today in radio test equipment. Cat. No. 1146-A. Immediate delivery from stock. Don't delay—order today!

DU MONT

**ALLEN B. DU MONT
LABORATORIES, Inc.**

Passaic • New Jersey

Cable Address: Albeedu, Passaic, N. J., U. S. A.



TUBULAR ELECTROLYTICS

Fresh stock Fully guaranteed

20 mfd. 150 V.	10 for \$1.79
20-20 mfd. 150 V.	10 for 2.49
8 mfd. 450 V.	10 for 1.85

Postage extra, 25% deposit on C.O.D.
Write for our free bargain lists featuring
"AMERICA'S BEST BUYS"

POTTER RADIO CO.

1314-M McGee Street Kansas City 6, Mo.

Plastic Molded Tubular Paper Capacitors

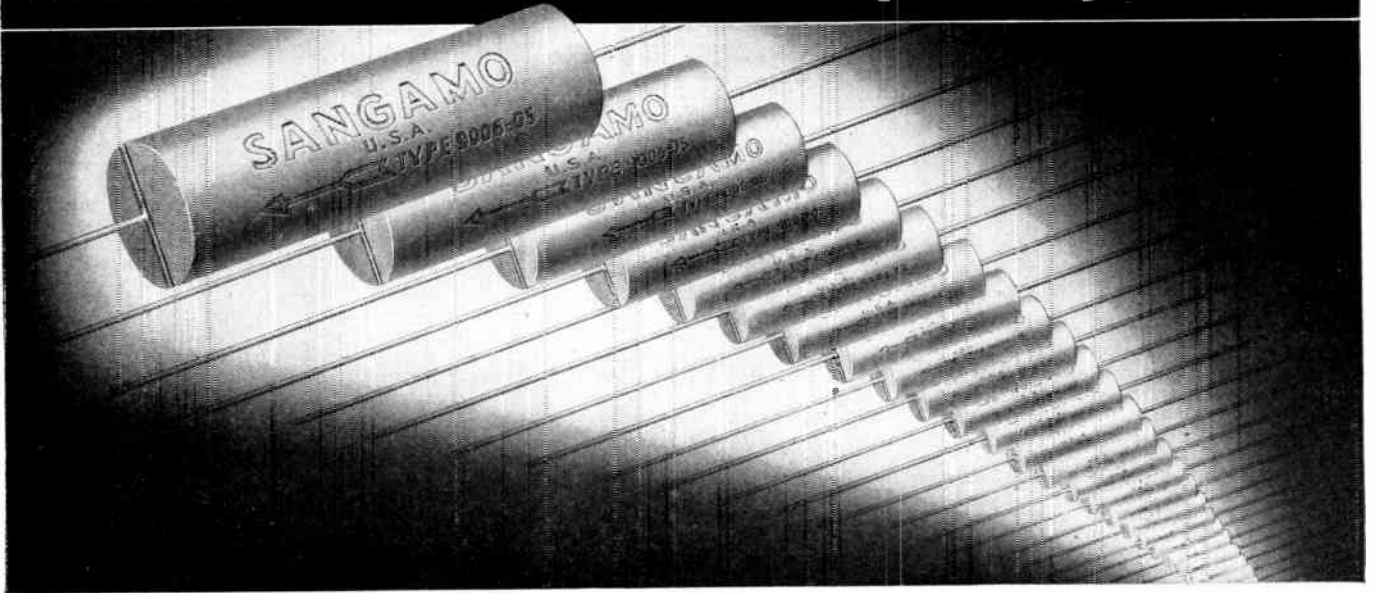

Pioneered by Sangamo!

Just as the *first* molded mica capacitor was designed by Sangamo in 1923, so the *first* plastic molded tubular paper capacitor was introduced by Sangamo in 1946. Today, after more than a year of constant improvement and development, based on reports of field service experience from coast to coast, the Sangamo Type 30 Capacitor will fully meet all new RMA Specifications.

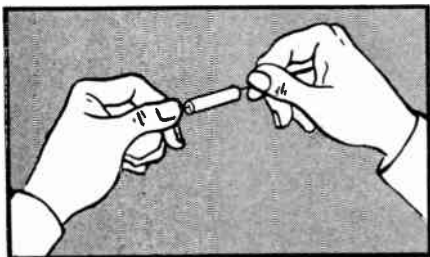

The same advantages that Sangamo pioneered in molded micas are now available in these new paper tubulars molded in a thermo-setting plastic: capacity values are permanently sealed in; no wax ends to melt out at high temperatures; and their mechanical stability has been

improved so that it does away with the necessity for delicate handling. These advantages mean better characteristics, longer life and more dependable performance.

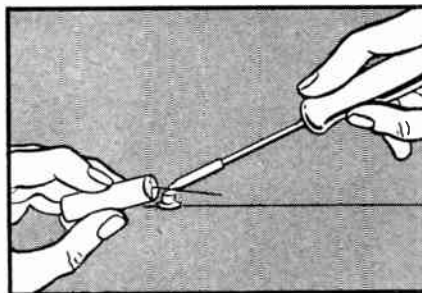

Sangamo Type 30 Plastic Molded Tubular Paper Capacitors can be used wherever ordinary paper capacitors are used! Heat from a soldering iron will not cause wax to run... nothing can burn! This means greater ease of installation—fewer damaged assemblies—and

more jobs finished in less time. Radio service men and manufacturers will readily appreciate the many improvements embodied in the new Sangamo Type 30 Capacitor. It is *definitely superior*.



Write for the new Sangamo Capacitor Catalog Number 23B. It gives full information on the complete range of Sangamo Paper, Mica and Silver Capacitors.

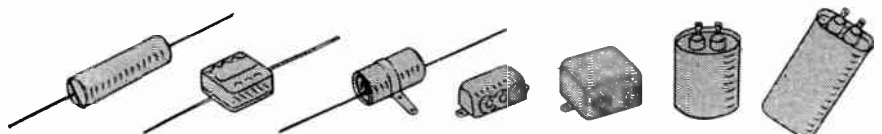

SANGAMO
ELECTRIC COMPANY
SPRINGFIELD • ILLINOIS

SC 481

THERE'S A LOT OF PROFITS PACKED INTO THE NEW SHURE CARTRIDGE REPLACEMENT PACK



MODEL W50A

... because you only need a small parts inventory to handle most of your cartridge replacement business.

The Shure Cartridge "PACK" is the serviceman's friend in more ways than one: Shure crystal cartridges have become a standard by which quality and dependability are judged; and they will now replace over 58 cartridges being used in phonograph reproduction today. The "PACK" contains five Shure lever-type cartridges including the "Muted Stylus"* cartridge with the osmium-tip. A Shure Replacement Chart is in each pack for handy reference. It picks out the particular cartridge you should use to replace another. The "PACK" speeds up your profits: no need to order a certain type cartridge—then have to wait until your order is filled. With the "PACK" you can service your customers faster, get profits quicker.

** The "Muted Stylus" combines high output with amazing needle quietness*

Model W50A (includes 5 Shure Cartridges) CODE: RUPAC LIST PRICE \$30.80



SHURE BROTHERS, INC.

Microphones & Acoustic Devices

225 W. HURON ST., CHICAGO 10, ILL.

CABLE ADDRESS: SHUREMICRO

Electronically Speaking

→ From page 30

eration can be likened to a powerful "electronic beacon" emitting signals invisible to the human eye but which will be detected by radar-equipped ships.

General Electric has shipped from its electronics headquarters here the first of a series of units which may eventually replace the time-honored lighthouse light. Called an "electronic beacon," the unit was built for the United States Coast Guard.

Designed to assist lighthouses during periods of fog, rain, snow and sleet, it sends out a continuous radar beam which is received on ships equipped with war-developed navigational radar equipment. Signals from the "electronic beacon" will appear as a bright ray on the radar's indicator showing the exact direction of the beacon in the same way that the conventional lighthouse is located by the beam of light it emits. " " "



BINDERS!

**PRESERVE YOUR
RADIO MAINTENANCE
MAGAZINES IN
THEM**

RADIO MAINTENANCE
460 Bloomfield Avenue
Montclair, N. J.
Please send me.....binders at \$3.00
each.

Total amount enclosed.....

Name

Address

City Zone.....

State

NOW!

at your
jobber's counter

THE RADIO DATA BOOK

All data and basic knowledge
in radio and electronics
digested into 12 sections . . .
in a complete, quick to find,
easy to read, handbook form.

Handsomely Bound in Red
& Gold

Plan every operation in radio and electronics with the *Radio Data Book*. This new radio bible will be your lifelong tool . . . you will use it every day, on the board, at the bench, in the field! Use it for construction, troubleshooting and testing. The RADIO DATA BOOK will be your invaluable aid in design, experiment and in layout. It will help make your production better, faster and easier. In any and every operation in radio and electronics, you will use the RADIO DATA BOOK!

The RADIO DATA BOOK is a work of complete authority, prepared by engineers with many years of practical experience. They have been assisted by the Boland & Boyce staff of editors skilled in preparing electronics manuals for the U. S. Signal Corps for many years. These men have worked for several years gathering material for this book . . . all the knowledge of radio principles and operation . . . all the statistics . . . all the newest developments in electronics . . . every possible angle and detail. Eighteen months were spent digesting this material into the most concise, the clearest, and the most readable form. The result is this invaluable manual . . . The RADIO DATA BOOK. Whether you use this book for general reference, for scientific instruction, or for education, one thing is certain—the practical help, the daily usefulness you will derive from it will prove to be worth many, many times its astonishingly low price!

Advanced Sale . . . first printing. Only 10,000 available . . . To make sure to get your RADIO DATA BOOK, mail your order NOW!

CONTENTS

Each section is a COMPLETE coverage of its subject . . . 12 sections 12 books in ONE! 1000 pages . . . Schematics . . . Accurate photographs . . . Specially prepared drawings . . . White on black charts . . . Diagrams . . . Isometric projections and exploded view.

- Section 1. **THE 150 BASIC CIRCUITS IN RADIO.**
Every circuit is analyzed and explained in a Johnny-or-the-spot reference for any occasion.
- Section 2. **COMPLETE TEST EQUIPMENT DATA.**
Know more about the test instruments you now have. . . . Find the new ones you want to buy . . . They're ALL in here—impartially described!
- Section 3. **TESTING, MEASURING AND ALIGNMENT.**
Simplified operation of the Oscilloscope . . . See what's happening inside any radio circuit . . . Dynamic alignment—AM, FM and TELEVISION made easy with the Oscilloscope . . . Scientific use of the Vacuum Tube Voltmeter, Signal Generating Equipment and other basic instruments.
- Section 4. **ALL ABOUT ANTENNAS.**
AM-FM-Television . . . design, installation, characteristics, construction and feed.
- Section 5. **SOUND SYSTEMS.**
Planning, installing and servicing a PA System. A complete chapter on every component . . . How to select and combine components . . . estimating costs . . . even acoustic requirements!

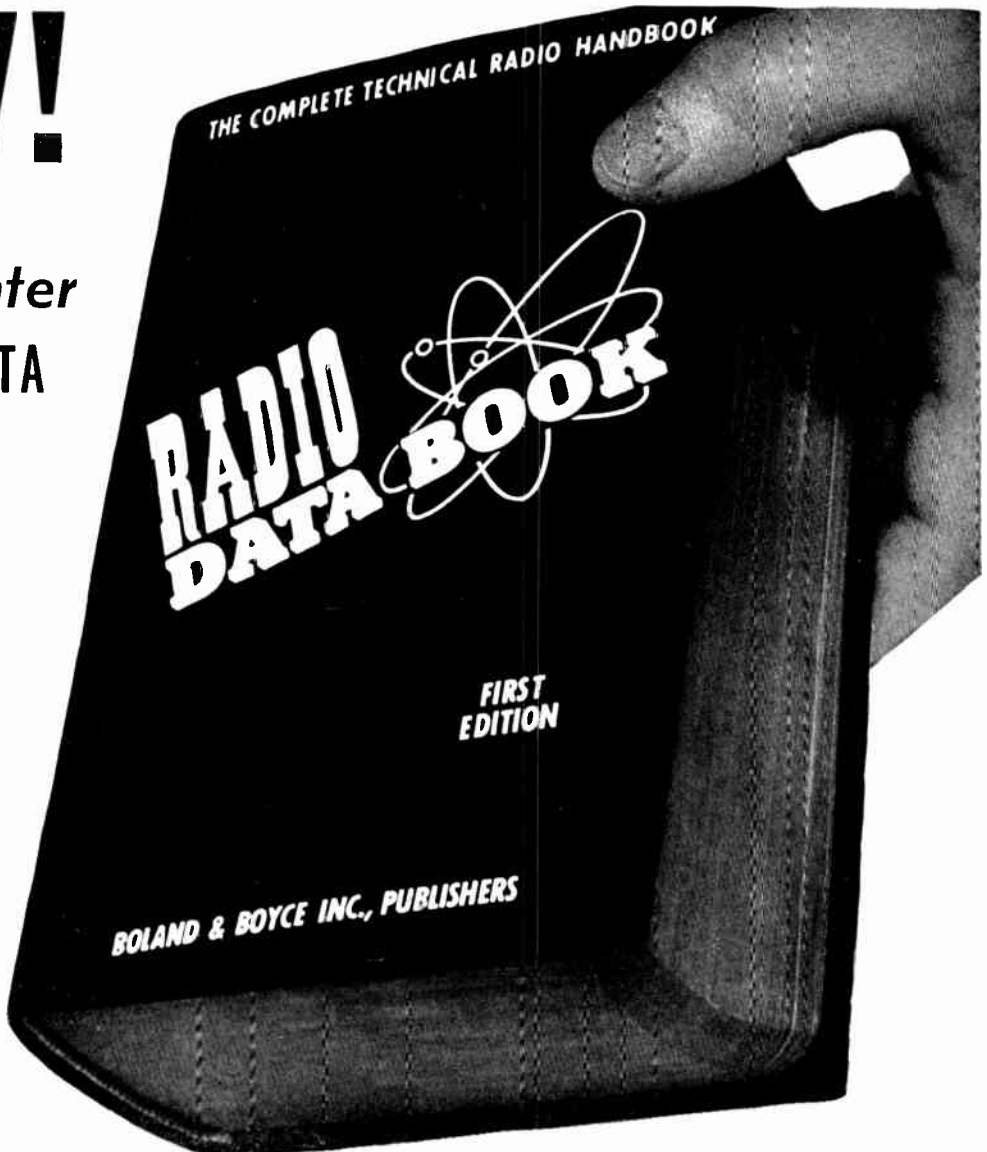

- Section 6. **ELECTRICAL AND PHYSICAL CHARACTERISTICS OF RADIO COMPONENTS.**
Know the size, the power, the shape! A quick reference on the construction and design of any circuit or equipment.
- Section 7. **COMPLETE TUBE MANUAL; Receiving, Transmitting and Commercial.**
A flick of the pages brings you to all the data and ratings of any tube model!
- Section 8. **CHARTS, GRAPHS AND CURVES.**
Quick calculation devices . . . Plotting curves, nomographs, rules and tables for speedy solutions to radio problems
- Section 9. **CODES, SYMBOLS AND STANDARDS.**
Handy reference to all radio symbols and abbreviations; code symbols, phrases and characters . . . Where you want them . . . When you want them!
- Section 10. **50 TESTED CIRCUITS DESIGNED FOR OPTIMUM PERFORMANCE.**
Find any circuit you want with complete parts lists and specifications. . . . One tube receivers to complete AM, FM and Television receiver circuits . . . Amplifiers . . . Transmitters . . . Test Equipment and Control Circuits . . . All with the latest engineering refinements.
- Section 11. **DICTIONARY OF RADIO AND ELECTRONIC TERMS.**
- Section 12. **RADIO BOOK BIBLIOGRAPHY.**

2 complete books in one only \$5.00. Less than 42c per book

Mail This Coupon To Your Jobber Today or Direct to:
BOLAND & BOYCE INC., PUBLISHERS
460 BLOOMFIELD AVE., MONTCLAIR 3, N. J.

Please send me a copy of
THE RADIO DATA BOOK Enclosed is \$5.00.

NAME

ADDRESS

CITYZONE.....

STATE

BOLAND & BOYCE INC., PUBLISHERS

ASTATIC Introduces NEW "LT" CARTRIDGE IN STAMPED HOUSING MODELS



Model "LT1-M"
Die Cast Housing
Weight 28 Grams

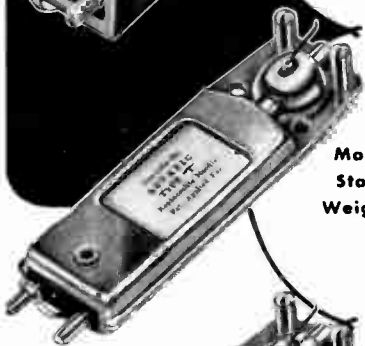

Model "LT2-M"
Stamped Steel
Weight 20 Grams

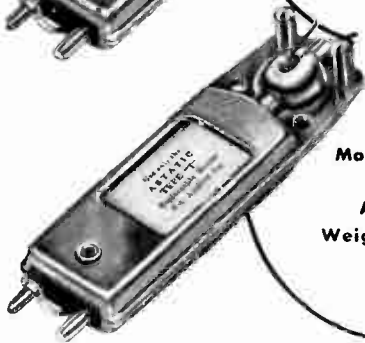

Model "LT3-M"
Stamped
Aluminum
Weight 11 Grams

In providing this selection, Astatic makes it possible to choose the cartridge models having the proper weight to provide optimum needle pressure and pickup inertia characteristics with various types of arms.

Note

THESE "LT" FEATURES

1. Low Needle Talk
2. Low Needle Pressure
3. Low Price
4. Replaceable "T" Needle
5. Cutoff Frequency, 4,000 c.p.s.
6. Output Voltage, 1.00 volt (Avg. at 1,000 c.p.s.).
7. Choice of three weights: Die Cast, 28 Grams; Stamped Steel, 20 Grams; Stamped Aluminum, 11 Grams
8. Needle Guard Posts
9. Standard Dimensions

Because of the LOW Needle Talk, LOW Needle Pressure and LOW Price, the "LT" Series Crystal Cartridges are highly recommended for use with all types of record changers and manually operated phonographs. The "LT" employs a Type "T," matched, replaceable Needle with an electro-formed precious metal tip. Special Literature is available.



For those who prefer a de luxe Reproducer, Astatic suggests earnest consideration of the "QT" (Quiet Talk) CRYSTAL CARTRIDGE—with matched, replaceable "Q" Needle, sapphire or precious metal tipped.



Copyright, Astatic Corp., 1947

Industry Presents

→ From Page 26

tube of flux paste and 100 inches of silver solder wire and strip sheet. The kit may also be used with an acetylene torch. Packed in a self contained permanent case, the outfit weighs only 3 lbs.

For further information, write to The American Products Corp., 803-36 Lowell Bldg., Chicago 5, Ill.



COIN OPERATED RADIO

The Radio-ett, a new coin operated, 6-tube receiver measures only 7 1/2" x 7 1/2" x 5". The unit features preset maximum volume, slug rejector for bad coins, adjustable timer and a squelch system to eliminate interstation noise. The cabinet is aluminum and is available in a variety of finishes and colors. No external antenna is needed. For further information, write to Radio Inc., Asbury Park, N. J.



DISTORTION METER

The Barker & Williamson Model 400 Dis-

→ To Page 36

Throw Away Your Old Instruments Remarkable New STETHOSCOPE Method Guaranteed to Lick Toughest Jobs

Why let old-fashioned methods and equipment hamper your servicing ability? Thousands of radio men—many with little experience—are already fixing radios this remarkable "automatic" way. It's as simple as A-B-C, because Stethoscope Servicing is the newest, most basic method yet devised to simplify all repairs. Right at this very moment, you probably have on your bench one of those familiar "stumpers" for repair. But now you can fix these "headaches" in a jiffy—the Stethoscope way. STETHOSCOPE SERVICING is guaranteed to speed up and improve your servicing ability, or your money will be refunded. You owe it to yourself to find out how you, too, can begin cashing in. Don't delay! Send for 24 page illustrated booklet, "The Inside Story." It's FREE!

Feiler Engineering Co.,

915 George St., Chicago 14, Illinois Dept. 2M8

OVER THE BENCH

by John T. Frye

YOU do not have to be an old-timer to remember the magazine article that appeared some six years ago reporting on an investigation of nineteen radio repair shops, seventeen of which, according to the magazine's finding, proved to be dishonest. Recently a radio trade sheet conducted another similar test. A reporter took a portable radio "in perfect operating condition" except for a simple short circuit "in plain view" to twenty Manhattan servicemen.

Hardly two shops agreed on what was the trouble. "A new condenser," "a short in the transformer," "complete realignment," and "a defective oscillator" were typical estimated repairs. Not one shop called attention to the short. What was worse, repairmen slyly wrecked the volume control, the tuning control, two tubes, and the batteries while the customer was supposedly not looking. Estimates for repairing the set ranged from nine to fifteen dollars. In six years time, apparently the percentage of dishonest servicemen has risen from seventeen out of nineteen to a round twenty out of twenty!

That is not a pretty story, but you should know it. Thousands of your customers have already read it in a news magazine of international circulation. The next time their radio needs repair, that story will be in the back of their minds. They will be wondering if your shop is an exception to what seems to be a pretty well standardized practice of larceny in the radio repair business.

First, I should like to say what can be said in defense of the radio service fraternity in this situation. I offer no excuses whatsoever for the practices exposed by the investigation. I do, though, take exception to the inference that these tests reveal the ethical standards of the radio service profession as a whole.

In the first place, neither of the

tests was of a kind that I should like to see given. In the first instance, a grid lead was removed; in the second, a simple short-circuit was contrived. Had I, as a serviceman, found either of these conditions in a set, I should have assumed that it was not *the original cause of trouble*. Grid caps very seldom come off of their own accord, nor do simple short circuits develop without cause. Seeing these things, I should have assumed that they had been brought about by amateurish attempts on the part of the customer to locate the difficulty. I should have corrected them and then gone on to try to locate an apparent intermittent condition in the set. This would have included testing all tubes, checking condensers, varying the supply voltage, checking alignment, etc. Considerable time would have been consumed in doing these things, and I should have charged for it. My bill would have revealed the discovery of the short, and it would also have included the various checks made to see if any intermittent condition was present. The bill would not have been nine dollars nor any large portion of that, but I should have been paid for my time.

The customer would have been getting his money's worth, too; for much of what I should have done would have been with the intent of preventing future trouble. When a set goes into a service shop, it should be checked completely and returned to as near a state of tip-top performance as the serviceman's art permits. It is the slovenly workman who locates a single cause of trouble and then slaps the chassis back in the cabinet without looking for any other defects that may exist. A good serviceman will locate and repair many incipient troubles that have not yet reached the point of causing

→ To Page 43



Servicemen's choice!
in . . .



● For 32 years, Cunninghams have carried New York State on a platform of quality and performance. That's why your customers are candidates for Cunninghams . . . why Cunninghams should be *your* choice.

See your
CUNNINGHAM DISTRIBUTOR

DYMAC, Inc. Buffalo
BARCLAY-NEW YORK, Inc. New York
ROCHESTER RADIO SUPPLY CO.,
Rochester
CITY ELECTRIC CO., Inc. Syracuse



The ONLY POWER SUPPLY

that gives these ratings*
without overheating

Electro
ELECTRICAL AND RADIO EQUIPMENT

MODEL "A"

* 6V at 15 amps. in parallel
* 12V at 7½ amps. in series
* 6V at 7½ amps. separately
115 volts 60 cycles input



Operates auto radios with solenoid tuning and tone controls — also 12 volt marine and aircraft radios.

Height: 7¾" Length: 11¾"
Width: 7¾" Ship. wt. 31 lbs.

DC OUTPUT

Oversize transformers, chokes and rectifiers insure against overheating. Large capacity condensers for wide-range voltage regulation. Instantaneous power for solenoid operation. Two separately filtered DC output sources.

Compact. Sturdy. 18-gauge steel construction. Handsome blue Hammerloid finish. Comes completely equipped including 6' rubber cord and plug. Vastly superior and costs no more than batteries for equal service.

Send for complete description of this up-to-the-minute power supply.

ELECTRO PRODUCTS LABORATORIES

Pioneer Manufacturers of Battery Eliminators

549 West Randolph Street

Chicago 6, Illinois



STANDARD BRAND LINES
RCA • AMPERITE • SIMPSON-JENSEN
STANCOR • OHMITE • SHURE • BLILEY
DUMONT • IRC • TRIPLETT • SPRAGUE
and hundreds of other well-known brands
COMPLETE STOCKS

New! Complete!

Concord Radio Catalog

**LOWEST PRICES
on Everything in...
RADIO-TELEVISION-RADAR
ELECTRONIC EQUIPMENT**

- Thousands of items for every Radio and Electronic need.
- Special Bargains—money-saving values in top quality Radio Parts.
- Immediate delivery from huge stocks at Chicago and Atlanta.

MAIL COUPON FOR FREE COPY

Concord Radio Corporation, Dept. RM-28
901 W. Jackson Blvd., Chicago 7, Ill.

Yes, rush FREE COPY of the comprehensive new Concord Radio Catalog.

Name.....

Address.....

City.....State.....

**CONCORD
RADIO CORPORATION**

CHICAGO 7 ATLANTA 3
901 W. Jackson Blvd. 265 Peachtree St.
Downtown Chicago Branch - 229 West Madison St.
LAFAYETTE RADIO CORP.

Industry Presents

→ From Page 34

ortion Meter is designed for measuring low level audio voltages and determining their noise and harmonic content. It is also useful in measuring frequency and gain characteristics of audio amplifiers, or for any other application where a vacuum tube voltmeter is required in the audio range. The variable frequency selective filter provides a single frequency suppression circuit for the range of 50 to 15,000 cycles. The unit comes complete with power supply. Further information may be obtained from Barker & Williamson, Inc., 237 Fairfield Ave., Upper Darby, Pa.

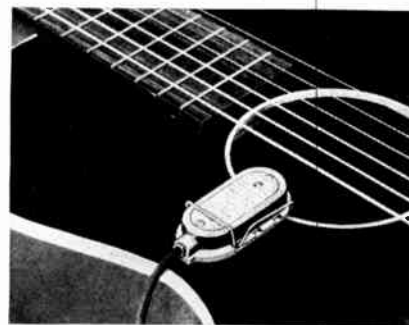

CONTACT MICROPHONE

A new contact microphone, Model 805, announced by Electro-Voice, Inc., is suitable for guitar, banjo, mandolin, violin, viola, cello, harp, drum and piano. Frequency response is from 40 to 8000 cps. It can be used with any amplifier having a high impedance input. The output level is 0.1 to 1 volt from an inertia-type crystal element. The 805 pickup is easily installed by means of a snap-on clip which attaches to the instrument in a few seconds. The pickup weighs two ounces and measures 2¼" x 1" x 7/16".

For further information, write to Electro-Voice, Inc., Buchanan, Michigan.

The Organizations

→ From Page 18

ufacture of a 6AK5 and Mr. Burkaw and Mr. Steinberg gave comprehensive talks on the manufacture, usage and inventory control of condensers.

The keynote of all talks was the greatly improved standing of the radio serviceman in his community and the far greater acceptance of standard brands by the servicemen in their work.

Chief Electronics, Inc., wholesale electronics distributors, Poughkeepsie, New York, sponsored the meeting. ✓ ✓ ✓

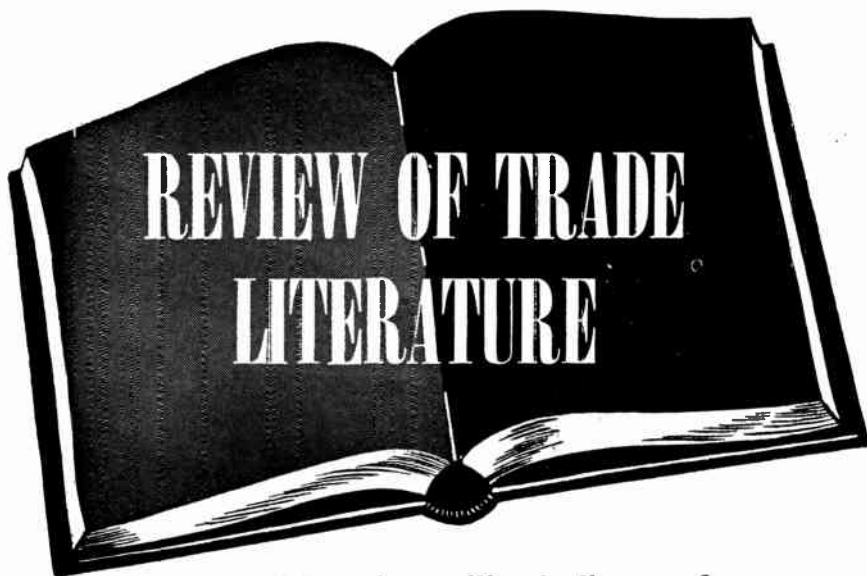

To avoid delay when writing to the manufacturer give issue and page number.

“VISUAL Alignment Techniques For FM Servicing” is the title of a new booklet just published by the Specialty Division of the General Electric Company. The booklet contains 28 pages including information on Cathode Ray Oscilloscope Theory, Sweep Signal Generators, Basic FM Circuits and Practical FM Alignment Information. Copies are available from GE distributors for twenty-five cents each.

Cornell-Dubilier has published a new catalog, designated as No. 200. It contains 24 pages and is illustrated with detail drawings and half-tones of more than 20 different classes of C-D capacitors. Both electrical and mechanical data are included for each type as well as list and net prices. Catalog 200 may be obtained by writing to Cornell-Dubilier Electric Corporation, South Plainfield, New Jersey.

The Burstein-Applebee Company's 1948 catalog No. 481 contains 114 pages of descriptions of all types of radio and electronic equipment. Of special interest are descriptions of the latest AM-FM signal generators, FM tuners, and inter-communication systems. There is also a complete coverage of components, test equipment, all types of receivers, antennas, tools, books and lighting equipment. The catalog is well illustrated and indexed. To obtain a copy, write to Burstein-Applebee Company, 1012-14 McGee Street, Kansas City 6, Mo.

RCA's Tube Department has printed a new edition of their Re-

ceiving Tube Manual. Features include information on new developments in FM, late technical data on miniature tubes and installation and application information on the latest models of television receivers. The sections on tube and circuit theory have been expanded to 55 pages. Useful formulas, data on resistance coupled amplifiers, and all the types of information found in previous editions are included. The manual is being distributed through RCA tube distributors. The price is thirty-five cents. A copy can be obtained by sending that amount to Commercial Engineering, RCA Tube Department, Harrison, N. J.

Allied Radio Corporation, announces the publication of a new 48-page supplement to their regular master catalog. The supplement features the most recent developments in radio and electronic equipment as well as latest price information. Included are new wire and disc recorders, test instruments, an added new line of transformers (UTC), a television kit and other new builders' kits, high-fidelity sound equipment, new amateur transmitting equipment, communications receivers and radio receiving sets. Latest price information is provided for standard tubes, test units, condensers and resistors, including many price reductions on this and other merchandise regularly used in the radio and electronics field. The new supplement No. 114 as well as Allied's regular 164-page master catalog No. 112 can be ob-

→ To Page 38



Servicemen's choice!
in . . .



● Cunninghams are a custom in Connecticut . . . because they're built for service. You can count on more customers if you replace with top-quality Cunninghams. Cast *your* vote for Cunninghams now!

See your
CUNNINGHAM DISTRIBUTOR

HATRY & YOUNG, Inc. Bridgeport
HATRY & YOUNG, Inc. Hartford
HATRY & YOUNG, Inc. New Haven
HATRY & YOUNG of New London, Inc.,
New London
HATRY & YOUNG, Inc. Stamford
HATRY & YOUNG, Inc. Waterbury



DRAKE HIGHLIGHTS THE 600-10



When the soldering job has to be done in close quarters use the Drake 600-10. This mighty mite of soldering irons is only 10 inches overall. Carries 100 watts and has a $\frac{5}{8}$ " tip.



DRAKE ELECTRIC WORKS, INC.

3654 N. Lincoln Ave.

Chicago 13

SEEING IS BELIEVING!

TUBES

MONEY BACK GUARANTEE

No "Off" brands, seconds or used tubes. Some in cartons.

1A5	\$.50	6SR7	\$.50	14R7	\$.75
1LM4	1.00	6V6	.50	25Z6	.60
1LN5	1.00	6X5	.60	26	.50
1N5	.60	6V6	.60	27	.50
1R5	.60	7A8	.60	30	.50
1S5	.60	7B6	.60	31	.50
1T4	.60	7B7	.60	35A5	.60
2C26	.50	7C5	.60	35L6	.50
2C40	1.00	7C6	.60	35W4	.50
3B24	1.00	7C7	.60	35Z5	.60
5U4	.50	7E5	.50	39/44	.50
5Y3	.50	7F8	.60	50B5	.60
6A8	.60	7G7	.95	50L6	.60
6AC7	.75	7N7	.50	50X6	.75
6AG5	.75	7Y4	.60	50Y8	.60
6AL5	.50	12A6	.50	75	.50
6C4	.50	12AH7	.60	76	.50
6C5	.50	12AT6	.60	77	.50
6H6	.50	12BA6	.60	78	.50
6J6	.50	12BE6	.60	80	.50
6J7	.60	12C8	.50	84/6Z4	.50
6K6	.50	12J5	.50	11ZL7	1.00
6K7	.60	12SF7	.60	FMT000	1.10
6S8	.50	12SG7	.60	XXRM	.95
6SA7	.50	12SH7	.50	XXL	.60
6SD7	.50	12SK7	.50	VR105	.80
6SG7	.50	12S17	.50	VR150	.60
6SH7	.50	12SN7	.50	826	1.00
6SJ7	.50	12SQ7	.60	954	.75
6SK7	.50	12SR7	.50	955	.75
6SL7	.75	14A7	.75	956	.75
6SN7	.50	14B6	.75	9001	.75
6SQ7	.50	14Q7	.75	9003	.75
		9006	.50		

Minimum Order \$2.00. All orders shipped F.O.B. Chicago. 25% Deposit on all C.O.D. Shipments. 10 days net to rated concerns.

DEDUCT 10% FROM ALL TUBE ORDERS \$20.00 OR OVER.

All items subject to prior sale. All prices subject to change without notice.

ORDER NOW!

IRVING JOSEPH

220 S. Halsted St.—Dept. A
Chicago 6, Illinois

Permoflux SPEAKERS

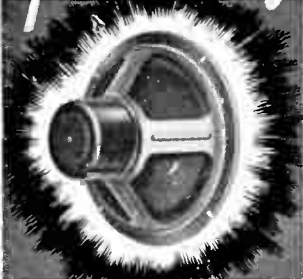

YOUR JOBBER CAN SUPPLY YOU!

Permoflux quality and dependability—the same as supplied to the major set manufacturers—is your assurance of complete customer satisfaction. You'll find Permoflux Speakers easy to install and readily available in both PM and Electrodynamic types. You'll find too, that it pays to give your customers "tops in tone" with a Permoflux Replacement Speaker.

TWO COMPLETE FACTORIES TO SERVE YOU

PERM-O-FLUX

WRITE FOR FREE BULLETIN

PIONEER MANUFACTURERS OF PERMANENT MAGNET DYNAMIC TRANSDUCERS

PERMOFLUX CORPORATION

4900 WEST GRAND AVE., CHICAGO 39, ILLINOIS
236 SOUTH VERDUGO ROAD, GLENDALE 5, CALIFORNIA

Trade Literature

→ From Page 37

tained without charge from the Allied Radio Corporation, 833 West Jackson Blvd., Chicago 7, Illinois.

Technical data covering twelve widely used crystal types are given in Bulletin No. 201, just issued by Premier Crystal Laboratories, Inc. Containing four pages and profusely illustrated with photographs and drawings, the new bulletin provides specifications of crystal character-

→ To Page 41

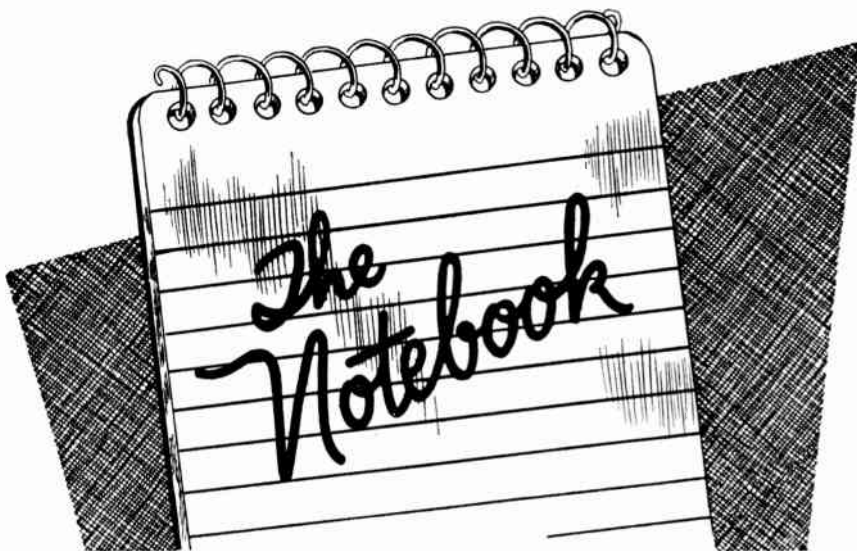

Each month the reader sending in the best suggestion receives a crisp ten dollar bill. For all others published, RADIO MAINTENANCE will pay five dollars. Let's hear from you.

Repairing Old IF Coils

Some of the IF transformers in the older sets have special trimmer assemblies and are difficult to replace. If you have trouble with the lower winding and you can't find a replacement, here's a way to repair the old one. (1) Measure the spacing between the coils. (2) Saw through the core just below

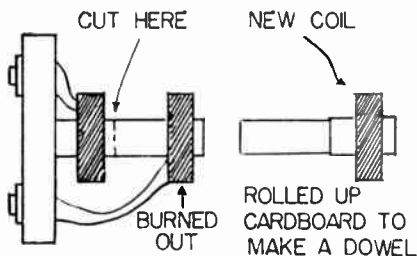

the top winding. (3) Remove bottom winding from a standard IF coil of the same frequency by sawing off the core. (4) Place rolled-up cardboard or some other material inside the new coil to form a dowel. (5) Glue the cores together as shown.

Lewis E. Wind
Wind's Radio Clinic
Jacksonville, Fla.

Soldering Iron Holder

A convenient soldering iron holder which keeps the hot tip off the top of the work bench can be made from an old adhesive tape

spool, set into the bench top as shown in the illustration. If a hole in the bench is used, the bottom

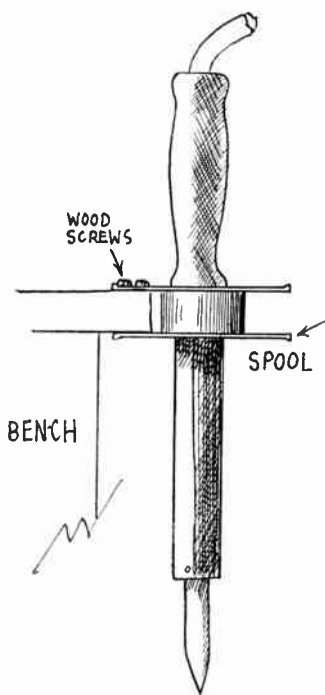

flange must be bent to slide through, then restraightened; otherwise a slot into which the spool will easily slide can be employed.

George G. Garmus, Jr.
Bronx 54, New York

Midget Set Prop

Chassis cradles are fine for working on the larger receivers, but often they are not much help with

→ To Page 42



Servicemen's choice!
in...



● Cunninghams continue to win new friends in Ohio because Cunninghams live up to their reputation for top quality and performance. You'll like Cunninghams, too!

See your CUNNINGHAM DISTRIBUTOR

- Holub & Hogg..... Cincinnati
- Radio & Electronic Parts Corp..... Cleveland
- Whitehead Radio Co..... Columbus
- Standard Radio & Electronic Products Co., Dayton
- Hutch & Son..... Lima
- Thompson Radio Supply..... Columbus
- Martin Sound System..... Massillon
- Sound Electronic Suppliers..... Portsmouth
- Thompson Radio Supplies..... Zanesville
- Radio Parts Co..... Youngstown





NOW! gigantic Double Feature trade-in on your used test equipment

(In Exchange for new post-war design **SUPREME** testers)

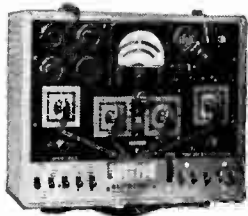

Tube and Battery Tester

Model 589 A
Roll chart and luggage type carrying case.

\$4797
NET

Think of it! Not one but two generous trade-in allowances on your used equipment! Yes, SUPREME Instruments Corp. and WALTER ASHE Radio Co. unite in a double feature trade-in to make this "two-way" offer the money-saving event of the year. To get SUPREME'S trade-in deal plus Walter Ashe's "Surprise" trade-in allowance act now, as this sensational bargain is good for a limited time only. Write, wire or phone today!

Signal Generator

Model 576
65 kc to 82 mc,
400 cy modulated

\$6757
NET

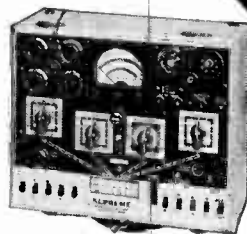

Tube and Set Tester

Model 599A
VOM and tube checker, roll chart, luggage type case.

\$6125
NET



Tube and Set Tester

Model 504B
VOM and tube checker, push button switching, roll chart, walnut case.

\$8771
NET

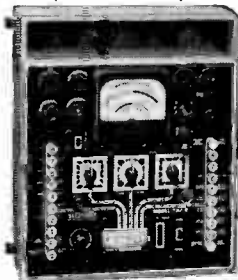

TEST EQUIPMENT IN STOCK

MEISSNER	TRIPLETT
McMURDO SILVER	R. C. A.
SPECIAL PRODUCTS CO.	BLILEY
INDUSTRIAL EQUIPMENT	WESTON
CORNELL - OUBILIER	SPRAGUE
COASTWISE ELECTRONIC	SUPREME
SUPERIOR	HICKOK
JACKSON	PRECISION
SIMPSON	WATERMAN
DOMONT	FEILER

Remember your Trade-In's Worth More at the Walter Ashe store! "Surprise" trade-in allowances on your used test equipment in exchange for the make or model of your choice.

TIME PAYMENTS AVAILABLE

Walter Ashe RADIO Co.

TEST EQUIPMENT HEADQUARTERS

1125 PINE ST. ST. LOUIS 1, MO. ALL PRICES F. O. B. ST. LOUIS

JUST OUT! **FM TRANSMISSION and RECEPTION**
by John F. Rider and Seymour D. Uslan

New BROADCAST OPERATOR'S HANDBOOK
by HAROLD E. ENNES, Engineer, Station WIRE

Here are coordinated facts, standards of good operating practice written by an operator in operators' language.
288 Pages \$3.30

2 NEW RIDER 99's
each over 130 pages
each only . . . 99c

PA INSTALLATION AND SERVICING
Provides the answers on what to do in making low power PA installations.

UNDERSTANDING VECTORS AND PHASE — Vector presentations are widely used in conveying latest radio technical information. This book is a must for students.

FOR radio servicemen who can look to FM as a big part of their future profits—for the "ham" who is considering narrow band FM—for the student who is grooming himself for activity in the electronic field—this new book explains both the theory and servicing of f-m receivers. Its text is equally valuable to every person interested in this phase of electronics and will serve as a valuable handbook for engineers.

The unique publication principle employed in the production of this new book is as practical as its contents. It is offered in two editions identical in contents, printing quality and paper—differing only in covers.

OVER 300 FACT-PACKED PAGES
(substantial paper cover) **\$1.80**
Hard back cloth cover, **\$2.70**

BY THE PUBLISHER OF RIDER MANUALS

JOHN F. RIDER PUBLISHER, INC.
404 FOURTH AVENUE, NEW YORK 16, N. Y.

Let's Work Together

→ From Page 24

jobbers who are sponsoring such serviceman aids are really taking care of their future. On the one hand, they are demonstrating that they have a sincere interest in the problems of the serviceman and that they stand ready to do what they can to help him. They will be repaid with loyalty from the customers they have helped, a loyalty that allows the jobber to expand with confidence to take care of the increased business that will be his. Such an increase in business is bound to come, too, for the educational program is certain to improve the quality and the income of the individual serviceman, and the jobber's business is firmly linked to that of these repairmen.

At the same time, the jobber who demonstrates a wide-awake, aggressive attitude toward the securing of new business is certain to win the respect and consideration of the manufacturers. The jobber who can give the servicemen what they want is exactly the kind of jobber the manufacturer wants.

So all down the line, from the manufacturer who makes the parts, to the jobber who distributes them, to the serviceman who installs them, to the customer who uses them, closer jobber-serviceman cooperation bestows benefits of increased efficiency and lowered costs. Let's see more of it!

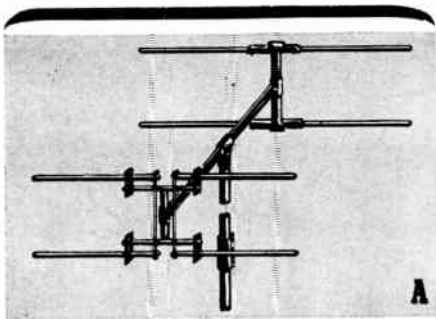

A

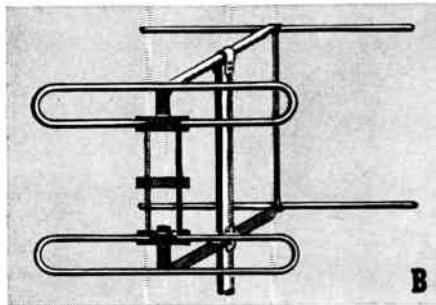

B

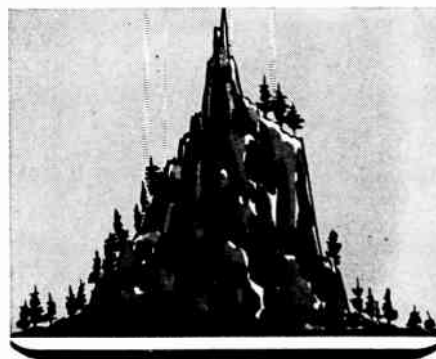

"TOPS"

IN TELEVISION

★What performance! That's what set-owners say about their TACO Television and FM antennas. ★H-type with reflector (A) covers two television bands plus FM bands. Frequency response flat within 3 db. Single H-type adequate within 15-20 miles of typical television transmitter; beyond, with reflector. ★Latest Type stacked folded dipole (B) intended for subnormal signal areas. Stepped-up gain. Highest signal-to-noise ratio. Makes television and FM feasible in otherwise hopeless locations. ★And very important, TACO antennas are exceptionally rugged.

State your reception requirements. Your jobber will provide the correct TACO antenna — for television, FM, AM or short-wave. Latest catalog on request.



Trade Literature

→ From Page 38

istics, frequency ranges, construction features and physical dimensions. Information on supersonic crystal blanks and helpful hints on ordering are also given. For a free copy write to Premier Crystal Laboratories Inc., 57-67 Park Row, New York 7, N. Y.

The Burlington Instrument Co. has published a bulletin on its Safety Cord Swivel. This new device is designed to prevent twisting, curling, and knots in electrical appliance and hand tool cords. The bulletin is done in color and explains the construction and operation of the safety cord. To obtain this bulletin free of charge write to Burlington Instrument Company, Burlington, Iowa.

The Cannon Electric Development Company's catalog no. C-46-A lists hundreds of types of plugs and receptacles. Containing 31 pages, it is well illustrated with both photographs and line drawings. Also included in the listings are such things as solenoids, battery connectors, panels and signal systems. To obtain a copy of this catalog write to Cannon Electric Development Company, 3209 Humboldt Street, Los Angeles, Cal.

BOOKS

Understanding Vectors And Phase by John F. Rider and Seymour D. Uslan published by John F. Rider Inc., price ninety-nine cents.

It may be argued that the radio serviceman can do his work quite well without the use of Vectors or Phase Angles. However, it is true that in reading technical articles he often has a desire for a more complete understanding of these subjects. This book is written for the practical man who hasn't had engineering training. It starts with a complete definition and description of vectors, explains how to manipulate them and concludes with applications to actual radio circuits. The book is well illustrated with line drawings and contains 153 pages.



Servicemen's choice!...
for counter or window



● Cunningham tubes and "Miss Cunningham," display top quality in this striking 8-color easel poster measuring 22"x28". It's the hottest traffic stopper in years . . . designed to draw more customers to your shop.

"Miss Cunningham" is ready to do a selling job for you. ASK YOUR CUNNINGHAM DISTRIBUTOR TO SEND HER OVER.



Insist on Genuine JAMES VIBRATORS

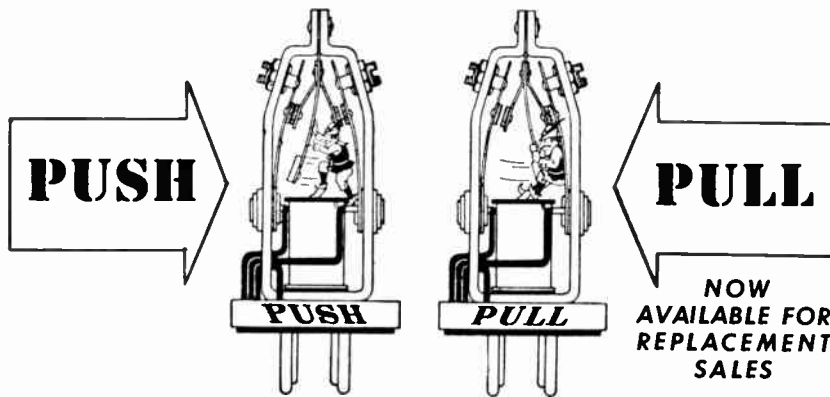

SYNCHRONOUS AND NON-SYNCHRONOUS TYPES

Over the years the James Vibrator has become famous for long life and extreme dependability. Note these outstanding features: (1) Patented Push-Pull Action (2) Frame-Mounted cooler-operating reeds (3) Adjustable contacts.

The war years and various shortages have kept the James Vibrator in short supply. New production facilities now permit prompt shipments on replacement vibrators of all types.

Ask your Radio Parts Distributor. Write for Interchangeability Chart, price list and catalog.

JAMES VIBRAPOWER Co.

3224 W. Armitage Ave.

Chicago 47, Illinois



ADD TECHNICAL TRAINING TO YOUR PRACTICAL EXPERIENCE

Use CIRE Training and Coaching Service — Get Your FCC "Ticket" in a Few Short Weeks!

Thousands of new jobs are opening up—FM, Television, Mobile Communication Systems. These are only a few of the radio fields which require FCC LICENSED radio technicians. These new fields offer to radio servicemen

exceptional opportunities to become specialists, to obtain dignified, high-paying technical employment, to get out of the rut of "fixing radios," to rise above run-of-the-mill, commonplace radio servicing.

Your FCC "Ticket" is Recognized in ALL Radio Fields as Proof of Your Technical Ability.

More than ever before an FCC Commercial License is a sure passport to many of the better paying jobs in this New World of Electronics.

Get your license without delay—Let Cleve-

land Institute prepare you to pass the FCC license examinations and to hold the jobs to which a license entitles you, using CIRE streamlined, post-war methods of coaching and training.

OTHER CLEVELAND INSTITUTE HOME STUDY COURSES OFFER COMPLETE TECHNICAL RADIO TRAINING FROM LOW-LEVEL TO COLLEGE-LEVEL, FOR THE RADIOMAN WITH PRACTICAL EXPERIENCE!

CLEVELAND INSTITUTE OF RADIO ELECTRONICS RM-2 TERMINAL TOWER CLEVELAND 13, OHIO

CLEVELAND INSTITUTE OF RADIO ELECTRONICS
RM-2 TERMINAL TOWER, CLEVELAND 13, OHIO Check here for Veteran's Information.

Gentlemen: Please send me your Booklet B, "HOW TO PASS FCC LICENSE EXAMINATIONS." (Does not cover Amateur License Exams.)
 Please send Catalog A describing all courses.

NAME

ADDRESS

CITY STATE

**How To Pass
FCC
LICENSE
EXAMINATIONS**

CLEVELAND INSTITUTE
OF RADIO ELECTRONICS
Terminal Tower - Cleveland Ohio

**Don't Delay—
Write Today!**

Approved
for Training
under
"G-I Bill
of Rights."

The Notebook

→ From Page 39

small chassis. Yet sometimes it is necessary to prop the small sets upside down with the danger of breaking the loop, station indicator, dial light, etc. A good way to overcome this difficulty is to use a 1/2" socket wrench for a prop. Slip the wrench (which is hollow) over the volume control shaft and fit it over the nut at the chassis. The set can then safely be worked on upside down, using the wrench as a prop.

John Barsophy
Williamsport 11, Penna.

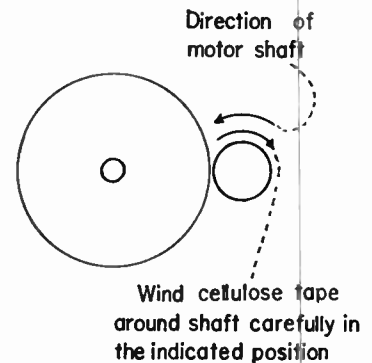

Adjusting Turntable Speed

It is often desirable to adjust 60 cycle phonograph motors to work on 50 cycles or simply to increase their speed on 60 cycles. Take a strip of scotch tape 3/16" x 1 1/2" and wrap it around the phono motor shaft as shown in the illustration. The tape must be wound in a direction opposite to the turning of the motor and be as smooth and tight as possible.

Joseph Barreca
New York, N. Y.

Cleaning Wire

Fine enameled wire, solid or stranded, is usually very difficult to clean when a connection is to be made. One way to solve this problem is to hold the wire over an alcohol flame, and, when the wire gets red hot, plunge it into alcohol. The wire will then be bright and clean. Care must be used, however, that the quenching alcohol does not spill or burn the fingers in case it catches fire. It can be snuffed out easily if you are prepared.

Leonard Aurzada, prop.
Aurzada Radio Service
Wadena, Minnesota

Over the Bench

→ From Page 35

annoyance to the customer but would soon do so.

When these tests are made, why do they not brew up a "natural" flaw in the set? Why not put in a shorted bypass condenser that will char a resistor and possibly ruin the rectifier tube? I should like to see if an honest trouble does not reveal a higher percentage of honest servicemen.

Another point that makes me certain that the shops cited in this test are not representative of all service shops lies in the estimates. According to the magazine article, these estimates ranged from nine to fifteen dollars; yet a recent survey showed that the national average service charge is five dollars and seventy cents. Why this discrepancy?

I cannot deny that radio servicing, by its very complexity, invites overcharges and other forms of deceit. The customer's ignorance of radio places him entirely at the mercy of the repairman. He cannot understand what repairs are necessary even when the serviceman tries to explain them to him. This results in the serviceman's conscience being the only restraining factor in the making of charges.

The times, too, are the worst ever for simple honesty. There is so much business that even inferior workmen have all the service they can do. Competition, that wonderful bolster to business ethics, does not exist as an important factor in charging. At the same time, the serviceman is confronted by outrageous prices on every side. The prices painted boldly on the butcher's window, those whispered by the used-car dealer, or the ones tagged to the wonderful "bargains" in shoddy furniture and building material are not calculated to encourage honest charging. In a world that is apparently ruled by the slogan of dog-eat-dog, it is all too human just to go along with the crowd.

Again, though, I want to repeat that there is nothing that can be said in defense of dishonesty such as was revealed by the investigation. The facts we have pointed out permit us

KEEP POSTED ON ELECTRON TUBES

Use this convenient coupon for obtaining the RCA tube reference data you need.

RCA, Commercial Engineering,
Section BW-59, Harrison, N. J.

Send me the RCA publications checked below. I am enclosing \$..... to cover cost of the books for which there is a charge.

Name _____

Address _____

City _____ Zone _____ State _____

- Quick-Reference Chart, Miniature Tubes (Free). [A]
- HB-3 Tube Handbook (\$10.00)*. [B]
- RC-15 Receiving Tube Manual (35 cents). [C]
- Receiving Tubes for AM, FM, and Television Broadcast (10 cents). [D]
- Radiotron Designers Handbook (\$1.25). [E]
- Quick Selection Guide, Non-Receiving Types (Free). [F]
- Power and Gas Tubes for Radio and Industry (10 cents). [G]
- Phototubes, Cathode-Ray and Special Types (10 cents). [H]
- RCA Preferred Types List (Free). [I]
- Headliners for Hams (Free). [J]

*Price applies to U. S. and possessions only.



TUBE DEPARTMENT

RADIO CORPORATION OF AMERICA
HARRISON, N. J.



to understand some possible causes of such behavior, but they do not give us reason to condone or imitate it. Sooner or later the radio servicing fraternity must develop an organization, set up ethical standards, establish rules of fair practice, and drive the shysters and incompetents from its ranks. The medical profession did just that, and we shall have to do so, too. I, for one, hope that this time is not too far distant; for I firmly believe that unless we clean our own house, we shall have it cleaned for us—and not too gently, either!

Photograph Credits

Page 10 Radio Corporation of America and Aaron Lippman Co.

Page 13 Top and bottom, Radio Corporation of America

Page 11 Top—Commercial Sound & Radio Co. Bottom—Almo Radio Co.

Page 16 Ebinger Radio Co.

RADIO TUBES

First Quality R.M.A. Guaranteed

50% DISCOUNT

off the regular list price

Plenty of hard to get numbers. Order any tubes you need. 25% Deposit on C.O.D. If you send cash we pay postage.

MIDWAY RADIO TUBE CO.

3858 South Parkway Chicago 15, Illinois

RADIO SERVICEMEN

STOP NOISY VOLUME CONTROLS



THE EASY WAY

WITH

QUIETROLE

WITHOUT removal from chassis.

This highly effective lubricant and cleaner stops your headaches and makes more profit for you on every radio you service. 2 oz. bottle \$1.75—50 applications.

WRITE FOR FREE SAMPLE
Distributors' Inquiries Invited

QUIETROLE DISTRIBUTING CO.
395 St. John St., Spartanburg, S. C.



Get Your Foot in the Door...

PREPARE FOR MONEY-MAKING
OPPORTUNITIES IN SERVICING

CREI Home Study Courses in Practical Radio-Electronics and Television Will Equip You to Do a Better Job—Enjoy a More Secure Future—Start a Business of Your Own.

Foresighted radio servicemen are looking ahead to the future. A future that has unlimited opportunities and real profits for those who have the "KNOW-HOW" to service the new types of broadcast and television receivers—and the multitude of complicated communication and electronic equipment being installed in cities and industries everywhere.

Your own field, that just a few years ago was confined to the servicing and maintenance of simple AM receivers, has expanded so fast, and in so many directions, that it is doubtful if many sincere servicemen can say they are fully qualified to meet present-day demands.

Now is the time to equip yourself with CREI up-to-date, radio-electronics training to keep pace with new developments and new techniques. This is the same practical home study training for which thousands of professional radiomen have enrolled since 1927.

It's up to you to decide whether you will be a "acrewdriver" mechanic or a trained service technician. It costs you nothing but a moment's time to find out by sending for complete, free details.

FREE SAMPLE LESSON!

Now, see for yourself! Mail the coupon for free sample lesson and see how simple it is to study at home and improve your ability the CREI way.

**MAIL COUPON
FOR FREE
BOOKLET &
SAMPLE LESSON**



Veterans! CREI Is "G.I." Approved

CAPITOL RADIO ENGINEERING INSTITUTE
16th & Park Rd., N.W., Dept. RT-2
Washington 10, D. C.

Mail me ONE FREE sample lesson and your 24-page booklet "CREI Training for Your Better Job in Radio Electronics." I am attaching a brief resume of my radio experience, education and present position.

Check Practical Radio Electronics
One Course Practical Television

Name
Street
City Zone State

I am entitled to training under G.I. Bill.

BACK NUMBERS

Get Them While They Last

JANUARY 1946

THE PROBLEMS OF ORGANIZATION
TELEVISION RECEIVER INSTALLATION
RADIO MAINTENANCE IN AVIATION
USING THE OSCILLOGRAPH FOR
DISTORTION MEASUREMENTS

APRIL 1946

A MIDGET AUDIO FREQUENCY
OSCILLATOR
IF I WERE A SERVICEMAN
AN EQUALIZED AMPLIFIER FOR
MAGNETIC PICKUPS

MAY 1946

PA SYSTEMS
TEST PANEL FOR THE MODERN BENCH
RINGING THE BELL

JUNE-JULY 1946

FUNDAMENTALS OF TELEVISION
VOLUME CONTROL TAPERS
THE ELECTRONIC OHMMETER
VECTOR ANALYSIS

AUGUST 1946

AVC CIRCUITS
FM TROUBLESHOOTING
TELEVISION RECEIVER FUNDAMENTALS
RECORD CHANGERS

DECEMBER 1946

TELEVISION RECEIVERS . . .
THE RF SECTION
TUNING THE INDICATORS
PART II—THE OSCILLOGRAPH
HOW TO USE IT
REPLACING AUTO CABLES

JANUARY 1947

SERVICING BY EAR
TELEVISION RECEIVERS . . . VIDEO
CHANNEL
PART III THE OSCILLOGRAPH . . .
HOW TO USE IT
MINIATURE TUBE CHART

FEBRUARY 1947

THE OSCILLOGRAPH . . . HOW TO USE
IT PART IV
TELEVISION RECEIVERS . . . THE SOUND
CHANNEL
THE AUDIO OSCILLATOR
SELENIUM RECTIFIERS

MARCH 1947

ANTENNAS . . . FM AND TELEVISION
PART I
SERVICING AUTOMATIC RECORD
CHANGERS
OSCILLATORS AND CONVERTERS
TELEVISION RECEIVERS . . . THE VERTICAL
SWEEP

APRIL 1947

ANTENNAS . . . FM AND TELEVISION,
PART II
PHASE INVERTER CIRCUITS
A UNIVERSAL SPEAKER
TELEVISION RECEIVERS . . .
THE HORIZONTAL SWEEP

MAY 1947

THE OPEN AND CLOSE CASES
VOLTAGE DOUBLERS
SIGNAL TRACER
TELEVISION RECEIVERS . . . THE
CATHODE RAY TUBE

JUNE 1947

WHEN THE CUSTOMER ISN'T RIGHT
TEST EQUIPMENT MAINTENANCE
CRYSTAL CONTROLLED SIGNAL
GENERATOR
TELEVISION RECEIVERS . . . THE
POWER SUPPLY

JULY 1947

SERVICING FM RECEIVERS
TEST EQUIPMENT MAINTENANCE, PART II
TELEVISION RECEIVERS . . .
FLYWHEEL SYNC

AUGUST 1947

SPEAKER MATCHING
TEST EQUIPMENT MAINTENANCE, PART III
SERVICING FM RECEIVERS
TELEVISION . . . HF POWER SUPPLIES

30,000

SERVICE TECHNICIANS

Read

RADIO MAINTENANCE

Every Month

Every day is

RADIO MAINTENANCE

day in your shop!

RADIO MAINTENANCE

460 Bloomfield Ave.,
Montclair 1, N. J.

Please send me RADIO MAINTENANCE for:

- 2 years at \$5.00
 1 year at \$3.00
 Check enclosed
 Bill me later

Name

Occupation

Address

City Zone

State

RADIO MAINTENANCE MAGAZINE

460 BLOOMFIELD AVE., MONTCLAIR, N. J.

Please send me the back numbers checked here
I am enclosing 35c for each copy, or \$2 for any 8 copies, or \$3.25 for all 14.

- | | | |
|---|--|--------------------------------------|
| <input type="checkbox"/> January 1946 | <input type="checkbox"/> December 1946 | <input type="checkbox"/> June 1947 |
| <input type="checkbox"/> April 1946 | <input type="checkbox"/> January 1947 | <input type="checkbox"/> May 1947 |
| <input type="checkbox"/> May 1946 | <input type="checkbox"/> February 1947 | <input type="checkbox"/> July 1947 |
| <input type="checkbox"/> June-July 1946 | <input type="checkbox"/> March 1947 | <input type="checkbox"/> August 1947 |
| <input type="checkbox"/> August 1946 | <input type="checkbox"/> April 1947 | |

Have selected 8 copies . . . enclosing \$2.00
 Send me all 14 . . . enclosing \$3.25

NAME

ADDRESS

CITY

ZONE STATE

THIS MONTH'S BEST BUYS IN RADIO!

NEW EQUIPMENT FOR OLD

Almo Radio Company is offering new equipment for old, under an unusual trade-in plan that gives you brand new Supreme test instruments for your old test equipment of any make, any type, regardless of condition.

Here's all you have to do. Look up the equipment you want on the chart. Read across to the discount you will receive on your old equipment. The third column tells you your new dealer net price.

This offer is for a limited time only, so act now. Bring in your old test equipment, or write to us for mail order information.

TRADE-IN ACCEPTED ON THESE MODELS

MODEL	REGULAR DEALER NET	TRADE-IN ALLOWANCE	DEALER NET AFTER TRADE-IN
504-B Tube & Set Tester	\$ 89.50	\$15.00	\$ 74.50
546-A Oscilloscope	89.75	20.00	69.75
561 Oscillator	136.50	25.00	111.60
562 Audolyzer	127.00	22.00	105.00
563 Generator	62.95	12.50	50.45
565 Vacuum Tube Voltmeter	63.50	20.00	43.50
567 Set Tester	63.40	12.50	50.90
574 Set Tester	67.45	12.50	54.95
576 Oscillator	68.95	12.50	56.45
589 Portable Tube Tester	48.95	10.00	38.95
589 Counter Tube Tester	58.95	10.00	48.95
592 Set Tester	58.95	15.00	43.95
599 Portable Tube Tester	62.50	10.00	52.50
599 Counter Tube Tester	74.00	12.50	61.50



Supreme 599-A tube and set tester is typical of the bargains offered under this unusual plan. You can use this fine Supreme instrument for measuring A.C. volts, D.C. volts, DC current, output volts. There's a 4 range ohmmeter, condenser checker, battery tester, tube tester and power supply of 100-133 volts—50/60 cycles. Stop in and see these fine instruments at their new trade-in prices.

PHONE WRITE OR WIRE TODAY TO:

Phone
LO 3-9225

Almo **RADIO CO.**
509 ARCH STREET
PHILADELPHIA, PENNA.

SAY YOU SAW IT IN RADIO MAINTENANCE!

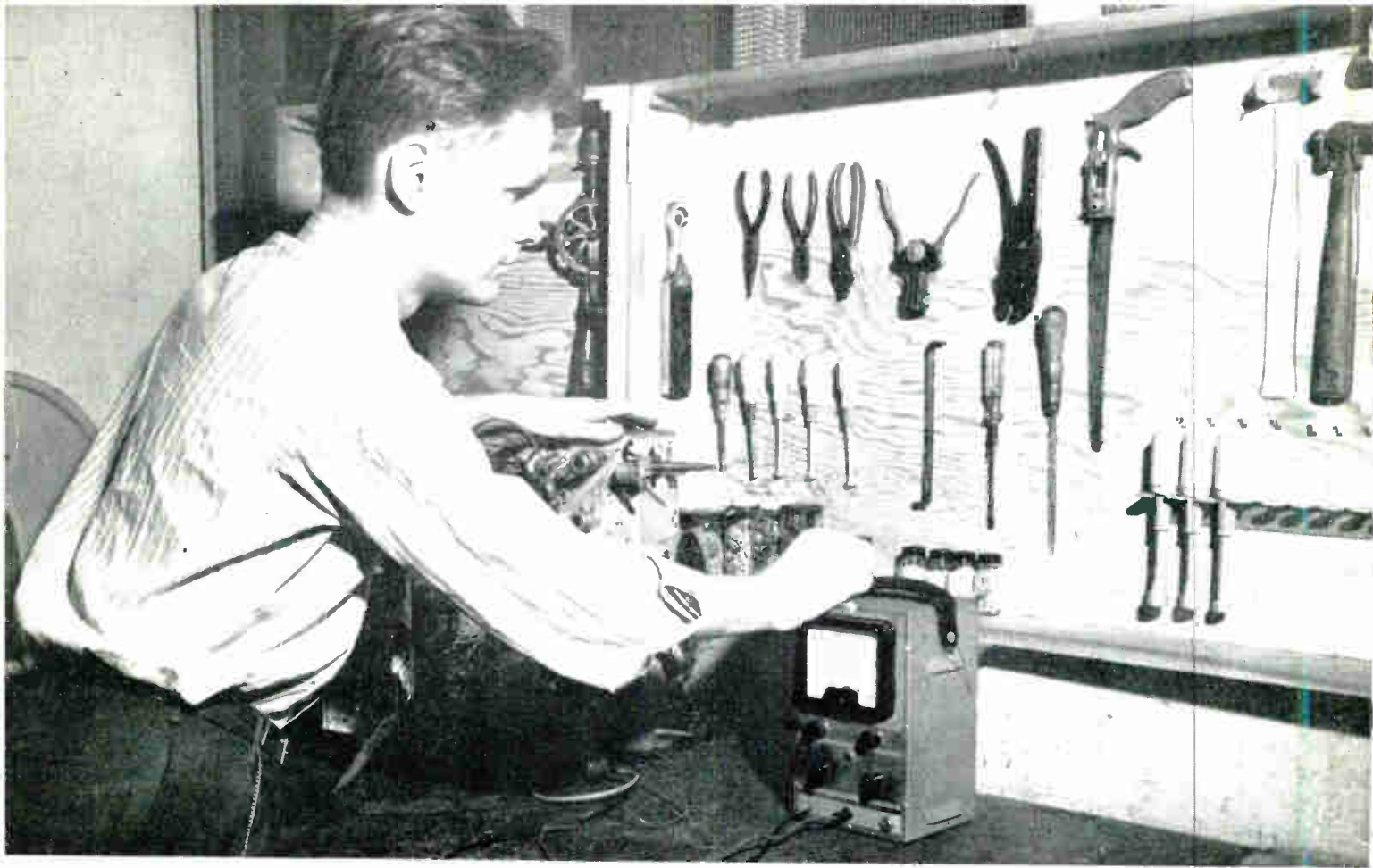

IS YOUR TOOL RACK COMPLETE?

An offset screwdriver or an Allen wrench is a small item. Not having them when needed, however, can mean a big loss in time—and time is money. The time to take inventory of your tool rack is now. We can supply you with all types of tools, parts and instruments. Stop in, call or write us today, say you saw this ad in **RADIO MAINTENANCE** and get the equipment you need. Be prepared . . . it's profitable!

DYMAC, INC.

RADIO PARTS & ELECTRONIC EQUIPMENT

2329-31 MAIN ST., BUFFALO 14, N. Y.

World Radio History
TEL. 4-1300