

RTJ

Radio & TELEVISION JOURNAL

SUMMERTIME
is **PORTABLE**
sales time—

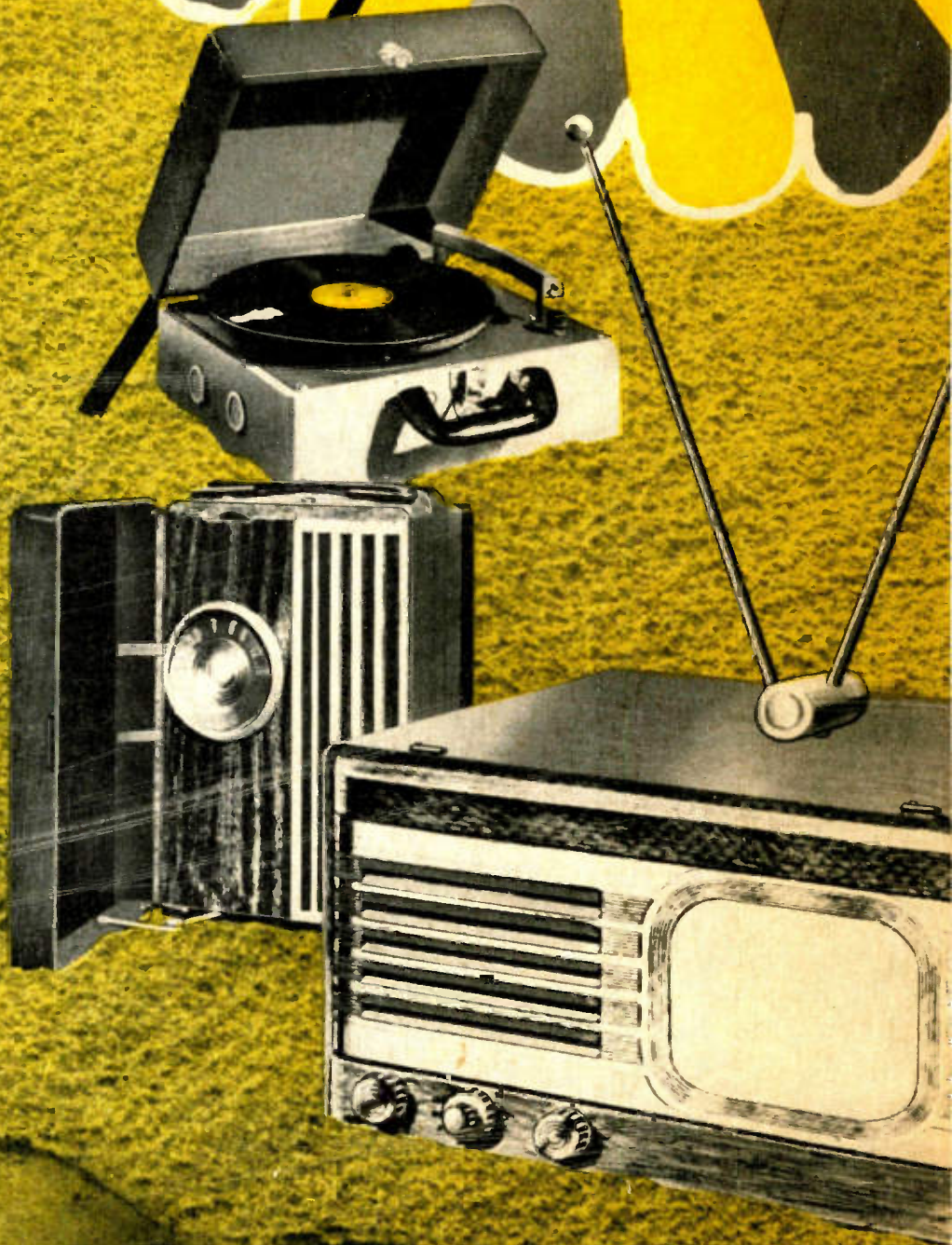

APRIL 1949

Sec. 562, P. L. & R.
U. S. POSTAGE
PAID
NEW YORK, N. Y.
Permit No. 10521

AJ D
HAROLD R. MOLTE
OMRO
MISC

From: RADIO & TELEVISION JOURNAL
A KOLBE PUBLICATION
RKO BUILDING, RADIO CITY, 1270 SIXTH AVE.
NEW YORK 20, N. Y.
RETURN POSTAGE GUARANTEED
Postmaster: If undeliverable FOR ANY REASON, notify sender.
Failure to return, on FORM 3517, postage for which is guaranteed.

NOW!

TWO SENSATIONAL LOW-COST RECORD PLAYERS FOR THE NEW 7-INCH DISCS

for



REG. U. S. PAT. OFF.

COBRA* EQUIPPED RADIO-PHONOGRAPHS



"MICRO COBRA" ADAPTER { ATTACHED IN A MOMENT... REMOVED JUST AS QUICKLY

Yes, here's the adaptor your customers are looking for! It's small, compact . . . fits IN the phonograph compartment—*not* on top of the cabinet. AND it reproduces the new 7-inch 33 $\frac{1}{3}$ and 45 RPM records with the superb tone quality of the world famous Cobra* Tone Arm! That's because this

latest Zenith triumph includes a specially designed MICRO COBRA! Its amazingly light needle pressure makes possible perfect tracking on the 7-inch records, thereby assuring the ultimate in tone quality and virtually eliminating record wear.

*Reg. U. S. Pat. Off.



Automatic RECORD CHANGER

Plays Eight 7-inch 45 RPM Records Automatically!

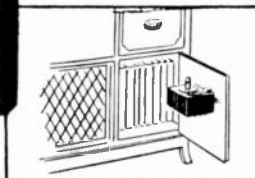

Every recorded note and delicate overtone is reproduced with unsurpassed fidelity. Unit can be placed on top of radio or mounted—out of sight—on door of record storage compartment by special mounting bracket.† Housed in attractively designed plastic case.

†Available Separately.

Order from Your Zenith Distributor.

ZENITH RADIO CORPORATION • CHICAGO 39, ILLINOIS

Truly Great Antennas...

Perfect Reception for Any Make Set!

LYTE

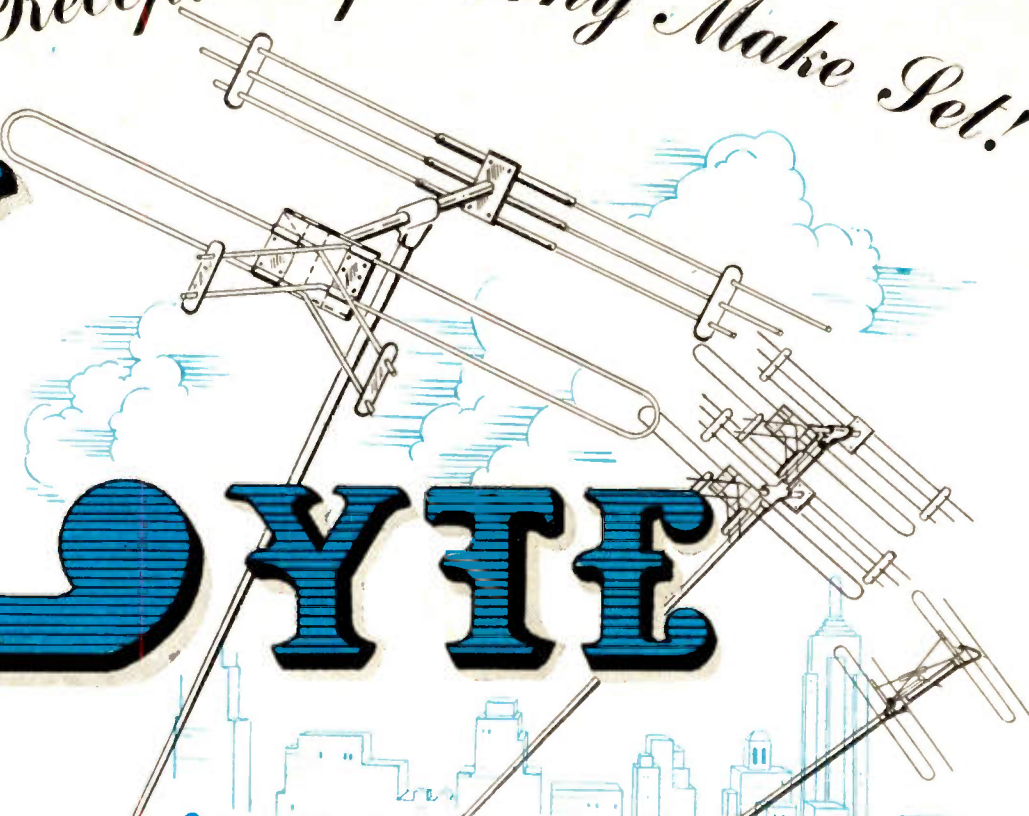

ANTENNAS

● Standard Model LTRC—The most widely accepted and successfully used antenna for all-round television and FM reception. Thousands of proud Standard owners boast the best reception on channels 2 to 13 and FM bands because of the LTRC's maximum signal strength.

● Supergain Model LTD—A double-decked antenna array proved across the nation to give highest possible signal gathering strength in the outlying districts and fringe areas of TV reception. Supergain blankets all 12 television channels, all FM bands.

Skybeam Model LHF—The best high-frequency, high-fidelity antenna manufactured today! For high-frequency channel reception the Lyte Skybeam combines all the proved Lyte features to provide outstanding results on channels 7 through 13.

DEALERS: Satisfied customers mean more profits for you. Guarantee maximum performance of the television sets you sell by recommending installation of Lyte antennas, for 100% brighter, clearer, sharper pictures!

PLAINFIELD, NEW JERSEY
15 Washington Ave.

Lyte

DUBUQUE, IOWA
199 Main St.

LYTE PARTS COMPANY



Publisher
ALEX H. KOLBE

Editor
NAT BOOLHACK

Associate Editor
JOHN A. RICHARDS

Business Department
AARON LAFER

Art Director
VINCENT T. COSTELLO

Circulation Manager
MARY LOUISE KAUFFMAN

West Coast Office
A. M. ROTHENBERG ASSOCIATES
2412 W. Seventh St., Los Angeles,
California
Telephone: Fairfax 6254

This Month's Cover



Summertime opens up a prosperous "portables" market for dealers. See pages 11 to 15 in this issue.

Member of



OVER 30,000

Controlled Circulation Audit, Inc.

IN THIS ISSUE

Television Roundup9, 10
A concise review of the month's significant happenings in radio and television.

Vacation Time Is Portable Sales Time11, 12, 13
During the hot summer months millions of Americans will splurge on vacations . . . and on portable entertainment equipment.

Don't Let Television Take a Vacation14, 15
The resort and portable markets are rosy ones for television. Dealers should cash in on them during vacation time.

Here's How Your Customers Are Buying Television16, 17
Surveys are a barometer of television buying habits and can be helpful guides to sound merchandising.

Illustrated Industry News22, 23
Photographic highlights of industry events.

Where Are Television Sets Being Shipped?25
Graphic illustration of television centers.



DEPARTMENTS

New Products26, 27, 30, 38, 40
(Radios, Television, Consoles, Phonographs, TV Accessories)

News and Notes of Manufacturers and Distributors42, 43

New Appointments45, 48, 49

Editorial50

Advertisers' Index50

RADIO & TELEVISION JOURNAL with which is combined RADIO & APPLIANCE JOURNAL and ELECTRIC APPLIANCE JOURNAL is the complete business magazine for retail dealers who buy and sell Radios, Television Receivers, Appliances, Phonographs, Records, Master Servicing Component Parts; and is published monthly for Radio & Appliance Dealers, Jobbers, and Service Men by Kolbe Publications, Inc., Radio City, 1270 Sixth Avenue, New York 20, N. Y. Phone: Circle 7-5842, Alex H. Kolbe, President and Treasurer. Subscription \$3.00 per year in U. S. A., its possessions, South America, Canada and all other countries \$4.00 per year payable in American currency in advance. Price 35 cents per copy. No material in RADIO & TELEVISION JOURNAL may be reprinted without consent of publisher.

Printed in U.S.A.

After 10 million phonographs ~
After 1 billion records . . .

Comes the new RCA VICTOR system of recorded music

CONGRATULATIONS to our associates, the RCA Victor Dealers everywhere, whose confidence in RCA Victor has made possible this 50-year marketing achievement.

To them must go much of the praise for these two newest and finest examples of research and engineering—the best automatic changer ever built—the finest record ever made. For, without the assurance of its dealers' confidence, no company could undertake *any* major improvement in home entertainment.

Without the confidence of its dealers in 1923, RCA Victor, founder of the phonograph and record business, could never have started radio down its billion-dollar road. Countless other improvements could never have reached the market if it were not for the great confidence RCA Victor dealers have in RCA Victor products. Include television! Here is a 50-million dollar RCA investment which is today establishing itself as another billion-dollar business for dealers across the country.

And, what inspires this great dealer confidence? Many things . . . too many to enumerate here. But, proof that it is worth having, lies in the fact that today the RCA Victor dealer franchise is the most profitable in the entire industry. With the continued confidence of dealers and with the unique foresight of RCA Victor management, an RCA Victor franchise *will remain* the most profitable in the entire industry.

The new RCA Victor system of recorded music is a shining example of management's foresight. With continued dealer confidence the ultimate profit is inevitable. Work started on the new system in 1939. RCA Victor engineers were granted complete freedom of action . . . freedom from even the major inhibitions, such as non-standardization of record sizes, and speed of turntables. Engineers had but a goal . . . to produce the finest changer and record ever conceived.

The customers' dollars will prove that these engineers reached their goal. The new RCA Victor record and changer constitute the sensible, modern, inexpensive way to enjoy recorded music. The product is ready . . . the public is ready. A demonstration, more than ever before, means a "close." Its advantages will eventually make it the only way to play music in the home.

Meanwhile, RCA Victor will continue to provide its dealers with 78 rpm records and record playing equipment. This period is not one of revolution but one of transition. There will be plenty of time for all dealers to adjust their inventories in making way for this new, improved, more profitable product.

To welcome change is to show a keen awareness of the principal factor lying behind all of our country's industrial progress. That factor is *the constant striving of the American public to own something finer*. In this light, the new RCA Victor system of recorded music will flourish. To RCA Victor's dealers, whose confidence makes such progress possible, will again go a rich reward of bigger profits through continued high turnover.



Greater Variety for Greater Sales!

... you can offer your customers the new RCA Victor system in their choice of 7 magnificent instruments... all (except the attachment, of course) with the exclusive RCA Victor "Golden Throat" tone system.



Model 9TW333—52-square-inch RCA Victor Eye Witness Television, FM-AM radio, 78 rpm automatic changer for 10- and 12-inch records, plus the new RCA Victor system of recorded music. Walnut, mahogany or blond finished cabinet with generous storage space for 7-inch records.



Model 9EY3—Smartly styled, compact RCA Victor Player in a rich maroon plastic cabinet with distinctive, gold-colored trim. Here is a complete phonograph to offer your customers the advantages of this new system at an amazingly low price.



THE MUSIC YOUR CUSTOMERS WANT IS ON THE NEW RCA VICTOR 45 RPM RECORDS

The Music Your Customers Love Best, by their favorite artists, is on the new RCA Victor records. This list is but a small sampling to give you an idea of the variety available in the introductory library. Additional standard top-selling favorites and current releases will be added regularly.

RED SEAL ALBUMS

- BOLERO (Ravel)—Boston Symph. Orch., Serge Koussevitzky, Cond. WDM-1220
- CONCERTO No. 1, IN B-FLAT MINOR, Op. 23 (Tchaikovsky)—Artur Rabinstein, Pianist, with the Minneapolis Symph. Orch., Dimitri Mitropoulos, Cond. WDM-1159
- PIANO MUSIC OF MENDELSSOHN—Vladimir Horowitz, Pianist WDM-1121
- ROMEO AND JULIET (Overture-Fantasia) (Tchaikovsky) WDM-1178
- COLAS BREUGNON: OVERTURE, Op. 24 (Kalbalevsky) (final side)—Arturo Toscanini and the NBC Symph. Orch. WDM-1178
- SLEEPING BEAUTY, THE (Music from the Ballet) (Tchaikovsky)—Leopold Stokowski and his Symph. Orch. WDM-1205

RED SEAL SINGLES

- AH! SWEET MYSTERY OF LIFE (Young-Herbert)
- INDIAN LOVE CALL — (Harbach-Hammerstein II-Friml)—Jeanette MacDonald, Sop., and Nelson Eddy, Bar., with Nathaniel Shilkret and Orch. 49-0200
- AUFENTHALT (Schubert)
- AVE MARIA (Schubert)—Marian Anderson, Contr., with Franz Rupp at the Piano 49-0136
- BECAUSE (Teschemacher-d'Hardelot)
- BLUEBIRD OF HAPPINESS (Heyman-Davies-Harmati)—Jan Peerce, Ten., with the RCA Victor Orch., Sylvan Levin, Cond. 49-0135
- CARMEN FANTASIE (Based on themes from Bizet's "Carmen") (Waxman)—Jascha Heifetz, Violinist, with the RCA Victor Orch., Donald Voorhes, Cond. 49-0130
- HUNGARIAN RHAPSODY No. 2, IN C SHARP (Liszt)—Alexander Brailowsky, Pianist 49-0262

COUNTRY AND WESTERN

- ALL-TIME HITS FROM THE HILLS—Eddy Arnold, The Tennessee Plowboy, and his Guitar WP-195
- MY HEART WENT THAT-A-WAY
- ND CHILDREN ALLOWED—Roy Rogers, Voc., with Country Washburne and his Orch. 48-0028
- ROOTIE TODDIE (V.R.)
- TENNESSEE WALTZ (V.R.)—Pee Wee King and his Golden West Cowboys 48-0003

MUSICAL SMART SETS

- DOWN MEMORY LANE—Vaughn Monroe and his Orch. WP-202
- THEME SONGS—Tommy Dorsey; Tex Beneke; Freddy Martin; Vaughn Monroe; Wayne King; The Three Suns; Sammy Kaye; Larry Green WP-217
- YOU AND THE NIGHT AND THE MUSIC—Tony Martin, Voc., with Earle Hagen and his Orch. WP-203

POP CLASSICS

- STUDENT PRINCE, THE (Donnelly-Romberg)—Al Goodman and his Orch.; Mary Martha Briney and Frances Greer, Sopranos; Donald Dame, Ten.; Earl Wrightson, Bar., with The Guild Choristers WK-8

POPULAR SINGLES

- ALICE BLUE GOWN—Waltz
- SMOKE GETS IN YOUR EYES—Waltz—Wayne King and his Orch. 47-2718
- BECAUSE
- IF YOU HAD ALL THE WORLD AND ITS GOLD Perry Como, Voc., with Russ Case and his Orch. 47-2728
- DANCING TAMBOURINE
- STUMBLING—The Three Suns, Instrumentalists 47-2756



Model 9W105—A console with AM and static-free FM radio with a powerful 12-inch speaker... 78 rpm record changer plus the new RCA Victor system of recorded music. Mahogany, walnut or blond finished cabinet has ample storage for records... 7-, 10- and 12-inch.



Model 9W101—Superb FM-AM radio... and the new RCA Victor system of recorded music. Rich traditional cabinet of attractive walnut or lovely mahogany finish. Storage for 216 singles or 24 albums... more than 38 hours of this great new listening pleasure.

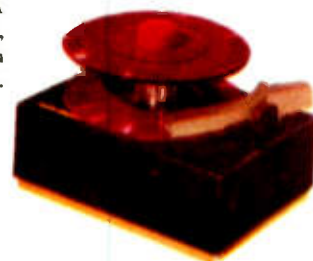

Model 9JY—Easily attached to any make set, this fully automatic new RCA Victor Player brings your customers the new distortion-free recordings—50-minute programs without need of attention—at a new low price!



Model 9Y7—The most amazing table combination ever offered. Imagine... an automatic record changer... powerful Standard Band radio plus storage space for as many as 60 playing sides—all in one compact table model. Finished in walnut, mahogany or blond.



Model 9W103—FM and AM radio, a big 12-inch speaker, plus the exciting new RCA Victor system of recorded music. Beautifully finished in lined oak, walnut or mahogany, the cabinet stores 33 hours of recorded music—189 singles or 24 of the new albums.

The new RCA Victor system is the modern, inexpensive way to enjoy recorded music. It offers more advantages and enjoyment than does any other type of record or record playing equipment. The advantages start with low cost and run a course of conveniences never before

heard of. The enjoyment starts with a distortion-free record and continues with exactly the music your customers want when they want it. This combination of advantages and enjoyment has been calculated to best suit the desires of the greatest number of your customers.



RCA VICTOR

DIVISION OF RADIO CORPORATION OF AMERICA

"Victrola"—T. M. Reg. U. S. Pat. Off.

ONLY RCA VICTOR MAKES THE VICTROLA

ROUNDUP

Auto Television

Following experiments with television installations in private automobiles, Walter H. Stellner, vice-president of Motorola, Inc., considers such use of television entirely feasible. He expects mobile television to become commonplace, as police cars, buses, trains, and boats are made to take advantage of the possibilities inherent in this instant medium of visual communication.

However, Mr. Stellner is emphatic about Motorola's stand on front-seat television, stating recently that his company is "firmly opposed to installation of automobile television sets which can be seen by the driver." In an effort to cooperate with agencies like the National Safety Council, Motorola is recommending installation of television sets for rear-seat passengers only. The firm's interest in the matter stems from successful experiments with a Motorola television installation in a Chicago taxicab last June. Following these experiments, a Milwaukee radio amateur put a Motorola set on the dashboard of his car. "Milwaukee authorities promptly passed an ordinance against such installations, a move with which we are in entire accord," Mr. Stellner said.

Radio Campaigns

Running for two weeks, February 27 to March 12, the Iowa Radio In Every Room campaign resulted in a 50 per cent increase in sales. The upswing in sales which every prior campaign had netted prompted the campaign planners to make the drive one which blanketed the state rather than confining it to one city in Iowa. Dealers, distributors, press, radio and allied industries cooperated to hammer home the theme of the campaign. Using window displays, posters, and banners, dealers utilized key department stores and smaller outlets. Broadcasters used spot announcements and special programs. The Press Association of Iowa made available for state newspapers editorial material, advertising mats, and news releases.

Taking a leaf from the book of Iowa's radio dealers, 500 retailers and their salesmen from Nebraska met in the Hotel Paxton, Omaha, on March 16, to continue sparking the state of Nebraska's Radio in Every Room campaign. Under the sponsorship of the Nebraska-Iowa Electrical Council, this latest drive got underway on March 20 and ran to April 3. As in the case of Iowa, Nebraska's participants in the

campaign pushed window display and tie-in advertising. State press associations also lent cooperation with mats and special editorial features. Radio was, on the whole, getting continuous sales boosts from grass roots areas in many sections of the country.

High Frequency Fracas

Zenith's ad campaign, which got rolling in early March, shook the television industry to its foundations, and seemed to blow off, rather than lift, the lid on the television obsolescence question. Basically the firm's advertising seemed to claim that its television receivers were the only sets which could receive new, ultra-high frequency channels—if and when the FCC permitted their use—without the use of a converter.

Reaction to the Zenith ads was quick and explosive. Most of the industry was dismayed, taking the position that customers usually had a difficult time making up their mind to buy television sets without throwing in the scare of obsolescence. One midwest reaction was contained in the Detroit News, which went into a lengthy explanation

of VHF and UHF and summarized by stating that anyone in the Detroit area who denied himself and his family the thrill of television while waiting for frequency changes might grow old and grey waiting for changes that might never come.

Compelled to address a letter to dealers as a result of inquiries from all parts of the country, Ross D. Siragusa, president of Admiral Corp., hastened to allay dealer fears. Disclaiming any possession of a crystal ball, which might help him predict television's future, Mr. Siragusa did, however, assure the firm's dealers that Admiral receivers were in no more danger of becoming obsolete than any other well-engineered standard make. He further pledged himself to keeping Admiral products in this position.

In reply to the storm his firm's ads had stirred up, H. C. Bonfig, vice-president of Zenith Radio Corp., made a statement on the whole matter before the Radio Manufacturers Association, sitting in annual session in Chicago on

(Continued on page 10)



The first console incorporating the new RCA 45-rpm. record changer gets a close inspection. H. G. Baker, general manager of the firm's home instrument department, and Harold Emlein, manager of the Indianapolis plant, examine the initial cabinet with the new music reproduction system as it comes off production lines. A second drawer has the radio. Storage space is on either side.

March 17. Mr. Bonfig suggested the whiskers be taken off the question of television obsolescence and that the facts as they are be faced. Then he recited the need for more channels than the present 12 VHF ones, the reason for the FCC freeze, and Wayne Coy's estimate of the need of from 50 to 70 channels for a nationwide competitive television system. Mr. Bonfig estimated there would therefore be needed 38 to 58 new UHF channels to supplement the present 12 VHF channels. He again quoted the FCC on the probable assignment of both VHF and UHF channels in the same city. With the freeze due to end in April or early May and possibility that UHF channels may have to be assigned to applications now pending in VHF, Mr. Bonfig was of the opinion that manufacturers should move quickly toward providing sets which would bring in both VHF and UHF channels. At the same time he felt any channel assignment changes should be made now, before additional millions of television receivers were purchased which would tune in only present channels.

RMA Takes Hand

An "objective, orderly and constructive" presentation of full information on television, including not only present broadcasting service and receivers in the VHF channels but also in the UHF channels was voted by the RMA board of directors at the Association's Spring Conference in Chicago, March 15-17. In voting for the public relations program to give the public, government, trade and all other interests, complete and accurate information regarding TV broadcasting and receiving sets, the board instructed President Max F. Balcom to appoint a special committee, widely representative of the manufacturing industry, to determine and direct the Association's TV public relations project. Substantial funds were immediately voted for the work, and the information program is expected to be started in the immediate future.

Such a program was first broached by Paul V. Galvin, Motorola's president and past RMA president in late February, immediately following presentations by RMA to the FCC's February 18 hearing. RMA's recommendations at that time included removal of the freeze on new television stations, extension of TV service on the 12 VHF channels, and prompt allocation of future UHF channels. RMA felt nationwide television service would thus be provided quickly, with a minimum of overlap between VHF and UHF services and with the same standards for both services.

New TM Association Formed



MICHAEL L. KAPLAN

Characteristic of the new energetic outlook in the television manufacturing industry is Michael Kaplan, left, who is president-elect of the newly-formed Television Manufacturers Association, now officially incorporated under the laws of New York State. Mr. Kaplan, former all-American football star, is president of Sightmaster Corp., and is the moving spirit behind TMA.

"We need a code of practices to fit the singular requirements of TV set manufacturers. We need a code of ethics as a standard for all and by means of which we can prevent, by unified action, the transgression of any one firm which will hurt us all; for, as manufacturers of a product to be used by the public, we have a high duty to the public." Thus spoke Michael L. Kaplan, president of Sightmaster, and president-elect of the newly-organized Television Manufacturers Association, to the 20 representatives who had gathered for the organizing meeting at the Advertising Club, N. Y., last month.

Pointing out that the television industry has grown so fast that "growing pains" have sometimes impeded its progress, Mr. Kaplan felt the time was ripe for removal of all hindrances to the industry. Already as early as five years ago, he felt, it was obvious that the television broadcasting industry was so aware of TV's difference from radio that it realized a radio association could not represent the new medium. He felt many were aware that television and radio do not mix in manufacturing and merchandising. Despite this, he pointed out, ancient radio practices unsuited to television have been allowed to blight the new industry.

Radio price-cutting, radio warranties and service contracts which were a poor fit for tie-in sales and linked TV to unwanted products, and careless bandying of technical and scientific information were some of the points Mr. Kaplan referred to. Indicating it might have been far better if television manufacturers had started out entirely divorced from radio, he further stated, "... we appear to have inherited all the bad, but none of the good prac-

tices. If we had started as a new industry, by now we would have had our own organization, and this meeting would not be necessary." The response to the call for the meeting indicated, he felt, that the television industry must be handled by a concentrated and exclusive effort concerning television set manufacturing, and nothing else.

Emphasis on what concerted action such a television manufacturers group might take was brought home by announcement at the meeting that Sightmaster Corp. and Empire Coil Co., Inc. were instituting a suit in Supreme Court, N. Y., in which damages of one million dollars—\$500,000 on behalf of each plaintiff—was sought from Zenith Radio Corp. for alleged damages to all phases of the television industry resulting from Zenith's recent television ads.

Attending the meeting at which the aims and purposes of the new organization were enunciated, and at which positive steps to further those aims were demonstrated by the announcement of the Zenith suit, were Irving Kane, Royal Television Corp.; Robert G. Kramer, Remington Radio Corp.; Joseph Green and E. M. Cohan, Transvision, Inc.; E. B. Hinck, Industrial Television Co., Inc.; Herbert Mayer and Alma Schmidt, Empire Coil Co., Inc.; Milton Grudin, Jack Sombers, and Miles Breger, Mars Television, Inc.; Lloyd S. Howard, Bobley Co.; Lee Bunting, Bell Television, Inc.; H. V. Nielson and R. M. Keator, Nielson Television; W. Schuck, Taybern Equipment Co.; Robert Erlichman, H. Roy Penzell, and P. Pokrass, Tele-King Corp.; Henry Weintraub, Major Television; W. R. Rich, International Television; Mitchell Fein, Starrett Television; Joseph Snaider and Michael Muckley, Snaider Television.

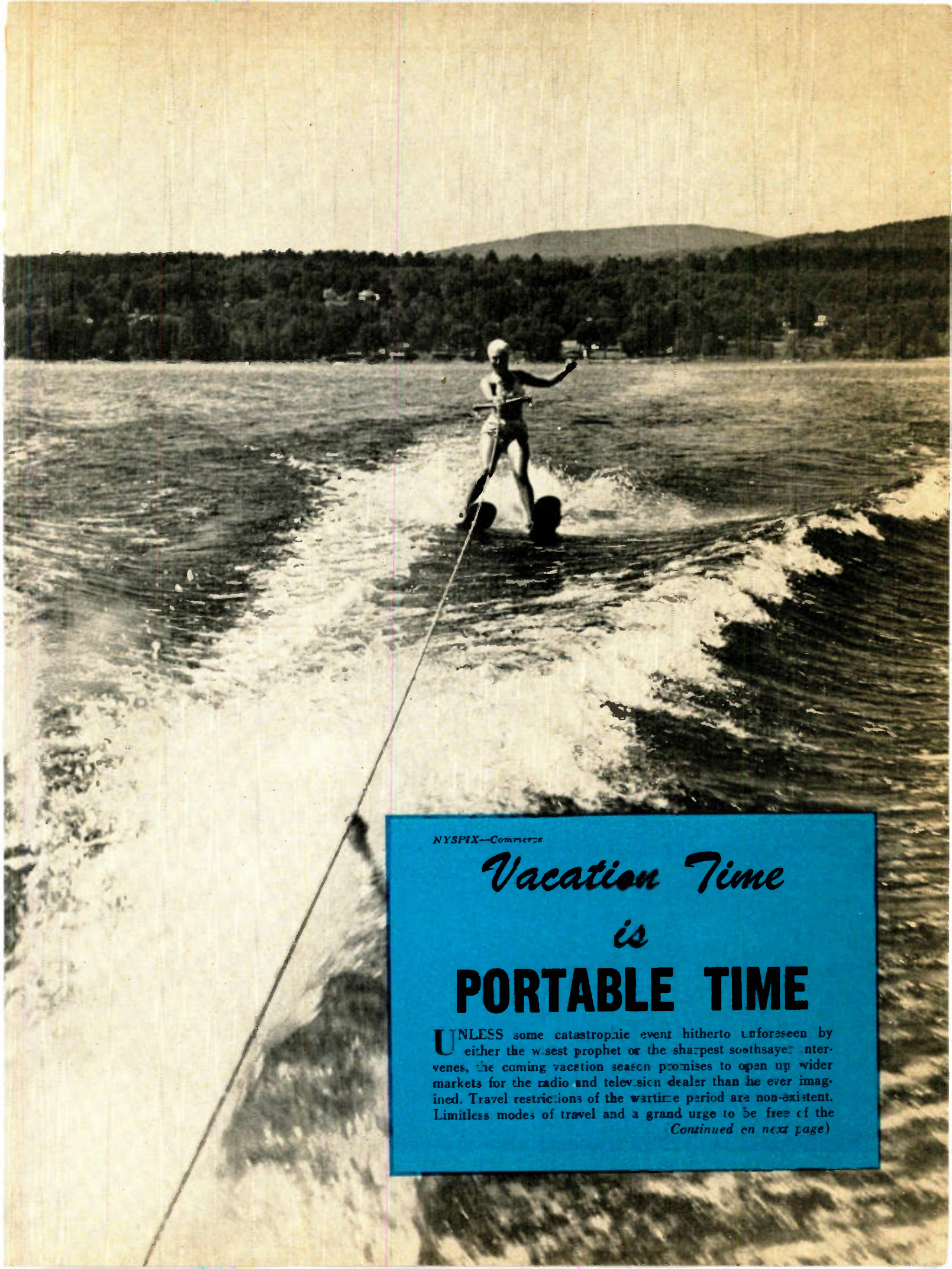

NYSPIX—Commerce

Vacation Time
is
PORTABLE TIME

UNLESS some catastrophic event hitherto unforeseen by either the wisest prophet or the sharpest soothsayer intervenes, the coming vacation season promises to open up wider markets for the radio and television dealer than he ever imagined. Travel restrictions of the wartime period are non-existent. Limitless modes of travel and a grand urge to be free of the

(Continued on next page)

Sell Portables to Vacationers



Whether at Lake George, N. Y., above, or on the California beaches, vacationists like to have their entertainment always at hand. *NYSPIX—Commerce*

shackles of humdrum existence will send millions of people scurrying from their homes by plane, train, and boat, by automobile, bicycle, haywagon and jeep, and even on foot. Week after hot week, the populace will flock from city to country, from country to city, seeking out favorite hideaways at the seashore, in the hills, on the farm, and along the shores of cool lakes. These vacationists will keep the dealer's summer market alive with unusual demands until the frosts come and the summer holiday is over. But during those torrid months the dealer should take a great deal of pains to see that items from his store are mingled with the luggage and equipment that vacationists bundle along with them on their holiday. For the approaching season will provide a hungry market for a special type of dealer item—portables.

All the Family

There's Mother, for instance. With many daytime hours to fill with pleasantries, she has grown accustomed to playing favorite records when the radio becomes a little wearisome. Even the children cherish their favorite kiddie albums. And you can bet your bottom dollar that there will be pressure from them to squeeze those favorite records into the back of the car along with a new portable phonograph when vacation time rolls around. Bigger Brother will remember he can't follow the diamond play of his "Giants" or his "Bums" unless he has a compact radio to tuck under his arm or sling over his shoulder when he's off in the hills. Even Dad may care for a little music while he dozes under his hat and waits for the fish to bite at his favorite lakefront spot.

Sis, on the other hand, knows she

and her bobbysocks friends can't always rely on juke boxes for their dance music, or she's "gone" on a portable radio for emergencies. Music—under bright stars and a soft moon, or for jive addicts on a village green, or even at a country hoedown—usually requires a portable radio of some kind. And where the radio doesn't fill the need, the portable phonograph does, providing appropriate jazz, folk songs, dance rhythms, or classical pieces to fit the occasion.

For the Camper, Too

Even the camper is not excluded from this summer vacation portables market. Like his friend down the block, who went off with his family on an informal vacation trip, the camping enthusiast, whether he goes to an organized camp or takes an impromptu jaunt into the mountains with a bunch of friends, also likes to follow the diamond doings in the major baseball leagues. Radio programs have many times taken their toll in undivided interest, all of which means that even campers, out roughing it, refuse to be cut off from their favorite adventure stories.

Like the schools which use radio to teach, progressive counsellors are putting the radio to work taking over some of the instruction chores. And even after the formalized program of the day, and the story-telling hour in the evening, there is still plenty of time in camp for enjoyment of the radio, either in groups or according to individual tastes. The camper may want to get away from his routine chores, but he still enjoys his favorite entertainment when it is brought within reach.

And camp is an ideal place for another piece of portable equipment, the wire recorder. For the harried counsel-

lors who cannot cram all the instruction necessary into their summer camp programs, instruction recorded on tape can put a class through a crafts lesson while another class in swimming or nature lore study goes on at the same time elsewhere. This same wire recorder has another important chore that it can perform, not only at camp but in any vacation spot. It can record for the future the memorable experiences of the holiday period. For the camper it can capture the flavor of the council fire ceremonies and the storyteller's gift. It can record the highlights of an amateur night at a dude ranch, or the harmonious strains at a songfest. People are sentimental enough to want to play back these experiences on the recorder, to recapture the enjoyable hours of vacation time during the long winter evenings. And people are practical enough to buy those items which will provide such sentimental pleasures.

Summer really opens up a wide and limitless market for the dealer's portable equipment—radios, phonographs, and wire recorders. It is up to each and every dealer to find ways and means of selling to this vast, sprawling, and profitable market.

Summer Merchandising

To do this every dealer will have to sharpen his merchandising tools and put them to seasonal work. Despite the fact that the radio and television industry broke all sales records last year with a greater than \$750 million volume, radio receiver sales were off by 20 per cent in comparison with 1947. This means that television has gained sales momentum and that, although there is still a wide market for radios, only strong merchandising measures will take the profits out of that market. This means, too, that the dealer will have to make a serious, deliberate pitch for the radio market. And, since there is a natural demand for portables in the summer season, every dealer would be wise to concentrate his merchandising on portable radios—along with phonographs and recorders—during that time.

Portable radios, phonographs, and wire recorders have been given the advantages of the newest look, featuring novelty styling, compactness, and wide utility. Every dealer has his share of the crop of new portables, which continue to flow off manufacturer's production lines. Of the 16,000,000 radio sets made last year, for instance, 17 per cent, or 2,114,133, were portables. Of the 10 to 12 million radios expected to be manufactured during 1949, portables will comprise a percentage close to what they hit last year. For the dealer, those 1949 port-

ables which have already reached his shelves will make ideal novelty displays.

Using late portable models along with manufacturers' merchandising kits, the alert dealer can make attractive sections out of his store, with portables featured and a spotlight centering attention on the merchandise. The window displays of portable radios, phonographs, and recorders can be in tune with the season. Luggage, camping equipment, appropriate beach, resort and mountain apparel can be used to intensify the appeal of the smaller items in the radio dealer's line of merchandise. Travel bureau information can be displayed in conjunction with an array of small sets, and anything a dealer can do to make his store appear to be a headquarters for travelers will mean greater profits in the long run.

Tie-In Merchandising

Not to be forgotten are the possibilities of displaying portable equipment in other shops. Down the street a luggage retailer may agree to include a portable radio in his window, or a camping supplier may include one among his camp wares and equipment. In such cases it is a simple matter for cross-reference of a customer. After an angler has purchased his supplies in the camp equipment shop, he will most likely turn to the dealer whose portable he saw in the window if he is interested in a radio.

Direct-mail promotions on portables can increase volume sales in the smaller items during the summer, too. Here again there need be no hit-or-miss method of directing the advertising effort. Travel bureaus, for instance, have leads on which an aggressive dealer can work. From a list of those people who have made inquiry at bus, railroad, plane and ocean transport depots, it may be possible to narrow down a select list of prospects to whom promotion material can be sent. The same camp supplier who was cooperative about the use of his store window can also furnish the names of customers who definitely will comprise part of the resort trade in the dealer's neighborhood. These prospects should be immediately placed on any direct-mail list.

Low Cost Feature

The most appealing feature of portables, of course, is their low cost. No one fails to appreciate the value of having a piece of merchandise which provides limitless hours of enjoyment and entertainment that can be bought for a nominal cost. That is why parents will agree to purchases by their children, knowing that the pleasure—both

Sell Portables to Sportsmen

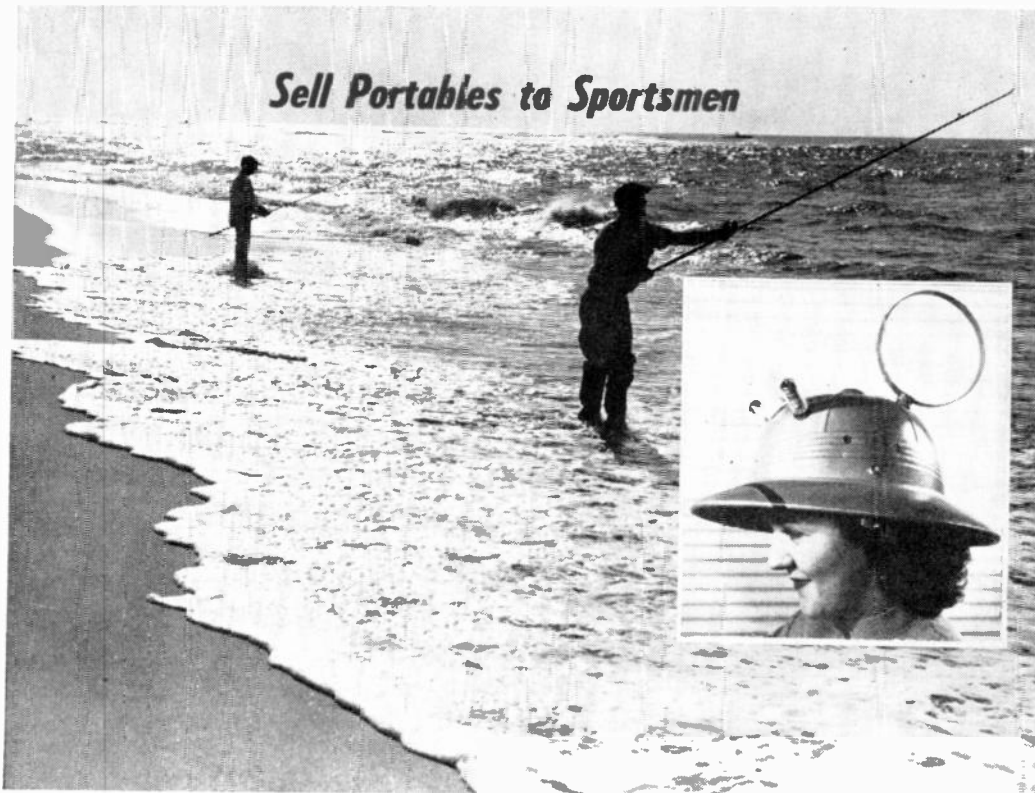

NYSPIX—Commerce

American Merri-Lei's helmet with a two-tube radio is sure to appeal to anglers, and indicates the vacationist market potential for portable sales is almost limitless.

of ownership and program enjoyment—will repay the cost over and over again. Other parents like to see their children work for pin money so that they can buy their own small sets, encourage it, and sometimes contribute to the project. Parents themselves ever find that taking a small sum out of operating expenses for entertainment conveniences for themselves is worth it in the end.

It is this attitude on the part of po-

tential customers which provides such a wide market in the summer season. It is the natural season for portables, the light, attractive, inexpensive items which are going to let vacationers carry their entertainment with them—to the country, to the mountains, to the seashore. The dealer who sharpens his merchandising to this resort trade will keep his summer sales from hitting those sloleful, depressing, and disturbing skids.

In the mountains, on the seashore, on sea-going craft, or aboard launches like the one below, portable entertainment equipment lives up every gathering. Dealers should bend their merchandising efforts to sell every prospect during the vacation splurge.

NYSPIX—Commerce

Sell Portables to Boatmen



DON'T LET TELEVISION SALES TAKE A VACATION . . .

Dealers may inadvertently try to make television take a vacation, but there is little likelihood they will succeed. Television just isn't an off-season industry. Not yet, anyway. It has its peculiarities during certain seasons of the year, but it is growing too fast to reflect any distinctive patterns or trends. Except that there is no question about its health. It is simply America's fastest growing industry and has limitless horizons. And now the opportunities for selling television to the country's resort trade is coming into sharp focus. The television boom, constantly sparked by wide set sales, improved programming, and expanding networks, has left its imprint on a television-conscious public. Whereas vacationers never thought of television when they packed themselves off for a holiday before, now television's impact is forceful enough to make itself felt throughout all levels of the travel and resort industry. Vacationers themselves may want to cut all home ties for a spell, but they want to take with them their favorite entertainment. And proprietors of resorts, inns, tourist camps, dude ranches, and seashore and mountain hotels have wisely added television to the list of customer whims to which they annually cater.

The resort business is a rambling but prosperous one. A hazardous guess would peg the resort and travel business in the country at about \$12 billion annually. Estimates as to the number of persons who contribute to the volume figures are equally hazardous. But something like 60 million people have some form of vacation every year, with 75 to 80 per cent taking a holiday from mid-June to mid-September. An approximate 30 million of these people have vacations with pay, and an estimated 75 to 80 per cent of these take some kind of trip.

This prosperous, widely participated in industry creates a peculiar market for television receivers, even while the normal family market remains undisturbed. A look at what happened in television last year will give dealers an inkling of what is in store for sales during the coming vacation period.

Production figures for 1948, May to September inclusive, for example, amounted to 323,767 television sets.

Already for the first two months of 1949, RMA reports the production of 240,176 television receivers. By long odds production of telesets during a comparable May-September period this year will far surpass that of last year. In the present state of the television industry, production figures are closely paralleled by shipment figures, and shipments are a sure barometer of sales. There is every reason to assume that television sales will continue upward. The summertime market this year, however, will widen the sales horizons beyond the normal home ownership market. The wise dealer will take a good, long look ahead at the sales potential of the resort and travel market, will single out the variety of prospects, and will concentrate on selling this special type of trade.

Second Round Sets

What are some of the unusual features of the resort and travel market so far as television is concerned? There are many of them. What this particular industry offers in the way of a special market for portables—radios, phonographs, and wire recorders—is covered elsewhere in this issue. With television, the vacation field does not necessarily make portable set sales take up the slack of a slump in console and table model sales. Instead it opens up new vistas for sales of all three types of television receiver.

Take for example the upper income or middle income families which already have television receivers in their homes. Countless numbers of these people have summer homes or cottages. If they don't own them, they rent them. Some rent them alone, others in a group. Are these people in the market for a second television set? Many of them are. The game room and recreation room are common in such summer homes. Why not a television room? More often than not, summer homes and cottages have a houseful of guests. With television taking on more and more significance as an entertainment medium, such guests would enjoy sports and special events coverage in the comfort of a small television theatre or salon. Portable, console, table, or even projection sets may be the answer for those vacationists who want to bring television into their summer

homes, and dealers should be alive to such potential sales.

Just as radios, phonographs, and wire recorders are becoming increasingly popular with families traveling to all sorts of resorts during the summer, so portable television will quickly catch on. Many set owners are in the market for a second set, particularly a portable one, and the dealer who neglects this market may be missing surefire sales. When the vacation splurge dies, the sales potential may disappear.

Small Fry Interest

Children in a family have an insatiable thirst for television and all it has to offer. Vacationing families will have to contend with the constant cries of the small fry who want to keep up with the adventures of their favorite television characters. Older members of television-owning families will also be interested in television coverage wherever they are. Dealers will have to sound out the individual prospects, clinching sales whenever pocketbook and desire balance out.

Aside from the family group—where children have a strong influence on television buying habits, there is another area where young people present a solid front of opinion which may benefit dealers in the long run. The number of boys and girls who make an annual pilgrimage to summer camps, either organized or informal, day or continuous, increases yearly. Most of these youngsters come from





families where radio has become an accepted part of their daily lives, and where television has begun to crowd radio a little. Those youngsters who have no sets in their own homes have at least seen television on a pal's set. The little folk, then, will demand their "Howdy Doody" and all their other favorite programs. In anticipation of this keen interest in television among their camp groups, progressive camp directors and counsellors will prepare against the time when the hue and cry from the youngsters will shake apart the roof if no television screen materializes. In self-defense, as well as in the interest of sound, wholesome, top-notch entertainment, camp personnel will be highly receptive to the dealer's television sales presentation. In the last analysis, telecast programs may be an excellent replacement for the puppet shows which have become highlights of special entertainment at camp.

Every Lounge a Screen

In television's earliest days, bars, restaurants, and taverns were the spots where television ownership first reached a saturation point. Public viewing of television became a national habit. Now that the habit has taken firm hold on the public, dealers should not rest until every hotel, every resort establishment, every roadside tavern, inn, tourist cabin, dude ranch, or overnight resting place has some form of television to offer its guests.

During the first spurt of sales to public places, the cream of the pros-

pects was skimmed off. What was at one time a saturation point for public establishment sales has been changed by the widespread use of television by individuals. Not everybody wants to settle in bars to watch television anymore. Couples and families like to gather in a homey atmosphere to watch telecasts. The hotel that bought a set for the bar the first time around may now be in the market for additional ones for lounges, even for some of their suites. The roadside tourist camp may also have bought a receiver for the bar long ago but now is interested in providing a set for the main recreation room, or even remote control units for individual cabins. The prospective customers for consoles, table models, remote control sets, portables, and even projection sets is only limited by a dealer's initiative and the drive he puts into his merchandising.

For a Prosperous Summer

While making his special appeal to the travel and resort market, the dealer must never forget the stay-at-home market. Every day, week in and week out, converts to television are hurdling their last major obstacles and are concluding purchases on television sets, walking into a dealer's shop and putting their money on the counter. Last year television's surge provided holiday sales of this sort, and, judging from the steady march of the medium, sets will continue to sell.

Like other consummated sales, however, television sales do not just hap-

pen. Dealers must keep up an active barrage of sound merchandising, shooting at every potential customer every time there is an opening. For the summer season the dealer can take additional steps to make his sales spurt. Just as with portable radios, phonographs, and wire recorders, dealers can keep a close check on vacationers in his community. Those who are prospects for portable television sets should be approached. Running a display of a portable television set in a window featuring camp supplies, resort and beach apparel, dude ranch clothes, and other summer supplies may very well steer prospects to a dealer's store.

Above all, the appropriate use of attractive, stimulating and effective window displays will help every dealer make those point-of-purchase merchandising techniques pay off. All summer the displays can be changing, both window and interior special feature corners. Radio, newspaper, and even television advertising can do a great deal toward giving summer selling the punch it needs.

The holiday months open up a vast playland market for television, one the dealer cannot afford to ignore. Television has no time for a vacation. If dealers let television sales take a vacation it will be because they have packed sound merchandising in a bag and have gone on a vacation themselves. Which would not be so good, for the tough buyer's market may make the vacation a permanent one.

Here's How Your Customers Are Buying Television . . .

These Recent Surveys Will Help You Plan Your Sales

Among the earliest surveys into television ownership was the one conducted by the Newell-Emmett Company in Videotown, population about 50,000 and located in New York City's hinterland (See "Television Town: America" in Radio Journal, September, 1948). Before manufacturers, distributors, and dealers were digesting and applying the findings of Newell-Emmett's study on this test community, the company's researchers were at work exploring the buying motives and viewing habits of television buyers. Recently the results of this second visit to the secret "guinea pig town" were divulged, and dealers should pay particular note to the findings, using the facts to guide their selling.

Whereas, for instance, Dad had been the chief instigator of television receiver purchases, other members of the family have been exerting pressure to buy. It is common knowledge that children exert considerable pressure on parents. Mother, however, is the chief source of opposition to buying TV in one out of five homes.

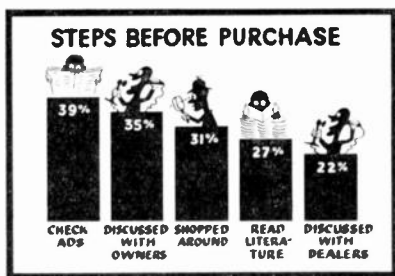

Chart Courtesy of Newell-Emmett Adv.

What the survey disclosed about the buying pattern of TV was revealing. Special events like the political conventions had sufficient pulling power to close sales in one-fifth of the purchases. Most buyers, however, had viewed television for close to a year before buying, either in taverns, at friends' homes, or during frequent visits to dealers. The lower the income bracket, the longer the exposure to the medium before the final purchase. Once prospects made up their minds to buy half of them completed the purchase within two weeks.

Large Screen Preference

Although the upper income brackets comprised the predominant purchasers of large screen sizes, price rather than preference accounted for this fact. Sixty-two per cent of purchasers of 7-inch screens admitted their choice was directly tied to what their pocket-books could afford. Thirty-one per cent of purchasers of 10-inch screens admitted price was the deciding factor. On the other hand, 10 per cent of 12-inch screen buyers and none of the purchasers of 15-inch screens and larger mentioned price as a deciding factor in their decision.

So far as listening habits and size of television audiences are concerned, 94 per cent of all sets are used every day, while the average length of time sets are used totals four hours, and the number of persons in the home audience comes to four. These figures are based on owners' estimates and actual usage may run around 86 per cent on any given day, for as long as three hours, with three people viewing.

Living Habits Changed?

Length of ownership has little influence on the use of television sets. Eighty per cent of Videotown owners who purchased receivers in early 1947 used their sets on any given day, compared to 88 per cent who purchased sets during later periods. Time being spent at home has been affected by television set ownership. Forty-three per cent of families in the upper bracket claim more company drops in while 31 per cent of lower income groups find the number of visitors on the increase. The bonds of family interest have been cemented by television set ownership among 35 per cent of Videotown's lower income group, and in 20 per cent of the upper income groups.

More and better programs have sharpened rather than dulled owners' interest in the television medium. Three out of four television owners in the hinterland survey town look ahead and plan their entertainment by checking program schedules and special events. A preponderant number of present set owners would advise friends to buy a set, too.

Another Part of the Television World

How much do television set purchasers shop around before buying? What influences play a major part in prompting people to visit stores and buy sets? How have television set own-

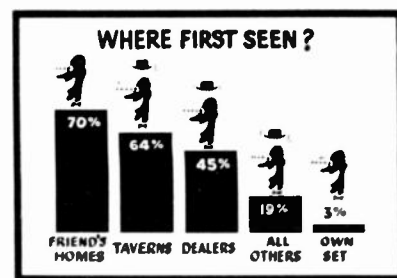

Chart Courtesy of Newell-Emmett Adv.

ers influenced others to buy sets? Answers to these questions have been revealed in another survey, this one conducted by House Organs Associates, New York City. In the main it substantiates the Newell-Emmett survey findings. House Organs Associates checked home television set owners in New Hyde Park, Long Island, an area about four square miles in size, where persons interviewed own their own homes—homes which have an average market price value of about \$14,000.

As to shopping around, it was found that about 45 per cent of Hyde Park TV set owners visited at least three television dealers before buying their sets. Four per cent visited two dealers. Of the remaining 51 per cent which bought sets in the first store visited, three-fourths were influenced to go to these dealers because friends and relatives had bought there. The remainder had invariably gone straight to a dealer from whom they had made previous purchases of radios and home appliances.

What prompted buyers to go to stores? Sixty-five per cent of those interviewed claimed seeing sets operating at the homes of friends, neighbors, and relatives, or hearing other people describe certain telecasts prompted the initial visit to shop for a set. Nearly 20 per cent attributed their interest in television to seeing telecasts in bars, hotels, or other public places. The

Even though the women in this family are enthused over their television set, women as such are, nevertheless, the ones dealers have to sell on the new medium. In one out of every five families questioned in Videotown, Mother was the chief source of opposition to buying TV.



remaining 15 per cent had various stimulating factors, such as having a vital interest in radio and television, having a desire to try something new, and being attracted by demonstrated sets in store window displays.

A Real Influence

How have set owners influenced others in regard to television set buying? A great deal, according to the House Organs Associates survey. Of all the owners interviewed, some 32 per cent were certain they had influenced the later purchase of sets by friends. By having these friends in to see various telecasts, they reasoned, they had encouraged the eventual purchase. As many as three friends, in some instances, bought sets following repeated home demonstrations by well-wishing friends. Of course, selling power of individuals was directly related to their range of acquaintances and to their sociability. People who rarely have a friend in to visit have no opportunity to demonstrate a set. On the other hand, an owner who is always having a party or a houseful of guests for some reason or other can demonstrate sets repeatedly. Among these people who customarily have frequent visitors, those interviewed at New Hyde Park were convinced that they had been responsible for the purchase of at least one set apiece.

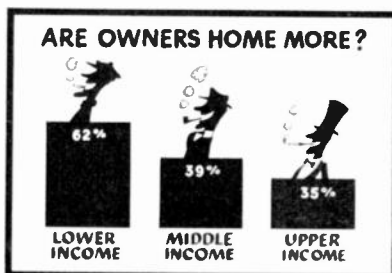

Chart Courtesy of Newell-Emmett Adv.

Current Trends in TV Buying Habits

Representing a sampling of the two and one-half million subscribers to The American Magazine, 1,063 respondents to a magazine questionnaire gave pertinent information on television habits applicable to December, 1948, when the survey was completed. Of these respondents, it was found that 3.2 per cent owned television sets, with 96.8 per cent still non-owners. Highlights of the survey are contained in the tables below.

BUYING INTENTIONS OF NON-OWNERS

Will buy in 1949	22.5%
Will not buy	23.1
Don't know	54.4

TYPES OF SET PREFERRED

Combination	33.8%
Table model	19.8
Console	10.4
Don't know	36.0

SIZE OF SCREEN PREFERRED

10-inch	27.1%
12-inch or larger	15.0
7-inch	10.7
Projection type	0.9
3-inch	—
Don't know	16.3

PRICE PROSPECTS EXPECT TO PAY

Less than \$100	2.8%
\$100-\$199	12.6
\$200-\$299	18.7
\$300-\$399	17.8
\$400-\$499	9.8
\$500 or more	7.9
Don't know	30.4

*REASONS FOR NOT BUYING

Can't afford	52.6%
Sets will be improved—will wait	15.7
Sets will be cheaper	24.1
Not interested in present programs	18.5
No need for additional entertainment	12.1
Lack space for set in home	6.0
All other reasons	9.5

* Based on 232 answers to this question.

TV Sales by Rental

Samuel Elovitz, manager of the leased television department in the Summerfield Co. department store, Boston, Mass., recently put in operation a new method of increasing television sales. He made available for rental such standard television sets as Philco, Motorola, RCA Victor, Zenith, and Admiral. Offered to customers at the rate of \$1 per day, with a minimum of 15 days rental and customer responsibility for willful or accidental damage, any such patron keeping the set for 90 days and deciding to buy was offered the opportunity of applying the rental payments to the purchase price. Customers interested in renting a set with large screens paid more, \$1.50 being the charge for a 10-inch screen.

Big TV Volume

Television should account for business activity totaling more than a billion dollars in 1949, John K. West, vice-president in charge of RCA Victor public relations, recently told members and guests of the American Management Association at a television session. Mr. West stressed the importance of the industry in maintaining the economic strength of the nation in the future, and indicated that American Management had a great responsibility in making the American economy work.

Citing the industry estimates of an annual production rate of about 5,000,000 television receivers by 1953, Mr.

A "Portable" Display With Zip



"Don't touch that portable! It's not luggage, but my traveling companion!" is what this lady is telling the porter. Both figures look big and real as life. A close look, however, will confirm the fact that this is an RCA portable display with plenty of sales appeal. Designed for floor or window locations, the multi-colored, life-size unit can support any portable radio. Displayed here is the firm's aluminum and plastic "Globe Trotter." For dealers who are seeking ways and means of capitalizing on vacationers' desire for portables—discussed on pages 11 to 15 in this issue—here is an example of how a display in tune with the portables season can do an aggressive merchandising job.

West indicated the huge bite the industry would thus make on other materials in the economy. He estimated this annual receiver production would require annually 200 million pounds of steel, 47½ million pounds of copper, 40 million pounds of aluminum, and, for picture tubes alone, 83 million pounds of glass. Wood required for television cabinets, at that annual production rate, would come to over 103 million board feet. As an advertising force, television will also make a great contribution to the economy, Mr. West indicated. In less than two years, advertisers have increased by 2,500 per cent, and \$25,000,000 is expected to be spent by advertisers on television this year.

TV "Synchronization"

A method of reducing interference between stations on the same television channel has been developed by the National Broadcasting Co. Known as television carrier synchronization, and described by Ray D. Kell, TV section head of the RCA Laboratories, Princeton, N. J., in a paper titled, "The Synchronization of Television Stations," and delivered before the recent convention of the Institute of Radio Engineers, the system is working between New York and Washington television stations and between NBC stations in Cleveland and Detroit.

Interference is due to characteristics of the troposphere, or upper air masses, which cause TV signals to be refracted over long distances. As a result, in certain localities—chiefly fringe areas of television reception—several transmitting stations are received simultaneously. The interference shows up on screens as "Venetian blinds." Amount of interference depends on the strength of the interfering signal and difference in carrier frequencies.

By installing permanent synchronization equipment in Wilmington, Del., signals from New York and Washington stations are compared electronically at the output of two radio receivers located in Wilmington. Frequency differences are registered by a tone carried over telephone lines. The frequency shift of this tone is utilized to keep the New York transmitter "synchronized" on the same frequency as the Washington transmitter. The same type of automatic system is used in Sandusky, Ohio, for cutting down interference between WNBK, Cleveland, and WWJ, Detroit. With construction of television stations held down by an FCC freeze, perfection of this system for reducing interference means two or more television stations operating on the same assigned channel will be able to transmit without producing coverage-reducing interference.

VETERANS ALWAYS GIVES YOU MORE

*Let's speak frankly
on the subject of*

TELEVISION

*Yes
we do give*

DISCOUNTS

*we meet
ALL COMPETITION*

and do even better

CASH OR TERMS

**VETERANS
HOUSEHOLD APPLIANCES**

238 HUGHEROT ST.

NEW ROCHELLE 2-0310

*Just a reminder of what dealers
are up against in television, and
a caution that sound, aggressive
merchandising cannot be relaxed
for even an instant.*

Emerson Radio

America's No. 1 Portable Line!

Never before in Emerson's history of leadership in Portable values has a line been offered with such sales and profit possibilities. Never before such style, tone, performance, at such sensationally low prices. Never before a line backed with such powerful promotions. If you're looking for new Portable sales records, concentrate on Emerson.



America's Greatest Portable Value!

**Emerson
Model 560**

16⁹⁵
less batteries



Self-powered, Superheterodyne—beautifully engineered into a light, compact, handsome maroon or green plastic cabinet—flawless tone, sensitive circuit designed for low battery drain. A really terrific value!

**EMERSON 3-WAY PORTABLE
Model 559**

24⁹⁵ *less batteries*

Operates on AC-DC, or self-contained batteries. Extra power, beautiful tone...no distortion. Alligator-grained plastic cabinet in maroon, green or sand.



**EMERSON 3-WAY PORTABLE
Model 568**

29⁹⁵ *less battery pack*

Amazing sensitivity—power to spare—gets more stations. Economical to operate. Long-lasting single battery pack. In maroon, sand or tan. Cabinet with basket-weave grille.



**EMERSON SELF-POWERED
PERSONAL PORTABLE
Model 558**

24⁹⁵ *complete with batteries*

A handful of radio...packed with power. Automatic lid-operated switch. Sensitive superheterodyne circuit—low battery drain. In beautiful green or ivory plastic, gold-colored hardware.

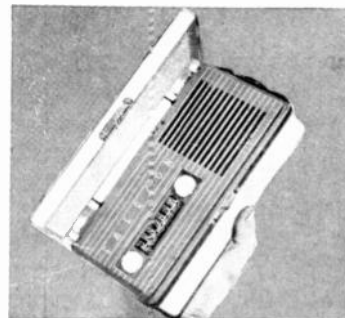

More People Ask For — More People Buy Emerson Portables
EMERSON RADIO & PHONOGRAPH CORPORATION • NEW YORK II, N. Y.



From Electronics Park...

4 NEW KING SIZE



MODEL 806—Here is a television dollar stretcher that puts sensational G-E Daylight Television within the easy reach of your customers at a surprisingly low price. It has everything to win friends and quick sales! 10-inch direct-view tube—all U. S. Channels—handsome mahogany finish cabinet. **\$279.95***

**Tax and installation extra, all models. Prices slightly higher West and South, subject to change without notice.*

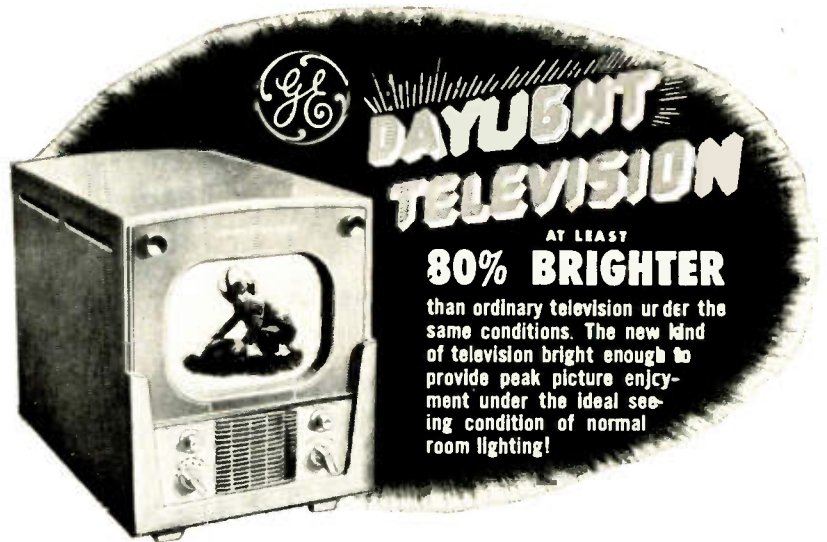

MODEL 807—Some prefer bland—cabinets, that is—and here is a beauty that is styled and priced for instant favor of smart television buyers! G-E Daylight Television. 10-inch direct-view tube—all U. S. Channels. Distinctive cabinet in genuine native American oak veneer. **\$289.95***

MODEL 809—Now your customers can enjoy the thrill of owning a G-E Daylight Television Console at little more than table model cost! 10-inch direct-view tube—all U. S. Channels. Stunning cabinet, paneled in genuine mahogany veneer. **\$329.95***



VALUES FROM \$239^{95*}

LOWER PRICES—UNMATCHED FEATURES FOR THE BIGGEST VOLUME MARKET IN HISTORY!

EVERY one of these value-packed models is a high-powered sales maker! Each one carries a price tag that calls for immediate and vigorous sales action! No more waiting for lower priced television—it's here! No more waiting for clearer, better, brighter television—it's here! . . .

here in a range of low-priced G-E models that will enable you to cash in on television's greatest year. It's the Bright Line for *king size* profits in '49. Call your General Electric Television distributor today or write to *General Electric Company, Electronics Park, Syracuse, New York.*

You can put your confidence in—

GENERAL  ELECTRIC

MODEL 805—General Electric Television at an amazing new low price! A quality performer with a dollar sign that will direct traffic to your store! 10-inch picture tube—all U. S. channels—compact cabinet of moulded rich rosewood plastic styled in the modern manner. \$239.95*



PERFORMANCE-ENGINEERED
at the World Center
of Electronic Progress





Flashy merchandising startles San Francisco's Chinatown, above. Libby-Owens-Ford plate glass gives the storefront of Chong Jan Co. a new look, turning the show window into what verges on a sidewalk display.



Three onlookers, above, view the recent Sparton television models premiere in Detroit. L. to r., H. Johnston, pres., Sparton TV division; H. L. Pierce, vice-pres., and D. O'Connor, mgr., J. L. Hudson Co., Detroit.



James M. Skinner, Philco, right center, receives plaque at a recent Harrisburg meeting of Federation of Radio Servicemen's Association. Award honored Philco's TV servicemen training program.

Motorola demonstrated TV reception in flight recently. Below, the dipole antenna fitted on the plane.

"Kansas City's Sweetheart," Kay Sears, center, brightened the proceedings at the Exposition of Electrical Progress recently. The other two beauties helped her demonstrate television.





Poster girl Linda Brown, San Antonio, Texas, absorbed in the captivating color book, "Alice in Philcoland." Income from the national sale of the books will be turned over to the "March of Dimes." Philce dealers are now selling them.



Above, Walter M. Skillman, mgr. GE receiver division sales, left, with E. J. Henrickson, TV sales mgr., inspects Electronics Park production lines where the firm's new, low-priced table receiver models are in mass production.



A new display for a new instrument. This RCA demonstration unit features a model 45-rpm. phonograph, five of the new, multi-colored records, and a front panel pocket for literature on the new system.



Above, W. W. Hensler, analysis engineer on the staff of Howard W. Sams, typifies the extensive study going into the firm's Photofact TV service folders.

The girl at right is removing the excess "flash" from the rim of one of the new, wafer-thin, vinyl plastic RCA records. To meet the advance demand of the new discs, RCA's Indianapolis plant had to work day and night shifts.



SMARTEST SELLING IDEA in TV!

Stromberg-Carlson advertising brings it home every month to the 18,000,000 families who read

LIFE • TIME
 •
 SATURDAY EVENING POST
 •
 HOLIDAY
 •
 BETTER HOMES and GARDENS
 •
 HOUSE and GARDEN
 •
 HOUSE BEAUTIFUL
 •
 NEW YORKER
 •
 NATIONAL GEOGRAPHIC

See
 it
 Better



Hear
 it
 Better

STROMBERG-CARLSON TELEVISION

“See it Better... Hear it Better”

... with STROMBERG-CARLSON TELEVISION! That is the challenge and the promise *you'll see and hear everywhere* this year! It will support your efforts from the pages of the magazines that have

the most influence on people in your community.

No other manufacturer can live up to such a convincing advertising theme with more authority than STROMBERG-CARLSON, famous for its tradition of fine craftsmanship in radio since 1924 and in video since 1939.

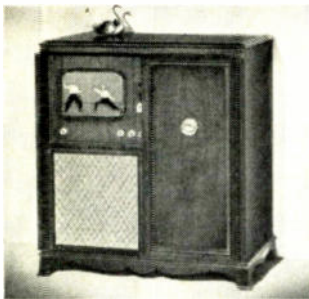

The LANCHESTER
 Television-Radio-Phonograph
 Mahogany

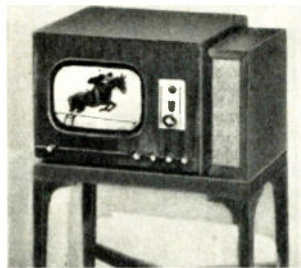

The ROCHESTER
 Television and FM Radio
 Mahogany



The HEPPLWHITE
 FM-AM Radio-Phonograph
 Mahogany



The WINDEMERE
 FM-AM Radio-Phonograph
 Blond or Mahogany

In television, as in radio, there is nothing finer than a
STROMBERG-CARLSON

Stromberg-Carlson Company, Rochester 3, N. Y.—In Canada, Stromberg-Carlson Co., Ltd., Toronto

Where Are Television Sets Being Shipped?



THE most spectacular postwar development in the nation's economy has been the growth of television. Where more than the approximate one million TV sets manufactured went in 1948 is shown in detail on the map above. Production for last year paced shipments with a comfortable lead, more than 970,000 sets rolling off production lines, according to Radio Manufacturers Association figures. With a goal of 2,000,000 TV receivers for 1949, the industry got off to a flying start this year, production figures skooting to 240,176 in only two months of the new year. It is now estimated that better than 40 per cent of the nation's population is within the range of telecasting stations, with television's scope remaining limitless. Anticipated FCC licenses to construct more stations, splitting wide open of the UHF channels controversy, and technical advances such as synchronization of stations on the same channel so as to minimize interference are expected to broaden television's scope even more, and in the immediate future.

"Trends and Prospects in Radio and Television Receivers," a report by Department of Commerce analysts James B. Forman and Charles P. Redick, forecasts a dip in radio sales to 10,000,000 for 1949 but a continued increase in total television sales, possibly in excess of \$500,000,000. Aggregate radio and TV receiver sales may be expected to approach the \$1,200,000,000 achieved last year, the report states.

RTJ

New Products



Radios
Television

Consoles
Recorders

Phonographs
TV Accessories

The New RCA Player

Manufactured by RCA Victor Division,
Camden, New Jersey.



Playing up to 10 of the new RCA Victor 45-rpm. records, this self-contained automatic table phonograph features a permanent-magnet electrodynamic speaker, two tubes and rectifier. Measures slightly less than eight inches high, 10 inches wide and 10 inches deep. Finished in deep maroon, with center spindle of brass and metal trim of golden finish.



A combination featuring a two-band AM-FM radio and the new 45-rpm. record changer, this RCA console has nine tubes and one rectifier. The new changer is installed in a special rollout drawer. Storage space for 189 single new, lightweight, non-breakable, 45-rpm. records, or for 24 albums of the same. Cabinet in mahogany and walnut finishes, also in limed oak.

Say you saw it in *Radio & Television Journal*, April, 1949

New GE Television Sets

Manufactured by General Electric Co.,
Electronics Park, Syracuse, N. Y.

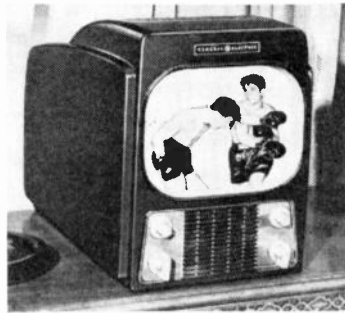

Set has 17 tubes, plus picture tube and three rectifiers, and is pretuned to all 12 television channels. Utilizes 10-inch picture tube, which provides 52 square inches of viewing surface. Cabinet is a compact one in rose-wood plastic.

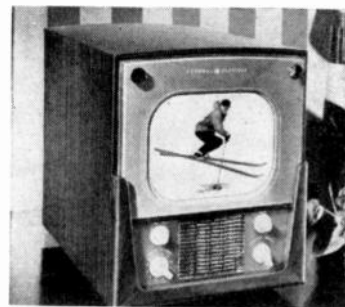

Also using a simplified circuit design necessitating 17 tubes and three rectifiers, this model features a 10-inch GE "daylight" tube for greater brightness. Program selection by switch of knob. Has GE automatic clarifier, and stabilization circuit for reduction of interference. Above model is in mahogany.

Say you saw it in *Radio & Television Journal*, April, 1949.

Freed-Eisemann Combo

Manufactured by Freed Radio Corp.,
200 Hudson St., New York.



This radio-phonograph model, the New World Hepplewhite, is equipped with automatic changers for playing all three types of records. Has 21 tubes, coaxial, high-fidelity speakers, separate amplifier which produces 20-watt output, and audible tonal range of 30 to 15,000 cycles. Plays AM, FM, and shortwave.

Say you saw it in *Radio & Television Journal*, April, 1949

Admiral Combination

Manufactured by Admiral Corp., 3800 W.
Cortland St., Chicago, Ill.

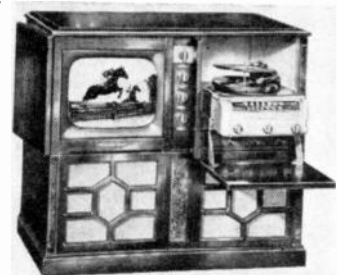

A television-radio-phonograph combination console which is equipped with a new "triple-play" automatic record changer. One tone arm will automatically play every size record, standard and LP, now on the market (78, 45 and 33 1/3). Picture tube is 16-inch, direct view. Console cabinet is in traditional mahogany.

Say you saw it in *Radio & Television Journal*, April, 1949.

New Emerson Sets

Manufactured by Emerson Radio & Phonograph Corp., 111 Eighth Ave., New York City.



In a console cabinet of crotch and striped mahogany veneers, this "4-way" television phonoradio combines television, FM and AM radio, and phonograph. The 12½-inch picture tube provides a 91-square-inch screen. The phonograph has an automatic record changer. Record album storage space is provided in the console beneath the phonograph unit.



This radio model in walnut is an AC-DC one, utilizing six tubes, including rectifier. Designed with advance electronic features including 5-inch "Sealed Unit" Alnico 5 speaker, built-in loop antenna, high-gain converter, beam power extra output, and automatic volume control.

Say you saw it in *Radio & Television Journal*, April, 1949.

Sightmaster's "Pandora 15"

Manufactured by Sightmaster Corp., 385 North Avenue, New Rochelle, N. Y.



This 15-inch tube television set has safety glass mirror and features Sightmirror on the viewing side. When not in use the front of set becomes a mirror. The remote-control unit allows tuning from points at a distance from the set and eliminates knobs on the set proper.

Say you saw it in *Radio & Television Journal*, April, 1949

Stromberg-Carlson's "Lancaster"

Manufactured by Stromberg-Carlson Co., Rochester, New York.



A television-radio-phonograph combination which is featured in a hand-decorated Regency cabinet with ancient Chinese motif. Is continuously tunable through complete range of TV and FM channels; has standard broadcast and shortwave; 12½-inch picture tube with AFC sync-lock; five-position tone control, and 12-inch Alnico 5 speaker. Also has intermix, duo-speed, automatic stop record player for standard or LP records, and single tone arm.

Say you saw it in *Radio & Television Journal*, April, 1949.

U. S. Television Combo

Manufactured by United States Television Mfg. Corp., 3 West 61st Street, New York City.

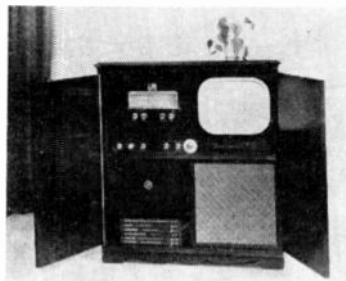

This new console combination has a 15-inch picture tube, provides AM, FM, and shortwave radio reception, and has an automatic, dual-speed phonograph unit. A total of 33 tubes are in the console's television section. Tone system is housed immediately below the television screen for permitting best possible acoustic value to sound received by 12-inch, electro-dynamic speaker. Album space for records is provided below phonograph unit. Cabinet is classic period style and is finished in mahogany.

Say you saw it in *Radio & Television Journal*, April, 1949

Zenith Combination Console

Manufactured by Zenith Radio Corp., 6001 W. Dickens Ave., Chicago, Ill.



Here is a radio-phonograph console combination featuring the Twin Cobra tone arms and dual-speed turntable for both long playing and standard records. Has tuned radio frequency amplification. Three-gang condenser is used in AM tuning; three-gang permeability tuning on the FM band. Speaker is 12-inch PM. Antenna system is built-in, with connection provided for outside dipole antenna for use where FM signals are weak. Cabinet is of mahogany veneer and selected hardwood, reflecting Hepplewhite design period.

Say you saw it in *Radio & Television Journal*, April, 1949.

Raytheon Circle TV

Manufactured by Belmont Radio Corp., Chicago, Illinois.



Offering 70 square inches of circular screen, this television receiver utilizes a 10-inch picture tube. Set operates on either AC or DC, with no converter needed where only DC power is available. Automatic tuner insures accurate tuning on all channels. Controls for volume, contrast, brightness and horizontal picture stability. Viewing tube tilted for eye comfort and recedes into cabinet interior when door is closed, shutting off television receiver.

Say you saw it in *Radio & Television Journal*, April, 1949

Announcing 2 SENSATIONAL

Only the very best indoor antenna is sufficient for excellent reception. WARD'S new TVI-43 and TVI-49 are the FINEST INDOOR ANTENNAS AVAILABLE TODAY FOR METROPOLITAN MULTI-STATION AREAS.

Ward is the largest exclusive manufacturer of the finest and fastest selling antennas in the world. Behind the Ward name and symbol stands a company, known and respected for a quarter of a century for exceptional quality. These antennas are creative masterpieces, superb in their performance, into which Ward has poured a host of new design and construction features.

WARD'S NEW TVI-43

The TVI-43 is the finest indoor antenna that modern skill and technology can produce—far superior, by any standard, than anything else on the market. It brings in all channels precisely and brilliantly. Most attractive—chrome-plated brass telescopic dipoles, satin beige brown finish—blends perfectly with the most exacting interior. List \$17.95



Marshall Goldberg, Pittsburgh ALL AMERICAN and famous Chicago Cardinal right halfback uses the Ward Magic Wand Indoor Antenna in his home for the most brilliant precise reception on all TV channels.



Cal. Thomas R. Warner, Chief Engineer of the joint Greyhound Corporation-National Bus Communications, Inc., two-way radio communications project. "We have found the Ward Indoor Antenna most suitable to our needs in monitoring transmissions on TV channels because it is easily adjustable for maximum gain on any channel!"

NEW INDOOR ANTENNAS

By **WARD**

WARD'S NEW TVI 49

And here is Ward's portable TVI-49. It will give excellent reception on all channels—orients easily in all directions. Chrome-plated brass telescopic dipoles. The TVI-49 is sturdily constructed and weighted perfectly—it will not tip over—designed to harmonize beautifully with living room decor. List \$7.50

Manufactured by Ward, a company that stresses utmost perfection. You owe it to yourself and your customers to see and inspect Ward's unique indoor antennas. See any leading parts distributors or write for catalog today.

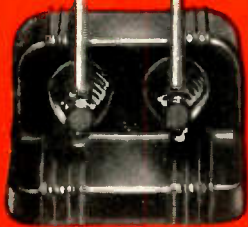
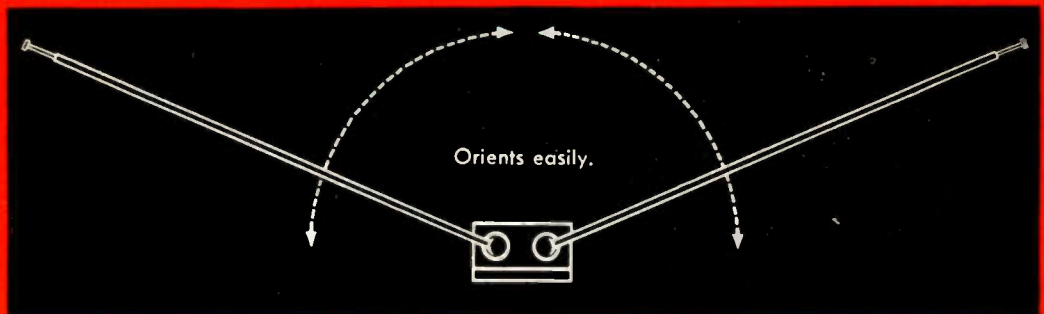

WARD PRODUCTS CORPORATION
1523 E. 45TH ST., CLEVELAND 3, OHIO
DIVISION OF THE GABRIEL CO.



Stewart-Warner Radio

Manufactured by Stewart-Warner Corp.,
1826 Diversey Parkway, Chicago, Ill.



Named the "Contemporary," this radio-phonograph console has a slide-out drawer located in the center of the cabinet. The radio has five tubes plus one rectifier, covers standard broadcasts from 540 to 1725 kilocycles, and has built-in high-impedance antenna. Record changer plays ten 12-inch or twelve 10-inch 78-rpm. records automatically and intermixed. Cabinet is finished in walnut.

Say you saw it in *Radio & Television Journal*, April, 1949

Crosley TV Console

Manufactured by Crosley Division, Avco
Manufacturing Co., Cincinnati, Ohio.

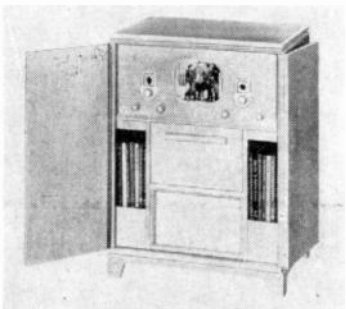

Equipped with a 10-inch, direct-view picture tube, this television console also offers complete FM and AM radio reception together with a phonograph with a two-speed changer for 33-1/3-rpm. and 78-rpm. records. Player is in convenient, pull-out drawer. Record storage space is provided on either side of the player compartment. Cabinet is in blond oak.

Say you saw it in *Radio & Television Journal*, April, 1949

New Arvin Radio

Manufactured by Nablitt-Sparks Industries,
Inc., Columbus, Indiana.

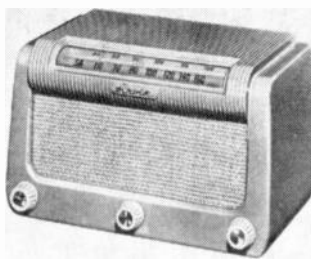

Incorporating six tubes, selenium rectifier, four-gang, variable condenser, and Alnico PM super-speaker, this table model features two wave band reception, AM and FM. Built-in loop antenna is mounted on back plate for AM reception, along with a 2 1/2-meter trace antenna for FM reception. Has slide-rule dial with burgundy characters, FM bands calibrated from 88 to 108 MC and AM bands from 540 to 1600 KC. Cabinets in either willow green or walnut brown.

Say you saw it in *Radio & Television Journal*, April, 1949.

Sparton 4-Way Combination

Manufactured by Sparks-Withington Co.,
Jackson, Michigan.



A new console combination, this model has a 10-inch screen which gives a 54-inch picture. Television chassis has 28 tubes, plus four dual-purpose tubes. Screen choice of mirror-view or direct-view screen is offered. Radio reception is AM and FM, and record changer plays standard and LP records. An adapter for the new 45-rpm. records is provided and can be installed in the record compartment.

Say you saw it in *Radio & Television Journal*, April, 1949.

DuMont's "Manchu"

Manufactured by Allen B. DuMont Laboratories, Inc., 515 Madison Ave., New York.



Featuring a 20-inch cathode-ray tube with a 213 square-inch screen, this latest model in DuMont's television line includes AM and FM radio, and an automatic record changer for standard and long playing records. Has dual speakers for full range tonal reproduction. Chinese chippendale cabinet is mounted on a teakwood table, which rotates on a wheel mechanism. Screen can be turned to any viewing position.

Say you saw it in *Radio & Television Journal*, April, 1949

DeWald Portable

Manufactured by DeWald Radio Manufacturing Corp., 35-15 37th Ave., Long Island City, N. Y.

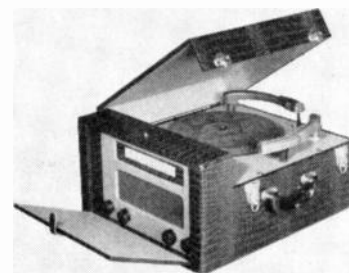

This radio-phonograph combination has five tubes plus rectifier, dynamic speaker, automatic volume control, built-in loop antenna, vernier tuning, and tone modulator. Phonograph operates on two speeds, has dual arms and a self-starting, silent, oversized motor. Plays up to 12-inch records with lid closed. Radio unit is concealed and cabinet is covered with leatherette.

Say you saw it in *Radio & Television Journal*, April, 1949.

Large Screen Television

Since the television industry really began to hit its stride last year, the trend of all set manufacturers has been in the direction of bigger and better screens. Twelve months ago, the vast majority of sets manufactured consisted of 7- and 10-inch direct-view tubes. Today, the 12-inch, 15-inch, and 16-inch tubes are taking precedence in response to the public's demand for "bigger pictures." When it comes to big pictures, projection television (which up to this point has been misunderstood and underestimated) has a decided advantage. Several leading manufacturers believe that projection TV provides the answer for big picture reception at a low cost. *Radio & Television Journal* will, therefore, devote part of its May, 1949, issue to a special section on projection television. Here is an unusual opportunity for manufacturers and suppliers to coordinate their advertising message with an editorial feature that will remain of lasting interest.

WALCO is sweeping the country!



WHAT'S IN IT FOR ME?

By *Television Mike*

Yes, Walco Tele-Vue-Lens is creating profits for dealers throughout the country and the new Tele-Vue-Lens Merchandiser is doing 99% of their selling job!



This Beautiful Shadow-box effect stops traffic — Pulls your customers right into the store! With it, your customers do their own demonstrating and sell themselves! You just wrap up the Tele-Vue-Lens and punch your cash register.

Don't miss this big profitable opportunity to convert your customers' 7", 10", or 12" sets to 16" screens with Walco Tele-Vue-Lens. You can sell a lens to every customer on your list!

This is your opportunity to make a fast dollar and keep your customers happy. Remember! There's no installation, no servicing! Your customers know they'll see a better T-V show with a Walco Tele-Vue-Lens! Make a profit with no fuss. Write me today. I'll send complete information to you immediately.

Television Mike

E. L. Courmand,
3835 Ninth Avenue,
New York City, N. Y.

**Better T-V for customers
BIGGER PROFITS
FOR DEALERS!**

Your customers want the Walco Tele-Vue-Lens—the world's finest T-V screen enlarger! They know it gives giant screen television pictures with no distortion from any viewing angle! Stock, display and demonstrate the most complete line of T-V screen enlargers model YOU double your profits with TELE-VUE-LENS!

Note to Distributors: Some territories still open. Write for details today.



MODEL 712 list price \$12.95
For 3" and 7" tubes.



MODEL 719 list price \$19.95
For 7" tubes.



MODEL 1029 list price \$29.95
For 7" and 10" tubes.



MODEL 1039 list price \$39.95
For 10" and 12" tubes.



MODEL 1059 list price \$59.95
For 10" and 12" tubes.

STAND MODEL 1040 list price \$39.95
For the 7" and 10" tubes.

STAND MODEL 1050 list price \$49.95
For the 10" and 12" tubes.

STAND MODEL 1075 list price \$59.95
For the 10" and 12" tubes.

*Prices slightly higher West of the Mississippi



The Walco TELE-VUE-LENS

a product of E. L. Courmand & Co., N. Y. C.

NATIONAL WALCO SALES COMPANY
SALES AGENCY 76 Franklin St., East Orange, N. J.

SEE THIS AMAZING
\$250,000.00 SERVICE
AT OUR EXPENSE

SEE FOR YOURSELF
Why Dealers and Distributors Everywhere
ACCLAIM IT A "MUST"

FREE
EXAMINATION

NELDA 1949 LOOSELEAF
SUBSCRIPTION

... Brings you the

LATEST PICTURES + PRICES + SPECS

of America's Leading Brands of

**TELEVISION • RADIO • MAJOR APPLIANCES
TRAFFIC APPLIANCES • CAMERAS • Etc.**

in compact convenient form for your everyday use as a

SALES BUILDER . . .

An attractive, comprehensive display for easier selling, in your store and outside in customer's home or office . . . kept CONSTANTLY UP-TO-DATE!

BUYING "BIBLE" . . .

Verify prices, descriptions and model numbers . . . see who makes it. Compare competitive models and prices . . . kept CONSTANTLY UP-TO-DATE!

Reference Manual

First and only authentic compilation of Standard Brands . . . complete with Pictures, Prices and Specifications . . . kept CONSTANTLY UP-TO-DATE!

REGULAR
WEEKLY and MONTHLY
SUPPLEMENTS
KEEP THIS SERVICE

Constantly Up-to-Date

1270 Sixth Ave., New York 20, N. Y.

Please enter immediately my subscription for Nelda's 1949 Looseleaf Service.

Bill me as per attached purchase order no. _____ and I will either return the Subscription within one week or remit \$50.00 plus postage.

Enclosed is remittance in full (\$50.00). Stamp the Binder as follows:

If I am not completely satisfied, I will return the Subscription within one week and you will refund my money.

Name _____

Company _____

Address _____

City _____ State _____

YOU CAN'T AFFORD TO BE WITHOUT IT
BECAUSE THIS \$250,000.00 SERVICE
COSTS YOU LESS THAN \$1.00 PER WEEK!

EXAMINE IT ENTIRELY AT OUR RISK

No Obligation on your Part!

If you are not completely satisfied,
return it in one week and you pay nothing!

Fill in this coupon NOW!

SPECIAL OFFER: YOUR NAME IN GOLD FREE!

If full remittance accompanies your order
we will **STAMP YOUR NAME IN GOLD** on the
DeLuxe Binder and **PREPAY THE POSTAGE!**

WRITE FOR PRICES ON MULTIPLE SUBSCRIPTIONS
AND SPECIAL SALES CREW OFFERS.

The Who's Who of America's Standard Brands:

For Your Convenience... every page in the Looseleaf Edition of the Standard Merchandise Manual is printed on one side only, to allow space for your own notes.



... with your

NELDA 1949

LOOSELEAF SUBSCRIPTION

YOU GET ALL THIS:

The **ADVANCE 1949 EDITION** of the **STANDARD MERCHANDISE MANUAL** — containing 992 illustrations, 1793 price listings, thousands of specifications and the **Blue Book Register of Manufacturers**. Here are the current models of America's foremost manufacturers in one compact compilation.

plus

WEEKLY PRICE-REVISION BULLETINS

—Every week you receive a bulletin with price changes listed page-by-page, to keep your Standard Merchandise Manual constantly up-to-date with latest prices.

plus

MONTHLY NEW-MODEL ILLUSTRATED SUPPLEMENTS

—Specifications and prices on new models released during the month, classified by type and brand-name, to keep your Standard Merchandise Manual constantly up-to-date with latest models.

plus

DeLuxe LOOSELEAF BINDER — A specially constructed seven-ring metal binder, covered in blue leather-grain fabricoid. Stamped with your company name or your own name in gold (see special offer).

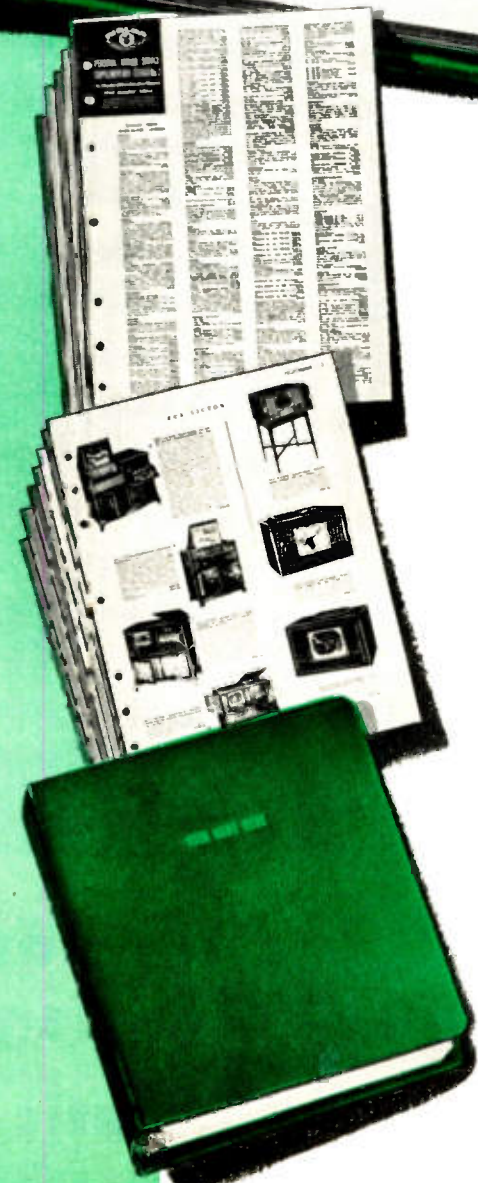

- ABC
- ADMIRAL
- AMERICAN
- AMERICAN BEAUTY
- AMPRO
- ANSCO
- APEX
- ARVIN
- BELL AND HOWELL
- BENDIX
- BISSELL
- BLACKSTONE
- BROILKING
- BROIL-O-MAT
- CARLTONWARE
- COMMUNITY
- CONLON
- CORY
- COUNSELOR
- CREAM KING
- CROSLEY
- CROWN GRAPHICS
- DEEPFREEZE
- DEJUR
- DETECTO
- DETROIT-JEWEL
- DISHAMATIC
- DUMONT
- EBERHARD FABER
- EDWARDS
- EKCO
- ELECTRESTEEM
- EMERSON
- ESTATE
- EUREKA
- EVERHOT
- EVERSHARP
- FARBERWARE
- FARNSWORTH
- FILTER QUEEN
- FLEX-SEAL
- FLOOR-O-MATIC
- FRIGIDAIRE
- FREE-WESTINGHOUSE
- GAROD
- GENERAL ELECTRIC
- GENERAL MILLS
- GILBERT
- GLENWOOD
- GRAFLEX
- HAMILTON
- HAMILTON-BEACH
- HANDYHOT
- HANKSCRAFT
- HANOVIA
- HOBART
- HOLLYWOOD
- HOOVER
- HOTPOINT
- ICE-O-MAT
- IRONRITE
- JOHNSON
- JUICE KING
- JUICE-O-MAT
- KELVINATOR
- KEM
- KITCHENAID
- KODAK
- KNAPP-MONARCH
- LAUNDERALL
- LEWYT
- LIONEL
- MAGIC CHEF
- MANNING-BOWMAN
- MAYTAG
- MELL-O-CHINE
- MONITOR
- MOTOROLA
- MUSAPHONIC
- NAXON
- NESCO
- NEW HOME
- HORGE
- NOTONE
- ODIN
- ONEIDA
- OSTER
- PARKER
- PETIPOINT
- PHILCO
- PILOT

- PREMIER
- PRESS-TO-MAGIC
- PRESTO
- PROCTOR
- RCA VICTOR
- REGINA
- REMINGTON
- REMINGTON-RAND
- REVERE
- RITTENHOUSE
- RIVAL
- ROGERS BROS. 1847
- WM. ROGERS & SONS
- ROLLS
- ROPER
- ROYAL
- SAHSON
- SCHICK
- SENTINEL
- SILEX
- SIMMONS
- SIMPLEX
- SMITH-CORONA
- SODA KING
- SON-CHIEF
- SPEED GRAPHICS
- STEWART-WARNER
- STEAM-O-MATIC
- STROMBERG-CARLSON
- SUNBEAM
- SUNKIST
- TAPPAN
- TELECHRON
- THOR
- TOASTMASTER
- TOAST-O-LATOR
- TRACY
- TUDOR
- UNDERWOOD
- UNITED STATES
- UNIVERSAL
- VICTOR
- WEAVER
- WESTINGHOUSE
- WESTON
- WHIRLPOOL
- WILCOX-GAY
- YALE & TOWNE



Admiral



America's Smart Set

**All Admiral Radio-Phonographs (from
Combinations (from \$399.95 and up)
"Triple-Play" automatic record changer**

sensational new "triple-play" Automatic record changer

PLAYS ALL RECORDS...ALL SIZES...ALL AUTOMATICALLY

78 RPM STANDARD

33 $\frac{1}{3}$ RPM LONG PLAY

45 RPM

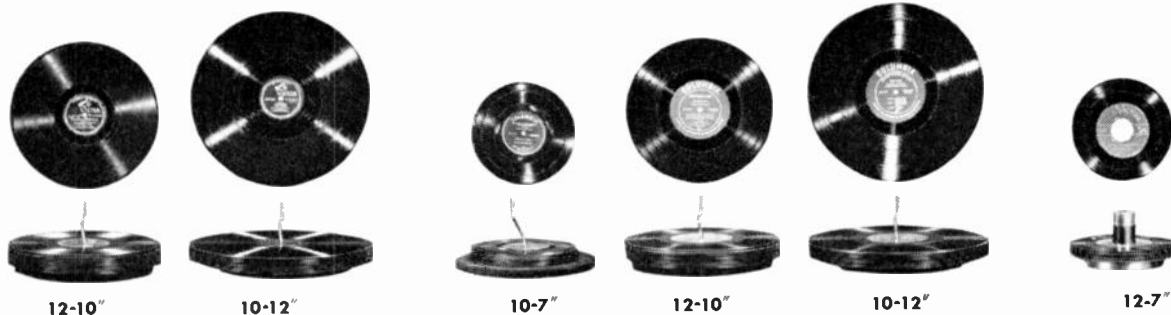

NOW! ONE FOR ALL . . . Admiral leads again with *one for all . . .* in a sensational new "triple-play" record changer that plays all records . . . all sizes . . . and all automatically.

Popularity of all the new LP records is growing by leaps and bounds. They are being backed by the strongest record promotion campaigns in years. Your customers will want to play both the 33 $\frac{1}{3}$ and 45 RPM records . . . and because most of them have extensive 78 RPM libraries, they will want to play those, too!

There is only one answer . . . a dependable, easy-to-operate instrument that plays them all . . . and Admiral has it! Admiral's new "triple-play" changer plays 78 RPM, 33 $\frac{1}{3}$ RPM and 45 RPM records . . . all sizes . . . all automatically. *Any record changer that fails to do as much is obsolete!*

ONE TONE ARM PLAYS ALL! You don't need an extra record player with the new Admiral . . . one instrument plays all records. Furthermore, the Admiral "triple-play" changer does away with extra tone arms . . . just one tone arm plays *all* records. Plays up to 12 records automatically with one loading. (Twelve 45 RPM records, for example, not merely eight.)

Two long-life, high fidelity needles are provided . . . one for standard records, the other for LP Microgroove records. Control switch at head of tone arm brings proper needle instantly into play. Click . . . and it's there!

THREE INTERCHANGEABLE CENTER POSTS. Three interchangeable center posts for automatic playing of all records. Take one out . . . slip another in its place . . . two seconds and it's done! Special receptacles provided on all consoles for center posts not in use.

Admiral's sensational new "triple-play" record changer is available exclusively on all Admiral radio-phonographs and television combinations. It's another big plus feature that's been added to the hottest line in the world today. Admiral Corporation, Chicago 47, Ill.—World's Largest Manufacturer of Automatic Phonographs.

SEE! HEAR! ON NBC TELEVISION! ADMIRAL "BROADWAY REVUE" EVERY FRIDAY, 8 TO 9 PM, EST

\$69.95 and up) and all Admiral Television are now equipped with sensational new at no extra cost.

Here from
PHILCO...

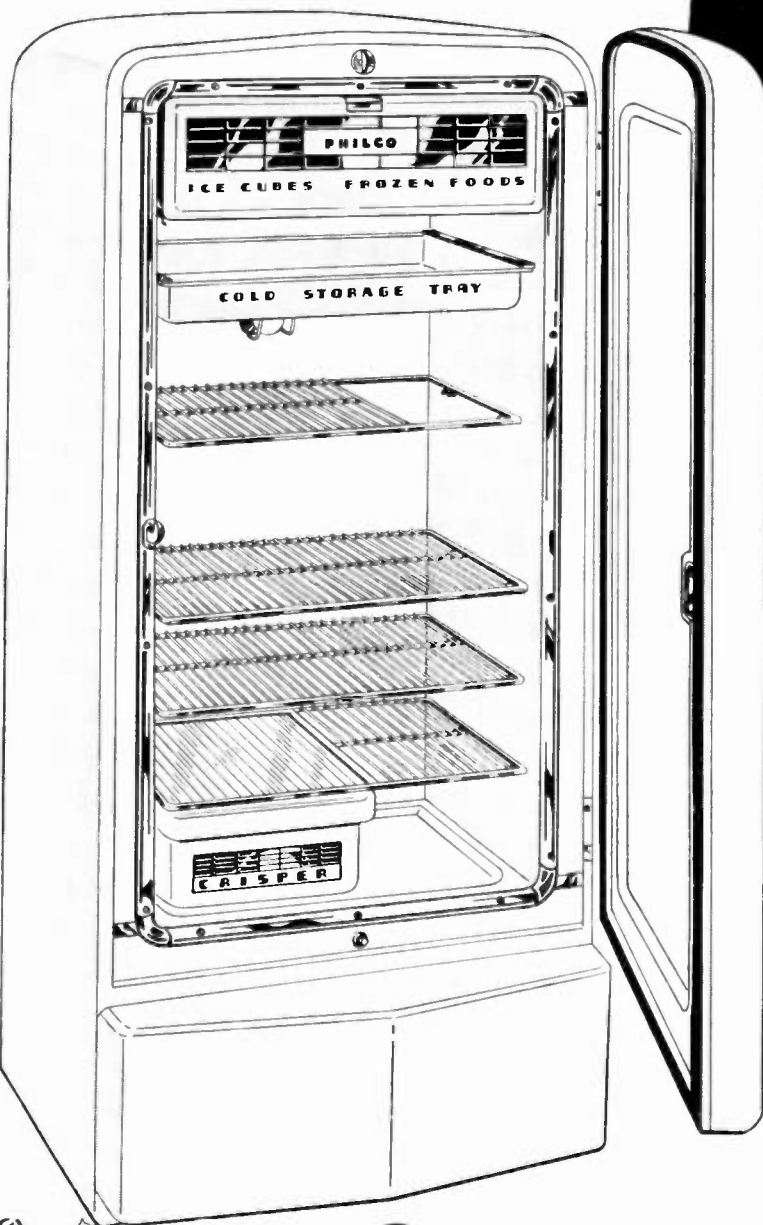

PHILCO
MODEL 793

\$ **229** ⁵⁰
*IN ZONE 1

A FULL WIDTH
FROZEN-FOOD
COMPARTMENT
at \$70 to \$100 less
than last year's
price!

**Yes... a Revolution in
Refrigerator Design
at the Lowest Price**

THE day of the "strip box" is gone! For the first time in refrigerator history Philco brings to the buying public **ADVANCED** features at the lowest price! The first refrigerator ever produced for the mass market with the greatest deluxe feature in the business today... a full width horizontal frozen food compartment! The biggest, *most usable* food storage capacity ever offered in its size and at its price! The most *different looking* low price refrigerator... unequalled in *wanted* features, in value, in promotional power. Nothing like this new Philco 793 has ever been seen... at *any* price. At \$229.50*, it's a revolutionary achievement of Philco leadership in refrigerator design, value and merchandising.

14 SQ. FT. OF SHELF CAPACITY...
7.2 CU. FT. FOR STORAGE OF FOOD
ALL IN THE FLOOR SPACE OF A "4"

SEE IT NOW AT YOUR PHILCO DISTRIBUTOR

PHILCO

Famous for Quality the World Over

Big Set Performance... IN A JEWEL CASE

Smaller than a telephone— weighs only 3½ lbs.—yet it's a full-power AC-DC radio with a voice like a console! In no sense a toy, Air Pal Sr. is built like a watch, with planetary drive, on-the-dot tuning . . . built-in Radair Antenna, and PM dynamic speaker. There's nothing like it!

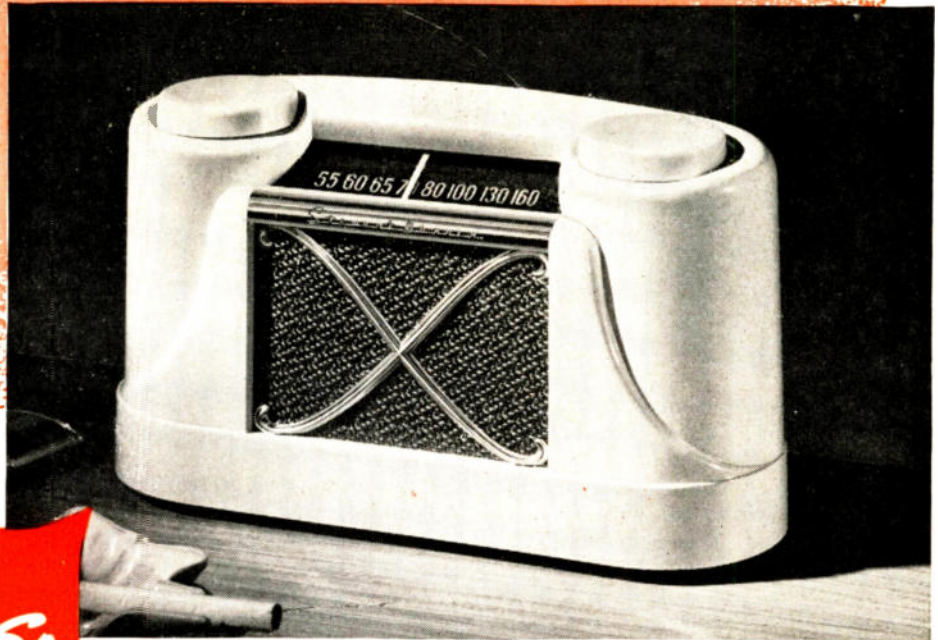

AIR PAL *Sr.*
by
Stewart-Warner

Plays Anywhere You Plug It In!

Railway trains, planes, ships . . . in hotels, offices, or any room in the house—Air Pal Sr. will perform anywhere it can be plugged in.

\$19.95

CALL YOUR NEAREST Stewart-Warner DISTRIBUTOR TODAY!

ALBANY, N. Y.
Ft. Orange Radio Distrib., Inc.
ALBUQUERQUE
Charles Iffeld Co.
ATLANTA
Cowan-Boze Co., Inc.
BALTIMORE
Baltimore Gas Light Co.
BINGHAMTON, N. Y.
Empire Distributors
BIRMINGHAM
Alobamo-Florida Distrib. Co., Inc.
BOISE
Graybar Electric Co.
BUFFALO
Lee Distributing Co.
BUTTE
Treasure State Gas & Electric Co.
CHARLOTTE, N. C.
Show Distributing Co.
CHATTANOOGA
Standard Appliances, Inc.
CHICAGO
Remco, Incorporated
CINCINNATI
Harry F. Knodel Distributing Co.
CLEVELAND
Cleveland Distributing Co.
DAVENPORT, IA.
Graybar Electric Co., Inc.
DENVER
Rolph Olsen Sales Co.
DES MOINES
Graybar Electric Co.
DETROIT
Specialties Distributing Co.
DUBUQUE
Diener Appliances

EUGENE, ORE.
Graybar Electric Co.
FARGO, N. D.
Shirley-Onstad, Inc.
FLINT, MICH.
Silkworth Distributing Co.
FT. SMITH, ARK.
Wise Radio Supply
GRAND RAPIDS, MICH.
Graybar Electric Co.
GREAT FALLS, MONT.
Treasure State Gas & Electric Co.
HARTFORD, CONN.
Wood-Alexander & Co.
HOUSTON
Lack's Wholesale Distributors, Inc.
HUNTINGTON, W. VA.
Emmons-Hawkins Hardware Co.
INDIANAPOLIS
McKee Distributing Co., Inc.
JACKSON, MICH.
Silkworth's
JACKSONVILLE, FLA.
L. Lurio & Son, Inc.
KANSAS CITY
Fitzgerald & Co.
LAWRENCEVILLE, ILL.
Suttle Equipment Co.
LITTLE ROCK
Connerly Radio Distributors
LONG ISLAND CITY
John W. Walter, Inc.
LOS ANGELES
Sherman-Swenson & Associates
LUBBOCK, TEX.
Anderson-Young Electric Co.
MANKATO, MINN.
So. Minnesota Supply Co.

MEMPHIS
Woodson-Bozemon, Inc.
MIAMI
L. Luria & Son, Inc.
MINNEAPOLIS
Elcon Products, Inc.
MINOT, N. D.
Shirley-Onstad, Inc.
NASHVILLE
Southeastern Appliance Dist. Co.
NEWARK, O.
William's Wholesale Distributors
NEWBURGH, N. Y.
Newburgh Distributing Co.
NEW ORLEANS
C. T. Patterson Co., Inc.
NEW ROCHELLE, N. Y.
Appliance Distributors, Inc.
OMAHA
Russell Harris, Inc.
PEORIA
Graybar Electric Co.
PHILADELPHIA
Philadelphia Distributors
PHOENIX
Arizona Mercantile Co.
PITTSBURGH
C. R. Rogers Corp.
PORTLAND, ME.
Frank M. Brown Co.
PORTLAND, ORE.
Graybar Electric Co., Inc.
PORTSMOUTH, O.
The Hibbs Hardware Co.
PROVIDENCE
Tracy & Co., Inc.
RALEIGH, N. C.
Blackwood's, Inc.

RAPID CITY, S. D.
Hills Gas & Appliance Co.
RICHMOND, VA.
Consolidated Sales Co., Inc.
RENO
Bender Warehouse Co.
ROANOKE, VA.
Cormell-Priddy, Inc.
ROCHESTER, MINN.
So. Minnesota Supply Co.
ST. LOUIS
Fridley Brothers, Inc.
SALT LAKE CITY
Graybar Electric Co., Inc.
SEATTLE, Graybar Electric Co.
SIOUX FALLS
Rudning-Robertson Co.
SOUTH BEND, IND.
Andrews Distributing Co., Inc.
SPOKANE
Graybar Electric Co.
SPRINGFIELD, MO.
Harry Cooper Supply Co.
TACOMA
Graybar Electric Co., Inc.
TOLEDO, Scott Sales Co.
TULSA, Looboyle, Inc.
UTICA, N. Y.
Miller Electric Co., Inc.
WHEELING, W. VA.
Ott-Heiskell Co.
WICHITA
Wichita Building Material Co.
WICHITA FALLS
White's Auto Stores
WILKES-BARRE, Kile-Jacobs, Inc.
YPSILANTI
Silkworth's Distributors, Inc.

Stewart-Warner Electric, Division of the Stewart-Warner Corporation, Chicago 14 • AM Radio FM • Radio-Phonographs • Television

General Industries' New Motor

Manufactured by General Industries Co.,
Elyria, Ohio.

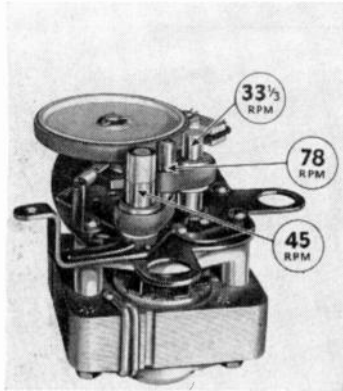

Positioning various spindles in contact with the idler wheel adjusts this phonograph motor for rotating at three speeds, permitting playing of 78-, 33 1/3-, and 45-rpm. records. Speed shifting is accomplished by movement of a detented shift lever. Entire mechanism is powered with a dynamically balanced two-pole, shaded-pole motor. Manual motor assemblies using 6 1/2-, 8-, and 9-inch turntables also incorporate three-speed principle.

Say you saw it in *Radio & Television Journal*, April, 1949.

Ward Indoor Antenna

Manufactured by Ward Products Corp.,
1523 E. 45th St., Cleveland, Ohio.

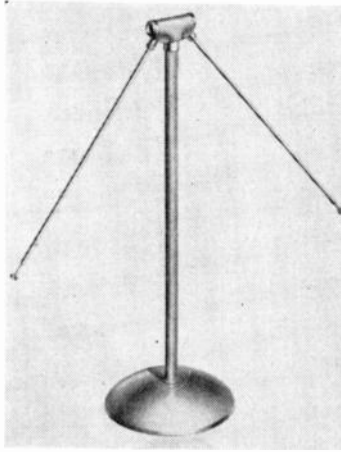

An indoor antenna which is designed to bring in all stations in metropolitan, multi-station areas. Chrome-plated, brass, telescopic dipoles in satin beige brown finish are features. Engineered and weighted so that it will not tip over. Will extend a full seven feet nine inches, but is constructed with unique compactness for easy storage.

Say you saw it in *Radio & Television Journal*, April, 1949.

"Aerosweep"

Manufactured by Aerosweep Motors,
New Brunswick, New Jersey.

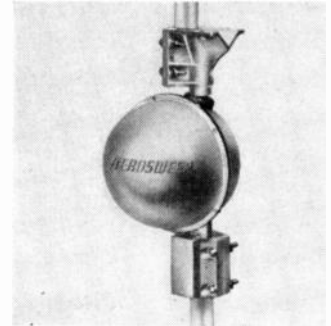

Designed for use with any antenna array, the Aerosweep motor works on a magnetic vibration principle and makes any antenna all-directional. Requires no lubrication upon installation. Rotates 10 degrees beyond 360 in one minute and 20 seconds and can thus eliminate any blind spot. Can be locked in position by control buttons when not in use.

Say you saw it in *Radio & Television Journal*, April, 1949.

General Instrument's Changer

Manufactured by General Instrument Corp.,
Elizabeth, New Jersey.



A new automatic record changer that plays records of all sizes and speeds. Has conventional spindle diameter and overcomes large hole diameter of 45-rpm. record by use of plastic adapter buttons. The same pick-up arm plays 10- or 12-inch 78-rpm. discs, the LP 7-, 10-, and 12-inch 33 1/3-rpm. records, and the new 45-rpm. records, all automatically.

Say you saw it in *Radio & Television Journal*, April, 1949.

... for

**INCREASED
SALES
and
PROFITS...**

in
RADIO
and
TELEVISION

for
SOMETHING
BETTER,
it's

DEWALD

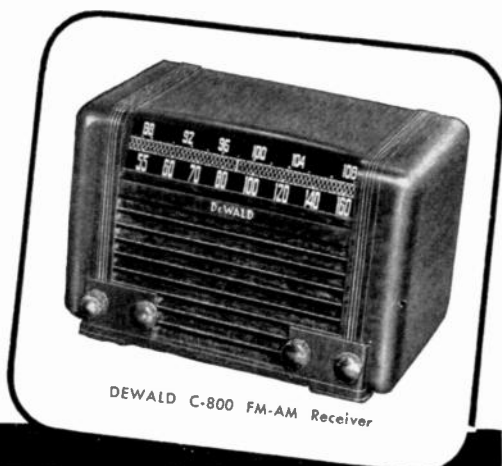

DEWALD C-800 FM-AM Receiver



DeWald CT-102 High Definition TELEVISION

During the NEDA SHOW in Chicago, May 16-20 the New DeWALD LINE of TELEVISION and RADIO will be on display at the Blackstone Hotel.

Be Sure To See It!

DEWALD RADIO MFG. Corp.
35-15 37th Ave., Long Island City 1, N. Y.

TV Booklet
A booklet on individualized television receiver installation has been printed by Sightmaster Corp., New Rochelle, N. Y., specifically for its custom built units featuring Sight-mirror. Using diagrams and specifications outlined in the booklet, decorative wall frames for living rooms, class rooms, offices, game rooms and reception rooms can be installed, with reception being controlled by means of a remote control unit.

*Sales-Building
Brand Name
Advertising—*



Photo by Ewing Galbreath

Are you letting this power flow over the dam?

Every year American manufacturers of brand name goods back up their products with a powerful stream of advertising messages.

This advertising goes into magazines, newspapers, outdoor boards, transit space and radio and is read and listened to in every city and hamlet in the nation . . . creating immeasurable buying interests and desires.

Some retailers are astute enough to harness this tremendous power to their own sales turbines by letting it be known that the advertised brands can be had at their stores.

But others let this power flow over the dam without hitching their turbines to this mighty cataract . . . and miss a big opportunity.

They overlook the fact that the brand tide is on the rise everywhere and that the unknown product is becoming increasingly difficult to sell. During the war the American people had sad experiences with substitutes. They want no more.

But in addition to the fact that name products by famous makers outsell "unknowns" nine times out of ten, brand lines have other healthy effects

on your balance sheet. For example:

1. Pre-sold by maker's advertising, well-known brands require less sales effort in the store.
2. Repeat demand levels off inventories and results in fewer markdowns.
3. Manufacturers with investments in public good will be quick to make adjustments on unsatisfactory goods.
4. Famous brand names have more compelling display value in your windows, and bring people into your store.
5. Because honored brand names enjoy national prestige they supplement the merit of your own good name.
6. The manufacturer of widely advertised brands is equipped to assist you with nationally tested selling methods, developed through his nation-wide experience in many different localities.

Why let the store traffic that can be yours go down the street to other stores? Why waste the business building force of the advertising dynamo? Build a reputation as famous brand headquarters and ride the tide to greater volume.

PARTIAL LIST OF ADVERTISERS:—ADMIRAL CORPORATION • AIR KING PRODUCTS • ANDREA RADIO CORPORATION • ANSLEY RADIO & TELEVISION • BENDIX RADIO DIVISION • CROSLY DIVISION, AVCO MFG. CORPORATION • DEWALD RADIO CORPORATION • EMERSON RADIO & PHONOGRAPH CORPORATION • FARNSWORTH TELEVISION & RADIO CORPORATION • GENERAL ELECTRIC • INDUSTRIAL TELEVISION • MOTOROLA, INC. • NOBLITT-SPARKS INDUSTRIES • OLYMPIC RADIO & TELEVISION • PHILCOR CORPORATION • RCA VICTOR—HOME INSTRUMENT DIVISION—TUBE DIVISION—RADIO CORPORATION OF AMERICA • REGAL ELECTRONICS CORPORATION • REMINGTON RADIO CORPORATION • SCOTT RADIO LABORATORIES, INC. • SONORA RADIO & TELEVISION • STEWART-WARNER • STROMBERG-CARLSON COMPANY • TELE-TONE RADIO CORPORATION • TRANSVISION • WESTINGHOUSE • ZENITH RADIO CORPORATION • RADIO & TELEVISION JOURNAL—OVER 30,000 CCA CIRCULATION

Philco TV Booster

Manufactured by Philco Corp., Tiago & C. Streets, Philadelphia, Pa.

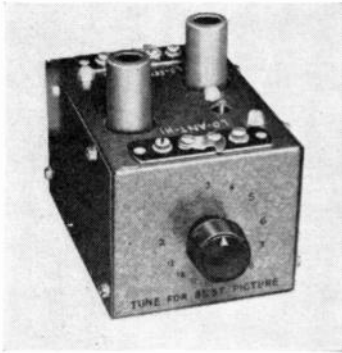

With two RF amplifier tubes, one for low- and one for high-band, this television booster is for amplifying signals in low-strength areas. Operates by means of a single dial, which can be tuned to all television channels. Can be mounted on back of all television receivers, except AC/DC (series filaments) models. Power obtained from audio output tube of TV receiver by means of adapter cable. Cabinet has green hammertone finish.

Say you saw it in *Radio & Television Journal*, April, 1949

Opti-Gem Lens

Manufactured by Opti-Gem, Inc., 320 East 39th St., New York

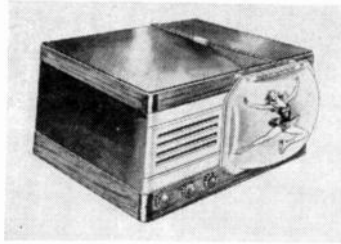

This television magnifying lens comes with an attractive wired cord that runs through a lucite tube for finer adjusting. Designed to give wider viewing range to television screens. Contact lenses come in three sizes, for 7-inch, 10-inch, and 12-inch picture tubes. All come in three finishes, clear, blue, and smoke.

Say you saw it in *Radio & Television Journal*, April, 1949

• **Tele-tone Radio Corp.**, N. Y., has named H. C. Noll Co., Omaha, Nebr., as the firm's distributor of its radio and television products. Headed by Herbert C. Noll, the distributing company has been in the radio field since 1920 and will cover all of Nebraska and eastern Iowa for Tele-tone.

Dynavox Player

Manufactured by Dynavox Corp., 40-05 21st St., Long Island City, N. Y.



Model 300 in the Dynavox phonograph line is a portable machine which incorporates an automatic changer. Has two tubes and one rectifier. Is equipped to play both 10- and 12-inch records. Light in weight it is easy to carry with the cabinet made in simulated leather which is of two tones, brown and tan.

Say you saw it in *Radio & Television Journal*, April, 1949

Price Slash by Air King

Two current television models of the Air King Products Co., Inc., Brooklyn, N. Y., underwent price reductions in a move by the firm to put more low-cost television on the market. A 10-inch table and a 10-inch console model were reduced 11 and 13 per cent respectively. Wide national acceptance of Air King's "Spotlite Brite" feature was credited with increasing sales and cutting production costs, allowing for the reductions. Both sets incorporate a 30 tube chassis.

Crosley Sales Spurt

The Crosley division, Avco Manufacturing Corp., Cincinnati, Ohio, reported distributor orders for television receivers during one week recently to be the highest in the company's television history. The week's volume orders topped by 55 per cent a comparable week in February, which had been one of the best months in Crosley's two years in television. A continued backlog of orders was deemed significant in view of the stir discussion of possible future television channels in the ultra-high frequencies was causing.

J. W. Craig, vice-president of Avco and general manager of Crosley indicated that dealers and distributors of the firm realized that opening up such ultra-high frequencies would not obsolete present receivers. "At such time as these additional channels may come into use," he said, "the industry will be ready with efficient, low-cost adapters designed for use with present-day receivers and engineered to fit the requirements as they may then exist."

METALACE offers 17 Different Types of Mounts

THE ONLY FULL LINE in the industry permitting you to obtain all your equipment from ONE manufacturer. A mount for every purpose . . . all constructed of heavy gauge steel—NOT castings—treated with a new and improved waterproof coating made to Navy specifications for complete protection against any weather conditions . . . in a handsome semi-glass silver finish. Vise-type clamps accommodating masts of 3/4" to 2 1/2" . . . all hardware pre-assembled so that no time is lost in installation.

Mounts for CHIMNEYS • EAVES • VENT PIPES • WALLS . . . also MAST JOINERS and EXTENDERS.

METALACE SETS THE PACE

Metalace
CORPORATION

Dept. 108
2101 GRAND CONCOURSE
NEW YORK 53, N. Y.

Model
CMA
\$475
LIST

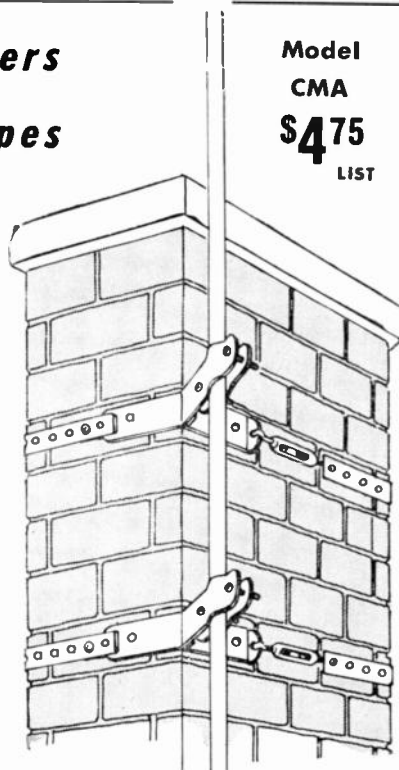

IMMEDIATE DELIVERY

Write today for illustrated circular
and discounts.

Here's what
radio men
say about

SYLVANIA'S DEALER CAMPAIGNS



TRY OUR RADIO SHOOTERS DEPENDABLE



MIKE'S
RADIO AND TELEVISION SERVICE
EXPERT SERVICE ON ALL MAKES

10025 WEST PICO
LOS ANGELES, CAL.

PHONE: ARB 2-1111

November 1, 1948

Advertising Department
Sylvania Electric Products Inc.
Emporium, Pa.

Gentlemen:

I would like this opportunity to tell you how much the Sylvania co-ordinated advertising campaign has helped my business.

Although I have used direct mail postal cards in the past for soliciting new business, the tie-in with national advertising offered in the Sylvania campaign was responsible for an extraordinary return. The response I have had from your campaign has been truly amazing.

As an example, I mailed 1000 postal cards in May at a cost to me of \$10.00. To date this investment has brought a return of \$352.19. During June, July and August I mailed another 1000 cards each month at a total cost of \$30.00. To date the return from this investment has amounted to \$760.46.

You will note that for a total investment of \$40.00 I have, to date, enjoyed an increase in business amounting to \$1,112.65 -- all from new customers. I can safely say that there is still more business to come from these cards in future months.

I mailed another 1000 cards to my prospect list of 12,964 names during October and November. I also expect to mail another 1000 cards during December.

Speaking for myself, I would certainly like to see this campaign become a regular 'shot in the arm' at least twice a year. It will do much to help business in the spring and early fall when business is usually slow.

Many thanks and best wishes.

Very truly yours
MIKE'S RADIO SERVICE

By *Michael Waxman*
Michael Waxman



BRING IN YOUR RADIO TUBES - WE TEST THEM FREE - DEALERS FOR SYLVANIA SEE TESTED TUBES

SCURLOCK'S RADIO SHOP

ELECTRICAL APPLIANCES -- HARDWARE
EVERYTHING PERTAINING TO RADIO
SUMITON, ALABAMA

September 18, 1948

Advertising Department
Sylvania Electric Products Inc.
Emporium, Pa.

Gentlemen:

In 1937 when we started our radio repair business, we used personal postal cards to get our name before our prospective customers. For a beginner, this kind of advertising seemed a little more than we could pay, although it did wonders for our business.

We are happy that the service industry has a great company behind us with national advertising and personal postal cards. During your first co-ordinated advertising campaign we bought 1200 cards and mailed them to our customers according to Sylvania's specifications. The results were so effective that we are going to use the campaign again. We want to see if the campaign is really responsible for the extra business we are enjoying.

The "funny cards", as our customers call them, are even responsible for payment of some of our past due accounts. Our radio sales are up. We are making allowance for old radios which our customers get out for us to repair after receiving our atomic reminder card.

We want to personally thank Sylvania for taking an interest in us and giving us this low cost, yet effective, advertising.

VERY KINDLY YOURS

J. B. Scurlock
J. B. SCURLOCK

Like these service dealers you can increase your business

Sylvania's May, June, July and August campaigns are ready for you. Here's what you receive:

- 4 Postal Card Mailings—one for each month.
- 4 Window Displays—one for each month.
- 4 Window Streamers—one for each month.
- 8 Newspaper Ad Mats—two for each month.
- Radio Spot Announcements—several for each month.

Send for full details now! Remember, you pay only the postage on the government postal cards you mail. Sylvania supplies everything else free!

SYLVANIA ELECTRIC

RADIO TUBES; CATHODE RAY TUBES; ELECTRONIC DEVICES; FLUORESCENT LAMPS, FIXTURES, WIRING DEVICES; PHOTOLAMPS; LIGHT BULBS

Sylvania Electric Products Inc.
Advertising Department, R-2804
Emporium, Pa.

Gentlemen: Send full information on your May, June, July and August Service Dealer Campaigns.

Name _____

Company _____

Address _____

City _____ Zone _____

State _____

NEWS AND NOTES OF MANUFACTURERS AND DISTRIBUTORS

• Net sales and net earnings of **Motorola, Inc.**, Chicago, Ill., reached new peacetime records in 1948. The firm's twentieth annual statement indicates. Sales rose to \$58,080,236 last year, compared with \$46,679,148 for 1947. Net earnings for 1948 amounted to \$3,332,739, or \$4.17 per share, as against \$2,510,410, or \$3.14 a share, in the previous year.

• **Tele-tone Radio Corp.**, N. Y., reports a record sales response to its latest 1949 line of low-cost radio and television receivers. Initial orders are thus far 50 per cent above similar periods of the previous year. Orders taken at the firm's February convention alone came to \$9,820,113, something Morton Schwartz, general sales manager of the company, ascribes to the firm's lower-prices policy.

• **Zenith Radio Corp.**, Chicago, Ill., reports estimated net consolidated operating profits for itself and its subsidiaries for the first nine months ended January 31, 1949, of its current fiscal year, of \$2,025,781, after federal income tax provision of \$1,227,450, depreciation, excise taxes and reserve for contingencies. Consolidated sales for the quarter ended on the same date were highest in the company's peacetime history, but for the nine month period were less than a similar period a year ago.

• The board of directors of **Admiral Corp.**, Chicago, Ill., declared for the first quarter of 1949 a dividend of 20 cents per share of common stock of the corporation, payable to stockholders of record at the close of business, March 22, 1949. Payment date was set for March 31, 1949.

• The **Stromberg-Carlson Co.**, Rochester, N. Y., has announced that net income after taxes, depreciation and so forth, for the year ended December 31 was \$877,602, equal to \$2.74 per share of common stock. Shipments by the company and its Canadian subsidiary totaled \$29,470,232 worth.

• **Veri-Best Television Products, Inc.**, Bklyn., N. Y., has occupied new, spacious quarters at 233 Spring St., N. Y. The move was necessitated by increasing demands for the firm's products and the consequent need to step up production. The Brooklyn plant at 8-10 Forrest St. is retained as a foundry and auxiliary plant.

• Last quarter sales of the **Magnavox Co.**, Fort Wayne, Ind., for the fiscal year closing February 28, 1949, were \$7,043,000, boosting the year's total sales to \$24,408,000. Estimated profits for the 11 months ended January 31, 1949, came to \$1,638,000.

• **Allen B. DuMont Laboratories, Inc.**, N. Y., reports a record year in volume sales and earnings. In a report to stockholders, sales for 1948 were set at \$26,859,000, compared with \$11,109,172 in 1947. Net profit advanced to \$2,701,000 or \$1.29 per share, after taxes, on 2,043,652 shares outstanding, compared to earnings of \$563,677, or 27 cents per share on 2,031,040 in 1947.

• Net sales of **Stewart-Warner Corp.**, Chicago, Ill., were \$72,534,085 for 1948, down by 5.7 per cent from the 1947 net sales of \$76,930,301. Net profit carried to surplus, however, was \$3,154,316, or equal to \$2.44 per share of \$5 par value common stock. This was 29.5 per cent greater than 1947 profits of \$2,436,634, or \$1.88 per share.

Felber

INVISIBLE MINUTE MOUNT

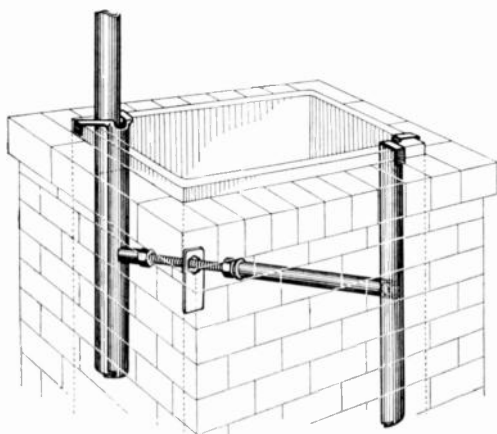

ADAPTABLE
FOR
CHIMNEY
OR
VENT PIPE

NO TOOLS REQUIRED

INSTALLED AND SECURELY
ANCHORED INSIDE OF CHIMNEY
OR VENT PIPE

•
NO DRILLING OR CUTTING
NECESSARY

•
ALL ALUMINUM - RUST PROOF

•
LOCKING DEVICE FURNISHED

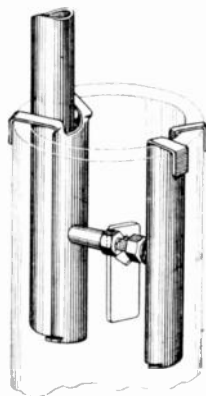

Some Distributor Territories Still Open

WRITE FOR COMPLETE DETAILS

PROGRESS MANUFACTURING CO.

PROGRESS BUILDING

UNION, N. J.

Ad Planners



• Seymour Mintz, left, director of advertising, **Admiral Corp.**, Chicago, Ill., discusses plans for the firm's \$8,000,000 advertising campaign for 1949 with John B. Walt, new assistant advertising manager. Mr. Walt was sales promotion manager of Webster-Chicago before his recent appointment to Admiral's advertising staff.

• Sales of **Philco Corp.**, Philadelphia, Pa., hit a new high in 1948, totaling \$275,424,000, an increase of \$48,916,000 over 1947. Earnings for the year came to \$10,532,000, equivalent to \$6.32 per share, after preferred dividends, on 1,607,576 shares of common stock outstanding at the end of the year, and following a 7 per cent stock dividend paid December 14.



The latest word in multiple remote control television, this system is made by Trans-Vue Corp., Chicago, Ill. Specifically designed for use in restaurants, hotels, theatre cafes and cocktail lounges, multiple remote control units give visibility from all angles, and are controlled by three knobs on the master tuner. The system features a new television filter made by Polaroid Corp., Cambridge, Mass., for reducing screen glare from fluorescent and incandescent lighting, and from ordinary daylight.

BIG PICTURE = BIG PROFITS

Model 15 TV Console

116 square inch direct view picture on 15" tube with finest noise-free sound.

COMPARE!

COMPACT SIZE • PICTURE STABILITY
NOISE-FREE TONE • SIMPLICITY OF CONTROLS

\$495 LIST

- ONLY THREE CONTROLS—VOLUME, CHANNEL SELECTOR and CONTRAST.
- New design Automatic Frequency Control locks picture in step with transmitter.
- Newly designed Audio Amplifier minimizes distortion.
- Special Picture Amplifier has sufficient band width to insure a picture of the utmost clarity.
- 26 Tubes including 3 rectifiers. Finest materials used throughout.
- Simplicity of Electronic and Mechanical Design permits easy and quick servicing.



DEALERS — JOBBERS — REPRESENTATIVES
SOME CHOICE TERRITORIES STILL AVAILABLE

WRITE FOR FURTHER DETAILS AND PRICE LISTS.
ATTRACTIVE DISCOUNTS MEAN BIG PROFITS FOR YOU.

VIDEODYNE INC.

33 JEFFERSON STREET

STAMFORD, CONN.

★ **QUALITY**
★ **PRICE**
★ **FEATURES**
found in no other mounting bases.

The New South River
Duo-Mount Antenna Base
Model No. DM 37 (Pat. Pending)

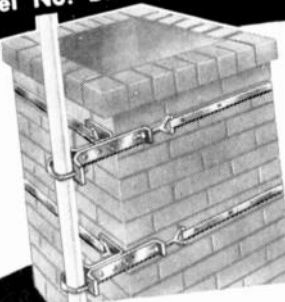

Holds antennas from 5/8" to 1 1/2" O. D. Made of riveted steel in hot dipped, everlasting galvanized finish. Features special "U" bolt.
List Price **\$4.50** Individually Boxed

The Original South River
Chimney Mount Antenna Base
Model No. SR 10 (Pat. Pending)
The Aristocrat of Antenna Bases

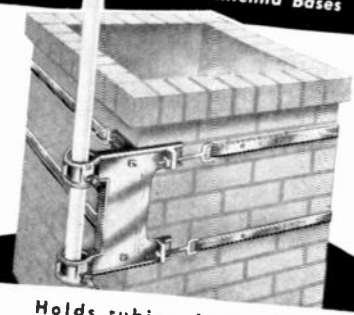

Holds tubing from 1/2" to 1 1/2" O. D., pipe from 1/4" to 1 1/4". Exceptionally durable. The four eye bolts enable straps to be tightened evenly. Also available in two sections if requested.

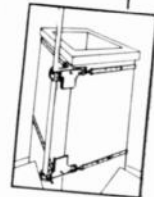

List Price **\$7.50** Individually Boxed

Both mounts can be installed in minutes by one man with no special tools.

See your jobber or write to
SOUTH RIVER
Metal Products Company, Inc.
South River, New Jersey

Sharpen a pencil  and prove it yourself!

Bendix Radio and Television

provides the finest

*Profit
plan*

IN THE INDUSTRY

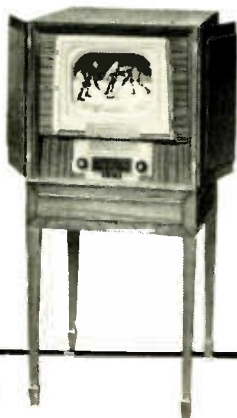

Sell "the Finest Picture
Money Can Buy"

The only top quality television franchise that allows you to make home demonstrations with the assurance that no competitor can cut the price and ruin the sale.

BE THE EXCLUSIVE BENDIX TELEVISION DEALER IN YOUR COMMUNITY!

Beats cutthroat competition

How much could you make if you could compete successfully for the 85% of business going to chain stores, discount houses and the like? *You can* with Bendix Radio and Television. Prices are competitive and quality so much finer that customers convince themselves of your superior values.

Stops seasonal price cuts

How much could you make by avoiding slow-season dumping and price-cuts? *You can* with Bendix Radio and Television. At their low "no middleman" prices, they remain bargains regardless of competitive price cuts—provide the "special offer" to build off-season business.

Ends "free riding" on your advertising dollar

How much more would your own advertising "pay off" if every buyer it moved to action came to *your* store. That has to happen when you feature Bendix Radio and Television. No dealer down the street can steal your prospects or undercut your advertised prices because your franchise is exclusive to your community.

Makes you sole beneficiary of factory advertising

How much more could you make if every national radio and television advertisement appearing in your community directed customers only to your store? That's exactly what happens with Bendix Radio and Television.

Exceptionally liberal discounts

Bendix Radio and Television discounts are better than many and equal to any—and, you don't have to give them away in price-cuts and "here's hoping" advertising.

What's the result of all these special franchise features? Year in and year out you can expect a higher net profit with Bendix Radio and Television—the direct-to-dealer plan with the biggest backing in the industry. Get the story now—this franchise is limited to select dealers only.

BENDIX RADIO DIVISION of

BALTIMORE 4, MARYLAND



BENDIX RADIO

REG. U.S. PAT. OFF.

Write for
Details of the

Bendix Radio
and **Television**

Direct-To-
Dealer **PLAN!**

favorite choice

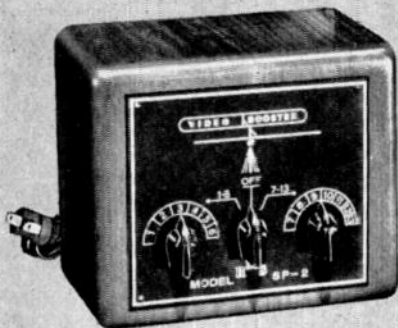

RMS SP-2

**video
antenna
booster**

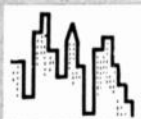

This is the **BOOSTER** that has become an accepted part of every **DEALER** and **SERVICE MAN'S** stock and kit. Tests have proved it the outstanding **BOOSTER** in the business



See the **RMS BOOSTER** at the **Parts Show, Stevens Hotel, Chicago, Booth 31.**

Send for "Data Sheet No. 215-B."



RADIO MERCHANDISE SALES, INC.
550 Westchester Avenue, New York 55

New Appointments



MICHAEL S. FREEMAN

• Michael S. Freeman has been appointed director of sales promotion and advertising of the **E. L. Courmand Co.**, 3835 Ninth Ave., N. Y. C., manufacturer of the Walco Tele-Vue lens. Mr. Freeman was formerly sales manager of Kompolite Building Materials, Inc.



H. G. KRONENWETTER

• H. G. Kronenwetter has been named manager of advertising production for the lighting fixture, lamp, radio, electronics and international divisions of **Sylvania Electric Products, Inc.** Mr. Kronenwetter has been with the firm since 1928 and moves up from his position as advertising production manager for the radio division. He will take care of company-wide advertising production in his new post.

• **Bell Television Inc.**, N. Y., has undertaken to distribute television tubes on the dealer level to meet increased replacement needs. Both 12½- and 15-inch tubes, all bearing the Bell label, are included in this latest phase of the firm's merchandising program. The program is expected to allow consumers to replace tubes which have given normal service but which are no longer covered by manufacturer warranties.

• **Bendix Radio**, division of **Bendix Aviation Corp.**, Baltimore, Md., has appointed Merritt and Andree, Rm. 1174 Merchandise Mart, Chicago, Ill., district merchandiser for the firm's radio and television lines.

it's new!

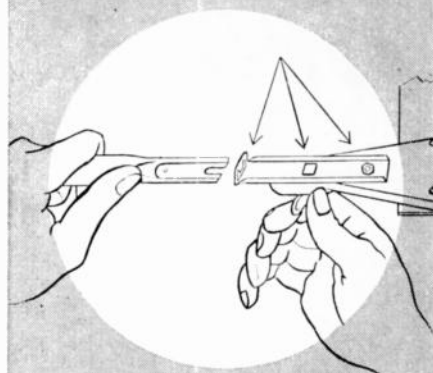

The **RMS TV**
ANTENNA LINE with the
New, Exclusive feature

SPEE-D-LOK*

assembly

Dealers and service men across the country recognize these facts about the **RMS Antenna Line**:

1. **GREATER EFFICIENCY — BETTER RESULTS**
2. **SPEEDIER INSTALLATION IN MATTER OF SECONDS**
3. **MODERATELY PRICED**

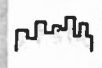
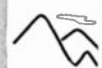

See the **RMS Antenna Line** at the **Parts Show, Stevens Hotel, Chicago, Booth 31.**

Send for the **NEW Spring 1949 Catalog # 215.**

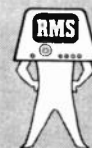

RADIO MERCHANDISE SALES, INC.
550 Westchester Avenue, New York 55

MAKE EXTRA PROFIT WITH TELEKIT LINE

TELEKIT NOW \$59.50

JOBBERS AND DEALERS:

WRITE FOR

CONFIDENTIAL DISCOUNT PRICES



This new modern Telekit 10-B is easy to sell and easy to keep sold. Sell it in kit form. All your customer needs is a soldering iron, pliers and screw driver. Over 18,000 Telekits have been successfully assembled. A big easy-to-follow illustrated instruction book guides simple assembly each step of the way. Jobbers and dealers

have no service worries—Telekit Guarantee includes free factory service and parts replacement.

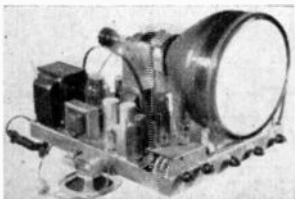

Note the clean simple tube line-up of the new Telekit 10-B. This sparkling new kit features a factory-built, pre-aligned tuner with stage of R.F. Video tube mounted directly on chassis. Everything has been engineered for simple construction. LIST PRICES: Telekit 10-B kit, \$99.50. Tube kit, including 10BP4 and all other tubes, \$59.30. 10-B cabinet \$24.50.

New 7-B kit (same as above but designed for 7 inch tube) \$59.50. Tube kit, including 7JP4, \$42.08. 7-B cabinet, \$24.50. ALL ABOVE PRICES LIST.



**13 CHANNEL
TUNER NOW
\$19.95 LIST**

THIRTEEN CHANNEL TUNER is a small compact unit with stage of R.F. Made to conform with Telekit or any other TV set having video I.F. of 25.75 Mc. Complete with tubes, pre-wired, pre-aligned; only three connections to make.

Send for free catalog of Telekit line, including antennas, boosters, television kits, tubes, tuners and parts.

TELEKIT

ELECTRO-TECHNICAL INDUSTRIES
1432 N. BROAD ST. PHILADELPHIA 21, PA.

Network Extension a Major Problem

Television's biggest problem is getting more stations on the air so as to bring down the cost-per station of network operation. This sentiment was expressed by Dr. Allen B. DuMont, president of Allen B. DuMont Laboratories, Inc., in a recent address before a luncheon meeting of the American Marketing Association. Dr. DuMont pointed out that synchronization now permits co-stations to operate within 150 miles of each other, and that a truly competitive television system could not exist unless as many as four stations were operating in every city of 50,000 population or over. He felt that allocation of UHF channels to towns and small cities would eventually make it possible to have four or five networks operating in the U. S. Color television, so far as the president of DuMont was concerned, lies about 10 or 20 years away. Cost of receivers for color would be two or three times monochrome sets, he felt, and color's band-width requirements are such that not only UHF channels would be necessary but transmission of color would also require use of the micro-wave region.

Town Meetings Have Wide Appeal

With one more Town Meeting of Radio Technicians conference to go, the series has already rolled up an impressive score of attendance, interest, and over-all participation. During the first four meetings thus far, 10,280 technicians, dealers, and distributors were in attendance. Total registration was set at 5,018, of whom many reappeared at various meetings and swelled the cumulative attendance. Technicians from 29 states, Canada, England, and Venezuela were among the registrants. A total of 15 television and 45 radio stations helped promote the meetings in New York, Boston, Atlanta, and Los Angeles. Twenty-five Chicago organizations are behind the final meeting, scheduled for the Windy City for April 11, 12, and 13.

Add Trade-Ins to Spark TV Sales

Bendix Radio and Television, a division of Bendix Aviation Corp., has inaugurated a new yet old method of sparking television sales. Effective April 1, 1949, consumers will be allowed a substantial allowance on old radio or TV sets against new Bendix television receivers. Commenting on the move, Edward C. Bonia, general manager of the radio and television division, stated that heretofore the low discount structure on TV precluded the acceptance of trade-ins, but that now, coupled with the firm's factory-to-dealer merchandising plan, consumer demand for TV will be stepped up.

Rochester Group Prepares for TV

More than 100 members of the Rochester Electrical Association met last month to discuss details about television receiver demonstrations coincident with the inauguration of relay service from Station WHAM, due to start June 11. Demonstrations of all makes distributed by members of the Association will be staged in Columbus Civic Center in a concerted effort to kindle widespread consumer interest in television receivers.

IMPROVE TELEVISION RECEPTION

EASILY, QUICKLY, ECONOMICALLY!

The new and improved AEROSWEEP is a scientifically designed magnetic vibration antenna rotator. The only vibration motor on the market. For perfect reception on all channels your antenna should be beamed directly to the channel. The AEROSWEEP eliminates ghosts, snow and man-made interference — minimizes imperfections due to atmospheric conditions.

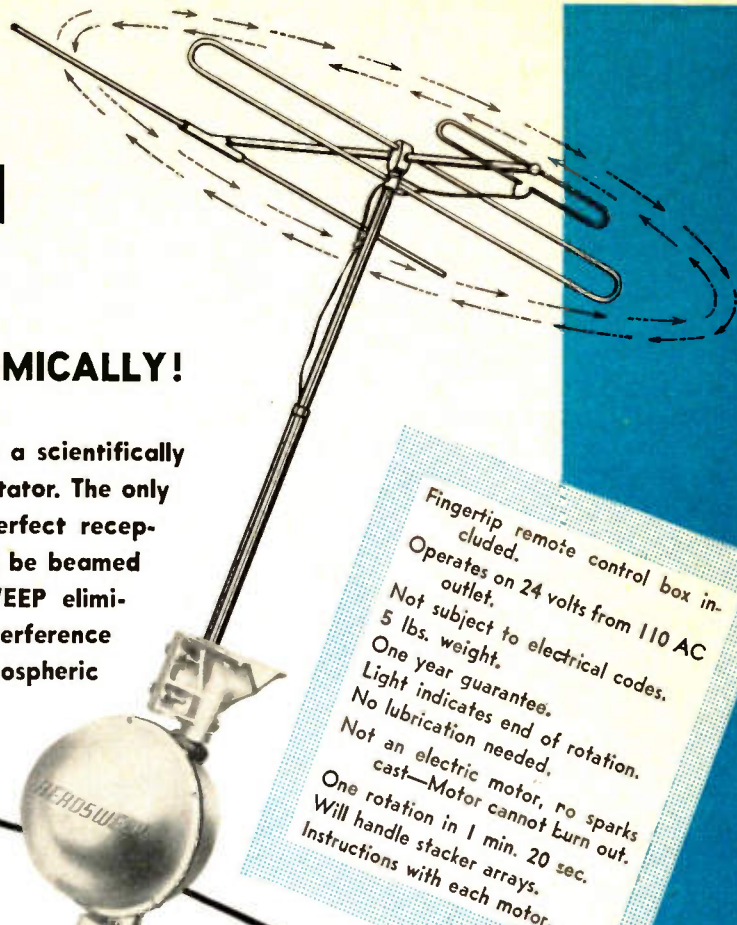

Fingertip remote control box included.
Operates on 24 volts from 110 AC outlet.
Not subject to electrical codes.
5 lbs. weight.
One year guarantee.
Light indicates end of rotation.
No lubrication needed.
Not an electric motor, no sparks cast—Motor cannot burn out.
One rotation in 1 min. 20 sec.
Will handle stacker arrays.
Instructions with each motor.



REACHES ALL COMPASS POINTS

\$39.95 LIST

The AEROSWEEP MOTOR is completely encased in weather resistant aluminum . . . all parts rustproof . . . not affected by any of the elements . . . withstands and turns 160 lb. antenna weight . . . rotates 370° — no blind spots . . . stops instantly . . . will not coast . . . locks where stopped . . . wind can't turn . . . reverses from any point . . . not a geared down motor . . . slowest moving motor ever made . . . top and bottom universal fittings included . . . install in 20 minutes . . . completely shockproof.

MANUFACTURED BY
• AEROSWEEP MOTORS •
 7 ELM ROW
 NEW BRUNSWICK, NEW JERSEY

*A Radio Industry
FIRST!*



**V-M TRI-O-SPEED PORTABLE
CHANGER
PLAYS ALL RECORDS**

- Three-speed changer plays standard 78 — 33-1/3 — 45 rpm records.
- Single Tone Arm to play all records.
- Three-tube Amplifier, 4" x 6" Speaker.
- Underwriters Lab. Approved.

Immediate Delivery!

**V-M
Corporation**

BENTON HARBOR, MICHIGAN

**AMERICA'S FOREMOST
MANUFACTURER
and DISTRIBUTOR of
CARRYING
CASES**

for personal radios
for

**AMERICA'S
LEADING
RADIO
MANUFACTURERS**

invites your inquiry



CARRIER CASE CO.

1 W. 34th St., New York 1, N. Y.

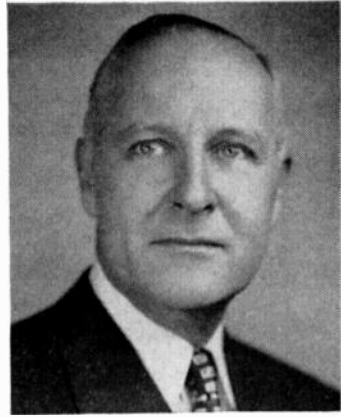

C. M. SHERWOOD

• C. M. Sherwood has been named sales manager of the Andrea Sales Corp., sales agents for the *Andrea Radio Corp.* Mr. Sherwood was formerly sales manager of the Elliott Lewis Corporation's major appliances division, divisional sales manager of Bendix Home Appliances, Inc., and was eastern sales manager for Stromberg-Carlson.



P. A. FUND A. M. FISHER

• The board of directors, *Farnsworth Television & Radio Corp.*, at its last meeting elected Paul A. Fund and Austin M. Fisher new directors of the firm. Mr. Fund is a director and vice-president in charge of corporate and industrial financing, James J. Garibaldi Organization, N. Y., and Mr. Fisher is president, Austin M. Fisher Associates, labor relations and public service consultants, N. Y. C.

• A \$300,000 common stock issue has been made available to the public by the *Major Television Corp.*, 19 W. 44 St., N. Y. to finance receiver and cathode-ray tube production. Mencher & Co., N. Y., are handling the financial transactions.

• *Radio Corporation of America* disclosed in its 29th annual report net earnings for 1948 of \$24,022,047, or \$1.50 per share of common stock. This compares with \$18,769,557 in 1947, when earnings after payment of preferred dividends were equivalent to \$1.12 per share. Net profit, after deductions, was 6.7 per cent of gross 1948 income. Total gross income from all sources amounted to \$357,617,231, representing an increase of \$43,593,659 over 1947.

**New
Appointments**



ELLIS L. REDDEN

• Ellis L. Redden has been appointed director of advertising and sales promotion for *Motorola, Inc.*, Chicago, Ill. Mr. Redden was formerly with the Crosley division of Avco Manufacturing Corp., with Norge division of Borg-Warner, and with McCann Erickson in similar positions.



W. A. MARA

• W. A. Mara has been appointed general manager of *Bendix Radio's* television and broadcast division. Mr. Mara was formerly director of advertising and publicity for the Baltimore, Md., corporation. The division under Mr. Mara will have its own accounting, credit, cost and service departments in addition to its present sales department.

• Harold D. Weiler, sales manager of *Eagle Electronics, Inc.*, N. Y., manufacturer of Teleric Television, is touring the South and Southwest to appoint distributors.

S. M. Abrams named sales manager of television at Emerson, Karlsruhe heads home radio division, Redden takes over ad spot with Motorola, W. A. Mara heads revamped Bendix TV division, Sherwood becomes manager of Andrea Sales, Fund and Fisher elected Farnsworth directors, A. Brown heads Tradivision.



ALEX. BROWN

• Alex Brown, formerly with Pilot Radio Corp. and Davega stores, has formed **Tradivision of New York, Inc.** The new company will operate as New York State distributor for Tradivision, television for public locations.



S. M. ABRAMS S. M. KARLSRUHER

• **Emerson Radio & Phonograph Corp.** N. Y. has announced the appointment of Stanley M. Abrams as sales manager of the firm's television division and of Harold E. Karlsruhe to head the home radio division. Mr. Abrams was formerly sales promotion manager and Mr. Karlsruhe was the company's eastern regional sales manager.

RCA's Newest Tube Production Center

This low, one-story, ultra-modern brick and steel structure, to be air-conditioned and fluorescent-lighted throughout upon completion, will be the home of RCA's 16-inch metal tubes. The site is located in Marion, Ind., and the building will provide 100,000 square feet of manufacturing space when it is completed by early fall. Meanwhile, in existing plant buildings providing 160,000 square feet of space, RCA's tube department plans to install temporary production machinery for 16-inch picture tube manufacture by this summer.

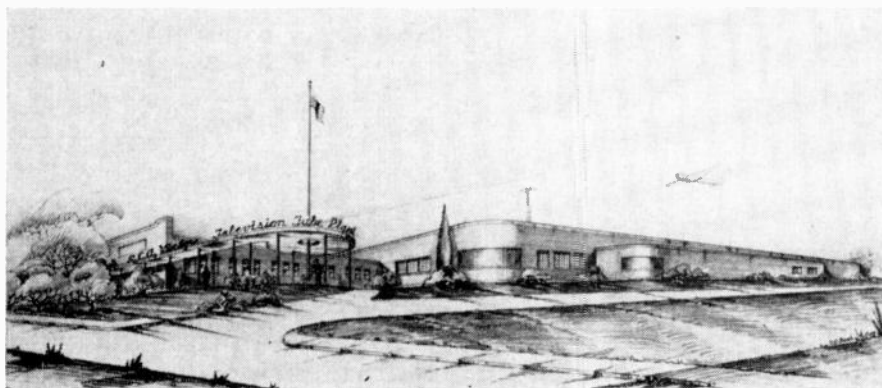

By this time next year, according to present plans, the new Marion plant will enter full-scale output of large metal tubes. Mass production of the 16-inch, direct-view metal tubes for television at Marion will make that city a new center for tube manufacture similar to the RCA center at Lancaster, Pa. In the past three years, picture tube production has multiplied about 40 times, from the paltry 24,000 tubes in 1946 to the estimated 900,000 for 1948. RCA's tube department has been able to produce something like 50 per cent of picture tubes used in television receivers. With demand for tubes for new sets and for replacement use increasing, the new plant at Marion becomes a new "feeder" plant for an industry which is growing by leaps and bounds.

NOW...
ANOTHER
GREAT
Recordis RECORDING WIRE PRODUCT...

Super-Tone
REG. U.S. PAT. OFF.
RECORDING WIRE

RECORDISC, the greatest name in home and professional recording... long the world's largest producers of blank recording discs, now adds another fine product to its long list of sales successes.

Made of high fidelity stainless steel with typical RECORDISC precision, Super-Tone® is the key to steady increased sales in the wire recording field. Superb sound reproduction, and the very name RECORDISC spell satisfaction to every wire recording enthusiast, and stepped-up sales for you, the dealer.

NEW, 1949 RECORDISC CATALOG IS READY
SEND FOR YOUR COPY TODAY

RECORDING WIRE
RecordisC

RecordisC RECORDING WIRE
STABILIZED STEEL
HIGH TEST
Precision Processed for Perfection
Super-Tone® REG. U.S. PAT. OFF. Erasable
"Snapshot in Sound"
THE RECORDISC CORP.
New York • MADE IN U.S.A.

"You Take No Risk With RecordisC"

THE RecordisC CORP.
395 Broadway, New York 13, N. Y.



About Business Hypochondriacs

What do you see in the space above?

We know the answer: "two large black dots", which is correct, except that this fails to take into account all the white space surrounding those dots.

We are indebted to W. A. Blees, General Sales Manager of the Crosley Division for this practical demonstration of how people will almost automatically notice the dark side of a picture while ignoring the bright side. Mr. Blees used this graphic illustration at a recent meeting of 400 television dealers in Columbus, Ohio, to drive home his point that "Too many people in business are seeing the black dots—not the white space." Too many people, especially those in the radio, television and appliance industry are complaining about a decline in trade from peak postwar years: crying about price-cutting and not doing anything constructive to overcome it; weeping about the disappearance of the 'sellers' market' and neglecting to go out and sell; wailing about 2,800,000 unemployed and completely losing sight of the 57,500,000 persons who are working at the highest wages the world has ever known.

Of course there has been a slowing down of consumer buying in all lines and industries. Of course orders are harder to get, people are harder to sell, and shoddy merchandise won't sell at all! Of course there have been shut-downs in some plants and temporary layoffs as management analyzed future market potentials and consumer demand. But such developments are quite normal and should not be seized upon by "business hypochondriacs"—those gloomy prophets who, starting with a simple headache, talk themselves—(and if we let them, they will talk us)—into a serious illness.

We admit that there are some irritating factors in the current business situation, but we shouldn't make the mistake of interpreting irritation for gloom. Some markets that boasted about 'backlog orders' stretching into 1951 seem to have collapsed overnight, notably automobiles.

But what about your own business, Television, the fastest growing industry in America? Will this market, too, vanish overnight? We don't think so . . . on the contrary, we are willing to go out on a limb by stating categorically that television will continue to grow and prosper year after year until it is in the very forefront of this country's economic life.

A television receiver is a complex mechanism. One typical table model contains a total of 692 components, 280 electrical components, 27 tubes (including the cathode-ray picture tube), and almost two miles—10,392 ft.—of wire. By contrast an average table radio is constructed with 87 mechanical and 37 electrical parts and six tubes. Thus, a television receiver is the equivalent of five or six radio sets!

With labor and material remaining high, how is it in the cards for TV sets to come down very much? How can dealers continue to give away their profits rather than take positive, aggressive action to go out and get sales?

We have stated in these columns time and again that television is the electronic marvel of the age, that more than being a scientific miracle, it meets basic human needs and hunger to be entertained and informed by sight.

A television picture is composed of hundreds of black dots. Stop concentrating on those black dots and look at the whole television picture. What you see there should make you glad that you're in the United States and that television happened during your lifetime.

April • 1949

ADMIRAL CORPORATION	34, 35
<i>Agency: Cruttenden & Eger Adv.</i>	
AEROSWEEP MOTORS	47
<i>Agency: Bert Paul Kun</i>	
BENDIX AVIATION CORP.	44
<i>Agency: MacManus, John & Adams, Inc.</i>	
CARRIER CASE COMPANY	48
<i>Agency: Artley Advertising</i>	
E. L. COURNAUD & CO.	31
<i>Agency: Rossum & Stanley Adv.</i>	
DE WALD RADIO MFG. CO.	38
<i>Agency: Morton M. Magidson</i>	
ELECTRO-TECHNICAL INDUSTRIES	46
<i>Agency: H. Lesserauz</i>	
EMERSON RADIO & PHONOGRAPH CORP.	19
<i>Agency: Grady & Wagner Co.</i>	
GENERAL ELECTRIC COMPANY	20, 21
<i>Agency: Mazon, Inc.</i>	
LYTE PARTS COMPANY	3
<i>Agency: Conti Advertising</i>	
METALACE CORPORATION	40
<i>Agency: Rex Ceder Adv.</i>	
MOTOROLA, INC.	Fourth Cover
<i>Agency: Gourfain-Cobb Adv.</i>	
NELDA PUBLICATIONS	32, 33
<i>Agency: Louis J. Albert</i>	
PHILCO CORPORATION	36
<i>Agency: Hutchins Adv.</i>	
PROGRESS MFG. CO.	42
<i>Agency: Direct</i>	
RADIO CORPORATION OF AMERICA	5-9
<i>Agency: J. Walter Thompson Co.</i>	
RADIO MERCHANDISE SALES CO.	45
RECORDISC CORPORATION	49
<i>Agency: Cromwell Advertising</i>	
SOUTH RIVER METAL PRODUCTS CO.	43
<i>Agency: Art-Copy Adv.</i>	
STEWART-WARNER CORPORATION	37
<i>Agency: Henri, Hurst & McDonald, Inc.</i>	
STROMBERG-CARLSON CO.	24
<i>Agency: Federal Advertising, Inc.</i>	
SYLVANIA ELECTRIC PROD., INC.	41
<i>Agency: Newell-Emmett Co.</i>	
TRANS-VUE CORPORATION	Third Cover
<i>Agency: Harry J. Lazarus & Co.</i>	
VIDEODYNE, INC.	43
<i>Agency: Dtraci</i>	
V-M CORPORATION	48
<i>Agency: Mayard Sales & Adv.</i>	
WARD PRODUCTS CORP.	28, 29
<i>Agency: Burton Browne Adv.</i>	
ZENITH RADIO CORPORATION	Second Cover
<i>Agency: Critchfield & Co.</i>	

**Are You in the
Commercial
Television Picture**

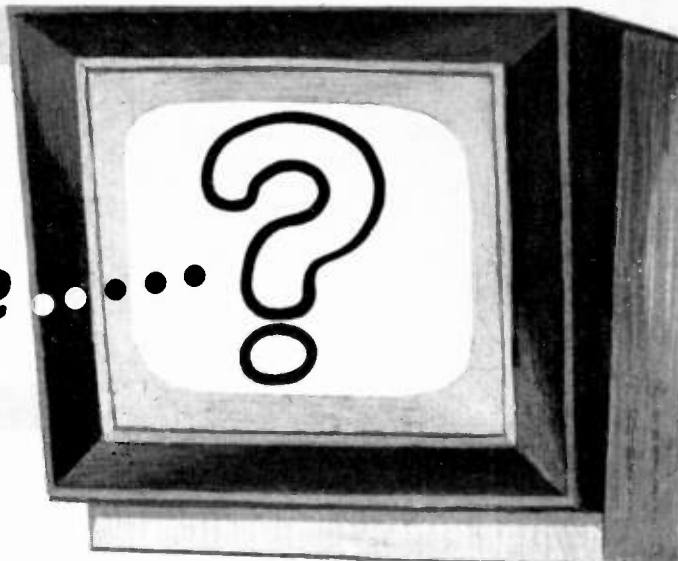

**Let Trans-Vue
Entertainer Build Profits for You!**

Every Hotel . . . Theater Cafe tavern, cocktail lounge and restaurant a sale. The untouched commercial television market is at your command . . . and waiting for Trans-Vue Entertainer. The only commercial television set with Multiple Remote Control Units. A number of viewing units may be placed separately in any part of the room or rooms . . . yet controlled simultaneously from a conveniently placed Master Tuner. These multiple remote control units give all angle — 360 Degree Visibility. Simplified control "locks" the television picture into sharp flicker-free focus easy on the eyes . . . three control knobs on the Master Tuner . . . quick, sure, simple!

Another TRANS-VUE EXCLUSIVE!



New Polaroid one-way filter . . . for greater contrast, sharper definition . . . eliminates fluorescent, incandescent and daylight glare . . . Trans-Vue—and only Trans-Vue—now gives your patrons the sharpest, clearest television picture . . . with no "television eyes"!
Trans-Vue puts YOU in the profitable commercial television picture!
Limited areas open for distributorships. For full details, write, wire or phone!

Trans-Vue

CORP.

**1139-41 S. WABASH AVE.
CHICAGO 5, ILLINOIS**

GET READY FOR FAST SALES!



PORTABLE!
Total weight with antenna only 33 lbs. Demonstrate it wherever AC current is available and wherever there is television broadcasting.



YOU INSTALL IT!

It's as simple as pressing a light switch button. Antenna snaps into place and rotates as necessary for peak performance.



COMPLETE!

There's nothing extra for your customers to buy. The case is handsomely covered in fine, long-wearing leatherette. The hardware is rugged and handsome. It's wonderful looking and it performs as well as it looks.

Here is the Sensational New

Motorola PORTABLE Television

INSTALL IT YOURSELF . . . NO LANDLORD'S PERMISSION REQUIRED

Here is the celebrated Motorola television receiver now known and enjoyed in thousands of homes coast to coast . . . the same star bright picture automatically synchronized with rich, Golden Voice sound . . . all beautifully redesigned for complete PORTABILITY. It's the new and excitingly handsome Motorola Model VT73 in a rich sun-tan leatherette cabinet.

Take it to your customer's home, snap the amazingly efficient antenna into position and you're ready to demonstrate television at its best. Point out how it can be easily moved from room to room . . . out on the porch . . . or to your customer's summer home. Anywhere within range of a television station, the Motorola Model VT73 will get a very satisfactory reception.

A mere demonstration is a sale. Ready quick, new profits now!

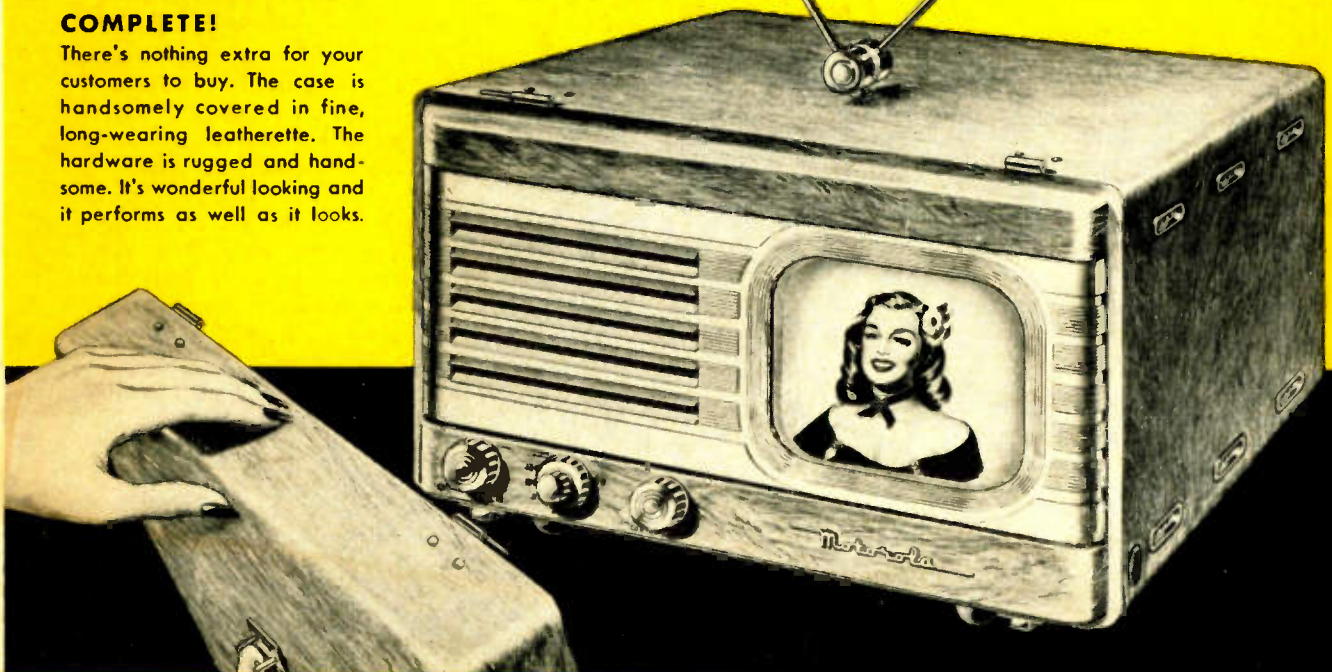

PHONE OR WRITE YOUR MOTOROLA DISTRIBUTOR TODAY

Motorola Inc.

4545 AUGUSTA BLVD., CHICAGO 51, ILLINOIS