

N. S. EDITION

Oct.-Nov.
1923

25c

Radio Journal

Los Angeles, California

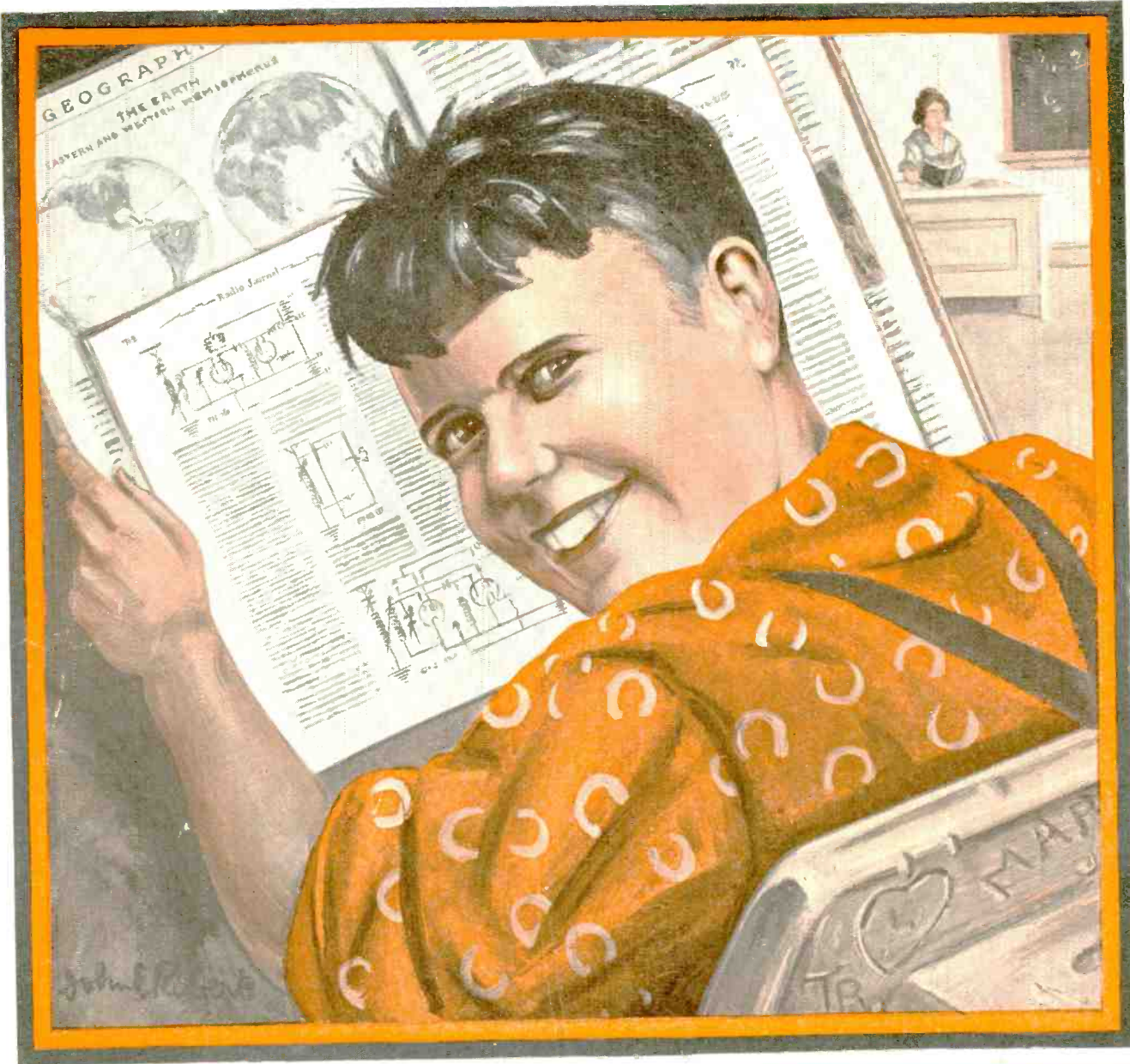

The Super Hetrodyne Neutrodyne Reflex
(The Unlimited Distance Receiver)

"ADVANCE" C. W. RECTIFIER

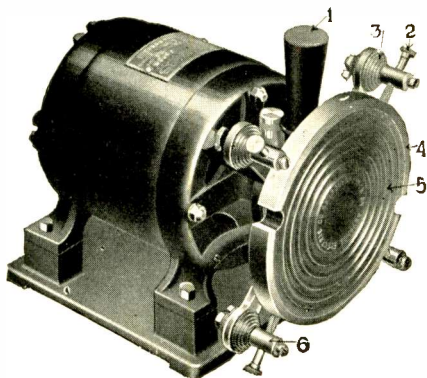

ADVANCE C. W. RECTIFIER

Rectifies A. C. from 500 to 3000 volts for the plate.
 Moulded bakelite disk (5) corrugated on sides to stand high voltage.
 Moulded bakelite bushings (3) which overlap in center, insuring perfect insulation between polished aluminum brush arm support.
 Nickel-plated brush holder (6) with adjustable gauze brushes which may be shifted to the proper non-spark position.
 One of the first stations to be heard in Australia, 6BVG, used this Rectifier.

This Rectifier is being used by some of the best known amateurs in Southern California, as 6EN-6ZR, 6EB, 6EA, 6ZAL, and many others who are getting excellent results.

These Rectifiers are guaranteed for one year. And to give service and satisfaction.

Price, complete with motor, \$40.00. Disk to fit your motor with complete brush assembly, \$15.00.

Announcement to Dealers:

See us for the BIG DISCOUNT on Advance Precision Condensers and Advance Unit Chargers, as we are discontinuing our jobber connections and will sell direct to you.

"ADVANCE" UNIT CHARGER

Most efficient, rigid and simple construction, built on an entirely new idea, which insures satisfactory operation.

Will stand rough use without damage to parts.

Very compact. Size five inches square. Handsome appearance.

Renewal parts after long service, fifty cents.

Self polarizing, which means that the battery may be connected to charger either way, or polarity.

Battery in ordinary condition may be charged over night.

Low price in comparison to the quality of apparatus.

The saving of much inconvenience, time and expense which will pay for the machine in a short time.

Will not injure the battery if left connected after the battery is fully charged.

Guaranteed for a period of one year.

Price, F. O. B. Los Angeles, Calif., \$18.50

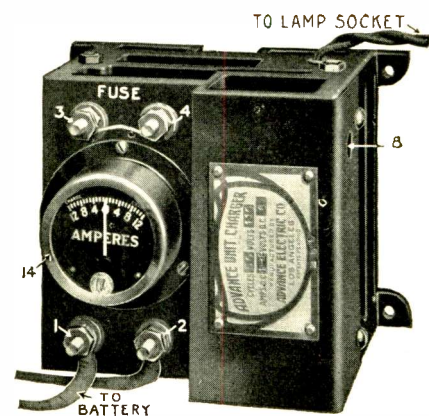

Advance Unit Charger
 For Auto and Radio Batteries

"ADVANCE" PRECISION CONDENSER

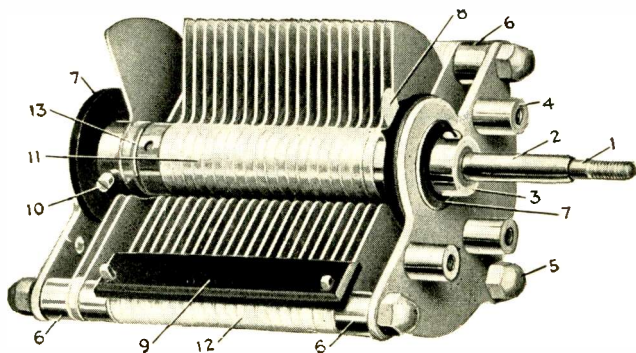

Rotor spacers (11) $\frac{5}{8}$ -inch diameter, machine turned.

All spacers aluminum to .001-inch insuring perfect alignment of plates. Liberal Discounts to Dealers.
 This condenser must be seen to be appreciated.

Made in Vernier and Plain That Has Met With the Approval of Those Who Demand the Finest

Stator spacers (12) $\frac{3}{8}$ -inch diameter.

Spring (13) perfect contact and friction for vernier plate.

Rotor tube (2) $\frac{1}{4}$ -inch diameter, brass nicked.

End collar (3) Adjustable for alignment.

Brass nicked spacers (6) $\frac{3}{8}$ -inch diameter accurately machined.

Beautiful in appearance. All trimmings polished nickel.

Vernier shaft (1) threaded $\frac{1}{8}$ inch, adjustable by set screw (10) to accommodate any thickness of panel or dial.

Mounting posts (4) $\frac{5}{16}$ -inch round $\frac{1}{8}$ inch, so spaced to accommodate any diameter dial.

Bakelite bearing (7) $\frac{1}{4}$ -inch shaft both ends.

Stop (9) full length of rotor.

Nicked acorn nuts (5) which insure strength.

Advance Electric Company

MANUFACTURERS
 1260 West Second Street

SEE US FOR PANEL ENGINEERING

Phone Pico 5990

ENGINEERS
 Los Angeles, California

Make Yourself a Present of This Lefax Radio Hand Book

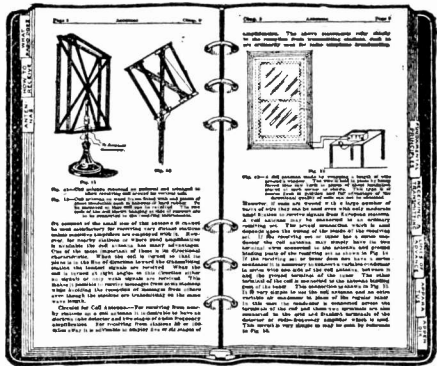

with one year's subscription to Radio Journal for \$5.00

Or with a two-year subscription to Radio Journal for \$6.00

Lefax Radio Handbook will be sent you, postpaid, with one subscription to Radio Journal, new or renewal, your own subscription or that of your friend, for \$5.00.

Keep Up-to-the-minute in Radio

Lefax Radio Handbook keeps abreast of developments. It is loose-leaf and every month additional pages are sent out covering new developments. All pages are numbered and properly classified and may be inserted in the handbook, thus keeping it *perpetually up-to-date*. This supplement has just been greatly enlarged.

These additional pages are the most reliable source of supplementary reference in the field of radio literature.

Additional loose-leaf pages are mailed to you as they are issued—free of charge for one year. Every Radio experimenter needs this book. *Fill in the coupon below today and get your copy.*



Radio Journal
113 Stimson Bldg.,
Los Angeles, Calif.

Enclosed find..... for which please send Radio Journal for (one) (two) years to

Name

City..... State

Street No.....

Also send Lefax Radio Handbook, postpaid, to

Name

CityState

Street No.....

The Whole Story of Radio

is told in this loose leaf book. Note the rings—they un-snap easily and leaves can be taken out or added as they come in. The material is prepared by the two chiefs of the Radio Department of the Bureau of Standards at Washington, Dr. Dillinger and L. E. Whittemore. Keeping abreast and ahead of radio development is their sole business.

These men are two of the foremost radio experts in the world. You have the opportunity to have these eminent radio experts guide you, too; to point out to you step by step what to do.

Radio Journal, which is included in this remarkable offer, keeps you up to the minute on every phase of radio, amateur, broadcast and commercial. You need both of these publications.

WorkRite Former

\$2.00



This Aircore Transformer has been perfected for use in the Neutrodyne method of receiving. It should be used with .0004 mfd. variable condenser for tuning to all broadcasting wave lengths. It can also be used as a transformer for tuned radio frequency reception, or fixed coupler with condenser across secondary. It is made with tubes of moulded Bakelite and wound with green silk wire. Extreme care has been taken to see that the tubes are properly spaced and just the right number of turns of wire are used, insuring maximum efficiency. Like all WorkRite products it has been thoroughly tested by other laboratories as well as our own before being put on the market. It will measure up to the "WorkRite" standard of quality and efficiency.

Watch for the WorkRite Variable Condenser

WorkRite Super Vernier Rheostat

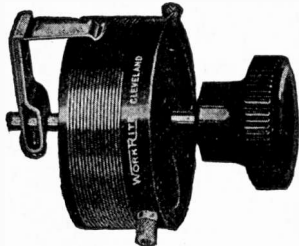

This improved WorkRite Vernier Rheostat is just the instrument you have been looking for, 50,000 possible adjustments. A turn of 1-32 inch will separate two stations or clear up one. Made in three different resistances so that there is a WorkRite Vernier Rheostat for every tube now on the market. 6 ohms, \$1.00; 15 ohms, \$1.15; 30 ohms

\$1.25

WorkRite E-Z Tune Dial
Snappiest Dial on the market. Has a knurled flange on the rim for delicate leverage.

Price 75c

WorkRite Resistance Cartridge

Raises the resistance of your 5 or 6 ohm Rheostat to the 15 or 30 ohms required for UV 199, and similar tubes. Price, either 15 or 25 ohms

40c

WorkRite Neutralizing Condenser



Neat, compact and very efficient. This instrument has a glass insulation on the outside which greatly expedites neutralizing the set. Price, each, 25c.

Work-Rite Tuner Team

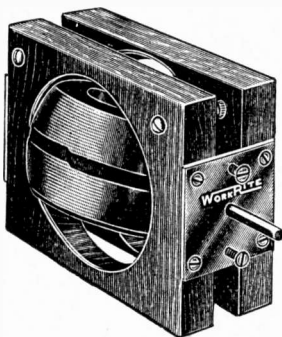

WorkRite Super Variometer

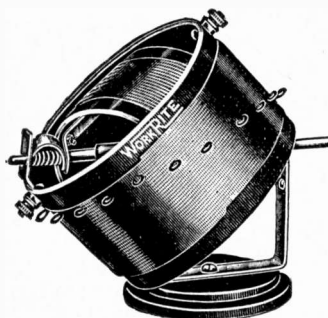

WorkRite 180° Super Variocoupler

Tunes out local stations and gets the one you want. This famous Tuner Team is made up of two WorkRite Super Variometers and one WorkRite 180° Super Variocoupler. Variometer is made from polished mahogany. Variocoupler made from moulded Bakelite and wound with green silk. Range 150 to 705 meters. Shafts 3-16-inch.

WorkRite Super Variometer, each.....\$3.50

WorkRite 180° Super Variocoupler, each.....\$3.50

**"WORKRITE RADIO PARTS
WORKRITE"**

WorkRite Nonmicrophonic Socket

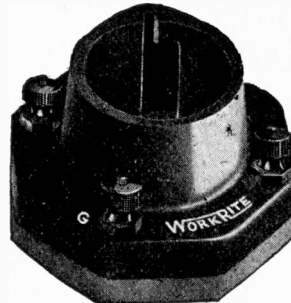

Here is the right socket for use with your UV 199 and C 299 tubes. It is moulded with a sponge rubber base in one piece which is even better than the soft rubber recommended for use with these tubes. Very neat and attractive.

Price 60c

WorkRite Hydrometer

You need one for your storage "A" Battery. Full instructions with each instrument.

Price 75c

WorkRite Head Set

Very sensitive. Light and sanitary. Try one and see.

Price \$6.00

WorkRite Switch Set

Just what you want. Use the block for drilling panel. Arms and points made to work together.

Price 50c

The WorkRite Manufacturing Co.

5535 EUCLID AVENUE

CLEVELAND, OHIO

(Pacific Coast Representative: B. Kruger & Co., 231 Douglas Bldg., Los Angeles, Calif.)



Volume Three

OCTOBER-NOVEMBER, 1923

Number Four

CONTENTS

MILWAUKEE RADIO ASSOCIATION OFFICERS.....	<i>Frontispiece</i>
EDITORIAL COMMENT	163
SUPER-HETERODYNE NEUTRODYNE REFLEX RECEIVER	A. L. MUNZIG 164
SOME MORE ABOUT ROFFY'S HETRO-TRANS.....	J. T. ROFFY 167
TRANS-PACIFIC TESTS THIS MONTH.....	168
CAT WHISKERS	169
ARCTIC READS COAST SIGNALS.....	170
THE NEW CR 12.....	170
NEW BROADCASTERS	170
VOLTAGE AMPLIFICATION IN AUDIO FREQUENCY.....	U. S. BUREAU OF STANDARDS 171
HOW ABOUT THE BATTERY?.....	C. T. HOLCOMB 172
THE BOHR ATOM, PART IV.....	PROF. H. LAV. TWINING 173
RADIO SIGNAL FADING PHENOMENA.....	J. H. DILLINGER AND L. E. WHITTEMORE 175
SPLIT VARIOMETER AND CAPACITY FEEDBACK.....	T. E. NIKIRK 179
TRANSFORMER AND CONDENSER POLARITY.....	F. T. SWIFT, JR. 180
SOME TELEPATHIC EXPERIMENTS IN RADIO MIND.....	BISHOP F. H. DUVERNET 181
SUMMER RADIO	181
HOW REMOTE CONTROL WORKS.....	182
HE BUILDS A NEUTRODYNE.....	182
RADIO FUNCTIONS IN STRANGE WAYS	CARR A. WAYSEED 183
AMATEURS' DEPARTMENT	185
QUESTIONS AND ANSWERS	186
TRADE TALKS	192
ECLIPSE TEST	196
RADIO "UP NORTH".....	196
CLASSIFIED ADVERTISEMENTS	198
LISTENING IN	199
WITH THE RADIO CLUBS.....	200
WITH THE EDITOR.....	206

Radio Journal

is published monthly by Radio Journal Publishing Company, 113 Stimson Building, Los Angeles, California. Telephone 877-726.

EDITORIAL BOARD

Editor.....K. P. FREDERICK
General Manager.....HUGH HARLAN
Advertising.....A. W. MAJORS

SUBSCRIPTION RATES

6 months.....	\$1.50
1 year.....	2.50
2 years.....	4.00
Canadian or Mexican—	
1 year.....	3.00
Foreign, 1 year.....	3.50

Change of Address—Notify us of any change in your address. Be sure to give both your old and new address.

Because of the fact that intense interest in radio is sweeping the entire country, causing a flood of inventive and research work, much of which will be duplicated, it is necessary to state that in the event of expressions of opinion and various statements from contributors and correspondents appearing in Radio Journal from month to month becoming the subject of litigation in courts, or of controversy in scientific circles, and which may involve questions of priority of invention and a comparison of merit of apparatus, the owners and publishers of Radio Journal positively and unequivocally disclaim any responsibility for any such expressions of opinion or partisan statements.

"Entered as second-class matter May 19, 1922, at the post office at Los Angeles, California, under the Act of March 3, 1879."

The entire contents of Radio Journal, including articles, stories, pictures, diagrams, etc. (unless otherwise credited), copyright 1923 by Radio Journal Publishing Company, which reserves all rights.

Denver Representative,
 Ira R. Alexander, 369 Lincoln Street.
 Printed in U. S. A.

OFFICERS
of the



*L.S. Hillegas-Baird,
Business Manager,
and A.R.R.L. Central div-
ision publicity manager*



*Herbert F. Wareing
3NY, pre-war 3AEX,
President*



*Edward T. Howell,
Sc.B. Eng., Sc.M. Chem.,
3CVI,
Vice President.*

MILWAUKEE
RADIO AMATEURS' CLUB

≈ Incorporated ≈

Editorial Comment

Help Congress Think

When Congress is asked to make adequate appropriation for the maintenance of the Radio Division of the Department of Commerce it is hoped that an intelligent public opinion will make itself felt through the representatives of the popular will. And it is not too early to begin thinking it over and passing the word along. That highly intelligent body of citizenry chosen to represent us at Washington should become aware of the tremendous service radio is rendering to literally millions in America. Many of them are aware of it. But unless something like a general demand for adequate funds for carrying on the tremendous burden of supervision is apparent, the need may become lost in the multitudinous shuffle at Washington and the Radio Division be forced to ride along as it has for four years, on a sum adequate in the days before broadcasting. There is a constant demand on each inspector's office for service which would require many times the men and equipment now available. The supervisors are not complaining, but much of this service is vital to the thousands of broadcast listeners and amateurs in every community from Bangor, Maine, to San Diego, California, and if the service is not adequate, the greatest unifying and vitalizing force of recent years will suffer in consequence. It is only just that radio should receive, from the government whose people it serves so unselfishly, the support necessary to enable it to control and direct its energies for the common good.

Yes, It's Quite the Thing

When we furl our sunshade and go trotting off to the North Pole we are going to take radio along. Mr. Mac-Millan is doing it for the first time this season, and it is proving very successful. In fact, the bear stories, battles with the ice, search for the pole itself, and all the other thrillers attendant upon such an expedition will seem much more real and close to us when relayed hot off the ether instead of coming to us written on the last unchewed boot heel found by the fifth rescue expedition ten years hence. We believe there are certain spots on the globe, probably in the heart of darkest Africa, where a man may still secure a certain modicum of seclusion, but we will have to hurry. The North Pole is gone, the Sahara Desert is as well "communicated" as the royal suite at a beach hotel and, before long, the only "Crime of the Congo" will be the elephant tusk prices they will be charging for headphones.

Two Issues in One

Readers will find the October and November dates combined in this issue of Radio Journal. The publishers decided upon this course after unforeseen and unavoidable circumstances had delayed publication. The combination was also made advisable by the desire to issue each month's magazine on the fifteenth of the preceding month. All advertising contracts will be extended one month to cover the required number of issues and all subscriptions now in force will also be extended one month.

Radio Again Justified

Again the world has been horrified by a tragedy so great in loss of human life as to leave our imagination, upon which man prides himself, unable to comprehend its magnitude. And again radio justified every dollar expended upon it in all these years, every drop of life blood, every ounce of brain energy put forth in its creation. For with cable communication temporarily destroyed, radio flashed the news of a sorely stricken people around the world and long before wires began telling their share of the gigantic disaster radio had started the relief ships on their way to Japan. In lives saved in this one great disaster radio has paid its way for many ages to come.

Big Things Ahead

The undercurrent of optimism in the radio trade, so evident in the west during the summer and even finding expression throughout the east during July and August, is swelling into a sound which can be heard from coast to coast. It is going to be a big "radio winter" and this Christmas is going to be a "Radio Christmas" to be remembered by the radio public and the radio trade alike for years to come. Predictions of this sort are easy to make, but in this case the prediction is based upon facts, upon observations of those accustomed to watch business tendencies with a wary eye, and upon that spirit which often stalks abroad to tell all who will listen which way the business wind is going to blow. The gods of trade have hung the "good business" sign on the radio door for the winter and it behooves everyone in the industry to heed and make preparations accordingly. Radio itself has undergone some marvellous changes within the past year. A highly alert, highly interested buying public has become convinced that radio is a necessary adjunct to the complete home. And nowhere has the complete home been brought to the perfection, the universal completeness, that is to be found in the average American home. With the public convinced that radio will complete the home, it is only a question of delivering the goods, in salesmanship and radio merchandise. And this winter, as never before, the public finds an array of real radio merchandise, sets and parts, which "deliver the goods" in radio, as never before. As the public's education in things radio progresses, it has acquired the faculty of selecting its radio equipment with an understanding mind, a faculty which works only for the good of the industry. The day when any kind of radio equipment could be shoved over the counter at an uninformed buyer has gone the way of the buffalo and the kitchen-loving wife. It is no more. The public wants real information about real radio merchandise, and it looks to two agencies to furnish it, the salesman and his chief ally, the advertising section of the radio magazine. The trade feels this change in the mental attitude of the buying public. It realizes that this winter is going to see more and better radio merchandise sold than ever before. And the trade is stepping forward to do its part in making this the biggest winter in the history of radio.

Super Hetrodyne Neutrodyne Reflex

By ARTHUR L. MUNZIG

When Mr. Munzig rose up and expounded upon the Neutrodyne in the August issue of Radio Journal he found literally thousands of readers eager to follow him. In fact, the weary postman is a pathetic figure as he tugs up our stairway with his load of mail for Mr. Munzig... And here is another thermostatic temblor to shake the radio world... Mr. Munzig, as president of the Ray-Dee-Artcraft Co., is a busy man, but he spends hours of each working day experimenting, and nothing he writes for Radio Journal has not been proven and tested beyond all possibility of doubt before it is given to the public.

THE super-hetrodyne method of obtaining radio-frequency amplification has been conceded the most efficient method of reception of radio signals at short wave lengths. The reason for this is that by the use of a frequency changer the received wave lengths can be changed into longer wave lengths where the frequencies are much lower, thus allowing radio-frequency amplification to be efficiently obtained, due to the fact that the tendency of the tubes to oscillate is greatly reduced. With the advent of Hazeltine's Neutrodyne method of neutralizing capacity coupling, the tendency to oscillate at these low frequencies is very easily curbed.

In the August issue of Radio Journal, in Fig. 14 of page 63, the writer suggested a super-hetrodyne circuit with the neutrodyne principle, using but one stage of radio-frequency amplification in the intermediate circuit. While this circuit is very sensitive, it is still possible to use two more stages of radio-frequency amplification, thus obtaining a sensitivity not equalled by any method known to date.

In Fig. 1 is given a super-hetrodyne neutrodyne circuit using five tubes,

ers are of special construction, details not being made public as yet. Each Transformer is tuned with a 23-plate variable condenser. The "C" battery has a voltage of approximately 4½ volts. It is best to experiment with this voltage until the correct bias is

windings are made with No. 24 DCC copper wire. There are several ways in which the hetrodyne circuit can be made, but the one given is about as practical as can be found. Later, in this article, two more methods will be given for the reader's convenience.

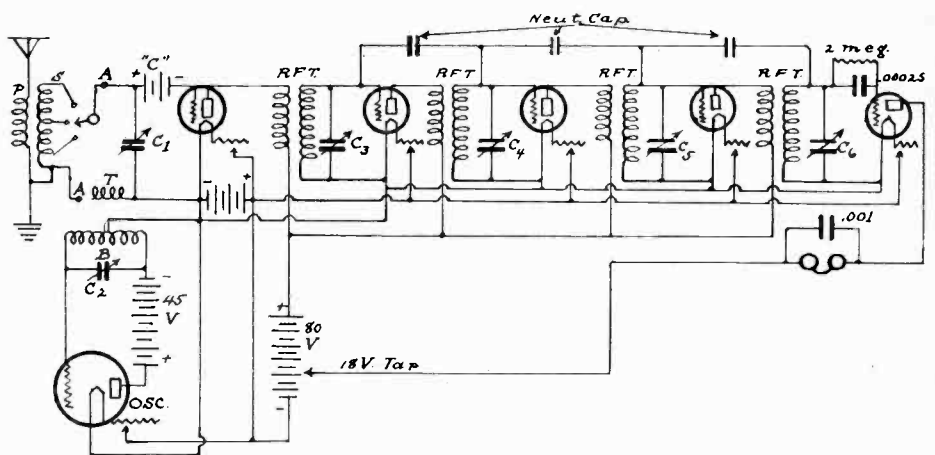

Fig. 2

found. It is safe to start preliminary experiments around 4½ volts, but it will vary with the type of tube used and the plate voltage. In the hetrodyne or oscillating circuit, the coils given consist of 40, 40 and 10 turns, respectively. The two 40 turn coils

The type of tubes used in the Fig. 1 circuit can be either the UV201A or UV201. The C301A and C301 are the same type. The tube marked "2nd Det." is a regular "soft" detector tube, functioning on low voltages on the plate. When "A" tubes are used, low filament consumption results. Furthermore, the type "A" tubes are more efficient amplifiers, thus being the ideal type to use in the super-hetrodyne, where extreme sensitivity is desired, and at the same time, low filament consumption results.

In Fig. 2 is shown the ideal super-hetrodyne circuit. This combines extreme sensitivity, selectivity, simplicity of control, together with low filament consumption, and the use of the neutrodyne principle. The oscillator or hetrodyne circuit coils are made as follows. The coil B consists of 50 turns of No. 24 DCC copper wire wound on a tube 4 inches in diameter, a mid-tap being taken at the 25th turn for common connection to negative of A battery. The coil, T, consists of 10 turns of No. 24 DCC copper wire, wound on a 3-inch tube so that it will rotate inside of coil B. The variable condensers C1, C3, C4, C5, C6 have 23 plates,

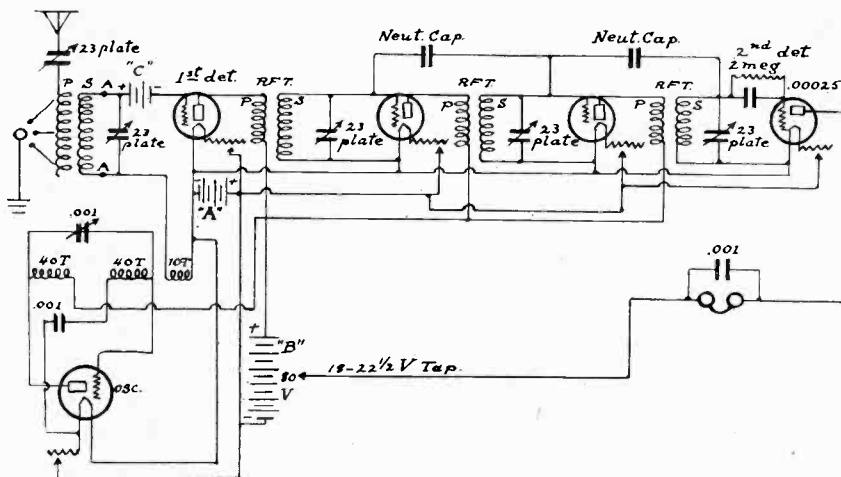

Fig. 1

two stages of amplification being used in the intermediate frequency. Neutralization of capacity coupling is accomplished by the neutrodyne method. The tuned radio-frequency transform-

are wound on a bakelite tube 4 inches in diameter, and are separated about ¼ inch. The 10 turn coil is wound on a tube of sufficient size so that it will rotate inside the 4 inch tube. All

while C2 has 43 plates. Connect the rotor terminal towards the filament connection, thus eliminating undesirable body capacity effects. This holds true when a variable condenser is used in any circuit. The antenna-grid tuning inductance is made as follows: On a bakelite, fibre or cardboard tube, wind 75 turns of No. 24 DCC copper wire, twisting taps at the 30th, 45th, 60th and 75th turns. Over this winding wind 10 turns of the same size wire, at any convenient place on secondary coil. This acts as the primary coil and the complete unit is connected as in Figs. 2 and 4. It can of course be connected in any of the others. Also the use of a neutrodyne neutroformer can be substituted with equal results. If the use of a loop is desired, connect to terminals marked AA, after disconnecting the antenna tuning inductance. UV201A tubes are used throughout, with the exception of the detector tube, which is a UV200.

Fig. 3 shows a super-hetrodyne receiver using tuned RFT's in the intermediate frequency but without neutralizing capacity coupling. However, the tendency to oscillate is curbed by providing a grid bias by shunting a 400 ohm potentiometer across the A battery and connecting the sliding contact arm to the grid connections. This circuit is superior by far to any untuned method and uses less tubes. The hetrodyne unit is made up of the three coils, B, C and D. Coils B and C contain 50 turns each and are wound on an insulating tube 3½ inches in diameter. Coil D contains 10 or 15 turns of the same size wire and is wound on a tube of sufficient size to rotate within coils B and C. Coil B is tuned with a .001 MF variable condenser with 43 plates, C2. C1, C3, C4, C5, C6 are variable condensers having 23 plates. All tubes used are the "A" type drawing but ¼ ampere at 6 volts, with the exception of the

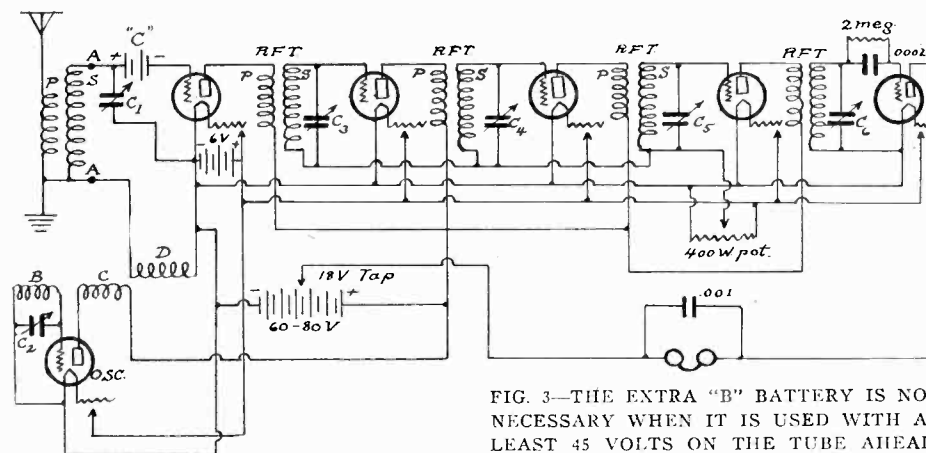

FIG. 3—THE EXTRA "B" BATTERY IS NOT NECESSARY WHEN IT IS USED WITH AT LEAST 45 VOLTS ON THE TUBE AHEAD, EITHER DETECTOR OR AMPLIFIER.

detector tube, which is of the "soft" type such as the UV200 or C300. If WD11's or UV199's are substituted, very good results will be had, for, in the case of these small element tubes, the internal capacity is so small that

the tendency to oscillate at low frequencies is reduced practically to zero. We have found it so in our case, but it is also necessary to shield each stage very thoroughly, in order to make this possible. If a storage battery is used to lower the amperage down to the current consumption of the WD11's or "99's." This can be done through the use of one master rheostat of not less than 80 ohms resistance, or through separate rheostats of 30 ohms each in series with a resistance coil of 50 ohms.

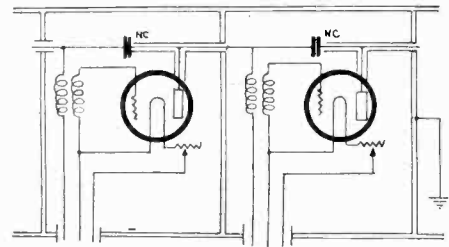

Fig. 5

is excellent. The antenna-grid tuning inductance can be any of the methods given. Fig. 1 is not recommended for this uses a variocoupler of stand-

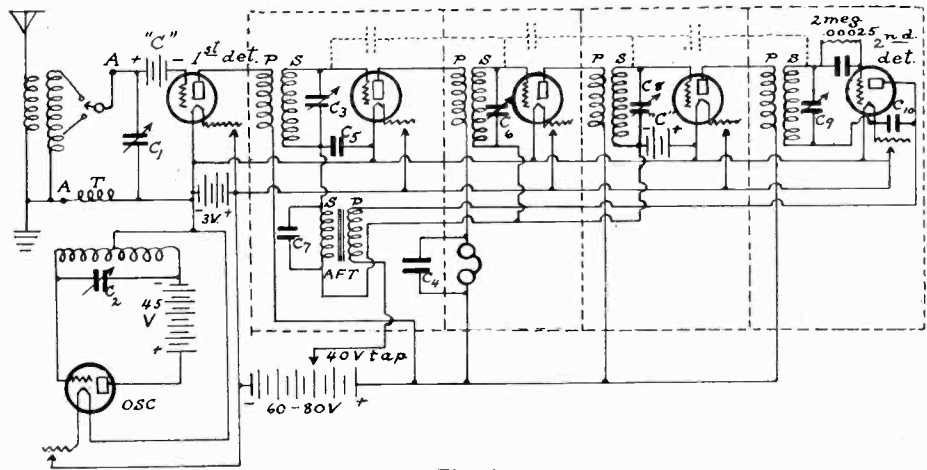

Fig. 4

Fig. 4 shows a circuit using UV199's in a super-hetrodyne receiver, reflexing one of the tubes in the intermediate frequency amplifier. This circuit has been used with complete success, coast to coast reception being *very common*. This coming winter it is predicted that greater distances than ever accomplished before, will be possible with this receiver. 2LO in London would be a fair example of extreme long distance reception.

The hetrodyne (marked OSC in Fig. 4) can be substituted with any of

and make, using another control for the antenna, viz.: series variable condenser. The method described and used in Fig. 2 is the type we use and gives very good results, being selective and efficient, and not obviating the use of an extra control.

All the variable condensers, with the exception of C2, have a maximum capacity of .001MF. C5 and C7 are fixed condensers of .001 MF capacity and C4 and C10 are fixed condensers of .002 MF capacity. These fixed capacities should preferably be Mica-done or some type made along the same order with mica insulation for the dielectric.

The audio-frequency transformer is a Federal or should be some type having a ratio of not more than 4 to 1. A higher ratio causes distortion. If another stage of audio-frequency is desired for loud speaker operation, all that is necessary is to disconnect the telephones and substitute the primary winding of an audio-frequency amplifying transformer. A transformer of a larger ratio should then be used, say 5 or 6 to 1. It is needless to say that audio-frequency can be added to any of the circuits given herein.

A grid bias is used in the first detector tube and in the grids of the intermediate frequency amplifiers, and should be of approximately 3 volts negative when the plate voltage is between 40 and 60 volts, and 6 volts when the plate voltage is between 60 and 80. Do not use over 80 volts with

the other methods shown in the other figures. The oscillator shown in Fig. 4 necessitates a separate B battery, so its selection will not be quite as favorable. The method shown in Fig.

the "99" type dry cell tubes. The grid bias or "C" battery negative voltage will vary and should be experimented with until properly found. Should it be found necessary to neutrodyne this circuit, connections are shown by dotted lines.

Each drycell tube should be mounted on a cushioned support, such as a rubber sponge. Sponges are ideal for this purpose and can be had at any store.

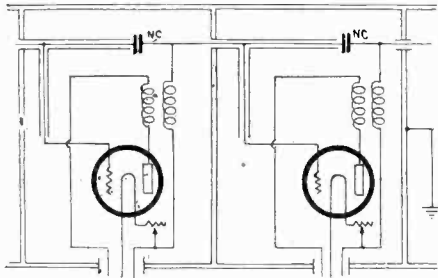

Fig. 6

This precaution is necessary to reduce microphonic noises caused by vibrations, etc., to a minimum.

The heavy dark dotted lines indicate the placing of the metal shields. These shields *must be* of one of the following metals: copper, brass, aluminum or tinfoil. *Never use galvanized iron or sheet iron of any kind.* Losses due to hysteresis are very noticeable. This shielding should be placed on all four sides. It isn't necessary to shield the top and bottom. If multistage amplification is used it will be necessary to shield all leads in addition to the aforementioned shielding. (See Figs. 5 and 6).

A suggested layout of a panel to mount the super-hetrodyne neutrodyne reflex receiver is shown in Fig. 7. This panel need not be all in one piece but can be divided into two or three parts. One panel 7x18 inches can contain the parts for the hetrodyne and the tuning inductance with the

first detector. The second panel 7x24 inches can contain the intermediate frequency amplifier. The third panel 7x14 inches can contain the second detector and a two stage amplifier equipped with jacks so that audio-frequency amplification can be plugged in at will for loud speaker operation. No detailed drilling instructions are given, for this will vary for various instruments used in its construction. The experimenter's initiative will be called upon to arrange his own parts.

A super-hetrodyne DX receiver such as given in Fig. 4 can be built for less than \$150. The average DX receiver that can be bought will run around this price and yet you haven't the range desired. With the super-hetrodyne the world is at your feet! Broadcast stations using comparatively low power can be heard with loud speaker intensity that were never heard before on *any receiver.* This super-hetrodyne Neutrodyne Reflex DX receiver is the ultimate in broadcast re-

- 6 UV199 or C299 VT's.
- 6 Remler Type 399 VT sockets.
- 6 Framingham 30 ohm rheostats.
- 4 Ray - Dee-Artcraft super - hetrodyne tuned R-F transformers.
- 5 23-plate variable condensers. 1 with vernier.
- 1 43-plate variable condenser. With vernier.
- ½ lb. No. 24 DCC copper wire.
- 1 60 or 80 volt B battery.
- 1 4 volt A battery. (Can be two cells of storage battery).
- 1 Federal audio-frequency amplifying transformer.
- 2 Micadons, .001 MF.
- 2 Micadons, .002 MF.
- 1 pair Brandes Superior phones.
- 1 .00025 MF Micadon grid condenser. Grid leak can be scratched between the two terminals and pencil marks filled in.
- 10 small flash light batteries for "C" battery.
- 1 switch arm.
- 4 contact points.

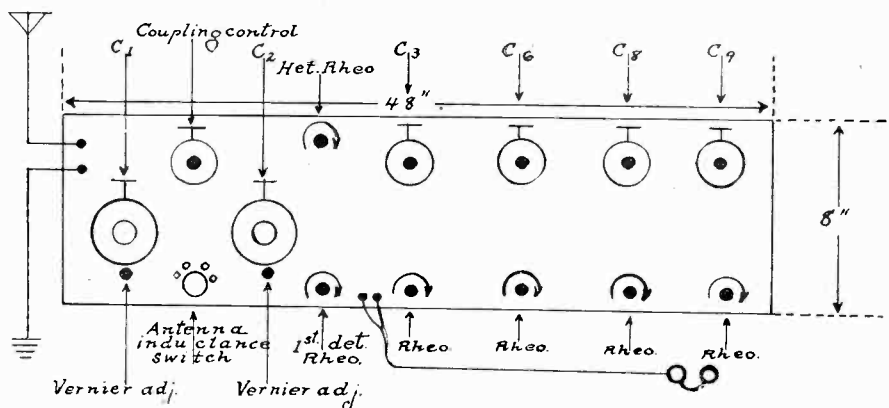

FIGURE NO. 7—SUGGESTED LAYOUT FOR SUPER-HETRODYNE NEUTRODYNE REFLEX RECEIVER.

ceivers operating on short wave lengths. It is a pleasure to operate this receiver.

Parts for building the receiver given in Fig. 4 are as follows:

- 2 stops.
- 2 Kellogg 4-in. dials.
- 4 Kellogg 3-in. dials.
- 1 2-in. dial (coupling.)
- 1 8x48-in. panel or its equivalent.
- 10 binding posts.
- Metal for shielding.

Necessary material for constructing inductances for antenna and oscillator.

In the August issue of Radio Journal the writer invited correspondence from readers contemplating the construction of neutrodyne receivers. So many letters were received that the writer has a hard time in answering them all completely. However, the time in answering each letter is fully compensated in valuable information received from many of the readers. Invitation is given to interested readers of this article on the Super-hetrodyne to write us in care of Radio Journal, should any points not be clear and if any constructional data is needed. Before writing please make sure that what you ask hasn't been explained in this article. Inclose a stamped, self-addressed envelope for reply.

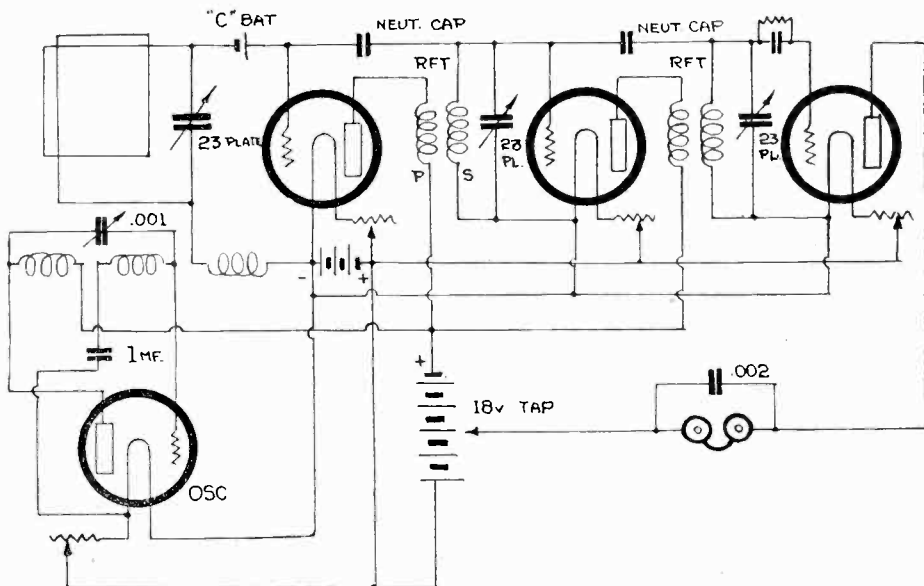

FIGURE NO. 14—THE SUPER-HETRODYNE NEUTRODYNE CIRCUIT, REPRINTED FROM AUGUST ISSUE OF RADIO JOURNAL.

Some More About the Hetro-Trans

By J. T. ROFFY

The first hill is not all there is to the mountain range. The first article on the Hetro-Trans is not all there is to the thing—not by a jug full o' Boston beans. Mr. Roffy here goes into some questions at once raised when our following of experimenters got busy. All is not gold that glitters—but some of it may be. Anyhow, it is worth a look.

THE first published description of the new Hetro-Trans Circuit appeared in the September issue of the Radio Journal and at the same time several hundred transformers were released for amateur use. The distance covered, volume and clearness recorded with this simple hookup have astonished experimenters who believed in the supremacy of the multi-stage radio frequency circuits.

Hetro-Trans receivers in the vicinity of Los Angeles in August weather have received from all important coastal stations as well as Calgary, Salt Lake City, Fort Worth, Denver, Kansas City, Chicago and Detroit on the broadcast wave lengths and Brooklyn, N. Y., on C.W. The facsimiles of the complete logs will be attested and published at an early date. Thus, the new Hetro-Trans circuit in its simple form, is a contender for the seven and nine bulb honors and with the experimenters greater familiarity with the new circuit, coupled with more favorable radio weather, interesting developments are looked for.

The Hetro-Trans circuit in conjunction with a standard two stage audio amplifier or with power amplification of the Western Electric or Magnavox type brings in distant stations booming clear and sonorous. In the case of standard two stage audio amplification the filaments of all the tubes may be controlled with one rheostat, diagram of which appears on this page.⁶ Thus the number of controls are kept to a minimum.

In experimenting with the Hetro-Trans circuit many an interesting phenomenon was observed and due to the simplicity of the circuit a vast amount of information was quickly gained which otherwise would have been lost in endless speculation over incorrect grid leaks or by-passes. A case to be cited is body capacity. This subject has been endlessly discussed and thousands spent on ineffectual shielding, etc., but the average experimenter is still struggling with that ever present instability.

Now if the Hetro-Trans circuit contained any critical piece of apparatus or device, whether acting as a load on the grid or on the plate of any one of the tubes, that device would be

blamed for the presence of body capacity. But not having such apparatus in the circuit, the variably appearing body capacity was attributed to the entire set or more particularly to the position of the set, electro statically, with respect to its aerial and ground. With this view in mind, the problem readily yielded to solution and its application to all sets is a milestone toward better reception. From the engineering point, the statement "Locate the receiver in a neutral electro-static position in respect to the aerial and ground," is a mathematical proposition if all variances are prop-

ger affect the apparatus by its proximity, the ground lead then is removed and placed at the terminal where the aerial lead has previously been. The operator is now required to assume a position before the instrument such as is generally used for long distance reception. These precautions are absolutely necessary, as we are now proceeding to raise the instrument to the "Nth" degree of instability and its tendency to body capacity. A local station is now to be tuned in, turning the filaments to their highest point and adjusting the vernier on the condenser to its finest adjustment. This

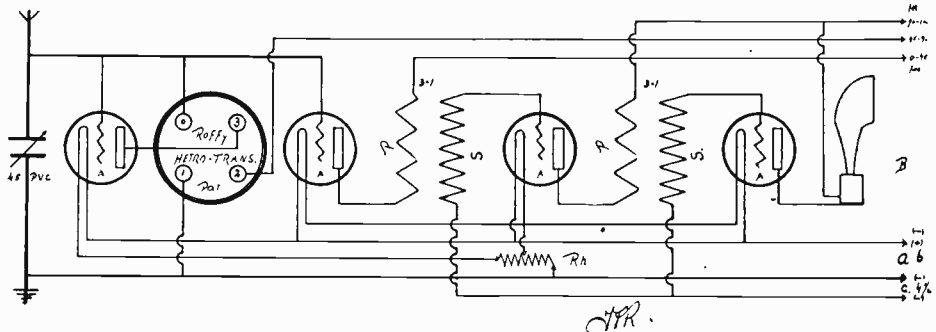

THIS IS THE ROFFY HETRO-TRANS CIRCUIT WITH AMPLIFIER, WHICH BRINGS IN THE DISTANCE THESE DAYS.

erly accounted for, such as area of foliage or moisture content of a chance apple tree in the vicinity of an aerial. Elaborate mathematics, however dwindle into approximates to be checked and rechecked with precision instruments designed for just such purposes. Thus, while the remedy is apparent, we still have our friend, the average experimenter, struggling with body capacity.

The next phase towards the solution of body capacity as a problem is to point out a ready means for the experimenter to find this elusive electro-statically neutral position for his set so that he may be able to repeatedly check up on the same as an evening progresses. The Roffy Hetro-Trans circuit possesses all of the elements of precision and the ability of almost instantaneous determination of electro static neutrality. The procedure is as follows: all leads entering the set such as A and B battery are made as short as possible, the output leads located at a fixed point, the aerial lead is removed from the set, placing as much distance between the free ends as possible so that the aerial will no lon-

accomplished, everything remaining the same, i.e., the rheostat and condenser settings, we now remove the ground connection from the aerial post back where it belongs, that is, negative A, and return the aerial lead to the aerial post into which circuit a small variable air condenser has been inserted. Now reassuming the same position as heretofore, the same station should be sharply tuned in on the aerial condenser alone and the position thereafter set. The apparatus at this particular balanced condition is devoid of body capacity. It is absolutely insensible to the actual electrical contact of the operator's body to the ground lead. The set is now able to reach out for extreme long distance signals, and is capable of faithful reproduction without distortion.

There have been extended discussions on how best to obtain this electro-static neutrality with other sets. The procedure in principle should be the same, but owing to variant conditions within some sets, especially with the hookups of regeneration, the application of the above procedure is more difficult.

Trans-Pacific Tests This Month

Are You Ready?

OCTOBER 15 the second big attempt to bridge the distance between America and Australia and New Zealand will start. Amateurs from every section of the country are getting their entries in and the affair promises to be even greater and more successful than that of last May.

Here are the dates and time American amateurs will transmit, from October 15 to November 3. Friday and Saturday nights will be free for all. Other nights schedule transmission, time to be arranged each entrant. Transmission will take place from 5:45 to 8:45 p.m., Melbourne time.

From November 5 to 17 the Australian and New Zealand amateurs expect to be able to transmit, with Americans at the receiving end. Hours will be the same.

This is some program. The A.R.R.L. and QST are lining up the Atlantic and Central sections of the country and entries are being made either with the Western committee, care of Radio Journal, or with the eastern headquarters, QST.

Code sentences, not letters this time, will be assigned each western entrant. The A.R.R.L. will also make assignments, to the end that each

entrant will have a distinct check verifying his reception, should he prove successful.

Fill out this blank and mail it today to enter the next Australian Trans-Pacific tests, sponsored by the Southern California Radio Association, to take place October 15 to Nov. 3.

Call letters

Name

Street number

City

State

CW, ICW or spark

Power

It costs nothing to enter. There are no restrictions. Address this blank and any other communications regarding it to: Australian Trans-Pacific Tests committee, care of Radio Journal, 113 Stimson Bldg., Los Angeles, California.

There is every likelihood that where a score or more got across last spring, hundreds will make it this fall. But the essential thing now is to get the entries in, get the set rigged up for maximum output, and to "key" properly. One of the big complaints during the last test was poor keying. Many amateurs who would, otherwise, have made Australia, failed to be read because of poor spacing or similar defects in operation. This is something that every amateur in the tests can guard against this year. Slow sending is also essential, about ten words a minute being right. Fast sending handicaps the chance of the signal being read properly. So let's go. The committee will notify every entrant of time schedule, etc.

Again 6AJF writes as follows: "Was heard down in New Zealand three times before the tests came off, time ranging from early January to April 1, by Messrs. Slade and Bell. Also heard again during tests. Was only on the air two or three times late during the tests in May. Use 15-watters, radiating $2\frac{3}{4}$ to $3\frac{1}{4}$ amps. —6AJF."

So don't worry about your 15 watts not having the punch. Put it there.

For the information of the amateur who fears he can not get across on 5 or 10 watts CW, take 6BUY as an example. Operator J. D. Holmes, Jr., Pasadena, got across to both Australia and New Zealand, and he at no time used over from 5 to 10 watts, radiation 3TCA.

Here is a description of Radio 5AEC, operated by R. L. Fish, Oklahoma City, Okla., who was successful in the first Australian trans-Pacific tests and who is strong for the next one:

"The antenna used at 5AEC is a conical cage suspended from a 71-foot steel pole to one 25 feet in height. It contains 8 wires and is 85 feet in length, including the lead-in.

The set is of 20 watts power, using 700 volts on plates and 7.5 volts on filaments. The power is supplied from a transformer through a synchronous rectifier which was built by the opera-

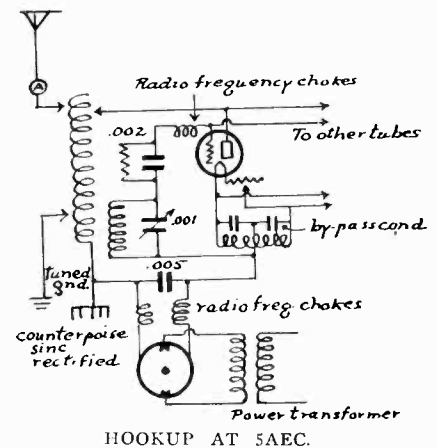

tors at school. The circuit used is the 1DH and is shown below. The main inductance is 3 inches in diameter and wound with No. 8 wire. The grid-coil is only 1 inch in diameter and contains 35 turns of No. 18 wire. The complete set is wired with No. 8 copper wire. All condensers were home-made, using tinfoil and mica. The radiation during the tests was 4.3 thermocouple amperes.

"The receiver used at 5AEC is a three circuit regenerative set with two step amplifier and Baldwin phones. This station has been in operation for one year and the DX during that time was 45 states, Canada, Alaska, New Zealand, Mexico, Hawaii, Porto Rico, Panama and Cuba. We will appreciate cards."

Capt. R. W. McNeely has been designated to relieve Commander S. C. Hooper as chief of radio section, Bureau of Engineering. Commander Hooper left to become Fleet Radio Officer under Admiral Coontz on July 14.

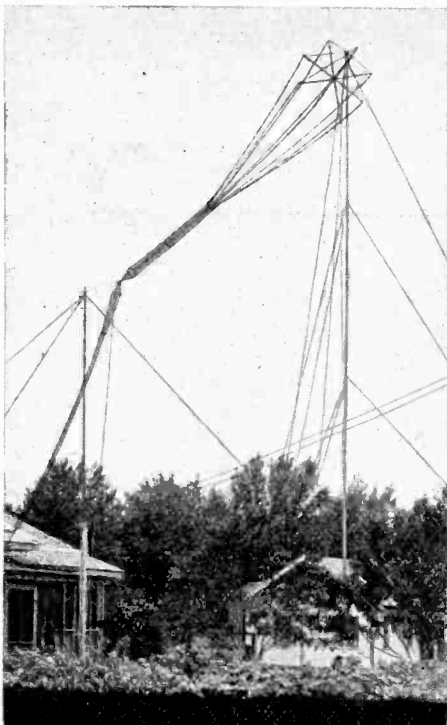

—Photo Courtesy Q.S.T.

THIS IS THE OUTSIDE OF 5AEC, OWNED AND OPERATED BY R. L. FISH, OKLAHOMA CITY. IT HAS BEEN HEARD IN AUSTRALIA, HAWAII, PORTO RICO, MEXICO, PANAMA, ALASKA AND CANADA. IT USES FOUR 5-WATTERS.

Cat Whiskers

By A TICKLER

IDYLLS OF COCONINO

On the desert Coconino
Lived a maiden, very fair.
And her lover was a miner
In a deep and
Gold Lined Lair.

And he saw her every Thursday,
Riding thence upon a mule.
When he fell into a chuck hole
There was weeping
As a Rule.



She would cry out to the desert
For some aid in her distress.
She would shake her bobby ringlets
And mayhap she'd
Tear Her Dress.

For he'd failed to eat his dinner
With his sunburned sweetie fair,
And she longed with all her being
To gouge out
His Sticky Hair.

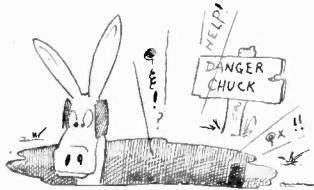

Then one day a passing tourist
Left our JOURNAL by the tank,
When he filled his boiling roadster
With the water
Thick and Rank.

As she conned its living pages
Then her eyes bugged full with tears.
Here was what she had been wanting
Lo, these
Many, Many Years.



So her miner dug some gold rock
From his lair beneath the hill
And they sent it off to market.
She was given
Quite a Thrill.

Now he phones his pretty maiden
From his dank but gold-lined lair
And she listens, on the desert,
With the headphones
On Her Hair.

What they whisper? Ah, my kindred,
These are things I cannot tell.
But the snakes of Coconino,
And the owls,
They Know Them Well.

QUICK WATSON, THE SKIDS

Letting himself in with his *key* he
found a *cold plate* lunch on the table:
*ham, egg insulators, pie coils, dough-
nut coils, pancake coils and currents*
gathered from the *electric fields*. Even
honeycomb coil was there and *peanut*
tube. He *quenched* his thirst with
crystal water and put the rest of the
feed back in the *cabinet*. Despite being
clamped by the *rain* his *skin effect* told
him all was *catwhiskers* now, as long
as the roof didn't *leak*.

BEHOLD THE GENTLE COW-BOY.

Some day the dairy lads of Wisconsin
will be calling the cows thusly:
"D a-a-a Dit D a-a-a Dit! D a-a-a
D a-a-a D a-a-a! D a-a-a-a Da-a-a!
Dit!!"

A LOOSE CONNECTION

Bacon may have written Shakespeare
but the Hams are writing radio history.

WE PREFER 'EM FRESH

Old Doc Columbus would have been
up against it if he had used a radio
egg.

And then Mama Isabella wouldn't
have bet her diamond-studded hair
curlers.

And the discovery business would
have been busted up.

And there wouldn't have been any
discovery and—

Ain't it funny what a difference an
egg can make anyway?

BOTH BADLY SHOT

He hung upon her every word, and
Hung, and hung—and hung.
He climbed into the aerial as she
Sung, and sung—and sung.
The darn thing busted under him. He
Clung, and clung—and clung.
And now his folks say he is all
Unstrung, unstrung—unstrung.

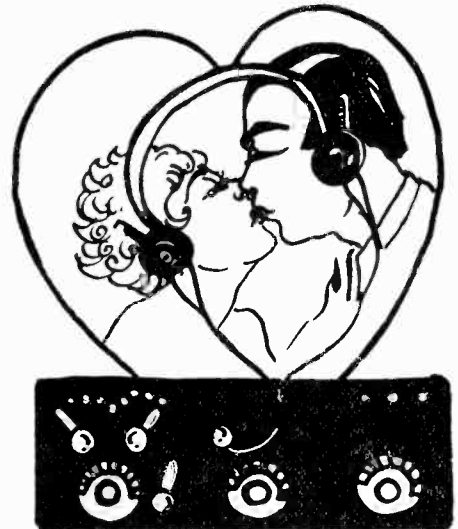

LEND US YOUR GAT

A twin headphone,
With a good kiss meter,
Makes the best chaperone,
A real world-beater,
For the flip young flapper
And her spruce and dapper
Cake-eater!

Arctic Reads Coast Signals

WEST coast amateurs are getting through to WNP, according to word from F. H. Schnell, traffic manager of the A.R.R.L. Here is a message from Mix, delivered to Mr. Schnell by 1AVK in person:

"To Schnell: Logged 6CMR and 6PL 50 miles west of Godthaalb, Greenland.—Mix."

6CMR is the call assigned to Radio Journal station, now operated by F. L. Wetzel and R. M. Maynard at Graham, California, near Los Angeles. 6PL is owned and operated by C. P. Brockaway, 4402 Sunset boulevard, Los Angeles, Calif.



From a glance at the map amateurs of the west will realize that their chances at WNP is about as good as any. In fact, Western amateurs are not given to letting mere distance worry them, as witness trans-Pacific and trans-Atlantic tests. Bad atmospheric conditions reported by Mix are responsible in part for the lack of station reports working WNP. The MacMillan party, of which Mix is the A.R.R.L. radio operator, is bound for Ellesmere land and some remarkable stories of the far north should come through the ether soon. IZE, 1ANA, 2CQZ, 1UJ have been standbys of Mix on working, while 1FD, 1CKP, 4JE, 1CPI, 1FB, 1MO, 2FB (Canadian), 9BJT, 1AR (Canadian), 9ALO, 1AR (Canadian), 1BCF and 1ARP, have been listed as either hearing or working WNP.

The schedule for WNP and complete data on when to look for the Bowdoin, MacMillan's arctic ship, on amateur wave lengths, has been published in both Radio Journal and QST.

"Located latitude 78:30," is one of the most recent messages from Mix, a mere fragment picked up by James A. Treanor former 7AXO, of 30 Bloomfield street, Dorchester, Mass., and R. B. Bourne, 1ANA, Chatham, Mass. It is the first message ever picked up from as far north as this, and it also indicated that the Bowdoin had reached Etah, within a few hundred miles of the pole. Etah was a base in the Peary voyage, participated in by Dr. MacMillan, which led to the discovery of the North Pole in 1909. Etah is on the northwest coast of Greenland, on Smith Sound, between Baffin Bay and Kana Basin.

The Bowdoin left Monhegan island, off Maine, June 26, with a crew of six men, including Dr. MacMillan, bound for scientific research and exploration. The schooner had a small but powerful radio receiving and transmitting apparatus, and messages were exchanged at her ports of call along the coast of Labrador, Cape Breton Island, Battle Harbor, Labrador, Turnavik Island and Godthaab, Greenland.

The message of July 28 said the vessel was leaving the following night after a day of scientific work in terrestrial magnetism, and would make the ninety mile run to Sukker Toppen,

a fishing hamlet half way between Godthaab and Godhaven. After that repeated calls sent out by the most powerful radio stations in this country brought no answer. Ice conditions had been reported extremely bad.

The New CR12

By V. M. BITZ

THE new CR12 circuit, recently put out by A. H. Grebe, has created no end of comment and many Radio Journal readers have sought details as to the method of tuning, etc., involved in the new set.

The tuning in the CR12 is done entirely by inductance. This principle is designed to deliver the highest possible voltage to the grid of the radio frequency amplifier and detector. The signal received depends largely upon the voltage delivered to the grid of the tube. It follows that, in a circuit such as that of the CR12, this ideal condition is obtained. It gives the minimum amount of capacity and the maximum of inductance.

Any capacity across an inductance lowers the voltage in that circuit. I am convinced, after considerable experimentation to check up theory, that maximum results from a receiving set can be obtained by following the inductance method of tuning.

New Broadcasters

New stations licensed:

WTAH, Ferro, Carmen, Belvidere, Ill.; class A; 236 meters, 10 watts.

KFJM, University of North Dakota, Grand Forks, N. D.; class A; 229 meters, 100 watts.

KFJQ, Valley Radio Div. of Electric Construction Co., Grand Forks, N. D. (portable station); class A; 252 meters, 5 watts.

KGB, Tacoma Daily Ledger, Tacoma, Wash.; class A; 252 meters, 50 watts.

Transfer Class C to Class A:

WDAH, Trinity Methodist Church, El Paso, Texas; class A; 268 meters, 100 watts.

KDZB, Seifert, Frank E., Bakersfield, Calif.; class A; 240 meters, 100 watts.

WNAL, Rockwell, R. J., Omaha, Neb.; class A; 242 meters, 20 watts.

WIAI, Heers Stores Co., Springfield, Mo.; class A; 252 meters, 20 watts.

KXD, Herald Publishing Co., Modesto, Calif.; class A; 252 meters, 10 watts.

WCAS, Dunwoody Industrial Institute, Minneapolis, Minn.; class A; 246 meters, 100 watts.

Amateurs, attention! Beginning next month Radio Journal will publish, each month, a department devoted to "Western Amateurs." This department will be conducted by A. L. Munzig, on the air as an active amateur since the days of the first spark, ex 6ZJ, and already known to thousands of Radio Journal readers. The Western amateur has wanted a magazine to which he could take his "dope," his problems and the like. Here it is. Mr. Munzig wants to make this a real amateurs' meeting place, wherein everything the amateur is interested in, from "amps" to DX records, can be discussed, not by Mr. Munzig alone, but by the amateurs. So write the new department today. Send in your troubles and your ideas. Photos, set tips, kicks on traffic, complaints on regulation, ideas for bettering the amateur and his field, anything and everything is wanted. Get it off your chest. Address A. L. Munzig, Western Amateurs' Department, Radio Journal, 113 Stimson Bldg., Los Angeles, Calif.

Voltage Amplification in Audio Frequency

The Bureau of Standards is constantly working toward the elimination of guess work in radio. This article, known as Letter Circular 98, gives some interesting data on voltage amplification which will be of interest to the seller and buyer of radio apparatus and, if thoroughly understood, will help in selecting equipment of desired characteristics.

THIS paper gives the results of voltage amplification measurements made on 16 audio-frequency amplifiers which are considered as being typical of those which were on the market during the years 1921-22. Measurements were made over a frequency range from 400 to 2100 cycles per second. The particular amplifiers studied are referred to by arbitrary reference numbers rather than by a statement of the manufacturers' names and type or model numbers. It is believed that the methods followed and the examples given in this report will be of assistance to manufacturers in the development of methods of testing and describing their own products and thus improving them. It is believed that purchasers will also be directly aided in deciding what features and characteristics to look for in the selection of apparatus.

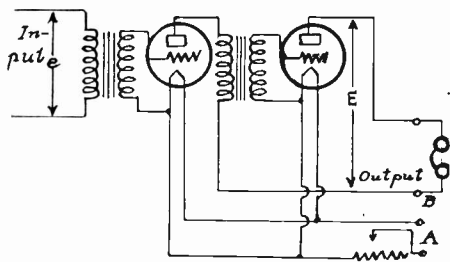

Fig. 1

All the amplifiers included in this paper employed transformer coupling. A typical schematic circuit diagram is shown in Fig. 1. The ratio E/e is measured directly by the method referred to. (e = in-input voltage, E = voltage produced across the telephones.) It is desirable that measurements be made with various amplitudes of the emf e as well as at various frequencies.

The values of voltage amplification at 500, 1000, 1500 and 2000 cycles per second are given in Tables I and II. Figs. 2 and 3 give curves of voltage amplification (E/e) plotted against frequency for 4 amplifiers. These curves are representative of those obtained for all the amplifiers covered by this test. Fig. 2 shows the results on 2 single-stage amplifiers and Fig. 3 on 2 two-stage amplifiers. It may be seen from these curves and from Tables I and II that the amplification is not uniform over the complete audio-frequency range, the amplification usually being greatest at one frequency which represents the natural period of

some circuit in the apparatus. This lack of uniformity is an indication of the amount of distortion in the received signal which will be introduced by the amplifier, the ideal amplifier for amplification of musical tones having a curve parallel to the frequency axis. It is not usually possible to secure all desirable characteristics in a single piece of apparatus. For example, in order to secure the best possible quality it may be necessary to use a set which sacrifices some amplification.

The values of e and E depend on the characteristics of the in-input and out-put circuit. It is probable that better ratio would be one that was

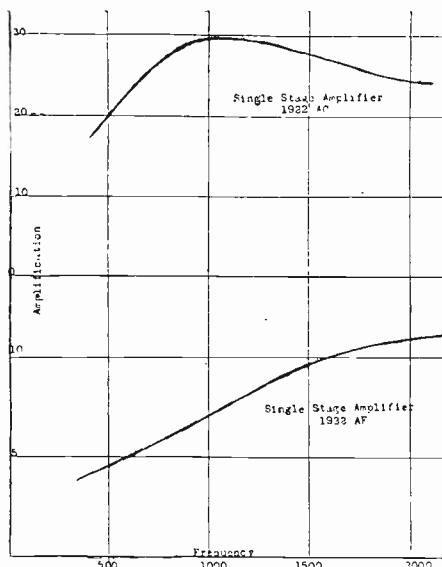

Fig. 2

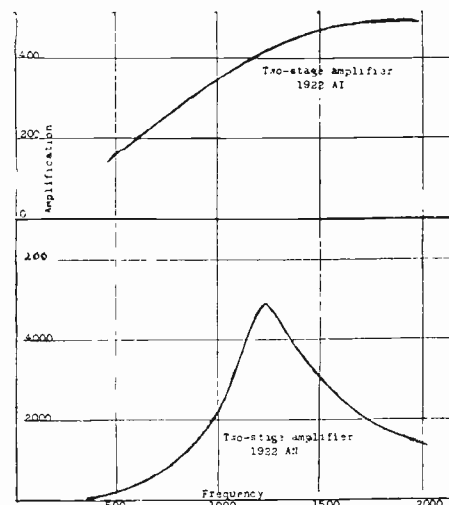

Fig. 3

related the value of $\frac{E}{e}$ for any known external circuits when the constants of the external circuits used during test are known. The ratio $\frac{E'}{e'}$ was not calculated in this series of tests.

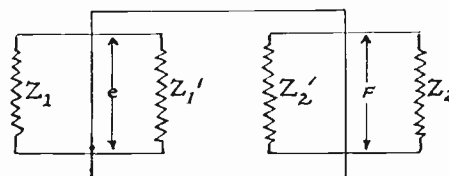

Fig. 4

independent of these circuits. Such a ratio may be calculated if the values of the various constants of the test circuits are known. Fig. 4 shows the external circuits of an amplifier. If Z_1 and Z_1' are known, a voltage e' which it would be necessary to insert in the in-input circuit to produce e may be calculated by

$$e' = \frac{e (Z_1 + Z_1')}{Z_1'}$$

additional being made vectorially. Likewise the voltage E' necessary in the out-put circuit to produce E may be calculated by

$$E' = \frac{E (Z_2 + Z_2')}{Z_2}$$

From the ratio of $\frac{E'}{e'}$ could be calcu-

Amplifier No.	Voltage Amplification			
	500	1000	1500	2000
One-stage Amplifiers.				
1922 AB	10	14.5	16.5	17.5
1922 AC	20	29.5	27.5	24.0
1922 AD	12.5	17.0	20	21.5
1922 AE	12.0	16.0	20	21.5
1922 AF	4.0	7.0	9.7	11.0
Two-stage Amplifiers.				
1922 AG	260	490	690	720
1922 AH	130	230	290	320
1922 AI	160	340	470	490
1922 AJ	85	190	300	330
1922 AK	120	300	660	920
1922 AL	130	330	430	380
1922 AM	140	300	400	420
1922 AN	300	2100	3100	1500
1922 AO	390	680	800	760
1922 AP	34	77	113	127
1922 AQ	25	85	150	180

How About The Battery?

By C. T. HOLCOMB

WHEN jazz, symphony or sermon comes forth from your radio blurred or drowned out by a medley of noises, what do you do?

If you are like a great many radio fans, you look to your connections to be sure they are tight, try to tune out the noise, and then, if you fail to get results, decide that it's due to static, and so can't be helped.

Perhaps you're right—it may be static that's causing the trouble, but did it ever occur to you that there might be another explanation—and one that could lead to quick relief?

Well, there frequently is, and it can be summed up in one word—*batteries*.

"But how can my batteries cause noises?" you ask. To understand the "how" and "why," first consider what your batteries do to keep your set in operation.

As you know, every radio set equipped with one or more tubes requires two kinds of batteries—an "A" battery to supply the current which heats the filament of the tube, and one or more "B" batteries to supply current for the plate circuit of the tube, which reproduces the incoming signals and causes the vibrations in the diaphragm of the phones that make the signals audible.

While battery noises may be due to either A or B batteries, or both, it is the B batteries which are the principal offenders, for the reason that they are right in the phone circuit, while A batteries are not.

Because they are in the phone circuit, any disturbances caused by or within the B batteries immediately affect the vibrations of the phone diaphragm, producing a variety of harsh, discordant sounds. The intensity of this disagreeable effect, of course, is greatly increased when amplified, especially wherever loud-speaking apparatus is used.

The battery disturbances which cause noise are set up in several ways, differing according to whether dry cells or storage batteries are used to supply the plate current.

In the case of dry batteries, these disturbances are the result of one or both of two conditions: 1—Internal electro-chemical action, and 2—Unseen wearing away of connections within the battery, due to corrosion.

Internal action is constantly going on in even the best dry batteries, due to the very nature of the construction of this type of battery. Each cell consists of a carbon electrode surrounded by what is known as the "mix" and around which is wrapped a thin sheet

of zinc to form the outside walls of the cell and also to act as the other necessary electrode. This internal action becomes more noticeable as the cell increases in age and the voltage drops.

Traveling instantly from batteries to phones, this disturbance is reproduced in the form of frying or hissing noises.

With regard to the other principal source of noise, where dry batteries are used, namely, the breaking down of connections, this is a common but often unrecognized cause of trouble—not recognized for the reason that it generally cannot be seen because the wires which connect the cells are covered by sealing compound.

Dry batteries, however, are not entirely responsible for battery noises. These noises may be present, too, where storage batteries are used, but here they are the results of a different cause—external electrical leakage.

Speaking of batteries—too many folks pay little attention to that angle of their radio set. Mr. Holcomb, manager of the Western Auto Electric Co., of Los Angeles, has here volunteered some information on the subject.

As you know, a B storage battery, like a B dry battery, also consists of a number of cells, each one a complete unit in itself producing a certain amount of electrical energy. From the first cell to the last this energy should follow a regular path. If it has the slightest opportunity, however, it will stray from this path, finding shortcuts for itself. When this occurs, the battery is said to leak electricity.

Electrical leakage causes disturbances in the circuit which issue from the phones in the form of noises. A

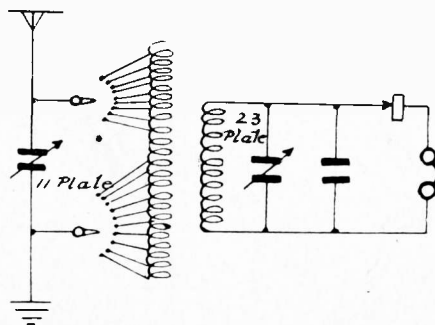

HERE IS ARTHUR DONKER'S HOOKUP, SUBMITTED IN RADIO JOURNAL'S CRYSTAL HOOKUP CONTEST. SHAKE A LEG, FOLKS, AND SEND US THOSE CRYSTAL HOOKUPS.

very small amount of leakage can produce plainly noticeable sounds, because of the sensitive character of radio apparatus and, further, because amplifying appliances are frequently used.

Electrical leakage, for several reasons, is a common fault of the ordinary radio B battery. One of these reasons is that as voltage is increased, the tendency towards leakage is also increased, and the voltage of the B batteries is comparatively high—24 volts for a B battery as contrasted with 6 volts for the A battery.

Another reason is that in many B batteries used in radio service, the tendency toward leakage has not been sufficiently taken into account.

You know, of course, that for your set to deliver the best results, your B batteries should work at a certain voltage. If the voltage drops, the volume of sound coming through your phones is reduced, and signals that you would get with the correct voltage in the batteries may either not be heard at all or may be so faint as to be of no practical value. Constant voltage, or as near it as possible, is what you want in your batteries.

In the properly built storage battery the voltage drop is comparatively very slow, so that a considerable period passes before there is noticeable weakness. The moment the battery begins to show signs of weakness, it should be recharged, either with your own rectifier attached to a lamp socket, or by a battery service station.

In fact, the right way to use a radio storage battery is to take full advantage of this recharging feature by always keeping the battery well charged, and not waiting for any indications of loss of voltage.

In connection with the subject of constant voltage, it is important to consider external electrical leakage, which, as we have said, is likely to be present in the ordinary radio storage battery. You will recall that we cited this as one of the two principal causes of battery noises.

In addition to causing noise, this has a decided effect upon the voltage of the battery, due to the fact that, however small it may be, it goes on constantly even while the battery is not in use, so that much of the energy is wasted and the battery discharged considerably faster than it should be.

Silver champagne buckets were put to a use which is a commentary on the times at a "good will luncheon" given by the United States Lines aboard the "Leviathan" in her dock at Southampton, England. These receptacles once a necessary part of a ship's dining service, were inverted on the tables and on them were placed the loud speakers of a voice amplifying system installed to make the speeches audible to everyone of the 500 guests present.

The Bohr-Atom Fundamental Conceptions

By PROF. H. La V. TWINING

Some very interesting conclusions, from a scientific as well as mathematical viewpoint, are reached in this article, one of a series by Mr. Twining, dealing with the fundamentals of electricity and matter from a new viewpoint. That portion pertaining to the density of the hydrogen atom is peculiarly worthy of notice and careful study.

It was our intention to compute the hydrogen spectrum in this issue, but there are some relationships that ought to be cleared up first. Consider the equation (28) of the previous article.

$$W_1 - W = h f = \frac{2\pi^2 M m B^3 E^2 e^2}{h^2 (M+m)} \left[\frac{1}{T_1^2} - \frac{1}{T_2^2} \right]$$

Let $\frac{1}{T_2^2} = 0$, i.e. $T_2 = \infty$ and solve for the frequency, then

$$f = \frac{2\pi^2 M m B^3 E^2 e^2}{T_1^2 h^2 (M+m)}$$

This is known as the Rydberg constant. Since certain factors occur in combination their value will be first computed.

$$\pi^2 = 9.87, \\ Mm = (1.66) (10^{-24}) (9) (10^{-28}) = (14.94) (10^{-52}) \\ B = 1.002172 \text{ (See computation below.)}$$

$$B^2 = 1.0043487 \text{ and } B^3 = 1.0065715. \\ E^2 = e^2 = (4.774)^2 (10^{-10})^2 = (22.79) (10^{-20}) \\ h = (6.547) (10^{-27}), \quad h^2 = (6.547) (10^{-54}) \text{ and } h^3 = (280.625) (10^{-81}).$$

$$M + m = (1.66) (10^{-24}) + (9) (10^{-28}) = (1.66 + .0009) (10^{-24}) = (1.6609) (10^{-24}).$$

$$M - m = (1.66) (10^{-24}) - (9) (10^{-28}) = (1.66 - .0009) (10^{-24}) = (1.6591) (10^{-24}).$$

$$E^4 = (4.774)^4 (10^{-10})^4 = (519.44) (10^{-40}).$$

$$\text{Gravitational constant} = (6.66) (10^{-8}).$$

Inserting these values in the formula the frequency of the radiated wave is

$$f = \frac{(2)(9.87)(14.94)(10^{-52})(1.00657)(519.44)10^{-40}}{(280.625)(10^{-81})(1.6609)(10^{-24})}$$

or $f = (3.29) 10^{15}$.

This is known as the Rydberg constant and formula (28) can be written

$$f = (3.29) 10^{15} \left(\frac{1}{T_1^2} - \frac{1}{T_2^2} \right)$$

The value of the Rydberg constant determined by experiment is the same, viz: $(3.29) (10^{15})$.

The factors

$$\frac{M}{M+m} = \frac{(1.66) (10^{-24})}{(1.6609) 10^{-24}} = .999$$

and

$$B = 2 \left(\frac{M+m}{M-m} - \frac{1}{2} \right) = \frac{(1.6609) 10^{-24}}{(1.6591) 10^{-24}} \\ B = 1.002172$$

from which

$$B^3 = 1.00657$$

are usually omitted since their product

$$(1.006) (.999) = 1.005$$

which is practically unity and very little error is introduced by their omission.

From formula (25) of the previous article

$$S = \frac{T_1^2 h^2 (M+m)}{4\pi^2 M m B^2 E e}$$

From this the distance S between the charges can be computed. Let $T_1 = 1$ then

$$S = \frac{(42.8632)(10^{-54})(1.6609)(10^{-28})}{(4)(9.87)(14.784)(10^{-52})(1.0043)(22.792)(10^{-20})}$$

hence $S = (.53) (10^{-8})$ cms. where $T_1 = 1$ or at the point rotation begins in the fall from infinity.

Fig. 1

Since the mass of the dextron is 1845 times the mass of the levulon,

$$(a) \quad r_d = 1845 r_z$$

(b) $r_d + r_z = (.53) (10^{-8}) = (b-a)$ of previous articles. Solving equations (a) and (b) for r_d and r_z we have

$$r_d = (.000287) (10^{-8}) \\ r = (.5297) (10^{-8})$$

where B is the center of rotation. These radii are inversely as the masses.

Since B is the center around which the levulon at C swings the diameter of the hydrogen atom is

$$D_h = 2 (.5297) (10^{-8}) = (1.0594) (10^{-8}) \text{ cms. this practically } 10^{-8} \text{ cms., as previously stated. The energy of rotation at this point is}$$

$$W_r = \frac{Ee}{2(b-a)} = \frac{(22.792)(10^{-20})}{2(.53)(10^{-8})} = (21.5)(10^{-12})$$

The total energy of fall from infinity

to this point is

$$W_f = \frac{Ee}{b-a} \left(\frac{M+m}{M-m} \right) = \frac{(22.792)(10^{-20})}{(.53)(10^{-8})} \left(\frac{(1.6609)(10^{-24})}{(1.6591)(10^{-24})} \right)$$

$$W_f = (43.05) (10^{-12}) \text{ ergs}$$

and

$$W_f - W_r = (43.05 - 21.5) (10^{-12}) = (21.55) (10^{-12}) \text{ ergs.}$$

This is the quantum radiated by the fall from infinity. Thus in the case of the dextron and levulon these energies are very nearly equal.

At this point the centrifugal force must just balance the electrostatic attraction, so that

$$\frac{Ee}{(b-a)^2} = \frac{M_1 V_1^2}{r_1} = \frac{M_2 V_2^2}{r_2}$$

or

$$\frac{(22.792) 10^{-20}}{(.53)^2 (10^{-8})^2} = \frac{(1.66) (10^{-24}) V_1^2}{(.000287) 10^{-8}}$$

from which $V_1 = (1.19) 10^8$ cms./sec. as the velocity of the dextron in its orbit around the center B. In a similar manner

$$\frac{(22.792) 10^{-20}}{(.53)^2 (10^{-8})^2} = \frac{(9) 10^{-28} V_2^2}{(.52971) 10^{-8}}$$

$V_2 = (2.2) 10^8$ cms./sec. as the velocity of the levulon in its orbit around the center B, Fig. 1.

These velocities are necessary to hold the two charges in their orbits to offset the attractive forces, i.e.,

The attractive force is

$$F_a = \frac{Ee}{(b-a)^2} = \frac{(22.792) 10^{-20}}{(.53)^2 (10^{-8})^2} = \frac{(22.792) 10^{-20}}{(.2809) (10^{-16})}$$

$$F_a = (81.139) 10^{-4} \text{ dynes.}$$

The centrifugal force is

$$F_c = \frac{M_1 V_1^2}{r_1} = \frac{M_2 V_2^2}{r_2}$$

$$F_c = \frac{(1.66) (10^{-24}) (1.19)^2 (10^{-5})^2}{(.000287) 10^{-8}} = \frac{(9) (10^{-28}) (2.2)^2 (10^8)^2}{(.5297) 10^{-8}}$$

or

$$F_c = (81) 10^{-4} \text{ dynes which is practically equal to } F_a \text{ previously computed. If the formulas}$$

$v_1 = 2\pi r_1 f$ and $v_2 = 2\pi r_2 f$ be used to calculate the frequencies of rotation which must be the same for the two charges we have

$$f = \frac{V_1}{2\pi r_1} = \frac{V_2}{2\pi r_2} = \frac{(1.19)10^5}{(2)(3.1416)(.000287)10^{-8}} = \frac{(6.6)10^{15}}{(2)(3.1416)(.5297)10^{-8}}$$

cycles per second. This frequency is twice the frequency before computed from formula (28).

The very remarkable fact here appears that the frequency of the revolution of the levulon and dextron about a common center is twice the frequency of the radiated wave, i.e.,

$$W_1 - W = hf$$

where h is Plank's constant of radiation and f is the frequency of the radiated wave. $W_1 - W_2$ = the energy radiated during the fall from infinity to $T=1$.

$$hf = (3.29) (10^{15}) (6.547) (10^{-27}) = (21.54) (10^{-12})$$

as previously computed. Referring to formula (28) and solving for h^3 we have,

$$h^3 = \frac{2\pi^2 Mm B^3 E^2 e^2}{f (M+m)}$$

It is readily seen that h is a numeric inserted in the formula to make the experimental data agree with the mathematical analysis. Since M, m, B, E, e and f have all been determined by experiment, h is experimentally determined.

For instance, the Rydberg constant $(3.29)10^{15}$ could have been experimentally determined if the radiated energy $W_1 - W$ had been measured and the relation

$$\left[\frac{1}{T_1^2} - \frac{1}{T_2^2} \right]$$

hit upon.

One can see in this case that the constant $(3.29) 10^{15}$ depends upon physical relationships within the atom.

So also Plank's constant of radiation depends upon some unknown physical relationship between the ether and the oscillating charges which is yet to be worked out.

The hydrogen molecule is a combination of two hydrogen atoms, in fact, the hydrogen atom does not exist as a separate thing. Hydrogen gas is made up of molecules of the composition H_2 .

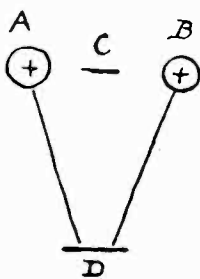

Fig. 2

When two hydrogen atoms come together the dextrans, being heavy, would both be forced to a central position and the levulons might exist in two conditions, only one of which is tenable.

One levulon would bind the two dextrans together, half of the field of A and of B absorbing all the field of C. The other halves being totally absorbed by the levulon D. Mosley's investigations would seem to indicate some such an arrangement.

The gravitational force of two levulons in contact is

$$F_g = \frac{(9)^2(10^{-28})^2(6.66)(10^{-8})}{(2)^2(10^{-13})^2} = (1.36)(10^{-36})$$

which is very minute.

The electrostatic repulsion between two levulons in contact is

$$F_k = \frac{(4.774)^2(10^{-10})^2}{(2)^2(10^{-13})^2} = (5.55)10^6 \text{ dynes}$$

which is very large. Hence the electrostatic repulsion is so great that they could not stay together.

For reasons given later the dextron is assumed to have the same radius as the levulon. Hence two dextrans would have to have a levulon between them in order to stay together. Thus the attraction between two dextrans and one levulon would be enormous.

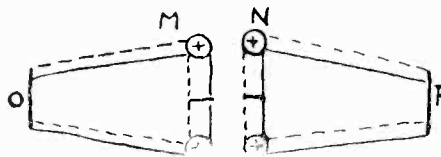

Fig. 3

The diameter of the hydrogen molecule would then be equal to twice the diameter of the atom, the same as given by Millikan on page 211 in his work on the Electron.

Since density equals mass divided by volume, the density of the levulon is

$$D = \frac{M}{V} = \frac{M}{\frac{4}{3}\pi r^3} = \frac{(9)(10^{-28})(3)}{4(3.1416)(2 \times 10^{-13})^3} = \frac{(27)10^{-28}}{(32)(3.1416)(10^{-39})} = (268)(10^{-28})(10^{39})$$

or $D = 2.68 (10^{10})$ grams per cu. cm.

The density of the hydrogen atom is

$$D = \frac{M}{V} = \frac{(1.66)(10^{-24})(3)}{(4)(3.1416)(10^{-8})^3}$$

$(.39)(10^{-24})(10^{24}) = (.39)10^0 = .39$ or $D = .39$ grams per cu. cm., i.e., if the material constituting the hydrogen atom were uniformly distributed throughout a sphere, it would have that density. Of course, we know that the hydrogen atom is not homogeneous, but that it is concentrated into two very dense centers, rotating in a plane.

The physical internal constitution of the dextron and levulon are not known and the phenomena of electrostatic fields and electromagnetic fields would lead us to assume an internal structure.

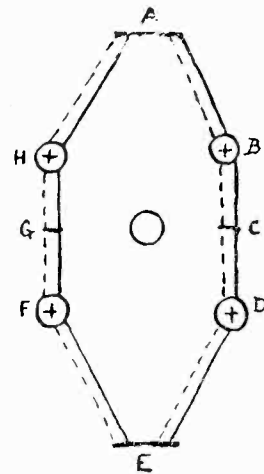

Fig. 4

In order to make an estimation later, the positive and negative charges are assumed to be equal both in mass $(9)10^{-28}$ grams, as in field $(4.774) \cdot 10^{-10}$ unit charges.

It is further assumed that the ether exists in particles and that these charges are an organized motion of the ether particles, one into a right-handed and the other into a left-handed movement.

By virtue of their electrostatic attractions 922 positive and 922 negative charges fall together until they are as close as the ether particles of which they are made will permit. Hence, $922 + 922 = 1844$ charges. Another positive charge falls into the mass along with the others making 923 positive charges and 922 negative charges, leaving one residual positive field. Another negative charge tries to fall in along with the others but finds the space fully packed so that it cannot get in. Then the central mass would consist of 1845 charges. Consider the formula

$$m = \frac{2 e^2}{3 a}$$

which gives the relation between the mass, the charge and the radius. From this

$$a = \frac{2 e^2}{3 m}$$

$e = (1.591)10^{-20}$ electromagnetic units, $m = (1.66)10^{-24}$ grams and there are 1845 charges crowded to the center, hence the radius of the center should be

$$a = \frac{(2)(1.591)^2(10)^{-40}(1845)}{(3)(1.66)(10^{-24})} = \frac{(2)(2.56)(10^{-40})(10)^{24}(1845)}{(3)(1.66)}$$

(Continued on Page 202)

Radio Signal Fading Phenomena

By J. H. DELLINGER and L. E. WHITTEMORE, U. S. Bureau of Standards

The work of Messrs. Dellinger and Whittemore in the field of radio needs no introduction. In this paper, originally published in the Journal of the Washington Academy of Sciences, they discuss natural phenomena as related to radio telegraphy in a highly instructive and entertaining fashion. Moreover, they delve into a new side of radio communication, which is to become vitally important as the scientific research for truth moves forward.

IN actual communication by radio, many difficulties are encountered that would not be expected by one who is familiar only with the rather precise and clear-cut theory of the subject in books. Some of the phenomena in radio-frequency circuits may be represented accurately by ordinary alternating-current theory, the mathematical treatment being even simplified at radio frequencies. However, the phenomena of transmission of radio waves from one place on the earth's surface to another are of quite a different kind, and involve so many variables that they are very difficult of analysis.

The difficulties which are peculiar to the transmission and reception of the waves in actual radio communication may be divided into: (1) "fading" or "swinging" of the received wave intensity; (2) strays; and (3) interference from other radio stations whose signals it is not desired to receive.

"Fading" is the rapid variation of intensity of the signals received from a given transmitting station, all circuit arrangements at the transmitting and receiving stations remaining constant. It is characteristically a night phenomenon.

"Strays" are electrical disturbances giving rise to irregular interfering noises heard in the telephone receivers of a receiving circuit. They are present in some degree at all times, though they are usually worse at night and in the summer time.

Interference from other stations differs from the other phenomena in that it can be eliminated. The means by which this may be done are: (a) frequency selection, (b) selection of wave direction, and (c) guiding the waves along a channel; for example, along a wire. It is interesting to note that the first and last of these means for eliminating interference are also used in sound, while the second, the selection of the direction, cannot be used in sound, since sound waves are longitudinal while the electric waves are transverse. The matter of station interference will not be discussed further in this paper.

In regard to fading and to strays, a considerable literature now exists, much of it being contradictory. The present authors have attempted to coordinate some of the outstanding and

fairly well established facts, and to present recent results. Because of the complexity and uncertainty of many of the phenomena, exceptions can be found to almost all generalizations.

Complexity of the problem.

The following four functions are characteristic of radio reception:

- Intensity of received signals.
- Fading of signals.
- Direction of signals.
- Strays.

In order to determine the facts regarding these functions, from the analysis of which the causes might be determined, research has to be undertaken to determine their behavior with respect to the following variables:

- Frequency of wave,
- Kind of wave (as continuous or damped),
- Distance,
- Time (e.g., day, night, sunrise, sunset, time of year),
- Place (e. g., sea, sea-shore, plain land, mountainous land, rivers),
- Occurrence of eclipse,
- State of solar activity,
- Atmospheric electricity,
- Terrestrial magnetism,
- Miscellaneous (as discontinuities observed in space and in time).

These variables are by no means independent; for instance, the frequency and kind of wave affect differently the phenomena observed at various places and distances. A complete study of the problem would require about 500 separate researches, each of them on a large scale. The completion of some of these researches would cost millions of dollars. The entire mass of data at present available can be considered as completing only a very few of these researches. The known facts about the variation of the four functions with a few of these variables will now be summarized. Following that, a theory will be given interpreting these facts.

Experimental and Observational Data

Intensity of signals in day. (Variation with distance, place, and wave-length.)—The current in a receiving antenna is given by the following expression:

$$I_r \propto \frac{1}{\lambda d} e^{-\alpha d} \frac{1}{\sqrt{\lambda}} \quad (1)$$

where λ is the wave-length, d is the distance from the transmitting station, $e = 2.718 \dots$ and α is a constant

known as the absorption coefficient. Quantitative measurements by L. W. Austin and others have shown that signals transmitted in the daytime follow this law within about 50 per cent particularly for the longer waves (over 1000 meters). Variations in received current are associated with variations of the absorption coefficient α . It is a minimum for transmission over ocean water and varies greatly over land, apparently depending largely upon the nature of the ground over which the waves travel.

It has been observed that city buildings obstruct short waves. There is some evidence that waves tend to follow water, thus traveling greater distances along the coast than inland, and following rivers very readily. The Alps and other mountains are said by Schwartzhaupt to obstruct signals greatly by day, but little by night.

The intensity of signals received from a given transmitting station varies greatly from day to day. Very long waves, such as those from the Lafayette station in France, vary as much from day to day as they do between day and night. Greater distances are covered by stations of a given power when transmission is along the Mississippi Valley than in other directions in the United States.

For small distances, the factor containing the absorption coefficient in equation (1) is very nearly unity. Within these distances (up to 200 miles in many cases), the intensities of signals during day and during night are about the same, over sea-water at any rate, according to Austin. In transmission entirely in mid-ocean, very little fading has been observed.

The absorption factor of equation (1) also approaches unity as the wave-length is increased. Thus for a given distance long waves are absorbed less than short waves and the falling off in intensity with distance is less marked for long than for short waves.

Intensity and fading of signals at night. (Variation with distance, place, wave-length and kind of wave.)—the average signal intensity is much greater at night than by day, and the fluctuation or fading is violent at night, these tendencies being more pronounced the shorter the wave-length. Thus abnormally great distances are obtained at night by stations using short waves, even though the power employed is as

small as one kilowatt. Signals from such stations in the northeastern part of the United States, have been heard across the Atlantic, and off the coast of South America, as well as across the North American continent.

The phenomenon of fading is much better known among amateurs than among commercial radio men because amateurs do most of their radio transmitting and receiving at night and they are limited by law to short wave-lengths. The great fluctuations in the intensity of signals and the extraordinary distances of transmission at night which have been reported by amateurs have not been taken very seriously by professional radio men because there are so many difficulties with radio apparatus that reliable results are hard to get.

What is probably the most comprehensive series ever made of co-operative transmission tests on the phenomenon of fading was conducted through the cooperation of the American Radio Relay League and the Bureau of Standards. Transmission took place from stations at a number of points in the northwest quarter of the United States according to a prearranged schedule, and simultaneous records of received signal intensities were made by about one hundred specially appointed receiving operators. Through the hearty and enthusiastic cooperation of the officers and members of the American Radio Relay League it has been possible to obtain many thousands of these records which would be difficult if not impossible to obtain otherwise without an enormous expenditure. The handling of the records made during these tests as well as many details of the management of the tests have been in the hands of Mr. S. Kruse at the Bureau of Standards. These tests have given an opportunity to confirm in a statistical way what had previously been the impressions received by operators and experimenters in the course of receiving signals for other purposes.

Fading of signals as well as signals of abnormal intensity are obtained only at distances beyond which the absorption has been found to be appreciable. On 200 meter communication, fading is not often found within a distance of 20 miles from the transmitting station, but fading is usually found at a distance of 60 miles or more from the transmitting station.

Three kinds of fading are observed: (1) Fading or swinging having a period of swing of the order of one second or less. This is associated with a given transmitting station. (2) Fading having a period of the order of one minute. This is associated with a region which may be that of either the transmitting or the receiving station. (3) Fading having a period of the order of one hour. This is asso-

ciated with a general direction of transmission or with a group of transmitting stations.

Signals from a given transmitting station may be received with violent fading by some transmitting stations and simultaneously with very small fading by others. Certain transmitting stations are heard very well by many receiving stations in all directions on some evenings, and heard by very few receiving stations or in only one direction on other evenings. A given receiving station usually "hears" certain transmitting stations with great fading and others with little fading.

Transmission wholly over water (both transmitting and receiving stations far from land) shows little if any fading, while a narrow strip of land intervening introduces fading, according to Nichols. Stations near the coast fade worse than inland stations.

For three successive nights, no short-wave signals were heard in Virginia, though signals 800 meters or longer in wave-length came in with usual intensity. The same phenomenon occurred one night a week later in Baltimore and the District of Columbia. Later on, the ninth radio district (the Middle West) suffered a similar blank. During the District of Columbia anomaly the atmospheric conductivity was very abnormal, changing from a very high to a very low value without a corresponding change in the atmospheric potential gradient. At 12:17 a.m. normal conditions abruptly returned, transmission becoming very good.

Signals on long wave-lengths, up to 23,500 meters, show very little variation in intensity. There is little if any difference in the fading from continuous wave and from spark stations on any wave-length.

Strays. (Variation with place and time.)—Strays are more intense in the summer than in the winter, and in the night than during the day. They are more frequent and more severe in the tropics than in temperate latitudes.

At a given locality most strays come from a given direction. For the northeastern part of the United States this direction is south or southwest. Strays are much less common in mid-ocean than near land, both by day and night. The change from day to night conditions is much more abrupt at sea than on land. Stray storms usually accompany convective weather.

On October 5, 1920, severe strays were observed by receiving stations in New England, and no New England short-wave transmitting stations were heard outside of that locality. Transmission elsewhere was excellent.

Direction of signals. (Variation with time, wave-length, distance and kind of wave.)—Changes in the direction of the wave front of waves reaching a receiving station from a given

transmitting station are observed only at long wave-lengths, but are especially marked with continuous waves. They are far more noticeable at night than in the daytime. On 15,000 meters enormous changes in direction are observed at night (as much as 90 degrees within half an hour), while the changes observed during the daytime are very small, seldom exceeding ten degrees. On 1000 meters, direction changes as great as ten degrees are seldom observed.

The readings of direction can seldom be made sharply while changes in direction are occurring. Sometimes when it has been changing very rapidly it becomes impossible to determine on any direction, the direction-finder giving no indication of a minimum signal in any position. The minima observable are less distinct at night than during the day. All direction changes are greater at night than in the daytime.

Direction changes are very small at very short distances from the transmitting station, are great at medium distances and small again at very great distances from the transmitting station. These facts have been observed particularly regarding signals from the New Brunswick, New Jersey, radio station.

Eckersley states the belief that waves are refracted in passing from sea to land and vice versa. Tests of radio compass stations indicate that those stations which receive signals entirely over water have no error.

Effects of sunrise and sunset. (Intensity, fading, strays, and direction. Variation with wave-length.)—Great variations in the intensity of radio signals of all wave-lengths, even up to 15,000 meters, are observed at sunrise and sunset. Such variations are especially noticeable when transmission is in an east and west direction.

Transmission is not as good between stations when the boundary between dark and daylight intervenes as at other times of the day. It has been reported that at sunrise and sunset the shorter waves have the advantage over the longer ones in transmission across the Atlantic.

At sunrise or sunset at the sending or receiving stations the intensity of signals on long wave-lengths becomes abnormally great. On short wave-lengths, at sunrise at the receiving stations, the signals from distant stations merely become steadier for a moment before they suddenly become inaudible.

It is possible that the reported differences in the abilities of inland and coastal stations in the United States to receive transatlantic signals may be the result of differences in their relation to the line of sunrise or sunset.

Effects of time of year. (Intensity and strays).—Signals from distant stations are much louder on winter nights

than on summer nights. Signals become poorer in the spring and it is a question whether this is caused by vegetation, ionization, change in temperature, or other factors.

Strays are much less frequent and normally much less intense, in winter than in summer.

Effect of eclipses.—The occurrence of an eclipse has been found to improve signals, even when they pass only through the penumbra.

Effects of atmospheric electricity, terrestrial magnetism, solar activity. (Intensity.)—In contrast to its effect on wire telegraphy, an aurora has very little effect on radio, except possibly short-wave signals. On an auroral evening none of the usual western stations could be heard at Hartford, Connecticut, but that city did succeed in communicating with Boston, a thing which, curiously, is usually impossible. On the day after an aurora a Chicago station copied signals from a station in Los Angeles.

An aurora is preceded by violent variations in the earth's magnetic field, and usually occurs during periods of great sunspot activity. An aurora would seem to be an extreme case of disturbance at or below the Heaviside surface, producing ionization and also strays.

The conductivity of the atmosphere is somewhat greater at night than during the day. The atmospheric conductivity decreases and the potential gradient increases at the ground level at sunrise and sunset.

Culver reports that when the potential gradient and the conductivity of the air fluctuate greatly, strays are intense. He reports also that the intensity of strays varies inversely as the solar constant and directly as the intensity of the earth's magnetic field.

Over sea the electrical conductivity of the air fluctuates less and is more uniform from day to day than over land.

Discontinuities in space and time (Intensity and strays).—It is found that some stations have great difficulty in establishing communication with other stations quite near them though they have no difficulty in reaching other stations much farther away. Stations in the neighborhood of Boston, Massachusetts, furnish examples of this. It has also been found impossible to transmit over 70 miles east from Hartford, Connecticut.

Silent zones, where signals cannot be heard from certain stations, are frequently found at sea, the most noted ones being along the coast or between two bodies of land.

Inland stations have been found to get copy when coastal stations cannot. This may possibly be a sunset phenomenon or the result of the location of the stations with respect to sources of strays.

Stations less than a mile apart may differ radically in the intensity of strays observed and in the intensity of signals received from a given transmitting station.

Meteorological effects. (Intensity, fading, strays).—A good radio night, that is, one when the signals are loud and the strays are weak, is usually cloudy or is preceded by a cloudy day. Fading, however, is not affected by clouds. Transmission is usually good during and immediately after a rain storm.

While correlations between meteorological and radio conditions have been sought repeatedly, little proof of such correlations has been found.

Indirectly, meteorological conditions such as temperature, convection, etc.,

Discussion and Explanation.

The complexity of the phenomena suggests that the causes are complex, so that no one explanation will fit all the observations. However, many of the more clearly established facts lend themselves very well to the explanation of the transmission of radio waves proposed below.

Daytime transmission.—The waves that travel along the earth's surface (roughly, the sliding waves), and not the waves in the upper atmosphere, are those which are utilized in the daytime. This is indicated by the formula given in equation (1) in which the absorption coefficient, α , varies with the character of the surface over which transmission takes place. It is a minimum for sea water, and is greatly

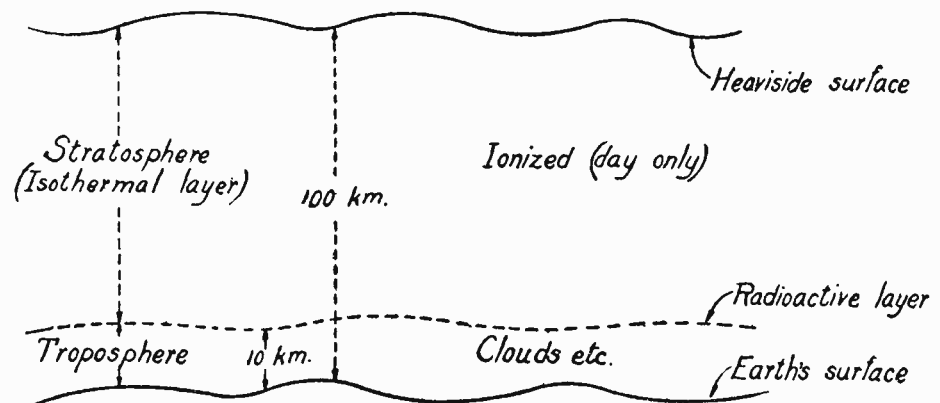

FIG. 1—VERTICAL CROSS-SECTION OF THE EARTH'S ATMOSPHERE.

at the earth's surface may somewhat affect the regularity of the boundary surface of the Heaviside or aurora layer, and may thus cause night strays and the disappearance of signals. Thus the difference in temperature between land and sea may cause an effect extending far up into the air.

The effect of weather conditions on the insulation of an antenna and the resistance of the ground are principally important in day transmission. The effect of weather conditions on ionization and on the boundaries of the ionized regions in the upper atmosphere are more prominent at night.

During the October, 1920, fading tests conducted by the American Radio Relay League and the Bureau of Standards, it was observed that fading was small, signals were good, and strays were weak when it was raining at the receiving station. (Cases of little fading, 17; medium fading, 18; severe fading, 9. Signals were weak 4, moderately loud 31, and very loud 7 times. Weak strays 24, medium strays 13, and loud strays 6 times.)

Clouds at the receiving station are conducive to good signals. (Weak signals 9, moderately loud 75, and very loud 17 times.)

It is possible that clouds blanket the upper air from the disturbances of temperature and other effects on the earth's surface.

dependent on land characteristics.

For short distances, short waves give the loudest signals, the absorption being negligible. For long distances, during the day time when formula (1) holds true, long-wave signalling is more efficient, for the absorption factor predominates and limits the transmission for short wave lengths.

During the day the waves which get up into the atmosphere can be considered as entirely absorbed by the upper ionized regions, known as the stratosphere. Thus the intensity of the transmitted waves depends on the ground conditions. This is borne out by the fact that day transmission over sea varies very little with time. This is to be expected, because the sea exhibits entire uniformity in its effect on waves passing over it, thus tending to confirm the idea that ground conditions determine wave intensity in the daytime.

The idea that waves are retarded by ionization is a very old one. Elihu Thomson and Fessenden, however, first localized the ionization on the ground, but it has since been assumed to have its seat at higher and higher levels. The ionization of the air, which is not nearly large enough near the ground to produce any effect, becomes larger as the distance from the earth increases.

The extreme ultraviolet rays of the

Split Variometer and Capacity Feed Back

By T. E. NIKIRK

We don't want to cause any split in the ranks of radio, but inasmuch as there is one, in some variometers at least, we feel no wiggles of conscience in exposing the fact to the vulgar gaze and, in fact, discussing it frankly. Capacity feed back has likewise lain hidden behind the parlor sofa long enough—so we have "drug him forth" for the edification of our multiferous admirers.

THE circuit which I am about to discuss is called, I believe, the Weagent. It has a number of advantages over most of the regenerative circuits, the main ones being the inductive and capacity feed backs which are different than in most types of receivers. The inductive back feed is accomplished by splitting the plate variometer, inserting half of the winding in the plate circuit and the other half in the filament circuit. The diagram shows this plainly. The capacity feed back is through the variable condenser which is shunted from the grid variometer to the plate. This condenser carries the full voltage of the B battery, so it is very essential that this condenser be of good quality and that the plates do not touch each other. A double spaced condenser such as that used for small vacuum tube transmitters has a very wide spacing between plates, assuring safety from shorting the B batteries through the head set.

There is another way in which this circuit may be hooked up, i. e., by reversing the positions of the B batteries and the plate winding of the plate variometer, but this prohibits the use of an amplifier, as the A and B batteries are connected through the plate half of the variometer.

The antenna condenser used is of the 43 plate type having a capacity of .001 MF. The stator of the variocoupler is used for the antenna winding. It has seven taps at every ten turns. No. 22 DCC wire is used. The rotor or the secondary has 36 turns, giving each half of the rotor 18 turns. In order to fill the rotor form full No. 18 DCC wire was used but any wire larger than No. 24 will serve. A piece of 3½ in. tubing is used for the stator and a regular 3 inch turned ball for rotor. The grid variometer is made of 3½ in. tubing for stator and 3 in. for the rotor, the same size being used on the plate variometer.

The windings on the variometer for the grid have 24 turns on each, giving 12 turns on each side of the support used to hold the stator and rotor. No. 22 wire was used.

The plate variometer requires two sizes of wire, No. 22 on the rotor with 24 turns and No. 24 on stator with 40 turns.

The rotors are 1¼ in. wide and it

may be necessary to trim a little off of the edge to insure free turning of the rotors, as one cannot very well trim anything off the stator.

The use of a vernier condenser in parallel with the feed back condenser helps wonderfully when weak and distant stations are being tuned in. Most of the tuning, in this set, is accomplished by the grid variometer and the feed back condenser. For the amateur and lower broadcast waves the feed back condenser can be kept at zero, the tuning being done with the

land, and between the United States and Caltano, Italy has just been established according to an announcement made by the Radio Corporation of America. The opening of these services raises the total number of direct radio circuits radiating to European countries from New York City from six to eight circuits and affects not only Holland and Italy but provides more direct routes between the adjoining countries and the United States. The addition of these new circuits to the already existing channels

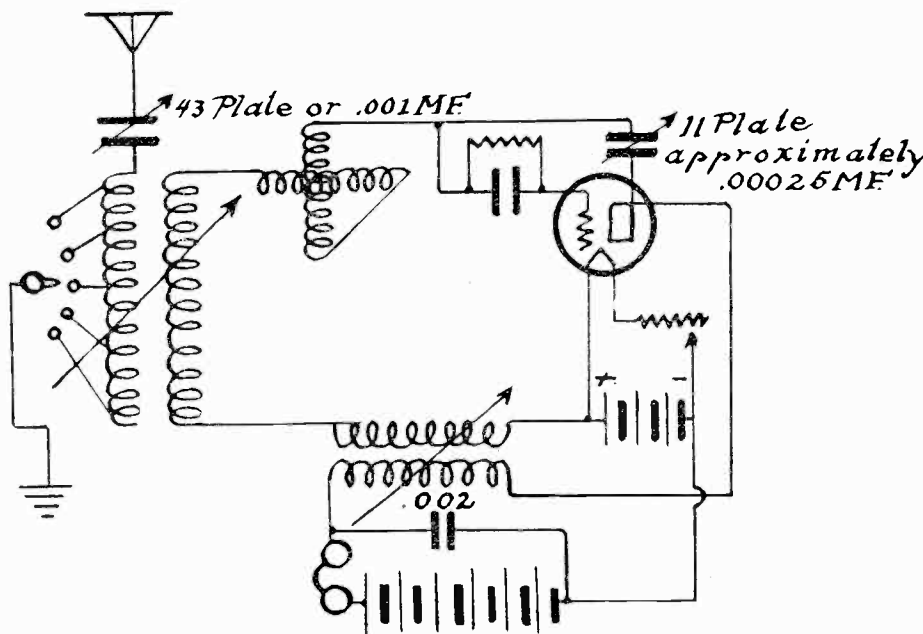

grid variometer and the antenna condenser. When higher waves are desired the feed back condenser can be used.

In tuning this set it was found to be at its best when the rotor and the stator of the variocoupler were at nearly right angles, thus cutting out much interference and a great portion of the static, when it was bad as it has been at times this past summer. It often takes quite a while to get onto the hang of working this set, but when you have found the ins and outs of it you will find it a very pleasing type of receiver to operate.

Trans-Atlantic Service

For the first time in the history of international communications, direct radio telegraphic service between the United States and the Hague, Hol-

of radio communication to many parts of the world materially advances the status of plans which are now being worked out by the Radio Corporation to make the United States the centre of a world-wide radio communication network. Because of the centralized location of the United States, with Europe to the east, South America to the South and the Orient to the West, this country enjoys a natural advantage which helps to make it possible to link the principal nations of the world by radio around New York as the pivotal centre. This plan is rapidly nearing completion, there being at present eight connections across the Atlantic and one bridging the Pacific.

"Just read your magazine and must say it is fine business. A brass pounder, Pittsburgh, Pa."

Transformer and Condenser Polarity

By FREDERICK T. SWIFT, Jr.

HERE are three ideas which I have had stored away in the back of my head for some time.

I possess a single circuit regenerative set and later, due to interference I wanted a three circuit set. This is how I did it, see Fig. 1. I took

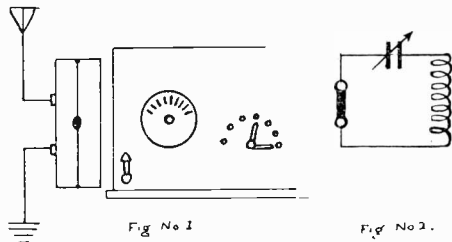

a variometer and placed it next to the tuner. I then disconnected the aerial and ground leads from the set and put them on the variometer. As the tuning condenser was in series with the aerial, I shorted the antenna and ground posts which put the condenser in shunt, see Fig. 2.

Although the coupling between the variometer and the coil in the set was 9 in. it worked very well, although signals were not quite as loud.

As I had an extra bulb, socket, rheostat, etc., but no amp. transformer I started to use the old Ford coil. Instead of taking it all apart and trying to make an audio transformer out of it I used it the way it was. This is the hookup which is self-explanatory, see Fig. 3.

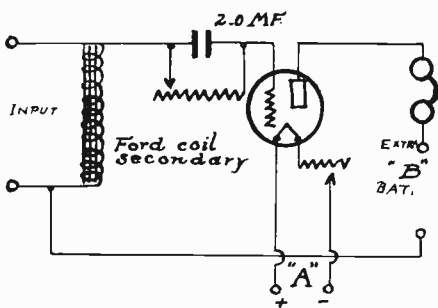

FIGURE NO. 3

A variable grid-leak is used, of the pencil-mark type, and it is very critical, the way I mounted my amplifier it looks something like Fig. 4. When this is wired up it makes a very handy instrument which works fully as well as the regular audio frequency amplifier.

Binding posts may be soldered to the secondary terminals for in-put leads, which makes it easier to hook up. It may be mounted on a panel if desired.

The third idea is for use for wherever it happens to fit. It is a known fact that a condenser reverses polarity,

as in Fig. 5, in which A is insulated from B and yet the polarity is not reversed. To simplify this it was done as in Fig. 6, which is really the same thing, only with the lead connecting the two condensers shortened. If this center plate were mounted to move in and out between the outside plates the effect would be something like Fig. 7, and the polarity could be varied at will.

This condenser, which I describe, was used in the grid circuit of the detector tube and no potentiometer was needed to vary the grid potential. Its construction is shown in Fig. 8. The middle plate slides in and out in a groove between the outside plates, the top and bottom were made of 3/4 in. hard rubber, but wood works very well.

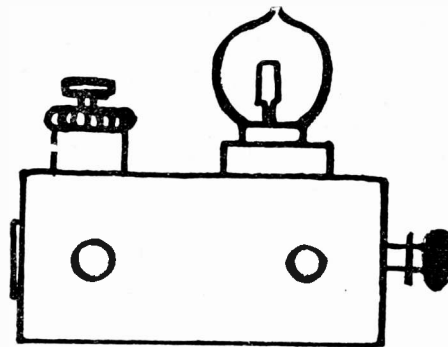

FIGURE NO. 4

What these ideas are worth I do not know, but I am sending them in to help someone else.

Way Down East

After spending nearly a million dollars to build a magnificent mansion on the ancestral lands of "the Pilgrim Fathers," Col. Edward H. R. Green, the multi-millionaire son of Hetty Green, South Dartmouth, Mass., looked around for "new worlds to conquer" and hit upon radio, not as a mere pastime, but an absorbing study. An aerial 100 feet high stands out against the sky-line and neighbors for miles around listen nightly to his station, "The Voice from Way Down East." This is one of a series of hobbies which began for the colonel as a boy when he started a chicken farm in Texas and ran the whole gamut from mules to fishing and politics to baseball. He introduced the first automobile and the first airplane in that state and topped off his career there when he purchased the world's largest private yacht. Few of his friends realize, however, that Col. Green was interested in radio before he came to Massachusetts. He was an amateur in Texas, when radio was young, and

began his experiments about the time that he became a member of the American Radio Relay League. He has since maintained active concern in the welfare of amateur radio.

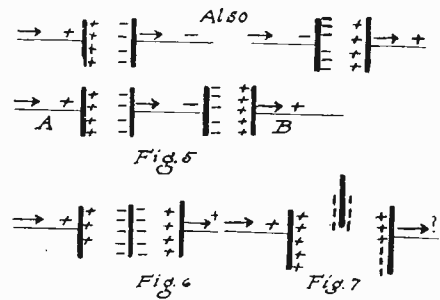

Amateurs and Navy

Radio amateurs of Springfield, Mass., are giving their services voluntarily in the first naval district by relaying official messages, requiring prompt attention, between the reserve division there and the brigade headquarters at Boston. Commander J. T. Nelson, in a recent letter addressed to Ensign H. F. Johnson, of Springfield, commended this work in these terms: "The work of your division in training men for radio operators is greatly appreciated and your division is the only unit where training of this nature is being carried on. It is the brigade commander's wish that you continue this work and expand this department if it can be done without detracting from the general training of your division."

Radio station WHA, of the University of Wisconsin, will be closed until Oct. 1, when services will be resumed under the direction of Prof. E. M. Terry, and Robert Ray, chief operator for the coming school year. During the regular school year, daily programs, with the exception of Sunday, have been given, and during the summer session tri-weekly evening programs were broadcasted.

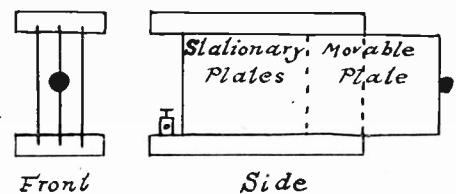

Figure No. 8

A flock of swallows recently roosted on the antenna of WCAP during broadcasting and the wave-length jumped from 469 to 479 meters. Engineers of the plant almost went insane trying to locate the trouble until one chanced to take a look at the bird roost. He said "shoo!", flapped his arms a couple of times, and as the birds departed the wave-length returned to normal.

Telepathic Experiments with Radio Mind

By F. H. DU VERNET, Archbishop of Caledonia

Bishop Du Vernet, some months ago, wrote a comprehensive article on "Radio Mind" for readers of this magazine. It created tremendous interest throughout the scientific world and Rev. Du Vernet here presents further instructions for those interested in conducting actual experimental work. His theory is that thought can be and is radiated very much as a radio message, the only thing lacking being a tuned receiver. His experiments, purely scientific, have aroused real interest on the part of scientists, hitherto given to considering thought transference as merely a form of "hokum."

SO many inquiries regarding my telepathic experiments are coming to me from different parts of Canada and the United States and there is so much misunderstanding in regard to details not mentioned in my former article in the June issue of the Radio Journal that, at the risk of some repetition, I wish to give to each experimenter the following definite instructions:—Take an ordinary pencil about eight inches long, and a bright latch-key weighing a quarter of a dollar. Tie a string to one end of the pencil. Allow eight inches of string and tie to the key. The bright metal helps to attract the eye and the weight of the key helps to keep the string taut and aid the swinging. There is no other virtue in it than this. The index card which I use is a little less than a semi-circle with a radius of six inches. The letters of the alphabet are arranged phonetically so as to economize space, on the circumference of this chart, as follows from left to right:—A, (BP), (DT), (EI), (FV), (KCGJQ), "Start and Stop," L, M, N, O, R, (SXZ), (UYW), making in all fifteen spokes to the fragment of the wheel. There is no merit in this arrangement except that it simplifies by similarity of sound. Begin by practicing alone. Place the card on a table. Stand erect without leaning on anything. Take the free end of the pencil and hold it between the thumb and finger of the right hand, with elbow clear from the side so as to allow the muscles fair play. Let the metal bob oscillate freely about half an inch over the hub or centre of the index card. Always begin and end on the "Start and Stop" spoke of the wheel which comes directly in front of you as you face the card. Concentrate your eye and mind on the key and think hard the movement "To and fro." Almost instantly the muscles of your body will respond to the thought of your mind and cause the pendulum to swing to and fro on the "Start" index. Next try spelling out a short word, letter by letter, timing the concentration of your thought to correspond with the rhythmic swing of the pendulum. For example, say mentally "Swing to H"

repeating this six times, then shift to "Swing to A," then to "Swing to T," and you have spelled "Hat." With practice you can go rapidly from letter to letter and even dispense with spelling but be content to go slowly at first. The next step is to get your co-operating friend to practise by himself in the same way. Both now being convinced that a thought in the mind can express itself through nerve force and muscular reaction you and your friend are ready for an experiment in thought transference. Let your friend as he stands beside you choose a word and spell it out beginning on the "Start" and ending on the "Stop," while you hold the pendulum. Before he begins to concentrate his mind energy you must have the pendulum swinging to and fro on the "Start" fully under the control of your own mind energy. You then throw yourself into a receptive attitude of mind as you sympathetically visualize your friend. While you must keep your eyes on the pendulum and the card you must not consciously allow your mind to think of any letter, otherwise you will prejudice the swing of the pendulum. Dimly you will see the word spelled out and the pendulum come back to the "Stop." After you have gained confidence and have learned the secret of visualizing each other you can increase the intervening distance until you realize that mind energy annihilates space. My daughter and I began side by side, then went to opposite ends of the room, then one upstairs and the other down. Then with fear and trembling I went out into the street as though material walls could intercept mind energy. Then a quarter of a mile away, a mile, three miles, seven, a hundred, five hundred, etc. No difference could be detected unless there was distraction of thought. It is well to arrange coincidence in time, although the subconscious mind can respond to the memory of a message sent some hours before. Do not spend more than two minutes at a stretch on any experiment, as the mind soon grows weary with concentrated thought.

Remember I want you to learn the scientific fact of thought transference, not that you may commercialize my system, but that you may without any

mechanical contrivance keep radiating helpful and healing thoughts. Think what this world might become if we all, by radio-mind, broadcasted peace and goodwill.

Summer Radio

Editor, Radio Journal:—You invite vacation pictures. Here's one taken in the Pocono Mountains, Pennsylvania. We were able to hear Kansas City Night Hawks and Detroit, Chicago,



THIS IS DR. ROACH AND FAMILY ENJOYING RADIO AWAY UP IN THE POCONO MOUNTAINS OF PENNSYLVANIA.

Pittsburgh, New York, Philadelphia and Schenectady. Back in the woods at night with no light but the stars overhead and your UV200's burning you can tell the world an orchestra sounds fine—and spooky. Sincerely,—DR. W. W. ROACH, 2905 Columbus ave., Phila.

New Station WRC

A giant broadcasting station "WRC" located at the New Riggs Bank Building at 14th Street and Park Road, Washington, D. C., began a regular broadcasting service August 1. Located in the Mount Pleasant District one of the highest points in the city where the antenna wires are suspended 150 feet above the street level, the waves radiating from the station have an unobstructed path in all directions. With the antenna system energized by powerful 500 watt transmitting set, radio reception from the station in Delaware, Maryland, Virginia, West Virginia, Eastern Pennsylvania and Southern New Jersey is particularly good.

How Remote Control Works

The accompanying sketch, from WJY and WJZ, indicates how remote control and broadcasting are accomplished. It must be remembered that the actual power of the singer's voice is astonishingly small. It is said that it would take thirty million cornetists blowing their hardest to produce just one horse-power of sound! The prospect is not an altogether attractive one. Actually, when the singer is carrying an average melody, the high quality telephone transmitter into which she

mitter thus supplies enough power to feed about five hundred million receiving sets, or more than there are likely to be in the whole world for some little time to come.

The radiotrons in the receiving set now take the enfeebled incoming power and strengthen or amplify it possibly one hundred thousand times until there is available about one one-hundredth of a watt for the loud speaker, which again fills the air with the original melody sung at the studio.

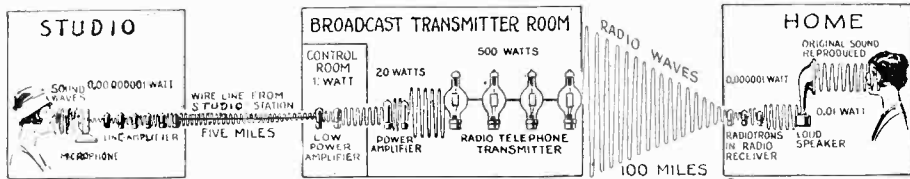

sings is delivering only one one-hundred-millionth of a watt! And one horse-power is just short of 750 watts. So that the first thing to be done is to increase the power of the electrical currents which carry the delicate inflections of the voice to some reasonable value, such as one-tenth of watt. This is done at the studio or theater by means of what is known as a line amplifier which increases the power of the currents literally millions of times.

The task of broadcasting has only begun, however, at the studio. It is then necessary to carry the telephone currents over a wire line to the broadcasting station, sometimes over miles of wire. In the control room of the broadcasting station, the first or low-power amplifier increases the power to about one watt. The second or higher power amplifier increases the power to about 20 watts, thus preparing the voice currents to control the actual radio telephone transmitter, with its power of 500 watts. From the transmitter, the waves are flung with a power of 500 watts into the air, but they lose power continuously in their long flight to the receiving station, ending with a power in the antenna or aerial of the receiving set that may be about one millionth of a watt. It is of interest to reflect, in this connection, that a single 500-watt trans-

He Builds a Neutrodyne

Here is a Neutrodyne built by J. C. Lenihan, 219 N. Avon Street, St. Paul, Minn., from circuit No. 10 in Arthur L. Munzig's article appearing in the August issue of Radio Journal. Mr. Lenihan added a 200 ohm Potentiometer across the A battery. Here is what Mr. Lenihan has to say about his set, in a letter to Radio Journal:

"The advantage of Neutrodyne

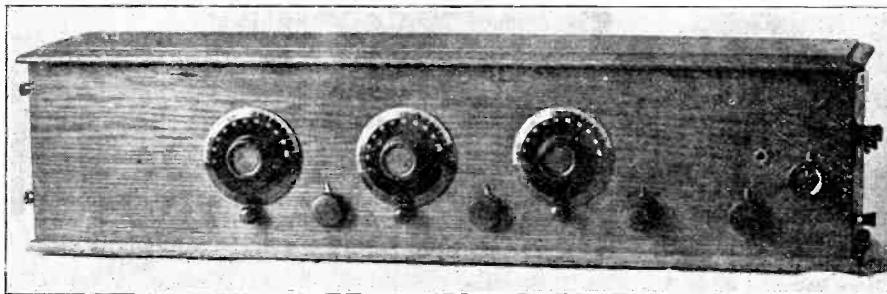

THIS IS THE COMPLETED SET BUILT BY J. C. LENIHAN, OF ST. PAUL, MINN., UPON SPECIFICATIONS BY ARTHUR L. MUNZIG, APPEARING IN THE AUGUST ISSUE OF RADIO JOURNAL.

circuit is its selectivity; it being possible to tune out any local broadcasting station located within a few blocks of the Radio set. By tuning out the station it is completely lost and cannot possibly be heard on this set, except at the one given place on the dials for this station.

"When a distant broadcasting station is heard for the first time, the

numbers on the dials one, two and three can be recorded and then this station will be at all times on the number recorded for this station; this being a great advantage when a program selected from a certain station is desired.

"The Neutrodyne circuit does improve the quality of reception twenty-five per cent, which is very noticeable. The circuit is capable of reaching long distance and raising the signal strength so that a loud speaker may be used at all times on all the distant stations. Another of the many advantages of the Neutrodyne circuit is that it eliminates distorting regeneration and local re-radiation.

"There is no doubt but that the Neutrodyne circuit will be the popular circuit in use this season. The owner of the above set listens to from five to ten long distant concerts each evening without any interference from the local broadcasting stations."

U. S. Vice-Consul Phelan, in the Canary Islands, reports active discussion in the Cabildo Insular de Tenerife of a proposal to establish in the near future wireless telephone stations at the various islands of the archipelago. The present cable service between the islands has been very inefficient and this condition has given rise to the suggestion of using wireless telephony.

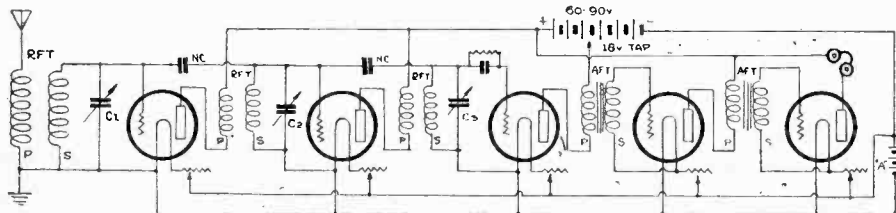

THIS IS THE HOOKUP EMPLOYED BY MR. LENIHAN, FIGURE 10 IN THE AUGUST ISSUE OF RADIO JOURNAL. MR. LENIHAN ADDED A 200 OHM POTENTIOMETER ACROSS THE "A" BATTERY. THE ORIGINAL HOOKUP APPEARED IN A COMPREHENSIVE ARTICLE BY MR. MUNZIG ON THE NEUTRODYNE.

The question of property rights in news items broadcast by radio now is up before the courts of Holland. One Dutch news agency has sued a second agency for intercepting and sending to its newspaper members news sent by radio by a third agency in Berlin, for the exclusive use of the first agency. Each of the press messages bore an indication of copyright in Holland by the addressee.

The Radio Division of the Department of Commerce plans to ask for at least \$100,000 more than is now appropriated for the maintenance of that Division when the next session of Congress is under way. The Division is today operating on funds but little above those available three and four years ago when broadcasting, as we know it today, was non-existent.

Radio Functions in Strange Ways

By CARR A. WAYSEED

When we get to thinking over the possibilities of the radio field in talking movies, movies by radio, mush and milk by wireless and what not, our imagination gets blind staggers. Sometimes we think ourselves to the point where one more think would make us go flooey. But we don't. We take a firm grip on our chair and turn to last month's bills or something else of a light and frivolous character and our reason is saved.

RADIO is functioning in some mighty strange ways these days. In fact, there is a vast multiplicity of counts wherein radio is serving different ends, and in fundamentally different ways.

In the case of the photophone, for example, if the octophone were used in radio broadcasting, and seven were set up in broadcast studios, the distortion attributed to receiving sets nowadays would be found to be located in the studios instead of the homes. The octophone, according to Delmar A. Whitson, would provide better broadcasting than we have today. In addition to the fact that it does not use granulated carbon, its most outstanding feature is that of its sympathetic note. It also employs an ionic converter, and ionic transmitter.

As light has been found to be so closely allied to radio in wave form (polarized light has established the connection with radio waves) by C. Francis Jenkins and Delmar A. Whitson, we discover one place where radio is solving and serving the purpose of transmitting radio sight or radio seeing, as well as the recording of sound by polarized light, which in turn is translated into radio waves, all in terms of wave forms.

Polarized light has been the connecting link between radio waves and light waves. As polarized light, that state of light identifies itself with electric magnetic phenomena. Faraday discovered the magnetic quality of light. What polarized light may mean to radio is still to be established.

Polarizing of radio waves proves again the alliance between light and radio. There is room for more work along the line of polarized radio waves.

Rosing employed the principle. Langmuir used it for photometric purposes. Whitson's work is on file in the patent office. Langmuir, under one patent, uses the photo-electric cell in a radio circuit and for photometric purposes, the only two patents on file in the patent office. Whitson took it into the photophone art, employing it in photographs.

Very little research work has been

done along this line. Undoubtedly the transmission of color, as well as of the image itself, will be possible through polarized light. Breaking up sound waves into color by polarization and using panchrometer film gives greater possibilities for recording sound in all of its true color, making the term color as applied to sound physical, as well as metaphorical.

In the realm of reproducing sound the same singular and distinct parallel of behavior of polarized light and photo-electric effects has meant the continuance of this applied phenomena, as witness C. Francis Jenkins and Delmar A. Whitson, in seeing by radio as well as in reproducing photographed sound.

Whitson's photo-active alkali has succeeded in overcoming all the inherent drawbacks found in the old photo-electric element known as selenium without decreasing the value of the element. Selenium is still an inefficient element in the solution of these super-radio problems.

As the sensitivity of the properly constructed photo-electric cell, utilizing the photo-active alkalis, will determine the nature of a star, whether it is twin or single, and, being abso-

lutely inertia-less, i.e., its response to any light impulse is represented by a lag of a hundred-thousandth part of a second, it approaches the absolute speed of light in its response to light reactions and consequently represents one of the most advanced applications of physical science to the radio field or to the accomplishment of the multifarious radio solutions which will undoubtedly account for, in time to come, the wonders spoken of as rather futuristic, to date, in our scientific novels.

The electric light, coming out of the light globe, varies in strength according to the amount of current flowing into it, whereas this cell reverses the procedure, permitting a current to flow through it according to the light flowing into it.

These effects, however, are not proportional, though analogous. Almost everything has its reverse or converse. The circuits now used for transmitting radio can also be used for receiving. The loud speaker makes an excellent transmitter. Light shining from the sun can be captured by polarized light. Who knows if, by rotating this light, cutting lines of force will not produce an immense quantity of current.



—Photo Courtesy Q.S.T.

THIS, FOLKS, IS 9AUL. COPIED IN BOTH AUSTRALIA AND NEW ZEALAND. LYNN C. SYMEBY, PROPRIETOR, IS THE GENT WITH THE EAR MUFFS. MR. SIMEBY IS PARTNER WITH D. C. WALLACE, 9ZT, IN THE ETHER BUSTING BUSINESS IN MINNEAPOLIS.

Million More Receivers

Figures compiled as a result of a recent canvass of all broadcast stations of the country for a close estimate of the number of receiving sets in operation in their immediate territory places the total of broadcast receivers in operation in the United States at close to three million. If this figure is correct, and we believe it shoots under the mark, if anything, another million should be added within the next twelve-month. Think of this, Mr. Commercial Radio Man! A million new sets a possibility, to say nothing of replacements and additions in homes already having equipment. The growth from a few thousand to three million has taken place within less than two years, and there are millions of homes, even in the cities, where radio, as yet, has not been suggested, to say nothing of any serious effort to sell. And in the small towns it is just beginning. The agricultural field is practically untouched. Yet the advance army is moving ever forward. A casual glance at the radio magazine on a newsstand or in the home of a friend, a conversation with a friend already interested, an experience at listening-in at the home of a neighbor, these and a thousand other agencies are spreading the lure of the voice of the air until soon, very soon, radio will be everywhere. And for the real Radio Man with a real service to offer, the field is tremendous, the harvest time assured.

Doc Radio Again

Angus Buchanan, an explorer for the British Museum, was badly hurt by a fall while out on the Sahara desert, 150 miles from the nearest settlement. Servants carried him miles to a small French military post which was equipped with radio. Medical advice from a distant city was obtained by radio and within a few days the explorer was able to sit up and soon

resumed his work. This is another version of the well known sea medical service offered by radio.

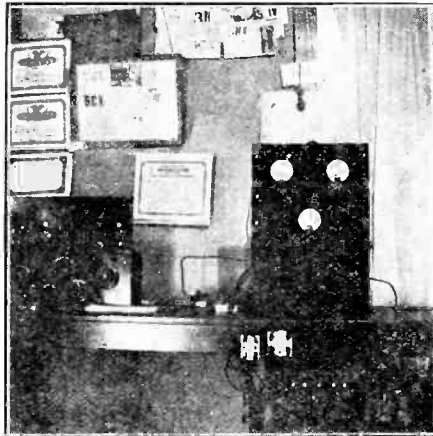

THIS IS 9ARZ. DON E. WATTS, ASST. DIVISION MANAGER OF IOWA. BEST DX SO FAR 4,000 MILES, USING 50 WATTS CW. BEST WORKING DX IS 2,400 MILES. EMPLOYS 1DH CIRCUIT, CHEMICAL RECTIFIER. RADIATES 4 TC AMPS, 5-WATT CW UNIT RADIATES 1.8 AMPS. REINARTZ RECEIVER AND 2 STEPS OF AMPLIFICATION. 50X50 L TYPE AERIAL. TEN WIRE FOR FAN COUNTERPOISE.

A party of ten explorers from the Geological Survey left Lees Ferry in Northern Arizona on August 1 for a three-hundred mile trip down the Colorado river to the mouth of the Virginia river at Rioville, Nev. Complete radio receiving equipment was taken along. It consisted of a special set re-constructed by R. L. Atkinson of the survey, two stages of amplification being employed. The outfit, including batteries, was packed in a water-proof wooden box lined with sponge rubber to prevent jarring. An antenna on a reel was quickly rigged at camp.

The United States Navy department is placing at the disposal of scientists studying radio and sound an entire floor of a newly completed laboratory costing \$1,500,000 at Bellevue, District of Columbia. This is the most pretentious laboratory for radio study yet established.

The U.S.S. "Pittsburgh" operating in the Mediterranean Sea, states in an official report that the Radio Station at Poitiers, France, was communicated with on 3,350 meters CW, using a 20 KW arc with 45 to 50 amperes radiation. The greatest distance traversed by the radio dispatches was approximately 1,800 miles, while the "Pittsburgh" was at Alexandria, Egypt. Poitiers reported that all signals were good in the evening, being heard through heavy static interference.

Commander R. R. Mann, U. S. N., has relieved Commander J. J. London as superintendent of Atlantic Coast Naval Communications. He is in charge of both radio and land line circuits.

Radio aids to navigation are essential. Their lack is often serious to the navigator. This is the conclusion arrived at by many officials as a result of the recent wreck of seven destroyers and the steamer Cuba off Point Arguello, Calif. A radio compass is located at Pt. Arguello lighthouse and another further down the coast at Pt. Hueneme. The Pt. Arguello station was within reach of the navigators but the other was not and two are needed for correct bearings.

A radio compass station gives the ship its compass bearings from the station in question. They are operated by the navy department. If a ship can get such bearings from two stations it can accurately determine its position. Radio beacons, on the other hand, are operated by the Lighthouse service and operate on much the same principle. The beacons send out radio signals in all directions. Ships equipped with "radio direction finders" pick up the signals and get the bearings of the sending station. By getting two such stations a ship can also work out its bearings. The Pacific coast has only two radio beacons, one on a lightship off San Francisco and the other off the Columbia river mouth, while radio compass stations are more numerous there are none between San Francisco and Pt. Arguello, where the crash occurred.

We want all of our readers to feel like this:

Editor Radio Journal.—Just received my issue of the August Radio Journal and I simply had to write this letter to let you know how much I liked it. Congratulations! Radio Journal is getting better and better each issue.

The Australian tests were certainly a great success, thanks to Radio Journal and Mr. Robert J. Portis of Long Beach. The next tests should be even greater. I am sure they will be. Best wishes for continued success of Radio Journal. Sincerely, Lester Picker, 6ZH.

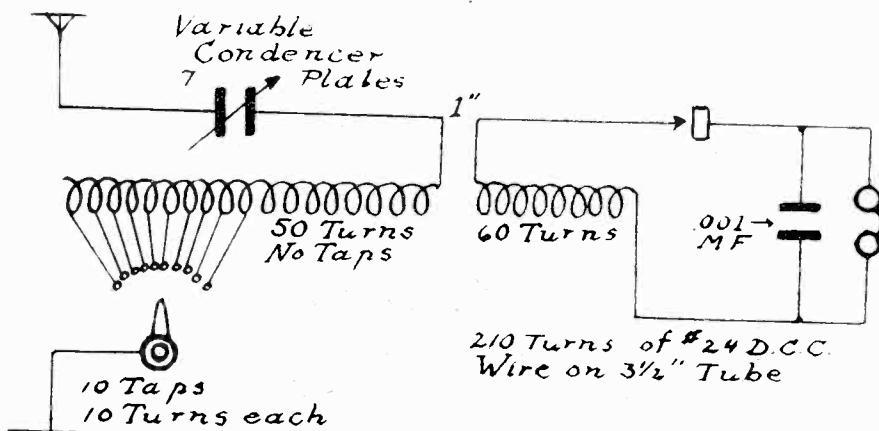

HERE'S ANOTHER LOUD AND SELECTIVE CRYSTAL DETECTOR CIRCUIT NOT ENTERED IN RADIO JOURNAL'S CONTEST, BUT SUBMITTED BY WALT. HUBER, 734 SOUTH OLIVE STREET, LOS ANGELES, CALIF. IT HAS SOME FEATURES WHICH SHOULD RECOMMEND IT TO CRYSTAL FANS.

Amateurs' Department,

Coast Convention

The Third Annual Radio convention will be held at the German House, Turk and Polk streets, San Francisco, from October 11 to 13, inclusive, together with a radio show, at the same time. The actual convention will be held on the afternoon and evening of October 13. The convention will be held under the auspices of the San Francisco Radio club, the secretary of which, H. A. Tattanham, 316 Richland Ave. (6AUU), San Francisco, will handle all correspondence.

The object of the convention will be a get-together meeting of all Pacific Coast amateurs, both from the Sixth and Seventh Districts. The old Pacific Plan, which expires on October 31, 1923, will be discussed and re-arranged, so as to conform to the new regulations governing amateur operation. A Sixth district executive council will be discussed, and it is hoped, organized in a manner that will be satisfactory to all concerned, which will bind the Sixth district amateurs together more strongly than before.

All amateurs and others interested are invited to attend, and all radio clubs which are regularly organized will be asked to send delegates, with proper official credentials for identification. For the benefit of those clubs that do not receive further notification, it is hoped that this will serve as proper notice, although it is hoped all clubs will be advised separately.

Conditions Better

Recent radio regulations are helping to bring harmony into the ether, where formerly chaos reigned, and this winter will see, doubtless, a vast improvement in receiving conditions, officers of the American Radio Relay League believe. This view is based on reports from all of the League's operating department subdivisions, which indicate that the "quiet hours" between 8 and 10:30 P. M. advocated by the Department of Commerce are being observed faithfully.

It should be noted particularly that the department specifies local standard time for amateurs, which means that, if the local community has adopted daylight saving time, the quiet period to be observed is between 9 and 11:30 o'clock. A letter from the Bureau of Navigation comments in part as follows:

"The bureau expects the amateurs to conscientiously adhere to these regulations—and when complaints are received from broadcast listeners that they are experiencing interference from code stations, which they believe to be amateurs, they will be required to furnish the name and address or the radio call letters of the station causing the disturbance.

"Where complaint is made that amateurs are causing interference after 10:30 p.m., local standard time, the parties making such complaints will be informed that the amateurs are required to observe a silent period of two and one-half hours each day to permit uninterrupted reception of the broadcast service, so far as the amateurs are concerned, and that as the amateurs are rapidly replacing their spark sets with tube transmitters and many of them using CW.,

it is believed that they are contributing their share in the matter of giving relief from interference.

Tried Munzig Hookup

Here is another Radio Journal reader who tried out one of Mr. Munzig's hookups with the usual good results:

Mr A. L. Munzig: I received your letter of July 6th in due time, correcting your receiving circuit as outlined in the Radio Journal. After making the changes as suggested in your letter this little outfit has been giving very good results. It pulls

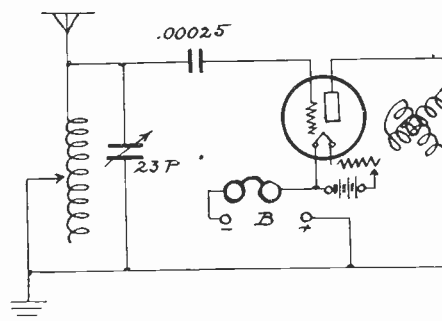

them in in good shape even thru heavy static, in fact, this little outfit is about the only one in town which has been giving any results at all during the last couple months. The last few nights have been cool and receiving conditions have greatly improved. I have been getting Minneapolis, Chicago, Kansas City, Jefferson City, Davenport, Omaha, regularly, and last night I got Dallas, Texas, loud and clear. Your receiver is good, better than anything I have yet tried.

I have a Magnavox loud talker and have decided to put two stages of amplification on this receiver for the special use of my wife, as I can think of nothing simpler to tune. If you will kindly send me diagram showing the proper way to do this, it will be very much appreciated. I am using the UV 199 tube in the set now, and I intend to keep this outfit to take along on camping trips.

Trusting that you will give me the information in regard to amplification, and thanking you for past advice, I remain, Yours very truly,

ELMER LARSON, Colton So. Dak.

British Test Results

The British Radio Society of Highgate, England, recently conducted a test of a transmitter mounted on an automobile, the car touring a portion of the country while transmission tests were made. J. F. Stanley, secretary of the society, writes of the tests as follows:

"As regards the D. F. competition held on July 15, I regret to say the results were very disappointing. Several people heard the transmissions on open aerials, but no satisfactory results were obtained with frame aerial receivers. The reasons for this are not far to seek, for the whole thing was rushed through in a hurry. The date of the test was changed to a fortnight earlier than had originally been fixed, owing to several

of our members going off on holiday. The circuit of the transmitter was changed at the last minute, owing to the fact that when mounted on an automobile the original transmitter was not found so satisfactory as had been expected from the preliminary tests. The outcome of this was that our radiation was much smaller than had been anticipated.

"We hope to repeat the experiment later on in the year, after some further tests have been made with mobile transmitting gear. We have been able to get fairly good transmission on C. W., but our results on phone are not yet satisfactory.

"As you will see from the club report, we have now closed down for the month of August. We start up again on Sept. 7, when I hope to resume sending you reports, which I trust are of interest to your readers. Personally I find "Radio Journal" of absorbing interest, from the technical point of view and also for the excellent opportunity it gives of studying American practice as compared with that of British amateurs.—J. F. STANLEY."

Government aid to the extent of \$55,000 has been extended in Canada for the purpose of establishing radio stations at McMurray, at the end of the railroad in Northern Alberta; Fort Simpson, on the MacKenzie River; and Dawson, in the Yukon, according to reports just received at the department of commerce. The new stations will displace the land lines at present in use from McMurray northward, for which the Canadian Government has appropriated from \$275,000 to \$300,000 annually for the past twenty-three years.

Radio is proving a wonderful boon to Alaskan light-keepers who often maintain a lonely vigil for months at a time. Radio communication has continued without interruption between these stations for a year.

Radiophone station WHAZ at the Rensselaer Polytechnic Institute, Troy, N. Y., the oldest engineering college in America, celebrated its first anniversary Monday evening, September 10, with a program by the same group which presented the first program when this station was opened a year ago.

Radio is employed generally by the fire-fighting forces of the forest service in Canada. Lookouts and even aeroplane scouts of the service are equipped to transmit word of any fire at once, by radio, to control fire-fighting stations of the forest service.

Questions and Answers

Q.—Referring to the Hazeltine Neutrodyne circuits that were described in the August issue of the Radio Journal, I would like to ask a few questions.

(1) Would you advise a Neutrodyne receiver as being superior to any other circuits in proportion to the number of tubes used?

(2) Will you kindly give me a hookup of a neutrodyne receiver whereby I could obtain trans-continental reception?

(3) Will you please give me a list of parts required for this set?

R. HALLILEY, Winnipeg, Man.

A.—The Neutrodyne method is unquestionably the most efficient method of receiving in proportion to the tubes used.

The circuit given in Fig. 8, p. 61 of August RADIO JOURNAL will give transcontinental reception without a doubt. Figs. 10 or 11 will give louder signals in the telephones but no greater distances will be covered. List of parts for the circuit given in Fig. 11 are:

3 UV201A amplifier tubes. 1 UV200 detector tube. 3 23-plate var. cond. 3 30-ohm rheostats for amplifier tubes. 1 6-ohm rheostat for detector tube. 3 RAY-DEE-ARTCRAFT NEUTRO-TRANSFORMERS Type 300. 1 .0005 grid condenser with 2 megohm leak. 1 pair phones (Brandes). 1 bakelite panel 7 in. x 24 in. x 3/16 in. 4 VT sockets. 1 Federal audio-frequency amplifying transformer. 3 storage "A" battery. 2 45-volt Burgess "B" batteries with taps. 2 RAY-DEE-ARTCRAFT NEUTRO-CAPACITIES.

Connect up exactly as given in Fig. 11 and you are sure of gratifying results.

ARTHUR L. MUNZIG.

Q.—A. L. Munzig: Your article on Prof. Hazeltine's neutrodyne receiver appearing in the August issue of the Radio Journal is both interesting and instructive. I have decided to build a set using the circuit in figure ten of your article and would be pleased to have you advise me more fully regarding the circuit, particularly the best type of transformers to use. I wrote that the WorkRite people and the Dayton Fan and Motor Co. both advertise radio frequency transformers for this circuit and I am undecided which to use. Can I purchase the small neutralizing capacities marked N. C. in your circuit diagram; if not will you sketch these for me—your explanation of same not being quite clear to me. May I use the new Federal audio transformers No. 65 to advantage? Will it be necessary to encase and shield each stage as per figures sixteen and seventeen in your article or does this apply to reflex circuits only?

HENRY J. ROWE, Wildwood Crest, N. J.

A.—Glad you found my article interesting and instructive as it was meant to be. If you build the circuit as given in Fig. 10 you can rest assured that reception from all points of the U. S. A. is yours. In regard to the best type of transformers to use, I have never used any of the other types of transformers other than the type I personally designed and was later perfected in the RAY-DEE-ARTCRAFT LABORATORIES, viz: the RAY-DEE-ARTCRAFT R-F TUNED NEUTRO-TRANS.

The new Federal audio-transformer No. 65

is very satisfactory. This is what we use throughout our sets etc., for experimental work.

It will not be necessary to shield any of the stages but it will be necessary to take a few precautions. Separate the neutro-transformers as much as you possibly can. Whatever you do, don't crowd them! Mount the transformers on the backs of the variable condensers and arrange them at an angle of 45 degrees as suggested in Fig. 15 p. 63 August RADIO JOURNAL. Set your audio-frequency transformers at right angles. Mount the whole works on a panel approximately 7 in. x 24 in. x 3/16 in. I wouldn't try to get it on a much smaller panel unless you mount your rheostats above the tuning condensers.

ARTHUR L. MUNZIG.

Q.—Read Mr. Munzig's article and would like to know what parts are necessary for No. 8 circuit. Also would it work on peanut tubes 199 or WD11? Any literature or print of circuit would be greatly appreciated. Read your Journal regularly and appreciate the nice large print and clear language used. What I am after is a peanut circuit with five or six tubes using peanut tubes that I can get distance.

W.M. FILLMORE, Fargo, N. D.

A.—Glad you liked the way my article was presented in RADIO JOURNAL on the Neutrodyne. The parts for building the circuit given in Fig. 8 p. 61 are as follows: 3 23-plate var. cond.; 3 NEUTRO-TRANSFORMERS; 3 UV199's or WD11's; 3 6-ohm or 3 25-ohm rheostats; 1 grid condenser .0005 mf; 3 sockets for tubes; an "A" battery depending on the type tubes used; 2 45-volt "B" battery; 3 tuning dials; panel 6 in. x 18 in x 3/16; 2 RAY-DEE-ARTCRAFT NEUTRO-CAPACITIES. Divide the space on panel up so that each NEUTRO-TRANS is as far apart as possible. When using peanut tubes connect the lead from grid, in the detector circuit, to the positive of "A" battery. These tubes function better as a detector with a slightly positive bias.

In the October issue of RADIO JOURNAL you will find information for constructing a 6 tube SUPER-NEUTRODYNE DX RECEIVER using peanut tubes. This is unquestionably the MOST SENSITIVE receiver ever devised using small tubes.—ARTHUR L. MUNZIG.

Q.—A. L. Munzig: I had the pleasure of reading your article in the August number of the Radio Journal on the Hazeltine Neutrodyne system of Radio Frequency amplification and I am very much interested. I have two WD11 tubes and one UV201A tube and one audio transformer designed for WD11 tubes. I have a Tricoil Radio Frequency transformer and all other parts necessary for a three tube set. Now what I would like to do would be to use these three tubes to build a one-step radio frequency amplifier with detector and one-step of audio amplification. I would like to build this using the Neutrodyne principle and to use these three tubes together. I would appreciate it very much if you will send me a diagram of such a set and also some data as to the construction of the neutralizing condenser as the instructions in

the Radio Journal are not very specific. I would also like to know where to use the 201A tube to best advantage, whether it would function best as radio frequency amplifier detector or audio amplifier when used in conjunction with WD-11 tubes.

ARNOLD S. HAGE, Oak Terrace, Minn.

A.—I received your very interesting letter and am glad to hear that you liked my article on the Neutrodyne method of receiving. Your two WD11 tubes and the UV201A tube will work very nicely together. Judging that you care to receive broadcast signals as loud as can be possible with the tubes used, I am giving you a circuit showing one WD11 tube acting as one stage of RF with the other WD11 as the detector and the UV201A tube for the audio-frequency amplifier.—ARTHUR L. MUNZIG.

Q.—Edwin S. Watkins: Reference June, 1923 issue, page 312, Reflex; This hookup works beautifully and with great volume on reception of local stations. Have devoted considerable time to the Grimes hookup for 201A tubes with WD12 detector, in July Radio Broadcast, but it would not reflex. This does.

I do not seem able, with your hookup, to bring in outside stations at all clearly; for instance, not nearly so well as a hookup of 2 radio with crystal detector and 1 audio. Last winter I brought in all stations from coast to coast with single circuit regenerative with 2 audio. Am trying to use these parts in your circuit, as follows:

3 201A tubes. 2 General Radio No. 243 Condenser, 26 plates, .0005 mfd. Fada 180 variocoupler, Radio Corp. UV712 Audio transformer, 9 to 1 (1st step) Jefferson Audio transformer, 4 to 1, 2 Acme radio transformers, R2 and R3. 4 Burgess "A" Batteries. 60 foot aerial, about 25 feet high.

The aerial is only half as long and half as high as I had last winter, on the single circuit; Will it improve results to use .00075 condenser in the aerial? At present the condenser across the loop produces regeneration in only 50 per cent of the dial, either going dead or producing a sharp howl over the rest of it.

How many plates should be in the Neutralizing Condenser from the grid of the 1st tube to the 1st Radio transformer? Have used two six-inch strips of tinfoil 1/2 inch wide around the 2 wires for fixed capacity, hooking the phones across the condenser, thereby replacing the primary of the 4 to 1, or 2nd audio transformer, but it seems to have little effect in reducing the volume with the 2nd tube unlighted. Am using Pacent 20-ohm rheostats; should they ever be fully opened? Could the Fada Neutrodyne be hooked up to the two wires of the fixed capacity and made to produce the desired results?

Am using 4 "A" batteries. To what do I connect the C batteries for grid biasing, and will it help?

In closing, let me suggest that radio magazines should check all hookups very carefully. The Grimes hookup in July Radio Broadcast seems to have omitted a connection on the negative filament of the second tube. A recent single tube Armstrong circuit called for a single honeycomb coil, 750 turns, which I bought only to find later that

it should have read 75 turns. I speak for the "dub" who constitutes quite a portion of the purchasers of radio supplies, and who cannot discover errors that may be quite obvious. Most articles talk over the heads of such a purchaser. This criticism distinctly does not apply to your article, with the possible exception of your reference to the "reflexed audio transformer." Where is that located on the hookup?

J. K. MAHONEY, St. Paul, Minn.

A.—You will find on page 11 of "Theory and Operation of Reflex Circuits" the simplified circuit which is the ultimate result of the circuit shown in June Radio Journal. This circuit gives a little better results for distance reception. Note that the minus B battery is connected to the plus A battery and that the filament return of the first audio transformer is connected directly to the negative filament wire rather than to the arm of the Potentiometer.

Neutralizing condensers have been done away with entirely due to the fact that relative polarity on different radio transformers is not the same and consequently when neutralizing is utilized with the wrong polarity results are diminished rather than increased.

In the way of apparatus, I would suggest that you replace the one hundred eighty degree vario coupler with one of the ninety degree type which has the secondary at least two inches away from the primary. Not having reference to a general radio catalogue at the present time, I do not know whether your condensers are of the vernier type or not. The secondary condenser should by all means have a vernier adjustment. It is not as essential in the primary.

I would replace the high ratio transformer which you have in the first stage with one having a ratio not greater than one to four. This is due to the fact that the voltage at the output of the second radio transformer is extremely high, whereas the available power is comparatively low. Consequently the high ratio transformer is only about half as efficient as the low ratio transformer on weak signals. No noticeable difference will be found on the louder signals. For this transformer I would recommend either a general radio 1 to 3.7 ratio type or a Wireless Shop 1 to 3.3 ratio type. You will probably notice a considerable improvement in the tone quality when this change is made.

The Acme R2 and R3 radio transformers have given me splendid results although not as good as the Erla, Union or Wireless Shop types. You might try reversing the primary connections of your radio transformers to secure the correct polarity. A .00075 variable primary condenser will not improve your set.

The reflex audio transformer mentioned in the article in June Radio Journal has reference to audio transformer No. 1 shown in the circuit diagram accompanying that article.—A. L. MUNZIG.

Q.—I read your very interesting article on "Hazeltine's Neutrodyne Receiver" which appeared in the August publication of the Radio Journal.

I was particularly interested in Fig. No. 9. It was a diagram of the circuit employed for short wave amateur work. (150 to 350 meters). The circuit contained two stages of tuned radio frequency amplification, and a vacuum tube detector employing a variometer in the plate circuit of the detector tube.

I would like to construct this set, but using only one stage of tuned radio frequency (Hazeltine's Neutrodyne Method), a vacuum tube detector and two steps of audio frequency amplification.

You state that information regarding the construction design of any of the circuits will be gladly furnished. I take this opportunity in asking a few questions regarding

the set I would like to make. The questions are as follows,

(1) Will you please send me the circuit diagram of a set using one stage of tuned radio frequency amplification, a vacuum tube detector and two steps of audio frequency amplification?

(2) Will you designate the constants of all variable and fixed condensers.

(3) Will you tell me how to make my own RFT transformer as I have wound all of my other coils. Please tell me what size wire, what length and diameter tube to be used and what number of turns the primary and secondary coils in the transformer have each.

(4) Are the coils in the RFT transformer wound with the secondary coil on top of the primary? If not, how?

(5) Is it possible to receive a band of waves ranging from 150 to 600 meters with one set of coils in the set? If so will you please give me data on them? If not will you give me the data on coils from 350 to 600 meters.

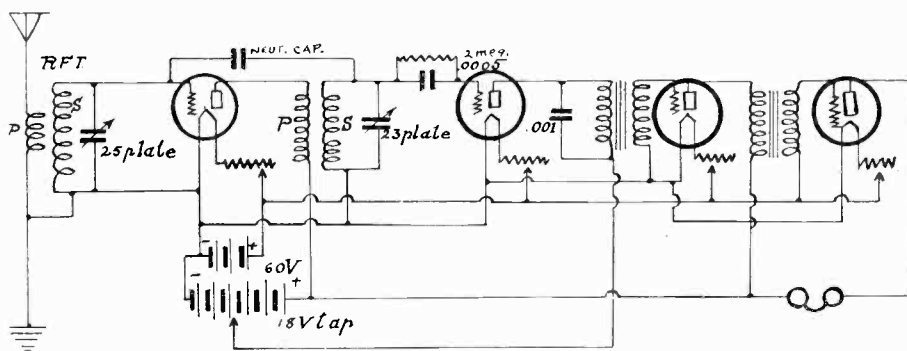

(6) Will you please give me constructional design of the small neutralizing capacities.

I will greatly appreciate it if you will help me out on this as it will be the first time that I will have anything to do with radio frequency amplification.

ELLIOTT MAERSCH, Fort Worth, Tex.

A.—Glad you liked my article on Hazeltine's Neutrodyne in August RADIO JOURNAL. Your questions will be answered in rotation:

- (1) The circuit is published herewith.
- (2) Everything is marked.
- (3) I cannot very well give you the correct information for the construction of the RF Transformers for it has taken quite a lot of experimental work to design and build a RFT that would give the correct results. The approximate ratio of turns is 4 to 1.
- (4) The secondary coils are wound on the outside of the primary to shield the primary winding partially.

(5) It is possible but it would be necessary to design a RFT having a tap for the longer waves for best results.

(6) This is made by inserting two lengths of bare copper wire in a 3 in. length of cambric sleeving or "spaghetti" spacing the ends about 3-4 in. Over this slide a 2 in. length of metal tubing that can be purchased at any garage.

ARTHUR L. MUNZIG.

Q.—A. L. Munzig: I am a reader of the "Radio Journal," and have been studying the drawing of radio sets you have explained in the August issue of this paper. Before I explain what I want to know I wish to explain myself and ask a few questions.

First, I am a beginner in radio work, and have never used a set, altho I have seen and heard several different kinds.

Second, I am working as a "Hydro-Electric Operator," our "high-line" voltage is 26,000 with two lines running, one north and one south. My residence is about 200 ft. from the "power house" and about 300 ft. from the "high-line." Will it be possible

for me to use a radio set, without too much interference.

I am interested in the set explained in fig. 8, p. 61, Radio Journal. What will this set cost complete without batteries, or outside fixtures? Can I use plate-glass for a case? And where can I get first-class parts for this set? Where can I get a good book of instructions, one which will explain what various radio terms mean, and which will explain the advantage of one fixture over another which serves the same purpose.

GEORGE W. HARGRAVES,
Spearfish, S. Dak.

A.—In answer to your recent letter in regard to receiving radio signals so close to 26,000 volts high-line, it is quite possible. However, there will be a little annoyance due to sparking contacts from brushes, opening on circuit breakers, etc. Place your aerial at right angles to the high-line and run it away from it, not towards it.

The cost of building a receiving set using the circuit given in Fig. 8 would run around \$40.00 without tube, phones or batteries. If

peanut tubes are used, that is tubes that use drycell filament supply, the cost will run about \$60.00 complete.

Plate-glass can be used for a case if you wish but it would be too expensive and difficult to use if I were building it.

ARTHUR L. MUNZIG.

Q.—A. L. Munzig: I am contemplating the construction of a Hazeltine Neutrodyne Receiving set and read with much interest your article in the August issue of Radio Journal. Should be glad to get any data on the circuit particularly the windings of the R. F. T. (300?600 M).

F. W. BECK, Winnipeg, Man.

A.—Glad you liked my article on the construction of Neutrodyne circuits in the August RADIO JOURNAL.

I appreciate your inquiry in regard to the NEUTRO-TRANSFORMERS but I do not care to make public the detailed construction of the NEUTRO-TRANS used by the RAY-DEE-ARTCRAFT INST. CO. It has taken a lot of time to perfect a model that would function properly in the neutrodyne circuits. However, if you care to experiment with various numbers of turns remember that the ratio of turns is 4 to 1 approximately. In practical use there is a deviation.—ARTHUR L. MUNZIG.

Q.—Mr. Watkins: I have read your articles in Radio Journal and built two reflex sets which are giving dandy results. I wish to ask you to kindly advise me as to your opinion on the relative values of superhetrodyne and the ordinary short wave radio frequency. The super referred to is the one by the Experimenter Information service of N. Y. Is it worth while to struggle with it for the results attained? Is it hard to build or to operate? We have had good results with short wave radio frequency and want something better.

ED. J. PERRIN, Lodi, Calif.

A.—The efficiency of short wave radio frequency amplification at the present time hardly warrants one to invest in a receiver

of the superheterodyne type as the difference in results does not compare with the difference in cost of the two types of receivers. Altho the superheterodyne has been developed to a point of comparative simplicity, it is as yet more or less of an experiment as far as the broadcast listeners are concerned.

The big difficulty with the receivers using so many vacuum tubes is the extraneous noises which are always present when more than three or four tubes are used. The trend of present day development is to decrease rather than increase the number of tubes used, thereby keeping extraneous noises at a minimum.

Q.—A. L. Munzig: Will appreciate any information relative to the construction of the superheterodyne neutrodyne circuit, the hookup of which appears in your article on the neutrodyne receiver in the August issue of Radio Journal. Your article is extremely interesting and the most readily understandable of any the writer has read on the neutrodyne.

The writer has built many successful sets from different hookups but has not attempted a neutrodyne. As I am just about to build another superheterodyne will hold off until I hear from you and try the combination you outline instead of the usual S. H. JOHN R. MARSHALL, Chicago, Ill.

A.—Complete information on the Superheterodyne appears in the October issue of RADIO JOURNAL. A SIX TUBE SUPER-HETERODYNE DX RECEIVER with one of these tubes reflexed is unquestionably the most efficient DX receiver ever devised. When peanut tubes are used it is unnecessary to use NEUTRALIZATION OF CAPACITY COUPLING. Using the UV201A tubes it is then necessary.

A. L. MUNZIG.

Q.—A. L. Munzig: I read your article on the Hazeltine Neutrodyne Receiver in the August number of the Radio Journal and am very much interested in the Neutrodyne receiver, so much so that I want to build one. What I want to know is, will you tell me how to make the transformers?

W. E. BALDWIN, Yonkers New York.

A.—Glad that you found my article on the Neutrodyne interesting and that you are contemplating building a receiver from one of the circuits given. I am sorry but I cannot give you the detailed description of the construction of the transformers used. I have spent much time in designing a transformer to function properly in the Neutrodyne circuit. If you care to experiment with different transformers I will inform you that the ratio of turns is 4 to 1 approximately. The RAY-DEE-ARTCRAFT R-F TUNED NEUTRO-TRANS is constructed somewhat different than the majority of transformers for this purpose. You will have better results if you purchase some reliable transformer designed for the Neutrodyne method.—ARTHUR L. MUNZIG.

Q.—A. L. Munzig: Am a constant reader of Radio Journal, and in this month's issue I saw an article on Hazeltine's Neutrodyne circuits. One of them interested me very much, the super-heterodyne neutrodyne. Am at present using a six tube set; three stages Radio frequency in cascade and I do not get the desired results, but I think the above circuit will give me the reception I have been trying for for the past year. Now if you have any working data on this circuit, or other information that would help me any, in changing over my set, I would be very much pleased to receive it.

W. E. BAKER, Los Angeles, Calif.

A.—A treatise on the construction of a six tube super-heterodyne receiver appears in the October issue of Radio Journal. The six tube heterodyne set that you have, using untuned radio-frequency transformers will not give very good results. The six tube

super-heterodyne receiver that I have worked out, uses tuned radio-frequency transformers. It is equal to at least 12 tubes used the other way. When using peanut tubes IT IS NOT NECESSARY TO NEUTRALIZE CAPACITY COUPLING. When using the UV201A tubes it then becomes necessary because the internal capacity of these tubes is much greater than the smaller ones.

ARTHUR L. MUNZIG.

Q.—A. L. Munzig: I have just finished reading your article on Prof. Hazeltine's Neutrodyne Receiver for the nth time, and would like to have a bit more information in regard to the Fig. 14 of the super-heterodyne neutrodyne circuit.

1st. What size coils and what kind are used in the oscillating tube circuit as per diagram—are these coils in inductive or non-inductive relation.

2nd. Do you think VT-1 tubes will work in this circuit.

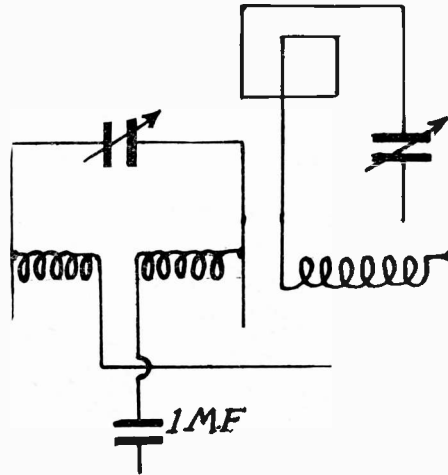

3rd. Do you advise shielding the tubes and leads, either grid or plate leads, and

4th. Will it be necessary to add a power amplifier for a loud speaker such as a magnavox.

At present I have a 10 tube super-heterodyne receiving set, but wish to build the set you refer to in Fig. 14 in your recent article. Any suggestions you may have to offer will be gladly received.

E. C. CHAPMAN, Hermosa Beach, Calif.

A.—Glad you found my article on the Neutrodyne of interest. In regard to the super-heterodyne: the coils from left to right consist of 50, 50 and 10 turns of No. 24 DCC on a tube 3½ inches in diameter. All windings are closely coupled say ¼ inch. All in the same direction. VT-1's should work O K in this circuit but I would recommend the use of the new "A" tubes if you possibly can use them. If you already have the VT-1's use them of course. It wouldn't be necessary to shield the leads etc., but it is absolutely essential to the efficient operation of the Heterodyne to SHIELD EVERY TUBE COMPARTMENT SEPARATELY. It isn't necessary to add a power amplifier to operate a loud speaker such as the Magnavox. An ordinary two stage amplifier is sufficient.

You understand of course that in order to use the circuit given in Fig. 14, it will be necessary to have special RF transformers for the intermediate frequency amplifier.

A. L. MUNZIG.

Q.—A. L. Munzig: After careful study of your article in Radio Journal for August last on page 61, Fig. No. 8, text of cut says: RFT same as No. 300 in Fig. No. 7, but can find no definite description of No. 300—unless it is the last four lines on page 62 and the first 6 lines on page 63. But in careful study of the article as a whole that statement seems to be a description of the RFT used

by the Clapp Eastham Co. described by you under Fig. 6. Does that apply also to all RFT used and will one so wound be right for Fig. 7, No. 8. I want to build No. 8, but think it possible to build No. 7 first to get to understand it thoroughly, then add another stage to it so as to have same as No. 8. Also on No. 8, coils tuned by condenser C-3 are not marked. Are they RFT same as other one tuned by C-2. Again the aerial in No. 8 goes to primary of RFT to ground. Is that correct? That perhaps that was a misprint, RFT to be over coils not marked and aerial going to primary of variocoupler as standard hookups usually do. Any information you could give me would be greatly appreciated for building No. 8. I want to use No. 301A tubes. Have a variometer, variocoupler in inductive relationship now working KFI, KHJ, KUS on loud speaker using 86 volts on plate, no transformers, can tune out local while on and get KPO and Oregon on phones. My set is very selective. Could I use it as a tuning unit on No. 8 or not. Now as to No. 13, how does it compare with Erla single tube reflex. Will it give enough volume to operate loud speaker. I am partial to crystal rectification myself.

CHAS C. CRAMER, Van Nuys, Calif.

A.—No detailed description of the construction of the Neutro-Transformers used in the circuits of my article on the Neutrodyne, is given. The description that you refer to is that of the RFT used in the Clapp-Eastham RF receiver and does not apply to the neutrodyne methods. I do not care to make public as yet, the construction of the RFT's used in the RAY-DEE-ARTCRAFT R-F TUNED NEUTRO-TRANS. This has taken me some time to work out a transformer suitable to use with the neutrodyne. The transformers used in Fig. 8 are the same as used in Figs. 7, 9, 10, etc., but not as used in Fig. 6. The connection of the RFT to ground and secondary winding is correct. All the circuits appearing in this article are correct as far as I am aware. If you have a tapped inductance and a variometer in inductive relation, using the stator winding of variometer as the secondary, and the rotor as the tickler coil, connect the variometer as it originally was with the stator and rotor in series and use the variometer as the secondary winding and the tapped inductance as the primary inductance of variocoupler. This will work very well for the tuning element of any of the circuits given. It would be ideal for Fig. 7.

Much greater distance can be covered using the circuit in Fig. 13, with greater volume. It will operate a loud speaker very well on local signals. ARTHUR L. MUNZIG.

Q.—A. L. Munzig, Esq: I read your article in Radio Journal for August, just received, on Hazeltine's neutrodyne receiver and as I am building a neutrodyne receiver—similar to that in your Fig. 8, I would be glad of any suggestions concerning this, as to number of turns in prim. and sec. coils of neutro formers for all waves 200 to 750 meters and also for waves 100 to 300 and any other suggestions you may think useful—not given in your article. I would like to build a super-heterodyne neutrodyne receiver—such as outlined in your Fig. 14, in place of the 3 tube receiver I started, so any suggestions you may have for details of this will be welcome. Sincerely,

E. FORSTER, Winnipeg, Canada.

A.—Glad you liked my article on Hazeltine's Neutrodyne in the August issue of RADIO JOURNAL.

In order to use a R-F transformer to tune between the waves of 200 and 750 meters it would be necessary to have taps on both the primary and secondary which would not be very satisfactory for practical use. The majority of broadcasting is done between

275 and 550 meters so that if these comparatively higher waves were wanted it would be only for experimental use or to listen to commercial stations using telegraph or phone. The best way would be to design a neutrodyne receiver, using transformers that tune between 600 and 1,000 meters and one that would tune between 150 and 600. You ask me to give you the number of turns on the primary and secondary of these transformers for wave lengths between 100 and 300 meters. I do not care to make this public just at present for it has taken me some time to work out the proper relation of these windings for proper results. It would be best for you to experiment a little using an approximate ratio of 4 to 1, the greater number of turns on the secondary winding.

Complete information will appear in the October issue of RADIO JOURNAL of the Super-heterodyne NEUTRODYNE receiver. We have designed a NEUTRO-TRANS to be used in the intermediate circuit of the amplifier and which, when used with the UV199 needs NO NEUTRALIZATION of capacity coupling!! When used with the UV201A it is necessary.

ARTHUR L. MUNZIG.

Q.—A. L. Munzig: Have read your article in "Radio Journal" for August on the Neutrodyne circuit. Am figuring on building circuit No. 8 as listed on page 61 of Radio Journal. What I want is a list of parts needed to build said circuit, also any information that would help me to build No. 8 circuit in Radio Journal of your article.

FRED RECHENMACKER, Auburn, Calif.

A.—Received your letter and am glad to hear that you are figuring on building the circuit given in Fig. 8, p. 61 of August RADIO JOURNAL.

The Neutralizing Capacities can conveniently be made as follows: two bare copper wires are inserted in a 3-inch length of cambric sleeving or "spaghetti," the ends being separated about $\frac{3}{4}$ inch. Over this slide a 2-inch length of metal tubing such as can be had at any garage. This metal tube is varied until the point is found where oscillations stop.

The list of parts needed to build the receiver given in Fig. 8 are:

3 RF Transformers (RAY-DEE-ART-CRAFT NEUTRO-TRANS Type 300 or FADA, etc). 3 23-plate variable condensers. 3 VT's (WD11, WD12, UV199 or any of the 6 volt tubes). 3 rheostats to correspond to the tubes used. 1 "A" battery corresponding to the type tubes used. 3 sockets to correspond to type tubes used. 1 grid condenser and leak (.0005 MF) 1 45 volt "B" Battery. (Two 45 volt "B" bats' can be used with better results. 1 bakelite panel 6 in. x 18 in. x 3/16 in. 3 3 in. variable condenser dials.

CAUTION: Do not crowd the parts too closely, especially the RFT'S. Keep them at least 6 in. apart.

ARTHUR L. MUNZIG.

Q.—Dear Mr. Munzig: Just read your dandy article on the Neutrodyne in August Radio Journal.

Am planning to make a five tube set at once using FADA parts but if possible wish to use UV199 tubes. How do you think they compare in the neutrodyne with 301A? I want dry battery operation if possible. UV199 probably won't give the volume of sound that 301A will, but should give the distance. Thanks in advance for your courteous invitation to write.

EARL OVINGTON, Santa Barbara, Calif.

A.—Received your complimentary letter of August 10th, for which I thank you. In regard to the use of the small UV199 tubes compared to A tubes when used with the neutrodyne method, I believe that the A tubes will give greater efficiency because of

their larger elements which would naturally give a greater output. However, the smaller element tubes have the advantage of possessing a lower internal capacity thus being a much more stable radio frequency amplifier. I have used the UV199 tubes in a super-heterodyne receiver using a special constructed NEUTRO-TRANSFORMER and which is tuned by a 23-plate variable condenser, in the intermediate frequency and find that it is unnecessary to NEUTRALIZE CAPACITY COUPLING, which proves beyond doubt that the smaller tubes contain a very low internal capacity. But when using the UV201A tubes it was necessary to neutralize the coupling with NEUTRO-CAPACITIES and when using the same number of tubes as used with the UV199's, greater range resulted. Using but two stages in the intermediate frequency compared to three stages when using the UV199's, the results were approximately equal.—ARTHUR L. MUNZIG.

Q.—Mr. A. L. Munzig: Have just read with interest your article on the Hazeltine's Neutrodyne in the August number of Radio Journal. Am especially interested in your description of the Super Heterodyne Neutrodyne Circuit. I am contemplating building this circuit and therefore will take advantage of your generous offer to furnish information regarding the construction of the receiver. I propose to build a five-tube set using a WE215A as audio amplifier and UV201K for the others. Will this give ample loud speaker volume or should I use two steps of audio. Please give me wiring diagram and a sketch of panel layout for a panel 12 in. x 19 in. (the cabinet is 10 in. deep.) Also please advise me regarding the proper instruments to use. Assuring you of my deep appreciation for any information and advice I may receive I am, A. M. SMITH, 4170 Redding St., Oakland, Calif.

A.—Glad that my article on the Neutrodyne proved of interest to you. The tubes that you suggest would be very satisfactory for both the intermediate frequency and the audio-amplifier. Two stages would be much better for loud speaker operation. However, I don't believe you will have much trouble in making a Magnavox operate with but the single WE215A tube.

The construction of the Super-heterodyne will be given in the October number of RADIO JOURNAL. However, if you do not care to wait until then I will be glad to help you construct the receiver. It will be necessary to use special RF transformers for the intermediate frequency or in other words the RF amplifier. These RFT's are for sale by only the RAY-DEE-ART-CRAFT INST. CO., to my knowledge.

ARTHUR L. MUNZIG.

Q.—In checking up some of the Hazeltine circuits shown in your August publication do you know what kind of tubes are used to get best results. Especially that Fig. 13 one-tube reflex. I get very good results with a WD-11 but a 301-A won't work very well in it. Please advise if you are able to say what tube to use.

E. H. HEINTZE, Needles, Calif.

A.—RADIO JOURNAL has forwarded to me a letter from you having an inquiry regarding the Neutrodyne.

All the small element vacuum tubes are ideal for radio-frequency amplification because of their low internal capacity. However, when compared to the "A" tubes viz: UV201A or C301A, they are considerably inferior as amplifiers. A tube with larger elements will give a greater output, hence the large element tubes are superior.

In the case of the Neutrodyne the "A" tubes are in my opinion superior. This single tube reflex circuit given in Fig. 13, August RADIO JOURNAL works surprisingly well with the WD11 or UV199.

But if properly neutralized the UV201A or C301A tube will give greater range and volume.

If you have got a good storage battery my advice is to use the "A" tubes. Otherwise use drycell tubes because of their lower filament consumption.

ARTHUR L. MUNZIG.

Q.—Mr. A. L. Munzig: After reading the article of Hazeltine's Neutrodyne receiver in the August number of Radio Journal, I have decided to build one of these sets, from hookup of figure No. 10. What tubes are recommended and capacity of rheostats? It is better to place tubes between transformers or are they in front of the other? Do you recommend 'spaghetti' tubing or naked wiring? Can a loop be used with this hookup? I have a 6 tube set, 3 stages untuned R. F. Detector and 2 stages audio, with which I am getting very good results, but am always looking for something better.

A. O. GINSON, Parkersburg, Va.

A.—Glad to hear that you are contemplating building a Neutrodyne receiver from the circuit given in Fig. 10 of the August issue of RADIO JOURNAL. With this circuit no trouble will be had in working a loudspeaker on the majority of broadcast stations in the U. S. A.

Most any type tube will work. Very good results are had when using the WD11 or UV199 dry cell tubes. I recommend for best results the use of the new A tubes, viz: UV201A or C301A. Rheostats for these tubes should have a minimum resistance of 30 ohms when used with a 6 volt storage battery.

Keep all RF amplifier tubes in the Neutrodyne at least 4 inches apart. The Neutro-transformers fastened directly to the back of the variable condensers thus saving space and is very convenient mounting. In diagram submitted place the tubes directly behind the Neutro-Transformers. Space the transformers at least 6 inches apart and at an angle of 45 degrees as suggested by Fig. 15 in my paper on the Neutrodyne.

Naked wire is much better for wiring the set. Use spaghetti at places where only the most insulation is imperative.

A loop can be used very effectively with the circuit in question. Substitute the first Neutro-trans with a loop having the variable condenser in shunt with it.

ARTHUR L. MUNZIG.

Q.—Mr. A. L. Munzig: I am writing you for some working data on a Super-heterodyne. For the past six months I have been studying radio-frequency before attempting to build a DXer supreme. From experience, study, etc., I have concluded that the super-heterodyne is the stuff, also that the neutrodyne is on the right track. Would be ever so much obliged for any inside dope on your experiments. Yours till we burn up the ether.

WENDELL FLETCHER, Pres. Santa Barbara, Calif. Radio Assn.

A.—You are right when you say the super-heterodyne neutrodyne circuit is the SUPREME RECEIVER for short-wave reception. Construction data is being prepared for distribution and will be mailed you as soon as it comes from the press. The October issue of RADIO JOURNAL will have a complete treatise on its construction. 6AAK has been worked many a time by 6ZJ. Will be on with a real ARRL station this coming winter.

ARTHUR L. MUNZIG. 6ZJ.

Q.—Mr. Munzig: I have been very much interested in your article in the August issue of "Radio Journal" entitled "Hazeltine's Neutrodyne Receiver." I have for some time, been using the "Jones" circuit and

have been obtaining very good results. However I would like to build up a set, embracing the advantages of the Super-Hetrodyne, the Neurodyne and the Reflex types of receivers. In your article you state that you hope to be able to present some working data on the Super-Hetrodyne Neurodyne circuit. In the set which I would like to build up I prefer using 199 tubes and filament control jacks. Can you advise me where I can obtain "working data" for the above?

E. R. WILLARD, Berkeley.

A.—Glad that you liked my article on the Neurodyne in RADIO JOURNAL. Working data on the Super-hetrodyne and its construction will be given in the October issue of RADIO JOURNAL.

ARTHUR L. MUNZIG.

Q.—A. L. MUNZIG: Your article in the August issue of Radio Journal interests me greatly and would like to construct one. In fact, I have already constructed such a set but with very poor results. Perhaps you can assist me to at least get signals. No sarcasm meant.

For the R. F. transformers I use two 3in. tubes wound with No. 23 D. C. C. with 17 turns for the primary and 65 turns for the secondary. Both coils start at the same end and the secondary is directly over the primary. Referring to the Diagram Fig. No. 8 on page 61. For the NC condensers I use two pieces of rubber covered wire about 5 in. long twisted together. For C1 I use a 23-Plate; for C2 I use an 11-plate and for C3 a 7-plate.

Regarding my tubes:—Which can I get the best combination with? I have one Cunningham detector tube, one same amplifier and two Audiotron detector-amplifier tubes.

I will appreciate very much hearing from you with information wherein I am not going ahead correctly and also as to how coils should be placed for best results. Also how the rest of the parts should be placed. I have no vernier condensers.

My aerial is about 125 ft long and 30 ft. high. What sized honeycombs should be used? Would a VC help in series with the aerial?

R. W. CARROLL, Ex 6BG, San Francisco, Calif.

A.—Glad your interest was aroused by my article on the neurodyne.

In regard to the RF transformers used, I do not believe they will function properly for there are several things to be taken into consideration when the ratio of turns are technically 4 to 1. These are distributed capacity, inductance, decrement and radio-frequency resistance at the wavelength used. However, it might work Okay if the following points are checked over:

Reverse the leads to plate.

Adjust neutralizing capacity until oscillations cease.

The neutralizing capacity that you are using is too large I am afraid. Construct one as follows:

Insert two bare copper wires in a 3in. length of cambric sleeving. Separate the ends $\frac{3}{4}$ in. Over this slide a two-inch length of metal tubing or wind on small narrow strips of tin foil. Move the metal tubing or tin foil until oscillation stops. Be sure and take the hand from the NC when listening for neutralization of capacity coupling.

The tubes you mention are alright for use in the neurodyne but be sure that you use for the detector a VT that is designed for detecting. The Cunningham 200 I imagine you have.

Two 50 turn honeycomb coils will work alright with your aerial, a series variable condenser being used in the primary circuits.

ARTHUR L. MUNZIG.

Q.—A. L. Munzig: Article in the August "Radio Journal" interested me as I am constructing a Neurodyne set similar to Fig. 10. I accept the invitation to ask questions. This wiring diagram has been given in several magazines and I note that in some the grid return of the detector tube goes to the positive filament, while in others, notably yours, it is connected to the negative. Is there any advantage to this or argument against it. I was considering connecting my rheostats as shown here with the idea of eliminating them from the "B" battery circuit. Do you know of any reason for not doing this? Is your Fig. 16 shielding required for Fig. 10 set? Those I have seen have had no shielding of any kind, but I have not operated one, hence the question.

A. K. HAINES, St. Louis, Mo.

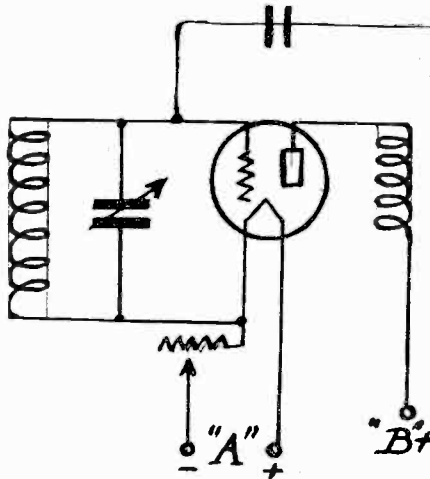

A.—When using amplifier tubes always connect the grid connection to the negative side for this gives a slightly positive potential to the grid, essential to the proper operation of any amplifier tube. Can't see any advantage in leaving the rheostat winding as you say, out of the B battery circuit. When using amplifier tubes it is good practice to connect the rheostat in the negative lead of A battery and then make connections below rheostat so that a slight potential drop will occur in the return to the grid.

No shielding is necessary for the circuit given in Fig. 10. Shielding is only necessary when multistage amplification is used or when three stages are used in the Super-hetrodyne. See the October issue of RADIO JOURNAL for a complete treatise on the construction of the most efficient broadcast receiver ever designed, viz: the Super-hetrodyne with neutralization of capacity coupling and one tube reflexed:

ARTHUR L. MUNZIG.

Q.—A. L. Munzig: I am very much interested in your article on the super-hetrodyne neurodyne circuit appearing in the Journal. As I had already conceived the idea of neurodying my hetrodyne circuit, I am somewhat stumped on how to design the air core transformers for the hetrodyne wave length. As the wave lengths of the R. F. stages are tuned sharply to a fixed wave length which does not vary. I am also at a loss to understand the use of variable condensers shown in Fig. 14 page 63, in the interstage trans. secondaries.

Could you please give me the necessary data of winding a R. F. transformer, the secondary wound on top of primary; that is, size of wire, number of turns to each of the coils that would give a sharp resonant point without the use of capacities across either P or Sec. winding for around 3,000 meters, or 5,000 meters?

I am using iron core 5,000 meter R. F. trans. now but know from past experiences that a higher ratio could be used with air-cored tuned transformers and feel confident that the heterodyne circuit would give al-

most unheard of results with the neurodyne principle as set forth in Fig. No. 17 of grid method of shielding.

Please give me any other data I could use as I am building a 14 tube (201A) set and I will be able to return the favor in letting you know of results obtained.

J. R. CLARK, Santa Barbara, Calif.

A.—Received your very interesting letter of the 22nd inst. You are mistaken when you say that the intermediate frequency is a fixed wavelength. As you generate your own wavelength this will vary at each setting of the first detector tuning and the oscillating frequency or hetrodyne. It is true to a certain extent that the tuned intermediate frequency amplifier need not be changed so frequently, yet it will be found that greater amplification can be had if the correct resonant point is found. This is ONLY POSSIBLE thru the use of tuned radio frequency transformers.

I have recently worked out a RF transformer designed for the intermediate-frequency of the superhetrodyne. I cannot give you the details of its construction because it has taken me some time to work out a transformer that would function properly in this conjunction. I may later make this public. You ask for a transformer of the untuned variety without the use of capacities across primary or secondary that would have a fixed wavelength in the neighborhood of 3,000 or 5,000 meters. A 500 turn honeycomb coil will be alright for the primary and secondary. It will be necessary to have grid bias to keep the amplifier from oscillating. I might add that you are tackling a big job. Good luck to you.

A. L. MUNZIG.

Q.—Mr. Munzig: I have read with interest your paper on Hazelyne's Neurodyne circuit as set forth in the Radio Journal for August. It so happens that I am planning to build a new set to use this fall and winter, and had about made up my mind to build the Neurodyne, using two stages of radio frequency, detector and two steps of audio. The Freed-Eisemann people put out a set of neuroformers mounted on variable condensers and publish a circuit which local engineers state is the nearest to the original Hazelyne circuit. I had decided to use their parts, but have not yet purchased them. Since reading your paper I decided to write to you for advice. Another fellow here will build a set identical to the one I build, and we both want sets that incorporate ability to receive extreme distances, good volume, and selectivity. Do you advise the Neurodyne receiver, or the Super-hetrodyne receiver, using neurodyne tuned radio frequency?

We will appreciate any information as to proper circuits, together with any advice you can give us with the end in view that our efforts will meet with success and that our sets will not prove mediocre. LEICESTER R. WATTS, Bristol, R. I.

A.—I am glad to hear that you liked my paper on the neurodyne and are contemplating the construction of a neurodyne receiver.

Of course, the most sensitive receiver would be the super-hetrodyne, provided you wish to use 6 tubes. However, if less than this is to be used, my advice is to build a three-tube neurodyne receiver. One of the RF tubes can be reflexed if a few precautions are taken, thus making four tubes actually in use. This is the most efficient method known to date compared to the number of tubes used. A. L. MUNZIG.

Q.—A. L. Munzig: To begin with, I am a "very much amateur," and have built a 5 tube neurodyne. I am using the Fada hookup, Fada neuroformers and condensers, exactly as outlined in their booklet (which you are no doubt familiar with), with the exception of a few things. I am

using 199 tubes, a C battery of 6 volts, about 6 volts on the filament and 90 on the plate. A 40 ohm rheostat controls the amplifier filaments and a Bradleystat on the detector.

On local broadcast, I am getting fine results, using an adaptor on my Victrola, and the signals are loud and clear, but when I set my dials at the loudest point, the signals become somewhat distorted and lose the clearness they have when the dials are moved over a few degrees.

I have tried to neutralize the capacities according to directions in the booklet, using local broadcast in place of the oscillating circuit they describe. Here is the funny part. I can slide the brass tubes all up and down the condenser with no change in signal strength whatever. Why?

As yet I have not been able to pick up any DX whatever, and according to the dope, I should get Frisco anyway. Of course, I do not expect the DX with 199's as I would with 201 A's, but I feel that I should get some DX, anyway.

My aerial is about 25 feet high and 60 feet long, using 1 wire. Is this sufficient?

I have a copy of this hookup, put out by the WorkRite people, for 199 tubes, and have thought of rebuilding the set with this hookup, but I can't see much difference. If you can give me any ideas as to what I can do to better these conditions, I will be indeed grateful. Another thing, is there any advantage in having a rheostat for each tube instead of one for the amplifiers? LEE MORRILL, Los Angeles, Calif.

A.—Received your very interesting letter of the 23rd inst. The trouble you are having is due no doubt to the receiver being improperly neutralized. Sliding the brass tube on the balancing condenser will have no effect if the proper phase is not found. Reverse the connections to the plate, for I do not believe that the FADA transformers are marked.

If your neutrodyne receiver was working properly, no trouble would be had in getting DX signals. The small "99" tubes should give approximately the same DX range as the larger element tubes. Your aerial is Okay if it does not touch any trees and is properly insulated.

In regard to using the WorkRite hookup with the FADA parts, it cannot be done. The FADA, WorkRite and Ray-Dec-Artcraft transformers are all entirely different. Follow the maker's instructions.

There is no advantage in having a rheostat for each individual tube. One master rheostat is sufficient and simplifies control. ARTHUR L. MUNZIG.

Q.—A. L. Munzig: After reading your article on the neutrodyne receiver in Radio Journal, I decided to build a super-hetrodyne-neutrodyne, using the hookup shown on page 63 of the August issue of Radio Journal, and I would appreciate any hints and criticisms on the construction and operation of the set.

Among other things, would it be advisable to employ more than two stages of radio frequency amplification? Is a radio frequency transformer used as the antenna tuning unit if an aerial is used? CHAS. GONNELLA, Lima, O.

A.—Received your letter of 22nd inst., and am glad to hear that you are contemplating the construction of a real broadcast receiver, viz.: a super-hetrodyne neutrodyne. The circuit as given on page 63, August Radio Journal, uses but 4 tubes, one tube acting as the intermediate frequency amplifier. Three stages should be used instead for extreme sensitiveness, only one stage being about equal to the three tube neutrodyne receiver given in Fig. 8.

In the October issue of Radio Journal will be given the construction of a 6-tube super-hetrodyne-neutrodyne receiver.

A radio frequency transformer can be used for tuning the grid circuit of first tube

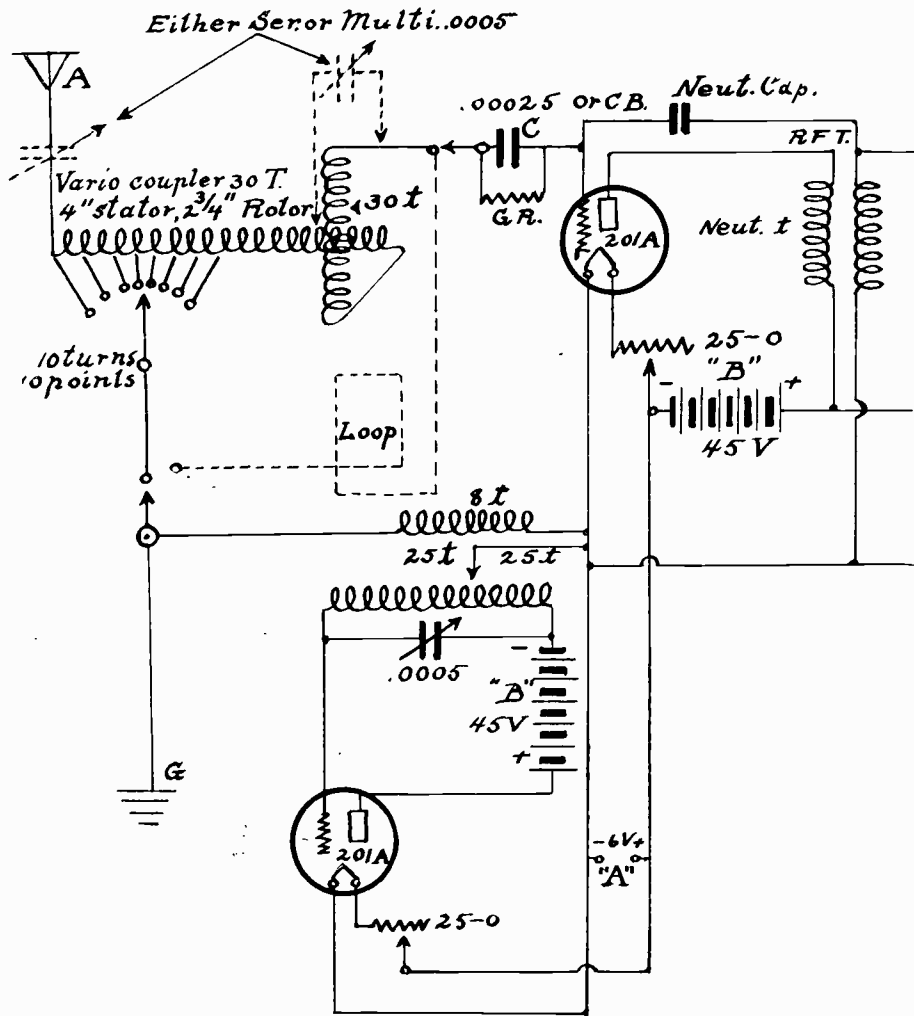

if desirable. A RFT should be used similar to the Ray-Dec-Artcraft R-F tuned neutro-trans, thus simplifying the control of the antenna-grid circuit.—ARTHUR L. MUNZIG.

Q.—A. L. Munzig: Your article in the August issue of the Radio Journal, page 60, is the most interesting, thorough and complete on the subject which the writer has ever had the pleasure of reading, covering the one principle of radio reception along the line of which the writer has been working and believes to be superior to any other known today.

It is the writer's desire to combine the Neutrodyne radio amplification and the Hetrodyne principals, and would greatly appreciate any further information that you may render, especially concerning the following mention.

Size of wire, tubing and number of turns on primary and secondary for each of the RFT?

Size of wire, tubing and number of turns for each of the three coils in the oscillator tube circuit, also whether a rather loose coupling is recommended in this circuit?

Inclosed herewith you will find a rough sketch of a circuit which I had planned before the publication of your article. The tuner designed to be used only with aerial, or loop can be switched in and tuner cut out.

Please give me your idea of using this tuner in connection to your circuit (Super-Hetrodyne-Neutrodyne) as you outline on page 63 in Radio Journal, instead of the oscillator circuit as I have it drawn. Using your circuit complete with the addition of the tuner as outlined for antenna connection. THOS L. BAYNE, Salina, Kan.

A.—Received your interesting letter regarding the Super-hetrodyne and am glad

to hear that you believe my paper on the Neutrodyne was thorough. Complete instructions for building a 6-tube Super-hetrodyne -Neutrodyne receiver appear in this issue of Radio Journal. The sketch you enclose will be satisfactory for the oscillator and antenna-grid tuning circuit. However, leave out the grid condenser and leak in the first tube and substitute with a grid bias of about 4½ volts with the negative terminal towards the grid. Also I would recommend the use of 40 turns in the oscillator plate and grid instead of 25 turn coils, otherwise there will be wave-lengths that cannot be heard. As you have it outlined, it would be ideal for 200 meter amateur reception.—ARTHUR L. MUNZIG.

Q.—A. L. Munzig: I am considering making a set similar to the one in Fig. 8 of your write-up. I had thought of using UV201A for the 1st two tubes and a UV200 for the last tube. Also figured on using a variometer in the plate circuit of last tube. Would greatly appreciate it if you could give me any other information on making this set. How many turns would I have to use on primary and secondary of the R. F. T. to receive from 300 to 600 meters. Would it be alright to use the tubes which I have specified.

C. W. COOPER, Waukegan, Ill.

A.—Glad you liked my article on the Neutrodyne and that you are contemplating building a receiver from one of the circuits given. The use of UV201A tubes is very satisfactory with neutrodyne circuits. I do not care to make public yet the exact construction of the NEUTRO-TRANS for I have put in a lot of time in designing a transformer that will give the desired results with the neutrodyne circuit. The ratio of turns is 4 to 1, approximately theoretically but in practical use there is a deviation.—ARTHUR L. MUNZIG.

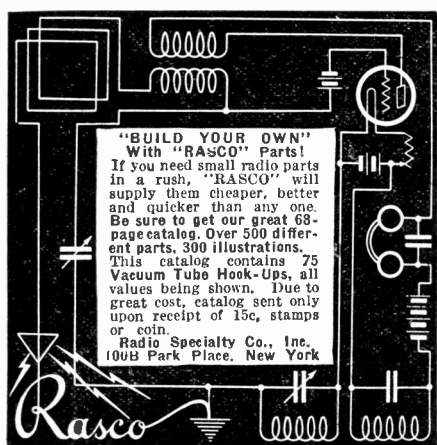

"BUILD YOUR OWN" With "RASCO" Parts!
 If you need small radio parts in a rush, "RASCO" will supply them cheaper, better and quicker than any one. Be sure to get our great 68-page catalog. Over 500 different parts, 300 illustrations. This catalog contains 75 Vacuum Tube Hook-Ups, all values being shown. Due to great cost, catalog sent only upon receipt of 15c, stamps or coin.
 Radio Specialty Co., Inc.
 100B Park Place, New York

Trade Talk FROM RADIO DEALERS AND MANUFACTURERS

More Equipment

One of the significant rumors emanating from those who have recently conferred with radio manufacturers of New York is that many, if not all, radio sets marketed next year will be equipped with tubes, batteries, speaker and aerial, all in the set. Sets are almost all marketed today without tubes or batteries, although sometimes equipped with aerial and speaker. Should the rumor be true, the completely equipped set of next year will

be like a phonograph, ready to operate on delivery. Of course this is, in effect, being accomplished today by dealers who install complete sets in the home. But in the present-day case, the dealer puts in the additional equipment, whereas if rumor is correct, the factory will complete the equipment next year.

Sees Big Year

Mr. E. O. Gerberding, in charge of the radio department of the Fitzgerald Music Company, of Los Angeles, Calif., recently returned from an extensive trip throughout the east, during which he visited most of the principal radio plants and establishments from Chicago and Detroit to New York, Newark and Schenectady. He was intensely interested in studying the manufacture of vacuum tubes, but said that the tube laboratories are not easy of access, owing to a certain secrecy maintained in connection with their operation.

Mr. Gerberding returns with the impression that the year 1924 will see a stabilization of radio, as an industry, and that it will take on all of the earmarks of a big business in which factors can be judged in advance. Up to the present time its instability, owing to many contributing influences, has been its big characteristic. All through the east they expect a big year, bigger than ever, he said.

GREBE CR 12

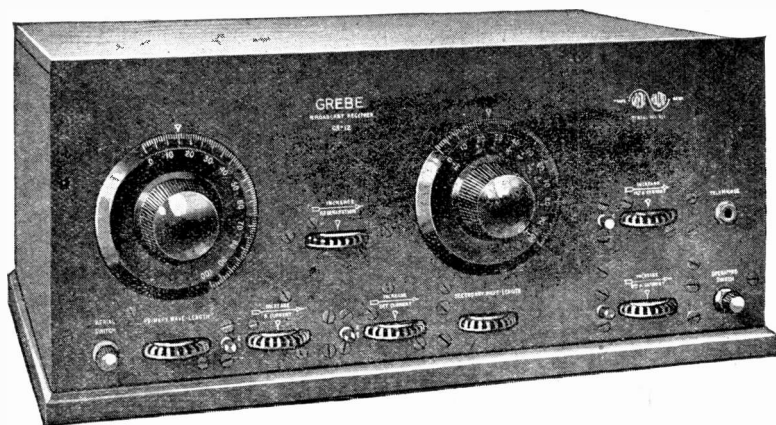

Employs the perfect combination of TUNED RADIO FREQUENCY amplification and REGENERATION. This receiver gives better reception than has been previously possible, through using only a twenty-foot indoor antenna.

DICTOGRAND COMPLETE,
 Installed with Loud Speaker

\$240.00

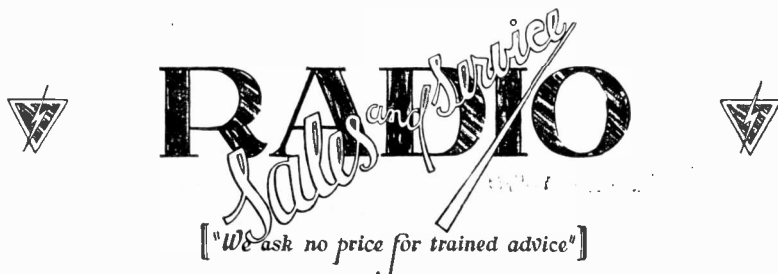

RADIO
Sales and Service
 ["We ask no price for trained advice"]

820 West Seventh St. - Los Angeles, Calif.
 Phone 824-627

Show Room Studio

The Newbery Electric Company of Los Angeles, in its radio department, has fitted up a rather elaborate demonstration room. The room is tastefully and comfortably decorated and furnished. Its walls are deadened to prevent resonant sounds from the busy city and from other parts of the establishment from interfering with radio reception.

New Equipment

The Tune Sharp Radio Equipment Co., Inc., of Los Angeles, Calif., has installed some new machinery and is now manufacturing the already well established line of Tune Sharp variometers and variocouplers on a much bigger scale. The equipment is now turned out in the natural brown (mahogany) bakelite wound with green wire, and constructed for table as well as panel mounting.

The radio filter problem of separating the signals of one wireless station from those of other stations is being studied by a University of Wisconsin professor.

Jewel Receiver

The new Jewel Concert Receiver recently introduced by the Patterson Electric Company, 239 S. Los Angeles street, Los Angeles, California, is one of the most attractive outfits yet offered by a manufacturer, inasmuch as it contains within one cabinet, size 9x14, a four tube set complete with all A and all B batteries and loud speaker. There are but two controls; one a tuner to locate the station you desire and the other a control for the volume. Certainly the ease of operation and the simplicity of arrangement of the new Jewel Concert Receiver is calculated to appeal to the most fastidious buyer. The appearance of the

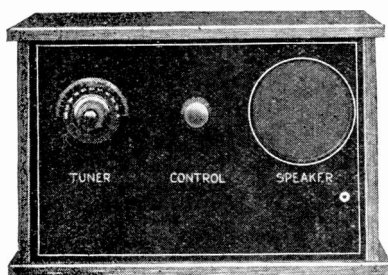

set is backed by the receptive quality of the instrument which is distinguished for its clarity.

The Receiver comes equipped with either dry battery tubes or the higher rated tubes for the wet cells. All of the parts used in assembling the set are standard apparatus, nationally advertised. This fact, coupled with the skill with which the Jewel Concert Receiver is designed, insures the quality of the new product.

The new Roffy Hetro-Trans circuit is used and is distinguishing itself for consistent long distance reception, picking up, through local broadcast interference, San Francisco, Portland and Salt Lake.

Until dealer arrangements are made, this receiver is distributed direct by the Patterson Electric Company.

New Columbia Coil

The accompanying photograph of the new coil put out by the Columbia Coil Company, of Vancouver, Washington, illustrates the design of the coil, which has created quite a sensation.

It consists of a single insulating tube on which is wound a single wire in diagonal lines at a semi-constant pitch from one edge of the tube to the other and then reversing direction, but at the same semi-constant pitch, so that this layer of wire runs in an opposite direction, and an insulating material such as impregnated thread or flax wound on the insulating tube in parallel lines and which separates each layer of wire from the other and prevents one turn of wire from lying on

(Continued on Page 195)

GET READY for the GREAT TRANS-PACIFIC TESTS

Type		Sale Price
Transmitting Equipment		
500	Watt CW Transmitter with Tubes.....	\$400.00
	Kluge 10 watt Radiofone and CW Transmitter	50.00

Condensers

UC-489	.5 mf. 1750 volt Condenser.....	1.60
UC-490	1 mf. 1750 volt Condenser.....	2.50
UC-1014	.002 mf. 3000 volt Condenser.....	2.50
UC-1803	.000025 10,000 volt Condenser.....	4.50
No. 577	.00025 Dublier Mica Condenser.....	2.00
No. 577	.00075 Dublier Mica Condenser.....	2.00
No. 580	.001 Dublier Mica Condenser.....	4.00
CD-888	Dublier Protective Condenser.....	3.00
No. 2747	Amrad Electrolytic Condenser, 38 mf.....	7.00

Inductances

	Acme CW Inductance.....	6.00
	Acme 1.5 h. 150 ma. double Choke Coil.....	6.00
	Acme 1.5 h. 500 ma. double Choke Coil.....	8.00
311-W	Standard 1.5 h. 150 ma. double Choke Coil.....	3.00
UP-415	Plate Circuit Reactor.....	5.75
UP-1626	160 ma. Filter Reactor (New No. UP-1653)....	11.50

Resistances

UP-1718	Gridleak	1.65
	Fada Power Rheostat.....	1.00
No. 813	Remler Power Rheostat.....	1.00
214-A	General Radio 2 ohm Rheostat.....	2.25
PR-539	Universal Rheostat	3.00

Transformers

75 w.	Acme Filament Heating Transformer.....	11.00
300 w.	Acme CW Transformer.....	24.00
300 w.	Thorardson Filament Heating Transformer....	14.00
500 w.	Acme CW Plate Transformer.....	25.00
750 w.	UP-1016 CW Transformer.....	30.00
UT-1643	Magnetic Modulator	5.00
UT-1357	Magnetic Modulator	6.00
UT-1367	Magnetic Modulator	8.50
UP-414	Microfone Transformer	6.00
236-W	Federal Modulation Transformer.....	6.50
231-M	General Radio Modulation Transformer.....	5.00

Miscellaneous Transmitting Equipment

ST-4	Magnavox Hand Microfone.....	15.00
PX-1638	Chopper Wheel	3.00
	Kilbourne-Clark Changeover Switch.....	6.00
	Perry Combination Practice and Receiving Set	3.00
R-69	Menominee Practice Set.....	3.00
	Mesco Key	2.75
178-B	General Radio Buzzer, back mounting.....	1.50
UT-541	50 watt Socket.....	2.50
UV-203	50 watt Tube, slightly used.....	20.00
S-325	30 watt 350 v. Ray-di-co Motor Generator.....	50.00

Paul Franklin Johnson

560 E. Colorado Street
PASADENA, CALIF.

"Everything Worth While in Radio"

Signal Fading Phenomena

(Continued from Page 178)

wave stations than spark stations, but apparently this is not the case. It seems probable that the reflection in the upper regions may more truly be considered a quasi-refraction resulting from an increase in the velocity of the waves as they enter the more highly ionized air.

Strays.—Of the several kinds of strays, some have their origin near the receiving station while others are waves sent out by electrical disturbances in certain definite regions such as the western part of the Gulf of Mexico or the central part of Africa. Such regions are mostly tropical. The fact that strays are more intense at night than in the daytime is explained by the greater ease of propagation of all waves at night so that strays which are only local in their effects in the daytime spread to a distance at night.

The strays at night seem to be caused by occurrences at or above the Heaviside surface, because there are times when the strays are intense and yet signals are inaudible or very weak and fading violently. This indicates a turbulent region of ionization over the area involved, which gives rise to strays and which absorbs waves that come into it. The aurora itself represents an extreme case.

Direction of signals.—There is no correlation between fading and direction changes except that both are greater at night. Thus fading is greatest for short waves and direction changes are greatest for long waves. This makes it appear that the explanations of the two may not be closely related. The interference caused by waves from the Heaviside surface may explain the direction changes observed at night (rapid direction changes on long waves), as it is too remote to cause interference with short waves.

Kinsley has suggested that the direction changes may be the result of reflection at the radioactive boundary between the troposphere and the stratosphere.

Effects of sunrise and sunset.—The change from the ionized sunlight condition to the insulating condition of darkness introduces a surface of discontinuity which acts as an obstacle to the waves, partly reflecting them back. It is to be noted that the change takes place in the stratosphere, above the clouds. This deflection of the waves depends on a change in velocity of the waves, produced by the ionization. Since this change in velocity is proportional to the square of the wavelength, the sunrise and sunset effects are greater for the longer wavelengths.

Effects of time of year.—The increase of signal strength at night and the scarcity of strays in winter indi-

cate that the Heaviside surface is more nearly level and encumbered with fewer masses of ionized air which are emitting disturbances. This more quiescent condition is probably a result of the sun's acting on the atmosphere for fewer hours each day.

Effects of atmospheric electricity, terrestrial magnetism, solar activity.—There is slight connection between radio phenomena and the usual variations of atmospheric conductivity and similar quantities at the surface of the earth. During intense strays and fading, the conductivity and potential gradient have been known to fluctuate more than usual. This indicates that the masses of ionized air that cause the radio phenomena have a slight effect extending down to the earth's surface.

The visible aurora seems to involve a lowering of the Heaviside surface

How about a crystal contest, folks? Lots of novices in the radio field are just starting their experiments with the crystal set. And they want hookups. So shoot 'em in. For the best crystal hookup submitted by December 15, Radio Journal will give an Advance 23 plate variable condenser. For the next best, we offer a year's subscription to Radio Journal. So hop to it. The chance is yours. Address your hookup diagram and a brief explanatory description to Radio Journal, 113 Stimson Bldg., Los Angeles, Calif.

far down into the stratosphere or even lower. It is known to extend down to about 60 kilometers above the earth's surface. This is done with much turmoil so that it usually stops short-wave radio altogether, or, if signals can be heard, the strays are violent. It completely upsets all usual radio conditions, in fact, in special cases it improves short-wave signal intensity over a certain territory, probably because in this case the lowering of the Heaviside surface envelops the usual source of disturbances.

Discontinuities.—While often difficult to explain, discontinuities are probably caused by some local ionization which acts like a barrier for that particular region. The fact that transmission is good for points beyond the silent zone substantiates the general theory of transmission of waves at night by the upper part of the stratosphere. In such a case they probably go around the barrier.

The origin of this local ionization is unknown. Apparently some local condition on the earth's surface may cause it. It may be direct, as by radioactive emission, or indirect, as by extreme

temperature differences or vertical convection currents in the air. Such indirect causes seem probable since there are many cases of discontinuities on or near the coast or in mountainous regions.

The cause of discontinuities is doubtless related to some sort of ionization change such as that accompanying sunrise and sunset.

It can be concluded that the causes or sources of fading and of strays are in the atmosphere between the earth's surface and the Heaviside surface. However, the origin or these causes, in turn, is undoubtedly from below the ground or from outside of the earth's atmosphere.

Daytime transmission is effected entirely by means of the waves carried along the ground, while night transmission, especially at great distances and on short waves, is by means of waves transmitted along the Heaviside surface. The latter, at night, are thus free from the absorption to which ground waves are subject in the daytime. They are, however, subject to great variations, caused by irregularities in the Heaviside surface and absorbing masses of more or less ionized air at or near that surface. These variations account for fading.

The theory here given may be only a very rough approximation but it has the advantage of giving a clearer picture than has been available. The inter-relation of radio phenomena and the atmosphere's electrical condition is very close. Subordinate in importance to the atmospheric conductivity are the other electrical properties, the solar constant, and the terrestrial magnetic and meteorological conditions.

Roffy Hetro-Trans

And 3 and 4-Tube Blue Prints
in Stock

For immediate delivery, we carry

The New Erla No. 2 Transformers
C.R.L. Grid Leaks
Baldwin Head Phones
All-American Transformers
Workrite Parts
Master Radio Parts
Eveready A Batteries
Howard Radio Parts
Dunham Loop Aerials
and other quality lines.

Full Line of Electrical Supplies

Cook-Nichols Co.

Wholesale only.

Special Manufacturer's Discount
411 So. San Pedro Street. Metro 3741
Los Angeles, Calif.

(Continued from Page 193)

the other. This causes a definite upward and downward variation of the winding pitch of each layer, and the turns of wire are thus built up in layers intersecting with layers of insulating material until the required height is reached, according to the specifications of the coil employed as to inductance therein. It differs from the ordinary diamond wound or lateral wound coil in that there is a variation of the winding pitch as often as

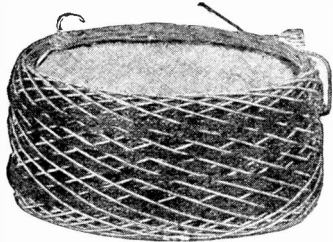

twenty times in each turn. Where the ordinary diamond or lateral wound coil intersects at the crossing of each turn of wire and forms a miniature capacity pocket, an impregnated special insulating material separates the two layers and reduces the capacity to nil. It differs also from some inductance coils in that the insulating material is not meshed, but is placed on the coil in parallel lines, while the wire is run on in diagonal lines from side to side of the insulating tube, forming a more attractive arrangement and reducing the capacity effect to a marked degree. The coil is moisture proof and extremely rigid in construction. It is estimated by Columbia engineers the resistance of this coil at high frequency, due to

Trade It

TRADE—NEW \$65 CROSLY MODEL XJ FOR Magnavox and transmitting apparatus or transmitting apparatus only. A. WELD, Cleveland, N. D.

Have you valuable radio equipment on hand for which you have no further need? Trade it for something you can use in your new set. You are constantly building new sets, trying out new circuits. You have valuable condensers, variometers, what-not, on hand, which you cannot use. Someone else may have discarded just what you need and may need just what you have discarded. Get together and "swap." To help you do it, Radio Journal will open an "Exchange" column in which you can list what you have to trade and what you want. Send us your "For Exchange" notice now for the November issue. It will cost you only 2½c a word, minimum listing 10 words. Address "Exchange Department, Radio Journal, 113 Stimson Bldg., Los Angeles, Calif."

The New Roffy Hetro-Trans

Four-Tube Circuit is Used in the New

Jewel Concert Receiver

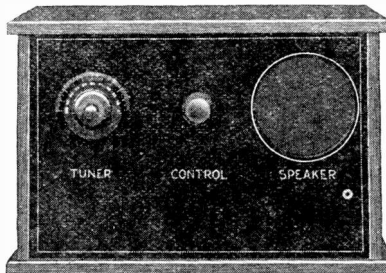

Distance—Volume
Quality—Selectivity

Complete in cabinet—only 2 controls—battery and loud speaker within the walls. The most complete and convenient receiver on the market—and the simplest to operate.

Because we buy everything in large lots—leaving nothing for you to get—this Jewel Concert Receiver sells at an amazingly low price—

\$97.50—and there's nothing else to buy!

For those who want to construct their own set, we will furnish cabinet, loud-speaker, 4-tubes, battery and wiring diagram for **\$77.50**

The New Roffy Hetro-Trans Selling at \$8.50

eliminates parts costing almost \$100.00. That is why the Jewel Concert sells at the surprisingly low price of \$97.50.

Build your own set. Save over \$90 and have your apparatus so simply constructed that it is hard to put it out of order. Get clearer tones—greater volume—better quality and perfect selectivity. Write us today if your dealer cannot supply you.



Patterson Electric Company, *Manufacturers*

239 So. Los Angeles Street

Telephone 828-139 Los Angeles, Calif.

For sale also at Brode Electric Co., 116 E. 3rd St., Los Angeles, Calif.

A MESSAGE FROM M. A. R. S.

We are ready with one, two and three-tube ERLA Sets for demonstrations; also all necessary parts and hook-ups.

Manual Arts Radio Shop

Phone Vermont 7836

4154 South Vermont Ave., Los Angeles, Calif.

its peculiar construction, is approximately thirteen ohms below that of any other coil of its type. The coil is built in sizes suited to broadcast wave lengths and may be secured in any number of turns, from 25 to 150.

New Speaker

Western Radio, Inc., of Los Angeles, Calif., has just secured the exclusive distribution, for the state of California, of the Morrison loud speaker. This speaker attaches to al-

most any make of horn, or on the arm of a phonograph. Attachment is made in less time than it takes to tell about it. A little nicked dial in the rear of the speaker provides for all the adjustment needed. The speaker can thus be controlled to give 100 per cent volume in true, full tone, or to give soft music or low spoken voices, a single turn of the knob doing it. The speaker unit is manufactured by the Morrison Laboratories, Inc., of Detroit, Mich.

INTRODUCING

The New PEARLCO REFLEX Transformer. A Superior Transformer for all Reflex Circuits. Price, \$4.50.

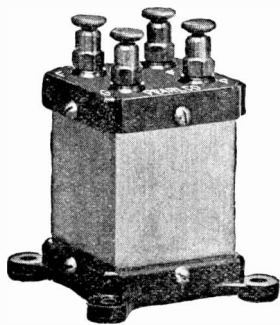

A stamp brings literature describing the entire PEARLCO line. Parts sent postpaid upon receipt of money order or certified check. No. C.O.D.

Satisfactory Discounts to Dealers.

Yale Radio Electric Company

4816 S. VERMONT AVE.

LOS ANGELES, CALIFORNIA

LONG DISTANCE IS WHAT YOU WANT

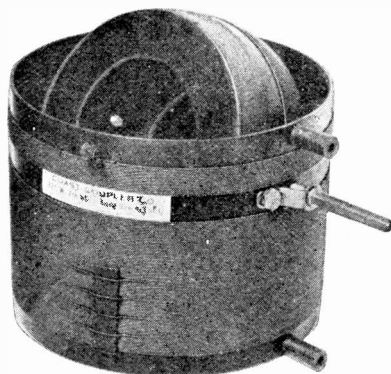

Use a COAST COUPLER and Long Distance is what you'll get. These stations have been heard in Long Beach with a COAST COUPLER:

- WDAP Chicago
- CFCN Calgary
- WWJ Detroit
- PWX Havana
- WSB Atlanta

Anywhere in the United States, \$5.00. Dealers and Jobbers, investigate.

Coast Coupler Company

245 E. 7th St. Long Beach, Calif.

RADIO BARGAIN

We must close out our \$6,000 stock of Radio Appliances, marked under name RACO on account of our other business. We offer for cash with order, subject to prior sale

- Sockets.....12c each
- Dials15c each Rheostats25c each
- 23 Plate Condensers.....50c each 43 Plate Condensers.....75c each

Or we will accept a low cash offer for the entire lot.

RADIO APPLIANCE COMPANY

ONTARIO

CALIFORNIA

Go to a Radio School Free

For a Little Work for Radio Journal.

Radio Journal is able to offer the complete International Correspondence School's course in Radio to any of its readers who can secure

Thirty-Four Subscriptions

to Radio Journal. They may be new or renewal. Get out and hustle during your spare time this summer and in a few days the course will be yours. This offer is limited, so get into action now. Address all subscriptions to

RADIO JOURNAL PUBLISHING CO.

113 Stimson Bldg.

Los Angeles, Calif.

Eclipse Test

Radio transmission during an eclipse of the sun has been the topic of much speculation and was tried out by 6BVE during the recent eclipse on the Pacific Coast. His address, RFD No. 2, Box S 38, Los Angeles, Calif, gives his location as in about the 99 per cent total phase of the eclipse area. He writes:

"DX sigs started as darkness began and faded out as it became lighter. The "A" battery was down or results would have been just like night. Calls heard (all time given is p.m., or shortly after noon): 7KU, 12:27; CQ de 6AON, 12:50; ? de 6AON, 12:52; 6FY de 6AFQ, 12:54; 6BQB de 6ANB, 12:55; ? de 6FY, 1:00; ? de 6BNU, 1:01; 6CN de 6FY, 1:03; end message de BQB, 1:04; ? de 6FY, 1:06; ? de 6AWT, 1:07; ? de 7AW, 1:08; 6ABZ de 6AFG, 1:10.

Evidently a lot of good amateurs are trying it out.

How about that transmitter you plan to build? Anything that puzzles you? Radio Journal is prepared to give assistance to any amateur or novice who wants to become an amateur, in the construction of transmitters. Send us your questions. Radio Journal will make a sincere effort to solve any radio problem, transmitter or receiver, submitted. Fire them along, folks. Address Radio Journal, Question and Answer Dept., 113 Stimson Bldg., Los Angeles, Calif.

Radio "Up North"

Editor Radio Journal: Having recently returned from a trip up the coast to Vancouver, B. C., I thought that you might be interested in knowing about what I saw "en route" in the way of radio. While nearly everyone was away on a vacation so that I could not get much dope, yet there are a few things that might be worth mentioning.

Probably among the foremost of interesting things, was the radio situation in Canada. While business in the way of selling broadcast receivers is not altogether nil, still it is very lax in comparison with the trade in the states. This is due, I think, to inferior broadcast stations in Canada, and also to a poor quality of receiving sets on the market. Two of the leading makes of radio equipment in this country are hardly known there, and are not on the market at all due to patent rights. What sets they have are nearly all U. S. design, and, while made in Canada, are exactly the same as the U. S. articles. The standard makes, such as Westinghouse, Western Electric, etc., are just the same as in this country, with the exception that the name is Westinghouse, Limited, etc.

The amateurs are not restricted as much as they are here and a license is obtained very easily. Supervision of amateurs does not seem to be strict, either, as one fellow told me that he had his station "on the air" for a while before he had a call, or knew the code. Can you imagine anything like that around here?

All tubes are of U. S. design (as are the sets) and are just one dollar more in price. I could find no English tubes at all, as they said they were more expensive and less efficient than the American tubes. Consequently, there is no market for them. Parts are about the same price as they are here,

possibly a little higher. Most of the standard make phones were the same price, with the exception of the English Brown's phone, with the adjustable diaphragm, which sold for \$18.00 a pair.

Practically the only Canadian radio equipment that I could see, was a loud-speaker and a small receiving tube. The latter was about two-thirds the size of the "99" tube and was said to have the same characteristics. I doubt, though, if it was as hard, as the glass was clear. I also saw a Marconi combined transmitter and receiver which was rated at 500 watts and sold for \$4,000. "Nuf sed!"

I had hoped to see most of the fellows that I have worked up north, on the way, but as there were not many of them at home and also due to my limited time, I only saw a few. Among those that I did see were 6AME, 6ATZ, 7LR, 7SF, 7HF, Canadian 50N (just his set), 6BU and one or two others. They were all anxious to get "on the air" this winter, and most of them are coming on with 50 to 100 watts. Sounds good for the trans-Pacifics.

I met 7SF by accident along the road, as he had his call letters on the windshield of his car (an example which I followed later). Saw him just north of Sacramento and had a talk with him after having chased him for about a mile.

Before leaving home, threw together a small set to take with me. It is the ordinary single circuit hookup in a cabinet four inches high and containing one C-299 tube with all batteries. I used this set a few times and the results, though nothing wonderful, may be of some interest to you.

At Sacramento, the set was used with a small aerial and water pipe ground. Heard the following stations during a period of not more than fifteen minutes on two consecutive nights. August 9th and 10th: 6FH, 7LN, 6PL, 6RM, 6CGD, 6CFI, 6COU, 7GP calling 4CH (Hihi), 6ARB calling 5LG, 6BUY calling 9CAA, 6PL calling 7GP (QSA), 6AWT calling CQ and 6BRF calling 6AWT. I also heard KHJ, which was QSA.

At another time in Rainier National Park, at an elevation of 5,557 feet, I again listened in. Was using an aerial that averaged about 8 feet high, and about 70 to 80 feet long. The only ground that I used was the body of the car. A good ground was hard to get, and as all amateur installations have to be finished in about three minutes, I did not take the trouble. I am sorry now that I didn't do it. This was August 22nd, from about 10:30 to 12:00, midnight. Heard the following stations: KHJ (loud enough to understand easily), 7GO, 7EO, 7EB, 7NN, 6TV (QSA), 7ADP, 7TO, 6VK, 7HF, 7WM, 7QJ, 7RC, 7AK, 7BJQ, 6AOS (QSA), 6AWT (very QSA), 7AVQ and 7AKT. I sent these fellows cards, and saw 7HF later in Eugene, Ore., as I was going through. He said that that night he had just come "on the air" for the first time. There was very little static and no "QRM."

By the way, the tube socket in the little set was not cushioned at all, and though the set was on the floor of the car all the time we were moving, the bumps did not seem to hurt it in the least, although I went over 4,200 miles with some "wild and woolly" roads, too.

I had a very pleasant trip and enjoyed the somewhat unusual customs in Canada very much. I might mention among other things, that it seemed queer to see right hand drive Fords which had been left over since the change in custom of driving on the left side of the street.

Didn't intend making this letter so long, so hope you will pardon me for taking so much of your time. Sincerely yours, WALLACE S. WIGGINS, 6AVI, 6CHZ, Los Nietos, Calif.

The
Artists of the Radio
are at their best
with
Morrison
Loud Speaker

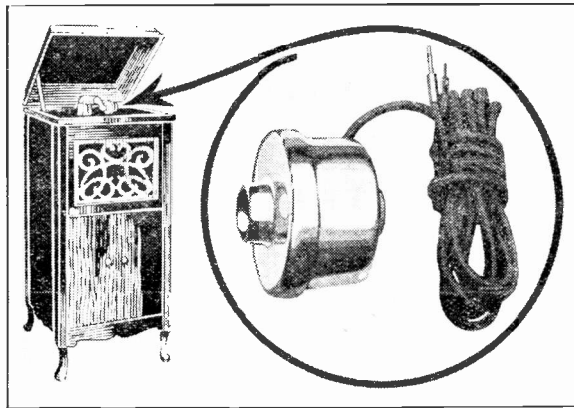

TRUE tones, sweet and clear, soft or loud, as you wish, are assured you when you use the Morrison Loud Speaker on your phonograph or radio horn. One hundred per cent volume by the turn of the knob on the rear of the Morrison—giving full, true tones without rattle or vibration, even when amplification is extreme—a very desirable feature for use in large rooms or for dancing parties.

If your mood demands soft music or low spoken voices, another slight turn of the knob—and you have it.

Adaptable for use with any bulb set, with one or more stages of amplification.

The Morrison Loud Speaker can not get out of order. It fits the tone arm of any phonograph or practically any make of horn. Any one can connect it in a moment. It functions perfectly thereafter.

The Morrison Loud Speaker is made of finest materials obtainable; each unit is thoroughly inspected for quality and it is sold under an unqualified guarantee.

Should you not be entirely satisfied with the Morrison Loud Speaker we want you to say so and your money will be refunded immediately.

Price \$10 Complete
Get it today — hear it tonight

Western Radio., Inc.
637 South Hope Street, Los Angeles, Calif.

Classified Advertising

Follow these advertisements every month. Reliable advertisers from all over the country offer their most attractive specials in these columns.

Objectionable or misleading advertisements not accepted. Advertisements received too late for current issue will be accepted for the issue following.

Name and address must be included at the above rate. Cash should accompany all classified advertisements unless placed by an accredited advertising agency. No advertisement accepted for less than 4 lines.

Classified Advertising Rates, 5c per word. Time discounts for consecutive insertions; 3 times, 5%; 6 times 10%; 9 times, 15%; 12 times, 20%. Minimum charge, \$1.00.

PERSONAL

PATENT FOR SALE—Foldable screened rocking chair, adapted for porches, country places, hospitals, seashore. Two articles in one invention. Address Stransky, 200 Greenway Ave., Darby, Pa.

PRINTING

CALLS HEARD POSTAL CARDS for DX reports. Station call letters in color. Printed on government or plain postals. 80c hundred up. "Used Everywhere—Go Everywhere." Write for samples. Radio Print Shop, Box 582, Kokomo, Indiana.

CALL CARDS—Printing only Amateur Call cards. I can make very low prices. The most popular kind: Red and Black, post-card size, 1st 100, \$2, each additional 100, 80c. Above printed on 1c stamped post-cards, 80c per 100 extra. Mail money order and correct wording to Joseph Boehm, 3511 Seminary Ave., Chicago, Ill.

RADIO EQUIPMENT

HELP YOUR SET cut out interference by using a circuit for every need. Blue Prints for constructing 9 circuits. Combination Primary Condenser Switch at fifty cents per set or three sets for one dollar. Sell two and get yours free. A. Franklin Starbuck. (61Y) 569 Franklin St., Whittier, Calif.

WAVEMETERS CALIBRATED without Bureau of Standards wavemeters. Send us a good variable condenser and we will make it into a wavemeter. Prices reasonable. Correspondence invited. Radio, 6GL, 465 North Lake St., Los Angeles, Calif.

BARGAIN—Brand new Grebe CR5 and ROK amplifier. Cost \$135.00, sell \$95.00. A. E. Alger, Lorain, Ohio.

FOR SALE—Hartley Modified Circuit Transmitter. Interchangeable for five, ten, fifty or 100 watt work. Chemical rectifier. All mounted on 20x14 panel. Set includes key and everything but tubes. Contains four sockets, two for 50 watters and two for 5 watters, all banked up. Built for 100 watts, now radiating 4 to 4.2 amperes. Can be shown in operation. Price \$200. Address F. L. Wetzel, 8735 Juniper street, Los Angeles, Calif. Phone South 6266-R.

RADIO FANS, equip your storage battery with SURE-GRIP connectors, they are easily attached, non-corrosive and will not jar loose. Price 25 cents per pair postpaid in United States or Canada. Southern Specialty Co., 2007 Everett Street, Houston, Texas.

MYER'S TUBES—Four tubes in A-1 condition, with receptacles, \$12, all four to one party. Postage 20c. Box 7, Radio Journal.

Vacuum Tube Hospital
We repair and guarantee them.
Agents, Dealers, and Customers Wanted.
George H. Porell Co., Inc.
West Somerville, Mass.

FOR SALE—One Reinartz Tuner Detector, Two Step in Cabinet \$45.00. One glass McTighe "B" Battery and Rectifier \$4.75. One Homecharger \$12.50. Albert W. Krug, Gardiner, Ill.

HAMS! Pure aluminum for rectifiers 1/16 inch \$1.50 per square foot. Electrical Specialty Co., 407 Indiana Ave., Valparaiso, Indiana 9DVK.

SCHOOLS

RADIO FANS AND PROFESSIONALS—How many of you know the correct CODIFICATION of all characters, punctuations and signs (such as \$, per cent, etc). We dare say that nine out of ten don't know them correctly! Our instructor who has had 35 years' experience, eight years of which were with Uncle Sam as MORSE and RADIO TELEGRAPHER, has just published the first and only CHART known to give fully a true and correct CODIFICATION of ALL characters used in both codes. This CHART is indispensable to all up-to-date beginners and veterans alike. Fifty cents (money order preferred) will bring CHART, also much information extremely interesting to BOYS and

GIRLS; because, with this information and a little PEP on your part, you can qualify shortly (as scores of our graduates have done) and secure positions paying \$1,500 to \$3,000 yearly. (See Civil Service Bulletins 215, 357 and 54.) We are registered with the U. S. C. S. Com. at Washington, and can help you. AMERICAN TELEGRAPHIC STUDIO, BOX 793, WORCESTER, MASS.

CORRESPONDENCE SCHOOLS

Used correspondence school courses only one quarter original price; bargain list 1000 courses free; used courses bought. Students' Exchange, 47A West 42nd Street, New York.

Double entry bookkeeping mastered in 60 hours; guaranteed; diploma. International Bookkeeping Institute, Springfield, Missouri, Desk 10.

FOR SALE

MYER'S TUBES—Four tubes in A-1 condition, with receptacles, \$12, all four to one party. Postage 20c. Box 7, Radio Journal.

A. B. C. of Radio by Waldemar Kaempfert—over 500,000 copies sold at 25c. a copy. One of best beginners' radio books on market. Special price 16c, each, postpaid. Western-Radio Supply Co., 418 Stimson Bldg., Los Angeles.

For Sale—\$30—Audion detector set, single tube, complete with phones and new UV200 tube. Address 2X, 113 Stimson Bldg., Los Angeles, Calif.

FOR SALE—High Class Table Type Radio outfit—two steps radio frequency-detector—two steps audio. Magnavox coupled to standard wood phonograph horn. Price complete with tubes and B Battery \$275.00. This is a real bargain. May be seen in Los Angeles. Address, Radio Journal, Box 200.

Audion Detector Set, with tube, brand new (not second-hand), in fancy box. Price, \$40. Address Box B-1, Radio Journal.

Ten per cent discount on all standard radio goods. Prompt service. Superior two-step Amplifier, \$25.00. QST Radio Service, Williamsport, Pa.

MISCELLANEOUS

FORMS to cast Tin Soldiers, Marines, Indians, Trappers, Hunters, and my Air Pressure Cannon Machine. Moulds from \$1.25 up to \$3.50, casting 3 to 4 pieces at once. Write for catalogue. H. Schiercke, 1034 72nd St., Brooklyn, N. Y.

ONE MILLION MARKS, \$5.00

40,000 GERMAN marks, \$1. 10,000 Austrian crowns \$1; one million Russian rubles \$1, all three for \$2.50. AMERICAN SALES CO., Box 1278, San Francisco.

BECOME a millionaire overnight. I'll mail you 1,000,000 Russian roubles bank notes for \$2; 5,000,000, \$7.50; 10,000,000, \$10. AMERICAN SALES CO., box 1278, San Francisco.

Homespun Tobacco—Chewing—5 lbs., \$1.25; 10 lbs., \$2.50; 20 lbs., \$4.50. Smoking, 5 lbs., \$1.25; 10 lbs., \$2.00; 20 lbs., \$3.50; Farmers' Union, Mayfield, Ky.

RADIO-APPLAUSE Post Cards. Encourage broadcasting by such acknowledgment. 2 dozen, 25c, postpaid. D. J. SPANGLER, Elkhart, Ind.

MAIL ORDER METHODS—\$50 WEEK, evenings. I made it; mail order business. Booklet for stamp tells how. Sample and plain, 25 cents. Free 12 articles worth \$3. Alraj Scott, Cohoes, N. Y.

Amrad Tuner and Detector Two Step, \$90.00. Clapp-Eastham H.R. receiver with H.Z. amplifier, mahogany, \$65.00. Magnavox R3, \$40.00. All new, perfect condition. Send money-order. Ridgewood Orchard, Winchester, Va.

Sell or Trade for Radio Parts, 15 Dial Omnigraph A1 condition. Write Wesley Kinan, 32 North Avenue, Canandaigua, N. Y.

AGENTS WANTED

Free Sample "Rain Shield Wiper"—retails \$1; cost you 25c (300% profit). Invention just out. Sold on clear and rainy days. Every automobilist buys quickly. No cloth. No paste. No mechanical attachment. 1 rub keeps windshields clear 48 hours against rain, snow storms. Prevents accidents. Riley made \$108 three days. Slocum makes \$10 hour. Experience unnecessary. Wonderful pocket sideline. Write quickly for your free sample. Nu-life Corporation, Hartford, Connecticut.

Amateur Agents wanted in every city and town to sell radio apparatus. A few stocking agencies will open. Delfelco, 12 Meeting Street, Pawtucket, R. I.

Agents wanted everywhere to sell those Wonderful California Herbs for Rheumatism. People from all over the U. S. have written us the last five years about the extraordinary results from these marvelous herbs. Send for free booklet. Pound \$1 postpaid. Rheumatism Herb Company, Sawtelle, California.

Agents—Try our needle cushions. Big profits. Good sellers. Sample 15c. Peters Mail Order House, 12 Harrison Avenue, Gardiner, Maine.

Stop Daily Grind. Dependable Plans Free. Easy silvering mirrors, headlights, tableware, etc. Clarence Sprinkle, Dept. 71. Marion, Indiana.

AUTOMOBILES

AUTOMOBILISTS—A pair of "Is-It-Lit" reflectors attached to your headlights will tell you when driving whether they are lighted. Two styles \$1.05 and \$1.58 the pair. The H. D. S. Co., 79 Walnut St., Somerville, Mass.

Automobile Mechanics, Owners, Garagemen, Repairmen, send for free copy America's Popular Motor Magazine. Contains helpful instructive information on overhauling, ignition wiring, carburetors, batteries, etc. Automobile Digest, Butler Bldg., Cincinnati.

Fords run 34 miles on gallon gasoline. Other cars show proportionate saving. Wonderful new carburetor. Starts easy in coldest weather. Fits any car. Attach yourself. Money back guarantee. Sent on 30 days' trial. Agents wanted. Air Friction Carburetor Co., Dept. 3222, Dayton, Ohio.

BATTERIES

Edison B. Battery Units—One positive and one negative plate for 10c. 18 sets will make a 24-volt battery. Wilkinsburg Wireless Shop, 711 Penn Ave., Wilkinsburg, Pa.

BB Batteries. Make Your Own Rechargeable from standard pasted plates. Negative or positive at \$.10. Jars for same \$.05. A sample postpaid for \$.30. A complete stock of parts ready for immediate shipment. Magnavox's, vacuum tubes, receivers, etc. Electric Service Shop, Bradford, Ill.

BOOKS—CATALOGS

Radio Dealers and Booksellers Attention! Attractive 16-page booklets. No. 1—"How to Build a Beginners' Simplified Receiving Set." No. 2—"How to Build a Simple Loose-Coupler Receiving Set" with diagrams to illustrate. Sale price 15c, marked on copies. Price to dealers \$8.50 per hundred. A fast seller. State assortment, or number of booklet wanted when ordering. Money orders by mail only. Dillinger, 115 Stimson Bldg., Los Angeles.

Radio Dealers Attention! Attractive folder with back blank for your advertisement. "Construction of a Simple Vacuum Tube Detector Set," with diagram with every part pictured as it actually appears in complete set. \$5 per hundred. Try a sample lot of 50 for \$3. Money orders by mail only. Dillinger, 115 Stimson Building, Los Angeles.

Listening In

A Goodly Batch

DX calls heard by 9BFT, Leon Mears, 4511 Colfax Ave., So., Minneapolis, Minn., during July and Part of August: IAEG, 1AJX, 1BAC, 1BBO, 1BCG, 1CCG, 1CMP, 1PJ, 2ANI, 2AWL, 2CBJ, 2CXL, 2CG, 2GD, 2IG, 2HP, 3ABW, 3BVY, 3COK, 3CSJ, 3BP, 3CO, 3CK, 3GD, 3OH, 3XN, 3ZS, 4CN, 4CS, 4FG, 4FT, 4GX, 4KU, 4MI, 4MK, 4US, 5AGJ, 5AHP, 5AIU, 5AIV, 5BE, 5CA, 5CC, 5FV, (5GJ), 5GM, 5HM, 5KU, 5KW, 5LL, 5MO, 5MN, 5MA, 5NH, (5NS), 5PS, (5RL), 5SN, 5XW, 5ZAV, 6CGD, 6KA, 7ZV, (8AAJ), 8AAP, 8AAG, (8ADA), 8AEB, 8AIO, 8AJU (8AOQ), 8AOT, 8APX, (8APT), 8AWP, 8AWS, 8AKN, 8AXO, 8AZO, 8BBG, 8BCI, 8BDA, 8BDU, 8BEI, (8BFH), (8BGL), 8BHE, 8BHY, 8BJU, 8BJV, 8BJO, 8BLC, 8BNO, 8BTT, 8BUR, 8BUB, (8BUZ), (8BWZ), 8BXH, 8BXX, 8ZC, 8BZY, 8CED, 8CEJ, 8CCR, 8CIE, (8CNR), 8CNW, 8CQH, 8CRW, 8CSJ, 8C-UJ, 8CUR, 8CUV, 8CVE, 8CXM, 8DAA, 8DFA, 8DGL, 8DKM, 8DZY, 8ZAL, 8AB, 8CP, 8ES, 8FM, 8GZ, 8HV, 8HW, 8IJ, 8IW, 8JJ, 8KG, 8NV, 8OE, 8PD, 8RJ, 8SS, 8UX, 8VY, 8VT, 8TX, 8WL, 8ZW, 8ZZ.

Canadians: 2RG, 3ADN, 3BP, 3GK, 3KO, 4GX, (3XN).

W1 QS1 to any of above if they request.

Call 6ZP has been assigned to Lloyd E. West, 342 Main Street, Riverside, Calif. Mr. West was formerly known as 6IV.

From 9ZT

Call report from 9ZT, D. C. Wallace, 54 Penn Ave. N., Minneapolis, Minn., for two weeks in August, distance over 1,000 miles: CW, 1ER, 1BBO, (1BCG), 1BES, 1BSJ, (1BWJ), (1CRW), 2BNZ, 2BRC, 3AB, 3BV, 3IW, 3SC, 3BRF, (3BVA), (3CHG), 4EB, 4CL, 5GJ, 5GN, (5GP), 5NJ, (5NS), 5SK, 5UC, 5UO, (5ABA), (5ACQ), 5AJJ, (5AKN), 5AMH, 5XAB, (6HP), (6KM), 6TV, 6ARB, (6ARU), (6AWT), (6BJQ), (6BVG), (6CBU), 7ZN, (7AGV).

Canada—2BN, MEX, JH.

Portable Record

6BUR, Portable 6AQF, L. Elden Smith, at Idylwild, Calif. (onc C299) Aug. 28 only: IA? (ICW), 1BBO, 2TT, 5ADB, 5AKY, 7GO, 7LH, 7AKV, 7AKZ, 8DIG (QSAVY), 9GD, 9AAU, 9BJK, 9BUN, 9BUO, 9CAJ, 8VC, 9EAE. My antenna was only about 20 feet high and 40 feet long. It was surrounded by large pine trees and to the east was a mountain 8,000 feet high, rather poor conditions for radio reception.

In Foreign Parts

C. W. Park, 6AOI, on part time with 10 watts and more often with 5 watts, has been heard three times in Alaska and over a dozen times in Hawaii, twelve successive nights in North Carolina and by station BX in Mexico several times. The station is located at Riverbank, Calif.

The First National Bank of Whitehouse, N. J., as an experiment, installed a radio receiving set with a loud speaker in its women's banking department. On "radio days" the First National's receiving teller is now kept busy opening new accounts.

The New ROFFY HETRO-TRANS



The simplest and most economical piece of apparatus so far perfected for Radio-Receiving Sets. Replaces parts costing \$100.00 or more.

Sells for
\$8.50

Distance Clearness Volume Selectivity
For those who wish to build their own sets we will furnish all parts, including tubes, batteries, speaker, cabinet, etc., complete for \$70.00. ALL DIAGRAMS FREE

Patterson Electric Company

DISTRIBUTORS
239 So. Los Angeles Street Los Angeles, Calif.
Telephone 828-139
DEALERS!-WRITE US FOR ATTRACTIVE PROPOSITION

TRIMM PHONES

Light, Easy and Comfortable

\$5 DEPENDABLE 2400 ohm. Guaranteed. Highly polished aluminum back. Scientifically correct, matched phones.

\$7.65 Professional 3000 ohm. Guaranteed 2 years. All bakelite. Ask your dealer. If he cannot supply you, write in giving your dealer's name.

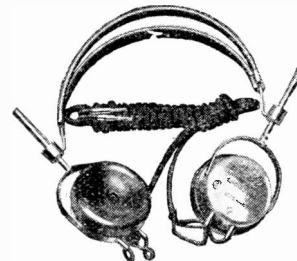

CARL A. STONE CO.

Representing Trimm Radio Mfg. Co., Chicago
538 San Fernando Building Los Angeles, Calif. 315 Foxcraft Building San Francisco, Calif.

WHEN ANSWERING ADDS PLEASE MENTION THE RADIO JOURNAL



Mounted 50c Unmounted 25c

[Work in Reflex? Yes! It sure will!]

"CATWHISKER" RADIO CRYSTALS

Our standard is set higher than was thought possible, and that is making better Radio reception for all.

Let them all meet our standard, and the day of bum radio crystals is gone!

To make BETTER crystals for you, we are going to MOUNT AND TEST THEM AT THE MINE! Out in the desert, beyond Death Valley, where the static is the worst on earth, EVERY CATWHISKER CRYSTAL WILL BE TESTED ON LONG DISTANCE CONCERTS. Does that mean anything to you? Our nearest station is 400 miles. Our farthest—well, WE HAVE PICKED UP CHICAGO AND FORT WORTH ON A CATWHISKER CRYSTAL! Think that over.

El Picacho Mining Company

LAS VEGAS, NEVADA

Radio Club Activities

Too Many Holidays

"Too Many Holidays" might be an appropriate title for the story of the meeting of the Southern California Radio Association Saturday evening, September 1, at Walker's Auditorium, Los Angeles. As the regular meeting night fell on Labor Day, a holiday, the meeting was shifted to Saturday. Apparently most everyone was taking advantage of the chance at a two-day week-end and had hiked to the mountains or sea shore. Anyhow, about twenty of the faithful were on hand for their semi-monthly talkfest.

A communication from Traffic Manager F. H. Schnell of the American Radio Relay League was read, relating to plans for the winter and proposed regulation of traffic. The communication was filed for further consideration in conjunction with the Association's traffic plans.

A. H. Babcock, Pacific Coast director of the League, explained plans of the League for a more definite organization on the Pacific Coast, and his position as a director of the League. The League, he said, plans to have each affiliated club organized as

a definite A.R.R.L. club. The South District will then be organized, probably with a board of governors elected from various parts of the district, the board to constitute the governing body in A.R.R.L. affairs for the district.

He went into details in explanation of the new League constitution, which is still being considered by the various directors in conference with their districts, and will be voted on soon. This constitution provides for the wider and more democratic organization of the League so that all parts of the country may be adequately represented in League affairs. He invited criticism of the League and said that it was his business to find out what is wanted, to explain the League's position to the members, and to adjust any difficulties which may arise in his district.

INDEPENDENT 100% RADIO SCHOOL

Arc—Spark—Tube Systems

Continental and Morse Codes
Travel—See the World—Receive a Radio Education

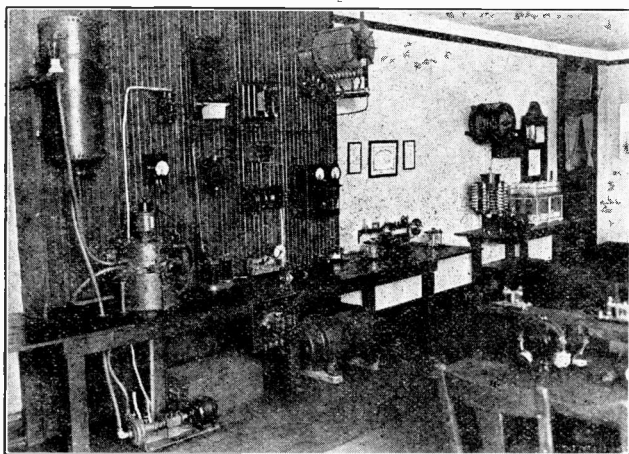

Federal Arc Equipment Installed in Independent Radio Institute

Classes—Evenings only, 7:00 to 9:30 p.m.
Tuition—\$10.00 per month.

Write for information on our Correspondence Course.

INDEPENDENT RADIO INSTITUTE

(Formerly the Los Angeles Radio Institute)

RADIO ENGINEERING

307 West First St. Tajo Bldg. Los Angeles, Calif.

10 INITIALED BINDING POSTS \$1

Beauties—Sent anywhere by mail on receipt of price. Fine panel design and 100 Station Log Free. Panels drilled. Wood for beautiful cabinets cut to size, with instructions for assembling and finishing like rosewood or mahogany. Will secure anything you want in the Radio Line and ship by parcel post, C.O.D. Send us your orders. Satisfaction guaranteed.

MAITLAND AND SPENCER ROACH
2905 Columbia Avenue. Philadelphia, Pa.

Do You Want a Book on Radio Free?

If you do, send us

75 Cents

for a three months' trial subscription to Radio Journal and take your pick of one of the following books:

How to Make Radio-Phone Receiving Sets

By R. Lacault

This is a non-technical book for the beginner, giving complete constructional data on the building of a crystal detector set, tuning coil, loose coupler and single tube audion set with amplifiers. Dimensions and working drawings for every part furnished.

Radio Frequency Amplifiers

By John M. Avery

is for more advanced amateurs, showing the construction of radio frequency amplifying transformers and giving complete constructional data. It shows how to apply radio frequency to any units which the amateur may already have in operation. It includes 15 hookups.

Address remittance to

Radio Journal Pub. Co.
113 Stimson Bldg., Los Angeles, Calif.

It was suggested that the members strive to construct and maintain stations using pure or well filtered CW, so that, within the next year, the Association members may be on the air as in the days of old, with no "quiet hours."

The president suggested that some coast station be designated by the A.R.R.L. or the Department, to broadcast wave-lengths.

President Nikirk also read a rough draft of the constitution, prepared by the committee, together with a draft of the by-laws, both submitted for consideration of the membership and to be discussed and voted on, section by section, at a later meeting.

Director Babcock, who visited the club while in Southern California on business connected with the Lick Observatory eclipse party, went into some detail in explaining the eclipse and the part radio is playing in the observation work of the Lick Observatory party.

Highgate, England

On July 20 a most instructive lecture was given by Mr. J. D. Steell on "How to learn the Morse Code." Mr. Steell was a telegraph operator during the war, and therefore had plenty of experience in learning the various codes used. There were several systems employed for teaching the Morse Code, but Mr. Steell confined himself to the system by which he had been taught, since by giving an account of all the systems the members of the Society would spend all their time making up their minds which system to adopt, instead of getting on with the job. The system described consists in learning the alphabet by ear, and not by eye. That is to say, the student is taught that . — means A, rather than that A is represented by . — . The letters of the alphabet are arranged in groups of "opposites," such as A—N, K—R, D—V, etc, and the student is taught to distinguish one side of the group from the other purely by ear. Mr. Steell concluded by giving some useful hints on the operation of a Morse key. This lecture was of great benefit to many members, and it is hoped that in future more interest will be shown in the buzzer class which is held every Friday for half an hour, prior to the general meeting at 8 o'clock.

The last meeting of the present session prior to the summer vacation, was held on July 27th, when Mr. F. L. Hogg gave a lecture on the Armstrong super-sonic Hetrodyne. Mr. Hogg first dealt with the great difficulty of operating a multi-valve short-wave high-frequency amplifier, such as is usually required by amateurs to work over a fairly wide band of wave-lengths. If longer waves are used, however, and if the wavelength is fixed, then untuned H. F. couplings can be used, and a multi-valve amplifier becomes quite simple to operate. The principle of the Armstrong super-sonic Hetrodyne was explained as follows: The incoming short-wave signals are heterodyned by a local oscillator of such frequency that the resultant beat frequency is that corresponding to a wave-length of, say, 1000 meters. The signal is then rectified, and afterwards passed through a H. F. amplifier constructed with transformers specially designed to work on the fixed wave-length of 1000 meters. The amplified current is then passed through a second detector, thus producing audible signals in the phones. Mr.

(Continued on Page 204)

The New ROFFY HETRO-TRANS

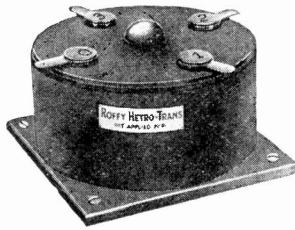

**DISTANCE
CLEARNESS
VOLUME
SELECTIVITY**

We guarantee this transformer when used in the Roffy Hetro-Trans circuit, to give distance, selectivity and quality far in excess of any circuit in use today.

Patterson Electric Co.

DISTRIBUTORS

239 So. Los Angeles Street Los Angeles, Calif.
Telephone 828-139

DEALERS!-WRITE US FOR ATTRACTIVE PROPOSITION

SPECIAL COMPLETE SET, \$25.00 SPECIAL

Don't listen to all stations at once. We sell a complete set, including one set head phones and installed, in Los Angeles County, for \$25.00. Other sets from \$10.00 up. Special sets built to order. We repair any kind of Radio equipment. Also install aeriels and sets of any make.

TERMS TERMS TERMS

Any of our sets sold on easy terms if desired. We take any kind of Radio parts or equipment in trade. Call us up or drop a line.

BURROUGHS RADIO COMPANY

4615 MONETA AVENUE Phone 298-318 LOS ANGELES, CALIF.

Carefully Selected Merchandise for Discriminating Purchasers

WALTER W. BIDDICK, INC.

(Wholesale Only to Dealers)

Jobbers of

Kilbourne and Clark Quality Parts
Tune-Sharp Variometers and Variocouplers
Trutone Loudspeakers
WorkRite Superior Parts
The AUTOSTAT--A Super Radio Rheostat

DeLuxe Homechargers
Advance Unit Chargers
Nathaniel Baldwin Headsets
WorkRite Hydrometers
Dunham Loop Aerials

Dealers:--Our representative will be glad to call.

WALTER W. BIDDICK, Inc.

1316 So. Grand

Los Angeles

Phone 213-01

A NATIONAL RADIO TUBE SERVICE

Send us your burned out or broken Detectors or Amplifiers and receive maximum allowance on the purchase of NEW TUBES.

UNLIMITED QUANTITY ALWAYS ON HAND FOR IMMEDIATE SHIPMENT

We allow you Seventy-Five Cents on an old U V 200 in the purchase of a new one and One Dollar on W D 11 and 12 when buying new Tubes. Corresponding allowances on all makes.

Radio Tubes Repaired in One Week

Customers who purchase new tubes from us are entitled to a special discount on repair work. In other words, we sell you new tubes and then keep them in shape for you.

We also usually have on hand a quantity of uncalled for refilled license tubes at very moderate prices, all guaranteed.

"OUR REPAIRED TUBES SPEAK FOR THEMSELVES"

Write today for Circular J 9 which will explain all the details. SHIPMENTS PROMPTLY MADE C. O. D. TO ALL POINTS IN THE U. S. A.

RADIO TUBE LABORATORIES

VACUUM TUBE SPECIALISTS

776 BROAD STREET.

NEWARK, N. J., U. S. A.

WE'RE READY—ARE YOU?

Our stock-room is full of good, fresh, standard radio parts and materials—ready to take care of your wants for this wonderful radio season which is here right now. Our mail order service is better organized than ever—and that means instant deliveries! Mail order with check or money order and we'll get materials to you RIGHT NOW.

Coast Radio Company, Inc.,

EL MONTE

CALIFORNIA

When Answering Ads Please Mention The Radio Journal.

Radio Builders Copy Our "Raflex" Receiver

Perfect reception and selectivity, correctly designed and enclosed in elegant cabinet. Complete, \$85.00, or we will sell you the parts and give you diagram and instructions free.

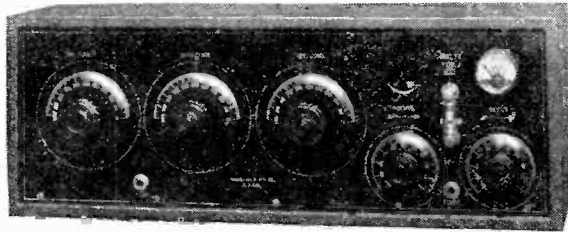

A small payment down, and balance on installments.

We make in our shop everything the Radio Builder needs, on short notice.

Bakelite Panels

Cut and engraved (absolutely perfect.)

Zaponized Cabinets

Any size, 24 hours' notice.

Neutrodyne Condensers and Coils

20 Point Back Panel Inductance Switches (in stock.)

Combined non-capacity Couplers with self-contained 20-point Switches.

Special Bakelite work and Coil Winding. In fact, everything that is needed in Shop Service.

Radio Lab. & Mfg. Co.

215 Court St., Los Angeles, Calif.

Telephone 827-247

Ray W. Scott, Master Mechanic.

H. LaV. Twining, Prof. of Physics and Electricity, Polytechnic High School.

The Bohr Atom

(Continued from Page 174)

$$a = (1890) \cdot 10^{-16} \text{ cms.}$$

or

$$a = (1.890) \cdot 10^{-13} \text{ cms.}$$

so that the radius of the dextron would be in this case very nearly $(2)10^{-13}$ which is the same as the diameter of the levulon. The density of the central mass would then be

$$D = \frac{M}{V} = \frac{M}{\frac{4}{3}\pi r^3} = \frac{(1.66)(10^{-24})(3)}{(4)(3.1416)(2)^3(10^{-13})^3}$$

or

$$D = \frac{(4.98)(10^{-24})(10^{30})}{100.5} = (4.95)10^{13}$$

which is in fair agreement with the estimation of Lodge's determination of the density of the ether.

The idea is this then: The levulons and dextrons fall together and come in contact by virtue of their electrostatic attractions and they condense and pack until the density of the compacting mass is equal to the density of the ether particles of which they are made.

When this point is reached no more packing can take place.

In the December-January issue of this journal on page 8, Mosley's discovery is mentioned in which it is stated that the number of positive charges in any atom is one-half the atomic weight. This should have been stated as the number of free positive charges.

The atomic weight of the helium atom is 3.99 or nearly 4. This indicates that it is composed of four hydrogen atoms and hence it has four central charges having the mass of the positive charge.

The charge can be imagined to be arranged as follows in order to account for the electrostatic equilibrium.

In Fig. 3 M and N are two hydrogen molecules as yet un-united. In this condition they would not unite but would exist as separate hydrogen molecules.

Under certain critical conditions of heat and pressure they could be brought close enough together to take the condition shown in Fig. 4.

The linkages shown in Fig. 3

(Continued on Page 205)

RADIO

All Standard makes of Radio Parts, Radio Sets from \$75.00 to \$825.00. Demonstration at your convenience at home.

Phone 641-79

Equipment Sales Co.

402 B Street, San Diego, California

Famous INTERNATIONAL Correspondence School Handbooks

22 Little Giants 22

WHAT THESE HANDBOOKS ARE Two Million Sold

A MINE OF INFORMATION—These Handbooks form a veritable mine of practical information; they are, in fact, condensed treatises on the subjects embraced in their titles.

PREFERRED TO A DICTIONARY—The definitions are so clear and full and the accompanying text so complete that many prefer to consult the Handbooks rather than a dictionary or an encyclopedia.

A VALUABLE HELP TO I.C.S. STUDENTS—No matter how extensive a man's knowledge may be, nor how large his library, one or more of these Handbooks will be a great convenience to him. Every I.C.S. student should possess a copy of at least one—it will help him with his studies and will be a ready and willing assistant at all times.

EVERYTHING ESSENTIAL INCLUDED—In preparing these Handbooks our object has been to include everything essential—everything about which information is likely to be required on short notice.

COMPACT YET COMPREHENSIVE—While the explanations are condensed, at the same time they are complete enough to be readily understood by one unfamiliar with the subject in question, or by one who wishes to recall forgotten facts.

PRACTICAL EXAMPLES GIVEN—Special attention has been given to the selection of practical examples, which with their solutions will show the application of rules, formulas, and tables.

EXCEPTIONALLY WELL INDEXED—The indexes will be a delight to any one having used other handbooks—it is not necessary to refer to half a dozen places to find the item sought for.

SPECIAL ILLUSTRATIONS—All the illustrations have been specially prepared and adapted to the size of the page.

RELIABLE AND USABLE—A Handbook will help you to remember, will be an invaluable assistance in connection with your work, and will be a constant source of reliable, usable information.

WRITTEN BY EXPERTS—Gathering and imparting technical knowledge is the specialty of the authors of these Handbooks. They are the work of experts.

At Last! A Practical Authoritative BOOK on RADIO

562 pages. Price only \$1. Compiled by HARRY F. DART, B.S., E.E. Formerly with the Western Electric Co., and U. S. Army Instructor of Radio. Technically edited by F. H. DOANE.

The most complete book of its kind ever published. Written, compiled and edited by practical radio experts of national reputation. Packed with concise, sound information useful to every radio fan—from beginner to veteran hard-boiled owl. Hundreds of illustrations and diagrams to make every point clear. Note this *partial* list of contents:

Different types of receiving and sending hook-ups, electrical terms, condensers, oscillating circuits, coupled circuits, induction coils, antenna systems, electric batteries, generators and motors, protective devices, crystal detectors, arc generators, transmitters, filters, wavemeters, radio experiments, International and Morse codes, commercial receiving sets, tables and data, radio transmitting and broadcasting stations (with call letters), Radio License Regulations, etc.

Send \$1 to-day and get this 562-page I.C.S. Radio Handbook before you spend another cent on parts. Money back if not satisfied.

TEAR OUT HERE AND MAIL TO

INTERNATIONAL CORRESPONDENCE SCHOOLS—714 SO. HILL ST.
SUITE 410, LOS ANGELES, CALIF.

I enclose \$..... Please send me postpaid—the I.C.S. Handbook, checked below. It is understood that if I am not entirely satisfied I may return any of them within five days and you will refund my money.

- | | | |
|--|---|--|
| <input type="checkbox"/> Radio Handbook | <input type="checkbox"/> Plumber's and Fitter's | <input type="checkbox"/> Salesman's |
| <input type="checkbox"/> Mechanics' | <input type="checkbox"/> Concrete Engineer's | <input type="checkbox"/> Window Trimmer's |
| <input type="checkbox"/> Electrical Engineers' | <input type="checkbox"/> Steam Engineer's | <input type="checkbox"/> Cotton Textile Worker's |
| <input type="checkbox"/> Building Trades | <input type="checkbox"/> Automobile | <input type="checkbox"/> Civil Engineer's |
| <input type="checkbox"/> Advertiser's | <input type="checkbox"/> Farmer's | <input type="checkbox"/> Chemist's |
| <input type="checkbox"/> Bookkeeper's | <input type="checkbox"/> Poultryman's | <input type="checkbox"/> Westinghouse Air-Brake |
| <input type="checkbox"/> Mariner's | <input type="checkbox"/> Correspondent's | <input type="checkbox"/> Traffic Manager's |
| <input type="checkbox"/> Stenographer's | | <input type="checkbox"/> Telephone and Telegraph |

Bound in cloth, gold titles, and red edges, each, \$1.00

Bound in cloth, gold titles, and red edges, each, \$1.00

(Continued from Page 201)

Hogg gave details for the construction of suitable transformers, and circuit diagrams were drawn on the board showing how the amplifier is coupled to the first detector valve.

The lecture was followed by an interesting discussion, in which the problem of interference, so near to the hearts of all London amateurs, was dealt with. Several members testified to the excellent results they had obtained by the use of the arrangement recently described and demonstrated by Mr. Stanley. It was pointed out that an interference eliminator, working on the same principle, had recently been put upon the market by a well-known firm, thus showing that there really is something in the idea, simple though it is.

After the Secretary had made some pre-

liminary announcements regarding next session's programme, the meeting was adjourned until September 7th, 1923.

J. F. STANLEY, Hon. Secretary.

Cuban Amateurs

Cuba has several live amateur radio organizations. Here are some of the English-speaking members: A. Brooks, president, Radio Club de Oriente, Maso Alta 11, Santiago de Cuba; Mr. T. Bremner, Concordia 3 Altos, Havana; Mr. H. F. Blancke, Oficios 40, Havana; Mr. B. A. Bode, president, Jaronu Club, Jaronu, Camaguey, Cuba; Mr. L. B. Fox, Central Florida, Florida, Camaguey, Cuba; Mr. F. H. Jones, Tuinucu, Cuba; Mr. F. Lavernia, Ferrocarril de Cuba, Camaguey, Cuba.

It will not be long before regular communication will be established.

A small radio receiving set has been installed at every bedside in Beth Israel Hospital, New York City. The superintendent hopes the device will lighten the patients' sufferings by turning their minds from their own discomfort and loneliness to concerts, lectures and news reports.

Radiophone communication with Massachusetts and Oklahoma has been carried on by WHA of the University of Wisconsin.

Three big broadcasting stations are to be set going in Italy in the course of a week or so—one at Turin for North Italy, one in Rome for the center and South, and a third at Palermo for Sicily and the Calabrias. Concerts, meteorological information and general news will be broadcast. A new decree is coming out soon to regulate the use and sale of small amateur receiving sets. The wireless habit is only now beginning to catch on there.

Bavaria is reported to be erecting a tremendous station near Munich, the aerial being suspended from two huge mountain crags, the power generated by a waterfall nearby. If the report is correct the station should have a tremendous wave length of low frequency, capable of being heard all over the world without hetrodyning.

For One Dollar

We will mail to any address *the secret formula* and detailed instructions, enabling you to manufacture marvelously sensitive Synthetic Radio Crystals in your own home or workshop---at a cost of less than twenty-five cents per pound.

WE GUARANTEE

Absolutely no special equipment, skill or experience is necessary. With our formula you can in a few minutes, using simple ingredients obtainable in every village, town or city in the United States, make any desired quantity of long-lived, ultra sensitive

Synthetic Radio Crystals

at a very small fraction of their usual cost

Artificial crystals made after our formula and instructions surpass the finest natural product in sensitiveness and in addition they are sensitive throughout their entire surface.

Your success and satisfaction is positively assured. Fans make them for your own use.

Dealers and jobbers make them in quantities for resale.

Pin a dollar bill or Postal Money Order to the Coupon below and mail it now. THIS FORMULA WILL SAVE YOU MANY DOLLARS AND WILL INSURE YOU AN INEXHAUSTIBLE SUPPLY OF TRULY MARVELOUS MINERAL.

..... Tear off here

Chemical Department
COLUMBIA COIL COMPANY
Vancouver, Washington

Gentlemen: Attached hereto please find Postal Money Order for One Dollar (Or United States Currency, Stamps not accepted) for which mail to the address given below Formula and instructions which it is understood will enable me to manufacture Ultra Sensitive SYNTHETIC RADIO CRYSTALS in my own home or Work Shop without the use of any special apparatus and with simple ingredients obtainable in every village, town and City in the United States at a cost of less than twenty-five cents per pound.

Name in Full

Street and Number..... City.....

Radiola

Dealers
and
Distributors

CALIFORNIA

Paul Franklin Johnson

560 E. Colorado St.
PASADENA, CALIF.

"Everything Worth While in Radio"

NEW JERSEY

Tri-City Electric Co.

52-56 Lafayette Street
NEWARK, N. J.

MINNESOTA

**STERLING ELECTRIC
COMPANY**

MINNEAPOLIS, MINN.

(Continued from Page 202)

would be dissolved under sufficient heat and pressure and assume the linkages in Fig. 4, producing a helium atom which is mon-atomic. Electrostatic binding and equilibrium is here secured, since H, G and F, and B, C,

and D are linked just as in the hydrogen molecule. The negative charge at O, Fig. 3, would readjust to A, Fig. 4, and link H and B. Also P of Fig. 3 would shift to E and link F and D. The center of the atom would be at O. This would give static equilibrium and also bind the two hydrogen molecules forming a new entity, helium. There would be two free levulons, A and B, and two free combinations, H F and B D that could radiate as the whole rotates around O, its center.

In the hydrogen molecule shown at M, Fig. 2, the two dextrons A and B rotate in equal orbits around the levulon C, which is at the center and the levulon D also rotates around C as a center, so that AB acts as a unit in radiating and D as a unit. I have not yet examined these two ideas mathematically and do not know how they would work out. They should satisfy the Bohr-Atom mathematics in order to be tenable.

If the above analysis be correct, it would be well to call the center of the hydrogen atom a Proton, as suggested by Mills.

Summary

Rydberg constant, or radiation frequency $(3.29)10^{15}$.

Planck's constant $(6.547)10^{-27}$.

Radius of hydrogen atom $(.53)10^{-8}$.

Diameter of hydrogen atom $(1.06)10^{-8}$.

Diameter of hydrogen molecule, 2 (10^{-8}) .

Quantum radiated by fall from infinity $(21.55)10^{-12}$ ergs.

Velocity of dextron in its orbit $(1.19)10^6$ cms.—sec.

LEARN RADIO

Here's your opportunity. Radio needs you. Win success in this fascinating field. Trained men in demand at highest salaries. Learn at home, in your spare time.

Be a Radio Expert

I will train you, quickly and easily, to design, construct, install, operate, repair, maintain, and sell all forms of Radio apparatus. My new methods are the most successful in existence. Learn to earn **\$1,800 to \$10,000 a Year**

FREE Wonderful, home-construction, tube receiving set, of latest design. Write for "Radio Facts" free. Engineer Mohaupt. American Electrical Association Dept. 21 4513 Ravenswood Ave., Chicago

WD-11 TUBES

Genuine and Guaranteed New

PRICE \$4.95

Unlimited Quantity

Tubes shipped same day order is received. If you remit with order, include postage.

Other Tubes at Low Prices

New Jersey Radio Co.

Box 43 Roseville Post Office
NEWARK NEW JERSEY

11

CALIFORNIA DEALERS AND JOBBERS ARE MAKING MORE MONEY TODAY

Last week they bought

CRYSTALS
DIALS
COILS
SWITCHES
BINDING POSTS
CONDENSERS

From
COLUMBIA COIL COMPANY
Vancouver, Washington

629

CALIFORNIA DEALERS AND JOBBERS ARE STILL PAYING HIGHER PRICES FOR THE SAME GOODS WE SELL FOR LESS

Why send East for goods when we are shipping our products to the largest distributors in Chicago, New York and Philadelphia? Let us prove it pays you to buy on the Pacific Coast. Save the transportation and get immediate shipment.

COLUMBIA COIL CO.
VANCOUVER WASHINGTON

A Battery

None Like It



B Battery

It Cuts Out Noise

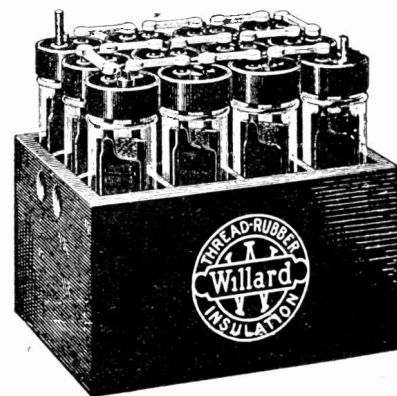

THE WILLARD

Research Laboratories

have developed these two great advances in Radio Battery construction. Investigate them. They cost no more.

WESTERN AUTO ELECTRIC CO.

16th at Hope St.

Service Stations Everywhere

Los Angeles, Calif.

Velocity of levulon in its orbit (2.2) 10^8 cms.—sec.

Frequency of revolution of both charges (6.6) $(10)^{15}$ cycles per sec.

Electrostatic attraction and centrifugal force (81) (10^{-4}) dynes.

Density of the dextron (4.95) (10^{12}) gms. per cu. cm.

Probable density of the ether (4.95) (10^{12}) grams per cu. cm.

Radius of levulon 2 $(10)^{-13}$ cms.
Probable radius of Proton 2 $(10)^{-13}$

cms.

Density of levulon (2.68) (10^{10}) per cu. cm.

It should be understood that these figures are correct to within a certain very small percent error.

We Repair the Following Radio Tubes and Guarantee Them



WD-11	\$3.50	UV-199	\$3.50
WD-12	3.50	C-299	3.50
UV-200	2.75	UV-201A	3.50
UV-201	3.00	C-301A	3.50
C-300	2.75	UV-202	4.00
C-301	3.00	C-302	4.00
DV-6	3.00	DV-6A	3.50

Mail Orders solicited and promptly attended to
Dealers and Agents write for Special Discount

H. & H. RADIO CO.

P. O. BOX 22-J

CLINTON HILL STA.

NEWARK, N. J.

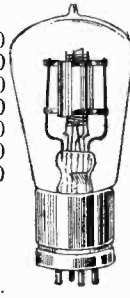

Ray-Dee-Artcraft SUPER-HETRODYNE Tuned Neutro-Transformer

Type 10-A

A. L. Munzig describes in this issue the construction of a *Super-Hetrodyne Receiver* in which the new *Ray-Dee-Artcraft Super-Hetrodyne Tuned Neutro-Transformer* is used. This is the *ultimate* in receiver design—range being unlimited!! Drycell tubes used throughout!! Two tuning controls!!

4 Super-Hetrodyne Tuned Neutro-Transformers, packed in an attractive box; price, prepaid \$25.00

New NEUTRO-TRANS Prices!!

Type 2A (150-350 Meters) **\$1.25**
Type 3A (275-600 Meters)

Mounted on 23-plate Variable Condenser \$4.00

These new type *Neutro-Trans's* are designed with transformer losses at zero. No distributed capacity; no losses between primary and secondary windings; hysteresis very low because of the absence of high constant dielectrics (bakelite, fibre, etc.), between windings and in the core.

This results in a *Neutro-Trans* with the radio-frequency resistance *very low* at a given wave length!

The *Neutro-Trans* can be used as a tuned radio-frequency amplifier if neutralization of capacity coupling is not desired. *Twice as sensitive as any untuned RFT known, bar none!*

Send for yours *today*, while prices are so low!! Prepare for extreme DX reception this coming winter with *Neutro-Trans* Radio-frequency Amplification.

The Ray-Dee-Artcraft Instrument Co.

1017 Tribune Street

REDLANDS, CALIF.

"Ray-Dee-Artcraft selection is YOUR protection"

With The Editor

And still they come,—we refer to the letters on A. L. Munzig's article on the Neutrodyne and its various combinations. Apparently, literally thousands of Radio Journal readers are building one of the Neutrodyne combinations. Mr. Munzig received hundreds of letters as a result of the article in the August issue—and he will probably receive hundreds more as a result of the Super-Hetrodyne Neutrodyne article appearing in this issue.

Almost invariably each letter opened with the statement "this is the best radio article I have read in any magazine." Certainly it does our heart good, folks. We like having hit a responsive chord in our readers and want to keep it up.

And that reminds us—in keeping it up we depend on our readers. Every one who dabbles in radio or studies it seriously is a discoverer. He is exploring a region wherein there is so much of the still unknown as to make it a frontier. Each one can help the other fellow by writing us a letter outlining any novel methods or new theories which he may have found in this romantic field of science, or mayhap it will be a novel radio experience he will have to tell. Anyhow—tell it to us. If our readers will do this Radio Journal will soon be a common meeting ground for thousands of readers.



Loud Speaker \$1

\$1 **Radio Adapter**
Hear all broadcasting through phonograph. Make your own horn. Attach B-R Phonadapter to YOUR phonograph. All can hear. Entire family, neighbors, guests can hear operas, lectures, latest news, with this adapter. Stretches over receiver of any standard type head-set and attaches to tone-arm of ANY phonograph. Made of soft, pure gum rubber. Quickly attached and removed. Thousands in use. Will not amplify or distort. For single receiver **.50**
For pair of receivers (more than twice the volume) **\$1**

Go to your dealer. If he cannot supply you send money order, check or currency at our risk. Prompt delivery—postpaid. Also send us name of favorite radio dealer.

The Beckley Ralston Company
1813 So. Michigan Ave., Chicago, Ill.

ONE TUBE—ONE CONTROL
AUTOMATIC REGENERATION
150,25,000 Meters
AND AN AUDION, ULTRA-AUDION
HOOKUP
NO Rheostat, Storage Battery, Variocoupler, Variometer, 3-coil Mounting, Variable Inductance, Taps, Dead End Losses or Radio Frequency. Complete Hookup, cuts, instructions, everything. Nothing left for you to guess about. No stamps or checks. Build your own receiver and save 50% or more and get better results. **RADIO EXPERIMENTAL LABORATORY, Box 194 H, Berkeley, Cal.**

IMITATION

IS THE SINCEREST FORM OF
FLATTERY

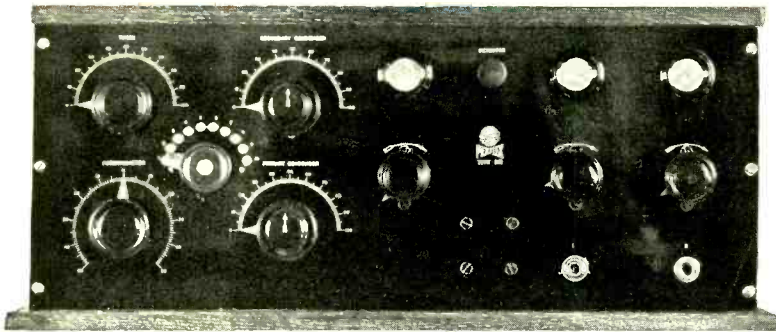

PERFLEX COMPLETED

turers and claimed to be original by their so-called "research laboratory," you would do exactly as we are doing now—

IF after you had spent over eight months in the development of a circuit and the correct apparatus for the most efficient use in that circuit—

and then published the circuit broadcast through thousands of dollars' worth of advertising for another eight months—

you should suddenly be confronted with the identical circuit, published by one of the country's largest radio manufac-

LET THE WORLD KNOW ABOUT IT

PERFLEX has been copied almost wire for wire by a large Chicago radio manufacturer, and given a name somewhat similar to **Perflex**.

But since they made their copy, Mr. Watkins, who developed the **Perflex**, has improved the original circuit, thus keeping

THE WIRELESS SHOP AHEAD OF THE FIELD

INFORMATION and constructional data on this and other REFLEX circuits is furnished in detail in our booklet—

"Theory and Operation of Reflex Circuits"

FILL OUT THE COUPON NOW AND MAIL WITH 25c

THE WIRELESS SHOP,
1262 West Second St., Los Angeles, Cal.

RJ10

Find enclosed 25c for which send me a copy of "Theory and Operation of Reflex Circuits."

Name Address

City or P. O. County State

Our Service Department will answer all questions you may have regarding reflex circuits.

THE WIRELESS SHOP
A. J. EDGCOMB

PACIFIC SOUTHWEST'S LARGEST EXCLUSIVE RADIO MANUFACTURERS

Office and Factory
1262 W. Second St.

LOS ANGELES, CALIF.

Store No. Two
1853 S. Hope St.

HAVE YOU SEEN

The New Tune Sharp Variocouplers and Variometers? They are without doubt the handsomest, as well as most efficient radio instruments on the market.

Tune Sharp instruments are now built of genuine natural brown color bakelite and green silk wire. All are now built for both table and panel mounting.

OUR NEW EQUIPMENT

Enables us to turn out better variometers and variocouplers than ever before and to turn them out on a much bigger scale.

Big presses, a larger working force, improved machinery, all conspire to place "Tune Sharp" equipment at the head of the list. And an enlarged organization enables us to back up a reputation for excellence and accuracy it has taken years of painstaking effort to establish.

Tune Sharp Radio Equipment Co., Inc.

6220-6222 VERMONT AVENUE, LOS ANGELES, CALIF.

Vermont 5040