

OCTOBER, 1932

# Radio Engineering

## IN THIS ISSUE



PRIMARY BATTERY SUBSTITUTES FOR AUTOMOBILE  
RADIO RECEIVERS

By John Dunsheath

POLICE RADIO SYSTEM IN NEW YORK CITY  
PROVING SUCCESSFUL

RECEIVING TELEVISION IN AN AIRPLANE

By Harry R. Lubcke

A THREE-SIDED RADIO TOWER

By Samuel Couzin

THE EFFECT OF THE SUN'S ECLIPSE ON  
RADIO WAVES

By Dr. E. F. W. Alexanderson

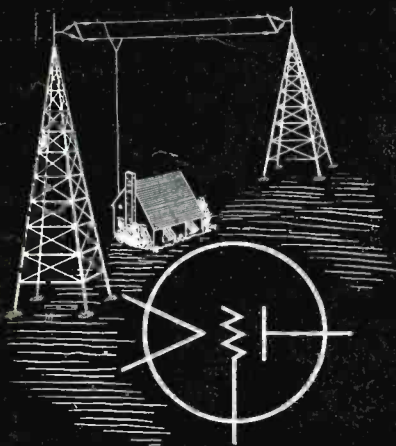

TWELFTH YEAR OF SERVICE

The Journal of the  
Radio and Allied Industries

BLUE TUBES in FRANCE

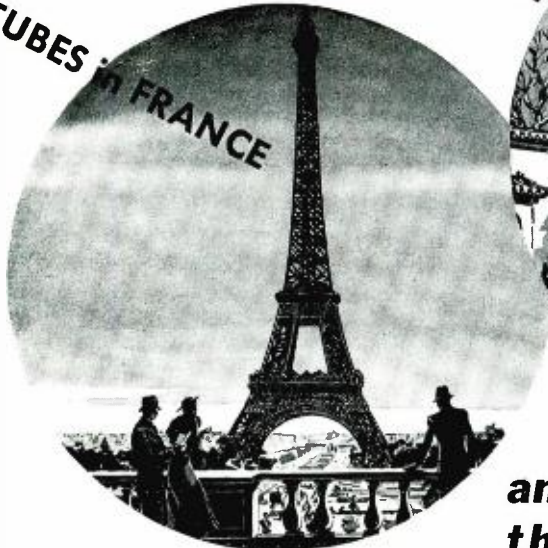

BLUE TUBES in CHINA



and in **74** other countries  
throughout the world

# ARCTURUS

## BLUE Tubes

ANY Set is Better  
with Arcturus Blue



THE world over, where quality is essential, Arcturus Blue Tubes are used. Many American set manufacturers, through experience, equip all their export sets exclusively with Arcturus Tubes. They, like their foreign accounts, cannot take chances with tubes that are put in service thousands of miles away.

No other radio tube has been paid as great a tribute.

In the United States, Arcturus Tubes are used by more set manufacturers as initial equipment than any other tube—a signal tribute to *the* quality tube.

When engineers include Arcturus Blue Tubes in their specifications, when radio jobbers and dealers offer them to the public, they have the ample justification of world-wide approval.

ARCTURUS RADIO TUBE CO., NEWARK, N. J.

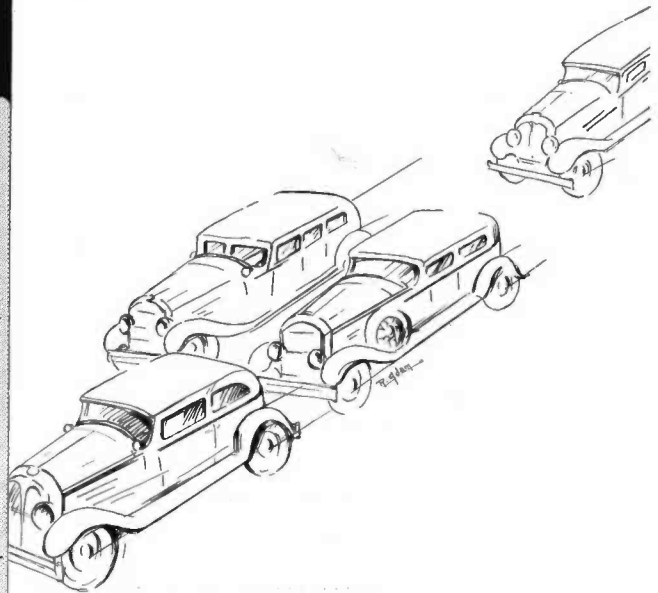

The resistance value of an Erie Suppressor Resistor is 25,000 ohms plus or minus 20%.

An Erie Suppressor Resistor will not change more than 10% in resistance value in 50,000 miles use, provided one Suppressor Resistor is used in each High Tension Lead.

The resistance unit is enclosed in a ceramic tube to protect it from mechanical breakage as well as from oil, dirt and moisture.

An Erie Suppressor Resistor will not fail mechanically at 120°C and 100% relative humidity.

Erie Suppressor Resistors are made in plug, screw and distributor types. Send for samples and additional information.



Erie Suppressor Resistors are made in plug, screw and distributor types.

# ERIE RESISTORS



ERIE RESISTOR CORPORATION, ERIE, PA.  
Factories in Erie, Pa., Toronto, Canada and London, Eng.

# RADIO ENGINEERING

Reg. U. S. Patent Office



Western Editor  
ULMER G. TURNER

Editor  
DONALD McNICOL

Managing Editor  
F. WALEN

Vol. XII

OCTOBER, 1932

Number 10

## Contents

	PAGE
EDITORIAL .....	4
PRIMARY BATTERY SUBSTITUTES FOR AUTOMOBILE RADIO RECEIVERS..... <i>By John Dunsheath</i>	9
POLICE RADIO SYSTEM IN NEW YORK CITY PROVING SUCCESSFUL.....	11
RECEIVING TELEVISION IN AN AIRPLANE <i>By Harry R. Lubcke</i>	12
POWER TRANSFORMER TESTING..... <i>By Richard F. Shea</i>	14
A CHRONOLOGICAL HISTORY OF ELECTRICAL COMMUNICATION—TELEGRAPH, TELEPHONE AND RADIO, PART X....	16
A THREE-SIDED RADIO TOWER..... <i>By Samuel Cousin</i>	17
THE EFFECT OF THE SUN'S ECLIPSE ON RADIO WAVES <i>By Dr. E. F. W. Alexanderson</i>	19

## Departments

NEWS OF THE INDUSTRY.....	26
NEW DEVELOPMENTS OF THE MONTH.....	28
INDEX OF ADVERTISERS.....	34

### MARKET FOR RADIOS

A CENSUS of the American public's need for goods as indicated by a national questionnaire survey conducted among the employees of the Graybar Electric Company in seventy-three leading cities of the country was made public. The census indicates the existence of a \$40,000,000,000 latent consumer buying power in the United States at present.

The survey was made, according to George E. Cullinan, vice-president of the company, to arrive at an accurate indicator in dollar volume of the pent-up demand now existing in this country for consumer goods; a demand which may be expected to be translated into actual orders with the return of public confidence in economic conditions.

Based on the figures, the total deferred demand in the United States, which will be purchased probably within the next two or three years as business conditions improve, includes 3,708,000 radio receivers, and the estimates were made on the basis of only 18,000,000 families instead of the 30,000,000 families usually considered.

BRYAN S. DAVIS  
*President*

JAS. A. WALKER  
*Secretary*

Published Monthly by

Bryan Davis Publishing Co., Inc.  
19 East 47th Street  
New York City

SANFORD R. COWAN  
*Advertising Manager*

J. E. NIELSEN  
*Circulation Manager*

Chicago Office—1221 Rosemont Ave.—Charles H. Farrell, Mgr.  
St. Louis Office—505 Star Building—F. J. Wright  
Kansas City, Mo. Office—306 Coca Cola Building—R. W. Mitchell  
Cleveland Office—Millard H. Newton, 416 National Bldg.



San Francisco Office—135 Sansome St.—R. J. Birch  
Los Angeles Office—846 S. Broadway—R. J. Birch  
New Zealand—Tearo Book Depot—Wellington.  
Melbourne, Australia—McGill's Agency.

Entered as second class matter August 26, 1931, at the Post Office at New York, N. Y., under Act of March 3, 1879. Yearly subscription rate \$2.00 in United States. \$3.00 in Canada and foreign countries.

# New Lapel Microphone keeps close to the speaker!



*Insures good pick-up . . . speakers  
or announcers can't get out of range!*

With its new Lapel Microphone, Western Electric makes another significant contribution to the art of sound transmission. This new member of the telephone family is highly efficient, small in size (1½" in diameter) and, as its name implies, is worn on the clothing. It may be used as the pick-up instrument for either public address or radio broadcasting systems.

With this microphone, speakers no longer need be confined to a fixed post in order to have proper microphone technique. Because the lapel microphone is flexible in operation and readily adaptable, the problem of picking up programs at political meetings, banquets and other events featuring speakers, is greatly simplified.

Manufactured by Western Electric, this tiny device has back of it more than 50 years' experience in the making of telephones for the Bell System.



The Lapel Microphone consists essentially of a carbon button transmitter encased in soft rubber and a 2 ft. cord terminated in a double contact plug.

Connection is made to the amplifying or speech input system by means of a 30 ft. length of flexible cording, which may be lengthened by the addition of a 50 ft. extension cord.

Control cabinets providing noiseless switching for a single microphone or for any one of five microphones are available.

## Western Electric

RADIO TELEPHONE BROADCASTING EQUIPMENT

Distributed by GRAYBAR Electric Company

GRAYBAR ELECTRIC CO.	RE 10-32
Graybar Building, New York, N. Y.	
Gentlemen: Please send me full information on the Western Electric Lapel Microphone.	
NAME.....	
ADDRESS.....	
CITY.....	STATE.....

# E d i t o r i a l

OCTOBER, 1932

## RADIO AND THE DAILY NEWSPAPER

ONE thing that appears to have happened during the now passing business slump is the disappearance of, or the curtailment of radio sections published in daily newspapers.

The radio section, or supplement, as a daily or a weekly feature of newspapers, first appeared as an institution in 1921. The peak year of popularity of the radio supplement was perhaps 1922, although for several years thereafter certain daily papers were able to make a go of a radio appendage.

For a time in 1922 metropolitan newspapers which carried voluminous radio supplements one day each week, sold from 25,000 to 40,000 additional copies of their sheets on newsstands on the day the radio section appeared. Indeed, many persons buying papers were observed discarding the news sections on politics, finance and murders; retaining only the radio supplement. Such was the reception accorded popular radio broadcasting when its possibilities became evident in 1920.

The radio section, or supplement, in the daily press, was the newspaper's bid for a spoonful of the sugar. In those days radio was not competing with the newspapers as an avenue of commercial publicity. Radio was a merchandising industry, as are soap and carpet sweepers. Radio manufacturers paid millions of dollars to the newspapers for advertising space, and this use of the daily press has continued.

The change that is taking place is that the broadcasting companies now derive their sustenance from manufacturers of nationally advertised products, thus competing with the press for paid publicity. It is perhaps natural that the press should now be reluctant to continue to further the interests of a competing industry. So far as the press is concerned the situation evidently is that the paid advertisements of radio manufacturers are welcomed; but, differentiating, publicity for broadcasting companies, and broadcast entertainment is taboo, and thus ends the need for radio sections and radio editors in the daily papers.

Throughout the lifetime of the radio supplements the daily press was served by numerous radio writers and experts of real ability. One wonders into what new ventures they are being absorbed.

## MOBILE RADIO

POSSIBLY it is only when we view progress by decades of time that what is taking place before our eyes from month to month can be measured in terms of noteworthy advance. Those elements which from day to day appear as of little consequence, when totaled over a period of years, disclose the actual degree of progress in unmistakable terms.

Communication between a fixed station and a moving station, and between two or more moving stations, was the novelty that attracted world-wide attention to the first crude, inefficient, short range "wireless" experiments. Thus, ship-shore wireless telegraphy was radio's first commercial venture.

Following the world-wide application of marine radio, invention and improvement made practical commercial communication by radio between fixed stations in competition with wires and cables. Then, the advent of broadcast radio telephony brought to the new art its great, popular opportunity; one way telephone communication between a fixed sending station and an unlimited number of other fixed or mobile receiving stations.

The technical problem for the fixed receiver station was simple compared to that of the mobile receiving station. But, over a period of four or five years advances have been made which make mobile radio reception satisfactory. Radio manufacturers and engineers with vision can now see developing a market for twenty millions of radio receivers for automobile, airplane, motorboat, police car, fire truck and other mobile uses.

*Donald Mc-nicol*  
Editor.

# Let this *free* Engineering Service



**IMPROVE  
Your Product**

and

**INCREASE  
Your Profits!**



Type 12. Internal. For S. A. E. and Standard Machine Screws

Type 11. External. For Standard Bolts and Nuts

Type 15. Countersunk. For all Countersunk Screws

Type 20. Locking Terminals. For Radio and Electrical Work

U. S. Patents  
1,419,564—1,604,122  
1,697,954—1,782,387  
Other Patents Pending. Foreign Patents.

**S**HAKEPROOF offers you a service that can definitely help you build a better product. Skilled engineers whose entire activities are focused on solving vibration and locking problems are at your call without cost or obligation. Many leading manufacturers have actually saved thousands of dollars and definitely improved the performance of their products by taking advantage of this free service. You, too, can profit by giving Shakeproof's Engineers an opportunity to inspect and check your product. Mail the coupon below for complete information regarding this service today!

## SHAKEPROOF Lock Washer Company

{Division of Illinois Tool Works}

2509 N. KEELER AVENUE  
CHICAGO, ILLINOIS



MAIL THIS COUPON FOR YOUR COPY OF THE NEW SHAKEPROOF CATALOG

Shakeproof representatives are located in the following cities:

New York City Philadelphia  
Boston Pittsburgh Schenectady  
Detroit Cleveland Milwaukee  
Cincinnati Los Angeles Toledo  
Dallas, Texas Birmingham, Ala.  
Seattle San Francisco Toronto,  
Ontario, Canada.

Gentlemen: Kindly give us complete details regarding your free Engineering Service. Also, please send us a copy of your new Shakeproof Catalog and price list.

Firm Name.....  
Address.....  
City..... State.....  
By..... Title.....

# “When Better Controls are Made—Clarostat Will Make 'Em!”

With Thanks To THE BUICK MOTOR COMPANY

Buick is internationally known as the largest selling motor car—Clarostat is the largest selling line of volume controls.

What are the reasons?—Primarily VALUE, CONSISTENT RELIABILITY, PRICE APPEAL, and last of all, THE INTEGRITY of the MAKER.

Cheap volume controls are available, but, experienced set builders have learned it is not the initial cost that counts! A cheap control that breaks down after short service not only must be replaced (plus labor charges) but also may cause the cancellation of the sale. Present day conditions permit but a small margin of profit on original sales,—you cannot afford to take a risk. Clarostats are your insurance.

It is generally agreed that the volume control of most receivers bears the brunt of hard usage and wear,—vibration and overloads are ever-present dangers. No other volume controls enjoy the extra safety factor built-into Clarostats.

*If you are one of the few manufacturers not already using them, write to*

CLAROSTAT MANUFACTURING CO.

# CLAROSTAT



285 North 6th Street, Brooklyn, N. Y.



Type P-58 Control  
Without Switch

*This standard type control provides minimum volume at its extreme left setting, and tapers smoothly and efficiently to maximum volume by clockwise rotation. Model P58 is available in single, dual and triple control unit on one shaft—with or without switches built-in.*



Type P-185 Control  
Fitted With Switch  
Dustguard Cover Plate

*This type wire-wound control is available with or without coverplate switches. These potentiometers are provided with three terminals and may be had in any taper desired. By using the center contact arm terminal and one of the resistance element terminals, they may be used as rheostats.*



# *S.S. White* MOLDED RESISTORS

## *and a few of their applications*

These Resistors are noted for noiseless operation, great mechanical strength, permanent resistance value, reliability. Com-

parative tests have won preference by engineers of leading radio and electronic equipment manufacturers. Besides those men-

tioned below, users include: General Electric, Westinghouse, Insuline Corp. of America, Naval Research Laboratory, Norden Hauck, Inc., and many others.



Type 15-X, actual size

### CONDENSER TRANSMITTER and MICROPHONE AMPLIFIERS

This instrument requires a resistor free from the slightest noise generation in operation and constant in resistance value. Its maker, the International Broadcasting Equipment Co., says: "We find your resistance excels in quietness of operation any other unit we have similarly tested, irrespective of price."

S. S. W. Resistors are also used in motion picture sound amplifiers, photoelectric cell amplifiers, geophysical instruments, etc.



Type 25-X, actual size

### AIRCRAFT RADIO RECEIVERS

S. S. WHITE Resistors are used in R. C. A. aircraft radio receivers. Their small size adapts them particularly for compact receivers, such as the R.C.A. Type A shown, without impairment of quality or efficiency.



Type 16-X, actual size

### VEHICLE ACTUATED TRAFFIC CONTROLS

The Automatic Signal Corp., makers of various types of vehicle actuated traffic controls, uses S. S. W. Resistors in all of them. They have found that these resistors assure uninterrupted service, despite the severe weather conditions under which this equipment must operate.

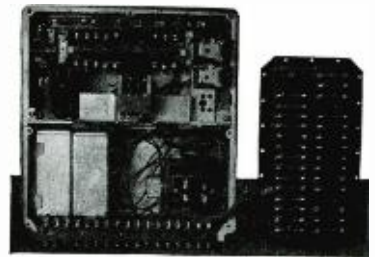

Type 40-X, actual size

### RADIO RECEIVERS—on passenger planes of the PAN-AMERICAN AIRWAYS

Communication Engineer of P. A. A. Writes:

*"Receivers in which your resistors are used have been flown in our aircraft all over South and Central America, Mexico and West Indies. They have been subjected to the most adverse climatic conditions imaginable and have never failed."*



P. A. A. Passenger Station and Terminal—Miami

S. S. WHITE RESISTORS are made in many types. Sizes range from 1 to 2 watts with resistances from 1000 ohms to 1,000,000 megohms.

**The S.S. WHITE Dental Mfg. Co.**  
INDUSTRIAL DIVISION  
152-4 West 42nd St., New York, N. Y.

WRITE for descriptive circular, prices or other information. Also put your resistor problems up to us.

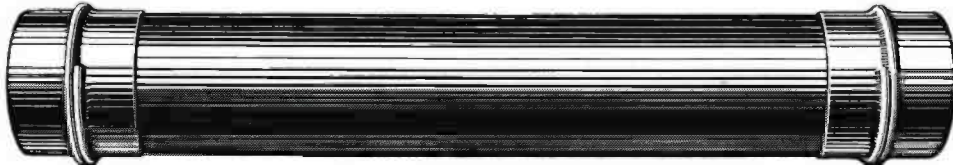

Bradleyunits for All Radio Circuits

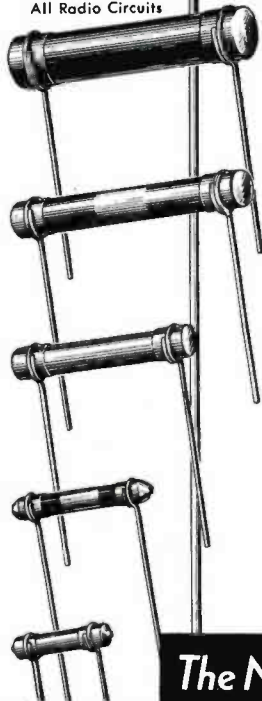

Bradley Suppressors for Auto Radio

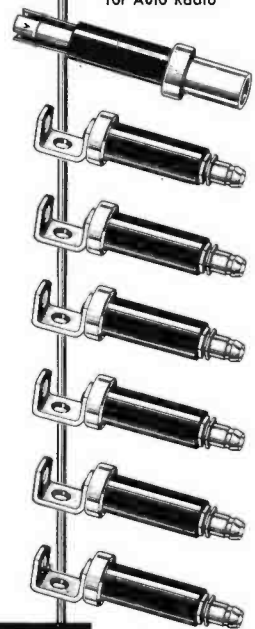

# Bradleyunits Solid Molded Resistors

The Choice of the World's Largest Radio Manufacturers

Don't risk the reputation of your receiver with poor resistors. Standardize on Bradleyunit Resistors because their resistance values are stable under varying conditions of load, temperature and moisture.

Bradleyunit Resistors are made in five sizes, with or without leads, and are R.M.A. color coded for resistance value identification. These solid molded resistors are accurately calibrated and have great mechanical strength. Get an Allen-Bradley quotation on your next order.

Allen-Bradley Co. 126 W. Greenfield Avenue., Milwaukee, Wis.



## The New Tapped Bradleyometer

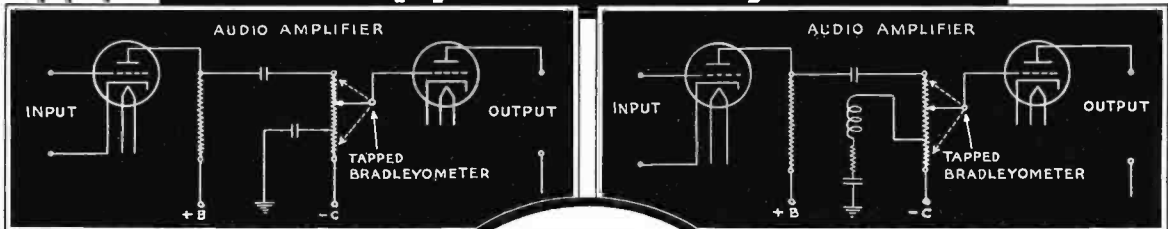

The new Tapped Bradleyometer provides automatic tone correction with volume control. It achieves this result in any one of several audio frequency networks. (See above diagrams.)

A tap on the resistance element is brought out to a fourth terminal. The network necessary to provide tone correction is usually connected between this tap and the grounded or low

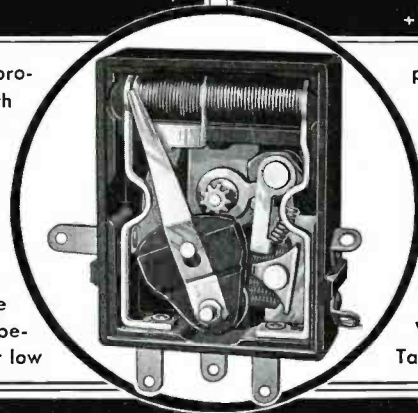

potential end of the Bradleyometer.

A single-pole line switch approved by the Underwriters' Laboratories and the Hydro Electric Power Commission of Ontario with a rating of 2 amperes, 125 volts, can be provided within the Bradleyometer and is operated by the regular control knob.

Write for complete data on the New Tapped Bradleyometer.

# ALLEN-BRADLEY RESISTORS

Produced by the makers of Allen-Bradley Control Apparatus

# RADIO ENGINEERING

Production, Administration, Engineering, Servicing

Vol. XII

OCTOBER, 1932

No. 10

## Primary battery substitutes for automobile radio receivers

By JOHN DUNSHEATH

A review of the subject of "B" battery substitutes, from the viewpoint of the manufacturers of radio receivers and the manufacturers of automobiles.

ONE radio manufacturer specializing in receivers for police patrol cars after trying out various types of "B" eliminators decided for the time being not to recommend to users any type of eliminator, depending upon battery units. The company's engineering department, however, has continued examination of all "B" power devices brought to their attention and it is expected that one or more types will shortly be approved for service in the company's automobile equipment.

It appears that with the rotating type of machine commutator trouble was experienced, while with vibrator types there was more or less sticking of contacts which introduced interruptions. One reason for some users of automobile radio receivers continuing the use of primary battery units is that so long as the batteries are securely connected there is always advance indication that the cells are reaching the end of their life. Thus, they may be replaced before service is interrupted, while with the earlier types of mechanical "eliminators" defects might develop without warning and the receivers be rendered inoperative at a time when they were most needed.

Highly developed "B" batteries which give about sixty-five days' service at an eleven milliamperere drain have been

satisfactory and economical for certain important services. If batteries could be produced which would give about one hundred days' service the manufacturers of battery eliminators would have a real problem to meet.

Recent models of automobile receivers with good range and volume possibilities consume between fifteen and eighteen milliamperes, with filament battery consumption about 1.8 amperes; "B" power being 135 or 180 volts. Obviously, designers of auto sets aim to produce receivers which will give serviceable reception with considerably less current in the plate circuits than eighteen milliamperes.

The astonishing increase this year in the demand for receivers for police patrol car service has given the manufacturers opportunity under paying conditions to develop suitable units, and to push the development of battery eliminators. Cities, counties and states, in the market for hundreds of receivers for police work are stipulating that receiving equipment must include provision for power other than primary batteries. The intensive development

work being done to perfect receivers for police car use will hasten the time when comparatively inexpensive, satisfactory receivers will be available for every man's car, along standardized lines.

### Using the Car Battery

There appears to be much objection on the part of police department officials to eliminators which are driven by the car's six-volt starting and lighting battery. They report that there are at present sufficient troubles from that source without giving the battery any more work to do. The answer, of course, is the development of a high voltage generator to be driven by the automobile engine. This, in turn, means that the receiver may be operated only while the engine is running. Several units which accomplish this have already been announced. For police car use there is little objection to the engine running while the car itself is parked, or otherwise stationary. For private car use there undoubtedly are occasions when it is desired to operate the receiver for an hour or more, when it would be desirable also that the engine should be stopped.

### Police Service Communication

The discovery by police departments in all parts of the country of the usefulness of radio equipped patrol cars, has suggested to many officials that perhaps other police communication services heretofore maintained at consid-

Sparton Model 34 automobile radio seven-tube superheterodyne chassis carries the new r-f pentode tubes No. 39, with a special tube for automatic volume control.

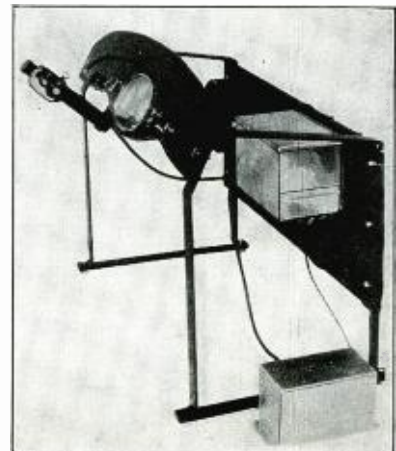

erable expense may be dispensed with, thus providing funds for the betterment of the radio equipment. Printing telegraph circuits widely installed by State police organizations almost simultaneously with the introduction of police radio, are now carrying information which will stand considerable delay.

The ideal system appears to be the use of the wire telephone from the public to police headquarters and the police radio from headquarters to patrolling cars. This is instantaneous and effective.

#### Engine Driven Generator

One company which has specialized in farm lighting equipment has developed an engine driven a-c. generator, 110 volts, 60 cycles, for automobile use. The same unit generates 6 volts d-c. for filament current. Here, the problem of voltage regulation presents itself, but no doubt the experience gained with voltage regulators in other lines of application will be of service in this respect.

Experimental dynamotor units have been developed which employ a 32-volt storage battery source, the generator output being 180 volts at thirty-five milliamperes.

#### Fire Department Radio

The outstanding success of police radio quite naturally has prompted fire departments of various communities to look into the possibilities of two-way radiophone communication between fire trucks and fire department headquarters. Such service available would vastly facilitate the calling of additional fire fighting equipment in case of "second alarm" needs, which now necessitate that firemen first on the scene of a fire have to hunt for a fire alarm box to send in the emergency



Ramona, blues singer and pianist of station WLW, in her roadster which she recently equipped with one of the new Crosley Roamio receiving sets.

alarm, or that they go to a public telephone and from there communicate with headquarters.

Two-way radiophone communication between fire headquarters and trucks away from their respective fire houses would also enable headquarters to order a truck to proceed to another fire reported after they had left their station, without having to await the return of the truck to headquarters.

#### Quandary of the Automobile Manufacturer

Naturally, the automobile manufacturer considering the cost of radio receiver equipment which may be an optional sales feature of his cars thinks of elements of the situation which might not occur to the radio manufacturer.

In normal times many persons turn in their cars after a year's service, being granted a certain turn-in price as part payment of a new car. The car owner might be satisfied with a radio receiver, battery operated, if an eliminator operated set cost more. This, on the ground that the battery would last a year anyway and he would be credited with no more by turning in a car eliminator-equipped than one battery-equipped. If the cost of the eliminator can be kept below \$25, or below the cost of two sets of "B" batteries, the consideration mentioned might become inconsequential.

In a recent survey fifty-five per cent. of the automobile owners queried replied that they are interested in having

their automobiles equipped with radio receivers. About five thousand owners answered the questionnaire. It is reported that even during these days of economic instability Philco are selling automobile radio receivers at the rate of about 70,000 per year.

#### An Improved Battery Driven Generator

It was stated previously herein that certain police departments have had unsatisfactory experience with receivers operated by eliminators driven by the car 6-volt battery. Notwithstanding this, types of eliminators are now appearing on the market which deliver 170 volts at forty milliamperes, drawing  $2\frac{1}{2}$  amperes from the battery, and which are said to be quite efficient. One type employs permanent "U" magnets for field excitation. In the automobile radio service, as in the airways radio service, experience indicates that where battery eliminators are used it is of the utmost importance that periodical inspection be given the equipment. By this means interruptions and irregularities are forestalled and service safeguarded.

Here, then, is presented a running commentary on the battery eliminator problem of interest to users of radio receivers in police cars, private automobile owners, airways radio service, motor-boat owners, fire departments, and others. The proportion of radio receiver installations operated by "B" batteries, vibrator type eliminators, rotating machine generators, or by tube rectifier systems, will depend upon the success attained by the various manufacturers of these sources of radio operating power in producing equipment which will meet all of the requirements and which will meet with popular favor.



Louis J. Labash, in the radio business at Ziegler, Ill., conducted a search for some sort of a sign or symbol that represents Dependable Radio. He selected the design which appears on the cover of RADIO ENGINEERING and had this painted on an automobile tire cover carried at the rear of his service truck. The device has attracted much attention in Mr. Labash's territory. It is a publicity stunt for Dependable Radio which has meant money to his shop.

# Police radio system in New York City proving successful

Valuable new arm for police service increases the hazards risked by gunmen.

Automobile radio receiving sets used by the New York police department are simple in construction but sturdy and durable, built to withstand 24-hour service under all weather conditions. They are equipped with Eveready Raytheon four-pillar tubes and also a special type of B battery designed by National Carbon Company for automobile service.

**A** BURGLARY reported and solved—the goods recovered and the thief in jail—all in four and one-half minutes.

Police radio did it.

The police department of New York City inaugurated the use of an automobile radio patrol early in February,



A 400-watt Western Electric transmitter in New York's police radio-telephone system. This one is located in Brooklyn; another identical one is located in the Bronx. The policeman, attached to the radio branch of the Telegraph Bureau, is broadcasting a message.

1932, since which time the service has been extended gradually, with increasing coverage and expanding results.

In the burglary case mentioned, police headquarters received the report at 5:30 o'clock in the morning. Immediately the news was broadcast and two patrolmen in a sector near the scene of the robbery picked it up. Almost simultaneously they sighted a taxi from which bundles were being unloaded and carted into a house. Suspicious doings that early in the morning! So, the patrolmen arrested the suspect who confessed without parley.

Radio equipment for the police cars is subjected to the severest of tests, both because of electric conditions in the metropolis and the fact that broadcasts must be over and through mountains of buildings into veritable canyons

of steel. It is subjected also to the wear and tear of high-speed vibration over rough streets and highways.

Police car radios are in use twenty-four hours a day, tuned in on the headquarters wave length; as one patrol goes off duty, the next lends an ear in constant readiness for a call. A complete check on the whereabouts of the radio patrol is kept at the central station by means of a map of the metropolitan districts on which numbered indications show the position of the cars.

Although in service only six months New York City's police radio system has enabled the department to quickly



apprehend hundreds of criminals who no doubt would have escaped had the radio system not been in operation.



A message is about to go on the air over New York City's radio-telephone system. In this scene at police headquarters, Centre Street, the nerve center of the radiophone system, the dispatcher, having just received a call over the telephone, has indicated the car or cars that are to respond and is handing the message to the radio man at the speech input panel who will repeat the message into the microphone and thus put it on the air. In selecting the cars that are to respond, the dispatcher has before him large maps of the city's five boroughs with metal discs showing the location and number of every car on duty. (Photograph from Western Electric Company)

In more than one hundred cities and towns throughout the country police radio systems are now in operation, giving law enforcement officers a new and effective arm with which it is now possible to meet the menace of bandits who employ high speed automobiles in attempting escape.

In addition there are many state police radio systems and county systems in operation and giving satisfaction. There remain some twelve thousand communities where, in time, will be installed police radio systems suitable to the needs.

# Receiving television in an airplane

By HARRY R. LUBCKE\*

**I**n order to prove beyond a doubt that a newly developed self-synchronized receiver would operate away from power lines common to the transmitter, it was taken aloft in an airplane and the reception images attempted. In spite of rapidly changing field strength, varying airplane power source, residual electrical interference and irregular mechanical shock, recognizable images were received and proper synchronization maintained on each flight.

A large tri-motored Fokker airplane of the Western Air Express was used for the flights. The cabin accommodated ten passengers and directly in front of it was the mail compartment, which was used to house a small dynamotor and an auxiliary battery. A 200-watt 24-v.d.c. to 115-v.a.c. dynamotor was used to provide alternating-current power for the receiver, rather than to rebuild it for battery operation.

## Cathode Ray Tube Used

The receiver is shown as it was installed, in Fig. 1. Besides the cathode-ray tube which can be seen at the top center, it comprises a 44,500 kc. receiver, a low frequency source, a high frequency source, a power unit, and a selecting amplifier. It is entirely a-c. operated, and for home use derives all of its power from the usual 110 volt a-c. supply. The selecting amplifier functions to supply the high and low frequency scanning sources with synchronizing pulses derived from the incoming signal, thus providing synchronization regardless of the power network on which the receiver operates. It was this feature that made reception in an airplane, removed from the power network of the transmitter, a possibility. So far as is known, the present occasion marked the first time that television images had been received in an airplane.

The regular ultra-high frequency television transmitter of the Don Lee Broadcasting System, W6XAO, was used to transmit the images. This station is located in the Don Lee Building in metropolitan Los Angeles, and has been transmitting television images of 80 lines repeated 15 times per second

\*Director of Television, Don Lee Broadcasting System.

on a nightly schedule since December 23, 1931, operating on the ultra-high frequency of 44,500 kilocycles with a power of 150 watts.

A photograph of the transmitter is shown in Fig. 2. A master oscillator, modulated power amplifier circuit is used. One hundred per cent modulation is obtained. The modulated radio-frequency energy is carried to the roof of the 8-story building by a two-wire feeder to a copper rod vertical doublet radiator.

A test flight was made to determine the distribution of the field strength over the country, previous to the reception of the image. A portable battery-operated 44,500 kc. receiver with a portable cathode-ray oscilloscope was used. The results of this work are shown in Fig. 3, in the form of a field strength contour map for an elevation of 3,000 feet. The figures on the contour lines give the signal strength measured in volts output of the portable receiver. The field strength in microvolts per meter is approximately four times the figures given.

## Reception in Plane

With the conditions existing above the city indicated by this flight, the alternating current cabinet receiver shown in Fig. 1 was checked and taken out to the airport for installation in the plane. Two front seats in the cabin were removed and it was installed as shown in the photograph. The windows were darkened with black cloth, with the dynamotor and auxiliary battery installed in the mail compartment directly ahead of the cabin. This accomplished, the plane was wheeled out of the hangar, and into the clear with respect to the direction of W6XAO, and the receiver snapped on. The signal of W6XAO was received; not with sufficient strength to give an image, but enough to give an aural signal which served to check the operation of the radio frequency receiver and associated equipment. With the blank field visible on the screen giving evidence that the scanning sources were operating satisfactorily, we were ready for flight.

We took off at 9:43 a. m. on May 21st. After gaining altitude, the re-

ceiver was snapped on, and after the usual a-c. heater tube warm-up period, an interference we had not experienced on the previous flight appeared on the screen. It took the form of bright dancing horizontal lines about an inch long. Notwithstanding, about a half minute later the image began to appear and soon came in with great intensity. It did not stay in, however, but faded continually over a great range of signal strengths. Although it was a fair day, occasional clouds caused the air to be very bumpy, and the plane rocked and dropped almost incessantly.

In the darkened plane, the constant bumping, the vibration, and the roar of the motors conspired to create a feeling of continual confusion, in which the receiver could hardly be expected to operate. Strangely, this did not affect the receiver in the least, and it did operate despite the constantly varying signal strength.

## Eight Miles Range

After a few minutes' experience it was possible to keep a tolerably good image on the screen by adjusting the volume control on the receiver. It became evident that we were experiencing the effect of motion through innumerable standing wave patterns, whether real or apparent, because of the continual rocking and dropping of the plane. The synchronization of the image was not greatly affected by the behavior. Cruising around within ten miles of the station verified the field strength distribution, as determined several days previously, and showed ample signal for an image up to eight miles away. The charging generator was suspected as the source of interference, and when shut off, the bright



Fig. 1. Receiver as installed in plane. Harry R. Lubcke, who developed receiver, at controls.

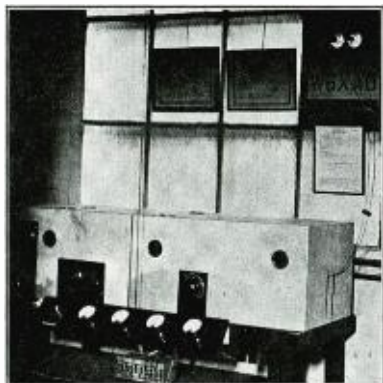

Fig. 2. Ultra-high frequency television transmitter, W6XAO.

lines disappeared. This accomplished, the plane was brought down and we were ready for the guests of the afternoon demonstration.

The flights were scheduled for 2:30 p. m. Shortly before this W6XAO was again received on the ground as a check, and after several passengers were accommodated, we took off. On this flight better performance was obtained. The charging generator was shut off when the receiver was operated and the air was not so bumpy, although one passenger became ill with air-sickness with the bumps that remained.

The head and shoulders closeup of the motion picture star, attired in a white hat and dress, transmitted from W6XAO, came through very clearly at times. All of the passengers recognized her features and motions.

After a five to ten minute demonstration the first group of passengers was brought down and a second group taken up. On this flight a better image was secured through the expedient of setting the receiver controls and allowing the image to fade and return at will. Most satisfactory operation was observed, in that *the image repeatedly came back intact and in frame*, signifying proper performance of the synchronizing system in spite of continual signal variations from zero to overload.

Later, with the flights over, the receiver was operated at a location in a reinforced concrete building having a field strength corresponding to five miles away and 3,000 feet in the air. The image was clear, constant, and steady, checking its previous operation at this location. It was possible to simulate the fading noted in the plane by varying the output of the radio frequency receiver, indicating that this behavior was a characteristic of flight. It is interesting to note that this location was in the building under the W6XAO antenna, but such that the waves had to penetrate six floors of reinforced concrete building to reach the receiver.

Several facts on the behavior of ultra-high frequency television waves were found. The reception of an image provides the most exacting test in the communication link. Wave form distortion and signal strength variation that make image reception impossible, still bring forth excellent voice quality when so modulated.

The field strength map of Fig. 3 shows a pattern similar to that obtained with a directional antenna pointed for maximum signal to the northeast. This was caused by an antenna stay wire of the broadcasting station KHJ occupying a position about one wavelength away from the W6XAO vertical-doublet. This wire, erected before ultra-high frequency television was thought of was cut into short lengths by the insertion of insulators in approved fashion, but into lengths corresponding too closely to  $6\frac{3}{4}$  meters, for convenience. The combination gave a maximum along the line passing through the two antennas in both directions; but a grounded steel tower intervened another wavelength away to the southwest which absorbed the southwest maximum. This condition is scheduled for correction in the near future, although it is not entirely unfortunate, in that it directs a strong signal to the city of Pasadena.

Many previous ground tests had proved that both the earth and steel buildings cast shadows, the latter about

half as effectively as the former for a given volume of material. The ordinary wood frame or stucco house does not present a shadow of any consequence, but they may give rise to standing waves when close to the transmitter because of their pipework.

In the airplane flight the effect of obstacles was almost entirely removed, of course, except for one very near obstacle; the plane itself. It is believed that this was a contributing factor to the rapidly changing field strength observed. The antenna being in the wing and extending from near one wing tip to the other. The metal containing motors, cabin, or tail was always between the antenna and the station, and constantly changing position with respect to it as the plane flew on its course, or was rocked or dropped by the bumpy air.

Another factor was the speed of the plane through the field strength pattern of the transmitter. Flying at a speed of 120 miles per hour, two miles were covered in a minute, and assuming a square law variation of signal strength with distance, the field strength experienced at a point two miles away from the transmitter was reduced to *one-fourth its value a minute later at a distance of four miles.*

As a result of the test, television reception on farms, in metropolitan hotels and office buildings served only with  
(Concluded on page 24)

Fig. 3. Field-strength contour map of W6XAO showing distribution of signal strength for an altitude of 3,000 feet.

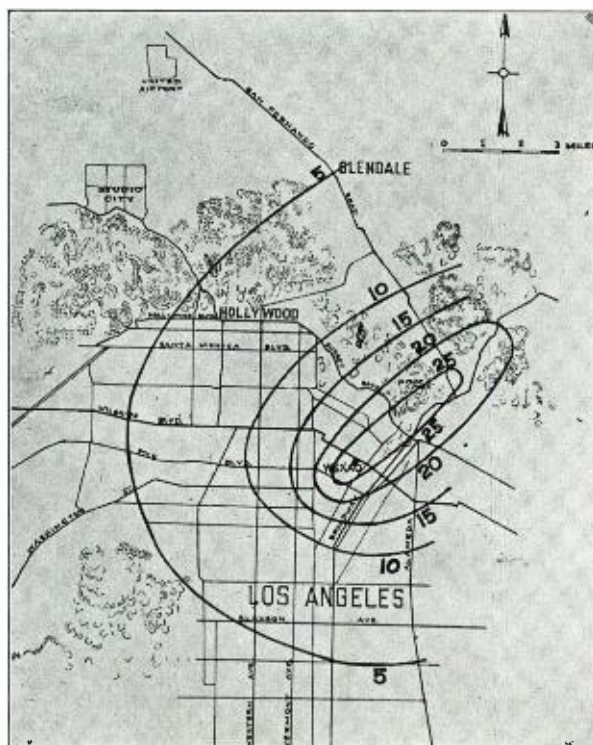

# Power transformer testing

RICHARD F. SHEA \*

Design of a test board by means of which tests are made on power units used in receivers and kits.

In this article is described a test board for power transformers, on which it is possible to make all the necessary current and voltage measurements under proper load conditions, and to also place the transformers on heat run for any length of time. This board may also be used to give complete receivers similar tests, and is capable of handling as many as ten or more transformers or sets at one time, or a total load of about 800 watts.

The complete test board is made up as a table with a high back. This table is about 6 feet long, 2 feet deep, with a back about 2½ feet high. On the table proper are mounted the binding post assemblies for the transformers under test, four of the load resistors, sockets, for the rectifier tubes, and the test wattmeters, which are set in flush with the top. The back carries the meters, switches for these, binding posts for meter connections and for load resistors, the remainder of the high voltage load resistors, and the controls for the line transformers. These transformers, which serve to step the 110 volt line up or down to the desired

\*President, United Radio Laboratories.

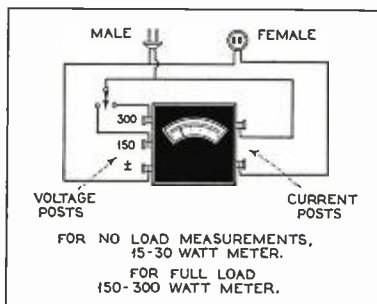

Fig. 1.

input voltage, are mounted in back of the back-drop, together with the meter shunts and multipliers, and the wiring.

Fig. 1 illustrates the connections of one of these line transformers, of which there are four. These transformers are in the form of auto-transformers, arranged by means of a primary center tap to give an output of either 110 volts plus or minus 30 volts, or 220 volts, plus or minus 60 volts, when operating from 110 volts, either 50 or 60 cycles. The transformers are wound on cores approximately three inches in cross-sectional area, with 440 turns of number 21 wire on the primaries, center-tapped, the secondary being 240 turns of number 18 wire, tapped every 20 turns. The center point of the secondary is connected to one side of the primary, as shown, and thus there is available between the other side of the primary and the taps of the secondary a voltage range of 80 to 140 volts, when the switch is in position 2, or 160 to 280 volts, when in position 1. In order to make this output voltage continuously variable a tandem switch is used, as shown, with 6-ohm heavy duty variometer connected between the two rotary arms of the switch. This potentiometer should be capable of at least 50 watts dissipation, and should be made up on asbestos, wound around a metal frame. The auto-transformer arrangement, as illustrated in Fig. 1, is capable of safely carrying a load of about 175 watts. Thus such an arrangement will take care of three ordinary radio receivers, or two larger ones.

### Heat Runs

There are four of these line transformers on the test board, and each of these is brought to a separate input line, so that they may be individually connected to either 50 or 60 cycles. Each line transformer supplies two test positions on the table, and also two outlets on the front apron, where any receiver may be plugged in for heat runs. By this arrangement it is possible to have simultaneous tests running at 50 and 60 cycles, 110 and 220 volts, or overload voltages, if desired.

The method of supplying the primary voltage to the test positions is as follows: the output from the line transformers is brought to two outlets on the back, as well as to the two on the front apron. There are two cords with attached plugs coming through the back, and these cords connect to the primary binding posts on the test positions. To connect any test position to a line transformer it is only necessary to plug the appropriate cord into the proper outlet. This arrangement is also very handy for wattage measurements. The wattmeters are set in the table

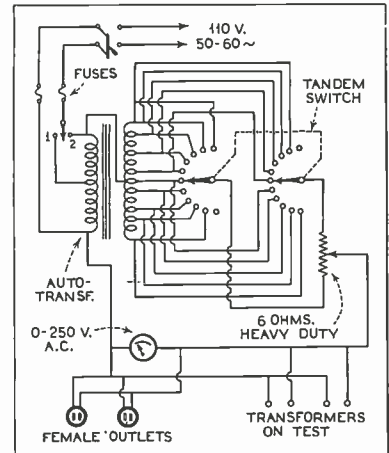

Fig. 2.

top, as mentioned before, with two outlets in the top of the table, connected as shown in Fig. 2. There is a double throw single pole switch beside the wattmeters, for connecting in either the 150 or 300 volt windings, in order that the wattmeters will not be damaged when testing 220 volt transformers. The male outlet from the wattmeters is for the supply line, the female outlet supplying the primary excitation to the test positions. Long cords with plugs attached are supplied for connecting the wattmeter outlets to the desired loads. Thus, if it is desired to measure the load taken by transformer position No. 1, it is merely necessary to disconnect the plug on the back from its outlet, run one cord from this plug to the female outlet for the wattmeter, and another cord from the supply outlet on the back to the male outlet for the wattmeter.

### Actual Voltage

In connection with the use of the load wattmeters, several points will bear emphasis. The supply voltage at the test transformer terminals will be less than the reading on the panel meter by the drop in the wattmeter current coil, which must be computed by measuring the load current, and knowing the current coil resistance. At full load it is fairly accurate to directly subtract this drop from the meter reading, but not at no load, as the subtraction is vectorial. It is best to connect the panel voltmeters on the supply cord side, whereby they will indicate the actual voltage supplied to the load. In this connection, however, the watts taken by the voltmeter must be subtracted from the wattmeter reading to get the actual load. Also, with the connections as shown, the wattmeter indicates the power consumed in the cur-



rent coil, and this must be likewise subtracted from the wattmeter reading. Best practice suggests the use of two wattmeters, one having ranges of 15 and 30 watts, for no load readings, another for 150 and 300 watts for full load. It is possible to use the former for both readings, by using a shunt across the current coil for the higher ranges. However, such a shunt must be reactive, with about the same power factor as the current coil, otherwise the shunt will not be correct at all values. Another disadvantage of using a shunt is that the maximum allowable current with a shunt is lower than when using a meter designed for this load. When using wattmeters care must be taken not to exceed the current and voltage readings, even though not exceeding the range of the meter. This is particularly important in making low power factor measurements, such as no load watts.

The test position connections are shown in Fig. 3. Each position has two binding post strips, one with five posts, for primary and secondary connections, the other with ten posts, thus making it possible to test four filament windings, in addition to the rectifier winding. Two sockets are mounted beside each position for the rectifier tubes, connected as shown. By this means it is possible to use either two 281 tubes in both sockets, or, if the transformer calls for a 280, it may be placed in either socket. Thus it is possible to use either type of tube without changing connections. The high voltage is by-passed by an arbitrary four ufd. condenser, and the load is supplied by a 5000-ohm, 200-watt variable resistor, thus providing the full variety of loads encountered in practice. These variable resistors were made up by smoothly wrapping sheet asbestos around an iron pipe, then winding nichrome wire over

the asbestos. Mounting brackets were fastened on the ends, also serving to support the contact bar, which carried the sliding contact. In making a resistor of this sort the ends of the pipe must be open for maximum radiation.

Binding posts are provided on the back for measuring the current taken by the load, and the voltage supplied to it. For low voltage terminals it is satisfactory to mount the binding posts directly on the asbestos, with which the table top and back is lined (to avoid burning the wood under heavy loads). However, for high voltages the binding posts must be insulated from the asbestos, as this material has some leakage, especially when the humidity is high.

**Load Connections**

Likewise, on the back are provided binding posts for connecting in the dummy filament loads, and also for measuring the current and voltage supplied to them. In Fig. 3 these posts are designated as 1, 1', 1'', 2, 2', etc. The load resistors are connected between the 2 and 3 posts, while jumpers are normally between 1 and 2. These jumpers may be removed, and the current measured by the insertion of the ammeter at this point.

It was found satisfactory to use fixed resistors for these dummy loads, as the usual filament loads are rather few in number, for example, four heater type tubes, 2½ volts at 7 amperes, or .357 ohm. Similarly, dummy resistors are used to duplicate the load of five tubes, six tubes, seven tubes, five volt and 7½ volt loads found in practise. These resistors are made up on porcelain tubing, the low resistance ones being wound with copper wire, and the whole amount of wire being as great as possible to secure maximum heat dissipation. In connection with the use of copper wire

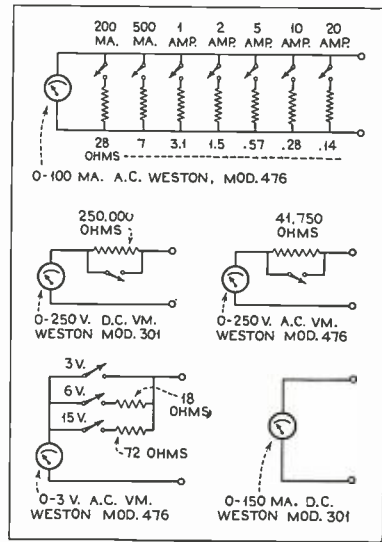

Fig. 4. Meters and Multiplier shunts.

for dummy resistances, it must be borne in mind that copper has a comparatively high temperature coefficient, hence these resistors must be made to have the correct resistance after they have reached a fairly steady temperature, under rated load.

Fig. 4 shows the meters and their shunts and multipliers, whereby it is possible to obtain the full range of desired current and voltage measurements, using only five comparatively inexpensive meters. The 0-100 milliampere, a-c. meter is used for no-load current measurement, and by means of the seven shunts shown can be used to measure full scale currents of 200 ma., 500 ma., 1, 2, 5, 10 and 20 amperes. The values of the shunts given are only approximations, as each shunt must be adjusted to the individual meter. Since the resistance of the leads enters into the adjustment of the shunts, heavy buss wire must be used, and it is suggested that the terminals be located at the end nearest the low resistance shunt, to reduce the effect of wiring to a minimum. The importance of this must be stressed, as the resistance of the wiring will change as the wire heats up, consequently the wire resistance must be kept down to an insignificant percentage of the whole. In connecting the meter binding posts to the load, heavy flexible cable must be used for the same reason, with large lugs on both ends, and the binding posts must be heavy and have positive contact.

**Voltage Multipliers**

Multipliers are provided for the three voltmeters, as shown, whereby their normal ranges may be considerably increased. The 0-3 a-c. voltmeter, with its two multipliers, will take care of

(Concluded on page 24)

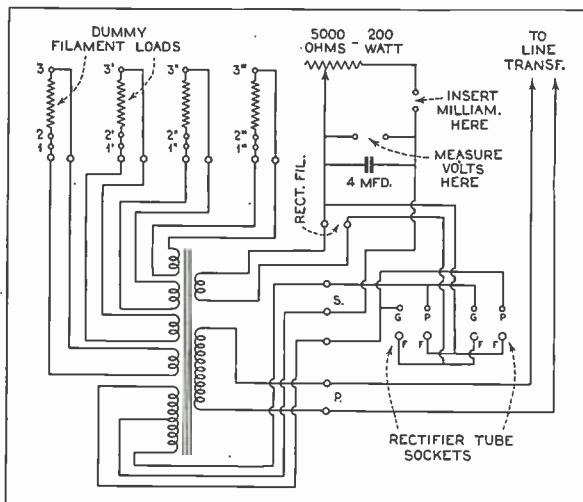

Fig. 3.

# A chronological history of electrical communication —telegraph, telephone and radio

▲

This history was begun in the January, 1932, issue of RADIO ENGINEERING, and will be continued in successive monthly issues throughout the year. The history is authoritative and will record all important dates, discoveries, inventions, necrology and statistics, with numerous contemporary chronological tie-in references to events in associated scientific developments. The entries will be carried along to our times.

▼

## Part X

1872 (cont.)

- (372) The European and South American Telegraph Company, formed in London, December 5, 1871, has a capital of £1,250,000, in 62,000 shares at £20 each
- (373) An International Telegraph Conference is held in Rome, Italy. At this conference the submarine cable companies are for the first time represented.
- (374) In the Argentine Republic 1,400 miles of public telegraph line is in operation, exclusive of railroad telegraphs.
- (375) The Dominion Telegraph Company, in Canada, has 1,176 miles of pole line and 2,265 miles of wire in operation, with eighty-three offices in Ontario. The company's capital is \$270,000. The company has acquired the lines of The People's Telegraph Company, of the Province of Quebec, with 364 miles of pole line.
- (376) The Western Union Telegraph Company acquires exclusive ownership of the patents of 1868 of J. B. Stearns, covering duplex telegraphy.
- (377) A movement is begun having in view the universal introduction of the French Metric System of weights and measures.
- (378) The Republic of San Salvador has about 500 miles of telegraph line in operation.
- (379) Colleges and laboratories in various parts of the country are supplied with vacuum tubes invented by Dr. Heinrich Geissler, of Bonn, Germany.
- (380) A telegraph line across the Andes, in South America, is completed, connecting Atlantic and Pacific coast cities.
- (381) At an exposition in Cincinnati, Ohio, the electrical exhibits consist mainly of telegraph apparatus.
- (382) The tangent galvanometer, invented by Pouillet and improved by Gaugain, is widely used for telegraph and cable testing purposes.
- (383) Professor Tyndall delivers a lecture at Lowell Institute, Boston, on the subject of advanced physics. Another British Scientist who visits America this year is Professor J. H. Pepper, who lectures on light and electricity.
- (384) The Western Electric Company, organized, with works at 220 Kinzie St., Chicago. The Chicago factory succeeded by purchase or consolidation to the business of the Caton Instrument Shop maintained by the Western Union Telegraph Company at Ottawa, Ill., and to the business of Gray and Barton, Chicago; George H. Bliss and Co., Chicago; Electric Improvement Co., Galesburg, Ill.; C. Williams, Jr., Boston; Gilliland Telephone Co., Indianapolis, Ind. The New York works of the Western

- Electric Company originally was an electric shop maintained by the Western Union Telegraph Co.
- (385) The West India and Panama Telegraph Company's submarine cable lines completed, connecting Cuba, Jamaica, Trinidad, Porto Rico, Panama, Colon and the west coast of South America.
- (386) Professor Morton, of Stevens Institute of Technology, Hoboken, N. J., delivers the first of a course of public lectures on Electricity.
- (387) Lodyguine, in Russia, exhibits an incandescent electric lamp, the glass chamber made in two parts, one cemented to the other.
- 1873 (388) Joseph B. Stearns is awarded the Medal of Honor by the American Institute for the invention of the duplex system of telegraphy.
- (389) Gramme's direct-current magneto-generator is used to produce electric light in the parliament houses in London.
- (390) A vote is taken (March 20) in the main operating room, Western Union Telegraph Company, New York, to determine sentiment among telegraphers relative to changing from American Morse to the Continental Morse alphabet. The proposal is rejected.
- (391) Taylor and Muirhead, in England, succeed in duplexing long submarine cables.
- (392) Willoughby Smith announces the discovery by Mayhew of the electric properties of selenium.
- (393) The Direct United States Cable Company, organized.
- (394) Thomas A. Edison and John E. Wright go to England to install high speed automatic telegraph apparatus.
- (395) The Anglo-American Cable Company lays a cable between England and Newfoundland.
- (396) Patrick B. Delany, in America, patents a telegraph relay considered a satisfactory substitute for the Page patent relay, which threatens a monopoly of the telegraph business.
- (397) The "Drum" armature for dynamo machines, introduced.
- (398) Metal posts are introduced on German telegraph lines between Berlin and Dresden.
- (399) The Electric Railroad Signal Company, controlling the patents of F. L. Pope covering track circuits, opens offices in New York.
- (400) Duplex telegraphy is introduced in England by W. H. Preece.
- (401) Mr. Eden, engineer in the Edinburgh, Scotland, office of the British Telegraph Department, devises a system of duplex telegraphy.
- (402) George B. Prescott, electrician, and Thomas T. Eckert, general superintendent, Eastern Division, Western Union Telegraph Company, are commissioned to go to Europe to examine the latest telegraph improvements introduced in the large cities. Particular attention is to be given to the operation of pneumatic tubes, and to underground cable construction.
- (403) Joseph B. Stearns goes to Europe to introduce his duplex system.
- (404) Norvin Green becomes acting vice-president of the Western Union Telegraph Company.
- (405) Auguste Arthur De La Rive dies. (Born in France 1801.)
- (406) For the year 1872 the net earnings of the Western Union Telegraph Company were \$2,790,232.61. The gross, \$8,457,095.77. The introduction of the half-rate night message on January 1, 1870, for a time caused serious losses in revenue, but general increase in telegraphing, with extension of lines, has overcome this.

(To be continued)

# A three-sided radio tower †

By SAMUEL COUZIN\*

Herein is described the method of erecting self-supporting radio towers, the main members being pipe sections, and the bracing pipe or double angles. Liberal use is made of welding.

THE tube section makes the most efficient type of strut as all the material is concentrated at the greatest radius where it is most required. Rolled steel sections of H section are suitable for stanchions as most of the material is disposed at the greatest distance from the neutral axis, in one direction. There is usually, however, a great difference between the radii of gyration about the two principal axes, and this makes the H section comparatively inefficient for this purpose. The H section is the least expensive steel section available for use as a stanchion, as tubular sections cost per pound almost twice as much as rolled sections.

Where the load is light and the ratio of slenderness of the strut is high, the disparity between the initial cost of the tube and that of the rolled section is lessened. In such cases the tube section can compete with the angle section. A common stiff strut with a comparatively high radius of gyration consists of two angles arranged in cruciform section and attached to each other by battens at intervals, alternate battens being at right angles to one another. Where such an arrangement is more economi-

cal than the H section, it is itself surpassed in economy by the tube section which may cost more in raw material but requires far less labor.

### Methods of Making Joints

In the past the tube section could not be used satisfactorily even in cases where, from the above considerations, its use would have been economical. This was due to the difficulty in making satisfactory joints to other parts of the structure, such as bracing. Clamped connections are undesirable from practical points of view, as well as being unsightly. The difficulty of connections disappears with the use of fusion welding combined with gas cutting, and the tube becomes feasible for stanchions, combining with its use strength, stiffness and economy.

It is being used with satisfaction for large steel staircases, up to 100 feet in height, and various other purposes where light loads are to be carried at comparatively great heights. The various salient points of design involved in the use of pipe stanchions with the help of fusion welding are brought out in the following description of a 200-foot, self-sustaining radio tower designed to the specification of the Post Office of the Union of South Africa.

Radio towers are commonly built up of angle and flat sections bolted together in a tapering structure whose plan is square. Three-sided structures have been used, but such design has introduced the complication of bent gussets, or the use of special angle sections of 120° for the main members, or alternatively of 150° for cleats between 90° main angles. With the use of pipes for the main member, gussets can be welded to them at any angle to one another, thus simplifying the use of the three-sided tower. The three-sided tower saves almost the equivalent of one-

fourth of the material required for bracing for a four-sided tower. In addition, there is the economy introduced with the use of the pipes as struts.

### Specification

The specification governing the design and construction of this radio tower was as follows:

Towers to be self-supporting, lattice-steel, 200 feet high. They are to be designed for a load giving a maximum horizontal pull of one ton at right angles to any face of the tower, and a vertical load at the top of 4 tons; wind load of 20 lbs. per square foot of exposed surface on one and one-half times the projected area of one side. With these loads acting simultaneously and in addition to the deadweight load of the tower, the factor of safety is not to be less than 3.

No member is to be less than 1/4 inch thick, and every joint must have at least two bolts.

All steelwork to conform to British

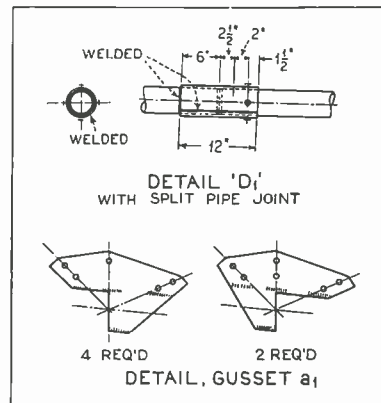

Fig. 2.

standard specification No. 15 for structural steel for bridges.

For erection, all parts to be bolted together, not riveted. Whitworth standard hexagon head black bolts and nuts to be used throughout; adequate spares to be provided.

The three-sided radio tower is designed for erection by bolting, the preparation of the material in the shop being carried out by means of gas-cutting and fusion welding. The general arrangement shows the mast to be 200 feet high, and to have a plan of an equilateral triangle, the side at the bottom being 30 feet. The main members are of pipe section, varying from 5 inches inside diameter at the bottom, to 2 1/2 inches inside diameter at the top. The bracing members are pipe sections or double angles, in cases where a high radius of gyration is required. For the shorter struts, angles are used. Angles are used for ties.

†A paper submitted for the second Lincoln arc-welding prize competition, sponsored by the Lincoln Electric Co., Cleveland, Ohio.  
\*Of Johannesburg, So. Africa.

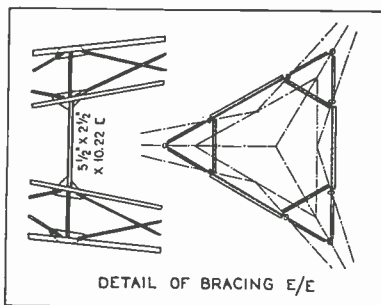

Fig. 1. Bracing of tower legs.

**Bracing of Members**

Owing to the great length they would need to be, the bracing between the main members of the tower has been omitted and, instead, three separate legs are used, each leg being composed of a main member of the tower (5-inch pipe), with two subsidiary members of 2½-inch pipe, the three being suitably braced together. In three places, the three legs of the tower are braced together horizontally as in Fig. 1, in order to hold them together during erection. The horizontal bracing members shown at these points are of joist and channel sections. A still platform is thus obtained at each point for the erection of the next portion of the tower. After erection is completed, the bracing at E/E can be removed, if desired.

**Base Plate Welded**

The base plate of each leg is welded to the 5-inch pipe, the latter being cut at a suitable angle to bear uniformly. Five base gussets are welded to each baseplate, and to the 5-inch pipe. Two of these are in the planes of the 2½-inch pipes (the subsidiary members of the leg of the tower) which have been slotted by the oxy-acetylene torch to fit over these gussets. The 2½-inch pipes are welded to these gussets as well as to the baseplate. To each of these gussets an angle is welded, the heel being vertical, and this forms a box, strongly joined to the leg of the tower. Through these boxes holding down bolts project from the foundation. A horizontal plate as a lid on each box has a hole in it to accommodate the bolt and takes the pressure of the nut. In the plate bisecting the angle between these two gussets, and on the opposite side of the 5-inch pipe, another gusset is similarly welded, and has attached to it two angles to take two more holding down bolts. Two more gussets at right angles to the last help to stiffen the baseplate.

The 2½-inch pipes, subsidiary members of the legs, end at a point where the 5-inch pipes, the main members of the legs, are close enough together to allow for bracing between them being

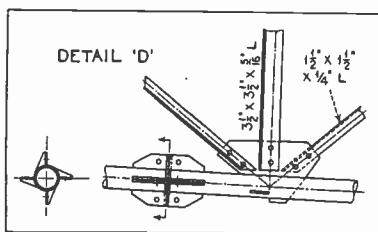

Fig. 3. Method of bracing.

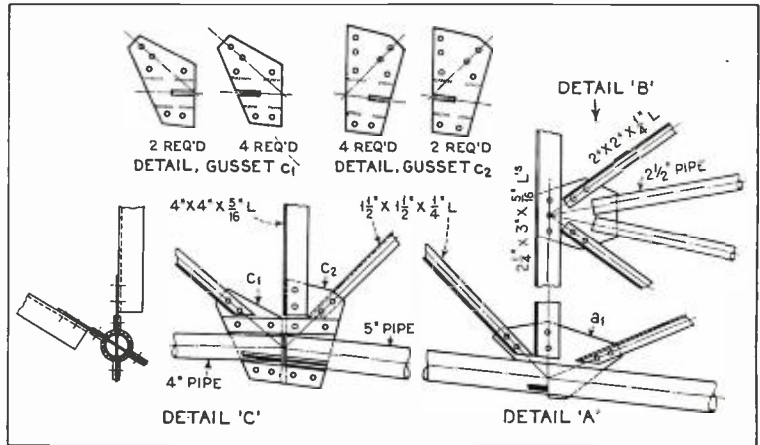

Fig. 4. B, upper end of subsidiary members. A, C, bracing details.

light while adequate. Detail B shows the upper end of these subsidiary members, and details A, C and D show how the bracing is continued.

**Method of Welding**

The bracing is joined to the legs by means of gussets welded into slots in the pipes. Each pipe has two sets of bracing in planes at approximately 60° to one another, but the horizontal members of all these bracings are in the same horizontal plane. To achieve this, each pipe has the slots for one set of bracing slightly above the slots for the other set, but the gussets are shaped to project below or above the slots, as the case may be. This is shown on the drawing in detail of gussets a. 1 with reference to joint A. These gussets are also marked to indicate how they would be welded to the pipe.

Where there is a joint in the pipe, the gussets are slotted to fit over one another inside the pipe. After the gussets are welded into the pipes to be joined, circular plates are welded over the ends of the pipes and the pipes are held together by means of flat bars or cover plates, bolted to the gussets in the same planes.

As an alternative the bracing can be connected as shown in A, and the joint can be made above the bracing, as shown in detail D. Here, four flat bars are welded to each pipe in planes radial to the pipe. The ends of these bars project beyond the end of the pipe and are holed to register with the holes in four similar bars on the pipe above. The end of each pipe is closed with a flat plate welded on. This plate is not circular but has four "rays" projecting from it; these are welded to the vertical bars and stiffen the latter. The rays on the upper pipe are opposite hand to those on the lower so as to clear the

vertical bars of the opposite pipe. If this joint is required for pipes of two sizes the vertical bars would be shaped to suit.

An alternative form of joint is shown on Detail "D 1," Fig. 2. Here a sleeve is placed over the pipes and bolted to each pipe by at least two bolts at right angles to one another. Such a sleeve is simply made by slotting a piece of pipe slightly larger than the pipes to be joined and altering its curvature somewhat to fit. For joining two pipes of different sizes, an inner sleeve is added for the smaller pipe.

These joints are all much quicker to effect in the field than the customary pipe joints. The top of the mast can take any suitable gear required to be placed there.

As shown on the drawing the main members of the tower are made of piping braced with angles, varying in size from 4 in. by 4 in. by 5/16 in. to 2 in. by 2 in. by ¼ in. for the horizontal members. Inclined members are made of 1½ in. by 1½ in. by ¼ in. angle. 5/16 in. gussets and ⅝ in. bolts are used throughout, except for the base. The baseplate is ⅝ in. thick, the base gussets ½ in. thick, and the holding down bolts 1¼ in. diameter.

The weight of this tower is approximately 10½ tons.

**MANUFACTURE OF OXIDE CATHODES FOR ELECTRIC-DISCHARGE TUBES**

**A** CORE, ex. of tungsten, molybdenum or nickel, is coated with tungsten- and/or molybdenum-bronze, ex. by electrolysis of BaW<sub>2</sub>O<sub>6</sub>, prior to deposition of alkaline earth metal vapor on the core.

Egyesult Izzolampa es Villamossagi Reszvenyarsasag. British Patent 356,715.

# The effect of the sun's eclipse on radio waves

DR. E. F. W. ALEXANDERSON\*

**W**HEN we try to interpret something about which we really know so little, as the effect of the sun's eclipse on the propagation of radio waves, the best we can do is to start with such theories as we may have and try to carry these theories somewhat further by establishing new facts. In equipping an expedition to make radio observations on this eclipse we had in mind particularly to follow out a suggestion made by Dr. Irving Langmuir, who desired to obtain more data regarding the theory that from the sun there is a corpuscular or electronic emission traveling at a rate of 1,000 miles a second.

For the test we selected a radio-frequency of 8,655 kilocycles because we thought that this wave would have a skip distance not much beyond the distance at which observations were made and that the fringe effects of fading at the edge of the skipping distance would be strongly pronounced. These phenomena are especially apparent in television under certain unfavorable conditions where the multiple reflections cause several images, both positive and negative, which rapidly appear and disappear, suggesting a dance of ghosts. We concluded, however, that television would not be the best medium for these observations because what we desired most of all was a permanent record so that the results could be accurately compared with other results at a later date.

## Ghost Images

In our test of facsimile transmission between San Francisco and Schenectady some years ago we had found that the ghost images of television can also be observed on the facsimile record. Instead of attempting to transmit facsimile of writing or pictures we selected a type of signal with continuous wave radiation interrupted sixty times per

second, each interruption being one-fifth-hundredth of a second. A facsimile record of this signal gave parallel black lines on a white background if the record was perfect. The signal from Schenectady recorded at Conway, N. H., during normal conditions in the afternoon previous to the eclipse proved, as was expected, that we had to deal with multiple reflections. Though the signal was strong, it was of a type with rapid fadings that gives distortions of speech and music. On the record it appears like an irregular mixture of black marks on white background and white marks on black background, alternating with totally black and totally white streaks. This is the kind of signal that is particularly useless for facsimile and television; and was just what was wanted.

The outstanding result of the observations was that this normally strong signal almost totally disappeared during the two hours preceding the optical

eclipse of the sun, which in accordance with the calculations of the astronomers would be the time during which the corpuscular or electronic eclipse would take place.

The nearly complete disappearance of the signal was so striking the observers were worried that something might have gone wrong with the receiver, but, when shortly before the optical eclipse began, the signal came back, first in a scattered way and then strongly and continuously, it was felt that we had a complete proof of the correctness of the theory of the electronic eclipse. This record, which was taken during the whole afternoon and evening, will be preserved for those to whom it is of scientific interest.

During this same period observations by earphones were made on other signals. We were particularly interested in a telegraph signal from Germany with approximately the same wave length as the signal from Schenectady. This signal was heard during the whole afternoon, but during the period when the Schenectady signal was at a minimum, the signal from Germany was at its maximum with a very substantial increase.

## Electronic Shadow

One fact which is important to keep in mind in attempting to interpret these observations is the calculations of the astronomers that the electronic shadow falls entirely east of the path of the total eclipse where the observations were made. The electronic shadow as shown on published graphs covered a

Dr. E. F. W. Alexanderson and E. L. Philippi within the radio-laboratory truck, showing the facsimile recorder used in registering the 500-cycle note.

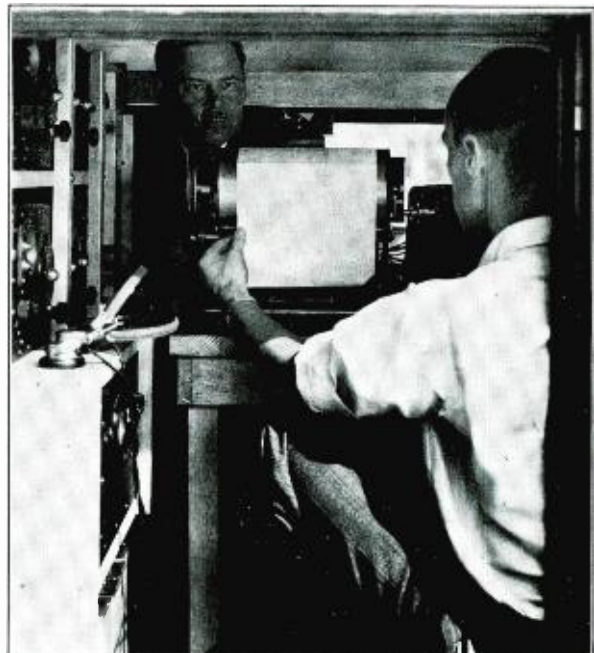

\*Radio Consulting Engineer, General Electric Company, Schenectady, N. Y.

▲

Observations made during sun's eclipse disclose additional information related to radio transmission.

large area nearly bridging the Atlantic Ocean. It is thus easy to see why the signal from Germany came in stronger during the eclipse, since the electronic shadow produced the effect of night over the Atlantic Ocean and a 30-meter signal is known to be stronger over such a distance at night. It is not so easy, however, to see why the presence or absence of electronic bombardment to the east of the point of observation should have such an effect on a signal from the west.

A clue to this apparent contradiction may be found in the observations of A. Hoyt Taylor, who has made elaborate measurements of the speed of wave propagation. These measurements indicate that a shortwave signal received a moderately short distance is delayed in arrival so that it appears as if the signal had traveled something like 2,000 miles farther than the direct distance from the transmitting station, thus indicating that it does not arrive by the direct path, but is reflected from some point 1,000 miles away.

On this basis the observations dur-

ing the eclipse may be explained. We can assume that the only signal received at our point of observation 200 miles from Schenectady arrived at that point not after a direct travel of 200 miles, but through one of these Taylor reflections from some point 1,000 miles east. The disappearance of the signal during the electronic eclipse can then be explained by assuming that the reflecting medium had something to do with an electronic bombardment which was absent at that time.

#### Two Reflections

With this assumption we can go further in attempting to explain what has taken place. In examining the graphic record we find that such a record could not have been made by one single ray. If the signal arrives at the receiving station after reflection, we must conclude that there are at least two such reflections, i. e., two rays arrive simultaneously, one having traveled a distance of several hundred miles more than the other. This would explain the double image on the record which oc-

asionally gives the appearance of white lines on black background instead of black lines on white background. This theory of reflection may also explain the recent findings of Marconi that even ultra-short waves may at times reach points far beyond the horizon.

If this theory is correct there remains to be explained the nature of the reflecting medium which is produced by the electronic bombardment. Possibly it is one of those phenomena which has become known as the Appleton layer and which must be recognized in addition to the Kennelly Heaviside layer to explain the phenomena of radio.

Fortunately we do not need to wait for the next eclipse in order to investigate this subject further, because the signals that have this peculiar character may be studied any day. The important fact established is that a signal of a particular wavelength and a particular distance is almost completely suppressed by the electronic eclipse if this eclipse area lies immediately beyond the point of observation as seen from the transmitting station.

▲ ▲ ▲

## New Auto Radio Receiver

**A**N exceptionally selective and sensitive automobile radio receiver, which incorporates many new and distinctive features of operation and installation, has recently been introduced by the RCA-Victor Company.

The new instrument, which is called the M-30, is a 9-tube superheterodyne receiver operating on current supplied by the automobile in addition to four intermediate size 45-volt "B" batteries which can be located in any convenient place in the car.

One of the outstanding features of the new automobile radio is that it incorporates the new Class B amplification, recently developed, which gives twice the output with half the battery drain, resulting, at a given battery drain, in four times the amplification available in ordinary circuits.

The receiver proper is mounted on the firewall by means of a bolted bracket. The control unit with station selector, dial and volume control, are mounted on a panel affixed to the steer-

ing post. The "on and off" switch is operated by a lock and key to guard against tinkering. All cables are adequately shielded and all wiring connections are of the plug and socket variety. A permanent magnet dynamic type of loudspeaker provides a quality of reproduction comparable to an a-c. powered speaker with the advantage, for automobile use, of exciting the field

by means of a permanent magnet, without using the battery current. A new automatic volume control circuit effectively maintains volume under varying conditions of reception.

Model M-30 draws only 2.85 amperes.

This is particularly important, because a drain of only 2.85 amperes is well within the limits provided on automobile generators for change in the charging rate.

It is stated by RCA engineers that the "B" battery drain is less than that of other receivers, ranging from 12 milliamperes, with no incoming signal, to a maximum of 25 milliamperes, with an incoming signal at full volume. It is estimated that, at this drain, the receiver will obtain at least twice the "B" battery life of other receivers.

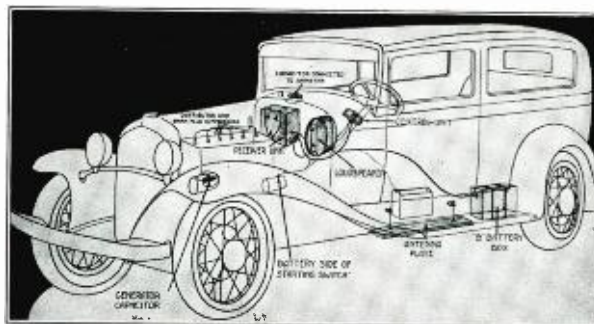

Disposition of equipment.

Motor vehicle radio  
M-30 RCA-Victor Co.

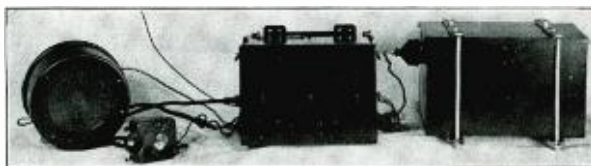

# Dynamic microphones create new requirements as to noise levels

By MAGNUS BJORN DAL\*

WITH the advent of the dynamic microphone broadcasting stations found themselves confronted with a new and perplexing problem. Due to the extremely low level of these microphones (about -90 db.) tremendous amplification was necessary to bring the program up to proper volume. Disturbing noises were, however, amplified to some extent so they threatened to become stronger than the program.

The most serious of these noises are usually caused by the volume controls. An ordinary carbon type volume control having a noise level of about -70 db. would completely drown out the program, while higher grade wire-wound attenuators ordinarily having noise levels around -80 to -90 db. would be very annoying every time the setting was changed.

Besides the technical reasons there were also other pertinent matters to consider. An enlightened and sophisticated public demanding higher quality broadcasting were becoming suspicious that not all so-called "static" noises were due to some mysterious atmospheric agent. Those engineers who took the trouble to investigate soon found the nigger in the wood-pile and suddenly it began to dawn upon broadcasters that the cheap and poorly constructed attenuators hitherto in use would no longer do. It was even found that the quality of broadcasting with ordinary carbon and condenser microphones could be materially increased and safeguarded by using better volume controls.

## Noises and Their Causes

Much confusion has existed as to what these noises are and what is their cause. It may therefore be well to define and limit the range to be considered. The present article is only concerned with those noises generated between the microphone and the transmitter and more particularly those which are due to the variable parameters in the speech input equipment. The most important of these are the

attenuators serving as volume controls to which the present notes shall be confined.

Disturbances generated in the attenuation networks are usually defined as being any e.m.f.'s other than those of the program. To be audible and appear as noise these e.m.f.'s must have a frequency between 18 c.p.s. and 20,000 c.p.s. or it may be direct-current changing value at such a rate that audible clicks and rattle appear. These noises may again be subdivided into two classes:

1. Those e.m.f.'s induced in the attenuators or circuit by stray electromagnetic fields from outside.
2. Those e.m.f.'s generated directly in the attenuator by thermoelectric forces, electrolytic forces, change in contact resistance and change in potential due to the variation of attenuation (step by step).

Under the first heading comes such items as cross-talk, electrostatic pickup from the operator's hand, and induction from other fields existing in the vicinity of the apparatus. It is well known that to eliminate cross-talk adjacent lines must be kept on the proper level and good metallic shields applied. The same applies to pickup from electrostatic and other fields. For this purpose all good makes of attenuators are designed with heavy copper or aluminum shields and front panels.

## Attenuators

Of the e.m.f.'s generated in the attenuator the thermal e.m.f.'s are the most serious in the better class step by step attenuators while carbon and graphite units are often more affected by changes in contact resistance, changes due to non-homogeneous conductors and electrolytic action. The thermoelectric power generated between two metals in a circuit is the electromo-

tive force produced by one degree C. difference of temperature between the junctions. This power varies with the temperature and may have a positive or negative characteristic according to the metals used. It may be expressed by the following equation:

$$Q = \frac{dE}{dt} = A + Bt \dots \dots (1)$$

Where Q = volts per degree C.  
 A = thermoelectric power at 0°C  
 B = constant.  
 t = temperature.

Now, it is plainly evident from this that there are two methods of reducing noises from thermoelectric forces, viz., first, selecting materials which have as nearly as possible zero thermal e.m.f., second, by skillful design, reducing the temperature of the hot junction. Both these methods are used to the largest possible extent in well designed attenuators.

Electrolytic disturbances may be caused in certain types of carbon and graphite attenuators using silicate binders. In moist air such volume controls may become very noisy and are therefore entirely unsuitable for high class broadcasting circuits. Such disturbances may also appear in wire-wound attenuators where the soldering flux has not been entirely removed in soldering two conductors far apart in the e.m.f. series of metals. This can be prevented by using non-aciduous fluxes and by careful cleaning.

In wire-wound attenuators variable in definite steps each contact will have slightly different potential due to the different loss, and audible clicks may therefore appear by rapidly moving the switch-arm from one contact to another. It has been found, however, that by making the loss of each step less than two decibels this noise is not noticeable. This is the reason why most standard attenuators have 1.5 db. loss per step.

## Contact Resistance

The last group of noises to be considered are those caused by changes in contact resistance. In any variable volume control having a sliding contact small dust particles may easily become lodged on the contact surface and momentarily break the current or by an abrupt change in contact resistance create an audible disturbance. A thin film of oxide coating will produce the same results. It is, therefore, extremely important to keep the contact surfaces entirely clean at all times. It will be found upon measurement that an attenuator with dirty contact surfaces will have a much higher noise level than a clean one. Of equal importance to cleanliness is the matter of contact

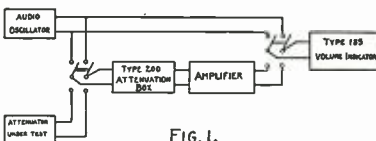

\*Chief Engineer, The Daven Co.

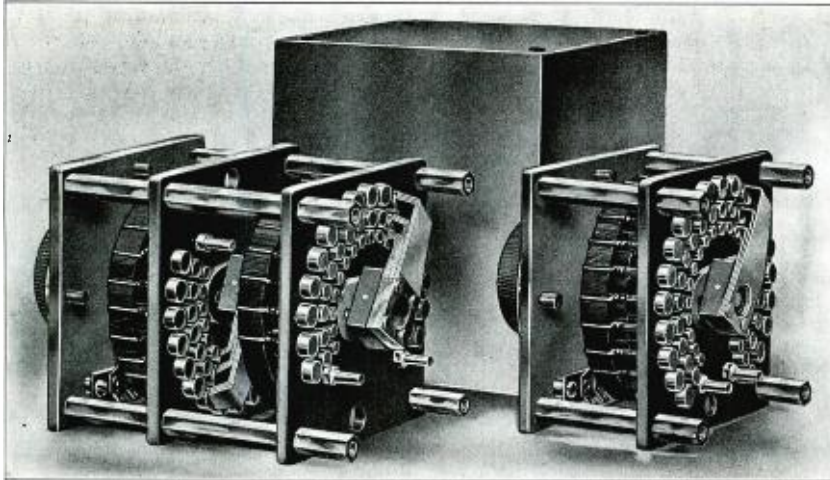

A modern attenuator.

pressure and wearing qualities of the materials used.

It has been found that almost any kind of cleaning fluid will slightly oxidize the contact surfaces. The best way of keeping the contacts in good shape is, therefore, to wipe off the dirt frequently with a clean cloth, polish with crocus-cloth and apply a thin film of clock oil for lubrication and to prevent oxidation.

The methods of measuring noise levels are so well known that there is not much to be said. Fig. 1 shows a simple hook-up for such measurements.

The gain of the amplifier is first measured by reading the output level of the oscillator and then by switching this into the amplifier through the attenuation box, which is set to give a suitable level on the volume indicator. The switch is then thrown over on the attenuator to be tested and while the attenuator knob is vigorously turned the attenuation box is adjusted until a good reading is obtained on the volume indicator. The total noise level is found as the algebraic sum of the readings.

In conclusion it may be said that by careful attention to the various points

mentioned above it has been possible for the author to design attenuators which consistently have a noise level of -150 to -160 db. This is satisfactory proof that the theories are correct and rather remarkable when it is remembered that 160 db. represent a voltage ratio of one hundred million. This also proves that either the thermal e.m.f. has been entirely removed or the temperature difference of the junctions is on the order of 0.01°C. This can easily be shown from equation (1) as the thermoelectric power is of the order of 10<sup>-6</sup> volts per degree C.



## Sound and vision broadcasting

THE simultaneous transmission of sound and visual effects from station W2XAB, New York, daily, except Saturday and Sunday from 8 to 10 p. m., is attracting considerable attention on the part of persons experimenting with television receivers.

William B. Lodge, development engineer for the Columbia Broadcasting System, and his engineering associates, appear to be making good progress with the new technique, which involves double modulation. A carrier beam of 45 kc. is modulated by the microphone

circuit. Signals picked up by a receiver comprise the carrier combined with the sound frequencies. The television signal may consist of frequencies up to 40 kc., the sound and picture signals being combined and transmitted together. The 40 kc. signals are applied to the terminals of a neon tube, reproducing the television impulses.

In the receiver it is necessary to insert a filter at the terminals of the neon tube to prevent the 45 kc. voice carrier from interfering with the picture transmission. A second detector circuit is added tuned to 45 kc. to pick up the sound signals.

An ordinary radio receiver tuned to 45 kc. above or below the transmitting frequency (in the case of W2XAB, 2755-2845 kc.) may be used to pick up the sound program.

The overall band for transmission extends from 2750 to 2850 kc., a channel 100,000 cycles wide, or ten times as wide as the usual broadcast band.

The picture is composed of 4320 picture elements, twenty complete pictures

per second. This requires 86 per cent of the 100 kc. channel. Nearly all of the remaining 14 per cent is used for the accompanying voice or music.

Although the problem of designing a combination television and sound receiver to operate from the single transmission is one which radio manufacturers are likely to have to solve, obviously two separate receivers may be used as has been the practice heretofore.

The objective of the system is to devise a system of transmission with two carriers, both operating within the wave band so far allotted to a television channel. In the design of the receiver for dual reception there is a nice problem of selectivity, but one which should not be very difficult with present equipment.

In Fig. 1 the carrier for the sound component is situated within seven kilocycles of the low limit of frequency for the channel. The picture carrier is 43 kilocycles below the upper frequency limit.

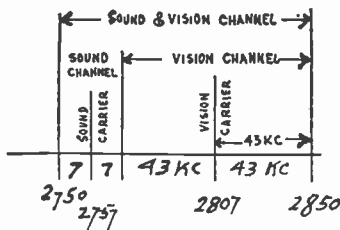

Fig. 1. Vision and sound over a single channel.





**T**HE Group Subscription Plan for RADIO ENGINEERING enables a group of engineers or department heads to subscribe at one-half the usual yearly rate.

The regular individual rate is \$2.00 a year. In groups of 4 or more, the subscription rate is \$1.00 a year. (In Canada and foreign countries \$2.00.)

The engineering departments of hundreds of manufacturers in the radio and allied industries have used this Group Plan for years, in renewing their subscriptions to RADIO ENGINEERING.

Each subscriber should print his name and address clearly and state his occupation—whether an executive, engineer, department head, plant superintendent, or foreman, etc.

**Remember this Group  
Plan when *Your*  
Subscription Expires**

*(Radio Engineering)*

**Bryan Davis Publishing Co, Inc.  
19 East 47th Street  
New York, N. Y.**

Los Angeles

Chicago

St. Louis

### AUTOMOBILE RADIO AND THE R. M. A.

WITH special public interest and sales activity in receiving sets for automobiles, the RMA is pressing development of this expanding market. Contacts between the RMA and the automotive industry, not only toward developing further use of radio in the automotive field, but also in its engineering improvement, are being widened, in the interests of members of both industries. Of special interest in automotive engineering are recent negotiations between Dr. C. E. Brigham of Newark, N. J., director of RMA engineering division, and John A. C. Warner, general manager of the Society of Automotive Engineers, toward development of a coordination committee between these two organizations for cooperative work in automotive radio design and installation. Some of the problems involved are space requirements for radio in automobiles, the new "B" eliminator, aerial installations and interference problems.

### RECEIVING TELEVISION IN AN AIRPLANE

(Concluded from page 13)

direct current, and to the host of homes off the power network common to a transmitter, becomes immediately possible. In the city of Los Angeles is the latter condition especially prevalent, in that three power companies, two operating on 50 cycles, serve the city and surrounding territory.

The writer acknowledges, in concluding, the excellent cooperation of Western Air Express, Inc., through the personages of J. H. White, R. C. Fell, M. Bell, and Pilot Allen Barrie; and the loyal and effective work of F. M. Kennedy, J. G. Turner, T. H. Denton, and P. C. Tait of the W6XAO Don Lee television staff.

### POWER TRANSFORMER TESTING

(Concluded from page 15)

all normal filament voltage measurements encountered in practise.

The switches used for cutting in the meter shunts must be of very positive contact, preferably heavy single pole, single throw knife switches, and must be kept clean. The voltmeter multipliers for the higher voltage meters may be ordinary on-off switches, as contact resistance is relatively unimportant here.

Wooden boxes are also used to enclose the test transformers, these wooden boxes being filled with small holes, to provide some ventilation. Thus it is possible to duplicate the most rigorous test conditions to be encountered.

In connection with the use of this test board, it might be appropriate here to speak of the methods of making heat runs. In most cases the winding resistances are taken before and after the heat run, and the rise in temperature computed by means of the equation:

$$R2 \quad 234.5 + T2$$

$$R1 \quad 234.5 + T1$$

Where R1 and R2 are the initial and final resistance, and T1 and T2 are the initial and final temperature, in degrees Centigrade. To get the rise in temperature subtract from T2 the room temperature at the end of the run. T1, of course, is the room temperature at the start. To reach a fairly steady temperature a heat run should extend for at least five hours, and preferably eight to twelve, or more.

This method gives the average temperature rise of the windings, but does not indicate the extent of hot spots in the windings. To obtain this data, it is necessary to insert thermocouples at various points of the windings, and thus obtain the actual rise at these points. It is of distinct advantage to have both sets of data, average and hot spot rises.

This test board was found very useful in power transformer design, and served admirably to test all transformers under conditions very close to those found in practice. It is felt that it is a very inexpensive construction, considering the great adaptability of the layout, and that such an instrument will be found of distinct help to any manufacturer of power transformers.

### AUTOMOBILE RADIO NOTES

W. D. Patterson is the engineer in charge of radio for the Pierce Arrow Automobile Company at Buffalo, N. Y.

Ford, Plymouth and Chevrolet automobiles are among the cars being used extensively as radio equipped machines for police use.

Robert Stimson is the engineer in charge of radio for the Chrysler Automobile Company.

Sixteen manufacturers have "B" battery mechanical substitutes on the market.

A survey reveals that there are approximately six hundred thousand radio equipped automobiles in service in the United States. There are 25,000,000 passenger cars in service.

In 1931 about 100,000 radio receivers for automobile service were sold. The first half of 1932 showed sales of about 72,000 receivers for such use.

### I.R.E. CONVENTION AT ROCHESTER

THE Fall Convention of the Institute of Radio Engineers will be held at Rochester, N. Y., November 14 and 15. The papers to be presented at this convention follow:

*Monday, 10 a. m.*—"Class B Amplifiers Considered from Class A Standpoint," by J. R. Nelson, Raytheon Mfg. Company. "New Methods of Solutions of Vacuum Tube Problems," by I. G. Maloff, RCA Victor Company.

*Monday, 2 p. m.*—"Principles of Frequency Conversion in Superheterodynes," by Wm. S. Barden, RCA License Laboratory. "New Vacuum Tube Constructions," by Henry Parker, Rogers Majestic Corp.

*Monday, 8 p. m.*—"Analogies Between Radio and Photographic Techniques," by B. V. K. French, United American Bosch Corp.

*Tuesday, 10 a. m.*—"Diode Detection Analysis," by S. E. Kilgour and J. M. Glessner, Crosley Radio Corporation. "Dynamotors for Automobile Radio," by C. T. Wallis, Delco Appliance Corporation. "Recent Developments in Signal Generators," by Lincoln Walsh, consulting engineer.

*Tuesday, 2 p. m.*—"Modern Developments on High Vacuum Tubes," by C. W. Taylor, R. T. Orth and L. B. Hedrick, RCA Radiotron Co. "What Do We Do Next," by Kenneth Jarvis, Zenith Mfg. Company.

*Banquet*—"Radio Engineering Principles in Non-Radio Fields," by A. F. Van Dyck, Radio Corporation of America.

### LUMINOUS ELECTRIC-DISCHARGE TUBES

A GAS-DISCHARGE tube having a thermionic cathode, ex. a hollow copper, iron, or nickel cylinder or cone coated with barium suboxide, supplied with current corresponding to a discharge current density of 0.03-1.25 amp./sq. cm. of tube cross-section, and a gas filling composed of helium and not more than 8 per cent. of neon, together with not more than 0.5 per cent. of argon, krypton, or xenon.

Beck, L. L. (Assigned to Claude Neon Lights, Inc.) British Patent 356,745.

### OUR APOLOGIES

It has been brought to our attention by the McGraw-Hill Company that in the R. G. Dun Company's survey of the radio industry, published in RADIO ENGINEERING of August, figures covering investment in radio and figures covering total sales, had appeared in "Radio Retailing" and "Electronics."

Acknowledgment is hereby made.

**CENTRALAB  
MOTOR RADIO  
NOISE  
SUPPRESSORS  
FORGE AHEAD  
TO POPULARITY**



*Real Quality at the Right Price*

**O**RDERS for these sturdy units are taxing production. No wonder; for here at last is a suppressor that is strong, sturdy, generous in size and gives from 50% to 500% more efficiency in reducing spark noise. The resistance material and the ceramic covering are baked *together* at a temperature of 2700 degrees. No wonder they're strong.

Conralab suppressors are built for performance . . . yet their very simplicity enables us to offer them at an exceptionally low price.

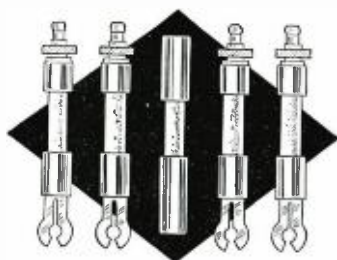

**WRITE FOR DESCRIPTIVE BOOKLET**

We have prepared a more detailed booklet called "MOTOR RADIO AIDS." Write for it today.



CENTRAL RADIO LABORATORIES, MILWAUKEE

*Speaking  
of Synthetic  
Enamels*

**ZAPON  
S-52**

**ZAPON  
S-53**



These two Zapon favorites are increasing in popularity on sheer merit. Available in all popular shades, they are finding greater acceptance wherever high gloss and durable finish are desired at a low cost. Both these enamels

- Spray evenly
- Give maximum coverage in one application
- Adhere tenaciously to metal or wood surfaces
- Dry with a high gloss.

Their economy is emphasized by the fact that best results are obtained when the enamels are thinned 30 to 40 percent.

**S-52—BAKING TIME**  
2 HOURS at 225° F

**S-53—AIR DRYING TIME**  
sets in half an hour, and hardens overnight to a tough flexible finish.

ZAPON LABORATORIES are prepared to supply specific information to all your questions about lacquers and enamels. This service is FREE TO YOU.

*"The Standard of Quality Since 1884"*

**THE ZAPON COMPANY**

A Subsidiary of Atlas Powder Company

Stamford  Connecticut



# NEWS OF THE INDUSTRY

## MALLORY-ELKON PUBLISH NEW MANUAL ON CONDENSERS

A complete catalog listing dry electrolytic condensers with full information as to capacity, working voltage, dimensions, price, etc., is made available by P. R. Mallory & Co., Inc., of Indianapolis, in their new catalog known as Form S-9.

One interesting feature of this comprehensive catalog is the replacement data chart for dry electrolytic Hi-volt d-c. condensers showing the proper Mallory-Elkon condenser for all the leading radio sets manufactured during the past few years. This bulletin is now available for distribution.

## AUTO RADIO

Makes of automobiles in which provision is made for installing radio receivers, or is contemplated, include: Studebaker, Packard, Pontiac, Buick, Plymouth, Auburn, Oldsmobile, Hudson, Oakland, Essex, Chrysler, Ford, Chevrolet, Dodge, Cadillac, Nash.

## LUBRICATION

"Colloidal Graphite and Its Uses as a Lubricant" is the title of a booklet just issued by the Acheson Oildag Company, Port Huron, Mich. A copy of this booklet should be in the hands of every radio manufacturer and engineer.

## ELECTRICAL LABORATORY APPARATUS

It is not often there comes to the editorial desk a catalog as well gotten up as the booklet just published by the Thordarson Electric Mfg. Company, 500 West Huron St., Chicago, Ill. This catalog describes and illustrates a complete line of high-grade electrical laboratory demonstration and measurement instruments. Copies may be procured by writing to the company.

## TRIANGLE SALES ASSOCIATES

Triangle Sales Associates, 27 Whittlesey Ave., East Orange, N. J., is organized to speed up and broaden the sale of manufactured products. Thomas Angell, formerly of the Polymet organization, together with Messrs. George S. Pfafs and Egbert T. Angell, are identified with this undertaking.

## MOTOR EFFICIENCY AND SPARK NOISE SUPPRESSION

Engineers of the Central Radio Laboratories, Milwaukee, Wisc., writing about suppressors, say:

"Ignition systems are carefully balanced to build up 10,000 volt surges of considerable current at the time of each spark.

Any large change in the capacity, inductance or resistance of the high tension circuit, therefore, may result in a diminished spark with attendant evils of hard starting and sluggish performance.

"The actual spark is represented as a direct-current pulsation. There immediately follows, however, a train of high frequency oscillations that radiate from wires of the entire ignition system. A pure resistance of proper value, located at the plug and at the common lead of the distributor head, will damp these oscillations without interfering with the spark.

"It is obvious that the effectiveness of any resistor in suppressing spark noise is determined by its r-f.—not its d-c.—resistance. It is equally obvious that the d-c. resistance must not be too high, or the spark will be weak.

"Centralab suppressors are designed for minimum capacity with resistance material having an unusually high ratio of r-f. to d-c. resistance. Since the d-c. rating is standard, Centralab Suppressors of a lower resistance than that usually recommended can be used.

"The resistance giving the desired balance between motor efficiency and noise suppression will vary with different installations. We advise that every radio dealer keep on hand suppressors in resistances of 8,000, 15,000, 25,000, and 50,000 ohms."

## DIALS

The De Jur-Amsco Corporation, 95 Morton St., New York, announce a new catalog listing and illustrating a complete line of ninety degree, full vision friction-drive dials.

These dials are designed to meet the latest trend in radio receiver design and are mechanically built for easy assembly on all variable condensers.

Calibrated scales and special arrangements of any of the standard forms can be made upon application. Reasonable and low initial costs for art work and name die work are offered.

## YAXLEY PUBLISHES NEW VOLUME CONTROL BULLETIN

This new bulletin contains the complete new line of Yaxley rheostats, potentiometers and volume controls and a replacement manual showing the right replacement control for each type set. Illustrations, dimensional drawings, resistance in ohms, carrying capacity in amperes and price are covered for each product.

This bulletin is known as Form S-18 and is published by the Yaxley Manufacturing Co., Indianapolis, Ind.

## NEW GOAT CATALOG

Goat Radio Tube Parts, Inc., of Brooklyn, N. Y., announce the recent publication of their new catalog, which is the

second edition of this loose-leaf data book, listing not only specifications of parts they manufacture, but considerable material specifications and tables, which are believed to be a more complete compilation of such data than is available under one cover in any other such catalog.

Although Goat Radio Tube Parts, Inc., limit the distribution of the catalog gratis to the purchasing agents and chief engineers among their direct customers, additional copies are available on a subscription basis to others interested.

## VOLUME CONTROLS AND CONDENSERS

The Yaxley Mfg. Co., Inc., division of P. R. Mallory and Co., Indianapolis, Ind., has issued three new illustrated bulletins for the radio manufacturing trade, and for replacement.

The items covered include rheostats, potentiometers, volume controls, resistances, dry electrolytic condensers, and wall outlets for radio.

## ACME APPOINTMENT

The Acme Electric Mfg. Co., Cleveland, Ohio, manufacturers of transformers, announce the appointment of A. D. Strathy and Associates as representatives for the sale of their products in Metropolitan New York.

Mr. Strathy was formerly sales manager of Cable Tube Company and has a broad acquaintance in radio and allied industries.

Acme manufactures transformers for radio and industrial purposes and for neon signs.

## THE RADIO CLOCK

The radio clock is a simple device designed to automatically switch the radio on and off at any time desired. This device will fill a need for all radio lovers, for time and again long-looked-for programs are missed because the time had slipped their attention.

The clock is either separate or built in the radio set and is placed between the incoming current and the radio.

Manufactured by E. R. Unglaub, 1611 Park Ave., Baltimore, Md.

## RESISTOR HAND BOOK

Electrad, Inc., 173-175 Varick St., New York, announces a resistor handbook which sells for \$1.00, including revised data four times per year. It quickly gives needed information about replacement resistor and volume control values, accurate lists, actual values and circuit diagrams, showing where and how resistors and volume controls are used in radio receivers.

*If you want dependable condenser performance . . . Specify the new ACRACON SEMI-DRY ELECTROLYTIC UNIT*

**Compare These Characteristics:**

- peak operating voltage 500
- surge voltage 600
- low initial leakage
- leakage current at 500 volts less than .2 mils per mfd.
- constant capacity; does not decrease with use
- stable power factor; does not increase with use
- non-corrosive connections
- metal or fibre container
- standard and special sizes

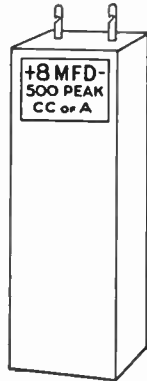

Type DC-8  
Acracon  
Semi-Dry Unit



*Write Today for Catalog!*

Patents Pending on All Acracon Features

**Condenser Corp. of America**

259 CORNELISON AVENUE  
JERSEY CITY, N. J.

Factory Representatives In:

Chicago Cincinnati St. Louis San Francisco Los Angeles Toronto

AND OTHER PRINCIPAL CITIES

..... **STRIDES**

made by **AUTO-RADIO**  
are matched by

▲ **HAMMARLUND** ▲

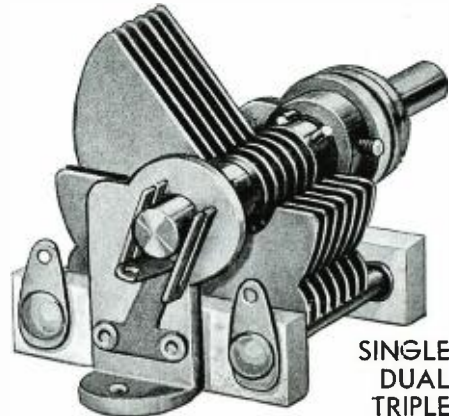

SINGLE  
DUAL  
TRIPLE

**MIDGET CONDENSERS**

THESE UNITS are as vibration proof as condensers can be made. Especially designed for mobile purposes, automobile, police, government and aircraft applications. Single (illustrated) dual and triple models—20 to 325 mmf. per section. Soldered brass plates, riveted frame, phosphor bronze rotor contact. Isolantite insulation.

Over 3,000,000  
used last year



**ADJUSTABLE  
PADDING CONDENSERS**

THE finest imported mica is used. In design and quality of raw materials—there is no equal to these efficient, trouble proof Hammarlund condensers. Seven years of experience, specializing in this type of equipment, permits us to offer this substantially improved line. Learn more about their technical advantages,—get our catalog!

Mail Coupon for Catalog and Quotations

For Better Radio  
**Hammarlund**  
PRECISION  
PRODUCTS

HAMMARLUND MFG. COMPANY  
421-428 New York, N.Y.  
Please send me free copy of your new Catalog  
containing data on Hammarlund, Booklet,  
Midget and Tuning Condensers.  
Name \_\_\_\_\_  
Address \_\_\_\_\_  
RE-10

# NEW DEVELOPMENTS OF THE MONTH

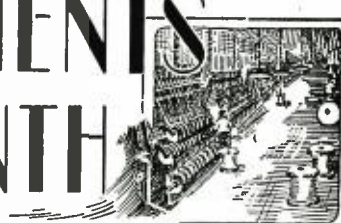

## A MULTIDAPTER

The Radio City Products Co., 48 West Broadway, New York, announces the Multidapter. The Multidapter combines many adapters in one. You need only one Multidapter, but without it you need many adapters. There is difficulty and loss of time in picking out the proper adapter from a lot of adapters. All this is eliminated by the use of a Multidapter.

Tests all of the new tubes including types 29-33-41-42-43-46-47-55-57-58-64-65-69-82-83-89 and second plate of 80, etc.

## TRANSMITTING CONDENSER

The Hammarlund Mfg. Co., 424 West 33rd St., New York, announces a new transmitting condenser of various sizes. It has heavy polished aluminum plates, with rounded edges; 10 per cent wider spacing than others; lowest-loss Isolantite insulation; rigid cast aluminum alloy frame; perfect-fitting bearings; smooth, self-cleaning rotor contact.

## CINCH OFFERS 7-PRONG RADIO SOCKET

In keeping with its policy of constantly keeping pace of new developments, the Cinch Manufacturing Corp., of Chicago, has just announced a new radio socket. It is a 7-prong socket for use with the new 7-prong radio tubes. The new Cinch floating contacts, provided thereon, are scientifically designed to eliminate all strain on the bakelite. Warping and loss of tension after tube is inserted is thus prevented. Soldering operation is simplified. All holes generally used for riveting contacts to bakelite are eliminated—making the socket considerably stronger. Contacts are self-aligning due to the floating principle, assuring constant, rigid contact on each tube prong.

## NEW CATHODE RAY OSCILLOGRAPH

The Egert Engineering Company, 175 Varick St., New York, announces a new cathode ray tube oscillograph for general laboratory use. The company also is marketing a new and simple audio oscillator and a useful distortion meter.

## GALVANOMETER SUSPENSION

Of interest to all who use galvanometers is the new galvanometer suspension announced by the G-M Laboratories, Inc., Chicago. This unit, embodying many refinements, is designed to provide a stable means of support for instruments of the suspended-mirror type for all kinds of measurements.

This new galvanometer suspension fills an urgent need among laboratories located

in factories, along car tracks and railroads, or near buildings housing heavy engines and machinery. In such locations it has heretofore been virtually impossible to obtain stable galvanometer readings for accurate measurement, and laboratories in such locations have been forced to make galvanometer measurements only at night. This new unit overcomes such difficulties, and even when attached to a ceiling which also supports heavy vibrating machinery, galvanometers of 1,100 megohm sensitivity have a perfectly stable index line on a scale nine meters distant. Information regarding this suspension can be obtained from the manufacturer by requesting Bulletin No. 149.

## AN IGNITION COIL FOR RADIO-EQUIPPED AUTOMOBILES

The Thordarson Electric Company, 500 West Huron St., Chicago, is introducing an ignition coil for automobiles which causes a minimum of spark disturbance

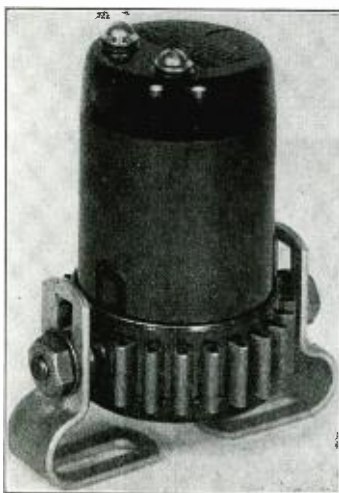

to radio receiving equipment installed in the car.

The primary is in two sections at one end of the unit. The secondary is mounted at the other end of the unit. The linking iron circuit extends through both windings. Heat dissipating fins prevent undue heating under any conditions of operation.

## HOT CATHODE CRATER LAMPS

Considerable progress in all elements of television receivers have brought the art to a point where it is now possible to project a picture of pleasing detail on the screen.

Sufficient brilliancy for comfortable view-

ing has been lacking. This was due mainly to the power limitations of cold cathode crater lamps which cannot be made conveniently to carry large currents through small orifices.

Vas hot cathode lamps, while giving greater light efficiency even at small currents, can be made to carry several amperes if desired. The standard types with craters of .050, .035, .025 crater are designed to carry a maximum of 500 ma mean dc. It will, however, work quite well on the output of a suitably designed amplifier with two 245's in the last stage.

Manufactured by Vas Corporation, 125 N. 3rd St., Newark, N. J.

## NEW LOW PRICED "B" BATTERY ELIMINATOR

The Pines Winterfront Company, Chicago, Ill., have announced a new model of their "B" battery eliminator, which, it is believed, will make the automobile radio a complete success.

This new eliminator requires only two bolts for mounting under the floor boards, on the dash, or in the battery box. It measures 5 3/4 inches by 8 inches and is 6 1/4 inches deep. Installation is so easy that any one who can put in "B" batteries can install the Pines new eliminator.

This new model employs the same ball-bearing rotor that has stood up under a continuous-run life test in the laboratory of more than 10,000 hours and that in actual use on police radios has had reported service of more than 8,000 hours. This new unit is very nearly universal. It is now possible with five models to do the work formerly requiring fourteen.

## AUTO RADIO SUPPRESSORS

With the advancement of automobile radio to a stage where it will be optional standard equipment for the car necessity arose for spark disturbance control. The new suppressor resistors just announced by the Erie Resistor Corporation, Erie, Penna., measure up to good engineering requirements. These are of 25,000 ohms, plus or minus 20 per cent. They will not change more than 10 per cent in resistance value in 50,000 miles use. The unit is inclosed in a ceramic tube, and the resistor will not fail mechanically at 120 deg. C and 100 per cent relative humidity.

## A "B" POWER UNIT

The Emerson Electric Mfg. Co., New York, announces a "B" power unit with low voltage tap, for automobile radio receivers. It is a rotating machine, operated from 6-volts d-c., with secondary outputs of 180-90 or 135-67 1/2 volts. At 180 volts the current is 40 milliamperes.



# Install 'em

AND

# forget 'em

Government approved for airplanes and aircraft radio. Used by all leading aircraft and rock drill manufacturers as the only solution for loose screw connections.

Elastic Stop Nuts will give unfailing service on permanent adjustment. Elastic Stop Nuts make trimmer condensers vibration proof, eliminate microphonic noises, are the only nuts that will make a satisfactory cushion mounting.

Where everything else has failed *TRY ELASTIC STOP.*

Mfg. by **ELASTIC STOP DIVISION**  
**A. G. A. COMPANY**  
 ELIZABETH                      NEW JERSEY

**Applications**

Used by  
leading manufacturers on

Trimmer Condensers  
 Speakers  
 Cushion Mountings  
 Replacing soldered connections  
 in aircraft radio  
 Telephone Circuits  
 Photo Cell Relay Circuits  
 Telegraph Circuits  
*and in a thousand other precision devices*

# RESINOX

*for beauty*  
*for rugged strength*

Resinox dependable quality plus Resinox helpful service assures fulfillment of the most exacting requirements for beauty and strength in molded articles.

MOLDING RESINS      MOLDING COMPOUNDS  
 LAMINATING VARNISHES

## RESINOX CORPORATION

A SUBSIDIARY OF COMMERCIAL SOLVENTS CORPORATION  
 AND CORN PRODUCTS REFINING CO.

230 PARK AVENUE

NEW YORK CITY

## BEAT-FREQUENCY OSCILLATOR

OPERATED ENTIRELY BY DRY BATTERIES

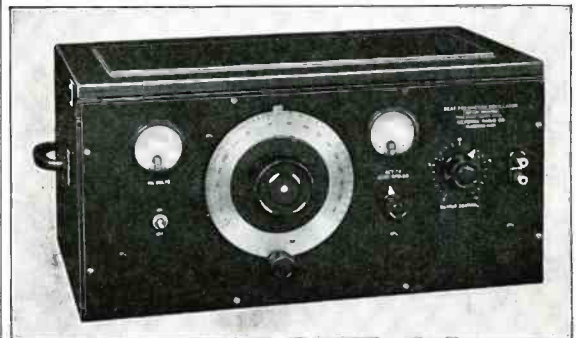

This beat-frequency oscillator is a new development in sources of audio-frequency voltage for test purposes. It covers a wide range (5 to 10,000 cycles per second) and its waveform is excellent. Accurately calibrated.

Price \$210.00

**GENERAL RADIO COMPANY**  
 CAMBRIDGE A,                      MASSACHUSETTS



## SERVIDOR-EQUIPPED

Every room in Hotel Fort Shelby is servidor equipped. This eliminates excessive tipping and insures the guest's privacy. Hotel Fort Shelby was the pioneer in installing this notable convenience eliminating any need of annoying intrusions. ¶ No other hotel in Metropolitan Detroit is so near the principal railway terminals, airports and steamship piers. Hotel Fort Shelby's location in the heart of the motor city's shopping, theatre, financial, insurance and wholesale districts is a happy one. ¶ You'll be delighted, too, with the efficient . . . unpretentious service offered by this truly fine hostelry. 900 rooms . . . all with private bath and circulating ice water. Rooms as low as \$3.00 per day . . . suites \$10.00 and upwards.

Motorists are relieved of their automobiles at the door without service charge. Write for free road map, and your copy of "Aglow with Friendliness," our unique and fascinating magazine.



**Hotel Fort Shelby**  
 "AGLOW WITH FRIENDLINESS"  
 E. J. BRADWELL, Manager  
 DETROIT

**NEW YORK'S BIGGEST VALUE**  
 • FINE ROOM *and* BATH •

**\$2.50 SINGLE**  
**\$3.00 DOUBLE**

A modern, new hotel located in heart of New York, 100 feet West of Broadway yet quiet and cool. Each room has bath, circulating ice water, electric fan, Beauty-rest mattresses, exceptional furnishings and atmosphere.

**Hotel Piccadilly**  
 227 WEST 45<sup>th</sup> ST. NEW YORK

**—NEW!**  
**MORRILL**  
 Uncased Condensers

Especially compact. A product of outstanding quality. The ultimate in reliability. Send for circular E-1.

**MORRILL & MORRILL**  
 30 CHURCH STREET NEW YORK CITY  
 Sole U. S. A. Distributors of the Siemens & Halske condensers and resistors.

**NEW DEVELOPMENTS** Complete Data on All Recent Radio Inventions Now Included in This One Big Guide Book of Radio

Byrd's Antarctic Radio Equipment—Television—Interference Elimination—Short-Wave Apparatus—Broadcasting Equipment—these are only a few of the NEW subjects in the most complete radio handbook ever published.

**The RADIO MANUAL**  
 A Handbook for Students, Amateurs, Operators, and Inspectors

Here's the answer to every question about the principles, operation, and maintenance of radio apparatus. A complete radio course in one volume. Prepared by G. E. Sterling, Official Examining Officer, Radio Division, U. S. Dept. of Commerce.

20 big chapters. 369 illustrations.  
**EXAMINE IT FREE! MAIL THIS COUPON**

D. VAN NOSTRAND CO., Inc., 250-4th Ave., N.Y.  
 Send me the Revised edition of THE RADIO MANUAL for examination. Within ten days after receipt I will either return the volume or send you \$6.00, the price in full. (R.E. 10-32)

Name .....

St. and No. ....

City and State .....

Business Connection .....



**FIVE TUBE SUPER COILS**  
*in step with*  
**RECENT TUBE DEVELOPMENTS**

**GEN-RAL  
 REG.  
 COILS**

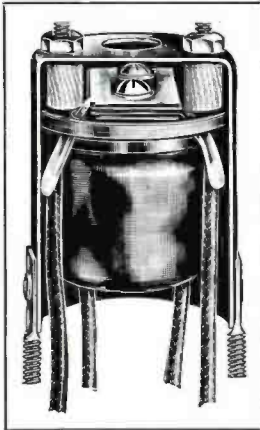

S.R.I.F. Unit—175 K.C.  
 Single Tuned

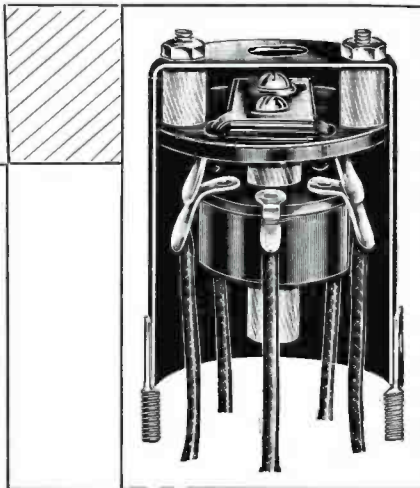

S.C.X. 200 D.V.M.  
 I.F. Unit—175 K.C.  
 Single Tuned Tapped

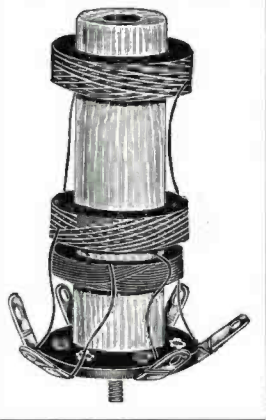

C.X. 100 D  
 Preselector

*Data on  
 Request*

**General Manufacturing Co.**  
 8065 So. Chicago Ave. Chicago, Ill.  
 Cable: GENERAL U. S. A.

*What you've waited for!!*

**Quality** wire wound **Resistors**  
 . . . . **at a price!!**



5 Watt type "BP"  
 3/8" wide by 1 1/2" long  
 Max. resistance 60,000 ohms

**use these**  
 NOISELESS  
 ACCURATE  
 DEPENDABLE  
**Precision Resistors**  
**AND SAVE!!**

PRECISION wire wound resistors have distinct advantages—aside from price! Every connection between terminals and wire element are hard soldered. The double insulated wire receives two baked coats of enamel insulation. Extremely accurate, acid, oil and moisture-proof resistors result!

PRECISION type "BP" 5 watts, and type "VP" 10 watts have soft drawn tin copper leads. Type "VP" is 1/2" wide by 2" long. Max. resistance 100,000 ohms. These high resistance, compact units are recommended for Midgets and Auto Receivers where space and price are limited.

**T - L - H - PADS MADE TO YOUR SPECIFICATIONS**  
**PRECISION RESISTOR COMPANY**  
 113-115 FRELINGHUYSEN AVE., NEWARK, NEW JERSEY



▲▲▲ reliable  
**HOT CATHODE  
 MERCURY VAPOR  
 RECTIFIERS**

by Thermionic

TYPE TL 1	
NO. TL 1	
Filament Volts.....	2.5
Filament Current.....	5.0
Max. Plate Volts.....	500.0
Min. Plate Volts.....	24
Average Plate Voltage Drop.....	10.5
Max. Plate Current.....	2.5
Average Life, Hours.....	3,000
TYPE TL 15	
Filament Volts.....	5.0
Filament Amps.....	20.0
Max. Plate Volts.....	500.0
Plate Current, Max. Average, Amps.....	15.0
Instantaneous Peak Plate Current—	
35 Amps.-30 Sec.	
Average Voltage Drop, Volts.....	12.5
Cathode.....	indirectly Heated Type
Base.....	Screw Type Mogul
Average Life, Hours.....	3,000



TYPE TL 15

**Thermionic Labs.**  
 102 N. 5TH ST. HARRISON, N. J.

**OTHER  
 TYPES:**  
 871 872  
 866 875

... for Tubes • Resistors • Relays ...

Carbonized Nickel  
Selvage Mesh  
(patented)  
Filament Wire  
Grid Wire



RESISTANCE  
WIRE  
Nickel Chrome  
Copper Nickel  
Nickel Wire  
and Ribbon

**GILBY WIRE**

MEANS  
MAXIMUM PRODUCTION  
With MINIMUM SHRINKAGE

**GILBY WIRE COMPANY**

150 Riverside Ave., Newark, N. J.

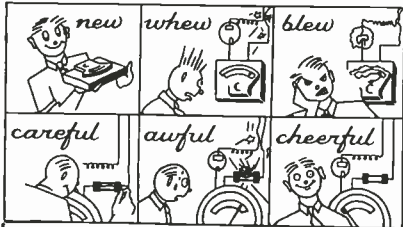

**MORAL**  
**USE A**  
**LITTEL**  
**FUSE**

INSTRUMENT LITTELFUSES will positively protect your meters and other delicate equipment. Stock sizes 1/100, 1/32, 1/16, 1/8, 1/4, 3/8, 1/2, 3/4, 1, and 2 amps. Get yours now—before you lose another meter.

Littelfuses are also made in High Voltage ranges—1,000, 5,000, and 10,000 volts.

Write today for instructive bulletin.

**"QUICKER THAN A SHORT CIRCUIT"**

Littelfuse Laboratories, 1778 Wilson Ave., Chicago Ill.

**MOTOR GENERATOR SETS**

A.C. to D.C. and D.C. to A.C.

Very Large and Varied Lot as to Sizes and Voltages

• **ALL ARE BRAND NEW** •

Were purchased for use in radio work amplifying equipment, etc. All General Electric and Westinghouse equipment, priced at less than one half new cost.

Send Us Your Inquiry

**L. J. LAND 142-144 GRAND ST.**

CAnal 6-3923-4

NEW YORK



**MIDWEST CONDENSER  
MICROPHONES**

Specifications of suspension model No. 150:  
TUBES—2 type 864

OUTPUT LEVEL—Minus 25db.

OUTPUT IMPEDANCE—200 or 50 ohms

UNIFORM RESPONSE—30 to 10,000 cycles

PHYSICAL DIMENSIONS—3 1/4" in diameter  
11" in height

REVOLVING SWIVEL HEAD

Remarkably low price.

**MIDWEST BROADCAST EQUIPMENT COMPANY**  
6007 Diversey Avenue Chicago, Ill.

• **TAUREX** •

The Full-wave Copper Oxide Rectifier for d.c. Milliammeters.  
Maximum Current Capacity, 15 M. A. size 1/4 by 3/8 inches.  
Price \$3.

**LEO TAUSSIG**

3245—37th Street

Long Island City, N. Y.

1922 **GATES CONDENSER** 1922  
**MICROPHONES**  
FOR GOOD PERFORMANCE  
**GATES RADIO & SUPPLY CO.**  
1932 QUINCY, ILLINOIS, U. S. A. 1932

**TRIMM FEATHERWEIGHT  
HEADSETS**



For Aircraft. Complete weight 4 ounces. May be worn over or under the Helmet. Furnished in any resistance desired. Satisfaction Guaranteed.

Quality Phones For All Purposes.

**TRIMM RADIO MFG. CO.**

"Earphone Specialists"

1528-38 Armitage Ave., Chicago, Ill.

**High Grade New and Used  
ELECTRON TUBE EQUIPMENT**

Vacuum Pumps, Stem Machines, Sealing Machines, Spot Welders, Air Blowers, Gas Boosters, Aspirators, Flare Machines, Basing Machines, Stem Benders, Transformers, Rheostats, Grid Winders, etc.

Write for Bulletin Showing Savings from 20% to 80%

**KAHLE ENGINEERING CO.**

300 Manhattan Ave., Union City, N. J.

**Waxes and Meltable Insulating and Weather-proofing Compounds**

IMPREGNATION—Condensers, Coils, Rubber-Covered and Weather-Proofed Wire, Telephone, and Electrical Cables, Etc.

SEALING COMPOUNDS—Coils, Condensers, Batteries (Wet and Dry), Pot Heads, Cabinets, Wiring Devices and Specials.

FINISHING—All grades of Weather-Proof and Rubber-Covered Wire.

SPECIAL COMPOUNDS made up on specifications.

**CANDY & COMPANY, INC.**

35th STREET and MAPLEWOOD AVENUE

CHICAGO, ILL.

1922 **GATES AMPLIFIERS** 1922  
FOR THEATRES, BROADCASTING  
**STATIONS & ADDRESS SYSTEMS**  
**GATES RADIO & SUPPLY CO.**  
1932 QUINCY, ILLINOIS, U. S. A. 1932

• **WAXES, COMPOUNDS** •  
• **and VARNISHES** •

for insulation of condensers

transformers, coils, power packs, pot heads, sockets, wiring devices, wet and dry batteries, etc. . . . WAX SATURATORS for braided wire and tape. WAXES for radio parts . . . Compounds made to your own specifications if you prefer.

**ZOPHAR MILLS, INC.**

FOUNDED 1846

Court and Lorraine Streets Brooklyn, N. Y.

Agents: Ralph B. Clark, 2007 Calumet Ave., Toledo, Ohio  
H. A. B. Sneve Co., San Francisco, Seattle, New Orleans

# Transformers

INSULATING » MODULATING » OUTPUT  
CHOKES » » COILS » » CONDENSERS

Write for No. 66 Radio-Industrial Catalog on your company letterhead

**Kellogg Switchboard and Supply Company**  
1066 West Adams Street . . . CHICAGO, ILLINOIS

**BRASS—BRONZE—COPPER**  
**NICKEL SILVER—ZINC**  
**PHOSPHOR BRONZE**

In Gauges .001 and Thicker. 1/16" to 16" Wide

**HOT TIN COATED METALS IN COILS AND STRIPS**

**THE BALTIMORE BRASS CO.**  
1206 WICOMICO ST., BALTIMORE, MD.

**FREE! BANQUET STAND**  
WITH EACH  
*New* **SHURE MODEL 22N**  
2 - BUTTON MICROPHONE

With all orders received for Model 22 N (List Price \$25.00—usual discounts apply) before October 30 mentioning RADIO ENGINEERING we will include one \$17.50 Banquet Stand absolutely FREE and—your money back if not satisfied! Write for full details at once.

**SHURE BROTHERS COMPANY**  
Manufacturers—Engineers  
S. N. SHURE, Pres.  
337 WEST MADISON ST. CHICAGO, ILLINOIS

**PIEZO-ELECTRIC CRYSTALS**

Since 1925 we have been recognized as the RELIABLE PRODUCERS of POWER CRYSTALS. We are at your service to supply your needs. Special prices for quantity lots. Your request will bring our price list.

**SCIENTIFIC RADIO SERVICE**  
"The Crystal Specialists"  
124 JACKSON AVE. (University Park), HYATTSVILLE, MD.

**PREMIER**  
**AUTO RADIO**  
**Remote Control**



Direct Flexible Shaft Drive—Mounts on Steering Column—Key Switch Lock—Illuminated Dial—Indestructible pressed steel—Rust proof—Small size 3 1/2" x 4 1/2".

Manufacturers Inquiries Solicited

PATENTS PEND.  
**PREMIER ELECTRIC COMPANY**  
Established 1905  
1802 Grace Street Chicago, U. S. A.

**FREE**  
**WHOLESALE RADIO CATALOGUE**  
**The Big Book**



Thousands of radio items at real bargain prices. Featuring Public Address and Sound Picture Equipment, Microphones, Amplifiers, Recording Equipment, etc.

Send for your copy today.

**American Sales Company**  
R-44 W. 18th St., New York City

**LAMINATIONS**

for Audio & Power Transformers  
SPECIALIZED METHODS—YEARS OF EXPERIENCE  
Wide Variety of Stock Standard Sizes  
Dimension and Price Sheets on request  
We Also Make  
PERMANENT MAGNETS—DIES—TOOLS—METAL STAMPINGS  
Facilities for prompt service

**Thomas & Skinner**  
Steel Products Co. 1100 to 1120 E. Twenty-Third St. INDIANAPOLIS, IND.

**NEW DAVEN LADDER ATTENUATOR**

FOR USE AS MIXER WITH DYNAMIC MICROPHONES

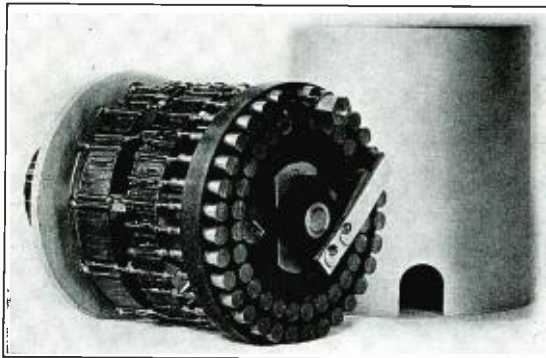

The Present Attenuator is the First Ever Made Which Is Entirely Free From Disturbing Noises.

**NOISE LEVEL—160 db.** Unexcelled as a Mixer Pad, may also be used as a "T" Pad and Master Control in broadcasting, sound recording and P. A. Systems. Size: 2 3/4" dia. x 3 1/8" deep, net weight 11 ounces, 30 Steps à 1.5 DB. 500/500, 200/200 & 50/50 ohms from stock.

ALSO "H", "T", "L" & POT'S., VOLUME INDICATORS, DECADE BOXES, ETC.

Write for Catalogue 532

**THE DAVEN COMPANY**

158-160 SUMMIT STREET NEWARK, NEW JERSEY

**ACME WIRE PRODUCTS**

All Acme Products are made to recognized commercial standards, including those of National Electric Mfrs. Assn., Radio Mfrs. Assn. and American Soc. for Testing Materials...

**COILS**

MAGNET WIRE WOUND

**AERIAL WIRE**

STRANDED AND SOLID

**MAGNET WIRE**

ALL INSULATIONS

**PARVOLT CONDENSERS**

FILTER AND BY-PASS—ALSO FOR POWER FACTOR CORRECTION

**VARNISHED INSULATIONS**

CAMBRIC, SILK, PAPER, TAPE

THE ACME WIRE CO., NEW HAVEN, CONN.

For over 25 years, suppliers to the largest radio and electrical manufacturers

**INDEX OF ADVERTISERS**

**A**

Acme Wire Co., The..... 34  
 A. G. A. Company..... 29  
 Allen-Bradley Co..... 8  
 American Sales Co..... 33  
 American Transformer Co..... 36  
 Arcturus Radio Tube Co..... Second Cover

**B**

Bakelite Corp..... Back Cover  
 Baltimore Brass Co., The..... 33

**C**

Candy & Co..... 32  
 Central Radio Corp..... Third Cover  
 Central Radio Labs..... 25  
 Clarostat Mfg. Co., Inc..... 6  
 Condenser Corp. of America..... 27

**D**

Daven Company, The..... 34

**E**

Erie Resistor Corp..... 1

**F**

Filtermatic Mfg. Co..... 35

**G**

Gates Radio & Supply Co..... 32  
 General Mfg. Co..... 31  
 General Radio Co..... 29  
 Gilby Wire Co..... 32

**H**

Hammarlund Mfg. Co..... 27  
 Hill Book Co..... 35

**I**

Institute of Radio Engineers..... 36

**K**

Kahle Engineering Co..... 32  
 Kellogg Switchboard & Supply Co..... 33

**L**

Land, L. J..... 30  
 Littelfuse Laboratories..... 32

**M**

Midwest Broadcast Equipment Co..... 32  
 Morrill & Morrill..... 30

**Mc**

McGraw-Hill Book Co..... 35

**P**

Precision Resistor Co..... 35  
 Premier Electric Co..... 33

**R**

Resinox Corporation..... 29

**S**

Scientific Radio Service..... 33  
 Shakeproof Lock Washer Co..... 5  
 Shure Brothers Co..... 33

**T**

Taussig, Leo..... 32  
 Thermionic Laboratories..... 31  
 Thomas & Skinner Steel Products Co..... 33  
 Trimm Radio Mfg. Co..... 32

**V**

Van Nostrand Co., D..... 30

**W**

Western Electric Co..... 3  
 White Dental Mfg. Co., S. S., The..... 7  
 Wireless Egert Engineering, Inc..... 35

**Z**

Zapon Company..... 25  
 Zophar Mills, Inc..... 32

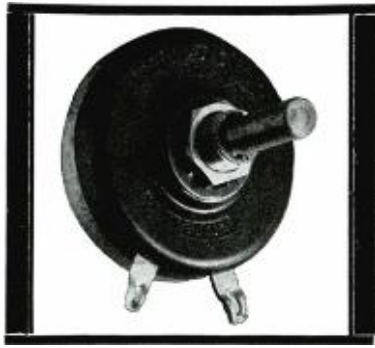

## OCTAVE TONE CONTROLS

Octave controls are the finest available — and they are priced right!  
Compact, moisture proof, rugged, capable of high voltage loads, easy to assemble. Life tests unequalled.  
Stock or special samples to your specifications.

**FILTERMATIC MFG. COMPANY**  
HUNTING PARK AVENUE and MARSHALL STREET  
PHILADELPHIA PENNNA.

**STATEMENT OF THE OWNERSHIP, MANAGEMENT, CIRCULATION, ETC., REQUIRED BY THE ACT OF CONGRESS OF AUGUST 24, 1912, OF RADIO ENGINEERING**  
Published monthly at New York, N. Y., for Oct. 1, 1932.

State of New York } ss.  
County of New York }

Before me, a Notary Public in and for the State and county aforesaid, personally appeared B. S. Davis, who, having been duly sworn according to law, deposes and says that he is the Business Manager of RADIO ENGINEERING, and that the following is, to the best of his knowledge and belief, a true statement of the ownership, management, etc., of the aforesaid publication for the date shown in the above caption, required by the Act of August 24th, 1912, embodied in section 411, Postal Laws and Regulations, to wit: 1. That the names and addresses of the publisher, editor, managing editor, and business manager are: Publisher, Bryan Davis Publishing Co., Inc., 19 East 47th Street, New York. Editor, Donald McNicol, Roselle Park, N. J.; managing editor, F. Walen, Union City, N. J.; Business Manager, B. S. Davis, Scarsdale, N. Y. 2. That the owners are: Bryan Davis Pub. Co., Inc.; B. S. Davis, Scarsdale, N. Y.; Roy T. Atwood, Albany, N. Y.; G. R. Bacon, Douglass, N. Y.; J. C. Munn, Union City, Pa.; J. A. Walker, Richmond Hill, N. Y.; A. B. Goodenough, New Rochelle, N. Y. 3. That the known bondholders, mortgagees, and other security holders owning or holding 1% or more of the total amount of bonds, mortgages, or other securities are: None. 4. That the two paragraphs next above, giving the names of the owners, stockholders, and security holders, if any, contain not only the list of stockholders and security holders as they appear upon the books of the company but also, in cases where a stockholder or security holder appears upon the books of the company as trustee or in any other fiduciary relation, the name of the person or corporation for whom such trustees is acting, is given; also, that the said two paragraphs contain statements embracing affiant's full knowledge and belief as to the circumstances and conditions under which stockholders and security holders who do not appear upon the books of the company as trustees, hold stock and securities in capacity other than that of a bona fide owner; and this affiant has no reason to believe that any other person, association, or corporation has any interest direct or indirect in the said stock, bonds, or other securities than as so stated by him.

(Signed) B. S. DAVIS, Business Manager.

Sworn to and subscribed before me this 29th day of September, 1932.  
(Seal) M. S. OELSNER, Notary Public.

N. Y. County.  
New York Co. Clerk's No. 27  
New York Co., Registers No. 3-0-10.  
Commission expires March 30, 1933.

## CATHODE RAY TUBE EQUIPMENT

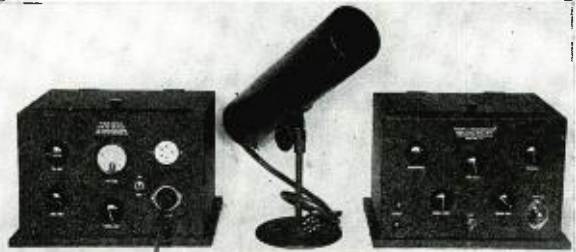

### WHERE IT IS USED

Radio set measurements. Insulation efficiency.  
Audio frequency measurements. Transient phenomena.  
Sound analysis. Circuit analysis. Operation of switching equipment and relays.  
Class room demonstrations. Resistance measurements.  
Vacuum Tube measurements. TELEVISION RECEPTION.  
Comparisons of current and voltage. Medical work (cardiograph).  
Hysteresis curves.

Model No. 209—3" Cathode Ray Tube.....List \$25.00  
Model No. 710—Cathode Ray Tube Holder..... " 40.00  
Model No. 709—Power Supply..... " 85.00  
Model No. 309—Sweep Circuit..... " 125.00

### MODEL 305 OSCILLATOR

Range 10 to 16,000 cycles

A new Beat Frequency Oscillator with many new improvements. List price \$185.00.



Write for further information on the above items.

**WIRELESS EGERT ENGINEERING, INC.**  
179 Varick Street New York City

## OVER 600 QUESTIONS AND ANSWERS COVERING ALL RADIO OPERATOR LICENSE EXAMINATIONS

This new edition of Nilson and Hornung's well-known book will help you pass examinations and to know your stuff better in any field of practical radio. Brought completely up to date. Enlarged to cover more amateur work; also police, aeronautical and other radio.

Just Published

NILSON AND HORNUNG'S

## RADIO OPERATING QUESTIONS AND ANSWERS

350 pages, 6 x 9, 131 illustrations, \$2.50

New 4th Edition

including:

- Information on broadcasting, marine, aeronautical, police and amateur operating
- many new questions and answers on latest types of transmitters and other equipment
- more information on amateur operation, including unlimited amateur telephone operator's license
- new radio laws
- new questions and answers on important technical, general and theoretical topics
- regulations governing issuance of all classes of radio operator's license examinations

Every question is typical of those you meet on examinations; answers are complete, illustrated, and give the information essential to meet every situation. For amateurs, short wave fans, men who are preparing for operator examinations or technical positions. Radio companies give preference to licensed operators for all positions. This book gives quick, direct preparation for all examinations. Examine it free.

### FREE EXAMINATION COUPON

McGraw-Hill Book Co., Inc., 330 W. 42nd St., New York.  
You may send me Nilson and Hornung's *Radio Operating Questions and Answers*, postpaid, for 10 days' Free Examination. I will send \$2.50 or return the book within 10 days of receipt.

Name .....  
Address .....  
City and State .....  
Position .....  
Company ..... RE-9-32

(Books sent for free examination to retail purchasers in U. S. and Canada only.)



# AMERTRAN



## New Type PA-86 M Public Address Amplifier

Type PA-86M is the ideal quality Amplifier of low cost for Public Address from a single microphone or phonograph pick up. It is a complete practical system of  $12\frac{1}{2}$  watts output and may be operated without the addition of accessory equipment, such as Input Matching Transformers and Volume Control.

All that is necessary to install Type PA-86M is to connect the input source and loud speakers to the proper terminals, plug in the 110 volts AC bracket, and insert tubes. The input source may have an impedance of either 200 or 500 ohms, and, if it is a double button carbon microphone, button current is provided by the power supply. The output source has 500 ohms impedance and an additional 15 ohm winding is provided for the connection of a monitor speaker.

The complete equipment is mounted on a compact metal chassis, thus making it ideal for portable service. It includes a three stage double push-pull Amplifier with self-contained power supply.

The Quality throughout is up to the usual AmerTran Standard. Write for prices and further information.

### American Transformer Company

*Main Office and Factory*  
180 Emmet Street, Newark, N. J.

#### BRANCH OFFICES

BOSTON  
CHICAGO  
CLEVELAND  
DETROIT  
KNOXVILLE  
MONTREAL



NEW YORK  
PHILADELPHIA  
PHOENIX  
ST. LOUIS  
SAN FRANCISCO  
ST. PAUL

## Service to Unemployed Radio Men and to the Radio Industry

This Committee of the Institute of Radio Engineers has a classified list of Institute members and other Radio men who are unemployed. Any needs the Radio Industry has for such men if addressed to the Committee will be answered with the names, addresses and an outline of the experience of the men we believe are suitable.

Also this Committee pays unemployed members for answers obtained in house to house interviews with families. The answers are designed to bring out what listeners dislike that cause them to turn off radio receivers, and which thereby prevent the sale of receivers, and what listeners like and are attentive-to which cause the sale of receivers and pay for the operation of transmitters. The answers are tabulated and sold to get sustaining funds and to help spread information that will result in the production of broadcasts that listeners and potential listeners will want.

Your inquiries are solicited both for men and for tabulations.

**Emergency Employment Committee,  
Institute of Radio Engineers,  
33 West 39th Street  
New York City**

# C. R. C. SOCKETS PROTECT LIFE AND PROPERTY

The failure of a socket on a receiving set may deprive the owner of the enjoyment of "Amos an' Andy" or Kate Smith for one evening—but the failure of a socket on amplifying or sound equipment may inconvenience thousands of people as well as cause a monetary loss. Quite a difference in the seriousness of the two failures. The failure of a socket on photo-cell equipment may cause hundreds of dollars loss or throw men out of work temporarily—quite a serious matter.

The failure of a socket on an aeroplane receiving set may result in death for one or more persons — that loss is incalculable.



The failure of a socket on police car radio may cause both monetary loss and death. On ship equipment the same holds true.

C. R. C. SOCKETS ARE INVARIABLY  
SELECTED WHERE SAFETY OF LIFE AND  
PROPERTY IS PARAMOUNT. NO FINER  
ENDORSEMENT COULD BE GIVEN.

CENTRAL RADIO CORPORATION  
BELOIT, WISCONSIN

# Daven finds Bakelite Materials superior *for quality Attenuators*

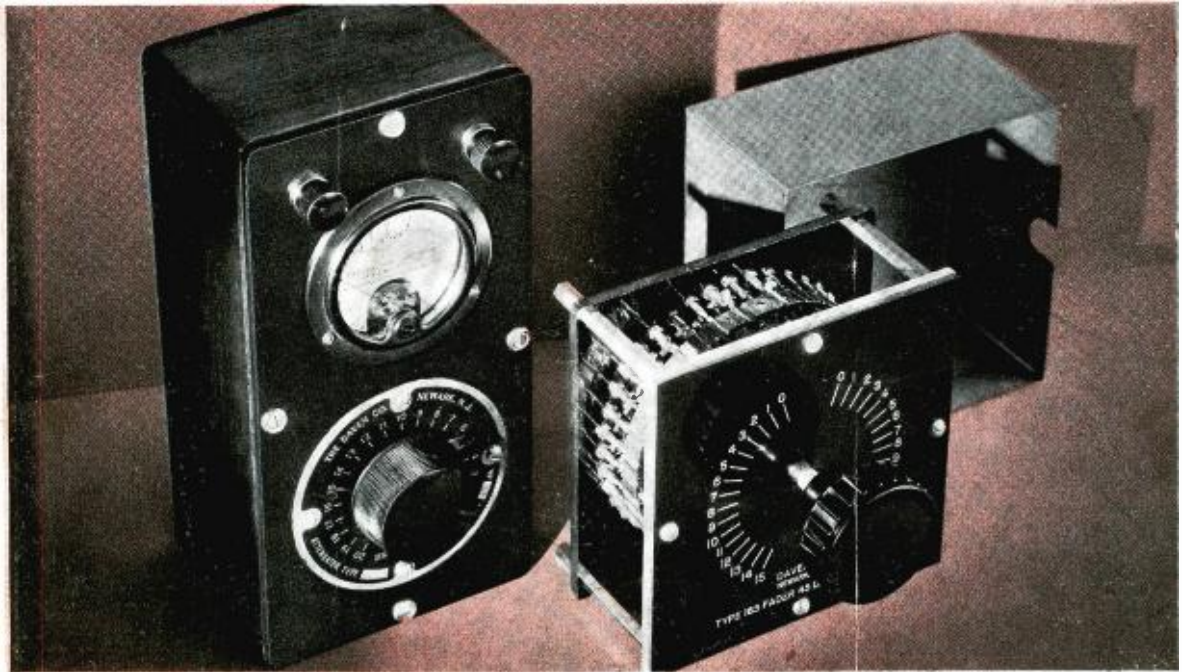

*Attenuators made with Bakelite Materials by The Daven Company, Newark, N. J.*

ENGINEERS who are responsible for improving the quality of performance in radio broadcasting and receiving equipment rely upon Bakelite materials for the solution of insulation problems as they have from the beginning of the industry. The Daven Company in designing their new line of attenuation networks have selected both Bakelite Molded and Laminated, which, because of their dielectric properties, have been instrumental in helping reduce "noise level" from 80-90 decibels to minus 140-160 decibels. The hearts of the attenuators are

the many resistors which have to be crowded into a small space. A Daven Balanced "H" contains 120 resistors all calibrated to a high accuracy. To obtain the best frequency characteristics the resistors are wound on thin Bakelite Laminated strips. The large attenuators have Bakelite Molded panels, and Bakelite Laminated is used for switch hubs. The small units use linen base Bakelite Laminated panels for increased strength and in addition, Bakelite Materials are used for shaft-couplings, terminal strips and knobs.

Whether in the Molded, Laminated or Varnish form, Bakelite Materials possess ideal properties for use as insulating materials in the electronics industry. Strong, highly insulating, non-corrodible and non-hygroscopic—these materials give constant and dependable service for a long period of time. We invite you to avail yourself of the assistance of our Laboratories and engineers. Write for illustrated Booklets 12M, "Bakelite Molded", 12L, "Bakelite Laminated" and 12V, "Bakelite Varnish" which fully describe these materials, their properties and uses.

BAKELITE CORPORATION, 247 Park Avenue, New York, N.Y. . . . . . 43 East Ohio Street, Chicago, Ill.  
BAKELITE CORPORATION OF CANADA, LIMITED, 163 Dufferin Street, Toronto, Ontario, Canada

## BAKELITE

The registered trade mark shown above distinguishes materials manufactured by Bakelite Corporation. Under the capital 'B' is the Bakelite logo, a stylized 'B' inside a circle with '1890' and '1937' on either side. The text below the logo reads: 'Bakelite is a registered trademark of Bakelite Corporation. It symbolizes the reliability, number of patents and long use of Bakelite Corporation's products.'

T H E M A T E R I A L O F A T H O U S A N D U S E S