

APRIL, 1932

Radio Engineering

IN THIS ISSUE



CIRCUITS TO OBTAIN DETECTION AND DELAYED AVC

By J. R. Nelson

IONIZATION IN VACUUM TUBES

By Rinaldo DeCola

A GIANT TUBE FOR RADIO TRANSMISSION

By A. Dinsdale

AUTOMATIC SUPPRESSION OF INTERCARRIER NOISE
IN RADIO RECEIVERS

By Paul O. Farnham

VOLUME CONTROLS

By W. S. Parsons

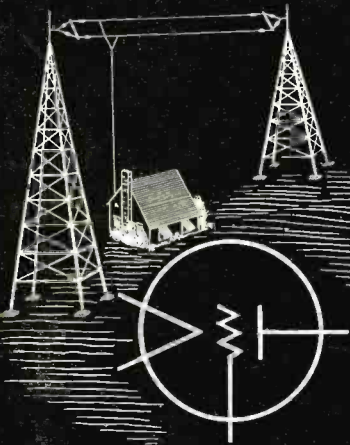

TWELFTH YEAR OF SERVICE

The Journal of the
Radio and Allied Industries

'Unitary Structure'

in TRANSMITTING TUBES

assures matched tubes . . . enduring uniformity . . . long-lived performance

Seldom have new products offered such a decided improvement over existing devices. The uniformity, performance and unique construction of Arcturus transmitting tubes establish a new basis for considering operation cost per hour.

The exclusive "unitary structure" principle employed in these tubes—the same as used in the well-known Arcturus *Blue* receiving tubes—assures unvarying uniformity even under most rigorous conditions. "Unitary structure" also insures matched tubes, so necessary for critical operation. These tubes are interchangeable with other makes whose last two digits are similar.

Write for technical data bulletins on the Arcturus Types E703-A, E711, E711-E, E745 (50-watt tubes) and E766 and E772 (mercury vapor rectifiers).

Arcturus Radio Tube Co., Newark, N. J.

UNITARY STRUCTURE

Note the extreme rigidity of these tubes. The Unitary Structure principle of interlocking the elements maintains the precise interrelation of parts through interdependence. Each rugged element is securely clamped at the top and bottom and the complete assembly is a sturdy unit—insuring constant uniformity.

ARCTURUS

*Quality Tubes for
Transmitting, Receiving
and Industrial Uses*



Is distribution sound? Does the advertising hit the market? How about overhead? *How about the product itself?*

Any radio manufacturer who asks himself these questions must come, sooner or later, to a consideration of the materials he uses. Which explains in part, at least, why Durez is being put to hundreds of new uses—not only in the radio industry, but in almost every other line of business!

A better product, at low cost

Durez frequently enables a manufacturer to make his product better, more quickly, and at less cost than he has made it before. A powdery, dust-like substance, Durez molds



under terrific pressure to take almost any required shape, pattern or design.

That finished product is tough, hard, durable. It needs no laborious finishing or polishing. It seldom chips or cracks. It has high tensile and dielectric strength. Its surface is naturally as smooth and beautiful as burnished ebony. Studs and inserts can be imbedded in the one molding operation. Intricate designs, trade-marks, insignias are accurately reproduced.

People who "do it with Durez"

The list of Durez users in the radio and electric fields alone reads like a Who's Who of business. Stewart-Warner, Delco, Turner Timer, Wagner Motor, Ford,

Westinghouse, Telechron, USL Battery—these are only a handful of hundreds of nationally known concerns who find Durez ideally suited to their needs. Remler Radio products, shown in the illustration, show how versatile this perfect molding compound really is.

We will be glad to point out how Durez fits into the plan of progressive manufacturers. Write now for information and free booklet. General Plastics, Inc., 45 Walck Rd., N. Tonawanda, N. Y. Also New York, Chicago, San Francisco, Los Angeles.

DUREZ
THE PERFECT MOLDING COMPOUND

RADIO ENGINEERING

Reg. U. S. Patent Office



Western Editor
ULMER G. TURNER

Editor
DONALD McNICOL

Managing Editor
F. WALEN

Vol. XII

APRIL, 1932

Number 4

Contents

	PAGE
EDITORIAL	4
A CHRONOLOGICAL HISTORY OF ELECTRICAL COMMUNICATION—TELEGRAPH, TELEPHONE AND RADIO, PART IV	11
CIRCUITS TO OBTAIN DETECTION AND DELAYED AVC <i>By J. R. Nelson</i>	13
IONIZATION IN VACUUM TUBES <i>By Rinaldo DeCola</i>	15
A GIANT TUBE FOR RADIO TRANSMISSION <i>By A. Dinsdale</i>	17
DISTANCE RANGES OF RADIO WAVES <i>By J. H. Dellinger</i>	18
SAVING INSTRUMENT LOSSES BY PROPER FUSE PROTECTION <i>By E. V. Sundt</i>	20
AUTOMATIC SUPPRESSION OF INTERCARRIER NOISE IN RADIO RECEIVERS <i>By Paul O. Farnham</i>	21
A NEW INDUSTRIAL AMPLIFIER TUBE FOR PHOTOTUBE CIRCUITS <i>By Lee Sutherland</i>	24
VOLUME CONTROLS <i>By W. S. Parsons</i>	25
RECENT DEVELOPMENTS IN PRECISION FREQUENCY CONTROLS <i>By D. E. Reptogle</i>	29
ACCURATE RACE TIMING BY PHOTOCELL CURRENT	32
A NEW HIGH QUALITY DETECTOR TUBE	33

Departments

NEWS OF THE INDUSTRY	38
NEW DEVELOPMENTS OF THE MONTH	40
INDEX OF ADVERTISERS	50

◆
JUNE 22d!

WHILE it is true that the Radio Commission's order to the effect that by June 22, next, broadcast stations will be required to maintain transmitting frequencies to within plus or minus 50 cycles of the station's assigned frequency was given out long in advance, it appears that it may be necessary to make allowances for unavoidable delays.

One difficulty is the present economic disturbance which has necessitated strict economy in the management of stations in order to continue service. Then, it is reported that manufacturers of frequency control and monitoring systems are experiencing delay in procuring approval from the authorities for the units made up for the purpose and which broadcasters desire to purchase. Obviously, a reasonable time period must intervene from the time approval is granted until the manufacturer has his product ready for shipment.

Following the vicissitudes incidental to packing, shipping and unpacking, there is required also reasonable time to install and place in operation the necessary equipment.

It is hoped that when June 22 arrives, and some of the smaller stations are still struggling to "make good," that due allowance will be made for all of the elements of delay.

BRYAN S. DAVIS
President

JAS. A. WALKER
Secretary

Published Monthly by

Bryan Davis Publishing Co., Inc.
19 East 47th Street
New York City

SANFORD R. COWAN
Advertising Manager

J. E. NIELSEN
Circulation Manager

Chicago Office—333 N. Michigan Ave.—Charles H. Farrell, Mgr.
St. Louis Office—505 Star Building—F. J. Wright
Kansas City Office—306 Coca Cola Building—R. W. Mitchell
San Francisco Office—155 Sansome St.—R. J. Birch



Los Angeles Office—846 S. Broadway—R. J. Birch
New Zealand—Tearo Book Depot—Wellington.
Melbourne, Australia—McGill's Agency.

Entered as second class matter August 26, 1931, at the Post Office at New York, N. Y., under Act of March 3, 1879. Yearly subscription rate \$2.00 in United States, \$3.00 in Canada and foreign countries.

Three more new units

that complete Radio's most comprehensive line of Volume and Tone Controls



No. 80 Series Single Unit, without switch

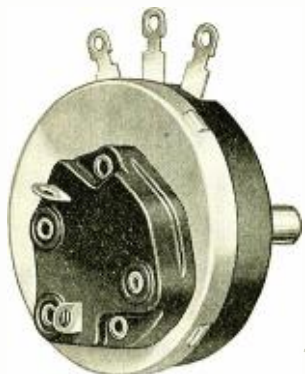

No. 80 Series Single Unit with S. P. S. T. low torque snap switch



No. 2-80 Series Tandem Unit without switch

HERE are three new Volume and Tone Controls that effectively round out the most comprehensive line of these units ever offered to set manufacturers. These new units are

No. 80 Series Single Unit, without switch.

No. 80 Series Single Unit, with S. P. S. T. low torque snap switch.

No. 2-80 Series Tandem Unit without switch.

These new units are of the carbon element type. They are of sturdy construction, designed for extremely rapid assembly, and are noiseless in operation. Capacity between thimble and shaft and the "live" parts of the control is practically nil.

The snap switch with which the No. 80 Single Unit is equipped is of our own design and manufacture. It is of the low torque, low contact resistance type, with "COLD" cam. When desired, we can furnish switch-equipped units with electrostatic shield, thus enabling the control to be directly associated with the grid circuit without any possibility of pickup from the power circuit.

We are prepared to supply these new controls in any desired resistance gradient. Write us today regarding your requirements. Let our Engineering Department work with you on a control or controls that will exactly meet your requirements.

With these new units you now can obtain from us every possible type and style of Volume and Tone Control, in either carbon element or wire wound type—by far the most complete line available.

CHICAGO TELEPHONE SUPPLY CO.

HERBERT H. FROST, Inc.

SALES DIVISION

General Offices and Plant

ELKHART, INDIANA

E d i t o r i a l

APRIL, 1932

TUBES FOR RADIO RECEIVERS

It is of course a question who is to blame when aggressive competition results in list prices being lowered and discounts increased to figures where it just is not possible to produce a high grade product. In the radio industry during the past year or so the rise of the midgets has had an understandable bearing upon the prices that could or would be paid for tubes and accessories.

The present low prices for vacuum tubes, for instance, is a result, among other reasons, of continuous pressure for reductions so that prices of midget receivers might in turn be lowered to the public.

When retail dealers, servicemen and the public begin to experience unsatisfactory service and money losses due to cheaply made tubes, in the case of any particular tube manufacturer explanations may be forthcoming which would go far toward explaining the increasing ratio of failures. But, there must be at some point an irreducible minimum of manufacture cost below which it is not possible to drop if the ratio of rejects to passed tubes is not to be at a level ruinous to the manufacturer. And, that the rigor of the tests applied before the carton is put on be maintained with a view to sending out 1,000 hour tubes that may be expected to live their natural lives.

According to information gleaned from a random list of dealers outside of the New York territory at present there is increasing trouble due to "shorted" tubes; in particular the tubes which come with equipped receivers.

Actually, it is a tribute to manufacturing genius that the tube factories have been able to do as well as they have in view of the net prices received for their products. So much so that it is apparent that if a few cents more could be added to the factory net all of the present difficulties would disappear.

As pointed out by the chief engineer of one of the large manufacturers of good tubes the introduction of the present types of superheterodyne receivers with increased gain per stage has given tube manufacturers new problems to meet.

The situation is one which requires the cooperative deliberation of the leaders of the industry—set manufacturers and tube manufacturers.

THE ELECTROLYTIC CONDENSERS

THE phenomenal increase in the number of both semi-dry and wet electrolytic condensers being used in the assembly of radio receivers registers a noteworthy advance in receiver construction in recent years. This, notwithstanding that there will always be a wide field for the use of condensers of the paper and foil type.

Difficulties experienced with the earlier types of "electrolytics" were, eating away of the aluminum electrode at the air line within a year or so after installation; and, in the case of the dry type, noise introduced due to condenser interaction.

It is reported, however, that electrolytic type condensers now being produced are less subject to these defects than were earlier units. It was well that the deficiencies were early identified and remedied. Otherwise an excellent product would have acquired an undesirable reputation.

AUTOMATIC VOLUME CONTROL

RIGIDLY interpreted, automatic volume control implies that with the device or the system operating effectively dial setting for the most distant station the receiver will bring in with desired volume, may be changed to bring in the strongest local station, without observable change in volume, and without altering the adjustment of the volume control.

At the present time this is a subject in which all design engineers are interested. The material which RADIO ENGINEERING is publishing on the subject should be educational.

Donald Mc Nicol
Editor



United Air Cleaner Corporation speedily run in Self-tapping Screws with spiral screw drivers.

Designs for latest Sentinel Radios specify More Self-tapping Screw fastenings

Experience shows they make better, cheaper assemblies

The popular Sentinel Radios made by the United Air Cleaner Corporation had been assembled with tubular rivets, machine screws, bolts and nuts. These methods of assembly were costly and troublesome. So Parker-Kalon Self-tapping Screws were adopted for several of the meanest assemblies. The results were highly pleasing, considerable savings being effected, production speeded up and better fastenings obtained. Thus, on new designs now being developed, these Screws have been specified for a large percentage of the fastenings that will be required. A comparison with other fastening devices has shown radio

manufacturers, large and small, that Self-tapping Screws offer the simplest, cheapest and most secure means of making many assemblies. Also tests prove that these unique Screws actually make stronger, as well as cheaper, fastenings.

Unskilled workers can make first-class fastenings with Self-tapping Screws. No special equipment is required. Find out whether you can use these Screws to advantage. Send us a description of one or more assemblies and our Assembly Engineers will report what you can save. The coupon brings two interesting booklets containing complete information.



Type "Z" Hardened Self-tapping Sheet Metal Screws
For joining and making fastenings to sheet metal up to six gauge, also aluminum, die castings, Bakelite, etc. Simply turn Screw into drilled, pierced or molded hole. It forms a thread in the material as it is turned in. Can be removed and replaced.



Type "U" Hardened Metallic Drive Screws
This type of Self-tapping Screw is used for making permanent fastenings to iron, brass and aluminum castings, steel, Bakelite, Durez, etc. Just hammer the Screw into a drilled or molded hole. It forms a thread in the material as it is driven.

PARKER-KALON *Hardened* Self-tapping Screws

PAT. IN U. S. AND FOREIGN COUNTRIES



← Application to well known radios.....Scientists Explain Fastening Security →

PARKER-KALON CORPORATION, Dept. L, 190-198 Varick Street, New York, N. Y.

- Send free booklets on Security and Uses of Self-tapping Screws in radio assemblies.
- Tell me whether I can successfully use them for fastenings described on attached sheet.

Name and Company.....

Address.....



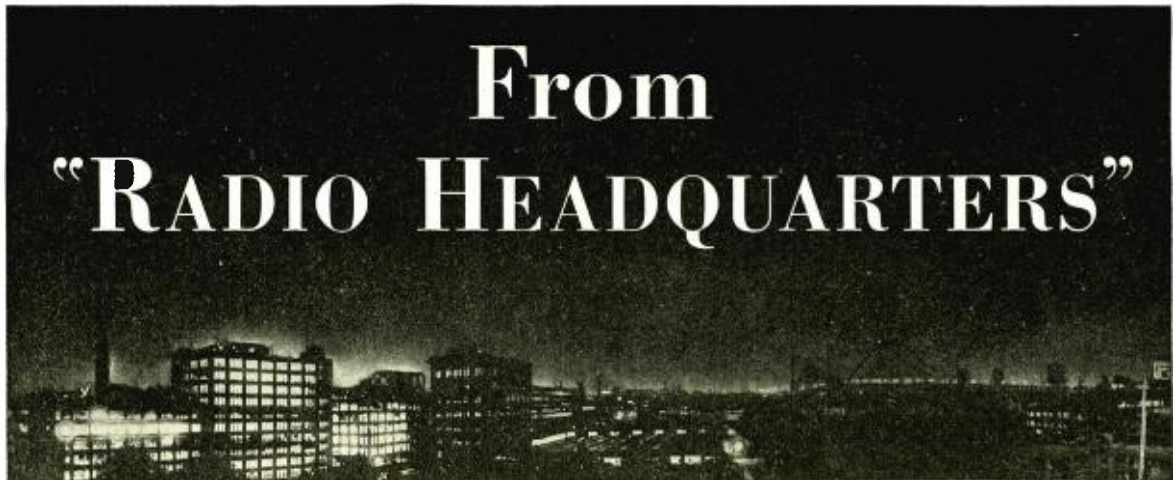

From "RADIO HEADQUARTERS"

a new and improved line of speech input panels

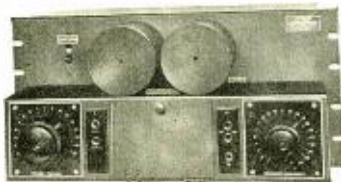

Type 24-B
Amplifier

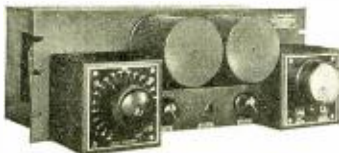

Type 13-C
Volume Indicator



See the above Panels and other new units, of RCA Victor Speech Input Equipment, at the I. R. E. Convention, Pittsburgh, April 7-10.

MUCH ballyhoo attended a recent announcement of Speech Input equipment—good for 30 to 10,000 cycle reproduction. Imitation is the sincerest compliment—the RCA Victor Company introduced several years ago, in its "A" series of Speech Input Panels, the first broadcast equipment capable of transmitting faithfully all frequencies in the range of 30 to 10,000 cycles.

Moreover, since the introduction of this first high-fidelity equipment, engineers of the RCA Victor Company, Inc., have been continuously employed in development work which would lead to the perfection of still better Speech Input units. They have laid particular stress on improved mechanical construction, greater accessibility of parts, elimination of microphonics, reduction of background noise, increased convenience and flexibility, and last but not least, greatly improved appearance.

The results of this comprehensive development program have been incorporated in the new line of Speech Input Panels offered by the RCA Victor Company, Inc. The Broadcast Engineer will find these Panels the finest Speech Input units yet designed



ENGINEERING PRODUCTS DIVISION

RCA Victor Company, Inc.

A Radio Corporation of America Subsidiary

CAMDEN, N. J.



From "RADIO HEADQUARTERS"



RCA Victor Standard Signal Generator Type TMV-18



Radio engineers interested in duplicating actual operating conditions in their laboratories will agree that:

- Frequency Modulation
- Percentage Modulation
- Frequency Range
- Range of Output
- Leakage

are points of paramount importance to be considered in a Signal Generator.

Write us today for information on the TMV-18 Standard Signal Generator, as well as other high quality Laboratory Equipment and Component Parts. Your inquiries will receive our prompt attention.



Universal Visual Test Set Type TMS-36



"Faradon" Capacitors



Magnetic Pickup and Inertia Tone Arm

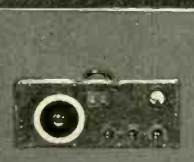

Beat Frequency Oscillator TMV-28



Type RL-36 Midget Electro-Dynamic Loudspeaker



Type RP-67 Automatic Record-Changer (Plays either 78 or 33 1/2 RPM records)



INDUSTRIAL PRODUCTS SECTION

RCA Victor Company, Inc.

CAMDEN, N. J.

A Radio Corporation of America Subsidiary

AD-A-SWITCH

another Clarostat achievement!

Remove the dust cap—replace it with an Ad-A-Switch—the one unit is now a complete and perfect Ad-A-Switch Volume Control and Switch combination.

Duplication of resistors to be carried in stock is eliminated, overhead is reduced, efficiency improved—and profits step in where there might have been a loss.

Service engineers can have full technical data about this truly great Clarostat achievement.

VOLTAGE REGULATION

BUILT-IN PROTECTION by means of the CLAROSTAT Line Ballast. Compensates for both Low and High voltages. For use in receivers and sound equipment with 85 volt transformers.

ACCESSORY TYPE, plugs-in between the electrical outlet and the cord. Protects 110 volt equipment from increased line voltage, automatically, not a fixed resistor. The Clarostat Automatic Line Voltage Regulator is made in five sizes from 50 to 250 watts.



Our new catalogue contains data valuable to every engineer. Write for your free copy today

CLAROSTAT MFG. CO. ^I _N ^{C.} _{C.}
 285 NORTH 6th STREET BROOKLYN, N. Y.

FROM THE COPPER MINE

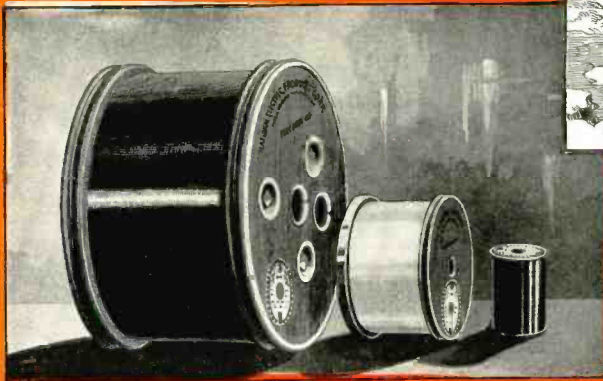

◆ ◆ ◆ ◆ TO THE FINISHED WIRE

In the broader sense Inca wire is created, not just fabricated. For through the Phelps Dodge Copper Products Corporation and its associated companies . . . there is continuous control over the manufacturing processes from the mining of the ore to the labeling and packing of the finished magnet wire.

The combined facilities thus employed are not merely adequate . . . they are outstanding.

Unusual, too, are the final wire drawing and enameling operations at the Inca mills. Here the most modern machinery in the industry plays an important part in upholding Inca standards of accuracy and quality.

These broad facilities embody not only all that is desirable and valuable in the older methods . . . but many new production refinements which have been made possible through extensive research and long practical experience.

Here are definite reasons why the electrical industry finds in Inca the characteristics which its exacting requirements demand.

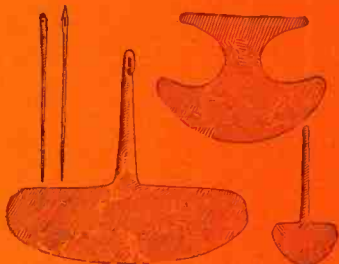

The articles shown above are interesting examples of the Inca's ability to create useful objects from raw copper ore. From left to right they are: two needles, two knives, and a shawl pin. These relics are now displayed in the American Museum of Natural History.

INCA

MANUFACTURING DIVISION



*Symbolic of the
best in copper
wire products.*

*Eastern Office: 40 Wall St.,
New York, N. Y.*

*Western Office: 2375 E. 27th St.,
Los Angeles, Calif.*

of PHELPS DODGE COPPER
PRODUCTS CORPORATION
FORT WAYNE, INDIANA

Instruments of Quality

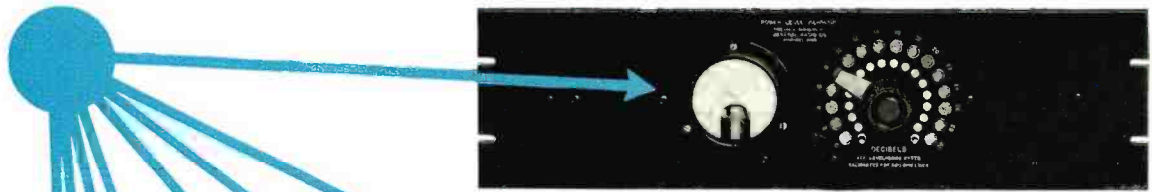

Power level indicator

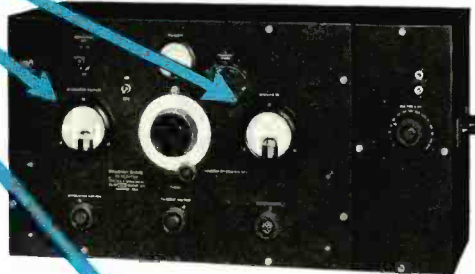

Standard signal generator



Field-intensity measuring set



A-c. beat frequency oscillator

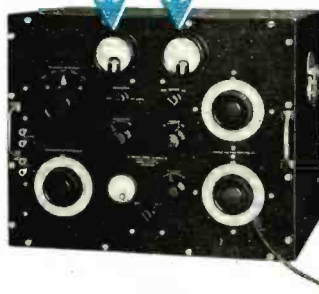

Standard signal generator

THESE few examples are selected at random from the General Radio Company's extensive line of apparatus for making electrical measurements at communication frequencies. It is significant that that company—one of the outstanding suppliers of equipment for the communication and allied fields—has selected General Electric miniature instruments for use in many of its products. General Electric instruments are available in wide variety also for laboratory use, field testing, and production control. Their recognized high quality commends them to you.

Send for complete catalog; address the nearest G-E office, or General Electric Company, Schenectady, New York.

GENERAL  ELECTRIC 610-67
SALES AND ENGINEERING SERVICE IN PRINCIPAL CITIES

A chronological history of electrical communication

—telegraph, telephone and radio

▲

This history was begun in the January, 1932, issue of RADIO ENGINEERING, and will be continued in successive monthly issues throughout the year. The history is authoritative and will record all important dates, discoveries, inventions, necrology and statistics, with numerous contemporary chronological tie-in references to events in associated scientific developments. The entries will be carried along to our times.

▼

Part IV

- 1840 (146) The Smee primary battery developed.
 (147) The American Association for the Advancement of Science, formed.
 (148) Alexander Bain, of Edinburgh, Scotland, introduces an electro-chemical telegraph.
- 1841 (149) Sir Charles Wheatstone, in England, constructs a direct-current magneto generator.
- 1842 (150) Joseph Henry, in America, points out that the discharge of a Leyden jar is oscillatory. Henry stated: "The discharge, whatever may be its nature, is not correctly represented (employing for simplicity the theory of Franklin) by the single transfer of an imponderable fluid from one side of the jar to the other. The phenomenon requires us to admit the existence of a principal discharge in one direction and then several reflex actions backward and forward, each more feeble than the preceding, until equilibrium is attained."
 (151) Soeren Hjorth, in Denmark, invents an electro-magnetic generator.
 (152) Joule discovers that iron alters its dimensions when magnetized.
 (153) Morse conducts experiments attempting to transmit signals through water without continuous conducting wires.
- 1843 (154) The Bunsen primary battery is developed, using a carbon negative element in place of the platinized negative element used in the Smee battery.
 (155) The United States congress authorizes (March 3) the expenditure of \$30,000 for the installation of an experimental Morse telegraph line between Washington and Baltimore.
 (156) Ezra Cornell leaves New York (October 17) for Baltimore to take charge of the work of laying the underground conductors for Morse's first line, that between Washington and Baltimore.
- 1844 (157) On May 24, the first official message is sent over Morse's telegraph line between Washington and Baltimore. The words of the message were: "What hath God wrought?"
 (158) A telegraph line is constructed between Paris and Rouen, France.
 (159) Rev. H. Highton, and Edward Highton, in England, invent a telegraph system employing relatively high tension currents, which at the receiving end of a one-wire line caused holes to be made through a strip of paper tape as the circuit was closed and opened at the sending end in forming signals.
- 1845 (160) Royal E. House, of Vermont, files a patent covering the invention of a printing telegraph system.
 (161) J. W. Starr, an American, procures a patent in England for a lamp consisting of a strip of carbon placed in a high vacuum existing at the top of a barometer tube. Starr, twenty-five years of age, died on his return voyage to the United States.
 (162) A Morse telegraph line is constructed between New York and Boston.
 (163) Faraday discovers that a light ray polarized in a certain plane can be twisted by magnetic means.
 (164) Cooke and Wheatstone, in England, patent their needle telegraph system.
 (165) Schoenbein identifies electrically produced ozone.
 (166) John Frederick Daniell dies. (Born in England 1790.)
 (167) Jean Charles Peltier dies. (Born in France 1785.)
 (168) A school of engineering is founded at Union College, Schenectady, N. Y.
 (169) Ezra Cornell lays and operates a submarine telegraph cable across the Hudson river between New York and Fort Lee, N. J. The conductors insulated with cotton and inclosed in a lead pipe.
- 1846 (170) Morse telegraph line opened between New York and Boston under the management of F. O. J. Smith, owner of one-fourth interest in Morse's patent. The other co-proprietors are Amos Kendall and Alfred Vail.
 (171) A telegraph line is constructed between Buffalo, N. Y., and Toronto, Canada.
 (172) Ezra Cornell introduces a telegraph repeater for repeating signals from one circuit to another.
 (173) James D. Reid, at Philadelphia, employs a lightning arrester to protect telegraph lines and apparatus from damage by lightning.
 (174) The Philadelphia-Pittsburg telegraph line opened. The second wire was added to this route in 1851.
 (175) Charles West granted permission by the British government to establish telegraphic communication between Dover, England, and Calais, France.
- 1847 (176) The Montreal Telegraph Company organized with a capital of \$60,000.
 (177) Ezra Cornell builds a telegraph line from Troy, N. Y., to Montreal, Canada.
 (178) A gutta-percha manufactory is established in Brooklyn, N. Y., by Samuel T. Thompson.
 (179) The American Association for the Advancement of Science, organized. The predecessor of this Association was the Association of American Geologists and Naturalists, which held its first meeting in the year 1840.
- 1848 (180) Zooke and Barnes, of Mississippi, bring out the "Columbian" (printing) telegraph instrument, employing the Hughes relay.
 (181) House's printing telegraph patent granted in the United States.
 (182) The Maine Telegraph Company constructs a line from Portland, Maine, to Calais, Maine, 306 miles.
- 1849 (183) An experimental gutta-percha cable is laid (January 10) two miles undersea in English waters.
 (184) A "House" telegraph line is constructed between New York and Boston and between New York and Philadelphia.
 (185) Walker employs a carbon electrode in a primary battery.
 (186) Alexander Bain, of Scotland, is refused an American patent covering his chemical recording telegraph system. The Patent Commissioner's decision later is reversed by the Supreme Court, and patent allowed. A Bain line is opened between New York and Boston in October, this year. Morse interests bring suit against the Bain company, and after keeping the case in court three years, the two companies consolidate under the name of the Union Lines, between New York and Boston.
 (187) During the winter the middle and gulf states, Kentucky and Tennessee, were without telegraph communication during a period of four weeks owing to sleet storms destroying lines.
 (188) Telegrams exchanged over a combination aerial and submarine line between London and Folkestone, England.

(To be continued)

SOLID MOLDED RESISTORS

FOR MOTOR CAR RADIO



FOR CONSOLE RADIO

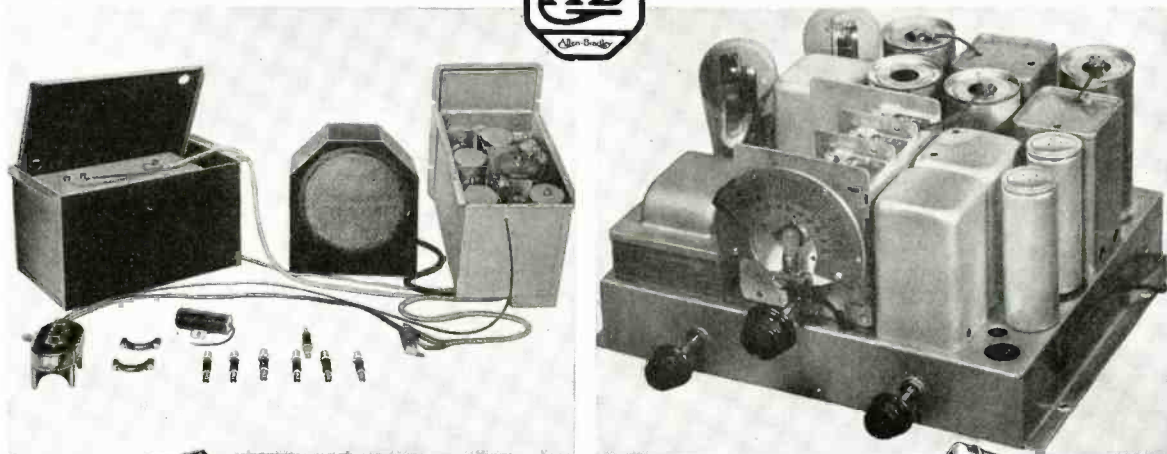

Do Your Sets go "Sour" in Service due to poor Resistors?

The satisfactory operation of your receivers depends to a great extent upon the accuracy of your fixed resistors. Bradleyunit Resistors are used by the world's largest radio manufacturers, because their resistance value is stable under varying conditions of load, temperature, and moisture. They are not subject to wide fluctuation due to long use. Don't risk the reputation of your receiver with poor resistors. Get an Allen-Bradley quotation on your next order.

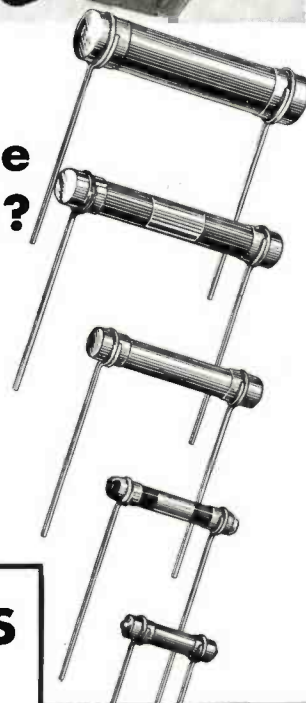

Interference from ignition systems in radio-equipped motor cars is suppressed with Bradley Suppressors. When used with suitable by-pass condensers in ignition circuit, shielded ignition cables are unnecessary.



Type A, Single Bradleyometer

BRADLEYOMETERS

The Bradleyometer is a potentiometer with approximately fifty solid resistance discs interleaved between metal discs.

The total number of discs can be arranged in accordance with any resistance-rotation curve.

One or more Bradleyometers can be arranged to operate with one knob. Mixer controls, T-pad and H-pad attenuators and other complex controls can be provided.



Type AA, Double Bradleyometer



Type AAA, Triple Bradleyometer

Bradleyunit Resistors are made in five sizes, with or without leads, and are color coded to meet set manufacturers' specifications. These solid molded resistors are accurately calibrated and have great mechanical strength.

Allen-Bradley Co., 126 W. Greenfield Ave., Milwaukee, Wisconsin

ALLEN-BRADLEY RESISTORS

Produced by the makers of Allen-Bradley Control Apparatus

RADIO ENGINEERING

Production, Administration, Engineering, Servicing

APRIL, 1932

Circuits to obtain detection and delayed AVC

By J. R. NELSON*

THE normal diode detector, a triode with the plate tied to either the cathode or grid when used also to obtain a d-c. voltage for AVC action is not altogether satisfactory for such use. This is because the voltage built up across the detector grid leak and condenser as soon as any signal is applied reduces the receiver sensitivity so that a signal which would give ample output without AVC in many cases does not give sufficient output with the diode AVC system. Also the AVC volt-

should increase rapidly to prevent the detector input voltage from rising beyond a predetermined value.

An Additional Tube

The ideal characteristics described above may be approximately obtained by the use of a separate tube in well known connections. The same features may also be obtained by the use of a triode connected as a combined detector and AVC tube. A circuit for obtaining delayed AVC was described by Farnham of the Radio Frequency Laboratories at the 1931 fall convention of the I. R. E. The schematic diagram of the proposed circuit is shown in Fig. 1. The voltage E_2 is the voltage causing delayed AVC action. The a-c. input voltage has to exceed the voltage E_2 before any AVC voltage starts to build up. The voltage E_1 delays the start of detection and also causes some noise suppression. It also causes intolerable distortion with weak signals. It will be beyond the scope of this article to consider the effect of making E_1 any value other than zero. The particular form of circuit described by Farnham has a very serious defect from a tube standpoint, that is, the cathode is at high a-c. potential so that some difficulty may be found with tubes having considerable heater-cathode leakage. This article will give a method of determining the necessary data to predict the performance of such a circuit with the elements rearranged so as to be better from a tube standpoint.

The two alternative circuits proposed by the writer are shown in Fig. 2, A and B. Both of these circuits operate with the cathode at zero a-c. potential. The circuit of Fig. 2A is for the case where it is necessary to ground the

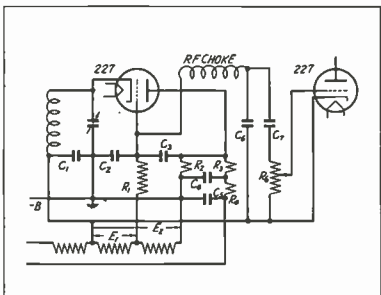

Fig. 1. Radio Frequency Laboratories circuit for detection and AVC.

age is proportional to the signal strength in the case of a diode detector. This feature is undesirable because the AVC voltage in an ideal system should be zero until a certain signal strength is reached after which the AVC voltage

* Raytheon Production Corp.

Proposed circuit arrangements for obtaining better AVC action than with a single diode.

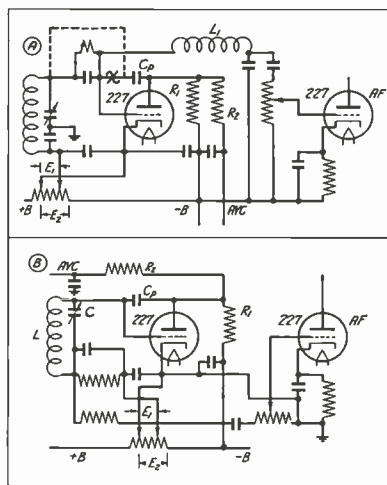

Fig. 2. Proposed circuits to obtain detection and delayed AVC.

tuning condenser as in a tuned r-f. receiver. If desired, the connection to C_2 may be broken at X and connected as shown by the dotted line. The circuit of Fig. 2B may be used where it is not necessary to ground the input condenser C. If possible, it is better to use the latter connection as it is necessary to shunt the input circuit in Fig. 2A.

An experimental study of tube characteristics was made before trying out the various proposed circuits. The setup shown in Fig. 4 was used. The Ig-Eg characteristics were taken first on an ER-227 tube by tying the plate to the grid and reading the combined plate and grid currents when the voltage E_c was varied for different values of a-c. input voltages as shown in Fig. 3. The Ig-Eg characteristics were next meas-

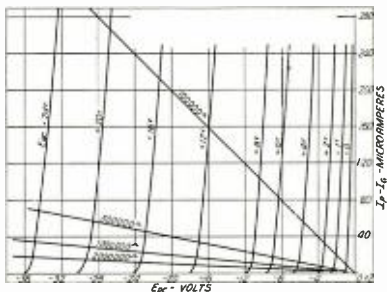

Fig. 3. ER-227 Ig-Eg static characteristics taken with various a-c. voltages connected as shown in Fig. 4, except plate tied to grid.

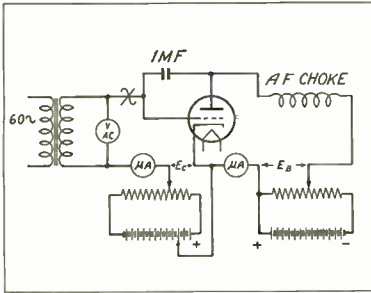

Fig. 4. Diagram of experimental setup to determine I_g - E_g and I_p - E_g characteristics with various a-c. input voltages.

ured with various a-c. input voltages using the connections shown in Fig. 4. The results are shown in Fig. 5 for the voltage E_b equal to -22.5 volts. Care was taken to avoid any resonant effects in the a-f. choke and 1 mfd. condenser.

A 0.5 megohm resistor by-passed with a 1 mfd. condenser was next inserted at X in Fig. 4. The I_p - E_p curves for various grid input voltages are shown in Fig. 6. The rectified voltage curve as calculated from the data of Fig. 6 is shown by Fig. 7C. The rectified voltage was calculated by dropping the intersection of the 500,000 ohm load line and the various curves to the voltage axis and subtracting 22.5 volts, the fixed bias, from the value found. The rectification curve calculated by drawing a 500,000 ohm load line from 22.5 volts, Fig. 5 is shown by Fig. 7B. The agreement is close enough so that diagrams similar to Fig. 5 may be used to calculate the AVC voltage available. The data calculated from a curve similar to Fig. 5 using E_b equal to -4.5 volts is shown by curve D of Fig. 7. Curve A, Fig. 7, gives the rectification curve plotted in the grid circuit for the same value of resistance.

The curves in Fig. 7 show up the action of the AVC. For example, curve A is almost linear and starts as soon as the signal is applied. Curve D is delayed and does not start until the peak

value of the signal is 4.5 volts, after which it is also linear but has a steeper slope than A so that the two curves intersect when the input voltage has a value of 19.0 volts r.m.s. Curves B and C also have a steeper slope than D and will intersect it at some voltage. Beyond the point of intersection the voltage built up across the plate becomes greater than the value found in the grid circuit with no delay as shown by curves A and B in Fig. 7.

It is of considerable interest to examine the subject somewhat closer in order to find the reasons for the theoretical results thus far obtained. In either Fig. 2, A or B, consider the voltage E_1 zero and values of resistance R_1 and R_2 in parallel large compared with the impedance of C_p . The drop across the resistor and condenser in parallel in the grid circuit is small so that most of the a-c. voltage is applied between the plate and cathode or between the grid and cathode as the drop across C_p is small

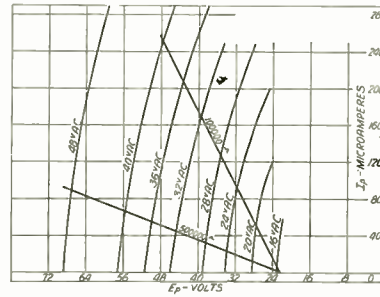

Fig. 6. ER-227 I_p - E_p curves with various a-c. voltages on grid using .5 meg. and 1.0 mfd. by-pass in grid circuit.

unless plate current flows. Plate current does not flow until the d-c. voltage between plate and cathode exceeds the voltage E_b . When this occurs a pulsating current flows through the network of R_1 and R_2 and the condenser connecting them and this network holds the

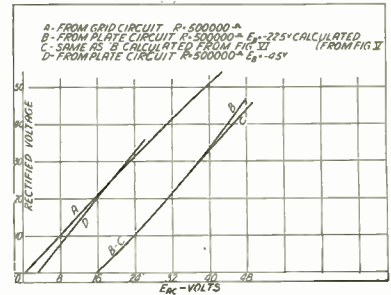

Fig. 7. Calculated rectification curves or voltage available for AVC using an ER-227 tube.

charge during any r-f. cycle, thus furnishing the AVC voltage. The energy to cause this current to flow must come from the condenser C_p and hence from the input circuit.

Grid Action

So far this action is exactly the same as if separate diode tubes were used. The action of the grid cannot be ignored, however, when a single triode is used. Assume that an unmodulated carrier is impressed in the input. When no plate current flows the grid and plate voltages are in phase so that the positive grid causes more plate current to flow than if the plate alone were positive. The phase shifts somewhat when plate current starts to flow, but the grid still has an appreciable effect. The above reasoning explains why curve D, Fig. 7, has a greater slope than A. If two separate diodes were used, curve D would not have a greater slope than A. For the above reasons the use of the term duo diode that Farnham has suggested is questioned by the writer, as it does not sufficiently distinguish the action described above from that of two separate diodes.

To sum up, the circuits proposed give better AVC action than a single diode, as shown by the data presented and as has been verified under actual operating conditions. The term duo diode does not quite describe the circuit operation, as basically, in the proposed circuits, the tube operates as a triode with a negative plate voltage and means for making the plate positive under certain conditions, namely, with signal voltages above a certain level. The soundness of the proposed method of obtaining AVC action is apparent and this method is likely to come into general use as the quality obtained by means of diode detection is good provided that the correct values of R and C are used in the input circuit. It suffers one defect, however, and that is that another tube must be used to amplify the generated audio-frequency output so as to obtain the same sensitivity with the diode as with a triode grid circuit detector.

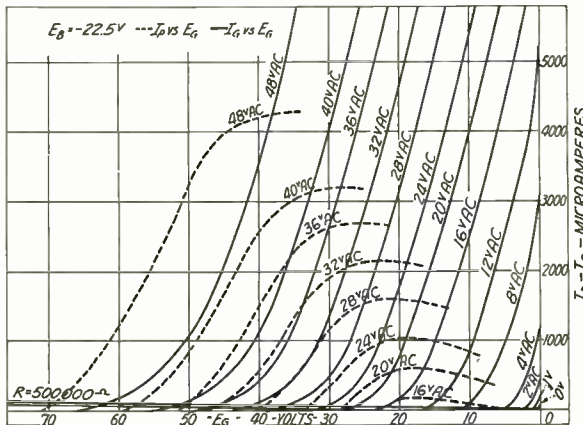

Fig. 5. ER-227 static characteristics taken with various a-c. voltages connected as shown in Fig. 4.

Ionization in vacuum tubes

By RINALDO DE COLA

THE measurement of gas content within a radio tube is generally not necessarily a matter of determining the absolute amount within the envelope, but rather to determine the amount of gas which becomes ionized within the envelope during the normal performance of the tube. The most common method among tube manufacturers to measure gas content, is to read the value of grid current with all applied voltages upon the tube, normal.

As shown in Fig. 1-A, this method uses a sensitive microammeter in the control-grid circuit, which, operating at a negative potential, will attract a con-

may be slightly below the average value but still within the manufacturer's limits. Such a tube, when allowed to operate over a period of time, will, due to the action of the getter, begin to clean up, with the result that a gas pressure low enough is obtained to result in considerable ionization, which is generally quite visible even to the eye.

Screen-Grid Tubes

In the measurement of the gas content within screen-grid tubes and with normal voltages applied to all the tube elements, and a microammeter connected in the grid circuit to measure the gas, numerous tubes can be found which show no deflection whatever on the grid-meter, but the tube shows a visible glow indicating ionization. This blue glow is generally concentrated only between the inner portion of the screen and the plate. Positive ions formed by such collisions are then attracted to the screen-grid, which is at a negative potential with respect to the plate.

Mean Free Path and Ionizing Potentials

The mean free path of an electron is the average distance it travels between successive collisions with gas particles. Because the velocity of an electron in order that it can ionize a gas particle must possess a certain minimum speed, called minimum ionizing potential (electron speeds are generally indicated in volts), it can be seen that if the potential gradient between gas particles is less than the ionizing potential, the electron cannot accelerate sufficiently between collisions to ionize the gas.

This phenomena is called ionization by collision. Of course, the collision of electrons with gas particles does not generally result in the total stopping of the electron; it frequently collides tangentially with gas particles, and although its path is considerably changed, it may not lose an appreciable amount of its speed. Under such conditions it receives more acceleration due to the

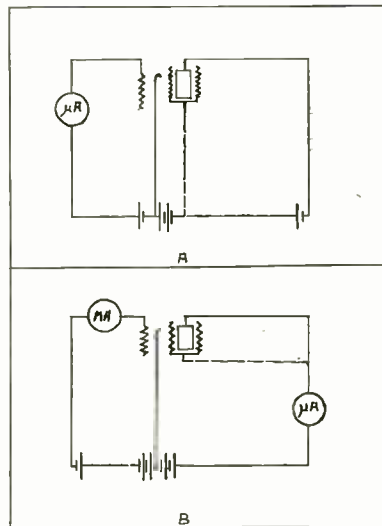

Fig. 1.

positive potential gradient within the tube, and may before it collides again acquire the additional speed necessary for ionization. It can be seen that ionization might only occur at a considerable distance from the source and quite close to its final stopping point. However, if the distance between gas molecules is sufficiently great so that an electron can accelerate to the ionizing velocity before it collides, ionization will result quite close to the electron source.

Fig. 2 shows roughly the potential distribution within a tube. It will be seen that an electron leaving the cathode must travel some distance to the plate before it acquires an appreciable acceleration. Since in most cases the control grid is operated at a negative potential, the acceleration which an electron receives is comparatively small until some time after it has passed through the grid and come under the direct influence of the plate potential. Consequently, ionization can only take place between the grid and plate.

If ionization occurs in a tube at comparatively high pressures this ionization will be almost totally confined to distances very close to the plate. Fig. 2 shows the potential gradient within the tube. It is obvious that the maximum potential gradient is in the immediate vicinity of the plate element. Also the positive ions have a very good chance of combining with other electrons before they reach the control grid, thus becoming a neutral gas particle again. In such cases the amount of recombination may be very nearly equal to the amount of gas particles ionized, and no appreciable reading would be indicated upon the gas meter.

This possibility is rather remote, however. The blue glow seen within tubes is not the process of ionization,

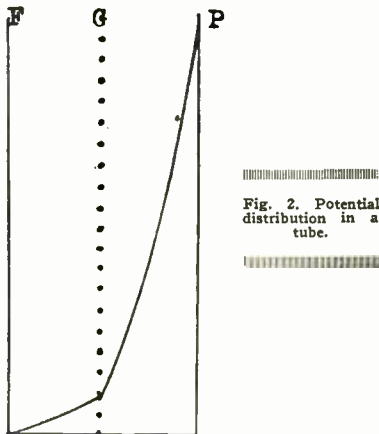

Fig. 2. Potential distribution in a tube.

siderable number of positive gas ions within the immediate vicinity. However, this method is subject to some limitations, particularly when the amount of gas within various tubes may vary through wide limits. For instance, the gas pressure within the tube may be so high that the velocity of the electrons leaving the cathode may not be great enough to ionize the gas particles which it encounters on its way to the plate. In such a case the gas meter would not show any deflection, and the tube would be accepted as normal, although the value of the plate current

A physicist's explanation of the blue glow within tubes, and of the processes of interaction between liberated electrons and ions.

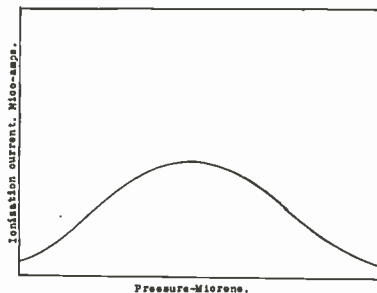

Fig. 3A. Variation in ionization current with pressure for Fig. 1-A.

but the act of recombination of electrons with ions. However, if the gas pressure is reduced somewhat, allowing the electron to accelerate to the ionizing speed before colliding with a gas particle, it can very likely collide again and ionize other gas particles before finally reaching the plate. In such a case ionization will be very intense because of the progressive ionization occasioned by numerous gas particles. The tube under this condition would appear very gassy, due to the practically complete ionization of the gas in the envelope. Further reduction of the gas pressure, will, if carried far enough reduce the number of collisions to a negligible value.

It will be seen therefore that if a curve is plotted for ionization current against the pressure, it would have the form shown in Fig. 3-A. It can be seen that the value of ions formed is not proportional to the pressure, but varies in the complex way discussed above. Obviously then this method of measuring gas has limitations. In a screen-grid tube this method is even more restricted than in a three element device. For if the gas pressure is sufficiently

high, ionization might only occur in the space between the inner portion of the screen-grid and the plate. The ions formed would then return to the screen to ground, and no gas reading would be recorded on the control-grid circuit. This effect has been noticed in a considerable number of tubes. In fact, ionization may be so prolific within this region that it is plainly visible to the eye.

An Alternative Method

A more reliable method of checking tubes for gas content is the one originated by O. E. Buckley. This method is not unknown by any means, but it is very little used. It is shown diagrammatically in Fig. 1-B. The advantages of checking by this method are obvious. Saturation current is drawn from the cathode. This increase in space current is sufficient to practically ionize all gas within the space of the cathode and control-grid. The control-grid potential should be at least 60 volts positive. Due to the small relative distance between the cathode and the control-grid, the electrons are subjected to a very steep potential gradient, and can acquire the proper speed for ionization at comparatively high pressures, much higher than in the previous system discussed.

This method of measuring gas is quite reliable and readings are proportional to the gas pressure up to reasonable limits. Fig. 3-B shows the greater range and the proportionality between ionization current readings and gas pressure. In this method the amount of gas ionized within the envelope is much higher than in the previous method and proper provisions should be made in test limits. The value of plate potential in this gas test should be negative with respect to the filament or cathode, say about ten or twenty volts.

▲ ▲ ▲

Distant-control for radio receivers

A PATENT, No. 1,841,283, has been issued to A. J. Fleig, 327 Broad St., Carlstadt, N. J.; covering the invention of a radio distant control device.

This distant control device consists of a small box showing on its top a dial suitably calibrated in kilocycles or in wavelengths in meters. A hand or pointer can be moved around the dial by means of a thumbscrew mounted on the box. Push-buttons for starting and stopping the radio set have also to be mounted on this box.

The radio set is tuned by setting the hand or pointer to the point of the dial corresponding to the wavelength of the station desired. After pressing the

push-button for starting the set, the radio set will tune itself automatically to the desired station and stay there until stopped or reset.

If it is desired to regulate the volume of the radio set by means of this remote control, another dial suitably calibrated "low," "loud," "medium," etc. should be provided on the box together with another thumbscrew to move a pointer around this dial. This second control can be dispensed with, of course, if the set is permanently held to a suitable volume by means of an automatic volume control.

This remote control can be used in the same fashion as the devices for remote control by means of presetting

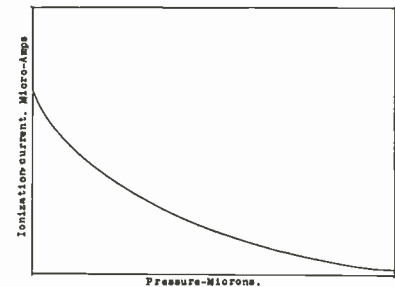

Fig. 3B. Variation in ionization current with pressure for Fig. 1-B.

Ionization Due to Heat

It frequently happens, particularly in cathodic type tubes, which, due to their relatively large mass, and possibility of containing considerable occluded gas, that the heating of this element is sufficient not only to liberate this gas but also to ionize a considerable portion of it. This phenomena has frequently led manufacturers to the belief that this was either leakage over the press or other insulating supports within the tube. With ionization by heat occurring at the cathode, increasing the value of negative grid bias with other potentials kept normal results in an increase in gas reading. This is contrary to the normal action, for even though the increasing negative potentials upon the control-grid represents an additional attraction to ions, less ions are actually formed due to the reduction in space current occasioned by the high grid bias, and the grid current should be less from this effect. However, if ionization is taking place due to the heat in the cathode, then with increasing negative potentials upon this element more ions will be attracted from the cathode and the current will increase.

apparatus used at present. That means this control, connected by a cable containing the necessary wires to the radio set, can be mounted on ash trays, placed on arm rests of easy chairs, etc. Its marked advantage is that it enables the operator to tune in any station desired within the tuning range of the set, not being confined to a certain number of stations.

This advantage is highly important in such cases where it is desired to remove the radio set from the living rooms and install it in an out-of-the-way place more or less inaccessible. In these cases the control box can be mounted on the walls of the rooms where it is desired to receive broadcasting.

A giant tube for radio transmission

By A. DINSDALE

THERE was a time, not so long ago, when the United States led the world in broadcasting on high power, and in the consequent development of high power transmitting tubes. But as a result of the congestion of the American ether, it became urgently necessary to effect some very firm regulation of broadcasting stations, and one result is that the power of our radio stations may not, under existing rules, exceed 50,000 watts.

In Europe, just as much congestion exists in the ether, but since the geographic area is not under one central government, it has not yet been possible to formulate and enforce a uniform set of rules applicable to all the European states. As a result, a battle is raging in the ether. If A will not listen to reason and govern his broadcasting in a sensible manner, so as not to interfere with B, the latter's only recourse is to increase the power of his station so as to swamp A's interference. Then B interferes with A, and we start all over again.

The net result of all this is that powers of 100,000 and 150,000 watts are not at all uncommon, and the tiniest state of all in Europe, Luxembourg, is building a 200,000 watt station which is expected to be used by commercial sponsors to blanket all Europe with their sales talk.

Powers of this order naturally call for transmitting tubes of higher power, and in anticipation of still further demands, England has developed tubes with a power capacity of 500,000 watts. One of these tubes, made by the Marconi-Osram Valve Co., is illustrated herewith. It is said to be the largest hard-pumped tube in the world. As can be seen from the photograph, the design follows somewhat general lines, the upper part being of glass fused on to the metal plate, which is eight inches in diameter and enclosed in a water jacket for cooling purposes. The general data of these tubes are given herewith:

British firm produces a tube of 500,000 watts which is now in service.

Filament voltage	32.5 volts
Filament current	460 amperes
Amplification factor	45
Mutual conductance	50 ma/v
Normal filament emission ..	100 amperes

The tube is designed to meet the following approximate operating conditions

	Telegraphy	
	Normal	Maximum
Ea	18 kv.	20 kv.
Ia	17.5 amp.	25 amp.
Input	315 kw.	500 kw.
Output	250 kw.	375 kw.

	Telephony (R-F. amplifier)	
	Normal	Maximum
Ea	18 kv.	20 kv.
Ia	10 amp.	12 amp.
Input (carrier) ..	180 kw.	240 kw.
Output, do.	60 kw.	85 kw.
Modulation ...	90%	90%

Necessary cooling water, 20 gallons per minute.

One of the greatest obstacles encountered by engineers in the development of these high power tubes is the necessity for sealing the electrodes of the tube in a high vacuum. Thus far it has not been possible to secure and maintain an adequate degree of vacuum unless the enclosing vessel be made in whole or in part of glass or silica, and the difficulties in this connection are too well known to require a detailed description here.

Continuous Exhaust

Some years ago two Frenchmen, MM. Belin and Holweck, developed an experimental tube, made mostly of metal, to which was attached a high-exhaust vacuum pump which operated continuously while the tube was in use. This tube could be taken apart for repairs, put together again, exhausted, and returned to service. This process of continuous evacuation was rendered commercially impracticable by reason of the fact that the mercury vapor used in the pump, due to its vapor pressure, prevented the necessary degree of vacuum from being maintained unless recourse was had to the expensive and unwieldy process of cooling with liquid air.

Now, however, the British firm of Metropolitan-Vickers has produced a 500,000-watt transmitting tube, built and operated in this fashion, which is said to be a commercial success. The

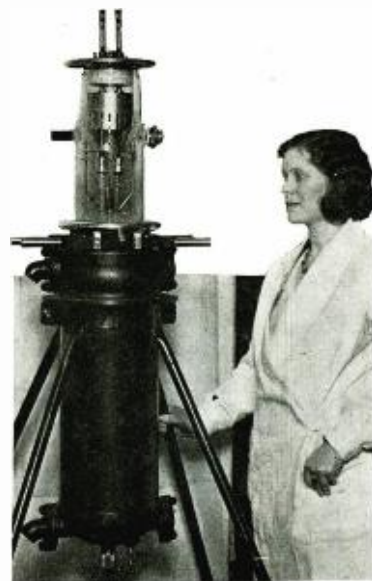

A British new 500 kw. tube.

discovery leading to this achievement was made three years ago and, oddly enough, it was made in the course of experiments in no way connected with radio communication or thermionic tubes, and indeed, not expected to be of any industrial consequence.

Mercury Replaced by Oil

The experiments in question led to the discovery and production of oil distillates having remarkable properties. They could be boiled at a fairly low pressure without decomposition, and yet at room temperature they could be placed inside a radio tube without impairing the vacuum. It was quickly realized that here was the ideal liquid to replace the mercury of the vapor pump since, due to its low volatility, cooling could now be effected with water and the cumbersome and expensive liquid-air process eliminated.

Two years ago a 25,000-watt tube, incorporating the new development, was constructed and put in service at the British post office station at Rugby. It proved so successful that the post office ordered a 500,000-watt tube of similar design. This has now been built and installed at Rugby, and is in regular operation in the high power, long-wave telegraph transmitter.

The physical dimensions of the new tube are imposing. It stands 10 feet high, is 14 inches in diameter, and weighs over 2,000 pounds complete. It is built on a welded-steel bedplate which measures 8 feet long by 3 feet wide. The water-cooled plate, which is made of steel, weighs 350 pounds, and is equipped with hydraulic jacks to

(Concluded on page 28)

Distance ranges

By J. H. DELLINGER*

RADIO wave transmission takes place by the propagation of a "ground wave" along the ground, or a "sky wave" reflected or refracted from the Kennelly-Heaviside layer, or by both means. The waves are subject to absorption, both in the ground and in the ionized upper atmosphere. The ground-wave absorption in general increases with frequency and is reasonably constant with time over a given path at a given frequency; it varies for earth of different conductivities and dielectric constants. The sky-wave absorption is not a constant with time, frequency, or path; it appears to be a maximum in the broadcast band (550-1500 kc.), decreasing with change of frequency in either direction. In the daytime this absorption of the sky wave is so great that there is practically no sky wave, from frequencies somewhat below to somewhat above the broadcast band, the specific limits varying with season. Hence sky-wave propagation in the daytime is only appreciable in the lower and higher frequency ranges. During the night, however, sky-wave propagation takes place on all except extremely high frequencies. Sky-wave propagation is subject to material variations, dependent upon conditions and changes in the ionization of the Kennelly-Heaviside layer. Besides daily variation of daylight and darkness, factors such as latitude, season, magnetic storms, and solar disturbances, have been found to have effects upon this ionization. These changes in ionization result in wide variations in the transmission of sky waves from hour to hour, day to day, and year to year. At the higher frequencies, received field intensities for a given season and frequency may vary as much as 1 to 10 from one year to another.

At the higher frequencies, reception at great distances is due entirely to the sky wave. Above a certain frequency, however, which may be as low as 4000 kc., Figs. 1 and 2, no appreciable por-

tion of the sky-wave radiation is reflected back to earth from the Kennelly-Heaviside layer in a certain zone surrounding the transmitter. In the area bounded by the inner edge of this skipped zone, the received wave may be composed of both ground wave and sky wave (the sky wave being appreciable on frequencies up to about 6000 kc. in the summer and 12,000 kc. in the winter); the sky wave intensity in this area is ordinarily much less at night than in the day. The outer boundary of the skipped zone is often called the skip distance. The skip distance increases with frequency, and varies diurnally and seasonally. Beyond the skip distance, the sky-wave radiation is received with useful intensity.

With present knowledge of propagation conditions, it is impossible to postulate any formulas or make any tables or charts which could be used to de-

termine distance range over any given path accurately. The graphs give average distance ranges as observed by a number of experimenters¹ to occur most frequently over a number of transmission paths. Through certain frequency ranges, available data were so incomplete as to require extrapolation which may be considerably in error. Wide variations of distance range and skip distance must be accepted as normal.

The scales of abscissas and ordinates are cubical, (i.e., numbers shown are proportional to cube of distance along scale, or, distance along scale is proportional to cube root of numbers). This was chosen because it spaces the data satisfactorily. A linear scale would crowd the low values too much and a logarithmic scale would crowd the high

¹ See references listed at end.

* Chief engineer, radio division, Department of Commerce, Washington, D. C.

Approximate distance ranges of radio waves throughout the frequency range

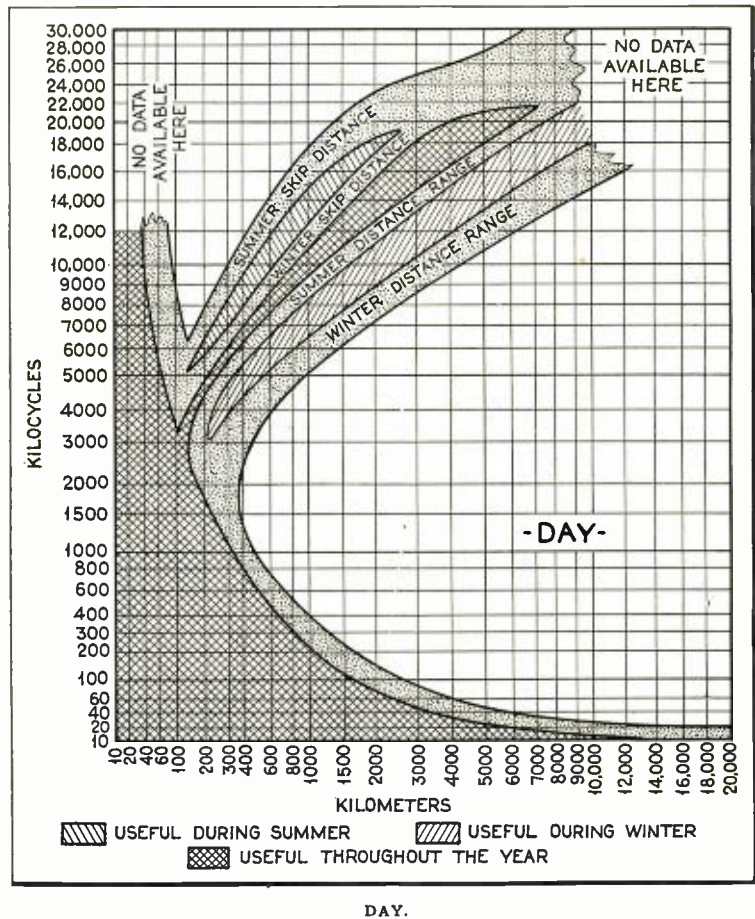

Width of shaded boundaries indicates variations of averages reported by different observers.

of radio waves

values too much.

The graphs show the limits of distance over which practical communication is possible. They are based on the lowest field intensity which permits practical reception in the presence of actual background noise. For the broadcasting frequencies this does not mean satisfactory program reception. The limiting field intensity is taken to be 10 microvolts per meter for frequencies up to 2000 kc., decreasing from this value at 2000 kc. to about 1 microvolt per meter at 20,000 kc. When atmospherics or other sources of interference are great, e.g., in the tropics, much larger received field intensities are required and the distance ranges are less. The graphs assume the use of about 5 kilowatts radiated power, and non-directional antennas. For transmission over a given path, received field intensity is proportional to the square root of radi-

ated power, but there is no simple relation between distance range and either radiated power or received field intensity.

Separate graph sheets are given for day and for night transmission. Above about 3,000 kc. as shown, the distance ranges (and in most cases also the skip distances) are greater in the winter than in the summer. The distance ranges in spring and autumn are intermediate between the limits shown for summer and winter. In general, the distance ranges for paths which lie partly in day and partly in night portions of the globe are intermediate between those shown in the day and the night graphs. For such paths, the distance ranges are greater than would be expected from inspection of the day graph, as the waves under these conditions travel over greater distances in the illuminated portion of the earth's surface; for this reason it is pos-

sible to use a lower frequency for a part day, part night path than is indicated for the day portion of the path on the day graph.

The distance ranges given in the graphs are the distances for reliable reception; they are not the limits of distance at which interference can be caused. A field intensity sufficient to cause troublesome interference may be produced at a much greater distance than the maximum distance of reliable reception.

A FEW REFERENCES ON DISTANCE RANGES

Report on Measurements Made on Signal Strength at Great Distances During 1922 and 1923 by an Expedition Sent to Australia. By H. J. Round, T. L. Eckersley, K. Tremellen and F. C. Lunnon. J.I.E.E., 63, p. 933; October, 1925.

An Investigation of Transmission on the Higher Radio Frequencies. A Hoyt Taylor. Proc. I.R.E., 12, p. 677; 1925.

Transatlantic Radio Telephone Transmission. Lloyd Espenschied, C. N. Anderson, and Austin Bailey. Proc. I.R.E., 14, p. 7; February, 1926.

Relation Between the Height of the Kennelly-Heaviside Layer and High-Frequency Radio Transmission Phenomena. A. H. Taylor. Proc. I.R.E., 14, p. 521, 1926.

Some Measurements of Short-Wave Transmission. R. A. Heising, J. C. Schelleng, and G. C. Southworth. Proc. I.R.E., 14, p. 613; 1926.

Short-Wave Commercial Long Distance Communication. H. E. Hallborg, L. A. Briggs, and C. W. Hansell. Proc. I. R. E., 15, p. 467; June, 1927.

The Diurnal and Seasonal Performance of High Frequency Radio Transmission over Various Long Distance Circuits. M. L. Prescott. Proc. I.R.E., 18, p. 1797; 1930.

Field Strength Measurements of Short-Wave Transmission. T. L. Eckersley. The Marconi Review, May-June, 1931. p. 1.

The Propagation of Short Waves Over the North Atlantic. C. R. Burrows. Proc. I.R.E., 19, p. 1634; 1931.

High Frequency Atmospheric Noise. R. K. Potter. Proc. I.R.E., 17, p. 1731; 1931.

Contribution à l'étude des lois de propagation des ondes Hertzienne dans la gamme de 150 à 1500 kc/s. (Contribution to study of laws of Hertzian wave propagation from 150 to 1500 kilocycles). International Broadcasting Union. Document No. 198 of the 1931 meeting of the C.C.I.R. at Copenhagen.

Some studies of Radio Transmission Over Long Paths, Made on the Byrd Antarctic Expedition. L. V. Berkner. Bureau of Standards Journal of Research, Feb., 1932. Research Paper No. 412.

Radio Field Intensity Measurements at Frequencies from 285 to 5400 Kilocycles per Second. S. S. Kirby and K. A. Norton. Bureau of Standards Journal of Research. In press.

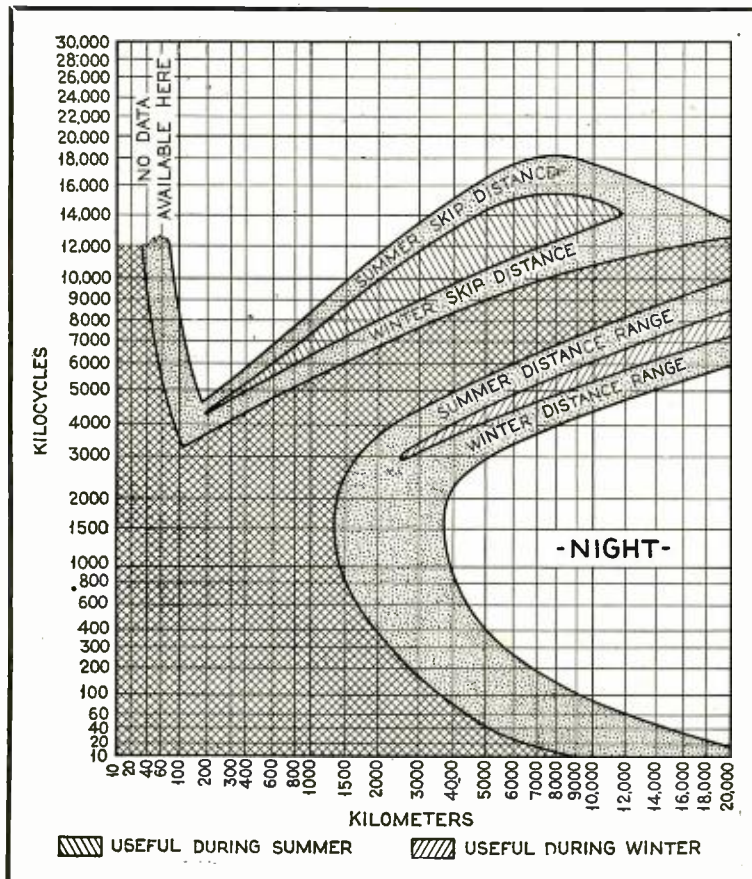

NIGHT.

Width of shaded boundaries indicates variations of averages reported by different observers.

Saving instrument losses by proper fuse protection

By E. V. SUNDT*

It may seem unreasonable that a 1 milliamper meter can be protected by a 1/32 ampere fuse. None the less the protection is real. Meters are not usually burned out by two or three times their rated current—that merely puts them off scale. Burnouts come when the meter is in some way overloaded so badly that one cannot get the circuit open in time when the needle makes a lightning leap to the right. Under these conditions the current is not two or three times normal, but far more. In these cases a properly designed fuse is real protection because its action is much faster than the meter burnout.

To illustrate this action and to get some visible information on it, a number of fuses, meters, and tubes were "blown" by being connected directly across a 110 volt d-c. generator line. An oscillograph record was taken in each case and some of these are shown herewith. In these oscillograms which are presented by courtesy of Dr. L. I. Bockstator, Physics Department, Northwestern University, the lower base line may be ignored. The zig-zag center line is a 1,000 cycle timing wave and each zig-zag represents 1/1000 of a second. The upper line shows the current through the device being "blown." As long as the line is straight there is no current. At the point "ON" the circuit has been closed; the current rises rapidly, and the burnout is completed at "END," and the line drops back to zero. By counting the number of timing waves between "ON" and "END" the burnout time in thousandths of a second is found.

As will be seen, the blowing-time of the 1/32 ampere fuse was rather less

*Manager, Littelfuse Laboratories, 1772 Wilson Ave., Chicago, Ill.



Fig. 3. 199 filament, .038 second. Can be protected by 1/4 amp. fuse, as can the T. G. above.

than .001 second while that of the 1 milliamper meter was .173 second, or 173 times as long. The oscillograph drum made almost a complete revolution. Thus the fuse was "quicker than a short-circuit."

110 Volt Burnout Speeds

Filament of 199 tube (.0006 inch tungsten in vacuum)—.038 second.
 115 mil. full scale thermo-galvanometer—.0035 second.
 0-1 mil. d-c. milliammeter—.173 second.
 1 amp. No. 1008 fuse—.013 second.
 1/4 amp. No. 1005 fuse—.003 second.
 1/32 amp. No. 1002 fuse—.001 second.
 1/100 amp. No. 1001 fuse. Too fast to record at all with this sensitivity of oscillograph.

It will be seen that under the conditions of test (and in most practical cases as well) the thermo-galvanometer and 199 tube filament would be saved by a 1/8 ampere fuse, the 0-1 milliammeter by the 1/32 ampere fuse.

The Need for Quick Acting Fuses

Some time ago a market survey of this and foreign countries revealed that nothing then existing was quick enough to protect such equipment as a 0-1 milliammeter, or the filament of a '99 tube. The desired device must evidently be accurate, more delicate electrically than anything else, very fast, and yet inexpensive and physically rugged. The cost is important. Something good and expensive is a mediocre achievement; something good and inexpensive is good engineering.

About this time the writer met Mr. Bernard Kollath, a mechanic and production-equipment designer, formerly a model maker for the "electrical wizard" Steinmetz. We tried every kind of wire and alloy available in sizes down to 10/1,000,000 of an inch (Walleston wire core), and metal foil as thin as .000,004 in. Nothing of reasonable cost acted as quickly as a thin wire, burned asunder by the current it carried. The secret of quick action lay, as



Fig. 1. 1 milliamper d-c. meter on 110 volts. d-c. burnout time .173 second. Time of needle-throw about .003 second.

expected, in keeping the diameter of the wire as small as possible. A year later we felt that we had a product which filled the bill.

The standard fuse for the purposes in view is glass enclosed, measures 1 inch by 1/4 inch and is made in ratings of 1/100, 1/32, 1/16, 1/8, 1/4, 3/8, 1/2, 1 and 2 amperes. In addition there are small-current high-voltage types for 1,000, 5,000 and 10,000 volt use. In these, the fuse element is made in small sections so that they will open separately, as it is easier to suppress several small arcs

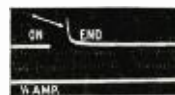

Fig. 5. 110 volt burnout 1/4 amp. fuse in .003 second.

than one large one. Arc suppression is further aided by threading the fuse filament through baffles inside the fibre casing. The principal applications for these fuses are in radio transmitters, high-voltage rectifiers, high-voltage generators, amplifier and filter systems. The very large short-circuit currents possible with the mercury-containing rectifier tubes makes fuse protection almost imperative.

Rating

These fuses are rated at their approximate blowing point. Since the ultimate blowing point varies with the rate at which the current is raised, a 10-second interval to the rated current is used in the values given. The time lag which might be quite an advantage in a 10-ampere fuse would usually be disastrous in instrument protection.

Voltage

All the instrument fuses may be used on 250 volts d-c. or a-c. The smaller sizes have been used without arcing up to 1,500 volts d-c. on a 2 kw. supply. Resistance in the line reduces the tendency to arc. The tendency to arc drops rapidly with the speed that the fuse blows and as the current values are diminished.

Resistance

The maximum resistance variation is about 20%. If very close limits are required they can be furnished at a slight additional charge.

(Concluded on page 37)



Fig. 6. 110 volt burnout of 1 amp. fuse in .013 second.

Automatic suppression of intercarrier noise in radio receivers

By PAUL O. FARNHAM*

THIS paper discusses the problem of suppressing the undesirable noise output in sensitive receivers employing automatic gain control, and some of the general methods for its solution are outlined. Particular methods for eliminating the intercarrier noise are described, in which a separate tube controls the gain of the receiving system beyond the point at which the normal automatic gain control circuit receives its input.

In view of the superiority of the diode over most types of rectifier from the standpoint of harmonic distortion particular attention is devoted to gain control systems in which one diode serves as a demodulator furnishing audio output while another operates as a rectifier with delayed action to furnish a control bias. Experimental data is included to show how closely the performance of an actual receiver embodying the noise suppression principle approaches the conditions set up as ideal.

In high-gain receivers using automatic gain control the noise output is undesirably high when the receiver is tuned off a carrier signal. A large part of this noise is "fluctuation" noise coming directly from the tubes and circuits at the beginning of the amplifying system and may give rise to peak voltages at the audio detector of the order of four or five volts. In addition to receiver noise there is an often greater component due to interference outside the receiver such as electrical disturbances on power lines.

Curve A of Fig. 1 illustrates the

*Radio Frequency Laboratories, Inc.

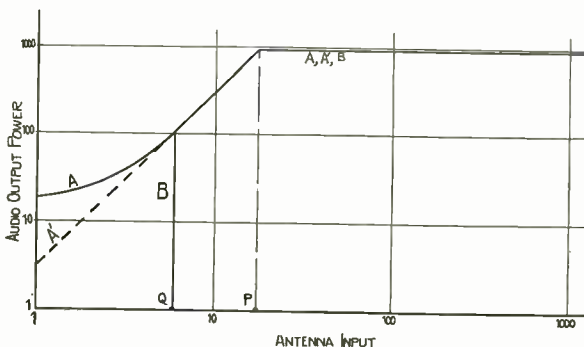

usual output-input characteristics of a sensitive receiver with automatic gain control. For antenna inputs below the level P, at which normal automatic control begins, the audio voltage output is related to the input by a first or second power law, depending upon the law of the detector. At very weak inputs the total audio output drops off much less rapidly, most of this output being furnished by the fluctuation noise within

Fig. 2. Functional diagram of receiving system with automatic controls oppositely directed.

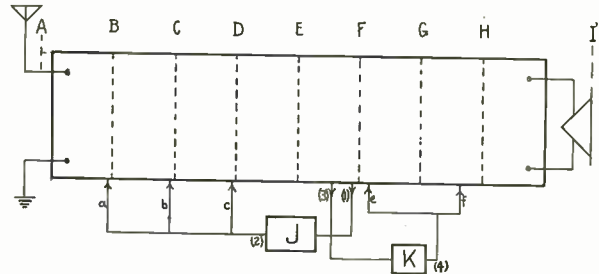

the receiver. Curve A' represents the signal output if all noise sources could be eliminated, the difference between the ordinates of A and A' becoming insignificant for the larger inputs. Since this fluctuation noise is always present in receiver circuits we might arrange the receiving system to have a characteristic like that shown by curve B. In this case for antenna inputs less than Q the output drops abruptly to inaudibility, point Q being taken as that input for which the noise output becomes insignificant in comparison with the desired signal output.

Referring to the functional diagram

of Fig. 2, we may point out some general methods used for suppressing this undesirable noise from the receiver output.

The complete receiving system from antenna to electrophone is included in the transmission system between A and I together with the appended units J and K. The units A-B, B-C, etc., represent stages of amplification and frequency changers such as the first detector in superheterodynes or the audio detector in all receivers, followed by a stage or more of audio amplification. We shall assume that unit J is the automatic bias-developing agency taking its input from the system at (1) and furnishing a control upon the carrier-frequency gain of the system preceding its input through the channels (a), (b), and (c). Since the input to J is in the form of a modulated carrier frequency voltage and since the output of J is usually in the form of a d-c. bias suitable for application to the vacuum tubes

of the preceding amplifier stages, it is apparent that J involves the process of rectification, though it may, in addition, include amplification preceding or following the rectification.

Suppose a second bias-developing agency K is connected to the amplifier at some point (3) which may be at a voltage level corresponding to that at (1). The actual point of connection (3) may be before, at, or after (1). We shall use the output of K at (4) through one or more channels, e, f, to control the transmission of the system after point (1) in such fashion that for voltage levels E_1 at (1) less than a certain critical value, unit K will not allow transmission through the remainder of the system to the audio output at I. It appears most convenient to make the output or the action of K affect the system after point (1). We may now consider in detail the characteristics of K suitable for satisfactory operation.

If the voltage level at (3), E_3 , required to make K permit transmission beyond (1) is only attained after unit J has begun to operate, the action of K will in general be sluggish referred to increasing antenna input levels, in which case there would exist a fairly wide range of signal input level over

Fig. 1. Hypothetical output-input relations for a receiver with automatic gain control and noise suppression. A. Normal automatic control action. A'. Normal automatic control action with noise sources eliminated. B. Automatic control plus noise suppression.

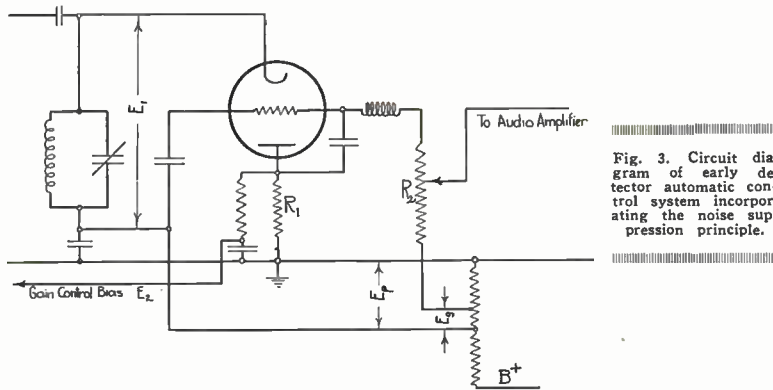

Fig. 3. Circuit diagram of early detector automatic control system incorporating the noise suppression principle.

which K would neither cut off nor pass properly the transmission beyond (1). It would therefore seem best to insure complete operation of K before the normal automatic gain control on the high-frequency amplifier begins. We shall now pass to specific illustrations of circuits based on these principles.

Fig. 3 illustrates a type of audio detector and automatic control arrangement including noise suppression which has been incorporated in one make of commercial receiver on the market for over a year. Two diode rectifiers in the same envelope and having a common cathode are connected across the tuned input circuit and supplied with a carrier input voltage E_1 corresponding to the voltage level at point (1) in Fig. 1. A vacuum tube suitable for this purpose is a typical triode Type 227. One rectifier circuit includes the bias-developing resistor R_1 in conjunction with the plate and cathode of the tube and is used to furnish automatic control bias to preceding amplifier stages. The elements just mentioned including the delay bias E_p constitute the unit J of Fig. 1 operating on an input E_1 and delivering a bias E_g for control. The other rectifier circuit comprising the resistor R_2 in conjunction with the grid and cathode of the tube is used as a detector. These last-named elements together with the small delay bias E_g constitute at the same time the unit K of Fig. 1 operating on an input E_1 , point (3) is at point (1), and arranged to render the system from point (1) to the audio output I insensitive to carrier levels below a peak value corresponding to E_g . Since E_g is preferably smaller than E_p , the action of the device is such that for increasing antenna inputs the elements constituting K in Fig. 3 are at first acting to cut off transmission beyond point (1) and then, at a peak value of E_1 corresponding to E_g , are acting to restore the transmission beyond point (1) to the audio output. At still higher values of antenna input corresponding to $E_1 = E_p$, the normal automatic gain control action through R_1 begins.

It will be apparent that unit K of Fig. 2 need not itself form a transmission path for the signal beyond E_1 , but may be simply a bias-developing agency such as a rectifier or a rectifier and amplifier, serving to control transmission beyond (1). Such a system was put into operation in connection with a special fixed-frequency receiver operating under adverse noise conditions. In this case the rectifier-amplifier stage K received its input from a point in unit J, and delivered its output to the audio system beginning at (1) so as to automatically vary the bias E_g of Fig. 3.

Another development in the direction of satisfactory noise-suppression arrangements consisted in the use of three diode rectifiers in a common envelope in parallel at point (1) in the system of Fig. 2. Fig. 4 illustrates features in its operation that are to be identified with the functional diagram in Fig. 2. The cathode, C, of tube T_1 , the outer electrode P, and resistor R_1 form one rectifier which together with a steady delay bias, E_p , constitutes unit J of Fig. 2. The input E_1 to unit J, point (1) in Fig. 2, is also the input to a second rectifier circuit employing C, G_2 , and R_2 . This second rectifier circuit together with its delay bias E_{g2} and d-c. amplifier tube T_2 constitutes unit K of Fig. 2. The rectifier elements C, G_1 , and R_2 serve as a detector.

The output of K is the d-c. bias de-

veloped across the independent output circuit resistors R_4 and R_5 . The output across R_4 is adjusted so that for peak carrier levels at E_1 less than E_{g2} a large delay bias is inserted in the third diode detector circuit of tube T_1 in series with R_3 . The transmission system after point (1), E_1 of Fig. 4, and leading to the audio output through diode element G_1 , choke L_1 , and resistor R_3 is thus rendered inoperative for the peak carrier levels less than E_{g2} . For values of E_1 greater than E_{g2} but less than E_p , the output across R_4 changes so as to remove the bias in series with R_3 , thus allowing the transmission system beyond E_1 and up to C_1 to regain its normal operation before the automatic gain control bias in R_1 begins. At the same time it will be noted that the elements of Fig. 4 constituting the unit K provide an additional output channel from resistor R_5 which leads to a control of bias in the grid circuit of the audio amplifier tube T_3 . Thus for weak carrier levels at E_1 less than E_{g2} the main transmission system beyond C_1 is also made inoperative and for values of E_1 in the range between E_{g2} and E_p , normal transmission beyond C_1 in the main system is restored. Adjustment of the arm S along the resistor between ground and the positive d-c. potential at point Y makes possible a selection of the carrier level at the antenna, below which no receiver output is obtained.

From the earlier remarks on the general requirements for satisfactory noise-suppression characteristics and reference to Fig. 2 it will be apparent that the input to tube T_2 may take the form of carrier frequency voltage, tube T_2 of Fig. 4 acting as a rectifier with a critical bias, in which case the d-c. output of T_2 should be obtained in an opposite sense to that shown if plate-circuit rectification is used. It is likewise apparent that the output of unit K may be made to act at any point or points in the main transmission system after (1), but that it is preferable to control the transmission beyond (1) at points where the voltage levels are as small as possible.

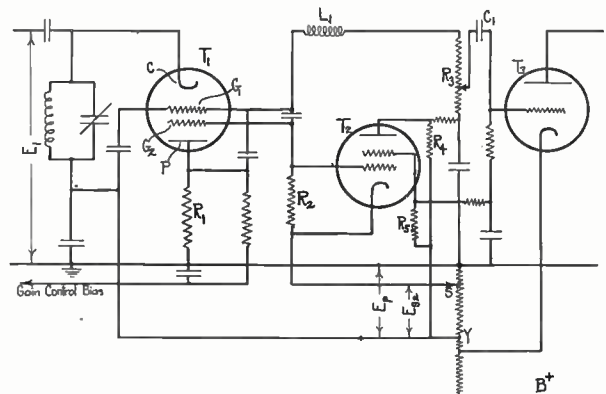

Fig. 4. Circuit diagram of detector-automatic control system using a relay tube to effect noise suppression.

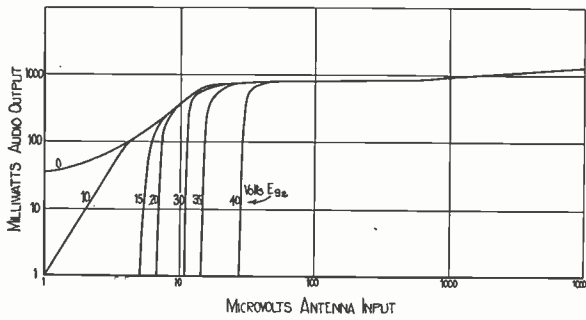

Fig. 5. Measured output-input relations in a high-gain receiver with the control system of Fig. 4. ($m = 10\%$. E_{22} varied.)

It is believed that a plot of receiver output power against antenna carrier input level for various settings of noise suppression bias should be of interest. Fig. 5 illustrates the operation of a high-gain receiver with normal automatic gain control supplemented by the noise-suppression circuit of Fig. 4 and is to be compared with the hypothetical case shown in Fig. 1. The carrier modulation was set at 10% and the various curves correspond to setting arm S of Fig. 4 at different positions, E_{22} thus varying from zero to a maximum value of 40 volts. With $E_{22} = 0$ considerable noise output is obtained at weak carrier levels, but E_{22} may be adjusted

so that for practically all levels below that required to start the carrier-frequency gain control the receiver output is substantially zero.

It will be apparent from the experiment curve $E_{22} = 0$ of Fig. 5 that the usual automatic gain control action through unit J begins at an input of about 15 microvolts. The curve for $E_{22} = 40$ volts represents a condition in which the transmission beyond E_1 is not fully restored until the automatic control through unit J is well established. The effect of an additional five volts at E_{22} is thus greater going from 35 to 40 volts than in going from 30 to 35 volts because the carrier voltage at

E_1 is not increasing proportionately with the antenna input after unit J comes into operation. In the case of the receiver used for this test a value of $E_{22} = 15$ volts was sufficient to suppress all the output due to fluctuation noise in the absence of a carrier. The suppression of some additional noise due to local electrical disturbances may be accomplished by increasing E_{22} to say 35 volts.

We may summarize the important conditions attending the operation of a receiver including automatic gain control and automatic noise suppression circuits as follows.

Two gain control paths are added to the main transmission system. One of these controls operates automatically upon the gain of the amplifier preceding its input to maintain the voltage level at some point in the transmission system at a substantially fixed value for a wide range of antenna voltage. The other control operates automatically to increase abruptly the gain of the system succeeding its input at a critical value of antenna voltage. These two automatic controls are hence oppositely acting, both as to their direction along the main transmission system and as to the sense of their controlling effects.

STANDBY OPERATORS AT BROADCAST STATIONS

On March 16, the Federal Radio Commission, Washington, D. C., made the following reply to questions propounded by a broadcast station asking for an interpretation of certain rules:

Questions

"We would appreciate an interpretation of the requirements of regulations 179 and 180, pertaining to distress traffic, particularly as to the following:

"a. Whether the listening watch on 500 kc. heretofore maintained at certain broadcasting stations must be continued;

"b. Whether the general call of 'QRT-SOS' transmitted by certain commercial or government stations is intended to apply to broadcasting stations;

"c. Assuming a negative reply to (a) and (b), whether specific notice to a broadcasting station in one manner or another may be expected from a commercial or government station in the mobile service if there should ever be an occasion when the transmission of the broadcasting station may in any way interfere with the reception of distress signals or traffic relating thereto."

Reply

"A listening watch on the distress frequency is no longer required of broadcast stations. If, however, undue interference should be reported on the

distress frequency against a broadcast station, or should it be determined that a broadcast station might cause interference to distress traffic, the Commission would then enforce its Rule No. 180 by requiring such broadcast station to maintain a continuous listening watch on the distress frequency during the hours when it is on the air.

"The general call 'QRT-SOS' transmitted by a commercial or government station is normally intended to clear the medium-frequency band, 375 to 550 kilocycles, of interference which may result from stations that operate on these frequencies to distress traffic on 500 kc. (410 kc. on the Great Lakes). In addition, the call is intended to apply to broadcast and other stations which may hereafter be designated by the Commission to maintain a listening watch on the distress frequency as specified above.

"Should interference from a broadcast or other station be experienced by a commercial or government station which is handling, or may momentarily be expected to handle, distress traffic, under Rules Nos. 179 and 210, such station must immediately cease operation upon receipt of notice directly or indirectly from the station experiencing the interference. Under the provisions of Rules Nos. 180 and 211, stations so notified shall not resume transmission until informed by the station which requested silence that the need for silence no longer exists."

JENKINS LICENSES CANADIAN TELEVISION COMPANY

THE licensing of Canadian Television, Ltd., Montreal, under the patents and patent applications of the Jenkins Television Corporation of Passaic, N. J., is announced by Leslie S. Gordon, president of the latter company. The arrangement placed the present and future patents at the disposal of the Canadian organization, together with the vast development and engineering experience of the Jenkins personnel gained during the past three years of costly and painstaking advancement in the television art. The Canadian organization will pay royalties to the Jenkins Corporation.

"There is much in favor of Canadian Television, Ltd., as the result of this arrangement," commented Mr. Gordon when interviewed in the matter. "Coming into the television field at this late date, after so many companies have spent huge sums of money and no end of time and effort, the new organization is certain to avoid many mistakes and costly efforts, while gaining the full advantage of our latest developments. Meanwhile, we are pleased to see the Jenkins patents recognized, and the present arrangement confirms our belief that our work and our investment of the past will soon bear fruit in the form of royalties from licensees operating under our patents."

A new industrial amplifier tube for phototube circuits

By LEE SUTHERLIN*

THE phototube is fast coming into use for measuring, indicating and relay circuits. There are two main types of phototubes, the gas-filled type and the high vacuum type. Either of these must generally be followed by one or more amplifier tubes in order to be of practical use. The RJ-553 tube recently made available commercially has been used in this type of application, particularly in smoke indicators and light control relays. This tube when properly operated gives exceptionally long average life.

A demand arose for a smaller and less expensive tube for this same general use. In some installations, the size and cost of the RJ-553 tube made it

*Westinghouse Electric & Mfg. Co.

undesirable. As a result of this demand, a new tube, the RJ-550, has been developed. The average life of the RJ-550 tube is very long as compared to the recognized life of radio tubes but not quite as long as the RJ-553 when both are worked at the same output.

The RJ-550 tube was designed primarily as a tube having a very low grid current and at the same time having high mutual conductance and reasonably high plate current. At the test point the maximum allowable grid current is .01 microampere. At this test point the average tube has a mutual conductance of 1650 and an average plate current of 6 milliamperes.

Its characteristics make this tube particularly well adapted as an amplifier of

SR-50 PHOTO TUBE

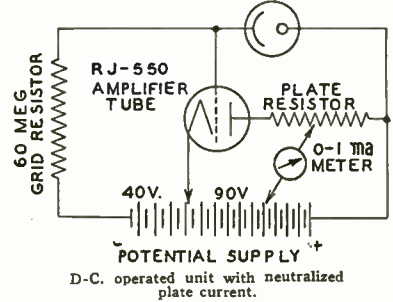

phototube, and other very small currents. The tube is generally used with a relay or meter in its plate circuit. In some cases constants other than those given may be used but these are given in the illustrations as a guide.

Grid resistances or impedances of 10 to 60 megohms are generally used for commercial applications. Values much higher than these may be used for experimental use and certain special applications.

CHARACTERISTICS OF INDUSTRIAL TUBE—TYPE—RJ-550

Main use.....Low grid current amplifier
 Number of electrodes.....3
 Type cathode.....Oxide coated filament
Rating
 Maximum plate voltage, d-c, E_p ...220 volts
 Maximum average current, d-c, I_p ...12 ma.
 Maximum crest voltage, e_p325 volts
 Maximum crest current, i_p20 ma.
 Recommended plate voltage,
 d-c.....45 to 115 volts
 Recommended plate voltage,
 r.m.s.....45 to 115 volts
 Maximum ambient
 temperature.....70°C. (160°F.)
Operating Conditions
 Filament voltage (volts).....2.5
 Plate voltage (volts).....95
 Grid voltage (volts) { —5 d-c filament
 { —6.25 a-c filament
Design (at above operating conditions)
 Average
 Filament current (amps.)......92
 Amplification factor.....8.5
 Plate resistance (ohms).....5150
 Mutual conductance (micromhos)...1650
 Plate current (ma.).....6.0
 Grid current (microamperes)
 maximum......01
Dimensions
 Maximum overall length.....6 inches
 Maximum overall diameter...23/16 inches

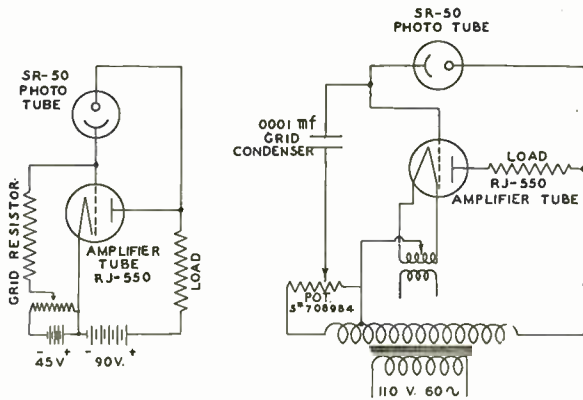

Left: D-C. operated unit.
 Right: A-C. operated unit.

Do you know that—

- ... By proper use of published information much useless research can be saved. Recently a certain manufacturer believed he had a new process, wanted it developed. Examination of published literature showed that it was developed and patented in four countries nearly 25 years ago.
- ... Copper harder than most common steels has been announced. No appreciable weight is added. Electrical conductivity is reduced about 30 per cent. Accurately speaking the product of the new process is a copper alloy.
- ... Photocells are now used to sort almonds by size, reverse ten-ton steel ingots by their own shadows, and inspect collapsible metal tubes for toilet creams to detect air-holes.
- ... Magnesium is now passing through the same stages as did aluminum. In 16 years it has declined from \$5.00 per pound to 30c.
- ... Synthetic rubber has been made on a semi-commercial scale from chlorinated isoprene. It cannot compete with the natural product at the present time.—"Chemical Digest."

Volume controls

By W. S. PARSONS*

IN articles on the performance of a radio set, selectivity and sensitivity are particularly stressed. No mention is made of the performance of the attenuator of such a receiver. We are, of course, interested in the sensitivity, selectivity and fidelity of the radio set, but how does the volume control function? The ultimate owner will use the volume control of his receiver frequently and it must be smooth to control evenly the most powerful or weakest station.

History of Volume Control Development

In the early battery operated sets a rheostat was used to control the heating of the filament, thereby controlling the emission of that element. Later it was found more desirable to have a fixed voltage impressed on the filament, and thus it was necessary to place the volume control in another part of the circuit. Several methods were developed at this time. Those of principal importance were the shunting of the input to the grid of the detector tube or a shunt across the primary of an r-f. transformer.

With the advent of the a-c. heated tubes we find a return to a control of the filament current, particularly in tubes of the '26 type. This practise was not successful and was attempted by only a few manufacturers. Many of the first a-c. sets still clung to the shunt type of control for detector or r-f., while others began using a resistance of a rather high value in series with the plate voltage supply of the r-f. tubes. As the '26 tube was discarded for the '27 type, controls were placed in the antenna circuit and we find the first cathode controls gaining prominence.

The advent of the screen-grid tube, or '24 type, gave engineers another circuit in which to insert a control. Many of the first screen-grid receivers relied upon the variation of the screen po-

*Central Radio Labs.

tential to provide control. This proved to be not entirely satisfactory as the increased sensitivity and gain available through the use of the '24 tube necessitated the control of more than one function of the circuit, for strong local signals. This condition brought about the popularity of twin controls, or the control of two circuits, of which there were many combinations; control of antenna and screen, bias and screen, antenna and audio, screen and audio, and others.

The use of controls in two circuits continued to be popular until the midget radio set was introduced. Several factors at this time caused changes in volume control practise. The small size of the midget receiver and low cost did not permit the use of a bulky or expensive control, and we find many of these sets returning to the single circuit control of antenna and bias. Some manufacturers still used the twin controls despite the cost and size to maintain a high efficiency of control.

In the early part of 1931, the vari-

vide proper attenuation when placed in the grid circuit of the audio tube.

Economics of Current Volume Control Design

The present-day controls have features which offer economies to the manufacturer. These developments have been brought about by the necessities of midget set design. The modern volume control must be reasonably small but still retain all the flexibility of resistance characteristics available in the larger controls. The a-c. power switch must be incorporated, and in this many improvements have been made. It has become a compact enclosed type adding only about 3/8" to the depth of the unit. They are thoroughly dependable and surprisingly free of trouble.

The most outstanding development is what is termed the fixed minimum resistance. To fully explain this term we must first consider a general practise in volume control use. This is the control of volume by varying the relation of the grid to cathode potential. It is

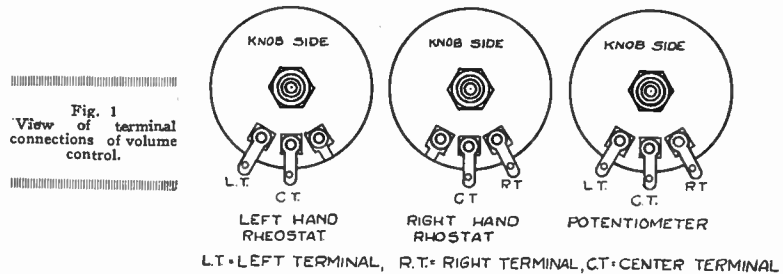

able-mu tubes No. 35 and No. 51 were announced. These tubes solved a good many control problems so far as size and cost were concerned, and after the pentode tube was introduced small sets of high sensitivity were developed. The popular controls of 1931 were single units used as bias controls or a combination of antenna and bias. In the latter part of 1931 the automatic volume control began to make its mark. At first a unit of low resistance and high current carrying capacity was necessary. This control was usually incorporated in the voltage divider system and varied the relation of the grid to cathode potential or the automatic control tube. With the new year we find this all changed and the popular control is one of high resistance from 100,000 ohms to 500,000 ohms, and in some cases as high as 1 megohm. These controls must be properly tapered to pro-

necessary to maintain a minimum bias on the tube and this is accomplished by a fixed resistor between the cathode of the tube and the control. The resistance value of this unit is governed by the number of tubes and the total cathode current flowing through it.

As an example, assume two tubes with the cathode connected together and returned to ground through a 300-ohm resistor and a volume control of 15,000 ohms. Now, if the current from each tube is 5 milliamperes, or a total of 10 ma. when the control is turned to maximum volume, the current through the 300-ohm external resistor produces a drop of 3 volts. or the required minimum bias.

The resistance sector of the new control is constructed to incorporate this fixed resistance value within the control. Thus a suitable control for the application described in the preceding paragraph requires a 300-ohm minimum resistance value provided for in the resistance sector at the right terminal of the control. If the resistance of the unit is measured when the control is turned to the extreme clockwise position or maximum volume point, the value would be 300 ohms. This value can be suc-

A review of the development of volume control systems for radio receivers including design to meet present-day requirements

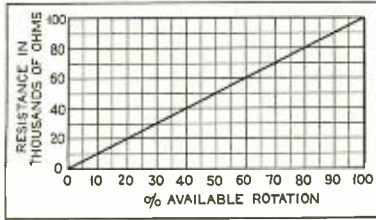

Fig. 2. Taper: Symmetrical Pot. Max. 100,000 ohms. 50% available Rot. 50,000 ohms. Min. L.T. less than 500 ohms; R.T. less than 500 ohms.

cessfully held to ± 10 per cent tolerance and is not restricted to only the right terminal, it being possible to provide a fixed value of resistance at either terminal. It has been noticed, however, that the majority of applications require the fixed value at the maximum volume position similar to the example given. The only requirements for such a value at the extreme anti-clockwise position are in a few automatic control circuits or grid attenuation circuits, such as a calibrated gain control.

From the description given it is possible to realize the resultant saving of such a control in the cost of manufacture.

Importance of Proper Resistance Taper Specifications

The manufacturer of volume controls is a specialist and the many thousand types which come to his attention are given real thought and scientific research. He is in a position to offer solutions to the various control problems due to his wide experience in the successful manufacture of the diversified needs of the radio industry. The volume control manufacturer can often suggest the use of controls which represent a saving not only in the original cost but in inspection and assembly costs. These recommendations result in ultimate long service and customer satisfaction.

During the past season it has been demonstrated conclusively that theoretical volume control specifications have proved extremely unsatisfactory. They are idealistic and when laid out on paper appear to have no loopholes. A specification of this type requires numerous test points along its resistance range thus increasing construction and inspection costs and, after all, defeating the purpose of a volume control which is smooth continuous variation of resistance and not definitely specified steps. Actual experience has proved that where controls of highly theoretical characteristics have been insisted upon, these controls have later become noisy the specification of minimum resistance end of grief to the manufacturer's service department.

Recommendation for Volume Control Specifications

It is an earnest hope that a more intimate idea of the necessary specifications for successful, economic volume control design may be given to those engineers who are interested in increasing the reliability of sets of their design.

Problems deal with variable resistance units, the potentiometer and rheostat. In radio set design it is customary to increase the volume by turning the control knob to the right or in a clockwise manner. Thus, if we face the shaft of the volume control unit, in the case of a potentiometer, we have three connections visible, see Fig. 1., the terminal at the left end of the resistance sector, or left terminal, the terminal for the variable contact, or center terminal, and the terminal at the right end of the resistance sector, or right terminal. In the case of a rheostat, we have either the right or left terminal and the center terminal, depending upon the direction of rota-

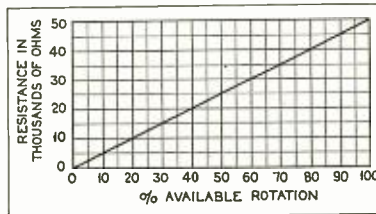

Fig. 3. Taper: L. H. Linear Pot. Max. 50,000 ohms. 50% available Rot. 25,000 ohms. Min. L.T. less than 5 ohms. R.T. less than 500 ohms.

tion in which the resistance is to increase. Therefore, if the resistance is increased by clockwise rotation, it is termed a left hand unit as it increases from the left terminal. Likewise, a resistance which is increased by a counter clockwise rotation is known as a right hand unit. This is true of either a potentiometer or a rheostat.

Now we shall consider the general forms of tapers. First, there is the symmetrical taper. This can only exist in a potentiometer, as the minimum values at both the right and left terminal are identical, see Fig. 2. This type of taper is essentially a potential divider and has no great value in any present day radio circuit. The control whose curve is illustrated by Fig. 2, has a maximum resistance of 100,000 ohms with a minimum resistance value at either terminal of 500 ohms or less. This is what is often called in error a "hop off" value.

We are not interested in providing an absolute zero resistance at either terminal as 500 ohms or less is a small percentage of the total value. This, of course, is in agreement with the fact that we are interested in variation of

the resistance through its midsection. To provide an absolute zero minimum upon such a unit would be an additional and useless expense. Therefore, the specification of minimum resistance value at the terminal is only consistent with use of the minimum value. Notice the typical specification of the unit illustrated by Fig. 2.

The next taper to take into consideration is the "linear" or "straight line taper." This can be applied to either potentiometer or rheostat. In the symmetrical taper we were not particularly interested in the minimum resistance value of either terminal. In the linear or straight line taper we are interested in a specific resistance at one terminal or the other if a potentiometer, and if a rheostat, the minimum value from which the contact is to travel, whether a clockwise or anti-clockwise rotation, or in other words, a left hand or right hand rheostat. Fig. 3 illustrates a 50,000-ohm linear potentiometer. Assume that the left terminal should be particularly low in resistance value, 5 ohms or less, it not being necessary to provide an absolute zero minimum, although this is possible. In a control of this specification the most critical area of control would fall close to the left terminal. Thus we have provided a suitable minimum at that point while at the right terminal which is not particularly critical, a minimum of 500 ohms or less is entirely satisfactory. See Fig. 4. The solid line represents a rheostat similar to the potentiometer in Fig. 3. This unit has a linear increase of resistance with a clockwise rotation of the shaft the same as the potentiometer, the only difference being that as there is no right terminal, we need make no other specification than that of the maximum resistance value. The dotted line of Fig. 4 indicates a rheostat which increases with anti-clockwise rotation. By consulting the figures we have specified the potentiometer Fig. 3, and the rheostat Fig. 4, as LH or RH, left hand or right hand units, thus definitely establishing the direction of rotation. Again, make

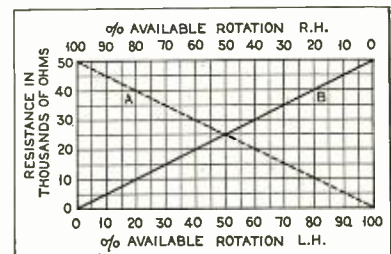

Fig. 4. A. Taper: R.H. rheostat. Max. 50,000 ohms. 50% available Rot. 25,000 ohms. Min. R.T. less than 5 ohms (dotted line). B. Taper: L. H. rheostat. Max. 50,000 ohms. 50% available Rot. 25,000 ohms. Min. L.T. less than 5 ohms. (solid line).

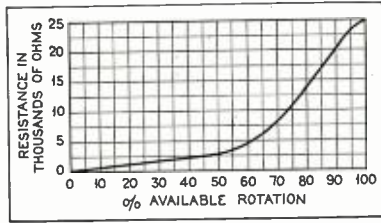

Fig. 5. Taper: L.H. Pot. Max. 25,000 ohms. 50% available Rot. 2,500 ohms. Min. L.T. less than 2 ohms. R.T. less than 50 ohms.

a careful note of the typical specification.

It has been pointed out that the examples given in the preceding paragraphs have no real place in the volume control design of the present day. They have been cited as examples of terminology in volume control design in order to promote a better understanding of the discussion which follows.

Volume controls in use at the present time have been enumerated in this article, and the antenna control is a good example to begin a specific study of correct specification. The type of control of this nature which is most popular is indicated by Fig. 5. This control is of the potentiometer type and was used in large quantities during the year 1929. The antenna coupling coil in this case is of high impedance value and the control has a maximum resistance of 25,000 ohms. The control is connected in circuit so that the left terminal is the antenna end and the right terminal the low end or ground. The ground is connected to the center terminal. In order to produce an absolute cut off of the signal it is necessary to provide a zero resistance at the left terminal, and here we find the term "hop off" used. From Fig. 5 we note the specification of Min. L. T. 0-ohm less than 2 ohm hop. This means that when the resistance is measured from C. T. to L. T. at full counter clockwise position the resistance must be zero. Then the hop-off is represented by the first reading of resistance as the contact is advanced to the right. This is necessary, for if the value were high upon leaving the zero minimum position a strong local station would blast in due to insufficient shunting of the antenna coil. It is also necessary to taper this unit for best results, for if we should not, the most critical portion of the control would fall very close to the left terminal and would be extremely irregular, due to the resistance being concentrated in a small area in the critical portion. Another reason for the taper is to compensate for peculiarity of the human ear and its response to sound. It has been found after an examination of many types of volume control circuits for the antenna that a taper of one-tenth the maximum value

at fifty per cent of the rotation of the unit will give satisfactory results in practically every instance. Thus, in Fig. 5 we see this specification of 2,500 ohms at fifty per cent of the rotation of the contact in a clockwise manner. The overall resistance of an antenna control should be selected so that when connected in circuit and adjusted to its maximum value there will be no attenuation of the r-f. signal.

For the conventional control of the cathode circuit, particularly of the new variable-mu tubes, we find many types of units necessary. This is dependent upon the number of tubes used and the combination of functions controlled. In the first place, we have the control of a single tube and the antenna. This type of control prevents the major portion of its influence upon the antenna. The maximum resistance of this unit should be 15,000 ohms and a taper similar to Fig. 5. Taper L. H. potentiometer; Max. 15,000 ohms; Center or 50 per cent rotation 1,000 ohms to 1,500 ohms; Min. L. T. 0-ohms less than 2-ohm hop off; Min. R. T. less than 20-ohms, and to insure an even control back from maximum value, "Test for smooth variation from R. T." Notice

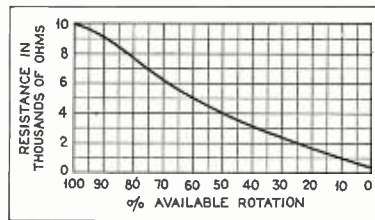

Fig. 6. Taper: R.H. Pot. Max. 10,000 ohms. 50% available Rot. 4,000 ohms. Min. R.T. 200 ohms. fixed. L.T. less than 20 ohms.

that the R. T. specification does not provide for a fixed value to maintain minimum bias on the tube. If an external resistor is used for this purpose, the minimum at the right terminal must be of low value to prevent an increase in the bias and a resultant loss of sensitivity. If we should provide a fixed minimum resistance value in this control for a single 35 tube, the specifications would be thus: min. R. T. 500-ohms \pm 10 per cent.

A similar control instead of varying the cathode of only one tube is connected in the cathode circuit of two tubes and also controls the antenna, see Fig. 6. The specification of a correct taper for this application naturally would have to take into consideration the increase in cathode current over that of the control of a single tube. Thus the major portion of the critical area would be at the cathode end of the unit or R. T. A 10,000 ohm control in this position would be specified as follows: Taper R. H. (for this is the critical

end). Blend from L. T. (for cut off of antenna no definite value of resistance is necessary.) Fifty per cent rotation (counter clockwise) 4,000 ohms; Min. R. T. (suitable for total current to produce minimum 3 volt bias); Min. L. T. (zero if set is highly sensitive and 20 ohms or less if sensitivity is moderate.) From this curve it is easily understood that the cathode control is effective in the first fifty per cent of rotation from the R. T. and from this point on the shunting of the antenna becomes an important factor.

Theoretically we could specify these points at twenty-five per cent rotation and seventy-five per cent rotation and we might even go so far as to specify values for each per cent of rotation, but were we to insist upon such a high degree of specification the curve would result in a series of straight line resistance values between each test point and would result in a series of steps or abrupt changes in resistance value. The introduction of these intermediate values increases the cost of the unit and strange to relate would be far less consistent in production than the simple specifications given.

Occasionally an engineer prefers to accomplish the entire volume control range in the cathode circuit, see Fig. 7. A R. H. rheostat is used in this case and controls from two to four tubes. It has been noticed that the maximum resistance value varies from 10,000 ohms to 100,000 ohms. The average value is 25,000 ohms. The maximum resistance is entirely dependent upon the amount of bleeder current passed through the control at minimum volume position to produce maximum bias upon the tubes. In the case of the 25,000 ohm resistor, a current of 2 ma. would be necessary to provide a 50-volt bias. This is neglecting the cathode current which is very slight at maximum bias.

In order to produce a linear voltage drop in a control of this type it is necessary to compensate for the reduction in cathode current and bleeder current as the control is turned from maximum to minimum volume. Accordingly, the taper becomes slower as the number of tubes controlled is increased. The resistance characteristic for the control

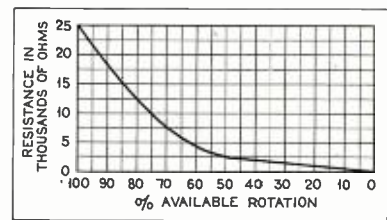

Fig. 7. Taper: R.H. rheostat. Max. 25,000 ohms. Min. R.T. 100 ohms fixed. 50% available Rot. 2,500 ohms.

of three tubes is a R. H. rheostat having a maximum resistance of 25,000 ohms and a resistance at fifty per cent of the rotation of 2,500 ohms. This is an average determined after plotting many voltage increase curves against plate current and bleeder current decrease.

Many problems are involved in the present method of automatic volume control. As we have observed this control is essentially a voltage divider and to produce a linear increase of audio level, theoretically it should have a logarithmic taper in the pure sense of the word. This compound term "logarithmic taper" is often sadly misused. It does not mean just any deviation from a straight line resistance characteristic. A logarithmic taper is entirely dependent upon the minimum resistance selected as a ratio to the maximum resistance for definite total decibel attenuation. This curve drawn upon regular logarithmic scaled paper would appear as a straight line. This type of curve alone can be called logarithmic.

We said that theoretically this control should be a logarithmic taper. Practically this is not the case. After a careful check of several various makes of radio sets using this principle of automatic control it was found that in

the majority of cases the value at fifty per cent of the rotation was ten per cent of the maximum resistance. This gave an excellent control of the audio output of the set. In a very few cases a center value of nine per cent of the total gave good variation of volume level which in others as high as 20 per cent of the total resistance at the fifty per cent rotation point was necessary to provide the correct control.

The deviation from a purely logarithmic taper is easily explained. The ideal automatic volume control should maintain constant level for a large variation of input values. This, however, is not the case in actual practise. In the laboratory it is simple to construct an automatic volume control which produces these ideal conditions, but the production set is an animal of an entirely different breed. Therefore, the control of automatic volume control characteristics is a compromise between the hypothetical and the practical.

It is difficult in this case to make a definite recommendation. However, it was found that the average curve was a L. H. potentiometer, maximum resistance 500,000 ohms; fifty per cent rotation 50,000 ohms; Min. L. T. 10-ohms or less; Min. R. T. 5,000 ohms or less.

Specification of Switches

In the examples given no mention has been made of switch type controls. In order to provide a switch on any of the controls mentioned, fifteen per cent of the rotation of the unit is sacrificed for this function. Thus we actually have 85 per cent of the rotation available for the distribution of the resistance sector. Thus, in specifications of intermediate resistance values between minimum and maximum they are a percentage of the available rotation. The mid-point of a resistance sector should be specified in a switch type control as fifty per cent of the available rotation.

Manufacturing Tolerance

Common practise has dictated that the manufacturing tolerance of any electrical value is ± 10 per cent. It has been found in volume control design that from ± 15 per cent to 20 per cent is acceptable. In fact, ± 20 per cent has been accepted by many of the largest and best known manufacturers in the industry. The acceptance of wider tolerance values does not mean that the manufacturer is obtaining inferior parts. It does mean, however, that he is receiving a more uniform product at a saving in cost.

R. M. A. ENGINEERING DIVISION PERSONNEL

DIRECTOR of Engineering: C. E. Brigham. Chairman of Standards Section: Virgil M. Graham. Chairman of Service Section: E. M. Hartley. Chairman of Safety Section: L. F. Curtis.

The committee chairmen of the Standards Section are: Receivers, A. Crossley; Vacuum tubes, Roger M. Wise; Television, D. E. Replogle; Acoustic devices, Peter L. Jensen; Component parts, D. S. W. Kelly; Cabinets, E. V. Hughes; Interference, Tobe Deutschmann.

A GIANT TUBE FOR RADIO TRANSMISSION

(Concluded from page 17)

facilitate demounting and re-assembly. The filament current is 500 amperes and the filament emission 160 amperes.

No glass is used in the construction of the giant tube, which is a robust combination of steel, porcelain and copper, the most common materials used in the manufacture of electrical equipment. As a result of the continuous evacuation process, and in sharp contrast to tubes of the permanently sealed type, this new tube improves with age, any gas generated during its operation being rapidly removed by the pumps.

Thus, an exceedingly high vacuum is maintained even at the highest power inputs. The pumps, with the exception of a simple type of primary extractor, have no moving parts, and mechanical trouble is therefore a remote possibility. Finally, the tube is completely demountable, so that in the event of filament failure or other breakdown, it may be taken to pieces very rapidly, the repairs executed, with ordinary engineering tools, and the whole reassembled and put back in service in the course of a few hours.

LONG DISTANCE AMATEUR RADIO TELEPHONING

Recently, Wallace Shields, of the Northwest Radio Supply Company, Portland, Oregon, from station W7EK, Portland, Oregon, carried on a two-way radio-telephone conversation with station K6BAL, at Honolulu, Hawaii. It is reported that Mr. Shields used two Speed type 210A tubes in push-pull, with 275 volts on the plate.

POINT-TO-POINT RADIO TELEGRAPHY

R. C. A. Communications, Inc., at the Rocky Point, N. Y., station has been granted a new license for point-to-point working on 7,510 kc., at 40 kw., emis-

sion A1, A2 for facsimile communication band width 5 kc. Also special for transmission of addressed program material intended for rebroadcasting at points beyond the continental limits of the United States communication band width, 10 kc.; to communicate primarily with Monrovia, Capetown, Pernambuco, and secondarily with any other points specifically named in point-to-point telegraph station licenses granted this company; equipment normally transmitter No. 42, and alternately any other transmitter of the same type which is licensed for fixed public service at location authorized.

E. A. TRACEY JOINS CABLE

Eugene Tracey is one of the most widely known figures in the radio industry and comes to Cable Radio Tube Corp., as its chief executive. This consolidation of Mr. Tracey with J. J. Steinharter and J. J. Grossman, establishes a strong trio of seasoned manufacturing and sales executives.

Mr. Tracey was at the head of the Northern Manufacturing Company, makers of Marathon tubes, until that firm was merged with the National Union Radio Corporation in 1929. From that time until he joined Cable he had been executive vice-president of National Union, in charge of sales and advertising.

Recent developments in precision frequency controls

By D. E. REPLOGLE*

THE high quality of broadcasting, increasing the interest of the public has made the importance of satisfactory reception of radio broadcasts increase greatly month to month and year to year.

The work of the Federal Radio Commission has already resulted in clearing up much of the interference on adjacent radio channels and there is still much they are now working on. In order to clear up such interference and in order to put as many stations on the air as possible, there is urgent need for every existing station to operate accurately upon its assigned frequency with the least possible deviation. Any deviation will use space in the ether which is wanted and can be used advantageously by others.

Accurate frequency control is essential in many other fields beside that of broadcasting. The transmitters for service other than broadcasting have increased in number and in importance much faster than new channels have been opened for them. Aviation, fixed point to point telephone, moving vehicles, communication, press transmission, fixed point to point telegraph communication, and the growing need of large corporations with wide flung interests for inter-communication, educational broadcasting, governmental, marine and civil services, all have increasing need for more wavelengths and for great use of the ether.

The space each service requires in the air is determined by the audio fre-

† Presented before the Radio Club of America, February 10, 1932.
* Vice-President, in charge of engineering, De Forest Radio Co.

▲
Description of the engineering of accurate frequency maintenance of radio transmitters.

quency bands to be transmitted and the degree of selectivity that can be obtained in the reception of these wavelengths. The obvious means of inserting more stations in a given ether spectrum is to prevent the use of a wider area in that spectrum by a given transmitter than is necessary. This again calls for precision in the control of the carrier frequency.

Frequency Control Up to Manufacturer

With a given piece of equipment no station could, beyond a certain limit, do much to hold its frequency closer than the original design of the transmitter permitted. Hence, all Federal agencies connected with radio transmission have been following with mounting interest the development of frequency control units. In fact, it is understood that so desirous has the Radio Commission been for greater precision in carrier frequency control in the broadcasting field that as soon as an accurate frequency control at a reasonable cost could be assured, General Order No. 119 was put into effect. It is reasonable to expect that even better control units will be developed with stricter requirements. This is definitely up to the manufacturers of the transmitting equipment, with the problem of meeting the requirements of the art, in both original installations and also in installations now in operation.

When the De Forest Company first started to build transmitters, we used a crystal control unit made by a well known manufacturer and which, from our experience, was the best obtainable. Trouble immediately developed with this unit so that the frequency control problem became the most difficult one in our design.

In sending transmitters to various parts of the United States, with different temperatures and different conditions of operations, we ran into an unusual amount of frequency control difficulty which proved very costly. We then decided to investigate the control

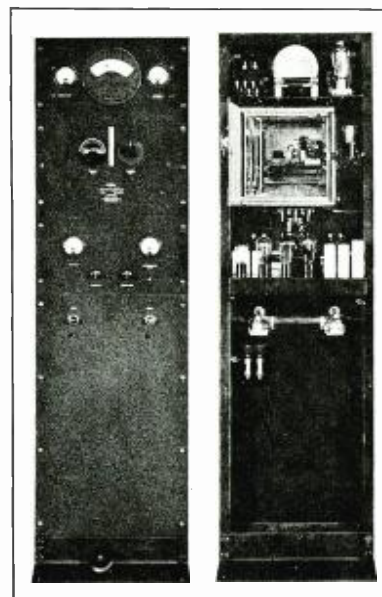

Fig. 1.

Fig. 2.

Fig. 1. Front of DeForest frequency monitor Type A.

Fig. 2. Back view of DeForest frequency monitor Type A.

field ourselves and with the aid of the Radio Research Laboratory in Washington, have developed what we believe to be one of the most reasonable and highly perfected control units yet known commercially. This unit has already gone through some very exhaustive and conclusive tests which have been passed satisfactorily.

Monitors Desirable for Station Operation

The first step in attempting to obtain greater precision of frequency control is to set up and consistently operate a monitor which will as accurately as possible tell the deviation of the carrier frequency from the assigned value. There are a number of places in the United States where checks on frequency can be made. A call to a local United States radio supervisor will usually bring a frequency check on the carrier. A telegram to the Department of Commerce, central monitor station at Grand Island, Neb., will always bring a response on frequency precision, but it is highly desirable that a monitor be in continuous operation so that the operator can check from time to time on the frequency deviations. Hence, the requirement of the Federal Radio Commission that such a monitor be in operation in every broadcasting station. The most successful form of a monitor is the use of a local precision oscillator which beats against a carrier frequency, the beat note being indicated by some accurate method.

Monitor Requirements

The following characteristics should be met in such a monitor if the best practice is used:

1. The local oscillator should be of the highest precision, if possible to be maintained within 4 cycles.
2. It should have precision heat control.
3. It should have a continuous means of indicating the beat note.
4. It should be entirely independent of temperature variations.
5. It should be independent of supply voltage variations as far as possible.
6. All the meters or indicating devices employed should be corrected for temperature variations.
7. It should be capable of operating through wide extremes of temperature.
8. It should be capable of being set up in the station to be monitored without complicating adjustments.
9. The indicating means, if possible, should be continuously and easily visible through months of operation without attention and without adjustment.
10. It is undesirable that the precision and accuracy of the monitor be dependent upon adjustments which must be made by an operator from time to time.

In the De Forest monitor the precision frequency control is the first and outstanding development which merits attention.

Precision Frequency Control for Transmitters

The definition of "precision frequency control" has changed rapidly

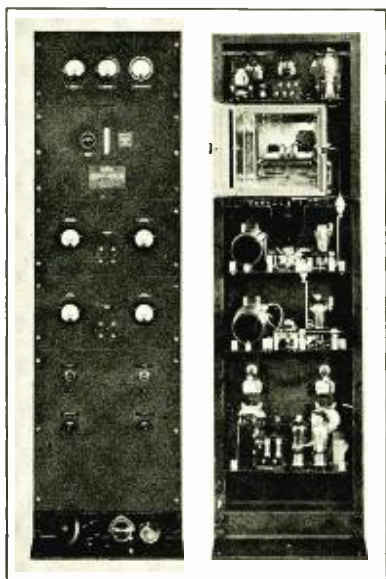

Fig. 3. Front of DeForest Type B crystal control unit. Note removable adjustment dials.
Fig. 4. Back view of DeForest Type B crystal control unit.

during the past few years. Not so long ago any vacuum tube oscillator was notable because of its excellent frequency stability. Later, a master oscillator circuit was regarded as the acme of perfection in frequency control, and even today any transmitter equipped for crystal control, whether or not the crystal is in actual command of the situation, is regarded with respect by a respectable percentage of the radio engineering talent.

The precision of any method of frequency control lies largely in the degree of engineering effort spent in the design of the circuits and in the care expended by the operating personnel in maintenance and supervision. It is a recognized fact that many self-oscillators are more stable in their frequency characteristics than some master oscillators, while a fair percentage of crystal controlled circuits are inferior to some well designed master oscillators.

While crystal control has in general led to better frequency stability with greater ease of operation there have been, and still are, many installations in which the frequency control is still poor and this despite the fact that the crystals are operated within cabinets supposedly maintained at a constant temperature. This paper deals with frequency control employing quartz crystals held at a constant temperature, as the frequency stabilizing means.

Crystal Cuts

There are two common cuts of quartz crystals known as the zero angle cut and the 30° cut. In the zero angle cut the crystal is manufactured from a quartz plate which has been cut through the plane, perpendicular to the X-axis of the natural quartz crystal. The 30° crystal is, as its name implies, made from a quartz plate cut from a natural crystal along a plane 30° from the X-axis.

Each cut has its advantages. The zero angle crystal is less likely to have spurious frequencies, while the 30° crystal is more active. From the manufacturing standpoint, the 30° crystal is the best product where immediate profit is concerned, since these crystals will generally oscillate readily and without a great deal of effort on the part of the grinder. These crystals, however, will frequently and without apparent reason shift their frequency of oscillation several kilocycles. This is particularly true if the load on the crystal changes or if the temperature of the crystal is subject to change.

Zero angle crystals are considerably more difficult to manufacture but when properly made will have little tendency to spurious frequencies and can be obtained with a guarantee that spurious

frequencies will not show up during a 30 per cent. change in plate voltage, a 10 per cent. change in filament voltage or a 10° change in temperature. The specifications under which crystals are purchased should by all means include these items as a safeguard against crystals having "doubles."

The size of the crystal has some influence on its desirability and in general, for power purposes, the crystal should be substantially square and of not less than 1 inch in surface area.

It should be stated here that the matter of zero angle crystals and 30° crystals is one in which there is still controversy between many radio engineering organizations. While the proponents for 30° crystals admit that the possibility of spurious frequencies exists, they claim that the spurious frequencies can be removed by proper treatment. It is for the purchaser to decide whether he cares to risk a type of cut which is only slightly cheaper and may have spurious frequencies as against a cut which probably will not have spurious frequencies at only a slight increase in cost.

Causes of Frequency Drift in Crystal Controlled Oscillators

The change in temperature of the crystal is probably the best advertised of the several factors which lead to frequency drift in a crystal controlled oscillator. This change, due to temperature, is caused by the fact that as the crystal becomes warmer it expands and therefore its natural frequency of vibration is retarded and vice versa. This shift in frequency may be from ten to twenty-five parts in a million; that is, ten to twenty-five cycles at 1000 kcs. for each Centigrade degree change in crystal temperature. The entire change is, however, not due to the crystal expansion alone but also to the type of mounting and kind of cut of crystal. A second factor which may cause frequency drift is a change in capacity or inductance of the tuned circuit to which the crystal is connected. By adjusting the tuned circuit it is often possible to shift the frequency as much as 50 cycles and if the components of the tuned circuit are such as changing temperature, aging, etc. or undergoing a process of expansion or contraction, the frequency must inevitably shift. Other factors leading to frequency drift are changes in the loading on the crystal due to shifting plate or filament voltages, reactions from amplifier circuits, or other similar causes.

Most of the causes which underlie frequency drift in oscillating crystal circuits have been known for some time but the means by which they may be eliminated have either been neglected

ot not sufficiently worked out to be incorporated in commercial designs.

Crystal Temperature

The temperature of an oscillating quartz crystal is dependent on two things: first the ambient temperature of the atmosphere immediately surrounding the crystal, and, secondly, upon the heat generated by the crystal itself.

The common way of maintaining the ambient temperature at a fixed value is to mount the crystal within a constant temperature cabinet. There are many types of constant temperature cabinets employed for maintaining constant crystal temperatures. Unfortunately, however, most of the cabinets have certain defects in design which make them of little or no value from the standpoint of crystal temperature regulation. The heart of a constant temperature cabinet is the thermostat by which the temperature is regulated. In the usual design of cabinet the thermostat is located at a point relatively remote from the crystal. The temperature at the thermostat may be constant but the temperature even an inch away from the thermostat may vary within considerable limits, as much as several degrees. Where a high capacity heater is employed together with insufficient insulation and where the room temperature of various points within a "constant temperature cabinet" will jump up and down a surprisingly large amount. This variation is noticeable when the thermometer is mounted with its bulb close to the crystal or where the bulb is in some part of the cabinet other than close to the thermostat, but such variations in indicated temperature do not improve sales so the practice has been to mount the thermometer close to the thermostat but to let the crystals remain at some point several inches away from the thermostat. With one exception the correct design of a constant temperature cabinet requires that the crystal, the thermometer and the thermostat be jammed as close together as is mechanically possible in order that the point of regulation shall be at the crystal and not at some point removed therefrom.

The exception referred to is where the crystal is mounted in an inside box having several attenuating layers between the crystal and the thermostat and between the thermostat and the heaters. This scheme will give extremely even temperature control, especially if two heaters and two thermostats are used in a series arrangement whereby the wide changes of room temperature are largely taken care of by the outside heater-thermostat-attenuating layer, while the finer temperature control is exercised by the inside heater-thermo-

stat-attenuating layer. We have then two methods for obtaining the desired constant temperature; first, to confine the thermostat and crystal within a small area in a well insulated box and, second, to have the crystal mounted within a series of attenuating layers in a box whose temperature is regulated by a thermostat in one of the outer layers.

The second arrangement, while ideal from the standpoint of maintaining constant the temperature of a non-oscillating or very weakly oscillating crystal, does not satisfy the requirements where the crystal is being operated under considerable load. During the development of constant frequency apparatus it was noticed that despite the most careful regulation of temperature with the crystal non-oscillating a rise of several degrees in crystal temperature as evidenced by frequency drift would take place during the first hour the crystal was in operation. By substituting a resistance element of small size in place of the crystal it was ascertained that the particular crystal involved would rise 3° in temperature when operated under a comparatively light load. The task of eliminating this rise in temperature due to molecular friction within the vibrating crystal proved to be rather difficult. It is obvious that the second type of cabinet mentioned (attenuating layers) would not be suitable since the transfer of heat from the crystal to the thermostat would take several hours and the entire system would not be stabilized unless the constant temperature cabinet were kept operating and the crystal oscillating continuously. Such an arrangement is neither satisfactory nor economical. By employing rapid circulation, properly designed crystal holders and mounting plates, and correct thermostat location, the temperature of the crystal may be held constant within a very small fraction of a degree whether oscillating or non-oscillating, and a state of equilibrium can be established from the cold, non-operative position to the 50° oscillating frequency within a few minutes.

With this description of the local oscillator, the next point of interest in the De Forest monitor is the method used to indicate the beat note. An amplifier is used to amplify the beat frequency, and this is fed directly into a temperature compensator, a highly accurate Weston frequency meter which has a large scale which can be seen for some distance. It will be noted that this meter is driven by frequency only, and if ample safety factor on output voltage is provided the indication meter will be independent of the strength of the beat signal. Hence, changes in voltage in the amplifier will relatively be unimportant with little or no effect on the indicating device. Thus, a visual indicator at all times is accurately available to the operator without a single adjustment.

We find that in these frequency control units the oscillator tube must be thoroughly seasoned in order to obtain a high degree of precision.

The frequency control units herein described are run for a week's period or until such time as there is no further deviation in the frequency due to possible changes in tube characteristics.

Chances for error in the frequency change of the local oscillator may be due to the following:

Temperature shift of 35° Centigrade may cause a maximum change in the oscillator of 12 parts in a million.

Change in oscillator tubes may cause a change of 4 parts in a million.

Ten per cent. plus or minus in the supply voltages will affect the local oscillator frequency less than 1 cycle.

Change due to heavy pounding or vibration will affect the frequency less than 2 parts in a million.

A change of ambient temperature 1° Centigrade in the outside of the heater box will cause 100° change in the temperature inside of the heater box, which is roughly one-half cycle change for each degree centigrade in the ambient temperature.

Hence, for temperature changes a calibration chart is furnished which will give an absolute frequency value

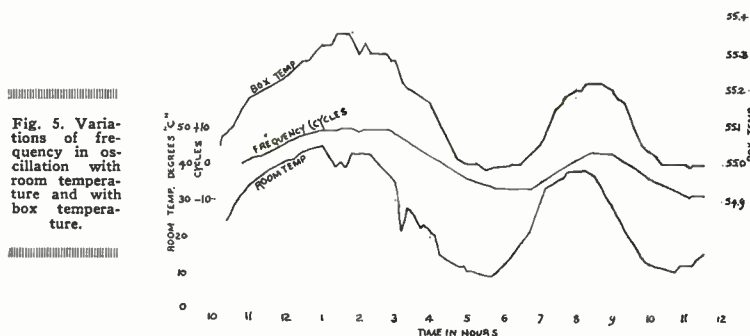

Fig. 5. Variations of frequency in oscillation with room temperature and with box temperature.

with the local oscillator in any degree of ambient temperature. The normal operating temperature in a heater is 55° Centigrade.

Crystal Control Units for Transmitters

The same type of crystal control units manufactured by the De Forest Radio Company in their transmitters are for use separately for other transmitters. This control is capable of precision up to one part in a million. It is possible to use these crystal controls for synchronization of broadcast stations. A very successful experiment is now in progress between stations WATC, Rochester; WAK, Albany; WHP, Harrisburg; WCAH, Columbia, Ohio, all operating synchronously on 1430 kc. These stations have been checked within two cycles for a period of a month, and for several months no station has been away ten cycles from the others. It might be of interest to note that the precision obtained here is even greater than at times obtained with wire synchronization from master frequency. One of the leading stations has recently

been measured more than ten cycles off from its fellow synchronizing station.

In connection with the degree of precision which has just been mentioned it may be interesting to note that the best of astronomical clocks is built with no better precision than one part in 10,000. Average observed accuracy shown on this crystal controlled unit of one part in a million can be regularly expected. The units as built, even with rough treatment, can be expected to hold within three parts in a million.

Every unit is made with a thermometer so that the oven temperature is observable at all times, and if desired, a meter can be put in that will indicate any change in oven temperature by audible means. At present we use a fusible link in the heater box to protect the heater from over-heating in case of thermostat failure.

In the crystal controls a ceramic holder is used with a very low temperature coefficient. The holder of the crystal itself is uniquely done, which facilitates slight changes of frequency, but maintains a given setting indefi-

nitely. In the frequency control units ample power is allowed so that we tune considerably away from resonance for greater stability. Crystals are guaranteed to arrive very near their absolute frequency. A selective service with proper control units allows measurements of all important circuits. Monitors and frequency controls are checked a long period of time before shipment. There are no buttons to push, no incorrect effects from temperature, nor voltage variations in any of the units.

Conclusion

Precision frequency controls of this type are making much easier the development of satisfactory transmitters for operation on the ultra high frequencies. Particularly is this desirable in the wide acceptance of the super-services for television where doubling and tripling is desirable and frequency errors are multiplied accordingly. Even aviation demands a crystal control unit with the result that greater accuracy in crystal units must be developed.



Accurate race timing by photocell current

CONTESTANTS in the Massachusetts speed championship races on the night of February 25 at the Eastern States arena, Springfield, Mass., were timed electrically to a hundredth of a second. The unusual feature of the timing device, developed by General Electric engineers, is that the timing is dependent entirely on the skaters themselves as they cross the finish line. The equipment eliminated human errors such as time lag resulting from human reaction and errors caused by optical illusion. While such errors are usually of minute nature, it is important to have accuracy when a fifth of a second determines whether or not a new record has been made.

The device goes into operation with the sound of the starter's gun. The report of the gun is picked up by microphone at the starting line, automatically starting in operation the electric machinery. A narrow beam of light is projected across the finish, and is concentrated on a photoelectric tube. The first skater to cross this beam times himself.

W. J. Bilodeau, manager of the General Electric skating rink at Pittsfield and director of the championship races, describes the timing device as follows: "The beginning and end of a race is a lapse of time between the sound of the gun and when the first skater crosses the finish line, but watches are often started as late as two-fifths of a

second after the gun goes off. This is the case where the start is on the far side of the track from the finish. For example, the start may be approximately one hundred feet from the timers. The gun goes off at the starting line. Sound travels approximately one thousand feet a second. In traveling one hundred feet one-tenth of a second is lost, the skaters having started with the gun which is less than five feet away from them. Then there is the time lag in

the watch and human error in starting it. This lapse is added to the one-tenth of a second lost in the sound traveling one hundred feet. The timers at the finish will clock the skater as he breaks the tape.

"If the same lag exists at the finish as at the start the only error will be in the time it takes the report of the starter's gun to reach the timers, but the error is often greater because of the optical illusions to contend with at the finish. The timer sees the skater come in contact with the tape. He is supposed to stop his watch at this instant but tests have shown that in many cases the tape had been broken and the skater had gone by before the clock had been stopped. We are assuming that the timers are all cool-headed and not affected by the excitement of the races, which is an assumption that a man who is easily excited should never be a timer. Electrical timing eliminates all possibility of such losses and insures positive timing to the 'Nth' degree."

The electric timing device is simple in construction and operation. The report of the starter's gun, picked up by the microphone, trips a Thyatron tube relay, wired to the apparatus at the finish line. This releases current, instantly starting an electric clock, which runs until the beam of light projected across the finish line is interrupted.

TUBE CHECKER FOR SALES PURPOSES

A tube checker for dealer use is not a final authority of tube merit. It is, however, a useful sales tool.

A good tube checker has the following features:

1. Indicates shorted tube elements.
2. Indicates tube value by some form of mutual conductance measurement. That is, by a direct reading, or shift of grid bias method.
3. Has a line voltage control with an indicating voltmeter to care for variations of line supply voltage.
4. Has a preheater for heater type tubes.

A new high quality detector tube

Simple tube and system, designed by Norman E. Wunderlich, combines full-wave detection, audio amplification and full automatic volume control.

THE Wunderlich radio tube, now in production at the plant of the Arcturus Radio Tube Corp., Newark, N. J., is intended to serve as a detector, amplifier, and as an automatic volume control member. It is a five-prong and cap tube the same size as the —37 tube (new —27), including two grids, plate, cathode and heater. A particular feature of the tube in its associated circuits is that it eliminates circulating r-f. currents in the plate circuit.

The new tube has had a sufficient number of applications to present standard radio receivers to indicate that it may be incorporated to advantage in all standard sets.

In the Wunderlich tube proper it is stated that automatic control of sensitivity (AVC) is an integral function of the detector, the automatic bias being obtained from the rectified carrier not appreciably related to percentage of modulation or to noise level, and the varying bias in relation to the incoming and detected carrier prescribes a curve which corresponds with the dynamic characteristics of the remote control (551-235) tubes which it is controlling.

It is general practice in the Wunderlich system to place as many of the radio tubes under control as are available, such as radio-frequency amplifier tubes, the first detector if separate from the oscillator, and the intermediate-frequency amplifier tube. This gives good control action. There are of course numerous variations equally effective such as controlling just one or two of the tubes, or a different percentage of control on the various tubes. The best arrangement is quite easily determined by experiment and usually dependent upon the gain ahead of the demodulator.

The Tube, Structure

The Wunderlich tube employs two input control grids which are symmetrically arranged in a co-cylindrical fashion about the cathode.

The standard vertical type of heater and cathode is used. Two supporting rods hold each of the two grid assemblies in an accurate position not likely to be shifted by rough handling. The plate is flat and the entire structure and supporting elements are locked into the dielectric separator top and bottom.

The small size S-14 glass envelope is used to make the tube correspond with the automotive bulbs and with the new series of tubes to be released shortly. The tube has a distinguishing red bakelite base and is available either with a 5-prong base and the cathode brought out the top or with all leads brought out the bottom by using the new standard 6-prong base similar to that on the heater type pentode tube.

Wunderlich Tube During Its Cycle of Detection or Demodulation

As previously noted, the Wunderlich tube has two input control-grids symmetrically arranged about the cathode, the capacity and impedance of each being balanced to the cathode-ground.

The radio-frequency voltage developed across the last tuned circuit is supplied to the two grids 180° out of phase with each other. A load resistor is employed between the cathode and a center-tap on the tuned input circuit. Thus, each half of the received signal is rectified, first from one grid to cathode and then, on the next half cycle, from the other grid to cathode, the result being full-wave rectification with the pulsating audio d-c. currents appearing as a voltage drop across the load resistor.

This voltage may then be fed back to the various radio amplifier tubes to

automatically control the sensitivity of the receiver. The characteristics of the Wunderlich tube have been so worked out that the voltage fed back for this purpose is correctly related to the dynamic characteristics of the .551 type of tube which is being controlled and in this way the voltage at the detector input is always held at the one level where best demodulation is secured.

The characteristics of the tube and system are such as to not impose any appreciable load upon the tuned circuit. It actually is the equivalent of a 2.0 megohm shunt.

The absence of r-f. in the plate circuit greatly improves the detector action and permits greater audio-frequency currents which are desired and useful, to be circulated for amplification.

Naturally, as stronger carriers only serve to produce larger rectified voltages and therefore larger bias for the radio amplifier tubes, a constant level is maintained at the detector input and the detector cannot be overloaded. This governor action is very desirable because turning the volume control "up" does not permit of the disturbing overload action common to receivers not so equipped.

This new tube is entirely non-micro-

Appearance of the Wunderlich radio tube.



phonic. Further, it requires no magnetic nor electrostatic shield about it as the elements are all balanced to ground.

The detector characteristic is linear over a wide range of input values and the action of the automatic control voltages is always to hold the incoming signal within the linear portion.

Wunderlich Tube During Its Audio Amplifier Cycle

The output of the tube is on comparatively low impedance being about like that of a standard type 227 tube so it can quite readily and efficiently be coupled either by inexpensive resistance coupling to the output stage or by choke or transformer to secure step-up or to operate push-pull output tubes. Any tubes up to a pair of push-pull type 245 tubes can be swung without any

other intermediate audio amplification.

The Wunderlich tube draws less than .002 ampere plate current so there is said to be no problem of hum or filtration.

The presence of a complete audio stage of amplification naturally permits of the detector being operated at correspondingly lower input levels, thus greatly improving the quality. Much of the criticism of pentodes today is really the result of the present type, poor detectors being operated always at high input levels and continually producing overload distortion and harmonics which are merely amplified by the output pentode to further destroy the quality.

As Automatic Control of Sensitivity

Voltage for regulation of the bias on the radio-frequency tube, the first de-

tor and the intermediate-frequency amplifier tube is derived from the rectified carrier appearing as a voltage drop across the detector load resistor. As the percentage of modulation and noise level have but very small effect upon this voltage, they do not enter into the regulation.

Some other systems of automatic control of sensitivity cause noticeable distortion in the demodulator because of the relatively high input levels at which they are worked. The diode method usually requires additional r-f. or audio gain, or both, to compensate for its own lack of detection efficiency and its loading of the input circuit.

With the tube herein described the system can be designed for any desired "time constant" from 1/20 of a second up to a condition where the return to sensitivity is so slow that it is possible to tune from one local station to another

before the sensitivity returns to the noise level.

It is usual with the Wunderlich system to tie the various cathodes directly to ground, the circuit bias providing sufficient initial bias for these tubes.

TUBE CHARACTERISTICS

Filament voltage, 2.5 (automotive type 6.3).

Filament current, 1.0 amp. (automotive type .4 amp.).

Mu, 10 to 12.

Gm 1,000 to 1,200.

Rp 10,000 to 12,000.

Glass bulb—small automotive size, S-14.

Base—red.

5-prong base with cathode terminal on top, or 6-prong base with all terminals at the bottom.

Type—Wunderlich.



Radio sales and prospects

Midget Sets Still in Popular Demand

A BIG business was done in midget radio sets during 1931, and the high sales level for that period has been carried through January and February, with but little diminution. While some of the eastern manufacturers now include these small sizes in their lines, a greater number of midget set manufacturers are located in Los Angeles than in any other city in the world. Several of these firms conduct a large export business. Many homes today are enabled to enjoy the delights and advantages of radio because of these inexpensive sets. Even though the trend today has shifted to the more expensive instruments, the midget occupies its own peculiar and individual market and has ceased to be the substitute which it was at first considered.

A large output is not necessary to make a little plant busy. Many busy little plants, each turning out a few sets at small overhead and sales expense will survive, and it is the general opinion that midget manufacturers will continue with little curtailment of production and sales during the balance of the year. Besides, it is expected that the midgets will be an influence in eliminating the radio season, and that the forthcoming events of national importance, such as political conventions, campaigns, and Olympic Games will add customers for midgets in a greater percentage than will the larger radio receivers.

Automobile Radio Sales Increasing

New business with a minimum of sales resistance and a real margin of

profit has been provided by the comparatively new auto-radio. Just a few years ago, the radio for the automobile was looked upon as an experiment, and little attention was given it. Today, many of the leading automobile manufacturers have taken cognizance of this new business stimulant. For, there are a few auto-radio receivers which actually have been developed to a point where they will give results equal to the best home reception. As there are only about half a million auto-radios now in use, the 25,000,000 passenger automobiles that are registered in the United States give some idea of the potential market for this newest addition to the radio industry. In 1931, sales of auto-radios had difficulty in reaching 100,000.

A number of manufacturers that furnish parts for radios are concentrating on the production of special tubes, batteries and other equipment for automobile receivers. Two of the largest spark plug organizations have perfected the radio spark plug, which serves more efficiently than does the ordinary suppressor to eliminate motor noises.

There are sixteen or more prominent motorcar builders that are including the built-in aerial, or antenna, in their cars as standard equipment. Several of these manufacturers are instructing their dealers to recommend the auto-radio as optional equipment and distributors are offering these receivers to their dealers as additional sales stimuli.

While television is destined to remain in the experimental stage during the ensuing year, some interesting advancement is being made. It is expected that a few hundred sets may be built to receive simultaneously on two channels, with the cathode-ray scanning and

viewing, but those close to the industry consider it extremely doubtful if any large sales will be possible before 1933. There is no fundamental obstacle to television; neither does it appear so hopeless or costly as it did a year ago, but the combined research by chemists, tube men, circuit engineers and others must be extended further to achieve a practical basis.

Experiment Develops Into World Industry

Its universal acceptance is the best guarantee of the continued popularity. To millionaire and laborer alike, it brings the vocal and instrumental genius of the world's foremost artists, reports of sporting events, political occurrences and the news of the world. It started as a mere experiment, yet in ten years it has grown into a world-wide industry, with sales of radio products in 1929 reaching a record total of \$842,548,000. That it has fallen from that peak of attainment in the last two years, is not an indication of waning popularity, but rather a sign of intense preparation for a period of greater achievement.

While radio broadcasting essentially is an American development, and activity in amateur radio work still is greater in the United States than in any other nation, the past few years have brought about marked changes in the radio situation of many foreign countries. Today, few are the nations that have not recognized the popular and growing interest in radio by the enactment or revision of their radio laws.—*Raymond Brennan, in Dun's Review.*

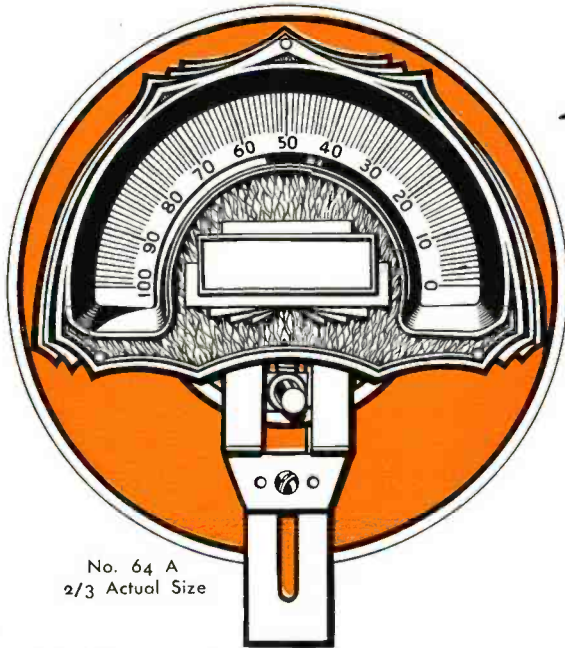

No. 64 A
2/3 Actual Size

The No. 77 Tuning Unit shown here is a remote control unit for Automobile Radios and is designed for attaching to the steering post. The dial revolves 360 degrees to 180 degree turn of the condenser. Ample space is provided in the case for volume control, switch lock and wire connections and is fitted with a pilot light attachment.

The 180 degree segmental gear which should be attached to the condenser shaft (as shown below) meshes with a pinion on a flexible shaft coming di-

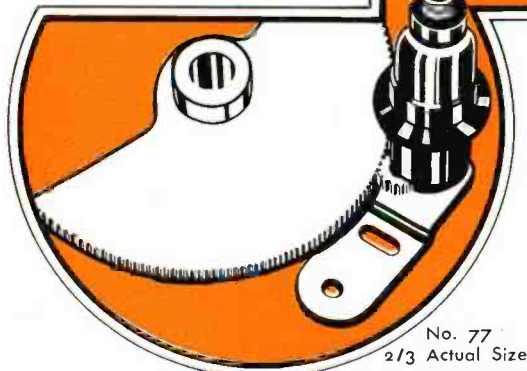

No. 77
2/3 Actual Size

Two new units for TUNING CONTROL

The No. 64-A Wedge Drive Tuning Unit with traveling light has a scale angle back 25 degrees. This unit is designed especially for those wanting a compact unit for medium size consoles. The escutcheon is designed for accommodating almost any stock name die. The scale usually supplied with this number is of tan pyralin.

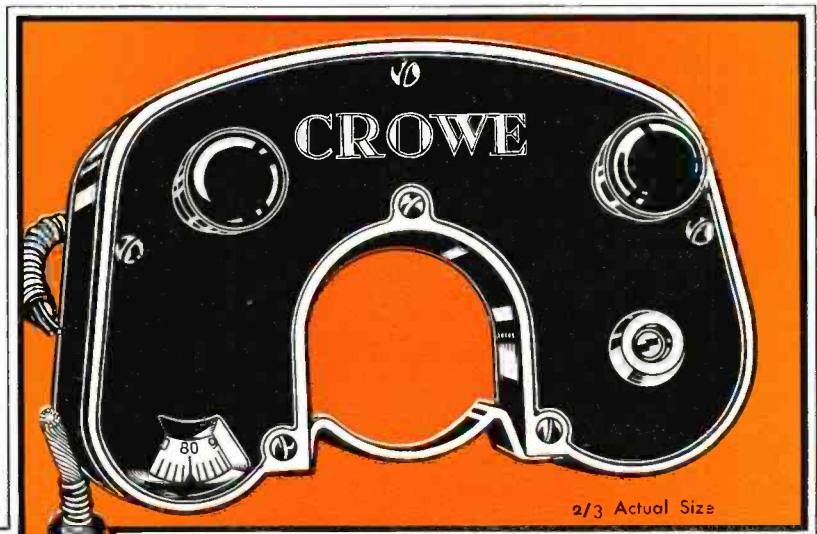

2/3 Actual Size

rect from the control box. This causes a positive drive without loss of motion. The flexible shaft is easily attached and has squared ends fitting into the couplings, making an absolute positive drive.

Those desiring a steady, trouble-free control, thoroughly tested, will be interested in this unit. Your own name or trade mark will be stamped in the space now occupied by the name "Crowe". This unit is usually furnished with the dial on the left although when ordered specially drive and dial may be placed on the right.

CROWE NAME PLATE & MANUFACTURING CO

1747 GRACE STREET

CHICAGO, ILLINOIS

● This startling NEW series needed no high powered sales campaign to get "over the top." Our sales methods are simple . . . make a BETTER product—PRICE it right—TELL' em about it.

● YOU will be interested in learning more about the product that made the Radio Industry "say it with orders."



CRC's **500 Series** *socket*

completes the CRC line, providing sockets well suited to present day price requirements. The ever popular 600 and 800 series with spring reinforced contacts will continue in production to take care of the demand for the best all around sockets obtainable. ● Send for blueprint showing various sizes and mounting center combinations available in the 500 series and the booklet entitled "NINE REASONS WHY."

CENTRAL RADIO CORPORATION
Beloit Wisconsin

CRC

R. M. A. CHICAGO SHOW

THE R. M. A. Trade Show to be held in Chicago, May 23-26, promises to be a successful meeting. Prominent speakers, a "national clinic" on important radio industry problems and considerable entertainment as well as business are to be features of the big annual radio gathering.

The program for the industry conclave at the Stevens and Blackstone Hotels was outlined at a meeting in Chicago March 9 of the convention and reception committee of which Leslie F. Muter of Chicago is chairman. The committee includes President Coit of the RMA, vice-president A. S. Wells, directors Henry C. Forster, R. T. Pierson and E. N. Rauland, and Thomas A. White, Harry Olson, Clarence Clago, Harry Simpson, Mortimer Frankel, P. V. Galvin, J. T. Beatty and Colonel George B. Gaw, official "greeter" of Chicago civic interests.

The RMA annual convention is scheduled for Wednesday morning, May 25, with prominent speakers being invited. For the thousands of radio jobbers and dealers in attendance there is planned the open "clinic" with other prominent speakers on Tuesday morning, May 24, together with other important group meetings to consider special subjects before the radio industry. Joint meetings of directors and others of allied radio organizations also are being arranged.

Chairman Muter and his committee will meet the special trains and other delegations on their arrival at Chicago. For social diversion and entertainment a program, including an "open" golf tournament for the entire radio industry, is being arranged by Henry C. Forster, chairman of the entertainment committee.

SUPPORT FOR BROADCAST ENTERTAINMENT

WRITING on the subject of financial support for radio broadcasting, M. H. Aylesworth, president of NBC, says:

"So far as the National Broadcasting Company is concerned, I feel certain we are travelling in the right direction. Upon the organization of the company and many times since, it has been stated that broadcasting should be self-supporting. The only feasible method of attaining this idea has been to turn for financial support to American industries interested in sponsoring programs for the purpose of building good will. Their contribution has indeed been generous and the American radio audience owes a great debt of gratitude for their sup-

port—without it our work would be impossible.

"In its efforts to provide the best in entertainment, education and information to the greatest possible audience, the National Broadcasting Company recognizes the interests of the public and of industry as being mutual. Without financial support by business, its extensive program service would be impossible; without its vast audience, financial support would not be forthcoming."

THE LOWELL-DUNMORE RADIO PATENTS

THE Radio Corporation of America, on March 19 issued the following statement:

"The United States Circuit Court of Appeals of the Third Circuit today handed down a decision in the case of Dubilier vs. Radio Corporation of America, which related to patents on radio sets employing alternating current.

The patents were Lowell and Dunmore 1,455,141, which related to the use of hum reducing means in a-c. sets, and Dunmore 1,635,117, which related to the use of rectified a-c. for procuring negative grid bias.

"The Dubilier Company contended that all sets operating on a-c. and not licensed under these patents were infringements. Suits have been pending for several years against the Radio Corporation of America alleging infringement of these patents. All patent claims in suit were held invalid by the United States Circuit Court of Appeals, which ordered the suits dismissed, reversing the decision of the lower court."

SAVING INSTRUMENT LOSSES BY PROPER FUSE PROTECTION

(Concluded from page 20)

Temperature Coefficient

In order to reduce this factor to a practical working basis, the temperature coefficient is expressed in terms of ohms per milliampere load. Every effort has been made to use materials for fuse elements which have low coefficients, but in some instances this is impossible.

Radio Receiver and Radio Amplifier Fuses

The radio receiver fuses are designed to meet the demand of the radio trade for a low-priced, serviceable fuse for use in the 110-volt primary line of the power supply. They are the 3AG Type (1¼ inches long by ¼ inch in diameter), glass inclosed, and have the same rigid "locked" construction as the instrument fuses. Pure zinc is used for elements since it is not subject to deterioration and crystallization with age and use. The relatively high conductivity of zinc permits a smaller diameter element, which means greater safety on high voltage short-circuits due to the smaller mass volatilized.

The Underwriters' specifications call for fuses to stand 10 per cent overload continuously and blow within one minute on 50 per cent overload. On short-circuit under-rated voltage they must hold the explosions within the inclosure.

The special radio amplifier fuses are also the 3AG Type and are designed for use in amplifier and filter circuits as employed in public address systems, theatre amplifiers, etc. Scientifically designed to suppress arcing, they will break 500 volts, and even more, when the current supply is about one kilowatt.

These instrument protection accessories have been given the name "Littel-fuses."

EXHIBITORS AT I. R. E. CONVENTION, PITTSBURGH, PA., APRIL 7, 8, 9, 1932

Exhibitors	Booth No.
1. Acme Electric & Mfg. Co.	3
2. Allen-Bradley Co.	23
3. Bryan Davis Publishing Co.	12
4. Cable Radio Tube Co.	38
5. Central Radio Corp.	21
6. Chicago Telephone Supply Co. (H. H. Frost)	42
7. Continental Carbon Co.	44
8. Central Radio Labs.	5
9. DeJur-Amsco Corp.	8
10. Dubilier Condenser Corp.	22
11. Erie Resistor Corp.	28
12. Electrad, Inc.	7
13. General Industries Corp.	18
14. Hammarlund Mfg. Co.	45
15. Hardwick-Hindle, Inc.	47
16. Hickok Electrical Instrument Co.	15
17. Hygrade Sylvania Corp.	27
18. International Resistance Co.	1
19. Isolantite, Inc.	43
20. Jensen Radio Mfg. Co.	29
21. Jewell Elec. Inst. Co. & Weston Elec. Inst.	9
22. Johnson Laboratories, Inc.	37
23. P. R. Mallory Co. & Yaxley Mfg. Co.	25
24. McGraw-Hill Publishing Co.	19
25. Ohmite Mfg. Co.	46
26. Parker Kalon Co.	6
27. RCA Radiotron & E. T. Cunningham, Inc.	36
28. RCA Victor Co.	24
29. Radio Condenser Co.	48
30. Scovill Manufacturing Co.	17
31. Shakeproof Lock Washer Co.	14
32. Shallcross Mfg. Co.	20
33. Soreng-Manegold Co.	2
34. Stackpole Carbon Co.	18
35. Synthane Corp.	26
36. Utah Radio Products Co.	35
37. Ward Leonard Electric Co.	37



NEWS OF THE INDUSTRY

VALUABLE CHART

The multiplier resistance chart which appears on page four of Bulletin No. 150, issued by the Shallcross Mfg. Co., Collingdale, Penna., is well worth having. Bulletin 10 also describes resistance systems for various purposes, also type 600 combination a-c.—d-c. voltmeter-milliammeters.

BATTERIES FOR RADIO

Notwithstanding the continuous increase in the use of radio and sound equipment operated from public service mains, there are many places in which the source of power remains primary batteries. In recent years considerable improvement has been made in dry battery units giving them longer life under operating conditions, and also longer shelf life.

Engineers and others desiring information in regard to the modern product now available in the way of A, B, and C dry batteries can procure technical literature from Stuart Mahany, Burgess Battery Co., Harris Trust Building, Chicago, Ill.

GILBY WIRE CO.

A. J. Marino has been elected a member of the Board of Directors of the Gilby Wire Company, and as vice-president. In 1929 Mr. Marino joined the company as sales engineer. A short time later he was appointed chief engineer and works manager. Before going to the Gilby Wire Company Mr. Marino was engineer with the P. R. Mallory Co., Elkon Works, and before that for 10 years with the General Electric Company.

MERCURY VAPOR RECTIFIER

The type 282 mercury vapor rectifier manufactured by the Cable Radio Tube Corp., 230 No. 9th St., Brooklyn, N. Y., is clearly described in the "Speed" circular issued by that company.

NEW SHOWROOMS FOR RADIO DISPLAYS

The Wholesale Radio Service Company, formerly at 38 Vesey St., New York, are now installed in their new location at 100 Sixth Ave., New York City. The new quarters are said to have about five times the floor space of the older ones.

The successful history of this company mirrors quite closely the unparalleled growth of the radio industry. From a modest start, the Wholesale Radio Service Company has expanded constantly until now it is one of the largest and best known concerns of its kind in the radio business.

Commenting on the recent move, one of the Wholesale executives said: "It became necessary for us to expand our facilities somewhat in order to properly take care of our growing business. The fact that we have taken five times our previous space is an expression of our unshaken faith in the future of business conditions generally and the radio business in particular. This expansion has not only increased our facilities along lines that are considered essen-

tial, but it has also afforded an opportunity to offer service extensions which we believe will be well received. For instance, our new home contains a completely equipped theatre, available gratis to those who wish to use it to further the interests of groups engaged in radio service work. The theatre and its facilities will serve as an open forum, where men of kindred interests may gather for the purpose of discussing the various aspects of their profession; where they may meet and be addressed by factory experts, engineers and recognized authorities on various radio and television subjects. In fact, we are now rounding out a definite program, which will bring to our forum lecturers of the highest standing in every branch of the radio industry."

KENYON TRANSFORMER CO.

Martin Fogel, formerly manager of the Todd Electric Company, has joined the Kenyon Transformer Company in the capacity of sales engineer. Mr. Fogel has been in the radio transformer field since radio was first commercialized and his many Eastern friends will undoubtedly appreciate the wider field which his activities can now cover.

The Kenyon Transformer Company is located at 122-124 Cypress Avenue, New York. I. A. Mitchell is vice-president.

ACME PURCHASED BY DELTA MFG. CO.

The business of Acme Apparatus has been purchased by the Delta Manufacturing Company. Dr. Frederick S. Dellenbaugh, Jr., is president of the new corporation and will have charge of engineering and development. George E. M. Bertram, for the past ten years associated with Acme Apparatus in various capacities, becomes treasurer and general manager of the new corporation. The remainder of the personnel of Acme Apparatus will continue with the new corporation.

The Delta Manufacturing Company intends to maintain and improve the high standard established by its predecessor and solicits inquiries for all types of transformers, choke coils, and associated apparatus.

PLASTICS IN RADIO

As viewed by General Plastics, Inc., manufacturers of Durez, one of the leading synthetic resinoids:

"Phenolic plastics, already used extensively as dials, resistors, tube bases and similar mechanical parts in radio construction, will find their greatest use as materials from which to make complete radio and television sets.

"Radio cabinets have used the old materials, wood and metal, in every conceivable form, and have imitated linen cabinets, clocks, tables, etc., until they have reached an impasse. As soon as cabinet designers divorce themselves from the past and cease making radios in outmoded and preposterous period designs, a new form will be born. Radio and television sets will look like radio and television sets. Function

will govern form. They will be machines and not furniture.

"Then will come the cry for new materials—materials of the machine age which will reflect the spirit of wireless communication. They will probably be synthetic. Plastic sheets will probably form the exteriors, and will be mold-formed to fit the mechanical parts within. And because of honest, functional design, freed from petty imitations, these new machines will be beautiful beyond any radio cabinet yet produced.

"The plastic materials which will figure so greatly in tomorrow's radio cabinet will be light, strong, dirt-proof, wear-proof, easily-formed, acoustically correct, and their colors will rival the rainbow. Although laminated phenolic materials now strive for wood-grain effects, this groping period will pass, and synthetic plastics will emerge with an identity all its own, imitating nothing, ready for the industrial sculptor.

"Already molded plastic radio cabinets are being made, and plastic sheet stock is being formed into hundreds of articles. Tremendous advances may be expected in the future."

WALTER GILBY ANNOUNCES FORMATION OF GILBY ALLOY COMPANY

Walter Gilby, pioneer wire manufacturer, recently announced the formation of the Gilby Alloy Company with offices and plant located at 850 to 854 Mt. Prospect Avenue, Newark, N. J.

Mr. Gilby has been affiliated with the wire industry since 1895 when he was employed by the De Witt Wire Cloth Company. When the Driver Harris Company was started five years later, Mr. Gilby was their first employee. This affiliation lasted nearly twenty years and for a period of twelve years he was factory superintendent. The major part of this time was spent in the manufacture of resistance wires. The first piece of nickel-chrome wire produced by this company was drawn by Walter Gilby.

After severing his connection with the Driver Harris Company, Mr. Gilby took part in the organization of the Gilby Wire Company in 1920. When this company was started, Mr. Gilby not only solicited business, but also manufactured the wire. Later as the company grew he supervised the setting up of branch factories in Chicago, and in Paris, France.

With thirty-five years' experience in the resistance wire industry, Mr. Gilby has started his own company, the Gilby Alloy Company, with new, up-to-date equipment for the manufacture of high-quality filament ribbon, also nickel chromes and various alloys in resistance wires, in the form of flat ribbons, round wire, and coiled elements.

DIALS

The Eddie Mfg. Company, 9 West 111 St., Chicago, manufactures a line of thirty different types of dials for radio and associated industries. They report business active.

BIG



*things are in store
.....for all who attend*

RMA

**SIXTH ANNUAL
TRADE SHOW
EIGHTH ANNUAL
CONVENTION**

CHICAGO

• STEVENS HOTEL •

RADIO'S BIG ANNUAL CONCLAVE

EXHIBITING ALL NEW LINES AND THE LATEST RADIO AND TELEVISION PRODUCTS.

ELECTRICAL PRODUCTS ALSO IN TRADE SHOW AND MANUFACTURERS' DEMONSTRATION ROOMS.

EVERYBODY IN RADIO (NEARLY 25,000 RADIO TRADESMEN LAST YEAR) ATTENDS THIS ANNUAL NATIONAL RADIO GATHERING, THE BIG INDUSTRY MEETING EACH YEAR.

Better business early in 1932

The RMA event this year is advanced to start sales early. In June, a few weeks after the RMA exhibits of manufacturers' latest products, there will come the big Republican and Democratic national conventions in Chicago to nominate presidential candidates. In June also another heavyweight championship match between Schmeling and Sharkey is scheduled.

GO TO CHICAGO MAY 23, SEE THE LATEST RADIO AND ALSO ELEC-

TRICAL PRODUCTS OF RMA MANUFACTURERS, AND GET IN EARLY ON THE 1932 TRADE.

This is the big and only national industry radio show, sponsored by the RMA and under its management, for RMA members, jobbers and dealers.

All exhibitors required to show current merchandise—no vacant booths.

Electrical products also displayed. Thirty thousand (30,000) square feet of radio and electrical exhibits in the official hotels—the Stevens and Blackstone.

ADMISSION TO THE TRADE ONLY. PUBLIC NOT ADMITTED.

Reduced railroad rates—special trains—one and one-half fare for round trip to Chicago from everywhere.

Official hotels—Stevens and Blackstone—together on Michigan Avenue. Regular rates. Make your reservations early.

Important and interesting business meetings of industry and allied organizations.

Invitation credentials for the trade show will be mailed about April 15th.

REMEMBER THE DATE—MAY 23—AT CHICAGO.

Official Hotels—

• • •

Stevens Hotel

Blackstone Hotel

MAY 23-26 1932

RADIO MANUFACTURERS ASSOCIATION
11-WEST 42nd ST. N.Y. CITY • 32 W. RANDOLPH ST. CHICAGO



NEW FULL-WAVE RECTIFIER

The Hygrade Sylvania Corporation, Emporium, Penn., announces a new full-wave vapor rectifier tube known as the SX-82.

This tube differs from the standard SX-280 tube in several respects. Because of the mercury vapor present in the tube, the voltage drop in the tube remains practically constant at 15 volts regardless of load as long as the load current maximum is not exceeded. This results in excellent regulation.

The filament rating is 2.5 volts and 3 amperes. It is essential that this voltage be held as closely as possible to this value.

This rectifier is mounted in a smaller bulb than the standard SX-280 tube. It employs the S-14 bulb, the same size as the SY-227 and SX-201A tubes.

This tube will find especial application in connection with power supply devices for class B amplifiers, where the load is constantly varying.

MALLORY-ELKON ANNOUNCES NEW AUTO "B" ELIMINATOR

P. R. Mallory & Co., Inc., Indianapolis, are in the field with a "B" battery eliminator for automobile radio.

This new unit is energized by the 6 volt "A" battery in the car which is constantly supplied with energy by the automobile generator. It ingeniously boosts the 6 volts in the "A" battery up to 180 volts or the equivalent of four 45 volt "B" batteries.

The Mallory-Elkon "B" eliminator is approved by all popular brands of automobile radio sets. It is compact (size 10 by



7 by 3 1/4 inches) and is easily installed in any one of many places in the car.

Although the first shipments have just gone out to the trade this new "B" eliminator is a proven product. During the last two years on the company's own test cars, these units have given perfect reception in 10,000 mile test runs.

A NEW "R-F." COIL

The RFB No. 10 special coil has been developed to fill a demand for a very small r-f. coil the efficiency of which is not hampered by small size. It requires

a mounting space of only 1 1/8 inches in diameter and 2 1/4 inches high.

The secondary is bank wound with Litz wire resulting in a coil of exceptional high gain (62.5 at 1,500 kc. and 42.5 at 550 kc.).

Mounting the coils in the shield, and matching, eliminates a great deal of testing and adjusting by the set manufacturer which facilitates the operation of phasing the r-f. system. Screw lugs are provided for mounting the entire assembly either above or below the chassis in exactly the same space and holes as provided by a standard 1 3/4 inch wide tube socket die, a feature of which avoids special tools for punching the chassis to mount the radio-frequency transformer.

The low r-f. resistance due to the bank wound "Litz" wire extends the range of the unit and with any good condenser of correct minimum, a band from approximately 1,700 kc. (police signals) to 550 kc. can be effectively tuned.

The low cost of the unit itself and the fact that it is a standard item carried in stock makes it an attractive economic item since it avoids much of the special work, both electrical and mechanical, in adapting special coils for the radio-frequency system.

The RFB No. 10 coil is made by the General Mfg. Co., 8066 So. Chicago Ave., Chicago, Ill.

A NEW SMALL CONDENSER

A new octave tone condenser, of the tapped, sliding contact type is offered by the Filtermatic Mfg. Co., 4458 Frankford Ave., Philadelphia. This is a well made, neat unit, which should have many applications in radio and sound work.

HOT-CATHODE MERCURY VAPOR RECTIFIERS

The Thermionic Laboratories announce a new hot-cathode, indirectly heated, half wave, high current density mercury vapor rectifier. This rectifier is rated at 35 amperes peak anode current and 500 volts inverse peak anode e.m.f. The heater rating is five volts at 35 amperes. The over-all height of the tube is approximately 15 inches and the diameter is approximately five inches. The indirectly heated cathode is so constructed as to prolong the life of the tube at least ten times over that of the usual hot filament cathode. Instantaneous peak electron emission 145 amperes.

Generally all rectifiers of the filament cathode type have a life rating in excess of 4,000 hours. The Hi-Watt 81 and the newly announced high-current rectifier, both of which are indirectly heated cathode tubes, have a conservative life rating in excess of 10,000 hours. All rectifiers for any radio, public address system or any other allied radio use are unconditionally guaranteed 1,000 hours and for any industrial use are unconditionally guaranteed 2,000 hours. All cathodes are of the oxide

coated low temperature variety developed for high electron emission and low evaporation of the oxide base metals by the Thermionic Laboratories for their hot-cathode mercury vapor rectifiers.

NEW RADIO TUNER

In cases where it is desired to reproduce radio programs through a sound system (as in centralized radio installations of hotels, apartments, hospitals, schools, etc.), a specially designed radio tuner is required to provide the source of signal. Tuner type RT-74, manufactured by the American Transformer Company, 178 Emmet St., Newark, N. J., possesses unusually satisfactory sensitivity and selectivity characteristics and has been designed to operate efficiently with standard AmerTran panels. 10-kc. selectivity; six microvolt (1.5 microvolts per meter) sensitivity; output impedance 500 ohms—works into Type C-93 or C-94; three-stage pre-selector; two stages of tuned r.f.; one stage semi-tuned r.f.; 22 detector; automatic volume control; local-distance switch; light-omatic tuning; 0-25 ma. d-c. meter for measuring total plate voltage to facilitate tuning to exact resonance; on-off switch.

GOOD LINE OF PAPER CYLINDERS

What is regarded as an excellent line of treated paper cylinders is manufactured by the Cross Paper Products Corp., Electrical Div., 2595 Third Ave., New York. Treated paper cylinders are said to have better electrical properties than similar cylinders of other material and higher price. According to comparative tests on these and other cylinders, conducted by a neutral testing laboratory, the Cross cylinders showed

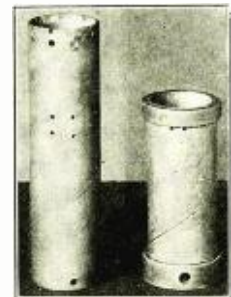

superior surface and volume resistivity as well as practically equal water absorption qualities. Although the surface resistivity of the Cross samples was greater as they were received than other similar cylinders, after 24 hours' exposure in an atmosphere of 90 per cent relative humidity the Cross samples showed superior resistivity qualities. Each cylinder is said to be rigid and precise.



AMERTRAN Transformers

Recognized for 10 years as the Standard of Excellence for every amplifying application.

The graph below illustrates a Representative Frequency Response Curve of an AmerTran Input Transformer.

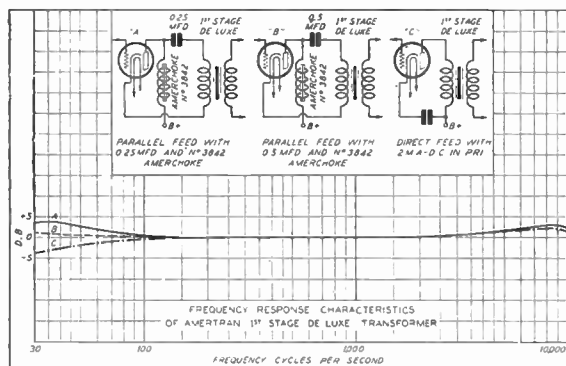

On request we will send you graphs giving similar curves on the following types of AmerTran Transformers—

- Output Transformers
- Interstage Transformers
- Impedance Matching Transformers
- Mixer Transformers

For further information write—

American Transformer Company
180 Emmet Street, Newark, N. J.

New York Office: Hudson Terminal, 50 Church St., Room 1936

AMERTRAN

YOU *Must* use A GOOD OSCILLATOR



For good superheterodyne servicing—the kind that builds profits and reputation—a complete, accurate Oscillator is vitally necessary.

Only with such an instrument as the Weston Oscillator, Model 590, can you reliably and accurately align I.F. stages and gang condensers, determine sensitivity and selectivity, check R. F. transformers, condensers and the oscillator stage of modern receivers.

Unusually complete, extremely practical, highly accurate—Model 590 covers the broadcast band of 550 to 1500 kilocycles, and the intermediate frequency band of 110 to 200 kilocycles. Frequencies between 200 and 550 and above 1500 kilocycles obtained by means of harmonics.

OUTSTANDING FEATURES

GRID DIP MILLIAMMETER—definitely indicates that Oscillator is functioning. Enables individual tests of each R. F. stage. Determines resonance point of any coil and condenser circuit within oscillator range. Also serves as filament and plate voltmeter.

ATTENUATOR—to control oscillator output. Special unique design. Permits unusually smooth and gradual adjustment of output over entire range.

TWO TYPE '30 TUBES—one for the R. F., the other to modulate the R. F. to produce an audible 400 cycle note with 30% modulation.

SELF-CONTAINED BATTERIES—a shielded compartment provided for one 22½ volt "B" battery and four 1½ volt flashlight cells.

COMPLETE SHIELDING—effectively shielded by thick cast aluminum case partitioned for batteries and Output Meter.



RADIO SET TESTER—Model 565. Complete portable radio laboratory. Contains A. C.—D. C. Radio Set Tester; checker for all A. C.—D. C. tubes, including pentode and automobile types; R. F. Oscillator; direct-reading Ohmmeter, Output Meter and Condenser Meter.

WESTON

ELECTRICAL INSTRUMENT CORP.

612 FRELINGHUYSEN AVENUE . . . NEWARK, N. J.

I want more information on that

- Model 590 Oscillator Model 565 Radio Set Tester

Name _____

Address _____

City _____ State _____

FILAMENT CURRENT FROM 110 A-C. SUPPLY

The modern trend in the construction of radio broadcasting equipment is towards unified construction and simplicity of control and maintenance of all component parts. B-L radio broadcast rectopacs are a step in this direction. They make possible the operation of amplifier tube filaments and speech input relay circuits from the common 110 volt a-c. line. These rectopacs employ B-L dry, metallic rectifiers and supply pure non-pulsating direct current. They are designed for panel mounting to conform with other associated equipment at the control panels, or may be obtained in cabinet form where a wall-mount-

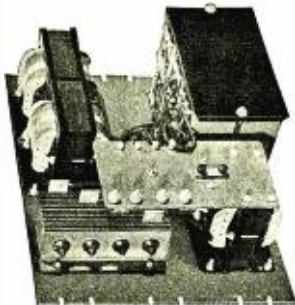

ed installation is desired. B-L rectopacs are compact, substantially constructed, dependable, and noiseless. There is no electrical interference in even the most sensitive of associated circuits. B-L rectopacs are made in several types with outputs ranging from three to six and five-tenths amperes at from two to twenty-four volts.

This new equipment is made by the B-L Electric Mfg. Co., 19th and Washington Ave., St. Louis, Mo.

SY-46 POWER AMPLIFIER TUBE

Sylvania Type 46 is a special power amplifier tube, intended for use as a Class "B" amplifier. The tube has been so designed that by rearranging the connections to the two grids it can also be used as a driver tube (Class A amplifier).

In structure the tube is very similar to the pentode, Type 247, except that no suppressor grid is provided, and the pitch of the control and screen grids is slightly changed to secure the desired characteristics. Each grid is provided with a separate base connection. When the two grids are connected together a high amplification factor is obtained and the tube may be operated at zero grid bias. Under these operating conditions a pair of these tubes is capable of delivering up to 20 watts of undistorted power. If the outer grid is connected to the plate, the tube may be used as a Class A amplifier tube to drive the Class B tubes.

The filament is intended for a-c. operation from a 2.5 volt secondary winding of the power transformer. The rated filament current for this tube is 1.50 amperes, and it is, therefore, necessary that the filament circuit wiring and filament contacts of the socket have sufficient current carrying capacity to handle this current.

The filament winding should either be center tapped or provided with a mid-tapped resistor of about 20 ohms resistance, which is shunted across the winding. The grid and plate returns should be connected to this mid-tap.

Care should be used in laying out the

circuit to keep the hum due to induction at a minimum if a filament type of tube is used as a "driver." This hum may be further reduced by employing a variable center-tapped resistor across the filament supply for the driver stage if a filament type tube is employed for this stage.

The base of the 46 is of the medium five-pin type. It fits the standard "Y" socket, the filament contacts of which must be capable of handling 1.50 amperes.

The bulb is the same size as that used for the 245 and 247 tubes, and becomes very hot under some conditions of operation, so that provision for ventilation should be made.

SELF-STARTING MOTORS FOR TELEVISION

Self-starting synchronous motors for television purposes are manufactured by the Ohio Electric Co., 5917 Maurice Ave., Cleveland, Ohio. These are wired all ready for connection to the public service mains. Bulletin No. 210 describes the line.

JEFFERSON TRANSFORMERS

Transformers perfected for use with the new type radio tubes now being marketed are available from the Jefferson Transformer Company, Bellwood (Chicago), Illinois, including units for the 282 mercury rectifier, -246 amplifier and the new low-current heater tubes. New transformers are ready for class B amplifiers.

NEW INSULATED MOUNTING STRIPS MADE BY CINCH

Insulated mounting strips with one or more soldering lugs and in various combinations are now being furnished by the Cinch Manufacturing Corp., Chicago. Important savings can be effected with the use of these inexpensive parts. Made of 1/16 bakelite with brass mounting and soldering lugs with Cinch solder coating. This coating assures uniformly perfect soldering results.

The company particularly recommends



the use of their insulated mounting strips on radio set chassis and dynamic speakers. They are useful for holding voltage divider resistors, bias resistors or grid leaks.

STEERING POST RADIO CONTROL

The new No. 77 tuning unit being marketed by the Crowe Name Plate & Mfg. Co., 1747 Grace St., Chicago, Ill., is a remote control unit for automobile radio receivers, designed for attachment to the steering post.

TUBE DEVELOPMENTS

The Chicago Miniature Lamp Works, 2423 Sheffield Ave., Chicago, Ill., has developed a successful business specializing

in all types of thermionic and other types of electronic lamps. These include radio tubes, glow tubes, photocells, and gas-filled tubes for special applications.

RADIO INDUSTRIAL PRODUCTS

The industrial products section of the R. C. A. Victor Company, Inc., Camden, N. J., is meeting with success in marketing an extensive line of radio and allied accessories.

Among the various items that have attracted attention are the Standard signal generator TMV-18, compactly mounted in portable form; a line of substantially constructed condensers known as Faradon capacitors; a portable heat frequency oscillator TMV-28. There is the Type RL-43 permanent magnet dynamic loudspeaker for automobile radio receivers, and Type RL-36 midget electro-dynamic loudspeaker, also units for public-address equipment such as Type RP-67 automatic record changes and a magnetic pickup.

RCA Victor also announces a new and improved line of speech input panels, with Type 24-B amplifier and Type 13-C volume indicator, particularly satisfactory for broadcast work.

INCA COILS

The Inca Manufacturing Division of Phelps Dodge Copper Products Corp., Fort Wayne, Ind., maintains offices at 40 Wall St., New York, and at 2175 East 27 St., Los Angeles, Cal. The Company manufactures coils of any type and any size to specifications.

VOLUME INDICATOR

A precision power level indicator for quantitative monitoring of audio frequency circuits with a range minus 8 to plus 48 db, manufactured by Silver-Marshall Inc., 6401 West 65 St., Chicago, is known as type PA 60 B.

MULTIPLE UNIT HORNS

The Racon Electric Company, Inc., 18 Washington Place, New York City, is now in a position to provide multiple unit horns, particularly for use with the new class B type amplifiers which are capable of two or three times the audio-frequency power output heretofore obtained in con-



ventional circuits. The 4 unit horn, for example, when used with the special public-address type unit, is adaptable to the 8-5 type 50 watt tube push-pull amplifier, and for the class B type amplifier. The 9 unit horn with the special public-address unit, will handle the output of 4-845 tubes, or 100 watts.

Acclaimed By The Industry!

The New

ACRACON*

DRY Electrolytic Condenser

THAT this latest Acracon condenser meets a long felt need in the industry is proved by the enthusiastic comment and SALES since the announcement last month of the Acracon Dry Electrolytic unit.

Note These Features:

- peak operating voltage 500
- surge voltage 600
- low initial leakage
- leakage current at 500 volts less than .2 mils per mfd.
- constant capacity; does not decrease with age
- stable power factor; does not increase with age
- non-corrosive connections
- metal or fibre container
- standard and special sizes

Write Today for Descriptive Literature!

* Acracon Features are Protected by Patents Pending

CONDENSER CORPORATION
OF AMERICA

259 Cornelson Ave., Jersey City, N. J.

Factory Representatives in:

Chicago Cincinnati St. Louis San Francisco
Los Angeles Toronto

And Other Principal Cities

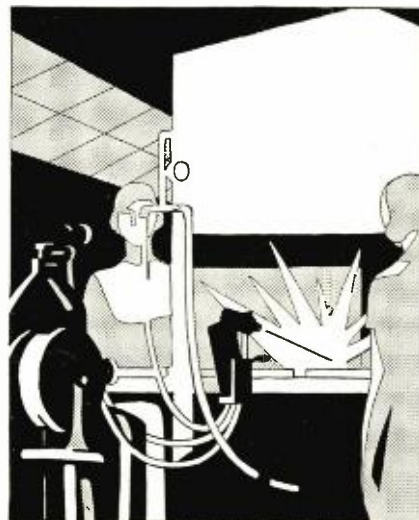

Spraying pure copper as a contact base for Centralab Fixed Resistors

SEND for this interesting, graphically illustrated booklet telling how Centralab Fixed Resistors are made. Explains why these popular resistors are different and better.



This book is of special value to the engineer and serviceman alike. It is free for the asking. Send for it today.

Now in its 3rd edition

Centralab's 3rd edition of the Volume Control Guide is now ready for distribution. Shows how to service all old and new sets with a mere handful of Centralab Replacement Units. Priced at 25c.

CENTRAL RADIO LABORATORIES
Centralab
MILWAUKEE, WISCONSIN

FILTERMATIC

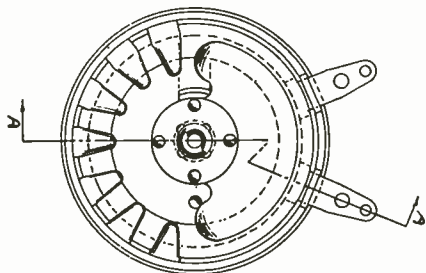

Announces an entirely new product, the "OCTAVE" Tapped Condenser Tone Control, eliminating the Resistance strip. Filtermatic Specialists have developed this unit after months of experimenting.

CHARACTERISTICS

Clear, filtered, unchoked tone; positive, accurate taper; very compact, measuring only 1 1/2 x 3/8". Rugged, non-corrosive, moisture-proof. Only two hot tin dipped terminals to solder.

CONSTRUCTION

Bronze condenser plates, plated steel stop and washers. Dust-proof bakelite case. Priced right. Samples made to your specifications. Fully covered by Patent Application.

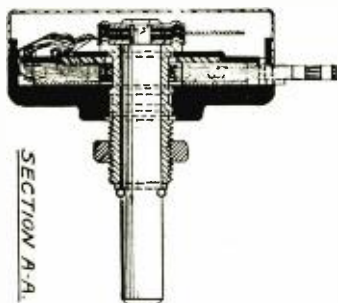

Filtermatic Mfg. Co.
4458 Frankford Ave.
Philadelphia, Pa.



**Silver-Marshall
Laboratory Quality
—Popular Price**



PA60B VOLUME INDICATOR

A precision power level indicator for quantitative monitoring of audio frequency circuits.

RANGE—Minus 8 to plus 48db.

CALIBRATION—Based on zero level of 6 milliwatts in 500 ohms.

BRIDGING IMPEDANCE—5,000 ohms.

METER—Copper-Oxide type.

SIZE—PA60B 4" by 2 1/2" for S-M racks.

PA60BW 5 1/4" by 19" for relay racks.

Many other rack and panel units are available

Write to Mr. Gray for prices, details and the new November Catalog.

SILVER-MARSHALL, Inc.

6401 West 65th Street

Chicago, U. S. A.

Export Division: 41 Water Street, New York City, U. S. A.

**This business
of CHASSIS and CASE
FINISHES**

Brevolite, manufacturing a full line of industrial finishes, is probably the best source of supply.

FOR BRONZE EFFECTS

BREVOLITE—Bronze Medium—An economical and durable clear lacquer for applying bronze powders direct on metal.

FOR UNIQUE ORNAMENTATION

BREVOLITE—Kristokrak—Like frost on a window pane. For decorative purposes there's nothing equal to this beautiful crystal finish. One-coat, air dry, durable.

FOR ALL AROUND USE

BREVOLITE—RV-Lacquer-Enamel—A one-coat lacquer having remarkable qualities of durability, flexibility and tenacity—which actually increases with age.

These BREVOLITE finishes have helped sales of many radio products. Write us.

**BREVOLITE
LACQUER COMPANY**

(Also Waukegan Chemical & Lacquer Co.)
NORTH CHICAGO, ILLINOIS

**MEASURE DISTORTION
SPEED — ACCURACY**



TYPE 536-A Distortion-Factor Meter—\$140.00

For speed and accuracy this new instrument surpasses anything you've ever used for determining the amount of distortion introduced by different circuit elements. It is direct-reading in percentage distortion factor, a quantity that lumps the effects of all harmonics. One measurement tells the whole story.

Write for Bulletin EX-3109

**GENERAL RADIO COMPANY
CAMBRIDGE A, MASSACHUSETTS**



**TRANSFORMERS
UP-TO-DATE**

Transformers up-to-date . . . that's the way Thordarson serves the manufacturers of receiving sets. For instance, whenever new tubes are announced—Thordarson is ready with a transformer to meet their characteristics. An intensive and continuous study of your requirements keeps us in step with every new development in the radio field. And our purchasing, production and distribution facilities keep costs low.

Radio manufacturers are invited to consult Thordarson engineers on the adaptation of our transformers to their particular requirements. Let us work with you. The experience of nearly 40 years' leadership in quality transformer production is at your service.

THORDARSON ELECTRIC MFG. COMPANY
500 WEST HURON STREET, CHICAGO, ILL.



**A FIRM
FOUNDATION**



for
CABINET FINISHING

SANDING Sealer #5959 contains a high percentage of solids and makes a perfect base.

It flows on smoothly and builds evenly. It is easily sanded, and it is the most "foolproof" of all pyroxylin sealers on the market.



Consult our local representative—a seasoned furniture expert—who will demonstrate the splendid features of Sanding Sealer #5959.

"The Standard of Quality Since 1884"

THE ZAPON COMPANY

A Subsidiary of Atlas Powder Company
Stamford * Connecticut

**22 Meters
for the Price
of 1**



The addition of 11 Super Akra-Ohm Resistors to a Weston A.C. and D.C. Type 301 Universal Meter will produce an instrument that will do the job of 22 separate meters.

This real
Universal Meter

which is creating such widespread interest has

- 6 D.C. voltage ranges
- 6 A.C. voltage ranges from 5 to 1000 volts A.C. or D.C.
- 5 D.C. current ranges
- 5 A.C. current ranges from 1 to 500 milliamperes A.C. or D.C.

Send now for Bulletin 150-M which contains a complete diagram of this circuit and full information on its construction.

Actual working drawing and construction diagrams supplied with the Type 600 Resistor Kit.



Shalleross Mfg. Company



ELECTRICAL SPECIALTIES
700 PARKER AVENUE
Collingdale, Pa.
(NEAR PHILADELPHIA)

ROEBLING

WIRE—Antennae (plain or enameled). Connecting and Ground (Rubber covered, braided or plain).

STRAND—Antennae (plain or enameled) — Double Galvanized.

BUS BAR—Litzendraht-Loop

MAGNET (Cotton or Silk)

WIRE PRODUCTS

JOHN A. ROEBLING'S SONS CO.
Trenton, N. J. *Branches in Principal Cities*

CONFIDENCE (ENGLISH READING)



Pats. Pending

**RADIO TUBE
MERCHANTISING
INTERPRETER
BAD-GOOD-GAS**

The Confidence English Reading Tube Tester is not just a tube tester—It is a selling, merchandising interpreter—It is the most efficient and appealing medium for quick and intensive tube sales. More tubes can be sold by application of the Confidence to sale than by

any other known medium. It has appeal. It has "FIT." Simple: ABSOLUTELY FOOL PROOF: Every short indicated automatically. The actual condition of all tubes is told immediately in English to complete satisfaction of all customers.

After 30 minutes use of a Confidence you would not part with it. Try that 30 minute test. In fact we will give you three days free trial. (See coupon.) We will ship the Confidence to jobbers on two to three weeks trial. Plan your tube merchandising by using the Confidence which reaches the 75% of public who cannot remove the tubes from their radio to take to a store for test.

Jobbers take advantage of our trial offer. Compare the Confidence with any other device. See its wonderful internal construction.

Dealers—buy through your jobber or use coupon.

TRIAL OFFER AND DEFERRED PAYMENT PLAN
APPARATUS DESIGN COMPANY—Dept. C
Little Rock, Arkansas

Gentlemen: Please ship immediately one Confidence Tube Tester for which I will either deposit \$59.50 with the express agent or deposit \$16.50 cash first payment and sign five monthly installment notes of \$10.00 each. If at any time within three days I do not want the Confidence Tester I may return it to the express agent, in good condition, and receive my money back. I will pay the small transportation charges.

NAME
ADDRESS

(Please attach three trade references if installment purchase—1st and 2nd credit ratings shipped open.)

The May Number of Radio Engineering

will feature

The R.M.A. Trade Show and Convention

Extra copies of the May issue will be available at the Radio Engineering Booth No. 106. Drop in!

Advertising Forms Close
MAY FIRST

Note—Among radio-industrial and electronic publications Radio Engineering is First in Circulation (over 9,000 A. B. C.). First in Number of Advertisers. Lowest in Advertising Rates per Reader.

AQUADAG

REG. U.S. PAT. OFF.

COLLOIDAL-GRAPHITED WATER

Forms homogeneous, conducting, graphite films on porcelain, glass, paper, etc. Easy to apply and control. Electrical properties vary with strength of solution employed.



FOR RESISTORS

Recommended for tone controls, volume controls, grid leaks and similar forms of fixed and variable resistors.

Send for Technical Bulletin No. R 11.3

ACHESON OILDAG CO.
PORT HURON, MICH.

FOR MOLDED PARTS

RESINOX

Resinox Quality plus Resinox Service assures you of great strength and high dielectric value in your molded radio parts, when you specify "Made with Resinox" on your purchase order. » » »

Our technical staff will gladly assist your molder with unusual or difficult molding problems. There is a Resinox compound for every type of molding job.

RESINOX CORPORATION

A SUBSIDIARY OF COMMERCIAL SOLVENTS CORPORATION AND CORN PRODUCTS REFINING CO.
230 PARK AVENUE NEW YORK CITY

wire

HOOK-UP » » »

All types of braided "push-back" wire. Specially processed for high insulation resistance.

CABLE » » » » BRAIDED CORDAGE

Send for No. 66 Radio-Industrial Catalog on your company letterhead.

Kellogg Switchboard and Supply Company

1066 West Adams Street . . . CHICAGO

OHIO Reliable MOTORS

Self Starting Synchronous Motors

FOR TELEVISION

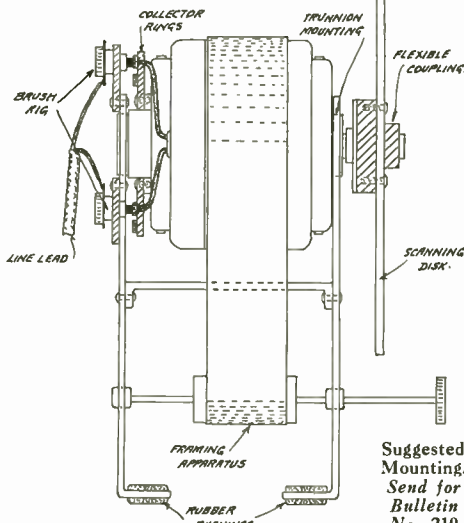

Suggested Mounting. Send for Bulletin No. 210

THE OHIO ELECTRIC MFG. CO.
5917 Maurice Avenue, Cleveland, Ohio

**Premier
AUTO RADIO
Control**



Universal mounting, steering column or instrument board—key switch lock—illuminated dial—indestructible pressed steel—black rust-proof finish—small size 3½" x 4½"—a real job. Manufacturers inquiries solicited.

PREMIER ELECTRIC COMPANY
Established 1905

1802 Grace Street Chicago, U. S. A.

CANDOHMS
ARMORED WIRE WOUND RESISTORS
WILL LOWER YOUR COSTS—May we sample and quote
The Muter Company
1255 S. Michigan Ave. CHICAGO, ILL.

**WAXES, COMPOUNDS
and VARNISHES**
for insulation of condensers
transformers, coils, power packs, pot heads, sockets, wiring devices, wet and dry batteries, etc. . . . WAX SATURATORS for braided wire and tape. WAXES for radio parts. . . . Compounds made to your own specifications if you prefer.

ZOPHAR MILLS, INC.
Court and Lorraine Streets *Founded 1846* Brooklyn, N. Y.

Recording on Metal

If you are interested in this new and profitable branch of Radio, get your name on our mailing list for our new bulletin describing our Crystal cutting head and complete recorders.

**Astatic Microphone
Laboratory**
21 Olive Street, Youngstown, O.

1922 **GATES AMPLIFIERS** 1922
FOR THEATRES, BROADCASTING
STATIONS & ADDRESS SYSTEMS
GATES RADIO & SUPPLY CO.
1932 QUINCY, ILLINOIS, U. S. A. 1932

PROTECT Those INSTRUMENTS

- Littelfuses afford complete protection for voltmeters, milliammeters, tube testers, etc. Range in size from 1/100 to 2 amps. capacity.
- Also Radio Receiver and Amplifier Littelfuses, and High Voltage Littelfuses for transmitting tubes, rectifiers, oscillators, etc.

Write for instructive catalog.
LITTELFUSE LABORATORIES
1778 WILSON AVE. CHICAGO, U. S. A.

"Quicker than a Short circuit" **LITTELFUSES**

For Your Experimental Department

A Tube of 500 Assorted Lugs and Terminals—Hot Tinned for Easy Soldering. Price \$1.00



We are also Prepared to Handle Production Stampings. Write us for quotations.

F. R. ZIERICK MANUFACTURING CO.
68-72 E. 131st ST., NEW YORK CITY

PIEZO-ELECTRIC CRYSTALS

Since 1925 we have been recognized as the RELIABLE PRODUCERS of POWER CRYSTALS. We are at your service to supply your needs. Special prices for quantity lots. Your request will bring our price list.

SCIENTIFIC RADIO SERVICE
"The Crystal Specialists"
124 Jackson Avenue, University Park, Hyattsville, Maryland

NICKEL CUT For Radio Tubes **FLAT ENDS**
between .070 and .006 dia.
±.002"—no burrs—every piece straight
Capacity 10,000,000 pieces daily
Small metal parts to your blue print. 100 to 675,000 pieces per lb.

Art Wire and Stamping Company
18-22 Boyden Place, Newark, N. J.

**BRASS—BRONZE—COPPER
NICKEL SILVER—ZINC
PHOSPHOR BRONZE**

In Gauges .001 and Thicker. 1/16" to 16" Wide
HOT TIN COATED METALS IN COILS AND STRIPS

THE BALTIMORE BRASS CO.
1206 WICOMICO ST., BALTIMORE, MD.

The May Issue
of
Radio Engineering
FEATURES
The 8th Annual Convention of
The Radio Manufacturers' Ass'n
CHICAGO, MAY 23-26

CONDENSER PAPER

182 Cornelson Ave. Jersey City, N. J. — Mills at — Newark Ave. Elizabeth, N. J.
PETER J. SCHWEITZER, Inc.,
200 Fifth Ave. New York

Equip your Midget Radios with

This sound absorption feature will give your set a distinct sales point. Receivers can then be set directly on polished surface without danger of scratches or marks.

Three types: machine screw, wood screw and nail.

Free sample of any type you want



T. R. BRAWLEY FELT COMPANY, INC.
279—20th Street, Brooklyn, N. Y.

STATEMENT OF THE OWNERSHIP, MANAGEMENT, CIRCULATION, ETC., REQUIRED BY THE ACT OF CONGRESS OF AUGUST 24, 1912, OF RADIO ENGINEERING
Published monthly at New York, N. Y., for April 1, 1932.

State of New York } ss.
County of New York }

Before me, a Notary Public in and for the State and county aforesaid, personally appeared B. S. Davis, who, having been duly sworn according to law, deposes and says that he is the Business Manager of RADIO ENGINEERING, and that the following is, to the best of his knowledge and belief, a true statement of the ownership, management, etc., of the aforesaid publication for the date shown in the above caption, required by the Act of August 24th, 1912, embodied in section 411, Postal Laws and Regulations, to wit: 1. That the names and addresses of the publisher, editor, managing editor, and business manager are: Publisher, Bryan Davis Publishing Co., Inc., 19 East 47th Street, New York. Editor, Donald McNicol, Roselle Park, N. J.; managing editor, F. Walen, Union City, N. J.; Business Manager, B. S. Davis, Scarsdale, N. Y. 2. That the owners are: Bryan Davis Pub. Co., Inc.; B. S. Davis, Scarsdale, N. Y.; Roy T. Atwood, Albany, N. Y.; G. R. Bacon, Douglaston, N. Y.; J. C. Munn, Union City, Pa.; J. A. Walker, Richmond Hill, N. Y.; A. B. Goodenough, New Rochelle, N. Y. 3. That the known bondholders, mortgagees, and other security holders owning or holding 1% or more of the total amount of bonds, mortgages, or other securities are: None. 4. That the two paragraphs next above, giving the names of the owners, stockholders, and security holders, if any, contain not only the list of stockholders and security holders as they appear upon the books of the company but also, in cases where a stockholder or security holder appears upon the books of the company as trustee or in any other fiduciary relation, the name of the person or corporation for whom such trustees is acting, is given; also, that the said two paragraphs contain statements embracing affiant's full knowledge and belief as to the circumstances and conditions under which stockholders and security holders who do not appear upon the books of the company as trustees, hold stock and securities in capacity other than that of a bona fide owner; and this affiant has no reason to believe that any other person, association, or corporation has any interest direct or indirect in the said stock, bonds, or other securities than as so stated by him.

(Signed) B. S. DAVIS, Business Manager.

Sworn to and subscribed before me this 22nd day of March, 1932.
(Seal) M. S. OELSNER, Notary Public.

N. Y. County.
New York Co., Clerk's No. 27
New York Co., Registers No. 3-0-10.
Commission expires March 30, 1933.

Electronic Tube Development

We have established modern laboratories and organized a staff of research engineers, highly skilled in the development of ALL types of electronic tubes, to assist manufacturers of electronic equipment in solving their tube problems.

Specializing in developmental work in rare gases, we are equipped to co-operate in the development and manufacture of all types of vacuum and gas filled tubes for specific applications.

PHOTO CELLS SURGICAL VACUUM TUBES
RADIO TUBES (RECEIVING AND TRANSMITTING)
SPECTRUM TUBES TELEVISION TUBES
GLOW TUBES (FOR MOTION PICTURE RECORDING)

Tell Us YOUR Problem

CHICAGO MINIATURE LAMP WORKS
2423 SHEFFIELD AVENUE - CHICAGO, ILL.

—FREE— WHOLESALE RADIO CATALOGUE



The Big Book (136 pages)

Thousands of radio items at real bargain prices. Featuring Public Address Equipment, Microphones, Amplifiers, Recording Equipment, etc.

Send for your copy today.

American Sales Company
R-44 W. 18th St., New York City

LAMINATIONS

for Audio & Power Transformers

SPECIALIZED METHODS—YEARS OF EXPERIENCE

Wide Variety of Stock Standard Sizes

Dimension and Price Sheets on request

We Also Make

PERMANENT MAGNETS—DIES—TOOLS—
METAL STAMPINGS

Facilities for prompt service

Thomas & Skinner
Steel Products Co. 1100 to 1120
E. Twenty-Third St.
INDIANAPOLIS, IND.

RADIO



FILAMENT

Gilgrid Wire and Plate Material
Special Alloys for Various Needs

Also Manufacturers of

Gilby Processed
Carbonized Nickel
For Plates
Gilby Patented
Selvage Mesh

Nickel-Chrome
Resistance Wire
Copper-Nickel
Resistance Wire
Nickel Wire
And Sheet

Our engineering department will meet your specifications.

GILBY WIRE COMPANY

150 RIVERSIDE AVE. NEWARK, NEW JERSEY

KEEP UP-TO-DATE IN DIALS 30 DIFFERENT TYPES

New Models Continually Being Developed

Write and tell us your problems

Eddie Mfg. Co., 9 W. Ill. St., Chicago

1922 GATES CONDENSER 1922
MICROPHONES
FOR GOOD PERFORMANCE
GATES RADIO & SUPPLY CO.
1932 QUINCY, ILLINOIS, U. S. A. 1932

Bring your
WIRE & WELD
problems to
CALLITE

for power tubes and
all special applications

TUNGSTEN
Filament — wire — rod — sheet — coils
special shapes
MOLYBDENUM
Wire — sheet — rod
Special Shapes
WELDS
Special Tungsten Welds—All Types
REFRACTORY METAL CONTACTS
—all types—

• We can supply the finest quality materials on short notice. Our engineers will co-operate with you •

CALLITE PRODUCTS CO., INC.
UNION CITY NEW JERSEY, U. S. A.

DEPENDABLE

QUALITY—UNIFORMITY
SERVICE

ON

WAXES—&—MELTABLE
INSULATING and WEATHER-
PROOFING COMPOUNDS

WAXES—All kinds.

IMPREGNATIONS—Condensers, Coils, Rubber-Covered and Weather-Proofed Wire, Telephone and Electrical Cables, Etc.

SEALING COMPOUNDS—Coils, Condensers, Batteries (Wet & Dry), Pot Heads, Cables, Wiring Devices and Specials.

FINISHING—All grades of Weather Proof and Rubber-Covered Wire.

SPECIAL COMPOUNDS



35th St. & Maplewood Ave.
Chicago, Ill.

"For over 35 yrs."

INDEX OF ADVERTISERS

A	E	O
Acheson Oildag Co. 47	Eddie Mfg. Co. 49	Ohio Electric Mfg. Co., The. 47
Acme Wire Co., The. 48		
Allen-Bradley Co. 12	F	P
American Sales Co. 49	Filtermatic Mfg. Co. 44	Parker-Kalon Corp. 5
American Transformer Co. 41	Frost, Inc., Herbert H. 3	Phelps Dodge Copper Products Corp. 9
Apparatus Design Co., Inc. 46		Premier Electric Co. 48
Arcurus Radio Tube Co. Second Cover	G	
Art Wire & Stamping Co. 48	Gates Radio & Supply Co. 48, 49	R
Astatic Microphone Lab. 48	General Electric Co. 10	RCA Victor Co., Inc. 6, 7
	General Plastics, Inc. 1	Radio Manufacturers Ass'n. 30
B	General Radio Co. 44	Resinox Corporation 47
Bakelite Corp. Back Cover	Gilby Wire Co. 49	Roebbling's Sons Co., John A. 46
Baltimore Brass Co., The. 48		
Brawley Felt Co., Inc., T. R. 49	I	S
Brevolite Lacquer Co. 44	Inca Mfg. Division. 9	Schweitzer, Peter J., Inc. 48
		Scientific Radio Service 48
C	J	Shallcross Mfg. Co. 46
Callite Products Co., Inc. 50	Jefferson Electric Co. 52	Silver-Marshall, Inc. 44
Candy & Co. 50	Jenkins & Adair, Inc. 48	
Central Radio Corp. 36		T
Central Radio Laboratories. 43	K	Thomas & Skinner Steel Products Co. 49
Chicago Miniature Lamp Works. 49	Kellogg Switchboard & Supply Co. 47	Thordarson Elec. Mfg. Co. 45
Chicago Telephone Supply Co. 3	Kester Solder Co. 48	
Clarostat Mfg. Co. 8		W
Condenser Corp. of America. 43	L	Western Television Corp. Third Cover
Continental Carbon, Inc. 48	Littelfuse Laboratories 48	Weston Elec. Instr. Corp. 41
Cross Paper Products Corp. 52		
Crowe Name Plate & Mfg. Co. 35	M	Z
	Muter Company, The. 48	Zapon Company 45
		Zierick Mfg. Co., F. R. 48
		Zophar Mills, Inc. 48

CONTINENTAL CARBON RESISTORS AND SUPPRESSORS

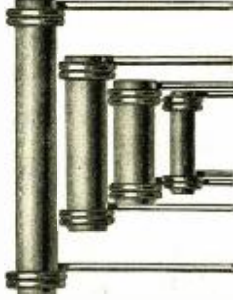

Continental Resistors, being made under strict laboratory and factory control, give entire satisfaction in service.

IN SEVEN SIZES

Continental Suppressors are standard with leading makes of automobile radio receivers.



CONTINENTAL CARBON INC.
SCREW IN CABLE TYPE SUPPRESSOR

SUPPRESSORS ARE MADE IN THREE TYPES OF TERMINALS

Inquiries invited

CONTINENTAL CARBON INC.
13900 Lorain Avenue, Cleveland, Ohio.

COURT DECISION

on plastic rosin-core solder

FULLY PROTECTS
KESTER SOLDER COMPANY!

Of interest to all users of solder

THE Kester Solder Company, owners of the Ripley Patent No. 1,724,680 granted August 13, 1929, covering Plastic Rosin-Core Solders, have successfully asserted their rights under this patent against two New York Companies.

Robert P. Patterson, of the U.S. District Court, Southern Division of New York, rendered an opinion holding the Kester patent valid and infringed by the Plastic Rosin-Core Solder being sold by the defendants, and the final decree states in part:

On August 13, 1931, Judge
"that the plaintiff, Kester Solder Company, is the lawful owner of the entire right, title and interest in and to said Letters Patent, including the right to sue and recover for past infringement thereof."

Judge Patterson's opinion, findings of fact and conclusions of law should be of interest to all classes of solder users. Copies are available to those interested.

The above patent is but one of a number of patents and applications for patent owned by the Kester Solder Company. All efforts to violate or infringe such patents will be vigorously prosecuted.

KESTER SOLDER COMPANY

4238 WRIGHTWOOD AVENUE, CHICAGO, ILL.

Eastern Plant: Newark, N. J.

Canada: Kester Solder Company of Canada, Ltd., Brantford

ACME WIRE PRODUCTS

All ACME products are made to recognized commercial standards, including those of:

- Nat'l Electric Mfrs. Assn.
- Radio Manufacturers' Assn.
- Amer. So. for Testing Materials.

Magnet Wire
(All Insulations)

Parvolt Condensers
(Filter and By-Pass)

Also Condensers for Power Factor Correction

Coils, Magnet Wire Wound

Varnished Insulations
(Cambric, Paper, Silk, Tape)

Aerial Wire
(Stranded and Solid)

For over 25 years, suppliers to the largest radio and electrical manufacturers.

THE ACME WIRE CO.
New Haven, Conn.

Volume Indicator Panel



For Broadcast Speech Input Systems,
Recording and Public Address Installations.
Rectifier type with

Range -16 DB to +32 DB

Mounted on Standard 19" x 7" x 1/4" Black
Enameled Aluminum Panel.

Price in U. S. A. net f.o.b. Chicago

(Code LISPS) \$80.00

Send for Bulletin 8c

JENKINS & ADAIR, INC.

ENGINEERS

CHICAGO, U. S. A.

Cable Address: JENKADAIR

Phone: Keystone 2130 3333 Belmont Avenue

British Offices: 76 Old Hall Street, Liverpool

40 Buckingham Gate, London, S.W. 1

French Office: 16 Rue de Chateaudun, Asnières

Mexican Office: Av. 5 de Mayo 10, Mexico, D. F.

Indian Office: Ismail Bldg., Hornby Road, Fortin, Bombay

43/1 D. Dharamtola Street, Calcutta

Japanese Office: 9 Minami-Sumiyama-Machi, Osaka

Chinese Office: 20 Nanking Road, Shanghai

Economy *without loss of efficiency.*



New! **CROSS Coil-O-Forms**

For lack of a better term, we call these "paper" tubes. In reality they are far superior to the popular conception of a paper product, and a vast improvement over the forms we have been furnishing the radio trade for the past few years. They were recently perfected by our laboratory to answer the need for *economy without loss of efficiency*. Made of a high dielectric material, each form is rigid and precise. They meet close tolerances and in every way, exemplify *precision manufacture*. The absence of deleterious chemicals and acids in the production of these tubes makes them especially suitable for electrical and radio requirements.

For less exacting demands, we make lower priced grades of forms that are suitable for all ordinary electrical applications. We also manufacture fixture and lamp tubes. List your requirements and we'll quote.

Excerpt from a typical letter received:
"At the present time we are faced with the necessity of reducing costs on our radio receivers to a rock bottom value, and for this reason we wish to have you quote upon these forms."

Radio Products Division
CROSS
PAPER PRODUCTS CORP.
2595 Third Ave., New York, N. Y.



Send for this report by the Electrical Testing Laboratories.

New! **A TUBE CARTON** *that offers every protection*

Here is a new tube carton that protects manufacturer, dealer, and customer against substitution, and the misrepresentation of used tubes for new. The tubes can be thoroughly tested without being removed from the carton, but it cannot be used in a radio set until the new patented "seal" inside has been broken. There are many new and desirable features incorporated in this container.

Write for descriptive matter.

CROSS-SECTION
PAT. No. 1664350

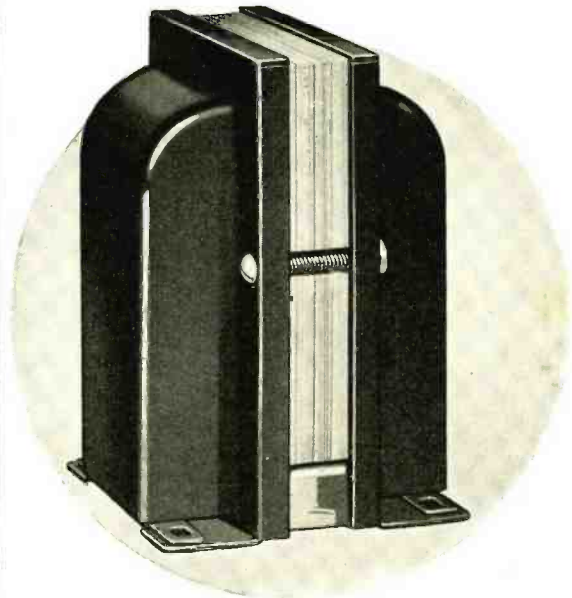

Look to **JEFFERSON** *for your* **TRANSFORMERS**

Long continuous experience, engineering knowledge—and now the newest and most modern manufacturing plant devoted to the production of transformers—are your guarantee of satisfaction—plus.

For New Type Tubes

Designs are perfected for use with new type tubes, including 282 mercury rectifier—246 amplifier and the new low current heater type tubes. Jefferson specialized engineers have accumulated a wide knowledge of radio-transformer design and construction, and are ready to help you with your transformer problems on Class "B" amplifiers.

You'll be safe and profit-wise to consult Jefferson now—and let the Jefferson plant be your transformer plant.

JEFFERSON ELECTRIC COMPANY
BELLWOOD (Suburb of Chicago) ILLINOIS

● Broadcast Engineers and Station Executives

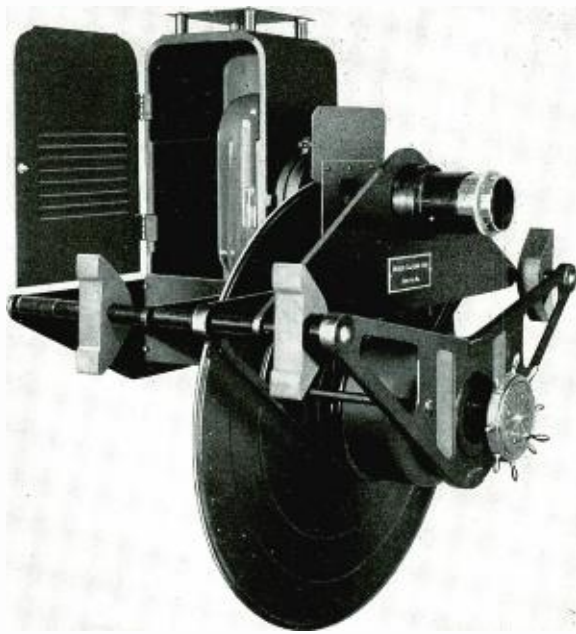

Junior Western Television Transmitter complete. Photocells not shown in this photograph.

An Audience of 120,000,000 is Waiting

Everybody admits that TELEVISION is the next big step in radio development, and as soon as enough television programs are on the air, they'll be received and enjoyed. Many prominent broadcasters are already beginning to take this step. Among those who have purchased Western Television Corporation transmitting equipment are the Chicago Daily News, W9XAP; Chicago Tribune, WGN; Milwaukee Journal, WTMJ; Montreal, Canada, CKAC; Kansas City, Kansas, W9ATU; State University of Iowa, Iowa City, Iowa, WSUI. The equipment purchased by these stations is the most modern type of television broadcast equipment and is being used by them in connection with their study of television problems. Most of these stations are already on the air, some with regular programs and some intermittently. Should any of these installations be near you, our customers will be glad to show this equipment by appointment.

Besides manufacturing this complete television equipment designed primarily for use by those broadcasters who are making substantial contributions to the development of this new art, the Western Television Corporation also manufactures a *moderately priced television broadcaster*.

This Junior Western Television Transmitter is ready NOW for general use by radio engineers as well as for the amateur. It is a complete television transmitter, ready to operate, except the amplifier. Complete blueprints, drawings and instructions for building this amplifier are included with each Junior Western. *Many advanced amateurs are*

buying the Junior Western and broadcasting television pictures on the amateur channels.

With this equipment, complete television programs can be broadcast—programs that can be received within the normal broadcasting range. Springer, W9BWI, Ft. Wayne, Indiana, with less than 100 watts power, was picked up in Indianapolis and Chicago. Hruska, W9GIM, at Cedar Rapids, Iowa, has transmitted pictures to a Chicago suburb. W9XAP, the Chicago Daily News station with 1,000 watts power is received regularly at Milwaukee, Minneapolis, Omaha, Lincoln, St. Louis, Indianapolis, Cincinnati, Detroit and occasionally as far west as New Mexico and California. Every short wave operator, every amateur, every radio experimenter and engineer will be vitally interested in this.

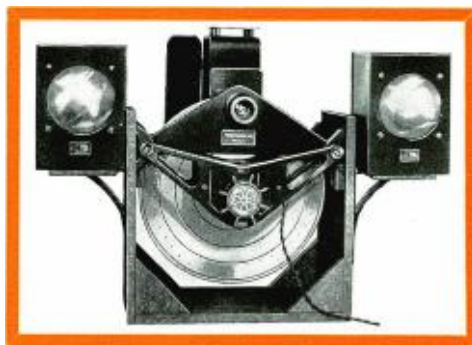

Junior Western Television Transmitter, front view, with the two 6-inch photocells mounted in position.

Every broadcast engineer who expects to maintain his standing in his profession should have a Junior Western transmitter. Buy, experiment with it and learn for yourself the basic fundamental facts about television. Radio station owners and executives should see that their engineering staff has this equipment so that with the advent of commercialized television, they may be immediately familiar with the stage and program technique in television.

A bulletin describing and illustrating this new equipment in detail sent upon request. Also ask about the Western Television Visionette. *Write for facts, data and prices.*

WESTERN TELEVISION CORPORATION

402 WEST MADISON STREET

CHICAGO, ILLINOIS



Weston Photronic Cell with Bakelite Molded case made by Weston Electrical Instrument Corp., Newark, N. J.

Attractive in design, rugged in construction— Bakelite Molded cell case

Photo-electric cells have been put to work by industry. They are found in hundreds of places, performing many highly important duties. Their increasing use requires them to be compact, strong, attractive and inexpensive, as well as efficient. The housing of the Weston Photronic Cell is an excellent example of how Bakelite Molded provides greater attractiveness and utility for industry's new "electric eye".

The use of Bakelite Molded for this cell case has resulted in a small compact unit that is exceptionally strong and attractive. This material provides lasting and constant insulation and is

unaffected by moisture, oils and most corrosive chemicals. In addition, Bakelite Molded permits the manufacture of this case in two simple molding operations, eliminating machining and finishing and simplifying assembly.

Because of its insulating efficiency, strength and durability, attractiveness and economical manufacture, Bakelite Molded is the logical choice for housings, bases, panels and countless other insulating parts used on electronic and radio devices of all kinds. We invite you to call upon us for information and for assistance in adapting this versatile material to your products.

Write for our illustrated booklet 12M, "Bakelite Molded". This booklet contains valuable information concerning the properties and uses of Bakelite Materials. There are also many special materials developed to solve particular insulating problems. Do not hesitate to call upon us for information regarding any of these materials.

BAKELITE CORPORATION, 247 Park Ave., New York...635 W. 22nd St., Chicago
BAKELITE CORPORATION OF CANADA, LIMITED, 163 Dufferin Street, Toronto, Ontario

BAKELITE

The registered trade marks shown above distinguish registered products manufactured by Bakelite Corporation. Under the capital "B" is the number of patent and U.S. use of Bakelite Corporation's products.

THE MATERIAL OF A THOUSAND USES

