

Eleventh Year of Service

RADIO ENGINEERING

100

Vol. XI

APRIL, 1931

No. 4

IN THIS ISSUE



THE NEW VARIABLE-MU VACUUM TUBES

By A. G. Campbell

ADJUSTING THE SUPERHETERODYNE FOR MAXIMUM SENSITIVITY

By Ralph J. Knouf

VACUUM TUBES IN INDUSTRY

By Dr. Paul G. Weiller

LOUDSPEAKER LISTENING TESTS

By Ralph P. Glover

TRANSMITTING TUBES

RADIO ANTENNAS

By E. F. Martin

Sold only by subscription
\$2.00 per year

Variable
Mu
Tube p21

Cathode Ray
TV
Television 29

Modulation
p46

Vacuum
Pump
in cover



The Journal of the Radio Industry

Instant recovery of vacuum

minimizes shrinkage

in high speed production

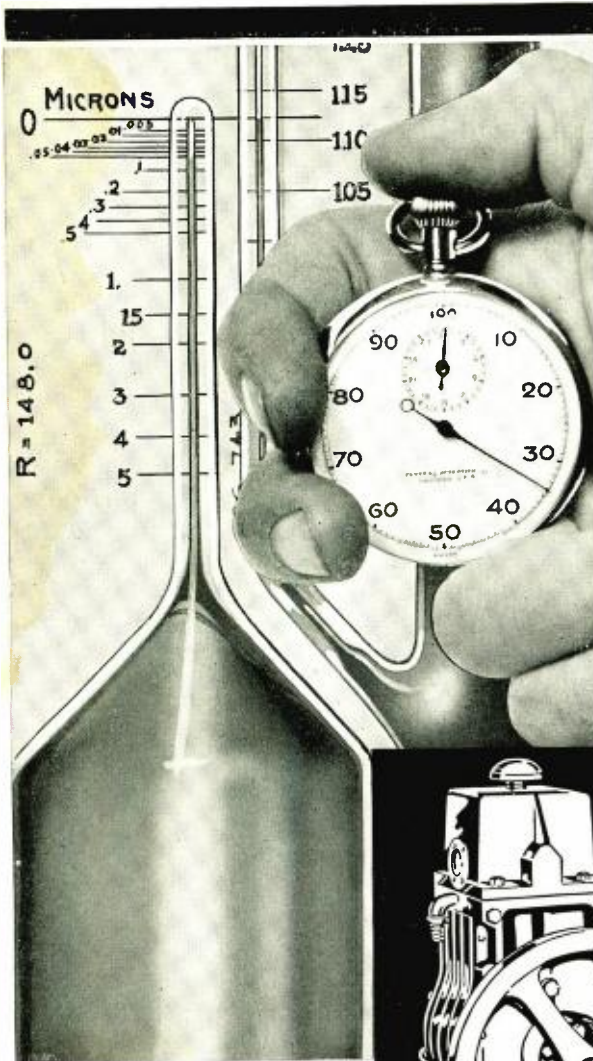

A McLeod gage and stopwatch will select pumps for your automatic machines more accurately than any specification talk. For speed, high vacuum and reliability, such a test invariably selects



You can't stop production to wait for slow pumps to recover and you can't get good tubes while your vacuum lags. Hence production shrinks. But you can use pumps that recover instantly. Cenco HYPERVACS take hold quickly and wipe out those costly minutes of uncertain pressure. They standardize the vacuum factor in production. Also, by their working pressure of 0.05 micron, Hypervacs

put an extra margin of safety in your schedule.

They not only come back faster... but exhaust better. That is no small factor in longer tube life. Then too, their ample volume capacity handles roughing as well as finishing. No pumps other than Hypervacs are necessary for complete exhaustion. This means economy and simplification of equipment

That Cenco HYPERVAC pumps cut tube costs and raise quality of product is being repeatedly proved in laboratories and confirmed in plants. You cannot afford to overlook the competitive seriousness of these facts. For details address, the Central Scientific Company, 460 East Ohio Street, Chicago.

Cenco *Hypervac* Pumps

CENTRAL SCIENTIFIC COMPANY
CENCO HIGH VACUUM PUMPS
Hypvac Megavac Super vac Rotovac Hypervac
NEW YORK - BOSTON - CHICAGO - TORONTO - LOS ANGELES



Depend on » » FORMICA for Your *punched & fabricated parts*

FORMICA is prepared to make the necessary dies for punching your insulating parts in its own tool room, and to punch those parts promptly in small or large quantities in its own plant.

Formica has the largest fabricating equipment for these purposes in the country.

For many years it has served the leading American electrical organization with sheets, tubes and rods, and with fabricated parts, ready for assembly.

Send your blue prints for estimates.

THE FORMICA INSULATION COMPANY
4654 Spring Grove Avenue
Cincinnati, Ohio

FORMICA

RADIO ENGINEERING

Reg. U. S. Patent Office

Member, Audit Bureau of Circulations

Western Editor
ULMER G. TURNER

Editor
DONALD MCNICOL

Managing Editor
F. WALLEN

Vol. XI

APRIL, 1931

Number 4

Contents

	PAGE
EDITORIAL	4
IMPRESSIONS AND EXPRESSIONS By Austin C. Lescarboursa	16
WHAT OF THE FUTURE OF INDUSTRY?	19
THE NEW VARIABLE-MU VACUUM TUBES By A. G. Campbell	21
SOME VIEWPOINTS OF TUBE MANUFACTURING EXECUTIVES ON THE VACUUM TUBE INDUSTRY	25
By Austin C. Lescarboursa	28
CATHODE RAYS IN TELEVISION	29
By H. R. Wright	
VACUUM TUBES IN INDUSTRY	31
By Dr. Paul G. Weiller	
LOUDSPEAKER LISTENING TESTS	35
By Ralph P. Glover	
TRANSMITTING TUBES	38
RADIO ANTENNAS	39
By E. F. Martin	
ADJUSTING THE SUPERHETERODYNE FOR MAXIMUM SENSITIVITY	42
By Ralph J. Knouf	
MODULATION AND ITS SUPPRESSION By Verne V. Gunsolley	46
Departments	
NEWS OF THE INDUSTRY	53
NEW DEVELOPMENTS OF THE MONTH	54



THE PENTODE TUBE

BEGINNING with the Arcturus company's interest in the pentode tube in the Fall of 1928, this tube has experienced an up-hill fight for recognition in America.

However, like all devices of merit, the pentode now emerges from the laboratories to take a place in the radio receiver industry.

The purpose of the pentode, in comparison with triode power output tubes, is to provide a tube having a high mutual conductance, and a high power sensitivity.

Because of its high power sensitivity, the pentode delivers an output of 2.5 watts with 11.7 volts input, as compared to the —45 triode which delivers a maximum output of only 1.6 with an input of 35.4 volts. This factor permits the operation of the pentode at maximum output, directly from the detector tube.

The amplification factor of the pentode is 95, as compared to 3.8 with —45 power output triodes. Both of these factors increase the amplification sufficiently to obtain maximum power output with a single a-f. stage, as compared to the usual two stages.

The pentode, it is stated is four times as sensitive as the —45 power tube—a property of no small economic importance when considering output, detector overload and pre-amplification.

Evidently no other tube yields as many milliwatts output per volt input as does the pentode. What we are to witness in this year's crop of radio receivers, no doubt will disclose the pentode at work at last.



BRYAN S. DAVIS
President

JAS. A. WALKER
Secretary

Published Monthly by

Bryan Davis Publishing Co., Inc.
52 Vanderbilt Ave.
New York City

E. M. BACON
Advertising Manager

J. E. NIELSEN
Circulation Manager

Publication Office—North Broadway, Albany, New York
Chicago Office—333 N. Michigan Ave.—Charles H. Farrell, Mgr.
St. Louis Office—505 Star Building—F. J. Wright

Kansas City Office—306 Coca Cola Building—R. W. Mitchell
San Francisco Office—155 Sansome St.—R. J. Birch
Los Angeles Office—846 S. Broadway—R. J. Birch

Entered as second class matter at the post office at Albany, N. Y., January 9, 1925, under the act of March 3, 1879. Yearly subscription rate \$2.00 in U. S. and Canada; \$3.00 in foreign countries.



Notice the END of the Spool

Every spool of Anaconda Magnet Wire bears a sticker which not only indicates size, weight, insulation, etc., but also assures you of dependable quality. Anaconda—the standard of quality . . . on magnet wire and on 64 other wire and cable products.



ANACONDA WIRE & CABLE COMPANY

GENERAL OFFICES: 25 BROADWAY, NEW YORK
CHICAGO OFFICE: 20 NORTH WACKER DRIVE

Sales Offices in Principal Cities

Magnet Wire Mills at Anderson, Indiana; Muskegon, Michigan; Sycamore, Illinois; and Ansonia, Connecticut

E d i t o r i a l

APRIL, 1931

TUBE
SALES TO
CONSUMERS

OUT of the experience gained thus far in the sale of radio receivers to the public, enough has been learned to point the way to stable systems of merchandising.

It is perhaps inescapable that in periods of business depression the scramble for business on the part of competing manufacturers results in practices developing which, although they may have temporary advantages in individual instances, ultimately result in general demoralization of sales.

So far as tube sales are concerned it should be apparent that either by association control or by cooperative deliberation between manufacturers, the large gross sales could be made profitable to the manufacturers and at the same time more satisfactory (less disturbing) to the ultimate consumer.

There are two factors of tube merchandising which cry aloud for sane adjustment. One is the matter of "guarantee," the other that of the universality of tube types applicable to most models of radio receivers. The set manufacturer who makes his own tubes or who "adopts" a certain make of tube for his receivers, may have an initial advantage in selling both receiver and tubes at the outset. But, from the viewpoint of the continuity of reception service so important to the best interests of radio, it is detrimental if the set owner is given the impression that only a certain make of tube will permit the set to do its best work. And, when a receiver manufacturer sets out to broadcast the idea that only a certain type of tube must be used in his receiver, one result that follows is the vicious circle of retaliation.

As has been pointed out before, in a given year, reasonably definite specifications govern the making of standard radio tubes.

Radio receivers, to be generally satisfactory, should be built to operate successfully with *all* standard tubes.

Responsible tube makers standardize their product and analyze its operation with the aid of precision equipment, designed by competent and experienced tube engineers. Extensive investigations are made of factors affecting vital phenomena as primary and secondary grid emission, noise (including hum), microphonics, heating time, reverse emission, interelectrode capacities, mechanical strength, etc. Then follows the all-important test under adverse operating conditions—the checkup during hundreds of hours of burning—mutual conductance, gas, oscillation, plate current, emission, voltage amplification and numerous other characteristics.

There is in this situation common ground upon

which either the organized radio industry, or its individual economics experts should meet without further delay.

On the subject of "guarantee," more anon.

▲
SUPER-
HETERODYNE
DIMENSIONS

IT WAS no doubt a fortunate thing for the superheterodyne's cyclic visitation of 1931, that the tendency in midget set design had turned toward larger dimensions. Receivers still designated as of midget construction have this year taken on housing proportions of little less bulk than the table models of a year or two ago.

In view of all that is required to make up a satisfactory superheterodyne radio, and in the interest of loudspeaker preservation of the low tones it is well that the trend was not toward vest pocket or thumb nail receivers.

▲
HARNESSED
ELECTRONS

MODERN vacuum tubes may be viewed from various angles when one attempts to form a picture of their utility in radio and in other applications. The tube may be considered as a piece of apparatus—an instrument—capable of performing known functions, or it may be viewed as an addition to or a complex element of an otherwise simple electric circuit.

There are five processes by means of which electrons may be caused to pass from a metal. In certain circumstances several processes may be involved at the same time. These are high temperature, photoelectric effect, bombardment by high speed particles, contact with excited molecules or atoms, and removal by strong electric action. The "pulling out" of electrons by high fields has caused no end of speculation on the part of research engineers working on vacuum tube problems.

The efficiency of an electron emitter, such as that forming an element of a vacuum tube may be rated in milliamperes of electrons furnished per watt of heating energy. It will be some time yet, however, before understandable, and dependable, laws are established in current terminology, which will explain surely the physics and chemistry of electron emission.

Donald Mc Nicol
Editor.

Scientific tests at N. Y. U.

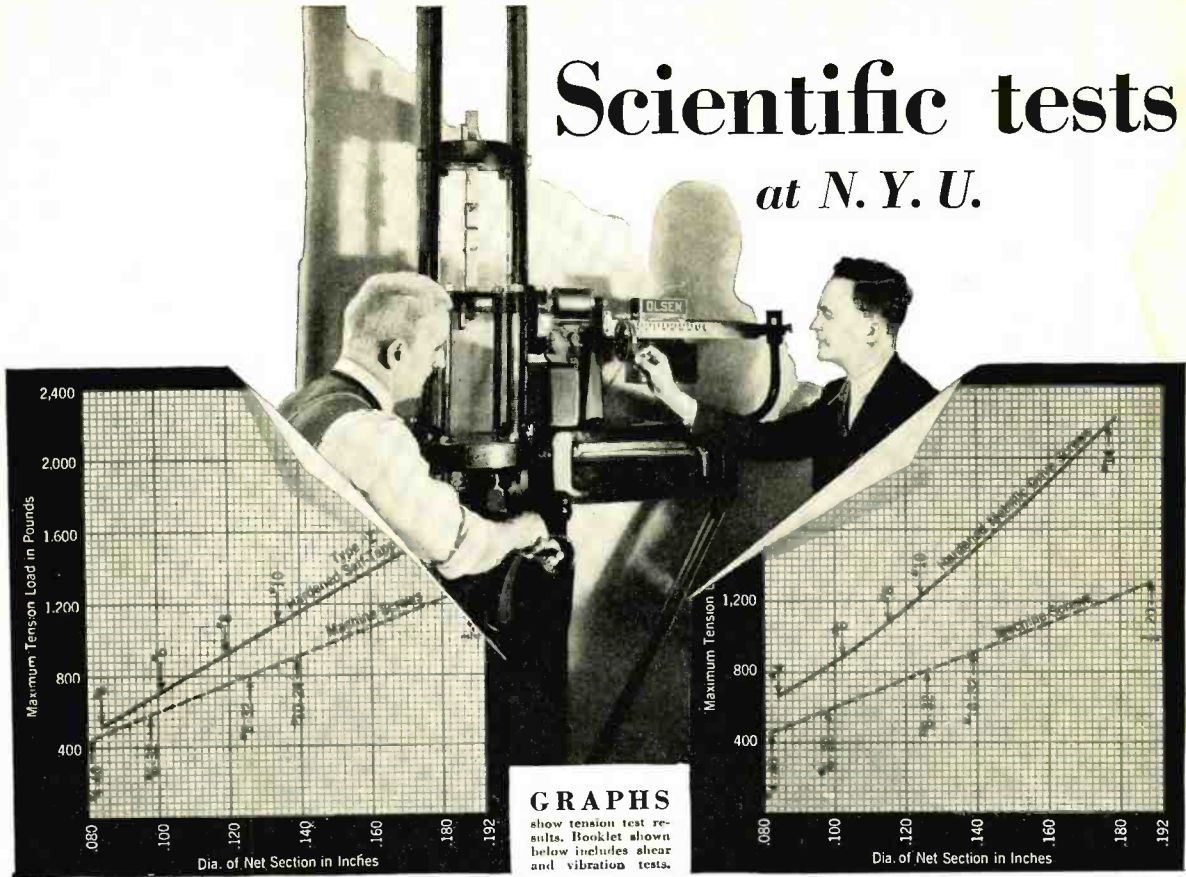

*prove that fastenings made with Self-tapping Screws
have **GREATER TENSION** and **SHEAR STRENGTH**
than fastenings made with machine screws*

THE question, "Do Self-tapping Screws, noted for economy in assembly work, have greater or less holding power than the fastening devices they usually replace?" has been answered by scientific tests conducted by the College of Engineering, New York University.

In an Olsen testing machine, tension and shear loads were applied to a number of metal assemblies made with the two types of Self-tapping Screws—Hardened Metallic Drive Screws and Hardened Self-tapping Sheet Metal Screws. Under identical conditions—machine screws—the most common alternative means of fastening, were also tested. These tests proved that fastenings

made with Self-tapping Screws have invariably higher tension and shear strength. Other tests demonstrated their superior holding qualities under vibration.

The booklet offered below completely describes and illustrates all of the tests—tension, shear and vibration—conducted at the College of Engineering, N.Y.U. It will be sent to you free—just mail the coupon. With it you get another interesting booklet, showing the large savings gained on the metal assemblies of many well-known products through the use of these unique Screws that eliminate tapping, fumbling with bolts and nuts, and other fastening difficulties.

PARKER-KALON *Hardened Self-tapping Screws*

PAT. IN U. S. AND FOREIGN COUNTRIES



PARKER-KALON CORPORATION, DEPT. L, 198-200 VARICK ST., NEW YORK, N. Y.

Send me free booklets on the Security and Economy of assemblies made with Self-tapping Screws.

Name and Co. _____

Address _____



You Don't Need A Can

With The

ELKON Non-Aqueous Hi-Volt Condenser!

**Specify Elkon
Without
the Can and
Reduce Your
Condenser
Cost**

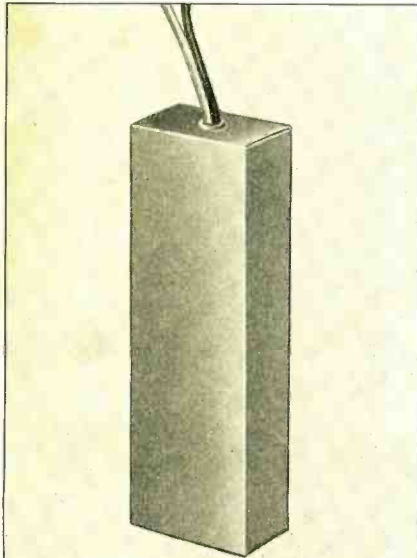

The sturdy, wax-dipped cardboard carton used on Elkon condensers is ample protection to insure efficient operation.

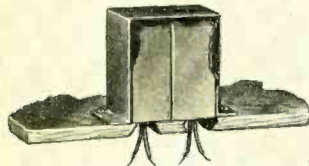

If your set is already designed for condensers on top of the chassis, the Elkon condensers may be placed under an inexpensive drawn metal cover.

otherwise—



—the condensers may be mounted directly to the under side of the chassis.

There's Nothing to Spill » » »
Nothing to Leak » » »

ELKON alone offers this opportunity to reduce your condenser costs by eliminating the can. The sturdy, wax-sealed cardboard container used on Elkon condensers is ample protection to insure efficient operation. The other features of the Elkon condenser also show why many leading set and instrument manufacturers have adopted the Elkon condenser as standard equipment:

- 1 Highest Filtering Capacity of any electrolytic condenser.
- 2 High Working Voltage: 450 volts—withstands without injury transient peaks in excess of 575 volts.
- 3 Absolutely Dry: A condenser from which all water is eliminated.
- 4 Low Leakage: Normal rated leakage 0.1 mil per mfd. (After operating short period the leakage is 0.025 mils permfd.)
- 5 Impervious to Low Temperatures: Operates efficiently from minus 40° F to 125° F.
- 6 Long Life: To reduce replacements and interrupted service periods to a minimum.
- 7 Self Healing: Transient peaks in excess of 575 volts do not injure the Elkon condenser.
- 8 Compactness: Smallest cubical volume per microfarad of any condenser on the market.
- 9 Stability in Operation: To guard against mechanical and electrical variation that would affect action of the circuit.
- 10 Low Cost Per Microfarad Per Voltage Rating: A large safety factor in volt rating for the same cost as lower voltage condensers.

Samples built to your specifications will be sent to all recognized manufacturers (metal cans will, of course, be supplied if desired).

Send for booklet giving complete technical data and general descriptions.

ELKON DIVISION

P. R. Mallory & Company, Incorporated
Indianapolis, Indiana



The new RCA 235 is not interchangeable with any other RCA Radiotron and must be used in circuits especially designed for its characteristics.

Announcing the New Super- Control Screen- Grid Amplifier

THE RCA Radiotron Company, Inc., is pleased to announce a screen grid radio frequency amplifier, designed especially for reducing cross-modulation and modulation distortion. Furthermore, its design is such as to permit easy control of a large range of signal voltages without the use of local-distance switches or antenna potentiometers. This feature makes the tube adaptable to automatic volume control design. It is designed for AC operation, and employs a cathode of the quick heater type.

Tentative ratings and characteristics of the RCA 235 are:

Filament Voltage	2.5 Volts.
Filament Current	1.75 Amps.
Plate Voltage (Recommended)	180 Volts.
Screen Voltage (Recommended)	75 Volts.
Grid Voltage	-1.5 Volts.
Plate Current9 Milliampères.
Screen Current	Not over 1/3 of plate current.
Plate Resistance	200,000 Ohms (Approx.)
Mutual Conductance	1100 Micromhos.
Effective Grid-Plate Capacitance	0.010 uuf. Max.

RCA RADIOTRON COMPANY, INC. — HARRISON, N. J.

A Radio Corporation of America Subsidiary

RCA RADIOTRONS

« « *The Heart of Your Radio* » »



The original research and development work of Dubilier engineers in the electrolytic condenser field is now at your disposal. Do not hesitate to place your condenser problems before us. Details and samples of Dubilier Hi-Mike Condensers will be cheerfully submitted.

DUBILIER Inverted Type HI-MIKE CONDENSER

● For sub-panel wiring jobs, the Dubilier engineers have developed the Dubilier Inverted Type Hi-Mike Condenser—a fitting companion for the standard type, with the same general characteristics:

1. Aluminum can $4\frac{1}{2}$ by $1\frac{3}{8}$ inches, interchangeable with other standard electrolytic units.
2. Standard capacity of 8 mfd., with highest percentage of effective capacity.
3. Working voltage conservatively rated at 400, peak of 430, and capable of withstanding 500 for short periods.
4. Fully self-healing, reforming faster than any other electrolytic condenser.
5. Lowest leakage at high voltages—approximately 0.2 milli-ampere at 430 volts peak, after 100 hours.
6. Power factor less than 10%.
7. Life expectancy in excess of requirements of usual radio assembly.
8. Compact, clean, non-spillable, efficient, inexpensive, self-healing, reliable.

DUBILIER
CONDENSER CORPORATION
4377 BRONX BOULEVARD · NEW YORK CITY

DISTINCTION

Everything in prehistoric Peru belonged to the Inca; the copper and gold mines were worked exclusively for their benefit. According to tradition the Incas governed wisely, and never made war without just cause. They were of a high order of intelligence and had that capacity for leadership which resulted in a most efficiently organized government.



Distinction in coils? Yes . . . distinction in appearance . . . distinction in performance . . . distinctions of utmost importance to the finished set or radio unit.

Inca coils have a practical side, too. Your engineers will recognize their superiority from an electrical standpoint; your plant manager will find them better to handle and assemble.

The patented field coil for dynamic speakers, audio coils, choke coils, radio frequency coils and power coils . . . all have outstanding features which distinguish them from the ordinary.

We would welcome the opportunity to furnish samples wound to your specifications.

INCA MANUFACTURING DIVISION



Symbolic of the best in copper wire products.

Eastern Office: 233 Broadway, New York, N. Y.

Western Office: 1547 Venice Blvd., Los Angeles, Calif.

of NATIONAL ELECTRIC
PRODUCTS CORPORATION
FORT WAYNE, INDIANA

PRACTICALLY ANY SPECIFICATION CAN BE FILLED FROM FANSTEEL STOCK

HOW often, for experimental purposes, have you ordered a small quantity of rare metal wire or sheet in an odd size, only to be told that it would take days or weeks to make this metal to your order — and at “special” prices?

It pays to turn to Fansteel first — always — because there is here main-



tained a complete stock of Tantalum, Tungsten and Molybdenum wire and sheet in a wide assortment of diameters and sizes — ready for immediate shipment.

Should it happen that your requirements are *most unusual*, we can draw, roll, or otherwise fabricate material exactly to your specifications, and ship it, usually, in a few hours.

Give this service a trial, also get quotations covering your regular production requirements

FANSTEEL PRODUCTS COMPANY, INC.,
NORTH CHICAGO, ILLINOIS

TANTALUM • TUNGSTEN • MOLYBDENUM • CAESIUM • RUBIDIUM AND ALLOYS

AEROVOX

BUILT BETTER
CONDENSERS AND RESISTORS

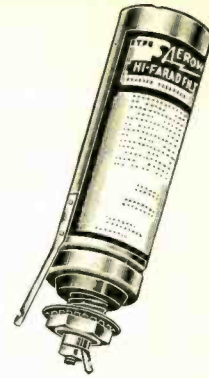
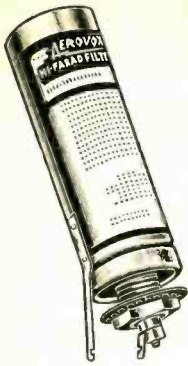

The Most Complete Line of Screw Mounting DRY Electrolytic Condensers in the Radio and Electrical Industries

Available in a wide variety of sizes, capacities, voltage characteristics and mounting features. These units are Dry, Low in Cost per Microfarad per Volt Rating, Compact, Light in Weight, Safe, Surge-Proof, Self-Healing, and provide Long Life, Stable Operation and High Filtering Efficiency. They may be mounted in any position—Upright, Inverted, Horizontal or at any other angle.

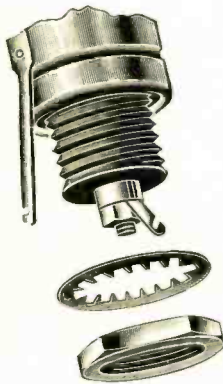
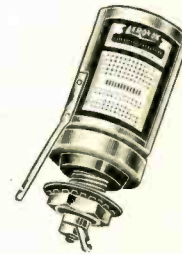

**Grounded Can
Mounting**

Disassembled view of nut, lock washer and screw mounting designed to automatically connect cathode (can) to metal chassis.

FREE!

A copy of a 32-page book, containing a wealth of information on all types of electrolytic condensers will be sent free of charge on request. Just mail the coupon below.

AeroVox Wireless Corporation,
76 Washington Street,
Brooklyn, N. Y.

Please send me, without charge or obligation, a copy of your 32-page book, "The Hi-Farad DRY Electrolytic Condenser."

Name

Address

City..... State.....

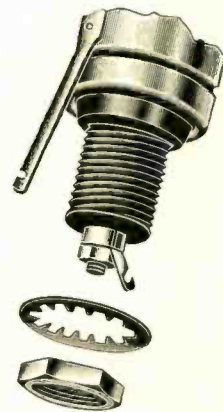

**Insulated Can
Mounting**

Disassembled view of nut, lock washer and screw mounting designed to insulate cathode (can) from metal chassis.

AEROVOX WIRELESS CORP.

76 Washington Street, Brooklyn, N. Y.

PRODUCTS THAT ENDURE

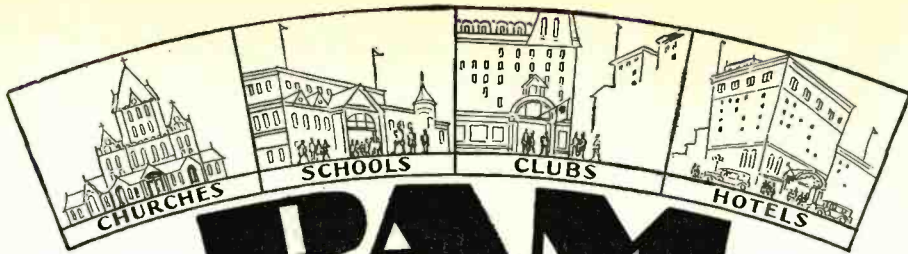
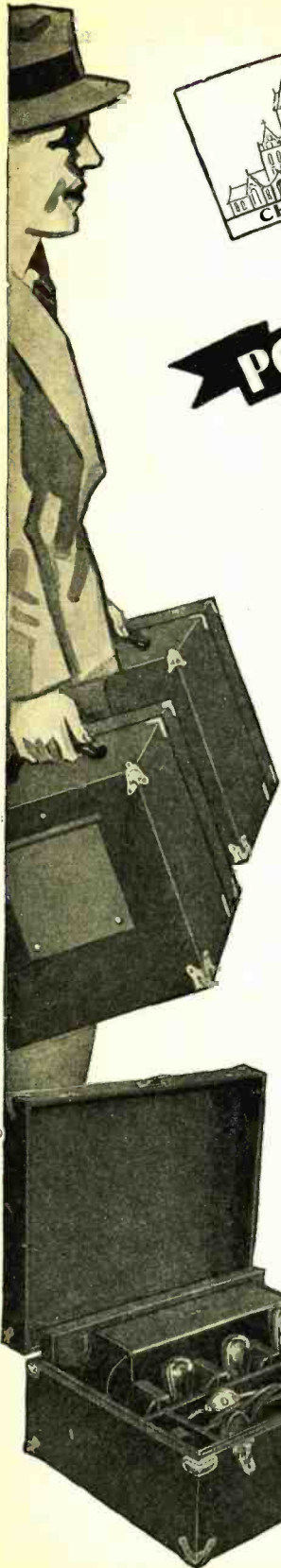

PAM

PORTABLE ADDRESS SYSTEM

quickly

Pays for Itself

Schools, churches, clubs, hotels need the portable PAM Address system. With it, a speaker addresses 500 people as easily as half a dozen. Speech and music, both vocal and instrumental, are amplified with excellent quality.

The units in this system are completely matched and designed to operate together. Naturally the results obtained are superior to a combination of units procured from different sources which were not designed to operate together.

The two units that are required (MIK 100 and PAM 100) together weigh less than 75 pounds, and the system can be set up ready for use in less than five minutes. No batteries are required . . . and the price complete with tubes, microphone, etc., and nothing left to buy, is \$343.00.

Send for twin folders RE4; one descriptive of the PAM-100 and the other of the MIK-100.

SELL
 Portable PAM Address system to institutions that hold regular meetings and need the equipment permanently. This price is reasonable and the profits are large.

RENT
 Portable PAM Address systems for special occasions. One man can transport the entire system and set it up in five minutes. After a few rentals the cost is recovered and future income is all profit.

Main Office:
 Canton, Mass.

Samson Electric Co.

Factories: Canton and
 Watertown, Mass.

MANUFACTURERS SINCE 1882

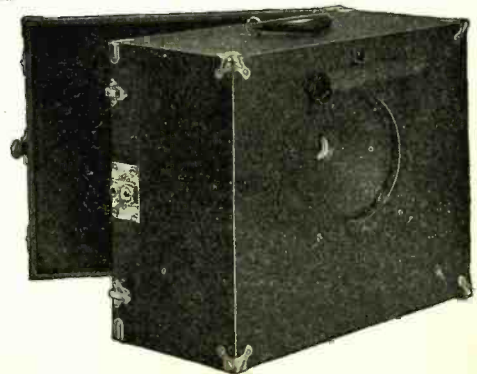

What a Whale of a Difference a Few Cents make

to paraphrase this popular slogan, CENTRALAB Volume Controls do cost more.

But it is hardly possible to build for less a control that embodies the exacting specifications, the painstaking care, the fine engineering skill that make CENTRALAB CONTROLS a necessary part of millions of modern radios.

When dealers predicate the purchase of a line with a definite demand that it be CENTRALAB equipped, it is safe to assume that "such popularity must be deserved." More than twenty million



Centralab

CENTRAL RADIO  LABORATORIES

VOLUME CONTROLS

have been built . . . a real tribute to *quality* . . . a splendid testimonial to the desire of the radio set manufacturer to give their public the best.

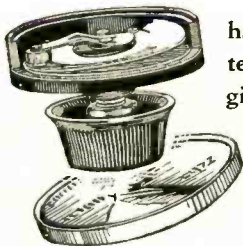

MAIL COUPON NOW

CENTRAL RADIO LABORATORIES
928 Keefe Ave., Milwaukee, Wis.
Enclosed find 25c for which send me new
VOLUME CONTROL GUIDE.

Name

Address

City..... State.....

R. ENG.

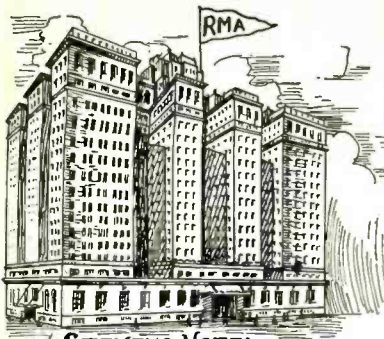

STEVENS HOTEL
(HEADQUARTERS)



GO!

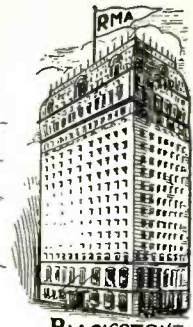

BLACKSTONE HOTEL

TO THE
FIFTH ANNUAL

RMA Trade Show

AND 7TH ANNUAL RMA CONVENTION

CHICAGO

JUNE 8 to 12th



BUSINESS\$ FOR YOU WITHOUT BALLYHOO

EVERYBODY WILL BE THERE.

Business will be the key-note during "Radio Week" of June 8th. This will be a "business" show and business for YOU. business for everybody in radio.

The National Furniture Industry and the Music Industry also will be holding conventions and exhibits in Chicago, drawing thousands of visitors, during "Radio Week."

All the new radio products on display in the trade show. Every leading manufacturer of receiving sets, tubes, speakers and accessories has reserved exhibit booths in the trade show and demonstration rooms in hotels. There will be more new circuits, new tubes, new speakers, new cabinet designs, and new radio products, including home talkies, television, remote control, and other radio devices and products than ever before in one year.

Thirty thousand (30,000) square feet of radio exhibits in the Grand Ball Room and Exhibition Hall of the Stevens Hotel.

ADMISSION TO THE TRADE ONLY — NO VACANT BOOTHS — ALL EXHIBITORS REQUIRED TO SHOW THEIR MERCHANDISE.

Twenty-five thousand radio manufacturers, jobbers and dealers expected to attend.

Reduced railroad rates have been granted on all lines — one and one-half fare rate. Secure certificates from local railroad agents. RMA special trains from all sections.

Official hotels — Stevens Hotel (headquarters), Blackstone, Congress and Auditorium Hotels, with demonstration rooms of manufacturers.

INDUSTRIES AND EXHIBITIONS

Radio industries, June 8-12 — RMA, National Federation of Radio Associations, Radio Wholesalers Association and National Association of Broadcasters.

Music industry convention and exhibits, Palmer House — June 8-10, during "Radio Week."

Institute of Radio Engineers annual convention, Sherman Hotel — June 3-6.

Annual national "Furniture Mart" with 25,000 furniture buyers, jobbers, dealers and manufacturers — June 1-15.

Business meetings and entertainment for visitors during entire "Radio Week" — June 8-12 — RMA "stag" party Wednesday, June 10 — Music Industry banquet, Tuesday, June 9.

Apply now direct to hotels for room reservations.

RMA invitation credentials mailed to the trade about May 1st. For information or credentials write to Bond Geddes, RMA Executive Vice-President, Stevens Hotel, Chicago, or.



CONGRESS HOTEL



AUDITORIUM HOTEL

RADIO MANUFACTURERS ASSOCIATION

11-W. 42ND ST. N.Y. CITY

32 W. RANDOLPH ST. CHICAGO

FROST-RADIO



Amazingly noiseless—

Frost-Radio engineers have been amazingly successful in removing the cause of noise from wire-wound controls. In the new Frost-Radio No. 20 Series there is an

entire absence of noise. The operation of these controls is velvety smooth and silent to a degree heretofore believed impossible in wire-wound units.

Specially designed variable contactor

This is accomplished by using a specially designed variable contactor which makes two separate and distinct line contacts with the resistance element, each contact being $\frac{3}{32}$ " in length, a total line contact of $\frac{3}{16}$ ". Frost-Radio construction makes it possible to employ more turns and larger wire. Space between turns has been successfully reduced to one ten-thousandth of an inch. Contact pressure has been greatly reduced, and danger of cutting and scoring practically eliminated. Nor can dirt, fragments of metal, etc., prevent the runner from making positive, continuous contact with the resistance element. Most amazing of all, fatigue tests have shown that our No. 20 Series Volume Controls can be depended on for 1,000,000 complete rotating operations without trouble of any kind developing. . . . Engineers are invited to send us specifications of their volume control requirements.



No. 20 Series
Single Control

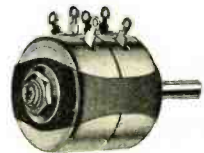

No. 20 Series
Tandem Unit



No. 20 Series
Tandem Unit
with A.C. Switch

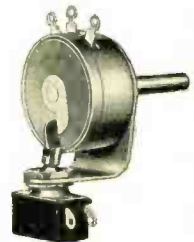

No. 20 Series Single
Control with A.C. Switch

CHICAGO TELEPHONE SUPPLY CO.

HERBERT H. FROST, Inc.
SALES DIVISION

General Offices ELKHART, INDIANA and Plant

Impressions and Expressions

By AUSTIN C. LESCARBOURA

DX DAYS AGAIN

WHATEVER the cause, radio reception has materially improved during the past sixty days. Suddenly, as though a veil were lifted from the average radio set, it is now possible to pull in distant stations with little or no effort. Coast-to-coast reception has become commonplace during the last month. DX days are here again, even with one-dial receivers which allow little if any skill in tuning in weak signals.

We are particularly fortunate in having this lucky break. The radio trade is going to cash in on the DX possibilities. After all, your public is always fascinated by the spanning of distance, and that ham-and-egg program from three thousand miles away is bound to prove more interesting than the wonderful program from the local station.

Meanwhile, we are wondering whether the proposed increase of power of many of our stations is wise at this time. During the past half dozen years, reception has been rather poor, as compared with the early days of radio. Hence power rating has been constantly increased in order to provide a reasonable service area. But now, with the atmosphere suddenly clarified and with signals reaching out several times as far as heretofore, we just wonder whether further increase in power is justified or even wise on other than cleared channels.

SHORT-WAVE CONVERTERS

THE general availability of the superheterodyne circuit to licensed set manufacturers is reflected in the sudden appearance of practical short-wave converters for use with the usual tuned r-f. receiver. Even the RCA-Victor organization, with its well-known conservatism in engineering and merchandising matters, has seen fit to introduce a superheterodyne short-wave converter.

The superheterodyne converter is, of course, a signal frequency changer. It intercepts the short-wave signal and, by means of heterodyning, converts it to an intermediate frequency falling within the usual broadcasting wave band. The output from the converter is fed into the usual tuned r-f. receiver, which serves as an intermediate frequency amplifier, second detector, audio amplifier and loudspeaker, complete. The results are truly remarkable: in broad daylight, the short-wave signals from England, Germany, Italy, Holland and other distant countries can be tuned in with almost as much volume as local stations, and with a reasonable minimum of background noise and fading.

The big problem in using the short-wave superheterodyne converter, however, is to find a blank spot on the usual broadcast receiver. This is especially true at night when the tuning dial from end to end is occupied, even when the set is disconnected from antenna and ground.

Just how soon the short-wave converter feature will be incorporated in the usual console is a matter for conjecture. We opine that it won't be long now. There are too many good things on the air among the short waves, while the superheterodyne converter makes the addition so simple, to put off this big sales point much longer.

TELEVISION REACHES FIFTH AVENUE

WITH the inauguration of a sight and sound broadcasting studio on Fifth Avenue, in the very heart of New York City, television may be considered as definitely emerging from the laboratories. Station W2XCR, rated at 5000 watts, is to broadcast the visual portion of the program, with Station WGBS, a well-known sound broadcaster, for the aural portion.

It is our personal belief that television only awaits the magic of showmanship to convert it from a laboratory experiment to a merchandising possibility. Until now, well-meaning engineers have operated the television transmitters, and while they have in some instances aspired to real program services, they have been seriously handicapped by training and by laboratory considerations from attaining true entertainment.

The sight and sound broadcasting studio in New York City is the first real test of television entertainment. Located in the heart of the largest entertainment center of the world, with an inexhaustible supply of talent to draw upon—much of it without cost because of the publicity accruing from an early television appearance, the studio should have no difficulty in evolving programs of real worth.

Frankly, the matter now comes down to the receiving end. Will an audience be created for the studio's efforts? Will the artists and speakers be assured of a worthy gathering of lookers-in, to make their efforts effective? In the answer to those questions lies the future of the television art from the practical, everyday standpoint.

LIGHT VALVES

WORD reaches us from England and Germany regarding the recent progress made in the light valve art. We cannot mention photoelectric cells in the same breath, for our British and German confreres have developed devices which do away with the intricate vacuum tube amplifiers heretofore associated with practical light-sensitive devices.

Simplicity itself is the keynote of the recent advances. Light valves are now available which can operate an inexpensive polarized relay. A B-battery completes the arrangement. The contacts of the relay can control the desired circuit, or if a considerable current is to be handled, a secondary relay may be added, with a most ingenious form of vacuum contact arrangement to handle large amounts of electricity.

When the many possibilities of a simple and inexpensive light valve are considered, it becomes apparent that we are about to enter still another era of commanding electricity to do our bidding. What the vacuum tube has made possible by way of impressing our will upon electricity, the light valve promises to duplicate in its respective field. Only the intricacy and high cost of the photoelectric cell and its associated equipment has heretofore stood in the way of a wider application of light-controlled devices.

APRIL, 1931

It's Easy To Identify 1931 Tubes

Look for Robust Rectifiers

Ample and uniform current supply for every tube in the A. C. radio set—that is the function of the rectifier tube. De Forest engineers have insured that function with these latest refinements:

1. Special alloy hooks maintaining uniform tension on filaments.
2. Ingenious clamping to insure accurate plate dimensions for equalized full-wave rectification.
3. Carbonized plates insuring maximum heat dissipation at higher outputs demanded by latest sets.
4. Tapped filament to insure low-resistance welds and prevent weakened filament due to spot welding.
5. Exhaust port positioned well below press to avoid leakage.

These and many other advanced features found in every type of fresh De Forest Audion, insure the 1931 performance of any radio set.

This is the fourth of a series of debunking messages dealing with 1931 radio tube features. The entire story can be sent to you immediately, if you so desire.

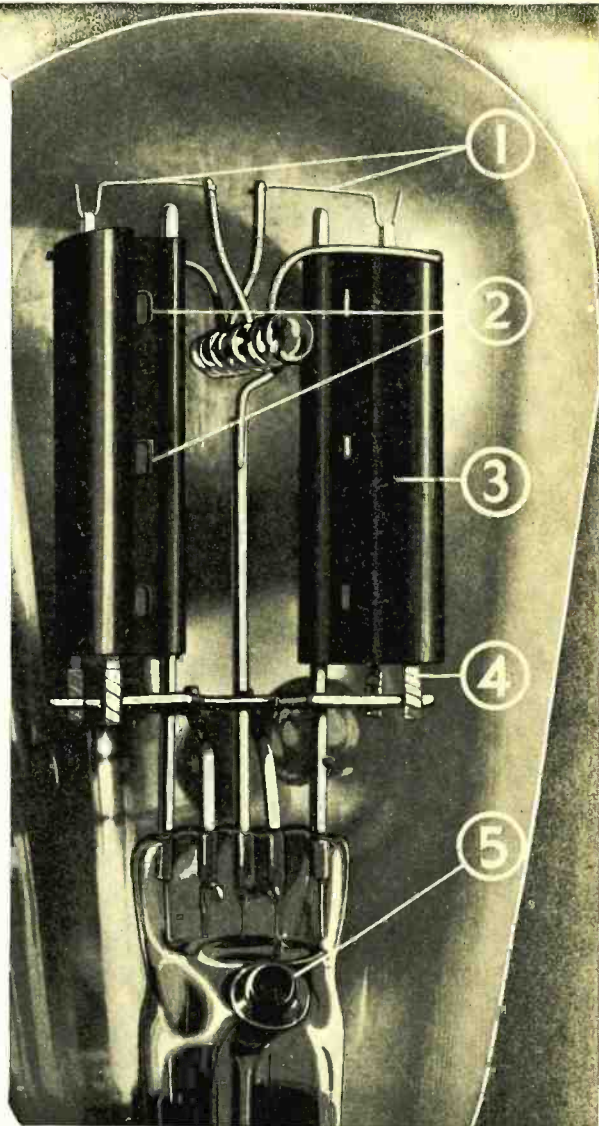

de Forest
AUDIONS
RADIO TUBES

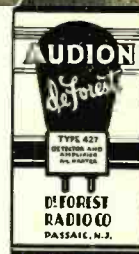

DE FOREST RADIO CO., PASSAIC, N. J.



After all, there's no substitute for 25 years' experience



S E L E C T I V I T Y S E L L S S E T S

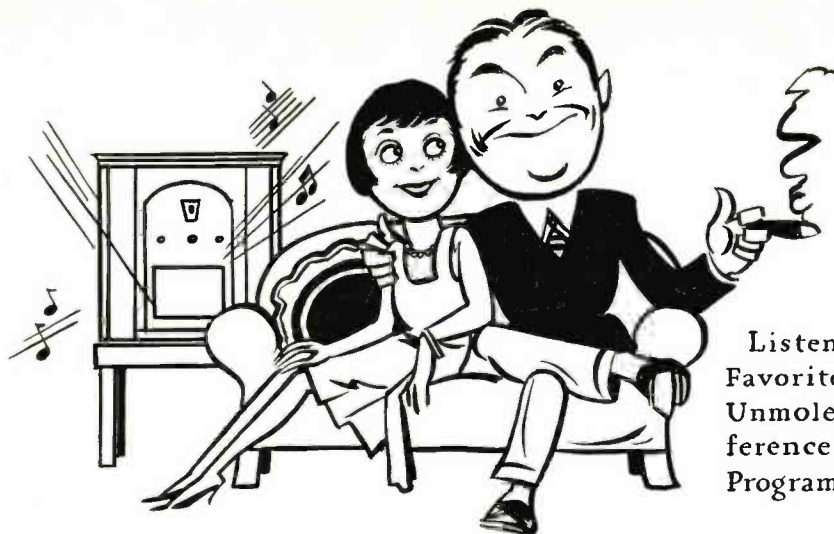

Listening to Your
Favorite Radio Program
Unmolested by Inter-
ference from Competing
Programs

Textolite Safeguards Selectivity

PROGRAMS that once quarreled their way through now flow in with satisfying clarity — where the insulation is right. That's why some of the most prominent radio manufacturers have intrusted the right insulation of their receivers to laminated Textolite.

Here is a superior material that emerged fully tested from one of the greatest research laboratories in the world. It has proved its ability to preserve the original precision of tuning with unflagging fidelity. It possesses a practically constant power-factor under varying conditions.

Don't hesitate to request information on Textolite — in sheets, rods, or tubes — from the eastern or western fabricators, or from the Textolite specialist in the General Electric office of your vicinity.

General Fabricating Co.
37 East 18th Street
New York City

Electrical Insulation Corp.
308 W. Washington St.
Chicago, Ill.

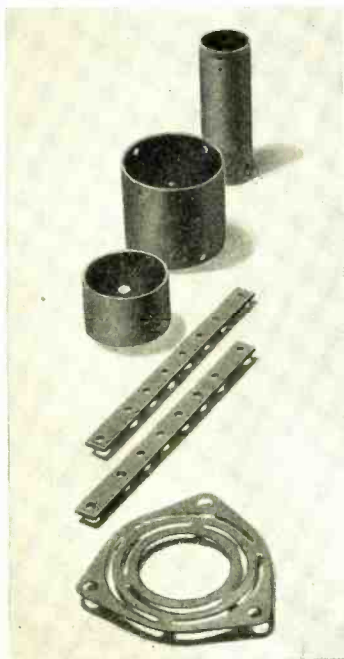

GENERAL  ELECTRIC

885.51

What of the Future of Industry?

THE survey just completed by the Sherman Corporation, industrial management engineers, contains more of common sense and constructive suggestion than any other inquiry carried on since the recession began in October 1929.

The analysis of the returns in connection with this study shows that of 2,304 responses, 1,028 of these executives consider that revision of sales and merchandising plans and reduction of operating costs are vital factors in meeting existing conditions and snapping business out of its present nebulous state.

There is one point on which there appears to be practical unanimity relative to the business recession that has cloaked America for almost the past two years; namely, that a greatly over-produced condition exists and that productive capacity in terms of brick and mortar and equipment, due to the buying instinct being dampened by the mist of nervousness as to the permanency of work, is far in excess of domestic requirements.

It is only natural, therefore, that at this time the weight of attention should be concentrated upon the selling, merchandising and distributing phases of business operation.

If people would buy to satisfy their normal requirements, says almost everybody reporting on the factors considered in the study, the fog would clear. The perplexing question, however, is — How to induce the public to open up and buy?

Advertising drew 511 affirmations as being a means of spurring business activity. The comments indicate that sane, honest advertising, when properly directed and fitted to the needs of specific products and markets can play an important part in creating the desire to buy.

The replies to specific questions, while varying somewhat in certain instances due to local conditions, were in the main uniform on various fundamental points.

The viewpoints expressed in the following quotations from the report are those in which there is wide agreement among business executives:

"The wastes of time spent in traveling, in waiting for buyers, in making personal calls on buyers whose total volume of business does not warrant such calls is enormous."

"We ought all to be spending more time to devising ways and means for cutting sales costs along with reduced operating costs."

"Lowering of salaries to the high salaried class

would show a reduction in operating costs and permit lower retail prices."

"Reduction of operating costs by better planning, lower material production cost, a more stabilized labor condition and freedom from welfare laws and bureaucratic control"

"Scrap obsolete machinery thereby reducing operating costs and in turn stimulate buying."

"Shorter working hours, with a high wage rate and greater production per man hour, should help to balance production and consumption and extend both. Such a programme must be predicated on low prices to stimulate more liberal buying."

"Intelligent levelling of overhead and unproductive expense, together with progressive merchandising methods, will solve the problem for most business activities."

"Intensified management will show the present leaks and failures of the business and allow the improving of manufacturing processes thereby reducing operating costs per unit."

"Consumer buying at present is discouraged by many retail establishments who frequently have none of the desired articles, or only one, which they will not sell. Very often the consumer is informed that they (the retail-

ers) do not expect to replenish their stocks this season, or before inventory, etc."

"Buying must be stimulated — first of all through the development of new products; secondly through efficiency in manufacturing which, however, should not be brought about through lowering of wages but through the new progressive devices."

"Improved manufacturing procedure — efficiency, and elimination of wastes, would certainly be helpful."

"Operating costs should be reduced, not by wage cuts but by installation of more improved methods and elimination of waste."

"With lower costs, America could sell much of its surplus to foreign countries."

Here, then, we have a survey the results of which are worthy of serious consideration and study by every executive and engineer engaged in the design, manufacture and sale of radio equipment.

Once there is general agreement as to the nature of the factors responsible for business depression, there is less difficulty in planning remedies.

What Business Executives Think of the Present State of Industry Constitutes the Most Informative Analysis Possible

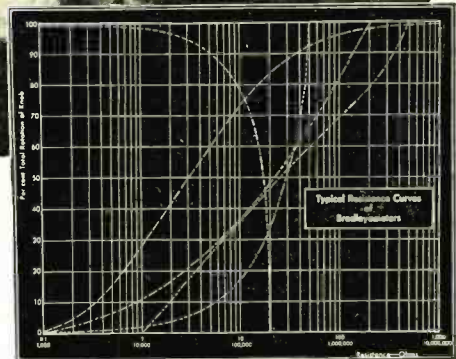
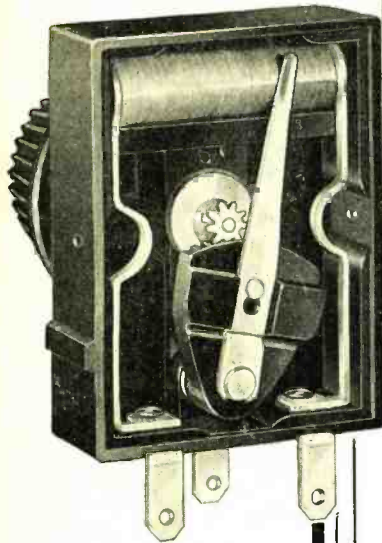

Other Allen-Bradley Radio Products

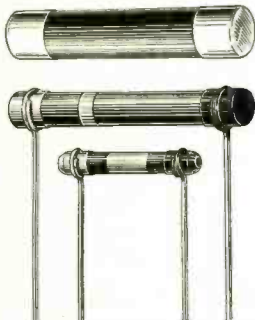

Bradleyunits are solid molded resistors, made in five sizes with or without tinned leads. They are color-coded to meet any manufacturer's specifications.

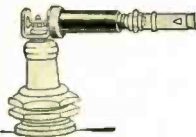

Bradley Suppressors for radio-equipped cars are used by leading car manufacturers and make shielded ignition cables unnecessary for good reception.

The Bradleyometer

Assembled by automatic machinery to produce any performance curve!

Manufacturing facilities in the Allen-Bradley plant keep pace with the rapidly increasing demand for the new Bradleyometer.

The Bradleyometer is a "stepped" potentiometer of about fifty steps and comprises a series of resistance disks. The resistance value of each step is separately controlled and the total number of disks are assembled by automatic machinery to conform with the Resistance-Rotation curve as specified by any manufacturer.

Bradleyometers are used extensively for volume controls, tone controls, mixer controls, attenuators, and in connection with telephone equipment, public address systems, radio receivers, phonographs, etc. Write for technical data today.



Type A, Single Bradleyometer



Type AA, Double Bradleyometer



Type AAA, Triple Bradleyometer

Allen-Bradley Co.

126 W. Greenfield Ave.

Milwaukee, Wisconsin



ALLEN-BRADLEY RESISTORS

Produced by the makers of Allen-Bradley Control Apparatus

RADIO ENGINEERING

Production, Administration, Engineering, Servicing

APRIL, 1931

The New Variable-Mu Vacuum Tubes

By A. G. CAMPBELL*

In superheterodyne circuits employing r-f. and i-f. amplifier stages, good volume control performance may be obtained by controlling the biases of the r-f. tube, the first detector, and first i-f. tube using 551 tubes in these stages

A Variable-Mu Radio Amplifier Tube

SINCE the first days of broadcasting the trend of receiver design has been toward high amplification before the audio system. This was required at first by the need of greater sensitivity to obtain good reception from distant stations. Later, when the maximum practical sensitivity had been reached, still higher amplification obtained by improved vacuum tubes and better receiver design, permitted, economically, the improvement in selectivity demanded by the increasing number of broadcast stations; improvements in tone quality by use of the high-voltage linear detector, simplified receiver operation by means of the automatic volume control, and various economies in receiver manufacturing and operation.

The screen-grid tetrode, with its high amplification factor, made it possible to obtain more economically the high amplification and extreme selectivity required in the modern receiver. It improved the operation of the high-voltage linear detector and automatic volume control. "Balanced" circuits were eliminated, simplifying the adjustment of receivers and improving reliability of operation after leaving the factory. These advantages led to almost universal use of this tube for high frequency amplification. The screen-grid tetrode of the -24 type

was an economic solution to many problems of modern receiver design.

Unfortunately, the very high amplification factor which resulted in improved performance, operated to increase modulation distortion, cross-talk

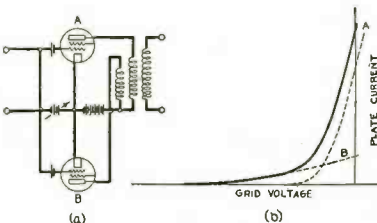
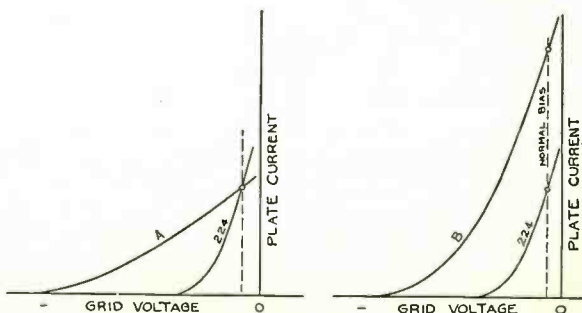

Fig. 2. Method of decreasing distortion and cross-talk.

and other associated modulation disturbances. With the modern trend toward an increasing number of high-power broadcast stations, these undesired effects are continually becoming

Fig. 1. Showing (a) decreasing transconductance and (b) increasing plate current accompanying attempts to decrease distortion by decreasing the mu-factor.



more serious and the fact that they are increased in the -24 type tube is a serious limitation to its use. Local-distance switches, antenna potentiometers, double and triple pre-selection and better power pack filtering were employed to overcome these faults.

Type 551 Variable-Mu Tetrode

The type 551 screen-grid tetrode has been designed to eliminate to a large extent the defects of the conventional -24 type tube, without losing any of its desirable characteristics.

This is accomplished by an entirely new principle in vacuum-tube construction. In ordinary tubes the structure is uniform and a constant geometrical mu factor is obtained over the cathode area. In the new variable-mu tube the structure is such as to provide a mu factor which varies from point to point of the cathode area. By means of this principle the plate-current control grid voltage characteristic can be given proper shape to reduce the higher order curvature responsible for distortion and cross-talk. The advantages of the high amplification factor of the -24 tube are retained at normal voltages, while at high biases the low distortion characteristics of a low mu tube are automatically obtained. Such a tube reduces by a large factor, modulation distortion, cross-talk, modulation hum, and associated modulation troubles encountered with the -24 type tube, and permits partially or wholly dispensing with the precautions necessary to overcome these faults.

At normal bias (-3 v.) the transconductances of both the 551 and type -24 tubes are about 1000 micromhos. The -24 tube reaches a transconductance of 1 at about -13 v. bias while the 551 attains this value at about -45 v. bias. It is seen that the transconductance of

* Research engineer, Arcturus Radio Tube Co.

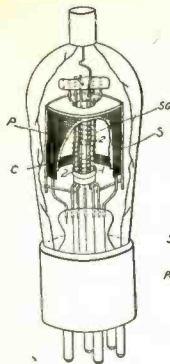

Fig. 3.

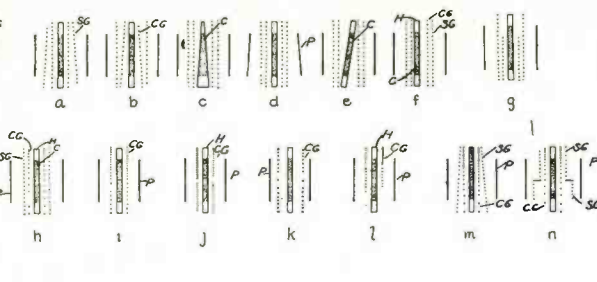

Fig. 4.

Fig. 3. Structure of tetrode of variable-mu type.
Fig. 4. Illustrating types of variable-mu tube structures.

the 551 tube varies more nearly exponentially with bias than that of the -24 tube. This results in a much more uniform control of gain when using the new tubes.

Modulation Distortion

Modulation distortion is caused by non-linear transmission characteristics of the r-f. amplifier tubes and occurs in ordinary receivers when receiving from nearby stations, the result being an increase in modulation of the signal, accompanied by increased distortion of the output. This distortion becomes worse as the input to the tube increases, and is particularly evident in the -24 tube owing to its sharp plate current cutoff.

Cross-Talk

The most common type of cross-talk is caused by intermodulation in the r-f. tubes between a desired signal and a strong interfering signal of different frequency and results in the two signals being heard simultaneously when tuning to the desired signal, both signals apparently tuning at the same point. The elimination of this type of interference has necessitated the use of double and pre-selector circuits between the antenna and the first tube of the receiver.

Volume Control

The 551 tube is designed for volume control by variation of the control grid bias. It is permissible to use the ordinary method of bias in which the cathodes are given a positive potential with respect to ground. Due to the variation of plate current and the imperfect regulation of the power supply apparatus, the screen-grid voltage with respect to ground will vary somewhat over the range of control. This variation is of advantage in that the potential difference between screen-grid and cathode tends to remain more nearly constant.

In superheterodyne circuits employing r-f. and i-f. amplifier stages, good

volume control performance may be obtained by controlling the biases of the r-f. tube, the first detector, and first i-f. tube, using 551 tubes in these stages.

The maximum bias required for complete control varies from 30 to 50 volts depending on the number of tubes controlled and the amplifier gain.

The grid bias should not be permitted to become more positive than the -3 volts specified; otherwise trouble may be experienced in control systems using high valued resistors due to relaxation oscillations and anomalies of the grid current characteristic.

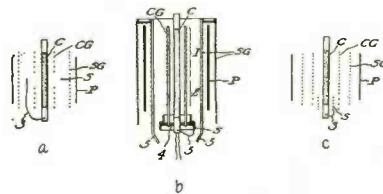

Fig. 5. Several types of variable-mu structure.

Advantages Obtained by Use of 551 Tubes

The important advantages offered by the 551 variable-mu tube may be summarized as follows:

1. Increase of maximum allowable input voltage for distortionless operation by a factor of about 20.
2. Extension of the range of automatic volume control by a factor of 20.
3. Reduction of cross-talk by a factor of several hundred times.
4. Improvement in uniformity of control over the entire range of volume control.
5. Reduction of "hum on carrier" (modulation of carrier in r-f. tubes) due to incomplete power pack filtering.
6. Reduction in receiver noise. This is brought about indirectly. In receivers employing double pre-selectors (two tuned circuits between antenna and the first tube) for the purpose of

reducing cross-talk the gain in voltage between antenna and first grid is comparatively low with the result that the "hiss" noise is high compared with the signal. The 551 tubes permit the replacement of the double pre-selector by a single tuned circuit with an increase in gain between antenna and first grid which reduces the hiss noise.

The foregoing advantages are of particular importance to the receiver manufacturer in that they permit several economies in receiver design, such as the elimination of antenna potentiometers, local-distance switches, double pre-selectors, etc. No changes are required in receiver design other than the trifling one of supplying the proper grid bias required for volume control. In automatic volume control systems extension of range furnished by the 551 tube is not at present attainable at the same cost by any other method.

Description and Characteristics of Types 550 and 551 Tubes

In a recent technical paper written by Stuart Ballantine and H. A. Snow, of the Radio Frequency Laboratories, tories. Boonton, N. J., these engineers report as follows:

Our solution of the problems of distortion and cross-talk in vacuum tubes consists essentially in re-shaping the plate current-grid bias characteristic in such a way as to minimize the higher order curvature, particularly at points where the transconductance is low. Of the many experimental tubes which have been tested two have been selected for commercial production and have been designated as Types 550 and 551. Both tubes are designed to operate at the same plate and screen voltages as the ordinary -24 type. Their characteristics, such as plate resistance and transconductance, are the same as normal operating voltages as those of ordinary tetrodes of present commercial types.

The Type 550 tube is capable of handling an input voltage of approximately

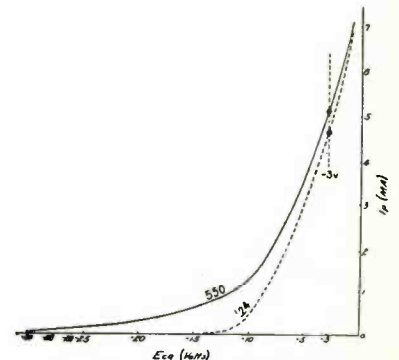

Fig. 6. Plate current-grid voltage characteristic of variable-mu tube showing reshaped characteristic for reduction of distortion and cross-talk.

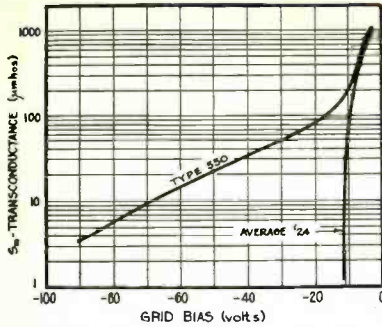

Fig. 7. Transconductance-grid voltage characteristic of Types 550 and -24 tubes.

15 with less than 20 per cent modulation rise, or about 50 times that of the standard -24 type; the Type 551 tube is capable of handling 7 volts, or 25 times that of the -24 type. Both tubes are fundamentally of the shielded tetrode type, although the principle by which the reduction of distortion has been achieved can be applied equally well to triodes and other types of structure. This principle may be explained as follows:

Fig. 1 shows the grid-plate transfer characteristic of an ordinary tetrode of the -24 type. To raise the input voltage at which distortion appears the design could be changed so as to decrease the mu-factor of the tube, thus spreading out the range of grid voltages and obtaining a characteristic of the type shown at A. This, however, entails a sacrifice in transconductance, and amplification, at the initial bias if the plate current at this point is adjusted to the same value. If the transconductance at the initial bias is to be maintained at the same value instead, then an increase in plate current must be tolerated as shown by the characteristic B.

A way out of this difficulty is illustrated in Fig. 2. The amplifier stage shown in Fig. 2a comprises two tubes in parallel. Of these tubes A is of the high-mu type, and B is of the low-mu type. A greater number of tubes, of properly graduated mu's may also be employed. The effective i_p-e_g characteristics of tubes A and B are suggested by the dotted lines in Fig. 2b and their combined effect by the solid line. The high-mu tube A yields high amplification, but can handle only small input voltages; the low-mu tube B yields low amplification but can handle high input voltages. In combination the two tubes complement each other to produce a characteristic of the desired type. At low biases, where amplification is required and the applied voltages are low, both tubes are active but due to its higher transconductance most of the amplification is produced by A. As the bias increases negatively tube A is automatically cut off and the operation is gradually shifted to tube B, which is

capable of handling the increasing input voltages. The arrangement may be regarded as one in which the mu-factor decreases continuously as the grid bias increases negatively to keep step with the increasing input voltage. The resulting i_p-e_g characteristic (Fig. 2b) resembles that of ordinary tubes at low negative grid bias, but is extended, or "tailed" at the higher grid biases.

For reasons of economy it is desirable to incorporate this principle in a single tube structure. One way of accomplishing this is shown in Fig. 3, as applied to a shielded tetrode with an equipotential cathode. The control grid is divided into two sections which are mounted with a gap between them. At low negative biases the entire cathode is operative and the tube has about the same characteristics it would have if the gap were not present; as the grid bias increases negatively the electron current through the upper and lower parts of the control grid are cut off leaving a low-mu control through the gap. At these bias voltages the tube acts as if the upper and lower sections of the control grid were formed of solid metal and controlled the current through the gap in the ordinary manner. Gaps may also be placed at the ends of the cathode (see Fig. 4g) instead of in the middle.

Some of the other structural embodiments of this principle which have been contemplated and tested are shown in Fig. 4. a, b, c and d show electrodes of variable diameter; e and f show cathodes in tilted and eccentric position; h and i show control grids of variable pitch in structures of the tetrode and triode type; j shows the mid-cathode control grid gap of Fig. 2 applied to the triode; k shows a double gap and l a combination of gaps and variable grid pitch; structure m is a combination of variable pitch and variable screen-grid diameter and n illustrates an abrupt change in electrode diameter as contrasted with the continuously variable diameters shown in some of the

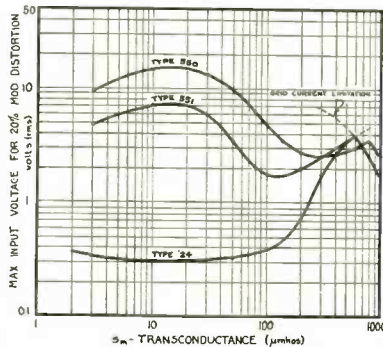

Fig. 8. Distortion limits for Types 550, 551 and -24 tubes; representing maximum input voltage which can be applied for 20 per cent modulation rise.

other structures. All of these structures provide a tube having a mu-factor which decreases continuously with increasing negative grid bias.

Somewhat more complicated types of structure having better economy of plate current at low grid bias are shown in Fig. 5. In these structures an additional low-potential element is provided for reducing the plate current at the portion of the electron stream which is controlled by the relatively open or coarse section of the control grid. The shielding S in Fig. 3b is connected to the cathode as shown at 3.

The transfer characteristic (i_p-e_g) of the Type 550 tetrode is shown in Fig. 6 together with that of the ordinary type -24 tube for comparison. The transconductance (mutual conductance) curves for the two types are shown in Fig. 7, as a function of the control-grid bias voltage. It will be observed that the transconductance of the Type 550 tube is about the same as that of the type -24 at low grid bias. This result has been attained with an increase of plate current at this voltage of only 10 per cent. The other characteristics

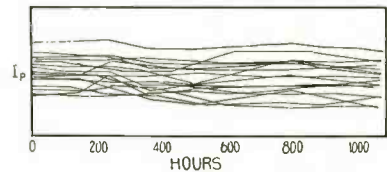

Fig. 9. Typical results of 1000-hour life test of current from low-mu area of Type 551 cathode.

of the tube (plate resistance, etc.) are also approximately the same as those of the type -24 at this point ($E_c = -3v.$).

Fig. 8 represents the input voltage which can be applied before the modulation rise reaches 20 per cent. It will be seen that the new tube is capable of handling input voltages approximately 50 times those which can be applied to the -24 type for the same distortion. An input voltage of approximately 15 volts is necessary to produce 20 per cent rise in modulation at $S_m = 15$ micromhos.

Fig. 7 shows that the grid bias required for control with the Type 550 tube is several times as large (ca. 80 volts) as that required by the 24 (ca. 15 volts). In many receivers the provision of such a range of bias may be inconvenient, especially in a-c. operated receivers, in view of the desirability of maintaining the screen-grid and plate voltages at their proper values with respect to the cathode. In broadcast receiver operation, the number of localities in which voltages as high as this are encountered is rather small. We have therefore designed a second tube, designated as Type 551, having characteristics intermediate to those of the

550 and -24 types. This tube is especially suitable for use in radio broadcast receivers. Its structure is somewhat simpler than that of the 550 type. Approximately 25-30 volts grid bias are required for full control (i. e., control for carrier voltage up to the distortion point) as compared with 80 volts for the type 550. This is easily provided.

The distortion characteristics of the Type 551 tube are shown in Figs. 4, 5. Fig. 8 shows the input voltage required to produce 20 per cent modulation rise. A maximum of 7 r-f. volts can be applied at $s_m=15$. The control diagram of Fig. 5 is of interest as indicating the improvement to be expected in a 3-stage amplifier with common bias control of the first two stages.

A comparative summary of the important characteristics of the Types 550, 551 and -24 tubes is given in Table I. In each case the values are the averages obtained from a large number of tubes of regular commercial production.

This tabulation indicates the interchangeability of the 551 tube with the present -24 types in the radio amplifier stages of a broadcast receiver. The only change necessary is an increase of the range of control-grid bias from about 15 to 30 volts. The ordinary method of inserting the grid bias in series with the cathode may be retained.

This tube is therefore not a "new tube" in the sense that it requires substantial readjustment of present types of receivers. It will make possible, in

future receivers, of both the ordinary and superheterodyne types, a number of important economies not realizable heretofore on account of the necessity of protecting the present tubes from high voltage amplitudes and interfering signals. One of its important uses will be in receivers employing automatic or remote volume control, where it extends the range of control by a factor of 25. In such receivers the use of a "Local-Distance" switch would be contrary to the object of the control system.

Manufacturing Aspects

A sufficient number of these tubes have been manufactured during the past year in three tube factories by regular production methods to verify that no extra cost or new manufacturing problems are introduced, and to secure evidence of reliability and longevity of the special characteristic. We were particularly anxious to check the longevity of the emission in the low-mu area, where the electron current density is somewhat higher than in the other parts. No evidence of premature failure of the current in this area was observed, however, in life tests extending to 3000 hours. A typical 1000-hour run is shown in Fig. 9. This represents the current at a negative grid bias sufficiently high to restrict the current to the area under suspicion.

TABLE I

CHARACTERISTIC	Type -24	Type 550	Type 551
Plate voltage recommended.....	180v	180	180
Screen voltage recommended.....	90	90	90
Normal grid bias.....	-3	-3	-3
Normal transconductance (micromhos).....	1000	1000	1000
Normal plate resistance (ohms).....	400,000	300,000	400,000
Normal plate current (ma.).....	4	5.6	5.3
Grid bias for $s_m = 10$ micromhos.....	-13	-70	-30
Maximum input voltage for 20% distortion.....	.3	.15	.7
Relative cross-talk factor (maximum).....	100%	0.5%	3%
Relative cross-talk at $s_m = 10$ micromhos.....	100%	None	0.12%



TENTATIVE RATING AND NORMAL CHARACTERISTICS OF NEW VARIABLE-MU TUBES

	RCA Radiotron 235	Arcturus 551	De Forest 451
Filament voltage.....	2.5 v.	2.5 v.	2.5 v.
Filament current.....	1.75 amp.	1.75 amp.	1.75 amp.
Plate voltage, recommended.....	180 v.	180 v.	180 v.
Screen voltage, recommended.....	75 v.	90 v.	90 v.
Grid voltage.....	-1.5 v.	-3 v.	-3 v.
Plate current.....	9 milliamperes	5.5 ma.	5.5 ma.
Screen current.....	Not over 1/3 of plate current	Less than 2 ma.	
Plate resistance.....	200,000 ohms (approx.)	300,000 ohms	
Mutual conductance.....	1100 micromhos	1000 micromhos	1000 micromhos

Approximate Interelectrode Capacitances

Grid to plate.....	.010 mmf. maximum	.006 mmf.
Input capacitance.....	5 mmf.
Output capacitance.....	10 mmf.

Overall Dimensions

Length.....	4 1/8 in.-5 1/4 in.
Diameter (maximum)....	1 1/16 in.
Cap.....	0.346 in.-0.369 in.
Base.....	UY
Socket.....	UY

Some Viewpoints of Tube Manufacturing Executives on the Vacuum Tube Industry

IMPROVEMENT IN TUBE CONSTRUCTION

By George Lewis, Vice-President,
Arcturus Radio Tube Company

▲ WE have recently perfected a very rugged type of construction which we term "unitary structure." This construction rigidly holds all major elements of the tube in precise inter-relation to one another and maintains accurate inter-element capacity at all times. The possibility of one of the elements shifting and thus affecting the characteristics of the tube has been definitely obviated.

Tests in high gain amplifiers have shown that this construction materially reduces noises and hum. It has been found that by tapping a tube of this construction with the finger does not have any effect whatever in the loud-speaker, whereas with other types of tubes the loud noise thus set up passes through the amplifier and to the speaker. Set manufacturers have found this new construction in Arcturus tubes to be very much more efficient in improving receiver performance.

With the advent of a-c. tubes, in which Arcturus blazed the trail in no small part, Arcturus pioneered the first quick-acting heater type tube. The Arcturus 127 detector was the first quick heating tube to be produced for a thermal lag of only seven seconds as compared to the usual thirty or sixty seconds lag of other tubes then on the market. Arcturus has since made famous the slogan "Acts In Seven Seconds."

On April 21, 1928, we placed twenty-five Arcturus No. 127 tubes on a life rack operating on 2.5 filament volts for the purpose of burning continuously to

ascertain the life of the filament oxides used in this quick heater construction. At this writing not a tube has burned out, establishing what we believe to be the longest record of life for any radio tube—25,561 hours.

Upon actual check in our factory we have found that each Arcturus tube goes through 137 different tests and checks before the tube is completed. This, of course, includes tests and checks of raw materials before the tube is started in production as well as the comprehensive electrical check for characteristics.

PROGRESS IN TUBE DEVELOPMENT

By Allen B. DuMont, Vice-President,
De Forest Radio Company

▲ THE past year has seen further development in the vacuum tube art. The a-c. receiving tubes have been improved as regards uniformity, characteristics and life. Heater type tubes such as the 424 and the 427 are now manufactured with a new type of notched insulator which insures rapid heating and freedom from burnouts. Many new mechanical refinements have been made to provide against change in characteristics in shipping or under severe service as is experienced in automobile and aeroplane sets. The battery operated sets using the 430, 431 and 432 type tubes enable the sets to compare favorably in performance with the a-c. receivers. From present indications the variable amplification constant tetrode and the pentode will be used to a large extent in the new sets to be brought out.

In the transmitting power tube field the new development has been in the high power three and four element tubes, as well as in the mercury vapor

rectifiers. Prior to 1930 these tubes were not available for sale except under restrictive license agreements. It is now possible to obtain all the necessary tubes for as high a power as is necessary in a 50 kw. broadcasting station. Commercial rectifiers capable of handling 20 amperes at 20,000 volts have been developed and are giving life in excess of 2,000 hours.

The caesium photocell is gradually displacing the older type potassium cell for both motion picture and television work. In our Type 601 neon glow lamp improved processing has enabled us to run these lamps at considerably higher currents thereby providing increased illumination for television pictures. The present work being done on crater type neon lamps shows considerable promise towards increasing the size of the television images and satisfactory pictures several feet square are now being obtained. The rotating grid tube is still in the experimental stage although in one instance it is being used successfully for high voltage inverter work. The application of the mercury filled Audion has made it necessary to develop a line of these devices in all sizes.

We believe that the application of vacuum devices to the power and industrial fields will be a very important factor in the new art but the rapid development of television this year should very materially increase the demand for receiving tubes and neon light devices.

COOPERATION BETWEEN SET AND TUBE MANUFACTURERS

By E. A. Tracey, National Union Radio
Corporation

▲ OUR activities in the past twelve months have indicated more than any other one thing, the value of and necessity for the establishment of a close engineering relationship between tube and set manufacturers.

We have demonstrated that a tube manufacturer's contributions to the set manufacturer's problems can be great, and, in some cases, decisive.

The desire of the set manufacturer to have a new feature in the set he offers for sale, creates a tremendous pressure on the set manufacturer's staff, whose efforts to produce new features of real value may be greatly aided by the intelligent cooperation of a skillful tube engineering staff.

This again emphasizes the need for an engineering department capable of not only making a product of high quality, but of also keeping abreast of or leading research and development work in the field of new tubes and in radical improvements on tubes now in use.

A Survey of the Vacuum Tube Industry

By AUSTIN C. LESCARBOURA

In this survey Mr. Lescarboursa presents the unvarnished facts about tube production and tube merchandising. Accurate knowledge of the elements of the situation is the first essential toward betterment.

LIKE all other industries at the present time, the radio industry has plenty of problems. One need merely scratch the surface to learn of the many difficulties of tube manufacturers. As for solutions, however, there is little or nothing forthcoming from the tube manufacturers themselves. One must do some deep digging in bringing constructive suggestions to light. The industry as a whole appears to be in need of leadership at this time.

The outstanding problem of the radio industry is a purely economic one of subnormal demand and abnormal supply. There are more tube manufacturers today than the market warrants. Until the number of tube manufacturers is reduced through the stern law of the survival of the fittest, reasonable profits are not likely to be made by most of the tube manufacturers. A bright hope at present is that the total of tube manufacturers has dwindled during the past two years, so far as numbers are concerned; but, to offset this promising news, some tube manufacturers, not forgetting the mergers of smaller manufacturers, have become more ambitious in their production efforts, thereby restoring a present surplus supply.

As anyone who has studied economics knows only too well, there is never over-production in the really practical sense. True, manufacturers may produce more goods than the market is absorbing, but the fault may really lie in under-consumption rather than over-production. In the case of tube production, this is decidedly the case. Market expectations have been reduced of late by a demand that falls short of reasonable estimates. Obviously, the public is buying less tubes than we have

every expectation of selling, with the result that we have many tubes on hand at the end of each season.

The Probable Market

For instance, it was generally predicted that during 1930 the market would absorb somewhere between 60,000,000 and 85,000,000. One guess is quite as good as another, notwithstanding the imposing array of figures presented by our statistical friends. From the most reliable sources of information, we gather that the total tube sales during 1930 were in the neighborhood of 50,000,000 or less, although some claim as high as 55,000,000. How many tubes were produced during 1930, not forgetting the huge inventories carried over from the wild production days of 1929, we shall never know. Such matters are a deep secret.

But 1930 is a thing of the past. What shall we do during 1931? With the idea of attempting to answer this timely query, your writer has just completed an extensive survey of tube manufacturers, obtaining a fair cross-section of opinions from the large and small organizations. The average estimate of total tube sales for 1931 is 50,000,000 tubes. One manufacturer hazarded the bold estimate of 90,000,000! More power to him, although we fear he is doomed to disappointment when he estimates 40,000,000 for initial equipment and 50,000,000 for replacements. He may not be so far off on the former figure, if we enjoy a good radio set season, but he is certainly way off on the latter figure. Tube replacement sales have failed to materialize. It is quite obvious that the public uses tubes far beyond any normal life expectancy.

Replacement Market

The average estimate for initial tube equipment for 1931 radio sets is from 25,000,000 to 30,000,000 tubes, while tube replacements are estimated at 14,000,000 to 16,000,000. It will be noted that there is practically a two-to-one ratio between initial equipment and tube replacements, whereas our original hopes were pinned on a rapidly growing tube replacement market, far outstripping the requirements of new sets.

Our survey has extended into the causes for the small tube replacement market, which has taken us into many radio shops and radio homes. It appears that tubes are used on an average of 2200 hours, or more than twice the guaranteed service life of 1000 hours. Indeed, even 1000 hours is considered more than ample by some tube manufacturers, who maintain that 800 hours would be more reasonable for a high performance standard. Actually the public is using tubes until they completely break down, instead of replacing them after their peak efficiency has been outlived. Since tubes are employed anywhere from two to three times their normal service life, it is at once apparent that our replacement market has been reduced by one-half and even two-thirds of the expected demand. If the public were educated to replace tubes every 1000 hours, we would be selling 15,000,000 to 20,000,000 more tubes per year, which would bring sales closer to the former expectations.

Therefore, the greatest problem facing the radio tube industry is to drive home the idea of changing tubes every one thousand hours. Although some tube manufacturers have done an excellent advertising job in this connection, the public has failed to respond because the messages have been too obviously selfish. The educational work must be done without suggestion of selfish motives. It must be carried on without reference to any one particular brand or maker of tubes. It must be accompanied by some convincing proof that tubes *must* be changed every one thousand hours.

Useful Life of Tubes

The writer finds a favorable reaction among many tube manufacturers to institute a campaign of education. Just as the lubricating oil companies have driven home the frightful lesson that automobile crank case oil must be changed every 500 miles, when many of us know that a good grade of oil will serve for twice that mileage without danger, so must tube manufacturers as a group, quite unselfishly, drive home the idea of changing tubes every one thousand hours. It has been suggested that convincing laboratory tests be conducted, showing how the average broadcast set loses in sensitivity, volume and

tone quality, while perhaps gaining in background noises, hum and distortion, as the tubes are used beyond the peak efficiency period.

The convincing data once at hand, the next problem is that of making it available to the public. Some tube manufacturers have suggested institutional advertising, without reference to any tube manufacturers or brands. Others have suggested certain forms of broadcasting, including short talks on the care of the radio set, as well as certain tests sent over the usual broadcast waves for actually testing the conditions of tubes used in receiving such waves. However, try and get radio tube manufacturers to co-operate! It is next to impossible while they are in their present mood.

Our personal suggestion is that the radio consumer press, and to some extent the radio trade and engineering press, should endeavor to carry on a campaign of education. It is to the interests of the press at large to create a greater demand for radio tubes, since ample advertising support will be forthcoming if tube manufacturers sense a growing market. Hence the press might conduct the laboratory tests and then make the findings available to their readers, in a purely editorial way, without any accusations of commercialism.

The fact already brought out that initial tube equipment outranks tube replacement sales by two to one accounts for the skirmish among tube manufacturers for radio set manufacturers' business. At the beginning of each year there is great sales activity among the tube manufacturers out to line up set accounts. Needless to say, with such abnormal selling efforts on the one hand and a limited buying power on the other, the set manufacturers get some mighty attractive bargains. Little wonder, therefore, that so many radio sets today come completely equipped with tubes. In some instances perhaps the set manufacturers make more money on the tube equipment than on the sets themselves.

Less Tubes or With Tubes

However, it is a much mooted question today whether it is good merchandising policy to equip sets with tubes at the factory. Of course opinions vary widely on this matter, depending entirely on whether figurative toes are being stepped on or not. The general consensus from the manufacturing end seems to be that where the set manufacturer is also in the tube manufacturing business, he is likely to equip his sets with his own make of tubes. Where the set manufacturer is not manufacturing tubes, he should ship his sets without tubes.

From the jobbing end and the retail-

ing end, there is also a wide divergence of opinion. Jobbers and dealers no doubt like the idea of fully guaranteed tubes, so that tube headaches are entirely eliminated from their selling troubles. When sets come equipped with tubes, the guarantee is on the entire merchandise. On the other hand, jobbers complain of instances where they are obliged to take more tubes than the sets really call for, although we strongly suspect that they can and do rid themselves of the surplus tubes with little difficulty, and at a profit.

All in all, the idea of equipping sets with tubes at the factory is apparently here to stay. Tube manufacturers are very insistent on the merits of this plan, especially since it gives them a nice piece of assured business at the beginning of the season. Set manufacturers appear to favor the plan, because they can better guarantee their sets when tubes of known quality are used. Jobbers and dealers are coming to like the plan, because the sets are fully guaran-

RMA SHOW AT CHICAGO

THE Fifth Annual Trade Show of the Radio Manufacturers Association, will be held at Chicago, June 8-12 inclusive. The headquarters will be at the Stevens Hotel.

This promises to be one of the most constructive gatherings of radio manufacturers, executives and engineers ever held by the RMA.

Being absent from this Convention will mean being months behind in benefiting from the sales promotion stimulus which will be set in motion.

teed without the buck-passing contest sometimes existing between set and tube manufacturers when in the past there has been poor performance.

Replacements

Returning for a moment to the question of tube replacements, we have queried tube manufacturers as to the possible merits of shortening tube life. It appears that electric lamp life has been somewhat reduced during the past few years, but this has been justified on the grounds of increased efficiency. Actually, the public buys more electric illumination today than ever before, even though lamp life has been reduced to probably 800 hours on an average. In the case of radio tubes, however, there is nothing to offer the public if life is reduced, so that the economic life must remain at 1000 hours, or approximately a year of average use.

Most tubes are built with a good performance life far beyond 1000 hours, for the reason that longevity is a natural sequence of really satisfactory service. It has been suggested by one of our humorists that tubes should be provided with an infernal machine set to blow up at 1001 hours of use, with appropriate notice to tube buyers! In the absence of such a brilliant invention, we must content ourselves with driving home the idea of changing tubes at least once each year, which means approximately 1000 hours of average use.

Tube Market Other Than Radio, of Little Volume

Having exhausted the possibilities of radio initial equipment and tube replacements, what next by way of marketing possibilities? We have been promised startling industrial applications, but truth to tell, we would starve to death if waiting for the promised Santa Claus. That there are possible and probable industrial applications, there can be no doubt; but as for immediate hopes, we can well forget the industrial market for the present. Whatever industrial market exists is pretty much occupied by the largest manufacturers who are in position to get the business through their control of the associated equipment, patents, and the ability to produce special tubes. Even the talking picture business is largely dominated by a few large tube manufacturers, so that the smaller manufacturer must be an exceptional merchandiser to succeed.

There is one important consideration as regards industrial applications, and that is the promise of light-sensitive cells in the near future which will largely do away with the need of radio size tubes. In England and in Germany, there are light-sensitive cells in use which operate relays directly without the intervention of vacuum tube amplifiers. Indeed, it is such cells or "bridges" that carry the greatest promise of a widespread application of light-controlled equipment, rather than the delicate photoelectric cells with extensive amplifying equipment. It is our guess that when industry calls for light-controlled equipment, radio type vacuum tubes will be sparingly employed. Hence the false hopes of the promised industrial age of the small vacuum tube.

Profits in Transmitting Tubes

While the prospects are not so glowing so far as the smaller radio tubes are concerned, it is interesting to note a steadily growing demand for the lar-

ger vacuum tubes such as those for transmitting and rectifying purposes. Only a handful of tube manufacturers, of course, are licensed to produce the larger tubes, so that a minimum of competition exists in this field. Profits are therefore derived from such production and an altogether healthy condition exists in the so-called transmitting tube field. Aside from transmitting requirements, the larger tubes are finding certain industrial applications of great importance.

Automobile Set Requirements

Some tube manufacturers direct our attention to the automobile radio possibilities as a means of increasing their tube sales. It appears that the automobile radio is going to be sent into the ring again this season, this time with better design and attractive price. Also, a special 6-volt heater type tube is being developed for the automobile radio set, which should make for greater efficiency. One tube manufacturer anticipates a 10 per cent increase in tube sales within the next two years, due to the widespread acceptance of automobile radio. Actually, he is doomed to disappointment. In time automobile radio will find a place in the picture, but its tube demand will be of the order of 1 or 2 per cent at most as contrasted with the more logical field of home radio.

The marked discrepancy between anticipated market and ambitious production schedules has necessarily brought about the sad condition of excessive competition for orders. For two years past, tube manufacturers have been operating in a buyer's market. While list prices have changed but little, the discounts have been constantly stretched until an average of 70 per cent discount to large buyers is accepted as standard practice, with some tube manufacturers offering as high as 80 per cent discount. Obviously, when such long discounts can be offered to buyers, it becomes apparent that list prices are somewhat out of line. Many tube manufacturers we have queried on this question have told us that list prices must be revised downward, but no one seems to want to set the pace. It is possible that a downward revision in tube prices will take place within the next few months, whereupon discounts will be shortened to former standards. Under existing circumstances, the selling prices are chaotic, ranging from 50 per cent discount to the consumer in the big city, to nothing off to the consumer on Main Street. With tighter discounts and lower list prices, all consumers will be buying at nearer the same price.

List Prices

There is room for a healthy discount at present list prices, particularly in the case of the larger tube manufacturers

provided with the latest automatic production equipment. In fact, it is the opinion of the larger manufacturers that a healthy squeeze in list prices, based on the labor-saving and cost-saving features of new automatic production equipment, may serve to eliminate the smaller or marginal tube manufacturers. Certainly the small chaps can hold on just so long as list prices are high and discounts are whatever you care to make them. In any production scheme based largely on manual labor, the smaller chap is quite comfortable in the picture. But let the introduction of entirely new automatic equipment reduce cost to a considerable degree, making manual labor all but obsolete, and the little fellow is soon happy in some other line of business.

It is only the fact that tube designs change so rapidly, making automatic machinery a serious gamble, that prevents the prompt squeezing out of the smaller manufacturer. At a time when some of the larger manufacturers have been considering automatic equipment, there looms up the prospects of new types of tubes, upsetting the production picture once more.

New Type Tubes

Which brings us to the question of new tube developments. It is apparent that several new types of tubes are coming through the laboratories and are in production. This season we see the introduction of the variable- μ screen-grid tube, which compensates automatically for the weak signal or the powerful signal in the usual screen-grid r-f. amplifier. We see the introduction of the pentode power tube, which is finding a place in the compact radio set that succeeds the original midget set. Strangely enough, the pentode is not being employed as yet to eliminate tubes because of its high gain, as was at first feared from the tube marketing standpoint. Sets employing this tube are employing about as many tubes as before, which is a comforting thought. There are new tubes coming along in the form of the 6-volt heater tube for battery operation, particularly in the automobile radio set, as well as the 32-volt tube for use on farm lighting plants.

Various suggestions have been elicited from tube manufacturers with regard to the betterment of the tube industry as a whole. The most sensible suggestion, but one perhaps impossible of realization at this time, is the elimination of about half the manufacturers in the business. Simple enough. But just what half should be eliminated is a matter for argument. Time alone will work out the proper elimination. Another suggestion is leadership in establishing list prices and discounts. Still another suggestion is an abrupt end of "life" for tubes, which,

unfortunately, does not seem practicable with present tube technique.

Our own suggestion is that tube manufacturers should get together about the round table and frankly discuss the troubles of the entire industry. Out of such gatherings would come many practical solutions of their troubles, together with a great enough demand for their wares to enable them to enjoy fair profits from their labors.

HIGHEST BROADCAST ANTENNA

Large scale experiment being watched closely by engineers

THE Atlantic Broadcasting Corporation is erecting a high vertical antenna at their new station at Wayne, N. J. Tests of this antenna will determine in a practical way the value of antennas greater than a half wave length high. The antenna will be about 675 feet high, by far the highest antenna in broadcast service. More remarkable than mere height is the fact that the structure itself is the antenna. A single tower, in the shape of two pyramids, with common bases midway to the top, will rest upon a huge articulated insulator and will be supported sideways by four guys also insulated from the structure. There are no auxiliary supports. So the antenna's performance will be free of all influence attributable to nearby towers.

Much credit is due to the Atlantic Broadcasting Corporation for their courage in undertaking this huge experiment—for an experiment it is. No antenna, not even a model of this type, has been constructed. The engineers are placing entire confidence in their calculations and the owners are placing their confidence in the engineers.

Seldom have experiments been on so vast a scale and certainly there is no record of a similar undertaking in the radio broadcasting field. All engineers, therefore, will watch the progress of construction and wait hopefully for the engineer's report of the value of the new antenna as compared with the present types.

I. R. E. CONVENTION AT CHICAGO

Preceding the RMA meetings, June 3-6, the annual convention of the Institute of Radio Engineers will be held at Chicago.

The entertainment and convention arrangements for the RMA will be in charge of Leslie F. Muter of Chicago who was appointed chairman of the Convention Committee. An RMA special train from the Atlantic Seaboard already is being arranged by the New York Central lines, and other special trains for the radio visitors from all parts of the country are being planned.

Cathode Rays in Television†

By H. R. WRIGHT*

Description of the System of Cathode-Ray Operation of Television Receivers and Transmitters

THOSE who have closely investigated the apparatus offered so far for use in assembling television transmitters and receivers no doubt have concluded that the system of mechanical scanning, widely used, is limited to the production of somewhat crude images.

In the year 1911, Mr. Campbell Swinton, an English scientist developed an intricate apparatus for television uses using cathode ray tubes at both transmitter and receiver. It is possible that a satisfactory solution of the general problem lies in this direction.

In this paper we shall deal with the application of cathode ray tubes¹ to television.

Advantages of the use of cathode ray tubes may be listed as follows:

- Absence of moving parts.
- Simplification of synchronization.
- Ample light for good visibility.

Persistence of the fluorescence of the screen used permits reduction of the number of pictures necessary per second without flickering.

Allowing more detail to be transmitted over the same frequency band.

The Cathode Ray Tube

For laboratory demonstrations a glass bulb such as shown in Fig. 1, is used. The glass at B is ground to form a screen for the study of the rays, and the electrodes are sealed approximately in the position shown. The bulb is then connected to a vacuum pump which is fitted with some form of manometer. A fairly high potential is applied be-

tween the electrodes and the evacuation commenced.

As the air is removed, and the pressure in the bulb approaches .05 to .005 mm. of mercury, the first change is noted. A greenish or bluish haze appears in the interior of the bulb, accompanied by streaks of pale light shooting off from the cathode or negative electrode. At the same time a conduction current through the bulb is indicated by the milliammeter in the high potential circuit. This current points to the presence of an electron stream which, in this case, is composed of what are known as cathode rays. The characteristics of these rays may be easily studied in the laboratory in the following manner:

1. A solid particle introduced at E (Fig. 1) casts a shadow of sharp, distinct outline at B, showing that the rays travel in straight lines.
2. The rays may be focused, showing that they leave the cathode perpendicularly.
3. A form of paddle wheel introduced into the bulb will rotate when acted on by a beam of the rays, which, from this, must have mass and inertia.
5. Since they evidently possess a relatively large amount of energy, they must have either great mass, or great velocity.
6. This velocity may be shown to be proportional to the voltage between the anode and cathode.
7. The rays are found to be deflected by either an electrostatic, or an electromagnetic field. By the direction of deflection they may be shown to consist of negative charges in motion.
8. When cathode rays strike a ground glass screen, or one coated with a sub-

stance such as calcium tungstate, they identify themselves by a sort of greenish fluorescence.

The usefulness of cathode rays for television purposes is bound up in the last two properties. Many other interesting phenomena may be seen during the study of cathode rays, but since they have no direct bearing on the instrument to be described, they will be omitted here.

Type of Tube

The type of tube to be used in this apparatus depends primarily upon the amount of light required. (The low potential type used in oscillographs gives insufficient brilliancy.) An operating potential of at least 3000 volts must be used for proper illumination of a 5-inch picture.

A general idea of the disposition of the tube elements may be gained from the diagram Fig. 1-B. The beam originates at an oxide coated filament, and passes first through a small hole in the control electrode. From there it passes through the barrel-like structure of the first anode, where the rays are accelerated to a velocity due to 300-400 volts, or approximately 3,000,000 meters-second. A second anode is located beyond the first leaving a space between them sufficient for the deflecting elements. The second anode consists of a metallic coating on the inside walls of the tube. It performs two duties: First, it accelerates the deflected beam to its final velocity due to 3,000-4,000 volts (30,000,000 meters-second), and, second, it focuses this beam, electrostatically into a sharp spot on the fluorescent screen.

The target wall, as this screen is called, is about 7 inches in diameter and is covered with a fluorescent material known as "willemite." Since it is important that the charges placed on the screen by the beam be rapidly dis-

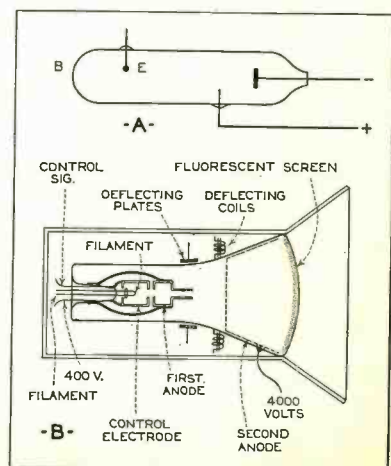

Fig. 1. Cathode ray tube, theory and construction.

† A paper presented before A.I.E.E. Branch, Vancouver, B. C.

* University of British Columbia.

¹As developed by the Westinghouse Laboratories.

sipated, the willemite is, in preparation, made slightly conductive.

The deflecting elements, of which there are two sets, are placed between the first and second anodes where they may act upon the comparatively slow moving electrons. The field strength for a given deflection is therefore much smaller than would be necessary had the final velocity been given to the electrons at the first anode.

The tube may now be described referring the different parts to the corresponding components of the conventional television apparatus.

The intensity of the beam is controlled by the voltage on the control electrode which, therefore, takes the place of the neon glow tube in the standard televisior. The mean intensity of the picture is controlled by a preliminary negative bias on this electrode.

The first set of deflecting elements controls the vertical or framing movement, and consists merely of a pair of deflecting plates arranged to give a vertical electrostatic field.

The second set consists of a pair of coils arranged to deflect the beam horizontally back and forth, when excited by an alternating current.

These two elements then, do the work of the conventional scanning disc, providing, of course, that the necessary voltages are correctly applied.

It is evident, from the foregoing, that, if we apply to the control electrode the amplified impulses from the transmitter, and, at the same time, deflect the beam in synchronism with the motion of the light beam at the transmitter, the original picture or scene will be reproduced on the fluorescent screen.

Clearly then, three sets of signals are required for the production of the complete image. First, the picture frequency, second, the horizontal scanning frequency, and third, the impulses for picture framing.

The first signal will be identical with that sent by transmitters of the present type. (For horizontal scanning, it is necessary merely to transmit a sinusoidal voltage of a frequency equal to the number of horizontal movements, per second of the scanning beam at the transmitter.) This voltage is impressed

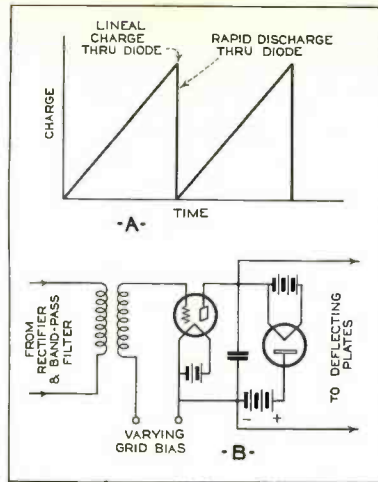

Fig. 3. A. Response characteristic of tube. B. Suggested circuit for framing voltage.

directly on the deflecting coils of the cathode ray tube.

Lastly, for vertical scanning, or framing, a voltage may be generated at the receiving end, which is controlled by signals from the transmitter. A condenser of suitable capacity is charged at constant rate by a device, such as a two electrode tube, so that the condenser voltage will rise lineally. The deflecting plates of the cathode ray tube are connected in parallel with this condenser so that when the former is charging the cathode beam is deflected at constant speed, from bottom to top of the fluorescent screen. (The speed may be controlled by the filament temperature of the two element tube.)

An impulse is sent from the transmitter after each cycle of scanning, which discharges the condenser and returns the beam to the bottom, ready for the next picture.

Composite Signal

The three signals may be sent separately, in which case three transmitting channels or frequency bands are needed. They may, however, be combined more economically into one composite signal, transmitted as such, and separated again at the receiver. This is accomplished in the following manner. The photo-cell voltage is first amplified to

a level sufficiently high for transmission. There is then superimposed upon it a series of high audio-frequency impulses, lasting a few cycles only, and occurring only during the interval between pictures. The resulting wave form of combined picture and framing frequencies is passed through a band eliminating filter, which removes the picture component of the same frequency as that of horizontal scanning. A voltage of the same frequency as that of horizontal scanning is then superimposed on this signal, and the whole used to modulate the radio frequency carrier.

At the receiver a reverse process is undertaken. The input is amplified and passed through a band pass, band eliminating filter, where the horizontal scanning frequency is separated from the remainder of the wave. This is amplified by a tuned amplifier, and applied directly to the deflecting coils.

The picture frequency plus the framing impulses are applied to the control electrode of the tube. The same voltage is applied to the input of a band-pass filter, which is tuned to the a-c. voltage used for the framing impulses. The output of the filter is amplified, rectified, and used to unbias a discharging triode. The latter is normally biased to zero plate current, and takes its plate potential from the condenser which supplies the vertical scanning voltage. Fig. 21 shows how this may be accomplished.

No attempt is made here to describe the details of the receiver design, but the foregoing may give the reader some idea of the possibilities of the system.

In closing, the important points wherein this system differs from the one in use, may be briefly summarized as follows:

The picture is green instead of orange.

It is visible to a large number of people, being bright and of considerable size.

The framing is automatic—no adjustments being required. Furthermore, no special apparatus is needed for synchronizing. Lastly, the power required is small—being of the order of that used by ordinary radio tubes.

NEW REMOTE CONTROL FOR RECEIVERS

A NEW remote control radio dial has been developed by the Engineering Products Division of the RCA-Victor Company. These dials, which are similar in operation to the telephone dial system, completely control all the functions of a master radio-phonograph outfit located in the attic or basement and wired to loudspeakers throughout the building. Simple number combinations are used to tune in up to 18 stations.

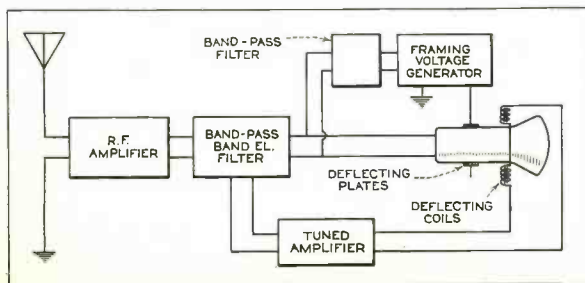

Fig. 2. Unit layout of television receiver.

Vacuum Tubes In Industry

By DR. PAUL G. WEILLER

IMPRESSIVE publicity blasts in some magazines and articles recurring more or less regularly in the daily press are apt to create with the reader the impression that wide application of vacuum tubes to manufacturing and power problems is imminent, and that momentous changes in our daily lives might be wrought by the wonderful vacuum tube. Such a picture is, of course, entirely misleading. Tubes are being used in industry now in numerous instances, but not for a great variety of purposes.

Compared with the vastness of our industries such application of tubes can as yet be truly called sporadic, and thinly scattered.

It can be predicted that tubes will be used in quantities in elaborate electrical installations, but before that comes to pass an enormous amount of development work must be done on the tubes themselves, and processes and installations in which they will be used must be revamped and redesigned to take advantage of the peculiar characteristics of vacuum tubes. There must also be a considerable change in attitude of mind of engineers who are not now using tubes, before much progress is made. At present the general attitude is somewhat hostile.

In the majority of cases tubes may do little that is not done now by other means, but they will help to do things better or at lower cost.

It is possible to foresee and predict some of the major trends and possibilities in industrial tubes. It is the purpose in this article to discuss the present use of tubes in industry and also, future possibilities. To do so intelligently it is necessary to deal first with

the problems generally met with in industry and with the adaptability of tubes to special problems.

Mercury Arc Rectifiers

The first use of tubes in industry was probably the use of mercury arc rectifiers and, later, of rectifiers of the tungar type. Both types were subject to severe limitations. The arc rectifier is a rather cumbersome machine. The tungar has reached the limit of its general usefulness with 15 amperes, and voltages in the neighborhood of 110.

Both will be replaced by hot cathode mercury vapor rectifiers, and probably rectifiers of sizes up to those large enough to operate railroads.

There is little to stand in the way of making such tubes for large current. At present most hot cathode vapor rectifiers are used in radio transmitters. Some of them are rated as high as 20,000 volts inverse peak rating, but recent work on the subject gives encouragement to the expectation of producing tubes good for much higher voltages.

Voltage Drop

The voltage drop in these tubes is of the order of 10 volts. Consequently their efficiency is good on all but the lowest voltages. There is, however, some hope of producing tubes with a drop of only two volts. Success in this direction will make vapor rectifiers available to such low voltage uses as electroplating, for which purpose tubes or tube banks must deliver several thousand amperes.

Tubes being made at present vary in filament efficiency from a maximum of 25 watts filament energy per ampere plate current to seven watts per ampere. We are, however, assured of tubes with two watts per ampere or better with the new enclosed cathode construction and we may expect to go much further in filament economy in cases where it is desirable.

The enclosed cathode is an interesting development. It is shown diagrammatically in Fig. 1.

A is a filament developing sufficient heat to bring the entire structure to emission temperature. B is a refrac-

tory insulator. C is a nickel can or a can of other bright metal. The inside of the can and the shelves, D, are coated. The discharge issues through opening, D.

Bright nickel indicates only 1/9 as much heat as the same surface with barium and strontium oxides.

This structure combines large emitting surfaces with a minimum of heat radiation.

The well-known six phase rectifier circuit employing six tubes, one of which is shown in Fig. 2, delivers d-c. with only 6 per cent a-c. ripple. If the input is 60 cycles the ripple is 360 cycles.

To be of general usefulness for certain industries the rectifier tubes will have to be built for a life expectation of 5,000 hours, some even for 10,000 hours, a few for as much as 10 years. All this is quite within the realm of feasibility but it is hardly necessary to enlarge on the vastness of the problems.

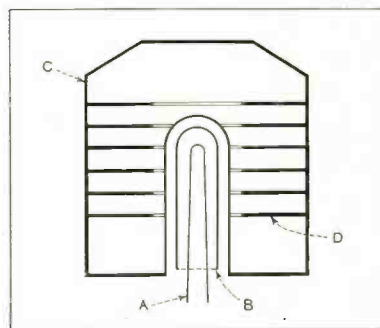

Fig. 1. Enclosed cathode tube structure.

The subsequent step to the rectifier is the hot cathode vapor tube with a grid, called grid-glow tube by some, thyatron or switch tube by others. A negative charge on the grid of these tubes is capable of preventing ionization as long as the grid voltage is higher than what in vacuum tube parlance is called the cutoff voltage. If the grid voltage is lowered below that point the tube ionizes and the drop in the tube then is equal to the characteristic drop in vapor tubes or of the order of 10 volts. In some tubes the presence of the grid causes a slight increase of the drop.

If the grid is of rather open construction it has no effect on the discharge after the tube is once ionized. Therefore, such tubes cannot be used to control d-c. If a-c. is passed through the tube and a sufficient negative voltage is placed on the grid this will have no effect until the half cycle

▲

Important progress is being made in the design and manufacture of mercury vapor rectifier tubes and tubes useful for automatic control of operating electric circuits. Many opportunities await cooperative studies between tube engineers and engineers engaged in the mechanical industries.

during which the grid voltage applied is completed. The subsequent half cycle will then be suppressed.

If the grid potential is insufficient to prevent ionization completely, ionization will occur at the point of each cycle where the plate potential is equal to the grid potential multiplied by the amplification constant of the tube; see Fig. 3.

In this way current will flow only during part of each permeable half cycle. This is equivalent to decreasing the mean current. This basic principle is used for regulation purposes. If the grid structure is made very close the drop in the tube is influenced by the grid potential. This method has, however, not as yet found much use in practical applications. In the design of switch and control tubes we have to deal with all the problems touched upon in discussion of rectifiers, and in addition all problems contingent on the grid control characteristics. There is here a great field for further study and development.

Large Amplification

We can visualize the magnitude of the task when we realize that switch and control tubes now can be made with amplification constants up to about 1,000, with a single grid and that it is necessary to contemplate the design and manufacture of tubes large enough to pass possibly 1,000 amperes.

Vapor tubes and gas tubes are apt to exhibit fits of erratic behavior at times. These are evidently due only to our scant knowledge of gas discharges in spite of the countless volumes written on the subject. It must be understood that gas or vapor tubes are more sensitive than vacuum tubes to the presence of even the minutest traces of gas other than the vapor used as a current carrying medium. These gases produce all sorts of effects which are hard to account for.

We have to deal with destruction of the cathodes by sputtering, by ionic bombardment, and possibly by other little understood effects. We have to deal with charges on the glass which may seriously affect the operation of the tube. In spite of these and many other difficulties, switch and control tubes are here to stay.

At the present stage of the art they can be used to great advantage in many ways, but only courageous application in the field, even when some risks have to be taken, can provide the incentive and financial backing indispensable to rapid progress.

Until much more is known of the characteristics of such tubes they will be used mostly as switch tubes or relays, for which purpose they offer some distinct advantages over electro-mechanical relays. Switch tubes require only a minimum amount of power. The

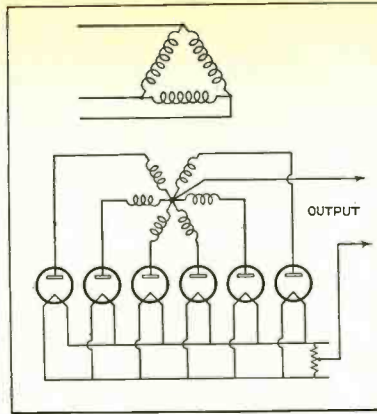

Fig. 2. Six-phase rectifier, employing six tubes.

grid current measures only a few microamperes.

If used at the end of long telegraph lines, for instance, they make the line resistance a negligible factor. They can be used to advantage in combination with the vacuum or gas filled photocell. The output of the latter can easily be made a substantial fraction of one volt, or more, while the current cannot be more than a few microamperes.

A photocell coupled to a switch tube can therefore be made to handle substantial amounts of power without the intervention of any mechanical relay or amplifier.

The operation of switch tubes causes no spark nor any other phenomenon tending to destroy them. They may be used in parallel with high voltage switches or switches handling large currents. In this way the switch or relay contacts are entirely freed from any corrosion due to arcing.

Switch tubes or rectifiers can be used to suppress transients in inductive circuits operated by d-c., as brake-switch, or relay solenoids, and other devices.

The tube is so connected that it is impermeable in the direction of the applied d-c. voltage in the closed circuit. When the circuit is opened the inductive surge in the reverse direction is discharged through the tube. A suitable voltage on the grid of the tube can be used with the assistance of resistances or reactances to control the form and duration of the transient.

Operation of large oil switches by rectified d-c. has long been desirable. As simplicity and availability for at least 220 volts is essential no suitable rectifiers have so far been available. The conversion of d-c. to a-c. is a large field by itself. Switch tubes are eminently suitable for this purpose. Most of the attempts in this direction have been based on the utilization of the time factor of a condenser discharge over a given resistance. The applications to high power technic mentioned

here are only some of the most obvious and most imminent.

In the field of automatic control the applications are more numerous. The control devices at present in use can be divided in three classes. In the first one belong all those control systems where 10 watts or more with a potential difference of 6 volts or more are available. Ordinary solenoids or relays may then be operated directly. In many of these cases the switch tube can be substituted to advantage for the relay. In this class belong a vast number of current and voltage regulators, over-voltage and no-voltage protection devices and a host of others.

In the second class belong those where a meter relay is inserted between the source of control and the operating device. Such meter relay consists of a d'Arsonval movement the pointer of which carries a contact which with one or two stationary contacts makes or breaks a circuit at a certain deflection. These contacts cannot carry substantial currents. Meter relays mostly actuate auxiliary relays which in turn actuate the control member.

Secondary Contacts

The meter relay depends for making contact on the slight pressure exerted by the coil of the meter movement. This is, of course, dependent on how much greater the energizing current is than that corresponding to a position of the pointer just touching the stationary contact. Therein lies an element of uncertainty in spite of the surprising perfection to which such instruments have been brought. As the force exerted by the spring of the movement is small contacts are apt to stick.

The substitution of switch tubes in this case eliminates both the meter relay and the auxiliary relay and increases certainty of operation and precision as it cuts off at a definite voltage.

The third class comprises devices which use as a source of control the deflection of a microammeter or millivolt meter. The pointers of these instruments are not sturdy enough to operate even small contacts, neither is the energy of the moving coil sufficient.

Operation of the control member is obtained by a device which taps the pointer periodically at intervals of a few seconds. If the pointer is in a given position it makes contact with a stationary member and causes an auxiliary relay to operate. Such devices are complicated and expensive. Their reliability depends greatly on careful installation and operation. A substitution of the switch tube in such a case would result in great simplifica-

tion and greater mechanical ruggedness.

As the drop in the switch tube is about ten volts, the minimum practical plate voltage would be of about 12 volts r.m.s. a-c.

If the control voltage is of the order of one millivolt the amplification of the switch tube would have to be of the order of 10,000 which at the present stage of the art is not very practical. Consequently, it is advisable to insert a vacuum tube amplifier between the switch tube and the source of control voltage. This amplifier can be much simpler than that necessary to operate an electro-mechanical relay which latter would be comparatively expensive.

At this point we meet with a problem which has been neglected so far, namely, the d-c. amplifier. Any engineer entering this field will find it as full of pit-falls as were the radio-frequency amplifiers, although the problems which are facing us are of a quite different nature.

We have, for instance, the biasing problem. In a-c. amplification we do not worry about small fluctuations of the biasing voltage due to line voltage variations or fluctuations in battery voltage as the case may be, because the d-c. is filtered out completely from the output.

With the control case it is different. If the amplifier is sensitive to one millivolt d-c. any bias fluctuations and any changes in static characteristics of the tubes would have to be eliminated. Off hand this means two things. We must work without bias on the first tube and the tubes used must be specially constructed for the purpose.

Ordinary receiving tubes with their flimsy construction, and their variations of 50 per cent or more between tubes, are not suitable for this purpose.

The control voltage is as a rule obtained from the unbalancing of a bridge circuit. To increase the voltages obtained in this way a constant current device may be inserted in the bridge circuit either in the power supply or as one of the arms of the bridge.

Fig. 4 shows a bridge suitable for the new device used to indicate the amount of carbon monoxide in the exhaust gases of an automobile engine. A ballast lamp in the power supply is the constant current element. When unburned gases strike the platinum wire which forms one of the bridge arms combustion takes place on the surface of the wire and thereby its temperature is raised. The attendant increase of resistance unbalances the bridge.

Without the constant current device in the circuit the sensitivity would be less. A bridge for line voltage control consists of four lamps. A lamp with positive temperature coefficient alternates with one with negative tem-

perature coefficient. A switch tube is connected across the bridge in either case.

Hot Cathode Vapor Tubes

Another constant current device consists of a hot cathode vapor tube operated at temperature saturation. Similar circuits are in use for indication or control of temperature, vacuum, speed of gas or vapor streams, flue gas analysis and numerous other purposes.

The many well-known applications of the photocell also belong in the realm of industrial application of tubes. For industrial use the caesium cell has so far been most satisfactory. It is, however, questionable whether it will not yield at least some of its popularity to the selenium cell. The latter had been abandoned in favor of the vacuum cell because of its time constant, but for many purposes this characteristic is not objectionable.

The photocell is used in many instances to operate mechanical devices when a light ray normally falling on the photocell is intercepted by some object. Such installations are electrically comparatively simple. Only one

output of the amplifier, even at best, is only sufficient to operate the pilot relay it is important to keep the amplifier properly adjusted.

It is, unfortunately, a general characteristic of the commercial type of receiving tubes that their static characteristics shift in time. This shift is called the drift of the amplifier.

This peculiarity of the tubes is, of course, very undesirable as the bias voltages have to be adjusted to compensate for such changes. It is plain that tubes which remain substantially constant will have to be produced before such an arrangement will be generally accepted. This is even more true for amplification where photocells are used to distinguish color shades as in the sorting of cigars.

So far we have dealt with the most important technical characteristics of vacuum tube control devices. We have found that a large amount of development work must be done before their general application follows.

There are, however, some peculiarities of human nature which stand even more in the way of any rapid progress in making these devices useful. In the first place vacuum tubes are still a mystery with seven seals to the majority of technical men not now concerned with their use or manufacture, and still more so with purchasing agents, general managers and other not technically inclined executives.

The writer had the opportunity to discuss at length the use of vacuum tubes with the engineers of one of the leaders in a line which admittedly is quite ripe for their application.

The attitude was about as follows:

"We have so far solved all our very complicated and delicate control problems electro-mechanically."

"We distrust tubes because they are made of glass and because they have filaments which may burn out and we hope they will not be used in connection with plants such as ours for a long time to come."

"Unfortunately some of our competitors are attempting to use tubes and we may have to follow suit."

And it was said just as bluntly as reported.

In another similar case the engineer

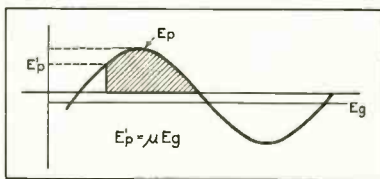
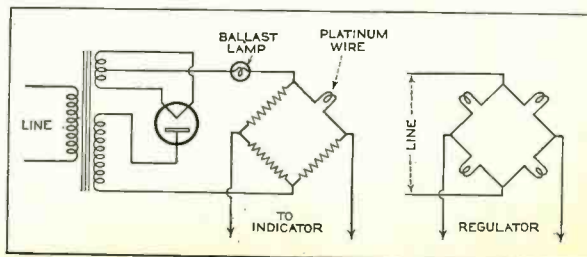

Fig. 3. Only the hatched portion of cycles is passed when Eg is applied. The amount of energy passed by the tube can thereby be controlled.

tube is necessary for the amplifier which operates a pilot relay. This in turn may be made to operate a heavier relay. If a hot cathode gas tube is used as amplifier and relay the pilot relay may be omitted.

In some cases, however, the photocell is acted upon only by the light reflected for instance by the paper fed into a printing and cutting machine. A black spot printed on the paper at desired intervals actuates the photocell. In this case the difference in intensity of illumination to which the device must respond is much less. Consequently the amplifier must be of a more elaborate nature. Furthermore, as the

Fig. 4.



was more inclined to make use of tubes but he complained that a filament transformer had to be used to keep the filament constantly lighted.

He objected very strenuously to this filament transformer.

When the writer pointed out that it was only a small one comparable in size and cost to a bell ringer, he answered: "Oh, no, it isn't that, but we do not care to have an additional gadget."

Another difficulty is the fact that switch or control tubes can very seldom be used in any existing device without considerable changes.

Many engineers after reading the fascinating articles in the daily and in certain periodicals of technical press have a feeling that if tube manufacturers would not be stubborn they could make a tube that would permit us to yank a relay from a switch panel and substitute a tube for it. Obviously, this is not so.

Very often also the price of a tube compares unfavorably with that of a relay. It is generally left entirely out of consideration that relays are today made by the millions and their price is accordingly low, while switch and control tubes necessarily must remain a custom made article until standards of general usefulness are established.

This can, of course, only be done through complete cooperation and exchange of information between the tube manufacturer and the designer of the control device.

Such cooperation and exchange of information is conspicuously absent in many cases.

In many instances very substantial electrical or mechanical changes have to be made before a control device can be useful, not because of the peculiarity of the tubes but because some effect is being accomplished which was not accomplished before.

Example of Use

An example of this nature is the following:

A soft drink company uses white, red and green bottles. When the bottles are returned they are placed on a conveyer and separated by hand according to color. Arrangements were made to have the picking done by photocells. Consequently, the bottles that had been placed on the conveyer in a helter-skelter fashion had to be placed on it in a single row, so that they would always pass the photocell in a proper way. A device had to be designed to pick the bottles up and transfer them to three separate conveyers before they had been placed in trays.

Anyone familiar with conveyer design will not be surprised that the changes necessary to make the photocell useful ran into many thousands of dollars.

Another instance nearer home to the radio fraternity is exemplified by the use of a switch tube as keying relay in a radio transmitter. Such a tube cannot be simply substituted for the original keying relay. It must be inserted either between the rectifier and the filter or in the primary of the power transformer. In both cases the rectifier unit must be changed for the purpose.

To allay the misgivings of those who

cannot think of an industrial device which is made of glass it may be mentioned that the larger types of vapor tubes will, of course, be made of metal.

It will be well for those interested in furthering the use of vacuum tubes for industrial purposes to replace the glowing accounts of a few rather spectacular unimportant uses with frank and open minded discussions of their characteristics and practical suggestions for their uses, not forgetting descriptions of the most important circuit.

RADIO RECEIVERS IN CANADA

ACCORDING to official records there were 472,531 radios licensed in Canada on December 31, 1930. This total shows a gain of 48,385 sets over the corresponding 1929 figures and gives a ratio of one radio to every 20.8 people in the Dominion. The number of sets licensed in Canada at the end of 1930 is shown, by provinces, in the following tabulation:

Prince Edward Island, 1,115; Nova Scotia, 14,920; New Brunswick, 10,514; Quebec, 86,724; Ontario, 238,504; Manitoba, 29,972; Saskatchewan, 29,709; Alberta, 21,433; British Columbia, 39,524; N. W. Territories, 116.

The six leading cities in Canada in number of radio sets licensed at the close of 1930 were: Toronto, Montreal, Vancouver, Winnipeg, Hamilton and Ottawa, in the order named. The number of gratis licenses issued to the blind during the period from April 1, 1930 to December 31, 1930 was 654 while in the corresponding period of 1929 the number issued was 589. (Consul Julian F. Harrington, Ottawa, Canada, 2/18/31.)



Pentode Tubes

WITH the possibility of simplified broadcast receivers in which the power tube of several times the usual amplification will serve to reduce the preceding amplification to a minimum, the new Pentode tubes now being introduced are worthy of note.

In general appearance these tubes are not unlike the —45 type of tube.

In the pentode vacuum tube a third grid is employed to turn back into the plate element of the tube those electrons which, to state it plainly, get "knocked out" by the electrons emitted from the filament. This third grid is very near the plate and is at the same voltage as the filament. Therefore, when an electron leaves the plate and tries to go back to the positive screen grid it must

pass across the grounded grid. The resulting effect is that the part of the tube curve that is useful is greatly increased.

CHARACTERISTICS

	Arcturus	DeForest
Filament voltage	2.5 volts	2.5
Filament current	1.5 amperes	1.5
Plate voltage	250 volts	250
Plate current	32.5 milliamperes	32
Control grid bias	—16.5 volts	—16.5
Space charge grid potential	250 volts	250
Space charge grid current	7 milliamperes	6.5
Cathode grid potential	0	0
Plate impedance	38,000 ohms	35,000
Transconductance	2500 micromhos	2300
Amplification factor	95	80
Power output	2.5	

Loudspeaker Listening Tests

By RALPH P. GLOVER

Description of Actual Switching Arrangement and Circuits Employed in Examining the Merits of Various Commercial Loudspeakers

ALTHOUGH great strides have been made in developing methods and apparatus for receiver and loudspeaker measurements during the last few years, it is still desirable to confirm and supplement the technical data of measurements by aural observations or listening tests. This is particularly true when an evaluation of the quality of reproduction of a particular receiving system must be made. It is not only difficult to accurately correlate graphic data with the corresponding sense impressions, but the methods of measurement themselves of necessity often neglect factors of vital importance.

One of the most useful aural tests is that which provides instant comparison of a number of complete radio receivers. The requirements of such a switching system vary with circumstances but usually the following conditions must be satisfied. (1) The switching system must permit of remote control. For convenience, it should be possible to operate the system from any point in the room which the observer elects. (2) The control should be simple and positive in operation. (3) All receivers except the one selected should be effectively and automatically silenced. The remote control should be equipped with a "silence key" which operates independently of the selector mechanism.

Another aural test which is valuable is the comparison of several loudspeakers fed from the same receiver chassis. Although the modern tendency seems to be inclined toward mutual compensation of receiver and loudspeaker characteristics (advertising managers, happily or otherwise, refer

to this principle as "matched tone" or "balanced unit") independent changes are frequently made in one or the other after the designs have been started. The loudspeaker switching apparatus provides a final check on the effect of changes in the loudspeaker construction and allows comparison of competitive or sample speakers against a temporary standard. The switching problems are quite different in this case and will be considered later on. However, the following conditions might well be imposed. (1) The receiver itself must be maintained under approximately normal operating conditions in regard to tube voltages, amount of plate-supply filtering in circuit, and the like. (2) It must be possible to compare dynamic speak-

ers having widely different field excitation requirements; it should also be possible to compare magnetic against dynamic speakers. (3) Convenient terminal facilities for non-standard as well as standard speakers, should be provided.

Concentration on Test Essential

Throughout the design of control and auxiliary apparatus, the real object of the tests must be kept in mind. *The observer's faculties should be free to concentrate at all times on the effects which are being compared.* The sensation of operating a mechanism is highly undesirable and to this end, control should be effortless, natural and unmarred by switching noises or breaks. This sort of test is naturally far more critical and enlightening than any ordinary sales demonstration with its distracting background of noise, however slight, and the diverting presence of a zealous salesman.

Fig. 1 is a photograph of a receiver and loudspeaker switching outfit which has been found to fulfill admirably the previously enumerated requirements. The small cylinders standing on the table contain the relays for receiver switching. Fig. 2 is a schematic diagram of the receiver switching system. Four relays are provided, thus making possible the comparison of four different receivers. All four relays are connected to common antenna and ground buses, the ground lead also serving as a common battery circuit. The relay contacts are adjusted so that the antenna is normally disconnected and the antenna and ground leads to the receiver shorted together. This has been found to silence adequately even the most sensitive receivers if operated at the reduced sensitivity which is usual for ordinary room levels on fairly strong broadcast signals. It is neces-

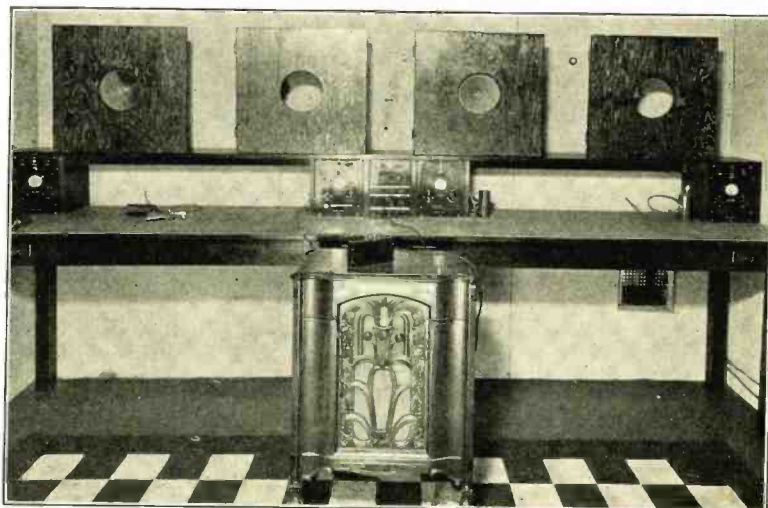

Fig. 1. Receiver and loudspeaker switching outfits.

sary, however, that the short-circuiting be done as close as possible to the antenna and ground terminals of the receiver. The relays were consequently assembled in protective formica cans with flexible leads of sufficient length to allow them to be placed at the input terminals of receivers standing in front of the table. Short clip leads furnish connection between the relay and the receiver, the relay being normally supported by the heavy ground clip which is bolted to the relay cover. A wire spur is provided on the ground clip for combined support and connection where "hole-through" binding posts are encountered. Fig. 3 shows details of the relay assembly.

When a particular antenna relay is energized, the receiver antenna lead is switched from ground to the antenna bus, thus placing the receiver in operating condition. The receivers are, of course, already tuned to the desired station, adjusted for approximately equal output as indicated by a preliminary test, and otherwise ready to operate. The relays are energized from a 6-volt storage battery and function perfectly in any position. Pilot lights in the respective channel control panels indicate the receiver which has been selected.

Remote Control of Switch

The actual switching is accomplished through a remote control box (standing on the top of the receiver in Fig. 1) with a long flexible cable terminating in a standard five-prong plug. The remote control box plugs into a receptacle on the remote control box outlet panel which is conveniently located near the floor on one of the side walls of the room.

A W. E. 211-B switch assembly, fitted into a small bakelite case which may be conveniently held in the hand, is the nucleus of the remote control box. The switch unit is actuated through a series of four push-buttons (one for each relay circuit) which are mechanically interlocked. When one of the buttons is depressed, the corres-

Fig. 4. Remote control box and outlet panel.

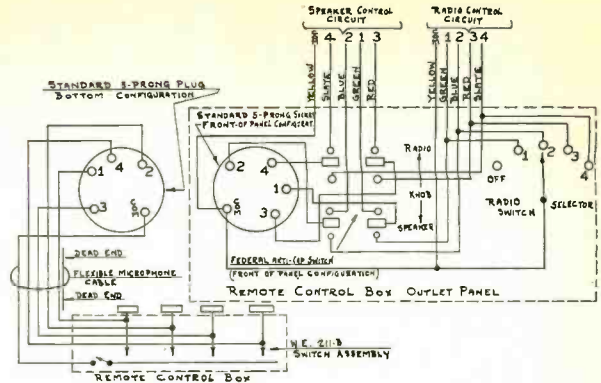

ponding circuit is closed and the button remains down until the next button is depressed. A key switch which is connected in the common lead allows the control circuit to be opened if it is desired to interrupt the test. The control system works very smoothly and

remote control box and outlet panel. The remote control box may be switched to either the radio (antenna relay) control circuit or to the speaker control circuit by means of an anti-capacity switch. When the speaker control circuit is in use, it is also necessary that one of the antenna relays be energized so that input to the receiver which feeds the speakers may be secured. The radio selector switch in the remote control box outlet panel is provided for this purpose and makes it possible to close any of the antenna relay circuits regardless of other switching. It is also useful when but one receiver is being tested and eliminates the necessity of connecting the remote control box in this case.

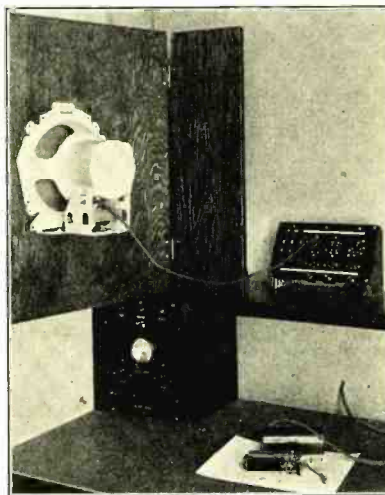

Fig. 3. Details of relay assembly.

changeover from one receiver to another is accomplished without objectional switching noise or delay.

Fig. 4 is a wiring diagram of the

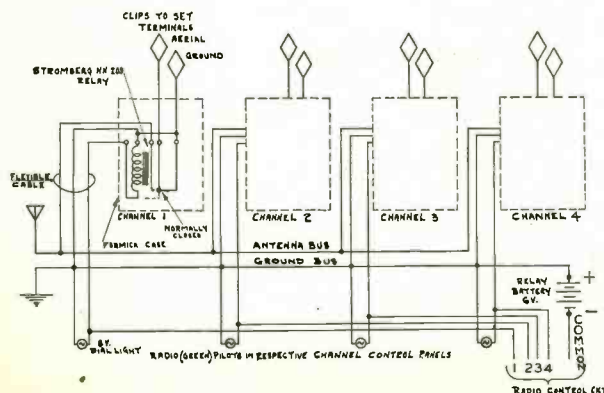

Fig. 2. Wiring diagram antenna relay switching system.

The Comparison Circuit

The four control panels and central master panel to be seen in Fig. 1 belong to the loudspeaker comparison circuit which is shown schematically in Fig. 5. The radio receiver which is to feed the speakers under test is connected to the master panel by means of a patch cord. A number of these patch cords are available with terminal plugs suitable for the various types of sockets used for speaker connection on the receiver chassis. Corresponding sockets are located on the master panel. The master unit also houses a set of field coils, together with the proper magnetic structures so that the receiver operates under normal voltage-drop and filtering conditions. These artificial fields are, of course, connected to the proper socket terminals corresponding to the receiver with which they are normally used. All of the voice terminals of these sockets are paralleled and lead to the voice coil bus which feeds the four loudspeaker channels.

Field Excitation Control

It is imperative that a separate and controllable source of field excitation be available for each loudspeaker channel. True, this represents a departure from the normal operating conditions of the receiver-loudspeaker system but experience has shown that this deviation is

permissible and highly desirable. A high degree of flexibility is thus secured and short circuits due to differences in common loudspeaker leads and connection coding are avoided.

In the case of the particular outfit described, it was necessary to provide for the extreme cases of magnetic speakers requiring 150 ma. at 5 volts and dynamic units operating at 30 ma. and 300 volts. Various intermediate current requirements also had to be met, at the same time avoiding the chances of possible damage to any speaker due to over-voltage. For this reason, each channel has its own high voltage rectifier-filter system and an individual 6-volt storage battery. These voltage sources are connected in series so that a 150 ma. meter in the common lead measures the field current from either supply.

Field control is centralized in the individual channel control panels which may be seen in Fig. 1. A "close-up" of the channel No. 1 panel is also given in Fig. 3. Three field current adjustments are provided. One of these is a heavy-duty voltage divider which governs the voltage impressed on the rectifier transformer primary. This method affords smooth control of the output voltage over a wide range and is highly recommended where efficiency is a minor consideration.

Appropriate rheostats, one for control of the storage battery circuit and the other for fine adjustment in the high-voltage line, complete the field excitation control system.

A master switch, located in the master unit, energizes the a-c. bus to the rectifiers and at the same time places voltage on the filament-heating transformer, thus lighting the filaments of all four rectifier tubes. This condition is indicated by a red pilot in the master unit. Individual switches and pilots in the channel control units enable the operator to place the desired rectifiers in service.

The speaker relays are also located in the channel control panels, together with their associated pilot lights, and provide means for connecting the desired speaker outlet panel to the voice coil bus. These relays are also operated through the remote control box previously described.

To facilitate the removal of the units for repair or relay maintenance, they were generously supplied with terminal strips. All of the leads were cabled and securely clamped in place. This greatly simplifies maintenance problems—although these have been few—and makes it possible to remove and replace units without consulting a wiring diagram. Color-coded wire, terminating on removable lugs, is an invaluable aid for such work.

Fig. 5. Schematic diagram loud-speaker comparison circuit.

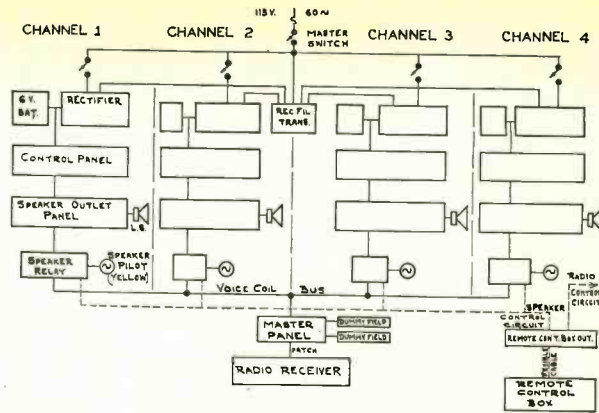

Arrangement of Baffles

Twenty-four inch baffles, symmetrically spaced along the top shelf, were provided for the speakers. These baffles (see Fig. 3) are hinged to facilitate mounting and removing the speakers, and conceal the speaker outlet panels when swung back into position. "Bullet" fasteners automatically latch the baffles in place. The arrangement is very convenient and highly economical of space.

The speaker outlet panels are each fitted with six sockets for the more common speakers of this particular line. The voice terminals are paralleled, as in the case of the master panel, and are thrown on to the voice coil bus by means of the corresponding speaker relay. The field terminals are connected either to the battery or high-voltage source as required for the particular speaker. Center-tap leads, where they occur, are cabled back to the master panel in order to complete the output stage plate supply circuit. In order to accommodate non-standard speakers, binding posts for high and low field voltage, voice coil and a spare circuit are placed on the speaker outlet panel. These spare circuits run to the master panel and are frequently used for center-tap returns. Protective fuses for each channel are also placed on the speaker outlet panel. Its sloping-front construction facilitates plugging-in the various speakers.

Similar binding posts are located on the master panel and give access to the various circuits when non-standard receiver output connections are encountered. To provide for future alterations and additions, the terminal facilities on both speaker outlet panels and the master panel were labeled with the telephone switchboard designation strips.

Resonance Effects of Cabinets

Many additional uses for this switching equipment have been discovered since its completion. For instance, cabinets can be compared and studied for resonant effects by the use of

identical speakers, plugged into the outlet panels through extension cords. The remote control system is, of course, used for switching.

As many other investigators have reported, it has been found necessary to conduct important tests "blind" if any importance is to be attached to the results. Consequently, a sliding curtain of monk's cloth screens the apparatus under test at such critical times. A case in point serves to emphasize the need for the screen in a rather amusing way. A manufacturer of loudspeakers, eager to secure orders for his product, was present at a "blind" test of one of his samples. Other speakers were on test for comparison. Without knowing which was which, he selected one of the speakers as being particularly unsuitable, and found to his evident discomfort that it was his own product!

I.R.E. CONVENTION

THE presentation of papers covering subjects of vital interest to the radio industry, valuable tours of modern factories, and novel entertainment will mark the Sixth Annual Convention of the Institute of Radio Engineers to be held at the Hotel Sherman in Chicago, June 4, 5, and 6, as an outstanding gathering.

Papers on the subject of acoustics and other timely topics are being arranged by the committee. Authorities on the various subjects have been enlisted to present the problems before the engineers assembled.

Plans are being formulated to give the visitors an opportunity to see some of the leading examples of modern industry.

Plan to attend the I.R.E. convention which assembles four days prior to the annual convention of the Radio Manufacturers' Association in Chicago.

Transmitting Tubes

It is evident that technical progress in the design and manufacture of transmitting vacuum tubes keeps pace with receiving tube advance.

The tubes used in the main rectifier at the new station KDKA, Saxonburg, Penn., are of the glass envelope mercury cathode type, somewhat similar to ones formerly used for operating direct-current series arc light circuits, except that they are larger and have three main anodes. Two small sustaining arc anodes and one starting mercury anode are also provided in each tube. One of these tubes is shown in Fig. 1. In operation, the tubes are fully immersed in oil, each mounted in a separate oil tank in a cradle by means of which it can be readily removed from the oil. All necessary connections are made when the cradle slides into place, thus permitting tube changes to be conveniently made with minimum effort. For interchangeability, tubes of the same rating are used in both main rectifiers.

Automatic tilting mechanisms for starting the sustaining arcs are provided. This permits the rectifier to be placed in operation from a remote push-button station with no more attention from the operator than the switching on of the filament heating circuit of hot cathode tubes. The starting mechanism functions in one to two seconds, after which it is immediately possible to apply full operating plate potential if desired. The sustaining arcs, once established, maintain the tubes in readiness for operation when desired without further use of the starting mechanism unless the power supply circuit is interrupted. Very little energy, about 120 watts per tube, is required to operate the sustaining arcs. This is low compared to filament type tubes since the mercury cathode automatically provides emission as needed at the hot spot in the mercury pool and therefore the power for the sustaining arc does not need to maintain the maximum emission at all times.

Mercury pool rectifier tubes such as these described, while not commonly employed heretofore for radio power apparatus, appear to have a number of desirable characteristics, particularly in installations of such size that the use of filament tubes would require a great number of them both in series and parallel to furnish the equivalent amount of high voltage direct current energy.

DeForest New Transmitting Tubes

The DeForest Radio Company announces two new Audions just added to its line of transmitting tubes.

Type 575 Audion meets the need for a power rectifier between the 572 and the 569 classes. It is rated at 15,000 volts inverse peak, and 2.5 amperes peak current. The design of this tube is such as to make it readily applicable to standard 572 power units when increased output voltage is required. The standard 50-watt base is used. The over-all length of the tube is approximately one inch greater than type 572. The filament rating is 5 volts and 12.5 amperes. This rectifier was developed for use in DeForest standard transmitters but is now included in the line of available transmitting tubes.

High-frequency experimenters and designers will be interested to learn that there is now available a high-power air-cooled tube with all the advantages of the popular Type 561 or 500-watt screen-grid tube yet free from

the loss in efficiency due to the presence of the screen at ultra-high frequencies. The 571 Audion is, in short, a 561 without the screen, or a big 552. As such, it is the highest power ultra-high-frequency Audion of the air-cooled class available. This type tube has been employed with unusual success at frequencies greater than 100 m.c. Although the engineers recommend the 561 for frequencies less than 7 m.c., they believe that the increased efficiency to be gained by using the 571 at higher frequencies far outweighs the inconvenience of neutralizing when the tube is employed as an amplifier. The internal capacity is so unusually low and the stability of this tube so great that neutralizing is not a problem.

Type 571 has a normal output of 500 watts, with a maximum output of 750 watts. The normal plate voltage is 3,000, with a maximum of 4,000. The maximum plate current is .350 ampere. The filament voltage is 11, with a current of 10 amperes. The amplification factor is 16.

To meet possible future requirements at station KDKA which quite likely may employ tubes much larger than any now known, it was deemed necessary to provide a plate voltage supply of 900 kw. at 30 kv. of high voltage direct-current energy for the standard broadcast transmitter. Similarly, the filament heating requirements, were set at 3000 amperes, 40 volts, and the grid voltage supply at 3000 volts direct current. In addition to the foregoing, a moderate amount of power at 10 to 15 kv. and still smaller amounts at 3 kv. and 400 volts are needed for the various intermediate amplifiers and the master oscillator.

Because of the probable limitation of the high frequency tubes it was not considered necessary to provide as large a main plate power supply system for the short-wave transmitter and therefore the second rectifier unit was designed for only 450 kw. at 22 kv. However, since either plate supply system may be used with either transmitter, the maximum plate power can also be used for any high frequency experimental work that may require it. Approximately the same power supplies are needed for the intermediate amplifiers and master oscillator of both the high frequency and the standard broadcast transmitter and therefore these were designed in duplicate to provide the greatest interchangeability of equipment. Filament heating requirements for the high frequency transmitter were set at 2000 amperes.

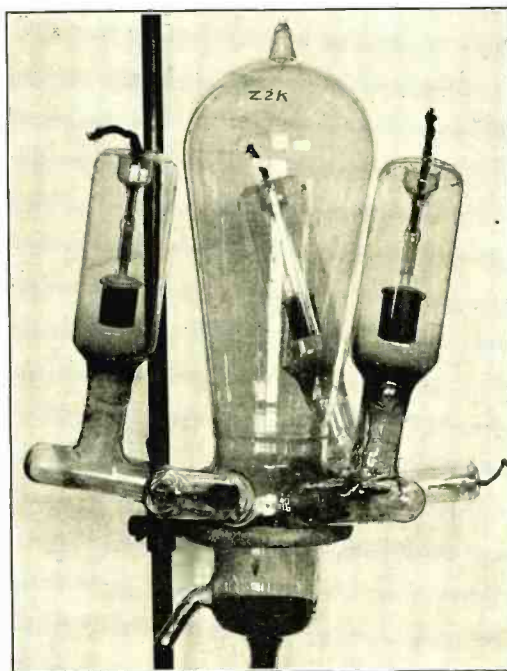

Fig. 1. High voltage mercury cathode tube.

Radio Antennas

By E. F. MARTIN *

Theory of Antenna Arrangements; Their Properties of Transmission and Reception

LAST June there appeared in this publication the first part of a new method of explaining antenna transmission, particularly directive transmission. This was based on the graphical analysis of wave motion. The simple and fundamental types were then treated, leaving the explanation of more complicated types, those used commercially, for a future article. It is the purpose of this article to cover the commercial applications of directive transmission.

Although some of the systems to be described are not new, inventively speaking, they are quite recent in their commercial application. It appears that future success with directive radio will be confined, almost entirely, to the so-called short waves. To these transmissions are due the remarkable success of point-to-point wireless transmission on a full day basis. More and more is being learned of the fading phenomenon, and it may be said with reasonable assurance, that it has almost ceased to be such a serious problem in point-to-point transmission of intelligence. Today there are numerous

* Consulting engineer. Engineer of General Trunk Studies, Illinois Bell Telephone Company.

directive transmission systems in regular use whose wave disturbances actually circle the globe. We see today the rapid expansion of voice communication; there is every reason to believe that it will not be far distant when the entire world will be covered by a network of telephone facilities, being assisted in the spanning of large bodies of water by directive radio transmission and reception.

The transmission of intelligence without use of wires has made possible an almost unlimited number of applications never before believed attainable. We have communication service to ships at sea, radio entertainment on moving trains, and, in some countries; communication service on moving trains, all-weather guiding service to ships at sea and aeroplanes in flight. We also transmit pictures with and without wires. Nor is this all. We have recently accomplished the transmission of colors with and without wires. To the early developments of wireless, the spark coil is claimant; latterly the three electrode tube. It is upon the study and application of electron action that future developments in this field will very likely depend.

As is generally known, the sharpest directional effects are produced when dealing with very short wavelengths. In fact, the shorter the wave, the greater the possibility of procuring a sharp beam. Although, as already stated, the fundamental principles of directing radio waves have been known for some time, economic limitations have effectively prevented their application, especially with the long waves.

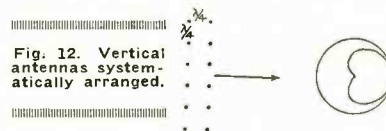

Long waves were virtually the only ones that were, up to a few years ago, in commercial use, the short-wave spectrum was thought impractical and unfit for consistent communication. Now, since the advent of short waves, conditions for economically making use of directional transmission have been altered greatly.

Though use of short waves has partly, indeed almost entirely, overcome the fading phenomena, it presents certain definite limitations even today. In

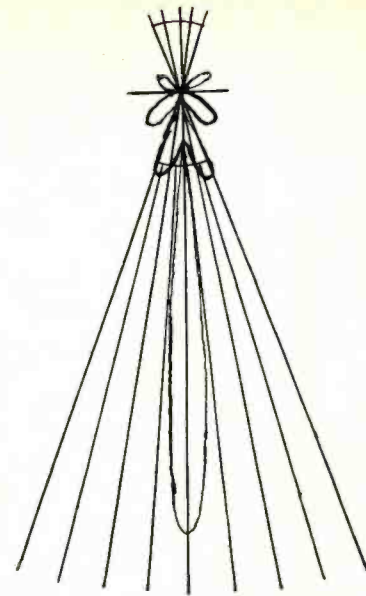

Fig. 11B. Polar diagram for Grecian curtain antenna system.

point-to-point transmission over a distance of a few thousand miles reception is good for only part of a day. Transmission of these waves is affected diurnally and nocturnally to such a degree that at times reception is entirely cut off. This limitation has been satisfactorily overcome by two very different methods. One through alternate use of two or three previously tested channels, so that when one fails, the others may be used. The other has been likewise successful, but uses the same channel continuously. When

transmission in one direction becomes poor, the direction of transmission is reversed, that is, turned about through an arc of 180 degrees. Thus energy is transmitted around the world in either of two directions. A method to prevent or counteract the fading of the longer waves has not, as yet, been disclosed by anyone.

The Vertical Antenna

Almost all of the directive antenna systems now in general use may be regarded as types of linear array. Such a system consists of two or more vertical radiators equispaced and having current supply of equal amplitude and in phase. Their properties were treated in part in RADIO ENGINEERING, of June, 1930.

Another type now in commercial use

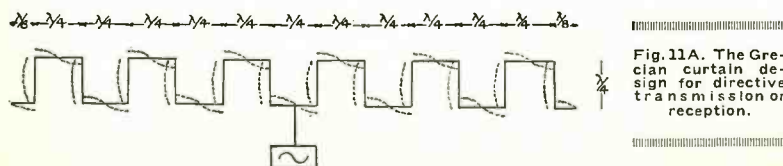

Fig. 11A. The Grecian curtain design for directive transmission or reception.

consists of two parallel linear arrays of these elements, the first row usually has its antenna group in pairs acting as transmitter, the other as reflector. The reflector row is not energized. When the transmitting row is operating without a reflector row the principal radiation is in the direction of the array, with the reflector row the principal radiation is at right angles to the array. In the conditions shown in Fig. 6, (RADIO ENGINEERING, June, 1930) it is not necessary that each radiator be excited, for one may derive its energy from the other and yet produce the same results. It would take the radiation from the energized antenna just one-quarter period to propagate itself to the unenergized antenna, so that the result would be of one-quarter period difference between them. The unenergized antenna would reradiate energy received from the other. In the former case the reflective row is sometimes grounded, thereby preventing radiation in the direction opposite to the desired transmission.

So that a sharper beam may be transmitted, a number of those antennas are arranged systematically in a horizontal plane, as shown in Fig. 12. The polar diagrams of Fig. 12 show that increasing the number of pairs of transmitting, and corresponding reflecting, antennas produces an increasingly sharper beam. Increasing the quarter wavelength separation between antennas tends toward formation of parasitic lobes, the results of which are to decrease the effectiveness of the array.

As seen from Fig. 13A, the principal radiation is at right angles to the array. This is because the individual antennas are in phase. The direction of the array produces a wave motion of 90 degree phase difference, therefore we have some radiation because a complete cancellation of energy is not affected (Fig. 13A). As the vertical radiators are increased, an increasing complexity of wave motions results which are too complicated to show diagrammatically so experimental results will serve to indicate the effects.

Various spacings of the vertical antennas and reflectors are used with considerable success, but are too numerous to mention here.

Adaptations of the Hertz Antenna

Modifications or variations of the Hertz antenna are very useful in

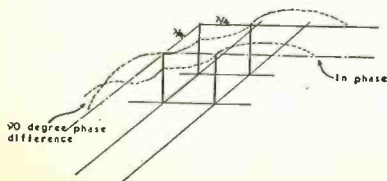

Fig. 13A. One pair of vertical antennas. Their radiation effects.

modern directive transmission and reception. One of these types is used, commercially, in this country with satisfactory results. It consists of a large number of radiating elements in a vertical plane array, spaced at suitable distances and interconnected in such a manner that the currents in all the radiating elements are in phase. This condition accomplished produces what are known as "standing waves;" waves that are always proceeding, in their parallel paths, in the same direction. It is generally known that current nodes and current maxima will recur along a straight conductor if its length be an exact multiple of one-half wavelength of the exciting e.m.f., and that the phase difference between successive current maxima is 180 degrees. Such a conductor, when arranged in a vertical

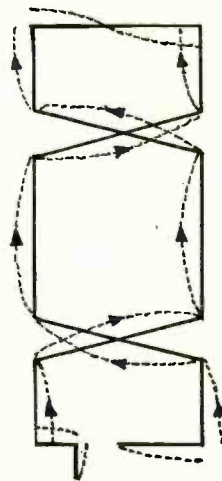

Fig. 14. Modification of Hertz antenna in vertical position.

plane, is shown in Fig. 14; it satisfies these requirements. The arrows indicate the relative direction of current flow and the dotted line indicates the current amplitudes along the conductor. It will be observed that the instantaneous currents in the vertical members are all in the same direction and that in the cross members their directions are opposed. This arrangement is designed so that as soon as the currents complete like portions of 180 degrees their conductors are crossed over to an adjacent side in order that the reverse 180 degree cycle may be completed, and the next vertical section be in the same direction as the one below, and so on to the top of the antenna. There is, of course, no resulting radiation in the crossed members, for the currents equal in magnitude and differ in phase by 180 degrees, amounting to destructive interference.

The vertical members combine their efforts for radiation in a perpendicular direction to the plane of the conductor. Actual tests have shown that there is

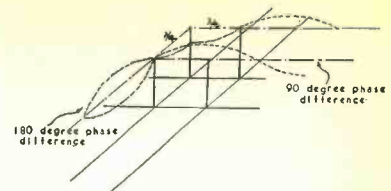

Fig. 13B. One pair of vertical antennas. Their radiation effects.

an improvement of signal intensity in the direction equal to four times the power which otherwise would be necessary for the same results.

If a second similar conductor system be placed in a parallel plane directly behind the first and excited parasitically from the radiator, the resultant action would be that of a reflector curtain creating a unidirectional system. The reflector curtain further reduces the power required by one-third. Comparing this system with a simple vertical antenna producing the same results, it is necessary to use only one-eighth of the power.

The system in Fig. 14 can be extended vertically to include more radiating elements. It can also be extended horizontally by placing several of these units alongside of each other, care being exercised that the proper phase relationships in all the individual elements is maintained.

The Grecian Curtain Pattern for Directive Reception

An antenna will develop directional properties if it is built up of elements spaced a fraction of a wavelength and is in a single conductor. This may be accomplished by folding the wire back and forth so as to cause desirable phase relations in certain elements; cancellation of energy in others. Such a structure is shown in Fig. 11A. The length of the vertical sections is one-quarter wavelength; that of the horizontal element occurs the current nodes. In the vertical elements the currents are always in the same direction. It can readily be seen that the currents in the horizontal elements will cancel, thereby delivering no received energy. Similarly, the currents in the vertical section will add, although in the alternate sections they are opposite in phase relationship. It will be particularly noted that the currents change in direction at the nodal points, allowing received currents in the vertical elements to be always in the same direction, regardless of whether they be positive or negative impulses.

This antenna has maximum sensitivity at a right angle direction to its plane, and none to a wave in its plane. To render this system unidirectional, another similar curtain, unexcited, is placed parallel to the first one a quar-

ter wavelength away. The directivity of this system then is equivalent to an increase of power of about 15 times. If used as a transmitter, this system emits a sharply polarized wave, such that a deviation of five degrees on either side of the axis of the beam produces a falling off of 50% in field strength. (Fig. 11B).

A valuable feature of this system is that it does not permit currents into the vertical elements to suffer loss through reradiation from its horizontal elements. Such loss could only be from passage of currents along the horizontal elements. Another important advantage of this system is the uniformity of current flow, there being no significant points of reflection throughout the wire. The sensitivity to radiation in a vertical direction is null within a short distance from the antenna. The horizontal sensitivity is unimpeded to the maximum permitted by the receiver. This system can be used for unidirectional transmission in two directions by using either curtain as receiver or transmitter, whichever the case may be.

Arrangement of Chireix

Another arrangement of this identical principle has been devised by H. Chireix and is shown in Fig. 15. The wire is bent in zig-zag fashion as shown. The current distributions are shown in dotted lines. Instead of one-quarter wavelength bends, however,



Fig. 15. The arrangement of Chireix.

this system requires one-half wavelength sections. The wire offers no appreciable changes in characteristic impedance and therefore energy is readily propagated from one end to the other with very little, if any, reflection.

A practical form of this antenna is shown in Fig. 16, and is obtained by two sections of Fig. 15. The curtain may be extended, by groups of sectional pairs, in a horizontal direction, usually to 32 of these half-wave elements. This system will also show maximum sensitivity bi-directionally; will be rendered unidirectional by a like unexcited curtain in a parallel plane one-half wavelength away. This again produces a horizontally polarized wave. It is about 20 degrees in breadth at the widest point. The total length of the curtains is usually five or six wavelengths. According to the inventor, this system is not critical in adjustment. When operating on 25 meters a variation of 200-kc. plus or minus is a permissible deviation without changing design. This will, of course, permit the simultaneous use of several frequencies

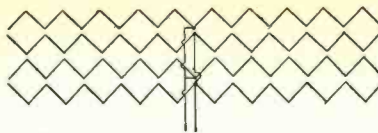

Fig. 16. Practical arrangement of antenna shown in Fig. 15. Vertical view.

with the same antenna. This system also permits unidirectional results in two directions by use of either curtain as either transmitter or receiver, depending on how the curtains are being employed. Both the Grecian curtain and this system effectively prevent "ghost signals," which are occasioned by currents travelling around the earth. Both of these systems are in actual operation and are giving satisfactory results.

Conclusion

The foregoing descriptions cover the important developments which have been made in directional wireless from

its discovery to the present day. They represent continued research over a period of about 30 years, during which time communication by voice has expanded from local to national, and from national to international.

That little is yet known of the principles of directive radio transmission is manifest by inspection of available data on the subject. Such knowledge is connected with that of the transmission of light—a phenomenon of which also little is known. It is likely that transmission of wave disturbances in the atmosphere will remain unsolved until more is known concerning transmission of light. Of that we may be reasonably certain, since their methods of propagation are similar. So far the wave theory has been most useful in wireless transmission study. It appears that the wave theory will remain an important part of electrical transmission phenomena.

SYNCHRONISM OF BROADCAST STATIONS

THE Federal Radio Commission on March 13, authorized the National Broadcasting Company and its two associate stations, WTIC, Hartford, and WBAL, Baltimore, to continue their synchronization work and to place in regular operation the synchronizing apparatus for which construction permits were granted several months ago, when NBC engineers announced that synchronism was ready for practical use.

Under the arrangement which is now in effect WBAL will synchronize during the time it is not operating on its own wavelengths with WJZ in New York, and similarly WTIC will synchronize with, and accept programs from WEA, NBC's other metropolitan key station. In the periods when they are not synchronized, WBAL and WTIC will broadcast independently on the wavelength of 1060 kilocycles which they now share in the federal allocations.

When the plan was first announced, the participating engineers pointed out that the immediate advantage of the synchronization will be to enable WTIC and WBAL to give full-time service in their respective areas. Under the old scheme one of the stations was necessarily silent on those days or during those hours, when the other was using their joint wavelength. Synchronization with one of NBC's stations in New York will permit them to serve their listeners during every broadcasting hour.

"The fundamental difficulty with all previous attempts to solve the problem of synchronization," an NBC engineer explains, is the fact that engineers have concerned themselves only with elimi-

nation of the so-called 'beat note,' which reproduces itself in loudspeakers as a discordant whistling noise when two stations are not maintaining exactly the same frequency.

"The 'beat note' we eliminated by controlling our frequencies from a central point. But this absolutely constant frequency did not quite do away with interference, because even in perfect frequency synchronism, the transmitters showed a tendency to vary in 'electrical distance' from one another.

"In other words, the line which controlled the frequencies, and kept them identical, created an effect known to engineers as a 'varying phase' difference. We finally solved the last obstacle to practical synchronization by evolving a device to overcome this difficulty."

The device, it is stated, is a stabilizer which is similar in effect to a fly-wheel. It automatically operates the station, and is itself governed by the frequency control which comes over the line from the central point. The stabilizer disregards line variations in voltage, momentary changes in frequency and other disturbing factors, and for all practical purposes maintains the phase relationship between the synchronizing stations in an ideal way.

Synchronization, as it is developed and applied, will be of importance to the listening public. If spaced geographically stations will be able to synchronize and still maintain their own program services without interference. And this possibility will enable many stations which are now limited in power, because they share channels with other stations, to increase their power and extend their service ranges.

Adjusting the Superheterodyne for Maximum Sensitivity

By RALPH J. KNOUF

THE adjustments of the various circuits of a superheterodyne receiver for maximum sensitivity offer a somewhat different problem than that of the usual r.f. receiver. This is due to the use of a low frequency in the intermediate frequency amplifier, and also because the oscillator tuned circuit must operate at a frequency differing from that of the radio-frequency amplifier and first detector circuits.

The following description of a test oscillator and method has been found useful for factory testing and could also be used to advantage in servicing superheterodyne receivers.

A calibrated test oscillator is used to adjust the first detector and oscillator circuits. Assuming that an intermediate frequency of 175 kc. is used, this oscillator is calibrated at 600, 750, 775, 925, 1400 and 1575 kc. The oscillator may be modulated either by a grid leak or modulator tube, but must be so arranged that an unmodulated output may be obtained when desired. A tube adapter for the first detector socket, with a flexible lead from the plate connection of the adapter terminating in a plug for the second detector socket, allows the circuit shown in the diagram to be obtained without changing the wiring of the receiver. The 224 tube working into a transformer designed

for a 227 tube is satisfactory in this case as only a resonance indication is desired.

The test oscillator is connected directly to the grid of the r-f. tube in order to eliminate any tuned circuits ahead of that point. Then adjust the test oscillator so that a 1400 kc. modu-



Description of the apparatus required and the procedure in determining superhet performance



lated signal is obtained, set the tuning dial of the receiver to read 1400 kc., and adjust trimmer condenser No. 1 until maximum output is indicated on an output meter, which may be a vacuum tube voltmeter or thermocouple milliammeter connected to the speaker voice coil. Then, without changing the position of the gang condenser, adjust the test oscillator for a 1575 kc. unmodulated signal and adjust trimmer No. 2 until zero beat is heard in the speaker.

After this is done set the test oscillator for a 600 kc. modulated signal and

adjust the gang condenser until maximum output is again indicated. Leaving the gang condenser in this position, adjust the test oscillator for a 775 kc. unmodulated signal and again obtain zero beat in the speaker by adjusting trimmer No. 3.

If the first detector and both oscillator trimmer condensers have been properly adjusted in these two positions, these circuits should be very nearly 175 kc. apart over their entire tuning range. In order to check this, the above operations should be repeated at 750-925 kc. and again at 1400-1575 kc.

When this has been done the adapter and plug may be removed and the first and second detector tubes placed in their sockets. With the test oscillator set at preferably 1400 kc., the intermediate frequency transformer adjusting condensers may then be adjusted until maximum output is obtained.

The last operation is to align the r-f. section of the gang condenser (or both sections if band pass input is used). This is done by using the 1400 kc. modulated signal from the test oscillator, first connecting it to the grid of the r-f. tube and obtaining maximum output by tuning the receiver, and then coupling this same signal to the antenna connection and again adjusting for maximum output by means of trimmer condenser No. 4.

In production testing, this procedure may be done by two operators, the first aligning the first detector and oscillator circuits and intermediate frequency transformers, and the second operator aligning the r-f. tuning circuit and checking overall sensitivity.

1930 NOT SO BAD

Statistical information compiled by the Department of Commerce shows that the average list price of radio receiving sets in the year 1930 was \$87.00, less tubes, in comparison with \$133.00 in 1929.

The total sales of radio receivers, including accessories, in 1930 amounted to \$500,951,500.

BROADCAST ANTENNA TOWERS

In the May issue of RADIO ENGINEERING will appear an illustrated technical story on modern broadcast antenna towers. This article will be of real engineering value to radio engineers who desire to keep abreast of the times in broadcast station work.

SUPER-CONTROL TUBES

In the May issue of RADIO ENGINEERING will be published additional information on the new super-control, or variable-mu vacuum tubes.

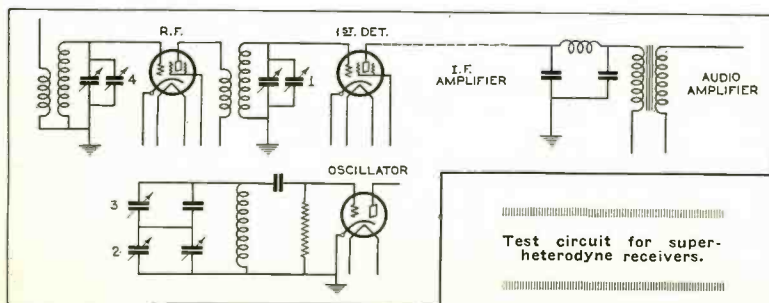



"Here's a New SPRAGUE INVERTED CONDENSER that does the work"

- Metal enclosed vent
- One piece anode
- One hole mounting
- Can—dull nickel finish
- Small space—high capacity
- High voltage—self-healing.

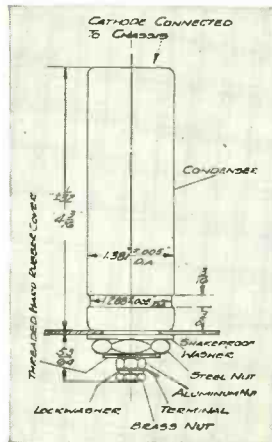

RADIO engineers of 1931 receiving sets will receive with unqualified approval this announcement of a Sprague Electrolytic Condenser that helps materially in their problems to make the new radio receivers as simple as possible, more efficient than ever before—and at the same time conserve time, space and expense.

Only an organization like SPRAGUE, with superb modern manufacturing facilities, highly developed research laboratories, an engineering department devoted to the problems of the set manufacturer, and a highly trained personnel could produce the tremendous improvement represented by this new SPRAGUE INVERTED ELECTROLYTIC CONDENSER in tremendous quantities with unqualified UNIFORMITY.

Send for illustrated booklet, diagrams, etc. Address Dept. 13B

SPRAGUE SPECIALTIES COMPANY
North Adams, Mass.

SPRAGUE

Electrolytic CONDENSERS

PROGRESS IN RADIO DEVELOPMENT IN AUSTRALIA DURING 1930

AN interesting review of the achievements and general progress in radio development in Australia during the past year is contained in a statement issued by Amalgamated Wireless (Asia), Ltd. It is mentioned that the year 1930 has been a period of considerable activities in the wider sense of radio development and that some of the achievements of the year are definitely of historical importance. On April 30, 1930, according to the statement, the wireless telephone service between Australia and England was opened. Next in importance of the year's achievements was the establishment of telephonic service between Australia and New Zealand on November 26. By the establishment of these services, which in turn are linked with the radio telephone services from Great Britain to Europe and North and South America, Australian telephone subscribers are brought into contact with about 50,000,000 telephone subscribers in other countries.

Picture Transmission

During the year developments have taken place in the transmission of pictures by wireless. Photographs transmitted from Sydney have been received in England with sufficient clearness to be published in the British press. The experts of Amalgamated Wireless (Asia), Ltd., are not yet satisfied, however, and further experiments must be conducted before anything in the nature of a commercial service can be established.

Beam Wireless Traffic

The Beam wireless service, which was inaugurated four years ago, has become more firmly established as the cheapest and fastest method of overseas telegraphy. The Beam now carries about 70 per cent of the traffic and during the past year its operation resulted in the Commonwealth Government receiving £126,000 as its share of dividends and terminal taxes on messages sent and received over the Beam wireless service.

GRAYBAR

ONE of the finest things that has been done in our times has been the naming of the Graybar Company. In recent times the tendency in naming companies has been to include in the title indication of the product or service. Many eminent and worthy names were shelved when the General Electric Company was named—formed from companies which bore personal names. We have the General Asphalt Company, the General Glue Company,

and the trend toward large consolidations has produced such cryptic titles as The AEF, etc.

In the early days of the telegraph there were the Wade and Speed Lines, The Bain Lines, The Morse Lines, The O'Reilly Lines, The Mackay-Bennett System, and so on, all later to be given more comprehensive names under consolidation.

The Graybar Company, was given its name by men still young in years—Gifford, Jewett, and others. The human touch of the thing is positively encouraging.

The name is formed from those of Elisha Gray and Enos M. Barton. Elisha Gray was born in 1835 and died in 1901. He was educated at Oberlin College. In 1867 he received his first patent, for a self-adjusting telegraph repeater. Later he invented telegraph switchboards, and annunciators, a harmonic telegraph system and a telegraph printer. Also, the Telautograph and numerous telegraph and telephone devices. He was close on the heels of Alexander Graham Bell in the invention of the telephone. For this he filed specifications on February 14, 1876 but a few hours after the filing of an application by Bell, to whom the patent was awarded and whose rights were sustained by the Supreme Court. Gray's associate, Barton, is said once to have remarked: "Of all the men who didn't invent the telephone Gray was the nearest."

Gray and Barton maintained an electrical manufacturing establishment in Chicago, at 479 State Street, from 1869 until 1872, in which latter year the business became a part of the Western Electric Company, then newly organized.

Mr. Barton became the head of the works of the Western Electric Company where he remained for a period of forty years.

It is a great personal credit to men identified with the destinies of the industry of telephone manufacture and communication service that in seeking a good name for the new division of the work they have placed permanently on letterheads and signboards the names of Elisha Gray and Enos M. Barton. The very fact that in years to come it may be necessary to explain to posterity what "Graybar" means will present opportunity to re-tell about the contributions of these pioneers to the beginnings of the art of communication.

REMOTE CONTROL

Remote control of radio telegraph transmitters is the subject of an informative technical article to appear in the May issue of RADIO ENGINEERING.

SHORT-WAVE HIGH-POWER RADIO TUBE

VACUUM tubes have been subjects of research for years. Approximately three years ago scientists in General Electric Research Laboratories succeeded in constructing a radio tube having a wavelength of six meters and a frequency of 50,000,000 cycles per second, capable of radiating 10 to 15 kilowatts of energy. This is fifty times as much power as any short-wave tube previously had been able to produce.

Early experiments with this tube were accompanied with some phenomena startling to a layman. Within the sphere of its influence a cold copper bar would blister the hand that picked it up; an incandescent lamp held in the hand, without wire connections with any electric circuit, would light to full brilliancy; similarly a neon tube, upon being touched by anyone, would emit its bright red glow. Electrical instruments, even in rooms other than the one where the tube was, were disturbed or broken. Persons approaching too close to the tube experienced suddenly a comfortable glow of warmth, but if they continued under the influence, increasing pain in limbs and joints. Blood temperatures rose to 100 degrees Fahrenheit in fifteen minutes.

Radio cooking was demonstrated as a possibility. A wire was suspended over a table at a distance of a few feet from the radiating aerial, which was a copper bar about ten feet long. A sausage in a glass container suspended from the end of the wire was soon cooked. Likewise an egg was "fried" in this container, and an apple spitted on the end of the wire was thoroughly baked in a short time. With suitable changes of utensils cookies were baked and water boiled. There were no flames nor other visible evidences of heat accompanying the cooking.







The vacuum tube from which this weird power emanated was only two feet long and five inches in diameter. However, auxiliary to it was a large and complex array of electrical equipment costing so much that the tube will have but little practical utility until researchers and developers shall have accomplished numerous simplifications.

Quite different applications of the capabilities of this tube have also been under investigation. For generations heat has been used to alleviate pain and cure some diseases. * * * As yet the high-power short-wave vacuum tubes are being used for experimental purposes only. To bring them into practical usefulness at reasonable cost and discover their many possibilities for service to mankind is now our task.—Willis R. Whitney, in *Engineering Foundation Research Narrative*.

YOU WOULDN'T TOLERATE AN ABSORBENT RAINCOAT



*How do your customers
feel about absorbent insulation?*

OF course the insulation in your product was supposedly good when it left your  plant. So was your raincoat when you bought it. But if it is unreliable, falls down under use, absorbs moisture—you lose customers. » » » That's the reason an increasing number of manufacturers are turning to Synthane  Laminated Bakelite. They know that it's reliable, that it stands up, that it makes  reliable products and in turn—satisfied customers. » » » In addition to low moisture absorption, Synthane has many other superior features, both electrical  and physical, which we will gladly explain to you. It is made only of the finest materials  giving you only the best results. » » » Your customers will not tolerate absorbent insulation any more than you would tolerate an absorbent raincoat. Be sure—use Synthane. Generous samples for testing  sent on request. Synthane Corporation, Oaks, Pennsylvania.

SYNTHANE
Laminated Bakelite

NEW YORK · CHICAGO · PHILADELPHIA · DAYTON · LOS ANGELES · SAN FRANCISCO

Modulation and Its Suppression

BY VERNE V. GUNSOLLEY*

WHEN a sinusoidal e.m.f., $E \sin \omega t$, is impressed on a circuit containing L , C and R in series, the instantaneous value of the current, as indicated by an inertialess galvanometer is, in general,

$$i = \frac{E \sin \left(\omega t - \tan^{-1} \left[\frac{\omega L - \frac{1}{\omega C}}{R} \right] \right)}{\sqrt{R^2 + \left(\omega L - \frac{1}{\omega C} \right)^2}} + I_0 \epsilon^{\alpha t} \sin (\omega_0 t - \psi_0) \quad (1)$$

If the impressed frequency is equal to the natural frequency of the circuit, then $\omega = \omega_0$, and, in particular;

$$i = \frac{E}{R} (1 + \epsilon^{\alpha t}) \sin \omega t \quad (2)$$

If, instead of instantaneous values we are satisfied with effective values, as would be indicated by an inertialess a-c. ammeter, the current amplitude would rise along a curve;

$$i = \frac{E}{R} (1 + \epsilon^{\alpha t}) \quad (\text{at resonance}) \quad (3)$$

Expression (3) will immediately be recognized as being of exactly the same form as the current rise in a direct-current circuit. This follows, naturally, from the fact that in the analysis of the electric circuit, e.m.f.'s., and currents, whether alternating or continuous, are treated as stationary. At resonance, the reactance to the permanent term is zero exactly as it is in the direct current circuit. It follows that if the time constants of the d-c. and the a-c. circuits are equal, then the reactance to the transient terms will also be equal and that (3) holds for both the d-c. and the resonant a-c. circuit.

The foregoing has been very brief, for we do not wish to spend time and space unnecessarily in reviewing the fundamental principles which may be verified by referring to any of the well-known treatises on transient phenomena.

Equation (1) is based on the condition that the e.m.f. be instantly applied

WHILE the solution of the tuned circuit either by the sideband method or by the direct method gives identical results, there are many who are not reconciled to this conclusion. The purpose of this article is to show the equivalence between the two methods and to show that the sideband theory while perfectly valid is nevertheless based on an imaginary conception having no part in the actual physical phenomena of broadcasting.

and then held steady at an unvarying amplitude. If this is done, then after a few cycles the transient term containing ϵ becomes negligible leaving nothing but the steady state term. If, however, the e.m.f. is not held in a steady state but is kept varying, the transient term does not have an opportunity to die out before a new transient term is generated by the variation in the amplitude of the applied e.m.f. so that the transient term becomes permanent and of a nature depending on the nature of the variations in the amplitude E .

It is at once evident that such a varying e.m.f. in addition to being an alternating current is also pulsating, for, an ammeter connected to such a current would show pulsations provided they were not too rapid, or, the meter inertialess.

What has been said of the alternating case is correspondingly true of the direct-current case. If the e.m.f. is held constant after being instantaneously applied, the transient term containing ϵ dies out after a short time. If however, the e.m.f. is not held steady, each new variation sets up a new transient, the nature of which will be the same as in the a-c. case provided the nature of the impressed variations is the same.

While it seldom happens in reality that the variations, or modulation, have any definite law of variation, for the

purposes of analysis we will choose the case where the variation is $kE \sin \omega' t$. This means that the modulated alternating e.m.f., which is also a pulsating alternating e.m.f. has the form;

$$E \sin \omega t + kE \sin \omega' t \sin \omega t \quad (4)$$

which may also be written;

$$E \sin \omega t (1 + k \sin \omega' t) \quad (5)$$

If we are satisfied with voltmeter readings instead of instantaneous values, and the voltmeter is quick enough to follow the modulation, we may strike out the term $\sin \omega t$ and obtain

$$E + kE \sin \omega' t \quad (5)$$

which is at once seen to be the same as the form of a modulated direct e.m.f.

Since the reactance to the permanent term is zero in both the d-c. and the a-c. circuits, and since for equal time constants the reactance to the transient terms of both currents is equal, it follows that a solution of the simple d-c. circuit is also a solution of the complex a-c. circuit when the time constants are equal.

The time constant of the d-c. circuit is, $1/\alpha' = L/R'$; while the time constant of the a-c. circuit is, in general, $1/\alpha = 2L/R$. There is no necessity for making the resistance in both circuits the same for equal suppression, but, in order to have both permanent terms of the same magnitude, $R' = R$, and

$$L' = 2L \quad (6)$$

It follows therefrom that the current in the pulsating d-c. circuit is given by the simple relation

$$i' = \frac{E}{R} + \frac{kE \sin (\omega' t - \phi)}{\sqrt{R^2 + (\omega' 2L)^2}}; \quad (7)$$

which is also the envelope of the modulated a-c. carrier wave, while the instantaneous value of the modulated carrier wave is given by the equally simple relation

$$i = \frac{E \sin \omega t}{R} + \frac{kE \sin (\omega' t - \phi) \sin \omega t}{\sqrt{R^2 + (\omega' 2L)^2}} \quad (8)$$

Thus is solved the complex modulated carrier wave, by the act of equating to its equivalent modulated direct current.

Having solved the current by the lag in the rise and fall of resonance, we will now turn to the sideband theory for that method of solution.

Equation (1) was derived by the solution of the equation

$$L \frac{d^2 i}{dt^2} + R \frac{di}{dt} + \frac{i}{C} = \frac{d}{dt} (E \sin \omega t) \quad (9)$$

But when we apply the modulating factor to $E \sin \omega t$, thereby giving (4) for the right-hand member of (9) instead of merely $E \sin \omega t$, it now becomes impossible to find a solution to the differential equation, (9). For some time this equation was never solved, and so far as we know is still unsolved though we know that the solution is (8); by the method already given. However, there is a way out of the difficulty.

In the May, 1930, issue of this magazine R. P. Glover gave the transform-

* Research Engineer, The National Battery Station, KSPT, St. Paul-Minneapolis.



Some speakers are only true on high notes



Others are only true on low notes



Still others compromise



But only Magnavox gives you full symphonic tone range

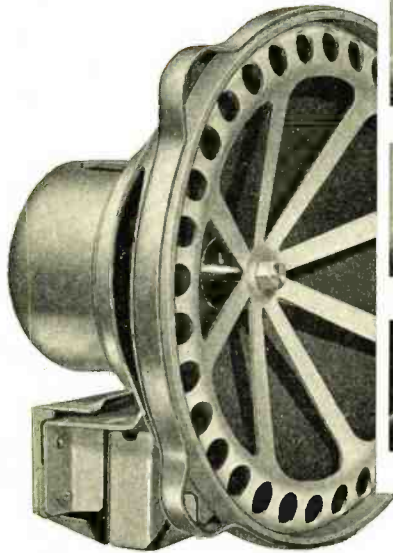

ANNOUNCING THE NEW MAGNAVOX "140" SYMPHONIC SPEAKER

AT last, a speaker that will reproduce the full range of the human voice, band or symphony orchestra from low G to high C—clear, true and undistorted on every note!

It's another Magnavox triumph—the ultimate in dynamic speaker construction, born of twenty years' pioneering in electro-dynamic sound engineering.

The new Magnavox has many revolutionary construction features, fully covered by patents and patent applications. And it is sturdier, more durable, easier to mount—wear-proof and trouble-proof—an end to rejections and service.

Only the superior resources, long experience and extensive facilities of the Magnavox Company could produce such an achievement—at a price so attractive no 1931-32 commitments should be made without investigating the new Magnavox "140" Symphonic Speaker.

Magnavox Company Ltd.

Executive and Sales Offices: 155 East Ohio St., Chicago, Ill.
Factories: Fort Wayne, Ind.

SUBSIDIARIES
The Magnavox Company
Elcetro Formation, Inc.



SUBSIDIARIES
Magnavox (Australia) Ltd.
Magnavox (Great Britain) Ltd.

A COMPARISON WILL PROVE IT A FAR BETTER SPEAKER THAN YOU HAVE EVER SEEN OR HEARD. SEND FOR ENGINEERING DATA.

mation of (4) into its components which are;

$$E \sin \omega t + \frac{1}{2}kE \sin(\omega + \omega')t + \frac{1}{2}kE \sin(\omega - \omega')t \quad (10)$$

which means that the modulated single carrier frequency of (4) may be imagined replaced by three carrier frequencies in a steady state; that is, unmodulated. This gives the unmodulated carrier wave and an upper and lower sideband; and, solving for the current in this case, the differential equation is

$$L \frac{d^2 i}{dt^2} + R \frac{di}{dt} + \frac{i}{C} = \frac{d}{dt} (E \sin \omega t + \frac{1}{2}kE \sin(\omega + \omega')t + \frac{1}{2}kE \sin(\omega - \omega')t) \quad (11)$$

$$i = \frac{E \sin \omega t}{R} + \frac{1}{2}kE \sin[(\omega + \omega')t - \tan^{-1} \dots]$$

$$\left[\frac{(\omega + \omega')L - \frac{1}{(\omega + \omega')C}}{R} \right] \sqrt{R^2 + \left((\omega + \omega')L - \frac{1}{(\omega + \omega')C} \right)^2} + \frac{1}{2}kE \sin[(\omega - \omega')t + \tan^{-1} \dots] \left[\frac{(\omega - \omega')L - \frac{1}{(\omega - \omega')C}}{R} \right] \sqrt{R^2 + \left((\omega - \omega')L - \frac{1}{(\omega - \omega')C} \right)^2} \quad (12)$$

It still may not be apparent that (12) is the equivalent of (8). Numerical calculation will closely show the equality if the fact that expression (4) is equal to expression (10) does not. However, it is not necessary to resort to numerical solution. We may show analytically that with negligible error such is the case. We shall do this by showing that when the suppression in both the d-c. and the a-c. circuits is equal that $L' = 2L$ independently of equating the time constants; also we shall show that the suppression is equal to the power factor of the modulation, and that this is in turn equal to the power factor of the sidebands; that is, that the reactance to the modulation in a d-c. circuit is equal to the reactance to the sidebands in the resonant a-c. circuit.

Let the degree of the modulation of the impressed e.m.f. be k . Then, as is well known, either sideband e.m.f. e is to the carrier e.m.f. E such that $2e/E = k$ (13)

Suppose now that the impedance to e is Z and such that the modulation in the resulting carrier current i is no longer k , but instead is equal to k' . Similarly the sideband current I is to the carrier current i such that $2I/i = k'$ (14)

It is understood that the suppression is brought about by the fact that when the components are impressed on a tuned circuit, the carrier wave meets only with resistance, while the sidebands meet with the higher off-resonance impedance, Z , so that they are suppressed relative to the carrier, thereby suppressing the modulation which is represented by the sidebands.

Dividing (14) by (13) gives

$$k'/k = \frac{I}{e} \times \frac{E}{i} \quad (15)$$

But $E/i = R$; $e = \frac{1}{2}kE$ and $I = e/Z = \frac{1}{2}kE/\sqrt{R^2 + X^2}$. Substituting these values in (15) gives

$$k'/k = \frac{R}{\sqrt{R^2 + X^2}}; \quad (16)$$

that is, the power factor of the sidebands. Dividing through by R and rearranging gives

$$k' = \frac{k}{\sqrt{1 + \frac{X^2}{R^2}}} \quad (17)$$

Since the sidebands are unequal, in solving for k' it is necessary to solve first with the upper sideband reactance and then with the lower sideband reactance, and take the mean value of the two results. For ordinary ratios of modulation to carrier frequencies the error in so doing is negligible.

We may express (17) directly in terms of the modulation and carrier frequencies f_m and f_c

$$k' = \frac{k}{\sqrt{1 + \frac{L}{C R^2} \left\{ 1 - \left(\frac{1}{1 \pm \frac{f_m}{f_c}} \right)^2 \right\}^2}} \quad (18)$$

Having found k' for the sideband theory and thus the a-c. case, we may now find an expression for k' in the d-c. case.

Upon referring to (7) it is very evident that k' is the amplitude of the modulation divided by the amplitude of the carrier current; that is

$$k' = (kE/Z) / (E/R) \quad (19)$$

from which; (Z being the modulation impedance in (7));

$$k'/k = \frac{R}{\sqrt{R^2 + X^2}}; \quad (20)$$

that is, the power factor of the modulation. By the same reasoning as before, (20) being equal to (16), then k' in the d-c. case is also equal to (17) with the modulation reactance substituted for the sideband reactance. That is, when (16) is equal to (20) as we deliberately oblige it to be; (since we could equate the two expressions for k'_{ac} and k'_{dc} irrespective of whether they were identical in form,) it follows that

$$X_{ac} = X_{dc} \quad (21)$$

when $k'_{ac} = k'_{dc}$ and since X_{ac} is $\omega'L$; and X_{dc} is $(\omega''L - 1/\omega''C)$ then by (21)

$$\omega''L = \left(\omega''L - \frac{1}{\omega''C} \right) \quad (22)$$

where ω'' is either sideband angular velocity.

In the capacity reactance component of (22), C may be replaced with its equivalent, LC/L , giving thereby in (22) for the capacity reactance component, $L/\omega''LC$. Let $\omega''/\omega' = b$ and equation (22) then becomes

$$L' = L \left(b - \frac{1}{\omega'^2 LC b} \right) \quad (23)$$

side bands, & beat frequency

Now if (23) and (6) are identities, then the term in parenthesis in (23) is always equal to 2, numerically. We can determine this by solving numerically for both the upper and lower sidebands and taking the mean value, a process which, with negligible error in every case results in the factor 2, thereby verifying (6).

For example: Let the carrier frequency be 550 kc. and the modulation 5 kc. The sideband frequency is either 555 kc. or 545 kc. From this, b is either 109 or 111. Substituting these values respectively in (23) gives 2.2L and 1.8L the mean value of which is 2L. At the other end of the dial, or 1500 kc. the sidebands are either 1505 or 1495 kc. and b is either 301 or 299. Substituting the new value of L corresponding to 1500 kc. and solving gives 2L by either sideband, (on a 20 inch slide rule).

Analytically, it may be shown that (23) is equal to (6) by putting (22) in the terms of the modulation and carrier frequencies, f_m and f_c . This gives

$$L' = L \left(\frac{f_c}{f_m} + 1 \right) - \frac{1}{4\pi^2 C f_m^2 \left(\frac{f_c}{f_m} + 1 \right)} \quad (23a)$$

If this holds for all values of modulation, it holds for $\frac{f_c}{f_m} = 1$, also for f_m

equal to infinity, in which cases (23) reduces to

$$L' = L(1 + 1) = 2L$$

and $L' = 2L$.

We have therefore, (with negligible error) established the equivalence between a resonant a-c. circuit and a d-c. circuit when the time constants are equal. We have yet to determine when the sidebands are real and when they are imaginary. Obviously this cannot be done mathematically since (4) is equal to (10). Where there is equivalence there cannot be difference, and where there is no difference, there can be no argument. This leaves mathematical proof out of the question. Sir Oliver Lodge says a deep philosophical question seems to be involved. Let us see.

One side of the argument concludes that it is the function of the apparatus to send out a modulated single frequency. The other side breaks the carrier wave up into its components, and concludes that it is the function of the apparatus to send out three unmodulated frequencies. Mathematically each side can prove its own case but cannot prove the other side wrong, for, it can be absolutely proven that the same resistance that is necessary to produce a given fidelity on the lag-in-the-rise-and-fall-of-resonance theory, also produces the proper breadth of selectivity to admit the sidebands. In fact that is just what we have proven in showing the equivalence between (8) and (12).



V

THE NEW
VARIABLE-MU TUBE

New in Design . . .
Advanced in Principle
. . . Efficient in Performance

EVERY set manufacturer, every radio engineer, the entire trade, will be vitally interested in this newest invention—the Arcturus Type 551 Variable-Mu Tube.

Seldom, in the rapidly changing radio industry, has one tube embodied so many advantages and presented to set manufacturers such splendid merchandising and economic possibilities for 1931 receivers—with practically no changes in existing circuits.

By shaping the plate current-grid voltage characteristic so as to minimize the higher order curvature over an extended range of control grid voltage, the Type 551.

1. Reduces cross-talk by a factor of several hundred times and eliminates modulation distortion and receiver "hiss";
2. Eliminates distortion of signals from high-power stations caused by the non-linear relation between the r. f. output voltage and the r. f. input voltage;
3. Minimizes hum in a-c receivers due to modulation of the carrier by low-frequency hum voltages inadvertently present in the control grid circuit;
4. Obviates the use of antenna potentiometers, local-long distance switches, double pre-selectors, etc.

These features are of important significance to manufacturers in designing 1931 sets where production costs and performance are paramount considerations.

A special technical bulletin on the Arcturus Type 551 Variable-Mu Tube will be sent upon request.

ARCTURUS RADIO TUBE COMPANY
Newark, New Jersey

ARCTURUS

RADIO TUBES

Licensed under patent applications of Boonton Research Corporation.



Arcturus' quick-action is another feature of the 551.

"THE TUBE WITH THE LIFE-LIKE TONE"

REAL PROTECTION

.. LESS COST

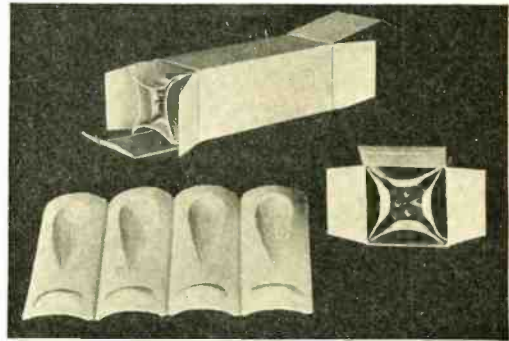

HOLED - TITE RADIO TUBE WRAPPER which is revolutionizing tube packing.

Check these features:

- 1 Wrapper is light and form fitting and designed especially for each size of tube. Consequently, it provides suspension and perfect protection.
- 2 Suspension packing protects against lateral shocks and distortion of elements.
- 3 Tube can be tested without removing from carton, without tearing or defacing the wrapper.
- 4 Wrapper is easily and quickly handled, even by unskilled packers.
- 5 Wrapper costs less than any other packing.

Holed-Tite Wrappers are made for all types of tubes to fit the standard bulb sizes.

Write for samples and prices to day. Protect your tubes; save money.

HOLED-TITE PACKING CORP.
220 E. 42nd St., New York City
Affiliated with International Paper Co.

Holed-Tite pad for packing standard cases of 25-50-100 radio tubes. Pad comes in 3 sizes. Do you want samples?

There is no use trying to prove reality by mathematics, so let us not cloud the issue with any complex equations. The dispute arises as to what are the physical facts of the case, not the equivalence.

Given a single pendulum modulated in amplitude. It may be imagined replaced by three pendulums unmodulated in amplitude and of component frequencies. What is the fact in nature? What is the physical event, and which is the imaginary or mathematical equivalent? On the other hand suppose we actually have three pendulums sending instead of one. They may be imagined replaced by a single pendulum. What now is the physical event in nature and which is the imaginary event? Is any deep philosophical question involved?

When once a thing has been proven mathematically or physically to be equivalent, it makes no difference how complex the mathematical expression for the components is, they may be substituted for the force of which they are the equivalent. If actual substitution is performed, then the components are real because we deliberately give them existence. Until we do actually perform the substitution they remain imaginary. Obviously it makes no difference in the solution of suppression whether they are real or imaginary. The final result is the same mathematically.

Now it happens that both the modulated carrier and the components can exist at the same time. Suppose we have a leather strap holding up a weight of ten pounds. This ten pound pull may be imagined as replaced by two diagonal pulls at 45° from the vertical pull and of 7.07 pounds each. Let the strap now be split with a knife half way up its length, from the bottom, and replace the 10 pound pull by the components as just described, thereby, instead of merely imagining the replacement by the components, actually performing the act of replacement. The system is now an inverted Y under tension. In the two arms of the inverted Y we have the components of the 10 pound force in the stem. By this means we have obtained the actual physical existence of both the components of the force and the resultant of the components. In the arms of the Y the resultant is a mathematical fiction and the components are real. In the stem of the Y the components are mathematical fictions and the resultant is real. The act of adding the components vectorially whether done physically or mathematically gives a single valued function, and it is this single valued function that is broadcast from an antenna, since it is not only the mathematical sum but also the physical sum of the components of the modulated carrier wave.

This transition, from the illustration of the forces, to the antenna is rather

abrupt, but to the point nevertheless. Suppose we have three very selective wave-meters each tuned to a component of a modulated carrier wave that has also been tuned-in on a regular coil-condenser combination of the usual broadcast selectivity. The modulated carrier in the broadcast receiving circuit is single valued and real while the components are imaginary, or, as more commonly expressed, mathematical fictions. In the wave-meters however, the components are real and the resultant a mathematical fiction. While the mathematical fiction is single valued, the components are triple valued and each has separate, real and actual existence. This follows from the fact utilized in the Y system of forces, that any force may if convenient, be analysed physically as well as mathematically into its components. If done physically the components so found are real, but if done mathematically, the result must be

THE VARIABLE-MU TUBES

ELSEWHERE in this issue of RADIO ENGINEERING is described the progress of research which has now made possible the new variable-mu, or super-control screen grid vacuum tubes for radio uses.

In the progress of development the characteristics have been subjected to modifications. In the schedule of ratings appearing elsewhere in this issue of RADIO ENGINEERING we have noted that the figures so far given out, are tentative.

a mathematical fiction as far as physical truth is concerned.

The laws of the analysis and resolution of forces into components and resultants are the same when once mathematical analysis proves the forces to be components or resultants, and this is true no matter how complex the expressions for the forces may be. Therefore the fact that an alternating e.m.f. when impressed on a circuit sets up very complex mathematical expressions for the current; resulting in still more complex expressions when it is modulated, does not in the least detract from the simple laws of resolution of forces once the currents are proved to be components.

The conclusion to be drawn is that while the sideband theory is perfectly valid and as such is our most useful tool when discussing modulation, suppression, interference areas of broadcasting stations, etc., nevertheless it is based on a mathematical fiction. Furthermore, the fact that the sideband theory is a mathematical fiction does not make it possible to ignore it, for, any

alteration of any component, causes a corresponding alteration in the resultant which is the single valued function of the components. In short we cannot accept a force without at the same time accepting its components, mathematical fictions though they may be, or, in spite of the fact that we may not even know what the components are.

Now it happens that the components to one kind of force are the components to that force only. They cannot be the components to some wholly different type of phenomena. For new phenomena we must find new components which may be as wholly different as the phenomena itself.

For instance, a frequency modulated carrier is an entirely different type of phenomenon and must not be confused with amplitude modulation. If it has any components, they must be entirely different. As long as there are different means of broadcasting it is folly to say that it is impossible to broadcast without sidebands, for, sidebands are the components only of one particular type of transmission; that of amplitude modulation. When the components of the frequency modulated transmission are found, then it will be impossible to disregard them when dealing with frequency modulation just as it is now impossible to disregard the sideband theory when dealing with amplitude modulation, and, any solution of the components will also be a solution for the resultant when resolution into the single valued function is performed.

It follows herefrom that it is also impossible to explain frequency modulation phenomena by using the components of amplitude modulation phenomena, and, that the entrance of frequency modulation as a means of voice transmission does not disprove the sideband theory. It proves only the existence of more than one form of modulation, and thus of voice transmission over a carrier wave. When this simple truth is realized there will be no confusion between the two types of transmission. It simply must be realized that amplitude modulation is not the only principle that can be used in the transmission of modulation, and that the sidebands are the components of amplitude modulation only and therefore cannot be used to analyze frequency modulation. Any attempt to do so must lead to ludicrous and fallacious results that are as far from the truth as the two systems are apart from each other in principle, if not more so. For this reason the inventors of frequency modulation devices will do well to revise their explanations to conform to the type of phenomena they are dealing with, and save themselves the disrepute that must result from trying to explain this phenomena with the components of another and entirely unrelated principle of transmission.

2 new units by Crowe



No. 50 IMPROVED TUNING DRUM

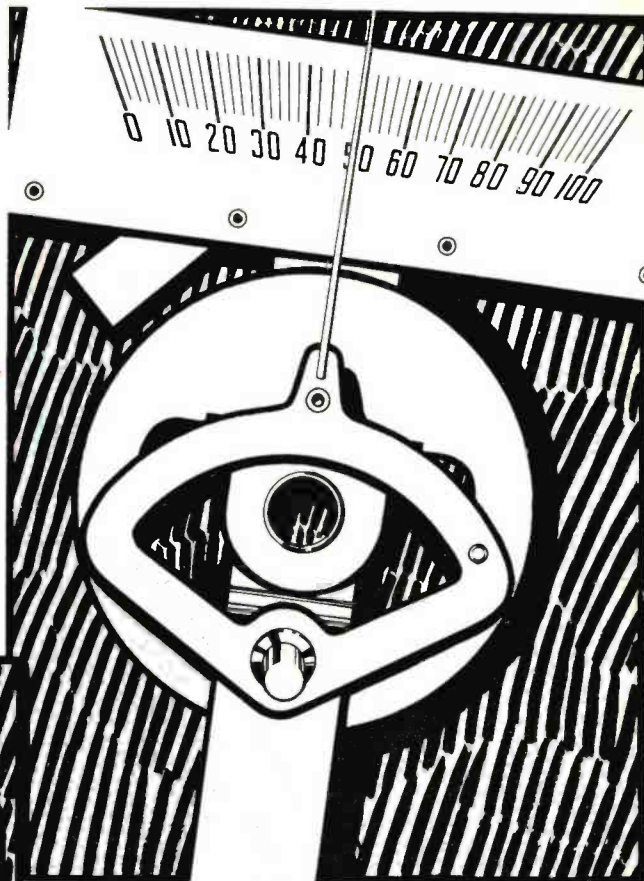

No. 38 FULL VISION TUNING UNIT

The new Number 38 tuning unit with straight line scale (shown above) and the Number 39 tuning unit with a flat arc scale are two new positive driven control devices which have advantages that will appeal to every radio engineer. The pyralin scale is securely fastened, and is not subject to warping or bending. Scales may be had to read in either direction or according to specifications if special graduations are required. Both the Number 38 and the Number 39 are equipped with projecting arm for attaching the Yoxley Spring Clip Pilot Light.

The new Number 50 Drum, together with its escutcheon is shown at the left. This new thumb control tuning unit has many advantages over previous types. The Number 50 may be provided with a variety of scales, both translucent for pilot lighting, or of etched metal for indirect lighting. The escutcheon for the Number 50 is so designed that lettering dies originally made to use on the escutcheons fitting the Number 29 drum may also be used on this new model.

Write for further details about these two new tuning units.

CROWE NAME PLATE & MANUFACTURING CO.

1737 GRACE STREET

CHICAGO - ILLINOIS

RADIO'S FOREMOST RESISTOR



now made even better by the new

TYPE "K" METALLIZED FILAMENT

LAST month, in this publication, we announced Type "K" *Metallized Filament*. The statement was made that it was this company's greatest contribution to the radio and vacuum tube industries since the introduction of *Metallized Resistors*.

In support of this assertion we now present facts taken from a few of the tests conducted over a period of eighteen months of intensive research.

The results of these tests have been confirmed by several of our larger customers in their own laboratories. They will interest every set manufacturer, every distributor of radio supplies, and every serviceman—for without question they stamp Type "K" *Metallized Filament* as the most advanced resistance unit available to the Radio industry today.

Curves and data bearing on these and other tests have been forwarded to our customers. If you have not received yours, please write us.

**International Resistance Company
Philadelphia**

*In Canada, International Resistance Co., Ltd.,
74 Wellington St., Toronto.*

PERMANENT

Type "K" *Metallized Resistors*, placed under intermittent rated wattage, show small change in resistance, the units always returning to their original values.

HIGH SAFETY FACTOR

With 100 per cent overload applied to type "K" *Metallized Resistors*, the change in resistance is not greater than 10 per cent. These units also return to within 2 per cent of their initial values.

MOISTURE PROOF

Type "K" *Metallized Resistors* will be found to be nearly impervious to moisture. Hot moisture and cold moisture tests, applied to these units, show a change in resistance of less than 10 per cent. The units return to their original values after these severe tests.

NOISELESS

Type "K" *Metallized Resistors*, under test, show extremely low noise level.

RUGGEDNESS

Type "K" *Metallized Resistors* are extremely strong. When a load of sixty-five pounds was placed across a resistor it showed no failure. Type "K" units will readily withstand abuses to which resistors are subject in production or shipment.

VOLTAGE COEFFICIENT

Test voltages applied on Type "K" *Metallized Resistors* from 0 to 350 volts show a maximum change of 2 per cent from original resistance value.

IRC

Metallized

RESISTORS

ALSO MANUFACTURERS OF I R C PRECISION WOUND RESISTORS



NEWS OF THE INDUSTRY

F. J. STOKES MACHINE CO.

Appointment of Lloyd C. Cooley as their mid-western representative with headquarters at 75 East Wacker Drive, Chicago, has been announced by the F. J. Stokes Machine Co., Philadelphia, manufacturers of chemical and pharmaceutical machinery and special process equipment.

Mr. Cooley, a graduate of the Massachusetts Institute of Technology, is a chemical engineer of many years' experience.

WIRE WOUND RESISTORS

The Daven Company, successors to the Daven Radio Corporation, manufacturers of the well-known Super-Davohm wire-wound precision resistor, located at 158-160 Summit Street, Newark, New Jersey, announce the purchase of the physical assets, patents, and trade marks of the former Superior Resistor Corporation recently located at 334 Badger Avenue, Newark, New Jersey.

The entire equipment of the former Superior Resistor Corporation has been moved and assembled at the Daven plant. With this addition in machinery and equipment the Daven Company has increased its production capacity over 25 per cent. This increase enables them to take care of the requirements of the trade supplied by the former Superior Resistor Corporation.

The Daven Company will retain the trade name Super-ohm in addition to their present trade names Super-Davohm and Davohm.

The Daven Company has specialized in wire-wound precision resistors for several years and are in a position to supply resistors from 0.1 ohm to 100 megohms for radio, sound equipment and industrial uses. They have also gone into the manufacture of the heavy duty type porcelain wire wound resistor. The outer covering will be of a specially prepared enamel instead of the vitreous type resistor. This new type has many advantages over the vitreous resistor.

ERIE RESISTOR CORPORATION

The Erie Resistor Corporation, Erie, Penna., has ready for distribution a color code indicator which specification engineers and service managers will find of great use.

SERVICING INSTRUMENTS

The Burton-Rogers Company, 755 Boylston Street, Boston, Mass., are manufacturers of a high-grade line of tube checkers, pocket meters, circuit testers, output indicators, analyzers and oscillators. Circulars will be sent on request.

PARTS FOR THE NEW TUBES

Parts and elements required in the manufacture of the new multi-mu tubes and power pentode tubes are manufactured by the Goat Radio Tube Works, Bush Terminal Building, Brooklyn, N. Y.

PROCURE A COLOR CODE

The International Resistance Company, 2006 Chestnut Street, Philadelphia, Pa., has gotten out a handy, well made standard R.M.A. resistor color code chart. One of these useful scales may be procured by writing to the company.

MOLYBDENUM RADIO TUBE GRID SCREEN

The Newark Wire Cloth Co., 351-365 Verona Ave., Newark, N. J., manufacturers of wire cloth for every industrial purpose and well known in the radio field as manufacturers of the "Sealedged" radio grid screen, advise that they are now furnishing a woven wire screen made of molybdenum for use on special tubes.

PENTODE TUBES

The Arcturus Radio Tube Company, Newark, N. J., has issued a new technical data booklet on the new Type PZ pentode tube. Copies of the booklet will be mailed upon request.

K G F F MOVES

Mr. R. U. Porter, manager of broadcasting station, reports that the station has been moved from Alva, Okla., to Shawnee, Okla. The station employs 100 watts and operates on full time on 1420 kc.

TUBE SHIPPING NO LONGER A HAZARD

Shipping radio tubes safely is not the problem it used to be. Packing methods have improved greatly since the days of the peanut tube. With the latest developments in packing, tubes can be shipped with safety whether sent out in standard cases of 25, 50, and 100 tubes or in small kits to accompany the set.

Most outstanding of the new packing developments are the Holed-Tite pads and tube wrappers, manufactured by Holed-Tite Packing Corp., New York.

Holed-Tite pads and tube wrappers are based on the suspension principle of packing. Tubes are held suspended away from jolts and bumps, effectively protected not only from actual breakage, but from shocks which might distort their elements.

TYPE L (SELF BIASING) TUBE CHECKER

The DayraD Type L (self biasing) tube checker manufactured by the Radio Products Company, 5th and Norwood Ave., Dayton, Ohio, is the result of long study, research, and experience. Most radio dealers and servicemen want a tube checker that needs no batteries, no adjustments, and no difficult mathematical calculations. The DayraD Type L (self biasing) tube checker is adapted for quick testing, simple manipulation, and profitable use. The number of radio tubes in use is rapidly growing so that the annual replacement market is becoming of first importance among progressive dealers and servicemen.

INCA MOVES EASTERN OFFICE

The Woolworth Building, 233 Broadway, is the new Eastern address of the Inca Manufacturing Division of the National Electric Products Corporation—Suite 2617 on the 26th floor.

The new office, which includes both sales and service organizations, is under the direct charge of Paul Stouffer.

The main plant and general offices are located at Fort Wayne, Indiana, where a complete line of magnet wire and coils for radio and electrical industries is manufactured.

CENTRALAB ON WEST COAST

Central Radio Laboratories, of Milwaukee, Wisconsin, announce William B. Winslow as their manager of West coast sales. Mr. Winslow will locate at a direct factory branch at 2149 E. Sacramento, Los Angeles, California.

Centralab products have been represented on the West coast for the past eight years by the sales agency of Spector & Company. The change to a direct factory branch and factory trained salesman has been found desirable because of the increase in radio set manufacturing on the West coast and the increased variety of products manufactured by Centralab. These products now include the carbon type of fixed resistor in a full range of sizes and resistance values in addition to the many types of volume controls for which Centralab has always been well known.

SCHWARTZ METAL PRODUCTS

Jerome A. Schwartz, metal products manufacturer, has moved to enlarged quarters at 51 West 24th Street, New York. This company specializes in chassis bases, amplifier boxes, microphone stands and control boards.

TRANSMITTING CONDENSERS

Morrill and Morrill, 30 Church Street, New York, will be glad to forward descriptive literature of the high-grade line of high-voltage transmitter condensers which they handle. These are for operating voltages of 1,000 to 3,000 volts, d-c.

NEW MICA PARTS FOR RADIO TUBES

The Mica Products Manufacturing Company of 54 Greene Street, New York City, have developed new mica supports for radio tubes. They call particular attention to the mica supports for the new Pentode Tubes, which have been developed by their engineering department and which will be adapted by many of the largest tube manufacturers.

They are now in production on these supports in addition to others they have developed for the numbers 230, 231 and 232 tubes.

This company is known for their high grade product, and before manufacturing their mica for radio tube parts, they put it through a special degassing process, which eliminates the moisture and a large part of the gas it may contain.



CRC SOCKETS

All models of CRC sockets, manufactured by the Central Radio Corporation, Beloit, Wis., are now available with the contacts attached to the base with eyelets, as well as with rivets.

The company offers all models of CRC sockets in the one-piece type, the combination insulator and guide plate being fastened to the base with two small eyelets, which are well removed from the center of the contact group. This construction provides a very satisfactory one-piece socket, electrically superior in contrast to other one-piece types made with the rivets or eyelets passing through the center of the contact group.

A DIFFERENT TYPE OF RHEOSTAT

A new rheostat of very unique design is announced by D. T. Siegel, general manager of the Ohmite Mfg. Co., 636 N. Albany Ave., Chicago. The rheostat incorporates the use of a circular porcelain core on which the resistance wire is wound, the core forming a solid non-shrinking backing for the wire. This wound core is mounted on a base also of porcelain, and the entire unit with the exception of the surface where the wiper arm makes contact, is covered with vitreous enamel which cements the whole unit together, and serves both to protect the wire and to carry off the heat generated in the wire.

The circular porcelain core is wound by an ingenious machine designed and built in their own tool room, so arranged that any resistance value from 2 ohms up to over 10,000 ohms can be wound.

These rheostats are 2¼ inches in diameter, are arranged for one hole mounting, and can be furnished with three terminals to form potentiometers. Connections between the resistance wire and the terminals are made in the same manner as in their fixed vitreous enameled resistance units.

TIME SWITCHES

M. H. Rhodes, Inc., Chamber of Commerce Building, New Haven, Conn., manufactures an electric light switch containing a time element which automatically turns off the current after any predetermined time. The time element is operated by throwing the toggle the desired number of times.

Mark-Time switches are made in three models; seconds, minutes; and may be used for controlling residential, factory, store window lights and signs, or for radio and household appliances.



TRANSMITTER CONDENSERS

The Igrad Condenser and Mfg. Co., Inc., Rochester, N. Y., has introduced a workmanlike high voltage transmitter type condenser. Circulars will be mailed upon request.

AMPLIFIER POWER STAGE PANEL

To meet the current need for a powerful amplifier for sound distribution systems which provides the advantages of larger units yet conserves space, Webster Electric Company, Racine, Wis., has developed a new power stage panel. With a 56 watt output this unit is particularly suited to outdoor installations where considerable power is required or for permanent installations in hotels or other public places requiring great output power.

The panel is known as Webster Model 6032-A and is part of the Webster line of power amplifier equipment for sound distribution systems.

OSCILLATOR FOR CONTINUOUS OPERATION

The Model "E" oscillator manufactured by the Lepel High Frequency Laboratories, 39 West 60th Street, New York, is of the quenched gap type, having tuned and loosely

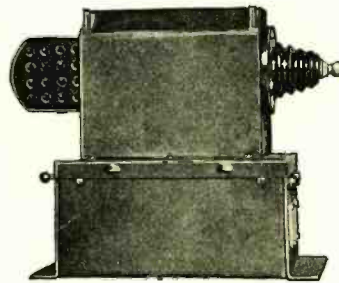

coupled primary and secondary high frequency circuits. It consists of a 60 cycle step-up transformer, two common lever adjustable tungsten gaps, two mica condensers, a high frequency transformer and the necessary switching and housing mechanism.

NEW CARDWELL TRANSMITTING CONDENSERS

The Allen D. Cardwell Mfg. Corp., 81 Prospect St., Brooklyn, N. Y., has recently placed on the market a group of special variable transmitting condensers, designed for medium powered installations and for amateur use.

Of particular interest, are the split stator condensers, having a common rotor and with the two stators insulated from each other. The two sections may be connected either in series or in parallel. For example, the type 510 B condenser, having 23 plates in each section with a capacity of .00011 mfd. per section, may be connected in series so as to have a maximum capacity of

.00055 mfd. or in parallel to have a maximum capacity of .0022 mfd. This condenser is recommended for c.w. or telephone work in connection with type -03A, -11A, and -04A tubes. When series connected, it is also suitable for neutralizing -49-type tubes.

The type 512B Cardwell split stator transmitting condenser has 11 plates in each section with a capacity of .0005 mfd. per section and with .00025 mfd. capacity when connected in series and .0011 mfd. capacity when connected in multiple. This condenser is ideal for neutralizing -04A type tubes.

ROTARY SWITCHES FOR CENTRALIZED RADIO

The Best Manufacturing Company, 1200 Grove Street, Irvington, N. J., is marketing a new multiple contact rotary switch. The Type 2N54-B3, is a special 2-pole, non-shorting unit with three break contacts for

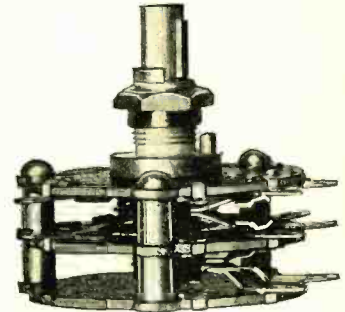

a three channel and off position centralized radio installation using line loading coils.

NEW D.C. POWER UNIT HAS ADVANTAGES

A compact, self-contained power unit, known as Type CAB-4, consisting of a 4-volt storage battery automatically kept at full charge by a rectifying unit, is announced by Fansteel Products Company, Inc., North Chicago, Illinois. The entire unit is housed in a ventilated steel cabinet, measuring only 9½ inches wide by 8½ inches deep by 8½ inches high. Six- and eight-volt models will soon be available also.

This unit is useful and economical for intercommunicating telephones, local telegraph circuits, signals, recording instruments, annunciator or calling systems, small electroplating or electro-chemical equipment—in short, any purpose where low voltage direct-current is required. The unit operates from an ordinary light socket, consuming only 10 watts when operating at full capacity.

Unusual simplicity in design and ruggedness of construction are combined in this unit. Openings in the cabinet permit inspection of the float balls indicating the state of charge of the battery, also the electrolyte levels in the battery and rectifier cell. One simple adjustment regulates the charging rate, and under normal operation, addition of water is necessary only 3 to 4 times a year.

“SEALEDGED”

REG. U. S. PAT. OFF.

RADIO GRID SCREEN ... READY ALSO TO SERVE THE NEW PENTODE AND VARIABLE-MU TUBES

“SEALEDGED” is admirably adapted to the latest technical advance in pentode and variable-mu tubes. Its brilliant performance in the new tubes parallels its successful operation in the regular. “Sealedged” is a 99 + % pure nickel cloth with a distinctive sealed, unraveling edge. Special precision machinery secures superior qualities for a tube component—uniform quality, unvarying weave, smooth finish.

Compare “Sealedged” with any other wire cloth and see the difference in material and construction. Remember, “Sealedged” costs only a trifle more than common raw cut wire cloth. What are your requirements?

MOLYBDENUM. A screen of molybdenum is now available for special tubes.

Micro-photograph of “Sealedged.” Carefully note the weave and edge.



Newark Wire Cloth Company

358-372 Verona Ave.

NEWARK

NEW JERSEY

- Without obligating us in any way please send sample and further particulars concerning “SEALEDGED” Grid Screen.
- Please send representative.

Name.....

Firm.....

Street.....

City..... State.....

You Can Count On Summerill Accuracy

Material reaches you as it leaves us



SUMMERILL SEAMLESS NICKEL TUBING

PROMPT DELIVERIES

—anywhere—any time
—any quantity

The scientific care used in making Summerill Seamless Nickel Tubing is carried through until it reaches you. It is packed in a sturdy box carefully made to insure the contents against all shocks in transport. It assures perfect condition of the tubing when it reaches you.

Every care is exercised so that Summerill Tubing is chemically pure—that accuracy is maintained in factory procedure.

Packed in the Summerill box, tubes reach customers as fine as they are here.

Let us send you a sample for inspection by your engineering and production departments.

The Summerill Tubing Co.

Founded 1899

Bridgeport, Penna.

(Philadelphia District)

GILBY RADIO FILAMENT....

GILBY Wire Company has been THE reliable source for radio tube filament, and today stands foremost in the opinions of radio tube engineers.

Our engineering department has done and is doing considerable research to produce the best filament obtainable. By development of materials together with real metallurgical control and precision measurement, we are able to produce a filament which is uniform and of stable characteristics.

We are able to supply material to strict specification thereby cutting down shrinkage, so essential at all times.

Gilby—a real dependable source of supply for filament.

GILBY WIRE COMPANY

Wilbur B. Driver, Pres.

NEWARK

NEW JERSEY



Manufacturers of
Nickel Chrome Resistance Wire
Copper Nickel Resistance Wire
Nickel Wire and Sheet
Gilby Processed Carbonized Nickel for Plates
Gilby Patented Selvage Mesh

THE Group Subscription Plan for RADIO ENGINEERING enables a group of engineers or department heads to subscribe at one-half the usual yearly rate.

The regular individual rate is \$2.00 a year. In groups of 4 or more, the subscription rate is \$1.00 a year. (In foreign countries \$2.00.)

The engineering departments of hundreds of manufacturers in the radio and allied industries have used this Group Plan for years, in renewing their subscriptions to Radio Engineering.

Each subscriber should print his name and address clearly and state his occupation—whether an executive, engineer, department head, plant superintendent, foreman or technician, etc.

**Remember this Group
Plan when Your
Subscription Expires**

(Radio Engineering)

**Bryan Davis Publishing Co., Inc.,
52 Vanderbilt Ave.,
N. Y., N. Y.**

Los Angeles

Chicago

Cleveland

*Plant Facilities Doubled
To Meet the Demand for*



**THE
ACRACON
ELECTROLYTIC
CONDENSER**

SALES tell the story of Acracon leadership in the condenser field more eloquently than any advertisement could.

Since its introduction, an ever increasing demand for the Acracon electrolytic unit has taxed our production department to such an extent that we have been forced to double our plant facilities. Now, we are equipped to supply the entire industry.

Follow the leaders of the industry. Specify Acracon Electrolytic Condensers. Also By-pass, Wax Impregnated, Oil Impregnated, Power and Transmitting types. Write today, enclosing specifications!

*Acracon Features Are Protected by Patents Pending

Condenser Corp. of America

259 Cornelison Ave., Jersey City, N. J.

Factory Representatives In:

CHICAGO ST. LOUIS SAN FRANCISCO
CINCINNATI LOS ANGELES TORONTO
And Other Principal Cities

die cast by Allied

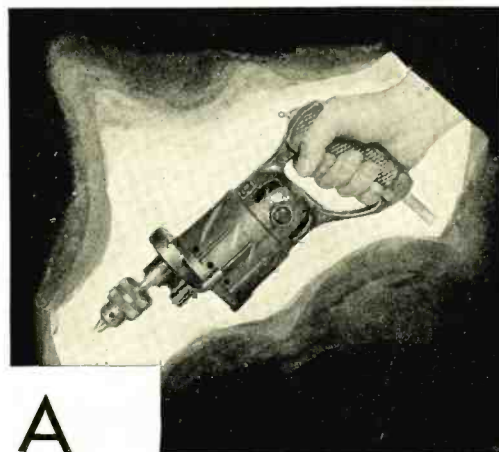

**A
snap
of the switch---**

and this electric drill whirrs its way swiftly through the toughest materials, every part of it under constant strain.

Mindful of this exceptional stress, plus the need for low cost, the manufacturers have standardized on parts die cast by Allied.

The Allied Process has similar applications in most other fields.

Parts and products, die cast by Allied, outstrip those produced by other methods, not only in accuracy and final strength, but also, due to the high speed production possible by the Allied Process, in the matter of reduced costs.

The Allied Die Casting Corporation, 43rd Ave. from 38th Streets, Long Island City, N. Y.



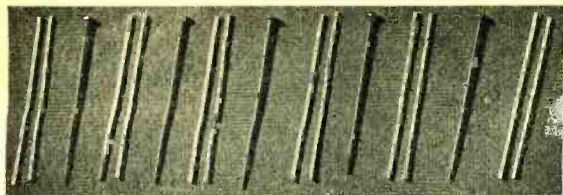

Pants for Tubes

INSULATOR tubing about the size of an ordinary pin as shown above, slips over each leg of the hair-pin filament in certain quick-heater radio tubes. A precise formula to meet thermal, electrical and chemical requirements, together with rigid mechanical tolerances, has assured the success of this and other applications of



Not just the name of a precision product for severe service applications, but a complete research and engineering service dedicated to the solving of difficult problems.

Write us regarding your severe service problems and we shall gladly supply engineering advice, samples and quotations.

HENRY L. CROWLEY & COMPANY, Inc.
Specialists in Severe Service Materials
 1 Central Avenue :::: West Orange, N. J.

ACME TRANSFORMERS



Acme Step Down Transformer. 50 to 350-watt sizes available.

Power and Audio Transformers for Radio Manufacturers' use. Prompt quotations given on your specifications.

Send for these new bulletins:—

Voltage Step Down Transformers for export shipments, Bulletin No. 121

Replacement Transformers for service organizations, Bulletin No. 122



The Acme Electric & Manufacturing Co.
 1440 Hamilton Ave. Cleveland, Ohio

Acoustics!



Projection Engineering deals editorially with the manufacturing, engineering, operating and servicing of all forms of theatrical equipment, home and theatrical movies, talking movies, television apparatus, etc.



**Keep Pace with Developments
 in Talking Movies and
 Television**

**PROJECTION
 ENGINEERING**

*Is Not Sold on
 Newsstands*

SUBSCRIBE NOW!

*Please Check Your
 Classification*

Manufacturer
(Including executives, plant superintendents, foremen, purchasing agents, etc.)

Engineer Technician Producer Distributor Theatre Projectionist

BRYAN DAVIS PUBLISHING CO., Inc.
 52 Vanderbilt Avenue, New York City

Enclosed find \$2.00 for which enter my subscription for **PROJECTION ENGINEERING** for one year. \$3.00 for two years.

Name
 Address
 Town and State

Beat-Frequency Oscillator

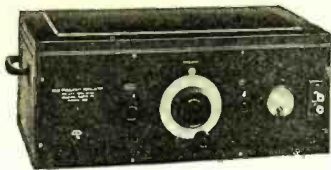

Type 413-B Beat-Frequency Oscillator
Price \$175.00

Any frequency in the band between 50 and 10,000 cycles per second is available by setting the single control of this beat-frequency oscillator. Operated by batteries, it is readily portable and makes a practically indispensable instrument for the laboratory engaged in measurements and other experimental work at audio frequencies.

A request on your business letterhead will bring you a catalog description of this and other General Radio laboratory instruments. Please ask for Catalog F-A.

GENERAL RADIO COMPANY

Offices Laboratories Factory

CAMBRIDGE A,

MASSACHUSETTS

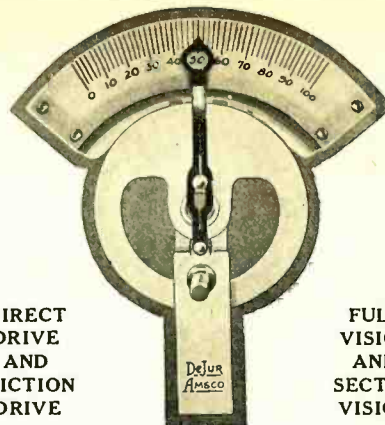

DIRECT
DRIVE
AND
FRICTION
DRIVE

FULL
VISION
AND
SECTOR
VISION

DIALS Meeting the manufacturer's predominant requirements of excellence, economy and standardization, these new Full Vision Dials combine the economical requirements of midget receiver design with the luxury and refinement of console types. In kc and metric scales.

Write for literature describing our complete line of dials, dial lights, escutcheons and tuning accessories.

DeJUR-AMSCO CORP.

Varitors — Variable Condensers — Power Rheostats — Dials
95 Morton Street New York City

JENKINS & ADAIR Condenser Transmitter

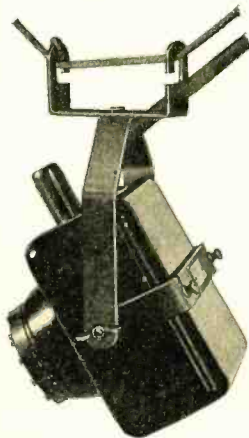

Type D-6
Patented U. S. A. No. 1790505
Other patents pending

A high quality sound translating device for broadcasting, recording sound measurement and announcing. Output impedance 200 ohms or 50 ohms.

Actuator response curves furnished for precision applications.

We have a large stock of accessories such as stands, suspension clamps, microphone booms, connectors, cable, etc.

Illustration shows D-6 Condenser Transmitter \$225.00 and Type C Clamp \$8.50. Both prices net F. O. B. Chicago.

Write for bulletin 6-D

JENKINS & ADAIR, INC. ENGINEERS

CHICAGO, U. S. A.

Cable Address: JENKADAIR

Phones, Keystone 2130 3333 Belmont Avenue

British Offices: 76 Old Hall Street, Liverpool, England
40 Buckingham Gate, London SW1, England
French Office: 18 Rue de Chateaudun, Asnières, France
Mexican Office: Av. 5 de Mayo 10, Mexico D.F., Mexico

DAYRAD TYPE L TUBE CHECKER

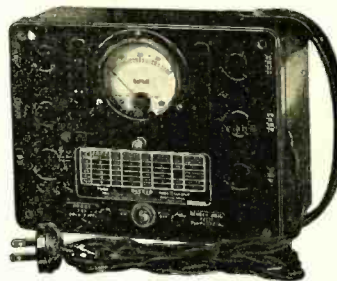

(Self-Biasing)

A revelation in accurate Tube Checking. Shows the "End of Life," the really important signal for replacement. All tests accomplished by means of three colored push buttons — Black for most

tests, red for screen grid and '80 Rectifiers, green for noisy tubes.

A complete A.C. operated, accurate and super-efficient instrument which corrects all hum and distortion in all types of receivers. Six sockets provide the needed filament, plate and grid voltages. By a special circuit arrangement the applied grid bias for each tube is automatically obtained. Complete "End of Life" readings shown on panel chart.

Dealers Net Price \$27.60

(Add \$1.00 for 25 cycles.)

Send for folder "The Final Word." Buy from your jobber.

THE RADIO PRODUCTS COMPANY

5th & Norwood Dept. E Dayton, Ohio, U.S.A.

Condensers..

FILTER » BY-PASS » IGNITION » TELEPHONE » TELEGRAPH
Kellogg Switchboard and Supply Company
 1066 West ADAMS Street - - - CHICAGO

Just published!

The most important radio book of the year

The RADIO HANDBOOK

Including Television and Sound Motion Pictures

By James A. Moyer and John F. Wostrel

Both of the Massachusetts Department of Education; Authors of *Radio Receiving Tubes, Practical Radio Construction and Repairing, etc.*

886 pages, 5½ x 8, 650 illustrations, flexible, \$5.00

HERE at last is a handbook that meets the need for a complete digest of authoritative radio data, both theoretical and practical, in one logically arranged and thoroughly indexed volume. From the fundamentals of electricity, magnetism and electron theory right down to full details on latest commercial and industrial applications, this book covers the whole field of radio, with descriptions, definitions, design data, practical methods, tables and illustrations in profusion.

Over 875 pages of latest data on such topics as:

—Modern transmitters, Pieze crystal, 100% modulation, short wave receivers and transmitters, Kennelly-Heaviside layer, marine radio equipment, auto alarm, all latest tubes, photo-electric cells, television, sound motion pictures, etc., etc.

See this book 10 days FREE
 Send this coupon

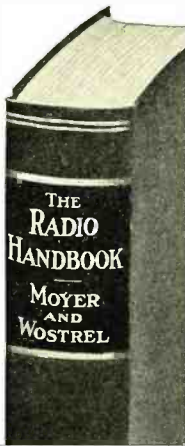

McGraw-Hill FREE EXAMINATION COUPON

McGraw-Hill Book Co., Inc., 370 Seventh Ave., N.Y.C.
 Send me Moyer and Wostrel's Radio Handbook postpaid for ten days' free examination. I agree to remit \$5.00 in ten days or return the book.

Name

Address

City and State

Position

Firm

R.E. 4-51

Welcome to
 New York and
 The HOTEL
GOVERNOR CLINTON
 Opposite Penn. R. R. Station
 New York's new hotel truly expressive of
 the greatest city. 1200 pleasant rooms
 each with Servidor, bath, circulating
 ice water and radio provisions.
 ROOMS from \$3.00

31ST STREET 7TH AVENUE

The Home Hotel of New York
 Homelike in service, appointments and
 location . . . away from noise and con-
 gestion, yet but a few minutes from
 Times Square . . . garage facilities for
 tourists.
 Room and Bath from \$3 single, \$4 double—500 rooms
 Home folks will like this hotel

HOTEL
BRETTON HALL
 BROADWAY at 86th STREET
 NEW YORK

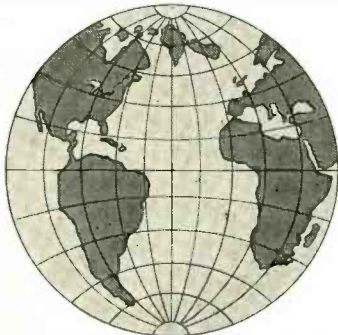

Anywhere * * *

POINT your finger at the globe—anywhere. If Radio is known there—so, most probably, are CARDWELL condensers. Countless "Cardwell condensed" installations, the pride of their designers, cover every wave band and reach every corner of the earth. That outfit you contemplate building, if worth building at all, *deserves*

CARDWELL CONDENSERS

Send for Literature

THE ALLEN D. CARDWELL MFG. CORP'N
 91 Prospect Street, Brooklyn, N. Y.

"THE STANDARD OF COMPARISON"

M&W.C.® 1876

LACQUERS ENAMELS

Specify M & W Lacquers

An ever growing number of Radio Engineers and Production men are realizing the importance of specifying Finishes designed by a manufacturer who understands their requirements. They also know that many others specify M & W products because they are reliable and are specially built for the purpose. A partial list follows—

Chassis	Clear Insulating Lacquer
Cadmium Lacquer	Black Insulating Enamel
Water Dip Lacquer	Winding Cement
Bronze Lacquer	Speakers
Prismac Enamel	Paper Cement
Shields	Metal Cement
Clear Lacquer	Leather Cement
Bronze Lacquer	Wire Cement
Cans	Voice Coil Cement
Lacquer Enamel	Waterproof Paper Enamel
Prismac Enamel	

May we have an opportunity to offer suggestions to you?

MAAS & WALDSTEIN CO.
Executive Offices and Plants:
438 Riverside Ave., Newark, N. J.
 Chicago Office and Warehouse: 1115 W. Washington Blvd.
 Los Angeles Office and Warehouse: 2416 Enterprise Street.

The border of this advertisement is a photographic reproduction of M & W Prismac.

No hum, noise
or moving parts...

FOREST RECTIFIER

Leading Sound Recording Studios, Theatres, and Laboratories where unfaltering current supply is required use FOREST—because it is superior.

Adaptable to all sound equipment—interchangeable with your present storage battery—several types.

Just turn the switch to convert a 110 or 220 v. a-c. into fully filtered d-c.



FOREST ELECTRIC CORP.
 New and Wilsey Steets
 Newark, N. J.

JOHNSON'S INDUSTRIAL TAPE

DOES not need a loud-speaker to broadcast its perfection.

Radio engineers all know of and recognize its superiority, its holding properties, lasting adhesion and non-corrosive action. It will outlast any other tape put to similar usage.

Write for free sample and convince yourself of its excellence

JOHNSON & JOHNSON
 New Brunswick, N. J.

MULTIPLE TAP SWITCHES

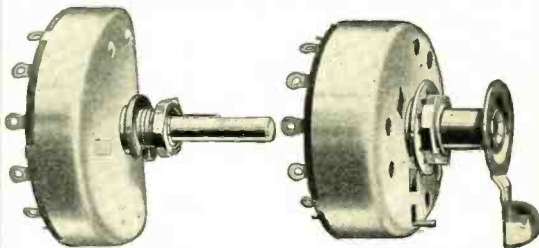

No. 7070 A No. 7000 A

Standard and special designs
PHONO-MOTOR SWITCHES

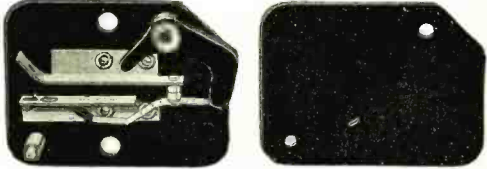

No. 7030 A

Our plant and engineering facilities lend themselves to the production of special requirements on short notice. Inquiries solicited.

Soreng Manegold Co.
 771 Mather St. Chicago, Ill.

AMPLION



TYPE T M
\$65.00
Less Stand



TYPE H M
\$25.00



TYPE J M
\$25.00
Less Stand

Transverse Current

MICROPHONES

Write for 20-page catalogue and price list describing microphones, microphone amplifiers, 50-watt power amplifiers, giant dynamic air column units, exponential horns, synchronous and non-synchronous turntables, and complete panel mounted equipment for schools, hotels, hospitals, parks, skating rinks, steamships, airplanes, auditoriums, theatres, etc.

Centralize Responsibility for the Success of Your Installations by Purchasing All the Parts From One Source.

Amplion Corporation of America
133 W. 21st St., New York City

STATEMENT OF THE OWNERSHIP, MANAGEMENT, CIRCULATION, ETC., REQUIRED BY THE ACT OF CONGRESS OF AUGUST 24, 1912, OF RADIO ENGINEERING.

Published monthly at Albany, N. Y., for April 1, 1931.

State of New York } ss.
County of New York }

Before me, a Notary Public in and for the State and county aforesaid, personally appeared B. S. Davis, who, having been duly sworn according to law, deposes and says that he is the Business Manager of RADIO ENGINEERING, and that the following is, to the best of his knowledge and belief, a true statement of the ownership, management, etc., of the aforesaid publication for the date shown in the above caption, required by the Act of August 24th, 1912, embodied in section 411, Postal Laws and Regulations, to wit: 1. That the names and addresses of the publisher, editor, managing editor, and business managers are: Publisher, Bryan Davis Publishing Co., Inc., 52 Vanderbilt Avenue, New York; Editor, Donald McNeil, Roselle Park, N. J.; managing editor, P. Walden, Union City, N. J.; Business Manager, B. S. Davis, Scarsdale, N. Y. 2. That the owners are: Bryan Davis Pub. Co., Inc.; B. S. Davis, Scarsdale, N. Y.; Roy T. Atwood, Albany, N. Y.; G. R. Bacon, Douglaston, N. Y.; J. C. Munn, Union City, Pa.; J. A. Walker, Richmond Hill, N. Y.; A. B. Goodenough, New Rochelle, N. Y. 3. That the known bondholders, mortgagees, and other security holders owning or holding 1% or more of the total amount of bonds, mortgages, or other securities are: None. 4. That the two paragraphs next above, giving the names of the owners, stockholders, and security holders, if any, contain not only the list of stockholders and security holders as they appear upon the books of the company but also, in cases where a stockholder or security holder appears upon the books of the company as trustee or in any other fiduciary relation, the name of the person or corporation for whom such trustee is acting, is given; also, that the said two paragraphs contain statements embracing affiant's full knowledge and belief as to the circumstances and conditions under which stockholders and security holders who do not appear upon the books of the company as trustees, hold stock and securities in capacity other than that of a bona fide owner; and this affiant has no reason to believe that any other person, association, or corporation has any interest direct or indirect in the said stock, bonds, or other securities than as so stated by him.

(Signed) B. S. DAVIS, Business Manager.

Sworn to and subscribed before me this 27th day of March, 1931.

(Seal) J. A. WALKER, Notary Public.

Kings County,
Clerk's No. 363.
Kings Co., Registers No. 1062.
New York Co., Clerk's No. 167.
New York Co., Registers No. 1W177.
Commission expires March 30, 1931.

FOR BETTER BUSINESS VISIT NEW YORK

★ **2⁵⁰** ★
daily

... secures a fine room and bath ...
others at \$3⁰⁰ and \$3⁵⁰

AT ONE OF NEW YORK'S BEST HOTELS

★ The BRISTOL

48th ST. EAST OF B'WAY ▲▲ NEW YORK CITY

OWNERSHIP MANAGEMENT ▲▲ T. ELLIOTT TOLSON, Pres.

Portable Condenser Microphones



2P 2 stage plate output... List \$110.00
 2C 2 stage 200 ohm output List 125.00
 Uses 2 type 230 low drain tubes.
 3P 3 stage plate output... List \$125.00
 3C 3 stage 500 ohm output. List 150.00
 Uses 2 240 and 1 112-A tube.

These prices for type "A" unit.
 For type "B" unit add \$40.00 each list. Standard finish is black and gold. Prices include tubes and 20 ft. cord. Interesting dealer proposition.

Astatic Microphone Laboratory
 21 Olive Street
 YOUNGSTOWN, OHIO

D'Arcy Laboratories

place at your disposal their laboratory facilities for your assistance in volume control problems.

Bulletin M.I. is now ready for those who inquire for it.

D'Arcy Laboratories
 160 A. East Illinois Street Chicago, Illinois

FORD MICA SERVICE

Submit your problems in Tube, Condenser or other radio design to us. Accurate workmanship, prompt deliveries.

Ford Radio & Mica Company
 830 Fourth Ave. Brooklyn, N. Y.

Help On Your SOUND EQUIPMENT PROBLEMS

ELECTRAD, persistently pioneering since the birth of radio, has now developed a highly perfected complete SOUND AMPLIFYING SYSTEM. There are standard, moderately-priced models which meet every modern requirement for large, small or portable installations—together with all accessories and expert engineering and acoustical counsel.

Write Dept. RE-4 for Descriptive Literature

175 Varick St., New York, N.Y.

ELECTRAD
 INC.

HOTEL MARTHA WASHINGTON

ATLANTIC AVE. AND EIGHTH ST. VIRGINIA BEACH VA.

Fireproof brick construction.
 The coolest spot on the beach.
 Invigorating breezes from ocean on East and Lake Holly on West.
 Bright, airy outside rooms, parlor suites and apartments, private baths, superior cuisine—Surf bathing, riding, fishing, golf, dancing, private tennis court and children's playground.

J. WESLEY GARDNER, Manager

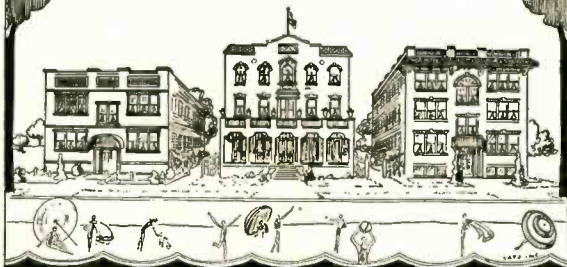

We Cater to Laboratories—Broadcasting Stations—Talking Movies, Etc. Parts for any and every item you may need always on hand. Call on us for your requirements



45 VESEY STREET, NEW YORK CITY

UNIVERSAL MICROPHONES

"HANDI-MIKE"
 MOST EFFICIENT GENERAL UTILITY MICROPHONE KNOWN
 List \$10 Complete

The truly perfected single button hand microphone. Two models, "Regular" and "Special Home Recording." Scientifically damped diaphragm, gold plated button, toggle switch, 15-foot cord. Finished bronze or gunmetal. Dealers, write for our "direct deal." Get our complete catalog.

UNIVERSAL MICROPHONE CO., Ltd.
 1163 Hyde Park Blvd.
 INGLEWOOD, CALIF.

Microphones \$5 to \$350. Also cables, plugs, transformers, mountings, stands, etc. Expert microphone repairs.

No. 1275 Transformer
 Input transformer designed for any single button microphone. 200 ohm Primary. 100,000 ohm on secondary side. List price \$6.

<p>"BEVERLY" A. C. TUBE CHECKER—At Popular Price Tests all types of tubes—including Pentode Shows indication of electronic emission and usual mutual conductance grid change. Tests both plates of 80 rectifiers. Special—\$8.75 Each</p>	<p>"GENERAL ELECTRIC" CHOKE COIL — 30 Henry 120 Mils. 200 Ohms Res. \$1.25 Each "STROMBERG-CARLSON" FILTER CONDENSER 7 Mfd. 600 D. C. Working Voltage \$1.35 Each POWER TRANSFORMERS — FOR R. C. A. — VICTOR — STROMBERG — SPARTON — FREED — EARL — ETC. Write For Special Price.</p>
<p>"SANGAMO" PUSH PULL TRANSFORMERS — Types BX — HX \$2.85 Per Pair "SANGAMO" AUDIO TRANSFORMER — Type AX 1.25 Each "GENERAL RADIO" AUDIO TRANSFORMER—Type 285D or 285H 1.25 Each</p>	<p>GENERAL REPLACEMENT POWER TRANSFORMER 2 1/2 Volt Center Tapped Six—227 or 224 Prim.—110-125 Sec.—350-350 \$2.85 Each 5 " " " Two—245 " " " One—280</p>
<p>New Bargain List Available. Write W. K. SKIDMORE & CO. 17 WARREN STREET NEW YORK CITY</p>	

WIRE

Quality wire for every type of hook-up
"Alpha" a slip back braided hook-up wire made under a patented process.
Alpha "HITension" Wire (colored Rubber) BARE-TINNED-ENAMELED, RUBBER COVERED—CABLES TO SPECIFICATION—
ALPHA WIRE CORPORATION
60 Howard St., New York City



TIPLESS EXHAUST TUBE BENDER-EISLER METHOD
AVOID PATENT SUITS
SEND FOR BULLETIN 7
EISLER ELECTRIC
760 South 13th Street,
NEWARK, N. J.

RADIO TUBE PARTS

Tools, Dies and Special Machinery

▲ ▲ ▲ ▲ ▲
Let us assist you in designs to meet exacting specifications.
PRECISION PRODUCTS, Inc.
6 Dawson St., Newark, N. J.

Baach-International Compound High Vacuum Pumps

We manufacture all sizes of High Vacuum Pumps from 1-200 cu. ft. per min. All pumps tested at 1/2 micron before leaving factory. Write for details.
INTERNATIONAL MACHINE WORKS, Inc.
527-529 Thirty-Second St., Union City, New Jersey



GEARS

In Stock—Immediate Delivery
Gears, speed reducers, sprockets, thrust bearings, flexible couplings, pulleys, etc. A complete line is carried in our Chicago stock. Can also quote on special gears of any kind. Send us your blue prints and inquiries.
Write for Catalog No. 60
CHICAGO GEAR WORKS
769-773 W. Jackson Blvd., CHICAGO, ILL.

* CLAMP NAILS

For All Mixed Joists



Use in Millwork, Cabinet, Construction, Furniture, Tables.
CLAMP NAIL CO.
4542 Palmer St., CHICAGO, ILL.

MICROPHONES

All kinds \$10.00 to \$350.00

For—Home Recorders, Type S. G. P.	List \$10.00
For Public Address Work, etc., Type S. S.	List \$25.00
Standard Broadcast Model, Type S. G. M.	List \$45.00
Standard Broadcast Model, Type S. G. S.	List \$62.50
Condenser Type for film and record recording, Type S. G. C.	List \$250.00

Also desk, floor stands, covers and etc. Export Microphone Repairs.
SILVERLEAF MICROPHONE COMPANY
2658 Pasadena Ave., Los Angeles, Calif.
Chicago Distributors—Dungan & Sternfeld—Radio Sales, Inc.
1507 Michigan Ave., So. Representatives wanted

DeWALD

Licensed by R.C.A. A.C. and D.C. Midget Receivers Licensed by R.C.A.
Write for complete details.
PIERCE AIRO, INC.
115-117 Fourth Ave., New York City

MANUFACTURER WANTS QUANTITY PRICE ACCURATE QUARTZ CRYSTALS

In reply give all information in first letter. We want quartz crystals 175 kc., ground to an accuracy of plus or minus 5%.
Quote price in 1,000, 5,000 and 10,000 lots, giving definite delivery schedule after order has been received. Give also outline present possible daily production and indicate how rapidly it may be increased.
Reply P.O. Box 5424, West Philadelphia, Pa.

CONDENSER PAPER

182 Cornelson Ave. — Mills at — Newark Ave.
Jersey City, N. J. Elizabeth, N. J.
PETER J. SCHWEITZER, Inc.,
200 Fifth Ave. New York

BARE AND TINNED COPPER WIRE

For All Purposes
Fine Sizes Our Specialty
SPARGO WIRE COMPANY
ROME, NEW YORK
Established 1885

Stampings

Pressed Metal for Radio Industry
Steel, Aluminum, Copper, Brass and all Alloys
Send Inquiries and Drawings
METAL SPECIALTY CO. 1533 Riverside Dr. Cincinnati, Ohio

Rocke International Electric Corp.

15 Light Street, New York
Export sales managers for nationally known radio manufacturers.

**NICKEL
WIRE CLOTH**

for the
RADIO TUBE INDUSTRY

Any mesh woven accurately to your specifications.
"CLEVELAND"

Wire Cloth renowned for its Uniformity, its Superiority,
its Durability.

Advise us of your Requirements

The Cleveland Wire Cloth & Manufacturing Co.
3571 E. 78th Street, CLEVELAND, Ohio

**CUT OUT
the NOISE!**



Are you troubled with room noises, studio noises, motor noises or "feed back"?

If any of these noises are present in the operation of your microphone you should know about a special feature of Ellis Model 20N.

Write for details on how Model 20N can be used to *Cut Out The Noise*.
Export "Simons," 25 Warren St., New York. Cable: "Simontrice."

ELLIS ELECTRICAL LABORATORY
Sales Corporation
337 WEST MADISON ST. CHICAGO, ILLINOIS

LAMINATIONS

for Audio & Power Transformers

SPECIALIZED METHODS—YEARS OF EXPERIENCE
Wide Variety of Stock Standard Sizes
Dimension and Price Sheets on request

We Also Make

PERMANENT MAGNETS—DIES—TOOLS—
METAL STAMPINGS

Facilities for prompt service

**Thomas & Skinner
Steel Products Co.**
1100 to 1120
E. Twenty-Third St.
INDIANAPOLIS, IND.

ELECTROHM (WIRE WOUND) RESISTORS

Durable—Dependable—Accurate—Economical
—Correctly Rated

Four Years' Service in the Equipment of the
New York Stock Exchange

Without a Breakdown

No Other Resistor Can Boast This Record.

Electrohm Resistors are not Fused—Fired—Baked—etc. to any degree beyond the annealing point of the resistance wire; contacts between wire and terminals are not Brazed—Spot-Welded—Soldered—Coated—etc.; all these methods cause nickel oxide which has been the "Waterloo" of resistors for nearly half a century. Electrohm Resistors have proven their superiority. Specify Electrohm Resistors in your new models. Ask your dealer for them. Manufacturers—Send us your Resistor specifications and we will submit samples and quotations.

ELECTRICAL RESISTORS, INC.
179 Riverdale Ave., 24 Onondaga St., Yonkers, N. Y.
Telephone Nepperhan 5658

**WE offer to manufac-
turers interested in**

EXPORT

the services of a dependable organization,
well established in the entire foreign field

AD. AURIEMA, INC.
Manufacturers' Export Managers
116 Broad Street, New York, N. Y.

Better Amplifying Equipment
especially for exacting amplification
requirements.

Special Matching Transformers
giving flat response curves . . . built
in U. S. A., shipped in 48 hours.

FERRANTI, Inc.
130 West 42nd Street -- New York



RADIO APPARATUS TESTING

Life tests and characteristics of vacuum tubes. Calibration of all kinds of instruments. Determination of inductance and capacitance at various frequencies. Resistance measurements, motor tests, magnetic tests, etc.

Electrical Testing Laboratories
80th St. and East End Ave.
New York



Indispensable to
MODERN RADIO

AMPERITE automatically equalizes line-voltage fluctuations. Helps radio sales and satisfaction. Improves tone, lengthens tube-life and insures uniformly perfect operation. Easily installed in 5 minutes without chassis changes. Makes your careful laboratory specifications mean something.

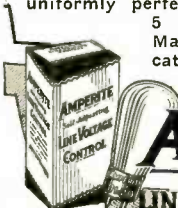

AMPERITE Corporation
501 BROADWAY, NEW YORK

AMPERITE
Self-Adjusting
LINE VOLTAGE CONTROL

Write Dept. RE-4 for full information and AMPERITE set chart.

DEPENDABLE

QUALITY — UNIFORMITY
SERVICE

ON
WAXES — & — MELTABLE
INSULATING and WEATHER-
PROOFING COMPOUNDS

WAXES—All kinds.

IMPREGNATIONS—Condensers, Coils, Rubber-Covered and Weather-Proofed Wire, Telephone and Electrical Cables, Etc.

SEALING COMPOUNDS—Coils, Condensers, Batteries (Wet & Dry), Pot Heads, Cables, Wiring Devices and Specials.

FINISHING—All grades of Weather Proof and Rubber-Covered Wire.

SPECIAL COMPOUNDS



35th St. & Maplewood Ave.
Chicago, Ill.

"For over 35 yrs."

ROEBLING

WIRE—Antennae (plain or enameled). Connecting and Ground (Rubber covered, braided or plain).

STRAND—Antennae (plain or enameled)—Double Galvanized.

BUS BAR—Litzendraht-Loop

MAGNET (Cotton or Silk)

WIRE PRODUCTS

JOHN A. ROEBLING'S SONS CO.
Trenton, N. J. Branches in Principal Cities

INDEX OF ADVERTISERS

A	
Acme Elec. & Mfg. Co., The.....	58
Ad. Auriema, Inc.....	65
Aerovox Wireless Corp.....	11
Allen-Bradley Co.....	20
Allied Die Casting Corp., The.....	57
Alpha Wire Corp.....	64
Amperite Corp.....	65
Amplion Corp. of America.....	62
Anaconda Wire & Cable Co.....	3
Arcturus Radio Tube Co.....	51
Astatic Microphone Lab.....	63

B	
Bakelite Corp.....	Back Cover

C	
Candy & Co.....	66
Cardwell Mfg. Corp., Allen D.....	60
Central Radio Laboratories.....	13
Central Scientific Co.....	Second Cover
Chicago Gear Works.....	64
Chicago Telephone Supply Co.....	15
Clamp Nail Co.....	64
Cleveland Wire Cloth & Mfg. Co., The.....	65
Condenser Corp. of America.....	60
Crowe Name Plate & Mfg. Co.....	51
Crowley & Co., Inc., Henry L.....	58

D	
DeForest Radio Co.....	17
DeJur-Amsco Corp.....	59, 67
Dongan Elec. Mfg. Co.....	Third Cover
Dubilier Condenser Corp.....	8

E	
Eisler Electric Corp.....	64
Electrad, Inc.....	63
Electrical Resistors, Inc.....	65
Electrical Testing Labs.....	65
Elkon Division.....	6
Ellis Elec. Laboratory.....	65
Erle Resistor Corp.....	68

F	
Fansteel Products Co., Inc.....	10
Ferranti, Inc.....	65
Ford Radio & Mica Co.....	63
Forest Elec. Corp.....	61
Formica Insulation Co.....	1
Frost, Herbert H., Inc.....	15

G	
General Electric Co.....	18
General Mfg. Co.....	67
General Radio Co.....	59
Gilby Wire Company.....	56

H	
Hammarlund Mfg. Co.....	67
Holed-Tite Packing Corp.....	51

I	
Inca Mfg. Division.....	9
Int'l. Machine Works, Inc.....	64
Int'l. Resistance Co.....	52

J	
Jenkins & Adair, Inc.....	59
Johnson & Johnson.....	61

K	
Kellogg Switchboard & Supply Co.....	60
Kester Solder Co.....	68

L	
Leeds Radio Co.....	63

Mc	
McGraw-Hill Book Co., Inc.....	60

M	
Maas & Waldstein Co.....	61
Magnavox Co., The.....	47
Mallory & Co., P. R.....	6
Metal Specialty Co., The.....	64

N	
Nat'l. Elec. Prod. Corp.....	9
Newark Wire Cloth Co.....	55

P	
Parker-Kalon Corp.....	5
Pierce Aero, Inc.....	64
Precision Products, Inc.....	64

R	
RCA Radiotron Co., Inc.....	7
Radio Mfrs. Association.....	14
Radio Products Co., The.....	59
Rocke Int'l. Elec. Corp.....	64
Roebling's Sons Co., John A.....	66

S	
Samson Electric Co.....	12
Schweitzer, Peter J., Inc.....	64
Silverleaf Microphone Co.....	64
Skidmore & Co., W. K.....	64
Soreng Manegold Co.....	61
Spargo Wire Co.....	64
Sprague Specialties Co.....	43
Summerill Tubing Co., The.....	55
Synthane Corp., Inc.....	45

T	
Thomas & Skinner Steel Products Co.....	65

U	
Universal Microphone Co., Ltd.....	63

Z	
Zapon Co., The.....	67



HIGH GAIN I-F

Design
With

STANDARDIZED UNITS

A shielded intermediate-frequency transformer with "Varitor" condenser tuning in primary and secondary circuits. One hundred and fifty to two hundred kc. with standard production windings or step-up ratios. Mechanically suited to upright or inverted mounting.

Write for circular giving complete specifications and Varitor's many uses in modern radio circuits.

DeJUR-AMSCO CORP.

Varitors—Variable Condensers—Power Rheostats—Dials
95 Morton Street New York City

GEN-ERAL COILS

Reg. U. S. Pat.

MIDGET SERIES

¾ Actual Size



S. H. Antenna—R. F. B. No. 10



S. H. Oscillator—R. F. B. No. 10

The above coils are wound with plain or "Litz" wire and with variations to meet special requirements.

GENERAL MANUFACTURING CO.

8065 So. Chicago Ave., Chicago

Strength

Our strength lies in our 47 years of research and experience, in our economical methods of manufacture and in our service to our customers.

ZAPON PYROXYLIN LACQUER

We assume full responsibility for the integrity of our product, with all the power and strength of our resources.

THE ZAPON COMPANY
A Division of Atlas Powder Company
STAMFORD, CONN.

This New
HAMMARLUND
MIDGET is
Vibration-Proof !

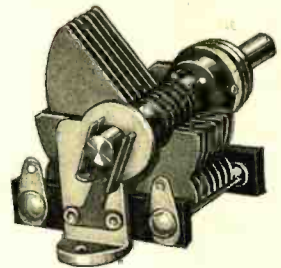

Without nuts or screws (*everything rivetted*) this new Hammarlund Midget Condenser is ideal for airplane or automobile receivers, or for any other use where vibration is difficult to overcome.

High capacity and wide-range—20 to 325 mmf. Soldered brass plates, rugged frame, accurately fitted bearings, double four-point bronze wiping contact. Parianic insulation. Adjustment screw works in a groove—cannot burr the shaft. Straight line or "Midline" tuning curve. Baseboard or one-hole mounting. Ideal for tuning Short-Wave Receivers.

Also a New Condenser for Tuning Intermediate Transformers

Isolantite base mounts inside shield. Self-aligning phosphor-bronze adjustable spring plates, double rivetted. Mica insulation. Proved design—will not change in resistance or capacity from humidity, temperature or vibration. Three ranges in single or double models—10 to 70 mmf.—70 to 140 mmf.—140 to 220 mmf.

Mail coupon for Technical Data

For Better Radio
Hammarlund
PRECISION
PRODUCTS

HAMMARLUND MFG. CO., New York, N. Y.
424-433 W. 33rd St.
Please send technical data on new
Midget Condenser and also on new
Mid. Transformer Condenser.
Name.....
Firm.....
Address.....
RE-4

*"Kester's in a class
by itself, Stevens!"*



"You and I know that the A. S. T. M. requirements for purity of metals is plenty high. But Kester Solder has *extra* quality — it exceeds even their class A specifications."

That's saying a lot. But even then the whole Kester story isn't told. For in addition to using only virgin tin and lead, Kester Rosin-Core Solder carries a special rosin flux inside itself — a flux that's safe and sure for radio work, and the most delicate electric manufacturing.

With Kester Rosin-Core Solder, radio manufacturers build better sets. Electrical manufacturers turn out uniform work and eliminate rejections. Both save soldering time, materials and labor — and cut down maintenance and operation costs.

There isn't a soldering problem our Industrial Development Department can't lick. Write us *today*.

Kester Solder Company,
4224 Wrightwood Avenue,
Chicago, Illinois.
Incorporated 1899.



KESTER
FLUX-CORE
SOLDER
Acid-Core · Paste-Core · Rosin-Core



**TRADE
MARKED
FOR YOUR
PROTECTION**

ERIE RESISTORS are now trade marked, for your protection, by embedding the name **ERIE** in the lead.

You will find **ERIE RESISTORS** foremost in quality and performance. They pass *every* test of the radio engineer and are dependable under all conditions of service.

Demand them in all of your production work requiring moulded resistors.

Samples and prices on request.

ERIE RESISTORS
Erie Resistor Corporation, Erie, Pa.
In the Center of the Radio Industry



DONGAN

Be Sure of the TRANSFORMER

You Choose for This Season's Models

Transformers for Replacements in Old Sets

Those who are interested in Set Rejuvenation will be interested in our new Replacement Transformer Booklet. A copy sent upon request.

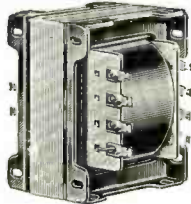

No. 6952

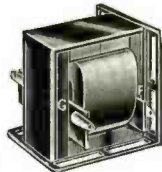

No. 5140

Your competition and ours—sets and transformers—gets keener every year. Your problem is of one sort, our's another.

You not only must offer a finer receiving set but likewise must meet the competition of price.

We too must meet these same conditions—but in a slightly different way.

Quality, we have never feared. Through the constant devotion of the men in Dongan Laboratories we have always kept a step ahead.

Dongan prices—considering the uniformly high quality of the product—are remarkably low because

First: having been fortunate in our selection of customers we have enjoyed a very satisfactory production.

Second: many short cuts in manufacturing have been perfected within the last twelve months.

You simply cannot afford less than the best Transformers this year. Test Dongans in your new models—they will speak for themselves.

*Power Supply Units or Any Special Transformer Unit for
Television Manufacturers*

Dongan Electric Mfg. Co.
2991-3001 Franklin St., Detroit



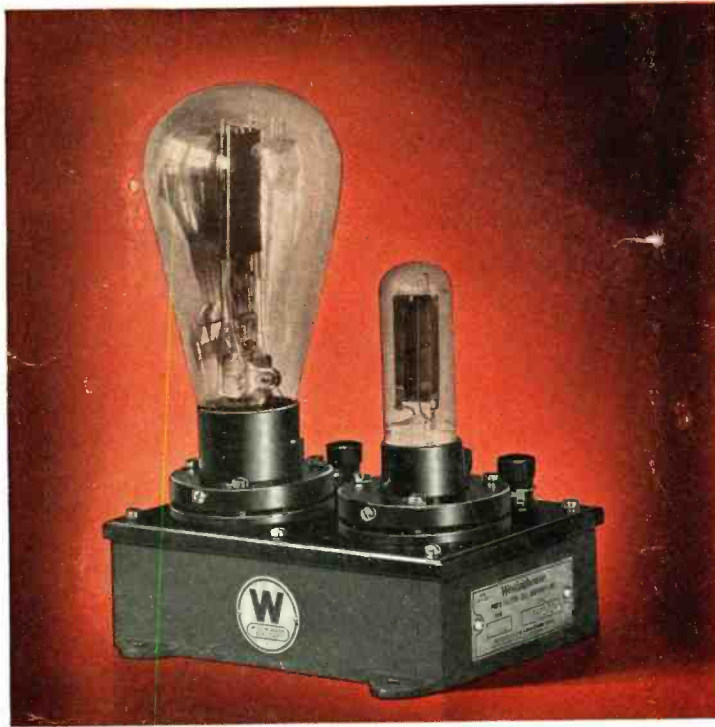

Photo-electric tube and amplifier unit, made by Westinghouse Electric and Manufacturing Co., E. Pittsburgh, Pa.

For insulating electronic devices *Bakelite Materials are exceptionally satisfactory*

Permanently adequate protection against current losses and short circuits is a primary requirement for insulation used on photo-electric devices. Such insulation must also be highly resistant to moisture, and free from swelling, shrinking, or distortion.

An excellent example of the way in which Bakelite Materials meet the needs of electronic service, is provided by the Westinghouse photo-electric tube and amplifier unit. Tube bases, sockets, and terminal thumb nuts are formed of Bakelite Molded. The box

cover, upon which the tubes are mounted, is of Bakelite Laminated, as is the interior sub-panel.

Because they possess an unusual combination of desirable properties, Bakelite Materials, Molded, Laminated, and Varnish are playing an important role in the progress of the electronics industry. These materials are constantly solving insulating problems in a wide variety of applications. Write us for full information—ask for Booklets 38M, "Bakelite Molded," 38L, "Bakelite Laminated," or 38V, "Bakelite Varnish."

Bakelite Engineering Service—We manufacture a wide variety of Bakelite resinoid molding materials, varnishes, lacquers, enamels, cements, and other products. Twenty-one years experience in the development of these materials for radio and other uses provides a valuable background for the cooperation offered by our engineers and laboratories.

BAKELITE CORPORATION, 247 Park Avenue, New York. CHICAGO OFFICE, 635 West Twenty-second Street
BAKELITE CORPORATION OF CANADA, LIMITED, 163 Dufferin Street, Toronto, Ontario

BAKELITE

The registered trade marks shown above distinguish materials manufactured by Bakelite Corporation. Under the capital "B" is the



numerical sign for infinity, or unlimited quantity. It symbolizes the infinite number of present and future uses of Bakelite Corporation's products.

THE MATERIAL OF A THOUSAND USES