

RADIO ENGINEERING

*The Technical Magazine of the
Radio Trade - Edited by M.B. Sleeper*

Radio Manufacturers' Issue

MAY, 1926

New Parts, Materials, and Supplies

Introducing the latest products from concerns which specialize in supplying the radio set manufacturers

Ideas for the Radio Designer

With illustrations of developments which are being incorporated in the new equipment planned for fall delivery

Short Wave Work to Hold Summer Business

Describing a short wave B battery phone transmitter, a particularly interesting outfit for summertime experiments



20c PER COPY \$2.00 PER YEAR
Sold Only by Subscription

VOLUME VI NUMBER 5
Sixth Year of Publication

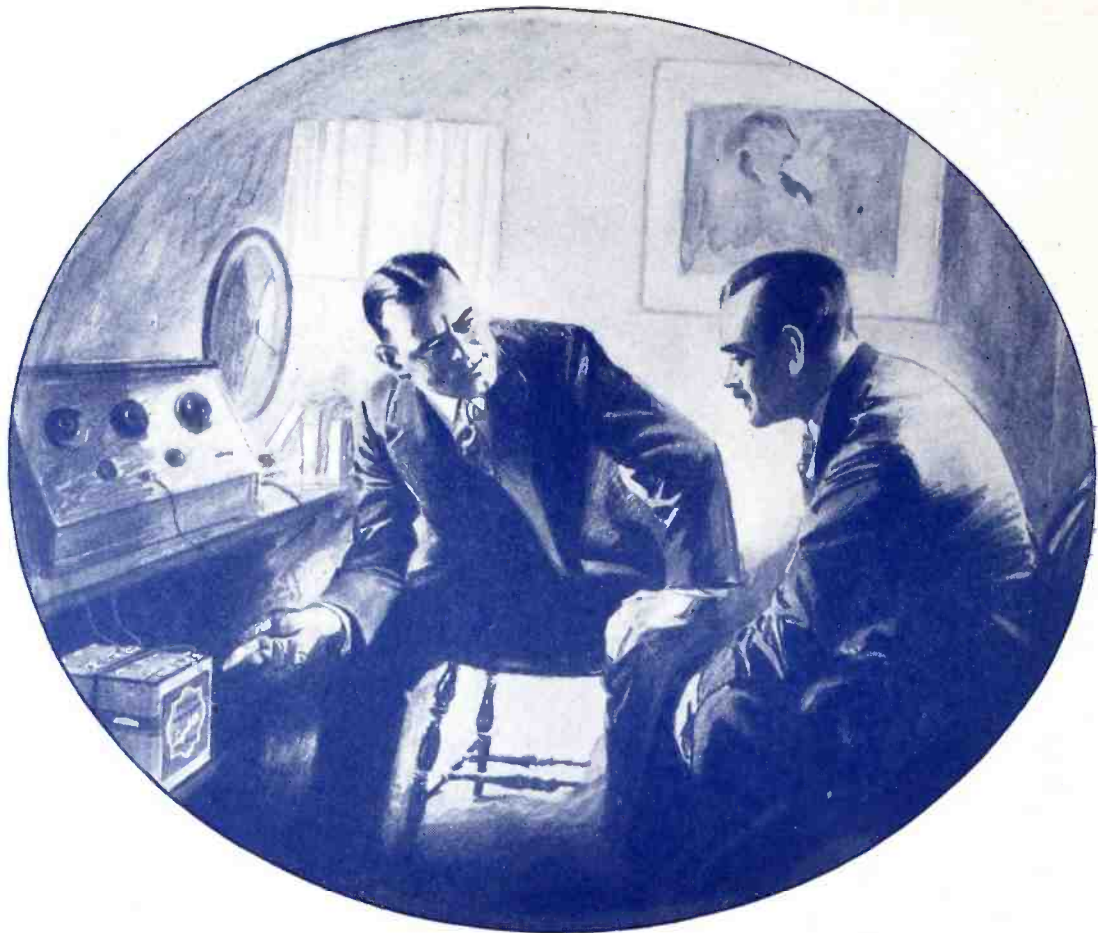

"The little wrinkle that makes my 'B' batteries last longer is using the right size Evereadys with a 'C' battery"

"I USED to think that because the Eveready 'B' Battery No. 772 cost less than either of the larger Heavy Duty Evereadys that I was saving money. As a matter of fact, on four or five tube sets, that was false economy.

"The right size Eveready 'B' Batteries to use depends on the number of tubes in your set. The life of the batteries depends on how much you listen in and on whether a 'C' battery is employed."

To get the maximum of "B" battery life and satisfaction, follow these simple rules:

On 1 to 3 tubes—Use Eveready No. 772.

On 4 or more tubes—Use the Heavy Duty "B" Batteries, either No. 770, or the even longer-lived Eveready Layerbilt No. 486.

On all but single tube sets—Use a "C" battery.*

Follow these rules, and No. 772, on 1 to 3 tube sets, will last a year or more; Heavy Duties, on sets of 4 or more tubes, eight months or longer.

The average year-round use of a set is two hours a day. If you listen longer,

your "B" batteries will have a somewhat shorter life. If you listen less, they will last longer.

Our new booklet, "Choosing and Using the Right Radio Batteries," is free for the asking. It also tells about the proper battery equipment for the new power tubes.

Note: A "C" Battery greatly increases the life of your "B" Battery and gives a quality of reception unobtainable without it. Radio sets may easily be changed by any competent radio service man to permit the use of a "C" Battery.

Manufactured and guaranteed by
NATIONAL CARBON CO., INC.
 New York San Francisco
 Canadian National Carbon Co., Limited
 Toronto, Ontario

Tuesday night means Eveready Hour—
 8 P. M., Eastern Standard Time, through
 the following stations:

WEAF—New York	WGR—Buffalo	WGN—Chicago
WJAR—Providence	WCAE—Pittsburgh	WOC—Davenport
WEI—Boston	WSAI—Cincinnati	WCCO—Minneapolis
WTAG—Worcester	WTAM—Cleveland	WCCO—St. Paul
WFI—Philadelphia	WWJ—Detroit	KSD—St. Louis

LEFT — No. 486, for 4, 5 or more tubes. \$5.50.

RIGHT — Eveready Dry Cell Radio "A" Battery, 1 1/2 volts.

EVEREADY
Radio Batteries
—they last longer



Radiotron UX-201-A
*which is illustrated is the standard
 tube for storage battery sets. (Radio-
 tron UV-201-A is exactly like it
 but has the old type base.)*

one fourth as much current as in 1921

When you tune in today on a storage battery set, your Radiotron UX-201-A uses only one fourth of the current a storage battery tube needed just five short years ago. This means that you need charge your "A" batteries only about one fourth as often!

The present Radiotron UX-201-A is also a better detector—is a better amplifier—has a greater output—all on less current.

RCA research has produced better tubes—better methods of making tubes, to lower their cost—and better test methods, too. These improvements have come from the laboratories of RCA and its associates, General Electric and Westinghouse—laboratories devoted to year-in and year-out study of vacuum tubes:

The standard of quality back in 1921 was an RCA Radiotron. And the standard of quality today is an RCA Radiotron!



RADIO CORPORATION
 OF AMERICA
 New York Chicago San Francisco

RCA Radiotron

MADE BY THE MAKERS OF RADIOLAS

EDITORIAL

THE flurry of excitement over toroidal coils has now passed, and those who came to swords' points over the toroid-solenoid issue have finally resumed at least a nodding acquaintance. While it may appear past time to discuss that matter, the principles involved are important, for they have applied to other things before, and will, no doubt, apply again.

As is so often the case, toroidal coils, a new item, were capitalized by the magazines and newspapers in order to provide light reading for impressionable enthusiasts. Whereupon the champions of solenoids retorted thru the press.

Immediately the heavy artillery in the research laboratories of the popular magazines directed their engineering effort to a definite solution of the problem. There was the opportunity to bring into action the high calibre of their intelligence by demonstrating to the world at large that they could settle such an issue in a spirit of pure scientific research, without regard to the affiliations of readers or advertisers.

They settled it, all right. They proved beyond the shadow of a doubt that single-layer solenoids, in simple oscillating circuits, had less high frequency resistance than toroidal coils.

And then, well pleased, they rested on the laurels of their accomplishments.

What this scientific gesture really did was to spoil the fun of thousands of people who wanted to play with toroidal coils, to disgust those who realized that the resistance of a coil in a plain oscillating circuit is no measure of its usefulness in a radio circuit, and to antagonize manufacturers who were making legitimate use of toroids in their sets.

Radio Engineering was as much interested in the applied value of toroids as anyone else, but with an eye to the application of such questions to the general development of the art and the industry, we went to the bottom of the question, realizing that the toroid should have a chance on its merits in a radio set—not in a wavemeter circuit.

It didn't require a research laboratory to prove that, for a given inductance, the resistance of the toroid is somewhat higher than the solenoid. The question is: Which will work better in a radio set?

There was something worth finding out. Anyone can measure high frequency resistance with fair precision. We went to engineers, not self-styled experts.

This is what we found: Most circuits employ such uncritical control of oscillations that ordinary differences of resistance between coils are not apparent in tuning or volume. As for external field, shielding to be fully effective must be so perfect that toroid or solenoid must be enclosed in a metal compartment, yet where that is too costly, the toroid does have the advantage of a more limited magnetic field.

Only a very few sets on the market to-day are so designed, mechanically or electrically, as to reach the point of efficiency where small differences of resistance in the coils show up in the operation or results, and those sets have to use solenoids to maintain absolute precision in the mechanical dimensions in order that they will match electrically.

The electrical superiority of the solenoid or toroid depends upon the particular limitations of the use to which it is put.

The foregoing is not meant to disparage the efforts at self-expression of those who mishandle technical matters of this sort, but to bring to the attention of manufacturers and the trade the importance of guiding and directing the radio press, rather than blindly putting these issues into the hands of the magazines and newspapers.

M. B. SLEEPER, *Editor.*

RADIO ENGINEERING

The Technical Magazine of the Radio Trade

Edited by M. B. SLEEPER

Vol. VI.

MAY, 1926

No. 5

Sixth Year of Publication

CONTENTS

Frequency Separation	193
<i>By Bert E. Smith</i>	
From Antenna to Air Column.....	194
<i>By A. W. Harris</i>	
Die-Cast Gang Condensers.....	195
<i>By H. Perlesz</i>	
Notes on Metallic Grid Leaks.....	196
Tests for Shielded Coils.....	196
<i>By S. Cohen</i>	
Shielding for Selectivity.....	197
<i>By C. J. Brown</i>	
Building Sets for Profit.....	198
<i>By E. J. Gearhart</i>	
Connection Cables for Manufacturers.....	200
A.F. Modulated Oscillator.....	200
Metal Panels and the B-T Set.....	201
<i>By C. F. McLaughlin</i>	
US-76 Telephone Transmitter.....	202
<i>By S. W. Nichols</i>	
Floating Reflex Circuit.....	206
<i>By G. H. Browning</i>	
Radio Manufacturers Association.....	207
With the Manufacturers.....	208
Index of Advertisers.....	230

In the June Issue

RADIO ENGINEERING for June will have a section specially devoted to the small parts and accessories manufacturers, detailing new things which will be incorporated this fall in complete sets, or sold separately. Another section has been reserved for the A. M. E. S. We hope that the new Raytheon dope will be ready, for we have an interesting surprise in preparation for dealers and set builders. The story of the Howard receiver was not ready for May, but it has been promised for June.

In the July Issue

It has been fairly well agreed among set manufacturers that the 1927 models will be ready on June 1, 1926. Most of the established companies are adhering to this schedule, and, as far as possible, we shall describe all the new models in the July issue, giving such details as are of importance to the technical men in the dealer and jobber organizations. In many respects, July will be the most useful issue of the year.

RADIO ENGINEERING

Published monthly by M. B. SLEEPER, Inc., Publication office, Lyon Block, Albany, New York. Editorial and General offices, 52 Vanderbilt Ave., New York, N. Y. Printed in U. S. A. Yearly subscription \$2.00 in U. S. and Canada; ten shillings in foreign countries. Entered as second class matter at the postoffice at Albany, New York, January 9, 1925, under the act of March 3, 1879.
Bryan S. Davis, Advertising Manager; E. H. Moran, Western Representative, 307 N. Michigan Blvd., Chicago, Ill.

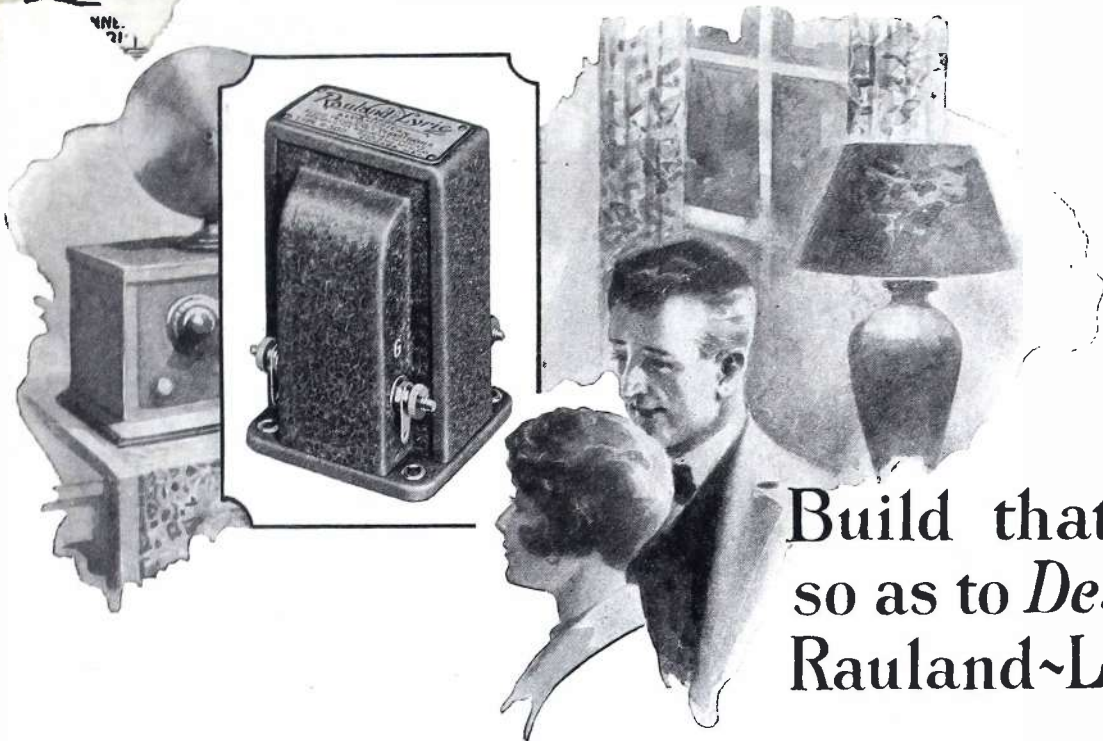

Build that Set so as to *Deserve* Rauland-Lyrics

Gone is the day of the jerry-built radio. Whether you build for use or for profit—one set or a hundred thousand—skimping on quality *does not pay*.

For the radio frequency stages, choose any good circuit and any type of coils you like—opinions differ. But, having chosen your circuit, *be fair to it*—let it show what it really can do—give it the benefit of *Rauland-Lyrics*.

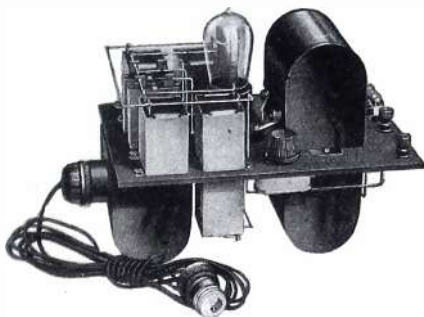

Build this B-Power—identical electrically with the well-known All-American "Constant-B." The following are the essential parts required:

B-Power Choke; inductance full 50 henries, in stout metal shield. Type R-8	\$4.50	Tube Socket; the popular All-American bakelite socket is ideal for this purpose. Type R-25	75c
B-Power Transformer with separable plug (short-circuit-proof). Type R-7	\$6.00	Raytheon Tube, each...	\$6.00

Send for Bulletin B-82, giving detailed directions with full-size templates for building the above illustrated B-Power unit. All-American Radio Corp., 4217 W. Belmont Ave., Chicago, U. S. A.

Rauland-Lyric
AN
ALL-AMERICAN
TRADE MARK
TRANSFORMER

FOR THE MUSIC LOVER
The Choice of Noted Music Critics

MEMBER **RMA**
OWNING AND OPERATING STATION WENR — 266 METERS
ALL-AMERICAN
Radio Built for the Years to Come

This new, permanent "A" power supply eliminates battery failure

The final answer to an important power problem

NO longer need "A" batteries fail when they are needed most—no longer must time and money be spent re-charging them. Three years ago the engineers of the Gould Storage Battery Company developed a new source of permanent "A" current power—the "trickle charge" principle. The result was Unipower—radio's first complete "A" power unit.

This "trickle charge" principle, perfected by Gould, has met the unqualified endorsement of both the Institute of Radio Engineers and the Associated Manufacturers of Electrical Supplies.

Unipower embodies every mechanical and electrical feature necessary to the efficient and economical performance of the "A" circuit in any radio set, from a simple one-bulb outfit, to the most elaborate multi-tube superheterodyne.

Unipower not only assures the set owner of continuous, quiet "A" power, always at full voltage; but the Unipower master control switch—an exclusive feature—makes it possible to coordinate both the "A" and "B" circuits under one control.

Unipower contains a Balkite charging unit of special design.

Attempts have been made to duplicate Unipower. But the reliability of such a "trickle charge" installation depends upon the proper relation of all the elements involved. Simply to approximate the "trickle charge" principle does not mean that the battery will not become over-charged, or that the "A" current supply will not fail when it is wanted most.

In Unipower only, are all these features incorporated. In Unipower only, have those qualified to know, found the final answer to the "A" power problem.

THE GOULD STORAGE BATTERY CO., Inc.
250 Park Avenue New York

Unipower

Off when it's on ~ On when it's off

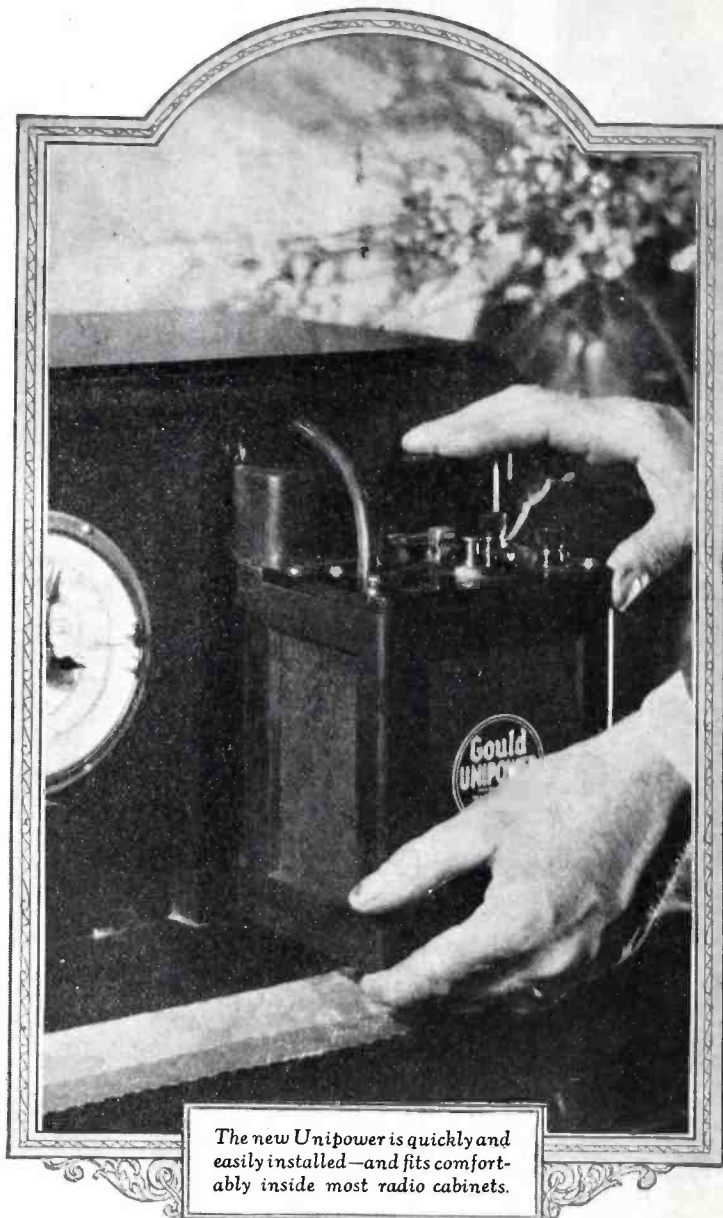

The new Unipower is quickly and easily installed—and fits comfortably inside most radio cabinets.

The first cost is the last!

Unipower's first cost is moderate—and the first cost is the last because Unipower contains no tubes, bulbs, lamps; nor any working parts that require frequent and expensive replacement. Unipower will last for years. Compared with dry "A" battery operation, Unipower pays for itself over and over again.

The standard Unipower operates from alternating current, 110-125 volt—60 cycle. The 4 volt type is for sets using 199 tubes or equivalent and retails for \$35.00. The 6 volt type is for sets using 201-A tubes or equivalent and retails for \$40.00. West of the Rockies, prices are slightly higher. (Special models, 25-50 cycle are available.)

FREE! Write for interesting booklet, "Unipower, a triumph in radio power."

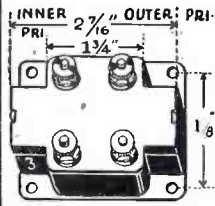
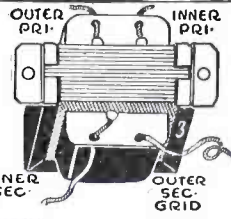
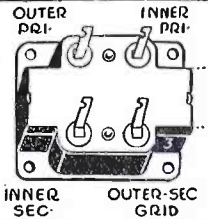
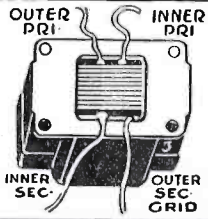
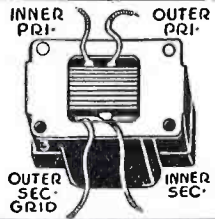
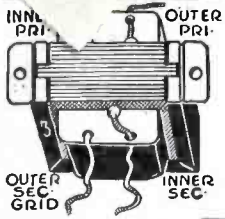

OUTER SEC GRID INNER SEC

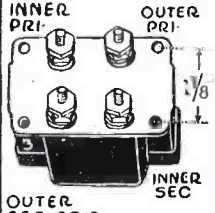

OUTER SEC GRID INNER SEC

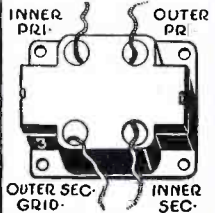

OUTER SEC GRID INNER SEC

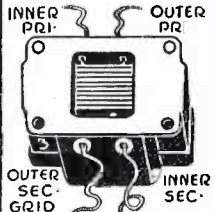

OUTER SEC GRID INNER SEC

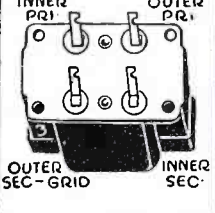

OUTER SEC GRID INNER SEC

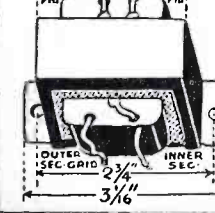

Every Set Manufacturer Knows:

-----that tone quality is the determining factor in the sale, and that the amplifying transformer is the determining factor in the tone quality of every receiver.

That is why today there are more Thordarson transformers used in manufactured sets than all competitive transformers combined.

Month after month, season after season, the leading set manufacturers listed below continue to specify *Thordarson* amplifying transformers.

They know that Thordarsons will "stand the gaff"—that in tone quality they satisfy even the most fastidious—that even in the hardest service they will not break down—that they are designed right, built right, and sound right. And, what is more, they know that their production will not be held up for want of transformers, for Thordarsons always meet their delivery schedule.

There are more than sixty different mountings and types of Thordarson transformers available for the set manufacturer. There is a transformer for every receiver.

Write for further information and quotations.

The following manufacturers equip their sets with Thordarson Amplifying Transformers

- | | | |
|-------------------------|------------------------------|-----------------------------|
| Colin B. Kennedy Co. | Langbein & Kaufman | Perlez Radio Co. |
| Pfanstiehl Radio Corp. | Better Radio Products Co. | Simplex Radio Co. |
| King Manufacturing Co. | Thermodyne Radio Corp. | Chicago Phonograph Co. |
| Ozarka, Inc. | Western Coil & Elect. Co. | Yale Radio Elect. Co. |
| Valley Elect. Co. | Ainsworth Radio Co. | Allen T. Hanson Co. |
| Andrews Radio Co. | Argus Radio Co. | Walbert Mfg. Co. |
| Globe Elect. Co. | Audiola Radio Co. | Harding Mfg. Corp. |
| Howard Mfg. Co. | Brenard Mfg. Co. | Triangle Elect. Co. |
| Sparks-Widington Co. | Cole Storage Battery Co. | H. M. Kipp Co. |
| Zenith Radio Corp. | Dray Radio Laboratories | Slagle Radio Co. |
| Mu-rad Lab. | Edwards & Crist Co. | Leich Elect. Co. |
| Wm. J. Murdock Co. | Eagle Radio Co. | Radio Products Corp. |
| Radio Master Corp. | Hartman Elect. Co. | Lighthouse Elect. Co. |
| Pollack Wilker, Ltd. | Hayes Products Co. | Master Radio Supply Co. |
| Mohawk Elect. Co. | Wells Radio Mfg. Co. | Progress Radio Service |
| Mantie Lamp Co. | Signal Elect. Co. | Nun-Landon |
| Kimberly Phonograph Co. | Radio Shops Co. | Peerless Radio & Elect. Co. |
| | Advance Auto Accessory Corp. | |

THORDARSON

Super

TRANSFORMERS

Standard on majority of quality sets

THORDARSON ELECTRIC MANUFACTURING CO.
 WORLD'S OLDEST AND LARGEST EXCLUSIVE TRANSFORMER MAKERS
 Chicago, U. S. A.

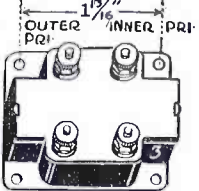

INNER SEC OUTER SEC GRID

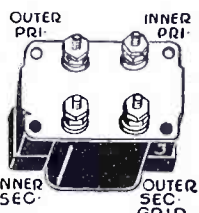

INNER SEC OUTER SEC GRID

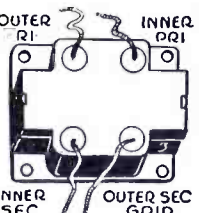

INNER SEC OUTER SEC GRID

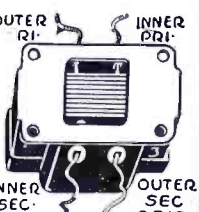

INNER SEC OUTER SEC GRID

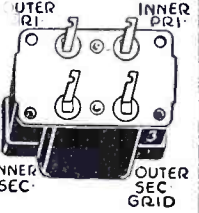

INNER SEC OUTER SEC GRID

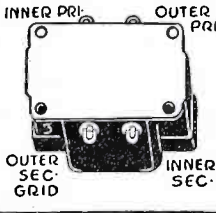

OUTER SEC GRID INNER SEC

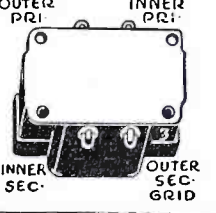

INNER SEC OUTER SEC GRID

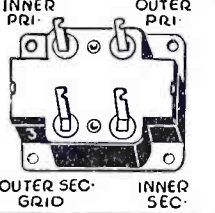

OUTER SEC GRID INNER SEC

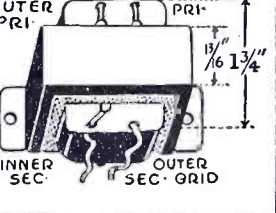

INNER SEC OUTER SEC GRID

What the Quadraformer Will Do

In Which is Told What You May Expect from a Quadraformer Receiver as Reported by the Men Who are Actually Building and Selling Them.

I MIGHT tell you as certain other set manufacturers seem fond of claiming, that with the *Quadraformer* you'll get from coast to coast. I have many letters from *Quadraformer* builders who have done this and more, but I am not going to tell you that you can do it, for frankly I don't know.

Reception in some localities is far superior to others—and even in the same location reception of distant stations is erratic on any radio set.

One night you may secure reception that is nothing short of marvelous and yet the very next night stations 500 miles away may not come in as they should.

That's the real truth about DX on any radio set—no matter what any one else may tell you.

I would rather underestimate the performance of our set than to make extravagant claims and then have you disappointed.

If our simple assembly instructions are faithfully and exactly followed, the *Quadraformer* will do more than any other five tube set under the same conditions. And that's saying a lot.

But after all, claims are merely claims. Unsupported they become simply boast, brag and bombast.

So I'm going to let a few of our set builders tell you their experiences with the *Quadraformer*. Discount their written statements 50%, if you will, and still you will find their reports unusual.

Read what Mr. P. E. Greer, 129 10th St., Manhattan Beach, wrote on November 18, 1925—

"On trying it out—and it went off on the first turning of the button—I was very much disappointed to think that you had not brought out the *Quadraformer* sooner—it would have saved me many, many sad experiences. "It is wonderful from every point of view: SELECTIVITY—VOLUME—DISTANCE—QUIETNESS. But you have gotten me into trouble. I had already sold five customers _____ receivers, and now since they have heard the *Quadraformer*, they won't take the _____! So I'll have to deliver Super-Fives."

Mr. Paul. G. Potter, of 1069 W. 31st St., Los Angeles, another experienced radio man, wrote on November 19, 1925:

"I completed my first *Quadraformer* Super-Five early this evening and got the results I have always dreamed of, and never had.

At ten minutes to nine I finished hooking it up. Follow me down the dials: KSD, St. Louis; KYW, Chicago; WHO, Des Moines; KLX, Oakland; KGW, Portland; KFI, Los Angeles; KPO, San Francisco; WLW, Cincinnati; KHJ, Los Angeles; KWSC, Pullman; WDAF, Kansas City; KGO, Oakland; KNX, Los Angeles; KOA, Denver; KTCL, Seattle; KSL, Salt Lake; KTBI, Los Angeles; KFKX, Hastings; CNRV, Vancouver; KFAD, Los Angeles; KFON, Long Beach; KFUU, Oakland; and KFVD, San Pedro!

"I have never heard so many out of town stations in one evening in my life. And volume! I could hear WHO on the front lawn with the doors closed!

Again on December 1, 1925, Mr. Potter wrote:

"Last night I received a letter from Station CNRA, Moncton, New Brunswick, Canada, confirming my reception of that station. Imagine it! A 500-watt station almost 4,000 miles away, on the loud speaker at seven o'clock in the evening!"

And he added an additional list of stations—seven Canadian and nineteen eastern, including WAHG, WSUI, WBBM and WKRC—that he had tuned in since his previous letter.

STATION OAX, LIMA, PERU

At 10:30 P. M. on the night of January 28, 1926, Mr. S. W. Billingsley of Route No. 1, Box 604, Park Place, Houston, Texas, tuned in Station OAX, Lima, Peru, and listened to their program for over forty minutes!

After reporting this remarkable reception to us Mr. Billingsley wrote:

"Received in my mail yesterday official certificate of verified International reception."

REMARKABLE DAYLIGHT RECEPTION

Des Moines, Iowa,
Feb. 4, 1926.

"I have had wonderful results with my *Quadraformer*.

"PWX, Havana, Porto Rico, Mexico come in quite often. I've had KDKA at 11 A. M., WTAM at 2 P. M., WLIT, WTAS, WSMB and even Montreal in the daytime."

—RALPH SHEARER,
1922 East 33d St.

CALIFORNIA TO CUBA

Detroit, Mich.
Feb. 18, 1926.

"I am more than satisfied with my *Quadraformer*. I have had California and Cuba on this set and I also had New Orleans on four tubes.

—PAUL MASURA,
6510 Epworth Boulevard.

THE BEST YET

Langhorne, Pa.
Feb. 15, 1926.

"The set works GREAT. I have built every known circuit and this is the best yet. Believe me, I expect to sell some of these sets. I tuned in 37 stations in three hours, with six old time hams standing by to prove it!"

—JOHN HILLIG.

OUR STATEMENTS TOO MILD

Willoughby, Ohio,
Jan. 28, 1926.

"I have tried out your set to my satisfaction. All the statements that you have made are true. The performance of the set surely is a surprise."

—E. W. HENGST,
42 Clark St.

Couldn't YOU sell the kind of set people talk that way about?

This is your opportunity to cash in on a real custom built set.

By buying the essential *Quadraformers* (the rest of the parts are standard)—or the complete knockdown kit—direct from us, assembling and mounting the set in a cabinet of your own choice, you can take care of the man who wants much for little, or the man who wants the best regardless of cost.

By buying direct from us for cash you save your share of the credit losses which the manufacturer or jobber who sells on time must sooner or later hand on to you in the cost of his goods.

By handling the *Quadraformer* as a custom built set you save both the manufacturer's and jobber's profit on the labor and the cabinet, which, by the way, is no small item.

Here is your opportunity for more profit—you can turn those idle hours into bankable dollars. Assemble just one *Quadraformer* set. You'll discover how easy it is to build, for as you follow our simple step-by-step instructions the instruments actually seem to mount and wire themselves. And the moment you put it on the air you'll understand why the folks who have tried the set write letters like those you have just read.

The *New* Quadraformer

that really does things which no set in radio history ever did before

It is easy to tune—no wiggling of rheostats or oscillation controls, no squeals or distortion.

The *Quadraformer* employs a new method of tuned radio frequency amplification in which all so-called "neutralizing" devices are done away with. They

are not needed. Internal set noises are eliminated, instead of being imperfectly suppressed.

It's a trouble-proof set, far more sensitive and far more selective, of greater volume and more natural tone than any radio receiver you have ever heard.

It Is the Only Successful HIGH-POWERED Non-Regenerative Set Ever Developed

It is a truly amazing five-tube receiver.

It is one of the simplest of all sets to build, requiring neither a large assortment of tools nor a wide technical knowledge of radio. The only tools needed are pliers, screwdriver and soldering iron, all of which are usually found in the average home. There is not the least chance of

going wrong or of not securing a neat workman-like job, as the instruments practically mount themselves as you follow the complete step-by-step instructions.

"Old stuff!" you say?

It does sound like it when you read the words, but not when you hear the results.

SPECIALLY DESIGNED FOR THE PROFESSIONAL SET BUILDERS

A world of reserve volume, more selective on the lower wave-lengths, more sensitive, still better

tone and much more easily built than any previous *Quadraformer*.

Here's What the Complete Kit Contains:

1 Quadraformer Essential Kit, containing one aerial coupler and two interstage Quadraformers.....	\$12.75	1 Gearhart-Schlueter Terminal Assembly complete with two drilled and engraved bakelite strips, eleven mounted binding posts with soldering lugs and nuts, four mounting pillars and mounting screws.....	2.25
1 Quadraformer Panel, 7" x 21" x 1/8" bakelite. Completely drilled and engraved.....	6.00	20 ft. Gosilco wire, sterling silver, 24-K gold plated.....	1.20
1 Hardwood baseboard, 9" x 20" x 5/8" non-warpable.....	1.00	6 ft. Flameproof black spaghetti.....	.50
1 Gearhart-Schlueter First-Stage Amplifier.....	4.75	1 .5 mfd. Dubilier by-pass condenser.....	.75
1 Gearhart-Schlueter Second Stage Amplifier.....	4.75	1 .002 mfd. Micamold fixed condenser.....	.35
3 Precise Syncrodensers, No. 790L.....	12.00	2 .00025 mfd. Micamold fixed condensers.....	.70
5 Naald tube sockets.....	1.75	1 5 megohm Micamold grid leak.....	.30
3 Four-inch bakelite dials, clockwise graduations 100-0.....	2.25	1 Grid leak mounting.....	.30
2 Six-ohm bakelite rheostats with knobs.....	2.00	40 Tinned soldering lugs.....	.20
1 Carter No. 3 jack switch.....	1.15	27 No. 4 5/16" R H N P wood screws.....	.20
1 Open circuit jack.....	.70	5 No. 6 5/8" O H N P wood screws.....	.05
1 Filament control jack.....	.90		
1 Filament switch.....	.60	Total.....	\$57.40

By buying in large quantities we are able to furnish you the complete kit containing every part necessary to complete the set for

NET PRICE
To Dealers and
Set Builders **\$36.75**

PREPAID TO YOU
(RETAIL PRICE \$55)

ALL SHIPMENTS CASH WITH ORDER OR C. O. D.

You may purchase any of the individual parts at 35% discount from the retail prices quoted. (Except the *Quadraformer* Essential kit which is \$7.88 net and our audio amplifiers which are \$5.70 a pair, net.)

We will assemble and wire the set for you complete for \$10.00 additional.

Mr. Gearhart will personally answer all your questions and give you any further instruction necessary without charge of any kind.

GEARHART-SCHLUETER RADIO CORP'N
P. O. Box 666, Fresno, Calif.

in radio little micadons make a big difference



MICADON 640
An improved design making possible a wider range of capacities.

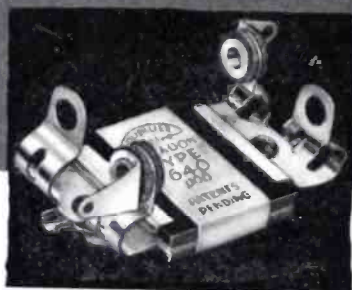

MICADON 640A
Compactly made for use in resistance coupled amplifiers.

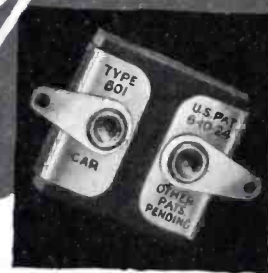

MICADON 601
The standard fixed condenser of radio.

THERE doesn't seem to be much to a Micadon when you look at it. The infinite care that is given to every detail in the manufacture of Dubilier Micadons is your assurance that they will always do their job.

Micadons are a small item in the cost of any radio set. But the difference between clear and poor reception, and the change from noise to natural tones may often depend upon their use.

Send 10c for our booklet which shows fourteen ways in which you can improve your set by simple applications of fixed condensers.

Address: 4377 Bronx Blvd., New York

Dubilier

CONDENSER AND RADIO CORPORATION

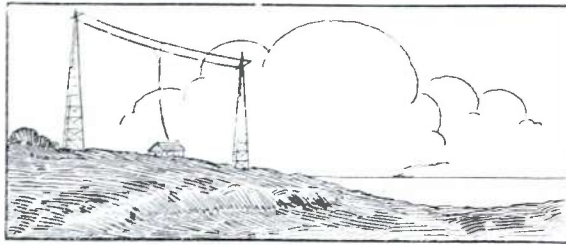

FREQUENCY SEPARATION

Should condensers be designed for straight line capacity, wavelength, or frequency calibration, or should they combine these characteristics?—

*By Bert E. Smith**

PROBABLY the most noticeable parts, at least to the buyer, of a radio receiver, are the variable condensers which are used for tuning. In most modern sets, when you look inside the cabinet, the only things visible are the condensers and tube sockets and, in some cases, the coils. The condensers call attention to themselves because they are the only moving parts and any difficulty the buyer has with the set in selectivity or sensitivity is usually blamed upon them.

Manufacturers whose selling prices permit them to be particular about the parts they use give a great deal of thought to these instruments, both because they are the most prominent parts of the set and also because the ease of tuning, selectivity and range of the set are all directly dependent upon the quality of condensers which are used in the tuning circuits.

If either the condensers or the coils

*Engineer, Allan D. Cardwell Mfg. Corp.

are bad, the set is a failure and it is a far more difficult job to make a really good condenser than a good coil.

One of the first considerations in the selection of a variable condenser is the type of tuning curve which is desired. Probably the largest proportion of the radio fans have been converted to the idea that straight frequency is the most desirable method of tuning because the Department of Commerce has committed itself to the division of broadcasting stations into kilocycle units. If, within the next year, the powerful stations are re-allocated so that they are evenly distributed according to kilocycles, the straight frequency tuning curve would certainly be far the best, but there is no prospect now that the frequencies will be so arranged and it is therefore questionable as to just how much advantage is to be gained by the use of this type of condenser.

One unfortunate fact is that many of the advertisers and press agents of

so-called straight frequency condensers have confused straight frequency tuning with selectivity. A large portion of the public has become imbued with the impression that by using a straight frequency condenser they can separate two stations which formerly would have interfered with each other. To them any condenser having peculiarly shaped plates is expected, by some miracle, to filter the babble of broadcasting and afford absolute isolation of each incoming signal from others. Incidentally, it is supposed to add a multitude of miles to the range of the receiver.

From this standpoint both claims are fallacies. There is just one thing which will give selectivity and is by far the greatest influence of distance-getting ability of the set and that is the radio frequency resistance of each condenser and inductor tuned circuit. Unless both coil and condenser are efficient a set will tune badly regardless of what the tuning curve of the

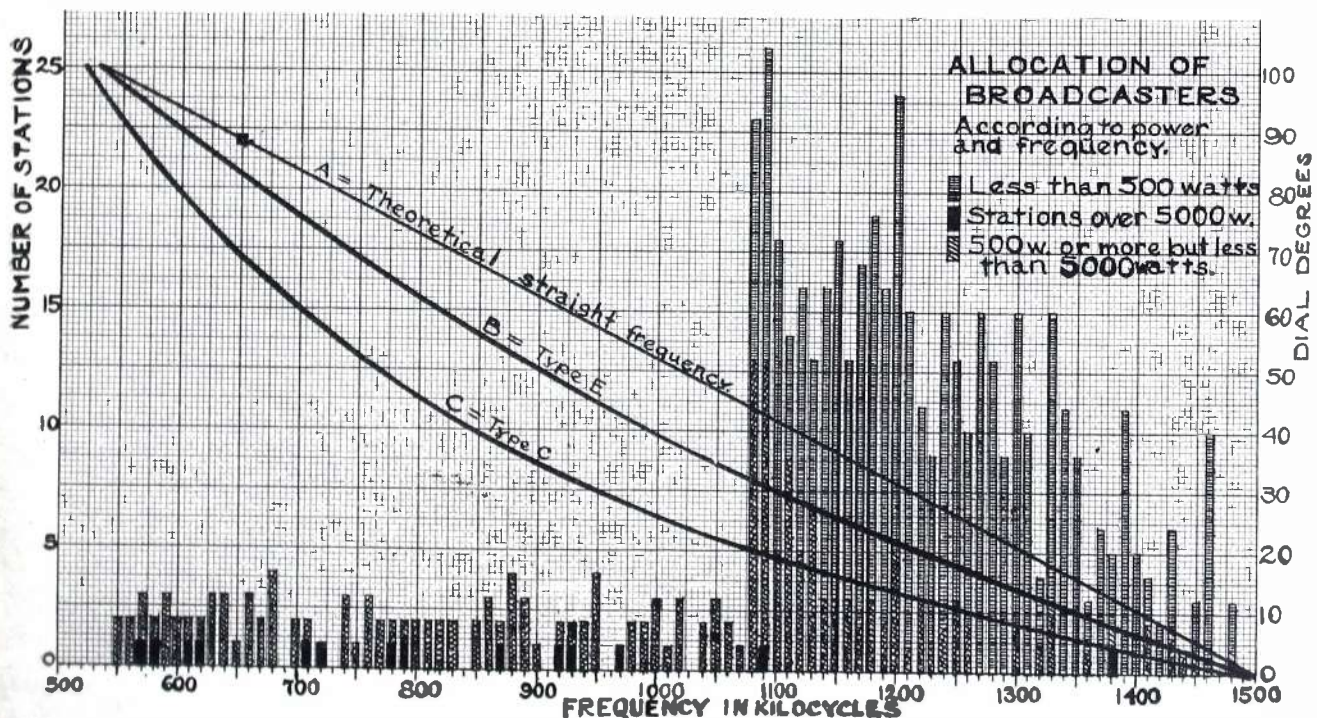

Fig. 1. Vertical lines show the number and power of broadcasting stations operating on various frequencies. Curves A, B, and C are calibrations of the three types of Cardwell condensers.

condenser may be and efforts to secure great distance will, in most cases, be failures. As a matter of fact, there have been, recently, a great many complaints of the lack of selectivity of straight frequency condensers because people who are used to having stations of say 250 meters tune sharply in and out in a degree or so of dial setting, now find that they can be heard for several degrees and are therefore apt to jump to the conclusion that the set tunes more broadly than before, whereas, it probably has just about the same excluding ability as previously. The only difference is that more degrees have been allotted to the short waves, with the natural result that the stations apparently tune more broadly.

Leaving all question of efficiency aside for the moment, however, it will be observed from the chart showing the actual allocation of broadcasting stations according to power rating, that the stations of 5,000 watts or more are decidedly crowded toward the upper end of the wave length scale and that the use of a straight frequency condenser would find twelve of these stations in the upper half of the dial and only two in the lower side. This would certainly not be even station separation. Now, let us take the 500 watt stations. Once again it will be found that using a straight frequency tuning condenser there would be a surplus of stations above 40 on the dial and a decided scarcity below that figure. This, naturally, calls out just one question.

Does the manufacturer wish to encourage the users of his set to receive the high powered stations where small fortunes have been spent to perfect modulation and which radiate sufficient energy to almost assure the receiver of picking up an undistorted wave with consequent perfection of reproduction, or does he want his patrons to receive the low-powered, short wave stations where, even with good modulation, the great amount of amplification with its attendant distortion necessary to bring them up to comfortable volume must necessarily cast reflection upon the quality of tone reproduction of the set?

There can only be one answer. The manufacturer who wants to keep his reputation must encourage reception of the long wave stations and, in order to do this, the logical thing is certainly to make it easy to tune these in and comparatively hard to tune in the less desirable stations.

If we take a straight wave condenser and look at the same graph, we find that this improves things considerably, but now we have reached the point where there is insufficient separation on both the very short and very long waves and the only inference, therefore, is that what we are really searching for is not a straight line tuning condenser at all but one with a properly designed tuning curve. This curve, plotted upon a wave length scale should be flat at the bottom, slightly steeper in the middle and flattened out again at the top. In other

words, a curve such as that shown as C in Fig. 1.

For the future, however, with the gradual increase in the evenness of allocation of stations from a kilocycle standpoint, it might be desirable to let the flat part of the curve extend further up the wave length scale and then just steepen it a trifle near the top. A curve of this type is shown as "B".

Either of these latter curves gives much more satisfactory and convenient operation of the dial than a straight line of any description.

The information given in Fig. 1 tells a strikingly different story from the ideas that most of us have had about tuning, for it gives a picture of the air situation which can only be expressed in this graphical way.

The Cardwell Company supplies a wide variety of condenser types to both set builders and manufacturers, so that we are chiefly interested in having our customers understand the true nature of the air situation in order that they may decide correctly in determining the particular plate design they want.

It does appear, however, that the condenser itself cannot solve all the tuning problems. It can be called upon only to do its share, along with the rest of the instruments which comprise a receiving set, and any manufacturer who offers a condenser with the promise that it will eliminate all tuning problems is either deceiving himself or his customers.

From Antenna to Air Column

—By A. W. Harris*

TOO many engineers last season made the mistake when designing their sets of stopping short at the last jack. They developed highly efficient circuits from the aerial to the jack. It followed that up to this point a large degree of distinctive merit and individuality belonged to their production. A large part of this, however, was then sacrificed by coupling the set to an air column and unit that appeared at the time of demonstration to give the best results. This was a very costly mistake, for many of the important features which had been so carefully developed in the set were entirely lost because of the unit and air column.

It must be admitted that in addition to D X qualities and volume, a set must have good tone quality. In other words the amplifier must be able to convey undistorted frequencies covering the entire musical range. Having achieved this result the next link in the chain is the unit.

The unit must be rugged in construction, fool proof, and adjustable so that its most sensitive point can be found. The pitch or fundamental frequency of the diaphragm must be such that its frequency curve will embrace the most

suitable range of the musical scale, and last but by no means least, the impedance of the windings should be balanced to the output circuit.

No single speaker unit made is capable of transforming electrical vibrations from the lowest bass notes to the highest over tones with equal volume. It therefore, follows that in choosing a unit, the range of the diaphragm must be carefully considered. Undoubtedly the finest compromise on the market today is a unit with a floating diaphragm. This feature enables a far wider range to be covered without undue fading.

Where price is not such an important factor, the engineer should consider carefully the use of two units. He might carry out some very interesting experiments, utilizing a very low pitch unit in conjunction with a very high pitch unit, the windings being of an impedance suitable for a power tube. He should couple these up in such a manner that by closing one switch the low pitch unit alone is operating, by closing another switch and opening the previous one, the high pitch alone is in operation. By pressing both switches the two units are working in parallel. He should then have a further switch which will change the coupling from parallel to series. He will note a distinct difference in tone value between series and parallel coupling. He will also find that a particular combination

which is suitable on one station will not necessarily be the best combination on a different station. There is no doubt, a combination of this description intelligently used and with a long air column will give the finest reproduction it is possible to obtain in the present known state of the art.

The next point to be considered is the air column. The orthophonic phonograph has demonstrated the fact that the longer the air column, providing the exponential curve is followed and its degree of expansion is such that the vibrations are exhausted into the atmosphere at or near atmospheric pressure, the more efficient the air column will be. Radio engineers will have to allow a far larger space in the console type cabinet for the air column than in the past to obtain true musical reproduction.

Considering all the above facts, it will be apparent that the engineer when considering the unit and air column for his set must get in touch with high grade manufacturers who have engineering staffs capable of co-operating with him, and who make units which, while complying with the above conditions, can be readily adapted to any required pitch, and the windings of which can be altered to any required impedance. In this manner alone is it possible for engineers to control their sets right from the aerial to the air column.

*Chief Engineer, Amplion Corp. of America.

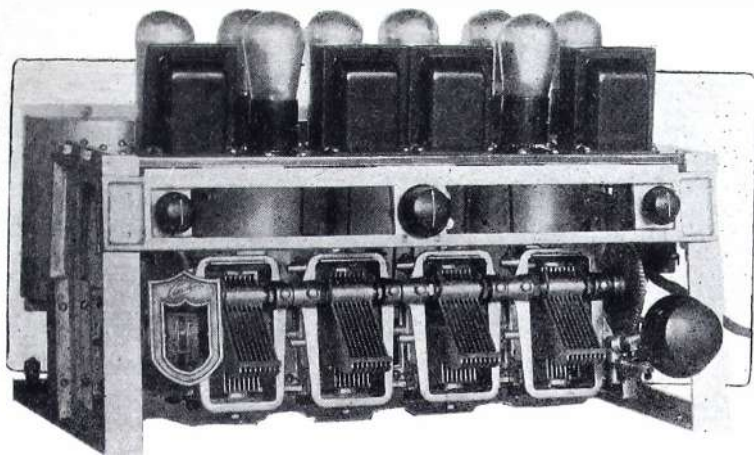

Fig. 1. The die cast gang condensers built into an eight-tube shielded tuned R. F. set. The tuning knob is at the right and the indicating wheel at the left.

Die Cast Gang Condensers

*Is gang control tuning practical?—Certainly, if the condenser design meets the requirements of precision—By H. Perlesz**

IT IS only natural, when a man falls down on a job, to assume that the task is impossible of solution, for most of us feel a little more confident of our own ability than of anyone else's.

This has been true of the manufacture of Gang condensers. So many times I have heard radio engineers say that it is impossible to make a 3 or 4-gang condenser in which the capacities will be absolutely matched over the entire range. They know it is impossible, for they have found it to be so.

Now, as a matter of fact, it isn't impossible at all. The only impossibility that we have run into is in getting manufacturers to whom the die-cast gang condensers have been submitted to find out whether there is any difference in capacity between the sections at any point over the range.

That is getting a little bit ahead of the story. Fig. 1 shows the die-cast gang condensers built into an 8-tube single control receiver. It may not be entirely clear from the illustration, but these condensers show up differently from types which don't track because they are made differently. There are just three major parts—a one-piece rotor, a one-piece stator, and a one-piece frame, each a solid die-casting.

The development of the gang condenser has been as much a question of research in die-casting alloy as it has been a mechanical design job.

That is, the commercial kinds of die-casting alloys are entirely unsuited for precision work of this sort. Not only does the metal warp as it cools

but it frequently flows after the part has been put into use. Therefore, a stable die-casting metal had to be produced. That done, we were ready to start work on the design. Even with the metal that is used, it would be any easy matter to turn out an unsatisfactory product, for there are limitations in die-casting which must be considered in order to use the metal successfully. That this has been accomplished in the die-cast gang condenser, is indicated not only by the results of tests which have been made in an effort to detect differences or capacity between sections but, what is of final importance, the actual operation when the condensers are built into complete receiving sets.

The condenser gang itself, with

either 3 or 4 units, is carried on its own framework. This includes the mounting of the worm-gear control and the dial and indicator. In the lower part of Fig. 2 you can see the condenser frame running along the lower part, beneath the bottom edge of the shielding. That makes the gang adaptable for building into any type of receiver.

The control knob has no play whatever, for the worm-shaft is of a semi-flexible mounting which keeps it pressed against the gear at all times. Space is allowed at the left hand end of the shaft for the cylindrical dial.

Fig. 2 shows some interesting details of shielding used in the complete receiver. One-half of the shielding has been removed, leaving half of a cylinder around each coil. The tops and bottoms of each can section are secured to horizontal strips, corresponding to those on the other half of the shielding, so that the set can be entirely assembled, wired, and adjusted, without any inconvenience from the shielding. Not until everything is ready is the other half of the shield put in place.

The framework which carries the rheostat, gang condenser, and the shielding also supports a horizontal panel on which the tube sockets and Thordarson transformers are mounted.

This particular set is generally made with a glass panel because the general construction and the high finish given to all the parts is so attractive that people want to be able to see it themselves and show it to others. However, a solid panel can be used just as well.

The die-cast gang condensers are available to set builders in 3 and 4-section units, and there is also a 2-section unit for the single control super-heterodyne. Blue prints can be obtained to show the circuit used with the gang condensers built into tuned R. F. receivers. They illustrate special circuit features which have been introduced in order to employ the common ground for all tuning circuits.

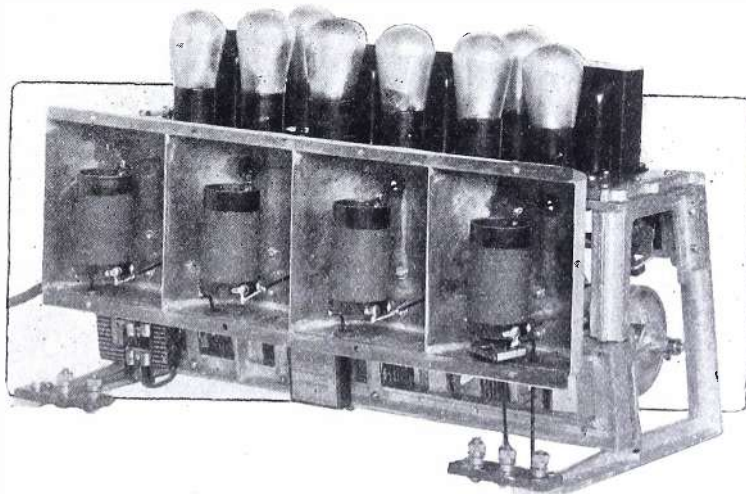

Fig. 2. Rear of the set with half the shielding removed. Note the convenience of this shield design, permitting adjustment and easy access to all the transformer terminals

*Pres., Perlesz Radio Corp., Chicago.

Notes on Metallic Gridleaks

Some interesting details concerning the manufacture of metallized gridleaks are given in a pamphlet published by the International Resistance Company of Philadelphia.

The resistance element is described as a glass fibre about 20 mils in diameter. Glass fibre is spun in reels containing approximately 400 feet. Over the entire length there is no substantial variation in the diameter of the fibre. This material is then coated with a metallic filament which ranges from 0.004 to 10.0 megohms per in. The coating is so accurately controlled that the variation over a length of the glass fibre is under 5 per cent.

The coating process completed, the conductor is cut at lengths of 1.5 ins. These are mounted in glass tubes fitted with the conventional brass caps.

It is interesting to note that the glass fibre, after coating, can be bent into any form by heating the glass to the softening point. This does not affect the resistance of the conducting filament.

In fact, metallic gridleaks can be loaded, in use, to a very high temperature. Upon cooling, they return at once to the original resistance. The temperature coefficient is numerically less than that of copper.

The International Resistance Company furnishes both the coated filament and complete resistors to the Trade. In the latter form they are made with various types of leads, both rigid and flexible, in addition to the usual design.

Tests on the 0.05 megohm gridleak show that, from a resistance of 0.046 at 25 volts the resistance drops to 0.028 megohms at 300 volts.

2.0 megohm resistance shows 1.93 megohms at 50 volts and 1.88 megohms at 300 volts.

An important characteristic of the metallized type of gridleak is that, on the shelf or in actual use there is practically no variation in resistance over a long period of time. That is, it does not evidence any aging characteristics.

Tip Jacks as Standard Equipment

AN increasing number of manufacturers are using tip jacks for voltmeter and loudspeaker terminals. The practice of putting tip jacks for plugging in a voltmeter may have originated with the Radio Corporation. At all events, it is a splendid method for providing connections to measuring instruments, particularly on sets where there is not room to mount a meter or where the cost will not permit its inclusion in the set.

On sets where it is desirable to measure a voltage at more than one point, a combination of tip jacks is generally easier and less expensive than any switching arrangement

built into the set. The tip jacks can be lined up at the side or along the lower edge of the front panel, with lettering between them to indicate the circuits measured.

Several concerns are manufacturing meters equipped with tips to fit the tip jacks. Jewell Electrical Instrument Company, in Chicago, is making an effort to standardize on the distance between centers of the tip jacks, and it might be helpful for engineers who are designing sets with tip jack meter connections to get the

dope first hand from the Jewell Company.

Some sets which have front panels designed in such a way that it is not convenient to use a jack, or where the plug protruding from the panel would not look right, are being made with tip jacks on the binding post strip at the back of the set. It is then necessary to have a filament switch at the front.

Another use for these devices is on plug-in coils, items which will be very popular during the coming season.

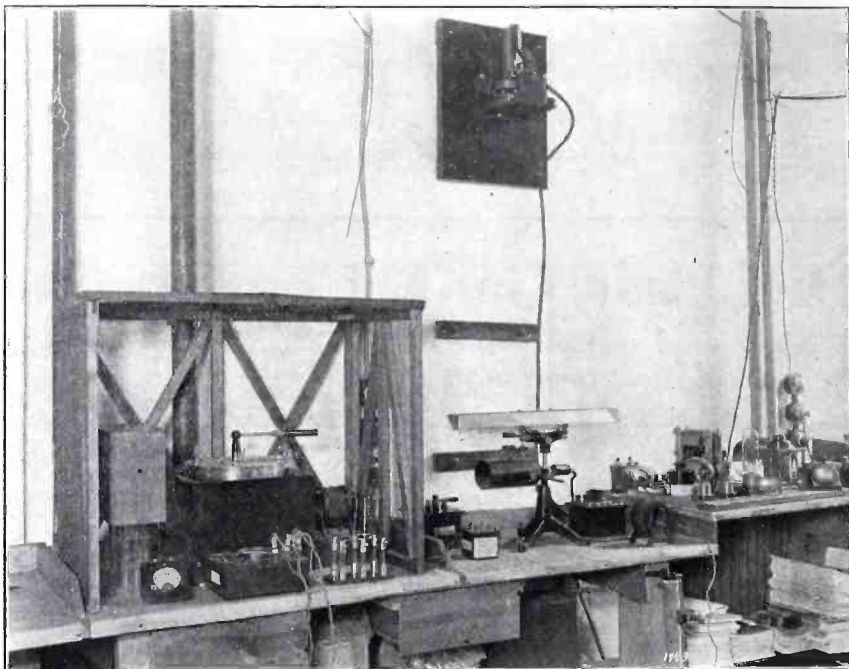

Fig. 1. Set-up for measuring R. F. resistance of shielded coils

Tests for Shielded Coils

*R.F. resistance can be measured simply and accurately by the voltage drop across the inductance under test—By S. Cohan**

THE work of designing shielded coils of highest possible efficiency requires a quick and accurate method of measuring R. F. resistance. The measurements we made originally were found to be much too slow for a job which is so new that it requires much of the cut and dry method.

The necessity for speed was responsible for our working out a different plan.

Fig. 1 shows the complete laboratory set-up. In the shielded cage at the left is a quartz-insulated condenser of the Bureau of Standards design, besides which is mounted the shield and coil under test. Just in front of the condenser is a vacuum tube voltmeter, and beside that a mercury cup switch for changing over into a standard inductance, just at the right of the variable condenser, for purposes of comparison. At the right there is an oscillator and the galvanometer set-up.

* Chief Engineer, Gen. Instrument Corp.

The oscillator is loosely coupled to a small coil, one side of which goes to the coil under test and the other side to a 0.0005 mfd. variable condenser, thermo-ammeter designated as I_1 , on to another thermo-galvanometer, I_2 , and from there to the standard variable condenser and to the other side of the coil under test. A resistance of Constantine wire, 2 ins. long and 6.5 mils in diameter, is connected to the circuit on one side between the two meters, and on the other side between the coupling coil and the test coil. Then the vacuum tube voltmeter is put across the Constantine resistance wire.

The circuit is carefully tuned to the frequency of the oscillator, and is so adjusted that the ratio of the current in the meter I_1 , is about ten times the current in meter I_2 .

Then, assuming zero losses in the variable condenser, the resistance of the coil can be determined by measuring the voltage and the current in the circuit.

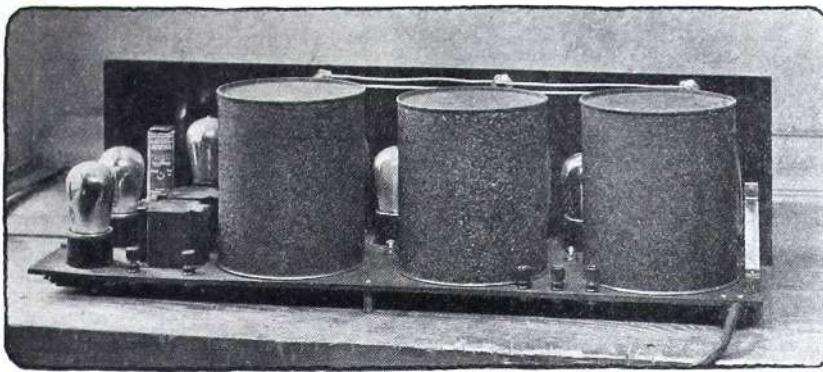

Fig. 1. Shielding is probably the most prominent contribution to efficiency which has been made in 1926.

Shielding for Selectivity

Shielding, added to the virtues of the Isosfarad circuit, makes an improvement which can be demonstrated in the loudspeaker—

By C. J. Brown

BECAUSE there are three dials on a neutrodyne set and I have only two hands, that type of receiver never had any appeal for me. Other three-dial sets are more undesirable. When they oscillate, with 45 to 90 volts on the tubes, radiation is worse than a two-control regenerative set. And with three oscillating or nearly oscillating circuits to bring into resonance with the distant station, tuning is hopelessly critical.

Here is a three-control set with two stages of balanced R. F., which is really easy to tune. The tuning of each transformer is sharp enough to make the Univerniers very acceptable, but there is no trouble in keeping the three all in step. The reason lies in the high amplification contributed by each stage. The dial readings are very closely alike. Then when the first two are in resonance, the signal, either background noise or a station, begins to come through and the third dial swings into line almost automatically.

The set has other virtues and all can be credited to the cans on the shielded transformers. Those who have used the Penetrola R. F. unit can imagine how a set using three of these units will perform. It more than fulfills such expectations as regards selectivity, sensitivity, and freedom from interaction.

The effect of shielding shows up in the balancing process. The procedure is the conventional one for neutrodyne—tuning in a strong signal and extinguishing the R. F. tubes, one at a time, with a piece of paper on one filament pin. The balancing condenser of the darkened tube is adjusted for a minimum signal, or, speaking of the Isosfarad, a zero signal. A perfect balance is easily obtained, the shields prevent direct pick-up, so no signal gets through. Once the adjustments have been made,

permanency is assured by screwing on the cap nuts over the adjusting screws.

An R. F. amplifier must provide a strictly one-way channel for the received energy. It is now generally known that although feedback is so useful in a single tube, in a cascade amplifier it causes more loss than gain. For a true one-way condition it is necessary not only to neutralize the tube capacity, but furthermore to eliminate feedback from coil to coil. The copper shields prevent interaction either by magnetic coupling or by condenser effect from one R. F. transformer to another.

There is an extra micro-condenser on the front panel, connected across the balancing inductance of the second tube, used to obtain a final balance. The condenser is set about two revolutions of the screw out from maximum. According to directions, the balancing process is carried out at 50 degrees on the scale, in the vicinity of 250 meters. Then at the upper end of the scale the full amplification is obtained. If oscillation is encountered here, the capacity of the front micro-

condenser is reduced and the stage rebalanced at 250 meters.

Although the parts are mounted on a conventional panel and base-panel, the design is thoroughly up to the minute. All wiring is under the base, protected from dust and mechanical disarrangement. So also are the socket and transformer terminals, protecting them from accidental contacts when replacing tubes, and making for short leads. The audio C battery is held in a clip beside the transformers. A two-cell flashlight battery is used, so that replacement is quick and positive. Condensers are said to be invariably better than coils in point of efficiency, but the condensers in this set are sure to remain so, being enclosed in their celluloid cases. They are S. L. F. condensers but require much less than an acre of celluloid to cover them.

The panelites, over the dials, are very useful as well as attractive. Even in a room with broad daylight it is rather difficult to pick out the exact setting of a station; in a comfortably illuminated den or salon the lights are almost a necessity. They also remind one to turn off the filaments. There is a separate lock-switch for each, but the filament switch is a master over the switch for the panelites. The wiring to the lights is the only portion in view from the top. Underneath, the parts are so laid out that the plate, grid, and high frequency leads are isolated as well as short and direct.

The effectiveness of the shielding against local pickup was demonstrated when the set was operated in the thick of the New York broadcasters where an ordinary set with open coils is out of the question unless one is satisfied to listen only to the local stations. Here the Isosfarad brings in a perfect selection of the locals, quite a performance in itself, and in addition gives daylight and mid-evening reception of powerful outside stations—KDKA, WGY, WTAM, WJR. The nearest outsider is WIP at ninety miles. A standard test in mid-town New York is to bring in WIP with a few locals running. Many five and six tube sets do not do it.

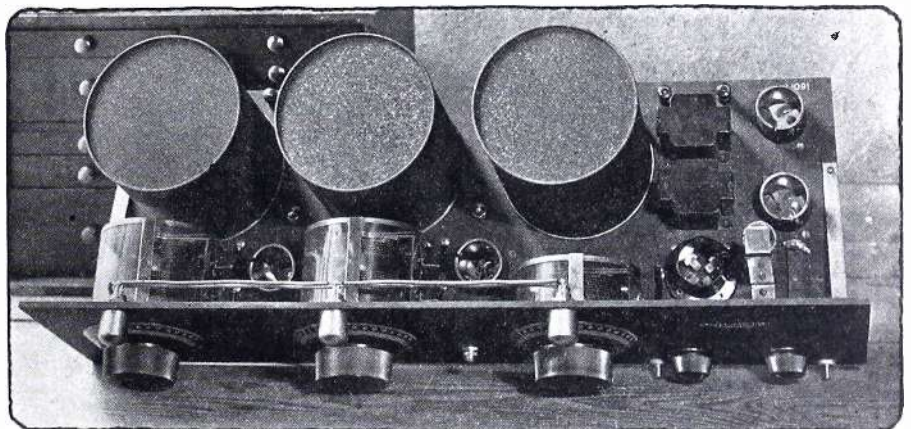

Fig. 2. All the wiring, except leads to the grids and from the plates, is cabled underneath this tube panel.

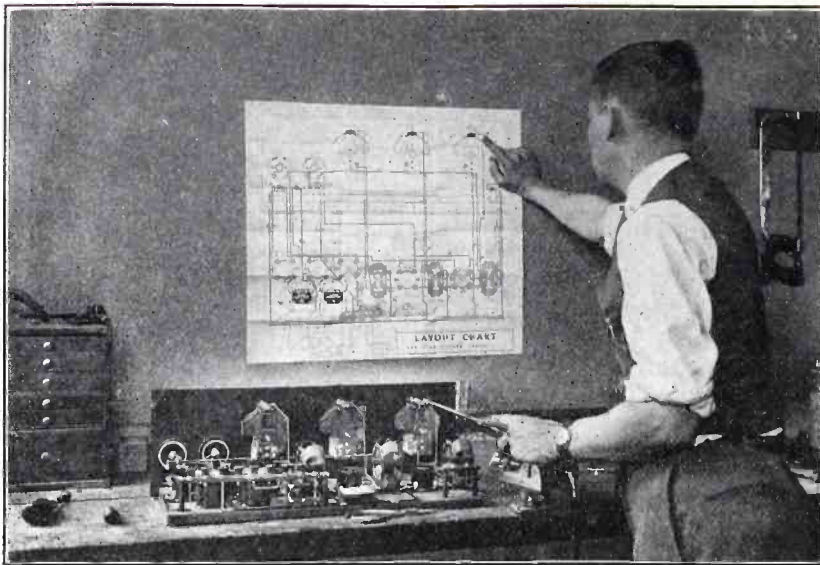

Fig. 1. Thoroughness in checking not only the wiring but the soldering at each terminal saves service work and dissatisfaction among customers.

Building Sets for Profit

The Quadraformer Set is designed particularly for Professional Set Builders who require ease of assembly and dependability—

*By E. J. Gearhart**

WHETHER or not the construction of sets for home consumption is increasing, activity among the professional set builders is very decidedly on the up grade. There may be other reasons, but it seems as if so many people had unfortunate experiences in trying to obtain service on complete sets that they are turning to the professional set builders with whom they are personally acquainted to assure themselves of thoroughly intelligent service after they have purchased their equipment.

Naturally, a man who can assemble a set and make it work well enough to sell can be relied upon to know enough to keep the set in good condition.

The Gearhart-Schlueter Company, recognizing the importance to professional set builders of being able to assemble outfits quickly that will give the kind of results their customers expect, has developed a complete business organization to handle the requirements of that class of trade. The Quadraformer receiver was designed specifically for professional set builders. Not only does it meet the general specifications which are imposed upon all types of outfits but it can be built quickly, accurately, and with a minimum amount of effort on the part of the assembler. Then it can be installed and, except for battery and tube service, entirely forgotten after it has left the set builder's hands.

The front panel is of standard size,

* Chief Engineer, Gearhart-Schlueter Corp.

7 by 24 ins., making it possible to build it into any of a wide variety of cabinet designs. No standard cabinet is furnished for it because one advantage to the customer in buying from a professional set builder is that he can have the set put into any kind of a cabinet he wants without having to discard the cabinet in which the set was originally supplied, as is the case with manufactured equipment.

The following description, together with the photographs, will give you an idea of what the Quadraformer set has in it and what it is capable of doing.

R. F. Amplifier

There are very few R. F. amplification systems which are powerful or even successful without being provided with some means of preventing feedback. Feedback is associated with regeneration but a cascade amplifier is supposed to pass the signal on from tube to tube like a multiplication table; introduction of feedback in this scheme is like applying division to every multiplication. The good R. F. amplifier should, like an A. F. amplifier, work well below the oscillation point. It is foolish to turn three dials when the apparatus behind them doesn't mean anything. To turn them is not enough—they must tune and amplify. The R. F. rheostat is marked volume and that is just what it is, a volume control, not an oscillation control. Furthermore, the grid returns are negative, outside the rheostat, always the sign of a good amplifier. The tuning condensers are 0.00035 which is small

enough to allow a good signal voltage from the coils. This value has the additional advantage, with small diameter, closed field coils, of not requiring an excessive number of turns or length of wire with its attendant resistance and area. If the bulk and area of a toroidal coil is too great, capacity effect between coils nullifies the benefits of closed inductive field.

The first quadraformer has no primary but is tapped at two points to couple the antenna conductively. The low-high switch at the left of the panel shifts from one to the other. In series with the longer tap is the 0.00025 fixed condenser for the purpose of keeping the antenna wave length down when close coupling is used. The other two coils, between the first R. F. and second R. F., and second R. F. and detector tubes, have two windings, primary and secondary, comprising each of the four sections. In the primary or plate circuit is a .5 mfd. by-pass condenser across the B battery, completing the R. F. circuit direct to filament. The detector is the usual non-regenerative type. A parallel gridleak connection is used. This has one advantage, the grid condenser being soldered directly between inductance and grid instead of depending upon the doubtful friction or wax-saturated joints often used. All the fixed condensers are mica, molded in solid Bakelite blocks. The detector plate by-pass is 0.002 mfd.

A. F. Amplifier

The last two tubes are connected as a straight transformer-coupled audio amplifier, brought strictly up to date by use of transformers carefully designed to match the tubes and be impartial to the music. Provision is made for a semi-power tube with proper grid and plate voltages in the last socket. This accounts for the nine battery binding posts—there are two B and two C terminals in addition to detector plus. The extra C voltage is important not only to prevent distortion in the tube but also to avoid pre-saturating the transformer core with a heavy D. C. plate current before any signal is applied. This is a frequent cause of distortion; intentional frequency-doublers are made by applying the low frequency to a core heavily magnetized by D. C. That, of course, is the extreme of distortion. A further improvement in operation quality, and volume can be obtained by using the B-6 Donle detector tubes with 45 volts on the detector plate.

When using the first output jack, the transformer primary is in parallel rather than cut out of the circuit. There are no extra contacts to introduce poor connections in the plate circuit or to require unnecessary wiring in loops. It is also possible to listen with phones on the first stage without cutting off the loudspeaker. The second jack is filament-control. Turning out the last tube by this means when it is not in use effects

quite a saving when it is a power tube drawing 0.5 or 2.0 ampere.

Assembly

While the wooden base is not as business-like in appearance as a construction of Bakelite, it has many points in its favor. Simplicity is the first advantage; the whole set is spread out just as in the wiring diagram so that it is easy to connect and to check or search for trouble. No compromises with efficiency for the

advisable to file the lugs of the fixed condensers to make the solder take hold better.

The A. F. transformers have flexible leads attached which must be covered with spaghetti. Instead of cutting the wires to length, the proper procedure is to cut pieces of spaghetti to length and slide them on to the leads as they are. Then the ends of the leads are pulled through the lugs until the spaghetti just fills the space. The connection is completed by solder-

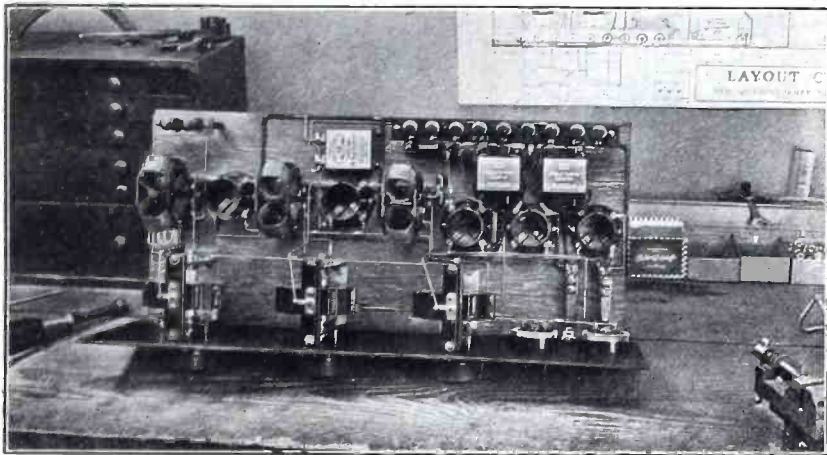

Fig. 2. Ready to put in the cabinet. This set, assembled with the utmost care in every detail, will be a silent salesman to everyone who sees it

sake of style are necessary. There is ample space for everything with short direct connections. It is naturally a saving to be able to screw all the parts down without first drilling holes. All that is necessary is to lay out the center lines, as specified on the plan sheet, with a square, rule and scribe. A punch with the scribe serves as a starter for the screws when the instruments are fastened in place.

The tuning condensers are S. L. F. type with a dust shield over the plates. They mount with three screws each. The rheostats, jacks and switch are all clamped with single nuts or bushings. A large Spintite or socket wrench is the best means of tightening them, especially the jacks, which are difficult to clamp in a straight position.

When mounting the panel itself, the baseboard should be clamped edgewise in a vise and the screws put in one at a time, successively from one end to the other. If the set is to be installed in a flat-bottomed cabinet, the edge of the panel should extend about 1/16-in. below the baseboard, so that if there is any irregularity in the cabinet, the panel will still make a good fit at the lower edge.

Before starting to wire, all the lugs should be clamped down, pointing in the directions shown by the plan sheet. It is well to tin them all with a drop of solder before placing any wires; it saves considerable time on the job. Allow room for the battery wires to the switch, first jack and detector tuning condenser. A small difference in the angle at which the bypass condensers are soldered makes it difficult to get these leads in. It is

ing the lug and cutting the end of the wire flush.

And remember, all the time you are working on the set, that the easiest way to avoid unnecessary service on the outfit after it is installed is to make each connection so perfect that it will last a life-time.

Once you have gone through the

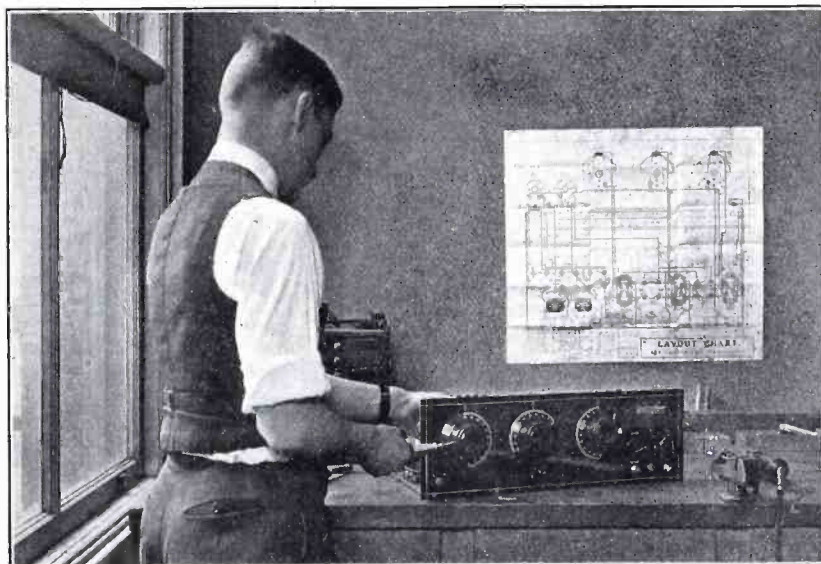

Fig. 3. Make every last adjustment in your own shop—not in the customer's home. That is the way to build confidence in your ability to turn out a well-finished product

various steps in assembling the Quadraformer receiver, you will find it hardly necessary to follow the picture wiring diagram, so carefully was the original design laid out.

Demonstrating the Set

Just a few words about demonstrating the Quadraformer receiver will be helpful to the professional set builder.

Before you deliver the set, check over the operation with utmost thoroughness. Record on a sheet of paper the logging for half a dozen local stations. It may vary slightly on the left hand dial, but there will be no difference with different antennas on the other two dials.

When you are ready to install the set in your customer's home, first make sure that his batteries are up to full voltage. Never permit yourself to give an unsuccessful demonstration, for you must never let the customer see his set fail to work.

As soon as the set has been hooked up, listen in on a pair of telephone receivers to assure yourself that signals are coming in properly. If the set doesn't work right, and you can't tell instantly where the trouble is, disconnect it and take it back. Do not work with it or experiment with it in front of the customer. He will wonder if the set is all right or if you know just what you are doing.

If the set is O. K., turn the filaments off, tune the center and right hand dials to a station you know is on the air, then turn the filaments on, adjust the left hand dial, and bring in the signals. Every time you tune to another station, turn the filaments out and make your adjustments. Do not play with the dials. If the customer sees you doing that, he will think that it will be necessary for him to do it also. These little points are mentioned because, if you will

observe them, they will help greatly in building up confidence in you on the part of each customer, and each customer, in turn, will then turn salesman for you.

Connection Cables for Manufacturers

AMONG the various methods that have been tried to simplify the wiring of radio sets, probably the most satisfactory is the solid connection cable.

The system of using metal strips secured to eyelets is all right in its way, but the most advanced practice requires all A battery leads and connections from the B+ sides of R.F. or A. F. transformers to the batteries to be bunched together. This usually assumes the use of by-pass condensers between B+ and the filament of each transformer, altho they are not always used.

A cable carrying all the wires mentioned forms practically all the connections for the set, excepting the leads to the grids and from the plates

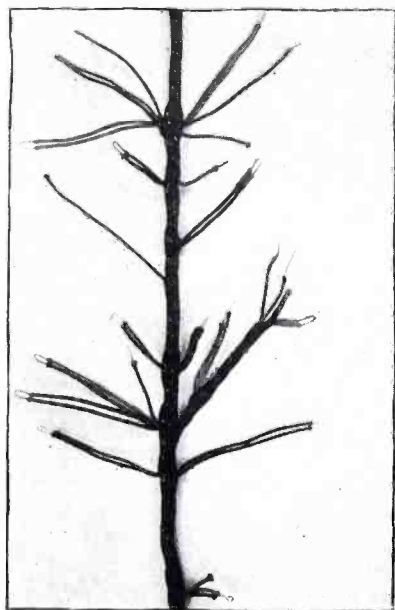

Fig. 1. Section of a wiring cable

to the plate side of the transformers. Those must, of course, be well spaced from the cable and run in the shortest paths possible.

Fig. 1 illustrates a battery cable which contains everything except the leads to the grids and from the plates. The concern which makes the cables takes a manufactured set and, removing one wire at a time, replaces it with a lead which can be put into the cable. From the skeleton built up in that way, a form is laid out whereby the wires are arranged in their correct length and where they come out at the correct points. Then, in an automatic cabling machine, they are put together in the form illustrated.

In addition to the obvious advantages of using a cable to speed up production and simplify the work, the cable system is particularly good because it is delivered with the ends of the wires stripped of insulation and tinned, all ready to solder in place. Moreover, the continuity of

the wires is not broken when the same line must be connected to several terminals.

This system is somewhat similar to that employed for telephone switch-

boards but is a commercial product to be built into radio sets, either complete outfits or construction kits, the cable is much easier to handle and, all around, far more satisfactory.

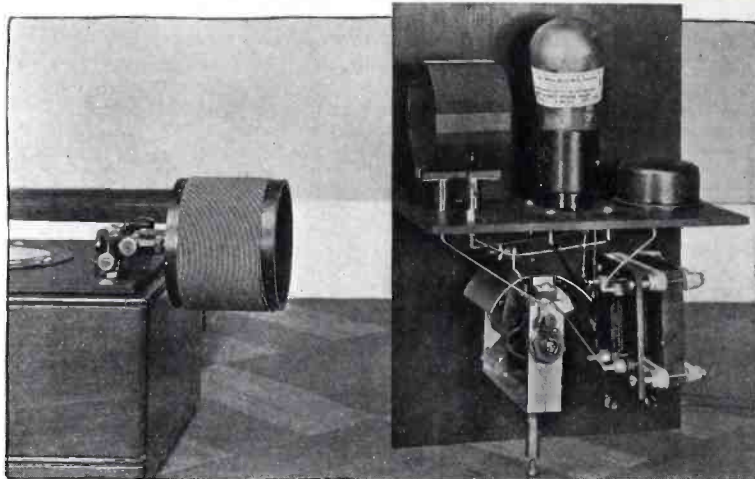

Fig. 1. The oscillator unit coupled to the wavemeter

A. F. Modulated Oscillator

Operating from 6 volts A battery only, this oscillator transmits an audio note on 200 to 600 meters

MANY experiments in the laboratory require some means of transmitting an audible signal at a given wave-length. The ordinary combination of coil and variable condenser with a buzzer and battery shunted around the coil used to be good enough, but nowadays it does not give a wave sufficiently sharp for most laboratory work.

The audio-modulated oscillator shown in Fig. 1 was built in accordance with suggestions of Mr. E. B. Dallin, of the Acme Apparatus Company. Not only does it give a sharply tuned wave but it has the interesting feature of operating without a B battery.

Fig. 2, the schematic diagram, shows how this is accomplished. The oscillator circuit is of the conventional arrangement, but the plate circuit has in it the secondary of an Acme modulation transformer.

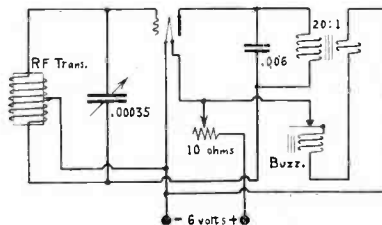

Fig. 2. Schematic of the oscillator.

The primary of the transformer is in series with a Federal high-tone buzzer. This circuit is connected

directly across the filament of the tube.

When the rheostat is turned up and the tube lighted, the buzzer starts. That induces a current in the primary of the modulation transformer. The voltage is stepped up in the secondary to a fairly high value which is applied to the plate.

In this way, the transformer is made to supply an audio frequency voltage to the plate. It is just like operating a continuous wave transmitter with a high frequency generator for the plate supply. The buzzer note determines the A.F. tone, and the tuning in the circuit comprising the inductance and variable condenser determines the R.F. frequency.

Altho parts which you have around the laboratory can probably be worked up into a device of this sort, the type shown in Fig. 1 has a pickle bottle inductance, Benjamin UX socket, Samson uniform frequency condenser, and a General Radio rheostat, in addition to the Federal buzzer and Acme modulation transformer previously mentioned. A pair of Eby binding posts, on the front panel, provide connection to the 6-volt battery.

There is quite a little output from this oscillator, so that it can be used in a variety of tests. In the illustration, the oscillator is set up next to the wavemeter, previously described, for purposes of calibration. The oscillator is put in operation, and resonance with the wavemeter is indicated by the hot-wire galvanometer in the wavemeter circuit.

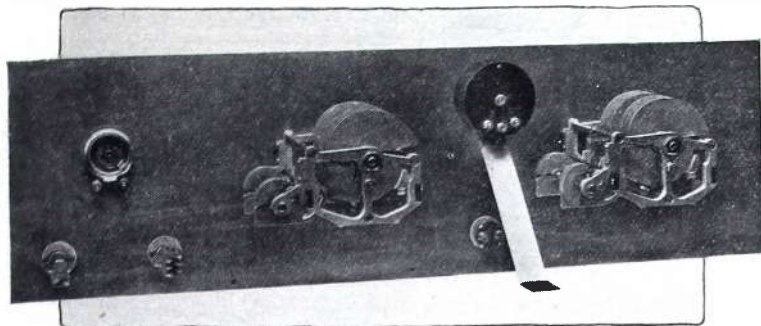

Fig. 1. Parts for the B-T receiver mounted on a metal panel which, in turn, is fastened to a wooden baseboard

Metal Panels and the B-T Set

*Describing the method of insulating the parts of the Counterphase, and other things we learned by doing it—By C. F. McLaughlin**

THIS seems to be open season for doing things which couldn't be done. Among others, this is true of the use of metal panels.

To be sure, there were obstacles in the way of finding out how to use metal panels, and then to get the public to accept them. We have accomplished the first, and the wide use of metal panels as well as their popularity among set builders indicates that metal panels have come to stay.

The accompanying illustrations show the special metal panel designed for the Bremer-Tully Counterphase Receiver. Fig. 1 shows the parts which are mounted on the front panel, and Fig. 2 the details of the insulation.

Not all parts required insulation for, particularly if a set is designed that way, the metal panel can be used as a common ground connection for many parts of the circuit, thus reducing the amount of wiring required.

This particular set has a wooden base panel, to which the metal panel is fastened by wood screws. As an additional support, a brace is provided, as shown in Fig. 1, although that is not necessary if the outfit is mounted in a cabinet for, when the panel is fastened around the edges to the cabinet it requires no other support. The heaviest parts can be mounted without fear of bending the metal panel.

Those who have not seen the Bremer-Tully Counterphase panel and the insulation provided for it will be interested in the methods employed. For small screws, we make a flanged washer, the outside diameter of which is a little larger than the hole in the panel, the shoulder of the washer just fits into the hole in the panel, while the hole through the washer is of the correct size to take the screw.

A similar arrangement is employed in insulating jacks, switches, or variable condensers of the single-hole-

mounting type. The washer at the rear of the panel is usually a little over size, while the washer at the front is slightly larger than the clamping nut. There is no strain on the washers themselves, for the shoulder is one-half as wide as the panel is thick. Therefore, the shoulders meet and are compressed against each other.

In the case of the Carter rheostat, used for the Counterphase Receiver, a small washer is put on the front, with a large one, almost the diameter of the rheostat at the rear. This positively prevents contact between the metal frame of the rheostat and the panel.

Washers for insulating on the front of the panel are very neatly made, so that they are not at all objectionable in appearance. We have been asked frequently about the use of parts on metal panels which are intended for panels 3/16-in. thick. These parts can be used without any alteration whatever, for the thickness of the metal panel, plus the two washers, brings it up to about the same.

The metal panel, used with the new metal cabinet lining, is bringing in some very interesting reports. Experi-

menters who have made tests with this type of construction say that the effect of the metal lining and panel is to move the receiving set 25 or 30 miles away from the nearest broadcasting station. In other words, the pickup on to the set itself is eliminated so that the only energy received is from the antenna, and it is then filtered through the tuning circuits. Therefore, even in the immediate neighborhood of a broadcasting station, where the signals cannot be tuned out at any setting of the dials, when the metal panel and cabinet are put on, the local interference is no greater than it would be if the set were 25 or 30 miles away from a station.

Further tests and experiments are under way to increase our knowledge of shielding methods, and they already indicate exceptionally useful possibilities along this line.

Another development in the use of metal panels will appeal to radio designers. Since the use of thumb-controlled dials—those with their axes parallel to the front panel—has become so popular, various kinds of metal stampings have been made to fasten to the panel, conforming in contour with the projections of the dials thru the panel.

Several of the latest metal panel designs are stamped and drawn so that the projections are of the panels themselves, instead of separate pieces fastened on. This is much less expensive, it eliminates operations in assembly, and, by etching on attractive designs, effects an improvement in appearance. There is no possibility that the slots will not line up with the dials, because they are located by accurate tools which also punch the mounting holes for the condensers. Separate pieces, however, are very liable to be just crooked enough to bind against the sides of the dials.

As so many manufacturers have discovered, it is so easy to lose money by doing things in such a way that they require readjustment and fixing during the assembly process that the extra time required to perfect the design and to make it proof against little troubles is invariably more than justified.

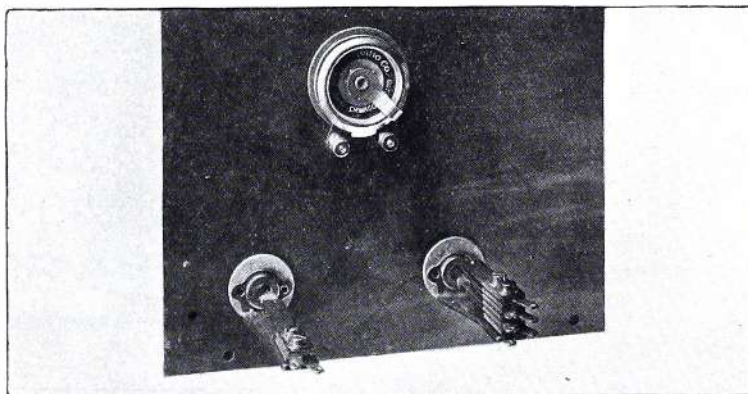

Fig. 2. The rheostat and jacks are insulated by bushings and discs at the rear of the front panel

*Crowe Name Plate & Mfg. Co.

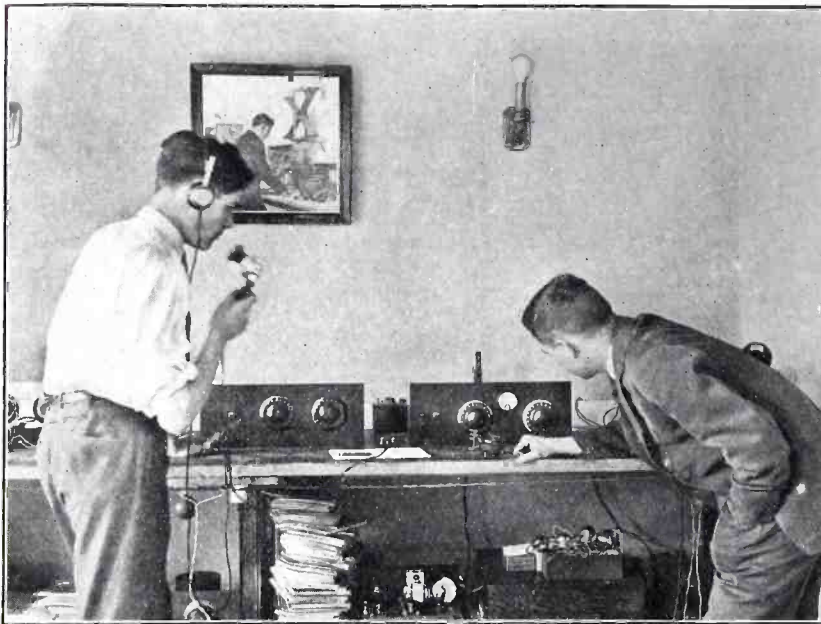

Fig. 1. A complete short wave installation—at the left, the 5-N-1 receiver, and at the right the US-76 telephone transmitter. You will find that most experienced operators prefer to use a head-set than a loud speaker for regular communication

U.S. Telephone Transmitter

Short wave telephone, working on B batteries, which can cover 50 to 200 miles, or up to 1,000 miles on telegraph code—By S. W. Nichols

SINCE the beginning of broadcasting, the B.C.L. has been perfectly content to listen while someone else does the talking. Most of us prefer to talk rather than listen, but, in the case of radio, there has been a veil of mystery hanging over the transmitting end of radio. In the first place, it used to be much simpler to make and operate a receiving set than a telephone transmitting set. Moreover, the public knows very little of transmitting equipment except for the photographs of commercial in-

stallations costing well into thousands of dollars

Once more we must thank the American Radio Relay League for bringing about the development of what was originally highly technical equipment and making possible its presentation in popular form.

There is no longer any reason why the owner of a receiving station should not get on the air himself, not simply by telegraph but by telephone.

This is an angle of the radio industry which jobbers and dealers should

put before their technical men in an effort to popularize the construction and use of telephone transmitting sets.

A telephone transmitter capable of covering 50 to 200 miles is far simpler and less expensive to build than the average 5-tube receiver. More important, there is tremendous lot of real fun to be had from holding conversations by radio telephone. It gives the DX hound some new fields to conquer. There is much more of a thrill in talking to someone 50 miles away than in listening to a station 1000 miles off.

On short waves, phenomenal distances are frequently covered with low-power equipment. An outfit such as the US-76, shown in the accompanying illustrations, in combination with the 5-N-1 short wave receiver previously described, is frequently capable of transmitting several hundred miles. On telegraph, the range, with favorable atmospheric conditions, can be extended to several thousand miles.

The equipment in the US-76 short wave transmitter consists of a short wave Aero coil unit, two Karas condensers, three Benjamin sockets, two Amperites, an Acme modulation transformer and an Acme choke, a Samson R. F. choke, three Garfield Radion brackets, a front panel of Celeron 7 by 18 ins., and a tube panel 3½ by 17 ins., both 3-16 in. thick.

All the constants and the complete parts list are given in the dataprints for the US-76 transmitter.

That information is not repeated here, for lack of space, but all necessary information, including the panel patterns, picture wiring diagram, assembly instructions, and terminal checking list are included in the dataprints. They are obtainable from the blue print department.

The following description takes up the individual circuits and describes the general assembly as well as the installation and operation of the US-76 short wave transmitter.

The Oscillator

The tube at the right is the oscillator which furnishes the power, or carrier wave. Since, unlike the receiving de-

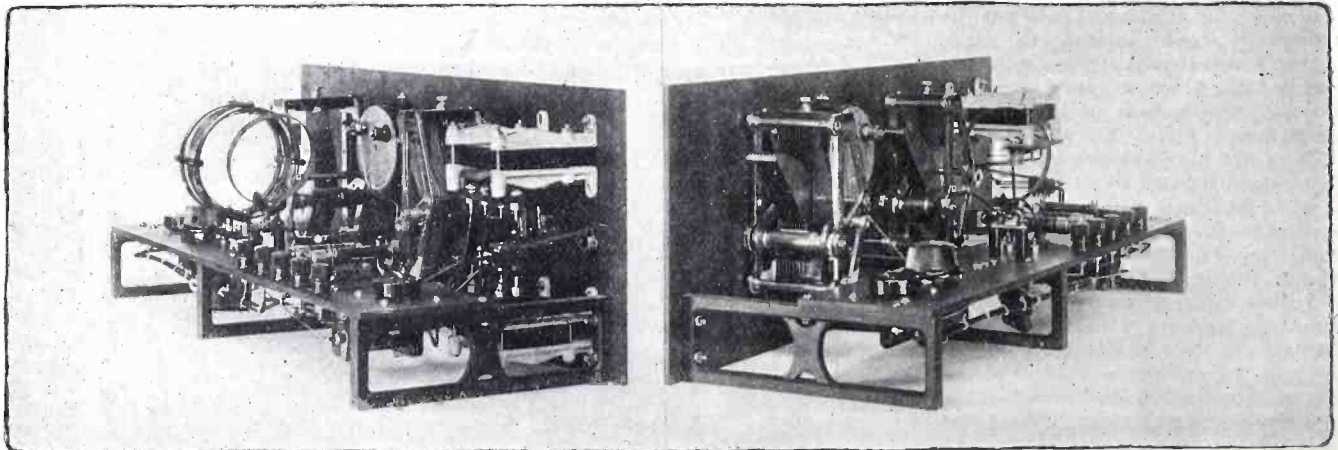

Fig. 2. Detail views of the US-76 telephone transmitter designed to work with the 5-N-1 receiver. The right hand view shows how the jacks and coupling coil were taken from the regular base and mounted directly on the tube panel

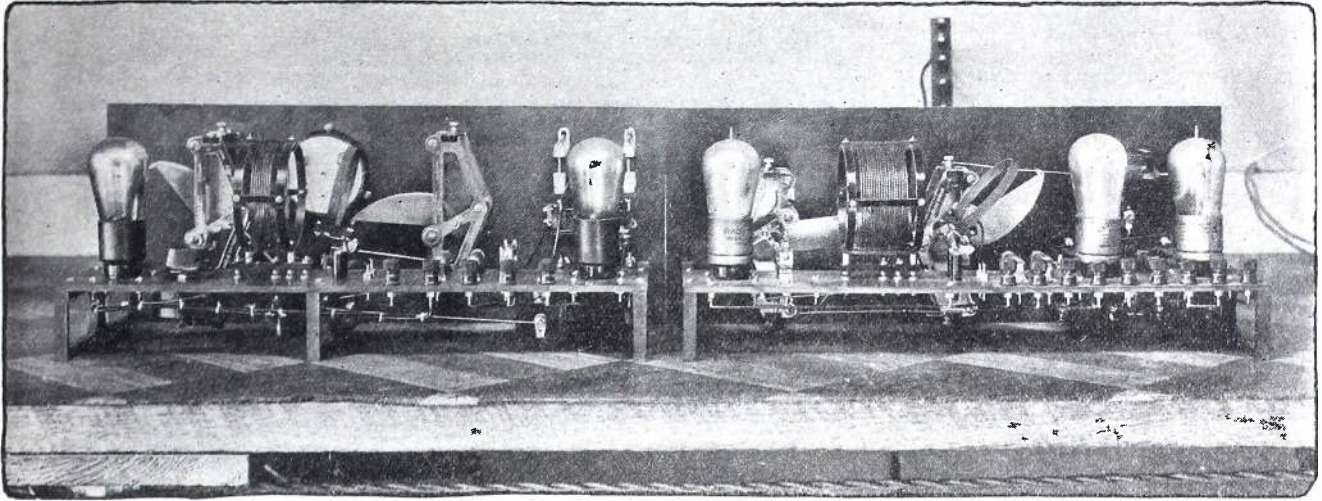

Fig. 3. As pretty a set-up as you ever saw—the telephone transmitter and receiver. The total cost is not much more than for a five tube receiving set, but it is so much more fun to hold regular conversations than to just listen in.

ductor, the tube is to oscillate as hard as possible, the functions of the coils are reversed. What was the secondary or grid coil in the receiver is used here in the plate circuit where the large wire is needed to carry the R. F. output of the tube. The small coil inside, intended for the tickler, becomes a grid tickler, connected to the grid through the heavy duty leak and condenser. The variable leak makes it possible to control the grid current, always a small fraction of the plate current.

As in the receiver, the tuning condenser is across the large coil. To make the wave steadier, the condenser is very large, 0.00035 mfd. Variation in voltage and instruments has less effect on the tuning when the inductance ratio is low. To tune the set to a given waveband requires plugging in a coil the next size smaller than is used with the 0.00014 mfd. condenser in the receiver. This brings the phone transmission bands in the vicinity of 80° on the 100-division scale, using the larger part of the condenser capacity, but allowing some leeway at the top. The antenna coil, instead of feeding the tuning coil, is instead fed by it when transmitting, so the hinged coil is the secondary and the heavy plug-in coil is the primary. All the parts in the receiver are found also in the oscillator circuit, the only difference being that the plate circuit is tuned instead of the grid circuit and all the condensers are larger, fixed as well as tuning. There is the grid condenser, 0.002 mfd. in place of 0.00015, the plate bypass, 0.002 mfd. where the receiver has a 0.00025 variable, and the R. F. choke as before, between the plate coil and the A. F. part of the circuit.

The Modulator

The second tube in the set is the modulator. It modulates the carrier wave with A. F. voltage from the microphone. The power from the microphone is very slight, insufficient to modulate the oscillator directly. Hence the modulator is a kind of A. F. amplifier. However, the action of this tube

on the other is not one of supplying it with the amplified A. F. energy. Instead, the modulator tube robs the oscillator of a certain amount of power when the microphone is spoken into. The plates of both tubes are fed from the B battery through the 60-henry choke which allows no variation of the B current at audio frequency. What one tube takes, the other cannot have. The modulator plate current increases proportionately to the volume of sound striking the microphone.

The modulation transformer is a high ratio audio transformer designed to match the resistance of the microphone to the input of the tube. The primary is energized by the 6-volt A battery in series with the microphone. On the secondary side the connections are conventional A. F. except for the resistance or leak, which improves the quality of the weaker, softer tones.

The Antenna Circuit

Except at very short wavelengths, the aerial or radiating system must be tuned to the working wave. This is done by means of the 0.00035 mfd. series condenser. Resonance is indicated by the hot-wire ammeter. With small aeriels it is necessary to short the series condenser by closing the S. P. S. T. switch, when working on the 170-meter band. The lower terminal of the antenna coil goes to either ground or counterpoise, preferably a counterpoise duplicating the aerial. With a ground the resistance is high and the radiation is not very efficient.

Batteries

To reduce the controls to a minimum, Amperites are used for the filaments of both tubes. The jack which takes the microphone connections also has two contacts serving as a filament switch. When the microphone plug is pulled out, the A battery is disconnected from both microphone and filaments. There is also a battery switch in the B+ lead which really turns off the set and stops radiation. A filament switch is not used for this purpose because the tubes

should always be lighted when the high voltage is applied to them.

Construction

A number of adaptations of standard parts are made, for the sake of both appearance and efficiency, but there is nothing difficult about the assembly or wiring of the set. The variable condensers are mounted by their center-hole bushings. Between them is the antenna meter and the single-pole knife switch on the back of the panel. One terminal of the meter, the insulated one, is used as the aerial terminal of the set. The aerial condenser is the one on the left. As the knife switch terminals are in parallel with it, there is liable to be some loss. As a precaution, the open terminal is reversed on the base to give better separation. The base is of hard rubber.

The audio frequency parts are at the left. Only the jack and switch show on the front, but the panel also supports the Acme modulation transformer and choke, at the rear. The two have identical frames, the latter being mounted at the top, the other at the extreme bottom. This gives the necessary spacing and makes the wiring to switch and jack convenient.

There are three Garfield Radion brackets supporting the rear panel and attaching it to the front panel, located at each end and just to the left of the knife switch, under the meter. The parts on the rear panel, Benjamin sockets, resistance clips, and coil mounting jacks, are all removed from their bases and mounted directly on the set, by providing holes in the Celoron to match. A much neater layout results and, as all screws are fastened underneath with Lastite terminals, the connections are better and more permanent. Especially in the case of the sockets, there is a great saving of space and elimination of useless bulk material. The only material in line with the inductance is the tubes, and they are spaced to the limit of short leads. Underneath, out of the field, is the grid-leak next to the oscillator and the R. F.

click near the modulator at the other end, turned at right angles.

Wiring

All the battery wiring is done with spaghetti tubing. In keeping them clear of the R. F. parts, the A and B battery leads are run close together and tied, as shown in the illustration. The R. F. wires are all bare Wirit as they must be kept in the clear, whether insulated or not. A. F. plate and grid wires are also considered as "live." The fixed condensers are located underneath the base, supported by the connecting wires and also acting as supports for the battery wires running through them.

Accessory Apparatus

Although designed for B battery operation, the high voltage can be supplied by a motor-generator or other type of machine, or from A. C. through a filter or B eliminator. The plate current is so low, with proper adjustments, that dry B batteries are satisfactory with any type of tube.

Several types of tubes can be used. The set was developed using a pair of UX-112's, and these are best from several viewpoints. They have oxide-coated filaments which are less affected by the transmitting plate current than a thoriated filament, like that of the 201-A and semi-power tubes. A very good range is obtainable with 201-A's, but of course they will not handle as much power as the 112's. Another objection to the 201-A arises in using the set for straight C. W. signalling; when the key closes, the plate current dims the filament and causes the note to change frequency so that it is hard to read. The maximum power is obtainable by using two 7½-watt power tubes. That requires 8 volts of A battery and 1 or 1½-ampere filament ballasts.

tor's breast type is also good and can be used if of equivalent resistance.

It is possible to hook the set on to practically any receiving aerial and ground system with surprisingly good results. If an ideal installation is desired, however, a well spaced antenna and counterpoise of enamelled wire are prescribed. A single wire for each is satisfactory and the length can range from 15 to 150 ft.

must be in the jack, of course, to keep the filament lighted. Possibly a deflection of the meter will occur at once. If not, the aerial condenser is tuned until a reading is obtained. To start with, the antenna coil is coupled closely to the primary. If, when the maximum current is obtained, the meter clicks and the needle suddenly drops, this indicates that the coupling is too close. It is possible to operate slightly below

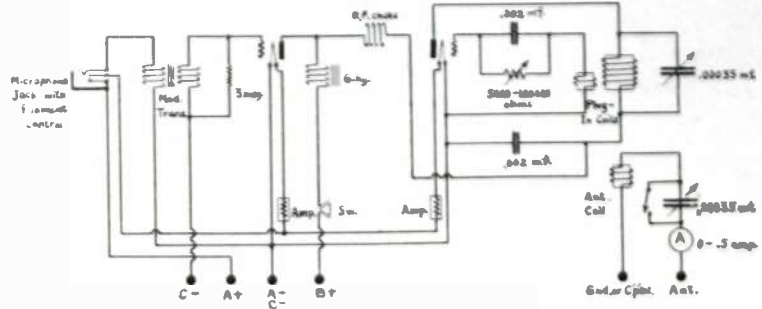

Fig. 3. There's nothing complicated about a telephone transmitting set, as you can see from the schematic diagram. The picture wiring diagram is given in the official dataprints

For ordinary two-way communication, a double-pole, double-throw change-over switch is needed. Either a knife switch or a panel mounting cam switch can be used. The cam switch is more convenient. Greater efficiency is obtained by removing half the contacts from a 4-pole 12-point switch so as to leave better spacing for the remaining 2 poles, or 6 points. One pole changes the aerial between the transmitter and receiver, the other is connected so as to throw on the transmitter B battery.

Operation

The easiest way to start tuning the set is with only the oscillator tube in place or lighted. The wavelength can

this clicking point, but the coupling should be reduced so that the aerial will not cause any unsteadiness of the wave. A harmonic of the transmitter can be found on the receiver and will tell whether the wave is swinging.

The variable gridleak controls the power input. It is maximum when screwed toward the bottom and should be adjusted by test, starting from minimum; do not go beyond the point where the best antenna current is obtained at a certain wavelength, or otherwise the plate current will be excessive. When using a small aerial, that requires shorting the series condenser to reach the higher wavelength, tuning is done by swinging the primary condenser into resonance with the aerial instead of the other way around.

After the set is radiating, the modulator tube can be put in and the microphone connected. The only further adjustments are C battery and grid leak on the modulator. The easiest way to adjust the C battery is by measuring the plate current with the modulator tube on and off. It should be almost twice as great with both tubes than with oscillator alone. That is, the modulator, with microphone quiet, draws a little less plate current than the oscillator, with aerial coupled to it. It can even be measured, or compared, by using a battery testing voltmeter as an ammeter, temporarily. For a 112 tube, the average C voltage is 10 for good quality. Both this and the leak value can be determined upon by listening in on a receiver located under the aerial or in another room. A crystal set with proper coil and condenser is convenient for the purpose. Listening on the receiver located near the transmitter is not satisfactory because of trouble with howling, and excessive pick-up. The object is, of course, to obtain the best quality of transmission.

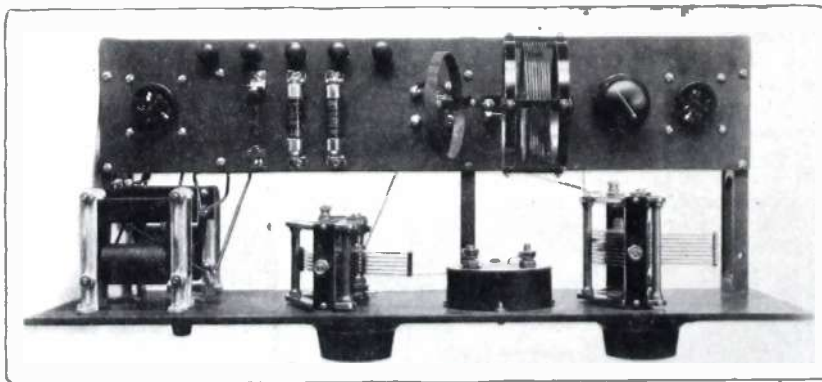

Fig. 4. Hardly a wire can be seen from the top, giving the set an unusually clean-cut appearance. Hard rubber brackets are used to fasten the tube panel to the front panel

The cartridge resistor beside the Amperite mountings is a standard receiving leak; it is well to have an assortment of them. Similarly, the C battery requires from one to three standard 4½-volt units.

The microphone used with the set was a Federal hand type microphone which is most convenient for use in an amateur station. A standard opera-

be judged by listening on the receiver. No carrier wave can be heard because the power is so great as to stop the receiver from oscillating when tuned to the same wave. That is one indication of resonance; another is to jar the oscillator tube and listen for the ringing in the receiver. The transmitter should oscillate as soon as the B battery is turned on. The microphone plug

Unfortunately for the Anti-Radiating-Receiver societies, the code range of the set is from 5 to 50 times the phone range. The unmodulated carrier wave, broken up into dots and dashes, is readable on an oscillating receiver far beyond where the voice can be heard. To use the set for C. W. it is only necessary to cut the B+ supply

the stations in the list following are among those licensed to which regular call letters have been signed.

Call signal	Location	Freq. in kc.	Wave-length in meters
POP	Nauen, Germany	22209	13.5
2XS	Rocky Point, New York	20982	14.93
2XAW	Schenectady, New York	19985	15
2BR	Chelmsford, England	19988	15
POF	Nauen, Germany	18738	16

5XH	New Orleans, Louisiana	7139	42
FW	Sainte Assise, France (6)	7139	42
WIZ	New Brunswick, New Jersey	6970	43.02
WQO	Rocky Point, New York	6814	44
KZA	Los Angeles, California	6814	44
KZB	Los Angeles, California	6814	44
PCLL	Kootwijk, Holland	6515	46
WHD	Sharon, Pennsylvania	6119	49
NPM	Honolulu, Territory of Hawaii	6119	49
2XAD	Schenectady, New York	5996	50
SAJ	Karlsborg, Sweden	5996	50
WQN	Rocky Point, New York	5522	51.5
NPI	Tutuila, Samoa	5657	53
NBA	Balboa, Canal Zone	5522	54
NKF	Anacostia, District of Columbia	5511	54.4
WQN	Rocky Point, New York	5591	54.5
KFKX	Hastings, Nebraska (10)	5354	56
ANF	Malabar, Java (3)	5354	56
1XAO	Belfast, Maine	5354	56
WQN	Rocky Point, New York	5260	57
KDKA	East Pittsburgh, Pennsylvania (S)	5100	58.79
KDC	Casper, Wyoming (7)	5082	59
2YT	Poldhu, England	4997	60
KDKA	East Pittsburgh, Pennsylvania	4759	63
8XS	East Pittsburgh, Pennsylvania	4475	67
NPO	Cavite, Philippine Islands	4409	68
WRB	Miami, Florida	4383	68.4
WRP	Miami, Florida	4383	68.4
2XAO	Belfast, Maine	4283	70
POX	Nauen, Germany	4283	70
NPO	Cavite, Philippine Islands	4283	70
NERM	USS Los Angeles	4283	70 to 84.5
NQG	San Diego, California	4253	70.5
NKF	Anacostia, District of Columbia	4205	71.3
NPL	San Diego, California	4182	71.7
WIR	New Brunswick, New Jersey	4052	74
SFR	Paris, France	3998	75
NUQB	USS Pope	3908	75
NIRX	USS Canopus	3908	75
NAJ	Great Lakes, Illinois	3945	76
NFV	Quantico, Virginia	3874	77.4
JIAA	Iwatsuki, Japan	3795	79
KFVM	SS <i>Idalia</i>	3748	80
NEL	Lakewood, New Jersey	3748	80
2XK	Schenectady, New York	3748	80
NPG	San Francisco, California	3701	81
NKF	Anacostia, District of Columbia	3679	81.5
RDW	Moscow, Russia	3612	83
NKF	Anacostia, District of Columbia	3569	84
SFR	Paris, France	3527	85
NQG	San Diego, California	3486	86

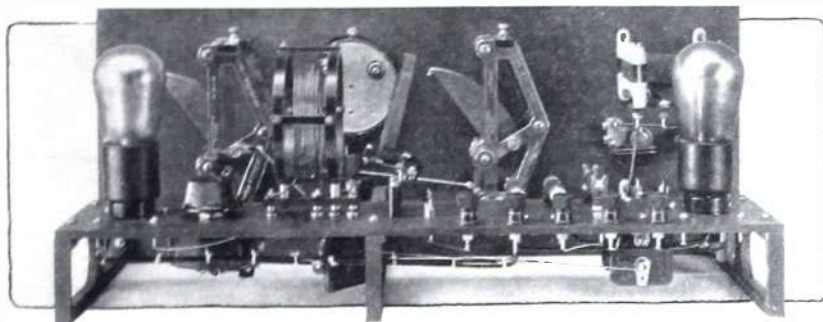

Fig. 5. All ready to set up. Binding posts for the antenna, ground, and batteries are lined up at the rear of the tube panel. The microphone plugs in at the front.

wire or B- If more convenient, and connect in a telegraph key. The modulator tube should be turned out, by removing its filament ballast, and to keep the microphone cool, one tip can be removed from the plug to disconnect it from the A battery.

Of course whether using code or phone, the set must be operated only under supervision of someone who has an amateur operator's license. A station license is necessary for the set.

Complete information can be obtained by writing to the Department of Commerce, Washington, D. C., for the radio regulations.

List of Parts

- Celoron panel, 7 by 18 by 3/16-in.
- Celoron panel, 3 1/2 by 17 by 3/16-in.
- 2 Kurz-Kasch dials, P-24 4-in.
- Carter jack, single F. C.
- Yaxley switch.
- General Radio meter, 127 hot-wire, 5 amp.
- 3 Garfield radion brackets.
- Acme choke.
- Acme modulation transformer, A3.
- 2 Karas V. condensers, 0.00035 mfd.
- Marco S. P. S. T. knife switch.
- 2 Benjamin UX sockets.
- Clarostat.
- Aero short-wave coils.
- 5 binding posts.
- 2 Amperites.
- Daven single mounting resistor.
- Sampson R. F. special choke.
- 2 Micamold 0.002 condensers.
- 2 112 tubes.
- 3 meg. leak, (Micamold).
- Federal 260W hand microphone.
- Screws, wire, Lastites, spaghetti.

Short Wave Transmitters

Within the past few months the number of short wave transmitting stations has increased tremendously. There is no complete official list now ready which is entirely up to date, but

NKF	Anacostia, District of Columbia	18738	16
2BR	Chelmsford, England	17636	17
POF	Nauen, Germany	16657	18
2XAD	Schenectady, New York	14991	20
KFVM	SS <i>Idalia</i>	14991	20
POF	Nauen, Germany	14991	20
NAL	Washington, District of Columbia	14991	20
NEPQ	USS <i>Relief</i>	14991	20
NKF	Anacostia, District of Columbia	14414	20.8
WIK	New Brunswick, New Jersey	13628	22
2YT	Poldhu, England	11993	25
POY	Nauen, Germany	11993	25
FW	Sainte Assise, France (6)	11993	25
NKF	Anacostia, District of Columbia	11758	25.5
AGA	Nauen, Germany (1)	11532	26
PCMM	Kootwijk, Holland	10903	27.5
POW	Nauen, Germany	10708	28
2XI	Schenectady, New York	9994	30
NAL	Washington, District of Columbia	9798	30.6

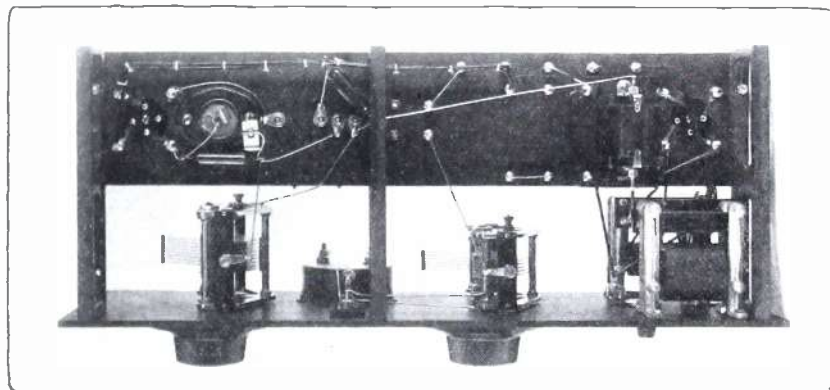

Fig. 6. Underneath the tube panel is the Clarostat variable grid leak and the R. F. choke. Notice how the leads are tied together at the rear.

2YT	Poldhu, England	9369	32
ANE	Malabar, Java (2)	9369	32
NAJ	Great Lakes, Illinois	8630	34
WQO	Rocky Point, New York	8560	35.03
PCMM	Kootwijk, Holland	8328	36
PCUU	Kootwijk, Holland	7890	38
KFVM	SS <i>Idalia</i>	7496	40
NAS	Pensacola, Florida	7496	40
NAJ	Great Lakes, Illinois	7496	40
NPG	San Francisco, California	7496	40
NRRL	USS <i>Seattle</i>	7496	40
NQW	USS <i>New Mexico</i>	7496	40
2XAC	Schenectady, New York	7496	40
NKF	Anacostia, District of Columbia	7260	41.3
2XAF	WGY—Schenectady	7160	41.88

KIO	Kahuku, Territory Hawaii	3331	90
2YT	Poldhu, England	3190	94
KEL	Bolinas, California	3156	95
8XS	East Pittsburgh, Pennsylvania	3123	96
POX	Nauen, Germany	2998	100
NAM	Norfolk, Virginia	2998	100
WGH	Tuckerton, New Jersey	2911	103
WHU	SS <i>Big Bill</i>	2855	105
2XK	Schenectady, New York	2751	109
KFTT	SS <i>Eloise</i>	2726	110
KFHV	SS <i>Facile</i> (9)	2726	110
KFWJ	SS <i>Gallivant</i> (12)	2726	110
1XAO	Belfast, Maine	2677	112
FL	Paris, France (4)	2607	115
KFWK	SS <i>Nirvana</i> (13)	2607	115
KFVP	SS <i>Bridget</i> (11)	2600	115.3

Portable Radio Equipment

IN contrast to the situation in the United States, where all the manufacturing of portable equipment is in the hands of one concern, a survey of the English market, made by the Wireless World of London, shows that there are three companies making six different types of portable sets which operate with headphones, and twenty-six companies making forty-five different types of portable outfits equipped with loudspeakers.

The cost of the headphone outfits ranges from \$13.00 to \$60.00, while the cheapest loudspeaker set is a 3-tube reflex priced at \$50.00, ranging up to \$240.00 for an 8-tube super-heterodyne. The average price is about \$90.00.

Practically all of these sets have built-in loop antennas. Only a few are designed for an external single wire antenna. Several have collapsible loops.

Most of the sets have one or two stages of radio frequency, and practically all stages of audio.

The fact that so many have two stages of untuned R.F. indicates that that type of amplification is still quite popular.

It is noticeable in the United States that, since untuned R.F. transformers lost their popularity, the loop antenna has not been as widely used.

Now, with the development of shielded sets, the loop seems to be coming back very strong as, with shielding, it can be used on tuned R.F. and Neutrodyne outfits.

It is hard to understand why one company is making practically all the portable receiving sets here when in England practically every well established set concern has at least one portable model and some have several. It may be that the small area of the British Isles makes it difficult to get out of range on one or more broadcasting stations, while in our country most people do not feel that they are going away unless they go off in the wilderness where high power equipment is necessary in order to bring in stations with good loudspeaker volume.

Radio Engineering for June will contain additional data on the KB-8 receiver.

Probably because of the unusual operating characteristics of the non-regenerative circuit, this set has been equalled in popularity only by the RX-1 and the 5-N-1 receivers. They are, of course, totally different from the KB-8, for the RX-1 is specially designed for high-priced results at a very low cost, and the 5-N-1 is intended particularly for short wave work, altho it is a splendid set for broadcast reception.

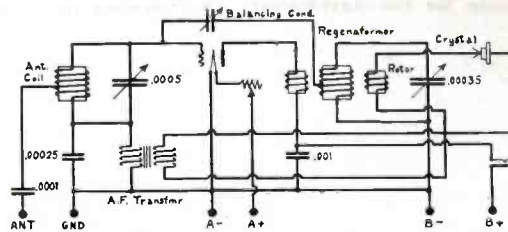

Fig. 1. Schematic diagram of the B-D reflex, in which the crystal detector and R. F. transformer are loosely coupled to the secondary of the R. F. transformer.

Floating Circuit Reflex

A circuit for reflexing which gives sharp tuning without the necessity of introducing regeneration

OF the many kinds of circuits to which the Browning-Drake tuning units can be applied, the floating reflex, developed by G. H. Browning, deserves some attention.

Fig. 1 shows the schematic wiring diagram. Examining it closely, you will see that it contains the essential elements of a one-tube reflex set and crystal detector. However, the primary of the R. F. transformer, which is in the plate circuit—the regular fixed primary winding of the Browning-Drake radio frequency transformer—is coupled to the secondary shunted by a 0.00035 mfd. variable condenser. One side of this circuit goes to the A filament terminal, and the tap provided on the secondary runs to a balancing condenser. The crystal detector and A.F. transformer, unlike the regular reflex circuits, is not connected to the secondary, but it

goes to the rotor of the transformer unit.

The result is that instead of having the crystal detector across the condenser, which is the equivalent of a low resistance around the condenser, the full efficiency of the condenser is maintained, and the sharpness of tuning correspondingly increased over that of the ordinary reflex hookup.

The rotor is in series with the detector and transformer, the latter being coupled back to the grid circuit of the tube. The results are surprisingly good. There is no tendency for the set to squeal and howl when the adjustments are a little off balance. Therefore, the tuning is quick and easy, and exceedingly sharp.

This makes a particularly good outfit for local reception, for, with a good crystal detector, an astonishing amount of volume can be obtained with the quality that a crystal detector always gives.

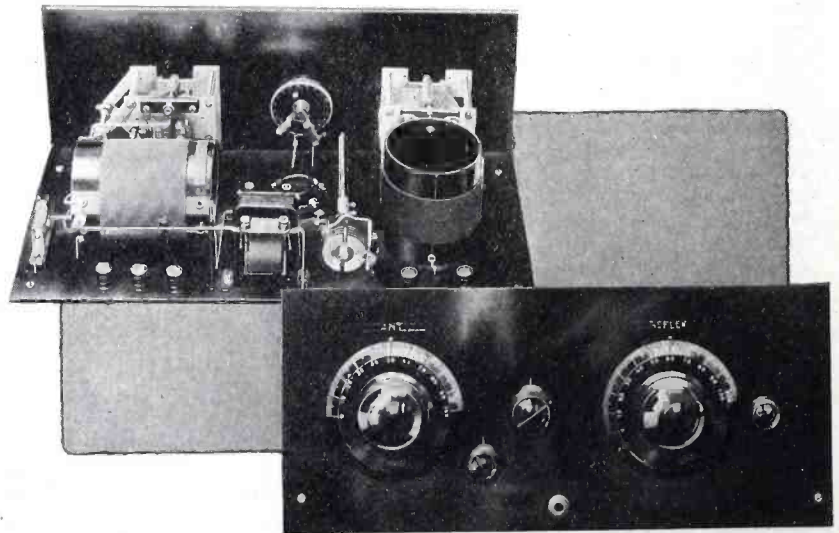

Fig. 2. Front and rear views of the Browning-Drake floating reflex receiver. This circuit eliminates instability from the tendency to oscillate, common to reflex sets, and sharpens the tuning.

R. M. A. Convention

The Radio Manufacturers' Association will hold their second annual convention at Atlantic City during the week of May 10th

JUDGING from the success which attended the first convention of the Radio Manufacturers Association at Atlantic City last year, the second convention, to be held during the week starting May 10th, should be of tremendous benefit to the manufacturers and to the trade in general.

A very businesslike atmosphere surrounded the individual committee meetings and the general meetings, at the first convention, for every effort was made to produce constructive results.

A tremendous amount of work is ahead of the radio industry in developing standards of practice, and the experiences of the past winter should make the committee reports most valuable.

The officers of the R. M. A. are: Herbert H. Frost, President, Carl D. Boyd, Secretary, S. I. Marks, Treasurer, and B. W. Ruark, Executive Secretary. The office of the Executive Secretary is at 123 West Madison Street, Chicago, Illinois. Mr. Ruark can be reached by telephone at State 8648.

Following is a list of the R. M. A. membership as of January 8, 1926:

The A-C Electrical Manufacturing Co., Dayton, Ohio; Acme Apparatus Co., Cambridge, Mass.; Aerovox Wireless Corp., New York, N. Y.; Air-way Electric Appliance Corp., Toledo, Ohio; Alden Manufacturing Co., Springfield, Mass.; All-American Radio Corp., Chicago, Ill.; Allen-Bradley Co., Milwaukee, Wis.; American Electric Co., Chicago, Ill.; The Amplion Corp. of America, New York, N. Y.; Amsco Products, Inc., New York, N. Y.; F. A. D. Andrea, Inc., New York, N. Y.; Andrews Radio Corp., Chicago, Ill.; Apex Electric Mfg. Co., Chicago, Ill.; Atwater Kent Manufacturing Co., Philadelphia, Pa.; Auburn Button Works, Auburn, N. Y.; Audiola Radio Co., Chicago, Ill.; Wallace Barnes Co., Bristol, Conn.; Beaver Electric Corp., Brooklyn, N. Y.; Belden Manufacturing Co., Chicago, Ill.; Benjamin Electric Mfg. Co., Chicago, Ill.; L. S. Brach Manufacturing Co., Newark, N. J.; Charles A. Branston, Inc., Buffalo, N. Y.; Bremer-Tully Manufacturing Co., Chicago, Ill.; Brown-Strickler & Brown, Chicago, Ill.; D. K. Bullens Co., Pottstown, Pa.; Cannon & Miller Co., Inc., Springwater, N. Y.; Carter Radio Co., Chicago, Ill.; Central Radio Laboratories, Milwaukee, Wis.; Colonial Radio Corp., Long Island City, N. Y.; Columbia Radio Corp., Chicago, Ill.; Compressed Wood Corp., Chicago,

Ill.; Connersville Furniture Co., Connersville, Ind.; Crosley Radio Corp., Cincinnati, Ohio; Crowe Name Plate & Mfg. Co., Chicago, Ill.; E. T. Cunningham, Inc., San Francisco, Calif.; Diamond State Fibre Co., Bridgeport, Pa.; Diamond Vacuum Products Co., Chicago, Ill.; Dongan Electric Mfg. Co., Detroit, Mich.; Dubilier Condenser & Radio Corp., New York, N. Y.; Dudlo Manufacturing Corp., Fort Wayne, Ind.; H. H. Eby Manufacturing Co., Philadelphia, Pa.; The Ekko Company, Chicago, Ill.; Electrical Research Laboratories, Chicago, Ill.; Fahnestock Electric Co., Long Island City, N. Y.; Fansteel Products Co., Inc., North Chicago, Ill.; Farrand Mfg. Co., Inc., Long Island City, N. Y.; Freed-Eisemann Radio Corp., Brooklyn, N. Y.; French Battery Co., Madison, Wis.; Herbert H. Frost, Inc., Chicago, Ill.; Garod Corp., Newark, N. J.; General Instrument Corp., New York, N. Y.; Gleason Corp., Chicago, Ill.; Globe Electric Co., Milwaukee, Wis.; Th. Goldschmidt Corp., New York, N. Y.; Grigsby-Grunow-Hinds Co., Chicago, Ill.; Hammarlund Manufacturing Co., Inc., New York, N. Y.; Howard Radio Co., Inc., Chicago, Ill.; Irvington Varnish & Insulator Co., Irvington, N. J.; Jefferson Electric Manufacturing Co., Chicago, Ill.; Jewell Electrical Instrument Co., Chicago, Ill.; Jewett Radio & Phonograph Co., Pontiac, Mich.; Howard B. Jones, Chicago, Ill.; Karas Electric Co., Chicago, Ill.; Kellogg Switchboard & Supply Co., Chicago, Ill.; Colin B. Kennedy Corp., St. Louis, Mo.; King Quality Products, Inc., Buffalo, N. Y.; The Kurz-Kasch Co., Dayton, Ohio; Liberty Transformer Co., Inc., Chicago, Ill.; Maring Wire Co., Muskegon, Mich.; Multiple Electric Products Co., Inc., New York, N. Y.; Mu-Rad Radio Corp., Newark, N. J.; Music Master Corp., Philadelphia, Pa.; Leslie F. Mutter Co., Chicago, Ill.; Mydar Radio Co., Newark, N. J.; Newcombe-Hawley, Inc., St. Charles, Ill.; The Operadio Corp., Chicago, Ill.; Pfanstiehl Radio Co., Highland Park, Ill.; Phenix Radio Corp., New York, N. Y.; Philadelphia Storage Battery Co., Philadelphia, Pa.; Polymet Manufacturing Corp., New York, N. Y.; Puritan Distributors Co., Chicago, Ill.; Rathbun Manufacturing Co., Inc., Jamestown, N. Y.; Raven Radio Inc., Albany, N. Y.; Raytheon Mfg. Co., Cambridge, Mass.; Reichmann Company, Chicago, Ill.; Reliable Electric Co., Chicago, Ill.; Richardson Radio, Inc., New York, N. Y.; Runzel-Lenz Electric Manufacturing Co., Chicago, Ill.; Samson Electric Co., Canton, Mass.; Schickerling Products Corp., Newark, N. J.; The Scranton

Button Co., Scranton, Pa.; The Siemon Co., Bridgeport, Conn.; Splittorf Electrical Mfg. Co., Newark, N. J.; Sterling Manufacturing Co., Cleveland, Ohio; Stewart-Warner Speedometer Corp., Chicago, Ill.; Stromberg-Carlson Tel. Mfg. Co., Rochester, N. Y.; Sunbeam Radio Corp., New York, N. Y.; Teleradio Engineering Corp., New York, N. Y.; R. E. Thompson Manufacturing Co., New York, N. Y.; Thordarson Electric Mfg. Co., Chicago, Ill.; Timmons Radio Products Corp., Philadelphia, Pa.; Trimm Radio Manufacturing Co., Chicago, Ill.; United Manufacturing & Dist. Co., Chicago, Ill.; U. S. Tool Company, Ampere, N. J.; Utah Radio Products Co., Chicago, Ill.; Walbert Manufacturing Co., Chicago, Ill.; Walnut Electric Manufacturing Co., Chicago, Ill.; Western Coil & Electrical Co., Racine, Wis.; Willard Storage Battery Co., Cleveland, Ohio; Windsor Radio Corp., Minneapolis, Minn.; Yaxley Mfg. Co., Chicago, Ill.; Zenith Radio Corp., Chicago, Ill.

The officers and committee chairmen comprise some of the most active and successful executives in the radio industry, as will be seen from the following list:

Eastern Division—Powell Crosley, Jr., Second Vice President; H. H. Eby, Alex. Eisemann, A. U. Howard, James L. Schwank, R. E. Thompson, S. B. Trainer.

Western Division—E. N. Rauland, Third Vice President; A. J. Carter, Herbert H. Frost, Walter H. Huth, L. E. Parker, Frank Reichmann, J. M. Stone, John Tully.

Committee Chairmen—Program and Convention, J. M. Stone.

Legislative—Ernest R. Reichmann.

Standards—A. J. Carter.

Publicity and Public Relations—George Lewis.

Merchandising—S. B. Trainer.

Membership—H. H. Eby.

Finance—Milton Alden.

Credit—Walter H. Trimm.

Patents—Clarence C. Colby.

Broadcasting—L. G. Baldwin.

Grievance—Edward H. Jewett.

Vigilance—E. M. Squarey.

Publications and Advertising—John C. Tully.

Show—Herbert H. Frost.

Power Equipment—C. A. Malliet.

Headquarters for the Convention will be at the Ambassador Hotel, Atlantic City. Last minute reservations can be made by telegrams addressed to the Ambassador.

The Convention Committee has made very complete plans for papers and lectures by engineers and men from the sales departments of some of the largest radio manufacturers. While the Convention offers an opportunity for the radio executives to get together informally outside of the business meetings, everything has been done to make the Convention thoroughly worth while from a business point of view.

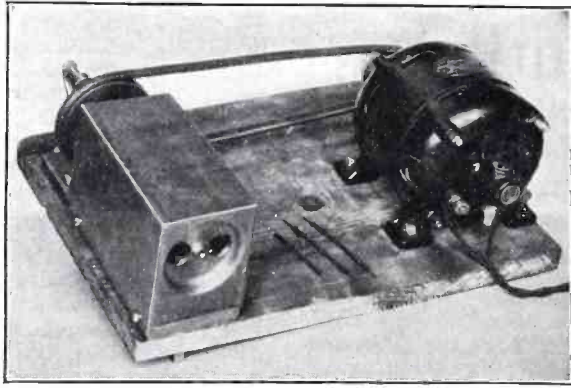

Zierick motor-driven insulation stripper which removes insulation on solid or stranded conductors without injuring the wire

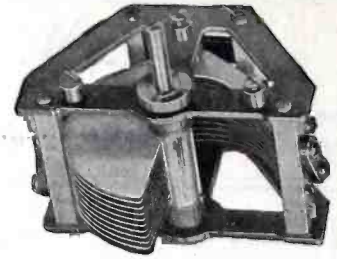

The standard design for Duplex low loss condensers is now available with S. L. F. capacity calibration

With the Manufacturers

Current news about the activities and plans of the radio manufacturers and concerns which make things used by the industry

F. R. Zierick

In addition to the wide range of lugs manufactured by F. R. Zierick Machine Works, New York City, they are producing a very interesting device for stripping insulation, particularly from stranded wire.

This machine, operated by a small 110-volt motor, automatically removes the insulation from copper wire and, if the wire is stranded, twists the strands into a firm conductor suitable for soldering.

It is surprising to see how quickly and neatly this device works. It does not cut the wire, and leaves no trace of the method used for removing the insulation.

This machine is particularly suitable for concerns using the cable system of wiring or for any method which calls for insulated conductor for the wiring.

Aalco

Aalco Radio Laboratories, Inc., Chicago, Ill., manufacturers of the Aalco collapsible loop, have recently issued a circular describing a 3-tube loop-operated receiver. This set employs a special circuit designed for a center-tap loop, such as the Aalco type.

Eisler

One of the most interesting catalogs ever published by a radio concern is that of the Eisler Engineering Co. Inc., Newark, N. J. This describes the most surprising line of automatic machinery for use in manufacturing vacuum tubes. The catalog not only lists glass-working machinery and exhausting equipment but a wide range of special raw materials.

Very nearly all of the vacuum tubes made in the United States are built on Eisler machines.

Muter

In preparation for the demand for lighting arresters, Leslie F. Muter Company, Chicago, Ill., has published some new literature on various types of lighting arresters.

Muter arresters are designed in accordance with the requirements of the fire underwriters, and are acceptable to insurance companies.

William Stevens

William Stevens Company, Roslindale, Mass., reports that, through their English agents, the American Radio

Company, they were advised that an English patent was issued previously to the application of the William Stevens Company covering the design of the Lastite. Subsequent investigation disclosed, however, that the Englishman who applied for the patent was just thirty days too late.

This item is of interest to radio manufacturers, for many concerns in the United States who are building complete sets are using Lastites throughout as soldering terminals because they not only serve as soldering lugs but, when the wires are soldered in place, they serve as their own lock nuts.

A number of engineers have remarked about the fact that, while Lastites are nickel plated, they take solder so easily. The truth is that the Lastites are not nickel plated, but are plated with tin by a chemical process. That accounts for the fact that, while they have the attractive finish of nickel, they are so easy to solder.

Pacent Electric

An interesting development in A. F. amplification is announced by the Pacent Electric Company, New York

Direct reading Weston instruments for manufacturers' use—The Microfarad-meter, for determining capacity, the Ohmmeter, for measuring the resistance of rheostats, potentiometers, coils, and transformers, and the Grid leak Tester, for checking grid leak resistance



Weston measuring instruments designed for accurate production and inspection checking

City. The Powerformer, as Mr. Pacent calls it, is a combination of super-power amplifier and B battery eliminator.

That is, the Powerformer, above the size of a small camera, operating on 60 cycles A. C., supplies B and C voltage for the regular radio receiving set, and in addition, contains a power amplifier.

The amplifier circuit of the Powerformer is plugged in at the detector for amplifying fairly strong local signals, or after the first audio stage in the set for distant stations. So great is the amplification that it is usually impractical to use two ordinary audio stages before the Powerformer.

The complete unit measures 8 by 8 by 10 ins. deep, and weighs 32 lbs. The tubes used are the 216B rectifier and 201 power amplifier types.



Klosner socket to take UX tubes. This is supplied with a supporting ring for UV tubes

Radiall

Some very clever design work has been done on the Radiall S. L. F. dial. In appearance, it is similar to the regular flat vernier dials, but by a series of offset gears, it imparts to a straight line capacity condenser a straight line frequency type of rotation.

The Radiall Company is now in full production on these dials and can make prompt delivery.



The Magnatron Rex eliminator tube

Connewey

Connewey Electric Laboratories, Hoboken, N. J., is producing the Magnatron Rex rectifier tube for B

battery eliminators. This tube, operating with a filament current of 0.6 ampere, carries a maximum load in the plate circuit of 0.05 ampere. The tube lists for \$2.00. Another tube is now in production which handles 0.07 ampere in the plate, with 1 ampere at 5 to 7½ volts on the filament.



Showing the Aerovox type of by-pass and filter condenser

Aerovox

A new line of high resistance elements is being marketed by the Aerovox Wireless Corporation, New York City. A wide variety of combinations and resistances can be obtained for various voltage taps to be used in B battery eliminators.

Amsco Products

Zeh Bouck has just written a short treatise on resistance coupled amplification, using parts manufactured by Amsco. A copy of this book can be obtained from Amsco Products Inc., Broome & Lafayette Sts., New York City.

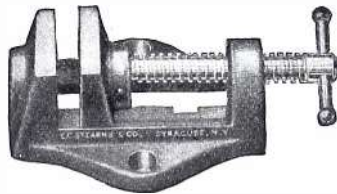

Stearns universal branch vise for the shop or tool room

E. C. Stearns

The E. C. Stearns Company, Syracuse, N. Y., has designed a special bench vise designed for small work such as is continually encountered in radio manufacturing and particularly in the construction of model receivers. This device will find many applications in the radio factories.

Photion

Considerable interest is developing in the Photo-electric cells manufactured by the Photion Electric Corporation of New York City.

It has been announced recently that the commercial transmission of photographs is to be established on a regular schedule and wavelength assignments made for that purpose. Numerous experimenters are now developing special circuits employing the

Phototron tube for that purpose. In addition, a wide range of uses is outlined in literature published by the Photion Corporation.

The Phototron tube is essentially a light sensitive relay. Used in conjunction with a vacuum tube amplifier it is suitable as a modulator for transmitting pictures or as a relay for receiving pictures and operating recording instruments.

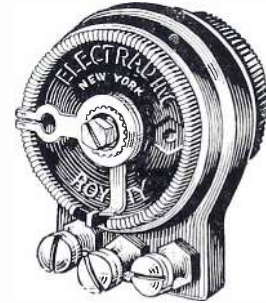

Electrad has redesigned the royalty variable resistance

Wallace

J. D. Wallace & Company, Chicago, Ill., has designed a semi-portable Universal saw, driven by an individual motor, for special work in radio factories. This saw is suitable for the ordinary production of parts which must be sawed from wood. It is equally suitable for limited production on special cabinets, and particularly for baseboards on which radio instruments are to be mounted.



Electrad metallic grid leak with non-slip terminal caps

Weston

Three instruments in the Weston line are particularly interesting to manufacturers who are lining up production test equipment for fall. These are the Ohmmeter, Microfarad meter, and the Grid Leak Tester. The Ohmmeter is designed for measuring the resistance of inductance coils and transformer windings. Since it is direct reading, it can be operated at high speed.

The Microfarad meter, model 372, replaces the bridge method for quick and accurate capacity measurements. While it does not go low enough for the minimum capacity of variable condensers, it is entirely suitable for checking purposes on variable condensers and particularly on all types of fixed condensers.

The Grid Leak Tester is also direct reading, and covers the full range of grid leak resistances.



New Polyplug for quality control

Polymet

Polymet Manufacturing Corporation, New York City, is making a special drive on the Polymet Claro-Plug and Polymet by-pass condensers.

The Claro-Plug, measuring 4 ins. long and 1½ ins. wide, is fitted with a special unit designed to overcome much of the distortion experienced in loudspeakers. This item lists at \$1.50.

The by-pass condensers, ranging up to 4.0 mfd., are tested at 800 to 1000 volts. They are built to give a very high D. C. resistance so that, when used in resistance or impedance amplifiers, there will be no leakage of positive potential from the plate to the grid of the succeeding tube.

Lynch

Arthur H. Lynch, until recently editor of Radio Broadcast Magazine, has at last organized his own company for the manufacture and distribution of gridleaks. A year ago, Mr. Lynch completed arrangements for this organization, but Radio Broadcast persuaded him to stay on until this spring. The gridleaks put out by the Arthur H. Lynch Company, Inc., are of the metallic type, employing a deposit on a thread of glass.

This type of gridleak is described as being superior to others for the reason that, with the carbon element eliminated, there is a far greater constancy of resistance, eliminating what appears to be microphonic noises during reception and also a change of resistance in use over a period of time.

Central Laboratory

Concerns designing radio sets for the Donle detector tubes will be interested to know that, while it is not necessary, the Donle-Bristol Corporation recommends the use of a high resistance in the detector plate circuit in order to adjust the voltage on the tube. For this purpose, the type 100M Radiom, of 0 to 100,000 ohms, manufactured by the Central Radio Laboratories, Milwaukee, Wis., is recommended.

General Electric

General Electric Company, Schenectady, New York, is now designing the 5-ampere Tungar charger for 2, 4, 6, and 12-volt A batteries and 24 and 96-volt storage B batteries.

A feature of the new design, which will appeal to those who live in apartment houses, is that the transformer is imbedded in insulating compound to prevent the hum from the transformer core.

Grigsby-Grunow-Hinds

Grigsby-Grunow-Hinds Company, Armitage Avenue, Chicago, Ill., has a very substantial looking B eliminator,

built for the Raytheon tube. It has a binding post for detector, intermediate voltage and high voltage connections. Both the detector and intermediate voltages can be adjusted. There is also a high and low voltage switch by means of which a heavy drain can be put on the amplifier voltage terminal without reducing the potential unduly. The voltage ranges from 164 at the low position to 226 at the high position of the switch with a 5 mil. drain up to 38 on the low and 94 on the high, with a 60 mil. drain. Intermediate points are on practically a straight line between these values.

Electrad

Electrad, Inc., 423 Broadway, New York City, well known as a manufacturer of gridleaks, now announces the

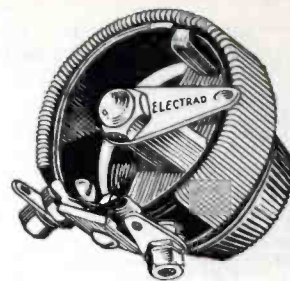

Air-cooled Electrad rheostat, the type used in the KB-8 receiver

successful development of fixed and variable resistances having sufficient current carrying capacity as to be suitable for B battery eliminator devices.

More Uses for the Raytheon

Possible uses for the Raytheon tube are not limited to the conventional eliminator. Here are some new suggestions

U P to the present time, the use of the Raytheon tube has been confined to eliminators to replace B batteries in the conventional types of receiving sets. While that may be the most important use, there are many other possible applications for the Raytheon tube, offering a wide range of experimental and development work. This is particularly true at the present time when the continuous research which has been carried on to increase the stability and capacity of the Raytheon has brought it to a point where uniform production maintains constant characteristics.

Two uses for the Raytheon are now being developed. The first is in connection with a circuit which provides filament current for at least three UV-199 tubes and plate voltage for these tubes plus the plate voltage for a last-stage power tube.

In designing such a circuit, it is advisable to select one particular type of receiver, rather than to attempt the construction of an A and B eliminator suitable for any set. There are individual problems in applying a unit of this sort to receiving outfits, particularly because it is necessary to put the filaments of the UV-199 tubes in series.

Tremendous volume can be obtained from an efficient tuning circuit with three 199's and a power tube in the last stage and, through the use of the power tube, the quality is excellent. Fortunately the filament of the power tube can be run from alternating current without causing any hum in the loud speaker. Several of the transformers now being built for Raytheon tubes have a 7½-volt tap on the secondary. This is to light the power tube filament. A rheostat can be inserted in the usual manner to regulate the filament voltage.

With this arrangement, a very simple and entirely dependable outfit can be made for full A. C. operation.

Another thing that is beginning to attract the attention of engineers and set builders is a simple A and B eliminator circuit for a power tube to be added to any type of receiver.

Many people have radio sets which do not give sufficient volume or which fail in quality when the tubes are pushed. Using the Raytheon tube in a simple eliminator circuit, about 400 volts can be obtained to put onto the power tube plate, while the filament is run directly from a 7½-volt tap on the power transformer secondary.

A great many sets will work better if the power tube is plugged in after the first audio stage in the receiving set. That gives the same number of tubes in use, but provides the power tube to handle big volume where an ordinary 201-A in the last stage would distort badly from overloading.

It has been pointed out elsewhere that the full benefit of a power tube cannot be obtained unless it is operated at at least 400 volts, using the proper C battery bias to keep down the plate current. That reduces the normal plate current so that it can be considerably increased by the incoming modulation from the broadcasting station without making the grid go positive. On the other hand, if the normal plate current was almost maximum, the amount it could be increased by the modulation would be comparatively slight, and distortion would result from a positive grid voltage.

Here is an opportunity for summer time development to be applied to your next receiving set. It is predicted that the use of the Raytheon tube this fall will be considerably increased by these two new applications.

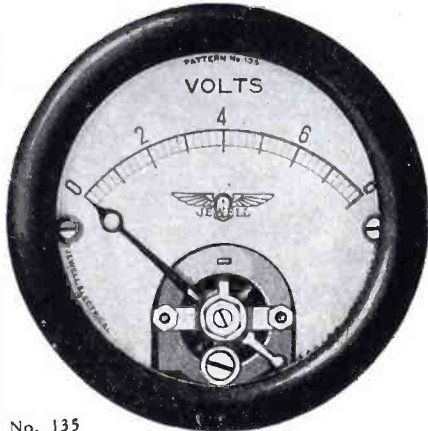

No. 135

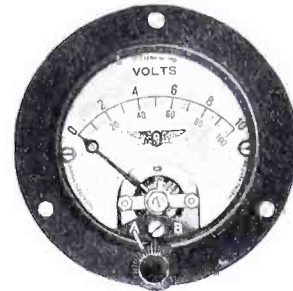

No. 140

RADIO ENGINEERS

Are you designing a new set? Perhaps you are consulting with some set manufacturers who are remodeling their sets. Have you seen the new Jewell Radio Panel Instruments Nos. 135 and 140?

These instruments are of the high resistance type with silver etched scales and zero adjusters.

Send for Circular No. 776.

Jewell Electrical Instrument Co.,
1650 Walnut St., Chicago
"26 Years Making Good Instruments"

AMPLION

QUALITY — RELIABILITY — TONE

The Amplion is Recognized Today as a Standard

When you use the Amplion Unit in your Console Sets you improve your set because:



MODEL MU-67

With small or large connector

New prices now in view.
Write for details and latest results of our research work.

AMPLION Design is the result of 38 years experience.
AMPLION Quality is the best that can be produced.
AMPLION Reliability is absolute and guaranteed by a world wide organization.

You Tell Us:

The pitch or fundamental frequency you require to tune with your set.
The impedance you require to get the utmost efficiency from your amplifier.
Your Engineers and ours get together to enable our MU-67 Unit to demonstrate to the public all the tone value and volume of which your set is capable. It is only by this cooperation that 100% efficiency can be obtained. By this means the individual character can be carried from aerial to air column.
Have you heard Amplion high and low pitch units which together cover the whole of the musical range?

THE AMPLION CORPORATION OF AMERICA

Executive Offices: Suite W. 280 Madison Avenue, New York City
Chicago Branch: 27-29 No. Morgan St.

Amplion Corporation of Canada, Ltd., Toronto

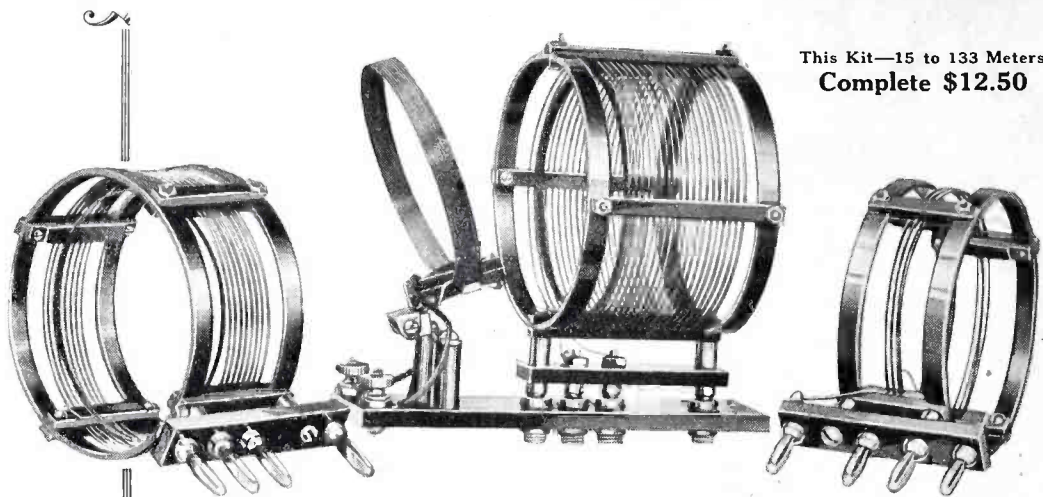

This Kit—15 to 133 Meters
Complete \$12.50

Aero-Coils

make Great Range of "B"
Battery-Operated Transmitter
-possible-

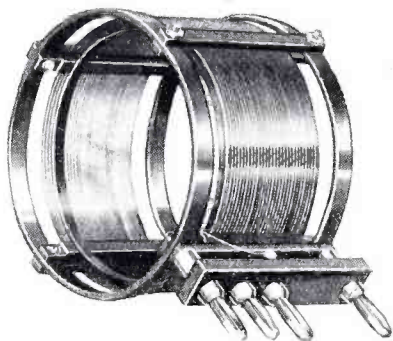

Coil No. 4
125-250 Meters
Price \$4.00



Coil No. 5
235-550 Meters
Price \$4.00

This Amazing Transmitter Built With Aero Coils

Read in this issue of Radio Engineering about the new "B" Battery Operated Transmitter. Aero Coils will improve your present one.

Probably one of the greatest factors contributing to the remarkable range of this simple transmitter is the extremely high efficiency of the inductances it uses. Examine one of these coils and you will readily see why.

Each turn of wire is uniformly air spaced from the next, and the patented bakelite form on which the wire is so perfectly wound, keeps the turns permanently even. Moreover, Aero Coils are of the exact right dimensions for efficient transmission work.

Obtain Aero Coils from your dealer or direct from factory.

AERO PRODUCTS, INC.,
1772 Wilson Ave., Dept. 17, Chicago.

New York Representative
KEYSTONE SALES AND
SERVICE Co.
321 B'way,—Mr. Johnson

Pacific Coast Representative
HENDER-SELTZER CO.,
1111 Wall St., Los Angeles, Calif.

AERO PLUG IN COILS

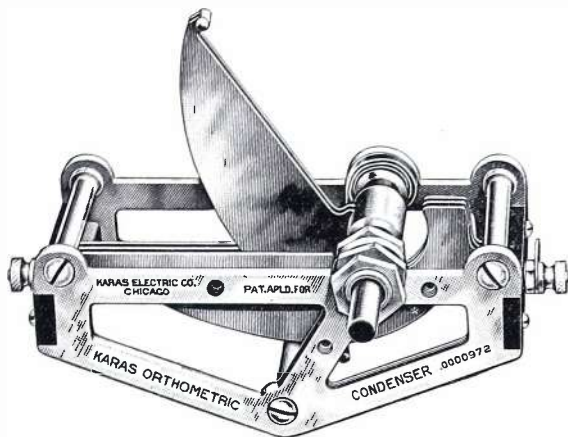

The KARAS Orthometric Straight - Frequency - Line Condenser

*Ideal for both Short Wave
and Broadcast Receivers*

The Condenser Recommended for the 5-N-1 Short Wave Receiver and the US-76 Telephone Transmitter

Karas has taken the lead in developing condensers to meet the exacting requirements of Short Wave work. Karas builds the only 140 mmfd. condenser on the market. The Karas Orthometric 7 plate and 11 plate condensers are recommended for the new 5 N1 short wave set described by Mr. Sleeper in this issue of Radio Engineering.

How many short wave experimenters appreciate the extremely exacting condenser requirements of a short wave set? How many realize that many condensers, satisfactorily adapted to the broadcast range, will prove quite worthless in short wave reception?

At 10 to 40 meters, radio energy performs many queer tricks. The dielectric MUST neither leak or absorb energy. It must be highly efficient as a dielectric, and be placed well without the effective electro-static field. The plates must hold the charge without variation. All these things are well accomplished in the design and construction of Karas Orthometric short wave condensers. They are as nearly perfect both electrically and mechanically as it is possible to build condensers.

The accurate straight-frequency-line characteristics of Karas Orthometrics are vitally important in short wave work. Think of it! There are as many channels of 10 kilocycle separation between 50 and 60 meters as there are between 200 and 500 meters.

Order Through Dealer, or Direct on This Coupon

Karas Condensers in the 23, 17 and 11 plate sizes are generally sold by good Radio Parts Dealers in most cities. They are sold subject to our regular 30 day guarantee of "Satisfaction or your Money Back." Due to the scattered demand for condensers built for short wave work, the 5 and 7 plate sizes are not so widely stocked by dealers. Orders will be filled direct, or may be placed through your dealer and his jobber. If you prefer to order direct, use this coupon. Send no money. Just pay the postman the price plus a few cents postage.

KARAS ELECTRIC CO.,

Manufacturing Plant: N. Rockwell St.

Offices: 1060 Association Bldg.,
Chicago, Ill.

Mechanical accuracy is vital. Slight variations in plate spacing that might be immaterial in broadcast work would upset frequency control at the tremendously high frequencies with which the short wave set has to deal. The spring pig tail connections on the 5 and 7 plate condensers are insulated to prevent contact noises at extremely high frequencies.

Karas Orthometric Condensers are mechanical masterpieces. They go far beyond the standards of accuracy heretofore considered necessary in condenser construction.

You will probably want one or two stages of audio in your short wave receiver. You cannot beat Karas Harmonik Transformers. Include one or two transformers with your order. They are \$7.00 each.

Specifications of Karas Orthometric Short Wave Condensers

Price \$6.50 each.

5 plate.	
Max. Cap.0001 mfd.
Min. Cap.00001 mfd.
7 plate.	
Max. Cap.00014 mfd.
Min. Cap.0000108 mfd.
11 plate.	
Max. Cap.00025 mfd.
Min. Cap.0000115 mfd.

Also—

Karas Orthometric Condensers for Broadcast Receivers

23 plate, .0005 mfd. price \$7.00

17 plate, .00035 mfd. price 6.75

Karas Harmonik Transformers, price \$7.00

Karas Electric Co.,
1060 Association Bldg., Chicago.

Please send me Karas Harmonik Transformers and
..... Karas Orthometric Condensers, sizes as checked be-
low. I will pay the postman the price plus postage upon deli-
very. It is understood that I have the privilege of returning
these condensers and transformers for full refund any time
within 30 days if they do not prove entirely satisfactory.

..... 5 plate; 7 plate; 11 plate;
..... 17 plate; 23 plate.

Name

Address

If you send cash with orders we'll ship condensers and trans-
formers postpaid.

Electrocon A & B Eliminator

The only successful eliminator which operates 201-A's in parallel

NO changes in the wiring of your set—connect the Electrocon just as you would dry cells and storage batteries. There are no chemicals, no moving parts, no hum.

Electrocon can run the filaments of two to seven 201-A's, and has B taps for 22, 45, 90, and 135 volts. At 40 mils plate current drain—twice the drain of most sets—the full 135 volts are delivered.

Electrocon has two units, the rectifier, measuring 6 x 11 x 8 ins., and the filter, 9 x 15 x 9 ins. Both are completely shielded, and free from all fire hazard. Electrocon complete, except for two small rectifier tubes, full instructions. \$85.00

(Particularly adapted to KB-8, RX-1, Isofarad, Zenith, Atwater Kent, and all Neutrodyne Sets)

Donle Detector Tubes

Durrant has a special testing outfit for Donle tubes, assuring each customer of highest efficiency from every Donle tube purchased from Durrant.

NOTE: All Donle tubes shipped by Durrant are of the latest type with bases which fit both UX and UV sockets without the use of adapters.

Full instructions accompany each tube.

For better quality, and to eliminate radiation and howling use the Donle Detector in all standard makes of receiving sets. Must be used for RX-1 and KB-8.

DONLE DETECTOR TUBE,
Shipped postpaid. \$5.00

Isofarad Set and Penetrola

After thorough tests, Durrant has chosen the Walbert Isofarad receiver, six tubes with three stages of R.F. and impedance coupled A.F., as the first complete receiver built in America today.

The Isofarad circuit with the shielded coils gives the unexpected range, sharpness, and quality that you have always wanted, but never hoped to get.

WALBERT ISOFARAD RECEIVER,
Ready to operate. \$180.00

If you want more volume or selectivity, put a Penetrola on your set.

The Penetrola kit costs only \$15.00. It will put fifty dollars worth of improvement into your set. Don't let the bad weather cut down your range. With the Penetrola you can get distance always.

WALBERT PENETROLA KIT, Shipped postpaid \$15.00

KB-8, the Newest Browning-Drake

When you see G. H. Browning's O. K. and signature on the KB-8 blueprints you'll know why he has approved this design.

Five tubes, S.L.F. tuning, combination resistance and impedance audio with the Donle Detector—these and many other features are built into this newest Browning-Drake set.

KB-8 KIT, all parts and Celoron panels drilled and engraved. \$59.50

RX-1 KIT

SETS COME AND GO, BUT THE RX-1 IS STILL THE OUTSTANDING VALUE FOR THOSE WHO WANT A SET SO DESIGNED THAT PARTS OF THE HIGHEST QUALITY CAN BE USED ECONOMICALLY. OVER 5,000 RX-1 KITS HAVE BEEN BUILT IN SEVEN MONTHS.

RX-1 KIT, all parts, Celoron panels drilled and engraved. \$32.50

DURRANT RADIO, Ltd.

Get-it-to-me-Quickly Mail Order Service

T-52 Vanderbilt Avenue

New York City

Look for this mark



It denotes the genuine

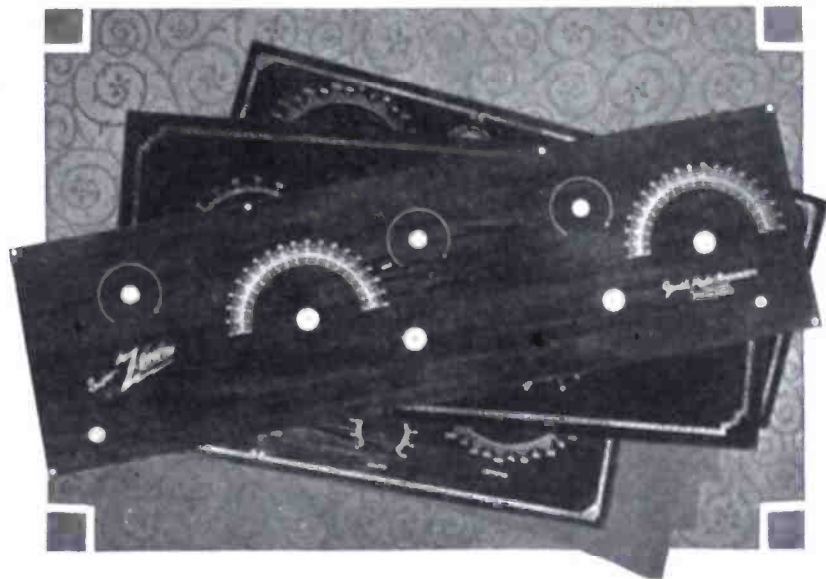

This Year

makers of quality radio receivers everywhere may avail themselves of the proven efficiency and undeniable economy afforded by

Crowe Metal Panels

Dependable deliveries—

A wide range of beautiful finishes—

Panels supplied completely drilled and decorated,
ready to assemble—

An educated radio public, fully acquainted with the
technical advantages of metal panels and shielding—

—all these, and many equally forceful reasons, combine to make Crowe panels the logical paneling medium for progressive set builders. Now is the time to investigate, before you go into production with your new models. Perhaps we can make suggestions that will mean big savings.

Crowe Name Plate & Manufacturing Co.

1749 Grace Street • Chicago



New Features

The KB-8 is built around the high-efficiency Browning-Drake tuning units in combination with the Donle detector tube circuit, by means of which greater sensitiveness is obtained than with the regular vacuum tube detectors, so that no regeneration is required.

In fact, regeneration is made impossible. Aside from the condenser dials, there are only two rheostat controls and, even when the tubes are turned on at full brilliancy, the set absolutely cannot be made to oscillate or even approach the unstable regenerating condition at which quality is destroyed.

Therefore, the quality is as pure as with a crystal detector yet, with Browning-Drake R.F. amplification and the Donle detector, the set is marvelously sensitive—equal in pick-up, on stations loud enough to hear clearly, to any regenerative set.

Add to these characteristics the S.L.F. tuning, impedance coupled A.F. amplification with high-mu tubes, the attractiveness of the set design, and simplicity of assembling and you will understand why over 470 jobbers are combining to push the KB-8 design and to help their dealers to sell these kits.

All KB-8 parts, including the panels, are standard merchandise.

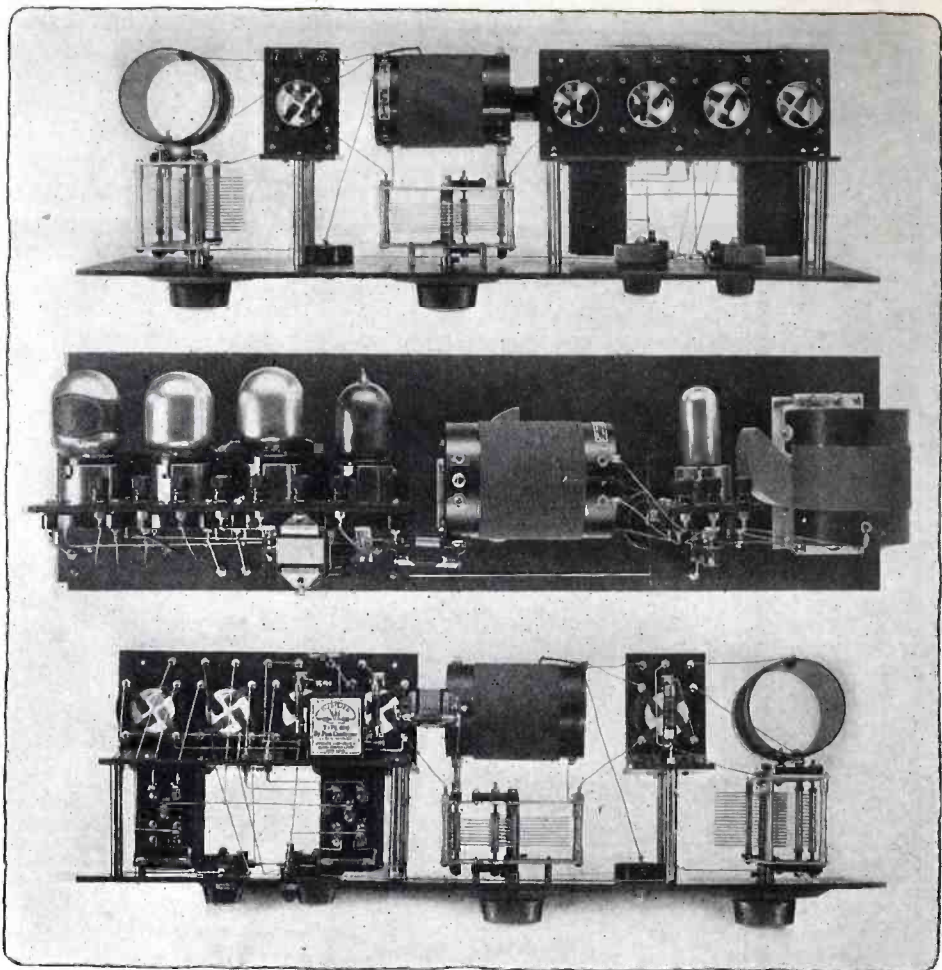

KB-8 for High Power and Quality

Non-Regenerative Browning-Drake Receiver

You'll never know the feeling of ease and power that the KB-8 gives until you have tuned a KB-8 set, because it is the only high-power non-regenerative receiver there is.

You'll like the looks of it from the start—it has that sleek, clean-cut appearance attained by few factory-built sets. It has that substantial, smooth-running look about it which is irresistible to the man who has outgrown his first radio set, and is ready for the real thing. With Crowe metal or Celoron panels specially made for it, there is nothing to indicate that this is a home-made set.

And as for operation—You can safely bet that you can tune your KB-8 in one-third the time required for a regenerative set. The quick, smooth adjustment of two dials and it's done. No verniers, ticklers, rheostats, or regulators to fiddle with—just the dials turned simultaneously and you've got the station right on the peak.

Build a KB-8 and show 'em how a real set behaves. KB-8 Dataprints, with panel patterns, picture wiring diagrams, parts list, instructions.....\$1.00

DEALERS: Keep 'em busy building and you'll keep 'em buying—right thru the summer. Sell 'em KB-8 Dataprints. All standard merchandise, sold thru over 470 jobbers. **DISCOUNT** on all Dataprints published by M. B. Sleeper, Inc., 50% on 6 or more. They are easy to handle because each set is sent in an individual tube.

M. B. SLEEPER, Inc. Technical Publisher
A-52 VANDERBILT AVENUE :: NEW YORK CITY

*Sharper tuning — higher
amplification*

The *New*
**NATIONAL
Tuning Units**

including the *genuine*

**BROWNING - DRAKE
TRANSFORMER**

and the

**NATIONAL EQUICYCLE
CONDENSER**

are now in the hands of
your dealer. Ask to see
them.

Radio experts pronounce
them "a revelation in radio
reception."



Write for Bulletins 105-RE and 110-RE



NATIONAL COMPANY, INC.
W. A. Ready, President
110 Brookline St., Cambridge, Mass.

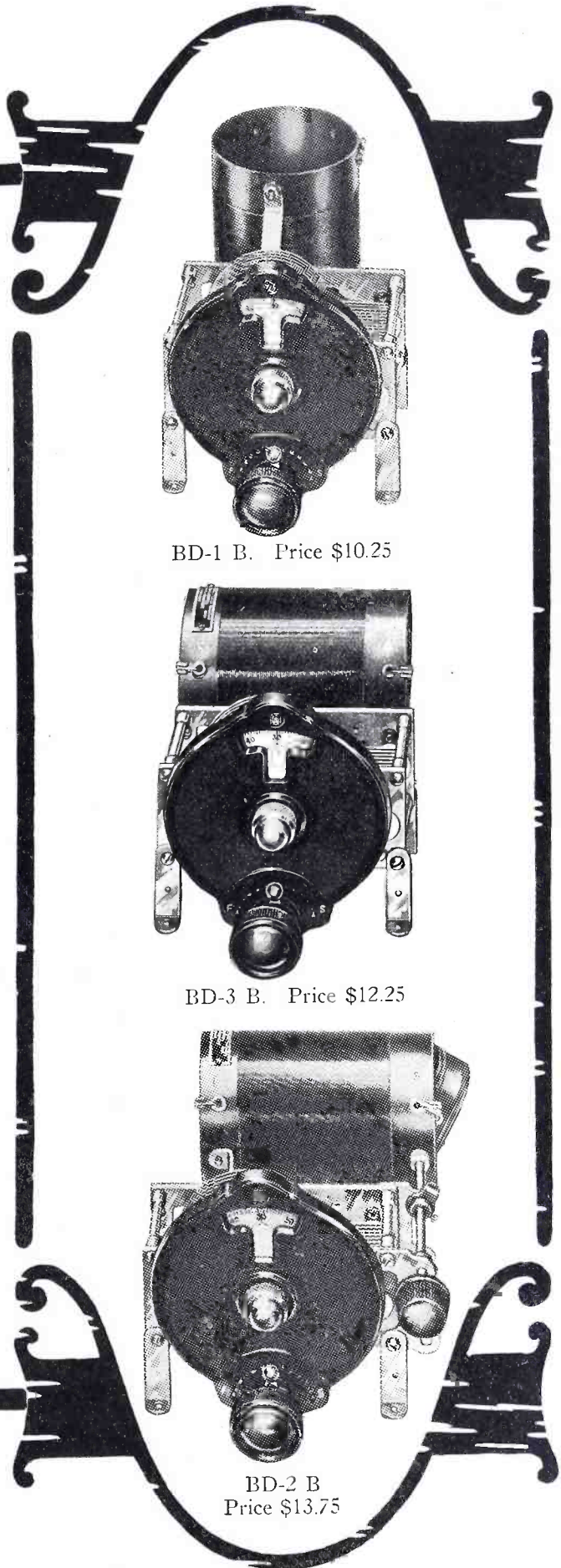

BD-1 B. Price \$10.25

BD-3 B. Price \$12.25

BD-2 B
Price \$13.75

PANELS

of BEAUTY
and MERIT



Lignole is a highly di-electric moisture resistant product. It retains all the natural beauty of woods with true graining, shadowing and finish. Available in many grades for every set.

*Write for information,
samples and
prices*

THE LIGNOLE CORP.
508 So. Dearborn St.
Chicago, Ill.

Sales Department
THE HARTZELL SALES CO.
961-50 Church St
New York City, N. Y.

ELECTRAD

Electrad Certified Fixed Mica Condenser

This is the famous "Six Point Pressure" Condenser, without an equal for consistent performance. Uniform pressure insured by rigid binding at six points. Sheet copper — not tinfoil — soldering iron can't hurt it. Certified electrically and mechanically. Guaranteed to remain within 10% of calibration. Standard capacities — all types. In sealed packages, list 30c to 75c — in Canada, 45c to \$1.50.

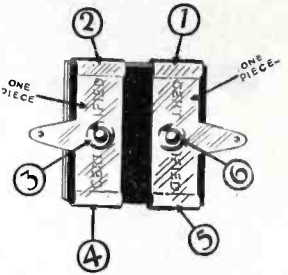

Electrad Certified Jacks, (Open & Closed)

Positive acting spring of phosphor bronze. Insulation of hard rubber. Tinned soldering lugs, placed to make good connections easy. Requires less than 1" behind panel. Sterling silver contact points. Certified and guaranteed electrically and mechanically. List, open 25c, closed 35c. In Canada, open 35c, closed 50c.

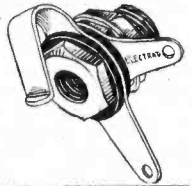

Write for information on the Electrad 500,000 ohm Compensator for perfect control of tone and volume.

ELECTRAD, INC., 428 Broadway, New York City



ELECTRAD

There is One Best Way!

Today the discriminate buyer chooses a set Multi-Plug equipped because it affords greater simplicity, safety, and more convenience than any other method used to connect the radio receiver with the current supply.

The additional cost — which incidentally is now only a few pennies more than other less practical methods — is offset by its many advantages. Then too, price is no factor when merchandise is superior.

Engineers and sales executives of reliable manufacturers are invited to write for experimental samples which will be forwarded without charge.

SIMPLIFY AND SATISFY WITH

Jones
MULTI-PLUG
THE STANDARD SET CONNECTOR

HOWARD B. JONES

618 So. Canal St.

::

Chicago



*The Big Selling
Success of
the Year*



\$1.50

Patented, other patents pending

In less than one month's time the Poly Claro-Plug has become the big accessory profit-maker of the year.

Not just another battery—not just another tube. Instead, a live new article that sells—Radio's Latest Development!

A PROFITABLE SUMMER SELLER

The Poly Claro-Plug is an ideal summer canvassing item. Everyone will pay \$1.50 to improve tone. Your service men and salesmen can sell one in every home visited when they demonstrate how it modifies summer static.

DEALERS CLEANING UP

Every live dealer will want to be in on Poly Claro-Plug profits. Don't miss this one. Get in touch with your jobber today!

Polymet Manufacturing Corp.

"World's Largest Manufacturers of Radio Essentials"

599-H Broadway New York City

POLYMET PRODUCTS



**8 out of 10 Manufacturers
Use Eby Binding Posts**

The chances are that the receivers you are selling in your store are equipped with EBY Binding Posts. 80% of the leading radio manufacturers have chosen EBY on performance.

Your customers all know EBY and your jobber has all of the 27 different markings.



LIST PRICE
15c

**And Now There's
Another Eby Leader**

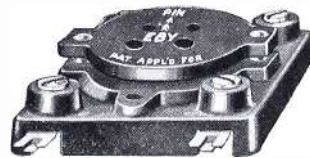

LIST PRICE
60c

The new Eby Quality Socket insures a positive wiping contact at all times. Its ingenious design allows the tube to "float" when in service, thereby reducing microphonic noises and protecting the tube against damage. It also permits interchangeability and other features of the new UX and CX tubes.

If your jobber can't accommodate you—Write to us

H. H. EBY MFG. COMPANY

4710 Stenton Avenue
Philadelphia, Pa.

CLAROSTAT

O. K.'d by RAYTHEON—

because CLAROSTAT passed with flying colors the most searching tests Raytheon had ever given a variable resistance.

CLAROSTAT has no equal for voltage control in "B" Battery Eliminators. Only CLAROSTAT gives you a wide range of control and a current carrying capacity greater than that of any other variable resistor.

P. S. A host of other nationally known eliminator makers have also approved and are using Clarostats.

American Mechanical Labs., Inc.
285-287 N. Sixth St., Brooklyn, N. Y.

Special types for "A" and "B" Battery Eliminators available for Manufacturers.



\$2.25

THE PHOTOTRON

represents the best
in

Photo-Electric Cells

Instantaneous in response, fatigueless in operation, and long-lived in sensitivity, this potassium-hydride photo-electric cell is just the thing for scientific research, picture transmission, and all light-actuated devices.

For descriptive circular
write

Photion Electric Corporation

342 Madison Ave.,
N. Y. C.

LIST \$20.00 EA.

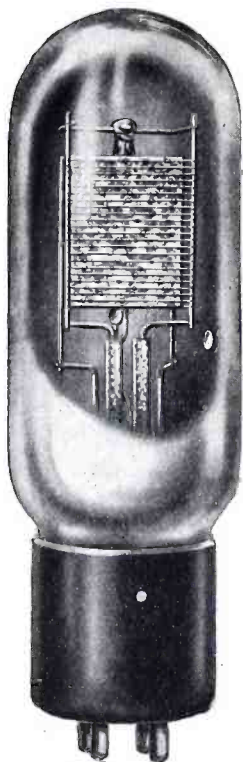

Radiolux AMPLION

The supreme achievement of 38 years' experience

Entirely
New!

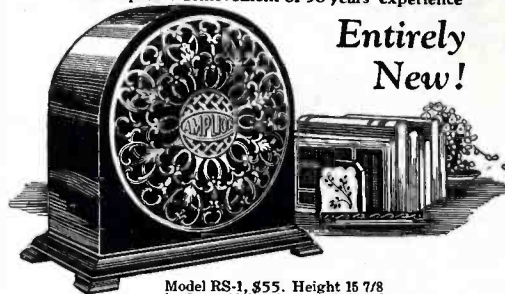

Model RS-1, \$55. Height 15 7/8 in. Beautiful mahogany finished cabinet, oxidized silver grille.

CLEARER, louder, more sensitive and more realistic in tone, by actual comparison, than any other existing type of radio reproducer, this newest addition to the Amplion family—the beautiful Radiolux-Amplion—is, in every acoustic and artistic sense a revelation! Outwardly resembling the distinctive English bracket clock, inwardly the Radiolux-Amplion

is a radical and complete departure in acoustic design. Hear the Radiolux-Amplion in comparison and you will agree it gives the most faithful reproduction of radio you have ever enjoyed. Price \$55.00. Six other popular models of Amplions, \$12 to \$42.50, equipped with cords and panel plugs. Write for full particulars and "Amplion Pedigree."

THE AMPLION CORPORATION OF AMERICA

Executive Offices: Suite W, 280 Madison Ave., New York City
Chicago Branch: 27-29 No. Morgan Street
Amplion Corporation of Canada, Ltd., Toronto

THE REAL STORY OF THE RADIO TRADE HEARING

before

The Federal Trade Commission

THE Federal Trade Commission charges restraint of trade in the manufacture, sale and use of radio apparatus against The General Electric Company, American Telegraph & Telephone Company, Western Electric Company, Westinghouse Electric & Mfg. Co., Inc., International Radio Telegraph Company, United Fruit Company, Wireless Specialty Apparatus Company and Radio Corporation of America.

The hearings began in New York City, October 20th, 1925, and are now in progress, and will result in many thousands of pages of minutes—too voluminous to serve most executives, engineers or attorneys.

As Official Reporters for the Federal Trade Commission we are prepared to deliver in abstract form (reduced to about one-eighth the volume) the information recorded at these hearings at a Syndicated Service Price—considerably below the usual cost.

Inquiries are invited. Address:

SIDNEY C. ORMSBY COMPANY
Official Reporters to the Federal Trade Commission
18 VESEY STREET, NEW YORK CITY
Telephone: Whitehall 4545

Have You the Maximum Coil Efficiency in Your Receiver?

Radio receiver manufacturers are giving more and more serious consideration to the inductance coils used in their products.

Upon competitive tests, many have learned that Hammarlund space-wound Coils combine the greatest amount of inductance with the lowest distributed capacity and dielectric losses.

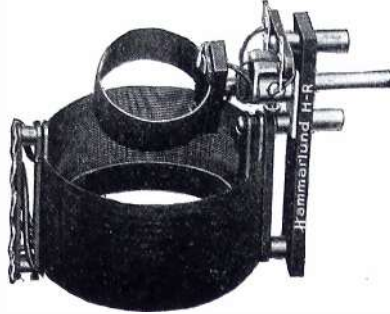

Perhaps you too can save money as well as increase the efficiency of your receiver by using Hammarlund Space-Wound Coils in your new models.

Send us your specifications and ask us for sample coil to test in your own laboratory in your own way.

HAMMARLUND MANUFACTURING CO.
424-438 W. 33rd St., New York City.

Perhaps you would be interested in the booklet, "How to Build the Hammarlund - Roberts Receiver." It will be sent on receipt of ten cents in stamps.

For Better Radio
Hammarlund
PRECISION
PRODUCTS

The famous Hammarlund Condensers offer you the best capacity tuning devices possible to build. Single, double and triple models, in all capacities. Mid get size also.

RADIO SPEAKER MANUFACTURERS

are invited to inspect the Best Line of Units. It comprises a complete assortment for all types of Speakers, including Built-in designs. Each is manufactured from the finest materials by standardized factory methods. Absolutely dependable performance is guaranteed.

**Do not fail to see the new
Best Unit for Cone type Speakers.**

It merits your approval on the basis of reliable, consistent results in actual use.

Write for samples, prices and information.

BEST MANUFACTURING COMPANY
75 Hudson Street Newark, N. J.

"All That The Name Implies."

Sales Department
The Hartzell Sales Company
961-50 Church Street, New York City, N. Y.



Radiohms and Potentiometers

Centralab non-inductive, variable resistances are controls of graphite type that insure smooth, noiseless tuning and *permanent service*. A single turn of the knob gives stepless variation of resistance from zero to maximum.

Centralab Radiohms have two terminals, and can be furnished with maximum resistances of 2,000, 25,000, 50,000, 100,000 or 200,000 ohms. Centralab Potentiometers have three terminals, and are furnished in resistances of 400, 2,000 and 500,000 ohms. There is a type adapted to every radio circuit for control of oscillation or volume.

Write for literature describing these and other Centralab super-quality radio Controls.

CENTRAL RADIO LABORATORIES
25 Keefe Ave. Milwaukee, Wis.

Centralab



AEROVOX

By-Pass and Filter Condensers
"Built Better"

Tested and approved by M. I. T., Yale, Radio News, Popular Radio and Popular Science. Used by over 200 of America's leading set manufacturers.

AEROVOX WIRELESS CORP.
489, 491 493 Broome St., New York City

Branch Offices:

CHICAGO, Ill.,
53 W. Jackson Blvd.
CINCINNATI, Ohio,
304 Palace Theatre Bldg.

BOSTON, Mass.,
104 Portland St.
LOS ANGELES, Cal.,
324 No. San Pedro St.

MUTER

DEPENDABLE FIXED CONDENSERS

MICA INSULATION
BRASS ELECTRODES
ACCURATE CAPACITIES

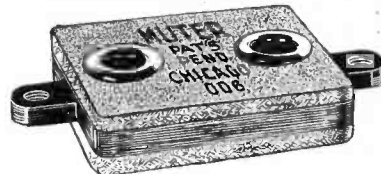

Used by Leading Set Builders

SAMPLES AND QUOTATIONS
PROMPTLY FORWARDED

LESLIE F. MUTER COMPANY
76th AND GREENWOOD AVE.
CHICAGO ILLINOIS

Mr. Radio Engineer

- To—Simplify set operation.
- To—Solve all tube control problems.
- To—Avoid the possibility of distortion.
- To—Decrease servicing need.
- To—Lower production costs.

COMMUNICATE—with an organization that has specialized in filament control ever since Radio was born.

Radiall Company

50 Franklin St., New York, N. Y.

Makers of



The "SELF-ADJUSTING" Rheostat

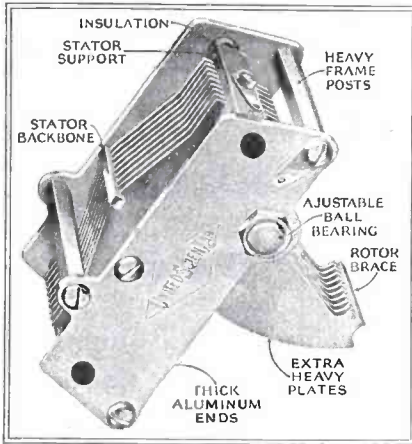

SPECIFICATIONS

- INSULATION—Radion hard rubber.
- STATOR SUPPORT—Extra heavy brass assuring a rigid frame.
- STATOR BACKBONE—Spaces stator plates rigidly and permanently making possible calibration.
- EXTRA HEAVY PLATES AND CORRECT SPACING—Eliminating misalignment and short circuits.
- ROTOR BRACE—Stiff brass bar aligns rotor plates and further aids calibration.
- ADJUSTABLE BALL AND CONE BEARINGS—Assures easy running and permanent accuracy.
- FRAME POSTS—Extra heavy nicked brass.

PRECISION

MADE



CALIBRATED INSTRUMENTS

It has been demonstrated beyond all doubt, that close spaced and cheaply built condensers are unsatisfactory, mechanically and electrically. More and more set manufacturers are coming to realize that no set is better than its parts and are demanding high grade precision made instruments.

To meet this demand, we have designed a new line of calibrated condensers. Our same high standards of quality and workmanship have been rigidly maintained but cost has been kept down to meet the modern manufacturing requirements of the receiving set maker and to assure good performance at the lowest cost.

Made in the Following Sizes and Types

.00025—.00035—.0005 MFD. Capacities—Singles—Doubles—Triples.

Write or Wire for Samples, Stating Your Requirements

UNITED SCIENTIFIC LABORATORIES, Inc.

80 Fourth Avenue, New York City

Branch Offices—Boston

Chicago

St. Louis

Minneapolis

San Francisco

Los Angeles

SM



**S-C
KIT
620**

Silver-Cockaday—All Wave Receiver

This famous, 4-tube, single-control receiver is now offered exclusively by Silver-Marshall, Inc., as a complete Kit including all parts necessary to build this remarkable set in a few hours' time.

Behind the S-C is the reputation of Popular Radio—Laurence Cockaday and McMurdo Silver. And behind each and every part stands the pick of the Radio Manufacturers: Beiden Mfg. Co.—Central Radio Labs.—Polymet Mfg. Co.—Poster & Co.—Silver-Marshall—Thordarson Elec. Mfg. Co.—Yaxley Mfg. Co. and the S-C Merchandising Co. What better guarantee could be demanded—or offered?

PRICE KIT No. 620 \$59.00

Licensed under Armstrong U. S. Patent Number 11113149. Mfd. by Tresco. Exclusive Dist. Agents: Silver-Marshall, Inc.

See SM parts at your dealers

SILVER-MARSHALL, INC.

854 W. Jackson Blvd.

Chicago

Radio Engineering, May, 1926

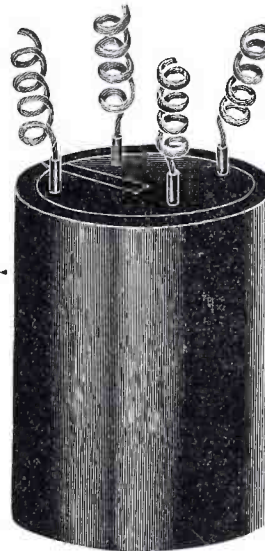

*Purer,
Better
Tones*

The new instrument for the most rigid requirements of audio amplification. Clear, pure, undistorted tones. Built on a *NEW Principle*. Set Manufacturers write for complete information and prices.

ROBERTSON-DAVIS CO.

420 Orleans Street

Chicago.

MELOFORMER

Thomas & Skinner Steel Products Co.

INDIANAPOLIS, INDIANA

Manufacturers of

PERMANENT MAGNETS

Exclusively

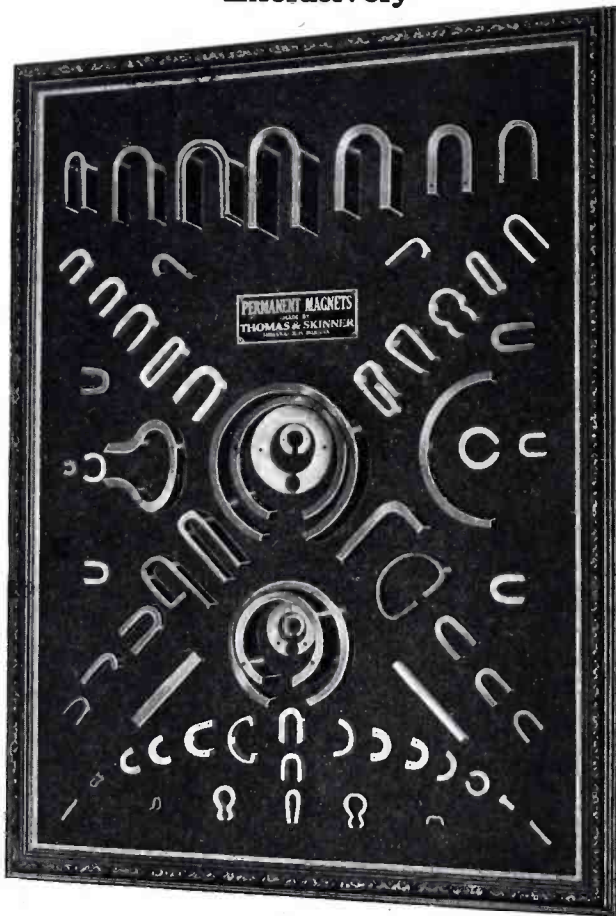

For Radio Loud Speakers, Electrical Instrument, Magnetos, Control Apparatus, Commercial Devices, Etc., Etc., Etc.

Thomas & Skinner Steel Products Co.

Indianapolis, Indiana

best for condensers —brass

As plates and columns BRASS has the right temper to preserve alignment with small clearances. BRASS is readily soldered in making proper electrical contact and its easy machining qualities give economy in production.

COPPER & BRASS
RESEARCH ASSOCIATION
25 Broadway, New York

PATENT SERVICE

FOR THE MANUFACTURER —

We have retained experienced patent lawyers to create patent situations around the manufacturer's products.

FOR THE INVENTOR —

We aid and assist in the development of his inventions and represent him in negotiations with manufacturers. In meritorious cases we finance the work.

RADIO PATENTS CORP.

INC. 1917

4377 Bronx Blvd. New York City

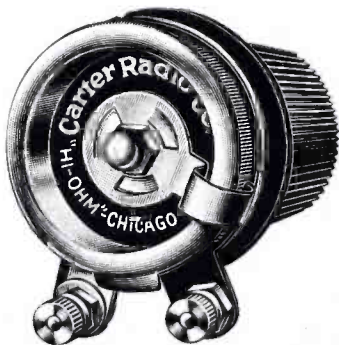

CARTER "HI-OHM"
(full size)

CARTER

NEW "HI-OHM" AND "HI-POT"

500,000 ohm

VOLUME CONTROLS

A non inductive wire wound variable resistance regulating volume gradually from full power to a whisper by turning a knob. Both in rheostat and in potentiometer

type. Adapted for use in all circuits. Already specified by many leading manufacturers. Same size and general style of construction as Carter "Imp" Rheostat.

In Canada:

Carter Radio Co., Ltd.

Toronto



IMPORTANT TO MANUFACTURERS:

POSITIVE,
PERMANENT
FINISH,
STRENGTH
IN THE CIRCUIT

*When you think
of perfect electrical contact
- as being permanent -
think of the*

Lastite
it locks!

the bus wire
the solder
thin, circular
flange



tube that
holds bus wire
threaded base
instrument
or panel

The Standard tubular Soldering Terminal
for making radio circuits mechanically strong
A refinement that saves time and material
Manufactured by

William Stevens Co.

27 Hammatt Road, Roslindale Mass.

PATENT APPLIED FOR

The biggest thing of its size in Radio

The S-C SILVER COCKADAY "All Wave Receiver"

ENDORSED
AND
APPROVED



By Radio Engineering, Radio News, Radio Age, Radio, On the Air, Popular Science Monthly, Christian Science Monitor and Newspapers throughout the country . . . The S-C Receiver, designed by Silver and Cockaday and sponsored by Popular Radio Magazine goes to the Set Builder with an overwhelming introduction. The daily flood of letters praising this startling new receiver proves that this universal endorsement is fully merited by the S-C.

The parts manufactured by the following reputable concerns are recommended for the S-C by the designers, and can be obtained in a complete Kit from any Radio Dealer

Belden Mfg. Co.—S-C Wiring Harness
Central Radio Laboratories—Centralab Resistance
Polymet Mfg. Corporation—Fixed Condensers, Leak and Leak Clips
Poster & Co.—Drilled and Processed Front Panel and Drilled Sub-Panel
Silver-Marshall, Inc.—Variable Condensers, Coil Sockets, Coils, Tube Sockets, Vernier Dial, Mounting Brackets
Thordarson Elec. Mfg. Co.—R200 Power Transformers
Yaxley Mfg. Co.—Rheostat, Jacks, Switch

GET The S-C Instruction Booklet from your dealer or send 25c to the following address.

S-C MERCHANDISING CO.

286 S. Peoria St.

Chicago



Oh boy
KESTER
Rosin Core
Radio SOLDER

Safe is Safe and Simple
APPROVED BY RADIO ENGINEERS
A GENUINE SOLDER
CHICAGO SOLDER COMPANY
4224 Wrightwood Av., Chicago, U.S.A.

Originators and World's Largest Manufacturers of Self-Fluxing Solder
YOUR DEALER CAN SUPPLY YOU

DeJUR STRAIGHT LINE FREQUENCY CONDENSER

SPACE-SAVING

LOW
LOSS

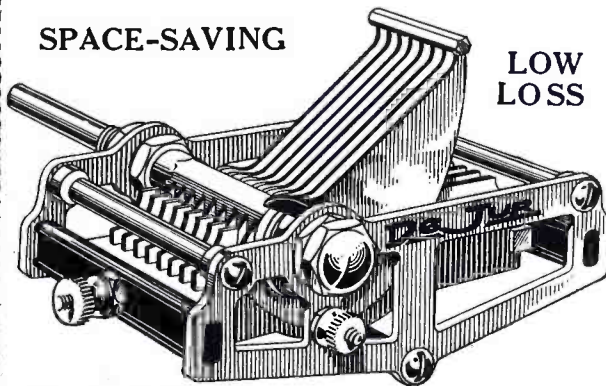

Occupies No More Space Than Old Type Condensers

Attractive heavy weight brass stator and rotor plates scientifically placed in relation to each other. Genuine Bakelite moulded insulation throughout. Rotor and stator plates swedged in by hydraulic pressure to insure permanent, perfect alignment. Stator plates rotate on ball-bearings. End plates are of brass, highly finished in solid nickel, buff polished. Grounded rotor with spring phosphor bronze pig-tail connection. Special guard on shaft prevents rotor plates from contact with frame posts. All body capacity effects and electrical annoyances during adjustment are eliminated.

Made in all standard sizes and in
Single, Double and Triple types.

Get our quotations for your requirements.

DeJUR PRODUCTS CO.

199 Lafayette St.

New York City

American Transformer Company



AmerTran Power Transformer
Type PF-52

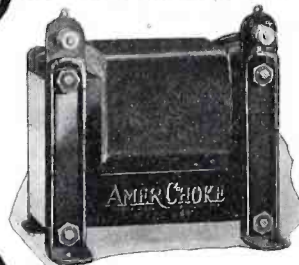

AmerChoke, Type 854.

A REPUTATION for fine transformers that has been maintained for over a quarter-century! Today this high standard of manufacture is more apparent than ever—for radio has adopted each of the advanced, dependable AmerTran Products as the leader of its field.

The new AmerTran DeLuxe Audio Transformer actually puts the development of the "audio side" ahead of existing acoustical devices. Faithful amplification with natural quality over the *entire* audible range is consistently obtained with this audio transformer. The new tubes, cone speakers, and clear signals from the detector tube bring the most satisfactory results in combination with the AmerTran DeLuxe.

It is significant that in 1926 the AmerTran DeLuxe is an essential unit in the finest set designs. One of these is the *Best 5 tube Super*. Before building this Receiver write us for complete information.

As the receiving set of the future is destined to be power operated the American Transformer Company is now offering two units of the finest type—especially adapted to the use of the new

7½ volt power tubes in the last audio stage. These are the AmerTran Power Transformer and the AmerChoke which are strictly up to standard, and may be depended on in the type of audio amplifier required. The Power Transformer, also has filament supply windings for the power tube in the last stage and for the rectifying tube, and supplies sufficient plate current, after rectification, for the operation of the set.

- AmerTran DeLuxe 1st Stage . . . \$10.00
- AmerTran DeLuxe 2d Stage . . . 10.00
- AmerTran AF-7 (3½-1) . . . 5.00
- AmerTran AF-6 (5-1) . . . 5.00
- AmerTran Power Trans. PF-45 . . . 15.00
- AmerTran Power Trans. PF-52 . . . 18.00
- AmerChoke Type 854 . . . 6.00

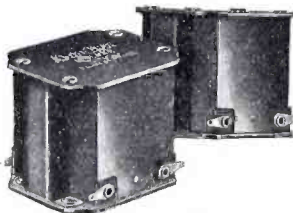

AmerTran DeLuxe
two types for first and second stages.

Whether or not you are actually building a set, our booklet "Improving the Audio Amplifier" will prove decidedly interesting. It costs nothing and includes the most advanced information made practical for your use by our engineering staff.

AmerTran Products
Sold Only At
Authorized
AmerTran Dealers

HOW TO BUILD Gerald M. Best's 5 TUBE SUPER 5c
Complete Instructions with Additional Working Data. Reprinted from: April 1926 RADIO
AMERICAN TRANSFORMER CO., 178 Emmet St., NEWARK, N. J.

**Transformer Builders for
Over Twenty-Five Years**

INDEX OF ADVERTISERS

	Page
Aero Products, Inc.	212
All-American Radio Corp.	187
American Hard Rubber Co.	229
American Mechanical Labs.	222
American Transformer Co.	228
Amplion Corp. of America	211, 222
B	
Best Mfg. Co.	223
Brown, C. J.	215
C	
Cardwell, Allen D., Mfg. Corp.	Inside Back Cover
Carter Radio Co.	226
Central Radio Labs.	224
Chicago Solder Co.	227
Copper & Brass Research Assoc.	226
Crowe Name Plate & Mfg. Co.	217
D	
DeLur Products Co.	227
Dongan Elec. Mfg. Co.	Back Cover
Dontle-Bristol Corp.	231
Dubilier Cond. & Radio Corp.	192
Durrant Radio, Ltd.	216
E	
Eby Mfg. Co., The H. H.	221
Electrad, Inc.	220
G	
Garfield Radio Mfg. Corp.	230
Gearhart-Schlueter Radio Corp.	190, 191
Gould Storage Battery Co., Inc.	188
H	
Hammarlund Mfg. Co.	223
I	
International Resistance Co.	231
J	
Jewell Elec'l Inst. Co.	211
Jones, H. B.	220
K	
Karas Elec. Co.	213
L	
Lignole Corp.	220
M	
Munn & Co.	230
Muter, Leslie F., Co.	224
N	
National Carbon Co.	Inside Front Cover
National Company, Inc.	219
O	
Ormsby, Sidney Co.	222
P	
Polymet Mfg. Corp.	221
Potter Mfg. Co.	231
R	
Radiall Co.	224
Radio Corp. of America	185
Radio Patents Corp.	226
Raytheon Mfg. Co.	230
Robertson-Davis Co.	225
S	
S-C Merchandising Co.	227
Silver-Marshall, Inc.	225
Sleeper, M. B., Inc.	214, 218
Steinen, Wm., & Co.	230
Stevens & Co., Wm.	227
T	
Thomas & Skinner Steel Products Co.	226
Thordarson Electric Mfg. Co.	189
U	
Union Radio Corp.	229
United Scientific Labs.	225

STATEMENT OF THE OWNERSHIP, MANAGEMENT, CIRCULATION, ETC., REQUIRED BY THE ACT OF CONGRESS OF AUGUST 24, 1912, OF RADIO ENGINEERING.

Published monthly at New York, N. Y., for April 1, 1926.

State of New York } ss.
County of New York }

Before me, a Notary in and for the State and county aforesaid, personally appeared M. B. Sleeper, who, having been duly sworn according to law, deposes and says that he is the Business Manager of RADIO ENGINEERING, and that the following is, to the best of his knowledge and belief, a true statement of the ownership, management, etc., of the aforesaid publication for the date shown in the above caption, required by the Act of August 24th, 1912, embodied in section 443, Postal Laws and Regulations, to wit: 1. That the names and addresses of the publisher, editor, managing editor, and business managers are: Publisher, M. B. Sleeper, Inc., 52 Vanderbilt Avenue, New York; Editor, M. B. Sleeper, Darien, Connecticut; Managing Editor, M. B. Sleeper, Darien, Connecticut; Business Manager, M. B. Sleeper, Darien, Connecticut. 2. That the owner is M. B. Sleeper, Inc., whose stockholders are: Anne B. Sleeper, Darien, Connecticut; Milton B. Sleeper, Darien, Connecticut; and Mae G. Murray, Halstead Avenue, Harrison, N. Y. 3. That the known bondholders, mortgagees, and other security holders owning or holding 1% or more of the total amount of bonds, mortgages, or other securities are: None. 4. That the two paragraphs next above, giving the names of the owners, stockholders, and security holders, if any, contain not only the list of stockholders and security holders as they appear upon the books of this company but also, in cases where a stockholder or security holder appears upon the books of the company as trustee or in any other fiduciary relation, the name of the person or corporation for whom such trustee is acting, is given; and also that the said two paragraphs contain statements embracing affiant's full knowledge and belief as to the circumstances and conditions under which stockholders and security holders who do not appear upon the books of the company as trustees, hold stock and securities in capacity other than that of a bona fide owner; and this affiant has no reason to believe that any other person, association, or corporation has any interest direct or indirect in the said stock, bonds, or other securities than as so stated by him.

(Signed) M. B. SLEEPER, Business Manager.
Sworn to and subscribed before me this 30th day of March, 1926.

(Seal) F. N. BUNGER, Notary Public.
Westchester County,
New York Co. Clerk's No. 852-A.
New York Co. Register's No. 6031.
Commission expires March 30th, 1927.

Quick Contacts That
Make Quick Sales

UNION RADIO TIP JACKS

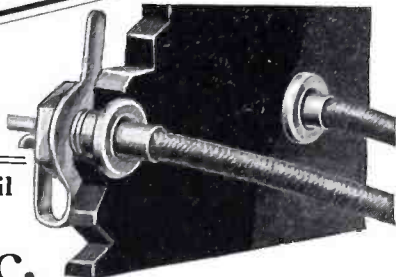

Retail
at
25c.
a pair

Many of the best sets on the market use these tip jacks as standard equipment.

YOU will find a quick selling demand for these positive connections, that are everywhere replacing troublesome binding posts. Fans appreciate the convenience of these quickly inserted, quickly removable, Tip Jacks.

Nothing to work loose, no parts to lose. Once connected, they stay secure, giving a firm, safe grip on the wire, yet an easy pull instantly releases them. Firmly grip all wires from No. 11 to No. 24 B & S gauge. Three sizes for all panels. TYPE A (Standard) for 3/16" to 1/4" panels. TYPE B (Special) for panels, cabinet walls and partitions from 5/16" to 1/2" thick. TYPE C (Special) for panels up to 1/8" thick.

They Are Specified In The HAMMARLUND-ROBERTS RECEIVER

The designers and engineers of this highly recognized circuit specify Union Radio Tip Jacks because of their convenience and security. It will pay you to stock them and also the other parts specified for this famous receiver. Thousands of these sets are being built daily and the base panel of the kit has been drilled especially for Union Radio Tip Jacks. Binding posts cannot be substituted. Packed in "self-selling" counter cartons of 1/2, 1/4 and 1 gross pair. Also in boxes of 5 pairs for Hammarlund-Roberts set builders.

Other Guaranteed Radio Products

VERNIER DIAL ADJUSTERS—In demand by fans for finer tuning. Permit instant adjustment of the dials. Retail price 60c.



IDENTIFICATION TAGS—For battery leads. Stamped from hard, red fibre, oval in shape, with proper battery identification marks. Set owners need them—they sell quickly. Holes take any wire up to 1/8" thick. Packed 100 in a box of one designation only. Retail price \$1.00. Also in set of nine. Retail price 10c.

To All Branches of the Trade

Send for literature N and samples of our reasonably priced Guaranteed Radio Products. Get details of our attractive proposition.

UNION RADIO CORPORATION
124 SUSSEX AVENUE, NEWARK, N.J.
NEW YORK OFFICE 116 WEST 32ND STREET.
00000

To Manufacturers of Sets, Condensers, Jacks, Transformers, Loud Speakers, Head Phones

who must get into production promptly for the fall rush. This coming season, like every other will bring still more rigid refinements in design and material. Production schedules that are expected to operate like clockwork in August must be planned *now*.

This is a good time to adopt RADION insulation. Many of the leaders have already done so. They recognize RADION high rated values and relatively low production costs.

We offer a complete RADION moulding and machining service on insulating parts backed by ample resources in money, men, methods and machinery—dependable deliveries in any quantity **ON TIME**.

Tell us what you need—when you need it—and we'll figure it out for you.

AMERICAN HARD RUBBER CO.
11 Mercer Street New York, N. Y.

RADION

The Supreme Insulation

Cabinets	Machinery	Patents
JORDAN CABINET CORPORATION Tel. Sunset 4453 Brooklyn, N. Y.	RADIO PRODUCTION CO. Coil Winding Machines Tel. Canal 0474 212 Center St. New York	PATENTS Write for free book MUNN & CO. Associated since 1846 with the Scientific American 648 Woolworth Bldg., New York City 537 Scientific American Bldg., Washington, D. C. 1326 Tower Building, Chicago, Ill. 638 Hobart Bldg., San Francisco, Cal. 549 Van Nuys Bldg., Los Angeles, Cal.
Compounds, Battery	BRANCH TOOL CO. Engraving Machines Forestdale Rhode Island	Screw Machine Products
MITCHELL-RAND CO. Dept. R. E. 18 Vesey St New York City Mfrs. of Spaghetti Tubing	EISLER ENGINEERING CO. Tube Machinery Newark New Jersey	WM. STEINEN & CO. Tel. Market 9077 297 Washington St., Newark, N. J. Screw Machine Products and Springs
Castings, Die	Magnets, Permanent	Buyers and Sellers of SURPLUS MATERIALS
MARF MACHINERY and DIE CASTING CO. 149 41st St. Brooklyn, N. Y. Tel. Sunset 9108	D. K. BULLENS CO. Hot Forged Radio Magnets Pottstown Pennsylvania	SLAP RADIO CO. 16 Hudson St. New York City Tel. Whitehall 5712
Hardware	Packing Materials	Wire
F. R. ZIERICK MACHINE WORKS 6 East Howard St., New York City Terminals—Lugs—Ground Clamps— Socket Springs—Socket Shells—Bus Bar Strips—Angles—Brass and Copper Specialties. Metal Stampings by the thousand or million Tel. Canal 0079-1279	PEQUOT MFG. CO. Specialist in Radio Packing Materials Long Island City New York	Antenna Magnet Litz Lead in Flexible Silk Bus Bar Annunciator Loop Aerial Guy Detector CORNISH WIRE CO. 30 Church St. New York City
Insulation, Moulded	Panels, Composition	JAS. GOLDMARK CO. Magnet All Insulations Litz Stranded Flexible Leads (Cotton or Silk Covered) Flexible Rubber Covered for Wiring Sole Manufacturers of WIRIT 83 Warren St. New York City
INSULATING CO. OF AMERICA (Radio Panel & Parts Co.) Insuline and Bakelite Panels Plain, Drilled and Engraved Sub-Panels Etch-O-Gravure and Other Methods of Panel Decorations Insuline Bldg. 59 Warren St. New York, N. Y. Branches in Principal Cities	POSTER & CO., INC. Drilling, Engraving, Decorating Genuine Bakelite New York Chicago 28 Barclay St. 721 Fulton St.	Panels, Metal
Lacquers	CROWE NAMEPLATE & MFG. COMPANY Quality Etched Metal Panels and Nameplates 1749 Grace St. Chicago, Ill.	STRAND—Antennae (plain or enameled)—Double Galvanized. WIRE—Antennae (plain or enameled) Connecting and Ground (Rubber) covered, braided or plain. BUS BAR—Litzendraht-Loop MAGNET (Cotton or Silk). JOHN A. ROEBLING SON'S CO. Trenton, N. J.
EGYPTIAN LACQUER COMPANY Dept. R. R. 90 West St. New York City		

SCREW MACHINE PRODUCTS & SPRINGS

Wm. STEINEN & CO.
297 Washington St.
NEWARK :: :: **N. J.**
TEL. MARKET 9077

2 inches high
3/8 inches thick
6 3/4 inches long



\$1.25
a pair

Non-Metallic Sub-Panel Brackets made of Radion for efficiency. No absorption. Will not vary inductive or capacity values. Especially adapted for short wave work. Does not create Stray Capacity.

If your dealer cannot supply you, send \$1.25 and a pair will be mailed direct to you.

Garfield Radio Mfg. Corp'n.
64 Vesey St. New York City



The Donle-Bristol Detector

Type B-6

\$5

*"The Only Tube of Its
Kind in the World"*

Send For Descriptive Bulletin

THE DONLE-BRISTOL CORPORATION
Cambridge & Tremont Sts.
Meriden, Connecticut

DURHAM

Metallized



*Used by Leading
Manufacturers*

A metallized high resistance element, impervious to atmospheric changes, maintains uniform resistance at all times, noiseless, guaranteed, made by a patented process.

Ask the manufacturer of quality sets—he knows.

500 ohms to 10 megohms

INTERNATIONAL RESISTANCE CO.
Philadelphia, Pa.

DURHAM

METALLIZED

RESISTORS



American-Made
Filter Condensers
For All Power
Supply Units

Fine condensers are essential for good results. Potter Condensers are *American-made*, of very best foil, insulation and impregnating compounds to be had. Eliminate all hum. Have remarkably long life under continuous use. ALL SIZES AND CAPACITIES.

At your dealer's—or write direct

Potter

FILTER

Condensers

POTTER MFG. CO., NORTH CHICAGO, ILL.

FACTS — for Manufacturers

THE coming developments in a.c. power for radio receivers will have far-reaching effects on the industry. To thousands—yes, millions—of people the fact that a receiver may be operated from power lines will mean that radio has “arrived.” It will at last be accepted in a class with the electric light, the vacuum cleaner, and other household necessities.

This day has not yet come; the battery has not been universally eliminated to complete satisfaction. Haphazard, hasty, and cocksure methods will not speed the work. As the president of one large company puts it, “I believe that general acceptance of battery eliminators will be delayed years if manufacturers, in their eagerness to meet the need, rush in without adequate consideration of all factors involved. . . . There must be a concerted effort to build public confidence by selling only power devices and power-operated receivers that work, not as good as batteries, but *better* than batteries.”

As manufacturers of rectifying tubes exclusively, the Raytheon Company's growth depends upon the proper application of a.c. power. Hence our entire organization and facilities are devoted to that one purpose. If you contemplate marketing a *quality* power unit in real quantities, we suggest that you investigate Raytheon.

RAYTHEON MANUFACTURING COMPANY, CAMBRIDGE, MASS.

THE RECTIFIER is the foundation rock upon which your power unit will stand or fall. Can you afford to adopt one which does not have all of the following advantages?

Good Will. Over 40,000 Raytheon B-power units are now in the homes of satisfied users. Hundreds of articles in all leading radio magazines and newspapers have told of this remarkable development. Nearly \$100,000 worth of advertising by our customers and ourselves has sold Raytheon B-power units. During this past season it has probably been accorded ten times the publicity that any other rectifier has received.

A Policy that convinces the consumer that his power unit will give satisfaction. We can approve only those units that pass our strict laboratory tests, and they must be backed by responsible companies whose facilities permit of large scale production.

A Laboratory whose staff includes Mr. C. G. Smith, inventor of the “S” tube, a physicist who has devoted the past ten years to fundamental research on gaseous conduction. His co-worker and consultant is Dr. Vannevar Bush, the professor in charge of graduate research in the Electrical Engineering Department of M.I.T. Dr. Bush divides his time between the school and our laboratory. Much of the practical work is done by John A. Spencer, a mechanical genius whose achievements include the noted Spencer Snap-acting Thermostat, and his brother P. L. Spencer, whose radio experience includes three years with the Wireless Specialty Company and six years with the Submarine Signal Company. A corps of six younger men, all technical graduates, three of them with the degree of Master of Science from M.I.T., carry on the detailed experimental and testing work on rectifiers and circuits. This laboratory is at the service of Raytheon customers.

A Future which never looked more promising than at present. Among the developments which we feel free to mention are: (1) a high-power B tube, capable of carrying more than 80 milliamperes at any output voltage up to 400 d.c.; (2) a lower power and lower priced B tube; and (3), before next season, a 300 milliamperer rectifier admirably suited to running 201-A filaments in series. The possibilities of gaseous rectifiers have hardly been touched, and with our basic patents as a foundation we propose to keep abreast of the radio art.

Resources. We have no hesitancy in furnishing complete information on this important point, or you may inquire of the Old Colony Trust Company of Boston. A complete new factory which has just been put into operation and cash assets of \$100,000 should give some indication that we are prepared to meet the tremendous demand for Raytheons which is sure to come this fall.

Cardwell

Acclaimed!

By Every prominent engineer who has seen them, Taper Plate Type E Condensers represent the foremost step in condenser design since the original low-loss metal endplate, first made by Cardwell five years ago.

CLAYTON—Cockaday—Lynch—Best—Wing—Neely—the list of those who specify Taper Plate Cardwells reads like a roster of the greatest Technical Editors of Radio.

The Taper Plate Type E Receiving Condenser is designed to be practical rather than theoretically perfect. Its tuning characteristic is straight frequency over the lower part of the scale, tapering to approach straight wave-length at the top. Full size plates, far heavier than ever used before, assure positively permanent calibration.

The Type C approaches straight frequency on the very low portion of the scale only, changing to a modified straight wavelength as capacity is increased.

Type "C"	Type "E"	Capacity (Mmfd.s.)	Price
168-C	167-E	150	\$4.00
170-C	168-E	250	4.25
171-C	169-E	350	4.75
172-C	192-E	500	5.00

The Allen D. Cardwell Mfg. Corp.
81 PROSPECT STREET, BROOKLYN, N. Y.

5c. in stamps brings this booklet on the Best Super-Heterodyne.

If your dealer can't supply you, order direct. Write for illustrated catalogue and handbook.

Under a revised distribution system, some territory is now available for jobbers, and inquiries from responsible firms will be welcomed.

The Type "C" has a modified straight wave length tuning curve

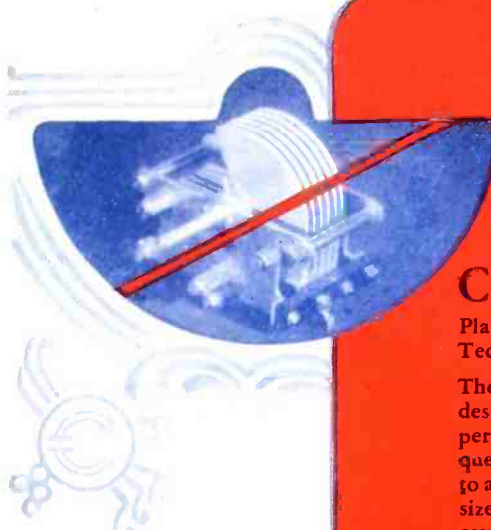

The Taper Plate Type "E" with straight frequency tuning characteristics

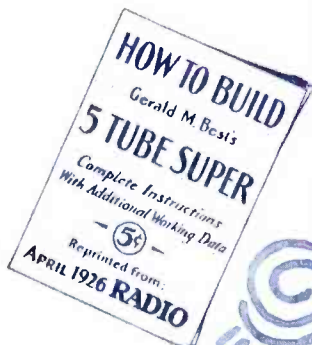
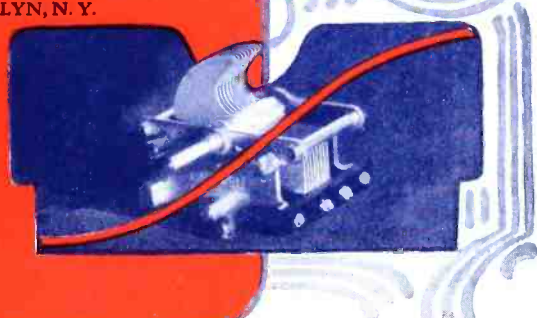

Condensers

"THE STANDARD OF COMPARISON"



New and Improved Parts Lower Prices

Set Manufacturers

Remarkable refinements in our new Audio Transformers combined with perfected manufacturing facilities add new efficiency of performance to Dongan quality parts. Lower prices are likewise possible on some models. No matter what type set you manufacture there is a Dongan Audio Transformer for the finest reception.

B—Power Units

Transformers and Chokes for all types of B-Eliminators. Dongan B-Power Units are the choice of leading Eliminator manufacturers. Samples of mounted and unmounted types available now—our engineering department will cooperate with you in perfecting your models.

TRANSFORMERS

Manufactured in 25, 40, 50 and 60 cycles



No. 509 Full Wave for Raytheon Tubes.
No. 537 Full Wave for R. C. A. UX-213 Tubes.
No. 538 Half Wave for R. C. A. UX-216-B Tubes.
No. 561 for R. C. A. UX-216 Tubes.
No. 1572 for New 80 Milli-Amp. Raytheon Tubes.

CHOKES



No. 514 20 henry
No. 506 30 henry.
No. 539 50 henry.

Raytheon Tubes \$6.00
List

Special Transformers for trickle chargers.

Fans: The better sets this year will get their B Power from the light socket. You can build your own B-Eliminator at small cost. Ask your dealer for information or send order to us direct.

DONGAN ELECTRIC MANUFACTURING CO.

2995-3001 Franklin Street, Detroit, Mich.

TRANSFORMERS of MERIT for FIFTEEN YEARS