

48783 **Radio** - BUILD A SUBWOOFER SIMULATOR

# Electronics®

TECHNOLOGY - VIDEO - STEREO - COMPUTERS - SERVICE

## THE ULTIMATE CONTROL COMPUTER

BUILD A RAM DISK AND  
PROM PROGRAMMER FOR  
RE's ADVANCED CONTROL SYSTEM

## DON LANCASTER

HARDWARE HACKER COLUMN:  
A LOOK AT TONER-CARTRIDGE  
REFILLING, POSTSCRIPT, AND MORE

## THERMOELECTRIC COOLERS

HOW SOLID-STATE HEAT PUMPS  
KEEP YOUR ELECTRONICS COOL

## WORKING WITH OTA'S

USE OPERATIONAL  
TRANSCONDUCTANCE  
AMPLIFIERS IN YOUR NEXT DESIGN

## COMPUTERDIGEST

BUILD A DIGITAL IC TESTER  
FOR YOUR COMMODORE 64

## BUILD THIS FUNCTION GENERATOR

A "MUST-BUILD" PROJECT FOR  
EVERY ELECTRONICS WORKBENCH

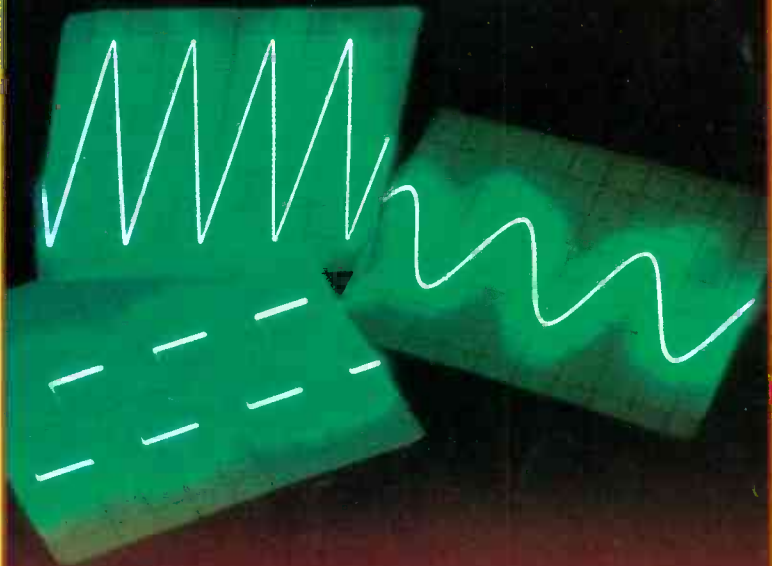

WAVEFORMS TO 100 kHz  
AND MORE!



\$2.25 MAY 1988  
IN CANADA \$2.75

A  
**GERNSBACK**  
PUBLICATION



# THE ANSWER IS IN TEK DIGITAL STORAGE:

**\$2995**  
**\$3995**  
**\$4995**

**Now! The new 60 MHz Tek 2221 joins the world's best-selling family of digital storage oscilloscopes.** All featuring 20 MS/s *digitizing* along with familiar, full-bandwidth analog operation. It's the best of both worlds in an easy-to-use portable.

**Discover the potential.** With digital storage you can freeze waveforms. Capture events invisible to nonstorage scopes. Find signals buried in noise. And build a library of reference waveforms.

Digital storage display accuracy enhances your confidence in measurements. And all you have to do is push a button for *real-time* display analysis.

**Compare the 2230, 2221 and 2220 to each other — and all others.** The new 2221 offers such advanced features as CRT readout and measurement cursors. For even more performance and flexibility, there's the 100 MHz, dual time base 2230 with optional battery-backed memory for saving up to 26 waveform sets. And if it's economy you want, choose the 60 MHz 2220 with many of the same features at an even lower cost.

Features	2230	NEW! 2221	2220
Analog/Digital Storage BW	100 MHz	60 MHz	60 MHz
Maximum Sampling Speed	20 MS/s	20 MS/s	20 MS/s
Record Length	4K/1K (selectable)	4K	4K
Peak Detect	100 ns	100 ns	100 ns
Save Reference Memory	One, 4K Three, 1K	One, 4K	One, 4K
Vertical Resolution	8 bits 10 bits (AVG mode) 12 bits (AVG mode over the bus)	8 bits 10 bits (AVG mode)	8 bits
CRT Readout/Cursors	Yes	Yes	No
GPIB/RS-232-C Options	Yes (\$750)	Yes (\$500)	Yes (\$500)
Battery-Backed Memory (save 26 waveform sets)	Yes (inc with GPIB/ RS-232-C)	No	No
Price	\$4995	\$3995	\$2995

With each scope you can capture events as narrow as 100 ns at any sweep speed thanks to Tek's proprietary peak detect mode. View events prior to or following a trigger event with pre/post trigger. Store waveforms into 4K records. Automate measurements with optional GPIB and RS-232-C interfaces. And output direct to a printer or plotter.

Tek software is available to help you make the most of the 2230, 2221 and 2220 in system configurations.

**Call Tek for a free video brochure or to place an order.**

Ask about free digital storage application notes and educational materials. Orders include complete documentation, manuals and 3-year warranty on labor, parts and CRT.

**Call Tek direct:  
1-800-426-2200**  
for free video brochure  
for orders/assistance.



CIRCLE 92 ON FREE INFORMATION CARD

**Tektronix**  
COMMITTED TO EXCELLENCE

## BUILD THIS

- 39 VERSATILE FUNCTION GENERATOR**  
Generates simultaneous square/triangle or square/sine output signals to 100 kHz.  
**John Wannamaker**
- 50 ADVANCED CONTROL SYSTEM**  
Part 4. Memory expansion with a high-speed disk storage system.  
**H. Edward Roberts, M.D.**
- 57 SUBWOOFER SIMULATOR**  
Movie-theater sound you can actually feel!  
**Norman M. Hill**
- 56 PC SERVICE**  
Foil patterns for the Function Generator and the Subwoofer.

## TECHNOLOGY

- 61 THERMOELECTRIC COOLERS**  
A look at solid-state heat pumps.  
**John Potter Shields**

## CIRCUITS AND COMPONENTS

- 63 WORKING WITH OTA'S**  
An introduction to operational transconductance amplifiers.  
**Ray Marston**

## DEPARTMENTS

- 6 VIDEO NEWS**  
What's new in this fast changing field.  
**David Lachenbruch**
- 19 EQUIPMENT REPORTS**  
Fluke's *Series 90* microprocessor tester.
- 31 SERVICE CLINIC**  
Ghost busting.  
**Jack Darr**
- 69 HARDWARE HACKER**  
Refilling toner cartridges—and more!  
**Don Lancaster**
- 76 AUDIO UPDATE**  
Predicting the future of audio.  
**Larry Klein**
- 80 COMMUNICATIONS CORNER**  
When a shield isn't a shield.  
**Herb Friedman**



**PAGE 85**



**PAGE 57**

## AND MORE

- 118 Advertising and Sales Offices**
- 118 Advertising Index**
- 12 Ask R-E**
- 119 Free Information Card**
- 16 Letters**
- 101 Market Center**
- 15 New Lit**
- 24 New Products**
- 4 What's News**

## ON THE COVER

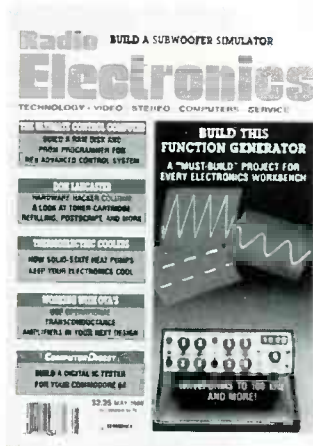

Gone are the days when a simple sine or square wave was sufficient to test electronic equipment. The diverse nature of today's electronics equipment demands more kinds of test signals, and control over their duration, size, and duty cycles. In short, what is needed is a laboratory-grade, multifunction signal generator, like the one we show you how to build on page 39. It delivers simultaneous square/triangle or square/sine output signals, as well as variable duty-cycle pulses and a linear-sawtooth ramp. With a built-in frequency counter, it is a truly versatile piece of test equipment.

## COMING NEXT MONTH

### THE JUNE ISSUE IS ON SALE MAY 3

#### BUILD A RADIATION DETECTOR

Test for radon gas, and other forms of radiation.

#### Radio Electronics ADVANCED CONTROL SYSTEM: PART 5

Add a universal input/output module

#### CALIBRATION

Why it's important, and who sets the standards.

#### COMPUTER DIGEST

All about mice.

As a service to readers, RADIO-ELECTRONICS publishes available plans or information relating to newsworthy products, techniques and scientific and technological developments. Because of possible variances in the quality and condition of materials and workmanship used by readers, RADIO-ELECTRONICS disclaims any responsibility for the safe and proper functioning of reader-built projects based upon or from plans or information published in this magazine.

Since some of the equipment and circuitry described in RADIO-ELECTRONICS may relate to or be covered by U.S. patents, RADIO-ELECTRONICS disclaims any liability for the infringement of such patents by the making, using, or selling of any such equipment or circuitry, and suggests that anyone interested in such projects consult a patent attorney.

RADIO-ELECTRONICS, (ISSN 0033-7862) May 1988. Published monthly by Gernsback Publications, Inc., 500-B Bi-County Boulevard, Farmingdale, NY 11735 Second-Class Postage paid at Farmingdale, NY and additional mailing offices. Second-Class mail registration No. 9242 authorized at Toronto, Canada. One-year subscription rate U.S.A. and possessions \$17.97. Canada \$23.97, all other countries \$26.97. All subscription orders payable in U.S.A. funds only, via international postal money order or check drawn on a U.S.A. bank. Single copies \$2.25. © 1988 by Gernsback Publications, Inc. All rights reserved. Printed in U.S.A.

**POSTMASTER:** Please send address changes to RADIO-ELECTRONICS, Subscription Dept., Box 55115, Boulder, CO 80321-5115.

A stamped self-addressed envelope must accompany all submitted manuscripts and/or artwork or photographs if their return is desired should they be rejected. We disclaim any responsibility for the loss or damage of manuscripts and/or artwork or photographs while in our possession or otherwise.

## Radio- Electronics

Hugo Gernsback (1884-1967) founder  
M. Harvey Gernsback,  
editor-in-chief, emeritus

Larry Steckler, EHF, CET,  
editor-in-chief and publisher

#### EDITORIAL DEPARTMENT

**Art Kleiman**, editorial director  
**Brian C. Fenton**, editor  
**Carl Laron**, WB2SLR, associate editor  
**Jeffrey K. Holtzman**,  
computer editor  
**Marc Spiwak**, associate editor  
**Jonathan A. Gordon**,  
assistant technical editor  
**Robert A. Young**, assistant editor  
**Julian S. Martin**, editorial associate  
**Byron G. Wels**, editorial associate  
**M. Harvey Gernsback**,  
contributing editor  
**Jack Darr**, CET, service editor  
**Robert F. Scott**,  
semiconductor editor  
**Herb Friedman**,  
communications editor  
**Robert Grossblatt**, circuits editor  
**Larry Klein**, audio editor  
**David Lachenbruch**,  
contributing editor  
**Don Lancaster**,  
contributing editor  
**Richard D. Fitch**,  
contributing editor  
**Teri Scaduto**, editorial assistant

#### PRODUCTION DEPARTMENT

**Ruby M. Yee**, production director  
**Robert A. W. Lowndes**,  
editorial production  
**Andre Duzant**, technical illustrator  
**Karen Tucker**, advertising production  
**Marcella Amoroso**, production traffic

#### CIRCULATION DEPARTMENT

**Jacqueline P. Cheeseboro**,  
circulation director  
**Wendy Alanko**,  
circulation analyst  
**Theresa Lombardo**,  
circulation assistant

Typography by Mates Graphics  
Cover photo by Nick Koudis

Radio-Electronics is indexed in  
*Applied Science & Technology Index*  
and *Readers Guide to Periodical Literature*.

Microfilm & microfiche editions are available. Contact circulation department for details.

Advertising Sales Offices listed on page 118.



# Eliminate Costly Guesswork And Interpretation Errors In LCR Testing!



- **Completely Analyze Capacitors**  
From 1pf to 20F for value, leakage, Dielectric absorption and ESR.
- **Thoroughly Test Inductors**  
From .1uH to 20H for value, opens and shorts even to one shorted turn!
- **Dynamically Test For Resistance**  
Measure resistances up to 1,000 Megohms, and leakage down to 1 microamp with 1,000 volts applied potential.
- **Good/Bad Tests Eliminal Guesswork**  
Exclusive good/bad readout gives you easy to read, reliable tests to internal EIA and industry standards
- **100% Portable**  
Works all day on one charge for testing in the field or on the bench.

**LC77 AUTO-Z™**  
Capacitor-Inductor Analyzer  
\$1895 Patented

IEEE 488  
BUS-COMPATIBLE



THE **Z** STANDARD

**SENCORE**

Call **1-800-843-3338** today.  
In Canada call **1-800-851-8866** today.

100% American Made CIRCLE 188 ON FREE INFORMATION

[www.americanradiohistory.com](http://www.americanradiohistory.com)

# WHAT'S NEWS

## Higher quality signals via CD radio system?

Digital Radio Labs, of Lomita, CA, has proposed a new music-broadcast service: 16 stereo channels of CD-quality digital music, 24 hours daily. Digital signals will be transmitted by satellite to local cable TV, MDS, and UHF-TV outlets for re-transmission to their customers as a premium pay-radio service for a low additional fee.

The special in-home receivers resemble FM tuners, and are expected to retail in the \$150 to \$200 range. Each contains a graphics/text generator, which connects to

a normal TV set, and can carry information about the music, or other text or art material.

The company expects the system to be fully operational by late 1988. For further information, contact Digital Radio Labs, P.O. Box 1256, Lomita, CA 90717.

## Multi-kilowatt fuel cells are operating in Japan

The first of Westinghouse's new solid-oxide fuel generators to be sent overseas have been put into operational research use by Tokyo Gas and Osaka Gas companies. Those third-generation Solid-Ox-

ide Fuel Cells (SOFC's) are rated at about 3 kilowatts and operate at a temperature of 1000°C.

The modules are 2.1 meters high by 2.4 meters wide by 0.8 meters deep, and weigh 1.3 tons. They consist of 144 single cells, each of which generates about 20 watts. Solid-oxide fuel cells operate by the reaction of coal-derived or natural gas fuel with the oxygen of the air.

Tokyo and Osada Gas are also operating first-generation fuel cells based on phosphoric acid, and second-generation cells using molten carbonate. R-E

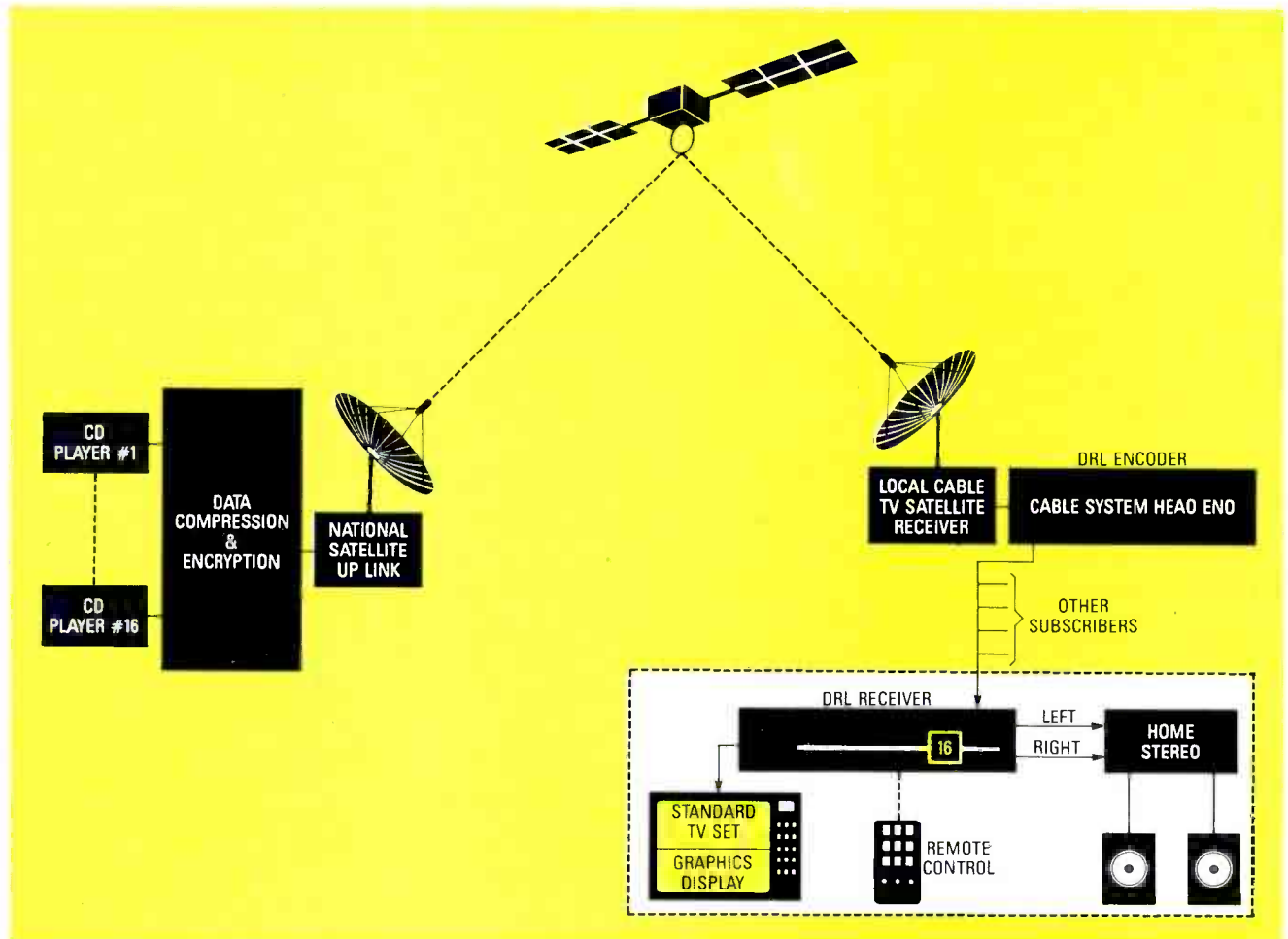

A CD MUSIC BY SATELLITE SYSTEM is shown here in block diagram form. The proposed system will broadcast 16 channels of music and text 24 hours a day.



# JDR INSTRUMENTS™

Complete customer satisfaction... superior service... friendly, knowledgeable personnel... quality merchandise... providing the best values in leading edge technology.

FULLY OVERLOAD PROTECTED

TRANSISTOR TESTER

9 FUNCTIONS 34 RANGES

CONDUCTANCE TESTER ADDS VERSATILITY

TEMPERATURE TESTER TO 2000° F



## Our DMM-300 A remarkable value! **7995**

This full function 3.5 digit DMM offers highly accurate performance and a host of added features to help you do the job—fast. Capacitance, transistor, temperature, conductance and audible continuity in addition to the ranges you'd expect from a DMM of this quality. Temperature probe, test leads and battery included. Input impedance: 10M ohm. Basic DC accuracy: plus/minus 0.25% Approx. 7" x 3 1/2" x 1 3/4" Wt. 13 1/2 ozs.

DC VOLTAGE TO 1000 VOLTS

AC/DC CURRENT 200µA to 10A

CAPACITANCE TESTER 2000pF to 20µF

### DPM-1000

**\$54.95**

3.5 DIGIT PROBE TYPE DMM

Custom 80 pin LSI chip provides accuracy and reliability in such a compact size. Autoranging, audible continuity and data hold feature help you pinpoint the problem quickly. Case and batteries included.

- Basic DC accuracy: plus/minus 1%
- DC voltage: 2v-500v, autoranging
- AC voltage: 2v-500v, autoranging
- Resistance: 2k ohms-2M ohms, autoranging
- Fully over-load protected
- Input impedance: 11M ohm
- Approx. 6 1/2" x 1" x 3/4" Under 3 ozs.



- ★ **2 YEAR REPLACEMENT WARRANTY**
- ★ **30 DAY MONEY BACK GUARANTEE**
- ★ **TOLL FREE TECHNICAL SUPPORT**
- ★ **NEXT DAY AIR SHIP AVAILABLE**

### MODEL 2000 **\$389.95**

20 MHz DUAL TRACE OSCILLOSCOPE

Model 2000 makes frequency calculation and phase measurement quick and easy. The component tester aids in fast troubleshooting. Service technicians appreciate the TV Sync circuits for viewing TV-V and TV-H and accurate synchronization of the video signal, Blanking, VITS, and V/H sync pulses.

- ★ Exceptionally bright 5" CRT
- ★ Built-in component tester
- ★ TV Sync filter
- ★ X-Y operation • 110/220 volts

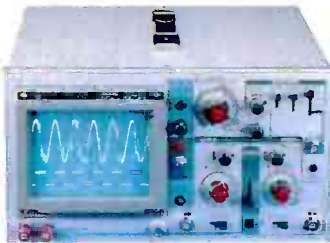

### MODEL 3500 **\$499.95**

35 MHz DUAL TRACE OSCILLOSCOPE

Wide bandwidth and exceptional 1mV/Div sensitivity make the Model 3500 a powerful diagnostic tool for engineers or technicians at a remarkable price. Delayed triggering allows any portion of a waveform to be isolated and expanded for closer inspection. Variable Holdoff allows stable viewing of complex waveforms.

- ★ Exceptionally bright 5" CRT
- ★ Delayed and single sweep modes
- ★ Z axis intensity modulation
- ★ X-Y operation • TV sync filter
- ★ Fast 10ns rise time

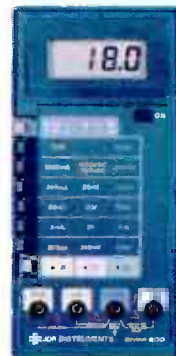

### DMM-200

**\$49.95**

3.5 DIGIT FULL FUNCTION DMM

Get highly accurate performance at a very affordable price. Rugged construction, 20 amp current capability and 22 ranges make it a perfect choice for serious field or bench work. Lo battery indicator and tilt-stand. Probes and 2000 hour battery included.

- Basic DC accuracy: plus or minus 0.25%
- DC voltage: 200mv-1000V, 5 ranges
- AC voltage: 200mv-750V, 5 ranges
- Resistance: 200 ohms-20M ohms, 6 ranges
- AC/DC current: 200µA-20A, 6 ranges
- Input impedance: 10M ohm
- Fully over-load protected
- Approx. 7" x 3 1/2" x 1 1/2" Wt. 11 ozs.



### DMM-100

**\$29.95**

3.5 DIGIT POCKET SIZE DMM

Perfect for the field service technician. Shirt pocket size without compromising features or accuracy. Large, easy to read 1/2" LCD display. Fully overload protected for safety. 2000 hour battery life with standard 9v cell. Probes and battery included.

- Basic DC accuracy: plus/minus 0.5%
- DC voltage: 2v-1000v, 4 ranges
- AC voltage: 200v-750v, 2 ranges
- Resistance: 2k ohms-2M ohms, 4 ranges
- DC current: 2mA-2A, 4 ranges
- Input impedance: 10M ohm
- Fully over-load protected
- Approx. 5" x 3" x 1". Under 7 ozs.

CIRCLE 59 ON FREE INFORMATION CARD

COPYRIGHT 1987 JDR MICRODEVICES

JDR INSTRUMENTS, 110 KNOWLES DRIVE, LOS GATOS, CA 95030  
RETAIL STORE: 1256 SOUTH BASCOM AVE, SAN JOSE, CA (408) 947-8881

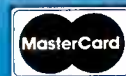

**ORDER TOLL FREE 800-538-5000**

# VIDEO NEWS



**DAVID LACHENBRUCH**  
CONTRIBUTING EDITOR

● **Stereoscopic TV.** The subject of stereoscopic, or 3D TV continues to carry an aura of fascination, even though: (1) 3D movies have failed in every attempt to foist them on the public. (2) Stereoscopic 35-mm still photography, which reached the craze stage shortly after World-War II, abruptly ended in dismal failure. (3) No one has yet devised a practical system of 3D photography or cinematography that doesn't require the use of viewing glasses (holography, which holds out hope for the future, can't yet be considered a practical system). (4) Every system ever demonstrated has the potential for creating nausea and headaches for viewers.

With those qualifications, we are pleased to report the following developments:

● **3D TV on the air.** As of our deadline, the first network-TV program broadcast in 3D is scheduled to air this month. It is the season's finale of *Moonlighting*, on ABC-TV. That program will use a stereoscopic process that developers claim is completely compatible; that is, those without viewing glasses don't see the customary double image.

Called *Nuoptix*, the system exploits a new variation of a technique that has been proposed many times for stereoscopic television. That is the *Pulfrich effect*, which combines a time delay between left and right images with movement on the screen to produce a "compatible" 3D effect. In the system, each eye sees a slightly different image as the result of camera panning or lateral movement of objects on the screen, and the brain translates that into a depth effect.

The glasses used for *Nuoptix* have one deep purple filter and one pale green filter to provide the unequal time delays to the eyes. The TV picture is on film, shot with a high-speed camera using a single lens and a proprietary film-to-video transfer system. Coca-Cola, the sponsor of the final program, says that it will distribute some 40,000,000 pairs of glasses in 40,000 retail outlets. *Nuoptix* says that the process has potential uses in home video.

● **And another one.** Another claimed compatible system, called *Aspex*, has been developed in England. Although *Aspex's* developers say that it's not based on the *Pulfrich effect*, that system also depends upon motion on the screen. *Aspex* is filmed using a Panavision camera whose rotary shutter is modified so that two side-by-side openings replace the single opening that normally exposes the film. One opening is covered by a red filter, the other by a cyan filter, and those are used to expose film frames sequentially.

The viewer uses glasses with one red filter and one cyan filter to observe a subtle effect of separation of foreground from background objects. As in the *Nuoptix* system, the stereo effect disappears when the foreground object or the camera is stationary. Unlike the *Nuoptix* system, there is a noticeable color-fringing effect around moving objects when the picture is viewed without the glasses.

And about the glasses: Those currently use glass lenses and are expected to sell for perhaps \$15 to \$45 a pair. The British developers of the system expect them to become a much-wanted "fashion item" for the youth market, and say that the glasses will be useful for 3D billboards and magazines.

Some day, television pictures will produce a true depth illusion without resorting to cumbersome glasses. Unfortunately, it appears that that day is hardly here.

● **Goals to Newcastle.** Two Japanese TV manufacturers with American assembly plants have announced they'll soon start exporting color sets from the U.S. to Japan. Toshiba says that starting April 1 it will ship about 100,000 color TV sets from its Lebanon, TN factory to its home country, and, beginning next year, Matsushita plans to ship 25- and 31-inch sets across the Pacific from its facility in Franklin Park, IL. Sony, which already ships U.S.-made Trinitron picture tubes from San Diego to Japan, says complete sets may follow in 1989.



**HANDHELD DIGITAL IC COMPARATOR/TESTERS FEATURE 20 CHANNEL LOGIC MONITOR**

B&K-PRECISION's Model 550 and 552 IC Comparator/Tester/Logic Monitors test IC's by comparison to a known good reference in one simple operation. As logic monitors, they simultaneously indicate the logic states of up to 20 IC pins. They test most 14 to 20 pin, 54 and 74 Series TTL (Model 550) or 4000 and 74C Series CMOS (Model 552) devices. Both models are available from distributors at \$395. Contact your local distributor or: B&K-PRECISION, Maxtec Int., 6460 W. Cortland St., Chicago, IL 60635. (312) 889-9087.



**LOGIC/PULSER PROBES HELP LOCATE DIGITAL FAULTS IN LAB OR IN FIELD SERVICE**

B&K-PRECISION now offers logic and pulser probes to fill the needs of engineers and technicians. The DP-21 is a 20 MHz probe that also displays pulse presence and logic status. Both LED and audible logic state indicators are featured. The DP-31 pulser probe can be used alone or with a logic probe or scope. It produces a 10µS pulse at 0.5 or 400 PPS rates and features an external square wave and synchronizing terminal. Both probes are multi-family compatible. The DP-21 is \$32. The DP-31 is \$33. Contact your local distributor or: B&K-PRECISION, Maxtec Int., 6460 W. Cortland St., Chicago, IL 60635. (312) 889-9087.

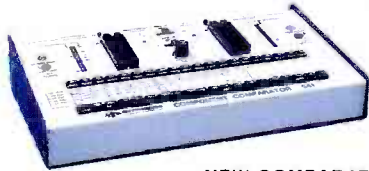

**NEW COMPARATOR**

**ADDS IC/COMPONENT TESTING TO SCOPE**

Test virtually any type of passive or active component or module with B&K-PRECISION's new 541 Component Comparator. The 541 is designed for use with the 540 component tester or virtually any x-y oscilloscope. It is well suited for both in-circuit and out-of-circuit tests. It's fast and easy to use. Unlike single function testing, the 541 can be used on series, parallel or series/parallel circuits. \$395. Contact your local distributor or: B&K-PRECISION, Maxtec Int., 6460 W. Cortland St., Chicago, IL 60635. (312) 889-9087.



**NEW COMPONENT TESTER LOCATES FAULTS ON UNPOWERED BOARDS IN FIELD OR PLANT**

The new Model 540 component tester is an extremely cost effective, highly flexible trouble-shooting aid that can assist in rapidly locating faults on unpowered boards. Faults can be traced to the component level without specific circuit knowledge. Individual components can also be tested. Test results are displayed as a curve on a built-in CRT display. Curve tracing allows matching of components. Two channels allow production testing against known good boards. Ideal for field service or production testing. \$995. Contact your local distributor or: B&K-PRECISION, Maxtec Int., 6460 W. Cortland St., Chicago, IL 60635. (312) 889-9087.



**PROGRAMMABLE IC TESTER TESTS TTL, CMOS, RAM AND ROM IC'S, IN OR OUT-OF-CIRCUIT**

Called the "first cost-effective way to test IC's both in and out-of-circuit," the new B&K-PRECISION Model 560 fills the void between basic component testers and costly ATE systems. Over 1500 different 14 to 24 pin devices can be tested, including TTL and CMOS digital IC's, RAMs and ROMs. The 560 speeds testing, simplifies diagnostics and doesn't require prior test skills. Plain-English user prompts guide every step of operation. Test results are displayed as positive "pass" or "fail." Test results can be fed to a printer. Applications include incoming inspection, QC, production line testing and troubleshooting faulty products. \$3,500. Contact your local distributor or: B&K-PRECISION, Maxtec Int., 6460 W. Cortland St., Chicago, IL 60635. (312) 889-9087.

**B&K-PRECISION**  
has what you need for  
fast, cost-effective  
IC or board testing.

Check it out!

- Programmable in/out-of-circuit IC tester
- Portable curve tracing component tester
- Portable IC comparator tester/logic monitors
- Benchtop IC component comparator tester
- Multi-family compact pulser probes
- Memory-mode multi-family logic probes

Whether your needs are for production board testing, incoming inspection or field service, B&K-PRECISION has you covered with time saving, accurate digital test products.

The Model 560 Programmable In/Out-of-circuit IC Tester is the first cost-effective way to rapidly test IC's both in and out-of-circuit. Punch up the number you need from a resident memory of over 1500 TTL, CMOS IC's, RAM's and ROM's.

The Model 540 Component Tester locates faults on unpowered boards, down to the component level. Curve-tracing method also allows fast comparison at components or boards.

The Model 541 Component Comparator is a companion instrument for use with your scope or the 540. It tests IC's, semiconductors, capacitors, inductors, transformers and more.

The Models 550 and 552 IC Comparator Tester/Logic Monitors are hand-held portables for TTL and CMOS applications. In-circuit dynamic tests compare a known-good IC to an on-board IC. A 20-channel logic monitor is built-in.

The B&K-PRECISION digital test line-up is rounded out by convenient and economical pulser and logic probes.

For immediate delivery or complete specifications and applications information, call your local distributor or B&K-PRECISION.



**BK PRECISION**

MAXTEC INTERNATIONAL CORP.

6460 West Cortland St. • Chicago, IL 60635 • 312-889-9087

International Sales, 6460 W. Cortland St., Chicago, IL 60635

Canadian Sales, Atlas Electronics, Ontario

South and Central American Sales, Empire Exporters, Plainview, NY 11803

## REASONS FOR SELECTING CIE

- Approved for educational benefits under the G.I. Bill for Veterans and other eligible persons.
- CIE provides printed job resumes, letters of recommendation, and lifetime Employment Service for all graduates at no extra charge.
- State-of-the-Art laboratory equipment is yours to keep and it comes assembled, ready for hands-on-experiments.
- Only CIE offers an Associate Degree program based on actual study time used. The faster you complete your degree, the less your overall tuition.
- Upon graduation, CIE offers you free preparation to pass the Certified Electronics Technician Exam.



# CIE

**CLEVELAND INSTITUTE OF ELECTRONICS** 1776 East 17th Street • Cleveland Ohio 44114  
PHONE TOLL FREE 1-800-321-2155 / In Ohio 1-800-523-9109

# LEARNING...

## THE KEY TO SUCCESS

### A CAREER IN ELECTRONICS STARTS WITH CIE.

**F**or the last few years, the electronics field and related industries have been growing at an incredible pace. And today, a career in electronics offers more opportunities and greater rewards than ever before.

Just ask any of the many graduates of the Cleveland Institute of Electronics who have landed high-paying positions with aerospace, computer, medical and communications firms. They'll tell you success didn't come easy... but that CIE made it all worthwhile.

**SPECIALIZED TRAINING** CIE isn't just another be-everything-to-everybody correspondence school. We're accredited by the National Home Study Council. And with more than 1100 graduates each year, we're the largest independent home study school specializing exclusively in electronics. CIE has been training career-minded students like yourself for over 50 years and we know the business inside and out.



Some courses feature the CIE Microprocessor Training Laboratory, an integral part of computers. You'll gain all the practical experience needed to work with state-of-the-art equipment of today and tomorrow.

**PRACTICAL TRAINING** CIE students learn by doing, using sophisticated electronic learning tools that we've designed and developed. One such tool, our 4K RAM Microprocessor Training Laboratory, teaches programming, interfacing and lets you work with a broad range of computers in a way that working with a single, stock computer simply can't.

We combine that valuable hands-on training with our unique Auto Programmed® lessons, designed to teach you step-by-step and principle-by-principle. The result is practical training... the kind of experience you can put to work in the marketplace.

**PERSONALIZED TRAINING** While some of our students have a working knowledge of electronics others are just getting started. That's why we have 10 career course levels from Basic to Advanced. They let you start where you want. Learn at your own pace. And learn as much as you like. You can even earn an Associate in Applied Science Degree in Electronics. And when you need help, our trained professionals are on hand to assist you by phone or mail.

Learning electronics isn't easy, but getting started is. For a CIE catalog and enrollment information, just mail the coupon below. Or call toll-free 1-800-321-2155. In Ohio, call 1-800-523-9109.

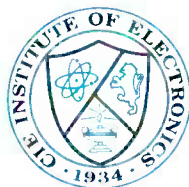

Accredited by the Accrediting Commission of the National Home Study Council, Washington, D.C.

CIRCLE 60 ON FREE INFORMATION CARD



**YES! I want to get started. Send me my CIE school catalog including details about the Associate Degree program.**

Print Name \_\_\_\_\_

Address \_\_\_\_\_ Apt. \_\_\_\_\_

City \_\_\_\_\_ State \_\_\_\_\_ Zip \_\_\_\_\_

Age \_\_\_\_\_ Area Code/Phone No. \_\_\_\_\_/\_\_\_\_\_

Check box for G.I. Bulletin on Educational Benefits

Veteran  Active Duty

**MAIL TODAY!**

**CIE** CLEVELAND INSTITUTE OF ELECTRONICS  
1776 East 17th Street, Cleveland, Ohio 44114

ARE 84

# ASK R-E

WRITE TO:

ASK R-E  
Radio-Electronics  
500-B Bi-County Blvd.  
Farmingdale, NY 11735

## LED VU METER

Is there any simple circuit I could use to have a series of LED's light in response to the volume of an incoming audio signal? The circuit should be battery powered and have a small amplifier in it to handle a variety of input signals.—J.K., Altoona, IA

What you're really talking about building is an LED VU meter. You could put one together with discreet parts but it's a lot smarter to use an LM3915. That IC has the buffers, drivers, and precision voltage reference on board to do the job. Best of all, they're not expensive and you can probably find one at your local supplier.

A circuit that does what you ask is shown in Fig. 1. You didn't say what kind of audio signal would be used as the input, but, as you can see from the schematic, the circuit has both a microphone and line-level input.

You only need two of the four

op-amps in the LM3900 package implement the basic circuit. You can use the extra amps to provide more gain, more inputs, etc. As shown in Fig. 1, I've elected to use them for additional inputs, but you can change that and use them for anything else you have in mind.

Switch S2 is used to change the display from a dot to a bargraph. You can use any construction technique you want. The circuit doesn't draw much current, so a nine-volt battery will keep the circuit going for a long time.

## NiCd CHARGING

I have a personal CD player that uses a 4-cell NiCd battery pack marked "140 mA, 8 hours." An LED lets me know that it's time to recharge the batteries by lighting up when, under load, the voltage falls to 4.5. Is there a "volts-per-cell" figure I can look for so I don't have to go

through the full 8-hour charge cycle?—G.D., San Rafael, CA

The answer is a resounding yes, and no! One of the nicest features of NiCd batteries is that they have a pretty flat voltage-over-time curve. The voltage won't drop much below 1.1 until its stored energy is just about gone. The charging curve is the same. The voltage will rise to 1.2, or more, near the beginning of the charge cycle and stay there. The bottom line is that cell voltage isn't a reliable indicator of the state of charge.

The best way to determine whether a battery is fully charged is to monitor the charging current. That may or may not be possible in your case, since it depends on the design of the charger. If your charger is a variable-current type, you can get an idea of the state of charge by watching the current—the lower the draw, the closer the cell is to a full charge.

You haven't told me enough for me to know what kind of charger you have, but the "8-hour" figure is a clue. The safest charging rate for a NiCd cell is the "C10" rate, where the charging current is limited to 1/10th the cell capacity. That trickle rate usually calls for a charging time of 14 or 15 hours. In your case, the 8-hour figure seems to indicate a higher charging rate—probably C6 or so—and a charger like that has to have some provision to drop the charging current as the cell accumulates energy. If it didn't, the internal cell chemistry would produce oxygen faster than it could be absorbed by the electrolyte, and the internal pressure would rupture the cell. Consumer units aren't designed like that.

Put an ammeter between the

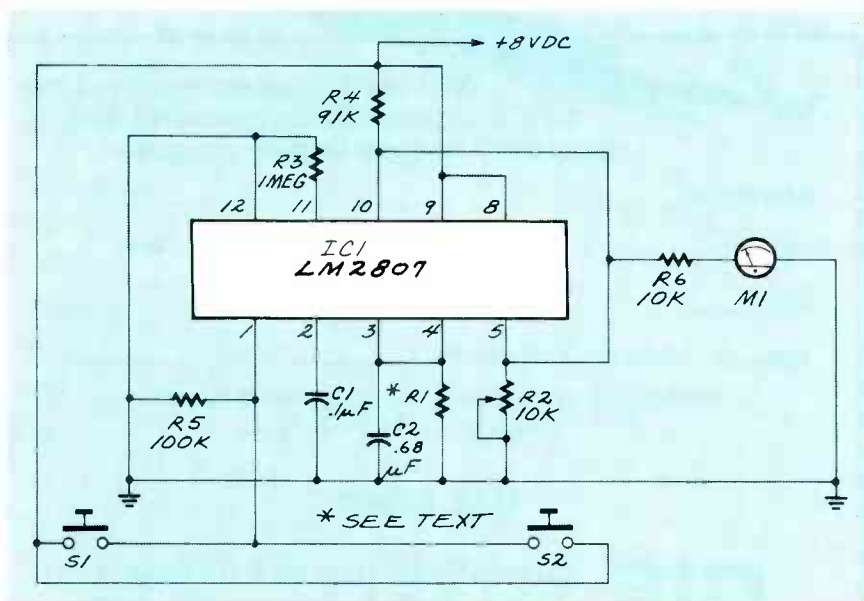

FIG. 1

charger and a completely discharged battery pack. The initial charging current will be high and rapidly fall off. Sometime during the 8-hour charge, the current draw will stabilize at one rate as the cell goes into a trickle charge. As soon as that happens, it's a safe assumption that the battery is fully charged.

Keep a log of the charging current over time for the complete 8-hour cycle; 15-minute increments are good. I know it's a drag but you only have to do it once. Graph the results and you'll be able to figure out exactly when the charger dropped to a trickle charge rate. Since the trickle charge is probably just maintaining the charge rather than adding energy, you can end the charge cycle there.

#### HELP WITH HEARING-AID PROBLEM

Can you help me with the design of a hearing aid? The units I've found aren't made with the bass boost and mid-range attenuation that I need.—J.B.C., McLeansville, NC

I have a personal interest in hearing problems so I'm surprised that you can't find a hearing-aid or have one especially tailored to give you the frequency response that you require. I contacted several otolaryngologists (ear, nose, and throat specialists), two of whom are specialists in audiology. They agreed that hearing aids can be made with response curves that complement the exact hearing curves of the user's ears.

Off-the-shelf hearing aids are made with a large variety of response curves. Until recently, most attention was paid to the high end of the hearing range, and designers made no effort to shape the low end to the user's needs. Now, most makers have some models with low-end boost. If you are going to a "hearing-aid center," be sure to select one that will permit you to try and wear several models until you find one that is satisfactory.

If you can't be fitted at a center, ask your physician to recommend an otolaryngologist who specializes

in audiology. He, or she, should be able to fit you with a suitable hearing aid.

#### SPEAKER OVERLOAD

I have a new pair of 4-ohm B.S.M. speakers that can handle up to 200 watts. The stereo amplifier is a Yamaha CR-44 that delivers up to 50 watts into 8 ohms. The problem: Each time that I bring the volume up to about half scale, distortion begins and then the speaker's thermal circuit breakers trip. The amplifier indicates only about 30 watts peak when the breakers open.—M.B., Opasatika, Ont., Canada

The trouble may be due to the fact that the amplifier is working into 4-ohm loads instead of the 8 ohms it is designed for. Some amplifiers can become unstable and develop inaudible oscillations, either below or above the normal audio spectrum, when driven hard while only lightly loaded.

The amplitude of those oscillations can be high enough to overload the amplifier and/or the speakers. You should be thankful

# PACESETTER PRODUCTIVITY

100 MHz TEK 2246A/2245A

Smart scopes, perfect setup! Tek sets the new, fast pace for frequent measurements with automatic front panel setup. Nonvolatile memory for up to 20 front-panel setups (2246A). Time and voltage cursors. Exclusive SmartCursors™ track waveform changes for voltage measurements. All backed by Tek's 3-year warranty.

NEW



Call Tek direct  
for PaceSetter specs!  
**1-800-426-2200**

Prices subject to change without notice.

Copyright ©1988, Tektronix, Inc. All rights reserved. TTA 906-A

**Tektronix**  
COMMITTED TO EXCELLENCE

CIRCLE 181 ON FREE INFORMATION CARD

Put Professional Knowledge and a  
**COLLEGE DEGREE**  
in your Technical Career through  
**HOME STUDY**

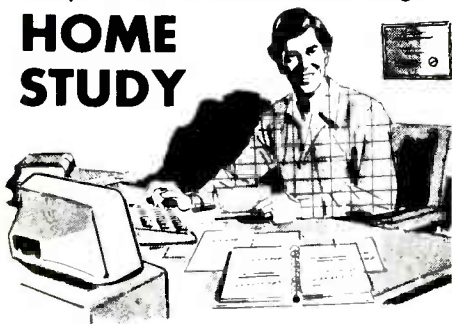

Add prestige and earning power to your technical career by earning your Associate or Bachelor degree through directed home study.

No commuting to class. Study at your own pace, while continuing on your present job. Learn from easy-to-understand lessons, with help from your Grantham instructors when you need it.

Grantham College of Engineering is a specialized institution catering to adults who are employed in electronics and allied fields such as computers. These fields are so enormous that opportunity to *move up* is always present. Promotions and natural turn-over make desirable positions available.

An important part of being prepared to *move up* is holding the proper college degree, but the essential part is *really knowing your field*. Grantham offers two B.S. degree programs — one with major emphasis in *electronics* and the other with major emphasis in *computers*. Both programs are offered by correspondence.

Write for our free catalog (see address below) or telephone us at (213) 493-4421 (no collect calls) and ask for our "degree catalog."

Accredited by  
the Accrediting Commission of the  
National Home Study Council

**GRANTHAM**  
**College of Engineering**  
10570 Humbolt Street  
Los Alamitos, CA 90720

that your speakers are protected by thermal circuit breakers. Otherwise, you would have to replace the speakers or have them repaired without finding and eliminating the cause of the problem.

Try working the amplifier into 8 ohms and see how it performs. Try connecting a 4-ohm, non-inductive power resistor in series with each speaker. A pair of 8-ohm, 20-watt non-inductive resistors (Radio Shack No. 271-120 or equal) connected in parallel will serve as the 4-ohm series resistor. If the system works OK without tripping the breakers, you've probably found the trouble. Your amplifier may be particularly sensitive to loads lower than their design center, or to loads having the characteristics of your 4-ohm speakers.

**HUM FROM CABLE-TV CONVERTER**

I have trouble with the Zenith Z1000 converter supplied by the cable-TV company. I hear a 60-Hz hum coming from the TV speaker when the incoming TV signal passes through the converter. The hum is not present when the signal comes directly from the cable or from a VHF or UHF antenna. A service "technician," sent by the cable company, at first claimed that he didn't hear the hum. Finally, when he did hear it, he said that nothing can be done about it. Is there anything that I can do, short of modifying the company's converter, to eliminate the hum?—B.B., W. Henrietta, NY

My guess is that trouble in the converter's power supply is allowing a 60-Hz hum voltage to modulate the TV signal being fed to the TV set. However, there is a remote possibility that the trouble is originating in the TV set but does not show up until the converter is connected to it. To eliminate that possibility, substitute another TV set and see if the hum is still present.

Try reversing the AC-line plug in the receptacle and see if that affects the hum level. Also, try another patch cable between the converter output and the antenna terminals on the TV set. Sometimes, an open ground (shield) can cause hum to develop.

If you can't locate the hum source, take the converter to the company's office and ask them to exchange it for another. R-E

**NEW FROM ETT**



**RATCHET — ELEVEN-PIECE RATCHET TOOL KIT.....\$10.00.** Includes reversible ratchet handle, extension bar, six bits, two precision screwdrivers, and a cutter. Comes in fitted case. Get one for your shop, another for your car, another for your tool kit.

**TOOL KIT—NINE-PIECE TOOL KIT.....\$10.00.** Includes saw, bubble level, three screwdrivers, torque multiplier, calipers for inside and outside measurements, nippers, and a tape measure.



**BP233—ELECTRONIC HOBBYISTS HANDBOOK.....\$7.95.** Provides an inexpensive single source of easily located data that the electronics enthusiast is likely to need in his day-to-day hobby activities. 8 x 10 inches.

**BP232—CONCISE INTRODUCTION TO MS-DOS.....\$5.95.** If you are a PC user and want to get the most out of your computer, you must learn its MS/PC-DOS operating system. That's what this book shows you.



**BP194—MODERN OPTO DEVICE PROJECTS.....\$6.25.** Provides a number of practical designs that use opto-electronic devices such as fiber optics, LEDs, and passive IR detectors.

**BP234—TRANSISTOR SELECTOR GUIDE.....\$10.00.** Prepared from a vast database of specifications. Unique guide offers a wide range of selection tables. More than 1400 devices are listed along with specs.



MAIL TO: Electronic Technology Today Inc.  
P.O. Box 240  
Massapequa Park, NY 11762-0240

SHIPPING CHARGES IN USA & CANADA  
\$0.01 to \$5.00 ..... \$1.00 \$30.01 to 40.00 ..... \$4.75  
\$5.01 to \$10.00 ..... \$1.75 \$40.01 to 50.00 ..... \$5.75  
\$10.01 to 20.00 ..... \$2.75 \$50.01 and above \$7.00  
\$20.01 to 30.00 ..... \$3.75

**OUTSIDE USA & CANADA**

Multiply Shipping by 2 for sea mail  
Multiply Shipping by 4 for air mail

Total price of merchandise ..... \$ \_\_\_\_\_  
Shipping (see chart) ..... \$ \_\_\_\_\_  
Subtotal ..... \$ \_\_\_\_\_  
Sales Tax (NYS only) ..... \$ \_\_\_\_\_  
Total Enclosed ..... \$ \_\_\_\_\_

Name \_\_\_\_\_  
Address \_\_\_\_\_  
City \_\_\_\_\_ State \_\_\_\_\_ Zip \_\_\_\_\_

# NEW LIT

**TEST- AND MEASUREMENT-INSTRUMENTS CATALOG.** The 1988 Transcat catalog is a comprehensive, 226-page book, divided into five categories of equipment: Electrical, Temperature, Pressure, Plant Maintenance, and Temperature Sensors. A small sample of the products mentioned includes multimeters, oscilloscopes, frequency generators, data-communications test equipment, logic probes and analyzers, digital temperature indicators and probes, pressure gauges, digital pressure indicators, tachometers and stroboscopes, analytical instruments, and thermocouples. The description of

each instrument includes full specifications. The catalog is indexed by product and by manufacturer. It can be ordered, free of charge, by calling 800-828-1470; in New York, 716-458-4801.—Transcat, Box D-1, Rochester, NY 14606.  
CIRCLE 20 ON FREE INFORMATION CARD

**PRECISION SWITCHES CATALOG.** Cherry Electrical Products' line of switches is described in catalog CE1287. It includes subminiature, sub-subminiature, ultra-subminiature, waterproof, international miniature, miniature panel-mount pushbutton, and general-purpose styles. Catalog descriptions include cut-away drawings of snap-action switches, engineering specifications, and operating characteristics. A selector/locator chart, plus alphabetical listing of all switch series, make it easy to find the type, size, and rated switch required. Catalog CE1287 is free.—Cherry Electrical Products, 3600 Sunset Ave., Waukegan, IL 60087.  
R-E

CIRCLE 21 ON FREE INFORMATION CARD  
continued on page 33

**NEW  
SUPER  
LONG PLAY  
TAPE RECORDERS**  
12 Hour Model — \$105.00\*

Modified Panasonic Slimline, high quality, AC-DC Recorders provide 6 continuous hours of quality recording & playback on each side of cassette for a total of 12 hours. Built-in features include:  
• Voice level control, • Digital counter, etc. TDK DC 120 Cassette Furnished.



**PHONE RECORDING ADAPTER**  
Records calls automatically. All Solid state connects to your telephone jack and tape recorder. Starts recording when phone is lifted. Stops when you hang up. \$24.50\*  
FCC APPROVED



**VOX VOICE ACTIVATED CONTROL SWITCH**  
Solid state. Self contained. Adjustable sensitivity. Voices or other sounds automatically activate and control recorder. Uses either recorder or remote mike. \$24.95\*  
\*Add for ship & hdg. Phone Adapter & Vox \$1.50 ea. Recorders \$4.00 ea. Cal. Res. add tax. Mail order, VISA, MIC, COD's OK. Money Back Guarantee. Qty. disc. ©  
Dealer Inquiries Invited, Free data.  
**AMC SALES INC.** Dept A 9335 Lubec St., Box 928, Downey, CA (213) 90421 Phone 869-8519



CIRCLE 108 ON FREE INFORMATION CARD

# PACESETTER PERFORMANCE

100 MHz TEK 2236/2235

100 MHz scope, counter, timer, DMM — just \$2795  
The ultra-versatile Tek 2236 makes measuring everything from frequency, period and width to delay time and  $\Delta$  time *push-button* easy — in addition to CRT display, you get digital readout display accurate to 0.001% and beyond. PaceSetter performance on a modest budget? Look at the 100 MHz, dual-trace Tek 2235 with the best of the basics — just \$1575!

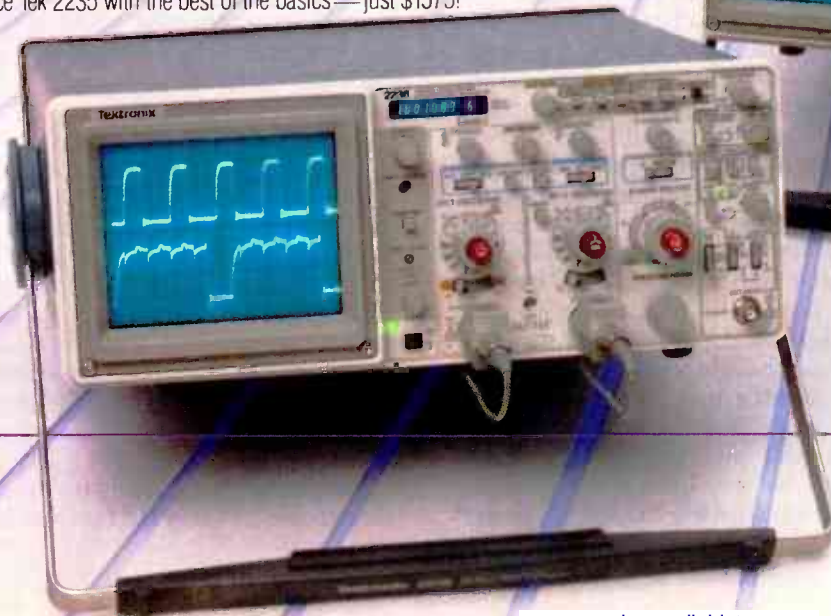
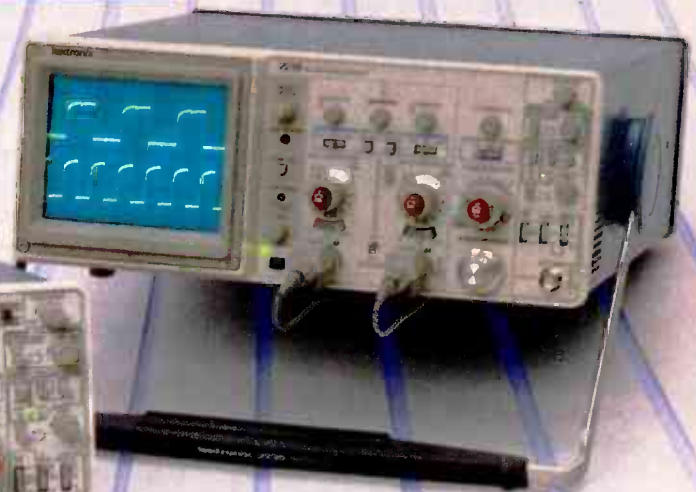

Call Tek direct  
for PaceSetter specs!  
**1-800-426-2200**

Prices subject to change without notice  
Copyright ©1988, Tektronix, Inc. All rights reserved. TA 906-B

**Tektronix**  
COMMITTED TO EXCELLENCE

CIRCLE 184 ON FREE INFORMATION CARD

# LETTERS

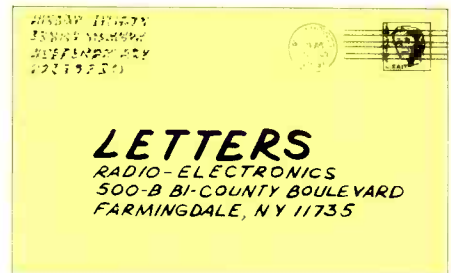

## SAY "NO" TO CENSORSHIP

Everyone keeps writing to you about how good your magazine is, and you can add my name to the list. I've enjoyed **Radio-Electronics** through the years, and look forward to it each month. Your overall view of all electronics, with computers added, is just the right touch. Don't change the format.

On the other hand, what ever happened to your pieces on satellite receivers? I've followed this subject with much interest, and would like to keep up with the latest information. Reading between the lines, a person could think that those articles have been dropped because of threats about lawsuits. I hope this is not the case.

I am apprehensive about censorship, and the censoring of technological ideas is particularly frightening. Several letters in recent months have argued against some articles you've printed, and I couldn't disagree more. **Radio-Electronics** is not showing "how to" evade radar speed traps, or break VideoCipher, but is giving *information* on how the technology works—two entirely separate concepts.

If we block the practice of technology exchange and discussion, how can we teach future generations? In the March 1988 "Letters" column, a young man gives thanks to **Radio-Electronics** for his education, training, and future. Can we stifle the future of others, because someone wants to curtail our exchange of ideas?

TOM KNIERIM  
Rock Port, MO

## LASER LISTENER

A letter I wrote appeared in **Radio-Electronics'** November 1987

"Letters" column. In it, I made two key points. First, federal law prohibits the assembly, possession and use of electronic eavesdropping devices. Second, **Radio-Electronics** erred in publishing plans for an electronic eavesdropping device and encouraging its readers to build and use it.

Please note that I did not chastise **Radio-Electronics** for publishing plans for a "Laser Listener" (October 1987). I did criticize the publication of such plans within the same article that encouraged the use of the device for illegal purposes.

Nevertheless, readers John Williams ("Letters," January 1988) and William Ritz ("Letters," February 1988) have criticized my letter. Mr. Williams implied that I oppose the Constitution's guarantee of freedom of the press. Mr. Ritz agreed with my contention that **Radio-Electronics** should warn its readers "...of the consequences of illegal usage..." But he incorrectly characterized me as wanting the magazine to withhold information. He implies that I also criticized the publication of "...detailed plans for various descramblers, decoders, transmitters..."—subjects not even mentioned in my letter. I'm offended that **Radio-Electronics** published letters criticizing my original letter for views it doesn't even contain.

As for the legal questions raised, thus far I've not seen **Radio-Electronics** take a stand. I believe, at this point, the magazine owes its readers an explanation of its position on the matter. Now that **Radio-Electronics** has been informed about the federal electronic eavesdropping law, does the magazine stand by the Richard Pearson's statement in the "Laser Listener"

article that "A better and safer way to bug a room is to use a laser beam to eavesdrop..."? Does the magazine stand by the article's subtitle, "Use a light beam to listen in to anything, anywhere, anytime," and the Table of Contents teaser, "Eavesdrop using a beam of light"?

Each of those quotes recommends that readers commit acts defined as felonies under state and federal statutes. It is entirely possible that **Radio-Electronics**, and Mr. Williams and Mr. Ritz, do not agree with those laws. I don't happen to agree with all aspects of them myself. On the other hand, I seriously doubt that your readers would want their homes monitored by a neighbor with a laser listener. Nor would **Radio-Electronics** want a competing publication to determine confidential publishing schedules with the help of such a device.

In recent years, the term "computer hacker" has been misapplied by the popular press to widely publicized computer criminals. That might happen to electronics experimenters if our magazines encourage us to build and use such illegal equipment as the Laser Listener.

FORREST M. MIMS, III

## AES AWARDS PROGRAM

The Audio Engineering Society Educational Foundation has announced the opening of its 1988 educational grant program for university studies with emphasis on audio topics. The awards—for graduate students only—are made annually. Successful applicants may request a one-time renewal of their grants.

Completed applications must be received by June 1 to be consid-



ered for the 1988-89 academic year. Additional information, and application forms, are available from:

AES EDUCATIONAL  
FOUNDATION  
60 East 42nd Street  
New York, NY 10165

### DESKTOP PUBLISHING/ PUBLISHING MANUALS

In his article, "Desktop Publishing," (*ComputerDigest*, March 1988) Josef Bernard reports a problem in *Ventura Publisher* relating to line positioning and spacing. He states, in the caption for Fig. 6, that there was no precise control of the free graphic horizontal line that was being placed over a mathematical symbol.

In both versions 1.0 and 1.1, the degree of control is set in the graphics-grid settings box. The grid resolution can be set as fine as .001 inch, or can be turned off entirely. That information is extremely difficult to locate in the *Ventura* user's guide.

It seems that the number of sec-

ond-party manuals available for a given product is dependent upon two major variables: market penetration and the quality of original documentation. Although alternate manuals provide a much-needed resource, why can't software vendors simply hire someone who has actually used the program to write the manual?

I'm sure there are many other people who have spent hours trying to decipher what the manual says, when what is actually needed is: Information which should have been translated from "program-ese;" information placed in a "convenient" (i.e., "somewhere else") appendix; information placed in a previous, or subsequent, section—like in another volume; or information not necessary because it is "self evident."

How about an article on both vendor-supplied and second-source user guides for some popular software? I suggest an evaluation based on such things as legibility, accuracy, completeness, and organization of material.

Thanks for a good article. I've been reading *Radio-Electronics* since I could afford a subscription.  
STEVE RUSSELL  
Redwood City, CA

### SPEAKER-LEAD RESISTANCE

In "Ask R-E" (*Radio-Electronics*, February 1988) the question on speaker-lead resistance was answered correctly, but not really completely.

Your answer addressed the problem of losses in the wiring, but there are two other effects that are more important in audio reproduction systems—frequency-response variations and damping reduction. The impedance of most speakers varies considerably over their operating range. A nominally 4-ohm speaker will go from perhaps 2 to 20 ohms over its part of the frequency spectrum. That impedance will typically contain large and varying reactive components also. If that were in series with as much as 1 ohm of wire, that effect alone would cause a frequency-response variation of

# PACESETTER PRICE

50 MHz TEK 2210/2225

Best-of-class performance at

**\$995/\$2195** Get the *PaceSetter* start in digital storage with Tek's NEW 50 MHz 2210. Featuring 20 MS/s per channel digitizing, 4K record length per channel plus familiar, full-bandwidth analog operation for just \$2195. And for pure and simple analog performance with unmatched economy, look at the popular, 2-channel Tek 2225—just \$995!

**NEW 2210**  
20 MS/s per channel

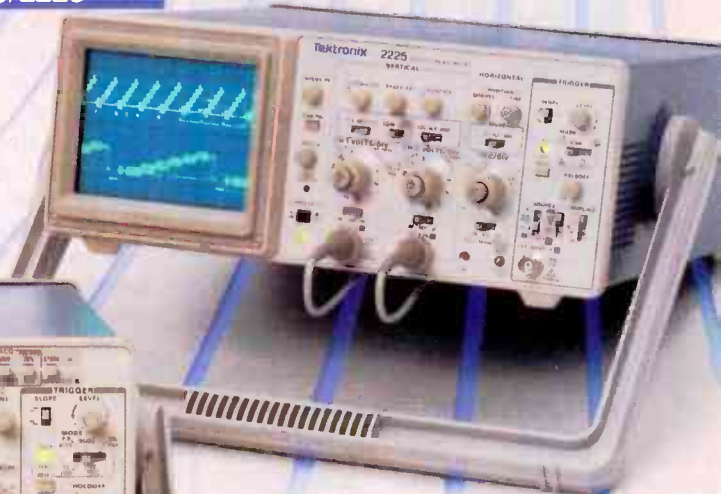
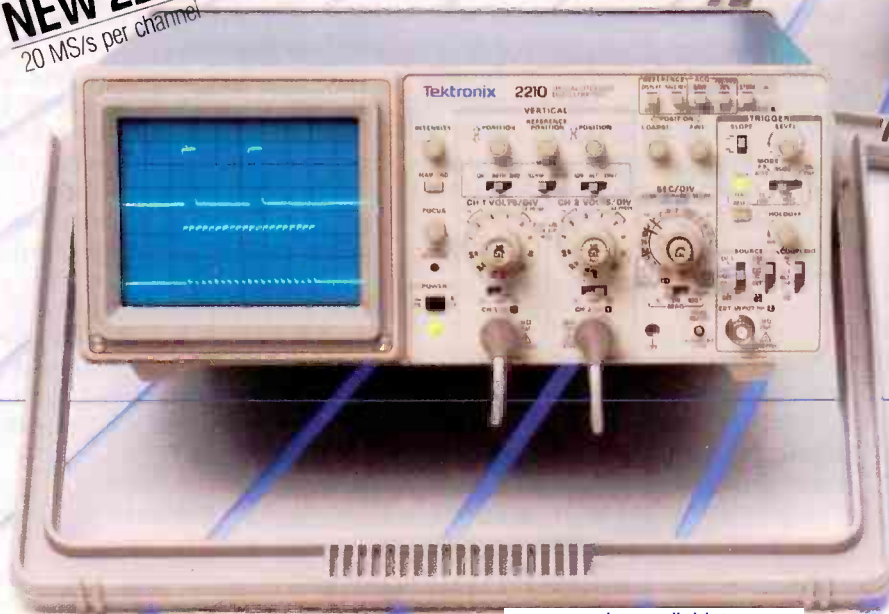

Call Tek direct  
for PaceSetter specs!  
**1-800-426-2200**

Prices subject to change without notice  
Copyright ©1988, Tektronix, Inc. All rights reserved. TTA 906-C

**Tektronix**  
COMMITTED TO EXCELLENCE

CIRCLE 182 ON FREE INFORMATION CARD

# Free Famous hi-tech catalog



A very special guide to what the exciting world of computer and electronics kit-building can do for you.

The informative Heathkit Catalog shows you more than 450 exciting electronic products that will challenge, instruct, and entertain you. You'll find countless kits that you can build and enjoy, from computers and robots to color tv's and a variety of home products. And each is backed by our years of experience and our promise, "We won't let you fail!"

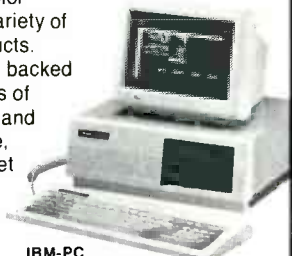

IBM-PC Compatible Expandable Computers



HERO® 2000 Educational Robot and Courseware

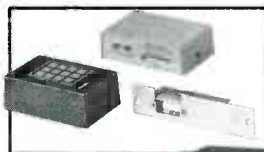

Precision Test Instruments

Electronic Keyless Doorlock



PackKit Multi-Mode TNC



Send NOW for your FREE Heathkit Catalog.

Send to: Heath Company, Dept. 020-652  
Benton Harbor, Michigan 49022

Name \_\_\_\_\_

Address \_\_\_\_\_

City \_\_\_\_\_ State \_\_\_\_\_ Zip \_\_\_\_\_

A subsidiary of Zenith Electronics Corporation CL-784R3

**Heathkit**  
Health Company

3.1dB—not an attractive prospect for anyone who has spent money to squeeze down such variations in his system.

The damping effect pertains to rise and hangover of transient sounds. That can be demonstrated with pulsed sine-wave tests. For a few years, those were a standard part of the tests done by audio magazines, but they had difficulty correlating the results with the sound. Since those tests are not part of any industry-standard test regimen, the magazines dropped them. (I think that they should try harder!)

High-fidelity speakers are designed to give proper response when driven from a zero-impedance ("constant-voltage") source. The cone position, or velocity, should correspond exactly with the voltage input. If a resistance, such as the 1 ohm mentioned above, is in series with the speaker, increased rise time and hangover of intrinsic speaker resonances will blur and color the sound. Power amplifiers are designed to have very low output impedances, usually on the order of hundredths or thousandths of an ohm, for just that reason.

There are a few rare amplifiers that run a feedback wire directly from the speaker to get the wiring in the loop, making only the losses important. However, as far as I know, none of those is available for autos.

Thus, the proper policy is to keep the wiring in series with a speaker at, say, a tenth of the lowest speaker impedance or less. For most auto-speaker runs, I would guess 14- or 16-gauge wire would suffice. At home I use 12-gauge for 20- to 25-foot runs. It's hard to find nice fine-stranded wire larger than 12-gauge for less than a king's ransom. Of course, two or more 12-gauge wires can be paralleled.

W.J. NEWELL  
Richardson, TX

## DIGITAL TACHOMETER

I recently built the Digital Tachometer that appeared in the June 1987 issue of *Radio-Electronics*, and it works very well. It is the only digital tachometer circuit I've ever seen that offers accurate

tachometer readings without calibration. That is accomplished by the use of a built-in 60-Hz crystal-controlled time base. The author is to be congratulated on that fine project.

It worked perfectly on several standard and Capacitive-Discharge (C-D) ignition systems. However, the tachometer will not work on some C-D systems that use input-triggering circuits that generate extremely low pulse levels across the ignition points. On one such system, which incorporates an unusual triggering network designed primarily to eliminate point "bounce" or "flutter" at high engine speed, the pulse obtained across the ignition points was far too small for tachometer pickup.

To eliminate that problem, I used a miniature broadband amplifier between the ignition points and the tachometer input. I chose the broadband amplifier described by Earl "Doc" Savage in "Hobby Corner" in the April 1980 issue of *Radio-Electronics*. It is small enough to fit easily within the tachometer enclosure. I added a switch to allow the amplifier to be switched in or out of the circuit.

I hope that my solution may prove useful to other readers experiencing similar difficulties. Many thanks for a fine magazine.  
PAUL SCHULTZ  
Carmichael, CA

## CALIBRATING VCR COUNTERS

I thought Fred Blechman's article, "Calibrating VCR Counters," (*Radio-Electronics*, January 1988) was interesting—but for cable subscribers there's a technique that's even easier.

Most cable systems use one channel as a 24-hour menu that shows program listings. At the top corner of the screen the day, date, and exact time are displayed. Just set your VCR to record for six hours, starting at any convenient on-the-hour time, and you will have accomplished the same thing Mr. Blechman did with a camera. Of course, that procedure must be repeated for each speed, plotting the results described in the article.  
GEORGE BERNSTEIN  
Tamarac, FL

*continued on page 79*

# EQUIPMENT REPORTS

## Fluke 90 Series Microprocessor Board Tester

Speed your testing of  
microprocessor-based  
systems.



CIRCLE 49 ON FREE INFORMATION CARD

Inc. (P.O. Box C9090, Everett, WA 98206) and N.V. Philips.

The 90 Series is available for the Z80, 6809, and 8085 microprocessors, and it is likely that future models will handle other microprocessors. We examined the tester for the Z80.

The tester is housed in an 11×6×3-inch package and weighs just over two pounds. A 2-line, 32-character LCD and 24-key keypad dominates the front panel. Sixteen of the keys form a hex keypad; the other eight are used to initiate and control various tests. Despite its powerful capabilities, the *Fluke 90* is surprisingly easy to use. But don't think that the tester is going to do all your work for you—it

IF YOU'VE EVER HAD TO DIAGNOSE problems in a microprocessor-based system, you know that finding the source of a problem can give you quite a headache. But put yourself in the place of an electronics technician who has to trace

and repair several such systems each day!

The only logical course of action is to get some help from a microprocessor-based tester, like the 90 Series microprocessor-board testers from the John Fluke Mfg. Co.,

## IESD-II PC/XT/AT BASED IC TESTER AND EPROM PROGRAMMER

IC TESTER: **\$349.00**

TTL — 74/54 SERIES  
CMOS — 40/45 SERIES  
SRAM — 2k — 32k  
DRAM — 4164, 41256, 4416, 4464

### EPROM PROGRAMMER:

FUNCTION MODES — READ, WRITE, BLANK CHECK, COMPARE, EDIT, FILE  
VOLTAGE LEVEL — SOFTWARE SELECTABLE (12.5V, 21V, 25V)  
WRITING MODES — INTELLIGENT, QUICK PULSE (SOFTWARE SELECTABLE)  
EPROM TYPES — 2716, 2732, 2764, 27128, 27256, 27512 (SOFTWARE SELECTABLE)

### EXPANDABILITY:

The IESD may be expanded to test 87-series microcontrollers, PAL's, P-ROM's, and many other device series by the addition of a "TEST BOX."

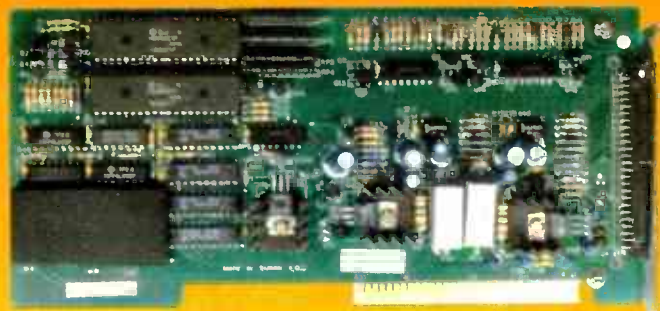
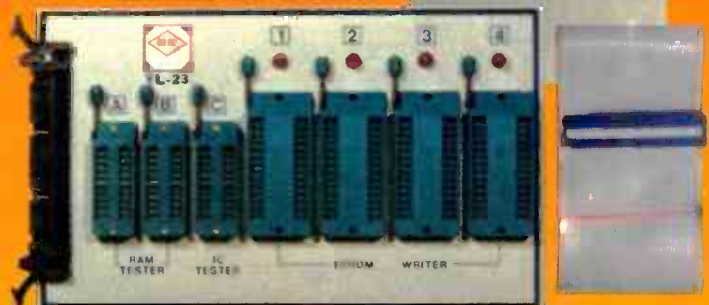
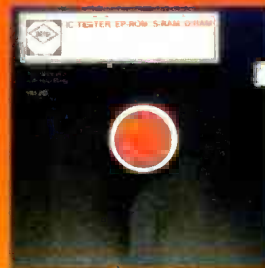

**R.S.R. ELECTRONICS, INC.**  
1560 HART STREET • RAHWAY, NEW JERSEY 07065  
(201) 381-8777 • TELEX NO.: 4940028 • FAX: (201) 381-1572

Please send \_\_\_\_\_ IESD-II units @ \$349.00 each.  
(NJ residents please add 6% sales tax) TOTAL \$ \_\_\_\_\_

- CHECK/MO  
 VISA  
 MASTERCARD

Name \_\_\_\_\_

Address \_\_\_\_\_

Card No. \_\_\_\_\_

City \_\_\_\_\_

Exp. Date \_\_\_\_\_ Signature \_\_\_\_\_

State \_\_\_\_\_ Zip \_\_\_\_\_

won't. It will make your work a lot easier by taking out some of the drudgery; but you have to know what you're doing. (You still make the decisions and the diagnoses.)

Setting up the tester consists of merely connecting its 40-pin test clip to the microprocessor you want to test, and plugging a supplied probe into the rear of the tester. The microprocessor to be tested is not removed from the circuit. To the contrary, the tester allows you to check some of the

microprocessor's circuitry, such as buffers, decoders, RAM, and ROM. In use, the tester emulates a DMA (Direct Memory Access) device, and forces the DMA and WAIT lines of the microprocessor under test, taking control of the bus from the microprocessor.

### Bus tests

Assuming that your power supply and clock are working correctly, the first thing to check if you have a problem in a micro-

processor system is the integrity of the bus lines. The *Flyke 90* offers several bus tests.

The primary use of the simple bus test is to check for bus lines that are shorted together, or for bus lines tied to the ground and supply lines. The test determines whether the data, address, and control lines can be driven by trying to force each line to a given state and then sensing whether that state was actually achieved. At the same time, it checks for shorts by making sure that nothing else on the bus changes state at the same time as the line being tested.

The simple bus test is a useful first test but, unfortunately, shorted bus lines are not the most likely problem to occur on a microprocessor board. What's more, they are among the easiest problems to diagnose, even without a dedicated tester. A second test, called the *ramp test*, allows you to make tests on the other side of address decoders and buffers. The test performs a memory write to each address in the microprocessor's memory space. That should, of course, enable all address decoders. The output of the decoders—or the CHIP-SELECT inputs of any memory IC's—can be monitored using an oscilloscope, a logic analyzer, or the probe supplied with the tester. Any lack of activity indicates a probable faulty component.

Shorted lines can be checked for during the ramp test by watching the frequency of each address line. As the complete address space is stepped through, the frequency of each line should be different—one half of the previous line's frequency. (Remember, the state of address line A0 changes each time the address is incremented. A1 changes every second increment, A2 changes every fourth increment, and so on.) The tester outputs a similar pattern on the data lines making data-bus shorts easy to find. A third bus test, called the *shift test*, is a variation of the ramp test. Only one address and data line is high at a time. That can make detecting some shorted lines easier. All of the bus tests can be made to cycle once, or to loop continuously.



# KIK

Factory Direct  
800-545-8784

Celebrating our 10th Year in U.S.A. . . .

Proven Quality . . .

Factory Direct Prices!

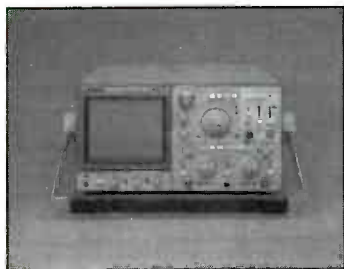

### COS 5100: 100 MHz

- 3 Channel, 8 Trace
- P-P level-lock auto-trigger
- Delayed Sweep

Now Only  
**\$999.00**

### COS 5042TM, 40 MHz **\$779.00**



#### COS 5041TM

- 40 MHz, Delayed Sweep
- 2 Channel
- Ch 1 Signal Output

**\$669.00**

#### COS 5021TM

- 20 MHz, Delayed Sweep
- 2 Channel
- Ch 1 Signal Output

**\$489.00**

255 Frequency Counter:  
150 MHz **\$299.00**

FCO1130 Frequency  
Counter: 1GHz **\$739.00**

677D Wow and Flutter  
Meter **\$949.00**

6701 Wow and Flutter  
Meter **\$999.00**

#### COS 5040TM

- 40 MHz
- 2 Channel
- CH 1 Signal Output

**\$639.00**

#### COS 5020TM

- 20 MHz
- 2 Channel
- CH 1 Signal Output

**\$449.00**

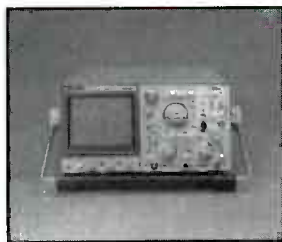

### COS 5060TM

- 3 Channel, 8 Trace
- P-P level-lock auto-trigger
- Delayed Sweep

**\$889.00**

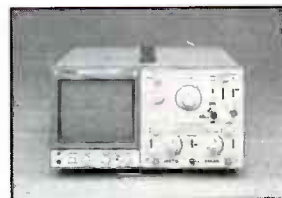

Add \$15 per unit shipping and handling.

**(800) 545-8784**

**(213) 371-4662**  
Collect CA & AK

Local Service Centers  
Nationwide



Kikusui International Corp.  
19601 Mariner Avenue  
Torrance, CA 90503

©Copyright Kikusui International Corp. 1988

CIRCLE 185 ON FREE INFORMATION CARD

## Memory and I/O tests

Once you're satisfied that your computer's bus lines are doing what you expect, the next step is to test the system's RAM. The first memory test reads the contents of each memory location in the user-selected range, then writes two patterns and verifies that each pattern was written correctly. Finally, it restores the original contents. The system under test can be operating normally during the memory test.

If the RAM checks out, the checksum of the ROM in the system can be tested. The tester reads the data from the user-specified range, and accumulates the 16-bit sum (which is the checksum generated by most EPROM programming equipment). All memory locations in the selected range are accessed, so faulty address decoders and shorted chip-select lines can be found.

The tester's memory-examine function allows you to easily examine the contents of any specific memory location in the address space. The *Fluke 90* makes it easy to increment one location at a time. A memory-verify test lets you verify a particular location by writing the bit pattern of your choice to the location of your choice. A read operation is then performed immediately. A separate memory-write test is also available.

The final memory test of the *Fluke 90* is *memory soak*, which checks that static RAM retains its memory for a user-specified length of time. It can also be used to fill memory with a given bit pattern.

*I/O examine*, *I/O verify* and *I/O write* tests are available on the *Fluke 90*, and are performed just as the similar memory tests are.

## Using the probe

We mentioned previously how the probe supplied with the tester could be used as a simple logic probe to check the state of data and address lines, and the like. In the *QuickTrace* mode, it can also be used to identify and trace bus lines. In that mode, the tester continually searches for the signal line being probed. When the probed line is identified, the probe's green LED lights, and the tester's display

# Now test and restore every CRT on the market . . . without ever buying another adaptor socket or coming up embarrassingly short in front of your customer . . . or your money back



with the new improved CR70 "BEAM BUILDER"<sup>TM</sup>  
Universal CRT Tester and Restorer  
Patented \$995

## Have you ever?

**Thrown away a good TV CRT, data display CRT, or scope CRT** that could have been used for another two or three years because you had no way to test or restore it?

**Lost valuable customers because you advised them that they needed a new CRT** when another technician came along and restored the CRT for them?

**Lost the profitable extra \$35 or more** that you could have gotten for restoring a CRT while on the job and locked in the profitable CRT sale later?

**Avoided handling profitable trade-ins or rentals** because you were afraid you'd have to replace the picture tube when you could have restored it?

**Had a real need to test a CRT on the job**, but didn't have the right adaptor socket or setup information in your setup book?

If any of these things have happened to you, **CALL TODAY, WATS FREE, 1-800-843-3338**, for a **FREE 15 day Self Demo**.

"BEAM BUILDER" is a trademark of Sencore, Inc.



Call Today Wats Free 1-800-843-3338

**SENCORE**

3200 Sencore Drive  
Sioux Falls, SD 57107  
605-339-0100 In SD Only

*innovatively designed  
with your time in mind.*

CIRCLE 189 ON FREE INFORMATION CARD

# Our guaranteed savings plan.



**Fluke 70 Series Analog/Digital multimeters are like money in the bank.** Buy one, and you're guaranteed to save both time and money.

Money, because you get longer battery life and longer warranty coverage — 3 years vs. 1 year or less on others.

And time, because 70 Series meters are easier to operate and have more automatic measurement features.

So before buying any meter, look beyond the sticker price. And take a closer look at the new low-priced \$79 Fluke 73, the \$119 Fluke 75, and the deluxe \$149 Fluke 77. In the long run, they'll cost less, and give higher performance, too.

And that, you can bank on.

For a free brochure, and your nearest distributor, call toll-free **1-800-44-FLUKE, ext. 33.**

FROM THE WORLD LEADER  
IN DIGITAL MULTIMETERS.



© 1985 Fluke, Ad No. 1271-F70

CIRCLE 121 ON FREE INFORMATION CARD

RADIO-ELECTRONICS

shows the line's name. The *QuickTrace* identification feature is ideal for getting your bearings on a tightly packed board, and it can also help you find shorted lines.

The *probe-address* test lets you indicate a line you're trying to find, say the microprocessor's WRITE line. You can then hunt around your board to find the line. (Should that be on pin 20 of the PROM or on pin 19?) When you do find it, the green LED on the probe lights, and the LCD readout also indicates that the signal was found. Similar functions are available to find data and control lines.

## Communications port

An RS-232 is available on the tester for control from a remote computer, or for uploading to and downloading from the memory of the system under test. The RS-232 jack is a 6-pin RJ-12 connector on the rear of the tester. A compatible cable is supplied. Communication rates from 300 to 9600 baud are supported.

The communication port lets you enter command strings for complex tests such as break-point. When a user-defined event occurs, the microprocessor under test is halted, and the states of its address and data lines are output to the terminal. Frame-point tests—where the status of the address and data lines are displayed without the halting of the processor—are also available. The tester can also be programmed to output a trigger pulse (from a rear-panel connector) when a specified event occurs.

All commands that can be entered from the tester's keypad can also be entered remotely. That can be a great convenience if your communications program or terminal allows you to define macro strings. It also allows some degree of automated testing.

Fluke's *90 Series* microprocessor board testers are obviously special-purpose tools, and are not designed for casual use. If you test microprocessor systems on a regular basis, however, the tester can greatly increase your productivity. The hours it will save you will quickly make up for its \$995 price. (\$1395 after June 30, 1988). **R-E**

Try the  
**Radio Electronics**  
bulletin board  
system  
(RE-BBS)  
516-293-2283

The more you use it the more useful it becomes.

We support 300 and 1200 baud operation.

Parameters: 8N1 (8 data bits, no parity, 1 stop bit) or 7E1 (7 data bits, even parity, 1 stop bit).

Add yourself to our user files to increase your access.

Communicate with other R-E readers.

Leave your comments on R-E with the SYSOP.

RE-BBS  
516-293-2283



Support America's colleges. Because college is more than a place where young people are preparing for their future. It's where *America* — and American business — is preparing for *its* future.

**Give to  
the college of  
your choice.**

Ad  
COUNCIL A Public Service of the Publishers

COUNCIL FOR AD TO EDUCATION

# AN OUNCE OF PREVENTION.



## The complete line of Flameproof Resistors from NTE Electronics.

NTE Flameproof Resistors are designed to provide you with a premium quality replacement device... that won't flameout or short even under the most severe overloads.

Our resistors range in capability from 1/8 Watts to 25 Watts with resistance values from 10 to 2.2 Megohms.

They're totally noncombustible with a metallic resistance material between a nonresistant core and a special ceramic outer cover.

NTE Flameproof Resistors are the ideal replacement components for electronic games, telecommunications, medical, data processing, military, broadcast and home entertainment equipment.

Don't take chances with your expensive equipment. Use NTE Flameproof Resistors ... they handle the current.

### LOOK FOR THE FULL LINE OF QUALITY NTE REPLACEMENT PARTS AND PRODUCTS:

- Transistors
- Thyristors
- Integrated Circuits
- Rectifiers and Diodes
- High Voltage Multipliers and Dividers
- Optoelectronic Devices
- Zeners
- Microprocessors and Support Chips
- Memory ICs
- Thermal Cut-Offs
- Bridge Rectifiers
- Unijunctions
- RF Transistors
- Microwave Oven Rectifiers
- Selenium Rectifiers
- Flameproof Resistors
- Wire Ties
- Electrolytic Capacitors
- Static Control Products



For more information or the name of your local distributor, call or write NTE.



### NTE ELECTRONICS, INC.

44 Farrand Street, Bloomfield, New Jersey 07003  
(Outside N.J.) 1-800-631-1250 • (N.J. only) 1-800-624-2624

CIRCLE 71 ON FREE INFORMATION CARD

# NEW PRODUCTS



CIRCLE 10 ON FREE INFORMATION CARD

**HOME SCANNER.** Regency Electronics introduces the model *R2060* featuring "TurboScan," which allows the device to scan at a rate of up to 50 channels per second. A special WEATHER-ALERT key provides instant awareness of severe weather: At the touch of a button, the *R2060* silently monitors the weather frequencies, broadcasting alerts in plenty of time for listeners to take safety precautions.

The unit covers seven of the most popular bands, including VHF low band, 30–50 MHz; VHF amateur, 140–148 MHz; VHF high band, 148–174 MHz; UHF low band, 406–440 MHz; UHF amateur,

440–450 MHz; UHF standard, 450–470 MHz; and UHF extended, 470–522 MHz.

Its 60-channel programmability provides instant access to favorite frequencies, either directly or in the scan mode. Bank scanning provides easy access to four groups of consecutive channels. A separate set of non-programmable channels provides exclusive scanning of NOAA weather frequencies in the U.S. and Canada. Additional features include priority, lockout, delay, and hold.

The model *R2060* has a suggested retail price of \$249.95.—**Regency Electronics**, 7707 Records St., Indianapolis, IN 46226.

**DIGITAL MULTIMETER.** The Philips model *PM 2525* is a general-purpose instrument with many extra functions. Eighteen measurement functions are standard, including volts AC/DC, amps AC/DC, both four-wire and two-wire resistance, capacitance, frequency, time, tem-

perature, dB, and continuity check. There are five voltage ranges, eight current ranges, and seven resistance ranges.

The model *PM 2525* also provides three functions, min/max, zero-set, and dBm, to enhance understanding of measured

values. For example, measurements such as volts and min/max, or capacitance and zero-set, can be combined to reduce manual calculations.



CIRCLE 11 ON FREE INFORMATION CARD

The model *PM 2525* has 4½-digit resolution with a 21,000-count display, or a 5½-digit resolution with a 210,000-count display in the high-resolution mode. In addition, a high-resolution analog bar-graph display gives a clear indication of signal trends. The bandwidth is up to 100 kHz.

The *PM 2525* is available in three versions: A benchtop model for general-purpose use in lab, workshop, and production-line environments; a portable model with battery power pack for field use; and a version with a choice of three built-in interfaces—GPIB, RS-232 for system applications, or analog output for use with hard-copy devices.

The *PM 2525* is priced at \$795.00.—**John Fluke Mfg. Co., Inc.**, PO Box C9090, Everest, WA 98206.

**MULTI-OPTION KEYBOARD.** Cherry's model *G80-2000* is IBM-compatible and has a card reader, mouse, and remote bar-code reader available as options.

The keyboard has a layout that is identical to IBM's 3270 with 24 function keys arranged in two rows along the top, in addition to ten at the left. The extra function keys are especially useful for rapid data entry, allowing input of lengthy product descriptions or



codes with just a few keystrokes.

The additional function keys are normally only recognized by software written for the 3270 PC, but Cherry has also made provisions for PC-XT and AT users. The enhanced versions of *SmartKey* software is bundled with the keyboard, giving it an extra 96 functions because each of the keys can function alone, shifted, CTRL-shifted, or ALT-shifted. An on-board LCD readout provides operator guidance. Also available are N-Key rollover, LED-actuation indicators, and programmable auto-repeat. The keyboard can be supplied with or without low-profile housing in order to conform to DIN standard.

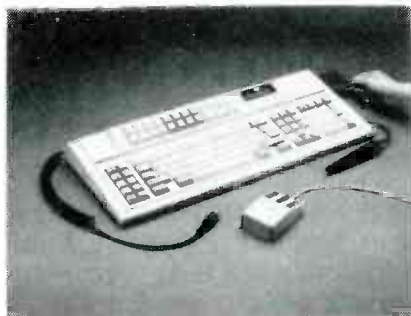

CIRCLE 12 ON FREE INFORMATION CARD

The G80-2000 123-key keyboard, completely assembled and electronically equipped for bar-code reading, mouse, and magnetic-card reader is priced at \$765.00. The bar-code-reader light pen (\$170.00) and mouse (\$45.00) are sold separately. The keyboard completely assembled and electronically equipped for bar-code reading only is \$680.00, and equipped for magnetic-card reading only, including the card-reader itself, is also \$680.00.—Cherry Electrical Products, 3600 Sunset Avenue, Waukegan, IL 60087.

**OSCILLOSCOPES.** Tektronix has introduced two oscilloscopes that offer automated-measurement features normally found only on more expensive oscilloscopes: The model 2245A and the model 2246A (shown).

The 2246A is the first 100-MHz scope to offer 20 store/recall setups, 4-channel testing capability, cursors, readout and automatic setup. It is priced at \$2395.00. The 2245A has almost all the features of

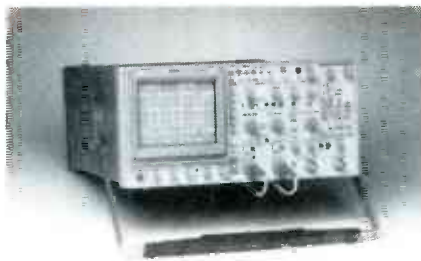

CIRCLE 13 ON FREE INFORMATION CARD

the 2246A, but not the 20 store/recall feature. It is priced at

\$1795.—Tektronix, Inc., PO Box 500, Beaverton, OH 97077.

**SERIAL SCANNING SWITCH.** B & B Electronics' model 232555 automatically scans two RS-232C serial ports waiting for data to be sent. Upon receipt of the data from either RD (pin 3) port, the switch then selects that port and passes all RS-232 data on pins 2-7, 8 and 20. Approximately 15 seconds after the data has stopped flowing on

**Joseph Electronics' 40th Anniversary Specials!**

<p><b>Model 2120 Oscilloscope</b> DC to 20 MHz, Dual Trace, 6" CRT-1mv Sensitivity Reg. \$479 <b>\$379.40</b> 40TH ANNIVERSARY PRICE</p> <p><b>Model 2125 Oscilloscope</b> Some great features as 2120, except with delayed sweep Reg. \$570 <b>\$469.40</b> 40TH ANNIVERSARY PRICE</p> <p><b>Model 1541A Oscilloscope</b> DC to 40 MHz, Dual Trace, 6" CRT 1mv Sensitivity Reg. \$845 <b>\$739.40</b> 40TH ANNIVERSARY PRICE</p> <p><b>Model 2520 Digital Storage</b> 20MHz, Dual Trace, 2mv Sens. Reg. \$1991 <b>\$1795.40</b> 40TH ANNIVERSARY PRICE</p> <p><b>Model 2521 Digital Storage</b> 20MHz, Dual Trace, CRT Readout, Cursors, RS232 Interface Reg. \$3053 <b>\$2745.40</b> 40TH ANNIVERSARY PRICE</p>	<p><b>Model 1249 NTSC/RGB Color Bar Generator</b>, Composite Video Output, RF Output Reg. \$475 <b>\$399.40</b> 40TH ANNIVERSARY PRICE</p> <p><b>Model 2009 MTS TV Stereo Generator</b> ideal for Stereo TV, Receivers, VCR's and Stereo Adapter Service Reg. \$495 <b>\$419.40</b> 40TH ANNIVERSARY PRICE</p> <p><b>Model 2830 3-1/2 DIGI BENCH Multimeter</b> DCV Accuracy, ALL 33 Ranges and Functions are Push Button Selectable Reg. \$233 <b>\$199.40</b> 40TH ANNIVERSARY PRICE</p> <p><b>Model 1045 Telephone Product Tester</b> Provides Basic Operation Tests for Corded and Cordless Telephones, Answering Machines and Automatic Dialers Reg. \$471 <b>\$399.40</b> 40TH ANNIVERSARY PRICE</p>	<p><b>Model 1803 Frequency Counter</b> 100 MHz, 8 digit display, zero blanking AC or Battery Reg. \$186 <b>\$159.40</b> 40TH ANNIVERSARY PRICE</p> <p><b>Model 2005 RF Signal Generator</b> 100 KHz to 150 MHz, in 6 fundamental bands and 450 MHz in harmonics Reg. \$195 <b>\$169.40</b> 40TH ANNIVERSARY PRICE</p> <p><b>Model 1603 Function Generator</b> 2 MHz, 4 digit display, TTL &amp; CMOS pulse outputs Reg. \$225 <b>\$189.40</b> 40TH ANNIVERSARY PRICE</p> <p><b>Model 1630 DC Power Supply</b> 0-30V, 0-3A, high-low current range, Low ripple Reg. \$233 <b>\$199.40</b> 40TH ANNIVERSARY PRICE</p> <p><b>Model 1601 DC Power Supply</b> isolated 0-50V, 0-2A in ranges, fully automatic shutdown, Adj. current limit Reg. \$440 <b>\$369.40</b> 40TH ANNIVERSARY PRICE</p> <p><b>Model 1650 Triple Output Power Supply</b> two 0-25 VDC @ 5A and 5VDC @ 5A, fully automatic shutdown Reg. \$455 <b>\$379.40</b> 40TH ANNIVERSARY PRICE</p> <p><b>Model 1653 AC Power Supply</b> variable isolated 0-150 VAC @ 2A, built-in isolation transformer Reg. \$190 <b>\$169.40</b> 40TH ANNIVERSARY PRICE</p>
---	--	---

We are celebrating our 40th Anniversary by offering you huge savings on B&K Test Equipment.

Send for FREE 480 page "Industrial Products Catalog". I understand it is FREE with any order or if requested on company letterhead. (Otherwise, \$4.95 to cover catalog and shipping costs.)

**ORDER TOLL FREE  
1-800-323-5925  
IN ILLINOIS  
312-297-4200  
FAX: 312-297-6923  
Our 40th Year**

**JOSEPH ELECTRONICS, INC.** Dept. R  
8830 N. Milwaukee Ave., Niles, IL 60648

Rush merchandise per attached order.  
I understand rated accounts are shipped open account, otherwise send per credit card.

Include \$5.00 per item for shipping and handling.

Visa  Master Card  Discover  
 Check  Money Order  Rush Catalog

Card No. \_\_\_\_\_ Exp. Date \_\_\_\_\_

Name \_\_\_\_\_  
Company \_\_\_\_\_  
Street Address \_\_\_\_\_  
City \_\_\_\_\_ State \_\_\_\_\_ Zip \_\_\_\_\_

IL Res. 7% Tax

# Macrovision ... now you see it, now you don't.

Remove copy-protection from video cassettes.



- Digital Filter Type, removes only Macrovision pulses
- No adjustments, crystal controlled
- Compatible with all VCR's, uses automatic vertical blanking level

Macro-Scrubber — We stock the exact parts, PC board, and AC adaptor for an article on Building a Macro-Scrubber appearing in *Radio-Electronics* December 1987 issue.

## JMAK-1 Parts Package ..... \$19.00

Includes all the original resistors, capacitors, diodes, transistors, integrated circuits, and crystal.

## JMAK-2 PC Board ..... \$9.95

Original etched and drilled silk-screened PC board used in article

## JMAK-3 AC Adaptor ..... \$7.95

Original (14 to 18 volt DC @ 285 ma) AC adaptor used in article.

Free reprint of article on building a Macro-Scrubber with any purchase above. Add \$2.50 shipping & handling; \$4.50 Canadian orders. Note: Unauthorized duplication of copyrighted material is illegal. Use Macro-Scrubber for viewing only.

## 72-CHANNEL CABLE CONVERTER WITH INFRA-RED REMOTE CONTROL

MC-702 CONVERTER  
\$79.95



Add \$3.50 shipping & handling  
\$9.50 Canadian orders

- 72-channel capability
- Wireless, Infra-Red remote control
- Channel output 2 or 3 switchable
- Microprocessor controlled PLL operation
- Skip channel memory eliminates unused channels
- Parental control for all channels
- Last channel recall
- Fine tune memory
- UL listed/FCC approved
- Simple installation with any TV
- Includes battery and 3 foot coax cable

## CABLEMASTER ..... \$19.95 Cable/VCR Timer

- Record multiple premium play channels
  - Turns cable box on and off
  - Selects channel for unattended recording
  - Thousands sold nationally for \$99.95
- Add \$3.50 shipping & handling  
\$4.50 Canadian orders

**ORDER TOLL FREE ANYTIME**  
**1-800-227-8529**

Ask for **FREE**  
**Color Catalog**

Inside MA: 617-695-8699

VISA, MASTERCARD,  
or C.O.D.



**J & W**  
**ELECTRONICS, INC.**

P.O. BOX 800 • MANSFIELD, MA 02048

©Copyright 1988 by J&W Electronics Inc.

CIRCLE 65 ON FREE INFORMATION CARD

pin 3, the switch then resumes scanning.

During the time that the switch is locked on to one port, the other port outputs (pins 2, 4, and 20) will be low to prevent the computer from outputting data.

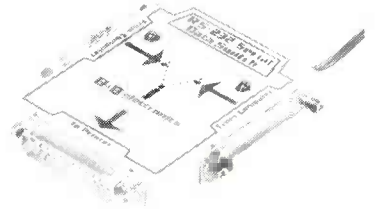

CIRCLE 14 ON FREE INFORMATION CARD

The model 2325SS comes complete with a 117-volt AC power supply. The two input-port connectors are female and the main connector is a male DB25P. The Scanning Switch is priced at \$119.95. —**B & B Electronics**, 1500P Boyce Memorial Drive, PO Box 1040, Ottawa, IL 61350.

**WIRE ANALYZER.** Polytronics presents *SureTest*, a portable handheld device that tests for current-carrying capacity using a built-in 15-ampere load. The multi-function analyzer applies the load and determines if the voltage drop is less than 5%, as recommended by the National Electric Code.



CIRCLE 15 ON FREE INFORMATION CARD

*SureTest* also checks circuits for voltage level, wiring connections, and operation of a ground fault circuit interrupter, thus saving any need on the owner's part to have or use separate testers.

*SureTest* is priced at \$89.95.—**Polytronics**, 2100 Old Union Road, Buffalo, NY 14227.

continued on page 28

# Simpson®

## Announces 9 NEW PRODUCTS!



**NEW - Models 422 and 421 5 MHz Sweep/Function Generators** that offer low distortion, harmonic-free sine, triangle and square wave outputs. TTL output will drive up to 10 TTL loads for logic and digital circuit testing. Selectable sweep frequencies (.05 Hz to 5.0 MHz), rates and sweep times. Model 422 features 6-digit LED display and frequency counter capability for circuit monitoring.

- |  |          |
|--|----------|
| <b>Model 421, 120 VAC, Cat. #12731</b> ..... |          |
| <b>220 VAC, Cat. #12733</b> .....            | \$535.00 |
| <b>Model 422, 120 VAC, Cat. #12732</b> ..... |          |
| <b>220 VAC, Cat. #12734</b> .....            | \$650.00 |



### NEW - Models 713 and 712 Universal Frequency Counters

Model 713 (to 520 MHz) and 712 (to 200 MHz) provide period, frequency, ratio, time interval and totalize functions for a wide range of applications from radio servicing to logic and control circuit testing and monitoring. Both feature an 8-digit, high visibility, orange LED display, selectable attenuation and self-check of the 10 MHz time base.

- |  |          |
|--|----------|
| <b>Model 712, 120 VAC, Cat. #12722</b> ..... |          |
| <b>220 VAC, Cat. #12723</b> .....            | \$525.00 |
| <b>Model 713, 120 VAC, Cat. #12724</b> ..... |          |
| <b>220 VAC, Cat. #12725</b> .....            | \$675.00 |



CIRCLE 192

### NEW - Model 159 AC/DC Clamp-On Probe

Extend the capability of VOMs and DMMs with the Model 159 current probe. Access cables in almost any position with its unique 1.3-inch (33 mm) jaw opening. 0.1 A to 500 A current range to 660 V (rms). Hall-effect technology for reliable, accurate results.

- |                                     |          |
|-------------------------------------|----------|
| <b>Model 159, Cat. #12120</b> ..... | \$169.00 |
|-------------------------------------|----------|

CIRCLE 250

### NEW - Models 488 and 487 Digital Multimeters

These new handheld DMMs feature autoranging and data/peak hold, and a 3-1/2 digit LCD plus 71-segment analog display. Housed in a shock resistant case for rugged use. AC and DC current measurements; 300  $\mu$ A to 20 A; 1000 VDC, 750 VAC (rms); diode check; and resistance to 30 M $\Omega$ . The Model 488 features true rms measurements.



- |                                     |          |
|-------------------------------------|----------|
| <b>Model 487, Cat. #48700</b> ..... | \$219.00 |
| <b>Model 488, Cat. #48800</b> ..... | \$275.00 |



CIRCLE 251

CIRCLE 253

### NEW - Model 460-6 DMM

High accuracy bench DMM with extended measurement capability. It is completely portable with a built-in, ni-cad battery pack and includes true rms measurement, pulse detection, selectable dB reference level and a 4-1/2 digit LCD readout with 22-segment bar graph. Designed to meet UL 1244 requirements.

- |  |          |
|--|----------|
| <b>Model 460-6, 120 VAC, Cat. #12538</b> ..... |          |
| <b>240 VAC, Cat. #12539</b> .....              | \$425.00 |

CIRCLE 252

CIRCLE 254



### NEW - Model 464-4 DMM

Provides true rms voltage and current readings. Big, orange 3-1/2 digit LED display for easy reading. 100 kHz frequency response. Designed to meet UL 1244 requirements.

- |  |          |
|--|----------|
| <b>Model 464-4, 120 VAC, Cat. #12677</b> ..... |          |
| <b>220 VAC, Cat. #12678</b> .....              | \$325.00 |
| <b>240 VAC, Cat. #12679</b> .....              |          |

AVAILABLE FROM LEADING ELECTRONICS/ELECTRICAL DISTRIBUTORS AND MODIFICATION CENTERS



### SIMPSON ELECTRIC COMPANY

853 Dundee Avenue, Elgin, Illinois 60120-3090  
 (312) 697-2260 • Telex 72-2416 • Cable SIMELCO • FAX (312) 697-2272  
 IN CANADA: Bach-Simpson Ltd., London, Ontario  
 IN ENGLAND: Bach-Simpson (U.K.) Ltd., Wadebridge, Cornwall

Prices and Specifications Subject to Change Without Notice

CIRCLE 191 ON FREE INFORMATION CARD

[www.americanradiohistory.com](http://www.americanradiohistory.com)

**MONITORING SYSTEM.** The Phonetics model 1100 Sensaphone communicates over phone lines to help avoid catastrophic loss or damage to your valuable property, products, or operating facilities. If any monitored condition changes, the model 1100 will automatically sound an alert, call you by phone, and deliver its message in English. You can also check on actual operating conditions by calling your Sensaphone from any phone worldwide to hear a complete status report.

In addition to its built-in elec-

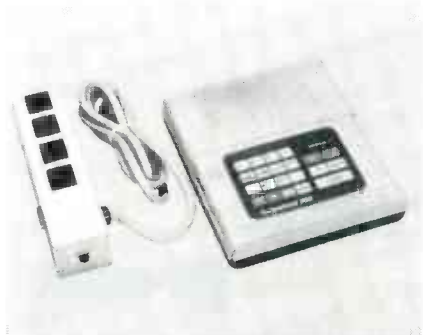

CIRCLE 16 ON FREE INFORMATION CARD

trical-power, temperature-level, and high-sound-level (from a smoke or fire alarm) sensing capabilities, you can configure your model 1100 to monitor other environmental conditions that are critical to you.

When an alert condition occurs, Sensaphone will immediately dial out up to four phone numbers in sequence, to warn key personnel that a problem or emergency exists. A prompt return call to acknowledge the alert stops the continuous call-out.

The model 1100 Sensaphone is priced at \$300.00.—Phonetics, Inc., 101 State Road, Media, PA 19063.

**FREQUENCY COUNTERS.** From Simpson Electric Company comes the model 712 and the model 713 (shown in photo).

Both models are designed for service, production, laboratory, and training operations. The model 712 has a range up to 200 MHz and the model 713 has a range up to 520 MHz. They both provide period (10 Hz to 2.5 MHz),

channel A/channel B frequency-ratio (10 Hz to 2.5 MHz/10 Hz to 10 MHz), time-interval (0.5  $\mu$ s to 200,000  $\mu$ s) and totalize (10 Hz to 10 MHz) functions.



CIRCLE 17 ON FREE INFORMATION CARD

Additional features of both models include self-check with display of internal time-base frequency (10 MHz), a 1-MHz lowpass filter, and selectable attenuation. The display for both models is an easy-to-read 0.56-inch orange LED. It has 8 digits with overflow, gate, and  $\mu$ s indicators.

Prices are \$525.00 for the model 712 and \$675.00 for the the model 713—Simpson Electric Company,

## HITACHI COMPACT SERIES

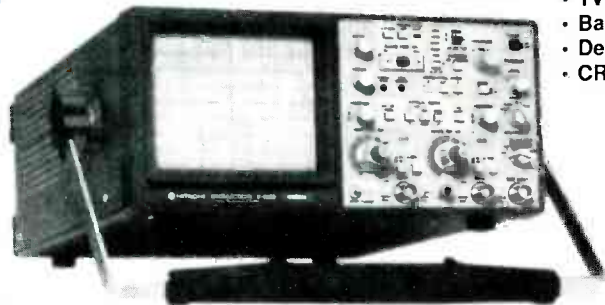

V-1065 DC to 100MHz With Cursor Readout

**\$1545<sup>95</sup> Save \$250!**

- 6" CRT with Internal Graticule
- Dual Channel X-Y Display
- Sweep Time Autoranging
- 400V High Input Voltage Protection
- TV Sync Trigger Circuit
- Bandwidth Limiter • Trigger Lock
- Delayed Sweep • Single Sweep
- CRT Readout •  $\pm 3\%$  Accuracy

V-1060 DC to 100MHz

**\$1295<sup>95</sup> Save \$200!**

V-665 DC to 60MHz

With Cursor Readout.

**\$1145. Save \$150!**

V-660 DC to 60MHz

**\$945<sup>95</sup> Save \$150!**

Best Deals in Test Equipment  
in USA... Ask for Bob Ladnier

### Dual Channel 6" CRT Scopes

V-425 DC to 40MHz, CRT Readout  
**\$845. Save \$150!**

V-423 DC to 40MHz, Single Time

Base Delayed Sweep  
**\$745. Save \$250!**

V-422 DC to 40MHz, DC Offset

**\$795. Save \$130!**

V-225 DC to 20MHz, CRT Readout

**\$720. Save \$75!**

V-223 DC to 20MHz, Delayed Sweep

**\$695. Save \$100!**

V-222 DC to 20MHz, DC Offset

**\$515. Save \$200!**

V-212 DC to 20MHz

**\$440. Save \$175!**

### Dual Channel Mini-Portable Scopes

V-509 DC to 50MHz,  
Delayed Sweep

**\$1195. Save \$250!**

V-209 DC to 20MHz

**\$822. Save \$175!**

### Quad Channel Multi-Function Scopes

V-1150 DC to 150MHz,  
Delayed Sweep

**\$2600. Save \$350!**

V-1100AU DC to 100MHz,  
Delayed Sweep

**\$2175. Save \$315!**

### Digital Storage Scope

V-6020 1MHz Sampling,  
Dual Channels

**\$1750. Save \$200!**

### NTSC Waveform Monitors

v-079 6" CRT

**\$1625. Save \$125!**

v-099 3.5" CRT

**\$950. Save \$300!**

### NTSC Vector Scopes

V-069 6" CRT

**\$1825. Save \$125!**

V-089 3.5" CRT

**\$1284. Save \$400!**

## Instant Hard Copy!! From Oscilloscopes

### POLAROID® DS-34 CAMERA

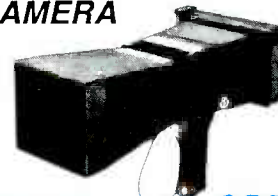

Save \$135! **\$290.**

- 5", 6" and 7" Hoops (Available separately @ \$51 ea. Please Specify size)
- Pistol Grip For Ease of Operation
- Works on Any Make of Oscilloscope
- Three Full Year Warranty

### Replacement Probes For:

Tektronix • Hewlett-Packard • Hitachi • Leader • B&K

• Philips • Kikusui • As Low as \$32.00!

Call for pricing and quantity discounts.

PROBES INCLUDED WITH ALL HITACHI  
SCOPES AT NO EXTRA CHARGE!



**W.M. B. ALLEN**  
SUPPLY COMPANY

ALLEN SQUARE  
300 Block North Rampart Street  
New Orleans Louisiana 70112

USA 800 535-9593 • LA 800 462-9520  
LOCAL 504 525-8222 • FAX 504 525-6361  
American Express • Visa • MasterCard • 928 pg Catalog FREE with your order

# SELECT 5 BOOKS for only \$3.95

(values to \$123.75)  
and get a Free Gift!

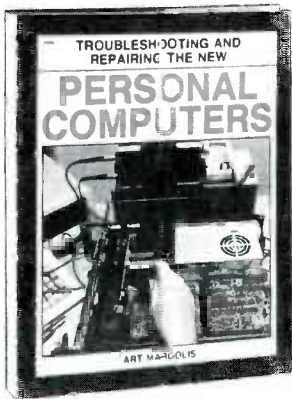
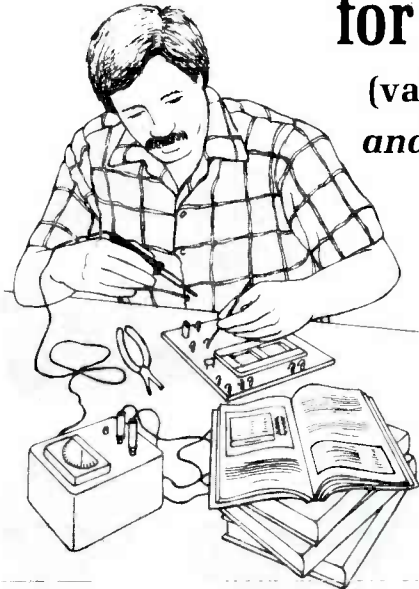

2809 \$26.95  
Count as 2

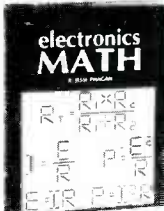

1962 \$22.95



1625P \$14.95



1960 \$24.95

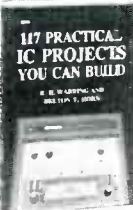

2645P \$10.95



1536P \$8.95



2887 \$16.95



1300P \$24.95  
Counts as 2



2613 \$23.95



2758 \$24.95



1604 \$16.95



2839 \$15.95

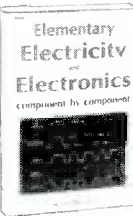

2753P \$16.95

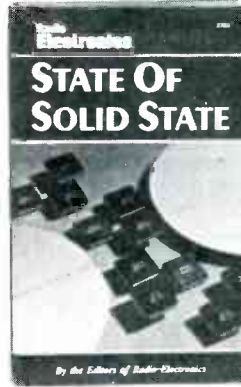

2733 \$14.95



2660P \$17.95

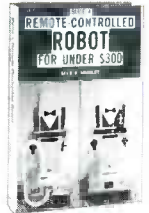

2617 \$17.95



1897P \$13.95



1999P \$14.95



2922 \$24.95

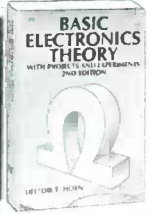

1775P \$18.95

Electronics projects . . . ideas . . . the latest technology  
all at up to 50% off publishers' prices!

**Membership Benefits** • Big Savings. In addition to this introductory offer, you keep saving substantially with members' prices of up to 50% off the publishers' prices. • **Bonus Books.** Starting immediately, you will be eligible for our Bonus Book Plan, with savings of up to 80% off publishers' prices. • **Club News Bulletins.** 14 times per year you will receive the Book Club News, describing all the current selections—mains, alternates, extras—plus bonus offers and special sales, with hundreds of titles to choose from. • **Automatic Order.** If you want the Main Selection, do nothing and it will be sent to you automatically. If you prefer another selection, or no book at all, simply indicate your choice on the reply form provided. As a member, you agree to purchase at least 3 books within the next 12 months and may resign at any time thereafter. • **Ironclad No-Risk Guarantee.** If not satisfied with your books, return them within 10 days without obligation! • **Exceptional Quality.** All books are quality publishers' editions especially selected by our Editorial Board.

All books are hardcover unless numbers are followed by a "P" for paperback. (Publishers' Prices Shown)

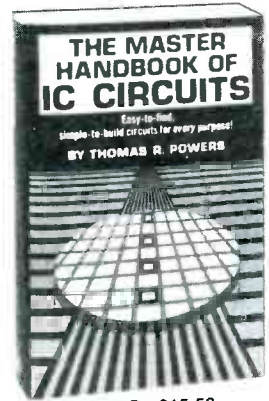

1370P \$15.50

FREE when you join!

Handy, Pocket-Sized  
Resistor and Inductor  
Color Code Calculator

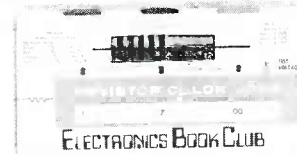

**ELECTRONICS BOOK CLUB**  
Blue Ridge Summit, PA 17294-0810

Please accept my membership in the Electronics Book Club® and send the 5 volumes listed below, plus my FREE Resistor and Inductor Color Code Calculator (502E), billing me \$3.95 plus shipping and handling charges. If not satisfied, I may return the books within ten days without obligation and have my membership canceled. I agree to purchase at least 3 books at regular Club prices (plus shipping and handling) during the next 12 months and may resign any time thereafter.

Name \_\_\_\_\_  
Address \_\_\_\_\_  
City \_\_\_\_\_  
State/Zip \_\_\_\_\_ Phone \_\_\_\_\_  
Signature \_\_\_\_\_

Valid for new members only. Foreign applicants will receive special ordering instructions. Canada must remit in U.S. currency. This order subject to acceptance by the Electronics Book Club. Signature of parent or guardian required for all new members under 18 years of age. RE-588

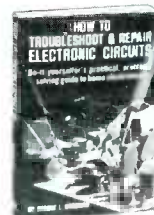

1218P \$14.95

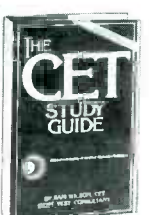

2941 \$21.95



2790 \$18.95



1199P \$14.95

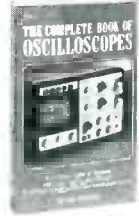

1532P \$14.95



2731 \$21.95

# HITACHI SCOPES AT DISCOUNT PRICES!

20MHZ



Model V212 \$475

Model V-212 20MHZ Dual Channel (1mV Sens.) \$475  
 Model V-422 40MHZ Dual Channel (1mV Sens.) \$699  
 Model V-425 40MHZ Dual Channel (with cursor) \$825  
 Model V-660 60MHZ Dual Channel (Delayed Sweep) \$990  
 Model V-1060 100MHZ Dual Channel (Delayed Sweep) \$1,375  
 All above scopes have a 3 year warranty on parts and labor

100MHZ



Model V1060 \$1,375

15-25%  
OFF LIST  
PRICE

# ELENCO PRODUCTS AT DISCOUNT PRICES!

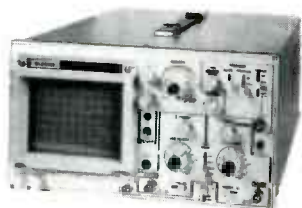

20MHZ DUAL TRACE OSCILLOSCOPE

\$349 MO-1251

MO-1253  
40MHz  
Dual Trace  
12KV HV  
Delayed Sweep  
\$550

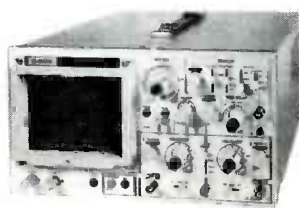

35MHZ DUAL TRACE OSCILLOSCOPE

\$498 MO-1252

Top quality scopes at a very reasonable price. Contains all the desired features. Elenco's 2 year guarantee assures you of continuous service. Two 1 x .10 x probes, diagrams and manual included. Write for specs.  
 60 MHz scope probes, switchable 1x, 10x, Ref. Model T-1 Fits Most Scopes \$19



MULTIMETER with CAPACITANCE AND TRANSISTOR TESTER  
 Model CM-1500A \$58  
 Reads Volts, Ohms, Current, Capacitors, Transistors & Diodes W/Case



TRUE RMS 4 1/2 DIGIT MULTIMETER  
 Model M-7000 \$135  
 .05% DC Accuracy  
 1% Resistance with Freq. Counter & Deluxe Case



Auto Ranging plus Manual Ranging 3 1/2 Digit Meter 28 Functions Fully protected  
 M-1180 .7% Acy \$36.95  
 M-1182 .25% Acy \$39.95  
 M-1181 .1% Acy \$42.95



GF-8016 FUNCTION GENERATOR with Freq. Counter \$239

- Sine, Square, Triangle
- Pulse, Ramp, 2 to 2MHz
- Frequency .1 thru 10MHz

GF-8015 without Freq. Meter \$179



10MHZ OSCILLOSCOPE \$239  
 Model S-3000

- 10MHz DC or AC
- Triggered Sweep
- Calibrated Vert & Hor
- Reads Volts & Freq



BREADBOARD  
 Model 9436 Shown  
 9430 1,100 pins \$15  
 9434 2,170 pins \$25  
 9436 2,860 pins \$35



DIGITAL TRIPLE POWER SUPPLY  
 Model XP-765 \$239

0-20V @ 1A  
 0-20V @ 1A  
 5V @ 5A

Fully Regulated, Short Circuit Protected with 2 Limit Cont. 3 Separate Supplies

XP-660 with Analog Meters \$169.50



DIGITAL LCR METER \$138

Model LC-1800 Measures: Inductors, Capacitors, Resistors



50MHZ LOGIC PROBE 20 nsec with memory LP-700 \$23

Logic Pulsar LP-600 \$23

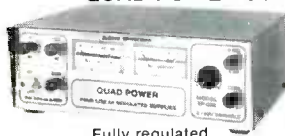

QUAD POWER SUPPLY

Model XP-580 \$59.95

Fully regulated and short circuit protected  
 Model XP-575 without meters \$49.95

2-20V @ 2A  
 12V @ 1A  
 +5V @ 3A  
 5V @ 4A



MULTI-FUNCTION COUNTERS

F-1000 1.2GH \$259

F-100 120MH \$179

Frequency, Period, Totalize, Self Check with High-Stabilized Crystal Oven Oscillator, 8 Digit LED Display

853 Dundee Avenue, Elgin IL 60120-3090.

**DESK BATTERY CHARGER.** MFJ Enterprises offers the model *MFJ-290*, a drop-in, rapid, desk-top battery charger. It is designed for all ICOM rechargeable battery packs. (The IC- $\mu$ 2 series battery packs require the ICOM AD-10 charger adapter.)



CIRCLE 18 ON FREE INFORMATION CARD

The model *MFJ-290* is made of high-impact plastic with ample ventilation holes to ensure cool operation; it measures 7 x 4 x 3 inches. It has an ON/OFF switch, power-on and charging indicators, and operates from 117 VAC. The unit is covered by an unconditional 1-year warranty.

The model *MFJ-290* is priced at \$59.95.—MFJ Enterprises, Inc., 921 Louisville Road, Starkville, MS 39759.

**AM/FM STEREO CASSETTE PLAYER.** The Sparkomatic *SR37* features an illuminated dial, and AM/FM, mono/stereo, and local/distance pushbutton selection. Other features include LED stereo and play indicators, tuning and balance controls, and a fast-forward/eject pushbutton. The radio/cassette player comes complete with mounting hardware.



CIRCLE 19 ON FREE INFORMATION CARD

Audio power specifications are 9 watts (RMS) at 10% THD, and 7.5 watts (RMS) at 1% THD. The model *SR37* is priced at \$69.95—Sparkomatic Corporation, Milford, PA 18337.

R-E

C&S SALES INC., 1245 Rosewood Dr. Deerfield, IL 60015 800-292-7711 312-541-0710 ASK FOR CATALOG VISA M-C

2 Year Limited Guarantee! Add 5% for Postage (\$10 max), IL Res., 7% Tax

CIRCLE 109 ON FREE INFORMATION CARD

# SERVICE CLINIC

## Ghost busting



**JACK DARR**  
SERVICE EDITOR

MOST OF US ARE FAMILIAR WITH ghosting. It's when the primary image on the screen is accompanied by one or more secondary images. The effect is most often caused by a reception problem, such as when the antenna receives signals both directly and via a time-delayed reflection from a building, hilltop, etc.

But ghosting can have other sources. A defect in the video-IF amplifier strip could cause regenerative feedback to occur. If that feedback's frequency falls within the amp's pass band, it will show up on the picture as ghosting. If fine tuning affects that ghosting, that's further confirmation that the video IF is indeed the culprit.

But what if fine tuning has no effect? Then, assuming the TV set is a color model, you should look to the delay line.

In color receivers, the video leaving the first video amp is split into luminance (brightness) and chrominance (color) information. Each signal is processed and then fed to the picture tube for display. However, the brightness information has fewer stages to pass through during processing. Hence, it tends to arrive at the picture tube slightly ahead of its related color information. If uncorrected, the result would be a picture where the color information is offset to the right of the black-and-white information.

The purpose of the delay line, then, is to slow down the brightness signal so that all the components of an image arrive at the picture tube at the same time. The

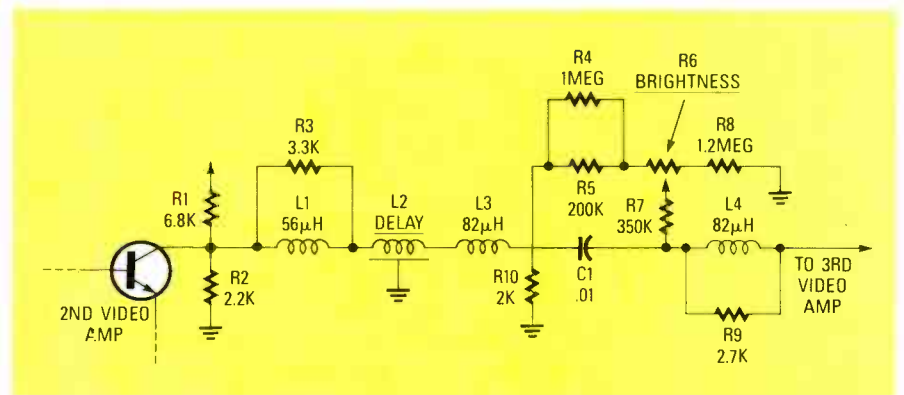

FIG. 1

delay line is inserted between two of the stages of the video amplifier. A typical setup is shown in Fig. 1.

A delay line is essentially a long inductor wound on a metal form. That form is lined with foil along its entire length, and the foil is tied to ground creating a ground plane, which causes a capacitance to exist between each turn of the coil and ground. That capacitance, along with the inductance of the delay line, introduces a time delay because it takes time for the capacitance to build a charge and the coil to produce its magnetic field.

Two types of delay-line failures could cause ghosting to occur. One is if the delay line is improperly terminated. Typically, that happens when a resistor changes value or the peaking coil becomes open. The other common cause is an open ground plane.

In short, then, a ghosting problem caused by the set itself is most likely the result of regenerative feedback or ringing in the video IF or video amps. If fiddling with the

fine tuning affects the ghosting, look to the video IF; if fiddling with the fine tuning has no effect, look to the delay line.

### Tracking intermittents

Anyone who has spent any length of time servicing TV sets has had some experience with intermittents. Sometimes the problem crops up rather quickly. Other times the TV set may seem fine for several weeks before cutting out; shortly thereafter, the set once again seems to be fine, for a while.

TV sets suffering from the latter symptoms can be a real pain to troubleshoot. Often, the best course to take is to force the intermittent to show up. There are several ways to go about doing that.

The simplest technique is to jar the chassis with the heel of your hand, or a small rubber mallet. You'd be surprised how often that does the trick.

If tapping the chassis fails, you'll have to apply more stringent methods. Hook up a Variac and drop the line voltage. If that fails,

# CRYSTEK

The pulse of dependable communications

Reliability & Quality  
From Start To Finished Product

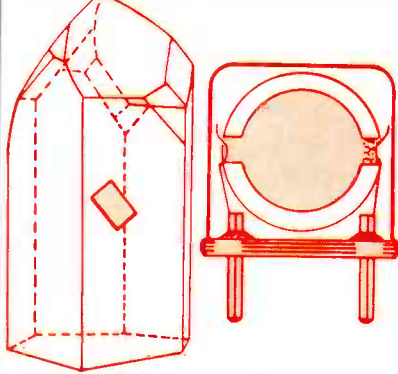

## QUARTZ CRYSTALS/OSCILLATORS FOR ELECTRONIC — INDUSTRIAL

- Micro-Processor Control
- Computers/Modems
- Test/Measurement
- Medical

### COMMUNICATIONS—REPLACEMENT

- Mobile/2-way/Channel Elements
  - Pagers
  - Marine
  - Aircraft
  - Telemetry
  - Monitors/Scanners
- AMATEURS**

- CB
- Hobbist
- Experimenter

- COST EFFECTIVE
- MODERATE PRICING
- FAST DELIVERY



## The Pulse of Dependable Communications

Crystek Crystals offers their new 16 page **FREE** catalog of crystals and oscillators. Offering state-of-the-art crystal components manufactured by the latest automated technology. Custom designed or "off the shelf," Crystek meets the need, worldwide. Write or call today!

### CRYSTEK CRYSTALS

2351/2371 Crystal Dr. • Ft. Myers, FL 33907  
P.O. Box 06135 • Ft. Myers, FL 33906-6135

**TOLL FREE 1-800-237-3061**  
(813) 936-2109 - TWX 510-951-7448

CIRCLE 196 ON FREE INFORMATION CARD

use a hair dryer or other heat source to warm up individual circuit components until the intermittent appears.

An old troubleshooter's trick for tracking down stubborn intermittents was to rig up a tapping tool and attack individual components. The tool was little more than a rubber washer slipped over an end of an alignment tool; the result was a miniature rubber mallet that was light enough to allow tapping without the fear of breakage, but heavy enough to send a noticeable shock through a component. Start tapping away at the components until one of those taps makes the intermittent appear.

While you're at it, don't overlook the solder joints. It doesn't matter how "perfect" the joint looks on the outside; inside that joint it could be a whole different story.

In one set, I had tracked the intermittent to a particular junction in the circuit. But the joint there looked textbook clean. Deciding that I had probably overlooked something, I wasted hours of time checking everything else in the vicinity of that joint. Finally, out of frustration I attacked that "clean" looking joint itself. Of course, I found that the wires beneath the solder were completely corroded! Rewiring and resoldering the connection restored proper operation, and the set has worked fine ever since.

If jarring the TV set makes the intermittent show up, then you should suspect bypass or coupling capacitors in the affected circuits. Attack each of those with your "mini-mallet" until the intermittent reveals itself.

Sometimes, irritation can be a helpful ally. In one particular instance, no matter what I did, including light tapping, the intermittent would not show up. In desperation, I drew back and gave the chassis a relatively healthy shot—strong enough to knock it about six inches. Apparently, that "scared" the intermittent enough to force it to show up. The moral is to not be afraid to use brute force—in moderation. Picking up a TV set and heaving it across the room is never a recommended servicing strategy!

R-E

## TV, RADIO COMMUNICATIONS



□ **BP91—INTRO TO RADIO DXING** . . . \$5.00. Everything you need to know about radio DXing and how you can get into this fascinating hobby area.

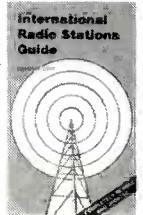

□ **BP155—INTL RADIO STATIONS GUIDE** . . . \$6.95. New edition lists station site, country, frequency, ERP provides for thousands of short wave radio stations. Nine sections cover a variety of broadcast services.



□ **BP105—ANTENNA PROJECTS** . . . \$5.00. Practical antenna designs including active, loop, and ferrite types that are simple and inexpensive to build, yet perform well. Also included are antenna accessories.



□ **BP125—SIMPLE AMATEUR BAND ANTENNAS** . . . \$5.00. Shows how to build 25 antennas starting with a simple dipole and working on up to beam, triangle and even a mini mombic.



□ **BP132—25 SHORT-WAVE BROADCAST ANTENNAS** . . . \$5.00. Good antennas can be inexpensive. Here's 25 different ones ranging from a simple dipole, through helical designs to a multi-band umbrella.



□ **BP136—25 INDOOR AND WINDOW ANTENNAS** . . . \$5.00. If you can't put up a conventional antenna because of where you live, one of these 25 designs is likely to solve your problem and deliver great reception.

MAIL TO: Electronic Technology Today Inc.  
P.O. Box 240  
Massapequa Park, NY 11762-0240

SHIPPING CHARGES IN USA & CANADA  
\$0.01 to \$5.00 . . . \$1.00 \$30.01 to 40.00 . . . \$4.75  
\$5.01 to \$10.00 . . . \$1.75 \$40.01 to 50.00 . . . \$5.75  
\$10.01 to 20.00 . . . \$2.75 \$50.01 and above \$7.00  
\$20.01 to 30.00 . . . \$3.75

### OUTSIDE USA & CANADA

Multiply Shipping by 2 for sea mail  
Multiply Shipping by 4 for air mail

Total price of merchandise . . . \$ \_\_\_\_\_  
Shipping (see chart) . . . \$ \_\_\_\_\_  
Subtotal . . . \$ \_\_\_\_\_  
Sales Tax (NYS only) . . . \$ \_\_\_\_\_  
Total Enclosed . . . \$ \_\_\_\_\_

Name \_\_\_\_\_

Address \_\_\_\_\_

City \_\_\_\_\_ State \_\_\_\_\_ Zip \_\_\_\_\_



**NEW LIT**

*continued from page 15*

**TOOL CATALOG.** Jensen's full-color *Winter 1988* catalog features pliers, screwdrivers, and other hand-tools; power tools; test and measurement instruments; and tool kits and cases. Test equipment for computers and telecommunications devices is also presented. An updated supplement is also available; both are free of charge upon request.—**Jensen Tools Inc.**, P. O. Box 50020, Phoenix, AZ 85076-0020.

CIRCLE 22 ON FREE INFORMATION CARD

**FULL-LINE CATALOG.** The 1988 catalog from **Parts Express** contains VCR parts, speakers, semiconductors, CATV products, tools, test equipment, chemicals, and cables. Also featured are computer accessories, and hardware. There is no charge for the catalog, which can be ordered by calling (800) 338-0531.—**Parts Express International Inc.**, 340 E. First St., Dayton, OH 45402.

CIRCLE 23 ON FREE INFORMATION CARD

**DOES YOUR DIGITAL CAPACITANCE METER DO THIS?**

FULL 4 DIGIT 0.5 INCH LCD DISPLAY COMPLETELY AUTORANGING WITH 10 RANGE MANUAL CAPABILITY

- AND THIS**  
RANGE OF 0.0 pF to 1 FARAD (999.9 mF)  
0.5% BASIC ACCURACY UP TO 100 uF
- AND THIS**  
READS DIELECTRIC ABSORPTION
- AND THIS**  
EXTENDED PSEUDO 5 DIGIT  
RESOLUTION ON SOME RANGES ONLY
- AND THIS**  
ABILITY TO ZERO LARGE CAPACITANCE  
VALUES UP TO 99.99 uF
- AND THIS**  
CALCULATES TRUE CAPACITANCE  
IF CAPACITOR IS LEAKY
- AND THIS**  
DIODE CLAMP AND FUSED  
PROTECTED INPUT.  
DISCHARGE RESISTOR IN OFF  
POSITION AT TERMINAL INPUTS.  
POWERED BY 9V BATTERY
- ONE YEAR PARTS &  
LABOUR WARRANTY**
- FOR ONLY THIS**



- AND THIS**  
IDENTIFIES TRANSISTORS (NPN, PNP)  
AND THEIR LEADS (E, B, C, ETC.)
- AND THIS**  
TESTS ZENER DIODES AND RECTIFIERS  
UP TO 20V ZENER WITH AC ADAPTOR,  
ZENER VOLTAGE WITH 9V BATTERY  
DEPENDS ON ITS CONDITION
- AND THIS**  
AUTOMATICALLY CALCULATES LENGTHS  
OF CABLES IN FEET, METRES, MILES,  
KILOMETRES (THEORETICAL RANGE  
OF 9,999 MILES)
- AND THIS**  
ABILITY TO SORT CAPACITORS IN  
MANY DIFFERENT MODES
- AND THIS**  
ABILITY TO READ LEAKY CAPACITANCE  
(INSULATION RESISTANCE OR CURRENT)
- AND THIS**  
CALCULATES TIME CONSTANTS WITH  
USER DEFINED RESISTANCE VALUES
- AND THIS**  
HOLD FUNCTION FREEZES DISPLAY

**SHIPPING INSTRUCTIONS:**

All units shipped out F.O.B. Buffalo NY via United Parcel Service (except Hawaii & Alaska) unless otherwise indicated (in which case shipments will be F.O.B. Canada)

**\$169.95**

MODEL  
**MC300** Approx. Size  
7" x 4" x 1 1/4"  
**DAETRON**  
a division of Bergeron Technologies Inc.  
935 THE QUEENSWAY, BOX 641  
TORONTO, ONTARIO M8Z 5Y9  
CANADA (416)676-1600

PLEASE SEND ME	U.S. FUNDS
(QUANTITY) MC300(S) @	\$ 169.95 \$ _____
CARRYING CASE	\$ 16.95 \$ _____
AC ADAPTOR	\$ 9.95 \$ _____
SHIPPING AND HANDLING @ \$5.00 PER INSTRUMENT	\$ _____
<input type="checkbox"/> CHECK <input type="checkbox"/> MONEY ORDER	\$ _____
<input type="checkbox"/> VISA <input type="checkbox"/> MASTERCARD	TOTAL \$ _____
<input type="checkbox"/> CARD NO.	SIGNATURE _____
EXPIRY DATE _____	TELEPHONE _____
NAME _____	ADDRESS _____
CITY _____	STATE _____ ZIP CODE _____

**DEALER ENQUIRIES INVITED**  
CIRCLE 197 ON FREE INFORMATION CARD

# NEW RUGGEDIZED SCOPE PROBES

Just a phone call away.

**\$35** P6103  
50 MHz 10x  
Compensation Range  
15 to 35 pF

**\$58** P6109  
150 MHz 10x  
Compensation Range  
18 to 22 pF

These new passive voltage probes can be used with any oscilloscopes having matching compensation ranges. Screw in tips mean easy repair, no downtime.

To order call toll free **1-800-426-2200**

VISA and MasterCharge accepted.

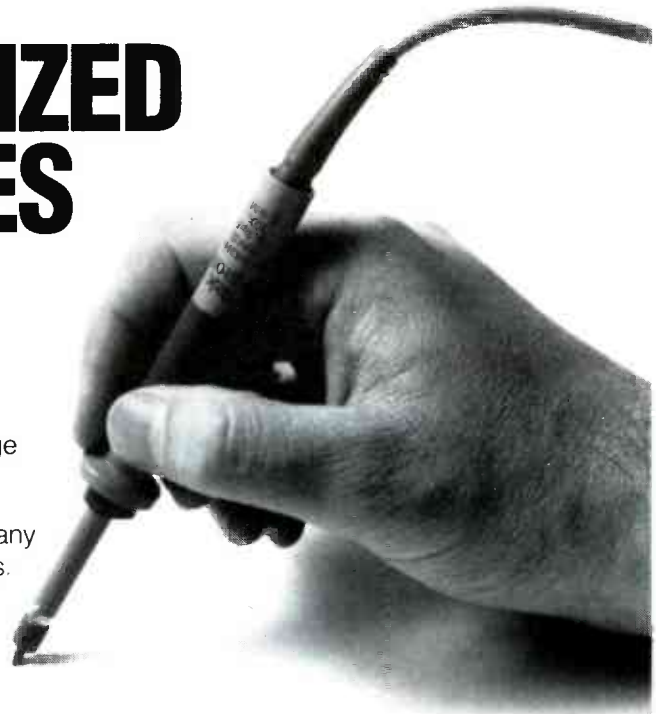

**Tektronix**  
COMMITTED TO EXCELLENCE

*Train for the Fastest Growing Job Skill in America*

# Only NRI teaches you to service all computers as you build your own fully IBM compatible microcomputer

With more and more new applications being developed for every facet of business, education, and personal computer use, the demand for trained computer service technicians surges forward. The Department of Labor ranks computer service high on its list of top growth fields, with accelerated demand creating more than 30,000 *new* jobs in the next 10 years.

## **Total systems training**

No computer stands alone . . . it's part of a total system. And if you want to learn to service and repair computers, you have to understand computer

*systems*. Only NRI includes a powerful computer system as part of your training, centered around the new, fully IBM PC compatible Sanyo 880 Series computer.

You start with the step-by-step assembly of the highly rated Sanyo 880 computer. You build and test the "intelligent" keyboard, install the power supply and 5¼" floppy disk drive, and interface the high-resolution monitor. But that's not all. You go on to install a powerful 20 megabyte hard disk drive—today's most-wanted computer peripheral, now included as part of your hands-on training.

It's confidence-building, real-world experience that includes training in programming, circuit design, and peripheral maintenance.

## **No experience necessary— NRI builds it in**

Even if you've never had any previous training in electronics, you can succeed with NRI training. You'll start with the basics, then rapidly build on them to master such concepts as digital logic, microprocessor design, and computer memory. You'll build and test advanced electronic circuits using the exclusive NRI Discovery Lab<sup>®</sup>,

## **Learn Computer Servicing Skills with NRI's "Hands-On" Training . . .**



Using NRI's unique Action Audio Cassette, you are talked through the operation and practical application of your hand-held digital multimeter—the basic, indispensable tool for the computer specialist.



You'll set up and perform electronics experiments and demonstrations using your NRI Discovery Lab. You'll even interface the lab with your computer to "see" keyboard-generated data.



After you build this digital logic probe, you'll explore the operation of the Sanyo detached "intelligent" keyboard and its dedicated microprocessor.

**NEW!**  
20 Meg  
Hard Disk  
Included!

Your NRI total systems training includes all this: NRI Discovery Lab to design and modify circuits • Four-function digital multimeter with walk-you-through instruction on audio tape • Digital logic probe for visual examination of keyboard circuits • Sanyo 880 Series computer with "intelligent" keyboard and 360K, 5 1/4" floppy disk drive • 20 meg hard disk drive you install internally • High-resolution monochrome monitor • 8K ROM, 256K RAM • Bundled software • Reference manuals, schematics, and bite-sized lessons.

professional digital multimeter, and logic probe. Like your computer, they're all yours to keep as part of your training. You even get some of the most popular software, including WordStar, CalcStar, GW Basic and MS DOS.

*Send for 100-page free catalog*

Send the post-paid reply card today for NRI's 100-page, full-

color catalog, with all the facts about at-home computer training. Read detailed descriptions of each lesson, each experiment you perform. See each piece of hands-on equipment you'll work with and keep. And check out NRI training in other high-tech fields such as Robotics, Data Communications, TV/Audio/Video Servicing, and more.

If the card has been used, write to NRI Schools, 3939 Wisconsin Ave., N.W., Washington, D.C. 20016.

**NRI SCHOOLS**

McGraw-Hill Continuing Education Center  
3939 Wisconsin Avenue, NW  
Washington, DC 20016



**We'll Give You Tomorrow.**

IBM is a Registered Trademark of International Business Machine Corporation.

## as You Build Your Own Sanyo 880 Computer System.



The power supply is assembled in the main unit of the computer. You check out keyboard connections and circuits with the digital multimeter included for training and field use.



Next, you install the 5 1/4" floppy disk drive, learning disk drive operation and adjustment. Later, you increase your data storage capacity dramatically by installing a 20 meg hard disk drive.



Using the monitor, you focus on machine language programming, an indispensable troubleshooting tool for the technician. You continue by learning BASIC language programming.

# With Instant Access, GE/RCA brings to the screen a world of replacement parts.

Now appearing at participating GE/RCA Distributors across the country is a new, highly efficient computerized replacement parts service called **Instant Access**.

With direct access to our main computer, a distributor can now learn the availability, pricing, and cross-referencing of whatever part you need, quickly and accurately.

Our massive inventory provides you with instant access to consumer parts, SK and MRO devices, broadcast parts, picture tubes, receiving tubes, electro-optics and devices, video accessories and video tape.

A precise cross-reference index automatically converts all leading industry

numbers for solid state devices (including MRO), and electro-optics and devices, into corresponding RCA part numbers. As well as converting RCA drawing numbers into RCA stock numbers for Consumer Electronics replacement parts.

Next time you need a replacement part in a hurry, look into

## **Instant Access.**

You can even specify delivery — in less than twenty-four hours if necessary. To find the participating **Instant Access** distributor nearest you, write: Sales Promotion Services, Distributor and Special Products, 2000 Clements Bridge Road, Deptford, NJ 08096-2088.

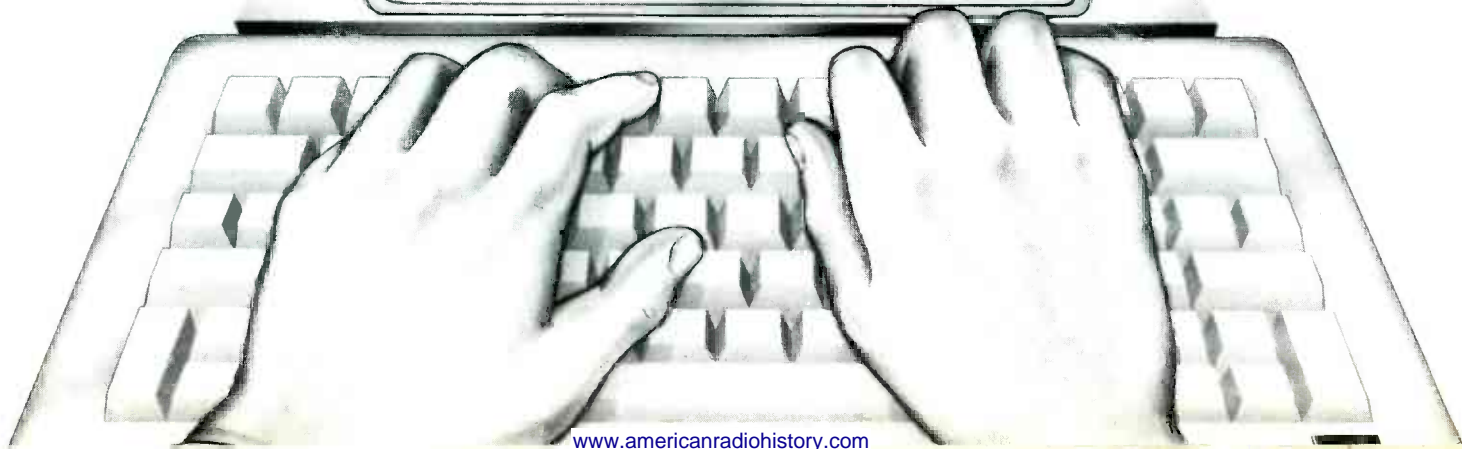
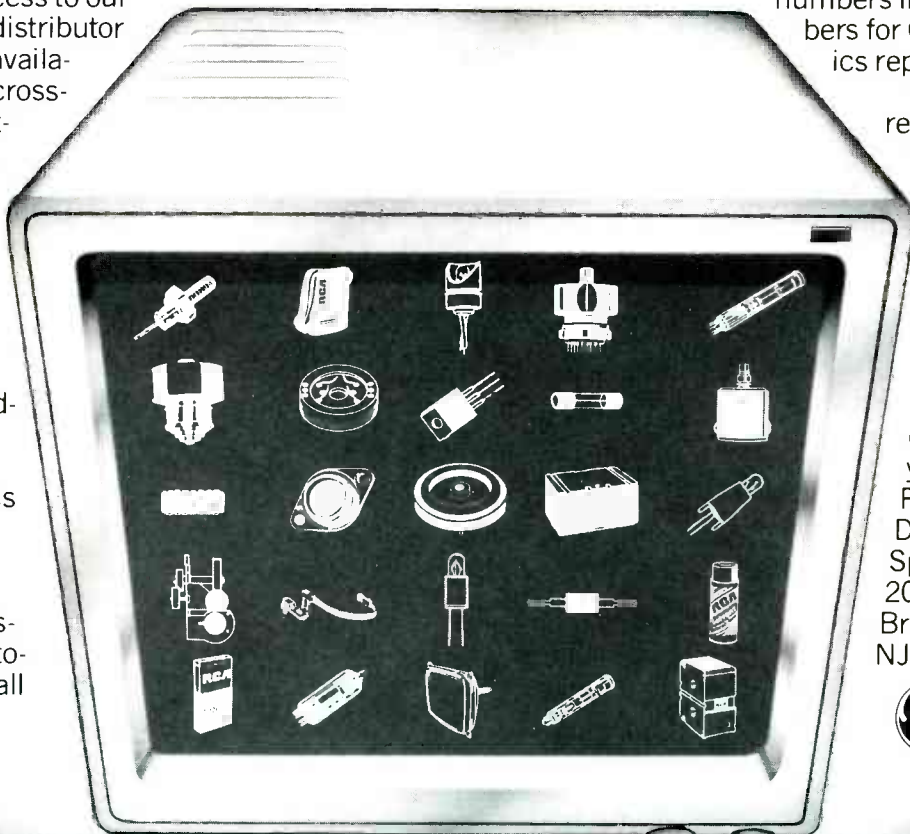

*This versatile signal generator can provide simultaneous square/triangle or square/sine output signals.*

**JOHN WANNAMAKER**



## VERSATILE FUNCTION GENERATOR

THERE WAS A TIME WHEN A SIMPLE SINE OR square wave signal was all that was needed to test electronic equipment. Today, we need many more kinds of test signals, as well as specific control over such things as their duration, shape, and duty cycle. Basically, what's needed is a laboratory-grade multifunction signal generator, such as the one described in this article. Using readily available parts, the signal generator provides a square wave output, with simultaneous triangle, and sine wave outputs; it can also supply variable duty-cycle pulses and a more-or-less conventional linear-sawtooth ramp.

All outputs have level controls, and the sine/triangle function makes provision for a fixed amount of attenuation. There's also a front-panel OFFSET control for the sine and triangle waveforms that provides  $\pm 1.5$  volts into a 600-ohm load, or 3 volts into an open load. Other waveforms are unipolar and may be used with CMOS and TTL circuits.

The variable duty-cycle output pulse, which has a timing value of 1–50 ms can sink more than 20 TTL loads. The linear output ramp is similarly variable. A built-in frequency counter monitors the output frequency using four decades of 100, 1000, 10,000, and 100k Hz.

Although the time-base accuracy and stability of the internal counter are exceptionally good, it would be fairly easy to add an external jack that switches out the internal monitoring and accepts a signal from the outside world. A 0–1-volt pulse is adequate input from 5 Hz to 2 MHz, but the four-digit counter and display can only handle up to 99.99 kHz.

### The circuits

The signal generator is divided into three sections: (1) the sine/triangle/square wave generator; (2) the counter; (3) the pulse/ramp.

As shown in Fig. 1, IC3, an Exar XR2206 Function Generator integrated circuit, provides the sine, triangle, and square waves. Normally, IC3's frequency adjustment is a 0.2–2-megohm variable resistor connected from pin 7 to ground, but that kind of adjustment often proves to be critical because only conventional single-turn potentiometers are normally available in such large values. In our prototype, however, the XR2206 is used as a voltage-controlled oscillator, and frequency-adjustment control R25 is a 10K 10-turn potentiometer. Adjusting the output frequency to within one cycle out of a thousand takes only a modest degree of dexterity.

Values other than 10K may be used if fixed-resistor R16 is changed. For a 2K potentiometer,  $R16 = 4.7K$ . For 5K,  $R16 = 20K$ . For 20K,  $R16 = 82K$ . Try to stay within that range, or the low-frequency adjustment trimmer may become ineffective.

The sine/triangle circuit is also unusual in that, unlike some commercial circuits, attenuation switch S3 affects only the signal amplitude and not the value of any offset voltage. You decide how much fixed attenuation the circuit is to have (up to -20 dB; a 10:1 voltage ratio) by making R26 larger than necessary, and then trimming its value by connecting another fixed resistor (R27) in parallel. If that method is too cumbersome, the two resistors can be replaced by a multi-turn trimmer resistor. (Although the trimmer is more costly, it's a great deal easier to use.)

### Output impedance

A sine or triangle output is selected by switch S2. Emitter-follower Q8 has an output impedance of about 20 ohms, which can supply a 1.5-volt p-p waveform into an 8-ohm speaker, or about twice that amount into 16 ohms. That holds true from 10 Hz to frequencies that are far above the audio range. (It's important to adjust for zero offset if testing speakers in that manner.)

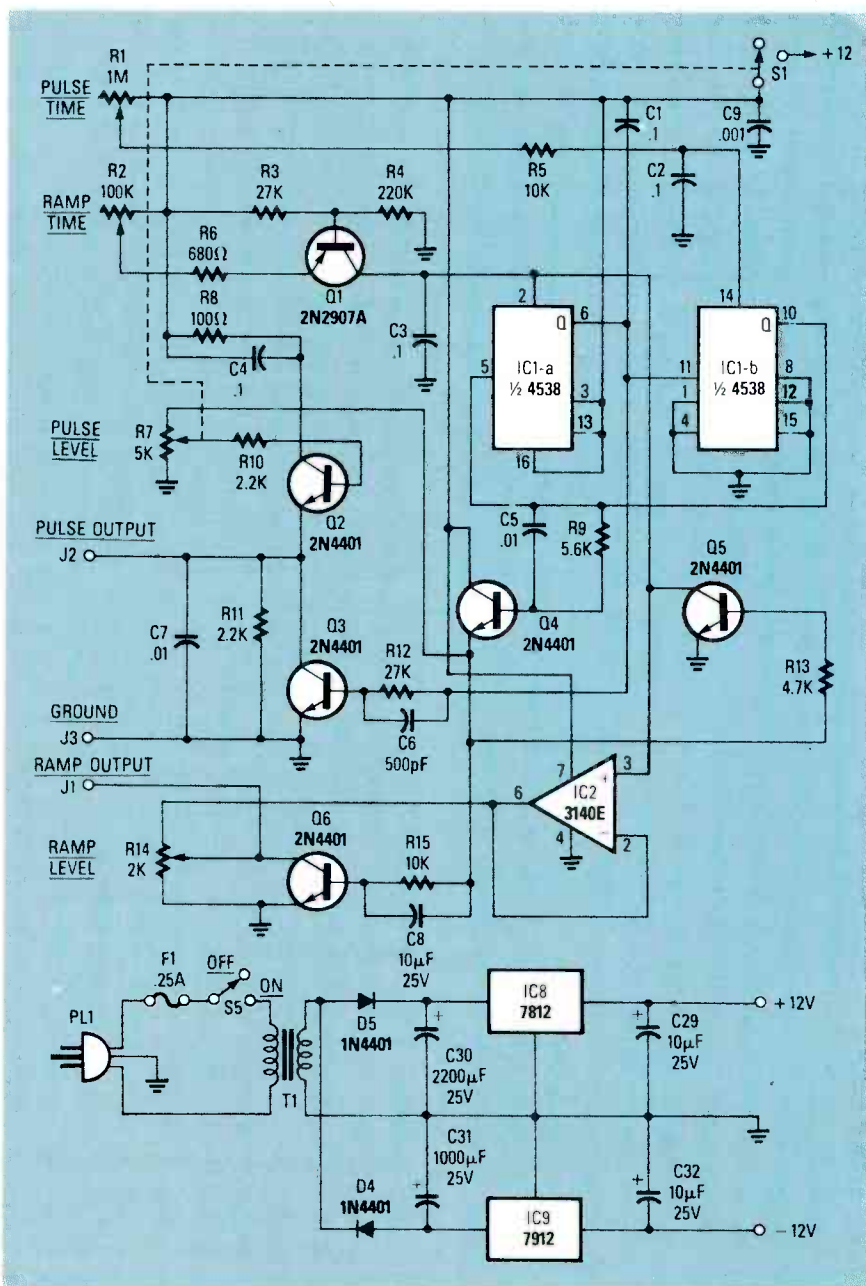

FIG. 3—THE RAMP/PULSE SECTION can be disabled by switch S1, which is part of PULSE-LEVEL control R7.

in a different way might increase noise on the sine-wave output.

Since the sine-wave output can be adjusted to a very low level, it is important to minimize the resident noise level on the output line. The use of wide foil in the power-supply circuit, plus a short length of hookup wire used as a supplemental ground bus, keeps powerline-related noise to about 200  $\mu\text{V}$  p-p. We found that grounding the resistor in the OFF-SET circuit to the front panel instead of to the ground foil on the PC-board made a significant reduction in random noise, again proving that all grounds are not equal. Noise spikes caused by

the counter's multiplexing (or pulse transitions) are suppressed by either removing power or reducing power to the offending area. The counter/display current is reduced by one section of attenuator-switch S3. Although that causes the readout to dim, it is still usable. The pulse/ramp circuitry may be switched off entirely by switch S1, which is part of PULSE LEVEL control R7. The overall noise is about 250  $\mu\text{V}$  p-p into a 600-ohm load, and about twice that value into an open circuit.

#### Low distortion

The sine-wave output's harmonic

distortion can be reduced to as little as 0.5% by adjusting trimmer potentiometers R18 and R19. However, the sine-wave output also contains a low-level distortion that appears in the form of a tenacious little blip that appears near the peaks of the sine and triangle waveforms during the transitions of the square wave. Although hardly noticeable when the sine-wave amplitude is high, the blip refuses to lose amplitude at the same rate as the sine wave when the sine-wave output level is reduced. Capacitors C18–21 minimize that blip to about 0.5- $\mu\text{s}$  duration, and to a peak amplitude of 400  $\mu\text{V}$ .

The user can very nearly eliminate the blip altogether by adding capaci-

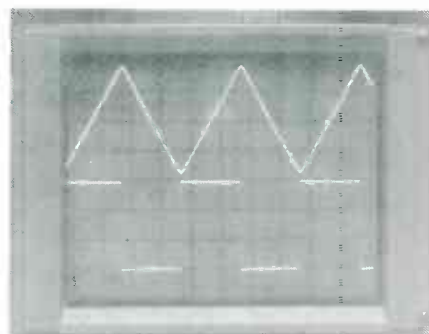

FIG. 4—THE SQUARE AND TRIANGLE WAVEFORMS are simultaneously available at independent output jacks. Note that the waveforms are in-phase.

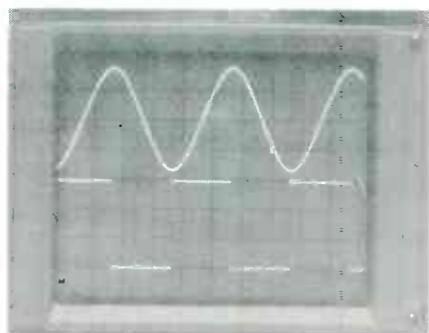

FIG. 5—THE SQUARE AND SINE WAVEFORMS are also in-phase and simultaneously available at independent output jacks.

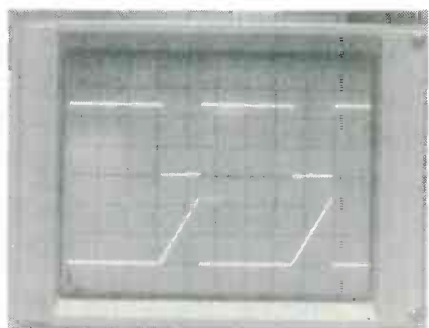

FIG. 6—THE RAMP OUTPUT OCCURS during the negative-going part of the square-wave's duty-cycle.

## PARTS LIST

All resistors are ¼-watt, 5% unless otherwise noted.

R1—1 megohm, linear potentiometer  
 R2—100,000 ohm, linear potentiometer  
 R3, R12, R30—27,000 ohms  
 R4—220,000 ohms  
 R5, R15, R21, R22, R32, R55—10,000 ohms  
 R6—680 ohms  
 R7—5000 ohm, potentiometer with switch  
 R8—100 ohms, 2 watts  
 R9—5600 ohms  
 R10, R11—2200 ohms  
 R13, R43—47—47000 ohms  
 R14, R23, R28—2000 ohm, linear potentiometer  
 R16—33,000 ohms  
 R17—10,000-ohm trimmer potentiometer  
 R18—500 or 1000 ohm, trimmer potentiometer  
 R19—50,000 ohm, trimmer potentiometer  
 R20, R57—1000 ohms  
 R24—9100 ohms  
 R25—10,000 ohms, 10-turn potentiometer (see text)  
 R26, R27—selected, see text  
 R29—10,000 ohms, linear potentiometer  
 R31, R59—47,000 ohms

R33—22,000 ohms  
 R34—50,000 ohms, trimmer potentiometer  
 R35, R52, R54, R56, R58—100,000 ohms  
 R36—27,000 ohms  
 R37, R38—1500 ohms  
 R39—42, R49—51—150 ohms  
 R48—100 ohms  
 R53—10 megohms  
 R60—330 ohms

### Capacitors

C1, C4—0.1 µF, ceramic disc  
 C2, C3—0.1 µF, Mylar  
 C5, C7, C23—0.01 µF, ceramic disc  
 C6, C18, C20—500 pF, ceramic disc  
 C8, C24—100 pF, ceramic disc  
 C9, C10, C16, C17, C29, C32—10 µF, 25-volts, electrolytic  
 C11, C27—47 µF, 25 volts, electrolytic  
 C12—.001 µF, Mylar, 1%  
 C13—.01 µF, Mylar, 1%  
 C14—0.1 µF, Mylar, 1%  
 C15—1 µF, 50 volts, electrolytic  
 C19, C21, C22, C28—.001 µF, ceramic disc  
 C25, C26—22 pF, ceramic disc  
 C30—2200 µF, 25 volts, electrolytic  
 C31—1000 µF, 25 volt, electrolytic

### Semiconductors

IC1—CD4538 or MC14538 dual monostable

IC2, IC4—CA3140E op-amp  
 IC3—XR2206 function generator  
 IC5—74C926 counter  
 IC6—ICM7207A time base  
 Q1—2N2907A PNP transistor  
 Q2—Q15—2N4401 NPN transistor  
 D1—3—1N914 small signal diode  
 D4, D5—1N4401 silicon rectifier

### Other components

F1—0.25-amp fuse  
 DSP1—NSB3881 Four-Digit display (National)  
 J1—J6—Insulated banana jack  
 J7—Miniature phone jack  
 PL1—Powerline plug  
 S1—SPST, part of R7  
 S2, S5—SPST switch  
 S3—DPST switch  
 S4—3-pole, 4-position rotary switch  
 T1—Power transformer; 117-volt primary; 12.6-volt, 1-amp secondary  
 XTAL1—5.24288-MHz crystal  
**Miscellaneous:** PC-board, IC sockets, enclosure, wire, solder, etc.

**Note: An etched and drilled printed-circuit board is available for \$17 postpaid (includes postage and handling) from John Wannamaker, Route 4, Box 550, Orangeburg, SC 29115. South Carolina residents must add appropriate sales tax.**

tance between the terminal and ground, although the cost of the extra capacitance is a rounding of the triangle-waveform's peaks. (With the built-in capacitors, that becomes objectionable only on the highest range.) The capacitance also causes 4-dB attenuation at 100 kHz. If that seems too stiff a price to pay for a clean low-level signal, simply remove the aforementioned capacitors, but expect a little rounding of the high-frequency triangle peaks anyway.

Since it is known that the square-wave output contributes significantly to the unwanted blip on the sine wave, the square-wave's output line should be kept short, and (it really hurts to say this) it should be shielded.

The 330-ohm current-limiting resistor for the counter section, R60, should be mounted directly between the terminals of the appropriate section of the DPST (or DPDT) ATTENUATE switch. Other front-panel mounted components are C20 (500 pF), which should be soldered across the outboard terminals of the SINE-LEVEL potentiometer, and C21 (.001

µF), which should be soldered between the SINE output jack and the nearby front-panel GROUND jack. (Separate GROUND jacks should be provided for the pulse/ramp signals and the sine/triangle signals.)

If the SINE output is to provide maximum current, wire it directly to its PC-board solder pad. If a 600-ohm output is desired, use a string of ¼-watt resistors with a nominal resistance of about 580 ohms in place of the direct wire connection. When the resistance value is just right, an open-circuit sine wave of any value will drop to exactly half of that value when a precise 600-ohm load is connected between the SINE and GROUND jacks.

Even though the PC board has two foils connecting the power-supply ground to the long ground foil on the "output" side of the board, there is sufficient inherent impedance to create some hum at the SINE output. To minimize the induced hum, solder a short—approximately 3 inches—insulated jumper between the ground foils, under the board. Solder one end to the wide foil where C30 is

grounded; solder the other end to the foil near the two ground pads on the opposite side of the board.

### Mounting

Each corner of the board has room for a 4–40 machine screw mounting hole. Be careful to not let a metal spacer under the board short to a nearby foil; or even better, use insulated spacers. It would be wise to pass the screws through the bottom of the cabinet so that the retaining nuts are on top of the board.

The LED-display assembly can be held in place by either 2–56 or 4–40 machine screws that extend through the front panel on each side of the display. They should pass through some kind of improvised insulated retaining bar across the back of the display. Take care, when installing the display, that its solder terminals do not short to the panel. Since the recommended display has a built-in red filter, no additional filter is necessary.

When mounting the power transformer, make provision for two lugs under one of the mounting screws.

# Join the Electronics and Control Engineers' Book Club®

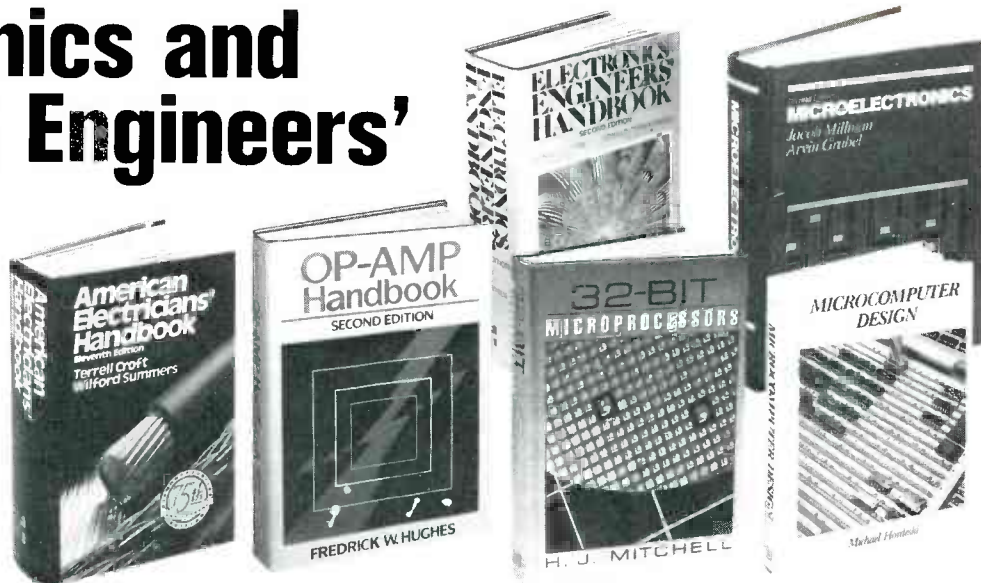

**ADVANCED DIGITAL COMMUNICATIONS: Systems and Signal Processing.** Edited by K. Feher. 768 pp., 436 illus. Emphasizes the newest advances and developments in telecommunications systems and networks. Chapters on subjects such as ISDN, speech coding algorithms, digital speech interpolation systems and interference are all written by international authorities to give you on-the-job expertise.  
583801-X Pub. Pr., \$59.95 Club Pr., \$42.50

**ELECTRONICS ENGINEERS' HANDBOOK, Second Ed.** Edited by D. G. Fink & D. Christiansen. 2,272 pp., 2,189 illus. This updated and enlarged edition covers all the latest knowledge in the field, including new advances in integrated circuits, pulsed and logic circuits, laser technology, telecommunications, and much more.  
209/812 Pub. Pr., \$89.00 Club Pr., \$61.50

**32-BIT MICROPROCESSORS.** Edited by H. J. Mitchell. 248 pp., 104 illus. and tables. A complete survey of the architecture, operation, and applications of today's most important new devices from AT&T, Immos, Intel, and Motorola.  
425/85X Pub. Pr., \$39.95 Club Pr., \$29.50

**MICROWAVE AMPLIFIERS AND OSCILLATORS.** By C. Gentili. 150 pp., 79 illus. A thorough, practical introduction to the theory and design of microwave amplifiers and oscillators, with coverage of the scattering matrix, the gallium arsenide field-effect transistor, and microstrip technology.  
229/953 Pub. Pr., \$31.95 Club Pr., \$24.95

**TROUBLESHOOTING ELECTRONIC EQUIPMENT WITHOUT SERVICE DATA** By R. G. Middleton. 303 pp., 162 illus. and tables. Packed with charts, diagrams, and case histories, this practical handbook shows you how to pinpoint defective electronic circuitry when no service data is available.  
583134-1 Pub. Pr., \$27.95 Club Pr., \$22.50

- your one source for engineering books from over 100 different publishers
- the latest and best information in your field
- discounts of up to 40% off publishers' list prices

New Members!  
Take any one of these great professional books for only **\$289** as a premium with your first selection!

Spectacular values up to **\$98.50**

**McGRAW-HILL CONCISE ENCYCLOPEDIA OF SCIENCE AND TECHNOLOGY.** Editor-in-Chief S. P. Parker and the Staff of the McGraw-Hill Encyclopedia of Science and Technology. 2,065 pp., 1,600 illus. This volume serves every need for understanding today's science and technology. Written by over 3,000 of the world's topmost experts, including 19 Nobel Prize winners, it covers 75 disciplines from Acoustics to Zoology.  
454/825 Pub. Pr., \$98.50 Club Pr., \$63.99

**CIRCUIT DESIGN FOR ELECTRONIC INSTRUMENTATION: Analog and Digital Devices from Sensor to Display, Second Ed.** By D. Wobbschall. 400 pp., 365 illus. Brings you the entire process of circuit design in a comprehensive, easy-to-follow format. This new edition reflects the latest in IC technology, including CMOS and ECL devices.  
712/31X Pub. Pr., \$49.50 Club Pr., \$36.95

**AMERICAN ELECTRICIANS' HANDBOOK, Eleventh Ed.** By T. Croft and W. Summers. 1,824 pp., 1,560 illus. This newly updated handbook shows you how to select, install, maintain, and operate all the latest electrical equipment and wiring. It includes the most recent code requirements, basic formulas, and a wealth of circuit diagrams and illustrations.  
139/326 Pub. Pr., \$64.50 Club Pr., \$49.50

**MICROELECTRONICS, Second Ed.** By J. Millman and A. Grabel. 1,001 pp., 646 illus. Takes you from the basics of semiconductor properties to an understanding of the operation of solid-state devices, and then to more advanced topics. Its up-to-date coverage, real-life examples, and practical data make this an ideal reference for the working engineer.  
423/30X Pub. Pr., \$49.95 Club Pr., \$36.50

**ENGINEERING MATHEMATICS HANDBOOK, Third Ed.** By J. J. Tuma. 512 pp., illus. This best-selling handbook gives you the essential mathematical tools—formulas, definitions, theorems, tables, and models for computer programming—that you need for your day-to-day engineering calculations.  
654/433 Pub. Pr., \$44.50 Club Pr., \$34.50

**ENGINEERING FUNDAMENTALS FOR THE PROFESSIONAL ENGINEERS' EXAM, Third Ed.** By L. M. Polentz. 432 pp., 170 illus. Features worked-out solutions and full explanations for all sample problems so you can learn how to solve them. It's a dependable way to prepare for the exam or a perfect on-the-job reference.  
503/931 Pub. Pr., \$36.50 Club Pr., \$27.95

**AUTOMATIC CONTROL SYSTEMS, Fifth Ed.** By B. C. Kuo. 736 pp., illus. Provides an overview of automatic control systems, including in-depth coverage of classical control techniques, optimal control theory, and analog and digital control system design. This updated edition discusses the latest ideas on the use of computers to design control systems and as components of such systems.  
583706-4 Pub. Pr., \$48.00 Club Pr., \$36.95

**OP-AMP HANDBOOK, Second Ed.** By F. W. Hughes. 320 pp., 231 illus. Organized for on-the-job reference, this handbook covers all facets of op-amps, from stability and protection to signal processing using op-amps. Includes a collection of over 60 practical circuits for a variety of applications, procedures, and experiments.  
583651-3 Pub. Pr., \$36.33 Club Pr., \$27.50

**THE LINEAR IC HANDBOOK.** By M. S. Morley. 614 pp., 163 illus. The one-stop sourcebook that helps you find—quickly and easily—the lowest-cost linear IC that will meet your needs. Includes specs, applications data, and prices of linear ICs from all major manufacturers, as well as design and fabrication techniques.  
583784-6 Pub. Pr., \$49.50 Club Pr., \$36.25

## HANDBOOK OF ELECTRONIC TABLES AND FORMULAS Sixth Edition

256 pages, illustrated. 583804-4

Up-to-date mathematical tables and electronic formulas in a convenient desk reference that you'll find indispensable. Included are basic formulas, constants, government/industry standards, symbols and codes, service data, and more. The handbook also has new sections describing how to do your calculations on a computer, and complete computer programs.

**A \$19.95 Value — Yours ABSOLUTELY FREE when you join!**



**PRINCIPLES OF PARALLEL AND MULTI-PROCESSING.** By G. R. Desrochers. 500 pp., illus. A highly practical guide to the best techniques in parallel problem-solving. Discusses parallel system design, architecture, implementation, software, and performance analysis.

165/793 Pub. Pr., \$49.50 Club Pr., \$36.95

**ANALOG ELECTRONIC CIRCUITS.** By G. M. Glasford. 480 pp., 350 illus. Gives you the detailed information and equations you need to create and analyze top quality circuit designs or effectively utilize the designs of others.

583768-4 Pub. Pr., \$52.33 Club Pr., \$37.95

**HANDBOOK OF ELECTRONIC NOISE MEASUREMENT AND TECHNOLOGY, Second Ed.** By C. A. Vergers. 440 pp., 213 illus. Provides answers to all your questions about noise origins, causes, effects. Also shows you how to predict and measure noise, and how to design low-noise circuits.

583947-4 Pub. Pr., \$39.95 Club Pr., \$29.95

**SWITCHGEAR AND CONTROL HANDBOOK, Second Ed.** Edited by R. W. Smeaton. 1,056 pp., 789 illus. The only handbook that treats all aspects of switchgear control, including design, applications, safety, and maintenance. Updated to reflect the changes brought about by the use of computers, solid-state devices, and programmable controls.

584/494 Pub. Pr., \$75.00 Club Pr., \$56.95

**ANTENNA APPLICATIONS REFERENCE GUIDE.** Edited by R. C. Johnson and H. Jaski. 496 pp., 368 illus. and tables. Covers the major applications of antenna technology in all areas of communications and their design methods. Emphasizes important new applications such as earth station, satellite, seeker, aircraft, and microwave-relay antennas.

322/848 Pub. Pr., \$49.50 Club Pr., \$36.50

**MICROCOMPUTER DESIGN.** By M. Hordeski. 406 pp., illus. Emphasizes the most current, cost effective methods for developing, debugging and testing all types of microprocessor products, including software and hardware.

583683-1 Pub. Pr., \$42.67 Club Pr., \$29.95

**DESIGNING ELECTRONIC CIRCUITS.** By R. G. Middleton. 351 pp., 192 illus. Covers virtually every category of circuits commonly used. This practical manual provides the basic design procedures, tables and formulas vital to effective electronic circuit design. Plus over 60 start-to-finish procedures are featured along with scores of computer programs to help you design and analyze electronic circuits.

583673-4 Pub. Pr., \$36.95 Club Pr., \$27.50

**Be sure to consider these important titles as well!**

**INTRODUCTION TO RADAR SYSTEMS, Second Ed.** By M. I. Skolnik. 579/091 Pub. Pr., \$51.95 Club Pr., \$38.95

**MICROPROCESSORS IN INSTRUMENTATION AND CONTROL.** By S. A. Money. 427/070 Pub. Pr., \$39.50 Club Pr., \$29.50

**OPERATIONAL AMPLIFIERS AND LINEAR INTEGRATED CIRCUITS, Third Ed.** By R. F. Coughlin and F. E. Driscoll. 583754-4 Pub. Pr., \$34.95 Club Pr., \$25.95

**MCGRAW-HILL'S NATIONAL ELECTRICAL CODE HANDBOOK, 19th Ed.** By J. F. McPartland. 457/077 Pub. Pr., \$42.50 Club Pr., \$31.95

**ELEMENTS OF ENGINEERING ELECTROMAGNETICS, Second Ed.** By N. N. Rao. 583774-9 Pub. Pr., \$49.00 Club Pr., \$35.50

**PROBABILITY, SIGNALS, NOISE.** By J. Dupraz. 183/309 Pub. Pr., \$39.95 Club Pr., \$29.95

**POWER GENERATION CALCULATIONS REFERENCE GUIDE.** By T. G. Hicks. 288/003 Pub. Pr., \$36.50 Club Pr., \$27.50

**HUMAN FACTORS REFERENCE GUIDE FOR ELECTRONICS AND COMPUTER PROFESSIONALS.** By W. E. Woodson. 717/664 Pub. Pr., \$32.50 Club Pr., \$23.75

**THE FOURIER TRANSFORM AND ITS APPLICATIONS, Second Ed., Revised.** By R. N. Bracewell. 070/756 Pub. Pr., \$49.95 Club Pr., \$38.95

**THE LASER GUIDEBOOK.** By J. Hecht. 277/338 Pub. Pr., \$49.50 Club Pr., \$37.50

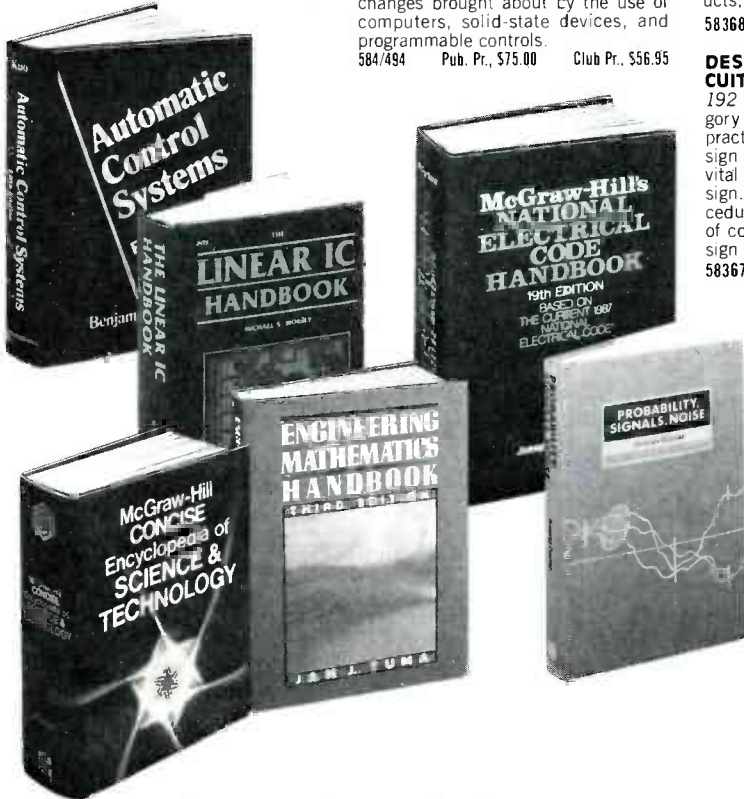

**68000 MICROPROCESSOR: ARCHITECTURE, SOFTWARE & INTERFACE TECHNIQUES.** By W. A. Triebel & A. Singh. 583613-0 Pub. Pr., \$42.67 Club Pr., \$29.95

## Here's how the Club works to serve YOU:

**■ IMPORTANT INFORMATION... WE MAKE IT EASY TO GET!**  
In our rapidly changing world, those who perform best are those who are best informed. Designed exclusively for the practicing engineer, the Electronics and Control Engineers' Book Club provides you with information that is relevant, reliable, and specific enough to meet your needs. Each Club bulletin comes your way 14-16 times a year and offers you more than 30 books to choose from — the best and newest books from all publishers!

**■ DEPENDABLE SERVICE... WE'RE HERE TO HELP!**  
Whether you want information about a book or have a question about your membership, our qualified staff is here to help. Just call us toll-free or write to our Customer Service. We also make sure you get only the books you want. All you do is simply tell us your choice on the Reply Card and return it to us by the specified date. If you want the Main Selection, do nothing — it will be sent to you automatically. (A small shipping and handling charge is added to each shipment.)

**■ CLUB CONVENIENCE... WE DO THE WORK!**  
Beyond the benefit of timely information, Club membership offers many other benefits. For example, you get a wide choice of books that cannot be matched by any bookstore — anywhere. And all your books are conveniently delivered right to your door. You also get the luxury of 10 full days to decide whether you want the Main Selection. If you should ever receive a Main Selection you don't want because the Club bulletin came late, just return it for credit at our expense.

**■ SUBSTANTIAL SAVINGS... AND A BONUS PROGRAM TOO!**  
In keeping with our goal to provide you with the best information at the greatest possible savings, you will enjoy substantial discounts — up to 40%! — on every book you buy. Plus, you're automatically eligible for our Bonus Book Plan which allows you savings up to 70% on a wide selection of books.

**■ EASY MEMBERSHIP TERMS... IT'S WORTHWHILE TO BELONG!**  
Your only obligation is to purchase 2 more books — at handsome discounts — during the next 12 months, after which you enjoy the benefits of membership with no further obligation. Either you or the Club may cancel membership anytime thereafter.

**FOR FASTER SERVICE IN ENROLLING  
CALL TOLL-FREE 1-800-2-MCGRAW  
MAIL THIS COUPON TODAY**

**McGraw-Hill Book Clubs  
Electronics and Control Engineers'  
Book Club®**

PO. Box 582, Hightstown, NJ 08520-9959

Please enroll me as a member and send me the two books indicated, plus the HANDBOOK OF ELECTRONIC TABLES AND FORMULAS. I am to receive one book for just \$2.89, the other at the discounted member's price, plus local tax, shipping and handling charges. I agree to purchase a minimum of two additional books during my first year of membership as outlined under the Club plan described in this ad. I understand that a shipping and handling charge is added to all shipments.

Your FREE Handbook	
583804-4	
Write Code No. of the \$2.89 selection here	Write Code No. for the First selection here
<input type="text"/>	<input type="text"/>

Signature \_\_\_\_\_

Name \_\_\_\_\_

Address/Apt. # \_\_\_\_\_

City \_\_\_\_\_

State \_\_\_\_\_ Zip \_\_\_\_\_

This order subject to acceptance by McGraw-Hill. All prices subject to change without notice. Offer good only to new members. Foreign member acceptance subject to special conditions.

E33972

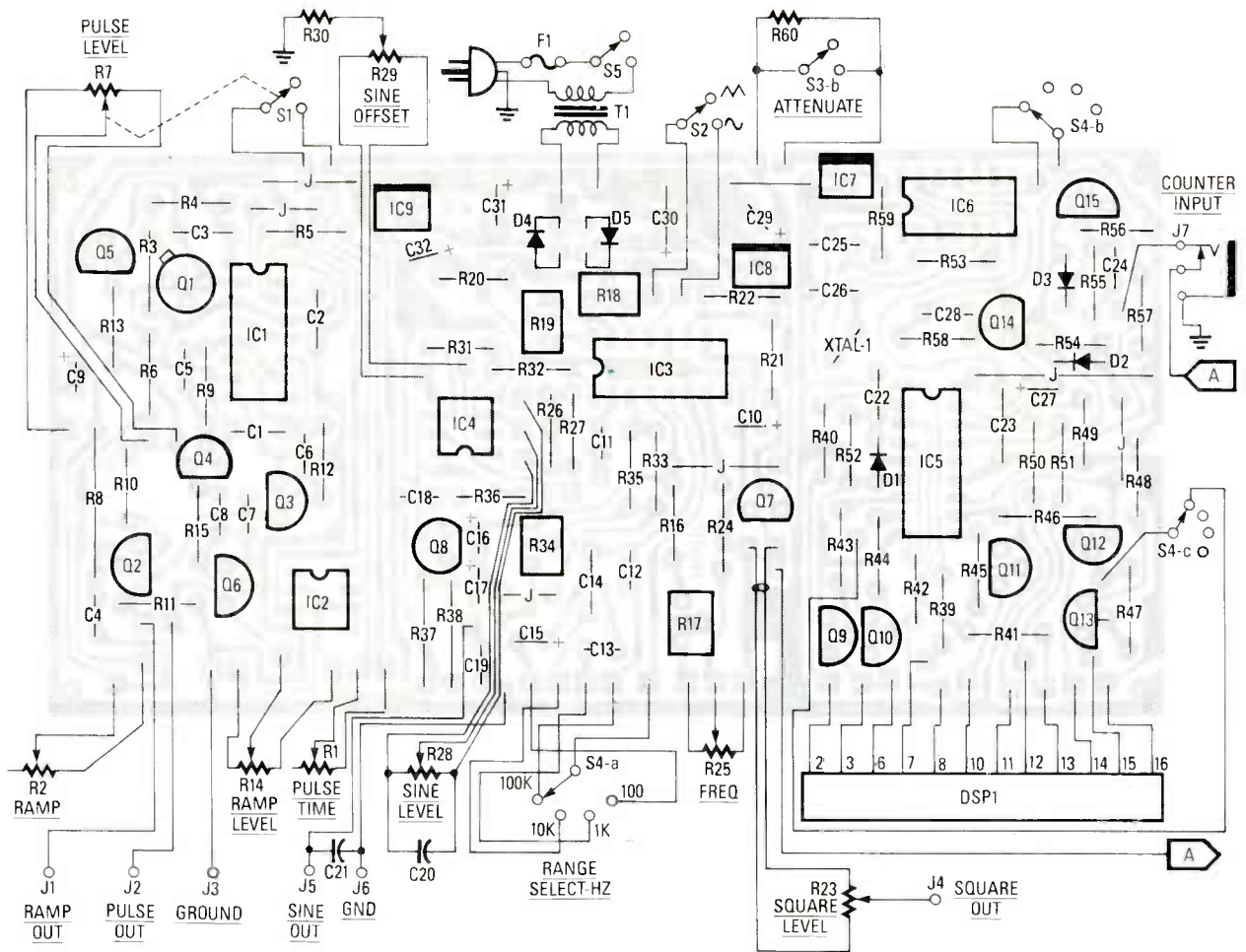

FIG. 7—THE PARTS PLACEMENT FOR THE PRINTED-CIRCUIT BOARD. Notice that not all of the 16 connections on display DSP1 are used.

Attach one to the green ground wire of the three-conductor line cord. The other should attach to an insulated wire to the PC-board's ground in the power-supply area. That has to be brought out from beneath the board and may be fairly long to allow the board to be turned over. Use stranded wire for its flexibility.

Jack J7, which is shown in Fig. 2, is needed only if you want to be able to measure the frequency of an externally generated external to the signal generator. If the feature isn't needed, using Fig. 4 as a reference, simply eliminate the jack and connect the wire going to J7's "hot" terminal to the PC-board terminal having the A-flag, which actually is a connection to the top of R23.

### Checkout

Don't install the IC's. Begin with the soldered-in voltage regulators. Using an oscilloscope, check each power source for proper voltage and polarity. Looking at the plastic front

of the regulators, the rightmost pin is the regulated output of both the positive and negative units. There should be no ripple. If everything checks out, unplug the power cord and let the voltages decay before inserting any IC's.

Plug in the IC5 and IC6 and apply power. The display should indicate 0000 for the three lowest frequency positions of the range switch, and 00.00 for the highest position. If counter is set for SINE ATTENUATE, the display will be very dim. Without any attenuation all digits will be bright.

A single dim digit can be due to insufficient multiplexing drive; check the 4700-ohm resistors at the bases of Q9-Q13. If the same segment of all digits is dim or will not light, check connections through to the display, particularly the 150-ohm resistors. At this point, of course, the middle bar cannot light. Once checked out, unplug power and allow time for voltages to decay.

To check out and adjust the sine/

triangle/square circuit, initially adjust all trimmer resistors and the front-panel potentiometers to mid position. The FREQUENCY control should be rotated five turns into its range. Select the highest frequency range with the RANGE switch and turn off any attenuation. Insert IC3 and IC4, then apply power. The counter should indicate a frequency of approximately 40 kHz. If not, check pin 11 of IC3 with an oscilloscope: You should measure a 12-volt square wave, which means that the IC is oscillating. Trace the signal through to the counter's input. If no problem is found along the route, the problem is most likely to be in the counter.

Adjust the FREQUENCY control to observe that the readout changes, updating every 0.2 seconds (2 seconds on the three lower ranges). Adjust for the lowest frequency on a particular range. Observe the readout while adjusting the low-end trimmer, R17, for a reading of approximately 9.40 kHz. You can then check each range for at

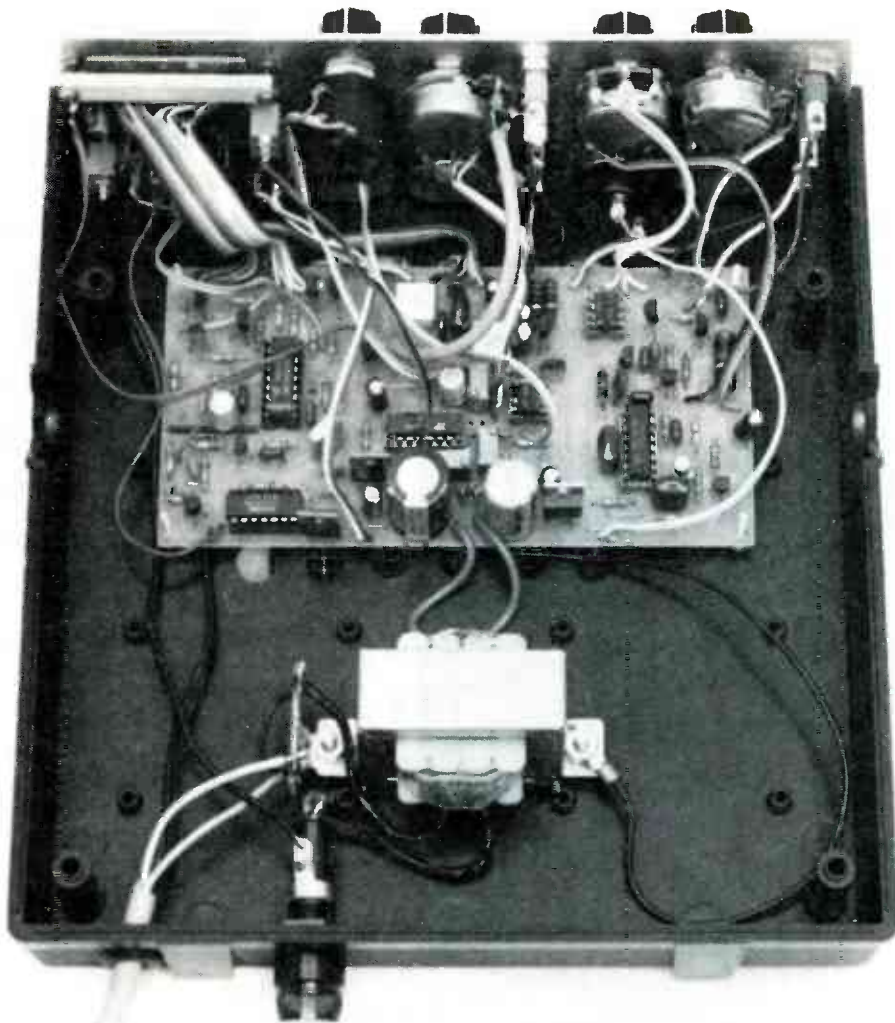

**FIG. 8—THE COMPLETED PROTOTYPE.** To reduce the possibility of hum pickup, the power transformer, T1, is located a considerable distance from the printed-circuit board. The ribbon cable at the upper left connect the display unit to the PC board.

least a 1:10 frequency variation: 10 Hz to 100 Hz; 100 Hz to 1000 Hz, etc. Of course, where a five-digit figure is given, the most significant digit is missing from the display. Correct the adjustment of R17 on any range that does not go down to, or below, the expected low value. If the highest range will not quite reach 100 kHz, it will be due to stray capacitance that parallels C12. You might try finding a capacitor with a slightly lower value, but a quick fix is to insert a 470-ohm resistor at the RANGE switch in series with the wire from S4 to C12.

Use the scope to check the square-wave output at J4. The SQUARE LEVEL control should vary the amplitude from near zero to 10 volts p-p. If there is a problem, trace the signal from pin 11 of IC3.

Set the frequency to 1000 Hz and select the triangle waveform. Observe the output at the SINE OUTPUT, J5. Ad-

just the SINE-LEVEL control for minimum (zero) output. Set the scope for measuring 2-volts DC per division and a time base of 0.2-ms/division. Position the trace so that the zero-volt line is across the center of the CRT. The front panel OFFSET adjustment should be able to create a variable output of approximately  $\pm 3$  volts.

Adjust the SINE-LEVEL control to mid-position and check for a triangle-like waveform of approximately 8 volts p-p (no attenuation). Either the top or the bottom of the waveform may be clipped. Adjust the internal OFFSET trimmer potentiometer, R34, to remove the clipping. Continue increasing the sine level and adjusting R34 until you get the maximum non-clipped waveform. A clean 16 volts p-p should be possible.

### Sine shaping

Select and observe the SINE output.

When the sine-shaping adjustments are completed, the sine wave's amplitude will be about half of that of the triangle wave. Shaping trimmers R18 and R19 interact, so alternate between the two until the scope displays the best shape. Consider that a perfect sine wave has equal areas above and below the zero line, and both peaks should have the same amount of rounding. Low distortion is definitely possible and if not attained, check your circuit, especially for improper trimmer values.

If you substitute a trimmer potentiometer for attenuating resistors R26 and R27, make the adjustment this way: With no attenuation, adjust the front panel SINE-LEVEL control for an output of precisely 8 volts p-p. Switch the attenuation in and adjust the trimmer potentiometer for whatever loss you want, up to  $-20$  dB (10:1).

If you decided to use the fixed attenuating resistors, then solder in a value for R26 based on the following:  $4.7K = -6$  dB (2:1),  $10K = -12$  dB (4:1),  $27K = -20$  dB (10:1). Resistor R27 is used as a fixed-value trimmer to bring the attenuation more nearly on target, and its value is either selected by trial and error, or it is "empirically" selected, depending on your particular view of reality. Start with a value ten times that of R26. The trimmer resistor must be tack soldered in place when determining its value to avoid introducing hum.

### The ramp

The remaining task is to check out the pulse/ramp circuit. Unplug the unit's power cord, insert IC1 and IC2, and set all pulse/ramp controls to mid range; then apply power.

View the pulse output at J2 with the scope's time-base initially at 20-ms/division. The pulse amplitude should be more than 3 volts p-p.

The PULSE-LEVEL control should allow varying the amplitude from near zero to more than 7 volts p-p. The PULSE-TIME control should vary the pulse width from 1 ms to more than 50 ms. The RAMP-TIME control determines the pulse's off time.

Observe the ramp output at J1. The RAMP LEVEL varies the ramp output from zero to  $+7$  volts. The RAMP-TIME control adjusts the duration of the ramp, which is equal to the off-time of pulse output. Switch S1, which is part of the PULSE-LEVEL control should kill both the pulse and ramp outputs. **R-E**

## Build REACTS: THE RADIO-ELECTRONICS ADVANCED CONTROL SYSTEM

*This month, we add a way to store your programs and data.*

**Part 4** LAST TIME, WE promised to show you a battery back-up system for the REACTS system. Well we will—but not this month! Instead, we will show you a powerful high-speed semiconductor-disk system for the control computer. That module will allow us to expand the size of our disk storage from the 20K provided by the CPU board to virtually any size desired, and to add read/write (RAM) storage to the disk system. And best of all, it will operate at speeds that are up to 1000 times faster than magnetic-disk systems.

### Using semiconductor disks

To the computer programmer/user, semiconductor disks are manipulated in the same way as floppies or hard drives. That is, all commands that are used with floppies or hard drives (DIR, ERA, etc.) work the same way with semiconductor disks, only much quicker.

For many reasons, semiconductor memory is ideal for process-control applications. It is low in cost compared to magnetic storage, except for applications requiring huge amounts of memory. It is much more tolerant of temperature and vibration extremes than magnetic memory. Power consumption is only a fraction of what typical magnetic-disk systems require. The size of a small semiconductor-disk system is much less than that of a conventional disk drive. The only real disadvantage of that type of disk is that the read/write portion of



H. EDWARD ROBERTS, M.D.

the disk is volatile; that means that it must be powered continually. That's really not much of a problem, and it can be made even simpler when you build the battery-backed switching power supply that will be discussed in a future article. For now, it only means that you will have to keep your computer powered up if you want to

save the contents of the RAM memory permanently.

The soft/hardware concept that we previously introduced is very evident in this module. For instance, you can configure the system to appear as 1 to 8 disk drives by simply setting switches on the back of the module. Also, multiple modules may be combined to increase the size of a single disk to over 2 megabytes. Any number of disks may be added to the system. By leaving out memory IC's, the cost of the disk system can be minimized in cost-sensitive applications. Once the hardware is customized as desired, the operating system can be changed using a configuration utility (more on that shortly). That will provide a truly customized system.

### The REACTS drives

The PROM/RAM disk portion of this month's module provides 256K of PROM and/or RAM space. It contains 8 IC sockets into which either 32K RAM or PROM IC's can be inserted; any 32K × 8-bit RAM or PROM can be used. You let the system know which type of memory each socket location contains by setting a DIP switch. As shown in Fig. 1, a PROM/RAM location is configured for a PROM if its corresponding switch is up, and configured for a RAM if the switch is down.

Throughout the rest of this article, we will refer to the disk system as a drive or drives. That allows us to follow the accepted convention used in most operating systems. For instance, the first floppy in a conventional PC is known as drive A: and the hard disk is usually labeled drive C:. Our system will support up to 16 drives, identified

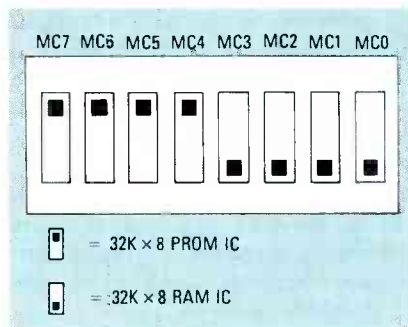

FIG. 1—THE SYSTEM IS CONFIGURED for RAM, PROM, or a combination of memory IC's using an 8-position DIP switch, S2.

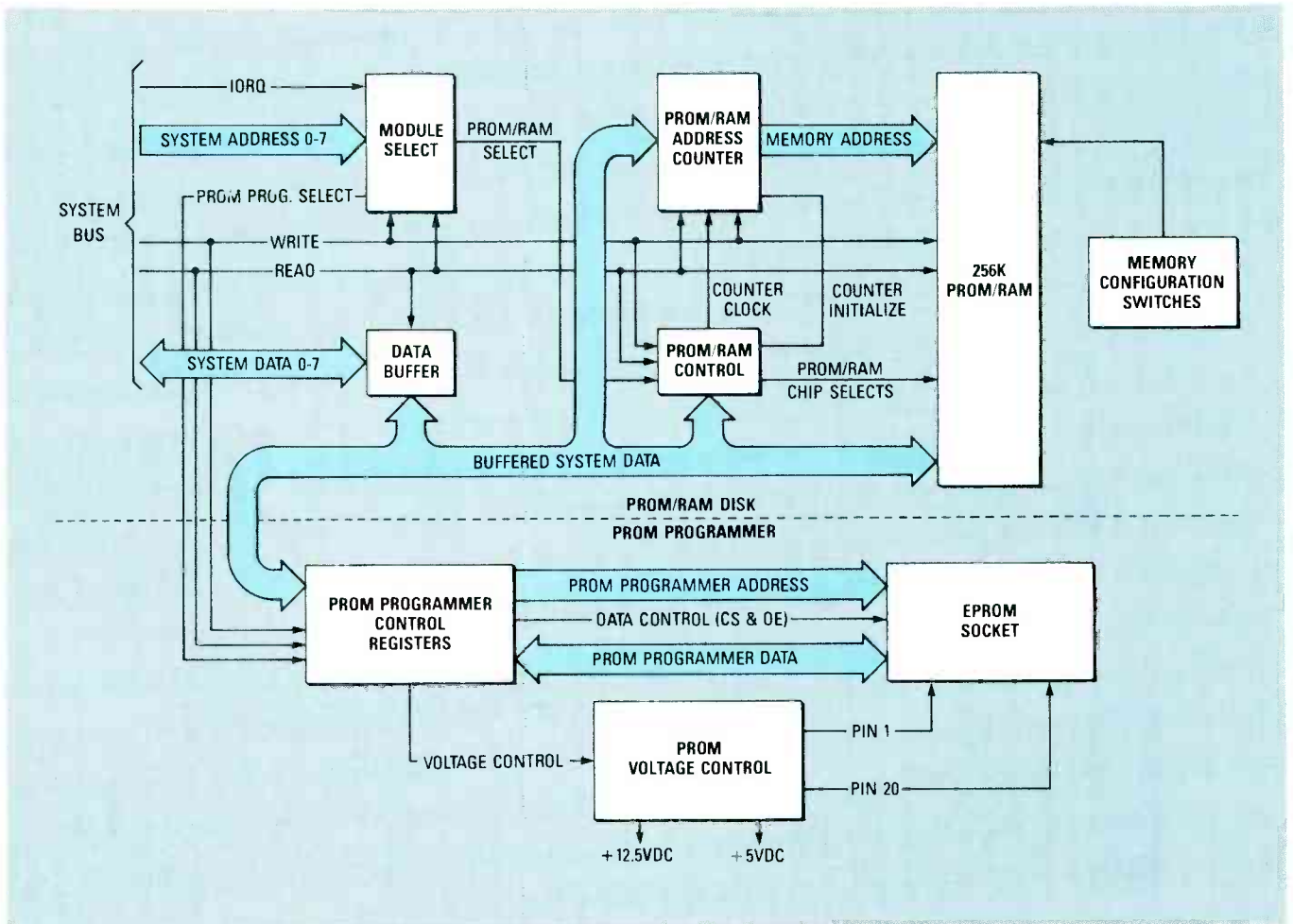

FIG. 2—THE PROM/RAM DISK and optional PROM Programmer are shown here in block-diagram form.

as drives A:-P:. Further, the REACTS operating system has been designed to divide the PROM or RAM disks into tracks and sectors, with each track made up of 8 sectors of 128 bytes each. That compares with the tracks and sectors of a floppy or hard disk.

Certain drives are reserved by the system for special operations; specifically, drive P: is reserved as the boot drive on the CPU. Future articles will provide the information necessary to add floppy and hard disk drives to the system. Those drives will be labeled in exactly the same manner. Indeed, a random mixture of floppies, hard disks, RAM and PROM disks is perfectly satisfactory from the system's standpoint.

It is not necessary to have all of the PROM or RAM space of a module designated as one drive. Up to 8 separate drives may be specified on one module; the only constraint is that the memory allocated to each drive must be a multiple of 32K (the size of a single memory IC). As an example,

you could configure the system to have 128K of PROM memory set up as drive A: and 128K memory set up as drive B:. Another option would be to have two 64K drives of PROM and two 64K drives of RAM; the four could be designated as drives A:, B:, C:, and D:, where A: and B: would be

RAM drives and C: and D: PROM drives.

It is even possible to have eight different drives on one PROM/RAM module, each containing 32K of PROM or RAM memory. At the other extreme it is possible to have more than two megabytes of PROM or

### Sources

The following items are available from DataBlocks, Inc., 579 Snowhill Road, Glenwood, GA. 30428; 800 652-1336 (in Georgia call 912 568-7101

DP-P/R/PP: Design package of schematics and instructions; \$10.00

PC-P/R/PP: PC Board for PROM/RAM/PROM Programmer module, includes design package; \$37.00

PROM/RAM: Complete set of parts, PC board, IC's for PROM/RAM portion of module (excluding PROM and RAM memory IC's); \$114.00

PROM PROG: Parts needed to add PROM Programming ca-

pabilities to module; \$59.95

MEMORY IC's: 32K x 8 bit UV EPROM's; \$10.50. 32K x 8 bit RAM IC's \$12.50.

SOFTWARE: Software is available on UVEPROMs as well as on 5/4-inch floppies for downloading from an IBM PC, XT, AT or compatible. Please call for prices on the different software packages.

Other REACTS systems and components are available; please call for information and prices.

Please add \$10 shipping and handling per order. Georgia Residents must add sales tax.

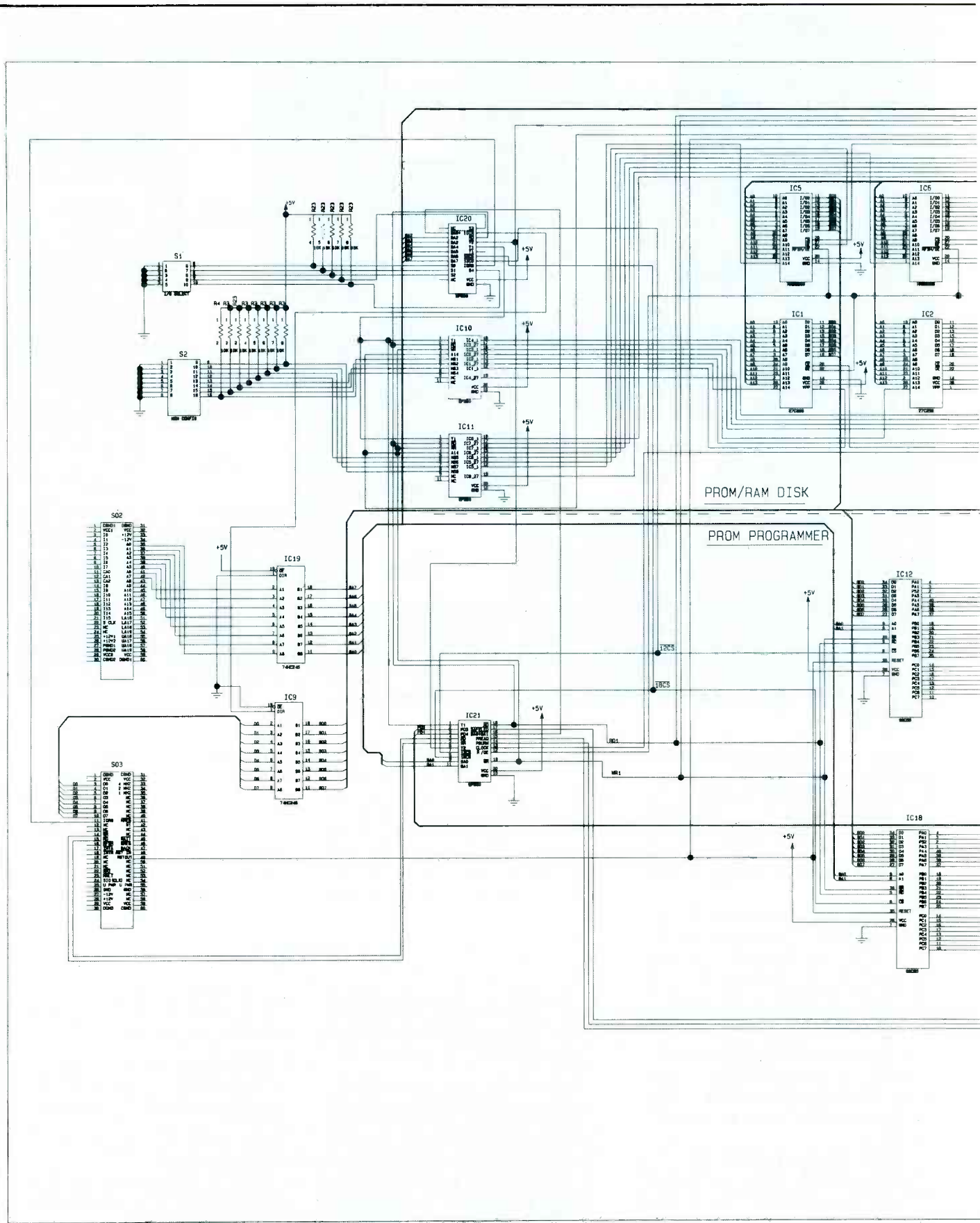
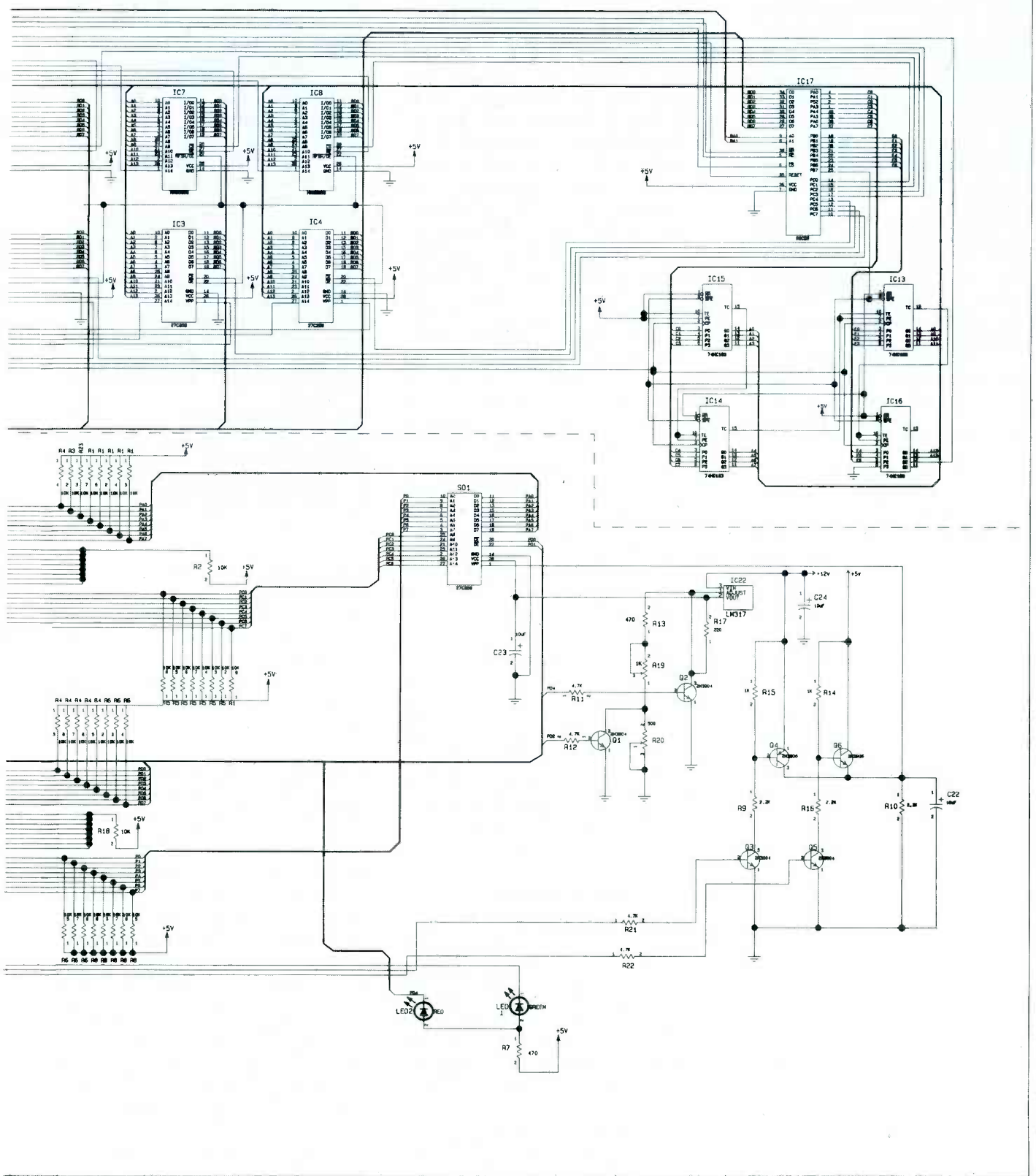

FIG. 3—THE MODULE'S CIRCUIT DETAILS are shown in this schematic.



### Parts List—PROM/RAM Drive

All resistors ¼ watt, 5% unless otherwise noted

R3, R4, R23—10,000 ohms, 10-into-1 SIP

R7—470 ohms

#### Capacitors

C1—C11, C13—C17, C19—C21—0.47 μF, ceramic disc

C25—47 μF, 16 volts, electrolytic

C26—47 μF, 10 volts, electrolytic

#### Semiconductors

IC1—IC8—32K × 8 RAM or EPROM, see text

IC9, IC19—74HC245 octal three-state transceiver

IC10, IC11, IC20, IC21—Programmable array logic IC's, custom components, see text

IC13—IC16—74HC163 synchronous binary counter

IC17—82C55 programmable peripheral interface

D2—Red LED, right-angle PC-mount

#### Other components

S1—5-position DIP switch

S2—8-position DIP switch

SO2, SO3—60-pin male and female bus connector set

**Miscellaneous:** PC board, IC sockets, hardware, case, wire, solder, etc.

RAM memory configured as one drive. In that case, each module is only ⅛ of the total drive (8 PROM/RAM disk modules times 256K per module = 2048K). The ability to custom design the PROM/RAM configuration of the disk drives fits in nicely with the concept of soft-hardware in that it allows the user to select the optimum disk size for a particular application.

(As discussed in the Feb. 1988 installment, soft-hardware is system hardware that can be changed as easily as software.)

After setting the memory configuration switches and installing the correct memory IC's (RAM or PROM) into their appropriate sockets, the operating system must be "told" about the current configuration of disks. The REACTS operating system handles that with a configuration utility called CONFIG. If the new configuration is to be permanent, which will usually be the case, it should be "burned" onto a boot PROM, using the PROM programmer, and that PROM then placed in the appropriate socket on CPU-module board.

### PROM/RAM disk operation

Referring to Fig. 2, a block diagram of the PROM/RAM disk and the optional PROM programmer, will help in following the discussion of the operation of the PROM/RAM portion of the module. Complete circuit details are shown in Fig. 3.

The REACTS CPU communicates with the PROM/RAM module via I/O ports. The system I/O ports used by the PROM/RAM module are user-selectable. The MODULE SELECT and PROM/RAM CONTROL blocks of Fig. 2 are implemented using PAL (Programmable Array Logic) IC's; those custom components are available from the supplier mentioned in the Sources box. PAL's are used in the PROM/RAM disk module, as they were in the CPU module, to reduce circuit cost and complexity. The I/O address of the module can be changed by resetting a 5-position DIP switch, S1. That allows you to use multiple PROM/RAM modules per system for greater storage capacity.

Basic operation of the PROM/RAM portion of the module calls for reading or writing to the correct PROM or RAM IC. That is done by the PROM/RAM CONTROL block. After selecting the correct type of memory IC (as determined by S2, the 8-position DIP switch previously discussed), the PROM/RAM ADDRESS COUNTER is loaded with the starting memory address of the file to be read, or in the case of a write to a RAM drive, the first unoccupied memory location. As each memory byte is read or written, the address counter is incremented to point to the next byte in memory so that that location can be read from or written to.

### The PROM programmer

If you are going to make full use of PROM memory, you need some way to get your programs into them. To that end, we have included an PROM programmer on the PROM/RAM disk module. (In order to accommodate cost-sensitive applications, the programmer has been made optional and can be omitted where it is not needed.)

In addition to being able to program 32K UV EPROM's (Ultra Violet Erasable Programmable Read Only Memory), the programming socket can be used as an independent disk drive. To the REACTS operating system, a PROM in the PROM program-

### Parts List—PROM Programmer

All resistors ¼-watt, 5%, unless otherwise noted

R1, R5, R6, R8—10,000 ohms, 9-into-1 SIP

R2, R18—10,000 ohms

R9, R10, R16—2200 ohms

R11, R12, R21, R22—4700 ohms

R13—470 ohms

R14, R15—1000 ohms

R17—220 ohms

R19—1000 ohms, potentiometer

R20—500 ohms, potentiometer

#### Capacitors

C12, C18—0.47 μF, ceramic disc

C22—C24—10 μF, 16 volts, tantalum

#### Semiconductors

IC12, IC18—82C55 programmable peripheral interface

IC22—LM317 voltage regulator

Q1—Q3, Q5—2N3904 NPN transistor

Q4, Q6—2N3906 PNP transistor

D1—Green LED, right-angle PC mount

#### Other components

SO1—28-pin ZIF socket

**Miscellaneous:** PC board, IC sockets, 28-pin hi-rise socket, hardware, wire, solder, etc.

mer's easily accessible ZIF (Zero Insertion Force) socket looks like a 32K disk drive. (The use of a ZIF socket allows you to insert and remove IC's many times without damage.) You will find that attribute to be a useful tool when developing software.

### PROM-programmer operation

The PROM programmer programs EPROM's one byte at a time. Referring to the PROM programmer portion of Fig. 2, the address of the memory location to be programmed is placed on the PROM programmer's address bus and the data to be programmed is placed on the data bus. To do the actual programming, 12 volts is placed on pin 1 of the EPROM, 5 volts on pin 28, and the EPROM's CE (CHIP ENABLE) input is brought low for a specified period of time. After a location is programmed, the address is incremented and the next byte to be programmed is placed on the PROM data bus.

Reading an EPROM (or PROM) is essentially done in the same manner as programming one, except that 5 volts are placed on both pin 1 and pin 28, and both the CE and OE (OUTPUT ENABLE) pins are brought low. Once



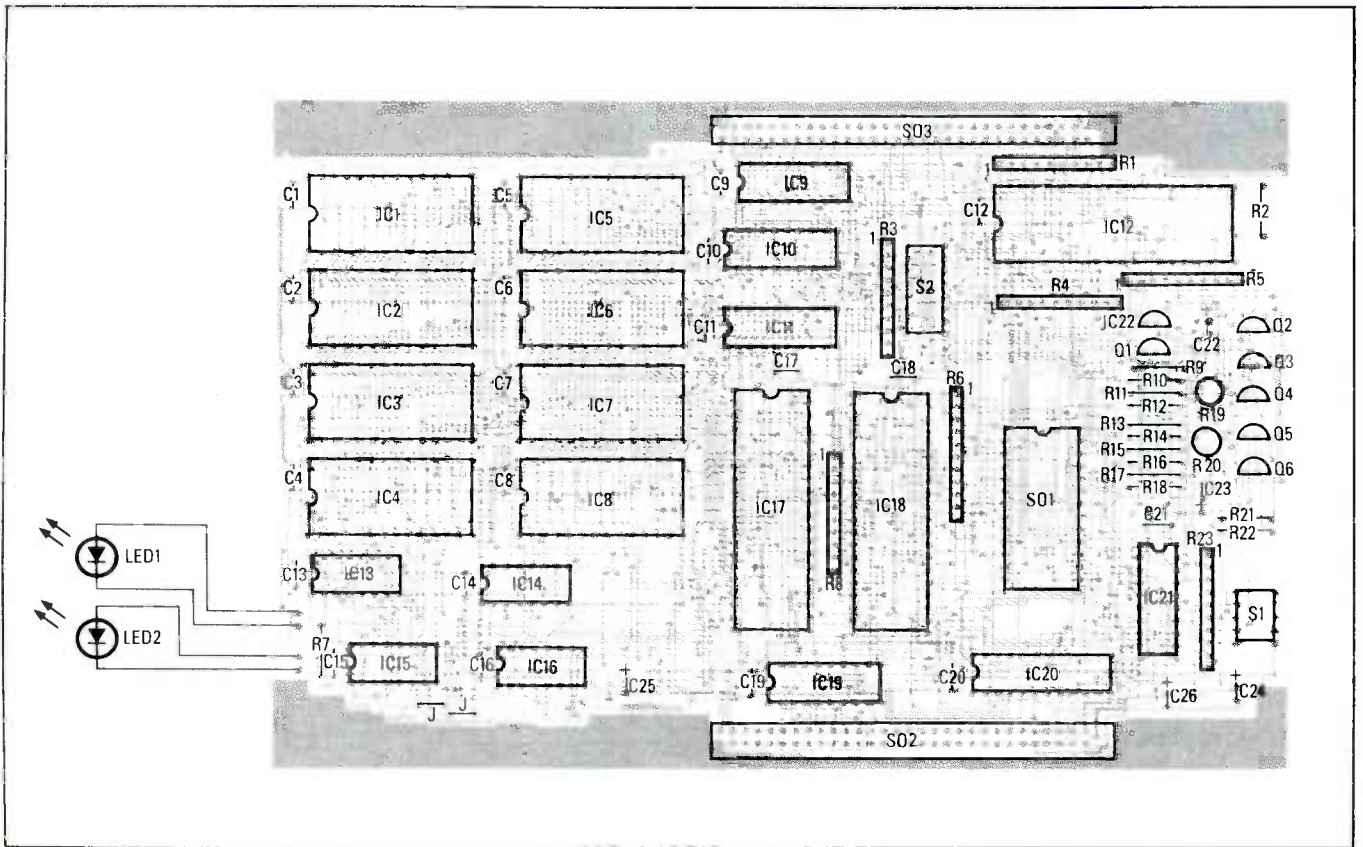

FIG. 4—CONSTRUCTION OF THE MODULE is fairly straightforward. Use this Parts-Placement diagram when mounting the components.

again, to keep circuit complexity and cost as low as possible, much of the programmer's circuitry is incorporated in a custom PAL. (That IC is available from the supplier.)

The REACTS operating system contains a utility called RBURN that makes programming EPROM's easy. That utility uses prompts to allow the user to select the file to be programmed, the drive that the file is located on, and the number of kilobytes to be programmed. In addition to burning EPROM's, the RBURN utility can be used to check an EPROM for complete erasure (i.e. to make absolutely sure that a PROM is blank before programming).

Two LED's are used by the module to display the state (idle or busy) of the PROM programmer. If the red LED is illuminated, the EPROM is either in the process of being burned or read and should not be disturbed. To avoid damaging the device, EPROM's should be placed in or removed from the programming socket only when the green LED is on.

When handling EPROM's, remember that they are CMOS components and all of the usual precautions regarding static electricity should be

followed to avoid inadvertently zapping them. Also, be sure that any EPROM's are oriented correctly in the socket before attempting to burn or read them otherwise, the device may be damaged.

### Building the module

Building the combination PROM/RAM disk and PROM programmer is basically a straightforward operation. Follow the parts-placement diagram shown in Fig. 4 when mounting the components. The pattern for that board can be found in PC Service; a pre-etched board is available from the supplier that is mentioned in the Sources box.

Be sure to observe the cautions outlined last time when installing the two 60-pin PC-board connectors. (Though they are rugged units once assembled, they can be easily damaged during assembly.) Also, take the usual precautions when handling the CMOS IC's. Finally, because we are putting so much circuitry in a small area, we have chosen to use Single In-line Package (SIP) resistors where applicable. Those are reasonably new components and you may not have used them before. However, SIP resistors are becoming more commonplace so they should not be difficult to locate.

### Software

Although we have not yet built any actual process-control modules, we can now start program development. We have a central processing unit, a means of communicating with it (a dedicated terminal or an IBM or compatible configured to act as a terminal; see the April issue for more on that), and at least one way of saving programs, that being the PROM-programmer/semiconductor-disk module. In order to create any programs

*continued on page 82*

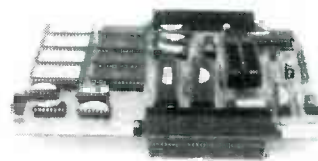

THE FINISHED PROM/RAM DISK. Note the ZIF socket near the center of the unit.

# PC SERVICE

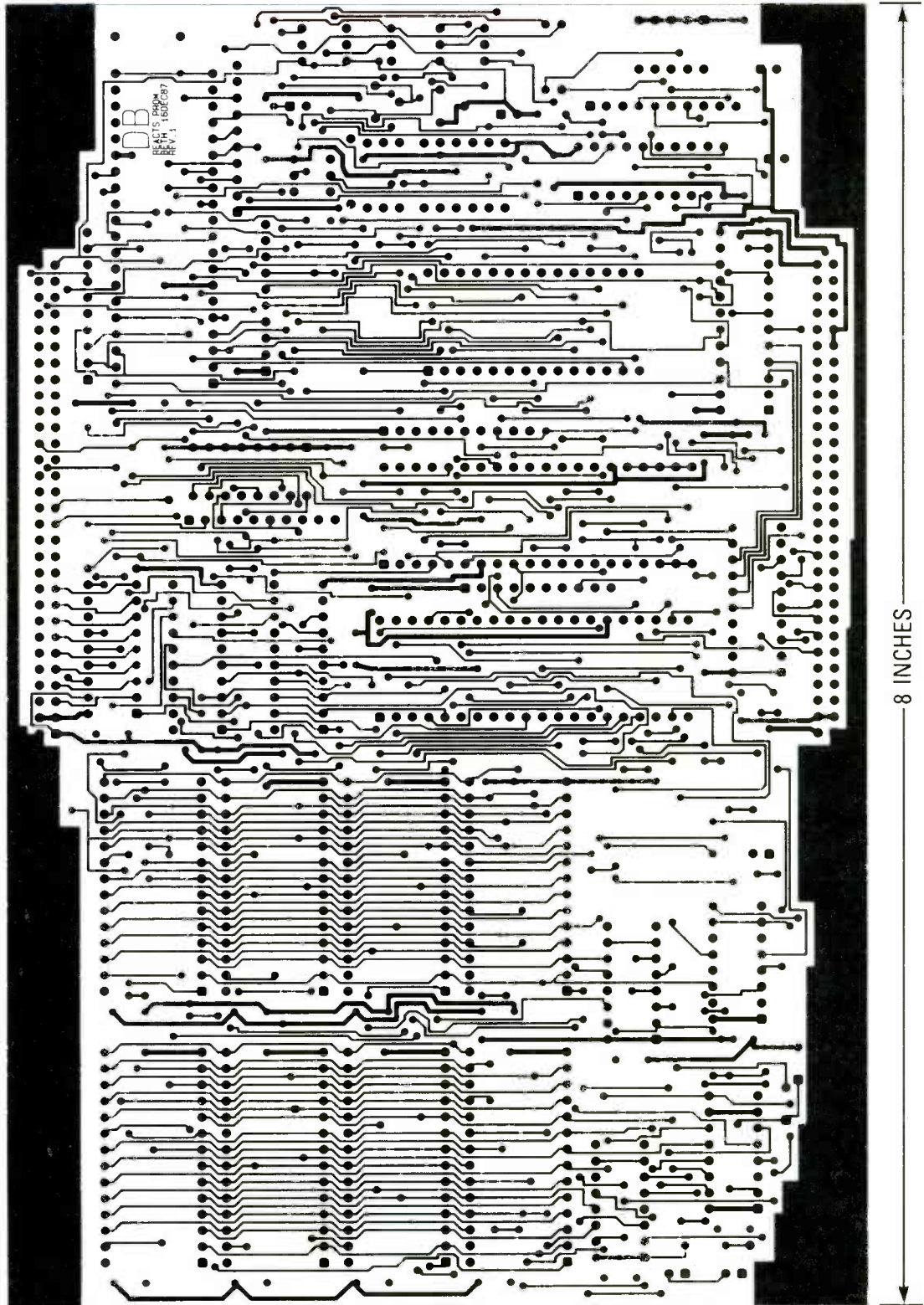

COMPONENT SIDE for the REACTS RAM/PROM Disk and PROM Programmer. The solder side will appear next time. See page 100 for more PC patterns.

# BUILD THIS

# SUBWOOFER SIMULATOR

NORM HILL

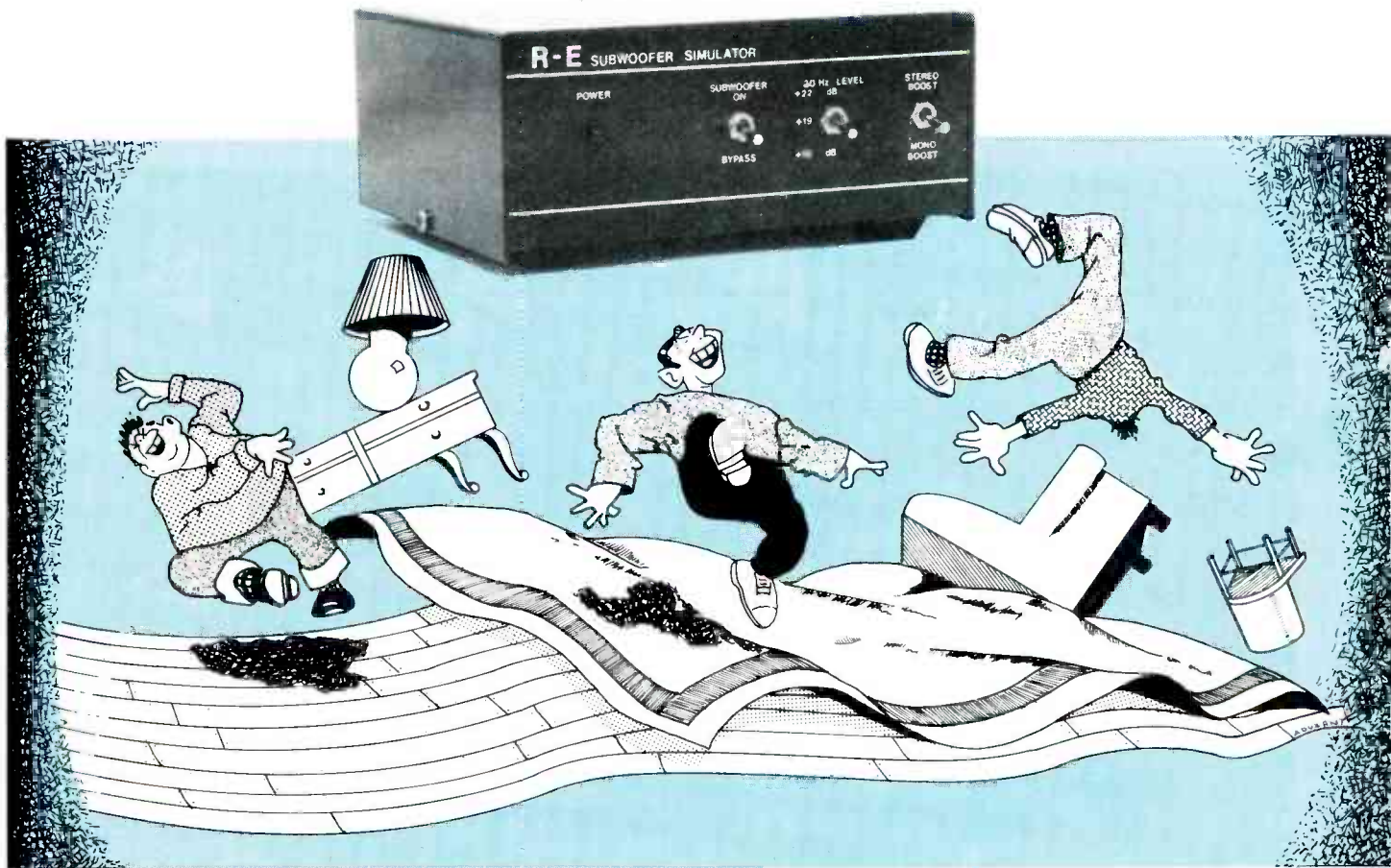

*Build a subwoofer simulator and fill your living room with movie-theater sound you can actually feel.*

A MOVIE THEATER CREATES REALISM BY projecting a large picture, using surround sound, and by extending the sound's low-frequency response with subwoofers so that the viewer can actually feel the special-effects. When a movie contains explosions, jet rumble, thunder, galloping horses, or other heavy-duty action, the subwoofer adds realism by literally shaking the floor.

Although it is generally accepted that a healthy ear can hear a frequency range of 20 Hz to 20 kHz, in fact, some of that range is not so much heard, but sensed. For example, many people cannot hear frequencies higher than 15 kHz, although they can sense that they exist. It's the same

thing for frequencies in the deep-bass range of 20–50 Hz; many persons cannot hear frequencies within that range, although they can feel and sense them as vibrations.

In a theater, special effects are often exploited by enhancing the deep-bass frequencies, so that when the jets rumble, they rumble so powerfully that you can actually feel the runway vibrating under your feet. (And a flat frequency response ceases to be desirable once your feet become the listening transducers.) Below 20 Hz, sound is neither felt nor heard; at best there is a strange sensation of changing air pressure.

But although most people can perceive sounds in the 20–50 Hz range,

because conventional woofers, even 12-inch and larger, roll off below 50 Hz, deep bass sounds are rarely heard unless some kind of deep-bass compensation is provided. The usual solution to providing deep bass in both theaters and the home is to add a monaural subwoofer that is driven off the front channels by an active filter and a separate amplifier.

### Not that perfect

Unfortunately, there are some drawbacks to using a monaural subwoofer. It is commonly assumed that deep-bass information has such a long wavelength that it will be summed by the room to a mono signal, and that therefore a single transducer can be

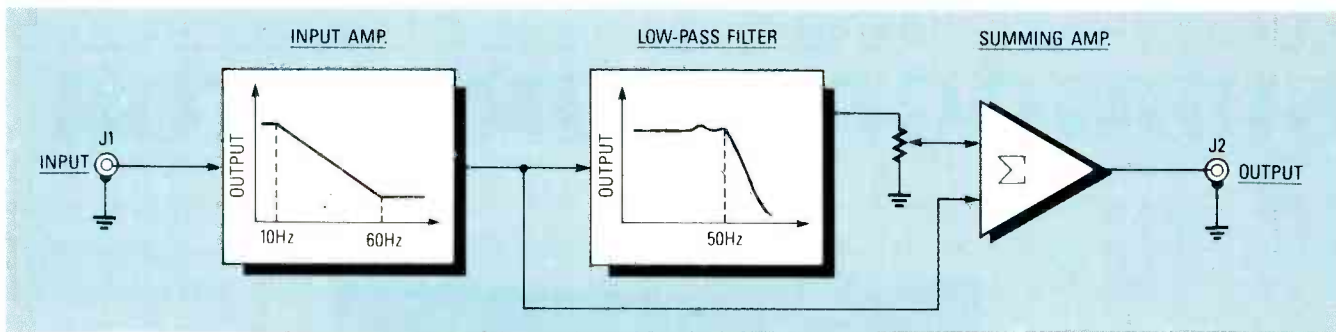

FIG. 1—TO ENSURE THAT ONLY THE DEEP-BASS FREQUENCIES are enhanced, the simulator's first stage amplifies the frequencies below 60 Hz before the low-pass filter attenuates all signals above 50 Hz.

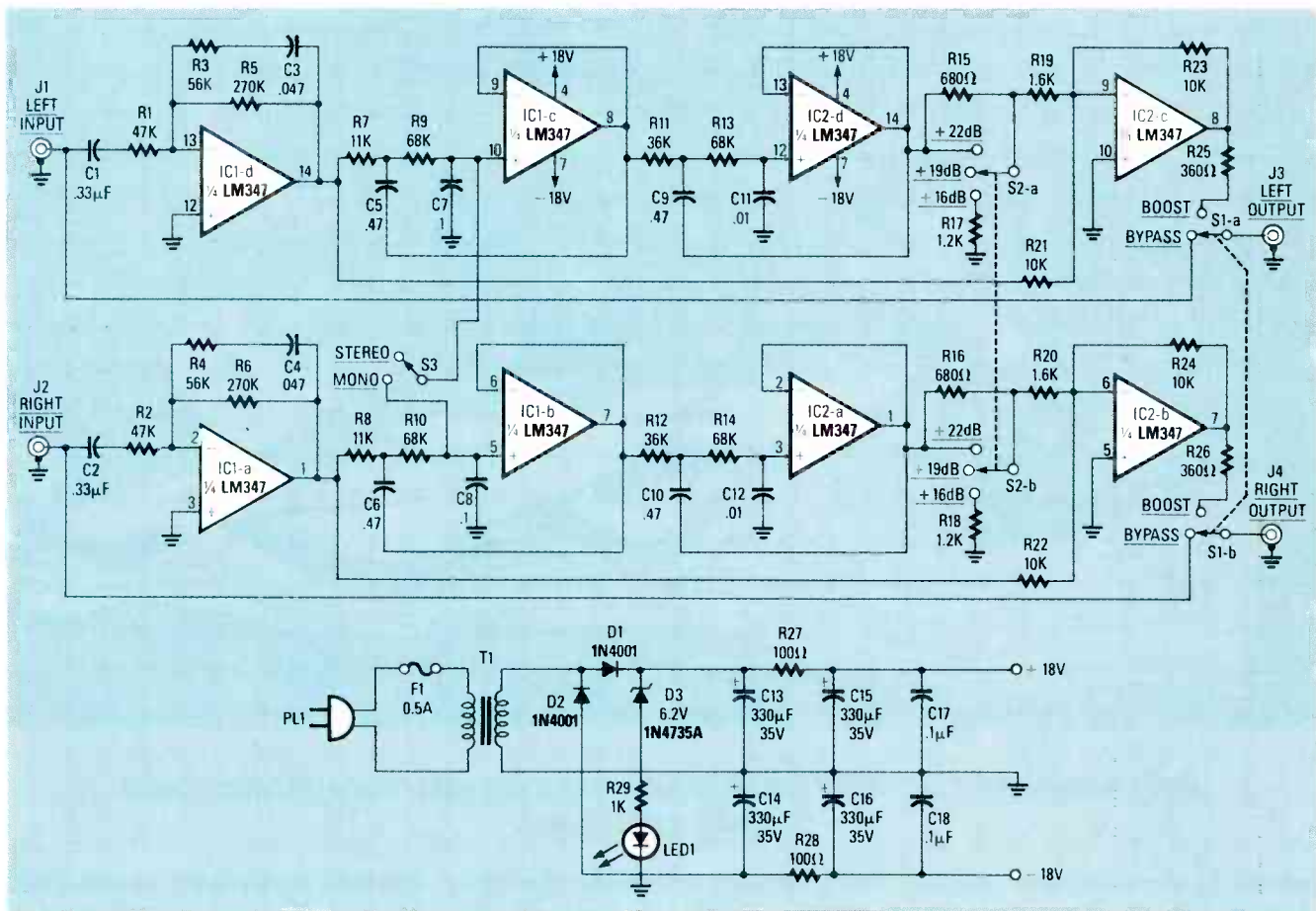

FIG. 2—THE LEFT AND RIGHT CHANNELS ARE IDENTICAL. Switch S3 blends the two channels when only mono deep-bass sounds are wanted. Switch S2 provides three levels of deep-bass amplification.

used. A simple comparison of mono and stereo bass-boosting calls that into question. Jet rumble, such as in the movie *Top Gun*, takes on a flatter, quieter, less spacious sound when boosted monaurally instead of stereophonically. A quick check of the low-frequency information (measured using a dual-trace scope and active 50-Hz stereo filters) shows that the two channels have little in common during jet rumble or numerous other situations. Only in music are the two channels similar.

Another concern is the type of filter used to feed the subwoofer. All filters have substantial phase shift at the roll-off frequencies. It can easily turn out that the high-band and low-band speaker cones will end up out of phase during the transition region, causing a loss of response over, say 60–90 Hz, which will produce a peculiar bass quality. It is likely that many subwoofer systems suffer that problem, especially those using simple passive crossovers for which 180° is a common roll-off phase angle.

Price is another objection to a mono-subwoofer system that includes a filter and separate amplifier: You'll have to spend a lot before your floor starts to shake, rattle, and roll.

### A cheaper way

A less expensive way to simulate the "feelie" effect of the movie theater's deep-bass system is to simply boost the bass signal delivered to your existing front speakers. (Most home-stereo systems are overbuilt, at least when listening to a video movie at the

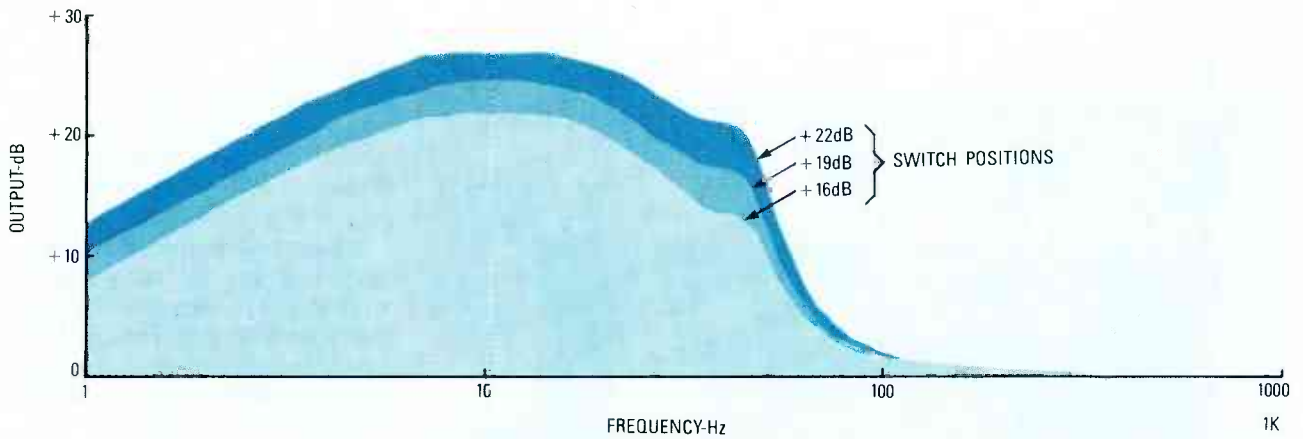

FIG. 3—MAXIMUM DEEP-BASS BOOST IS ATTAINED AT approximately 12 Hz. Note that the curves shown are unattainable with conventional tone controls.

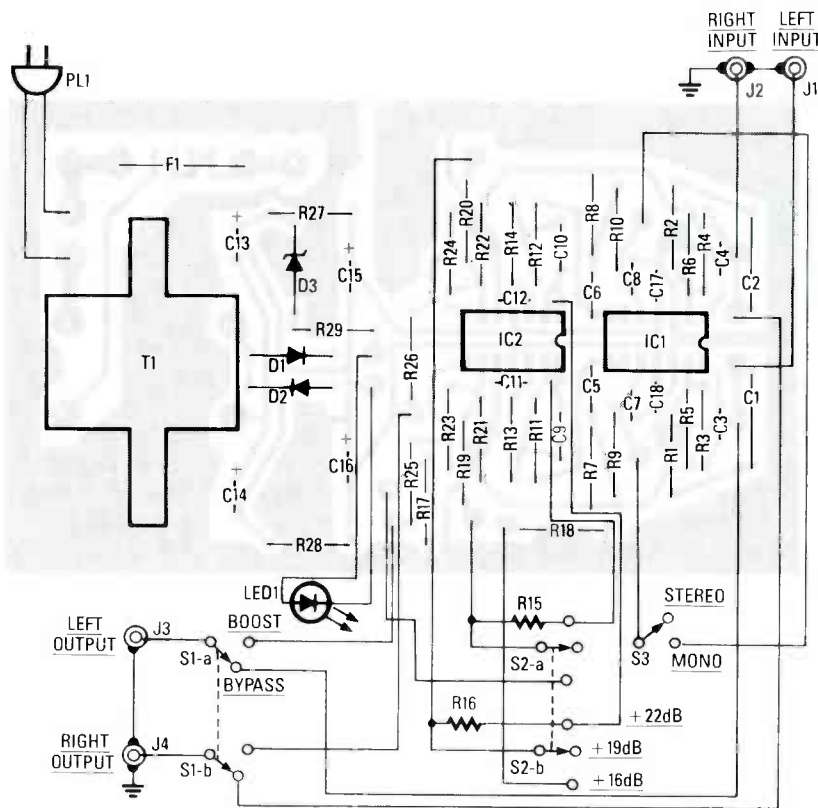

FIG. 4—THIS IS THE PARTS LAYOUT for the printed-circuit board. Take note that resistors R15 and R16 are mounted on switch S2, not on the board.

usual living-room volume level.) Although home-speaker systems having a 10- or 12-inch woofer may be rolling off between 20–50-Hz, that doesn't mean that they can't radiate energy in that range. We merely need to provide compensation so that they get more power in the deep-bass frequency range. An analogy is hitting the loudness switch or turning up the bass, except that the boost must be more selective to create the illusion of a subwoofer's sound & feel.

Figure 1 shows the block diagram of a subwoofer simulator that can be used for either the left or right channel. The first stage is a buffer-amplifier that provides gain below 60 Hz to compensate for the fact that most speakers roll off in that range. The buffer is followed by an active low-pass filter that removes everything except the deep-bass frequencies. The output from the filter is summed with its input so that the total bandwidth is at a substantially higher level than it

### PARTS LIST

- All resistors are ¼-watt, 5%.
- R1, R2—47,000 ohms
  - R3, R4—56,000 ohms
  - R5, R6—270,000 ohms
  - R7, R8—11,000 ohms
  - R9, R10, R13, R14—68,000 ohms
  - R11, R12—36,000 ohms
  - R15, R16—680 ohms
  - R17, R18—1200 ohms
  - R19, R20—1600 ohms
  - R21–R24—10,000 ohms
  - R26, R28—360 ohms
  - R27, R28—100 ohms
  - R29—1000 ohms

### Capacitors

- C1, C2—0.33  $\mu$ F, 100 volts
- C3, C4—0.047  $\mu$ F, 50 volts
- C5, C6, C9, C10—0.47  $\mu$ F, 50 volts
- C7, C8, C17, C18—0.1  $\mu$ F, 50 volts
- C11, C12—0.01  $\mu$ F, 50 volts
- C13–C16—330  $\mu$ F, 35 volts, electrolytic

### Semiconductors

- IC1, IC2—LF347N, Quad JFET op-amp
- D1, D2—1N4001 rectifier diode
- D3—1N4735A, Zener diode, 6.2 volts,
- LED1—Light-emitting diode

### Other components

- F1—½-amp slo-blo fuse
- J1–J4—Phono jack
- S1—Switch, DPDT
- S2—Switch, DPDT, center off
- S3—Switch, SPST
- T1—Power transformer, 117 volt primary; 12.6-volt, 300-mA secondary.

**Miscellaneous:** PC-board materials, fuse clips, wire, linecord, solder, enclosure, etc.

An etched and drilled PC board is available for \$10.25 postpaid from Fen-Tek, P.O. Box 5012, Babylon, NY 11702-0012. NY residents must add appropriate sales tax.

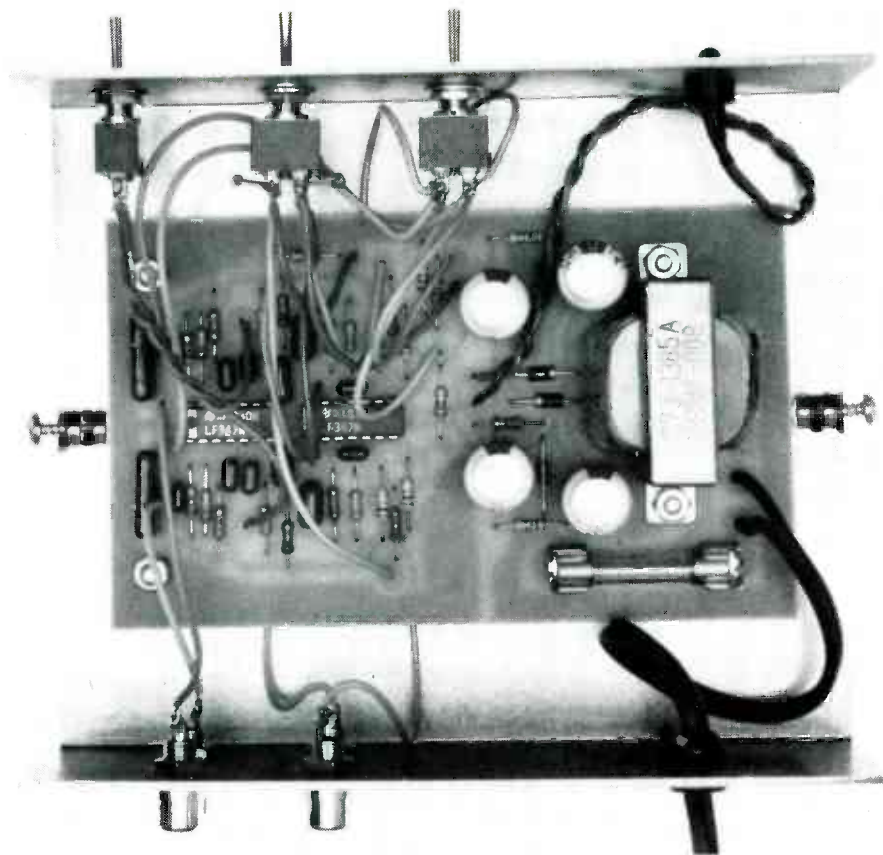

FIG. 5—TO AVOID NOISE PICKUP the simulator should be enclosed in a metal cabinet. Cabinets that are partially metal and partially plastic aren't suitable.

would be if only the deep-bass frequencies were filtered.

Figure 2 shows how the block diagram becomes the schematic for our stereo-subwoofer simulator.

### How it works

Both channels are identical. Buffer amplifier IC1-a has unity gain above 60 Hz, and a rising gain characteristic below 60 Hz to compensate for the speaker's deficiency in the deep-bass range. Active low-pass filters, IC1-b and IC2-a, pass the frequency components below 50 Hz. Amplifier IC2-b sums the input and output signals of the filters. Switch S2-a provides three levels of bass summation—a fancy way of saying "bass boost." The subwoofer simulator's frequency-response curves for the three switch positions are shown in Fig. 3.

### Construction

The project should use printed-circuit assembly to avoid introducing noise. A foil template for the PC board is provided in PC Service. You'll find that the template has holes

to accommodate either a pigtail-lead fuse (F1), or individual fuse clips (which take two holes per clip) Use whatever is most convenient for you.

The parts layout for the PC-board and the connections for the panel-mounted components are shown in Fig. 4. For simplicity, an on/off power switch was not included so that the unit would be switched on and off by the master power switch for the entire system. If you want separate power control for the subwoofer simulator, simply install a SPST switch in series with one leg of the power cord.

Although the circuit will accept conventional part tolerances for the resistors and capacitors, for best results we suggest you use 5% capacitors for the active-filter components. As shown in Fig. 5, the prototype is mounted in a metal enclosure; do not use a cabinet that is part metal and part plastic.

### Hookup

If your sound system has a separate pre-amp and power-amp, the subwoofer simulator connects imme-

diately before your front power amplifier—after any surround-sound decoder. If you have a receiver, your only option is to connect the simulator before the receiver's AUX input, or within the tape-monitor loop—which isn't quite ideal because the simulator will be receiving a line-level 1-volt rms signal

**Since the bass boost can exceed a factor of 10, the subwoofer simulator may occasionally output more than 10-volts rms, so to avoid blowing out your speakers, be careful when first trying the subwoofer simulator.**

Increase the amplifier's gain slowly. Back off the amplifier's output power if you hear distortion. The author developed the circuit using a 200-watt-per-channel amplifier and speakers rated for 250 watts. If your system is more modestly powered, you may not want to use S2's higher boost positions. Also, if your amplifier is rated for less than 60 watts per channel, or if your woofers are smaller than 10-inches, you may not attain sufficient deep-bass output to create the sense of feeling.

Clipping within the simulator is possible, although we have seen no problems because of the device's relatively high DC supply voltage. A bigger concern is an audio amplifier that wasn't built to handle an unusually large deep-bass signal. For example, one time we absent-mindedly installed the simulator between a VCR and a *Trinitron* monitor, which has an audio switching function. It took quite a while to figure out that the sound's distortion was caused by the *Trinitron* monitor's inability to handle more than a few volts of input. Moving the simulator so that it was installed after the monitor, between the TV and preamplifier, completely resolved the problem.

### The payoff

Once your system is wired for surround sound you'll discover that some movies have effects that you can literally feel, while others don't. There is a wide variation in the quality of the effects, usually from one studio to the next, not from one movie to the next. Some outfits put in plenty of enjoyable, surround-sound and "feelie" effects, while others put in few sound effects. Unfortunately, the only way to find which is which is through trial and error.

R-E

## Thermoelectric Coolers

JOHN POTTER SHIELDS

SINCE THE LAST CENTURY WE'VE KNOWN that when you form a closed circuit of two dissimilar metals and two junctions, a current may flow between the junctions. That happens when there is a temperature difference between the junctions, or when the metals have different temperatures.

The phenomenon is known as the *Seebeck effect*, and is the fundamental principal behind the thermocouple. Generally speaking, the greater the temperature differences, the higher the current. Also, the combination of metals that are used will affect the current flow.

The reverse of the Seebeck effect was discovered in 1834 by James C. Peltier. He found that passing an electric current through a junction formed by certain types of dissimilar materials could cause an increase or decrease in temperature. Peltier also found that the direction of current flow dictated whether heating or cooling occurred, and that the amount of temperature change was determined by the type of material and the size of the junction. In his honor, that effect is called the *Peltier effect*, and it is the fundamental principal behind Peltier devices. In this article, we'll examine Peltier devices, and how they are used, in more detail.

### Semiconductor thermoelectric devices

Since the discovery of the Seebeck and Peltier effects, we've discovered that they are not necessarily limited to metals. In fact, they are seen strongly in semiconductors. Figure 1 shows the arrangement of a simple semiconductor Peltier device. It consists of two pieces of semiconductor material; one is p-type, and the other is n-type.

When current is applied, charge carriers move through the two materials; causing cooling of the top surface and heating of the bottom surface. That action is basically that of a heat pump—heat is pumped from the top to the bottom of the device. If the applied current is reversed, then the top surface will be heated, and the

*Here's a look at Peltier devices—tiny solid-state heat pumps that can be used in a wide variety of cooling or heating applications.*

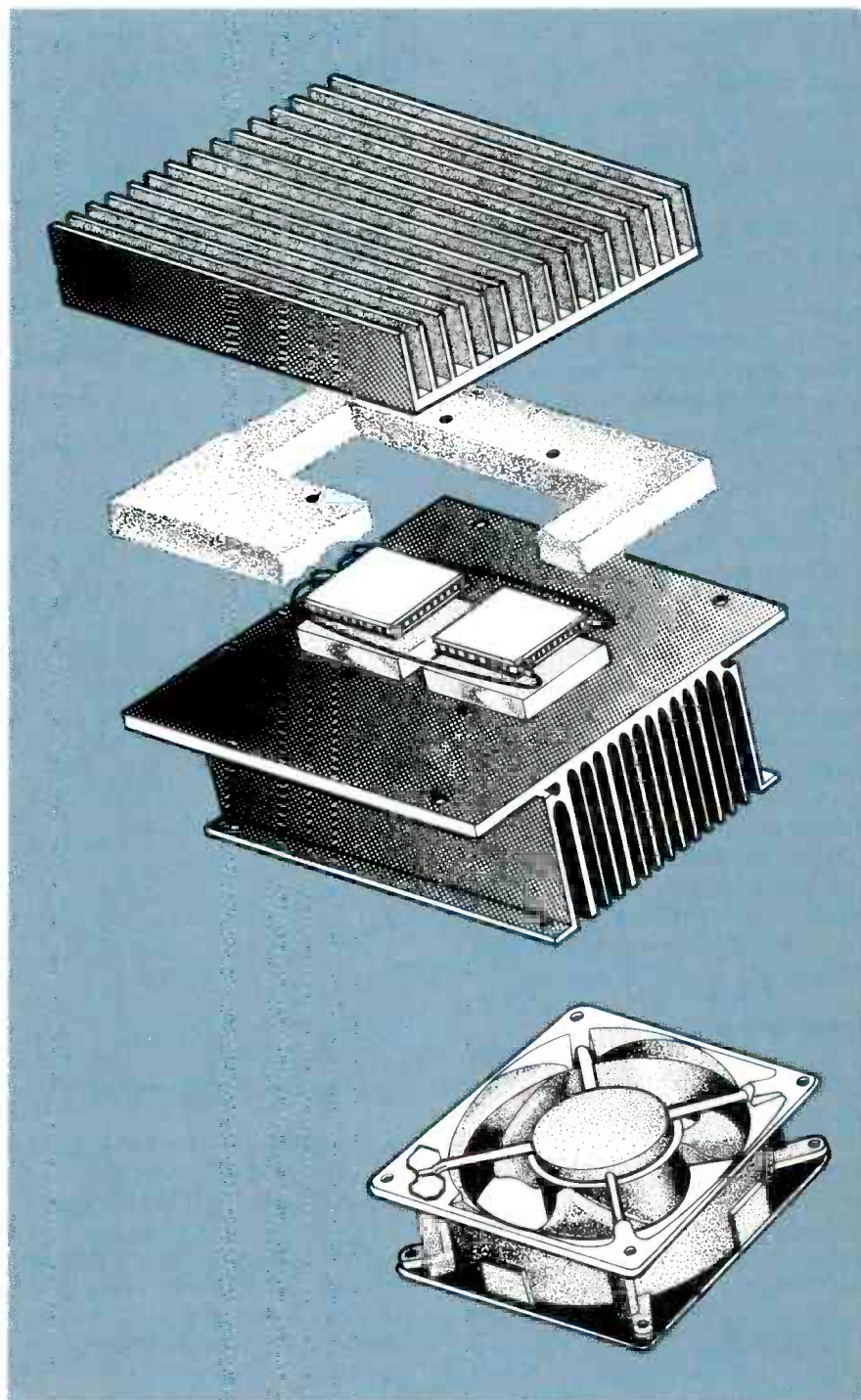

bottom surface cooled. The device is then a heater. Most practical thermoelectric devices, like the Marlow (10351 Vista Park Road, Dallas, TX 75238) MI 1069 shown in Fig. 2, consist of many such elements. In those, the elements are connected in series electrically, and in parallel thermally.

The tiny devices are capable of putting out great quantities of cold and heat, regardless of whether they are used as a cooler or heater. Therefore, a practical semiconductor cooler or heater absolutely requires a heat sink. Otherwise, the device would overheat and fail within seconds.

### Applications

One of the most interesting applications, especially for the electronics experimenter, is localized cooling of electronic components. For that, the cold side of the Peltier device is mounted directly to component using thermal epoxy, solder, or thermal grease. When power is applied to the Peltier device, heat is drawn away from the component being protected. Those components can include IC's, power transistors, laser diodes IR detectors, and solid-state imaging devices.

Peltier devices can also be used to cool moderate volumes of air or other gasses. In that application, a finned heat sink is attached to the cold side of the Peltier device. That heat sink thus becomes a *cold sink*. The Peltier device cools the cold sink; when air passes over the cold sink, a small air conditioner is created. The cold sink serves the same function as the evaporator coil in a conventional air-conditioner design.

Likewise, Peltier devices can be used to cool liquids. In that application, liquid is pumped through the cold sink and is cooled to the desired temperature.

### Power generators

One interesting, and little-discussed application of Peltier devices is as power generators.

The circuit shown in Fig. 1 can be used as a power generator by simply replacing the DC power source with a load and applying heat to the top surface of the Peltier device. Note that the delivered power will have a polarity that's the opposite of the battery polarity shown.

One consideration when using a Peltier device as a power generator is

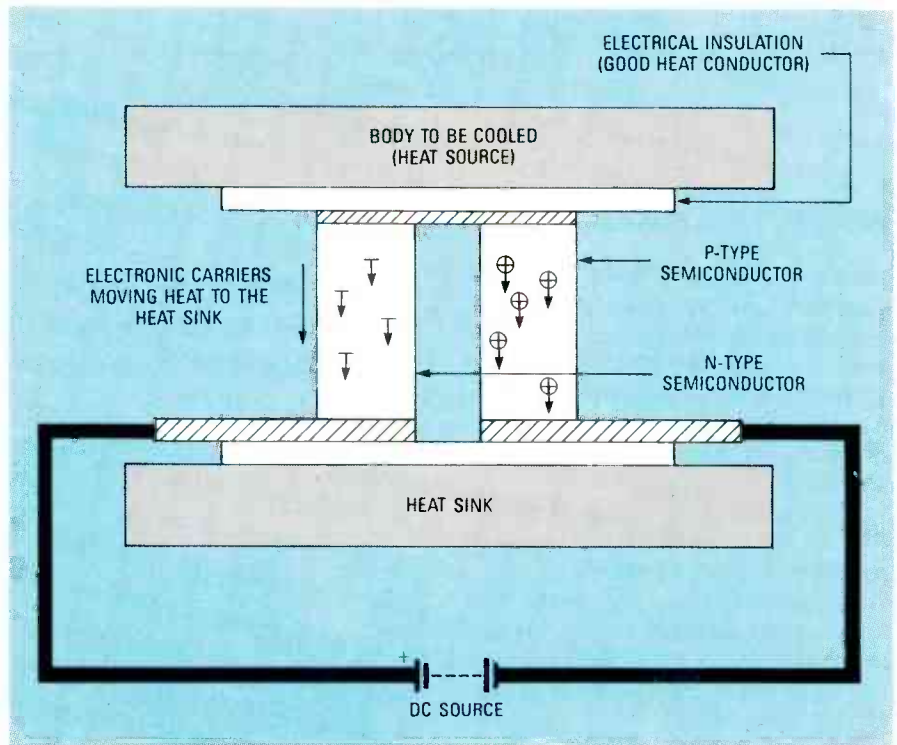

FIG. 1—A BASIC THERMOELECTRIC COOLER. The action is similar to that of a heat pump, conducting heat away from the cold side to the hot side.

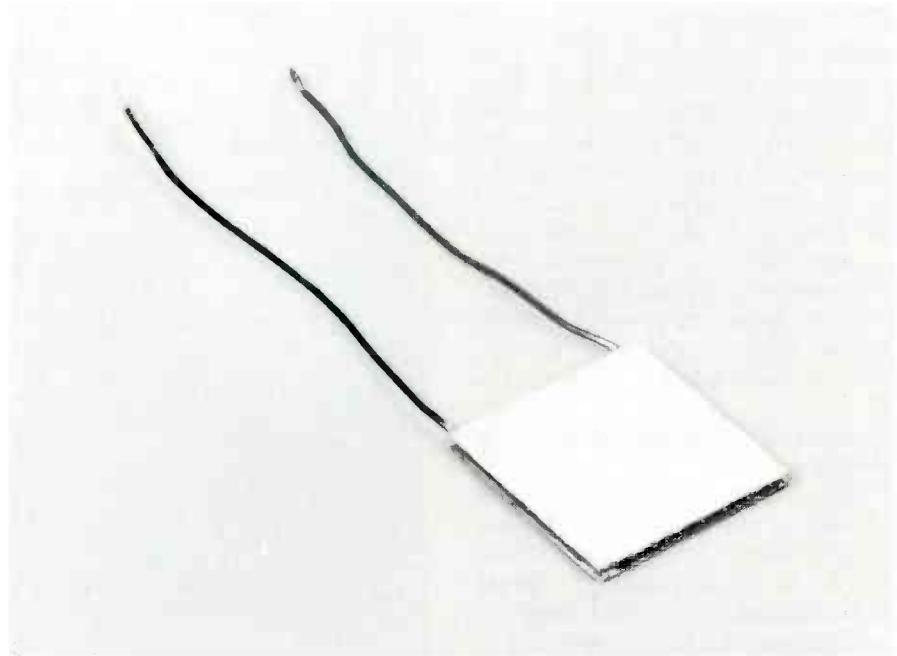

FIG. 2—A COMMERCIAL PELTIER DEVICE. This single-stage unit is the Marlow MI 1069.

that the solders used in most devices melt at about 138°C (although some units use solders that are designed to withstand short term exposure to temperatures as high as 200°). That limits the maximum efficiency of Peltier devices, but it is still possible to use a solar collector to heat a Peltier device and achieve outputs and efficiencies that rival those of solar cells.

Thermoelectric coolers are available in single-stage configurations at prices that range from about \$15 to \$50. For applications where a high degree of cooling is required, single-stage units can be ganged; that is the hot side of one unit is attached to the cold side of the other. Commercial units with up to six stages are available.

R-E



# WORKING WITH OTA'S

*How to use operational transconductance amplifiers in your designs and projects.*

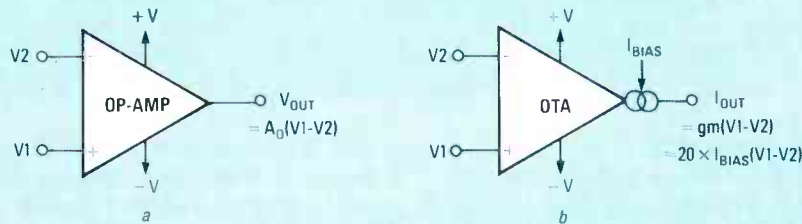

**FIG. 1**—A CONVENTIONAL OP-AMP (a) is a fixed-gain voltage-amplifying device, whereas an OTA (b) is a variable-gain voltage-to-current amplifier.

**RAY MARSTON**

THERE ARE MANY DIFFERENT TYPES OF OPERATIONAL amplifiers in use today, but an Operational Transconductance Amplifier, or OTA, is one that you may not be familiar with. This month we'll introduce you to the CA3080 OTA.

### Op-amps and OTA's

Conventional op-amps are essentially voltage-amplifying devices. As figure 1-a shows, a conventional op-amp has differential input terminals and produces an output voltage of  $A_O \times (V_1 - V_2)$ , where  $A_O$  is the open-loop voltage gain (that gain is typically 100,000),  $V_1$  is the signal voltage at the non-inverting input, and  $V_2$  is the signal voltage at the inverting input. Also, a conventional op-amp has a fixed open-loop voltage gain, a high input impedance, and a low output impedance.

Like a standard op-amp, an OTA has differential input terminals, but, as shown in figure 1-b it is a voltage-to-current amplifier, as indicated by the constant-current symbol at its output. The input voltages produce an output in the form of a high-impedance current with a value of  $g_m \times (V_1 - V_2)$ , where  $g_m$  is the transconductance in mhos, or the *voltage-to-current gain* of the device. The transconductance is directly proportional to an external bias current ( $I_{BIAS}$ ) fed into the amplifier's bias input. In an OTA, that current can be

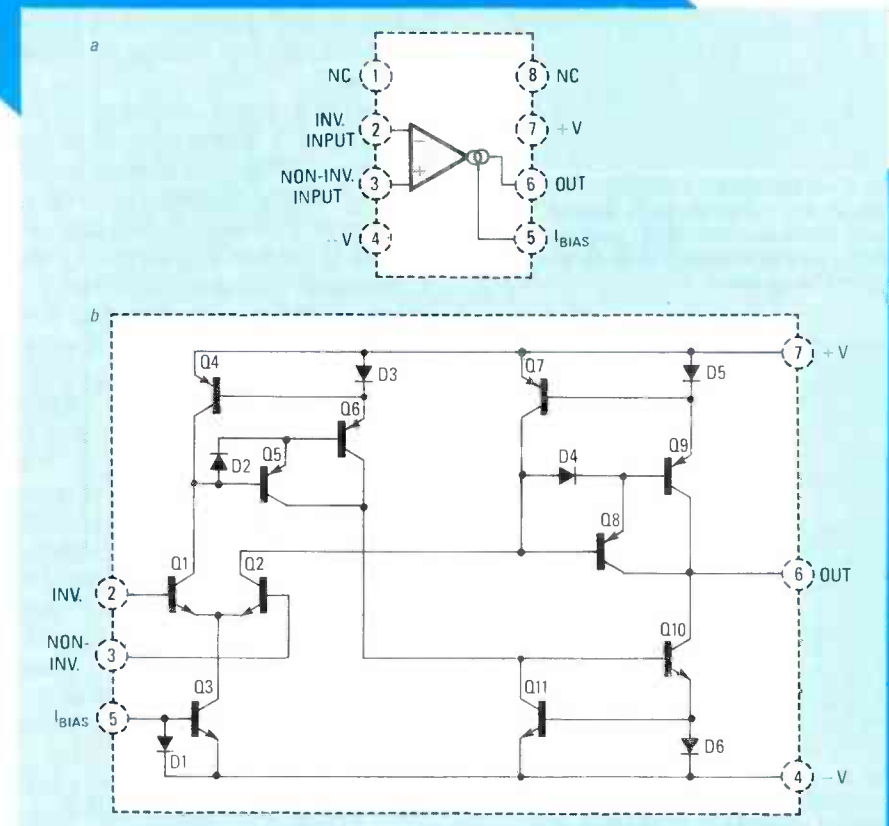

**Fig. 2**—THE PIN CONNECTIONS of the 8-pin dip version of the CA3080 are shown in (a), and the internal circuitry is shown in (b).

varied from  $0.1 \mu A$  to  $1 \text{ mA}$ , providing a 10,000:1 gain-control range.

An OTA can be made to operate like a conventional voltage-amplifying op-amp by connecting a suitable load resistance to its output terminal so that its output current is converted to a proportional voltage. The total current consumed by an OTA is double the value of  $I_{BIAS}$ , which may be as low as  $0.1 \mu A$ . That means that the device can be used in true micropower

applications. The amount of  $I_{BIAS}$  can be controlled easily using an external voltage and a series resistor. An OTA can be used as a Voltage-Controlled Amplifier (VCA), Voltage Controlled Oscillator (VCO), or Voltage Controlled Filter (VCF).

One of the best known OTA's is the CA3080. Figure 2-a shows its pin connections, and Fig. 2-b shows its internal circuitry. Table 1 lists the basic parameters of the device.

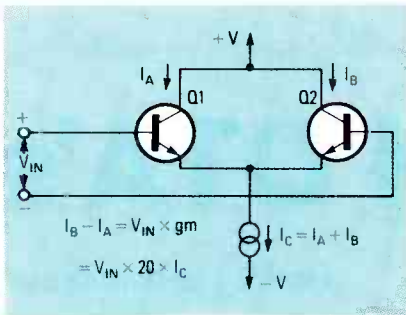

FIG. 3—A DIFFERENTIAL AMPLIFIER is at the heart of the CA3080.

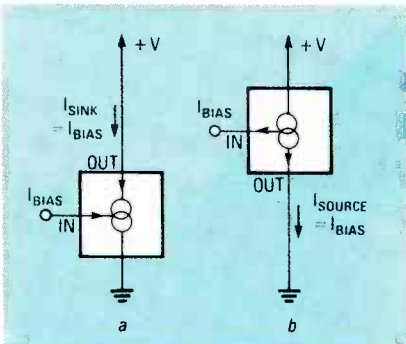

Fig. 4—A CURRENT-MIRROR SINK (a) will sink as much current as is applied to its input, and a current-mirror source (b) will supply as much current at its output, as is applied to its input.

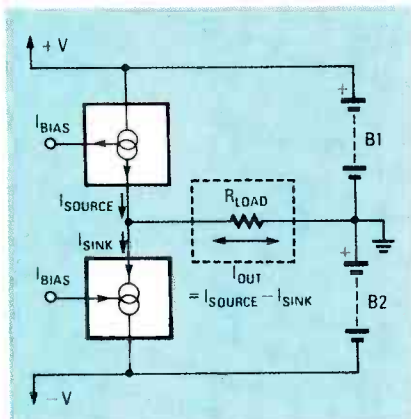

FIG. 5—WHEN TWO CURRENT MIRRORS are wired as shown, they generate a differential current in an external load.

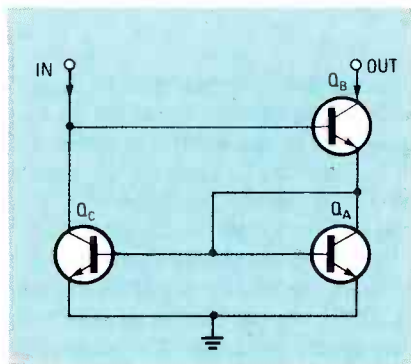

FIG. 6—A SINK-TYPE CURRENT MIRROR is made up of the circuitry shown here.

TABLE 1

CHARACTERISTIC	LIMITS
Supply Voltage Range	+4V to +30V DC or ±2V to ±15V
Max Differential Input Voltage	±15V
Power Dissipation	125 mW MAX
Input Signal Current	1 mA MAX
Amplifier Bias Current	2 mA MAX
Output Short-Circuit Duration	INDEFINITE
Forward Transconductance, gm	9600 μmho typ
Open Loop Bandwidth	2 MHz
Unity-Gain Slew Rate	50 V/μs
Common-Mode Rejection Ratio	110 dB typ

### CA3080 operation

The CA3080 consists of one differential amplifier and four Current Mirrors (CM). A current mirror is a 3-terminal circuit that, when an external bias current is provided at its input terminal, will produce an in-phase current of identical value at its output terminal.

The basic circuit and formulas for the CA3080's differential amplifier are shown in Fig. 3. The emitter current ( $I_C$ ) of the amplifier is equal to the sum of the two collector currents ( $I_A$  and  $I_B$ ). When  $V_{IN}$  is zero,  $I_A$  and  $I_B$  are equal and have a value of  $I_C/2$ . When  $V_{IN}$  has a value other than zero ( $\pm 25$  mV maximum),  $I_A$  and  $I_B$  differ and produce an  $I_B - I_A$  value of  $V_{IN} \times gm$ . The transconductance value is directly proportional to  $I_C$ , and at  $25^\circ\text{C}$  roughly equals  $20 \times I_C$ .

By itself, the circuit in Fig. 3 is not very useful. However, in an OTA such as the CA3080, the circuit is useful because by using a current mirror to externally control  $I_C$ , the amplifier's transconductance can then be controlled. By using three more current mirrors, the difference current between  $I_A$  and  $I_B$  can be made externally available.

There are two types of current mirrors. Some are current sinks, as shown in Fig. 4-a, and others are current sources, as shown in Fig. 4-b. When a current mirror source and current mirror sink are connected as shown in Fig. 5, and powered from a bi-polar power supply, they generate a differential current ( $I_{SOURCE} - I_{SINK}$ ) in any load that is connected between the junction point and the circuit ground.

Figure 6 shows the actual circuit of a sinking-type current mirror. Transistor  $Q_A$ , which operates like a diode, is wired across the base-emitter junction of a second, closely-matched transistor. The mirror accuracy of that

circuit is less sensitive to the current gains of the transistors, and has improved (greater) output impedance than in a more-simple circuit.

Figure 7 shows how the differential amplifier and four current mirrors are connected in the CA3080 to make a practical OTA. Bias current ( $I_{BIAS}$ ) controls the emitter current, and thus the transconductance of the Q1/Q2 differential amplifier via current-mirror C. The collector current of Q1 is mirrored by current-mirror A and fed to the bias terminal of current-mirror D, and the collector current of Q2 is mirrored by current-mirror B and fed to the sink terminal of current-mirror D, so that the externally available output current is equal to  $I_B - I_A$ .

If you refer back to Fig. 2-b, you will notice that Q1 and Q2 form the differential amplifier, D1 and Q3 make up current-mirror C, and current-mirror D is comprised of D6, Q10, and Q11. Current-mirror A (Q4-Q6, D2, and D3), and current-mirror B (Q7-Q9, D4, and D5) are slightly more complex than the others, using Darlington pairs of transistors and speed-up diodes to improve their performance.

### Some finer points

All of the major operating parameters of the CA3080 are adjustable and depend on the value of  $I_{BIAS}$ . The maximum output current is equal to  $I_{BIAS}$ , and the total operating current of the IC is double the  $I_{BIAS}$  value. The input bias currents drawn by pins 2 and 3 when the IC is operating in the linear mode are each equal to approximately  $I_{BIAS}/200$ , with the actual values depending on the current gains of Q1 and Q2 within the chip.

The transconductance (Fig. 8-a) and the input and output impedances (Fig. 8-b) vary with  $I_{BIAS}$ . Figure 8 shows typical parameter values when the IC is driven from a bi-polar 15-volt

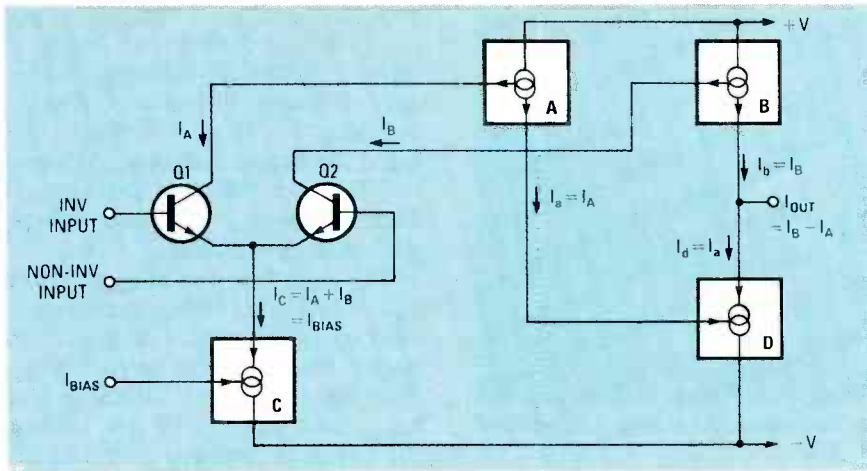

FIG. 7—THE CA3080 IS COMPRISED of one differential amplifier and four current mirrors.

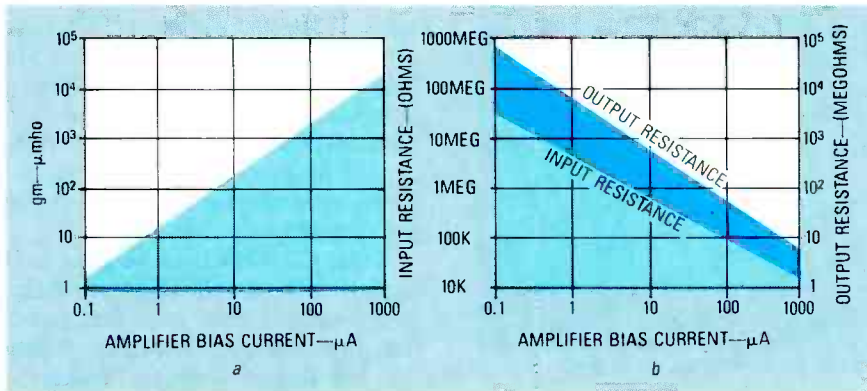

FIG. 8—THE TRANSCONDUCTANCE (a) and the input and output resistances (b) of the CA3080 vary with the bias current.

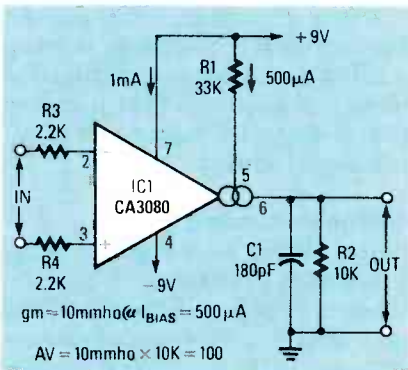

FIG. 9—THIS DIFFERENTIAL AMPLIFIER has 40-dB voltage gain.

supply at an ambient temperature of 25°C. Therefore, at a bias current of 10μA, gm is typically 200 μmho, with an input resistance of 800K and an output resistance of 700 megohms. At 1-mA bias current, those values change to 20 mmho, 15K, and 7 megohms respectively.

The output voltage of the IC depends on the values of I<sub>BIAS</sub> and an external load resistor connected to the output (pin 6) of the device. If the

load impedance is infinite, the output can swing to within 1.5 volts of the positive supply and within 0.5 volt of the negative supply. If the impedance is not infinite, the peak output swing is limited to I<sub>BIAS</sub> × R<sub>L</sub>. Thus at a 10-μA bias with a 100K load, the output swing is 1 volt.

The slew rate and bandwidth of the IC depend on the value of I<sub>BIAS</sub> and any external loading capacitor connected to pin 6. The slew-rate value,

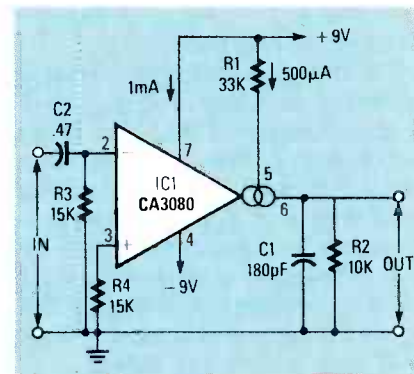

FIG. 10—AN AC-COUPLED 40-dB inverting amplifier.

in V/μs, equals I<sub>BIAS</sub>/C<sub>L</sub>, where C<sub>L</sub> is the loading capacitance value in pF, and I<sub>BIAS</sub> is in μA. With no external loading capacitor connected, the maximum slew rate of the CA3080 is about 50V/μs.

### Basic circuits

The CA3080 is very easy to use. Its I<sub>BIAS</sub> terminal (pin 5) is internally connected to the negative supply (pin 4) by a base-emitter junction, so the biased voltage of the terminal is about 600 mV above that of pin 4. I<sub>BIAS</sub> can be obtained by connecting pin 5 to either the ground line or the positive supply via a current-limiting resistor of suitable value.

Figures 9 and 10 show two ways of using the CA3080 as a linear amplifier with a voltage gain of about 40 dB. The circuit in Fig. 9 is a direct-coupled differential amplifier, and Fig. 10 shows an AC-coupled inverting amplifier. Both designs operate from bi-polar 9-volt supplies, so 17.4 volts is generated across bias-resistor R1, which feeds about 500 μA into pin 5 causing each IC to draw another 1 mA from their supply.

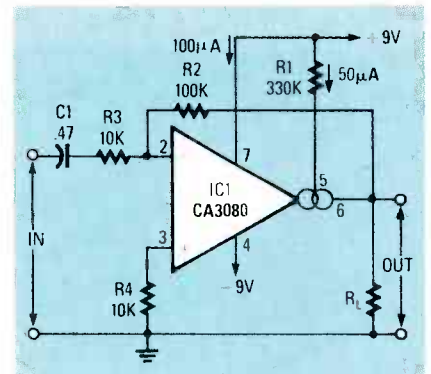

FIG. 11—THIS 20-dB MICRO-POWER inverting amplifier consumes very little power.

At a bias current of 500 μA, the transconductance of the CA3080 is approximately 10 mmho. The outputs of Figs. 9 and 10 are loaded by a 10K resistor (R2), and therefore provide an overall voltage gain of 10 mmho × 10K = 100, or 40 dB. The peak current that can flow into the 10K load is 500 μA (equal to I<sub>BIAS</sub>), so the peak output is 5 volts. The output is also loaded by a 180-pF capacitor (C1), giving the circuit a slew-rate limit of 500 μA/180pF = 2.8V/μs. The output impedance of each circuit equals the R2 value of 10K. Note that in those two circuits the IC is used in the

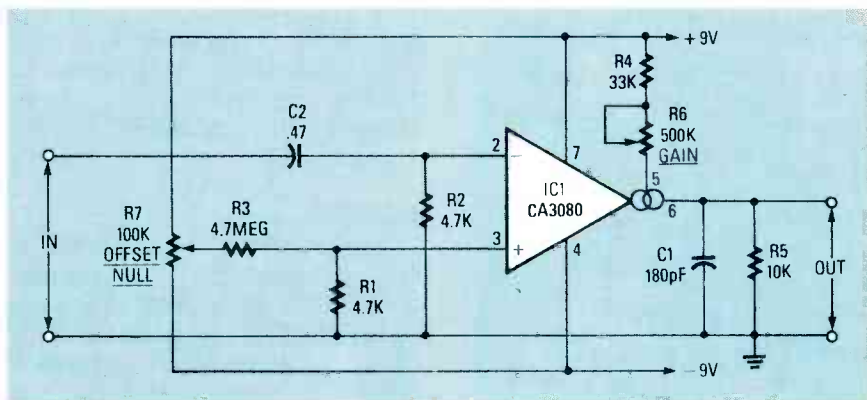

FIG. 12—A VARIABLE-GAIN AC amplifier has a gain that can range between  $\times 5$  and  $\times 100$ .

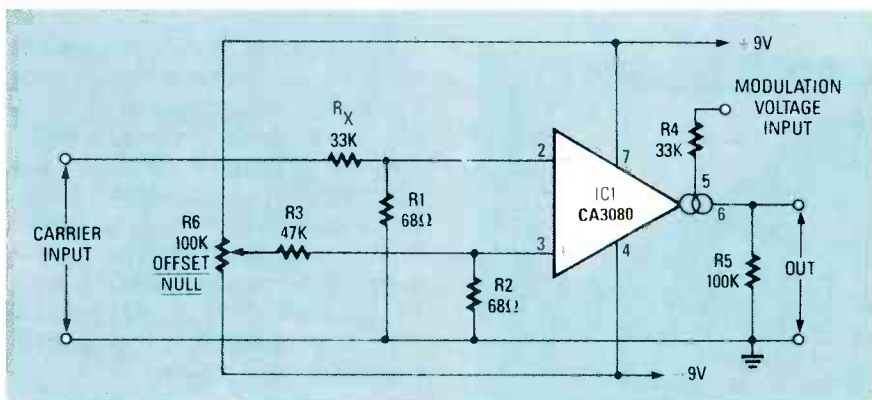

FIG. 13—AN AMPLITUDE MODULATOR or 2-quadrant multiplier has unity gain.

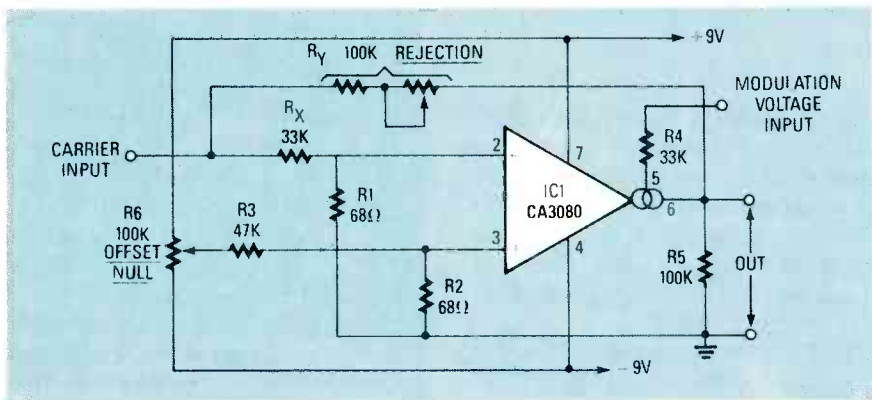

FIG. 14—BOTH PHASE AND AMPLITUDE can be controlled by the modulation signal in this ring modulator or 4-quadrant multiplier.

open-loop mode, and that if the slew rate is not externally limited by C1, the IC will operate at its maximum bandwidth and slew rate. Under those conditions the CA3080 may be excessively noisy.

In the circuit in Fig. 9, the differential inputs are applied via series resistors R3 and R4, which help equalize the source impedances of the two signals and maintain the DC balance of the IC. The circuit in Fig. 10 has both inputs tied to ground via 15K resistors and the input signal applied to one terminal only. With the input

connected to pin 2, the circuit is a 40-dB inverting amplifier.

The voltage gains in Figs. 9 and 10 depend on the value of  $I_{BIAS}$ , which in turn depends on the value of the supply voltage. The voltage gain of the CA3080 can be made almost independent of the  $I_{BIAS}$  and supply-voltage values by using conventional op-amp techniques, as shown by the 20-dB AC-coupled inverter circuit of Fig. 11, which consumes a mere 150  $\mu A$  from its bi-polar 9-volt supply.

The circuit in Fig. 11 is wired like a conventional inverting amplifier, with

its voltage gain ( $A_V$ ) determined primarily by the R2/R3 ratio (equal to 10, or 20-dB). The gain equation is only valid when the value of an external load,  $R_L$ , is infinite. That's because the output impedance is equal to  $R2/A_V$ , or 10K, and any external load lessens that value and reduces the output of the circuit.

The main function of  $I_{BIAS}$  in the circuit of Fig. 11 is to determine the total operating current of the circuit and/or the maximum output swing. With the component values shown,  $I_{BIAS}$  has a value of 50  $\mu A$ , causing the circuit to consume a total of 150  $\mu A$ . When  $R_L$  is infinite, the output is loaded only by R2, which has a value of 100K, so the maximum output is 5 volts. If  $R_L$  has a value of 10K, the maximum output voltage is limited to 0.5 volt. That circuit can therefore be designed to have any desired voltage gain and peak output, and since the IC is used in the closed-loop mode, external slew-rate limiting is therefore not required.

If the CA3080 is to be used as a high-gain DC amplifier, or as a wide-range variable-gain amplifier, input-bias levels must be balanced to ensure that the output correctly tracks the input signals at all values of  $I_{BIAS}$ . Figure 12 shows how to bias an inverting AC amplifier in which the voltage gain is variable from roughly  $\times 5$  to  $\times 100$  via R6, and the offset balance is pre-set via R7. The circuit is set up by adjusting R6 to its minimum value (maximum gain) and then trimming R7 to give zero DC output with no AC input signal applied.

### Voltage-controlled gain

Some of the most useful applications for the CA3080 are in true micropower amplifier and oscillator circuits, and when important parameters are controlled by an external voltage. In the latter category, one major application is as a VCA or amplitude modulator, in which a carrier signal is fed to the input of the amplifier, and the output amplitude is controlled or modulated by another signal fed to the  $I_{BIAS}$  terminal. Figure 13 shows a practical version of such a circuit.

The circuit in Fig. 13 is a variable-gain inverting amplifier. Input-bias resistors R1 and R2 have low values to minimize the noise levels of the IC and eliminate the need for external slew-rate limiting. Offset biasing is applied to the non-inverting input via

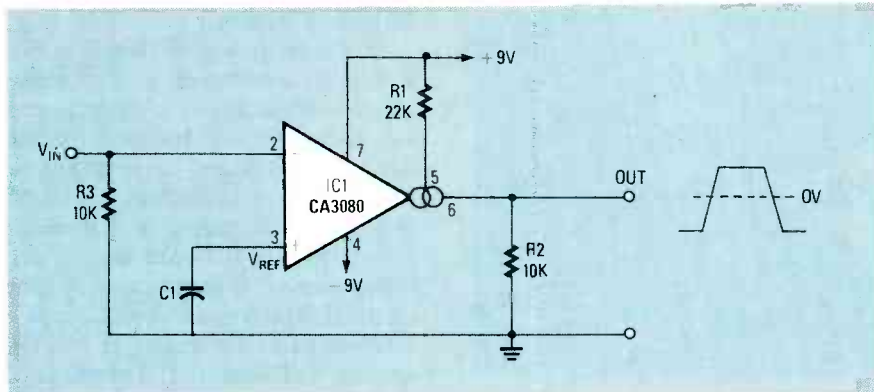

FIG. 15—A FAST INVERTING VOLTAGE comparator has a high output when its input falls below  $V_{REF}$

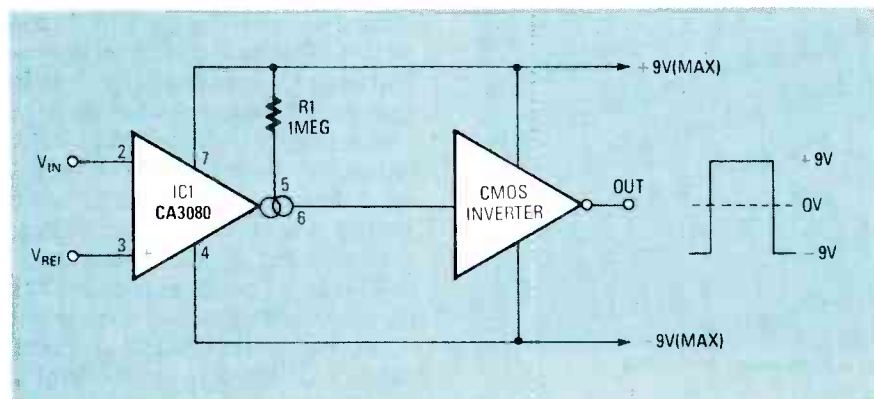

FIG. 16—A NON-INVERTING micropower voltage comparator has inputs that are sensitive to small changes.

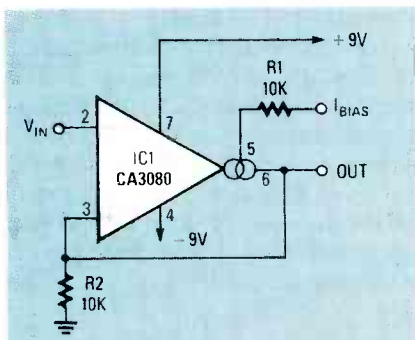

FIG. 17—THIS SCHMITT-TRIGGER circuit has programmable trigger-thresholds and peak-output.

$R3/R6$ . The carrier signal is applied to the inverting pin of the CA3080 by the voltage divider  $R_x/R_1$ . When  $R_x$  has a value of 33K as shown, and the modulation input terminal is tied to ground, the circuit basically has unity gain. The gain doubles when the modulation terminal is tied to +9 volts (+V), and when the modulation terminal is tied to -9 volts (-V) the circuit has roughly 80 dB of signal rejection.

The instantaneous polarity of the output signal of the circuit in Fig. 13 is determined entirely by the instantaneous polarity of the input sig-

nal. The amplitude of the output signal is determined by the product of the input and the gain-control values. That type of circuit is known as a 2-quadrant multiplier.

Figure 14 shows how the circuit in Fig. 13 can be modified so that it can be used as a ring-modulator or 4-quadrant multiplier, in which the output-signal polarity depends on the polarities of both the input signal and the modulation signal.

The circuits of Figs. 13 and 14 are identical, except that in Fig. 14, resistor-network  $R_y$  is connected between the input and output terminals. When the modulator input is tied to ground, the inverted signal flowing into  $R_5$  from the OTA's output is balanced by the non-inverted signal flowing into  $R_5$  from the input signal via  $R_y$ . Therefore, zero volts is generated across  $R_5$ . If the modulation input goes to +V, the output of the OTA exceeds the current of the  $R_y$  network, and an inverted gain-controlled output is obtained. If the modulation input is -V, on the other hand, the output current of  $R_y$  exceeds that of the OTA, and a non-inverted gain-controlled output is obtained. So, both the phase and the amplitude of

the output signal of the 4-quadrant multiplier circuit are controlled by the modulation signal. The circuit can be used as a ring modulator by feeding independent AC signals to the two inputs, or as a frequency doubler by feeding identical sine-wave signals to the two inputs.

Note that with the  $R_x$  and  $R_y$  values shown in Fig. 14, the circuit has a voltage gain of 0.5 when the modulation terminal is tied to +V or -V. The gain doubles if the values of  $R_x$  and  $R_y$  are halved. Also note that the Fig. 13 and Fig. 14 circuits each have a high output impedance, and that in practice an output buffer must be added between the output terminal and the outside world.

### Comparator circuits

The CA3080 can easily be used as a programmable or micropower voltage comparator. Figure 15 shows the basic circuit of a fast, programmable, inverting comparator, in which a reference voltage ( $V_{REF}$ ) is applied to the non-inverting terminal and the test input is applied to the inverting terminal. The circuit's operation is such that the output is driven high when the test input is below  $V_{REF}$  and is driven low when the test input is above  $V_{REF}$ . The circuit can be used as a non-inverting comparator by reversing the input connections of the IC.

With the component values shown in Fig. 15, the  $I_{BIAS}$  current is several hundred  $\mu A$ , so the device has a slew rate of about  $20V/\mu s$ , and operates as a fast comparator. When the test voltage and  $V_{REF}$  are almost identical, the IC operates as a linear amplifier with a voltage gain of  $g_m \times R_2$  or about 200. When the two input voltages are significantly different, the output voltage is limited to values determined by the values of  $I_{BIAS}$  and  $R_2$ . In Fig. 15, the output is limited to about 7 volts when  $R_2$  has a value of 10K, or about 700 mV when  $R_2$  has a value of 1K.

The circuit in Fig. 15 can be modified so that it is an ultra-sensitive micropower comparator, as shown in Fig. 16. That circuit typically consumes only 50  $\mu A$  but has an output that fully swings between the +V supply and the -V supply, and can provide drive currents of several mA. In Fig. 16 the CA3080 is biased at about 18  $\mu A$  via  $R_1$  but has its output fed to the near-infinite input impedance of a CMOS inverter stage. That

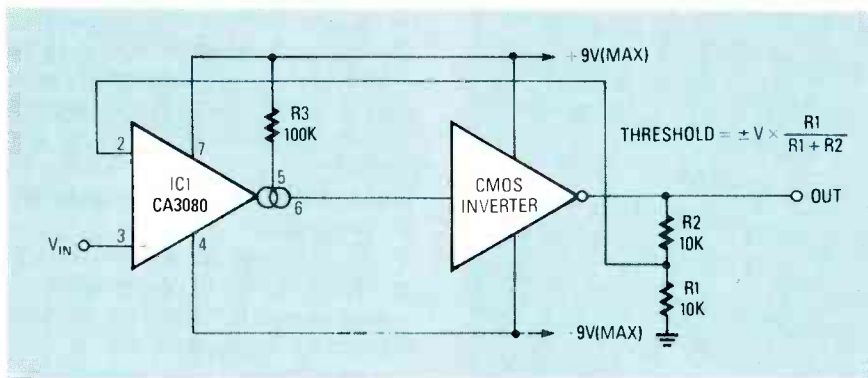

FIG. 18—A MICRO-POWER Schmitt trigger is shown here.

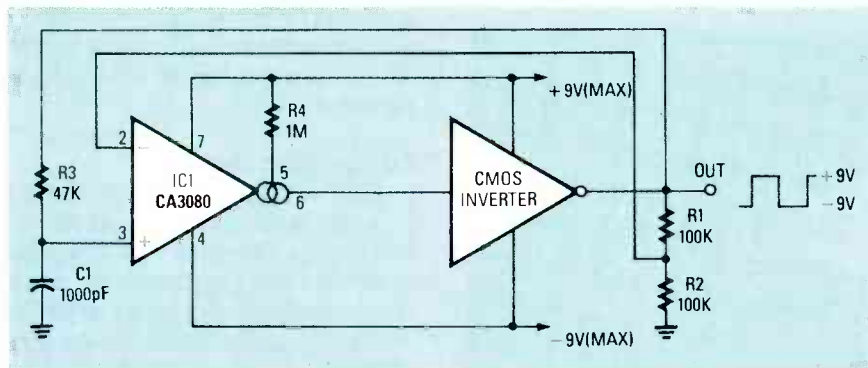

FIG. 19—A LOW-POWER astable multivibrator or square-wave generator.

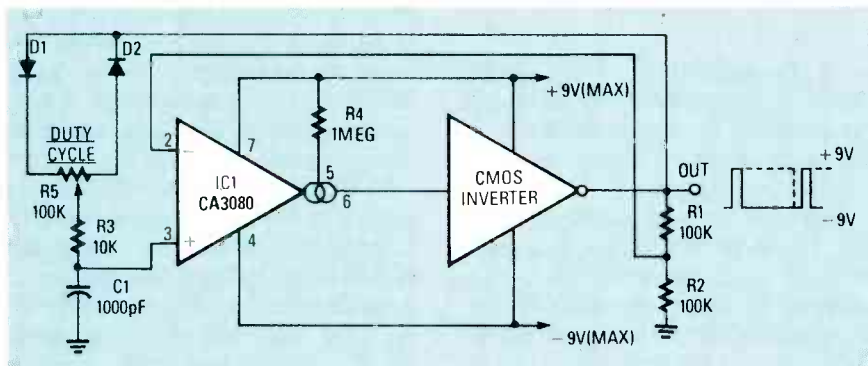

FIG. 20—THIS VARIABLE DUTY-CYCLE oscillator has an output that can be varied from 10:1 to 1:10. D

combination gives the circuit an overall voltage gain of about 130 dB, so that input-voltage changes of only a few  $\mu\text{V}$  are enough to switch the output from one supply level to the other.

### Schmitt-trigger circuits

The voltage comparator circuit of Fig. 15 can be used as a programmable Schmitt trigger by connecting the non-inverting reference terminal directly to the output of the CA3080, as shown in Fig. 17. In that case, when the output is high, a positive reference value of  $I_{\text{BIAS}} \times R2$  is generated. When  $V_{\text{IN}}$  exceeds that value, the output regeneratively switches low and generates a negative reference voltage

of  $I_{\text{BIAS}} \times R2$ , and when  $V_{\text{IN}}$  falls below that value, the output is regeneratively switched high and once more generates a positive reference voltage of  $I_{\text{BIAS}} \times R2$ . Therefore, the trigger thresholds, and also the peak output voltages of the Schmitt circuit, can be precisely controlled or programmed by changing the value of either  $I_{\text{BIAS}}$  or  $R2$ .

Figure 18 shows another type of Schmitt trigger, in which the output fully switches between the supply-voltage values. The switching-threshold values are determined by the  $R1/R2$  ratio and the supply-voltage values, and is equal to  $+V \times R1/(R1 + R2)$ .

### Astable circuits

The Schmitt-trigger circuit in Fig. 18 can be used as an astable multi-vibrator or square-wave generator circuit by connecting its output to the non-inverting input terminal via an RC time-constant network, as shown in Fig. 19. The output of that circuit fully switches between the supply-voltage values, is approximately symmetrical, and has a frequency that is determined by the values of  $R3$ ,  $C1$ , and the  $R1/R2$  ratio. The operation is such that, when the output is high,  $C1$  charges via  $R3$  until the  $C1$  voltage reaches the positive reference-voltage value determined by the  $R1/R2$  ratio. At that value the output switches low. Capacitor  $C1$  then discharges via  $R3$  until the  $C1$  voltage reaches the negative reference-voltage value determined by the  $R1/R2$  ratio. At that value the output switches high again, and the whole process then repeats.

Finally, Fig. 20 shows how the circuit in Fig. 19 can be modified to have an output waveform with a variable duty cycle. In that case,  $C1$  alternately charges via  $D1$ ,  $R3$ , and the left half of  $R5$ , and discharges via  $D2$ ,  $R3$ , and the right half of  $R5$ , to provide a duty-cycle ratio that is fully variable from 10:1 to 1:10 via  $R5$ .

Note that in the two astable circuits of Figs. 19 and 20, the CA3080 is biased at only a few  $\mu\text{A}$ , and the total current consumption of each design is determined primarily by the series values of  $R1$  and  $R2$ , and by the value of  $R3$ . In practice, total current consumption of only a few tens of  $\mu\text{A}$  can easily be achieved.

R-E

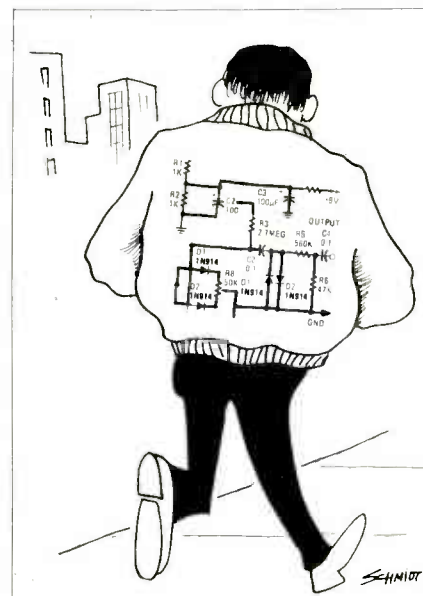

# HARDWARE HACKER

A new A/D converter  
The PostScript language  
Telephone ring detectors  
Toner cartridge reloading  
Replacement semiconductors

DON LANCASTER

## Refilling toner cartridges, and more!

I JUST GOT WIND OF A STUNNING NEW mid-level hacker integrated circuit that should cheaply and elegantly solve a lot of sensing and analog interface problems for you. That IC is the new LTC1092A by Linear Technology. While I don't yet have any samples or even any complete data, some preliminary technical info did appear over in *Electronic Design* for December 10, 1987.

That little \$12, 8-pin mini-DIP gem is a one-piece 10-bit low-level and high-speed analog-to-digital converter. What it does all by itself is take a small analog signal sitting on a large or even a slowly varying offset voltage and convert it into an 0.1-percent accurate 0-1023 digital numeric value.

The LTC1092A should serially interface beautifully with most any personal computer. It does appear especially good for talking through Apple's game ports.

Unlike previous A/D converters, that is a floating point unit that can have its maximum full-scale value set anywhere from 150 millivolts(!) on up to 10 volts. Which gives you a mind-numbing dynamic range of nearly 97 decibels. The same IC can measure anything from a mere 150 microvolts up to 10 volts.

The potential hacker uses boggle the mind. A recent help-line caller wanted an expanded scale voltmeter. Another asked for a way to accurately measure the charging voltage of a large industrial battery, since you can detect the end of charge when the voltage starts to rise suddenly.

You are able to directly input such things as "raw" data from a strain gauge, pressure transducer,

thermocouple, or other temperature sensor, and in one step get a numeric result. No more instrument amplifiers, voltage references, awkward board layouts, precision resistors, and all of the hassles that go with them.

And, yes, that IC is fast enough for almost any high-quality audio use. You can even digitize 19-kHz audio at a 38-kHz sampling rate.

Operation could not be simpler. There are two supply pins that can work from a single +5- or a +10-volt supply and ground. You have two differential input pins and a reference input that sets the full-scale amplitude. A precision reference is not needed, since you can get that signal from the same source that is driving your sensor or whatever.

The remaining three pins are digital. You'll find a clock input, a "start-converting" input, and a serial output. Which all should be able to interface quite well with just about anything.

We'll be seeing lots more on that beauty here. Yes, there definitely will be one of our usual contests. To get a head start, just pick up some data sheets, samples, and "ap" notes, and see what you can come up with.

### NEED HELP?

Phone or write your **Hardware Hacker** questions directly to:

Don Lancaster  
Synergetics  
Box 809  
Thatcher, AZ 85552  
(602) 428-4073

This is your column, and tech help is available per the help line. Let's start off with a great business idea...

### Tell me all about toner cartridge reloading

Toner cartridges, such as those used in all of the Canon personal copiers, in those Hewlett Packard *LaserJets* or the Apple *LaserWriters*, cost as much as \$124 each and are good for only a maximum of 2500 or so copies.

Yet, with a simple two minute operation, you can reload all those empty cartridges three or more times with new toner at a cost of only \$7.50. At the same time, you will get better and blacker images, since the rest of that cartridge mechanism does not even begin to get up to its maximum blackness until after its second reload, and since the refill toner materials are much blacker than the original toner.

If you now own one of those machines, you could dramatically reduce your operating costs and improve the quality of your output by doing your own refilling. If you do not, chances are others in your neighborhood will be glad to pay you as much as \$24 for a local and custom refilling.

One good source of refill toner is Lazer Products, while one reliable, independent, toner-refill testing and reporting service is now available through Thompson and Thompson. Note that the refill toner must be exactly matched to its target cartridge. Copier toner won't work in a laser printer, and vice versa.

Let us look at how you can refill a Canon CX cartridge. The details will vary with other systems. You can get your empty cartridges by accepting exchanges or else by putting an ad in the local paper. The current street price of empty but virgin cartridges is \$5 in urban areas and \$10 in small towns.

In fact, there is never any point at all in buying a brand new CX cartridge. You might as well let someone else condition the drum and get rid of the less-than-perfect factory toner for you.

There's usually no good reason to completely tear down a cartridge. All that does is introduce more problems than it solves. I will show you the "punch and go" method here, since that is far more cost effective. However, if you absolutely insist on tearing one apart, the magic tamperproof *Torx* bit is available as EVCO part #945B700 from Jensen Tools.

With the punch-and-go method, you have to make two holes in the cartridge, as shown in Figs. 1 and 2. The easiest way to make those holes is to melt them using a

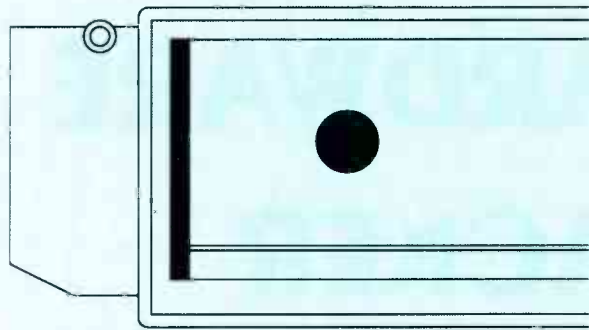

FIG. 1—A CANNON CX TONER CARTRIDGE has to be modified before it can be refilled. First, remove the large cardboard label (not shown here) by lifting it up from each end. Then, melt a clean 1/2-inch hole in the fresh-toner tank.

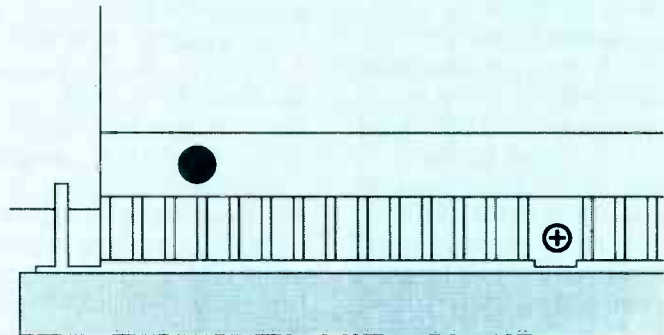

FIG. 2—CONTINUE MODIFYING THE CX CARTRIDGE by melting this 1/4-inch hole in the spent-toner holding tank beneath the cartridge. When finished reloading, seal up both holes with a very aggressive tape. Replace the cardboard label and the fuser wiper pad after refilling.

small soldering iron. You can also make them with a heated-up, spent 0.45-caliber cartridge shell or with a special *Unibit* drill intended for thin plastic.

One 1/2-inch hole is placed in the toner filling tank, and another 1/4-inch one is placed in the spent-toner holding tank, as shown. The holes should both be trimmed flush, being very careful to get no scraps of plastic inside the tanks themselves.

The toner filling tank is reached by popping off the large cardboard label. Do that from the ends, and not from the sides.

Suitable tape, such as the metal tape used in some floppy-disk write-protect tabs, is used as a seal. It is of the utmost importance that your sealing tape is both aggressive and secure.

To actually refill a cartridge, first open the holding tank hole and drain out the old toner. Do that outdoors and avoid breathing the toner. Then reseal the holding tank. Next, use a plastic funnel to dump one bottle (typically 400 grams) of toner into the filling tank via the 1/2-inch hole. Then reseal.

Follow that up with a stick-on label that holds the refilling history of the cartridge. Finally, replace the original cardboard label and clean the corona wire with the usual little green tool.

When you refill the cartridge, you should also replace the wiper pad that tracks the fusion rollers. Those pads contain a small amount of a special silicon oil, so they must be replaced, rather than just cleaned or recycled.

Wiper pads are usually included

**NEW FROM  
DON LANCASTER**

**HANDS-ON BOOKS**

Ask the Guru Reprints	24.50
CMOS Cookbook	15.50
TTL Cookbook	15.50
Active Filter Cookbook	15.50
Micro Cookbook vol I or II	16.50
Enhancing your Apple vol I	15.50
Enhancing your Apple vol II	15.50
Applewriter Cookbook	19.50
Apple Assembly Cookbook	21.50
Incredible Secret Money Machine	9.50
Postscript Ref. Man. (Adobe)	22.50
Postscript Cookbook (Adobe)	16.50

**UNLOCKED SOFTWARE**

Absolute Reset IIe & IIc	19.50
Applewriter/Laserwriter Utilities	49.50
Postscript Show & Tell (IIe/Mac/PC)	39.50
Postscript Technical Illustrations	39.50
Intro to Postscript VHS Video	39.50
Postscript BBS stuff	19.50
Apple Ram Card Disassembly Script	24.50
Enhance vol I Companion Disk	19.50
Enhance vol II Companion Disk	19.50
Assembly CB Companion Disk	19.50
Applewriter CB ProDOS C. Disk	24.50

FREE VOICE HELPLINE      VISA/MC

**SYNERGETICS**  
Box 809-RE  
Thatcher, AZ 85552  
(602) 428-4073



free when you order toner. Simply scrape the original pad out of its holder and secure the new one with a drop or two of glue.

Refilled cartridges must be hand carried. They cannot be shipped without adding an additional and specialized sealing strip. Thus, cartridge reloading is best done as a local service.

More details on doing cartridge reloading appear in my *Ask The Guru* reprints, while a step-by-step toner-reloading demonstration is included in my *Introduction to PostScript* video.

### What is PostScript?

Several help-line callers have



FIG. 3—AN ORDINARY WORD PROCESSOR is all that is needed with the PostScript language to create graphics that look this good. These examples show you several of PostScript's powerful curve tracing and cubic spline abilities. Any personal computer can be used.

## NAMES AND NUMBERS

**Adobe Systems**  
1585 Charleston Rd.  
Mountain View, CA 94039  
(415) 961-4400

**Computer Shopper**  
Box F  
Tutusville, FL 32781  
(305) 269-3211

**EGC**  
70 Empire Dr.  
West Seneca, NY 14224  
(716) 325-2620

**EVCO**  
3451 Lorna Road  
Birmingham, AL 35236  
(205) 822-5381

**General Electric**  
Electronics Park Bldg 7  
Syracuse, NY 13221  
(800) 626-2001

**General Instruments**  
2355 W Chandler Blvd.  
Chandler, AZ 85224  
(602) 963-7373

**Jensen Tools**  
7815 South 46th St.  
Phoenix, AZ 85044  
(602) 968-6231

**Lazer Products**  
PO Box 4947  
Englewood, CO 80155  
(303) 721-9990

**Linear Technology**  
1630 McCarthy Blvd.  
Milpitas, CA 95035  
(408) 432-1900

**Mini-Circuits**  
PO Box 350166  
Brooklyn, NY 11235  
(718) 934-4500

**NTE**  
44 Farrand St.  
Bloomfield, NJ 07003  
(201) 748-5089

**PostScript BBS**  
2504 Sycamore  
Bay City, TX 77414  
(409) 244-4704

**Speleonic**  
Box 5283  
Bloomington, IN 47402  
(812) 335-7305

**Synergetics**  
Box 809  
Thatcher, AZ 85552  
(602) 428-4073

**TecSpec**  
3 Mine Mountain Rd  
Cornwall Bridge, CT 06754  
(203) 672-0123

**Texas Instruments**  
Box 5012  
Dallas, TX 75265  
(214) 995-3821

**Thompson & Thompson**  
23072 Mullin Dr.  
El Toro, CA 92630  
(714) 855-3838

**Thomson Semiconducteurs**  
43, Avenue De L'Europe  
78140 Velizy-Villacoublay  
FRANCE  
(1) 3946-9719

now complimented me on the technical illustrations for this column and have wondered just who the artist is. Well, the artist is not a he or a she. It is an it.

All of the artwork you see in this column is prepared in camera-ready form using nothing but the *AppleWriter* word processor on a *Ile*, printing onto a *LaserWriter Plus*. That is all made possible by a unique graphics and typesetting language that is known as *PostScript*.

*PostScript* is new industry-standard page-description language that is also making strong bids to become a screen-description stan-

dard, a fax standard, a BBS graphics-interchange standard, a signmaking and engraving standard, and even a printed-circuit layout standard.

The good news about *PostScript* is that you can simply and quickly use any old world processor on any old computer and create graphics that can meet and often ridiculously exceed the finest graphics output available from the most expensive custom programs running on the fanciest of computer systems.

The bad news is that *PostScript* only works on premium printers and typesetters that have

PostScript capabilities already built into them. Current examples are the Apple LaserWriter and LaserWriter Plus printers and the Linotron 100 and 300 phototypesetters. Those are still a tad on the pricey side.

Some important advantages of PostScript include its device independence, which means that the very same code and very same text file can be used for 300 DPI personal laser printing or for 2560 DPI commercial typesetting.

PostScript can be used to do professional-quality typesetting, and its fonts can be set to any size from two points up to 40,000 points or even higher, and may be independently rotated, translated, scaled, or have any of hundreds of other special treatments applied to them.

Thousands of different PostScript fonts are now available, and each of these individual fonts can be shown in a nearly infinite number of variations.

Full page PostScript text and graphics can be freely intermixed in any combination in most any direction in most any manner.

PostScript, like its second cousin (three times removed and five times disowned) Forth, is a threaded and extensible language. Which means that you can add anything you like to the language anytime, creating custom and reusable code.

One of the neatest features of PostScript is its ability to handle a powerful means of drawing smooth curves that go by the name of *cubic splines*. Figure 3 shows a few of the awesome things you can do with PostScript's cubic spline capabilities.

And, yes, PostScript is incredibly easy to learn. In fact, it becomes downright addictive. Off-the-street students in my beginning PostScript courses are doing their own superb custom letterheads, business cards, badges, forms, ads, line art, decals, and bumper stickers after as little as three hours of instruction.

Those of you hackers that have also been following me over in *Computer Shopper* know that I am into PostScript in a very big way. You can get started in all this on your own by calling our free PostScript voice help line at (602) 428-4073, by calling our free PostScript BBS at (409) 244-4704, by getting a free subscription to the *Colophon* magazine from Adobe Systems, or by picking up any of my other Postscript goodies that are mentioned at the end of this column.

### Where can I get replacement entertainment semiconductors?

While nearly all transistors and integrated circuits are made in the same way by the same people, there are several different ways those devices are sold. If you are a manufacturer of, say, television sets, you will buy them direct in huge-quantity lots, already custom numbered for you per your own internal needs.

If you are a hacker, designer, or developer, you won't do that; instead you'll buy your standard-numbered parts from any of the usual industrial or new-age distributors, including many of our



# SEEK PROFESSIONAL HELP

Servicing electronic equipment isn't always easy, especially if you're doing it in the field. At Chemtronics we can help with over 200 specially engineered products for the maintenance, repair and production of high technology equipment. Call today for our latest problem solving catalog.

**Chemtronics**  
Keeping pace with advanced technology

Chemtronics Inc. 681 Old Willets Path Hauppauge, NY 11788 516-582-3322 Telex 968567

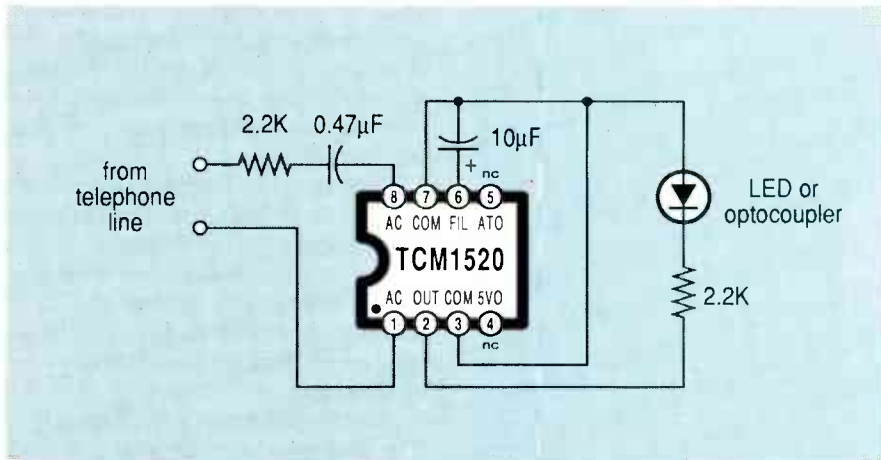

FIG. 4—THIS TELEPHONE-RING DETECTOR might be used to light an LED, or to power an LED optocoupler to create an isolated "the phone is ringing" optical signal.

### Radio-Electronics advertisers.

Finally, you will find yet a third distribution channel. That one is intended specifically for technical training, for maintenance services, and consumer-electronics repair. Those sources stock small quantities of the house-numbered devices specifically for service and warranty-repair uses.

As a hacker, you'll want to tune into both of the standard-numbered parts sources as well as the service and warranty-replacement sources. More often than not, what you get from one distribution channel is totally unheard of by the other.

Two of the leading sources of replacement semiconductors are the ECG people and the competing folks over at TCE. Both sources have fat and low-cost technical guide directions that list and then cross reference zillions of house part-numbers. Package details, pin-outs, and limited technical data is also included.

No hacker can afford to be without current copies of those.

### Show me a telephone-ring detector.

A typical home-telephone line normally consists of a 48-volt DC supply that drops to half of that when you are off-hook. That DC supply is amplitude modulated in order to provide voice or data communications.

Ringling is separately done by superimposing a very strong AC ringing signal. That is typically a sinewave of 40 to 150 volts rms at a frequency of 16 to 68 Hz.

Traditionally, the ringing voltage would be capacitor coupled to a mechanical bell whose resonant frequency matched that of the ringing signal. Some older party lines used several different resonating frequencies for the bells, so that each party could be selected by changing the ring frequency.

You might like to build your own ring detector, possibly as an aide

for the deaf, for use as a modem or answering-machine actuator, for automated computer communications, or simply for an outside, a remote, or a super-loud or a super-quiet way to tell when your phone is ringing.

One way to do that is with a plain old neon lamp. Take a NE-2 and put it in series with a 470K resistor and a 0.47-µF, 400-volt capacitor, and hang in across the phone line. Or use a neon night light instead. The neon lamp lights whenever the phone is ringing.

To get a safety isolated ringing signal, just tape a photoconductive cell or phototransistor to the neon lamp, and input the photodetector into your whatever.

These days, though, you will find simple, low cost, and sophisticated integrated circuits that you can use to detect ringing and directly drive a piezotransducer or a speaker.

Many of those are described in the new *Telecommunications Data Book* by Texas Instruments. Let us look at two different examples.

# INTRODUCING THE AR-100 MAXI-PROBE™

## The World's First Pen-Style DMM with Built-In 10MHz Logic Probe

**INNOVATION NOT IMITATION**

The AR-100 Maxi-Probe, Unheard-of features and performance in one small package. Volts. Ohms. Audible continuity. Data Hold.

Then add a full-function, TTL/CMOS logic probe. Screw-on accessory tips. Diode Test. Test Leads. And a storage case.

Result: All the functions you need for both analog and digital testing in one small package, at one low price.

Get the small local ARI distributor and take hold of the future, today. The AR-100 Maxi-Probe. All others pale by comparison.

**Features:**

- Screw-On Accessory Tips
- Data Hold

**And:**

- TTL & CMOS Logic Probe

**AMERICAN RELIANCE INC.**  
VALUE BEYOND MEASURE  
(800) 654-9838

ARI manufactures a complete line of electronic test equipment, including EPROM, EEPROM, and PLD programmers, IC testers, Cable testers, DPMs, DMMs, and Logic testing devices. Call or write today for your free catalog.

CIRCLE 187 ON FREE INFORMATION CARD

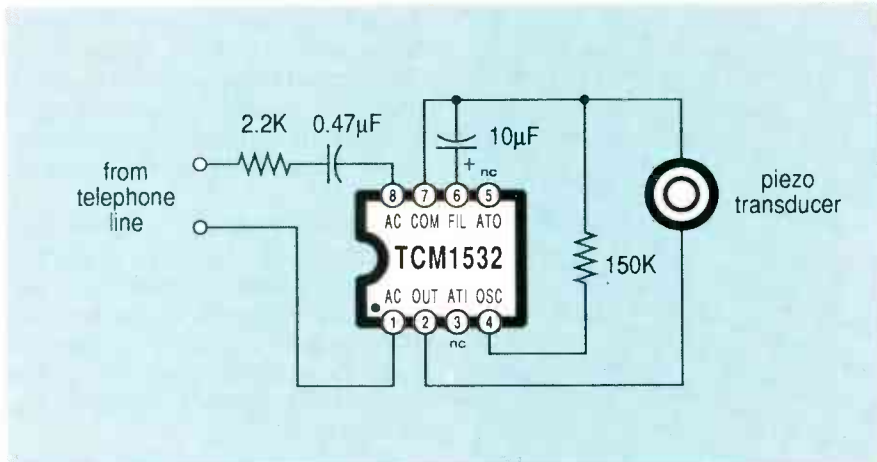

FIG. 5—A COMBINED RING DETECTOR AND DRIVER that directly powers a piezotransducer. Speakers or external amplifiers can be driven by transformer coupling. Note that all of the needed power is derived directly from the AC ring signal. Use a 400-volt input capacitor.

Figure 4 shows you a detect-only circuit that uses a TCM1520A to light an LED or drive the input of an LED optocoupler. The output is a pulsed DC signal that is present when the phone is ringing and absent otherwise.

Figure 5 shows you a detect-and-drive circuit that uses a TCM1532 to

directly drive a piezotransducer, or else lets you transformer couple to a speaker or an external and isolated amplifier.

To get a decent-sounding ring, you really want to pick a pair of frequencies and warble between them. Further, you will want to match those frequencies to what-

ever you are driving. That is done automatically for you inside the IC. A number of different part numbers are available that give you various ring frequencies and warble rates.

Note that the second circuit can also drive an LED, and the LED will even appear to light continuously on a ring. But remember that the actual waveform across the LED will be a complex audio signal that may need further treatment if you optocouple it.

There's other uses for those IC's that include burglar and process alarms, or even low-power, direct line-operated power supplies. See the data book for more details.

### Any new tech lit this month?

Newsletters are often a very high-energy source of hacker ideas. One new one is called *TecSpec*, and is quite strong on lasers and optical communications. The coverage is all very hacker oriented. The cost is \$1.50 per issue.

My favorite technical newsletter

# CONNECTION PROTECTION

SWITCHES & RELAYS

**CRAMOLIN®**

• CLEANS  
• PRESERVES  
• LUBRICATES

CONNECTING CABLES

EDGE CONNECTORS

POTENTIOMETERS

BATTERY CONTACTS

PLUGS & SOCKETS

GOLD PLATED CONNECTORS

**CRAMOLIN®**

Even the finest equipment in the world cannot guarantee noise-free operation. One "dirty" connection anywhere in the electrical path can cause unwanted noise or signal loss.

**"MORE THAN A CONTACT CLEANER"**

**CRAMOLIN®** is a fast-acting, anti-oxidizing lubricant that cleans and preserves all metal surfaces, including gold.

When applied to metal contacts and connectors, **CRAMOLIN®** removes resistive oxides as it forms a protective molecular layer that adheres to the metal surfaces and maintains maximum electrical conductivity.

**CRAMOLIN® - USED BY THOSE WHO DEMAND THE BEST:**

Beil & Howell	Hewlett Packard	MCI(Sony)	Nakamichi
Boeing	John Fluke Mfg.	Motorola	RCA
Capitol Records	McIntosh Labs	NASA	Switchcraft

SINCE 1956

**CAIG LABORATORIES INC.**

1175-O Industrial Ave., (P.O. Box J) - Escondido, CA 92025-0051 U.S.A. • (619) 743-7143

## You got it to work? Good!



## NOW MAKE IT LOOK GOOD

Let DATAK be your designing partner. Use our dry transfer title sets to put that finishing touch to your custom project. Over 2200 titles plus alphabets and numbers insure that you'll have the words you need. Switch markings and dial plate arcs are in a companion set. Use DATAKOAT spray for complete protection. Sprays are not available.

- 948 Blk (949 Wht) 10 pt .105" Electronic Titles (24 sheets) ..... \$11.95
- 9581 Blk (9591 Wht) 12 pt .125" Electronic Titles (24 sheets) ..... 11.95
- 968 Blk, Wht, Red asst. Meter dial & Switch Markings (12 sheets) .. 11.95
- 04177 DATAKOAT Gloss Spray (12 oz) ..... 5.75
- 04178 DATAKOAT Matte Spray (12 oz) ..... 5.75

Minimum order: \$20.00 (add 7% shipping. NJ and CA also add sales tax)  
**WRITE FOR A FULL CATALOG AND SAMPLES TODAY**  
**DATAK Corp. • 3117 Paterson Plank Rd. • N. Bergen, NJ 07047**

CIRCLE 186 ON FREE INFORMATION CARD

of all, though, is *Speleonics*, which weights in at a budget-breaking \$6 per year. That newsletter is written by and for spelunking cavers who have a technical bent. Topics of special interest to electronics hackers include underground location finding, low-frequency radio communications, laser mapping and geophysical exploration, and innovations in lighting.

General Instrument Microelectronics has a short-form product portfolio out. Among the products included are sound generation integrated circuits, character generators, some keyboard encoders, and even credit-card size memory devices.

There is a new and free *Triac Applications Handbook* you can get from Thomson Semiconductors. While full of good ideas, it is poorly written and the translation is even worse. To this day, the best reference book on power-control semiconductors remains the ancient *GE SCR Manual*. I'm not even sure that the book is still in print, though.

The Mini-Circuits people have a new how-to-use guide for their MAR drop-in amplifiers. Those are a series of very low-cost, ultra high-frequency transistor-amplifier IC's that are usable as high as 2 GHz.

Turning to my own products, if you want to know more about the *PostScript* language, I have scads of *PostScript* stuff for anyone from a rank beginner on up through some testing, development, and leading-edge advisory services for even the most gonzo of advanced *PostScript* developers.

For beginners just getting started who do not yet own a *Postscript* printer, I would suggest my new *Introduction to Postscript* videotape and Adobe's *PostScript Cookbook*. If you already do own a *PostScript* printer, there's my *PostScript Show and Tell*, my *PostScript Technical Illustrations*, and my *PostScript BBS Stuff*, available for all of the major personal computers.

Write or call (see the box on the first page of this article), and I'll be most happy to send you a brochure on all of this and lots more; some free, and some not. **R-E**

### CONSUMER



New solid-state and digital TV sets, stereos, and videorecorders are tougher to repair than old-fashioned tube type sets and require special training for the service technician who works on them.

Only a few states have laws requiring competency tests for licensing technicians who repair consumer electronics, but fifteen years ago the International Society of Certified Electronic Technicians (CET) began its own certification program to qualify these technicians and those in industry. To carry the CET designation, technicians must have four years experience and pass a rigid examination on general electronics and a specific area of expertise such as audio or radio-TV.

Many consumers look for a Certified Electronic Technician in the shop when they need any electronic item repaired.

#### Free Consumer Checklist

A consumer checklist for selecting a service shop is available free by sending a

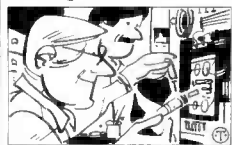

Modern electronic equipment such as digital TVs or stereos should be repaired by specially trained people.

stamp. self-addressed envelope to: Checklist, ISCET, 2708 West Berry, Fort Worth, TX 76109. The list reminds consumers to check such items as "Does the business have the parts for your particular brand?", "Did you get an estimated price?", and "Did you check this company with the Better Business Bureau?"

## Nine Test Probes with only one difference between them and your scope's original equipment

Manufacturers Scope	Original Probe	Price	Coline/TPI Equivalent	Price	
<b>TEKTRONIX</b>	2300 Series	P6101A	\$53	M12X1	<b>\$38</b>
		P6108A	\$75	M12X10	<b>\$62</b>
	2200 Series	P6121	\$100	M12X10AP	<b>\$68</b>
		P6122	\$58	P100	<b>\$38</b>
	2400 Series	P6131	\$140	M15X10HFAP	<b>\$87</b>
		P6133	\$115	M12X10AP	<b>\$68</b>
	400 Series	P6105A	\$93	M12X10AP	<b>\$68</b>
		P6106A	\$140	M15X10HFAP	<b>\$87</b>
		P6130	\$130	M12X10AP	<b>\$68</b>
<b>IWATSU</b>	SS-5321	SS-0014	\$92	M12X10	<b>\$62</b>
	SS-5711	SS-0012	\$77	M12X10	<b>\$62</b>
<b>LEADER</b>	LBO-315	LP-060X	\$60	SP100	<b>\$43</b>
	LBO-518	LP-100X	\$76	SP100	<b>\$43</b>
<b>PHILIPS</b>	PM3267	PM8924	\$60	M12X1	<b>\$38</b>
	& PM3256	PM8926	\$70	P100	<b>\$38</b>
	PM3264	PM8928	\$95	M12X10	<b>\$62</b>
<b>HITACHI</b>	V-1100A	AT-10AL1.5	\$64	SP100	<b>\$43</b>
	V-670				
	V-509				
<b>HEWLETT PACKARD</b>	1715A	10018A	\$135	M20X10	<b>\$68</b>
	1722B	10017A	\$130	M15X10HF	<b>\$79</b>
	1725A	10017A	\$130	M15X10HF	<b>\$79</b>
	1740 Series	10041A	\$135	P100	<b>\$38</b>
		10021A	\$85	IP20	<b>\$29</b>

Take up the TPI challenge and compare our prices with the probes you currently use. In many cases you can replace both probes on your dual trace scope at the cost of one probe from the scope manufacturer. Plus, bandwidth and overall performance of the TPI probe typically exceed that of the original equipment. Satisfaction is guaranteed with a ten day return privilege. TPI Specialists in probes for over 15 years.

Available from your local distributor.

TOLL FREE INFORMATION LINE

1-800-368-5719,

1-800-643-8382 in California

**TEST PROBES, INC. TPI**

9178 Brown Deer Road,  
San Diego CA, 92121  
Phone: (619) 535 9292

CIRCLE 123 ON FREE INFORMATION CARD

Sent to: 9178 Brown Deer Road, San Diego CA, 92121

Please send full line catalog

Name \_\_\_\_\_

Company \_\_\_\_\_

Address \_\_\_\_\_

Phone: \_\_\_\_\_

# AUDIO UPDATE

## Some thoughts on predicting the audio future

BEFORE WE LOOK AHEAD AT THE FUTURE of audio, let's finish up the backward look that we began in last month's column.

By 1959 a new type of component—the tuner-amplifier—had appeared and was gaining popularity; it would be several years before it was called a "receiver." Transistorized equipment also began to appear at that time. Audiophiles incautious enough to invest in the new technology found themselves with tuners having front-end overload problems and low sensitivity, and amplifiers that suffered from crossover distortion, overload, and other repeated failures.

Although a few early starters among the manufacturers had dropped out, the total number of audio manufacturers had grown significantly over a 10-year period. And, in fact, some of them were beginning to make model changes every couple of years.

### The stereo sixties

I shouldn't leave the 1950's without acknowledging the introduction of the first acoustic-suspension speaker in 1955. The development by Edgar Villchur of a speaker system with remarkable bass and compact dimensions would ultimately dovetail neatly with stereo's need for two speakers. In the 1960's, the company he founded—Acoustic Research—managed to take over a third of the speaker market with various models that they were producing.

In 1963 Philips introduced their Compact Cassette system. I don't think anybody (including Philips) would have predicted that the



FIG. 1

book-size, low-fi portable unit introduced as a "sound camera" 25 years ago would one day evolve into a product that at its best would provide performance equivalent to that heard from the finest LP's—and that would virtually wipe out the home open-reel tape machine.

In 1967 the first Dolby-A mastered discs appeared. Several years later, Advent incorporated a heavily modified version of the studio A system into a cassette machine. Referred to as the B system, it ultimately became a necessary part of virtually every cassette machine. But it didn't happen instantly or easily. Ray Dolby spent years in licensing negotiations with the Japanese (and Philips, who weren't all that sure that Dolby encoding



LARRY KLEIN,  
AUDIO EDITOR

didn't circumvent the compatibility requirement in the Philips licensing agreement). Philips ultimately gave tacit approval, and one by one the Japanese signed up.

By now I've reached a time period probably familiar to most of my readers—and I'm running out of space. One final thought: In the summer of 1970 I wrote a prophetically titled article "The Four-Channel Follies." A year later, when I followed up with "The Four-Channel Follies: Act 2", I could see the handwriting on the wall—all four of them. Quadraphonics was killed by a combination of inept promotion and marketing, the presence of three competing incompatible systems, and off-target engineering. However, when writing about the death of quad in early 1978, I predicted that multi-channel sound in some format would one day reappear. It appears that that day is now here with components such as the new Dolby Stereo sound-track processors and sound-field synthesizers such as Yamaha's DSP-1 digital processor. I'm looking forward to reconvert my system to the new formats.

### Into the future

In the years that I've been playing audio oracle, my crystal ball, shown in Fig. 1, has usually provided relatively clear reception, albeit with an occasional glitch to remind me that marketplace prediction is a tricky business. When I call a wrong turn as a journalist, I'm embarrassed; but when a manufacturer misjudges the potential demand for a prod-

# R-E Engineering Admart

Rates: Ads are 2 1/4" x 2 7/8". One insertion \$825. Six insertions \$800 each. Twelve insertions \$775 each. Closing date same as regular rate card. Send order with remittance to **Engineering Admart**, Radio Electronics Magazine, 500-B Bi-County Blvd., Farmingdale, NY 11735. Direct telephone inquiries to Arline Fishman, area code-516-293-3000. *Only 100% Engineering ads are accepted for this Admart.*

## MIDI PROJECTS

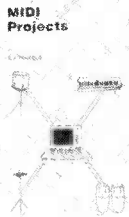

**BP182**—MIDI interfacing enables any so equipped instruments, regardless of the manufacturer, to be easily connected together and used as a system with easy computer control of these music systems. Combine a computer and some MIDI instruments and you can have what is virtually a programmable orchestra. To get your copy send **\$6.95 plus \$1.00 for shipping** in the U.S. to **Electronic Technology Today Inc.**, P.O. Box 240, Massapequa Park, NY 11762-0240.

## FCC LICENSE PREPARATION

The FCC has revised and updated the commercial license exam. The **NEW EXAM** covers updated marine and aviation rules and regulations, transistor and digital circuitry. **THE GENERAL RADIOTELEPHONE OPERATOR LICENSE - STUDY GUIDE** contains the necessary preparation for **ONLY \$25.00.**

WPT PUBLICATIONS  
979 Young Street, Suite A  
Woodburn, Oregon 97071  
Phone (503) 981-6122

CIRCLE 179 ON FREE INFORMATION CARD

## Circuit Board Layout Made Easy!

Create and Revise  
P-C-B Artwork on your

### IBM or Compatible

- User Friendly
- On-line Help Screen
- Supports Mice
- Auto-Router available
- Printer or Plotter
- Dip & Sip Library
- New ver. 1.6
- 2x Artwork

**Requirements:** IBM or compatible PC-384K memory-CGA card-IBM graphics compatible printer-H.P. or H.I. plotters



**ONLY \$99.00**

2145 Highland Ave.  
Suite 201  
Birmingham, Al. 35205  
(205) 933-1122

**DEMO DISK \$10.00**

CIRCLE 205 ON FREE INFORMATION CARD

uct, millions of dollars and many people's jobs may be at risk.

Why are the twists and turns of the audio marketplace so hard to anticipate even by experienced marketeers? Probably because the public's reaction to a particular new format or product is based on a difficult-to-sort-out mix of elements. Those include satisfaction of a real or imagined need, personal taste, and what I call the "oh-wow!" factor. And we shouldn't overlook the importance of effective promotion and marketing know-how.

Is it possible to tell in advance what will be *hot* and what will *not*? Not infallibly; but here are some thoughts and case histories that should provide insights into the social, psychological, economic, and technical factors that determine whether a particular audio product will fly—or never get off the ground.

### Taste factors

Some audio features, such as product cosmetics, are essentially a matter of taste. About 10 years ago, Yamaha bucked then-current design trends by producing a line of receivers with very clean, almost sterile looking, matte-silver

front panels. When they asked my opinion of their new look, I said that I liked it, but that I didn't think it would be attractive to an audio public conditioned to visual pizzazz. Not only was I wrong, but Yamaha's cosmetic approach established a styling trend that lasted for years. Today, black is considered beautiful. Why? Your guess is as good as mine.

### Technological trends

Can an inside knowledge of upcoming technical developments be helpful in predicting product trends? Sometimes, but not always. For example: Perhaps a dozen years ago I heard about Hall-effect magnetic-sensing heads. (Unlike conventional tape heads that depend on tape movement to generate a signal, Hall-effect heads produce a signal proportional to a stationary magnetic field.) At the time, I wrote a short piece extolling the virtues of Hall-effect heads for wide-range slow-speed recording, and predicted that they would shortly be found in a large variety of home recorders. In truth, Hall-effect heads did become popular, but only for credit-card readers and similar non-audio applications. I've never

pursued the matter to find out where I went wrong, but I certainly proved to myself that a *little* technical knowledge can be terribly misleading.

On the other hand, I correctly predicted that the well-publicized and well-promoted Elcassette-tape format would fail. The projected audience were those who found open-reel tapes too inconvenient and regular cassettes too low in fidelity. It was clear to me—if not to the manufacturers—that the targeted market was just too small. The Elcassette turned out to be a very expensive fiasco for a number of major Japanese recorder and tape manufacturers.

At the press conference where Sony introduced their *Walkman* format, I judged it an instant winner based on the excited "Oh wow!" reactions of the normally blase magazine editors that were present. And it didn't hurt the *Walkman's* sales that at about the time it was introduced, pre-recorded cassettes were on the verge of outselling LP's.

### The Japanese influence

There are several factors, aside from the particular technologies involved, that make it difficult to

Get A Complete Course In

## ELECTRONIC ENGINEERING

8 volumes, over 2000 pages, including all necessary math and physics. 29 examinations to help you gauge your personal progress. A truly great learning experience.

Prepare now to take advantage of the growing demand for people able to work at the engineering level.

Ask for our brochure giving complete details of content. Use your free information card number, or write us directly. **\$99.95**, Postage Included. Satisfaction guaranteed or money refunded.



**Banner  
Technical  
Books, Inc.**

1203 Grant Ave.  
Rockford, IL 61103

CIRCLE 190 ON FREE INFORMATION CARD

## ATTENTION! ELECTRONICS TECHNICIANS

EARN YOUR  
**B.S.E.E.  
DEGREE**

THROUGH HOME STUDY

Our New and Highly Effective Advanced-Placement Program for experienced Electronic Technicians grants credit for previous Schooling and Professional Experience, and can greatly reduce the time required to complete Program and reach graduation. No residence schooling required for qualified Electronic Technicians. Through this Special Program you can pull all of the loose ends of your electronics background together and earn your B.S.E.E. Degree. Upgrade your status and pay to the Engineering Level. Advance Rapidly! Many finish in 12 months or less. Students and graduates in all 50 States and throughout the World. Established Over 40 Years! Write for free Descriptive Literature.

**COOK'S INSTITUTE  
OF ELECTRONICS ENGINEERING**



4251 CYPRESS DRIVE  
JACKSON, MISSISSIPPI 39212

CIRCLE 58 ON FREE INFORMATION CARD

predict the success or failure of Japanese audio innovations. For example, their marketing plans in the U.S. are sometimes inappropriately based on early enthusiastic reactions in Japan. And when things do not go according to plan, Japanese companies will usually persist in their marketing efforts long after the usual U.S. company would have thrown in the towel. Sources of capital in Japan are much more supportive than in the U.S., and the tendency is to invest for the long haul rather than fast return for stockholders. In that regard, it's instructive to contrast RCA's videodisc pullout with JVC's continuing support of their VHD disc format in Japan and Pioneer's ongoing backing of the *LaserDisc* both here and in Japan.

The Japanese tendency to support a format or product, despite disappointing initial sales, sometimes appears to be based on ego or face-saving, and at other times is the direct result of their enlightened business/social philosophy. For example, when times are rough, the upper executives of major Japanese companies are likely to take a salary cut and reduce profit margins—sometimes to the break-even level or below—in order to avoid layoffs and keep the factory wheels turning. How un-American can you get!

### The CD situation

During a series of annual-trips to Japan, I had an opportunity to closely monitor the technical development of the compact-disc format from its very beginnings. I was terribly impressed both by the complexity of the technology and by the sonic potential. But I felt that the format was inherently too expensive to be widely popular and that the price of CD units would not readily come down because of the astronomical development costs.

I guessed that perhaps 50,000 machines would be snapped up by those well-heeled first-on-the-block U.S. buyers who will go for any new and apparently improved format. But after the supply caught up with the initial demand, I expected sales to plummet—and then take considerable time to recover. I was right about the

post-50,000 depression, but I was very wrong about the recovery time. I forgot that Japanese companies are willing to go for the long haul, operating from the supportive ground rules previously mentioned.

As soon as player sales began to fall, so did the prices. And obviously when a CD player is available for a price that's the same or lower than that of a reasonable turntable and phono cartridge, then a new and larger group of mainstream audio consumers will become instantly interested in the product. However, after that new group is saturated, and the initial 50,000 have traded in their first players for new and improved high-end models, I see another slowdown in CD-player sales, perhaps occurring as you read this. CD sales are still being moderated by the relatively high cost of discs, and the hard-to-face fact that the general public is not terribly concerned with ultimate sonic quality.

Consider this: Several years ago, prerecorded-cassette sales for the first time exceeded those of LP's, even though most LP's had better fidelity and lower noise than cassettes. To me that meant that the major concern of the mass consumers of music were convenience and durability, *not* fidelity. If I'm right, that will certainly have bearing on the progress of the CD format. Automobile CD players won't make it since they are less convenient than cassettes, and the sonic virtues of a CD will almost all be obscured by road noise. In fact, the wide dynamic range of CD is an annoyance rather than an advantage in a car. (Soft passages will be lost in the road noise unless the volume is turned up, in which case the loud passages will be *much* too loud.) If I'm right about the importance of the convenience factor, cassettes will continue to win out for car use.

### The DAT dilemma

Here's a chance to really stick my neck out. It seems to me that the new Digital Audio Tape (DAT) format is a technological tour-de-force that is the answer to a question no one has asked. When DAT finally comes to market, I expect



that—at best—it will go through the same 50,000 sales and subsequent plummet experienced by CD's. But unlike CD's, I don't expect a strong recovery even if the price comes down, simply because the mainstream audio consumers won't be sufficiently interested to stimulate demand.

And, if I'm right about convenience being a stronger buying motivation for the mass market than fidelity, DAT has no advantage over cassettes except its near-instant program access and a somewhat longer playing time. Offsetting that small advantage is the fact that prerecorded DAT tapes in automobile use will suffer from the same excessive dynamics as CD's, unless the player manufacturers provide built-in switchable compression circuits.

Today it's possible to copy a CD with sufficient fidelity on a top-model cassette deck that even an audiophile would have difficulty telling the dub from the original during playback. Given that fact, I think that it's going to be very difficult to convince even sound-conscious consumers that the extra cost of the DAT format buys advantages they simply *must* have. It seems to me that the major accomplishment of the Japanese in introducing the DAT format has been to confuse the high-end CD and cassette marketplace. In light of all that, the current brouhaha about the installation of copy-prevention circuits in DAT machines is pure silliness.

A year from now, or less, we will all know to what extent I'm right, or wrong!  
R-E

## LETTERS

*continued from page 18*

### SPEAKER REPAIR

I'd like to pass along a tip on an area of audio electronics that is seldom touched—fixing tears and holes in old-fashioned paper-cone speakers.

If the damage is on the flat area of the cone, try coating the rip with black nail polish about ¼ to ½ inch to each side. Place a piece of single-ply tissue, trimmed to size, over the area. Then give another coating of nail polish, extending at least ¼ inch beyond the edges of the tissue. Let it dry thoroughly before sending the driver a signal.

Of course, if the corrugated suspension has been torn, that won't do, since it must remain flexible. In that case, cover the damage with a generous coating of rubber cement. Again, let it dry completely before cranking the tunes.

MATT ION

*Vancouver, BC*

### A WELCOME ADDITION

I am delighted to find that Don Lancaster has become one of your regular contributors. I've been a fan of his since I discovered his book *The TTL Cookbook*.

He manages to inject an invigorating irreverence into his work, without the "here's how to steal

from the phone company" stuff that seems so prevalent today. I'm glad to find Don among your editorial ranks.

ART HANSEN

*Oak Park, IL*

### SURFACE-MOUNT COMPONENTS SERVICING

I've owned an electronics-service business for many years, and I've adjusted to the changes in technology from the days of tube sets to today's microprocessors. But there is one horror that I really fear—the repair of circuits using Surface Mount Components.

After some nightmare experiences with products using that technology, I refuse to service anything that uses them anymore. If it gets to the point where everything is using them, I'll get out of the business.

Those components have no lead slack. They cannot tolerate circuit-board flexing as lead components can. That will lead to a new batch of intermittent problems—the worst type of service problem. I've spent many hours trying to track down intermittent problems caused by those little monsters, and, in every case, it was a separation—invisible to the naked eye—of the end of the component from its tab.

JOHN AUGUSTINE

*Reading, PA*

R-E

# ELECTRONIC COMPONENTS CATALOG

yours **FREE**  
by dialing

**1-800-992-9943**

In Texas: 1-800-346-6687

Call Today for your **FREE** subscription to the 1988 Mouser Electronics Catalog. Contains 176 pages featuring over 16,000 in-stock, quality electronic components.

..PLUS..Mouser's proven service and prompt delivery.

(Outside U.S.A., Send \$2.)



**MOUSER ELECTRONICS**

2401 Hwy 287 North  
Mansfield, Texas 76063

**DISTRIBUTION CENTERS NATIONWIDE**

CIRCLE 117 ON FREE INFORMATION CARD

## CONVERTERS & CABLE DECODERS

INFORMATION  
**402-554-0417**  
Orders & Free Catalog  
**1-800-624-1150**

ALL PRODUCTS GUARANTEED

New Stargate 2000	\$99.00
SB-3/2.....	\$89.00
Tri-Bi Mode.....	\$99.00
Hamlin MLD-1200.....	\$100.00
Oak N-12 W/V.S.....	\$99.00
Panasonic.....	\$99.00
Oak-M-35-B W/V.S.....	\$100.00
Zenith SSAVI.....	\$185.00
Eagle PD-3.....	\$110.00
Scientific Atlanta.....	\$120.00
Pioneer W/ Parental.....	\$105.00
Tocom.....	Call
Oak N-12 W/ Auto.....	\$140.00
Evaluator Tap Detector..	\$495.00
ViewStar Volume+.....	\$129.95
Jerrold Starcom CSV....	\$139.95

**M.D. ELECTRONICS**  
**5078 SO. 108th**  
**SUITE 115MD**  
**OMAHA, NE. 68137**

CIRCLE 53 ON FREE INFORMATION CARD

MAY 1988

# COMMUNICATIONS CORNER



HERB FRIEDMAN,  
COMMUNICATIONS EDITOR

## When a shield isn't a shield

WHETHER WE'RE DEALING WITH DIGITAL or analog circuits, shielding often seems to resemble a kind of magical force that works in its own mysterious way. Quite possibly, had electronics existed back in the days of the Salem witchcraft trials, Cotton Mather would have condemned a piece of metal to be dunked in the river until drowned.

My first introduction to the mysteries of shielding came about with the introduction of the aluminum chassis and cabinet. Prior to aluminum, all audio circuits were assembled on and/or in an iron or steel chassis or enclosure because iron was a magnetic shield. It kept the 60-Hz hum radiated by adjacent powerlines from entering the unshielded wires that interconnected the high-impedance vacuum-tube audio circuits. Quite often, it was necessary to place an iron shield between a power transformer and audio-circuit wiring in order to "shield" the wiring from the transformer's radiated hum field.

I have no idea how many Greenlee punches I wore out punching socket holes in No. 16- and 18-gauge steel chassis and cabinets, but I do remember much of my allowance being spent on Greenlee punches.

I think it was out of pure desperation—meaning I had run out of funds for Greenlee punches—that I built a tubed dynamic noise suppressor on an aluminum chassis and used an aluminum cabinet (I think it was a Budd *Minibox*). Wonders of wonders: the Sun did not stand still, rivers did not stop flowing, and the multi-tubed project (it



FIG. 1

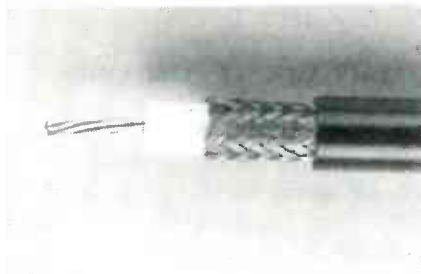

FIG. 2

seemed more as if it were megatubed) worked without any hum. I don't think I ever built another project on, or in, iron or steel again, although I have used iron as transformer shields, just as I have used aluminum for transformer shields. But regardless what I used for the chassis, the one thing I did know was that the entire circuit had to be shielded. If I left off a chassis bottom plate, and the project wasn't *totally* shielded, I was just asking for hum or RF-radiation problems.

### Percentage shielding

On the other hand, I have had more than my share of troubles with "total" transmission-line shields that weren't. When I first

started out in electronics, the metal braid of any kind of shielded wire—audio, RF, powerline, whatever—was wound so tightly around the center conductor that I remember having to pick away at the shielding braid for what seemed like hours in order to make a "shield pigtail" for circuit or socket connections. The magic number that sticks in my mind was 95%. In other words, as I understand it (and I'm certain someone will write in with a college-level thesis on why I am wrong), the shield could reduce radiation into or out of the center conductor by 95%. (As I recall, the surplus military cables used by my first employers were rated at almost 100% shielding; 95% was the minimum acceptable value for non-military industrial shielded cable.)

When I got into both SWL and amateur radio I discovered that some of my antenna systems were fantastic, while others of the exact same design suffered from local noise pickup on reception, or radiated RF from what was supposed to be a "flat" (non-radiating) transmission line.

In virtually every instance the problem was traced to a manufacturer's greed. In order to undersell their competition, some manufacturers were reducing the number of strands in the shield wrap, or stretching the wrap, actually creating "holes" in the shield through which energy could radiate into or out of the center conductor. An example of "stretched" shielding is shown in Fig. 1. Use that stuff for a high-impedance audio signal running adjacent to, or through a

powerful 60-Hz field, and I will guarantee the signal will pick up hum. Similarly, if used as an antenna's transmission line, and you run the cable through a strong RFI or EMI field, I'll give you an odds-on bet that you'll hear interference you never expected.

### Keep it tight

In many instances, it doesn't matter what kind of metal the braid is made of as long as it is tightly wound. For example, Fig. 2 shows the new Radio Shack coaxial cable, which is rated for at least 95% shielding. Notice that you cannot see the insulation under the braid, which is probably the best visual test you can make on any kind of shielded cable. Comparing Fig. 2 with Fig. 1 gives you a good idea of what to look for as far as the shield itself is concerned. (In fact, much professional shielded audio cable no longer uses braid at all. Instead, the shield is actually a wrapped foil with a drain wire running its entire length.)

A tight braid is particularly important when handling digital signals. You've probably experienced the RF interference on a radio or telephone that is in close proximity to a personal computer. Those of you who have a short-wave receiver may have experienced RFI from a computer in the next house. Often, the interference is caused by RFI leaking through "shielded" cables.

The RFI is created because digital signals are squarewaves, and squarewaves generate at least five harmonics if they're to retain their square shape. Let's assume that you have an early computer having a slow clock of approximately 2 MHz. Since the clock signal is a square wave, you really are generating strong harmonics up to at least 10 MHz. If any of it radiates into a shielded wire that leads from the computer to a peripheral, and the shield isn't too efficient or if the braid is stretched, the RF is going to radiate right through the shield just as if it were broadcast by an antenna. R-E

# Be an FCC LICENSED ELECTRONIC TECHNICIAN!

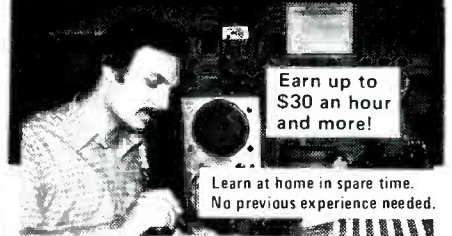

Earn up to \$30 an hour and more!

Learn at home in spare time. No previous experience needed.

No costly school. No commuting to class. The Original Home-Study course prepares you for the "FCC Commercial Radiotelephone License". This valuable license is your "ticket" to thousands of exciting jobs in Communications, Radio-TV, Microwave, Computers, Radar, Avionics and more! You don't need a college degree to qualify, but you do need an FCC License.

**No Need to Quit Your Job or Go To School**  
This proven course is easy, fast and low cost! **GUARANTEED PASS** - You get your FCC License or money refunded. **Send for FREE facts now. MAIL COUPON TODAY!**

### COMMAND PRODUCTIONS

FCC LICENSE TRAINING, Dept 90  
P.O. Box 2223, San Francisco, CA 94126

Please rush **FREE** details immediately!

NAME \_\_\_\_\_  
ADDRESS \_\_\_\_\_  
CITY \_\_\_\_\_ STATE \_\_\_\_\_ ZIP \_\_\_\_\_

### How to live with someone who's living with cancer.

When one person gets cancer, everyone in the family suffers.

Nobody knows better than we do how much help and understanding is needed. That's why our service and rehabilitation programs emphasize the whole family, not just the cancer patient.

Among our regular services we provide information and guidance to patients and families, transport patients to and from treatment, supply home care items and assist patients in their return to everyday life.

Life is what concerns us. The life of cancer patients. The lives of their families. So you can see we are even more than the research organization we are so well known to be.

No one faces cancer alone.  
AMERICAN CANCER SOCIETY

Technicians,  
Get Serious  
About Your  
Profession



Being a certified electronics technician lets people know that you are a professional in your field. It tells them that you are serious about your work and can perform up to CET standards.

Now you can order the "Study Guide for the Associate-Level CET Test" from the International Society of Certified Electronics Technicians. It includes material covering the most often missed questions on the Associate CET exam. 8 1/2" x 11", paperback, 60 pages.

For More Information Contact:

IS CET, 2708 W. Berry, Fort Worth, TX 76109; (817) 921-9101

NAME \_\_\_\_\_  
ADDRESS \_\_\_\_\_  
CITY \_\_\_\_\_ STATE \_\_\_\_\_  
ZIP \_\_\_\_\_

\_\_\_\_\_ copies @ \$5 (+ \$1 postage.)

\_\_\_\_\_ send material about IS CET and becoming certified.

## At KELVIN... Price, Service & Quality for over 42 years.

B & K · FLUKE · UNGAR  
HITACHI · WELLER  
BECKMAN · DREMEL  
STANLEY · MAKITA  
X-ACTO · KEPRO · XCELITE



LISA HADAR  
EXECUTIVE VP, CPA

### METERS/OSCILLOSCOPES

B & K	2120	20Mhz Dual Trace	\$ 375 *
Beckman	9020	20Mhz Dual Trace	425
Hitachi	V212	20Mhz	\$365
Fluke	73	3 1/2" Digit DMM	SPECIAL
Fluke	75	3 1/2" Digit DMM	
Fluke	77	3 1/2" Digit DMM	

\*PLUS Shipping & Insurance. Prices subject to change without notice.

WE HAVE IT ALL...

• COMPONENTS • TOOLS • KITS • SECURITY • SEMI-CONDUCTORS • ELECTRICAL SUPPLIES • SOLDER EQUIPMENT • KELVIN KITS • TSM KITS • DRAFTING SUPPLIES

Volume Quotes, Industrial & School Bids Welcome.

ORDER TOLL FREE FOR INQUIRES & N.Y.S.  
1-800-645-9212 516-349-7620

## KELVIN ELECTRONICS

NEW ADDRESS:

7 Fairchild Avenue • Plainview, NY 11803 • FAX: 516-349-7830

VISA/MASTER CARD ACCEPTED

CIRCLE 195 ON FREE INFORMATION CARD

MAY 1988

81

## REACTS

*continued from page 55*

though, we must have a programming language.

One of the simplest and most universal languages is BASIC. A version of BASIC called ZBASIC is available from the Supplier listed in the Sources box. If you have programmed with BASIC in the past, you'll have no trouble at all using ZBASIC. The ZBASIC language is especially geared for use in a process-control environment.

For most applications, ZBASIC should suffice; however, if more speed is needed, you may want to consider purchasing a C compiler and/or Z80 assembler and linker for use with the REACTS system. Those, too, are available from supplier listed in the Sources box. If you are using an IBM machine, or a compatible, you can get the software on a 5¼-inch floppy and download it from the computer to REACTS. If you do not have access to an IBM PC (or compatible), you can purchase the software on 32K PROM's. The PROM's can either be loaded into the PROM programmer, and the software can be loaded from there, or they can be mounted in the PROM/RAM module and accessed. Because of the much greater speed of the PROM/RAM drives, even if you purchase your software in floppy format, you may want to eventually burn the software onto PROM's and place them in the PROM/RAM module as a PROM drive.

### Coming soon

Now that we have built the two modules necessary for program development, we are ready to start building more of the actual process-control modules. The particular application will determine the types of process control modules you will need. That is, not all of the modules discussed and constructed in the months to come will be required for every application. You only build the modules that you need. We'll also be building some support modules, including a dedicated CRT-terminal/printer-interface module, and the previously promised battery-backed-up switching power supply.

Next time, we'll look at a universal input/output module. **R-E**



**DECODE NEARLY ANY SINGLE LEVEL GATED PULSE SIGNAL.** New circuit works with Hamlin, Jerrold, Sylvania, and Eagle systems. Decodes In-band, Out-band, AM or FM reference. Complete educational kit including P.C. board, parts, case, and 40 page gated pulse theory booklet is only **\$47.00** plus **\$3.00** shipping. Order no. 1PFD-1K. **ELEPHANT ELECTRONICS INC. P.O. Box 41865-R, Phoenix, AZ 85080. (602) 581-1973**

**CIRCLE 120 ON FREE INFORMATION CARD**

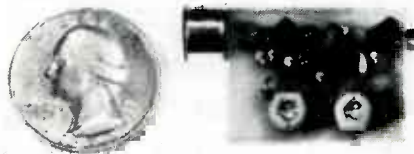

**SIMPLY SNAP THE WAT-50 MINIATURE FM TRANSMITTER** on top of a 9v battery and hear every sound in an entire house up to 1 mile away! Adjustable from 70-130 MHz. Use with any FM radio. Complete kit **\$29.95** + **\$1.50** S + H. Free shipping on 2 or more! COD add \$4. Call or send VISA, MC, MO. **DECO INDUSTRIES, Box 607, Bedford Hills, NY 10507. (914) 232-3878.**

**CIRCLE 127 ON FREE INFORMATION CARD**



**APPLIANCE REPAIR HANDBOOKS—13** volumes by service experts; easy-to-understand diagrams, illustrations. For major appliances (air conditioners, refrigerators, washers, dryers, microwaves, etc.), elec. housewares, personal-care appliances. Basics of solid state, setting up shop, test instruments. **\$2.65 to \$5.90 each.** Free brochure. **APPLIANCE SERVICE, P.O. Box 789, Lombard, IL 60148. (312) 932-9550.**

**CIRCLE 84 ON FREE INFORMATION CARD**

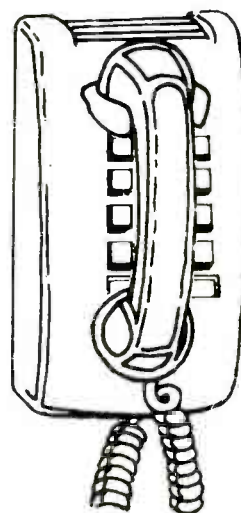

## CALL NOW AND RESERVE YOUR SPACE

- 6 x rate \$815.00 per each insertion.
- Fast reader service cycle.
- Short lead time for the placement of ads.
- We typeset and layout the ad at no additional charge.

Call **516-293-3000** to reserve space. Ask for Arline Fishman. Limited number of pages available. Mail materials to: mini-ADS, RADIO-ELECTRONICS, 500-B Bi-County Blvd., Farmingdale, NY 11735.

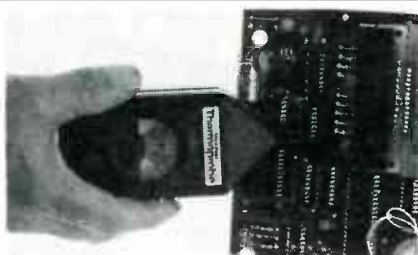

**THERMOPROBE—QUICKLY IDENTIFIES DEAD PC BOARD COMPONENTS.** Locates dead resistors, transistors, IC's, diodes, and transformers without direct contact, in seconds. Operating active components radiate heat, dead components don't. **Thermoprobe** is sensitive to 1/25°F change in temperature. A must for your workbench or field service. Order #209TM. ONLY **\$24.99** + \$3.50 shipping, NY Res. add tax (no COD's). **BUYUS, INC., Dept. RE588 10 White Birch Dr., Ossining, NY 10562, Visa or Mastercard (914) 762-4799.**

**CIRCLE 194 ON FREE INFORMATION CARD**

# Radio-Electronics mini-ADS

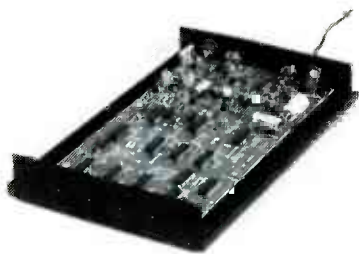

**TRI-MODE DESCRAMBLER PARTS** Original parts as called up in Radio Electronics Feb 1987 article on tri-mode descrambling. Includes pc board, ac adaptor, resistors, capacitors, diodes, pots, transistors, IC's, LED's, toko coil and Plessey SAW filter. Article included. **\$59 plus \$2.50 shipping. ELECTRONIC PARTS, Box 276, Alburt, VT 05440 (514) 739-9328.**

CIRCLE 80 ON FREE INFORMATION CARD



**FREE CATALOG OF HARD-TO-FIND TOOLS** is packed with more than 2000 quality items. Your single source for precision tools used by electronic technicians, engineers, instrument mechanics, schools, laboratories and government agencies. Also contains Jensen's line of more than 40 tool kits. Send for your free copy today! **JENSEN TOOLS INC., 7815 46th St., Phoenix, AZ 85044. (602) 968-6231.**

CIRCLE 115 ON FREE INFORMATION CARD

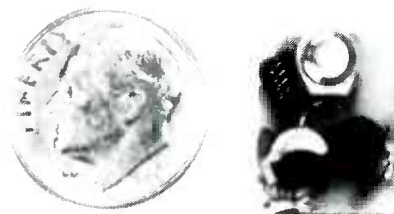

**THE MODEL WTT-20 IS ONLY THE SIZE OF A DIME**, yet transmits both sides of a telephone conversation to any FM radio with crystal clarity. Telephone line powered - never needs a battery! Up to 1/4 mile range. Adjustable from 70-130 MHz. Complete kit **\$29.95 + \$1.50 S+H.** Free Shipping on 2 or more! COD add \$4. Call or send VISA, MC, MO. **DECO INDUSTRIES, Box 607, Bedford Hills, NY 10507. (914) 232-3878.**

CIRCLE 127 ON FREE INFORMATION CARD

## CALL NOW AND RESERVE YOUR SPACE

- 6 x rate \$815.00 per each insertion.
- Fast reader service cycle.
- Short lead time for the placement of ads.
- We typeset and layout the ad at no additional charge.

Call **516-293-3000** to reserve space. Ask for Arline Fishman. Limited number of pages available. Mail materials to: mini-ADS, RADIO-ELECTRONICS, 500-B Bi-County Blvd., Farmingdale, NY 11735.



**ZENITH SSAVI UHF** input from \$169, ch. 3 input \$229, reconditioned. UHF SSAVI project handbook \$6.50 ppd. Used Sylvania 4040s \$169. N-12s & MLD-1200s. Converters, amplifiers & accessories. Satellite systems. Radar speed guns for car/boat racing, bowling, skiing, baseball, etc., from \$275 used. Professional police models. Multi-line business telephone systems from \$1395. Catalog \$1. **AIS SATELLITE, INC., P.O. Box 1226-RE, Dublin, PA 18917. 215-453-1400 or 215-249-9411.**

CIRCLE 81 ON FREE INFORMATION CARD



**DEC. R-E ARTICLE ON MACRO SCRUBBER**, the original parts as mentioned MAK-1. All components shown on parts list and much more. Silk screened and etched P.C. board, power supply, IC sockets, precut jumpers, power jack, plug and pre-drilled enclosure. **\$52.95 & 3.00 S/H.** Order today from: **THE HOBBY HELPER, P.O. Box 308, Bridgewater, MA 02324, or call (617) 339-1026. Visa/MC accepted.**

CIRCLE 70 ON FREE INFORMATION CARD



**FREE TOOL & INSTRUMENT CATALOG.** The 1988 General Catalog contains 116 pages of test instruments, precision hand tools, tool cases, soldering equipment and much more. Over 5,000 quality products for testing, repairing and assembling electronic equipment are shown in full color with detailed descriptions, pricing and a 100% satisfaction guarantee. **CONTACT EAST, P.O. Box 786, No. Andover, MA 01845. Call (800)-225-5370 or in MA (617)-782-2000.**

CIRCLE 55 ON FREE INFORMATION CARD

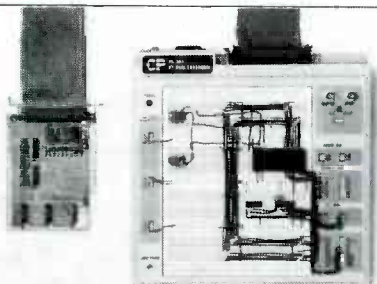

**PC-601 XT BUS EXTENDER BREADBOARD LAB** connects to any IBM PC compatible computer and extends all PC electrical bus connections out to the PC-601 for easy circuit prototype connection, testing and trouble-shooting. Includes large 3060 tie-point breadboard,  $\pm 5V$  and  $\pm 12Vdc$  AC line powered power supplies. Includes buffer card, 2' ribbon cable & 1-Year warranty. Price: **\$369.95 CHENESKO PRODUCTS, 21 Maple St., Centereach, NY 11720. 516-736-7977, Fax: 516-732-4650**

CIRCLE 193 ON FREE INFORMATION CARD



**PANASONIC CABLE CONVERTERS**, Wholesale and Retail. Scientific Atlanta and Pioneer Cable Converters in stock. Panasonic model 140N 68 channel converter **\$79.95**, Panasonic Amplified Video Control Switch Model VCS-1 **\$59.95**. Scientific Atlanta Brand new Model #8528 550MHZ 80 Channels Converter **\$89.95**. Video Corrector (MACRO, COPYGUARD, DIGITAL) ENHANCER **\$89.95**. We ship to Puerto Rico, Caribbean countries, & So. Amer. Write or call **BLUE STAR IND., 4712 AVE. N, Dept 105, Brooklyn, NY 11234. Phone (718) 258-9495.**

CIRCLE 85 ON FREE INFORMATION CARD

# R-E Service Admart

**Rates:** Ads are 2 1/4" x 2 7/8". **One** insertion \$825. **Six** insertions \$800 each. **Twelve** insertions \$775. each. Closing date same as regular rate card. Send order with remittance to **Service Admart**, Radio-Electronics Magazine, 500-B Bi-County Blvd., Farmingdale, NY 11735. Direct telephone inquiries to Arline Fishman, area code-516-293-3000. **Only 100% Service ads are accepted for this Admart.**

## VCR MAINTENANCE AND REPAIR ON VIDEO TAPE

There is no other tape like ours on the market.

Learn how to clean the entire tape path as well as replace the belts in any VCR. You need no special schooling or tools to perform the simple task shown on our video. **To save time and money on your VCR repairs, order your tape NOW!**

**Price \$32.95**

**Simply call:**

**(513) 548-6113**

**MASTER CARD**

**and VISA are**

**accepted.**

**UCANDO**



**VCR EDUCATIONAL PRODUCTS CO.**

**BOX 386**

**GREENVILLE, OHIO 45331**

## ELEVEN-PIECE RATCHET TOOL KIT



Includes reversible ratchet handle, extension bar, six bits, two precision screwdrivers, and a cutter. Comes in fitted case. Get one for your shop, another for your car, another for your tool kit. To order **send \$10.00 plus \$1.75 for shipping** in the U.S. to **Electronic Technology Today Inc., P.O. Box 240, Massapequa Park, NY 11762-0240.**

## POCKET BATTERY TESTER



Tests all 1.5-volt cells including A, AA, AAA, C, and D. Also checks miniature watch and calculator batteries. Special side connector provides rapid check of square 9-volt batteries. Positive meter reading shows "GOOD, LOW, REPLACE". **\$6.00 each. Two for \$10.00.** Add \$1.75 for UPS. Send check to **Electronic Technology Today Inc., P.O. Box 240, Massapequa Park, NY 11762.**

CIRCLE 204 ON FREE INFORMATION CARD

## USING THE RE-BBS

To access the RE-BBS, you need a personal computer and a modem capable of communicating at 300 or 1200 baud. Set the modem for 8 data bits, 1 stop bit, and no parity. (Other formats will work, but you may be unable to upload and download files.) You'll also need a communications program that runs on your computer and can control your modem. If you have an IBM-PC and a modem, but no communications program, get a friend to download the QMODEM.ARC file for you. It contains a user-supported communications program and complete documentation.

The BBS runs 24 hours a day, seven days a week. To sign on the first time, dial 516-293-2283. If your system is working properly, you'll be presented with an identifying message. Type in the requested information. At that point you'll be able to access some, but not all of the BBS. After the Sysop verifies your account, you'll be able to access all relevant areas of the BBS.

You can do several things on the RE-BBS: send and receive messages, and upload and download files. Sending messages is simple, and only requires you to type at your keyboard. Receiving messages is also simple, but to save messages, your communications program must allow you to set up a capture buffer.

Uploading and downloading files is easy after you get the hang of it; just follow directions, and remember always to start the transmitter before starting the receiver—which ever end is transmitting or receiving.

Because of our background and interests, the RE-BBS will be oriented toward IBM-PC's and compatibles. But you can access the RE-BBS with any computer (or ASCII terminal) and modem, so if your interest lies in Apples, Ataris, Commodores, Sinclairs, etc., feel free to participate. If you have public-domain software of interest to other owners of your type of machine, feel free to upload it. The contents of the BBS will in large part be determined by what you post there, so if you feel your machine is being neglected, do something about it!

On the RE-BBS, any file whose name ends in the three letters ARC is an archive file. An archive file is a group of related files that are collected together and compressed in order to save space and download time. Archive files are

useful only to owners of IBM-PC's or compatibles. You use a program called ARC.EXE to add to, delete or extract from, list the contents of, etc., an archive.

Similar to archive files are library files, which have the file type .LBR (e. g., HIDDEN.LBR). Like archive files, libraries are also composed of compressed, inter-related programs and data files, but they are incompatible with .ARC files. So an additional utility is necessary to process library files; one such utility is LSWEET, for Library SWEEP. Library files are used on both CP/M and IBM BBS's, and versions of LSWEET are available for both types of system. And, although you can unpack a CP/M library file on an IBM-PC, you can't run the .COM files! Nor can you run .COM files from a CP/M library on an IBM!

A method of compressing files is popular on CP/M and some IBM BBS's. On IBM BBS's the file-compression program is usually called SQ.COM (for squeezing) or something similar, and the de-compression program is usually USQ.EXE (for unsqueezing). *SQ and USQ work only on individual files; a squeezed file always has a Q in the second position of the file type (e. g. RIDDLES.TQT). USQ automatically restores the proper file name.*

For maximum flexibility, you'll need copies of ARC.EXE, SQ.COM, USQ.EXE, and LSWEET.EXE. A version of each has been posted on the RE-BBS. If you can't find programs with those exact names, check the directory listing carefully; many of those programs also contain version numbers in their names (e. g., LSWP103.EXE).

A related utility for IBM's, which is based on a popular public-domain CP/M utility, is called PCSWEEP. It allows multi-file copying, deleting, etc. In addition, it can squeeze and unsqueeze files, and process library files. Its biggest limitation is that it can't process archive files.

We've posted much public-domain and user-supported software on the RE-BBS. Feel free to download it and try it out. If you use it, please send the requested donation to the author of the program.

Don't hesitate to upload your own programs, and don't hesitate to participate in the various conferences we've set up. If you're working on a project of general interest, share your thoughts. If you need help—ask!

**RE-BBS**

# COMPUTER DIGEST

VOL. 5 NO. 5

MAY 1988

A NEW KIND OF MAGAZINE FOR ELECTRONICS PROFESSIONALS

## BUILD A DIGITAL IC TESTER

For your Commodore 64

Page 89

A  
HERNSBACK  
PUBLICATION

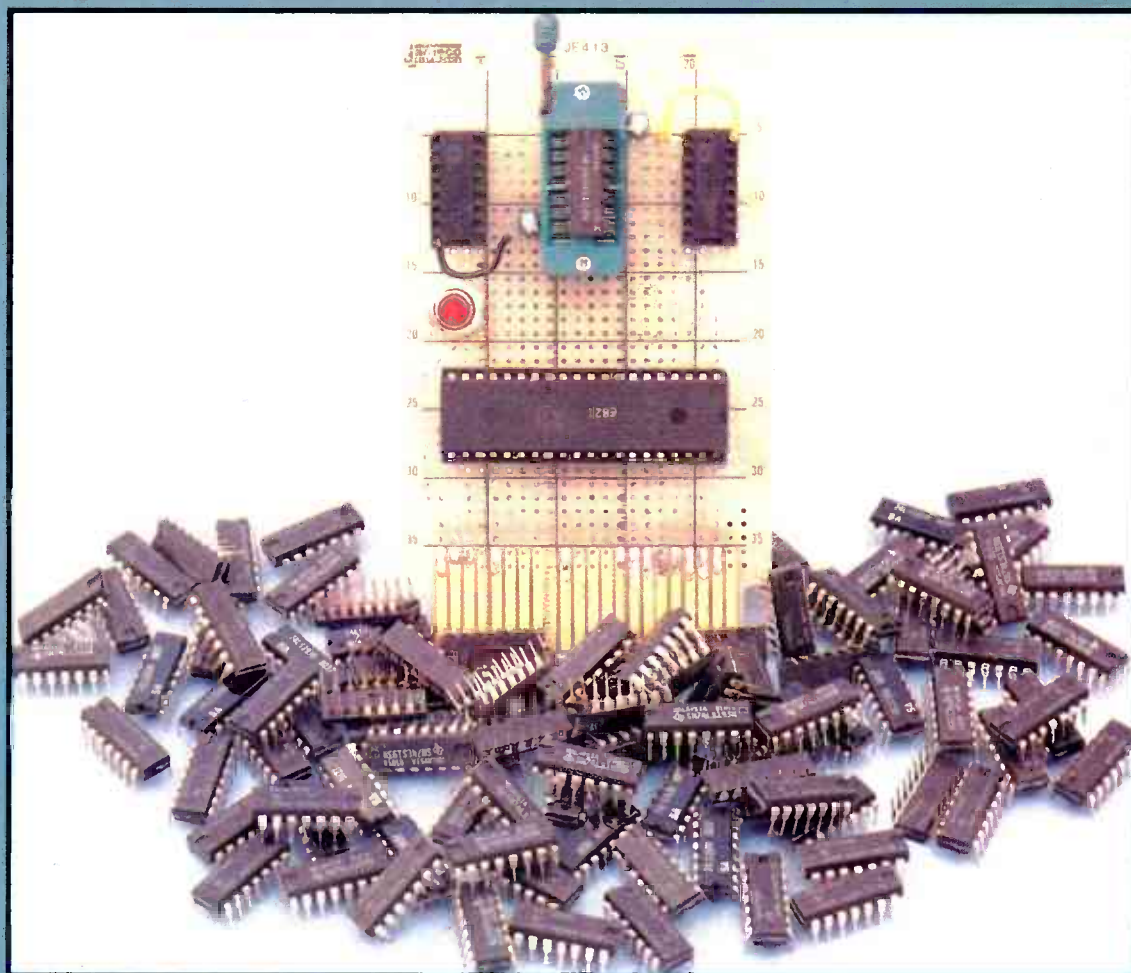

## CD CLASSROOM

Troubleshooting your PT-68K

Page 95

## MULTITASKING

With OS/2, DESQview and TaskView

Page 86

# EDITOR'S WORK- BENCH

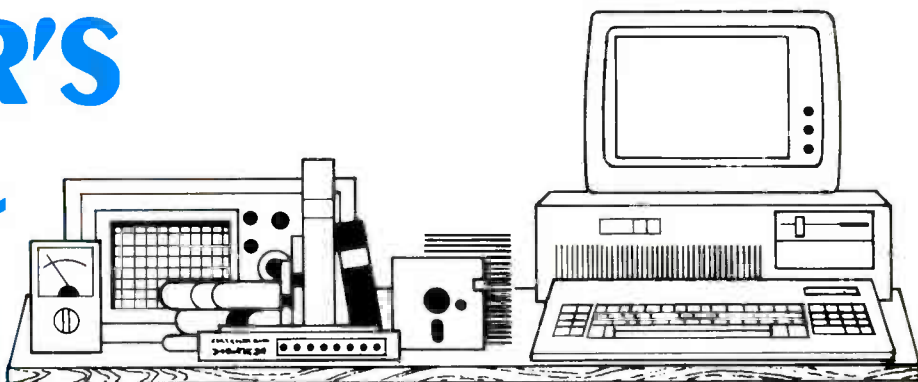

## Multi-tasking with DESQview, TaskView, and OS/2

How do you do two things at once on a PC? You don't—not under DOS anyway. Either get a second PC, or switch to Unix or Xenix.

That used to be true, but not any more. Now there are several ways to get multi-tasking on a PC. DESQview and TaskView allow limited multi-tasking, along with highly useful task swapping; OS/2 allows true multi-tasking.

DESQview and TaskView run on any PC-compatible computer (PC, XT, AT, 80386, or compatible); OS/2 requires an 80286 or 80386 microprocessor that runs in its own address space (i.e., it won't run on most accelerator cards, but see note below), and it requires at least 1.5 megabytes of extended RAM. DESQview and TaskView also function much better with extra RAM, either extended (AT) or expanded (EMS or EEMS).

What's so good about multi-tasking and task swapping? With a large system, you could, for example, sort a database or compile a program in the background while you worked on a spreadsheet or in an editor in the foreground.

With a small system, you could format disks or copy files in the background while you worked in your editor or spreadsheet.

Plain task swapping—wherein the background task does no useful work, and which requires the least hardware investment—can also be highly useful. Suppose you're writing a report and constantly need to refer to data in a spreadsheet. With task swapping, you could switch between the two instantly, without having to quit one application, load the other, quit it, and re-load the first.

### OS/2

For test purposes, IBM's version of OS/2 was installed on an AST Premium/286 (a 10-MHz 0-wait state AT compatible) with 640K of conventional RAM, 1.5M of extended RAM, a 40M hard disk, and a NEC MultiSync monitor and EGA adapter. The operating system was supplied on four high-density (1.44M) 3

1/2 floppy disks; the Premium/286's BIOS directly supports that format, so it was simple to configure the micro disk drive as drive A and run the installation there.

OS/2 comes with an automated installation program that automatically copies the appropriate files—about 2.5 megabytes worth—to your hard disk. In doing so, some of your DOS system files are overwritten, so to run your machine in DOS mode, you'll have to boot from floppy. (Other OEM versions of OS/2, from AST and Zenith, for example, will allow you to choose either DOS or OS/2 when booting.)

OS/2 runs in two modes: OS/2 and DOS compatible. The latter is not an actual copy of DOS, but a compatibility mode, so software incompatibilities are sure to surface. In fact, although we had

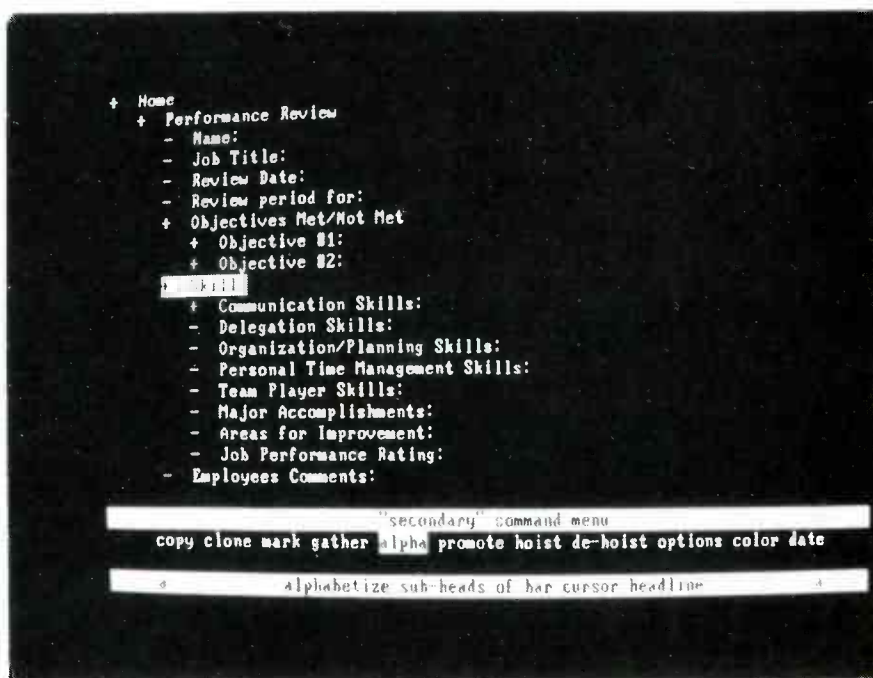

FIG. 1



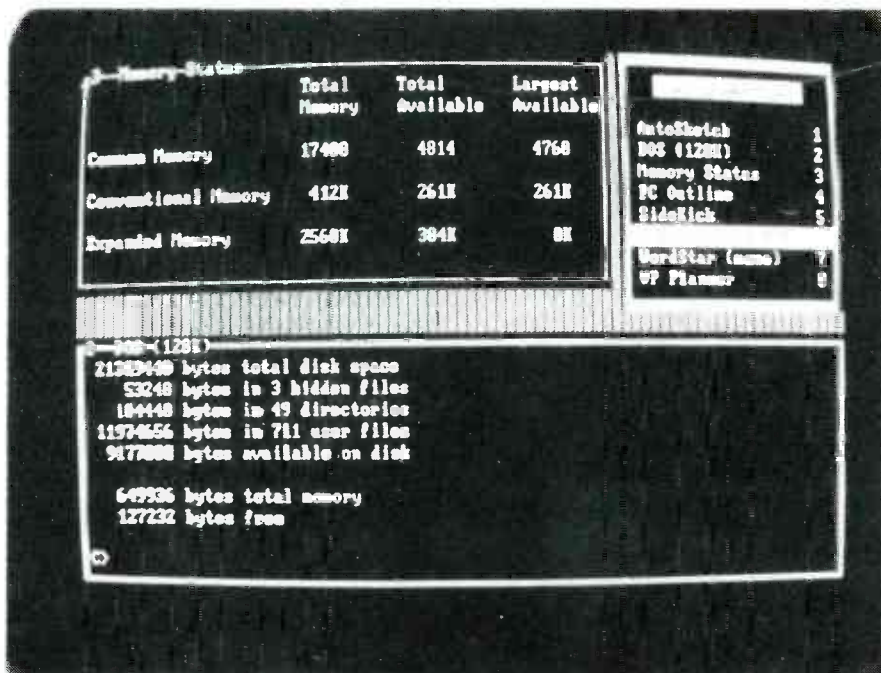

FIG. 2

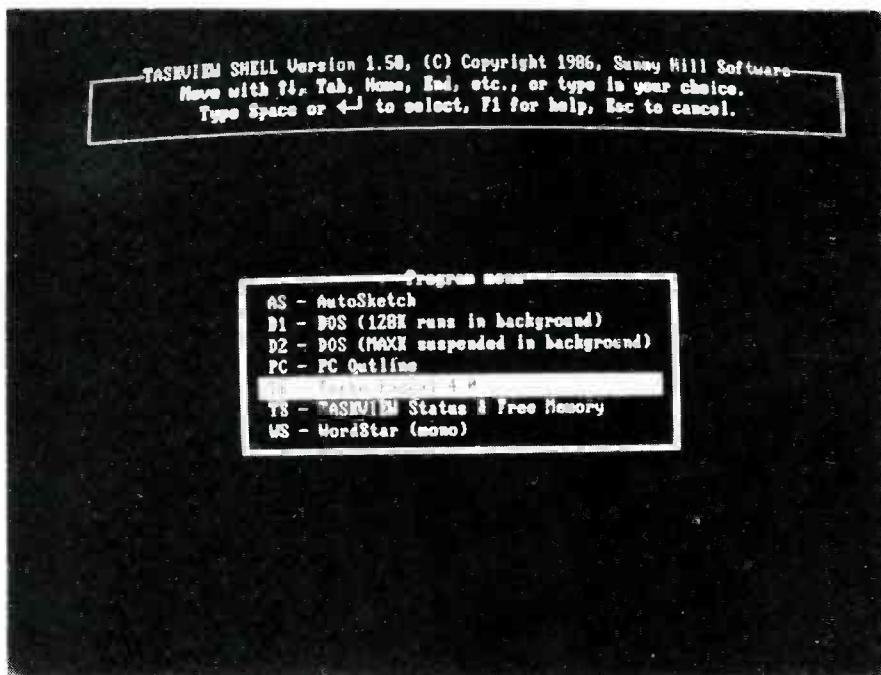

FIG. 3

no trouble running some fairly tough software (Windows 2.0 and PageMaker, among others) the DOS mode repeatedly crashed when bringing up SideKick's calculator. In addition, even with 640K of RAM allocated for the compatibility mode, only about 520K is available for running programs.

Those are not serious problems, because eventually, anyway, you won't run OS/2 for the compatibility box, but for OS/2 applications. However, currently OS/2 is more promise than presence. In fact, as this is written (early February) only one OS/2 application is actually shipping: Living VideoText's excellent outline

processor, ThinkTank. The program is a straight port of the DOS version, and in fact operates identically to it. The OS/2 version doesn't take advantage of any OS/2 features (other than the fact that you can run more than one copy of it at a time). Almost unbelievably, ThinkTank comes with both DOS and OS/2 versions—at no extra cost. See Fig. 1.

When you first start OS/2, you're presented with the Program Selector Screen. There you can start a program running, switch to a currently running program (including the DOS box, as well as one or more copies of the OS/2 command line), add a program to OS/2's list, and obtain

help in the form of a simple tutorial. To save disk space, the tutorial can be deleted later.

After starting a program, you can return to the Program Selector at any time by pressing Ctrl-Esc; you can cycle among currently running programs without going through the Program Selector by pressing Alt-Esc.

At the command line, OS/2 is quite similar to DOS. Nearly all commands function the same in both environments, except that many OS/2 commands provide more powerful options (TYPE \*.TXT, for example).

Both OS/2 and DOS device drivers are specified in the same CONFIG.SYS file, and many more options can be specified in OS/2's CONFIG.SYS file than in DOS's. Many of those options will allow a great deal of customizability for systems integrators when real applications become available.

You can't do much with OS/2 right now. But all major software vendors are scrambling both to port current DOS applications and to write new ones specifically for OS/2. Complicating the scenario (and delaying eventual applications) is the fact that a Windows-like graphical user interface is due to be released sometime this fall. The so-called Presentation Manager (which is reputedly identical to the user interface in Windows 2.0 and Windows/386) provides a completely different programming interface, so it is highly unlikely that we'll see ports of existing applications that run under the Presentation Manager. In fact, new applications must be written from scratch, which is a slow process, due to the complexity of the interface.

IBM and Microsoft are to be commended for introducing OS/2 at this time. Compromises were made (the slow and buggy DOS box, the 32-megabyte file and disk size limit, no inherent 80386 support), but those compromises provide an upgrade path so that current users simply weren't abandoned. We eagerly await the new applications that will justify our patience, and that will, over the next few years, make us regard DOS much as we now regard CP/M: useful in its day, but outmoded by advances in both hardware and software.

As for running OS/2 on an accelerator card, it is claimed that both SOTA Technology's MotherCard 5.0 and Microsoft's much-delayed Mach 20 will run OS/2. We hope to be able to verify those claims next time.

### Multi-tasking today

Don't want to wait for OS/2? With DESQview (shown in Fig. 2) or TaskView (shown in Fig. 3) you'll be able to achieve one of the main benefits of a true multi-tasking operating system: the ability to run several programs simultaneously.

Even without expensive hardware, you can still do task swapping, which can provide a tremendous boost in overall productivity.

Your microprocessor, type(s) of memory, and control software will determine your ability to multi-task and task swap. On an 80386-based machine with several megabytes of memory and a special memory manager that takes advantage of the 80386's ability to re-map physical memory, you can run several very large programs (about 550K each) simultaneously. DESQview's 80386 memory manager is called QEMM; other companies market similar products.

On 80286 and lesser machines with EEMS (Enhanced EMS) or EMS 4.0 memory, you can run several medium-sized programs (about 400K, depending on how your computer's memory is configured) simultaneously.

On 80286 and lesser machines with plain EMS (i.e., version 3.2) memory, extended memory, or no non-DOS memory at all, you can multi-task whatever you can fit into the first 640K of memory. Inactive tasks will be swapped to mass storage: either directly to EMS memory, to a RAM disk in EMS or extended memory, or, with no extra memory, to disk, a relatively slow process that negates most of the advantage of the software.

That's not to imply that you need a huge 80386 system to benefit from DESQview or TaskView; if you can get by with simple task swapping, an inexpensive EMS board is sufficient.

To run either TaskView or DESQview, you'll want to unload all but the basic necessities from your AUTOEXEC.BAT and CONFIG.SYS files. The reason is that the larger the initial chunk of memory you have available after loading DV or TV, the larger will be the largest partition you can allocate.

For example, on a standard IBM PC XT (with a Hercules monochrome adapters) that has about 590K of DOS memory after booting and loading an EMS driver and a mouse driver, the largest DOS partition under DESQview is about 415K. Adding the ability to display text and graphics simultaneously drops that figure to about 400K. On an AT, you can load part of DESQview in extended memory and save an additional 50K or so of memory.

On the other hand, in its default state TaskView uses quite a bit less memory than DESQview—about 100K, leaving about 490K as the largest partition—but TaskView unbundles some features that are standard with DESQview (an auto-dialer, a keyboard macro processor, and better support for graphics programs.) You can also load part of TaskView in expanded memory, leaving a maximum partition of almost 540K.

Both programs allow you to start programs running, switch among them, and

set up special parameters that determine how each program runs (in graphics mode, with direct screen writing, use of a math co-processor, etc.) using several easy to navigate menus. In addition, you can set up TaskView so that you can control operations at the command line, rather than through the menus. On the test system, that left a maximum partition of about 510K.

In a system without EMS memory, you'd want to give serious consideration to mastering command-line operation. At the command line, you can open a program (which loads it and makes it the current program), spawn a program (which loads it and leaves it in the background or swapped to mass storage), and switch to a currently running program using either hotkeys or an executable file. The latter option allows you to use DOS batch files for switching among tasks. The only disadvantage to command-line operation is that you must master use of a number of poorly documented "switches" that specify how a program should run.

TaskView comes with a powerful keyboard macro processor that, in addition to allowing you to create macros, allows you to cut and paste data among programs running in different partitions. Also, a simple cut and paste program that uses less RAM is included.

TaskView's main weakness is difficulty in handling graphics programs. On an EGA, colors aren't always restored right, and on a Hercules monochrome screen, the program has trouble switching between text and graphics modes. However, the company is aware of those problems, and fixes are expected by the time you read this. In addition, new versions of the program that make full use of EMS 4.0 memory and the 386's hardware address-mapping capabilities are also due to be released before you read this.

### DESQview

Quarterdeck Office Systems' DESQview has been on the market quite a bit longer than TaskView, so the company has already been able to meet some of the challenges that TaskView still faces. (Mainly, its graphics handling is impeccable.) DESQview doesn't include a command-line version, and, whereas TaskView can load part of itself only in expanded memory, DESQview can load part of itself only in extended memory. Therefore, an AT is required to get a RAM partition greater than about 420K. On an 80386 system, by adding Quarterdeck's memory manager (QEMM), you can obtain a much larger partition.

In its default configuration, DESQview uses more RAM than TaskView. There are several reasons for that. One is a built-in keyboard macro processor. Also, DESQview provides more of a Windows-

### PRODUCTS REVIEWED

- OS/2, Microsoft Corporation, 16011 NE 36th Way, Box 97017, Redmond, WA 98073-9717.
- DESQview (\$130), Quarterdeck Office Systems, 150 Pico Blvd., Santa Monica, CA 90405 (213) 392-9701.
- TaskView (\$80), Sunny Hill Software, P.O. Box 33711, Seattle, WA 98133-3711 (206) 367-0650.
- ThinkTank (\$195), Living VideoText, 117 Easy Street, Mountain View, CA 94043 (415) 964-6300.

like environment than TaskView; that may or may not be useful to you. For example, you can define a "window" for running each of your applications. As long as your application uses the BIOS for display, it can run in that window.

The problem is that the vast majority of programs do write directly to video memory, so DESQview's windowing capability goes unused. However, some programs can be configured to use the BIOS. WordStar 4.0, for example, can be configured to use BIOS output routines, and when it is, the program runs in a DESQview window nicely. The problem is less severe on 386 machines, again because of hardware re-addressing.

Both TaskView and DESQview contain memory-status programs that show total, used, and unused amounts of various types of memory. DESQview's program is slightly better in that it runs in the background and constantly maintains updated information.

DESQview also includes a DOS services program that aids file and disk maintenance, but it's no match for any half-decent DOS shell. Other desktop accessories are available at extra cost.

Documentation for both products is somewhat problematic; TaskView's manual is brief, and DESQview's manual is poorly organized. To get either program running with your applications, count on spending some time reading and experimenting. As for on-line help, DESQview has a definite advantage.

### Conclusions

I like both programs; choosing between them is difficult, especially because new versions of both will be released soon. DESQview does more hand holding, but uses more memory; TaskView uses less memory, but has problems with graphics. TaskView's cost is about two-thirds that of DESQview, but it only does 90% as much.

If you've run out of room trying to cram RAM-resident programs (SideKick, CED, etc.) in your machine, either TaskView or DESQview can help. You won't gain all the advantages of a true multi-tasking operating system, but both products offer a good interim solution. ▶◀

# DIGITAL IC TESTER An Accessory For Your Commodore 64

Your Commodore C64 computer can pretest digital components.



JIM BARBARELLO

An important part of building a digital project is to make sure that all the active components work properly before they're installed. That is even more critical when you deal with sensitive devices like CMOS integrated circuits. Unfortunately, few of us do pre-installation tests because it's somewhat difficult to routinely test digital devices of any kind. We simply solder the parts into the circuit, cross our fingers, and apply power. If the circuit doesn't work, we poke around until we find the bad part. Then we replace it, hoping we don't damage the PC board, or install another defective component. Clearly, a better way is to test each part (especially IC's) before using it.

If you're fortunate enough to own a Commodore C64 computer you can easily and inexpensively assemble a special kind of tester that will automatically perform up to 100 user-programmed tests on most TTL and CMOS 14- and 16-pin digital IC's; and it is also a simple matter to use the tester to check the switching action of transistors and diodes.

The tester, whose schematic is shown in Fig. 1, is a simple device that actually depends on special software to run the tests. That software allows you to specify how you want a specific TTL or CMOS device tested, and then tests as many units of that device as you like, one after the other, with each complete test taking less than five seconds. If the device doesn't function properly, the software stops the test and tells you specifically how the device failed.

To avoid creating damage where none existed before, the DUT (*Device Under Test*) is installed in a ZIF (*Zero Insertion Force*) socket; a special kind of IC socket that applies virtually no strain or force to the pins of the DUT.

As an added bonus, the tester includes a hardware reset switch (S1) that resets the computer at the push of a button (no more powering down and then up again). No external power supply is required to use the unit because the tester gets its power directly from the computer's expansion port.

## The circuit

As shown in Fig. 1, the tester consists mainly of IC1, a 6821 PIA (*Peripheral Interface Adaptor*), two resistors, and ZIF-socket SO3. In addition, two 16-pin DIP sockets (SO1 and SO2) are used as terminal blocks to apply power to the DUT. Switch S1 connects between the computer's RESET line and ground: pressing S1 brings the RESET line low and restarts the system without actually having to re-power the computer.

PIA IC1 receives its power, timing, addressing, and data from the computer's expansion port. The sixteen individual peripheral lines are programmed as inputs or outputs by software. IC1 is addressed at decimal memory locations 57100 to 57103. Output lines remain in the previously set state until changed. Input lines are not latched, and therefore show the momentary status of any device connected to them.

## Two halves

Since the computer has an 8-bit data bus and the PIA has 16 data lines, the PIA is divided into two halves: side A with PA0-PA7, and side B with PB0-PB7. There are individual control, data direction, and peripheral registers for each side. The control registers allow you to select either the data-direction register (for configuring the peripheral lines as input or output), or the peripheral register (for sending and receiving data). The peripheral registers (when selected as data-direction registers) are located at decimal memory locations 57100 (side A) and 57102 (side B). The control registers are located at 57101 (side A) and 57103 (side B).

## Construction

The tester is assembled on a Jameco JE413 or similar wiring board using wire-wrap connections. Because the edge of the board also serves as plug P1, Fig. 1 shows the connections to both sides of P1 as they actually appear on the board. The half of P1 indicated as TOP are the gold-plated finger connections on the component side of the

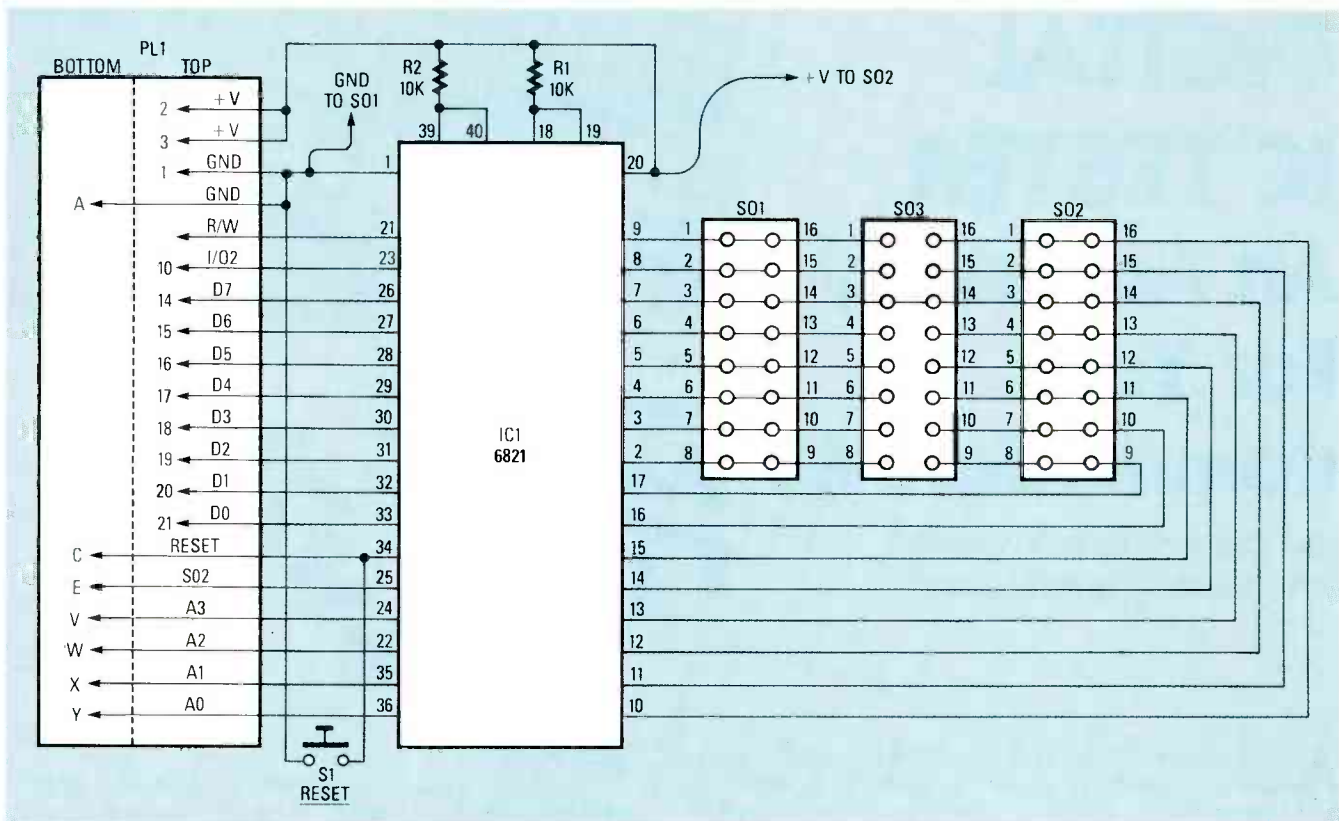

FIG.1—THE SOCKET TERMINALS are specially wired to provide almost automatic selection of the ground and power terminals.

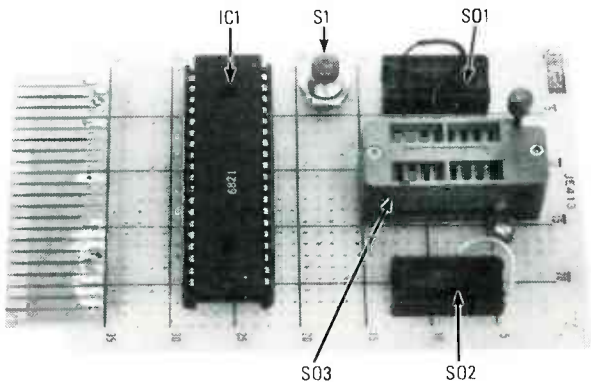

FIG. 2—THE PARTS WILL FIT WITHOUT CROWDING on a Jameco JE413 board. Wire-wrap is used for all connections except those soldered to the fingers.

board. The half of P1 indicated as BOTTOM are the gold-plated finger connections on the wiring side of the board.

However, the connections to both sides of the board are made from the bottom side. The bottom connections have obvious solder pads that extend from the fingers. The connections to the top fingers are made by passing wires through the appropriate holes on the board. Although wire-wrap connections are used to interconnect the components, those to the fingers should be soldered; don't use stake-on or wire-wrap terminals at the fingers.

The general parts layout isn't critical, although operation will be somewhat more convenient if you follow the one shown in Fig. 2. Make certain you install SO3 so that its lever faces the back edge of the board. Drill two 1/8-inch holes near SO1 and SO2 for the power leads.

### Wire across

As shown in Fig. 1, the pins on SO1 and SO2 are wired straight across: pin 1 connects to pin 16, pin 2 connects to pin 15, etc. That is done so you don't have to figure out the convolution of the pins when inserting the +V and ground wires in SO1 and SO2. To determine the power connections to the DUT, simply count from 0-14 or 0-16 starting on either row of pins and you'll automatically end up on the correct connections. (It might appear confusing

### PARTS LIST

R1, R2—10,000-ohms, 1/4-watt, 10%

IC1—6821 PIA (Jameco 68B21)

SO1, SO2—16 pin wire-wrap socket

SO3—16 Pin ZIF socket

S1—Momentary N.O. pushbutton switch

**Miscellaneous:** Wiring board Jameco JE413, No. 24, solid wire (black and red), wire-wrap wire, wire-wrap tool, solder, etc.

**NOTE:** The following are available from J. J. Barbaro, RD#3, Box 241H, Tennent Road, Manalapan, NJ 07726. IC Tester program (No. IC64) on Commodore C64 disk (IC64): \$5.00. Enhanced program (No. (TTLDB) with TTL library of the most commonly used TTL IC's on a Commodore C64 disk, along with instructions for use: \$20.00. Enhanced program (No. CMOSDB) with CMOS library of the most commonly used CMOS IC's on disk, along with instructions for use (CMOSDB): \$20.00. Enhanced program with both CMOS and TTL libraries and instructions: \$30.00. Please include \$2.00 shipping with each order. New Jersey residents must add appropriate sales tax.

```

1 REM *****
2 REM ** IC64 TESTING SOFTWARE **
3 REM ** NAME: IC64 167305 **
4 REM ** (C) 1987, J.J. BARBARELLO ** 5 REM ** MANALAPAN, NJ 07726 **
6 REM *****
7 GOSUB 5000:PRINTCHR$(147);RCS=CHR$(18)+CHR$(156);NCS=CHR$(146)+CHR$(15)
10 DIM I$(100),I2(100),O1(100),O2(100),DOS(16),LSS(16);RCS=CHR$(18)+CHR$(156)
15 PRINTCHR$(147);R0=4;C0=4;FOR I=1 TO 2:T(I)=2*(I-1);NEXT
16 T1$=" "RCS+" THE IC64 INTEGRATED CIRCUIT "NCS
17 T2$=" "RCS+" AUTOMATED TEST SYSTEM "NCS:PRINTT1$:PRINTT2$
18 GOSUB5050:PRINTBL$:GOSUB5050:INPUT"WHICH SIZE IC (14 OR 16 PINS)";IC
19 IF IC<14 AND IC>16 THEN 18
20 PRINT" WAIT...";CHR$(14)+CHR$(29)+CHR$(157)
25 L0$="SETUP PHASE: DEFINE SOCKET PINS "
30 IFIC=16THENL1$=" 0 0 0 0 0 0 0 0 0 0 1 1 1 1 1 1 " :GOTO 40
35 L1$=" 0 0 0 0 0 0 0 0 1 1 1 1 1 1 " :GOTO 40
40 IFIC=16THENL2$=" 1 2 3 4 5 6 7 8 9 0 1 2 3 4 5 6 " :GOTO 50
45 L2$=" 1 2 3 4 5 6 7 8 9 0 1 2 3 4 "
50 L3$=" C C C C C C C C C C C C C C C C "
60 GOSUB5050:PRINTL0$:PRINTL1$:PRINTL2$:PRINTL3$
70 R0=16;C0=4;GOSUB5050:PRINT RCS;" SETUP COMMANDS:"NCS:PRINT
80 PRINT" I = INPUT PIN";TAB(22);"O = OUTPUT PIN"
90 PRINT" ;" = VSS (GND);TAB(22);"V = VDD (PWR)
100 PRINT" N = NOT USED";TAB(22);"E = END DEFINE";PRINT" "CHR$(60);" ";
110 PRINT"CRSR = LEFT";TAB(22);"CHR$(62);"CRSR = RIGHT"
120 R0=9;C0=4;GOSUB 5050;SS$=CMS:PT=1
130 GOSUB 6100;GOSUB6000
140 ON SS GOSUB 150,160,170,180,190,200,210,220;GOSUB5050;GOTO130
150 PRINT"O";DOS(PT)"":RETURN
160 PRINT"O";DOS(PT)"":RETURN
170 PRINT"O";DOS(PT)"":RETURN
180 PRINT"O";DOS(PT)"":RETURN
190 PRINT"O";DOS(PT)"":RETURN
210 IF PT=18 THEN RETURN
212 IF IC=14 AND PT=7 THEN PT=9;C0=C0+4
215 PRINTCHR$(157);"(SS)";PT-PT+1;C0=C0+2;RETURN
220 IF PT=1 THEN RETURN
222 IF IC=14 AND PT=10 THEN PT=8;C0=C0-4
225 PRINTCHR$(157);"(SS)";PT-PT-1;C0=C0-2;RETURN
230 PRINTCHR$(157);"(SS)";
235 R0=18;C0=14;GOSUB5050:PRINTRCS;" W A I T ...";NCS
236 FOR I=1 TO 16
237 IFDOS(I)<>" "ANDDOS(I)<>"0"ANDDOS(I)<>"1"ANDDOS(I)<>"-"THENDOS(I)"":N"
238 NEXT
240 FOR I=1 TO 8:IF DOS(I)="I" THEN PA=PA+T(I)
245 IF DOS(I)="M" THEN MA=MA+T(I)
250 NEXT:MA=255-MA
260 FOR I=1 TO 8:IF DOS(I+8)="I" THEN PB=PB+T(I)
265 IF DOS(I+8)="M" THEN MB=MB+T(I)
270 NEXT:MB=255-MB
280 POKE SA+1,0;POKE SA,PA;POKE SA+1,4;POKE SB+1,0;POKE SB,PB;POKE SB+1,4
285 POKE SA,0;POKE SB,0
290 R0=4;C0=4;GOSUB5050:PRINT" " I.C. INITIALIZATION
300 R0=16;C0=8;GOSUB5050:PRINT"INSTRUCTIONS: MOVE CURSOR WITH LEFT/"
310 PRINT" RIGHT CURSOR KEY. CHANGE INPUTS "
320 PRINT" BY TYPING I OR O. BRING IC TO "
330 PRINT" INITIALIZED STATE, THEN PRESS ";RCS;" E ";NCS:PRINTBL$:PRINTBL$
340 PRINT" STEP: ";TAB(22);"MAX STEPS=100";NS=1;PH=0
345 R0=9;C0=4;GOSUB5050:FOR I=1 TO 16:PRINTDOS(I)"(SS)";:NEXT:PRINT:PRINT" ";
350 FOR I=1 TO 16:IF DOS(I)="I" THEN PRINT"Z ";:PU=:GOTO 370
360 PRINT"(SS)";
370 NEXT:CMS="DIE";CHR$(29)+CHR$(157);R0=11;C0=3;GOSUB5050:PH=0
380 SS$=CMS:PT=1;N=PEEK(SA) AND MA;GOSUB3000:PRINTAS;N=PEEK(SB) AND MB
385 GOSUB 3000:PRINTAS
390 FORPT=1 TO 16:IFDOS(PT)<>"I"THEN NEXT:GOTO 7000
400 C0=4+(PT-1)*2;GOSUB 5050;PX=PT
410 GOSUB6100;GOSUB6000:IF SS=0 THEN 410
420 ON SS GOSUB 430,440,530,450,460;GOSUB5050;GOTO410
430 PRINT"O";LSS(PT)"":GOTO 470
440 PRINT"1";LSS(PT)"":GOTO 470
450 IF PT=PUTHENRETURN
453 PT=PT+1:IFDOS(PT)<>"I" THEN 450
456 PRINTCHR$(157);"(SS)";C0=4+(PT-1)*2;RETURN
460 IFPT=PXTHENRETURN
463 PT=PT-1:IFDOS(PT)<>"I"THEN460
466 PRINTCHR$(157);"(SS)";C0=4+(PT-1)*2;RETURN
470 PRINTCHR$(157);CHR$(157);RCS;"NCS:C=C0
475 N1=FOR I=1 TO 8:IFLSS(I)"I"THENN1=N1+I(1)
480 NEXT:N2=0;FOR I=9 TO 16:IFLSS(I)"I"THENN2=N2+I(I-8)
490 NEXT:O1(NS)=N1;O2(NS)=N2;POKE SA,N1;POKE SB,N2;R0=11;C0=3
495 IF PH=0 THEN I1(NS)=999;I2(NS)=999
500 IF PH=1 THEN I1(NS)=PEEK(SA) AND MA;I2(NS)=PEEK(SB) AND MB
505 GOSUB5050:N=PEEK(SA) AND MA;GOSUB3000:PRINTAS;N=PEEK(SB) AND MB
507 GOSUB 3000:PRINTAS
510 IF NS=100 THEN SS$="YN";GOTO 570
520 R0=22;C0=9;GOSUB5050:PRINTNS;R0=11;C0=C0;GOSUB5050;NS=NS+1;RETURN
530 IF PH=1 THEN SS$="YM";N8=NS-1;GOTO 570
535 PH=1;C0=C0;R0=4;C0=4;GOSUB5050:PRINT" " I.C. TESTING PHASE
540 R0=15;C0=8;GOSUB5050:PRINTRCS;BL$:NCS;R0=18;C0=23;GOSUB5050
550 PRINT"PRESS ";RCS;" E "NCS" TO END ";RCS;BL$:NCS
560 R0=11;C0=C0;RETURN
570 PRINTCHR$(147);PRINTT1$:PRINTT2$:PRINT:PRINT" TEST ANOTHER IC (Y/N)...";
580 GET AS:IF AS="" THEN 580
590 GOSUB 6000:IF SS=0 THEN580
600 IF SS=2 THEN 900
610 R0=4;C0=4;GOSUB5050:PRINT" <<< TESTING PHASE >>>"
620 PRINT:PRINT" INSERT NEXT DEVICE TO BE TESTED."
630 PRINT:PRINT" PRESS ";RCS;" F1 "NCS" WHEN READY...";
640 GET AS:IF AS="" THEN 640
650 IF ASC(AS)<133 THEN 640
660 R0=4;C0=4;GOSUB5050:PRINTBL$:BL$:BL$:R0=4;C0=4;GOSUB5050
670 PRINT"TESTING. STEP: ";C0-19
680 FOR I=1 TO NS:IF I(1)<999 THEN 690
685 POKE SA,O1(I);POKE SB,O2(I);GOSUB 5050:PRINT:NEXT
690 S=I;FOR I=8 TO NS:GOSUB5050:PRINT:POKE SA,O1(I);POKE SB,O2(I)
700 IF(PEEK(SA) AND MA)<I(1) OR(PEEK(SB) AND MB)<I(2) THEN 730
710 NEXT
720 PRINT:PRINT" PASS. IC PERFORMS AS EXPECTED"
723 PRINT:PRINT" PRESS ANY KEY..."
725 GET AS:IF AS="" THEN 725
726 GOTO 570
730 C0=4;GOSUB5050:F=I:PRINT" IC FAILS AT STEP";F
735 PRINT" PIN #"(SS)(I+INPUT,0 OUTPUT);
740 PRINTL1$:PRINTL2$:PRINTL3$:PRINT" ";FOR Q=1 TO 16:PRINTDOS(Q)"(SS)";:NEXT:PRINT
750 PRINT:PRINT" EXPECTED RESPONSE"
760 N=I(F);GOSUB 3000:PRINT" ";AS;N=I(F);GOSUB 3000:PRINT AS
765 IF IC=14 THEN R0=14;C0=18;GOSUB5050:PRINT" "
770 PRINT:PRINT" OBSERVED RESPONSE"
780 N=PEEK(SA) AND MA;GOSUB 3000:PRINT" ";AS;N=PEEK(SB) AND MB
790 GOSUB3000:PRINTAS:PRINT:IF IC=14 THENR0=17;C0=18;GOSUB5050:PRINT" " :PRINT
795 GOTO 723
900 PRINTAS;R0=12;C0=12;GOSUB5050:PRINT"PROGRAM ENDED.";PRINT:PRINT:END
2999 END
3000 REM** CONVERT TO BASE2
3010 AS="" :FOR I=8 TO 15STEP-1:IF T(I)N THENAS="" O**AS:GOTO 3030
3020 N=N-T(I):AS="" I**AS
3030 NEXT:RETURN
5000 REM* CURSOR CONTROL USING PLOT KERNEL ($FFFB)
5005 SA=57100;SB=5A+2;POKE SA+1,0;POKE SA+1,4;POKE SB+1,0;POKE SB,0
5050 POKE SB+1,4
5010 DATA 162,0,160,0,24,32,240,255,96,999
5020 A=49300;SC=A
5030 READ B:IF B<999 THEN POKE A,B;A=A+1;GOTO 5030
5040 POKE53200,6;POKE53201,6;RETURN
5050 POKE SC+3,COL:POKE SC+1,ROW:SYS SC
5060 BL$=" " :RETURN
6000 REM** INSTR ,SEARCH=SS$,IN=AS
6010 FOR SS=1 TO LEN(SS$)
6020 IF AS=HDS(SS$;SB,1) THEN RETURN
6030 NEXT SS:SS=0;RETURN
6100 REM** CURSOR BLINK
6110 PRINTCHR$(157);">"
6120 GET AS:IF AS="" THEN 6140
6130 RETURN
6140 PRINTCHR$(157);" " :GOTO 6110
7000 REM** NO DEFINITIONS
7010 PRINTCHR$(147);PRINT:PRINT
7020 PRINT" NO DEFINITIONS MADE. PROGRAM ABORTEO":PRINT:PRINT:END

```

at first glance, but if you study Fig. 1 a few times you'll understand how it works out automatically.)

Connect R1 and R2 after all the wire-wrap connections are made. Solder R1 to IC1 pins 18 and 20. Similarly, solder R2 to pins 20 and 39. Cut 6-inch lengths of red and black No. 24 solid wire. Solder one end of the black wire to S1. Solder one end of the red wire to the junction of R1 and R2. Bring each wire through the board to the component side through drilled holes after first making a knot in each wire to serve as a mechanical stop. Make two additional stop-knots on the component side of the board, then strip 1/4-inch of insulation from the end of each wire. The uninsulated ends will remain free for later use in applying power (red) and ground (black) to the DUT.

As with all wire-wrapped projects, check for wire knots or other faults. You may want to do a continuity check on each connection to ensure proper wiring.

### Using the tester

Insert the tester into the computer's expansion port before applying power to the computer. Enter the pro-

gram shown in Table 1 (the program is available on disk—see the Parts List) and save it using the filename "IC64." Run the program by typing LOAD "IC64", 8 (notice that the comma is after the close-quotation mark), and then press the RETURN key. Then type RUN and press RETURN. Then install the DUT in the ZIF socket.

As shown in Fig. 3, 16-pin IC's just fit the ZIF socket. However, 14-pin IC's must be positioned towards the front of the socket because the rear two ZIF pins aren't used when testing 14-pin IC's. Take particular note from Fig. 3 how the pin numbering of the ZIF socket is modified for 14-pin IC's.

The program begins by asking you to specify whether the IC you'll be testing has 14 or 16 pins. Next, the program enters the Setup Phase and displays the screen shown in Fig. 4. Under the pin labeled O1 (meaning pin 1), is a blinking cursor that resembles the greater-than (>) symbol. (You can move the cursor with the right or left arrow keys.) Note from Fig. 4 that when a 14-pin test is selected the two center positions are marked "N," meaning that the two lower pins in the ZIF socket (SO3) aren't used. The

cursor will automatically skip over the unused pins as the data is entered.

The bottom of the Fig. 4 screen defines the setup commands. As shown in Fig. 5, you identify each pin as an input (I) to the IC, an output (O) from the IC, a ground pin (-), or a voltage-supply pin (+). A pin that will not be used, or a pin where you do not particularly care what happens, is identified with an N or left blank. As an example, the pin identification for a 7408 TTL quad 2-input AND gate would be:

110110- 011011+

For pins 1 through 7, pins 1 and 2 are identified as gate inputs with pin 3 being an output; pins 4 and 5 are inputs with pin 6 an output; pin 7 is ground (-). Similarly, we see that pins 8 and 11 are outputs, pin 14 is where the power

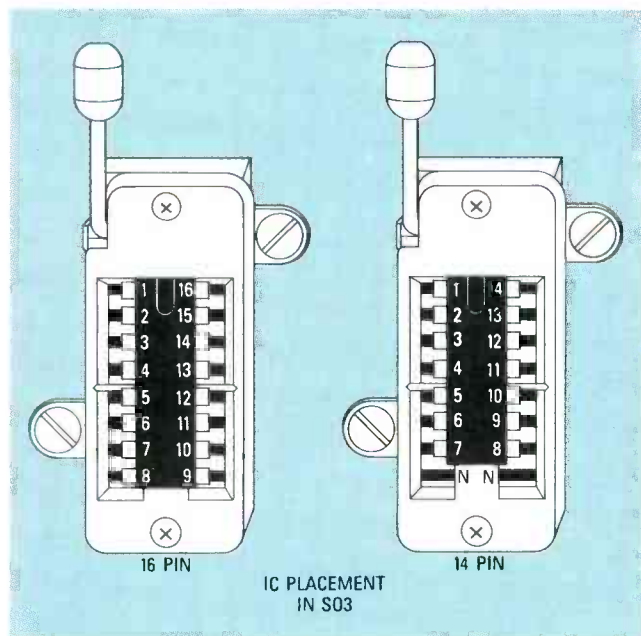

FIG. 3—ALTHOUGH A 16-PIN IC FITS the entire ZIF socket, a 14-pin IC must be positioned forward, so that the rear two ZIF pins aren't used.

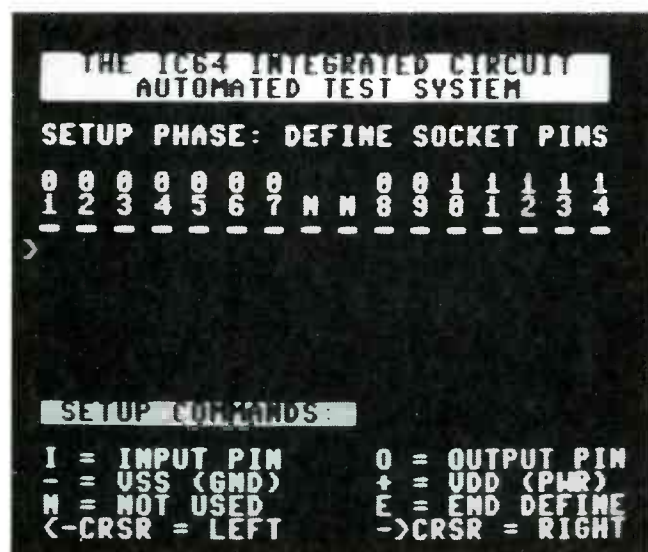

FIG. 4—IF YOU SELECT 14-PIN IC'S FOR TESTING the setup screen will indicate an N for the two unused ZIF socket terminals. The actual IC terminals are indicated as 01-14.

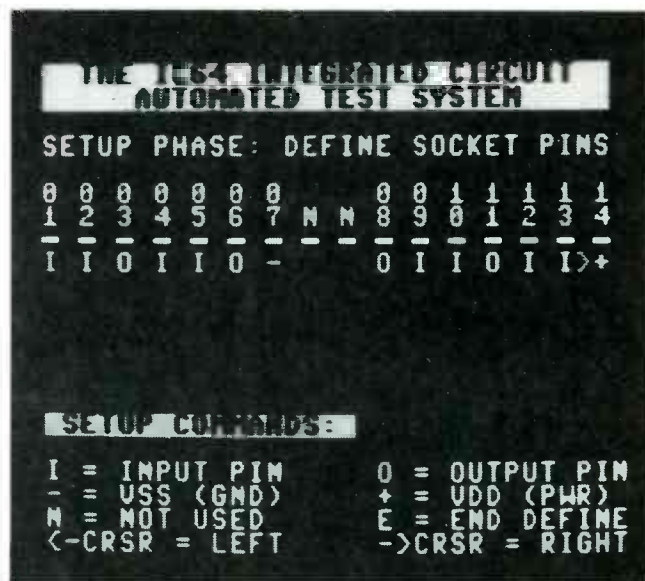

FIG. 5—FIRST STEP IN ANY TEST is to define the function of each socket pin, including the ground and +V connections.



FIG. 6—THE FIRST TEST INITIALIZES each IC to a standard setup. The N shown for pin 11 indicates we don't care what the result will be on that particular pin.

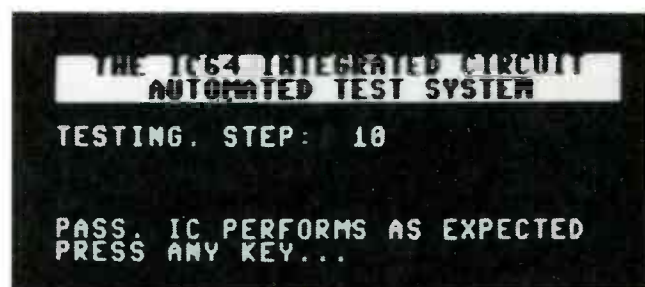

FIG. 7—THE SCREEN INDICATES WHEN the IC PASSES all tests that were established by the user.

(+V) is applied, and the remaining pins are inputs. The space between the - and the O indicate that the two lower pins in the ZIF socket are not used for the 14 pin device. To make any corrections, position the cursor and enter the desired data. Once the IC's I/O definition has been completed, press  $\epsilon$  to end the setup phase.

The next screen, IC Initialization, shows the definitions

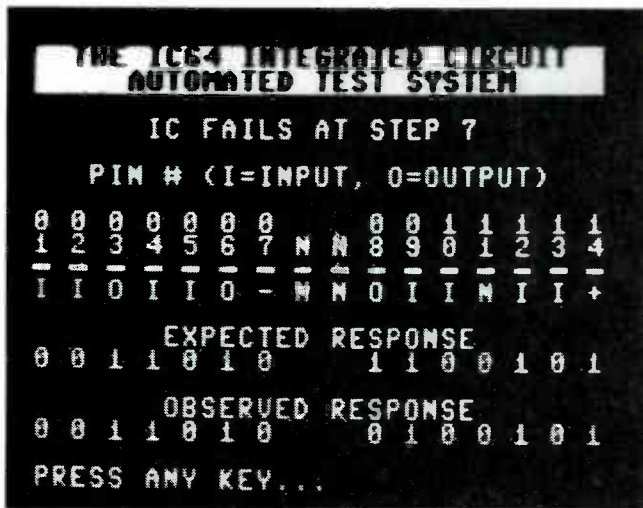

FIG. 8—THE SCREEN NOT ONLY INDICATES AN IC HAS FAILED, but it also shows what test (step) it failed and the manner in which it failed.

with each input pin marked with a diamond. During initialization the cursor will only move to the defined input pins. To illustrate the power of the tester, we will deliberately attempt to fool it by entering false data. As shown in Fig. 6, the definition for a NAND gate, we have defined output pin 11 with an N; meaning that we aren't interested in its result. It automatically displays a 0 even though its inputs, pins 12 and 13, should produce a high output. If you haven't done so yet, insert a known-good NAND GATE IC into the ZIF socket. Insert the black ground wire into position 7 or 10 of SO1 to apply ground to pin 7 of the DUT. Insert the red power wire into position 1 or 16 of SO2 to apply power to pin 14 of the DUT.

You want to initialize the IC to insure that all DUT's start out in the same state. As shown in Fig. 6, we'll change all the inputs to a low (0): Start by positioning the cursor at pin 1 and enter 0; then move the cursor to pin 2 and press 0. Since both inputs to the AND gate are now a 0, note that pin 3 changes to 1.

Continue the procedure, changing all inputs to a 0. It is important to note that you can initialize the IC in any way you want. For instance, you could have made pin 1 a 0, pin 2 a 1, pin 4 a 1, pin 5 a 0, and so on. The only rule for a valid test is to make sure your initialization values allow the test for each IC to begin in the same condition. But notice that pin 11, which we defined with an N, incorrectly indicates 0 because it's a "don't care" value.

When you press E to end the initialization phase, the title changes to the IC Testing Phase. As you did during the initialization phase, change the outputs one at a time to exercise all of the functions of the DUT. The number of test steps that you have defined are shown at the bottom left of the screen (you can define up to 100 steps, including initialization). As you change each input you will see its output change as per the IC's logic.

After performing all the steps necessary to exercise the IC, press E to end the testing phase. The program has now stored all conditions and responses of how you expect the IC to perform. The next screen, Auto Testing Phase, allows you to test as many IC's of this type as you desire. In answer to the question TEST ANOTHER DEVICE (Y/N)?, press the Y (Yes) key. As requested by the next message to appear, insert the next device to be tested into the ZIF socket and

press any key to begin testing. The program will begin counting through the test steps. If the device is good, you'll see the screen display shown in Fig. 7. If the device does not perform as expected, the sequence will stop, and as shown in Fig. 8, the display will show what was expected and what was actually observed. You can then press a key to return to the auto-testing phase.

### Additional capabilities

You can leave the tester connected when it's not being used. During that time, if you need to perform a complete (cold) reset of the computer, simply press the RESET button momentarily and then release it. As shown in Fig. 9, the computer will reset as if you had powered down and then up again.



FIG. 9—THE RESET BUTTON ACCOMPLISHES THE SAME THING as if the computer was powered down up again. It makes a reset easier.

Since the tester can determine digital transitions of any device, you can also test the switching action of diodes and transistors. For example, place a 1,000-ohm resistor between pins 1 and 3, a 10,000-ohm resistor between pins 2 and the base of an NPN transistor, the collector of the transistor to pin 3, and the base of the transistor to pin 4. To accomplish that, you may wish to use a 16 pin DIP jumper cable with one end inserted into the ZIF socket and the other end attached to a solderless breadboard (Radio Shack parts 276-1976 and 276-175 respectively, or their equivalents). You can then make the connections on the breadboard.

Back on the tester, position the +V wire to pin 1 and the ground lead to pin 4. Using the program, define pin 1 as +, pin 2 as I (Input), pin 3 as O (Output) and pin 4 as - (ground). Initialize by changing pin 2 to 0. For the test, change pin 2 to 1, noting that pin 3 will change to 0. Change pin 2 back to 0 and note that pin 3 changes back to 1. That tests the digital switching action under a reasonable load and ensures the device will switch properly in a circuit. A similar setup can be used for a switching diodes such as the 1N914 and 1N4148.

You can also expand the program to allow saving of device setups and responses in a disk file, so you would not have to set them up manually each time. You could then build a library of files for devices. (A CMOS and a TTL library, along with an enhanced program is available. See the Parts List.)

# R-E Computer Admart

Rates: Ads are 2 1/4" x 2 7/8". One insertion \$825. Six insertions \$800 each. Twelve insertions \$775. each. Closing date same as regular rate card. Send order with remittance to Computer Admart, Radio Electronics Magazine, 500-B Bi-County Blvd., Farmingdale, NY 11735. Direct telephone inquiries to Arline Fishman, area code 516-293-3000. Only 100% Computer ads are accepted for this Admart.

## LOW COST MOTION CONTROL, INPUT, OUTPUT DATA ACQUISITION, RELAYS, A/D, Etc.

Analog Input Card 8 channel, 8 bit, 0-5 V AD-142: \$129  
 Input card 8 channel on/off with opto isolators IN-141: \$59  
 Relay card 8 relays, 3 Amp contacts RE-140: \$129  
 24 Line TTL I/O General purpose programmable I/O (255) DG-148: \$65  
 Touch Tone Decoder for keypad or phone interface PH-145: \$79  
 12 bit Analog Input Card 1 channel, 1mV resolution AN-146: \$139  
 Stepper Motor/Lamp driver 8 outputs, 350mA ea. ST-143: \$79  
 Clock/Calendar with alarm CL-144: \$89  
 Quad Smart Stepper Controller, World's Best SC-149: \$299

On board Z-80 controls 4 stepper motors simultaneously, 100 Hi-Level commands. Adapters make any combination of cards work with: IBM PC, XT, AT & compatibles; Apple II, IIe; Tandy Models 100, 102, 200, 1, III, 4, 4P, 4D CoCo 1-3; Commodore 64, 128.

Please call (203) 656-1806 for Catalog



CIRCLE 208 ON FREE INFORMATION CARD

Why waste time?

## ACCELERATE with VCACHE™

### HARD DISK ACCELERATOR

- Caching eliminates repetitive disk accesses
- Use up to 15 Mb of extended/expanded or 500 Kb of standard memory

### DISKETTE ACCELERATOR

### SCREEN ACCELERATOR

FAST - FRIENDLY - SAFE

### VCACHE

### GOLDEN BOW SYSTEMS

\$49.95

Add \$3 for shipping/handling  
 California residents add 6% sales tax



2870 Fifth Avenue  
 Suite 201  
 San Diego, CA 92103  
**800/284-3269**

CIRCLE 206 ON FREE INFORMATION CARD

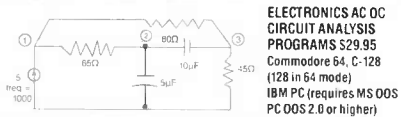

... you type ... computer displays ...

F 0 1 5	current source	#1 NV MG = 27 285	A = -19 47
R 1 2 65	resistor from 1 to 2	#2 NV MG = 11 163	A = -55 18
C 0 2 SE-6	capacitor from 0 to 2	#3 NV MG = 13 124	A = 43 35
C 2 3 10E-6			
R 1 3 80	ect.		
R 0 3 45			
FD 1000	set frequency		
SV	solve		

Program calculates and displays general numerical solution to up to 40 node electronic circuits of resistors, capacitors, inductors, voltage or current sources, or 4 types of controlled sources: VCCS, CCCS, VCVS or CCVS. Computer displays node voltages, branch voltages branch powers and power factors (AC). Menu commands make it possible to change parameters and recalculate the solution. Programs also allow log or linear stepping of frequency or branch parameters with solution graphically displayed. Programs are menu controlled, user friendly and very easy to use.

**Computer Heroes**  
 P.O. Box 79 S  
 Farmington, CT 06034

**ORDERS ONLY**  
 1-800-622-4070

CIRCLE 203 ON FREE INFORMATION CARD

## COMPUTER ASSEMBLY MANUALS



Eliminate  
 Guesswork!  
 Build with  
 Confidence!

**BIG BLUE SEED for IBM™ BUILDERS!**  
 Parts list, placement diagrams, instructions, mods, for assembling over 90 IBM-compatible bare cards. Latest version with guides for 640K, Turbo, AT & Baby AT MthBds. .... \$17.95

**APPLE™ BUILDERS NEED APPLE SEED!**  
 Instructions for assembling over 90 Apple-compatible bare cards including II+ & IIe MthBds. For ALL Apple enthusiasts and hobbyists ..... \$14.95

**SAVE 10% - ORDER TWO OR MORE MANUALS  
 OVER 40 BARE IBM & APPLE CARDS IN STOCK**  
 (MthBds • Disk • Video • Burner • MultiFn • I/O • Modem • Proto • etc)

Check/Money-order, VISA/MasterCard to:  
**NuScope Associates\*, Dept RE**  
 In U.S.A. In CANADA  
 P.O. Box 790 P.O. Box 742, Str B  
 Lewiston, NY 14092 Willowdale, Ont. M2K 2R1  
 \*A Division of Kosmic MicroTech Inc.

CIRCLE 72 ON FREE INFORMATION CARD

**3M**  
 5 1/4" 5 Box 10 Box  
 D-Side 950 850 795  
 D-Den. HIGH 1750 1650 1600  
 Den.

3.5 S-Side 1195	DATA CARTRIDGES	8" S-Side
3.5 D-Side 1650	DC 1000 12.95	8" S-Den. 1540
3.5 H-Den. 4795	DC 2000 17.50	8" S-Side 1895
	DC 300XP 19.75	8" D-Den. 2095
	DC 600A 21.95	

Authorized Distributor  
 Magnetic Media Division **3M**

Delaware 1-800-451-1849  
 P.O. Box 1024, Wilmington, DE 19800  
 Oklahoma 1-800-654-4058  
 P.O. Box 1674, Bethany, OK 73008  
 Nevada 1-800-621-6221  
 P.O. Box 10395, Las Vegas, NV 89112

Minimum Order: \$25.00. Visa, MasterCard accepted. C.O.D. orders add \$3.00. Surface Shipping add \$3.75 add \$3.00 per 100 disks. \$1 add \$4.00 per 100 disks. UPS delivery only. US mail for 400, 1700, 48, 51 or PC add an additional \$5 for PS. Prices subject to change without notice.

CIRCLE 200 ON FREE INFORMATION CARD

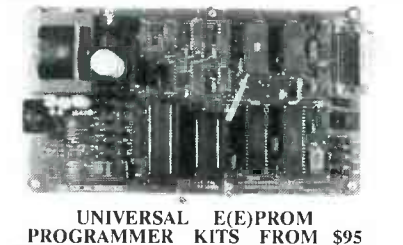

- No personality modules; Menu-driven device selection.
  - On board power supply (110/220V AC).
  - Direct technical support; Full 1 year warranty.
  - User friendly software; Complete help menu.
  - Quick pulse algorithm (2725c under 60 sec).
  - Programs 27bx to 1 Mbit, 25xx, 68xx, CMOS; EEPROMS.
  - Micro: 8741, 8742, 8748, 87481, 8749, 874911 & more.
  - IBM-PC, Apple, CPM or Unix driver; Autobaud RS232.
  - Offset/split Hex, Binary, Intel & Motorola 8,16,32 bit.
  - Manual with complete schematics.
- VISA & MC Call today for datasheets!!

**B&C MICROSYSTEMS**  
 355 WEST OLIVE AVE. SUNNYVALE, CA 94086  
 PH: (408) 730-5511 FAX: (408) 730-5521 TELEX: 984185

CIRCLE 202 ON FREE INFORMATION CARD

## ICs PROMPT DELIVERY!!!

SAME DAY SHIPPING (USUALLY)  
 QUANTITY ONE PRICES \$10.00 for Flat 15 1988  
 OUTSIDE OKLAHOMA: NO SALES TAX

640K MOTHERBD UPGRADE - Zenith 150, IBM PC/XT, Compaq Portable & Plus, hp Vectra	<b>DYNAMIC RAM</b>		
	1Mbit	1048Kx1	100 ns \$36.00
	51258 *	256Kx1	100 ns 9.25
	4464	64Kx4	120 ns 6.95
	41256	256Kx1	80 ns 9.85
	41256	256Kx1	100 ns 9.75
	41256	256Kx1	120 ns 8.95
	41256	256Kx1	150 ns 6.65
	41264 +	64Kx4	120 ns 9.25
		<b>EPROM</b>	
27C1024	64Kx16	150 ns \$37.95	
27C1000	128Kx8	200 ns 37.50	
27C512	64Kx8	200 ns 14.95	
27256	32Kx8	250 ns 6.75	
27128	16Kx8	250 ns 6.50	
	<b>STATIC RAM</b>		
43256L-12	32Kx8	120 ns \$10.95	
5864LP-12	8Kx8	120 ns 4.85	

OPEN 6 1/2 DAYS 7:30 AM-10 PM SHIP VIA FED-EX ON SAT  
 SUNDAYS & HOLIDAYS SHIPMENT ON DELIVERY VIA U.S. EXPRESS MAIL

SAT DELIVERY INCLUDED ON FEDEX ORDERS RECEIVED BY: Th: Std Air \$4 1 lb Fr: P-1 \$10.50 2 lb

MasterCard VISA or UPS CASH COD  
**Factory New, Prime Parts µP**  
 MICROPROCESSORS UNLIMITED, INC.  
 24 000 S. Peoria Ave., J  
 BEGGS, OK 74421 (918) 267-4961

No minimum order. Please note that prices are subject to change. Shipping & insurance extra & up to \$1 for packing materials. Orders received by 9 PM CST can usually be delivered the next morning, via Federal Express Standard Air in \$4.00, or guaranteed next day Priority One in \$10.00!

CIRCLE 61 ON FREE INFORMATION CARD

## CALL NOW AND RESERVE YOUR SPACE

- 6" x rate \$800.00 per each insertion.
- Fast reader service cycle.
- Short lead time for the placement of ads.

Call 516-293-3000 to reserve space. Ask for Arline Fishman. Limited number of pages available. Mail materials to: Computer Admart, RADIO-ELECTRONICS, 500-B Bi-County Blvd., Farmingdale, NY 11735.

## GRAPHICS TOOLKIT COMPATIBLE WITH PC/XT/AT AND NEW PS/2 \$59.95 LIMITED INTRODUCTORY OFFER (ADD \$3 S/H)

- SUPPORTS NEW VGA GRAPHICS MODES
- 50+ FUNCTIONS
- MEMORY/DISK SAVE AND RESTORE
- FREE LISTING UTILITY
- DATA COMPRESSION ALGORITHM
- ALL SOURCE CODE INCLUDED
- ROUTINES WRITTEN IN MICROSOFT C AND ASSEMBLER
- NO ROYALTIES
- PROGRAMMER SUPPORT PROVIDED

**DEVTRONICS, INC.**  
 1571 MAIN STREET  
 ATLANTIC BEACH, FLA. 32233

ORDERS ONLY: 1-800-332-4230 AMEX/COD  
 TECHNICAL INQUIRIES: (904) 241-3281

CIRCLE 201 ON FREE INFORMATION CARD



# BUILD THE PT-68K

*Troubleshooting hints, with a step-by-step checklist of everything installed so far.*

**PETER A. STARK,**  
STARK SOFTWARE SYSTEMS CORPORATION



Copyright (C) 1988 by Peter A. Stark

**Part 7** last time we stopped after installing enough input/output circuitry to let us communicate with the computer via keyboard and video screen. This month we'll pause to learn some troubleshooting tricks that you'll want to study even if your system is working fine, because the tips we'll present will deepen your understanding of how both the 68000 microprocessor and the PT-68K computer system work.

## Step 17. Troubleshooting tricks

If your computer worked properly at the end of step 16, you could skip this step, but it is recommended reading. On the other hand, if your system isn't working properly, this section will help you locate and fix the problem.

In the last installment, we covered the two ways of talking to the PT-68K computer:

- In Step 14, we discussed the serial RS-232C port, which allows us to connect the PT-68K either to a serial terminal, or to another computer with a serial port and a terminal-emulation program. For the remainder of this article, we'll refer to either option as *serial terminal*.
- In Steps 15 and 16, we discussed the circuit that allows us to connect a PC-compatible keyboard, and the inter-

face connectors that allow us to plug in a PC-compatible monochrome or color video adapter and matching monitor (or possibly both simultaneously).

Because the MC68681 DUART used in the serial port is not used just for serial interfacing, but for other functions as well (to generate the speaker tones, for example), the serial port circuitry must be installed on every PT-68K system. The PC interface circuitry, on the other hand, is an option and may not be present on your board.

Before discussing troubleshooting techniques, first let's discuss what should happen when everything is working correctly, and how the computer decides which I/O devices to use. To summarize, there are five basic ways of talking to the PT-68K:

- With a serial terminal operating at any baud rate from 300 to 9600.
- With a PC-compatible keyboard, a monochrome or color video adapter, and a matching monitor.
- With a serial keyboard (connected to the RS-232C port) for input, but a video board and monitor for output.
- With PC-compatible keyboard for input, but a serial terminal for output (set to 2400 baud).
- Several of the above simultaneously.

When you turn on the power (or short the reset pins at J23), HUMBUG (the PT-68K's ROM-based monitor program) tries to initialize the input and output ports, makes a list of installed options, and sounds the "beep-boop" from the speaker. If HUMBUG detects that a PC-compatible video board is installed, it then displays the message "Please press Enter" in the upper left corner of the screen. HUMBUG does not, however, display that message on a serial terminal, because it doesn't yet know what baud rate to use.

Now HUMBUG monitors both the serial input and the keyboard connector, waiting for you to press the Enter key

## Ordering Information

Complete details were given in part one (in the October issue). To summarize: The basic kit (PT1, \$200) contains all parts except power supply, case, and video terminal or personal computer to get a small system (ROM monitor, 2K RAM) up and running. The full basic system (PT68K, \$460) includes 512K of dynamic RAM, floppy-disk controller, parallel port, battery-backed clock/calendar, and three PC-compatible expansion slots. To order, or for more information, contact Peripheral Technology, 1480 Terrell Mill Road #870, Marietta, GA 30067, (404) 984-0742.

TABLE 1—HUMBUG COMMANDS

AD — ASCII Dump	LO — LOAD S1–S9 FORMAT
AI — ASCII Input FCC	MC — Memory Compare
AO — ASCII Output	ME — Memory Examine
BA — BASIC	MO — MOVe memory
BP — Breakpoint Print	MS — Memory Store
BR — BReakpoint set/ reset	MT — Memory Test
CO — COntinue	RC — Register Change
CS — CheckSum	RD — Return to DOS
FD — Boot SK*DOS / Floppy Disk	RE — Register Examine
FI — FInd 1-5 bytes	SS — Single Step
FM — Fill Memory	ST — STart single-step
HA — Hex and ASCII dump	WA — Boot SK*DOS / Winchester WX1
HD — Hex memory Dump	WB — Boot SK*DOS / Winchester HDO
HE — HElp	X1 — eXtra option 1
JS — Jump to System program	X2 — eXtra option 2
JU — Jump to User program	!! — Force reset

(also called Return or CR), so it can determine (a) which keyboard you are using, and (b) the baud rate if you're using the serial keyboard. Both keyboards can be connected electrically; whichever one receives a keypress first will be chosen as the input device. (In order to make sure the correct baud rate is chosen, you may have to press Enter several times on a serial keyboard.)

After the Enter is received, HUMBUG displays its sign-on message, HUMBUG (R) Copyright (C) 1986, 1987 by Peter A. Stark, the prompt (\*), and a cursor.

Whichever keyboard you use, that message will go to the video board(s), if any. If you use a serial keyboard, then it will also go out the serial port to the terminal (at the same baud rate as the keyboard). After the prompt is displayed, you may type in and execute any of the 32 HUMBUG commands, shown in Table 1. We'll discuss further use of them in a moment. For now, try typing anything to see whether it appears on your screen. If so, then the computer is in working condition.

If your computer doesn't function as described above, then some troubleshooting is in order. We'll start with the obvious possibilities.

First, using a good magnifying glass, carefully examine all solder joints to make sure all connections are soldered, but no shorts exist between adjacent lands on the board. Ensure that all IC socket pins really go through the board to the bottom side—sometimes a pin bends under the socket and never makes it through the board. Make sure that all IC's point in the same direction—pin 1 toward the left rear corner of the board—and that each socket contains the correct IC. Also make sure that all capacitors and resistors are in the correct places. It may also be a good idea to check power-supply voltages.

Speaking of power-supply voltages, note that the wide copper strip around the edge on the bottom of the board is electrical ground, but the strip on the top of the board is +5 volts. **If you mount the board with metal hard-**

**ware, you will short +5 volts to ground. You'll do the same thing if you attach the ground clip of an oscilloscope or voltmeter to the edge of the board.**

Another warning: Some early PC boards were shipped with a note regarding two possibly defective traces; if you have an early board, make sure you followed the directions to correct those problems.

Next, make sure that all the correct components are installed, but no others. Table 2 lists all components installed so far, in the order we installed them. It includes all connections, including the two jumpers and Molex pins installed in step 7 that were later removed in steps 9, 11, and 12; hence they should no longer be on your board. Extra oscillators, resistors and capacitors can stay, but any extra IC's (i.e., those not listed in the Table) should be removed during the following troubleshooting procedure, as they can cause undesirable results.

Also check all jumpers and other connections. The speaker should be connected to the two outer pins of J18; J25 should connect the center pin to pin 2; J24 should connect the center pin to pin 1; both J19 and J20 should connect the center pin to pin 2 for EPROM's shipped by Peripheral Technology (27256's). Incidentally, should you want to re-program those EPROM's, they require 12.5 volts for programming, and—as I have discovered—will be damaged at the more common 21 or 25 volts.

If all the simple tests reveal no problems, then it's time for more drastic action. Let's break the situation down into two types: either the speaker beeps or it doesn't.

### If the speaker beeps

If the speaker does beep, then the system works, more or less, so troubleshooting will be easier. Regardless of which keyboard you ultimately intend to use, for now connect a serial terminal to J22 and perform the tests in Step 14 (see the last installment for details)—there are very few things that can go wrong between the beep-boop (Step 13) and the operation of the serial port (in Step 14), so the serial port should be checked before continuing with the PC-compatible keyboard and video interfaces.

If the serial port works and a video board is installed, output should go to both. If the HUMBUG messages go to the serial port but not to the video board, then examine the PC interface-connector circuitry closely. One problem that has shown up with some clone CGA color boards is a slight amount of noise on the  $\overline{\text{BRESET}}$  line, which prevents the board from working. A simple fix is to place a 0.1  $\mu\text{F}$  disk capacitor right on the CGA board, from pin B2 to pin B1 (ground). Don't solder to the edge connector; find a nearby solder pad or feedthrough. (The pins on the right side of the connector are labeled A1–A31; the pins on the left side are B1–B31; in both cases, pin 1 is toward the rear of the board.)

If both the serial board and the video board work correctly, the last item to check is the PC-compatible keyboard. Make sure you press Enter on this keyboard as soon as the "Please press Enter" message appears, so that HUMBUG uses the PC keyboard, rather than the serial terminal. If the keyboard still does not work, make sure that the XT/AT switch (present on the bottom of many clone keyboards) is in the XT position, and try again. Then borrow a keyboard from a friend's PC or XT, and try it.

**TABLE 2—PARTS INSTALLED SO FAR**

**Step 3. The Power Connector**

J10A, J10B	Power connectors
C65	10 $\mu$ F tantalum (near J9)
C3, C4, C5	47 pF
C6	0.1 $\mu$ F

**Step 4. LED Indicators**

R14, R15, R16	320 ohms
R24	2200 ohms
C11	0.1 $\mu$ F
IC32	7406
R25	33 ohms
J18	4-pin header
LED's	J15, J16, and J17

**Step 5. The Reset Circuit**

R22, R23	1 megohm
R20, R21	2200 ohms
C57, C61, C62, C64	0.1 $\mu$ F
C63	1 $\mu$ F, 16 volts, tantalum
IC91	555
IC22	7406
IC66	74LS04
J23	Two-pin single header
unmarked	Two 0.1 $\mu$ F capacitors to the left of IC66

**Step 6. The Master Clock Circuit**

IC78	16 MHz oscillator (no socket)
IC77	74ALS74
J24	3-pin header, jumper center to 1
C58, C59, C60	0.1 $\mu$ F

**Step 7. The 68000**

IC47	68000
IC37	74LS10 triple 3-input NAND
IC89	74LS148 priority encoder
R19	10K SIP resistor (no socket)
C14, C48	0.1 $\mu$ F
Jumper	IC47-22 to IC47-14 to negate $\overline{BERR}$
Jumper	IC66-1 to IC166-14 to assert $\overline{TACK}$
Sockets	IC27 and IC21
Molex pins	Short pins 9-17 of IC21 socket
Molex pins	Short pins 11-19 of IC27 socket

**Step 8. The MAP circuit**

IC90	74LS164
J25	Three-pin header, jumper center to 1

**Step 9. The Bus Error Circuit**

Remove jumper	between IC47 pins 14 and 22
IC76	74LS175

**Step 10. The Address Decoder**

IC63	16L8 PAL
R17, R18	33-ohm resistor packs (no sockets)
IC64	74LS139 dual decoder
IC34	74LS138 decoder
C13, C67, C70	0.1 $\mu$ F
Jumper	J25 center to pin 1
C68	33 pF, not 0.1 $\mu$ F

**Step 11. The DTACK Circuit**

Remove jumper	Between IC66 pins 1 and 14
IC33	74LS175
IC36	74LS30
Jumper	J25 center to pin 2

**Step 12. ROM and RAM**

Remove Molex pins	from the IC21 and IC27 sockets
IC26	74LS32
C12, C66	0.1 $\mu$ F
IC20	EPROM marked "UPPER"
IC27	EPROM marked "LOWER"
IC21	6116 SRAM
IC28	6116 SRAM or MK48T02 clock
J19, J20	three-pin headers; set both jumpers on position two for 27256 EPROM's.

**Step 13. Running at Last!**

IC3	3.6864-MHz oscillator (no socket)
IC10	MC68681 DUART
R9, R10, R12, R13	10K
Speaker	To two outer pins of J18

**Step 14. The Serial Ports**

IC30	1488 TTL-to-RS232C converter
IC29	1489 RS232C-to-TTL converter
J21, J22	Six-pin header strips

**Step 15. The PC-Compatible Keyboard**

R7	4.7K
R8	10K
IC23	74S74
IC24	74LS175
IC25	74LS322
IC17	74LS373
IC19	74S373
C7, C8, C9, C10	0.1 $\mu$ F
C65	0.1 $\mu$ F (near IC16)
J9	Keyboard connector

**Step 16. The PC-compatible Bus Connectors**

J1-J6	62-pin card edge connectors
IC18	74LS373
IC15	74LS00
IC14	74LS32
IC1	74LS245
IC48	74LS08
IC35	74LS00
IC51	74LS32
IC31	74LS175
IC13	74LS74
IC92	14.31818-MHz oscillator (no socket)
R26	2.2K
C1	0.1 $\mu$ F
Jumper	From IC15 pin 12 to pin 7

**If you use a modern CGA board (with surface-mounted components), then**

IC65	74LS390
Cut Trace	Between IC76-9 and IC47-20
Jumper	IC65-9 to IC76-9.

**TABLE 3—ROM CONTENTS**

Address	Data
00000000	00FF0FEA
00000004	00F800C0

**If the Speaker Doesn't Beep**

If the speaker doesn't beep, then the going is a bit tougher. Still, start with the obvious: check the speaker connections.

If you are using a color (CGA) video board, then note that, as pointed out last time, some new CGA boards have a very long wait period after some operations, and that causes the Bus-Error timer to time out; the result is that the system may not work at all, so the microprocessor will halt, and the HALT LED will light. Refer to Fig. 8 in the February issue for a solution to that problem.

At this point, there are two ways to go. The brute-force method is to return to Step 7 and try to retrace our steps. But there is another, more elegant method that lets us use the 68000 itself to help us debug the problem.

Let's review how the 68000 works. When it wants to access memory or I/O, it outputs an address on the address bus, along with the appropriate control signals on  $\overline{UDS}$ ,  $\overline{LDS}$ , etc. When the memory or I/O is finished with the requested operation, it returns a  $\overline{DTACK}$  (data transfer acknowledge) signal, which tells the 68000 that the operation is finished. If, for any reason, an operation cannot be completed within a specified time, then the bus error

circuit sends a  $\overline{BERR}$  signal to the 68000, which attempts to recover. If the recovery procedure results in another bus error, then the 68000 simply halts and the HALT LED goes on.

To proceed, disable the  $\overline{BERR}$  circuit by removing IC76 and connecting a 10K resistor from pin 14 to pin 16 of the vacant socket. Doing so forces  $\overline{BERR}$  high, so the 68000 will never receive a bus error. (Solder Molex pins to the leads of the resistor; don't force the naked leads of the resistor into the socket, because they could stretch the socket pins.)

Next, disable the  $\overline{DTACK}$  circuit by removing IC36 and connecting a 330-ohm resistor from pin 8 to pin 7 of the socket. Because IC66 is still installed, the  $\overline{DTACK}$  input to the 68000 is forced high, so the microprocessor will never receive a  $\overline{DTACK}$ .

Now apply power. The first thing the 68000 tries to do is to obtain two addresses (where to locate the stack and where to start execution) from locations 000000 through 000007, which at power up are at the very beginning of the ROM. Their contents are shown in Table 3.

Some explanation is in order. Although addresses inside the 68000 consist of 32 bits, the actual address bus consists of only 24 lines (counting A0, even though it only exists internally within the 68000). Thus the first two hex digits of any address in the PT-68K are generally 00.

Furthermore, the 32-bit address for the stack (00FF0FEA) can not fit into an eight-bit memory location. Therefore, it is stored in four consecutive locations, 00000000–00000003. That explains why the second address in Table 3 is 00000004.

**TABLE 4—68000 SIGNALS WAITING FOR DTACK**

Pin	State	Signal	Description	Comment
1-5	High	D4-D0	Data bus	FF
6	Low	AS*	Address strobe	On
7	Low	UDS*	Upper data strobe	On
8	Low	LDS*	Lower data strobe	On
9	High	R/W*	Read/Write*	Read
10	High	DTACK*	Data Xfer acknowledge	Forced to off
11	High	BG*	Bus granted	Off
12	High	BGACK*	BG acknowledge	Off
13	High	BR*	Bus request	Off
14	High	V <sub>CC</sub>	+5 volts	
15	Pulses	CLK	8 MHz clock	Clock pulses
16	Low	GND	Ground	
17	High	HALT*	Halt	Not halted
18	High	RESET*	Reset	Not reset
19	High	VMA*	Valid Memory Address	Off
20	Pulses	E	E clock	Clock pulses
21	High	VPA*	Valid Peripheral addr	Off
22	High	BERR*	Bus Error	Forced to off
23	High	IPL2*	Interrupt input 2	No interrupts
24	High	IPL1*	Interrupt input 1	No interrupts
25	High	IPL0*	Interrupt input 0	No interrupts
26	High	FC2	Function Code 2	Currently in
27	High	FC1	Function Code 1	supervisor
28	Low	FC0	Function Code 0	program mode
29-48	Low	A1-A20	Address bus	000000
49	High	V <sub>CC</sub>	+5 volts	
50-52	Low	A21-A23	Address bus	000000
53	Low	GND	Ground	
54-61	Low	D15-D8	Data bus	00
62-64	High	D7-D5	Data bus	FF

Last, although a four-byte address is stored in four one-byte locations, the 68000 can read or write two bytes at a time via its sixteen-bit data bus. Therefore the microprocessor must read the four-byte address in two chunks.

In detail, what happens is this: when the 68000 tries to read the stack address from memory, it outputs address 000000 on the address bus, asserts both  $\overline{UDS}$  and  $\overline{LDS}$  to signal that it is trying to access both an upper byte and a lower byte, asserts  $\overline{AS}$  to activate the address decoder, and releases  $\overline{RW}$  to indicate that memory is being read.

The address decoder then decodes address 000000 and sends a low to both EPROM's to enable them. The EPROM's, in turn, output the contents of the first two bytes (the number \$00FF, the upper half of the \$00FF0FEA stack address) to the data bus, which sends this data to the 68000. The 68000 receives the data, and now waits for  $\overline{DTACK}$  so it can continue.

But we've disabled  $\overline{DTACK}$ ! So the microprocessor just sits there. Take a scope or logic probe and examine some of the important signals. You'll see address 000000 on the address bus, 00FF on the data bus, both  $\overline{UDS}$  and  $\overline{LDS}$  low,  $\overline{AS}$  low, and  $\overline{RW}$  high. You will also see lows on the  $\overline{CE}$  and  $\overline{OE}$  pins of both EPROM's, and a low on pin 4 of IC64-a.

So, even with fairly simple test equipment, it's easy to check the circuit and make sure the right signals are there. Table 4 is a complete list of what you should find on every pin of the 68000 at this point. Make sure they're all there at the appropriate levels, and trace the signals if not. Remember, a high should be +3 volts or more; a low should 0.4 volt or less. If you see any voltages between those levels, suspect a short.

Here are several examples of how to interpret "strange" results. Suppose all the signals on the 68000 are correct except for the sixteen data-bus lines. If the data bus reads \$FFF0 instead of \$00FF, are the EPROM's interchanged? Or if the data bus is completely different than expected, are the EPROM's selected (lows on their  $\overline{OE}$  and  $\overline{CE}$  inputs)? If yes, are they getting the correct address? Is pin 4 of IC64 low? If not, are the select inputs (pins 1-3) of IC64 low?

If everything seems normal, the next step is to pulse  $\overline{DTACK}$  low so the 68000 will proceed to the next step. The pulse must be wide enough so the 68000 will recognize it, yet narrow enough so that the 68000 will only go forward one step and no more. The timing is touchy, but I have found that momentarily connecting a discharged 0.001  $\mu$ F capacitor from pin 8 to pin 14 of IC36 works quite well. Pin 8 is held low by the 330-ohm resistor added above, but the 0.001  $\mu$ F capacitor pulls it high for about a quarter of a microsecond. That signal is inverted by IC66-a into a low  $\overline{DTACK}$  pulse.

As a result, the 68000 now tries to read the next two bytes of the stack address from memory, so the address bus should contain 000002, and the data bus should have

**TABLE 5—ADDRESS AND DATA BUS CONTENTS DURING THE FIRST FEW MEMORY ACCESSES**

Address	Data	Explanation
000000	00FF	Initial stack address = \$00FF0FEA
000002	0FEA	
000004	00F8	
		HUMBUG starting address = \$00F800C0
000006	00C0	JUMP (op code 4EF9) to \$00F80126 instruction
F800C0	4EF9	
F800C2	00F8	A CLR.B instruction
F800C4	0126	
F80126	4239	
F80128	00FF	
F8012A	002D	
F8012C	4239	Another CLR.B instruction
F8012E	00FF	A MOVEM instruction
F80130	0C85	
F80132	48F9	
F80134	7FFF	
F80136	00FF	
F80138	0C0E	

0FEA—the lower half of stack address 00FF0FEA. It's possible that the pulse from the capacitor may be too wide or too narrow, or that more than one pulse may be generated, in which case you may either stay at the same step, or may skip ahead several steps. In that case, refer to Table 5, which is a list of the information on the address and data busses during the first dozen or so steps.

Assuming nothing turns up from those tests, remove the 330-ohm resistor, replace IC36, and restart the system. The computer will now start executing at high speed the steps we were just tracing one-by-one. However, whenever the 68000 tries to access a memory or I/O address that either doesn't exist or that is not working properly, it will fail to get  $\overline{DTACK}$ . We're still forcing  $\overline{BERR}$  high with a 10K resistor, so the 68000 will stop and we can examine the address bus to see where the 68000 got stuck.

HUMBUG tries to compile a list of installed hardware, so it intentionally tries to access addresses that may not yet exist on your system. Those addresses include \$FE0089 (68230), \$FE000B (DUART1), \$FE004B (DUART2), and either \$C00001 or \$D60001 (PC-compatible connectors). So the first address you see on the bus should be \$FE0089. Of course, you cannot see A0. Instead,  $\overline{UDS}$  will be low or on, and  $\overline{LDS}$  will be high or off, to signify that the address is \$FE0089 and not \$FE0088. If there is any other address on the address bus, the 68000 is trying to access a location that does not work or does not exist.

Once you see the \$FE0089 address of the 68230, you may pulse  $\overline{BERR}$  low once to get the 68000 to continue until the next bus error. That can be done with the same 0.001- $\mu$ F capacitor as before, except this time connect it between pin 8 and pin 14 of IC76. As before, you may skip ahead a few extra steps if the pulses introduced by the capacitor are not quite right. In that case, to view each step, just start over by resetting.

Note that your computer should not stop at address \$FE000B, because you have already installed DUART1 at IC10. If it does stop, then there is something wrong with the DUART1 circuit.

Next time we'll install the dynamic RAM. 

#### FURTHER HELP

If you need further help, contact us through our BBS at (914) 241-3307. If that is not possible, hardware questions can be answered by Peripheral Technology, 1480 Terrell Mill Rd., No. 870, Marietta, GA 30067, (404) 984-0742. Software questions dealing with HUMBUG or SK\*DOS can be answered by Star-K Software Systems Corp., P.O. Box 209, Mt. Kisco, NY 10549, (914) 241-0287.

# PC SERVICE

Here are the PC patterns for the construction projects in this month's issue. All patterns are right reading and full sized, unless otherwise noted.

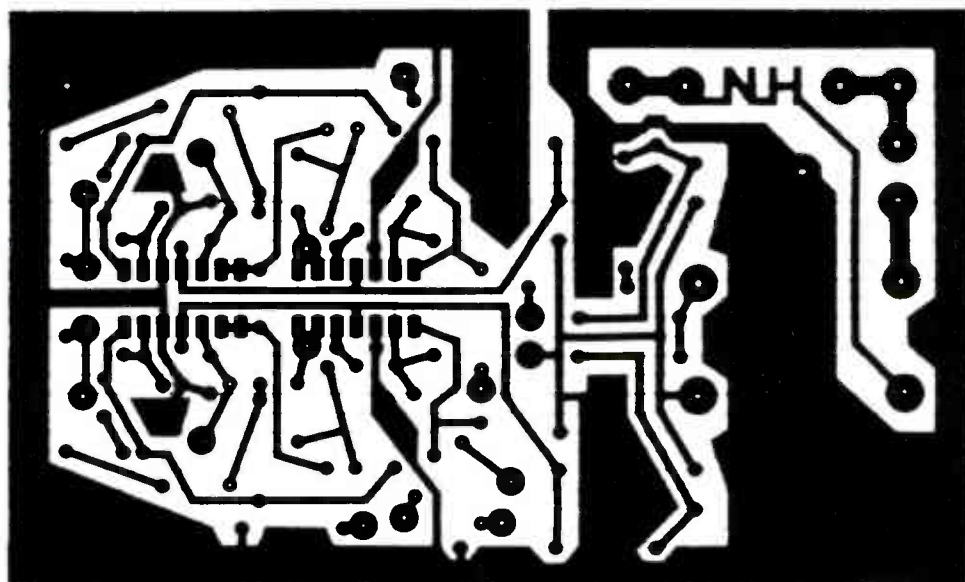

5 INCHES

BUILD THE SUBWOOFER SIMULATOR using this board.

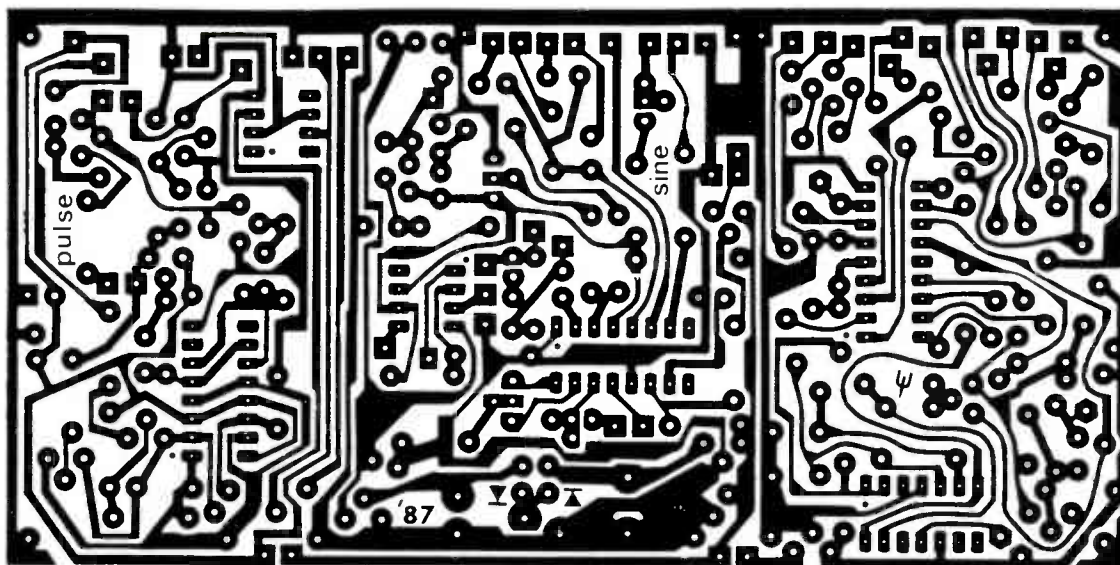

6 INCHES

PC-BOARD PATTERN for the Versatile Function Generator.

# MARKET CENTER

## FOR SALE

**TUBES**, new, unused. Send self-addressed, stamped envelope for list. **FALA ELECTRONICS**, Box 1376-2, Milwaukee, WI 53201.

**DESCRAMBLERS**. All brands. Special combo Jerrold 400 and SB3 \$165. Complete cable descrambler kit \$39. Complete satellite descrambler kit \$45.00. Free catalog. **MJM INDUSTRY**, Box 531, Bronx, NY 10461-0531.

**COMMODORE** Chips Or Repairs. C-64 repair \$39.95 includes parts/labor. We sell low cost Commodore chips—6526/6510—\$8.95, 82S100/PLA—\$11.95 and many others. HD/C 64 P.S. \$27.95. + PP. "Commodore Diagnostician," a complete chart for diagnosing faulty ICs \$6.95 + PP. Send for complete catalog. **VISA/MC. KASARA INC.**, 31 Murray Hill Drive, Spring Valley, NY 10977, 1-(800) 248-2983 (Nationwide) or (914) 356-3131.

**SATELLITE & cable equipment**. We have those hard-to-find units ready to go. Tired of junk that doesn't work properly? Try our 10 day satisfaction guarantee & 90 day warranty (wholesale only). **HI TECH ELECTRONICS**, PO Box 42423, Detroit, MI 48242, (313) 722-9381.

**MICROWAVE** antennas, multichannel 1.9-2.7 GHz dual polarity. From only \$49.95. "Best in the west!" **GALAXY ELECTRONICS**. Call 1 (602) 939-1151.

**TUBES**, name brands, new, 80% off list. **KIRBY**, 298 West Carmel Drive, Carmel, IN 46032.

**IS it true...Jeeps for \$44 through the government?** Call for facts! 1-(312) 742-1142, ext. 4673.

**LEADER LFC-945A** signal level meter \$395.00 (312) 771-4661.

**SURPLUS** Zenith Z100 computer motherboards. No RAM/ROM, over 100 chips in sockets including 8088, 8085, 74LSxxx, 74LSxx, crystals and more, \$49.95. Boards without chips \$12.95 shipping included. Visa Master. **LYNBAR INDUSTRIES**, (616) 983-3389.

**STEREO** TV decoders: Canadian electronics distributor with inventory liquidation. Plug-in stereo TV synthesizer with amplifier \$49.95 with shielded speakers + A.N.R. \$69.95 U.S. Frt. ppd. Guaranteed satisfaction. Catalogue \$2.00 send money order to: **MTS ELECTRONICS**, P.O. Box 385—Snowdon, Montreal, Canada H3X 3T6 FAX # (514) 481-3612.

**LASER information**—List of over 200 suppliers of laser and laser-related equipment. Send \$4.00 for print, \$6.00 for labels to **PAUL PHRAMPUS**, P.O. Box 61913, Va Beach, VA 23462

**FAIR prices**, SB-3-\$65. Tri Bi-\$90, SA3-\$95. N-12VS-\$85, MLD-1200-3 \$85, Zenith \$165 filters for beeping any channel 2 to 22, converters all types, hand remotes. **No Michigan sales. BENNY-(313) 979-8356**. Note any order over \$200 dollars will get a six-outlet surge protector goes into wall socket.

TV tunable notch filters, free brochure. **D.K. VIDEO**, Box 63/6025, Margate, FL 33063 1-(305) 752-9202.

**RUN** three-phase motors on single phase, free brochure. **MOTORS**, Box 63/6025, Margate, FL 33063 1-(305) 752-9202.

**RESTRICTED technical information**: electronic surveillance, schematics, locksmithing, covert sciences, hacking, etc. **Huge selection. Free brochures. MENTOR-Z**, 135-53 No. Blvd., Flushing, NY 11354.

**TUBES**. "Oldest," "latest." Parts and schematics. **SASE** for list. **STEINMETZ**, 7519 Maplewood Ave., R.E. Hammond, IN 46324.

**SOLAR** battery chargers. Homes, RVs, boats. From \$30.00. Brochure. **SUNPOWER**, Texas, Dept. 01B, P.O.B. 2788A, Freeport, TX 77544.

**SALE!** SCR, transistor, diode tester. Dropproof jeweled meter. \$69.00 + UPS shipping. **GALAXY**, 1834 S.E. 22nd, Portland, OR 97214.

**SAVE \$s!** We will beat your best deal. Zenith Z-tac, Ssavi, Jerrold, Oaks, Hamlins, Scientific Atlanta, lots more. **HOTRONICS**, (313) 675-5834.

**HACKER'S Handbook** \$12.95, \$1.00 postage. **Computer Underground**, \$14.95, \$1.00 postage. **CABLETRONICS**, Box 30502R, Bethesda, MD 20814.

**CREATE** 1X or 2X PCB artwork with ease on your IBM-PC or compatible. Requires 256K memory—CGA card—IBM graphics or compatible printer. **Software** \$49.95 or \$10.00 for demo disk. **SHEA, LTD.**, 2105 Waveland, Chicago, IL 60618.

**ATTENTION laser holographic experimenters**: optical computer components, instructions. \$22.95 postpaid. **STELLAR TECHNOLOGIES**, 4710 University Way N.E., #1003, Seattle, WA 98105.

**GREAT buys!** Surplus prices, ICs, linears, transformers, PS, stepping motors, vacuum pump, phototransistor, meters, Isase, **FERTIK'S**, 5400 Ella, Phila., PA 19120.

**TWO-Way-Radio**, Atari, Uniden service. General Radiotelephone licensed technician. Catalog-**RAYS**, 2025 Moline, Ft. Worth, TX 76117 (817) 831-7717.

## FREE CATALOG

**FAMOUS "FIRESTIK" BRAND CB ANTENNAS AND ACCESSORIES. QUALITY PRODUCTS FOR THE SERIOUS CB'er. SINCE 1962**  
**FIRESTIK ANTENNA COMPANY**  
2614 EAST ADAMS  
PHOENIX, ARIZONA 85034

**TESLA coils**—Kirlian electrophotography—plasma bulbs...Free 1988 science plan catalog! **SCIEN-TIFIC**, Box 1054HRH, Duvall, WA 98019.

**ELECTRONIC** liquidators, thousands of parts, kits, computers, hardware, send \$3.50 for catalog. **BOX 27656**, Lansing, MI 48901.

**COMPONENTS!** IC's, capacitors, resistors, etc. Lowest prices! Example: 10µf 25V Tantalum capacitor—19 cents. Free catalog. **CRC ELECTRONICS**, 13547 S.E. 27th Pl., Bellevue, WA 98005. (206) 747-9636.

**CATV** Descrambling manual. 220 + full pages with schematics, \$24.95. Others available. Catalog \$2.00. **DATA DISTRIBUTORS**, P.O. Box 5612, Springfield, VA 22150. C.O.D.'s welcome (703) 425-0652.



## TUBES - 2000 TYPES DISCOUNT PRICES!

Early, hard-to-find, and modern tubes. Also transformers, capacitors and parts for tube equipment. Send \$2.00 for 20 page wholesale catalog.

**ANTIQUE ELECTRONIC SUPPLY**  
688 W. First St. • Tempe, AZ 85281 • 602/894-9503

**TRANSISTORS-tubes**: MRF421 \$24.00, MRF454 \$14.50, MRF455-MRF477 \$11.75, MRF492 \$16.00, SRF2072 \$12.75, SRF3800 \$17.50, 2SC2290 \$16.75, 2SC2879 \$22.00, 6LF6, 6LQ6, 6JS6, 8950, etc.-call. New **Ranger AR3500** all mode 10 Meter transceiver \$319.00. Quantity discounts! Best prices on hard-to-find parts, antennas, mics, power supplies, & equipment! Catalog \$1.00 (refundable), or free with order. **RFPC**, Box 700, San Marcos, CA 92069. For information or same day shipment—(619) 744-0728 Visa/MC/C.O.D.

**LASERS**, components and accessories. Free catalog. **M.J. NEAL COMPANY**, 6672 Mallard Court, Orient, OH 43146.

**REPAIR your own TV...it's easy**. Write **RESEARCH**, Rt. 3, Box 601BR, Colville, WA 99114.

**PICTURE** flyer lists quality surplus electronics at low prices. Since 1970. Send for the last 3 issues. **STAR-TRONICS**, Box 683, McMinnville, OR 97128.

**CABLE TV Converters**. Scientific Atlanta, Jerrold, Oak, Zenith, Hamlin, Many others. "New" **Video Hopper** "The Copy Killer." Visa, M/C & Amex. **1(800) 826-7623. B&B Inc.**, 10517 Upton Circle, Bloomington, MN 55431.

600 ohm Hybrid term sets complete, \$22.50 pp with full specs. R.E. March, '88, 2G.H. point to point M.W. systems 24 + channels including signaling. S.A.S.E. for details. **B. McLain**. R.R. 1 Box 165, Colville, WA 99114.

**PHOTOFACT** folders, under #1400 \$3.00. Others \$5.00. Postpaid. **LOEB**, 414 Chestnut Lane, East Meadow, NY 11554.

**Ti-99/4a** software/hardware bargains. Hard-to-find items. Huge selection. Fast service. Free catalog. **DYNA**, Box 690, Hicksville, NY 11801.

"**CB Trick of the Trade** book." Learn CB repair tricks and transmitting theory. Send \$19.95 to **MEDICINE MAN CB**, P.O. Box 37, Clarksville, AR 72830.

## CB RADIO OWNERS!

We specialize in a wide variety of technical information, parts and services for CB radios. 10-Meter and FM conversion kits, repair books, plans, high-performance accessories. Over 12 years of satisfied customers! Catalog \$2.

**CBC INTERNATIONAL**  
P.O. BOX 31500RE, PHOENIX, AZ 85046

## CABLE-TV AT IT'S BEST

**SCIENTIFIC Atlanta** Models 8500—8550, remote included...\$240.00. **SB-3's**...\$74.00. **TRI-BI's**...\$95.00. **SA-3's**...\$99.00. **Zenith (Z-Tac)** Descramblers...\$169.00. **N-12 (Vari-sync)**...\$89.00. **M-35 B (Vari-sync)**...\$99.00. **Hamlin MLD-1200's**...\$89.00. **80-Channel converters**...\$95.00. Dealer discounts on (5) units. Call...**N.A.S. INTERNATIONAL**, (213) 631-3552.

**THIS IS A BOLDFACE EXPANDED AD with a tint background.** If you like this format, request it. Your cost is \$6.25 per word.

## INVENTORS

**INVENTORS!** Can you patent and profit from your idea? Call **AMERICAN INVENTORS CORPORATION** for free information. Over a decade of service. 1-(800) 338-5656. In Massachusetts or Canada call (413) 568-3753.

**NUTS & VOLTS** MAGAZINE P.O. Box 1111-E Pleasanton, CA 94567 714-932-7721

**GIVE YOURSELF A BREAK—A PRICE BREAK! NUTS & VOLTS WILL Save YOU MONEY ON ELECTRONIC PARTS & EQUIPMENT. Plus SHOW YOU WHERE TO FIND UNIQUE, UNUSUAL AND HARD-TO-FIND ITEMS. SUBSCRIBE TODAY!**

Subscription Rates:  
3rd Class Mail: USA  
1st Class Mail: CANADA  
1st Class Mail: AIR MAIL

A National Publication For The Buying And Selling Of Electronic Equipment

## ROBOTIC SENSORS

**TACTILE** and pressure sensors, \$5/element, singles and arrays available. For info, send address to: **RECEPTOR TECHNOLOGY INC.**, 2 Kenwood Street, Somerville, MA 02144.

## DESCRAMBLER MODULE

**COMPLETE** cable-TV decoder in a mini-module. Latest technology upgrade for Jerrold SB-3 or Radio-Electronics Feb. 1984 project. Versatile, sophisticated, and low cost. For literature, **SOUTHTECH DISTRIBUTING**. (813) 527-2190.



**SING WITH THE WORLD'S BEST BANDS!**

An Unlimited supply of Backgrounds from standard stereo records! Record with your voice or perform live with the backgrounds. Used in Professional Performance yet connects easily to a home component stereo. This unique product is manufactured and sold Exclusively by LT Sound - Not sold through dealers. Call or write for a Free Brochure and Demo Record.

**LT Sound, Dept. RL-3, 7980 LT Parkway**  
Lithonia, GA 30058 (404) 482-4724  
Manufactured and Sold Exclusively by LT Sound  
**24 HOUR PHONE DEMO LINE: (404) 482-2485**

**EDUCATION & INSTRUCTION**

**F.C.C. Commercial General Radiotelephone license.** Electronics home study. Fast, inexpensive! "Free" details. **COMMAND, D-176, Box 2223, San Francisco, CA 94126.**

**SUPERFAST Morse Code** supereasy. Subliminal cassette. \$10. Learn Morse Code in 1 hour. Amazing new supereasy technique. \$10. Both \$17. Moneyback guarantee. Free catalog: **SASE. BAHR, 2549-E3 Temple, Palmbay, FL 32905.**

**MOVING?**

Don't miss a single copy of **Radio - Electronics.** Give us:

Six weeks' notice

Your old address and zip code

Your new address and zip code

ATTACH LABEL HERE

name (please print) \_\_\_\_\_  
address \_\_\_\_\_  
city state zip code \_\_\_\_\_

Mail to: Radio-Electronics  
SUBSCRIPTION DEPT., P.O. BOX 51866,  
BOULDER, COLO. 80321-1866

**MICROPROFESSOR** 8 bit trainer, Z-80 C.P.U., 158-instruction set, 8K monitor ROM, enter programs in assembly, machine, basic, or forth. **ETRONIX, 5326-9th Ave. N.E., Seattle, WA 98105 1-(800) 426-1044.**

**MICROPROFESSOR** 16 bit trainer, 8088 C.P.U., 8 bit data bus, 4.77MHz, 59-key, full-size keyboard, Centronics parallel interface. Design, write, debug, and execute assembly language programs. **ETRONIX, 5326-9th Ave. N.E., Seattle, WA 98105 1-(800) 426-1044.**

**Power transformers.** Rewind them to your specs. For instructions send \$7.00 to **Bross Electronics, 350 Tremont, Suite D51, Murfreesboro, TN 37130.**



DETAILED PLANS: \$4.95

**TV-SCOPE**

PENN RESEARCH,  
Box 3543  
Williamsport, PA 17701

**FINALLY!**

An interesting and worthwhile project. This **EASY-TO-BUILD** circuit lets you use any regular TV set as a simple **OSCILLOSCOPE.** Build for less than \$10. **NO MODIFICATIONS TO TV!** Single or dual trace. Send for **FREE CATALOG** of other plans and kits.

**PLANS AND KITS**

**Hi-Fi speaker systems,** kits and speaker components from the world's finest manufacturers. For beginners and audiophiles. **Free literature. A&S SPEAKERS, 3170 23rd Street, San Francisco, CA 94110. (415) 641-4573.**

**PROJECTION TV.** Convert your TV to project 7 foot picture. Results comparable to \$2,500 projectors...total cost less than \$30.00. Plans and 8" lens \$21.95...Illustrated information free... **MAC-ROCOMA-GI, Washington Crossing, PA 18977. Creditcard orders 24hrs (215) 736-3979.**



Open your eyes and see just how many subjects are covered in the new edition of the Consumer Information Catalog. It's free just for the asking and so are nearly half of the 200 federal publications described inside. Booklets on subjects like financial and career planning; eating right, exercising, and staying healthy; housing and child care; federal benefit programs. Just about everything you would need to know. Write today. We'll send you the latest edition of the Consumer Information Catalog, which is updated and published quarterly. It'll be a great help, you'll see. Just write:

**Consumer Information Center  
Department TD, Pueblo, Colorado 81009**

U.S. General Services Administration

**VOICE** disguisers! FM bugs! Telephone transmitters! Phone snoops! More! Catalog \$1.00 (Refundable): **XANDI ELECTRONICS, Box 25647, Dept. 60A, Tempe, AZ 85282.**

**BUILD** this five-digit panel meter and square-wave generator including an ohms, capacitance and frequency meter. Detailed instructions \$2.50. **BAG-NALL ELECTRONICS, 179 May, Fairfield, CT 06430.**

**TOP quality** imported, domestic kits, surplus, discount electronics, computer components. **free catalog. TEKTRASONIX, 1120 Avenue of the Americas, 1/11 suite 4038, New York, NY 10036.**

**Cable TV Converters  
Why Pay A High Monthly Fee?**

Jerrold Products include "New Jerrold Tri-Mode," SB-3. Hamlin, Oak VN-12, M-35-B, Zenith, Magnavox, Scientific Atlanta, and more. (Quantity discounts) 60 day warranty. For fast service C.O.D. orders accepted. Send SASE (60 cents postage) or call for info (312) 658-5320. **MIDWEST ELECTRONICS, INC., 5143-R W. Diversey, Chicago, IL 60639. MC/Visa orders accepted. No Illinois orders accepted. Mon.-Fri. 8 A.M.-5 P.M. CST**

**STRANGE** stuff. Complete items, plans, kits. Laser eavesdropping, hidden weapons, bugging and countermeasure sources, adult toys. Informational photo package \$3.00 refundable. **DIRIJO CORPORATION, Box 212-R, Lowell, NC 28098. Information (704) 868-3408.**

**COMPUTER** owners Commodore and Atari. Design your own custom circuits, oscillators, amplifiers, layouts, and more! Just enter specifications and the computer designs the circuit. Free information! Send today! **WEASELGRAPHICS, Dept. R57, 606 Thomasville, Pochahontas, AR 72455. Specify computer.**

**FREE power supply, connectors (\$8.95 value) with Assortment #103** (February 1984 article) has **printed circuit, TOKO coils, transistors, IC's, diodes \$25.00. Five/\$112.50 shipping \$2.00. JIM RHODES, INC., P.O. Box 3421, Bristol, TN 37625.**

**R-DAP** digital audio recorder/player. Record and playback :10 seconds of audio on a self contained 256K Ram. Complete kit including microphone and speaker. Detailed documentation \$59.95 plus \$1.00 postage. **DJ INC., Suite 108, 217 East 85th Street, New York, NY 10028.**

**VIDEOCIPHER II** technical manuals. 120+ pages. **Volume 1—hardware, Volume 2—software.** Either \$29.95 both \$49.95. Catalog—\$3.00. **MICROTRONICS, Box 6426, Yuma, AZ 85364-0840.**

**FREE** catalog 99-cents kits—audio, video, computer parts. **ALLKIT, 434 W. 4th St., West Islip, NY 11795.**

**CHEMICAL** magic. Those hard-to-find formulas. Catalog \$1. **CFC, Box 30007 Des Moines, IA 50310.**

**DECODING** plans and theory booklets. Video tape copy protection, removes flashing and jitter, 30 pages, \$15.45. Jerrold DI and DIC decoder theory, 12 pages, \$6.95. Gated pulse decoding plus new universal single level suppression decoder, works on Hamlin, Jerrold, Sylvania, Eagle, 39 pages, \$15.00. Video scrambling techniques, the original secret manual. Sinewave and Zenith SSAVI, 57 pages, \$14.95. Hidden signals on satellite TV, 178 pages, \$16.95. P.C. board and kits available. **ELEPHANT ELECTRONICS INC., P.O. Box 41865-J, Phoenix, AZ 85080, (602) 581-1973.**

**MAKE** your light bulbs last 10 years. **Free information. INTERNATIONAL, 5425-E West Almeria, Phoenix, AZ 85035.**

**THE** decoder. National monthly technical newsletter covering Satellite/Cable descrambling systems. Includes: news, schematics, modifications, reviews, tips and more!!! \$18.00 per year. Sample \$2.00. **TELECODE, Box 6426, Yuma, AZ 85364-08740.**





**\*\*\*\*SCRAMBLING NEWS\*\*\*\*  
PAY TV AND SATELLITE DESCRAMBLING**

Schematics, theory, bypasses. 13 cable, 7 satellite. New SA turn-on. MLD-1200-3 \$14.95. Experiments With Videocipher Cloning, musketeering \$14.95. Cable TV Security design \$12.95. MDS MMDS Handbook Microwave hacking \$9.95. Build Satellite Systems Under \$600 \$12.95. Any 3-5? Scrambling News. Monthly feature articles product reviews, law history, patents \$24.95/yr. Sample \$5. Catalog \$1. RTV vol. 2 \$12.95.

Shojiki Electronics Corp, 1327A Niagara St., Niagara Falls, NY 14303. COD's 716-284-2163

TAKE the beep out and get a clear picture any channel call now (313) 979-8356. BENNY.

SATELLITE system troubleshooting techniques excellent resource by experienced technician, send address \$7.95 to JIM BLACKFORD, 703 11th Ave., Evansville, IN 47712.

VIDEOCIPHER II descrambling manual schematics, video and audio, DES, Cloning, Musketeering, Eprom Codes. (HBO, Cinemax, Showtime, Adult channels) \$12.95, \$1.00 postage. Cabletronics, Box 30502R, Bethesda, MD 20814.

**SCRAMBLE FACTS  
718-343-0130**

PHONE TODAY for 3 minutes of satellite TV industry news, technical tips, and new product information.

SATELLITE TV receiver kits! Instruction manual, boards, semiconductor parts! 59" LNA's! LNB's! Ku-Band LNB's! Catalog \$1.00 (refundable): XANDI ELECTRONICS, Box 25647, Dept. 21EE, Tempe, AZ 85282.

DESCRAMBLERS for movies, networks, \$149. video only. \$390 complete. Catalog \$4 SKYWATCH, 238 Davenport Road, Toronto, Ontario, Canada, M5R-1J6.

DISHES systems upgrades, Chaparral, Drake, Houston, etc. SAVE \$\$\$\$ Toll free, 800/334-6455 SKYVISION, 2066R Collegeway, Fergus Falls, MN 56537

COMPUTER repairs. Flat rate. Commodore C64 \$44.95, 1541 \$49.95, 1571 \$54.95, SX64 \$64.95, Atari 800XL \$49.50, 130XE \$65.00, 1050 \$85.00, 810 \$70.00. Includes most parts. ST's \$89.95 plus parts \$5.00 shipping. MIDTOWN, 27 Midway Plaza, Tallmadge, OH 44278, (216) 633-0997.

WANTED excess inventories of I.C.s, disk drives, circuit boards, computers, etc. WESTERN TECH, (818) 882-1355 (CA)

**CABLE T.V.  
"BOXES"**

**Converters—Descramblers  
Remote Controls—Accessories**

- ★ Guaranteed Best Prices ★
- ★ 1 Year Warranty—COD's ★
- ★ Immediate Shipping ★
- ★ FREE CATALOG ★

Call or Write:

**TRANS-WORLD CABLE CO.**  
HC 83, Box 531  
Pequot Lakes, MN 56472  
(218) 543-6671

**BIG PROFITS  
ELECTRONIC ASSEMBLY BUSINESS**

Start home, spare time, investment knowledge or experience unnecessary. BIG DEMAND assembling electronic devices. Sales handled by professionals. Unusual business opportunity.

FREE: Complete illustrated literature  
BARTA, RE-O Box 248  
Walnut Creek, Calif. 94597

**BUSINESS OPPORTUNITIES**

EARN thousands with your own part time electronics business. I do. Free proof, information. INDUSTRY, Box 531, Bronx, NY 10461.

EASY, lucrative. One man CRT rebuilding machinery. Free info: (815) 459-0666 CRT, 1909 Louise, Crystalake, IL 60014.

MECHANICALLY inclined individuals desiring ownership of small electronics manufacturing business—without investment. Write: **BUSINESSES**, 92-R, Brighton 11th, Brooklyn, NY 11235.

PROJECTION TV..Make \$\$\$s assembling projectors...easy...results comparable to \$2,500 projectors... Total cost less than \$30.00. Plans, 8" lens and dealers information \$20.50... Illustrated information free. **MACROCOM GIX**, Washington Crossing, PA 18977. Creditcard orders 24hrs (215) 736-2880.

**WANTED**

INVENTORS! AIM wants—ideas, inventions, new products, improvements on existing products. We present ideas to manufacturers. Confidentiality guaranteed. Call toll free 1-(800) 225-5800 for information kit.

INVENTIONS, ideas, new products wanted! Industry presentation/national exposition. Call free 1-(800) 288-IDEA. Canada, 1-(800) 528-6060. X831.

**JUST SIMPLY PUT . . .**

"When you're looking for a company that provides service and up-to-date technical advances, call us. That's what we're here for."  
**800-85-AMCOM**

<b>CABLE EQUIPMENT</b>		<b>T O C O M</b>																																													
<p><b>Super Z-TAC ADD-ON</b> ELIMINATES LINE 20 FALSE FLASHING AUTOMATICALLY HANDLES NORMAL &amp; INVERTED VIDEO. NO SWITCHES. <b>\$219.00</b></p> <p><b>Standard SSAVI ADD-ON</b> CH #3 IN CH #3 OUT</p> <p><b>VHF TUNER \$149.00</b> NO BLOCK CONVERTER</p> <p>5 UNITS \$130.00 10 UNITS \$110.00 50 UNITS \$100.00 100 UNITS \$ CALL</p> <p><b>INTERFERENCE FILTERS \$15.00</b> CHANNEL #2, 3, 8, 9, 17 ONLY</p> <p><b>ADVANCED TRIMODE ADD-ON</b> <b>\$99.00</b></p> <p><b>TV TUNER VARACTORS</b></p> <p>VHF/MID/UHF MITSUMI \$25.00 UHF ONLY MITSUMI \$ 5.00</p>	<p><b>THIS KIT WORKS ON ALL TOCOM SYSTEMS, CHANNEL #3 IN/CHANNEL #3 OUT. BUILD IT YOURSELF AND SAVE.</b></p> <p>Assembled and tested <b>\$150.00</b> Kit includes all parts <b>89.00</b></p>		<p><b>"BLASTER" \$25.00</b> UHF PREAMP KIT</p> <p>25 db gain with only .5 NF loss when mass mounted. USES PHANTOM POWER STRIPLINE CIRCUITRY</p> <p><b>UHF SSAVI UNIT</b> w/power supply <b>\$40.00</b></p> <p>ORIGINAL Z.TAC AND SSAVI POWER SUPPLY <b>\$15.00</b></p>																																												
	<p><b>WALL PWR SUPPLIES</b></p> <p>21 VAC 525 MA N/C 5.0 12 VAC 600 MA W/C 2.00 12 VAC 265 MA W/C 1.75</p>																																														
	<p><b>CALL US!!!</b> WE BUY EXCESS INVENTORY</p>																																														
	<p><b>LINEAR</b></p> <table border="1"> <tr> <td>LM318 90</td> <td>MC1310 1.00</td> <td>CD4002 20</td> <td>CD4027 35</td> <td>CD4520</td> </tr> <tr> <td>LM319 80</td> <td>MC1330 .75</td> <td>CD4011 .15</td> <td>CD4040 55</td> <td>CD4526</td> </tr> <tr> <td>LM224 25</td> <td>MC1350 1.25</td> <td>CD4012 25</td> <td>CD4047 55</td> <td>7490</td> </tr> <tr> <td>LF193 80</td> <td>CA1388 4.00</td> <td>CD4013 25</td> <td>CD4050 50</td> <td>74LS04</td> </tr> <tr> <td>LM238 1.25</td> <td>MC1488 25</td> <td>CD4015 35</td> <td>CD4066 25</td> <td>74LS14</td> </tr> <tr> <td>LM2903 40</td> <td>LM1486 75</td> <td>CD4016 25</td> <td>CD4069 25</td> <td>74LS174</td> </tr> <tr> <td>LM555 35</td> <td>LM1989 1.00</td> <td>CD4017 25</td> <td>CD4071 20</td> <td>74LS123</td> </tr> <tr> <td>LM565 75</td> <td>TL082 75</td> <td>CD4018 45</td> <td>CD4081 25</td> <td>74LS123</td> </tr> <tr> <td>NE502 75</td> <td>TL084 1.25</td> <td>CD4024 .40</td> <td>CD4082 20</td> <td>74C906</td> </tr> </table>			LM318 90	MC1310 1.00	CD4002 20	CD4027 35	CD4520	LM319 80	MC1330 .75	CD4011 .15	CD4040 55	CD4526	LM224 25	MC1350 1.25	CD4012 25	CD4047 55	7490	LF193 80	CA1388 4.00	CD4013 25	CD4050 50	74LS04	LM238 1.25	MC1488 25	CD4015 35	CD4066 25	74LS14	LM2903 40	LM1486 75	CD4016 25	CD4069 25	74LS174	LM555 35	LM1989 1.00	CD4017 25	CD4071 20	74LS123	LM565 75	TL082 75	CD4018 45	CD4081 25	74LS123	NE502 75	TL084 1.25	CD4024 .40	CD4082 20
LM318 90	MC1310 1.00	CD4002 20	CD4027 35	CD4520																																											
LM319 80	MC1330 .75	CD4011 .15	CD4040 55	CD4526																																											
LM224 25	MC1350 1.25	CD4012 25	CD4047 55	7490																																											
LF193 80	CA1388 4.00	CD4013 25	CD4050 50	74LS04																																											
LM238 1.25	MC1488 25	CD4015 35	CD4066 25	74LS14																																											
LM2903 40	LM1486 75	CD4016 25	CD4069 25	74LS174																																											
LM555 35	LM1989 1.00	CD4017 25	CD4071 20	74LS123																																											
LM565 75	TL082 75	CD4018 45	CD4081 25	74LS123																																											
NE502 75	TL084 1.25	CD4024 .40	CD4082 20	74C906																																											
<p><b>DEALERS WANTED!! GREAT QUANTITY PRICES</b></p>																																															
<p><b>AMCOM</b> P. O. Box 68391 Virginia Beach, VA 23455 804-456-5505 (TECHNICAL) 800-852-6266 (ORDERS ONLY)</p>		<p><b>UPS DAILY</b> COD ACCEPTED MINIMUM ORDER \$15.00 CALL ANY DAY BEFORE 3PM ORDER WILL BE SHIPPED THAT DAY NO INSTANT SALES</p>																																													

**Parts Express  
International Inc.**



**10" WOOFER**

Heavy duty paper cone with 20 oz magnet. 60 watts RMS, 90 watts max. Response 35-3,500 Hz

#290-083 **\$1880** **\$1690**  
(1-3) (4-UP)

**FREE CATALOG**



Call or write today for your free catalog containing speakers, semiconductors, CATV products, tools, hardware, TV-VCR parts, and more.



**HORN TWEETER**

3" wide dispersion horn tweeter. 1800-15,000 Hz response. 35 watts RMS, 50 watts max. 8 ohm impedance.

#270-050 **\$650** **\$590**  
(1-8) (10-UP)

**CROSSOVERS**



2-Way, 30 watt #260-190 **\$395**

3-Way, 60 watt #260-200 **\$750**

3-Way, 100 watt #260-210 **\$1250**



**PIEZO TWEETER**

Mfg #KSN1005A, 3/4" x 3/4". No crossover required. 50 watts maximum input power.

#270-010 **\$495** **\$395**  
(1-79) (80-UP)



**8" POLY WOOFER**

Clear ribbed polypropylene cone. 60 watts RMS, 90 watts max power. 20 oz magnet. 35-2500 Hz. 4-8 ohm compatible.

#290-055 **\$2050** **\$1895**  
(1-3) (4-UP)



**15" WOOFER**

20 oz magnet. 60 watts RMS, 90 watts max. 8 ohm impedance. 1 1/2" voice coil. 25-2000 Hz

#290-160 **\$3095** **\$2840**  
(1-3) (4-UP)



**5 1/4" CUP MIDRANGE**

Tuned cup. Paper cone. 1" voice coil. 9.3 oz magnet. 50 watts RMS. 70 watts max. Response: 320-6000 Hz. 8 ohm impedance.

#280-020 **\$1190** **\$995**  
(1-9) (10-UP)

**CALL TOLL FREE  
1-800-338-0531**

Local: (513) 222-0173

- 15 day money back guarantee.
- \$10.00 minimum order.
- COD orders accepted.
- 24 hour shipping.
- Shipping charge - UPS chart rate (\$2.50 minimum charge). Hours 8:30 a.m. - 6 p.m. EST M-F

**PARTS EXPRESS INT'L INC.**  
340 East First St  
Dayton, Ohio 45402



**YOUR own radio station!** AM, FM, TV, cable. Licensed/unlicensed. **BROADCASTING**, Box 130-F(5), Paradise, CA 95967.

**BURGLAR alarms—booming business.** Get started now. Information \$2.00. **DYNAMIC SECURITY**, P.O.B. 1456-B Grand Rapids, MI 49501.

**PC board/circuit design, prototyping, and manufacture. Plotting services;** schema, smartwork, **EE-DESIGNER** supported call (609) 586-4469.

**ASSEMBLE digital car dashboards.** Plans: \$14.45, free details, **MODERN LABS**, 2900c Ruisseau, St. Elisabeth, QC, J0K2J0, Canada.

**how would you like to earn \$60,000 to \$80,000 in 3yrs with potential for over \$100,000 per year.** Video and electronics now paying top salaries for technical and nontechnical people. Some jobs work right from home in your home town. Find out more in this **New Industry Report and Career Guide**. Send check or MO for \$12.95 plus \$1.25 shipping and handling to: **AMERICAN BUSINESS AND VENTURE PUBLISHERS**, 114-41 Queens Blvd., Suite 189-R, Forest Hills, NY 11375. Hurry! Order today, limited quantity in print.

### NOTCH FILTERS

**THE POSITRAP Cookbook:** Build 50-60dB filters for pennies. Construction, alignment, fixed, tunable, trimable. Comprehensive **Cable TV scrambling and descrambling** theory and practice. Identifying various systems \$9.95. **CLEARVIEW CABLE COMPANY**, PO Box 207, Sterling Heights, MI 48311.

**MASTERCARD AND VISA** are now accepted for payment of your advertising. Simply complete the form on the first page of the Market Center and we will bill.

## BUY BONDS

### MARK V ELECTRONICS INC.,

8019 E. SLAUSON AVE.  
MONTEBELLO CA90640  
TELEX: 3716914 MARK 5

1-800-423-3483  
TOLL FREE

Only for orders paid by Master or Visacard  
IN CAL.: 1-800-521-MARK

INFORMATION: (213) 888-8988

### 300W HQ HI-FI POWER AMPLIFIER (MONO)

TA-3600   
QUASI-COMPLEMENTARY SYMMETRY WITH PARALLEL HIGH OUTPUT TRANSISTORS

**SPECIFICATIONS**  
\*POWER OUTPUT 300W (RMS) INTO 8 OHMS  
2450W (P.M.P.O.) INTO 8 OHMS  
540W (MUSIC POWER) INTO 8 OHMS  
\*LOAD IMPEDANCE 4 OHMS OR 8 OHMS  
\*FREQUENCY RESPONSE: 10Hz-200,000 Hz  
\*TOTAL HARMONIC DISTORTION LESS THAN 0.05%  
\*INPUT SENSITIVITY AND IMPEDANCE AT 1kHz:  
1V-14V 47K OHMS  
\*SUPPLY VOLTAGE DC: 1.75V OR AC 53V + 2.8A  
KIT/ASSM WITH TESTED \$80/92  
X'FORMER (WEIGHT: 15 lb.) \$38 00

### 120W MOSFET POWER AMPLIFIER

TA-477   
BUILD A PROFESSIONAL AMP BY YOURSELF

KIT \$61.28  
Metal Cabinet/X'Former (Optional) \$26.00/\$1988

### MULTIFUNCTIONAL LED D.P.M.

**LARGE 3 1/2 DIGIT 0.6 LED DISPLAY**  
MEASUREMENT RANGE  
D.C. VOLTAGE 1mV-1000V  
A.C. VOLTAGE 1mV-1000V  
DIGITAL THERMOMETER 0°C-100°C  
D.C. CURRENT 1uA-2A  
CAPACITOR METER 1pF-2uF  
DIMENSIONS 3 3/4" x 1 7/8" x 4 1/16"  
KIT \$30.00  
ASSM WITH TESTED D.P.M. \$36.00

**FREE GOLD-PLATED EDGE CONNECTOR ONLY**

# DIGITAL CLOCK & APPLIANCE TIMER

## \$4.95

each, plus UPS shipping, \$10. minimum order

### URNS ON HOUSEHOLD LIGHTS, COFFEE POTS, RADIOS, ETC.

Capable of switching up to 10 amps!  
Operates from 120 vac, 60 Hz. Automatically turns off after two hours or schematic available for bypassing automatic turn-off.  
Includes plastic mounting bezel, as pictured.  
MODEL #591F17 \$4.95. Bare bones models available in catalog.

**SEND FOR FREE CATALOG**

**R&D ELECTRONICS CATALOG INCLUDES:** rechargeable batteries, cable, capacitors, connectors, converters, diodes, displays, fans, filters, hardware, heatsinks, integrated circuits, LEDs, lights, motors (all kinds), MOVs, PMTs, pots, power supplies, rectifiers, recorders, relays, resistors, SCR & TRIACS, switches, toroids, transformers, transistors, and wire.

**ALL AT DISCOUNT SURPLUS PRICES! SATISFACTION GUARANTEED.**

Brand new 40 page 1988 catalogs  
AVAILABLE NOW!  
**(813) 772-1441**

R&D Electronics is the mail order branch of ELECTRONIC SURPLUS of Cleveland, Ohio



CIRCLE 207 ON FREE INFORMATION CARD

**MARK V ELECTRONICS INC.,**  
8019 E. SLAUSON AVE.  
MONTEBELLO CA90640  
TELEX: 3716914 MARK 5

1-800-423-3483  
TOLL FREE

Only for orders paid by Master or Visacard  
IN CAL.: 1-800-521-MARK

INFORMATION: (213) 888-8988

### 300W HQ HI-FI POWER AMPLIFIER (MONO)

TA-3600   
QUASI-COMPLEMENTARY SYMMETRY WITH PARALLEL HIGH OUTPUT TRANSISTORS

**SPECIFICATIONS**  
\*POWER OUTPUT 300W (RMS) INTO 8 OHMS  
2450W (P.M.P.O.) INTO 8 OHMS  
540W (MUSIC POWER) INTO 8 OHMS  
\*LOAD IMPEDANCE 4 OHMS OR 8 OHMS  
\*FREQUENCY RESPONSE: 10Hz-200,000 Hz  
\*TOTAL HARMONIC DISTORTION LESS THAN 0.05%  
\*INPUT SENSITIVITY AND IMPEDANCE AT 1kHz:  
1V-14V 47K OHMS  
\*SUPPLY VOLTAGE DC: 1.75V OR AC 53V + 2.8A  
KIT/ASSM WITH TESTED \$80/92  
X'FORMER (WEIGHT: 15 lb.) \$38 00

### 120W MOSFET POWER AMPLIFIER

TA-477   
BUILD A PROFESSIONAL AMP BY YOURSELF

KIT \$61.28  
Metal Cabinet/X'Former (Optional) \$26.00/\$1988

### MULTIFUNCTIONAL LED D.P.M.

**LARGE 3 1/2 DIGIT 0.6 LED DISPLAY**  
MEASUREMENT RANGE  
D.C. VOLTAGE 1mV-1000V  
A.C. VOLTAGE 1mV-1000V  
DIGITAL THERMOMETER 0°C-100°C  
D.C. CURRENT 1uA-2A  
CAPACITOR METER 1pF-2uF  
DIMENSIONS 3 3/4" x 1 7/8" x 4 1/16"  
KIT \$30.00  
ASSM WITH TESTED D.P.M. \$36.00

**FREE GOLD-PLATED EDGE CONNECTOR ONLY**

**\* FREE BALL POINT-PEN WITH ANY PURCHASE**

**\* FREE T-SHIRT**  
(ONE SIZE FITS ALL) WITH EVERY PURCHASE OF \$100 OR MORE  
\* AVAILABLE UNTIL STOCKS LAST!

**WALK IN FOR YOUR FREE GIFT!**

**STATE OF ARTS HQ FET ST. PRE-AMP**

TA-377A   
0.007% T.H.D.

**8 Digit 1 GHz Multifunctional Counter SM/FC-1000A**

**DIGITAL MENO TA-28** 

OFFICE HOURS: (PACIFIC TIME)  
MON.-FRI. 9:30 to 5:00 SAT. 10:00 to 5:00

TERMS: \$10 min order • \$20 min charge card order • Check, money order or phone order accepted • We ship UPS Ground • Add 10% of total order (min \$2.5) for shipping outside USA add 20% (min \$5.00) • Transit insurance add 5% of total (outside USA only) • CA residents add sales tax • All merchandise subject to prior sale • Prices are subject to change without notice • Any goods proved to be defective MUST BE RETURNED IN ORIGINAL FORM WITH A COPY OF YOUR INVOICE WITHIN 30 DAYS FOR REPLACEMENT

**FREE CATALOG**  
4 1/2 HI-PRECISION D.P.M.  
SM-48A   
**NEW**

**SPECIFICATIONS:**  
\*4 1/2 digit 14mm red large display with overload flash  
\*Multi-functions including BCD, BUSY, STROBE output, very suitable for micro computer  
\*MEMORY SYSTEM CAN HOLD the input reading for comparison and monitor:  
\*Range DC voltage DC: 1mV-2000A  
DC current DC: 1uA-20A  
\*Accuracy DC: 0.025% - 2 digit  
\*Power DC: 6V at 200mA  
DIMENSIONS: 3 3/4" (W) x 1 7/8" (H) x 4 1/16" (D)  
(MEET WITH DIN STANDARD OF W. GERMANY.)  
KIT/ASSM WITH TESTED & CAL. \$415/51

**PROFESSIONAL COLOR LIGHT CONTROLLER SM-328** 

**FEATURES:**  
1. FOUR GROUPS OF INDEPENDENT OUTPUT SYSTEM 1000W/CH MAX  
4680W (100 117V) 2. PROFESSIONAL COLOR CONTROL SYSTEM (KEY BOARD TYPE) 3. INDEPENDENT INPUT SIGNAL ADJUSTMENT 4. FOUR GROUPS OF INDEPENDENT DIMMER CONTROL 5. SPEED CONTROL CHASER 6. AUTOMATIC CHASING CONTROL SYSTEM 7. FOUR KINDS OF SPECIAL CHASING PROGRAM 8. COMBINATION OF PROGRAM AND MUSIC CHASING EFFECT 9. FORWARD BACKWARD CHASING CONTROL SM-328 color light controller is specialized for ballroom, night club disco and advertisement lighting. It conforms with several color control characteristics, which employ professional color control system and keyboard program selection. Therefore, it is capable of producing lighting effects by using chasing program and fluctuating music signal. There are two kinds of lighting effects. The first type is controlled by "music" signal. In order to adjust the brightness of four groups of lightings, each music signal will be separated into high, medium low A and low B frequency range. Furthermore, each group of lightings is incorporated with an independent signal adjustment. The second kind is composed of electrical circuits and this is the main part for creating a special lighting effect. It has four chasing programme.  
Dimensions 14 5/16" x 8 15/16" x 3 3/16"  
Ass. with tested \$150.00 **ONLY**

**ELECTRONIC ECHO AND REVERBERATION AMPLIFIER**   
TR-2400A  
**RECORDS W/ ECHO EFFECT YOURSELF!**

**8 Digit 1 GHz Multifunctional Counter SM/FC-1000A**

A versatile laboratory bench digital counter with FIVE FUNCTION performance FREQUENCY, PERIOD, UNIT DIGITALIZED DATA, HOLD & RELEASE, CHASE. The period function makes the instrument outstanding for video tape recorder service applications. D.S. Bright LED display assure easy readability of values. High stabilized dual crystal oscillators are used to ensure the accuracy in measurement. Durable alloy cabinet with "lock" keying panel. Comes complete with test lead and owners manual.

**FEATURES:**  
Frequency range 10Hz-1GHz GUARANTEED 5Hz-1.2GHz typically  
Input sensitivity: 10Hz-100MHz 10mV-20mV  
100MHz-1.2GHz 15mV-20mV  
Rival range: 0.5uS-10uS  
Unit counting capacity: 99999999  
Accuracy: ±1 count, ±1ms tape accuracy  
Hole function: Holds the last input signal (Max 8 digit)  
Power supply: 117V AC ±10% 50-60Hz  
Dimensions: 8.65" (W) x 7.87" (D) x 4.12" (H)  
ASSM WITH TESTED & CAL. \$318.00

**DIGITAL MENO TA-28** 

**NO TAPE REQUIRED**

**NEW FOR 1988**

**SPECIFICATIONS:**  
16 SEC. RECORD TIME • LED FUNCTION INDICATOR  
AUTO RECORD CIRCUIT • INTERNAL 256K DRAM MEMORY  
• INTERNAL MIC AMPLIFIER • ONE PUSH ON/OFF POWER • TWO RECORD FUNCTION TALK-BACK MODE & MESSAGE MODE • LOW POWER CONSUMPTION • SUPPLY VOLTAGE 9V 20MA D.C.  
KIT \$20.00

**FREE CATALOG**  
4 1/2 HI-PRECISION D.P.M.  
SM-48A   
**NEW**

**PROFESSIONAL COLOR LIGHT CONTROLLER SM-328** 

**FEATURES:**  
1. FOUR GROUPS OF INDEPENDENT OUTPUT SYSTEM 1000W/CH MAX  
4680W (100 117V) 2. PROFESSIONAL COLOR CONTROL SYSTEM (KEY BOARD TYPE) 3. INDEPENDENT INPUT SIGNAL ADJUSTMENT 4. FOUR GROUPS OF INDEPENDENT DIMMER CONTROL 5. SPEED CONTROL CHASER 6. AUTOMATIC CHASING CONTROL SYSTEM 7. FOUR KINDS OF SPECIAL CHASING PROGRAM 8. COMBINATION OF PROGRAM AND MUSIC CHASING EFFECT 9. FORWARD BACKWARD CHASING CONTROL SM-328 color light controller is specialized for ballroom, night club disco and advertisement lighting. It conforms with several color control characteristics, which employ professional color control system and keyboard program selection. Therefore, it is capable of producing lighting effects by using chasing program and fluctuating music signal. There are two kinds of lighting effects. The first type is controlled by "music" signal. In order to adjust the brightness of four groups of lightings, each music signal will be separated into high, medium low A and low B frequency range. Furthermore, each group of lightings is incorporated with an independent signal adjustment. The second kind is composed of electrical circuits and this is the main part for creating a special lighting effect. It has four chasing programme.  
Dimensions 14 5/16" x 8 15/16" x 3 3/16"  
Ass. with tested \$150.00 **ONLY**

**ELECTRONIC ECHO AND REVERBERATION AMPLIFIER**   
TR-2400A  
**RECORDS W/ ECHO EFFECT YOURSELF!**

CIRCLE 93 ON FREE INFORMATION CARD

[www.americanradiohistory.com](http://www.americanradiohistory.com)



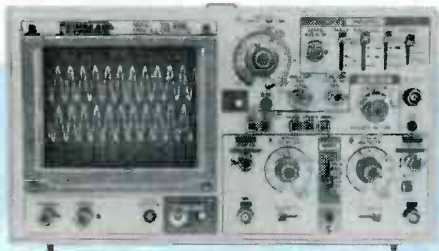

**TENMA** 35MHz Dual Trace Oscilloscope

- Two high quality 10:1 probes included
- For additional specification see MCM Catalog #17

#72-330

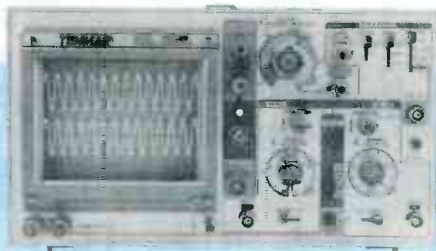

**TENMA** 20MHz Dual Trace Oscilloscope

- Two high quality 10:1 probes included
- For additional specification see MCM Catalog # 17

#72-320



**TENMA** 3 1/2 Digit LCD Multimeter

- Measures resistance, AC-DC voltage and current
- Diode and hFe transistor tests
- Overload protection
- 10Mohm input impedance
- Carrying case included

#72-050



**TENMA** 30A Power Supply

- Output voltage: 1-15VDC
- Lighted cross needle meter: Displays voltage, current and power simultaneously
- Output current: 30A, 22A continuous
- Fan cooled

#72-035



**TENMA** 0-18V 3A

Power Supply

- Regulated outputs — constant volt or constant current, both are continuously variable
- Can be connected in series or parallel for more voltage or current output
- Reverse polarity and overload protected
- Isolated output

#72-420

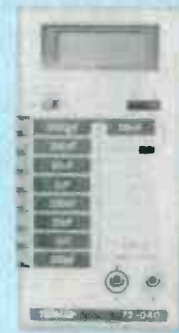

**TENMA** Digital Capacitance Meter

- Measurement range from 0.1pF to 19,999µF
- Sampling time: .5 seconds
- Accuracy: ± 1% full scale
- Checks capacitors in or out of circuit
- Carrying case included

#72-040



**TENMA** Frequency Counter

- 8 digit LED display
- Measurement range: 1Hz-120MHz
- High input sensitivity of 20mV RMS

#72-375



**TENMA** Combination Function Generator and Frequency Counter

- 6 digit display
- Output range: 2Hz-2MHz: seven ranges
- Counter range: 1Hz-10MHz
- 5-15V TTL and CMOS output
- Wave forms: sine, triangle, square, pulse, and ramp

#72-380

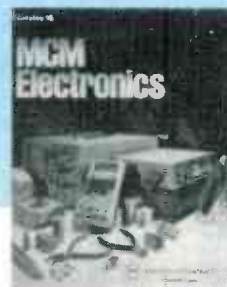

**Be Sure To Call For Your FREE Catalog! Over 6,000 Items!**

We also have . . . a fullline of test equipment, computer accessories, telephone accessories, speakers, television parts, flybacks, yokes, switches, fuses, lamps, capacitors, resistors, cartridges, styli, wire, CATV equipment, the largest selection of original Japanese semi-conductors in the country and more.



**MCM ELECTRONICS**  
858 E. CONGRESS PARK DR.  
CENTERVILLE, OH 45459 4072  
A PREMIER Company

SOURCE NO. RE-44

© 1988, MCM ELECTRONICS



**THE NAME YOU CAN TRUST IN ELECTRONIC TEST EQUIPMENT**

**CALL TOLL FREE 1-800-543-4330**

**In Ohio 1-800-762-4315 • In Alaska and Hawaii 1-800-858-1849**

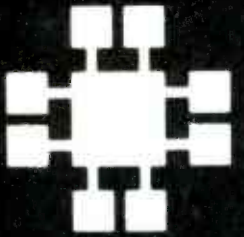

# JDR Microdevices®

Complete customer satisfaction... superior service... friendly, knowledgeable personnel  
quality merchandise... providing the best values in leading edge technology.

### STATIC RAMS

2112	256x4	(450ns)	2.99
2114	1024x4	(450ns)	.99
2114L-2	1024x4	(200ns)(LOW POWER)	1.49
TMM2016-100	2048x8	(100ns)	1.95
HM6116-4	2048x8	(200ns)(CMOS)	1.79
HM6116-3	2048x8	(150ns)(CMOS)	1.85
HM6116LP-4	2048x8	(200ns)(CMOS)(LP)	1.85
HM6116LP-3	2048x8	(150ns)(CMOS)(LP)	1.90
HM6116LP-2	2048x8	(120ns)(CMOS)(LP)	2.45
HM6264LP-15	8192x8	(150ns)(CMOS)(LP)	3.95
HM6264LP-12	8192x8	(120ns)(CMOS)(LP)	4.49
HM43256LP-15	32768x8	(150ns)(CMOS)(LP)	12.95
HM43256LP-12	32768x8	(120ns)(CMOS)(LP)	14.95
HM43256LP-10	32768x8	(100ns)(CMOS)(LP)	19.95

### DYNAMIC RAMS

4116-250	16384x1	(250ns)	.49
4116-200	16384x1	(200ns)	.89
4116-150	16384x1	(150ns)	1.49
4116-120	16384x1	(120ns)	1.99
MK4332	32768x1	(200ns)	6.95
4164-150	65536x1	(150ns)	1.79
4164-120	65536x1	(120ns)	1.99
MCM6665	65536x1	(200ns)	1.95
TMS4164	65536x1	(150ns)	1.95
4164-REFRESH	65536x1	(150ns)(PIN 1 REFRESH)	2.95
TMS4416	16384x4	(150ns)	3.75
41128-150	131072x1	(150ns)	5.95
TMS4464-15	65536x4	(150ns)	4.95
41256-150	262144x1	(150ns)	3.95
41256-120	262144x1	(120ns)	4.95
41256-100	262144x1	(100ns)	5.49
HMS1258-100	262144x1	(100ns)(CMOS)	6.95
1 MB-120	1048576x1	(120ns)	31.95
1 MB-100	1048576x1	(100ns)	34.95

### EPROMS

2708	1024x8	(450ns)(25V)	4.95
2716	2048x8	(450ns)(25V)	3.49
2716-1	2048x8	(350ns)(25V)	3.95
TMS2532	4096x8	(450ns)(25V)	5.95
2732	4096x8	(450ns)(25V)	3.95
2732A	4096x8	(250ns)(21V)	3.95
2732A-2	4096x8	(200ns)(21V)	4.25
2764	8192x8	(250ns)(12.5V CMOS)	4.95
2764-250	8192x8	(450ns)(12.5V)	3.49
2764-200	8192x8	(250ns)(12.5V)	3.69
MCM68766	8192x8	(200ns)(12.5V)	4.25
27128	16384x8	(350ns)(21V)(24 PIN)	15.95
27C256	32768x8	(250ns)(12.5V CMOS)	7.95
27256	32768x8	(250ns)(12.5V)	5.95
27512	65536x8	(250ns)(12.5V)	11.95
27C512	65536x8	(250ns)(12.5V CMOS)	12.95

1xV-Program Voltage

## ★★ HIGH-TECH ★★

### 8052AH WITH BASIC \$3495

- \* SINGLE CHIP MICRO-CONTROLLER WITH BASIC IN ROM
- \* BUILT-IN SERIAL PORT, THREE 16 BIT TIMERS, FIVE INTERRUPTS AND 256 BYTES OF RAM
- \* REQUIRES VERY FEW PARTS TO BUILD AND EASY-TO-PROGRAM CONTROLLER
- \* BASIC INTERPRETER IS OPTIMIZED FOR CONTROL APPLICATIONS

## ★★ SPOTLIGHT ★★

8000		8200	
8031	3.95	8203	14.95
8035	1.49	8205	3.29
8039	1.95	8212	1.49
8052AH BASIC	34.95	8216	1.49
8080	2.49	8224	2.25
8085	1.95	8228	2.25
8086	6.49	8237	3.95
8088	5.99	8237-5	4.75
8088-2	7.95	8243	1.95
8155	2.49	8250	6.95
8155-2	3.95	8251	1.29
8741	9.95	8251A	1.69
8748	7.95	8253	1.59
8749	9.95	8253-5	1.95
8755	14.95	8255	1.49
8255-5	1.59	8259-5	1.95
8259-5	2.29	8279	2.49
8279	2.25	8279-5	2.95
8272	4.39	8282	3.95
8274	4.95	8283	3.95
8275	16.95	8284	2.25
8279	2.49	8286	3.95
8279-5	2.95	8287	3.95
8282	3.95	8288	4.95

### MATH COPROCESSORS

8087	5 MHz	\$99.95
8087-2	8 MHz	\$159.95
8087-1	10 MHz	\$229.95
8087-8	6 MHz	\$179.95
80287-8	8 MHz	\$249.95
80287-10	10 MHz	\$309.95
80387-16	16 MHz	\$499.95
80387-20	20 MHz	\$799.95



### 74LS00

74LS00	16	74LS112	29	74LS241	.69
74LS01	18	74LS122	45	74LS242	.69
74LS02	17	74LS123	49	74LS243	.69
74LS03	18	74LS124	2.75	74LS244	.69
74LS04	16	74LS125	39	74LS245	.79
74LS05	18	74LS126	39	74LS251	.49
74LS08	18	74LS132	39	74LS253	.49
74LS09	18	74LS133	49	74LS257	.39
74LS10	16	74LS136	39	74LS258	.49
74LS11	22	74LS138	39	74LS259	1.29
74LS12	22	74LS139	39	74LS260	.49
74LS13	26	74LS145	99	74LS266	.39
74LS14	39	74LS147	99	74LS273	.79
74LS15	26	74LS148	99	74LS279	.39
74LS20	17	74LS151	39	74LS280	1.98
74LS21	22	74LS153	39	74LS283	.59
74LS22	22	74LS154	1.49	74LS290	.89
74LS27	23	74LS155	59	74LS293	.89
74LS28	26	74LS156	49	74LS299	1.49
74LS30	17	74LS157	35	74LS322	3.95
74LS32	18	74LS158	25	74LS323	2.49
74LS33	28	74LS160	25	74LS365	.39
74LS37	26	74LS161	39	74LS367	.39
74LS38	26	74LS162	49	74LS368	.39
74LS42	39	74LS163	39	74LS373	.79
74LS47	75	74LS164	49	74LS374	.79
74LS48	85	74LS165	65	74LS375	.95
74LS51	17	74LS166	95	74LS377	.79
74LS73	29	74LS169	95	74LS390	1.19
74LS74	24	74LS173	39	74LS393	.79
74LS75	29	74LS174	39	74LS541	1.49
74LS76	29	74LS175	39	74LS624	1.95
74LS83	49	74LS191	49	74LS640	.99
74LS85	49	74LS192	69	74LS649	.99
74LS86	22	74LS193	69	74LS670	.89
74LS90	39	74LS194	69	74LS682	3.20
74LS92	49	74LS195	69	74LS688	2.40
74LS93	39	74LS196	69	74LS783	22.95
74LS95	49	74LS197	59	25LS251	2.80
74LS107	34	74LS221	59	26LS31	1.95
74LS109	36	74LS240	69	26LS32	1.95

### 7400

7400	19
7402	19
7404	19
7406	29
7407	29
7408	24
7410	19
7411	25
7414	49
7416	25
7417	25
7420	19
7430	19
7432	29
7438	39
7442	49
7445	69
7447	89
7473	34
7474	33
7475	45
7476	35
7483	50
7485	59
7486	35
7489	215
7490	39
7493	35
74121	29
74123	49
74125	45
74150	135
74151	55
74151	65
74154	1.49
74157	55
74159	65
74161	65
74164	85
74166	1.00
74175	.89
74367	65

### LINEAR

LM567	.79
NE570	2.95
NE592	.95
LM723	.29
LM733	.95
LM734	.98
LM741	.29
LM747	.69
MC1330	1.69
MC1350	1.19
LM1458	35
LM1488	.49
LM1489	.49
LM1496	.85
ULM2003	.79
ULM2003	3.95
XR2211	2.95
LM2917	1.95
CA3046	.89
CA3146	1.29
LM330	1.75
LM3373	1.29
MC3470	1.95
MC3480	8.95
MC3487	2.95
LF356	99
LF356	99
LM3911	2.25
LM3909	.98
LM3914	1.89
MC4024	3.49
LM3913	1.95
RC4136	1.25
RC4558	.69
LM13600	1.49
75107	1.49
75110	1.35
75150	1.95
75154	1.95
75188	1.25
75189	1.25
75451	.39
75452	.39
75477	1.29
H-TO 5 CAN. K-TO 3. T-TO 220	

### 6500

6502	2.25
65C02 (CMOS)	7.95
6520	1.65
6522	2.95
6526	13.95
6532	5.95
6545	2.95
6551	2.95

### Z-80

Z80-CPU	1.29
Z80A-CTC	1.69
Z80A-DART	5.95
Z80A-DMA	5.95
Z80A-PIO	1.89
Z80A-SIO 0	5.95
Z80A-SIO 1	5.95
Z80A-SIO 2	5.95
Z80B-CPU	2.75
Z80B-CTC	4.25
Z80B-PIO	4.25
Z80B-DART	6.95
Z80B-SIO 0	12.95
Z80B-SIO 2	12.95
Z8671 ZILOG	9.95

### DISK CONTROLLERS

1771	4.95
1791	9.95
1793	9.95
1795	12.95
1797	12.95
2791	19.95
2793	19.95
2797	29.95
8272	4.39
UPD765	4.39
MB8876	12.95
MB8877	12.95
1691	6.95
2143	6.95
9216	6.29

### V20 SERIES

V20 5 MHz	8.95
V20 8 MHz	10.95
V20 10 MHz	12.95
V30 8 MHz	13.95

\*Replaces 8088 to speed up PC 10.40%

### PALS

16L8	\$2.95
16R8	\$2.95
16R6	\$2.95
16R4	\$2.95

### 6800

6800	1.95
6802	2.95
6803	3.95
6809	3.95
6809E	2.95
6810	1.95
6820	2.95
6821	1.25
6840	3.95
6843	4.95
6844	6.95
6845	2.75
6847	4.75
6850	1.95
6883	22.95

### CLOCK CIRCUITS

MM58167	9.95
MM58174	9.95
MSM5832	2.95

### BIT RATE GENERATORS

MC14411	9.95
BR1941	4.95
4702	9.95
COM8116	8.95

### UARTS

AY5-1013	3.95
AY3-1015	4.95
TR1602	3.95
2651	4.95
IM6402	3.95
IM6403	9.95
INS8250	6.95
NS16450	10.95

### MISC.

ADC0804	2.99
ADC0809	3.85
DAC0800	3.29
DAC0808	1.95
OAC1022	5.95
MC1408L8	1.95
8T28	1.29
8T97	.59
DP9304	2.29
9334	1.75
9368	2.85
9602	6.9
UIN2003	7.9
MAX232	.75
MC3470	1.95
MC3487	2.95
AY5-3600 PRO	11.95

### OSCILLATORS

### CAPACITORS

TANTALUM				
1.0µf	15V	12	1.0µf	35V 45
6.8	15V	42	2.2	35V 19
10	15V	45	4.7	35V 39
22	15V	99	10	35V 69

### DISC

10µf	50V	05	001µf	50V 05
22	50V	05	005	50V 05
33	50V	05	01	50V 07
47	50V	05	05	50V 07
100	50V	05	1	12V 10
220	50V	05	1	50V 12

### MONOLITHIC

0.01µf	50V	14	1µf	50V 18
0.047µf	50V	15	47µf	50V 25

### ELECTROLYTIC

RADIAL		AXIAL	
1µf	25V 14	1µf	50V 14
4.7	50V 11	10	50V 16
10	50V 11	22	16V 14
47	35V 13	47	50V 19
100	16V 15	100	35V 19
220	35V 20	470	50V 29
470	25V 30	1000	16V 29
2200	16V 70	2200	16V 70
4700	25V 1.45	4700	16V 1.25

### RESISTOR NETWORKS

SIP	8 PIN	9 RESISTOR	.69
SIP	8 PIN	7 RESISTOR	.59
DIP	16 PIN	8 RESISTOR	1.09
DIP	16 PIN	15 RESISTOR	1.09
DIP	14 PIN	7 RESISTOR	.99
DIP	14 PIN	13 RESISTOR	.99

### 38 PIN CENTRONICS

IDCEN36	RIBBON CABLE	3.95
CEN36	SOLDER CUP	1.85
IDCEN36/F	RIBBON CABLE	4.95
CEN36PC	Rt Angle PC Mount	1.85

### EDGE CARD CONNECTORS

100 Pin	ST	S-100	125	3.95
100 Pin	WW	S-100	125	4.95
62 Pin	ST	IBM PC	100	1.95
50 Pin	ST	APPLE	100	2.95
44 Pin	ST	STD	156	1.95
44 Pin	WW	STD	156	4.95

### BYPASS CAPACITORS

0.1µf	CERAMIC DISC	100	\$5.00
0.1µf	MONOLITHIC	100	\$10.00
1µf	CERAMIC DISC	100	\$6.50
1µf	MONOLITHIC	100	\$12.50

### 25 PIN D-SUB GENDER CHANGERS \$7.95



### EMI FILTER \$4.95

### LINE CORDS

2 conductor	39c
3 conductor	99c
3 conductor w/ female socket	\$1.49

### SOLDER STATION

- UL APPROVED
- ADJUSTABLE HEAT SETTING W/ TIP TEMP READOUT
- QUICK HEATING & RECOVERY
- RANGE 200°-900°F

**\$49.95**

### EXTENDER CARDS FOR IBM

EXT-8088 \$29.95  
EXT-80286 \$39.95



### SHORTING BLOCKS \$1.00



### WHY THOUSANDS CHOOSE JDR

- QUALITY MERCHANDISE
- COMPETITIVE PRICES
- MOST ORDERS SHIPPED IN 24 HOURS
- FRIENDLY, KNOWLEDGEABLE STAFF
- 30-DAY MONEY BACK GUARANTEE
- TOLL FREE TECHNICAL SUPPORT
- EXCELLENT CUSTOMER SERVICE

**CALL FOR VOLUME QUOTES**

### WIREWRAP PROTOTYPE CARDS

FR-4 EPOXY GLASS LAMINATE  
GOLD PLATED EDGE-CARD FINGERS  
SILK SCREENED LEGENDS  
MOUNTING BRACKET

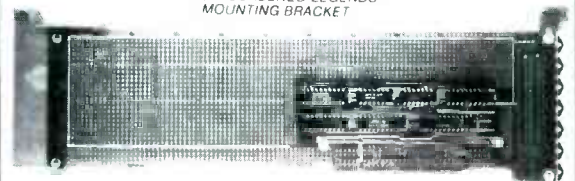

### FOR PS/2

JDR-PR32	32 BIT PROTOTYPE CARD	\$69.95
JDR-PR16	16 BIT WITH I/O DECODING CIRCUITRY	\$49.95
JDR-PR16-PK	PARTS KIT FOR ABOVE	\$15.95
JDR-PR16V	EXTENDED CONNECTORS FOR VIDEO APPLICATIONS	\$39.95

### FOR XT

IBM-PR1	WITH +5V AND GROUND PLANE	\$27.95
IBM-PR2	AS ABOVE WITH DECODING LAYOUT	\$29.95

### FOR AT

JDR-PR10	16 BIT WITH DECODING LAYOUT	\$34.95
JDR-PR10-PK	PARTS KIT FOR ABOVE	\$12.95

### SOLDERLESS BREADBOARDS

WBU-D	100 TIE POINTS	2.95
WBU-T	630 TIE POINTS	6.95
WBU-204.3	1360 TIE POINTS	17.95
WBU-204	1660 TIE POINTS	24.95
WBU-206	4390 TIE POINTS	29.95
WBU-208	3220 TIE POINTS	39.95

### PAGE WIRE WRAP WIRE

PRECUT ASSORTMENT IN ASSORTED COLORS \$27.50  
100ea: 5.5", 6.0", 6.5", 7.0"  
250ea: 2.5", 4.5", 5.0"  
500ea: 3.0", 3.5", 4.0"

### SPOOLS

100 feet	\$4.30	250 feet	\$7.25
500 feet	\$13.25	1000 feet	\$21.95

Please specify color: Blue, Black, Yellow or Red

### SOCKET-WRAP 1.0™

- SLIPS OVER WIRE WRAP PINS
  - IDENTIFIES PIN NUMBERS ON WRAP SIDE OF BOARD
  - CAN WRITE ON THE PLASTIC, SUCH AS AN IC #
- | PINS | PART #    | PCK. OF | PRICE |
|------|-----------|---------|-------|
| 8    | IDWRAP 08 | 10      | 1.95  |
| 14   | IDWRAP 14 | 10      | 1.95  |
| 16   | IDWRAP 16 | 10      | 1.95  |
| 18   | IDWRAP 18 | 5       | 1.95  |
| 20   | IDWRAP 20 | 5       | 1.95  |
| 22   | IDWRAP 22 | 5       | 1.95  |
| 24   | IDWRAP 24 | 5       | 1.95  |
| 28   | IDWRAP 28 | 5       | 1.95  |
| 40   | IDWRAP 40 | 5       | 1.95  |
- PLEASE ORDER BY NUMBER OF PACKAGES (PCK. OF)

### SWITCHES

SPDT	MINI TOGGLE ON-OFF	1.25
DPDT	MINI TOGGLE ON-OFF	1.50
DPDT	MINI TOGGLE ON-OFF-ON	1.75
SPST	MINI PUSHBUTTON N/O	.39

### OIP SWITCHES

4 position	85	7 position	95
5 position	90	8 position	95
6 position	90	10 position	1.29

### "SNAPPABLE" HEADERS

CAN BE SNAPPED APART TO MAKE ANY SIZE HEADER. ALL WITH .1" CENTERS

1x40	STRAIGHT LEAD	99
1x40	RIGHT ANGLE LEAD	49
2x40	2 STRAIGHT LEADS	2.49
2x40	2 RIGHT ANGLE LEADS	2.99

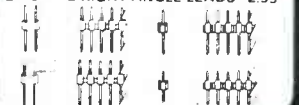

### SPECTRONICS CORPORATION EPROM ERASERS

Model	Timer	Chip Capacity	Intensity (uW/cm²)	Unit Cost
PE-140	NO	9	8,000	\$89
PE-140T	YES	9	8,000	\$139
PE-240T	YES	12	9,600	\$189

### DATASRE

- ERASES 2 EPROMS IN 10 MINUTES
- VERY COMPACT, NO DRAWER
- THIN METAL SHUTTER PREVENTS UV LIGHT FROM ESCAPING

**\$34.95**



### LIGHT EMITTING DIODES LED DISPLAYS

FND-357(359)	COM CATHODE	362"	1.25
FND-500(503)	COM CATHODE	5"	1.49
FND-507(510)	COM ANODE	5"	1.49
MAN-72	COM ANODE	3"	.99
MAN-74	COM CATHODE	3"	.99
TIL-313	COM CATHODE	3"	.45
TIL-311	4x7 HEX W/ LOGIC	270"	10.95

### DIFFUSED LEDs

	1-99	100-UP
JUMBO RED	T1 1/2	10 09
JUMBO GREEN	T1 1/2	14 12
JUMBO YELLOW	T1 1/2	14 12
MOUNTING HDW	T1 1/2	10 09
MINI RED	T1	10 09

**3 VOLT LITHIUM BATTERY \$1.95**  
**HOLDER \$1.49**



TERMS: MINIMUM ORDER \$10.00 FOR SHIPPING AND HANDLING INCLUDE \$2.50 FOR UPS GROUND AND \$3.50 UPS AIR. ORDERS OVER 1 LB. AND FOREIGN ORDERS MAY REQUIRE ADDITIONAL SHIPPING CHARGES—PLEASE CONTACT THE SALES DEPARTMENT FOR THE AMOUNT. CA RESIDENTS MUST INCLUDE APPLICABLE SALES TAX. PRICES ARE SUBJECT TO CHANGE WITHOUT NOTICE. WE ARE NOT RESPONSIBLE FOR TYPOGRAPHICAL ERRORS. WE RESERVE THE RIGHT TO LIMIT QUANTITIES AND TO SUBSTITUTE MANUFACTURER. ALL MERCHANDISE SUBJECT TO PRIOR SALE. A FULL COPY OF OUR TERMS IS AVAILABLE UPON REQUEST. ITEMS PICTURED MAY ONLY BE REPRESENTATIVE.

### IDC CONNECTORS/RIBBON CABLE

DESCRIPTION	ORDER BY	CONTACTS				
		10	20	26	34	40 50
SOLDER HEADER	IDHxxS	.82	1.29	1.68	2.20	2.58 3.24
RIGHT ANGLE SOLDER HEADER	IDHxxSR	.85	1.35	1.76	2.31	2.72 3.39
WIREWRAP HEADER	IDHxxW	1.86	2.98	3.84	4.50	5.28 6.63
RIGHT ANGLE WIREWRAP HEADER	IDHxxWR	2.05	3.28	4.22	4.45	4.80 7.30
RIBBON HEADER SOCKET	IDSxx	.63	.89	.95	1.29	1.49 1.69
RIBBON HEADER	IDMxx	---	5.50	6.25	7.00	7.50 8.50
RIBBON EDGE CARD	IDExx	.85	1.25	1.35	1.75	2.05 2.45
10' GREY RIBBON CABLE	RCxx	1.60	3.20	4.10	5.40	6.40 7.50

FOR ORDERING INSTRUCTIONS SEE D-SUBMINIATURE CONNECTORS BELOW

### D-SUBMINIATURE CONNECTORS

DESCRIPTION	ORDER BY	CONTACTS					
		9	15	19	25	37	50
SOLDER CUP	MALE	DBxxP	.45	.59	.69	.69	1.35 1.85
	FEMALE	DBxxS	.49	.69	.75	.75	1.39 2.29
RIGHT ANGLE PC SOLDER	MALE	DBxxPR	.49	.69	---	.79 2.27	---
	FEMALE	DBxxSR	.55	.75	---	.85 2.49	---
WIREWRAP	MALE	DBxxPWW	1.69	2.56	---	3.89 5.60	---
	FEMALE	DBxxSWW	2.76	4.27	---	6.84 9.95	---
IDC RIBBON CABLE	MALE	IDBxxP	1.39	1.99	---	2.25 4.25	---
	FEMALE	IDBxxS	1.45	2.05	---	2.35 4.49	---
HOODS	METAL	MHOODxx	1.05	1.15	1.25	1.25	---
	GREY	HOODxx	.39	.39	---	.39 69 .75	---

ORDERING INSTRUCTIONS:

INSERT THE NUMBER OF CONTACTS IN THE POSITION MARKED 'xx' OF THE ORDER BY PART NUMBER LISTED. EXAMPLE: A 15 PIN RIGHT ANGLE MALE PC SOLDER WOULD BE DB15PR.

**MOUNTING HARDWARE 59¢**

### IC SOCKETS/DIP CONNECTORS

DESCRIPTION	ORDER BY	CONTACTS								
		8	14	16	18	20	22	24	28	40
SOLDERTAIL SOCKETS	xxST	.11	.11	.12	.15	.18	.15	.20	.22	.30
WIREWRAP SOCKETS	xxWW	.59	.69	.69	.99	1.09	1.39	1.49	1.69	1.99
ZIF SOCKETS	ZIFxx	---	4.95	4.95	---	5.95	---	5.95	6.95	9.95
TOOLED SOCKETS	AUGATxxST	.62	.79	.89	1.09	1.29	1.39	1.49	1.69	2.49
TOOLED WW SOCKETS	AUGATxxWW	1.30	1.80	2.10	2.40	2.50	2.90	3.15	3.70	5.40
COMPONENT CARRIERS	ICCxx	.49	.59	.69	.99	.99	.99	.99	1.09	1.49
DIP PLUGS (IDC)	IDPxx	.95	.49	.59	1.29	1.49	---	.85	1.49	1.59

FOR ORDERING INSTRUCTIONS SEE D-SUBMINIATURE CONNECTORS ABOVE

JDR MICRODEVICES, 110 KNOWLES DRIVE, LOS GATOS, CA 95030  
LOCAL (408) 866-6200 FAX (408) 378-8927 TELEX 171-110

RETAIL STORE: 1256 SOUTH BASCOM AVE., SAN JOSE, CA (408) 947-8881  
HOURS: M-F 10-7 SAT. 9-5 SUN. 12-4

**ORDER TOLL FREE 800-538-5000**

COPYRIGHT 1988 JDR MICRODEVICES

CONTINENTAL U.S. AND CANADA

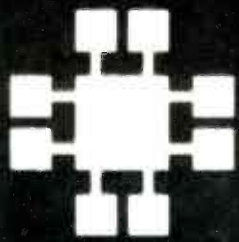

# JDR Microdevices®

Complete customer satisfaction...superior service...friendly, knowledgeable personnel  
quality merchandise...providing the best values in leading edge technology.

**EASYDATA**  
**2400 BAUD**  
**\$149<sup>95</sup>**  
**NEW LOW PRICE!**

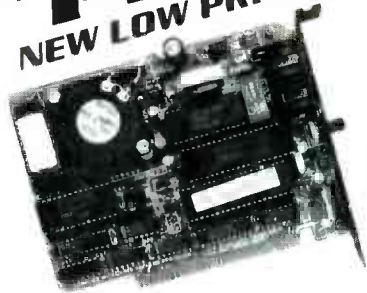

IT'S TIME TO TRADE UP NOW THAT JDR BREAKS THE PRICE BARRIER ON 2400 BAUD MODEMS

- AUTO DIAL ANSWER
- SELF TEST ON POWER UP
- TOUCHTONE OR PULSE DIALING
- HAYES & BELL SYSTEMS COMPATIBLE
- FULL OR HALF DUPLEX
- PC TALK III INCLUDED WITH INTERNAL MODEMS

12H 1200 BAUD 1/2 CARD \$69.95

### EXTERNAL MODEMS

12D 1200 BAUD \$119.95  
24D 2400 BAUD \$219.95

## COMPUTER CASES

ATTRACTIVE, STURDY STEEL CASES FIT THE POPULAR SIZED MOTHERBOARDS AND INCLUDE SPEAKERS, FACEPLATES, EXPANSION SLOTS, FRONT PANEL KEYLOCKS, LED INDICATORS AND ALL NECESSARY HARDWARE



XT STYLE FLIP-TOP \$34.95  
XT STYLE SLIDE TOP \$39.95  
AT STYLE SLIDE-TOP \$89.95  
JR. AT STYLE FLIP-TOP \$149.95  
● INCLUDES 150 WATT POWER SUPPLY

## POWER SUPPLIES

FOR IBM XT COMPATIBLE \$59.95

- UL APP. 135 WATTS
- 5V 15A 12V 4.2A
- 5V 5A 12V 5A

PS-135

PS-150 150W MODEL \$69.95



FOR IBM AT COMPATIBLE \$89.95

- 200 WATTS
- 5V 22A 12V 8A
- 5V 5A 12V 5A

PS-200



**DIABLO**  
**PRINTER**  
**\$279<sup>95</sup>**

- LETTER QUALITY AT 20 CPS, 132 COLS
- 10/12/15 PITCH & PROPORTIONAL SPACING
- SERIAL & PARALLEL INTERFACE
- AUTO PAPER LOAD, FRICTION FEED
- FULL XEROX WARRANTY



**CENTRONICS**  
**LASER \$1195**  
**PRINTER**

NEAR TYPESET QUALITY  
AFFORDABLE AT LAST

- 8 PAGES PER MINUTE ■ 300 DPI RESOLUTION
- 1 YEAR WARRANTY ■ CHOICE OF EMULATION BOARDS
- MULTI-PRINTER EMULATION BOARD**
- PERSON FX 80 EMULATION - NOTHING ELSE REQUIRED
- IBM PC GRAPHICS, PROPRINTER & DIABLO 630
- EMULATION REQUIRES ADDITIONAL FONT CARD
- HP LJ+ EMULATION BOARD**
- HP LASERJET EMULATION - 3 RESIDENT FONTS & 2 PITCHES ADDITIONAL FONT CARD AVAILABLE

1.5MB PAM CARD \$139.95  
EXTRA FONT CARDS \$199.95  
TONER CARTRIDGES \$69.95  
PFS FIRST PUBLISHER \$89.95

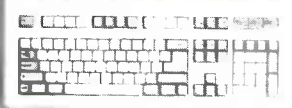

**IBM**  
**COMPATIBLE**  
**KEYBOARDS**  
FULL ONE YEAR WARRANTY

IBM ENHANCED STYLE LAYOUT \$79.95

- AUTOSENSE FOR XT OR AT COMPATIBLES
- LED INDICATORS ■ AUTO REPEAT FEATURE
- SEPARATE CURSOR PAD

MCT-5339

IBM AT STYLE LAYOUT \$59.95

- SOFTWARE ALTUSENSE FOR XT OR AT COMPATIBLES
- LED INDICATORS ■ AUTO REPEAT FEATURE

MCT-5060

### MAXI-SWITCH KEYBOARDS

ENHANCED STYLE LAYOUT \$84.95

- STANDARD ENHANCED KEYBOARD LAYOUT
- TACTILE FEEDBACK
- LIGHTED NUM. CAPS AND SCROLL LOCK
- NUMERIC & CURSOR KEYPADS 12 F. KEYS

MAX-5339

MAX-5060 MAXI-SWITCH AT STYLE \$64.95

**SAMSUNG**  
**MONOCHROME**  
**MONITOR**  
**\$129<sup>95</sup>**

- IBM COMPATIBLE TTI INPUT
- 12" NON GLARE LOW DISTORTION AMBER SCREEN
- 720 X 350 RESOLUTION
- SWIVEL BASE



**NEC MULTISYNC \$599.95**

- ORIGINAL CGA/EGA/PGA COMPATIBLE MONITOR
- AUTO FREQUENCY ADJUSTMENT
- RESOLUTION AS HIGH AS 900 X 560

**CASPER EGA \$399.95**

- 15.75 21.85 KHz SCANNING FREQUENCIES
- 640 X 200 350 RESOLUTION ■ 31 MM DOT PITCH
- 14" BLACK MATRIX SCREEN ■ 16 COLORS

**CASPER RGB \$279.95**

- COLOR GREEN AMBER SWITCH ■ 39MM DOT PITCH
- 640 X 240 RESOLUTION ■ 14" NON GLARE SCREEN
- RGB/IBM COMPATIBLE ■ CABLE INCLUDED

**SAKATA**  
**MONOCHROME \$69.95**

- IBM COMPATIBLE TTI INPUT
- 12" NON GLARE SCREEN
- CABLE FOR IBM PC INCLUDED

### MONITOR STANDS

MODEL MS-100 \$12.95

- TILTS AND SWIVELS
- STURDY PLASTIC CONSTRUCTION

MODEL MS-200 \$39.95

- TILTS AND SWIVELS ■ BUILT IN SURGE SUPPRESSOR
- INDEPENDENTLY CONTROLS UP TO 5 AC OUTLETS

**LOGITECH**  
**MOUSE**  
**\$79<sup>95</sup>**



PC MAGAZINE'S EDITORS CHOICE  
ALL MODELS HAVE SERIAL SUPPORT (COM1/COM2) 200 DPI RESOLUTION LOTUS 1 2 3 SHELL SELF-INSTALLING SOFTWARE AND POINT EDITOR

SERIAL MOUSE W/PC PAINTBRUSH \$99.95

BUS MOUSE W/PC PAINTBRUSH \$99.95

BUS MOUSE W/PC PAINTBRUSH/CAD \$149.95

**3.5" FLOPPY**  
**DISK DRIVE**  
**\$129<sup>95</sup>**



- IBM COMPATIBLE DRIVE ■ AT AND XT VERSIONS AVAILABLE ■ FORMATS TO 720K DS/DD UNDER DOS 3.2
- MEDIA COMPATIBLE WITH PS/2 & LAPTOP MACHINES
- INCLUDES HARDWARE FOR MOUNTING IN 5 1/4" SLOT
- QUIET OPERATION
- FDD-3.5X (FOR XT)
- FDD-3.5A (FOR AT)





## 1/2 HEIGHT HARD DISK SYSTEMS

20 MB **\$269**  
30 MB **\$299**

SYSTEMS INCLUDE SEAGATE 1/2 HEIGHT HARD DRIVE, DRIVE CONTROLLER, CABLES & INSTRUCTIONS. ALL DRIVES ARE PRE-TESTED & WARRANTED FOR 1 YEAR.

## 1/2 HEIGHT HARD DISK DRIVES

40 MB **\$429**  
60 MB **\$649**

DRIVES ARE SEAGATE MODELS ST-251 (40 MB) & ST-277 (60 MB RLL) 5 1/4" HALF HEIGHTS FAST 40MS ACCESS TIME!

## INTERFACE CARDS FROM MODULAR CIRCUIT TECHNOLOGY

### DISPLAY ADAPTORS

**MONOCHROME GRAPHICS CARD \$59.95**  
TRUE HERCULES COMPATIBILITY SUPPORTS LOTUS 123  
DRIVER ALLOWS COLOR GRAPHICS SOFTWARE TO RUN ON A MONOCHROME MONITOR  
PARALLEL PRINTER PORT  
MCT-MGP

**ENHANCED GRAPHICS ADAPTOR \$149.95**  
100% IBM COMPATIBLE PASSES IBM EGA DIAGNOSTICS  
256K OF VIDEO RAM ALLOWS 640 X 350 IN 16 OF 64 COLORS  
COMPATIBLE WITH COLOR AND MONOCHROME ADAPTORS  
MCT-EGA

**COLOR GRAPHICS ADAPTOR \$49.95**  
COMPATIBLE WITH IBM GRAPHICS STANDARDS  
SUPPORTS RGB, COLOR & COMPOSITE MONOCHROME  
640 320 X 200 RESOLUTION LIGHT PEN INTERFACE  
MCT-CG

### MULTIFUNCTION CARDS

**MONOGRAPHICS MULTI I/O \$119.75**  
TOTAL SYSTEM CONTROL FROM A SINGLE SLOT!  
CTRL 2 FLOPPY S, SERIAL, PARALLEL, GAME PORT  
CLOCK CAL  
RUN COLOR GRAPHICS SOFTWARE ON A MONOCHROME MONITOR  
MCT-MGM10

**MULTI I/O FLOPPY CONTROLLER \$79.95**  
A PERFECT COMPANION FOR OUR MOTHERBOARDS  
SUPPORTS UP TO 2 360K FLOPPIES 720K WITH DOS 3.2  
SERIAL PARALLEL GAME PORT CLOCK CALENDAR  
MCT-MIO  
MIO-SERIAL—2ND SERIAL PORT \$15.95

**MULTI I/O CARD \$59.95**  
USE WITH MCT-FH FOR A MINIMUM OF SLOTS USED  
SERIAL PORT CLOCK CALENDAR WITH BATTERY BACK-UP  
PARALLEL PRINTER PORT ADDRESSABLE AS LPT1 OR LPT2  
MCT-IO

**AT MULTI I/O CARD \$139.95**  
ADDS UP TO 3 MEGABYTES OF RAM TO THE AT  
USER EXPANDABLE TO 15MB (ZERO K INSTALLED)  
INCLUDES SERIAL PORT AND PARALLEL PORT  
MCT-ATMF  
ATMF SERIAL—2ND SERIAL PORT \$24.95  
MCT-ATMF-MC—PIGGYBACK BOARD (NO MEMORY) \$29.95

**AT MULTI I/O CARD \$59.95**  
USE WITH MCT-ATFH FOR MINIMUM OF SLOTS USED  
SERIAL PARALLEL AND GAME PORTS  
USES 16450 SERIAL SUPPORT CHIPS FOR HIGH SPEED OPS  
MCT-AT10  
AT10-SERIAL—2ND SERIAL PORT \$24.95

### MEMORY CARDS

**576K RAM CARD \$59.95**  
A CONTIGUOUS MEMORY SOLUTION IN A SHORT SLOT  
USER SELECTABLE CONFIGURATION UP TO 576K  
USES 64K & 256K RAM CHIPS (ZERO K INSTALLED)  
MCT-RAM

**EXPANDED MEMORY CARD \$129.95**  
2 MB OF LCTUS INTEL MICROSOFT COMPATIBLE MEMORY FOR AN XT  
CONFORMS TO LOTUS INTEL EMS  
USER EXPANDABLE TO 2 MB  
CAN BE USED AS EXPANDED OR CONVENTIONAL MEMORY RAMDISK AND SPOOLER  
MCT-ATEMS  
MCT-ATEMS-AT VERSION \$139.95

### DRIVE CONTROLLERS

**FLOPPY DISK CONTROLLER \$29.95**  
QUALITY DESIGN FOR SINGLE SLOT CONTROL OF 4 FLOPPY'S  
INTERFACES UP TO 4 FDD'S TO AN IBM PC OR COMPATIBLE  
SUPPORTS BOTH DS DD AND DS OD WITH DOS 3.2  
MCT-FDC

**1.2 MB FLOPPY CONTROLLER \$69.95**  
ADD VERSATILITY AND CAPACITY TO YOUR XT  
SUPPORTS 2 DRIVES, BOTH MAY BE 360K OR 1.2 MB  
ALLOWS DATA TO FLOW FREELY FROM XT'S TO AT'S  
MCT-FDC-1.2

**FLOPPYHARD CONTROLLER \$139.95**  
XT SYSTEM STARVED FOR SLOTS? THIS CARD FREES ONE UP  
INTERFACES UP TO 2 FDD'S & 2 HDD'S, CABLING FOR 2 FDD-1 HDD  
SUPPORTS BOTH DS DD & DS OD WITH DOS 3.2  
MCT-FH

**AT/FH CONTROLLER \$149.95**  
FLOPPYHARD DISK CONTROL IN A TRUE AT DESIGN  
SUPPORTS UP TO 2 360K 720K 1.2MB FDD'S AS WELL AS 2 HDD'S USING STANDARD CONTROL TABLES  
MCT-ATFH

**RLL DISK CONTROLLER \$199.95**  
IMPROVE SPEED AND STORAGE OF YOUR AT COMPATIBLE  
SUPPORTS UP TO 2 RLL HARD DISCS AND 2 FLOPPY DRIVES  
SUPPORTS 360/720 1.2 MB FLOPPIES IN 5 25" & 3 5"  
MCT-ATFH-RLL

### INBOARD 386/PC \$895.00

UPGRADE YOUR XT TO A 386 FOR LESS THAN \$1000  
16 MHZ PROCESSOR REPLACES 8088  
1 MB INSTALLED  
EXPAND TO 3MB WITH PIGGYBACK CARD  
5 YR WARRANTY

INBOARD 386/AT \$1199.95  
ABOVE BOARD PS 286 \$399.95  
ABOVE BOARD 286 \$369.95

## DISK DRIVES

### 5 1/4" SEAGATE HARD DISK DRIVES

ST-225 HALF HEIGHT 20MB 65MS \$255.00  
ST-238 HALF HEIGHT 30MB 65MS (RLL) \$249.00  
ST-4038 FULL HEIGHT 30MB 40 MS \$559.00  
ST-4096 FULL HEIGHT 80MB 28MS \$895.00

### 1/2 HEIGHT FLOPPY DISK DRIVES

5 1/4" TEAC FD-55B DS/DD 360K \$99.95  
5 1/4" TEAC FD-55G DS/HD 1.2M \$129.95  
5 1/4" FUJITSU M2551A DS/DD 360K \$89.95  
5 1/4" FUJITSU M2553K DS/HD 1.2M \$119.95  
5 1/4" DS/DD 360K \$69.95  
5 1/4" DS/HD 1.2M \$109.95  
3 1/2" MITSUBISHI DS/DD (AT OR XT) \$129.95

## ARCHIVE XL TAPE BACK-UP \$369<sup>95</sup>

BACK UP 40 MB IN 40 MINUTES!  
EASY-TO-USE MENU DRIVEN SOFTWARE  
USES STANDARD QIC DATA FORMAT  
FULL & INCREMENTAL BACK-UP  
PARTIAL & FULL RESTORE  
AR 5240 XT—FOR XT'S & AT'S  
AR 5540 AT—AT'S ONLY, 2X FASTER TAPE NOT INCLUDED  
TAPE CARTRIDGE—40 MB \$24.95



## 20MB HARD DISK ON A CARD \$349

SAVES SPACE AND REDUCES POWER CONSUMPTION  
IDEAL FOR PC'S WITH FULL HEIGHT FLOPPIES  
LEAVES ROOM FOR A HALF LENGTH CARD IN ADJACENT SLOT



" I'M WRITING TO EXPRESS MY PLEASURE WITH THE PC-XT TYPE COMPUTERS BUILT FROM MCT COMPONENTS THAT WE HAVE OBTAINED FROM YOUR COMPANY. AFTER 3 YEARS OF DAILY USAGE I AM EXTREMELY PLEASED WITH THE LEVEL OF COMPATIBILITY AND PERFORMANCE. WITH A RECENT PURCHASE, I WAS ELATED WITH THE PROMPT MANNER IN WHICH OUR ORDER WAS HANDLED. AFTER DEALING WITH OTHER MAIL ORDER FIRMS, I HAVE FOUND ONLY JDR AND 2 OTHER SOFTWARE VENDORS HELPFUL AND RELIABLE. KEEP UP THE EXCELLENT WORK."

J.R.D.  
OMAHA, NE.

## BARGAIN HUNTER'S CORNER MACINTOSH FLOPPY DRIVE

100% MACINTOSH COMPATIBLE 3 1/2" ADD-ON DRIVE  
HIGH RELIABILITY DRIVE WITH AUTO-EJECT MECHANISM  
DOUBLE SIDED—800K  
ONLY **\$169<sup>95</sup>**  
WE HAVE JUST 48 DRIVES LEFT SO HURRY TO GET THIS UNBELIEVABLE PRICE!  
SPECIAL ENDS 4 30 88



JDR MICRODEVICES, 110 KNOWLES DRIVE, LOS GATOS, CA 95030  
LOCAL (408) 866-6200 FAX (408) 378-8927 TELEX 171-110

**ORDER TOLL FREE 800-538-5000**

COPYRIGHT 1988 JDR MICRODEVICES

CIRCLE 172 ON FREE INFORMATION CARD  
[www.americanradiohistory.com](http://www.americanradiohistory.com)



CONTINENTAL U.S. AND CANADA

# BUILD YOUR OWN SYSTEM



OVER 20,000 JDR SYSTEMS HAVE ALREADY BEEN BUILT. EASY TO ASSEMBLE IN JUST 2 HOURS WITH A SCREWDRIVER. SAVE MONEY AND LEARN ABOUT YOUR COMPUTER AT THE SAME TIME.

**12 MHZ AT COMPATIBLE**  
**\$1034<sup>20</sup>**

- 12 MHZ BABY AT MOTHERBOARD
- 256K RAM MEMORY
- MINI-AT CASE W POWER SUPPLY
- AT STYLE KEYBOARD
- 1.2 MB FLOPPY DRIVE
- FLOPPY/HARD DRIVE CONTROLLER
- MONOCHROME MONITOR
- GRAPHICS ADAPTOR

**10 MHZ XT COMPATIBLE**  
**\$589<sup>00</sup>**

- INCLUDES SERIAL PORT, 2 PARALLEL PORTS, CLOCK/CALENDAR AND GAME ADAPTOR. RUNS COLOR GRAPHICS ON A MONOCHROME MONITOR
- MOTHERBOARD
- 256K RAM MEMORY
- 135 WATT POWER SUPPLY
- FLIP-TOP CASE
- AT STYLE KEYBOARD
- 360K FLOPPY DRIVE
- MONOGRAPHS I/O CARD
- MONOCHROME MONITOR

**16 MHZ 1 MB 386**  
**\$2298<sup>65</sup>**

- MYLEX 386 MOTHERBOARD
- 1 MB RAM ON BOARD
- 200 WATT POWER SUPPLY
- AT STYLE CASE
- ENHANCED AT STYLE KEYBOARD
- 1.2 MB FLOPPY DRIVE
- AT FLOPPY/HARD CONTROLLER
- MONOCHROME MONITOR
- MONOGRAPHS CARD

**VIDEO INSTRUCTIONS \$4.95**  
**WITH KIT PURCHASE**  
**IT'S A JDR EXCLUSIVE!**  
**EASY TO FOLLOW 20 MINUTE VHS TAPE SHOWS YOU STEP-BY-STEP HOW TO BUILD AN XT COMPATIBLE SYSTEM.**  
**WITHOUT KIT \$19.95**

## MOTHERBOARDS

**TURBO 4.77/8 MHZ \$99.95**    **12 MHZ MINI 80286 \$399.95**

- 4.77 OR 8 MHZ OPERATION WITH 8088-2 & OPTIONAL 8087-2 CO-PROCESSOR
- FRONT PANEL LED SPEED INDICATOR AND RESET SWITCH SET SUPPORTED
- CHOICE OF NORMAL TURBO MODE OR SOFTWARE SELECT PROCESSOR SPEED

**MCT-TURBO**  
**MCT-XTMB STANDARD MOTHERBOARD \$87.95**

- 6 MHZ, 10 MHZ (0.1 WAIT STATE), 12 MHZ (1 WAIT STATE)
- USES ZYMOSS ASIC'S FOR LESS CHIPS, GREATER RELIABILITY
- SUPPORTS 256K-1024K MEMORY
- RE-CHARGEABLE HIGH CAPACITY NI-CAD BATTERY
- 6 16-BIT SLOTS, 2 8-BIT SLOTS
- MOUNTS IN STANDARD XT CASE

**MCT-BATMB-12**  
**MCT-BATMB 6/10 MHZ MINI 80286 BOARD \$389.95**

**80286 6/8 MHZ \$379.95**    **16 MHZ MYLEX 386 \$1649.00**

- 8 SLOT (2 EIGHT BIT, 6 SIXTEEN BIT) AT MOTHERBOARD
- HARDWARE SELECTION OF 6 OR 8 MHZ
- 1 WAIT STATE
- KEYLOCK SUPPORTED, RESET SWITCH, FRONT PANEL LED INDICATOR
- SOCKETS FOR 1 MB OF RAM AND 80287
- BATTERY BACKED CLOCK

**MCT-ATMB**

- 1 MB RAM ON BOARD
- 8 SLOTS, 2 8-BIT, 6 16-BIT
- SUPPORTS 80287 MATH CO-PROCESSOR
- SUPPORTS 80387 W ADAPTOR
- 64 KB CACHE FOR NEAR 0 WAIT STATE
- USES AMI BIOS

**MCT-386 MB**  
**MCT-386 MB-4 4 MB MEMORY INSTALLED \$2649.00**  
**MCT-386 MB-MCB MATH CO-PROCESSOR ADAPTOR BOARD \$149.00**

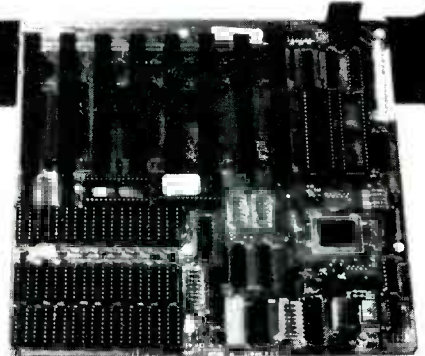

**10 MHZ SINGLE CHIP XT**  
**\$129<sup>95</sup>**

- SINGLE CHIP USES LESS POWER, IMPROVES RELIABILITY
- KEY SELECTABLE SPEED, 4.77 MHZ OR 10 MHZ
- 2.3 TIMES FASTER THAN A STANDARD
- RESET SWITCH, KEYLOCK AND SPEED/POWER INDICATORS SUPPORTED

**MCT-TURBO-10**

## DEVELOPMENT TOOLS

**EPROM PROGRAMMER**  
**\$129<sup>95</sup>**

- PROGRAMS 27XX & 27XXX EPROMS UP TO 27512
- SUPPORTS VARIOUS PROGRAMMING FORMATS AND VOLTAGES
- SPLIT OR COMBINE CONTENTS OF SEVERAL EPROMS OF DIFFERENT SIZES
- READ, WRITE, COPY, ERASE CHECK AND VERIFY
- SOFTWARE FOR HEX AND INTEL HEX FORMATS

**MCT-EPROM**  
**MCT-EPROM-4 4 GANG PROGRAMMER \$189.00**  
**MCT-EPROM-10 10 GANG PROGRAMMER \$299.95**  
**MCT-PAL PAL PROGRAMMER \$269.95**  
**MCT-MP PROCESSOR PROG. \$199.95**

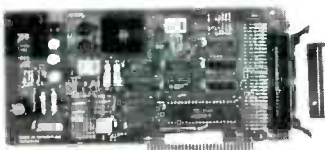

- 1 YEAR WARRANTY ON MCT PRODUCTS**
- 30 DAY MONEY BACK GUARANTEE**
- TOLL-FREE TECHNICAL SUPPORT**
- NEXT DAY AIR SHIP AVAILABLE**

**JDR Microdevices®**

JDR MICRODEVICES, 110 KNOWLES DRIVE, LOS GATOS, CA 95030  
LOCAL (408) 866-6200 FAX (408) 378-8927 TELEX 171-110

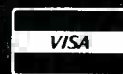

**ORDER TOLL FREE 800-538-5000**

COPYRIGHT 1988 JDR MICRODEVICES

CONTINENTAL U.S. AND CANADA

# Radio Shack Parts Place<sup>TM</sup>

THE BUILDER'S STORE! OVER 1000 COMPONENTS IN STOCK

## Our Finest Benchtop LCD Multimeter

**99<sup>95</sup>**

Low As \$15  
Per Month\*

- Manual or Autoranging
- Min/Max Values Can Be Stored

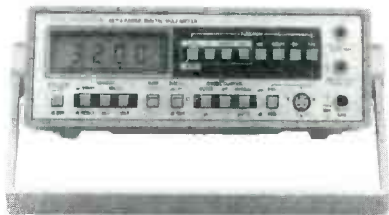

A champion performer for lab or home shop. The 31-segment analog bar graph display makes input peaks and trends easier to follow. Transistor checker measures  $h_{FE}$  (gain) and tests semiconductor junctions. Buzzer continuity checker. Measures to 1000 VDC, 750 VAC, AC/DC current to 10 amps, resistance to 30 megohms. Fused, overload protected. #22-195

## Sight'n Sound

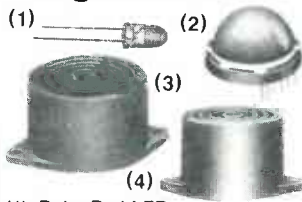

- (1) Ruby Red LED. #276-066 ..... 1.19  
 (2) Jumbo Red LED. #276-064 ..... 3.49  
 (3) Tri-Sound Siren. #273-072 ..... 5.95  
 (4) IC Chime. #273-071 ..... 7.95

## Builder Bargains

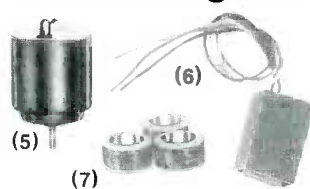

- (5) 1.5-3 VDC Motor. #273-223 ..... 79c  
 (6) 1:1 Audio Transformer. For phone interconnects. #273-1374 ..... 3.49  
 (7) Magnet Wire. Three-spool set—22, 26, 30 gauge. #278-1345 ..... 4.49

## Data-Connector Headquarters

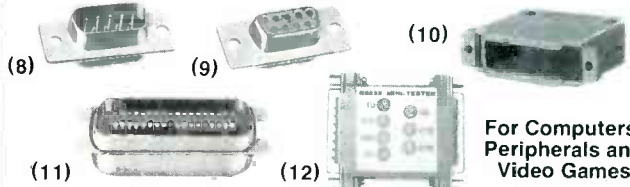

For Computers,  
Peripherals and  
Video Games

Fig.	Type	Positions	Cat. No.	Each
8	Male	9	276-1537	1.49
9	Female	9	276-1538	2.49
10	Hood	9	276-1539	1.99
	Male	25	276-1547	1.99
	Female	25	276-1548	2.99
	Hood	25	276-1549	1.99

(11) Printer Connector. Solder type, 36-position. For parallel printers. #276-1534 ..... 4.99

(12) RS-232 Inline Tester. Diagnose interface problems without repair calls. #276-1401 ..... 14.95

## Coax Cable Tools

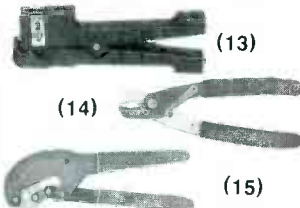

- (13) Cable Stripper. For all popular sizes. #278-240 ..... 11.95  
 (14) Coax Cable Cutter. Preserves cable impedance. #278-244 ..... 4.95  
 (15) Professional Crimp Tool. For all coax connectors. #278-243 ..... 12.95

## The Right Stuff

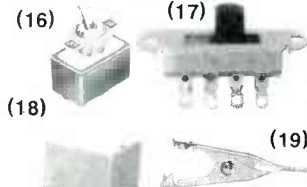

- (16) Toggle Switch Set. One DPDT, two SPST. #275-322 ..... Set of 3/2.59  
 (17) Slide Switch Kit. Assorted one or two poles/throws. #275-327 ..... Set of 6/1.89  
 (18) Micromini Relay. #275-248 ..... 2.79  
 (19) Micro Clips. #270-373 ..... 10/1.59

## Exciting New ICs For Hobbyists

**TDA7000 FM Receiver on a Chip.** Combines RF mixer, IF and demodulator stages in one IC. Just what you need to build a small, inexpensive FM band receiver, repeater monitor or public service band monitor. Mute circuit reduces spurious reception. Includes application notes. #276-1304 ..... 5.95

**TDA1520A 20-Watt High-Power, High-Fidelity Audio Power Amp.** Build your own quality audio amplifier! Nine-pin single inline package. Very low distortion. 20 to 20,000 Hz response. Requires 15 to 50 VDC. With data. #276-1305 ..... 5.99

## Add Speech to Your Computer

**SP0256-AL2 Speech Synthesizer IC.** Cut 23%. Uses a stored program to produce natural sounding speech. Easy to interface with most computers. Requires 3.12 MHz crystal (special order). 28-pin DIP. Includes data. Reg. \$12.95. #276-1784 ..... Sale 9.95

**CTS256-AL2 Text-to-Speech IC.** 30% Off. Preprogrammed 8-bit processor translates ASCII characters into control data for #276-1784 above. With data and schematics. Requires 10 MHz crystal (special order). 40-pin DIP. Reg. \$16.95. #276-1786 ..... Sale 11.88

## Finishing Touches



- (20) Experimenters' Boxes. Plastic with aluminum covers. Includes screws. #270-627 ..... 2.39  
 6 1/4 x 3 3/4 x 2" ..... 1.59  
 3 1/4 x 2 1/8 x 1 1/8" ..... 1.69  
 4 x 2 1/8 x 1 5/8" ..... 2.99  
 7 1/4 x 4 3/8 x 2 3/8" ..... 1.99  
 5 1/16 x 2 5/8 x 1 1/8" ..... 2.79  
 (21) Dry-Label Transfers. Letters, symbols, numbers. 4 sheets. #270-201 ..... 2.79

## Hard-to-Find Caps

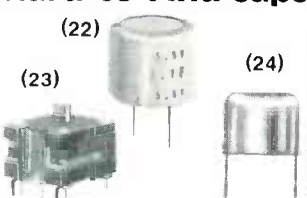

- (22) CPU/RAM Backup. Backs up CMOS microprocessors for brief AC failure. 0.1 farad. 5.5 VDC. #272-1440 ..... 2.95  
 (23) Dual-Ganged 335 pF Variable. PC mount. With knob. #272-1337 ..... 4.95  
 (24) 6-50 pF Trimmers. PC/perboard-mount. #272-1340 ..... Set of 2/1.59

## Dynamic RAM

**4164-64K.** Warranted RAM chips are as close as your neighborhood Radio Shack. 150 ns access. Uses single 5 VDC supply. #276-2506 ..... 3.95

**TMS 4256-256K.** 150 ns access. Low-power design (230mV typical). Uses single 5 VDC supply. 16-pin DIP. #276-1252 ..... 6.95

## Line Driver ICs For Data-Transfer

**MC1488 RS-232 Quad Line Driver.** Hook up terminals and remote peripherals with a simple "twisted pair" cable. 14-pin DIP with data. #276-2520 ..... 1.29

**MC1489 RS-232 Quad Line Receiver.** For use with above line driver. #276-2521 ..... 1.29

## Operational Amps

**741.** General-purpose, single channel. Frequency-compensated. 8-pin DIP. #276-007 ..... 79c

**1458 Dual Op Amp.** Internally compensated. Low power consumption. Two independent op amps in a 8-pin DIP. Split supply 5 to 16 VDC. #276-038 ..... 99c

**LM324 Quad Op Amp.** Operates on 3 to 30 VDC or split 1.5 to 15 VDC supply. 14-pin DIP. #276-1711 ..... 1.29

**TL082 Dual High-Performance Op Amp.** Low-noise, high-Z biFET inputs. Low distortion. Split 4 to 18 VDC supply. 8-pin DIP. #276-1715 ..... 1.89

**LM339 Quad Comparator.** Four independent voltage comparators in a 14-pin DIP. Single 2 to 32 VDC. #276-1712 ..... 99c

**LM567 Tone Detector.** Touch-Tone, RC and FSK decoding. Requires 4.75 to 9 VDC. 8-pin DIP. #276-1721 ..... 1.99

## Musical Chips

**UMC 3482 12-Tune Melody Synthesizer IC.** 33% Off. Just the thing for musical doorbells, clocks, games and phone music-on-hold. Has an on-chip audio preamp. Tunes include Happy Birthday, Row-Row-Row Your Boat and other all-time "camp" favorites. Operates on 1.5 VDC, 16-pin DIP. With data and circuit examples. Reg. \$2.99. #276-1797 ..... Sale 1.99

**AY-38910A Programmable Sound Generator.** Cut 21%. Use with a computer to provide an astonishing variety and range of sounds! Three independent outputs. Single 5 VDC supply. 40-pin DIP. With data. Reg. \$9.95. #276-1787 ..... Sale 7.88

## CMOS and TTL ICs

All are 100% prime and include pin-out and specs.

Description	Type	Cat. No.	Each
Quad 2-Input NOR Gate	4001	276-2401	99
Quad 2-Input NAND Gate	4011	276-2411	99
Dual Type-D Flip Flop	4013	276-2413	1.19
Decade Counter/Divider	4017	276-2417	1.49
Inverting Hex Buffer	4049	276-2449	1.19
Quad Bilateral Switch	4066	276-2466	1.19

Description	Type	Cat. No.	Each
Quad 2-Input NAND Gate	7400	276-1801	89
Hex Inverter	7404	276-1802	99
Quad 2-Input AND Gate	7408	276-1822	1.29
BCD to 7-Seg. Driver	7447	276-1805	1.69
Div. by 2/5 BCD Counter	7490	276-1808	1.19

Over 1000 items in stock: Binding Posts, Books, Breadboards, Buzzers, Capacitors, Chokes, Clips, Coax, Connectors, Fuses, Hardware, ICs, Jacks, Knobs, Lamps, Multitesters, PC Boards, Plugs, Rectifiers, Resistors, Switches, Tools, Transformers, Wire, Zeners, More!

\*Revolving credit from Radio Shack. Actual payment may vary depending on purchases.

Prices apply at participating Radio Shack stores and dealers

**Radio Shack<sup>®</sup>**  
The Technology Store<sup>TM</sup>

A DIVISION OF TANDY CORPORATION

CIRCLE 78 ON FREE INFORMATION CARD

www.americanradiohistory.com

### NEC V20 & V30 CHIPS

Replace the 8086 or 8088 in Your IBM-PC and Increase Its Speed by up to 40%!

Part No.	Price
UPD70108-5 (5MHz) V20 Chip...	\$ 7.49
UPD70108-8 (8MHz) V20 Chip...	\$ 8.95
UPD70108-10 (10MHz) V20 Chip...	\$21.95
UPD70116-8 (8MHz) V30 Chip...	\$11.95
UPD70116-10 (10MHz) V30 Chip...	\$24.95

### 7400

Part No.	1-9	10+	Part No.	1-9	10+
7400	29	19	7485	65	55
7402	29	19	7486	45	35
7404	29	19	7489	2.05	1.95
7405	35	25	7490	49	39
7406	39	29	7493	45	35
7407	39	29	74121	45	35
7408	35	25	74123	55	45
7410	19	14	74125	55	45
7414	49	39	74126	69	59
7416	39	29	74143	3.95	3.85
7417	39	29	74150	1.35	1.25
7420	35	25	74154	1.35	1.25
7430	35	25	74158	1.99	1.89
7432	29	19	74173	85	75
7438	39	29	74174	59	49
7442	55	45	74175	59	49
7445	79	69	74176	99	89
7446	89	79	74181	1.95	1.85
7447	89	79	74189	1.95	1.85
7448	2.05	1.95	74193	79	69
74172	89	79	74198	1.85	1.75
7473	39	29	74221	99	89
7474	39	29	74273	1.95	1.85
7475	49	39	74365	65	55
7476	45	35	74367	65	55

### 74LS

Part No.	1-9	10+	Part No.	1-9	10+
74LS00	29	19	74LS165	75	65
74LS02	29	19	74LS166	99	89
74LS04	35	25	74LS173	59	49
74LS05	35	25	74LS174	49	39
74LS06	1.09	99	74LS175	49	39
74LS07	1.09	99	74LS189	4.59	4.49
74LS08	29	19	74LS191	59	49
74LS10	29	19	74LS193	79	69
74LS14	49	39	74LS221	69	59
74LS27	35	25	74LS240	69	59
74LS30	29	19	74LS243	69	59
74LS32	35	25	74LS244	69	59
74LS42	49	39	74LS245	89	79
74LS47	99	89	74LS259	99	89
74LS73	39	29	74LS273	89	79
74LS74	35	25	74LS279	49	39
74LS75	39	29	74LS322	4.05	3.95
74LS76	55	45	74LS365	49	39
74LS85	59	49	74LS366	49	39
74LS96	35	25	74LS367	49	39
74LS90	49	39	74LS368	49	39
74LS93	49	39	74LS373	79	69
74LS123	59	49	74LS374	79	69
74LS125	49	39	74LS393	89	79
74LS138	49	39	74LS590	6.05	5.95
74LS139	99	89	74LS591	2.05	1.95
74LS151	1.09	99	74LS629	95	85
74LS157	45	35	74LS640	1.09	99
74LS158	45	35	74LS645	1.09	99
74LS163	59	49	74LS670	1.09	99
74LS164	59	49	74LS688	2.39	2.29

### 74S/PROMS\*

Part No.	1-9	10+	Part No.	1-9	10+
74S00	29	19	74S198*	1.49	
74S04	29	19	74S199*	1.69	
74S08	35	25	74S196	2.49	
74S10	29	19	74S240	1.49	
74S32	35	25	74S244	1.49	
74S74	35	25	74S253	79	
74S85	1.79	1.49	74S271*	79	
74S86	49	39	74S288*	1.49	
74S124	2.75	2.45	74S373	1.49	
74S174	79	69	74S374*	1.49	
74S175	79	69	74S472*	2.95	

### 74F

Part No.	1-9	10+	Part No.	1-9	10+
74F00	29	19	74F139	69	
74F03	29	19	74F157	69	
74F08	29	19	74F193	2.95	
74F10	29	19	74F240	99	
74F32	29	19	74F244	99	
74F74	39	29	74F253	69	
74F86	39	29	74F373	99	
74F138	69	59	74F374	99	

### CD-CMOS

Part No.	1-9	10+	Part No.	1-9	10+
CD4001	19	14	CD4076	59	
CD4008	69	59	CD4081	25	
CD4011	19	14	CD4082	25	
CD4013	29	19	CD4093	35	
CD4016	29	19	CD4094	89	
CD4017	49	39	CD40103	2.49	
CD4018	59	49	CD40107	49	
CD4020	59	49	CD40109	79	
CD4024	59	49	CD40510	69	
CD4027	35	25	CD40511	69	
CD4030	29	19	CD40520	75	
CD4040	65	55	CD40522	79	
CD4049	29	19	CD4538	79	
CD4050	29	19	CD4541	89	
CD4051	49	39	CD4543	79	
CD4052	59	49	CD4553	4.95	
CD4053	59	49	CD4555	79	
CD4063	1.49	1.19	CD4559	7.95	
CD4066	25	19	CD4566	2.49	
CD4067	25	19	CD4583	89	
CD4069	25	19	CD4584	39	
CD4070	25	19	CD4585	89	
CD4071	25	19	MC14411P	8.95	
CD4072	25	19	MC14490P	4.49	

### MICROPROCESSOR COMPONENTS

MISCELLANEOUS CHIPS	Price	6500/6800/6800 Cont.	Price	8000 SERIES Cont.	Price
D785AC	4.95	6845	9.95	8228	2.95
WD93216	9.95	6850	1.95	8237-5	4.95
95490	9.95	6852	1.49	8243	2.25
<b>Z80, Z80A, Z80 B SERIES</b>					
Z80	+25	MC68000L5	11.95	8250B (For IBM)	6.49
Z80-CTC	+79	MC68000L10	13.95	8251A	1.89
Z80-DART	4.95	MC68000RC12B	169.95	8253-5	1.95
Z80-P0	+79	MC68881RC12A	149.95	8254	4.95
Z80A	1.69	<b>8000 SERIES</b>			
Z80A-CTC	1.79	8031	3.95	8255-5	1.89
Z80A-DART	4.95	80C31	9.95	8257-5	1.95
Z80A-PIO	1.69	8035	1.95	8259-5	2.25
Z80A-SIO/U	5.75	8073	3.95	8272	4.95
Z80B	3.49	8080A	2.95	8279-5	2.95
Z80B-CTC	3.95	8085A	2.49	8741	9.95
Z80B-PIO	+29	8086	5.95	8748 (25V)	7.95
<b>6500/6800/6800 SER</b>					
6502	2.65	8086-2	6.95	8748H (HMOS) (21V)	3.95
65C02 (CMOS)	6.95	8087-1 (10MHz)	129.95	8749	9.95
6520	1.95	8087-2 (8MHz)	159.95	8755	14.95
6522	3.95	8088	5.49	<b>DATA ACQUISITION</b>	
6532	4.49	8088-2	6.95	ADC0804LCN	3.19
6551	4.49	8155	4.95	ADC0808CCN	5.95
65C802 (CMOS)	17.95	8155-2	3.49	ADC0809CCN	9.95
6800	1.95	8156	3.95	ADC1205CCJ-1	19.95
6802	3.95	8202	5.95	ADC0808LCN	1.95
6810	1.75	8203	9.95	DAC0808LCN	4.95
6821	1.75	8212	2.29	AY-3-1015D	4.95
6840	3.95	8224	2.25	AY-5-1013A	2.95

### MICROPROCESSOR SALE!

8052AHBASIC CPU w/BASIC Interpreter	\$ 29.95
MC68008L8 32-Bit MPU (8-Bit Data Bus)	\$ 16.95
MC68701 8-Bit EPROM Microcomputer	\$ 14.95
MC68705P3S 8-Bit EPROM Microcomputer	\$ 14.95
MC68705U3L 8-Bit EPROM Microcomputer	\$ 10.95
80286-10 16-Bit Hi Performance MPU	\$ 99.95
80287-8 Math Co-processor (8MHz)	\$ 259.95
80287-10 Math Co-processor (10MHz)	\$ 309.95
80387-16 Math Co-processor (16MHz)	\$ 494.95
80387-20 Math Co-processor (20MHz)	\$ 895.95

### DYNAMIC RAMS

Part No.	Price	Part No.	Price
*1116-15 16,384 x 1 (150ns)	1.09	LAG570	10.95
*1120-20 131,072 x 1 (200ns) (Piggyback)	9.25	WD1770	11.95
*1164-120 65,536 x 1 (120ns)	2.75	SI3052P	2.49
*1164-150 65,536 x 1 (150ns)	2.49	6502	2.65
*1164-200 65,536 x 1 (200ns)	1.95	6504A	1.95
*TMS4416-12 16,384 x 4 (120ns)	4.9	6507	4.39
8118 16,384 x 1 (120ns)	4.9	6510	9.95
*41256-100 262,144 x 1 (100ns)	8.49	6520	1.95
*41256-120 262,144 x 1 (120ns)	7.95	6522	3.95
*41256-150 262,144 x 1 (150ns)	7.75	6525	4.95
*50464-15 65,536 x 4 (150ns) (4464)	5.95	6526	14.96
*511000P-10 1,048,576 x 1 (100ns) 1 Meg	49.95	6529	2.95
*514256P-10 262,144 x 4 (100ns) 1 Meg	89.95	6532	6.49

### STATIC RAMS

Part No.	Price	Part No.	Price
2016-12 2048 x 8 (120ns)	1.69	6560	10.95
2018-45 2048 x 8 (45ns)	6.95	6567	14.95
2102-21 2048 x 1 (250ns) Low Power	5.49	6569	24.95
2114N 1024 x 4 (45ns)	9.9	6572	8.95
2114N-2L 1024 x 4 (200ns) Low Power	1.49	6581 (12V)	14.95
21C14 1024 x 4 (200ns) (CMOS)	2.49	6582 (9V)	14.95
2149 1024 x 4 (45ns)	4.9	8360	14.95
5101 256 x 4 (45ns) CMOS	1.95	8501	10.95
6116P-3 2048 x 8 (150ns) CMOS	2.49	8502	7.95
6116LP-3 2048 x 8 (150ns) LP CMOS	2.95	8563	15.95
6264LP-12 8192 x 8 (120ns) LP CMOS	+25	8564	9.95
6264P-15 8192 x 8 (150ns) CMOS	3.49	8566	24.95
6264LP-15 8192 x 8 (150ns) LP CMOS	+75	8701	9.95
6514 1024 x 4 (35ns) CMOS	3.49	8721	14.95
43256-15L 32,768 x 8 (150ns) Low Power	11.95	8722	9.95

### EPROMS

TMS2516 2048 x 8 (450ns) 25V	6.95
TMS2532 4096 x 8 (450ns) 25V	6.95
TMS2532A 4096 x 8 (450ns) 21V	5.95
TMS2564 8192 x 8 (450ns) 25V	9.95
TMS2716 2048 x 8 (450ns) 3 Voltage	9.95
1702A 256 x 8 (1µs)	6.95
2708 1024 x 8 (450ns)	4.95
2716 2048 x 8 (450ns) 25V	3.75
2716-1 2048 x 8 (350ns) 21V	4.25
2716-16 2048 x 8 (450ns) 25V (CMOS)	5.49
2732 4096 x 8 (450ns) 25V	3.95
2732A-20 4096 x 8 (200ns) 21V	4.25
2732A-25 4096 x 8 (250ns) 21V	3.95
27C32 4096 x 8 (450ns) 25V (CMOS)	5.95
2764-20 8192 x 8 (200ns) 21V	4.25
2764-25 8192 x 8 (250ns) 21V	3.75
2764A-25 8192 x 8 (250ns) 12.5V	3.95
2764-45 8192 x 8 (450ns) 21V	6.49
27C64-15 8192 x 8 (150ns) 21V (CMOS)	2.95
27128-20 16,384 x 8 (200ns) 21V	6.95
27128-25 16,384 x 8 (250ns) 21V	5.95
27128A-25 16,384 x 8 (250ns) 12.5V	5.25
27C128-25 16,384 x 8 (250ns) 21V (CMOS)	6.95
27256-20 32,768 x 8 (200ns) 12.5V	6.95
27256-25 32,768 x 8 (250ns) 12.5V	5.95
27512-20 65,536 x 8 (200ns) 12.5V	13.49
27512-25 65,536 x 8 (250ns) 12.5V	11.25
6876A 8192 x 8 (450ns) 25V	13.95

### EEPROMS

||
||
||

**Now Available...Jameco's NEW Winter/Spring Flyer #136 with 48 pages of Computer Peripherals, Components & More!**

### PROTOTYPING PRODUCTS

#### Jameco Solderless Breadboard Sockets

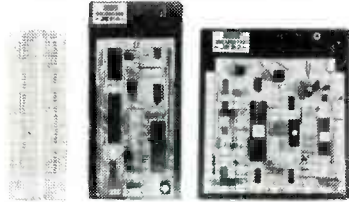

Part No.	Dim. L x W"	Contact Points	Binding Posts	Price
JE20	6 1/2 x 3 1/4	200	0	\$ 2.29
JE21	3 1/4 x 2 1/8	400	0	\$ 4.49
JE22	6 1/2 x 1 3/8	630	0	\$ 5.95
JE23	6 1/2 x 2 1/8	830	0	\$ 7.49
JE24	6 1/2 x 3 1/8	1,360	2	\$14.95
JE25	6 1/2 x 4 1/4	1,660	3	\$22.95
JE26	6 7/8 x 5 3/4	2,390	4	\$27.95
JE27	7 1/4 x 7 1/2	3,220	4	\$37.95

#### Jameco's IBM PC/XT/AT Compatible Motherboards



- Award BIOS ROMs included
- JE1001 4.77MHz (PC/XT) . . . . \$ 84.95
- JE1001 4.77/8MHz (PC/XT) . . . . \$ 99.95
- JE1002 4.77/10MHz (PC/XT) . . . \$119.95
- JE1007 6/8/10/12MHz (AT) . . . . \$349.95

#### Jameco Computer Power Protection



- JE1190 Power Base . . . . . \$29.95
- JE1191 6-Outlet Power Strip . . . \$119.95
- JE1192 300 Watt Back-Up . . . . \$269.95
- JE1193 500 Watt Back-Up . . . . \$349.95

#### Zuckerboard TANDY 1000 Expansion Memory Half Card



Expand the memory of your Tandy 1000 (128K Version) to as much as 640K. Also includes DMA controller chip.

- TE512 Includes 512K RAM . . . . . \$199.95
- TANC Plug-in Clock option chip (only) . . \$39.95
- 30Meg Hard Disk Drive Board for Tandy 1000, 1000A, 1000SX, 1200, 3000 and 3000HL
- T30MB 30MB Hard Disk Drive Board . . . . . \$599.95

#### DATA BOOKS

- 30005 Logic Data Book - Vol. II (84) . . . . \$19.95
- 30009 Intersil Data Book (87) . . . . . \$14.95
- 21398 CMOS Cookbook (86) . . . . . \$14.95
- 210830 Intel Memory Handbook (87) . . . \$17.95
- 230843 Intel Microsystem Hndbk. Set (87) . \$24.95

#### MUFFIN/SPRITE-STYLE FANS

- TA450S . . . . . \$11.95
- Torin Industries (4.68" sq., 50 cfm)
- SU2A1 . . . . . \$11.95
- EG&G Rotron (3.125" square, 34 cfm)

### NEW! Turbo 10MHz PC/XT Compatible Kit! FREE! PC Write Word Processing Software Included!

JE1059 . . \$499.95 (EGA Monitor and Card not included)

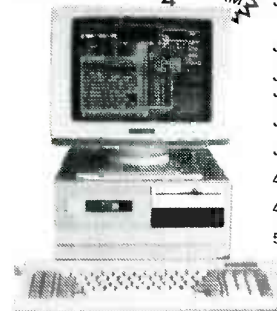

#### Jameco's 4.77/10MHz Turbo IBM PC/XT Compatible Kit

- JE1002 4.77/10MHz Turbo Motherboard (Zero-K RAM - Includes Award BIOS ROMs) . . . . . \$119.95
- JE1014 Mini Turbo PC/XT Compatible Case . . . . . \$69.95
- JE1015 XT/AT Comp Keyboard . . . . . \$59.95
- JE1021 5 1/4" DSDD Disk Drive (Beige Bezel) . . . . . \$89.95
- JE1031 Mini 150W Turbo PC/XT Comp. Power Supply . . . \$69.95
- JE1043 360K/720K/1.2M Floppy Controller Card . . . . . \$49.95
- 4164-150 16K RAM (65,536x1) (2 Chips, 150ns) . . . . . \$4.98
- 41256-150 512K RAM (262,144x1) (18 Chips, 150ns) . . . \$139.50
- 50464-15 112K RAM (65,536x4) (4 Chips, 150ns) . . . . \$23.80

**Regular List \$627.98 SAVE \$128.03!**

**JE1006 IBM PC/XT Comp. 10MHz Turbo Kit . . \$499.95**

#### IBM COMPATIBLE DISPLAY MONITORS

12" Amber Monochrome - TTL Input, High Resolution (PC/XT/AT) AMBER . . . . \$109.95 \$99.95

14" RGB Color - CGA Compatible Amber/Green/Color Switchable. 640 x 200 Resolution (PC/XT/AT) TTX1410 . . . . . \$279.95

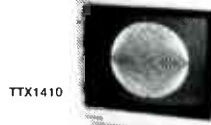

14" EGA Color - EGA/CGA Compat., 720 x 350 (max.) resolution (PC/XT/AT) TE5154 . . . . . \$399.95

14" Ultrascan Color - CGA/EGA/PGC/VGA Compatible, 800 x 560 (max.) Resolution (PC/XT/AT) 4375M . . . . . \$579.95 \$549.95

#### IBM PC/XT/AT COMPATIBLE CARDS

#### Graphic Display Cards

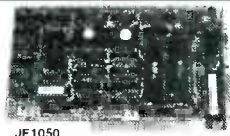

- JE1050 Mono Graphics Card w/Printer Port (PC/XT/AT) . . . . \$59.95
- JE1052 Color Graphics Card w/Printer Port (PC/XT/AT) . . . . \$49.95
- JE1055 EGA Card with 256K Video RAM and Printer Port (PC/XT/AT) . . . . \$149.95
- JE1071 Multi I/O with Drive Controller and Mono Graphics (PC/XT) . . . . \$119.95

#### Multifunction, I/O and Expansion Cards

- JE1060 I/O Card with Serial, Game, Parallel Printer Port and Real Time Clock (PC/XT) . . . . \$59.95
- JE1061 RS232 Serial Half Card (PC/XT/AT) . . . . . \$29.95
- JE1065 I/O Card with Serial, Game and Parallel Printer Port (AT) . . . . . \$59.95
- JE1078 Expand to 384K (incl. zero-K) Multifunction w/Serial, Game, Parallel Printer Port & Real Time Clock (PC/XT) . . \$79.95

#### Floppy and Hard Disk Controller Cards

- JE1040 360KB Floppy Disk Drive Controller Card (PC/XT) . . . . \$29.95
- JE1041 20/40MB Hard Disk Controller Card (PC/XT) . . . . . \$79.95
- JE1043 360K/720K/1.2MB Floppy Disk Cont. Card (PC/XT/AT) \$49.95
- JE1045 360K/720K/1.2MB Floppy/Hard Disk Controller Card (AT) . . . . . \$159.95

**Additional Add-Ons Available!**

### COMPUTER PERIPHERALS



**Seagate 20, 30, 40 and 60MB Half Height Hard Disk Drives**

- ST225 20MB Drive only (PC/XT/AT) . . . . \$259.95
- ST225K 20MB w/Controller (PC/XT) . . . \$289.95
- ST238 30MB Drive only (PC/XT/AT) . . . \$299.95
- ST238K 30MB w/Cont. (PC/XT/AT) . . . \$329.95
- ST251 40MB Drive only (PC/XT/AT) . . . \$439.95
- ST251AT 40MB w/Cont. Card (PC/XT) . . . \$499.95
- ST251AT 40MB w/Cont. Card (AT) . . . . \$539.95
- ST277 60MB Drive only (PC/XT/AT) . . . \$549.95
- ST277K 60MB w/Cont. Card (AT) . . . . \$659.95



#### Jameco PC/XT & AT Compatible Disk Drives

- JE1020 360K Black Bzd (PC/XT/AT) . . . \$ 89.95
- JE1021 360K Beige Bzd (PC/XT/AT) . . . \$ 89.95
- JE1022 1.2MB Beige Bzd. (AT) . . . . . \$109.95

#### Datronics

#### 2400/1200/300 Modems



- 1200H 1200/300 Baud Internal Modem . . . \$ 79.95
- 2400S 2400/1200/300 Internal Modem . . \$174.95
- 1200C 1200/300 Baud External Modem . . \$119.95
- 2400E 2400/1200/300 External Modem . . \$219.95

**Prometheus 1200B Internal Modem PM1200B-2S (Software incl.) \$149.95 \$119.95**

#### Jameco Extended 80-Column Card for Apple IIe



• 80 Col / 64K RAM • Doubles amount of data your Apple IIe can display as well as its memory capacity • Ideal for word processing • Complete with instructions

**JE864 \$39.95**

**ADD12 (Disk Drive II, II+, IIe) \$99.95**

#### TEST EQUIPMENT

#### Kingdom and Metex Digital Multimeters



- KD302: • Pocket Size in handy carry case • 3 1/2 Digit LCD • Auto or manual ranging • Audible continuity tester • Tests AC/DC Voltage, Resistance and Continuity • One Year Warranty • Size: 7 1/4" L x 2 1/2" W x 1 1/2" H
- KD302 . . . \$27.95



- M4650: • Handheld, high accuracy • 4 1/2 Digit LCD • Manual ranging with Overload Protection • Audible continuity tester • Tests AC/DC Voltage, Resistance, Continuity, Capacitance and Frequency • One Year Warranty • Size: 7 1/4" L x 3 1/2" W x 1 1/2" H
- M4650 . . . \$79.95

#### U.S. Funds Only

Shipping: Add 5% plus \$1.50 Insurance (May vary according to weight)

California Residents: Add 6%, 6 1/2% or 7% Sales Tax  
FAX 415-592-2503  
5/88



\$20 Minimum Order  
IBM is a registered trademark of International Business Machines



Data Sheets - 50¢ each  
Prices Subject to Change

Send \$1.00 Postage for a FREE 1988 CATALOG

Telex: 176043

© 1988 Jameco Electronics

1355 SHOREWAY RD., BELMONT, CA 94002 • FOR ORDERS ONLY 415-592-8097 • ALL OTHER INQUIRIES 415-592-8121

### INTEGRATED CIRCUITS

Part	Price	Part	Price	Part	Price	Part	Price
7400 TTL	1.37	74125N	1.87	74180N	1.37	74255N	1.37
7401	1.37	74126N	1.87	74181N	1.37	74256N	1.37
7402	1.37	74127N	1.87	74182N	1.37	74257N	1.37
7403	1.37	74128N	1.87	74183N	1.37	74258N	1.37
7404	1.37	74129N	1.87	74184N	1.37	74259N	1.37
7405	1.37	74130N	1.87	74185N	1.37	74260N	1.37
7406	1.37	74131N	1.87	74186N	1.37	74261N	1.37
7407	1.37	74132N	1.87	74187N	1.37	74262N	1.37
7408	1.37	74133N	1.87	74188N	1.37	74263N	1.37
7409	1.37	74134N	1.87	74189N	1.37	74264N	1.37
7410	1.37	74135N	1.87	74190N	1.37	74265N	1.37
7411	1.37	74136N	1.87	74191N	1.37	74266N	1.37
7412	1.37	74137N	1.87	74192N	1.37	74267N	1.37
7413	1.37	74138N	1.87	74193N	1.37	74268N	1.37
7414	1.37	74139N	1.87	74194N	1.37	74269N	1.37
7415	1.37	74140N	1.87	74195N	1.37	74270N	1.37
7416	1.37	74141N	1.87	74196N	1.37	74271N	1.37
7417	1.37	74142N	1.87	74197N	1.37	74272N	1.37
7418	1.37	74143N	1.87	74198N	1.37	74273N	1.37
7419	1.37	74144N	1.87	74199N	1.37	74274N	1.37
7420	1.37	74145N	1.87	74200N	1.37	74275N	1.37
7421	1.37	74146N	1.87	74201N	1.37	74276N	1.37
7422	1.37	74147N	1.87	74202N	1.37	74277N	1.37
7423	1.37	74148N	1.87	74203N	1.37	74278N	1.37
7424	1.37	74149N	1.87	74204N	1.37	74279N	1.37
7425	1.37	74150N	1.87	74205N	1.37	74280N	1.37
7426	1.37	74151N	1.87	74206N	1.37	74281N	1.37
7427	1.37	74152N	1.87	74207N	1.37	74282N	1.37
7428	1.37	74153N	1.87	74208N	1.37	74283N	1.37
7429	1.37	74154N	1.87	74209N	1.37	74284N	1.37
7430	1.37	74155N	1.87	74210N	1.37	74285N	1.37
7431	1.37	74156N	1.87	74211N	1.37	74286N	1.37
7432	1.37	74157N	1.87	74212N	1.37	74287N	1.37
7433	1.37	74158N	1.87	74213N	1.37	74288N	1.37
7434	1.37	74159N	1.87	74214N	1.37	74289N	1.37
7435	1.37	74160N	1.87	74215N	1.37	74290N	1.37
7436	1.37	74161N	1.87	74216N	1.37	74291N	1.37
7437	1.37	74162N	1.87	74217N	1.37	74292N	1.37
7438	1.37	74163N	1.87	74218N	1.37	74293N	1.37
7439	1.37	74164N	1.87	74219N	1.37	74294N	1.37
7440	1.37	74165N	1.87	74220N	1.37	74295N	1.37
7441	1.37	74166N	1.87	74221N	1.37	74296N	1.37
7442	1.37	74167N	1.87	74222N	1.37	74297N	1.37
7443	1.37	74168N	1.87	74223N	1.37	74298N	1.37
7444	1.37	74169N	1.87	74224N	1.37	74299N	1.37
7445	1.37	74170N	1.87	74225N	1.37	74300N	1.37
7446	1.37	74171N	1.87	74226N	1.37	74301N	1.37
7447	1.37	74172N	1.87	74227N	1.37	74302N	1.37
7448	1.37	74173N	1.87	74228N	1.37	74303N	1.37
7449	1.37	74174N	1.87	74229N	1.37	74304N	1.37
7450	1.37	74175N	1.87	74230N	1.37	74305N	1.37
7451	1.37	74176N	1.87	74231N	1.37	74306N	1.37
7452	1.37	74177N	1.87	74232N	1.37	74307N	1.37
7453	1.37	74178N	1.87	74233N	1.37	74308N	1.37
7454	1.37	74179N	1.87	74234N	1.37	74309N	1.37
7455	1.37	74180N	1.87	74235N	1.37	74310N	1.37
7456	1.37	74181N	1.87	74236N	1.37	74311N	1.37
7457	1.37	74182N	1.87	74237N	1.37	74312N	1.37
7458	1.37	74183N	1.87	74238N	1.37	74313N	1.37
7459	1.37	74184N	1.87	74239N	1.37	74314N	1.37
7460	1.37	74185N	1.87	74240N	1.37	74315N	1.37
7461	1.37	74186N	1.87	74241N	1.37	74316N	1.37
7462	1.37	74187N	1.87	74242N	1.37	74317N	1.37
7463	1.37	74188N	1.87	74243N	1.37	74318N	1.37
7464	1.37	74189N	1.87	74244N	1.37	74319N	1.37
7465	1.37	74190N	1.87	74245N	1.37	74320N	1.37
7466	1.37	74191N	1.87	74246N	1.37	74321N	1.37
7467	1.37	74192N	1.87	74247N	1.37	74322N	1.37
7468	1.37	74193N	1.87	74248N	1.37	74323N	1.37
7469	1.37	74194N	1.87	74249N	1.37	74324N	1.37
7470	1.37	74195N	1.87	74250N	1.37	74325N	1.37
7471	1.37	74196N	1.87	74251N	1.37	74326N	1.37
7472	1.37	74197N	1.87	74252N	1.37	74327N	1.37
7473	1.37	74198N	1.87	74253N	1.37	74328N	1.37
7474	1.37	74199N	1.87	74254N	1.37	74329N	1.37
7475	1.37	74200N	1.87	74255N	1.37	74330N	1.37
7476	1.37	74201N	1.87	74256N	1.37	74331N	1.37
7477	1.37	74202N	1.87	74257N	1.37	74332N	1.37
7478	1.37	74203N	1.87	74258N	1.37	74333N	1.37
7479	1.37	74204N	1.87	74259N	1.37	74334N	1.37
7480	1.37	74205N	1.87	74260N	1.37	74335N	1.37
7481	1.37	74206N	1.87	74261N	1.37	74336N	1.37
7482	1.37	74207N	1.87	74262N	1.37	74337N	1.37
7483	1.37	74208N	1.87	74263N	1.37	74338N	1.37
7484	1.37	74209N	1.87	74264N	1.37	74339N	1.37
7485	1.37	74210N	1.87	74265N	1.37	74340N	1.37
7486	1.37	74211N	1.87	74266N	1.37	74341N	1.37
7487	1.37	74212N	1.87	74267N	1.37	74342N	1.37
7488	1.37	74213N	1.87	74268N	1.37	74343N	1.37
7489	1.37	74214N	1.87	74269N	1.37	74344N	1.37
7490	1.37	74215N	1.87	74270N	1.37	74345N	1.37
7491	1.37	74216N	1.87	74271N	1.37	74346N	1.37
7492	1.37	74217N	1.87	74272N	1.37	74347N	1.37
7493	1.37	74218N	1.87	74273N	1.37	74348N	1.37
7494	1.37	74219N	1.87	74274N	1.37	74349N	1.37
7495	1.37	74220N	1.87	74275N	1.37	74350N	1.37
7496	1.37	74221N	1.87	74276N	1.37	74351N	1.37
7497	1.37	74222N	1.87	74277N	1.37	74352N	1.37
7498	1.37	74223N	1.87	74278N	1.37	74353N	1.37
7499	1.37	74224N	1.87	74279N	1.37	74354N	1.37
7500	1.37	74225N	1.87	74280N	1.37	74355N	1.37

### 1% METAL FILM RESISTORS

Value	1/4W	1/2W	1W	2W
10	1.37	1.37	1.37	1.37
15	1.37	1.37	1.37	1.37
20	1.37	1.37	1.37	1.37
25	1.37	1.37	1.37	1.37
30	1.37	1.37	1.37	1.37
35	1.37	1.37	1.37	1.37
40	1.37	1.37	1.37	1.37
45	1.37	1.37	1.37	1.37
50	1.37	1.37	1.37	1.37
55	1.37	1.37	1.37	1.37
60	1.37	1.37	1.37	1.37
65	1.37	1.37	1.37	1.37
70	1.37	1.37	1.37	1.37
75	1.37	1.37	1.37	1.37
80	1.37	1.37	1.37	1.37
85	1.37	1.37	1.37	1.37
90	1.37	1.37	1.37	1.37
95	1.37	1.37	1.37	1.37
100	1.37	1.37	1.37	1.37

### 5% WIREWOUND RESISTORS

Value	1/4W	1/2W	1W	2W
10	1.37	1.37	1.37	1.37
15	1.37	1.37	1.37	1.37
20	1.37	1.37	1.37	1.37
25	1.37	1.37	1.37	1.37
30	1.37	1.37	1.37	1.37
35	1.37	1.37	1.37	1.37
40	1.37	1.37	1.37	1.37
45	1.37	1.37	1.37	1.37
50	1.37	1.37	1.37	1.37
55	1.37	1.37	1.37	1.37
60	1.37	1.37	1.37	1.37
65	1.37	1.37	1.37	1.37
70	1.37	1.37	1.37	1.37
75	1.37	1.37	1.37	1.37
80	1.37	1.37	1.37	1.37
85	1.37	1.37	1.37	1.37
90	1.37	1.37	1.37	1.37
95	1.37	1.37	1.37	1.37
100	1.37	1.37	1.37	1.37

### 4000 CMOS

Part	Price	Part	Price
7400	1.37	7400	1.37
7401	1.37	7401	1.37
7402	1.37	74	

Send for a **FREE** copy of our **NEW** 52 page **CATALOG**

**\*QUALITY PARTS \*DISCOUNT PRICES \*FAST SHIPPING!**

# ALL ELECTRONICS CORP.

## TRANSFORMERS

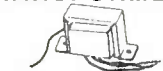

**5.6 VOLT - 750ma**  
CAT# TX-56 \$3.00

**12 V.C.T. - 1 amp**  
CAT# TX-121 \$4.00

**12 V.C.T. - 2 amp**  
CAT# TX - 122 \$4.85

**12 V.C.T. - 4 amp**  
CAT# TX-124 \$7.00

**18 VOLT - 650 ma**  
CAT# TX-186 \$2.00  
10 for \$17.50

**24 V.C.T. - 1 amp**  
CAT# TX-241 \$4.85

**24 V.C.T. - 2 amp**  
CAT# TX-242 \$6.75

**24 V.C.T. - 3 amp**  
CAT# TX-243 \$9.50

**24 V.C.T. - 4 amp**  
CAT# TX-244 \$11.00

## A/B SWITCH

JVC# PU53593-2

High quality  
A/B switch.

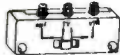

75 OHMS IN/OUT

Measures: 3 3/4" X 1 7/16" X 1"

CAT# ABS-2 \$3.50 each

## 48 KEY ASSEMBLY



NEW T.I. KEYBOARDS.

Originally used on computers, these keyboards contain 48 S.P.S.T. mechanical switches. Terminates to 15 pin connector. Frame size 4" X 9".

CAT# KP-48 \$3.50 each

## WALL TRANSFORMER

11.5 Vdc 1.95 AMP.  
Input: 120 Vac  
Size: 3 3/4" X  
2 7/8" X 2 5/8"



CAT# DCTX-11519  
\$6.50 each

## SOUND & VIDEO MODULATOR

Ti# UM1381-1.

Designed for use with T.I. computers. Can be used with video cameras, games, or other audio/video sources. Built in A/B switch enables user to switch from T.V. antenna without disconnection. Operates on channel 3 or 4. Requires 12 Vdc. Hook up diagram included.

CAT# AVMOD \$5.00 each



## LED'S STANDARD JUMBO DIFFUSED

T 1-3/4 size

RED 10 for \$1.50 · 100 for \$13.00

CAT# LED-1 1000 for \$110.00

GREEN 10 for \$2.00

CAT# LED-2 100 for \$17.00

1000 for \$150.00

YELLOW 10 for \$2.00

CAT# LED-3 100 for \$17.00

1000 for \$150.00

## FLASHING LED

with built in flashing circuit operates on 5 volts. 

RED \$1.00 each

CAT# LED-4 10 for \$9.50

GREEN \$1.00 each

CAT# LED-4G 10 for \$9.50

## BI-POLAR LED

Lights RED one direction, GREEN the other. Two leads. 

CAT# LED-6 2 for \$1.70

## COMPUTER GRADE CAPACITORS

1400 MFD 200 VDC

2" dia. X 3" high

CAT# CG-1420 \$2.00

7500 MFD 200 VDC

3" dia. X 5 3/4" high

CAT# CG-75 \$4.00

22000 MFD 25 VDC

2" dia. X 4 3/4" high

CAT# CG-22 \$2.50

## 13.8 VDC REGULATED POWER SUPPLY



Solid state, fully regulated 13.8 Vdc power supplies. Both feature 100% solid state construction, fuse protection and LED power indicator. UL listed.

2 AMP CONSTANT, 4 AMP SURGE

CAT# DVP-412 \$22.50 each

3 AMP CONSTANT, 5 AMP SURGE

CAT# DVP-512 \$30.00 each

## BLACKLIGHT ASSEMBLY



Complete, functioning assembly including ballast, on-off switch, power cord, sockets and F4T5-BL blacklight. Mounted on a 7 1/8" X 3 1/8" metal plate. Use for special effects lighting or erasing EPROMS.

CAT# BLTA \$10.00 each

## POLARITY SWITCH



Designed to control an external coaxial relay on a satellite t.v. system. Ideal for parts. Contains a 5 Vdc relay and many other parts on a P.C. board.

CAT# RDPS

\$1.75 each · 10 for \$15.00

## LIGHT ACTIVATED MOTION SENSOR

This device contains a photocell which senses sudden change in ambient light. Could be used as a door annunciator or modified to trigger other devices. 5 1/2" X 4" X 1". Operates on 6 Vdc. Requires 4 AA batteries (not included).

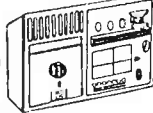

CAT# LSMD \$5.75 per unit.

## 6-12 VDC MOTOR

Mabuchi# RS-550S  
Permanent magnet motor.  
1 7/16" dia. X 2 1/4" long.   
2600 RPM @ 6 V 5300 RPM @ 12 Vdc

CAT# DCM-7 \$3.00 each

## LED HOLDER

Two piece holder. 

CAT# HLED

10 for 65c

## CLIPLITE LED HOLDER



Makes a L.E.D. look like a fancy indicator. Fits T 1-3/4 size LED.

CLEAR CAT# HLED-C

RED CAT# HLEDCL-R

GREEN CAT# HLEDCL-G

YELLOW CAT# HLEDCL-Y

4 for \$1.00

## SWITCHES

MINIATURE TOGGLE SWITCHES

all rated 5 Amps

### S.P.D.T. (on-on)

Solder lug terminals.

CAT# MTS-4

\$1.00 each

10 for \$9.00



### S.P.D.T. (on-on)

Non threaded bushing.

P.C. mount.

CAT# MTS-40PC

75c each

10 for \$7.00



### D.P.D.T. (on-on)

Solder lug terminals.

CAT# MTS-8

\$2.00 each

10 for \$19.00



## MINI PUSH BUTTON

S.P.S.T. momentary.

Push to make. 1/4"

threaded bushing.

Red button.

CAT# MPB-1

35c each · 10 for \$3.25



## BATTERY AND CHARGER SET

Two rechargeable 6 Volt 9.5 Amp / Hr. gel cell batteries and a charger to charge both batteries at the same time. Batteries measure 2 3/4" X 5 1/2" high. Ideal as a 6 or 12 Volt D.C. back-up system. CAT# AH-695 \$35.00 per set

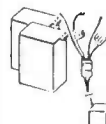

## VIC 20 MOTHERBOARD



26 IC's including 6520A and 6560. Not guaranteed but great for replacement parts or experimentation.

CAT# VIC-20 \$15.00 each

## SOUND EFFECTS BOARD

P.C. board with 2 1/4" speaker, 2 LED's, IC, battery snap, other components 2 3/8" X 3". When switch is pulled board beeps and LED's light. Operates on a 9 volt battery (not included). CAT# ST-3 \$1.25 each



## NICKEL-CAD CHARGER/TESTER

Will charge most nickel cad batteries even button & N size. CAT# UNCC-N \$15.00

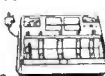

## RECHARGEABLE NICKEL-CAD BATTERIES

AAA SIZE 1.25V 180mAh \$2.25  
AA SIZE 1.25V 500mAh \$2.00  
AA with solder tabs \$2.20  
SUB-C 1.2 V 1200mAh \$4.25  
C-SIZE with solder tabs \$4.25  
D SIZE 1.2V 1200mAh \$4.25

## XENON FLASH TUBE

3/4" X 1/8" dia.  
CAT# FLT-1 2 for \$1.00



Sleek high-tech lamp assembly. Could be used as a third auto tail light, emergency warning light, or special effects lamp. Red reflective lens is 2 3/4" X 5 1/2" is mounted on a 4" high pedestal with up-down swivel adjustment. Includes 12 V replaceable bulb. CAT# TLB \$3.95 each

## STORES:

LOS ANGELES  
905 S. VERMONT AVE.  
LOS ANGELES, CA 90006  
(213) 380-8000

VAN NUYS  
6228 SEPULVEDA BLVD.  
VAN NUYS, CA 91411  
(818) 997-1806

MAIL ORDERS TO:  
ALL ELECTRONICS  
P.O. BOX 567  
VAN NUYS, CA  
91408

TELEX 51010163  
(ALL ELECTRONIC)  
CUSTOMERS  
OUTSIDE OF THE U.S.  
SEND \$1.50 POSTAGE  
FOR CATALOG

TOLL FREE  
800-826-5432  
INFO: (818) 904-0524  
FAX: (818) 781-2653

QUANTITIES LIMITED  
MINIMUM  
ORDER \$10.00  
CALIF. ADD SALES TAX  
USA: \$3.00  
SHIPPING  
NO C.O.D.



# ADVERTISING INDEX

RADIO-ELECTRONICS does not assume any responsibility for errors that may appear in the index below.

**MOTION CONTROL SYSTEM**

**COMPUTER-MONITOR-KEYBOARD MOTOR CONTROLLER FLOPPY CONTROLLER 4 MOTORS-SOFTWARE A.C. POWER SUPPLY** ADD \$12 FOR FREIGHT

**\$149<sup>00</sup>**

GENERAL PURPOSE 64K SINGLE BOARD COMPUTER HAS 2 SERIAL PORTS & 1 CENTRONICS PORT ■ AMBER MONITOR WITH 80 BY 24 LINES OF TEXT DISPLAY ■ HIGH-QUALITY KEYBOARD THAT HAS A SEPARATE NUMERICAL KEYPAD ■ LIGHTED CAPS LOCK AND ENTER KEYS ■ 10 FUNCTION KEYS ■ STEPPER MOTOR DRIVER KIT WITH 4 OF OUR "EASY STEPPER" MOTORS ■ PDS DOS ■ MICROSOFT BASIC ■ PILOT LANGUAGE ■ MOTOR CONTROL PROGRAM WITH SOURCE LISTING ON DISK ■ SCHEMATICS INCLUDED ■ JUST ABOUT EVERY THING YOUR ROBOT WILL NEED FOR "BUILT IN" SMARTS!

WE PROVIDE AN A.C. SUPPLY FOR BENCH TESTING. OUTPUT VOLTAGES ARE +12VDC @ 2.5 AMPS, -12VDC @ 5 AMPS, +5VDC @ 5 AMPS, +24VDC @ 1.5 AMPS ■ EXCEPT FOR THE STEPPER DRIVER KIT ALL BOARDS ARE ASSEMBLED AND TESTED JUST WIRE THEM TOGETHER. ■ SOLDERING IS REQUIRED ■ DISK STORAGE (NOT INCLUDED) IS EXPANDABLE TO 3.2 MEG

**HAVE A COMPUTER? THEN ORDER JUST THE MOTORS AND DRIVER BOARD \$49<sup>00</sup>**

WORKS FROM YOUR CENTRONICS PORT ■ DEMO PROGRAM GETS YOU UP AND RUNNING FAST ■ 100K OF SAMPLE PROGRAMS SHOW HOW TO GET YOUR CUSTOM PROGRAM WORKING ■ INCLUDES 4 STEPPER MOTORS ■ 2 AC POWER SUPPLIES ■ DEMO SOFTWARE ■ DRIVER BOARD KIT ■ TERMINAL STRIPS FOR STEPPERS AND COMPUTER ■ SPECIFY FORMAT IBM, MORROW, CPM

Call for a copy of 15 day trial agreement. Tax & freight extra. COD ok just add \$2.20 to freight Price may change. Store price may differ. While supplies last. No P.O.s, terms, or credit cards

**Silicon Valley Surplus** 4401 OAKPORT OAKLAND CA, 94601  
 415-261-4506  
 OPEN 10am-6pm  
 CLOSED SUN & MON

CIRCLE 51 ON FREE INFORMATION CARD

## AMAZING SCIENTIFIC & ELECTRONIC PRODUCTS

- PLANS**—Build Yourself—All Parts Available In Stock
- LC7—BURNING CUTTING CO<sub>2</sub> LASER \$20.00
  - RUBA—PORTABLE LASER RAY PISTOL 20.00
  - TCC1—3 SEPARATE TESLA COIL PLANS TO 1.5 MEV 20.00
  - IOG1—ION RAY GUN 10.00
  - GRA1—GRAVITY GENERATOR 10.00
  - EML1—ELECTRO MAGNET COIL GUN/LAUNCHER 6.00
- KITS**
- MFT3K—FM VOICE TRANSMITTER 3 MI RANGE 49.50
  - VWPM7—TELEPHONE TRANSMITTER 3 MI RANGE 39.50
  - BTC3K—250,000 VOLT 10-14" SPARK TESLA COIL 199.50
  - LHC2K—SIMULATED MULTICOLOR LASER 39.50
  - BLS1K—100,000 WATT BLASTER DEFENSE DEVICE 69.50
  - ITM1K—100,000 VOLT 20" AFFECTIVE RANGE INTIMIDATOR 69.50
  - PSP4K—TIME VARIANT SHOCK WAVE PISTOL 59.50
  - PTG1K—SPECTACULAR PLASMA TORNAO GENERATOR 149.50
  - MVPIK SEE IN DARK KIT 199.50
- ASSEMBLED**
- PTW1K—SPECIAL EFFECT VISUAL PLASMA GENERATOR FOR GLOBES/NEON TUBING ETC. \$59.50
  - BTCTD—50,000 VOLT—WORLD'S SMALLEST TESLA COIL 49.50
  - LGU40—1MW HeNe VISIBLE RED LASER GUN 249.50
  - RAT30 AUTO TELEPHONE RECORDING DEVICE 24.50
  - GPV10—SEE IN TOTAL DARKNESS IR VIEWER 349.50
  - LST10—SNOOPER PHONE INFINITY TRANSMITTER 169.50
  - IPG70—INVISIBLE PAIN FIELD GENERATOR—MULTI MODE 74.50
- CATALOG CONTAINING DESCRIPTIONS OF ABOVE PLUS HUNDREDS MORE AVAILABLE FOR \$1.00 OR USE OUR PHONE FOR "ORDERS ONLY" 603-673-4730.
- PLEASE INCLUDE \$3.00 PH ON ALL KITS AND PRODUCTS PLANS ARE POSTAGE PAID. SEND CHECK, MO, VISA, MC IN US FUNDS

**INFORMATION UNLIMITED**  
 P.O. BOX 716 DEPT. RE. AMHERST, NH 03031

Free Information Number	Page	Free Information Number	Page
81	A.I.S. Satellite	83	OCTE Electronics
108	AMC Sales	15	PC Boards
—	AMCOM	104	Pacific Cable
107	All Electronics	117	Parts Express
103	Allen, Wm B	28	R & D Electronics
208	Alpha Products	94	R.S.R. Electronics
—	Amazing Devices	118	RCA D&SP
106	American Design Components	106	Radio Shack
187	American Reliance	73	188, 189 Sencore
84	Appliance Service	82	51 Silicon Valley Surplus
202	B & C Microsystems	94	191, 192 Simpson
77	B&K Precision	7	250 to 254
194	BUYUS	82	83 Synergetics
190	Banner Technical Books	78	92 Tektronix
85	Blue Star Industries	83	181, 184 Tektronix
109	C & S Sales	30	182, 183 Tektronix
60	CIE	8	123 Test Probes
50	Caig Laboratories	74	186 The Datak Corporation
54	Chemtronics	72	70 The Hobby Helper
193	Chenesko Products	83	73 TSM
—	Command Productions	81	204 UCANDO VCR Educational Prods.
203	Computer Heroes	94	179 WPT Publications
55	Contact East	83	
58	Cook's Institute	78	
196	Crystek	32	
197	Daetron	33	
127	Deco Industries	82, 83	
201	Devtronics	94	
82	Digi-Key	116	
200	Diskette Connection	94	
—	Electronic Technology Today	14, 32	
—	Electronics Book Club	29	
120	Elephant Electronics	82	
121	Fluke Manufacturing	22	
—	Fordham Radio	CV4	
206	Golden Bow Systems	94	
—	Grantham College of Engineering	14	
86	Heath	18	
—	ISCET	81	
65	J & W	26	
59	JDR Instruments	5	
113, 176	JDR Microdevices	108, 109	
177, 178	JDR Microdevices	110, 111	
198	JDR Microdevices	112	
114	Jameco	114, 115	
115	Jensen Tools	83	
—	Joseph Electronics	25	
195	Kelvin	81	
185	Kikusui	20	
87	MCM Electronics	107	
53	MD Electronics	79	
93	Mark V. Electronics	105	
—	McGraw Hill Book Club	44	
61	Microprocessors Unltd.	94	
117	Mouser	79	
—	NRI	34	
71	New-Tone Electronics	23	
72	NuScope Associates	94	

**Gernsback Publications, Inc.**  
 500-B Bi-County Blvd.  
 Farmingdale, NY 11735  
 (516) 293-3000  
 President: Larry Steckler  
 Vice President: Cathy Steckler

**For Advertising ONLY**  
 516-293-3000

**Larry Steckler**  
 publisher  
**Arline Fishman**  
 advertising director  
**Shelli Weinman**  
 advertising associate  
**Lisa Strassman**  
 credit manager  
**Christina Estrada**  
 advertising assistant

### SALES OFFICES

**EAST/SOUTHEAST**  
**Stanley Levitan**  
 Eastern Sales Manager  
 Radio-Electronics  
 259-23 57th Avenue  
 Little Neck, NY 11362  
 718-428-6037, 516-293-3000

**MIDWEST/Texas/Arkansas/Okla.**  
**Ralph Bergen**  
 Midwest Sales Manager  
 Radio-Electronics  
 540 Frontage Road—Suite 339  
 Northfield, IL 60093  
 312-446-1444

**PACIFIC COAST/ Mountain States**  
**Marvin Green**  
 Pacific Sales Manager  
 Radio-Electronics  
 5430 Van Nuys Blvd. Suite 316  
 Van Nuys, CA 91401  
 1-818-986-2001



# T S M

GENERAL DISTRIBUTOR  
PROSPECT ELECTRONICS  
PO BOX 9144 ALLENTOWN, PA 18105  
TEL: (215) 770 - 9029

# ELECTRONICS KITS

HEADQUARTER - TSM IN AMERICA INC. 2065 BOSTON POST ROAD LARCHMONT N.Y. 10538

## ACTIVE DISTRIBUTORS IN CANADA

ALBERTA, CALGARY T2A 5N1  
NBR 2-3220 5 TH AVE N.E.  
TEL:(403) 235-5300  
FAX:(403)248-0750

ALBERTA, EDMONTON T6H 4J8  
5312 CALGARY TRAIL  
TEL:(403) 438-5888  
FAX:(403) 434-0812

B.C. VANCOUVER V5R 5J7  
3070 KINGSWAY  
TEL:(604) 438-3321

MANITOBA, WINNIPEG R3H 0H8  
106 KING EDWARD ST E  
TEL:(204) 786 3075

ONTARIO, MISSISSAUGA L4W 4M1  
MATHESON CENTRE  
NBR 2-1350 MATHESON BLVD  
TEL:(416) 238-8825

ONTARIO, DOWNSVIEW M3J 1Z3  
TORONTO-DOWNSVIEW  
86 ST REGIE CR N  
TEL:(416) 630-0400  
FAX:(416) 638-2936

ONTARIO, TORONTO M5C 1M3  
TORONTO DOWNTOWN  
100 LOMBARD ST  
TEL:(514) 367-2911

ONTARIO OTTAWA K1Z 6A6  
1023 MERIVAL ROAD  
TEL:(613) 728-7900

QUEBEC, MONTREAL-WEST H4P 1N7  
3651 FERRIER ST  
TEL:(514) 731-7441

QUEBEC, MONTREAL EAST H1S 1A9  
6080 METROPOLITAN BLVD E.  
TEL:(514) 256-7538

QUEBEC, STE FOY G1N 4K8  
1990 BOUL CHAREST O  
TEL:(418) 682-5775  
FAX:(418) 682-8303

## ACTIVE IN U.S.A

MASS. BOSTON WESTBORO 01581  
133 FLANDERS ROAD  
TEL:(617) 366-8899  
FAX:(617)366-1195

WA. BELLEVUE SEATTLE 98005  
131307 NORTHUP WAY  
20 TH ST N.E.  
TEL:(206) 881-8191

AUTO SOUND SYSTEM  
1269 EAST MAIN STREET  
EL CAJON CA 92021  
TEL:(619) 442-70-22

CC ELECTROWARD  
716 W ST GEORGE AVE  
LINDEN NJ  
TEL:(201)925-83-33

DOW RADIO  
2001 HARBOR BLVD  
COSTA-MESA CA 92627

ELECTRO CITY  
801 EAST BROADWAY  
TUCSON ARIZONA 85719

ELECTRONIC OUTLET  
2815 FONDREN  
HOUSTON TEX. 77063

ELECTRONIC WAREHOUSE  
2691 MAIN ST  
RIVERSIDE CA 92501  
TEL:(714)686-61-86

KELVIN ELECTRONICS  
7 FAIRCHILD AVE.  
PLAINVIEW N.Y 11803  
TEL:(516)349-7620  
FAX:(516)349-7830

NUTRON COMPUTER ELECTRONICS  
821 E ROOSEVELT ROAD LOMBARD  
IL. 60148  
TEL:(312)691-89-00

MAC'S ELECTRONIC  
191 SOUTH E STREET  
SAN BERNARDINO CA 92401  
TEL:(714)884-31-87

ORVAC ELECTRONIC  
1645 EAST ORANGETHORPE  
FULLERTON  
CA 92631-5294  
TEL:(714)871-12-20

TRI-TEK ELECTRIC  
9014 NORTH 23 AVENUE PHOENIX  
ARIZONA 85021  
TEL:(602)371-08-60

RF ELECTRONICS  
11645 HARBOR BLVD  
FULLERTON CA 92632  
TEL:(714)635-50-90

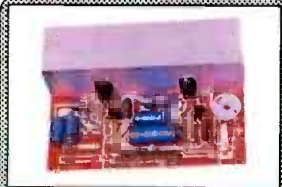

**TSM 5A** \$26.30  
AUDIO POWER MODULE 70W PEAK POWER  
35W RMS, INPUT SENSITIVITY 47K/800MV  
OUTPUT 4Ω/8Ω. POWER SUPPLY 39V D.C.  
/0.5A



**TSM 67** \$39.74  
STEREO AMPLIFIER 2X40W PEAK POWER  
SENSITIVITY INPUT 47K/300mV, OUTPUT  
2.5/8Ω. VOLUME, BALANCE, BASS,  
TREBLE, CONTROLS. POWER SUPPLY  
12V D.C. /34 A.

**TSM 44** \$18.88  
AUDIO POWER MODULE 50W PEAK POWER  
25W RMS, INPUT SENSITIVITY 800mV/47K  
OUTPUT IMPEDANCE 4Ω/8Ω. POWER SUPPLY  
40V D.C./2A

**TSM 11** \$15.50  
AUDIO AMPLIFIER 30W PEAK POWER, 15W  
RMS, INPUT SENSITIVITY 47K/150mV, 2.5  
TO 8Ω OUTPUT. COMPLETE WITH VOLUME  
BASS, TREBLE CONTROL. POWER SUPPLY  
12/16V D.C. /2A

**TSM 5B** \$33.70  
AUDIO POWER MODULE 90W PEAK POWER  
45W RMS. INPUT SENSITIVITY 47K/800mV  
OUTPUT 4Ω/8Ω. POWER SUPPLY 39V D.C./3A

**TSM 18** \$12.97  
AUDIO AMPLIFIER 15W PEAK POWER, 7.5W  
RMS, INPUT SENSITIVITY 47K/150mV, 2.5  
TO 8Ω OUTPUT. COMPLETE WITH VOLUME  
BASS, TREBLE CONTROL. POWER SUPPLY  
12/16V D.C. /1.5A

**TSM 19** \$52.05  
AUDIO 240W PEAK POWER, 120W RMS  
SENSITIVITY 47K/0.8 V. OUTPUT 4 Ω.  
THD 0.3 %. RESPONSE 15 HZ - 100 KHZ.  
POWER SUPPLY 79V MAX. HEAT-  
SINKS NOT INCLUDED WITH THE KIT.

**TSM 66** \$16.50  
AUDIO POWER MODULE 40W PEAK POWER  
20W RMS, INPUT SENSITIVITY 47K/300mV  
OUTPUT 2.5/8Ω. POWER SUPPLY 12V D.C./2A

**TSM 68** \$22.66  
STEREO AMPLIFIER 2 X 20W  
INPUT 47K/300mV, OUTPUT 2.5/8Ω. SUPPLI-  
ED WITH HEATSINK AND BALANCE,  
VOLUME, BASS, TREBLE, POWER SUPPLY  
12V D.C./2.5A

**TSM 155/1** \$46.30  
STEREO AMP. 2 X 50W  
PEAK. INPUT SENSITIVITY 47K/300mV  
OUTPUT 4/8Ω. SUPPLIED WITH HEATSINK  
AND BALANCE, VOLUME, BASS, TREBLE  
CONTROLS. POWER SUPPLY 40V D.C./2A-3A

**TSM 118** \$62.31  
320W PEAK POWER AMPLIFIER MODULE.  
8Ω OUTPUT IMPEDANCE INPUT 47K/800mV  
FREQUENCY RESPONSE 15HZ TO 60KHZ,  
POWER SUPPLY 2 X 40V D.C./6A  
HEATSINKS NOT INCLUDED IN THE KIT.

**TSM 89** \$30.38  
AUDIO BOOSTER STEREO 2 X 40W FOR  
CAR RADIO, OUTPUT 2.5Ω. POWER SUPPLY  
12/16V D.C./4A.

**TSM 102** \$22.50  
18 LED OUTPUT POWER LEVEL METER,  
POWERED BY THE MODULATION.

**TSM 128** \$20.31  
2 X 6 LED OUTPUT LEVEL METER, STEREO  
2 X 50W. POWER SUPPLY 15/20V D.C.

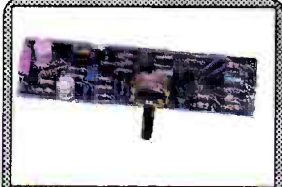

**TSM 9** \$14.00  
AUDIO PREAMPLIFIER FOR GUITAR, INP  
SENSITIVITY 47K/5mV, OUTPUT LEVEL  
47K/1.5V, VOLUME CONTROL, VARIABLE  
POWER SUPPLY 25V D.C. /0.1A

**TSM 34** \$9.19  
STEREO RIAA PREAMPLIFIER, INPUT  
SENSITIVITY 47K/3mV, OUTPUT 700mV.  
POWER SUPPLY 12V D.C. /0.1A

**TSM 35** \$9.19  
MICROPHONE STEREO PREAMPLIFIER,  
INPUT SENSITIVITY 5mV/200Ω OR MORE.  
OUTPUT 700mV, POWER SUPPLY 12V D.C.  
/0.1A

**TSM 122** \$13.96  
ALL-BAND FM/VHF/UHF ANTENNA, 200B  
AMPLIFIER. POWER SUPPLY 8/12V D.C./  
0.15A

**TSM 31** \$14.77  
FM STEREO DECODER, POWER SUPPLY  
12V D.C. /0.1A

**TSM 62** \$13.00  
CAR ANTENNA PREAMPLIFIER MW/LW/FM,  
POWER SUPPLY 12/16V D.C./0.1A

**TSM 335** \$15.65  
PHYSIOLOGIC TONE CONTROL, STEREO,  
INPUT IMPEDANCE 150mV/160K, OUTPUT  
LEVEL 800mV. POWER SUPPLY 25V D.C.



**TSM 146** \$33.99  
STEREO 2X5 BANDS EQUALIZER, SUPPLIED  
WITH 10 POTENTIOMETERS, FREQUENCY  
RESPONSE 50HZ TO 15 KHZ, POWER SUPPLY  
2 X 12V D.C./0.2A

**TSM 147** \$18.88  
MONO 5 BANDS EQUALIZER, SUPPLIED WITH  
5 POTENTIOMETERS, FREQUENCY RESPONSE  
50 HZ TO 15KHZ, POWER SUPPLY 2 X 12V  
D.C./0.15A.

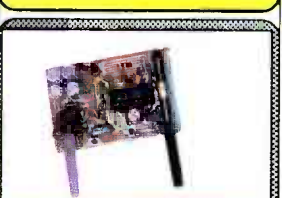

**TSM 61** \$25.48  
FM RECEIVER, OUTPUT 1 WATT 4/8Ω,  
POWER SUPPLY 12/16V D.C. /0.2A.

**TSM 158** \$27.42  
FM RECEIVER, OUTPUT 20 WATTS/8Ω  
POWER SUPPLY 12/16V D.C. /2A

**TSM 211** \$10.00  
MEDIUM WAVE RECEIVER, 1 W, 0.5 W RMS  
AUDIO POWER, POWER SUPPLY  
9-12V D.C./0.1 A

**TSM 205** \$35.40  
FM RECEIVER, HEADPHONE STEREO OUTPUT  
POWER SUPPLY 9/12V D.C./0.1A

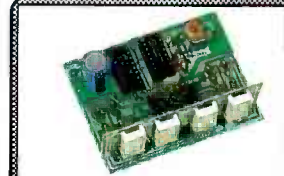

**TSM 201** \$26.77  
DIGITAL CLOCK, 5/16" READ OUT; POWER  
SUPPLY 12V D.C./0.2A WITH HOUR AND  
MINUTE SETTING CONTROLS

**TSM 157** \$40.00  
DIGITAL CLOCK AND UP TO 24 MN  
1/100 S. CHRONOMETER. COUNT DOWN  
CAPABILITY FOR THE CLOCK.  
POWER SUPPLY 12V D.C. OR A.C.

**TSM 177** \$33.20  
DIGITAL VOLTMETERS 0 V TO 999 V D.C.  
POWER SUPPLY 12V D.C./0.5A

**TSM 206** \$10.15  
METRONOME, POWER SUPPLY 9 - 12V D.C.

**TSM 210** \$10.50  
FULLY RANDOMISED ELECTRONIC DICE,  
POWER SUPPLY 9 - 12V D.C./0.1A

**TSM 54** \$13.85  
FM TRANSMITTER, POWER SUPPLY 9V  
D.C. /0.5A

**TSM 150** \$82.50  
HOME PROGRAMMER, 4 DEVICES CONTROL  
20 PROGRAMS, OPERATION WITH RELAYS.  
POWER SUPPLY 12V D.C./0.8A.

**TSM 130** \$26.77  
24 TUNE DOOR CHIME, OUTPUT 3/4 WATTS  
POWER SUPPLY 12V D.C./1A

**TSM 123** \$46.15  
SOUND CONDITIONER, OUTPUT LEVEL 800mV  
TO BE CONNECTED TO AMPLIFIER AUXILIA  
RY INPUT. POWER SUPPLY 12V D.C.

**TSM 78** UNIVERSAL ALARM FOR  
HOME AND CAR, DELAYED EXIT TIME, AD-  
JUSTABLE SOUND ALARM, TAMPER PROOF.  
OPERATION WITH CONTACT SWITCHES.  
POWER SUPPLY 12V D.C./0.15A \$33.23

**TSM 121** \$17.54  
16 LED DISPLAY THERMOMETER, POWER  
SUPPLY 15/18V D.C./0.15A

**TSM 105** \$15.15  
ELECTRONIC ALARM SIREN, 8Ω IMPEDAN-  
CE, 10 WATTS RATING. POWER SUPPLY  
12V D.C. /HORN SPEAKER NOT INCLUDED

**TSM 85** \$22.52  
TIME DELAY SYSTEM FROM 1 SEC TO 15  
MINUTES. POWER SUPPLY 12V D.C.

**TSM 69** \$15.93  
TELEPHONE AMPLIFIER WITH INDUCTIVE  
PICK-UP AND SPEAKER, ADJUSTABLE  
VOLUME, POWER SUPPLY 9/12V D.C./0.1A

**TSM 168** \$12.92  
MOSQUITO REPELLER, POWER SOURCE  
9V D.C.

**TSM 88** \$38.77  
FUNCTION GENERATOR, FREQUENCY RANGE  
8HZ TO 200KHZ, PROVIDING SINE/TRIANGLE  
/SQUARE/SAW TOOTH WAVE FORMS, PO-  
WER SUPPLY 12V D.C./0.3A

**TSM 58** \$19.94  
TWO-STATION INTERCOM WITH SPEAKER  
VOLUME CONTROL, POWER SOURCE 9/12V  
D.C. /0.4A

**TSM 160** \$16.62  
STEREO SIMULATOR, POWER SUPPLY 12V  
D.C./0.1A.

**TSM 196** \$19.71  
7 INPUT MIXER STEREO PREAMPLIFIER OR  
14 INPUT MONO WITHOUT ATTENUATION,  
INPUT 47K/100 TO 700mV, OUTPUT 47K/  
100 TO 750mV, POWER SUPPLY 24V D.C.  
/0.1A

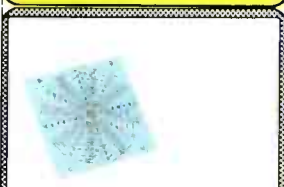

**TSM 99** \$130.00  
VEGAS KIT - FESTIVE LIGHT DISPLAY (LED  
POWER SUPPLY 12V D.C. /2.5A  
64 LEDS, AS MANY AS 800 PROGRAMS



**TSM 212** \$17.50  
LOW OPERATING VOLTAGE  
SPOT TSM 220 AND TSM 221 COMPATIBLE  
CONTROLLED BY A MICROPHONE  
POWER SUPPLY 12V 1A, OUTPUT 0.5A  
MODULATOR. SAFE 3-CHANNEL LIGHT

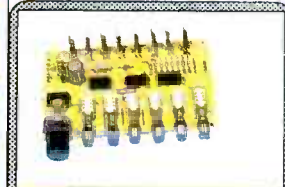

**TSM 214** \$29.50  
8-CHANNEL CATERPILAR. SAFE LOW  
VOLTAGE OPERATION USING TSM 220  
AND 221 SPOT. 9V D.C. /0.5 A

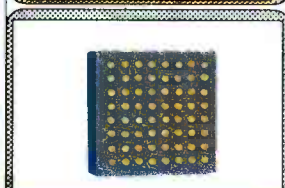

**TSM 220** \$25.30  
64 LED'S SPOT FOR SAFE LIGHT MODUL-  
ATION. SUPPLIED WITH BOX.

**TSM 213** \$16.20  
SAFE LOW VOLTAGE 2-WAY CATERPILAR  
RANDOMLY FLASHING AND WINKING. TSM  
220 AND TSM 221 SPOT COMPATIBLE.  
POWER SUPPLY 12V/0.5A

**TSM 221** \$17.20  
25 LED'S SPOT FOR SAFE LIGHT MODUL-  
ATION. SUPPLIED WITH BOX.



**TSM 2 V2** \$22.20  
VARIABLE SOLID STATE REGULATED PO-  
WER SUPPLY 8V TO 38V/2A.  
TRANSFORMER IS NOT INCLUDED WITH THE  
KIT.

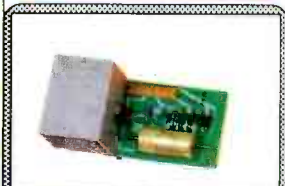

**TSM 116 V5** \$11.50  
REGULATED POWER SUPPLY 5V D.C.  
POWER TRANSFORMER NOT INCLUDED WITH  
THE KIT

**TSM 116 V12** \$11.50  
REGULATED POWER SUPPLY 12V D.C.  
POWER TRANSFORMER IS NOT INCLUDED  
WITH THE KIT.

**TSM 163** \$12.92  
POWER SUPPLIES 5, 7.5, 9, 12V/1A.  
POWER TRANSFORMER NOT INCLUDED  
WITH THE KIT.

**TSM 2 V4** \$25.85  
VARIABLE SOLID STATE REGULATED PO-  
WER SUPPLY 3V TO 14V/5A TRANSFORMER  
NOT INCLUDED IN THE KIT.

GENERAL DISTRIBUTOR  
PROSPECT ELECTRONICS  
PO BOX 9144 ALLENTOWN, PA 18105  
TEL: (215) 770 - 9029

WELCOME  
DISTRIBUTORS - RETAILERS  
WRITE FOR AN INTERESTING PROPOSAL

# Fordham measures up

Quality • Price • Delivery

## Mini-Meters with Maxi-Specs



### SCOPE 3 1/2 Digit LCD Meter

- 0.5% Accuracy • DC Voltage • AC Voltage • DC Current • Resistance • Diode Test • Battery Life 300 Hrs. • Overload Protection: DC 500V, AC 350V, ohms 250V DC/AC.

Model DVM-630 **\$2995**  
Our Price

Zippered carrying case CC-30 \$4.50

### NEW! SCOPE 3 1/2 Digit, LCD 8 Function with Transistor Tester

- 0.5% Accuracy • Audible continuity and diode test • 10 Amp measurement • Resistance • DC/AC Voltage.

Model DVM-632 **\$4495**  
Reg. \$60.00 Our Price

Zippered carrying case CC-30 \$4.50

### SCOPE 3 1/2 Digit LCD with Autoranging

- 0.5% Accuracy • Auto/Manual range selection • DC Voltage • AC Voltage • AC Current • DC Current • Resistance.

Model DVM-631 **\$4995**  
Our Price **Special**

Deluxe carrying case CA-92 \$9.95

## SCOPE Hand-Held Digital Multimeters

- Overload protection • Auto-decimal LCD readout • Polarity indication • 300 hr. 9V battery life • Low battery indicator.

- 8 Function, 37 ranges including Transistor and Capacitance measurements

Model DVM-636 **\$6750**  
Our Price



CA-92 Deluxe Padded Case for DVM meters. \$9.95  
TL-216 Transistor and Capacitance Test Leads \$9.90

- 11 Function, 38 ranges including Logic Level Detector, Audible and Visual Continuity, Capacitance and Conductance measurements

Model DVM-638 **\$8750**  
Our Price



NEW!

- SCOPE Frequency Counters
- 8-digit LED • Compact • lightweight
- High performance • Automatic range and Hold function • High stability in reference oscillator.

Model FC-7011 **\$16995**  
100 MHz Our Price

Model FC-7051 **\$24995**  
550 MHz Our Price



### FORDHAM Frequency Counter

- 10 Hz - 150 MHz Range • 7-digit LED display • VHF/HF selection • Gate time 1 sec., 5 sec. • ±1 count accuracy.

Model FC-150 **\$13990**  
Our Price



NEW

### FORDHAM Function Generator

- 0.5 Hz - 500 KHz in 6 ranges • Sine, square & triangle wave forms • VCA and VCF inputs • Accuracy ±5% of full scale.

Model FG-202 **\$14990**  
Our Price



### FORDHAM Signal Tracer / Injector

- Easy to operate • VU meter • Two LED mode indicators • 1 KHz test tone • 8 ohm speaker • Test leads.

Model SE-610 **\$11990**  
Our Price



### FORDHAM LCR Bridge Meter

- Fully transistorized • 1 KHz signal generator • Measures resistance • Inductance • High mechanical and electrical stability • Battery operated.

Model LC-340 **\$14995**  
Our Price

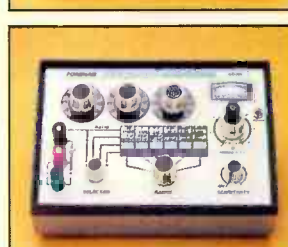

### SCOPE Digital Capacitance Meter

- Digital LCD display • LSI-circuit • High accuracy: 100 ppm 0.5% • Broad test range • Fast sampling time • Capacitor discharge protection • Compact, lightweight design • One-hand operation.

Model DCM-602 **\$5995**  
Our Price

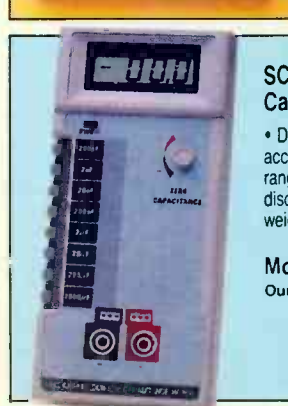

Telephone Orders Now! EVERYDAY INCLUDING SATURDAY  
Mon. - Fri. 8 a.m. - 8 p.m. EST. Sat. 9 a.m. - 3 p.m. EST

ASK FOR FREE CATALOG. Money orders, checks accepted. C.O.D.'s require 25% deposit



# Fordham

Toll Free **800-645-9518**

260 Motor Parkway, Hauppauge, NY 11788

In NY State 800-832-1446

### Service & Shipping Charge Schedule Continental U.S.A.

FOR ORDERS	ADD
\$25-100	\$4.50
\$101-250	\$6.00
\$251-500	\$8.00
\$501-750	\$10.50
\$751-1,000	\$12.50
\$1,001-1,500	\$16.50
\$1,501-2,000	\$20.00
\$2,001 and Up	\$25.00