

# Radio- Electronics

**BUILD A COMPUTER POWERLINE  
TRANSIENT SUPPRESSOR**

\$1.50 SEPT. 1983  
U.K. 85p

DGS

COMPUTERS - VIDEO - STEREO - TECHNOLOGY - SERVICE

A  
GERNSBACK  
PUBLICATION

Build this  
**MINI-PLAYER PIANO**  
with keyboard, LED's and memory

From the CES Show:  
**UNUSUAL CONSUMER PRODUCTS**

1983 design competition winners

The in's and out's of  
**ECL LOGIC CIRCUITS**  
and how to use them

Build a digital  
**PRESSURE GAUGE**

car  
design  
**FREQUENCY  
BITS**

the pitfalls

**PLUS:**

- ★ Videogames
- ★ Hobby Corner
- ★ Drawing Board
- ★ Service Clinic
- ★ New Idea
- ★ State-Of-Solid-State



390735 UHM U9976093 6V R NOV83  
MR ROBERT DAHM  
997 GRAND AV  
AURORA IL 60505 09\*\*55

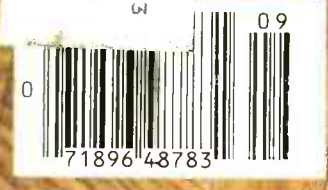

# Take a good look at VACO.



THE SUPER CASE  
70260

The world famous Super Case. Complete with 48 of the most popular and professional problem-solving tools. From screwdrivers and nutdrivers to pliers, wrenches, crimping tools and more. A super variety and super value. All unconditionally warranted from Vaco, of course. The Super Case and all the other fine Vaco tools can be seen in our new 1983 catalog. It's free, just write. Say you want to take a good look at VACO.

Vaco Products Company, 1510 Skokie Blvd.,  
Northbrook, IL 60062 U.S.A.

**VACO**<sup>®</sup>

CIRCLE 14 ON FREE INFORMATION CARD

# Double Your Troubleshooting and Testing Productivity . . . Or Your Money Back!

**Six-digit readout:** Automatically tracks every CRT test. We call it digital autotracking. It's patent pending.

**Bright dual-trace CRT:** 60 MHz (-3 dB); 100 MHz (-12 dB).

**Delta PPV, Time, Freq:** Measure any part of a waveform for PPV, time or frequency using Delta measurements. Just dial in the waveform section you want to measure and push.

**Simplify Freq ratio tests:** Automatically compare input/output ratio of multiply/divide stages from 1:1 to 1:999,999 with the push of a button.

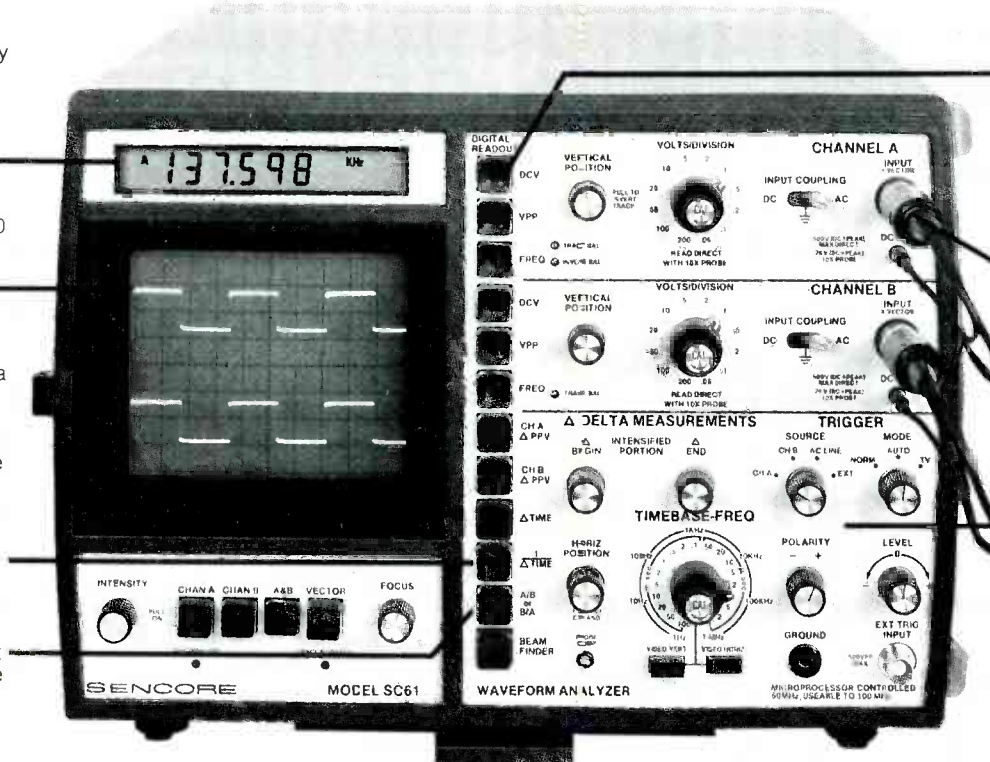

**Autotracking DCV, PPV, Freq:** Measure DCV to .5%; PPV to 2%; freq. to .001%. Just push a button for either Channel A or B.

**One probe input:** One probe input per channel for all measurements - digital and scope - with 5 mV to 2000 V measuring range. (2 lo-cap probes provided.)

**Super sync:** ECL provides rock-solid sync trigger circuits with only 4 controls; includes TV sync separators for video work.

U.S. Patent Pending  
Financing Available

**The first scope with push button digital readout.** If you use general purpose oscilloscopes for troubleshooting or testing, we can double your present productivity with the SC61 Waveform Analyzer, the first instrument to turn every conventional scope measurement into an automatic digital readout.

**No more graticule counting.** Connect only one probe to view any waveform to 100 MHz. Then, just push a button to read DCV, PPV, frequency and time — automatically!

There are no graticules to count or calculations to make, which speeds every measurement.

The digital readout is from 10 to 100,000 times more accurate as well.

Plus you have everything you want to know about a test point, at the push of a button, which speeds troubleshooting tremendously.

A special Delta function even lets you intensify parts of a waveform and digitally measure the PPV, time or frequency for just that waveform section.

And it's neat. No more tangled leads, piles of probes or dangling cords. The SC61 is an entire test station in one unit.

**The one and only.** There are other scopes with digital readout, but none of them completely automate every conventional scope measurement so you can automatically analyze any waveform without counting one single graticule. Totally automatic waveform analyzing at the push of a button. It will make all the difference in your productivity.

**Double your productivity.** When we say the SC61 will double your productivity, we're being conservative. We've seen cases of

three, four, even ten time increases in productivity with this first-of-its-kind, automated oscilloscope. Every situation is different, however, so try the SC61 and judge for yourself. Here's our offer.

**Money back guarantee.** If the SC61 does not at least double your productivity during the first thirty days, you may return it for a full refund, including freight both ways.

**Call today.** Get the entire SC61 Waveform Analyzer story. Call toll-free today, and ask for our eight page color brochure. It could be the most productive call you make this year!

**Phone Toll-Free  
1-800-843-3338**

Alaska, Hawaii, Canada and South Dakota call collect (605) 339-0100

**SENCORE**  
3200 Sencore Drive, Sioux Falls, SD 57107

CIRCLE 87 ON FREE INFORMATION CARD  
CIRCLE 71 FOR DEMONSTRATION

[www.americanradiohistory.com](http://www.americanradiohistory.com)

# wabash<sup>®</sup> diskettes \$1.29 each!

for  
as  
low  
as

## Now get Wabash Quality at a CE Price

For over 17 years, Wabash has been making high quality and dependable computer products. Wabash diskettes are made to provide error-free performance on your computer system because every diskette has been totally and hypercritically tested. Since you can now buy Wabash computer products directly from CE, the world's largest distributor of magnetic media, you can now get maximum savings on every order. You can even order toll-free.

## New Wabash Six Year Warranty

The quality of Wabash diskettes is stressed throughout the entire manufacturing process. After coating, all Wabash diskettes go through a unique burnishing process that gives each diskette a mirror-smooth appearance. Wabash then carefully applies a lubricant that is specially formulated to increase diskette life. Then, to keep out foreign particles, a unique heat seal bonds the jacket and liner together to help prevent contamination. After 100% hypercritical testing and certification, Wabash then packages each diskette, (except bulk pack) in a super strong and tear resistant Tyvek<sup>®</sup> envelope. The final Wabash product is then shrink-wrapped to insure cleanliness and reduce contamination during shipment. Wabash diskettes are so very reliable that Wabash now offers a six year warranty in case of defects in materials or workmanship on all diskettes purchased directly from Communications Electronics.

## New...Wabash Diskette Duplication Services

Communications Electronics has teamed up with Wabash to provide a single-source solution for the diskette duplication requirements of software developers, OEM's and distributors. All service is in-house, to give you fast, dependable service. In most cases, delivery can be completed in five days. Whether you require 100, 1,000, or 10,000 copies per week, call CE first for a no obligation price quote. For additional information, please write us on your letterhead with your requirements.

### SAVE ON WABASH DISKETTES

Product Description	Part #	CE quant. 100 price per disk (\$)
8" SSSD IBM Compatible (128 B/S, 26 Sectors)	F111	1.89
8" SSSD Shugart Compatible, 32 Hard Sector	F31A	1.89
8" SSDD IBM Compatible (128 B/S, 26 Sectors)	F131	2.39
8" DSDD Soft Sector (Unformatted)	F14A	2.99
8" DSDD Soft Sector (256 B/S, 26 Sectors)	F144	2.99
8" DSDD Soft Sector (512 B/S, 15 Sectors)	F145	2.99
8" DSDD Soft Sector (1024 B/S, 8 Sectors)	F147	2.99
5 1/4" SSSD Soft Sector w/Hub Ring	M11A	1.49
5 1/4" Same as above, but bulk pack w/o envelope	M11AB	1.29
5 1/4" SSSD 10 Hard Sector w/Hub Ring	M41A	1.49
5 1/4" SSSD 16 Hard Sector w/Hub Ring	M51A	1.49
5 1/4" SSDD Soft Sector w/Hub Ring	M13A	1.79
5 1/4" Same as above, but bulk pack w/o envelope	M13AB	1.59
5 1/4" SSDD 10 Hard Sector w/Hub Ring	M43A	1.79
5 1/4" SSDD 16 Hard Sector w/Hub Ring	M53A	1.79
5 1/4" DSDD Soft Sector w/Hub Ring	M14A	2.69
5 1/4" Same as above, but bulk pack w/o envelope	M14AB	2.49
5 1/4" DSDD 10 Hard Sector w/Hub Ring	M44A	2.69
5 1/4" DSDD 16 Hard Sector w/Hub Ring	M54A	2.69
5 1/4" SSQD Soft Sector w/Hub Ring (96 TPI)	M15A	2.59
5 1/4" DSQD Soft Sector w/Hub Ring (96 TPI)	M16A	3.69
5 1/4" Tyvek Diskette Envelopes - Price per 100 Pack	TE5	12.00

SSSD = Single Sided Single Density; SSDD = Single Sided Double Density;  
DSDD = Double Sided Double Density; SSQD = Single Sided Quad Density;  
DSQD = Double Sided Quad Density; TPI = Tracks per inch.

## Quantity Discounts Available

Wabash diskettes are packed 10 disks to a carton and 10 cartons to a case. The economy bulk pack is packaged 100 disks to a case without envelopes or labels. Please order only in increments of 100 units for quantity 100 pricing. With the exception of bulk pack, we are also willing to accommodate your smaller orders. Quantities less than 100 units are available in increments of 10 units at a 20% surcharge above our 100 unit price. **Quantity discounts** are also available.



Order 500 or more disks at the same time and deduct 1%; 1,000 or more saves you 2%; 2,000 or more saves 3%; 5,000 or more saves 4%; 10,000 or more saves 5%; 25,000 or more saves 6%; 50,000 or more saves 7%; 100,000 or more saves 8%; 500,000 or more saves 9% and 1,000,000 or more disks earns you a 10% discount off our super low quantity 100 price. Almost all Wabash diskettes are immediately available from CE. Our efficient warehouse facilities are equipped to help us get you the quality product you need, when you need it. If you need further assistance to find the flexible disk that's right for you, call the Wabash compatibility hotline. Dial toll-free 800-323-9868 and ask for your compatibility representative. In Illinois or outside the U.S. dial 312-593-6363 between 9 AM to 4 PM Central time.

## Buy Wabash Diskettes with Confidence

To get the fastest delivery from CE of your Wabash computer products, we recommend you phone your order directly to our Computer Products Division and charge it to your credit card. Be sure to calculate your price using the CE prices in this ad. Written purchase orders are accepted from approved government agencies and most well rated firms at a 30% surcharge for net 30 billing. For maximum savings, your order should be prepaid. All sales are subject to availability, acceptance and verification. All sales are final. All prices are in U.S. dollars. Prices, terms and specifications are subject to change without notice. Out of stock items will be placed on backorder automatically unless CE is instructed differently. Minimum *prepaid* order is \$50.00. Minimum *purchase order* \$200.00. All shipments are F.O.B. Ann Arbor, Michigan U.S.A. No COD's please. Non-certified and foreign checks require bank clearance.

For **shipping charges** add \$8.00 per case or partial case of 100 8-inch flexible disks or \$6.00 per case or partial case of 100 5 1/4-inch mini-diskettes for U.P.S. ground shipping and handling in the continental U.S.A.

**Mail orders to:** Communications Electronics, Box 1002, Ann Arbor, Michigan 48106 U.S.A. If you have a Visa or Master Card, you may call and place a credit card order. Order toll-free in the U.S. Dial 800-521-4414. In Canada, order toll-free by calling 800-265-4828. If you are outside the U.S. or in Michigan dial 313-994-4444. Telex anytime 810-223-2422. Order your Wabash diskettes today.

Copyright ©1983 Communications Electronics™

Ad #U12483



Order Toll-Free!  
**800-521-4414**

In Michigan 313-994-4444

**wabash**  
error-free  
diskettes

**COMMUNICATIONS  
ELECTRONICS™**

**Computer Products Division**

818 Phoenix □ Box 1002 □ Ann Arbor, Michigan 48106 U.S.A.  
Order TOLL-FREE 800-521-4414 or outside U.S.A. 313-994-4444

## SPECIAL FEATURE

- 49 **INNOVATIVE CONSUMER PRODUCTS OF 1983**  
A look at some of the outstanding products of the past year as honored at this past summer's CES. **Danny Goodman**

## BUILD THIS

- 43 **MINI PLAYER-PIANO**  
A music box that can "remember" up to four tunes. **Robert Grossblatt**
- 57 **POWERLINE TRANSIENT SUPPRESSOR**  
Keep your computer and its contents safe with this simple yet effective device. **Herb Friedman**
- 59 **DIGITAL PRESSURE GAUGE FOR YOUR CAR**  
A handy instrument that can warn you of problems before they become critical. **Fred L. Young Sr. and Fred L. Young Jr.**

## TECHNOLOGY

- 4 **VIDEO ELECTRONICS**  
Tomorrow's news and technology in this quickly changing industry. **David Lachenbruch**
- 10 **SATELLITE/TELETEXT NEWS**  
The latest happenings in communications technology. **Gary H. Arlen**
- 12 **VIDEOGAMES**  
Rolling your own. **Danny Goodman**
- 62 **FREQUENCY CALIBRATION USING WWV**  
How to calibrate your own frequency standard using WWV. **R.W. Burhans**

## CIRCUITS AND COMPONENTS

- 53 **ECL LOGIC CIRCUITS**  
A look at a little-used logic family that offers some interesting capabilities. **TJ Byers**
- 67 **HOW TO DESIGN ANALOG CIRCUITS**  
Working with high-frequencies. **Manny Horowitz**
- 80 **NEW IDEAS**  
An award-winning project from one of our readers.
- 82 **HOBBY CORNER**  
Some questions and answers. **Earl "Doc" Savage, K4SDS**
- 84 **DRAWING BOARD**  
Designing and breadboarding. **Robert Grossblatt**
- 90 **STATE OF SOLID STATE**  
Thermometer circuits and more. **Robert F. Scott**

## VIDEO

- 64 **SERVICING HORIZONTAL SWEEP CIRCUITS**  
Some helpful hints. **Frank A. Salerno**
- 96 **SERVICE CLINIC**  
Opening your own shop. **Jack Darr**
- 97 **SERVICE QUESTIONS**  
Radio-Electronics' Service Editor solves technicians' problems.

## RADIO

- 94 **COMMUNICATIONS CORNER**  
Phones are for more than talking. **Herb Friedman**

## COMPUTERS

- 92 **COMPUTER CORNER**  
Shopping for a word processor. **Les Spindle**

## EQUIPMENT REPORTS

- 24 **Microbuffer In-Line Printer Buffer**
- 30 **Vidicraft Model IVE-100 Integrated Video Enhancer**
- 38 **Tektronix Model 212 Dual-Trace Oscilloscope**

## DEPARTMENTS

- |                                 |                   |
|---------------------------------|-------------------|
| 8 Advertising and Sales Offices | 104 New Books     |
| 136 Advertising Index           | 91 New Literature |
| 137 Free Information Card       | 100 New Products  |
| 20 Letters                      | 6 What's News     |
| 105 Market Center               |                   |

## ON THE COVER

Projects that are built just for fun are sometimes enjoyed most of all. But what's even better is a fun project that can teach you something new. The Pianomatic mini player-piano does just that. Sure to be an entertaining conversation piece when it is finished, building it will introduce you to such topics as computer memory organization and retention, digital logic, keyboard encoding and decoding, and the like. As a bonus, the techniques you'll pick up here can easily be adapted for use in your own designs. The story begins on page 43.

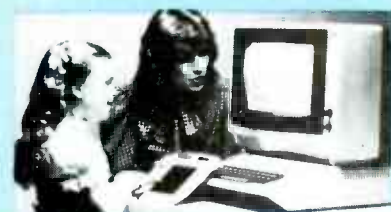

**THE KOALAPAD** from Koala Technology, Inc., allows you to control your computer's cursor movement by just tracing on the touch-sensitive pad. It's just one of the most innovative products of the past year as honored at the Summer CES. Turn to page 49 to find out more about it, and others similarly honored.

## COMING NEXT MONTH On Sale September 15

Our special supplement: Your Own Computer. Among the things we'll look at are:

- **Hardware**—a comprehensive look at systems, and their cost!
- **Word-processing software**
- **Software and hardware compatibility**
- **Everything you need to know about CP/M**
- **And lots more!**

**Radio-Electronics**, (ISSN 0033-7862) Published monthly by Gernsback Publications, Inc., 200 Park Avenue South, New York, NY 10003. Second-Class Postage Paid at New York, N.Y. and additional mailing offices. One-year subscription rate: U.S.A. and U.S. possessions, \$14.97. Canada, \$17.97. Other countries, \$22.47 (cash orders only, payable in U.S.A. currency.) Single copies \$1.50. © 1983 by Gernsback Publications, Inc. All rights reserved. Printed in U.S.A.

**Subscription Service:** Mail all subscription orders, changes, correspondence and Postmaster Notices of undelivered copies (Form 3579) to Radio-Electronics Subscription Service, Box 2520, Boulder, CO 80322.

A stamped self-addressed envelope must accompany all submitted manuscripts and/or artwork or photographs if their return is desired should they be rejected. We disclaim any responsibility for the loss or damage of manuscripts and/or artwork or photographs while in our possession or otherwise.

# VIDEO ELECTRONICS

DAVID LACHENBRUCH  
CONTRIBUTING EDITOR

## FLAT PANEL COLOR

The first giant-screen flat-panel color display has been developed—and is being offered for sale—by Mitsubishi. As demonstrated at the Chicago Summer Consumer Electronics Show, the screen was about 1-½ inches thick. The diagonal measurement can range from 5.3 to 17.6 feet, and even larger.

The panel contains a matrix of LCD's. Each is about two square inches and contains an 8 × 8 array of individually addressable red, green, and blue elements. The size of the panel is determined by the number of the LCD squares that are used. Thin fluorescent tubes illuminate the panel from the rear, providing a surface brightness of 120 footlamberts—about the same as a direct-view color picture tube.

Before you run out and try to buy one, there are a few things you should know about Mitsubishi's *Crystal Color*. First, the minimum cost is \$100,000. Second, because of the coarseness of the picture, the minimum viewing distance is about 12 feet. Initially the computer-controlled viewing system will be used for advertising and informational purposes in airport terminals, hotel lobbies, and other places people gather. However, Mitsubishi says that it is developing a home version—there's no estimate on when it will be ready.

## POCKET COLOR TV

Seiko has succeeded in making a prototype of a pocket color-TV with a liquid crystal screen that measures 2-inches diagonally. It could be on the market in about a year for less than \$500. The 240 × 240 pixel display uses nematic liquid-crystal technology. Like Mitsubishi's giant flat-panel screen, Seiko's midget uses a diffused fluorescent backlight with individual red, green, or blue filters above each pixel electrode.

## TELETEXT LAG

Although, CBS, NBC and some major cable groups plan to begin teletext "magazine" transmissions using TV's vertical blanking interval this year, most set manufacturers have adopted a policy of watchful waiting before committing themselves to producing receiving equipment for the mass-consumer market. An exception is Zenith, which says that its entire 1984 model line will be equipped for teletext adaptors, which it plans to have on the market this year. General Electric and the Matsushita group (Panasonic, Quasar) also say they'll have adaptors, but haven't specified when.

Teletext adaptors are expected to be quite expensive, at first, figures mentioned varying from \$150 to \$250; but they're expected to drop rapidly if the new medium wins consumer-market acceptance. ITT, developer of the digital TV signal-processing circuit, claims that it will have a low-cost teletext adaptor IC for sets which use its digital IC's. That IC, it estimates, will add about \$21 to manufacturers' costs—meaning that it probably will increase the cost of a set by about \$60—still an appreciable expense. The networks' teletext systems are expected to use the NABTS system, a variation of the French Antiope technique, and each will have about 100 pages.

## SOLID-STATE LASER PICKUP

A major improvement is in sight for the *LaserVision* videodisc system. After years of promises and speculation, the solid-state laser pickup is virtually here, thanks at least partly to the mass production of the CD digital-audio-disc system, which has generated methods of producing semiconductor lasers in volume. Although the videodisc laser pickup is different from that used in the audio disc, production methods for the two pickups are similar. Hitachi has introduced two industrial-model laser disc players with solid-state pickups, one of which will sell in Japan for as little as \$800; that is not much more than Pioneer's consumer model with the helium-neon laser.

Among the immediate advantages of the semiconductor laser is elimination of the bulky and costly power supply required by the helium-neon version and consequent reduction in size and cost of the player. In addition, random access—one of the major features of the optical disc—can be speeded up, perhaps to three seconds from the current six. And the life of the pickup is increased (at least in the Hitachi version) to 5,000 hours from 2,000 claimed by conventional laser players. It wouldn't be surprising to see new consumer *LaserVision* players soon adding the advantages of solid-state pickups. In fact, Pioneer hints that it is considering development of a player that will play both optical-video and CD-audio discs. R-E

# IT'S HERE AT LAST!

THE FIRST LOW COST 6502 COMPUTER WITH 48K RAM THAT'S COMPLETELY COMPATIBLE WITH APPLE II®

Introducing the RAM-TECH\*RT 2 computer which offers you greater flexibility than the Apple II+® at a price that's easier on your finances. The RT 2 will run all software and use all peripheral hardware designed for the Apple II+®. It's 100% Apple® compatible yet it offers you features not available on the Apple II+®.

## COMPARE THESE FEATURES:

- supports upper & lower case characters from the keyboard
- high quality ABS case will not crack and is light weight
- RF modulator included in addition to composite video output
- high quality light-touch keyboard with upper/lower case key
- 15 key numeric key pad for fast data entry (optional)
- high power switching power supply (8.5 amps total) will power two disk drives and several peripherals easily, has internal circuit breaker
- eight expansion slots to increase flexibility with peripheral cards
- 48K RAM expandable to 64K (192K RAM upgrade card available soon)
- socketed IC's for quick and easy service
- thousands of programs (business & home) available
- operates identically to the Apple II+® with exception of extra features on RT 2
- full 90 days parts and labor warranty with fast service turn-around



THE RAM-TECH\* RT 2 IS EVERYTHING YOU ALWAYS WANTED FROM AN APPLE® (AND MORE), BUT THOUGHT YOU COULDN'T AFFORD. AND THAT'S GOOD NEWS!

### BUT THE BEST NEWS IS THE PRICE:

\$525.00 + \$18.00 shipping & handling

### WITH OPTIONAL NUMERIC KEYPAD:

\$575.00 + \$18.00 shipping & handling

COMPARED TO APPLE II® WHICH RETAILS AT MORE THAN DOUBLE THIS PRICE AND OFFERS YOU LESS, YOU CAN SEE WHY THE RAM-TECH\* RT 2 SHOULD BE YOUR CHOICE. MAKE NO SYNTAX ABOUT IT, THE RT 2 IS FOR YOU!

**PERSONAL I.D. OPTION** — We will burn your name into ROM. When you power up your Ram-Tech your name will be displayed on the screen. **AN EXTRA MEASURE OF SECURITY AGAINST THEFT.**

Indicate on your order what name you wish to use (maximum 8 letters including spaces) — ADD: \$25.00 for I.D. option.

**ALSO AVAILABLE:** (sub-assemblies for do-it yourselfers) — 90 days warranty

- |   |          |
|---|----------|
| 1 - ABS case, high quality, Apple® look-a-like and color matched, will replace Apple® case .....              | \$ 68.50 |
| 2 - same as #1 above but with numeric keypad cutout .....   | \$ 84.00 |
| 3 - keyboard with upper/lower case key, direct replacement for Apple® or Ram-Tech* .....                      | \$110.00 |
| 4 - same as #3 above but with numeric keypad, use in combination with #2, also fits Apple® .....              | \$139.50 |
| 5 - RF modulator with TV switch and cable, also fits Apple® .....   | \$ 19.50 |
| 6 - switching power supply, 8.5 amps, internal circuit breaker, high power, also fits Apple® .....            | \$112.00 |
| 7 - motherboard, completely assembled & tested, fully operational with burned ROMS .....                      | \$295.00 |
| 8 - bare motherboard w/ parts discription screened on board and instructions, highest quality G10 epoxy ..... | \$ 48.00 |

SHIPPING & HANDLING FOR ABOVE: cases #1 & 2 add 10%; all others add 5%

## PERIPHERALS, CARDS & ACCESSORIES FOR YOUR RAM-TECH\* OR APPLE®

all items #1 to 19 guaranteed for one year (disk drives for six months)

- |   |          |                                |          |
|---|----------|--------------------------------|----------|
| 1 - 16K RAM card .....  | \$ 58.00 | 11 - interger card .....       | \$ 97.50 |
| 2 - 80 column card .....  | \$ 94.50 | 12 - PAL card .....            | \$114.00 |
| 3 - clock card .....  | \$135.00 | 13 - language card .....       | \$ 72.50 |
| 4 - communications card .....                                   | \$ 89.00 | 14 - RS-232 serial card .....  | \$ 84.00 |
| 5 - disk controller card .....                                  | \$ 58.00 | 15 - Z-80 CP/M card .....      | \$ 92.00 |
| 6 - EPROM writer card .....                                     | \$124.50 | 16 - VERSA card .....          | \$345.00 |
| 7 - FORTH card .....  | \$ 98.50 | 17 - analog/digital card ..... | \$116.50 |
| 8 - IEEE-488 card w/cable .....                                 | \$186.00 | 18 - system cooling fan .....  | \$ 63.00 |
| 9 - parallel printer card w/cable .....                         | \$112.00 | 19 - joy stick w/button .....  | \$ 24.50 |
| 10 - parallel printer buffer and grappier card with cable ..... | \$245.00 |                                |          |

**DISK DRIVES:** Guaranteed high quality for use with all Apple® compatible (or Ram-Tech\*) controllers - DOS 3.3 & 3.2

**USES SPECIAL LOW POWER CONSUMPTION CIRCUITRY**

- |                |          |                          |
|----------------|----------|--------------------------|
| TEAC 55A ..... | \$325.00 | \$370.00 with controller |
| SHUGART .....  | \$285.00 | \$330.00 with controller |

SHIPPING & HANDLING: add \$3.50 per item #1 - 19 . . . disk drives add \$10.00

## TO ORDER

- ALL PRICES IN U.S. CURRENCY
- VISA OR MASTER CARD: SEND NUMBER, EXPIRY DATE, BANK NAME & CARD HOLDER'S NAME, INCLUDE PHONE NUMBER.
- CHECKS & MONEY ORDERS O.K. - CHECKS NEED THREE WEEKS TO CLEAR. (NO C.O.D.'S TO U.S. DUE TO POSTAL REGULATIONS)
- CANADIAN ORDERS ADD 25% FOR CDN FUNDS EXCHANGE.
- U.S. CUSTOMERS WILL HAVE TO PAY U.S. CUSTOMS 4.7% DUTY. DUTIES COLLECTED BY POST OFFICE. WE ASSUME NO LIABILITY FOR CUSTOMS CLEARANCE.

## DEALER INQUIRIES REQUESTED

**BYTE-RYTE**  
DEPT. RE  
P.O. BOX 205, STATION CART.  
MONTREAL, QUEBEC, CANADA H4K 2J5  
**(514) 335-1717**

®Apple is a trademark of Apple Computer Inc.

\*Ram-Tech is a trademark of 99506 CANADA INC.

# WHAT'S NEWS

## Capt. Inman receives Gold Medal Award

Capt. Bryce D. Inman, USN (ret.), Manager of Advanced Radar Development at RCA Missile and Surface Radar, has received the Gold Medal of the American Society of Naval Engineers. He was cited for visionary leadership, engineering excellence, and initiative in defining and directing the integration of the first AEGIS Combat System. AEGIS is a radar-based, computer-controlled air-defense system developed for the Navy by RCA.

A pioneer in the areas of the phased-array radar and the guidance-system computer while

in the Navy, Capt. Inman directed his design team through the difficult task of successfully integrating the first AEGIS Combat System into the first AEGIS Guided Missile Cruiser, *USS Ticonderoga*, which was commissioned in January.

In 1978, Capt. Inman organized the first efforts to develop enhanced-capability versions of the AEGIS Weapons System and the AN/SPY-1 radar in a smaller, lighter mode. The AN/SPY radar is used to detect air targets in the AEGIS Weapons System.

He also promoted vigorously the concept of a combat system "grooming site." As a result of his efforts, the AEGIS Production Test

Center, dedicated in 1979 to provide a site for testing and evaluating the integrated AEGIS Combat System, has reduced the cost, time, and risk of shipboard testing.

## Atari gives computers to train teachers

Atari, Inc. has donated 20 Atari 800 home-computer systems, including peripherals and software, to the Graduate School of Education at Fordham University's Lincoln Center Campus in New York City. They are to be used to instruct teachers in methods of computer use and classroom instruction.

Since about half the high schools in the country have computers, says an Atari spokesman, it is crucial that teachers be familiar with basic computer concepts.

The Fordham-Atari Center will offer courses in computer programming as well as in the use of computers for research and educational applications. It will become a major center for the development of teacher-training materials in computer literacy and also for the testing of educational software.

## Satellite services for individuals?

Geostar Corp of Princeton, NJ, proposes a satellite-communications system that would permit persons to send messages via satellite, using devices no bigger than pocket pagers. The system will locate the exact position of the sender, and handle messages of up to 36 characters.

In its application to the FCC. Geostar states that a person confronted by a mugger could press a single button on his communicator. That would send out a signal that would go to three satellites in geostationary orbit over the Equator, and from them back to a computer on Earth. The computer would determine instantly the exact location of the sender by noting the difference in the time it takes for signals to reach the computer from the different satellites. It would then notify the nearest police car or station.

The system would also be valuable to hunters and others lost in the woods, and would be of great value to trucking companies, who

would make large savings if they could determine the location of—and communicate with—their trucks at all times.

The proposal has not found favor in all quarters. The cellular radio services—some of whose allotted frequencies Geostar proposes to use—are particularly unhappy. AT&T and Motorola Inc., both of whom are heavily involved in cellular radio, have opposed plans of Geostar's type, stating that such systems would waste frequencies in serving remote areas; such frequencies could be used better in urban areas.

## FM car radio supplies traffic information to drivers

Blaupunkt Car Radio Division has initiated its Automatic Radio Information (ARI) system in the New York metropolitan area. Designed to improve and speed up traffic flow, ARI gives timely traffic information to motorists via a special FM broadcast signal.

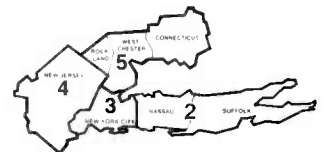

**THE AREAS COVERED BY ARI, each with automobile traffic reports for its own zone, around New York City. Zone 2 is covered by WALK-FM. Zone 3 by WNEW-FM, Zone 4 by WVNJ-FM, and Zone 5 by WZFM. ARI follows television practice (there is no Zone 1).**

Four stations in the New York area broadcast signals that activate special car radios to draw traffic reports for their zones to the driver's attention. With the commuter's ARI-equipped FM radio tuned on and tuned to his zone's ARI station, the traffic reports he needs will be boosted in volume to stand out over the regular programming. The station will come in loud and clear even if volume is low, or a cassette is playing.

Drivers in Nassau and Suffolk counties will get their ARI traffic reports from WALK-FM on Long Island; WNEW-FM serves New York City; residents of New Jersey will tune their ARI-equipped radios

*continued on page 8*

## Six-legged robot



"A MAJOR TECHNICAL ADVANCEMENT in the field of Robotics" is how Odetics, Inc. describes its new walking robot, or "functionoid." Odetics claims that it is the first mobile exploratory multifunction robot combining electronics, mechanical engineering, and computer science.

The robot, Odex I, can carry a load of 860 pounds at ordinary walking speed (or about a ton with all six legs down) can step up or down 33 inches, can go through a 21-inch door, and can be maneuvered through very tight places. (It doesn't have to turn around to change direction.) It is controlled with seven computers, six for the legs and one handling all other controls, and receives commands via radio link from the teleoperator, who works with two joysticks and six leg-control knobs.

The robot weighs 370 pounds and is powered by a 369-watt hour, 24-volt battery. The cameras shown are currently not operable—they are intended for experiments in vision sensing.



# Now 60 MHz or 100 MHz Tek quality is just a free phone call away!



Tek has expanded its best-selling 2200 scope line up to 100 MHz. And brought it all as close as your phone. Tek's revolutionary, reduced-component architecture brings unprecedented quality, reliability and affordability to the 60 MHz 2213 and 2215, and now, the 100 MHz 2235.

All three of these lightweight (13.5 lb.) scopes feature 2 mV/div vertical sensitivity and 5 ns/div sweep speeds, plus a complete trigger system for stable triggering on digital, analog or video waveforms.

**Scopes with a comprehensive 3-year warranty\*... probes... and expert advice. One free call gets it all!** You can order, or obtain literature, through the Tek National

	2213	2215	2235
Bandwidth	60 MHz	60 MHz	100 MHz
No. of Channels	2	2	2 + Trigger View
Alternate Sweep	—	Yes	Yes
Vert/Trig B/W Limit	—	—	Yes—20 MHz
Single Sweep	—	—	Yes
Accuracy: Vert/Horz	3%	3%	2%
Delay Jitter	1:5,000	1:10,000	1:20,000
Trigger'g Sensitivity	0.4 div at 2 MHz	0.4 div at 2 MHz	0.3 div at 10 MHz
Input R-C	1M $\Omega$ -30pf	1M $\Omega$ -30pf	1M $\Omega$ -20pf
Variable Holdoff	4:1	4:1	10:1
Price	\$1200†	\$1450†	\$1950†

Marketing Center. Technical personnel, expert in scope applications, will answer your questions and expedite delivery. Direct orders include operating and service manuals, two 10X probes, 15-day return policy, and worldwide service back-up.

**Order toll-free:  
1-800-426-2200  
Ext. 26**

In Oregon call collect:  
(503) 627-9000 Ext. 26

†Price F.O.B. Beaverton, OR.  
\*3-year warranty includes CRT and applies to 2000 family oscilloscopes purchased after 1/1/83.  
Scopes are UL Listed, CSA and VDE approved.

**Tektronix**  
COMMITTED TO EXCELLENCE

CIRCLE 74 ON FREE INFORMATION CARD

# WHAT'S NEWS

## Radio-Electronics

Hugo Gernsback (1884-1967) founder  
 M. Harvey Gernsback, editor-in-chief  
 Larry Steckler, CET, publisher  
 Arthur Kleiman, editor  
 Carl Laron, WB2SLR, associate editor  
 Brian C. Fenton, assistant editor  
 Jack Carr, CET, service editor  
 Robert F. Scott, semiconductor editor  
 Herb Friedman, communications editor  
 Gary H. Arlen, contributing editor  
 David Lachenbruch, contributing editor  
 Earl "Doc" Savage, K4SDS, hobby editor  
 Danny Goodman, contributing editor  
 Dan Rosenbloom, production manager  
 Robert A. W. Lowndes, production associate  
 Joan Roman, circulation director  
 Arline R. Fishman, advertising coordinator  
 Cover photo by Robert Lewis

Radio-Electronics is indexed in *Applied Science & Technology Index* and *Readers Guide to Periodical Literature*.

Gernsback Publications, Inc.  
 200 Park Ave. South  
 New York, NY 10003  
 President: M. Harvey Gernsback  
 Vice President: Larry Steckler

**ADVERTISING SALES 212-777-6400**

Larry Steckler  
 Publisher

### EAST/SOUTHEAST

Stanley Levitan  
 Radio-Electronics  
 200 Park Ave. South  
 New York, NY 10003  
 212-777-6400

### MIDWEST/Texas/Arkansas/Okla.

Ralph Bergen  
 Radio-Electronics  
 540 Frontage Road—Suite 325  
 Northfield, Illinois 60093  
 312-446-1444

### PACIFIC COAST Mountain States

Marvin Green  
 Radio-Electronics  
 413 So. La Brea Ave.  
 Los Angeles, Ca 90036  
 213-938-0166-7

continued from page 6

to WVNJ-FM in Newark, and the northern suburbs are served by WZFM.

Only FM car radios with built-in ARI decoders will respond to the control signal (that will cause the volume of the station to be increased). At present, those radios are available exclusively from Blaupunkt, who plans, however, to license the technology, as has already been done in Europe. (West Germany has been covered nationwide since 1974. P. 47, R-E March 1982.)

### Thyristor turns on bigger thyristor

Scientists of the General Electric Research Development center, Schenectady, NY, have developed a light-sensitive thyristor that will

turn on larger power thyristors—normally activated by an electric signal—to convert them into light-triggered devices.

In addition, the new device will be welcomed by the electric-utility industry, which uses thyristors to convert high-voltage AC into DC for long-distance transmission, and back again to AC for distribution to consumers. The new device would be less expensive and more reliable than systems using electrical triggering. It would also improve immunity to electrical interference.

GE's new light-triggered thyristor is supplied in a hermetically-sealed, ready-to-use package. That package is smaller than a stick of chewing gum, and has leads for anode and cathode as well as a standard coupling for an optical fiber from the light source.

### International carriers need safeguarding

Testifying before the Senate Subcommittee on Communications, Eugene F. Murphy, President of RCA Communications, Inc., called for Congressional action to assure competing carriers of cost-based access to Intelsat facilities.

Recent FCC action permits Comsat to serve end-users direct, putting it in direct competition with the international carriers. "If Comsat is to act both as wholesaler and retailer," said Mr. Murphy, "legislation must allow the other international carriers to compete with Comsat on a relatively equal footing."

He went on to say that, because of AT&T's continuing monopoly of international voice communications (which accounts for two-thirds of the total U.S. international communications market) AT&T's expansion into other markets should be accompanied by such safeguards as may be necessary to permit and insure full and fair competition.

Any legislation regarding the use and resale of international communications circuits would have to take the concerns of our overseas operating partners into account, Mr. Murphy said. "The role of our overseas correspondents, without whose cooperation there cannot be effective international telecommunications service, is critical."

### Bankers get food tips from talking computer

A talking computer was used to help bankers find a good place to eat while attending the American Bankers Association conference in Miami Beach last May.

The computer, manufactured by Periphonics of Bohemia, NY, spoke by telephone to visitors who stopped at the Periphonics booth. Among the questions asked of the visitors were how much they wanted to spend, what kind of food they preferred, and what part of the town they'd like to eat in.

The computer provided a print-out of restaurants to choose from that met specifications of each respondent.

R-E

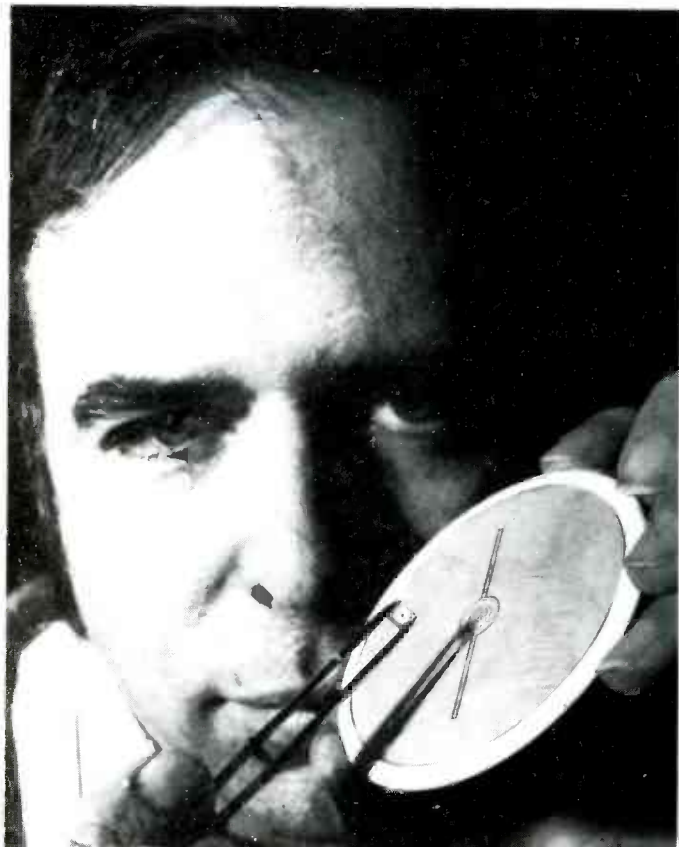

THE NEW LIGHT-SENSITIVE THYRISTOR, held above one of the power thyristors it turns on by its developer, Dr. Victor A.K. Temple. Working something like a pilot light on a gas stove, it is activated by pulses of light, and emits pulses of electricity that operate the bigger thyristor to which it is attached.





# affordable precision

## Excellence by Design

BBC has been building multimeters and other instrumentation for European engineers and technicians for over 7 decades. And now, twelve advanced technology BBC meters with a complete line of accessories are available in the U.S. Prices range from under \$50.00 to \$595.00. No other manufacturer offers you comparable price and performance values.

## Forms that Follow Function

To achieve a family of "hands free" instrumentation designed for heavy-duty use in a wide variety of environments, BBC relied on the industrial design skills of the Porsche Design Studios. You'll like the results.

The unique folding design lets you adjust the viewing angle. Extra large LCD displays make the meters easy to read. The exclusive function and range switch is logically laid out. And the folding meters even turn off automatically when you close the case.

## Accuracy Where it Counts

Precision is a tradition at BBC. The 3 1/2 digit folding models feature 0.1% basic dc accuracy. For higher precision measurements, the model MA 5D delivers 0.05% basic dc accuracy and 30,000 counts.

## Precision Values

Some of the best news about BBC meters is that you can get them for less than you've been paying for old technology meters. They are built to the world's highest safety standards, VDE/DIN, and are backed by one of the strongest warranties in the industry.

## Local Availability

BBC has worked hard to make these meters available through leading U.S. distributors and representatives. There is an outlet close to you. And, if your instrumentation supplier doesn't carry BBC yet, we'll gladly tell you who does. Call toll free: 1-800-821-6327. (In CO, 303-469-5231)

## BBC-METRAWATT/GOERZ

6901 W. 117th Avenue  
Broomfield, CO 80020  
Telex 45-4540  
(303) 469-5231

Send me information on BBC meters.

I'd like to be on your mail list.

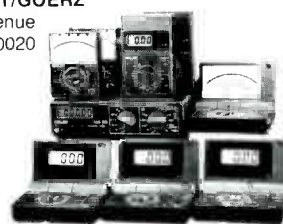

Name \_\_\_\_\_

Title \_\_\_\_\_

Company \_\_\_\_\_

Address \_\_\_\_\_

City \_\_\_\_\_ State \_\_\_\_\_ Zip \_\_\_\_\_

Telephone (\_\_\_\_\_) \_\_\_\_\_

Engineering Excellence in Test and Measurement



CIRCLE 60 ON FREE INFORMATION CARD

# SATELLITE/TELETEXT NEWS

GARY ARLEN  
CONTRIBUTING EDITOR

## LOWER PRICES, MORE DISHES

Trend-watchers at the Consumer Electronics Show got an eyefull when it came to satellite systems. The show featured the most impressive display yet of home equipment, including more than four dozen dishes. Also noticeable was the continuing decline in prices, with many systems priced in the \$1400 to \$1700 range, and most now under \$2000. A few systems came in just under \$1000 (such as the Galaxy Video system, which features a 7-foot dish). Among the trends seen at CES was a move toward smaller antennas, with some experts predicting that two-meter dishes will become commonplace for home reception of C-band satellite signals in the next few years.

The impending arrival of DBS is on many experts' minds—as is how Ku-band DBS will compare to existing C-band service. Although DBS has been touted as a low-priced service (under \$500 for reception equipment), some are now predicting that the price may actually be closer to \$1500 per site. That would mean conventional satellite service would have a better "cost-per-channel" than DBS—a conclusion that is reached when you compare the three to five channels proposed for DBS to the two dozen or so signals available on current satellites.

There was also speculation at CES that the Japanese are ready to unveil their home satellite-equipment, probably for DBS service. (As we've reported in the past, Sony and other major Japanese manufacturers are working with NHK and other TV broadcasters to develop new satellite facilities for home reception.)

Another indicator that home satellite-service has come of age is that the business is being analyzed and studied. One company reported a tripling of its business from 1981 to 1982, with expectations that home-dish users would triple again this year. Channel Master, a major equipment supplier, revealed its research findings that showed, among other things, that 90% of home satellite-users live in small towns or rural areas and that about 40% of dish-owners also have a videocassette recorder (about ten times the national average for VCR use).

Quite a variety of ancillary satellite equipment was also introduced at the CES. Among the add-on products were a receiver made by Intersat that features a two-year programmable memory, and an antenna-control unit that will allow a dish to cover up to 50 birds. (That, by the way, is far more than will be in place over North America in the foreseeable future.)

## NEW TECHNOLOGY

**Sat-Trol**, an actuator and control system for satellite earth stations, includes "touch-label" switches with selectable fast and slow travel rates for pinpoint location of satellites. The new \$400 unit was developed by Burr Engineering, of Battle Creek, MI, and features a self-contained power supply and "over-travel" protection to prevent a dish from going beyond the signal reach of a bird.

**Satellite Television Corp.** will test "multiplexed analog components," a system created by England's Independent Broadcast Authority to increase video resolution on the direct broadcast satellite service it is developing. The MAC technique transmits luminance and chrominance in time succession rather than simultaneously, a process that may improve definition of video images compared to the current NTSC technique. Satellite Television Corp. has not committed to using the system, nor has it made any other specific plans for high-definition video on its DBS signal.

**Antenna Technology Corp.** now offers a Tri-Sat dish that allows the signals from three adjacent satellites to be received simultaneously. The four-meter version costs \$1390 and a five-meter version sells for just under \$6400. The Las Vegas-based company already offers other multi-beam dishes in sizes ranging from three to seven meters.

**ABC Radio** has started digital transmissions via Satcom I, and the network hopes to have all 1850 of its radio affiliates on satellite by the end of the year. CBS, RKO and NBC also plan to inaugurate digital-audio networks via satellite this year.

## DIRECT-TO- THEATRE MOVIES

Direct-to-theater video is being considered by several companies. Greater StarLink wants to use the 14/12 GHz band on the upcoming SpaceNet bird (to be launched by Southern Pacific Satellite Co.) to send high-definition TV to movie theaters for display on a 40- x 100-foot screen. Several movie studios have expressed interest in the project, which is several years away. In another development, United States Satellite Systems plans to test a similar HDTV transmission, beaming signals to about 50 video centers around the country. USSS may use local facilities operated by the Campus Entertainment Network.

**We got bigger because  
we're better.**

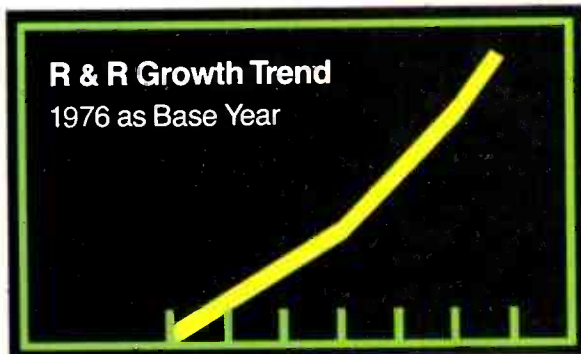

**Now we're better  
because we're bigger.**

Year in and year out, Zenith's remanufacturing business gets bigger and bigger. And 1983 appears to be no exception.

That is why we are forecasting our remanufacturing business this year to be bigger than last year. Our remanufacturing business next year to be bigger than this year. And our remanufacturing business in the foreseeable future to be bigger and better each succeeding year.

But it's one thing to forecast and quite another to increase production year after year. That's why we at Zenith are thinking in terms of larger facilities and newer techniques in remanufacturing to meet the demand of the marketplace.

You should be as ready, willing and eager to look into the future as we have and, having seen the kind of growth we anticipate, position yourself as we have to meet and capitalize on it.

Right now you should be in the habit of purchasing a Zenith repaired and reconditioned replacement at your participating Zenith distributor's — with an exchange allowance in most instances — for every tired and worn-out module, tuner, channel selector and sub-assembly you remove from a Zenith TV.

Exchanging with your Zenith distributor is the one sure way to receive a genuine Zenith replacement part repaired, reconditioned and serviced for reliability by people as knowledgeable as those who made the original. And also a replacement updated to incorporate the latest factory technical improvements.

Make sure you are taking advantage of your participating Zenith distributor's exchange program. Call now and tell the Zenith Parts Manager we sent you!

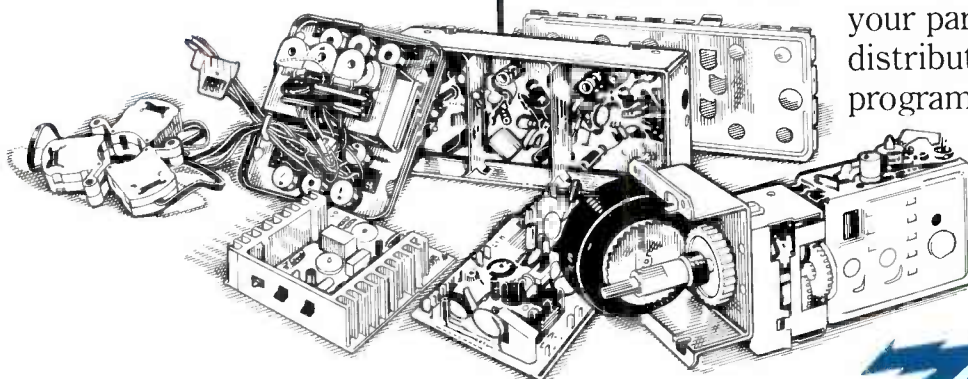

Zenith Radio Corporation/Service, Parts & Accessories Division  
11000 Seymour Avenue/Franklin Park, Illinois 60131

**ZENITH**  
The quality goes in before the name goes on.®

# VIDEOGAMES

## Rolling your own

DANNY GOODMAN, CONTRIBUTING EDITOR

LAST MONTH, WE SAW HOW AN APPLE computer, a working knowledge of 6502 microprocessor assembly-language, and a special development system can help you design your own games for the Atari 2600 and 5200 systems. But for those who like to program their own games, there is another game system—and a darn good one at that—that has been open to user programming for years. And you don't need assembly language or a computer to get anywhere. I'm talking about the unit that started out as the Bally Professional Arcade, more recently known as the *Astrocade* (shown in Fig. 1).



FIG. 1

The system has had a long and checked career in the volatile videogame industry. As we go to press, the future of Astrocade is unsure as they attempt to extricate themselves from Chapter XI. But that's not what this story is about.

As a good many of the estimated 120,000 *Astrocade* owners know, the *Astrocade*, in addition to playing some of the graphically and sonically best videogame cartridges ever, is programmable in BASIC with the help of the BASIC language/cassette-interface adapter. In recent times, this accessory and well-prepared BASIC tutorial/reference manual has been included as standard equipment with the unit.

The open access to the *Astrocade* has caused a closely knit and loyal following of *Astrocade* enthusiasts to band together in users groups and in an open exchange of information via the major news pipeline for Astrocadars called *The Arcadian*, a monthly newsletter published by Bob Fabris (3626 Morrie Dr., San Jose, CA 95127). Each issue contains program listings and more advanced programming tips from experienced users like Andy Guevera.

Andy has taken his interest in the *Astrocade* up to the assembly-language level (Z80 microprocessor). But in so do-

ing, he left tracks for others to follow. He now produces a plug-in cartridge called the *Machine Language Manager* (The Bit Fiddlers, P.O. Box 11023, San Diego, CA 92111-0010), which guides the way for novice programmers. You'll still need to know Z80 machine language, but in the manual that comes with the cartridge, Andy recommends some introductory books. Machine language allows you to program faster action within the limited built-in RAM of the *Astrocade*. But there is still plenty going on in BASIC.

The 114-page *Astrocade Sourcebook* (635 Los Alamos Ave., Livermore, CA 94450), produced semi-annually by Richard Houser, lists practically every one of the hundreds of third-party programs available—a large percentage of them in BASIC on cassette. Most of these tapes have been designed by dedicated hobbyists with a love for the capabilities of the *Astrocade* system. Every once in a while, one of these hobbyists finds a programming specialty.

George Moses, for example, has unlocked the secrets to the three-voice music synthesizer of the *Astrocade*. His company (George Moses Co., P.O. Box 686, Brighton, MI 48116) offers several cassettes of straight music (Scott Joplin rags, Christmas carols, Bach, and more) playable through the console's synthesizer. For the musically creative, he also has a music-assembler program to let you try your hand at it.

George, by the way, produced the continuously running musical score for one of the first third-party game cartridges for the *Astrocade*, a family-oriented game called *Treasure Cove* by Spectre Systems (Box 1741 Dearborn, MI 48121). Bret Bilbrey, one of the principals at Spectre was attracted to the Bally system back in 1977 (in the days of the Fairchild *Channel F* and dedicated Atari videogames) because he could do things with the BASIC cartridge that no other videogame could let him do. Since then, Bret and a few others have turned what was a hobby interest into a career, designing games for the *Astrocade*.

With the right system, imagination, and a strong desire to master the technical side of programming in BASIC or (preferably) machine language, rolling your own videogames is certainly within almost everyone's reach.

## Fox Video Games' Flash Gordon for Atari 2600



CIRCLE 101 ON FREE INFORMATION CARD

Fox Video Games Flash Gordon																				
GRAPHICS																				
SOUND																				
EASE OF LEARNING																				
CHALLENGE																				
VALUE																				
		1	2	3	4	5	6	7	8	9	10									
		Poor		Fair			Good			Excellent										

I'd hate to be in the shoes of the videogame designer who steps into the boss' office to receive an order to develop a game around a popular theme. It can't be easy to force a game to fit a particular mold. That's what I expected to find when I plugged Fox Video Game's *Flash Gordon* cartridge into my 2600 console. But after playing the game for a while (and being a Flash Gordon fan), I got the impression that somebody came up with a space game, and Fox simply pulled "Flash Gordon" out of its list of space movie titles.

The screen is divided into two main game-action areas. The top half is where the prime action is located—your rocket ship, targets, and stranded spacemen you can rescue. In the lower half is an aerial map of tunnels through which your rocket ship travels. Your goal is to clear each tunnel level of hatching pods and the spider warriors they produce. Two amorphous alien fields, called Disrupters, pursue your every step, trying

continued on page 14

HITACHI

NLS Non-Linear Systems

HICKOK

WESTON

DATA PRECISION

KEITHLEY

AWS  
A.W. SPERRY  
INSTRUMENTS, INC.

FLUKE

TRIPLETT

PHILIPS

BK PRECISION

Simpson

LEADER

VIZ RBA

## 15 MHz DUAL TRACE PORTABLE W/INTERNAL BATTERY PAK

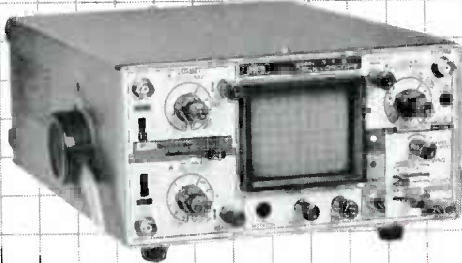

MODEL  
315P

**THE SMALL PORTABLE  
WITH BIG FEATURES**

### FEATURES

- AC/DC powered • 2mV Vertical sensitivity • TV (Video) sync filter • 3/4" internal graticule, high brightness CRT • X-Y display mode • Add/Sub mode with ch.2 invert • Automatic and triggered time base • Trace rotation adjustable from front panel • Internal rechargeable pak included • Lightweight 12.1 lbs with battery • Small size (4.4" x 8.8" x 11.7")

### SPECIFICATIONS

Vertical System: CH. A and CH. B - Deflection Factor, 2mv/div - 10v/div, 12 steps • Frequency Response, DC - 15 MHz (-3 dB) • Risetime, 24 - ns • Maximum Input Voltage, 300-V (DC + AC peak) • Input Impedance, 1MΩ ± 5%, 20pF ± 3pF • Display Modes: CH-A, CH-B, DUAL, ADD, CHOP • Internal Horizontal System (Sweep Operation) • Deflection Factor, 0.5μs/div - 0.5s div (±5%), 19 steps • Magnification, 5x all ranges • Trigger System - Sources: INT, CH-A, CH-B, EXT • Modes: AUTO, NORMAL • Sensitivity, INT: 1 Div or more, EXT: 1V p-p • Coupling, DC, TV, SYNC

## AWS DIGITAL MULTIMETERS

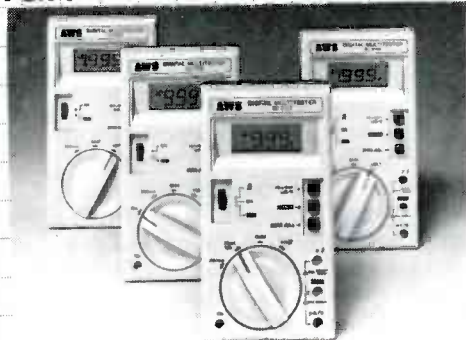

QUANTITIES  
LIMITED

EZ6200 **\$69<sup>95</sup>** reg. \$110.  
EZ6220 **\$79<sup>95</sup>** reg. \$130.  
EZ6100 **\$89<sup>95</sup>** reg. \$148.  
EZ6110 **\$99<sup>95</sup>** reg. \$168.

- Autoranging on volts and ohms
- Self-contained 10 Amp AC/DC ranges (EZ-6110 & 6220)
- Low power ohm ranges — applied voltage ≤ 0.3V
- Continuity buzzer (EZ6100 & 6110), 5 settings
- Range hold (EZ6100 & 6110)
- Large 3 1/2 digit LCD display
- 300 hours continuous operation

### SPECIFICATIONS

DC Volts: 200 mV, 2 V, 20 V, 200 V, 1000 V  
AC Volts: 2-V, 20-V, 200-V, 600-V  
Ohms: 200, 2 K, 20 K, 200 K, 2000 K  
Low power ohms: 2 K, 20 K, 200 K, 2000 K  
AC/DC Amps: 20 mA, 200 mA (EZ-6100)  
20 mA, 200 mA, 10 A (EZ-6110)  
200 mA (EZ-6200)  
200 mA, 10A (EZ-6220)  
Dimensions: 6.2" h. x 3.4" w. x 1.1" d.  
Weight: 8.8 ozs.

**5**

**YEAR  
WARRANTY**

## A.W. SPERRY INSTRUMENTS INC.

FEATURES A FULL 2-YEAR PARTS AND LABOR WARRANTY ON OSCILLOSCOPES.



**DIGISNAP DSA-1000**  
Digital  
Snap-Around-Volt  
Ammeter

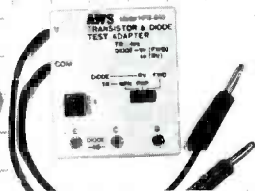

**Transistor/  
Diode Test  
Adapter—  
HFE-840**

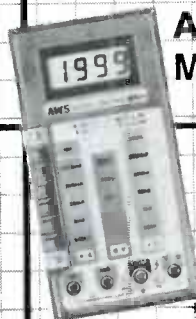

**Continuity Test Buzzer.**

**Drop-proof  
AC/DC Multimeter—  
Model DP316**



**3 1/2 Digit  
Handheld Pushbutton Digital  
Multimeter—Model DM3010**



TOLL FREE HOT LINE  
**800-223-0474**

THE TEST EQUIPMENT SPECIALISTS

26 WEST 46th STREET, NEW YORK, N.Y. 10036 212-730-7030

**ADVANCE  
ELECTRONICS**

# VIDEOGAMES

continued from page 12

to enshroud your ship in deadly debris. Every time you successfully shoot five spider warriors from a hatching pod, you have the added power of a temporary shield. Floating through the tunnels at random are your fellow spacemen whom you must pick up by touching them with your ship.

Hatching pods are distributed unequally through the maze of tunnels. When they are grouped together, there is a likelihood that the sluggish Disrupters will catch up to you. Unless your shields are intact while you escape from the Disrupter's field, you'll have a tough battle on your hands trying to survive the onslaught of debris. Occasionally, however, a Disrupter Generator flies across the screen. If you can shoot one, the Disrupter is stalled momentarily, giving you a head start away from it.

The joystick control in this game is a bit odd at first. When you want to move your rocket ship to the left on the tunnel map, for example, the rocket ship on the screen glides toward the left margin. But if a spaceman comes into view on the right, and you push your joystick to the right, your blip on the map immediately reverses direction while your rocket ship slowly glides over to the right of the screen. I suppose that it is the two speeds (instant on the lower map, gradual on the top screen) that makes it feel awkward. I'm sure it was designed that way, too, so that the lure of the spacemen would perhaps draw you backwards toward an oncoming Disrupter.

But after being tricked into retrieving spacemen for bonus points a few times, only to be annihilated by a disrupter, you lose interest in rescuing spacemen. Even though you're passing up extra bonus points, you'll gather more points in the long run if you simply ignore the men and go after the next hatching pod as planned. That takes away from the urgency of rescuing spacemen. If the game play required you to pick up spacemen by penalizing you if you didn't, then you'd have a more interesting game on your hands.

But with the same screen images reappearing wave after wave, the game doesn't hold interest for long. That's true even though the waves rapidly become more difficult. There is little in the way of discovery in this cartridge—it becomes a

simple durability contest from the first wave.

And if this game action has some connection with Flash Gordon, it eludes me. At least there should be *some* reference to Ming, Dale, and Dr. Zarkhov.

## Coleco Donkey Kong Junior for Colecovision

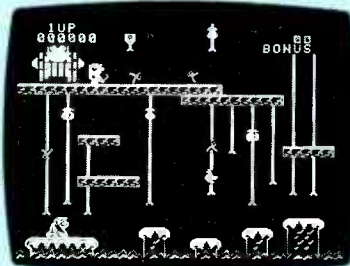

CIRCLE 102 ON FREE INFORMATION CARD

Coleco Donkey Kong Junior	
GRAPHICS	■ ■ ■ ■ ■ ■ ■ ■ ■ ■
SOUND	■ ■ ■ ■ ■ ■ ■ ■ ■ ■
EASE OF LEARNING	■ ■ ■ ■ ■ ■ ■ ■ ■ ■
CHALLENGE	■ ■ ■ ■ ■ ■ ■ ■ ■ ■
VALUE	■ ■ ■ ■ ■ ■ ■ ■ ■ ■
	1 2 3 4 5 6 7 8 9 10
	Poor Fair Good Excellent

If you have ever followed the exploits of Mario and his efforts to rescue his girl from the clutches of the fierce Donkey Kong, then you'll better understand the story behind *Donkey Kong Junior*, another stunning arcade translation by Coleco for their *Colecovision* system.

The story goes that Mario finally captured Kong. Now the tables are turned. Mario is the bad guy, as jailor of Kong. Kong's pint-sized protege, Kong Junior, is on the trail of his father, trying to reach the key that unlocks cages and chains.

With the typical *Colecovision* high-resolution graphics, *Junior* is certainly one of the cutest games available for a home videogame, yet the cuteness doesn't get in the way of

sincerely challenging game play.

The game features three completely different game screens, each with its own particular challenge. The first screen makes Junior swing from vine to vine while eluding the harmful Snapjaws (they like to climb vines at random). Swinging Junior from vine to vine is accomplished by moving the joystick to one side, unless he needs to leap from a platform to a vine, in which case you need to use a side action-button to make him jump.

On to the second screen, which has Kong's cage chained down. Junior must swing to six dangling chains. As he pushes each lock to the platform, the chain holding the cage is released. All six locks need to be pushed to the top while avoiding both Snapjaws and flying Nitpicker birds.

The third screen is a repetition of the first screen, but the fourth screen features a unique jump board (a precisely timed bounce buys Junior some extra time and bonus points), moving platforms and chains, and egg-dropping Stookybirds, which Junior must swing amidst on his way to the key for dad's cage.

I find the game graphically interesting for longer periods than the excellent-looking *Donkey Kong*. For instance, the graphic depiction of this little diapered chimp character swinging from vine to vine is clever.

Each screen has its own background music or sound, and the tune played at the end of a successful screen is catchy. Moreover, as Junior makes his way through a screen, the sound he makes is believably ape like.

I wasn't sure whether the greater ease of attaining higher levels was a result of playing so many dozens of hours of *Donkey Kong* or whether it was because *Junior* is actually a little easier to control. It may just be that I have become accustomed to *Colecovision*'s controllers and response-time characteristics. But whatever the reason, you will probably find that you can progress through at least one shot at all the screens within a couple of hours of dedicated play.

Unlike most spin offs (Ms. Pac-Man, most noticeably), *Donkey Kong Junior* is a far differently playing game from its predecessor. It's different enough to warrant placing *Junior* high on your "to buy" list for the *Colecovision*. R-E



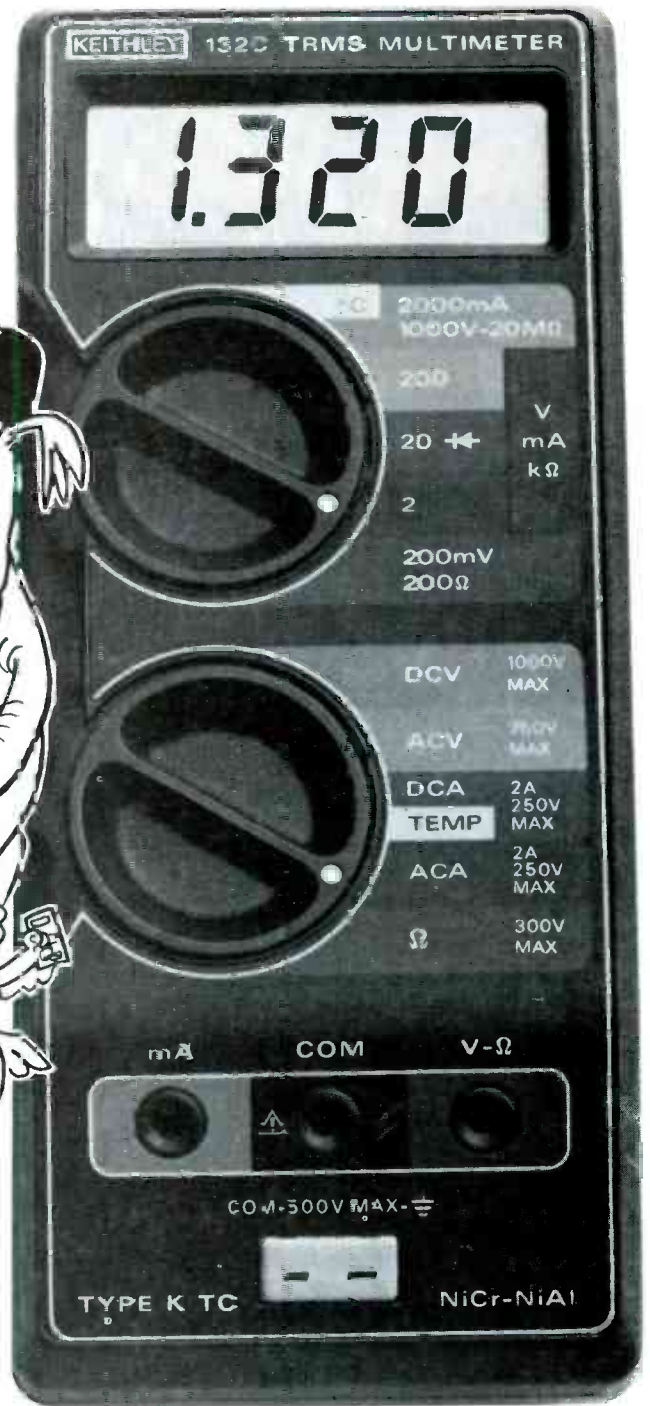

# FREE temperature.

New from Keithley. TRMS DMM and Digital Thermometer all-in-one.

It's two-for-one to give you one less tool to worry about when you're fighting electronic and temperature dragons both. And both for the price of a TRMS DMM alone. It's the only combination DMM and digital thermometer to give you all the features listed here **and** our one-hand, no-mistake rotary thumb wheels. All backed by Keithley's 30-year reputation for lab accuracy. Keithley DMMs and thermometers. **The Dragon Slayers.**

# KEITHLEY

Write Tom Hayden for your free, frameable 9 x 12" dragon poster. Keithley Instruments, Inc., 28775 Aurora Road, Cleveland, Ohio 44139. Phone 216-248-0400. Telex: 98-5469.

- 132 Features**
- DMM**
- Full range and function
  - True RMS
  - 0.25% DCV accuracy
- THERMOMETER**
- Fast response
  - Thermocouple-based (Type K)
  - Integrated TC connector — requires no adapter
  - Choice of °F or °C models
  - 0° to 2000°F, 1370°C
  - \$199 °C/\$209 °F

Prices USA only

CIRCLE 43 ON FREE INFORMATION CARD

KE-1002

**Wouldn't you like to have a new skill you could call your own? Learn TV, audio, and video servicing with at-home training from NRI.**

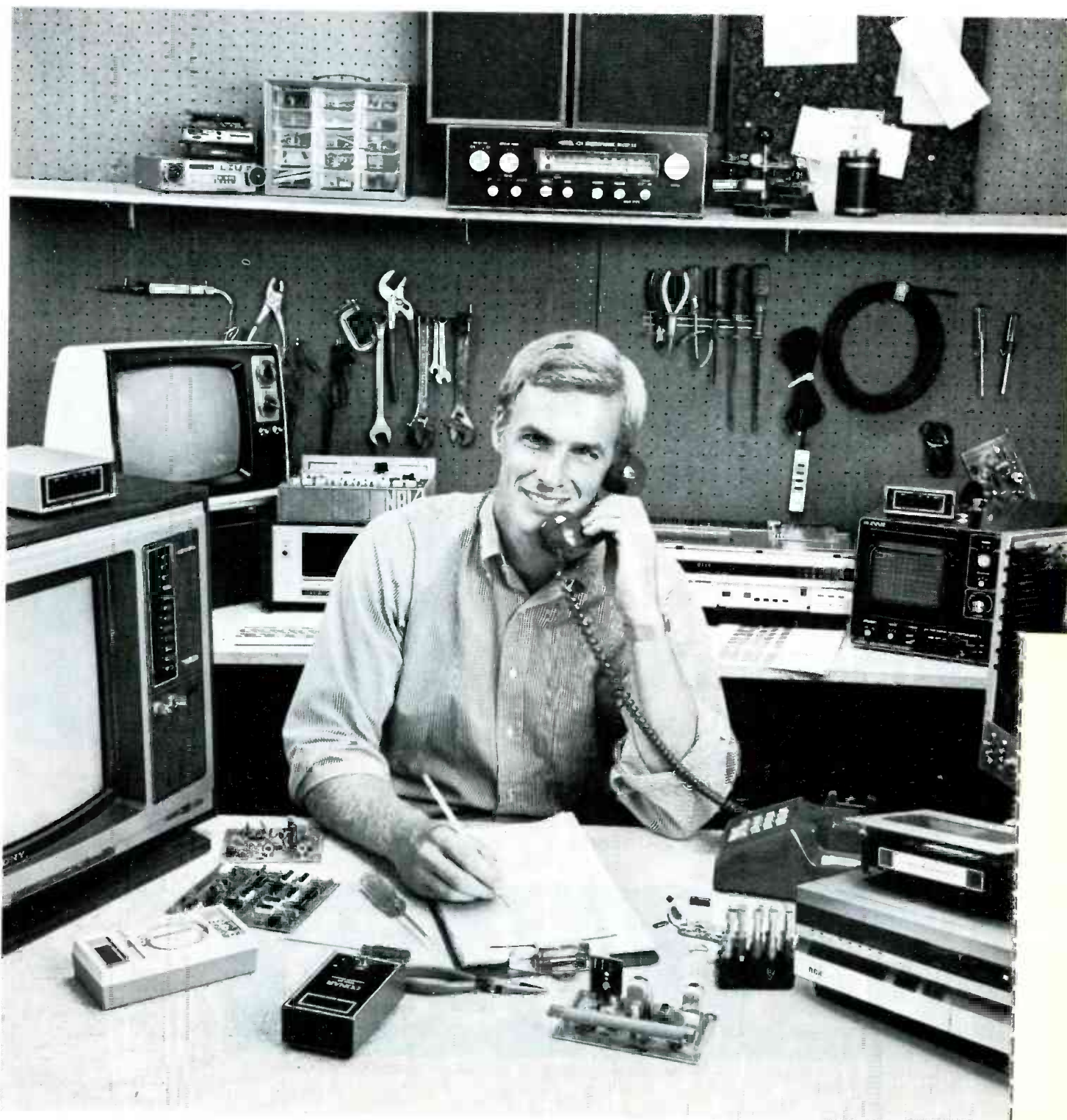

You can learn to service and repair TVs, stereos, electronic musical instruments and amplifiers, car and portable radios, record and tape decks, videocassette recorders and disc players, almost any kind of electronic equipment on the market. And you can learn to do it at home, in your spare time, without quitting your job or wasting time and gasoline on night school. NRI will train you, as it has over a million and a quarter others, with effective methods proven over 69 successful years.

### Hands-On Training

NRI training is practical training all the way. Throughout your course, you'll perform hands-on experience projects that make theory come to life and give you real understanding.

### Includes Both 25" TV And VCR, Plus DMM And More

As part of your training, you'll build your own 25" Heath/Zenith color TV, a state-of-the-art unit with infrared remote tuning, programmable channel selection, and the incredible space phone for remote calling. You also get a front-loading, remote-controlled videocassette recorder to play your videotaped lessons and learn about servicing this complex instrument.



Practical training on a real state-of-the-art TV, VCR or stereo, using professional equipment

You'll learn troubleshooting techniques using a professional 3½-digit digital multimeter. You'll use it when assembling your TV to check demonstration circuits you build on the NRI Discovery Lab, and in your professional work. It's the equipment and training you need for success.

### Exclusive NRI Training On Videotape

In addition to profusely illustrated lessons, you get NRI Action Videocassettes . . . videotaped lessons that show you graphic presentations of electronic systems, vivid closeups of servicing techniques and professional "shortcuts" to study and replay as often as you want.

### Training For Success

NRI not only prepares you to become a top technician, we get you ready for independence. NRI Video/Audio servicing gives you a great new way to earn

extra money doing part-time servicing for appliance and department stores—building a good-paying, new career with an electronics firm . . . or even starting your own business. You can start small, even part-time in your basement or garage, make the most of your opportunities to grow into a successful businessman.

### Free Catalog . . . Mail Card Today

Send the postage-paid card for our free 104-page color catalog describing our courses in full, showing all equipment, lesson outlines, and career opportunities. It also shows other exciting courses like Microcomputers, Electronics Design, Industrial Electronics, Digital Electronics, and more. Mail the postage-paid card today for your copy. And



see how you can make the most of your talent. If card has been removed, please write to:

**NRI** NRI Schools of Electronics  
McGraw-Hill Continuing Education Center  
3939 Wisconsin Avenue  
Washington, DC 20016

We'll give you tomorrow.



# LETTERS

Address your comments to: Letters, **Radio-Electronics**,  
200 Park Avenue South, New York, NY 10003

## NONVOLATILE-MEMORY NOTES

When reading my article on the 8K nonvolatile memory expansion for the Timex/Sinclair computers (**Radio-Electronics**, July 1983) I noticed an error that potentially could confuse some readers. The memory map in Fig. 1 says that the "System variable 'D. File' can appear ..." There are two things wrong with that. First, it's not the variable D. File but rather the actual display file that is echoed in the 48K to 64K region. Second, how do 64K RAM packs work then? Since an op-code fetch cannot be made with A15 high, simply gating A15 with M1 through an AND gate for the upper 32K will prevent a clash between the echo of the display file and any data stored in the 48K to 64K region.

In Fig. 7, the parts-placement diagram, capacitor C3 is missing. It should be installed from the empty pad at R5 to the pad directly below it.

One further note: The RAM board is com-

patible with the new Timex/Sinclair 1500, but not with the *Spectrum* or the Timex/Sinclair 2000.

PAUL W. W. HUNTER

## HELP NEEDED

I need some help in locating some information. Back in 1968, I built a Delco-designed 160-watt stereo amplifier from one of their application notes. Instead of using the Delco-designed pre-amp, I used a design from a G.E. transistor manual. After I had built it, I encountered some personal problems and had to shelve the whole unit. Unfortunately, all my design layouts and schematics got lost, and the unit is just collecting dust.

Now, my problem is this: I have just received the application note from Delco. What I need now is some information on the pre-amp and its power supply. I've tried the library, but they do not have the manual; and I don't know how to get in touch with G.E. even

to see if the manual is still available. Could any of your readers help me?

The pre-amp uses 3 2N508A transistors per channel, 1 volume control, 2 tone controls, has a phono (RIAA) input, and tuner input with a future tape input. The circuit is supplied with -22 volts and is shielded from the main amplifier. The power supply delivers -44 volts, using 4 1N91 diodes with 2 1N91 diodes for regulation along with 3 1500- $\mu$ F 50-volt capacitors.

I would appreciate any information anyone can send me on the pre-amp.

B.E. BROSKI  
5912 West Clinton,  
Cleveland, OH 44102

## DRIVERS' BEHAVIOR

In the March 1983 issue of **Radio-Electronics**, Mr. Kolasinski tells about his attempt to check on drivers' behavior by motoring at the speed limit and observing

**NOW!**

GET IBM-PC Capacity at a Fraction of IBM'S Price!

New NETRONICS 16 Bit EXPLORER 88-PC Kit  
Starts at Just ~~\$399.95~~ - Accepts All IBM Peripherals.

It's true! Now you can enjoy the power of the Intel 8088—the same microprocessor which powers the IBM-PC—and run any program compiled for the IBM-PC...starting at only \$399.95!

Take this easy, low cost way to learn 16-bit technology! Two-board system features:

1. 8088 mother board with 5-slot expansion bus; accepts any hardware designed for IBM-PC; and
2. 64K memory board, expandable to 256K; with IBM compatible RS232 communications port.

Any disk-operating system which works on the IBM will work directly on the EXPLORER 88-PC, and all programs compiled for the IBM will run on it.

The system monitor ROM included in the Starter system features a user-friendly operating system that allows easy program generation and debugging. The commands include display/modify memory...display/modify registers...input/output data to I/O ports...block moves...single-step trace mode...go/run with optional breakpoint and register reports...cassette load/save with file labels...plus a complete system test program that tests and reports condition of ROM, RAM, cassette interface, timer, DMA controller, interrupt controller, and the communications port. These test programs not only allow easy debugging of software but they serve as hardware and software learning tools.

The EXPLORER 88-PC STARTER KIT includes a mother board, memory/I/O board, all components needed, sockets for IC's used, one 62-pin bus connector and complete assembly/test instructions. All you need is a soldering iron, solder, a power supply, and a standard RS232 terminal (Netronics has 2 low-cost ones to choose from).

- Explorer 88-PC Starter Kit...\$399.95  
+ 10.00 p&i  
 (wired & tested, add \$100.00)  
 Extra 62-pin connectors at \$4.25 ea.  
+ 1.00 p&i.

Use your own terminal with the EXPLORER 88-PC or, if you plan to expand it to be fully IBM compatible, we offer our IBM compatible keyboard and an IBM compatible color graphics board (only available wired and tested).

- IBM compatible keyboard...\$299.95 + 10.00 p&i.
- IBM compatible color board...\$299.95 + 10.00 p&i.
- Additional ROM required...\$35.00.

Set your own pace! Invest and learn, at the rate YOU want! Add to your EXPLORER 88-PC:

Deluxe heavy-duty steel cabinet that houses either two 5 1/4" floppies or a 5 1/4" hard disk with one floppy. This cabinet features a brush-finish front panel and a wood-grained sleeve.

- EXPLORER 88-PC Cabinet...\$199.95 + 18.00 p&i.

A heavy-duty open frame power supply with fan that can be used in your own cabinet or installed into the Netronics cabinet is available as follows:

- 10 amp power supply for system + 2 floppies...\$149.95 + 8.00 p&i.
- As above + extra power for 1 hard disk...\$169.95 + 8.00 p&i.
- IBM compatible disk controller board. Controls four 5 1/4" floppy drives (w/2 drive cable). Available wired and tested only...\$250.00 + 8.00 p&i.
- Monitors and BIOS source listings: available on either disk or hard copy at \$35.00.

- Please specify format and system required.
- INTEL 8086/8088 user manual...\$15.00 + 1.50 p&i.
- THE 8086 BOOK by RECTOR & ALEX...\$16.00 + 1.50 p&i.

- Special IBM compatible system: with keyboard, color graphics board, floppy disk controller, 64K RAM, cabinet, standard power supply and a single 5 1/4" floppy drive...\$1899.95 + 25.00 p&i.

IBM compatible hard disks, built-in modern board, eprom burner, print buffer system plus more will be available shortly.

Over 100 EXCLUSIVE Products and Kits—including the "Speak Easy" universal voice synthesizer, a Diagnostic card with built-in logic probe for the IBM-PC, terminals, monitors, the ELF and EXPLORER 85 computers, and much more, are described in our upcoming catalog. It's yours FREE if you check here



"p&i" stands for "postage and insurance".

CALL TOLL FREE 1-800-243-7428 for Charge Card Orders.  
In Conn., call 203-354-9375. Conn. res. add sales tax.

TO ORDER BY MAIL, CHECK BOXES FOR PRODUCTS DESIRED AND MAIL ENTIRE AD TO:

**NETRONICS R&D LTD.**

333 Litchfield Rd., New Milford, CT 06776

- Amount enclosed, OR Charge my  VISA  MASTERCARD  
Acct. No. \_\_\_\_\_ Exp. Date \_\_\_\_\_

Signature \_\_\_\_\_  
PRINT NAME \_\_\_\_\_  
Address \_\_\_\_\_ City \_\_\_\_\_ State \_\_\_\_\_ Zip \_\_\_\_\_

## MOVING?

Don't miss a single copy of **Radio-Electronics**. Give us:

Six weeks' notice

Your old address and zip code

Your new address and zip code

ATTACH  
LABEL  
HERE

name \_\_\_\_\_ (please print)  
address \_\_\_\_\_  
city \_\_\_\_\_ state \_\_\_\_\_ zip code \_\_\_\_\_

Mail to: Radio-Electronics  
SUBSCRIPTION DEPT., P.O. BOX 2520,  
BOULDER, COLO. 80322

# EXTRA EXTRA VALUES

## MONEY SAVING SALES SPECIALS



# Cobra®

## TELEPHONES



### CORDLESS TELEPHONE- CLOCK RADIO

**119<sup>95</sup>** ea. MODEL RP-740S

- For inside or outside your house (up to 100 ft.)
- Automatically redials last telephone number called
- Mute button for privacy

**AM-FM ELECTRONIC DIGITAL CLOCK RADIO FEATURE:** • Large LED time display • Hi-Lo dimmer switch • Snooze alarm • Walnut styling • Slide rule dial indicator

### PORTABLE CORDLESS EXTENSION TELEPHONE

- Exclusive clear call selector allows optimum voice clarity within operation range

**89<sup>95</sup>** ea. MODEL CP205S

- Portable handset allows you to place or answer calls up to 600 feet from base unit... inside or outside

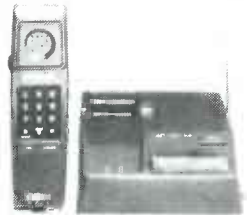

### CORDLESS TELEPHONE

**88<sup>00</sup>** ea. MODEL CP-110S

- Mute button on handset allows you to talk to someone in room without party on line listening to conversation. Remote Rechargeability • Works up to 600\* feet from base unit.

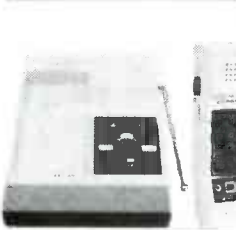
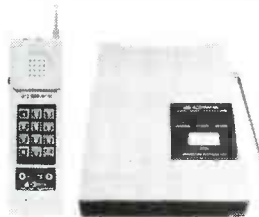

### CORDLESS SPEAKERPHONE

**149<sup>95</sup>** ea. MODEL CP-130S

- Speakerphone is built into base unit. Allows entire family to speak and listen without passing around the handset. You get Hands Free Conversation • 9 Number Automatic Dialer • Last number redial • 2-Way intercom with Hold • Works Up to 600\* feet • Exclusive Clear Call Selector

### PAIR-O-PHONES: COMPLETE PHONE SYSTEM

**165<sup>00</sup>** ea. MODEL CP-140S

- 1 Cordless Telephone with memory that stores and automatically dials up to 9 numbers plus last number redial • 2-Way intercom that allows paging from remote handset and base, plus hold • 1-Standard Telephone with 10 foot cord and RJ-11 modular plug, mute button and last number redial button • 1-Telephone Wall Holder • 1-Remote Charger.

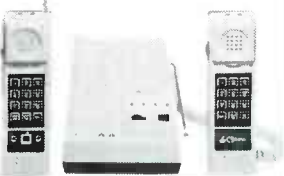

# Cobra®

## CB RADIOS & ACCESSORIES



### SUPER HETERODYNE RADAR DETECTOR

**139<sup>95</sup>** ea. MODEL RD-4000

Dual Band Super Sensitivity/Dual Alarm... Audible and Visual with exclusive SIGNAL

ELIMINATES FALSE ALARMS • Responds to X and K band Speed radar frequencies. The only one approved by the FCC.

### AM CB RADIOS

**119<sup>95</sup>** ea. MODEL 29LTD

"The Truckers Choice" with an instant emergency channel 9 switch • Delivers maximum power output, 100 per cent modulation and fine receiver sensitivity. Features: SWR bridge and antenna warning indicator.



### SSB MOBILE

**179<sup>95</sup>** ea. MODEL 148GTL

Precision AM/SSB mobile unit for CB. Features: DynaMike, Volume, ON/OFF control, Squeal, RF gain, SWR CAL control, Voice Lock, S/RF/CAL/SWR switch, LSB/AM/USB mode switch, switchable automatic noise limiting and noise blanking, CB/PA switch and much more.



### 40-CHANNEL CB 2-WAY MINI-MOBILE RADIO

**39<sup>95</sup>** ea. MODEL 19XS

- Combination Squeal/PA/CB Control
- ANL Switch automatically reduces the high-pitched noises
- S/RF PWR Meter
- Off/On/Volume • PA



### S.O.S. 40 CHANNEL EMERGENCY 2-WAY RADIO

**55<sup>00</sup>** ea. MODEL 39LTD

Needs no installation. Simply plug into cigarette lighter. Features a built-in microphone, LED channel display, emergency channel 9 indicator plug a host of others.



# FORDHAM

260 Motor Parkway, Hauppauge, N.Y. 11788

Master Charge  
 VISA  
 COD  
 Money Order  
 Check

N.Y. State residents add appropriate sales tax.

COD's extra (required 25% deposit)

ADD FOR SHIPPING AND INSURANCE:  
 \$250.00 ..... \$4.50  
 \$251.00 to 500.00 ..... \$6.50  
 501.00 to 750.00 ..... \$8.50  
 751.00 to 1000.00 ..... \$12.50  
 over 1000.00 ..... \$15.00

**TOLL FREE**  
**(800) 645-9518**  
 in N.Y. State call 800-832-1446

# Three New Simpson 3½ Digit DMMs!

## FOR THE MAN ON THE JOB...

Professional-grade instruments have: continuity beeper, diode test, transient protection and double fusing. UL Recognized test leads and a full line of optional accessories.

The **470™** is our new low-cost, full-function, hand-held DMM with 25 ranges, 0.15% basic accuracy, thumbwheel knobs, and a 2-way fold-out stand. The **467E** hand-portable DMM has 0.1% basic accuracy, peak hold, true RMS and 26 ranges. The **360 Series 3** digital VOM (with world famous 260® styling) has 0.1 basic accuracy, 28 ranges, bright LED display, rechargeable batteries.

These 3 new DMMs will join the family of 29 other UL Listed Simpson Instruments... available at leading electrical/electronics distributors worldwide.



### SIMPSON ELECTRIC COMPANY

A Katy Industries, Inc. Subsidiary  
853 Dundee Avenue, Elgin, IL 60120  
(312) 697-2260  
Telex 72-2416  
Cable SIMELCO



how many drivers passed him when the police weren't around. But his simple test is inherently faulty.

Fact: Nobody also going at the speed limit can pass him or be passed by him. Two bodies going at the same speed in the same direction can only keep station with each other. And so, all exactly law-abiding citizens are eliminated from his count. In fact, the more closely other drivers match his speed, the less likely that he will encounter them. But the faster (or slower) they drive relative to Mr. Kolasinski, the more likely that he will observe them. Not exactly a fair test of drivers' general behavior, is it?

That is not to say that he is wrong in thinking that people do tend to speed when not in the presence of the police. Or that the average speed is higher than the posted speed in most circumstances. It's just that he'll need a more objective test in order to satisfactorily prove his point.

Some Purdue University studies suggest the majority of drivers move at a speed that they find comfortable and efficient, with only small regard for the posted speed. It is not their intent to break the law, but to get where they are going at a rate they perceive as safe and efficient, based on traffic, road conditions, and other factors. That speed is often marginally above the posted speed. Indeed, some communities set the posted speeds by observing general speeds in practice, and then posting a rate that agrees with (typically) 85% of the drivers using that road. That's a pragmatic approach, which also guarantees a constant supply of "speeders."

BRUCE LOGAN  
South Bend, IN

### OOOOOPS

I want to thank you for the excellent job of editing you did on my recent articles in **Radio-Electronics**. The end results were simply beautiful!

I did notice one error in each article, though, and those should really be pointed out to the readers. In the article, "Music Synthesizer IC's," (May 1983), on page 67, Fig. 3, the control-voltage reject trim (R7) was altered from my original artwork. While it is shown in the article as a rheostat, it should actually be set up as a potentiometer, with one side going to +15 volts and the other side to -15 volts. So, break the rheostat connection (on the left-hand side) from the wiper, and send it to -15 volts.

A more serious error occurs in the article, "How to Use Transconductance Operational Amplifiers" (July 1983), on page 57, Fig. 5. On my original artwork, R5 is shown as being 15K, and that suitably restricts the current into the 3080. However, it is shown in the magazine as being 1.2K. That value is far too low, and will lead to excessive current flow that will destroy the chip! As stated in the text, that current should be restricted to a value between 0.5  $\mu$ A and 0.5 mA. With the 1.2K resistor, the current will exceed 10mA! Thermal runaway is almost guaranteed. The solution is simple: Change the value of resistor R5 to 15K.

I hope those corrections will save your readers some blown chips and blown tempers. Once again, let me say that I was very pleased with the fine way in which you presented my articles. I feel very honored that **Radio-Electronics** picked them up.  
THOMAS HENRY



470™  
\$139

360 Series 3  
\$275

467E  
\$225

CIRCLE 54 ON FREE INFORMATION CARD

# The First Shirt-Pocket TV With a PERFECT PICTURE!

Less Than an Inch Thick, Weighs Less Than 12 Ounces

## The CASIO POCKET TV

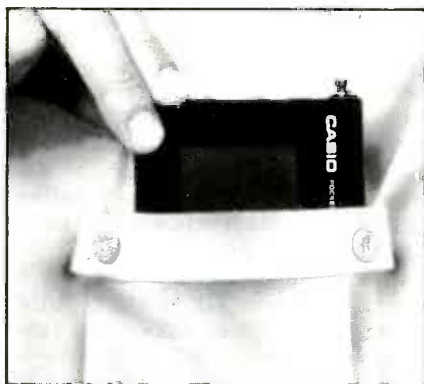

*Slips into your shirt pocket  
or small purse.*



*It's only an inch thick!*

A whole new world of technology has made possible unbelievable picture quality on a TV set so compact it slips easily into your shirt-pocket.

Technically, it's **nematic liquid crystals** and **electroluminescence**. From your viewpoint, it's a sharp, brilliant black-and-white picture on every commercial channel, 2 to 83.

### Outperforms Sony and Seiko

We didn't say we have the only miniaturized TV set; we said ours has the only **perfect picture**. Sony has a set for \$50 more, and Seiko has one for \$150 more, and in our opinion neither of them is within light-years of the picture quality ours has. Side by side, our set's picture, like our description, is absolutely clear.

We've picked up signals 75 miles and more away from a station, because the built-in antenna really grabs the signal. If you're near an antenna connection, in ten seconds you can connect the Casio Pocket TV to that antenna.

Watch and enjoy in complete privacy. We include an earphone jack. Plug it in and the speaker is bypassed; only you will hear the sound.

### 4-Way Power Supply System

Three tiny AA batteries will power this TV for hours and hours (power consumption is only one watt). Or use the rechargeable battery-pack, and after viewing, plug it in the wall to recharge overnight.

That isn't all. With an optional adapter you can plug the Casio Pocket TV into your car's cigarette lighter; it uses almost no power.

Or, with the optional AC adapter, you can watch TV forever with your set plugged directly into a wall outlet.

### Sunlight or Pitch Dark - No Difference

Unlike old-fashioned conventional television sets that need a shadow-box in sunlight or a room light inside, the Casio Pocket TV delivers its perfect picture under any lighting conditions.

The picture is strong and easy to see even on the brightest sandy beach with the sun glaring right into the set. And it's equally clear in the dark.

An LCD brightness control guarantees perfect picture quality no matter where you are.

### You Get All These

As "standard equipment" with your Casio Pocket TV, you'll get —

- test batteries (UM-3)
- earphone
- built-in VHF/UHF rod antenna
- wire antenna
- carrying strap and soft case

If you want the rechargeable battery-pack, the cigarette-lighter power adapter, or the AC power adapter, they're optional extras, but they aren't expensive.

Your Casio Pocket TV not only will be the talk of the neighborhood; you'll be able to watch your favorite shows no matter where you are.

### WE ABSOLUTELY GUARANTEE!

Use your Casio Pocket TV for up to 30 days, entirely at our risk. If for any reason you decide not to keep it, return it for a 100% refund.

### THIS HAS TO BE THE ELECTRONIC ENGINEERING ACHIEVEMENT OF THE DECADE!

The CASIO POCKET TV  
complete with test batteries, earphone,  
antenna, strap, and soft case **\$299.95**  
two for **\$275** each  
Rechargeable Battery-Pack, **\$7.95**

Cigarette-lighter Power Adapter, **\$14.95**

AC Power Adapter, **\$14.95**

(+ \$3.80 per total order for shipping)

Order **TOLL-FREE**  
For fast delivery on credit card orders  
call toll-free 24 hours a day, 7 days a week:

**800-443-0100**

Ask for Ext. 111  
Or send check or money order.  
Please add indicated shipping cost.

The Casio Pocket TV  
is another electronic marvel from  
**NEW HORIZONS**  
Dept. RE-9, 5-31 50th Avenue  
Long Island City, NY 11101

© 1983 New Horizons

# EQUIPMENT REPORTS

## Microbuffer In-Line Printer Buffer



CIRCLE 103 ON FREE INFORMATION CARD

	1	2	3	4	5	6	7	8	9	10
OVERALL PRICE										
EASE OF USE										
INSTRUCTION MANUA.										
PRICE/VALUE										
	1	2	3	4	5	6	7	8	9	10
	Poor		Fair			Good			Excellent	

A COMPUTER CAN RUN NO FASTER THAN its printer. While even the least expensive, unsophisticated computer can process data at a nominal rate of 20,000 characters per second (cps), the typical

low cost daisy-wheel printer loafs along at 12 cps, while the average matrix printer speeds along at 80 cps. Translated into real time, it means your system is tied up for anywhere from 20 seconds to 2 mi-

minutes when printing a standard double-spaced page of 250 words. A ten page report can easily tie up your system upwards of 20 minutes, while a longer report would still be printing when you returned from an extended lunch.

One of the most convenient ways to release your computer from the strings that tie it to the printer—and have the computer available for use even when printing a long report—is to use a *Microbuffer In-Line* (Practical Peripherals, Inc., 31245 La Baya Drive, Westlake Village, CA 91362) between your computer and your printer.

Basically, the *Microbuffer In-Line* is a cabinet that houses 32K or 64K of RAM (user expandable to 258K) that substitutes for the computer's RAM during a  
*continued on page 28*

## New! A solid wood Work Center as efficient as your computer

The Exeter, the complete computer work center, and also a tall, handsome cabinet which conceals work clutter! Finished cabinet is antique (dark) pine. 62" h x 32" w x 25 3/4" d. Also available unfinished in kit form.

- Fits most computers — IBM, Apple, TRS 80, etc.
- Pull-out shelves for computer keyboard and printer
- Paper tray below printer
- Adjustable/removable shelf for CRT

Call toll-free: 1-800-258-4720

In New Hampshire: 1-800-552-0320

Visa, MasterCard, American Express

## Yield House®

Quality pine furniture for over 35 years  
Dept. RE39, North Conway, N.H. 03860

- Please send the Exeter Computer Work Center. Enclosed is \$499.95 plus \$50.00 shipping. (Requires minor assembly)
- Please send the easy-to-build unfinished Exeter kit. Enclosed is \$349.95 plus \$35.00 shipping.
- Please send free additional information.

Name (please print)

Address

City

State

Zip



Closed, it's a handsome armoire

Only \$499.<sup>95</sup> plus shpg.

CIRCLE 15 ON FREE INFORMATION CARD



# The best 60MHz scope costs only \$1150. It's from Kikusui.



That's right. Only \$1150 for Kikusui's top-of-the-line 5060 model oscilloscope. And we also have four other scopes for as low as \$600 in our new 5000 Series.

Not only that, we're offering a two year warranty on each of them, compared to other big name companies' limited one year warranties.

When it comes to performance, our 5000 Series has the edge over the Tektronix 2200 Series in lab quality, chop frequency, and trigger view. Ours also have more display modes, higher acceleration for better brightness, and sharper focus for better resolution.

Each scope in our 5000 Series is crafted so that it can be used for production, field service, consumer electronics servicing, or even personal use. The 5060 is a 60MHz scope with 3 channels, eight traces, delayed sweep, delay line and alternate sweep, and priced at \$1100. Models 5040 and 5041 are 40MHz, dual channel scopes, featuring peak-to-peak automatic triggering, automatic focus control and a delay line. If you're interested in a 20MHz scope, we have our 5020 and 5021 models with features similar to our 40MHz scopes. Both the 5041 and 5021 also have delayed sweep. Prices at \$920 for the 5041, \$795 for the 5040, \$690 for the 5021 and \$595 for the 5020. So, whatever model suits you best, you can't get a better scope for the money.

Of course, there's a reason we're able to offer these bargains and quality. We're one of the biggest manufacturers of scopes in the world, with over 30 years in the business. Another reason is KIK's nationwide network of lab quality maintenance facilities.

Write us and we'll send complete specifications back to you. Or just take a little time to call us. It's a small price to pay to get big time quality and service.

For sales and technical information  
call toll free **800-421-5334**  
(in Calif., Alaska, Hawaii 213-515-6432).

Order Toll Free  
800-421-5334



17819 Figueroa Street  
Gardena, Calif. 90248  
TWX 910-346-7648

🍁 In Canada call: Interfax Systems, Inc. 514-366-0392

Subsidiary of Kikusui Electronics Corp., 3-1175 Shinmaruko-Higashi, Nakaharu-Ku, Kawasaki City, Japan [044] 411-0111

CIRCLE 48 ON FREE INFORMATION CARD



HITACHI

**NLS** Non-Linear Systems

HICKOK

WESTON

DATA PRECISION

KEITHLEY

**AWS**  
A W. SPERRY  
INSTRUMENTS INC.

FLUKE

PHILIPS

**BK PRECISION**

VIZ RGA

TRIPLETT

Simpson

LEADER

**NLS** Non-Linear Systems, Inc.  
**OSCILLOSCOPES**

MS15 15 MHz Single Trace  
MS215 15 MHz Dual Trace  
MS230 30 MHz Dual Trace



Non-Linear Systems' trio of miniscopes are accurate, affordable, portable. And there's one to match nearly every budget and need. Standard features on all models include an input impedance of 1 megohm with 50 pF; maximum input voltage of 350 V; trigger modes in auto, internal, external and line; slope that's + or - selectable; graticule (4x5 division of 0.25" each); dual power sources operating either internally from rechargeable lead acid batteries or externally from 115 VAC or 230 VAC (50-60 Hz) via plug-in transformer; handy size (2.9"H x 6.4"W x 8.0"D) and weighs just 3 lbs.\*

(\*Exception: model MS-230 is slightly deeper, at 8.6", and heavier, at 3.6 lbs.)

**BK PRECISION**

**POWER SUPPLIES**



MODEL 1601

**\$299<sup>95</sup>**  
WAS \$359.

- Isolated 0-50VDC, continuously variable; 0-2A in four ranges
- Fully automatic shutdown, adjustable current limit
- Perfect for solid state servicing



MODEL 1650

**\$319<sup>95</sup>**  
WAS \$390.

- Functions as three separate supplies
- Exclusive tracking circuit
- Fixed output 5VDC, 5A
- Two 0 to 25VDC outputs at 0.5A
- Fully automatic, current-limited overload protection

**BECKMAN'S CIRCUITMATE**

**AVAILABLE NOW ALL UNDER \$100**



Circuitmate DM 20—3½-digit, pocket-size multimeter; 0.8% Vdc accuracy, diode test, hFE test, conductance, 10 amps AC and DC ranges, auto-polarity, auto-zero, auto-decimal

**\$64<sup>95</sup>**



Circuitmate DM 40—3½-digit multimeter; 0.8% Vdc accuracy, diode test, auto-polarity, auto-zero, auto-decimal

**\$69<sup>95</sup>**



Circuitmate DM 25—3½-digit, pocket-size multimeter; 0.5% Vdc accuracy, diode test, capacitance, continuity beeper, conductance, 10 amps AC and DC ranges, auto-polarity, auto-zero, auto-decimal

**\$79<sup>95</sup>**



Circuitmate DM 45—3½-digit multimeter; 0.5% Vdc accuracy, diode test, continuity beeper, 10 amps AC and DC ranges, auto-zero, auto-polarity, auto-decimal

**\$89<sup>95</sup>**

**BK PRECISION**

**FUNCTION GENERATORS**



MODEL 3010 **\$179<sup>95</sup>**  
WAS \$229.

MODEL 3020 **\$319<sup>95</sup>**  
WAS \$394.

**MODEL 3010**

- Sine, square and triangle output
- Variable and fixed TTL outputs
- 0.1 Hz to 1MHz in six ranges
- Push button range and function selection
- Typical sine wave distortion under 0.5% from 1 Hz to 100kHz

**SWEEP FUNCTION MODEL 3020**

- Four instruments in one package—sweep generator, function generator, pulse generator, tone-burst generator
- Covers 0.02Hz-2MHz
- 1000:1 tuning range
- Low-distortion high-accuracy outputs

**BK PRECISION**

**CAPACITANCE METERS**



**\$189<sup>95</sup>**  
WAS \$238.

MODEL 830

- Automatically measures capacitance from 0.1pF to 200mF
- 0.1pF resolution
- 0.2% basic accuracy
- 3½ digit LCD display



**\$159<sup>95</sup>**  
WAS \$192.

MODEL 820

- Resolves to 0.1pF
- 4 digit easy-to-read LED display
- Fuse protected against charged capacitors
- Overrange indication

**BECKMAN DIGITAL MULTIMETERS**



300 310 320  
330 350 360

ALL IN STOCK  
CALL FOR PRICES

**ORDERING INFORMATION**

We don't just take orders, we ship them. *Advance Electronics* endeavors to keep everything we advertise in stock for immediate delivery.



- Mastercharge & Visa shipped within 24 hours.
- Bank checks or Money Orders shipped within 24 hours.
- Personal checks — please allow 3 weeks for check to clear.
- All prices plus shipping charges. Please call for appropriate charges. Use our toll free number.
- New York State residents add appropriate sales tax.
- PRICES SUBJECT TO CHANGE WITHOUT NOTICE.

Quantities are limited

HITACHI

NLS Non-Linear Systems

HICKOK

WESTON

DATA PRECISION

KEITHLEY

AWS  
A.W. SPERRY  
DISTRI BUTANTS INC.

FLUKE

PHILIPS

BK PRECISION

VIZ RGA

TRIPLETT

Simpson

LEADER

HITACHI

**A 30 MHz  
SCOPE AT A  
15 MHz PRICE  
\$549<sup>95</sup>**

Dual Trace  
w/Delay

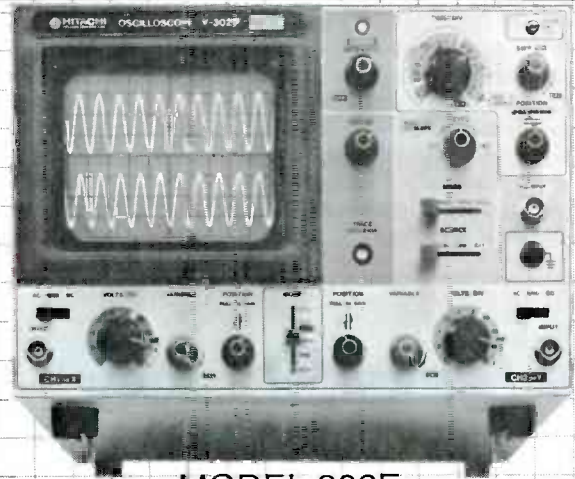

MODEL 302F

Price does not include probes.  
Probes \$50. a pair when purchased with  
scope. \$10. shipping within continental U.S.

All Hitachi Oscilloscopes feature  
2 year parts and labor warranty.

**WE CARRY  
A FULL LINE  
OF HITACHI  
OSCILLOSCOPES  
CALL FOR  
OUR PRICES**

BK PRECISION

INDUSTRIAL  
TRANSISTOR  
TESTER



\$199<sup>95</sup>

WAS \$249

MODEL  
520B

- Now with H/L/O Drive
- Works in-circuit when others won't
- Identifies all three transistor leads
- Random lead connection
- Audibly and visually indicates GOOD transistor

**PROBES  
FOR SALE**

FROM THE BEST SOURCE FOR OSCILLOSCOPE  
PROBES AND DMM/VOM TEST LEAD SETS

- Low Cost
- High Quality
- Excellent Performance
- Slender, Flexible Cable
- Wide Range of Choice
- Switchable X1 and X10 Attenuation Factor
- 100 MHz Bandwidth

MODEL SP100

\$39<sup>95</sup>



**TEST  
PROBES, INC. TPI** Your Probe  
Specialists

AVAILABLE FOR IMMEDIATE DELIVERY

Circle Reader Service 7 for more information



TOLL FREE HOT LINE  
**800-223-0474**

THE TEST EQUIPMENT SPECIALISTS

**ADVANCE  
ELECTRONICS**

26 WEST 46th STREET, NEW YORK, N.Y. 10036 212-730-7030

## EQUIPMENT REPORTS

continued from page 24

printing job. The input to the *Microbuffer*'s RAM comes from the computer's printer output connection; the *Microbuffer*'s output connects to the printer. When the computer is commanded to PRINT, it dumps what is to be printed from its RAM directly into the *Microbuffer*'s RAM at almost lightning speed. For example, a 4000 word document dumps to the *Microbuffer* in less than 3 seconds.

If the number of bytes being dumped to the buffer is less than, or equal to, the

capacity of the buffer, the computer itself is free and ready for use within seconds. If the length of the document exceeds the capacity of the buffer, the computer holds the remainder in its RAM. As the document prints, the data in the buffer slides forward, producing free RAM at the tail end. Eventually, the computer will dump into the free RAM. Then, the computer is free for use—as far as it is concerned, it is finished printing and ready for another job. The task of driving the printer is now controlled entirely by the *Microbuffer*.

The word "controlled" is appropriate because the buffer is more than just a storage memory for driving the printer; it also determines the various ways in which

the printer is driven. On the front panel are three membrane button switches labeled CLEAR, COPY, and PAUSE, along with matching LED indicators to show the selected mode(s). The PAUSE switch does exactly what its name implies: it pauses the output to the printer so that the user can make adjustment or alignment tests or anything else you can do when the printer drive is halted. The computer can dump to the buffer while the PAUSE is set.

The COPY switch programs the *Microbuffer* for up to 255 repeat copies of the document. Normally, the buffer provides a single copy. If the copy switch is depressed, say, three times, three additional copies will be automatically printed. To print a copy, the entire document must be in the buffer. If the document is larger than the buffer it will overrun the first part of the document. If the buffer receives a document larger than its RAM, the LED above the CLEAR switch goes on to indicate that the complete document cannot be held in the buffer's memory. Normally that is not a major difficulty because the buffer is matched to the available memory in the computer.

If the user is reasonably certain of the document size and can be certain that there is RAM available for a new document, he can dump additional documents into the buffer even while the printer is running. That's because the buffer provides a form-feed command for the printer between documents.

For example, assume you are preparing four form letters and you will print two copies of each. As the first letter is printing, you prepare the second letter and dump it into the buffer, then perhaps a third letter, and a fourth. As long as you are certain there is RAM available in the buffer, you can continuously dump additional documents or even pages of a manuscript. Just keep in mind that the buffer issues a form feed to the printer after each complete dump, so each document starts on a fresh page.

The CLEAR switch instantly clears the buffer's RAM so you can go on with other printing jobs.

The *Microbuffer* works exceptionally well and fuss-free. Its only limitation appears to be that it does not respond to a page stop. For example, if the word processor, such as *Scriptit* or *Typit*, is instructed to stop after each page is printed, the instruction is ignored when printing through the buffer; the buffer simply provides the standard form feed at the end of each page. For documents or listings greater than one page in length, the paper should be tractor-fed.

The *Microbuffer In-Line* is housed in a cabinet 5½ by 7½ by 1½ inches. It is AC powered through a wall transformer. The parallel-printer model is supplied with a standard Centronics-type input connector and a 3-foot output cable terminated in a Centronics-type connector. In the serial-printer version, RS-232 connectors are

Vector Electronic Company announces newly improved

## SLIT-N-WRAP® tools

now also for

### 30 gage wire

but if you prefer—

### conventional wrap.

Just change wrap bit, pull off wire bracket and make equally perfect wraps —

BUT, consider these advantages of Slit-N-Wrap:

- Speeds up non-automated wraps — 4 TIMES FASTER.
- Eliminates single wire loading.
- Lowers wrapost profile due to 'daisy-chain' in + out wiring.
- No pre-stripping. No pre-measuring. No pre-cutting.

- ✓ Electronic counter sets 3, 5, 7 turns or 'RUN'.
- ✓ Quick change bits and sleeves.

#### HOW SLIT-N-WRAP WORKS:

Sharp cutter cuts insulation forming longitudinal slit. Insulation spreads to fit space between coils. See below.



P184-6 hand turned tool, \$34.00, includes bit and 75' of 30 gage Tefzel insulated wire. Bits also available to Slit-N-Wrap 28 g. Tefzel or 28 g. polyurethane wire or to CONVENTIONAL WRAP 26 g. to 30 g. Kynar on .025" sq. posts. Only Vector does all this with versatile quick change tools and accessories. Send for FREE CATALOG.

 **Vector Electronic Company**  
INCORPORATED

12460 Gladstone Avenue, Sylmar CA 91342-0336; phone (213) 365-9661

U.S. & foreign patents.

CIRCLE 19 ON FREE INFORMATION CARD



NEW!

NEW!

P184-7-30  
110V AC with 200'  
30 gage Tefzel wire  
and electronic turns  
counter. \$168.00.

NEW!

Stable Push-Pull  
Tension Regulator  
ends wire breaks;  
assures reliable gas-  
tight contacts per  
Mil-Std 1130B.

NEW!

Milli-Ohm Probe  
checks contact  
integrity quickly.  
P210, \$69.50.

PROBE PROVES RELIABILITY

100

# SIMPLY AMAZING.

## B&K-PRECISION's under \$170 100 MHz frequency counter.

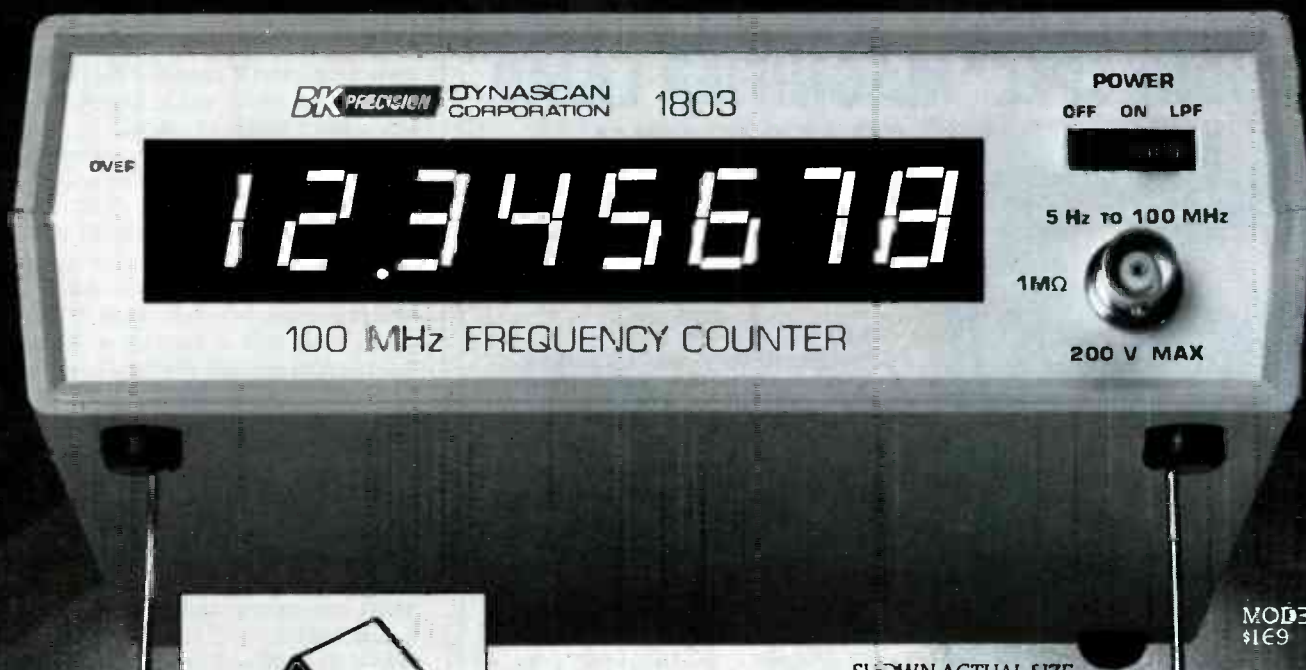

MODEL 1803  
\$169

SHOWN ACTUAL SIZE

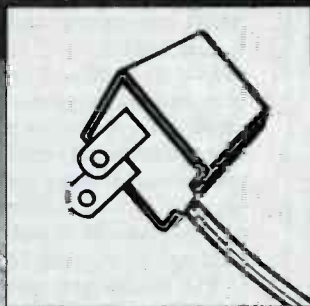

SIMPLE TO POWER  
BATTERY OR AC LINE  
OPERATION  
(ADAPTER INCLUDED).

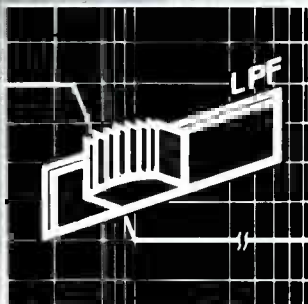

SELECTABLE LOW-PASS  
FILTER FOR ACCURATE  
LOW-FREQUENCY  
MEASUREMENTS.



BNC INPUT CONNECTOR  
SIMPLIFIES HOOK-UPS  
—ELIMINATES NEED FOR  
ADAPTERS.



EASY-TO-READ,  
8-DIGIT DISPLAY  
PROVIDES 1 Hz RESOLUTION

For more details on the amazing 1803 and the full line of new B&K-PRECISION frequency counters, see your local distributor or call 1-312-889-9087.

**B&K PRECISION** DYNASCAN CORPORATION

International Sales, 6460 W. Cortland St., Chicago, IL 60635  
Canadian Sales, Atlas Electronics, Ontario  
South and Central American Sales, Empire Exporters, Plainville, NY 11803

CIRCLE 77 ON FREE INFORMATION CARD

[www.americanradiohistory.com](http://www.americanradiohistory.com)

used. The input and output baud rates and assorted handshaking protocols are individually programmable. Both the serial and parallel versions are priced at \$299 (32K model) and \$349 (64K model). User-installed 64K add-ons are \$179. Specially configured models (without housings) of the *Microbuffer* are available for direct installation in the Epson printers (with and without *Graftrax*) and the Apple computers.

While the price might appear to be somewhat high at first glance, consider that it frees some expensive computer hardware for more productive use. What is high for home and family use can be a real buy for business use. **R-E**

## Vidicraft Model-IVE 100 Integrated Video Enhancer

IT'S QUITE AN UNDERSTATEMENT TO SAY that the video marketplace has changed dramatically in the past few years. For one thing, products that once were only used by video professionals, and others that had never even been thought of, are now commonplace in the home. Those products include such things as image enhancers, sync stabilizers, video distribution amplifiers, and commercial-elimination systems. There are few video enthusiasts that, at one time or another, have not wished they had one or more of



CIRCLE 104 ON FREE INFORMATION CARD

Vidicraft		IVE-100												
OVERALL PRICE														
EASE OF USE														
INSTRUCTION MANUAL														
PRICE/VALUE														
		1	2	3	4	5	6	7	8	9	10			
		Poor		Fair			Good			Excellent				

those products. Of course, if they had all of them the result would be four more boxes and a tangle of cables.

There is an alternative, of course—one of the new all-in-one video accessory systems such as the Vidicraft (0704 S.W. Bancroft St., Portland, OR 97201) *IVE-100* integrated video enhancer. It features all of the systems we've mentioned, as well as a simple switcher and an RF modulator. Let's look at the various features this unit contains and how they work, and then look at the system as a whole.

### An image enhancer

Anyone who's ever recorded a TV program while watching it and then later viewed the tape, is sure to have noticed that the recording is of inferior quality. Granted, the quality improves with top-notch equipment and high recording speeds, but there will always be some loss of overall quality or detail. The purpose of an image enhancer is to restore that lost quality. The enhancer incorporated in the unit can be used to enhance the quality of pre-recorded tapes and off-the-air TV viewing, as well as to improve the quality of camera-to-VCR and VCR-to-VCR recordings as they are being made.

The results provided by the unit are dramatic, but vary according to the quality of the original source. Video enhancers work by amplifying the high-frequency video information, which in turn increases the detail and sharpness of the picture. But if that high-frequency information is for the most part missing, as is often the case with multi-generation tape recorded at slow speeds, there is nothing to amplify. Needless to say, the enhancer can not bring out detail that has been lost forever.

There is a drawback with all video enhancers; when you amplify the high-frequency video you also amplify the high-frequency video noise. That noise shows up on the screen as snow. The Vidicraft unit compensates for that problem with their *VNX* noise-reduction circuit. That circuit suppresses certain low-amplitude, high-frequency signals. Thus,

## STUDIO SPEC™ MAGNIFIER LAMP AT \$59.95 YOU CAN'T AFFORD TO BE WITHOUT IT



ORDER NO.  
MX114

ORDER NO.  
LTS103

This quality all-metal construction UL recognized lamp uses a standard 22 W fluorescent circline bulb (the bulb is included!). Features of this great buy include a polished, distortion-free glass magnifier (X3); a 4-way, all metal clamp bracket; a full 45" reach. The lamp is available in two colors: Ivory or chocolate brown.

You must agree, it's a steal at only \$59.95 ea. (plus shipping). If you buy 5 or more, it's only \$54.95 (plus shipping). Order No. MX114.

Shipping is only \$5.00 ea. in the continental USA.

**SPECIAL BONUS!** If you buy one or more of the magnifier lamps, you can get our LTS103 bench lamp for only \$10.95 ea. (plus \$2.80 ea. shipping). The LTS103 is UL listed to 100 W, utilizes a porcelain socket, and includes mounting brackets.

**ORA**  
ELECTRONICS  
A DIVISION OF ALLIANCE RESEARCH CORPORATION

"OUR SERVICE MAKES THE DIFFERENCE"

18215 Parthenia Street, Northridge, CA 91325

To Order Call Toll Free  
**(800) 423-5336**

Calif. Toll Free  
**(800) 382-3663**

Local  
**(213) 701-5848**



QTY	ORDER NO.	COLOR	PRICE	SHIPPING	EXT
_____	85-MX114	_____	\$59.95*	\$5.00	_____
_____	85-LTS103	_____	10.95	2.80	_____
_____	85-MX115-FL	_____	5.95	2.00	_____
*Only \$54.95 for 5 or more				<b>TOTAL</b>	_____
Credit Card # _____		Exp. Date _____			
Name (Please print) _____					
Signature _____					

CIRCLE 37 ON FREE INFORMATION CARD

# ANNUAL INVENTORY REDUCTION... TEST INSTRUMENT SALE!

NOT SECONDS, NOT REBUILTS, NOT REJECTS—  
ALL ARE BRAND NEW-IN FACTORY CARTONS!  
HAVE NOT BEEN USED FOR DEMOS.

	LIST	SALE		LIST	SALE
HITACHI V-099 WAVE FORM MONITOR	\$1350.	\$ 468.	↳ SOLD OUT	SIMPSON 452 15 MHz SCOPE	\$ 919. \$ 827.
HITACHI V-089 VECTOR SCOPE	\$1684.	\$ 468.	↳ SOLD OUT	SIMPSON 454 15 MHz SCOPE	\$ 730. \$ 657.
HITACHI V-152F 15MHz SCOPE	\$ 595.	\$ 468.		SIMPSON 260-7 MM	\$ 119. \$ 103.
HITACHI V-1050F100MHz SCOPE	\$1980.	\$1589.		SIMPSON 260-7M MM	\$ 127. \$ 114.
HITACHI V-151F 15MHz SCOPE	\$ 495.	\$ 388.		SIMPSON 269-3 MM	\$ 218. \$ 196.
HITACHI V-202F 20MHz SCOPE	\$ 695.	\$ 546.		SIMPSON 360-2 DMM	\$ 375. \$ 337.
HITACHI V-650F 60MHz SCOPE	\$1195.	\$ 665.	↳ SOLD OUT	SIMPSON 463 DMM	\$ 210. \$ 174.
HITACHI V-302F 30MHz SCOPE	\$ 799.	\$ 665.		SIMPSON 461-2 DMM	\$ 204. \$ 174.
BECKMAN TECH300 DMM	\$ 120.	\$ 108.		SIMPSON 461-2R DMM	\$ 246. \$ 219.
BECKMAN HD-100 DMM	\$ 169.	\$ 152.		SIMPSON 464A-3 DMM	\$ 304. \$ 273.
BECKMAN TECH 310 DMM	\$ 145.	\$ 130.		SIMPSON 464D-3 DMM	\$ 355. \$ 319.
BECKMAN TECH 330 DMM	\$ 219.	\$ 197.		SIMPSON 460-5 DMM	\$ 397. \$ 357.
BECKMAN TECH 350 DMM	\$ 229.	\$ 206.		SIMPSON 467-E DMM	\$ 225. \$ 202.
BECKMAN TECH 360 DMM	\$ 289.	\$ 260.		BBC MA3E MM	\$ 179. \$ 161.
LEADER LBO-514A SCOPE	\$ 695.	\$ 589.		BBC MA1H MM	\$ 49. \$ 44.
LEADER LFG-1300S, FUNCTION GEN.	\$ 495.	\$ 419.		BBC MA2H MM	\$ 79. \$ 71.
LEADER LSG-17, SIGNAL GEN.	\$ 190.	\$ 160.		BBC M2011 DMM	\$ 119. \$ 107.
LEADER LAG-27 SINE/SQ. WAVE GEN.	\$ 205.	\$ 184.		BBC M2012 DMM	\$ 139. \$ 125.
LEADER LDC-823S FREQ. COUNTER	\$ 450.	\$ 405.		BBC MA5D DMM	\$ 595. \$ 535.
LEADER LDC-822 FREQ. COUNTER	\$ 320.	\$ 288.		BBC M2030 DMM	\$ 199. \$ 179.
LEADER LBO-524, 35 MHz SCOPE	\$ 995.	\$ 848.		BBC M2031 DMM	\$ 219. \$ 197.
VIZ WP-704A POWER SUPPLY	\$ 139.	\$ 115.		BBC M2032 DMM	\$ 259. \$ 233.
VIZ WP-702A POWER SUPPLY	\$ 184.	\$ 165.		A.W. SPERRY 315P, 15MHz SCOPE	\$ 800. \$ 720.
VIZ WP-708 POWER SUPPLY	\$ 499.	\$ 399.		A.W. SPERRY 620C, 20MHz SCOPE	\$ 785. \$ 706.
VIZ WE-130A SOUND LEVEL METER	\$ 179.	\$ 133.		A.W. SPERRY EZ-6110 DMM	\$ 168. \$ 89.88
VIZ WA-504B/44D AUDIO GENERATOR	\$ 184.	\$ 127.		A.W. SPERRY SP-10 MINI-METER	\$ 17.75 \$ 15.88
SIMPSON 7016 COUNTER TIMER	\$ 447.	\$ 183.	↳ SOLD OUT	A.W. SPERRY SP-15 MINI-METER	\$ 19.95 \$ 17.88
SIMPSON 7020 SCALER	\$ 506.	\$ 183.	↳ SOLD OUT	A.W. SPERRY SJ-25 MINI-PROBER	\$ 32.95 \$ 29.88
SIMPSON 420A FUNCTION GEN.	\$ 204.	\$ 183.			

ALL ITEMS CARRY FULL MANUFACTURERS  
WARRANTY PLUS ELECTRONICS WAREHOUSE  
FULL 45 DAY MONEY BACK GUARANTEE!

**SALE  
EXTENDED  
TO SEPT. 30<sup>TH</sup>  
1983!!**

**ELECTRONICS  
WAREHOUSE**

Halls Rd. - P.O. Box 624 - Old Lyme, CT 06371

TERMS: U.S. funds, Visa, Amex, MC, Money Order, Check (allow 2 weeks to clear). CT residents add 7 1/2% sales tax. Sale prices for prepaid orders only. Prices and availability of product subject to change without notice. Write for free catalog. C.O.D. orders cash or certified check add \$1.60. Shipping and handling charges add \$3.60 for orders under \$100., add \$7 for orders over \$100. (air freight extra).



TELEPHONE ORDERS FILLED  
FAST! ORDER DESK OPEN  
FROM 9 AM TO 5 PM E.S.T.  
CALL (203) 434-8308

its purpose is the exact opposite of the enhancement, but it operates only on low-amplitude signals. The result is the removal of much of the increased snow, but at the expense of some of the recovered detail. Even so, the overall quality of the picture will be much improved.

### Stabilizer

By now, most VCR owners know about the various anti-piracy schemes used by tape distributors, and the havoc even authorized copies can play with some older sets. The purpose of the stabilizer, then, is to eliminate the roll and jitter caused by those anti-piracy schemes. It is also useful in the dubbing

of home tapes because it reduces the chances of roll and breakup (due to drop-outs) during that process.

### Commerical alert

There are various schemes for automatically removing commercials from programs for taping. They all have one thing in common—the don't work very well. The ones that search for a color burst are fine for old black-and-white movies and shows, but are useless for color. The ones that search for a fade to black are fouled up by multiple commercials and by the fact that such fades are often found in the middle of movies.

The *IVE-100* gets around the problem

by not removing the commercials—instead it warns you about them. It searches for a fade-to-black, and when it finds one it emits a rather loud beep.

The feature is, of course, only useful for attended recording of programs as it does not actually remove the commercials. What it does is give you enough warning so that you can hit the pause button.

The manufacturer states that it is also possible to use the feature for recording one program while watching another, but to do that would require you to switch channels to the one being recorded to check for a commercial. If one were found, the tape would have to be rewound slightly, played up to the beginning of the first commercial, paused, and then taping restarted when the program resumed. Only then would you be able to return to the program you were watching.

The unit incorporates two additional features. An RF amplifier for connecting units with video outputs to your TV, and a distribution amplifier that allows three separate outputs without a loss in apparent picture quality.

### Installation and operation

Installing the unit is a snap; it should take no more than five minutes from box to use. Three installation diagrams, complete with clearly written descriptions, cover the most common setups.

Turning on the front panel, the unit is turned on and off, and the inputs and the functions are selected using a row of pushbutton switches located at the left. On the right are three controls that are used to adjust the enhancement, noise reduction, and the stabilizer circuit.

Operation is fairly straightforward; the only thing that is the least bit tricky is the setting of the enhancement level. That level is a matter of personal preference and you'll have to play around with the controls a bit until you are satisfied. The effect of all of the controls can be seen by simply switching a particular function in and out; that makes comparisons easy.

One thing that was a little annoying was the fact that once the unit was wired into a video system, it had to be turned on any time the system was used, even if none of the features were needed. A bypass provision would have been nice.

The instruction booklet was well written, clear, and certainly better than some we've seen for this type of equipment. Of course it still leaves a lot to be desired for those technically inclined (no schematics, etc.), but that is typical.

If you take your video seriously, and are in the market for a versatile accessory to upgrade the performance of your video system, the *IVE-100* deserves your attention. It is well made, as witnessed by the limited two-year warranty on parts and labor it carries, and works as claimed. The unit lists for \$229.00.

R-E

continued on page 38

# GOTCHA!

READING OUR **NEW** CATALOG!



**IT'S FREE! ORDER YOURS NOW.**

**Consolidated Electronics, Inc.**

**YOUR COMPLETE ELECTRONIC PARTS SOURCE!**

**CALL TOLL  
FREE TODAY!**



MOST ORDERS SHIPPED  
WITHIN 24 HOURS.

COMPARE OUR LOW PRICES  
AND SAVE!

**1-800-543-3568**

NATIONAL WATS

**1-800-762-3412**

OHIO WATS

705 WATERVLIET AVE., DAYTON, OHIO 45420  
IN DAYTON • (513) 252-5662

**TELEX NO. 288-229**

CIRCLE 18 ON FREE INFORMATION CARD





Three separate DC power supplies in one

Digital monitoring for voltage or current

Two built-in external digital voltmeters

Featuring current limiting—short circuit protection.

**Model WP-714 \$399.95**

# THE 40W TRIPLE SUPPLYST™

## Newest in the VIZ power supply family

### Power supply economy

Buy a WP-714 Supplyst and you actually get five pieces of equipment: three DC power supplies and two digital voltmeters. And you have the convenience of having all these functions in one compact instrument—at one attractive price, much lower than if you bought each piece of equipment separately.

### Power supply versatility

Here's power for a broad range of uses: circuit breadboarding, production testing, servicing, repair and educational applications. The WP-714 has two variable DC power supplies 0 to 20V at 0.75A and one fixed, remote sensing, 5V supply at 4A. The two variable supplies

may be connected in series to provide 0 to 40V at 0.75A. Built-in digital instruments make it possible to monitor voltage or current from either of the variable supplies. Separate inputs on the front panel provide for measuring two external voltages up to 99.9V—even while the unit is being used as a power supply. The WP-714 features fully adjustable current limiting as well as automatic short circuit shutdown (resettable) on the two variable supplies, and current fold back on the fixed supply.

### Power supply quality

The WP-714 is a laboratory quality, fully regulated source of DC power. You can set your desired voltage and current limits by convenient panel controls—

with instant pushbutton reset. Load regulation is 0.075% max. over the full range. Line regulation is 0.05% max. at full output voltage. Ripple is max. of 10 mV peak-to-peak. There is no overshoot at turn on, turn off or reset. All VIZ power supplies are U.S. made and are fully warranted, parts and labor, for a year. All units are tested to NBS Standards.

### Three other 40W Supplysts

Offering same quality, digital monitoring and measuring features.

WP-711. Single supply. 0-40V 0-1A. \$264.95

WP-712. Single supply. 0-20V 0-2A. \$277.50

WP-713. Dual supply. Two 0-20V 0-1A supplies (0-40V in series). \$349.95

## The 100W Supplyst Family



**WP-709 \$324.95**

- WP-705. Single supply. 0-50V 0-2A. \$315.95
- WP-706. Single supply. 0-25V 0-4A. \$329.95
- WP-707. Dual supply. Two 0-25V 0-2A supplies (C-50V in series). \$409.95
- WP-708. Triple supply. Two 0-20V 0-2A supplies (C-40V in series). One 5V 0-4A fixed supply. \$479.95
- WP-709. Dual slotted. 5/13V, 0-7.5A supply. \$324.95

## Other quality VIZ Power Supplies



**WP-702A \$167.00**

Fully regulated, continuously adjustable voltage outputs with short circuit protection. Analog meters.

WP-702A. Dual. Two 0-20V 0-200mA \$167.00

WP-703A. Single. 0-20V 0-500mA. \$119.00

WP-704A. Single. 0-40V 0-250mA. \$125.95

### VIZ RELIABILITY

VIZ is a 50 year-old company. Our instruments are fully warranted, parts and labor, for a year. All items tested to NBS standards. We offer service and parts availability for a minimum of ten years. Over 15 repair depots in U.S.A.

Want full technical details and a demonstration? Call toll-free, 1-800-523-3696, for the VIZ distributor near you.

# VIZ

**Look to VIZ for value, quality, availability.**  
**Over 70 instruments in the line—PLUS full accessories.**

VIZ Mfg. Co., 335 E. Price St., Philadelphia, PA 19144

CIRCLE 58 ON FREE INFORMATION CARD

[www.americanradiohistory.com](http://www.americanradiohistory.com)

**Learning  
electronics  
is no picnic.**

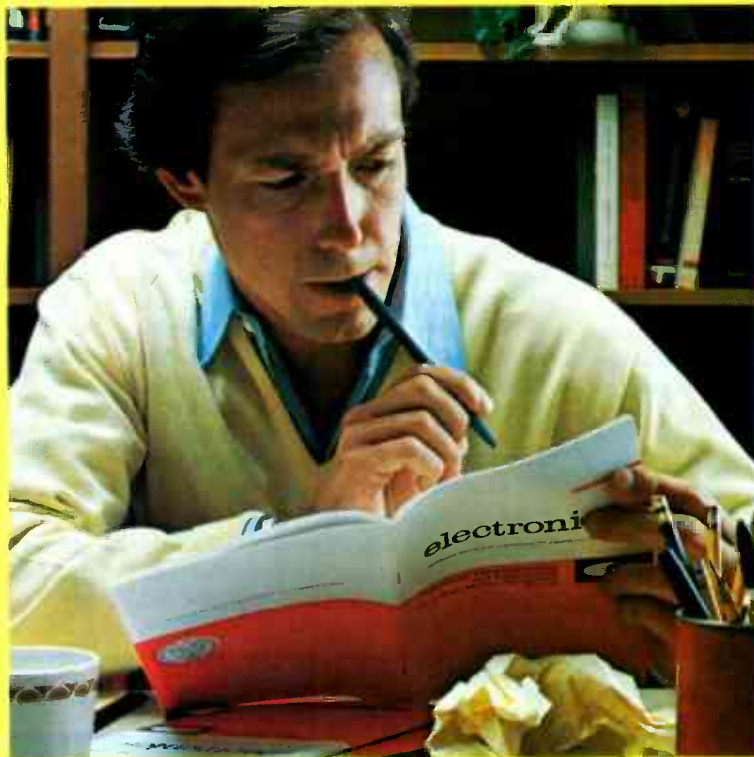

**At any level it  
takes work and  
a few sacrifices.  
But with CIE,  
it's worth it.**

Whoever said, "The best things in life are free," was writing a song, not living a life. Life is not just a bowl of cherries, and we all know it.

You fight for what you get. You get what you fight for. If you want a thorough, practical, working knowledge of electronics, come to CIE.

You can learn electronics at home by spending just 12 hard-working hours a week, two hours a day. Or, would you rather go bowling? Your success is up to you.

At CIE, you *earn* your diploma. It is not handed to you simply for putting in hours. But the hours you do put in will be on your schedule, not ours. You don't have to go to a classroom. The classroom comes to you.

### Why electronics training?

Today the world depends on technology. And the "brain" of technology is electronics. Every year, companies the world over are finding new ways to apply the wonders of electronics to control and program manufacturing, processing...even to create new leisure-time products and services. And the more electronics applications there are, the greater the need will be for trained technicians to keep sophisticated equipment finely tuned and operating efficiently. That means career opportunities in the eighties and beyond.

### Which CIE training fits you?

Beginner? Intermediate? Advanced? CIE home study courses are designed for ambitious people at all entry levels. People who may have:

1. No previous electronics knowledge, but do have an interest in it;
2. Some basic knowledge or experience in electronics;
3. In-depth working experience or prior training in electronics.

You can start where you fit and fit where you start, then go on from there to your Diploma, FCC License and career.

### Many people can be taught electronics.

There is no mystery to learning electronics. At CIE you simply start with what you know and build on it to develop the knowledge and techniques that make you a specialist. Thousands of CIE graduates have learned to master the simple principles of electronics and operate or maintain even the most sophisticated electronics equipment.

### CIE specializes exclusively in electronics.

Why CIE? CIE is the largest independent home study school that specializes exclusively in electronics. Nothing else. CIE has the electronics course that's right for you.

Learning electronics is a lot more than memorizing a laundry list of

facts about circuits and transistors. Electronics is interesting! It is based on recent developments in the industry. It's built on ideas. So, look for a program that starts with ideas and builds on them. Look to CIE.

### Programmed learning.

That's exactly what happens with CIE's Auto-Programmed® Lessons. Each lesson uses famous "programmed learning" methods to teach you important principles. You explore them, master them completely, before you start to apply them. You thoroughly understand each step before you go on to the next. You learn at your own pace.

And, beyond theory, some courses come fully equipped with electronics gear (the things you see in technical magazines) to actually let you perform hundreds of checking, testing, and analyzing projects.

### Experienced specialists work closely with you.

Even though you study at home, you are not alone! Each time you return a completed lesson, you can be sure it will be reviewed, graded and returned with appropriate instructional help. When you need additional individual help, you get it fast and in writing from the faculty technical specialist best qualified to

answer your question in terms you can understand.

### CIE prepares you for your FCC License.

For some jobs in electronics, you must have a Federal Communications Commission (FCC) License. For others, some employers tend to consider your license a mark in your favor. Either way, your license is government-certified proof of your knowledge and skills. It sets you apart from the crowd.

More than half of CIE's courses prepare you to pass the government-administered exam. In continuing surveys, nearly 4 out of 5 graduates who take the exam get their licenses! You can be among the winners.

### Associate Degree

Now, CIE offers an Associate in Applied Science Degree in Electronics Engineering Technology. In fact, all or most of every CIE Career Course is directly creditable towards the Associate Degree.

### Today is the day. Send now.

Fill in and return the postage-free card attached. If some other ambitious person has removed it, cut out and mail the coupon. You'll get a FREE school catalog plus complete information on independent home study. For your convenience, we'll try to have a CIE representative contact you to answer any questions you may have.

Mail the card or the coupon or write CIE (mentioning name and date of this magazine) at: 1776 East 17th Street, Cleveland, Ohio 44114.



Pattern shown on oscilloscope screen is simulated.

## CIE Cleveland Institute of Electronics, Inc.

1776 East 17th Street, Cleveland, Ohio 44114  
Accredited Member National Home Study Council

**YES...** I want to learn from the specialists in electronics — CIE. Send me my FREE CIE school catalog...including details about the Associate Degree program...plus my FREE package of home study information.

Print Name \_\_\_\_\_

Address \_\_\_\_\_ Apt. \_\_\_\_\_

City \_\_\_\_\_

State \_\_\_\_\_ Zip \_\_\_\_\_

Age \_\_\_\_\_ Phone (area code) \_\_\_\_\_

Check box for G.I. Bill bulletin on Educational Benefits:  Veteran  Active Duty

**MAIL TODAY!**

# EQUIPMENT REPORTS

continued from page 32

## Tektronix Model 212 Dual-Trace Oscilloscope



CIRCLE 105 ON FREE INFORMATION CARD

Tektronix 212 Oscilloscope		1	2	3	4	5	6	7	8	9	10
OVERALL PRICE											
EASE OF USE											
INSTRUCTION MANUAL											
PRICE/VALUE											
		1	2	3	4	5	6	7	8	9	10
		Poor	Fair	Good	Excellent						

IT WASN'T TOO LONG AGO THAT OSCILLOSCOPES were huge and heavy, and they

doubled as the primary source of heat for the test-bench area. But nothing will make you forget those days faster than the model 212 oscilloscope will. That dual-trace scope from Tektronix (PO Box 500, Beaverton, OR 97077) measures approximately 3 × 5¼ × 9 inches—so you might even be tempted to call it a pocket oscilloscope (especially if you're wearing a bulky winter coat). The lack of air vents alone indicates that the 212 is a cool-running unit. Let's take a look at the features that Tektronix managed to fit in such a small package.

The CRT screen, as you might expect, is rather small (approximately 1¼ × 2 inches). But even so, it dominates the front panel of the scope. It's graticule is an internal 6 × 10 division grid. It is not illuminated; we presume that's to ensure as long a life as possible from the 10 internal, rechargeable, nickel-cadmium "A" cells.

Those batteries can run the scope for 3–5 hours on a full charge (even longer if maximum trace intensity is not used). While they are meant to be the primary power source for scope operation, the 212 can also be operated from line voltages between 104 and 126 volts. (However, when the unit is operated below 110 volts, the internal batteries will be slowly discharged.)

The 212 incorporates an internal battery charger, but the scope must be turned

off for it to work.

A protection circuit in the scope protects against excessive discharge. The scope automatically shuts down if the battery charge drops below 10 volts. A front-panel LED labeled POWER, that normally lights whenever the scope is turned on, will not light when there is less than 10 minutes of scope-operating time left in the batteries.

### Controls

All of the operating controls are located on the side panel of the scope. But that's not an entirely fair statement. The two VOLTS/DIV controls, though located on the side panel, are read from the front panel. And the SEC/DIV, while located on the side, near the rear, can be read reasonably conveniently by viewing the scope from a slight angle. All the other controls are in a recess on the side. Until you become familiar with them, you pretty much have to turn the scope 90° so that you can read the labels.

The POWER switch is particularly hard to find without turning the scope to look for it. It is a slide switch that is located at the center of 4 larger rotary switches. That's not really a disadvantage, though. The 4 rotary controls "protect" the POWER switch from being turned on accidentally. That's especially important for portable battery operation, and shows that Tektronix gave its panel layout a little

## FIRST QUALITY COMPONENTS — NOT MAIL ORDER "SECONDS"

Send for Free Catalog — over 1100 parts.

### ARIES ZERO INSERTION FORCE SOCKETS



cam actuated, true zero insertion—tin plated solder tail pins—capable of being plugged into dip sockets, including wire wrap.

Stock No.	No. of Pins	1-9	10-49	50
11055	24	4.98	\$4.35	\$3.90
11056	28	5.15	4.50	4.05
11057	40	6.81	5.95	5.35
11058	64	12.02	10.50	9.45

**IC-KOOLERS<sup>®</sup>** from UNITRACK<sup>®</sup> dissipate over 2 watts of heat from IC's producing longer life and better performance. Just push IC-Kooler on heat is collected from top and bottom of IC and dissipated. Won't shake loose!



### WILD ROVER

Touch switch capsule. Operating motion is .005" without the use of a levered arm. Extremely fast on and off with low noise. Normally open, rated 115 VAC, 1.6 amp, 30 milliohm resistance—615 radius by .160 thick.

Stock No.	1-9	10 & Up
12098	\$1.42	\$1.28

**DIGITAL MULTIMETER** Single rotary switch operation. Large, easy to read 5 1/2 digit display. 800 hours operating life with single 9v battery. Seven functions—(DC Volts, DC Amps, Ohms, AC Volts, AC Amps, Diode and Resistor Junction, Audible Continuity Check).

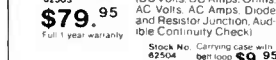

**60/40 ROSIN CORE SOLDER**

Stock No.	Dia. (inches)	Length (feet)	Weight (oz)	Price
50075	062	9	1.5	\$1.16
50076	062	25	4	2.39
50077	062	50	8	4.25
50078	032	33	1.5	1.31
50079	032	88.5	4	2.47
50080	032	175	8	4.57

### TI WIRE WRAP SOCKETS



Tin plated phosphor bronze contact—3 wrap.

Stock No.	No. of Pins	1-99	100-499	500
11301	8	\$4.00	\$3.36	\$3.30
11302	14	.59	.54	.45
11303	16	.64	.58	.48
11304	18	.73	.66	.55
11305	20	.99	.90	.75
11306	22	1.12	1.02	.85
11307	24	1.25	1.14	.95
11308	28	1.52	1.38	1.15
11309	40	2.05	1.86	1.55

### TI LOW PROFILE SOCKETS



Tin plated copper alloy. 688 contact pins with gas tight seal.

Stock No.	No. of Pins	1-24	25-99	100-999
11201	8	\$1.0	\$0.9	\$0.8
11202	14	.14	.13	.12
11203	16	.16	.15	.14
11204	18	.18	.17	.15
11205	20	.20	.18	.16
11206	22	.22	.20	.18
11207	24	.24	.22	.20
11208	28	.28	.25	.25
11209	40	.40	.37	.33

### ELPAC POWER SUPPLIES — DC/DC CONVERTERS



SINTEC Stock No.	ELPAC Part No.	Input Voltage (VDC)	Output Voltage (VDC)	Output Current (mA)	Dimensions (HxWxD) in inches	Price
13825	CB3801 3.0-7.0	12±0.6	0-25	48x51x3.05	\$5.95	
13826	CB381 3.0-7.0	12±0.6	0-25	48x51x3.05	7.95	
13827	CB3802 3.0-7.0	15±0.7	0-20	48x51x3.05	7.95	
13828	CB3812 3.0-7.0	15±0.7	0-20	48x51x3.05	7.95	
13829	CB3804 3.0-7.0	28±1.4	0-10	48x51x3.05	7.95	
13830	CB3814 3.0-7.0	28±1.4	0-10	48x51x3.05	7.95	
1.5 W TYPE:						
13831	CL3801 4.0-7.0	12±0.6	125	65x11.2x1.77	\$24.95	
13832	CL381 4.0-7.0	12±0.6	125	65x11.2x1.77	24.95	
13833	CL3802 4.0-7.0	15±0.7	100	65x11.2x1.77	24.95	
13834	CL3812 4.0-7.0	15±0.7	100	65x11.2x1.77	24.95	
13835	CL3804 4.0-7.0	28±1.4	50	65x11.2x1.77	24.95	
13836	CL3814 4.0-7.0	28±1.4	50	65x11.2x1.77	24.95	
13825-1	DATA SHEET FOR DC/DC CONVERTERS					.25

Stock No. 13801 — "Floppy Disc" Power Supply For Winchester Drives \$109.00  
13801-1 Data Sheet for 13801... 25

### Special of the Month!

**USE YOUR OFFICE COPIER TO MAKE YOUR FORMS! SAVE TIME • WORK • MONEY**

Stock No.

- 23001 Make your own graph & chart paper
- 23002 Make your own data & column sheets
- 23003 Make your own memo & office forms

**ONLY \$7.50 each**

### MODTEC

**Miniclamp AC Volt-Ammeter** allows singling one conductor out of many without disarrangement.  
Stock No. AC Amperes Price  
13730 0-25A \$39.50  
13731 0-50A 39.50  
13732 0-100A 39.50

**ACCESSORY LINE SPLITTER** allows fast readings of AC power consumption of plug in equipment without separation of leads.  
Stock No. 13727 **\$9.95**

**POCKET SIZED BATTERY TESTER** for all types of small batteries from 1.35v to 4.5v.  
Stock No. 13733 **\$13.95**

**VOLT-I-CATOR** automotive diagnostic meter plugs into lighter socket and indicates battery condition and charging rates.  
Stock No. 13736 **\$15.95**

**AC VOLTAGE TESTER** plugs into any 110v service receptacle to check line voltage over 50-150 VAC.  
Stock No. 13735 **\$14.95**

**VOM-MULTIESTER** versatile Volt-Ohm-Milliammeter in small package.  
Stock No. 13729 **\$13.95**

### ELPAC POWER SUPPLIES — SOLV SERIES FULLY REGULATED

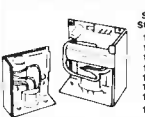

SINTEC Stock No.	ELPAC Part No.	Output Voltage (VDC)	Output Current Rating (mA)	Dimensions (HxWxD) in inches	OVP	Price	
13802	SOLV15-5	5	3.0A	4-7/16x4-1/2	Fixed included	\$39.95	
13803	SOLV15-12	12	1.5A	4-7/16x4-1/2	Fixed included	39.95	
13804	SOLV15-15	15	1.2A	4-7/16x4-1/2	Fixed included	39.95	
13805	SOLV15-24	24	0.75A	4-7/16x4-1/2	Fixed included	39.95	
13806	SOLV30-5	5	6.0A	5-5/8x4-7/8x3-1/16	OVP-4	59.95	
13807	SOLV30-12	12	4.0A	5-5/8x4-7/8x3-1/16	OVP-4	59.95	
13810	SOLV30-15	15	3.3A	5-5/8x4-7/8x3-1/16	OVP-4	59.95	
13812	SOLV30-24	24	2.0A	5-5/8x4-7/8x3-1/16	OVP-4	59.95	
13802-1	Data Sheet for SOLV Series						.25

### PIN FORMING TOOL

puts IC's on their true row to row spacing. One side is for 300 centers. Flip tool over for devices on 600 centers. Put device in tool and squeeze.  
NEW! Stock No. 10200 \$14.95 (ANTI-STATIC MODEL)  
ONE TOOL DOES 8 thru 40 PINS! Stock No. 11059 \$12.95

**OK MACHINE AND TOOL**

**IC INSERTION/EXTRACTION KIT**  
Includes DIP, IC extractors and inserters to accommodate all IC's from 14 to 40 pins. Tools that engage conductive surfaces are CMOS safe and include ground and logic. Stock No. 13309 **\$37.74**

**SOCKET WRAP ID**  
DIP socket-sized plastic panels with numbered holes in pin locations. Slip onto socket before wire wrapping to identify pins. Also write on them for location. Kit part number function etc. Simplifies initial wire wrapping. Trouble-shooting and repair.  
\$1.82 per pack

**IC EXTRACTOR**  
One-piece, spring steel construction. Will extract all LSI, MSI and SSI devices with 8 to 24 pins.  
Stock No. 13313 **\$2.10**

**VOM-MULTIESTER**  
versatile Volt-Ohm-Milliammeter in small package.  
Stock No. 13729 **\$13.95**

CIRCLE 82 ON FREE INFORMATION CARD [www.americanradiohistory.com](http://www.americanradiohistory.com)

Is something wrong in your home?  
You can listen from any phone in the world.

# The SENSAPHONE Protects Your Home Whether You're There Or Not— And You Can Listen to What's Going On When You're Away!

## New! From Gulf & Western

Connect the Sensaphone to your telephone and at once you have an alarm system, an environmental monitor, an ear that lets you listen to "live" sounds in your home or office, and an automatic dialer that dials any of eight pre-set numbers when you push one digit. Read on:

### Sophisticated Alarm System

Your Sensaphone system never sleeps. If power fails, if the temperature rises beyond the pre-set limit or falls below the pre-set minimum, if an unusual sound occurs, or if any of three other conditions of your choosing develop, this remarkable system will dial automatically, and in sequence until someone answers, you, a neighbor, the fire department, the police, or whatever group of numbers you've entered. Your Sensaphone won't quit calling until someone answers or you turn it off.

### "Call-In" Monitor

If you're away from home and are worried about the kids or about break-ins, call home from any phone. Your Sensaphone will report to you (privately, because your call will include a private code) on the monitored conditions. Then you can listen to the room sounds for yourself.

You can install a Sensaphone in your office too. At night, if you're driving by and see a light, call your Sensaphone. You'll quickly learn whether it's the cleaning service or an unwelcome intruder.

### Automatic Dialer

Enter the eight numbers you call most frequently. Then, when you want to call one of those numbers (up to 16 digits each), press just one dial-key and your Sensaphone will call the whole number for you.

Your Sensaphone won't lose its memory if the power fails, because a battery backup protects it. What's more, the Sensaphone will call the preprogrammed numbers to warn that the power is off and it'll also warn you if the battery power is low.

- A product of Gulf & Western, made in U.S.A.
- Occupies only 7¼" x 8½" of space.
- Connects to your phone in 10 seconds.
- "Standby" mode remembers information but prevents function.

#### SPECIAL PRE-HOLIDAY ALLOTMENT!

The Sensaphone wasn't supposed to be available until 1984. New Horizons has moved up the delivery date, so we can ship your Sensaphone immediately, unless the demand is even greater than we expect.

#### A special note:

As an executive gift for someone "who has everything" - consider the Sensaphone. We guarantee, it's a gift he or she will use and appreciate for years to come!

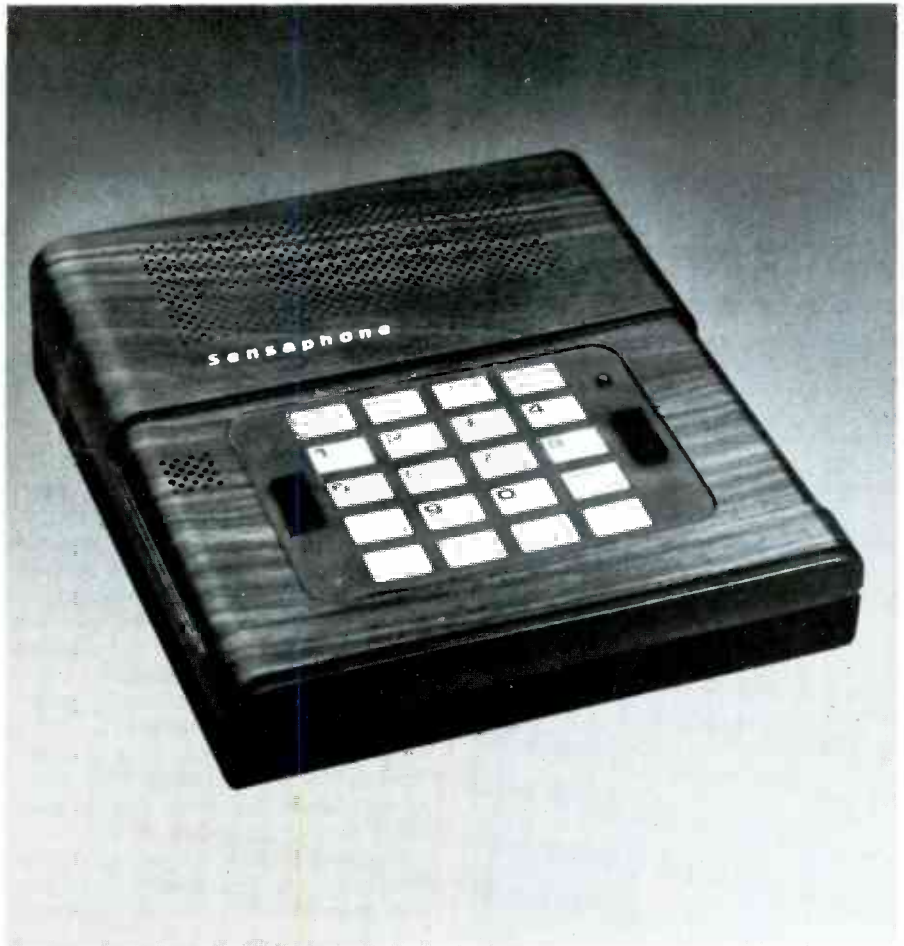

## WE ABSOLUTELY GUARANTEE!

Plug your home or office phone (or both) into the Sensaphone. Use it for up to 30 days. If you decide for any reason you don't want to keep it, return it for a 100% refund.

The Sensaphone is  
another electronic marvel from

# NEW HORIZONS

Dept. RE-9, 5-31 50th Avenue  
Long Island City, NY 11101

THE SENSAPHONE \$249.95  
(two for \$229.95 each)  
add \$3.50 per total order for shipping

Order TOLL-FREE  
For fast delivery on credit card orders,  
call toll-free 24 hours a day, 7 days a week:

## 800-443-0100

Ask for Ext. 111

Or send check or money order.  
Please add \$3.50 per total order for shipping.

# The "OUT FRONT" DMM



## HICKOK'S LX-306 PIED PIPER with exclusive Vari-Pitch®

... combines the best of DMM's, analog meters, logic probes, tracers and continuity testers into one compact unit. The LX-306 offers 0.25% accuracy and all functions and ranges featured by other leading DMMs; PLUS, VARI-PITCH, the audible DMM tone system that obsoletes all others.

VARI-PITCH changes tone proportionate to the signal input. Its usage is limited only by your imagination. Imagine:

- Troubleshooting by character or "signature" sound.
- Detecting ripple or noise on the power supply line.
- Quickly locating intermittents.
- Locating and testing capacitors in a circuit.
- Making analog-type peaking and nulling adjustments.
- Reducing troubleshooting time by 25% or more.

The LX-306 is the ideal DMM for tough jobs and busy schedules. Built to fit your hand and your budget!

LIST PRICE ~~\$155.00~~

LIMITED TIME OFFER \$139.00

See your Hickok distributor, or contact:

**HICKOK**  
the value innovator

THE HICKOK ELECTRICAL INSTRUMENT CO.  
10514 Dupont Avenue • Cleveland, Ohio 44108  
(216) 541-8060 • TWX: 810-421-8286

bit of thought.

Other controls include an INPUT COUPLING switch for each channel (AC, GND, and DC); a POSITION control for each channel (with a click-stop OFF position), and a variable VOLTS/DIV control for each channel (with a click-stop CAL position).

A three-position TRIG SOURCE slide switch is used to choose the appropriate trigger signal source. In the EXTERNAL mode, the sweep is triggered from the signal applied to the EXT TRIG banana jack. In the COMP position the sweep is triggered from a sample of the vertical deflection signal after the vertical switching, while in the CH-2 position the sweep is triggered from a sample of the vertical deflection signal before the vertical switching and only from Channel 2.

There are also seven screwdriver adjustments. They can be used to balance the vertical-amplifier system (for minimum trace shifts when the deflection multiplier is changed); to set the gain of the vertical-amplifier system; to set the trigger point for automatic trigger operation; to focus the display; to calibrate the horizontal gain and to calibrate the horizontal sweep timing.

You might have noticed that we never mentioned the probe-input jacks. That's because there are none. Two probes are included, but they are hard-wired to the scope. They are neatly stored at the rear of the cabinet, as is the power cord.

### Using the scope

Until you get used to the side-panel layout, the 2/2 can be a chore to use. However, to be fair, the 2/2 is meant to be portable and its side-panel controls help to keep its size to a minimum.

The oscilloscope that we received came with both an operator's manual and a service manual. The operator's manual is a 37-page, shirt-pocket-sized booklet. Amazingly enough, however, it does a creditable job in describing the fundamentals of using the scope. The service manual fills in the details that the operator's manual leaves out. It includes a description of the scope as well as sections on preventive maintenance, calibration, troubleshooting, circuit description, and corrective maintenance. Lists of all parts, both electrical and mechanical, are included as are schematics, circuit-board photos, and exploded drawings.

Tektronix's 2/2 is a great portable oscilloscope. But we would not recommend using this scope for a bench-top unit (although we are sure that some people will try). Because of its small CRT, it can be tiring to use. And its \$1775 price is certainly not cheap for a scope with its bandwidth. (When the input is DC coupled, the bandwidth is at best DC to 500 kHz. That decreases to 100 kHz when the vertical sensitivity is increased to 1mV/division.) But if you're in the field and in need of a dual-trace scope, then it's hard to find fault with this unit.

R-E

## INTRODUCING

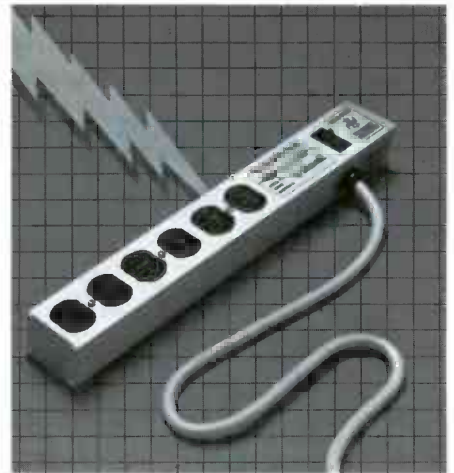

# THE PROTECTOR 6000™

### TOTAL PROTECTION FOR YOUR SENSITIVE ELECTRONIC EQUIPMENT.

Something that you can't even see may be slowly but surely killing your expensive electronic equipment. It's transient voltage, and it can be fatal to computers, medical equipment, electronic games, videotape recorders, electronic test equipment, electronic cash registers — almost any of today's sophisticated solid state equipment.

### THE TRANSIENT VOLTAGE PROBLEM.

Most of this modern electronic equipment uses LSI and MOS semiconductor devices which are extremely sensitive to voltage transient surges or "glitches." In fact, a large percentage of equipment failures can be directly linked to the damaging effects of over-voltage line transients to unprotected, highly fragile components.

### THE PROTECTOR 6000™ SOLUTION.

Not to be confused with other transient voltage protection units available today, THE PROTECTOR 6000 uses state-of-the-art solid state components and exclusive circuitry to provide you with complete and total protection from transient voltage surges of up to 6,000 volts. THE PROTECTOR 6000 uses silicon PN junction devices — proven to provide the fastest response to surges! They have a statistical life expectancy of over 20 years. THE PROTECTOR 6000 has a maximum clamping voltage of only 335 volts, well below the voltage rating of other transient protection devices which commonly use much less effective MOV's or gas discharge tubes. It also provides full protection from electro-magnetic and radio frequency interference. The unit operates in both common and differential modes, and is outfitted with a circuit breaker to guard against severe current overloads over 15 amps.

Why take chances with your expensive electronic equipment? For full details contact your local NTE distributor or write:



NEW-TONE ELECTRONICS, INC.  
44 Farrand St., Bloomfield, NJ 07003

THE PEOPLE WHO BRING YOU THE TCG LINE OF SEMICONDUCTORS.

© 1983 New-Tone Electronics, Inc.

# VARIABLE MICROWAVE DOWN CONVERTER



**THIS IS NOT A KIT!!**



### QUANTITY DISCOUNT

1.....	79.95
10.....	74.95
25.....	69.95
50.....	64.95
100.....	59.95

All down converters built with New **HOT** Transistor for more amplifier gain.  
**GREATER DISTANCE**

**NEW**—Power supply built with push button simplicity  
**ABC** Switch built in

★ Coax cable not included

PLEASE ADD SUFFICIENT POSTAGE

1 Unit weighs 5 lbs.

To order by Visa or Master Charge  
No C.O.D. orders

**Call 800-428-3500**  
Information 317-291-7262  
6254 La Pas Trail  
Indianapolis, Indiana 46268

## ELECTRONIC RAINBOW INC

CIRCLE 64 ON FREE INFORMATION CARD



**ONLY FROM ELECTRONIC RAINBOW**

**\$485<sup>00</sup>**

## LIQUID CRYSTAL 1 GHz FREQUENCY COUNTER

- ★ .75" 9 Digit L.C.D. Display
- ★ 24 Hr Clock Wr.-Min.-Sec.
- ★ 10 Min. Timer with warning tone
- ★ Low-Low sensitivity less than 15 Mv from 10 Hz to 1 GHz
- ★ 4 Gate Times .5, 5., 1., 10. Sec.
- ★ Resolution: .1 Hz to 20 MHz 10Hz to 1 GHz

- ★ Time Base: .1 PPM TCXO Standard (10 MHz Crystal)
- ★ Push Button simplicity
- ★ Liquid Crystal Easy to read in direct sunlight
- ★ Size 11¼" W x 4" H x 8¼" D

### OPTIONS:

- ★ Internal battery source available
- ★ .01 Crystal oven timebase available

100% Parts and Labor guarantee for 1 year

To order by Visa or Master Charge  
No C.O.D. orders

**Call 800-428-3500**  
Information 317-291-7262  
6254 La Pas Trail  
Indianapolis, Indiana 46268

**DEALER INQUIRIES INVITED**

## ELECTRONIC RAINBOW INC

CIRCLE 64 ON FREE INFORMATION CARD

# The Smarter Thinking Cap™



Now — a smarter way to measure capacitance!  
Global Specialties' New

## 3002 AUTORANGING CAPACITANCE METER

Use the Thinking Cap™ to determine true capacitance in cable, switches, components, hardware and naturally, capacitors. From 1 pF to 19,990 μF, the 3002 provides highly accurate, uncomplicated capacitance measurement.

In the lab or in the field . . . for quality control, production, inspection, design, or systems installations . . . You can rely on the Thinking Cap™. And THINK about this — at only \$210 the 3002 is a SMART buy! Grab the telephone and call us TOLL FREE to find out how to get your Thinking Cap™ today!

- Handheld, battery-operated
- Measures capacitance from 1 pF to 19,990 μF
- 8 automatically selected ranges
- Typical 0.2% accuracy
- 3½ digit, 0.5 inch LCD display
- LED range indicators

### SPECIFICATIONS

<b>Ranges:</b>	8 automatically selected ranges from 1999 pF to 19.99 mF (full scale)
<b>Resolution:</b>	1 pF in lowest range, 0.05% of full scale on all other ranges
<b>Accuracy:</b>	0.2% of reading ± 1 count ± 1 pF from 1 pF to 199.9 μF; 1.0% of reading ± 1 count from 200.0 μF to 19.99 mF
<b>Display:</b>	3½ digit, 0.5 inch LCD, low battery (LOBAT), over compensation indication (—), and 4 LEDs to indicate pF, nF, μF, and mF
<b>Reading Update Time:</b>	350 ms to 19.99 μF, 200 ms to 1.25 s from 20 μF to 20 mF
<b>Controls:</b>	POWER (ON/OFF) switch, ZERO calibration adjustment to null out stray capacitance up to 100 pF
<b>Test Technique:</b>	Measures ΔT/ΔV (Dual Threshold slope integration)
<b>Power:</b>	6 AA Alkaline or Nicad batteries or optional AC Adapter/Charger, 16 hours continuous use
<b>Dimensions:</b>	(LxWxH) 7.6x3.75x1.72 inches (193x95x44mm)
<b>Weight:</b>	12 oz. (340 grams) without batteries



## GLOBAL SPECIALTIES CORPORATION

70 Fulton Terr., New Haven, CT 06509 (203) 624-3103 TWX 710-465-1227

### OTHER OFFICES:

San Francisco (415) 648-0611, TWX 910-372-7992,

Europe: Phone Saffron-Walden 0799-21682, TLX 851-817477

Call toll free for details 1-800-243-6077 during business hours

CIRCLE 31 ON FREE INFORMATION CARD



# BUILD THIS

ONE OF THE FIELDS THAT HAS BENEFITED MOST FROM THE revolution in digital electronics is electronic music. That's because the relationships between notes can be expressed mathematically, making music the perfect candidate for digital logic. These days, the use of electronically generated music is limited only by imagination and the demands of the marketplace, and common applications include everything from doorbells to watches.

Anyone who has dabbled in electronics knows that there are an infinite number of sounds that can be produced electronically. Unfortunately, the majority of them are the squeals and yowls of wayward circuitry. Producing music electronically means being able to control not only what sounds you produce, but the order in which you produce them. This project, the Pianomatic, is a good beginning for anyone who is interested in designing control circuitry for electronically generated music. The unit has a keyboard that will play a full

## mini player-piano

*Build the Pianomatic and make beautiful music—electronically.*

ROBERT GROESLATT



octave, and a memory section that will remember as many as four tunes even when it is turned off. The notes are entered into the memory from the keyboard and either a half or full rest between notes can be programmed.

Although a full-blown electronic piano has a much wider range of notes and features, the principles used by the Pianomatic are exactly the same. Once you understand how it works, we'll show you how it can be expanded to provide as many features as you want. The keyboard can be extended to cover a range of several octaves and much more attention can be focussed on refining the sound. But we're getting ahead of ourselves. Let's first look at Fig. 1, a block diagram of the device. Then, we'll examine each section in detail.

### An overview

The keyboard encoder translates the pressing of each key into a unique binary four-bit word. At the same time, it generates an "any key pressed" signal that the Pianomatic uses to increment its counters and to control several of its automatic functions. If we're writing a tune into memory, that signal is also used to generate the "write" pulse.

The memory of the Pianomatic can be organized into either two or four pages at the throw of a switch. That means you have the choice of programming either two longer tunes or four shorter ones. Addressing is controlled by the note counter and the tune selector.

What we mean by "paging" is that some of the address lines are used to select which part of the memory is going to be accessed. That technique of memory management is frequently used whenever lots of information is stored in system memory—the more extensive the memory, the more useful the technique. Let's suppose, for example, that you had a system that used an address bus that was ten bits wide. That would mean you could address 1K words of memory ( $2^{10} = 1024 = 1K$ ). (A word is a group of bits that are considered as a whole. In a personal computer, for example, a word might be 8 or 16 bits long, depending on the machine.) If you wanted to organize that memory into two pages, you would have to break the memory down and think of it as being made of two parts, each being a page that was 512 words long. The most significant address line would then be used to select the page of memory you wanted to access. That system is shown in Fig. 2. In that example, address line A9 is switched between +V and ground, and is used to select the page of memory that will be accessed. Address lines A0 to A8 are used to select a memory location on that page. Once the memory location is selected, the data is stored.

The data bus of the Pianomatic is four bits wide, so we can select 16 separate four bit words ( $2^4 = 16$ ). Thirteen of

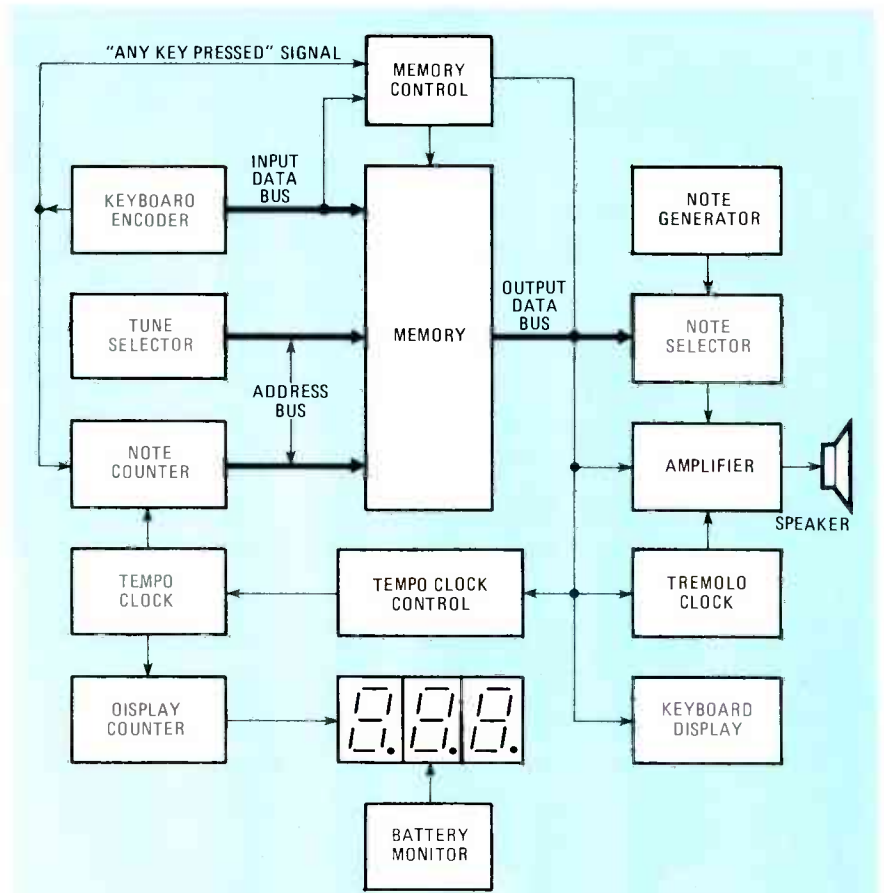

FIG. 1—THIS BLOCK DIAGRAM shows how the various functions of the Pianomatic are interrelated.

those are used for individual note selection, one is for a full rest, and the remaining two words are decoded by the tempo clock control to, logically enough, control the tempo clock during playback from memory. One of the two words causes the tempo clock to speed up and create a half rest and the other disables the clock at the end of a tune.

The tempo clock increments both the note counter and the display counter. The former addresses the memory and the latter controls a three-digit display that allows you to easily keep track of which note is being played.

The note generator is composed of two parts—an oscillator, and a top-octave generator, shown in Fig. 3; that IC performs the frequency division necessary to produce thirteen notes of the equally tempered scale. Each note is related to the others by some multiple of  $12\sqrt{2}$ . In other words, since the frequency of a middle A is 440 Hz, an A-sharp would be  $440 \times 12\sqrt{2}$ , or about 466 Hz.

The outputs of the top-octave generator are connected to the note selector—a one-of-sixteen analog switch that is controlled by the output data bus. Once the note is selected, it is passed on to the amplifier and speaker; the sound is given a bit of coloring by having the tremolo clock rapidly vary the gain of the amplifier.

Each key on the keyboard has a small LED in it, and whenever a note is played the corresponding LED lights up. That

makes it easy to keep track of which note is being played and provides a bit of visual appeal when you are playing a tune back from memory.

As you can see by now, the organization and operation of the Pianomatic are logical and straightforward. When you're writing a tune into memory, a key is pressed and the corresponding word is latched onto the data bus. The "any-key-pressed" signal generates a write pulse

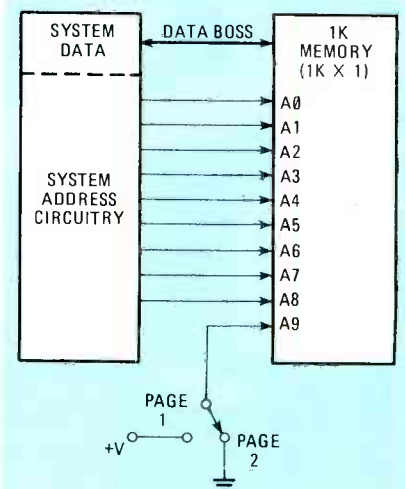

FIG. 2—HOW A 1K MEMORY can be organized into two pages, each 512 words long. In this simplified circuit, the most-significant-address line is switched to choose between two pages of memory.

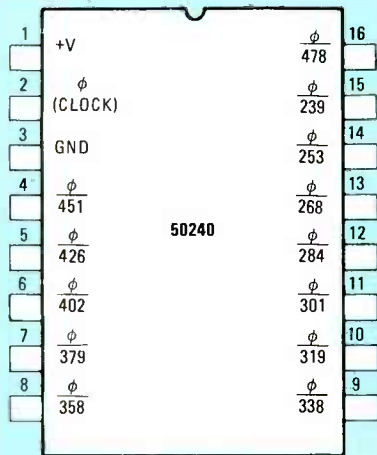

FIG. 3—PINOUT OF THE 50240 top-octave generator. Although the specifications for that IC call for a supply voltage of between 11 and 16 volts, the device will operate reliably at the Pianomatic's 7.3 volts.

and the note is written into memory. It appears on the output data bus and the note selector connects the chosen note to the amplifier. When you release the key, the keyboard encoder starts scanning again and the note counter is automatically incremented by one. In playback, the note counter is advanced by the tempo clock and addresses the memory. The stored binary information is sequentially put on the output data bus and the note selector connects the note to the amplifier.

Let's next look at each of the sections in detail and see how they work. The schematic diagram for the Pianomatic is shown in Fig. 4. You'll probably want to refer to it now and then as we discuss the various sections.

### Keyboard encoder

The keyboard encoder is of the scanning type and is made up of a clock (IC14-c), a binary counter (IC2-a), and a one-of-sixteen data selector (IC1). The keyboard itself is a series of normally-open, momentary SPST switches connected to the outputs of the data selector. As long as no key is pressed, the clock is enabled and causes the binary counter to count at about 1.5 kHz. That makes the outputs of the data selector go high in sequence. When a switch is closed, nothing happens immediately because the unselected outputs of the data selector, IC1, are low. When the binary counter causes the chosen output to go high, D11 is forward biased and disables the clock input of the counter. The same signal is inverted by IC15-c and disables the clock. The effect of all that activity is to stop the scanning dead in its tracks and latch a binary word on the input data bus corresponding to whichever switch was closed. Diode D9 is also forward biased and increments both IC3, a 4040 binary ripple counter that serves as our note counter, and IC12, a 4553 three-digit counter that is our dis-

play counter. The inverted version of the "any-key-pressed" signal, available at the output of IC15-c and through C12, is used to generate the "write" pulse for the RAM IC, IC4. Since keyboard switches S9-S24 are mechanical, R8 and C10 are used to debounce them.

Pin 23 of IC1 is the inhibit input of that device and it gives us a simple way of disabling the entire keyboard. If we make that pin positive, we force all the outputs to remain at ground, so closing a switch on the keyboard will have no effect on the rest of the keyboard encoder. That's handy because there are times when we don't need or want the keyboard to be working. If we're playing a tune back from memory, for example, there's no need for the keyboard to be operating. If it were, and you pressed a key during playback, a write pulse would be generated causing a glitch in the memory.

### PARTS LIST

#### All resistors ¼ watt, 5%, unless otherwise noted

R1, R7, R10, R17—8200 ohms  
R2—6800 ohms  
R3, R8, R29—1 megohm  
R4, R38—10,000 ohms  
R5—3000 ohms  
R6, R12, R30—1000 ohms  
R9—150,000 ohms  
R11, R15—100,000 ohms  
R13—470 ohms  
R14, R19—R28, R36, R40—160 ohms  
R16—1500 ohms  
R18—82,000 ohms  
R31—22,000 ohms  
R32, R33—560,000 ohms  
R34—390 ohms, ½ watt  
R35—15,000 ohms  
R37, R39—2200 ohms  
R41—500,000 ohms, multi-turn potentiometer, PC mount

#### Capacitors

C1, C4, C6, C8, C9, C13, C15, C18, C20, C23, C28—0.47 µF, 35 volts, tantalum  
C2—0.5 µF, ceramic disc  
C3, C22—100 pF, ceramic disc  
C5, C16—0.22 µF, 35 volts, tantalum  
C7, C19—2.2 µF, 35 volts, tantalum  
C10, C11, C14, C25, C26, C29—0.01 µF, ceramic disc  
C12—47 pF, ceramic disc  
C17—.001 µF, ceramic disc  
C21—10 µF, 16 volts, electrolytic  
C24—500 µF, 25 volts, electrolytic  
C27—100 µF, 16 volts, electrolytic

#### Semiconductors

IC1—4514 1-of-16 data selector  
IC2—4520 dual binary counter  
IC3—4040 12-stage binary ripple counter  
IC4—5101L-1 256 × 4 static RAM  
IC5—4066 quad analog switch  
IC6—4515 1-of-16 data selector  
IC7—50240 top-octave generator (AMI, Mostek)  
IC8—4067 1-of-16 analog switch  
IC9—4082 dual 4-input AND gate  
IC10—386 ½-watt audio amplifier  
IC11—4511 BCD-to-7-segment-display decoder/driver

IC12—4553 3-digit counter  
IC13—7805 five-volt positive regulator  
IC14—4093 quad 2-input NAND Schmitt trigger  
IC15—4049 hex inverter  
SCR1—ECG 5400 or equivalent  
Q1—2N2222A or equivalent NPN silicon transistor  
D1—D3, D5—D7, D9, D11, D13, D17, D18—1N34A germanium diode  
D4, D8, D10, D12—1N914 silicon diode  
D14, D15—1N4001 silicon diode  
D16—1N4003 silicon diode  
DISP1—DISP3—FND 359, common cathode 7-segment displays with decimal point  
LED1—LED13—miniature red LED  
LED14—LED16—miniature green LED  
S1—S3, S7—DPDT miniature switch  
S4—S6—SPST normally open momentary switch  
S8—SPDT miniature switch  
S9—S24—SPDT miniature lever-type switch, Radio Shack 275-016, or equivalent  
J1—miniature N.C. chassis-mount phone jack, Radio-Shack 274-253 or equivalent  
SO1, SO2—female header strips, AP Products 929974 or equivalent  
PL1—PL5—male header strips, right-angle, AP Products 929835 or equivalent  
PL6—male header-strip, AP Products 929834 or equivalent  
B1—B8—1.5-volt alkaline "AA" cell  
B9 B11—nickel-cadmium "button" cell, 20 mAh, or larger  
**Miscellaneous:** PC boards, IC sockets, female header-strips (AP Products 929974 or equivalent) for interconnections (see text), solder, wire, case, etc.  
**A set of the five PC boards, etched and drilled, but not plated through, is available from Hal-Tronix, PO Box 1101, Southgate, MI 48195. The price is \$39.95. Please add \$2.00 for shipping and handling. MI residents add 4% tax.**

### Memory

As we mentioned before, the memory of the Pianomatic can be organized into either two or four pages. The addressing of the memory is done by the note counter, IC3, and the tune selector, IC2-b. Since the memory, IC4, is a 1K memory organized into 256 words by 4 bits, it has eight address lines, ( $2^8 = 256$ ) labelled A0 through A7 (pins 4, 3, 2, 1, 21, 5, 7, and 6 respectively). The six least-significant address lines are connected directly to the corresponding outputs of the note counter. One of the two most significant address lines, A6, is connected to the least significant ("A") output of the tune selector (pin 11 of IC2-b). The ability to select either two or four pages of memory is made possible by how we handle address line A7. If we want to organize the memory into four pages, the seventh output of the note counter, (pin 4 of IC3), is

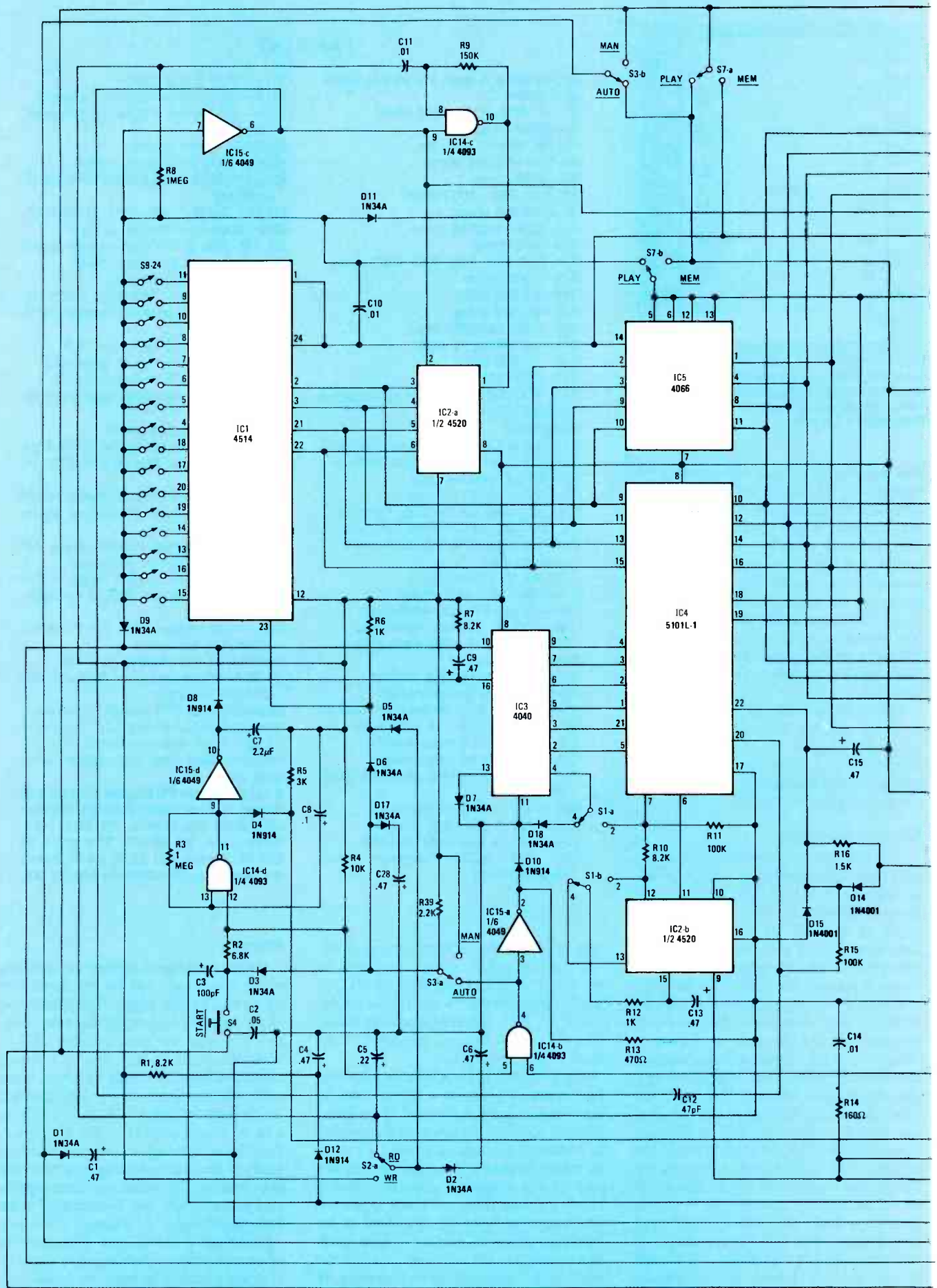

FIG. 4—SCHEMATIC DIAGRAM OF THE PIANOMATIC. This circuit can store either two long tunes or four shorter ones.

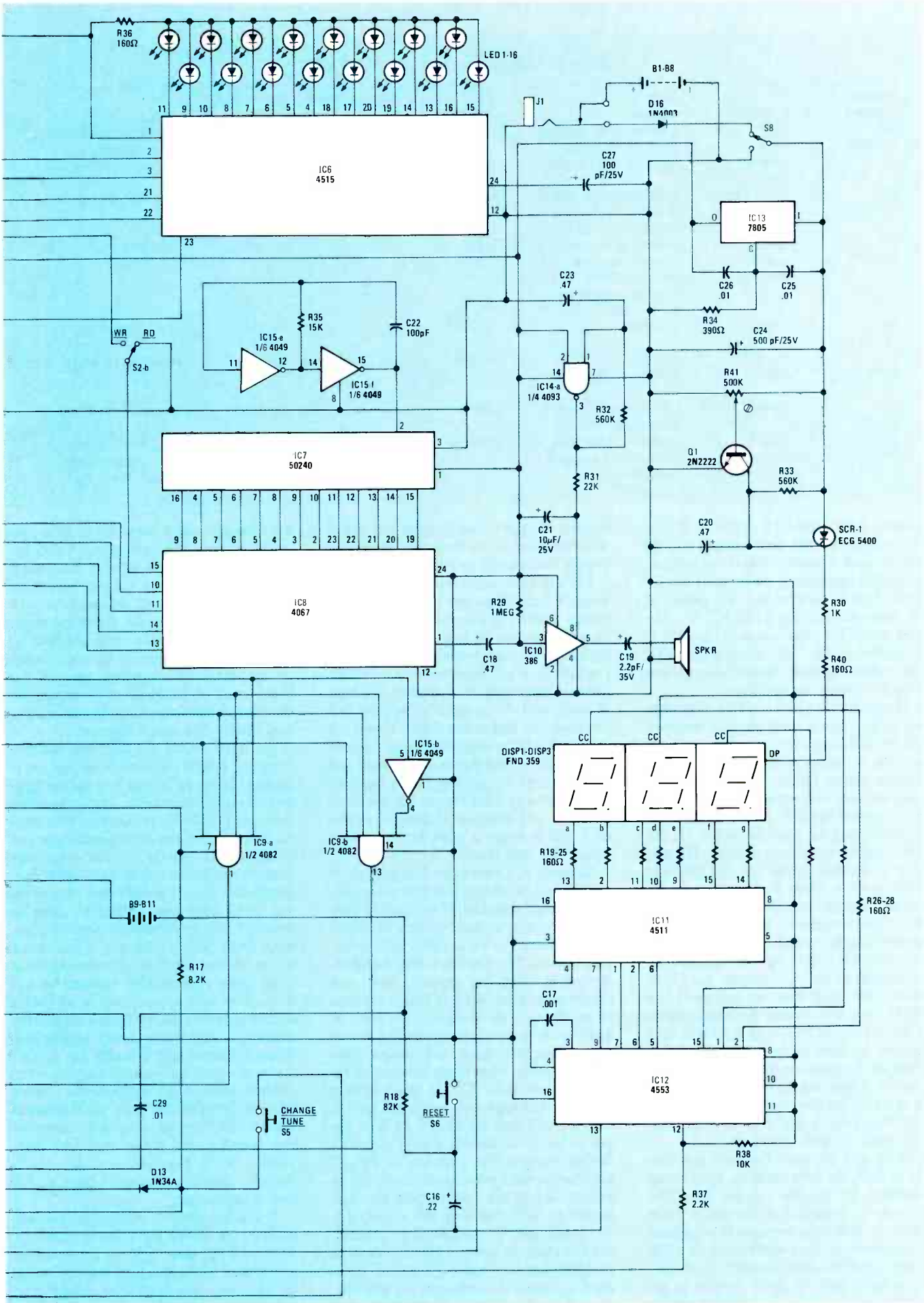

TABLE 1—SWITCHING OF THE PIANOMATIC

Switch number	Function	Note counter	Keyboard	Note counter display	Keyboard display	Misc.
S1 (DPDT)	2 or 4 tune memory paging	Causes reset at count of 64 (4 tunes) or count of 128 (2 tunes).	No effect	No effect	No effect	Changes resetting of tune selector, IC2-b. Mounted on Board 3.
S2 (DPDT)	Read and write operation	Switching from write to read causes reset through D2 and C6.	Disabled in read via D5.	No effect	No effect	Mounted on Board 3.
S3 (DPDT)	Manual or automatic playback	Switching from manual causes reset via D17 and C28. Switching to manual causes reset via D1 and C1.	Disabled in automatic via D6.	Blanked in automatic	No effect	Mounted on Board 3.
S4 (SPST)	Start	No effect	No effect	No effect	No effect	Mounted on Board 2.
S5 (SPST)	Tune select	Causes reset in all modes via D12 and C4.	No effect	No effect	No effect	Mounted on Board 2.
S6 (SPST)	Reset	Causes reset in all modes via C16.	No effect	No effect	No effect	Mounted on Board 3.
S7 (DPDT)	Play or memory	Switching from Play to Memory causes a reset via C2.	No effect	No effect	Disabled in play	Disables memory in play. Mounted on Board 3.

connected through D18 to the reset pin. That means that the note counter will be reset to zero whenever the count reaches 64. At the same time, we connect the A7 input of the memory to the "B" output of the tune selector (pin 12 of IC2-b). The reset pin of the tune selector, (pin 15) is connected to the "C" output (pin 13). That makes the tune selector reset to zero when the count reaches four.

Things get a bit trickier if we want only two pages. Since each page of memory will be 128 notes long, we have to connect the A7 input of the memory to the seventh output of the note counter and make the note counter reset to zero when the count reaches 128. That is easily done by connecting the reset pin to pin 13, the eighth output of the note counter. We also have to arrange things so that the tune selector resets when the count in the IC reaches two instead of four. As you can see in the schematic, we can make that happen simply enough by connecting the reset pin of IC2-b to the "B" output, pin 12, instead of the "C" output, pin 13, as before. By doing that, we can use S1, a DPDT switch to change the organization of the memory. Resistors R10 and R11 bias the A6 input of the memory and C13 gives us a power-on reset for the tune selector. Capacitor C5 provides a power-on-reset for the note counter to make sure that things start out at zero when the Pianomatic is first turned on.

Diode D7 prevents the reset pin (pin 11) of IC3, the note counter, from being swamped by the low on pin 13 if the memory is switched to the FOUR PAGE position. When the memory is organized in that manner, there will always be a low at pin 13 of the note counter. That's because the count will never be able to get past 64 and pin 13 won't go high until a count of 128 is reached. When the count

reaches 64, pin 4 will go high and, since it's connected to the reset bus, we would expect the counter to reset to zero.

Let's imagine what would happen if D7 weren't there. Since pin 13 would be connected directly to the reset pin and, since its output would be low, the high signal appearing on pin 4 would conflict with it. Digital IC's are temperamental and go bananas when they're faced with any kind of ambiguity. What usually happens in a situation like that is that the IC would see the conflict at the reset pin, recognize it as an ambiguity, and throw in the towel and destroy itself. By putting D7 on the line, things become a lot clearer for the reset pin. The only time pin 13 makes its presence felt is when it goes high, forward biases D7, and resets IC3.

Memory IC4 stores the data put into it and, during playback, puts that same data on the output data bus. If we want to play the Pianomatic without writing the notes into the memory, we're faced with several problems. The first one is that the memory we're using has separate input and output pins. Since we don't want the data to go through the memory, we have to have some method of bypassing it and connecting the input and output data buses together. That is the function of the memory control, IC5, a quad analog switch. (Although you can route analog data through that device, all we'll be using it for is to handle digital signals.) We've ganged the switches in the IC together to make a four-pole single-throw switch. When the control pins are connected to +V, the switches are closed, and when they're connected to ground, the switches are open. That still leaves a problem because although we've managed to bypass the memory, it's still connected to the circuit. Fortunately that problem was foreseen by the designer of

the memory—he's provided us with two enable-control inputs at pins 18 and 19. Making pin 18 positive will disconnect the outputs but leave the rest of the IC functions unaffected. Making pin 19 positive will disable the entire memory. To be on the safe side we'll use both of them and connect them to the control pins of the 4066. Now when we put the Pianomatic in the PLAY ONLY mode, we disable the memory and connect the input and output data buses together.

As soon as we do that, we quickly discover another problem we've overlooked. If we press any key on the keyboard we generate the corresponding note, but if no key is pressed the Pianomatic makes one of the worst sounds you can imagine. The reason for that is obvious when we consider one thing—we've forgotten that there's always data present on the input data bus. When no note is selected, the keyboard encoder is scanning from zero to fifteen. Thus, what we're hearing when no note is selected is every note sequentially selected at 1.5 kHz. The way around that is to find a means to enable the 4066 (and disable the memory) only when a key is pressed. Since the keyboard encoder has a high "any-key-pressed" output, our answer is evident. Instead of connecting the control pins of the 4066 to +V, we'll connect them to the "any-key-pressed" output of the encoder. By doing that, the only sounds we'll hear will be, to coin a phrase, "music to our ears." Switch S7-b does exactly that.

When the memory of the Pianomatic is enabled by S7-b, the other half of the switch, S7-a, puts +V on the MANUAL terminal of S3-b. One look at the schematic will show you that we're using that to control several different functions of the

*continued on page 81*



## Innovative Consumer Products of 1983

*At each Summer Consumer Electronics Show the outstanding designs of the past year are honored. Here are some of the highlights of this year's exhibition.*

ONE OF THE MOST EXCITING DISPLAYS AT every summer consumer electronics show in Chicago is a special exhibit of design and engineering accomplishments of the past year. Sponsored by the Consumer Electronics Group of the Electronic Industries Association (EIA), that event is the only place at the vast show where the entire industry—manufacturers of everything from hand-held games to esoteric audio—comes together to honor innovative design and the application of state-of-the-art technology. This year, the eighth time that the special exhibit has appeared, judges from the consumer-electronics press honored more than 125 individual products and, in a separate event, over 60 computer, game, videodisc, and videocassette software titles as the most innovative products in their categories. Let's take a look at some of the highlights.

### DANNY GOODMAN

#### Audio

There is little question that the compact disc (CD) in general won the hearts of judges. Several new players were on display. But to see all those machines together, it is apparent that the only "compact" thing about most CD players is the disc; practically all of the first-generation players are rather large. The exception is the Magnavox (1-40 and Straw Plains Pike, Knoxville, TN 37914) *FD 1000SL*, which may be the smallest CD player in production.

Controls are kept at a minimum on that low-profile player, shown in Fig. 1, yet with the nine front-panel function buttons and the LED track indicators, the audiophile has full programmability for setting up any sequence of tracks on the disk, as well as forward and reverse

search. For that premium design there is fortunately not a premium in price, at least not when compared to other CD players. The *FD 1000SL* has a suggested retail price of \$800.

One hi-fi technology that's getting off to a slow start is AM stereo. With the lack of a standard or recommended AM-stereo transmission method, broadcasters are free to select whichever system they want, even though each is incompatible

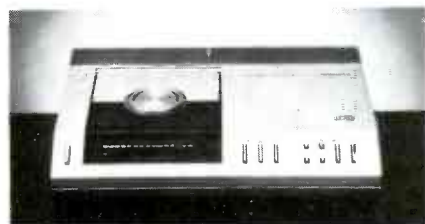

FIG. 1—THE MODEL *FD1000* from Magnavox; a truly compact, compact-disc player.

with all others. Needless to say, that creates quite a dilemma for receiver and tuner manufacturers. But with the Sansui (1259 Valley Brook Ave., Lyndhurst, NJ 07071) *TU-S77AMX* tuner, the listener doesn't have to worry about which systems the various stations in his area are using. That's because that new tuner (see Fig. 2) automatically detects which of the four AM-stereo methods is received and adjusts to the proper decoding circuitry automatically. All of that operates invisibly to the listener, without any indication as to which stereo method is in use. The tuner also features a few other state-of-the-art listener features. Up to eight preset stations can be stored for both AM and FM, and the memories can be scanned.



**FIG 2—BILLED AS A UNIVERSAL RECEIVER,** the model *TU-S77AMX* is capable of receiving all of the four AM-stereo systems.

### Video

While Metal-Oxide Semiconductor (MOS) cameras for VCR recording have been more or less a novelty item for the last year-and-a-half, the technology of that solid-state image sensor has improved. Hitachi (401 W. Artesia Blvd., Compton, CA 90220) now feels confident enough about it to package a full-featured portable camera using the tiny sensor instead of a pickup tube. The compact, five-pound *VKC3400* camera, shown in Fig. 3, is one of the first cameras to include a color viewfinder as well. Thus, the video-camera operator will see that all settings are accurate before shooting, and can play back any segment of tape, in full color, to double check. Also built into the small unit are automatic focus, even in macro (closeup) settings; a character generator for titles; a date timer; a time-lapse counter; negative/positive reverse, and VCR transport controls. As



**FIG. 3—HITACHI'S *VKC3400*** boasts an MOS image sensor, a full-color electronic viewfinder, and a range of special-effects features.

far as optics go, the camera uses an *f*1.2 lens and a six times power-zoom lens. Iris and white balance adjustments can be set automatically or manually. Surprisingly, the camera lists at about the same price as the first, rather featureless MOS camera of about a year ago: \$1995.

High-quality, stereo sound for videocassette recordings was the big announcement last January by a consortium of Beta-format VCR manufacturers. They had agreed on a standard for the Beta format to put two audio channels on the tape (with rotating drum heads) with more impressive specifications than traditional analog audio. Those specifications included a dynamic range of 80dB and a frequency response of 20hz–20kHz with less than 0.3% harmonic distortion. Now the products are starting to appear, and the Sanyo (1200 W. Artesia Blvd., Compton, CA 90220) *VCR 7300* is one of the first "portables" to include Beta Hi-Fi. The unit features separate audio inputs (as from a stereo tuner for use during a simulcast) and outputs (for playing through a stereo system), and claims a dynamic range greater than 80dB. A separate, stationary audio-head makes all Beta-format tapes playable on the *VCR 7300*; and all tapes recorded on the deck will play back (in mono) on other Beta decks. Other features include: 105-channel cable-ready tuner with 12 push-button channel selectors; one week, one event programmable timer; 8-function wired remote control, and Betascan picture search. It weighs 15 pounds including the rechargeable battery. It operates from that battery, or from AC or a 12-volt car battery. The price of the unit, (see Fig. 4) is \$1000.

As more television manufacturers join in the move toward component TV, Proton (19600 Magellan Dr., Torrance, CA



**FIG. 4—THE SANYO *VCR 7300*** is the first portable unit to make use of Beta Hi-Fi.

90502) is taking a different tack by building component-quality video, audio, tuning, and switching sections into their model 619 19-inch receiver/monitor (see Fig. 5). The video-monitor section limits overscan to 5%. Horizontal resolution is rated to be in excess of 370 lines. Built into the receiver is an automatic flesh-tone adjustment, which can be manually



**FIG. 5—A 19-INCH RECEIVER/MONITOR,** the Proton model 619 features component-quality video, audio, tuning, and switching sections in a single cabinet.

overridden. Picture brightness also automatically adjusts to ambient lighting conditions. There are four video inputs; two for RF and two for composite video. Front-panel pushbuttons select the input. There are also provisions to handle stereo-audio inputs from such sources as stereo-videodisc players and VCR's (the set has only a mono speaker, however). Outputs include one for video (for recording) and two for two-channel audio.

With the proliferation of home audio and video equipment, the cable and cable-switching mess gets increasingly more complex. To combat that problem, what may be the ultimate home-electronics switcher was introduced by Video Interface Products (1930 Ecorse Rd., Allen Park, MI 48101). The *From-To* routing computer, shown in Fig. 6, not only accommodates 10 inputs and 8 outputs, but also has a number of microprocessor-controlled features that allow it to be used as a control board for a small-scale television production. For simple selection of inputs and outputs, all the user needs to do is press the appropriate FROM and TO squares on the grid. More complex combinations involving multiple audio and

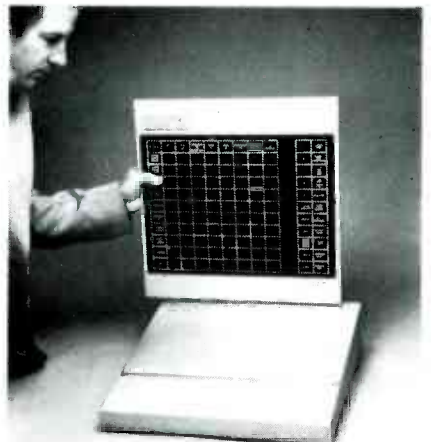

**FIG. 6—THE ULTIMATE** in convenience and flexibility, the microprocessor-controlled *From-To* switcher from Video Interface Products can handle 10 inputs and eight outputs.



video gear can be stored in up to 5 memories. Two outputs can be RF modulated (built-in) in case you want to display a composite video signal on a standard TV-set. A scan mode automatically switches through up to ten video inputs at infinitely selectable scan rates. The unit was engineered with extensive internal shielding. Crosstalk is less than -60dB. Of the three RF inputs, one features a VHF input amp, while the other two use broadband input amplifiers capable of handling frequencies through 900 MHz. The control pad of the two-piece unit can be wall hung, if desired, with a 5-conductor cable linking it to the central console. The suggested retail price is \$999.

### Games and computers

A relatively new company, Koala Technologies Corp. (4962 El Camino Real, Suite 125, Los Altos, CA 94022), has developed a low-cost touch panel for use on Apple, Atari, Commodore, and IBM personal computers. The *Koalapad*, shown in Fig. 7, may eventually be used as a 40-function controller for some rather sophisticated software, in addition to its obvious applications in computer graphics. The unit's four-inch-square touch-sensitive surface can be used with either a stylus or a finger to move a screen pointer (cursor). In conjunction with the graphics software included with the pad, the neophyte computer artist can have the computer draw straight lines between two points, fill segments with various colors, magnify a segment to rearrange pixels, and create free-form drawings on the screen in response to the tracing on the pad.

From Xonox (11311 K-tel Dr., Minnetonka, MN 55343), a division of K-Tel (the same people who bring us 50 original hits on two LP's or cassettes), comes a new brand of videogame cartridge with something really different: *Double-Enders*, a cartridge that is actually two

cartridges. Not just two games—that's been done years ago—but two separate cartridges packaged as if they were glued end-to-end, with their edge connectors facing away from each other; see Fig. 8. While that is certainly clever packaging, a sneak preview of the actual games at the Consumer Electronics Show revealed some interesting play in these 8K (per game) cartridges. Most of the cartridges have from three to five game screens.

One of the smallest direct-connect, RS-232 compatible telephone modems is the *J-CAT* by Novation (18664 Oxnard St., Tarzana, CA 91356). That 300-baud modem, shown in Fig. 9, can be set for auto answer/originate, as well as manual

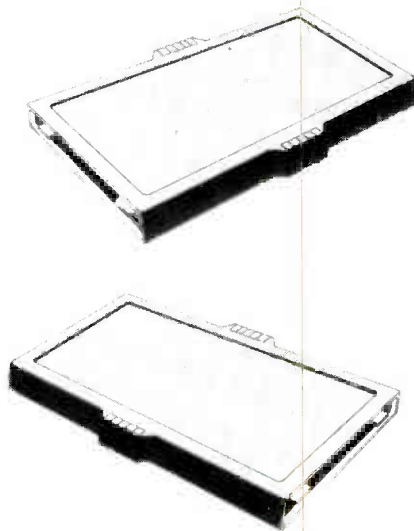

FIG. 8—TWO FOR ONE. The *Double-Enders* cartridges from Xonox feature two separate 8K games in a single, two-ended cartridge.

answer/originate. An audio indicator gives the operator the status of the phone line (dial tone, busy signal, etc.). It features full-duplex operation only and carries a suggested retail price of \$149.

### Personal Electronics

In use in Europe for some time, and now available in the New York metropolitan area, a new traffic-conditions alert system is being introduced by Blaupunkt (2800 S. 25th St., Broadview, IL 60153). Called *Automatic Radio Information*, or ARI, the system uses existing selected FM-broadcast stations to bring timely, localized traffic data to commuters. With an ARI-equipped car stereo, a driver can turn down the radio volume or turn on the tape player without missing traffic reports. When the report comes on, a sub-carrier signal sent by the broadcaster activates the car radio to a pre-set volume, making sure the driver hears it. If the tape player is going, it is paused during the report. Participating broadcasters each have limited geographic zones, thus making sure the driver tuned into that local



FIG. 9—THE *J-CAT* from Novation, one of the smallest direct-connect RS-232 modems available.

station hears only about relevant road information. Blaupunkt is offering ARI adapters for some of its auto-stereo models (see Fig. 10), and is building ARI capability into some of its stereo radio/cassette decks. The company is currently licensing the technology to other manufacturers and plans to bring this system to more cities in the U.S.

Although automatic dialers aren't new, the shirt-pocket-sized *Dial-It*, shown in Fig. 11, from Dictograph (3573 Warden Ave., Buffalo, NY 14086) packs an impressive roster of features in its tiny case. The unit stores up to 100 telephone numbers and then audibly tone-dials them



FIG. 10—IN THE ARI SYSTEM, special signals keep a driver informed of traffic reports in his area. The adapter shown here will adapt a Blaupunkt car stereo to receive those ARI signals.

through a small speaker at the back of the case. Each memory can store up to 32 digits, leaving plenty of room for MCI, Sprint, or other budget long-distance-service access codes. An LCD display shows the number being dialed. For dialing numbers not stored in memory, the keypad can be used just as a pushbutton dialer. Also included is a clock (programmable in 12 or 24-hour time), alarm, memory calculator, and low-battery warning. The circuit lets you change batteries without losing what is in memory. The suggested retail price is \$65.

As frequent users of walkman-type tape players know, batteries are an expensive habit. Clear Electronics (5362 Bolsa "B", Huntington Beach, CA



FIG. 7—THE *KOALAPAD*, from Koala Technologies Inc., is a low-cost touch panel for use with microcomputers.



FIG. 11—THIS TINY AUTOMATIC DIALER, the *Dial-it* from Dictagraph, can store up to 100 numbers.

92649) has combined an AM/FM stereo tape-player and a slide-on rechargeable battery pack that will stop the endless purchases of batteries in their 818 AM/FM stereo tape-player shown in Fig. 12. The power pack has its own retractable AC power-plug; it plugs directly into the wall receptacle for recharging. Each charge keeps the player going for 6 to 10 hours. Packaged with the player and power pack are two pair of lightweight headphones and carrying case; it all sells for a suggested retail price of \$140.

What makes the Regency Electronics Inc. (7707 Records St., Indianapolis, IN 46226) *MX 7000* noteworthy is the fact that it covers more of the frequency spectrum than any other consumer-oriented programmable scanner ever has. In addition to the standard VHF and UHF commercial bands, the unit, shown in Fig. 13, has continuous coverage from 27-1250 MHz (that's 1.25 GHz). Services covered in that range include Citizen's Band, FM broadcast, aircraft, 800-MHz public service, and cellular telephone. Front-panel selection is available for three receive modes: narrow-band FM, wide-band FM, and AM. The scanning interval is selectable; the intervals available are 5, 12.5, and 25 kHz. Up to 20 frequencies can be stored. Availability is scheduled for late 1983 and the suggested retail price will be \$599.



FIG. 12—NEVER NEEDS BATTERIES. This personal stereo, the 818 from Clear Electronics, is powered from a rechargeable battery pack.

It may look at first like an electric flyswatter, but it's really a new design for a microphone for use in recording sound in noisy rooms or in rooms with a lot of hard surfaces. The *Sound Grabber*, from Crown International (1718 West Mishawak Rd, Elkhart, IN 46517) lies inconspicuously face-down on a table. The microphone element is set in place about one-quarter inch above its large, flat, plastic surface. The element captures sound in front of it such that all sound reaching the element is in phase. In a demonstration we had of the device, the improvement in recording quality, especially the quality of voices, over a built-in condenser microphone was considerable. The suggested retail price is \$99.

The *Energy\$Teller* from Advanced Micro Products, Inc. (150 W. Meramec, Suite 205, Clayton, MO 63105) keeps an eye on energy usage in the home or plant. The sensor module plugs into the wall socket, and the appliance under test plugs into the module. A six-foot cable with a plug resembling a modular-phone plug attaches to the processor unit. After the user keys in the kilowatt-hour rate paid for electricity, the processor auto-



FIG. 13—THE REGENCY *MX 7000* offers continuous coverage from 27-1250 MHz.

matically keeps track of how much the electricity used by that appliance costs. A log book, called the *Energy\$Checkbook*, is included to record the interval between readings. Tracking actual cost can help isolate wasteful appliances or equipment. The 120-volt module handles up to 25 amps. A 240-volt module will also be available. Suggested retail price for system shown in Fig. 14, is \$80.

American Bell (5 Wood Hollow Rd., Parsippany, NJ 07054), one of the companies created in the break up of AT&T, has introduced a line of telephones for sale to the general public. Of interest here is their *Genesis* system, a microprocessor-controlled, modular telephone that takes on powerful attributes with the addition of plug-in cartridges and modules. The alphanumeric display on the main console, for example, shows names and numbers stored in the electronic directory module shown in Fig. 15. By it-

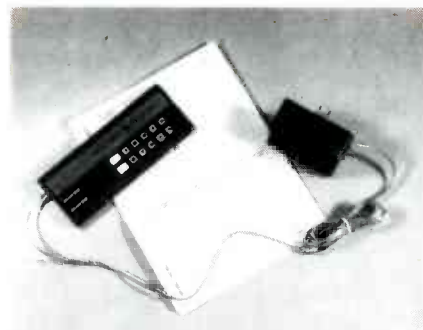

FIG. 14—THE *ENERGYSTELLER*, sensor module, and log book help keep track of electricity consumption. The system is manufactured by Advanced Micro Products, Inc.

self, the main console can store seven numbers plus three emergency numbers; the emergency numbers stand out on the console in red. Also built in is a call timer and alarm. Plug-in cartridges feature additional memories or custom-calling functions such as 3-way calling, call forwarding, and call waiting. Each cartridge redefines the keys on the console; slide in cards rename the keys.

*Sound Plus* from Controlonics (5 Lyberty Rd., Westford, MA 01886) is about the only device singled out for recognition for using electronics to aid the handicapped—in this case, the hard-of-hearing. When a roomful of TV watchers contains one or more people who are hard of hearing, the volume almost always goes up to accommodate the one with the worst hearing, perhaps to the discomfort of the others. But *Sound Plus* lets the hard-of-hearing in the audience hear as

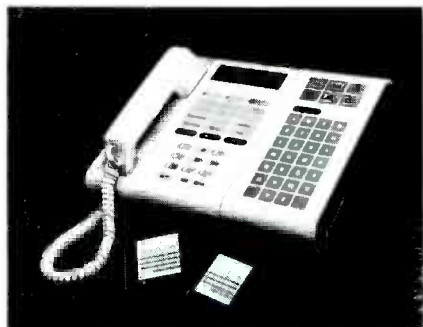

FIG. 15—THE *GENESIS* from American Bell, a modular, microprocessor-controlled telephone.

loudly as they want, while the rest of can have the speaker volume at a lower level. The principle is quite simple. Each listener who needs one has an individually controlled amplifier-headphone combination. The device picks up the sound from the TV speaker with its microphone (plugging any device into the external speaker or earphone jack would cut off the internal speaker for the others in the room). Then the sound is transmitted via infrared up to 50 feet to all wearers of the headset/receiver, a stethoscope-like device. R-E

# ECL

# LOGIC CIRCUITS

*Emitter-coupled logic, though not as popular as other logic families, is by far the fastest available commercially. Let's take a look at some ECL basics.*

**TJ BYERS**

WHAT WOULD YOU SAY IF I TOLD YOU that there are IC's available that can process data at the rate of 500 million bits per second? Some new laboratory discovery, you ask? Hardly. I'm talking about ECL (*E*mitter *C*oupled *L*ogic) circuits. Although ECL IC's became commercially available in 1962, they are still not very popular with hobbyists. However, due to their ultra-high-speed switching properties, they are popular in the data-processing, test-equipment, and digital-communications industries.

ECL IC's can be purchased today for about the same price as you're paying for TTL IC's. Does all this sound too good to be true? Well, before you rush out to replace your "antiquated" designs with ECL, first let me tell you that the average ECL circuit is nothing at all like the standard TTL format you've grown to love and understand.

### ECL theory

Unlike the popular TTL-style logic, which exploits the two states of a transistor (either on or off), ECL is biased so that the transistors are in the active region at all times. (That is why ECL is often called nonsaturated logic.) Because the transistor does not go into saturation, there is no stored-base-charge problem; so propagation-delay times are very small. The IC's have speed capabilities a full order of magnitude faster than other existing technologies.

Figure 1 shows a complete ECL gate. If you look at it closely, you'll recognize the

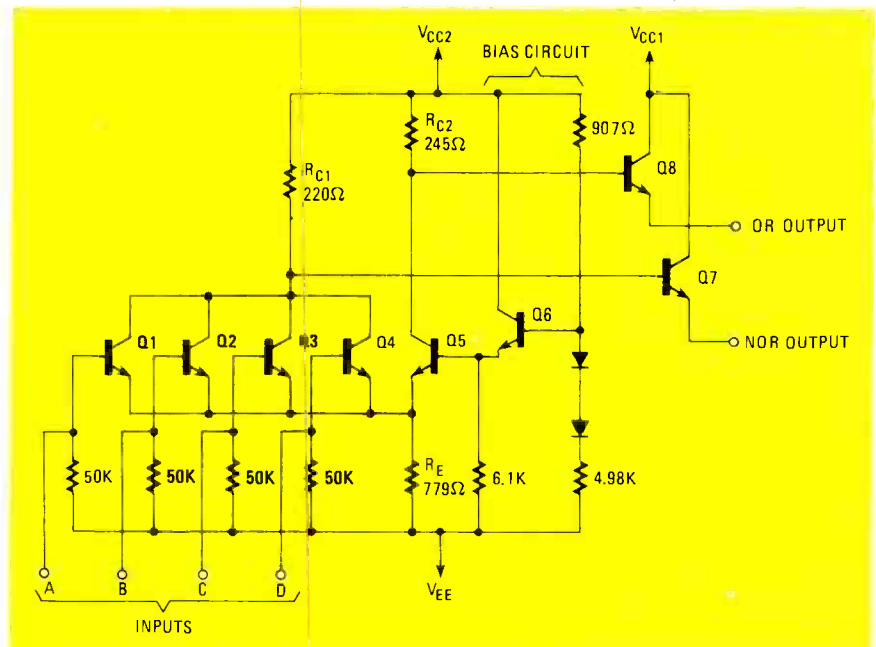

**FIG. 1—AN ECL GATE.** Although there are two  $V_{CC}$  connections shown, there is only one power supply. The connections are, however, separate on the chip.

input section as being a slightly modified differential amplifier—similar in design to the input of an operational amplifier. However, also notice that one side of the differential "pair" includes four transistors, all in parallel. Each represents a separate gate input.

To the right of the differential amplifier is a biasing network that provides a stable, temperature-compensated voltage source. That voltage is input to differential-transistor Q5, establishing a reference level for differential op-

erations. With no signal present on any of the inputs, Q5 conducts, resulting in a voltage drop across  $R_{C2}$ . Output transistors Q7 and Q8, whose base circuits are coupled directly to the collector resistors  $R_{C1}$  and  $R_{C2}$  respectively, monitor the status of the differential amplifier. Let's see what that means.

With no inputs, Q5 conducts, and little current flows in the other leg of the differential amplifier; there is no appreciable voltage drop across resistor  $R_{C1}$ . Thus the voltage at the base of Q7 is  $V_{CC}$ . Because

the output circuit is being operated as an emitter follower, the voltage developed at the emitter (output) of Q7 will be  $V_{CC}$  plus the voltage drop across the base-emitter junction—or approximately 0.9 volts less than  $V_{CC}$ .

Unlike  $R_{C1}$ , there is a voltage drop across  $R_{C2}$  when Q5 is conducting. In fact, with the resistor values shown, the voltage drop is very nearly 1 volt. As before, the voltage developed at the emitter of Q8 will be the base voltage plus the voltage drop across the base emitter junction. The emitter voltage of Q8 will be about 1.75 volts less than  $V_{CC}$ . With the outputs configured this way ( $V_{E7} = -0.9$ , and  $V_{E8} = -1.75$ ). We define it as our OFF state.

If we now apply a voltage—which is in excess of the reference voltage established by the bias network—to the base of one of the input transistors, it will conduct. That increases the current flow through the emitter resistor  $R_E$ .

The increase in current raises the voltage drop across the  $R_E$ , causing a proportional decrease in the current flowing through Q5—as is the nature of a differential circuit. Very little current will flow through  $R_{C2}$ , but there is still heavy current flow through  $R_{C1}$ . The values of the resistors have been selected so that there will be approximately a one-volt drop across  $R_{C1}$ , and almost no voltage drop across  $R_{C2}$ . In effect, the roles of the output transistors are reversed from the previous case. Now the output of Q7 is about  $-1.75$  volts and the output of Q8 is about  $-0.9$  volts; that represents the ON logic state.

When the input signal is removed, the input transistor(s) drop out of operation, and the current reverts back to Q5, which in turn toggles the outputs again. That switching action is very smooth; a steady current flows from the power supply, reducing switching transients.

Since the transistors never go into saturation—a requirement for stable TTL operation—there is no charge buildup at the junction. That means no storage-time effect to slow down the switching action. The design is so effective that the ECL gate is able to alternate states in a matter of picoseconds.

### Power supply

In order to effectively use these fast switching times, which are equivalent to 1 GHz in some IC's, other parts of the circuit take on a different look. One of the changes you'll see is in the power supply.

Characteristic to ECL circuits, the  $V_{CC}$  voltage—which is our positive line—is grounded. That means that our  $V_{EE}$  line must therefore assume a negative potential (usually  $-5.2$  volts). Although any voltage source of the ECL family can be designated as ground, there is a valid reason for selecting the  $V_{CC}$  source.

To better understand the reasoning behind this, again think of an ECL gate as a

differential amplifier (which it is, basically). Differential amps have the capacity for very high common-mode rejection, allowing the input circuit to ignore many sources of noise and interference that are inherent in switching circuits. However, noise generated on the  $V_{CC}$  line is not canceled out by the differential circuit. However, by referring  $V_{CC}$  to ground, good noise suppression can be accomplished.

That changes our way of thinking somewhat, because a "1" level is now represented by ground potential. Consequently, the "0" logic assumes a negative value, which is consistent with our new thinking.

That brings up another point about the  $V_{CC}$  voltage. If you look again at the schematic in Fig. 1, you'll notice that there are two  $V_{CC}$  connections to the gate. That is quite intentional. The output transistors drive the load using emitter followers, and the currents (particularly surge currents) are at times very heavy. That is reflected back into the  $V_{CC}$  line as a voltage spike, or a glitch. At the speeds involved, crosstalk inside the integrated circuit is a real problem. To keep crosstalk to a minimum, the two power sources are separated inside the package. However, that doesn't mean that you need two  $V_{CC}$  power supplies. Both pins are returned to the same place (the positive leg of the power supply). However, in order to achieve the isolation intended, heavy bus lines are used to avoid coupling between the voltage pins. In fact, the entire plane of a double-sided PC board is often used for the  $V_{CC}$  connections, and will provide a substantial low-impedance ground at the same time. Using the ground-plane construction brings us other benefits, as we will see a little later on in our discussion.

Although the ECL family of circuits is intended to operate from a  $-5.2$  volt source, it is capable of working over a much broader range ( $-3.0$  to  $-8.0$ ). Unfortunately, performance (with respect to speed and noise) is not always predictable across the entire range, and it's best to keep the voltage within 10% of the  $-5.2$  volts specified.

### Power dissipation

One of the major complaints that has been lodged against the ECL family is that of excessive power dissipation. Since the transistors operate in their active region, it is naturally assumed they will dissipate more power than other, saturation-type logic families. However, that is not always the case. If you look at the power-dissipation curve in Fig. 2, you will see that although the TTL-style logic does use less power initially, the condition soon changes as the input frequency increases. As a matter of fact, even the power-miserly CMOS gate (operating with a 10-volt source) soon dissipates more power than what is dissipated by an

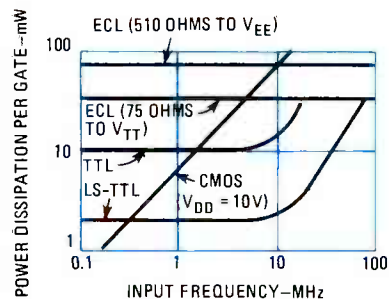

FIG. 2—POWER-DISSIPATION CURVES for various logic families shows that while ECL is often considered to be a power waster, at high frequencies it is quite miserly.

ECL gate—and before the operating frequency even reaches 10 MHz!

Even though TTL and LS-TTL seem to fare better at first, at high frequencies they, too, end up wasting as much power as an ECL gate. The ECL gate, on the other hand, keeps right on switching along, maintaining the same level of power regardless of the input frequency. In fact, in many situations the ECL design becomes a strong watt-for-watt competitor at frequencies as low as 20 MHz.

### Logic levels

Since differential currents are used to represent the logic states, the logic voltages center around a threshold voltage that is established by the bias network. That can be seen from the transfer characteristics of the ECL gate, shown in Fig. 3. The "1" level is defined as  $-0.9$  volts and the "0" level is  $-1.75$  volts. Notice the use of negative values when expressing the logic levels, keeping consistent with our earlier observations.

The reference voltage for Q5 is set at approximately  $-1.3$  volts. You'll see that the levels defined for our logic states pivot about the reference by just about 0.4 volts. By keeping the voltage levels confined to a narrow voltage band, rather than setting them at  $V_{CC}$  and  $V_{EE}$ , the slew effect is minimized. Slew is best defined as the amount of time it takes a pulse voltage to travel from one level to another. You probably know it better as rise time.

The greater the voltage transition, the more time it takes for the gate to switch. In other words, you can increase the op-

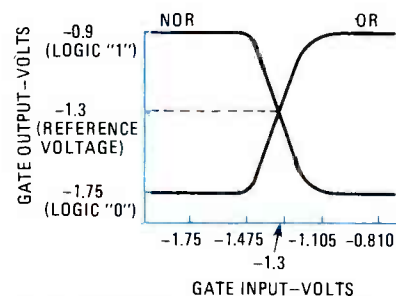

FIG. 3—TRANSFER CHARACTERISTICS of an ECL gate.

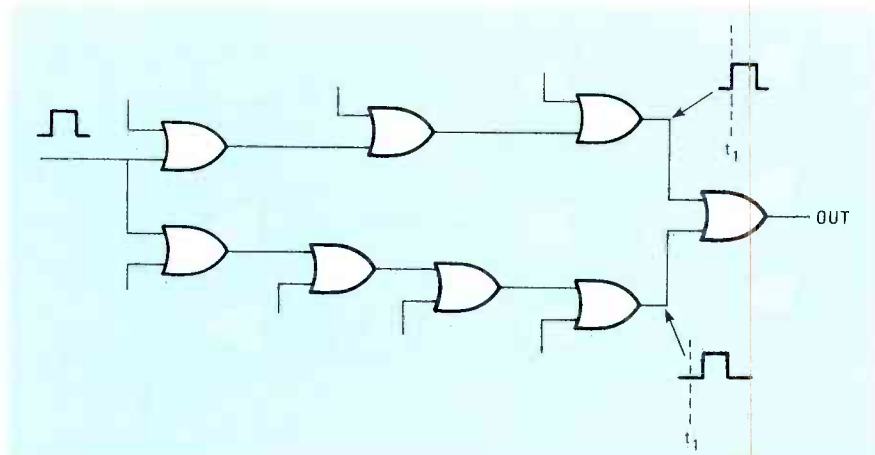

FIG. 4—THE EXTREMELY HIGH clocking speed used with ECL circuits demands that careful attention be paid to design.

erating speed by limiting the voltage swing. That is not to say that the devices won't accept voltage levels beyond those defined as the logic states. They will. In fact, the situation often occurs at lower operating speeds. It is quite acceptable for the input pulse to run the entire gamut from  $V_{EE}$  to nearly  $V_{CC}$ .

### High-speed logic

Basically, designing with ECL logic is pretty much like using standard logic IC's—if you remember that  $V_{CC}$  is ground. Because of the higher speeds involved, though, certain parameters require some important consideration. It's not unusual to find ECL gates operating comfortably at 500 MHz. At that speed, restrictions are frequently placed on pulse timing to a degree unimaginable with other forms of logic.

Assuming for the moment that the pulse width is 3 ns and that the delay per gate is 1.5 ns, the circuit in Fig. 4 will demonstrate our point. When a pulse is input to this configuration, it is split, with the signal traveling two different paths. (To simplify our example, only the actual signal paths are shown, but bear in mind that other inputs are present along the way, influencing the logical decisions.)

The pulse travels through the circuit and finally arrives at the last logic gate. However, the bottom signal arrives ex-

actly 1.5 ns later than the top one. Now, one and one-half nanoseconds is not a very long time, and it would be ignored using standard logic practices. However, at the clocking speed we have set for ourselves in this circuit, it amounts to a full 25% of the clock cycle—and 50% of the pulse width!

At the beginning of the clock cycle, the final gate senses the inputs and makes its decision. However, 1.5 ns later the logic pulse from the lower path arrives at the input. Now, depending upon the logic states involved, the later signal could abruptly alter the status of the output. Furthermore, if there were a total of five gates involved in the lower path, the pulses would never coincide because they would be separated by 3 ns.

### ECL clock skewing

Lead lengths must also be considered because of the high operating frequencies. A mere 12 inches of wire will delay a signal by about the same amount as one gate does. To emphasize that, let's take the circuit layout in Fig. 5, depicting, more or less, the physical positioning of several ECL gates on a PC board. The clock pulse is tied into the board at the top, and distributed to the IC's as shown. I'll bet you can see the problem already.

By the time the pulse reaches the fifth IC, the timing signal is skewed by a full

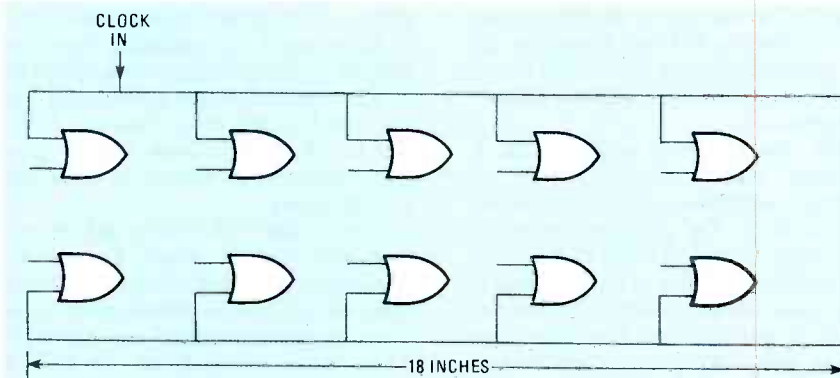

FIG. 5—LEAD LENGTHS become critical in ECL circuits.

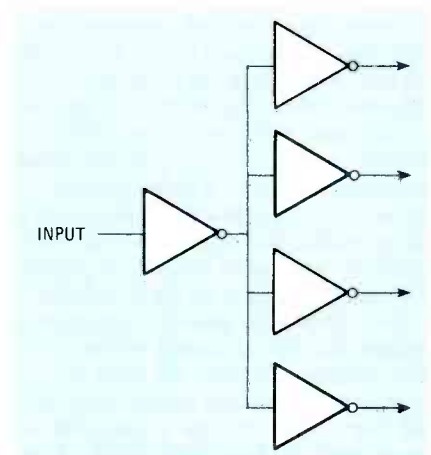

FIG. 6—AN ARRANGEMENT like this helps to minimize clock-skewing problems.

2.0 ns; on the back swing, the entire bottom row of chips is off by nearly 3 ns. As a matter of fact, the last chip is clocking more than 4 ns late; that is an intolerable situation!

To minimize such clock skewing problems, line delays must be matched to each other by better than 1 ns. A practical way to accomplish that is to use a logic-tree arrangement, such as is shown in Fig. 6. The timing signal is fed to one centrally located IC. From there, lines of matched length carry the timing pulses to the individual gates.

NOR logic should always be used when developing clock trees, and OR and NOR outputs should never be mixed within the chain. Due to lumped capacitance and other factors, loading of the outputs causes the gates to respond more slowly. So for high-speed performance, it is recommended that no more than four to six loads be applied to any one driver. Furthermore, when more than one gate is driven by a single output, it's better to run separate lines—of equal length—to each input rather than lump the loads at the end of a signal line. It is sometimes necessary (and usually desirable) to include an extra gate in a line to match delayed pulses from longer runs.

Parallel gates can be used to increase the bandwidth of an ECL driving gate when clock repetition rates are high, or when large capacitive loads are involved. Bandwidths can be extended by 40 or 50 MHz just by paralleling both halves of a dual gate.

As you may suspect, the timing problem becomes even more critical when more than one circuit card is involved in a system. Since the master clock is normally located on just one card, with output lines sent to the other cards in the system, it becomes imperative that all the feedlines be identical in composition (all coax, for example) and of *exactly the same length!*

### Unused inputs

There always comes a time when there

are more logic functions contained on a chip than the designer needs. When that happens, something has to be done with the unused pins. The differential input of an ECL gate represents a very high impedance, and ordinarily a floating input would spell trouble. With no planned direction, reverse-bias leakage builds up a charge on the base-input lead. That often produces ambiguous outputs or power-dissipation problems for the IC involved.

To overcome the problem, a pulldown resistor has been included on the chip. The resistor references the input to  $V_{EE}$  (thus bleeding off any charge build-up), but has a large enough value—50K in most cases—to have little effect on the signal. As a result, all unused inputs can be left unconnected.

Be that as it may, there are exceptions. Several ECL devices don't have internal pulldown resistors; an example is a line receiver. In the case of a line receiver, one input must be tied to the  $V_{BB}$  pin ( $V_{BB}$  is a reference source used for Schmitt trigger applications) and the other returned to  $V_{EE}$  when the receiver is unused.

It frequently occurs during the analysis of a logic design that one of the inputs must assume a constant state. You see this configuration all the time in decision-making circuits that compare the input pulse to a fixed frame of reference. And, as has been the practice with standard logic, the inputs are hard-wired to either  $V_{CC}$  for a fixed HIGH, or  $V_{EE}$  for a LOW.

Although it is acceptable to tie the input to the  $V_{EE}$  line to simulate a low input with ECL gates, the reverse should not be attempted. Tying the input to  $V_{CC}$ —or ground, as is the case—to imitate a high input is not recommended. Due to their design, many of the ECL IC's won't operate properly when that method is used.

The proper way to force a logic "1" is to provide  $-0.9$  volts at the input. You can use a resistor voltage-divider but most manufacturers recommend you use the forward voltage drop across a diode junction, as shown in Fig. 7, to provide the voltage required.



FIG. 7—A DIODE IS USED to imitate a "high" input for an ECL gate.

## Outputs

Since the ECL output is an open emitter, an external load resistor is required to provide a current path for the output transistor. Normally, a resistance between 270 and 510 ohms is selected.

We should note that almost no dedicated driver circuits exist in the ECL family. That is because every gate is capable of becoming a driver. In fact, with the values so far specified, each output is capable of driving approximately 20 gate

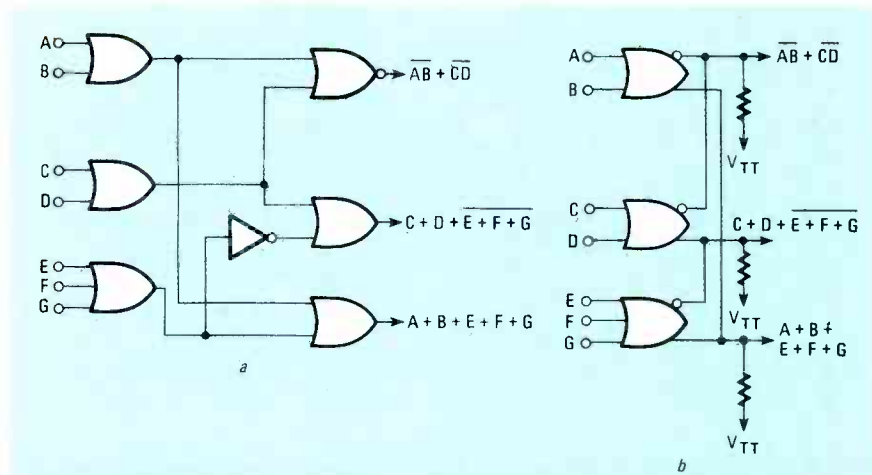

FIG. 8—THE NOR OUTPUT can be used to keep your designs more efficient, by reducing delay times and the number of gates required.

loads. The maximum fanout, however, is not limited by the gate's DC driving capacity as you may think.

While DC loading, such as the pulldown resistors in the input circuits, can produce a shift in output voltage levels, it does little to alter processing times. AC loading, on the other hand, increases as the capacitance across the output circuit increases. The AC considerations are what determine the maximum fanout. If not for those considerations, the fanout drive capability would be greater than that which is required for most any practical application.

Driven through a typical output impedance of 7 ohms, the output transistor is able to force current through the capacitance, hastening the charge time and leaving the rise time less affected. Fall time, however, must depend on the discharge rate through the load resistor. Therefore, it is beneficial to keep the load resistance as small as practical. Unfortunately, as the load resistance decreases, power dissipation (in both the IC and resistor) increases. For that reason, 200 ohms to  $V_{EE}$  is suggested as the smallest value you should use. However, the gate input doesn't require that the logic voltage swing all the way to  $V_{EE}$ , remember? Any level in excess of  $-1.65$  volts is all that's really necessary. Therefore, if we were to provide another power supply—one nearer the "0" level—and if we returned our load resistors to that line instead of the  $V_{EE}$  line, resistance values could be reduced with no burdening increase in power dissipation.

Well, that is exactly what is done. A  $-2.0$ -volt source, labeled  $V_{TT}$ , is established, and the output load resistors are returned to it. The pulldown-resistance now ranges from 150 ohms to 50 ohms, with 35 ohms specified as the minimum in most cases. Consequently, rise and fall times are less influenced by capacitive loading, power dissipation is reduced by a factor of four, and the "0" logic level is still within limits.

Of course, it must be decided during the course of design whether or not the cost and distribution of a  $-2.0$ -volt power supply is warranted. In many small systems, it isn't—in which case a resistor to  $V_{EE}$  is preferable.

## Design shortcuts

The open-emitter drive makes it possible to engineer logic shortcuts into your designs. In particular is the wired-OR function. Wired-OR is the process of combining two (or more) outputs and OR-ing the results—without the use of a separate gate.

In general, it is recommended that the equivalent of only one pulldown resistor be used for the wired-OR design; although two resistors will improve fall times, it does so at the expense of added power dissipation. Due to LOW level current flow through the resistor, the number of gates paralleled in the wired-OR fashion should be limited to six in order to maintain a suitable level for LOW logic.

It is important that you keep the outputs involved physically close (from the same IC when possible). Anything else only aggravates the timing problems.

Another convenience of the ECL family is the inclusion of the complementary NOR output on most chips. Use of the NOR function eliminates the need for time-delaying inverters, reduces package count, and improves propagation time.

An example of combining these two features in a single design is shown in Fig. 8. The standard design is shown in Fig. 8-a, and Fig. 8-b shows how the design can be changed to save several gates while obtaining an increase in signal processing speed.

If you think ECL is reserved for only high-speed circuits... don't. They are just as effective in slower circuits. Moreover, many of their unique characteristics make them desirable in circuits now served by TTL. When we continue, we will investigate how to get the most from your ECL IC's.

R-E

## Powerline Transient Suppressor



HERB FRIEDMAN

*All it takes is a single glitch, transient, or surge on a power line to wipe out hours of work on a personal computer. Here's a simple yet effective device that helps eliminate those three serious power-line-related problems.*

THERE ARE THREE DIFFERENT TYPES of power-line disturbances that can affect the operation of small computers: RF interference, line transients, and power-line surges. Each can affect different computers in different ways. Also, some computers are more easily affected than others. For example, short of a direct lightning hit, no power-line disturbance will disrupt a Heathkit/Zenith H8 or Z/19 computer. One H8 we know of was running when the opposite wire of a 120/120 (240 volt) power line took a direct lightning hit only 100 feet away; the H8 just kept on working. On the other hand, simply turning on one of the most popular printers will cause an equally popular personal computer to re-boot—and wipe the program you've been writing for three hours right out of memory.

Let's look at the three types of disturbances and some of their causes. Turning first to RF interference, we were asked to cure such a problem plaguing a TRS-80 Model III used for demonstrations in a Radio Shack store. It turned out that the source of the interference was a Color Computer that was also being used for demonstrations. All that was needed for a quick and inexpensive fix was a \$12 RF filter that Radio Shack itself sold.

Line transients are another simple-to-cure but nevertheless bothersome problem. They are generated by power transformers and inductors when the current through them is turned on or off (although it's most severe when turned off.) Consider this case involving an Epson Printer and a TRS-80 Model I computer. If *scripsit* text-editing software was running, simply turning the printer on caused a line transient that scrambled the memory but not the video display.

Everything looked just fine on the video screen, but what was saved to disk or sent to the printer came from memory, and that was pure garbage.

Transient "ride-through" was the reason for the scrambled memory. It's not unusual for line transients caused by inductors and even lightning discharges in the neighborhood to range as high as 1000 volts; and those transients can ride right through the power-supply regulators and into the five-volt computer power supply. The result can be scrambled memory or "blown" ICs. The cure for the problem is a General Electric MOV (Metal Oxide Varistor) that more or less clips instantaneous line-transients at about 180 volts, a safe value that is generally handled (as far as we can tell) by all personal computers.

Finally, we can come to the third disturbance, one that causes the "silent death" of software, and sometimes of hardware: power-line surges caused by the local electric company's trying to maintain service after a power interruption. As a general rule, if a power line fails, the utility company will attempt to maintain service; often, the line may surge several times before failing completely, or the line may "hold," and power will be restored. The first interruption will probably wipe out or scramble whatever is in the computer's memory. The transients caused by the surges that follow as the utility tries to maintain power are quite capable of zapping your IC's and

disks. If the first failure takes your disk drives out of service, you want to keep them out of service until things are safe for them once more. Applying power again and again—particularly in the case of start-up transients—to a disk drive with the door closed is an odds-on bet to wipe out a disk. For software protection, a good rule of thumb for personal computers is that when the power takes the computer down even for an instant, keep the computer and all its peripheral equipment out of service until you are absolutely certain that steady, reliable power has been restored.

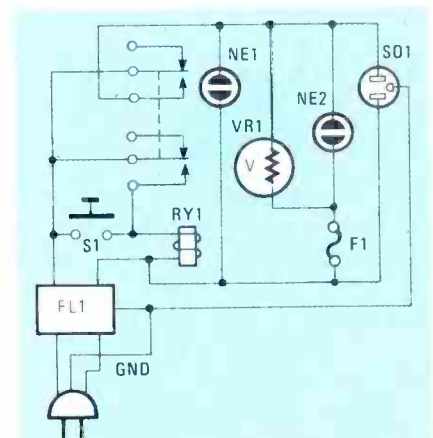

FIG. 1—THIS EASY-TO-BUILD CIRCUIT can provide better power-line protection for a personal computer than many commercial devices costing as much as \$150.

### Three in one

One way to eliminate, or at least sharply reduce, the problems caused by the unusual power-line conditions we've discussed is with the simple yet effective device described by this article. A schematic diagram of that device is shown in Fig. 1.

Although relatively unsophisticated, it does protect your computer against the three most common forms of power-line disturbances. First, there's FL1, an RF filter that keeps RF from entering into your computer through the power line, and RF from your own computer from getting into the power line (see Fig. 2).

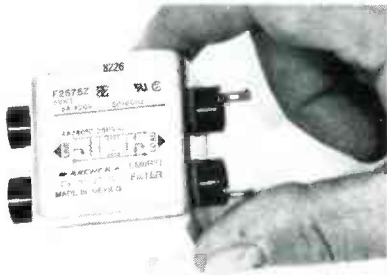

FIG. 2—THIS RF FILTER keeps RF power-line interference from leaking into your computer, and keeps your computer from interfering with other devices. It is particularly good at keeping two computers on the same power line from interfering with each other.

Second, it has a General Electric MOV, VR1, across the outlet receptacle to reduce the effects of line transients (see Fig. 3). Finally, relay RY1 is wired so that it drops out and *stays out* after the first power-line interruption until deliberately reset by the user. If the power fails at night, and in the darkness you forget to turn off your computer system, hours later—when the utility restores power—your disk drives won't start by themselves. Also, if the utility creates surges on the line while trying to maintain power, your computer will be safely dis-

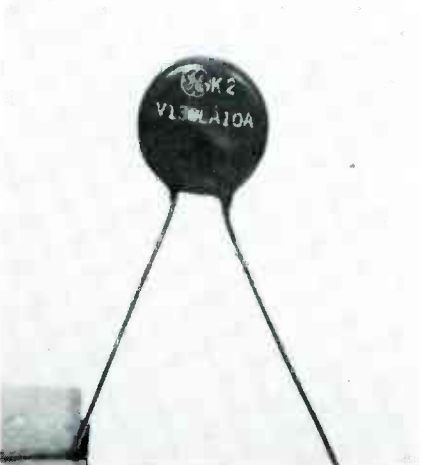

FIG. 3.—IT LOOKS LIKE A DISC CAPACITOR, but it's really a metal oxide varistor that limits transient line-voltage surges to about 180 volts.

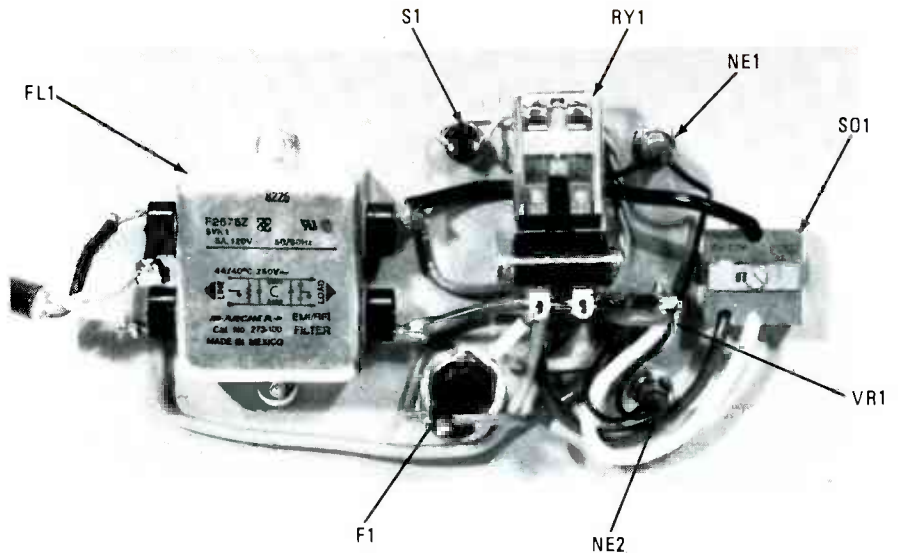

FIG. 4—ALL OF THE COMPONENTS mount on the metal front panel of a plastic utility cabinet.

connected from any consequences of that surging.

Two neon indicator lamps show the condition of the power line and of VR1. Lamp NE1, an amber-colored power indicator, will always be lit if there was no interruption of the power source. If NE1 is out it means there was a power-line interruption and the power to receptacle SO1 is locked out (RY1 dropped out). Power is restored by pressing RESET switch S1, which causes RY1 to pull in and latch, and apply power to SO1.

Lamp NE2, a green LIMIT indicator, shows that the safety fuse in series with VR1 is intact and the power line is protected against transients. Lamp NE2 must always be on when NE1 is on. If NE2 is out it means there was an excessive transient that caused fuse F1 to blow, or—more seriously—that VR1 is damaged. Replace fuse F1. If it blows again (as indicated by failure of NE2 to light), simply replace the varistor. It is rare for a varistor to be damaged by a transient, but it can happen.

No provision is made for an on-off switch because the unit is intended always to be on; it is simply a safety device. If you want to use the device as a master power-control for your computer system, you can install an on-off switch in series with either power-line connection to the RF-filter input. Keep in mind, however, the fact that S1 must still be depressed to turn the power on.

### Construction

The unit described was built on the metal panel supplied with a  $7\frac{3}{8} \times 2\frac{3}{8} \times 4\frac{5}{16}$  plastic utility-cabinet. There are two versions of that cabinet around: the U.S.-made Bakelite cabinet with a sturdy metal panel, and the "imported" model made of soft plastic with a relatively thin metal panel. If the thin panel is all you can get and you want something more sturdy, you can cut a duplicate from a sheet of a

### PARTS LIST

- FL1—EMI/RF filter (Radio Shack 273-100 or equivalent)
- VR1—V130LA10A metal-oxide varistor (General Electric)
- RY1—DPDT plug-in relay, 125-volts AC (Radio Shack 275-217 or equivalent)
- S1—pushbutton switch, normally open
- NE1—neon lamp assembly with built in resistor, 120 volts, amber
- NE2—neon lamp assembly with built in resistor, 120 volts, green
- F1—fuse, 3AG, 10 or 12 amps (see text)
- SO1—AC receptacle, three-pronged, grounded type
- Miscellaneous—cabinet, fuseholder, 3-wire line cord, relay socket (Radio Shack 275-220 or equivalent), No. 14 solid wire, etc.

heavier grade aircraft-quality aluminum.

As shown in Fig. 4, all components except RY1 mount directly on the metal panel. Relay RY1 is mounted on a small L-bracket fashioned from scrap aluminum. (See Fig. 5.) Form the bracket to the shape required to mount the particular relay you use. The relay specified in the Parts List is easy to obtain, and mounts in a socket that is similarly easy to obtain and install. Its use is recommended.

When you form the L-bracket, make certain there will be clearance for the small terminal-strip used to mount the VR1—that terminal strip is secured by one of the rivets or screws used to mount the bracket on the panel; alternatively, you can leave room for the terminal strip next to the bracket. Take note that the power line for a computer must be 100% free of interruptions. Make sure that all components are tied down and expertly soldered; leave no connections hanging in space even if they are soldered and taped (see Fig. 6).

*continued on page 78*



# BUILD THIS

## Digital Pressure Gauge

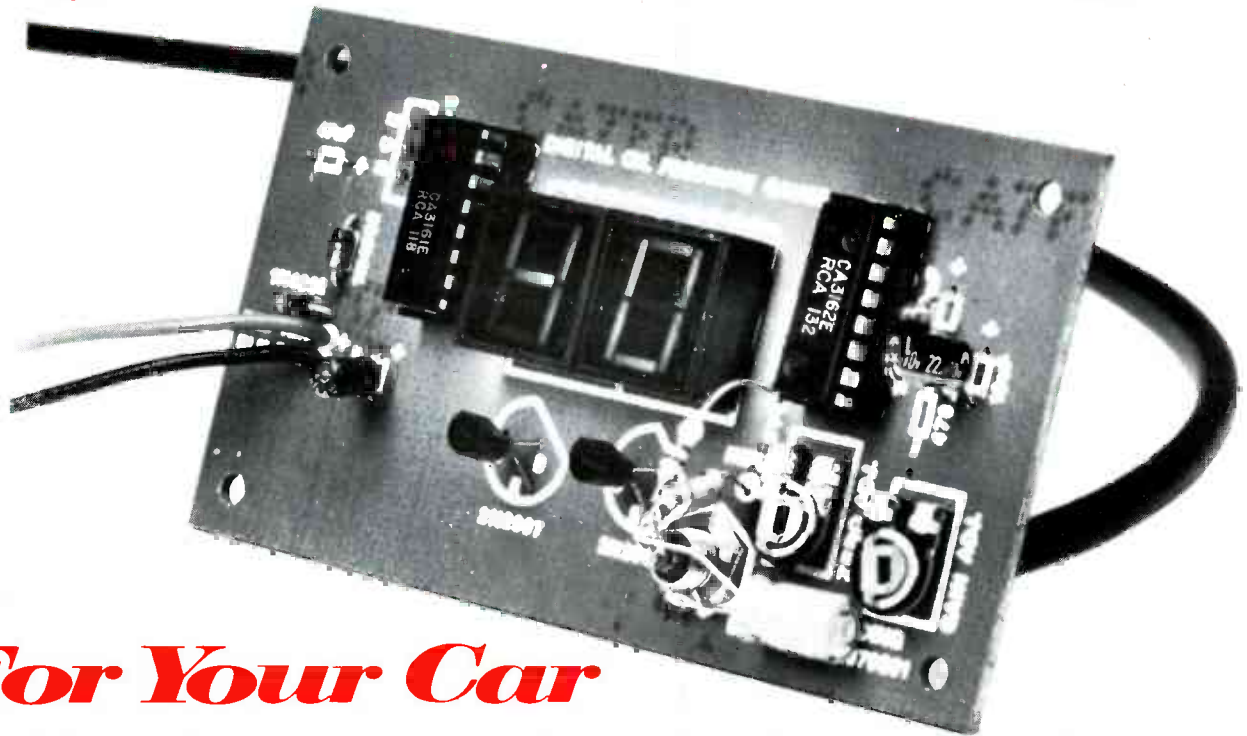

### For Your Car

Those "idiot lights" on your car's dashboard are great for telling you when something has gone wrong...but by then it's usually too late. This digital gauge will constantly monitor your oil pressure and warn you of problems long before they become critical.

FRED L. YOUNG, SR. and FRED L. YOUNG, JR.

A READING OF THE OIL PRESSURE IN YOUR car can tell you many things about what's going on in the engine—whether there's enough oil, whether a component (such as the oil pump) is beginning to fail, or whether there's a leak. The digital pressure gauge described here provides a two-digit display of the oil pressure—between 25 and 75 psi (Pounds/Square Inch)—updated four times a second. It's easy to build, and can save you a lot of trouble and expense.

Before you begin, a word of advice: Despite the fact that the digital gauge provides a lot more information than the idiot-light indicator you presently have, don't get rid of that indicator. It will act as a backup device should the digital gauge fail for some reason, and should you be unfamiliar with low oil-pressure warning signs, will give a definite indication that something is wrong.

#### How it works

The circuit is similar in operation to the digital voltage and temperature meters described in recent issues of **Radio-Electronics** (July and August 1983, respectively). Its schematic is shown in Fig. 1. A regulated five-volts DC is derived

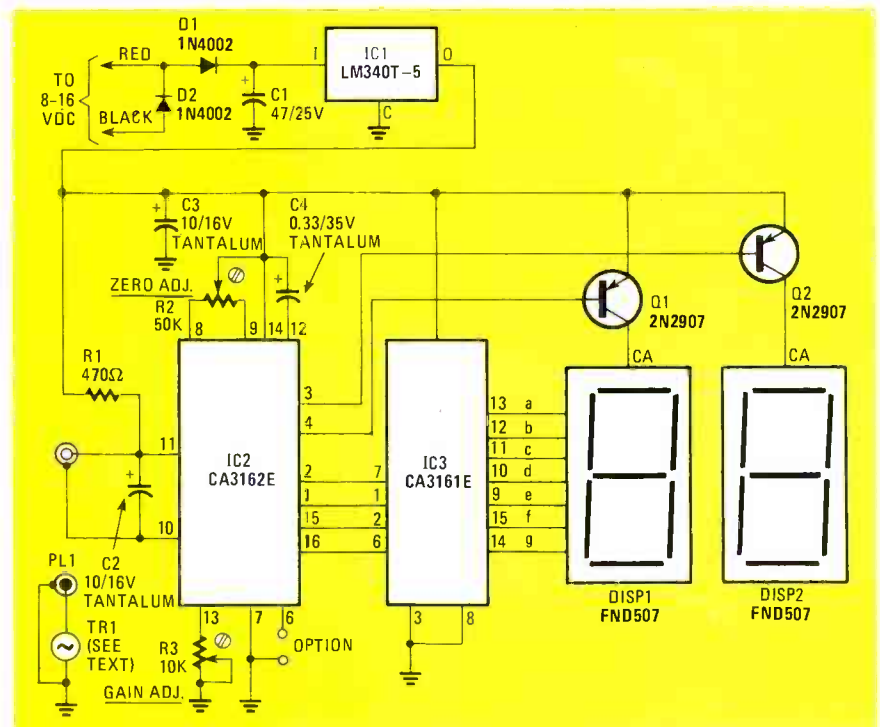

FIG. 1—TWO IC's, a CA3161E and a CA3162E do the whole job—from converting the analog voltage from the sensor to digital form to driving the display LED's.

from IC1, an LM340T-5 regulator, and supplies power for the rest of the circuit. The voltage coming from the pressure sensor (see below) is applied to IC2, a CA3162E dual-slope, dual-speed analog-to-digital converter with BCD (Binary Coded Decimal) outputs. The BCD signals are converted by IC3, a CA3161E, into signals to drive two 7-segment LED's. The CA3161E takes care of decoding the BCD signals, multiplexing the displays (to save power), and driving the LED's. Because that IC controls the amount of current supplied to the displays, no external current-limiting resistors are needed.

Only two adjustments have to be made—one (R2) to set the "zero-point" of the conversion circuit, and one (R3) to scale it; i.e., to match it to the sensor.

### The sensor

Many oil-pressure sensor units will not work properly with the digital gauge. There are three, though, that we know *will* work: the General Motors GM 370801, GM 547034, and GM 14039612. One or more of them should be available at a local automotive-parts supply house or GM dealer.

As (oil) pressure is applied to the sensor, its electrical characteristics change almost linearly; each pound of pressure causes a corresponding change in the resistance of the unit. At 40 psi, the resistance is approximately 40 ohms.

To convert that resistance into the voltage required by the meter circuit, a current is passed through R1 (470 ohms) to the sensor. As the resistance of the sensor changes with the pressure applied to it, so, then, does the voltage across it. Since the resistance varies linearly, and the current is constant, then the voltage, also, is directly proportional to the pressure. At 40 psi, a potential of approximately 400 mV is developed.

That voltage is applied to pin 11 of IC2, where it is converted to a digital value and processed for display on the LED's.

### Construction

A foil pattern for the digital pressure gauge PC board is shown in Fig. 2, and a parts-placement diagram for the circuit in Fig. 3. You can etch your own board, if you like, or purchase one from the supplier indicated in the Parts List.

The article in the July 1983 issue of **Radio-Electronics** describing a digital voltmeter for your car goes into great detail about circuit-board assembly techniques; if this is your first construction project, we suggest that you read it before going to work.

A red plastic front panel will make the displays easier to read. It should be prepared before you begin work on the board. Cut a piece of 1/8-inch red plastic about the same size as the board and lay it on a clean soft cloth. Then position the PC board on it, component-side down, and

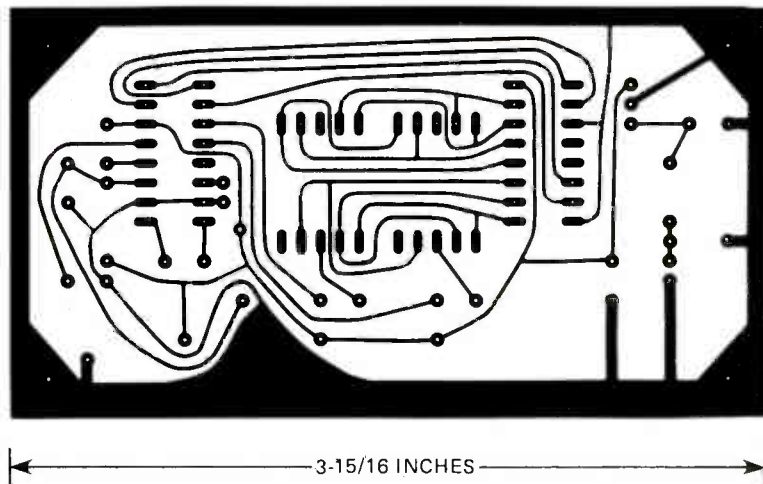

FIG. 2—FULL-SIZE FOIL PATTERN for etching the printed-circuit board. See the Parts List for a supplier of ready-to-use boards.

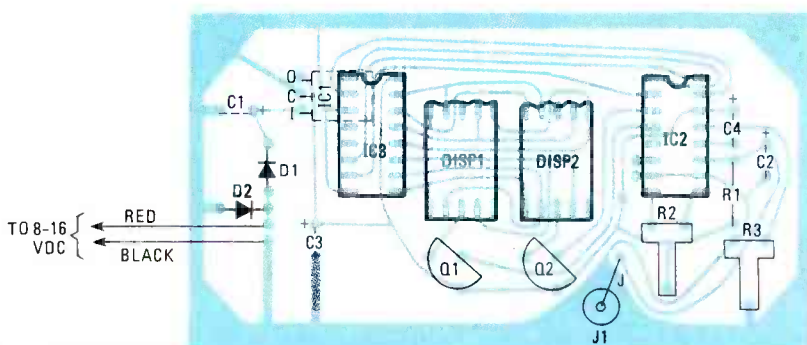

FIG. 3—WHEN YOU INSTALL the LED's, solder only two corner pins at first. That will let you adjust their positions easily should they not be in straight.

mark the plastic with the positions of the board's four corner holes. Then carefully drill holes at the four positions marked on the plastic to accept 4-40 bolts. Don't split the plastic—use a fine drill-bit first, and then a larger one until the hole is the size you want it. Then you can start on the board, so you'll want to set the plastic aside temporarily.

After installing the sockets for IC2 and IC3 (but do not install those IC's at this time) on the board, mount the resistors, capacitors, and other components. Be sure to mount the LED's so that the ridges indicating their tops face the top of the board. Don't forget to run a jumper from the center lug of J1 to the board; note that the jack is mounted from the foil side of the board. The last parts to be installed should be IC1 and C1, which you can mount on the foil side of the board as shown in Fig. 4. Connect three-foot lengths of red and black 22-gauge wire to the points indicated in the parts-placement diagram.

Before inserting IC1 and IC2 in their sockets, make sure that their supply voltages are correct. Apply about 12-volts DC to the board through the red and black wires. You should measure +5 volts at pin 14 of IC2 and at pin 16 of IC3. Pins 7 and 8, respectively, should be at ground potential.



FIG. 4—INSTALL IC1 and C1 on the foil-side of the board. Make sure that the body of the regulator does not come into contact with the board.

If the voltages you measure are correct, you can remove power and install the two IC's. If they are not, recheck your work carefully for solder bridges and other errors.

A completed board—modified for noise reduction (we'll talk about that a little later) is shown in Fig. 5.

### Calibration

To calibrate the pressure gauge, first apply between 10 and 16 volts DC to the red and black wires; 13.8 volts is ideal (it's the voltage that would normally be supplied by the car's electrical system). Then, with the sensor unit *not* connected, temporarily ground pins 10 and 11 of IC2 and adjust the 50K ZERO ADJUST potentiometer (R2) until the display reads "00."

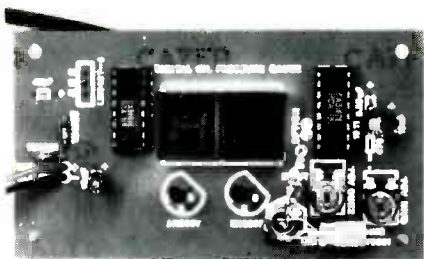

FIG. 5—THE COMPLETED oil-pressure gauge board. This version has been modified to incorporate noise reduction (see Fig. 7).

## PARTS LIST

### All resistors ¼-watt, 5%, unless otherwise specified

- R1, R4—470 ohms (R4: see text)
- R2—50,000 ohms, trimmer potentiometer
- R3—10,000 ohms, trimmer potentiometer
- R5—150,000 ohms (see text)

### Capacitors

- C1, C5—47 µF, 25 volts, electrolytic (C5: see text)
- C2, C3—10 µF, 16 volts, tantalum
- C4—0.33 µF, 35 volts, tantalum
- C6—22 µF, 16 volts, tantalum (see text)

### Semiconductors

- IC1—LM340T-5 (7805) five-volt positive regulator
- IC2—CA3162E dual-slope, dual-speed, A/D converter (RCA)
- IC3—CA3161E BCD-to-seven-segment decoder/driver/multiplexer (RCA)
- Q1, Q2—2N2907 or equivalent PNP-type
- DISP1, DISP2—FND507 (FND510) 0.5-inch common-anode display LED
- D1, D2—1N4002
- TR1—GM370708, GM547034, or GM14039612 oil-pressure sending unit
- J1—RCA phono jack
- PL1—RCA phono plug

**Miscellaneous:** PC board, RG58A/U coax, red plastic, wire, solder, hardware for sensor mounting, etc.

The following are available from Digital World, PO Box 5508, Augusta, GA 30906: Pressure gauge PC-board only, \$7.50; pressure gauge PC-board with schematics and diagrams, \$8.50; IC2 and IC3, \$12.50; pressure gauge PC-board with IC1-IC3, \$20.00; kit of all parts (excluding plastic panel, solder, chassis, sensor, and sensor mounting-hardware), \$32.50. The PC board, and PC board with schematics and diagrams are shipped postpaid within the U.S. and Canada. For all other items add \$2.00 within the continental U.S., and \$3.00 for APO, FPO, other U.S., and Canada. Canadians please use U.S. dollar postal money order. For shipment to other areas, write for prices and shipping costs. Please allow 4-6 weeks for delivery.

You'll need a fine screwdriver—and some patience—to do this. When you're satisfied with your work, remove the ground connection.

Next, temporarily connect a 47-ohm resistor across J1 to simulate the presence of the sensor unit and adjust the 10K GAIN ADJUST potentiometer (R3) until "47" is displayed. Again, work slowly and be patient until you have it just right. When you're done, remove the resistor.

If you are using either the GM370801 or GM547034 unit for pressure sensing, you're done with the calibration. If, however, you have a GM14039612 unit, you *must* also carry out the additional step that follows.

Because of its characteristics, the GM14039612 sensor tends to give readings about 10 psi too high if used with the pressure gauge as calibrated above. To compensate for that, connect the sensor (see below for installation instructions) and, with the vehicle's motor *off*, apply power to the circuit board. Adjust the ZERO ADJUST potentiometer, R2, for a reading of "-9" or "- -." The final setting of the potentiometer should be so that it is midway between the positions that give those readings. With that, the board is correctly adjusted for the GM14039612 sensor.

When you've finished the calibration procedures, install the red plastic faceplate over the board with 4-40 hardware. Use either spacers, or standoffs made from nuts threaded on bolts.

## Installation

Since you want to retain your original oil-pressure sensor, it will have to be connected physically in parallel with the new one. Figure 6 shows how that can be done. You'll require a ¼-inch, 3-input "T" adaptor, which should be available

at a local plumbing or hardware-supply outlet. You will also need a one- or two-inch piece of standard ¼-inch brass tubing, threaded at both ends, to act as an extender. It should be long enough to allow the sensor to clear the engine block and other parts in the area in which the sensor is mounted; it's better to have the tubing a little too long, than too short.

Screw one end of the extender tube into the center hole of the "T" adaptor, and the other end into the engine block where the original pressure sensor (which you've removed, of course) had been installed. Then attach the original sensor to one arm of the "T," and the new one to the other. Be careful when working with the brass tubing—it's rather fragile. Don't use too much force when you tighten the fittings, or the tubing may break.

When you assemble the fittings, use pipe cement or plumber's tape to prevent oil leaks.

If you have a foreign car that uses metric fittings, you may have to use an adaptor for the extender tubing, or secure a length of unthreaded tubing and have a machine shop thread it to metric specifications.

Use RG58A/U coaxial cable to connect the sensor to the circuit board. You can get an idea of how long the cable will have to be by running a piece of string from the sensor position through the firewall to where the circuit board will be mounted. Allow enough slack to keep the cable away from hot parts of the engine, and be sure to allow an extra 18 inches so the board can be installed (and removed) conveniently.

After cutting it to size, strip one end of the cable and connect it to the sensor. Tape the cable securely to the sensor unit to keep it from breaking loose. Connect

*continued on page 134*

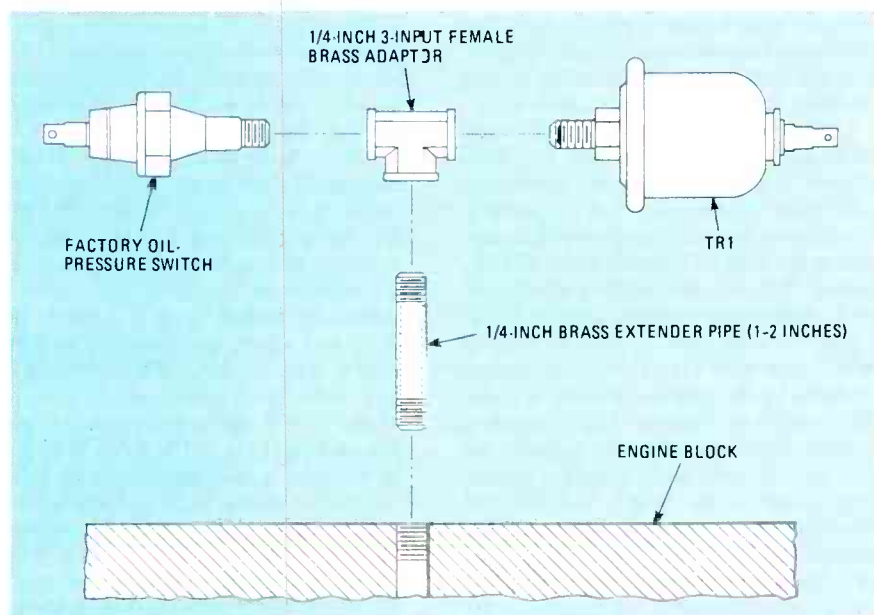

FIG. 6—THIS ARRANGEMENT will let you use both your new gauge and the old "idiot light."

# FREQUENCY CALIBRATION USING

# WWV

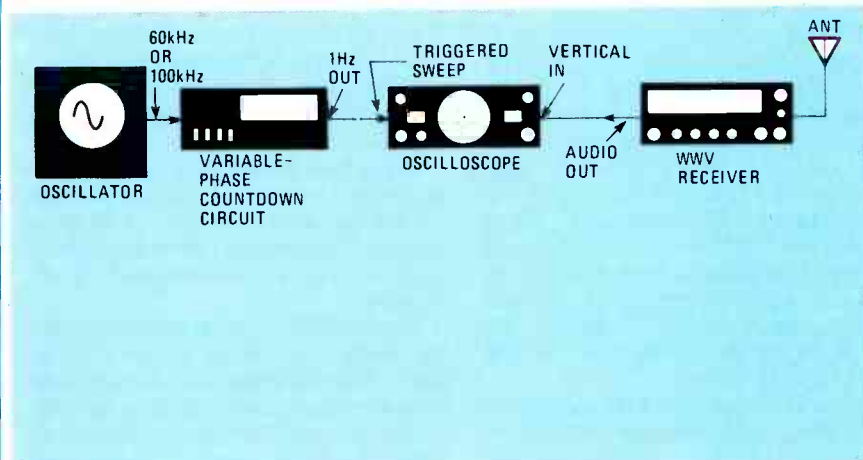

FIG. 1—BLOCK DIAGRAM OF TEST SETUP used to determine the drift of the local clock.

R.W. BURHANS

*WWV is a source of highly accurate time- and frequency-signals. Here's a method that lets you use those signals to calibrate your own frequency standards.*

AS ELECTRONIC CIRCUITS GET MORE COMPLEX, the level of accuracy needed to test those circuits also increases. While accurate measurement of voltage, current, and resistance present their own problems, often it's even harder to perform accurate frequency measurements. That's because they can only be as accurate as the crystal timebase in your frequency counter.

Getting a high degree of accuracy when calibrating a crystal timebase has been almost impossible without expensive calibration equipment. That's especially true if you want the calibration to be traceable to the NBS (National Bureau of Standards). The only inexpensive alternative is to calibrate the timebase using the time signals transmitted by radio stations WWV and WWVH. Those stations are operated by the National Bureau of Standards and they transmit highly-accurate cesium-clock derived time signals on 2.5-, 5-, 10-, 15-, and 20-MHz. (A complete guide to the WWV and WWVH broadcast services can be found in NBS Special Publication 432, *NBS Frequency and Time Dissemination Services*. The document is available for 60 cents from the Superintendent of Documents, U.S.

Printing Office, Washington, DC 20402.) The commonly accepted method for calibrating an oscillator using WWV transmissions is to zero-beat the oscillator against the WWV carrier frequency.

However, a small controversy has developed as to whether or not crystal oscillators such as those found in frequency counters can be accurately calibrated using that method. (See "Equipment Reports," *Sabtronics 8610A*, **Radio-Electronics**, February 1982, and John H. Hennings rebuttal letter, **Radio-Electronics**, June 1982). The controversy arises from the fact that the ionosphere is unstable (its condition fluctuates cyclicly over a 24-hour period), and affects the propagation of the WWV transmissions. The unstable nature of the ionosphere limits the accuracy of the WWV transmissions to 0.1 part-per-million (1 Hz in 10 MHz). However, by applying a technique used long before the days of atomic clocks, it is possible to obtain an accuracy of 0.001 part-per-million (1 Hz in 10 GHz) using WWV transmissions, provided that the oscillator you're calibrating is kept operating continuously for long periods of time.

### The calibration technique

Rather than calibrate the oscillator against the WWV carrier frequency, the technique outlined here uses the audible ticks that are transmitted by WWV and WWVH to identify the seconds. Each tick transmitted by those services consists of a 1000-Hz, 5-ms tone. The actual tick, therefore is composed of five cycles of a 1000-Hz sinewave.

The technique is illustrated in the block diagram in Fig. 1. The received time tick from WWV is displayed on the vertical axis of an oscilloscope. The output of the crystal oscillator is connected to a variable-phase countdown circuit that divides the oscillator frequency down to one pulse per second. Thumbwheel switches in the countdown circuit vary the phase of that 1-pulse-per-second waveform, which is used to trigger the oscilloscope. The sweep rate is set to 1-ms-per-division and the thumbwheel switches on the countdown circuit are adjusted until a sinewave appears. Since the 1000-Hz tone from WWV occurs only once each second and lasts for only 5 ms, the thumbwheel switches may have to be adjusted almost through their entire range before

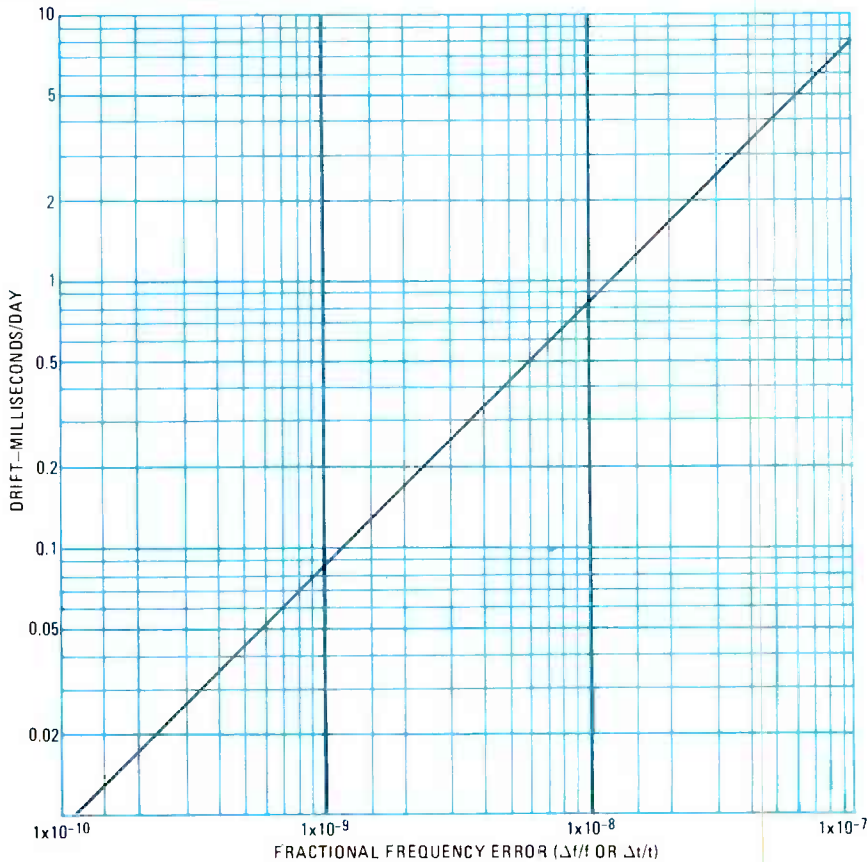

FIG. 2—THE FRACTIONAL FREQUENCY ERROR of the local clock can be determined from this graph once the drift is known.

the sinewave can be seen. Remember, it lasts for only  $\frac{1}{200}$  second.

After the sinewave does appear, the thumbwheel switches are again adjusted until the leading edge of the first cycle of the sinewave aligns with the start of the oscilloscope trace. The drift of that trace determines the frequency error of the crystal oscillator. If the sinewave drifts one full cycle in about a minute, then the crystal oscillator is set to within only  $\pm 10$  parts-per-million. If the sinewave drifts one cycle in 15 minutes then the frequency stability is about 1 part-per-million. The rate of change of that drift is called the aging rate of the crystal.

To obtain higher accuracies, it is necessary to measure the drift over several days. The ionosphere will indeed affect the accuracy of the results, but its effect will be minimized if the measurements are always made at the same time of day. The change in the settings of the thumbwheel switches required to align the sinewave with the beginning of the trace is recorded every day at the same time each day. The drift can be estimated to within perhaps 0.1 millisecond by observing where the leading edge of the first cycle of the sinewave is with respect to the starting point of the trace. The drift (in milliseconds) over a 24-hour period of time can be used to determine the fractional frequency error of the clock by using the graph shown in Fig. 2. Although that may be a lot more trouble than the average observer is willing to take to determine his clock error, the point is that if accuracy is necessary, it can be obtained using WWV time signals.

The aging rate of a crystal itself changes with time, so it is necessary to reset the fine trim on the local clock-oscillator about once a month to maintain accuracy. An additional problem with temperature-compensated and oven-controlled crystal oscillators is that when they are shut off and then turned back on again, the aging rate starts at a new point. However, that problem is eliminated if the oscillator is kept running continuously, as in the frequency counters now sold that have standby operation, in those, an oven-stabilized crystal oscillator is always on.

### The countdown circuit

The variable-phase countdown circuit is shown in Fig. 3. This circuit is intended to be driven from a 100-kHz or 60-kHz source, but it can easily be driven from a 1-MHz or 10-MHz source with the addition of a couple of decade dividers using Schottky TTL or even some CMOS IC's. The thumbwheels can be adjusted to provide any phase of a 1-second tick from 0 to 999 milliseconds in one-millisecond increments.

R-E

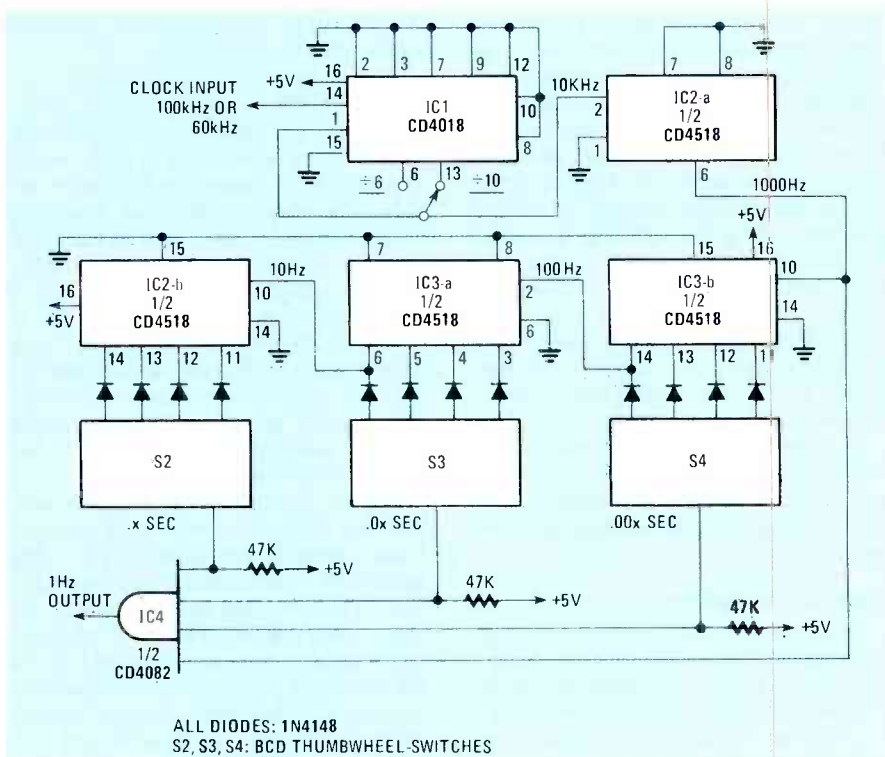
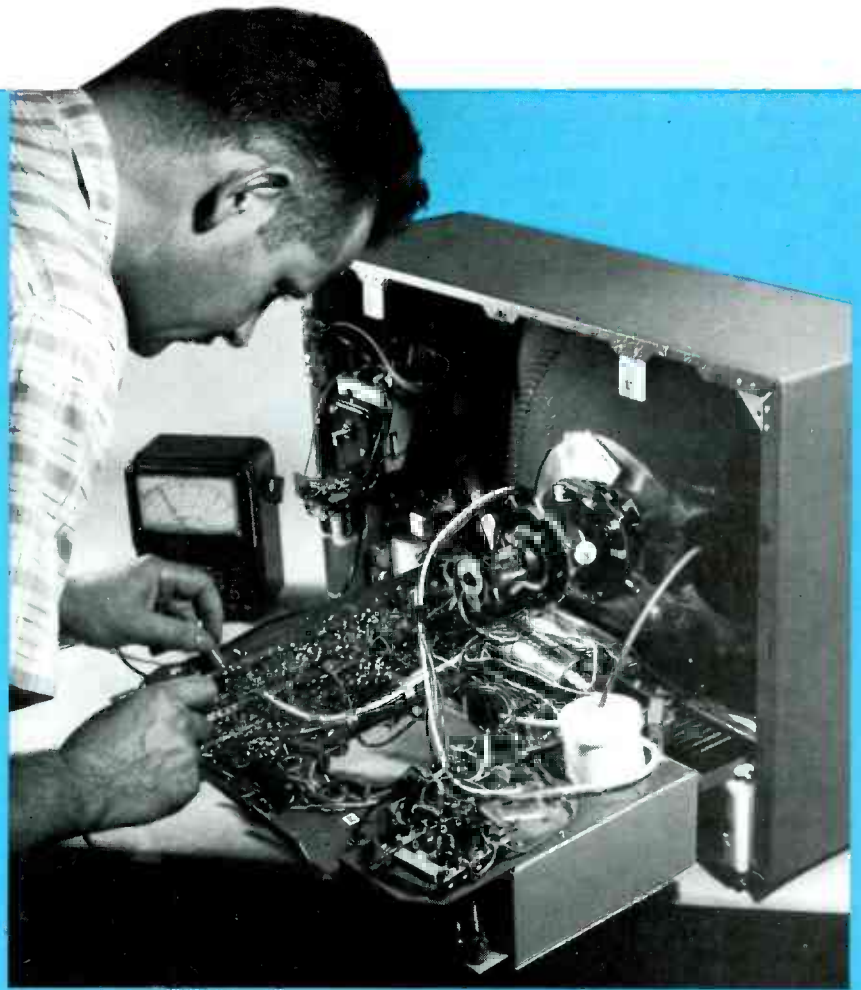

FIG. 3—VARIABLE PHASE COUNTDOWN CIRCUIT. The thumbwheels are adjusted until the sinewave is aligned with the beginning of the tick trace.

## SERVICING HORIZONTAL SWEEP CIRCUITS

FRANK A. SALERNO

*Here are some hints and tricks that may help you out the next time you run across that tough one.*



TV SETS ARE GETTING TOUGHER TO FIX every day. Nowhere is that truer than in the horizontal-sweep circuit sections. Gone forever are the days when a simple multivibrator fed an output tube that drove a flyback transformer, which in turn energized the deflection yoke and the high-voltage rectifier. That was the basic sequence, with only slight variations, which was followed by just about all the manufacturers.

There were, to be sure, peripheral circuits that varied from system to system, and those could and did cause problems, but those problems were minor compared to what we face now. For openers, there's the switch from tube to solid-state stages. Even with a severely overloaded circuit, and the output tube glowing red, you could usually pull the plug in time to prevent any great damage. In modern, solid-state sets, however, it takes no time at all to lose a couple of expensive transistors to a sudden short.

Early solid-state sets tended to follow the design pattern of the tube models. The advent of modular sets made things even more simple, with many manufacturers putting the oscillator on one tiny plug-in board and keeping the output uncomplicated. A classic design was the Zenith EC/FC chassis of a decade ago. That set was so easy to service that few

ever required shop repair.

That kind of a set just isn't made anymore. With most manufacturers abandoning modular construction, and with each one trying to outdo the others in sophistication, it's the home repair that has become the rarity. Oscillators and drivers now can consist of more than five transistors, and the failure of any of those, or their surrounding circuitry, could disable the system. In addition, we have overload protectors, shut downs, fail safes, and what-have-you's that are supposed to disable the system should the high voltage go beyond specified limits. Needless to say, those suffer breakdowns of their own, compounding the problems they were designed to prevent.

In repairing modern sets, there's no room, or time, for error. It takes a fraction of a second to blow a \$12 transistor, and only a fraction of a second more to blow another.

### Essential equipment

Two pieces of equipment are essential in the repair of a modern set—an oscilloscope and a Variac. The scope is used to tell you if and how well things are working, and the Variac lets you work at relatively low voltage, giving you the time required to make some measurements before blowing things out. A variable DC

supply is also nice to have, but a few six-volt dry-cell lantern batteries will do the job just as well; those are needed to check out the start circuits.

### Start circuits

Oh yes, the start circuit, one of the nastiest things ever found in a TV set. Of course, we all know that transistors are incredible things; when one compares them with the slow-warming, hot-running, energy-wasting vacuum tubes that they replaced, one can really get to love them. One of the nice features of transistors is that give them 20, 10, or even just a few volts on which to run and they go into operation instantly. Using that feature, however, someone originated the start circuit, and like most bad habits, it proliferated.

Figure 1 shows two such start circuits. The one in Fig. 1-a was used by Sony some years ago, and the one in Fig. 1-b is used by RCA in some of their more recent sets. The principle behind both is the same. They generate a pulse of voltage at the moment of turn on; that pulse is fed to the horizontal oscillator and excites it into operation. The start circuit, having served its purpose, is then disabled. The voltage needed to keep things running—called, naturally enough, the run voltage—is taken from the flyback, recti-

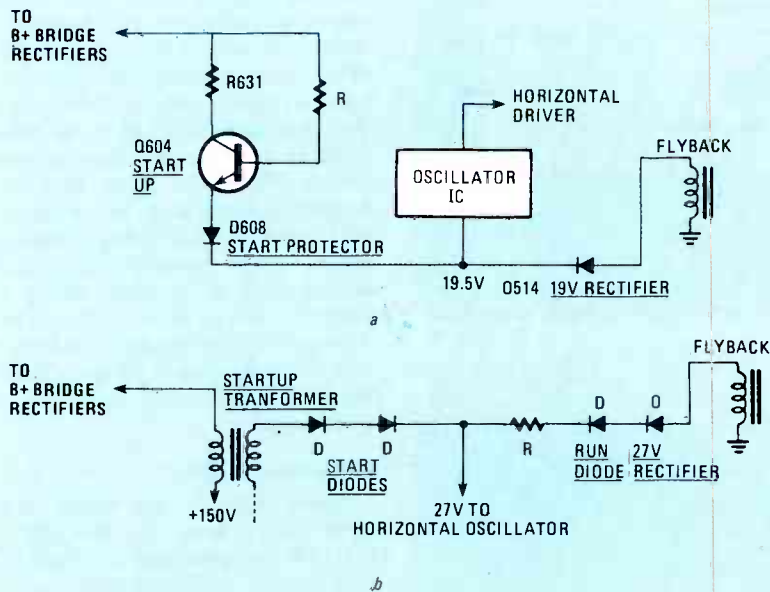

FIG. 1—TWO START-UP CIRCUITS. The one shown in *b* is used by RCA in many of their more recent sets.

fied, and fed to the oscillator at the same point in the circuit as the start pulse.

Now, that's all very nice, but it certainly has complicated life. If there is anything wrong on the output side of the circuit, loading it down, the run voltage will be affected, cutting off the oscillator. That can be quite a problem all around, but especially in those Sony receivers that used an SCR in the output. Sony called that SCR a GCS (Gate Controlled Switch). The nature of that particular device is that if it fails to receive its input signal, it self-destructs—instantly; it has no patience with a lazy oscillator. We have a "Catch 22" here. If the start circuit fails and/or the oscillator does not take off, the GCS shorts out. If the oscillator does in fact start up but is unable to keep running, due to some malfunction in the output side, the GCS shorts out. Either way, you lose.

When you come across a Sony with a shorted GCS (along with an open four-amp fuse and a shorted regulator transistor), the first step to take is to check out the oscillator. Using the start-up circuit for the Sony KV1920, shown in Fig. 1-a, we can see that the 19.5-volt bus supplies the power to the oscillator. The oscillator, however, can run on far less power than that, a fact that works to our advantage when troubleshooting the chassis.

We start by examining the collector of the driver transistor with the oscilloscope. Without plugging the set in, feed six volts DC to the circuit (positive to the 19.5-volt bus, negative to chassis); use either the variable DC supply or the batteries we talked about earlier. You should get a rock-solid signal at the hori-

zontal frequency. It will be less than the 70 volts called for in the schematic, and it will be distorted, but this is not an operational set; all we are interested in now is whether or not the signal is there. If the signal is missing, find out why by working backwards. If it is there, tap the PC board in and around the oscillator. If you see any movement in the waveform when you do that, look for a poor solder joint, or other mechanical problem, somewhere. Even a slight flutter could be what caused the GCS to blow in the first place, so the importance in making sure that the signal you see is rock steady can not be overemphasized.

If you are satisfied with things to this point, it's time to get up your courage and install a new GCS. Once that's done, apply power to the circuit slowly, using the Variac. Start with 50 volts, and keep the oscillator running with the DC supply (or battery). As you increase the voltage, you should hear a rush of noise through the speaker at 75 volts, and at 80 volts a small raster should begin to appear.

If you do not hear that sound, stop! It means that the sound section is not getting its scan-derived voltage because the sweep system is not working. Increasing the applied voltage any farther is tempting fate.

The place to look for trouble now is on the output side of the GCS. Keeping the voltage at 75 volts will minimize the danger of destroying the GCS while using conventional troubleshooting techniques to track down the culprit: defective tripler, shorted scan rectifier, etc.

On the other hand, if sound and picture appear, back the voltage down to 75 and

remove the battery; leave the scope attached, however. Check to see if the oscillator starts when the set is turned on. If it doesn't, the start circuit is probably bad. Check Q604, D608, and R631; that resistor will frequently be burned open. The cause of that can often be traced to a shorted 200-volt scan rectifier, or anything else that might knock out the run voltage forcing the start circuit to do more than was intended.

It's much easier to service a set in which the output is separated from the oscillator. A Philco 5CY81 that we recently came across is a perfect example (see Fig. 2).

The circuit breaker in that set was tripping. When the screws holding down the output transistor were removed, however, the breaker held. When the output of the oscillator module was scoped it turned out to be normal. Reinstalling the screws, the Variac was used to slowly apply power. When the voltage got to about 70, the breaker tripped. Troubleshooting was done by simply lifting each component in turn and reinstalling it until the culprit was found. In this case, when the pincushion transformer was unsoldered the breaker held. It turned out that the transformer had shorted turns.

That troubleshooting process was simple and straightforward in that instance because the oscillator module depended solely on the regular power supply for its operating voltage. By keeping the Variac at 75 volts, we were able to protect the transistor. Otherwise, at full AC voltage, each turn-on might have been its last.

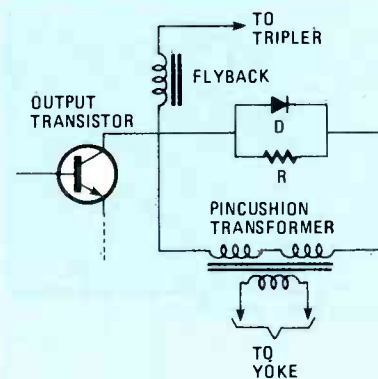

FIG. 2—A SIMPLE REPAIR. A shorted pincushion transformer was the cause of the excessive current drain in this Philco circuit.

### Regulator outputs

In addition to run-start circuits, the newest RCA sets, such as the CTC97 (see Figs. 3 and 4), have another wrinkle to worry about: a regulator output. That is an SCR that supplies a regulated 114 volts to the output transistor.

Here's how to troubleshoot problems

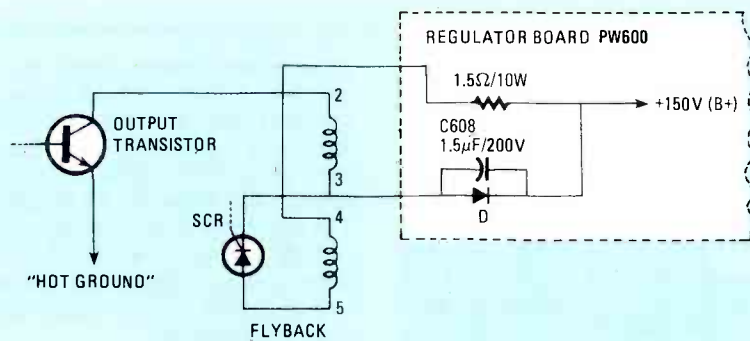

FIG. 3—THE SCR IN THIS CIRCUIT supplies a regulated 114 volts to the output transistor. The circuit is from an RCA CTC97.

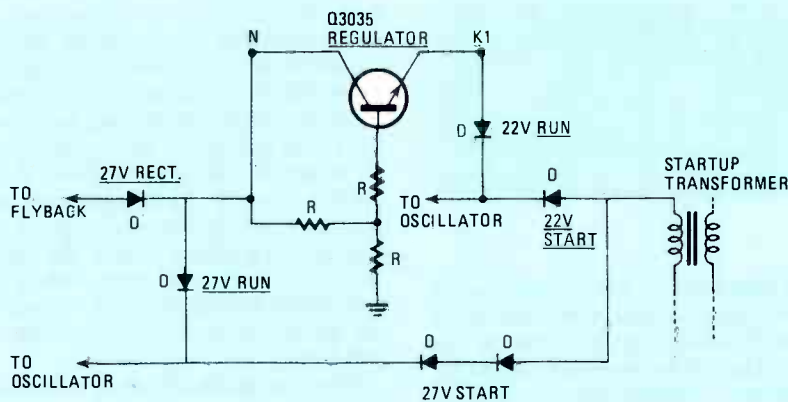

FIG. 4—ONLY THE 27-VOLT run voltage, applied to terminal N, need be supplied for testing. The 22-volt run voltage is taken from the regulator transistor, Q3035.

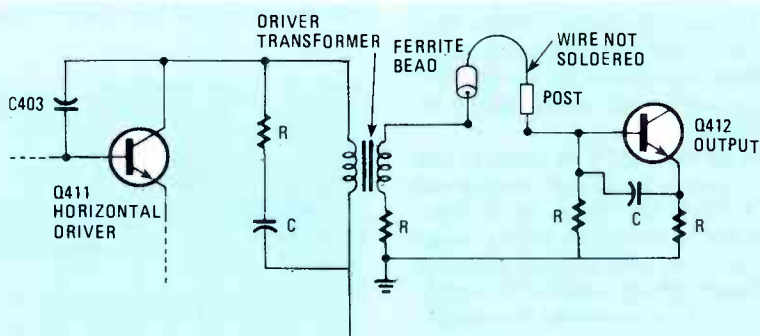

FIG. 5—AN UNSOLDERED WIRE and a leaky capacitor caused two unusual and hard-to-diagnose problems in the CTC108

involving that circuit. If a dead set has no output collector voltage (reading to a hot ground, not the chassis), and the B+ is OK, remove the SCR as a precaution and install a jumper between the anode and cathode connections in the circuit. Again using the Variac, bring the voltage to 90. Using the scope, keep an eye on the output transistor's collector voltage and make sure that it does not exceed 114. If the set comes on, that means that there is trouble somewhere in the regulator circuit that is preventing the SCR from being

gated on. Check all components on PW600, the regulator board.

If, on the other hand, there is collector voltage, we have to troubleshoot the oscillator/output system shown in Fig. 4. Looking at that figure, we see that the oscillator depends on two run voltages—27 and 22. But we need only to supply the 27 volts at terminal N; the other voltage is supplied by Q3035. That 27 volts is supplied once again either with the DC supply or four six-volt lantern batteries in series; the negative connection from the

supply or batteries is made to the chassis.

Once more we use the Variac and scope to go through the system. One CTC97 we saw required just about every technique mentioned so far to track down what was making the output transistor run so hot. With a jumper across the SCR, and four batteries running the oscillator, one after the other each part had to be patiently lifted until the cause of the problem was found. That may seem like an unprofessional way to go about things, but with complex closed-loop circuits like those, scope measurements become almost useless; as such, lifting components is all that is left. In the set in Fig. 3, when C608 on the regulator board was unsoldered, high voltage crackled. Replacing that leaky capacitor cured everything.

### Unsoldered wire

Some problems are harder to track down than others. We remember one CTC108 that gave us a particularly bad time (see Fig. 5). With the battery hooked up, there was a perfect signal coming out of the driver transformer. With no signs of anything being shorted, we decided to temporarily clip a new output transistor into the circuit. Happily, that seemed to cure the problem as the set came on.

Changing that transistor on that particular set was no easy matter as it was soldered in and mounted in a difficult position. You can understand the dismay, then, when the set didn't respond with the new transistor installed. The funny thing was that when the old transistor, the one that was thought to be bad, was clipped into the circuit along with the new one, everything worked once again.

If you've ever been stuck with an odd-ball situation like this one, you know how time can melt away. You also know that sometimes, after spending hours looking at the underside of the chassis, the answer suddenly becomes obvious.

That was the case here. We knew there was an oscillator signal, but was it reaching the transistor? Being mounted on the rear apron, both the base and the collector were returned to the chassis by wires (the emitter was grounded to the apron). The base wire went to the bottom of a hollow metal post that served as a test point. A loop of bare wire came out of the top of that post, passed through a ferrite bead, and then was soldered to the foil connecting the driver transformer. As it turned out, the looped wire was just sitting inside the metal post—it had never been soldered—so the base was getting no signal. Had the transistor been more accessible, and had the signal been traced through, that would have been just a routine repair. Instead, confusion reigned as it appeared as if two transistors were needed. Of course, that was not the case because the one soldered on the apron was never really in the circuit.

*continued on page 78*



## How to Design

# High Frequency Analog Circuits

MANNY HOROWITZ

*Many factors that up to now could be ignored when designing a circuit become critical at high frequencies. This month, we'll look at those factors and the role they play in designing a successful circuit.*

UP TO NOW, WE'VE BEEN DISCUSSING CIRCUITS that operate at fairly low frequencies. As operating frequencies become higher, however, factors that were previously unimportant become critical. That's because the effects of stray capacitance, both of the components and the circuit itself, become more pronounced as the frequency increases. Thus, any successful design must take into consideration the selection of the components as well as their placement in the circuit.

Before we begin, let's review a couple of points. It was previously stated that a resonant circuit in an oscillator consists of a capacitor and an inductor. The capacitor in that circuit has a reactance,  $X_C$ , equal to  $1/2\pi fC = 1/6.28fC$ , where  $f$  is the frequency of the signal applied to the component and  $C$  is its capacitance in farads. Obviously then, as frequency increases the reactance of the capacitor is reduced. In the case of an inductor,

however, its reactance,  $X_L$ , is equal to  $6.28fL$ , where  $L$  is the inductance in henrys; thus, the reactance increases with increasing frequency.

### Figure of merit

Inductors and capacitors store energy. That energy is applied to those components when a voltage is placed across their terminals and a current is fed through them. If the capacitor or inductor were ideal, all of the energy stored in them would be returned to the circuit eventually regardless of the operating frequencies. Of course, the components we are dealing with are real, not ideal. They all have some element of resistance associated with them that causes losses. Consider, for instance, a capacitor. Under DC conditions that component is considered an open circuit with infinite resistance. That being the case, no current should get through. We all know, however, that some small leakage current almost

always exists. The effect is the same as if a large valued resistor were in parallel with the capacitor as shown in Fig. 1. That figure illustrates the model used when analyzing the behavior of a real capacitor.

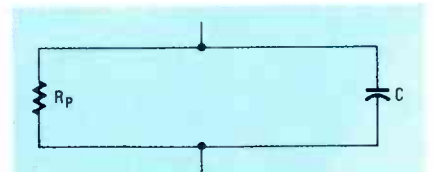
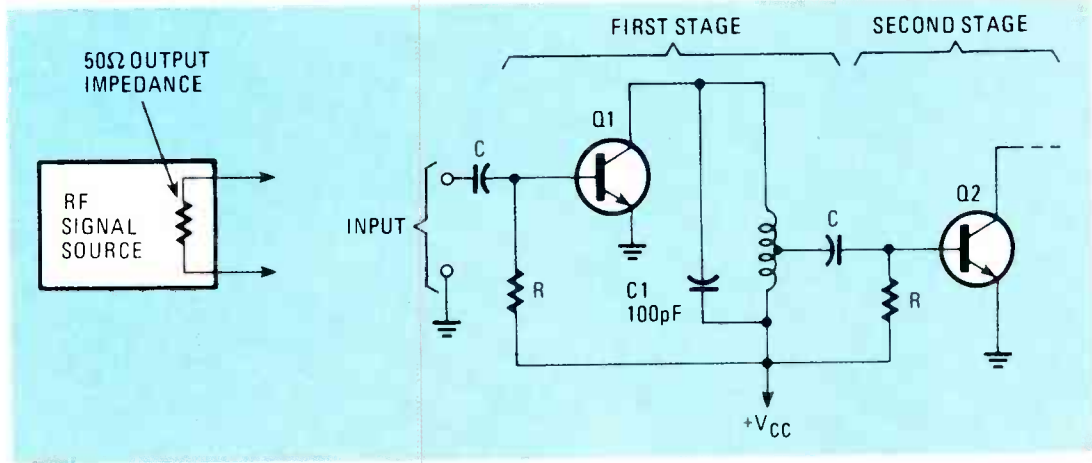

FIG. 1—A REAL CAPACITOR can be thought of as an ideal capacitor in parallel with a very large resistance.

Inductors, on the other hand, are treated as short circuits under DC conditions. Since they theoretically present no resistance, there should be no voltage drop across them. Of course, that is not



Introducing A 16-Bit  
Microprocessor System  
Designed To Expand  
Your Knowledge.



ET100 Educational Systems  
ET100 LEARNING COMPUTER



# Here's How You Can Learn 16-Bit Technology. And Graduate To One Of Today's Most Powerful And Advanced Microcomputers.

Now you can master 16-bit technology with an all-new Advanced Microprocessor course. And build hands-on experience with the only 16-bit microcomputer specifically designed for the hobbyist, working engineer and student.

## Advanced Microprocessor Course

This all-new self-study course (EE-8088) provides in-depth coverage of 16-bit, state-of-the-art technology.

You will gain a thorough understanding of microprocessors from this 1200 page course. In 10 easy-to-understand units, starting with microcomputer basics, you'll cover all phases of 16-bit micro-processing. Assembly language. Program writing. Addressing modes. Dynamic and static RAM. And hardware interfacing.



And by using your 16-bit Trainer/Learning Computer for hands-on experiments (over 60 included), you'll gain actual circuit interface and software programming experience with an

8088 microprocessor system.

## Trainer/Learning Computer

A unique combination of design features makes this versatile microprocessor system much more than a "teaching machine." Use it as a trainer with the Advanced Microprocessor course. Use it as an experimental design computer. And use it to run a wide variety of 16-bit software - including Z-Dos, Multiplan, Z-Basic, Condor File Manager, and much more.



In its most basic form, the Trainer/Learning Computer is a 16-bit, cassette-based microcomputer.

Its unique design features access ports and solderless breadboards to allow you to build interfaces, design and modify circuits, or simply experiment with the inner workings of the microprocessor system.

The basic system has an 8088 processor, 32K ROM (including assembler, editor and debugger) and 16K RAM.

The unit also features a serial I/O printer port, cassette interface and a detached 95-key keyboard (including 16 function keys and a numeric keypad) which generates a full ASCII character set. It's available either in kit form or factory assembled.

And you can take advantage of the system's H/Z-100 computer design heritage by easily upgrading it to a disk-based, 16-bit microcomputer that will run H/Z-100 series software and many other forthcoming programs.



## Fully Upgradeable

The powerful upgrade package and variety of accessories allow you to make the basic 16-bit system more powerful and versatile. You can add 128K or 192K bytes

of RAM. Floppy disk controller. 48TPI double-sided, double-density, single or dual floppy disk drive. Bit-mapped video graphics or full-color graphics. Two RS-232 ports. Programmable timer. And a Centronics-compatible printer port.

## Learn on it. Design with it. Use it as a 16-bit computer.

It's the only 16-bit microprocessor system specifically designed to integrate theory with a hands-on understanding of how 16-bit computers work. And it's from Heathkit/Zenith Educational Systems, the world-leader in problem-solving courses, trainers and accessories to help you learn state-of-the-art technology.

**Heathkit**<sup>®</sup>  
Heath  
Company

A subsidiary of Zenith Radio Corporation

CIRCLE 16 ON FREE INFORMATION CARD



Get more information in the  
**FREE  
HEATHKIT CATALOG**

Mail to: Heath Company, Dept. 020-094  
Benton Harbor, MI 49022

Name \_\_\_\_\_

Address \_\_\_\_\_

City \_\_\_\_\_

State \_\_\_\_\_ Zip \_\_\_\_\_

ED-199

what happens. There is a voltage drop that is caused by the resistance of the wire that makes up the inductor. Although that resistance is distributed along the length of the wire, the effect is the same as if that resistance were in series with an ideal inductor. That is the model used in analyzing the behavior of a real inductor and is shown in Fig. 2.



FIG. 2—A REAL INDUCTOR can be represented as an ideal inductor in series with a resistor.

When discussing such components, it is useful to know how close to ideal they are. To do that, a value  $Q$ , called the figure of merit, can be determined for each component. That value relates the amount of energy returned to the circuit to the amount of energy lost in the component due to its inherent resistance. A high value of  $Q$  indicates a more ideal component, and hence less loss than one with a low  $Q$  rating.

The  $Q$  of an inductor or capacitor is related to the reactance and series resistance of the component through the equation  $Q = X/R_s$ ; and is related to the reactance and parallel resistance by  $Q = R_p/S$ . Thus (using the equivalent circuits shown), for an inductor,  $Q = 6.28fL/R_s$ , while for a capacitor it equals  $6.28fCR_p$ .

While we represented a real inductor as an inductance in series with a resistance, and a real capacitor as a capacitance in parallel with a resistance, those are not necessarily the only ways those components can be shown. For instance, there is no reason why an inductor could not be shown as an inductance in parallel with a resistance. After all, it is the same component so the impedance and the  $Q$  will be the same. When the way that the component is shown changes, the only thing that changes is the way in which  $Q$  is calculated. Instead of  $6.28fL/R_s$ , it is now found from  $R_p/6.28fL$ . But since the value of  $Q$  is identical,  $6.28fL/R_s = R_p/6.28fL$ . After rearranging the terms and simplifying, that equation yields the relationship  $R_p = Q^2R_s$ . That relationship also holds true for capacitors.

### Dissipation factor

Instead of  $Q$ , the quality of a capacitor is frequently described by the dissipation factor, or  $DF$ . That is a quantity indicating a loss of energy, usually due to the conversion of that energy to heat and is equal to  $1/Q$ . Thus, the quality of a capacitor is best when the dissipation factor is at a minimum.

Although most frequently used when specifying the quality of a capacitor, the dissipation factor can also be used to describe the quality of an inductor. Such use is rare, however.

### Resonance

Inductors and capacitors are used to tune a circuit so that it is resonant at a specific frequency such that  $X_L = X_C$ . By substituting and rearranging terms it can be shown that that frequency,  $f_0$ , is equal to  $1/6.28\sqrt{LC}$ . Resonant circuits can take one of two forms: series or parallel. If the inductor and capacitor are in series, the circuit presents a low impedance at resonance. If the inductor and capacitor are in parallel, the circuit presents a high impedance at resonance.

Let's first consider a series L-C circuit, such as the one shown in Fig. 3. The current in any series circuit is the same through all the components in the circuit. In a series L-C circuit, however, the phase of the voltage across the capacitor is  $90^\circ$  ahead of the current through it, while the voltage across the inductor is  $90^\circ$  behind the current through that component. Thus, the voltages across those components are  $180^\circ$  out of phase. What that means is that when the reactive voltages are equal, the voltage across the capacitor will completely cancel the voltage across the inductor. That happens when  $X_L = X_C$ , which is the condition at resonance.

If the circuit were ideal, at resonance it would present zero inductance, zero reactance, and zero impedance. Real capacitors generally do resemble the ideal model and have negligible series resistance associated with them, but that is not the case with inductors. As previously mentioned, those components are coils of wire and as such generally have a substantial series resistance associated with them. Thus, since the resistance of the inductor can be drawn as a discrete component in series with it, Fig. 3 can be redrawn as shown in Fig. 4, where  $R_s$  is the series resistance of the inductor.

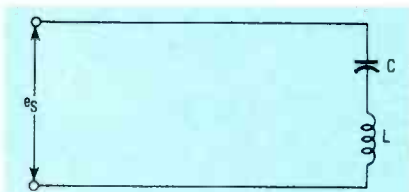

FIG. 3—A SERIES L-C CIRCUIT presents, in theory, zero impedance at resonance.

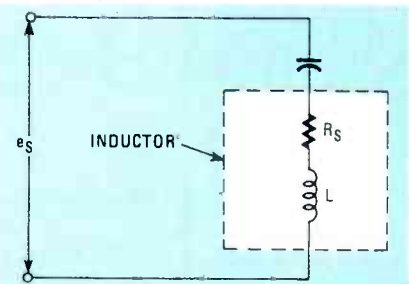

FIG. 4—TO ANALYZE a series L-C circuit's behavior, redraw the circuit as shown.

A parallel L-C circuit is shown in Fig. 5. In all parallel circuits, the voltage across each branch is identical. In a parallel L-C circuit however, the phase of the current leads the voltage by  $90^\circ$  in the capacitor, while the current lags the voltage by  $90^\circ$  in the inductor. At resonance, since the reactances are equal, whatever current is flowing upward in the capacitive branch of the circuit, is flowing downward in the inductive branch, and vice versa.

Let's examine what the importance of that is a little more closely. From Kirchhoff's current law we know that the sum of the currents flowing into a junction of circuit branches must equal zero. Looking at the point labeled A in Fig. 5, we see that at resonance the same current flowing into it from one of the reactive elements is flowing out of it into the other. That means that there is no current drawn from the source, which means that the impedance presented by the circuit is infinite ( $Z = e_s/I_s = e_s/0 = \infty$ ).

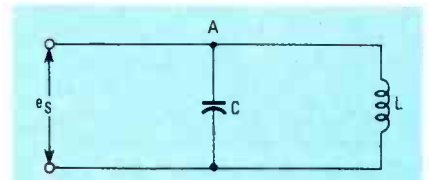

FIG. 5—AN IDEAL PARALLEL L-C CIRCUIT will present an infinite impedance at resonance.

That, of course, assumes ideal components. If those components were indeed ideal, and the source were disconnected, the current would flow back and forth between the reactive elements indefinitely. Of course, that never would happen because of the losses introduced by the series resistances of the components. Here, we once again can consider the series resistance of the capacitor to be negligible and concern ourselves just with the series resistance of the inductor. Thus, Fig. 5 can be redrawn as shown in Fig. 6, where  $R_s$  is the series resistance of the inductor.

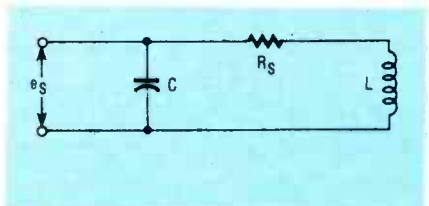

FIG. 6—A PARALLEL L-C CIRCUIT can be redrawn as shown here.

Before we go any farther, let's look at one other aspect of inductors that's important, especially when dealing with higher frequencies. As inductors are composed of turns of wire, stray capaci-

tances can form between turns, whether or not they are adjacent; between the coil and ground; between the leads connected to the terminals of the coil, and so on. Thus, any inductor is in essence a large inductor in parallel with a very small capacitor. At lower frequencies, those *distributed capacitances* are rarely important, but at higher frequencies, they can make the inductor self resonant. That effect must be considered in high-frequency designs because if the signal frequency exceeds the inductor's self-resonant frequency, that device will behave like a capacitor rather than an inductor. Thus, those distributed capacitances place an upper limit on the frequencies at which the inductor can be used. Self-resonance can also occur if the self-resonant frequency is a harmonic of the signal frequency.

### Filters

Since series L-C circuits present a low impedance at the resonant frequency, but high impedance at others, they make excellent bandpass filters. Such an application is shown in Fig. 7-a. In it, the input signal  $e_S$ , is fed to a series L-C circuit. Assuming that the circuit is designed to be resonant at  $e_S$ 's fundamental frequency, only that frequency will be passed; all other frequencies will be sharply attenuated. Finally, the signal appears across  $R_L$  as  $e_{OUT}$ .

In the circuit shown in Fig. 7-b, all frequencies except the resonant frequency are shorted by the L-C circuit. The resonant frequency, however, appears across L. From there it is coupled into L2 and on to the output. Ideally, only the resonant frequency should pass through those L-C circuits to the output. In most cases, however, a band of frequencies is passed. The width of that band can be determined from the circuit Q, and through use of a graph of the frequency response of a circuit similar to the one shown in Fig. 8. Looking at that curve, the maximum output of a circuit is  $e_{OUT}$ , and  $f_H$  and  $f_L$  are the -3-dB points. The bandwidth of the circuit,  $f_H - f_L$ , is equal to the resonant frequency divided by Q. Thus the bandwidth is inversely proportional to Q.

As an example, assume a circuit where  $C = 10\text{pF}$ ,  $L = 25.4\mu\text{H}$ , and  $Q = 20$ . Using the equation for the resonant frequency, we find that  $f_0 = 10\text{ MHz}$ . If  $Q = 20$ ,  $f_H - f_L = (10\text{ MHz})/20 = 500\text{ kHz}$ . Because  $f_L$  should be the same distance below  $f_0$  as  $f_H$  is above that resonant frequency,  $f_L = 10\text{ MHz} - 250\text{ kHz} = 9.75\text{ MHz}$ , and  $f_H = 10\text{ MHz} + 250\text{ kHz} = 10.25\text{ MHz}$ . Signals with frequencies between 9.75 MHz and 10.25 MHz are passed rather easily by that circuit.

In many applications it is desirable to attenuate signals at frequencies below and above the active band. To achieve that, L-C circuits can be placed in series

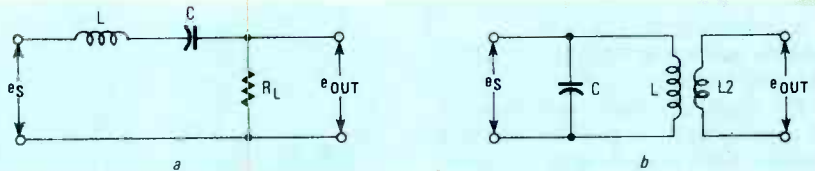

FIG. 7—TWO BANDPASS FILTERS. The one in a uses a series L-C circuit and presents a high impedance at all frequencies except the resonant one. The one in b uses a parallel L-C circuit; at resonance, only the resonant frequency appears across L.

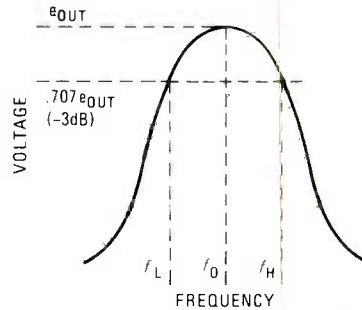

FIG. 8—THE LIMITS OF A BAND are defined by its upper and lower -3-dB points. Those are the frequencies at which the signal has dropped 3 dB from its level at resonance.

with the signal. The circuit shown in Fig. 9-a is a simple *low-pass filter*. It is called that because it will only pass frequencies less than a certain cut-off frequency,  $f_C$ . The values of L and C can be found from  $L = R/4\pi f_C$  and  $C = 1/4\pi f_C R$ , where R is the impedance of the source and the load.

The circuit shown in Fig. 9-b is a simple *high-pass filter*. It will only pass frequencies that are higher than the cut-off frequency. The appropriate values of L and C can be found from  $L = R/\pi f_C$  and  $C = 1/\pi f_C R$ .

### Bipolar transistors

Inductors, capacitors, and resistors are not perfect components at high frequencies. We saw that an inductor has stray capacitances associated with it. Similarly, a capacitor has stray inductances. Resistors also exhibit some capacitance and inductance; some types of resistors cannot be used at high frequencies.

Such imperfections are not limited to passive components alone; transistors, for instance, exhibit stray capacitance between their terminals. Those capacitances are their primary imperfections when they are used at high frequencies.

Because of that, many types of transistors can only be used in low-frequency circuits. On the other hand, some devices have been developed that are capable of operating in the high GHz range. We will start this part of our discussion by describing the use of bipolar devices in RF circuits and by noting how those devices limit the performance of those circuits. The discussion continues by describing how FET's behave under similar situations.

### Alpha and beta

When describing a transistor's characteristics, and the effect of those characteristics on a circuit, the alpha and beta of the transistor were treated as constant values. The only deviation from the stated constants was to note how they varied with collector current. But alpha and beta also vary with frequency; they become smaller as the frequency becomes higher. As a result, the input impedance of a particular transistor circuit, equal approximately to  $\beta R_E$ , is much higher at low frequencies than at high ones.

If we consider  $\alpha_0$  as the low-frequency current gain between the collector and emitter,  $\alpha$  decreases 3 dB to .707 of  $\alpha_0$  at what is referred to as the *alpha cutoff frequency*. Several symbols are used to denote that frequency, including  $f_{\alpha}$ ,  $f_{h\beta}$ , and  $f_{\alpha b}$ . Once the frequency is determined from the transistor's specifications,  $\alpha$  at any frequency can be determined using the curve in Fig. 10. At  $f_0$ , alpha is 1/1.4 of its specified low-frequency value; at  $2f_0$ , alpha is 1/2.24 of  $\alpha_0$ , and at  $4f_0$ , alpha drops to 1/4 of its low-frequency figure. From that frequency on, every time the frequency doubles, alpha drops by one-half. Thus at  $8f_0$ , or double the  $4f_0$  frequency, alpha dropped from 1/4 of  $\alpha_0$  to 1/8 of  $\alpha_0$ . That relationship remains constant on up to extremely high frequencies.

Since beta decreases at the same rate as

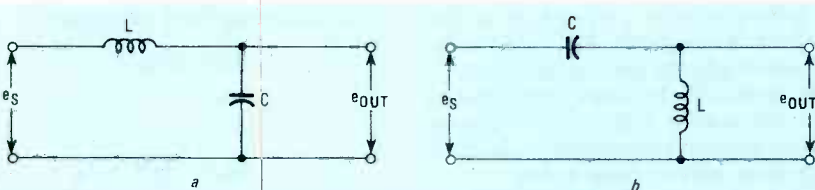

FIG. 9—SIMPLE LOW-PASS AND HIGH-PASS FILTERS. The low-pass filter shown in a attenuates all frequencies below the resonant one while the high-pass filter in b attenuates all frequencies below resonance.

alpha, the beta at any frequency can also be determined using Fig. 10.

Alpha and beta at a specific frequency can be calculated easily. Simply divide  $f_0$  by the frequency under consideration, and multiply by  $\alpha_0$  or  $\beta_0$  of the transistor involved. For a limited range of frequencies,  $\alpha$  and  $\beta$  can be estimated from the curve in Fig. 10.

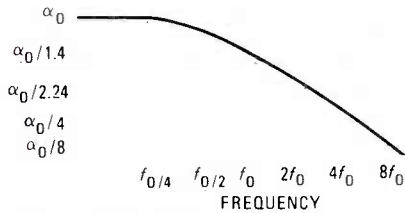

FIG. 10—HOW ALPHA VARIES with frequency. The value of beta varies in an identical manner.

Finally, the *gain-bandwidth product*,  $f_T$ , a value found on most transistor spec sheets, is useful in determining  $\beta$  at any operating frequency. That quantity,  $f_T$ , is defined as the product of beta and the upper 3-dB limit of a band. By simply considering the band here to stretch from 0 Hz to the operating frequency, it is possible to find beta by dividing  $f_T$  by the operating frequency. For example, if the  $f_T$  for a transistor is specified as 100 MHz, and you want to find the beta at 10 MHz, it is  $100/10 = 10$ .

### Equivalent circuits

At low frequencies, the equivalent circuit of a transistor was considered to be composed of two diodes. One diode, located between the base and collector terminals, was reverse biased. The second one, located between the base and emitter terminals, was forward biased. That circuit can be simplified farther by replacing the diodes with their internal on- and off-state resistances. The forward-biased diode could be replaced with a low value resistor connected from the base to the emitter,  $r_{be}$ , and the reverse-biased diode could be replaced with a large resistor connected between the base and collector,  $r_{bc}$ . There are, of course, also capacitances between the various terminals of the equivalent circuit. At low frequencies, those can be ignored; that, of course, is not true at high frequencies. An equivalent circuit including those capacitances, is shown in Fig. 11.

In that circuit, almost all components are referenced to  $b'$ , a point inside the transistor. For instance,  $R_{bb'}$  is the resistor located between the base and point  $b'$ . That resistance becomes important at high frequencies because it is almost equal to the high-frequency impedance of the various internal capacitances.

It is obviously just about impossible to measure the various resistances and capacitances in the equivalent circuit be-

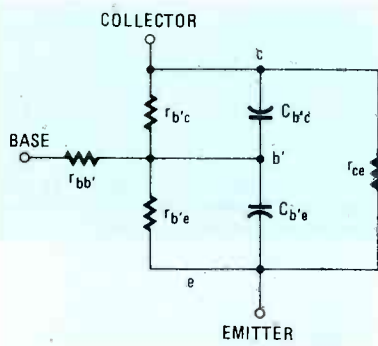

FIG. 11—EQUIVALENT CIRCUIT for a transistor in a common-collector configuration. The values of all the resistances and capacitances can be found using data on the device's specification sheet and readily measurable quantities.

cause those are all referred to a point inside the transistor. But their values can be estimated using either measurable or specified quantities. Those are  $g_m$ ,  $\beta$ ,  $h_{oe}$ ,  $h_{re}$ ,  $h_{ie}$ , and  $C_{ob}$ . All those factors, with the exception of  $g_m$ , can be found on most complete specification sheets. Let's look at them briefly.

The transconductance of a transistor,  $g_m$ , relates the collector current to the base-emitter voltage; in an FET it relates drain current to gate voltage. Transconductance is roughly equal to the quiescent collector current, in amperes, divided by 0.026.

Beta, of course, is the low-frequency current gain as specified by the manufacturer of the device. The no-load admittance seen when looking back into a transistor is  $h_{oe}$ . Since admittance is the inverse of resistance, the output resistance of the transistor is given by  $1/h_{oe}$ .

Consider two voltages. One,  $V_1$ , is the voltage at the input due to voltage present at the output of the transistor. The other,  $V_2$ , is the voltage at the output. The ratio  $V_1/V_2$  is equal to  $h_{re}$ . That again assumes no load at the output. The impedance seen by looking into the input when the output is short circuited is called  $h_{ie}$ . The collector-to-base capacitance of a transistor's common-base equivalent circuit is  $C_{ob}$ .

All of the above parameters, with the exception of  $C_{ob}$ , are for a common-emitter circuit. If the specification sheets should list the h-factors for the common-base circuit,  $h_{ob}$ ,  $h_{rb}$  and  $h_{ib}$ , rather than the h-factors for the common-emitter circuit as noted above, the common-base factors can be converted back to common-emitter parameters through use of the following three equations:

$$h_{oe} = \beta h_{ob} \quad (1)$$

$$h_{re} = \frac{h_{ie} h_{oe}}{\beta} + h_{rb} \quad (2)$$

$$h_{ie} = \beta h_{ib} \quad (3)$$

In each case, all factors should be altered to conform with the emitter current and collector-emitter voltage conditions under which the transistor is being used. Curves are usually supplied by the manufacturer of the device to help in that task. If no such curves are available, the data can be used as supplied but the circuit will have to be tweaked up once it is built. (More on that later.)

Using the h-factors, the values of the resistances and capacitances in the high-frequency equivalent circuit can be found from the following:

$$r_{bb'} = h_{ie} \quad (4)$$

$$r_{b'e} = \frac{\beta}{g_m} \quad (5)$$

$$r_{b'c} = \frac{r_{b'e}}{h_{re}} \quad (6)$$

$$r_{ce} = \frac{1}{(h_{oe} - g_m h_{re})} \quad (7)$$

$$C_{b'e} = \frac{g_m}{2\pi f_T} \quad (8)$$

$$C_{b'c} = C_{ob} \quad (9)$$

At low frequencies, the voltage gain can be found without resorting to complex mathematics. But like  $\alpha$  and  $\beta$ , voltage gain drops at higher frequencies. The frequency at which the voltage gain has dropped to  $1/1.414$  of its low-frequency level (3 dB) is:

$$f_0 = \frac{\beta + g_m (\beta R_E + r_{b'b} + R_S)}{2\pi \beta (C_T) (R_T)} \quad (10)$$

where:

$$C_T = (C_{b'e} + C_{b'c} g_m R_L + C_{b'c} g_m R_E)$$

$$R_T = (R_E + r_{b'b} + R_S)$$

In that equation, all factors, with the exception of  $R_E$ ,  $R_L$ , and  $R_S$ , are found as shown above. As for the exceptions,  $R_E$  is the emitter resistor,  $R_L$  is the load resistance, and  $R_S$  is the resistance of the signal source. The gain of the device varies as shown in Fig. 10.

The above details apply to a common-emitter circuit. To find the high-frequency voltage gain of a transistor in a common-base or common-collector circuit, proceed as you would in a low-frequency situation, except use the values of  $\alpha$  and  $\beta$ , and the effective load on the transistor, at the frequency in question.

Let's now apply what we've learned. Assume you have a 10-MHz signal source with an output impedance of 50 ohms.

That source is feeding a transistor in a common-emitter circuit. In order to get good gain, a transistor with a high  $f_T$  should be used. Use a 2N5354; it has an  $f_T$  of 250 MHz. In that transistor,  $C_{ob} = 8$  pF,  $\beta$  at low frequencies is 100,  $h_{ie} = 1300$ ,  $h_{oe} = 24 \times 10^{-6}$ , and  $h_{re} = 1.5 \times 10^{-4}$ . If we assume that the idling current,  $I_E$ , is 2 mA (.002 amperes), then  $g_m = 0.002/0.026 = 0.077$  mhos. We can use the common-emitter h-factors as supplied by the manufacturer without modification. The various components in the high-frequency equivalent circuit of the transistor are found by substituting into equations 4 through 9:

$$r_{bb} = 1300 \text{ ohms}$$

$$r_{b'e} = 100/0.077 = 1300 \text{ ohms}$$

$$r_{b'c} = 1300/1.5 \times 10^{-4} \\ = 870 \times 10^{-4} \text{ ohms}$$

$$r_{ce} = 1/[24 \times 10^{-6} - 0.077(1.5 \times 10^{-4})] \\ = 28000 \text{ ohms}$$

$$C_{b'e} = 0.077/6.28(250 \times 10^6) = 49 \text{ pF}$$

$$C_{b'c} = 8 \text{ pF}$$

As for the load, assume there is a parallel resonant circuit in the collector circuit consisting of a 100-pF capacitor and a 2.5- $\mu$ H inductor. The series resistance of the inductor is 0.2 ohms. That circuit resonates at 10 MHz. The Q is primarily equal to that of the inductor, which is  $6.28fL/R_S = (6.28 \times 10^7)(2.5 \times 10^{-6})/2 = 80$ . Thus the series resistor, when converted to the parallel resistance across the L-C circuit, is equal to  $Q^2R_S = 80^2 \times 0.2 = 1280$  ohms. Because the impedance of the inductor cancels the impedance of the capacitor at resonance,  $R_L$  is equal to that parallel resistance. Use 1300 ohms as a close approximation.

This transistor performs well without a resistor in its emitter circuit so one will not be used here. Substituting all necessary information into equation 10 to determine  $f_O$  while letting  $R_E$  equal 0 gives us  $f_O = 283,419$  Hz.

Use  $f_O = 250,000$  Hz as an approximation for the calculated frequency. That means that the gain at 250 kHz is 1/1.414 of what it is at low frequencies (3 dB below the low frequency gain). At 500 kHz, the gain drops another 4 dB, and at 1 MHz the gain is another 5 dB down for a total drop in gain of 12 dB. From that frequency on, the voltage gain drops an additional 6 dB each time the frequency doubles, so that it is 18 dB down at 2 MHz, 24 dB down at 4 MHz, 30 dB down at 8 MHz, and a little more, about 32 dB, down at the 10 MHz we are concerned with. The 32 dB figure indicates that the gain at 10 MHz is about 1/40 of the gain at low frequencies.

Considering that the only resistor in the

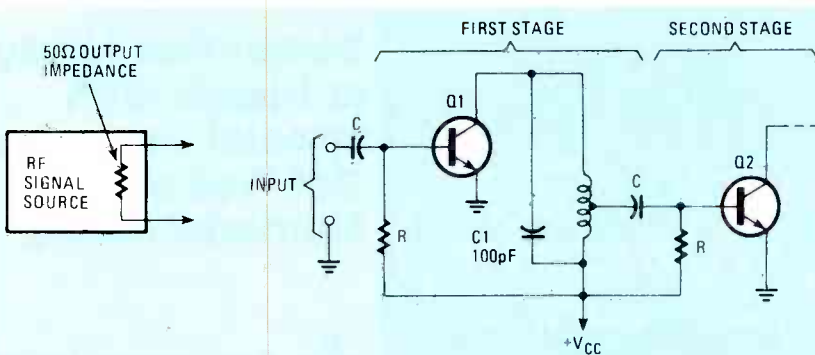

FIG 12—SIMPLE HIGH-FREQUENCY AMPLIFIER. Because of the complex factors involved in designing such a circuit, the values used for the various components will always differ from those initially calculated.

emitter circuit is the  $r_e$  of the transistor, and that  $r_e$  is equal to  $26/2 = 13$  ohms when 2 mA of current flows through the device, the gain at low frequencies is  $R_L/13 = 1300/13 = 100$ . Because gain dropped to 1/40 of that at 10 MHz, the voltage gain of the overall circuit is 1/40 of that 100, or 2.5.

As the gain-bandwidth product equals 250 MHz,  $\beta$  at 10 MHz is equal to 250 MHz/10 MHz = 25. That is approximately equal to the current gain of the device at 10 MHz. Power gain is the product of the current and voltage gains at 10 MHz, or  $2.5 \times 25 = 62.5$ .

Those results must be tweaked-up in the amplifier after it has been built. There are many reasons for that. For one, approximations have been used in the design. Also, the various stray capacitances in the equivalent circuits of Q1 and Q2 were not considered. Although not shown in the equation, they do affect the resonant frequency and must be compensated for in the final design.

A basic schematic using two transistors and the components we've described here is shown in Fig. 12. In our design example, Q2 was not in the circuit, so that the complete load on the transistor was the L-C resonant tank. Should the L-C circuit feed another transistor as shown, its load should be considered to be in parallel with the calculated  $R_p$  of the tank. In the figure, the tap on the transformer is used to match the impedance of the re-

sonant circuit to the impedance at the input of Q2. That is done to maximize the transfer of power from the first stage to the second stage.

### FET'S

Practical circuits involving FET's do not differ radically from those using bipolar devices. There are differences, however. Because of an FET's high input impedance, the transistor does not contribute substantially to the load on a preceding stage but the various capacitances in the FET's equivalent circuit can effect the load. As for those loads, they are almost always resonant tank circuits so it's clear that those capacitances will change the tank's resonant frequency.

As an example, consider the circuit drawn in Fig. 13. For simplicity, we'll use the same values for L and C that were used in the previous example. Thus,  $L1 = 2.5 \mu$ H,  $C1 = 100$  pF, and the parallel resistance is 1300 ohms; the tank, then, resonates at 10 MHz. The impedance of the source has no effect at high frequencies and is thus ignored.

We'll use a 2N5397 transistor here; it has excellent characteristics even at 450 MHz. That transistor's capacitance from the gate to the drain,  $C_{rss}$ , is specified as 1.3 pF. That capacitance added to the gate-to-source capacitance of the FET is specified as 5.5 pF. That sum is the  $C_{iss}$  of the device. The  $g_m$  of the transistor is about  $7.5 \times 10^{-3}$  ohms.

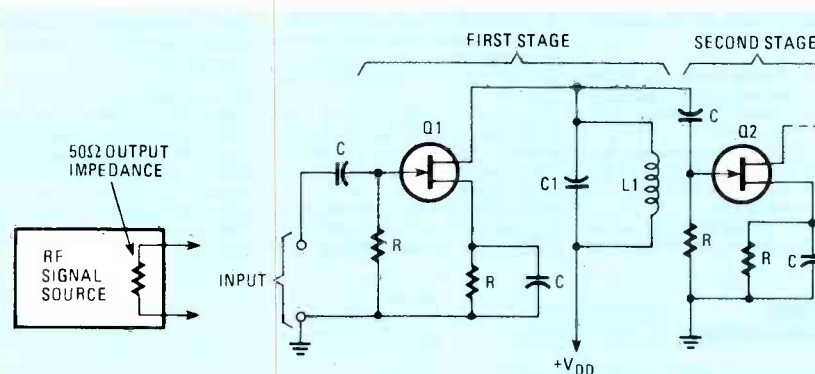

FIG. 13—PRACTICAL FET HIGH-FREQUENCY AMPLIFIER CIRCUITS do not differ greatly from those using bipolar devices.

*A Time to Remember*

**Remember family or friends with Special Occasion, Get Well or Memorial cards.**



**American Heart Association**

WE'RE FIGHTING FOR YOUR LIFE

Using this data, gain at low frequencies is  $g_m R_D$  or  $(7.5 \times 10^{-3})(1300) = 9.75$ . Voltage gain is 3 dB down at:

$$f_o = \frac{1}{6.28 (R_D)(C_{ds} + C_{gd})}$$

In that equation,  $C_{gs}$ , the gate-to-drain capacitance, is equal to  $C_{rss}$ . Because  $C_{ds}$  is insignificant in JFET transistors, that factor can be ignored and:

$$f_o = \frac{1}{6.28 (1300)(0 + 1.3 \times 10^{-12})} = 94 \text{ MHz}$$

Because of that high cut-off frequency, voltage gain at 10 MHz is not reduced noticeably from its low-frequency value of 9.75. If the impedance of the signal source were comparable to the impedance of the circuit (which it is not),  $f_o$  would differ from the frequency just calculated. It would be

$$f_o = \frac{1}{6.28 (R_S) (C_{iss} + g_m + R_D C_{gd})} = 175 \text{ MHz}$$

Because  $f_o$  is at a much higher frequency in that case, the effect of the transistor on voltage gain would be even less than when the source was ignored. As for the effect of Q2 on the load of Q1, it is negligible because of its extremely high input impedance as previously noted.

#### Stability

RF circuits have a tendency to be unstable because of undesirable positive feedback from the output back to the input of a transistor. Oscillation caused by such feedback is eliminated through a technique called neutralization. In that, a capacitor feeds a signal from a circuit at the output of an amplifier stage back to its input. The signal through the capacitor is adjusted so that it is 180° out of phase with the feedback and at the same level. When that is done, the effects of the positive feedback are cancelled.

#### Filters

When working at high frequencies, a considerable number of factors in the circuit must be calculated. Even so, due to stray capacitances and inductances, as well as the fact that approximations are used in some steps in the design, the values of most of the capacitors and inductors must be adjusted after the circuit has been built. The same factors occur in high-frequency filter design. There, however, the technique of approximation and trimming is not satisfactory. Therefore, more precision is required. In the next part of this series, we'll look at what's involved, as well as at the design of different types of high-pass, low-pass, bandpass, and band-rejection filters. **R-E**

# Radio-Electronics

SPECIAL REPRINT  
BUILD A BACKYARD SATELLITE TV RECEIVER



**Sixth Printing: Sold Out!  
Seventh Printing—Just Off Press!  
Reprints Now Available!**

## Don't miss out again!

Send away today for your 36-page booklet containing a complete reprint of all seven articles in the series on Backyard Satellite TV Receivers by Robert B. Cooper Jr.

This all-inclusive report gives you all the data you need to build your own Backyard Satellite TV Receiver.

- TELLS ALL ABOUT domestic satellite communications, with full details on how you can pull those elusive TV signals from space.
- LEGAL REQUIREMENTS, technical specifications, and how you, the

home constructor, can meet them. Find out what mechanical and electronics skills you need.

- RECEIVER CHARACTERISTICS, technical details and specifications, along with examples of actual receivers built at comparatively low cost.
- ANTENNA DESIGN... and exactly how you can build a spherical antenna, while keeping total earth-station cost for the complete system under \$1,000.
- THE FRONT END is critical when you build your own system. We help you explore several different ap-

proaches to making one that will work for you.

- RECEIVER-SYSTEM hardware, and how it goes together to bring you direct-from-satellite TV reception in your own home.

To order your copy: Complete coupon and enclose it with your check or money order for \$7.00, plus \$1.00 for postage and handling. We will ship your reprint within 6 weeks of receipt of your order. All others add \$4.00 for postage. New York State residents must add 5% sales tax.

**Radio Electronics**

Satellite TV Reprints  
45 East 17th Street  
New York, N.Y. 10003

Please print

9-83

I want \_\_\_\_\_ reprints @ \$7.00 each, plus \$1. Handling & Postage.  
I have enclosed \$ \_\_\_\_\_ N.Y. State residents must add sales tax.

(Name) \_\_\_\_\_

(Street address) \_\_\_\_\_

(City) \_\_\_\_\_

(State) \_\_\_\_\_

(Zip) \_\_\_\_\_



# Electronics Paperback Books

## Quality Paperbacks at Affordable Prices



**30 SOLDERLESS BREADBOARD PROJECTS BOOK-1.** \$5.75. Whenever possible the same parts are used in several projects. Even a first-time builder can complete these circuits.

**HOW TO GET YOUR ELECTRONIC PROJECTS WORKING.** \$5.00. Helps you troubleshoot and repair home-built projects of every description.

**MINI-MATRIX BOARD PROJECTS.** \$5.00. A variety of projects that can all be built upon a mini-matrix board that has 10 strips and is 24 holes long.

**MODERN OP-AMP PROJECTS.** \$5.00. Wide range of specialized op-amp circuits including lo-noise, lo-distortion, ultra-hi input impedance, etc.

**MULTI-CIRCUIT BOARD PROJECTS.** \$5.00. 21 fairly simple projects that can all be built on a single printed-circuit board. All are powered by a 9V battery.

**IC PROJECTS FOR BEGINNERS.** \$5.00. Inexpensive digital and linear IC's are used to assemble this selection of circuits intended for the beginner.



**ART OF PROGRAMMING THE 1K ZX81.** \$6.25. Topics include full screen, scrolling, PEEK & POKE, plus actual working programs.

**THE 6809 COMPANION.** \$5.00. Written for the average assembly language programmer. A discussion of 6809 features & reference work for the 6809 programmer.

**PRACTICAL COMPUTER EXPERIMENTS.** \$4.50. Fills in background to microprocessor by constructing typical computer circuits using discrete logic components.

**ART OF PROGRAMMING THE 1K ZX81.** \$5.00. How to use the features of the ZX81 in programs that fit the 1K machine and are still fun to use.

**INTRODUCTION TO BASIC PROGRAMMING TECHNIQUES.** \$5.00. Based on author's own experience in learning BASIC and helping others learn to program.

**A MICROPROCESSOR PRIMER.** \$4.50. Painless approach to computing for the beginner. Step-by-step explains computer operations and assembly.

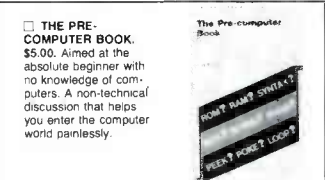

**THE PRE-COMPUTER BOOK.** \$5.00. Aimed at the absolute beginner with no knowledge of computers. A non-technical discussion that helps you enter the computer world painlessly.

**AN INTRODUCTION TO VIDEO.** \$5.00. Perfect for the person just about to buy a VCR. Discusses pros & cons of the various formats: video discs, videotape, tape copying and more.



**BASIC & PASCAL.** \$4.00. Takes BASIC & Pascal and develops programs in both languages simultaneously.

**FIRST BOOK OF TRANSISTOR EQUIVALENTS & SUBSTITUTES.** \$3.75.

**PRACTICAL COMPUTER EXPERIMENTS.** \$4.50.

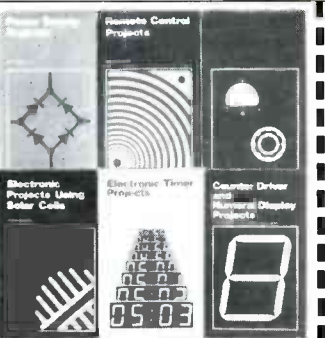

**POWER SUPPLY PROJECTS.** \$4.50. Contains designs and construction details for almost any power supply the experimenter is likely to need.

**REMOTE CONTROL PROJECTS.** \$5.00. Radio-control infra-red, visible light, & ultrasonic systems are all included, along with methods of applying them.

**ELECTRONIC TEST EQUIPMENT CONSTRUCTION.** \$4.50. Construction details of a wide range of test equipment the experimenter can build at home.

**ELECTRONIC TIMER PROJECTS USING SOLAR CELLS.** \$5.00. Simple circuits that have numerous applications around the home.

**ELECTRONIC TIMER PROJECTS.** \$5.00. Timing circuits for almost any application the experimenter might need. A most valuable reference.

**COUNTER DRIVER & NUMERICAL DISPLAY PROJECTS.** \$4.50. Features applications & projects using various types of numerical-display devices.



**PRACTICAL ELECTRONIC BUILDING BLOCKS—Book 1.** \$5.00. All electronics circuits consist of simple building blocks. When you know how to make the blocks you can easily create your own projects.

**HOW TO MAKE WALKIE-TALKIES.** \$5.00. Describes equipment for low-power handheld operation. 112 pages of must reading for the dedicated experimenter.

**ELECTRONIC CALCULATOR USERS HANDBOOK.** \$3.95. Presents formulae data, methods of calculation, conversion factors & more from the view of the calculator user.

**LINEAR IC EQUIVALENTS AND PIN CONNECTIONS.** \$8.25. Shows equivalents & pin connections of a popular user-oriented selection of linear IC's.

**INTERNATIONAL DIODE EQUIVALENTS GUIDE.** \$5.75. A basic reference work that bridges the gap between complicated technical theory & cut and tried methods.

**INTERNATIONAL TRANSISTOR EQUIVALENTS GUIDE.** \$5.75. Helps you find substitutes for the many different types of semiconductor diodes in use today.

**INTERNATIONAL TRANSISTOR EQUIVALENTS GUIDE.** \$7.50. Products of more than 100 manufacturers are listed & cross-referenced with possible replacements.

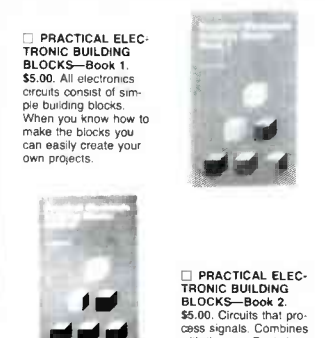

**PRACTICAL ELECTRONIC BUILDING BLOCKS—Book 2.** \$5.00. Circuits that process signals. Combines with those in Book 1.

**SPECIAL OFFER Book 1 & Book 2 PRACTICAL ELECTRONIC BUILDING BLOCKS.** \$9.00. Shipping Included. Save \$1.75.

**RADIO CONTROL FOR BEGINNERS.** \$4.50.

**ELECTRONIC GAMES.** \$4.50.

**SINGLE IC PROJECTS.** \$4.25.

**RADIO CIRCUITS USING IC'S.** \$4.50.

**ELECTRONIC HOUSEHOLD PROJECTS.** \$4.50.

**ELECTRONIC MUSIC PROJECTS.** \$4.50.

**POPULAR ELECTRONIC PROJECTS.** \$3.75.

**PROJECTS IN OPTO-ELECTRONICS.** \$5.00.



**ANTENNA PROJECTS.** \$5.00. Covers practical antenna designs including active, loop & ferrite types that are easy & inexpensive to build.

**RADIO STATIONS GUIDE.** \$4.75. Comprehensive listing of transmitters around the world. Presents location, frequency, power.

**LONG DISTANCE TV RECEPTION (TVDX) FOR THE ENTHUSIAST.** \$5.00. Practical & authoritative introduction to this unusual aspect of electronics.

**CB PROJECTS.** \$5.00. A number of useful and interesting designs for CB accessories. Speech processor, interference filter & more.

**CRYSTAL SET CONSTRUCTION.** \$4.50. Packed full of easy to duplicate designs for crystal radio receivers.

**AN INTRODUCTION TO RADIO DXING.** \$5.00. Listen, in your home, to broadcasts originating thousands of miles away. Tells how you can do it.

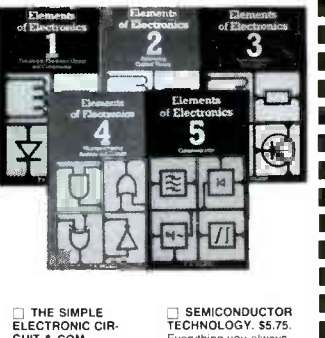

**THE SIMPLE ELECTRONIC CIRCUIT & COMPONENTS.** \$5.75. All the fundamental theory needed to lead to a full understanding of the simple electronic circuit and its components.

**ALTERNATING CURRENT THEORY.** \$5.75. Alternating current theory without which there can be no comprehension of speech, music, radio, or television.

**MICROPROCESSING SYSTEM & CIRCUITS.** \$7.50. A truly comprehensive guide to all of the elements of a microprocessing system.

**SEMICONDUCTOR TECHNOLOGY.** \$5.75. Everything you always needed to know about solid-state devices in one volume.

**COMMUNICATIONS.** \$7.50. Covers most modern communication systems. Line, microwave, submarine, satellite, digital multiplex, radio & telegraphy.

**FIRST BOOK OF HI-FI SPEAKER ENCLOSURES.** \$4.50.

**SOLID STATE NOVELTY CIRCUITS.** \$3.50.

**28 TESTED TRANSISTOR PROJECTS.** \$4.25.

**ELECTRONIC TECHNOLOGY TODAY INC.**  
P.O. Box 83, Massapequa Park, NY 11762

Number of books ordered

Total Price of Books ..... \$ .....

Sales Tax (NY State Residents) .....

Shipping (75c 1st two books, 30c ea additional) .....

TOTAL ENCLOSED ..... \$ .....

Name.....

Address.....

City..... State..... ZIP.....

**Prices good until November 30, 1983**

CIRCLE 72 ON FREE INFORMATION CARD

## SERVICING SWEEP CIRCUITS

continued from page 66

Of course, you don't just get one type of problem in a particular set. Consider another CTC108 with a completely different set of symptoms. In this instance, with the battery in place there was a signal, but a poor one that in no way resembled what was called for. Thus, there was obviously some sort of problem with the oscillator. But was it the circuit itself or was it some problem in the shutdown circuit that was reacting with the oscillator?

The first thing to do was to isolate the oscillator from the shutdown circuit. To do that, the shutdown transistor, which was directly tied to the oscillator, was lifted. But that had no effect and the signal was unchanged. All the oscillator/driver transistors checked out as OK, so the next step was to take some resistance measurements. An unstable reading between the driver collector and ground finally led to the answer—a leaky 27-pF capacitor, C403, across the driver.

It's enough to make one wish for the "good old days!" **R-E**

## TRANSIENT SUPPRESSOR

continued from page 58

The relay specified handles 10 amps, and all circuit wiring should, similarly, be capable of handling 10 amps. This means No. 14 wiring for all circuits associated with receptacle SO1. (The wires to the relay coil and the lamps can be No. 20, or No. 18.) Solid wire is recommended. You can obtain No. 14 solid wire by purchasing a few feet of No. 14 Romex electrical-wire at your local hardware store and stripping off the outer skin. Under the skin will be two (or three) insulated No. 14 solid wires and a bare ground-wire. Save the bare wire for some future project.

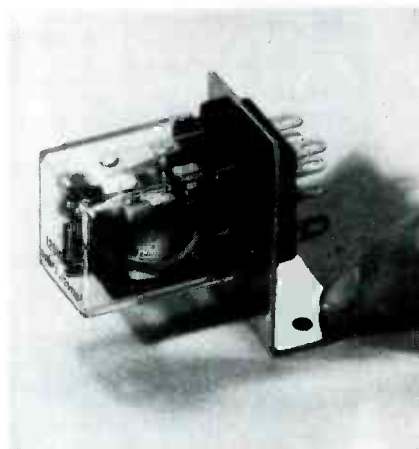

FIG. 5—TO PROVIDE CLEARANCE for the power-drop-out relay, mount it on an L-bracket made from scrap aluminum.

Receptacle SO1 must be of the three-pronged, grounded type. The particular unit you get may have screw or solder terminals, or may be prewired. If there are screw or solder terminals use your No. 14 wire. If the receptacle is prewired the wire is probably No. 12 stranded. Simply twist the free strands together tightly and tin them with solder. Take care to be sure you locate the correct "ground" terminal on SO1. If SO1 is prewired the wires will be color-coded red, black, and green. The green one is the ground wire, and is soldered to the ground lug on FL1. The power-line ground, also green, must be soldered to the filter's ground terminal, as well.

### Neatness doesn't count

Insulated No. 14 wire is not the easiest material to work with. Usually, forming "square corner" bends will put undue strain on the associated components. Don't try to be extremely neat; bend the power wires in gentle arcs. There's plenty of room on the panel, so don't crowd the wiring. Bending No. 14 wire around a relay socket's solder lug is a sure way to break the lug, so lay the wire on the lug (use a clamp if necessary) and make a

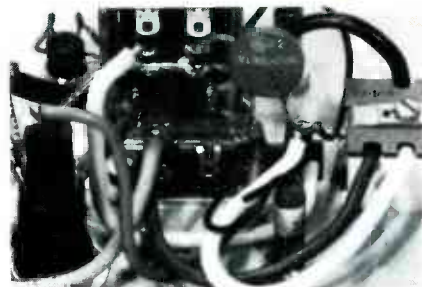

FIG. 6—MAKE CERTAIN THAT ALL components and wires are securely soldered to a terminal. No components should "float," and no wires should have in-line splices. Such construction will help ensure glitch-free operation for your computer.

secure tack-solder connection.

Use a 3AG fuse rated at 12 amps (*not* the "Slo-Blo" type) for F1. If you can't get a 12-amp one, a 10-amp fuse will do. We have never run across a varistor's protection fuse that opened, or a "shorted" varistor, but since the possibility exists that it can happen, don't eliminate F1.

### Checkout

Measure the resistance across the line cord's terminals with an ohmmeter. It should be "infinite," even though the RF filter's schematic, printed on the filter's case, shows a resistance across the input terminals.

Check the resistance across SO1's output connections; it should also be "infinite." If not, check the connections to the varistor.

Check the resistance from both sides of the line-cord plug's prongs, and SO1 to ground. It too should be "infinite;" if not, there is a wiring error.

If everything checks out up to this point, connect the unit to the power line. Nothing should happen. Next, press RESET switch S1. You should hear RY1 switch in and both NE1 and NE2 should light. If NE1 does not turn on, check RY1 for a wiring error. If NE1 turns on but NE2 does not, check the wiring of F1 and the varistor.

If both lamps turn on, the device should be OK. As a final check of the device's latching function, simply remove then restore power. To do that, simply plug a load such as a table lamp into SO1 and then cut power either by throwing a circuit breaker or pulling the device's plug. Restore power and if the lamp will not light the device is ready for use. Connect your computer system's main power-cord to SO1, or better yet, connect a power strip to the socket, and the computer and the disk drives to the strip. Your printer should then be plugged into the same socket that's used by the protection device. That ensures that any RF or glitch generated by turning the printer on must feed through the RF filter before reaching the varistor. That provides double protection, and you can never be too safe. **R-E**

## CABLE TV

Buy Direct & Save

### SUPER SPECIALS



40 CHANNEL  
CONVERTER  
\$29<sup>95</sup>

Advanced Solid State design and circuitry allows you to receive mid & super band channels. Restores programming to Video Recorders.



36 CHANNEL  
REMOTE CONTROL  
CABLE CONVERTER  
\$69<sup>95</sup>

JERROLD 400  
THE ULTIMATE CABLE TV  
CONVERTER



60 CHANNEL  
INFRARED  
REMOTE  
CONTROL  
\$129<sup>95</sup>

Send \$5 for Complete Catalog

**DIRECT VIDEO SALES**

P.O. BOX 1329

JEFFERSONVILLE, INDIANA 47130

CALL

1-812-282-4768

CIRCLE 53 ON FREE INFORMATION CARD

There is a road.

Many cancer patients need transportation to and from treatments. That's why the American Cancer Society has formed groups of volunteers across the United States who give a few hours of their time each month to drive them. The road to recovery can be a long and difficult one, but it can be that much easier when there are friends who can help along the way.

AMERICAN CANCER SOCIETY

This space contributed as a public service.

**TIMEX/SINCLAIR COMPUTER USERS**  
We Have The Books You Need



- ART OF PROGRAMMING THE 1K ZX81.**  
How to use the features of the ZX81 in programs that fit into the 1K machine. 96pp. \$5.75 postpaid.
- ART OF PROGRAMMING THE 16K ZX81.**  
How to use your 16K RAM pack and ZX printer to the full. 144 pp. \$6.95 postpaid.
- ART OF PROGRAMMING THE ZX SPECTRUM.**  
Everything you need to know to put the ZX Spectrum to work for you. 144 pp. \$8 postpaid.

ELECTRONIC TECHNOLOGY TODAY, INC.  
P.O. BOX 83  
MASSAPEQUA PARK, NY 11762

Name: \_\_\_\_\_  
Address: \_\_\_\_\_  
City: \_\_\_\_\_ State: \_\_\_\_\_ Zip: \_\_\_\_\_  
 Number of books ordered

**POWER LINE PROBLEMS?**



**SPIKE-SPIKERS™... The Solution!**

Minimize equipment damaging spikes and conducted RF noise to or from sensitive equipment. Transient surge protection plus low pass RFI hash filtering. All units 120V 15A.



**MINI II \$44.95**

Wall Mount  
3-stage filter  
2 sockets

**QUAD II \$59.95**

Wall mount. Dual 3-stage filter  
4 sockets & light

**DELUXE \$79.95**

Dual 5-stage filtered  
ckts. 8 switch sockets  
main switch, fuse, light

**Kalglo Electronics Co., Inc.**  
65 84 Ruch Rd., Dept. Fe  
Bethlehem, PA 18017

Order Factory Direct  
**215-865-0006**

Out of State  
**800-523-9685**

DEALERS INVITED

PA Res. Add 6% \* COD add \$3.00 + Shipping

CIRCLE 46 ON FREE INFORMATION CARD

Take  
stock  
in America.

**GLOUCESTER COMPUTER**

PD/64, all features of Promqueen less mimic mode. Software enhanced to include EPROM QC utilities, RS-232 communication, printouts. 28 pin ZIF socket.

Reads, edits runs and programs all 5 volt 2500 and 2700 series EPROMS plus variety of EEPROMS all without personality modules. Commodore C-64 host computer. Inquire about the mimic mode capability in our VIC Promqueen.



**\$299.00**

ROM Packs Industrial quality circuit cards are socketed, solder masked, fully bypassed, and include a ground plane for low noise operation. Includes 1 EPROM. 8K & 16K models for VIC-20 and C-64. Specify 2732 or 2764 EPROM type. Molded plastic case. **\$39.00**

**GLOUCESTER COMPUTER**  
1 Blackburn Center, Gloucester, MA 01930 617-283-7719

CIRCLE 26 ON FREE INFORMATION CARD

**WHY SPEND A FORTUNE ON A DIGITAL CAPACITANCE METER?**

As a matter of fact you don't have to pay \$180 to \$500 and up anymore for a Digital Capacitance Meter that is both dependable and rugged with good accuracy. The MC100A comes completely assembled and calibrated and at \$79.95 is an outstanding value. The extensive range of 30 pF to 9,999 uF (no external meters required) and true hand held portable size (only 4 3/4" x 2 1/2" x 1 1/2") make the MC100A an extremely practical and easy to use instrument for the hobbyist technician or engineer.

**CHECK THESE OTHER FEATURES**

- \*Basic accuracy 2% (± one count) on pF, nF ranges, 5% (± one count) on uF range.
- \*Uses single 9V battery (not included).
- \*Decimal points light up when battery is low or when capacitor is overrange.
- \*Full 4 digit high efficiency LED display uses special circuitry to save on batteries.
- \*Maximum conversion time for 9,999 uF is less than 6 seconds.
- \*Constructed with a tough impact resistant plastic case.
- \*90 day parts and labour warranty.



**\$79.95**

**DAETRON**  
935 THE QUEENSWAY, BOX 641  
TORONTO, ONTARIO M8Z 5Y9  
(416) 499-7221  
DEALER ENQUIRIES INVITED

**PLEASE SEND ME**

(Quantity) MC100A(s) @ \$79.95 U.S. (Canadian residents send \$89.95 CDN) \$ \_\_\_\_\_  
Ontario residents add 7% PST \$ \_\_\_\_\_  
Postage — \$2.25 for U.S. \$1.85 for Canada (per instrument) \$ \_\_\_\_\_  
 I ENCLOSE CHECK  MONEY ORDER  BILL MY VISA  SIGNATURE TOTAL \$ \_\_\_\_\_  
 VISA CARD NO. \_\_\_\_\_ EXPIRY DATE \_\_\_\_\_  
Immediate shipping on orders with money orders or VISA  
Personal checks please allow 2 to 3 weeks for clearance.  
NAME \_\_\_\_\_  
ADDRESS \_\_\_\_\_  
CITY \_\_\_\_\_ STATE \_\_\_\_\_ ZIP CODE \_\_\_\_\_

MAIL TO DAETRON 935 THE QUEENSWAY BOX 641  
TORONTO ONTARIO M8Z 5Y9

**DON'T FORGET**

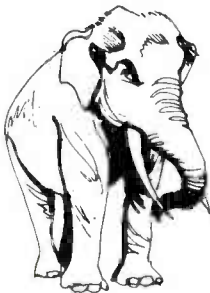

USE  
YOUR  
READER  
SERVICE  
CARD

**VIC-20**

**VIC-20 INTERFACING BLUE BOOK**  
Did you know that your VIC can be used to control a 99¢ toy motor so effectively that it runs like a precision machine? Or that you can build an accurate digital thermometer using the VIC and four parts costing less than \$5?  
These and other 28 interfacing projects selected for usefulness, ease of construction and low cost are detailed in the VIC-20 Interfacing Blue Book, a veritable gold mine of practical information on how to build a variety of interfaces for your computer.

Projects include: Connecting VIC to your stereo; Pickproof digital lock; Capacitance meter; Liquid level sensor; Telephone dialer; Voice output; 8K/16K RAM/ROM expansion; 128K RAM expansion; 8-bit precision D/A; 8-bit A/D converter; MX-80 interface and more.

Written by a college professor in a friendly and informative style, the Blue Book gives you theory of operation, schematics, program listings, parts list, construction hints and sources of materials for each one of the 30 projects.

If you want to get the most out of your VIC-20, this book is a must. Cost is \$14.95 (less than 50¢ per project!). Price includes postage.

**microsignal** Dept M  
P.O. BOX 32  
MILLWOOD NY 10546  
**VIC-20**

# NEW IDEAS

## Protecting your car

HERE IS AN ALARM CIRCUIT FOR YOUR car that uses only one IC and is rather easy to build. But it still has many desirable features, including entrance- and exit-delay times, an auto reset control, automatic shutoff, and low power consumption. The schematic of the alarm is shown in Fig. 1.

First we'll look at the two switches, S1 and S2. Opening switch S1, which is a normally-open door-mounted switch, activates the alarm after an 8-second delay. However, if S2—a hidden switch inside the car—is closed within that 8-second delay time, the alarm will not be activated. That switch always takes priority over S1. Whenever it is closed, the alarm is off. Even when S2 is opened again, it still inhibits the alarm activation—but only for an additional 20

seconds. (That delay is determined by the combination of R4 and C3.) That's enough time to get out of the car and close the doors. Switch S2 can be a momentary normally-open switch, but you may prefer using a toggle switch. That way you can disable the alarm if you have to keep your car open for more than 20 seconds, such as when you are loading it with luggage.

Integrated circuit IC1 is a quad 2-input NAND Schmitt trigger. The output of IC1-c latches IC1-b to a high output state once switch S1 is opened. After that, only S2 can stop the alarm oscillator, IC1-d, from being triggered after the 8-second delay (determined by R9 and C6). That drives transistors Q1 and Q2, which switch the load (the coil of the horn relay, RY1) to ground. Thus the horn sounds in-

termittently. The maximum current that transistor Q2 can sink safely is about one amp.

After about 2 1/2 minutes (controlled by the R7-C4 combination), which is called the alarm cycle time, IC1-b is unlatched when pin 6 goes high via C4. If S1 at that time is not open, pin 4 of IC1-b goes low and the alarm stops and is once again ready to receive triggering signals from S1. If S1 is still open, the alarm will continue to sound. Remember though, that S2 inhibits both the detection and activation of the alarm at any point of the cycle.

I used RCA IC's when building my alarm. If you substitute those of another manufacturer, you may have to adjust the values of the timing resistors and capacitors. Some experimentation may be required before everything works as it should.—Ronald Ham-Pong

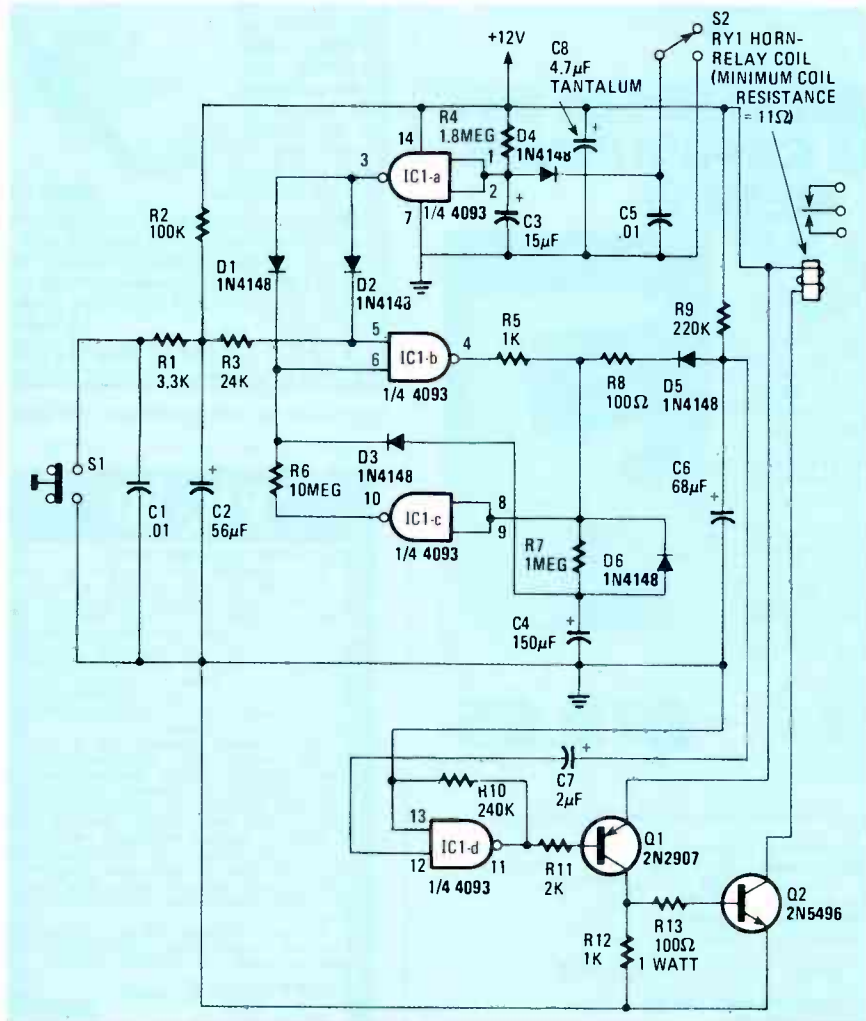

FIG. 1

### NEW IDEAS

This column is devoted to new ideas, circuits, device applications, construction techniques, helpful hints, etc.

All published entries, upon publication, will earn \$25. In addition, Panavise will donate their model 333—The Rapid Assembly Circuit Board Holder, having a retail price of \$39.95. It features an eight-position rotating adjustment, indexing at 45-degree increments, and six positive lock positions in the vertical plane, giving you a full ten-inch height adjustment for comfortable working.

I agree to the above terms, and grant **Radio-Electronics** Magazine the right to publish my idea and to subsequently republish my idea in collections or compilations of reprints of similar articles. I declare that the attached idea is my own original material and that its publication does not violate any other copyright. I also declare that this material has not been previously published.

Title of Idea \_\_\_\_\_

Signature \_\_\_\_\_

Print Name \_\_\_\_\_ Date \_\_\_\_\_

Street \_\_\_\_\_

City \_\_\_\_\_ State \_\_\_\_\_ Zip \_\_\_\_\_

Mail your idea along with this coupon to: **New Ideas Radio-Electronics**, 200 Park Ave. South, New York, NY 10003

## MINI PLAYER-PIANO

continued from page 48

Pianomatic—the enabling of the keyboard display, IC6, the display counter, IC11, the TUNE SELECTOR switch, S5, and finally, the START switch, S4. Let's take a look at the last of those first and see how the Pianomatic operates when it plays a tune back from memory.

### Playback

The circuit consisting of IC14-d, R3, and C-8 is a gated oscillator. By "gated oscillator" we mean that a high logic level turns it on, and a low turns it off. The Pianomatic has two modes of playback—AUTOMATIC and MANUAL. In MANUAL, switch S3-b puts +V on one side of the START switch, S4. The other side of the START switch is connected through resistor R2 to the control pin, pin 12, of the tempo clock, IC14-d. As long as the START switch is kept closed, the tempo clock will operate, be inverted by IC15-d, and, through D18, increment the note counter, IC3. That will sequentially address the memory in binary form, causing the tune to be played. When S4 is open, resistor R2 pulls pin 12 (IC14-d) low and the tempo clock stops.

The AUTOMATIC PLAYBACK mode is one of the nicest features of the Pianomatic. When the START switch, S4, is pressed, the Pianomatic reads out the data on the selected page of memory and stops. The interesting point of that is that it doesn't stop at the end of the page; it stops wherever you've programmed it to stop. We accomplish that piece of magical business by some creative gating and selective decoding. Let's now see exactly how that is done.

As we've seen before, when we're playing back from memory in MANUAL, S3-b puts +V on the C2 side of S4. As long as S4 is kept closed, IC14-d is enabled and the tune plays. In order to have the tune continue playing after S4 is released, we need some way of keeping IC14-d enabled. We do that by using the b half of the MANUAL/AUTOMATIC switch, S3-a. In the MANUAL position, the switch is connected to ground, but in the AUTOMATIC position it's connected to the output of IC14-b. The operation of that gate is the key to the automatic-playback feature of the Pianomatic.

The output of IC14-b is controlled by the voltages on pin 12 of IC14-d, the enabling pin of the tempo clock, and the output of AND gate IC9-a. That gate monitors the output-data bus and is set to decode a binary 15 (1111). In other words, the output of IC9-a will be low unless a binary 15 appears on the output-data bus. Let's assume that S3 is set on AUTOMATIC, the START switch, S4 hasn't been pressed, and that any number but 15 is on the output-data bus. Since the output of IC9-a is a low and pin 12 of IC14-d is low,

the output of IC14-b will be high. That will bias D6 and disable the keyboard by making pin 23 of IC1 high. It will also forward bias D3 and slightly raise the voltage at pin 12 of IC14-d.

When S4 is pressed, IC14-d is enabled just as it was in MANUAL playback. In AUTOMATIC, however, releasing the switch won't disable the clock because the output of IC14-b remains high and doesn't let R2 pull the enabling pin low enough to stop the clock. Remember that IC14 is a Schmitt trigger, so there is a certain amount of hysteresis inherent in the device. Because of that, it takes more than a 50% voltage swing to make the gate change state. By choosing appropriate values for R2 and R4, we can take advantage of the "dead band" area of the Schmitt trigger. As long as we don't allow pin 12 of IC14 to drop below the trip voltage point, it will remain high and the clock will remain enabled. In manual playback, R2 was able to pull pin 12 low, but in AUTOMATIC, the high output of IC14-b raises the voltage just enough to prevent that from happening.

Even though pin 12 remains high, the output of IC14-b doesn't change because IC9-a is still presenting a low to the other input leg of the gate at pin 6. Let's suppose that a binary 15 appears on the output-data bus. That will be detected and decoded by IC9-a, and the output state of that IC will change to a high. Since a high signal is being presented to both legs of IC14-b, its output will change and it will go low. That will put a low at pin 12 of IC14-d, lower the voltage past the trip point, and disable the clock. Thus, when we are writing a tune into memory the last thing to put in the program is a binary 15. By doing that, playback will stop at that point in memory. A low at the output of IC14-b will be inverted by IC15-a and present a high to the reset pins of the note counter IC3. When a "stop" signal is present on the output data bus, therefore, not only will the Pianomatic stop playing, but the device will also reset itself to zero again.

In order to make the Pianomatic easier to use, there are several things that will make the note counter, IC3 reset to zero. A glance at the schematic will show you that there is a whole bunch of "Mickey Mouse logic" (M<sup>2</sup>L) tied to the reset pin of IC3. That takes the form of diode-capacitor combinations that cause various switching of the Pianomatic's controls to put a positive pulse on the reset bus. Rather than go through all of it here, it's much easier to put it in table form; we've done that in Table 1. That table shows the actions and effects of the switches in the Pianomatic. In general, the only action that won't reset IC3 is going from READ to WRITE. That was done to make it easier to correct mistakes in programming a tune. If you single-step through a tune in MANUAL and come across a mistake, it's a simple matter to move the READ/WRITE

switch, S2, to the WRITE position and program in the correct note...but we're getting ahead of ourselves. We'll completely discuss how to program the Pianomatic later in this article.

The other half of IC9 is used to decode a binary 14 (1110) when it appears on the output-data bus. That is done by using IC15-b to invert the least-significant line on the output-data bus. When a 14 appears on the bus, the output of IC9-b goes high, reverse biases D4, and force feeds a clock pulse to pin 9 of inverter IC15-d. That has the effect of speeding up the clock for as long as the 14 remains on the output-data bus. Since the clock increments the note counter, IC3, immediately, the next note is put on the bus and the output of IC9-b goes low again. That lets you program a temporary speedup in the clock and is used when you want a definite attack on a note or a half rest between notes.

### Next time

When we continue, we'll finish up our look at how the Pianomatic works and then begin the construction. By the way, the project is built on five PC boards, two of which are double-sided. While the board patterns will appear in the next part of this article, you can order the boards from the source listed in the Parts List.

R-E

**Philmetric**

**Q** **MULTIMETERS**

**NEW 10 AMP RANGE**  
**MODEL MD 210 @ \$99.95** <sup>sugg.</sup> <sub>list</sub>  
**NOT JUST A FLUKE!**

Computer age testing is yours with this new, 10 Amp range, .025% accuracy, 3 1/2 digit DMM. Features 2000 hr batt'y life, 34 range pushbutton select and a 2 year warranty. You get quality that's no accident, at lower cost — \$99.95 (sugg. list).  
Want more? Ask for special, \$5.00 cash factory direct bonus when you buy this proven product.  
Other Philmetric "Q/A" Quality Assured multimeters available from \$14.95 retail. Send for catalog and dealer name.

**Philmetric** "We Measure Up..."  
Philmetric,  
(a Div. of Philmore Mfg. Co.)  
40 Inip Drive, Inwood, NY 11696 Tel: 516-239-6161

CIRCLE 42 ON FREE INFORMATION CARD

# HOBBY CORNER

## A few quick answers

EARL "DOC" SAVAGE, K4SDS, HOBBY EDITOR

THIS MONTH I WANT TO REDUCE THE SIZE of the pile of letters here. I'm going to try to look at as many of your comments, and try to answer as many questions, as possible. Of course, to do that, I'll answer only those questions that don't require going into too much detail.

We'll start with a letter from Tom Talley (OH). He included a couple of suggestions for improving the performance of the high-voltage generator we discussed in the February 1983 column. First, the relay coil and the transformer primary should be in parallel to give more punch to the output. Second, a small capacitor (around .001  $\mu\text{f}$ ) across the relay contacts will suppress arcing and make the contacts last longer. Tom knows whereof he speaks. As a lad of 10, he made and sold a couple of dozen to neighborhood farmers for use as cattle prods.

George Ovat (IA) wants to know how to build a negative-ion generator and he questions some of the claims about their benefits. Well, George, take a look at the "Hobby Corner" in the May 1981 issue of **Radio-Electronics**. Another ion generator was discussed in a feature article in the July 1981 issue. As far as their benefits go, why not build one and see if it does anything for you!

We discussed cassette-speed modifications in the May column. Dick Fur-

nas (NY) offers a very simple method to slow the speed on most cassette recorders—a method that doesn't even require tearing into the machine. He points out that because the remote-control (on/off) jack is in series with the motor, it can be used for ready access to that circuit. So, without even opening the case, you can put a resistor or a potentiometer across a spare plug and simply insert it when you need it! The resistance value will be determined by the characteristics of the machine and, of course, the speed you want. Here again, experimentation is the key to finding the correct value for your needs.

Anthony Maunuis (CA) wants to know how to build a "Jacob's Ladder." That's the rising arc that you sometimes see in science fiction movies. Well, Tony, I don't want to get too specific because (1) those things can cause a nasty burn if you aren't very careful and (2) the radio and TV interference problems that they cause are no joke.

You mentioned the use of a flyback transformer and some tubes. Perhaps, I'll just point you in a couple of other possible directions and let you take it from there. Give a bit of thought to Tesla coils and to ignition transformers (the kind used in oil furnaces).

### Where's the zero?

The tricky question for this month is from Robert Bainbridge (NY). He asks how to determine the "zero" or base line in relation to voltages of various wave shapes. Well Bob, there are probably as many answers (or more) than there are types of waves!

In practice, the base or zero line can be anywhere you want it to. Rather than use the words "base" or "zero," let's call it the reference line. Using that name gives you an entirely new perspective on the question.

In Fig. 1 you see a single cell and a voltage divider. If you make your measurements in relation to point A, then both B and C will be negative *as far as the point-A reference is concerned*. Here, then, A is called the zero or base line. Relative to point C, A and B are positive and C is the zero line. Thus, the base line is *your choice*. If you chose A, then B is negative. If you chose C, then B is positive. It's up to you.

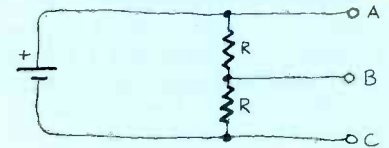

FIG. 1

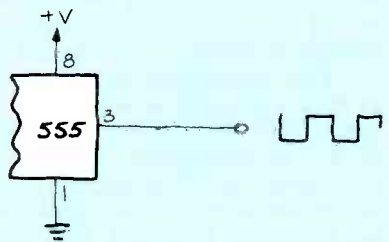

FIG. 2

The same logic applies in the case of waveforms. It all depends upon your reference point. For example, look at Fig. 2, which is a fragment of a 555 squarewave-oscillator circuit. When measured with respect to pin 8, the waveform varies from approximately zero to a negative value. Measured from pin 1, however, it varies from zero to a positive value. Asking which is which is like asking whether the chicken or the egg came first!

Of course, the accepted convention is to measure voltages from circuit ground but this is not always best.

Bob's second question had to do with how to determine whether or not a wave is inverted. Here, again, the answer is the same: it all depends upon your reference point, which would be another wave in this case. When measured against itself, it is not inverted, obviously. When measured against another wave, it can be inverted, non-inverted, or at any phase-angle. Take your choice. Bob.

### Timer problems

William Schreiber (HI) is dissatisfied with the performance of the AC-powered timer he uses to control his nightlights. When he is away for a week or more, he frequently finds that the power company had problems in his absence. Of course, that causes his timer to be off schedule—even as much as having his lights turn on during the day and turn off at night!

Bill, you may have seen the versatile digital clock timer in the April "Hobby

### AN INVITATION

To better meet your needs, "Hobby Corner" has undergone a change in direction. It has been changed to a question-and-answer form. You are invited to send us questions about general electronics and its applications. We'll do what we can to come up with an answer or, at least, suggest where you might find one.

If you need a basic circuit for some purpose, or want to know how or why one works, let us know. We'll print those of greatest interest here in "Hobby Corner." Please keep in mind that we cannot become a circuit-design service for esoteric applications; circuits must be as general and as simple as possible. Please address your correspondence to:

Hobby Corner  
**Radio-Electronics**  
200 Park Ave. South  
New York, NY 10003

Corner." There is no reason to assume that the clock must run from the AC line. The use of a battery operated clock would make the timing cycle completely independent of the power company's problems. Certainly, the AC lights would not come on during a power outage (neither would anyone else's) but, when power is restored, you would be on your schedule rather than on theirs.

Incidentally, it has always appeared to me that there is a fundamental inequity in my relationship with the power company. Actually, there are several, but Bill's problem relates to one of them. If, without notice, they cut my power in order to make some adjustment in their equipment, it's tough luck that I may have been inconvenienced. Example: such action can cause the loss of hours of computer work—especially when it causes part or all of a disk to "go west." On the other hand, just let me interfere with them and see what happens.

Gene Fisher (AR) wants to build a strong electromagnet for retrieving items that have been dropped overboard. There are several considerations in the design of such a magnet. For one thing, it should be waterproof. Even though it is safe to assume there is no salt water in Arizona, other chemicals in the water can have an effect.

The strength of an electromagnet is determined partially by its core but primarily by the number of turns of wire and the amount of current flowing through those turns. Because of that, an increase in the number of turns and/or in the amount of current will obviously create a stronger magnetic field.

The resistance of various types and sizes of wire can be found in any standard reference book. For example, 39 feet of 24-gauge copper wire has a resistance of one ohm, and one pound of it has a resistance of 21 ohms. Most reference books will also give you the approximate length of a wire that is wound on a core of given dimensions. With the information for the type of wire you are using and good old Ohm's law ( $E = IR$ ), you can determine how much current will flow in a given coil.

So, Gene, you see that there is a kind of balancing act involved here: turns, current, and wire size. Of course, you must be concerned with overall weight and the current capability of the power supply you will be using. Unfortunately, I have been unable to find the relationship for all these factors and the number of pounds that a magnet will lift. Once again, it is a matter of experimentation to determine the optimum factors for your particular use.

Thanks for the interesting questions, gang. Be sure to keep them coming and don't forget that although we are especially glad to receive questions from you, suggestions and comments are also always appreciated.

R-E



# FORDHAM CUTS PRICES ON HITACHI SCOPES

**SPECIAL**

**30 MHz  
Dual Trace**



**Model V-302F**

High sensitivity. Bright screen. Rise time 12ns (for x 5) 70ns. Comes with probes.

**\$569<sup>95</sup>**  
with probes

**20 MHz Dual Trace**



**Model V-202F**

5.5" square CRT • Vertical sensitivity 5m V/div to 5 V/div and 1m V/div to 1V/div with 5X amplifier • Display modes Ch1, Ch2, Dual, Add, Diff. • Comes with probes.

**Model V-203F** - Same as above but with Delayed Sweep **\$635**

**\$590<sup>75</sup>**  
with probes

**35 MHz DUAL TRACE**



**Model V-352F**

Vertical sensitivity 5m V/div to 5V/div and 1m V/div to 1V/div with 5X amplifier • Trigger modes Automatic, Normal, TV(+), TV(-) • Comes with probes.

**Model V353F** - Same as above but with Delayed Sweep. **\$799.95**

**\$760<sup>75</sup>**  
with probes

**60 MHz DUAL TRACE  
DELAYED SWEEP**



**Model V-650F**

High sensitivity • 1 mV/div (10MHz) • 5 ns/div sweep rate • 3rd channel display (trigger view) • Variable trigger hold-off • Full TV triggering • Single sweep • Automatic focus correction • Comes with probes.

**\$995**  
with probes

**100 MHz QUAD  
TRACE DELAYED SWEEP**



**Model V-1050F**

Large, bright 8x10 cm screen • Quad trace operation/Ch1, Ch2, A trigger and B trigger • High sensitivity 500  $\mu$  V/div (5 MHz) • Full TV triggering • Comes with probes.

**\$1590**  
with probes

**MINI-PORTABLE  
DUAL TRACE**



**Model V-209**

3-way power supply, compact, light-weight package • High sensitivity 1m V/div at 10m Hz and fast sweep times 50 ns/div • Built-in TV sync separation circuit/TV-V & TV-H modes • Auto-focus • Comes with probes.

**\$790**  
with probes

**TOLL FREE**  
**(800) 645-9518**  
in N.Y. State 800-832-1446

## FORDHAM

260 Motor Parkway, Hauppauge, N.Y. 11788

VISA    COD    Master Charge  
 Money Order   N.Y. State residents add appropriate sales tax.  
 Check  
 COD's extra (required 25% deposit)  
**ADD FOR SHIPPING AND INSURANCE**  
 \$250.00 ..... \$4.50  
 \$251.00 to 500.00 ..... 6.50  
 501.00 to 750.00 ..... 8.50  
 751.00 to 1000.00 ..... 12.50  
 over 1000.00 ..... 15.00

SEPTEMBER 1983

83

# THE DRAWING BOARD

## Successful designing and breadboarding

ROBERT GROSSBLATT

JUST ABOUT EVERYONE IS FAMILIAR WITH Zeno's story about Achilles' race with the tortoise. But for those of you out there who *don't* remember the story, it goes something like this: Achilles and a tortoise decided to have a race. Since Achilles was the Jesse Owens of his day and the tortoise even slower than an apology, they gave Achilles a handicap by letting the tortoise have a fifty-foot head start. (It was only fifty feet because even ancient bookies didn't like to take chances.) On the day of the race, the tortoise moved up fifty feet, Achilles laced up his sneakers, the gun went off, and so did Achilles.

Here's the twist: Every time Achilles covered half the distance to the tortoise, he still had half the remaining distance to go. And, according to Zeno, since time and space are infinitely divisible, Achilles never even passed the tortoise, much less got to the finish line. What Zeno didn't tell us was that even though Achilles never passed the tortoise, when he got close to him, he caught him, cooked him, and ate him.

Believe it or not, there's a valuable lesson to be learned from that story for all of us who like to design our own equipment. Culinary tastes aside, the moral of the story is really that even though you may not be able to get there, you can get close enough for all practical purposes—never mind what the mathematicians tell you!

### Paper and the real world

In a nutshell (which is where all valuable lessons are to be found), there's a big difference between brainwork and boardwork. Things that work out perfectly well on paper have a nasty habit of blowing up when you build them. Sometimes it's because you overlooked something in designing them, and sometimes it's because you messed up in building them, but most of the time it's just because we live in the real world. Formulas, graphs, and tables of values stretched out to endless significant figures can lull you into thinking that the same sort of precision exists here in the real world. It doesn't.

Not only do unexpected things crop up when you start breadboarding, but even before that. The final paperwork often turns out to be the result of compromises and approximations. The difference be-

tween the words "standard value" and "calculated value" is what keeps the variable-resistor and -capacitor manufacturers prosperous and smiling. I challenge you to take any design problem and solve it using only standard-value components. That's only one example of how things on paper differ from things in the real world.

One of the magic moments in life comes when power is first applied to the first breadboard version of an original circuit design. Since it never works the first time around, the first thing to do, obviously, is to check the breadboard against the paperwork. Let's assume everything checks out. Now, the problem can only be in one of two places: the physical devices or the original design. I'm going to show you how you can cut the amount of your troubleshooting by as much as fifty percent, and maybe even more.

### Using the right parts

Creating a completely workable electronic system is a difficult job any way you look at it—no matter what you want it

to do. Even a fairly simple design-goal can involve some rather complicated circuit parameters. What you should be aiming for is a method that makes your life as simple as possible. One way to do that is to make sure that the components you're using in the breadboard circuit are all 100% functional.

Anyone who breadboards circuits using "junkbox" parts is asking for trouble. Those components are available all over the place—unmarked IC's ("you test 'em...we don't have the time") and surplus boards loaded with everything imaginable except an explanation. As far as the former is concerned, if their time is too valuable why should yours be any less so? And surplus boards hardly ever have socketed IC's. Removing one of those non-socketed packages safely is something like trying to fix a lightbulb. I suppose it's possible, but since you can get a new one for thirty-nine cents, why bother? Anyway, the chances are that you're going to destroy the IC as you remove it.

In a circuit design that calls for loads of IC's I don't think you'll save more than a

TABLE 1

**American Microsystems**  
3800 Homestead Rd.  
Santa Clara, CA 95051

**Exar Integrated Systems, Inc.**  
750 Palomar Avenue,  
PO Box 62229  
Sunnyvale, CA 94088

**Fairchild Semiconductor**  
313 Fairchild Avenue  
Mountainview, CA 94040

**General Instrument Corporation**  
600 W. John Street  
Hicksville, NY 11802

**Gould Batteries**  
931 Vandalia  
St. Paul, MN 55114

**Intel Corporation**  
3065 Bowers Avenue  
Santa Clara, CA 95051

**Intersil, Inc.**  
10710 N. Tantau Avenue  
Cupertino, CA 95014

**Motorola Semiconductor**  
Box 20912  
Phoenix, AZ 85036

**National Semiconductor**  
2900 Semiconductor Drive  
Santa Clara, CA 95051

**RCA**  
Box 3200  
Somerville, NJ 08876

**Signetics**  
811 East Arques Avenue  
Sunnyvale, CA 94086

**Solid State Scientific**  
Montgomeryville Industrial Park  
Montgomeryville, PA 18936

**Sprague Electric Company**  
Semiconductor Division  
115 Northeast Cutoff  
Worcester, MA 01606

**Texas Instruments**  
Box 5012  
Dallas, TX 75222



few dollars by using surplus ones. Considering the price of IC's today, salvaging surplus ones isn't worth the bother unless you put a really low value on your time. I don't mean the time it will take to find and remove the components, either. You're going to spend a lot of time troubleshooting your circuit when it doesn't work. And that's to say nothing of the damage a bad IC can do to the more expensive parts of your circuit. Blowing up a twenty-dollar memory because you used a bad surplus twenty-cent gate is, to say the least, ridiculous.

One of the least discussed linear qualities of digital IC's is their degree of "goodness." Although they basically operate with only high and low states, they can be 100-percent functional, pretty good, OK, pretty bad, or any degree in between. A surplus IC that tests OK may blow up in your circuit. That's because your testing probably won't make the exact demands on the IC that your circuit will. Internal diodes may be marginal, pass transistors may be degraded, and so on.

Another problem with surplus parts: A manufacturer may have made a seemingly standard part with different specifications to meet the particular requirements of a customer. For example, Radio Shack used what looked like a quad OR gate in the early version of the TRS-80. One of the gates wasn't used—because the chip had only three functional gates on it!

As I've said before, when you design your own equipment, you're the one responsible for the warranty. The key to making your bench time as productive as possible is to eliminate any possible source of error. Breadboarding with anything other than brand-new components is the best way I know to grow gray hair. As far as prototyping is concerned, junkbox components are just that—junk.

### Data books

Successful original design is the result of three things: a clear bench, a clear mind, and a clear understanding. The first you get with a broom, the second with a brain, and the third with a stamp (your brain will help here too). Major component-manufacturers publish data sheets, application notes, and data books. (Figure 1 shows one such data manual from Signetics.) Those not only provide you with the operating parameters of the various devices, but they are loaded with suggestions and hints that can make your design work a lot easier.

Once you've decided what components you're likely to need in your design, find out who makes them and drop them a note requesting information. Chances are you'll get back a listing of the data sheets and application notes they have available. There's usually a nominal charge for those things, but the information that you'll get will save you all sorts of bench time. The application notes are



FIG. 1

particularly useful because they can give you ideas about how to begin your design. More often than not they'll suggest an approach to the problem that never occurred to you.

In Table 1 I've given you a list of some of the major manufacturers who publish data books. It's by no means an exhaustive list, but it's a good beginning.

Next month we'll be jumping into a discussion of counters—what kinds are available, how they differ, and, how and when to use them.

I should point out that I learn as much by writing these columns as you (I hope) learn by reading them. Since we both profit from them it's only fair to let you have a say in what we talk about. If you have a particular area of interest, let me know. If it's possible, we'll spend some time on it.

One final note: All the circuits we develop here are ones that I've at least breadboarded. If you take them farther or find problems, let me know. I'll pass the information along. **R-E**



"Next time you check resistance ranges around here, leave me out of it!"

# Digital Features.



# Analog Prices.

Now you can get all the measurement capability you've been looking for in a digital multimeter for the price of an analog.

Priced as low as \$59.95, the Circuitmate™ Series DMMs from Beckman offer a superior combination of standard features including:

- DC + AC Volts
- DC + AC Amps
- Resistance
- Diode Test
- 0.8% or 0.5% DC Accuracy (depending on model)
- Single Rotary Selection Switch

Depending on the model you choose—you can enjoy the added capability and convenience of 10 Amps AC + DC, audible continuity checking, hFE testing, capacitance and conductance capability.

Get your hands on a Circuitmate™ DMM today. For the dealer nearest you, write or call Beckman Instruments, Inc., Instrumentation Products, 2500 Harbor Blvd., Fullerton, CA 92634, (714) 993-8803.

## BECKMAN

CIRCLE 41 ON FREE INFORMATION CARD

# NTS Electronics

**Learn Robotics, Microcomputers, Microprocessors, Digital Video, Test Equipment and more with NTS INTRONIC™ home training. Courses include state-of-the-art equipment, lessons and texts to make your hands-on programs exciting and down-to-earth practical.**

HERO 1 is included in two courses, one basic and one advanced. You'll cover principles of industrial electronics, microprocessor troubleshooting, fundamentals of mechanics, and robotic applications in industry. You'll learn analog and digital skills, radio control, fluidic, pneumatic and servo-mechanisms, as well as computer interfacing and robotic programming. HERO 1, complete with arm, gripper and speech synthesis board, is a fully self-contained electro-mechanical robot—the featured unit in the most exciting training programs ever offered in home study.

NTS Intronic Training is a carefully developed and tested learning system providing a thorough integration of advanced electronic hardware with modern lesson texts. The relationship between theory and practical applications is made clear through the hands-on experience of building and assembling kits of state-of-the-art equipment. Courses include a wide variety of test instruments, both digital and analog, as well as other units not shown here. And, depending on the NTS program you select, you can earn up to 30 CEU credits for successful completion. Our full-color catalog has complete details. NTS has taught industrial skills for over 78 years—a record that has no equal.



# Training.....

## FIRST WITH TOMORROW'S TECHNOLOGY

1. **Advanced "Z Chassis" NTS/HEATH "Smart Set"** with computer space command remote control and space phone. Originate or receive telephone calls through this set and the number appears on the screen-store your police and other emergency numbers into memory which may be recalled and auto-dialed at any time. Traditional and incomparable picture quality. Unit has Quartz Controlled Tuning, 178 channel capacity, remote antenna switch accessory for reception of VCR, VDR, Broadcast, Cable, Video Games, and Personal Computer Input (no cable change) plus computer-controlled color. Featured in all-new Video Technology Course.

2. **NTS/HEATH HN89A Microcomputer** is included in two programs. This famous and reliable unit features Floppy Disc Drive, 48K Memory on Board, CRT Terminal with its own Z-80 Processor, and standard keyboard as well as Numerical Input Keyboard. The growing importance of computer knowledge and skills have made these programs increasingly significant. The experience gained in assembling these kits is invaluable in the understanding of computer troubleshooting skills.

**NTS Microprocessor Trainer** is included in our Industrial and Microprocessor Technology Course. It is a portable unit, contained in a convenient high-impact carrying case. Hardware/Software includes Monitor Operating System-Expandable User Memory-User Experimental On-Board Section-Breakpoint Editor-Single Step Trace-Printer/Printer I/O.

NO OBLIGATION NO SALESMAN WILL CALL



NATIONAL TRADE TRAINING SINCE 1905  
 Day and Home-Study Schools  
 4000 So. Figueroa St., Los Angeles, CA 90037



Use the mail-in card or fill out and mail the coupon. Indicate the field of your choice. (One, only please.) FREE full color catalog will be sent to you by return mail.

**NATIONAL TECHNICAL SCHOOLS** Dept. 206-093  
 4000 South Figueroa Street, Los Angeles, CA 90037

Please send FREE color catalog on course checked below:

<input type="checkbox"/> Robotics	<input type="checkbox"/> Computer Electronics
<input type="checkbox"/> Digital Electronics	<input type="checkbox"/> Video Technology
<input type="checkbox"/> Auto Mechanics	<input type="checkbox"/> Home Appliances
<input type="checkbox"/> Air Conditioning/Solar Heating	

Name \_\_\_\_\_ Age \_\_\_\_\_  
 Address \_\_\_\_\_  
 Apt. \_\_\_\_\_ City \_\_\_\_\_  
 State \_\_\_\_\_ Zip \_\_\_\_\_

Check if interested in G.I. information.  
 Check if interested ONLY in classroom training in Los Angeles

# STATE OF SOLID STATE

## Thermometer circuits and more

ROBERT F. SCOTT SEMICONDUCTOR EDITOR

IN THE AUGUST ISSUE OF **RADIO-ELECTRONICS**, we looked at the REF-01 and the REF-02 from PMI (1500 Space Park Drive, Santa Clara, CA 95050). Accurate thermometers, reading directly in °C or °F can be built using either device, a few external parts, and a voltmeter. Scales can be based on references such as 10 mV/°C, 100 mV/°C, or 10 mV/°F, and direct voltage-readings such as -0.55 volts at -55°C, 0 volts at 0°C, and +1.25 volts at +125°C.

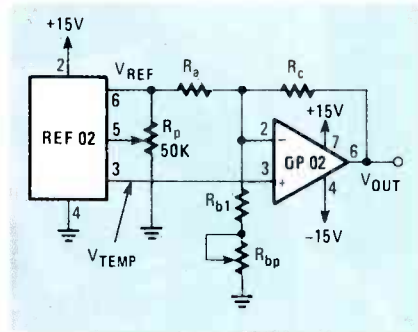

FIG. 1

Figure 1 shows a simple thermometer circuit that is built around the REF-02. The only additional components are an op-amp and three resistors. Those components, and the 5-volt output of the REF-02, scale and amplify the temperature-dependent  $V_{TEMP}$  to produce a usable  $V_{OUT}$  at the op-amp's output. That voltage output is determined from the equation:

$$V_{OUT} = \left(1 + \frac{R_c}{R_a \parallel R_b}\right) V_{TEMP} - \frac{R_c}{R_a} (V_{REF})$$

where  $R_a \parallel R_b$  is the parallel combination of  $R_a$  and  $R_b$ . The term enclosed in the parentheses is the circuit gain when  $V_{REF}$  equals zero. The term to the right of the parentheses is the circuit gain when  $V_{TEMP}$  equals zero. The slope,  $S$ , of the temperature-versus-output curve ( $TCV_{OUT}$ ) is a factor of the value of the three resistors and is determined from:

$$S = 2.1 \text{ mV/}^\circ\text{C} \left(1 + \frac{R_c}{R_a \parallel R_b}\right)$$

From the above equation, we can see that the ratio of  $R_c$  to  $R_a \parallel R_b$  determines

TABLE 1—TEMPERATURE SCALING RATIOS

$V_{OUT}$ at 25°C	$TCV_{OUT}$	$R_c/R_a$	$R_c/R_a \parallel R_b$
(77°F)	(Slope)		
250mV	10mV/°C	0.55	3.76
2.5V	100mV/°C	5.50	46.6
770mV	10mV/°F	0.926	7.57

$V_{REF} = 5.000\text{V}, V_{TEMP} = 630\text{mV}$  at 25°C,  $TCV_{TEMP} = 2.1\text{mV/}^\circ\text{C}$

the slope of  $V_{OUT}$  and the ratio of  $R_c$  to  $R_a$  and  $V_{REF}$  determines the level of  $V_{OUT}$  at 25°C. Table 1 shows typical scaling-ratios for different values of  $V_{OUT}$ .

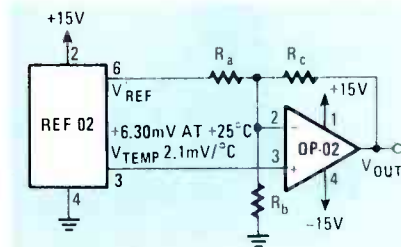

FIG. 2

TABLE 2—RESISTOR VALUES

$TCV_{OUT}$ slope (S)	10mV/°C	100mV/°C	10mV/°F
Temperature range	-55° to +125°C	-55° to +125°C	-67°F to +257°F
Output voltage range	-0.55V to -1.25V	-5.5V to -12.5V*	-0.67V to +2.57V
Zero scale	0V at 0°C	0V at 0°C	0V at 0°F
$R_a$ (±1% resistor)	9.09K	15K	8.25K
$R_{b1}$ (±1% resistor)	1.5K	1.82K	1.0K
$R_{bp}$ (potentiometer)	200Ω	500Ω	200Ω
$R_c$ (±1% resistor)	5.11K	84.5K	7.5K

\*For 125°C operation, the op amp output must be able to swing to +12.5V; increase  $V_{IN}$  to +18V from +15V if this is a problem.

A practical circuit—ready to drive a suitably calibrated voltmeter—is shown in Fig. 2. The 50K potentiometer,  $R_p$ , is used to adjust  $V_{REF}$  over a range of 5 volts  $\pm$  300 mV to compensate for any error introduced by the circuit, and to permit precise calibration using 1% resistors. Resistor values are given in Table 2.

Detailed calibration instructions and performance specifications for the REF-02 when it is used as a temperature transducer can be found in PMI'S Application Note AN-18, "Temperature Applications of the REF-02."

### Low-drain voltage-regulator IC's

The new Intersil (10710 Tantau Ave., Cupertino, CA 95014) ICL7663 and ICL7664 monolithic voltage regulators feature a maximum quiescent current ( $I_Q$ ) of only 4  $\mu$ A—1000 times better than a typical bipolar voltage-regulator. With a 1-mA load, the  $V_{IN}/V_{OUT}$  differential is only 50 mV. The low  $I_Q$  and low voltage differential make possible the use of smaller batteries and possibly allow longer battery life.

The devices handle operating loads ranging from 1  $\mu$ A to 40 mA at from 1.6 to 16 volts. Output voltage is set by a two-resistor voltage divider—the only external components required. The ICL7663 is for positive voltages and the ICL7664 for negative voltages.

### Slotted optocouplers

A series of six new slotted optocoupler/interrupter devices has been introduced by Motorola that are drop-in replacements for the GE H21 and H22 series. The devices, encapsulated in a molded plastic housing, consist of a gallium-arsenide infrared-emitting diode facing a silicon NPN phototransistor. The housing

has a slot so that an opaque material such as a card, tape, or disc can be placed between the emitter and detector.

The Motorola MOC7811, -7812, and 7813 are flanged drop-in replacements for the H21A1, HA21A2, and HA21A3., respectively. Similarly, the MOC7821, -7822 and 7823 are non-flanged replacements for the H22A1, H22A2, and H22A3, respectively. Those devices are available through Motorola distributors.—**Motorola Semiconductor Products**, Opto Marketing, PO Box 20912, Phoenix, AZ 85036. **R-E**

# NEW LITERATURE

For more details use the free information card inside the back cover

**BROCHURE** is 4-color, letter size, six pages and features three 4½-digit low-cost multimeters—two handheld and one benchtop unit.

The brochure contains full product descriptions, full specifications, and pricing and ordering information for all three instruments. Included are the model 8060A and model 8062A handheld DMM's—and the model 8050A benchtop unit. The brochure is free upon request.—**John Fluke Mfg. Co., Inc.**, PO Box C9090, Everett WA 98206.

**CIRCLE 111 ON FREE INFORMATION CARD**

**CATALOG**, 2-color, 40 pages letter-size, describes a wide range of electronics components and supplies from AC adaptors to Zeners. Included are books, cases, drafting aids, enclosures, IC inserters, generators, jumpers, keyboards, LED displays, matrix program boards, meters, PC boards and breadboards, power supplies, resistors, sockets, switches, templates, terminal blocks, test

clips, transistors, voltage regulators, and many others. Free upon request.—**Sintec Company**, Drawer Q, Milford, NJ 08848-9990.

**CIRCLE 112 ON FREE INFORMATION CARD**

**AUDIO-ACCESSORIES CATALOG** is 16 pages, 5½ × 8½ inches, glossy, listing many hard-to-find accessories. Included are stereo phones, anti-static mats, record and head cleaners, speaker mounts, low-mass cartridges, protective alarms, remote headphone controls, and cassette cabinets. Free upon request.—**Herrington**, 7265 Shadowbrook Dr., Kirtland, OH 44094.

**CIRCLE 113 ON FREE INFORMATION CARD**

**PRODUCT-INFORMATION CATALOG** is 38 pages, letter-size, on glossy paper, and deals with mobile top-loaded antennas, cordless-telephone antenna systems, CB base antennas, antenna-installation accessories, miniature speakers, monitor-

scanning base antennas, complete antenna kits, and much more. Fully illustrated, it includes camera-ready advertising copy for use in catalogs, newspaper advertisements, etc. Free upon request.—**Firestick Antenna Company**, 2614 East Adams, Phoenix, AZ 85034-1495.

**CIRCLE 114 ON FREE INFORMATION CARD**

**BROCHURE**, 2 pages, describes a new "intermediate" line of wire cutters for the electronics industry. The wire cutters include such features as chrome vanadium tool steel, two types of cut (semi-flush and ultra-fine flush) color-coded handles, and precision screw joints.

All of the specifications describing sizes and cutting capacities, as well as a wide selection of handles (including static-dissipative) are included in this glossy technical brochure, free upon request.—**EREM Corporation**, PO Box 2909, Torrance, CA 90509.

**CIRCLE 115 ON FREE INFORMATION CARD**

## TAFT

## ELECTRONIC SALES

## HAS IT ALL FOR LESS

### INTEGRATED CIRCUITS



1-7 8 UP

- 2114- \$3.45 \$2.75
- 2708- 5.65 4.50
- 2716- 6.90 5.95
- 2732- 7.50 6.50
- 4116- 2.50 1.95
- 4164- 5.75 5.50
- Z80ACPU- 4.50 3.75

### CONNECTORS

- DB25P(RS232)- \$1.95
- DB25 FEMALE - 2.50
- HOOD - .89



**FLUKE**

- 8060A \$345
- 8062A \$275
- 8022B \$143
- 8020B \$193
- 8024B \$247

### BECKMAN

- 300 \$109
- 310 \$129
- 330 \$199

### Xcelite®



- TC-100ST XCELITE'S BEST CONTAINS 53 TOOLS \$329
- TC-150ST SMALLER VERSION \$279



- 99SM ROLL KIT \$65

### BK PRECISION

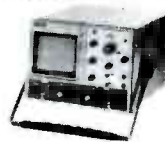

- 1476P-10MHZ DUAL TRACE \$439
- 1477P-15MHZ DUAL TRACE \$495
- 1479BP-30MHZ DUAL TRACE \$609
- 1570P-70MHZ QUAD TRACE \$1079

PRICES INCLUDE PROBES

OVER 10,000 PARTS IN STOCK. CALL FOR LOW PRICES.

### COMPUTER POWER SUPPLY

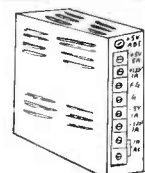

\$69

### 4 CHANNEL SWITCHING

- +5V @5A, -5V @1A, +12V @1A, -12V @1A
- INPUT 90-130V AC
- REGULATION: LINE ±0.2% LOAD ±1%
- RIPPLE: 30MV P-P



### 150 MHZ FREQUENCY COUNTER



\$149

- 4½ DIGIT LED
- 5HZ-1999.9KHZ and 0.01MHZ-150MHZ RANGES
- BATTERY OR AC

### VIDEO CONTROL CENTER



\$16.88

REMOTE CONTROL ACCESS OF ALL VIDEO, TV OR CABLE INPUTS TO TV SET. 4 INPUTS TO ONE OUTPUT

### 46 CHANNEL VCR CONVERTER WITH FINE TUNING



WATCH ONE CHANNEL AND RECORD ANOTHER

### VIDEO PROCESSING CENTER

STABILIZER • IMAGE ENHANCER VIDEO FADER • RF CONVERTER DISTRIBUTION AMPLIFIER



ONE UNIT DOES IT ALL \$99.88

## TAFT ELECTRONIC SALES

68 W. 45th Street  
N.Y.C., N.Y. 10036

CALL  
212-575-8632

- MASTER CHARGE • VISA
- MONEY ORDER • CHECK
- 25% DEPOSIT ON C.O.D.'s

ADD FOR SHIPPING  
UP TO \$300.00 • \$5.50  
OVER \$300.00 • \$8.00  
N.Y.S. ADD SALES TAX

CIRCLE 38 ON FREE INFORMATION CARD

[www.americanradiohistory.com](http://www.americanradiohistory.com)

# COMPUTER CORNER

## Shopping for a word processor

LES SPINDLE\*

WORD PROCESSING IS ONE OF THE MOST widespread—and most misunderstood—computer applications. Writers, secretaries, research reporters, scientists, doctors, lawyers—people in all types of professional endeavors—depend on processing text in one form or another as a part of their daily routines. Yet, those accustomed to old-fashioned typewriters are often skeptical about just how a word processor is better than their familiar IBM *Selectric*—at least until they try one.

Once they've been introduced to the flexibility, the ease-of-use, and the versatility of a good word-processing program, they are apt to have second thoughts. When they discover that many modern word-processing programs also serve as grammarians, spelling experts, and synonym and antonym authorities—even reference sources—they are likely to junk the old typewriter for good.

Word processing allows more than simply editing and revising text. It also makes possible the quick recall of stored text, manipulation of text from various files, and integration of office records with letters or other important documents. Professional writers probably stand to benefit the most from this versatile tool, but its value for a multitude of personal and business applications can't be overstated.



FIG. 1

### What to look for

What are the primary features that you should look for in a word-processing program? First of all, let's assume that you have decided against investing \$12,000 or more for a dedicated word-processing

TABLE 1—SOME SAMPLE WORD-PROCESSING PROGRAMS

Manufacturer	Product name	Price*	System Requirement
Aspen Software Box 339-A Tijeras, NM 87059	Grammatik (grammar checker)	\$75	TRS-80 I, II, III; CP/M; IBM PC
C.E. Software 238 Exchange St. Chicopee, MA 01013	Letter Writer II	\$20	Atari 400 and 800
Hayden Software 600 Suffolk St. Lowell, MA 01853	Pie Writer	\$150	Apple II
Howe Software 14 Lexington Road New City, NY 10956	TYPITALL	\$129.95	TRS-80 Model I and III
Liftetree Software 177 Webster, Ste. 342 Monterey, CA 93940	Volkswriter	\$195	IBM PC
MicroPro 33 San Pablo Ave. San Rafael, CA 93940	WordStar (spelling option is extra)	\$495	CP/M, IBM PC
Oasis Systems 2765 Reynard Way San Diego, CA 92103	The Word + (proofreader)	\$150	CP/M
On Line Systems 36575 Mudge Ranch Road Coarsegold, CA 93614	Screen Writer II	\$130	Apple II Plus
Peachtree Software 3445 Peachtree Rd., N.E. Atlanta, GA 30326	PeachText (formerly Magic Wand)	\$500	CP/M

\*Accurate at press time; check with manufacturer for most up-to-date information.

hardware/software system (such as a Xerox 860, or a Wang or Lanier system), and want a program that will run on your desktop computer—the same computer that you use daily for accounting, filing, and other purposes. For large offices, or highly demanding word-processing applications, the dedicated units are feasible but many users will want to invest in a microcomputer that can perform many tasks besides word processing. Let's take a look at some of the criteria to keep in mind when seeking the package most appropriate for your needs.

A good place to start your evaluation is with the instructions provided with the program. Many word processors, such as *Select* (Select Information Systems, 919 Sir Francis Drake Blvd., Kentfield, CA

94904), are extremely user-friendly, with extensive on-screen tutorials to guide the novice until he is familiar enough to use the program without assistance. *WordStar* (MicroPro, 33 San Pablo Ave., San Rafael, CA 93940) offers the user a choice of several levels of "help" menus, depending upon his level of experience with the program.

If the program will be used by beginners, it would be wise to ask a salesperson to demonstrate for you the thoroughness of its menus and tutorial sections. If that form of prompting is not particularly important to you, it is still a good idea to check the manuals supplied with the program to make sure that a comprehensive run-down is provided of the various commands and modes of operation available.

\*Managing Editor, *Interface Age* magazine

Even an experienced word-processor user will have difficulties working with a program if its workings are not clearly spelled out.

Another important selection criterion is the relationship between what you see on the terminal screen and what will ultimately appear on the printed page. Some users only feel comfortable with programs that attempt to make the text on the screen resemble the final output. Several programs are designed with such users in mind. The other school of thought seems to feel that this method is ultimately more confusing, since such subtleties as boldface type and proportional spacing cannot be depicted accurately on the screen. Test a variety of programs as you shop to discover what type of display is most comfortable for you to work with.

Another useful feature for those who need to visualize page formats is a marker that sits at the top of the screen indicating where you are on the page (by line and column) and/or tab settings. That will be helpful in manipulating text if you need to place copy at various spots on the page. An additional feature found on many programs is an automatic-centering command that makes the placement of subheads, titles, etc. very simple.

One function to keep in mind is the program's ability to append or insert text to the document you are preparing from

other files on the disk. If you are printing out late-payment notices, for example, and wish to insert the same standard wording in every one, along with other data that will differ on each statement, you want to be able to retrieve that data easily and be able to incorporate it where it belongs.

You will also want to check the "delete" functions that are included. Can you delete a word at a time? A paragraph? A line? How much flexibility is there for removing various portions of the text?

If you are creating a document that requires multiple columns to be printed out, look for a word processor that permits that to be done. Standard business forms or newsletters might require such a format.

For accounting or scientific functions, some programs integrate computational functions with word processing. Columns and rows of figures can be automatically calculated and the result printed out after the figures are placed using normal text-entry procedures.

The flexibility in margin setting is one feature that will vary significantly from program to program. Can you set more than one margin for various sections within a single page? Can you have more than one setting that can be easily called forth at various times during the preparation of the document? Can you set tab positions? Those are key questions to ask in

ascertaining whether or not the program will meet your requirements.

Does the program include automatic indexing or table-of-contents features? Some word processors do, or have compatible indexing programs that work with them. This is handy for writers.

The newest, most sophisticated capabilities, as mentioned earlier (spelling and grammar checkers, thesauruses, etc.) are often available only in separately-purchased programs (see Fig. 1). Some can be integrated with existing word processing programs; some not. Try to decide what you're going to want beforehand, and determine whether the auxiliary program(s) will work with the word processors that appeal to you.

Table 1 lists just a few of the many word-processing packages on the market. The wise shopper will examine a number of offerings until he finds the one that includes the greatest number of features he needs in his application. One word of caution: while the prices of seemingly similar products vary widely, so do their capabilities. The inclusion of some features that seem highly sophisticated at first glance may mean the lack of other features too important to be without. Before being tempted by what seems like a bargain, make sure that the program offers sufficient versatility to handle your needs. Take your time to pick the product that you find easiest to work with. **R-E**

## CANCER. NOT KNOWING THE RISKS IS YOUR GREATEST RISK.

A lot of people think cancer is unbeatable.

That simply isn't true. In fact, over two million people have had cancer and survived to lead happy, normal lives.

And not only can cancer be beaten, it can also be prevented.

There are definite precautions that have been proven to decrease your risk of getting certain cancers.

Ask your local American Cancer Society to send you a free booklet about cancer risks.

Learn the facts about cancer.

And make not knowing the risks, one less risk.

**AMERICAN CANCER SOCIETY**  
How you live may save your life.

This space contributed as a public service

**ANYONE CAN!**

**CUSTOM BUILD YOUR OWN... ONLY! \$49.95**

... ELECTRIC VICE PANELS OR METAL BOXES WITH THIS EASY TO OPERATE... BENDER, EASILY BENDS ANY LIGHT GAUGE SHEET METAL TO AN 18" WIDTH. ALSO INCLUDED, FREE WITH PURCHASE, ARE EASY TO FOLLOW PLANS TO CONSTRUCT THE 3 ENCLOSURES SHOWN.

PLEASE SEND CASHIER'S CHECK OR MONEY ORDER AND RETURN ADDRESS PLUS \$4.50 SHIPPING AND HANDLING. MS. RES. ADD 5% SALES TAX. VISA & MASTERCARD ONLY. INCLUDE, ACTIVE & EXPIRATION DATE, OR CALL DIRECT. ANY TIME 1-601-957-3407

MAIL ORDER TO: **HANDY MAN, INC.** P.O. BOX 12284 JACKSON, MS. 39211

## ACTIVE RECEIVING ANTENNA

Gives excellent reception, 50 KHz to 30 MHz.

New MFJ-1024 Active Receiving Antenna mounts outdoors away from electrical noise for maximum signal.

Gives excellent reception of 50 KHz to 30 MHz signals. Equivalent to wire hundreds of feet long. Use any SWL, MW, BCB, VLF or Ham receiver.

High dynamic range RF amplifier. 54 in. whip. 50 foot coax. 20 dB attenuator prevents receiver overload. Switch between two receivers. Select auxiliary or active antenna. Gain control. "ON" LED. Remote unit, 3x2x4 in. Control, 6x2x5 in. 12 VDC or 110 VAC with optional adapter, MFJ-1312, \$9.95.

**\$129.95** (+\$4.00 shipping)

Order from MFJ and try it. If not delighted, return within 30 days for refund (less shipping).

One year unconditional guarantee.

Order today. Call TOLL FREE 800-647-1800. Charge VISA, MC. Or mail check, money order. Write for free catalog. Over 100 products.

**CALL TOLL FREE 800-647-1800**

Call 601-323-5869 in Miss., outside continental USA, tech/order/repair info. TELEX 53-4590.

**MFJ ENTERPRISES, INCORPORATED**

Box 494, Mississippi State, MS 39762

CIRCLE 66 ON FREE INFORMATION CARD

# COMMUNICATIONS CORNER

Phones are for more than talking.

HERB FRIEDMAN, COMMUNICATIONS EDITOR

ONE OF THE LATEST BUZZWORDS IS "high-tech"—meaning high technology. I dislike the term because it connotes snobbery, as in "if it ain't high tech it ain't no good 'cause it ain't up to date."

Actually, high technology is a relative term. For example, schools don't even teach spark-gap transmitters any more...who wants to know about that old stuff? In Marconi's day, however, spark gap was high tech. So was the Marconi antenna, and skip. (Did you ever stop to consider that if Marconi had picked some other month for his transatlantic experiments, or the frequency he'd used was closed at that hour, it might have taken the world some 20 years to stop laughing at someone silly enough to think he could transmit across the "big pond"?)

But high technology does tend to sneak up on us, and because the field of electronics is so fragmented, we often have little idea of, or can't keep up with, the spectacular developments in specific areas of interest. We're going to talk about one such rapidly developing area—that of signalling telephone-equipment.

## Telephone control

It seems that almost weekly some new service is announced that uses *Touch-Tone* or DTMF (*Dual-Tone Multi-Frequency*) signals to make it work. We have recently covered the special low-cost telephone services (such as Sprint and MCI—see the July 1983 issue of **Radio-Electronics**) that provide reasonably inexpensive long-distance service from your local phone—providing you have some form of *Touch-Tone* signalling device to control their computer(s).

Well, the same signalling methods can be used to control the computer or telephone-answering machine back at the office. They can also be used to turn on the air conditioner before you get home, to key a sensitive telephone amplifier to check the kids while you're away for the evening, or to do any of a hundred other things. Combine a microprocessor (computer) with the *Touch-Tone* signaling and you can accomplish just about anything using the telephone system.

However, not everyone has *Touch-Tone* service—mainly because that service usually is more expensive. And why pay for it just to key your gadgets?

Up until very recently, the standard

way to be certain you had *Touch-Tones* available when you needed them was to carry around a small keypad device that generated the tones directly into a tele-



FIG. 1

phone handset. You dialed on the rotary (dial) telephone, held the tone device over the mouthpiece (transmitter), and when you heard the answer signal you beeped the keypad.

Now, all that is great for a few tones, but what do you do when it can take up to 26 individual tones to place a Sprint call, turn on an air conditioner, or access a computer? Right! You use a computerized keypad "dialer," one with lots of non-volatile (permanent) memory; the kind of device just starting to make its way into the local general stores. Who needs them, you ask? Isn't that the same question you asked last year about personal computers?

To date, the most convenient way I've seen to provide relatively massive memory, automatic dialing, and a host of other computerized telephone functions is the *SoftTouch* auto dialer, a device that substitutes for the existing telephone

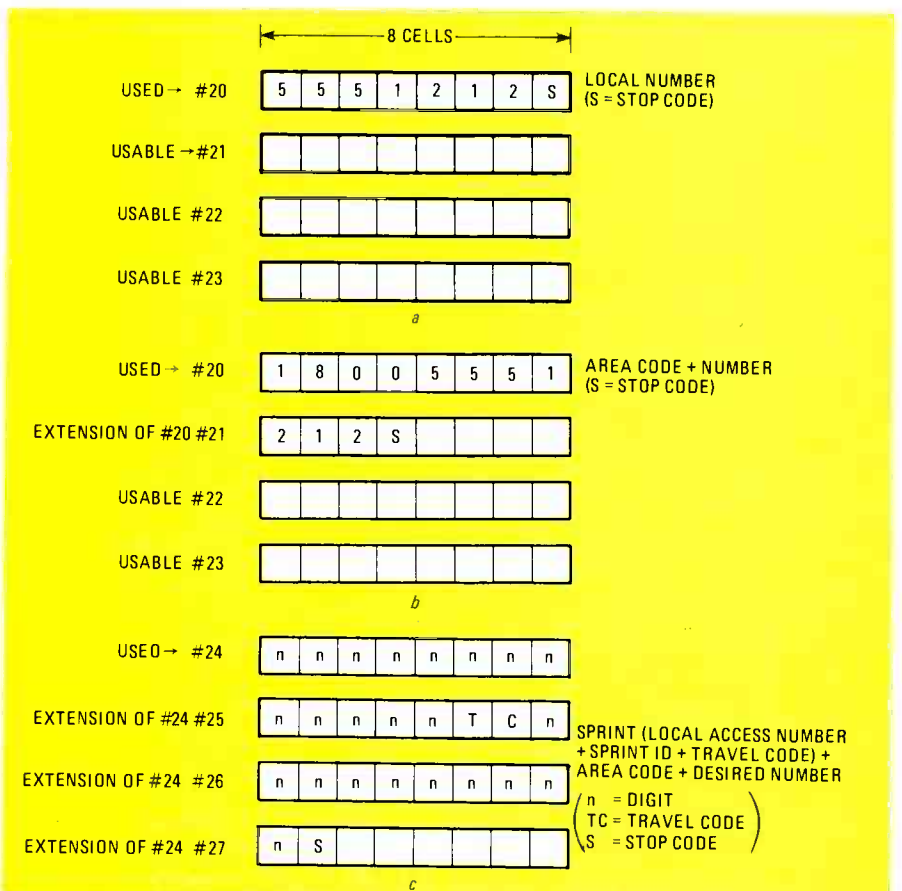

FIG. 2



transmitter (mouthpiece). We've had devices in the past that replaced the transmitter with a combination microphone and tone pad, but adding memory is a different ballgame. We looked at that auto dialer briefly in July's column. Now, we'll take a closer look.

The *SoftTouch 83* from Buscom Systems, Inc. (4700 Patrick Henry Drive, Santa Clara, CA 95050) is shown in Fig. 1. (It sells for about \$90, but there are models with less memory that are less expensive.) It is powered by the telephone line but it is backed up by lithium batteries. (There is nothing more frustrating than losing the contents of a device's memory because of an interruption in power.) What happens when you have to replace the batteries? Do you lose all the memory programming? No! When the handset is off the hook the telephone line voltage is applied to the memory; if that's when you change the batteries, you'll save the programming.

But the most important feature of the 83 is its flexibility. When you make a local call, a long distance call, or a call using a service such as Sprint, you are going to be using tone-groups of different lengths. The *Soft-Touch AutoDialer*, uses a convenient and practical technique—one that is certain to be copied by others.

Figure 2 shows how it's done. The autodialer has 80 stackable memories numbered from 20 through 99. Each memory holds 8 characters, but they can be strung together to hold any size number (up to 640 characters). Two additional memories of 16 characters (which can also be strung together) are also included. Keying any memory number causes a complete tone-sequence of any needed length to be transmitted.

Each numbered memory has 8 cells, and each entry must be terminated by a "stop" command. If your number plus the stop fits into the 8 cells, the single memory is used for the information. For example, if memory no. 20 uses 8 or less cells, the no. 21 memory can be used for a different entry. But if the number plus the stop require more than 8 cells, you can simply get the required number of cells—the number automatically spills into the next memory. For example, one call might require a dialing sequence of 1-800-555-1212S (S for stop). That's 12 digits. When you enter the sequence it simply uses as much memory as it needs. When you punch up the no. 20 memory, the correct tone sequence will be transmitted. But the next usable memory is now 22 because 21 has been linked to 20.

Let's carry this further. We'll examine a Sprint call using *Touch-Tone* for local telephone access. The local access number could, of course, be rotary-dialed, but we'll make the whole dialing procedure automatic. Also, we'll presume that the two 16-digit memories are already full. Under the most favorable conditions the

dialing sequence for the Sprint call will be: nnn-nnnn-nnnnnn-*nnn-nnn-nnnnS*. That's 24 digits; it will just fit into 3 memories. But assume you're out of your local area and are using a travel code (TC). That adds two more units and the sequence becomes: nnn-nnnn-nnnnnnTC-*nnn-nnn-nnnnS*. Because that's 26 digits, 4 memories will be required. If the starting memory is no. 24, the next available memory will be no. 28. Memories 24 through 27 are used for one single (but long) sequence.

Of course, sequences can also be manually keyed. For example, assume that after you dial the 26 digits your computer answers and needs an 8-frequency access command. Well, you can place that sequence in another memory that you key when you hear your call answered by the computer. Or, you can use the standard keypad built into the device.

If you think you can handle it all manually, keep that 26-digit dialing sequence in the back of your mind. It's even more difficult than it sounds, particularly if you get a busy signal from the other end. As we are forced to memorize seemingly endless digit sequences to communicate with computers, etc., the pocket-sized telephone autodialer is certain to become as commonplace for business people as the ballpoint pen and car keys. R-E

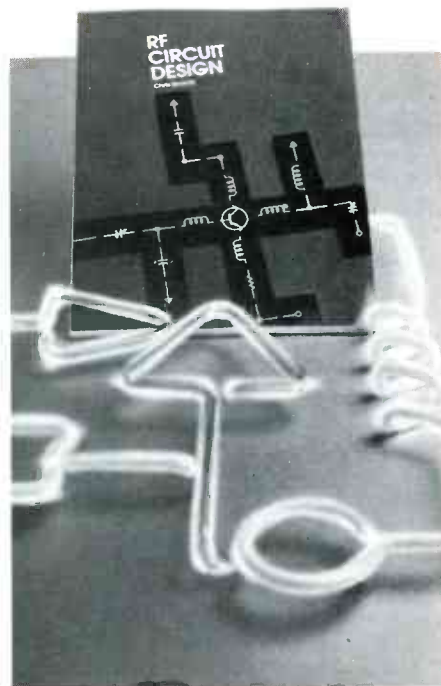

## PRACTICAL RF DESIGNS BEGIN WITH SAMs.

Let Sams' RF CIRCUIT DESIGN help you bridge the gap between RF circuit theory and real-world applications!

Unlike other circuit design books, RF CIRCUIT DESIGN presents a detailed, practical approach to RF circuitry. It's a cookbook for builders, an excellent reference book for designers and engineers, and a complete sourcebook for students.

RF CIRCUIT DESIGN is entirely user-oriented, and includes many hands-on examples that cover such topics as RF amplifiers, filters, oscillators, components and impedance matching networks. It utilizes a minimum of complex math.

Practice Sams' practical approach with your own copy of RF CIRCUIT DESIGN, No. 21868 at only \$22.95. To order or get the name of your Sams retailer, call 800-428-3696 or 317-298-5566 and ask for Operator 419.



### SAMS BOOKS AND SOFTWARE

HOWARD W. SAMs & CO., INC.  
4300 West 62nd Street, P.O. Box 7092  
Indianapolis, IN 46206

Offer good in USA only and expires 1/31/84  
Prices subject to change without notice. In  
Canada, contact Lenbrook Electronics, Markham,  
Ontario L3R 1H2. AD419

CIRCLE 32 ON FREE INFORMATION CARD

# SAVE!

MONEY • TIME • FREIGHT

QUALITY STEREO EQUIPMENT  
AT LOWEST PRICES.

YOUR REQUEST FOR QUOTA-  
TION RETURNED SAME DAY.

FACTORY SEALED CARTONS—  
GUARANTEED AND INSURED.

SAVE ON NAME BRANDS LIKE:

PIONEER	JVC
KENWOOD	TEAC
MARANTZ	SANSUI
TECHNICS	SONY

AND MORE THAN 50 OTHERS  
BUY THE MODERN WAY  
BY MAIL—FROM

**ia**  
**illinois audio**

BANK CARDS ACCEPTED

12 East Delaware

Chicago, Illinois 60611

312-664-0020

800-621-8042

CIRCLE 94 ON FREE INFORMATION CARD

# SERVICE CLINIC

## Opening your own shop

JACK DARR, SERVICE EDITOR

WE'VE BEEN GETTING QUITE A FEW letters from young men who are learning electronics in the Armed Services and want to open their own shops when they get out. So, we decided to run a column dealing with it. I'm the staff expert on one-man shops (I've been running one for the last 50 years!), so I get to write it. There are a lot of things, all of them important, about opening your shop, and a lot of mistakes you can make. (I know, I've made them.) So, I may sound like the Dutch Uncle at times, but it's all based on actual experience! Let's start out with the shop itself

### Location

Whether you settle in a small town or city, you should follow the same rules when trying to find a suitable location. Don't try to find one on the main street; rents are much higher there, and you really don't need "store traffic." Look for the secondary streets; a block or so off the main one. Rents are lower, and you are a service industry—people will look you up when they need you.

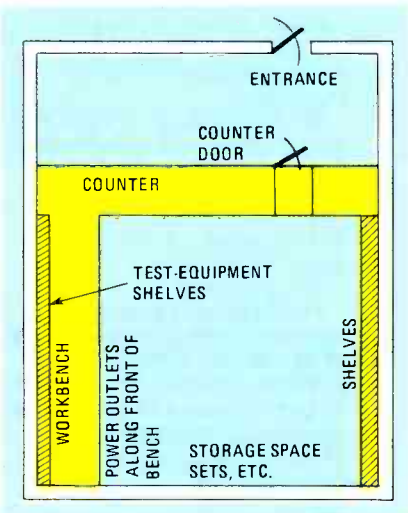

FIG. 1

Look for a fairly large room, with parking space in front or back. That will give you room to make a workbench, and a small place with a counter or railing to keep the customers off your neck while you're working (see Fig. 1). A back door on an alley is very handy; you can drive up there and unload sets quickly. Check

the roof of the building, too; nothing's worse than a leaky roof!

### The bench

Your bench is important. It should be big enough to hold the largest TV set you plan to service. Mine is four feet wide, with a shelf along the back to hold test equipment. Wire a string of outlets along the front of your bench, *not* the back. On the other side of the shop, build shelves for parts storage. That gives you the fastest way to operate; when you need a part, just turn around and get it. Parts should not be on the bench itself; they'll just get covered up. Make a small set of drawers under the middle of the bench for hand tools and other things. (I keep the most-used hand tools, long-nose, screwdriver, soldering iron, nut driver etc., at the right end of my bench. I'm right handed—they're right there when I need them.)

### Test equipment

Now we come to the subject of the most-asked question: what test equipment you'll need. To me, the essential instruments are a good VOM (digital or analog), a scope (which doesn't have to be a triggered-sweep type—a good recurrent-sweep scope can do a good job). Next is a color-bar generator, with both RF and IF outputs. With the IF output, it becomes a tuner subber. With those, you can read any voltage or current, feed test signals into the set, and trace them through it with the scope. A transistor tester, preferably one with a good leakage test, can be very handy. Leaky transistors are responsible for a lot of problems. Other instruments can be added later as the need arises, but I think these are the essential ones, and will be the most-used.

### Service data

Now we come to one really essential thing: service data on the TV sets. You've got to have that; modern TV sets simply can't be fixed without it. For one thing, you can't even find the parts! The two major sources for data are Sams *Photo-facts* (Howard W. Sams & Co., Inc., Indianapolis, IN 46206), and the factory data from the maker. Personally, I like to have both. With the factory data, you usually get a newsletter, etc. which often has valuable hints on certain models.

The Sams folders come in small boxes each month; these can be stacked on shelves with the edge out, and you can locate any folder quickly; the numbers of the folders are printed on the edge. Filing cabinets can be added later. The Sams Index is an invaluable source of data. Keep it handy.

Parts data, on transistors, IC's, etc is another handy thing. All of the replacement-transistor makers put out big guides, with many, many types listed with their substitutes. Companies like RCA, GE, Sylvania, and many others have them; get all you can. I've had no problems at all in using such parts in place of originals, and in some cases they're better. You can get a starter stock of the most popular types and fix quite a number of sets out of it.

### Getting the parts

I hate to tell you how easy it used to be to get parts! Many sets used standard parts, and you could stock them. Nowadays, it isn't easy at all. There are so many specialized parts that it gets rough at times. There are two major sources; the radio-TV supply houses, and the factory distributor for the make. Universal replacement parts come from the supply houses, and in many cases they stock factory parts for popular makes, as well. The distributor will have parts on hand; call him and introduce yourself, and make arrangements to get parts at discounts. They often have catalogues, etc. that are useful.

Several makers have hotlines, with a toll-free number, if you have problems getting parts. GE's number is 1-800-241-6696; Admiral's is 1-800-447-8361; Thordarson's (for flybacks and transformers) is 1-800-851-3583. Those numbers can be useful in emergencies.

If you're in a small town, there will be a radio-TV supply house in the nearest small city. They often have a salesman who calls on you once a week. If you need a part fast, you can call them and have them put it on the bus—you'll get it in a few hours. (Be sure to charge the customer for the long distance call and the freight!)

Here's a useful hint: Try to do most of your parts buying from only one firm. That will make your account much bigger, and they'll be very polite to you!

Spraying small orders all around won't get it. If you buy open-account you can often get a 2% cash discount by paying the bill before the 10th of the month. Check up on that. It doesn't sound like much but it really does help. R-E

## SERVICE QUESTIONS

### LOOSE YOKE

*The deflection yoke on this Admiral 4M10 chassis is permanently bonded to the neck of the CRT—or at least it was until it became unbonded. The customer didn't want to spring for a new CRT/yoke. I am wondering if I should try to cement it back. What will happen to the convergence if I do?—W.L., Ozone Park, NY*

Yes, you should try to cement it back on. An old trick I used to use on old CRT replacements is to put a cross-hatch pattern on the set and hold the yoke (carefully!) in place. Watch the pattern and move the yoke around until it's converged, and mark the places where the mounting pads are. Then move the yoke back and put cement where the pads were. Put the yoke into position again, watching the pattern, and hold it until the cement sets. (Any fast-setting epoxy will work well, probably better than the original "permanent" cement.) For temporary adjustments, put a bit of double-sided tape under each pad. That will hold everything while you fiddle with the adjustments.

### HOT RESISTOR

*In this Sears 529.72940, the color and the convergence are a little bit off. Resistor R26 on the convergence board is hot as a firecracker, but opening the coupling capacitor, C160, cools it down. My old instructors said that some heat should be expected here, but I don't think that the smoke should be! Any advice?—D.M., Huntsville, TX*

I think I know what's wrong: a mis-adjustment of the blue shape coil. If you look at page 29 of the Sam's folder, you'll find the adjustment procedure. It's really quite simple. Adjust the coil until the waveform "hump" is where it should be and things will get much better.

### POSITIVE GRID VOLTAGE

*In this Philco 19FT00B, I not only have no high voltage, but the screen grid of the 6JS6 reads full B+ (294 volts) while the control grid is +50 volts instead of -74 volts. I've checked everything I can think of and I'm stuck.—J.J., Farmington, IA*

Instant analysis: you're not going to get anything until you get that +50 volts off the 6JS6 grid! The tube is being driven far above its normal current. The B+ on the

screen shows that the tube is drawing no current at all. It's evidently completely exhausted.

The positive grid-voltage could be due to a shorted coupling capacitor between the oscillator and the grid. I seem to remember other letters on this same chassis with the same complaint. Check to see if the oscillator is running. The oscillator grid should read -34 volts if it is running, and the plate should read +180 volts.

### LOOK AT THOSE WAVEFORMS!

I wrote to you a while back asking for help with a Panasonic with a sync problem. After that I again looked at the signal at the video amplifier with a scope and found that I'd made a mistake. Now I could see white compression! The collector of the first video transistor had only two volts on it. Resistor R323 was wide open. Replacing the resistor fixed everything up. I'm puzzled as to how the thing made a picture at all!

*Thanks to W.J. McClain of Phoenix, AZ. That is something we should all (including a certain guy I know very well) keep in mind. Look at those waveforms very carefully.*

### VERTICAL PROBLEMS

*The vertical linearity is bad on this Magnavox T939, and the top of the picture is distorted. I tried a new 6LR8 with no improvement. I was using a scope, and when I touched the probe on the pentode grid, the screen filled out! In desperation, I "shotgunned" (that's what you once called it) the set: I checked out every part one at a time, out of the circuit. Of course, all of them checked out good. And when I put them back, the story was the same. Any ideas on what's going on?—G.Y., West Yellowstone, MT*

I had the same symptoms on a horizontal output tube! It worked fine if I held the VTVM probe on it. A big resistor in the grid was open. I think you have the same problem. Try replacing some of those high-value resistors in the pentode grid circuit. Some of them may be breaking down under load.

*(Feedback: Both of the 4.7 megohm resistors had checked out OK. I replaced them anyway and that solved the problem!)*

### SUBSTITUTE FILTER

The complaint about this Quasar TS-951 was that the line fuse would open intermittently when it was turned on. I had no service data, so I went at the problem blind. I found a few leaky diodes, but new ones didn't help any. I also checked the main filter capacitor and found that it took too long to charge on a leakage test. I got an exact replacement from Quasar and it was bad too! Other parts also turned out to be bad. Finally, though, I used a Cornell-Dublier CC0129.7 along with a

Sprague PC-8 PC-board adapter. The set's worked fine ever since.

*Thanks much to Dave Horning of Mole Electronics, Westlake, OH for that one. Dave, you're just like the namesake of your shop—you just keep digging until you find what you're after. Keep up the good work.*

### BURNING CAPACITOR

*This Admiral K-1904-1 had a very small raster. I found that capacitor C111 had burned up. When I replaced it, I got a full raster back. But the new capacitor gets too hot to touch. What's up?—J.T. Delanson, NY*

Capacitor C111 in that set is the boost capacitor, from boost to B+. It normally has quite a high spike-voltage on it from the flyback. For that purpose (and any other capacitors used in flyback circuits) you need a capacitor with a special dielectric that can withstand high spike-voltages (which most of us refer to as "RF"). Sprague and others have those in many sizes. Ordinary types won't stand up too long, as you found. Your set was suffering from a bad case of dielectric heating.

### SUGGESTIONS

If you have a loss of color sync in a GE KC chassis, look at the little neon bulb in the middle of the chassis. If it's blackened or not glowing, replace it; the color sync is fed through it.

In a Panasonic CT925 chassis with no sound or picture except for a flash when it's turned off, the problem is probably a defective video/sound-IF IC.

In a Magnavox T982-12 with a high voltage that's about 4KV higher than it should be, check transistor Q2 on the regulator pincushion-board. The base and collector are reversed! They apparently came out of the factory that way. The board is marked right, but the transistor is in wrong.

*Thanks to John Osborne of Winthrop Electronics, Winthrop, ME.*

### THREE HINTS AND A QUESTION

On a Magnavox T995 series set, the lack of vertical deflection can be due to open coils, L1 or L2, on the vertical module. They open very easily, usually when the output transistors go out, but sometimes they do it all by themselves! You can get the parts from N.A.P. (North American Philips) Consumer Parts.

On the same set, the 300-megohm bleeder resistor coming from the tripler burns out about every year and a half. Transistor Q4 in the power-supply module shorts out. That causes the high voltage to go up to 37KV. It also keeps the 24-volt supply from adjusting properly. After replacing Q4, I've had no further problems.

Loss of video and weak distorted sound in an Admiral 1M30B can be due to a bad



**FREE**  
**10**  
**L.E.D.s**  
**A \$2.00 VALUE**

You can now receive ten prime T-1¾ or T-1 red LEDs absolutely free. It is our way of introducing you to the quality parts we offer.

**ETRONIX**  
14803 N.E. 40th Dept. RE9-03  
Redmond, WA 98052

Yes, Please send me 10 Free LEDs, plus your brochures on additional products available. I prefer  T-1  T-1¾.

NAME \_\_\_\_\_

ADDRESS \_\_\_\_\_

CITY \_\_\_\_\_ ST \_\_\_\_\_ ZIP \_\_\_\_\_

Please include \$1.00 to help cover postage and handling.

CIRCLE 10 ON FREE INFORMATION CARD

**SEE YOUR DEALER TODAY**

FROM

**'Firestik'**  
ANTENNAS  
ACCESSORIES

HERE'S A TIP  
THAT'S PERFECT!

AM/FM AUTO RADIO  
AND CB

**'Firestik' II**

GOLDEN SERIES

BARE-HANDS TUNABLE  
"NO TOOLS NEEDED"  
HIGH PERFORMANCE ANTENNAS

ALSO ANTENNAS FOR  
CORDLESS TELEPHONES  
MONITOR SCANNERS

Dealer & Distributor Inquiries Invited  
SEND FOR FREE CATALOG

'Firestik' Antenna Company  
2614 East Adams Phoenix, AZ 85034

Name \_\_\_\_\_  
Street \_\_\_\_\_  
City \_\_\_\_\_  
State \_\_\_\_\_ Zip \_\_\_\_\_

Serving the CB and  
Communications Market Since 1962.

**5-YEAR REPLACEMENT WARRANTY**

CIRCLE 40 ON FREE INFORMATION CARD

third-IF transistor. Rockwell International developed a special heat sink (part No. 90A66-1) that should help solve the problem. You can order it through Admiral National Parts. The newer video-IF modules have the heat sink, but the older ones don't.

Now, here's the question: This Magnavox T991 has a narrow picture with wavy lines on the edges. Also, the picture is cut in half, with the left half on the right side and the right half on the left side. After a few tests, the base and collector of the horizontal output transistor shorted, which also shorted the switching regulator, Q6. I replaced both of those but still get no raster. Any ideas?

*Before I answer the question let me say thanks to Terry Erickson of Las Animas Electronics, Las Animas, CO for the helpful hints.*

*Now for the problem: Something is surely messed up in the horizontal-oscillator/AFC circuit. Check all the parts around that IC to make sure that none of them are bad. If everything checks out OK, then try a new horizontal module. All of the frequency-determining parts are inside that IC. Also check the 4-legged capacitor, C220. A couple of parts on the regulator seem to give trouble. Check the string of three diodes in series in the base circuit of the regulator; those set the bias on the regulator-driver. Also check the 50 µF electrolytic on the*

*+88-volt line and the pulse-regulator diode, D11, on the power supply board. If that shorts, you've got trouble.*

### SOUND PROBLEM

I finally fixed the "no sound" problem in this B/W Panasonic 429B set. Transistor TR53 was bad, so I replaced it with a GE-63 PNP-type. That promptly burned up. I checked the schematic again and found that TR53 should be an NPN! I substituted a GE-67, replaced TR54 with a GE-63 and also replaced R510. Now everything works fine. I hope this information can help some others.

*Thanks to Terry Dick of Corbin, KY for that bit. Yep, it helps to use the right type transistor. But sometimes it's almost impossible to find out what's what with the minute schematics we get with some sets. For a quick check, note the polarity of the collector voltage. If it's positive, the transistor should be NPN (and vice versa.)*

### SOME BIG-AMPLIFIER ADVICE

Here's a problem that I came across when working on a 100-watt guitar amplifier—but you could find a similar problem anywhere. The amp contained a full-wave bridge rectifier with four separate diodes, marked 3 amps, 300 volts. Someone had replaced bad diodes with the familiar 1-KV, 2.5-amp types that we always use. I put in two more; they promptly shorted out. I checked for shorts, put in two more and ran the line voltage up slowly with a Variac. It worked fine.

I turned the amp off, and then back on. The new diodes blew again. I sat and thought. Then I checked the RCA SK substitution manual. Those diodes have a peak rating of 50 amps. With one exception, 3-amp diodes will have a peak rating of 200–300 amps. The amplifier had a very large input capacitor and a low-resistance power-transformer winding. The surge current charging that huge capacitor was simply too great, and the diodes blew from the overload. Finally, I replaced all the diodes with a SK3987 encapsulated bridge rated for eight amps and 400 PIV/300-amp surge. Now the unit can be turned on safely.

*Thanks go out to Bill Styles of Hillsboro, MO (The Sage of the Ozarks). I hope that helps a few people out.*

### LINE FORMS ON THE LEFT

*I asked you for help on a problem in a Quasar TS934. It had a black line on the left side of the screen, about one inch wide. You told me to check the coil-resistor gadget on the plate cap of the 6LF6. I took it off and the line was still there. I tried several other things with no results. I noticed that the bias was low on the 6LF6 grid and the waveform had "fuzz" on top. I took off the violet wire from the flyback and the line went away! Also, the bias jumped to normal (59 VDC) and the current went down. What hap-*

## The world of electronics gee-wizardry

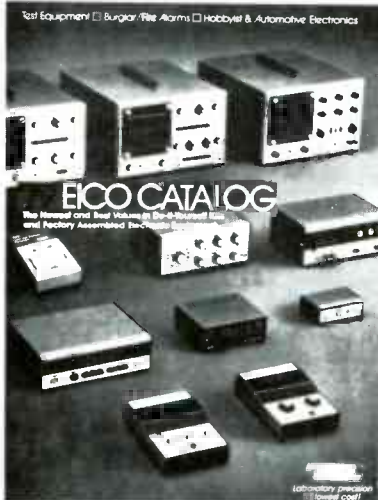

## -YOURS FREE.

32-pages of test instruments—from the latest digital multimeters to the famous EICO scopes. Security systems. Automotive and hobbyist products. Kits and assembled. EICO quality. EICO value. For FREE catalog, check reader service card or send 50¢ for first class mail.

**EICO** 108 New South Road  
Hicksville, N.Y. 11801

CIRCLE 59 ON FREE INFORMATION CARD

[www.americanradiohistory.com](http://www.americanradiohistory.com)

pened here?—H.A., Baltimore, MD

I think you hit it! The violet lead from the flyback feeds pulses through an RC network (R506/C501) to the VDR (Voltage-Dependent Resistor) in the 6LF6 grid. That is supposed to control the bias. I'd suspect the VDR. It could be arcing at the peak of the pulse, which would not only cause the "fuzz" on the pulse, but also reduce its amplitude by flattening the peak (causing cathode current to go up). But the "fuzz" is HF oscillation and that causes the line.

### BAD CAPACITOR

I asked a little while ago about a problem in a Quasar TS929. You told me to check some capacitors. Capacitor C2 on the BA panel was open. That let horizontal pulses get into the IF. Also, I had an intermittent convergence problem, which was traced to a jumper wire on the convergence yoke plug. (The way it was traced was very scientific—an arc happened to catch my eye.)

### THAT'S A GOOD QUESTION!

I'm looking at a CTC-108C (RCA) schematic. The block diagram shows a sandcastle generator. What is that and where did they get the name? None of the local TV shops seem to know.—S.C., Mentone, CA

Unfortunately, no one around here knows either. (Neither does RCA!) Maybe some of our readers do?

### MORE HINTS

If you come across a B/W 19EB12 that loses horizontal sync when changing channels, check R715, a 10K, 1/2-watt resistor. It's probably open.

If you have no raster after a few minutes on a Zenith 19HC48, the 24-volt regulator is probably opening up.

Now here's a problem I had with a Sears 563.51170701. It had bottom foldover and not enough sweep. Cool-spraying transistor Q502, the vertical driver, brought the sweep back. A new transistor did not change symptoms. Replacing C504, a leaky 1-μF coupling capacitor didn't help either. I then looked at the two vertical-output transistors, Q505 and Q506. I noticed that the case of the Q506 was much cooler than that of Q505. I put in a new ELM153 for Q506 and full sweep returned.

Thanks to Mike Danish, Danish TV, Aberdeen Proving Ground, MD.

### VERTICAL PROBLEM

I've got a Sears set, chassis number 529-72912, that is giving me fits. The problem is in the vertical stages. I replaced a capacitor four months ago, and everything seemed fine, at least for a while. The set recently came back with the same problem, however. I replaced the same capacitor, and this time the set played for just 20 minutes before it went out again. I'm baffled.—D.P., Sacramento, CA

That all sounds very familiar. Some years ago we had an RCA chassis that had continual vertical problems. We finally got to where if one came in we simply replaced all of the capacitors in the vertical stage. It really was not that big a job as there were only five of them in all. That nearly always cleared up the problem. Be sure to use good-quality capacitors with a high enough voltage rating when you do that job; after all, you don't want to do it twice.

### MANY SYMPTOMS

I had a GE 16JA come in with multiple symptoms. They were a herringbone pattern on the screen, odd results when using the brightness control, brightness varying with the channel, and a buzz in the sound. When I checked the B+, it measured only 13 volts instead of 22. I checked the regulator board and replaced the regulator transistor, Q400, with no results. I finally found that R414, Q400's emitter resistor, read 4.5 ohms; it should have read 2.2. Replaced it with a 2.2-ohm, 5% resistor and everything seemed fine except that the brightness was still low. After quite a bit of head-scratching, I finally realized that someone had turned the brightness centering control all the way down. Once that control was reset everything was fine again. Thanks for teaching me the method.—Don Wainwright, Taos, NM

R-E

## A NEW STAR IS BORN!



The Wersi Comet opens the way to the fascinating world of music and electronics.

- Most powerful research and development in the organ industry
- Lowest price
- Fastest organ kit to build
- No technical experience needed
- Biggest sound in the smallest cabinet
- Easiest to play, highest technology, most economical. The unbelievable, new Wersi Comet!

Features: CX1 preprogrammable rhythm and accompaniment unit, the Wersi Sound Memory, multi-guitar group, piano section, couplers, incredible magic finger group including automatic chords, glissando, arpeggios, and many, many more.

Los Angeles, Cal. (213) 802-2891

(714) 739-4909

Lancaster, Pa. (717) 299-4327

**WERSI**  
Organ & Pianos

- Free Organ Info.
- Free Piano Info.
- Complete WERSI Info.

WERSI  
Dept. M 51, P.O. Box 5318  
Lancaster, Pa. 17601  
Call Toll Free: 800-233-3865

CIRCLE 95 ON FREE INFORMATION CARD

For Home or Business  
WHAT...WHEN...HOW...

## BE A COMPUTER PROGRAMMER



Train at home in spare time! No previous experience needed! Now you can learn it all! Computer programming...computer applications...computer games...everything you ever wanted to know about computer operations! Write your own computer programs or use hundreds of programs already available...budgeting, real estate, bookkeeping, expenses, investments, interest, taxes, shopping lists, vacation planning, addresses, phone numbers, routing...even foreign languages and graphics.

You'll know what really happens when you have a computer problem with a bank, store, loan company, oil company, utility or anyone else. You'll be able to talk their language...understand why and how things happen...to be able to take the offensive when you're the victim of a computer error. Experts explain everything in easy-to-understand language with step-by-step directions.

• TIMEX COMPUTER INCLUDED WITH YOUR TRAINING • Plugs into any TV

• SEND FOR FREE FACTS!

**IGS** COMPUTER TRAINING, Dept. DE083  
SINCE 1981 Scranton, Pennsylvania 18515

Please rush me free facts and color brochure that tells how I can learn computer applications, programming and operation at home in spare time. No cost. No obligation.

Name \_\_\_\_\_ Age \_\_\_\_\_  
Address \_\_\_\_\_  
City/State/Zip \_\_\_\_\_

# NEW PRODUCTS

For more details use the free information card inside the back cover

**POWER SUPPLY**, the *LIFELINE*, is an uninterruptible AC power supply that was designed specifically to furnish the microcomputer market with true UPS (Uninterruptible Power Supply) protection at an affordable cost. The "no-break" power feature provides voltage regulation and line filtering at all times, plus an inverter that supplies power only during power outages. There is no interruption to the critical load.

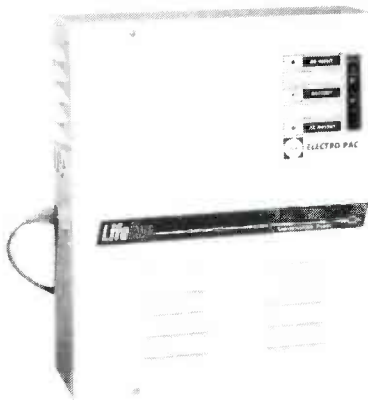

CIRCLE 121 ON FREE INFORMATION CARD

A maintenance-free internal battery handles the full power of the system for 5 to 10 minutes. Recharge to 95% of the full charge requires less than 40 minutes. A larger bank of batteries may be used to extend operation to several hours.

The *LIFELINE* plugs into a normal 120-volt AC wall outlet; the critical load is simply plugged into the dual-convenience outlet on the UPS. The many applications include telephone PBX and PABX's, communications systems, microcomputers, and instrumentation. The 200VA *LIFELINE* unit is priced at \$1042.00. (600- and 1200VA units are also available.)—**ICS**, Electro-Pac Division, 520 Interstate Rd., Addison, IL 60101.

**KEYBOARD**, the *PRO-100*, is an intelligent, detachable, capacitance keyboard with enclosure for use with the *Apple II* and *Apple II+* personal computers. It offers 100 keys supporting all existing Apple functions, plus horizontal and vertical cursor movement, separate number pad with enter key, auto-repeat, relocated RESET key, CAPS LOCK key, power-ON indicator, upper/lower case, 22 *VisiCalc* keys, 25 Apple BASIC keys, and 18 programmable keys.

The *VisiCalc* keys assist the user to access all *VisiCalc* commands through the use of one key. That reduces the user-training time and creates a friendlier program for novices



CIRCLE 122 ON FREE INFORMATION CARD

as well as dedicated programmers. The Apple BASIC keys help the user to access BASIC commands that were otherwise confusing to remember or to use into one key function, speeding up computer use. Supplied with the *PRO-100* keyboard is a pre-boot diskette containing BASIC disk utilities, user-friendly menu, keyboard information, and a useful word-processor and graphics program that demonstrates the programming flexibility at the function keys. The detached *PRO-100* keyboard make the *Apple II* and *Apple II+* a user-friendly computer. It is priced at \$265.00, including shipping and handling.—**AMKEY, Inc.**, 200 Ballardvale Street, Wilmington, MA 01887.

**AMPLIFIERS**, the model *ML-11* Power Amplifier (shown) and the model *ML-12* pre-amplifier, are designed to be used together, but the model *ML-11* may be used with any other preamplifier.



CIRCLE 123 ON FREE INFORMATION CARD

The model *ML-11* is a universal stereo power amplifier, providing accuracy and reliability where relatively low power is required; it is rated at 50 watts per channel. It can elicit from many loudspeakers the same clear, clean, and alive quality of music reproduction that larger amplifiers have established. It is priced at \$1700.00.

The model *ML-12* is designed to be used only with the model *ML-11*. Line amplification and power-supply redundancies have been

eliminated by using the model *ML-11* power amplifier for those functions. That design allows for an optimum match of preamplifier and power amplifier, while offering the advantages of discrete circuits and external pre-amplifier power supply. The model *ML-12* is priced at \$1200.00.—**Mark Levinson Audio Systems, Ltd.**, 2081 South Main St., Route 17, Middletown, CT 06457.

**RESISTANCE SUBSTITUTERS**, model *RS-200W* and model *RS-201W* use nine side-by-side thumbwheel switches. The desired resistance is simply dialed in, and they are ready for use. Both are error-proof, because the resistance is set and read directly as an unambiguous number on color-coded switches. Unlike the case with conventional decade boxes with rotary or slide switches, there is no need to examine or sum a whole group of



CIRCLE 124 ON FREE INFORMATION CARD

separate numbers. These are laboratory tools for a variety of uses in engineering, design, troubleshooting, or service.

The model *RS-200W* is the economy version, using 1%, 0.5-watt metal film resistors; it is priced at \$189.00. The model *RS-201W* is the high-precision version with 0.1% tolerance; it is priced at \$379.00.—**IET Labs, Inc.**, 534 Main Street, Westbury, NY 11590.

**MICROCOMPUTER**, the *MPF-IP*, has for its brain a Z80 microprocessor, which features a 158-command instruction set. The 8K monitor ROM also supports the functions of a text editor, two-pass assembler, and line assembler. The optional thermal printer (20 characters per line, 0.8 lines per second) incorporates a memory-dump utility, and a Z80 disassembler-listing utility. The user's RAM of the *MPF-IP* is 4K, but can be expanded using the optional input/output and memory board (IOM-MPF-IP).

A standard ASCII keyboard is provided, enabling a user to enter programs in assembly language, machine code, BASIC, or FORTH. A 20-digit, 14-segment alphanumeric green tube display, together with the line-scrolling ability, allows the *MPF-IP* to accept

or display an input line of 40 characters. There is also a built-in speaker, audio cassette tape interface for program storage and reading, battery-operated memory back-up

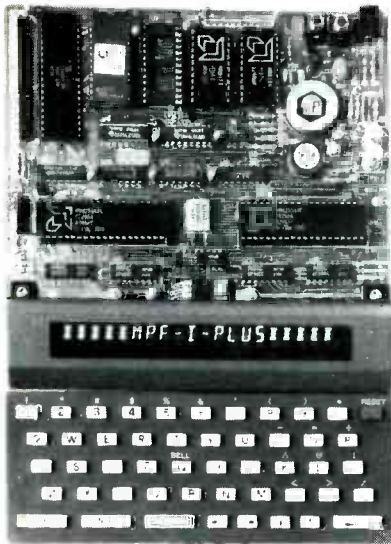

CIRCLE 125 ON FREE INFORMATION CARD

circuit, and many useful optional boards. The MPF-1P comes with detailed instructional self-learning manuals, enabling a user to get familiar with microcomputer hardware and software step-by-step. Its suggested retail price is \$199.00.—Multitech Electronics, Inc., 195 W. El Camino Real, Sunnyvale, CA 94086.

**VIDEO PROCESSOR**, the model V-1880, has a stabilizer (video guard remover), image enhancer, video-to-RF converter, video fade in/out, and a dual-output distribution amplifier. All five functions are contained in one compact tabletop box that features easy dial operation.



CIRCLE 126 ON FREE INFORMATION CARD

The stabilizer lock control corrects the entire range of "copy guard" distortion such as jitter, vertical roll, or traveling black bar, and ensures a continued stable picture. An enhancer, regulated by the DETAIL control reduces grain and gives the user the opportunity to select the best picture, according to preference.

The RF converter allows the TV set to receive video and audio signals from the image enhancer, guard stabilizer, video camera, computer, and VCR. It does that by converting direct video signals from any video component to usable RF signals that can go into the TV antenna terminals. The video fader produces a gradual transition from full video to black and back to full video, just as if it were done in a professional studio.

The model V-1880 is priced at \$250.00.—**BP Electronics, Inc.**, 260 Motor Parkway, Hauppauge, NY 11787.

**TOOL**, the TP-1, will cut and crimp component leads flush to the PC board with one motion. Designed to permit maximum operation visibility, the TP-1 is used for lead trimming before soldering; it's ideal for laboratory, production, or personal projects. Rated for up to 20 AWG (0.8mm) soft wire leads, the tool is constructed of high carbon steel with a

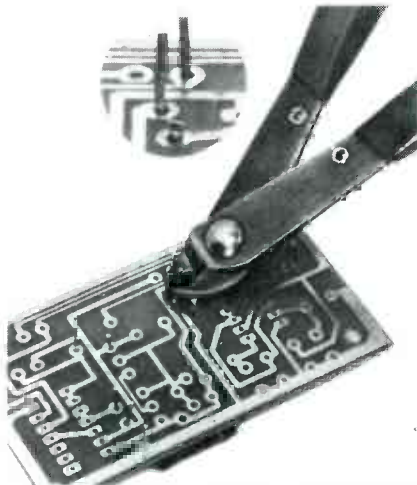

CIRCLE 127 ON FREE INFORMATION CARD

black oxide finish, a double coil spring, and cushioned plastic grips. The TP-1 is priced at \$10.75.—**OK Industries, Inc.**, 3455 Conner Street, Bronx, NY 10475. R-E

## Guitar Tuner

# \$34.95

easy to build kit  
\$49.95  
assembled



Accurate  
Easy to use

Unbelievably inexpensive

... that's our new BANANA quartz guitar tuner kit. Thru-jacks let you tune electric guitars without unplugging. Acoustic guitars tune with built in condenser mic. Internal speaker produces by-ear tones if you want them.

Two easy to use tuning indicators — a meter to indicate pitch deviations up to 1/2 semi-tone and LED go-no-go indicators, both with quartz accuracy.

Runs for months on a single AA penlight and one 9v. battery. Easy to assemble kit with step-by-step instructions.

No. 9700 only \$34.95 plus \$2.00 shipping.  
No. 9700A Assembled & Tested... \$49.95  
Order yours today . . .

CHARGE TO VISA OR MC TOLL-FREE  
1-800-654-8657 9AM to 5PM CST MON-FRI

Ask for your free PAIA Kit catalog  
Direct mail orders and inquiries to: Dept. 8R

**PAIA Electronics, Inc.**

1020 W. Wilshire, Oklahoma City, OK 73116 - (405) 843-9626

CIRCLE 52 ON FREE INFORMATION CARD

## Put Professional Knowledge and a COLLEGE DEGREE in your Electronics Career through HOME STUDY

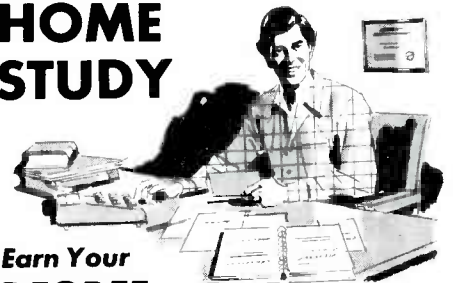

### Earn Your DEGREE

No commuting to class. Study at your own pace, while continuing your present job. Learn from easy-to-understand lessons, with help from your home-study instructors whenever you need it.

In the Grantham electronics program, you first earn your A.S.E.T. degree, and then your B.S.E.T. These degrees are accredited by the Accrediting Commission of the National Home Study Council.

Our free bulletin gives full details of the home-study program, the degrees awarded, and the requirements for each degree. Write for *Bulletin R-83*.

**Grantham College of Engineering**  
2500 So. LaCienega Blvd.  
Los Angeles, California 90034

## QUALITY SPECIALS

### SOPHISTICATED I.C.'S

DATA SHEETS ARE PROVIDED FREE WITH ALL INTEGRATED CIRCUITS LISTED BELOW

PART #	DESCRIPTION	PRICE (#*)
LS7232	TOUCH SENSITIVE LIGHT DIMMER SWITCH MOMENTARY TOUCH TO SENSOR PLATE TURNS LIGHTS ON OR OFF. PROLONGED TOUCH GRADUALLY DIMS OR BRIGHTENS. A SLOW CLOCK INPUT ALLOWS AUTOMATIC SLOW DIMMING TO OFF IDEAL FOR SOLVING CHILD'S FEAR OF DARK BEDROOM.	\$4.50
RDD104	CMOS DIVIDER I.C. HAS TRUTH-TABLE SELECTABLE INPUT TO YIELD DIVIDE BY 10, 100, 1000 OR 10000 OUTPUTS.	\$3.50
LS7031	D.C. TO 5MHZ SIX DECADE MOS UP COUNTER WITH 8 DECADE LATCH AND MULTIPLEXED BCD OUTPUTS AND DIGIT STROBES. ACCESS TO LSD LATCHES ALLOWS ATTACHMENT OF PRESCALERS FOR COUNTING TO 500MHZ.	\$11.75
LS7220	14 PIN DIP AUTOMOTIVE MARINE ANTI-THEFT DIGITAL LOCK CIRCUIT HAS 5380 3-DIGIT COMBINATIONS WITH 25 MICROAMP STANDBY SAVE MODE FOR VALET PARKING.	\$3.50
XR2228CN	MULTIPLIER DETECTOR I.C. FOR ANALOG SIGNAL PROCESSING. CONTAINS 4 QUADRANT ANALOG MULTIPLIER. MODULATORS AND INDEPENDENT HIGH GAIN OP-AMP DIFFERENTIAL X-Y INPUTS. APPLICATIONS FOR PHASE DETECTION UP TO 100 MHZ. PLL DESIGN IN SYNC AM DETECTION OR GENERATION. TRIANGLE TO SINEWAVE CONVERSION OR FREQUENCY TRANSLATION.	\$3.20
ICL8038	PRECISION WAVEFORM GENERATOR I.C. PRODUCES SINE SQUARE TRIANGLE SAWTOOTH OR PULSE WAVEFORMS WITH MINIMAL EXTERNAL COMPONENTS. FROM 0.01HZ TO 101 MHZ FOR PRECISION PLL TEST INSTRUMENTS.	\$3.75
XR215CN	HIGH-FREQUENCY PHASE LOCKED LOOP (PLL) I.C. FOR BOTH ANALOG AND DIGITAL COMMUNICATIONS 0.5HZ TO 350MHZ. USES INCLUDE FM DEMODULATION, FREQUENCY SYNTHESIS FOR CODING/DECODING, MODEM, DTL, TTL, ECL LOGIC COMPATIBLE.	\$4.20
CS258A	INTRUSION ALARM OPTICAL TRANSDUCER I.C. NEEDS IR LED PHOTO DIODE A PASSIVE PARTS TO BE COMPLETE OPTICAL TRANSDUCER SYSTEM. CAN BE FAIRLY OPEN TO AMBIENT LIGHT WITHOUT FALSE ALARMS.	\$5.95

### HALL EFFECT DEVICES

UGN3501T	HALL EFFECT SENSOR FOR MAGNETIC FIELD CHANGES TOO SMALL TO OPERATE THE HALL SWITCHING OUTPUT IS A LINEAR FUNCTION OF MAGNETIC FIELD INTENSITY MONOLITHIC I.C. INCLUDES HALL I.C., AMPLIFIER AND VOLTAGE REGULATOR FOR 4.5 TO 24 VDC SOURCE. HIGH SENSITIVITY AND FLAT RESPONSE. 3 PIN 1 PACK.	\$2.80
UGN3501M	SAME AS UGN 3501T BUT WITH PROVISION FOR NULLING THE OUTPUT OFFSET VOLTAGE. 8 PIN DIP.	\$2.80
UGN3804M	HALL EFFECT SENSOR WITH DIFFERENTIAL OUTPUT. A LINEAR FUNCTION OF MAGNETIC FLUX SUPPLIED WITH IN DIVISIONAL CALIBRATION CHART AT 25 DEGREES CELSIUS. 5.5 VOLTS FOR CALIBRATING, TESTING AND ALIGNING MAGNETIC SENSING DEVICES. 8 PIN DIP.	\$8.50

FREE CATALOG OF NEW DEVICES

**GOLDSMITH SCIENTIFIC**

CORPORATION

P.O. BOX 318R, COMMACK, NY 11725

PHONE ORDERS WELCOME—(516) 979-7944

MASTER CARD AND VISA ACCEPTED

NEW YORK STATE RESIDENTS ADD SALES TAX

POSTAGE—ADD 5% PLUS \$1.50 INSURANCE, C.O.D. \$2.00 EXTRA

AVAILABILITY OF CERTAIN ITEMS MAY BE LIMITED

CIRCLE 69 ON FREE INFORMATION CARD

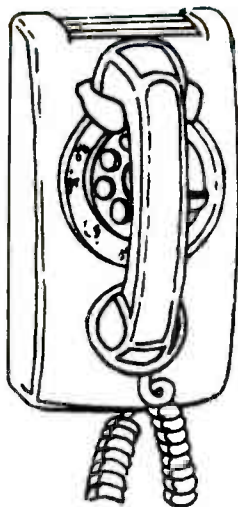

## CALL NOW AND RESERVE YOUR SPACE

- 6x rate \$550 per each insertion.
- Reaches 220,500 readers.
- Fast reader service cycle.
- Short lead time for the placement of ads.
- We typeset and layout the ad at no additional charge.

Call 212-777-6400 to reserve space. Ask for Arline Fishman. Limited number of pages available. Mail materials to: mini-ADS, RADIO-ELECTRONICS, 200 Park Ave. South, New York, NY 10003



**THE MEAN LITTLE KIT** New compact kit of electronic tools. Includes 7 screwdrivers, adjustable wrench, 2 pair pliers, wire stripper, knife, alignment tool, stainless rule, hex-key set, scissors, 2-flexible files, burnisher, soldering iron, solder aid, solder and desoldering braid. Highest quality padded zipper case. Send check or charge BankAmericard, Mastercard, or American Express. The JTK-6 sells for \$95.00—**JENSEN TOOLS INC., 7815 S. 46th Street, Phoenix, Arizona 85040, (602) 968-6231.**

CIRCLE 70 ON FREE INFORMATION CARD

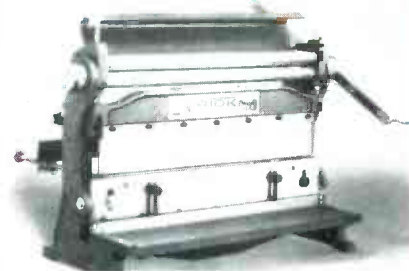

**SHEET METAL WORKER - The 24" TRIOK** is a Press Brake, Shear and Slip-roll machine—perfect for research and development or maintenance shops. Over a thousand machines world wide in little to the largest companies. For free literature on this and our other sheet metal working machines contact: **PACIFIC ONE CORPORATION, 513 Superior Ave. Suite K301, Newport Beach, CA 92663, (714) 645-5962.**

CIRCLE 91 ON FREE INFORMATION CARD

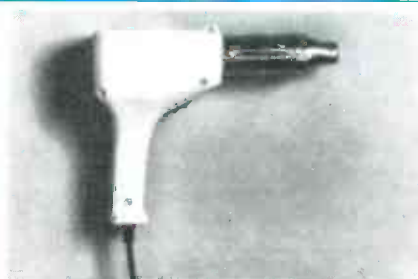

**PROFESSIONAL HEAT GUN 6977** has the capacity to master such heavy-duty jobs as molding and welding plastics, softening & forming plastic laminates, paint stripping, curing large volumes of epoxies, heat-shrinking cables and softening floor tiles and putty. **Specifications:** Temperature 975°F, 800 watts at 120 volts, AC only, Air flow 6.9 cfm at 2650 fpm, 3-wire grounded cord, 6 ft. cord, oil and heat resistant. Weight: 28 oz. **\$85.00.** See a demo at your Ungar distributor or call **Ungar, (213) 774-5950.**

CIRCLE 57 ON FREE INFORMATION CARD



**MODERN ELECTRICS.** Miniature souvenir of the first publication ever produced by Gernsback Publications. This issue appeared in April 1908—just 75 years ago. You can own your own reprint of this unique first edition for just \$2.50 plus 75c P&H. It's available from **R-E BOOKSTORE, Radio-Electronics, 200 Park Avenue South, New York, NY 10003**



**CLOSE OUT - BLOW OUT - LIQUIDATION SALE - AMATEUR MICROWAVE RECEIVER - REGULARLY \$99.50. NOW LIQUIDATING AT ONLY \$59.95 EACH!** (Dealer "eight-pack" for just \$399.00) Complete system includes dish, probe/downconverter, co-ax cables, power supply, hardware and instructions. Top quality units with genuine #2137 transistors for hi-gain, lo-noise. **ORDER TODAY!** Supply limited. Money order, VISA or Mastercard only. (No C.O.D. at this price.) **T.V. PRODUCTS CO., 635 Park Ave., Dept. 222, Idaho Falls, Idaho 83402. DESCRABLERS??** We stock all types. Send \$3.00 for catalog!



**APPLIANCE REPAIR HANDBOOKS—13** volumes by service experts; easy-to-understand diagrams, illustrations. For major appliances (air conditioners, refrigerators, washers, dryers, microwaves, etc.), elec. housewares, personal-care appliances. Basics of solid state, setting up shop, test instruments. **\$2.65 to \$5.90 each.** Free brochure. **APPLIANCE SERVICE, PO Box 789, Lombard, IL 60148. 1-(312) 932-9550.**

CIRCLE 64 ON FREE INFORMATION CARD



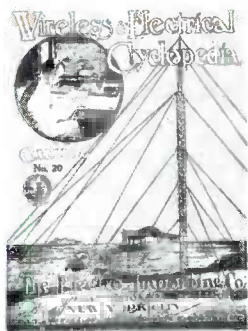

**ELECTRO IMPORTING CO. CATALOG.** This reprint of the historic 176-page catalog No. 20 gives you an accurate look at the state of electronics in 1918. Contains everything from a Zinc Spark Gap to a 1000-Mile Receiving Outfit. You can get your own copy of this modern antique, profusely illustrated, for only **\$4.95** plus \$1.00 P&H. Order yours from **R-E BOOKSTORE, Radio-Electronics, 200 Park Avenue South, New York, NY 10003.**

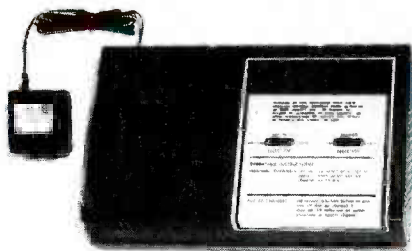

**PAY T.V. DECODERS** Completely assembled and tested. Compatible with ZENITH Z-TAC and SSAVI systems. No internal T.V. connections. Built in VARACTOR TUNER. **\$129.00** VISA, M/C, and C.O.D. orders accepted. **DECODER DISTRIBUTORS CO.,** 23400 Michigan Avenue, Suite 502 Deaborn Michigan MI 48124 (313) 562-9661. Other models available, we also ship to Canada  
**CIRCLE 92 ON FREE INFORMATION CARD**



**NEW DTMF Receiver Kit turns phones into control devices.** With Teltone's TRK-956 kit, you get all the parts necessary to breadboard a central office quality DTMF detection system for only **\$22.75**. That's the lowest installed cost for a DTMF system. All you provide is 5V dc. For decoding DTMF signals from telephone lines, radios, and tape players, use the TRK-956. To order call: **Teltone, (800) 227-3800 ext. 1130. (In CA, (800) 792-0990 ext. 1130).**

**CIRCLE 65 ON FREE INFORMATION CARD**

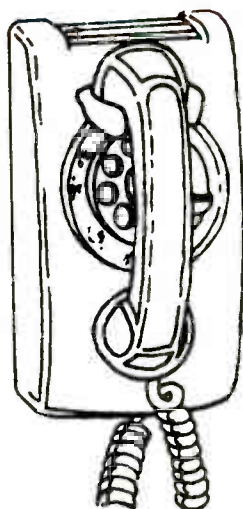

**CALL NOW  
AND  
RESERVE  
YOUR SPACE**

- 6 x rate \$550 per each insertion.
- Reaches 220,500 readers
- Fast reader service cycle.
- Short lead time for the placement of ads.
- We typeset and layout the ad at no additional charge.

Call **212-777-6400** to reserve space. Ask for Arline Fishman. Limited number of pages available. Mail materials to: **mini-ADS. RADIO-ELECTRONICS, 200 Park Ave. South, New York, NY 10003.**

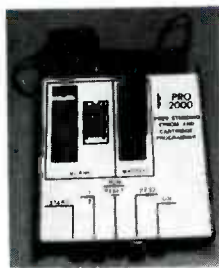

**EPRO 2000—EPROM & GAME CARTRIDGE DUPLICATOR**—Make copies of most of your Atari 2600® game cartridges, as well as 2732 & 2716 Eproms. No computer necessary. Easy to use. **EPRO 2000 \$199.95, EPROM 2732 \$4.25.** NOTICE the EPRO 2000 is offered for the purpose of enabling you to make ARCHIVAL copies of your computer programs entitled to you under US COPYRIGHT LAW. Atari 2600 is a trademark of Atari Inc. **MICHIGAN ELECTRONIC PRODUCTS INC.,** P.O. Box 50 E., Detroit, MI. 48021. (313) 791-3324.  
**CIRCLE 97 ON FREE INFORMATION CARD**

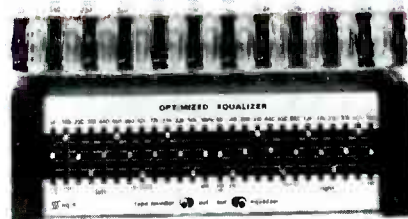

**New REAL TIME ANALYZER**—Meters (?) are better for setting up our graphic equalizers to flatten out your room acoustics. Model AN-1 (shown, \$60) works with our 13-band optimized equalizer (\$100); see *Computers & Electronics* 12/82-1/83. M/C, Visa ok; free shipping w/check. Free catalog. **SYMMETRIC SOUND SYSTEMS, INC.,** 856M Lynn Rose Ct., Santa Rosa, CA 95404, (707) 546-3895.



**CONVERTERS-DESCRAMBLERS-MICROWAVE**—Not C OR D grade. Only grade A new, genuine Oak, Jerrold, Zenith, Hamlin, Pico, Bogner, Pioneer! Name it! Sine-wave, gated-sync, vari-sync, in-band, out-band. We sell 'em all! No order too big or small. Dealers-we can beat any price. Mastercard and Visa. Send \$3.00 for catalog to: **TV PRODUCTS CO.,** 635 Park Avenue, Suite 222, Idaho Falls, ID 83402.

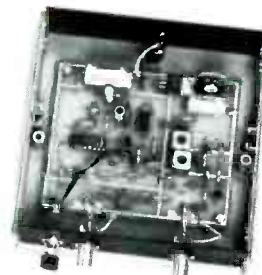

**CABLE TV DESCRAMBLER KIT \$39.95** Computerized addressable gated sync type. We also have complete line of Jerrold and Oak cable TV converters and descramblers. Such as, Jerrold gated sync (SB-3), Oak sinewave (N12), and Jerrold 61 channel remote control converter descrambler (DRX-DIC-105). 90 day warranty. **SEND \$2.00** for "INFORMATIVE CATALOG" for prices and availability to: **J & W ELECTRONICS, INC.,** P.O. Box 61-X, Cumberland, RI 02864.  
**CIRCLE 63 ON FREE INFORMATION CARD**

# NEW BOOKS

For more details use the free information card inside the back cover

**WORLD RADIO TV HANDBOOK, The Authoritative Directory of International Radio and Television; World Radio TV Handbook, 1515 Broadway, NY 10036; 608 pages; 9 x 5 3/4 inches; \$17.50.**

This 37th edition, celebrating the World Communications Year (1983) is a complete almanac of radio and TV broadcast sources in every country on earth. It is designed to help the international radio listener obtain maximum enjoyment from his receiver.

The first section of the Handbook contains instructive articles relating to broadcasting, and information about broadcasting organizations.

The main section contains detailed information, country by country, on the radio and television stations of every country in the world, including names and addresses of broadcasting organizations, names and titles of leading officials, lists of transmitting stations in each country (including frequencies; power; call signs, if used; and location, when

known). Program information is also given, including times, frequencies, and target areas of the broadcasts in each language.

There is also a listing by frequency of the shortwave stations of the world, and long- and mediumwave stations by regions, to assist in the identification of stations.

**CIRCLE 131 ON FREE INFORMATION CARD**

**PRACTICAL REPAIR AND MAINTENANCE OF COMMUNICATIONS EQUIPMENT, by Albert D. Helfrick; Prentice-Hall, Inc., Engelwood Cliffs, NJ 07632; 308 pages, including index; 9 1/4 x 6 inches; hardcover; \$29.95.**

This book is for technicians who repair and maintain radio-communications equipment, and is particularly suited to radio amateurs. It covers all the popular forms of radio-communications equipment from the low end of the high-frequency spectrum through the UHF spectrum, AM and SSB to FM and tone signaling. Special emphasis is placed on the

most-used modes of transmission for the frequency range covered.

The text starts with a general discussion of repair, failures, and reliability. The responsibility of the designer to produce reliable equipment and the responsibility of the service technician to provide a safe and operable product are discussed. Chapter 2 covers basic parameter measurements and circuit analysis. It stresses the use of modern equipment and gives alternate methods when the repair-shop budget does not allow for a complete complement of test equipment.

Single-sideband is covered in chapter 3 with high-frequency transmitters and receivers. FM is covered in chapter 4, which analyzes UHF and VHF systems. Both amateur and commercial systems are covered.

Further chapters deal with analyzing synthesizers, repairing accessory systems, and preventive maintenance and restoration of performance.

**R-E  
CIRCLE 132 ON FREE INFORMATION CARD**



**\$72.50**

### Weller WTCPN Soldering Station

W.S. Jenks & Son--tool distributors since 1866--features the very practical Weller WTCPN soldering station at a substantially reduced price through October 31, 1983. Be sure to send for the Winter '83-84 Electronic Tool Catalog with great prices on many brands like: Ungar, Hexacon, Xcelite, Desco...

Exclusive Weller closed loop, low-voltage circuit is safe for IC soldering. Temperatures of 600 F., 700 F. and 800 F. are selected by changing the grounded heat-sensing tip with knurled thumbscrew. Power unit has utilized on/off toggle switch, neon indicator light, non-heat sinking iron holder, storage tray for extra tips, and tip cleaning sponge with receptacle. Furnished with 1/16" screwdriver tip for 700 F. range.



W.S. Jenks & Son  
2024 West Virginia Ave. N.E.  
Washington, D.C. 20002 1-800-638 6405

Please send the indicated material:

\_\_\_\_\_ Weller WTCPN Soldering Station @ \$72.50  
\_\_\_\_\_ FREE Winter '83-84 Electronic Tool Catalog  
\_\_\_\_\_ Mastercard \_\_\_\_\_ Visa \_\_\_\_\_ American Exp.  
\_\_\_\_\_ Check/Money Order

Card No. \_\_\_\_\_ Exp: \_\_\_\_\_  
Signature \_\_\_\_\_  
Name \_\_\_\_\_  
Address \_\_\_\_\_  
City \_\_\_\_\_ State \_\_\_\_\_ Zip \_\_\_\_\_

**CIRCLE 62 ON FREE INFORMATION CARD**

## Radio-Electronics REPRINT BOOKSTORE

- |   |         |  |        |
|---|---------|--|--------|
| <input type="checkbox"/> Build Your Own Satellite TV Receiver .....   | \$7.00  | <input type="checkbox"/> Special Projects (Spring 1981) .....            | \$4.00 |
| <input type="checkbox"/> 8-Ball Satellite TV Antenna .....            | \$5.00  | <input type="checkbox"/> Special Projects #4 (Summer 1982) .....         | \$4.00 |
| <input type="checkbox"/> Build Your Own Robot .....                   | \$12.00 | <input type="checkbox"/> Special Projects #5 (Winter 1983) .....         | \$3.00 |
| <input type="checkbox"/> TV Descrambler (January/February 1981) ..... | \$3.00  | <input type="checkbox"/> Special Projects #6 (Spring 1983) .....         | \$3.00 |
| <input type="checkbox"/> Radio-Electronics back issues (1983) .....   | \$3.00  | <input type="checkbox"/> Radio-Electronics Annual 1983 .....             | \$2.50 |
| (January, February 1983 not available)                                |         | <input type="checkbox"/> How to Make PC Boards .....                     | \$2.00 |
| Write in issues desired _____   |         | <input type="checkbox"/> All About Kits .....                            | \$2.00 |
| <input type="checkbox"/> Radio-Electronics back issues (1982) .....   | \$3.00  | <input type="checkbox"/> Modern Electrics (Vol. 1, #1, April 1908) ..... | \$2.25 |
| (January 1982 not available)  |         | <input type="checkbox"/> Electro Importing Co. Catalog .....             | \$4.95 |
| Write in issues desired _____   |         | (1918) (176 pp)  |        |
| <input type="checkbox"/> Radio-Electronics back issues (1981) .....   | \$3.50  |  |        |
| (March, December 1981 not available)                                  |         |  |        |
| Write in issues desired _____   |         |  |        |
| <input type="checkbox"/> Etch your own PC Boards .....                | \$3.00  |  |        |

To order any of the items indicated above, check off the ones you want. Complete the order form below, include your payment, check or money order (DO NOT SEND CASH), and mail to Radio-Electronics, Reprint Department, 200 Park Ave. South, New York, NY 10003. Please allow 4-6 weeks for delivery.

If you need a copy of an article that is in an issue we indicate is unavailable you can order it directly from us. We charge 50¢ per page. Indicate the issue (month & year), pages and article desired. Include payment in full, plus shipping and handling charge

ARTICLE \_\_\_\_\_

MONTH \_\_\_\_\_ YEAR \_\_\_\_\_

PAGES \_\_\_\_\_

TOTAL PAGES \_\_\_\_\_ @ 50¢ each TOTAL PRICE \_\_\_\_\_

MAIL TO: **Radio-Electronics**

Reprint Department, 200 Park Ave. South, New York, NY 10003

All payments must be in U.S. funds

Total price of order ..... \$ \_\_\_\_\_  
Sales Tax (New York State Residents only) ..... \$ \_\_\_\_\_  
Shipping & Handling (U.S. & Canada only) (Includes FIRST CLASS POSTAGE) \$1.00 per item ..... \$ \_\_\_\_\_  
All other (\$2.00 per item, sea mail) ..... \$ \_\_\_\_\_  
(\$4.00 per item, air mail) ..... \$ \_\_\_\_\_

Total Enclosed ..... \$ \_\_\_\_\_  
Name \_\_\_\_\_  
Address \_\_\_\_\_  
City \_\_\_\_\_ State \_\_\_\_\_ Zip \_\_\_\_\_

# MARKET CENTER

## PLANS & KITS

**CATALOG!** 40 pages of neat electronics parts and kits. Send 50 cents, refundable first order. **BEC ELECTRONICS**, Box 401244R, Garland, TX 75046.

**FUN kits— low cost.** Easy to build educational electronics projects. Handbook/catalog \$1.00. **TRIANGLE ELECTRONICS**, 89 Arkay Drive, Hauppauge, NY 11788.

**PRINTED circuit boards.** Quick prototypes, production, design, reflow solder. Send print or description for quote to **KIT CIRCUITS**, Box 235 Clawson, MI 48017.

**PROJECTION TV ...** Convert your TV to project 7 foot picture. Results comparable to \$2,500 projector... Total cost less than \$30.00 ... Plans and lens \$19.95... Illustrated information free... Credit card orders 24 hours. (215) 736-3979. **MACROCOMA-GA**, Washington Crossing, PA 18977

**ELECTRONIC touch light control pad** five modes dim, medium, bright, delay, and off. Two kits available. Write for free brochure. **EXOTIC ELECTRONIC IDEAS**, PO Box 446, Lake Bluff, IL 60044.

**NEW!... Repair any TV... Easy.** Anyone can do it. Write: **RESEARCH**, Box 517E Brea, CA 92621.

**MOST advanced sine converter descrambler** available. PCB and plans \$15. **JIM RHODES**, 1025 Ransome Ln., Kingsport, TN 37660.

**CABLE TV converters and equipment.** Plans and parts. Build or buy. For information send \$2.00. **C & D ELECTRONICS**, PO Box 21, Jenison, MI 49428.

**SUBSCRIPTION TV** out of set UHF sine wave type, PCB and plans \$16.50. In set UHF/VHF type, PCB and plans \$12.50. **RVB INDUSTRIES**, Box 663, Skokie, IL 60076.

**FREE KIT Catalog**

FUNCTION GENERATOR KIT \$59.95  
Auto-Ranging Cap-meter kit \$79.95

Phone 209-772-2076

Write or Phone for FREE CATALOG

**DAGE SCIENTIFIC INSTRUMENTS**  
BOX 144 VALLEY SPRINGS CA 95252

contains TEST & EXPERIMENTER'S EQUIP.

**FIND electronics parts!** Our buyers' guide lists thousands of radio, computer, electronics, micro-wave, and mechanical parts, with who sells them by mail order to hobbyists. 75 suppliers and addresses. \$6.95 ppd. Fast response. **HALLWARD PRODUCTS**, 39N Sunset Court, St. Louis, MO 63121.

**DESCRAMBLERS!** Largest supply U.S.A.— catalog \$3.00. **TV PRODUCTS CO.**, 635 Park Ave., Idaho Falls, ID 83402.

**PRINTED circuit boards and components** per published projects. **GEMINI PROJECTS**, PO Box 35251, Chicago, IL 60635 or 312/456-4709.

To run your own classified ad, put one word on each of the lines below and send this form along with your check for \$1.90 per word (minimum 15 words) to:

**Radio-Electronics, 200 Park Avenue South, N.Y., N.Y. 10003**

### ORDER FORM

PLEASE INDICATE in which category of classified advertising you wish your ad to appear. For special headings, there is a surcharge of \$15.00.

( ) Plans/Kits ( ) Business Opportunities ( ) For Sale  
( ) Education/Instruction ( ) Wanted ( ) Satellite Television

Special Category: \$15.00

PLEASE PRINT EACH WORD SEPARATELY, IN BLOCK LETTERS.)

1	2	3	4	5
6	7	8	9	10
11	12	13	14	15
16	17	18	19	20
21	22	23	24	25
26	27	28	29	30
31	32	33	34	35

PLEASE INCLUDE FOR OUR FILES YOUR PERMANENT ADDRESS AND PHONE NUMBER.

**CLASSIFIED COMMERCIAL RATE** for firms or individuals offering commercial products or services). \$1.90 per word prepaid (no charge for zip code)...**MINIMUM 15 WORDS.** 5% discount for 6 issues, 10% for 12 issues within one year, if prepaid.

**NON-COMMERCIAL RATE** (for individuals who want to buy or sell a personal item) \$1.25 per word prepaid...no minimum.

**ONLY FIRST WORD AND NAME** set in bold caps. Additional bold face (not available as all caps) at 15¢ per word. All copy subject to publisher's approval. **ADVERTISEMENTS USING P.O. BOX ADDRESS WILL NOT BE ACCEPTED UNTIL ADVERTISER SUPPLIES PUBLISHER WITH PERMANENT ADDRESS AND PHONE NUMBER.** Copy to be in our hands on the 20th of the third month preceding the date of the issue (i.e., August issue closes May 20th). When normal closing date falls on Saturday, Sunday, or a holiday, issue closes on preceding working day.

## DESCRAMBLERS

AMERICAN—CANADIAN

### C-1000 / ZENITH TYPE

Descrambles "over the air" and "cable" sync suppressed active video inversion signals

Ready to go C-1000 **379.95**  
Complete Kit C-1000K **274.95**  
Printed Circuit & Manual **74.95**

### C-100 / JERROLD TYPE

Cable Descrambler for in-band gated suppressed systems

Ready to go C-100 **119.95**  
Complete Kit C-100K **54.95**



SEND \$2 FOR COMPLETE INFORMATIVE CATALOG TO DETERMINE WHAT TYPE YOU NEED.

**FALL SPECIAL**  
Buy 1 kit  
Get 2nd kit  
at 1/2 price

Offer ends 10/1/83

**J & D ENGINEERING**  
P.O. Box 6099  
Falmouth, Maine 04105

Dealers Wanted  
Special Quantity Pricing  
COD's—OK

All J & D products are engineered, not copied, all are guaranteed 90 days & we stand behind our products where others fail to.

**GIANT screen oscilloscope** converted from any size TV. Technicians, Hams, broadcasters, hobbyists; minor **inexpensive** changes convert TV to super-sensitive testing device. No experience needed. Follow clear-cut plans. **Fully illustrated.** Perfect for workshop, lab, school, etc. **Any size screen... Any size TV complete plans ... \$4.00** (plus \$1.00 postage & handling). **MILLCO**, Dept. OP-03, Box 8561, Waco, TX 76714.

**VIC-20 owners,** use any tape deck. Interface drives one or two cassettes, with displays. Free brochure. Plans \$5.00. **EDWARD'S**, Box 4723, Culver City, CA 90230-8323.

## CB MODIFICATIONS

Increase channels, range, privacy! We specialize in frequency expanders, speech processors, FM converters, PLL & slider tricks, how-to books, plans, kits. Expert mail-in repairs & conversions. 16-page catalog \$2.

**CBC INTERNATIONAL, P.O. BOX 31500RE, PHOENIX, AZ 85046 (602) 996-8700**

**LASERS** surplus units, parts, kits, books, lowest prices. \$2.00 for listing and laser poster. **MEREDITH INSTRUMENTS**, 6517 W. Eva, Glendale, AZ 85302.

**CABLE TV descrambler kits** plans \$4.00. For information send \$2.00. **DOMCAN ELECTRONICS**, PO Box 605, Downsview A Downsview, Ontario, Canada M3M 3A9.

**TECHNI-TOOL inc.**  
TOOLS—TOOL KITS  
FREE CATALOG  
CALL (215) 825-4990

EXPERIENCE \* QUALITY \* VARIETY



Mixers, Equalizers, Limiters, Pre-Amps, VCA's, Power supplies, parts, and more . . . . **CATALOG**

## NEW AUDIO KITS

Modular design featuring plug-in construction. Design your own combination of functions. Write. **RODCAR ELECTRONIC SALES** 214-351-9895  
9983 Monroe Drive Dallas, Texas 75220

SEPTEMBER

## PLANS & KITS

### SATELLITE TV WEEK

The most complete weekly listings.  
Send \$1 for sample copy.



P.O. Box 308, Fortuna, California 95540  
Call (800) 338-9997 • California (800) 556-8787  
(707) 725-2476

UHF types all deluxe, cable units. Dealers wanted for Zenith systems. Excellent pricing now available. Quantity pricing by phone 301-882-9362. Send \$2.00 for catalog to **SATELLITE ELECTRONICS**, PO 9534, Baltimore, MD 21237.

**MOST** comprehensive video book and manual on the market, 150 pages all types, UHF, cable, satellite. Complete troubleshooting for Zenith systems. 24 hour COD hotline for orders 301-668-7099, or send \$21.95 plus \$1.50 shipping to **TELE-PUBLICATIONS**, PO 16693, Baltimore, MD. 21206.

**UP-TO-DATE** design and high quality kits. Write for absolutely free catalog. You will be amazed by our unbelievable low price. **INTERNATIONAL POLYTECHNIQUES**, PO Box 862T, New York, NY 10002.

**CONVERT** your TV to an oscilloscope. A simple, fun, plan \$5.00 to L.S.E., Box 8402, Madison, WI 53708.

### Worlds Most Remarkable Radar Jammer!



Causes speed radar guns and devices to read out your choice of either a percentage of your true speed when in automatic mode (example: Your speed; 76 mph, auto mode set for 75%, speed displayed — 57 mph), or the speed that you dial in when in manual mode. Transmits only in the presence of speed radar, or by manual override. Operates on both X and K bands. **WARNING:** The device described in this literature is not legal for use against police radar, and is not FCC approved.

For complete literature and plan package, send \$14.95 to:

**Philips Instrument Design Co. Inc.**  
8135 S.W. Nimbus, Building #11, Suite #114 S  
Beaverton, Oregon 97005

## SATELLITE TELEVISION

**SATELLITE** antennas; build or buy 8-10-12 foot wood or metal from \$43.00 send \$2.00 **PRO-TOTYPE ENGINEERS**, Box 1812 Deming, NM 88030.

**SATELLITE TV** receiver breakthrough! Build your own commercial quality receiver now! Complete instruction manual \$8.00! **XANDI**, Box 25647, Dept. 21N, Tempe, AZ 85282.

**DESCRAMBLERS!** Largest supply U.S.A.— catalog \$3.00. **TV PRODUCTS CO.**, 635 Park Ave., Idaho Falls, ID 83402.

**HBO** satellite signal scrambler information \$2.00 plus SASE. **SATCOM EXPERIMENTER**, 656 Manor Place, Melbourne, FL 32901.

**BUILD** your own satellite dish. Complete system less than \$800.00. Plans \$20.00. **KINSAT**, Box 18, Clearcreek, WV 25044.

**SECRET** satellite information new facts never before available only \$5.00. **SATELLITE INC.**, Rt 13, Box 1876, Conroe, TX 77303.

**SATELLITE TV** system \$1295 complete! 8' antenna, polar mount, 120 LNA, receiver. Handbook and buyer's guide, \$10.00. Dealers wanted. **MICROWAVE SYSTEMS**, 1101 E. Chestnut, Santa Ana, CA 92701.

## UPGRADE YOUR TELEPHONES

ADD THESE EASY-TO-INSTALL SPECIAL FEATURES

**Hold/Busy Silencer Circuit**  
Allows you to put calls on hold. Also lets you silence bell or put phone on busy. Plans \$4.00. Kit \$4.00 — \$2.00 phone.  
**Intercom Circuit**

Lets you use phones as an intercom. No extra wiring required. Less costly than wireless models. Plans \$7.00. Kit \$15.00 — \$5.00 phone.  
Kits include plans, parts and board. When ordering kits add \$2.00 for postage. Send SASE for more information.

dB Enterprises Box 8 Oradell, NJ 07649

**SATELLITE** cables, connectors: Type-N UG-21D/U \$3.00, Elbow \$4.95, UG-57B/U \$5.25, UG-29B/U \$3.90, F-59A 10/2.15, RG-6/U 12 cents ft., RG-59/U copper 12 cents ft., RG-213/U 36 cents ft., RG-214/U \$1.55 ft., shipping: 10%, \$3.00 minimum. Free catalog. **NEMAL ELECTRONICS**, 1325 N.E. 119th Street, N. Miami, FL 33161 (305) 893-3924.

**ORDER** the 2-year-warranted **Dexcel/Gould** 1100-01 receiver/L.N.C. with precision 9' spun aluminum antenna and ball-bearing polar mount at our call-for-current lowest price (approximately \$1498.00) and we'll complete the system with a Chaparral Polarator I/control, hook-up assembly, 125' line and installation instructions and assistance. **VIDEOSAT, INC.**, Electronic Dept., (602) 445-0383, Box 449, Prescott, AZ 86302.

**FREE!** Information on 100 satellite television channels plus free catalog of proven do-it-yourself plans/kits for easy, low-cost, attractive satellite antennas. Wholesale electronic components. **GFI-5**, Box 9108, Missoula, MT 59807. "Consumer Guide to Satellite Television" \$6.95.

## BUSINESS OPPORTUNITIES

**PROJECTION TV...** Make \$\$\$ assembling projectors... Easy... Results comparable to \$2500.00 projectors... Your total cost less than \$20.00. ... **Plans, lens & dealers** information \$17.50. ... Illustrated information **free** ... **MACROCOM-GAX**, Washington Crossing, PA 18977. Credit card orders 24 hours. (215) 736-2880.

**DESCRAMBLERS!** Largest supply U.S.A.— catalog \$3.00. **TV PRODUCTS CO.**, 635 Park Ave., Idaho Falls, ID 83402.

**WHOLESALE** MATV/CATV/VCR equipment, antennas, audio cables, adaptors, original/replacement cartridges & styli, telephone accessories, radios, cassette recorders, speakers, etc., send letterhead for free catalog (212) 897-0509 **D&WR**, 66-19 Booth, Flushing, NY 11374.

**MONEY** broker, commercial business loans to start, expand, etc. \$50.00 to millions. Send \$2.00 **LOREDO ENTERPRISES**, Box 2243 APO NY 09009.

**MECHANICALLY** inclined individuals desiring ownership of small electronics manufacturing business—without investment. Write: **BUSINESSES**, 92-R, Brighton 11th, Brooklyn, NY 11235.

**LCD** watches \$2.50, penwatch \$3.60, catalog \$1.00. **RELIANT ENGINEERING COMPANY**, PO Box 33610, Sheungwan, Hongkong.

**VIDEO** game repair business (Atari and Intellivision). Start your own. Information/parts list \$5.00. **IRATA**, 2562 East Glade, Mesa, AZ 85204.

## HIGHLY PROFITABLE ONE-MAN ELECTRONIC FACTORY

Investment unnecessary. Knowledge not required. Sales handled by professionals. Ideal home business. Write today for facts!

**Postcard will do, Barta-RE-X, Box 248, Walnut Creek, CA 94597.**

**NEW** original business whose time is come! \$1000 weekly possible, minimal mechanical skill, send \$6.00. **QUANTUMSOUND**, 1731 Howe Ave., No. 192, Sacramento, CA 95825.

**GUARANTEED** money making opportunity with our agency \$200.00 weekly possible in spare time details \$3.00. **N.L.P.A.**, 1287 Spur Dr. So., Islip, NY 11751.

## COMPUTERS

**TI-99/4A** owners. Send for free list of new and exciting, low cost software. **DYNA**, Box 124, Hicksville, NY 11801.

**MAX** \*CZ \*C tech Timex hi-tech lo-price educational programs. Dataaquis. Hardware upcoming. For samples mail \$2.00 to: **CASH PROG.**, POB 318R, Nfld., NJ 07435.

## REEL TO REEL TAPES

**TRUCKLOAD** sale Ampex high quality open reel tape, 1800' or 2400' on 7" reels, used once. Case of 40, \$45.00. Cassettes available. **VALTECH ELECTRONICS**, Box 6-RE, Richboro, PA 18954.

## Be an FCC LICENSED Electronic Technician



Earn up to \$600 a Week & More!  
No costly school. The Original Home-Study course prepares you to pass FCC General Radio-telephone License exam. No previous experience required. Updated, low cost course covers all questions on actual FCC Govt exam. **GUARANTEED PASS!** You get license or money refunded. Send for **FREE** facts now.  
**COMMAND PRODUCTIONS** - FCC License Training Dept. 89 P.O. Box 2223, San Francisco, CA 94126

## EDUCATION & INSTRUCTION

**EARN** your university degree through evaluation assessment, of existing education, experience, achievements. Call, (614) 863-1791, or write, **ASSESSMENT**, Box 13130 R, Columbus, OH 43213.

**UNIVERSITY** degrees by mail! Bachelors, Masters, Ph.D's... Free revealing details, **COUNSELING**, Box 317-RE9, Tustin, CA 92680.

**PSYCHIC** phenomena explained through psychic theory learn to read minds and develop a photographic memory and how Jesus, Moses, modern day psychics perform their miracles all secrets revealed \$3.50 order no. 1. Theory that explains how U.F.O.'s work, actual diagrams of how to build a small model, combines works of Tesla and theory of Einstein produces artificial gravity \$3.50 order no. 2. Send to **MIKE REILLY**, 3520 S.E. 5th Ave., Cape Coral, FL 33904.

**ELECTRONICS** computer books. International publishers. Lowest rates. Ask list. **BUSINESS PROMOTION**, Lajpat Rai Market, Delhi, India.

## ATTENTION ELECTRONIC TECHNICIANS



Highly Effective Home Study BSEE Degree Program for Experienced Electronic Technicians Our New Advanced Placement Program grants Credit for previous Schooling & Professional Experience Advance Rapidly! Our 36th Year!

FREE DESCRIPTIVE LITERATURE!

**Cook's Institute of Electronics Engineering**  
DESK 15. P.O. BOX 20345, JACKSON, MS 39209

## CABLE TV

**CHANNEL 3**—60dB notch filter. 63.5MHz. \$32. **CROSLY**, Dept 606, Box 840, Champlain, NY 12919.

**CHANNEL 3**- 65dB super notch filter. 63.5 mHz. \$29.00 postpaid. **TV PRODUCTS**, 635 Park Ave., Idaho Falls, ID 83402.

## \*C SALE \*C LSR UHF CONVERTERS \*C SALE \*C

**GATED** pulse wave (speaker box type), has true AGC, parts \$125.00. The following have sound out of the TV like normal with only an antenna connection to the TV, VCR, or RF distribution switch box. Deluxe III sine wave, has true AGC, parts \$125.00. Digital sync suppression/active video inversion FV-400, has true AGC, parts \$225. Quantity discounts. Plans: large SASE (54 cents postage). Free shipping/handling. 1-312/267-3455. **LSR ENGINEERING**, Dept. RE, PO Box 6075, IL 60680-6075.

THE BEST PLACE to BUY, SELL or TRADE NEW and USED EQUIPMENT

## NUTS & VOLTS MAGAZINE

BOX 1111-E • PLACENTIA, CA 92670

(714) 632-7721

Join Thousands of Readers Nationwide

Every Month

ONE YEAR U.S. SUBSCRIPTIONS

\$7.00 - 3rd Class • \$12.50 - 1st Class

\$25.00 - Lifetime - 3rd Class

## NUTS & VOLTS

HAM GEAR  
COMPUTERS  
SOFTWARE  
SCANNERS • OPTICS  
TEST EQUIPMENT  
MICROWAVE  
SATELLITE  
AUDIO VISUAL  
NEW PRODUCTS  
COMPONENTS • KITS  
ANTIQUE ELECT.  
PUBLICATIONS  
PLANS • SERVICES

## REVERBERATION FOR ORGANS

Solid state with controls for reverberation and room size.

**EVERY ORGAN SHOULD OWN ONE.** Send for free flyer—

DEVTRONIX ORGANS, INC.

6101 WAREHOUSE WAY

SACRAMENTO, CALIFORNIA 95826 Dept. B

## CB EQUIPMENT

CB radio books, kits, modifications, catalog \$1.00 refundable, APS, POB 263RE, Newport, RI 02840.

## VIC-20

ADD 16K RAM card. Plugs into back of VIC. \$53.50. MASSLOGIC 47 Edgewood, Westwood, MA 02090.

"SOFTWARE Pirates Handbook" protection methods, laws, includes software and schematics book \$6.95. Cartridge backup kit \$24.95. Cassette interface kit \$12.95. \$1.00 shipping. More information SASE. PSIDAC, 7326 N. Atlantic, Portland, OR 97217.

## SINCLAIR/TIMEX

DESIGN fully regulated dc pwrsppls to your specs using our software. 16k \$24.95. MINDGATE, Box 74, Kenmore, NY 14217.

## DESCRAMBLERS — CABLE — UHF — TVRO

DESCRAMBLERS! Largest supply U.S.A.— catalog \$3.00 TV PRODUCTS CO., 635 Park Ave., Idaho Falls, ID 83402.

## WANTED

WANTED: old Western Electric, RCA, tubes, speakers, amplifiers. 713 7284343. MAURY CORB, 11122 Atwell, Houston, TX 77096.

INVENTIONS, ideas, new products wanted for presentation to industry and exhibition at national technology exposition. Call 1-800-528-6050. Arizona 1-800-352-0458 X831.

## BOOKS

NIKOLA Tesla's autobiography! Quality illustrated paperback, 111 pages, \$7.95. HART BROS., Box 205K, Williston, VT 05495.

## SINCLAIR TIMEX COMPUTERS

TOP name brand programs and games — try before you buy! Don't get burned, info: SEMI-Z, R.D. #4, Box 69, Danville, PA 17821.

## HOME ROBOTS

WORLD'S largest supplier of Home Robot kits/parts. Motors, seeing/hearing sensors, batteries, robot mounted computer for programming controls and playing video games. Inexpensive, easy construction. Complete kits \$99.95. Send \$3.00 (refundable with order) for information package, photos, catalog, club membership to: ROBOT SHACK, Department 10, PO Box 583, El Toro, CA 92630.

## EPROM PROGRAMMER

FOOLPROOF. Programs 2716 through 27128; 2508 through 2564; 2815/16 eeproms! Others too! Features: single board design. Zif eprom sockets. Automatic duplication. Program verify. Regulated power supply — requires only power xfmr. A/T \$149.00 Compare! Why pay more? NY residents add 7% tax. LUBOMIR COPORATION, PO Box 511, Rensselaer, NY 12144.

## FV-4 REPAIR SERVICE

FV-4 board troubleshooting and repair. Our technicians specialize in servicing the entire FV-4 addressable system. Also available are complete addressable part kits which include our exclusive service policy. Call us at 301-465-8116. HOWARD RESEARCH AND DESIGN, PO Box 204, Ellicott City, MD 21043.

## DESCRAMBLER TROUBLES

SINE wave descrambler problems? Manual includes trouble shooting, alignment, antenna hookup, improvements, theory. \$15.00. SIGNAL, Box 2512-R, Culver City, CA 90230.

## ROBOTIC BOOKS

ROBOTICS books— build your own robot. Write now for free catalog. H. D. KOHN CO., RE2, Box 16265, Alexandria, VA 22302.

## FANTASTIC SAVINGS

DELUXE UHF converters, cable TV descramblers, microwave antennas, personal computers, VCR's, cassette recorders, mini TV's, protection electronics, and much more in our new catalog. Send \$2.00. THREE CROWNS ELECTRONICS, Dept-R9, Box 343, Brooklyn, NY 11230.

## USA PAY-TV STATIONS

COMPLETE and latest data on: locations, equipment, programming, and more. Just \$9.95. TCE, Dept-R9, Box 343, Brooklyn, NY 11230.

## FOR SALE

CABLE TV products, Wireless corded & settop converters. Send \$3.00 for catalog ADDITIONAL OUTLET CORP., 231 E. Commercial Blvd., Ft. Lauderdale, FL 33334.

CABLE TV SECRETS—the outlaw publication the cable companies tried to ban. HBO, Movie Channel, Showtime, descramblers, converters, etc. Suppliers list included. Send \$8.95 to CABLE FACTS, Box 711-R Pataskala, OH 43062.

PCB 15 cents sq-in. Free drilling. Quantity discount. INTERNATIONAL ENTERPRISE, 6452 Hazel Circle, Simi Valley, CA 93063.

RESISTORS 1/4 & 1/2 W 5% C.F. 3 cents. 1% M.F. All values. No minimums. Volume discounts. Write JR INDUSTRIES, 5834-B Swancreek, Toledo, OH 43614.

COLOR computer VIC-20 programs hardware Rtty code EPROM Programmer RS-232. FRANK LYMAN, Box 3091, Nashua, NH 03061.

THE Intelligence Library. Restricted technical secrets—books on electronic surveillance, lock-picking, demolitions, investigation, etc. Free brochures: MENTOR, Dept. Z, 135-53 No. Blvd., Flushing, NY 11354.

WRITE FOR  
**McGEE'S**  
SPEAKER & ELECTRONICS CATALOG  
1001 BARGAINS IN SPEAKERS  
Tel.: 1 (816) 842 5092  
1901 MCGEE STREET KANSAS CITY, MO. 64108

SURVEILLANCE device schematics, books on electronic surveillance methods & equipment, locksmithing, covert technologies, etc. Catalog, \$1.00. MENTOR, Dept. Z, 135-53 N. Blvd., Flushing, NY 11354.

PRINTED-circuit boards: single side, prototype, and quantity, quick delivery. Send positive, free quotes. FABTRON, Box 925, Dept. C, Columbia, TN 38401 (615) 381-1143.

RADIO West — still the best for SW/MW DX receivers and receiver modifications! Catalog 50 cents. RADIO WEST, 3417 Purer Road, Dept RE, Escondido, CA 92025 (619) 741-2891.

SCANNER/monitor accessories— kits and factory assembled. Free catalog. CAPRI ELECTRONICS, Route 1R, Canon, GA 30520.

FAST, dependable mail-order! Prime semiconductors, parts, supplies. Free 55 page catalog. THE PARTSTORE, Dept. 165, 999 44th St., Marion, IA 52302 (319) 373-1803.

DESCRAMBLERS! Largest supply U.S.A.— Catalog \$3.00. TV PRODUCTS CO., 635 Park Ave., Idaho Falls, ID 83402.

FREE speaker catalog! Woofers, mids, tweeters, hardware, crossovers, grille cloth, kits, information, much more. Discount prices. UNIVERSAL SOUND, Dept. RE, PO Box 36052, Sarasota, FL 33583 (813) 953-5363.

FREE catalog of surplus electronics parts and hardware. UNIVERSAL SOUND, Dept. RES, PO Box 36052, Sarasota, FL 33583 (813) 953-5363.



**RELIABLE MICROWAVE TV ANTENNAS**  
2.1 to 2.6 GHz  
Frequency Range  
34db System Gain (or Greater)

**COMPLETE SYSTEM**  
Dish Style \$ 99.95

**S&W ELECTRONICS**  
145 North Main  
Bountiful, UT. 84010  
**(801) 295-1166**

SPECIAL QUANTITY PRICING  
Dealers Wanted - COD'S

2 Year Warranty  
Parts & Labor

RECORDS— tapes! Discounts to 73%; all labels; no purchase obligations; newsletter; discount dividend certificates; 100% guarantees. Free details. DISCOUNT MUSIC CLUB, 650 Main Street, PO Box 2000, Dept. 30983, New Rochelle, NY 10801.

COMPUTER cables, RS232, VIC 20 and C64 cables, breakout boxes, and switch boxes. More! For free catalog, write COMPUCOMM, Box 211, South Sioux City, NE 68776.

FREE money-saving bulletin on popular brand name programs and books for your small computer. SUPERIOR, Dept. RE, 8030 Westchester Road, Westchester, OH 45069.

LATEST bug-detection equipment for home or office. Literature, \$1.00. CLIFTON, Box 220-X, Miami, FL 33168.

FREE VIC-20 software and hardware catalog. Fast service. LIGHTHOUSE SALES, Dept. 1, PO Box 68, Trenton, MI 48183.

DIGITIZER/Graphics Tablet. Connects to 9-pin game port of VIC20/64, Atari, TI etc. 16" x 20" drawing board, two function keys. Demo programs. \$44.50 from PERSIMMON PERIPHERALS, Box 2306A-RE, Clayton, GA 30525.

RESISTANCE calibration box .25% five ranges \$14.95 plus \$2.25 postage and handling. OHIO INSTRUMENTS, 16659 Broadway, Maple Heights, OH 44137. Allow 4 to 6 weeks for delivery.

PRINTED circuit boards: quotes free. SASE to JAHMAAL ELECTRONIC SUPPORT, P.O. Box 397, Troy, NY 12181.

EPROM programmer programs 2716, 2732, 2764, and 27128. For IBM PC \$225.00 each. For Apple II, ROM version \$195.00 each, diskette version \$225.00 each. Also 64k add-on RAM card for IBM PC \$140.00 each. \$3.00 ship/hndlg. Check, money order, no COD please. Quantity discount. Dealer inquiries invited. LSG ELECTRONICS, INC., 3122 Hollowcreek Dr., Houston, TX 77082 (713) 558-3613.

\*\*\*\*\*  
\* **QUALITY MICROWAVE TV SYSTEMS** \*  
\*\*\*\*\*  
\* **Complete Systems From \$69<sup>95</sup>** \*  
\*\*\*\*\*  
\* **1.9 to 2.5** \*  
\* **GHz** \*  
\* **Antennas** \*  
\*\*\*\*\*  
\* **Galaxy** \*  
\* **Electronics** \*  
\* **6007 N. 61st Ave.** \*  
\* **Glendale, Az.** \*  
\* **85301** \*  
\* **1-602-247-1151** \*  
\* **1-800-247-1151** \*  
\*\*\*\*\*  
\* **COD's / Dealers Wanted** \*  
\*\*\*\*\*  
\*  \*  
\*  \*  
\*\*\*\*\*

GOLD STAR  
SILVER STAR  
TELE STAR  
STAR II

SEPTEMBER 1983

**FOR SALE**

**SUBSCRIPTION TV manual**, covers all three major scrambling systems, only \$12.95. Includes theory, circuits, waveforms, and trouble shooting hints. Save your video game cartridges on EPROM with our EPROM duplicator. Plans \$9.95. Catalogue \$2.00, refundable. **RANDOM ACCESS**, Box 41770R, Phoenix, AZ 85080.

**ELECTRICAL formula calculator** for 32k Atari computers. A must for engineers and hobbyists. Write: **MILES SOFTWARE**, Vance Rt., Barksdale, TX 78828.

**OFFSET printing equipment**. Small rebuilt. Economical. Free flyer ... **MUREL**, 139 Gunckel Ct., Dayton, OH 45410 (513) 256-1452.

**FREE electronic parts catalog**. Product lines include solar, video, audio, phones, fans, batteries, capacitors, resistors, relays, transformers, and a variety of electronics parts. Write **HORIZON SALES, INC.**, PO Box 646, Framingham, MA 01701, or call 617-875-4433.

**XENON FLASH LAMPS**

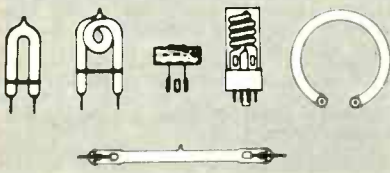

ASK FOR OUR NEW CATALOG.  
CALL OR WRITE FOR INFORMATION.

**TEC/WEST (USA) INC.**

10889 WILSHIRE BLVD., SUITE 740  
LOS ANGELES, CA 90024-4299

CA: 213/208-5529 • OUTSIDE CA: 1-800-421-7215

**DIGITIZE** voltages with Apple, CBM computer. ADC/DAC \$149.00. **NALAN**, 106 Highland Park Lane, Boone, NC 28607.

**MINI speakers**— round 2.25" ferrites \$1.00 each. Fujitsu mini relays— SPDT 6 amp 12 volts \$1.50 each, subminis— 1 amp \$3.00, switches, battery snaps, catalog deposit \$1.00, \$3.50 handling cost/order plus shipping. **INTERNATIONAL DISTRIBUTORS**, 503-648-6024, PO Box 1141, Hillsboro, OR 97123.

**SATELLITE**, microwave, video, audio components and equipment. Send \$1.00 for 1983 catalog. **DSCo**, Department F, 3110 Evelyn Street, Roseville, MN 55113.

**DESIGNING** analog circuits? Four output power supply, tracking outputs;  $\pm 5@.5A$ ;  $\pm 15@3A$ , adjustable. Glass epoxy board, quality components. Assembled, \$79.00 ppd. Info **SASE IMAGE TECHNOLOGY**, 23475 Northwestern Hwy, Southfield, MI 48075.

**VIC-20 Commodore-64 cassette adaptor**. Use your cassette player. LED lights with correct volume. \$19.95; kit \$14.95. **PRICCOM**, PO Box 17, Huntington, IN 46750.

**TI-99/4A software**. Free price list plus newsletter. **GLEN DOBBS**, Box 801 RE, Santa Maria, CA 93456.

**PICTURE tube rebuilding equipment**— we sell & buy new & used equipment. Free training. **ATOLL TELEVISION**, 6425 Irving Park, Chicago, IL 60634. Phone (312) 545-6667.

**RELIABLE MICROWAVE TV ANTENNAS**  
2.1 to 26 GHz  
Frequency Range



**34db System Gain (or Greater)**  
Complete System (pictured) \$119.95  
Down Converter Probe Style  
(Assembled & Tested) \$ 49.95  
Power Supply (12V to 16V DC+)  
(Assembled & Tested) \$ 39.95

**PETERSON ELECTRONICS**

4558 Auburn Blvd  
Sacramento, CA 95841  
(916) 486-9071

**SPECIAL QUANTITY PRICING**  
Dealers Wanted - COD'S

**1 YEAR WARRANTY**  
PARTS & LABOR



Cardiovascular diseases will cause one-half of all deaths this year.



**American Heart Association**

Your gift can make a difference.

WE'RE FIGHTING FOR YOUR LIFE

**Get it all!**

**Radio Electronics**

COMPUTERS - VIDEO - STEREO - TEC

Build this **DIGITAL IC TESTER** for your workbench

How to **ETCH PC BOARDS** at home

Back-to-school series **OP-AMPS** How to properly use them

How to **INTERFACE PROCESSORS** and make them useful

Build a **LOW-BAND CONVERTER** and listen-in below 535 kHz

PLUS:  
State-of-the-Art Digital lock circuit  
New Idea Output sound effects generator  
Service Clinic  
Computer Corner  
Equipment Reports

**Radio-Electronics** covers all aspects of the fast moving electronics field... featuring **COMPUTERS VIDEO • STEREO TECHNOLOGY SERVICE COMMUNICATIONS PROJECTS**

Subscribe today to **Radio-Electronics**. Don't miss a single issue and... you save as much as \$7.03 off the newsstand price.

When you select one of the subscription offers listed on the handy coupon—you'll be assured of having your copy reserved even if it sells out on the newsstand. Make sure you get all the excitement in every issue of **Radio-Electronics**, every month, by filling in and mailing the coupon, today.

**Every Month! Get the Best—Mail Today!**

Mail to: **Radio-Electronics**, P.O. Box 2520, Boulder, CO 80322 **7HJ39**

- 1 year—12 issues only \$14.97 (You save \$3.03 off newsstand price.)
- 2 years—(Save More)—24 issues—\$28.97 (Save \$7.03 off the newsstand price.)

Payment Enclosed  Bill Me

Name \_\_\_\_\_ (please print)

Address \_\_\_\_\_

City \_\_\_\_\_ State \_\_\_\_\_ Zip Code \_\_\_\_\_

Offer Valid in U.S. Funds Only  
Allow 6-8 weeks for delivery of first issue

Canada add \$3.00 per year  
All other countries add \$7.50 per year

# BUILDERS GET MORE AT RADIO SHACK!

Low Prices!

High Quality!

Wide Selection!

## Replacement Transistors

Type		Cat. No.	Each
2N1305	PNP	276-2007	1.19
MPS222A	NPN	276-2009	.79
PN2484	PNP	276-2010	.89
MPS3904	NPN	276-2016	.69
TIP31	NPN	276-2017	.99
TIP3055	NPN	276-2020	1.59
MPS2907	PNP	276-2023	.79
MJE34	PNP	244-2027	1.49
2N3053	NPN	276-2030	.89
MPS3638	PNP	276-2032	.79
TIP120	NPN	276-2068	1.29
2N3055	NPN	276-2041	1.99
MJ2955	PNP	276-2043	2.19
2N4124	NPN	276-2057	.59
2N4401	NPN	276-2058	.59
MPSA06	NPN	276-2059	.59
MPSA13	NPN	276-2060	.59
MPSA42	NPN	276-2061	.69
MU4891	UJT	276-2029	.99
2SD313	NPN	276-2048	1.79
2SC945	NPN	276-2051	.79
2SC1308	NPN	276-2055	7.95
2N3819	N-FET	276-2035	.99
MPF102	N-FET	276-2062	.99

## 4000-Series CMOS ICs With Pin-Out And Specs

Type	Cat. No.	Each
4001	276-2401	.79
4011	276-2411	.79
4013	276-2413	.99
4017	276-2417	1.49
4023	276-2423	.99
4049	276-2449	.99
4066	276-2466	.99

## TTL Digital ICs

With Pin-Out and Specs

Type	Cat. No.	Each
7400	276-1801	.59
7404	276-1802	.79
7408	276-1822	.79
7447	276-1805	1.19
7490	276-1808	.89

## Operational Amplifiers

Type	Cat. No.	Each
741	276-007	.79
MC1458	(Dual) 276-038	.99
LM324	(Quad) 276-1711	1.29
TL082	(Dual) 276-1715	1.89
TL084C	(Quad) 276-1714	2.99
LM3900	(Quad) 276-1713	1.39
LM339	(Quad) 276-1712	1.49

## Audio Power Amplifiers

Type	Cat. No.	Each
LM383/TDA2002	276-703	3.19
LM386	276-1731	1.09
TA7205AP	276-705	2.99
LM380	276-706	1.59

## Voltage Regulator ICs

Type	Adjustable	Cat. No.	Each
LM723	0 to 40 VDC	276-1740	.89
LM317T	1.2 to 37 VDC	276-1778	2.79

Type	Fixed Output	Cat. No.	Each
7805	+5 VDC	276-1770	1.59
7812	+12 VDC	276-1771	1.59
7815	+15 VDC	276-1772	1.59
7905	-5 VDC	276-1773	1.59
7912	-12 VDC	276-1774	1.59

## Computer Connectors

Type	Positions	Cat. No.	Each
ID Card Edge	34	276-1564	4.95
ID Card Edge	50	276-1566	4.95
Card-Edge Socket	44	276-1551	2.99
ID D-Sub Male	25	276-1559	4.99
ID D-Sub Female	25	276-1565	4.99
Solder D-Sub Male	25	276-1547	2.99
Solder D-Sub Female	25	276-1548	3.99
Hood	—	276-1549	1.99

## Power Transformers 120VAC Primaries

Type	Volts	Current	Cat. No.	Each
Mini	6.3	300 mA	273-1384	2.59
Mini	12.0	300 mA	273-1385	2.79
Mini	24.0	300 mA	273-1386	2.99
Mini	12.0 CT	450 mA	273-1365	3.59
Mini	24.0 CT	450 mA	273-1366	3.99
Std.	6.3	1.2A	273-050	3.79
Std.	12.6 CT	1.2A	273-1505	3.99
Std.	25.2	1.2A	273-1480	4.39
H-D	12.6 CT	3.0A	273-1511	5.99
H-D	25.2 CT	2.0A	273-1512	6.29
H-D	18.0 CT	2.0A	273-1515	6.99

## Tantalum Capacitors

• 20% Tolerance  
• Standard IC Pin Spacing

µF	WVDC	Cat. No.	Each
0.1	35	272-1432	.49
0.47	35	272-1433	.49
1.0	35	272-1434	.49
2.2	35	272-1435	.59
10	16	272-1436	.69
22	16	272-1437	.79

## Electrolytic Capacitors

**Axial Leads**

µF	WVDC	Cat. No.	Each
4.7	35	272-1012	.49
10	35	272-1013	.59
22	35	272-1014	.69
47	35	272-1015	.69
100	35	272-1016	.79
220	35	272-1017	.89
470	35	272-1018	.99
1000	35	272-1019	1.59
2200	35	272-1020	2.49
3300	35	272-1021	2.99
4700	35	272-1022	3.59
470	50	272-1046	1.59
1000	50	272-1047	1.99
2200	50	272-1048	3.49

## PC-Mount Leads

µF	WVDC	Cat. No.	Each
220	16	272-956	.79
470	16	272-957	.89
1000	16	272-958	.99
4.7	35	272-1024	.49
10	35	272-1025	.59
22	35	272-1026	.69
47	35	272-1027	.69
100	35	272-1028	.79
220	35	272-1029	.89
470	35	272-1030	.99
1000	35	272-1032	1.59
100	50	272-1044	.89

## 1/4-Watt, 5% Resistors 39¢ Pkg. of 5

Ohms	Cat. No.	Ohms	Cat. No.
10	271-1301	10k	271-1335
100	271-1311	15k	271-1337
150	271-1312	22k	271-1339
220	271-1313	27k	271-1340
270	271-1314	33k	271-1341
330	271-1315	47k	271-1342
470	271-1317	68k	271-1345
1k	271-1321	100k	271-1347
1.8k	271-1324	220k	271-1350
2.2k	271-1325	470k	271-1354
3.3k	271-1328	1 meg	271-1356
4.7k	271-1330	—	271-1365
6.8k	271-1333	—	—

## Miniature PC-Mount Pots

1/8-Watt, Horizontal-Mount Type

Ohms	Cat. No.	Each
1k	271-333	.49
10k	271-335	.49
25k	271-336	.49
100k	271-338	.49
500k	271-339	.49

1/4-Watt, Vertical-Mount Type

Ohms	Cat. No.	Each
500	271-226	.59
1k	271-227	.59
5k	271-217	.59
10k	271-218	.59
50k	271-219	.59
100k	271-220	.59
500k	271-221	.59
1 meg	271-229	.59

## Submini Toggle Switches

10A at 125VAC. Each includes 4 colored handle covers. 1/4" mounting holes.

Type	Cat. No.	Each
SPST	275-324	1.89
SPDT	275-326	1.99
SPDT Center-Off	275-325	2.19
DPDT	275-1546	2.39
DPDT Center-Off	275-1545	2.59

## RF/IF Components

MC1330 Video Detector IC. 8-pin DIP with data. 276-1757 ..... 2.29  
 MC1350 Universal IF Amp IC With AGC. 8-pin DIP with data. 276-1758 ..... 1.99  
 MC1358/CA3065 FM Detector. 14-pin DIP with data. 276-1759 ..... 1.79  
 SFE4.5MB. 4.5 MHz Ceramic TV-Sound Filter. 272-1304 ..... 69¢  
 CDA4.5MD3 4.5 MHz Ceramic Discriminator. 274-1305 ..... 79¢

## 18-Range Multitester 1995

Big 3" Meter With Color-Coded And Mirrored Scale

Measures 0 to 1000 volts, AC and DC. 0 to 250 milliamps DC current. 0 to 2 megohms resistance. -20 to +62 decibels. 5 1/8 x 3 1/2 x 1 7/16". With test leads and manual. Requires "AA" battery. 22-201 ..... 19.95



OVER 8800 LOCATIONS WORLDWIDE

# Radio Shack®

Prices apply at participating Radio Shack stores and dealers.

CIRCLE 36 ON FREE INFORMATION CARD

A DIVISION OF TANDY CORPORATION

7400

\*Number of Pins of each I.C. for easy Socket purchase

MICROPROCESSOR COMPONENTS

Digitalker™

Applications: Teaching aids, appliances, clocks, automotive, telecommunications, language translators, etc.

The DT1050 is a standard DIGITALKER kit encoded with 137 separate and useful words, 2 tones, and 5 different sentence durations. The words and tones have been assigned discrete addresses, making it possible to output single words or words concatenated into phrases or even sentences. The "voice" output of the DT1050 is a highly intelligible male voice. Female and children's voices can be synthesized. The vocabulary is chosen so that it is applicable to many products and markets.

The DT1050 consists of a Speech Processor Chip, MM545104 (40-pin) and two (2) Speech ROMs MM52164SSR1 and MM52164SSR2 (24-pin) along with a Master Word List and a recommended schematic diagram on the application sheet.

DT1050 Digitalker™ \$34.95 ea.

DT1057 Expands the DT1050 vocabulary from 137 to over 260 words. Incl. 2 ROMs and specs.

DT1057 \$24.95 ea.

Table with columns: Part No., Pins, Function, Price. Includes models like 7045PI, 7045EV/Kit, 7106CP, etc.

3009 1983 INTERSIL Data Book (1356p) \$9.95

NEW PRODUCT! 74HC High Speed CMOS

Table listing various 74HC CMOS chips with columns for Part No., Pins, Function, Price. Includes models like 74HC00, 74HC02, etc.

Programmable Array Logic (PALs)

Table listing PAL chips with columns for Part No., Pins, Function, Price. Includes models like PAL10H8, PAL12H8, etc.

30012 1982 NATIONAL PAL Data Book (176p) \$5.95

Table listing 74C-C/MQs chips with columns for Part No., Pins, Function, Price. Includes models like 74C00, 74C02, etc.

LINEAR

Table listing linear chips with columns for Part No., Pins, Function, Price. Includes models like LM709N, LM710N, etc.

MICROPROCESSOR CHIPS

Table listing microprocessor chips with columns: Part No., Pins, Function, Price. Includes models like CDP1802, CDP1803, etc.

Z80, Z80A, Z80B, Z8000 SERIES

Table listing Z80 series chips with columns: Part No., Pins, Function, Price. Includes models like Z80, Z80A, Z80B, etc.

6800/68000 SERIES

Table listing 6800 series chips with columns: Part No., Pins, Function, Price. Includes models like MC6800, MC6801, etc.

8080 SERIES

Table listing 8080 series chips with columns: Part No., Pins, Function, Price. Includes models like IN8080A, IN8080B, etc.

DISK CONTROLLERS

Table listing disk controller chips with columns: Part No., Pins, Function, Price. Includes models like IN5177-1, IN5177-2, etc.

SPECIAL FUNCTION

Table listing special function chips with columns: Part No., Pins, Function, Price. Includes models like DS09205A, DS09206A, etc.

LOW PROFILE (TIN) SOCKETS

Table listing low profile sockets with columns: Pin Count, Price. Includes models like 8 pin LP, 14 pin LP, etc.

SOLDERTAL (GOLD) STANDARD

Table listing solderтал sockets with columns: Pin Count, Price. Includes models like 8 pin SG, 14 pin SG, etc.

DYNAMIC RAMS

Table listing dynamic RAM chips with columns: Part No., Pins, Price. Includes models like 1103, 4027, 4118N-2, etc.

STATIC RAMS

Table listing static RAM chips with columns: Part No., Pins, Price. Includes models like 1101, 2101, 2102, etc.

EPROMS

Table listing EPROM chips with columns: Part No., Pins, Price. Includes models like I202A, I202B, etc.

DATA ACQUISITION

Table listing data acquisition chips with columns: Part No., Pins, Price. Includes models like DC10, MC3247P, etc.

SOLDERTAL STANDARD (TIN)

Table listing solderтал sockets with columns: Pin Count, Price. Includes models like 14 pin ST, 16 pin ST, etc.

WIRE WRAP SOCKETS (GOLD) LEVEL #3

Table listing wire wrap sockets with columns: Pin Count, Price. Includes models like 8 pin WW, 14 pin WW, etc.

WIRE WRAP SOCKETS (GOLD) LEVEL #3

Table listing wire wrap sockets with columns: Pin Count, Price. Includes models like 8 pin WW, 14 pin WW, etc.

MINIMUM ORDER — U.S. Funds Only

California Residents Add 6% Sales Tax Shipping Add 5% plus \$1.50 Insurance Send S.A.S.E. for Monthly Sales Flyer!

1355 SHOREWAY ROAD, BELMONT, CA 94002

9/83 PHONE ORDERS WELCOME — (415) 592-8097 Telex: 176043

CIRCLE 20 ON FREE INFORMATION CARD

www.americanradiohistory.com

30003 1982 Nat. Linear Data Book (1952 pp.) \$11.95



## 5 1/4" HALF-HEIGHT DISK DRIVES

FIT TWO DRIVES IN THE SAME SPACE AS ONE CONVENTIONAL 5 1/4" DRIVE

### TEAC FD55A COMPATIBLE WITH SHUGART SA455

**SINGLE-SIDED:**

- 48 tpi
- 40 Tracks
- 250Kbytes double-sided
- Single double density
- Brushless DC direct-drive motor
- Low 5W power consumption
- Power req.:
- 12VDC @ 3A
- 5VDC @ 55A
- 6 msec. track to track
- One year warranty
- Size 5 1/4" W x 1 1/2" H x 8" D
- Weight: 3 lbs. 5 oz.

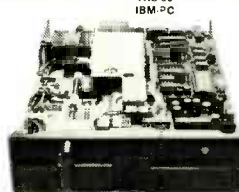

**DOUBLE-SIDED:**

- 48 tpi
- 40 Tracks
- 500Kbytes double-sided
- Single double density
- Brushless DC direct-drive motor
- Power req.:
- 12VDC @ .75A
- 5VDC @ 7A
- 6 msec. track to track
- Compatible with SA400/450
- One year warranty
- Size: 5.75" W x 1.63" H x 8" D
- Weight: 3.3 lbs.

Shugart SA455  
**FD55A \$249.95 SA455 \$259.95**

## COMPUTER-PERIPHERAL SWITCHERS

Connect any number of peripherals to a single I/O port — use a single printer to support several microcomputers — use two or more printers to support a single microcomputer — access a modem from any of several microcomputers — Ideal for demystifying or comparing equipment. The Selecto Switchers are designed to eliminate the unnecessary plugging & unplugging of cables which connect printers, terminals, or modems to various computers. By using a Selecto Switch, you achieve more efficient system operation, better utilization of peripherals & computer ports, eliminate redundant hardware & reduce service calls. 3 yr. limited warranty on all Selecto Switchers. No power required. Size (inches): 10L x 7W x 3H. 2 1/2 lbs.

**RS232 SERIAL SELECTO-SWITCH**

- Switches all lines of asynchronous data • Easy expansion of serial ports • Connectors are female DB25 type

PART NO.	DESCRIPTION	PRICE
GRS232-AB	2-Way Switch	\$139.95
GRS232-ABC	3-Way Switch	\$179.95

**DB25 PARALLEL SELECTO-SWITCH**

- TRS-80, Apple, and IBM compatible • Switches 24 lines (line 1 is ground) • Connectors are female DB25 type

PART NO.	DESCRIPTION	PRICE
GP24-AB	2-Way Switch	\$139.95
GP24-ABC	3-Way Switch	\$179.95

**CENTRONICS-STYLE SELECTO-SWITCH**

- Switches all 36 lines • Connectors are female Centronics

PART NO.	DESCRIPTION	PRICE
GCENT-AB	2-Way Switch	\$199.95
GCENT-ABC	3-Way Switch	\$229.95

## Micro-Logic Corp. MICRO-CHARTS

- Fully decoded data • Instant access • 2-sided, totally comprehensive • Compact 8 1/2 x 11 in. durable credit card plastic
- Perfect for programmers & engineers
- Clear & concise tables for full instruction set disassembly, ASCII, base conversion, effect of flags, compare vs jump, interrupt structure, priority, cycle times, diagrams, bug notes, & much more

PART NO.	REFERENCE	PRICE
ML-Z80	Z80 CPU	\$5.95
ML-8080A	8080A/8085A	\$5.95
ML-6502	6502 (65XX)	\$5.95
ML-8048	8048, Relatives, Algorithms	\$5.95
ML-7400	5400/7400 TTL	\$5.95

## BOOKS

30001	National CMOS Data Book (1981) (640 pages) 74C, CD4000, and A/D Converters	\$6.95
30003	National Linear Data Book (1982) (1376 pages) LM, LF, ADC, DAC, LH Series	\$11.95
30008	National Memory Data Book (1980) (464 pages) RAMs, ROMs, PROMs, EPROMs Series	\$6.95
30009	Intersil Data Book (1983) (1356 pages) Complete line.	\$9.95
30010	National Audio/Radio Handbook (1980) (240 pages) Pre-Amps, AM, FM & FM Stereo, Power Amps	\$5.95
30011	National Linear Application Handbook (1980) (736 pages) Application Notes, Linear Briefs, etc.	\$15.95
30012	National PAL Data Book (1982) (176 pages) Application Notes, Linear Briefs, etc.	\$5.95
30013	Zilog Data Book (1983) (641 pages) Microprocessors and Support Chips	\$7.95
210630	Intel Memory Components Handbook (1983) (798 pages) Contains all Application Notes, Engineers Reprints, Data Sheets, and other design information on Intel's RAMs, EPROMs, EPROMs & Bubble Memories.	\$14.95
210844	Intel Microprocessors & Peripheral Handbook (1983) (1027 pages) Contains Data Sheets on all of Intel's Microprocessors and Peripherals.	\$14.95

## ATARI

### ATARI PADDLES

JSP (2) ..... \$2.95 pair

### ATARI DRIVER

JSD (1) ..... \$2.95 ea.

### TV GAME SWITCH

Used on Atari. Cosmetically blemished. 100% functional.

TGS-1 ..... \$1.95 ea.



## Digital Thermometer Kit

Dual sensors — switch controls for indoor/outdoor or dual monitoring — can be extended to 500 feet. Control sensor LED 8" ht. display. Res. 1/10 °F to 199.9 °F, 40°C to 100°C. Accuracy ±1% nominal. Calibrates for Fahrenheit/Celsius. Simulated input case. AC wall adapter. Cased. Size: 6 1/2" L x 3 1/2" W x 1 1/2" D.

JE300 ..... \$39.95

## Universal Computer Keyboard Enclosures

"DTE" Blank Desk-Tu. Enclosures are designed for easy modification. High strength epoxy molded end pieces in mocha brown finish. Sliding rear/bottom panel for service/component access. Top/bottom panels 0.001" thick alum. anodized type 1200 finish (gold tint color) for best paint adhesion after modification. Ventilated top & bottom panels for cooling efficiency. Rigid construction provides unlimited applications. Assembly instructions included.

DTE-8	Panel Width 7.5"	\$24.95
DTE-11	Panel Width 10.13"	\$27.95
DTE-14	Panel Width 13.5"	\$29.95
DTE-20	Panel Width 19.25"	\$34.95

## Keyboard Mask for Your ZX81/1000\* Computer

**JE681 KEYBOARD MASK** \$9.95 each  
 \*ZX81/1000 is a trademark of Sinclair/Times

## ZX81/1000\* Keyboard Conversion Kit

**JE682 AK Keyboard Conversion Kit** \$99.95 ea.  
**JE682 Keyboard Conversion Kit** \$59.95 ea.

## 80-Key Keyboard

**CA150C** ..... \$69.95

## 95-Key Keyboard

**CA154A** ..... \$79.95

## CONTROL DATA KEYBOARDS

- ★ 7-bit Parallel ASCII
- ★ SPST Switching
- ★ FTZ Shielded Base
- ★ N-Key Rollover
- ★ 128 Character ASCII
- ★ Non-Slip, Non-Glare Keycaps
- ★ CDC752 Terminal Keyboards
- ★ Attractive Case

These Control Data Keyboards consist of a base, color the keyboard assembly, and an interface cable. Color (case): Harvest gold and black. Color (keycaps): Black, blue, and red. Electrical requirements: +5V @ 600mA, -12V @ 50mA. Size: 21 1/2" W x 9" D x 3 1/2" H. Weight: 6 lbs. All units brand new in original boxes, specifications included.

## Keytronics 90-Key Soft-Programmable Keyboard WITH SECURITY KEYLOCK SWITCH

**Part No. KB270** ..... \$79.95 each

Made for Visual Technology, this keyboard features: a security keylock (includes two keys) to guard against unauthorized use; an 11-key numeric keypad, cursor controls; and 10 user-programmable keys. Electrical requirements: +5VDC Gndr (case); White Color (keycaps); Black Complete with case, keyboard assembly, 40-inch interface cable, and schematics. Weight: 7 lbs.

**MICRO SWITCH 85-KEY KEYBOARD**  
 Word Processing Keyboard, 25 Pin Edge Card Connection. Supply Voltage +5VDC. Main Keyboard is QWERTY. Additional Key Pads for Cursor and word processing functions.  
**Part No. 85SD18-1** ..... \$29.95 each

**HI-TEK 14-KEY NUMERIC KEYPAD**  
 SPST Switching. Charcoal grey keycaps. Mounted on printed circuit board.  
**Part No. K-14** ..... \$9.95 each

**POWER SUPPLY +5VDC @ 1 AMP REGULATED**  
 Output +5VDC @ 1A (also +30VDC) reg. Input: 115VAC 50/60Hz. 2-line (black/white) self-enclosed case. 6 in. 3 card. black power cord. 8 1/2" W x 7 1/2" D x 3 1/4" H. Wt. 3 lbs. Data sheet incl.  
**Part No. PSS1194S** ..... \$14.95 each

**POWER SUPPLY +5VDC @ 3 AMP REGULATED**  
 Input: 115VAC, 67.44kHz. Output: 5VDC Adjustable @ 3 amp, 6VDC @ 2.5 amp. Adjustable current limit. Ripple & Noise: 1mV rms. 50W p-p. — 2 mounting surfaces. UL recognized. Size: 4" W x 4 1/2" L x 2 7/8" H. Wt. 2 lbs. Data sheet included.  
**Part No. OPS-1** ..... \$29.95 each

**POWER SUPPLY +5VDC @ 7.5 AMP, 12VDC @ 1.5 AMP SWITCHING**  
 Input: 115VAC, 50-60Hz @ 3 amp/230VAC, 50Hz @ 1.5 amp. Fan vol./power supply select switches (115/230VAC). Output: 5VDC @ 7.5 amp, 12VDC @ 1.6 amp. 8 in. blk. pow. cord. 11 1/2" W x 12 1/2" D x 3 1/2" H. Wt. 6 lbs.  
**Part No. PS94VDS** ..... \$39.95 each

**POWER SUPPLY 4-Channel Switching - Apple Compatible**  
 FOR USE AS AN EXTERNAL POWER SUPPLY FOR APPLE Microprocessor, mini-computer, terminal, medical equipment and process control applications. Input: 90-130VAC 47-440Hz. Output: +5VDC @ 5A, +12VDC @ 1A, -12VDC @ 1A. Line reg. ±0.2%, Ripple: 30mV p-p. Load reg. ±1%. Overcurrent protection. Adj. SW main output ±10%. 6.5A (81) x 12 1/8" W x 4.5/5 1/8" H. Wt. 1 1/2 lbs.  
**Part No. PCS-604A** ..... \$69.95 each

\$10.00 Minimum Order — U.S. Funds Only  
 California Residents Add 6 1/2% Sales Tax  
 Shipping — Add 5% plus \$1.50 Insurance  
 Send S.A.S.E. for Monthly Sales Flyer!

Spec Sheets — 30c each  
 Send \$1.00 Postage for your  
**FREE 1983 JAMECO CATALOG**  
 Prices Subject to Change

MasterCard **Jameco ELECTRONICS** VISA®  
 1355 SHOREWAY ROAD, BELMONT, CA 94002  
 983 PHONE ORDERS WELCOME — (415) 592-8097 Telex: 176043



## JE664 EPROM PROGRAMMER

8K TO 64K EPROMS — 24 AND 28 PIN PACKAGES — PROGRAMS 2716's IN 16 SECONDS — PROGRAMS 2764's IN 64 SECONDS

• Programs, validates, and checks for properly erased EPROMs • Emulates PROMs or EPROMs • RS232C Computer Interface for editing / program loading • Loads data line from keyboard • Changes data in RAM by keyboard • Loads RAM from an EPROM • Compares EPROMs for content differences • Copies EPROMs • Power Input: 115VAC, 60Hz, ±10W power consumption • Enclosure: Color-coordinated, light tan panels w/ mottled mocha brown and pieces • Size: 15.5/8" L x 8 1/2" W x 3 1/4" H • Weight: 5 1/2 lbs.

**JE664-A EPROM Programmer** ..... \$995.00  
 Assembled and Tested (Includes JM16A Module)

**JE665 — RS232C INTERFACE OPTION** — The JE665 RS232C Interface Option implements computer access to the JE664 A. Sample software written in BASIC provided for TRS-80™ Model I. Level II Computer. Baud rate: 9600. Word length: 8 bits. odd parity. Stop bits: 2. Option may be adapted to other computers. The JE665 can be interfaced to any computer with an RS232 port. Information is also provided for interfacing to any CP/M system with an RS232 port.

**JE664-ARC EPROM Prog. w/ JE665 Option** ..... \$1195.00  
 Assembled and Tested (Includes JM16A Module)

**EPROM JUMPER MODULES** — The JE664 G JUMPER MODULE (Personality Module) is a plug-in Module that pre-sets JE664 for proper programming pulses to the EPROM & configures EPROM socket connectors for that particular EPROM.

PIN	EPROM	EPROM MANUFACTURER	PRICE
JM26A	2708	AMD, Motorola, National, Intel, TI	\$14.95
JM16A	2716 IMS2516	Intel, Motorola, National, NEC, TI	\$14.95
JM16B	IMS2716	Motorola, TI (+5, -12, +12)	\$14.95
JM32A	IMS2532	Motorola, TI	\$14.95
JM32B	2732	AMD, Fujitsu, NEC, Hitachi, Intel, Fujitsu, Intel	\$14.95
JM32C	2732A (21V)		\$14.95
JM64	MCM68754	Motorola	\$14.95
JM64B	2764	Intel	\$14.95
JM64C	IMS2564	TI	\$14.95
JM64D	HM-682764G-4	Hitachi (21V)	\$14.95

## iii's Black Hole EPROM Eraser

9 Chips — 8 Minutes

The Black Hole EPROM Eraser will completely and safely erase 9 EPROMs in less than 8 minutes. The Black Hole is a fully automatic cassette loading eraser. Featuring a slotted 4000 Hz UV lamps mounted in a special ALZAK (UV reflectivity of 9) parabolic light tunnel. In operation, the user slips in an anti-static Bug Box (3 aa incl.) containing the EPROMs to be erased into the loading slot on the front panel of Black Hole. The rest is fully automatic. The Black Hole latches the Bug Box into place, turns on the UV lamps and starts its fully solid state (CMOS) UV integration cycle timer. The percentage erasure time is monitored and displayed on a front panel LED readout. At the end of the erase cycle, the Black Hole ejects the Bug Box containing the 9 erased EPROMs and turns off power.

**Part No. ULV-008** Replacement Lamp for ERS-008 ..... \$29.95  
**ERS-008** Eraser, Auto Eject & LED Readout ..... \$249.95

## IBM MEMORY EXPANSION KIT

SAVE HUNDREDS OF \$\$\$ BY UPGRADING MEMORY BDARDS YOURSELF!

Most of the popular memory boards allow you to add an additional 64K, 128K, 192K, or 256K. The IBM64K Kit will upgrade these boards in 4K bit increments. The kit is simple to install — just insert the nine 64K RAM chips in the provided sockets and set the two groups of switches. Directions are included.

**IBM64K (Nine 200ns 64K RAMs)** ..... \$59.95

## EXPAND YOUR MEMORY

**TRS-80 to 16K, 32K, or 48K**

Model 1 = From 4K to 16K Requires (1) One Kit  
 Model 3 = From 4K to 48K Requires (3) Three Kits  
 Color = From 4K to 16K Requires (1) One Kit

\*Model 1 equipped with Expansion Board up to 16K Two Kits Required — One Kit Required for each 16K of Expansion —

**TRS-16K3 \*200ns for Color & Model III** ..... \$12.95  
**TRS-16K4 \*250ns for Model I** ..... \$19.95

## TRS-80 Color 32K or 64K Conversion Kit

Easy to Install kit comes complete with 8 ea. 4164-2 (200ns) 64K dynamic RAMs & conversion documentation. Converts TRS-80 color system with E circuit board to all new color computers to 32K. Minor modifications of 32K memory will allow the use of all the 64K of the dynamic RAM providing you have a FLEX DOS operating system.

**TRS-64K2** ..... \$54.95

## 5 1/4" Mini-Floppy Disk Drive

FOR TRS-80 MODEL I - COLOR COMPUTER  
 Features single or double density Recording mode. FM single density double density. Seek time: 20msec. Track to track Power: +12VDC (1.0A) 1.5A max +5VDC (1.0A) 2.5V 0.5A max. Unit as pic. all right does not incl. case, power supply cables, 30pin data book incl. Wt. 3 1/2 lbs. Size: 5 1/4" W x 8 1/4" H x 1 1/2" D.

Part No.	Limited Quantity!	Price
FD200	Single-sided, 40 tracks, 260K bytes capacity	\$179.95
FD250	Double-sided, 35 tracks, 438K bytes capacity	\$199.95

## 8" FLOPPY DISK DRIVE

The FDD100 8" Floppy Disk Drive (Industry Standard) features single or double density Recording mode. FM single, MFM double density. Transfer rate: 250K bits/sec. single density, 500K bits/sec. double density. The FDD100 is designed to work with the single-sided soft sector IBM Diskette I or II, or disk cartridge. Power: 115VAC @ 50/60Hz, +24VDC @ 1.7 amps max. +5VDC @ 1.2 amps max. Unit as pictured above does not include case, power supply, or cables. Size: 8 1/2" W x 14" L x 4 1/2" H. Weights 12 lbs. Incl. 36pg. manual.

Part No.	Price
FDD100-8	\$169.95 ea.



# FORMULA INTERNATIONAL INC.

12603 Crenshaw Blvd., Dept. B, Hawthorne, CA 90250

For information (213) 973-1921 • Orders Only (outside Calif.) (800) 672-8758



### POCKET LIGHT

Complete with 5" fluorescent tube, powerful bulb and handy strap. Runs on 3 pcs 1.5V "C" size batteries (not included). It's a practical, convenient, powerful spotlight and fluorescent light. Its superior quality is ideal for indoor or outdoor use.

LOW PRICE \$7.50

### SANYO UHF VARACTOR TUNER

FOR UHF CHANNELS 14-83

Tuning voltage +1 to +28VDC. Input impedance 75Ω. IF band width 7-16MHz. Size 2 1/4" x 1 1/4" x 3/4". Supply voltage 15VDC.

Model 115-B-403A, Video IF 45.0MHz  
Model 115-B-405A, Video IF 62.5MHz

\$35.00 ea.

Tuner is the most important part of the circuit. Don't let those \$19.00 tuners fool you. All units are brand new from Sanyo. When ordering please specify model number.



### AUDIO FREQUENCY SPECTRUM ANALYSER KIT TA-2900

This Audio Frequency Spectrum Analyser analyses audio signals in 10 octaves over a dynamic range of 30dB. The technique allows the sound coloration introduced by unwanted room and speaker resonances to be substantially eliminated.

The TA-2900 provides a visual presentation of the changing spectrum thru 100 red LED displays, so you can actually see proof of the equalized sound you've achieved. The TA-2900 kit comes with all the electronic components, IC's, predrilled PC Board, the instructions and a 19" Rack Mount type metal cabinet with professional silk screen printed front panel.

- Input Sensitivity Tape Monitor/10mV-18mV 50KΩ. Speaker Terminal/0.2W-100W 8Ω.
- Display Level Range (all octaves) 2dB per step -14dB to -4dB.
- Delay Time (1KHz) Fast/18dB/s Slow/6dB/s.
- Power Input 117.220VAC, 50/60Hz.
- Power Consumption 36W.
- Dimensions 482(W) x 102(H) x 250(D) mm.

\$99.50 per Kit



### TA-1000 KIT

\$51.95

Power Transformer \$24.00 ea.



### 100W CLASS A POWER AMP KIT

Dynamic Bias Class "A" circuit design makes this unit unique in its class. Crystal clear, 100 watts power output will satisfy the most picky fans. A perfect combination with the TA-1020 low TIM stereo pre-amp.

Specifications • Output power 100W RMS into 8Ω. 125W RMS into 4Ω • Frequency response 10Hz-100KHz • THD less than 0.01% • S/N ratio better than 80dB • Input sensitivity 1V max. • Power supply ±40V at 5A.

### 1 WATT AUDIO AMP

All parts are pre-assembled on a mini PC Board. Supply voltage 6-9VDC. Special Price \$1.95

### 6W AUDIO AMP KIT

TBA810 with Volume Control. Power Supply 6-18VDC. Only \$7.50 ea.

SEND ONE DOLLAR FOR OUR DETAIL CATALOG

Inside California  
Outside Calif. (Incl. Mexico & Canada)  
Overseas

Shipping & Handling Charges	
Under \$50.00	Under \$50.00
Purchase	Purchase
10%	5%
15%	10%
25%	20%

Minimum Order \$10.00/Calif. Residents add 6.5% Sales Tax. Phone Orders Accepted on VISA or MC ONLY. NO C.O.D.'s. Prices subject to change without notice.

\*Apple and Apple II are the trademark of APPLE COMPUTERS, INC.



### LASER SUPER LATERN

Brilliant fluorescent lantern with 9" 6 watt fluorescent tube. Features include: Powerful direct beam spotlight with 9V pre-focus bulb. Buzzer horn - either constant or time intervals of sonic alarm; Twin blinker - red amber flashing or red & amber flashing on time intervals; Fully adjustable nylon strap. Operates from D size batteries or plugs into vehicle cigar lighter socket.

SPECIAL \$11.95

### 6-WAY A/C ADAPTOR

Input: 110VAC. Output: 3V, 4.5V, 6V, 7.5V and 12VDC. Current: 300mA.

OUR LOW PRICE \$5.50 ea.



No FCC License Required  
OUR PRICE \$49.50  
Additional Microphone (Transmitter) Available at \$28.00 ea.  
MURA WMS-49

### CRYSTAL CONTROLLED WIRELESS MICROPHONE SYSTEM

Transmitter: FET mic for flat 30Hz-18KHz response. Xtal controlled 49MHz AM Band for drift-free performance. 100mW output (range approx. 1/4 mile) for reliable long range transmission. Powered by a 9V radio battery.



Receiver: Xtal controlled locks on 49MHz transmitter signal. On panel VU meter, monitors the signal strength from the microphone. Standard phone jack outlet connection to a P.A. or other phone input. 9V battery included. This professional set is ideal for on stage, in field, church, in house or outdoor use.



A GOOD BUY at \$65.00  
TA-800

### 120W PURE DC POWER STEREO AMP KIT

Getting power hungry from your small amp? Here's a good solution! The TA-800 is a pure DC amplifier with a built-in pre-amp. All coupling capacitors are eliminated to give you a true reproduction of the music. On board tone and volume controls combined with built-in power supply make the TA-800 the most compact stereo amp available. Specifications: 60W x 2 into 8Ω. Freq Range: 0Hz-100KHz ±3dB. THD: .01% or better. S/N Ratio: 80dB. Sensitivity: 3mV into 47KΩ. Power Requirement: ±24-40 Volts.

### "FISHER" 30 WATT STEREO AMP

MAIN AMP (15W x 2). Kit includes 2 pcs. Fisher PA 301 Hybrid IC, all electronic parts with PC Board. Power supply ±16VDC (not included). Voltage gain 33dB, 20Hz-20KHz.

Super Buy Only \$18.50

### WHISTLE ACTIVATED SWITCH BOARD

All boards are pre-assembled and tested. You whistle to its FET condenser microphone from a distance, as far as 30 feet away (sensitivity can be easily adjusted), and it will turn the switch on. If you whistle again it will turn off. Ideal for remote control toys, electrical appliance such as lights, coffee pots, TV, Hi-Fi, radio or other projects. Unit works on 9VDC.

Model 968 ..... \$2.50 ea.

### ULTRASONIC SWITCH KIT

Kit includes the Utra Sonic Transducers, 2 PC Boards for transmitter and receiver, all electronic parts and instructions. Easy to build and a lot of uses such as remote control for TV, garage door, alarm system or counter. Unit operates by a 9-12VDC. \$15.50 ea.

### UNIVERSAL NI-CD BATTERY CHARGER MW-398



Charges 9V, AA, C or D size Ni-CD batteries all at one time.

Part No. 050-0190 \$11.50 ea.

### SUPER FM WIRELESS MIC KIT

This new designed circuit uses high FREQ FET transistors with 2 stage pre-amp. Transmits FM range (88-120MHz) up to 2 blocks away and with the ultra sensitive condenser microphone that comes with the kit allows you to pick up any sound within 15 ft. away. Kit includes all electronic parts, OSC coils and PC Board. Power supply 9VDC.

FMC-105 \$11.50 per Kit

### PROFESSIONAL FM WIRELESS MICROPHONE

Made by one of the leading Japanese manufacturers. This factory assembled FM wireless microphone is powered by two AA size batteries. It transmits in the range of 88-108MHz. Element is built in a plastic tube type case with an omni-directional electronic condenser microphone unit. By using a standard FM radio, signal can be heard anywhere on a one acre lot. Sound quality was judged "very good." MODEL WEM-36 was \$16.50.

ON SALE \$8.25 ea.

### HEAVY DUTY 500mA MULTIPLE AC-DC ADAPTOR

For all battery operated electronic equipment up to 500mA with LED indicator.



Input: 117/220VAC, 50/60Hz  
Output: 3, 4, 5, 6, 7.5, 9 and 12VDC.  
Model SA-8112A \$25.00 ea.

### SANYO ANTENNA SIGNAL BOOSTER

This Booster is specially designed for UHF Channels (14-83). After installing (between the antenna input cable and the UHF tuner), this unit will provide a minimum of 10dB gain, that is approximately 2 times better than you are seeing now. Ideal for those who live in apartments that can not put up an outdoor antenna. Small in size, only 2" x 1 1/2" x 1". Supply voltage is 15 VDC.

Model 001-0076

\$12.50



### PROFESSIONAL REGULATED VARIABLE DC POWER SUPPLY KIT

All solid state circuitry with high efficiency power transistor 2SD388 and IC voltage regulator MC1733. Output voltage can be adjusted from 0.30V at 1A current limited or 0-15V at 2A current limited. Internal resistance is less than 0.005Ω, ripple and noise less than 1mV, dual on panel meters for voltage and current reading, also with on board LED and audible over load indicator. Kit comes with pre-drilled PC Board, instructions, all necessary electronic components, transformer and a professional looking metal cabinet. The best project for school and the most useful instrument for repairmen. Build one today!

Model TR88A 0-15VDC (r 2A

Model TR88B 0-30VDC (r 1A

\$59.50 per Kit

### FLOURESCENT AUDIO LEVEL MONITOR

This is the kind of VU monitor that is being used by most amplifier manufacturers. IC's are used to simplify circuit layout. Easy to assemble and can be used with all power level amplifiers. Power requirement 12VDC.



TE-221 KIT For Just \$28.50 (Limited Stock)

### REGULATED DUAL VOLTAGE SUPPLY KIT

±10-30VDC (r 250mA adjustable fully regulated. Kit includes all electronic parts, filter capacitors, IC's, heat sinks and PC Board.

\$12.50 per Kit

### MARK IV — 15 STEP LED POWER LEVEL INDICATOR KIT

This new stereo indicator kit consists of 36 4-color LED's (15 per channel) to indicate the sound level output of your amplifier from -36dB to +3dB. Comes with a well designed silk screen printed plastic panel and has a selector switch to allow floating or gradual output indicating. Power supply is 6-12VDC with THG on board input sensitivity controls. This unit can work with any amplifier from 1W to 200W. Kit includes 70 pcs driver transistors, 38 pcs matched 4-color LED's, all electronic components, PC Board and front panel.

MARK IV KIT \$31.50

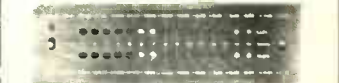

### LOW TIM DC STEREO PRE-AMP KIT TA-1020

Incorporates brand-new DC design that gives a frequency response from 0-100KHz ±0.5dB. Added features like tone defeat and loudness control let you tailor your own frequency supplies to eliminate power fluctuations!

Specifications: • THD/TIM less than .005% • Frequency response DC to 100KHz ±0.5dB • RIAA deviation ±0.2dB • S/N ratio better than 70dB • Sensitivity: Phone 2mV 47KΩ, Aux 100mV 100KΩ • Output level 1.3V • Max output 15W • Tone controls: Bass ±10dB (r 50Hz, Treble ±10dB (r 15Hz) • Power supply ±24VDC (r 0.5A. Kit comes with regulated power supply. All you need is a 48VCT transformer (r 0.5A.

Only \$44.50 Transformer \$4.50 ea.



★ SPECIAL ★ Excellent Price! Model 001-0034 \$29.50 per Kit Transformer \$10.50 ea.

### TA-322 30 WATTS TOTAL 15W + 15W STEREO AMP KIT

This is a solid state all transistor circuitry with on board stereo pre-amp for most microphone or phone input. Power output employs a heavy duty Power Hybrid IC. Four built on board controls for, volume, balance, treble and bass. Power supply requires 48VCT 2.5A transformer. THD of less than 0.1% between 100Hz-10KHz at full power (15 Watts + 15 Watts loaded into 8Ω).

### ELECTRONIC SWITCH KIT

CONDENSER TYPE. Touch On — Touch Off. Uses 7473 IC and 12V relay. \$5.50

### POWER SUPPLY KIT

0-30VDC REGULATED. Uses UA723 and 2N3055 power transistor. Output can be adjusted from 0-30V (r 2A. Complete with PC Board and all electronic parts. Transformer \$9.50 ea. POWER SUPPLY KIT \$10.50 ea.

### FLOURESCENT LIGHT DRIVER KIT

12VDC Powered. Lights up 8-15 Watt Fluorescent Light Tubes. Ideal for camper, outdoor, auto or boat. Kit includes high voltage coil, power transistor, heat sink, all other electronic parts and PC Board. Light tube not included. \$6.50 per Kit

### ELECTRONIC DUAL SPEAKER PROTECTOR

Cuts off when circuit is shorted or over loaded to protect your amplifier as well as your speakers. A must for OCL circuits. Kit Form \$8.75

### SOLAR CELLS

0.5V 200mA. Ideal for all kinds of solar projects. Cells can be put in series to double voltage or parallel to double current. 99c ea.

STORE HOURS MON-FRI—10-7 SAT—10-6

# WE HAVE QUALITY PARTS, DISCOUNT PRICES AND FAST SHIPPING!

### TRANSFORMERS



120 volt primaries

5.6 VOLTS at 750 MA	\$3.00
6 VOLTS at 150 MA	\$1.25
16.5 V. at 3 AMPS	\$6.50
18 V at 650 MA	\$3.50
18 VOLTS at 1 AMP	\$4.50
18 V.C.T. at 2 AMP	\$5.50
24 VOLTS at 250 MA	\$2.50
24 VCT at 1 AMP	\$4.50
42 V.C.T. at 1.2 AMP	\$4.50

### HELPING HAND



WILL HOLD P.C. BOARD OR OTHER SMALL ITEMS AND ALLOW BOTH YOUR HANDS FREEDOM TO WORK.

**\$6.50 EACH**

### LIGHTS

#### GRAIN OF WHEAT

##### T1 SIZE



.125" DIA. (3.15mm)

3 to 6 VOLTS	3 for \$1.00
Rated: 55ma @ 5 VOLTS	
6 to 12 VOLTS	3 for \$1.00
Rated: 55ma @ 8 VOLTS	
12 to 24 VOLTS	3 for \$1.00
Rated: 45ma @ 14 VOLTS	

### SOLDERING IRON STAND



SPRING STEEL IRON HOLDER ON WEIGHTED BASE.

**\$5.00 EACH**

### WALL TRANSFORMER



ALL ARE 115 VAC PLUG IN

4 VDC at 70 MA	\$2.50
9 VDC at 225 MA	\$3.00
16.5 VAC at 10 VA	\$3.50
17 VAC at 500 MA	\$4.00
22 VDC at 60 MA	\$2.50

### BLACK PLASTIC CASE



PAC-TEC SERIES C

BLACK PLASTIC ENCLOSURE ADJUSTABLE HEIGHT FROM 1.63" TO 2.93"; WIDTH 6.85"; DEPTH 8". BUILT-IN STAND OFFS FOR P.C. BOARDS. FRONT AND BACK PANELS NOT INCLUDED.

**\$5.25 PER CASE**

### S.C.R.

0.8 AMPS 30 VOLTS	5 for \$1.00
4 AMPS 200 VOLTS	65¢ EACH
4 AMPS 400 VOLTS	75¢ EACH
12 AMPS 400 VOLTS	\$1.00 EACH

### T1 SIZE WITH WIRE LEADS



3 to 6 VOLTS	2 for \$1.00
Rated: 55ma @ 5 VOLTS	
6 to 12 VOLTS	2 for \$1.00
Rated: 55ma @ 8 VOLTS	
12 to 24 VOLTS	2 for \$1.00
Rated: 45ma @ 14 VOLTS	

### 12 VOLT A.C. POWER UNIT



THIS UNIT CONSISTS OF A 12 VOLT 2 AMP TRANSFORMER, 1 AMP CIRCUIT BREAKER, 4 PRONG CINCH JONES SOCKET AND A 3 WIRE A.C. CORD ALL MOUNTED IN AN ATTRACTIVE 4 1/2" x 5 1/2" x 3" CHASSIS BOX GOOD FOR PARTS OR A NICE START FOR D.C. POWER SUPPLY.

**\$8.50 PER UNIT**

### 2K 10TURN



MULTI-TURN POT SPECTROL #MOD 534-7161

**\$5.00 EACH**

### VARACTOR DIODE



BB-103	3 for \$1.00
33 PF	100 FOR \$30.00

### MIKE CONNECTOR



5 CONDUCTOR IN-LINE PLUG AND CHASSIS MOUNT JACK TWIST LOCK STYLE. SAME AS SWITCHCRAFT 12CL5M.

**\$2.50 PER SET**

### TRIAC

6 AMPS 400 VOLTS

**75¢ EACH**

### T1- 3/4 SIZE WITH WIRE LEADS



.163" DIA. (4.14mm)

3 to 6 VOLTS	2 for \$1.00
Rated: 45ma @ 6 VOLTS	
6 to 12 VOLTS	2 for \$1.00
Rated: 55ma @ 8 VOLTS	
12 to 24 VOLTS	2 for \$1.00
Rated: 45ma @ 14 VOLTS	

### METERS

#### 0 - 20 V.D.C.



0-20 VDC FULL SCALE FACEPLATE BATTERY TEST SET-UP AS INDICATOR

**\$5.50 EACH**

#### 1 MA



2 5/16" SQUARE PANEL METER MOUNTS IN 2 1/8" HOLE

**\$5.50 EACH**

### SWITCHES

#### MINI-PUSH BUTTON



S.P.S.T. MOMENTARY NORMALLY OPEN 1/4" BUSHING

**35¢ EACH**

10 FOR \$3.25

100 FOR \$30.00

SPECIFY COLOR: RED, BLACK, WHITE, GREEN, YELLOW.

### 2 CHANNEL LIGHT ORGAN



EASILY HOOKS INTO STEREO SPEAKERS AND ALLOWS 110 VAC LIGHTS TO DANCE WITH MUSIC. TWO SEPARATE 110 VAC OUTPUTS FOR HIGH AND LOW FREQUENCY AUDIO SIGNALS. USE TWO ORGANS FOR STEREO.

**\$6.50 PER UNIT**

COLOR LIGHT STRING AVAILABLE \$1.75 EA

### TRANSISTORS

2N706	5 for \$1.00
2N2222A	4 for \$1.00
PN2222	8 for \$1.00
2N2904	4 for \$1.00
2N2955	4 for \$1.00
2N2907	4 for \$1.00
MJ3030	\$2.50
2N3555	\$1.00
2N3585	\$1.00
2N3904	5 for \$1.00
2N3906	5 for \$1.00
2N4401	5 for \$1.00
2N4403	5 for \$1.00
2N4898	\$1.50
D43C8	2 for \$1.00
D44C2	.75
TIP 31	.75
TIP 32	.75
TIP 121	.75
TIP 126	.75

### NEON W/ RESISTOR



DIRECT OPERATION FROM 120 VOLT

**7 for \$1.00**

### 0 - 15 V.D.C.



THIS 2-1/4" SQUARE METER MEASURES 0-15 VDC

**\$4.50 EACH**

### KEY SWITCH



S.P.S.T. 4 AMPS @ 125 VAC KEY REMOVES BOTH POSITIONS

**\$3.50 EA**

### 120V INDICATOR



NEON INDICATOR RATED 120 V 1/3 W. MOUNTS IN 5/16" HOLE. RED LENS.

**75¢ EACH**

10 FOR \$7.00

100 FOR \$65.00

### METAL OXIDE VARISTOR



G.E. # V822A12

50 VOLTS, NOMINAL D.C. VOLTAGE, 5/8" DIAMETER.

**2 FOR \$1.50**

### LIGHTED PUSH BUTTON



RED LIGHTED 120 VAC 10 AMP S.P.S.T.

"POWER" PRINTED ON FACE. MOUNTS IN 7/8" SQUARE HOLE

**\$1.50 EA**

10 FOR \$13.50

## FREE! FREE! FREE! SEND FOR NEW LARGER! 48 PAGE CATALOG FREE! FREE! FREE!

### POWER SUPPLY



REGULATED FULLY ADJUSTABLE 5 VDC AT 3 AMPS.

**\$18.50 EACH**

### LINE CORDS



**TWO WIRE**

6' 18ga TWO WIRE 3 FOR \$1.00

**THREE WIRE**

18 INCH 18ga THREE WIRE 2 for \$1.00

8 FOOT 18ga THREE WIRE \$2.00 EACH

### RELAYS

6 VDC RELAY



MINIATURE D.P.D.T. 3 AMP CONTACTS FUJITSU # FBR321D006

**\$1.75 EA**

10 / 16.00

**MINIATURE 6 VDC RELAY**



SUPER SMALL SPDT RELAY; GOLD COBALT CONTACTS.

RATED 1 AMP AT 30 VDC; HIGHLY SENSITIVE. TTL DIRECT DRIVE POSSIBLE. OPERATES FROM 4.3 TO 6 V. COIL RES. 220 OHM.

1 3/16" x 13/32" x 7/16" AROMAT # RSD-6V

**\$1.50 EACH**

10 FOR \$13.50

### COMPUTER GRADE CAPACITORS



1700 mfd. 150 VDC	\$2.00
2 1/2" DIA. x 4 3/4" HIGH	
3,600 mfd. 40VDC	\$1.00
1 3/8" DIA. x 3" HIGH	
6,400 mfd. 60 VDC	\$2.50
1 3/8" DIA. x 4 1/4" HIGH	
18,000 mfd. 75 VDC	\$4.00
2 1/2" DIA. x 4 1/2" HIGH	
22,000 mfd. 15 VDC	\$2.00
2" DIA. x 2 1/2" HIGH	
22,000 mfd. 40 VDC	\$2.00
2" DIA. x 6" HIGH	\$3.00
24,000 mfd. 30 VDC	\$3.50
1 3/4" DIA. x 4" HIGH	
31,000 mfd. 15 VDC	\$2.50
1 3/4" DIA. x 4" HIGH	
72,000 mfd. 15 VDC	\$2.00
2" DIA. x 4" HIGH	\$3.50
180,000 mfd. at 6V	\$2.00
2 1/2" DIA. x 4 1/2" HIGH	\$1.50

CLAMPS TO FIT CAPACITORS 50¢ ea.

### EDGE CONNECTORS



ALL ARE 156" SPACING

15 PIN GOLD SOLDER EYELET	\$1.75 EACH
15/30 GOLD SOLDER EYELET	\$2.00 EACH
18/36 GOLD SOLDER EYELET	\$2.00 EACH
22/44 TIN P.C. STYLE; NO MOUNTING EARS	\$2.00 EACH
10 FOR \$18.00	

### L.E.D.'S STANDARD JUMBO DIFFUSED



RED	10 FOR \$1.50
GREEN	10 FOR \$2.00
YELLOW	10 FOR \$2.00

**FLASHER LED**

5 VOLT OPERATION RED JUMBO SIZE

**\$1.00 EACH**

**BI POLAR LED**

2 FOR \$1.70

**SUB-MINI LED**



079" x 098"

RED	10 FOR \$1.00
200 FOR \$18.00	
GREEN	10 FOR \$1.50

**LED HOLDERS**

TWO PIECE HOLDER FOR JUMBO LED

10 FOR 65¢

200 FOR \$10.00

### KEY ASSEMBLY

#### 5 KEY



CONTAINS 5 SINGLE-POLE NORMALLY OPEN SWITCHES. MEASURES 3 3/4" LONG.

**\$1.00 EACH**

#### 6 KEY



CONTAINS 6 SINGLE-POLE NORMALLY OPEN SWITCHES. MEASURES 4 1/4" LONG.

**\$1.25 EACH**

### SLIDE POTS



**100K linear tape**

2" LONG 1 5/8" TRAVEL 75¢ EACH

**500K linear taper**

2 7/8" LONG 1 3/4" TRAVEL 75¢ EACH

**DUAL 100K audio taper**

3 1/2" LONG 2 1/2" TRAVEL \$1.50 EACH

### 13 VDC RELAY



CONTACT: S.P.N.C. 10 AMP @ 120 VAC ENERGIZE COIL TO OPEN CONTACT.

COIL: 13 VDC 650 OHMS

**SPECIAL PRICE \$1.00 EACH**

### MINIATURE TOGGLE SWITCHES

ALL ARE RATED 5 AMPS @ 125 VAC

S.P.D.T. (on-on)	P.C. STYLE NON-THREADED BUSHING. 75¢ EACH 10 FOR \$7.00
S.P.D.T. (on-off-on)	NON-THREADED BUSHING. P.C. STYLE 75¢ EACH 10 FOR \$7.00
S.P.D.T. (on-on)	SOLDER LUG TERMINALS. \$1.00 EACH 10 FOR \$9.00 100 FOR \$80.00
S.P.D.T. (on-on)	P.C. LUGS, THREADED BUSHING. \$1.00 EACH 10 FOR \$9.00 100 FOR \$80.00
S.P.D.T. (on-off-on)	SOLDER LUG TERMINALS. \$2.00 EACH 10 FOR \$19.00 100 FOR \$180.00

### SOLID STATE RELAY



CONTROL: 3-32VDC

LOAD: 10 AMP 140 VAC

**\$9.50 EACH**

### PHOTO-FLASH CAPACITORS

35 MFD 330 VOLT

1" x 5/8" DIA. 45¢ EACH... 10 FOR \$4.00

170 MFD 330 VOLT

1 1/8" x 7/8" 2 FOR \$1.50 10 FOR \$7.00

750 MFD 330 VOLT

2" HIGH x 1 1/4" DIA. \$1.25 EACH 10 FOR \$11.00

### POWER SUPPLY W/ PRE-AMP

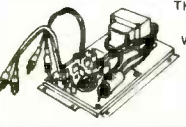

THIS SUPPLY WAS USED TO POWER AN 8 TRACK CASSETTE UNIT. IT WILL SUPPLY APPROX. 18 VDC AND INCLUDES A SMALL PRE-AMP TO BOOST SIGNAL LEVEL. RCA PLUGS FOR LINE IN/OUT.

**\$4.50 EACH**

### 4 PDT RELAY



• 14 pin style

• 3 amp contacts

• 24 volt d.c. or 120 volt a.c. coil

• Used but fully tested

**\$1.70 EACH**

specify coil voltage

LARGE QUANTITIES AVAILABLE

SOCKETS FOR RELAY 50¢ each

TOLL FREE ORDERS ONLY  
1-800-825-5432 (ORDER ONLY)  
(IN CALIFORNIA: 1-800-258-6666)  
ALASKA, HAWAII, OR INFORMATION  
(213) 380-8000

# ALL ELECTRONICS CORP.

905 S. Vermont Ave. P.O. BOX 20406 Los Angeles, Calif. 90006

QUANTITIES LIMITED  
MINIMUM ORDER \$10.00  
USA: \$2.50 SHIPPING  
FOREIGN ORDERS:  
INCLUDE SUFFICIENT SHIPPING  
CALIF. RES. ADD 6 1/2%  
NO C.O.D!

# “The Deluxe II”

Is The Ultimate In UHF Sine Wave Converter Technology

**PC BOARD & PLANS \$20.00**

With purchase of COMPLETE SET OF PARTS & ENCLOSURE

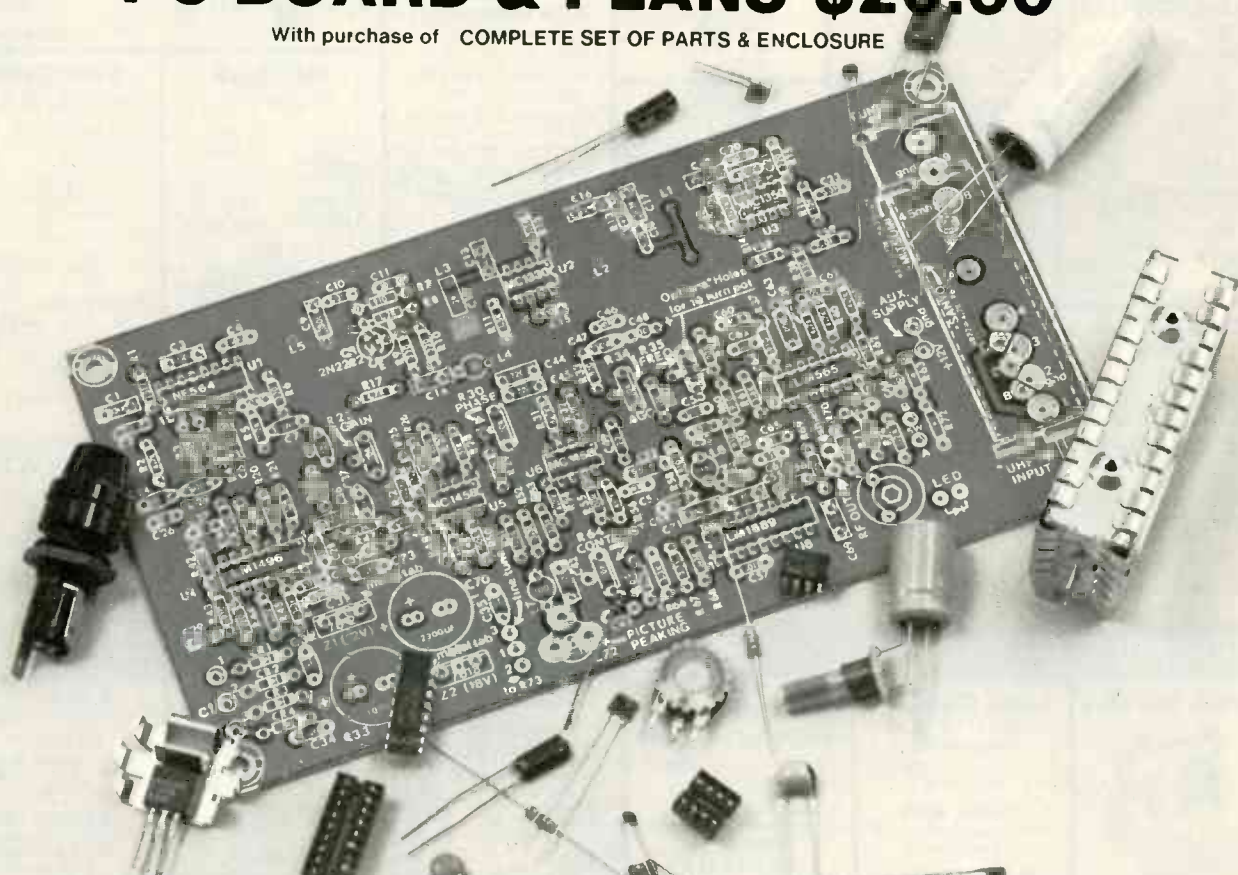

The latest state of the art electronics combined with the excellence in printed circuit manufacturing creates this high performance UHF Sine Wave Converter kit that outperforms the imitations by a long shot.

Engineered for reliable stability and outstanding reception clarity, uninterrupted modulated audio and fully illustrated instructions with the amateur in mind.

TOLL FREE

BETA ELECTRONICS, 1700 E. DESERT INN ROAD, SUITE 222, LAS VEGAS, NEVADA, 89109 **1-800-782-2701**

QTY	DESCRIPTION OF ITEM	COST EACH	SHIPPING EACH	TOTAL
	PC BOARD, PLANS, PARTS & ENCLOSURE	\$152.99	\$4.95	
	PARTS & ENCLOSURE ONLY	\$132.99	\$4.95	
	PC BOARD & PLANS ONLY	\$30.00	\$1.50	
			GRAND TOTAL	\$

PLEASE PRINT CLEARLY

SEND THIS ORDER FORM

NAME \_\_\_\_\_

ADDRESS \_\_\_\_\_

CITY/STATE/ZIP \_\_\_\_\_

ORDER DATE \_\_\_\_\_

QUANTITY DISCOUNTS AVAILABLE

VISA  MST. CARD CARD NO. \_\_\_\_\_ EXP. DATE \_\_\_\_\_

MO. DAY YR.

FOR IMMEDIATE DELIVERY MONEY ORDERS OR CERTIFIED CHECKS PREFERRED PERSONAL CHECKS ALLOW 4 WEEKS FOR DELIVERY

CIRCLE 67 ON FREE INFORMATION CARD

# Do Kay Computer Products, Inc.

VISIT OUR RETAIL STORE

2100 DE LA CRUZ BLVD.

SANTA CLARA, CA 95050

### EPROMS

1702	1ns	2.95
2708	450ns	2.98
2716	450ns	3.90
2716-1	350ns	5.90
2532	450ns	5.35
2732	450ns	4.90
2764	450ns	CALL

### STATIC RAMS

2101	450ns	1.80
2102L-2	250nsLP	1.44
2111	450ns	2.48
2114	450ns	1.74
2114L-4	450nsLP	1.84
2114L-3	300nsLP	1.84
2114L-2	200nsLP	1.94
TMS4044-4	450ns	3.15
TMS4044-3	300ns	3.45
TMS4044-2	200ns	3.89
MK4118	250ns	9.69
TMM2016	200ns	4.15
TMM2016	150ns	4.89
HM6116-4	200ns	5.90
HM6116-3	150ns	6.90
HM6116-2	120ns	8.95
Z6132	300ns	32.95

LP = LOW POWER

### DYNAMIC RAMS

TMS 4027	250ns	.79
UPD 411	300ns	2.89
MM 5280	300ns	2.89
MK4108	200ns	1.74
MM 5298	250ns	1.74
4027	250ns	2.00
4116	200ns	CALL
4116	150ns	CALL
4164	200ns	CALL
4164	150ns	CALL

### 5 1/4" DISKETTES ATHANA OR NASHUA

SSSD	18.95
SSDD	22.95
DSDD	27.95

BULK SSDD SOFT \$1.65 EA

### CRYSTALS

32.768 KHz	1.90	6.144	2.69
1.00 Hz	4.50	6.5536	2.69
1.8432	4.50	8.0	2.69
2.0	3.90	10.0	2.69
2.097152	3.90	12.0	2.69
2.4576	2.69	14.31818	2.69
3.2768	2.69	15.0	2.69
3.579545	2.69	16.0	2.69
4.0	2.69	17.430	2.69
5.0	2.69	18.0	2.69
5.0688	2.69	18.432	2.69
5.185	2.69	20.0	2.69
5.7143	2.69	22.1184	2.69
6.0	2.69		2.69

### DISC CONTROLLERS INTERFACE

1771	15.95	8T26	1.65
1791	27.95	8T28	1.95
1793	29.95	8T95	.95
1795	49.95	8T97	.95
1797	49.95	8T98	.95
6843	32.95	DM8131	2.90
8272	39.00	DP6304	2.25
UPD765	34.95	DS8835	1.89
1691	17.95	DS8836	.99

### EPROM ERASERS

HOLDS 15 EPROMS  
ERASES IN 20 MINUTES  
**59.95**

### 6500 1 MHz

6502	5.25
6504	6.85
6505	7.60
6507	9.85
6520	3.95
6522	4.95
6532	5.95
6545	16.95
6551	10.95

**UPGRADE YOUR APPLE or TRS-80 4116 200ns CALL**

### CONNECTORS

RS232 Male	3.00
RS232 Female	3.50
RS232 Female RA	4.95
RS232 Hood	1.20

### 8000

8035	4.95	8251	4.39
8039	5.95	8253	6.89
8080A	3.89	8253-5	7.89
8085A	5.89	8255	4.39
8086	24.95	8255-5	5.19
8088	34.95	8257	7.89
8155	7.75	8259	6.85
8156	8.75	8272	39.00
8185	29.00	8275	29.00
8202	27.95	8279	8.89
8205	3.45	8279-5	9.89
8212	1.79	8282	6.49
8214	3.75	8283	6.49
8216	1.69	8284	5.49
8224	2.19	8286	6.49
8226	1.79	8287	6.49
8228	3.34	8288	24.95
8237	19.00	8289	39.00
8238	4.39	8741	34.95
8243	4.39	8748	14.95
8250	10.49	8755	29.95

### 74LS00 SERIES

74LS00	23	74LS123	.77	74LS253	.57
74LS01	23	74LS124	2.88	74LS257	.57
74LS02	23	74LS125	.47	74LS258	.57
74LS03	23	74LS126	.47	74LS259	2.73
74LS04	23	74LS132	.57	74LS260	.57
74LS05	23	74LS136	.37	74LS266	.53
74LS08	23	74LS137	.97	74LS273	1.47
74LS10	23	74LS138	.53	74LS275	3.33
74LS11	25	74LS139	.53	74LS279	.47
74LS12	25	74LS145	1.18	74LS280	1.96
74LS13	39	74LS147	2.47	74LS283	.67
74LS14	39	74LS148	1.33	74LS290	.87
74LS15	29	74LS151	.53	74LS293	.87
74LS20	23	74LS153	.53	74LS295	.97
74LS21	23	74LS154	1.88	74LS298	.87
74LS22	23	74LS155	.67	74LS324	1.73
74LS26	29	74LS156	.67	74LS352	1.27
74LS27	23	74LS157	.63	74LS353	1.27
74LS28	29	74LS158	.57	74LS363	1.33
74LS30	23	74LS160	.67	74LS364	1.93
74LS32	25	74LS161	.63	74LS365	.47
74LS33	49	74LS162	.67	74LS366	.47
74LS37	29	74LS163	.63	74LS367	.43
74LS38	29	74LS164	.67	74LS368	.43
74LS40	23	74LS165	.93	74LS373	1.37
74LS42	43	74LS166	1.93	74LS374	1.37
74LS47	49	74LS168	1.73	74LS377	1.37
74LS48	74	74LS169	1.73	74LS378	1.17
74LS49	74	74LS170	1.47	74LS379	1.33
74LS51	23	74LS173	.67	74LS385	1.88
74LS54	23	74LS174	.53	74LS386	.43
74LS55	28	74LS175	.53	74LS390	1.17
74LS63	1.23	74LS181	2.13	74LS393	1.17
74LS73	37	74LS189	8.93	74LS395	1.17
74LS74	33	74LS190	.87	74LS399	1.47
74LS75	37	74LS191	.87	74LS424	2.93
74LS76	37	74LS192	.77	74LS447	.35
74LS78	47	74LS193	.77	74LS490	1.93
74LS83	58	74LS194	.67	74LS668	1.67
74LS85	67	74LS195	.67	74LS669	1.87
74LS86	37	74LS196	.77	74LS670	1.47
74LS90	53	74LS197	.77	74LS674	9.63
74LS91	87	74LS221	.87	74LS682	3.18
74LS92	53	74LS240	.93	74LS683	3.18
74LS93	53	74LS251	.59	74LS684	3.18
74LS95	73	74LS242	.97	74LS685	3.18
74LS96	87	74LS243	.97	74LS688	2.38
74LS107	37	74LS244	1.27	74LS689	3.18
74LS109	37	74LS245	1.47		
74LS112	37	74LS247	.73	81LS95	1.47
74LS113	37	74LS248	.97	81LS96	1.47
74LS114	37	74LS249	.97	81LS97	1.47
74LS122	43	74LS251	.57	81LS98	1.47

### IC SOCKETS

ST	W/W
8 PIN	.10 .49
14 PIN	.12 .50
16 PIN	.15 .57
18 PIN	.20 .85
20 PIN	.25 .99
22 PIN	.25 1.30
24 PIN	.25 1.40
28 PIN	.35 1.50
40 PIN	.40 1.80

ST = Solderetail  
W/W = Wirewrap

### Z 80

### SERIES

#### 2.5 MHz

Z80-CPU	3.35
Z80-PIO	3.35
Z80-CTC	3.35
Z80-DMA	12.49
Z80-DART	14.98
Z80-SIO/O	16.95
Z80-SIO/1	16.95
Z80-SIO/2	16.95
Z80-SIO/9	16.95

#### 4.0 MHz

Z80A-CPU	4.90
Z80A-PIO	4.90
Z80A-CTC	4.90
Z80A-DMA	21.95
Z80A-DART	15.95
Z80A-SIO/O	20.95
Z80A-SIO/1	20.95
Z80A-SIO/2	20.95
Z80A-SIO/9	18.95

#### 6.0 MHz

Z80B-CPU	14.95
Z80B-PIO	12.95
Z80B-CTC	12.95

### ZILOG

Z6132	32.95
Z8671	38.95

## ORDER TOLL FREE

**(800) 538-8800**  
**(800) 848-8008**

(CALIFORNIA RESIDENTS)

ALL MERCHANDISE IS 100% GUARANTEED

**APPLE JOYSTICKS**  
**29.95**

**APPLE PADDLES**  
**9.95**

**APPLE SUPER COOLING FANS**  
**49.95**  
WITH SURG PROTECH  
**69.95**

**APPLE\* II COMPATIBLE DISK DRIVE CONTROLLER CARD**  
**225.95**  
**79.95**

## Do Kay Computer Products, Inc.

2100 De La Cruz Blvd.  
Santa Clara, CA 95050  
(800) 538-8800

Calif. Residents (800) 848-8008



### STORE HOURS:

MON-FRI 8:30 A.M.-5:30 P.M.

SAT 10:00 A.M.-3:00 P.M.

TERMS: For shipping include \$2.00 for UPS Ground. \$3.00 for UPS Blue Label Air. \$10.00 minimum order. Bay Area residents add 6 1/2% Sales Tax. California residents add 6% Sales Tax. We reserve the right to limit quantities and substitute manufacturer. Prices subject to change without notice. Send SASE for complete list.

CIRCLE 99 ON FREE INFORMATION CARD

CPU's & SUPPORT CHIPS table with columns for part numbers and prices.

SCR's and TRIAC's tables with columns for part numbers and prices.

EPOXY GLASS VECTOR BOARD table with dimensions and price.

SHIFT REGISTERS table with columns for part numbers and prices.

C/MOS table with columns for part numbers and prices.

TRANSISTOR SPECIALS table with columns for part numbers and prices.

DISC CONTROLLERS table with columns for part numbers and prices.

INTER FACE & DRIVERS table with columns for part numbers and prices.

TTL IC SERIES table with columns for part numbers and prices.

RAM's and ROM's tables with columns for part numbers and prices.

NO. 30 WIRE and CRYSTALS tables with columns for part numbers and prices.

74S SERIES table with columns for part numbers and prices.

4164-2 - \$5.50, 4164-2 - 100/\$500.00, 4116-2 - 100/\$90.00, 2114-2 - 100/\$100.00

LINEAR CIRCUITS table with columns for part numbers and prices.

74LS SERIES table with columns for part numbers and prices.

DISC CAPACITORS table with columns for part numbers and prices.

DAQ08EQ and other components table with columns for part numbers and prices.

74LS SERIES table with columns for part numbers and prices.

PRINTED CIRCUIT BOARD table with columns for part numbers and prices.

FULL WAVE BRIDGE table with columns for part numbers and prices.

12V DC RELAYS table with columns for part numbers and prices.

TOGGLE SWITCHES table with columns for part numbers and prices.

SILICON POWER RECTIFIERS table with columns for part numbers and prices.

REGULATORS table with columns for part numbers and prices.

FLAT RIBBON CABLE table with columns for part numbers and prices.

TANTALUM CAPACITORS table with columns for part numbers and prices.

MULTI TURN TRIM POTS table with columns for part numbers and prices.

WIRE WRAP SOCKETS table with columns for part numbers and prices.

DB CONNECTORS table with columns for part numbers and prices.

UHF/VHF Conversion Kit table with columns for part numbers and prices.

POSTAGE RATES, TERMS FOR CAMBRIDGE MASS SEND CHECK OR MONEY ORDER, MINIMUM TELEPHONE PURCHASE ORDER OR CHARGE \$20.00, MINIMUM MAIL ORDER \$5.00

SEND \$25 FOR OUR CATALOG FEATURING TRANSISTORS & RECTIFIERS 145 HAMPSHIRE ST. CAMBRIDGE, MASS 02139

TELE (617) 547-7053, WE SHIP OVER OVER 85% OF OUR ORDERS WITHIN 24 HOURS OF RECEIPT, TOLL FREE 1-800-343-5230 FOR ORDERS ONLY

Advertisement for SCR Electronics Center featuring computers, telemarketing, and discount prices. Includes contact information for 2803 Thomasville Road East, Cairo, Georgia 31728.

Free Buyers Guide advertisement for SCR Electronics Center, providing pages of the latest in components, tools and instruments.

COMPUTER KEYBOARDS advertisement, highlighting an excellent keyboard with 54 single pole normally open switches for \$19.95.

TELEPHONE HANDSET advertisement, featuring a handsome black executive telephone handset for \$1.95.

RESISTOR BUYOUT advertisement, offering most standard values resistors for \$6.50 per 1,000.

UHF/VHF Conversion Kit advertisement, featuring a genuine Mitsumi tuner for \$119.95.

CALL OUR HOT LINES advertisement, providing contact information for California (714) 527-2554 and outside California (800) 854-8660.

(602) 971-0990 (602) 971-0996

# ARIZONA ELECTRONIC

**SURPLUS**  
Wholesale - Retail - Surplus  
Electronic Parts

12627 N. Cave Creek Rd. • Phoenix, AZ 85022

**HOT PLATES**  
**\$150**



**\$100**



**Carbide Drill & Router Bits**

**MICROWAVE KIT**  
**\$14<sup>95</sup> COMPLETE**



- P.V.C.
- PC Board
- 2 - 2SC2369
- 1 - MRF911
- Resistors
- Capacitors
- "F" Connector
- Chip Cap

**10" FIBERGLASS SCREW DRIVER**  
with Plastic Handle  
**3/\$100**

**Latching Relay**  
**\$4<sup>95</sup>**  
24V Coil  
110V @ 15A D.P.S.T.



**Regulated Supply 5V, 2A**  
w/Transformer and 4" x 2.3" Heat Sink  
**\$5.50 each -or- 2/\$10.00**



Items MC, VISA, COD via UPS (Plus Shipping/Handling)

CIRCLE 89 ON FREE INFORMATION CARD

**TUSA**  
A WHOLE NEW WORLD OF TV VIEWING WITH TUSA'S NEW MODEL CVU-40, 40 CHANNEL CABLE TV CONVERTER

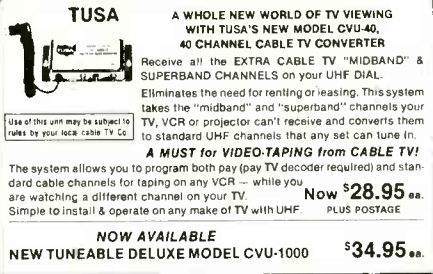

Receive all the EXTRA CABLE TV "MIDBAND" & SUPERBAND CHANNELS on your UHF DIAL. Eliminates the need for renting or leasing. This system takes the "midband" and "superband" channels your TV, VCR or projector can't receive and converts them to standard UHF channels that any set can tune in.

**A MUST for VIDEO-TAPING from CABLE TV!**

The system allows you to program both pay (pay TV decoder required) and standard cable channels for taping on any VCR — while you are watching a different channel on your TV. **Now \$28.95 ea.** Simple to install & operate on any make of TV with UHF. PLUS POSTAGE

**NOW AVAILABLE**  
NEW TUNEABLE DELUXE MODEL CVU-1000 **\$34.95 ea.**

**Lindsay**

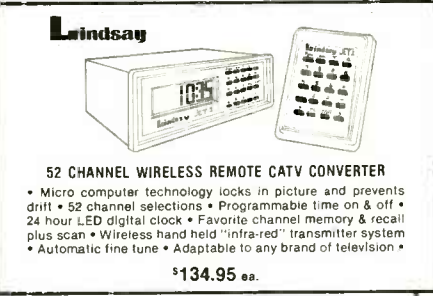

**52 CHANNEL WIRELESS REMOTE CATV CONVERTER**

- Micro computer technology locks in picture and prevents drift • 52 channel selections • Programmable time on & off • 24 hour LED digital clock • Favorite channel memory & recall plus scan • Wireless hand held "infra-red" transmitter system • Automatic fine tune • Adaptable to any brand of television •

**\$134.95 ea.**

**NEW 1984 B&K AUTO / MANUAL RANGE MULTIMETER**



**SPECIAL PRICE! \$94.00 ea.**

**BK PRECISION**

**COLORMAX**  
36 CHANNEL REMOTE CATV CONVERTER

Now you can change channels or fine-tune your TV set by remote control up to 20 ft. away. This unit receives channels 2-13 plus mid and superband cable channels then outputs them on Channel 3.

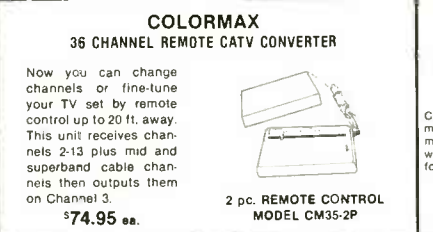

**2 pc. REMOTE CONTROL MODEL CM35-2P**  
**\$74.95 ea.**

**UHF TUNERS**

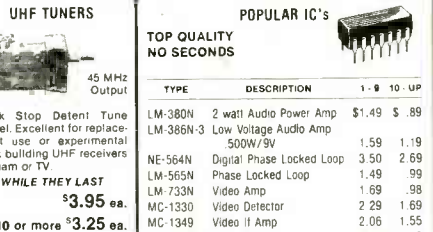

Click Stop Detent Tune model. Excellent for replacement use or experimental work building UHF receivers for ham or TV.

**WHILE THEY LAST**  
10 or more **\$3.95 ea.**  
**3.25 ea.**

**WINEGARD**  
75 OHM UHF YAGI ANTENNAS

12 db GAIN

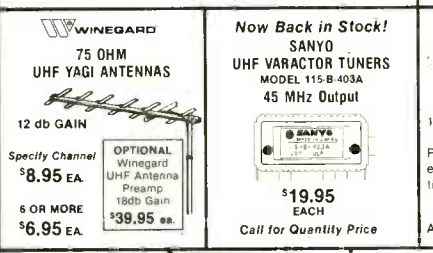

Specify Channel  
**\$8.95 EA.**  
6 OR MORE **\$6.95 EA.**

**OPTIONAL Winegard UHF Antenna Preamp 18db Gain**  
**\$39.95 ea.**

**POPULAR IC'S**

TOP QUALITY NO SECONDS

TYPE	DESCRIPTION	1-8	10 UP
LM-380N	2 watt Audio Power Amp	\$1.49	\$ .89
LM-386N-3	Low Voltage Audio Amp 500W/9V	3.50	2.69
NE-564N	Digital Phase Locked Loop	1.49	.99
LM-565N	Phase Locked Loop	1.49	.99
LM-733N	Video Amp	1.69	.98
MC-1330	Video Detector	2.29	1.69
MC-1349	Video If Amp	2.06	1.55
MC-1350	Video If Amp	1.75	1.19
MC-1352	Video If Amp AGC	2.69	2.09
MC-1358	Audio If Amp	1.95	1.64
MC-1374P	R.F. Modulator	3.19	2.39
MC-1458	Dual Comp. Op Amp	.88	.59
MC-1496N	Balanced Mod/Demod.	1.79	1.34
LM-1800	PLL Stereo Decoder	2.29	1.99
LM-1889	Video Modulator	2.79	1.95
<b>LINEAR VOLTAGE REGULATORS</b>			
LM-7805	5 Volt Positive Volt. Reg.	1.19	.89
LM-7808	8 Volt Positive Volt. Reg.	1.19	.89
LM-7812	12 Volt Positive Volt. Reg.	1.19	.89
LM-7815	15 Volt Positive Volt. Reg.	1.19	.89
LM-7818	18 Volt Positive Volt. Reg.	1.19	.89
LM-7824	24 Volt Positive Volt. Reg.	1.19	.89

**SPEAKER CABINET**

Dimension: 7 1/2" wide x 9 1/2" high x 5 1/2" deep. Removable 1/8" thick back cover.

Popular speaker cabinets for those famous homebrew TV circuits. Speakers included SC001 **\$12.05 ea.**  
2 or more **\$8.95 ea.**

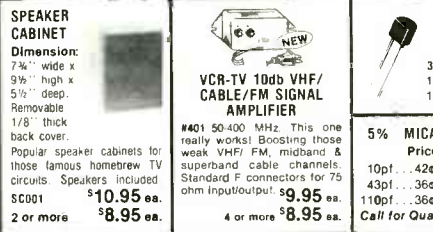

**Special Purchase**  
MV-2109  
33pt Tuning Diodes  
1-9 ... \$ .69 ea.  
10-Up ... .39 ea.

**5% MICA CAPS 5% Price Each**  
10pf ... .42c 560pf ... .66c  
43pf ... .36c 1200pf ... .89c  
110pf ... .36c 3000pf ... 1.39  
**Call for Quantity Discount**

**75 OHM CORD SETS**  
75 ohm RG-59 low loss foam coaxial cable with heavy duty F59 fittings installed or both ends. Specify color — black, white or tan. Special lengths available. Made in U.S.A. FOR SIMPLE HOOKUP OR VIDEO RECORDING, TV SETS, ANTENNA SYSTEMS, ETC.

LENGTH	PART #	NOW
1 ft.	CSF-1	\$1.49 ea.
2 ft.	CSF-2	\$1.69 ea.
3 ft.	CSF-3	\$1.89 ea.
6 ft.	CSF-6	\$2.39 ea.
10 ft.	CSF-10	\$2.89 ea.
15 ft.	CSF-15	\$3.39 ea.
20 ft.	CSF-20	\$3.99 ea.
25 ft.	CSF-25	\$4.49 ea.
50 ft.	CSF-50	\$7.15 ea.
75 ft.	CSF-75	\$10.49 ea.
100 ft.	CSF-100	\$13.39 ea.

(Quantity discounts available)

**VCR-TV 10db VHF/ CABLE/FM SIGNAL AMPLIFIER**

#401 50-400 MHz. This one really works! Boosting those weak VHF FM, midband & superband cable channels. Standard F connectors for 75 ohm input/output. **\$9.95 ea.**  
4 or more **\$8.95 ea.**

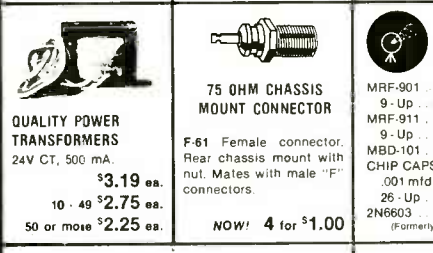

**POPULAR MICROWAVE PARTS**

MRF-901 ..... \$2.39  
9-Up ..... 1.95  
MRF-911 ..... 3.46  
9-Up ..... 3.12  
MBD-101 ..... .98  
CHIP CAPS  
.001 mfd ..... .50  
.26-Up ..... .30  
2N6603 ..... 11.96  
(Formerly MRF-902)

**PROJECT BOXES**  
Woodgrain

This box is 11 1/4" W x 4 1/2" H x 6 1/2" D with a removable aluminum U-shaped chassis 11" W x 3 1/2" H x 6" D inside.

**\$12.50 ea.**  
4 or more **\$10.95 ea.**  
**Call for Larger Quantities**

**UHF - VHF - FM 2-WAY SPLITTER**  
WINEGARD  
Model PM-1030  
75 Ohm  
40-900 MHz  
Low Loss 3.5-4 db  
Low VSWR  
Waterproof Housing  
1-9 **\$1.98 ea.**  
10-Up **\$1.59 ea.**

**QUALITY POWER TRANSFORMERS**  
24V CT, 500 mA. **\$3.19 ea.**  
10 - 49 **\$2.75 ea.**  
50 or more **\$2.25 ea.**

**75 OHM CHASSIS MOUNT CONNECTOR**  
F-61 Female connector. Rear chassis mount with nut. Mates with male "F" connectors.  
**NOW! 4 for \$1.00**

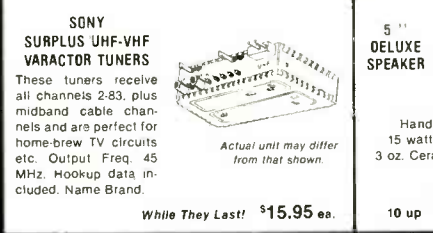

**DELUXE A-B SWITCHES**  
Specify Pushbutton Or Lever Type

For CATV - MATV - VCR  
75 ohm - 90 db Isolation  
**\$6.95 ea.**

**POPULAR MISCELLANEOUS PARTS**

IN4001 Diodes  
15 for ..... \$1.00  
100 for ..... 5.00  
1/4 w 10K  
Thumbwheel pots  
1-12 ..... .39  
13-Up ..... .29  
Toroids - T30-12 ..... .46  
20-Up ..... .25  
Toroids - T37-2 ..... .38  
20-Up ..... .25

**R.F. ELECTRONICS**  
1056 N. STATE COLLEGE BLVD., DEPT. R  
ANAHEIM, CALIFORNIA 92806

**ORDER NOW TOLL FREE**  
800-854-4655  
OUTSIDE CALIFORNIA  
714-635-5090  
INSIDE CALIFORNIA

PERSONAL CHECKS HELD FOR CLEARANCE — NO MINIMUM ORDER  
ALL PREPAID ORDERS 2 LBS OR LESS MUST INCLUDE \$2.50 SHIPPING & HANDLING — SHIPPED SAME DAY RECEIVED

OPEN TUES - FRI 10 - 6  
SAT 10 - 5  
CLOSED SUN & MON

SEND FOR FREE MAILING CATALOG

CIRCLE 27 ON FREE INFORMATION CARD

# MORE GAIN

## Than a Varactor UHF Tuner

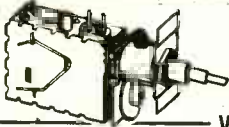

**\$15<sup>00</sup>**

**SATISFACTION GUARANTEED**  
Frequency Range 470-899 MHz Channels  
14-83. Output Channel 3, Ch 2 or 4 Avail.

**\$15<sup>00</sup>**

**PART #B20**  
**WHAT'S IN IT?**

To make a regular UHF tuner into a **GILCO HIGH GAIN TUNER**, each and every one of the following steps is painstakingly taken by a certified technician:

1. The first thing GILCO does is change the standard diode to a **hot carrier diode**.
2. The tuner's output is then measured on our JERRQLD field strength meter and compared to a computer derived chart from which we determine the correct value coil to add across the IF output for **maximum pre-peaked gain**.
3. The tuner is then fed a standard 10db 300 ohm antenna input and while monitoring the output on our HEWLETT PACKARD spectrum analyzer, the tuner is tuned to the desired channel and its oscillator is offset for the desired output frequency as follows:  
Channel 2: 58 Mhz, Channel 3: 63 Mhz, Channel 4: 68 Mhz

We call this step peaking because the tuner's output looks like a peak on our spectrum analyzer and the highest point of that peak is actually adjusted for the desired output.

4. The last step is one more measurement on the field strength meter which is again compared to our performance chart to calculate the correct value of the second coil which is added to the tuner's internal connections.

This procedure was developed by GILCO and it is our computer derived performance charts that make our tuner better, that's because **almost every tuner gets a different value coil before it's peaked** and again a different value coil after it's peaked. The combinations are endless and **the way we determine the values is our secret...**

### GILCO PARTS KIT & PRINTED CIRCUIT BOARD

- Use with GILCO High Gain Tuner
- Requires **NO** Modification to Your Television
- **Individually Packaged and Labeled Parts Save Guesswork**

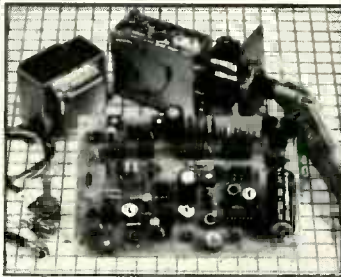

Pre-drilled, pre-screened, plated through the holes P/C board. All hardware, connectors, 22 page illustrated instruction manual, & Gilco Hy-Gain tuner. Kit assembles in just 4 hours.

- The only tools required for assembly are: screwdriver, soldering iron, voltmeter. No drilling is required to the P/C board.
- This kit was designed to take advantage of the GILCO high gain tuner which means its circuitry is **simpler and more efficient** than those circuits that require inferior varactor tuners.

**FREE 22 Page Instruction Book** included with each P/C Board or Parts Kit. This instruction book will guide the builder through every step of the assembly. **Nearly every page is illustrated.** With this Instruction Book, estimated assembly time is 4 hours.

#### HERE'S WHAT YOU GET FROM GILCO

##### Part No. B21 Printed Circuit Board

**\$17<sup>00</sup>**

1. This Printed Circuit Board uses **only one jumper, others use nine**.
2. The component layout is **screen printed** on the component side of the P/C board.
3. The solder side of the P/C board is covered with high temperature solder
4. **Newest Addition:** the P/C board is plated through the holes. This allows for easier and more positive soldered contact between the parts and the P/C board.

##### Part No. B22 Complete Electronic Parts Kit

**\$80<sup>00</sup>**

All resistors (30), Potentiometers (1-5K, 3-10K), Panel Mount Potentiometer (10K), Electrolytic Capacitors (6), Ceramic and Mylar Disc Capacitors (35), Variable Capacitors (4), All Integrated Circuits (7), Voltage Regulator, Heat Sink, Diodes (4), IC Sockets (4-8 pin, 3-14 pin), Power Transformer (24V, 1A), Coil Kit with No. 26 wire (4), Speaker (4" 3oz.), Standoffs, Coaxial Cable, All Miscellaneous Hardware, Etc. All parts are individually packaged and labeled.

All components including the Wire, Hardware, Coaxial Cable and Heat Sinks are included in the parts kit. This means your assembly time from start to finish is just 4 hours.

#### GILCO ACCESSORIES & AMPLIFIER KITS

- #A02 New 2 stage, low noise, 28db gain, RF Amplifier Kit ..... Kit **\$18<sup>00</sup>**  
#A03 New 1 stage, low noise, 14db gain, RF Amplifier Kit ..... Kit **\$10<sup>50</sup>**

#### GILCO ORDER FORM

#B20 GILCO Hy-Gain Modified Tuner.....	<b>\$15<sup>00</sup></b>
#B21 GILCO Predrilled, Screen Printed, Circuit Board	<b>\$17<sup>00</sup></b>
#B22 GILCO Parts Kit (Less P/C Board)	<b>\$80<sup>00</sup></b>
#B20, B21, B22 Complete P/C Board and Parts Kit (all three) ..	<b>\$110<sup>00</sup></b>
#A02 Two stage, 28 db gain, Amplifier Kit	<b>\$18<sup>50</sup></b>
#A03 One stage, 14db gain, Amplifier Kit	<b>\$10<sup>50</sup></b>
Name _____	Total _____
Address _____	Tax _____
City _____ State _____ Zip _____	Ship _____
Mail Order Only. Send check or money order to:	
<b>GILCO INTERNATIONAL, INC.</b>	
P.O. Box 8817, Coral Gables, Florida 33124	
CALL (305) 823-5891 for COD orders <b>PLEASE WRITE FOR OUR FREE CATALOG</b>	
Shipping Orders under \$50 add 10%. Orders over \$50 add 5%. FL residents +5% Tax	

CIRCLE 84 ON FREE INFORMATION CARD

The Most Spectacular Deal Ever! Only While They Last!!!

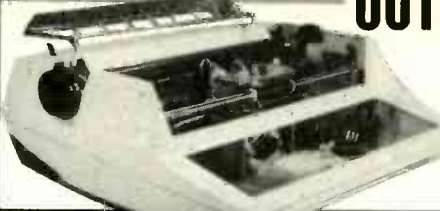

# OUTSTANDING SURPLUS BARGAIN!

## The Original Diablo Hytype II Daisy Printers w/KSR Case

**\* READY TO USE**  
**Limited supply, while they last**

**NOW ONLY**

**\$549**

- used, refurbished, tested & fully operational!
- capable of metal or plastic wheel operation!
- 35 characters per second!
- 10 pitch, 12 pitch & proportional space plus plotting!
- uses standard "Diablo" Daisy Wheels!
- we have **MANY** spare parts in stock!
- Interface (RS232 & Centronics) available too!

Please add \$25 for packaging & handling

\*This printer requires ±15VDC and +5VDC to operate.

A Micro-processor interface board for RS-232 and Centronics I/O is available for **\$295<sup>00</sup>**

External Diablo power supply for the above: **\$79<sup>00</sup>**

We Offer New & Used FLOPPY DRIVES, DISK DRIVES, PRINTERS, & MORE at BARGAIN PRICES!!  
Write or Call for Our Latest Flyer NOW!!!

**Computer Products & Peripherals Unlimited**

WAREHOUSE: 18 Granite St., Haverhill, Mass. 01830  
MAIL ORDERS: Box 204, Newton, New Hampshire 03858

**617/372-8637**

Sorry No Collect Calls  
MasterCard & VISA Accepted

CIRCLE 68 ON FREE INFORMATION CARD

**PROFESSIONAL TECHNICIANS & SERVICEMEN**

**WE CAN SUPPLY ALL THE COMPONENTS FOR YOUR MAINTENANCE, REPAIR & DESIGN WORK**

**REPLACEMENT FOR ECG® TYPES (Min. 5 pcs. each type)**

TYPE NO.	YOUR PRICE	TYPE NO.	YOUR PRICE	TYPE NO.	YOUR PRICE
85	.30	152	.40	375	.99
123A	.25	153	.40	500A	8.95
124	.95	154	.65	523	10.20
128	.45	165	2.25	526A	10.75
129	.45	238	2.25	712	1.25
130	.85	291	.99	852	4.95

**SUPER SPECIAL (Min. 5 pc. each)**

<b>TYPE NO.</b>	<b>YOUR PRICE</b>	<b>EXACT REPLACEMENT FOR SG613H</b>
<b>276</b>	<b>6.95</b>	<b>2SC1172B 100 PCS. FOR 1.60 EACH</b>

**SPECIAL JAPANESE TYPES (Min. 5 pcs. each)**

2SC867A .... <b>2.75</b>	AN214Q .... <b>1.45</b>	UPC1181H ... <b>1.25</b>
2SC1172B ... <b>1.95</b>	M51515BL ... <b>2.95</b>	UPC1182 ... <b>1.25</b>
2SC1308K ... <b>1.95</b>	TA7205AP ... <b>1.25</b>	STK435 ..... <b>3.95</b>

FOR A COMPLETE 1983 COMPONENT CATALOG CALL OR WRITE

**CALL TOLL FREE 800-526-4928**

IN NEW JERSEY (201) 379-9016

**COD ORDERS WELCOME (\$25 Min. Order)**

**DIGITRON ELECTRONIC**

110 Hillside Avenue, Springfield, N.J. 07081

\*ECG IS A TRADE MARK OF PHILIPS ECG.  
DIGITRON ELECTRONIC IS NOT ASSOCIATED IN ANY WAY WITH PHILIPS ECG.

CIRCLE 11 ON FREE INFORMATION CARD



ramsey

the first name in Counters!



9 DIGITS 600 MHz \$129<sup>95</sup> WIRED

**PRICES:**

CT-90 wired, 1 year warranty	\$129.95
CT-90 Kit, 90 day parts war- ranty	109.95
AC-1 AC adapter	3.95
BP-1 Nicad pack + AC Adapter/Charger	12.95
OV-1, Micro-power Oven time base	49.95
External time base input	14.95

The CT-90 is the most versatile, feature packed counter available for less than \$300.00! Advanced design features include: three selectable gate times, nine digits, gate indicator and a unique display hold function which holds the displayed count after the input signal is removed. Also, a 10MHz TCXO time base is used which enables easy zero beat calibration checks against WWV. Optionally, an internal nicad battery pack, external time base input and Micro-power high stability crystal oven time base are available. The CT-90, performance you can count on!

**SPECIFICATIONS:**

Range:	20 Hz to 600 MHz
Sensitivity:	Less than 10 MV to 150 MHz Less than 50 MV to 500 MHz
Resolution:	0.1 Hz (10 MHz range) 1.0 Hz (60 MHz range) 10.0 Hz (600 MHz range)
Display:	9 digits 0.4" LED
Time base:	Standard-10.000 mHz, 1.0 ppm 20-40°C Optional Micro-power oven-0.1 ppm 20-40°C
Power:	8-15 VAC @ 250 ma

7 DIGITS 525 MHz \$99<sup>95</sup> WIRED



**SPECIFICATIONS:**

Range:	20 Hz to 525 MHz
Sensitivity:	Less than 50 MV to 150 MHz Less than 150 MV to 500 MHz
Resolution:	1.0 Hz (5 MHz range) 10.0 Hz (50 MHz range) 100.0 Hz (500 MHz range)
Display:	7 digits 0.4" LED
Time base:	1.0 ppm TCXO 20-40°C
Power:	12 VAC @ 250 ma

The CT-70 breaks the price barrier on lab quality frequency counters. Deluxe features such as: three frequency ranges - each with pre-amplification, dual selectable gate times, and gate activity indication make measurements a snap. The wide frequency range enables you to accurately measure signals from audio thru UHF with 1.0 ppm accuracy - that's .0001%! The CT-70 is the answer to all your measurement needs, in the field, lab or ham shack.

**PRICES:**

CT-70 wired, 1 year warranty	\$99.95
CT-70 Kit, 90 day parts war- ranty	84.95
AC-1 AC adapter	3.95
BP-1 Nicad pack + AC adapter/charger	12.95



7 DIGITS 500 MHz \$79<sup>95</sup> WIRED

**PRICES:**

MINI-100 wired, 1 year warranty	\$79.95
AC-Z Ac adapter for MINI- 100	3.95
BP-Z Nicad pack and AC adapter/charger	12.95

Here's a handy, general purpose counter that provides most counter functions at an unbelievable price. The MINI-100 doesn't have the full frequency range or input impedance qualities found in higher price units, but for basic RF signal measurements, it can't be beat! Accurate measurements can be made from 1 MHz all the way up to 500 MHz with excellent sensitivity throughout the range, and the two gate times let you select the resolution desired. Add the nicad pack option and the MINI-100 makes an ideal addition to your tool box for "in-the-field" frequency checks and repairs.

**SPECIFICATIONS:**

Range:	1 MHz to 500 MHz
Sensitivity:	Less than 25 MV
Resolution:	100 Hz (slow gate) 1.0 KHz (fast gate)
Display:	7 digits, 0.4" LED
Time base:	2.0 ppm 20-40°C
Power:	5 VDC @ 200 ma

8 DIGITS 600 MHz \$159<sup>95</sup> WIRED



NEW  
READ  
FREQUENCY

**SPECIFICATIONS:**

Range:	20 Hz to 600 MHz
Sensitivity:	Less than 25 mv to 150 MHz Less than 150 mv to 600 MHz
Resolution:	1.0 Hz (60 MHz range) 10.0 Hz (600 MHz range)
Display:	8 digits 0.4" LED
Time base:	2.0 ppm 20-40°C
Power:	110 VAC or 12 VDC

The CT-50 is a versatile lab bench counter that will measure up to 600 MHz with 8 digit precision. And, one of its best features is the Receive Frequency Adapter, which turns the CT-50 into a digital readout for any receiver. The adapter is easily programmed for any receiver and a simple connection to the receiver's VFO is all that is required for use. Adding the receiver adapter in no way limits the operation of the CT-50, the adapter can be conveniently switched on or off. The CT-50, a counter that can work double-duty!

**PRICES:**

CT-50 wired, 1 year warranty	\$159.95
CT-50 Kit, 90 day parts warranty	119.95
RA-1, receiver adapter kit	14.95
RA-1 wired and pre-program- med (send copy of receiver schematic)	29.95



DIGITAL MULTIMETER \$99<sup>95</sup> WIRED

**PRICES:**

DM-700 wired, 1 year warranty	\$99.95
DM-700 Kit, 90 day parts warranty	79.95
AC-1, AC adaptor	3.95
BP-3, Nicad pack + AC adapter/charger	19.95
MP-1, Probe kit	2.95

The DM-700 offers professional quality performance at a hobbyist price. Features include: 26 different ranges and 5 functions, all arranged in a convenient, easy to use format. Measurements are displayed on a large 3 1/2 digit, 1/2 inch LED readout with automatic decimal placement, automatic polarity, overrange indication and overload protection up to 1250 volts on all ranges, making it virtually goof-proof! The DM-700 looks great, a handsome, jet black, rugged ABS case with convenient retractable tilt bail makes it an ideal addition to any shop.

**SPECIFICATIONS:**

DC/AC volts:	100uV to 1 KV, 5 ranges
DC/AC current:	0.1uA to 2.0 Amps, 5 ranges
Resistance:	0.1 ohms to 20 Megohms, 6 ranges
Input impedance:	10 Megohms, DC/AC volts
Accuracy:	0.1% basic DC volts
Power:	4 °C cells

**AUDIO SCALER**

For high resolution audio measurements, multiplies UP in frequency.

- Great for PL tones
- Multiplies by 10 or 100
- 0.01 Hz resolution!

\$29.95 Kit \$39.95 Wired

**ACCESSORIES**

Telescopic whip antenna - BNC plug	\$ 7.95
High impedance probe, light loading	15.95
Low pass probe, for audio measurements	15.95
Direct probe, general purpose usage	12.95
Tilt bail, for CT 70, 90, MINI-100	3.95
Color burst calibration unit, calibrates counter against color TV signal.	14.95

**COUNTER PREAMP**

For measuring extremely weak signals from 10 to 1,000 MHz. Small size, powered by plug transformer-included.

- Flat 25 db gain
  - BNC Connectors
  - Great for sniffing RF with pick-up loop
- \$34.95 Kit \$44.95 Wired

ramsey electronics, inc.

2575 BAIRD RD. • PENFIELD, NY 14526



TERMS

PHONE ORDERS  
CALL 716-586-3950

Satisfaction guaranteed - examine for 10 days, if not pleased return in original form for refund. Add 5% for shipping - insurance to a maximum of \$10. Overseas add 15%. COD, add \$2. Orders under \$10. add \$1.50. NY residents add 7% tax.

CIRCLE 79 ON FREE INFORMATION CARD

www.americanradiohistory.com

SEPTEMBER 1983

119





# THE SOLUTION COMPUTER

An Affordable 64K Assembled Computer With These Features:



- Fully compatible with Apple® II +
- Original design!
- Fully assembled and tested!
- Detachable keyboard for easy use.
- Uses 64K × 1 Dynamic Ram.
- 9 on board peripheral connectors for expansion.
- Uses 6502 mpu.

**\$675<sup>00</sup> each (Monitor not included)**  
**Add \$110 for 12" Amber Monitor.**  
**Add 5% shipping and handling.**

We believe the Solution Computer will be the answer for people who realize a great product when they see one. Many other peripheral card products are available for the Solution Computer. Send for a free color brochure today.

For Information Call (312) 564-0104  
 To Order Call (800) 323-1327

*Note: Due to the demand of this computer, delivery will vary from 2-4 weeks.*

**VISA and MASTERCARD acceptable.**

Minimum order \$15.00. Add 10% shipping on orders under \$35.00. Orders over \$35.00 add 5%. Illinois residents add 6% Illinois State Tax.

## SEI, Inc.

657 Academy Drive  
 Northbrook, Illinois 60062



CIRCLE 55 ON FREE INFORMATION CARD

## ELECTRONIC COMPONENTS

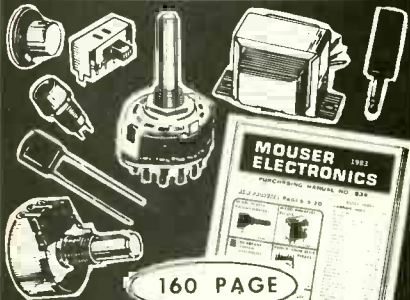

**FREE CATALOG**

**MANUFACTURERS OF QUALITY ELECTRONIC COMPONENTS**

Battery Clips & Holders  
 Cable Sets Connectors Capacitors  
 Displays, LED Fuses Jacks & Plugs  
 Knobs Lamps Potentiometers  
 RF Coils Relays Resistors  
 Switches Semiconductors Speakers  
 Test Equipment Transformers Tools  
 Wire & Cable

**WE STOCK What We Catalog !**

- Sales and Order Desk Open from 6:00a.m. (PST)
- Phone and Mail Orders Welcome
- TERMS: C.O.D. Visa MasterCharge (Open Accounts Available)
- Over 10,000 Different Items in Stock

**MOUSER ELECTRONICS**  
 11433 WOODSIDE AVE., SANTEE, CA 92071  
 PHONE: (619) 449-2222 TWX: 910-331-1175

CIRCLE 12 ON FREE INFORMATION CARD

## PREVENT HI-TECH HEADACHES

Our Isolators eliminate equipment interaction, clean up interference, curb damaging power line spikes and lightning bursts.



**ISO-1 Isolator**  
 3 isolated sockets; quality spike suppression; basic protection. . . \$76.95

**ISO-3 Super-Isolator**  
 3 dual isolated sockets; suppressor; commercial protection. . . . . 115.95

**ISO-17 Magnum Isolator**  
 4 quad isolated sockets; suppressor; laboratory grade protection. . . 200.95

**ESP Electronic Specialists, Inc.**  
 171 S. Main St., Box 389, Natick, MA 01760

Toll Free Order Desk 1-800-225-4876  
 MasterCard, VISA, American Express

CIRCLE 6 ON FREE INFORMATION CARD

[www.americanradiohistory.com](http://www.americanradiohistory.com)

## CABLE TV

### CONVERTERS DESCRAMBLERS

**Largest Selection of Equipment Available**  
*\$ Buy Warehouse Direct & Save \$*



36 channel converter  
**\$45<sup>95</sup>**

36 channel wired remote converter  
**only \$88<sup>95</sup>**



*Send \$2 for complete catalog of converters and unscramblers*

Quantity Discounts • Visa • Master Charge  
 Add 5% shipping—Mich. residents add 4% sales tax

**C&D Electronics, Inc.**  
 P.O. Box 21, Jenison, MI 49428  
 (616) 669-2440

# JDR SUPER SPECIALS!

**THE LEADER IN  
COMPUTER  
COMPONENTS  
BRINGS YOU THESE  
FANTASTIC  
SUMMERS-END  
CLEARANCE BARGAINS**

## OKI MSM5832RS

MICROPROCESSOR  
COMPATIBLE  
CLOCK/CALENDAR CHIP  
**3.95** 100/3.25 ea.  
32.768KHZ XTAL .95  
**OTHER CRYSTALS**  
3.579545MHZ .95  
5.0688MHZ 1.95  
18.432MHZ 1.95

## 78M05

VOLTAGE  
REGULATOR  
TI PART #UA78M05C  
STANDARD TO-220 CASE  
5 VOLT AT 500MA CAN BE  
USED AS 7805T IN MOST  
APPLICATIONS  
**.29** 100/.25 EA.

**ORDER TOLL FREE  
800 538-5000  
800 862-8279  
(CA Residents)**



## CONNECTORS

IDP-16 IDC DIP-PLUG .95  
IDE-34 IDC EDGE-CARD 1.95  
ICC-14 DIP "HEADER" .49  
ICC-16 DIP "HEADER" .59  
44P-ST PC EDGE-CARD 1.95  
DB25PC/P VERTICAL  
PC-MOUNT 1.49  
DB25PC/S VERTICAL  
PC-MOUNT 1.69

## TRANSISTORS

2N3904 TO-92 100/7.95  
2N3906 TO-92 100/7.95  
PN2222 TO-92 100/7.95

## CERAMIC MONOLITHIC CAPS AT THE PRICE OF DISC!

.1UF-MONO 100/12.00  
.047UF-MONO 100/11.00  
.01UF-MONO 100/10.00

## PRIME LED'S

JUMBO RED 100/ 8.00  
JUMBO YELLOW 100/12.00  
JUMBO GREEN 100/12.00  
5082-7760 10/ 7.95

## JDR MICRODEVICES

**IS PROUD TO INTRODUCE  
ARK ELECTRONIC ENTERPRISES  
AS AN AUTHORIZED DISTRIBUTOR  
SERVING THE MIDWEST WITH HIGH  
QUALITY JDR MERCHANDISE  
CALL OR STOP BY**

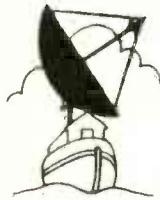

**ARK**  
ELECTRONIC ENTERPRISES  
734 Phillips Avenue  
Toledo, Ohio 43612  
(419) 476-6727

## MICROPROCESSOR

Z80A-CPU 3.95  
Z80A-CTC 3.95  
Z80A-PIO 3.95  
Z80A-SIO/1 12.95  
Z80A-DART 6.95  
8086 16-BIT 5MHZ 19.95  
68A00 CPU 1.5MHZ 2.95  
68A10 RAM 1.5MHZ 1.95  
68A21 PIA 1.5MHZ 2.95  
68A50 ACIA 1.5MHZ 2.95  
6520/6820 PIA 2.95

## MEMORY

2102L-4 450NS-LP .55  
2111L 450NS-LP 1.49  
2112 450NS 1.99  
2114 450NS .99  
2114-25 250NS 1.09  
TMS4027 250NS .99

## SPECIAL TMS4060/2107

4096 x 1 DYNAMIC  
RAMS TI OR INTEL  
YOUR CHOICE .69

**SPECIAL THANKS  
TO MATT FOR HIS  
RECENT SOFTWARE  
DEVELOPMENTS  
WHICH WILL ENABLE  
JDR TO BETTER SERVE  
OUR CUSTOMERS**

## LINEAR I.C.'S

LM1800 1.95  
LM1310 .99  
MC1330 .99  
MC1350 .89  
MC1358 .99

## HARD TO FIND BLACK CONDUCTIVE FOAM

14" x 26" SHEET 12.00  
12" x 13" SHEET 6.00

## DISK CONTROLLERS

1771 11.95  
1791 18.95  
1793 18.95

## CRT CONTROLLERS

DP8350 19.95  
CRT5027 9.95  
CRT5037 9.95

## D-RAM CONTROLLERS

8202 17.95  
8203 32.95  
3242 5.95

**Visit Our  
EXPANDED  
Retail Store  
NEW SATURDAY  
HOURS 10-3**

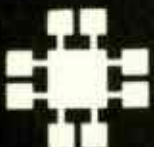

**JDR Microdevices**

1224 S. Bascom Ave. • San Jose, CA 95128  
(408) 995-5430 • Telex 171-110

1983 JDR MICRODEVICES, INC.

## VISIT OUR RETAIL STORE

HOURS: M-W-F, 9-5 T-Th., 9-9 Sat. 11-3

**PLEASE USE YOUR CUSTOMER NUMBER WHEN ORDERING**  
TERMS: For shipping include \$2 for UPS Ground or \$3 for UPS Blue Label Air. Items over 5 pounds require additional shipping charges. Foreign orders, include sufficient amount for shipping. There is a \$10 minimum order. Bay Area and Los Angeles Counties add 6% Sales Tax. Other California residents add 6% Sales Tax. We reserve the right to substitute manufacturer. Not responsible for typographical errors. Prices are subject to change without notice. We will match or

# 4164 64K DYNAMIC \$595

200 NS

# TMM2016 2KX8 STATIC \$415

200 NS

## STATIC RAMS

2101	256 x 4 (450ns)	1.95
5101	256 x 4 (450ns) (cmos)	3.95
2102-1	1024 x 1 (450ns)	.89
2102L-4	1024 x 1 (450ns) (LP)	.99
2102L-2	1024 x 1 (250ns) (LP)	1.49
2111	256 x 4 (450ns)	2.49
2112	256 x 4 (450ns)	2.99
2114	1024 x 4 (450ns)	8/9.95
2114-25	1024 x 4 (250ns)	8/10.95
2114L-4	1024 x 4 (450ns) (LP)	8/12.95
2114L-3	1024 x 4 (300ns) (LP)	8/13.45
2114L-2	1024 x 4 (200ns) (LP)	8/13.95
2147	4096 x 1 (55ns)	4.95
TMS4044-4	4096 x 1 (450ns)	3.49
TMS4044-3	4096 x 1 (300ns)	3.99
TMS4044-2	4096 x 1 (200ns)	4.49
MK4118	1024 x 8 (250ns)	9.95
TMM2016-200	2048 x 8 (200ns)	4.15
TMM2016-150	2048 x 8 (150ns)	4.95
TMM2016-100	2048 x 8 (100ns)	6.15
HM6116-4	2048 x 8 (200ns) (cmos)	4.75
HM6116-3	2048 x 8 (150ns) (cmos)	4.95
HM6116-2	2048 x 8 (120ns) (cmos)	8.85
HM6116LP-4	2048 x 8 (200ns) (cmos)(LP)	5.95
HM6116LP-3	2048 x 8 (150ns) (cmos)(LP)	6.95
HM6116LP-2	2048 x 8 (120ns) (cmos)(LP)	10.95
Z-6132	4096 x 8 (300ns) (Qstat)	34.95

LP - Low Power    Qstat - Quasi-Static

## Z-80

### 2.5 Mhz

Z80-CPU	3.95
Z80-CTC	4.49
Z80-DART	10.95
Z80-DMA	14.95
Z80-PIO	4.49
Z80-SIO/0	16.95
Z80-SIO/1	16.95
Z80-SIO/2	16.95
Z80-SIO/9	16.95

### 4.0 Mhz

Z80A-CPU	4.95
Z80A-CTC	4.95
Z80A-DART	11.95
Z80A-DMA	16.95
Z80A-PIO	4.95
Z80A-SIO/0	16.95
Z80A-SIO/1	16.95
Z80A-SIO/2	16.95
Z80A-SIO/9	16.95

### 6.0 Mhz

Z80B-CPU	11.95
Z80B-CTC	13.95
Z80B-PIO	13.95
Z80B-DART	19.95

### ZILOG

Z6132	34.95
Z8671	39.95

## 8000

8035	5.95
8039	6.95
INS-8060	17.95
INS-8073	24.95
8080	3.95
8085	5.95
8085A-2	11.95
8086	29.95
8087	CALL
8088	39.95
8089	89.95
8155	6.95
8155-2	7.95
8156	6.95
8185	29.95
8185-2	39.95
8741	39.95
8748	24.95
8755	24.95

## 6800

68000	59.95
6800	3.95
6802	7.95
6808	13.90
6809E	19.95
6809	11.95
6810	2.95
6820	4.35
6821	3.25
6828	14.95
6840	12.95
6843	34.95
6844	25.95
6845	14.95
6847	11.95
6850	3.25
6852	5.75
6860	9.95
6862	11.95
6875	6.95
6880	2.25
6883	22.95
68047	24.95
68488	19.95

### 6800 1MHZ

68B00	10.95
68B02	22.25
68B09E	29.95
68B09	29.95
68B10	6.95
68B21	6.95
68B45	19.95
68B50	5.95

### 68B00 2MHZ

## 8200

8202	24.95
8203	39.95
8205	3.50
8212	1.80
8214	3.85
8216	1.75
8224	2.25
8226	1.80
8228	3.49
8237	19.95
8237-5	21.95
8238	4.49
8243	4.45
8250	10.95
8251	4.49
8253	6.95
8253-5	7.95
8255	4.49
8255-5	5.25
8257	7.95
8257-5	8.95
8259	6.90
8259-5	7.50
8271	39.95
8272	39.95
8275	29.95
8279	8.95
8279-5	10.00
8282	6.50
8283	6.50
8284	5.50
8286	6.50
8287	6.50
8288	25.00
8289	49.95

## CRYSTALS

32.768 khz	1.95
1.0 mhz	4.95
1.8432	4.95
2.0	3.95
2.097152	3.95
2.4576	3.95
3.2768	3.95
3.579535	3.95
4.0	3.95
5.0	3.95
5.0688	3.95
5.185	3.95
5.7143	3.95
6.0	3.95
6.144	3.95
6.5536	3.95
8.0	3.95
10.0	3.95
10.738635	3.95
14.31818	3.95
15.0	3.95
16.0	3.95
17.430	3.95
18.0	3.95
18.432	3.95
20.0	3.95
22.1184	3.95
32.0	3.95

## DYNAMIC RAMS

TMS4027	4096 x 1 (250ns)	1.99
UPD411	4096 x 1 (300ns)	3.00
MM5280	4096 x 1 (300ns)	3.00
MK4108	8192 x 1 (200ns)	1.95
MM5298	8192 x 1 (250ns)	1.85
4116-300	16384 x 1 (300ns)	8/11.75
4116-250	16384 x 1 (250ns)	8/11.95
4116-200	16384 x 1 (200ns)	8/12.95
4116-150	16384 x 1 (150ns)	8/14.95
4116-120	16384 x 1 (120ns)	8/29.95
2118	16384 x 1 (150ns) (5v)	4.95
4164-200	65536 x 1 (200ns) (5v)	5.95
4164-150	65536 x 1 (150ns) (5v)	6.95

5V - single 5 volt supply

## EPROMS

1702	256 x 8 (1us)	4.50
2708	1024 x 8 (450ns)	3.95
2758	1024 x 8 (450ns) (5v)	5.95
2716	2048 x 8 (450ns) (5v)	3.95
2716-1	2048 x 8 (350ns) (5v)	5.95
TMS2516	2048 x 8 (450ns) (5v)	5.50
TMS2716	2048 x 8 (450ns)	7.95
TMS2532	4096 x 8 (450ns) (5v)	5.95
2732	4096 x 8 (450ns) (5v)	4.95
2732-250	4096 x 8 (250ns) (5v)	8.95
2732-200	4096 x 8 (200ns) (5v)	11.95
2764	8192 x 8 (450ns) (5v)	9.95
2764-250	8192 x 8 (250ns) (5v)	14.95
2764-200	8192 x 8 (200ns) (5v)	24.95
TMS2564	8192 x 8 (450ns) (5v)	17.95
MC68764	8192 x 8 (450ns) (5v) (24 pin)	39.95
27128	16384x8 Call	Call

5v - Single 5 Volt Supply

## EPROM ERASERS

	Timer	Capacity Chip	Intensity (uW/Cm <sup>2</sup> )	
PE-14		6	5,200	83.00
PE-14T	X	6	5,200	119.00
PE-24T	X	9	6,700	175.00
PL-265T	X	20	6,700	255.00
PR-125T	X	16	15,000	349.00
PR-320	X	32	15,000	595.00

## CRT CONTROLLERS

6845	14.95
68B45	19.95
HD46505SP	15.95
6847	11.95
MC1372	6.95
68047	24.95
8275	29.95
7220	99.95
CRT5027	39.95
CRT5037	49.95
TMS9918A	39.95
DP8350	49.95

## KEYBOARD CHIPS

AY5-2376	11.95
AY5-3600	11.95
AY5-3600 PRO	11.95

## DISC CONTROLLERS

1771	16.95
1791	24.95
1793	26.95
1795	49.95
1797	49.95
1799	54.95
2793	54.95
2795	59.95
2797	59.95
6843	34.95
8272	39.95
UPD765	39.95
MB8876	29.95
MB8877	34.95
1691	17.95
2143	18.95

## CONNECTORS

RS232 MALE	2.50
RS232 FEMALE	3.25
RS232 HOOD	1.25
S-100 ST	3.95

## 6500

### 1 MHZ

6502	4.95
6504	6.95
6505	8.95
6507	9.95
6520	4.35
6522	7.95
6532	9.95
6545	22.50
6551	11.85

### 2 MHZ

6502A	6.95
6522A	9.95
6532A	11.95
6545A	27.95
6551A	11.95

### 3 MHZ

6502B	14.95
-------	-------

## UARTS

AY3-1014	6.95
AY5-1013	3.95
AY3-1015	6.95
PT1472	9.95
TR1602	3.95
2350	9.95
2651	8.95
TMS6011	5.95
IM6402	7.95
IM6403	8.95
INS8250	10.95

## GENERATORS

### BIT-RATE

MC14411	11.95
BR1941	11.95
4702	12.95
COM5016	16.95
COM8116	10.95
MM5307	10.95

### FUNCTION

MC4024	3.95
LM566	1.49
XR2206	3.75
8038	3.95

## 74LS00

74LS00	.24	74LS173	.69
74LS01	.25	74LS174	.55
74LS02	.25	74LS175	.55
74LS03	.25	74LS181	2.15
74LS04	.24	74LS189	8.95
74LS05	.25	74LS190	.89
74LS08	.28	74LS191	.89
74LS09	.29	74LS192	.79
74LS10	.25	74LS193	.79
74LS11	.35	74LS194	.69
74LS12	.35	74LS195	.69
74LS13	.45	74LS196	.79
74LS14	.59	74LS197	.79
74LS15	.35	74LS221	.89
74LS20	.25	74LS240	.95
74LS21	.29	74LS241	.99
74LS22	.25	74LS242	.99
74LS26	.29	74LS243	.99
74LS27	.29	74LS244	1.29
74LS28	.35	74LS245	1.49
74LS30	.25	74LS247	.75
74LS32	.29	74LS248	.99
74LS33	.55	74LS249	.99
74LS37	.35	74LS251	.59
74LS38	.35	74LS253	.59
74LS40	.25	74LS257	.59
74LS42	.49	74LS258	.59
74LS47	.75	74LS259	2.75
74LS48	.75	74LS260	.59
74LS49	.75	74LS266	.55
74LS51	.25	74LS273	1.49
74LS54	.29	74LS275	3.35
74LS55	.29	74LS279	.49
74LS63	1.25	74LS280	1.98
74LS73	.39	74LS283	.69
74LS74	.35	74LS290	.89
74LS75	.39	74LS293	.89
74LS76	.39	74LS295	.99
74LS78	.49	74LS298	.89
74LS83	.60	74LS299	1.75
74LS85	.69	74LS323	3.50
74LS86	.39	74LS324	1.75
74LS90	.55	74LS352	1.29
74LS91	.89	74LS353	1.29
74LS92	.55	74LS363	1.35
74LS93	.55	74LS364	1.95
74LS95	.75	74LS365	.49
74LS96	.89	74LS366	.49
74LS107	.39	74LS367	.45
74LS109	.39	74LS368	.45
74LS112	.39	74LS373	1.39
74LS113	.39	74LS374	1.39
74LS114	.39	74LS377	1.39
74LS122	.45	74LS378	1.18
74LS123	.79	74LS379	1.35
74LS124	2.90	74LS385	1.90
74LS125	.49	74LS386	.45
74LS126	.49	74LS390	1.19
74LS132	.59	74LS393	1.19
74LS133	.59	74LS395	1.19
74LS136	.39	74LS399	1.49
74LS137	.99	74LS429	2.95
74LS138	.55	74LS447	.37

**2114** 450 NS **8/\$995**

**2114** 250 NS **8/\$1095**

**7400**

7400	.19	74132	.45
7401	.19	74136	.50
7402	.19	74141	.65
7403	.19	74142	2.95
7404	.19	74143	2.95
7405	.25	74145	.60
7406	.29	74147	1.75
7407	.29	74148	1.20
7408	.24	74150	1.35
7409	.19	74151	.55
7410	.19	74152	.65
7411	.25	74153	.55
7412	.30	74154	1.25
7413	.35	74155	.75
7414	.49	74156	.65
7416	.25	74157	.55
7417	.25	74159	1.65
7420	.19	74160	.85
7421	.35	74161	.69
7422	.35	74162	.85
7423	.29	74163	.69
7425	.29	74164	.69
7426	.29	74165	.85
7427	.29	74166	1.00
7428	.45	74167	2.95
7430	.19	74170	1.65
7432	.29	74172	5.95
7433	.45	74173	.75
7437	.29	74174	.89
7438	.29	74175	.89
7440	.19	74176	.89
7442	.49	74177	.75
7443	.65	74178	1.15
7444	.69	74179	1.75
7445	.69	74180	.75
7446	.69	74181	2.25
7447	.69	74182	.75
7448	.69	74184	2.00
7450	.19	74185	2.00
7451	.23	74190	1.15
7453	.23	74191	1.15
7454	.23	74192	.79
7460	.23	74193	.79
7470	.35	74194	.85
7472	.29	74195	.85
7473	.34	74196	.79
7474	.33	74197	.75
7475	.45	74198	1.35
7476	.35	74199	1.35
7480	.59	74221	1.35
7481	1.10	74246	1.35
7482	.95	74247	1.25
7483	.50	74248	1.85
7485	.59	74249	1.95
7486	.35	74251	.75
7489	2.15	74259	2.25
7490	.35	74265	1.35
7491	.40	74273	1.95
7492	.50	74276	1.25
7493	.35	74279	.75
7494	.85	74283	2.00
7495	.55	74284	3.75
7496	.70	74285	3.75
7497	2.75	74290	.95
74100	1.75	74293	.75
74107	.30	74298	.85
74109	.45	74351	2.25
74110	.45	74365	.65
74111	.55	74366	.65
74116	1.55	74367	.65
74120	1.20	74368	.65
74121	.29	74376	2.20
74122	.45	74390	1.75
74123	.49	74393	1.35
74125	.45	74425	1.15
74126	.45	74426	.85
74128	.55	74490	2.55

**LINEAR**

LM301	.34	LM340(see 7800)			
LM301H	.79	LM348	.99		
LM307	.45	LM350K	4.95		
LM308	.69	LM350T	4.60		
LM308H	1.15	LM358	.69		
LM309H	1.95	LM359	1.79		
LM309K	1.25	LM376	3.75		
LM310	1.75	LM377	1.95		
LM311	.64	LM378	2.50		
LM311H	.89	LM379	4.50		
LM312H	1.75	LM380	.89		
LM317K	3.95	LM380N-8	1.10		
LM317T	1.19	LM381	1.60		
LM318	1.49	LM382	1.60		
LM318H	1.59	LM383	1.95		
LM319H	1.90	LM384	1.95		
LM319	1.25	LM386	.89		
LM320(see 7900)	LM387	1.40	LM1303	1.95	
LM322	1.65	LM389	1.35	LM1310	1.49
LM323K	4.95	LM390	1.95	MC1330	1.69
LM324	.59	LM392	.69	MC1349	1.89
LM329	.65	LM394H	4.60	MC1350	1.19
LM331	3.95	LM399H	5.00	MC1358	1.69
LM334	1.19	NE531	2.95	MC1372	6.95
LM335	1.40	NE555	.34	LM1414	1.59
LM336	1.75	NE556	.65	LM1458	.59
LM337K	3.95	NE558	1.50	LM1488	.69
LM337T	1.95	NE561	24.95	LM1489	.69
LM338K	6.95	NE564	2.95	LM1496	.85
LM339	.99	LM565	.99	LM1558H	3.10

LM566	1.49	LM1800	2.37
LM567	.89	LM1812	8.25
NE570	3.95	LM1830	3.50
NE571	2.95	LM1871	5.49
NE592	2.75	LM1872	5.49
LM709	.59	LM1877	3.25
LM710	.75	LM1889	1.95
LM711	.79	LM1896	1.75
LM723	.49	ULN2003	2.49
LM723H	.55	LM2877	2.05
LM733	.98	LM2878	2.25
LM741	.35	LM2900	.85
LM741N-14	.35	LM2901	1.00
LM741H	.40	LM3900	.59
LM747	.69	LM3905	1.25
LM748	.59	LM3909	.98
LM1014	1.19	LM3911	2.25
LM1303	1.95	LM3914	3.95
LM1310	1.49	LM3915	3.95
MC1330	1.69	LM3916	3.95
MC1349	1.89	MC4024	3.95
MC1350	1.19	MC4044	4.50
MC1358	1.69	RC4136	1.25
MC1372	6.95	RC4151	3.95
LM1414	1.59	LM4250	1.75
LM1458	.59	LM4500	3.25
LM1488	.69	RC4558	.69
LM1489	.69	LM13080	1.29
LM1496	.85	LM13600	1.49
LM1558H	3.10	LM13700	1.49

**RCA**

CA 3023	2.75	CA 3082	1.65
CA 3039	1.29	CA 3083	1.55
CA 3046	1.25	CA 3086	.80
CA 3059	2.90	CA 3089	2.99
CA 3060	2.90	CA 3096	3.49
CA 3065	1.75	CA 3130	1.30
CA 3080	1.10	CA 3140	1.15
CA 3081	1.65	CA 3146	1.85
CA 3160	1.19		

**TI**

TL494	4.20	75365	1.95
TL496	1.65	75450	.59
TL497	3.25	75451	.39
75107	1.49	75452	.39
75110	1.95	75453	.39
75150	1.95	75454	.39
75154	1.95	75491	.79
75188	1.25	75492	.79
75189	1.25	75493	.89
75494	.89		

**BI FET**

TL071	.79	TL084	2.19
TL072	1.19	LF347	2.19
TL074	2.19	LF351	.60
TL081	.79	LF353	1.00
TL082	1.19	LF355	1.10
TL083	1.19	LF356	1.10
LF357	1.40		

H - TO-5 CAN      T - TO-220      K - TO-3

**74S00**

74S00	.32	74S163	1.95
74S02	.35	74S168	3.95
74S03	.35	74S169	3.95
74S04	.35	74S174	.95
74S05	.35	74S175	.95
74S08	.35	74S181	3.95
74S09	.40	74S182	2.95
74S10	.35	74S188	1.95
74S11	.35	74S189	6.95
74S15	.35	74S194	1.49
74S20	.35	74S195	1.49
74S22	.35	74S196	1.49
74S30	.35	74S197	1.49
74S32	.40	74S201	6.95
74S37	.88	74S225	7.95
74S38	.85	74S240	2.20
74S40	.35	74S241	2.20
74S51	.35	74S244	2.20
74S64	.40	74S251	.95
74S65	.40	74S253	.95
74S74	.50	74S257	.95
74S85	1.99	74S258	.95
74S86	.50	74S260	.79
74S112	.50	74S274	19.95
74S113	.50	74S275	19.95
74S114	.55	74S280	1.95
74S124	2.75	74S287	1.80
74S132	1.24	74S288	1.90
74S133	.45	74S289	6.89
74S134	.50	74S301	6.95
74S135	.89	74S373	2.45
74S138	.85	74S374	2.45
74S139	.85	74S381	7.95
74S140	.55	74S387	1.95
74S151	.95	74S412	2.98
74S153	.95	74S471	4.95
74S157	.95	74S472	4.95
74S158	.95	74S474	4.95
74S161	1.95	74S482	15.25
74S162	1.95	74S570	2.95
		74S571	2.95

**IC SOCKETS**

1-99	100
8 pin ST	.13 .11
14 pin ST	.15 .12
16 pin ST	.17 .13
18 pin ST	.20 .18
20 pin ST	.29 .27
22 pin ST	.30 .27
24 pin ST	.30 .27
28 pin ST	.40 .32
40 pin ST	.49 .39
64 pin ST	4.25 call
ST - SOLDER TAIL	
8 pin WW	.59 .49
14 pin WW	.69 .52
16 pin WW	.69 .58
18 pin WW	.99 .90
20 pin WW	1.09 .98
22 pin WW	1.39 1.28
24 pin WW	1.49 1.35
28 pin WW	1.69 1.49
40 pin WW	1.99 1.80
WW - WIREWRAP	
16 pin ZIF	6.75 call
24 pin ZIF	9.95 call
28 pin ZIF	10.95 call
ZIF - TEXT TOOL (Zero Insertion Force)	

**VOLTAGE REGULATORS**

7805T	.75	7905T	.85
78M05C	.35	7908T	.85
7808T	.75	7912T	.85
7812T	.75	7915T	.85
7815T	.75	7924T	.85
7824T	.75		
7805K	1.39	7905K	1.49
7812K	1.39	7912K	1.49
7815K	1.39	7915K	1.49
7824K	1.39	7924K	1.49
		79L05	.79
		79L12	.79
		79L15	.79
78L05	.69		
78L12	.69		
78L15	.69		
78H05K	9.95	LM323K	4.95
78H12K	9.95	UA78540	1.95

C, T - TO-220      K - TO-3  
L - TO-92

**DIP SWITCHES**

4 POSITION	.85
5 POSITION	.90
6 POSITION	.90
7 POSITION	.95
8 POSITION	.95

**INTERFACE**

8T26	1.59
8T28	1.89
8T95	.89
8T96	.89
8T97	.89
8T98	.89
DM8131	2.95
DP8304	2.29
DS8835	1.99
DS8836	.99

**MISC.**

ULN2003	2.49
3242	7.95
3341	4.95
MC3470	4.95
MC3480	9.00
11C90	13.95
95H90	7.95
2513-001 UP	9.95
2513-002 LOW	9.95

**LED DISPLAYS**

HP 5082-7760	.6"	CC	1.29
MAN 72	.3"	CA	.99
MAN 74	.3"	CC	.99
FND-357 (359)	.375"	CC	1.25
FND-500 (503)	.5"	CC	1.49
FND-507 (510)	.5"	CA	1.49

**EXAR**

XR 2206	3.75
XR 2207	3.75
XR 2208	3.75
XR 2211	5.25
XR 2240	3.25

**DATA ACQUISITION**

ADC0800	15.55	DAC0808	2.95
ADC0804	3.49	DAC1020	8.25
ADC0809	4.49	DAC1022	5.95
ADC0817	9.95	MC1408L6	1.95

### CABINETS FOR 5 1/4" DISK DRIVES

#### CABINET #1 \$29.95

- \* DIMENSIONS 8 1/2 x 5 1/2 x 3 1/2"
- \* COLOR MATCHES APPLE
- \* FITS STANDARD 5 1/4" DRIVES, INCL SHUGART
- \* INCLUDES MOUNTING HARDWARE AND FEET

#### CABINET #2 \$79.00

- \* COMPLETE WITH POWER SUPPLY, SWITCH, LINE CORD, FUSE & STANDARD POWER CONNECTOR
  - \* DIMENSIONS: 11 1/2 x 5 1/2 x 3 1/2"
  - \* -5V @ 1 AMP, +12V @ 1.5 AMP
  - \* FITS STANDARD 5 1/4" DRIVES
  - \* PLEASE SPECIFY GRAY OR TAN
- NOTE: Please include sufficient amount for shipping on above items.

### CONNECTORS

RS232 MALE	2.50
RS232 FEMALE	3.25
RS232 FEMALE	
RIGHT ANGLE	5.25
RS232 HOOD	1.25
S-100 ST	3.95
S-100 WW	4.95
72 pin ST	6.95
72 pin WW	7.95
50 pin ST	4.95
44 pin ST	2.95
44 pin WW	4.95
72 pin SE	3.95

### MUFFIN FANS

NEW UN-USED

4.68" Square	14.95
3.125" Square	14.95

### OPTO-ISOLATORS

4N26	1.00
4N27	1.10
4N28	.69
4N33	1.75
4N35	1.25
4N37	1.25
MCT-2	1.00
MCT-6	1.50
MCA-7	4.25
MCA-255	1.75
IL-1	1.25
ILA-30	1.25
ILQ-74	2.75
H11CS	1.25
TIL-111	1.00
TIL-113	1.75

### TRANSISTORS

2N918	.50	MPS3706	.15
MPS918	.25	2N3772	1.85
2N2102	.70	2N3903	.25
2N2218	.50	2N3904	.10
2N2218A	.50	2N3906	.10
2N2219	.50	2N4122	.25
2N2219A	.50	2N4123	.25
2N2222	.25	2N4249	.25
PN2222	.10	2N4304	.75
MPS2369	.25	2N4401	.25
2N2484	.25	2N4402	.25
2N2905	.50	2N4403	.25
2N2907	.25	2N4857	1.00
PN2907	.125	PN4916	.25
2N3055	.79	2N5086	.25
3055T	.69	PN5129	.25
2N3393	.30	PN5139	.25
2N3414	.25	2N5209	.25
2N3563	.40	2N6028	.35
2N3565	.40	2N6043	1.75
PN3565	.25	2N6045	1.75
MPS3638	.25	MPS-A05	.25
MPS3640	.25	MPS-A06	.25
PN3643	.25	MPS-A55	.25
PN3644	.25	TIP29	.65
MPS3704	.15	TIP31	.75
		TIP32	.79

### MICROCOMPUTER HARDWARE HANDBOOK FROM ELCOMP — \$14.95

Over 800 pages of manufacturers data sheets on most commonly used IC's.

Includes:

- \* TTL — 74/74LS and 74F
- \* CMOS
- \* Voltage Regulators
- \* Memory — RAM, ROM, EPROM
- \* CPU's — 6800, 6500, Z80, 8080, 8085, 8086/8
- \* MPU support & interface — 6800, 6500, Z80, 8200, etc.

### HEAT SINKS

TO-3 style	.95
TO-220 style	.35

### DISK DRIVES TANDON

TM100-1	5 1/4" (FOR IBM) SS/DD	229.00
TM100-2	5 1/4" (FOR IBM) DS/DD	295.00

### SHUGART

SA 400L	5 1/4" (40 TRACK) SS/DD	199.95
SA 400	5 1/4" (35 TRACK) SS/DD	189.95

### SIEMENS

FD100-8	8" SS/DD (SHUGART 801 EQUIVALENT)	189.00
---------	-----------------------------------	--------

FD200-8	8" DS/DD (SHUGART 851 EQUIVALENT)	239.00
---------	-----------------------------------	--------

### PERTEC

FD-200	5 1/4" SS/DD	179.95
FD-250	5 1/4" DS/DD	199.95

### MPI

MP-52	5 1/4" (FOR IBM) DS/DD	295.00
-------	------------------------	--------

NOTE: Please include sufficient amount for shipping on above items.

### RESISTORS

1/4 WATT 5% CARBON FILM ALL STANDARD VALUES FROM 1 OHM TO 10 MEG OHM

50 PCS. SAME VALUE	.025
100 PCS. SAME VALUE	.02
1000 PCS. SAME VALUE	.015

### BYPASS CAPS

.01 UF DISC	100/6.00
.1 UF DISC	100/8.00
.1 UF MONOLITHIC	100/15.00

**WE HAVE THE COMPLETE LINE OF DISC, TANTALUM AND ELECTROLYTIC CAPACITORS IN STOCK!**

### POWER SUPPLY MODEL 2 \$39.95

MOUNTED ON PC BOARD MANUFACTURED BY CONVERTER

+5 VOLT 4 AMP  
±12 VOLT 1 AMP

NOTE: Please include sufficient amount for shipping on above items.

### DIODES

1N751	5.1 volt zener	.25
1N759	12.0 volt zener	.25
1N4148	(1N914) switching	25/1.00
1N4004	400PIV rectifier	10/1.00
KBP02	200PIV 1.5amp bridge	.45
KBP04	400PIV 1.5amp bridge	.55
VM48	Dip-Bridge	.35

### D-SUBMINIATURE

DESCRIPTION	SOLDER CUP		RIGHT ANGLE PC SOLDER		IDC RIBBON CABLE		HOODS	
	MALE	FEMALE	MALE	FEMALE	MALE	FEMALE	BLACK	GREY
ORDER BY	DBxxP	DBxxS	DBxxPR	DBxxSR	IDBxxP	IDBxxS	HOOD-B	HOOD
CONTACTS 9	2.08	2.66	1.65	2.18	3.37	3.69	---	1.60
15	2.69	3.63	2.20	3.03	4.70	5.13	---	1.60
25	2.50	3.25	3.00	4.42	6.23	6.84	1.25	1.25
37	4.80	7.11	4.83	6.19	9.22	10.08	---	2.95
50	6.06	9.24	---	---	---	---	---	3.50

For order instructions see "IDC Connectors" below.

**CALL FOR MOUNTING HARDWARE**

### RIBBON CABLE

CONTACTS	SINGLE COLOR		COLOR CODED	
	1'	10'	1'	10'
10	.50	4.40	.83	7.30
16	.55	4.80	1.00	8.80
20	.65	5.70	1.25	11.00
25	.75	6.60	1.32	11.60
26	.75	6.60	1.32	11.60
34	.98	8.60	1.65	14.50
40	1.32	11.60	1.92	16.80
50	1.38	12.10	2.50	22.00

### IDC CONNECTORS

DESCRIPTION	SOLDER HEADER	RIGHT ANGLE SOLDER HEADER	WW HEADER	RIGHT ANGLE WW HEADER	RIBBON HEADER SOCKET	RIBBON HEADER	RIBBON EDGE CARD
ORDER BY	IDHxxS	IDHxxSR	IDHxxW	IDHxxWR	IDSxx	IDMxx	IDExx
CONTACTS 10	.82	.85	1.86	2.05	1.15	---	2.25
20	1.29	1.35	2.98	3.28	1.86	5.50	2.36
26	1.68	1.76	3.84	4.22	2.43	6.25	2.65
34	2.20	2.31	4.50	4.45	3.15	7.00	3.25
40	2.58	2.72	5.28	4.80	3.73	7.50	3.80
50	3.24	3.39	6.63	7.30	4.65	8.50	4.74

ORDERING INSTRUCTIONS: Insert the number of contacts in the position marked "xx" of the "order by" part number listed. Example: A 10 pin right angle solder style header would be IDH10SR.



## JDR Microdevices

1224 S. Bascom Avenue  
San Jose, CA 95128  
800-538-5000 • 800-662-6279 (CA)  
(408) 995-5430 • Telex 171-110

1983 JDR MICRODEVICES, INC.

**VISIT OUR RETAIL STORE** — NEW HOURS —  
M-W-F, 9-5  
T-Th., 9-9 Sat. 11-3

PLEASE USE YOUR CUSTOMER NUMBER WHEN ORDERING

TERMS: For shipping include \$2 for UPS Ground or \$3 for UPS Blue Label Air. Items over 5 pounds require additional shipping charges. Foreign orders include sufficient amount for shipping. There is a \$10 minimum order. Bay Area and Los Angeles Counties add 6% Sales Tax. Other California residents add 6% Sales Tax. We reserve the right to substitute manufacturer. Not responsible for typographical errors. Prices are subject to change without notice. We will match or beat any competitor's price provided it is not below our cost.



# FOR APPLE COMPUTER USERS

## FD-35 DISK DRIVE

- ★ Direct Replacement for Apple Disk II
- ★ Compatible with Apple Controller or other Apple compatible controllers
- ★ Specially designed electronics with **low power consumption**
- ★ DOS 3.3 and 3.2 compatible
- ★ Owner's Manual and Warranty Card included

**NOW**  
**WITH ONE YEAR WARRANTY** \$229<sup>95</sup>  
 CONTROLLER CARD \$89.95

## VIEWMAX-80

A Full Function  
 80 Column Card for Apple II\*  
 ★ Soft Video Switch ★ Shift Key Support  
**2 YEAR WARRANTY**  
 NOW ONLY \$189<sup>95</sup>

## 5 1/4" DISKETTES VERBATIM DATALIFE

SS/DD SOFT SECTOR . . . . . 29.95  
 SS/DD 10 SECTOR HEAD . . . . . 29.95

## NASHUA

SS/DD SOFT SECTOR WITH HUB RING . . . . . \$19<sup>95</sup>

Ask about our full line of Nashua diskettes

**BEST BUY**

## THOUSANDS SOLD JDR 16K RAMCARD

- ★ Expand your 48K Apple to 64K
- ★ Fully compatible with Apple Language System — Use in place of Apple Language card
- ★ Provides extra memory for Visicalc™
- ★ Run PASCAL, FORTRAN, Integer Basic with appropriate software
- ★ Highest quality card features: gold edge connector, sockets for all IC's

WITH 2 YEAR WARRANTY

ASSEMBLED & TESTED WITH WARRANTY . . . . . \$44<sup>95</sup>

KIT — INCLUDES ALL PARTS & INSTRUCTIONS \$40<sup>95</sup>

BARE PC CARD WITH INSTRUCTIONS . . . . . \$14<sup>95</sup>

## APPLE COMPATIBLE POWER SUPPLY \$99.95

- ★ Compact Switching Design
- ★ All Outputs regulated
- ★ Short Circuit and Overload Protection
- ★ Complete with Apple-type plug-in power cord
- ★ Apple Compatible — Yet higher output allows more disk drives and cards without overheating
- ★ +5V @ .5A, +12V @ .3A, -5V @ .5A, -12V @ .5A
- ★ Shielded enclosure, 10 3/4" x 3 1/2" x 2 1/8"

## NEW IMPROVED JDR COOLING FAN

- ★ Easy modification — no modification of Apple required
- ★ Eliminates overheating problems
- ★ Switch on front controls fan, Apple, and extra outlet
- ★ Rotron whisper fan is the quietest, most reliable on the market

**NOW WITH SURGE SUPPRESSION**

**\$69.95**

WITHOUT SURGE SUPPRESSION \$59.95

## MONITORS MONOCHROME

NEC JB1201M - 20 MHZ GREEN \$169

ZENITH ZUM-121 - 15 MHZ GREEN \$99

TAXAN 18 MHZ AMBER \$139

## COLOR

AMDEK COLOR I - COMPOSITE \$335  
NO C.O.D. ORDERS PLEASE

**ORDER TOLL FREE**  
**800-538-5000**  
**800-662-6279**

(CALIFORNIA RESIDENTS)

## ACCESSORIES FOR APPLE II & IIE

ALL WITH 1 YEAR WARRANTY BY



### PRINTERLINK

CENTRONICS PARALLEL INTERFACE

- ★ Simple to use — No configuring required
- ★ Use with any centronics printer — EPSON, OKIDATA, etc.
- ★ Includes Cable & Manual

**\$59<sup>00</sup>**

### MESSENGER

SERIAL INTERFACE

- ★ Connects to any RS-232 serial device
- ★ 8 switch selectable drivers for printers, terminals and modems
- ★ Includes Cable & Manual

**\$99<sup>00</sup>**

### TIMELINK

REAL TIME CLOCK

- ★ Applications in file management, word processing, communications, etc.
- ★ Exclusive Alarm Clock feature
- ★ Battery recharges automatically

**\$84<sup>00</sup>**

### NEW BUFFERLINK

ADD-ON PRINTER BUFFER

- ★ Saves Time — No more waiting for printed output
- ★ Connects easily to any parallel interface
- ★ Expandable from 16K to 64K

**\$139<sup>00</sup>** (16K)

**ORDER TOLL FREE**  
**ALL MERCHANDISE**  
**100% GUARANTEED**

**800-538-5000**

**800-662-6279**  
 (CALIFORNIA RESIDENTS)



**CALL US FOR VOLUME QUOTES**

1983 JDR MICRODEVICES, INC.

## "THE NEW DELUXE II"

The new leader in sinewave technology is now available at industry shattering prices. We also have the new and improved plusewave kit.

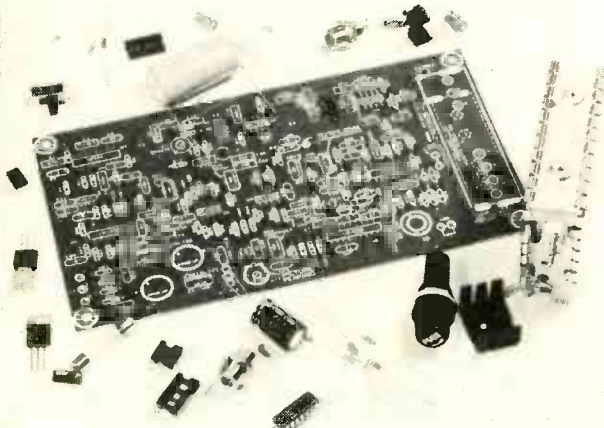

New Deluxe II Board with free-complete assembly plans ..... 20.00  
 New Deluxe II complete kit and enclosure ..... 119.95  
 Pulse Wave AD-1 board with free complete assembly plans ..... 20.00  
 Pulse Wave AD-1 complete kit and enclosure ..... 119.95  
 Add 5% shipping and handling for Continental U.S. Add 10% shipping and handling for outside Continental U.S.

**GAMMA ELECTRONICS**  
 455 Massachusetts Avenue  
 Arlington, Mass. 02174  
 To Order Call:  
 1-617-641-0778



**DEALERS WANTED**

CIRCLE 21 ON FREE INFORMATION CARD

QUALITY  
 SERVICE  
 AVAILABILITY



ACTIVE, YOUR  
 NUMBER ONE  
 CHOICE

## Active Electronics

**WE ARE THE LARGEST BECAUSE WE ARE THE BEST.**  
 Over \$40 million in stock. The world's most complete hobbyist inventory.

Active Electronics is your one stop source for the widest variety of top quality semiconductors, microprocessors, memories, microcomputer systems, peripherals and electronic components.

**NOW AVAILABLE!**  
**Absolutely FREE**



**Active's Newly Revised 1983 Spring/Summer Catalog**

*Whether you're a serious hobbyist, experimenter, student or professional you shouldn't be without it. Call for your free copy today.*

Circle No. 3 on free information card or write:  
 P.O. Box 8000, Westboro, Mass. 01581  
**CALL TOLL FREE: 1-800-343-0874**  
 MASS. customers call (617) 306-0500

CIRCLE 3 ON FREE INFORMATION CARD

## Components is Our First Name Call Us with Your Requirements

### APPLE IIe 64K RAM CARD

80 column x 24 lines  
 64K RAM  
 Compatible with  
 Apple IIe Software

**\$149<sup>00</sup>**

for APPLE

### 16K RAM CARD

Language Transparent  
 COEX FACTORY WARRANTY **\$69<sup>95</sup>**

### 5 1/4" Floppy DISKETTES

All Certified-100% Guaranteed  
 BOX of 100 ... **\$149<sup>00</sup>**  
 Above with  
 Hub Rings ..... **\$169.00**

### FLOPPY DISK DRIVE

Apple IIe Compatible  
 with • Track Zero Micro Switch  
 • DOS 3.2.1 & DOS 3.3  
 • CP/M and PASCAL

DESIGNED FOR YOUR  
 APPLE™ ..... **\$235<sup>00</sup>**  
 Controller Card  
 for above ..... **\$75.00**

### COEX 80-FT DOT MATRIX PRINTER

- 9x7 Dot Matrix, 80 CPS, Bi-Directional Printing
- 2K Buffered Memory
- 80, 96, 132 Columns, Graphics and Block Printing
- Selectable Char Pitch, Line Spacing and Feed



PARALLEL  
 COEX Interface Card to Apple .. \$49.95  
 Commodore Interface Card to  
 VIC, 64, PET ..... \$79.95

**\$275<sup>00</sup>**

### VISION-80® \$229<sup>00</sup>

80x24 Video Display Card  
 Vista Computer Company's new Vision-80 board is a sophisticated yet easy to use video display card for the Apple™ computer.

### EXTENDER CARDS

for APPLE... **\$16.95**  
 for I.B.M. .... **\$19.95**

### DO YOU HAVE A COMMODORE?

NEW ROM for COEX 80 & DP8480  
 Allows Full Graphics Compatibility  
 with All Commodore Computers ..... **\$29<sup>95</sup>**

### PARALLEL INTERFACE EPSON TO APPLE

New From  
 COEX **\$49<sup>95</sup>** CABLE INCLUDED

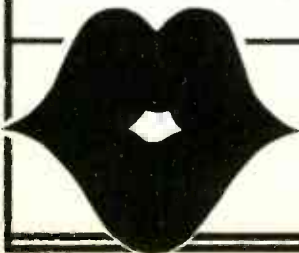

## "Have You Kissed Your Computer Lately?" Components Express, Inc.

1380 E. Edinger • Santa Ana, Calif. 92705 • 714/558-3972

TWX 910-595-1565 • ADVACON SNA • International Orders Welcome  
 Terms of Sale: Cash, Checks, Credit Cards, M.O., C.O.D. FOB Santa Ana. Calif. residents add 6% sales tax.



# ADVANCED COMPUTER PRODUCTS



## 16K Apple™ Ramcard

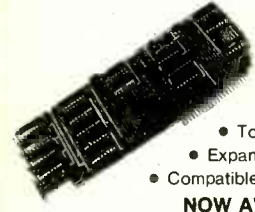

LIST 195  
ACP  
**\$59.95**

- Full 1 year warranty
- Top quality — gold fingers
- Expand Apple II 48K to 64K
- Compatible with Z-80 Softcard™

**NOW AVAILABLE**  
Apple IIe 64K Add-in Memory with 80 Columns **\$149.95**

## 32K STATIC RAM

2 or 4 MHz  
Expandable  
Uses  
2114's  
**\$129.95**

16K 4 MHz Kit \$159.95  
16K 4 MHz A&T 217.95  
32K 4 MHz Kit \$129.95  
32K 4 MHz A&T \$39.00  
BARE BOARD 39.95  
Bare Bd w/all parts less mem. 99.95

## 64K CMOS RAMCARD

IEEE  
Compatible  
Uses  
Low Power  
6116 IC's  
5 Volt  
Single Supply  
Asm and Tested  
**\$269.00**

## REPEAT OF SELL-OUT

**58 Key Unencoded Keyboard**  
**\$19.95**

This is a new 58 key terminal Keyboard manufactured by a major manufacturer. It is unencoded with SPST keys unattached to any PC board. Solid molded plastic 11" x 4" base.

## INTEL 4K STATIC RAMS

Super Fast!  
Super  
Low Power  
Part No. 2147 ..... **\$1.95 ea.**

## Unencoded Key Pad

15 key keypad with  
1-key keys and tab.  
return, (-), (j) and (i).  
Only **\$9.95**

## STEPPER MOTOR

Operates by applying  
12VDC in one direction  
and then reversing  
polarity for square  
wave. Uses 12VDC,  
Clock Wise Rotation,  
Rated 3 RPM at  
P.P.S., with a 5 degree  
stepping angle.  
**\$3.95 ea.** 10 for \$34.95

## UV "EPROM" ERASER

Model  
DE-4  
**\$89.95**  
Holds 4 EPROM's  
at a time.  
Model S-52T **\$325.00**

## RS232 SIGNAL TESTER

COEX RS232  
Line Tester  
(7) LED Indicators  
only **\$24.95**  
Other Styles Also Available

## 16K Memory Expansion Kits for Apple/TRS-80

8 pcs 4116 16K  
200/250's  
Special computer  
**\$12.95**  
CALL FOR VOLUME PRICING

## INTEL CODEC IC

P/N 2910A  
For Digital  
Voice  
**\$9.95**  
For Filter P/N 2912A ... **\$4.95 ea.**

## CORCOM FILTER

Popular  
CORCOM  
Filter  
**\$4.95**  
6 amps  
Compatible Line Cord Add. ... **\$3.50**

## SURGE SUPPRESSOR

"Surgeonics"  
Power Sentry  
15 Amps 250 Volts  
transient suppression  
ACP  
Low Price **\$39.95**

## 9 pcs 4164 D-RAM

**\$50.00**

## CONNECTORS

DB25P (RS232) \$32.25  
DB25 Female 3.75  
Hood 1.25  
Set with Hood, Sale 7.50  
22/44 S/T, KIM 2.95  
43/86 S/T, MOT 6.50  
50/100 S-100 Connector W/W 4.95  
50/100 S-100 Connector S/T 3.95

## AMD MODEM IC

P/N AM7910  
1200Baud  
5 Volts  
Special ACP Price **\$99.00**

## PARALLEL ALPHA NUMERIC PRINTER

19 Column Printer prints 16 numerical columns plus 3 columns which math, alpha and other notations. Each wheel has 12 positions with position 12 blank. Printing with four bit BCD comparator circuit. Print rate, 3 lines per second. Operating voltage 22-28VDC with typical cycle time of 340ms. Size 6 1/2" W x 3 3/4" H x 5 1/2" Dp. New. **\$8.95 ea. 3/\$25**

## MICROPROCESSORS

Z8001	\$85.00	8008-1	\$14.95	8020P	14.95
Z8002	89.00	2801	9.90	8030	14.95
Z80	9.95	2901A	14.95	8038	12.95
Z80A	11.95	8900JL	49.95	8073AN	34.95
I-8 (3850)	18.95	8502	8.95	8756	14.95
2650	18.95	6502A	18.95	8748	49.95
1802	8.75	IM6100	28.95	8909	30.00
8080A	4.75	8800	11.75	8086	49.95
8085	14.95	6800B	19.95	88000	109.95

## RAMS

6116/2016	\$7.95	2147	\$5.99	5290	\$1.99
8264-64K	5.95	411	5.99	5298	1.49
4116-2	1.99	414	4.89	6508	4.50
4116-2	8/12.95	1101	9.99	6518	6.79
2101	3.99	1103	9.99	6561	3.79
2102	7.79	4027	4.69	6604	3.99
21102-2	1.49	4044	3.99	6805	7.99
21102-4	1.29	4050	4.69	9130	8.99
2111	3.49	4060	4.69	9140	8.99
2112	3.49	4096	3.99	93415	6.99
2114	1.99	4115	1.49	93425	6.99
2114L-2	3.25	4200	7.95		
2114L-4	2.29	4402	1.99		
2125	6.99	5280	4.60		

## SUPPORT

8155	\$9.95	8259	\$8.95	68047	\$22.95
8156	9.95	8275	19.95	68488	19.95
8202	29.95	8279	9.50	46505	22.95
8205	2.69	6810	4.75	6520	8.95
8212	2.75	6820	2.50	6522	9.95
8214	4.95	6821	6.50	640-X	24.95
8216	2.75	6828	10.50	6532	17.95
8224	2.95	6834	16.95	6551	19.95
8228	2.95	6845	22.95	Z80-PIO	6.50
8228	3.95	6847	27.95	Z80A-PIO	9.50
8243	9.90	6850	5.25	Z80-CTC	6.50
8250	14.95	6821	6.50	6530-X	24.95
8251	6.50	6860	10.95	Z80-DMA	19.95
8253	11.95	6862	10.95	Z80A-DMA	27.95
8255	4.50	6875	5.95	Z80-SIO	24.95
8257	9.50	6880	2.49	Z80A-SIO	29.95

## MOS PROMS

2784 (8Kx8) TS	\$69.95	2708 (450ns)	\$5.75
2732 (4Kx8) TS	12.95	2708 (60ns)	5.25
2716/2516; SV		1702A	5.75
(2Kx8) TS	7.95	MM520A30	14.50
MS2716; SV, 12V	17.95	MM5204Q	9.95
2758; SV, (450ns)	3.95		

## HI-TECH

2513-001 (5V) Upper	\$3.50	DAC08	\$9.95
2513-005 (5V) Lower	10.95	DAC100	9.95
2513-ADM3 (5V) Lower	14.95	8338 Function Generator	4.50
MC166710 ASIO Synthesizer	12.95	MC4024 VCO	2.95
MC166710A Math Symbol	13.95	LM566 VCO	1.95
MC166710A Math Symbol	13.45	XR2206 Function Generator	5.25
1771-011 8" & Memory	24.95	TR16028 (5V, 12V)	3.95
1781 Dual Floppy	29.95	AF51013 (5V, 12V)	3.95
1791-01 Dual Floppy	36.95	AF51014 (5V12 15-14V)	6.95
1791-01 Dual Floppy	44.95	AF51015 (5V12 15-14V)	6.95
1793 OD, DS Floppy	44.95	IM6402	7.95
1797 OD, DS Floppy	54.95	IM6403	8.95
1891 Data Separator	18.95	2350 RS10	24.95
2143 Clock Generator	18.95	18718 Astros	24.95
6703 8 bit Binary	13.95	MC4114	11.95
8701 10 bit Binary	22.00	7102	14.95
8708 8 bit TS	13.50	W01941	9.95
9400 Volt to Freq Conv.	7.25	COM5016	16.95
9406 8 bit BCD	13.95	IN58250	15.95
1408 6 bit B	3.95	AF5-3776	14.95
1408 8 bit	5.95	AF5-3800	13.75
DAC01 to A	5.95	MM5740AAC	8.95

## SOCKETS

8 pin LP	16	15	14
14 pin LP	20	19	18
16 pin WW	22	21	20
18 pin LP	29	28	27
20 pin LP	34	32	30
22 pin LP	29	27	24
24 pin LP	38	37	36
28 pin LP	45	44	43
40 pin LP	60	59	58

## LOW PROFILE SOCKETS (TIN)

1-24	25-49	50-100	
8 pin WW	.55	.54	.49
10 pin WW (Tin)	.65	.63	.58
14 pin WW	.75	.73	.67
16 pin WW	.90	.71	.70
18 pin WW	.95	.90	.81
20 pin WW	1.15	1.08	.99
22 pin WW	1.45	1.35	1.23
24 pin WW	1.35	1.26	1.14
28 pin WW	1.90	1.53	1.38
40 pin WW	2.20	2.09	1.89

## 3L WIREWRAP SOCKETS (GOLD)

1-24	25-49	50-100	
8 pin WW	.55	.54	.49
10 pin WW (Tin)	.65	.63	.58
14 pin WW	.75	.73	.67
16 pin WW	.90	.71	.70
18 pin WW	.95	.90	.81
20 pin WW	1.15	1.08	.99
22 pin WW	1.45	1.35	1.23
24 pin WW	1.35	1.26	1.14
28 pin WW	1.90	1.53	1.38
40 pin WW	2.20	2.09	1.89

## LINEAR

78H05K	\$5.95	LM1414N	\$1.90
78M06	1.49	LM1458CN	.49
78M.G.	1.49	MC1488N	.99
LM108AH	2.95	MC1489N	.99
LM300H	.99	LM1496N	.99
LM300N	.35	LM1558N	1.50
LM304H	1.98	LM1820N	.95
LM305H	1.89	LM1850N	.95
LM308H	3.25	LM1889N	3.10
LM307CN	.29	LM2111N	1.75
LM308CN	.98	LM2900N	.99
LM309N	1.40	LM2901N	1.40
LM310CN	1.25	LM2917N	2.95
LM311D/CN	.89	CA3013T	2.19
LM312H	1.75	CA3018T	1.99
LM317T	1.70	CA3021T	3.49
LM318CN	1.49	CA3023T	2.99
LM319NH	1.25	CA3035T	2.75
LM320K-XX*	1.35	CA3039T	1.29
LM320T-XX*	1.39	CA3046N	1.29
LM320H-XX*	1.25	LM3053N	1.49
LM323K	4.95	CA3059N	3.19
LM324N	.95	CA3060N	3.19
LM326K	5.95	CA3062N	4.99
LM338K	8.95	LM3065N	1.49
LM339N	.95	CA3080T	1.29
LM340K-XX*	1.75	CA3081N	1.69
LM340H-XX*	1.25	CA3082N	1.69
LM344H	1.95	CA3083N	1.55
LM348N	1.20	CA3089N	2.99
LM350K	5.60	CA3096N	3.49
LM358CN	.98	CA3097N	1.09
LM360N	1.49	CA3130T	1.30
LM372N	1.95	CA3140T	1.19
LM376N	1.15	CA3146N	3.49
LM377N	2.75	CA3160T	1.19
LM380CN/N	1.25	CA3190N	1.95
LM381N	1.79	CA3410N	.59
LM383T	1.95	MC3423N	1.49
LM389N	1.25	MC3460N	3.95
LM390N	1.95	CA3069N	8.00
LM390N	1.95	CA3060N	3.39
NE531V/T	3.75	LM3900N	.59
NE555V	.39	LM3905N	1.19
NE556N	.98	LM3909N	.98
NE561T	19.95	LM3914N	3.75
NE565N/H	1.95	LM3915N	2.95
NE566H/V	1.75	LM3918N	3.75
NE567H/V	1.50	RC4131N	2.95
NE592N	2.75	RC4138N	1.10
LM702H	1.99	RC4151N	3.70
LM709NH	.29	RC4194TK	4.95
LM710NH	.75	RC4195TK	4.95
LM711NH	.39	ULN2001	1.25
LM715N	1.95	ULN2003	1.50
SN7523H/H	.65	SN75400N	5.59
SN7533H/H	.98	SN75451N	.36
SN7537K	1.95	SN75452N	4.49
LM741CN/H	.33	SN75453N	.49
LM741CN-14	.19	SN75454N	.89
LM747N/H	.75	SN75491N	.89
LM748N/H	.39	SN75492N	.89
LM780CN	2.95	SN75493N	.89
LM781CN	1.90	SN75494N	.99
MC1330	1.95	TL494CN	4.20
MC1350	1.95	TL496CP	1.65
MC1358	1.75		

## 7400

7400 \$ 1.29	7475 \$ 3.38	74161 \$ .88
7401 \$ .22	7476 \$ .34	74162 \$ .89
7402 \$ .22	7479 \$ 4.60	74163 \$ .87
7403 \$ .22	7480 \$ .49	74164 \$ .87
7404 \$ .22	7482 \$ .95	74165 \$ .87
7405 \$ .23	7483 \$ .95	74166 \$ 1.00
7406 \$ .35	7485 \$ .65	74167 \$ .95
7407 \$ .35	7486 \$ .35	74170 \$ 1.69
7408 \$ .26	7489 \$ 1.75	74172 \$ 4.75
7409 \$ .23	7490 \$ .39	74173 \$ .79
7410 \$ .22	7491 \$ .57	74174 \$ .69
7411 \$ .25	7492 \$ .95	74175 \$ .85
7412 \$ .29	7493 \$ .45	74176 \$ .75
7413 \$ .29	7494 \$ .69	74177 \$ .75
7414 \$ .59	7495 \$ .65	74179 \$ 1.34
7416 \$ .29	7496 \$ .69	74180 \$ .75
7417 \$ .29	7497 \$ .90	74181 \$ .75
7420 \$ .22	74100 \$ 2.90	74182 \$ .75
7421 \$ .35	74107 \$ .32	74184 \$ 2.25
7422 \$ .29	74109 \$ .37	74185 \$ 2.25
7423 \$ .29	74116 \$ .95	74186 \$ 9.95
7425 \$ .29	74121 \$ .29	74188 \$ 3.90

# A 10 HOUR TAPE RECORDER

**NOW only \$9500\***

was \$125.00

LONG PLAY

Modified Panasonic Slimline high quality AC-DC Recorder provides 5 continuous hrs. of recording & play back of top quality sound on each side of cassette for a total of 10 hrs. Built-in features include:

- Voice level control
- Digital counter, etc.



TDK DC-180 Cassette included.

## PHONE RECORDING ADAPTER

Records calls automatically. All Solid state connects to your telephone jack and tape recorder. Starts recording when phone is lifted. Stops when you hang up.

\$24.50\*

FCC APPROVED

## VOX VOICE ACTIVATED CONTROL SWITCH

Solid state. Self contained. Adjustable sensitivity. Voices or other sounds automatically activate and control recorder. Uses either recorder or remote mike.

\$24.95\*

\*Add for ship. & hdg. Phone Call Adapter & VOX Recorder \$4.00. Cal. Res. add tax. Mail order, VISA, M/C, cod's ok. Qty. dir. inv. Money back guar. Free data. Dir. A. 9335 Lubec St., Box 928, Downey, CA (213) 90241 Phone 869-8519

CIRCLE 51 ON FREE INFORMATION CARD

# CHANEY electronics inc.

• Minimum Order \$9.00  
• Please include \$1.50 for shipping (UPS)

• We accept VISA and MASTERCARD  
• EXTRA FAST SERVICE

P.O. BOX 27038, DENVER, COLO. 80227  
PHONE ORDERS: 303-781-5750

### 120VAC VARIABLE STROBE LIGHT KIT

Complete variable rate strobe light kit produces brilliant flashes of light. Operates from standard 120VAC. Reliable design—thousands of these are in use throughout the world. Overall size of completed board: 3"L x 2"W x 3"H.

C3071 \$9.99



### 3VDC ELECTRONIC WARNING FLASHER KIT

This portable battery operated device continuously emits bursts of intense light at a fixed repetition rate. Can be seen for great distances making it a great safety device. Features xenon flashtube. Operates on 3VDC (two 1.5V Batteries). Size of board: 2 1/2"L x 2"W.

C3207 \$7.95



### FASCINATION STAR KIT

Produces an "exploding star" visual effect using 25 LEDs and IC circuitry. The center LED lights first then the next group of LEDs light and then another set of lights until the outer edge of the star lights up. The process then reverses itself. Operates from 9V battery.

C4432 \$10.95



### SEQUENTIAL LED FLASHER KIT

This kit combines IC circuitry and 10 jumbo red LEDs to produce a unique visual display. LEDs continuously light sequentially from right to left. Easy to build kit. Operates from 9V battery. Size of board: 5.25" x 1.5".

C4431 \$6.75



### MICRO-MINIATURE SPEAKER

Only 1/8" dia. mounted on a 1" square PC board.

C4832 \$1.49 ea.



### SOLID CARBIDE PC DRILL BIT

#65 035 Standard size for PC boards.

C4800 \$1.49 ea.  
10 for \$12.00



### KESTER PC TYPE SOLDER

6 foot coil of ultra thin diameter low melting temperature 60/40 rosin core.

C4456

\$1.00



## Kits!!!

We offer over 70 complete electronic kits. Send for our free catalog

CIRCLE 34 ON FREE INFORMATION CARD

# TEK-EL

## TECHNICAL ELECTRONICS YOUR SUPPLY SOURCE WITH ASSORTMENTS LIKE THESE:

**LED ASSORTMENT** 25 LEDs at a price everyone can afford! Red, Green, Yellow, Amber in all shapes and sizes.

Stock No. 10-1501

\$2.95 pkg.

**SWITCH ASSORTMENT** 8 general purpose toggle switches. Includes single, double, and three pole switches from top manufacturers such as Cutler-Hammer and others!

Stock No. 12-2230

\$6.95 pkg.

**FOOT ASSORTMENT** Plastic, rubber, snap-fit, felt bottom, stud mount, you name it—it's in this assortment of approx. 100 feet.

Stock No. 49-2398

\$2.95 pkg.

**SLIDE SWITCH ASSORTMENT** Includes SPDT and DPDT slides. 10 pieces per package.

Stock No. 12-1400

\$1.50 pkg.

**ODDS-N-ENDS BARGAIN BOX** 5 pound Random assortment of good quality components and parts. Includes items such as capacitors, diodes, motors, transformers, printed circuit boards, and much much more!

Stock No. 49-3041

\$10.00 pkg.

**TERMINAL STRIP ASSORTMENT** Half pound of approx. 100 pieces. Random assortment of sizes and lengths.

Stock No. 49-2400

\$2.95 pkg.

ORDER TODAY! VISA, MASTERCARD & COD accepted for phone orders. Please add \$3.00 for UPS ground. Satisfaction guaranteed. Call or write for your **FREE CATALOG!**

## TECHNICAL ELECTRONICS

Dept. L P.O.: Box 2361  
Woburn, MA 01888 (617) 935-1717

CIRCLE 8 ON FREE INFORMATION CARD

## MICROWAVE TV ANTENNA SYSTEMS

Freq. 2.1 to 2.6 GHz • 34 db Gain +



### COMPLETE SYSTEMS

(as Pictured)  
Commercial 40" Rod Style \$ 89.95  
Parabolic 20" Dish Style \$ 79.95

### COMPONENTS

Down Converters (both types) \$ 34.95  
Power Supplies (12V to 16V) \$ 24.95  
Data Info (Plans) \$ 9.95

CALL OR WRITE FOR KITS, PARTS, INDIVIDUAL COMPONENTS

We Repair All Types Down Converters & Power Supplies

## Phillips-Tech Electronics

P.O. Box 34772  
Phoenix, AZ 85067  
(602) 265-8255

Special Quantity Pricing Dealers Wanted



TWO YEAR WARRANTY PARTS & LABOR



CIRCLE 9 ON FREE INFORMATION CARD



# KCS

## ELECTRONICS CORPORATION

### SEMICONDUCTOR PARTS & PRODUCTS

#### FACTORY PRIME DEVICES INCLUDE:

- Capacitors all types & styles
- Chokes & Coils
- Connectors
- Digital & Linear IC's
- Hardware & Accessories
- IC Sockets
- Memory
- Microwave Semiconductors
- Resistors fixed & variable
- Transformers
- Transistors & MORE!

MANUFACTURERS SUCH AS: Motorola, National, NEC, J.W. Miller, Texas Instruments and more!

WE STOCK & SUPPLY DEVICES FOR: OEM's, Distributors, Hobbyists, Magazine Projects, Engineers, Schools, Technicians & You!

Call or Write for Quantity Pricing and FREE Catalog.

P.O. Box 33205  
Phoenix, AZ 85067

(602) 274-2885

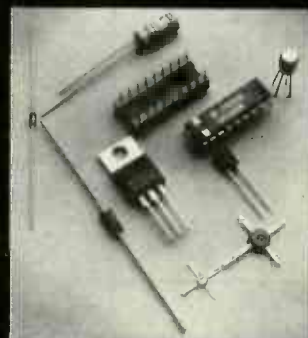

CIRCLE 83 ON FREE INFORMATION CARD



# POPULAR TELEVISION CIRCUITS

## Miste SATELLITE TELEVISION RECEIVER

\$349.95

### SATELLITE TELEVISION

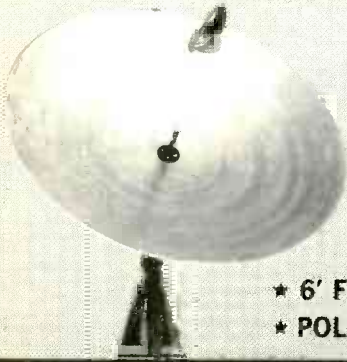

Modern  
Inexpensive  
Satellite  
Television  
Equipment

\$349.95

- \* 6' FIBERGLASS DISH
- \* POLAR MOUNT AND FEED

### PANASONIC RF MODULATORS

ENC 16505 crystal controlled

BRAND NEW! \$24.95



VIDEO TAPE RECORDERS, SATELLITE TV RECEIVERS  
FOR BRILLIANT PICTURES ON CHANNEL 3 OR 4

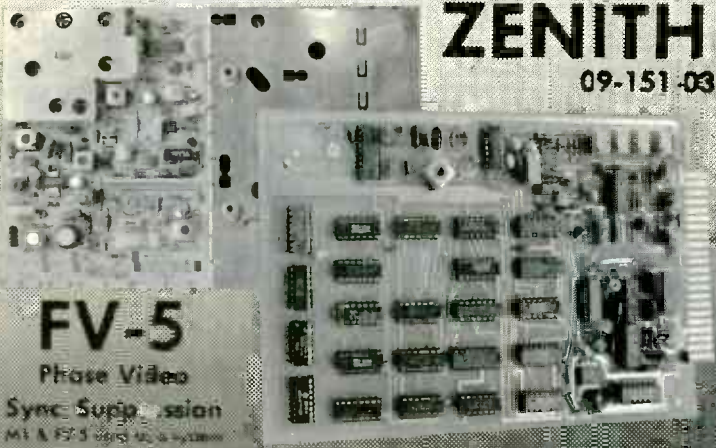

## ZENITH M1

09-151-03

### FV-5

Phase Video  
Sync Suppression  
M1 & FV-5 boards available

- \* No Internal Connection to T.V.
- \* Continuous Audio/Video Modulation
- \* AGC FOR STABILITY
- \* Quality Circuit Board
- \* Fully Illustrated Instructions
- \* Quantity Discounts Available
- FV-5 Board and Plans \$30.00 + \$3.00 Shipping and Handling
- FV-5 PCB, Plans and Parts \$149.95 + \$6.00 Shipping and Handling
- M1, FV-5 PCB, Plans, Parts, Woodgrain Cabinet \$169.95 + \$6.00 Shipping and Handling

## SINE WAVE

- \* Fully Illustrated Instructions
- \* NO Internal Connection to T.V.
- \* Continuous Audio/Video Modulation
- \* AGC FOR STABILITY
- \* Quality Circuit Board
- \* Silk Screened Parts Layout

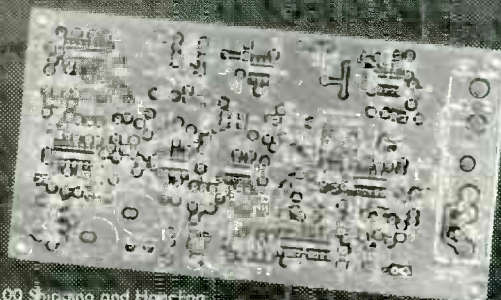

- P.C. Board and Plans \$20.00 + \$3.00 Shipping and Handling
- All Parts and Wood Grained Cabinet \$99.95 + \$5.95 Shipping and Handling
- P.C. Board, Plans, All Parts and Wood Grained Cabinet \$119.95 + \$5.95 Shipping and Handling

\* AVAILABLE BY MAIL ORDER ONLY \* SEND FOR INFORMATION ON OTHER KITS  
\* COMPLETE REPAIR SERVICE \* HOBBY USE ONLY, NOT FOR UNAUTHORIZED RECEPTION OF T.V. SIGNALS

## MICROWAVE PROBE KIT

- \* P.C. Board
- \* Microwave Transistors
- \* All Parts and Plastic Housing \$24.95 + \$3.00 Shipping & Handling

## POWER SUPPLY COMPLETE KIT

\$19.95 + \$3.00 Shipping & Handling

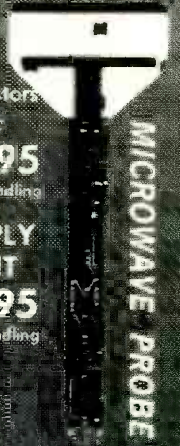

CERTIFIED FUNDS AND MONEY ORDER  
REFUNDED IMMEDIATELY  
PERSONAL CHECKS BEGINS 2 WEEKS  
FOR CLEARANCE  
MASTERCARD, VISA, DISCOVER



INFO PHONE

WESTECH ELECTRONICS \* 4242 SOUTH 48TH STREET, PHOENIX, ARIZONA 85040  
(602) 829-6700

ORDERS ONLY:

(800) 243-6700

HIGH QUALITY <sup>UP TO</sup> 55dB GAIN

# MICROWAVE TV SYSTEM

Variable from 1.9 to 2.5 GHz



The latest advance in microwave technology with a **SNOW-FREE PICTURE.**

Introductory **SPECIAL**

**\$124<sup>95</sup>** Includes Shipping & Handling

THIS UNIT COMES COMPLETE WITH:

- 20' Fiberglass Parabolic Dish
- Pre-Assembled Probe with Down Converter
- Power Supply and Coax Switch
- 60' of RG-59/U Coax with Connector
- Transformer for 75 to 300 Ohms
- All Mounting Hardware for Fast and Easy Installation

Send Cashiers Check or Money Order to: (Personal Checks, allow 2-5 weeks to clear)

**PROFESSIONAL VIDEO, Inc.**

4670 Hollywood Blvd., Hollywood, Calif. 90027

For C.O.D. Orders Call (213) **219-0227**  
**352-9681**

CIRCLE 30 ON FREE INFORMATION CARD

## DON'T FORGET

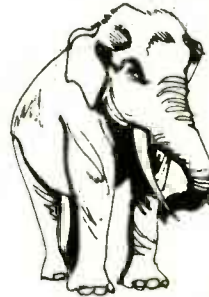

USE YOUR READER SERVICE CARD

## JAVANCO

YOUR PARTS SUPERMARKET

160 Second Avenue South  
Nashville, Tennessee 37201



FPK-7 \$5.75  
7 assorted sizes  
FP twist-lok can  
filter capacitors



MCK-36 \$4.35

6 ea. of 6 assorted useable mylar capacitors with PC leads in a reuseable plastic box.

THE ULTIMATE SPEAKER



ADO210 808 \$12.50 ea. 2/\$22.50

Philips 8 ohm mid-range, full power speaker

*If'n yer not satisfied, we'll get ya full credit within 30 days*

ADA-1001 \$1.25

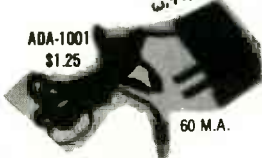

60 M.A.

6 volt DC wall transformer in reuseable plastic container 7 ft. cord with 1/8" pin plug.

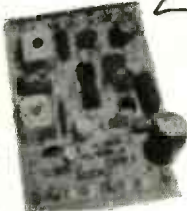

9-103-04 \$6.75  
Zenith audio module



ECK-50 \$3.75

50 assorted PC and axial lead electrolytics



Bargains!!!

90 assorted fuses (5 each of 18 types) 3 AG & 5x20 mm sizes in good useable ampers



Fuse Kit 80 \$13.75

Call toll-free 1-800-251-5555 (TN. 1-615-244-4444)

\$15.00 minimum order plus \$2.75 shipping and handling (\$4.75 shipping on COD orders)

Tennessee residents add 6.75% tax Visa and Mastercharge accepted.

CIRCLE 29 ON FREE INFORMATION CARD

☆ ORDER LINE ☆

(800) 435-0907

(Outside Calif.)

\*Please use for Ordering !!

**BMC "HALF-HIGH"**  
(Apple Drive)

- 40 track
- Full compat.
- \$335.00 w/contrl.
- \$285.00 w/o contrl.

**SUPER 3.5amp POWER SUPPLY**  
for APPLE → \$88.00 ☆

**Diskette Storage BOX**

5 1/4 in. > 5/8" : 8 in. > 5/8"  
\$2.50 ea. \$10.00 : \$3.50 \$15.00

**Bare Bones APPLE II EURO**

w/o Keyboard = 48K RAM =  
**\$399.**  
w/o Pwr. Supply

Microswitch: Power Supply: APPLE  
Keyboard : w/ Purchase : Reference Manl.  
\$ 75.00 : \$ 79.00 : \$18.00

## CONCORD COMPUTER PRODUCTS

2910 B E LA PALMA ANAHEIM CA 92806  
(714) 632-6790 CHECK - M O

10 MIN ORDER (CALIF RES ADD 6% PERSONAL CHECK \$ SER) FREIGHT: \$10-49 \$200-499 \$100-999 \$1000+ \$1000

**MONITORS ☆ ☆**

**BMC# BM-12AUW**

12in. 15MHz./GREEN Phos. I → \$94.00 ☆

**BMC# BM-12NU**

12in. 18 MHz./GREEN Phos. Non-Glare Screen I → \$114.00 ☆

**BMC#BM1401RGB**

13in. "RGB" COLOR with Apple interface!! I → \$425.00 ☆

**Diskette SALE!!**

call for Qty. Price "Wabash"  
5 1/4 8inch  
SS/SD \$17.50 \$20.00  
soft  
SS/DD 27.40 30.40  
DS/SD 34.90  
DS/DD 32.40 37.40

## COMPONENTS

74LS				74S				EPROMS				Z80				RAMS			
74LS00	24	74LS55	25	74S00	30	74S32	40	1702	385	2718	395	8038	255	8155	775	2114L2	1.85	4116-150NS	8/1495
74LS02	24	74LS73	38	74S02	30	74S37	40	2708	385	355	4708	8080A	375	8202	24.50	410 4027	7.75	4116-200NS	8/1295
74LS04	32	74LS74	45	74S04	30	74S38	40	8708	355			8085A	775	8224	8.50	195 4116-200NS	8/1295	8116-200NS	6.95
74LS08	28	74LS78	38	74S08	30	74S42	40									1050 8850	3.25	8116-150NS	7.95
74LS16	28	74LS85	45	74S16	30	74S45	40									1050 8850	3.25	8116-150NS	7.95
74LS20	28	74LS88	80	74S20	30	74S48	40									1050 8850	3.25	8116-150NS	7.95
74LS24	28	74LS90	50	74S24	30	74S51	40									1050 8850	3.25	8116-150NS	7.95
74LS28	28	74LS93	85	74S28	30	74S54	40									1050 8850	3.25	8116-150NS	7.95
74LS32	24	74LS96	85	74S32	30	74S57	40									1050 8850	3.25	8116-150NS	7.95
74LS36	24	74LS99	85	74S36	30	74S60	40									1050 8850	3.25	8116-150NS	7.95
74LS40	28	74LS100	85	74S40	30	74S63	40									1050 8850	3.25	8116-150NS	7.95
74LS44	28	74LS103	85	74S44	30	74S66	40									1050 8850	3.25	8116-150NS	7.95
74LS48	28	74LS107	85	74S48	30	74S69	40									1050 8850	3.25	8116-150NS	7.95
74LS52	24	74LS109	85	74S52	30	74S72	40									1050 8850	3.25	8116-150NS	7.95
74LS56	28	74LS112	85	74S56	30	74S75	40									1050 8850	3.25	8116-150NS	7.95
74LS60	24	74LS113	85	74S60	30	74S78	40									1050 8850	3.25	8116-150NS	7.95
74LS64	28	74LS114	85	74S64	30	74S81	40									1050 8850	3.25	8116-150NS	7.95
74LS68	28	74LS118	85	74S68	30	74S84	40									1050 8850	3.25	8116-150NS	7.95
74LS72	28	74LS122	85	74S72	30	74S87	40									1050 8850	3.25	8116-150NS	7.95
74LS76	28	74LS123	85	74S76	30	74S90	40									1050 8850	3.25	8116-150NS	7.95
74LS80	28	74LS128	85	74S80	30	74S93	40									1050 8850	3.25	8116-150NS	7.95
74LS84	28	74LS132	85	74S84	30	74S96	40									1050 8850	3.25	8116-150NS	7.95
74LS88	28	74LS138	85	74S88	30	74S99	40									1050 8850	3.25	8116-150NS	7.95
74LS92	24	74LS144	85	74S92	30	74S100	40									1050 8850	3.25	8116-150NS	7.95
74LS96	24	74LS152	85	74S96	30	74S103	40									1050 8850	3.25	8116-150NS	7.95
74LS100	28	74LS156	85	74S100	30	74S106	40									1050 8850	3.25	8116-150NS	7.95
74LS104	28	74LS160	85	74S104	30	74S109	40									1050 8850	3.25	8116-150NS	7.95
74LS108	28	74LS164	85	74S108	30	74S112	40									1050 8850	3.25	8116-150NS	7.95
74LS112	28	74LS168	85	74S112	30	74S114	40									1050 8850	3.25	8116-150NS	7.95
74LS116	28	74LS172	85	74S116	30	74S118	40									1050 8850	3.25	8116-150NS	7.95
74LS120	28	74LS176	85	74S120	30	74S122	40									1050 8850	3.25	8116-150NS	7.95
74LS124	28	74LS180	85	74S124	30	74S124	40									1050 8850	3.25	8116-150NS	7.95
74LS128	28	74LS184	85	74S128	30	74S126	40									1050 8850	3.25	8116-150NS	7.95
74LS132	28	74LS188	85	74S132	30	74S128	40									1050 8850	3.25	8116-150NS	7.95
74LS136	28	74LS192	85	74S136	30	74S130	40									1050 8850	3.25	8116-150NS	7.95
74LS140	28	74LS196	85	74S140	30	74S132	40									1050 8850	3.25	8116-150NS	7.95
74LS144	28	74LS200	85	74S144	30	74S134	40									1050 8850	3.25	8116-150NS	7.95
74LS148	28	74LS204	85	74S148	30	74S136	40									1050 8850	3.25	8116-150NS	7.95
74LS152	28	74LS208	85	74S152	30	74S138	40									1050 8850	3.25	8116-150NS	7.95
74LS156	28	74LS212	85	74S156	30	74S140	40									1050 8850	3.25	8116-150NS	7.95
74LS160	28	74LS216	85	74S160	30	74S142	40									1050 8850	3.25	8116-150NS	7.95
74LS164	28	74LS220	85	74S164	30	74S144	40									1050 8850	3.25	8116-150NS	7.95
74LS168	28	74LS224	85	74S168	30	74S146	40									1050 8850	3.25	8116-150NS	7.95
74LS172	28	74LS228	85	74S172	30	74S148	40									1050 8850	3.25	8116-150NS	7.95
74LS176	28	74LS232	85	74S176	30	74S150	40									1050 8850	3.25	8116-150NS	7.95
74LS180	28	74LS236	85	74S180	30	74S152	40									1050 8850	3.25	8116-150NS	7.95
74LS184	28	74LS240	85	74S184	30	74S154	40									1050 8850	3.25	8116-150NS	7.95
74LS188	28	74LS244	85	74S188	30	74S156	40									1050 8850	3.25	8116-150NS	7.95
74LS192	28	74LS248	85	74S192	30	74S158	40									1050 8850	3.25	8116-150NS	7.95
74LS196	28	74LS252	85	74S196	30	74S160	40									1050 8850	3.25	8116-150NS	7.95
74LS200	28	74LS256	85	74S200	30	74S162	40									1050 8			

# AMAZING DEVICES

**PHASORS**  
**PHASOR PAIN FIELD** — Patented and recently developed in our labs is being tested by Gov't for riot control. Soon to come under weapons restrictions as an internal machine. Easily hand-held. Hazardous IF NOT USED WITH DISCRETION.  
 PPF-1 PLANS (sold for animal control) ..... \$15.00  
**INVISIBLE PAIN FIELD GENERATOR** — Produces a directional field of moderately intense pain to back of head up to 50'. Cigarette pack size enclosure is easily hidden.  
 IPG-3 PLANS ..... \$7.00 IPG-3K KIT & PLANS ..... \$44.50  
 IPG-30 (assembled for animal control) ..... \$59.50  
**PHASOR STUN/BURNING WAND** — Produces sufficient electrical energy capable of burning flesh. Intended as a personal defense device.  
 PSW-3 PLANS ..... \$8.00 PSW-3K KIT & PLANS ..... \$59.50

**LASERS**  
**RUBY LASER RAY PISTOL** — Intense visible red, burns, hazardous, with parts sources.  
 RUBY PLANS (includes all part sources) ..... \$15.00  
**CARBON DIOXIDE LASER** — Generates 20-40 watts of continuous power capable of burning, cutting, hazardous. (with all part sources) ..... \$15.00  
**LASER RIFLE** — Produces 200-3000 pulses of 30 watt optical energy. Portable and easily hand-held.  
 LRG-3 PLANS ..... \$10.00  
 LRG-3K KIT PLANS (minus diode) ..... \$129.50  
**POCKET LASER** — For the beginner, visible red "optical version", non-hazardous.  
 LHC-2 ..... \$5.00 LHC-2K KIT & PLANS ..... \$24.50  
**HIGH POWERED PORTABLE ENERGY SOURCE FOR LASERS AND MAGNETIC WEAPONS** — Exploding wires, shockwave, etc. Miniature size.  
 HPS-1 PLANS ..... \$8.00 HPS-1K KIT & PLANS ..... \$49.50  
**PARTICLE BEAM WEAPON** — PLANS ..... \$15.00

**SECURITY**  
**INFINITY XMTR** — Uses telephone lines for selective home or office listening while away on business or vacation.  
 INF-1 PLANS ..... \$15.00  
**SEE IN DARK** — Long range, total darkness.  
 SD-4 PLANS ..... \$10.00  
**LONG RANGE WIRELESS MIKE** — Crystal clear quality miniature.  
 FBT-7 PLANS ..... \$7.00 FBT-7K PLANS & KIT ..... \$34.50  
**WIRELESS TELEPHONE TRANSMITTER** — Long range, automatic.  
 VWPM-5 PLANS \$10.00 VWPM-5K PLANS & KIT ..... \$34.50

Send for **FREE** catalog description of above plus hundreds more plans, kits and completed items. We accept MC or Visa or when ordering, send check or money order. We pay shipping charges on orders over \$50.00; otherwise include 10% with remittance.  
**SEND TO: SCIENTIFIC SYSTEMS**  
 DEPT. R8, BOX 716, AMHERST, N.H. 03031

**THE WORLD FAMOUS**  
**ETCO**  
 CATALOG OF ELECTRONICS

**FREE** **LOW PRICES**

- VIDEO
- TELEPHONE
- CABLE TV
- PARTS
- AUDIO
- ELECTRONICS
- and much, much more!

1000's OF FASCINATING FACTORY CLEAROUTS, SURPLUS SPECIALS AND BARGAIN OFFERS NOT FOUND IN STORES OR CATALOGS ANYWHERE!

**ETCO ELECTRONICS**  
 DEPT. 591  
 Mailing List Control Center  
 Box 840  
 Champlain, N.Y. 12919

**Now 112 PAGES**

I Enclose \_\_\_\_\_ (cash OK);  
 Please rush postpaid

\$1 for 1 year subscription to the world famous ETCO catalog.  
 \$3 Canadian & Foreign 1 year subscription to the ETCO catalog.  
 304 page handbook "BUILD YOUR OWN EARTH STATION". (TA025) \$10.00  
 360 pages MASTER HANDBOOK OF TELEPHONES. (TA001) ..... \$11.00  
 FREE - sample copy of the bargain packed ETCO catalog. (USA only)

Name \_\_\_\_\_  
 Address \_\_\_\_\_  
 City \_\_\_\_\_  
 State \_\_\_\_\_ Zip \_\_\_\_\_

**CIRCLE 50 ON FREE INFORMATION CARD**

**ELECTRONIC KITS FROM HAL-TRONIX**

2304 MHZ DOWN CONVERTERS. TUNES IN ON CHANNELS 2 TO 7 ON YOUR OWN HOME T.V. HAS FREQUENCY RANGE FROM 2000 MHZ TO 2500 MHZ. EASY TO CONSTRUCT AND COMES COMPLETE WITH ALL PARTS INCLUDING A DIE-CAST ALUM CASE AND COAX FITTINGS. REQUIRE A VARIABLE POWER SUPPLY AND ANTENNA (Antenna can be a dish type or coffee can type depending on the signal strength in your area.)

2304 MOD 1 (Basic Kit) ..... \$19.95  
 (Less case & fittings)  
 2304 MOD 2 (Basic Pre-amp) ..... \$29.95  
 (less case & fittings)  
 2304 MOD 3 (Hi-Gain Pre-amp) ..... \$39.95  
 (Includes case & fittings)

POWER SUPPLY FOR EITHER MODEL ABOVE IS AVAILABLE. COMES COMPLETE WITH ALL PARTS, CASE, TRANSFORMER, ANTENNA SWITCH AND CONNECTORS (Kit) \$24.95  
 Assembled ..... \$34.95  
 Slotted Microwave Antenna For Above Downverters ..... \$39.95

**PREAMPLIFIERS**

HAL PA-19—1.5 mhz to 150 mhz. 19db gain operates on 8 to 18 volts at 10ma. Complete unit \$8.95.  
 HAL PA-14—3 mhz to 1.4 ghz. 10 to 12 db gain operates on 8 to 18 volts at 10 ma. Complete unit \$12.95.  
 (The above units are ideal for receivers, counters, etc.)

16 LINE TOUCH TONE DECODE KIT WITH P.C. BOARD AND PARTS ..... \$69.95  
 12 LINE TOUCH TONE DECODE KIT WITH P.C. BOARD AND PARTS ..... \$39.95  
 16 LINE ENCODER KIT, COMPLETE WITH CASE, PAD AND COMPONENTS ..... \$39.95  
 12 LINE ENCODER KIT, COMPLETE WITH CASE, PAD AND COMPONENTS ..... \$29.95

Complete Sets of P.C. Boards Available For: Unicorn Robot Project and Heart-A-Matic Project.  
 MANY, MANY OTHER KITS AVAILABLE

Send 20 cents stamp or S.A.S.E. for information and list on other HAL-TRONIX products. To order by phone: 1-810-265-1182

**HAL-TRONIX**  
 P.O. Box 1101  
 Southgate, MI 48195

SHIPPING INFORMATION: ORDERS OVER \$25.00 WILL BE SHIPPED POSTPAID EXCEPT ON ITEMS WHERE ADDITIONAL CHARGES ARE REQUESTED. ON ORDERS LESS THAN \$25.00 PLEASE INCLUDE ADDITIONAL \$1.50 FOR HANDLING AND MAILING CHARGES.

**CIRCLE 75 ON FREE INFORMATION CARD**

**POPULAR CHIPS**

LM 301	.39
LM 380	1.25
LM 386	.79
NE 564	2.50
LM 565	.89
MC 1330	1.10
MC 1350	1.00
MC 1358	1.10
MC 1458	.49
MC 1496	1.50
LM 1889	1.95
7808	.75
7812	.75
7815	.75
7818	.75
MV 2109	.69
2N2222A	.30
MC1349	1.39

**MITSUMI UES A55F VARACTOR TUNER**  
 CHAN. 14-83  
 400 ohm INPUT \$17.95

**DELUXE PARTS ASSORTMENTS**

#1 Resistors & Trimpots  
 68 .1 watt 5% resistors & 5 PT-15 10K trimpots. 1 each - 51, 75, 100, 470, 1.5K, 3.6K, 51K, 470K, 13-1.2K, 2-220, 3-100K, 6-330, 6-12K, 7-910, 9-3.9K, & 14-4 7K. \$5.25 each

#2 Capacitor "A"  
 Monolytics - 1-560pf, 7-1 mfd, & 1-22 mfd. Silver Micas - 2-10pf, & 1 each of 43pf, 110pf, 560pf, 1200pf, 3000 or 3300pf. \$5.95 each

#3 Capacitor "B"  
 Mylars 4-.001, 2-.047, 29-.01. Radial electrolytics 3-10 mfd 16V, 1-1000 mfd 50V, 1-2200 mfd 35V. Disc Caps 1 each of 5-12, 27, 36, 110, 330pf, 2-120pf, 3-39pf, 3-220pf, and 1 Var. Cap 5-35pf. \$7.50 each

#4 Coil & Chokes  
 1 each of 15, 33, and 100 (uh) micro henries chokes, 1-variable RF coil (same as #49A537MPC) \$3.25 each

#5 IC's, Sockets, & Semi's  
 1 each of: NE564, LM565, MC1330, MC1350, MC1496, LM1889, 7812, 7818, 2N2222A, MV2109, heat sink 2-MC1458, 4-1N4002, 4-8 pin, 2-14 pin, 1-16, & 1-18 pin socket. \$13.25 each

#6 Misc. Hardware  
 LED & holder, fuse & holder, line cord, grommet, SPST switch, DPDT switch, 2-F61 conn. & lugs, knob, 4-spacers, 6-screws & nuts, 2-RG-174, matching transformer w/nut \$5.95 each

## NETWORK SALES, INC.

**RIBBON CABLE CONNECTOR**  
 These very popular 40 PIN ribbon cable connectors are used by a number of mfgs. of micros for internal board to board terminations and I/O port connections.  
**W/strain relief \$2.50**

**DIP SWITCHES**  
 High quality DIP switches mfg. by CTS. Available in the following configurations.

4 POS—80¢ 6 POS—80¢  
 5 POS—80¢ 7 POS—80¢

**40 CONDUCTOR RIBBON CABLE**  
 gray color 70¢/ft.

**DB-25 S (FEMALE)**  
 The most popular computer connector. Mfg. by AMP. .025" gold PC pins with mfg. holes.  
**\$1.95**

**MINI FAN 3.125" SQ.**  
 40 CMF  
 115VAC-60hz  
 REMOVED FROM NEW EQUIP.  
 TESTED \$6.95

**BRIDGE RECTIFIERS**

35A 200 PIV \$2.00  
 25A 100 PIV \$1.50  
 3A 400 PIV \$1.00

**POWER TRANSFORMERS**

Pri: 115V AC  
 Sec: 24 volts @ .350 A  
 Dim: 2 1/4 x 1 x 1 H

\$1.95 ea. 10/\$15.00 100/\$125.00

**THUMBWHEEL SWITCH**  
**\$7.95** BCD 0-9 W/COMPLIMENT  
 (EACH DIGIT ILLUMINATED W/LED)

4 DIGIT W/END PLATES FOR EASY MTG.

**THUMBWHEEL TRIMMER POTS**  
**VERTICAL MOUNT**  
 OHMS 500, 1K, 2K, 5K, 10K, 25K  
 50K, 100K, 200K, 500K, 1 MEG.  
 4/\$1.00 100/\$20.00

**4 TURN TRIM POTS**  
**BOURNS #3339B**  
 1K — 6K R/A — 10K  
**\$1.49 EA.**

**MINI COAX CABLE**  
 RG-174 50ohm .100 OD  
**10 feet/\$1.00**

**SOLID CARBIDE PC DRILL**  
 #55 1/8 in. SHANK FOR USE WITH DREMEL TOOL  
**\$1.00**

**RF COIL**  
 Same as #49A537MPC  
**\$1.50 ea. 10/\$12.50**

**CHOKES**

.33 uh 33 uh  
 .47 uh 100 uh  
 15 uh 10 mh  
 18 uh 69¢ each

**UHF AMP KIT**  
 25 db gain stripline PC board using (2) BFR-90's \$9.95 power supply for above \$3.49

**METAL BOX—PRE-DRILLED**  
 DIM: 10 1/2" W x 4 1/2" D x 3" H  
 HOLES: 4% in back, 1% in front 2 1/4" in front. 6 #6 on bottom  
 PAINTED \$10.95 ea., 10/\$99.50 25/\$223.75

**VARI CAPS**  
 10 - 60 pf 69¢ each  
 30 - 90 pf 69¢ each

**NETWORK SALES, INC.**  
 2343 W. BELMONT AVE.  
 CHICAGO, IL. 60618  
 312-248-3202

TERMS: Visa, M.C., Check, Money Order or COD (add \$3.00). Min. Order \$10.00. Add \$2.50 S&H for USA. Ill. add 7% Tax. **MAIL ORDER ONLY.** Prices subject to change without notice. Phone Orders Welcome. **WRITE FOR OUR MONTHLY UN-ADVERTISED SPECIALS**

“Your dollars fight heart disease and stroke.”



We need your help.

WE'RE FIGHTING FOR YOUR LIFE

# Radio-Electronics

SPECIAL REPRINT  
BUILD THIS ROBOT FOR UNDER \$400



BUILD THIS ROBOT FOR UNDER \$400

**AVAILABLE—COMPLETE for the FIRST TIME!**

## BUILD YOUR OWN ROBOT!

Send today for your 52-page (8½ × 11") booklet containing complete reprints of all eleven articles in the Build Your Own Robot series by Jim Gupton.

This all-inclusive reprint gives you all the data you need to build your own Robot.

■ TELLS EVERYTHING YOU NEED TO KNOW to build the Unicorn-1 Robot without the need for an engineering degree or special equipment. The robot is fully mobile with manipulator arms to grasp, lift and carry.

■ MANIPULATOR ARMS and end-effectors (hands) are what enable the robot to perform useful tasks. Details of construction techniques and considerations are fully explored.

■ MOBILITY BASE is not a lunar space station. It is the drive system that permits the robot to move from here to there. Full construction details along with a discussion of power sources is included.

■ THE BODY—FRAME AND ROTATION MECHANISM. This is the part that makes Unicorn-1 look like a robot. Wood and Formica are the materials for the body. Motors and gears are what make it function.

■ COMMUNICATIONS. How you can tell your robot what to do. Preprogramming techniques...radio control...computer control are all detailed.

■ SENSORS. How to add sensors so your robot doesn't bump into things.

## DIGITAL PRESSURE GAUGE

continued from page 61

both the center conductor and the shield to the sensor—don't rely on the automobile chassis for a ground. Attach an RCA plug (PL1) to the other end of the cable.

The circuit board can be mounted in or under the dashboard. Connect the red wire coming from the board to a source of 12 volts—the point on the fuse block that powers the radio is a good place. (Whenever you take the supply voltage from, make sure that, when the ignition is off, the power is off, too.) Connect the black wire to a point that goes to the negative pole of the car battery. Finally, with the board in place, connect the cable coming from the sensor to J1.

### Noise reduction

There are two types of electrical noise that may give you problems. First, the conversion and display-multiplexing circuitry on the board may cause interference with your AM radio. If that happens first try taking the supply voltage from a point other than the radio fuse. Make sure, though, that the point you choose is active only when the ignition switch is on. Next, move the digital unit away from the radio. Finally, you can enclose the board in a grounded metal case. Just make sure that the board is adequately ventilated.

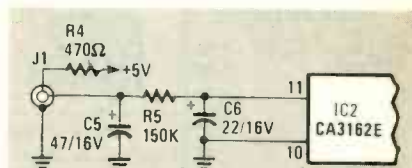

FIG. 7—SOME PRESSURE SENSORS may create electrical noise. This modification will help get rid of it (see text).

The other type of noise can be caused by the sensor unit, particularly the GM547034 or GM14039612 models. That noise can cause the pressure gauge to function erratically. A noise-reduction "fix" is shown in Fig. 7. It consists of first removing R1, C2, and the wire that runs from the center lug of J1 to the board. (These part numbers are the ones shown in Figs. 1 and 3). Then, referring to Fig. 7, install a new 470-ohm resistor (R4) from the five-volt line (there's a trace provided on the board to the left of pin 8 of IC2) to the center lug of J1. Also connect to that lug a 150K resistor (R5). The other end of that resistor goes to the hole in the board that was occupied by the old R1. Connect a 47-μF electrolytic capacitor (C5) between the center lug of J1 and the ground foil on the board. That's done either by soldering the capacitor lead to the shell of the jack, or by running it over the edge of the board to the foil side. Finally, connect a 22-μF electrolytic capacitor (C6) in place of the old C2. R-E

### Radio-Electronics

Robot Reprints  
200 Park Ave. South  
New York, N.Y. 10003

Please print

9-83

I want to order \_\_\_\_\_ reprints @\$12.00 plus \$1.00 postage and handling for U.S., Canada and Mexico.  
Add 99c sales tax for New York State residents only.  
U.S. Funds only.  
I want to order \_\_\_\_\_ reprints @\$12.00 plus \$3.00 Air Postage and handling for all other countries.  
U.S. Funds only.

(Name)

(Street address)

(City)

(State)

(Zip)

Allow 6-8 weeks for delivery.

We do not bill, check must be enclosed.



**Radio-Electronics** #7 \$2.25 SUMMER 1983 48784

# Special Projects

The magazine for people who build electronic projects

**SYNDLE**  
The Electronic Candle that flickers like a Wax Taper

**MAKE PRO CABINETS**  
for Home-Brew Projects

**Build it for FUN**

- 3-Band Shortwave Converter
- Electronic Slot Machine
- Preamplifier for moving coil Phono Cartridge
- Soundbox-80 for Computer Game Sounds
- Prototyping Power Supply

**Test Gear Projects**

- Ribbon-Cable Tester
- Meg-O-Dapter for DVM
- Mini-Audio Generator
- Scope Calibrator
- Single Sweeper One Blanker

**PLUS....**

**JBL Sound System**  
for the musician!

# INTRODUCING OUR NEW SUBSCRIPTION OFFER!

## Become a Charter Member Subscriber!

## Get every issue!

## SUBSCRIBE TODAY!

## Use the order form below.

## Subscribe Today!

■ IF YOU'RE THE KIND OF READER that doesn't want to wait, you can order your next copy of **Special Projects** now. **Special Projects** is crammed full of electronic projects that you won't be able to wait to build for yourself. You can expect top-notch digital projects, fun-to-play electronic games, valuable add-on computer projects, BCB and shortwave receivers, photographic/darkroom gadgets, devices to improve your car's performance, test equipment ideas, and more in every jam-packed issue of **Special Projects**.

■ TO HELP YOU TO BE SURE that you don't miss any future issues of **Special Projects**—SUBSCRIPTIONS ARE NOW AVAILABLE!

■ YOU CAN HAVE THE NEXT FOUR ISSUES of **Special Projects** delivered directly to your home for only \$9.00. We pay the postage. If you want the next eight issues, you can even save a dollar off the newsstand price. Get eight issues for \$17.00.

■ EVERY ISSUE OF SPECIAL PROJECTS will continue to contain a variety of construction articles to suit every taste. In addition, feature articles on electronics fundamentals, test equipment and tools will round out each issue. Of course, we will continue to provide new product and literature listings to keep you up to date on the latest developments in electronic technology.

■ GET IN ON THE ACTION! Order your next issue of **Special Projects** today. Use the convenient order coupon below.

### Special Projects SUBSCRIPTION

Detach and mail today to:  
SPECIAL PROJECTS  
SUBSCRIPTION DEPT.  
200 PARK AVE. SOUTH  
NEW YORK, N.Y. 10003

CASH WITH ORDER ONLY **RE9-83**  
Allow 6-8 weeks for the first issue to arrive.

Please print

- I want to be sure I don't miss any issues. Send me the next four issues of **Special Projects** for \$9.00; starting with #8. Postage is free in U.S. For Canada add \$3.00. Foreign add \$7.00.
- I want to be sure I don't miss any issues and want to save \$1.00 too. Send me the next eight issues of **Special Projects** for \$17.00; Starting with #8. Postage is free in U.S. For Canada add \$6.00. Foreign add \$14.00.
- Send me \_\_\_\_\_ copies of **Special Projects** #8 at \$2.25 plus \$1.00 postage and handling for U.S., Canada and Mexico. U.S. funds only. All other countries add \$2.00.

(Name)

(Street Address)

(City)

(State)

(Zip)

DSP

# SPARTAN Electronics Inc.



CALL MAIL  
(516) 499-9500

6094 Jericho Tpke.  
Commack, N.Y. 11725

CTC9R

## Philips Remote Cable Converter

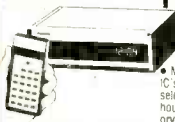

• Micro computer technology • Quartz controlled IC's lock in picture & prevent drift • 60 channel selections • Programmable time on & off • 24 hour LED digital clock • Favorite channel memory & recall plus scan • Wireless hand held infra-red transmitter system • Automatic fine tune • Adaptable to any brand television • One year warranty service.

**\$139.95**

## CABLE TV ACCESSORIES

2 set coupler	2.95
Coax Cable 100'	9.95
4 set coupler	4.50
F Connectors	.25
Matching transformer	.99
TV Game Switch	3.95
VHF-UHF AMP-28DB	29.95
Crimp Tool for F Conn.	8.95

## 700' CORDLESS PHONE

FM duplex circuitry. Last number redial. Base can signal remote to pick-up. Rechargeable ni-cad batteries.



Mura 400

**\$89.95**

## SGL WABER \$35.95

Protect your computer and electronic equipment from voltage spikes

DG115P  
DG115S  
(6 Outlet)  
**\$45.95**



## WINEGARD FM CAR ANTENNA BOOSTER



Amplifies FM radio signals an average of 18dB (8 times) improves car radio reception and extends range to allow greater selection of stations. Switch and indicator light attaches to lower edge of dash. 24" cable with Motorola plugs provided. Installs in minutes. Great for window antennas.

**\$26.95**

## REFURBISHED MONITORS

9", 12", Commercial Grade as low as **\$39.95**



## 10KM Cordless Telephone



Model 5500M (modified) **\$325.00**  
External Antenna required  
For export use only

## BECKMAN CIRCUITMATE 20

8 functions and 30 ranges - Diode/transistor test function - auto-polarity, auto-zero, and auto-decimal - 10 Amps AC and DC Current Capability - Transistor Gain Test (hFE) - Conductance



**\$64.95**

## Jerrold 36 Channel Remote CATV Converter

w/on/off Fine Tuning \$94.95  
58 Channel Wireless \$109.95



## 40 Channel VHF to UHF Block Converter



28.95 Ea.  
24.95 4 & up

Deluxe Version - Features fine tuning knob, matching X former & 2 cables \$38.95

Dealers Welcome

Visa, MC, BAC, Amex. All above prices include 4% cash discount. C.O.D. money order, check Add for Shipping.

## Volume Discounts

Min. Order \$25.00		
International Shipping Add'l.	76.00 to 250.00	\$4.50
Prices subject to change without notice.	251.00 to 500.00	\$6.00
COD 2.00 Extra	501.00 to 750.00	\$8.50
*Add'l. shipping for monitors	751.00 to 1000.00	\$12.00
	Over 1000.00	\$12.50

(516) 499-9500 Mon Th Tu W F Sa  
9-8 9-6 9:30-5

# ADVERTISING INDEX

RADIO-ELECTRONICS does not assume any responsibility for errors that may appear in the index below.

## Free Information Number Page

3	Active Electronic	128
7	Advance Electronics	13,26,27
80	Advanced Computer Products	129
73	All Electronics Corp.	113
51	AMC Sales	130
56	AP Products	Cover IV
64	Appliance Service	102
89	Arizona Electronic Surplus	117
60	BBC Metrawatt	9
41,78	Beckman Instruments	85, Cover III
67	Beta Electronics	114
77	BK Precision Dynascan	29
5	Byte-Ryte	5
18	C D Electronics	122
34	CEI	32
—	Chaney Electronics	130
—	CIE, Cleveland Institute of Electronics	34-37
81	Communications Electronics	2
88	Components Express	128
68	Computer Products & Peripherals	118
61	Concord	132
92	Daetron	79
—	Decoder Distributors	103
39	Digi-Key Corporation	120,121
11	Digitron	118
53	Direct Video Sales	78
99	Dokay Computer Products	115
59	EICO	98
45	Electronic Rainbow	41
6	Electronic Specialists	122
72	Electronic Technology Today	77
33	Electronic Warehouse	31
50	ETCO	133
10	Etronix	98
40	Firestick Antenna	98
—	Fordham Radio	21,83
76	Formula International	112
21	Gamma Electronics	128
84	Gilco International	118
31	Global Specialties	42
26	Gloucester Computer	79
69	Goldsmith Scientific	101
—	Grantham Schools	101
75	Hal-tronix	133
—	Handyman	93
16	Heath	68-71
85	Hickok Electrical Instrument	40
—	ICS Computer Training	99
94	Illinois Audio	95
20	Jameco Electronics	110,111
29	Javanco	132
49	JDR Microdevices	123-127
62	Jenks, W.S. Son	104
70	Jensen Tools	102
63	J W Electronics	103
46	Kalgo Electronics	79
83	KCS Electronics	130
43	Keithley	15
48	Kikisui	25
66	MFJ Enterprises	93
97	Michigan Electronic Products	103
17	Micro Management	116
—	Microsignal	79
12	Mouser Electronics	122
—	Netronics R D Ltd.	20
90	Network Sales	133
—	New Horizons	23,39
—	Newtone Electronics	40
—	NRI Schools	16-19
—	NTS Schools	86-89
37	Ora Electronics	30
91	Pacific I	102
52	PAIA Electronics	101
—	Philips-Tech Electronics	130
42	Philmetric	81
30	Professional Video	132
—	Radio-Electronics Reprint Bookstore	104
86	Radio Shack	109
79	Ramsay Electronics	119
27	R.F. Electronics	117
32	Sams Books	95
—	Scientific Systems	133
25	SCR Electronics Center	116

55	SEI	122
71,87	Sencore	1
54	Simpson Electric	22
82	Sintec Co.	38
23	Solid State Sales	116
47	Spartan Electronics	136
—	Symmetric Sound Systems	103
38	Taft Electronics	91
8	Technical Electronics	130
74	Tektronix	7
65	Teletone	103
—	T.V Products	102,103
57	Ungar	102
14	Vaco Products	Cover II
19	Vector Electronic	28
58	VIZ Manufacturing	33
95	Wersi	99
13	Westech	131
15	Yield House	24

Take stock in America.

## MOVING?

Don't miss a single copy of **Radio-Electronics**. Give us:

Six weeks' notice

Your old address and zip code

Your new address and zip code

ATTACH LABEL HERE

name (please print)

address

city state zip code

Mail to: Radio-Electronics  
SUBSCRIPTION DEPT., P.O. BOX 2520,  
BOULDER, COLO. 80322



Drop-proof



Overload-proof



Contamination-proof

# Oops proof.

Now there's a new breed of Beckman hand-held DMMs tough enough to withstand accidental drops, input overloads and destructive environments.

The new HD100 and HD110 DMMs are drop-proof, packed with overload protection and sealed against contamination. You won't find more rugged meters than the Beckman HDs. Inside or out.



## Drop Proof

Constructed of double-thick thermoplastics, the HD100 series DMMs resist damage even after repeated falls. All components are heavy-duty and shock mounted.

## Contamination Proof

The HD series meters are designed to keep working even around dirt, heavy grime, water and oil. The special o-ring seals, ultrasonically-welded display window and sealed input jacks protect the internal electronics of the HD meters. The oops-proof meters are sealed so tightly, they even float in water.

## Accidental Overload Protection

All DC voltage inputs are protected up to 1500 Vdc or 1000 Vrms. Current ranges are protected to 2A/600V with resistance ranges protected to 600 Vdc. Transient protection extends up to 6KV for 10 microseconds.

## More Meter for Your Money

For starters you can get 2000 hours of continuous use from a CIRCLE 78 ON FREE INFORMATION CARD

common 9V transistor battery. You can run in-circuit diode tests and check continuity. You even get a one year warranty.

The 0.25% basic dc volt accuracy HD meters serve you with 7 functions and 27 ranges. The HD 110 also gives you 10 AMPS ac and dc. With one simple turn of the single selector switch, you can go directly to the function and range you need. There's less chance of error.

Also available is the electrical service kit. It includes the meter of your choice, a current clamp, deluxe test leads and a heavy-duty case designed to carry both meter and accessories, conveniently.

Feature for feature you can't find a more dependable meter with prices starting at just \$169 (U.S. only).

To locate your nearest distributor, write Beckman Instruments, Inc., Instrumentation Products, 2500 Harbor Blvd., Fullerton, CA 92634 or call (714) 993-8803.

# BECKMAN



# Last night Mark Davis started over from scratch. Without wasting so much as a lead wire.

Some day Mark will be working on bigger projects. But right now, he's learning. Fortunately, the new ACE 109 solderless breadboard from A P PRODUCTS, just made learning a lot more affordable.



**ACE 109 SOLDERLESS BREADBOARD  
PRICED UNDER \$20\***  
\* SUGGESTED U.S. RESALE PRICE

The ACE 109 is the newest, lowest priced All Circuit Evaluator in the A P PRODUCTS line. It has a universal matrix of 840 solderless plug-in tie-points. And is ideal for designing, testing and modifying small circuits. ACE 109 has three, standard 5-way binding posts for easy access to power sources.

With an ACE 109, there's no wiring, soldering or desoldering. Just plug in your components and interconnect them with ordinary solid hook-up wire. If you want to make a circuit change, just unplug the components involved and start over. It's just that easy.

Every ACE breadboard makes circuitry easy, fast, flexible. Now A P PRODUCTS has made it even more affordable. The **ACE 109 is priced under \$20\***

Look for the complete line of ACE breadboards and other A P PRODUCTS at your favorite electronics distributor. For the name of the A P PRODUCTS distributor nearest you, call Toll-Free: (800) 321-9668.

(In Ohio, call collect (215) 354-2101.)

**Make the A P connection.**



A P PRODUCTS INCORPORATED • 9450 Pineneedle Drive • P.O. Box 540 • Mentor, Ohio 44060 • (216) 354-2101 • TWX: 310-425-2250  
In Europe, contact A P PRODUCTS GmbH • Baumlesweg 21 • D-7031 Weil 1 • West Germany

CIRCLE 56 ON FREE INFORMATION CARD