

# Radio-Electronics®

FOR MEN WITH IDEAS IN ELECTRONICS

**NEW DVM FITS  
YOUR HAND**

## COMMUNICATIONS 1974

- CB equipment roundup
- modern receiver circuits
- CB radio alignment
- new CB designs

**LEN FELDMAN  
EXAMINES NEW  
HI-FI CIRCUITS**

**CHECK  
ELECTRONIC FLASH  
BUILD A  
BLITZMETER**





# Stocking only 49 ECG™ semiconductors is like having thousands of audio transistors on hand.

Manufacturers of TV, radio and stereo systems have audio transistor replacements listed under thousands of different part numbers.

But, thanks to the Sylvania ECG semiconductor replacement guide, you can replace practically all of them with just 49 different transistors.

And that can save a lot of hunting and stocking, especially when you're a busy service dealer.

For example, if you need a low-noise, high-gain NPN-silicon transistor for an audio preamp, check out our ECG-199. It fits a lot of sockets.

And if import parts are bugging you, our ECG-158, 176, 226 and 226MP are direct replacements for parts like the 2SB405, 2SB474 and 2SB492 plus a lot of others you'll find in our guide.

But, our cross-reference guide (ECG-212E) lists a lot more than just audio transistors. It lists over 75,000 parts that can be replaced with a minimum number of Sylvania ECG parts.

For you, it means one source for practically all your replacement needs, including industrial components.

What more could anyone ask for?

**GTE SYLVANIA**



# A SPECIAL OFFER FROM MITS

Purchase a MITS 941M or a MITS 908M – and for an additional \$20, receive a 605M.

Soon the world will be calculated by the metric system

## The MITS 941M handheld

calculator converts to metric instantly – accurately – electronically.



### 41 FUNCTIONS:

- ARITHMETIC + - x ÷ %
- METRIC
- 8 LENGTH
- 8 VOLUME
- 8 AREA
- 2 TEMPERATURE
- 6 LIQUID
- 4 MASS

### FULL OPERATION MEMORY.

- Chain calculation
- Full floating decimal
- Leading and trailing zero suppression
- True credit balance
- Algebraic entry system
- 8 digit read out

### INDICATORS Sign

- Low battery • Overflow
- Math error

941M PRICES\* Assembled ..... \$149.95  
Kit ..... \$129.95

SIZE 146.05mm x 82.55mm x 38.10mm  
(5-3/4" x 3-1/4" x 1-1/2")

**The MITS 605M** handheld calculator / 6-digit readout / 5 functions (addition, subtraction, multiplication, division, and percentages).

**MEMORY:** • Stores intermediate results  
• Stores a constant  
• Accumulates results

Fixed or Floating Decimal... and much more

**The MITS 905M** handheld calculator (same features as 605M, plus an 8-digit readout).

Size of Both: 5-3/4" x 3 1/4" x 1 1/2"

Kit Assembled

Prices: 605M \$49.95 \$59.95  
905M \$59.95 \$69.95

\*Prices subject to change without notice

## The MITS 908M handheld

calculator offers 8 functions (addition, subtraction, multiplication, division, square root, square, percentage, and reciprocal) and a handful of features

### MEMORY can be used as:

- a constant
- a temporary storage
- register
- an accumulator

### Fixed and floating decimal (operators choice)

- Chain and mixed operations
- 8 digit readout – bright LED display
- 100% American made
- Algebraic entry system



### Special Readouts

- Negative result • Entry overflow • result overflow
- low battery • Math error

SIZE 5-3/4" x 3-1/4" x 1-1/2"

908M PRICES\* Assembled ..... \$129.95  
Kit ..... \$99.95

\*Prices subject to change without notice

### ACCESSORIES

AC adapter for 117 VAC operation ..... \$6.95  
Carrying case (leatherette) ..... \$5.95

### WARRANTY

Full two-year warranty on assembled models, including parts and labor; on kit models: ninety-day warranty on parts

• Available from your local  
**Olson Electronics Dealer.**

# MITS®

## Micro Instrumentation & Telemetry Systems, Inc.

6328 Linn, N.E., Albuquerque, New Mexico 87108  
505/265-7553 Telex Number 660401

Enclosed is a Check for \$ \_\_\_\_\_

or  BankAmericard # \_\_\_\_\_ Accessories

or  Master Charge # \_\_\_\_\_  AC Adapter

Credit Card Expiration Date \_\_\_\_\_  Carrying Case

Include \$5.00 for Postage and Handling  Kit  Assembled

Model # \_\_\_\_\_ Model # \_\_\_\_\_

Please Send Information on Entire MITS Line.

NAME \_\_\_\_\_

ADDRESS \_\_\_\_\_

CITY \_\_\_\_\_

STATE & ZIP \_\_\_\_\_

MITS/ 6328 Linn, N.E., Albuquerque, New Mexico 87108 505/265-7553 Telex # 660401



Modular sound control center I.\*

**Mix, shape, add reverb for \$223.**

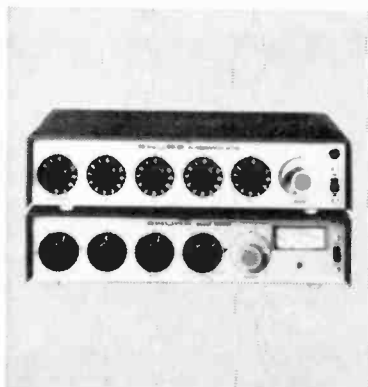

Shure supplies the ingenuity and the components—but you take the credit for one of the most clever, most economical sound reinforcement “consoles” ever devised! Here’s how: Install a Shure M68RM mixer, stacked with a Shure M63 Audio Master. The M68RM handles the input of up to four microphones, accepts a separate high level signal (such as a tape recorder or tuner signal), and has variable-intensity reverberation capability. The ingenious M63 gives you high and low frequency filters with separate bass and treble controls, so output signals can be tuned to a wide variety of response characteristics to suit program material to room acoustics—providing low-cost room/system equalization and better feedback control. It delivers precisely the audio control needed—no more, no less. And it’s expandable for future needs. Great idea, great components, great price!

\*More to come . . . other ingenious sound control centers will be discussed.

Shure Brothers Inc.  
222 Hartrey Ave., Evanston, Illinois 60204  
In Canada: A. C. Simmonds & Sons Ltd.



# Radio-Electronics

FOR MEN WITH IDEAS IN ELECTRONICS  
More than 65 years of electronics publishing

JANUARY 1974

- COMMUNICATIONS**
- 24 **CB Round-up; What's New**  
What's available in transceivers and accessories now.  
*by Herb Friedman*
- 33 **Modern Receiver Circuits**  
Take a look at the modern communications superhet. It's an eye-opener. *by Raymond S. Moore*
- 36 **New CB Circuits**  
Frequency synthesis, channel 9 monitor, SSB noise eliminators and agc circuits are examined.  
*by Robert F. Scott*
- 44 **CB Alignment**  
Use another CB rig as your alignment equipment.  
*by Andrew Mueller*

- HI-FI STEREO AUDIO**
- 40 **New Stereo Circuits**  
Improved two-channel multiplex decoding and direct-drive turntables. *by Len Feldman*

- TELEVISION**
- 22 **Equipment Report**  
Hewlett-Packard 970A multimeter probe
- 60 **Step-By-Step Troubleshooting**  
Power supplies in the solid-state receiver. *by Stan Prentiss*
- 62 **R-E's Replacement Transistor Guide**  
2N2402 to 2N2619. *by Robert & Elizabeth Scott*
- 65 **Service Clinic**  
OTL vertical sweep. *by Jack Darr*
- 72 **Reader Questions**  
R-E's Service Editor solves reader problems.

- BUILD**
- 50 **Blitzmeter For Electronic Flash**  
Electronic meter measures the output of your strobe.  
*by James Gupton*

- GENERAL ELECTRONICS**
- 4 **Looking Ahead**  
Tomorrow's news today. *by David Lachenbruch*
- 14 **Appliance Clinic**  
Solid-state ignition for lawn mowers. *by Jack Darr*
- 53 **Technical Topics**  
Two new pieces of test equipment, a regenerative detector and a random-order flasher are described.  
*by Robert F. Scott*

- DEPARTMENTS**
- |    |                |    |              |
|----|----------------|----|--------------|
| 16 | Letters        | 78 | New Products |
| 6  | New & Timely   | 88 | Next Month   |
| 81 | New Literature |    |              |

## ON THE COVER

It's a cinch to take resistance readings with Hewlett-Packard's new digital multimeter. Here we are probing inside a Lafayette model 625 CB transceiver. For a full report on this unit turn to page 22.



NEW CB EQUIPMENT is full of the latest circuit features. Learn what they are and how they work.

... see page 36

Hugo Gernsback (1884-1967)  
founder  
M. Harvey Gernsback, editor-in-chief  
and publisher  
Larry Steckler, CET, editor  
Robert F. Scott, W2PWG CET, technical editor  
Jack Darr, CET, service editor  
I. Queen, editorial associate  
Leonard Feldman, contributing high-fidelity  
editor  
David Lachenbruch, contributing editor  
Barbara Schwartz, editorial assistant  
Vincent P. Cienca, production manager  
Sarah Martin, production assistant  
Harriet I. Matysko, circulation director  
Arlene R. Fishman, advertising coordinator

Radio-Electronics is indexed in *Applied Science & Technology Index* and *Readers Guide to Periodical Literature*.



Radio-Electronics, January 1974, Vol. 45, No. 1. Published monthly by Gernsback Publications, Inc., 200 Park Avenue South, New York City 10003. Second-class postage paid at New York, N.Y., and additional mailing office. One-year subscription rate: U.S.A., U.S. possessions and Canada, \$7. Pan-American countries, \$8. Other countries, \$8.50. Single copies 60c. © 1973 by Gernsback Publications, Inc. All rights reserved. Printed in U.S.A.

**Subscription Service:** Mail all subscription orders, changes, correspondence and Postmaster Notices of undelivered copies (Form 3579) to Radio-Electronics Subscription Service, Boulder, Colo. 80302.

A stamped self-addressed envelope must accompany all submitted manuscripts and/or artwork or photographs if their return is desired should they be rejected. We disclaim any responsibility for the loss or damage of manuscripts and/or artwork or photographs while in our possession or otherwise.

As a service to readers, Radio-Electronics publishes available plans or information relating to newsworthy products, techniques and scientific and technological developments. Because of possible variances in the quality and condition of materials and workmanship used by readers, Radio-Electronics disclaims any responsibility for the safe and proper functioning of reader-built projects based upon or from plans or information published in this magazine.

# looking ahead

## Compatible videodisc?

**Cannes, France** — This month Telefunken begins marketing the world's first home videodisc system, as reported in this column in December. Telefunken's is a mechanical system, a "pressure stylus" reading out hill-and-dale impressions embossed on a flexible disc revolving at 1,500 rpm (for European color TV standards).

Several other firms—notably Philips of Holland and MCA Disco-Vision of Universal City, Calif.—have offered all-electronic approaches to videodiscs, using low-cost lasers to read out "pits" in a reflective disc. Although neither the Philips nor the MCA system is due on the market before mid-1975, their imminence has raised a question of standardization of home TV disc techniques.

Now along comes a major French firm which claims it has a laser-beam opto-electronic videodisc system which can play back its own discs and the Telefunken discs, and potentially any other disc which spins at a rate synchronous with the TV frame rate (1,500 rpm in Europe, 1,800 for the American and Japanese TV systems).

At the VIDCA videocassette-videodisc conference here, Thomson-CSF announced (but didn't demonstrate) the development of this compatible system, designed to retail at a price rivalling the Telefunken system's \$450, and claimed it would play back 20- to 25-minute LP discs as well as Telefunken's 10-minute records.

The Thomson-CSF disc, as already reported here, is already reported here, is transparent, rather than reflective. A low-powered laser is beamed through the disc, and tiny "pits" in the flexible disc's surface refract the light. The refracted light is then trans-

lated into video and audio signals. The Thomson disc, like the Telefunken version, floats on an "air cushion," and Thomson engineers claim that this air-bearing effect makes unnecessary elaborate servo systems to keep the laser beam focused exactly on the pits pressed into the disc.

Thomson claims that its system can play back a Telefunken pressure-type disc, if the latter is pressed on transparent plastic. The laser beam is said to be able to read the hill-and-dale impressions on the Telefunken disc system as well as the pits on Thomson's own discs. Thomson officials also said they are working on techniques to play back Philips discs with their equipment. As are Philips, MCA and Telefunken, Thomson is currently wooing manufacturers in the United States, Japan and Europe.

## One for the road

A unique highway radio system is now being phased into operation in Germany through the cooperation of the federal government, the state-operated radio systems and car radio manufacturers. The system, whose development is credited to Blaupunkt (Robert Bosch Co.), is designed to keep motorists fully informed of highway conditions, detours, traffic jams, etc. at all times, with a minimum effort on the part of the driver.

The system is being introduced in three phases, and depends on interaction between the broadcasting station and the car radio. Phase 1 is currently in operation: A regular FM station transmits highway information supplied by the police, auto clubs and other sources, along with its regular programming. In addition, it transmits a 57-kHz pilot signal. In Germany, 80% to 90% of auto radios have FM, and all car radios built in the

last five years contain tape jacks. Radio manufacturers are offering (at about \$20) an adaptor which plugs into the tape jack.

A light on the adaptor, activated by the pilot signal, indicates when the highway information is on the air. A special pushbutton mutes all stations not carrying the road information, so that the information channel may be easily found. A second version, for signal-seeking radios, automatically tunes to the highway station when the pushbutton is pressed.

All of West Germany eventually will be divided into seven sectors for highway information. Phase 2 of the program, currently being tested, permits the motorist to select the highway-information station from a neighboring sector, to get a preview of road conditions ahead, or to determine whether to move to the adjoining sector for better driving.

Phase 3 is aimed at people who don't like to drive with music. It will permit the motorist to tune to the highway information station, push a button and enjoy silence—muting all programming except road condition bulletins.

## Satellite broadcasting

**New Delhi, India**—India is currently preparing for the first regular system of direct satellite-to-TV-set broadcasting. Scheduled to start in June 1975, the system will be designed to bring educational broadcasts to remote villages which can't be reached by conventional TV. The satellite, to be launched by NASA, will first be tested over the Rocky Mountain states, then moved to a synchronous position over India. An Indian government-controlled factory is already preparing to manufacture ruggedized solid-state receivers designed to be powered by 12-volt storage batteries—

since many of the villages have no electricity. Each receiver will be fitted with a special front-end adaptor tuned to the satellite's frequency and a portable parabolic antenna. The receiver-antenna system will cost less than \$400 to produce.

The receiver installations will be located in school and other public places, to carry school, agricultural and public health information. Although the test satellite will be stationed above India for only one year, the Indian government already has plans to build its own synchronous satellite for 1976 launching by "a friendly country," to continue the program.

## Super-8 TV

Another delay in do-it-yourself video: Eastman Kodak's introduction of a super-8 vision-and-sound cartridge film attachment for home color sets has been postponed until spring. Initially, it was to have been introduced at the end of 1973. The Kodak unit is only one of three systems which permit hobbyists—or professionals—to display their super-8 films on conventional TV screens. The first to reach the market is being built in Japan by Fuji Film. In Germany, television manufacturer NordMende is aiming at marketing next May of its own system. None of the systems are compatible because they use different types of super-8 film cartridges—a Kodak cartridge for the Kodak unit, Fairchild cartridge for NordMende, special Fuji cartridge for Fuji's unit (although an adapter permits the showing of open-reel super-8 on the latter). All three systems are designed to accommodate film made with magnetic soundtracks.

by DAVID LACHENBRUCH  
CONTRIBUTING EDITOR

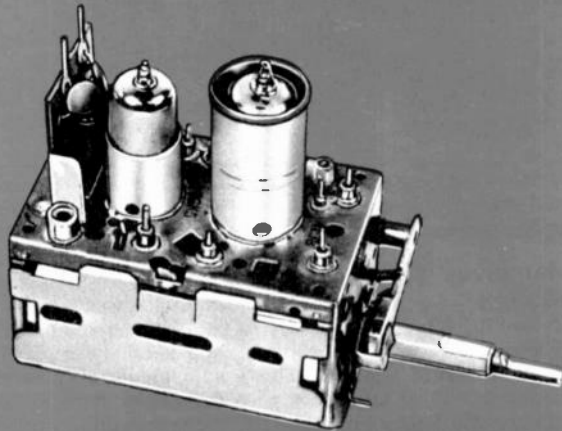

# \$9.95

ALL PARTS INCLUDED

except tubes and transistors

ONE YEAR GUARANTEE

## TUNER SERVICE CORPORATION

PROVIDES YOU WITH A COMPLETE SERVICE FOR ALL YOUR TELEVISION TUNER REQUIREMENTS.

### REPAIR

VHF Or UHF Any Type \$9.95.  
 UHF/VHF Combo \$15.00.  
 In this price all parts are included. Tubes, transistors, diodes, and nuvistors are charged extra.  
 Fast efficient service at our conveniently located service centers. This price does not cover mutilated tuners.  
 All tuners are cleaned ultrasonically, repaired, realigned and air tested.

### REPLACE

Universal Replacement Tuner \$9.95.  
 This price buys you a complete new tuner built specifically by SARKES TARZIAN INC. for this purpose.  
 All shafts have a maximum length of 10" which can be cut to 1 1/2".  
 Specify heater type parallel and series 450mA or 600mA.

### CUSTOMIZE

Customized tuners are available at a cost of only \$15.95. (With trade-in \$13.95)  
 Send in your original tuner for comparison purposes to:

## TUNER SERVICE CORPORATION FACTORY-SUPERVISED TUNER SERVICE

Backed by the largest tuner manufacturer in the U.S.—SARKES TARZIAN, Inc.



WATCH US GROW

HEADQUARTERS . . .	BLOOMINGTON, INDIANA 47401, . . .	537 South Walnut St. . . . .	Tel: 812-334-0411
ARIZONA . . . . .	TUCSON, ARIZONA 85713, . . . . .	1528 S. 8th St. (P.O. Box 4534) . . . . .	Tel: 602-7919243
CALIFORNIA . . . . .	BURLINGAME, CALIFORNIA 94010, . . . . .	1324 Marsten Road . . . . .	Tel: 415-347-5728
CALIFORNIA . . . . .	MODESTO, CALIFORNIA 95351, . . . . .	123 Phoenix Ave. . . . .	Tel: 209-521-8051
CALIFORNIA . . . . .	NORTH HOLLYWOOD, CALIF. 91691, . . . . .	10654 Magnolia Blvd. . . . .	Tel: 213-769-2720
FLORIDA . . . . .	TAMPA, FLORIDA 33606, . . . . .	1505 Cypress St. . . . .	Tel: 813-253-0324
GEORGIA . . . . .	ATLANTA, GEORGIA 30310, . . . . .	938 Gordon St., S.W . . . . .	Tel: 404-758-2232
ILLINOIS . . . . .	CHICAGO, ILLINOIS 60621, . . . . .	737 W. 55th St. . . . .	Tel: 312-873-5556-7
ILLINOIS . . . . .	SKOKIE, ILLINOIS 60076, . . . . .	5110 W. Brown St. . . . .	Tel: 312-675-0230
INDIANA . . . . .	INDIANAPOLIS, IND. 46204, . . . . .	817 N. Pennsylvania St. . . . .	Tel: 317-632-3493
INDIANA . . . . .	HAMMOND, INDIANA 46323, . . . . .	6833 Grand Ave. . . . .	Tel: 219-845-2676
KENTUCKY . . . . .	LOUISVILLE, KENTUCKY 40208, . . . . .	2920 Taylor Blvd. . . . .	Tel: 502-634-3334
MARYLAND . . . . .	BALTIMORE, MD. 21215, . . . . .	5505 Reisterstown Rd. (P.O. Box 2624) . . . . .	Tel: 301-358-1186
MISSOURI . . . . .	ST. LOUIS, MO. 63132, . . . . .	10530 Page Ave. . . . .	Tel: 314-429-0633
NEVADA . . . . .	LAS VEGAS, NEVADA 89108, . . . . .	3816 Vegas Drive . . . . .	Tel: 702-648-1450
NEW JERSEY . . . . .	JERSEY CITY, NEW JERSEY 07307, . . . . .	547-49 Tonnele Ave. (On U.S. Highway 1 & 9) . . . . .	Tel: 201-792-3730
NEW JERSEY . . . . .	TRENTON, NEW JERSEY 08638, . . . . .	901 N. Olden Ave. . . . .	Tel: 609-393-0999
OHIO . . . . .	CINCINNATI, OHIO 45216, . . . . .	7450 Vine St. . . . .	Tel: 513-821-5080
OHIO . . . . .	CLEVELAND, OHIO 44109, . . . . .	4597 Pearl Road . . . . .	Tel: 216-741-2314
OHIO . . . . .	TOLEDO, OHIO 43624, . . . . .	119 N. Erie St. . . . .	Tel: 419-243-6733
OREGON . . . . .	PORTLAND, OREGON 97210, . . . . .	1732 N.W. 25th Ave. . . . .	Tel: 503-222-9059
TENNESSEE . . . . .	GREENVILLE, TENNESSEE 37743, . . . . .	1215 Snapps Ferry Rd. . . . .	Tel: 615-639-8451
TENNESSEE . . . . .	MEMPHIS, TENNESSEE 38111, . . . . .	3158 Barron Ave. . . . .	Tel: 901-458-2355
TEXAS . . . . .	DALLAS, TEXAS 75218, . . . . .	11540 Garland Rd. . . . .	Tel: 214-327-8413
VIRGINIA . . . . .	NORFOLK, VIRGINIA 23502, . . . . .	4538 E. Princess Anne Rd. . . . .	Tel: 804-855-2578-9955

Franchises available-Contact headquarters for information.  
 Circle 3 on reader service card



## New pacemaker battery will run for 10 years

A new chemical (sodium-bromine) cell with an estimated life five times that of the mercury-zinc batteries now used in pacemakers is now undergoing tests in General Electric's Medical Systems Business Division, Milwaukee. The new battery is only half the size and quarter the weight of the mercury-zinc cells now used, and its voltage (3.6) is nearly three times that of the mercury cell. It can store 170 watt-hours of energy per pound, or 15 watt-hours per cubic inch, as compared to the mercury-zinc's 50 watt-hours per pound, or 8 watt-hours per cubic inch.



**NEW BATTERY WILL LAST TEN YEARS.** Designed for use as an implanted battery for pacemakers (devices that keep the heart beating in correct time) it will last five times as long as conventional pacemaker batteries, which have to be replaced by surgery every two years.

The new discovery established the chemical cell as the ultimate answer to the problem of powering pacemakers, believes Dr. Arthur Bueche, GE's vice president for research, and as superior to nuclear power sources or other proposed means of powering the devices. "The new long-life electrochemical power source," he pointed out, "would completely eliminate any hazard with the radioactivity of nuclear batteries and would greatly extend the intervals between replacement surgery for users of chemically powered pacemakers." In addition, the price of pacemakers powered with the new battery is expected to be a fraction of the cost of nuclear pacemakers (now estimated to be about \$4,800).

The cell has a bromine cathode, a sodium-amalgam anode and a beta alumina ceramic electrolyte. Sodium ions travel through the ceramic electrolyte and react with the bromine, forming sodium bromide salt. The ceramic electrolyte prevents contact between reactive materials, eliminating the self-discharge and cell shorting that reduces the life of batteries that have a liquid electrolyte. Shelf

life is virtually unlimited. Size of the unit is 1¼ inches in diameter by ⅜ inch high. It weighs about one ounce.

## Avery Fisher gives \$8-million to Philharmonic Hall

High-fidelity enthusiast and manufacturer Avery Fisher has made a donation estimated to be between \$8 and \$10 million to Philharmonic Hall of New York's Lincoln Center for the Performing Arts. Philharmonic Hall was immediately renamed Avery Fisher Hall.

Unlike many such large donations, which are often tagged for new buildings or ambitious projects, eighty per cent of the donation will be used for the running expenses of Philharmonic Hall, which up to the present have exceeded receipts by about half a million dollars a year. Twenty per cent of the grant will be devoted to a fellowship program designed to encourage and develop the careers of young American instrumentalists.

Mr. Fisher, himself an amateur violinist and a professional and amateur book designer and typographer, started his high-fidelity business in 1937, after a period of home construction of high-quality audio equipment for friends. Interestingly, the new venture was at first called Philharmonic Radio. Later, the name Fisher was adopted and became synonymous to knowledgeable audiophiles with the best in audio equipment.

In 1971, Mr. Fisher sold his Fisher Radio Co. to the Emerson Electric Co. of St. Louis for about \$30 million. "From that point on," he says, "I began to think about what I would want to do with such assets, far beyond the needs of myself and my family." Realizing that he "owed it all to live music and live musicians," he decided on the gift, which some believe to be the largest ever made in the United States "for direct operation of a theater, rather than for bricks and mortar."

## Four winners of the 1973 Gernsback Scholarship Award

Grantham School of Engineering has selected Carl C. Dick for the 1973 Hugo Gernsback Award which is given annually



to an outstanding student in each of nine electronics home-study schools.

Mr. Dick's first contact with electronics was through the RCA Tube Manual in 1950. Reading the principles of radio there sparked his interest in electronics. In 1957, he opened his own parts-sales and service business. Today, he is the sole in-warranty service dealer of RCA and Zenith in the Republic of Panama, besides accepting work on any make or type of electronic equipment.

In addition to all this, he finds time to study the Grantham course, direct the choir at church and enjoys his hobby of deep-sea fishing.

NRI's candidate for the 1973 Hugo Gernsback Scholarship Award, a \$125 grant, is Hennen J. Blanton, Leavenworth, Kan.

Blanton's case tends to be unique, in that he is an inmate in a penal institution. Born in 1933 in Pittsburgh, Pa., he lost



both parents at an early age, and led a somewhat nomadic existence. First involvement with the law was at age 11.

Previous to his present incarceration, he was variously employed as a vacuum cleaner technician, motor rewinder, maintenance electrician and computer operator. He became interested in education while in prison, completed his G.E.D. tests and received a high school equivalency diploma. He registered for NRI training because, as he says, "I have had a number of jobs and almost all of them required more knowledge than I had. I want to get training in various fields so that I will have more to offer than an untrained or partially trained person."

He worked in Federal Prisons Industries to obtain money to finance his studies. At present enrolled in the Electronics Technology course, he plans to enroll in an additional NRI course as soon as he completes the present one. The Gernsback Award, he says, will definitely benefit him in the pursuit of his goals, and he hopes that his newly acquired skills will enable him to "make it" on his release in 1977 or on parole in 1974.

*(continued on page 12)*



# free

**OVER 93  
FAMOUS NAME  
ELECTRONICS  
PRODUCT LINES . . .  
MOST IN FULL COLOR**

**1974 VALUE PACKED**

## **Olson** CATALOG

YOUR COMPLETE ELECTRONICS BUYING GUIDE for home or business . . . over 8,000 quality-tested items clearly described and illustrated on big 8 1/4 x 10 3/4" pages. Shop leisurely in the comfort of your own home — order what you want by mail or through the catalog order station at your nearby Olson store. Any way you do it — you pay the same low Olson catalog price!

**FEATURING THE BEST OF THE NAME BRANDS PLUS EXCLUSIVE TELEDYNE AND OLSON PRODUCTS**

- Stereo and 4-Channel Sound Systems • Tape Recording Equipment • Car Stereo and Accessories • Easy-to-Build Electronic Kits • Citizens Band Radios • Police Receivers • Books • Amateur Radio Equipment • Antennas • Radios • PA • Test Equipment • Electronic Security Systems • Electronic Calculators and Timepieces • PLUS 1000's of PARTS, TUBES, BATTERIES, HARDWARE!



**SAVE ON "THE ELECTRONICS  
IN YOUR LIFE"  
— Buy with Confidence**

**FREE  
SEND  
TODAY!**

**Olson**  
for the electronics in your life

The VALUE Leader  
Since 1931

**STORES NATIONWIDE  
Check Your Yellow Pages  
or Shop by Mail**

**Olson electronics** Dept. LP  
260 S. Forge St., Akron, Ohio 44327

Rush me your free 1974 Electronics Catalog

Name \_\_\_\_\_ Apt. \_\_\_\_\_

Street \_\_\_\_\_

City \_\_\_\_\_ State \_\_\_\_\_ Zip \_\_\_\_\_

Send a 1974 Olson Electronics Catalog to my friend.

Name \_\_\_\_\_ Apt. \_\_\_\_\_

Street \_\_\_\_\_

City \_\_\_\_\_ State \_\_\_\_\_ Zip \_\_\_\_\_

Circle 4 on reader service card

# NOW you can train at home building a NEW 25"<sup>DIAGONAL</sup> Solid State Color TV engineered by NRI for learning and trouble-shooting

*So much better for learning TV servicing than any hobby kit, because NRI designed and created it as an educational tool.*

Unlike hobby kits which are designed for creating a TV set as the end product, NRI built its exclusive 25" Diagonal Solid State Color TV kit as a real training kit. You can introduce and correct defects . . . for trouble-shooting and hands-on experience in circuitry and servicing. The kits include a wide-band oscilloscope, color bar crosshatch generator, transistorized volt-ohmmeter and other valuable equipment that can soon have you earning \$5 to \$7 an hour servicing color sets in your spare time.

Handsome woodgrain cabinet, at no extra cost. (Offered only by NRI)

New square-cornered Sylvania picture tube

100% solid state chassis

6-position detented UHF channel selector



Modular construction with plug-in circuit boards

Automatic degaussing

Automatic fine tuning

Automatic tint control

Automatic color control

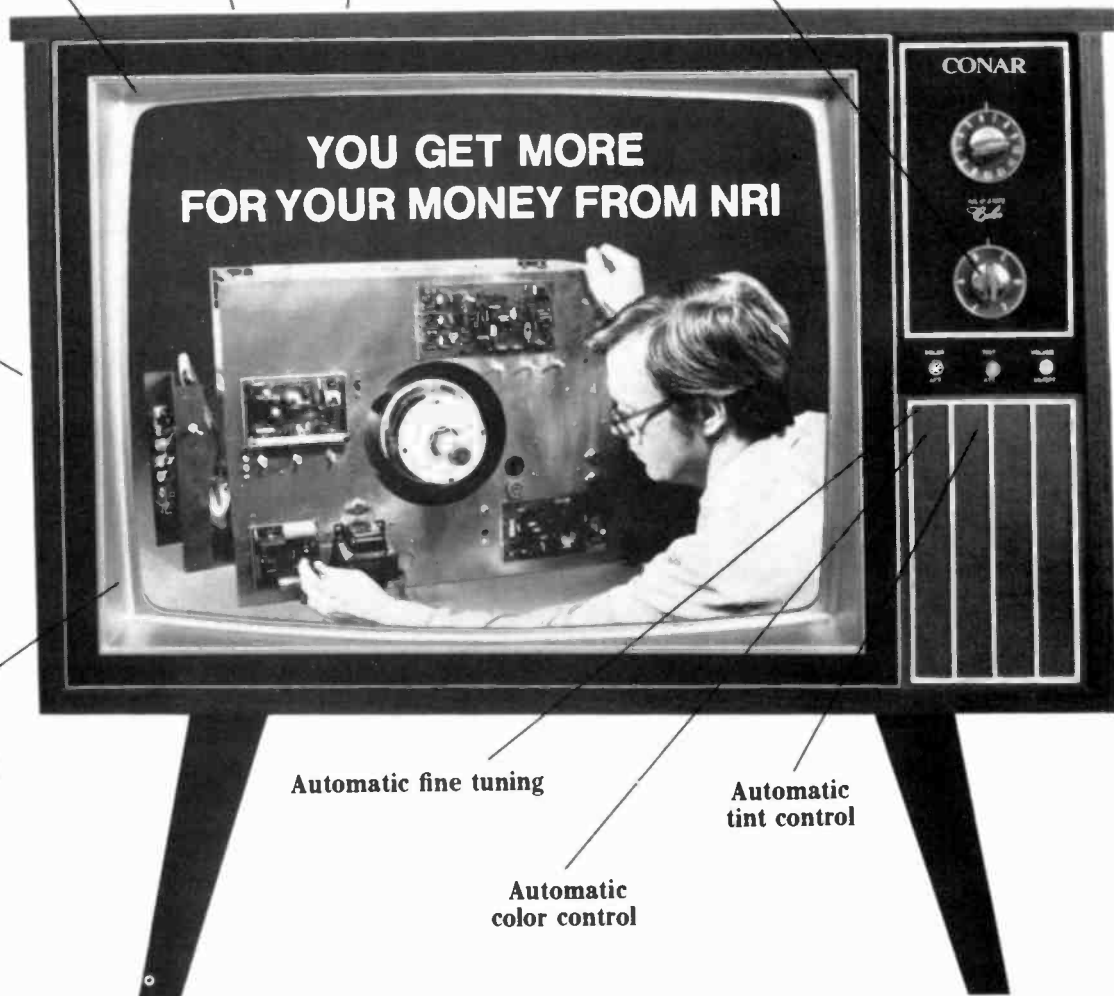

# NRI FIRSTS make learning Electronics fast and fascinating—to give you priceless confidence

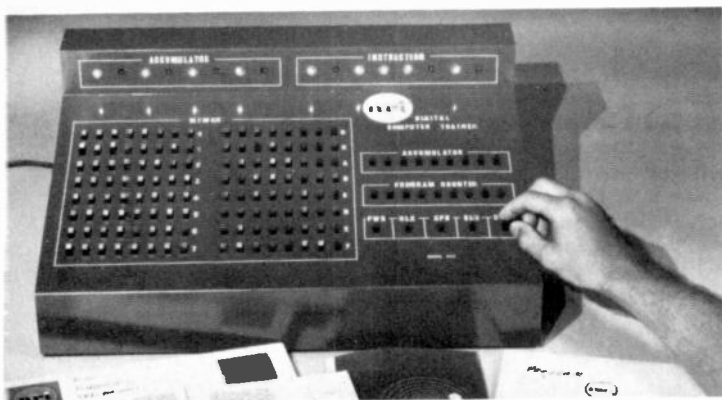

**FIRST** to give you a complete programmable digital computer, with memory, you build yourself . . . to learn organization, operation, trouble-shooting and programming. This remarkable computer is one of ten training kits you receive with the new NRI Complete Computer Electronics Course.

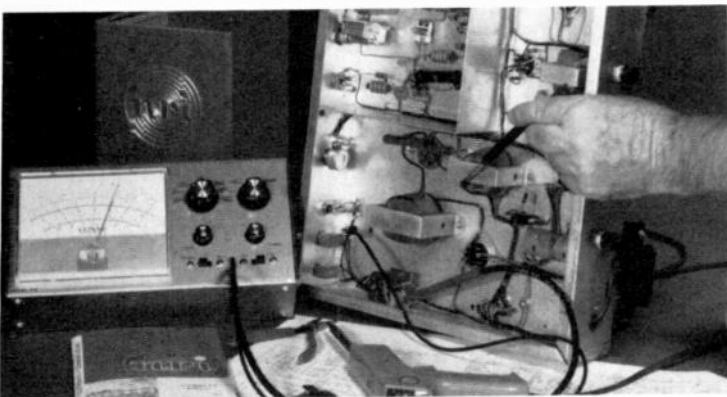

**FIRST** to give you true-to-life experiences as a Communications Technician. Every fascinating step you take in NRI Communications training, including circuit analysis of your own 15-watt, phone/cw transmitter, is engineered to help you prove theory and later apply it on the job. Studio equipment operation and trouble shooting become a matter of easily remembered logic.



**FIRST** to give you completely specialized training kits engineered for business, industrial and military Electronics Technology. Shown is your own training center in solid-state motor control and analog computer servo-mechanisms. Telemetering circuits, solid-state multivibrators and the latest types of integrated circuits are included in your course.

The NRI color TV and digital computer kits are the latest in a long line of "firsts" for NRI. For more than fifty years, NRI has been providing unique 3-dimensional home-study training that has helped hundreds of thousands of students reach their goals quickly and easily.

What NRI provides is a combination of kits and bite-size texts that give you hands-on experience while you are learning. The texts average only 40 pages each, and they are fully illustrated. You are taken step-by-step from the first stages into the more advanced theory and techniques . . . with an expert instructor ready at all times to provide valuable guidance and personal attention. (The level of personal attention provided is more than you would receive in many classrooms.) Once you've grasped the fundamentals, you move with confidence and enthusiasm into new discoveries in the fascinating world of electronics.

You start out with NRI's exclusive Achievement Kit, containing everything you need to get moving fast. Lessons have been specifically written so that experiments build upon one another like stepping stones. You can perform a hundred experiments, build hundreds of circuits . . . as you learn to use the professional test equipment provided, building radios and TV sets, transmitter or computer circuits. It's the priceless "third dimension" in NRI training . . . practical experience.

## Train with the leader—NRI

Compare training kits, texts, techniques and overall training . . . and you'll find that you get more for your money from NRI. Whatever your reason for wanting more knowledge of Electronics, NRI has an instruction plan that will meet your needs. Choose from major programs in Advanced Color TV Servicing, Complete Computer Electronics, Industrial Electronics and the other special courses designed to meet specific needs. With NRI home training, you can learn new skills while you're still working at your present job . . . and turn yourself into the man in demand.

### GET FACTS ABOUT GI BILL

If you have served since January 31, 1955, or are in service now, check GI line on postage-free card.

## Send for free NRI catalog

MAIL THE POSTAGE-FREE CARD FOR THE FREE NRI CATALOG IN THE FIELD OF YOUR CHOICE. YOU WILL BE UNDER NO OBLIGATION. NO SALESMAN WILL CALL.

If the card has been used, write direct to:



**NRI TRAINING**

3939 Wisconsin Ave.  
Washington, D.C. 20016



**International** ©  
SERVICEMASTER



**International**  
SERVICEMASTER

### The Money Making line.

- The most complete range of consumer and industrial receiving tubes in the world – over 2000 domestic and foreign types
- Complete range of replacement Semiconductors.
- Discounted to give you higher profit margins
- Quality your customers can depend on

For complete details, call (516) 293-1500.

Or write,  
**International Components Corporation**  
10 Daniel Street,  
Farmingdale,  
New York 11735.

Circle 5 on reader service card

# new & timely (continued from page 12)

The winner from CREI is Fred Reynolds, Jr., now with the U.S. Navy. He received his CREI diploma, and is now continuing with a course in Complete Communications, preparatory to sitting for his First Class Radio Telephone license examination. He has also been attending—under Navy orders—the Satel-



lite Communications School in Washington, DC, during the winter.

Vincent Lozupone, Brooklyn, NY, who has just completed the International Correspondence Schools Television Service Technician program, under the GI Bill,

was unemployed when he enrolled in the course in March, 1972. He is one of the 1973 winners of the Hugo Gernsback Scholarship awards. He writes: "I'm 23



years old, and now working for Tele-Prompter, the largest cable corporation in the nation, as a CATV installer. Graduating from high school with no special interests, I worked as a clerk for two years. Then I was drafted. In the Army I became a radio teletype operator.

When I was discharged I decided to go to school for radio and TV repair. I took the ICS course. R-E

**Radio-Electronics** is published by Gernsback Publications, Inc. 200 Park Ave. S. New York, N.Y. 10003 (212) 777-6400  
President: M. Harvey Gernsback  
Secretary: Bertina Baer

#### ADVERTISING SALES

**EAST**  
Stanley Levitan, Eastern Sales Mgr.  
Radio-Electronics  
200 Park Ave. South  
New York, N.Y. 10003  
(212) 777-6400

**MIDWEST/Texas/Arkansas/Okla.**  
Ralph J. Bergen  
The Ralph J. Bergen Co.  
6319 N. Central Ave.  
Chicago, Ill. 60646  
(312) 792-3646

**PACIFIC COAST/Mountain States**  
Jay Eisenberg  
J.E. Publishers Representative Co.,  
8732 Sunset Blvd., 4th Floor  
Los Angeles, Calif. 90069  
(213) 659-3810  
420 Market St.,  
San Francisco, Calif. 94111  
(415) 981-4527

**SOUTHEAST**  
E. Lucian Neff Associates  
25 Castle Harbor Isle,  
Fort Lauderdale, Florida 33308  
(305) 566-5656

### MOVING?

Don't miss a single copy of **Radio-Electronics**. Give us:

Six weeks' notice

Your old address and zip code

Your new address and zip code

ATTACH LABEL HERE

name (please print)

address

city state zip code

Mail to: **Radio-Electronics**  
SUBSCRIPTION DEPT., BOULDER, COLO. 80302



# Protect your valuables & lovable ...with the Archer Photoelectric Warning System



Low-cost 24-hour protection for 27<sup>95</sup>

Guards any entranceway or area with a beam of light. Use it as an intruder alarm or to announce visitors. Sounds an accessory siren or bell either of two ways: (1) Continuously, once the beam is broken or (2) Only during the time the beam is

interrupted. Easy setup — just aim the light beam at the "eye" of the receiver. Sensitivity control adjusts for various ambient light levels. AC powered for economical continuous operation. Assembled and ready to use. #275-489.

## ... and this Archerkit™ Disaster Alarm System



19<sup>95</sup>

Protects your home & family from gas & smoke—electronically. Build yourself a really safe home! Assemble this kit tonight and rest assured that you're protected from unseen gas leaks, auto exhaust and smoke from impending fires. Loud buzzer sounds if semiconductor detects as little as 500 PPM of carbon monoxide or 2-4% smoke. Sensitivity control. Keyhole slots for wall mounting. Easy one-evening assembly. AC powered. #28-4006.

## Photoelectric Accessories



21<sup>95</sup>

Siren. You can hear it for blocks. For above or any 120 VAC system. U.L. listed. #275-497.



4<sup>95</sup>

Bell. Overcomes high-level background noises. For above or any 120 VAC system. 4x2" metal base. #273-020.

We're near you, wherever you are—see your phone book.

**ARCHER®**  
at  
**Radio Shack®**  
and ALLIED RADIO STORES

A TANDY CORPORATION COMPANY 324  
P. O. Box 1052, Fort Worth, Texas 76107

**FREE! 1974 CATALOG**  
AT YOUR NEARBY STORE OR MAIL COUPON  
180 Pages . . . Full Color! Hi-Fi, Recorders,  
Radios, CB, Kits, Antennas, Parts, More!

PLEASE PRINT CLEARLY

Name \_\_\_\_\_ Apt. # \_\_\_\_\_  
Street \_\_\_\_\_  
City \_\_\_\_\_ State \_\_\_\_\_ ZIP

Retail prices may vary at individual stores.

Are you ready  
for a REAL



## CONTROL CENTER?

If you're a music lover looking for more enjoyment from your music collection, we have a pleasant surprise for you. Up to now you've enjoyed the few control functions on your tape deck, amp or receiver. But think what you could do with a discrete control center! Not a lo-fi economy model, but the famous CROWN IC150, with a variety of versatile controls unavailable in any other model under \$300, and some models over \$500.

This is the control center praised by that dean of audio, Ed Canby: "This IC150 . . . is the finest and most versatile control unit I have ever used. For the first time I can hook all my equipment together at once. I find many semi-pro operations possible with it that I have never before been able to pull off, including a first-class equalization of old tapes via the smooth and distortionless tone controls. I have rescued some of my earliest broadcast tapes by this means, recopying them to sound better than they ever did before."

The IC150 will do the same for you. You could record from any of seven sources: tuners, turntables, guitars, tape players, microphones, etc. You could also tape with one recorder while listening to a second one. Even run two copies of the same source at once while monitoring each individually. How about using the IC150's exclusive panorama control to improve the stereo separation of poorly produced program material or to correct that ping-pong effect with headphone listening? It's all up to your creativity.

You'll feel perfectly free to copy and recopy through your IC150, since it creates practically no deterioration whatsoever. Cleaner phono and high-level circuits cannot be found anywhere. Harmonic distortion is practically unmeasurable and IM is less than 0.01% (typically 0.002%).

Of course, construction is traditional Crown quality, backed with a three-year warranty. The price is \$299. The enjoyment is unlimited. The opportunity is yours. Visit your local Crown dealer to discover if you are ready for a real control center, the IC150.



**CROWN**

BOX 1000, ELKHART, INDIANA 46514  
Circle 7 on reader service card

# appliance clinic

## SOLID-STATE IGNITION— NEW FOR LAWNMOWERS

by JACK DARR  
SERVICE EDITOR

EVERYTHING'S "GOING SOLID-STATE" now—even the lawnmower! This also includes snowmobiles, small garden tractors, and outboard motors—anything powered by small gasoline engines. For a typical example, here's the system used in the Lawn-Boy mowers, in their 1973 line. It is actually a capacitor-discharge ignition system, "self-powered" in the same way as the old magneto systems. There are no

current reverse. The ac voltage is fed to a diode rectifier (3), converted to dc, and then fed to the capacitor (4) to charge it to about 300 volts.

The other plate of the capacitor is connected to the anode of the silicon controlled rectifier (6). The SCR cathode is connected to the primary winding of the spark coil, (7). The SCR's gate is connected to the trigger coil (5). When the magnet passes the trigger-coil lamination, it generates a small voltage, only 1 volt or so. This gates the SCR on, and the capacitor is discharged through the spark coil. The

*(continued on page 75)*

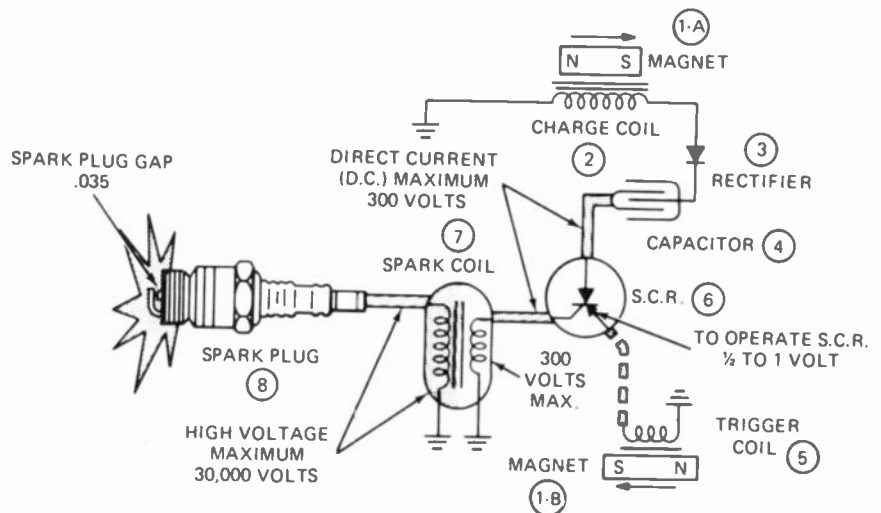

FIG. 1—COMPONENTS OF THE SOLID STATE UNIT. Numbers are explained in text.

moving parts in the system itself; no breaker points, no "condenser", etc.

Fig. 1 is a schematic diagram of the whole system. Three coils are used. One is the "charging coil" (2), another the "trigger coil" (5), and the last, the "spark coil" (7), which is the same as that used on automobiles. Output of this system is up around 30,000 volts.

All coils are energized by a magnet built into the rim of the flywheel. As the flywheel turns, the magnet moves past the laminated cores of the coils. (We're going to do something else with that spark coil in just a moment.) Fig. 2 shows how the unit and magnet are mounted.

Here is the sequence of events which happen as the flywheel turns. When the magnet passes the charge-coil laminations, it induces a voltage in that coil. This is true ac, since the magnetic field is built up, then collapses to make the

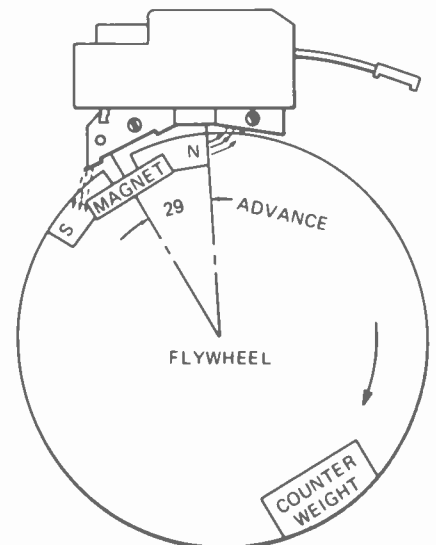

FIG. 2—MECHANICAL DETAIL, showing how magnet advances spark with increasing speed.

# Stocking these 9 ECG™ semiconductors is like having hundreds of solid-state deflection circuit devices on hand.

GTE Sylvania has checked out hundreds of different TV set models to find out what they have in common.

And we've been able to boil down practically all of their deflection circuit needs to just nine parts.

Then, we put together a brand-new cross-reference guide (ECG-212E) that tells you which of the nine units replaces which numbers.

But, we didn't stop at deflection circuits.

Our new guide also covers over 75,000 other parts including industrial components as well as all types of home and auto entertainment equipment.

Because we've reduced the number of parts that you have to have on hand, it's easier to keep a complete stock.

And that makes it easier for you to be sure you have the part you want when you want it.

**GTE SYLVANIA**

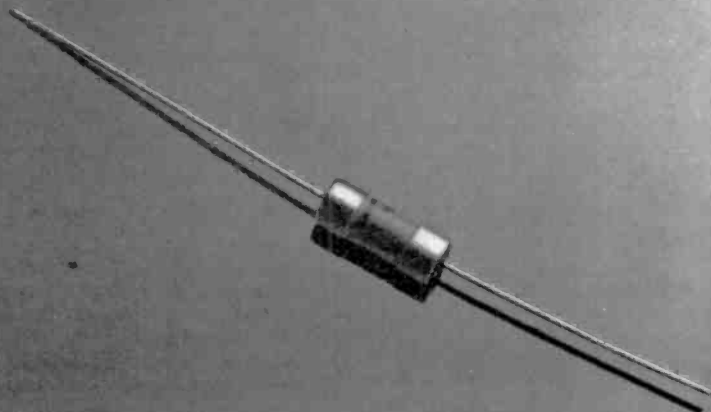
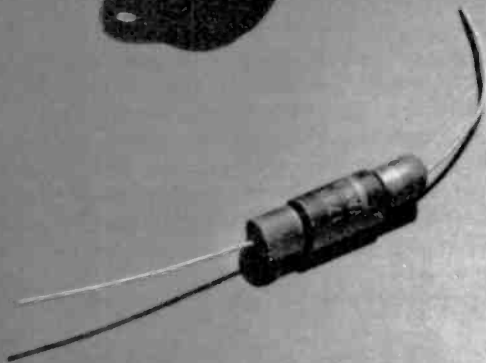
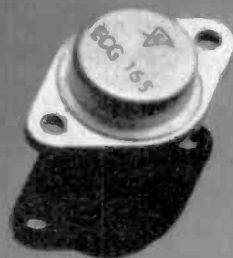

# letters

## WARRANTY PROBLEMS

Just a few weeks ago a major tape recorder manufacturer more than doubled its warranty protection period. Recently I received the announcement of a major advertising campaign being launched by this same company. It's really wonderful—better equipment, purchasers protected by longer warranties, more advertising to sell more components. What is good for the high-fidelity industry is good for Eastern Stereo Servicer . . . or, at least, that used to be our attitude.

But what about service for these growing quantities of all this wonderful new equipment? Equipment is becoming more complex with every new model introduced. First a channel was added to make stereo; now the industry is in the process of doubling the number of channels again, more than doubling our job of servicing. And with more complex technology involved—Dolby or other noise

reduction systems, matrix or discrete demodulators—the investment in test equipment and people to use it is costly.

We independent service organizations are being expected to keep pace with changing technology and extended warranty periods without any increase in compensation. Getting good service on a piece of hi-fi gear is a problem that already exists in many areas. If manufacturers continue their present policies and attitudes, it will get much worse.

I wrote to the tape recorder company's president at the time his firm extended its warranty period, but didn't even receive the courtesy of a reply. Another manufacturer recently demonstrated its interest in its equipment purchasers being able to get qualified in-warranty service by reducing its labor rate. Getting parts orders filled within a reasonable amount of time and being supplied adequate servicing literature continues to be a major problem with a number of companies. (The

customer blames us, not the manufacturer, for delays caused by this deficiency.)

The facts appear to be adding up to one thing. Too many manufacturers look at warranty service as being a necessary evil, responding principally to sales needs and governmental and consumerist demands. While it may not matter to the manufacturers, I don't believe that the industry as a whole can afford to lose the few good service facilities that do exist. If service were not important to dealers, why is it so many of them promote their service department (when most don't have even one qualified technician or any good test gear) and extra long warranties?

We believe ours is a badly-needed commodity, with the need increasing as the industry continues to grow. If service truly is important, I challenge those concerned to place the service function on an equal level with manufacturing and sales.

## Now two RCA 5-inch scopes... DC to 10 MHz response

The Triggered/Recurrent  
Sweep WO-535A . . .  
\$349.00 (Optional Price)  
including probe

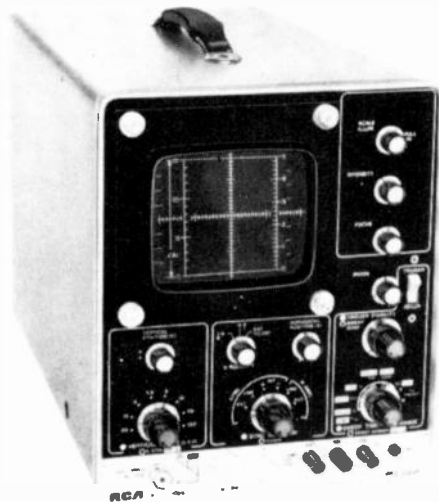

The Recurrent  
Sweep WO-505A . . .  
\$329.00 (Optional Price)  
including probe

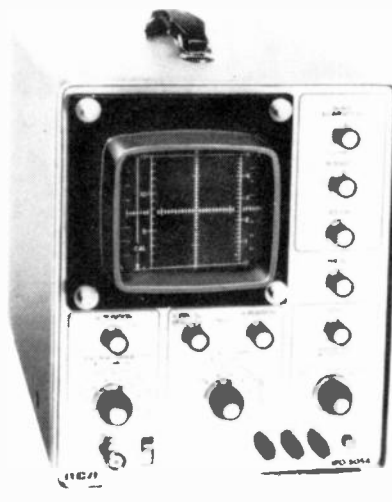

### To buy:

order from any one of the more than 1,000 Authorized RCA Distributors worldwide, or through RCA Electronic Instruments Headquarters, Harrison, N.J. 07029. (RCA will forward your order to the distributor of your choice.) Also ask for your copy of the new full-line Electronic Instruments 1Q1218F catalog.

**RCA** Electronic  
Instruments



and begin giving it fair and honest treatment. Manufacturers . . . Industry . . . What is your response?

We at Eastern Stereo stand ready to participate with those interested in opening up a dialogue and serious discussion.

MARLIN R. TAYLOR  
Eastern Stereo Servicenter, Inc.  
Upper Saddle River, N.J.

### LEE de FOREST

This comes to you with heartfelt appreciation for the splendid article written in your magazine about Lee. And especially the part in regard to the serious wrong in comparing Lee's great invention—the vacuum tube—with the Fleming valve. The article also will be a great help to me in clarifying this wrong in my talks to organizations and to the school students.

The fine photograph of the two friends together brings back fond memories to me when I first met Mr. Gernsback on my first visit to New York from California over forty years ago as Lee's bride. Perhaps you have heard that a commemorative stamp was issued for Lee in New York on July 12, 1973.

Thank you again for everything. Thank you too for your kindness in sending me the extra copies of your magazine. They are being put to good use. One has been placed in the Electronics Museum to add to Lee's archives.

MARIA de FOREST  
Hemet, Calif.

### IT'S A TRADEMARK

We read the article "Secrets of Ion Plasma Tubes" by James A. Gupton which appeared in the September 1973 issue of *Radio-Electronics*. We note with interest that both Dr. Bennett and Mr. Gupton recognize that "Aquadag" is a standard and well-known product in the electronics field. However, we would like to point out to you that "aquadag" is a registered trademark of Acheson Industries, Inc., and when used should be properly referenced and identified as our trademark. We are confident that your misuse of "aquadag" trademark was purely unintentional and know that you will cooperate in helping us to protect this valuable name in future articles.

M. T. MUSGRAVE  
Port Huron, Michigan

### NEW ASSOCIATION

The Amateur Television Association has been founded in 1967. It aims at promoting interest and stimulating experiments in the amateur video communication field.

The association is a purely non-profit one, organized by radio-amateurs and based on voluntary cooperation at the service of its members. It publishes a three-monthly, mainly technical magazine, entitled *ATA International*.

JOHN SMET, ON5EX  
Acaciaaan 27  
De Pinte, Belgium

## BOOKS & UNIQUE NEW BOOK/KITS FOR HOBBYISTS & EXPERIMENTERS!

A Unique New Concept in Kits!



### TAB Electronic BOOK/KITS

Book & Kit for the Price of Kit Alone!

FOR THE PRICE OF A KIT ALONE, you get a book by an expert who opens the world of electronics to you—PLUS a complete kit to help you start building and learning. You have fun putting together easy-to-build projects that are both useful and instructive.

**20W FOUR-CHANNEL "QUAD" AMPLIFIER** Extremely High Fidelity—20-100,000 Hz. Plug in your stereo record player (ceramic cartridge) or stereo tape deck, and connect 4 speakers for full derived quadrasonic sound. Recovers back-channel ambience signals from any regular stereo input. Contains volume control. Requires 16-18V dc input. Frequency response 20-100,000 Hz. flat. Book is "Stereo Quad Hi-Fi Principles and Projects"

Order No. K-11 Total Value \$24.90 **\$19.95**  
**WAILING ELECTRONIC SIREN.** A real siren wait that you control with pushbutton. When used with external amplifier, siren is suitable for civil defense, boat, and burglar alarm applications. Book is "Electronic Hobbyist's IC Project Handbook."

Order No. K-12 Total Value \$8.90 **\$4.95**  
**INTRUSION ALARM.** Makes Futuristic Pulsing Sound. Connect to any door or window—when entryway opens, alarm is triggered. Alarm sound is same "relaxation oscillator" used in science fiction movies. Operates from small 9V battery for applications. Connect to car battery for burglar alarm use. Book is "Electronic Hobbyist's IC Project Handbook."

Order No. K-13 Total Value \$11.90 **\$7.95**  
**TUNABLE ELECTRONIC ORGAN.** Full Octave—Plays through any Hi-Fi. Full 8 button keyboard—a real musical instrument. Each note fully adjustable. May be tuned to any key in music range. Output is extremely stable sine wave from phase shift oscillator network. Just connect to any audio amplifier with standard interconnecting cables. Book is "New IC FET Principles & Projects"

Order No. K-14 Total Value \$13.90 **\$9.95**  
**AUDIO MIXER** Mixes audio from 3 sources! A 3 channel input—mixes sound from all three without circuit loading or impedance mismatching. Book is "125 One Transistor Projects."

Order No. K-1 Total Value \$11.90 **\$7.95**

**5-WATT HI-FI AMPLIFIER** High power transformerless circuit! The hi-fi amplifier you complete from this kit will provide 5 watts or more of audio into your speaker. No preamps or transformers required. Book is "125 One Transistor Projects."

Order No. K-2 Total Value \$13.90 **\$9.95**  
**ELECTRONIC FORTUNE TELLER** Have fun with the laws of chance! Answer all yes-no questions at the touch of a button! Book is "104 Easy Projects for the Electronics Gadgeteer."

Order No. K-3 Total Value \$8.90 **\$4.95**  
**AM WIRELESS MIKE** Broadcasts through any AM radio! "Broadcast" through any AM radio set . . . from up to 100 ft. away. Book is "Transistor Circuit Guidebook."

Order No. K-4 Total Value \$11.90 **\$6.95**  
**ELECTRONIC TOUCH SWITCH** Touch and light goes on! Lamp automatically comes on when you touch switch, goes off when you stop touching the switch. Book is "Transistor Projects for Hobbyists and Students"

Order No. K-5 Total Value \$10.90 **\$6.95**  
**GARAGE LIGHT CONTROL** Unit switches when light hits it. Your headlights will turn on either inside or outdoor garage light. Turn them off manually when you're safely inside. Book is "Transistor Projects for Hobbyists and Students."

Order No. K-6 Total Value \$13.90 **\$9.95**  
**AUDIO SIGNAL GENERATOR-INJECTOR** Use as a tester, audio oscillator, or RF generator! Makes a precision instrument for checking frequency response of amplifiers and for signal tracing. Can be used as an RF signal generator. Book is "Transistor Projects for Hobbyists and Students"

Order No. K-7 Total Value \$9.90 **\$5.95**  
**LOW-VOLTAGE DC POWER SUPPLY** Well filtered, half-wave miniature circuit. An effective DC power source (10V, 1A) for test bench applications, powering transistor circuits, etc. Book is "104 Easy Projects for the Electronic Gadgeteer."

Order No. K-8 Total Value \$8.90 **\$4.95**  
**DIODE TESTER** Checks diodes in or out of circuit! The diode tester you complete from this kit gives a quick go/no go test for all types of diodes. Also identifies polarity of unmarked diodes. Book is "104 Easy Transistor Projects You Can Build"

Order No. K-9 Total Value \$9.90 **\$5.95**  
**HIGH POWER LAMP DIMMER** Replaces wall-mounted light switch. Provides full adjustment of lamp brilliance. Handles any number of lamps up to 1000 watts. Book is "104 Easy Transistor Projects You Can Build"

Order No. K-10 Total Value \$8.90 **\$4.95**

## HERE ARE LITERALLY HUNDREDS OF PROJECTS FOR HOBBYIST AT ALL LEVELS!

### BOOK FOR BEGINNERS

**TRANSISTOR CIRCUITS.** 160 pps. 144 ill. No. 63 **\$3.95**  
**TRANSISTOR TECHNIQUES.** 96 pps. 76 ill. No. 61 **\$2.50**  
**FUN WITH ELECTRICITY.** 128 pps. Fully ill. No. 83 **\$2.95**  
**TRANSISTORS—HOW TO TEST, HOW TO BUILD,** 96 pps. 65 ill. No. 94 **\$2.95**  
**LEARN ELECTRONICS BY BUILDING.** 208 pps. 214 ill. **\$4.95**  
**GETTING STARTED WITH TRANSISTORS.** 160 p. 90 ill. **\$3.95**  
**104 HAM RADIO PROJECTS FOR THE NOVICE TECHNICIAN** 192 pps. 104 ill. No. 468 **\$3.95**  
**104 SIMPLE ONE-TUBE PROJECTS.** 192 pps. 104 ill. No. 486 **\$3.95**  
**CB RADIO OPERATOR'S GUIDE.** 224 pps. No. 499 **\$3.95**  
**125 ONE-TRANSISTOR PROJECTS.** 192 pps. No. 537 **\$3.95**  
**TRANSISTOR PROJECTS FOR HOBBYISTS AND STUDENTS** 192 pps. 153 ill. No. 542 **\$4.95**  
**ELECTRONICS SELF-TAUGHT WITH EXPERIMENTS & PROJECTS** 288 pps., 191 ill. No. 553 **\$4.95**  
**MINIATURE PROJECTS FOR ELECTRONIC HOBBYISTS.** 168 pps., 77 ill. No. 667 **\$3.95**

### INTERMEDIATE-LEVEL BOOKS

**STEREO, QUAD HI-FI PRINCIPLES & PROJECTS** 192 pps., 105 ill. No. 647 **\$4.95**  
**PRACTICAL SOLID-STATE PRINCIPLES & PROJECTS** 176 pps., 127 ill. No. 590 **\$3.95**  
**104 EASY PROJECTS FOR THE ELECTRONICS GADGETEER** 160 pps., 105 ill. No. 524 **\$3.95**  
**64 HOBBY PROJECTS FOR HOME & CAR.** 192 p. No. 487 **\$3.95**  
**104 EASY TRANSISTOR PROJECTS YOU CAN BUILD** 224 pps., 105 ill. No. 462 **\$4.95**  
**TRANSISTOR PROJECTS.** 160 pps., 123 ill. No. 89 **\$2.95**  
**ELECTRONIC PUZZLES & GAMES** 128 pps., No. 70 **\$2.95**  
**TRANSISTORS—THEORY & PRACTICE** 160 pps., No. 75 **\$3.95**  
**ELECTRONIC HOBBYIST'S HANDBOOK** 160 pps., No. 69 **\$2.95**  
**HOW TO READ ELECTRONIC CIRCUIT DIAGRAMS** 140 ill. 192 pps., 18 page foldout section. No. 510 **\$3.95**  
**DIGITAL ELECTRONICS—PRINCIPLES & PRACTICE** 288 pps., 191 ill. No. 585 **\$5.95**

### FOR THE ADVANCED HOBBYIST

**HANDBOOK OF CIRCUIT PROJECTS.** 224 pps. No. 629 **\$4.95**  
**NEW IC FET PRINCIPLES & PROJECTS.** 160 p. No. 613 **\$3.95**  
**VHF PROJECTS FOR AMATEUR & EXPERIMENTER** 224 pps., fully ill. No. 608 **\$4.95**  
**HOW TO BUILD SOLID-STATE AUDIO CIRCUITS** 320 pps., fully ill. No. 606 **\$5.95**  
**SOLID-STATE PROJECTS FOR EXPERIMENTER** 224 pps., 228 ill. No. 591 **\$3.95**  
**RADIO-ELECTRONICS HOBBY PROJECTS** 192 p. No. 571 **\$3.95**

### IC PROJECTS FOR AMATEUR & EXPERIMENTER

192 pps., 252 ill. No. 568 **\$3.95**  
**ELECTRONIC HOBBYIST'S IC PROJECT HANDBOOK** 160 pps., 86 ill. No. 464 **\$3.95**  
**NEW SKILL-BUILDING TRANSISTOR PROJECTS & EXPERIMENTS.** 192 pps., 129 ill. No. 129 **\$3.95**  
**ADVANCED RADIO CONTROL.** 192 pps. 181 ill. No. 122 **\$4.95**  
**TRANSISTOR CIRCUIT GUIDEBOOK.** 224 pps. No. 470 **\$4.95**  
**ELECTRONIC CIRCUIT DESIGN HANDBOOK—NEW 4TH EDITION** 416 pps., 811, 111, 966 ill. Hardbound **\$17.95**

### BOOKS OF GENERAL INTEREST TO HOBBYISTS

**UNDERSTANDING & USING THE VOM & OVM.** 192 p. 672 **\$4.95**  
**BASIC ELECTRICITY & BEGINNING ELECTRONICS** 256 pps., 191 ill. No. 628 **\$4.95**  
**BASIC ELECTRONICS COURSE.** 384 pps., 275 ill. No. 588 **\$5.95**  
**THE FASCINATING WORLD OF RADIO COMMUNICATIONS** 176 pps., 56 ill. No. 586 **\$3.95**  
**AMATEUR RADIO NOVICE-CLASS LICENSE STUDY GUIDE** 180 pps., 57 ill. No. 573 **\$3.95**  
**DICTIONARY OF ELECTRONICS.** 420 pps., 487 ill. No. 300 **\$3.95**  
**TUBE TRANSISTOR SUBSTITUTION GUIDE.** 256 pps., No. 570 **\$2.95**  
**HOW TO USE YOUR VOM, VTVM & OSCILLOSCOPE** 192 pps., 120 ill. No. 438 **\$3.95**

### NO-RISK COUPON—MAIL TODAY!

ITAB BOOKS, Blue Ridge Summit, Pa. 17214

Please send me the following BOOK KITS on 10 Day

FREE Trial

No. \_\_\_ No. \_\_\_ No. \_\_\_ No. \_\_\_ No. \_\_\_ No. \_\_\_

No. \_\_\_ No. \_\_\_

Please send me the following Books on 10 Day FREE

Trial.

No. \_\_\_ No. \_\_\_ No. \_\_\_ No. \_\_\_ No. \_\_\_ No. \_\_\_

No. \_\_\_

I enclose \$ \_\_\_\_\_ (postage prepaid)

Please invoice me, plus postage & handling

Name \_\_\_\_\_ Phone \_\_\_\_\_

Company \_\_\_\_\_

Address \_\_\_\_\_

City \_\_\_\_\_ State \_\_\_\_\_ Zip \_\_\_\_\_

Save postage by remitting with order Foreign add 10%

Pa. add 6% tax **RE-14**

# Build your own Bell & Howell solid-state 25-inch diagonal color TV!

It's an enjoyable way to learn valuable skills in the exciting new field of *digital electronics* and also get a brand-new color TV you build yourself! For free information, mail the postage-free card today!

## Enjoy the personal satisfaction of building your own color TV

It's not an ordinary accomplishment. You can take pride in it because you did it all yourself. And you'll find *digital electronics* a fascinating world to explore. It's an absorbing way to spend your spare time . . . tinkering with the equipment . . . reading up on electronic principles . . . and finding out how they work in practice.

## Not just a kit — a complete at-home learning program in home entertainment electronics

Skilled instructors at Bell & Howell Schools have carefully prepared a program that starts you off with the basics and guides you smoothly through the course with step-by-step instructions. You'll enjoy the challenge of learning something new that could lead to extra income opportunities for you.

## Attend special "help sessions" . . . talk to your instructors in person

A unique advantage of your learn-at-home program is the "help session." Scheduled regularly at Bell & Howell Schools and in cities around the country, these informal seminars give you face-to-face, personal assistance from our instructors. You'll meet other students and enjoy talking shop.

## Master the most up-to-date solid-state and digital technology

As color TV moves closer toward total solid-state, and as the more accurate and reliable digital systems begin to appear in home entertainment gear, you'll be thoroughly familiar with the most

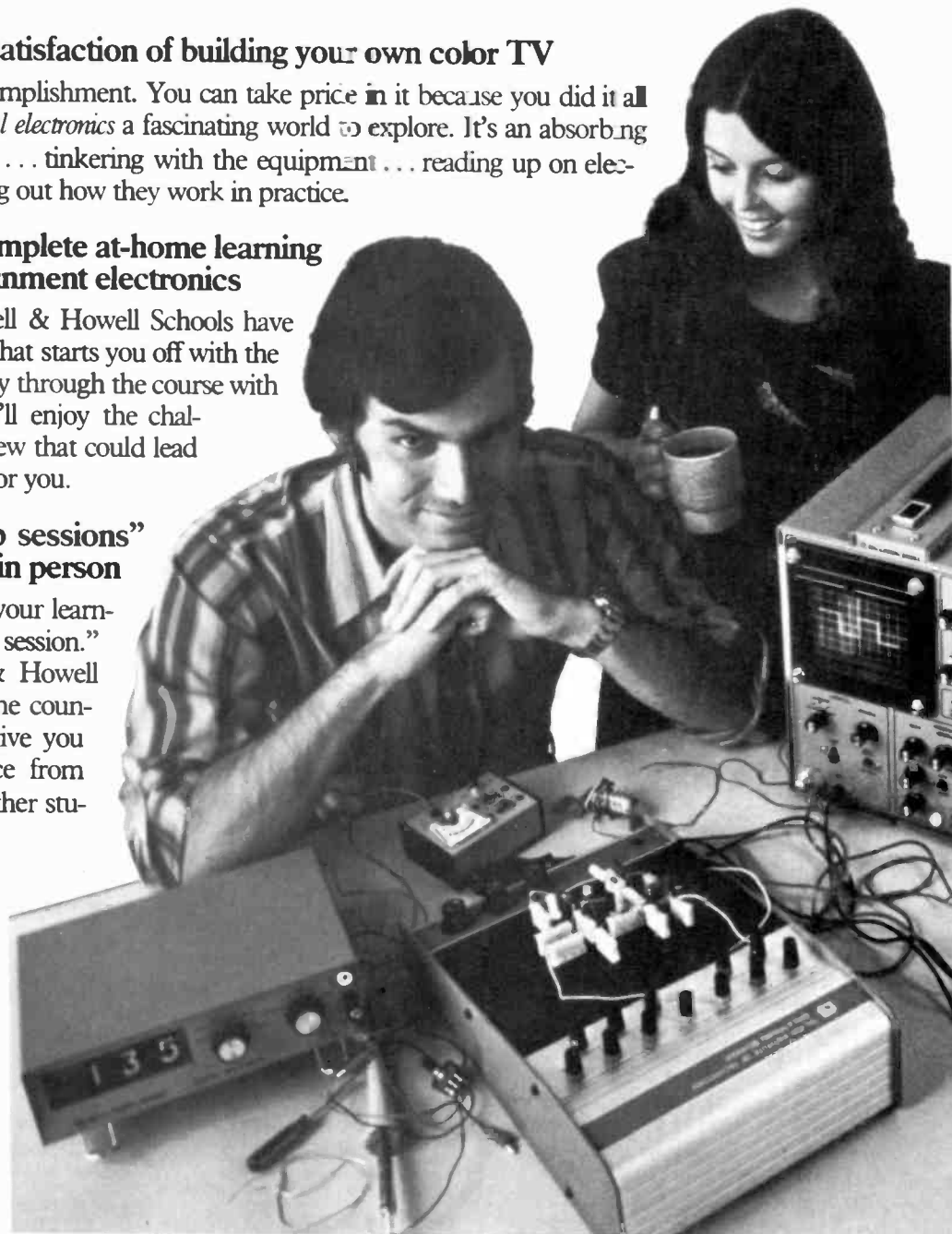

advanced troubleshooting techniques for these sophisticated circuits.

## **Digital electronics is growing everyday – and you can cash in on it!**

Digital clocks and pocket calculators are already on the market. Soon, everything from speedometers to stereos to kitchen stoves will have digital readout and control systems in place of conventional dials and needles. During your program, you can gain the know-how to build, service or repair this new digital equipment, part-time or full-time!

## **You also build and keep the NEW Electro-Lab® electronics training system**

Three professional instruments . . . a digital multimeter, design console and solid-state oscilloscope designed exclusively for Bell & Howell students . . . provide you with necessary practical experience during your program. It's the equipment you need to successfully analyze and master the principles of today's digital technology.

## **Earn extra income part-time or get ready for your own service business**

We'd like to tell you more about this fascinating *digital electronics* program – and how it can lead to a promising future – full or part-time. Mail the attached card today and get all the facts.

## **NEW from Bell & Howell Schools . . . first time ever offered!**

When you build your color TV, we include a complete volume on the "Guidelines For Starting Your Own Repair Business." It gives you all the basics including setting up shop, basic bookkeeping and income tax, small business legal requirements and customer relations. It's just another way we can help people get going in electronics.

**FOR FREE INFORMATION, MAIL CARD TODAY!**

If the card has been removed, write:

An Electronics Home Study School  
DEVRY INSTITUTE OF TECHNOLOGY



ONE OF THE

**BELL & HOWELL SCHOOLS**

4141 Belmont, Chicago, Illinois 60641

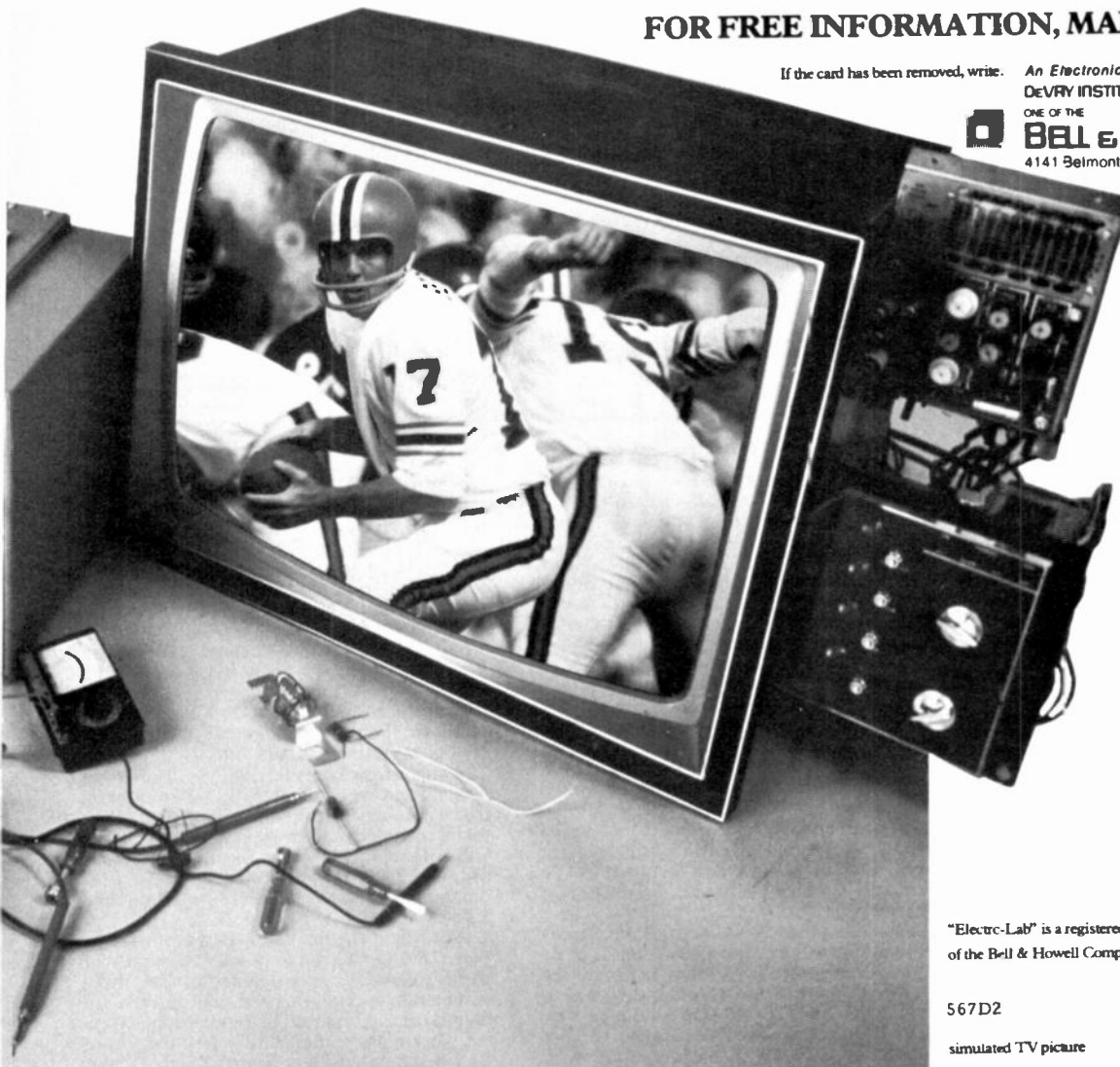

"Electro-Lab" is a registered trademark  
of the Bell & Howell Company

567D2

simulated TV picture



## Have power — will travel

If you're working on mobile equipment for roadway, seaway or skyway, Triad has the right transistor power supply transformer for you.

For example, if you're after high power, you'll want to take a hard look at Triad's TY-85. This sturdy, epoxy-molded toroidal unit works from a 12-volt source and puts out 350 DC milliamps at 600 DC volts from a full-wave bridge rectifier. Peripheral terminals and single mounting hole simplify installation, facilitate stacking.

The TY-85 is only one of a complete line of epoxy-molded toroidal transformers for use with 6, 12 and 28-volt battery-driven transistor inverters. The feedback winding is split on most of these units, allowing operation in either common emitter or grounded collector circuits.

Triad also makes and stocks DC to AC and DC to AC open style, ferrite core transformers, and DC to AC vertical-shielded types. Write for information: Triad-Utrad Distributor Services, 305 N. Briant Street, Huntington, Ind. 46750.

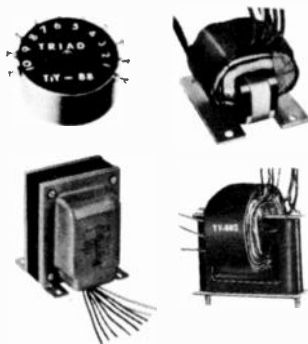

**TRIAD-UTRAD**  
Litton Distributor Services

# equipment report

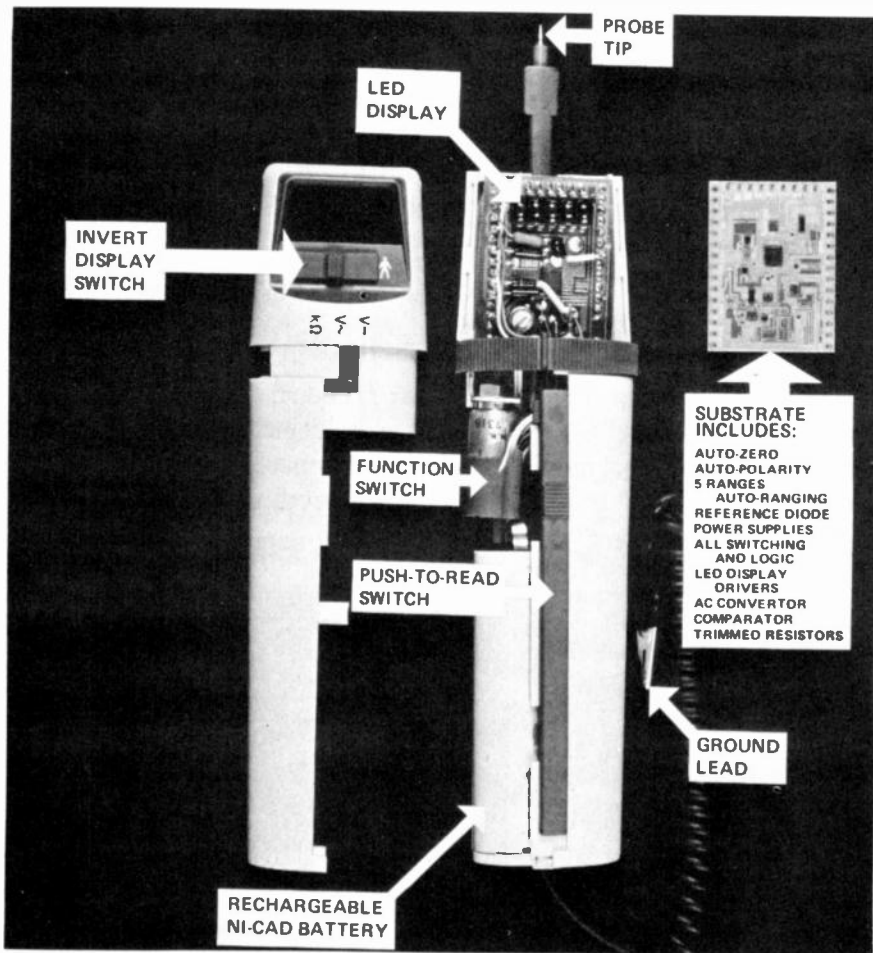

Circle 86 on reader service card

I THOUGHT I'D LOST THE CAPACITY FOR being amazed, but I really haven't. They handed me a beautiful little soft leather pouch, about the size and shape of a big hot dog bun. "What's that?" "Oh, that's just a self-contained, automatic-ranging digital multimeter. It'll read ac or dc up to 500 volts, and resistance up to 10 megohms." "Oh, is that all? Hmm." Opening the zipper pouch, I found a device not as big as an electric toothbrush, with a coiled pigtail lead! (See this month's cover.)

It was a DVM, with all of the features mentioned above. This is the Hewlett-Packard HP-970A Probe Multimeter. It is, too—a "probe". A folding test prod on the business end can be set to several angles. To take a reading, just clip the pigtail lead to the low side or ground of any circuit, and use the instrument itself as the "test prod"! The readout is a 5-digit LED unit, on the end of the case.

A flexible plastic band around the case is the function switch. It can be set for ac or dc volts, or resistance (in kilohms). From then on, all you have to do is touch the prod to the circuit; the HP-970A does the rest by itself! Voltages read in five ranges; 0.1, 1.0, 10, 100 and 1000 (500 V maximum input, ac or dc).

The HP-970A is an "auto-ranging" type meter. Special circuitry adjusts the readout to whatever scale will display the reading best. Oddly enough, I used it for quite a while, taking several different voltage readings, before it dawned on me what this little thing was doing! It was setting itself to display the voltage, anywhere from about 0.5V up to about 250V. The decimal point moves, so that you always know what the reading is.

For resistance, the HP-970A reads in kilohms; thousands of ohms. For example, a 470-ohm resistor reads out as 00.470. A 2200-ohm resistor as 02.200, etc. For those times when we inadvertently do something that we know better than to do, a fuse resistor is included, in the ohmmeter circuit! It will withstand 115V rms for up to one minute, and 250V rms for 10 seconds. It is recommended that we take HP's word on this: I know I will!

Accuracy: the manual says 2% of reading plus 0.5% of the range in use. Accuracy of these tolerances is guaranteed, with measurements traceable to National Bureau Of Standards calibration. The input impedance is a very high 10 megohms on all ranges.

A separate Current-Shunt/Bench Cradle  
(continued on page 81)



# TEST RIG FOR TUBE & SOLID STATE

THE COMBO RIG  
MODEL CJ-175

**\$89<sup>95</sup>**  
less picture tube



- ELIMINATES HAULING CABINET & TUBE
- SPEEDS TROUBLE SHOOTING
- SERVICES TUBE & SOLID STATE

TELEMATIC TEST RIG CJ-175  
CONSISTS OF:

- ★ • Compact metal case
- Universal Yoke
- Convergence Yoke
- Blue Lateral Magnet
- Solid State Transverter
- 4' Anode Extension
- 4' 90 degree CRT Extension
- 4' Yoke Extension
- Convergence Load
- 4 Yoke adaptors for Solid State

## Telematic

Write us for free subscription of current cross-reference charts.  
2245 Pitkin Avenue, Brooklyn, N.Y. 11207

Circle 11 on reader service card

The Mark Ten B Capacitive Discharge Ignition System keeps your car in tune ... and everyone knows that a well-tuned car gets better mileage, requires less maintenance, runs longer and better, and helps in the quest for cleaner air.



... Just ask Detroit

Circle 12 on reader service card

Order your Mark Ten B today! Please send me free literature.

Enclosed is \$ \_\_\_\_\_ Ship ppd.  Ship C.O.D.  
Please send: \_\_\_\_\_ Mark Ten B, assembled, @ \$59.95 ppd. \_\_\_\_\_ Mark Ten B Kit @ \$44.95 ppd.  
(12 Volt Negative Ground Only) • \_\_\_\_\_ Standard Mark Ten, assembled @ \$44.95 ppd.  
6 Volt: Neg. Ground Only \_\_\_\_\_ 12 Volt: Specify \_\_\_\_\_ Pos. Ground \_\_\_\_\_ Neg. Ground  
\_\_\_\_\_ Standard Mark Ten Deltakit® @ \$29.95 ppd. (12 Volt Positive or Negative Ground Only)

Car Year \_\_\_\_\_ Make \_\_\_\_\_  
Name \_\_\_\_\_  
Address \_\_\_\_\_  
City/State \_\_\_\_\_ Zip \_\_\_\_\_

**DELTA PRODUCTS, INC.**  
Dept. RE - P.O. Box 1147 - Grand Junction,  
Colo. 80501 (303) 242-9000

# WHAT'S NEW in CB

*Citizens band equipment has come a long way since the 27-MHz sector opened just over a decade ago. Here is a glance at what's available in transceivers and accessories.*

by HERB FRIEDMAN

JUDGING BY THE AMOUNT OF NEW equipment coming out almost daily, the only things certain in life are death, taxes and the Citizens band. Never in the history of consumer electronics has there been such a diverse selection of equipment. As far as the CB user is concerned virtually anything desired in the way of features and/or performance can now be found in the CB marketplace. And it's a good safe bet that if you can dream up some feature not yet available some manufacturer will go all-out to incorporate that feature in his new equipment just as soon as he hears about it.

Fact is, there is so much differing CB gear available it's difficult to even start to describe the features available which could be of use to you or your customers. Perhaps the best way is to detail the features common to most, if not virtually all, CB transceivers and then break similar equipment down to common categories.

## Features worth noting

Heading the list of common features is an external speaker (or remote speaker) output jack, previously common primarily to the full-feature transceivers only. Whether it's a need to get the signal over the ambient noise level by placing a speaker on the truck's dash directly in front of the driver, or a way to get the signal from the living room to a shop or backyard speaker, or

just a quick and dirty way to connect headphones, all CB manufacturers have finally recognized the fact that an external speaker output is a *must have* and is not necessarily restricted to top-of-the-line transceivers. Now, even rock-bottom priced, limited-channel transceivers have this feature.

Another almost universal feature, found on mobile transceivers and some base station models is the PA (public address) output jack, which permits the transceiver to be used as a public address system. Except for the very lowest priced models, this is also a common feature found in CB transceivers.

Metering is another biggie. Virtually all transceivers (except the budget models) have some sort of metering to show the relative signal strength of a received signal and the relative power output of the transmitter. In the high priced, or more deluxe transceivers—both AM and SSB models—there is likely to be more extensive metering including perhaps transmission (antenna) line SWR and perhaps relative or percent modulation. For example, some models from Browning, Dynascan, Midland, Pearce-Simpson, Regency, Robyn, Teaberry, and Tram have at least an SWR meter, while Browning and Dynascan also include a modulation meter in some models.

While everyone makes available a transceiver with full 23-channel coverage there are still many transceivers

around which accommodate only 3 or perhaps 6 channels, for the user who has no need for full coverage. If you don't need full 23-channel coverage, you'll find a model in the lines from Dynascan, E.F. Johnson, Lafayette Radio, Midland, Pathcom (Pace), Pearce-Simpson, Realistic, Royce and Teaberry, just to name two handfuls. Actually, if you're not a CB hobbyist there's no real percentage in a full-23 rig as the extra, rarely used crystals can easily represent \$50 or more in additional cost.

To meet the need of the CB user who must conceal his equipment, say in the



SKIPPER 73 is a hybrid rig from Palomar.

car's glove compartment, or who needs a rig that can be easily plugged in and set on the seat next to the driver, full 5-watt models have been shrunk down to the size of a child's walkie-talkie—the type sold for "Christmas presents". Some typical examples of the powerhouse handfuls are Lafayette's



HY-GAIN 623 has features and looks of a ham-band transceiver.

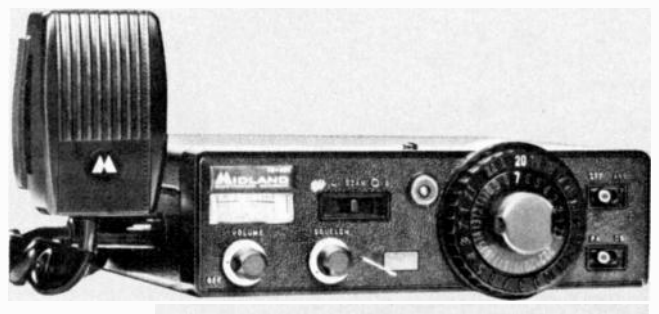

MIDLAND MODEL 13-881 scans any two selected CB channels.

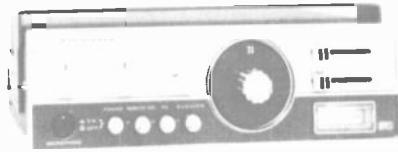

REALISTIC TRC-46, a top-notch mobile rig.

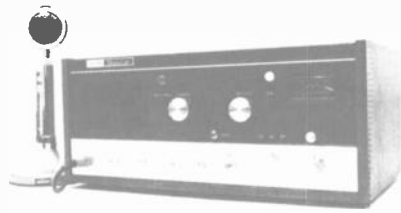

PEARCE-SIMPSON Lynx 23 base transceiver.



TRAM TITAN IV resembles hi-fi gear.

*Micro 12* which measures in at about  $1\frac{3}{4}'' \times 5'' \times 7\frac{1}{2}''$ , *Realistic's Mini-23* which shrinks a ruler to  $1\frac{1}{2}'' \times 5\frac{1}{4}'' \times 8''$  for full 23-channel coverage, *Teaberry's* really mini *MINI-T II* at  $1\frac{3}{8}'' \times 4\frac{3}{4}'' \times 6\frac{1}{32}''$ , and *Royce's* model *I-590* which puts a full 5 watts into a jacket pocket. A feature of the Royce mini-mini sure to catch on is a plastic, rather than metal cabinet—which cuts the weight down almost to nothing. A camper can pack away a plastic-housed transceiver into his backpack and add virtually nothing in the way of extra weight.

Just as some transceivers have shrunk down to pocket size, the base-station models have grown larger and larger, jam-packed with features to spare. One particular feature coming into prominent use is the built-in digital clock such as used on some models by Dynascan, Courier, Fanon, Midland and others. In addition to indicating time, the clocks can be used to turn on the transceiver at a preset time to receive a scheduled "call". On the other hand, Browning and Tram use the giant size cabinets to house relatively large speakers, oversize easy-to-read meters and the extra controls needed for such things as microphone gain, SWR calibrator, etc.

### Emergency services

With many CB'ers getting actively involved in volunteer rescue and emergency services it's only logical that they would have good reason and need to monitor the vhf public-service

frequencies. While they can always use a separate vhf monitor radio, it is a convenience to have the vhf monitor built right into the CB transceiver. Presently, Courier and Lafayette have the only CB rigs with integral vhf monitors, but rumor has it at least two other manufacturers will soon have CB/vhf models.

And while we're on the subject of



COURIER REBEL 23 mobile transceiver.

emergency services, let us not overlook the channel-9 emergency frequency. For REACT, ALERT and other "emergency CB groups" who provide full- or part-time monitoring of the national emergency channel, there are several transceivers with integral channel 9 monitoring. In almost all instances the channel-9 monitor consists of a fixed-frequency front end, i.f. amplifier and detector in addition to the regular CB receiver section. Even if the main receiver is tuned to a different channel, say channel 16, a signal appearing on channel 9 will cause some sort of panel indication, such as a lamp

lighting, to indicate there's someone calling for HELP.

In some of the rigs with dual-receiver capability a signal on channel 9 will actually over-ride the main receiver reception, or the main reception will be interrupted and only channel 9 will be heard. Since the exact method of alerting the user to the presence of a channel 9 signal differs from model to model it's best to look for the exact type of operation desired; among the brands offering channel 9 or dual-receiver capability are Dynascan, E. F. Johnson, Lafayette and Realistic.

Unlike the conventional AM (amplitude modulation) CB transceivers which are available in everything from budget priced single-channel models from about \$40—which feature just about enough circuitry and performance to get a message through if the CB band isn't jammed with stations, to high-performance models with performance levels matching the finest in equipment from any radio service, SSB (single sideband) CB transceivers have only one level of performance—as high as possible.

SSB rigs are available in mobile and base versions—the main difference being the power supply and perhaps a digital clock in the base models; otherwise, circuits and performance are essentially the same. All CB SSB rigs feature operation on both sidebands and AM, and if we'd look for one outstanding feature it would be super-selectivity for both the AM and SSB models. Either way, these are the rigs



TELEDYNE RA-510 has a push-button sensitivity selector switch.



TELSAT SSB-50, a 23-channel powerhouse from Lafayette.



that get the message through under the most severe interference conditions.

In addition to super-selectivity, a highlight feature of the SSB transceivers is a noise-blanker—a device that just about eliminates all impulse noise by literally punching a hole in the signal where a noise pulse should be—or would be even with an ordinary *noise limiter*. Though a few of the high performance AM transceivers feature a noise-blanker—generally in addition to a noise limiter for the “grinding” type of continuous noise, all SSB transceivers we have seen feature a noise-blanker.

Almost all CB manufacturers now have at least one—generally more. SSB model in their line. Most all have essentially similar features and performance specifications, the major difference between models of the same family (mobile and base) being physical size, mounting convenience or power supply—some mobile models are negative ground only, some are negative or positive ground and some are 12Vdc/117Vac.

Walkie-talkies are still just walkie-talkies; everything from 100-mW “toys” to full-feature 5-watt models are available from endless sources under endless brands. The only thing that’s really new are the full 23-channel models, which are basically high-performance 5-watt units packed into a walkie-talkie sized cabinet—generally

TS-1 CUSH-CRAFT 27-150-MHz dipole.

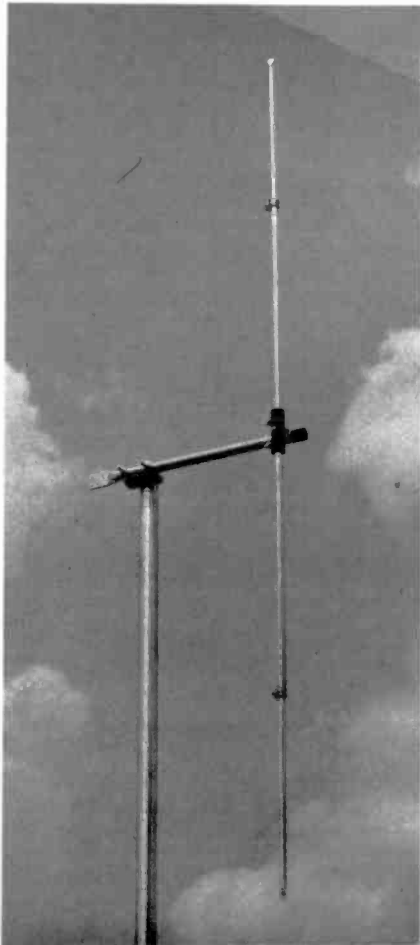

CUSH-CRAFT RINGO has 3.75 dB gain.

with a shoehorn. Using optional NiCad batteries, or a “penlight” battery pack, these units usually feature everything you’d find on a full-scale transceiver such as remote speaker output, external (12 Vdc) power supply, antenna jack, etc. So far, Lafayette and Realistic have had their full-23 walkie-talkies on the counters, with Midland, among others, announcing similar models at the time this is being written.

#### About antennas

Citizen band antennas come in every size and shape in almost every conceivable price range from a few dollars up. While there are still the old reliable ground planes, coaxial, and mobile whip antennas available, there are also



TURNER CB MIKE has a built-in preamp.

highly directional models that look like they were used on the last moon shot—fact is, one model is called a “moon-raker”. As we move up the base station price range we find the antenna “gain” almost proportional to the price increase. For a few dollars more than the price of a basic groundplane there are “stretched groundplanes” with a few dB of extra gain—attained by beaming the energy usually radiated skyward down on the ground where it does some good. Add a few dollars more and we find 3-element beams such as used by the radio amateurs, only the CB beams are vertically oriented.

Keep moving up the price ladder and we get to 4-, 5-, and 6-element beams—each element (usually) adding a little more extra forward gain in a narrower forward radiation angle. Even the familiar “quad” (four-sided) element design of the radio amateurs has made its way into CB; and depending on how much you’re willing to spend it’s possible to get slightly more than 12-dB forward gain, which is like running almost

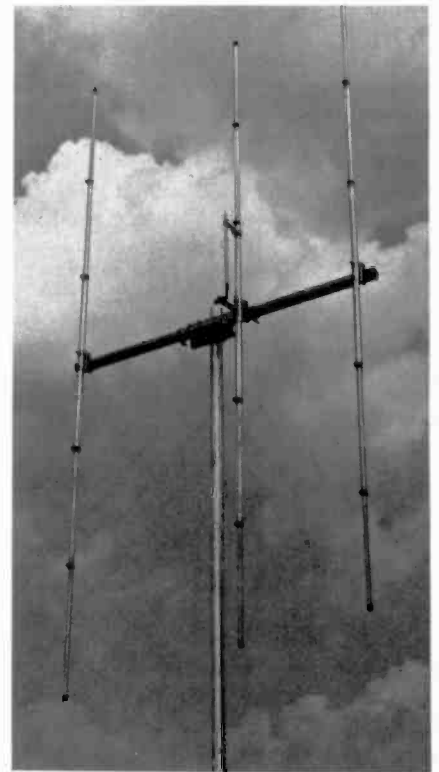

VERTICAL BEAM with 8 dB gain by Cush-Craft.



TRAM DIAMOND 60 has antenna protection.



80 watts into a standard groundplane antenna. At the receiving end the effect is almost the same as if the transmitter suddenly increased its power input almost 16 times.

Both standard and super-gain base station antennas are available—in a rather broad selection, under the old familiar brands such as Antenna Specialists, Avanti, Cush-Craft, Hy-Gain, and Mosley.

Mobile antenna are available in every possible mounting system, from the standard body or bumper mount to magnetic and vacuum types which leave not a mark when they're removed. Among the manufacturers who offer a large variety of mobile antennas and mounting devices are Antenna Specialists, New-Tronics and Shakespear, Lafayette and Radio Shack (Realistic) have a large "house brand" assortment. Though the selection is not

as great or varied as it is for automobile antennas, there are enough marine CB antennas to meet just about any type of mounting requirement.

### Extras you might want

Gimmicks—*operating aids*, if you prefer, abound in CB. For those who need more microphone gain—perhaps to compensate for a low voice level—there are microphones with built-in amplifiers from Turner, who also produces an amplified model(s) with a built-in speech compressor for greater "average" modulation (talk power). For those who need only speech processing or compression without a new microphone there's equipment from Ascom and Gold Line, among others. Hy-Gain has a receiver preamplifier for souping the transceiver's sensitivity, while Johnson has a 6-Vdc converter for powering "modern" 12 Vdc transceivers from 6-volt power sources. There are also antenna meters and antenna matching devices from Johnson; phone patches from Gold Line, Lafayette and Realistic (among many others); TVI (television interference) filters from Drake; and a super-deluxe base station control center with just about every conceivable station-accessory feature from Hy-Gain.

If you need a CB "station" tester for measuring SWR (standing wave ratio), power output and perhaps modulation the catalogs from Burstein-Applebee, Lafayette, Olson and Radio Shack list just about everything that's available, as well as most other CB "operating aids". Fact is, the best place to browse



TRANSCIVER TESTER aids troubleshooting.

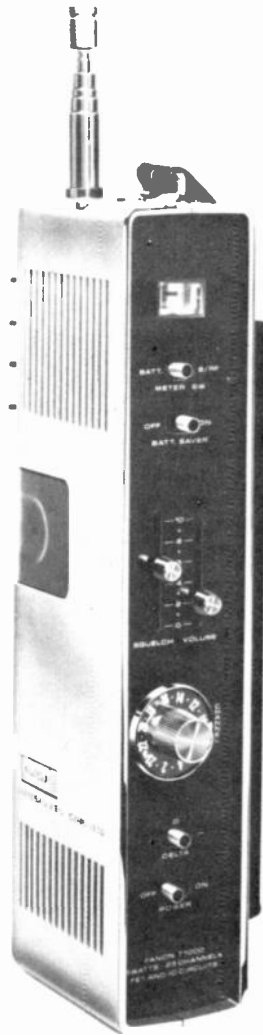

FANON T-1000, 23 channels, 5 watts.



PEARCE-SIMPSON TIGER 23 is a mobile synthesizer rig.



MESSENGER 323-M is Johnson rig with dual receive capability.



PACE CB-9 is a mobile channel-9 monitor.

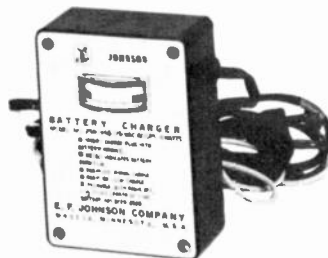

JOHNSON BATTERY CHARGER for NiCad's.

for most CB equipments are in these catalogs.

Summing up, we can safely state that except for photography no other hobby or interest has as great a selection of equipment and accessories. There is a transceiver, antenna, walkie-talkie and accessory to meet virtually every possible operating need. There is no CB idea so far out that some one hasn't already thought of it and manufactured the necessary equipment.

R-E

# YOU'LL BE DYNAMITE!

Build your own  
CIE color TV!

Learn Electronics!

Create a new career!

Enjoy a whole new  
life style!



Mail the postage-  
free card today  
for free information.

Television reception is simulated.



Imagine what your friends will say when they see your new solid-state 25-inch diagonal CIE color TV — and find out you built it yourself!

### **Learn Electronics this new enjoyable way.**

When you earn Electronics with CIE, you not only get to build your own solid-state color TV (worth \$599.95), you acquire a knowledge of Electronics that can open up a whole new world of exciting, high-paying opportunities in a broad selection of career fields!

### **You also get to work with your own CIE Experimental Electronics Lab.**

In addition to building your own solid-state TV, you get to perform hundreds of fascinating electronics experiments and projects with your own 161-piece CIE Electronics Laboratory. The lab includes electronics testing gear and dozens of the same components you'd use in your own electronics business or in a key industry job. You actually apply what you learn in the most enjoyable and practical way possible.

### **You can use your new skills to become your own boss or to make big money in business and industry.**

Look around you — everything is "going electronic"! Electronic equipment is the heart of today's entertainment and communications industries. It's the "nerve system" of our newest office buildings, manufacturing plants, transportation systems, financial institutions, hospitals — even the newest super-



markets. Your electronics skills and knowledge will put you among the elite in this continuing technical revolution! According to a U.S. Office of Education Bulletin, **25 Technical Careers You Can Learn In 2 Years Or Less**, "The demand for people with technical skills is growing twice as fast as for any other group, while jobs for the untrained are rapidly disappearing."

### **CIE has trained thousands of men like you.**

CIE's special **AUTO-PROGRAMMED®** Lessons are designed to make learning easier — even if you've never done anything more complicated than wiring a lamp. And when you've completed your course, you'll be prepared to take the Government FCC License exam — a must for top paying jobs in such fields as broadcasting. Best of all — you learn it all at home, in your spare time, while you go right on picking up your regular paycheck.

If you are in the service or are a veteran, check the box on the attached reply card for complete information on educational benefits under the G.I. Bill.

**Detach the postage-paid reply card and mail it today for complete FREE information!**

If the card has been removed, write to:

**CIE** Cleveland Institute of Electronics, Inc.

1778 E 17th St., Dept. PH-C2, Cleveland, O. 44114  
Accredited Member National Home Study Council

# This 10 MHz Triggered Scope is 1/3 the size of comparably performing scopes.

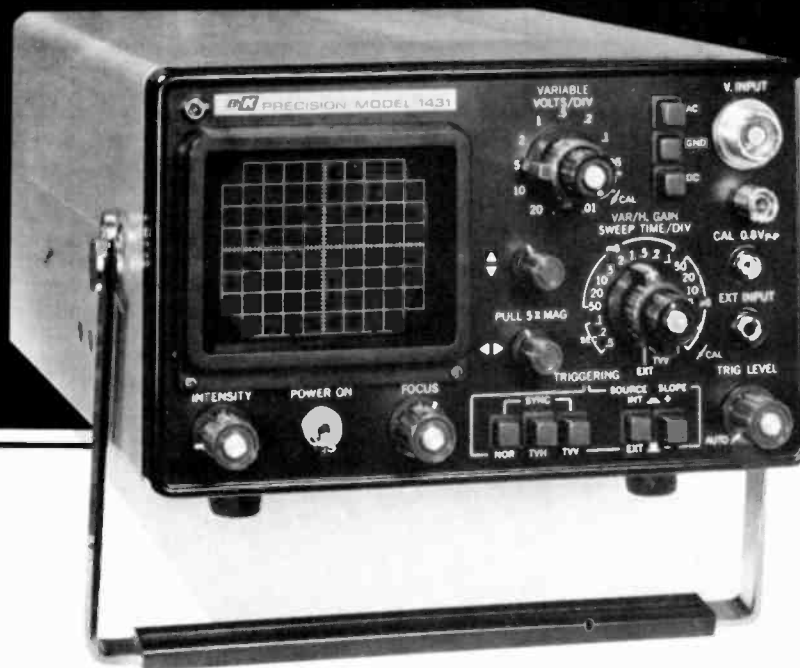

**MODEL 1431 \$399.95**

It's a lightweight 13 pounds in your hand and a heavyweight performance wideband scope with a 35 nanosecond rise time on your bench or jobsite. Whether you're servicing or designing industrial equipment or TV, there's the right sweep speed and sync for easiest operation. If you know our Model 1460, the leader in wideband 5" CRT scopes, you know our new 3" Model 1431 which gives you the same high performance in one third the size. (Only 4 $\frac{3}{4}$ "Hx7 $\frac{7}{8}$ "Wx12 $\frac{1}{2}$ "L)

Servicing, production, inspection, quality control and lab applications are all easier with this versatile all solid-state instrument. Triggering is accomplished with only 0.5V peak-to-peak. Ten millivolts per division sensitivity, 0.5 usec/cm to 0.5 sec/cm automatic and triggered sweep in 19 calibrated ranges, and external trigger input are just a few of the reasons you'll like it.

If you have been waiting to buy a portable scope until you could get all the features you'll ever need at a price you want to pay, you've been waiting for Model 1431. Contact your distributor or write Dynascan Corporation.



Shown with optional carrying cover and probe pouch.

**B&K** PRODUCTS OF  
**DYNASCAN**  
1801 W. Belle Plaine Ave.  
Chicago, IL 60613 • (312) 327-7270



# MODERN RECEIVER CIRCUITS

*The communications superhet has made some startling strides during its 42 years of existence. Here's what its latest versions look like.*

by RAY MOORE

THE SELF-CONTAINED, VERSATILE INSTRUMENT WE CALL THE communications receiver is becoming more complex these days. It has come a long way since James Lamb described the first one in *QST* in 1932. In his historic article Lamb defined the need for good selectivity and described the crystal filter to provide it. He also showed how to obtain the necessary oscillator stability to go along with high selectivity and he told how to tame an amplifier to get adequate sensitivity with the superheterodyne circuit. By 1934 and 1935 units which we would recognize today as communications receivers were on the market—National HRO, Hallicrafters Sky rider, Hammarlund Super-Pro.

The basic design described by Lamb remained the exclusive configuration until 1947 when Collins introduced the 75A. This receiver had a variable first i.f. and a constant tuning rate and set new standards for frequency stability and readout. The 75A was an amateur-bands-only design but was later followed by the general coverage 51J series. The variable first i.f. design is now used in most professional class communications receivers and many models in the low and medium price range.

In the early 1960's frequency synthesis techniques were used in communications receivers for the first time and the first all-solid-state receivers appeared on the market. Early in 1962 Davco announced the DR-30, a solid-state amateur receiver, and later in the year SBE introduced the SB-33, an amateur-band transceiver which contained a completely transistorized receiver. In 1964 National came out with the HRO-500 which was the first solid-state, general-coverage receiver. The same receiver incorporated a frequency synthesizer with a phase-locked oscillator to generate the 500 kHz, stepped injection frequencies for the first mixer.

## Classes of communications receivers

Until the late 1940's all communications receivers were much the same. They varied only in the number of rf and i.f. stages used and in the quality of construction. They were general-purpose instruments and were sold largely to amateurs and SWL's, with some

going to laboratory, commercial and military users. Point-to-point communications systems and others who needed more sophisticated and reliable equipment used custom-built receiving systems which often occupied several relay racks. Then, about 1949, the professional class of receiver appeared, a receiver priced beyond the mass amateur market and intended for military and commercial users who could afford the cost of the ultimate in stability and reliability. Some of the well-known receivers which appeared at that time were the Collins 51J, Hammarlund SP-600, and Hallicrafters SX-73. The difference between professional and general purpose receivers has continued to grow since then. Not many years ago a dual-diversity, independent sideband receiving system would have consisted of four separate receivers, combiners, oscillators and single sideband adaptors in several racks. Today such a system can be purchased in a single receiver cabinet.

Any attempt to classify communications receivers is bound to be arbitrary and subject to argument but the classifications that follow may be useful in picturing the wide variety we now have.

1. Professional receivers are priced from \$2000 to \$10,000 and are intended for communications circuits handling voice and data transmissions. Receivers in this class are invariably solid-state and cover the entire high-frequency range.
2. Intermediate professional receivers are found in the \$800 to \$2000 price range. They are general-coverage and solid-state. They are intended for the budget minded professional user and for the individual who can afford the best.
3. General-purpose, medium-price (\$300 to \$800) receivers are sold mainly to individuals, amateurs and short wave listeners. There are both specialized, amateur bands only, and general-coverage models. They may use vacuum tubes, transistors, or both.
4. Low-priced receivers (under \$300) often provide a great deal of performance per dollar. Many of them tend to be quite similar to

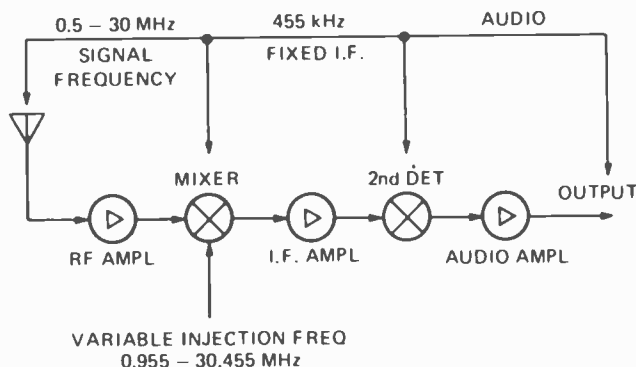

FIG. 1—BLOCK DIAGRAM of a conventional single-conversion superheterodyne receiver. Graphic symbols show each circuit function. The i.f. and audio amplifiers may each consist of one or several stages.

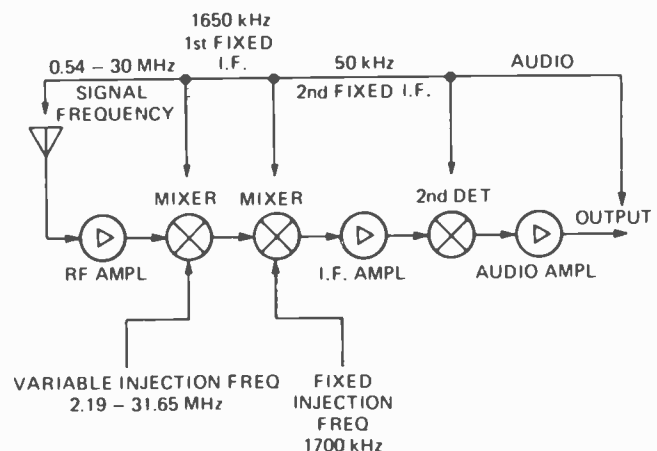

FIG. 2—A DOUBLE-CONVERSION SUPERHET. In this basic type, the first and second intermediate frequencies are fixed. The first i.f. may be passive or an amplified bandpass circuit.

medium-priced receivers with some relaxation in electrical and mechanical specifications. A large number are imported.

### Basic receiver signal paths

A complete receiver is a system consisting of several distinct circuit groups:

1. Signal path circuits
2. Frequency determining circuits
3. Control circuits
4. Power circuits

We will discuss the first two of these in more detail in the balance of this article since it is in the signal path and frequency determining circuitry that modern receivers are most dramatically different.

The signal path describes the sequence of circuits through which the intelligence-carrying signal travels from the antenna input to the audio output of the receiver. There are really only two basic signal path configurations. The first intermediate frequency of a superheterodyne can be either *fixed* or *variable*. To look at it in

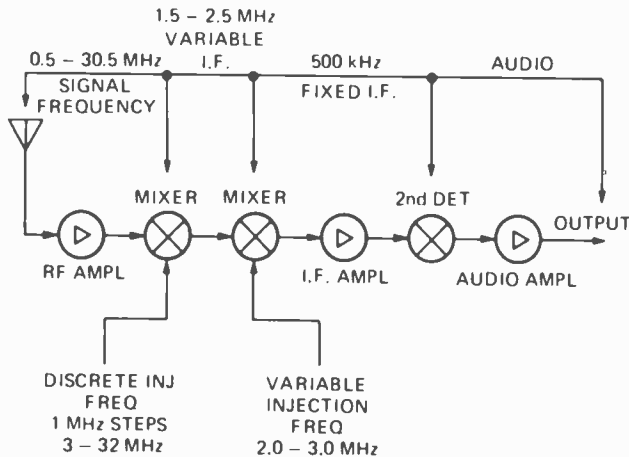

FIG. 3—THE FIRST I.F. IS VARIABLE in this dual-superhet. The first injection signal varies in 1-MHz steps so the tuning range can be covered in a number of bands, each 1 MHz wide. The second i.f. provides the selectivity and may include a crystal or mechanical filter.

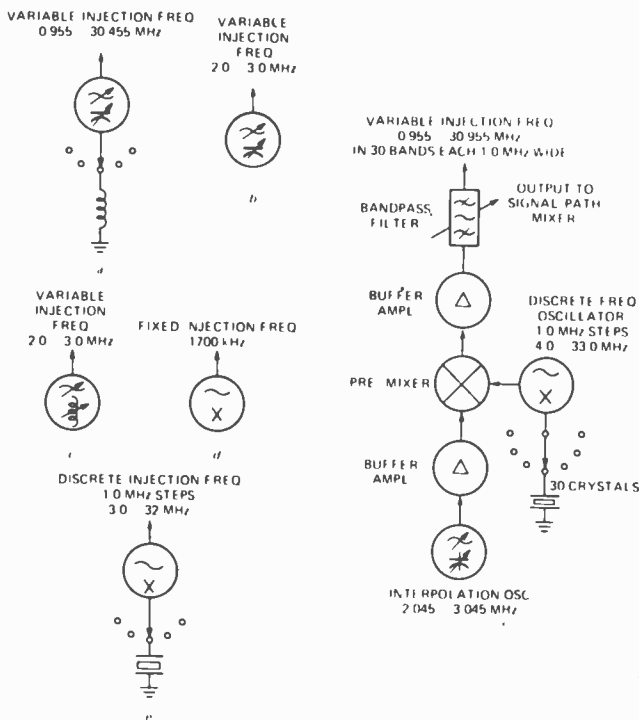

FIG. 4 (left)—GRAPHIC SYMBOLS representing different frequency-determining circuits.  
FIG. 5 (right)—PRE-MIXER OR PARTIAL SYNTHESIS makes it possible to develop a single-conversion superhet with good stability, constant tuning range and precise calibration. Interpolation oscillator with range of 1 MHz (or 500kHz in some designs) develops a signal that is heterodyned against a crystal.

another way, a variable oscillator can be used to beat with the different signal frequencies in the first mixer to produce a fixed i.f., or, a fixed frequency oscillator can feed the first mixer to produce a variable-frequency i.f. A fixed first-i.f. receiver can be either single or multiple conversion. The receiver with a variable first i.f. has at least two conversions.

The fixed first i.f. was used by Lamb and by all commercial communications receivers until 1947. The incoming signal is converted to a fixed i.f. by a variable injection frequency in the mixer (see Fig. 1). The variable injection-frequency source, often from a simple tuned oscillator, must cover the entire frequency range of the receiver plus the value of the i.f. If a receiver has a fixed first i.f. at 455 kHz and tunes from 0.5 to 30 MHz, the injection frequency must cover the entire range from 0.955 to 30.455 MHz—usually in bands with a frequency tuning ratio of around 3:1.

Simplicity is a virtue in receiver design and for that reason the fixed first i.f., single-conversion receiver is attractive. However, as usually designed, the single-conversion receiver has two serious drawbacks when compared to modern receiver standards. First, the i.f. is a serious compromise between image rejection ratio which requires a high-frequency i.f. and adjacent-channel selectivity requiring a low-frequency i.f. Second, the local oscillator, which provides the mixer injection frequencies, covers such a wide range of frequencies that it is almost impossible to build it to conform to modern standards for stability, constant and linear tuning rate, and calibration accuracy. With the availability of high-frequency crystal lattice filters (and various types of mechanical filters) and pre-mixer and synthesizer frequency generation techniques, it is now possible to overcome the drawbacks, and we may soon see a trend back to the single-conversion receiver.

The variable first-i.f. configuration is used in almost all professional-type receivers and in many medium-priced receivers. The advantages, over ordinary fixed first-i.f. receivers, are a *constant tuning rate and calibration* on all ranges and much better stability. These advantages are possible because the variable injection-frequency source which feeds the second mixer covers only a single, small band of frequencies. The smaller the frequency range to be covered and the lower the frequency, the easier it is to build a stable and linear oscillator.

A typical variable first-i.f. receiver is shown in Fig. 3. The circuit after the first mixer consists of a conventional fixed first-i.f. receiver tuning from 1.5 to 2.5 MHz. The first mixer translates all incoming signals to the 1.5 to 2.5 MHz range by mixing them with a series of stepped injection frequencies spaced one MHz apart.

If you want to receive the 4.5 to 5.5-MHz band, for instance, a 7-MHz frequency is injected into the first mixer. A 5.5 MHz incoming signal beating with the 7-MHz injection frequency will produce a difference frequency of 1.5 MHz which falls within the range of the variable first i.f. A 4.5-MHz incoming signal will produce a difference frequency of 2.5 MHz ( $7 \text{ MHz} - 4.5 \text{ MHz} = 2.5 \text{ MHz}$ ) which is at the other extreme of the variable i.f. range. Similarly, any other signal between 4.5 and 5.5 MHz will be converted to some frequency in the variable i.f. range. To tune signals in the 5.5 to 6.5 MHz range you inject an 8-MHz frequency into the first mixer, and so on in 1-MHz steps.

The signals from the variable i.f. go to the second mixer where they are mixed with a variable injection frequency covering 2.0 to 3.0 MHz and converted to the 500-kHz fixed i.f. The 5.5-MHz signal which was converted to 1.5 MHz (as just described) would be mixed with a 2.0 MHz injection frequency in the second mixer and converted to a frequency of 500 kHz. When the variable injection frequency is tuned to 3.0 MHz it will beat with a 2.5-MHz signal from the variable i.f. to form a 500-kHz signal. Thus, any signal between 1.5 and 2.5 MHz from the variable i.f. can be changed to 500 kHz by injecting the proper frequency in the range of 2.0 to 3.0 MHz.

The injection frequencies for the first mixer can be from a crystal oscillator (*translation oscillator*) with switchable crystals spaced 1 MHz apart. The variable injection frequencies for the second mixer can be from an oscillator which is sometimes called an *interpolation oscillator* from its function of filling in between the steps of the translation oscillator.

### Frequency-determining circuits

The second important group of circuits in a receiver are the frequency-determining circuits. In Lamb's receiver the frequency-determining circuit was a single high-frequency oscillator. In a modern, professional type receiver the frequency-determining circuits may be more complex and contain more active devices than the signal path.

There are four types of injection frequencies required in the different receiver configurations.

1. **Wide range**, continuously variable frequencies for the first mixer of fixed first i.f. receivers (Figs. 1, 2).
2. **Limited range**, continuously variable frequencies for the second mixer of variable first-i.f. receivers (Fig. 3)
3. **Fixed**, single-frequency injection for the second mixer of fixed first-i.f. double-conversion receivers. (Fig. 2)
4. **Discrete**, stepped frequencies for the first mixer of variable first-i.f. receivers. The frequencies must be spaced by the width of the first i.f. (Fig. 3)

The four types of injection frequencies are usually supplied by simple oscillators in low and medium-priced receivers. Oscillators have the advantage of simplicity and low cost. They have two disadvantages which can sometimes justify the use of more complex circuits. First, some commercial applications require stability on the order of a few hertz per day. Limited-range variable oscillators used in commercial receivers have stability specifications ranging from 100 Hz per two hours to 30 Hz per day. Better stability than this requires the use of frequency synthesis techniques. Secondly, the discrete, stepped injection frequency for the first mixer of a variable first i.f. receiver must be crystal controlled if a simple oscillator is used. This is not a problem in an amateur-bands-only receiver which may have eight 500-kHz bands, but a general-coverage receiver covering 0.5 to 30 MHz in 500-steps kHz would require 59 crystals and a 59-position switch. There is also the problem of zeroing in each crystal to maintain calibration accuracy.

The different types of simple oscillators which can be used to provide injection frequencies are shown in Fig. 4. The continuously variable injection frequency required by the first mixer of a fixed first-i.f. receiver can be supplied by a switched high-frequency oscillator (Fig. 4-a). The wide frequency range which this type of oscillator must cover is achieved by switching inductors which are tuned by a variable capacitor. The disadvantage of this type of oscillator is that there is a different tuning rate and calibration on each band—the tuning rate becomes faster and the calibration becomes more crowded as you go higher in frequency. Also, it is almost impossible to meet modern stability requirements with an oscillator covering such a wide frequency range. Top quality receivers using this type of oscillator have stability specifications of 300 to 3000 Hz per day at 30 MHz.

Limited-range variable-frequency oscillators can be either capacitively or inductively tuned (Figs. 4-b, 4-c). Their stability can be as good as 30 Hz per day because of their limited range and the relatively low frequency at which they operate. They can also be made quite linear so that a given frequency increment occupies the same space anywhere on the dial.

Only a single frequency is required for injection to the second mixer of a double conversion, fixed first-i.f. receiver and this can be supplied nicely by a crystal-controlled oscillator. (Fig. 4-d)

The discrete, stepped frequencies for the first mixer of a variable first i.f. receiver can also be derived from a crystal oscillator. (Fig. 4-e) Different crystals are switched in to change bands.

The pre-mixer technique of frequency generation makes possible a single-conversion, fixed first-i.f. receiver with the stability, constant tuning rate, and calibration accuracy of the variable first-i.f. receiver. The complexity removed from the signal path, however, is added to the frequency determining circuitry. Pre-mixing is a form of frequency synthesis since the final frequencies applied to the signal mixer are synthesized from other frequencies in a series of circuits (Fig. 5).

The outputs of a limited-range, variable-frequency oscillator and a crystal oscillator are both applied to a mixer. The difference between the two frequencies is then applied to the signal-path mixer through a buffer amplifier and filter. Crystals, 1.0 MHz apart, are switched in the crystal oscillator to change bands. The disadvantage of this technique for general-coverage work is the large number of frequencies put out by the pre-mixer—the interpolation oscillator frequency, the crystal oscillator frequency, the sum and difference frequencies, and higher order combinations of all these frequencies. All these unwanted frequencies can cause spurious responses if they get into the signal-path mixer. One solution is to put a tunable filter between the pre-mixer and signal-path mixer. Another is to use the output of the pre-mixer to control a phase-locked oscillator whose output is fed to the signal-path mixer.

A simplified block diagram of the frequency synthesizer used in the Galaxy R-530 receiver is shown in Fig. 6. The R-530 covers a frequency range of 0.5 to 30 MHz in 500 kHz wide bands with a variable first i.f. of 41.625 to 42.125 MHz. This conversion scheme requires a series of discrete frequencies every 500 kHz from 42.625

to 71.625 MHz for injection to the first mixer. These frequencies are provided by the frequency synthesizer to be described.

The actual frequency injected into the first mixer is generated by a tunable *phase-locked oscillator*. This oscillator is tuned manually by a variable capacitor and it can also be controlled electronically by a dc voltage applied to a varactor diode. The desired output of the phase-locked oscillator is any one of 59 discrete frequencies spaced 500 kHz apart from 42.625 to 71.625 MHz, the injection frequencies required by the first mixer. The oscillator will tune the entire range continuously but is *held in and locked* only at 500 kHz intervals by a series of control frequencies derived from the 1000-kHz reference oscillator, much as the local oscillator in an FM receiver is locked to the signal by the afc circuit.

The output of the crystal controlled 1000-kHz *reference oscillator* *l* in Fig. 6 goes through a divide-by-two circuit to produce a

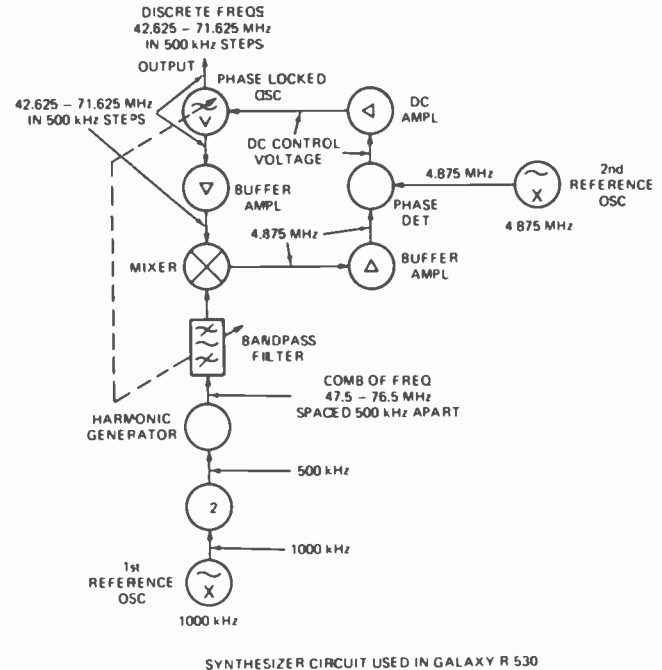

FIG. 6—FREQUENCY SYNTHESIZER used in the Galaxy R-530 general-coverage receiver covers 500 kHz to 300MHz in 500kHz bands.

500-kHz frequency which is applied to a harmonic generator which produces what is called a *comb of* frequencies. A comb of frequencies is a series of uniformly spaced discrete frequencies spread simultaneously across a portion of the rf spectrum. The output of the crystal calibrator in a communications receiver can be considered a comb of frequencies spaced 100 kHz apart. The output of the harmonic generator in the R-530 is a comb of frequencies spaced 500 kHz apart between 47.5 and 76.5 MHz. The appropriate frequency from the comb is selected by the filter following the harmonic generator. The tuning of the filter is ganged with that of the phase-locked oscillator.

The frequency selected by the filter from the comb is used as a reference to which the phase-locked oscillator is locked and it is always 4.875 MHz higher than the desired output of the phase-locked oscillator. The selected reference frequency is combined with the output of the phase-locked oscillator in the mixer. The difference between the two frequencies is applied through a buffer amplifier to the phase detector.

The phase detector has two frequencies applied to it, the output of the mixer and the output of the 4.875-MHz crystal-controlled reference oscillator. If the outputs of the mixer and the second reference oscillator are exactly the same frequency there will be no dc output from the phase detector. If the two frequencies are *not* exactly the same the phase detector generates a control voltage which is applied to the phase-locked oscillator to pull it into tune. Of course, there is a limit to the range over which the phase-locked oscillator can be pulled. Auxiliary circuits actuate a panel light and audio tone which tells when the phase-locked oscillator is not locked. The procedure is to tune the phase-locked oscillator tuning control until the light and audio tone go off, indicating lock has been achieved.

The R-530 synthesizer, in summary, produces 59 discrete frequencies, one at a time, each one phase-locked to the reference crystal oscillators. Thus 59 crystal controlled injection frequencies are generated with only two crystals and no switches.

R-E

# NEW CB Circuits



Some CB transceivers are as sophisticated as some of the more advanced gear used by hams and other 2-way operators. Here are details on circuits in 1974 rigs.

by ROBERT F. SCOTT  
TECHNICAL EDITOR

SINCE THE 11-METER (27 MHz) BAND WAS assigned for Citizens band service early in 1959, the equipment has evolved from superregenerative receivers and modulated-oscillator transmitters to solid-state complexities operating in both AM and single sideband modes and featuring such goodies as 23-channel frequency synthesis, razor-sharp selectivity, and automatic noise limiters and blankers. This article describes some of the circuit features in the latest CB gear.

First, we'll take a look at the block diagram (Fig. 1) of the Lafayette Micro 923, one of the more sophisticated transceivers that has frequency synthesis, Range Boost and a separate built-in monitor for channel 9.

Frequency synthesis is a system that provides crystal-controlled transmission and reception on 23 channels while using only about one-fourth of the 46 crystals required without frequency synthesis. In the diagram, we have a total of 14 crystals in the synthesizer. The 33-MHz oscillator uses one of the six crystals 50 kHz apart between 33,000 and 33,250 MHz. When transmitting, one of the 33-MHz crystals is selected and its signal heterodyned against a 6-MHz (6,035, 6,025, 6,015, 5,995 MHz) crystal producing a difference frequency equal to the precise frequency of the desired CB channel.

The receiver circuit is a double-conversion superhet with a 5.995-6.035-MHz first i.f. and 455-kHz second i.f. The first oscillator uses one of the 33-MHz crystals that is between 5.995 and 6.035 MHz above the incoming signal frequency. The 6-MHz output of the first mixer beats against a 6.4-MHz (6,490, 6,480, 6,470 or 6,450 MHz) signal from the second oscillator to produce the 455-kHz second i.f.

To see how this works out, let's see what's needed for transmitting and receiving on channels 1 and 23—26.965 and 27.255 MHz, respectively. On channel 1, 33,000-MHz beats against 6.035 to develop the difference frequency (26.965 MHz) that we need. Similarly, when transmitting on 27.255, we beat 33,250 and 5.995 to come up

with the desired frequency.

When receiving, we use the same 33-MHz crystals to develop the first i.f.—difference frequencies—of 6.035 MHz for channel 1 and 5.995 MHz for channel 23. The second conversion oscillator frequency (6,490 for channel 1 and 6,450 for channel 23) provides the 455-kHz difference frequency for the second i.f. amplifier.

## Channel-9 monitor

The monitor section of the transceiver is a crystal-controlled single-conversion superhet that permits the CB operator to keep a constant "watch" on channel 9—the

emergency channel set aside by the FCC for calls related to assistance to the motorist and emergency communications involving safety of life or protection of property—while at the same time handling traffic on any of the other 22 channels. A signal on channel 9 flashes a special indicator light on the panel. Pressing a switch transfers the output of the monitor to the common audio output circuit. To respond to the emergency call, the operator disables the monitor, switches the channel selector to 9 and operates in the normal manner.

Some transceivers include complete transmit and receive circuits for channel 9.

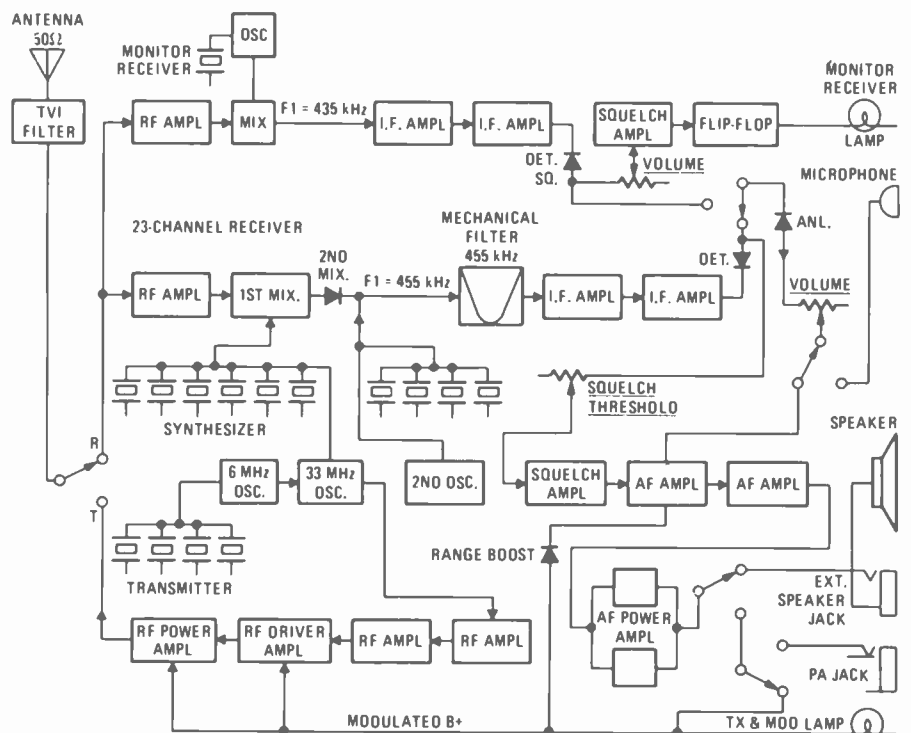

FIG. 1—BLOCK DIAGRAM OF THE MICRO 923, a sophisticated AM rig from Lafayette Radio Electronics featuring frequency synthesis, Range Boost and a channel-9 monitor.



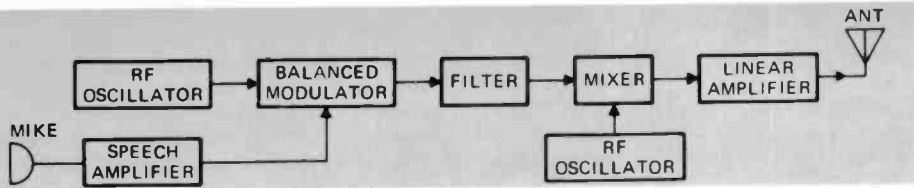

FIG. 2—FILTER METHOD of generating a single-sideband signal. The first rf oscillator is at the filter frequency. The second heterodynes the sideband to the desired frequency.

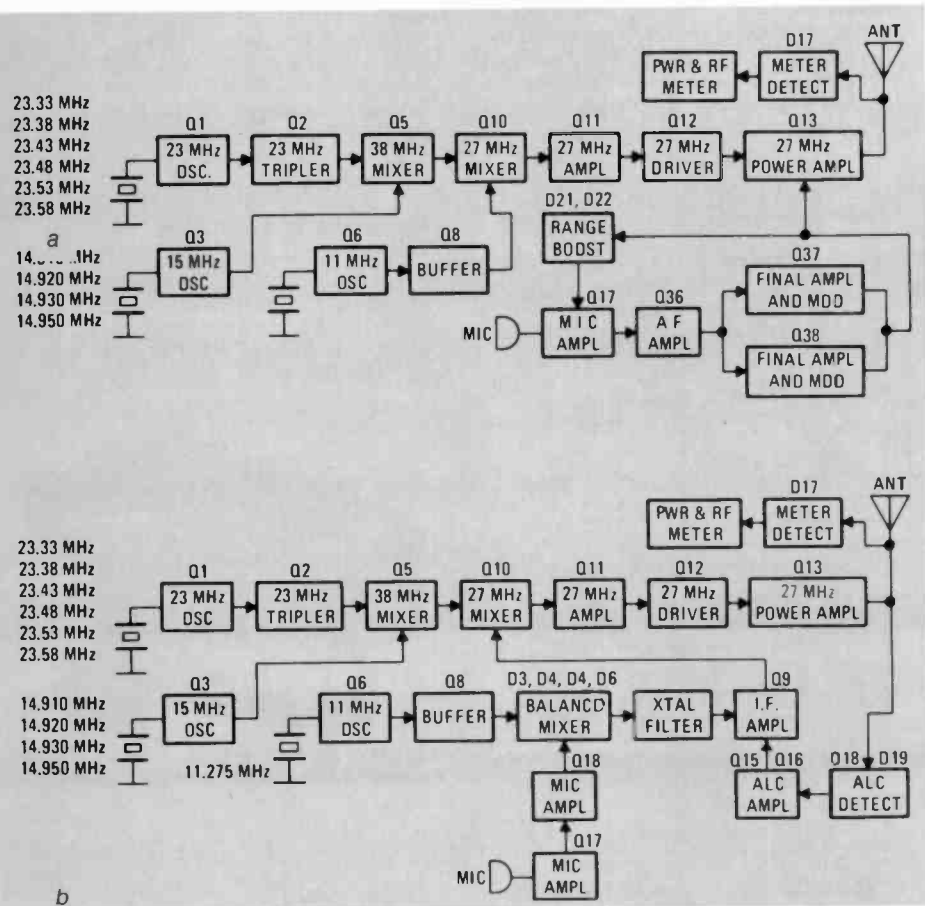

FIG. 3—A COMPARISON OF THE AM AND SSB CIRCUITS in a typical deluxe transceiver. The Range Boost circuits in the AM transmitter (a) are akin to the a/c circuits in the SSB mode (b). However, the former works at audio frequencies and the latter at rf.

For example, Radio Shack's Realistic model TRC-49 Navaho Pro Niner includes a synthesized 23-channel, 5-watt transceiver, plus a separate crystal-controlled 5-watt transceiver.

Many of the more sophisticated CB rigs operate in the AM mode and in the single-sideband mode using either the upper or lower sideband as desired. Single-sideband (SSB) operation offers the CB operator quite an improvement in performance over conventional AM. First, when transmitting, all the available legal power can be concentrated in one sideband to provide an effective power gain of around 8 dB (at the receiver). Too, being able to use either sideband at will effectively triples the number of available channels. On receiving, the SSB mode offers improved sensitivity and selectivity and a better signal-to-noise ratio to contribute further to an increase in operating range.

### The SSB transmitter

In the SSB mode, the typical CB transceiver uses the balanced modulator/filter combination (Fig. 2) to generate the single-sideband signal. The rf oscillator signal—at the filter frequency—combines with the

audio signal in the balanced modulator so the carrier (the rf oscillator frequency) is suppressed and only the upper and lower sidebands appear in the output. The filter—generally a mechanical or crystal-lattice filter in the range of around 5.6 to 11 MHz—has sufficient selectivity to pass one sideband while rejecting the other.

The SSB signal from the filter is then mixed with an rf signal from the synthesizer, or an rf oscillator, to produce output on the desired 27-MHz channel after being amplified in a linear amplifier. In the LSB mode the rf injection frequency is the *difference* between the carrier and filter frequencies. When the upper sideband is transmitted, the rf injection frequency equals the *sum* of the carrier and filter frequencies.

For example, take the Pace *Sidetalk* model CB 1023 that incorporates a 7.8025-MHz crystal filter. Consider channel 13 (27.115 MHz). On the lower sideband transmit (and receive and AM transmit) the rf injection frequency required for 27-MHz output is 19.3125 MHz (27.115 - 7.8025). For USB transmit and receive the injection frequency is 34.9175 (27.115 + 7.8025) MHz.

The circuitry used when the transmitter is

used in the AM mode is quite simple compared to that used for SSB operation—even when frequency synthesis is used for carrier generation. On AM, we generate a 27-MHz signal, amplify it to the desired output level and then use an audio power amplifier to modulate the B+ supply to the rf power amplifier.

Fig. 3-a is a block diagram of Lafayette's Telsat SSB-50 transceiver when transmitting in the AM mode. The Range Boost circuit maintains a high level of modulation without over-modulating. The feedback or control voltage is tapped off the high side of the modulation transformer secondary. The modulator's output is sampled, rectified by D21 and D22 and then filtered to develop a variable bias to control the gain of the mike preamplifier.

Compare Fig. 3-b, the block diagram of the SSB-50 when transmitting on the upper sideband—with Fig. 3-a. (When operating on the lower sideband, the circuit is the same except in the 15-MHz oscillator. On LSB, the frequencies of the four crystals are each 3 kHz lower than those used in the USB mode.)

The a/c circuit—alternatively called automatic load control and automatic level control—is a form of delayed a/c that is applied to the transmitter to insure that the modulation peaks do not drive the linear power amplifier so hard that it operates in the nonlinear region. A portion of the output of the final (linear) amplifier is tapped off and rectified to provide a dc control voltage for the a/c amplifier—a dc amplifier controlling the bias for the i.f. amplifier following the crystal filter.

### The SSB receiver

The receiver in the SSB rig is generally a double-conversion superhet with the first i.f. centered on the filter frequency. The incoming signal passes through a broadband 27-MHz amplifier to the first mixer where it combines with the local oscillator signal from the synthesizer. The local oscillator frequency is *below* the signal frequency in the LSB and AM modes and *above* the signal in the USB mode.

The receiver in the AM/SSB rig includes a Noise Blanker and automatic noise limiter (anl) to eliminate impulse-type noise on SSB and AM signals, respectively; envelope-type AM detector, product detector for SSB and separate a/c circuits for AM and SSB. We will now cover some of these features in detail.

### Noise elimination

Impulse-type noise as from automobile ignition systems and atmospheric can make CB reception very difficult if it is not eliminated. The AM noise limiters generally use a pair of diodes biased to clip the noise pulses at the level of a 100% modulated signal. In the SSB mode, the noise eliminator—called a noise blanker—is designed to eliminate the noise pulse before it reaches the selective circuits in the receiver. Figure 4 is the noise blanker circuit in the Pace *Sidetalk* CB-1023 transceiver.

The incoming signal—along with any noise pulses—is amplified in the rf amplifier and converted to a 7.8-MHz i.f. signal in the mixer. In the absence of noise, the i.f. signal passes through D4 to the crystal filter and on to the i.f. amplifier. The noise component is rectified by D5 and D6 to produce a

positive pulse that is differentiated by C413 and R411. This differentiated pulse is fed to the gate of the FET where it is amplified to the level needed to control gate diode D4. The amplified noise pulse back-biases D4 so it cuts off for the duration of the noise pulse. Thus the receiver's signal path is interrupted and the noise pulse is eliminated before it reaches the i.f. circuits where it can cause "ringing" in the high-Q selective circuits.

### Agc circuits

In an AM receiver, agc voltage is developed by the audio detector or by a special

agc detector. This dc voltage varies with carrier level. There is no carrier on an SSB signal so special agc circuits are needed to hold the receiver's output signal relatively constant. In some sets SSB agc is obtained by rectifying the audio in a full-wave rectifier to develop the dc bias voltage to control the rf and/or i.f. amplifiers.

In the Pace *Sidetalk*, the agc circuit is as shown in Fig. 5. The output of the last i.f. amplifier is used to develop two levels of voltage. The voltage tapped directly off the i.f. output collector is fed through the 47-pF capacitor to D14 and D15 to develop the low *attack* agc voltage. The higher voltage is

the *release* agc voltage developed by D12 and D13. Resistor R429 and capacitor C452 form the time constant of the release delay. The capacitor returns to ground through diode D17. On SSB, the diode is biased on, connecting the capacitor directly to ground. The release delay is not needed on AM so the diode biasing voltage is removed when the mode switch is in the AM position.

The FET acts as an agc amplifier. When a strong SSB signal is tuned in, the agc attack detectors (D14 and D15.) act quickly to charge C434 and C435. The release agc diodes charge C432 with a voltage that acts as a reverse bias on D16. The voltage on C434 and C435 remains constant until the voltage on C432 has bled off through R429.

### Automatic level control

The synthesizer and most of the low-level rf and i.f. circuits are common to the receiver and transmitter. In the Pace CB-1023, the rf power amplifier operates Class C on AM and is biased into the A or AB region for linear operation on SSB.

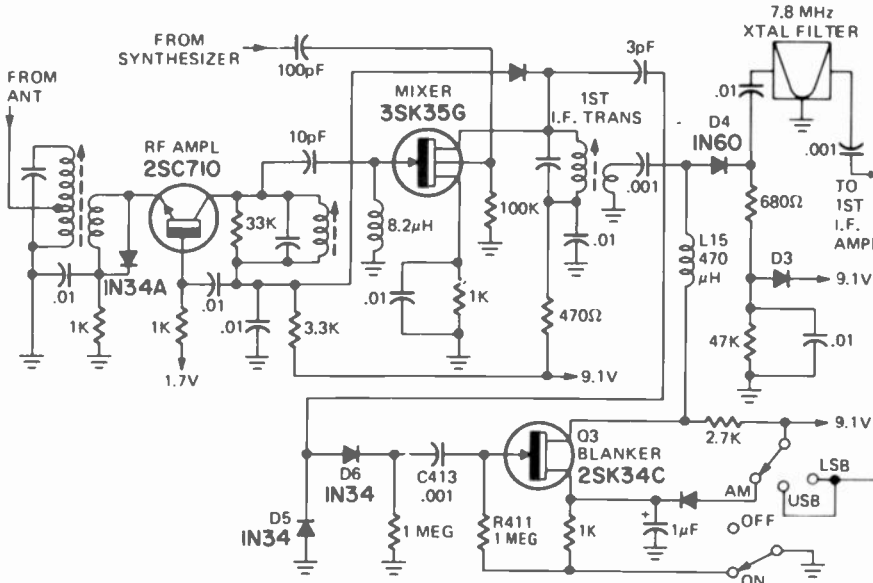

FIG. 4—NOISE BLANKER is a form of i.f. noise limiter. Noise pulses are rectified and amplified to turn off gate diode D4 in the Pace *Sidetalk*.



MIDLAND MOBILE MODEL 13-862 has top-mounted meter and dial for easy visibility.

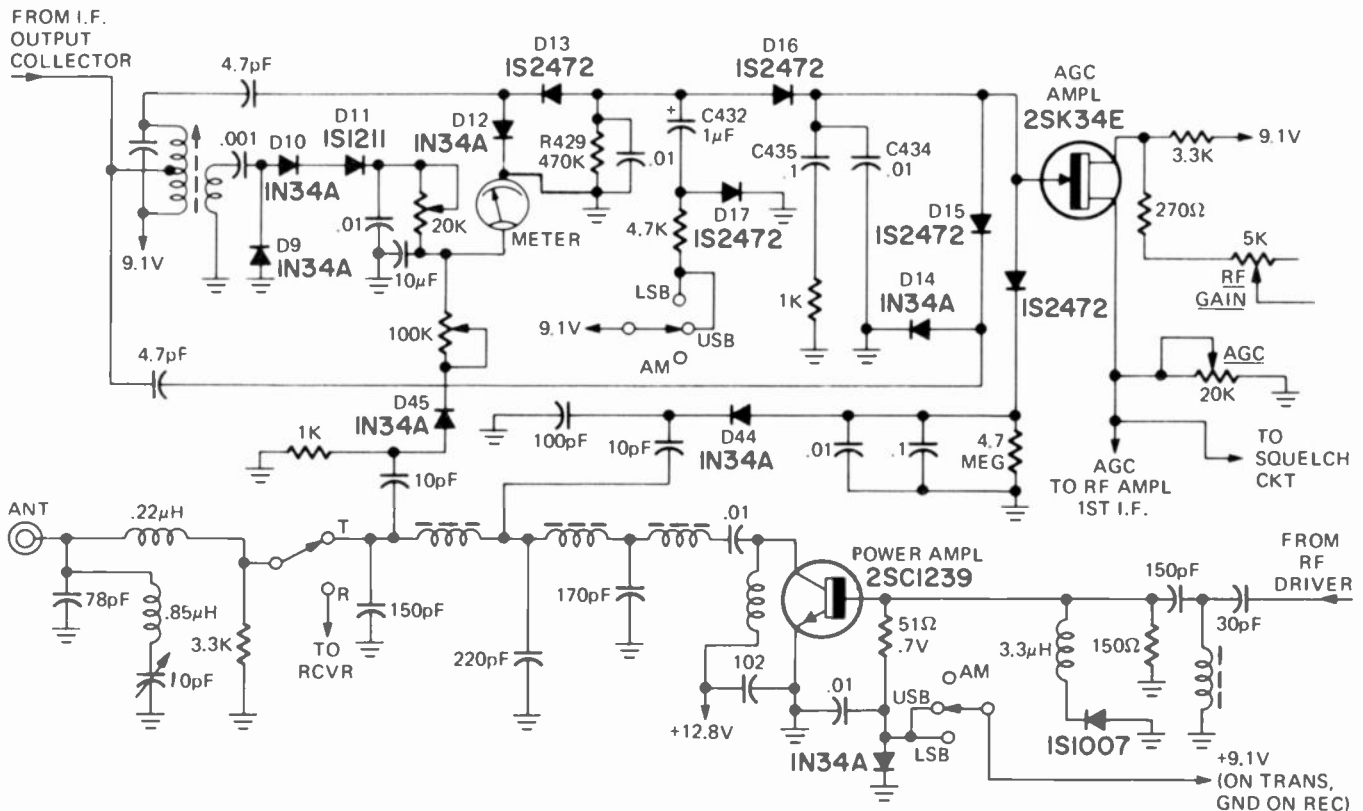

FIG. 5—SPECIAL AGC CIRCUITS are needed when the receiver is in the SSB mode. The agc circuit used by Pace has separate attack and release time-constants for sideband operation.

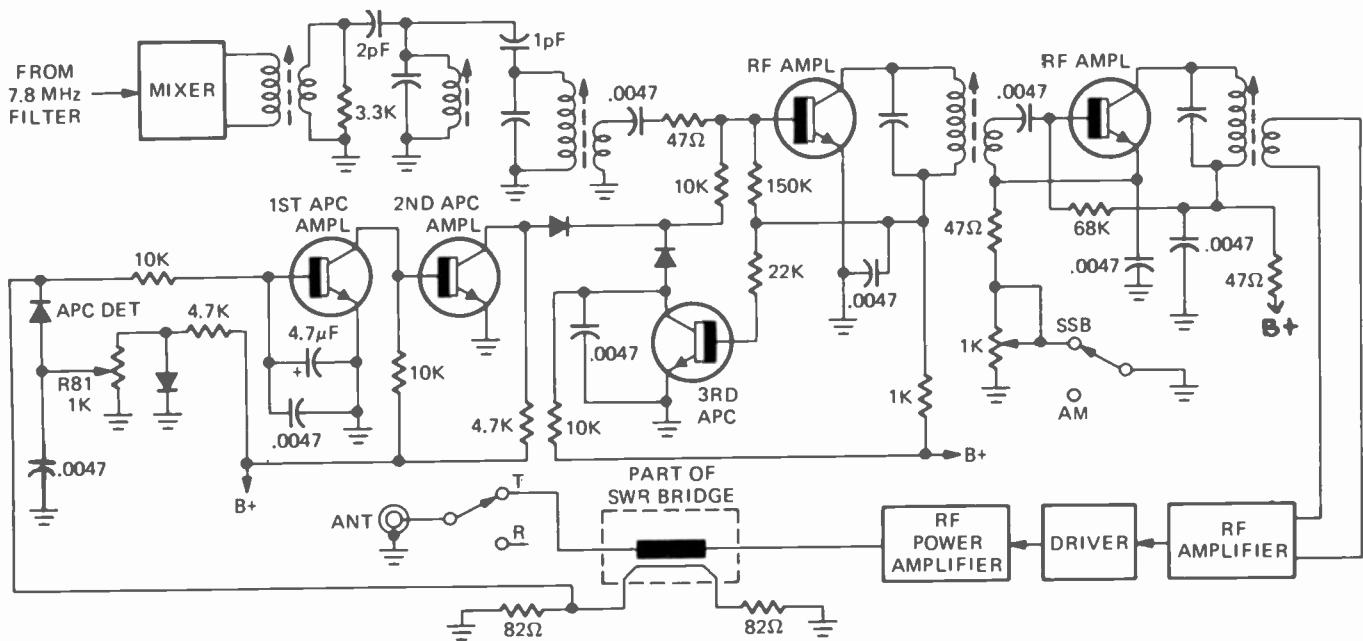

FIG. 6—ANTENNA PROTECTION CIRCUIT in the Tram Diamond 60 disables low-level rf stage to protect the rf power amplifier when the swr on the transmission line rises.

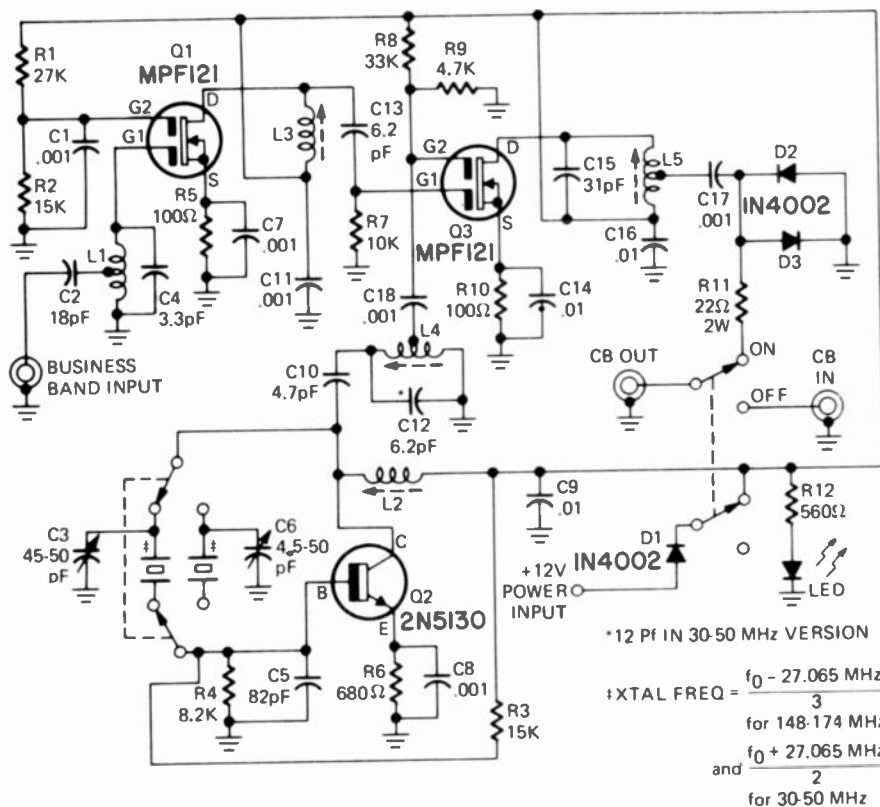

FIG. 7—VHF AND UHF converters for public and emergency services feed their output signals into a CB rig on channel 9. The two vhf Ascom translators use this circuit.

In the alc circuit, a portion of the rf output voltage is tapped off the antenna tuning network, rectified, filtered and applied as gate bias to the FET age amplifier. When transmitting, this age amplifier controls the gain of low-level rf stages ahead of the rf driver and power amplifier.

The alc circuit is adjusted by setting the mode switch in the 1.SB position on channel 13. A 1-kHz tone is fed into the mike at a level high enough to produce 9 or 10 watts output. A trimmer pot in the age circuit is set for 8 watts output.

The meter indicates the relative strength of incoming signals when receiving and rf power output when transmitting.

#### Swr fail-safe circuit

Solid-state rf power amplifiers are particularly vulnerable to damage from high voltages caused by a high standing-wave ratio on the antenna transmission line. Thus, an unprotected rf output stage can be damaged by a high SWR resulting from an off-resonant antenna, a poor ground or ground-plane or a defective lead-in.

The Tram Diamond 60 transceiver employs a circuit to remove the drive to the final linear amplifier when the SWR rises above a preset level. Figure 6 is a simplified schematic of the Tram apc (antenna protection circuit). The section of the swr bridge that develops reflected voltages is used as the control element. The rf voltage developed by a high swr is rectified, amplified in a 2-stage dc amplifier and then fed to the apc control amplifier connected across the base circuit of the first 27-MHz amplifier. A high swr cuts off the drive to the 27-MHz amplifier circuits.

The circuit is adjusted with a 250-ohm resistor connected across the 50-ohm antenna output terminals. Resistor R81 is adjusted to reduce the rf output to zero across the 250-ohm mismatched load.

#### Vhf and uhf monitors

Many people engaged in various forms of public and emergency services need to monitor one or two specific frequencies in the 30–50-MHz, 148–175-MHz and 450–470-MHz bands. This has been made



HIGH-BAND VHF CONVERTER from Ascom.

easy by a group of three converters—Antenna Specialists call them translators—that feed into a CB transceiver tuned to channel 9. The narrow-band FM is converted to AM by slope detection.

Figure 7 is the circuit used in the two vhf translators. It consists of a MOSFET rf amplifier with high-Q tuned circuits for maximum sensitivity. This is followed by a dual-gate MOSFET mixer. A 2N5130 transistor is the conversion oscillator. One of two crystals is selected by a push-button switch.

There are many more new and interesting circuit innovations in the latest CB gear but this is all that we have space for in this issue. Watch for more circuit details. R-E

# Improvements in

*The new and unique innovations in the field of high fidelity are those that have been momentarily to bring you up to date and starts with monplace-Kenwood's double switching demod-*

by **LEN FELDMAN**  
CONTRIBUTING HIGH-FIDELITY EDITOR

WITH SO MUCH RECENT EMPHASIS IN PRINT on four-channel circuit developments (logic circuits, CD-4 demodulator chips, logic chips, etc.) we tend to overlook some of the really important circuit refinements that continually appear in equipment designed by high-fidelity component manufacturers intent upon improving performance of more "traditional", seemingly perfect components. Two examples of such circuit refinements will be analyzed this month. The first is an improved form of stereo multiplex decoding circuit developed by the engineers of Kenwood Electronics, while the second is representative of a whole new breed of direct-drive turntables which have recently appeared on the market from such companies as Pioneer, Technics (by Panasonic) and Sony, whose servo-controlled electronic turntable will be described.

## Double switching demodulation

A block diagram of a conventional switching demodulation circuit used in most stereo FM decoders is shown in Fig. 1. During the positive half cycle of the 38-kHz switching signal, the loop shown by the solid line conducts while during the negative half cycle, the loop shown by the dotted line conducts. The stereo signal, therefore, is "sampled" and separated into left and right outputs. If the switching waveform were a square wave, perfect separation of channels could be achieved.

Actually, however, the switching waveform is a sine wave, either internally generated by a local 19-kHz oscillator-doubler arrangement or by amplification and doubling of the incoming 19-kHz pilot signal. With the use of this kind of switching waveform, it can be shown that the subcarrier would have to be made larger than main channel components by a factor of  $\pi/2$  for perfect channel separation to take place at the outputs.

Normally, in simpler circuits, attempts are made to pre-emphasize the high frequency subcarrier components before they are applied to the switching demodulator. Since R-C networks are usually used to do this, it is impossible to boost the entire subcarrier component spectrum (23 kHz to 53 kHz) by an equal amount, and improved separation usually occurs at mid-band audio frequencies only.

Alternatively, differential amplifiers have

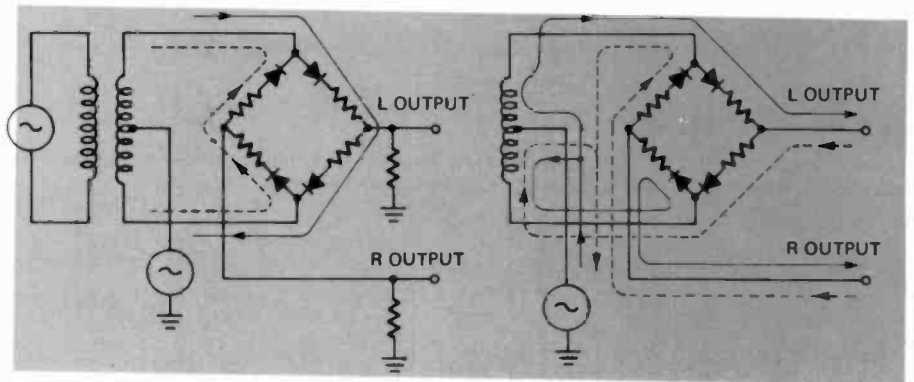

FIG. 1—CONVENTIONAL BALANCED-BRIDGE multiplex demodulator circuit.

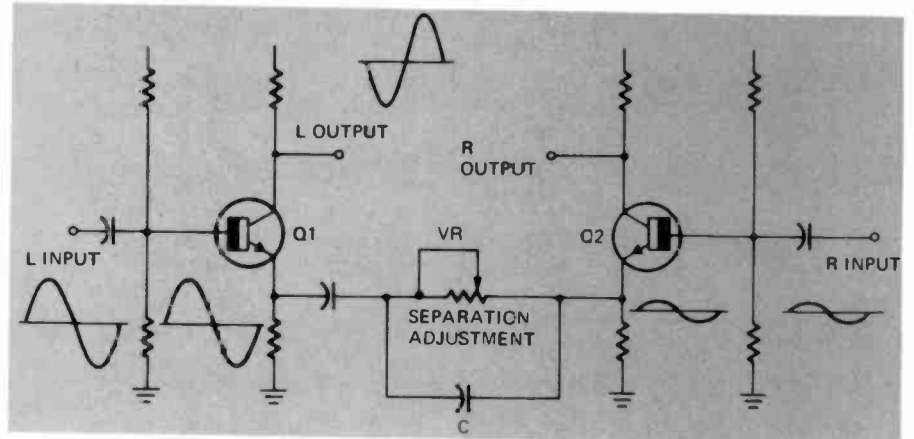

FIG. 2—DIFFERENTIAL AMPLIFIER USED FOR "cross-cancellation" of unwanted crosstalk components following switching demodulator.

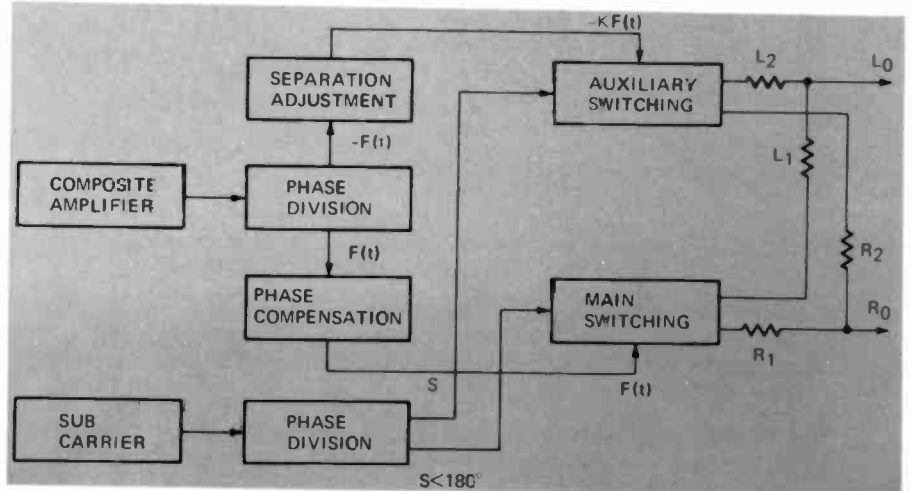

FIG. 3—BLOCK DIAGRAM OF KENWOOD'S DSD multiplex decoding circuit.



# Stereo Circuitry

fidelity are not all limited to quadraphonics. There passed over. Our High-Fidelity Editor intends two new concepts that may shortly be com- ulator and Sony's direct-drive turntable.

been used between the output amplifiers of more elaborate decoder circuits, as shown in Fig. 2. If we assume that the recovered "L" output really consists of  $L + 1/a(R)$ , [where  $1/a(R)$  is the unwanted cross talk appearing there because of improper switching demodulation]; then if  $1/a [R + 1/a(L)]$  is fed to the emitter of Q1, the phase inverted input signal plus this signal applied to the emitter will appear at the collector of Q1:  $- [L + 1/a(R)] + 1/a [R + 1/a(L)]$ , which, expanded, equals:  $-L - 1/a(R) + 1/aR + 1/a^2L = -(L - 1/a^2L)$ .

The R component is completely removed. Potentiometer VR adjusts the  $1/a$  signal. Capacitor C compensates, to some degree, for level and phase of the higher frequency range of the demodulation differential signal. The reverse analysis holds true for the "R" recovered signal. Even with this more sophisticated approach, it is difficult to make the level differential between main and sub channel components equal over the entire 50-Hz to 15,000-Hz audio range. Normally, additional phase and amplitude differences are produced in earlier parts of

the multiplex circuit because of SCA filter circuits which are usually present in typical decoder circuits.

Kenwood's Double Switching Demodulation system was developed to solve these problems. A block diagram of the system is shown in Fig. 3 and a portion of an actual circuit is shown in Fig. 4.

A composite stereo signal can be represented by the general formula:

$$F(t) = L + R - (L - R)2\pi 38000t$$

In the circuit of Fig. 4, this function is divided into  $F(t)$  and  $-F(t)$  by the phase division circuit. The  $-F(t)$  is reduced in amplitude by coefficient K through the separation adjustment potentiometer and is applied to the auxiliary switching circuit. The 38-kHz subcarrier signal is applied to the two switching circuits 180° out of phase with respect to each other. If we consider the 38-kHz subcarrier to be in the form of a square wave, it can be expressed by the following formula, corresponding to its negative and positive half cycles:

$$S_1(t) = \frac{1}{2} + \frac{2}{\pi} \sin 2\pi 38000t - \frac{2}{3\pi} \sin 2\pi 38000t + \dots$$

$$S_2(t) = \frac{1}{2} - \frac{2}{\pi} \sin 2\pi 38000t + \frac{2}{3\pi} \sin 2\pi 38000t - \dots$$

If only the audio component is extracted, the main switching circuit output becomes:  $L_1 = F(t) \times S_1(t) \cong (\frac{1}{2} + 1/\pi)L + (\frac{1}{2} - 1/\pi)R$   
 $R_1 = F(t) \times S_2(t) \cong (\frac{1}{2} + 1/\pi)R - (\frac{1}{2} - 1/\pi)L$   
 The outputs from the auxiliary switching circuits become:

$$L_2 = -KF(t) \times S_2(t) \cong -K [(\frac{1}{2} + 1/\pi)R - (\frac{1}{2} - 1/\pi)L]$$

$$R_2 = -KF(t) \times S_1(t) = -K [(\frac{1}{2} + 1/\pi)L + (\frac{1}{2} - 1/\pi)R]$$

The combined outputs then become:  
 $L_o = L_1 + L_2 = [(\frac{1}{2} + 1/\pi) - K(\frac{1}{2} - 1/\pi)]L$   
 $L + [(\frac{1}{2} - 1/\pi) - K(\frac{1}{2} + 1/\pi)]R;$

and  
 $R_o = R_1 + P_2 = [(\frac{1}{2} + 1/\pi) - K(\frac{1}{2} + 1/\pi)]R + [(\frac{1}{2} - 1/\pi) - K(\frac{1}{2} - 1/\pi)]L.$

From the above, it is easy to see that to remove the "R" component from the  $L_o$  output and the "L" component from the  $R_o$  output, value K must be set to equal:

$$K = \frac{\pi - 2}{\pi + 2}$$

or approximately 0.222. The DSD circuit, therefore, cancels unwanted crosstalk components and, as a by-product, helps reduce residual subcarrier components in the outputs as well. By including a phase compensation circuit in the main switching diode arrangement, separation deterioration due to phase shifts be-

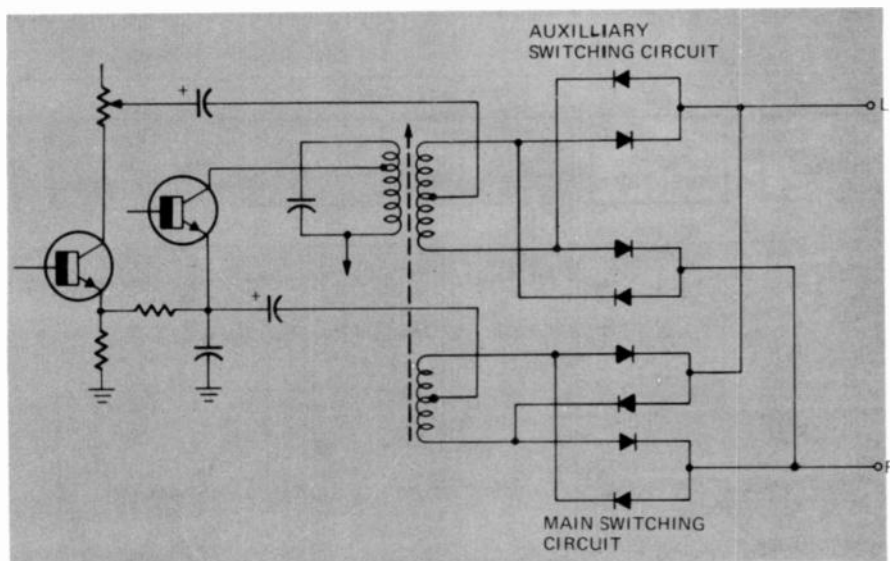

FIG. 4—ACTUAL PARTIAL SCHEMATIC shows main and auxiliary diode bridge circuits used in the Double Switching Demodulator.



FIG. 5—KENWOOD'S KR-6340. One of many models using DSD circuit in stereo decoding section. Unit is a Quadraphonic receiver.

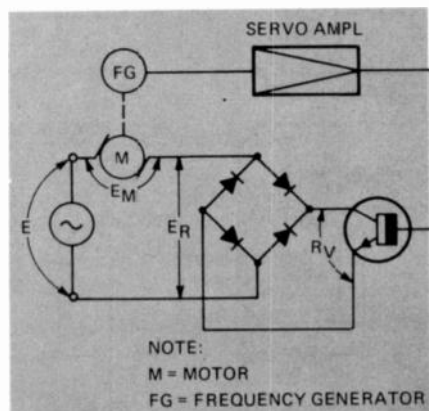

FIG. 6—PRINCIPLE OF SERVO-CONTROLLED motor in Sony PS-2251 direct-drive turntable.

tween main and sub-channel signals, appearing in the higher audio frequency range, can be eliminated. Typically, separation well in excess of 30 dB is reached at 10 kHz using the DSD circuit. Another improvement in performance is reduced amplitude of "interference frequency beats" sometimes caused by the interaction of residual 19-kHz and 38-kHz products and high frequency program signals. Figure 5 shows Kenwood's new four-channel receiver, Model KR-6340, one of many receiver and tuner models which employ this DSD stereo decoding principle.

### Direct drive turntable system

Less than .04% (weighted) wow and flutter, and a signal-to-noise ratio of better than 58 dB (weighted) are just two of the impressive specifications claimed for the new Sony PS-2251 Direct Drive Turntable System. These and other superb specs result from using an ac servo-controlled motor which is directly coupled to the turntable. This eliminates idler wheels, belts, pulleys or any other speed-reduction schemes normally associated with turntables and record changers.

Figure 6 is a simplified diagram of the servo system in this unit. Motor speed is proportional to the applied ac voltage and is controlled by varying the applied voltage  $E_m$  to the motor. Voltage variation is controlled by the diode bridge and the collector-emitter impedance ( $R_v$ ) of the

power transistor.

Motor speed is converted into an ac signal by a frequency generator directly coupled to the turntable motor. A servo-amplifier compares this signal with a very stable dc reference voltage and controls the impedance of the power transistor. Any error in motor speed generates a correction voltage which is then applied to the motor.

A more detailed analysis of the servo action can be gained by examining the block diagram of Fig. 7. When the main power switch is turned on, C8 is charged through VR2, R10, VR1 and R9 when the controls are set to 33-1/3 rpm. Note that for 45 rpm operation, VR2 and R10 are shorted out. The voltage comparator circuit in IC1 is biased into conduction when C8 is charged to a predetermined voltage. As a result, Q3 and Q4 are turned on and an ac voltage is applied to the motor.

A frequency generator (FG) is directly coupled to the drive motor shaft and generates an ac voltage whose frequency is proportional to the motor speed. Q1 and Q2 form a differential amplifier which increases the level of the generated signal to that required by limiter diodes D1 and D2. These diodes conduct whenever barrier potential of 0.6 volt is exceeded, limiting their output signal to 1.2 volts, peak-to-peak.

The integrated circuit (IC1) which follows contains four separate circuit elements: a flip-flop, a dc buffer amplifier/phase inverter, a sawtooth waveform generator and a

voltage comparator. The flip-flop produces square-wave output frequencies based upon the input-limited trigger signal. The dc buffer/phase inverter amplifies and inverts the square wave signals which are then converted into spike-shaped pulses through a differentiation circuit (C7 and the input impedance of the sawtooth waveform generator that follows). The frequency of the sawtooth is determined by the externally connected time constant circuits (C8, R9, VR1, R10 and VR2).

The voltage comparator generates negative pulses whose width is proportional to the time the sawtooth voltage exceeds the reference voltage. The reference voltage is determined by the pitch control (VR3) setting. The dc buffer/phase inverter stage which follows supplies positive pulse signals to the low-pass filter circuit and buffer amplifier Q3. The low-pass filter has a sharp roll-off characteristic and acts as an integrating circuit, converting the positive input pulses into a dc voltage proportional to the input pulse-width. Dc output from the low-pass filter is applied to the base of Q4. Since Q4, Q5 and Q6 are all directly coupled, a change in input dc voltage alters the conduction of Q6 which varies the voltage applied to the turntable motor.

Waveforms appearing at various points numbered in Fig. 7 are illustrated in Fig. 8.

### Speed variation and control

If motor speed should vary, becoming

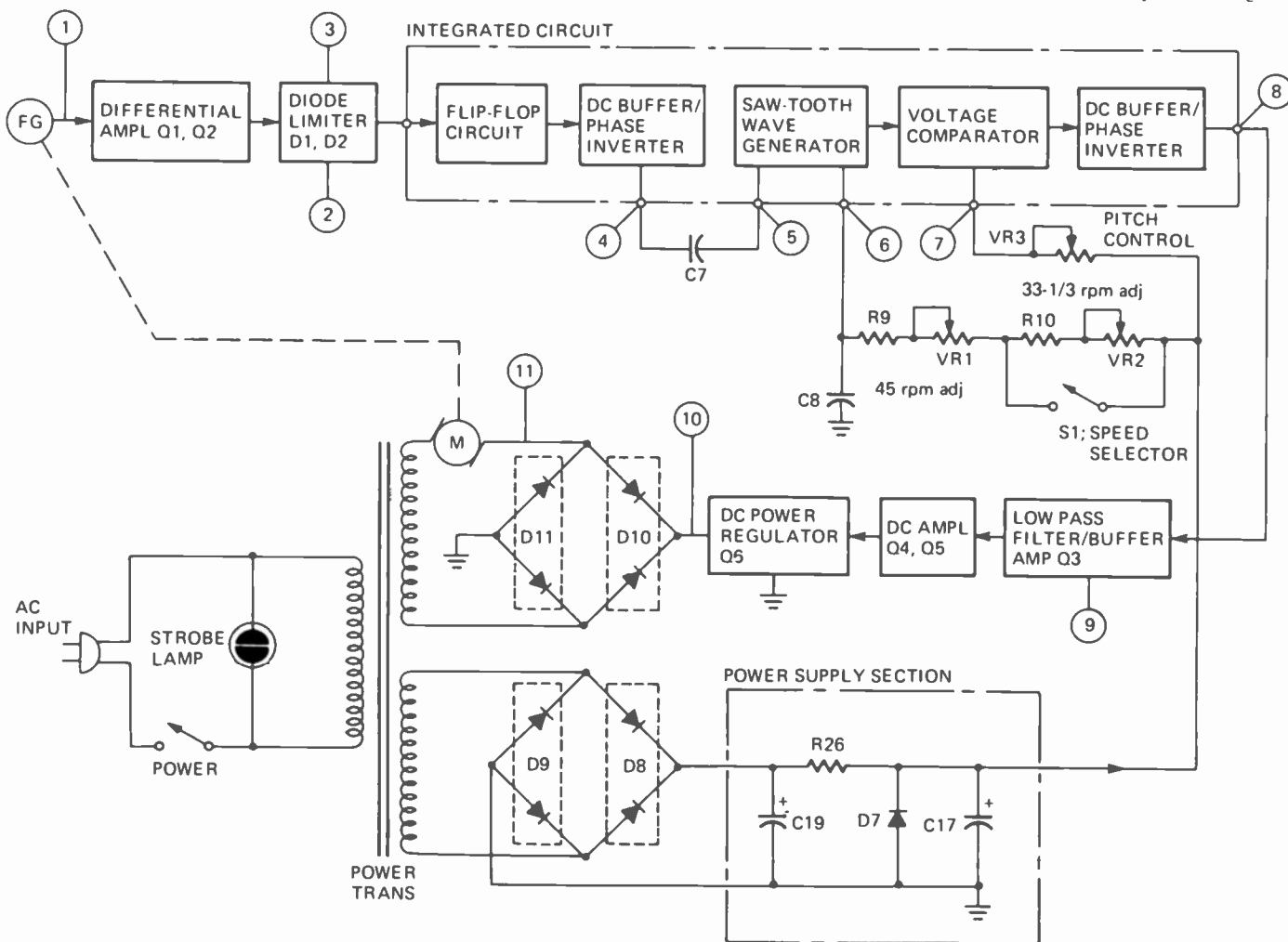

FIG. 7—COMPLETE BLOCK DIAGRAM of circuits used in Sony PS-2251 direct-drive turntable system. Circled numbers refer to waveforms shown in Fig. 8

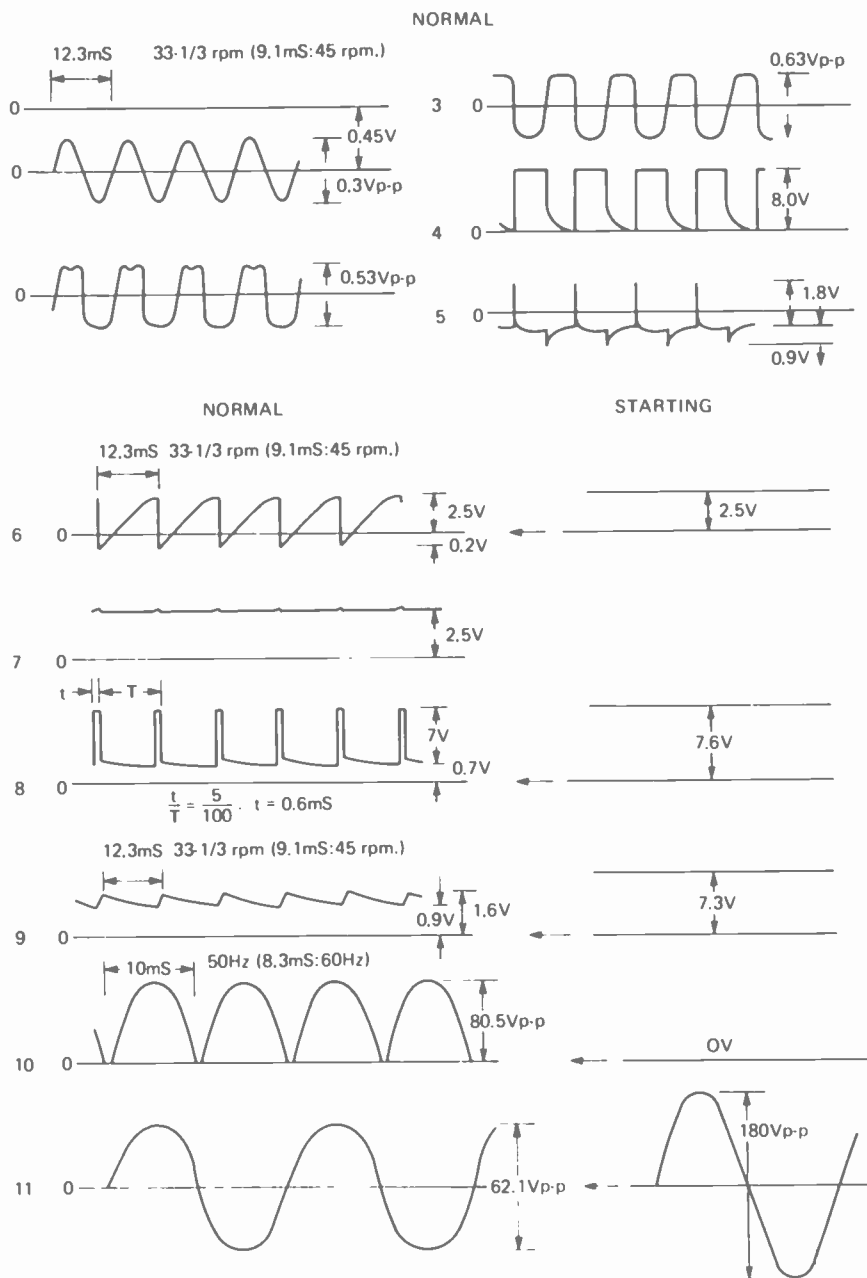

FIG. 8—WAVEFORMS appearing at numbered points in the block diagram of Fig. 7.

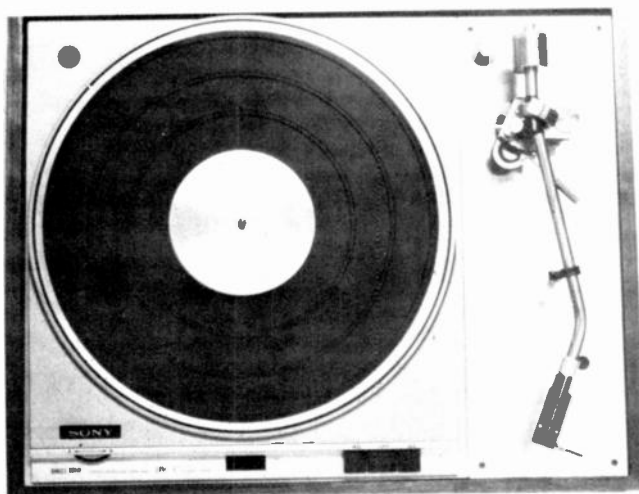

FIG. 9—TOP VIEW OF SONY PS-2251 turntable/tone arm assembly.

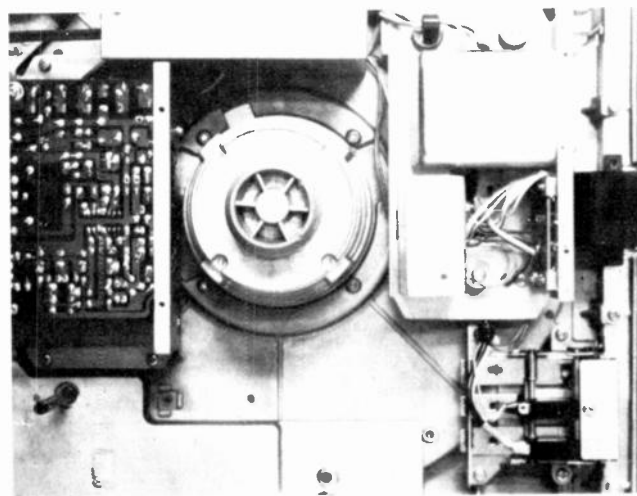

FIG. 10—UNDERSIDE OF PS-2251 shows circuit board for servo-control electronics mounted adjacent to direct drive ac motor.

either too fast or too slow, the servo system compensates and adjusts the speed. Let's assume that the motor starts to run too fast. The frequency generator signal frequency increases, which results in shorter intervals between the pulses used to trigger the sawtooth waveform generator. This causes lower-amplitude sawtooth waveforms which in turn result in a shorter "on" period for the comparator. The output waveform from the comparator then is reduced in pulse width, thereby reducing the positive bias applied to Q4. As a result, the collector impedance of Q6 increases, reducing motor speed. Conversely, if the motor speed tends to decrease, the collector-emitter impedance of Q6 is made to decrease, thereby increasing the motor speed.

Positive 12 Vdc for the system is provided by the full-wave rectifier consisting of D8 and D9, filter capacitors C19, C17 and Zener diode D7.

Speed changeover from 33-1/3 rpm to 45 rpm is done by changing the sawtooth waveform frequency externally. Since the sawtooth waveform frequency is determined by the external RC time constants, a speed selector switch is connected across VR2 and R10. Shorting out these two components results in faster motor speed (45 rpm) and the switch is set to the open position for slower, 33-1/3 rpm operation.

A top view of the complete turntable assembly is shown in Fig. 9, in which the associated statically balanced tone arm and the front panel speed selector buttons and pitch control knob are visible. Figure 10 shows the underside of the system. The circuit board containing the servo-electronics is seen alongside the direct-drive motor housing. The actual motor used is an eddy-current ac motor with a cup-shaped copper rotor which generates smooth linear rotating torque. Because of the nature of the motor drive system, the turntable system can be used with either 50-Hz or 60-Hz house current, since, unlike hysteresis motors found in speed-reduction systems, the incoming power line frequency has little to do with the ultimate speed of the drive motor. Since some variation in strobe light effect would take place when switching from 50-Hz to 60-Hz house currents, the illuminated strobe lines visible through a window in the front edge of the unit are repeated for 50 Hz use and differ from the set inscribed for 60 Hz operation.

R-E

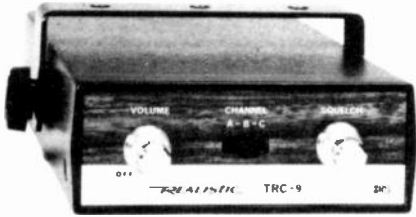

# CB Alignment

RADIO SHACK'S REALISTIC TRC-9 works on channel 9 and two other channels.

*Alignment of CB receiver and transmitter circuits is simple and need not require precision test instruments and a laboratory setup. Use another CB rig as your alignment equipment.*

by ANDREW J. MUELLER

IF THE ALIGNMENT OF YOUR CB RADIO is not right on the button, you can have problems! Weak or noisy reception, splatter from adjacent channels, are the commonest troubles you can run into if the alignment is off. Misalignment has various causes. The first and biggest is "diddl-itus". This results from the would-be technician—armed with a handful of alignment tools—attempting to "just tweak it up a little". The rest of the causes include from normal aging, parts replacement or defective associated components.

Aligning a CB radio is easy once you become familiar with the procedure. The first thing you need to start with is a set of proper alignment tools. This is no place for metal screwdrivers or Allen wrenches. When these metal

tools are withdrawn from the coil, they can detune the circuit you have just aligned. If the tool size is not right, the slugs can be cracked or broken and will have to be replaced. The following alignment tools should cover just about every radio.

- 1 GC 8282
- 1 GC 8276
- 1 GC 5097
- 1 GC 9304
- 1 GC 2520

These can be purchased through any radio parts distributor for around \$3.00. Next you will need a 20,000 ohms per volt vom or vtvm and another CB unit with a dummy load. A walkie-talkie is OK but a 5-watt unit is better.

Referring to the schematic of SBE Capri in Fig. 1, hook up the voltmeter at point A to ground. Set the meter on the 5V dc scale. Connect the other CB radio to a dummy load, place it in the

vicinity of the unit to be aligned and set both to the same channel. Transmit and observe the meter reading on the set to be aligned. If the meter reads over 3 volts, move the sets farther apart until you get a reading of between 1 and 2 volts. Now take the proper alignment tool and adjust L9 through L4 for a peak reading on the meter. If the reading goes over 3 volts at any time, move the sets farther apart. This will make sure that you are not overloading the unit. If any of the coils will not peak, try reducing the signal input and try to retune. If this fails, you must troubleshoot the radio. More than likely you will find an open resonating capacitor or defective associated components. Once this is corrected, you can continue the alignment.

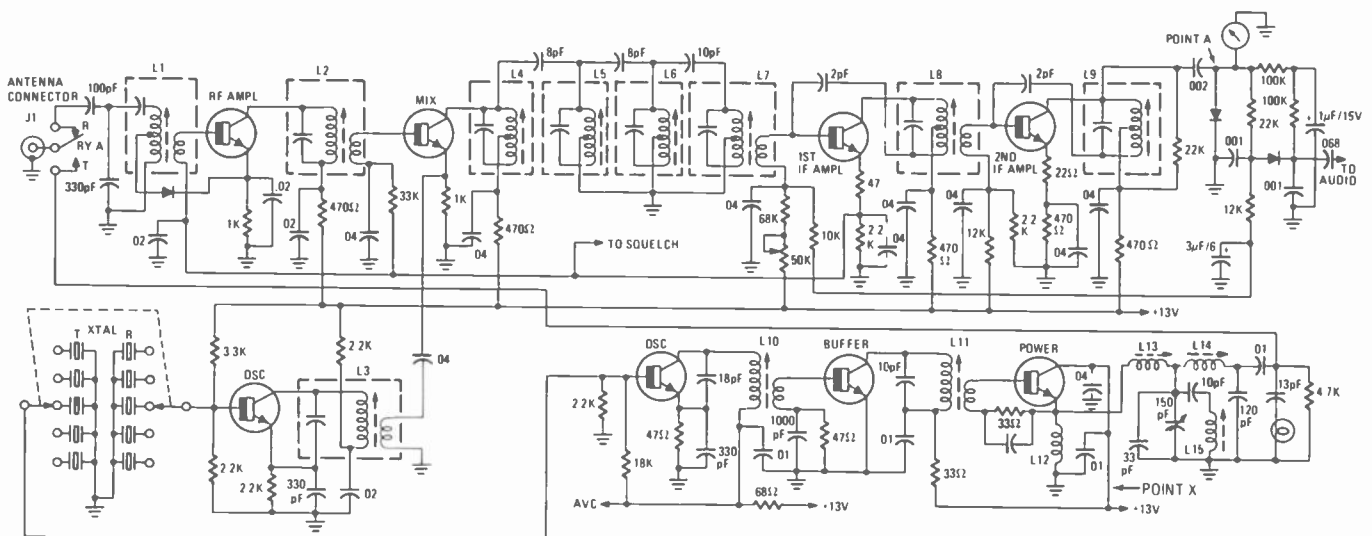
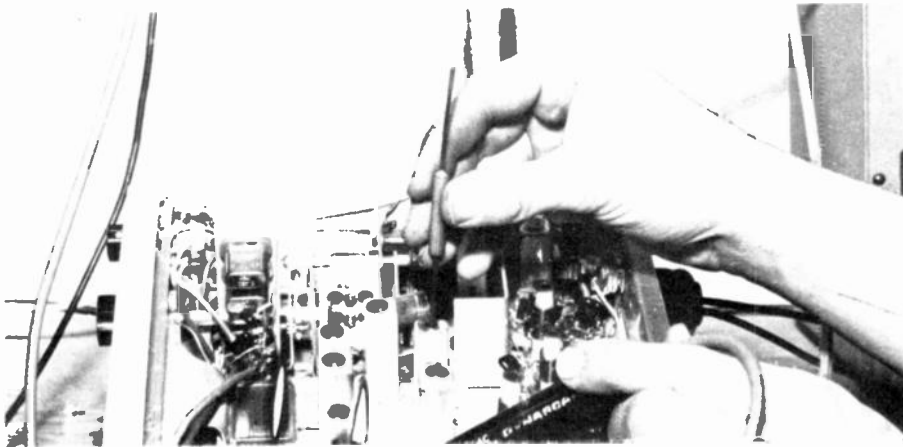

FIG. 1—THE SBE CAPRI, partial schematic showing those portions on which the technician will work when aligning the transmitter and receiver. Circuits are typical of AM-only transceivers.



# Made Easy



When all of the i.f.'s are aligned, the only thing left to do is to tune the front end. Leave the meter connected and hook an antenna to the unit. Select a quiet channel between channel 9 and 12. While receiving a weak signal tune L.1 and L.2 for maximum. Peak the receiver local oscillator coil, L.3, for maximum reading. Then back it off about  $\frac{1}{2}$

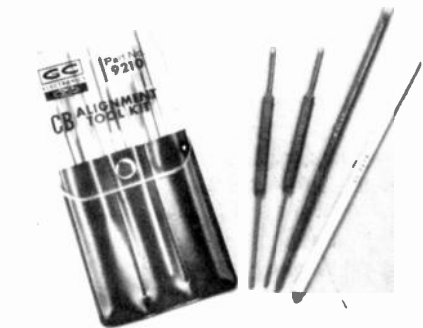

**ALIGNMENT TOOLS and kit.** The suggested GC-5097 (not shown) is for K-Tran i.f.'s.

turn. Check the oscillator operation by switching channels and noting if all of the receive crystals "fire". If they all do not, back off another  $\frac{1}{8}$  to  $\frac{1}{4}$  turn and check again.

This completes the alignment. We are assured that the receiver is on frequency because it has been tuned to another unit that is working normally and is on frequency.

## The transmitter

The last section to align is the transmitter. Connect an indicating type dummy load to the antenna jack. Do not use the type that uses a No. 47 lamp, but rather a unit similar to the Courier Porta-Lab. Depress the mike



**THE HY-RANGE V** is a synthesizer AM/SSB rig whose circuitry is more complex.

switch and observe the output. Adjust L.10 for maximum output. This must be done carefully to insure proper oscillator operation. Follow the same procedure as you did when L.3 was adjusted above. Next adjust L.11, L.13, and L.14 for maximum output. When adjusting L.13, make sure that this is set so that when you talk, the output power increases. Keeping in mind that the power input is also adjusted by L.13

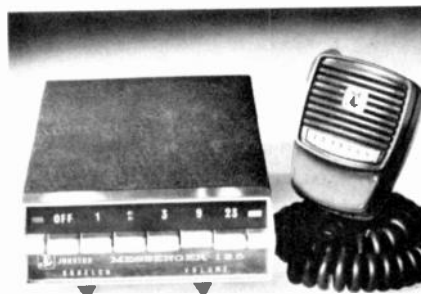

**MESSENGER 125**, a 5-channel AM rig featuring pushbutton switching.

and L.14, the input power must be checked to not exceed 5 watts. This can be done by inserting a 0-500 mA meter at point X. Take this reading in mA and multiply it by the voltage measured to ground at this point. The resultant figure should not exceed 5,000 mW (5 watts). If it does, adjust L.13 for a lower mA reading while still

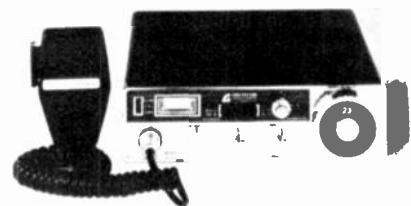

**THE CHEETAH** is a SSB synthesizer rig. Leave frequency determining circuits alone.

maintaining upward modulation. If upward modulation cannot be obtained within the 5-watt limit, take the set to a CB service center for repairs.

L.15, the TVI trap, is the last adjustment to make. This is done by tuning a nearby TV set to channel 2 and adjusting L.15 for minimum TVI.

This completes the alignment of the unit. While you make the above adjustments on a dummy load, *all final adjustments must be checked by an FCC licensed technician.* This must be done before the set is put on the air. It is required by the rules and regulations, and you can be assured that you did the job right. You also will be avoiding a citation from the FCC.

R-E

# Changes come fast in electronics.

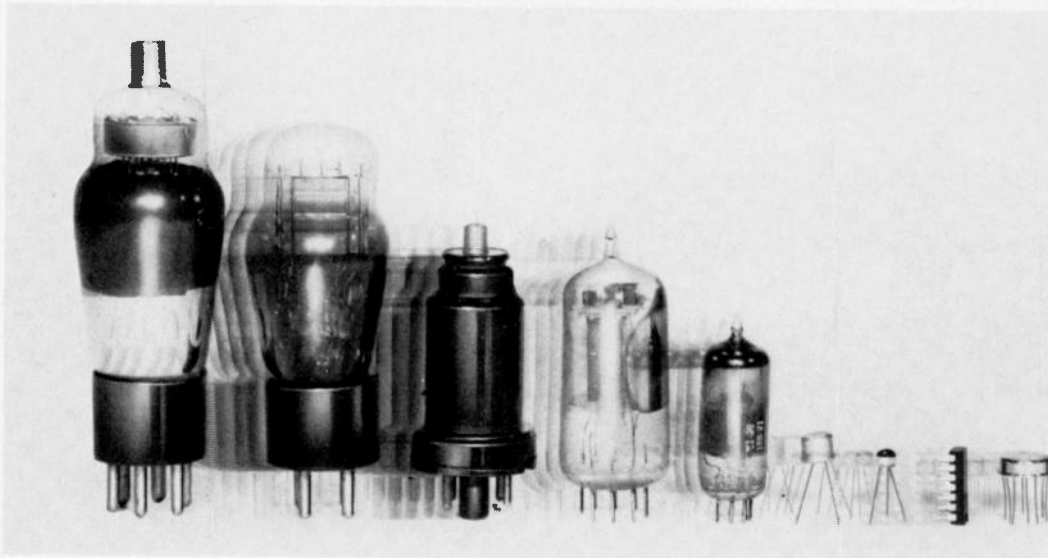

From  
tube  
to  
LSI



Take a look at the race in circuit technology. In the 1960's the tubes at the left made way for the transistors at the right. Today, transistors are surpassed by the large scale integrated circuit (LSI) at the far right. This circuit, less than a quarter inch square, replaces over 6000 transistors!

There's big money to be made by the men who stay ahead of this technology race. Put yourself

ahead with NTS Home Training! You get the latest, most advanced equipment (at no extra cost). More solid-state units, and more advanced technology. Plenty of training with integrated circuits, too! As an NTS graduate, you enter a world of electronics you're familiar with. You have a thorough working knowledge of solid-state circuitry. You're ready to tackle bigger jobs at higher pay!

## NTS COLOR AND B & W TV SERVICING

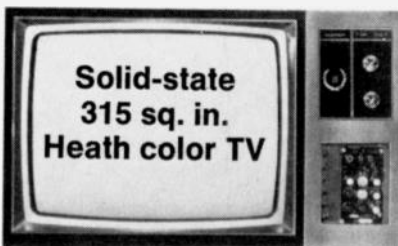

Build and keep the largest, most advanced color TV made! Over-all solid-state design, ultra-rectangular screen, matrix picture tube, built-in self-servicing features, "Instant On," A.F.T., solid-state, 24-channel detent UHF/VHF power tuning, and much more! Also build and keep AM-SW Radio, Solid-State Radio, FET Volt-Ohmmeter, and Electronic Tube Tester. Learn trouble-shooting, hi-fi, stereo, multiplex systems, radio, color and B & W TV servicing.

Learn sophisticated solid-state circuitry as you build this B & W TV receiver. Lo-Silho "Superhet" Radio, FET Volt-Ohmmeter, Solid-State Radio, Electronic Tube Checker, and Signal Generator. TV

and all other equipment are yours to keep.

Solid-state  
B & W TV,  
74 sq. in.  
picture  
(cabinet  
included)

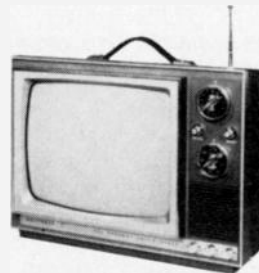

## NTS ELECTRONICS & COMPUTER TECHNOLOGY

Build and keep this exclusive NTS Compu-Trainer. It teaches you the

Solid-state  
Compu-Trainer  
14 integrated  
circuits replace  
198 transistors!

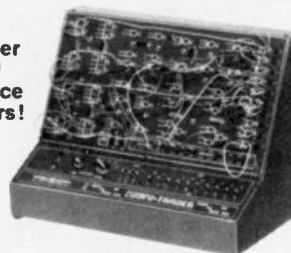

same principles used in million-dollar systems. Contains 14 inte-

grated circuits! All Solid-State! You perform all wiring and patchcording. No shortcuts. No pre-wired circuit boards. Your training is complete! Also receive an FET Volt-Ohmmeter and a 5" wide-band Solid-State Oscilloscope.

## NTS ELECTRONICS COMMUNICATIONS

Gain the prestige and earning power of owning an F.C.C. First Class Radio-Telephone License. Two comprehensive NTS courses cover the big opportunity field of transmitting and receiving.

You build and keep 14 kits, including this amateur phone 6-meter VHF Transceiver, NTS's exclusive 6-transistor Solid-State Radio, and a fully transistorized Volt-Ohmmeter. Also, learn 2-way radio, Citizens Band microwaves, and radar.

5-watt AM  
transmitter/  
receiver



# NTS Home Training puts you in the lead.

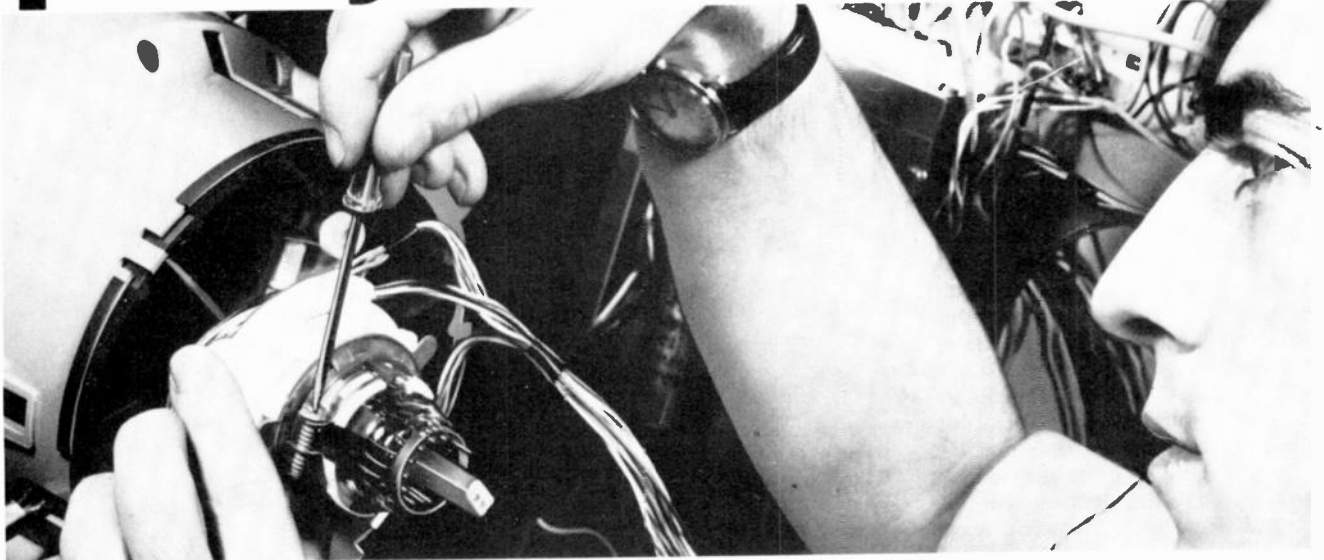

## NTS INDUSTRIAL & AUTOMATION ELECTRONICS

Automation is the future of industry and you can play an important part! Learn industrial controls by training on the NTS Electro-Lab (a complete workshop). You also build and operate this 5" Solid-State oscilloscope. And you perform experiments that involve regulating motor speeds, temperature, pressure, liquid level, and much more. All equipment is yours to keep.

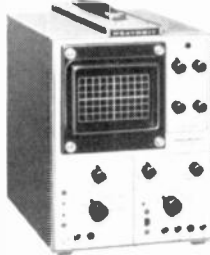

## NTS AUDIO ELECTRONICS SERVICING

Learn basic sound theory—how it works in home radio, car tape

decks, stereo multiplex component systems, and more! Set up a spectacular music system. Learn about



Build and keep this famous Heath Stereo Receiver and Speakers.

sound distortion, amplification and control, loud-speaker baffles, problems of system installation, etc. Included is Volt-Ohmmeter, In-Circuit Transistor Tester, and Solid-State

Radio. Prepare yourself for great opportunities in the Home Entertainment Industry!

## CLASSROOM TRAINING AT LOS ANGELES

You can take classroom training at Los Angeles in sunny Southern California. NTS occupies a city block with over a million dollars in technical facilities. Check box in coupon below.

## NATIONAL TECHNICAL SCHOOLS

WORLD-WIDE TRAINING SINCE 1905  
Resident & Home Study Schools  
4000 S. Figueroa Street  
Los Angeles, California 90037

## APPROVED FOR VETERAN TRAINING

Accredited Member: National Association of Trade and Technical Schools; National Home Study Council.

Big, Colorful NTS Guide to new opportunities in Electronics. Yours FREE!



NATIONAL TECHNICAL SCHOOLS  
4000 S. Figueroa Street  
Los Angeles, California 90037

Please rush me FREE Color NTS Electronics Guide & FREE lesson, plus information on course checked at right. No obligation. No salesman will call.

- MASTER COURSE IN COLOR TV SERVICING
- COLOR TV SERVICING (FOR ADVANCED TECHNICIANS)
- MASTER COURSE IN B&W TV & RADIO SERVICING
- MASTER COURSE IN ELECTRONIC COMMUNICATIONS
- PRACTICAL RADIO SERVICING
- FCC LICENSE COURSE
- MASTER COURSE IN ELECTRONICS TECHNOLOGY
- AUTOMATION & INDUSTRIAL ELECTRONICS
- COMPUTER ELECTRONICS
- BASIC ELECTRONICS
- AUDIO ELECTRONICS SERVICING

Dept. 206-014

NAME \_\_\_\_\_ AGE \_\_\_\_\_

ADDRESS \_\_\_\_\_

CITY \_\_\_\_\_

STATE \_\_\_\_\_ ZIP \_\_\_\_\_

- Check if interested in Veterans Training under new G. I. Bill.
- Check if interested ONLY in Classroom Training at Los Angeles

# build a **BLITZMETER**

by **JAMES A. GUPTON**  
PHOTOGRAPHIC EDITOR

WHAT PHOTOGRAPHER WOULD EVER attempt to make an exposure without first measuring the light with a meter? What photographer would attempt to process film without first measuring the temperature of his chemical solutions? Yet, put an electronic photoflash in the hands of almost any photographer and he immediately relies on *guesswork*! His standard exposure meter is valueless for measuring the split-second flash of the electronic photoflash units. He is forced to guess his exposure by the hit-or-miss device known as the "Guide Number."

The GN is a flash exposure factor by which the supposed exposure value can be determined by dividing the GN by the distance from the camera to the subject. While this can be reasonably accurate *if . . .* you are accurate in your mathematics, distance value and . . . your flash unit is fully charged. But what happens to the GN exposure factor if you are wrong or your flash is fired before it reaches full charge? Don't chance it! For just a few dollars for components and an hour or two of time you can have a reliable exposure meter that works on

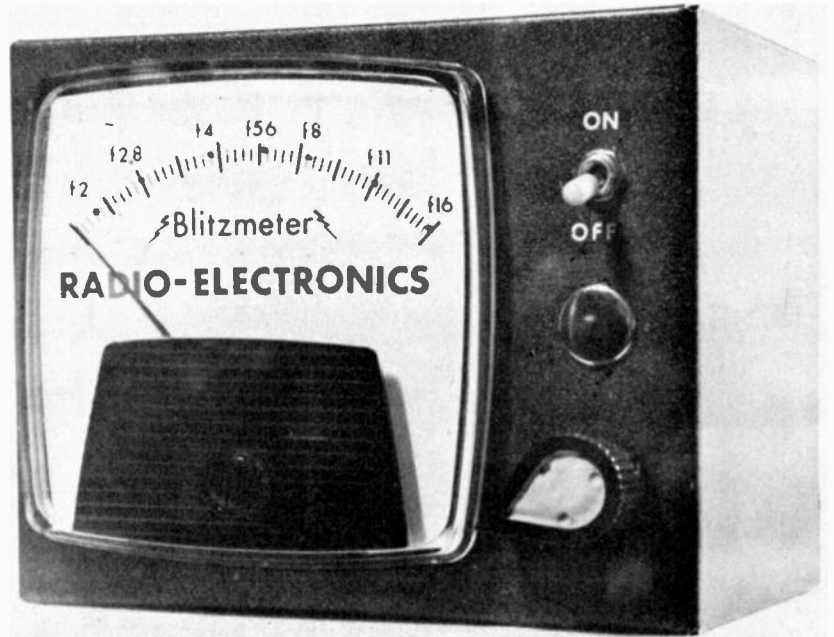

**ONE VERSION OF THE BLITZMETER.** This model uses rectangular meter and point-to-point wiring on perforated board. The other type uses a PC board and an edgewise panel meter.

the reflected light from your electronic photoflash unit to provide you with accurate flash exposure data.

## How it works

The "Blitzmeter" is appropriately titled—the brief duration of the electronic photoflash parallels that of the bolt of lightning in a summer thunderstorm. "Blitz" is the German word for "lightning." The Blitzmeter can be sectionalized into three circuits: The photo detector; the trigger circuit; the metering circuit.

The photo detector has a very high resistance to ambient light, even daylight on a bright and sunny day.

## PARTS LIST

All resistors are 1/4-watt 10%

- R1—4,700 ohms
- R2—52 ohms
- R3—10,000 ohms
- R4—1,000 ohms
- R5—22 megohms
- R6—150 ohms
- R7—27,000 ohms
- R8—75,000 ohms Mallory MC-1/2, 1/4 watt
- R9—100,000 ohms IRC CTS-X201 carbon trimmer
- R10—27,000 ohms\*\*
- C1—0.02  $\mu$ F ceramic, 10 V
- C2—100  $\mu$ F tantalum, 10 V
- C3—75  $\mu$ F, 30 V
- PC—Motorola HEP-312, CL902, or CL903
- Q1, Q2—Motorola HEP-729, MPS-3710, 2N2219
- Q3—Motorola HEP-F2004, HEP-2005, 2N4303, 2N4351, 2N5458
- S1—switch spd, miniature type
- Battery—22.5 V.
- Cabinet—Bud 4 x 2 1/4 x 2 1/4
- Knob—1/2-in. dia. aluminum, 1/8-in. shaft
- Meter—100 microampere, 2 1/2-in.

\*HEP numbers and acceptable substitutes  
\*\*used only to permit R-10 to adjust meter above or below zero

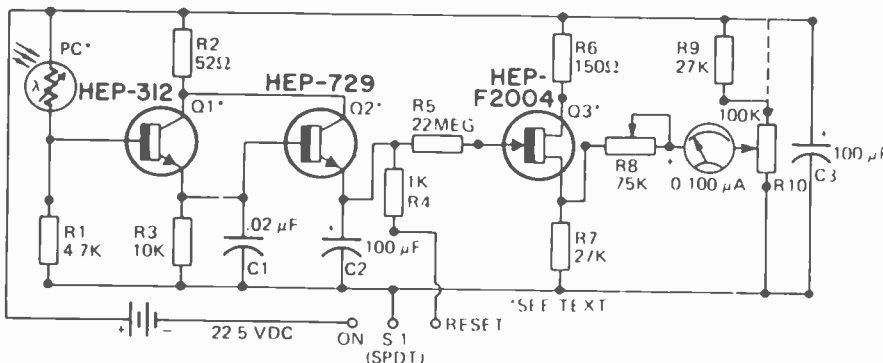

**FIG. 1—THE BLITZMETER:** It uses only three transistors and one photocell to measure the short-duration flash to an electronic unit.

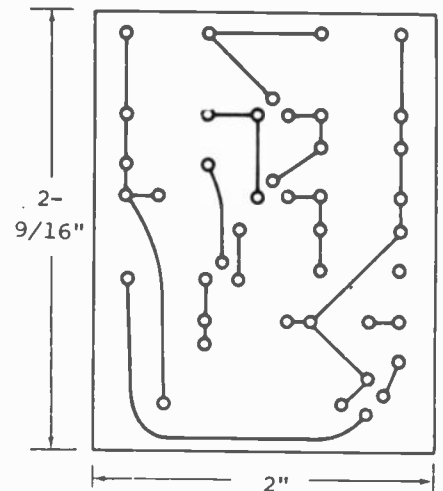

**FIG. 2—PRINTED CIRCUIT LAYOUT** is shown here full size (2 x 2-9/16 in.).



INTERIOR VIEW OF A BLITZMETER. This model uses point-to-point wiring on a perforated board mounted directly on the terminals of the panel meter.

This high resistance keeps the trigger transistor circuit biased off until the energy from an electronic photoflash is received. The energy from the photoflash drops the photo detector's resistance enough to "pulse" the trigger circuit that causes transistor Q2 in Fig. 1 to charge capacitor C2 to a value that depends on the amount of bias change in Q1, which is controlled by the total energy of the photoflash light reaching the photo detector, PC. The charge in C2 is then measured by FET Q3 and indicated on the meter. The high input resistance of Q3 prevents discharge of C2; it becomes necessary to connect R4 to ground to provide a discharge path. R8 adjusts the sensitivity of the Blitzmeter for various film speeds and R10 is used to null or zero the meter. Note the double function of S1. The spdt action turns on the power and—in the off position—discharges C1 to ground through R4.

The Blitzmeter may be built on a perforated or Vectorboard breadboard or with a printed circuit. Both methods are used in the models that illustrate the construction. The key component is the photo detector. The Motorola HEP-312 npn silicon phototransistor is ideal for this use. It not only has the necessary high ambient light resistance to keep the trigger circuit in the off condition; it has an epoxy lens, which tends to increase its sensitivity by directing maximum light.

There are limited substitutes for the HEP-312, such as the Clairex CL902 or CL903. You might also find that some npn transistors in the TO-5 can will work when the top of the can is cut off. While there may be other suitable substitutes, the author has tried these and found them workable in the Blitzmeter circuitry. The remaining components may be substituted without hesitation. However, should the action of the meter prove

erratic or it is difficult to maintain a fixed reading, look to the possible substitution of the FET as the cause.

### Calibrating the meter

The "Blitzmeter" reads only the photoflash reflected light from the subject and indicates the light value by the meter indication at which the pointer comes to a stop. Calibration is the process of translating the meter indication into usable camera lens f stops and including calibrating potentiometer R8's settings as film speed values in ASA numbers. To assist in calibrating your meter, the Table compares 50 and 100 watt-second photoflash units for guide numbers, film speed, and for typical f-stop values for lens to subject distances.

To calibrate your Blitzmeter, place the meter 5 feet from a neutral gray wall or cloth and discharge the photoflash toward the wall from a position above the Blitzmeter. (Adjust-sensitivity control R8 for maximum resistance.) Now adjust sensitivity control R8 to give full-scale deflection of your meter. Identify this point as f 16—or if your camera lens stops down to f 22, use that value. Next, move Blitzmeter and flash to a distance of 10 feet and repeat the process. Keep the sensitivity control R8 at the initial adjusted setting. The meter pointer will now give a lower indication. Mark it and label it f 8 (or f 11). Now move both units to a distance of 20 feet and repeat the process. Mark the new meter indication f 4. This will calibrate your meter for one film speed only. Place a marker at the sensitivity control and identify by ASA number, using the Table as a guide.

To calibrate for other film speeds, you need only repeat the step at which the meter indicated full-scale pointer movement. At full scale, adjust sensitivity control to move pointer from f 16 (or f 22) to the next lower f-stop. In this case, f 11. Mark the sensitivity control for this setting with the next higher ASA number. Now again adjust sensitivity control for the next lower f-stop and mark the setting with the next higher ASA number. This method will enable you to calibrate your Blitzmeter accurately for any specific film speed, while the meter readings will automatically compensate for lens-to subject distance and indicate the proper f-stop setting for your lens.

R-E

TABLE: FILM SPEED AND F-STOPS

FILM SPEED [ASA]	50 WATT-SECOND Guide Number	100 WATT-SECOND Guide Number	f-STOP FOR		
			5ft	10ft	20ft
40	55	76	f 11	f 5.6	f 2.8
			f 16	f 8	f 4
65	70	95	f 16	f 8	f 4
			f 22	f 8+	f 5.6
125	95	125	f 22	f 8+	f 5.6
			f 22	f 11	f 6.3
165	110	145	f 22	f 11	f 6.3
				f 16	f 8
400	170	250		f 16+	f 8+
				f 22	f 16



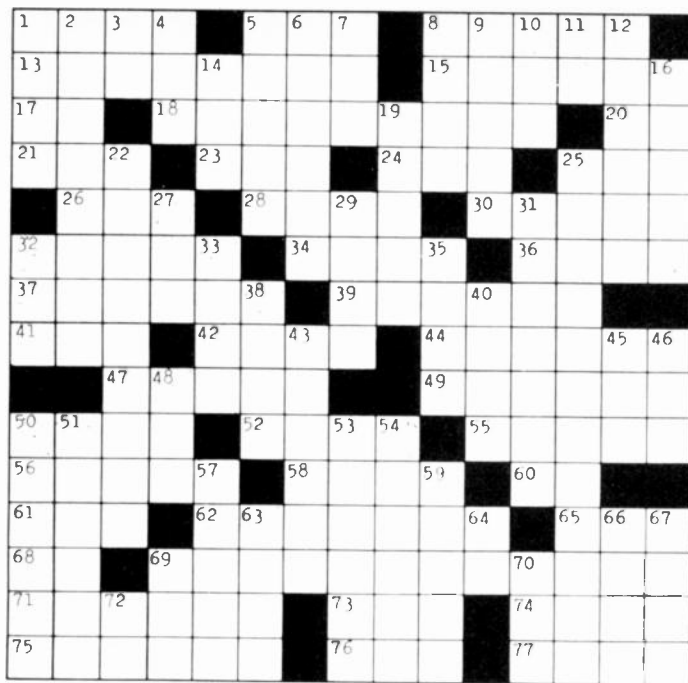

**ACROSS**

- 1 Spin below required speed
- 5 Electric guitarist's burden
- 8 Component of hi-fi set
- 13 Yachting events
- 15 Trued so all parts are correctly adjusted
- 17 External power supply not needed by Koss electrostatic type stereophones
- 18 System receiving simultaneous signals on one frequency
- 20 Loudspeaker hookup
- 21 Distortion from slowed record speed
- 23 Unit of music
- 24 Clear throat
- 25 "Is Anybody Going to \_\_\_\_\_ Antone?"
- 26 Tape tear
- 28 Chinese
- 30 Storage place
- 32 \_\_\_\_\_ Ababa
- 34 Fear of foreigners: \_\_\_\_\_ phobia
- 36 Used to be
- 37 Home of the brave
- 39 Bass loudspeaker
- 41 Blunder
- 42 Macaws
- 44 Armadas
- 47 Speak without script
- 49 Skip one dance: 2 words
- 50 Eat in style, perhaps to music!
- 52 Invented Stereophones
- 55 Crisply vigorous
- 56 Radio communications for "OK, will do."
- 58 Philippine Negrito
- 60 Symbol for rhodium
- 61 Chemical suffix for electro-negative element of a compound
- 62 Aural coverings of Stereophones
- 65 Harem room
- 68 Roman six
- 69 Stereo-times-two sound
- 71 Enclose equipment in covering material
- 73 Schubert's "The \_\_\_\_\_ King"
- 74 Exact path of radio signal
- 75 Tenant
- 76 Teletypewriter: Abbr.
- 77 Capri, for example

**DOWN**

- 1 Attract magnetically
- 2 Tape device for getting music
- 3 Automatic Gain (Control)
- 4 Slangy leg
- 5 Book of maps
- 6 Quadraphonic system encoding two channels for broadcast, decoded into four by listener equipment. Or, in - discrete!
- 7 Twenty third Greek letter
- 8 Story
- 9 Council of Moslem scholars
- 10 Nothing doing!
- 11 Half an em
- 12 Kind of bills Koss can save you
- 14 Saturday night watering place
- 16 Music to wiggle to
- 19 Record player, for short
- 22 Responsive to music highs and lows. 2 words
- 25 The Koss contribution to private listening
- 27 It's a dandy!
- 29 Radio fare, besides music
- 31 Treble loudspeaker
- 32 Consumed
- 33 Achieved by fluid-filled stereophone ear cushions
- 35 Grunts from people punched in the stomach
- 38 Scandinavian man's name
- 40 Other side of hit record
- 43 On the ship
- 45 Ram, male sheep
- 46 Untidy place
- 48 Low mark, in school
- 50 Sound transmitter in the earcup
- 51 Antiseptic for bruises
- 53 Quality is the open \_\_\_\_\_ of success
- 54 British royal house
- 57 Reclaim for further service
- 59 Put on, or use a method
- 63 Amer. Assoc. of Elec. Engrs.
- 64 Quiet!
- 66 Radio indication panel
- 67 Peak of perfection
- 69 Arabian narcotic shrub
- 70 Kimono sash
- 72 Credit note: Abbr.

# Can anyone do what you do any better?

Probably not. All things considered you do what you do pretty doggone well. After all, no one has taken your job. And you're eating regularly. But...

But have you ever considered what doing your job just a little better might mean?

Money. Cold hard coin of the realm.

If each of us cared just a smidge more about what we do for a living, we could actually turn that inflationary spiral around. Better products, better service and better management would mean savings for all of us. Savings of much of the cash and frayed nerves it's costing us now for repairs and inefficiency.

Point two. By taking more pride in our work we'll more than likely see America regaining its strength in the competitive world trade arena. When the balance of payments swings our way again we'll all be better off economically.

So you see—the only person who can really do what you do any better is you.

## America. It only works as well as we do.



The National Commission on Productivity, Washington, D. C.

**SOLUTION**



# TECHNICAL TOPICS

Two of this month's selected circuits are for test instruments—a FET voltmeter and a shorted-turns tester. The others include an unusual regenerative detector; a random-order flasher and a kink for mobile radio operators.

by **ROBERT F. SCOTT**  
TECHNICAL EDITOR

FIRST, LET ME THANK THOSE WHO answered my requests for help in selecting material for future Technical Topics columns. I am especially grateful for your kind remarks and for the suggestions that I hope will enable me to tailor future columns to fit your needs. Most of you suggested broad subjects you want to see covered. This is what I need—ideas that can be developed so they are of interest to the greatest number of readers. Technical Topics tries to present workable ideas that you can use directly or adapt to meet more specific requirements.

A few of you wanted answers to specific problems. We don't want Technical Topics to become a Readers' Question Box. If you need immediate help with a specific problem, write to the Technical Editor, or to the Appliance or Service Clinic. We'll do our best to help you.

Several readers wanted a circuit for four or more neon lamps that flash in a random order. The circuit to be used in Christmas decorations, games, "do-nothing" boxes, clearance markers, docking beacons, etc. The circuit in Fig. 1 should do the trick. The flashing rate is determined by the values of R and C.

## More on the unusual superregenerative

In October 1969 we described an unusual superregenerative receiver developed by Ted Hart. The receiver uses a multivibrator quench-frequency oscillator for a crystal-controlled vhf oscillator. A couple of months earlier (August, 1969, page 48) Frank Tooker described a novel square-wave generator using a pair of FET's connected as a multivibrator.

Charles Derven, of Poultney, Vt., has come up with an FET version of Ted Hart's superregenerative using 2N3819 FET's (see Fig. 2). Coil L1 consists of 32 turns of No. 26 enameled wire closewound on a 1/4-inch

plastic soda straw (an idea copied from I. Queen's "Pocket VHF Receiver", January 1961 issue). L2 consists of 3 turns wound around the B+ end of L1. The tuning capacitor was made by removing all except four rotor and four stator plates from an inexpensive 365-pF tuning capacitor.

Mr. Derven reports receiving sev-

eral Latin-American stations while using a 36-inch whip antenna. He added that tuning was critical and the smooth hiss indicating superregeneration could be obtained only when the tuning capacitor was nearly wide open. Closing the capacitor further caused the circuit to whistle.

(It sounds like this circuit now

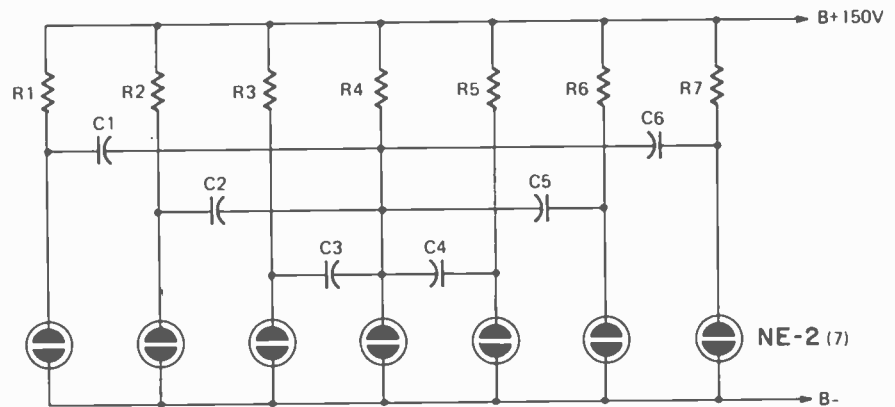

R1 - R7 = 220K to 2.2 MEGS  
C1 - C6 = 0.1 to 1  $\mu$ F LOW LEAKAGE TYPE

FIG. 1—RANDOM-ORDER FLASHER is a group of neon lamps interlocked as multivibrators. It can be used as a highway obstruction marker, docking beacon or do-nothing toy for tots.

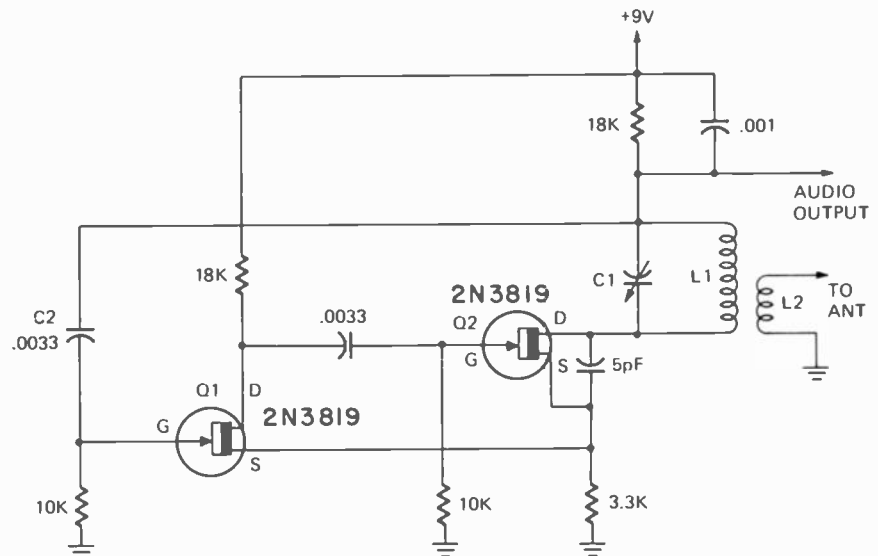

FIG. 2—UNUSUAL SUPERREGENERATIVE DETECTOR uses FET's connected as multivibrator quench oscillator. Designer reports receiving South American shortwave stations.

needs a regeneration control. One possible way is to try replacing C2 with a variable capacitor of much lower capacitance, say 365 pF. Another possible approach is to feed the gate of Q1 from a tertiary coil of a few turns around L1. One end of the coil would be grounded or returned to ground through a variable capacitor. The other end goes to Q1 through C2.)

### Power supply hang up

A reader in Crescenta, Calif.—his signature was not clear—ran into trouble when he decided to modify his bench power supply along the lines of the dual supply in the November 1972 issue. He found the CA3055 IC had been discontinued and replaced by the CA3085A and CA3085B IC's.

He used the 5.6-ohm resistor between pins 1 and 8 as specified in the CA3085 data sheets instead of the 45-ohm resistor and 1000-ohm pot combination used in the original dual power supply. He reports that the supply works quite well. A TO-5 type heatsink on the IC keeps it close to room temperature.

### Sensitive squelch circuit

The squelch circuit in Fig. 3 can be added to most FM monitor receivers. It is used in Zenith's RD52 AM-FM receiver. The circuit is switched into operation when the bandswitch is set to the PS (public service) position for receiving transmissions from U.S. Weather Service, fire, police, public utilities and other services operating between 148 and 174 MHz.

Transistors Q1 and Q2 form the carrier-operated circuit that controls conduction through Q3, the audio pre-amplifier and switch used for public-service audio. When Q3 turned off, it mutes the receiver; when this transistor is turned on, it amplifies the incoming audio signal.

When the SQUELCH control arm is advanced toward the B- end, a point is reached where Q1 is biased to cut-off and Q2 is biased on. The voltage on Q2's collector is transferred through D3 to Q3's base, turning off the audio and efficiently silencing the receiver.

When an incoming signal appears at the collector of the i.f. output stage, a portion is applied to a voltage doubler consisting of D1 and D2. The voltage-doubler output develops across C3 and is applied to the base of Q1 through the 1000-ohm decoupling resistor. When the voltage is high enough to over-ride the fixed cutoff bias from the SQUELCH control, Q1 turns on. Q2 is turned off and Q3 turns on, thereby passing the audio signal through the bandswitch to the volume control and the balance of the audio circuits.

### Shorted-turns tester

Shorted turns in a TV flyback transformer, deflection yoke, width coil or other inductors in the deflection circuit can produce annoying symptoms that can be difficult to track down. This is particularly true when the shorted condition does not cause charring or overheating that can be detected easily by sight or smell.

The shorted-turn detector in Fig. 4, described originally in *Electronics Australia*, can be tucked into the tube caddy so coils with shorted turns can be isolated and replaced without having to pull the set to the shop for service.

Q1 is a Colpitts oscillator using a standard horizontal "ringing" or "sine-wave" coil. Q2 is a transistor voltmeter that monitors the oscillator output. The 470-ohm emitter resistor was selected to limit current through the meter to less than 1 mA when the oscillator is developing maximum output—the 1000-ohm pot will be set for minimum resistance.

When the device is first turned on the meter reads around 0.1 mA, indicating that the oscillator is not operating. As the pot resistance is reduced, the oscillator starts operating and the meter reading jumps to about 0.4 mA. Shorting the test leads causes the meter reading to drop, indicating that the oscillator has been loaded down and has stopped oscillating.

To test a suspected inductor or transformer, set the pot so the meter reads about 0.6 mA and then connect the test leads. With this level of activity, the oscillator will not be affected by a high-impedance shunting the coil under test but will show up a shorted turn or a low-impedance shunt path in the circuit.

Familiarize yourself with the tester by checking the windings of a good flyback and then, with the test leads across one winding, thread a short piece of wire around the core and connect the ends together and watch the meter. You should easily perceive the difference.

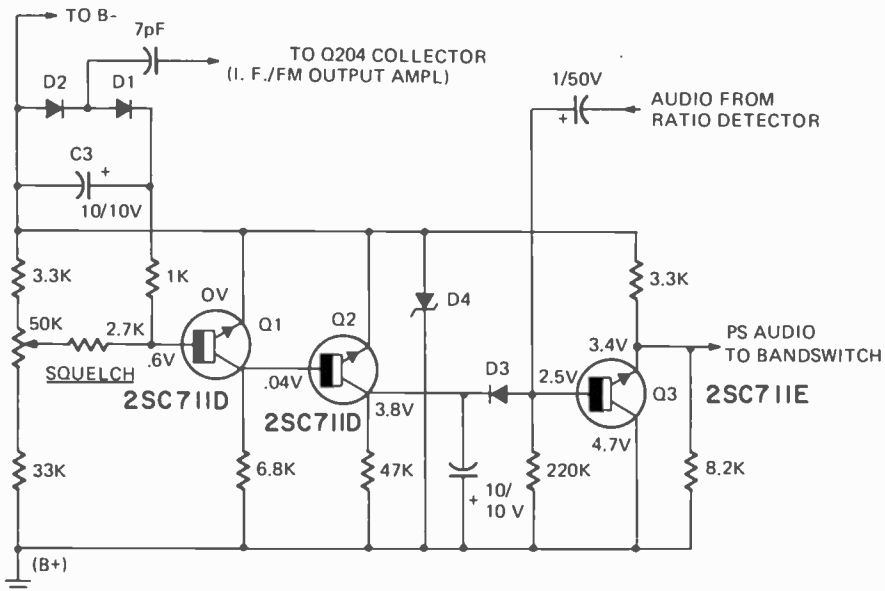

FIG. 3—EFFECTIVE SQUELCH CIRCUIT is from Zenith's RD52 receiver. Circuit cuts in automatically when receiver bandswitch is set for monitoring the 148-175-MHz range.

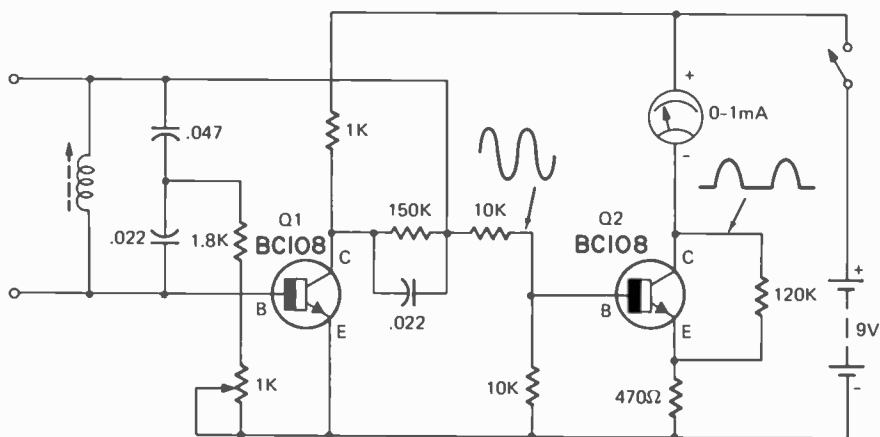

FIG. 4—SHORTED TURNS IN TV INDUCTORS are easy to locate with this tester. Oscillator is loaded down so meter reading drops when shunted by coil or transformer with shorted turns.

## Simple FET voltmeter

The voltmeter in Fig. 5 was taken from a Mullard *Educational Projects in Electronics* booklet. Input resistance is at least 10 megohms on its eight dc voltage ranges. It uses an N-channel FET operating as a source follower. The voltage being measured is applied across the voltage divider consisting of 10 megohms in series with a shunt resistance—selected by the RANGE switch—between the FET gate and ground. The shunt resistance selected is such that the voltage between FET gate and ground is 200 mV for full-scale voltage on all ranges. The inherent high input resistance of the FET and the negative feedback across the unbypassed source resistor insure that there is never less than 10 megohms in parallel with lower end of the input voltage divider, even on the lowest range.

Potentiometer R24 sets full-scale deflection on the 250-mV range and compensates for the difference in transfer conductance—roughly gain—of different FET's. All other ranges are adjusted for full-scale deflection by using the preset potentiometers in series with the shunt leg of the input voltage dividers. The 250-ohm wire-wound [zero adjust] pot is mounted on the

front panel and used to zero the meter with the input leads shorted.

The FET voltmeter can be calibrated using an adjustable power supply and a vtvm or digital voltmeter across the FET meter's input terminals or by using the scheme in Fig. 6. With this setup, a dc microammeter measures the current through R2, a precision resistor. The voltage applied to the FET is then  $R2 \times I$ . The calibration procedure:

1. Switch to the 250-mV range, set R24 for minimum resistance. Short the input terminals together and use R26 to zero the meter. Remove the short from the input terminals.
2. Apply 250 mV to the input and adjust for full-scale deflection.
3. Repeat steps 1 and 2 until the meter reads correctly at zero and full-scale.
4. Switch to the 500-mV range, short the input terminals and check for zero deflection on the meter. If not, repeat steps 1 and 2. Remove the short, apply 500 mV to the input and adjust R8 for full-scale. Do not adjust R24.
5. Switch to the other ranges and apply full-scale voltages to the input and adjust R11, R16, R18, R20 and R22 for full-scale deflection on the appropriate range.

## Battery isolation scheme

A ham reader asked for a circuit that

would permit him to add a second battery to his car. The auxiliary battery is for operating only the 2-way radio equipment. Both batteries are to be charged from the car's generator or alternator.

Digging into my files, I came up with the circuit in Fig. 7. It appeared in *Electronics Australia*. In this case, four 25-ampere silicon diodes of the type used in automobile alternators are used to isolate the two batteries.

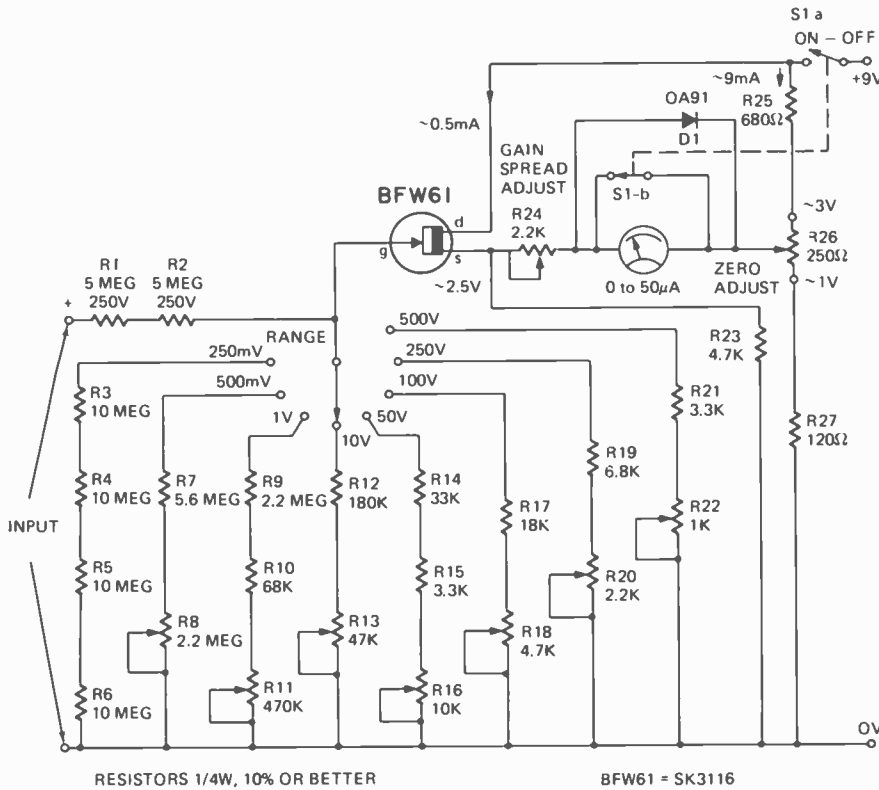

FIG. 5—DC VOLTMETER USES FET to give it a very high input impedance on its eight dc ranges. Construction and calibration are simple and straightforward.

FIG. 6—METER CALIBRATOR develops reference voltage by controlling the current flowing through a precision resistor.

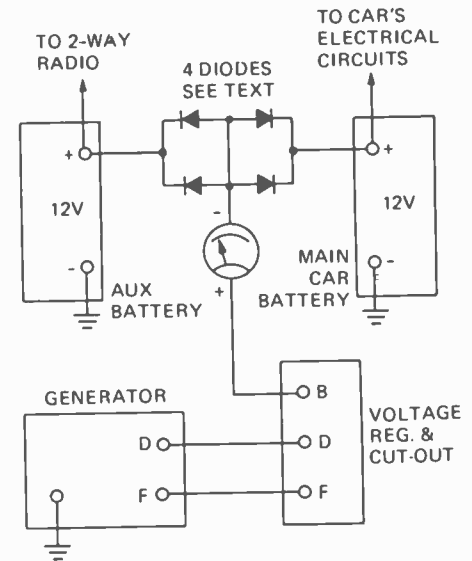
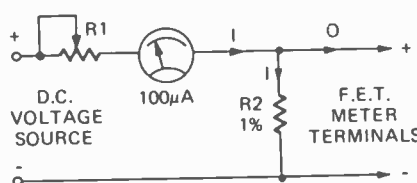

FIG. 7—DUAL BATTERIES in car with 2-way radio insure more reliable radio operation and quick and easy starting.

The diodes are Mullard BYX21-200R's (the "R" suffix indicates reverse polarity—the anode is connected to the case) pressed into a 6-inch length of Mullard type 35D6C heatsink. The heatsink itself is used as the common anode connection. Equivalent silicon diodes are the HEP RO222-R and similar types. If a suitable heat sink is not available, use stud-mount diodes.

Well that's it for now. Keep those cards and letters coming. Give me an idea as to how much text is needed with the average diagram. The space allotted for Tech Topics is limited so if we can cut down a little on text we can squeeze in an extra diagram or two. But, remember that this may mean cutting down on the construction tips, calibration aids and "how-it-works" dope that I've been including. Let's hear from you.

R-E

## NEXT MONTH

Three special articles highlight developments in solid-state electronics. We start with an article on a new kind of color TV that has special circuit features we know you want to read about. Then Don Lancaster explores the world of the ROM (Read Only Memory). Last, there's an IC Gyrator—that's a device that behaves like an inductor but has no coil. Don't miss the February issue.

# CREI—the only home-study college-level training

## and now

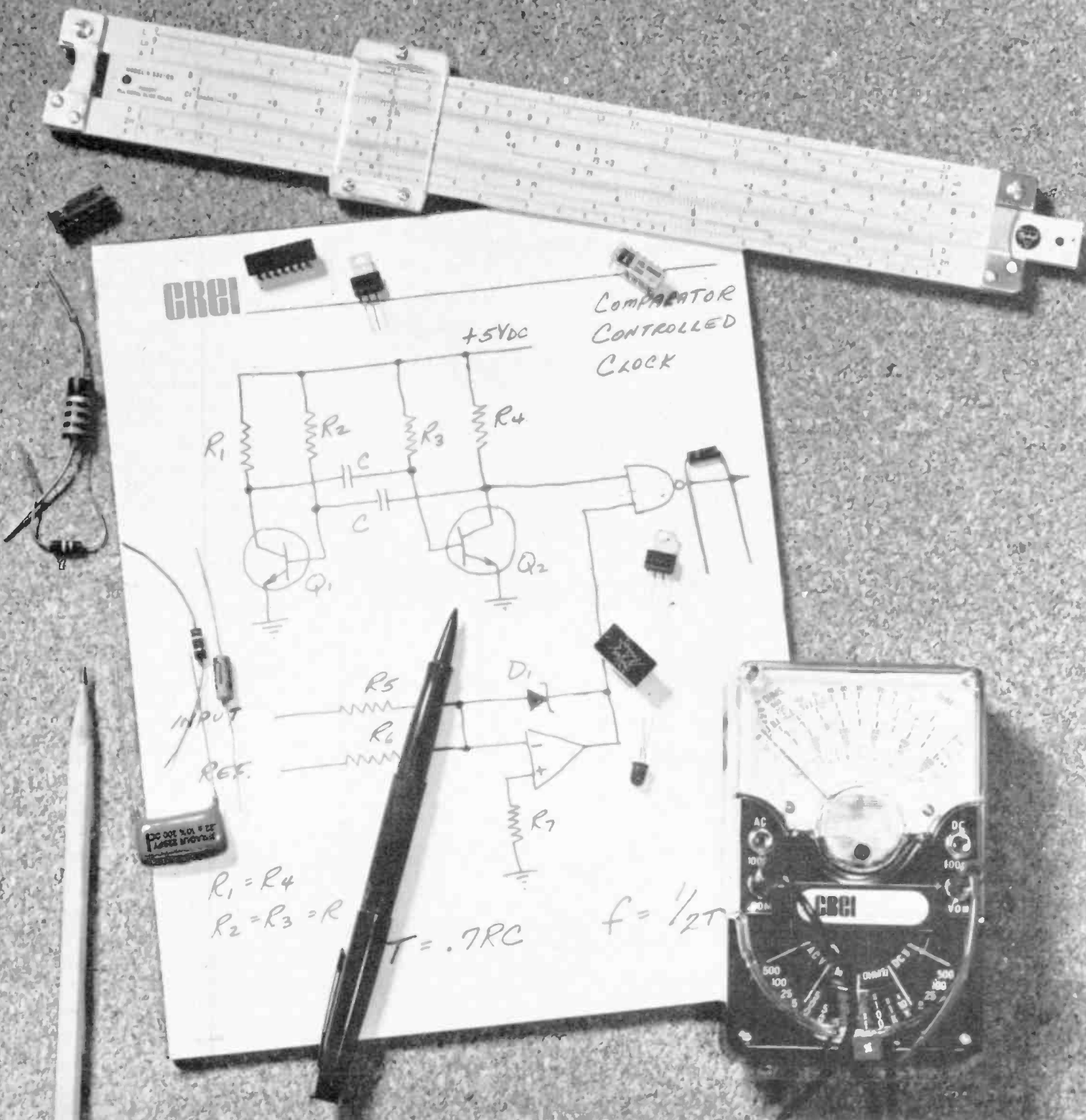



# program which gives you in electronic circuit design

## only CREI offers you a complete college-level Electronic Design Laboratory to speed your learning

**Electronic circuit design**—source of all new development in the application of electronics to new products and services. Without this skill, we would be unable to monitor the heartbeat of men in space. Without it, the computer revolution would never have occurred. And we would have yet to see our first TV show. *Yet, only CREI teaches electronic circuit design at home.*

### ELECTRONIC CIRCUIT DESIGN

A key skill which paces our nation's progress in countless fields—from pollution control to satellite tracking to modern medicine to exploring the ocean's depths. And beyond. A skill which *you* must have to move to the top in advanced electronics.

### CREI programs open up new worlds of opportunity for you.

In addition to electronic circuit design, CREI provides you with a full advanced electronics education in any of thirteen fields of specialization you choose. Communications, computers, space operations, television, nuclear power, industrial electronics—to mention just a few of the career fields for which CREI training is qualifying. With such preparation, you will have the background for a career which can take you to the frontiers of the nation's most exciting new developments. And around the world.

### This free book can change your life. Send for it.

If you are a high-school graduate (or equivalent) and have previous training or experience in electronics, then you are qualified to enroll in a CREI program to move you ahead in advanced electronics.



Send now for our full-color, eighty page book on careers in advanced electronics. In it, you will find full facts on the exciting kinds of work which CREI programs open up to you. And full facts on the comprehensive courses of instruction, the strong *personal* help, and the professional laboratory equipment which CREI makes available to you. All at a surprisingly low tuition cost.

### And when you have it, talk with your employer about it.

Tell him you're considering enrolling with CREI. He'll undoubtedly be happy to know you are planning to increase your value to him. *And he may offer to pay all or part of your tuition cost.* Hundreds of employers and government agencies do. Large and small. Including some of the giants in electronics. *If they are willing to pay for CREI training for their employees, you know it must be good.*

**Send for Advanced Electronics today. You'll be glad you did.**



CREI Dept. E. 1401E  
3939 Wisconsin Avenue  
Washington, D.C. 20016

Rush me your FREE book describing my opportunities in advanced electronics. I am a high school graduate.

Name \_\_\_\_\_ Age \_\_\_\_\_

Address \_\_\_\_\_

City \_\_\_\_\_ State \_\_\_\_\_ ZIP \_\_\_\_\_

If you have previous training in electronics, check here

Employed by \_\_\_\_\_

Type of Present Work \_\_\_\_\_

Veterans and servicemen, check here for G. I. Bill Information

# CREI

**CAPITOL  
RADIO  
ENGINEERING  
INSTITUTE**

WASHINGTON, D.C. 20016

# Step-by-step TV Troubleshooters Guide

by STAN PRENTISS

IF DRS. BRATTAIN, BARDEEN, AND Shockley had to sit down and troubleshoot some of our modern communications equipment, they might have momentary second thoughts about their invention of the transistor in 1947. For in 1973, solid-state engineering of consumer electronics is complex indeed. Take, for instance, the switched low-voltage power supply. Motorola had its TS-938 over two years ago (June 1971). Zenith followed with their EC45, EC58 series with loosely wound primary-secondary coils, where the secondary is shunted by several microfarads of capacitance and core-saturated. It regulates respectably from about 95 to 135 or so volts ac and maintains short-circuit resistance for 10 or more seconds before popping the circuit breaker.

The switched power supplies may

not have quite the broad voltage range of the capacitor-shunted secondary types, but their regulation will be somewhat more precise. This year both U.S. and Japanese appear to be moving towards such low-voltage sources.

How about the service technician? What does he do when there's power but no high voltage; no high voltage and no power; sound and no high voltage; set blows fuses; power is applied and smoke spirals? Suppose, for instance, you have problems with the newest Panasonic or Sony? Delivering the same end product, in design and execution you'll find them totally different.

## Panasonic ETA-2 Chassis

This is a modern group of 19 and 25-inch receivers (models CT-701, CT-252 through CT-254) with an almost

completely modularized chassis—six major plug boards, and more, plus 40 transistors, six integrated circuits and 51 diodes. IC's include aft, sound detection and amplification, color processor, subcarrier regenerator, and chroma demodulator; as well as a video jungle circuit containing agc, noise canceller, abl (automatic brightness limiter), sync separator, and 1st video amplifier. The power supply "S" board is a plug-in on the right wing (next to the high voltage), while all signal and sync circuits are on the left. The block diagram in Fig. 1, along with the schematic of Fig. 2, shows the signal flow.

The bridge rectifier (D801 through D804) picks up incoming ac from the power line. The pulsating dc output of the rectifier is smoothed by filter choke L801 to some extent for the 115-V switching regulator.

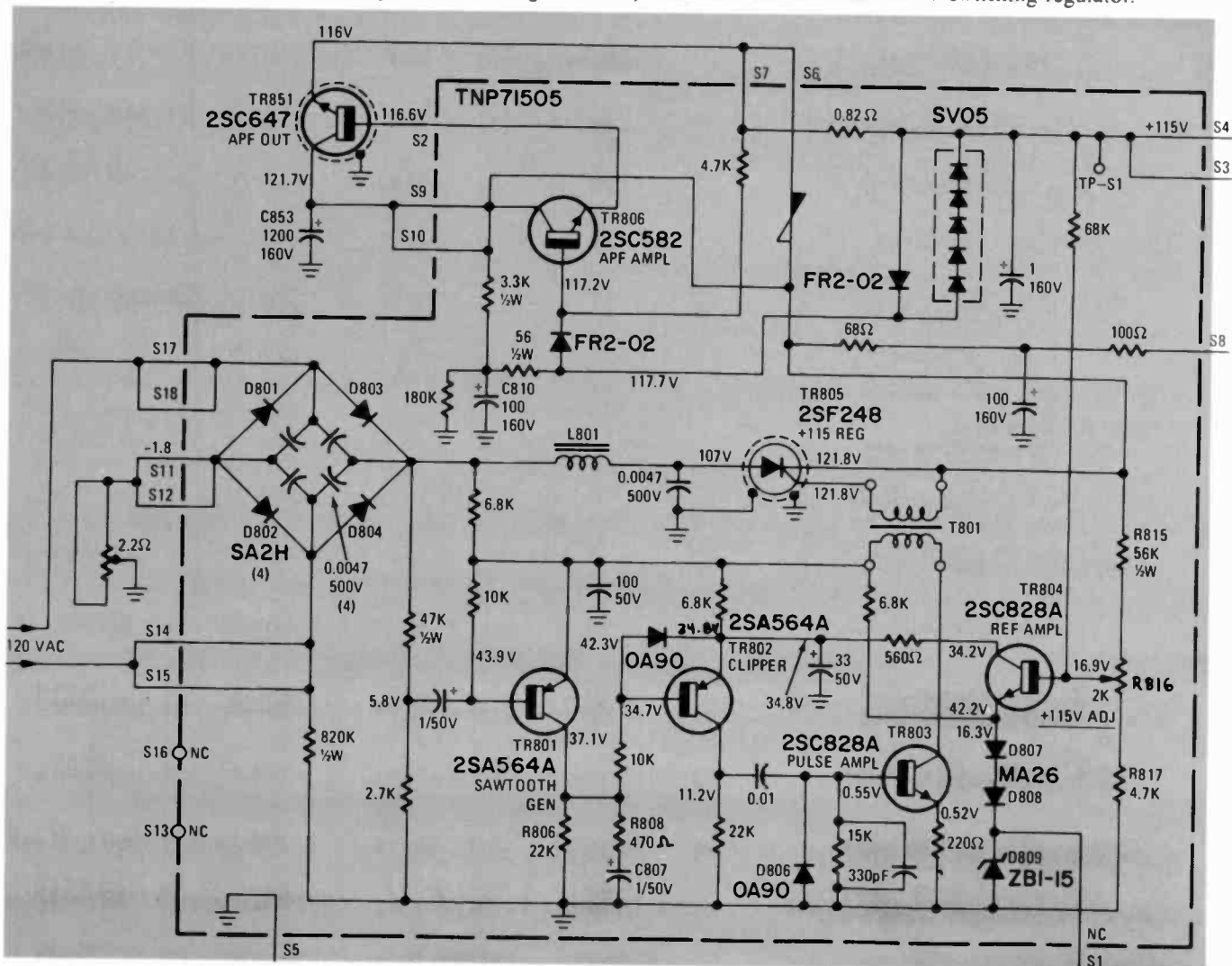

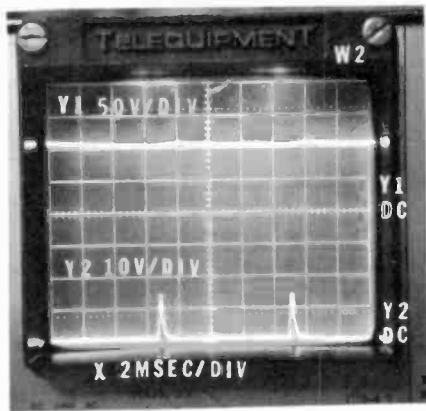
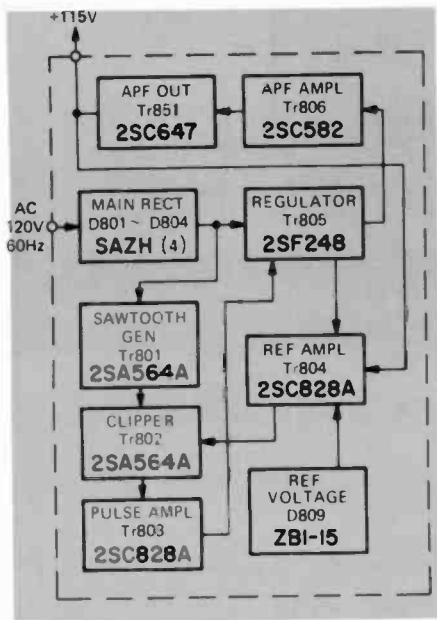
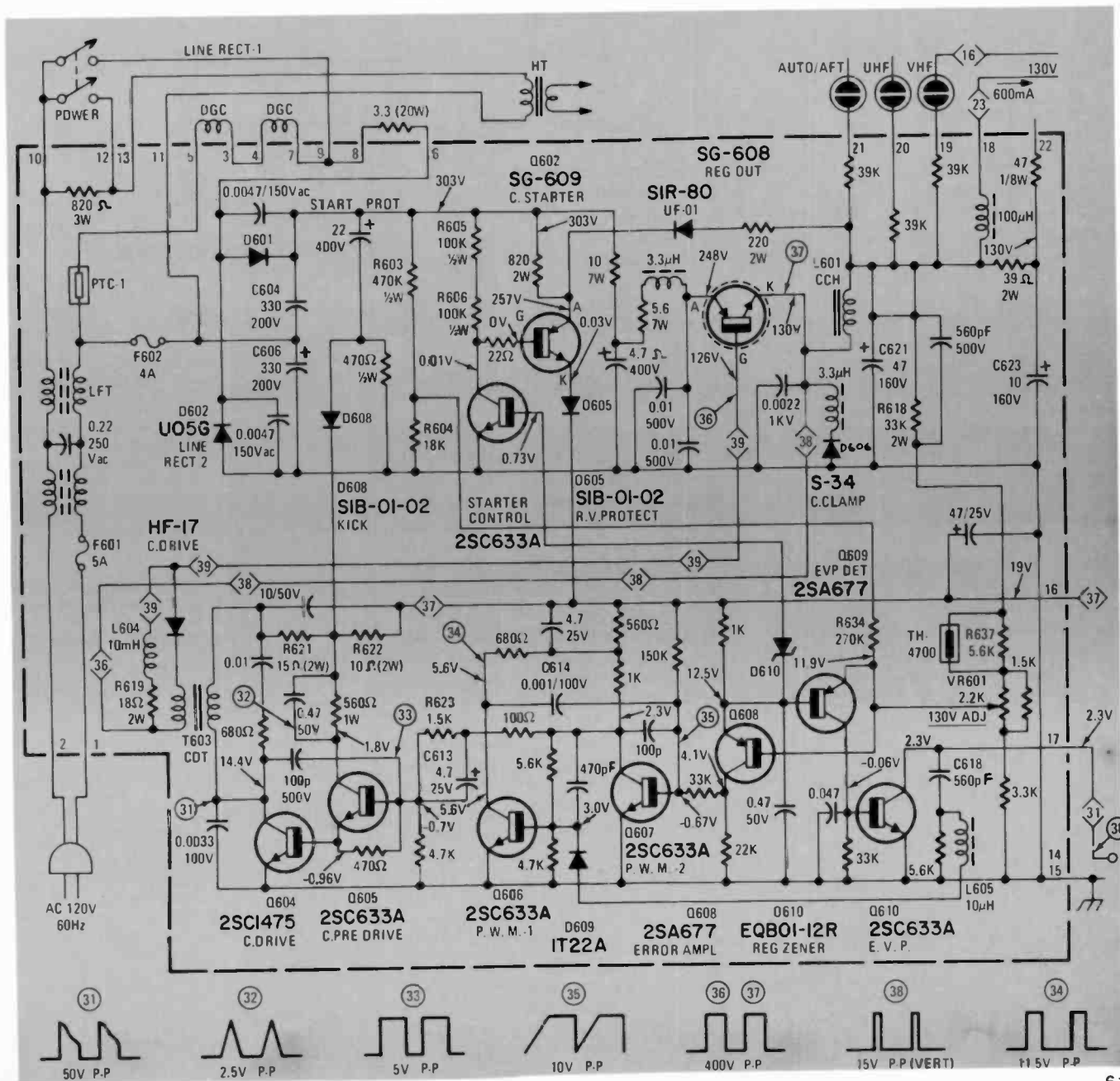
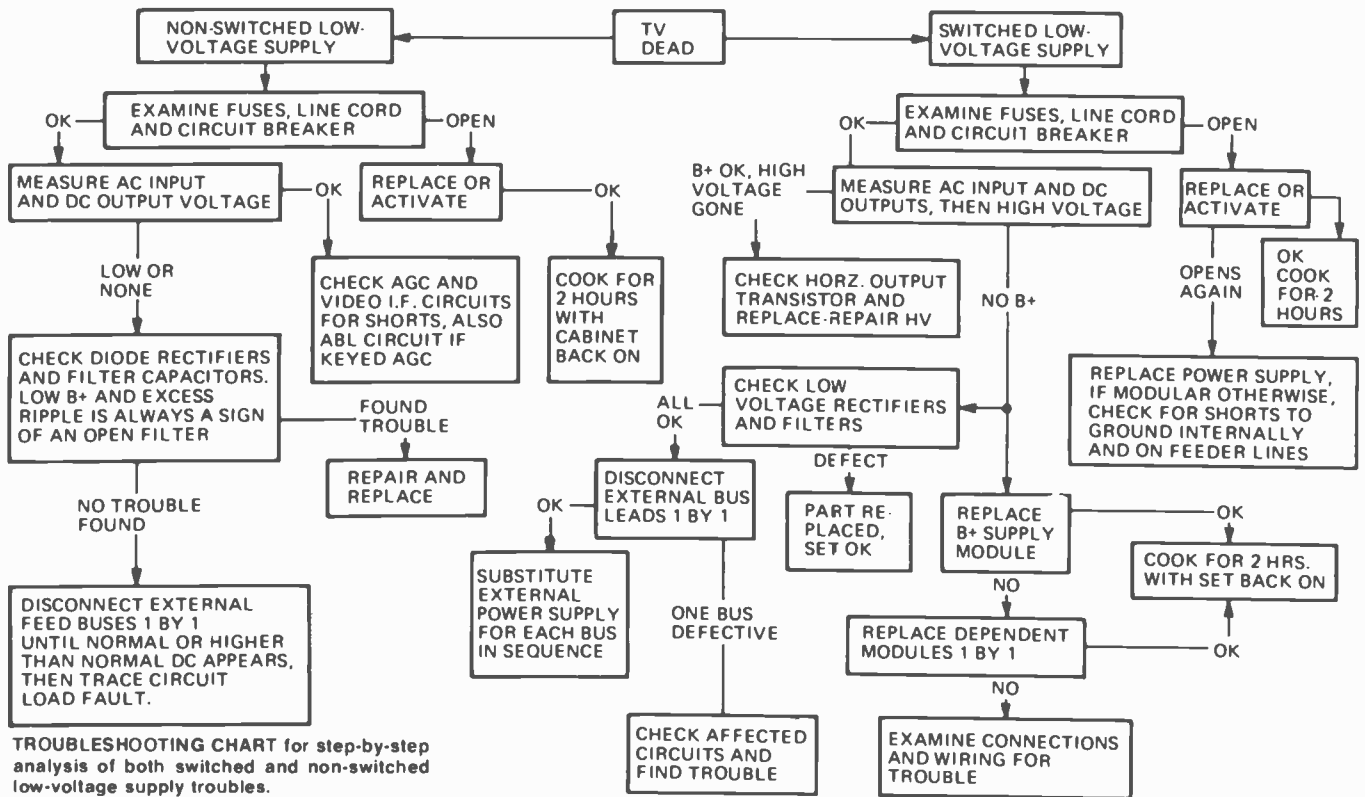

FIG. 1 (left)—BLOCK DIAGRAM shows signal flow in the low-voltage power supply in Panasonic's ETA-2 chassis. POWER SUPPLY SCHEMATIC (FIG. 2, on previous page) shows circuit complexity. FIG. 3 (above)—Y1 and Y2 are anode and cathode waveforms, respectively, of TR805 in Fig. 1. FIG. 4 (below)—SONY'S SWITCHED SUPPLY.

At 140 V p-p, this same waveform also couples through saw-tooth generator TR801, is inverted and converted to a sawtooth by R806, R808, and C807 whose inverted p-p voltage is now only 12. TR802 now does some clipping, while pulse amplifier TR803 again inverts the D806-clamped waveform and puts it through transformer T801 as a trigger pulse. This transformer triggers the SCR gate for longer or shorter periods so its current and voltage develop the necessary 115-V regulated output. Active power filters (apf) TR806 and TR851 now take over and complete the dc smoothing operation, along with large filters C810 and C853. Overall filter action for this power supply, then, is the beta of the transistors times the filter capacitance—forming a powerfully active filter indeed.

Regulating action for Panasonic's





supply is generated by feedback through divider resistors R815, R817, and +115-V adjust R816. TR804 establishes a reference through Zener D809 and temperature compensation diodes D807 and D808. Changes in output voltage induce TR804 to conduct proportionately, driving clipper TR802 more or less and delaying or expanding the drive waveform's duration through pulse amplifier TR803, producing greater or smaller output potentials through the TR805 115-V regulator. Fig. 3 shows the waveforms at two points in the circuit.

### Sony KV-1722

Sony's new receiver (Fig. 4) is a 17-inch, 114-degree deflection Trinitron type in a compact cabinet with six IC's, 26 transistors, 33 diodes, and three gate controlled switches (GCS's) in the power supply and horizontal output—and *don't* forget them. The IC's include aft, sound if., demodulation, and amplification; the complete video i.f., detector, sound detector and driver, automatic noise canceller (anc), i.f. and rf agc and video drive; com-

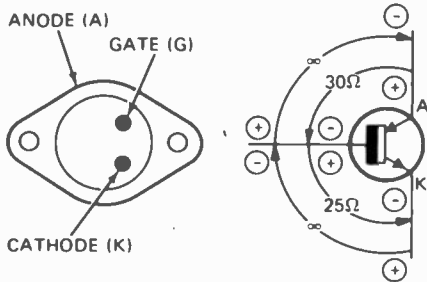

FIG. 5—A QUICK CHECK FOR GCS'S

plete subcarrier regenerator with automatic color killer (ack), automatic chroma control (acc), burst amplifier, color and hue amplifiers, and 3.579,545-MHz color sync oscillator; the chroma demodulator with sharpness acr, a luminance amplifier, and blanker; and a deflection chip with sync amplifier, afc gate, horizontal oscillator and protect circuit, vertical oscillator, buffer, and horizontal pre-amplifier.

The power supply—in which we're interested—is a separate board mounted on the back of the receiver with one ac (F601) and one dc (F602) fuse between the entire receiver and its power line. D601 and D602 are full-wave doubler rectifiers that alternately charge C604, and C606, so that output is 310 V (303 V loaded) of relatively smooth dc. D608 is now ready to protect against too much sudden voltage at the junction of R621 and R622, and GCS starter Q602 now becomes active through divider resistors R605 and R606. This gated switch conducts momentarily through D605, supplying immediate dc for the collectors of the entire group of current drivers, pulse-width modulators, and error-evp (excess voltage protector) detectors and amplifiers plus vertical and horizontal circuits as well. Both the horizontal oscillator and outputs now start and the regular 19-V supply kicks in through the 19-V rectifier connected to a winding of the horizontal output transformer. Zener D610 then conducts and turns on Q610

(continued on page 76)

## R-E's Substitution guide for replacement transistors

### PART XI

compiled by ROBERT & ELIZABETH SCOTT

- ARCH**—Indicates the Archer brand of semiconductors sold only by Radio Shack and Allied Radio stores. Allied Radio Shack, 2725 W. 7th St., Ft. Worth, Texas 76107
- DM**—D. M. Semiconductor Co., P.O. Box 131, Melrose, Mass. 02176
- GE**—General Electric Co., Tube Product Div., Owensboro, Ky. 42301
- ICC**—International Components, 10 Daniel Street, Farmingdale, N.Y. 11735
- IR**—International Rectifier, Semiconductor Div., 233 Kansas St., El Segundo, Calif. 90245
- MAL**—Mallory Distributor Products Co., 101 S. Parker, Indianapolis, Ind. 46201
- MOT**—Motorola Semiconductors, Box 2963, Phoenix, Ariz. 85036
- RCA**—RCA Electronic Components, Harrison, N.J. 07029
- SPR**—Sprague Products Co., 65 Marshall St., North Adams, Mass. 01247
- SYL**—Sylvania Electric Corp., 100 1st Ave., Waltham, Mass. 02154
- ZEN**—Zenith Sales Co., 5600 W. Jarvis Ave., Chicago, Ill. 60648

Radio-Electronics has done its utmost to insure that the listings in this directory are as accurate and reliable as possible, however, no responsibility is assumed by Radio-Electronics for its use. We have used the latest manufacturers material available to us and have asked each manufacturer covered in the listing to check its accuracy. Where we have been supplied with corrections, we have updated the listing to include them. The first part of this Guide appeared in March 1973

	ARCH	DM	G-E	ICC	IR	MAL	MOT	RCA	SPR	SYL	ZEN
2N2402	RS276-2003	T-3	GE-9	ICC-3	NA	PTC 102	HEP-3	NA	NA	ECG 160	ZEN 301
2N2403	NA	NA	GE-63	NA	NA	PTC 144	HEP-S3001	NA	NA	NA	NA
2N2404	NA	NA	GE-63	NA	TR-25	PTC 144	HEP-S3011	NA	NA	NA	NA
2N2405	NA	T-714	GE-27	ICC-714	NA	PTC 144	HEP-714	SK 3024	RT-114	ECG 128	NA
2N2406	NA	T-251	GE-52	NA	TR-05	PTC 102	NA	SK 3123	NA	NA	NA
2N2410	NA	TS-3001	GE-63	NA	IRTR-65	PTC 144	HEP-S3001	NA	NA	NA	NA
2N2411	RS276-2023	T-52	GE-22	ICC-52	TR-19	PTC 103	HEP-52	SK 3114	RT-115	ECG 159	NA
2N2412	RS276-2023	T-52	GE-22	ICC-52	TR-30	PTC 103	HEP-52	SK 3114	RT-115	ECG 159	NA
2N2413	RS276-2009	T-50	GE-20	ICC-50	TR-51	PTC 136	HEP-50	SK 3122	RT-102	ECG 123A	NA
2N2414	NA	NA	NA	NA	NA	NA	HEP-S0004	NA	NA	NA	ZEN 100
2N2415	RS276-2003	T-3	GE-51	ICC-3	TR-17	PTC 107	HEP-3	NA	NA	ECG 160	ZEN 301
2N2416	RS276-2003	T-3	GE-51	ICC-3	TR-17	PTC 107	HEP-3	NA	NA	ECG 160	ZEN 301
2N2417	NA	T-736	NA	NA	TR-25	NA	NA	SK 3124	NA	ECG 123A	NA
2N2418	NA	NA	NA	NA	NA	NA	HEP-310	NA	NA	NA	NA
2N2419	NA	NA	NA	NA	NA	NA	HEP-310	NA	NA	NA	NA
2N2420	NA	NA	NA	NA	NA	NA	HEP-310	NA	NA	NA	NA
2N2421	NA	NA	NA	NA	NA	NA	HEP-310	NA	NA	NA	NA
2N2422	NA	NA	NA	NA	NA	NA	HEP-310	NA	NA	NA	NA
2N2423	RS276-2006	T-232	GE-16	ICC-232	TR-01	NA	HEP-232	SK 3009	RT-127	NA	ZEN 326
2N2424	RS276-2021	T-51	GE-21	ICC-51	NA	PTC 103	HEP-51	SK 3114	RT-115	ECG 121	ZEN 101
2N2425	RS276-2021	T-51	GE-21	ICC-51	TR-28	PTC 103	HEP-51	SK 3114	RT-115	ECG 159	ZEN 101
2N2426	RS276-2002	T-641	GE-54	ICC-641	TR-10	PTC 108	HEP-641	SK 3011	RT-119	ECG 159	ZEN 315
2N2427	RS276-2009	T-50	GE-21	ICC-50	IRTR-51	PTC 121	HEP-50	SK 3122	RT-102	ECG 101	ZEN 100
2N2428	RS276-2005	T-251	GE-52	ICC-251	IRTR-85	PTC 135	HEP-251	SK 3004	RT-121	ECG 123A	ZEN 303
2N2429	RS276-2004	T-253	GE-53	ICC-253	IRTR-85	PTC 135	HEP-253	SK 3004	RT-121	ECG 102A	ZEN 304
2N2430	RS276-2001	T-641	GE-59	ICC-641	TR-09	PTC 108	HEP-641	SK 3010	RT-122	ECG 102A	ZEN 315
2N2431	RS276-2006	T-238	GE-53	ICC-238	TR-14	PTC 109	HEP-238	SK 3004	NA	ECG 103A	ZEN 329
2N2432	RS276-2009	T-50	GE-62	ICC-50	IRTR-51	PTC 139	HEP-50	SK 3122	RT-102	ECG 158	ZEN 100
2N2433	NA	T-706	GE-27	NA	IRTR-87	PTC 144	HEP-S3020	NA	NA	ECG 123A	NA
2N2434	NA	NA	NA	NA	IRTR-87	NA	HEP-S3020	NA	NA	NA	NA
2N2435	NA	T-706	GE-27	NA	IRTR-87	PTC 144	HEP-714	NA	NA	NA	NA
2N2436	NA	NA	NA	NA	IRTR-87	NA	HEP-714	NA	NA	NA	NA
2N2437	NA	T-706	GE-27	NA	IRTR-87	PTC 144	HEP-714	NA	NA	NA	NA
2N2438	NA	T-706	GE-27	NA	IRTR-87	PTC 144	HEP-714	NA	NA	NA	NA
2N2439	NA	T-706	GE-27	NA	IRTR-78	NA	HEP-714	NA	NA	NA	NA
2N2440	NA	NA	NA	NA	NA	NA	HEP-714	NA	NA	NA	NA
2N2443	NA	T-706	GE-27	NA	IRTR-78	PTC 125	HEP-713	NA	NA	NA	NA
2N2444	NA	NA	NA	NA	NA	NA	HEP-626	NA	NA	NA	NA
2N2445	NA	NA	NA	NA	NA	NA	HEP-236	NA	NA	NA	NA
2N2446	RS276-2006	T-232	GE-16	ICC-232	TR-01	NA	HEP-232	SK 3009	RT-127	ECG 121	ZEN 326
2N2447	RS276-2007	T-631	GE-2	ICC-631	IRTR-85	PTC 102	HEP-631	SK 3004	RT-121	ECG 102A	ZEN 307
2N2448	RS276-2007	T-631	GE-2	ICC-631	IRTR-85	PTC 109	HEP-631	SK 3004	RT-121	ECG 102A	ZEN 307
2N2449	RS276-2003	T-633	GE-53	ICC-633	IRTR-85	PTC 109	HEP-633	SK 3004	RT-121	ECG 102A	ZEN 309
2N2450	RS276-2003	T-633	GE-53	ICC-633	IRTR-85	PTC 109	HEP-633	SK 3004	RT-121	ECG 102A	ZEN 309
2N2451	RS276-2003	T-3	GE-51	ICC-3	TR-12	PTC 107	HEP-3	SK 3006	NA	ECG 126	ZEN 301
2N2453	NA	NA	NA	NA	NA	NA	HEP-S0007	NA	NA	NA	NA
2N2454	NA	NA	NA	NA	NA	NA	HEP-R1245	NA	NA	NA	NA
2N2455	NA	T-2	GE-9	ICC-2	TR-17	NA	HEP-2	NA	NA	ECG 160	ZEN 300
2N2456	RS276-2003	T-2	GE-9	ICC-3	TR-12	NA	HEP-3	NA	NA	ECG 126	ZEN 301
2N2459	NA	NA	NA	NA	NA	PTC 123	HEP-S0005	NA	NA	NA	NA
2N2460	NA	NA	NA	NA	NA	PTC 123	HEP-S0005	NA	NA	NA	NA
2N2461	NA	NA	NA	NA	NA	NA	HEP-S0005	NA	NA	NA	NA
2N2462	NA	NA	NA	NA	NA	NA	HEP-S0005	NA	NA	NA	NA
2N2463	NA	T-706	GE-27	NA	NA	PTC 123	HEP-S0005	NA	NA	NA	NA
2N2464	NA	NA	NA	NA	NA	PTC 123	HEP-S0005	NA	NA	NA	NA
2N2465	NA	NA	GE-54	NA	NA	NA	HEP-S0001	NA	NA	NA	NA
2N2466	RS276-2009	T-50	NA	ICC-50	NA	NA	HEP-50	SK 3122	RT-102	ECG 123A	ZEN 100
2N2467	RS276-2006	T-238	NA	ICC-238	NA	NA	HEP-238	NA	NA	NA	ZEN 129
2N2468	NA	T-251	GE-51	NA	TR-05	PTC 102	HEP-239	SK 3004	RT-120	ECG 102	NA
2N2469	NA	T-250	GE-2	NA	NA	PTC 102	NA	SK 3004	RT-120	ECG 102	NA
2N2472	NA	T-247	GE-20	NA	NA	PTC 144	HEP-714	NA	NA	NA	NA
2N2473	NA	T-247	GE-20	NA	NA	PTC 144	HEP-714	NA	NA	NA	NA
2N2474	NA	T-51	GE-21	NA	TR-30	PTC 131	NA	NA	NA	NA	NA
2N2475	RS276-2011	T-56	GE-61	ICC-56	NA	PTC 126	HEP-56	NA	NA	NA	ZEN 104
2N2476	RS276-2009	T-53	GE-18	ICC-53	IRTR-62	PTC 136	HEP-53	SK 3122	RT-102	ECG 123A	ZEN 102
2N2477	RS276-2009	T-53	GE-18	ICC-53	IRTR-62	PTC 136	HEP-53	SK 3122	RT-102	ECG 123A	ZEN 102
2N2478	NA	T-714	GE-18	NA	NA	NA	HEP-714	NA	NA	NA	NA
2N2479	NA	T-714	GE-18	NA	NA	PTC 144	HEP-S3011	NA	NA	NA	NA
282480*	NA	NA	NA	NA	NA	NA	HEP-S0005	NA	NA	NA	NA
2N2481	RS276-2009	T-50	GE-20	ICC-50	IRTR-21	PTC 136	HEP-50	SK 3122	RT-102	ECG 123A	ZEN 100

NA=NOT AVAILABLE

(turn page)



	ARCH	DM	G-E	ICC	IR	MAL	MOT	RCA	SPR	SYL	ZEN
2N2482	RS276-2002	T-641	GE-54	ICC-641	TR-08	PTC 108	HEP-641	SK 3010	RT-122	ECG 103	ZEN 315
2N2483	RS276-2009	T-50	GE-18	ICC-729	IRTR-51	PTC 121	HEP-729	SK 3122	RT-102	ECG 123A	ZEN 115
2N2484	RS276-2009	T-50	GE-63	ICC-S0007	IRTR-21	PTC 121	HEP-S0007	SK 3122	RT-102	ECG 123A	NA
2N2487	RS276-2003	T-3	GE-9	ICC-3	NA	PTC 107	HEP-3	SK 3006	NA	ECG 126	ZEN 301
2N2488	RS276-2003	T-3	GE-9	ICC-3	NA	PTC 107	HEP-3	SK 3006	NA	ECG 126	ZEN 301
2N2489	RS276-2003	T-3	GE-9	ICC-3	NA	PTC 107	HEP-3	SK 3006	NA	ECG 126	ZEN 301
2N2490	NA	T-233	GE-4	ICC-233	NA	PTC 106	HEP-233	SK 3012	NA	ECG 105	ZEN 327
2N2491	NA	T-233	GE-4	ICC-233	NA	PTC 106	HEP-233	SK 3012	NA	ECG 105	ZEN 327
2N2492	NA	T-233	GE-4	ICC-233	NA	PTC 106	HEP-233	SK 3012	NA	ECG 105	ZEN 327
2N2493	NA	T-233	GE-4	ICC-233	NA	PTC 106	HEP-233	SK 3012	NA	ECG 105	ZEN 327
2N2494	RS276-2003	T-3	GE-9	ICC-3	NA	PTC 135	HEP-3	SK 3006	NA	ECG 126	ZEN 301
2N2495	NA	T-2	GE-9	ICC-2	NA	PTC 107	HEP-2	SK 3006	NA	ECG 160	ZEN 300
2N2496	NA	T-2	GE-9	ICC-2	NA	PTC 107	HEP-2	SK 3006	NA	ECG 160	ZEN 300
2N2497	NA	NA	NA	NA	NA	NA	HEP-803	NA	NA	NA	NA
2N2498	NA	NA	NA	NA	NA	NA	HEP-803	NA	NA	NA	NA
2N2499	NA	NA	NA	NA	NA	NA	HEP-803	NA	NA	NA	NA
2N2500	NA	NA	NA	NA	NA	NA	HEP-803	NA	NA	NA	NA
2N2501	RS276-2009	T-50	GE-17	ICC-50	IRTR-21	PTC 121	HEP-50	SK 3122	RT-102	ECG 123A	ZEN 100
2N2509	NA	T-714	GE-18	NA	NA	PTC 125	HEP-S0005	SK 3045	RT-110	ECG 154	NA
2N2510	NA	T-53	GE-20	NA	NA	PTC 123	HEP-S0001	SK 3045	RT-110	ECG 154	NA
2N2511	NA	T-53	GE-20	NA	NA	NA	HEP-S0001	NA	NA	NA	NA
2N2512	NA	T-636	NA	NA	TR-17	PTC 107	NA	NA	NA	ECG 160	NA
2N2514	NA	T-714	GE-18	NA	TR-25	PTC 121	HEP-S3011	NA	NA	NA	NA
2N2515	NA	NA	NA	NA	NA	PTC 121	HEP-S3011	NA	NA	NA	NA
2N2516	NA	NA	NA	NA	NA	PTC 121	HEP-S3011	NA	NA	NA	NA
2N2517	NA	T-714	GE-18	NA	NA	PTC 125	HEP-714	NA	NA	NA	NA
2N2518	NA	NA	NA	NA	NA	NA	HEP-714	NA	NA	NA	NA
2N2519	NA	NA	NA	NA	NA	NA	HEP-714	NA	NA	NA	NA
2N2520	RS276-2009	T-53	GE-18	ICC-53	IRTR-25	PTC 121	HEP-53	SK 3122	RT-102	ECG 123A	ZEN 102
2N2521	RS276-2009	T-53	GE-63	ICC-53	IRTR-25	PTC 121	HEP-53	SK 3122	RT-102	ECG 123A	ZEN 102
2N2522	RS276-2009	T-53	GE-63	ICC-53	IRTR-25	PTC 121	HEP-53	SK 3122	RT-102	ECG 123A	ZEN 102
2N2523	RS276-2009	T-53	GE-18	ICC-53	IRTR-25	PTC 121	HEP-53	SK 3122	RT-102	ECG 123A	ZEN 102
2N2524	RS276-2009	T-53	GE-63	ICC-53	IRTR-25	PTC 121	HEP-53	SK 3122	RT-102	ECG 123A	ZEN 102
2N2525	NA	NA	NA	NA	NA	NA	HEP-714	NA	NA	NA	NA
2N2526	NA	T-627	NA	ICC-627	TR-27	PTC 122	HEP-627	NA	NA	ECG 127	NA
2N2527	NA	T-234	GE-25	ICC-234	TR-27	PTC 122	HEP-234	NA	NA	ECG 127	NA
2N2528	NA	T-644	GE-25	ICC-644	TR-27	PTC 122	HEP-644	NA	NA	ECG 127	NA
2N2529	RS276-2009	T-50	GE-61	ICC-50	IRTR-51	PTC 132	HEP-50	SK 3124	RT-102	ECG 123A	ZEN 100
2N2530	RS276-2009	T-50	GE-61	ICC-50	IRTR-51	PTC 132	HEP-50	SK 3124	RT-102	ECG 123A	ZEN 100
2N2531	RS276-2009	T-50	GE-61	ICC-50	IRTR-51	PTC 132	HEP-50	SK 3124	RT-102	ECG 123A	ZEN 100
2N2532	RS276-2009	T-50	GE-61	ICC-50	IRTR-51	PTC 132	HEP-50	SK 3124	RT-102	ECG 123A	ZEN 100
2N2533	RS276-2009	T-50	GE-61	ICC-50	IRTR-51	PTC 132	HEP-50	SK 3124	RT-102	ECG 123A	ZEN 100
2N2534	RS276-2009	T-50	GE-61	ICC-50	IRTR-51	PTC 132	HEP-50	SK 3124	RT-102	ECG 123A	ZEN 100
2N2537	NA	T-714	GE-18	NA	IRTR-25	NA	HEP-S3001	NA	NA	NA	NA
2N2538	NA	T-714	GE-18	NA	IRTR-25	NA	HEP-S3001	NA	NA	NA	NA
2N2539	RS276-2009	T-50	GE-20	ICC-50	IRTR-51	PTC 136	HEP-50	SK 3122	RT-102	ECG 123A	ZEN 100
2N2540	RS276-2009	T-50	GE-20	ICC-50	IRTR-51	PTC 136	HEP-50	SK 3122	RT-102	ECG 123A	ZEN 100
2N2541	NA	T-255	GE-53	NA	NA	NA	HEP-238	NA	RT-127	ECG 176	NA
2N2551	NA	T-706	GE-27	NA	IRTR-78	PTC 117	NA	NA	NA	NA	NA
2N2564	RS276-2006	T-238	GE-3	ICC-238	NA	PTC 102	HEP-238	SK 3004	RT-120	ECG 102	ZEN 329
2N2565	RS276-2006	T-238	GE-3	ICC-238	TR-05	PTC 102	HEP-238	SK 3004	RT-120	ECG 102	ZEN 329
2N2566	NA	T-239	NA	ICC-239	NA	NA	HEP-239	NA	NA	NA	NA
2N2567	NA	T-239	NA	ICC-239	NA	NA	HEP-239	NA	NA	NA	NA
2N2569	RS276-2009	T-50	GE-62	ICC-50	IRTR-21	PTC 121	HEP-50	SK 3122	RT-102	ECG 123A	ZEN 100
2N2570	RS276-2009	T-50	GE-62	ICC-50	IRTR-21	PTC 121	HEP-50	SK 3122	RT-102	ECG 123A	ZEN 100
2N2571	RS276-2009	T-50	GE-20	ICC-50	IRTR-51	PTC 133	HEP-50	SK 3122	RT-102	ECG 123A	ZEN 100
2N2572	RS276-2009	T-50	GE-20	ICC-50	IRTR-51	PTC 133	HEP-50	SK 3122	RT-102	ECG 123A	ZEN 100
2N2586	RS276-2009	T-50	GE-17	ICC-50	IRTR-21	PTC 133	HEP-50	SK 3122	RT-102	ECG 123A	ZEN 100
2N2587	RS276-2003	T-3	GE-51	ICC-3	TR-17	PTC 107	HEP-3	NA	NA	ECG 160	ZEN 301
2N2588	NA	T-2	GE-1	NA	TR-12	PTC 109	HEP-638	NA	NA	ECG 126	NA
2N2590	NA	T-51	GE-21	NA	TR-88	PTC 127	HEP-S0005	NA	NA	NA	NA
2N2591	NA	T-51	GE-21	NA	TR-88	PTC 127	HEP-S0005	NA	NA	NA	NA
2N2592	NA	T-51	GE-21	NA	TR-88	PTC 127	HEP-S0005	NA	NA	NA	NA
2N2593	NA	T-51	GE-21	NA	NA	PTC 127	HEP-S0005	NA	NA	NA	NA
2N2594	NA	T-706	GE-27	NA	IRTR-78	PTC 144	HEP-S3011	SK 3024	NA	NA	NA
2N2595	RS276-2023	T-52	GE-21	ICC-52	TR-88	PTC 103	HEP-52	SK 3114	RT-115	ECG 159	NA
2N2596	RS276-2023	T-52	GE-21	ICC-52	TR-88	PTC 103	HEP-52	SK 3114	RT-115	ECG 159	NA
2N2597	RS276-2023	T-52	GE-21	ICC-52	TR-88	PTC 103	HEP-52	SK 3114	RT-115	ECG 159	NA
2N2598	NA	T-708	GE-21	NA	NA	PTC 127	NA	SK 3114	RT-115	ECG 159	NA
2N2599	NA	T-708	GE-21	NA	NA	PTC 127	NA	SK 3114	RT-115	ECG 159	NA

\* Indicates a dual transistor for high-speed switching, diff amplifier etc. Likely to be a matched pair. Use two of the type specified, matching when necessary, on a curve tracer or lab-type transistor checker.

NA=NOT AVAILABLE

(continued next month)





Wm. D.  
*Electric*

NORRISTOWN

Electric HEATING CONTRACTOR  
FLAMELESS  
ELECTRIC HEAT

CALL US FOR  
AND AN

WORTHMAN

# "Learn an honest trade," my old man used to say, "and you'll never have to knuckle under to any man."

(A TRUE STORY)

Bill De Medio of Conshohocken, Pa., has it made.

At 23, he's a licensed master electrician. The top of a trade where there aren't enough good men to go around.

But more important, Bill's his own boss and calls his own shots.

"I just went into my own business. And even before the sign on my truck was dry, I got my first big job.

"The contractor for a new group of houses asked me to do all the wiring. And there's bound to be a lot more work from him and other builders.

"If it wasn't for my ICS training as an electrician, I'd still be in some dead-end job—hating what I was doing, taking orders from everyone, and never getting any thanks for it.

"As a master electrician, you're the boss on the job—even when you're working for someone. You get respect, good money, and like my old man said, you don't have to take baloney from anyone."

## The right combination for success

Bill De Medio has the right combination for success. He's in a growing field. And he has good training for it. You could, too.

Especially if you're interested in one of the fast-growing careers where ICS concentrates its training. Like Electrician. Engineering. Automotive Mechanic. TV Repair & Servicing. Drafting. Air Conditioning. (Check your choice on attached card.)

## Ideal way to learn

As an ICS student, you study at home, on your own schedule. You waste no time traveling to and from class. And you never have to miss a paycheck.

*At 23, Bill De Medio has more freedom, more security, and gets more respect than guys twice his age. (Photograph by Frank Cowan.)*

But you're never alone. Skilled instructors are always ready to help you.

If you ever have doubts or problems or just want to talk to your instructor, you can call ICS from anywhere, Toll-free.

## ICS training works

More than 8,500,000 men and women have turned to ICS for career training in the past 80 years.

Government agencies, unions and some of America's top corporations (including Ford, U.S. Steel, Mobil, Alcoa, Pan Am, GE, Motorola and RCA) use ICS courses in their own training programs.

## Free demonstration lesson

If you want your job to give you more, (more money, more day-to-day satisfaction, and more future) send for our career guide booklets and free demonstration lesson.

Remember, it's your life. You might as well make the most of it. © 1973 ICS

## ICS

*We'll show you a better way to earn a living.*

**ICS** International Correspondence Schools  
Scranton, Pennsylvania 18515

Please send me the Free Career Guidance Booklets and Free Demonstration Lesson for the field I have checked below. I understand I am under no obligation

- |   |  |
|---|--|
| <input type="checkbox"/> Electrician                                | <input type="checkbox"/> Air Conditioning        |
| <input type="checkbox"/> Airline-Travel Training                    | <input type="checkbox"/> Refrigeration & Heating |
| <input type="checkbox"/> Computer Programming                       | <input type="checkbox"/> Engineering             |
| <input type="checkbox"/> Accounting                                 | <input type="checkbox"/> TV Servicing            |
| <input type="checkbox"/> Motel/Hotel Management                     | <input type="checkbox"/> Electronics             |
| <input type="checkbox"/> Business Management                        | <input type="checkbox"/> Automotive              |
| <input type="checkbox"/> Business Management                        | <input type="checkbox"/> Drafting                |
| <input type="checkbox"/> Business Management                        | <input type="checkbox"/> Architecture            |
| <input type="checkbox"/> Business Management                        | <input type="checkbox"/> High School             |
| <input type="checkbox"/> Check for special booklet, if 16 or under. |  |

XA665Q

Name \_\_\_\_\_ Age \_\_\_\_\_

Address \_\_\_\_\_

City \_\_\_\_\_

State \_\_\_\_\_ Zip \_\_\_\_\_

APPROVED FOR EMPLOYMENT TRAINING APPROVED FOR FEDERAL EMPLOYMENT AND ACCREDITED BY NATIONAL HOME STUDY COUNCIL

(If card is missing, please fill in the coupon and mail it to: ICS, Scranton, Pennsylvania 18515.)



**SERVICE CLINIC**

(continued on page 65)

which we'll get to in a minute).

The only difference between this and an audio amplifier is the signal input. Instead of rock music, we are dealing with a sawtooth signal, developed by an oscillator. The phase inversion needed for push-pull output is handled in a differential-pair stage, and a driver.

Some circuits use a buffer amplifier between the oscillator stage and the diff-amp stage. The output circuit here is a true complementary-symmetry

type, with opposite polarity voltage supplies for the npn and pnp output transistors. So the big capacitor used in single-ended audio circuits like this isn't needed. The yoke returns to ground, usually through the pincushion corrector and a feedback network.

In the GE circuits, this feedback goes to the differential-amplifier stages, and is used to correct for any distortion in the output. A perfect sawtooth is developed, and there goes another old familiar component—the vertical linearity control. It isn't needed in this kind of circuit (and it won't be missed). Figure 2 shows the complete circuit, as used in

the GE JA chassis.

Along with the new circuitry, you will see some "different" symptoms, as compared to our old "stock" vertical symptoms. For example, if you get a set with a nice linear picture, but only on the top half of the raster, or on the bottom half of the rasters, what would you say? The picture isn't compressed; half of it's not there!

This is a real dandy and it can lead us straight to the trouble. (And we love them, don't we?) In Fig. 2, if the top half of the picture is missing, Q268 is open. If the bottom half is gone, Q267 is open. Egg in your beer?

The VERTICAL CENTERING control voltage is fed to the differential-amplifier stage. So if the picture will not center properly, go straight to this stage, and make sure that it will "balance": both transistors good, etc. There is another handy trick you can use, on certain chassis. (These are the ones where the vertical output transistors are not on the vertical module itself, but on the chassis.) If you have the old familiar symptom of "Thin horizontal line—no vertical sweep", try moving the VERTICAL CENTERING control. If the line moves up and down about the right amount, the vertical output transistors are good. Go and look in the vertical oscillator stage for the cause of the trouble (and thanks to GE's GENial



FREE



The World's Largest  
Consumer Electronics Catalog

The world's Foremost consumer electronics catalog is yours for the asking! Over 25,000 items . . . jam-packed with illustrations and descriptions of the very latest in Hi-Fi, CB, Tape recorders, Radios, Television, Electronic Parts, Technical Publications.

Everything in Electronics For Home, Business,  
Industry PLUS The Latest in 4-Channel Stereo!

LAFAYETTE 1974 CATALOG 740

Our 53rd Year
Stores From Coast-to-Coast

MAIL  
THE  
COUPON  
TODAY

LAFAYETTE RADIO ELECTRONICS

P.O. Box 10, Dept. 17103  
Syosset, L.I., N.Y. 11791

Send For Your Free Lafayette Catalog Today!

Send me the FREE LAFAYETTE Catalog 17 014

Name \_\_\_\_\_

Address \_\_\_\_\_

City \_\_\_\_\_ State \_\_\_\_\_ Zip \_\_\_\_\_

Circle 14 on reader service card

## ELECTRONIC TECHNICIANS!

Raise your professional standing  
and prepare for promotion! Win  
your diploma in

### ENGINEERING MATHEMATICS

from the Indiana Home  
Study Institute

We are proud to announce two great  
new courses in Engineering Mathematics  
for the electronic industry.

These unusual courses are the result of  
many years of study and thought by the  
President of Indiana Home Study, who  
has personally lectured in the classroom  
to thousands of men, from all walks of  
life, on mathematics, and electrical and  
electronic engineering.

You will have to see the lessons to appreciate them!  
NOW you can master engineering  
mathematics and actually enjoy doing it!

**WE ARE THIS SURE:** you sign no  
contracts—you order your lessons on a  
money-back guarantee.

In plain language, if you aren't satisfied  
you don't pay, and there are no  
strings attached.

Write today for more information and  
your outline of courses.

You have nothing to lose, and every-  
thing to gain!

### The INDIANA HOME STUDY INSTITUTE

Dept. RE-1, P.O. Box 1189, Panama City, Fla.  
32401

Circle 15 on reader service card

Gentleman from Memphis: John Stoll, for that one!)

In the JA chassis circuit shown in Fig. 2, observe the novel method of supplying power to the vertical output transistors, driver and diff-amps. Note the arrows saying "To Pin-7 HVT", "Pin 6 HVT" and "Pin 9 HVT" (High Voltage Transformer). These go to a winding on the flyback, which supplies 60V p-p pulses, of opposite polarities, to rectifier diodes Y268 and Y270. Pin 6 is the center tap on the winding. The rectified pulses are filtered by the two big capacitors and provide the dc power needed for the vertical output stage. This has one benefit: if the horizontal output stage fails, you do not have the very bright, thin horizontal line, which might burn the screen of the picture tube. When the high voltage goes out, the vertical sweep goes with it.

In the next version of this chassis, the later MA, the dc voltage for the vertical output comes from the low-voltage power supply. A +13 V supply feeds the npn transistor, and a -34 V supply feeds the pnp. A +130V supply feeds the vertical buffer transistor, through the SIZE control (and SERVICE SWITCH), and a +23V supply feeds the oscillator.

For a final "new symptom", in the JA chassis, if you see no video and no raster, and the fuse, F405, is open, check the vertical output transistors.

# END OF THE REPLACEMENT TRANSISTOR NIGHTMARE

**just 47 transistors replace over 22,500 O.E.M. part numbers.**

Finding the right replacement transistor has been a real toughie for most service technicians. Over 22,500 existing part numbers have made life difficult. Now, they can be replaced with just 24 small-signal, 18 power, and 5 field effect transistors. You can get any or all of the 'Fantastic 47' on the self-service Semiconductor Q-Mart at your Sprague distributor's. While you're there, pick up a free copy of the 48-page K-500 Semiconductor Replacement Manual. Or . . . write to Sprague Products Co., 81 Marshall St., North Adams, Mass. 01247.

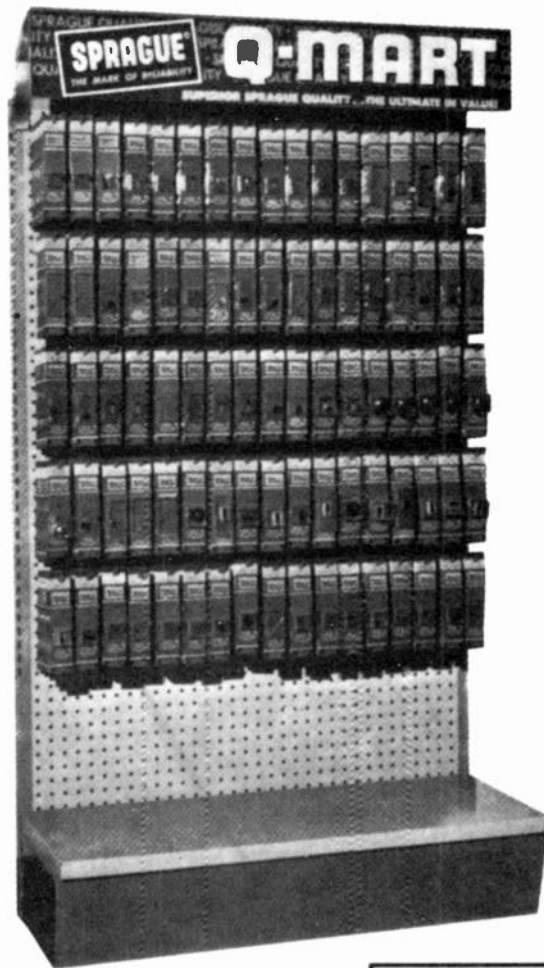

**FREE** catalog

over **1000** unique tools, handy kits, precision instruments, technical supplies.

Our 21<sup>st</sup> year of service to the World's finest craftsmen and technicians.

**National Camera**  
2000 West Union Ave. Dept. G88  
Englewood, Colorado, 80110

Send a FREE copy of the ne Flasher

name \_\_\_\_\_

address \_\_\_\_\_

city \_\_\_\_\_

state \_\_\_\_\_ zip \_\_\_\_\_

**National Camera**  
2000 West Union Ave. Dept. G88  
Englewood, Colorado, 80110

Circle 16 on reader service card



THE BROAD-LINE PRODUCER OF ELECTRONIC PARTS

Circle 17 on reader service card

raster, and the fuse, F405, is open, check the vertical output transistors; both of them may be shorted.

## reader questions

### 6BK4 PLATE GLOWING RED

*The 6BK4 high-voltage regulator plate glows red, in this RCA CTC-25, at all settings of the horizontal efficiency coil. Cathode current of the 6JE6 is about 220 to 240 mA. 6BK4's have short life, too. - L.B. Marysvale, Utah.*

I've seen some that would "show color" if the TV scene went dark. (Regulator taking all the current). However, I don't like to run them with red-hot plates at all times.

This naturally means that the 6BK4 is drawing too much current. "Too much" in this tube means more than 1.5 mA. Check the 6BK4 cathode current, and adjust the control so that you do not draw more than 1.0mA, with the screen dark. At average brightness, you should draw something like 0.2 mA, or 0.2V across the 1K 6BK4 cathode resistor. This will put the dissipation of this tube in the ballpark. If it won't, check the grid resistors!

### PLYMOUTH RADIO

*This Plymouth 9BBCC radio will only play on strong local stations. When I opened it up, I found that someone had connected a .001-µF capacitor from the antenna trimmer to the emitter of the rf amplifier. This capacitor should go to one of the tuner coils; when I put it back there, nothing. What's going on? - J.S. Decaturville, Tenn.*

Nothing is "what's going on." As far as rf gain is concerned, anyhow. You'll probably find that the rf coil is open, and that someone found out that he could shunt the signal around it, to the rf stage. This practically kills all gain in the rf stage, of course. Replace the coil, and realign.

### INTERMITTENT STEREO

*I'm an old tube-type technician, and I do get lost in some of the new jobs. Take this Sherwood S-7100A. While it's cold, it will play in the stereo mode, then it will switch back to mono. Plays fine, but not stereo. Need advice. - E.S. Vancouver B.C.*

If you do not lose the signal, but only the stereo effect, this is a loss of pilot carrier. Signal-trace this through the MPX decoder circuit, frequency doubler, and so on. You'll find a "thermal" part somewhere along the way. Your scope will show this up very easily.

### STATEMENT OF OWNERSHIP, MANAGEMENT AND CIRCULATION (Act of August 12, 1970; Section 3685, Title 39, United States Code)

- Title of publication: RADIO-ELECTRONICS
- Date of filing: October 5, 1973
- Frequency of Issue: Monthly
- Location of known office of publications: 200 Park Avenue South, New York, New York 10003
- Location of the headquarters of general business offices of the publisher: Ferry Street, Concord, Merrimack County, New Hampshire 03301
- Names and addresses of publisher, editor and managing editor: Publisher and Editor-In-Chief, M. Harvey Gernsback, 200 Park Ave. South, New York, N.Y. 10003; Editor, Larry Steckler, 200 Park Avenue South, New York, N.Y. 10003
- Owner: Gernsback Publications, Inc., 200 Park Avenue South, New York, New York 10003; M. Harvey Gernsback, 200 Park Avenue South, New York, New York 10003; Mary H. Gernsback, M. Harvey Gernsback, Benjamin I. Winston as trustees under trust agreement dated September 30, 1965 c/o Benjamin F. Winston, Esquire, 2W 46th Street, New York, N.Y., 10036
- Names and addresses of publisher, editor and managing editor: Publisher and Editor-In-Chief, M. Harvey Gernsback, 200 Park Ave. South, New York, N.Y. 10003; Editor, Larry Steckler, 200 Park Avenue South, New York, N.Y. 10003
- Owner: Gernsback Publications, Inc., 200 Park Avenue South, New York, New York 10003; M. Harvey Gernsback, 200 Park Avenue South, New York, New York 10003; Mary H. Gernsback, M. Harvey Gernsback, Benjamin I. Winston as trustees under trust agreement dated September 30, 1965 c/o Benjamin F. Winston, Esquire, 2W 46th Street, New York, N.Y., 10036
- Names and addresses of publisher, editor and managing editor: Publisher and Editor-In-Chief, M. Harvey Gernsback, 200 Park Ave. South, New York, N.Y. 10003; Editor, Larry Steckler, 200 Park Avenue South, New York, N.Y. 10003
- For optional completion by publishers mailing at the regular rates (section 132.121 Postal Service Manual, in accordance with provisions of U.S.C. 3626, I hereby request permission to mail the publication named in item 1 at the reduced postage rates presently authorized by 39 U.S.C. 3626 (signed) H. T. Matysko, Circulation Manager.
- For completion by nonprofit organizations authorized to mail at special rates: Does not apply in this case.
- Extent and nature of circulation: Average number of copies each issue during preceding 12 months: (A) Total No. of copies printed (net press run) 209,438; (B) Paid circulation: (1) Sales through dealers and carriers, street vendors and counter sales 51,089; (2) Mail subscriptions: 108,966; (C) Total Paid circulation 160,055; (D) Free distribution by mail, carrier or other means: (1) Samples, complimentary, and other free copies, 1,136; (2) copies distributed to news agents, but not sold 45,926; (E) Total distribution 207,117; (F) Office use, left over, unaccounted, spoiled after printing 2,321; (G) Total 209,438. Actual number of copies of single issue published nearest filing date: (A) Total No. of copies printed (net press run) 211,833; (B) Paid Circulation: (1) Sales through dealers and carriers, street vendors and counter sales 53,641; (2) Mail subscriptions 112,919; (C) Total Paid circulation 167,560; (D) Free distribution by mail, carrier or other means: (1) Samples, complimentary, and other free copies, 1,115; (2) Copies distributed to news agents, but not sold 42,567; (E) Total distribution 211,242; (F) Office use, left over, unaccounted, spoiled after printing 591; (G) Total 211,833.

I certify that the statements made by me above are correct and complete.  
(Signed) H. T. Matysko, Circulation Manager

# INTERNATIONAL Frequency meter FM-2400CH

- Tests Predetermined Frequencies 25 to 1000 MHz
- Extended Range Covers 950 MHz Band
- Pin Diode Attenuator for Full Range Coverage as Signal Generator
- Measures FM Deviation

The FM-2400CH provides an accurate frequency standard for testing and adjustment of mobile transmitters and receivers at predetermined frequencies.

The FM-2400CH with its extended range covers 25 to 1000 MHz. The frequencies can be those of the radio frequency channels of operation and/or the intermediate frequencies of the receiver between 5 MHz and 40 MHz.

Frequency Stability:  $\pm .0005\%$  from  $+50^\circ$  to  $+104^\circ\text{F}$ .

Frequency stability with built-in thermometer and temperature corrected charts:  $\pm .00025\%$  from  $+25^\circ$  to  $+125^\circ$  (.000125% special 450 MHz crystals available).

Self-contained in small portable case. Complete solid state circuitry. Rechargeable batteries.

**WRITE FOR CATALOG!**

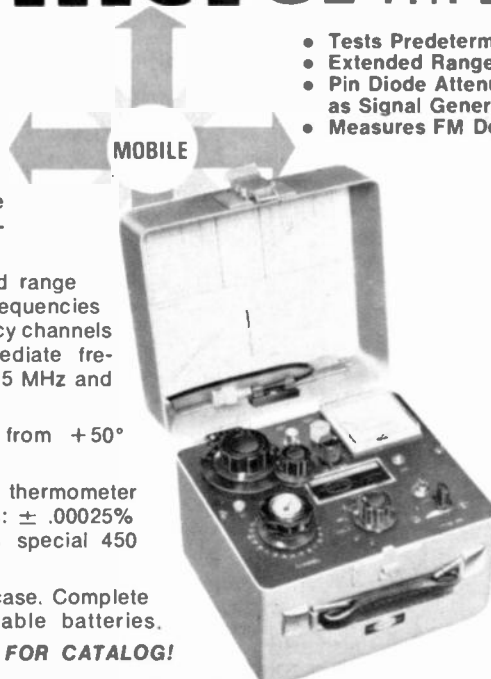

FM-2400CH  
(meter only).....\$595.00  
RF crystals (with temperature correction)..... 24.00 ea.  
RF crystals (less temperature correction)..... 18.00 ea.  
IF crystals.....catalog price

**INTERNATIONAL**  
CRYSTAL MFG. CO., INC.  
10 NO LEE • OKLA CITY OKLA 73102

**BLUE BOW**

This CTV6F Motorola Quasar chassis has an odd convergence problem. Everything else seems OK, but the blue horizontal lines won't straighten out; they stay bowed upward at the ends. Checked coils and controls, which all seem to be working. Could this be something in the convergence yoke? J.S. Lubbock Tex.

This sounds as if you don't have enough control of your blue vertical tilt. This circuit makes the blue horizontal lines bow up at the ends. There is a hint on this in the manual. Note the tap on the convergence board with the blue and brown wires. Reverse these jumpers to get greater range on the blue vertical amplitude and blue vertical tilt.

Before you do anything too drastic, demagnetize the whole thing very thoroughly. I've seen this affect 'em.

**SYNC "DROP-OUT"**

They brought us a Motorola TS-597 chassis that had been dropped by movers. We replaced a couple of tubes, straightened up some more, and got pix and sound. Now all we need is some horizontal sync. The picture will barely hold, but if you move the core of the stabilizer coil even a tiny bit, out goes the sync. Very odd. - H.B., Hopewell, Va.

This has a very familiar sound! "Deductions"—If the picture will hold at all, the chances are your hold coil.

# START THE NEW YEAR WITH A GREAT BARGAIN!

GET THESE TWO TV TECH AID BOOKS AT REDUCED PRICES:

1971 B&W BOOK — NOW \$3.95  
1970-BOOK FORM — NOW \$3.95

TV TECH AID BOOKS ARE FILLED WITH THE LATEST QUICK-SERVICING INFO ON COLOR TV, B&W TV, AND STEREO

TV Tech Aid Takes you right to the source of the trouble without guess work and wasted time. In each monthly issue you receive over 40 actual causes and cures of color and B&W TV trouble symptoms. You also receive timely and complete information about circuit modifications and other valuable service data.

USE THE COUPON BELOW TO PLACE YOUR 1974 SUBSCRIPTION (12 ISSUES \$7.95) OR VALUABLE BACK ISSUES

SEND YOUR CHECK OR MONEY ORDER TO:

- 1969 12 Issues \$3.95
- 1970-Book Form \$3.95
- 1971 B&W Book \$3.95
- 1971 12 Issues \$4.95
- 1972 12 Issues \$5.95
- 1973 12 Issues \$7.95
- 1974 series 12 Issues \$7.95

## TV TECH AID

P. O. Box 603  
Kings Park  
N.Y. 11754

Name.....  
Address.....  
City.....  
State.....Zip.....

Circle 20 on reader service card

Everything you wanted to know about CD Ignition Systems but didn't know whom to ask.

Send for FREE Tiger booklet (20 pages) which answers all your questions.

Name.....  
Address.....  
City.....  
State..... Zip.....

CLIP OUT THIS AD AND SEND TO—

TRI-STAR CORP.  
P. O. Box 1727 Dept. H  
Grand Junction, Colo. 81501

Circle 19 on reader service card

## Assemble this digital clock and calendar in just one evening...get continuous readout of hour, minute and second, plus month and day.

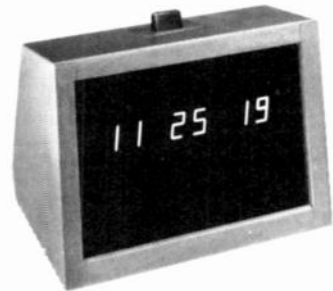

This new Digital Concepts electronic digital clock and calendar indicates the hours, minutes and seconds or the month and the day... or alternates between time and date at 10 second intervals. Glowing orange digital readout (a continuous character .55 inch high) is visible from almost any viewing angle, no matter how light or dark the room.

Operation is totally silent, with accuracy to within seconds a month, life expectancy is an incredible 100,000 hours

**CHOICE OF DISPLAY MODES**

You can decide to display time only, date only, or a continuous 10-second cycle in which time alternates with date. You can operate on a 12 hour or 24-hour international time sequence. And you can change all display modes instantly — any time you wish — by flicking simple controls

**BEAUTIFUL, AND BEAUTIFULLY EASY TO ASSEMBLE**

The contemporary hand rubbed oiled walnut cabinet is ideal for home, office or place of business. And a very memorable gift. All components of the kit mount on two interlocking printed circuit boards, for easy assembly in one evening, using only a soldering iron and a pair of diagonal cutters. The only wire in the kit is the line cord. Accuracy is assured by one MOS/LSI integrated circuit "chip" and top quality electronic components throughout.

The Digital clock and calendar is also available factory assembled

**ORDER NOW FOR IMMEDIATE DELIVERY**

Send this coupon with your check or money order for fast delivery anywhere in the world. Money back guarantee if not fully satisfied

### digital concepts

249 Route 46, Saddle Brook, New Jersey 07662

Enclosed please find my check or money order for \$ \_\_\_\_\_ or charge my Mastercharge account number \_\_\_\_\_ expiration date \_\_\_\_\_ to cover the following order

- \_\_\_\_\_ kit(s) of electronics only Model CK-100 @ \$68.00 each
- \_\_\_\_\_ cabinet(s), with face and mounting hardware Model C-31 @ \$18.00 each
- \_\_\_\_\_ factory assembled calendar / clock(s) Model EC-102 @ \$108.00 each

Add \$3.00 to cover costs of postage and handling

Name.....  
Address.....  
City.....  
State..... Zip.....

Circle 21 on reader service card



# EV•GAME makes replacing cartridges a snap.

We offer virtually all originals or exact replacements. No one else comes close.

Here's an example of what that means to you:



UNRETOUCHED PHOTO

## THE ORIGINAL

### ZENITH 142-163

Typical of cartridges you replace every day. A quality 2G floating cartridge.



UNRETOUCHED PHOTO

## THE EXACT REPLACEMENT

### EV5371D

A perfect match to the original in shape, size, color, needle and especially the 2G quality. Installation takes seconds in old bracket. No need to explain any differences, there aren't any.



UNRETOUCHED PHOTO

## THE SUBSTITUTE ASTATIC 605

Totally different in appearance; something a Zenith owner will immediately notice. Takes considerable time to install. Requires modification of tone arm by covering up hole with a paper decal where original needle shaft was. Will not accept original needle.



Tools you may need for a substitute

Needle for needle, cartridge for cartridge and pin for pin, you can't beat an Electro-Voice. The fact is, when you specify Electro-Voice you save time and effort and you don't have to make embarrassing excuses for a cartridge that doesn't look or work like the original. You don't need special tools or parts. There's no unusual handling or installation. The result is that you have the best chance to maximize cartridge profits and customer satisfaction with EV • Game.

So see your local distributor for Electro-Voice replacement cartridges. Also ask him for the new EV • Game catalog. It's the most comprehensive and easiest-to-use. Simplifies selection of nearly 700 cartridges. And write to us for our revealing Replacement Cartridge Comparison Chart. Learn more about how we make it a snap for you to replace cartridges. EV • Game, Inc., Box 711, Freeport, N.Y. 11520.

# EV•GAME inc.

DIVISION OF ELECTRO-VOICE INC. • A **Gulton** COMPANY

In Canada: E-V of Canada, Ltd., Gananoque, Ontario

## READER QUESTIONS

(continued from page 72)

afc diodes, etc. are OK. However, the reactions you're getting are those of a complete loss of the horizontal sync to the afc stage.

Under the circumstances, I'd start at the plate of the sync separator and check for correct amplitude horizontal sync at that point. Now, follow this through the PC board to the afc unit. You'll probably find a hairline crack, keeping it from getting to the diodes.

## BUZZ ON "OVERLAY"

*I have a problem I can't get rid of. In many of the sets I service, the owners complain of a buzz in the sound, whenever white letters or numbers are superimposed on the screen, over a picture. What can I do about this? - R.H., Cleveland Ohio.*

That's right! You can't get rid of it. Not in the TV sets themselves, that is. It's not in them. It is something in either the network, "overlay unit" or audio of the TV transmitter. I have seen and heard this on both local and network programs.

A properly-operated overlay unit will *not* produce this buzz. The cause is probably something like a slight over-modulation, which punches holes in the audio signal, making a buzz.

## TOOL KITS

### FIELD ENGINEER TOOL KIT JTK-17

Includes more than 100 tools!



Write for brochure

More than 100 fine tools used for servicing in the field. Used on communications equipment, business machines, computers, all kinds of electronic systems. All tools and VOM tester are furnished in deluxe attache' case.

### FIELD ENGINEER ATTACHE CASES



Five styles available

Pockets for 60 tools. Solid wood frame. Scuff-proof Mar-velon cover, all brass hardware. Compartments in base for spare parts and a test meter. Dimensions: 18 x 13 x 4-1/2". Write for catalog.

### Free Catalog

#### ELECTRONIC ASSEMBLY TOOLS

Lists more than 1700 items—pliers, tweezers, wire strippers, vacuum systems, relay tools, optical equipment, tool kits and cases.

**JENSEN TOOLS and ALLOYS**  
4117 N. 44TH STREET, PHOENIX, ARIZONA 85018

**APPLIANCE CLINIC**

*(continued from page 14)*

high voltage in the secondary fires the spark plug (8).

There's some very clever engineering here! Due to the special design of the flywheel magnets and core laminations, this system has an automatic spark-retard. This makes it easier to start (anyone who has ever cranked a Model T Ford with the spark *advanced* knows why!) An automatic retard of about 9° is achieved by this design. After the engine has caught, and run up to speed, anywhere from 800 rpm on up, the system automatically advances the spark by about 29°, which makes the engine run much better.

A "kill-switch" grounds the CD system, to stop the engine. This is connected through the ignition switch. This switch is used, even on hand-cranked models, for safety. It must be turned on before you can start the engine.

Troubleshooting these systems is very simple. They're purely Aristotelian: they work, or they don't! To test the system, take out the spark plug (and check it or clean it, or replace it; plugs cause most of the trouble in all small engines!). Clip the spark-plug lead to it again, and ground the shell, preferably with a dual clip lead, to the engine. Turn the ignition switch on, and crank the engine. You should get a hot, fat blue spark across the plug's electrodes. If you don't, pull the kill-switch lead, and make sure it isn't grounded. (It has a push-on connector on the ignition switch.) If you still get no spark, the CD unit could be bad

Replacement is simple: only two screws hold it after you take off the air baffle, which has only three screws.

If the module must be replaced, you'll have to use a special non-metallic gauge to get it spaced properly with respect to the flywheel. Without this, the flywheel magnets will pull the laminations against the outside of the flywheel. Clearance at one end is .010 inch, and about 1/4 inch at the other. This odd spacing is the key to proper operation of the solid-state system.

Caution: if the engine has been running, don't mess around the spark plug for at least 10 seconds! Just allow the CD pack charge to leak off. **R-E**

DIGITAL THEORY, DESIGN, CONSTRUCTION

**LOGIC NEWSLETTER** ©

SAMPLE COPY \$1.00  
LOGIC NEWSLETTER  
POB 252  
WALDWICK, N.J. 07463

**DISCOUNT TEST EQUIPMENT SPECIALISTS**

**B&K**

**EICO**®

**SENCORE**

**Leader**

COMPLETE LINE OF ELECTRONIC SUPPLIES  
ICC/Mullard & Raytheon Tubes  
Telematic Test Rigs  
TV Tuner Subber

**FREE CATALOG**

**FORDHAM**

Radio Supply Co., Inc.  
558 Morris Ave., Bronx, N.Y. 10451  
Tel: (212) 585-0330

Circle 24 on reader service card

**you'll have a ball WITH THIS PERMA-POWER BRITENER SPECIAL!**



some packages contain basketballs... buy both!

You're really on the ball if you buy Perma-Power Color-Brites NOW during this special promotion. The kids on your gift list will enjoy the miniature football or basketball that comes free with 4 Perma-Power Color-Brites (1 Model C-501 for round tubes, 3 Model C-511 for rectangular tubes.) You'll enjoy the special savings... as well as the appreciation from your customers when you brighten their color TV picture and thus extend its useful life.

Hurry Please... This is a limited time offer. Call Your Distributor Now.

**Perma Power**®

845 Larch Avenue  
Elmhurst, Illinois 60126  
(312) 279-3600  
Division of Chamberlain Manufacturing Corporation

Circle 25 on reader service card

# Plug in...wire...modify...build...test

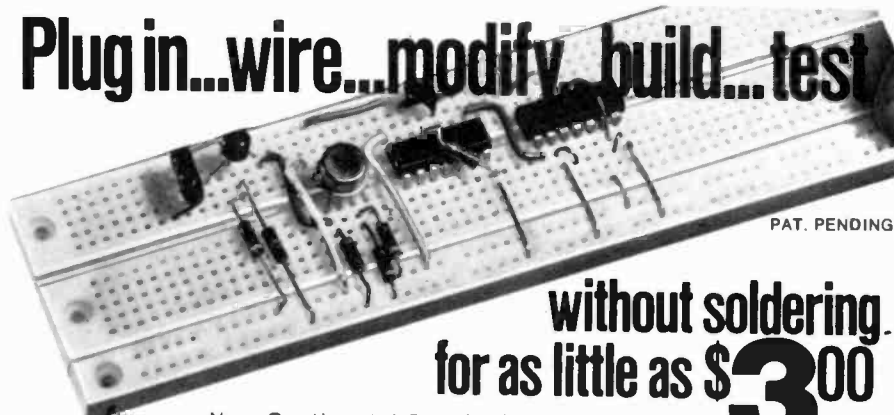

without soldering.  
for as little as \$300

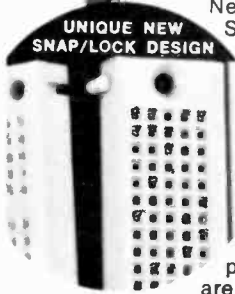

New Continental Specialties QT SOCKETS® and BUS STRIPS offer expanded, flexible breadboarding without shorts or burnt fingers. Simply SNAP/LOCK together as many QTs as you need and you can test ICs, transistors, resistors, capacitors and more. Just plug-in, connect with solid #22 AWG hook-up wire — no soldering or patch cords needed! And QTs are totally reusable. 10 different sizes. Prices from \$3 for QT Sockets ... from \$2 for Bus Strips.

Write or phone today for **FREE Selection Guide**, with applications, photos, drawings, specs, socket sizes and ordering information.



Continental Specialties Corporation  
325 East St., New Haven, CT 06509, 203/624-1811

Circle 26 on reader service card

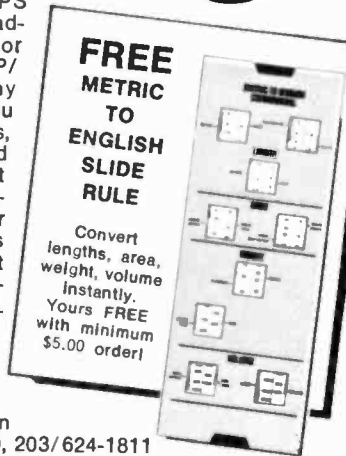

**FREE METRIC TO ENGLISH SLIDE RULE**

Convert lengths, area, weight, volume instantly. Yours **FREE** with minimum \$5.00 order!

STEP-BY-STEP  
(continued from page 62)

hard, dropping the gate voltage of starter Q602 to zero, shutting it firmly off.

With the horizontal oscillator operating, terminal 17 of the power supply board receives the IC oscillator output and routes it through C618, L605 and D609 to the base of pulse-width modulator Q606. This amplifier feeds its output back to the base of pulse-width modulator (P.W.M.) No. 2 through C614. There is another phase inversion and the resulting voltage from the collector of Q607 now passes through parallel R-C self-bias R623 and C613 to the base of current pre-driver Q605 and then on to the rest of current amplifier-chopper Q604. The 50V p-p pulse output swing at this point passes through transformer T603 R619 and L604 to the gate of GCS Q603, the large, heatsunk, regulator output. Smoothing choke L601 and filter capacitors C621, C623 do the rest.

Now, resistive dividers R603 and R604 supply a calculated 11.4 V to the top of R634 and then to the base and emitter of Q608, Q609, respectively. These are the EVP detector and error amplifiers which also receive an addi-

## Now...the most enjoyable do-it-yourself project of your life—A Schober Electronic Organ!

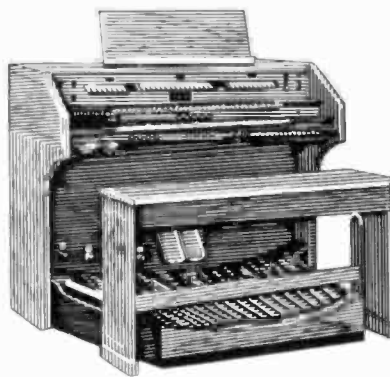

You'll never reap greater reward, more fun and proud accomplishment, more benefit for the whole family, than by assembling your own Schober Electronic Organ.

You need no knowledge of electronics, woodwork or music. Schober's complete kits and crystal-clear instructions show you — whoever you are, whatever your skill (or lack of it) — how to turn the hundreds of quality parts into one of the world's most beautiful, most musical organs, worth up to twice the cost of the kit.

Five superb models with kit prices from \$500 to around \$2,000, each an authentic musical instrument actually superior to most you see in stores, easy for any musically minded adult to learn to play, yet completely satisfying for the accomplished professional. And there are accessories you can add any time after your organ is finished—lifelike big auditorium reverberation, automatic rhythm, presets, chimes, and more.

Join the thousands of Schober Organ builder-owners who live in every state of the Union. Often starting without technical or music skills, they have the time of their lives — first assembling, then learning to play the modern King of Instruments through our superlative instructions and playing courses.

Get the full story **FREE** by mailing the coupon **TODAY** for the big Schober color catalog, with all the fascinating details!

The *Schober Organ Corp.*, Dept. RE-122  
43 West 61st Street, New York, N. Y. 10023

- Please send me Schober Organ Catalog.  
 Enclosed please find \$1.00 for 12-inch L.P. record of Schober Organ music.

NAME \_\_\_\_\_  
ADDRESS \_\_\_\_\_  
CITY \_\_\_\_\_ STATE \_\_\_\_\_ ZIP \_\_\_\_\_



# EDI

**THOUSANDS OF BARGAINS — TOP VALUES IN Electronic Parts**

Transistors, Modules, Speakers, Stereo, Hi-Fi, Photo Cells and thousands of other Electronic Parts. Send for **FREE Catalog**





**ELECTRONIC DISTRIBUTORS INC.**  
Dept. TA-2, 4900 Elston  
Chicago, Ill. 60630

RUSH CATALOG

Name \_\_\_\_\_  
Address \_\_\_\_\_  
City \_\_\_\_\_ State \_\_\_\_\_ Zip Code \_\_\_\_\_

tional potential from 130-v ADJUST pot VR601, whose wiper is connected through R637 and R618 to the 130-V output. Small changes in the regulated supply induce small deviations in the base-collector of Q608, producing longer or shorter pulse intervals in the pulse width modulators, and therefore more or less conduction in the Q603 regulator output. A considerable change indicating a breakdown, however, will force Q609 into a conduction, firing Q610 and robbing current from the IC horizontal amplifier output, kicking the oscillator either out of sync or, removing drive altogether, killing high voltage.

### The cure is not always easy

When a switched power supply is contained within itself, smart money disconnects one or more of the external loads and starts looking for a fault if there is any indication that the supply is operating at all. With external excitation—such as those being driven by the horizontal oscillator, as in the case of Motorola and Sony—you first measure the doubler voltage to see if there is a bad filter or if a diode is open or shorted. Next (with Motorola) remove the DA/F power supply panel. If sound returns, your probable trouble is in the power supply. If the entire power supply is

changed and you still have problems, go to the output feeder lines and disconnect them one by one to find your problem.

With both Sony and Motorola, remember that the power supply will furnish *no* regulated output unless the horizontal oscillator and driver are operating. Therefore, a fault in the horizontal circuits can kill your low-voltage supply dead. In the Sony, for instance, while looking at waveforms around Q608 and Q609, the scope probe slipped suddenly, there was a sign of escaping high voltage, and the set gave up the ghost. F602 was

blown, and a new one promptly got itself blown again.

Under these circumstances, an additional power supply for the 130-V and 19-V outputs might have helped considerably, but were not available. So we had to make resistance measurements by the score, several transistor checks (especially the GCS transistors), until we finally found horizontal output GCS transistor shorted. When such occurs, also check the base-emitter of horizontal driver Q509 (not shown) to make sure it hasn't gone too.

(continued on page 94)

**PAIA**  
MAKES THE ONLY  
**SYNTHESIZER**  
KIT

MODELS PRICED  
FROM \$139



**but you know  
we also have ....**

THE SURF  
A BIRD  
THE WIND  
PING-PONG  
WIND CHIMES  
DRUMMER BOY  
STEAM WHISTLE  
SYNTHESIZER MK-II  
A FAZE SCHIFTER  
A CHATTER JAMMER  
INFINITY PLUS SUSTAIN  
BALANCED MODULATOR  
AND MANY MORE IN OUR  
FREE CATALOG .....

PAIA ELECTRONICS  
BOX R14359, OKLAHOMA CITY, OK 73114

Circle 29 on reader service card

# LEADER



LBO-310  
3" GENERAL SERVICE SCOPE



LPS-155  
REGULATED DC POWER SUPPLY



LSG-15  
RF WIDEBAND SIGNAL GENERATOR



LT-70  
VOLT/OHM METER

## THE SOLID STATE ELECTRONIC TEST INSTRUMENTS YOU CAN AFFORD.

### LBO-310 3" GENERAL SERVICE SCOPE

A rugged, low cost, Solid State 3" Scope for service, prod'n & short wave use, too. AC/DC coupled vert & hztl inputs. Monitors 100MHz waveforms, direct conn. 10Hz-100KHz sweep, 4 steps, cont. adj DC to 1MHz b'width. Easy to read. Use side by side to view sep. phenomena Compact. \$199.95

### LT-70 VOLT/OHM METER

A smart, Portable Tester, more accurate & sensitive than expensive units. Overload protected, + polarity reversal. Reads as low as 0.25V & 75µA. Measures small solid state DC readings: 20,000Ω/VDC; 8000Ω/VAC sens. & to 40MΩ resistance. Battery operated \$34.95

### LPS-155 REGULATED DC POWER SUPPLY

A stable transistorized Regulated DC Power Source for testing home entert'm't products — line & batt. operated. Useful production line tester. 35V output cont. var. w/0.5A max current. Trans'rtzd overload protection; = polarity. 3mV/p-p max ripple. 115V input. \$129.95

### LSG-15 RF WIDEBAND SIGNAL GENERATOR

A solid state Wideband RF Signal Generator with calib. freq dial plus FETs. 400Hz & 1,000Hz int'l mod. source; 120KHz-450MHz. Locate problems quickly. RF, IF, video circuits \$109.95

**LEADER**  
INSTRUMENTS CORP

151 Dupont Street Plainview, L.I., N.Y. 11803 (516) 822-9300

"Put us to the test"

Circle 30 on reader service card



**'ORDER'  
PRODUCTION LINE  
QUALITY  
RECTIFIERS**

Item No.                      Item                      Price \$

**Radio/TV Applications**

1	6500 PRV Sel. Focus Rectifier	4/\$2.00
2	5 Pin Convergence Rect./Magnavox	4/\$1.00
3	7 Pin Convergence Rect./Wells-Gard	4/\$1.25
4	7 Pin Convergence Rect./Misc Makes	4/\$1.25
5	9 Pin Convergence Rect./RCA	4/\$1.50
6	Selenium Voltage Tripler	4.95 Ea
7	Silicon Voltage Tripler	5.50 Ea
8	800 PRV Sel. Boost Rect. (Zenith/Wells-Gard)	4/\$1.00
9	1200 PRV Sel. Boost Rect. (Wells-Gard)	4/\$1.50
10	Sil. 1B3 Retro-Fit Rect.	6.50 Ea
11	Sil. 5R4 Retro-Fit Rect.	4.75 Ea
12	Sil. 5U4 Retro-Fit Rect.	3.30 Ea
13	Sil 5V4 Retro-Fit Rect.	3.30 Ea
14	Sil 5Y3 Retro-Fit Rect.	3.10 Ea
15	Sil. 5Z4 Retro-Fit Rect.	3.30 Ea
16	Sil. 6X4 Retro-Fit Rect.	4.35 Ea

**General/Industrial Applications**

**Silicon Single Phase Bridge Rectifiers**

17	2A, 50 PRV—BRE200.5	\$1.15 Ea
18	2A, 100 PRV—BRE201	1.20 Ea
19	2A, 200 PRV—BRE202	1.30 Ea
20	2A, 400 PRV—BRE204	1.40 Ea
21	2A, 600 PRV—BRE206	1.70 Ea
22	2A, 800 PRV—BRE208	1.90 Ea
23	6A, 50 PRV—BRH600.5	3.40 Ea
24	6A, 100 PRV—BRH601	3.80 Ea
25	6A, 200 PRV—BRH602	4.20 Ea
26	6A, 400 PRV—BRH604	5.15 Ea
27	6A, 600 PRV—BRH606	6.35 Ea
28	6A, 800 PRV—BRH608	6.95 Ea

**Silicon H.V. 1/2 Wave Rectifiers**

29	1A, 5000 PRV—RC5477	\$6.85 Ea
30	1A, 6000 PRV—RC5478	7.65 Ea
31	1A, 7000 PRV—RC5479	8.40 Ea
32	1A, 8000 PRV—RC5480	9.25 Ea
33	1A, 10,000 PRV—RC5481	10.20 Ea

**Silicon Retro-Fit Rectifier Tubes**

34	250R	\$104.00 Ea
35	371	40.30 Ea
36	575	72.00 Ea
37	576	\$42.75 Ea
38	673	72.00 Ea
39	866	8.50 Ea
40	872	21.25 Ea
41	8008	21.25 Ea
42	8020	46.30 Ea

**ORDERING INFORMATION**

- Minimum Order—\$10.00
- Prices include shipping charges to anywhere within Continental U.S.A.
- Complete order blank with—"Item No.", Qt. of each item being ordered, & total price—Send order form & accompanying money order or check to:

**RECTIFIER COMPONENTS CORPORATION**  
1112 LOUSONS RD.                      UNION, NJ 07083

NAME .....

ADDRESS .....

CITY/STATE/ZIP .....

ITEM NO.    QT        \$    ITEM NO.    QT        \$

TOTAL \$ AMOUNT ENCLOSED.....  
(SORRY—NO CASH OR COD ORDERS, PLEASE)

Circle 61 on reader service card

# new products

More information on new products is available from the manufacturers of items identified by a Reader Service number. Use the Reader Service Card inside the back cover.

**CB TRANSCEIVER, model 13-862** uses synthesized 23-channel circuit and advanced integrated circuitry. Transmits with full 5-watt rf input and contains selective dual-conversion receiver with tuned rf and agc. Automatic noise limiter and fully variable squelch are provided. Large back-lighted S/RFO meter and "luna dial" channel indicator have been placed on



sloped top panel that is right in sight for the driver in normal underdash installations. Channel numbers are large; all controls, on/off/volume, variable squelch and channel selector, are clearly marked. 2 x 5-1/8 x 9"; 3 lbs.; \$99.95 — complete with full-size plug-in mike, clip and mounting bracket. — Midland Electronics Co., Box 19032, Kansas City, Mo. 64141.

Circle 31 on reader service card

**PHONO CARTRIDGE, model AT12S** is a dual-magnet cartridge to be used with CD-4 discs. Shibata diamond tip; reduced record wear and improved tracking with stereo or matrix discs;

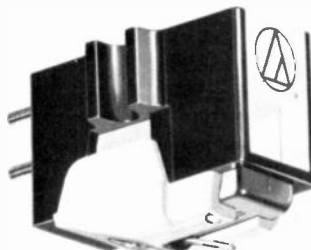

for use in manual or automatic turntables. Frequency response: 15-45,000 Hz; channel separation (at 1 kHz): 25 dB; \$49.95. — Audio Technica U.S., Inc., 1655 West Market Street, Fairlawn, Ohio 44313.

Circle 32 on reader service card

**SOLDERING GUN ELEMENT, Gunmaster** uses interchangeable soldering tips and solder removers. Element will fit most soldering guns and is permanently installed. For soldering, plastic sealing, marking, etc., a tip called the "slug" is screwed into the front end of the element. For removing solder by capillary action, the hollow bore desoldering tip called the "dum dum" is screwed into place. For removing heavy solder deposits, a solder sucker may be attached to the back end of the "dum dum".

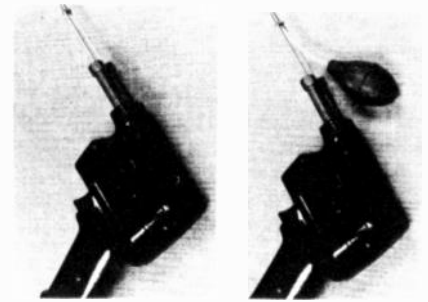

Tip-holding element resists solder and will not weld itself to "slug" or "dum dum". Element heats a bit more slowly than conventional copper wire solder gun elements. — Gunmaster Universal Industries, P.O. Box 743, Kings Park, N.Y. 11754.

Circle 33 on reader service card

**TOOL DEPOT, part No. TD123.** Bracket is positioned at arm's length for people who like their tools nearby. Can be easily mounted in



work area. Makes a convenient place to store all your soldering tools and supplies. \$1.00. — Edysn, Inc., 14250 Dearborn Street, Panorama City, Calif. 91402.

Circle 34 on reader service card

**DIGITAL PANEL METER, model 1230.** 3-1/2-digit bipolar unit uses the company's patented





dual-slope integration, 0.5" Sperry display and automatic zeroing. Standard features include: 2-nA input bias current, choice of 7.5, 15 or 30-per-second sample rate or user-controlled conversion and is accurate to 0.1% of reading, 1 digit accuracy and provides 100% overrange operation. Uses CMOS and TTL logic; 7-segment display; \$135.00. — **Weston Instruments, Inc.**, 614 Frelinghuysen Avenue, Newark, N.J. 07114.

Circle 35 on reader service card

**CB MICROPHONE**, model DM 301 is omnidirectional and has a 50K impedance and a frequency range of 100 to 8,000 Hz. Sensitivity is -52 dB at 1,000 Hz. Has non-locking, push-to-talk switch and is equipped with a three-



conductor, shielded curl cord that extends to 6 feet in length. Can be hand-held or operated from a fixed position; less than 6 oz. — **Shigoto Industries Ltd.**, 350 Fifth Ave., New York, N.Y. 10001.

Circle 36 on reader service card

**MOTO-TOOLS**, model 370 & 380 have built-in finger-tip speed control that lets the user dial optimal rpm settings for any material. Speed



Dremel Model 370  
V - ob - Sperry Motor Tool

range of 5,000 to 25,000 rpm provides precise control for delicate and rough sanding, drilling, cutting, etc. in a variety of material, including wood, metal, glass and plastics.

Model 370 has an 0.8-amp permanent magnet motor, oil impregnated bronze bearings, is 7-1/4" long by 1-1/16" in diameter and costs \$39.95. Model 380 features ball-bearing construction, 0.9 amp permanent magnet motor, is 7-1/4" long by 1-1/32" in diameter and costs \$49.95. Both operate on 115V, 60 Hz ac, weigh 11 oz. and have 6'-3"-long connector cord with three-pronged safety plug. — **Dremel Manufacturing Co.**, Marketing Dept., RP, P.O. Box 518, Racine, Wisc. 53401.

Circle 37 on reader service card



# CHANNELLOCK

## Gives You More In Hand Tools Including

### THE WIREMASTER

40% More Cutting Power  
Perfect Cutter Alignment, Always



**40% MORE CUTTING POWER**  
The joint rivet in a cutting plier is a fulcrum. The closer it is to the cutting edges, the greater your leverage and the greater your cutting power with less effort. In Channellock's WIREMASTER, the joint rivet is



**PERFECT CUTTER ALIGNMENT**  
Unique enclosed joint design holds cutting edges in factory-perfect alignment for the long life of the plier. No way for the jaws to get out of line... ever.

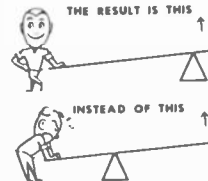

**WANT TO KNOW MORE?**  
You'll get a lot of hand tool information in our catalog. It's yours for the asking. Write us.

## the Audio Amateur

A quarterly for the craft audio buff  
**FUTURE FARE:** A tonearm, pre-amp, a custom Dyna Stereo 70, Hiss filter, Synthesizer, Transmission Line Speakers, A variable inflection 3-way tone control—and much more.

**PROJECTS PUBLISHED:** a 9 Octave equalizer, Dyna PAT-4 update, power amps and preamps, a simple mixer, two 4-channel decoders and two encoders, 9 octave electrostatic speaker with a matching 900 W., Direct coupled tube amplifier... plus much more.

"Absolutely top quality...the only U.S. publication completely devoted to the really serious audiophile constructor."  
— **Craig Stark**, Columnist, Stereo Review

For a free prospectus & full details:

Name \_\_\_\_\_  
Address \_\_\_\_\_  
City \_\_\_\_\_ State \_\_\_\_\_  
ZIP \_\_\_\_\_

Quarterly: \$7 yr.; 3 years \$20.  
P.O. Box 30,  
Swarthmore PA 19081

Circle 62 on reader service card

TOOLS BY  
**CHAN NEL LOCK**  
MEADVILLE, PA. 16335

Circle 63 on reader service card

# new literature

All booklets, catalogs, charts, data sheets and other literature listed here with a Reader Service number are free. Use the Reader Service Card inside the back cover.

**SYNTHESIZER MODULES**, catalog 573. 4-page booklet describes voltage-controlled amplifier, voltage-controlled oscillator, voltage-controlled filters, function generator, control oscillator/noise source, power supply, controller/case, keyboard/case, envelope follower/trigger, inverter/buffer, sine converter/PWM and kits.—**PAIA Electronics, Inc.**, P.O. Box 14359, Oklahoma City, Okla. 37114.

**RESISTOR CATALOG, C-509**. 8-page booklet contains 5,980 catalog items with 616 different resistance values (from 0.1 ohm to 250,000 ohms) and 15 wattage ratings (from 1 to 120 watts). Includes basic descriptions and physical sizes; complete listings of the company's wirewound resistors.—**Sprague Electric Co.**, 81 Marshall Street, North Adams, Mass. 01247.

**NRI HOME TRAINING IN AIR CONDITIONING, REFRIGERATION AND HEATING**. Outline of 45 lesson course covering servicing electric motors, refrigerant connections and servicing automotive heaters and air conditioners. Training units include circuit demonstrator (for learning fundamentals of electrical circuits) and control simulator (for learning electric controls). Each student receives a 5,000 BTU York window air conditioner to use as a practice unit and later for his personal use.—**NRI Training**, 3939 Wisconsin Avenue, N.W. Washington, D.C. 20016.

**1973 SEMICONDUCTOR INTERCHANGEABILITY & CROSS REFERENCE GUIDE, #451.104**. 44-page catalog lists over 6,000 semiconductor types including 1N, 2N, 3N and industry house numbers with cross references to either an exact General Electric type or a suggested replacement.—**General Electric Co.**, Semiconductor Products Dept., Electronics Park, Bldg. #7, Mail Drop 49, Syracuse, N.Y. 13201.

## ZENERS

All Units Tested And Guaranteed

**400 MILLIWATT UNITS** — 3, 3.3, 3.6, 3.9, 4.3, 4.7, 5.6, 6.2, 6.8, 7.5, 8.2, 9.1, 18, 22, 24, 27, Volts.

**1 WATT UNITS** — 10, 11, 12, 13, 15, 16, 18, 20, 22, 27, 30, 33, 39, 43, 47, 51, 56, 62, 68, 75, 82, 91, 100, 110, 120, 130, 150, 160, 180, Volts. ALL UNITS 10% — 4 for \$1.00 ppd. 5% — 3 for \$1.00 ppd.

**6.3 Volt 1 Amp Transformer, Fully Shielded** \$1.60 Each ppd.

**Transformer — 115 Volt Primary — 12 Volt 1.2 Amp Secondary** \$2.45 ppd.

**113 VOLT TRANSFORMER** 32-0-32 Volts At 1 Amp Secondary. Also Low Current 6.3 Volts Secondary For Pilot Lights. \$2.50 Each ppd.

**115 VOLT TRANSFORMER** 17-0-17 Volt @ 150 ma. Secondary With Tap At 6.3 Volts For Pilot Light. \$1.50 Each ppd.

**Transformer — American Made — Fully shielded, 115 V Primary, Sec. — 24-0-24 @ 1 amp with tap at 6.3 volt for pilot light.** Price — A low \$2.90 each ppd.

**Transformer, 115 VAC Primary, 12 Volt, 4 Amp Secondary** \$4.00 Each ppd.

**Tubular Polystyrene Capacitors. All 125 Volts — 2.5% tolerance. .003 Mfd, .01 mfd .018 mfd, .022 mfd. Your Choice 15 for \$1.00 ppd.**

**ELECTROLYTIC CAPACITORS** Dual Section, Common Ground 100 x 100 Mfd @ 380 Volts. Ideal for Xcvr Power Supplies \$1.00 ea ppd.

SEND STAMP FOR BARGAIN LIST

Pa. Residents add 6% State sales tax

ALL ITEMS PPD. USA

**m. weinschenker**  
K 3DPJ BOX 353 · IRWIN, PA. 15642

Circle 65 on reader service card

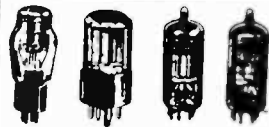

70% OFF LIST!

1AD2	1.28	6AV6	.89
1B3	1.30	6AW8	1.47
1BC2	1.13	6AX4	1.22
1K3	1.30	6AY3	1.22
1S2A	.90	6BA6	1.08
1U5	1.13	6BA11	1.61
1V2	.78	6BC8	1.61
1X2	1.33	6BE6	1.13
2AS2	1.28	6BH6	1.32
2AV2	1.02	6BH11	1.80
2D21	1.35	6BJ6	1.32
2GK5	1.26	6BK4	2.45
3A3	1.32	6BL8	.89
3AT2	1.28	6BM8	1.05
3AW2	1.32	6BN8	1.41
3BS2	1.39	6BQ5	1.28
3BZ6	1.22	6BQ6	1.77
3CA3	1.22	6BQ7	1.64
3CU3	1.61	6BQ8	1.67
3DB3	1.44	6BV11	1.92
3DC3	1.80	6BX6	.92
3EJ7	.83	6BZ6	1.02
3GK5	1.26	6C4	1.22
3HA5	1.26	6CA4	1.23
3HO5	1.86	6CA7	2.10
3JC6	1.67	6CB6	1.08
3KT6	1.23	6CE3	1.29
4BZ6	1.22	6CG7	.98
4DT6	1.25	6CG8	1.41
4EH7	1.17	6CJ3	1.23
4EJ7	1.17	6CL6	1.56
4HS8	1.22	6CL8	1.47
4JC6	1.65	6CW4	1.86
4KE8	2.00	6CW5	.90
5AQ5	1.22	6DJ8	1.50
5AR4	1.73	6DQ5	2.61
5BC3	1.12	6DQ6	1.76
5GH8	1.55	6DT6	1.07
5GJ7	1.20	6DW4	1.22
5GS7	1.04	6DX8	1.20
5LJ8	1.44	6EA7	1.85
5U4	1.01	6EA8	1.29
5V4	1.41	6EB8	1.86
5Y3	.98	6EH7	1.26
6AB4	1.19	6EJ7	1.17
6AC10	1.80	6EU7	1.30
6AK8	.99	6EW6	1.17
6AL5	.98	6FG7	1.52
6AM8	1.52	6FM7	1.67
6AN8	1.65	6GE5	1.88
6AQ5	1.11	6GF7	1.73
6AQ8	.90	6GH8	1.04
6AU4	1.58	6GJ7	1.20
6AU6	.98	6GK5	1.52
6AU8	1.86	6GK6	1.22

## EDLIE BARGAIN BONANZA OF HIGHEST QUALITY TUBES

BUY BRAND NEW MANUFACTURER'S BOXED TUBES (Raytheon, Dumont IEC Mullard, etc.) AT 70% OFF LIST!

70% OFF LIST

ALL TUBES BRAND NEW MANU. BOXED 70% OFF

6GM6	1.28	6JS6	2.42
6GU7	1.36	6JT8	1.47
6GW8	1.35	6JU8	1.46
6GX6	1.10	6JW8	1.02
6HA5	1.26	6KA8	1.61
6HB7	1.41	6KD6	2.93
6HE5	1.80	6KE8	2.00
6HF8	1.95	6KG6	2.88
6HQ5	1.67	6KN6	2.39
6HS5	3.00	6KT8	1.77
6HS8	1.56	6KZ8	1.33
6HV5	3.08	6LGCC	1.95
6HZ6	1.04	6LB6	2.79
6J10	2.00	6LE8	1.83
6JC6	1.47	6LF6	2.78
6JD6	1.52	6LF8	1.68
6JE6	2.85	6LJ8	1.44
6JH6	1.17	6LM8	1.61
6JH8	1.77	6LN8	.80
6JM6	2.55	6LR6	2.66
6JN6	1.76	6LU8	1.58

WRITE FOR FREE VALUE PACKED CATALOG

MINIMUM ORDER \$7.50

MONEY BACK GUARANTEE

Terms: Minimum order \$7.50. Include postage. Either full payment with order or 20% deposit, balance C.O.D.

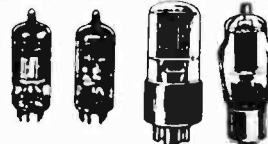

70% OFF LIST!

6LY8	1.28	12FQ7	1.11
6MD8	1.73	12GE5	1.71
6ME8	4.30	12GN7	1.82
6SJ7	1.76	12HL7	1.61
6SK7	1.65	12SA7	1.65
6SN7	1.32	12SQ7	2.10
6SQ7	1.62	13GF7	1.71
6T8	1.55	14BR11	1.91
6T10	1.77	15BD11	1.80
6U8	1.28	15CW5	.90
6U10	2.40	15KY8	2.09
6V4	.68	16A8	1.14
6V6	1.47	17AY3	1.22
6X4	1.13	17BE3	1.22
6X5	1.17	17BF11	1.95
6X8	1.47	17BS3	1.22
6X9	2.10	17CU5	1.02
6Z10	1.99	17DQ6	1.82
7C5	1.41	17J86	2.10
7DJ8	1.95	17JZ8	1.35
7F8	3.00	17KV6	2.84
7V7	1.80	18GV8	1.53
8A8	1.02	19T8	1.61
8AW8	1.76	20AQ3	1.08
8CG7	1.85	21GY5	1.65
8GJ7	1.20	21JZ6	1.61
8JH8	1.35	21LR8	1.80
8JV8	1.41	21LU8	1.80
8KR8	1.86	23J56	3.74
8LT8	1.32	23Z9	1.56
9GH8	1.33	24JE6	2.76
9JW8	1.17	25CG3	1.11
10CW5	.90	27GB5	2.55
10GK6	1.47	30AE3	1.08
10GN8	1.61	30KD6	2.59
10GV8	1.23	33GY7	2.10
10JY8	1.20	35C5	1.05
10KR8	1.39	35L6	1.28
11BM8	1.73	35W4	.65
11BQ11	1.76	35Z5	1.11
12AE10	1.89	36KD6	2.91
12AT7	1.13	38E7	2.39
12AU7	.99	40KD6	2.91
12AV6	.77	50C5	.99
12AV7	1.52	50EH5	1.17
12AX7	.92	50L6	1.47
12AZ7	1.32	117P7	4.80
12BA6	.93	5879	1.80
12BE6	.99	6267	1.50
12BH7	1.28	70Z5	.92
12BY7	1.17	7189	1.39
12DK6	1.20	7199	2.10
12DQ6	1.70	7408	1.50
12DT8	1.17	7591	1.80
12DW4	1.22	7868	1.95

EDLIE ELECTRONICS, INC. 2700-B HEMPSTEAD TPKE., LEVITTOWN, N. Y. 11756

Circle 67 on reader service card

**EQUIPMENT REPORT**  
(continued on page 22)

unit can be used with the 970A for reading alternating or direct current. Current ranges are from 100µA up to 1.0 A. The insertion voltage drop is only 0.2V or less.

The HP-970A is powered by a self-contained NiCad battery, which is somewhere between 9 and 11V (depends on state of charge). It slips into the end of the probe case. A special charger is included; the battery unit slips out and plugs into the charger housing. Both probe and charger are completely idiot-proof. A rib along one side of the battery case must fit into a slot in both housings before the battery will go in.

The battery will operate the 970A for about three hours; when it drops below about 9.5 volts, the display dims and it's time for a recharge. The on-off switch has a "push-to-read" position for the first click. This can extend battery life considerably. The second click is normal on position.

The LED display is bright enough to read even in pretty bright sunlight. A Display Invert slide switch can be used to turn the figures over so that the readout can be right side up no matter what position you or the instrument are in. (They have a cute little thing for this! Tiny man-figures are on the case; one is always covered by the invert switch slider. Set this so that the little man you see is not standing on his head, and there you are!)

The actual test-prod is a short one, mounted on the underside of the case. It can be folded out, with several detents so that it can be set at any angle you want. The center part telescopes, and is completely insulated. It has a very sharp tip, to make perfect con-

tact to PC boards, etc. Two extension test prods are provided; one is a 5-inch with a sharp tip, and the other a special 2-inch, with a hollow, cupped tip. This one is very handy for hitting test-points, wire-wrap terminals, ends of wire leads on a PC board, and similar things. These extra tips fit in the socket on the end of the prod; the regular one just pulls out. Special pockets in the carrying case keep the extra rods safe.

The electronics in the 970A are a miracle of compactness. Out of the 6 inches of the case, three inches is battery, and the rest is the works. Out of this small number, most of the space is taken up by the switches. The heart of the unit is a monstrous (electronically) device roughly 0.5 by one inch. All that this contains is an analogue to digital converter, the attenuators, the auto-ranging circuitry, the auto-polarity circuitry and the logic! Outside of this, only 19 components

and three switches are needed to make the whole thing!

The whole instrument is designed for "one-hand operation". This makes it potentially very useful in today's crowded instruments. The zippered carrying case even has a clip for carrying on your belt. With this, you can be the "Quick-Draw McGraw" of the electronics maintenance set!

I know too well the hazards inherent in firm statements; I have the lumps to prove it. So, I'll confine myself to saying that *as of right now*, this instrument looks to like the ultimate in "portability" when its versatility is taken into account. It should certainly be very useful to field engineers and anyone working with solid-state equipment. It would be most appreciated where the equipment to be checked is located in tight places!

R-E

# A LITTLE SQUIRT stops all the noise.

A squirt of Quietrol from the handy Spray Pack silences any moving T.V. part. Cleans as it lubricates, too. Guarantees quiet, trouble-free operation. Absolutely safe for any black and white or color set. Try it and see why it's preferred by top servicemen everywhere.

Also available in bottles, and the new silicone—"Siltron."



Product of

## QUIETROLE

COMPANY

Spartanburg, South Carolina

Circle 66 on reader service card

# TV TUNER SERVICE

**PTS ELECTRONICS, INC.**  
also available in . . .

**MINNEAPOLIS — ST. PAUL**  
**KANSAS CITY**  
**NEW ORLEANS**  
**WASHINGTON, D. C.**  
**BUFFALO**

HOME OFFICE — INDIANA:  
BLOOMINGTON, IND. 47401  
TEL. 812 824 9331

CALIFORNIA — NORTH:  
PTS ELECTRONICS, INC.  
P.O. BOX 41354  
SACRAMENTO, CALIF. 95841  
TEL. 916 487 6720

CALIFORNIA — SOUTH:  
PTS ELECTRONICS, INC.  
P.O. BOX 5794  
SAN DIEGO, CALIF. 92105  
TEL. 714 790 7070

COLORADO:  
PTS ELECTRONICS, INC.  
P.O. BOX 672  
DENVER, COLO. 80201  
TEL. 303 423 7080

FLORIDA:  
PTS ELECTRONICS, INC.  
P.O. BOX 7923  
JACKSONVILLE, FLA. 32210  
TEL. 904 389 9952

INDIANA:  
PTS ELECTRONICS, INC.  
P.O. BOX 27  
BLOOMINGTON, IND. 47401  
TEL. 812 824 9331

KANSAS:  
PTS ELECTRONICS, INC.  
3116 MERRIAM LANE  
KANSAS CITY, KANSAS 66100  
TEL. 913 831 3227

LOUISIANA:  
PTS ELECTRONICS, INC.  
P.O. BOX 73247  
METairie, LA 70033  
TEL. 504 885 7349

MARYLAND:  
PTS ELECTRONICS, INC.  
1105 SPRING ST.  
SILVER SPRING, MD 20910  
TEL. 301 565 0075

MASSACHUSETTS:  
PTS ELECTRONICS, INC.  
P.O. BOX 3189  
SPRINGFIELD, MASS 01103  
TEL. 413 734 2717

MINNESOTA:  
PTS ELECTRONICS, INC.  
815 W. LAKE ST.  
MINNEAPOLIS, MINN. 55408  
TEL. 612 824 2333

NEW YORK CITY — NEW JERSEY:  
PTS ELECTRONICS, INC.  
158 MARRET ST.  
PATERSON, N.J. 07407  
TEL. 201 791 6300

NEW YORK:  
PTS ELECTRONICS, INC.  
903 SYCAMORE ST.  
BUFFALO, N.Y. 14212  
TEL. 716 881 4035

OHIO:  
PTS ELECTRONICS, INC.  
5687 STATI RD.  
CLEVELAND, OHIO 44134  
TEL. 216 845 4480

OKLAHOMA:  
PTS ELECTRONICS, INC.  
P.O. BOX 60566  
OKLAHOMA CITY, OKLA. 73106  
TEL. 405 947 2013

OREGON:  
PTS ELECTRONICS, INC.  
P.O. BOX 12096  
PORTLAND, OREGON 97213  
TEL. 503 782 9616

PENNSYLVANIA — EAST:  
PTS ELECTRONICS, INC.  
P.O. BOX 16856  
PHILADELPHIA, PA. 19142  
TEL. 215 724 0991

PENNSYLVANIA — WEST:  
PTS ELECTRONICS, INC.  
P.O. BOX 4130  
PITTSBURGH, PA. 15202  
TEL. 412 761 7648

TEXAS — NORTH:  
PTS ELECTRONICS, INC.  
P.O. BOX 7332  
LONGVIEW, TEX. 75601  
TEL. 214 753 4334

TEXAS — EAST:  
PTS ELECTRONICS, INC.  
P.O. BOX 76616  
HOUSTON, TEX. 77032  
TEL. 713 644 6791

WASHINGTON, D.C.  
PTS ELECTRONICS, INC.  
1105 SPRING ST.  
SILVER SPRING, MD 20910  
TEL. 301 565 0075

*now you too...  
...get Fast 8 hr. Service!*

**\$9.95**  
**1 YEAR GUARANTEE**

ALL PTS BRANCHES are wholly owned subsidiaries of PTS ELECTRONICS, INC. (NO FRANCHISE!) and report directly to the Home Office in Bloomington, Indiana. Only this way can we guarantee the same quality—PRECISION TUNER SERVICE—has made PTS the leader in this field.

PTS is proud to be the only tuner service to publish a TUNER REPLACEMENT PARTS CATALOG (80 pages of tuner blow ups, tuner antenna coil and shift replacement guides available for \$1.00)

WE OFFER MORE SERVICE IS EVERYTHING WITH US  
WE ARE DYNAMIC AND FAST TRUSTWORTHY

**YOU AND US — A TRUE PARTNERSHIP**

Color • Black & White • Transistor  
Tubes • Varactor • Detent UHF

All Makes

VHF, UHF or FM ..... \$ 9.95  
UV-COMBO ..... 16.95  
IF-SUBCHASSIS ..... 12.50

Major-parts and shipping charged at cost.  
(Dealer net!)

over 4000 exact tuner replacements available for \$15.95 up (new or rebuilt)

**PTS ELECTRONICS, INC.** is recommended by more TV manufacturers and overhauls more tuners than all other tuner services combined!

for finer, faster,  
... Precision Tuner Service

send faulty unit with tubes, shields and all broken parts to

Circle 64 on reader service card

# SIZZLING DOLLAR VALUE

**FREE \$1 BUY WITH EVERY 10 YOU ORDER** Only applies to "\$1" Buys  
**FREE GIFT WITH EVERY ORDER**  
 CANADIANS: Ordering is easy - we do the paperwork - try a small order

**IBM COMPUTER SECTIONS**

8 assorted Units we sell for \$1 are loaded with over 150 valuable parts.

Incl. - Transistors  
 Condensers, Resistors,  
 Heat Sinks,  
 Diodes, Etc.

**8 for \$1**  
**100 for \$10**

**WESTINGHOUSE ALL TRANSISTOR HOME/OFFICE MESSAGE CENTER**

Leaves messages for other for replay... Built in speaker/microphone for talk-into convenience... Records up to 3 minutes of messages... Illuminated signal shows when a message is waiting. Control adjusts playback volume without affecting recording volume... Capstan Drive;  
**BRAND NEW SOLD AS IS \$7.95**

**SHANNON MYLAR RECORDING TAPE**

3"	- 225'	.19
3 1/4"	- 600'	.58
5"	- 800'	.82
5"	- 900'	.80
5"	- 1200'	.97
5"	- 1800'	1.49
7"	- 1200'	.77
7"	- 1800'	1.12
7"	- 2400'	1.79
7"	- 3600'	2.95

**CASSETTE C-60** ..... .59  
**CASSETTE C-90** ..... 1.19  
**CASSETTE C-120(TDK)** ..... 1.97  
**8-Track - 60 Min.** ..... 1.29  
**8-Track - 84 Min.** ..... 1.59  
**8-Track - Cleaner** ..... 1.49

●

**3" TAPE REEL** ..... .07  
**3 1/4" TAPE REEL** ..... .09  
**5" TAPE REEL** ..... .19  
**7" TAPE REEL** ..... .24

**RCA 110° FLYBACK TRANSFORMER**

We scooped the Market Latest type - standard for all 110° TV's

RCA's design of large Coil produces 18KV assuring adequate width Incl. Schematic Diagram application for any TV

List price \$13.90  
**Your price... \$3.95**  
 10% off in lots of 3

**MARKET SCOOP COLUMN**

- ZENITH COLOR DEMODULATOR CHIP PART #221-39 (Sprague Eqv TVC-M-1) ..... \$3.95
- BLUE LATERAL MAGNET ASSY. Re- placement for most color TV's ..... \$1.59
- UNIVERSAL TV ANTENNA Back of set mounting . . . 5 section rods ..... \$2.79
- COLOR CONVERGENCE ASSEMBLY Universal type-good for most sets ..... \$2.49
- COLOR TV RECTIFIER - Used in most color sets -6500 kv 3 for..... \$1.95
- 2 COLOR-TV CRT SOCKETS Wired leads, for all color TV's ..... \$1.11
- 3 - RCA 110° CRT SOCKETS Wired leads, for all TV's ..... \$1.11
- 70° COLOR TUBE BRIGHTNER ..... \$3.95
- 90° COLOR TUBE BRIGHTNER ..... \$4.95
- 2 - COLORBURST QUARTZ-CRYSTAL For Most Color TV sets 3579.545 KC ..... \$1.89
- 5 ASSTD. GLOBAL VARISTOR Popular re- placements for most COLOR TV

**KNOB SPECIAL**

- 100 - ASSORTED RADIO KNOBS All standard type \$20 value ..... \$1
- 50 - TV KNOBS - POPULAR TYPES Mostly Selector & Fine Tuning ..... \$1
- 20 - VERTICAL LINEARITY KNOBS Long shank . . . Front mount . . . as- assortment ..... \$1
- 20 - VERTICAL LINEARITY KNOBS Side mount . . . Standard sizes ..... \$1
- 25 - KNURLED SHAFT KNOBS Hard to get Best selection ..... \$1
- 25 - CLOCK & RADIO KNOBS most popular types ..... \$1

**ANY 6 KITS FOR \$5**

- 300 - ASSORTED HEX NUTS 2/56, 4/40, 5/40, 6/32, 8/32 ..... \$1
- 250 - ASST. SOLDERING LUGS heat types and sizes ..... \$1
- 250 - ASST. WOOD SCREWS finest popular selection ..... \$1
- 250 - ASST. SELF TAPPING SCREWS #6, #8, etc. .... \$1
- 150 - ASST. 8/32 SCREWS and 150- 6/32 HEX NUTS ..... \$1
- 150 - ASST. 8/32 SCREWS and 150- 8/32 HEX NUTS ..... \$1
- 150 - ASST. 2/56 SCREWS and 150- 2/56 HEX NUTS ..... \$1
- 150 - ASST. 4/40 SCREWS and 150- 4/40 HEX NUTS ..... \$1
- 150 - ASST. 5/40 SCREWS and 150- 5/40 HEX NUTS ..... \$1
- 500 - ASSORTED RIVETS most useful selected sizes ..... \$1
- 300 ASSORTED WASHERS most useful selected sizes ..... \$1
- 100 - ASST. RUBBER PUMPKERS for cabinet bottoms - other uses ..... \$1
- 100-ASSORTED RUBBER GROMMETS best sizes ..... \$1

- 110° TV DEFLECTION YOKE for all 110° TV's incl schematic ..... \$4.95
- "COMBINATION SPECIAL" RCA 110° FLYBACK plus 110° DEFLECTION YOKE..... \$6.95
- 90° FLYBACK TRANSFORMER for all 90° TV's incl schematic ..... \$2.95
- 90° TV DEFLECTION YOKE for all type 90° TV's incl schematic..... \$2.95
- 70° FLYBACK TRANSFORMER for all type 70° TV's incl schematic..... \$2
- 70° TV DEFLECTION YOKE for all type 70° TV's incl schematic..... \$2
- SHARP 110° FLYBACK & YOKE COMBINATION #RPT-592 Good for most portable TV ..... \$5.95
- 90° COLOR YOKE For all Rectangu- lar 19 to 25" Color CRT's ..... \$10.95
- RCA COLOR FLYBACK Part #1139229 (Stancor #HO-901C) ..... \$12.95
- 1 - RCA COLOR YOKE PART #206214-50 ..... \$5.95
- 70° COLOR YOKE for \$12.95 all round color CRT's
- SONY UHF TUNER-TRANS- ISTOR TYPE exact replacement, complete w/knobs..... \$3.95
- 4 - TV ALIGNMENT TOOLS most useful assortment #1 ..... \$1
- 4 - TV ALIGNMENT TOOLS For Color TV #2..... \$1.49
- 6 - TV COLOR ALIGNMENT TOOLS Most popular type ..... \$2.79

**KLEPS "CLEVER" TEST PROOS**

"Third-hand" test prods, reach into out of way places - Insulated - cannot slip - accommodates bare wire or banana plug - no soldering.

- PRUF 10 - VERSATILE TEST PROBE ..... \$1.89
- KLEPS 10 - BOATHOOK CLAMP 4 1/2" long ..... \$1.39
- KLEPS 20 - BOATHOOK CLAMP 7 1/2" long ..... \$1.49
- KLEPS 30 - FLEXIBLE-FORKED TONGUE 6" long ..... \$1.79
- KLEPS 40 FLEXIBLE-PC BOARD TERMINALS 8 1/2" long ..... \$2.59
- KLEPS 1-ECONOMY KLEPS-FOR LIGHT WORK ..... \$1.99

- TRANSISTOR RADIO *asst type* good, had, broken, as-is, potluck ..... \$1.50
- TAPE RECORDER - assorted types good, had, broken, as-is, potluck ..... \$4
- 300 - ASST. 1/2 W RESISTORS Top Brand, Short Leads, Excellent Selection ..... \$1
- 100 - ASST 1/2 WATT RESISTORS stand. choice ohmages, some in 5% ..... \$1
- 100 - ASST 1/2 WATT RESISTORS stand. choice ohmages, some in 5% ..... \$1
- 70 - ASST 1 WATT RESISTORS stand. choice ohmages, some in 5% ..... \$1
- 35 - ASST 2 WATT RESISTORS stand. choice ohmages, some in 5% ..... \$1
- 50 - PRECISION RESISTORS *asst list* price \$50 less 98% ..... \$1
- 20 - ASSORTED WIREDWOUND RESIS- TORS, 5, 10, 20 watt ..... \$1
- 10 - ASSORTED SLIDE SWITCHES SPST, SPDT, DPDT, etc. .... \$1
- 25 - SYLVANIA HEAT SINKS For Transis- tors ..... \$1
- 20 - ASSORTED TV COILS I.F., VIDEO, sound, radio, etc. .... \$1

- 1 - ELECTROLYTIC CONDENSERS 200/200/100/100 MPD - 25 V. .... \$1
- 1 - ELECTROLYTIC CONDENSERS 100 MPD-40V ..... \$1
- 3 - ELECTROLYTIC CONDENSERS 20/20 MPD-45V ..... \$1
- 5 - 9 VOLT MOTORS Excellent for hobby- ist ..... \$1
- 6" PHILIPS "INVERTED CONE" SPEAKER Top quality. Thinline ..... \$2.29
- 1-8" x 9" HEAVY DUTY 10 OZ. SPEAKER Ceramic Type . . . 8 Ohm ..... \$3.95
- 10-ASSORTED DIODE CRYSTALS IN34, IN48, IN60, IN64, etc. .... \$1
- 6 - TOP BRAND SILICON RECTIFIERS amp. 100 PIV ..... \$1
- 5 - PNP TRANSISTOR general purpose. TO-5 case ..... \$1
- 5 - NPN TRANSISTORS general purpose. TO-5 case ..... \$1
- 50 - ASSORTED TRANSISTORS big factory scoop-sold as-is ..... \$1
- TV TWIN LEAD-IN 300 ohm 500 - \$7 100' - \$1.50, 50' ..... \$1
- 12-MINIATURE ELECTROLYTIC CONDENSERS For Transistor & miniature work ..... \$1
- CLARICOM AM FM TUNER Solid state, walnut cabinet ..... \$59.95
- WEN SOLDER GUNS Model 225K ..... \$8.50 Model 288 ..... \$7.50 Model 250 ..... \$9.95 Model 100K ..... \$5.95
- 8 ELEMENT COLOR OUTDOOR AN- TENNA Big shot Jr. List \$11.95 ..... \$5.95
- 4 - POLARIZED CHEATER CORDS (7'x) ..... \$1
- ARISTO WIRELESS INTERCOM Walnut Cabinet, with buzzer call, AC operation ..... \$15.95
- 4 - ELECTROLYTIC CONDENSERS 75/70mfd-150v ..... \$1

**SARKES TARZIAN TUNER 41mc**

Latest Compact Model good for all 41 mc TV's.  
**BRAND NEW**

Best TUNER "SARKES TARZIAN" ever made—last word for stability, definition & smoothness of operation. An opportunity—to improve and bring your TV Receiver up-to-date.  
**COMPLETE with Tubes \$7.95**

- ASTATIC PICKUP MODEL 700-89T Contains 89T ceramic cartridge LIST PRICE \$17.00 ..... \$2.95
- 20 - DIPPED MYLAR CAPACITORS 01-100V ..... \$1
- 20 - DIPPED MYLAR CAPACITORS 033-600V ..... \$1
- 20 - DIPPED MYLAR CAPACITORS 0033-1000 V ..... \$1
- 20 DIPPED MYLAR CAPACITORS 047-400 V ..... \$1
- 15 - MOLDED TUBULAR CAPACITORS .068-400 V ..... \$1
- 20 - DIPPED MYLAR CONDENSERS 0339-400 V ..... \$1
- 10 SPRAGUE "ORANGE DROP" CAPACITORS 0055-2000 Volt. .... \$1
- TACHOMETER 2 1/4" SQUARE PANEL METER 1-VDC full scale, 33 Ohm coil resistance 0-6000 R.P.M. .... \$2
- 1 - CASSETTE TYPE DYNAMIC MICROPHONE with universal plugs-200 Ohms ..... \$2.49
- 10 - SETS PHONO PLUGS & PIN JACKS RCA type ..... \$1
- 8-PRINTED CIRCUIT IF TRANSFORMERS 4-Iug, 456 KC ..... \$1
- STEREO TONE ARMS Most popular type-turn over cartridge ..... \$2
- 4-50' HANKS HOOK-UP WIRE assorted colors ..... \$1
- 100'-SPOOL SPEAKER WIRE 2 cond., 1/2 mini zip, clear, 101 uses ..... \$1.50
- 10 - ASST. RADIO & TV TUBES Every Tube a good number ..... \$1
- 5 - AUDIO OUTPUT TRANSFORM Sub-min for Trans Radios ..... \$1
- 5 - I.F. COIL TRANSFORMERS 456-kc for Transistor Radios ..... \$1
- 6" UNIVERSAL SPEAKER Top quality Special buy Ea. .... \$1.29
- ALL AMERICAN TUBE KIT (12AV6-12BD6-12BA6-35W4-50C5) ..... \$2.99
- 1 - GARRARD RECORD CHANGER Special buy ..... \$21.50
- UTAM "CELESTA" 3-WAY CO-AX SPEAKERS 8"-10 oz. Mag.-30 Watts ..... \$16.95
- UTAM "CELESTA" 3-WAY CO-AX SPEAKERS 12"-20 oz. Mag.-45 Watts ..... \$24.95
- VU 1" PANEL METER 0-20 db Scale ..... \$1.29

**TEST EQUIPMENT SPECIAL DISCOUNT PRICES**

**BK** **TEICO** **Leader** **SENCORE**

- 2 1/2" x 4" SPEAKER Special Buy 1069c Ea. For \$5 ..... \$1
- 4" x 8" "QUAM" 16 OHM SPEAKER Large magnet . . . Special BUY (10 for \$15.00) ..... \$1
- ROMETTE STEREO CARTRIDGE latest dual sapphire flipover type ..... \$2
- STEREO HEADPHONES Hi-Fi Quality Complete with Stereo plug. .... \$5.95
- 10 - STANDARD TRANSISTORS NPN & PNP 2N404, 2N414, etc. .... \$1
- UTAN 8" - HEAVY DUTY 10 OZ. SPEAKER Ceramic Type - 8 Ohm ..... \$3.95
- 2-ELECTROLYTIC CONDENSERS UNECAP - 200/1000 mfd. . . 30 Volt ..... \$1
- 2 - SPRAGUE Elec. Condensers 80/30/4 mfd. - 475 V ..... \$1
- 2 - ELECTROLYTIC CONDENSERS 200/30/4 mfd - 350V ..... \$1
- 8-TRACK TAPE PLAYBACK DECK Compact design fits anywhere ..... \$27.50
- 3-ELECTROLYTIC CONDENSERS 100 mfd. 100 V. 50 mfd-75 V ..... \$1
- 32' - TEST PROO WINE DELUXE QUALITY, red & black ..... \$1
- SOLID STATE UHF CONVERTOR Chan-16 nels 1-85, easy to install ..... \$17.95
- WACO STEREO CARTRIDGE-CN-72 With mounting bracket, flipover needle. ELECTROLYTIC CONDENSER ..... \$2.95
- 300 Mfd.-30V ..... \$1
- CO-AX CABLE RG59U grey or black 250'-\$9 100' - \$3.69 50' ..... \$2
- 15 - MINIATURE 458KC IF TRANSFORMERS PC 1/2" X 1/2"-good value ..... \$1
- 2 - 12BH7 RCA TUBES ..... \$1
- ELECTROLYTIC CONDENSERS 200/200 mfd. - 200V ..... \$1.00
- 2 - ELECTROLYTIC CONDENSERS 1500 mfd - 35V ..... \$1
- 1 - 5" SPEAKER with output transformer ..... \$1.39
- MERCURY TUBE TESTER MODEL 990 Compact latest model ..... \$39.95
- MIDLAND STEREO AMPLIFIER Model 26-002, 12 Watt, solid state ..... \$36.50
- MIDLAND STEREO AMPLIFIER Model 26-008, 25 Watt, Solid State ..... \$55.00
- 2 - ELECTROLYTIC CONDENSERS 400 mfd - 500V, 40 mfd - 400V ..... \$1.00
- COLOR POWER TRANSFORMER -Good for most sets 26T150 List Price-\$36.75 ..... \$6.95
- TUBE & CONTINUITY CHECKER Model FT425 (Tests fuses, heaters, lamps, Etc.) ..... \$1.98

IMMEDIATE DELIVERY . . . Scientific light packing for safe delivery at minimum cost.  
 HANDY WAY TO ORDER . . . Send check or money order, add extra for shipping. Lists of new offers will be returned in your order.  
 Please specify refund on shipping overpayment desired:  CHECK  POSTAGE STAMPS  MERCHANDISE (our choice) with advantage to customer

**BROOKS RADIO & TV CORP., 487 Columbus Ave., New York, N. Y. 10024** 212-874 5600 TELEPHONE

# GRANTHAM OFFERS YOU College-Level Training and a college degree.

**Electronic Circuit Design, Engineering Analysis (including mathematics thru calculus), Classical and Solid-State Physics, Engineering Design, etc., etc., are all part of the Grantham home-study degree program in Electronics Engineering.**

*(Regardless of what you may have read in another school's ad, Grantham does teach college-level circuit design by home study.)*

By adding college-level home training and a college degree to your experience, you can *move up* to greater opportunities in electronics.

Grantham offers the A. S. E. T. degree by correspondence. After earning this degree, you may continue with additional correspondence plus a one-week residential seminar and certain transfer credits, to earn the B. S. E. T. degree. Then, the B. S. E. E. is available through further residential attendance.

## GRANTHAM SCHOOL OF ENGINEERING

2000 Stoner Ave., Los Angeles CA 90025

● Telephone (213) 477-1901 ●

Established in 1951 — G.I. Bill approved.  
Mail the coupon below for free bulletin.

**Grantham School of Engineering** RE-1-74

2000 Stoner Ave., Los Angeles, CA 90025

I have been in electronics for \_\_\_\_\_ years. Please mail me your free bulletin which gives details concerning your electronics degree programs.

Name \_\_\_\_\_ Age \_\_\_\_\_

Address \_\_\_\_\_

City \_\_\_\_\_ State \_\_\_\_\_ Zip \_\_\_\_\_

Circle 69 on reader service card

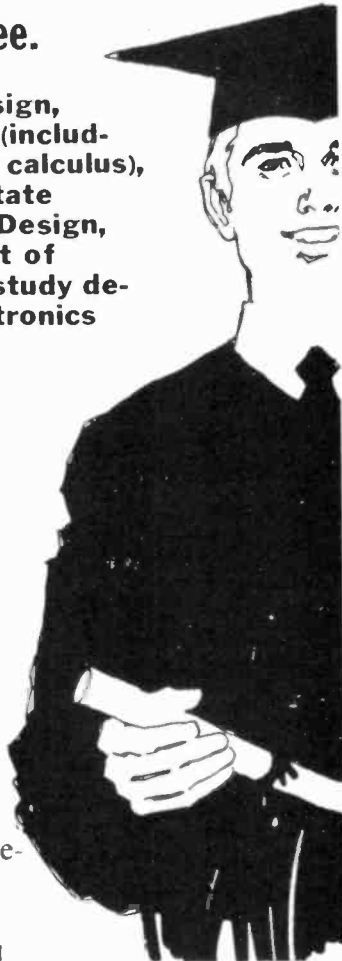

# Printed Circuit Kits

**P. C. BOARD ETCHING SOLUTION**  
PRINTED CIRCUIT MATERIALS

**ETCH RESIST SENSITIZER**  
AUTO SENSITIZES PRINTED CIRCUIT BOARD  
HOW TO SPRAY ON. AIR DRIES.

**SILVER PRINT CONDUCTIVE PAINT**  
PRINTED CIRCUIT MATERIALS

**PRINTED CIRCUIT MATERIALS**

GC ELECTRONICS  
DIVISION OF HYDROMETALS INC.  
ROCKFORD, ILLINOIS 61101

## FOR THE HOBBYIST & PROFESSIONAL

**FREE**

PRINTED CIRCUIT HANDBOOK  
WHEN YOU TAKE THIS AD TO  
YOUR ELECTRONIC SUPPLIER.



**GC ELECTRONICS**

DIVISION OF HYDROMETALS, INC.  
ROCKFORD, ILLINOIS 61101 U.S.A.



Circle 70 on reader service card



# There are more low-cost Heathkit projects than ever...

starting for as little as \$5!

These low-cost Heathkit projects represent great values on electronic items you could pay up to twice as much for in assembled form. But they are also great kits for the first-time Heathkit builder, or the youngster who has been wanting to try a sophisticated electronics project. All the kits shown can be assembled in one or two evenings' time with conventional hand tools and a soldering iron. The assembly instructions begin with a quick course in soldering then take the builder into the famous Heathkit check-by-step assembly manual. After the kit is completed and working, the builder can go on to the circuit description sections which tell him how and why his kit works.

And finally, only Heath gives its customers this unique pledge: "We won't let you fail". If a Heathkit builder has any problem before, during or after assembly, he has a nation-wide technical consultant staff backing him up. These technicians, at the Benton Harbor plant and Heathkit Electronic Centers in major metropolitan areas are the "big brothers" of the Heathkit fraternity. They are always pleased to lend a helping hand... free. For as little as \$5, a Heathkit product could be the most worthwhile investment you'll ever make.



A

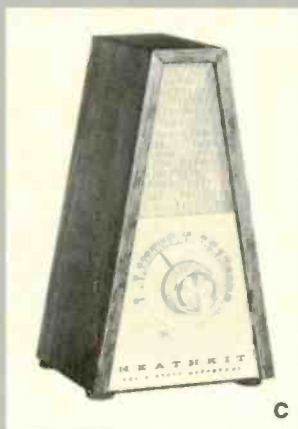

C



B



D



E

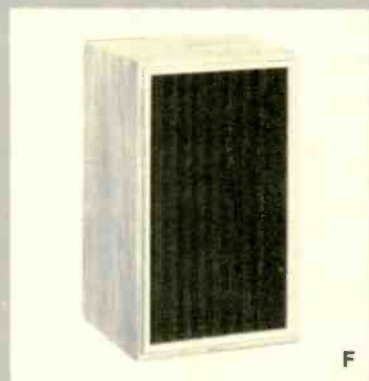

F



G



**A. Heathkit Lamp Dimmer** — lets you adjust brightness of table or floor lamps smoothly from full on to complete invisibility. A simple, useful kit, and an interesting introduction to Triac and Diac phase-controlled switches. Handles up to 300 watts.

Kit GD-1018, 2 lbs. .... 7.95\*

**B. Heathkit Tune-up Meter** — a 3-in-1 diagnostic instrument for 4-cycle, 3, 4, 6 and 8-cylinder engines having conventional (Kettering) ignition systems. Includes two-range tachometer to 4500 rpm, dwell meter, and voltmeter reading 0-15 volts. Completely portable.

Kit ID-29, 5 lbs. .... 29.95\*

**C. Heathkit Electronic Metronome** — provides professional accuracy in tempos from 40 to 210 beats per minute. Has adjustable volume control and includes chart relating tempos in time signatures to beats per minute. Uses two 9-volt batteries (not supplied).

Kit TD-17, 2 lbs. .... 9.95\*

**D. Heathkit Cab-to-Camper Intercom** — gives instant two-way communication between truck cab and cab-over camper or shell. Great for boats, too. Camper unit has switch position for listening to cab radio. Includes mounting brackets and 15' cable. 12-volt automotive system provides power.

Kit GD-160, 5 lbs. .... 25.95\*

**E. Heathkit Photoelectric Lamp Switch** — turns on a lamp when you're away. Adjustable sensitivity control lets you set unit to operate at various levels of darkness. No timers to set — electronic circuitry is fully automatic to compensate for changes in daylight hours during the year. Operates on 120 VAC household current.

Kit GD-600, 1 lb. .... 5.00\*

**F. Heathkit Bookshelf Speaker System** — excellent reproduction with any audio system having 4 watts or more per channel. Has 4½" high-compliance cloth-suspension speaker with sealed acoustic suspension cabinet. Measures 12" H x 7" W x 6" D. Useful frequency response extends from 70 Hz to 16 kHz. Order a pair for stereo.

Kit AS-106, 10 lbs. .... 19.95\*

**G. Heathkit Code Practice Oscillator** — great for beginning and novice amateur radio operators. Has tone and volume controls, built-in speaker, headphone jack, blinker light. Includes key, phone plug, cord. Uses two 9-volt and one "C" battery (not supplied).

Kit HD-16, 3 lbs. .... 9.95\*

**H. Heathkit Thermo Fish Spotter** — an all-solid-state thermometer with self-contained reel and 100' cable so you can find the depth where your gamefish are likely to be feeding. Kit includes fish temperature preference charts, calibrating thermometer and line depth marking material. Uses one 9-volt battery (not supplied).

Kit MI-104, 3 lbs. .... 24.95\*

**I. Heathkit 4-Watt Monophonic Amplifier** — all solid-state. Excellent frequency response and low distortion. Has inputs for ceramic phono cartridge, mono AM or FM tuner or tape recorder, plus front-panel headphone jack. Drives 4 to 16 ohm speakers.

Kit AA-18, 4 lbs. .... 19.95\*

**J. Heathkit Portable AM Radio** — tuned-in to today's look, turns on to the sounds of AM. Has big 3½" speaker, RF amplifier stage, automatic gain control — quality features not usually found on portables. Uses one 9-volt battery (not supplied).

Kit GR-1008, 2 lbs. .... 14.95\*

**K. Heathkit Telephone Amplifier** — lets you carry on conference calls or cook dinner while using the phone. And the special acoustic-coupled design means you can use it with virtually any telephone hand set. Amplifies incoming signal only. Includes speaker and 8' extension cord. Uses one 9-volt battery (not supplied).

Kit GD-1024, 2 lbs. .... 14.95\*

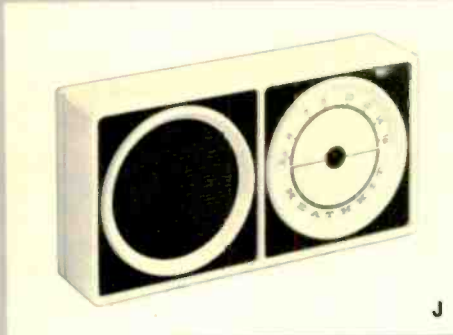

Visit your nearest Heathkit Electronic Center... or send for FREE catalog

**HEATHKIT ELECTRONIC CENTERS** — ARIZ.: Phoenix; CALIF.: Anaheim, El Cerrito, Los Angeles, Pomona, Redwood City, San Diego (La Mesa), Woodland Hills; COLO.: Denver; CONN.: Hartford (Avon); FLA.: Miami (Hialeah); GA.: Atlanta; ILL.: Chicago, Downers Grove; IND.: Indianapolis; KANSAS: Kansas City (Mission); MD.: Baltimore, Rockville; MASS.: Boston (Wellesley); MICH.: Detroit; MINN.: Minneapolis (Hopkins); MO.: St. Louis; N.J.: Fair Lawn; N.Y.: Buffalo (Amherst), New York City, Jericho; L.I.: Rochester; OHIO: Cincinnati (Woodlawn), Cleveland; PA.: Philadelphia, Pittsburgh; R.I.: Providence (Warwick); TEXAS: Dallas, Houston; WASH.: Seattle, WIS.: Milwaukee.



World's largest selection of electronic kits

HEATH COMPANY, Dept. 20-1  
Benton Harbor, Michigan 49022

HEATH  
**Schlumberger**

Please send FREE Heathkit Catalog.

Enclosed is \$ \_\_\_\_\_, plus shipping.

Please send model(s) \_\_\_\_\_

Name \_\_\_\_\_

Address \_\_\_\_\_

City \_\_\_\_\_

State \_\_\_\_\_

Zip \_\_\_\_\_

\*Mail order prices; F.O.B. factory.

CL-480

# 4 Money-saving reasons to buy EICO's Solid State Test Equipment.



**EICO 242 FET-TVOM.** Peak-to-peak measurements of AC volts and milliamps. 6½" meter. 7 non-skip ranges. High input impedance. Low 1 volt scale. DC/AC Multi-Probe. AC or battery operated. Kit \$79.95, Wired \$109.95.

**EICO 330 RF Signal Generator.** 5 bands cover a range from 100 kHz to 54 MHz. Calibrated modulation adjustment control. 400 Hz audio output. Provision for modulating RF with internal or external signal source. Kit \$64.95, Wired \$99.95.

**EICO 379 Sine/Square Wave Generator.** Simultaneous sine and square wave outputs. Covers 20 Hz to MHz in five ranges. Low distortion sultzer feedback circuit. Square wave rise time better than 0.1 microseconds. Kit \$74.95, Wired \$109.95.

**EICO TR-410 Triggered Sweep Scope.** 100% solid state. DC to 10MHz bandwidth. Sweep synchronized gate output. Z-Axis input. Use as vectorscope for color TV servicing. One probe for direct and 10:1 measurements. Wired \$429.95.

## FREE 32 PAGE EICO CATALOG

For latest catalog on Eico Solid State Test Equipment, Automotive and Hobby Electronics, Burglar-Fire Alarm Systems, Stereo, and name of nearest EICO Distributor, check reader service card or send 25¢ for fast first class mail service.

EICO, 283 Malta Street, Brooklyn, N.Y. 11207



Circle 71 on reader service card

# next month

FEBRUARY 1974

## ■ New Kind Of Color TV

IC circuit features make this set something special. We explain the operations of special functions that have not been seen in an American TV before.

## ■ What Is A ROM?

A Read-Only-Memory of course. But do you know how they work and what you can do with them? No! Find out in our February issue.

## ■ CD-4 Records The Problems & The Promise

Discrete 4-channel sound from records means CD-4. But there are problems. Be up-to-date on the latest developments.

## FOR TIGHT SPOTS!

# CHAPMAN

## Midget RATCHET SET plus ADAPTERS

Seventeen different interchangeable adapters with a screwdriver attachment and extension, plus the world's mightiest MIDGET RATCHET in a compact 4" x 6" steel case. The strength of this twenty tooth stainless steel ratchet far exceeds torque standards set by military specifications. Requiring only an 18° working arc, reverse action is obtained by simply turning the ratchet over. Kit includes 12 Allen Hex Adapters from .050" to 3/16", 2 popular Philips sizes (#1 and #2), 2 Slotted Head sizes (1/4" and 3/8"), plus a 1/4" Square Drive for use with standard sockets.

Only \$12.95  
Send Check  
or Money Order

POCKET SIZE  
NO. 6320 KIT

THE CHAPMAN MANUFACTURING COMPANY

Send Check or Money Order to ... DURHAM, CONNECTICUT 06422 Dept. RE-1

Circle 72 on reader service card

**Kleps 10**  
Boathook clamp grips wires, lugs, terminals. Accepts banana plug or bare wire lead. 4¾" long. \$1.39

**Kleps 20**  
Same, but 7" long. \$1.49

**Kleps 30**  
Completely flexible. Forked-tongue gripper. Accepts banana plug or bare lead. 6" long. \$1.79

**Kleps 40**  
Completely flexible. 3-segment automatic collet firmly grips wire ends, PC-board terminals, connector pins. Accepts banana plug or plain wire. 6¼" long. \$2.59

**Kleps 1**  
Economy Kleps for light line work (not lab quality). Meshing claws. 4½" long. \$ .99

**Prof 10**  
Versatile test prod. Solder connection. Molded phenolic. Doubles as scribing tool. "Bunch" pin fits banana jack. Phone tip. 5½" long. \$ .89

All in red or black - specify. (Add 50¢ postage and handling). Write for complete catalog of - test probes, plugs, sockets, connectors, earphones, headsets, miniature components.

Available through your local distributor, or write to:



**RYE INDUSTRIES INC.**  
129 Spencer Place, Mamaroneck, N.Y. 10543  
In Canada: Rye Industries (Canada) Ltd.

Circle 73 on reader service card



## STEREO AMPLIFIER CHIP KIT

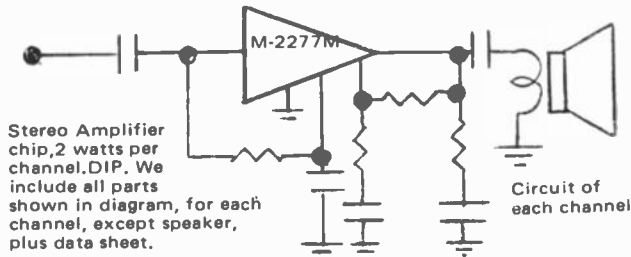

Stereo Amplifier chip, 2 watts per channel, DIP. We include all parts shown in diagram, for each channel, except speaker, plus data sheet.

STOCK NO. F5139 complete parts kit, \$8.95 ea. 2/\$16.00

## TUNG-SOL DIGIVAC FLUORESCENT READOUT TUBE.



Tung-Sol DT17048 7 segment fluorescent 9 pin miniature readout tube. Character size .360x570. Height 1 1/4". Fil. volts 1.6 AC or DC. Segment voltage 12 to 50 volts, 25 volts typical. Electrically identical to G.E. Y4075 & Y-1937. Readout color is green, but can be filtered to any color. We supply a socket for each tube, and many pages of application data.

STOCK NO. F5140 \$2.65 ea. 2/5.00 6/14.00

## HEWLETT *hp* PACKARD SOLID STATE NUMERIC INDICATOR

4 useable digit clusters of 7 segment readouts, contained on a 14 pin dual in line pack. Readouts are end stackable, to make up to 8 digits. Used by HP in their own digital devices. Available in 3 styles, 4 digits with space on left (X8888), 4 digits with space on right (8888x), and 4 digits with space in middle, (88x88), ideal for hour and minute clocks; x= space. With data and diagrams. \$7.95 per 4 digit cluster

STOCK NO. F5141 left space, F5142 right space, F5143 center space.

Include sufficient postage. Excess will be refunded. Send for free new 56 page catalog. Minimum order \$5.00.

## DELTA ELECTRONICS CO.

BOX 1, LYNN, MASSACHUSETTS 01903  
Phone (617) 388-4705

Circle 83 on reader service card

## DOTHATCH®

an exclusive Lectrotech development

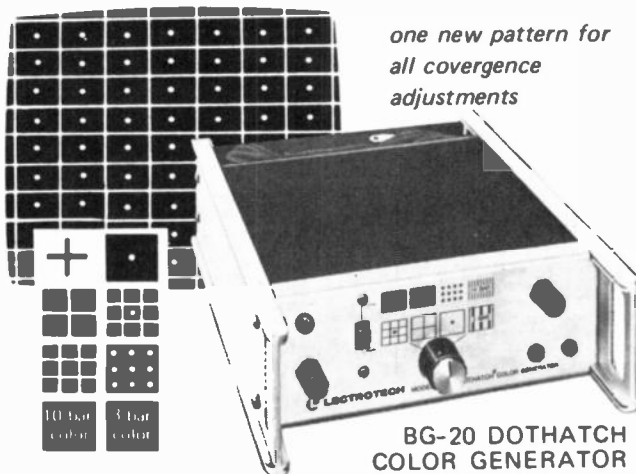

one new pattern for all coverage adjustments

### BG-20 DOTHATCH COLOR GENERATOR

The ultimate in pattern stability, at all temperatures, provided by Digital IC Counters. No internal adjustments. RF output channel 3 or 4 Video output 3v. P-P. 4.5 MHz crystal sound carrier. With shoulder strap and self-contained cable compartment. Net 129.50



See your distributor or write Dept. RE-1

## LECTROTECH, INC.

5810 N. Western Ave., Chicago, Illinois 60659 · (312) 769-6262

Circle 74 on reader service card

# AUTO AIDS

Do-It-Yourself—Save Time, Money, Gas.

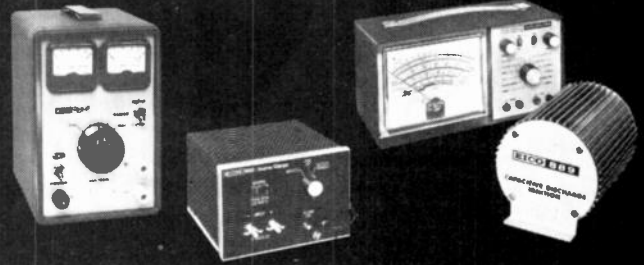

EICO 1064 Dual purpose Battery Eliminator and Charger incorporating an extra low ripple filter circuit. Ideal for servicing and powering 6-12 volt auto and marine equipment. \$64.95 Kit \$84.95 Wired

EICO 888 Portable Universal Engine Analyzer. Keeps your car or boat engine in tip-top shape. Complete with "How-to-Use" tune-up and troubleshooting manual. Kit \$54.95 Wired \$79.95

EICO 1080 200 watt Solid State Power Inverter and Battery Charger. Converts 12 volts DC to 117V, AC current. For use in cars, mobile homes and boats to operate recorders, appliances, etc. Kit \$44.95 Wired \$59.95

EICO 889 Solid State C-D Ignition System adds power to any engine. Boosts gas mileage up to 20%. Points and spark plugs last up to 5 times longer, instant cold weather starting. Kit \$29.95 Wired \$39.95

## FREE 32 PAGE EICO CATALOG

For latest catalog on EICO Test Instruments, Stereo, EICOCRAFT Projects, Environmental Lighting, Burglar/Fire Alarm Systems, and name of nearest EICO Distributor, check Reader Service Card or send 25¢ for First Class mail service.

EICO, 283 Malta Street, Brooklyn, N.Y. 11207



Circle 71 on reader service card



## STOP ERRATIC TUNERS!

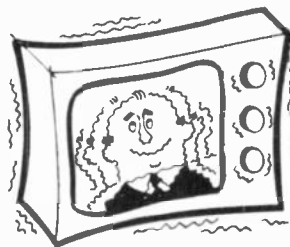

Designed For B/W and Color Strip Type VHF Tuners

- RESTORES NORMAL SIGNAL PATH IN TUNER CONTACTS
- DISSOLVES SULPHUR, OXIDES AND OTHER FILMS
- NON-EVAPORATING CLEANER
- WILL NOT CAKE OR HARDEN
- MAKE A PROFIT ON TUNER MAINTENANCE

Available at your local electronics distributor or for further information contact:

UNIVERSAL TUNER TABS MFG., INC.

12400 Minnetonka Blvd.  
Hopkins, Minn. 55343

Circle 75 on reader service card

# MOW

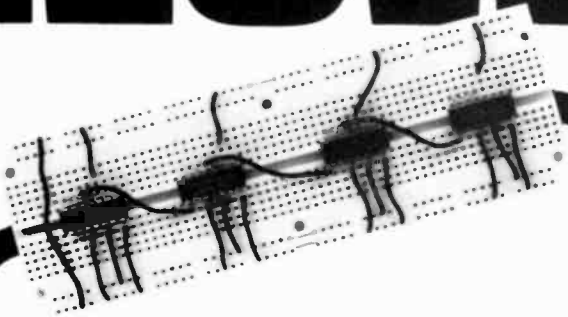

... TEST  
NEW CIRCUIT IDEAS,  
I.C.'s, DISCRETE COMPONENTS  
WITH NO SOLDERING!

Only **\$17.75** The E&L SK-10 SOCKET

Just plug in 1/4 watt resistors, ceramic capacitors, diodes, I.C.'s, transistors and more, and your circuit is built! No soldering! No special patch cords needed. All components reusable! Interconnect with any solid #22 gage wire.

- Nickel/silver terminals — low contact resistance
- Low insertion force
- Initial contact characteristics beyond 10M insertions
- Vertical and horizontal interconnecting matrices
- Handles wide range of wire leads from .015" to .032"

### MONEY-BACK GUARANTEE

Try it with absolutely no risk for 5 days. If not satisfied, return your SK-10 socket and get a full refund. Trying is believing. How can you go wrong? Send check or M.O. today!

- Add 50¢ for postage and handling
- 25% deposit for C.O.D.'s

Ask for FREE IDEA-PACKED,  
ILLUSTRATED CIRCUIT DESIGN  
CATALOG.



**E&L INSTRUMENTS, INCORPORATED**  
61 First Street, Derby, Conn. 06418

Circle 76 on reader service card

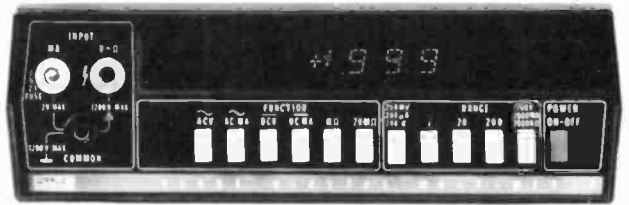

Think of it as the best tester  
in your bag. Only **\$299**

Now you can get a high performance Model 8000A Digital V.O.M. from Fluke, America's foremost maker of quality digital multimeters, especially designed for TV, radio, stereo and audio service. No other digital V.O.M. gives you the resistance range to check breakers and switches, the high resolution voltage to look at emitter base and other transistor voltages, excellent accuracy and full accuracy with a 30 second warm-up.

Measures in 26 ranges 100  $\mu$ V to 1200 V, 0.1  $\mu$ A to 2A, and 100 milliohm to 20 megohm with a basic dc accuracy of 0.1%. Full year guarantee. Low cost options include rechargeable battery pack, printer output, deluxe test leads, HV, RF & 600-amp ac current probes, carrying case, and rack mount. Unique self zero eliminates offset uncertainty. Electronics securely mounted in high-impact case. Service centers throughout U.S., Canada, Europe and Far East for 48-hour turnaround repair.



P. O. Box 7428,  
Seattle, Washington 98133.

Get all the details from your nearest Fluke sales office. Dial toll-free 800-426-0361 for address of office nearest you.

Circle 77 on reader service card

Accuracy like a VTVM...  
Convenience like a VOM...

NEW BATTERY-OPERATED FET  
SOLID-STATE VOLT-OHMMETER #116

Easy-to-build KIT

**\$32.40** =116K

Factory-Wired & Tested

**\$44.90** =116W

Now you can get all the benefits of a VTVM (laboratory accuracy, stability and wide range) but with its drawbacks gone: no plugging into an AC outlet, no waiting for warm-up, no bulkiness. New Field Effect Transistor (FET) design makes possible low loading, instant-on battery-operation and small size. Excellent for both bench and field work.

Compare these valuable features:

- High impedance low loading: 11 meg-ohms input or; DC, 1 megohm on AC
- 500-times more sensitive than a standard 20,000 ohms-per-volt VOM
- Wide-range versatility: 4 P-P AC voltage ranges: 0-3.3, 33, 330, 1200V; 4 RMS AC voltage ranges: 0-1.2, 12, 120, 1200V; 4 DC voltage ranges: 0-1.2, 12, 120, 1200V; 4 Resistance ranges: 0-1K, 0-100K, 0-10 meg., 0-1000 meg.; 4dB ranges: -24 to +56DB.

Sensitive easy-to-read 4 1/2" 200 micro-amp meter. Zero center position available. Comprises FET transistor, 4 silicon transistors, 2 diodes. Meter and transistors protected against burnout. Etched panel for durability. High-impact bakelite case with handle useable as instrument stand. Kit has simplified step-by-step assembly instructions. Both kit and factory-wired versions shipped complete with batteries and test leads. 5 1/4"H x 6 3/4"W x 2 7/8"D. 3 lbs.

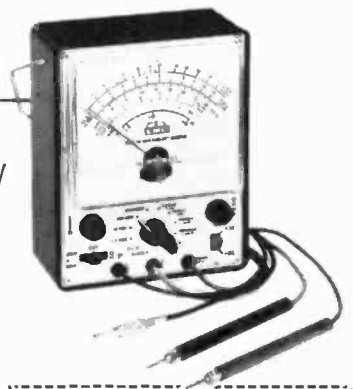

Send FREE catalog of complete EMC line and name of nearest distributor.

RE-1

Name \_\_\_\_\_  
Address \_\_\_\_\_  
City \_\_\_\_\_  
State \_\_\_\_\_ Zip \_\_\_\_\_

**EMC**

ELECTRONIC MEASUREMENTS CORP.  
625 Broadway, New York, N.Y. 10012



# equipment report

## RCA WR-525A MARKER/SIGNALYST.



Circle 89 on reader service card

THE PEOPLE AT RCA TEST EQUIPMENT have come up with another very useful unit. This is one of those little "attachment" devices, which can also work by itself. It's the WR-525A Marker/Signalyst; a solid-state rf signal generator, which covers all of the vhf TV channels, and can also be used on harmonics for uhf. It is a true Black-Box, meaning a simple, self-contained unit with useful outputs. (Actually, it's a very pretty light blue, but that's immaterial)

By plugging the WR-525A into the WR-514A TV Chanalyst, or similar sweep generator with continuous-tuning sweep on the vhf channels, you can get picture-carrier markers for each channel. By turning on the 4.5 MHz marker in the sweep generator, both sound and picture carrier markers can be used. This is a valuable test, for cases where you must know whether a set does have the correct response on all, or certain channels. For example, a set which comes from a rural or suburban area, and uses a channel not available on the air at the shop.

Two separate transistor oscillators are used, one for low channels, the

other for highs. The output of these goes to an rf amplifier stage. A modulator circuit is provided. You can modulate the rf output of the WR-525A with any kind of signal desired, up to 4.5 MHz: audio, video, colorbar, crosshatch, etc. You can even use actual program material, by feeding the video detector output of a working TV set to the modulation input of the WR-525A. You'll come out with picture and sound, which can be checked on all vhf/uhf channels of the tuner under test.

This makes the instrument very handy for checking out tuners, by the signal-tracing method. The rf signal can be fed into the mixer input, then to the rf input, and finally to the antenna. This will tell you very quickly if the tuner is working, and how well. In fact, this test will give you a better idea of how a tuner is working than a sweep-alignment test. Faster, anyhow—if the tuner under test produces a clear picture or pattern on all channels; it's good!

In a few cases, when using the video signal from a color-bar generator for modulation, you'll note spurious responses 3.58 MHz above

the correct frequency. This is caused by a beat in the tuner or signal generator; ignore it. Tune the dial of the WR-525A to the dot which indicates center frequency for each channel, and you'll get the right one. Incidentally, these dots are very accurate, I checked them.

Video modulating signal should be not more than 1.0 volt p-p. If it's greater than this, you may see signs of overloading. When using a color-bar generator, the attenuator will hold it down to the correct level. If you are using the video signal from another set, it may be too high. A schematic for a simple attenuator is including the instruction book.

This handy little unit has several other uses, and you'll probably find more as you go along. For example, you can feed an audio modulated marker signal into the WR-525A, and use it for setting traps, by the "dip" method. Connect the scope to the video detector output, then tune the trap for minimum audio signal; this dip shows the proper setting for the trap. An accurately calibrated marker generator is needed, of course.

The WR-525A is powered by an internal 9-volt battery, RCA VS-323 or equivalent. An external 9-volt dc supply can be used. A jack is provided on top of the case, and they even included the correct tiny phone plug to fit it. Battery life should be very good; that is, unless you leave the switch on, which isn't recommended. **R-E**

# We need you.

If you can spend some time, even a few hours, with someone who needs a hand, not a handout, call your local Voluntary Action Center. Or write to "Volunteer," Washington, D.C. 20013.

The National Center for Voluntary Action..



### NO COLOR

*This one's got me. It's a Curtis-Mathes CMC-33, a lot like an RCA, and the complaint is simply "No color". Still, I get good color-bar patterns on the scope, at the output of the bandpass amplifier, and at the color control. Not a thing at the input of the demodulators, though. Can't figure where it's losing it. There's an odd little "box" mounted on a bracket above the control cluster. This is not shown on the schematic. Help! - R.M.G., Honobia Okla.*

This is iffy, but I may know what is going on, since I fell over the same thing not long ago. Trace out your coaxial leads from the color control, and see if they don't go through this extra "little box". If so, this is the Automatic Tint Control unit they used on some models.

If you'll check, I think you'll find that one of the transistors in the ATC unit is bad. This is a "Chroma Amplifier" and must be operating, regardless of whether the ATC unit is turned on or not! (This is the same basic circuit found in the Magnavox T940 ATC unit, though the circuitry is different. This one had a chroma amplifier stage also)

If you can't get the service data on the ATC unit, it is possible to "jump" it, by running a new lead directly from the COLOR control to the demodulator input. This will disable the ATC, but let the color through.

### INTERMITTENT VIDEO

*This CTC-38 will play for some time, then pow! White screen, with a very faint video signal visible. Turn it off for a while, and it will come back. It's thermal, but where? - J.N., Magnet Cove, Ark.*

When the video goes out, read the emitter voltages on each of the i.f. transistors. (I'll bet you a cuppa cawfee that it's the 3rd video i.f. transistor. I'll also bet that it's intermittently opening.) If so, you will see its emitter voltage drop to zero when it cuts out. You can speed this up by spraying it with coolant.

### SNAP, CRACKLE, POP

*I've replaced a bad driver transistor in this Morse 77J stereo amplifier. Now, it plays, but it has a very bad crackling sound at all times. Tried a new preamplifier transistor, which didn't help. Have you run into this? - R.J., Bogalusa La.*

Yes. There are a couple more preamp transistors over on the other board, but check that little 4.7- $\mu$ F electrolytic coupling capacitor first. We have found some of these which would cause the crackling sound, but stop when you melted the solder on the

joints. Needless to say, we replaced the capacitors anyhow.

### TUNER AGC VOLTAGE

*According to Sams, the rf age voltage on the tuner (Zenith 21Y1C37) is supposed to be +4V. It won't play unless I set it for -0.3V at the tuner. What should I adjust? - E.N., Elgin Ore.*

Nothing. The +4V on the rf age should be measured with NO SIGNAL input. Actual age voltage, with signal, at this point will run from +25V to +0.3V. Check the 1.5-megohm bucking resistor from the age line to +230V. If this goes off-value, it upsets the age very badly.

### HV PROBLEMS

*There's ample grid drive in this Sylvania DO-3. In fact, it looks like a little too much. When I try to adjust the high-voltage to get the voltage down, the breaker trips. Am I over-driving it, or what? - E.W., Tuscaloosa, Ala.*

There are a couple of things which could be causing this. For one, check that .05- $\mu$ F bypass in the high-voltage regulator tube cathode. If this opens, it will foul up the action of the regulator, and cause the breaker to trip.

Also check that little neon lamp in the high-voltage regulator circuit. If this is bad, it upsets things. Replace with an exact duplicate; this is a polarized type.

### SQUIGGLES, WIGGLES, NO HV

*This Zenith 14N29 chassis is driving me up the wall. While it's warming up, the waveforms around the horizontal oscillator look fine. On frequency, correct amplitude, etc. As soon as the output tube warms up, the whole thing goes all to pieces; wild oscillations, etc., and no high voltage. DC voltages close to normal on 17JN6 horizontal output tube, quite a bit off on oscillator. Halp! - R.B., Orinda, Calif.*

Cheer up; "halp" is on the way. The first one of these I ran into took me two weeks. Try this test: kill the horizontal oscillator and drive the output with signal from another set. If this works, kill the output stage and scope the horizontal oscillator. If it works, then it's certain.

You have an open filter capacitor somewhere. This is allowing a feedback loop to set up as soon as the output stage gets to full operation. So you'll find that the two stages will work separately, but not together.

### TOO MUCH BRIGHTNESS

*I can't get the brightness to turn down on this Airline GAI-17423B color set. Also have had vertical retrace lines. Checked all transistors, cathode voltages on picture tube, and so on. The brightness control will vary the grid voltage on the 11CH11 tube. I'm stuck. - J.T.'s Radio-*

*TV, Elk City, Okla.*

From the long list of voltages you gave, I'm beginning to suspect one fairly simple thing. Everything looks normal. Check the setting of the three picture tube screen controls; I think you'll find them cranked wide open. Check the BRIGHTNESS RANGE control setting while you're there. (I got booby-trapped on one like this, and not too darn long ago, either.) Some previous tinkerer must have turned them up.

### MORE ON "MANY, MANY SYMPTOMS"

*Referring to your answer on the "Many, many symptoms" question, in the Aug. 1973 issue, on a CTC-38, I have found this kind of trouble in this chassis. It was due to a leaky capacitor between the 1st video amplifier and the video-sync-chroma amplifier. This is a .047- $\mu$ F V; C41 in the Sams Photofact 1000-3. Replace it with a 100V unit for safety. - Dan Scott, Scotty's TV Service, Madison, Wis.*

R-E



Every child matters  
to The Salvation Army.  
The lonely child  
in affluent suburbia.  
The neglected child  
in the ghetto.  
The hungry child  
in a pocket of rural poverty.  
With God's help, and within  
the limits of its resources,  
The Salvation Army reaches  
out to help children.  
You can help, too,  
by volunteering your time  
and talents at the nearest  
Salvation Army center.

# market center

CLASSIFIED COMMERCIAL RATE (for firms or individuals offering commercial products or services) \$1.15 per word . . . minimum 10 words.  
NONCOMMERCIAL RATE (for individuals who want to buy or sell personal items) 70c per word . . . no minimum.

FIRST WORD and NAME set in bold caps at no extra charge. Additional bold face at 10¢ per word. Payment must accompany all ads except those placed by accredited advertising agencies. 10% discount on 12 consecutive insertions, if paid in advance. Misleading or objectionable ads not accepted. Copy for March issue must reach us before December 28.

## ELECTRONIC ENGINEERING & INSTRUCTION

LOGIC newsletter, design and construction, sample copy \$1.00. LOGIC NEWSLETTER, Box 252, Waldwick, N.J. 07463

**CALCULATOR owners:** Use your calculator to compute square roots, trigonometric functions, logarithms, exponentials, and more! Quickly, accurately, easily! Send today for the improved and expanded edition of the first and best calculator manual — sold throughout the world . . . only \$2.00. Absolutely unconditional money-back guarantee — and fast service!  
**MALLMANN OPTICS AND ELECTRONICS**, Dept. — 3B, 836 South 113, West Allis, Wisc. 53214

## 313,344 CORE MEMORY \$125.00

From SPECTRA computer, visually OK. 64x 68x4x18 core stack. Figures out to 35K Byte.

## LED 7 SEGMENT READOUT SALE — 1 FREE W/EACH BOT



Similar to MAN-1. Factory seconds but functionally OK. Fit 14 pin DIP socket.  
7 segment w/left decimal  
#LED-A-L \$3.00  
7 segment w/right decimal  
#LED-A-R 3.25  
7 segment no decimal  
#LED-A 2.75  
Socket for above, gold plated leads 3/1.00

## IC SALE YOUR CHOICE 3 for \$1.00

ul 900 BUFFER TO-5  
ul 914 DUAL 2 INPUT GATE TO-5  
ul 923 JK FLIP FLOP TO-5  
ul 926 Hi speed JK FLIP FLOP TO-5  
ul 931 JK/RS FLIPP FLOP (DIP)  
10 pin socket for TO-5 IC 3/1.00

## GIANT NIXIE B7971

Used \$1.00 Brand New \$2.00  
With schematic for GIANT clock.

## COMPUTER TAPE DECK \$75.00

Takes 1/2 inch tape, made by Computer Entry Systems. Visually ok, with electronics, no data available.

LASER DIODES, new listing just arrived, send SAE.

## AM-FM RADIO \$5.50

Fully built, with AC supply, no cabinet, no speaker. Send for free catalog. Postage extra on above items.

MESHNA PO Bx 62,  
E. Lynn, Mass. 01904

Circle 87 on reader service card.

TV tuner repairs—Complete course details. 12 repair tricks. Many plans. Two lessons, all for \$1. Refundable. FRANK BOECK, Box 3236 (Enterprise), Redding, Calif. 96001.

## WANTED

QUICK cash . . . for electronic equipment components, unused tubes. Send list now! BARRY, 512 Broadway, New York, N.Y. 10012, 212 Walker 5-7000

"CASH" paid for unused teletype parts and assemblies. "PHILMAR", Box 96, Morrisonville, N.Y. 12962 518-561-3479

PROPOSED computer service for individuals and small businesses. Providing file, terminal, and program support. If interested contact: CLIFFORD BAILEY, 126 W. Needles, Bixby, Okla. 74008.

**YEATS dollies**

MOST VERSATILE Color Television TRUCK DEVELOPED!

FREE-illustrated brochure

**YEATS dollies**  
1324 W. FOND DU LAC AVE.  
MILWAUKEE, WIS. 53205

FURNITURE PADS \$1.99 EACH

ROLLS UP & DOWN STAIRS

YEATS Model No 5 \$76.50

## REBUILD YOUR OWN PICTURE TUBES?

With Lakeside Industries precision equipment, you can rebuild any picture tube!

For complete details, send name, address, zip code to:

LAKESIDE INDUSTRIES  
3520 W. Fullerton Ave  
Chicago, Ill. 60647  
Phone: 312-342-3399

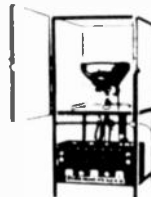

## MOVABLE CROSS HATCH FOR COLOR TV SET CONVERGENCE

\$18.50  
POST PAID  
IN USA

THE GENERATOR IS A TV TRANSMITTER GENERATING ONE VERTICAL AND ONE HORIZONTAL LINE EACH MOVABLE OVER THE TV SCREEN OUTPUT CONNECTS DIRECTLY TO SET ANTENNA ONLY 3 1/2 X 6 X 2. IDEAL FOR CARRYING IN TOOL CADDY. KIT IS COMPLETE WITH ALL PARTS, DIAGRAMS AND INSTRUCTIONS

PHOTOLUX CORPORATION  
BOX 139 NEW YORK NY 10016

WRITE FOR CATALOG.

# IC PRICES SLASHED

## FACTORY FIRSTS

Only quality parts are available from DIGI-KEY. We do not sell retested, rebranded or other reject parts.

## DIGITAL TTL

7400N	32¢	7446N	\$1.30	7496N	\$.120
7401N	32¢	7447N	\$1.30	74107N	\$.55¢
7402N	32¢	7448N	\$1.35	74121N	\$.70¢
7403N	32¢	7450N	32¢	74122N	\$.72¢
7404N	35¢	7451N	32¢	74123N	\$.11
7405N	35¢	7453N	32¢	74141N	\$.16
7406N	52¢	7454N	32¢	74150N	\$.156
7407N	52¢	7459N	32¢	74151N	\$.120
7408N	36¢	7460N	32¢	74153N	\$.158
7409N	36¢	7470N	36¢	74154N	\$.225
7410N	32¢	7472N	40¢	74155N	\$.146
7411N	35¢	7473N	52¢	74156N	\$.117
7413N	63¢	7474N	52¢	74157N	\$.156
7416N	50¢	7475N	85¢	74158N	\$.156
7417N	50¢	7476N	60¢	74159N	\$.195
7418N	35¢	7480N	74¢	74161N	\$.195
7420N	32¢	7482N	\$1.02	74162N	\$.195
7423N	75¢	7483N	\$.158	74163N	\$.195
7426N	36¢	7486N	60¢	74164N	\$.195
7430N	32¢	7489N	\$.450	74165N	\$.248
7437N	51¢	7490N	85¢	74166N	\$.203
7438N	51¢	7491N	\$.137	74180N	\$.120
7440N	32¢	7492N	85¢	74181N	\$.338
7441N	\$.145	7493N	85¢	74182N	\$.117
7442N	\$.120	7494N	\$.120	74192N	\$.180
7445N	\$.162	7495N	\$.120	74193N	\$.180

Discounts offered in quantities  
of 100 pcs TTL in mixed lots. 74198N. \$2.78  
74199N. \$2.78

## LINEAR INTEGRATED CIRCUITS

NE555V MiniDIP	\$.100	723C DIP	\$.115
NE565A DIP	\$.357	741C MiniDIP	\$.60¢
NE567V MiniDIP	\$.357	747C DIP	\$.110
N5558V MiniDIP	\$.95¢	748C MiniDIP	\$.60¢
709C MiniDIP	\$.44¢	Quantity Discounts	

## GENERAL PURPOSE SILICON TRANSISTORS

2N3638	PNP	20¢	10/\$1.65	100/\$15.00
2N3638A	PNP	22¢	10/\$1.80	100/\$16.50
2N3641	NPN	23¢	10/\$2.00	100/\$17.50
2N3643	NPN	23¢	10/\$2.00	100/\$17.50
2N5133	NPN	15¢	10/\$1.25	100/\$10.00
2N5134	NPN	15¢	10/\$1.25	100/\$10.00
2N5137	NPN	18¢	10/\$1.50	100/\$13.65
2N5138	PNP	15¢	10/\$1.25	100/\$10.00
2N5139	PNP	15¢	10/\$1.25	100/\$10.00
2N3055	NPN	\$.10	10/\$9.50	100/\$86.25

## 1 AMP SILICON RECTIFIERS

1N4001	50PIV	12/\$1	100/\$6	1M/\$49
1N4002	100PIV	11/\$1	100/\$6	1M/\$51
1N4003	200PIV	10/\$1	100/\$7	1M/\$53
1N4004	400PIV	10/\$1	100/\$8	1M/\$55
1N4005	600PIV	9/\$1	100/\$8	1M/\$61
1N4006	800PIV	7/\$1	100/\$9	1M/\$75
1N4007	1000PIV	6/\$1	100/\$10	1M/\$83

## SILICON SIGNAL DIODES

1N4148 (1N914 equiv.) 20/\$1 100/\$4.50 1M/\$35

## ELECTROLYTIC CAPACITORS

Values from 1 ufd through 2200 ufd. Competitive prices listed in latest flyer.

## MOLEX IC SOCKET PINS

100/\$1.00 200/\$1.80 300/\$2.60 500/\$4.20  
700/\$5.80 1000/\$8.20 ea addn 1000/\$7.50

## DISPLAY DEVICES

5 VOLT 7 SEGMENT TUBE .....\$3.75  
DISPLAY KIT (TUBE+7447+7475+7490) \$6.15  
3/\$17.50

7 SEGMENT LED (MAN-1 TYPE) .....\$4.00  
DISPLAY KIT (LED+7447+7475+7490+RESISTORS) .....\$6.40 3/\$18.25

1/4 & 1/2 WATT 10% RESISTORS  
1/4W 5¢ 30/\$1.20, 100/\$3.00, 500/\$13.75 as low as 1.7¢ ea in quantity-see catalog

1/2W 4¢ 30/90¢, 100/\$2.50, 500/\$11.25 as low as 1¢ ea in quantity-see catalog  
COD orders accepted for same day shipment.  
Call 218 681 6674.

Free Catalog—Large Quantity Discounts—Orders Less Than \$10.00 Add 25¢—Others Postpaid

**DIGI-KEY** PRICE PACESETTER  
FOR QUALITY IC'S  
BOX 126K THIEF RIVER FALLS, MN56701

Circle 88 on reader service card

## TUBES

SAVE money on parts and transmitting-receiving tubes, foreign-domestic. Send 25c for Giant Catalog. Refunded first order. **UNITED RADIO COMPANY**, 56-R Ferry Street, Newark, N.J. 07105

RECEIVING & industrial tubes, transistors. All brands-biggest discounts. Technicians, hobbyists, experimenters—request free giant catalog and save! **ZALYTRON**, 469 Jericho Turnpike, Mineola, N.Y. 11501

## BUSINESS OPPORTUNITIES

START small, highly profitable electronic production in your basement. Investment, knowledge unnecessary. Postcard brings facts. **BARTA-AZ**, Box 248, Walnut Creek, Calif. 94597

BUILD your own speaker systems. Lowest wholesale prices on famous brands. Write for 176 page catalog. **MCGEE RADIO COMPANY**, 1901 McGee Street, Kansas City, Missouri, 64108

## PLANS & KITS

ELECTRONIC organ kits, keyboards and many components. Independent and divider tone generators. All diode keying, IC circuitry. Build any type or size organ desired. Supplement your Artisan Organ. 25c for catalog. **DEVTRONIX ORGAN PRODUCTS**, Dept. B, 5872 Amapola Dr., San Jose, Calif. 95129

FREE catalog. Most unusual electronic kits available. Music accessories, surf, wind synthesizers, wind chimes, many others. **PAIA Electronics**, Box B14359, Oklahoma City, OK 73114.

SOLDERLESS IC prototyping techniques. 76-page illustrated manual \$4.95 postpaid. Experimenter publications catalog 25c. **MP PUBLISHING CO.**, Box 378, Belmont, Mass. 02178

JOYOUS TV viewing! Silent commercials, sound returns automatically! Novel circuit. Fun project. Description, parts list and schematic \$2.00. **HOBBY ELECTRONICS**, Box 2172, Capistrano Beach, Ca. 92624.

COMPUTER laboratory! New! Advanced technology. Integrated circuits. Transistors. Dozens experiments. Free information. **LINDSAY**, Box 12-T, Brady, Ill. 60915

FUN kits novel, entertaining, educational. Build electronic touch switch, audio alarm, digital clock, others. Send for free flyer. **ADVANT ELECTRONICS**, Dept. RE, P.O. Box 252, Lafayette Hill, Pa. 19444.

## FOR SALE

LOGIC probes from \$9.95. Free catalog. **ELECTRO INDUSTRIES**, 4201 Irving Park, Chicago, Ill. 60641

BURGLAR alarm system—Do it yourself. Installed in minutes. Free literature. **EMRAD CORPORATION**, P.O. Box 1341 Kokomo, Ind. 46901

CANADIANS. Parts for general experimenters. Free list. **HOBBYTRONICS**, Box 5385, Station—F. Ottawa, Ontario

CT5005: \$11.95, laser diode: \$5.95. Digital, linear IC's; LED's; readouts. Free catalog. **ELECTRONIC DISCOUNT SALES**, 138 North 81st Street, Mesa, Ariz. 85207

FREE bargain catalog. Transistors, computer boards, diodes, thermocouples, parts. **CHANEY'S**, Box 15431, Lakewood, Colo. 80215

MANUALS for Govt. surplus radios, test sets, scopes. List 50c. **BOOKS**, 7218 Roanne Drive, Washington, D.C. 20021

SEMICONDUCTOR and parts catalog. J. & J. **ELECTRONICS**, Box 1437, Winnipeg, Manitoba, Canada

SURPLUS opamps—25 different schematics for the hobbyist. \$2.00 postpaid. **GRAY**, P.O. Box 576-J, Ann Arbor, Mich. 48107

SCHEMATICS \$1.00. TTL logic probe, power supply 0-25vdc 1A. **KNOWLAR ENGINEERING**, Box 671, Stouffville, Ontario L0H1L0

REGULATED power supplies 5V-1A complete with leads, cord, case, etc., fully assembled \$24.50. (\$20.95 from this ad.) Ten day trial. **BAUER ELECTRONICS OF AMERICA**, Box 48, Nebraska City, Nebr. 68410.

## MAN 3M

- 0.127" High LED 7-Segment
- Displays All Numbers and Nine Letters
- Compact Spacing--5 Per Inch
- Bright Red 400FT-L at 10 MA Per Segment

Each, only . . . . . \$2.50  
Ten or more . . . . . 1.90  
W/D Decimal . . . . . 1.50

## LED's

MV-50 Red Emitting 10-40MA @ 2V \$ .25; 5/\$1.00

MV-5054 Red LED 15-100MA @ 2V \$ .30; 10/\$2.50

MV-108 Visible Red 5-70MA @ 2V \$ .30; 10/\$2.50

## ACA 2010

Numitron Digital Display Tube, Incandescent Five Volt Seven Segment

- .6" High Numeral Visible From 30 Feet
- Standard Nine Pin Base (Solderable)
- Left Hand Decimal Point

Each...\$ 5.00  
5 for... 20.00

## CT5005

A Single MOS Chip With All The Logic Necessary For A --Twelve Digit--Four Function Calculator With An Extra Storage Register For Constant or Memory Application

- 28 Lead DIL Package
- Capabilities (+, -, x, ÷)
- Chain Calculations
- True Credit Balance Sign Display
- Automatic Keyboard De-bounce
- Single Voltage Supply is Possible

Complete With Data...\$14.95  
Data Only... 1.90  
(Refundable With Purchase of Chip)

## General Telephone

Touch-Tone, Encoding, Programming Devices. 10 Push-button Switches. Size: 3" x 2 1/4" x 1"

only \$5.95

## SINGLE CHIP 40 PIN

- Add, Subtract, Multiply, and Divide
- 12-Digit Display and Calculate
- Chain Calculations
- True Credit Balance Sign Output
- Automatic Overflow Indication
- Fixed Decimal Point at 0, 2, 3, or 4
- Leading Zero Suppression

Data Only...\$1.00  
(Refundable with purchase of Chip)  
Complete with Data... 9.95

## MOS DYNAMIC SHIFT REGISTERS TO-5

MM502	Dual 50	Bit 1.25
MM506	Dual 100	Bit 1.75
MM5006	Dual 100	Bit 1.50
MM5013	1024	Bit 2.25
MM5016	512	DIL 1.50

STATIC SHIFT REGISTERS

MM504	Dual 16	Bit 1.50
MM505	Dual 32	Bit 1.75
MM550	Dual Differential	Analog Switch 2.50

## 7400dip

7400	.....	\$ .35
7400C	.....	.50
7401	.....	.35
7401C	.....	.50
7402	.....	.50
7404	.....	.35
7404C	.....	.50
7405	.....	.35
7405C	.....	.50
74121	.....	1.60
7413	.....	1.75
7410	.....	.35
7420	.....	.50
7420C	.....	.50
7422	.....	.50
7430	.....	.35
7430C	.....	.50
7440	.....	.35
7440C	.....	.50
7441	.....	1.60
7442	.....	1.30
7446	.....	1.75
7447	.....	1.75
7448	.....	1.15
7450	.....	.35
7451	.....	.35
7451C	.....	.50
7453	.....	.35
7453C	.....	.50
7454	.....	.35
7454C	.....	.50
7460	.....	.35
7471	.....	.30
7472	.....	.50
7472C	.....	.60
7473	.....	.65
7473C	.....	.90
7474	.....	.65
7474C	.....	.90
74154	.....	2.50
7476	.....	.70
7480	.....	.65
7483	.....	1.30
7489	.....	4.75
74192	.....	2.50
7490	.....	1.50
7491	.....	1.15
7492	.....	1.15
7493	.....	1.15
7495	.....	1.25
74195	.....	2.00
74107	.....	.70
74H30	.....	.50
74123	.....	2.00
74193	.....	1.50
74195	.....	1.10

## CMOS

CD4001	.....	\$ .75
CD4002	.....	.75
74C00	.....	.75
CD4012	.....	.75
CD4023	.....	.75

## LINEARS

LM100	.....	\$1.00
LM309H	.....	1.00
LM309K	.....	2.00
NE5556	.....	1.00
741(TO-5)	.....	.65
1595	4-multiple quadrant	2.00
747	.....	1.00
709	.....	.45
710	.....	.50
711	.....	.40
723 DIP	.....	1.00
748(TO-5)	.....	1.00

## POWER SUPPLY SPECIAL

723 T (TO-5) variable regulator chip 1-40V, + or - output @ 150MA 10A with external pass transistor...with diagrams for many applications.

Each...\$ .75  
Ten for... 5.95

## TRIAC

2N6344 600V BA TO-220.....\$ .75

## ZENER DIODES

IN4651	3.9V
IN4735	6.2V
IN4740	10.0V
Each	.....\$ .25

SEND FOR FREE FLYER!! C.O.D. PHONE ORDERS ACCEPTED--\$10 MINIMUM

All IC's new and fully tested, leads plated with gold or solder. Orders for \$5.00 or more are shipped prepaid, smaller orders---Add 35c. California residents add Sales Tax.....IC's shipped within 24 hours.

**BABYLON ELECTRONICS**  
P. O. Box J  
Carmichael, CA  
95608  
(916) 966-2111

Circle 81 on reader service card



**GREGORY ELECTRONICS**  
Reconditioned & Used  
FM 2-WAY RADIO SAVINGS  
Send for New Catalog

You Save **\$44** WITH THIS AD ONLY

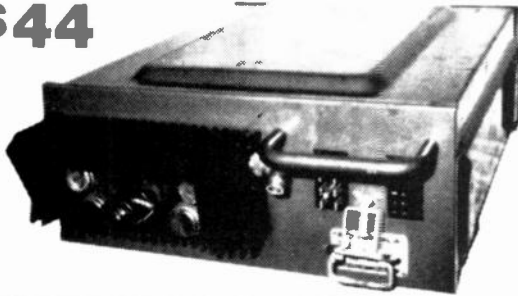

## MOTOROLA SPECIAL EXCELLENT CONDITION

X71GJT-1190B. 12 volts, 100 watts, full transistor power supply. 2 freq. 40-50 MHz transmit, 3 freq. receive (dual freq. 40-50 MHz, single freq. 30-40 MHz) with dual front end for simultaneous receive.

Including accessories. Bench checked. Reg. **\$228** Now **\$184**



**GREGORY ELECTRONICS CORP.**  
251 Rt. 46, Saddle Brook, N. J. 07662  
Phone: (201) 489-9000

For faster service  
USE ZIP CODE  
on all mail

# Opto Electronics Sale

LIGHT EMITTING DIODE GaAs INDICATORS

- 2-MV1, amber, visible jumbo epoxy lens upright 1.00
- 1-MV2, TO-18, dome, green, visible 1.00
- 1-MV2, green small dome, green diff. lite 1.00
- 1-MV2, clear small plastic dome, green diff. lite 1.00
- 1-MV3, micro-mini, pin header, TO-18, green lite 1.00
- 4-MV3, visible, "coax pin pak", red, mini dome lens 3.95
- 1-MV4, stud, high power, hi-dome, red, 2-watts 3.95
- 1-MV4M, stud, high power, hi-dome, red, 2-watts 3.95
- 4-MV10B, visible, red, clear dome lens TO-18 1.00
- 4-MV10C, visible, red, diffused, dome lens, TO-18 1.00
- 1-MV10D, diffused lens, green visible lite, TO-18 1.00
- 4-MV50, axial leads, micro-mini dome, clear, red, TO-18 1.00
- 1-MV52, micro-mini, axial green lens, green lite 1.00
- 1-MV53, micro-mini, axial yellow lens, yellow lite 1.00
- 4-MV54, micro-mini, axial leads, red lens, red lite 1.00
- 4-MV55, micro-mini, axial leads, red lens, red lite 1.00
- 4-MV5012, red small dome lens, red lite, TO-18 1.00
- 4-MV5013, sm. dome, 2 hi red dome, soft red diff. lite, TO-18 1.00
- 4-MV5020, jumbo clear dome, visible, red, TO-18 1.00
- 4-MV5021, jumbo red diffused lens, visible, lite, red 1.00
- 4-MV5022, jumbo red lens, visible red lite, spade, upright 1.00
- 4-MV5024, jumbo purple dome, purple flooded lite, TO-18 1.00
- 4-MV5026, jumbo red diffused lens, red lite, spade 1.00
- 1-MV5040, 4-LED red array, with 5-lead pak 1.49
- 4-MV5054, red jumbo dome lens, TO-18 red lite, upright 1.00
- 4-MV5080, TO-18, micro-mini red dome, red lite 1.00
- 4-MV5080, TO-18, micro-mini flat clear lens, red lite 1.00
- 4-MV5082, red clear flat lens, TO-18 red lite 1.00
- 1-MV5094, red bi-polar, solid state lamp V to 110-115VAC-DC 1.98
- 1-MV5222, green hi plastic dome, diffused green lite 1.00
- 1-MV5222, green hi dome, diff. green lite 1.00
- 1-MV5222, green jumbo dome, green lite, panel snap-in 1.49
- 1-MV5282, micro-mini, green lens TO-18, green lite 1.00
- 1-MV5322, yellow jumbo dome, yellow lite, panel snap-in 1.98
- 1-MV5491, jumbo, Tri-State, RED, GREEN, OFF, special 1.98
- 1-MV9000, cartridge panel lamp, sealed, red, clear lens 1.00
- 2-MT2, photo transistor, light sensor, TO-18 1.00
- 2-ME1, infra-red, parabolic lens, pin type 1.00
- 3-ME3, infra-red, invisible lite, "pinhead", single lead 1.00
- 3-ME4, infra-red, "invisible", TO-18, diff. dome 1.00
- 3-ME60, infra-red, "invisible", axial, micro-mini 1.00

- OPTO COUPLERS**
- MCD1, 4000V isolation photo transistor \$2.95
  - MCD2, 1500V isolation photo diode 1.00
  - MCT1, 4000V isolation photo transistor 3.95
  - MCT2, 1500V isolation photo transistor 1.00
  - MCT10, 10,000V isolation photo transistor 3.95
  - MCT5-25, 25,000V isolation photo transistor 2.95

## LITRONIX-OPCOA-MAN "7-SEGMENT" LED Readouts

All fit 14-pin IC sockets. All 7-segments. MAN Series "all LED" and made by well-known West Coast mfr. Others Reflective Bar type made by OPCOA and LITRONIX. The Reflective Bar types are low-cost versions of the MAN's, except 33 character height! If one LED blows you lose a segment. MAN's you DO NOT! All readouts 0-to-9 numerals, plus letters and decimal. \*Opcoa and Litronix products pin-for-pin replacements for MAN-1 MAN-4. All 5V TTL compatible.

ALL LED READOUTS	TYPE	character	Color	Decimal	Miss	Driver	Each	Special
MAN-1 equal	.27	Red	Yes	20	SN7447	\$4.50	3 for \$12.	
MAN-1A equal*	.27	Red	Yes	20	SN7447	4.95	3 for \$13.	
MAN-3 equal	.115	Red	Yes	10	SN7448	2.50	3 for \$6.	
MAN-3A equal*	.115	Red	Yes	10	SN7448	2.50	3 for \$6.	
MAN-3M equal*	.127	Red	Yes	10	SN7448	2.50	3 for \$6.	
MAN-3 equal	.115	Red	***	10	SN7448	1.95	3 for \$5.	
MAN-3M equal*	.127	Red	Yes***	10	SN7448	1.95	3 for \$5.	
MAN-4 equal*	.190	Red	Yes	15	SN7448	3.25	3 for \$9.	
MAN-4 equal*	.190	Red	Yes***	15	SN7448	2.75	3 for \$8.	

"REFLECTIVE LITE BAR" (Segment LED Readouts)

707** (MAN-1)	.33	Red	Yes	20	SN7447	3.25	3 for \$9.
704** (MAN-4)	.33	Red	Yes	20	SN7448	3.25	3 for \$9.
SLA-1** (MAN-1)	.33	Red	Yes	20	SN7447	3.25	3 for \$9.
SLA-2 + - 1	.33	Red	No	15	SN7447	3.25	3 for \$9.
SLA-3M Giant	.70	Red	Yes	20	SN7447	6.50	3 for \$18.
SLA-11C** (MAN-5)	.33	Green	Yes	40	SN7447	5.95	3 for \$15.
SLA-12** ± 1	.33	Green	No	40	SN7447	3.50	3 for \$9.

\* Red epoxy case, others clear. \*\* Litronix and Opcoa's pin-for-pin equals and electrical specs as MAN-1 or MAN-4. \*\*\* LED "dot" missing.

**HI-FI 1" SQUARE MINI METERS** \* Plastic case \* Red needle indicators

- Balancing, stereo, tape, amps. 3 for \$3.75
- VU, side mtg, plus 3 minus 20 db. \$1.49
- VU, front mtg, plus 3 minus 20 db.

**SPERRY "ORANGE" TWIN DIGIT ARRAY**

Type SP332, each digit is individually controlled, operates off 180VDC, 100 ma, 200 mw. Color: ORANGE. 7-digits, glass protection over digits. Character height: 0.33. P.C. mounting. Size: 3/4" x 3/4". 9-pins per digit. Driver: SN7447.

7-seg. (MAN-3 type) and internally "multiplexed" and driven by one SN7448. Intended for calculators, clocks, test equipment, etc. Encapsulated in red transparent epoxy in 14-pin dip pak. With decimals. High brightness, character .12 x .077-.5V, 10 ma.

3 LED DIGITS ON A DIP \$7.95

**LED MITY DIGIT "DCM'S"** \*Your choice of 5 red LED readouts!

Scientific Devices "Digital Counting Modules" outperform any other DCM on the market today. More features than ever before! Not gaseous, not incandescent, not nixie but the modern LED. Choose from such famous manufacturers as Monsanto's MAN-1, MAN-4, Litronix 707 and Opcoa's SLA-1 (the last 4 having character heights of 0.33 at no extra charge). Each kit includes 3x2" p.c. board with fingers for a FREE edge connector, side-mounting dip socket, LED readout of your choice, resistors, IC's, and Molex connectors (this ELIMINATES SOLDERING VOLTS IC's) and booklet. INCLUDES P.C. EDGE CONNECTOR — FREE!

Only \$9.99

Buy 3 — Take 10%

READOUT Char. Maker  
 MAN-1 27 h. Monsanto  
 MAN-4 19 h. Monsanto  
 707 33 h. Litronix  
 704 33 h. Litronix  
 SLA-1 33 h. Opcoa

100-PC. JUMBO CORNING "METAL OXIDE" RESISTOR KITS Only \$2.50

## KRONOS WITH "TIME BASE"\*

6-digits **CHOOSE YOUR READOUT** **\$47.** Any Type Clock less time-base **NEW FOR 1974!**

\* With TIME BASE \$64.95

Scientific Devices introduces the new any LED Kronos digital clock. That's right, you can choose the "ALL-LED" Man-1, Man-3, and Man-4, and the new reflective bar types with the larger digits, at only one price, \$47. This is a Scientific Device first! We even have the GREEN LED readouts at a slightly extra cost. We have more... for \$19.95, we have available as an extra option to Naval Observatory your clock, or making it an all-purpose all-duty unit. For indoor and outdoor activity. This "TIME BASE" is the simplest on the market today with the help of one of the largest time base manufacturers for the famous digital wrist watches. Therefore, current drain is negligible, not like other cumbersome types. It's easy to construct, easy to slip into the Kronos of your choice and connect with easy instructions. Its overall design is simple and easy to construct. The kit is complete with famous black-and-white TEN-TEC cabinet, plus all accessories with booklets. Features include 3 setting controls, 1-hour per second, 1-minute per second, and hold button. KR100 series is a Scientific Device exclusive!

- Now two clocks in one!
- For 12VDC or 110VAC!
- Now adaptable to boats, planes & cars too!
- One price for any LED!
- The only clock of its kind in USA today!
- Compare and see!
- 12 or 24-hr clock

**CRYSTAL TIME BASE FOR ANY KRONOS**

\$19.95

Includes precision crystal, time-base IC, p.c. board & accessories with info.

**SPECTROL CERMET "MICRO" POTS**

Ohms: 10, 20, 50, 100, 200, 500, 1K, 2K, 5K, 10K, 20K, 50K, 100K, 200K, 500K, 1 Mck

Your Choice Any 2 for \$1

Model No. 53-2-1 — 3/16" cube, single-turn, screw-adjust, front, 1/2 watt 20%.

Model No. 41-2-1 — 3/16" x 3/16" x 160" rectangular, 15-turn, wedge-shaped pins, for easy pe work. 1/4 watt 20% screwdriver side.

Model No. 53-1-1 — 3/16" dia. x 5/16" high. Single-turn, 3-leads, screwdriver top, 1/2 watt. TO-5 transistor size, fits transistor sockets.

**NIXIE**

Includes SN7490, decade counter, SN7475 latch, SN7448 BCD decoder, driver, 0-to-9 Nixie With socket.

5 for \$1

1-WATT FLANGELESS TOP HAT ZENERS

Type TK, Metal Case

Volts	Volts
4.7	9.1
6.2	12
8.2	15
10	18
12	25
15	30
18	36
22	45
27	54
33	66
40	80
47	95
56	112
68	135
82	162
100	180
120	225
150	270
180	330
220	405
270	495
330	594
400	720
475	855
560	1008
680	1224
820	1485
1000	1800
1200	2160
1500	2700
1800	3240
2200	3960
2700	4752
3300	5670
4000	6720
4750	7965
5600	9360
6800	10980
8200	12852
10000	15120
12000	17820
15000	21600
18000	25560
22000	30240
27000	35280
33000	40680
40000	47520
47500	54780
56000	62520
68000	71880
82000	81960
100000	93600

**COUNTING SYSTEM**

Includes SN7490, decade counter, SN7475 latch, SN7448 BCD decoder, driver, 0-to-9 Nixie With socket.

5 for \$1

**MUX'D DIGITAL CLOCK PC BOARD** \$2.50

MAN-1 Litronics 707 (MAN-1)  
 MAN-4 Opcoa SLA-1 (MAN-1)  
 S-MAN-3A\* for above board, \$9.50

\* Elec char. same as MAN-1 or 4.

**STUD "TRIACS"**

PRV 15 amp 25 amp

50	5.65	5.85
100	8.5	1.05
200	1.25	1.45
300	1.45	1.65
400	1.85	1.95
500	2.25	2.35
600	2.65	2.85

**CALCULATOR KEYBOARD SWITCH KITS**

Kit of 17 for \$7.50

10-pc. kit, 0-to-9 only, 3.50

Each switch made by Oak #415, SPST normally open, 24V 1 amp contacts. Kit includes 0-to-9 (10 switches white with black numerals) decimal, white with black dot, and CE, CL and 4 functions blue with white same type as above. 3.50 characters.

**12- "CALCULATOR CHIP" DIGIT**

Similar to Mostek 5001. Outperforms Texas K digit TMS1802. A 40-pin DIP. Adds, multiplies, subtracts, and divides. Use with 7-segment readouts, Nixies, and LEDs. We include schematic, instructions to build calculator.

CT5002-9 Volt version of above — \$8.88

CT5005-Same as above with MEMORY — \$14.95

CT5001 Chip \$6.95

**NATIONAL EQUALS ON "DIGITAL CLOCK on a CHIP"**

Any "Chip" \$9.95

\*Money Back Guarantee!

Mfrs #	Description	Sale
5311	28-pin, ceramic, any readout, 6-digits A-B-D	\$12.88
5312	24-pin, ceramic, any readout, 4-digits: C-D	\$ 9.95
5313	28-pin, ceramic, any readout, 6-digits: A-C	\$ 9.95
5314	24-pin, plastic, LED and incandescent readouts, 6-digits: A-B	\$12.88

Code: A—Solid Green, C—1 PPS output, B—Output Strobe, D—BCD

**NATIONAL MM5316 EQUAL-ALARM CLOCK ON A CHIP!**

100S 40-pin dip kit. Four display modes (time, seconds, alarm and sleep) for a variety of digital clocks. Interfaces directly with 7-segment fluorescent and liquid crystal displays. Requires single power supply, 12 or 24 alarm setting, featuring 9-minute SNOOZE ALARM and pre-settable 30-minute sleep timer. Low power design only 32mw @ 8V. Operates from 8 to 29 volts. NO REGULATION REQUIRED! Only needs 4-digits. Has seconds provision, with instant press a button. Has many, many other features. The only ALARM CHIP on the market today at this low Poly Pak price. With 5 pages of tech. info, plus applications.

Removed from new equipment! Includes popular 2N174 diode, germanium PNP, 150, watts, VCHO 80V, 15 amps, 10 hfe. For ignition, high power transmitters, etc. Mounted on heat sink 5 x 2 1/2" x 1 1/4".

3 for \$7.95

**HIGH POWER TRANSISTOR WITH HEAT SINK** 3 for \$3

**Potter & Brumfield KAP RELAYS**

Excellent for "MAN" use as antenna switching, latching, transmit, receive, etc. and 100's of commercial or industrial uses. Includes plastic dust-cover with diagram and hookup info, 11-pin plug-in base. Contacts movable, 100% stationary overlay with high purity platinum oxide movable. All contacts 10 amp SPDT. Coil data: 115VAC 2250 ohms, 17.5 ma, 12 VDC 21 ma 168 ohms. Size: 2 3/4" x 1 5/16". Wt. 4 ozs. Center pin missing. Comar Mfg. type equal too.

3 for \$2.98

Each board properly multiplexed for 6 digits, to hold MAN-1, MAN-3, MAN-4, and 704 (MAN-1) and 704 (MAN-4), and Opcoa's SLA-1 (MAN-1). Board 6 7/8" long with spacers.

**POLY PAKS**

P.O. BOX 942R, LYNNFIELD, MASS. 01940

Terms: add postage. Rated: net 40

Photo Orders: Wakefield, Mass. (617) 245-1829

Retail: 68-18 Del Carmine St., Wakefield, Mass. (off Water Street) C.O.D.'S MAY BE PHONED

15¢ CATALOG on Fiber Optics, IC's, Semi's. Parts



## U.S. GOV'T ELECTRONIC SURPLUS

• Nationally Known-World Famous SURPLUS CENTER offers finest, most expensive, Government Surplus electronic units and components at a fraction of their original acquisition cost.

### IBM COMPUTER POWER SUPPLY

• (ITEM #22-934-XYZ) Expensive, regulated unit. Fine for college labs, research co's, service shops, etc. Pure DC over a wide range of voltages. DC output voltages 5, 12, 15, 18, etc. Wide range of AC voltages available.

• Excellent transformers filter transistor load regulation system. Independent of line voltage fluctuations. Contains five separate rectifier systems. Unit is furnished without main "regulating card" which can be easily made or can be bypassed. Data and circuit diagrams furnished. 20" x 12" x 10" (125 lbs.)



Cost Gov't Over \$500.00 **\$26.95**

ONCE-IN-A-LIFETIME SPECIAL

### BURGLAR-FIRE ALARM SYSTEM



**\$39.95**

• (ITEM #1135-A) -- Dual alarm system gives warning of fire or break-in. Operates on 115V AC. Limited unit. 2-baffle flash fire 2-mercury column. 3 door window activations. Alarm bell 100 ft. wire. Includes tones. 8 1/2" x 7 1/2" x 3 1/2" (3 lbs.)

### STANDARD DIAL TELEPHONE

• (ITEM #718) -- Standard, commercial telephone same as used throughout U.S.A. Attractive polished black. Like new condition. Use an extension phone or private system. Use to connect several phones together for local intercom system. Full instructions are furnished. Wt. 9 lbs.



Original Cost **\$8.79**

### STEP-BY-STEP TELEPHONE SWITCH

• (ITEM #738) -- Amazing "up-and-around" switch. Great experimental item. When used with two wire telephone dial will select any number from 0 to 100. Also intercom or private system. Use to turn on remote lights, start motors, etc. Complete with contact bank 1 1/2" x 6 1/2" x 5 1/2" (16 lbs.) Cost (over \$90.00) **\$8.95**



• Telephone dial for use with above switch. Order as ITEM #700 V. (1 lb.) **\$1.97**

### MAGNETIC DIGITAL COUNTER (12 to 18-VDC)

• (ITEM #21-958) -- Use to count electrically. Use to count number of times door is opened after business is closed. Use to show changing prices. Laborer uses, etc. Will count 1 for each pulse and will transfer 10th count to next unit. 2 1/2" x 1 1/2" x 1 1/2" (1 1/2 lbs.) Orig. Cost Each **\$1.99** Four **\$4.99** Over \$15.00



• Telephone dial for use with above switch. Order as ITEM #700 V. (1 lb.) **\$1.97**

### 200 AMP., 50 VOLT, SILICON DIODE

• (ITEM #22-963) -- A Four Star Bus New, leading make. Heavy duty units excellent for use in 24-volt fuel chargers, high current power supply systems, etc. 2 1/2" x 1 1/2" x 1 1/2" -- 1/2" x 3/8" mounting threads. (1 lb.) List Over \$15.00 **\$4.98**



### AC PROGRAM TIMING CLOCK

• (ITEM #158) -- Zenith 115-V AC unit. Use for periodic signaling with breaks, classes, turn on radio, etc. Will skip permit 15-45 min. anytime in 24 hour period. Also has "skip days" feature. Can be multiple programmed. 15 amp. contacts. 8 1/2" x 6 1/2" x 4" (9 lbs.) Cost (over \$30.00) **\$15.75**



### SNAP AROUND VOLT-OHM-AMMETER

• (ITEM #21-944) -- Measures AC current without opening the line. Simply grab handle and snap the probe around the conductor. Reads currents from .25 to 125-amps. Reads voltages to 500 volts ohms up to 500. Test motors, appliances, etc. Three current ranges (two voltage ranges). With case. Test leads. 7 1/2" x 3 1/2" x 1 1/2" (2 lbs.) **\$39.95**



### SPECIAL SALE Correspondence Course in ELECTRICAL ENGINEERING

• (ITEM #9-181) -- Obtain technical training at low cost! Lincoln Engineering School has suspended its Correspondence Courses because of rising costs. A limited number of Electrical Engineering Courses are available but without the examination grading service. The course consists of 15 lesson books, each with associated exams and standard answers. Book describing price naming home & experimental laboratory bench furnished at no extra cost. **\$8.79** Prepaid in U.S.A. **\$10.79** Outside U.S.A.



### RUNNING TIME METER

• (ITEM #2180) -- Record number of operating hours of electric light and electrical devices such as refrigerators, furnaces, etc. Records total hours, months and hundredths up to 9,999.99 hours. Four 1 1/2" x 1 1/2" x 1 1/2" (2 lbs.) Shipping weight 2 lbs. **\$4.39** Cost Over \$20.00



### COMPUTER TRANSISTORS ON HEAT SINKS

IBM Computer Quality Units  
• (#22-928) -- Unit consists of one 150-mill power transistor on heavy, ribbed, aluminum heat sink. Many experimental uses. (1 lb.) Cost Gov't Over \$10.00 **\$1.98**



• (#22-918) -- Unit consists of two 150-mill power transistors, 2 diodes, several diodes, capacitors, resistors, etc. on heavy, ribbed aluminum heat sinks. Ideal for use as motor speed control. (4 lbs.) Cost Gov't Over \$15.00 **\$4.91**



ALL ITEMS SHIPPED F.O.B. LINCOLN, NEBR.  
Order Direct From Ad. Money Back Guarantee.

## SURPLUS CENTER

DEPT. RE-014 LINCOLN, NEBR. 68501

FREE catalog offers diodes, resistors, IC sockets, capacitors, crystals, power supplies, pots. Unbelievably low price. **PARSAD ELECTRONICS**, Box 32, Addison, Ill. 60101

ETCHED circuit supplies, chemicals, solder, specialized products. Free catalog. **TECHNICAL SERVICES**, Box 687R, Arlington, Mn. 55307

HIGH quality components at low cost. **SOLAR ELECTRONIC ENTERPRISES**, Box 778, Edmonton, Alberta, Canada T5J 2L4

NAME brand digital test equipment, discount prices. Free catalog and price list. **SALEN ELECTRONICS**, Box 82, Skokie, Ill. 60076

PARTS trays — 3 for \$1.00, 12 sections each tray. **SANTANA**, P.O. 3477, Los Angeles, Calif. 90028

CONVERT any television to sensitive big-screen oscilloscope. Only minor changes required. No electronic experience necessary. Illustrated plans \$2.00. **RELCO**—A25, Box 10563, Houston, Tex. 77018

TWENTY disc, or 10 bar magnets. \$1.00. **MAGNETS**, Box 192-E, Randallstown, Md. 21133

FREE catalog lists resistors, tubes, transistors, rectifiers, condensers, tools, tuners, etc. etc. **HYTRON HUDSON**, Dept. RE 2818 Kennedy Blvd., Union City, N.J. 07087.

GIANT 126 page Canadian surplus catalog. \$1.00. **ETCO ELECTRONICS**, Dept. RE, Box 741, Montreal, Canada.

NEW FM deviation meters \$75.00. Free information. Write ECM, 412C N. Weinbach, Evansville, Indiana 47711.

WHOLESALE prices on electronic parts. Large discounts. Free catalog. **DONLYN ELECTRONICS**, P.O. Box 15421, Phoenix, Ariz. 85060

DIGITAL electronics! Complete schematics, parts lists, theories—Discrete Component Digital Clock, \$3.00. Increase technical competence, hobby skills — Complete course in Digital Electronics is highly effective. \$10.00. Free literature. **DYNASIGN**, Box 60R2, Wayland, Mass. 01778

FACTORY outlet — stereo — quadraphonic — multiplex auto decks, radios and accessories \$15.00 up — \$1.00 for dealer lists. **BIDCO CONSUMER ELECTRONICS**, 565 East McMurray, McMurray, Pa. 15317

NEW! "Radiotelephone Exam Manual". First, second, radar, third classes with multiple-choice questions—answers, diagrams, formulas, rules, regulations. Recap from actual FCC material. "Score high" memorize, pass phone exams. \$15.00. "Act Now"! **EVALUATION RESEARCH HILL**, Dept-RR3, Box-19A56, Ahoskie, N.C. 27910.

## F.C.C. EXAM MANUAL

PARS FCC EXAM! Memorize study — Tests Approved for FCC 1st and 2nd class Radiotelephone Licenses. Heavy revised multiple-choice questions and diagrams cover all areas listed in FCC exam plan. Self Study Ability Test 99 99 postage. Moneyback guarantee

Test Approved for FCC First and Second Class Commercial License

COMMAND PRODUCTIONS P.O. BOX 26348 — E  
RADIO ENGINEERING DIVISION • SAN FRANCISCO, CALIF. 94126

## PARTS! CORNELL TUBES!

FREE Send For FREE CORNELL'S New Color Catalog 43 Pgs. New Items IN LOTS OF 100

**33¢** per tube **36¢** per tube

ORDER FREE IF NOT SHIPPED IN 24 HOURS!

4215 E UNIVERSITY AVE. SAN DIEGO, CALIF. 92105

## A NEW INSTRUMENT TO USE WITH YOUR SCOPE MULTITRACER

Use with your present Oscilloscope to trace Resistors, Capacitors, Transistors, Diodes, Transistors, Zeners, Tristors, most Semiconductors, IC's, etc. • Also shows continuity, in circuit and go/no-go checks. • Complete with diagrams and instructions. No internal scope connections. • For medium or small production runs or for hobbyist, experimenter, engineer, or ham.

ONLY \$19.95—CHECK OR MONEY ORDER. WHY PAY MORE?

BOX 14, LESCO ELECTRONICS, SKOKIE, ILL. 60076

## HIGHLY PROFITABLE ONE-MAN ELECTRONIC FACTORY

Investment unnecessary, knowledge not required, sales handled by professionals. Ideal home business. Write today for facts! Postcard will do. Barta-BA, Box 248, Walnut Creek, CA 94597.

FREE catalog. Tremendous electronic bargains **AMERICAN**, Box 4188X, Mountain View, Calif. 90040.

FREE book about digital logic and computers, and how you can design and build your own. **EEW**, Box 8204-CA, Pittsburgh, Pa. 15217.

LOGIC probe—LED's indicate logic state \$10.00, kit \$6.00. **SOLIDTRONICS**, Box 96, Union City, Conn. 06770

TRANSFORMERS—\$9.50—225VA-117V pri. You can specify sec. voltage 10-300 & C.T. Additional secondaries \$1.00. Shield covers add \$1.00. American parts & labor.—Add 9lbs. shipping. **HOBBY FORMER MFG.**, P.O. Box 222-RE, Port Arthur, Texas 77640. Phone 1-713-983-1555

TUNERS repaired realigned and neutralized by specialists. Uhf or Vhf \$9.75, combo \$15.00. Major parts extra. Ship to: **RAINBOW TUNER LABS**, 4158 Greeby St., Phila., Pa. 19135.



## STEP-BY-STEP TROUBLESHOOTING (continued on page 77)

Throughout the entire proceeding, your author (for once) wasn't able to use an oscilloscope—simply a 20-kilohm/voltmeter. Obviously in the low ranges, this instrument has a lower impedance than any fet meter or vtvm and will supply enough current and voltage to forward-bias both transistors and diodes. If you wish to 'scope this supply, we'd suggest you solder a number of small wires to the various terminals of interest, so that another probe slip won't cost you time, frustration and money.

A prime suggestion in working with any of these gate controlled switches is a little diagram Sony has been careful to include (Fig. 5), and we'll pass on to you. As you can see, ohmmeter measurements are between gate and K (cathode) and A (anode) in the polarities indicated and at the approximate resistances given. Similar measurements forward and backward decidedly means you have a bad (probably shorted) gs. If in doubt, compare its measurements (out of circuit) with another new one.

These switches, it seems, can prove somewhat tender. In checking RCA SCR switching (also Heath and Philco) high-voltage circuits, use a variable line voltage transformer (Variat, etc.) and proceed slowly after 85 volts. You'll save lots of SCR's.

The rest of your troubles can at least be approached by the troubleshooting chart printed here. It is impossible, of course, to cover all the possibilities in switched and non-switched power supplies. But the directions given can go a long way toward relieving your troubles. **RE**

**BRAND NEW LOWEST PRICES**

# GENERAL ELECTRIC \$2.50 3 FOR \$6.00

## 3-WATT AUDIO AMP

Delivers 3 watts continuous, 10 watts peak. With heat sinks: micro-mini size: 3x4x2 1/2", 9 to 30V supply. High sensitivity, 0 to 16 ohms. For mono and stereo phonos, tape, FM, AM, TV, servos.

**PA 263**

**Money-Back GUARANTEE on ALL ITEMS**

**Lowest Prices** **Brand New** **\*"DIP" Packages**

# Largest Selection T T L IC's

\* Factory Marked Order by type number! Spec sheets on request "ONLY" Buy 100 — Take 20%

Type	Sale	Type	Sale	Type	Sale	Type	Sale
SN7400	\$0.30	SN7437	.55	SN7472	.50	SN74112	.95
SN7401	.30	SN7438	.55	SN7473	.55	SN74113	.95
SN7402	.30	SN7439	.30	SN7474	.55	SN74114	.95
SN7403	.30	SN7440	1.40	SN7475	1.00	SN74121	.60
SN7404	.35	SN7441	1.50	SN7476	.65	SN74122	.95
SN7405	.35	SN7442	1.50	SN7477	.95	SN74123	1.20
SN7406	.45	SN7443	1.50	SN7478	.95	SN74125	.71
SN7407	.55	SN7444	1.50	SN7479	.65	SN74126	.71
SN7408	.35	SN7445	1.50	SN7480	1.25	SN74129	1.25
SN7410	.35	SN7446	1.65	SN7481	1.25	SN74139	1.25
SN7411	.35	SN7447	1.45	SN7482	1.25	SN74140	1.25
SN7413	.95	SN7448	1.50	SN7483	1.25	SN74145	1.55
SN7415	.55	SN7449	1.50	SN7484	1.41	SN74149	1.55
SN7416	.55	SN7450	.30	SN7485	1.41	SN74148	4.50
SN7417	.55	SN7451	.30	SN7486	.55	SN74150	1.61
SN7420	.30	SN7452	.30	SN7489	4.50	SN74151	1.25
SN7421	.30	SN7453	.30	SN7490	1.49	SN74152	4.95
SN7422	.35	SN7454	.30	SN7491	1.35	SN74153	1.60
SN7423	.35	SN7455	.55	SN7492	1.35	SN74154	2.10
SN7425	.50	SN7456	.30	SN7493	1.35	SN74155	1.55
SN7426	.36	SN7460	.30	SN7494	1.35	SN74157	1.55
SN7430	.30	SN7461	.35	SN7495	1.35	SN74158	1.45
SN7432	.35	SN7463	.30	SN7496	.35	SN74159	1.55
		SN7470	.50	SN74106	.95	SN74160	1.95
		SN7471	.55	SN74107	.70	SN74161	1.95
				SN74108	.95		

## WORLD FAMOUS SEMI-KON Dollar Stretchers

20-HEAT SINKS for all types of TO8 trans, makes 'em high power! \$1.

- 2-2N5296 35-WATT NPN PLASTIC TRANSISTORS, for NE-540 \$1.
- 2-2N6109 40-WATT PNP PLASTIC TRANSISTORS, for NE-540 \$1.
- 10-1N82 GERMANIUM UHF diode, clip-in type\* \$1.
- 5-SCRs 7-AMP TO220, 6-12-24 prv. power tab \$1.
- 5-SCRs 7-AMP TO220, 6-12-24 prv. power tab \$1.
- 10-MOS FETS, 3N187, 3N200, 3N128, TO-18, Fairchild \$1.
- 5-SCRs & FETs up to 25 amps, 6-12-24 prv. studs too \$1.
- 2-2N3819, Texas, 40 channel, 6500 umho TO-18 \$1.
- 2-2N2646 UNIJUNCTIONS, plastic transistors, Texas \$1.
- 5-2N107, GE, most commonly used pnp, germanium \$1.
- 50-SILICON, glass rectifiers, computer, axial leads \$1.
- 50-GERMANIUM, glass rectifiers, signal, axial leads \$1.
- 2N170, GE, 40 channel, 6500 umho, TO-22 \$1.
- 6-1 AMP 1000 PIV, epoxy, submini, silicon rectifiers \$1.
- 30-5000W ZENERS, axial 4, 6, 9, 10, 12V rectifiers \$1.
- 4-2N3055, HOBBY, 40W npn silicon transistors, TO-3 \$1.
- 30-3 AMP RECTIFIERS, silicon, epoxy, assorted V. axial \$1.

1-PHOTO TRANSISTOR, with darlington amp filter, lens \$1

2-PHOTO TRANSISTORS, with darlington amp, 2N5777, GE \$1

4-PHOTO CELLS, Charac, p/n/pack, -10K-70 ohms \$1

### "C-MOS" IC CIRCUITS

Type	Sale	RCA TYPE "C-MOS" IC's	Type	Sale
74C00	\$ .95	CD4001AE	\$ .71	
74C02	.75	CD4002AE	.71	
74C04	1.15	CD4046AE	1.69	
74C10	.95	CD4011AE	.71	
74C73	1.79	CD4012AE	.71	
74C74	1.59	CD4013AE	1.62	
74C76	1.79	CD4016AE	1.62	
74C157	2.50	CD4023AE	1.71	
74C160	3.50	CD4035AE	4.16	
74C161	3.50			
74C163	3.50			
74C195	4.50			

### "AEROSPACE" BABCOCK & LEACH CRYSTAL CAN RELAYS

All hermetically sealed. Submini, 1/8, half, and full crystal, 1.5V types in 6-12-24V in ast contacts up to 4PDT, 1 amp up to 10 amps. Such types as HR40, 41, 10, 46, 16, 24, etc. Sorry, no choosing voltages or types. From factory mixtures to your Good RELAY if you'd like recommended, at low prices.

**12 for \$3.50**

### I.C. & LED HOBBY-ONICS

Factory fallouts, good-bad-no good, money-back guarantee!

- 1-2N3055 npn, 100W, 15A, TO-3, transistor \$1.
- 5-ER900 TRIGGER DIODES for SCRs & Triacs \$1.
- 2-FETs 2N5457 N channel 5000 umhos, TO-92 plastic \$1.
- 10-1N914 fast swt. diodes, silicon, 4 nanoseconds \$1.
- 2-6 AMP TRIAC 200 PRV, TO-5 \$1.
- 4-ITT MICRO MINI RECTIFIERS silicon porcelain to 1KV\* \$1.
- 30-WORLD'S SMALLEST RECT. & zeners, 1W, assorted volts \$1.
- 4-2N4269 Nixie tube driver transistors, 100V, npn \$1.
- 2-PNPs, pnp, uni-transistors, similar to GE-D13T \$1.
- 2-6000 PIV 50 mil epoxy rectifiers, axial leads \$1.
- 10-BENDIX 25 WATT "pellet" power transistors, silicon \$1.
- 1-PHOTO ELECTRIC FET, 10,000 umhos, n channel \$1.
- 4-80 WATT, 2N1488, silicon, TO3, 60 Vpn, npn \$1.
- 4-1000 HFE DARLINGTON Transistors, TO-18 case \$1.
- 1-2N5035 N channel 10K umhos 100V, TO-18 case \$1.
- 4-2N5296 HOBBY, 35 watts, plastic powers, NPN \$1.
- 4-2N6109 HOBBY, 40 watts, plastic powers, PNP \$1.
- 5-PLASTIC 35W powers, npn, silicon, hobby 2N8121 \$1.
- 5-PLASTIC 35W powers, pnp, silicon, hobby 2N8122 \$1.
- 2-MOS FETS, DUAL GATE, N chan, 3N187, TO-18, RCA \$1.
- 2-MOS FETS, DUAL GATE, N chan, 3N140, TO-18, RCA \$1.
- 4-RCA 2N3600 NPN, UHF transistors, tv-fm, TO-18, 1000mc \$1.
- 1-300V PLASTIC POWER TAB transistors, 6A \$1.

## 20-WATT STEREO AM-FM MULTIPLEX SOLID STATE TUNER & AMPLIFIER!

AM-FM

**Only 29.95**

**FM freq: 88 to 108 mc! AM: 550 to 1600 kc!**

Lucky purchase enables us to give you this console type unit at portable prices. Consists of solid state products throughout. Made by Symphonie Mfg. AM section 550 to 1600 kc, FM section 88 to 108 mc. Excitecon, glass with all proper markings. Complete with AFC. Slide rule tuning. Built-in AM antenna. Built-in all SOLID STATE 20 watt stereo amplifier. With MULTIPLEX! Has tape input and outputs, phono input. Light indicators for dial and stereo. Compact chassis only 13 x 6 x 4". Modular technique used in design. 6 controls: VOLUME, TREBLE, BASS, TUNING, BALANCE, and multi-position switch control for AM-FM-AFC. AUXILIARY PHONO, TAPE. Wt. 4 lbs. With hookup diagrams. With knobs.

### 3-1-WATT AUDIO AMPLIFIERS, Westinghouse, TO-5 \$1.

- 15-709 FLAT PAK OP AMPS, 100% good \$1.
- 50-710-711 flip flop COMPARATORS, untested \$1.
- 4-DUAL 709, dip pak, op amps, untested \$1.
- 5-7474D triggered flip-flops, dip, no test \$1.
- 2-1101 256 BIT ram special, dip, no test \$1.
- 5-SN7447 7-Seg. decoder-driver fallouts \$1.
- 10-TO-5 Case 536, 540, 565, 567, 741 \$1.
- 5-MOS REGISTERS, 5013-17, mini dips, no-test \$1.
- 5-MOS REGISTERS, 501-6, etc., TO-5, no-test \$1.
- 5-SN7441N, hobby, BCD-to-Nixie driver IC, DIP \$1.
- 10-LINEAR AMPS, 709, 710, 711, TO-3 \$1.
- 10-709 LINEAR AMPS, DIP \$1.
- 5-HOBBY MEMORY CELLS, SN7481, up to 16-cell, DIP \$1.
- 10-RCA CA-3000 OP AMPS, TO-5 case \$1.
- 5-723 VOLTAGE REGULATORS, TO-5 \$1.
- 4-PHASE LOCK LOOPS, hobby 565, 560, 561 \$1.
- 10-MINI DIPS phase lock loops, 741, 301, 307, hobby \$1.
- 2-VOLTAGE REGULATORS, LM309K, hobby, TO-3 \$1.
- 10-SIGNETIC OP AMP, 831, 533, 536, 550, 555, DIPs, TO-5 \$1.
- 1-5311-14 CLOCK ON A CHIP, 4-or-6 digit, 24-or-28-pin \$1.
- 1-CALCULATOR ON A CHIP, hobby, exp. 40-pin, specs \$1.
- 4-DECADE COUNTER, hobby special, SN7490, DIP pak \$1.
- 1-2516 CHARACTER GENERATOR, hobby, for MAN-2 \$1.
- 1-2513 CHARACTER GENERATOR, Hobby for MAN-2 \$1.
- 4-SN74193 UPDOWN COUNTER, dip, factory fallouts \$1.
- 4-SN7442, SN7445 BCD-to-decimal, factory fallouts \$1.
- 10-SN7476 DUAL JK M/slave FFF, factory fallouts \$1.
- 5-SN7413 DUAL NAND SCHMIDT trigger, factory fallouts \$1.
- 5-SN74123 Betric, M. vibrator w/clear fallouts \$1.
- 4-SN74193 UPDOWN decade counter, dip, factory fallouts \$1.
- 10-SN7432 Dual JK Master S/flip flops \$1.
- 10-555 HOBBY TIMER special, in the mini DIP paks \$1.
- 10-NATIONAL 301 and 307, HOBBY OP AMP SPECIAL TO5 \$1.
- 15-NATIONAL & SIGNETIC TTL dip special, all marked \$1.
- 20-SN7400 DIP, manufacturers' fallouts, u test 'em \$1.
- 20-SN7404 DIP, manufacturers' fallouts, u test 'em \$1.
- 7-SN74121 DIP, multivibrator, fallout, u test 'em \$1.
- 5-LM-300 Super 723, manufacturers' fallouts, u test 'em \$1.
- 5-IBM IC's with pb board, many parts, from computers \$1.
- 1-AM RADIO-ON-A-CHIP, by Sprague, DIP, u test 'em \$1.
- 1-DUAL 2-WATT "Stereo-Amp-On-A-Chip", fallout Sprague, u test \$1.

\*Untested, guaranteed satisfaction.

## 8-TRACK CAR RADIO STEREO TAPE TRANSPORT \$8.88

Contains complete 8-track stereo recording playback unit. You find it expensive car tape deck. Excellent direct replacement unit if your own does not function properly. Priced to toss away old, and replace with new. Less amplifier. Design your own hi-fi stereo systems around it. Uses standard 8-track cartridge. With hi-fi stereo tape and all its mechanical parts that go with it. Operates at 12VDC. Automatic parts changing plus track indicator output. 34 ips speed, WOW and FLUTTER less than 0.5%. MU metal shield motor reduces motor noise to an inaudible one. Uses separate 739 preamp and is ready to go. Size: 5 x 5 x 2".

### GI "GLASS AMP II" SPACE AGE FEATURES

Meets critical JAN specs. A class "B" push-pull strength that meets JAN specs, high reliability, withstands avalanche power surges to 1K watts. ONE amp ratings in 2 amp capabilities. Axial leads.

Type	PIV	Sale
1N4245	200	\$ .14
1N4246	400	\$ .22
1N4247	600	\$ .39
1N4248	800	\$ .49
1N4249	1000	\$ .59

### NATIONAL 'OP' AMPS

BUY ANY 3 — TAKE 10%

Type	Description	Sale
LM-300	Super 723 V. reg.	\$1.49
LM-301	Hi-performance amp	.49
LM-302	Voltage follower	1.49
LM-304	Neg. V. reg.	1.49
LM-305	Pos. V. reg.	1.49
LM-307	Super 723	.59
LM-308	Hi-Fet Type Op Amp	1.50
LM-309H	SV 200 mil V. reg.	1.50
LM-309K	5V 1-amp V. reg.*	2.25
LM-311	Comparator	1.50
LM-320	Minus 5V 1-amp V.R.*	1.95
LM-320	Minus 12V 1-amp V.R.*	1.95
LM-320	Minus 15V 1-amp V.R.*	1.95
LM-350	Dual peripheral driver	.59
LM-370	AGC squelch op amp	1.49
LM-371	R-F, I-F, op amp	.69
LM-373	AM-FM, SSB, I.A.D.	3.75
LM-374	AM-FM, SSB, IVAD	3.75
LM-380	2-watt audio amplifier	1.95
LM-3028	Differential RF/IF amp	1.50
LM-3070	Chrome regenerator	1.50
LM-3071	TV chroma IF amp	1.50

\*TO-3 case, — others TO-5

### "MEMORY LANE"

1101	256 Bit RAM MOS	
1103	1024 Bit RAM MOS	\$3.50
2516	Character Gen. ROM	8.50
7489	64 Bit RAM TTL	12.50
8223	Programmable ROM	3.50
MMS260	1024 Bit RAM	7.95
MMS262	2048 Bit RAM	7.95

### EPOXY SILICON BRIDGE RECTIFIERS

PIV	2amp	6 Amp
50	\$ .05	\$ .08
100	.07	.11
200	.15	.22
400	.30	.45
600	.45	.68
1000	.75	1.10

Code: 2 amp TO-5 case 6 Amp 1 1/2 x 1 1/2 x 1/16 sq

### LOWEST PRICES

PIV	2amp	2Amp	4Amp
50	\$ .05	\$ .05	\$ .08
100	.06	.07	.11
200	.12	.15	.22
400	.25	.30	.45
600	.38	.48	.70
1000	.65	.85	1.25

### INTEGRATED CIRCUIT SOCKETS

14-Pin, DIP	\$ .45
14-Pin, Wire Wrap	.59
14-Pin, Side Mount	1.00
16-Pin, DIP	.50
TO-5, 8 or 10-Pins	.29

Buy Any 3 Take 10% Discount!

## POLY PAKS

Terms: add postage. Rated: net 30. Phone Orders: Wakefield, Mass. (617) 245-3829. Retail: 16-18 Del Carmine St., Wakefield, Mass. (off Water Street) C.O.D.'S MAY BE PHONED.

15¢ CATALOG on Fiber Optics 'IC's, Semi's, Parts

P.O. BOX 942R, LYNNFIELD, MASS. 01940

# INTERNATIONAL ELECTRONICS UNLIMITED

## TTL

7400	\$ .25	7446	\$1.45	74122	\$ .55
7401	.25	7447	1.45	74123	1.15
7402	.25	7448	1.50	74126	.95
7403	.25	7450	.29	74145	1.25
7404	.29	7451	.32	74150	1.25
7405	.27	7453	.32	74151	1.05
7506	.55	7454	.45	74153	1.45
7407	.53	7455	.32	74154	1.75
7408	.29	7460	.30	74155	1.35
7409	.29	7461	.30	74156	1.50
7410	.25	7464	.45	74157	1.50
7411	.35	7465	.45	74161	1.65
7413	.95	7470	.50	74163	1.80
7415	.50	7472	.45	74164	2.95
7416	.50	7473	.55	74165	2.95
7417	.50	7474	.55	74166	1.95
7420	.25	7475	.95	74173	1.95
7421	.32	7476	.55	74175	1.95
7422	.32	7478	.95	74176	.95
7423	.37	7483	1.25	74177	.95
7425	.39	7485	1.20	74180	1.15
7426	.35	7486	.55	74181	4.25
7427	.39	7489	3.25	74182	1.10
7430	.25	7490	1.25	74190	1.65
7432	.30	7491	1.40	74192	1.65
7437	.50	7492	1.05	74193	1.65
7438	.55	7493	1.05	74194	1.65
7440	.25	7494	1.10	74195	1.15
7441	1.25	7495	1.05	74196	1.35
7442	1.15	7496	1.05	74197	1.15
7443	1.25	74100	1.40	74198	2.50
7444	1.30	74107	.55	74199	2.50
7445	1.25	74121	.65		

### Low Power TTL

74L00	\$ .40	74L42	\$1.75	74L85	\$1.25
74L02	.40	74L45	1.45	74L86	.95
74L03	.40	74L51	.40	74L90	1.75
74L04	.40	74L71	.60	74L91	1.50
74L06	.40	74L72	.60	74L93	1.75
74L10	.40	74L73	.80	74L95	1.75
74L20	.40	74L74	.80	74L164	2.95
74L30	.40	74L78	.80		

### 8000 Series TTL

8054	\$ .45	8123	\$1.75	8570	\$2.95
8060	.30	8182	1.75	8600	1.15
8091	.69	8214	1.95	8810	.95
8092	.69	8230	2.95	8812	1.25
8093	.69	8280	.95	8822	2.95
8094	.69	8288	1.05	8830	.69
8122	1.05	8520	1.45	8831	2.95

ALL DIP PKGS.  
Specify spec. sheets required with order. Add \$.50 per spec sheet for items less than \$1.00 ea.

## Linear

LM 300	Pos V Reg (super 723)	TO5	\$ .95 ea.
LM 301	Hi performance AMPL	TO5	.45 ea.
LM 302	Voltage Follower	TO5	.95 ea.
LM 304	Negative Voltage Regulator	TO5	1.25 ea.
LM 305	Positive Voltage Regulator	TO5	1.25 ea.
LM 307	Op AMP (super 741)	TO5	.45 ea.
LM 308	Micro Power Op Amp	TO5	1.25 ea.
LM 309H	5 V Regulator	TO5	1.95 ea.
LM309K	5 V 1A Regulator	TO3	1.95 ea.
LM 310	Voltage Follower Op Amp	TO5	1.45 ea.
LM 311	Hi Perf. Voltage Comp.	TO5	1.25 ea.
LM 320	5.2 V Negative Regulator	TO3	1.95 ea.
LM 320	12 V Negative Regulator	TO3	1.95 ea.
LM 320	15 V Negative Regulator	TO3	1.95 ea.
LM 370	AGC/Squelch Amp	DIP	1.29 ea.
LM 372	AF - IF Strip-detector	DIP	.85 ea.
LM 376	Pos. Voltage Regulator	DIP	.65 ea.
LM 380	2 watt Audio Amplifier	DIP	1.75 ea.
LM 550	Precision Voltage Regulator	DIP	.95 ea.
LM 709	Op Amp	TO5 or DIP	10/\$3.25 .39 ea.
LM 723	Voltage Regulator	TO5 or DIP	5/\$3.25 .75 ea.
LM 741	Comp. Op Amp	TO5 or DIP	10/\$3.95 .45 ea.
LM 747	Dual 741 Op Amp	TO5 or DIP	4/\$3.50 .95 ea.
LM 3900	Quad Amplifier	DIP	.50 ea.
LM 75451	Dual Peripheral Driver	DIP	.49 ea.
LM 75452	Dual Peripheral Driver	DIP	.49 ea.

Specify TO5 or Dip Package  
Specify spec sheets required with order. Add \$.50 per spec sheet for items less than \$1.00 ea.

## Phase Locked Loops

NE 565	Phase locked loop	TO5 or DIP	\$2.95 ea.
NE 566	Function Generator	TO5 or DIP	2.95 ea.
NE 567	PLL/TONE Gen.	TO5 or DIP	2.95 ea.

## Memories

1101	256 bit RAM MOS (2501)	\$2.50 ea.
1103	1024 bit RAM MOS	7.95 ea.
7489	64 bit RAM TTL	3.25 ea.
8223	Programmable ROM	6.95 ea.

### \* NEW ITEM \*

MM 5260	1024 bit RAM Second generation version of 1103 . . . Featuring 16 pin DIP rather than 18 pin . . . 30% less power consumption Introductory Price . . .	9.95 ea.
---------	---	----------

# NEW YEAR SPECIALS

1101	256 Bit RAM MOS 2501	\$2.00 ea.
8223	Programmable ROM	5.95 ea.
LM309K	5V 1A Regulator	1.75 ea.
9501	Retriggerable One Shot	.85 ea.
LM75451	Dual Peripheral Driver	.39 ea.
7437	Quad 2 in NAND Buffer	3/\$1.00
7438	Quad 2 in NAND Buffer	3/\$1.00
7453	Expandable AND-OR-INVERT gate	4/\$1.00
7490	Decade counter	1.10 ea.
74121	One Shot (monostable multivibrator)	.39 ea.
74193	Up/down binary counter	1.39 ea.

## 5002 LSI Calculator Chip

Battery powered version of 5001 with 12 MAN 3M LED  
Complete with Data . . . . . \$19.95/set

## MM5312 Digital Clock Chip

28 pin - any readout - 6 digit BCD with 4 MAN 3M LED  
Complete with Data . . . . . \$11.95/set

## MOS Grab Bag

8 Untested MOS MIX (dip)	\$ 2.00
50 Untested MOS MIX (dip)	\$10.00

## 5001 LSI Calculator Chip

Overstocked on this popular calculator chip. This month only . . . With Data . . . . . \$ 4.95 ea.

## NEW YEAR SPECIALS IN EFFECT THROUGH JANUARY

## CMOS

74C00	\$ .90	74C73	\$1.70	74C161	\$3.25
74C02	.90	74C74	1.50	74C162	3.25
74C04	1.10	74C76	1.70	74C163	3.25
74C10	.90	74C107	1.50	74C192	3.25
74C20	.90	74C157	2.25	74C195	3.00
74C42	2.15	74C160	3.30	80C97	1.50

## 4000 Series - RCA Equivalent

CD 4001	\$ .65	CD 4011	\$ .65	CD 4025	\$ .65
CD 4002	.65	CD 4012	.65	CD 4030	.65
CD 4009	1.50	CD 4016	1.50	CD 4035	3.65
CD 4010	.65	CD 4023	.65		

## Digital clock . . . on a Chip

MM 5311 (28 pin) Any readout 6 digit BCD with spec. sheet	\$11.95 ea.
MM 5312 (24 pin) Any readout 4 digit 16pt BCD with spec. sheet	8.95 ea.
MM 5313 (28 pin) Any readout 6 digit 16pt BCD with spec. sheet	10.95 ea.
MM 5314 (24 pin) LED-incandescent readout 6 digit with spec sheet	10.95 ea.
MM 5316 (40 pin) Normal alarm, snooze alarm, sleep timer 12 or 24 hr. operation with spec sheet	15.95 ea.

## UNTESTED SECONDS

MM502	Dual 25-bit dynamic shift register	TO5	\$ .35 ea.
MM503	Dual 50-bit dynamic shift register	TO5	.35 ea.
MM504	Dual 16-bit static shift register	TO5	.35 ea.
MM505	Dual 32-bit static shift register	TO5	.55 ea.
MM5006	Dual 100-bit register	TO5	.35 ea.
MM5010	Dual 64-bit accumulator	TO5	25 ea.
MM5016	512 bit dynamic shift register	TO5-DIP	25 ea.
MM5013	1024 bit dynamic shift register/accum.	TO5-DIP	55 ea.
MM5019	Dual 256 bit mask prog. shift register	TO5	25 ea.
MM5050	Dual 32-bit static shift register	TO5	.35 ea.
MM5053	Dual 100-bit static shift register	TO5	.25 ea.
MM5054	Dual 64/72/80 bit static shift register	DIP	.35 ea.
MM5230	2048-bit read only memory	DIP	1.00 ea.
MM5240	2560-bit static character generator	DIP	1.00 ea.
MM1403	1024 bit dynamic shift register	DIP	.65 ea.
MM1404	1024-bit dynamic shift register	DIP	.65 ea.

MOS Shift Registers 2500 Series  
2502 2506 2509 2510 2511 2518 2519 2521 2522  
Untested seconds . . . . . 4/1.00

Grab Bag Specials  
15 Assorted TTL's (dips) . . . . . \$1.00/bag  
25 Assorted DTL's (dips) . . . . . \$1.00/bag

## Opto Isolators

MCA 2-30	Darlington	\$ .95 ea.
MCD 2	Diodes	1.95 ea.
MCT 2	Transistor	1.45 ea.

## ON ORDERS OVER \$25.00 DEDUCT 10%

Satisfaction guaranteed. All items except as noted are fully tested. Minimum order \$5.00 prepaid in U.S. and Canada. Calif. residents add sales tax. Orders filled within three days from receipt.

INTERNATIONAL ELECTRONICS UNLIMITED  
P.O. BOX 1708R  
Monterey, Calif. 93940

**MORE BARGAINS IN SURPLUS ELECTRO-OPTICS from B & F ENTERPRISES**

Just off the press our Best Catalog yet with 104 Illustrated pages of Surplus Electronics, Optics, and Much More...

**NICKEL CADMIUM BATTERIES**



- 0.5 ampere hour 1.25 volt sealed button cell ..... 2 for \$1.00
- Vented 4.0 ampere hour cell, plastic case ..... \$2.75
- 24 volt pack, sealed cells, mfg. sonotone, size 12" x 1 1/2" x 1 1/2" capacity 0.6 ampere hours ..... \$11.75

**CORE MEMORY STACKS**



RCA for Honeywell. Ideal for Minicomputers, some electronics, but no power supplies are included on the card.

One of our most popular sellouts. Two types available are the 4096 words x 9 bits (36, 864 bits) easily organized as 4096 x 8 bits, and 8192 words x 4 bits (32,768 bits), manufactured by Litton Industries and RCA for Honeywell. Ideal for Minicomputers, some electronics, but no power supplies are included on the card.

4096 x 9 Memory ... \$60.00  
8192 x 4 Memory ... \$45.00

**LED READOUTS**



Popular OPCOA SLA-7, without decimal point. 0.27" numeral height, we formerly sold these at \$4.25, and they sold extremely well. Because of a fortunate purchase we can offer them at a super-low price. Use for clocks, counters, calculators

SLA-7 Readouts ..... \$2.50

**CALCULATOR KEYBOARD**



Smooth quiet key travel, double shot keys, completely sealed, impervious to dust, moisture and even direct liquid spills.

This is a Flex-Key series SK keyboard made for pocket calculators. Only 2.36" x 3.76" x 0.45" thick; Switch matrix for Cal Tex 5001, 5002 or Mostek 5010 or 5012 chips.

CK ..... \$8.00  
10 or more ..... \$6.00

**12 VOLT 0.750 AMPERE HOUR SEALED NICKEL CADMIUM BATTERIES**



quantities are limited, won't last long, so order now!

Brand new, manufactured by Gould National. Size: 1" dia. x 9-3/8" L. Manufacturer's list price is \$24.50. Excellent for photo-flash, burglar alarms, etc. Fully guaranteed, available at a fraction of original cost—

12V 0.75 AHSNCB ... \$9.75

**7-SEGMENT DIGITAL DISPLAY — \$1.70 each**



decade counting unit or a 6-digit clock. Tubes are brand new, bulk packed, and manufactured by Tung-Sol, no. 1705. Sh. Wt. 4 oz.

Bright blue-green display tube, with numerical display characters. Tube exhibits very fast display speed and easy-to-read characters of .57" H x .36" W, with decimal point. Complete with instructions to make a

7SD-1705 ... \$1.70 each; or 6 for \$8.50,  
10 for \$14.00, 100 for \$125.00, 1000 for \$950.00

**COLLINS CRYSTAL FILTERS**



Anyone who is familiar with super high quality communications receivers is familiar with the Collins filter. 455 Kc center frequency, 300 Hz bandwidth. Part number 526 7073 009, type X455-KF 300. Full technical information provided.

Collins Crystal Filter ... \$14.75

**LOUDSPEAKER SYSTEM COMPONENT SPECIAL!**

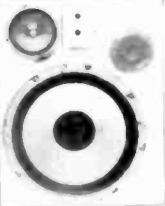

Crossover between woofer & mid-range is by an R-L-C network, while high frequency crossover is by an R-C network. Balance controls are provided for both mid-range and tweeter. Plans for a suitable enclosure are provided. The level controls provide frequency response to suit room acoustics, with realism that will delight even the most critical listener. Response — 25 to 20K + Hz., Power — 40 watts RMS. Impedance — 8 ohms.

Sh. Wt. 12 lbs.  
 LSCS ..... \$36.00  
 2LSCS ..... 2 for \$65.00

**TELSA COIL KIT**



Here's a truly basic kit for those who like to "roll their own." All the parts for an exciting adventure into high-frequency, high voltage. Add your own metal housing — a small chassis or universal box is ideal.

Tesla coils are patterned after the design of Nikola Tesla (1857-1943) an American electrical genius who built versions many feet tall. His dream was to light and power entire cities with energy radiated from such coils — but no luck!

Today's Tesla coils are popular with experimenters and students, and especially for science fair and educational demonstrations. Ours is a high-frequency push-pull oscillator coupled to a television flyback transformer, which steps up an external 12 VDC power supply to many thousand volts.

SPECIAL NOTE: Although current output is relatively low, some hazard is inherent in all high voltage devices. This kit is intended for the experimenter who is mature enough to observe reasonable precaution in its use.

TESLA COIL KIT ..... \$7.50

**DECADE COUNTING UNITS WITH READOUTS**

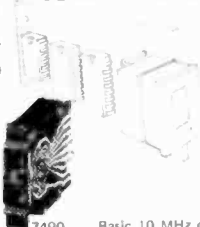

Always one of B & F's most popular items, now revised to include drilled boards, I.C. sockets, and right-angle socket for readout. Arranged so that units can be stacked side by side and straight pieces of wire bussed through for power, ground and reset. Several different units are available as follows:

- 7490 Basic 10 MHz counter. Used in frequency counters and events.
- 74196 Same as 7490 except presettable 50 MHz unit. Used where higher speed and/or presettable is required.
- 74192 Bi-Directional Counter. 32 MHz operation. Has two input lines, one that makes the unit count up, the other down. Uses include timers, where the counter is preset to a number and counts down to zero, monitoring a sequence of events, i.e. keeping track of people in a room by counting up for entries and down for departures.
- 7475 Adds latch capability. Used in counter so displays continue displaying frequency while new frequency is being counted for uninterrupted display.
- 7447 Basic decoder module. Drives basic seven segment display which is included for all modules.

NEWEST DCU!  
This DCU combines all of the features of our other counting units, that is, high speed counting, up-down operation, storage, and preset. In addition it includes a comparator (7485) and a thumbwheel switch in order to provide comparison and preset capability. With this combination you can do the following:

1. Count up or down at speeds to 33 MegaHertz.
2. Store previous count during new count.
3. Preset to any number, count down (or up) and generate a logic level when count of zero is reached. Stack several units and generate logic level for any count greater than zero.
4. Preset to zero, count up (or down) and generate a logic level for any number greater or equal to the number preset in the thumbwheel switch. Stack several DCU's and generate a logic level showing whether number is greater than, equal to, or less than numbers preset on switches.

- 910 K 7490-7447 Counter ..... \$8.25
- 910 LK 7490-7475-7447 Counter ..... \$9.25
- 911 LK 74196 7475-7447 Counter ..... \$10.25
- 912 K 74192 7447 Counter ..... \$9.25
- 913 K 74192 7475-7447-7485 Universal DCU ..... \$14.50

**I.B.M. POWER SUPPLY REGULATOR PARTS!**



Like-new assembly surplus from the I.B.M. Company contains the following: (6) 150-Watt transistors, (6) heat sinks, (6) 1 1/2 5W resistors, 12V, 20 Amp circuit breaker, a 16-ohm 10-Watt resistor, 50-Watt resistor, terminal strip, (2) 16-pin P.C. edge connectors for regular cards. An 8000 mfd., 15V computer grade capacitor is also provided. All in a nice mounting looks as if it could be a neat

unit to make a lab-type power supply. Unit is sold as an assembly, or in parts. Quantity is limited.

Sh. Wt. 20 lbs. IBMPSRA ..... \$7.50  
3 for \$20.00 IBMPSRA ..... \$20.00/3  
8 for \$52.00 IBMPSRA ..... \$52.00/8

Heat sinks capable of dissipating 150 watts of power  
Price ..... \$1.00 ea.  
Transistors, 2N441 or 2N442 type, TO-36 case ... \$1.00 ea.  
Heat sink with transistor ..... \$1.50 ea.  
4 for \$5.00 ..... \$5.00/4  
Connectors, 2 for \$1.50 ..... \$1.50/2  
Capacitor, \$1.50 ..... \$1.50 ea.

**HEWLETT PACKARD SOLID STATE NUMERIC INDICATOR**

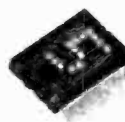

These fantastic L.E.D indicators have built-in decoder/driver with memory. They use a 4 x 7 dot array for much better readability. They are packaged in a standard Dual-In-Line (DIP) package with built-in contrast filter. Completely DTL TTL compatible. HP part number 5082-7300 (right hand decimal) HP 5082 ..... \$9.75

**COMPACT 1 mW LASER TUBE**



**LASER TUBE**

Large manufacturer sells his over-stock tubes to us, all guaranteed to be in perfect condition. Most compact 1mW laser tube (TEM.) on the market, only 8-1/2" long, uses a special tapered bore design, unique in the industry. Cavity design, internal hemispherical mirror system with co-axial mounting of all elements, maintain beam alignment and power stability under mechanical stress and changes in temperature. SPECIFICATIONS: red laser, 1mW power, TEM., 632.8nm wavelength, 1.10mm beam diameter, 0.85 mrad divergence, linear polarization, size: 8.5 x 1.75" diameter. These can be useful for alignment systems, measurement systems, and for illumination, etc., in equipment such as levels, transits, ranging, inspection displays, holography, etc. Operation life beyond 10,000 hours. This is not a t-y tube, but a laser designed to meet rigid industry standards. List price is over \$200.00 each.

Sh. Wt. 3 lbs. C1mWLT ..... \$97.50  
2 for \$180.00 C1mWLT ..... \$180.00/2  
10 for \$850.00 C1mWLT ..... \$850.00/10  
100 for \$7500 C1mWLT ..... \$7500.00/100  
Portable supply — operates from 12 vdc input. Useful for field experiments with laser. Available only with purchase of tube.  
Price ..... \$25.00

**AIRCRAFT AUTO BOAT QUARTZ CRYSTAL CHRONOMETER**

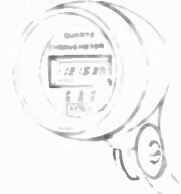

Revolutionary! was the reaction of our customers when they saw our latest kit. Measuring only 2 1/2" x 2 1/2" x 23/8", and accurate to 10 seconds a month, this chronometer promises to entirely replace mechanical clocks in cars, boats and airplanes.

Fits into a standard 2 1/2" instrument panel cutout. The displays are bright L.E.D. displays that should last a lifetime. Setting controls are recessed and operate from a pointed object such as a pencil point or paper clip, in order to keep non-authorized hands off! The clock should only have to be reset at very great intervals, or in the event of power loss (i.e., replacing battery in car). The clock is wired so that the timing circuits are always running, but the displays are only lit when the ignition is on, resulting in negligible power drain. The low price is only possible because of a new one chip MOS clock. Operates from 10-14 Volts D.C. An accessory unit which mounts on the back adapts the unit 59-20-28 volts for twin engine aircraft and larger boats using 24 Volts ignition. Know how disgusted you are with the usual car clock? Order this fine unit now for rallying, sports events, navigation, or just to have a fine chronometer that will give you a lifetime of superbly accurate time.

- Quartz Chronometer, Kit Form ..... \$69.50
- Quartz Chronometer, Wired ..... \$99.50
- 24 Volt Adapter ..... \$10.00

**New-Style AUTO/BOAT/PLANE QUARTZ CRYSTAL CHRONOMETER**

As you can see from the illustration, we have provided a new enclosure for our most popular kit, the ARIES Model AR-720K Quartz Crystal Chronometer. This enclosure can be mounted in many convenient variations, i.e., over or under the dashboard, over the center drive tunnel, or under the roof above the windshield.

- Automotive style quartz crystal chronometer ..... \$75.00
  - Same assembled, calibrated, tested ..... \$99.00
- Send in an order and get on our special custom customer Mailing List.

CATALOG: Check reader's card or write.

ALL ITEMS (WHERE WEIGHT IS NOT SPECIFIED) POSTAGE PAID IN THE U.S.A.

CHARGES WELCOME!

Phone in charges to 617 531-5774 or 617 532-2323. BankAmericard — Mastercharge. \$10.00 minimum. No C.O.D.'s please.

**B.&F. ENTERPRISES Mass. 01960**  
Phone (617) 531-5774  
119 Foster Street  
Peabody, Mass. 01960



**World Famed BREVETTATA TEAR GAS PISTOL**

Appearance of this fine tear gas weapon is similar to real gun. It is ideal for people who work in lonely dark locations and require protection. Men give this gun to wives and daughters for night security. Many industrial applications. Shooting of gun stops aggressor without permanently injuring him. It fires six cartridges without reloading. Each gun comes with six tear gas shells and six blanks for practice and is shipped prepaid. Gun unit prices include 12 shells and all shipping costs, and this pistol is not intended for sale or possession in any locality where it is prohibited by law. Not sold to minors.



1 Gun-unit .....\$15.00  
 2 Gun-units at \$14.50 ea., total \$29.00  
 3 Gun-units at \$14 ea., total \$42.00  
 6 Gun-units at \$12 ea., total \$72.00  
 Extra Boxes of Ten Tear-Gas Shells \$2 per box.  
 Extra Boxes of Blanks, \$1.25 per box  
 Holsters \$2 each. We prepay shipping costs on all of these items—when shipped with gun units.

**BREVETTATA**  
Dept RE-73, 310 W. 9th St., Kansas City, Mo. 64105

# Technical Excellence in Electronics.

On our small, friendly campus the emphasis is on Living as well as Learning. Extra-curricular social activities, student clubs, a student operated radio station, student government, new dormitory and a full sports program help provide a world of your own in which to prepare for tomorrow. Associate Degree in Engineering Electronics. B.S. obtainable. G.I. approved.



**VALPARAISO TECHNICAL INSTITUTE**  
Dept. C, Yellowstone Trail, Valparaiso, Indiana 46383

**BUILD A "SPACE-AGE" TV CAMERA!**

ONLY KNOWN SOLID-STATE CAMERA IN KIT FORM! Also available factory assembled. Ideal for experimentation, industry, education, etc. High quality, performance tested by over seven years of lab and field testing. Fully Guaranteed. Completely self-contained. Conforms to any TV set without modification. Easy-to-follow assembly manual. Model KT-1A, Series D complete with vidicon \$149.95. PP anywhere in USA. & Canada. Free vidicon tube \$16.50. Many other kits, parts and plans also available.

PHONE or WRITE for CATALOG...DIAL 402-987-3771  
BOX 453-RE **ATV Research** DAKOTA CITY, NEBR. 68731

## ADVERTISING INDEX

RADIO-ELECTRONICS does not assume responsibility for any errors which may appear in the index below.

READER SERVICE CARD NO.	PAGE
62	Audio Amateur..... 79
13	Bell & Howell Schools..... 18-21
68	B & K Division of Dynascan Corp..... 32
	Brooks Radio & TV Corp..... 82
80	Castle TV Tuner Service, Inc..... Cover-1V
63	Channellock Inc..... 79
72	Chapman Manufacturing Co., Inc..... 88
10	Cleveland Institute of Electronics..... 28-31
26	Continental Specialties Corp..... 76
	CREI, Division of the McGraw-Hill Continuing Education Co..... 56-59
7	Crown International..... 14
83	Delta Electronics..... 89
12	Delta Products, Inc..... 23
21	Digital Concepts..... 73
67	Edlie Electronics..... 80
78	Edmund Scientific Co..... 100
71	EICO, Electronic Instrument Co..... 88, 89
28	Electronic Distributors, Inc..... 76
	FMC, Electronic Measurements Corp..... 90
76	F & I Instruments Inc..... 90
22	FV Game, Inc..... 74
74	Fordham Radio Supply Co..... 75
27	Fluke..... 90
70	GC Electronics..... 83
69	Graham School of Electronics..... 83
	GTE Sylvania Electronic Components..... Cover-11
	GTE Sylvania Electronic Components..... 15
100	Heath Co..... 84-87
	ICS School of Electronics..... 66-69
15	Indiana Home Study Institute..... 70
5	International Components Corp..... 12
18	International Crystal Mfg. Co..... 72
23	Jensen Tool & Alloys..... 74
14	Lafayette Electronics..... 70
30	Lender Instruments Corp..... 77
74	Lectrotech, Inc..... 89
	Logic Newsletter..... 75
1	Micro-Instrumentation Telemetry Systems, Inc..... 1
16	National Camera Co..... 71
	National Technical Schools..... 46-49
	National Radio Institute..... 8-11
4	Olson Electronics..... 7
29	PAIA Electronics..... 77
25	Perma-Power..... 75
64	PTS Electronics, Inc..... 81
66	Quietrol Co..... 81
6	Radio Shack..... 13
	RCA Electronic Components Test Equipment..... 16
81	Rectifier Components Corp..... 78
73	Rye Industries..... 88
27	Schober Organ..... 76
2	Shure Bros., Inc..... 2
79	Southwest Technical Products..... Cover-111
17	Sprague..... 71
9	Tab Books..... 17
11	Telenatic..... 23
	Triad-Utrad Distributor..... 22
19	Tri-Star Corp..... 73
3	Tuner Service Corp..... 5
20	TV Tech Aids..... 73
75	Universal Tuner Labs Mfg., Inc..... 89
65	M. Weinschenker Elec..... 80
<b>MARKET CENTER</b>	
	ATV Research Corp..... 98
81	Babylon Electronics..... 92
	Baria..... 94
82	B & F Enterprises..... 97, 99
	Brevettata..... 98
	Command Productions..... 94
	Cornell Electronics..... 94
88	Digi-Key..... 91
	Gregory Electronics Corp..... 92
84	International Electronics Unlimited..... 96
	Lakeside Industries..... 91
	Lesco Electronics..... 94
87	Meshna Electronics, John Jr..... 91
	Photolum Corp..... 91
85	Polypaks..... 93, 95
	Solid State Sales..... 98
	Surplus Center..... 94
	Valparaiso Technical Institute..... 98
	Yeats Appliance Dolly Sales Co..... 91

**SLA-3 7 segment LED readouts**  
77" numbers. 45 Mas/seg. \$7.95

**MINIATURE TRIM POTS**  
5K, 10K, 20K, 25K, 50K, 100K, \$1.50 ea. 3/\$2.00

**MULTI-TURN TRIM POTS**  
Similar to Bourns 3010 style  
3 1/16" x 5/8" x 1 1/2"  
50, 100, 500, 2000, 5000, 10,000 and 20,000 ohms.  
\$1.50 ea. 3/\$4.00

**PRINTED CIRCUIT BOARD**  
4 1/2" x 6 1/2" double sided fiberglass board, 1/16" thick, un-etched \$1.50 ea. 5/\$2.50

**NIXIE TUBES**  
Similar to Raytheon 8650 tubes, with socket & data sheet \$2.25 3/\$6.00

TIS 73 N FET \$ .60  
2N4891 UJT \$ .50  
ER 900 TRIGGER DIODES 4/\$1.00

**VERIPAX PC BOARD**  
This board is a 1/16" single sided paper epoxy board, 4 1/2" x 6 1/2" (standard veripax), DRILLED and ETCHED which will hold up to 21 single 14 pin IC's or 8, 16 or LSI DIP IC's with buses for power supply connections. Is also etched for 22 pin connector. \$4.35

FLV 100 Visible LED..... \$ .59	ME-4 IR LED..... \$ .59	MV5026 Vis. LED..... \$ .59	MT-2 PHOTO TRANS..... \$ .80	MCT-2 OPTO-ISOL..... \$ .90	MCD-2 OPTO-ISOL..... \$ .90	Green GAP OSL-16 LED \$ .90	Red GAP OSL-3 LED..... \$ .60	Hi intensity VIS. Red with reflector \$ .60	MCA 2-30 photo darlington relay \$ .90	14 PIN DIP SOCKETS..... 3 \$1.00
Silicon Power Rectifiers										
PRV 1A.....	3A.....	12A.....	50A.....							
100.....	.06.....	.11.....	.30.....	.90.....						
200.....	.07.....	.16.....	.35.....	1.25.....						
400.....	.09.....	.20.....	.50.....	1.50.....						
600.....	.11.....	.25.....	.70.....	1.80.....						
800.....	.15.....	.35.....	.90.....	2.30.....						
000.....	.20.....	.45.....	1.10.....	2.75.....						

Terms: FOB Cambridge, Mass. Send check or Money Order. Include Postage. Minimum Order \$3.00

Send 20c for our latest catalog featuring Transistors and Rectifiers; 325 Elm St., Cambridge, Mass.

**TRANSISTOR SPECIALS**

2N3137 NPN SI TO-5	6W	20V	.5A	70MHZ 500HFE	4 \$1.00
MPS3393 NPN SI TO-92	3W	25V	1A	190	2.4 \$1.00
2N3866 NPN SI TO-5	5W	30V	RF	Power	\$ .75
2N1605 NPN GE TO-5	.15W	24V	1A	14	125 \$ \$1.00
2N5324 PNP GE TO-3	60W	250V	10A	20	35 \$1.50
2N404 PNP GE TO-5	25W	2V	15A	0	40.4 \$1.00
2N3767 NPN SI TO-66	80W	4V	20A	0	80 \$ .70
2N2222 NPN SI TO-92	30W	.8V	5A	250	80 \$1.00
2N3055 NPN SI TO-3	115W	100V	15A	.01	50 \$1.00
2N3772 NPN SI TO-3	150W	60V	30A	.2	30 \$1.35
2N5296 NPN SI TO-220	36W	40V	4A	.8	60 \$ .50
2N6109 PNP SI TO-220	36W	40V	4A	.8	60 \$ .50
2N4898 PNP SI TO-66	25W	40V	4A	4	46 \$ .60
MJ2251 NPN SI TO-66	10W	225V	5A	10	40 \$ .70
2N3638 PNP SI TO-5	3W	25V	5A	10	67 \$1.00

<b>CAPACITORS</b>	<b>DATA-LIT 707 LED readouts</b>	<b>Full Wave Bridges</b>
6V 30 UF TANT 5 \$1	MAN-3 LED READOUTS \$1.75	PRV 2A 6A
20V 4.7UF TANT 5 \$1	MAN-4 LED READOUTS \$2.50	200 95 1.25
12V 10UF ELECT. 5 \$1		400 1.15 1.50
50V 100UF ELECT. \$4.0		600 1.35 1.75

1103 1024 bit RAM..... \$ 7.25	5311—Clock Chip, 6 Digit BCD hold count, Output Strobe \$11.95
NEC 6003 2048 bit RAM..... \$14.50	5314—Clock Chip, 6 Digit hold count, Output Strobe..... \$9.95
1101 256 bit RAM..... \$ 3.25	
8225 64 bit-read-write RAM..... \$ 3.50	

Conductive Elastometer low profile calculator keyboard. A 2 3/4" x 3 3/4" 1/2" flex key. 19SK-6 keyboard having 0-9, \* K, C buttons with off, on, switch. \$6.50

Injection laser—a single diode 6W, 25A Ga As unit similar to RCA 40859 \$10.95

Dual tapered CdS photo cell used for optical alignment with a single plane lens. (Not included). \$ .95

ASC II ENCODED TERMINAL KEY BOARDS..... \$60.00

**LINEAR CIRCUITS**

LM309K 5V 1A regulator..... \$2.25	723 Regulator..... \$ .75
536 FET input oper amp..... \$3.25	741 operational Amp..... \$ .47
537 Precision 741..... \$2.50	747 Dual 741..... \$1.25
540 70W Power driver..... \$2.04	CA3065 FM/TV amp..... \$1.10
560 phase lock loop..... \$2.95	LM 308 oper amp..... \$1.50
561 phase lock loop..... \$2.95	101 oper amp..... \$ .75
565 phase lock loop..... \$2.95	741A oper amp..... \$ .47
567 Tone decoder..... \$2.95	320—5V reg..... \$1.75
703 RF-IF amplifier..... \$ .80	320—15V reg..... \$1.75
Dual 709..... \$ .95	748 oper amp..... \$ .95
709C operational Amp..... \$ .47	LM 300H—Vol reg..... \$1.25
723 Regulator..... \$ .75	LM370—AGC squelch oper. amp \$1.25
741 operational Amp..... \$ .47	LM 380—2 W audio amp..... \$1.75
747 Dual 741..... \$1.25	2W Stereo audio amp IC (14 pin) \$3.95
CA3065 FM/TV amp..... \$1.10	
LM 308 oper amp..... \$1.50	
101 oper amp..... \$ .75	
741A oper amp..... \$ .47	
320—5V reg..... \$1.75	
320—15V reg..... \$1.75	
748 oper amp..... \$ .95	
LM 300H—Vol reg..... \$1.25	
LM370—AGC squelch oper. amp \$1.25	
LM 380—2 W audio amp..... \$1.75	
2W Stereo audio amp IC (14 pin) \$3.95	

Similar to 8038C IC Voltage controlled oscillator, as featured in Oct. 73 P.E. they have sine, square and triangular outputs good to 1MHz. Two of them can be used to make an FM generator. \$9.95

<b>TRIACS</b>		<b>SCR'S</b>	
PRV 1A.....	10A.....	25A 1.5A 6A.....	35A.....
100.....	40.....	70.....	1.30.....
200.....	70.....	1.10.....	1.75.....
400.....	1.10.....	1.60.....	2.60.....
600.....	1.70.....	2.30.....	3.00.....

**SOLID STATE SALES**  
Post Office Box 74D Somerville, Mass. 02143 Tel. (617) 547-4005



## MORE BARGAINS IN SURPLUS ELECTRONICS from B & F ENTERPRISES

Just off the press our Best Catalog yet with 104 illustrated pages of surplus Electronics, Optics, and Much More...



### DIGITAL CLOCK CHIP

These large scale integrated (LSI) chips eliminate 14 to 20 MSI TTL chips in the design of an electronic clock. Features 12 or 24 hour operation, 6 digits, internal multiplexing, operated on 50 or 60 Hz input, or a schematic is provided for crystal control. Logic gates between the counter allow setting at the rate of one hour digit per second, or, one minute digit per second. A "hold" input allows stopping the chain. The multiplexer samples the outputs of the hours, minutes and seconds counters (in the six digit model), routing this data to a programmable read only memory (ROM), which is programmed to provide BCD and seven segment outputs. All outputs are compatible with bipolar devices, necessitating few external components for the display interface. Only one power supply is required for operation.

- 5314 chip (24 pin plastic) used for 7 segment displays such as LED's, numitrons, minitrons and Sperry displays. Price ..... \$9.95
- 5311 chip (28 pin ceramic) includes BCD output to above for interface to nixies, computer inputs, etc., in addition to 7 segment outputs. Price ..... \$14.95

### 1/4-Watt RESISTOR ASSORTMENT!!



Brand-new 5% tolerance resistors, individually bagged 5 to a bag, each bag marked with values. 70 different values, 10 ohms to 10 megohms in a 1.5 2.2 3.3 4.7 6.8 1 sequence. A complete laboratory supply of resistors at less than 5 cents apiece.

Sh. Wt. 2 lbs. ..... \$15.00  
4 bags for \$55.00 ..... \$55.00/4

### KEYBOARDS:



Teletype format ASCII coded keyboard, with parity check line (see fig. A). Coding is by means of a built in diode matrix, which can be modified from ASCII by inserting or removing diodes. Keys are 26 characters, all numbers, plus shift, ctrl, alt, line feed, carriage return, rept, bkr, rub out, here is, and usual typewriter symbols. Mix controls research and microswitch. Requires 45 volts, uses DTL circuitry, compatible with DTL or TTL. 52 keys, 3 integrated circuits, about 200 diodes. Brand new, guaranteed. 15 pin connector on 10" cable.

- KB-01 ..... \$44.50
- Non-decoded alphanumeric keyboard, Figure "C", single form, SPST contact on each key.
- KB-3 ..... \$24.50
- Figure "D", calculator keyboard in calculator case, pressure sensitive elastomer contacts, manufactured for Arles.
- KB-4 ..... \$9.50
- Touch-tone keyboard, Figure "E", manufactured by Chrometics. No electronics included.
- KB-5 ..... \$9.00
- Desk calculator keyboard, Figure "F", manufactured by Controls Research.
- KB-6 ..... \$15.75

### RT 270A/GRC TRANSCEIVER



This is a prime government surplus item, until recently in scarce supply and selling for hundreds of dollars. Consists of a double conversion FM superhetrodyne receiver and a FM transmitter linked thru a common antenna circuit. Range is 47 to 58.4 MHz continuous. Size is 7-3/8 x 4-3/16 x 12-15/16. Built-in calibrator and heat oscillators permit fast alignment.

- RT 270A/GRC New, including 1 MHz crystal ..... \$35.00
- RT 2700A/GRC Used, excellent, less crystal ..... \$20.00
- \*\*\* 1 MHz crystal only ..... \$5.00

### TRANSISTORIZED FLUORESCENT CAMPING/EMERGENCY LIGHT KIT!

This transistor inverter powered camping and emergency light will provide a bright portable light from a 12-Volt D.C. battery. A cigarette lighter adapter is provided for automotive operation, or the unit may be run from other 12-Volt lantern batteries. The advantages of this unit over more conventional incandescent lamps is the vastly greater light output for equivalent power input and the superior distribution and color of the light. The camping/emergency light is enclosed in a weather-tight plexiglas tube, with the electronics built into the tube. Completion time should be less than two hours, making it a nice evening's project, even for the beginner.

Sh. Wt. 3 lbs. TFCELK \$12.50

### ATTENTION MANUFACTURERS - LED RIOT!

B & F has bought over 500,000 7-segment LED numeric displays and over 1,000,000 LED lights. These are available in manufacturing quantities for immediate delivery.

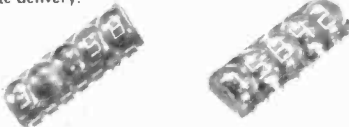

### 5082 - 7400 SERIES DIGITS FROM HEWLETT PACKARD

Hewlett Packard, one of the world's largest manufacturers, has sold us his surplus of multiple digit clusters with one bad digit per cluster. They were for use in the HP35 calculator, 970A DVM, and other products. The remaining digits are guaranteed perfect in all respects and are Intensity graded (marked on the back with letters A thru F) and matched, so that several strips can be combined and still result in a perfect match. These monolithic GaAsP displays require as little as 7 mW per digit, are highly readable at arm's length, and lend themselves well to hand-held portable applications.

Applications include hand-held calculators, digital thermometers, stopwatches, darkroom timers, DVM's, clocks and watches, or any other product requiring low cost, low power, long lifetime indicators.

The unit is common cathode, set up for multiplexed operation. Two decimal point styles are available; center decimal for PN 7804/05, and right decimal for PN 7814/15, as illustrated. The following configurations are available, where "8" represents a perfect digit, "X" a non-functioning digit:

X8888 7405-1 or 7415-1, X888 7414-1  
8X888 7405-2 or 7415-2, 8X88 7414-2  
88X88 7405-3 or 7415-3, 88X8 7414-3  
888X8 7405-4 or 7415-4, 888X 7414-4  
8888X 7405-5 or 7415-5, X88X 7556-1

All products are available at the following price rate:

1 - 24 digits ... \$1.875/digit  
25 - 99 digits ... \$1.50/digit  
100 - 499 digits ... \$1.25/digit  
500 - 999 digits ... \$1.00/digit

Higher quantity price on request.

For the following applications we recommend the following configurations:

Pocket calculators: 7405-1 & 7405-5, which results in X88888888X, eight consecutive perfect digits @ \$1.875 = \$15.00.

Recommended Calculator chips:

Nortec 4204 @ \$19.75 (\$15.00 when ordered with displays).  
Catex 5005 @ \$9.75 (\$7.50 when ordered with displays).

Clocks: 7405-3 & 7556-1, which results in 88X88X88X, six perfect digits at \$1.875 = \$11.25.

Recommended clock chips:

National MM5314 @ \$9.75 (\$7.50 ordered with displays).  
National MM5316 @ \$19.75, includes alarm, (\$15.00 ordered with displays).

For only hours and minutes, order 7405-3 only.

Digital thermometers, DVM's, stopwatches, darkroom timers, frequency counters, etc., order 7415-1 or 7415-5 for four digits (\$7.50) or 7414-1 or 7414-4 for three digits (\$5.60). Use Solltron CM 4102AE 3 1/2 digit counter decoder @ \$19.00. (\$15.00 ordered with displays).

Schematics for calculators, clocks and counters using these components free with order.

### LED SOLID STATE LAMPS



Plastic encapsulated gallium arsenide phosphide light emitting diodes. Designed for low power consumption, as low as 5 milliwatts. Red diffused lens.

10 pcs. ... \$2.00  
100 pcs. ... \$15.00  
1000 pcs. ... \$100.00

Higher volume prices on request.



### SUPER QUALITY I.C. SOCKETS

Sockets made by T.J. and Cinch. All are low-profile, compact types.

- 14 Pin Dip Solder Tale Sockets 3 for \$1.25 16 for \$5.00
- 16 Pin Dip Solder Tale Sockets 2 for \$1.00 13 for \$5.00
- 14 Pin Dip Gold Wire Wrap Socket 2 for \$1.25 10 for \$5.00
- 16 Pin Dip Gold Wire Wrap Socket 2 for \$1.50 8 for \$5.00
- 10 Pin to 5 Gold Sockets (Cinch) 2 for \$1.00 13 for \$5.00

Now available 24, 28 & 40 Pin sockets Only \$1.00 ea.

October 2, 1973

Dear Customers,

Due to a variety of circumstances in past months, some customer orders, refunds and exchanges have been lost or otherwise snafu'd. I would like to take this opportunity to point out that we have now solved our internal difficulties to the point where we can and will take immediate action on any such complaints. Any customer having any problem can be assured prompt action by writing to Ms. Lynn Chafey, Customer Relations Director, B & F Enterprises, 119 Foster St., Peabody, Massachusetts, 01960.

Without making excuses, I think some of you readers might be interested in the changing nature of the "surplus" business, which I believe we were instrumental in changing. In early 1970 electronic manufacturers were in the doldrums, due to the changeover from military to commercial business. Items (particularly TTL integrated circuits and other semiconductor items) were sold to original equipment manufacturers, (OEM's) at a fraction of catalog price, to stimulate business. This prompted us to negotiate directly with manufacturers for large quantities of items at low cost, and to offer these to hobbyists and electronic experimenters who buy in small quantities, at a fraction of catalog price. This was the experiment that revolutionized the surplus business, and we became more "cut-rate distributors" than "surplus dealers".

There were some problems, though. First, the commercial business took a wild upswing, and manufacturers who were begging us to accept products suddenly found they couldn't supply enough material, and deliveries became slow or nonexistent. Second, with slow deliveries, the amount of paperwork and handling to ship orders in two or three partial shipments became overwhelming. With a small mark up on sales, it simply was impossible to devote much time to correspondence. Third, quite frankly, was that Pete and myself as engineers, were not used to the problems of inventory control, and shipping management. In a period of time when our sales were tripling every year, we had trouble keeping up with the greatly increased sales.

At the present time, I truly believe we have our problems solved, and can offer our customers both good service and low price. We have been shipping all stock items within 48 hours. We have refrained from advertising any items not in good inventory. And our rate of growth, while still good, is at a sufficiently slow pace now so that we can solve problems as we encounter them. As a parting word, I would like to say that we are interested in getting feedback from readers on other matters. What would you like to see us carry? We welcome any other comments that will help us improve service. Thank you in advance.

Very truly yours,

*Franklin G. Fink*  
Franklin G. Fink, Partner  
B & F Enterprises

### NEW - COSMOS INTEGRATED CIRCUIT



Said to be the "New Wave" in integrated circuits of the future. Ultra low power drain (microwatts)

- 4000AE Dual 3 Input Nor & Inv ..... \$ .99
- 4001AE Quad 2 Input Nor ..... \$ .99
- 4002AE Dual 4 Input Nor ..... \$ .99
- 4006AE 18 Stage Static Shift Register ..... \$4.99
- 4007AE Dual Complementary Pair & Inv ..... \$ .99
- 4009AE Hex Buffer, Inverting ..... \$2.19
- 4010AE Hex Buffer, Non Inverting ..... \$2.19
- 4011AE Quad 2 Input Nand ..... \$ .99
- 4012AE Dual 4 Input Nand ..... \$ .99
- 4014AE 8 Stage Static Shift Register ..... \$5.99
- 4017AE Decade Counter W/Decoder ..... \$5.99
- 4020AE 14 Stage Binary Ripple Counter ..... \$5.99

Send in an order and get on our special customer Mailing List.

CATALOG: Check reader's card or write.

ALL ITEMS (WHERE WEIGHT IS NOT SPECIFIED) POSTAGE PAID IN THE U.S.A.

CHARGES WELCOME!

Phone in charges to 617 531-5774 or 617 532-2323. BankAmericard - Mastercharge \$10.00 minimum. No C.O.D.'s please.

**B & F ENTERPRISES Mass. 01960**  
Phone (617) 531-5774  
119 Foster Street  
Peabody, Mass. 01960

# LIVE IN THE WORLD OF TOMORROW...TODAY!

## A BETTER LIFE STARTS HERE

### 3-CHANNEL COLOR ORGAN KIT

Easy to build low-cost kit needs no technical knowledge. Completed unit has 3 bands of audio frequencies to modulate 3 independent strings of colored lamps (i.e. "lows"-reds, "middles"-greens, "highs"-blues. Just connect hi-fi, radio, power lamp etc. & plug ea. lamp string into own channel (max. 300w ea.). Kit features 3 neon indicators, color intensity controls, controlled individ SCR circuits; isolation transformer; custom plastic housing; instr.



Stock No. 41,831EH .....\$17.50 Ppd.



### KNOW YOUR ALPHA FROM THETA!

For greater relaxation, concentration, listen to your Alpha-Theta brainwaves. Ultra-sensitive electrode headband slips on/off in seconds—eliminates need for messy creams, etc. Atch'd to amplifier, filters brainwaves, signals beep for ea. Alpha or Theta wave passed. Monitoring button simulates Alpha sound audio & visual (L.E.D.) feedback. Reliable, easy-to-use unit—comparable to costlier models. Completely safe. Comprehen. instr. bklt. No. 1635EH (8x3x4"; 24 oz.) .. \$124.50 Ppd. LOW COST "Starter" Unit Stock No. 71,809EH .....\$49.95 Ppd!

### 130 EXPERIMENTS IN OPTICS . . .



and photography! Optix® Experiments Kit is a complete optical & photography lab for 130 exciting experiments. Lets you recreate the periscope, telescope, microscope, kaleidoscope! . . . Build a 35mm reflex camera with interchangeable lens system! Make, develop photographic film! Make, develop photographic film! Enjoy the fun and fascination of having your own optics lab. Fully illustrated 112-pg. manual, 8 1/2"x11", clearly explains usage of this stimulating kit's 114 precision engineered components.

Stock No. 71,646EH ....\$22.50 Ppd.

(And our FREE CATALOG is packed with exciting and unusual ecological & physical science items—plus 4,500 finds for fun, study or profit . . . for every member of the family.)

### ELECTRONIC SLIDE RULE: \$99.95

Price breakthrough! Texas Instrument calculator easily does classic slide rule wk. w/split-sec. accuracy. 8-digit #s, 2-digit exponents, minus signs, overflows show in red. Besides 4 std. functions, does sq roots, squares, reciprocals, auto. conversion to scientific notation, mixed calc. Max. & min. #s. Great for tchrs, students on the go (9 oz). Incls long-life Ni-Cad rechargeable batts. & AC converter-charger.

(A) No. 78,011EH (6-1/4x3x1-1/4") .. \$99.95 Ppd.  
(B) No. 78,014EH (ENGR's DESK MOD.) \$179.95 Ppd.

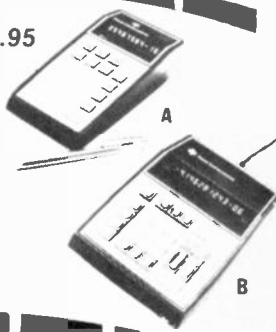

### TERRIFIC BUY IN HE-NE LASERS

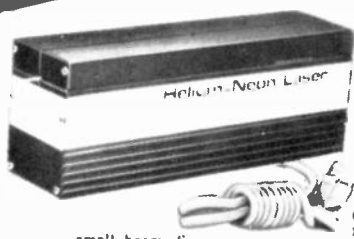

Low price on 0.5mW Laser (random mode); 0.9mm beam dia. (at 10M.-16mm) belies its quality. New cold aluminum cathode tube for more life stability (hi beam: 9000-hr tube life under normal cond.) Ready to plug in, turn on. Starts instantly. Safe, easy for holography, interferometry, alignment. Metal case, 2.8 x 3.8 x 10", 110v AC, 633nm wavelength, small beam divergence.

Stock No. 79,020EH .....\$88.50 Ppd.  
0.7mW (SINGLE TEM. MODE), 0.8mm BEAM DIA.  
Stock No. 79,024EH .....\$99.50 Ppd.

### 3" ASTRONOMICAL REFLECTOR TELESCOPE



See moon shots, orbits, stars, phases of Venus, planets close up. 60 to 180 power. New Improved, aluminumized and overcoated 3" diameter f/10 primary mirror, ventilated cell. Equatorial mount with locks on both axes. Equipped with 60x eyepiece and mounted Barlow lens. 3x finder telescope, hardwood tripod. Included FREE: "STAR CHART", "HOW TO USE YOUR TELESCOPE" book.

Stock No. 85,050EH .....\$36.95 Ppd.  
DELUXE 3" REFLECTOR TELESCOPE  
Stock No. 80,162EH .....\$62.50 Ppd.  
4 1/4" REFLECTOR TELESCOPE (45x to 270x)  
Stock No. 85,105EH .....\$115.00 FOB  
4 1/4" REFLECTOR TELESCOPE WITH CLOCK DRIVE Stock No. 85,107EH \$145.00 FOB  
6" REFLECTOR TELESCOPE Stock No. 85,187EH .....\$215.00 FOB  
6" REFLECTOR W/(ELECTRIC) CLOCK DRIVE No. 85,086EH .....\$259.50 FOB

## MAIL COUPON FOR GIANT FREE CATALOG!

180 PAGES • MORE THAN 4,500 UNUSUAL BARGAINS!

Completely new '74 Catalog. Packed with huge selection of telescopes, microscopes, binoculars, magnets, magnifiers, prisms, photo components, ecology and Unique Lighting items, parts, kits, accessories — many hard-to-get surplus bargains. 100's of charts, illustrations. For hobbyists, experimenters, schools, industry.

**EDMUND SCIENTIFIC CO.**  
300 Edscorp Building, Barrington, N. J. 08007

Please rush Free Giant Catalog "EH"

Name \_\_\_\_\_  
Address \_\_\_\_\_  
City \_\_\_\_\_  
State \_\_\_\_\_ Zip \_\_\_\_\_

## COMPLETE & MAIL WITH CHECK OR M.O. EDMUND SCIENTIFIC CO.

300 Edscorp Building, Barrington, N.J. 08007

How Many	Stock No.	Description	Price Each	Total

PLEASE SEND  GIANT FREE CATALOG "EH" MERCHANDISE TOTAL \$  
ADD HANDLING CHARGE—\$1.00 ON ORDERS UNDER \$5.00; 50¢ ON ORDERS OVER \$5.00  
TOTAL \$



I enclose  check  money order for \$ \_\_\_\_\_  
NAME \_\_\_\_\_  
ADDRESS \_\_\_\_\_  
CITY \_\_\_\_\_ STATE \_\_\_\_\_ ZIP \_\_\_\_\_

# SOUTHWEST TECHNICAL PRODUCTS CORPORATION

219 W. RHAPSODY  
SAN ANTONIO, TEXAS 78216  
PHONE. 512 DI 4-3140

January 1974

Dear Radio-Electronics Reader,

As we all start another year, it looks like this one will go down as the year of the shortage for those of us in electronic manufacturing. Delivery on more and more parts is getting into the "order now for delivery next Christmas" category. Capacitors, transistors, diodes, wire, even resistors are three months and more for some types. Don't know where it will all end, but it sure makes it spooky when you need to order parts for a new product before it is designed in order to get them when they will be needed for shipment.

Have you ever noticed how things seem to go around in large circles and finally get back to the same place they started from. It's interesting how amplifier design has gone from the old triode class A Williamson of the late fortys and early fifties, to ultralinear and finally to the early transformer coupled transistor circuits. High fidelity amplifiers used to be designed to be as clean and linear as possible without feedback, then enough feedback was added to give the bandwidth and flat response that was desired. As power transistors became available that could handle the current to directly drive a speaker, it became possible to eliminate the output transformer and make a circuit that was considerably wider in bandwidth on both the low and high frequency ends. The only problem was that the power transistors only came in one polarity and you had to use a so called quasi-complementary output circuit. Now this beast is just inherently nonlinear. No matter what kind of clever things you do to it, it just isn't going to make a pretty waveform without lots of feedback. As a result of this situation we got the—"build it crooked and then bend it back straight with tons of feedback"; school of amplifier design. The final result was amplifiers that were very clean—they should be, some had open loop gains of 100 to 125 dB. Since you only need, or want, 25 or so dB of gain in a power amplifier you have up to 100 dB of negative feedback to clean things up and you get a really superior amplifier—right? wrong!! What you get is an amplifier with miserable transient response that has a very inferior slew rate. The phase compensation needed to keep an amplifier with this much gain stable requires a roll-off beginning well down in the audio range for the dominant pole. This creates the "741" problem made famous by the op-amp of the same name. You have a very limited ability to handle large amplitude signals with a fast rise time. Result—poor transient response and distortion that is heard, but impossible to measure with normal steady state harmonic and IM analyzers. It measures great, but your ears insist that something is not quite right.

Our solution to this dilemma was to return to the basic idea of building a linear circuit and then adding enough feedback to get the desired results. Our amplifiers have a completely complementary circuit from the input all the way through to the output. They have less than 70 dB of open loop gain. The result of this return to original principles is distortion lower than you can easily measure, bandwidth (1.0 db down points) of 10 Hz to 500 KHz and beautiful sound. Due to the reasonable gain, there are no phase margin, slew rate, or transient problems.

We would be happy to send you a catalog listing all of our kits, and a reprint of the "Tiger .01" article if you are interested. This kit comes complete with a bronze anodized chassis and perforated metal cover, front panel output meter and highest quality components. The instructions include pictorial diagrams and step-by-step wiring. You will have to accept the fact that to get the best you are going to have to pay a little less. We hope that this will not cause you any hangups.

Sincerely,



Daniel Meyer



SOUTHWEST TECHNICAL PRODUCTS CORPORATION  
DEPT. RE-L  
219 W. RHAPSODY, SAN ANTONIO, TEXAS 78216

# The Timesaver!



Latest, all solid state version of the sensational signal circuit analyzing timesaver originated by Castle.

Invaluable for locating the break in the tuner and i.f. signal chain or analyzing agc system defects in tube TV receivers . . . essential for speedy location of signal circuit defects in modular IC, solid state and hybrid TV receivers.

## A NEW APPROACH to agc system analyzing!

Permits signal injection after the agc controlled stages to simplify testing for agc defects.

- Works with any 40MHz receiver . . . color or black and white . . . solid state, tube or hybrid.
- High level, low impedance output furnishes signal usable at input of final i.f. stage.
- Special output circuit works equally well into first i.f. input of late model, link coupled systems and older, low "C" bandpass coupled systems.
- Antenna input and i.f. output electrically isolated; no "hot" chassis hazards.
- No need to disconnect supply leads from suspected tuner being tested. Substitutes the VHF tuner and tests the UHF tuner.
- Tunes all 12 VHF channels, has preset (memory) fine tuning on all channels.
- Higher overall gain than previous models with wide range gain reduction control of 60db.
- Completely self contained and battery operated, uses popular batteries available everywhere. Simple battery replacement; battery compartment in rear of custom molded case.
- Reduced current consumption extends battery life to as much as double that of previous models. Bright LED indicator warns when unit is ON.
- Use on the bench or in the home . . . anywhere.
- Comes complete with extension cables, batteries and instructions.

**TV TUNER SUBBER, Mark IV net \$45.95**

Contact your distributor

### Specifications

Inputs:	300 ohms balanced VHF antenna terminals, electrically isolated. 75 ohms 40 MHz amplifier (Ch. #1) RCA phono jack.
Sensitivity:	30 microvolts. Input signal handling capability: over 100,000 microvolts.
Output:	40 MHz TV i.f.; bandwidth 6 MHz. "Mastermatchcoupler" output circuit with matched cable to furnish usable signal for all input circuits. Termination is RCA phono jack, electrically isolated.
Tuning Range:	All 12 VHF TV channels, plus Ch. #1 40 MHz amplifier position for testing UHF tuners. High stability of 40 MHz amplifier permits two Mk. IV Subbers to be cascaded for high level 40 MHz output signal from any VHF channel.
Tuning:	Preset (memory) fine tuning.
Gain Control:	Gain reduction 60 dB.
Power supply:	18 volts. Uses two 9v transistor batteries.
Size & Weight:	6.5" x 6.5" x 3.25" exclusive of control knob and handle. 1.5 lbs complete with batteries.
Accessories:	"Mastermatchcoupler" output cable with RCA phono jack termination. "Mastermatchcoupler" output cable with alligator clip terminations. UHF tuner test cable.



**CASTLE TV TUNER SERVICE, INC.**

5715 N. Western Ave., Chicago, Illinois 60645 • Phone: (312) - 561-6354

In Canada: Len Finkler Co., Ontario

Circle 80 on reader service card