

Radio IND Electronics®

FOR MEN WITH IDEAS IN ELECTRONICS

SPECIAL ISSUE 4-CHANNEL STEREO

4-Channel Sound Today

- The Systems • The Adapters

4-Channel IC Amplifier

- 50 Watts rms Per Channel
- Less Than 1% Distortion
- One IC Per Channel

Build R-E's

4-Channel IC-preamp

- Two IC's For 4 Channels
- Inputs For Phone And Tape
- Ganged Controls

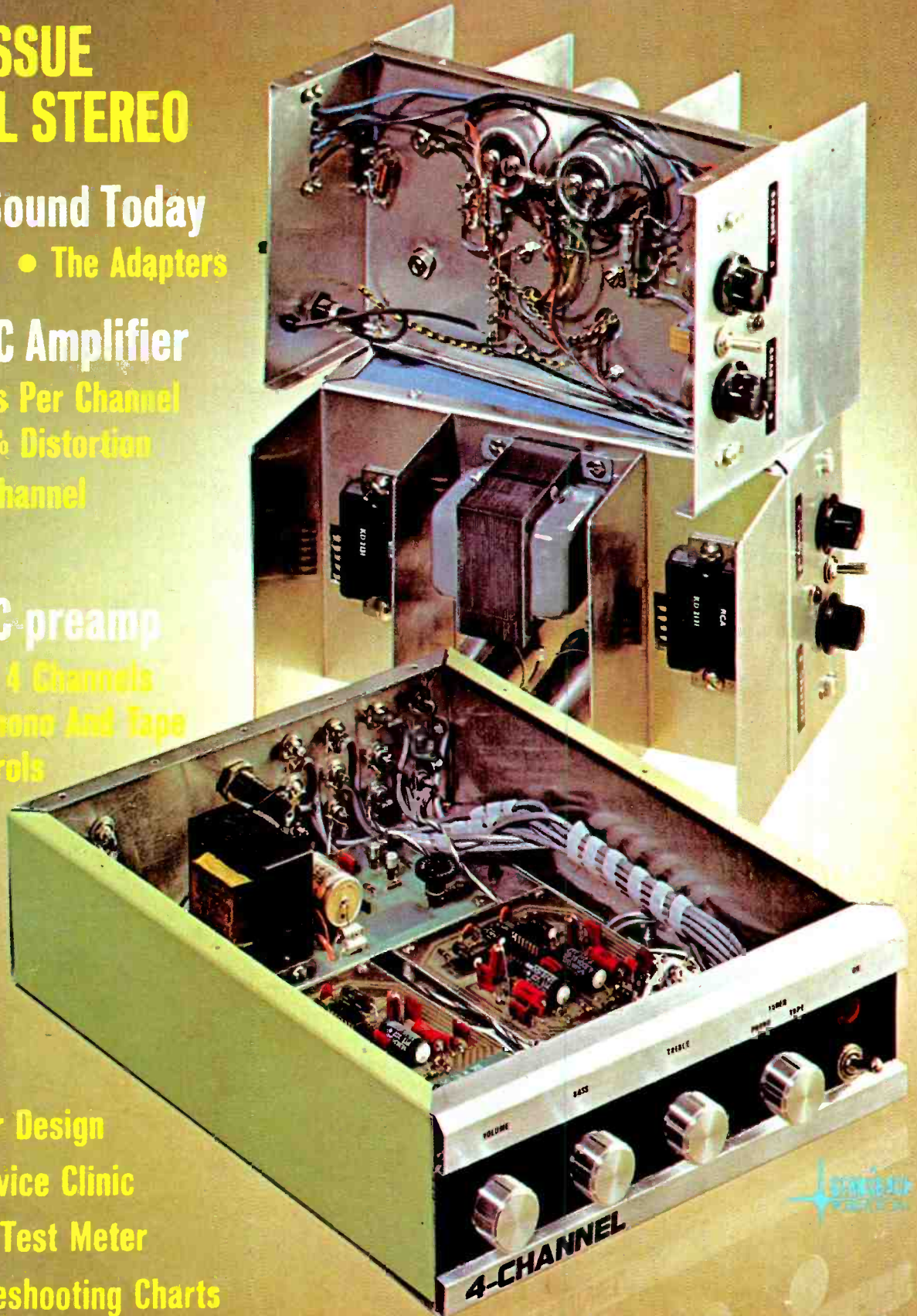

PLUS

Stereo Amplifier Design

Jack Darr's Service Clinic

Photographer's Test Meter

Kwik-Fix Troubleshooting Charts



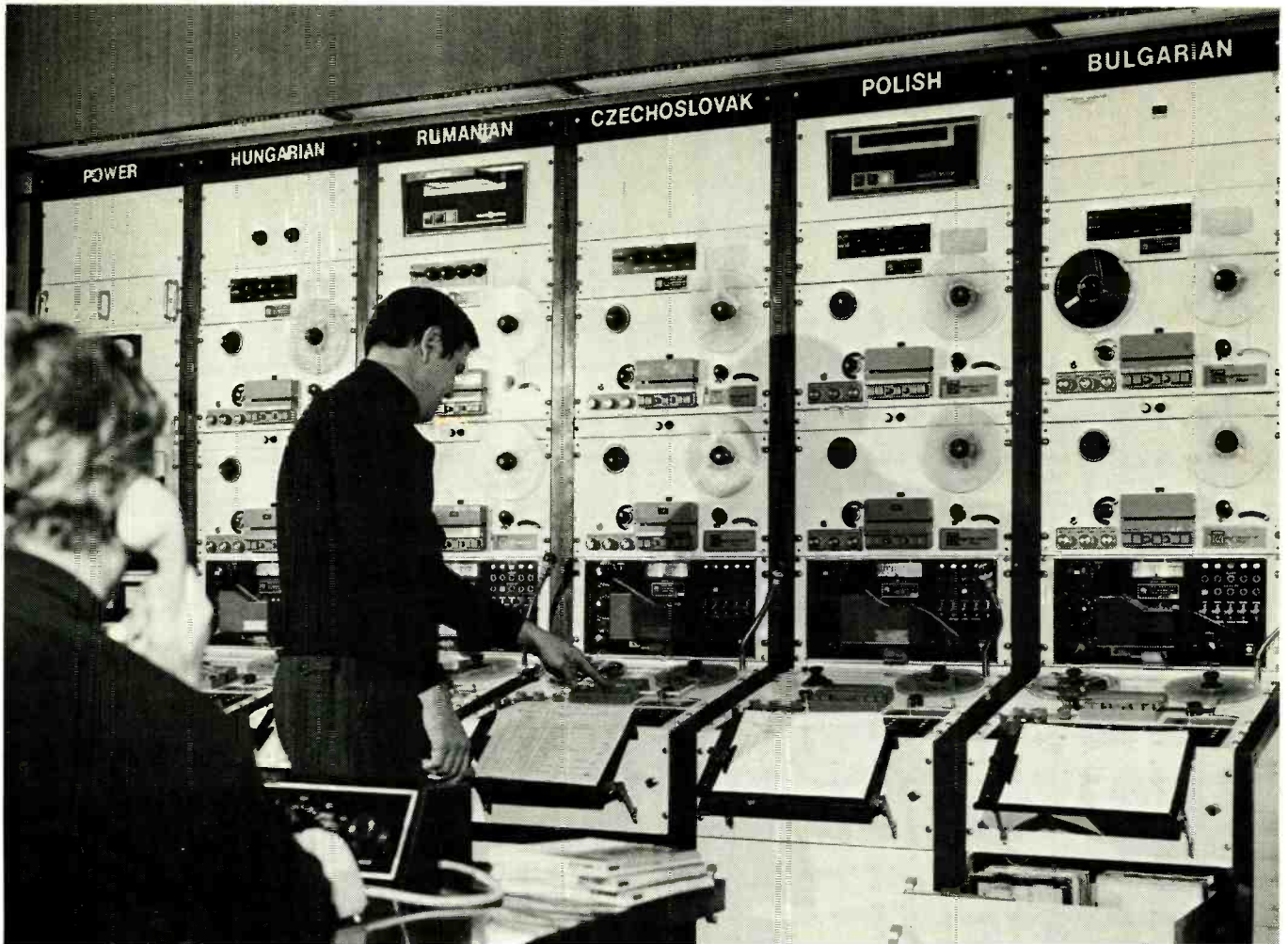

**Thirty million
people behind
the iron curtain
rely on Radio
Free Europe...
and Radio Free
Europe relies on
MAGNECORD**

PRODUCTS OF SOUND RESEARCH
TELEX[®]
 COMMUNICATIONS DIVISION
 9600 Aldrich Avenue South
 Minneapolis, Minnesota 55420

CANADA: DOUBLE DIAMOND ELECTRONICS, LTD., Ontario
 EXPORT: ROYAL SOUND COMPANY, INC., 409 North Main Street, Freeport, New York 11520

RFE is the leading free radio station broadcasting to East Europe. These Magnecords are a key part of RFE's master control system, the heart of their broadcasting operation.

RFE designed and built the master control system and had to meet unique engineering requirements with the best possible equipment. That's why they chose Magnecord.

Magnecords are used to program simultaneously in five languages, beamed to five separate countries. Each language has a bank of rugged, reliable Magnecords for consistently high performance under the most demanding conditions.

Magnecord die-cast mainplate assures permanent mechanical alignment. Program timing accuracy is held constant by the hysteresis synchronous capstan drive. And, each reel has its own heavy duty permanent split capacitor motor.

RFE can't afford to take any chances with its equipment. When field proven dependability and professional quality are available, why settle for anything less? Select Magnecord. Made in the U.S. by Telex.

Put yourself on TV for under \$200⁰⁰

Now . . . for the first time anywhere, a quality closed circuit television camera is available for less than \$200. Due to our extremely low offering price, we cannot publish the maker's name. We can tell you that the "Teleguard" is built by one of the world's largest electronic companies. A company with 20,000 employees and sales in excess of 700 million dollars per year.

The camera features a built-in RF modulator allowing it to be used with any standard TV receiver. Merely plug the "Teleguard" into any AC outlet and run a piece of coaxial cable to the VHF antenna terminal on the set. The result will be a clear sharp picture on channel 4, 5 or 6. (The camera is tunable.)

The camera can see where your eyes cannot, and will operate on as little as 1/2 foot candle power. The unit is shipped complete with a high quality 16mm lens. Both parts and labor are warranted for one full year.

The "Teleguard" is not available in retail stores. The only way to obtain one is direct from Video Systems. To order yours, send check or money order for \$199.50 to Video Systems. Add \$3.00 per unit to cover shipping. (California residents must add 5% sales tax.) If you prefer, it can be charged to your BankAmericard or Master Charge. For prompt delivery, fill in the information requested below

and mail to Video Systems, 12530 Beatrice St., Los Angeles, Calif. 90066.

If not completely satisfied, return the unit within ten days for a full refund.

TECHNICAL SPECIFICATIONS

Vidicon Tube	Type 8844, separate mesh	
Semiconductors	36 Transistors 17 Diodes	
Output Signal	Provides both unmodulated video signal for appropriate video monitor and modulated RF signal for home TV receiver function switch on back panel.	
Output Level	VIDEO	RF
	1.4vp-p, negative sync.	0.03V RMS
Output Impedance	75 ohms	75 ohms
Resolution (center)		
Horizontal	650 (Center)	350 lines
Vertical	450 lines	350 lines
Scanning	Random interlace	
Horizontal	15,750 (525 line system)	
Vertical	Line frequency, 60 Hz	
Light Compensation	5000:1	
Ambient Temperature	14° to 118° F	
Power Source	117V ± 10V AC, 60 Hz	
Power Requirement	Approx. 10 W	
Lens Mount	"C" Mount	
Lens (Supplied)	16mm F1.6	
Size	5" H x 2 2/8" W x 8 2/3" L	
Weight (without lens)	Approx. 4.5 lbs.	

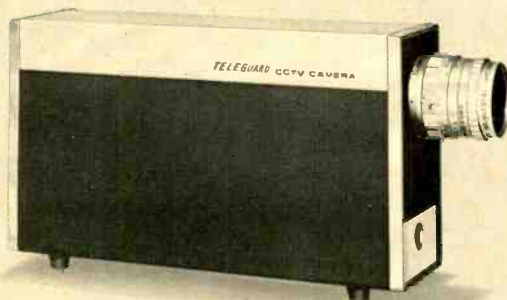

VIDEO SYSTEMS, INC.

12530 BEATRICE STREET
LOS ANGELES, CALIFORNIA 90066

Name: _____

Address: _____

City: _____ State: _____ Zip: _____

Ship _____ Teleguard Cameras at \$199.50

Charge on BankAmericard Master Charge

Card No: _____ Expiration Date: _____

Bank # _____

Total Order \$ _____

NEW & TIMELY

NEW MINI CARTRIDGE

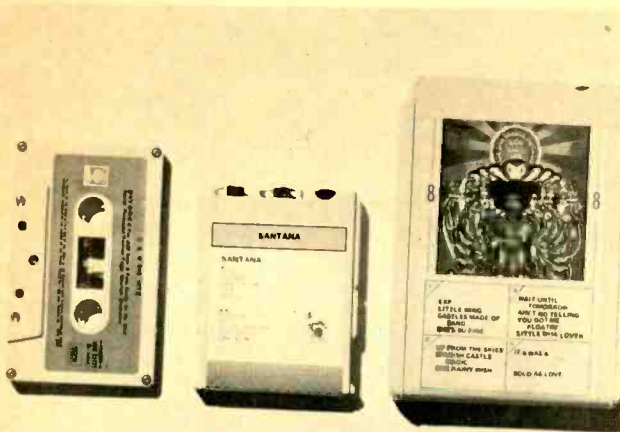

STANDARD CASSETTE HIPAC CARTRIDGE STANDARD CARTRIDGE

CHICAGO, ILL.—Pioneer Electronic Corporation announced the development of a new mini stereo tape cartridge system, one quarter the size of an 8-track cartridge and smaller than a cassette.



The new tape system, called *Hipac*, is the combined result of research by ten companies.

"Our new *Hipac* cartridge will fill needs brought about by the ever increasing de-

mand for compactness in automobiles and pending safety requirements," states John F. Doyle, director of marketing for Pioneer's general products division.

The endless reel cartridge, about the size of a pack of cigarettes, provides the same performance as larger, conventional cartridges, with the additional feature of playing without break or interruption. An endless loop system is used in winding the tape so that it operates continuously when snapped into the player. A special adapter permits *Hipac* cartridges to be played in present 8-track equipment. ★

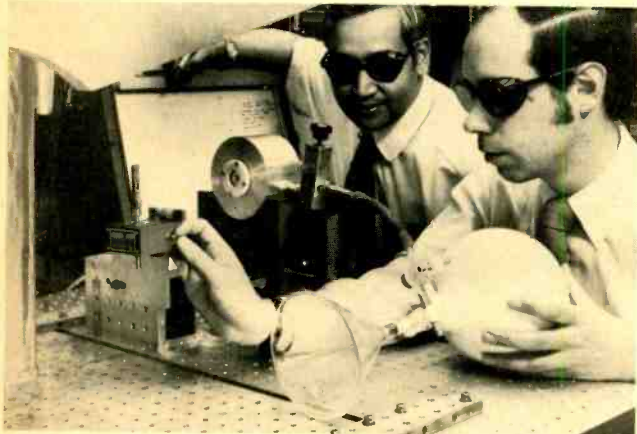

BELL LAB SCIENTISTS C. Kumar N. Patel and Lloyd B. Kreuzer measure the amount of nitric oxide gas in an air sample using a new laser-light absorption technique they devised. The air sample from the flask enters a cylindrical absorption cell where it contacts an invisible, infra-red laser beam. The gas quantity is plotted on the recorder. Nitric oxide is among the main pollutants in auto exhaust and smokestack emissions.

Crystal Stores Holograms

PRINCETON, N.J.—RCA reports the development of a crystal that stores hologram images as atomic patterns. These patterns can be read out one by one by slow motion rotation in a laser beam, similar to photographic slides in a projector. This advance could lead to a new document storage system to retain statistics, architectural drawings, photographs, maps and other graphic materials permanently in crystals the size of sugar cubes.

The holograms are stored

two light beams meet, an interference pattern (like the one that results when waves in water collide) is formed and stored in the recording medium.

In volume holograms, the brighter portions of the interference pattern excite certain electrons, freeing them to drift, or diffuse, through the crystal to form a charge pattern in the region where the two beams overlap that corresponds to the original holographic interference pattern.

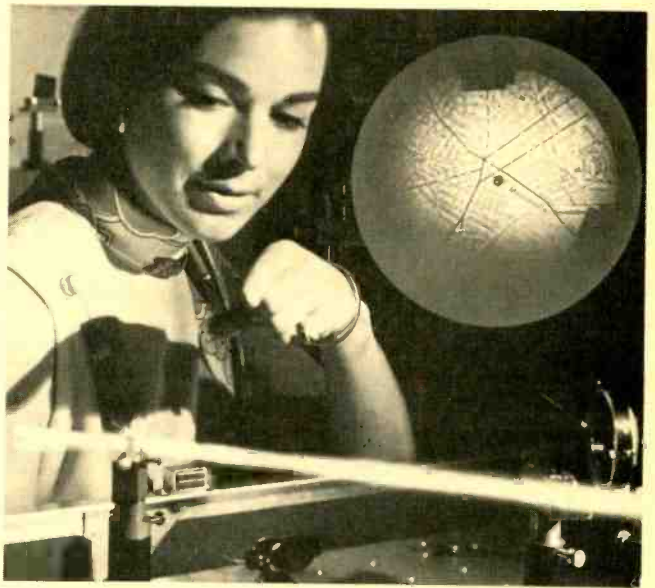

in crystals of lithium niobate or barium sodium niobate, 500 times more sensitive than any used thus far. A technique for permanently "fixing" the holograms has been developed, an advance over earlier methods where a very powerful laser was needed to do the job and the holograms have tended to be erased by the read-out process.

Crystal or volume holograms are made in much the same way as conventional holograms recorded on photographic film. A laser beam is split, half going directly to the recording medium, the other to the object to be holographed and then to the recording medium. Where the

The field resulting from this charge pattern, in turn, varies the index of refraction of the crystal in accordance with the holographic pattern. As a result, when a laser beam is directed through the crystal it reconstructs and projects the original holographic image onto a screen.

To prevent pattern erosion during readout, the crystal is heated to about 100°C after the pattern is stored, freeing the ions which form a pattern similar to the original hologram, and are locked into place when the crystal cools. Then, even though the electrons that originally stored the pattern are excited

(continued on page 6)

Radio-Electronics

FOR MEN WITH IDEAS IN ELECTRONICS

October 1971 • Over 60 Years of Electronics Publishing

4-CHANNEL—STEREO—HI-FI

- Equipment Report 26**
Toyo 4-channel tape player
- 4-Channel Sound Today 33** Harry Maynard
The latest happenings in 4-channel
- Build R-E's 4-Channel Preamp 37** Len Kaplan
Two IC's, ganged controls, make this unit perform
- Build R-E's 4-Channel Amplifier 41** . . . George Hanchett
50-watts rms per channel with one IC per channel
- Solid State Amplifier Design 50** . . . Mannie Horowitz
What to do about noise
- Equipment Report, 82**
Pioneer PL-A25 turntable

GENERAL ELECTRONICS

- Looking Ahead 4** . . Dave Lachenbruch
Current happenings with future overtones
- Home Appliance Electronics 16** Jack Darr
Fail safe! What is it?
- Photographer's Test Meter 59** . . . Marshall Lincoln
Handy instrument drops into the gadget bag

TELEVISION

- Kwik-Fix Troubleshooting Charts 55** Forest H. Belt
6JE6 horizontal output amplifier
- Zenith's Dual 12 62** Stan Prentiss
A look at a modular color TV chassis
- TV Service Clinic 69** Jack Darr
Hot spots, heat sinks, and thermal resistance

DEPARTMENTS

- | | | |
|---------------------------------------|-----------------------------------|----------------------------------|
| Coming Next Month 83 | New Products 74 | Technotes 94 |
| Correspondence 24 | New & Timely 2 | Try This One 96 |
| New Literature 77 | Service Notes 86 | |

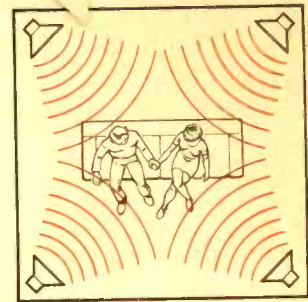

4-channel sound is now. Find out what's been happening. Look at the equipment, the tapes, the records.
 . . . see page 33



4-channel amplifier uses four new power IC's. Build this new R-E circuit and find out what a hybrid IC amplifier can do.
 . . . see page 41



Interested in photography? Then here's a little meter for your gadget bag. Use it once and you'll wonder how you ever got along without it. . . . see page 59

RADIO-ELECTRONICS, October 1971, Vol. 42, No. 10
 Published monthly by Gernsback Publications, Inc., at 200 Park Avenue South, New York, New York 10003.
 Editorial, Advertising, and Executive offices: 200 Park Ave. S., New York, N.Y. 10003. Subscription Service: Boulder, Colo. 80302.
 Second-class postage paid at New York City and additional mailing office. Printed in U.S.A. One-year subscription rate: U.S.
 and possessions, Canada, \$7. Pan-American countries, \$8. Other countries, \$8.50. Single copies 60¢.
 ©1971 by Gernsback Publications, Inc. All rights reserved.
 POSTMASTER: Notices of undelivered copies (Form 3579) to Boulder, Colo. 80302.



Radio-Electronics is indexed in *Applied Science & Technology Index* and *Readers Guide to Periodical Literature*

LOOKING AHEAD

Volume 42 Number 10

RADIO-ELECTRONICS . . . FOR MEN WITH IDEAS IN ELECTRONICS

October 1971

by **DAVID LACHENBRUCH**
CONTRIBUTING EDITOR

Quadridiculous!

If you listen carefully to any of the four-channel stereo systems, you're likely to hear, mixed in with all that concert-hall ambience, cries of "help" emanating from all four corners of the room, either in or out of phase, with reverberation, discrete or indiscrete. The most promising new development in sound since stereo is in grave danger of strangling on a multiplicity of mutually non-compatible and semi-compatible systems and techniques.

There isn't even any agreement on what to call it. Aside from the many proprietary tradenames for the various systems, the generic term for four-channel stereo has been spelled quadraphonic, quadrisonic, quadrophonic, quadrasonic, quadrosonic and quatrasonic. It would be nice to be able to call it just "quad"—but this is verboten, since "Quad" is the trade name of Acoustical Manufacturing Co. of England, whose attorneys have been particularly vigilant in their fight to prevent generic use of the name. They have suggested use of the term "fourchan" instead—but that just ain't got it. So for brevity, I'm just going to use "sono-4" to cover all four-channel systems (hoping against hope that nobody has yet registered the phrase as a tradename, and knowing full well that there's already something called "Stereo-8," which, of course, is a two-channel system).

But the confusion in names is nothing compared with the confusion among systems. There are discrete systems, there are psychological systems, there are matrix systems, there are phase-shift systems, there are pseudo systems, there are reverb systems, and there are combinations of a couple of these, as well as instruments designed to play all (well, almost all) systems. There isn't agreement on where to place the speakers (square, diamond-shaped, parallelogram or tetrahedron configurations)—or even on how many speakers to use. The instructions for one system (Nippon Columbia's "Triphonic") indicate that the optimum number of speakers is five, but that three or four may be used.

It's generally agreed that discrete systems (which use four separate sound tracks) inherently can provide the purest of four-channel sound. There's already one widely used discrete tape system employing eight-track cartridges, along with an open-reel discrete system. And already two mutually non-compatible but discrete sono-4 cassette systems have been announced—one with four tracks and one with eight. Of course, discrete systems (so far, at least) are limited to tape, and can't be broadcast without using two stereo-FM stations or introducing a new type of stereo-FM (or "FM-sono-4") broadcasting. Several such four-channel broadcast systems have been proposed, and one (the Dorren system) is being tested.

The non-discrete systems, which can use programming from disc, tape, or stereo FM, vary all over the lot. There are the various mathematical matrixing systems, including the E-V system and the Scheiber system (which were incompatible until they were merged and pronounced compatible). Then there's the CBS-Sony SQ matrixing system which is incompatible with the others. E-V decoders and records are already on the market. Columbia Records says it will have 50 titles in its SQ record collection (at a one-dollar premium) on the market by year's end. What does RCA Records say? Well, it doesn't like the CBS system. It

prefers something closer to the Japan Victor CD-4 system, which has a modulated subcarrier on the disc, but it doesn't plan to adopt this system; instead, it's working to develop its own "4-discrete" channel phonograph and disc.

And then, of course, there are the "derived" or "pseudo" sono-4 systems, which can get a four-channel effect from conventional two-channel material or from special four-channel programs (including some of the matrix discs) and which employ phase-shift, reverb and other mysterious ingredients.

Virtually all the systems mentioned are commercially available, many of them being released with great hoopla and large advertising budgets. They do all have one thing in common: They're expensive, if you want good sound from them. All of them require four speakers. All except some of the phase-shift devices require four channels of amplification. From there on, you take your choice. Want to play Columbia Records? Buy an SQ system. Enoch Light records? The choice is E-V. Are you a fan of Oriental popular music? Get CD-4. What happens when a Columbia SQ disc is played on a stereo-FM station and you have an E-V decoder? Maybe you should just switch on your Dynaco and enjoy the ambience.

If you're not an ambience-chaser, perhaps your best bet is the discrete eight-track cartridge system (sometimes called Q8)—the only thing that even remotely resembles a standard. But even this is a highly specialized system, which may not offer programming to your liking. The plain fact is that sono-4 appears to be headed toward disaster, toward strangulation by confusion.

What is really needed right now is some type of compatibility among systems—which means the scuttling of many existing and proposed systems. But standards are usually set by the consumer at the marketplace—nobody can impose them from above. This means that some people may buy systems which later turn out to be orphans—or, quite possibly, that few people will buy any sono-4 systems at all. The buyer is easily turned off by such minor discomforts as having to choose between a number of wildly different techniques for producing a service which he's not certain he wants in the first place. In the case of sono-4, incompatibility may well turn out to be the pea under the matrix.

VTRs at Sears & Ward's

Giant retailers Sears, Roebuck & Co. and Montgomery Ward are both planning market tests of the Cartrivision color videocassette system, probably starting shortly after the middle of next year. This will probably be the first consumer exposure to a home videoplayer system. The first systems offered by Sears will be combined with color TV receivers in 19-, 21- and 25-inch sizes, and probably will be featured in selected retail stores, rather than in mail-order catalogs. It's expected that an accessory black-and-white camera will also be offered, along with some 850 different program titles (on a rental basis) for the video tape system. Admiral and Emerson are also expected to offer Cartrivision recorder-players next year. Motorola is manufacturing the CBS EVR player system, which uses encoded black-and-white film to produce a color picture, but is concentrating on the industrial-educational-institutional market.

R-E

Tailor your own Security Systems with Mallory Crime Alert[®] Components.



PLUG-IN COMPONENTS.



RST1 CRIME ALERT REMOTE TRANSMITTER. Plugs into CA1A CRIME ALERT accessory outlet and activates the remote alarms. List price \$11.95.

RSR1 RECEIVER HORN. For indoor use. Plugs into 120 VAC outlet. List price \$29.95.



RSR2 OUTDOOR HORN. Loud and weatherproof. Plugs into 120 VAC outlet. It has a 30-second delay feature to allow the CRIME ALERT to be reset before the horn sounds. List price \$49.95.



CAC1 CABINET. If a burglar can wear a mask, why can't a CRIME ALERT. This is the perfect disguise. List price \$8.95.



SST SECURITY SWITCH. Designed for shut-ins and heart patients. A push of the button sounds alarm until help comes. Can be connected to receiver switch or receiver horns. List price \$39.95.

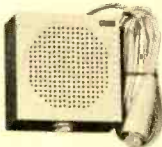

CAT 100 TIMER. Automatically shuts off and resets CRIME ALERT after alarm sounds for approximately 2 minutes. List price \$21.95.

CA1A CRIME ALERT. This is what makes our system tick. (Or screech, buzz, ring or flash.) Detects the slightest movement up to 22 feet away. Available with manual, automatic, remote or instant reset. List price \$99.95.

WIRED COMPONENTS.

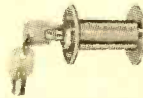

RS1 LOCKSWITCH. Deactivates and resets CRIME ALERT from remote location. 120 VAC 10 amp. switch. Adjustable to any door thickness. Special round key cannot be duplicated. List price \$10.95.



RRL1 ROTATING RED LIGHT. All-weather operation. Rotates 360°. 10,000 candlepower locates alarm site instantly day or night. 120 VAC. List price \$49.95.



87600 WEATHERPROOF HORN. High intensity sound level of 103 db @ 10 ft. 120 VAC. UL listed. List price \$36.00.

BATTERY SYSTEMS.



CA1DC CRIME ALERT. If power should fail, the ultrasonic alarm automatically changes to battery operation. Operates from 120 VAC or 12-18 VDC. List price \$99.95.

LCM1 POWER FAILURE ALARM. Sounds alarm when AC power is lost. Perfect for freezers, pumps or anything where a loss of power would be critical. List price \$24.95.



60007 VIBRATING BELL. Battery powered. Three Mallory M915 batteries will power it for at least 8 hours. List price \$22.50.

M 915 BATTERY. 6 volts. Three of these will power the CA1DC model for over a year. List price \$1.69.



M 918 BATTERY. A heavy-duty six-volt battery. List price \$3.45. (Not illustrated.)

Write for Bulletin 9-616 describing Mallory Security Systems in detail.

MALLORY

MALLORY DISTRIBUTOR PRODUCTS COMPANY

a division of P. R. MALLORY & CO. INC.
Box 1284, Indianapolis, Indiana 46208; Telephone: 317-636-5363

Batteries • Capacitors • Controls **CRIME ALERT** • DURATAPE[®] • Recorders • Resistors • Semiconductors • SONALERT[®] • Switches • Timers

Circle 2 on reader service card

New & Timely

(continued from page 2)

by the readout laser and drift away, the ions remain in the holographic pattern, unless the crystal is again heated to around 100°C. ★

4-CHANNEL TODAY

A lot of new things are happening. Bring yourself up to date. Read 4-Channel Sound Today. It starts on page 33.

RECORDS FOR DYNAQUAD & QUADAPTOR

Dynaco finds this group of records particularly effective when played on the Dynaquad 4-channel system. Those with an asterisk (*) exhibit substantial directional effects as well when played through a Quadaptor system.

- | | |
|---|---------------------------------|
| *Beach Boys: Sunflower | Reprise S-6382 |
| Beatles: Let It Be | Apple 34001 |
| Berlioz: Requiem | Philips 6700.019 |
| Bizet/Shchedrin: Carmen Ballet | Melodiya/Angel S-40067 |
| *Blood, Sweat & Tears: Spinning Wheel | Columbia CS-9720 |
| Boston Pops: An Evening At The Pops | RCA Red Seal LSC2827 |
| and Irish Night At The Pops | RCA Red Seal LSC2946 |
| *Fiddler On The Roof | RCA Victor LSO-1093 |
| *Last Night of the Proms | Philips 6502.001 |
| *Lee Michaels | A & M 4199 |
| *Pink Floyd: Ummagumma | Harvest STBB-388 |
| Shakespeare: Macbeth | Caedmon SRS-S-231 |
| Jimmy Smith: The Best of Jimmy Smith | Verve 68721 |
| *Stockhausen: Electronic Music | Deutsche Grammophon SPLM-138811 |
| *Simon & Garfunkel: Bridge Over Troubled Waters | Columbia KCS-9914 |
| *Stockhausen: Kurzwellen | Deutsche Grammophon 2707045 |
| *Wagner: Siegfried | London OSA-1508 |

Dynaco also recommends any disc recorded in the Electro-Voice 4-D matrix format.

BEAM LEADS FOR LINEAR IC's

PHOENIX, ARIZ.—A versatile operational amplifier is the first device in the Motorola beam-lead linear series. The beams are cantilevered gold structures extending from the IC chip, which bond readily

to a gold-metallized substrate. They replace the usual fragile connecting wires and provide one of the most reliable interconnection systems known. As an additional step, chip separation is done by an etching process eliminating possible fissures caused by mechanical stresses.

The assembly is protected by a layer of silicon-nitride



ASSORTED BEAM-LEAD IC's of the type described here.

passivation which is impervious to degrading ions.

Motorola performs a test which assures the effective protection provided by the silicon-nitride junction seal. It consists of applying table salt to the chip, reverse biasing the junctions for 8 hours at 300°C. in a forming gas atmosphere (N₂ and H₂) and then performing a complete

set of dc electrical tests. This test amounts to the worst possible case of sodium ion contamination.

The beam lead chip suitable for hybrid circuits provides the user who is not able to handle IC chips with the reliability advantages of the beam lead concept. ★

ACOUSTIC MICROSCOPE

CHICAGO, ILL.—A new type of microscope using high-frequency sound waves instead of light to probe a biological specimen has been developed by P. R. Palermo of Zenith Radio Corporation, along with Dr. A. Korpel and Dr. L. W. Kessler.

The experimental microscope may have important applications in pathological study of cell tissues and non-destructive materials testing and analysis. Though the concept of an acoustic microscope is not new, this working instrument did not become possible until Zenith developed novel acoustic holography techniques using its new acousto-optic laser deflector.

The specimen to be ob-
(continued on page 12)

Radio-Electronics

HUGO GERNSBACK (1884-1967)
founder

M. HARVEY GERNSBACK,
editor-in-chief and publisher

LARRY STECKLER, editor

Robert F. Scott, W2PWC
senior technical editor

Jack Darr, service editor

I. Queen, editorial associate

Matthew Mandl, contributing editor

David Lachenbruch, contributing editor

James A. Gupton, Jr.,
photographic electronics editor

Maxine C. Lipp, editorial assistant

Vincent P. Cicenia, production manager

Barbara Rosefelt, production assistant

H. Matysko, circulation

Cover design by Marius Trinqué

Cover photo by Phil Koenig

RADIO-ELECTRONICS is published by Gernsback Publications, Inc. 200 Park Ave. South New York, N.Y. 10003 (212) 777-6400

President: M. Harvey Gernsback
Secretary: Bertina Baer

ADVERTISING SALES

EAST
Stanley Levitan, Eastern Sales Mgr. N.Y.C. (212) 777-6400

MIDWEST/Texas/Arkansas/Okla.

The Ralph Bergen Co.
6319 N. Central Ave.
Chicago, Ill. 60646
(312) 792-3646

PACIFIC COAST/Mountain States

J. E. Publishers Representative Co.,
8560 Sunset Blvd., Suite 601
Los Angeles, Calif. 90069
(213) 659-3810

420 Market St. San Francisco, Calif. 94111, (415) 981-4527

SOUTHEAST

E. Lucian Neff Associates
25 Castle Harbor Isle
Fort Lauderdale, Florida 33308
(305) 566-5656

SUBSCRIPTION SERVICE: Send all subscription orders and correspondence to RADIO-ELECTRONICS, Subscription Department, Boulder, Colo. 80302

MOVING? For change of address, allow six weeks, furnishing both the old and new addresses and if possible attaching label from a recent issue below. Otherwise please print clearly your name and address exactly as it appears on your label.

ATTACH LABEL HERE

name (please print)

address

city state zip code

Mail to: RADIO-ELECTRONICS
SUBSCRIPTION DEPT., BOULDER, COLO. 80302

Circle 3 on reader service card ➤

ZERO 100 is the newest, most advanced automatic turntable. The name stands for Zero Tracking Error—up to 160 times less than with any conventional tone arm—new freedom from distortion—new life for your records. This revolutionary Garrard unit, priced at \$189.50, was recently introduced with a special presentation booklet. There are 12 explanatory pages, with clear illustrations and diagrams, valuable to anyone interested in fine record playing equipment. We'll be glad to send you a copy. We'll also include two full-color comparator guides, showing all the Garrard models, and a list of recommended dealers. The coupon is for your convenience.

CUT OUT AND MAIL

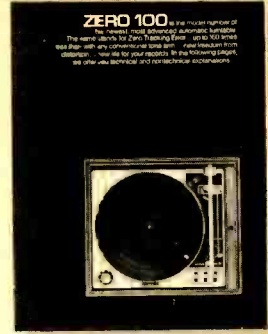

British Industries Company
Dept. J241
Westbury, N. Y. 11590

Gentlemen: Please send me the Garrard Zero 100 presentation booklet, comparator guides, and list of dealers.
Name _____

Address _____

City _____

State _____ Zip _____

British Industries Company, a division of Avnet, Inc.



Garrard[®]
WORLD'S FINEST
Mfg. by Plessey Ltd.
Dist. by British Industries Co.

Discover the ease and excitement of learning Electronics with programmed equipment NRI sends you

When you train at home with NRI, you train with your hands as well as your head. You learn the WHY of Electronics, Communications, TV-Radio the NRI pioneering "3-Dimensional" way. NRI training is the result of more than half a century of simplifying, organizing, dramatizing subject matter, and providing personal services unique for a home study school. You get the kind of technical training that gives you priceless confidence as you gain experience equal to many, many months of training on the job.

NRI—The 53 Year Leader in Electronics Training



APPROVED UNDER NEW GI BILL

If you served since January 31, 1955, or are in service, check GI line in postage-free card.



*Earn \$5 or more an hour
spare or full time in*

TV-RADIO SERVICING

Color Television has arrived. Sales are soaring, along with the continuing popularity of other home entertainment equipment like portable radios, tape recorders, hi-fi sets, phonographs and auto radios. TV-Radio servicing is one of your best routes to spare-time earnings, a good paying job or a business of your own. NRI not only trains you quickly and expertly, but also shows you how to get started in Servicing soon after you enroll, earning as you learn. NRI trains you in today's methods of installing and repairing all Electronic equipment for the home—including booming Color TV. You even build, experiment with and keep to enjoy your own solid-state radio and your choice of black-and-white or Color TV receiver. Like thousands of others, you can be earning \$5 or more an hour extra in spare time starting soon.

*There's money and
success awaiting you in*

BROADCASTING— COMMUNICATIONS

The experience you gain from intensely practical NRI training in Complete Communications equals as much as two years of training on the job. With NRI, you can train for a choice of careers ranging from mobile, marine and aviation radio to TV broadcasting and space communications. You learn how to install, maintain and operate today's remarkable transmitting and receiving equipment by actually *doing* it. You build and experiment with test equipment, like a VTVM you keep. You build and operate amplifier circuits, transmission line and antenna systems, even build and use a phone-cw transmitter suitable for transmission on the 80-meter amateur band. Whichever of five NRI Communications courses you choose, you prepare for your FCC License exams, and *you must pass your FCC exams or NRI refunds your tuition in full.*

*Move ahead in America's
fast growing industry as*

ELECTRONICS TECHNICIAN

Electronics touches everyone's lives. This vast field of opportunity is open to you with NRI training. Industrial/Military Electronics training—like all NRI courses—prepares you quickly, thoroughly the practical "hands on" way. You build with, and learn to understand the functions of, today's miracle solid-state components like printed circuits, diodes and transistors. You build and experiment with Electronic circuitry used in automation, data processing, ultrasonics, telemetry. Whatever your interest in Electronics, NRI training can fill your needs. Prove to yourself what nearly a million NRI students could tell you . . . that you get more for your money from NRI. Check the postage-free card and mail it today for your FREE NRI Color Catalog. No salesman will call. NATIONAL RADIO INSTITUTE, Electronics Division, Washington, D.C. 20016.

YOU GET MORE FOR YOUR MONEY FROM NRI — Build, test, explore, discover. Everything you see here is included in one NRI course—including Color TV. Other courses equally complete. And you'll be surprised at the low tuition costs. Text for text, kit for kit, dollar for dollar—you get more for your money from NRI.



Put it to Work!

NEW AND ONLY FROM EICO—THE INDUSTRY'S LOWEST-PRICED PROFESSIONAL FET-TVM.

Model 239
\$39.95
KIT



Use the battery powered Solid State EICO 239 on your bench or in the field. Check semiconductor and vacuum tube circuits. 11 Megohm DC input impedance. Read AC rms and DC voltages in seven steps from 1 to 1000 volts on large 4½" meter. Measure and read peak-to-peak AC to 2800 volts. Check resistance from 0.2Ω to 1000MΩ on seven ranges. Provides a total of 28 useful ranges on 12 accurate scales. Automatic battery check. Includes exclusive DC/AC ohms Uniprobe™. Factory Assembled, \$59.95.

FREE 32 PAGE EICO CATALOG

For latest catalog on EICO Test Instruments, Stereo, EICOCRAFT Projects, Environmental Lighting, Burglar/Fire Alarm Systems, and name of nearest EICO Distributor, check Reader Service Card.

EICO, 283 Malta Street, Brooklyn, N.Y. 11207



Circle 4 on reader service card

10 CHANNELS SONAR-SCAN™

FM MONITOR RECEIVERS



EXCLUSIVE!

NOBODY CAN TOP THESE FEATURES!

- ★ PRIORITY CHANNEL—LOCKS OUT ALL OTHER SIGNALS*
- ★ CARRIER DELAY—YOU HEAR MOBILE CALLBACKS*
- ★ MANUAL SELECTION BY SLOW SCAN TECHNIQUE*

A proven professional performer with the most advanced technology in design, circuitry and solid state electronics assures flawless performance you can hear with extreme clarity. SONAR-SCAN will search and automatically lock a signal on any of 10 pre-programmed channels • Noise free squelch • 10 crystal controlled channels • Adjustable scan sensitivity • Narrow band operation • 117 VAC or 12 VDC, negative ground only

FR-2516 (25-50MHz) FR-2517 (150-175MHz)
Comes complete with AC and DC power cables,
mounting bracket less crystals—Crystals \$5.00 ea.

\$159.95

EXCLUSIVE WITH SONAR and PATENT PENDING*

SONAR RADIO CORPORATION
73 Wortman Avenue
Brooklyn, N.Y. 11207

Send information on Model FR-2516/17 SONAR-SCAN. Dept. 403

Name

Address

City..... State..... Zip.....

Circle 5 on reader service card

New & Timely

(continued from page 6)

served is immersed in water and a high-frequency sound wave (100 MHz) is sent

the laser beam. Picked up by a photodiode, the beam is converted to an electrical signal which produces an acous-

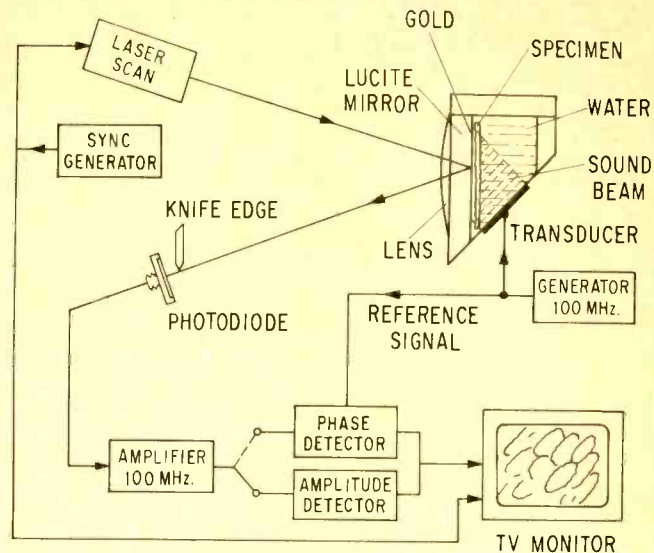

SCHEMATIC DIAGRAM of acoustic microscope.

through it. This wave, now carrying spatial information about the specimen, strikes a plastic mirror mounted at 45° to the direction of the sound, and causes a minute

hologram or a magnified picture of the sound field on a television monitor.

The fact that sound is a mechanical wave motion, while light is not, makes it

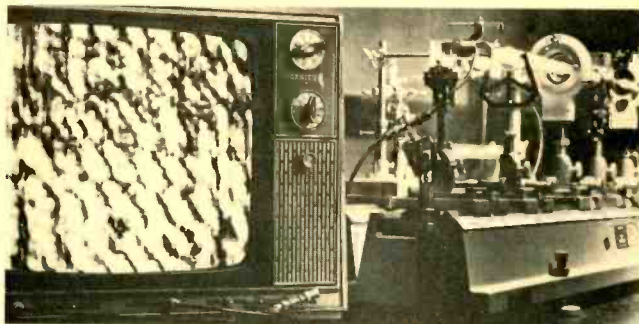

INDIVIDUAL CELLS of an onion skin magnified 400 times.

ripple pattern (a dynamic acoustic hologram) on the mirrored surface.

At the same time, a focused laser beam scans a selected area of the mirror with two acousto-optic laser deflector cells. The ripples on the mirror surface cause periodic angular deflections of

possible for an acoustic microscope to show features of a specimen which may go undetected by an optical microscope, and it also makes possible the study of live specimens. With an optical microscope, specimens must often be killed and chemically stained before study. ★

Ladies In TV Servicing Form Club

SIMI VALLEY, CALIF.—A nationwide club exclusive to women engaged in professional electronic servicing has been formed by Mrs. Sandra Schaffner who works with her

husband at his TV servicing firm. Ladies in Technical Electronic Servicing (LITES) has a two-fold purpose. First, to encourage more women to

(continued on page 14)

New & Timely

(continued from page 12)

enter the field of consumer electronics repair and second, to serve as a forum for exchanging ideas and technical developments for women al-

number of women professionally employed in consumer electronic servicing now is relatively small, the vocational opportunity is

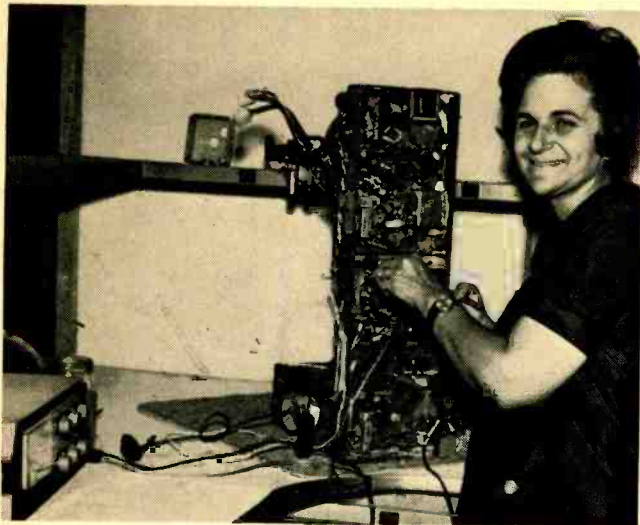

ready in the field.

Mrs. Schaffner says "the feminine concern for detail and for wanting everything working properly in its place makes television a natural vocation for women." While the

great. "There is not only a tremendous shortage of qualified . . . repair personnel today, but the field is highly compatible for women's capabilities," states Mrs. Schaffner. ★

NEA ANNUAL ELECTIONS

PORTLAND, ORE.—The National Electronic Association at its 7th Annual Convention elected the following men to serve throughout this coming year:

Association Officers

Norris R. Browne, President, Houston, Texas
Emmett Mefford, Past Pres., Fontana, Calif.
Henry Hyde, Secretary, Omaha, Nebraska
Tom Cooper, Treasurer, Marion, Indiana

Regional Vice Presidents

Jesse Leach, Linthicum, Md.
Charles Couch, Gainesville, Fla.
Al Powers, Hammond, Ind.
Charles Cave, Louisville, Ky.
Emmett Hughes, Hutchinson, Kans.
Sid Sabel, Houston, Tex.
Enos R. Rice, Seattle, Wash.
Virgil Gaither, Los Angeles. ★

TAKE PHOTOGRAPHS?

If your answer is yes, take a look at the photographer's test meter on page 59. You'll want one of your own.



MASSIVE TV BROADCASTING antenna, made at RCA's Gibbstown, N.J. plant, is readied for installation on 170-foot tower atop a new 50-story building in Houston, Texas. The 12-ton antenna was hoisted to the roof in two sections and joined into the 111-foot structure shown. It will broadcast programs originated by KVRL-TV, a new uhf station. R-E

True 4-Channel Sound

[\$42.50 per 20-watt channel]

There are several components on the market that you can take home and get true 4-channel sound out of today.

All are expensive.

Except ours.

We call ours QAUDIO. It's an amplifier and player with 4 discrete channels. And we designed it primarily to play the new 8-track 4-channel cartridges.

But we also give it the capability of playing ordinary 8-track stereo cartridges, because there are a lot more of them around today than there are 4-channel cartridges. And QAUDIO makes even ordinary stereo cartridges sound fuller and richer than they ever have before.

But of course it takes a specially recorded 4-channel cartridge to give you the real QAUDIO experience, and there's no point in try-

ing to describe what *that's* like. It's simply something that has to be experienced.

And you can experience it today—at a price that's almost as unbelievable as the sound: \$169.95. (That's \$169.95 for a true 4-channel amplifier-player with 80 watts of total music power.) A QAUDIO unit for your car or boat is just \$129.95.

A free call to **800-631-1971** (in N.J. 800-962-2803) will give you the names of stores where you can experience a Qaudio demonstration.

For brochure: Toyo Radio Co. of America, Inc., 1842B W. 169th St., Gardena, Calif. 90247.

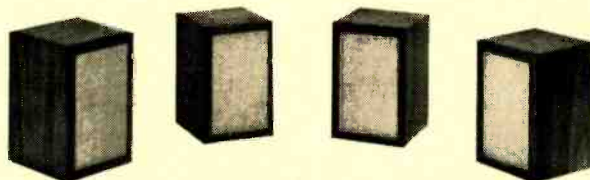

QAUDIO™
BY TOYO
A SHOCKING EXPERIENCE IN SOUND.

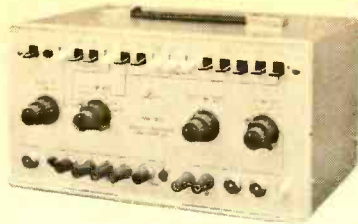

MODEL LSW-330-SOLID STATE, POST INJECTION SWEEP-MARKER GENERATOR. Compact utility unmatched for color alignment, testing and servicing! Accurate, stable, rugged, it provides all sweep and marker signals for circuit alignment of video and sound IF's; chroma, too! Features automatic limit control and a 10.7MHz sweep for FM-IF use. A great time saver! **\$399.50**

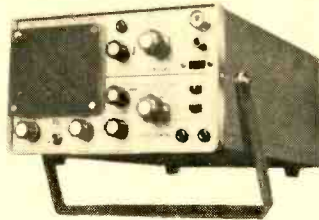

MODEL LBO-301-3" PORTABLE TRIGGERED SCOPE. All solid state, it's the only 3" scope with vertical and horizontal calibration plus all the features you need for bench or field use: DC to 7MHz bandwidth, 1 μ s/div. sweep speed, 5X magnification (max. speed 0.2 μ s/div.), and a horiz. front panel design. A space-saver and a time saver! **\$334.50**



MODEL LBO-54B-5" WIDEBAND OSCILLOSCOPE. Calibrated vertical input; 10MVp-p/cm sensitivity; DC to 10 MHz bandwidth; high linearity sweep range with automatic synch; distortion-free displays! This high performance Leader scope is a real money maker for every service operation. **\$249.50**



MODEL LCG-384-MINI-PORTABLE, BATTERY OPERATED COLOR BAR GENERATOR. With its digital clock binary system for high quality test patterns, the LCG-384 uses just four 1.5V penlight cells and fits into all tool caddies. Has 2 TV selectable ch. frequencies; 4 basic patterns including gated rainbow; and is fully protected against ambient temperature and line voltage changes. With carry case and extra battery compartment. **\$109.50**

THE TIME SAVERS ARE HERE FROM THE LEADER

Your time is money. The more you save of one the more you make of the other. That's why LEADER Instruments are time savers . . . and money makers, for you! They're designed and built to the highest performance standards, with rugged reliability and precision. What's more LEADER Instruments combine more features at far more realistic prices than competitive products. They are simple to use, worry free — clearly your best value in test instrumentation. See your distributor. He carries a complete line of LEADER Instruments — ready to save time and make more money for you.

Send for catalog.

Seeing is believing.

Leader

INSTRUMENTS CORP.

37 - 27 Twenty-Seventh Street,

Long Island City, N.Y. 11101 (212) 729-7410

Circle 7 on reader service card

1ingle

TRACE-5" FULLY TRIGGERED OSCILLOSCOPE

AT A PRICE YOU CAN'T AFFORD TO MISS!

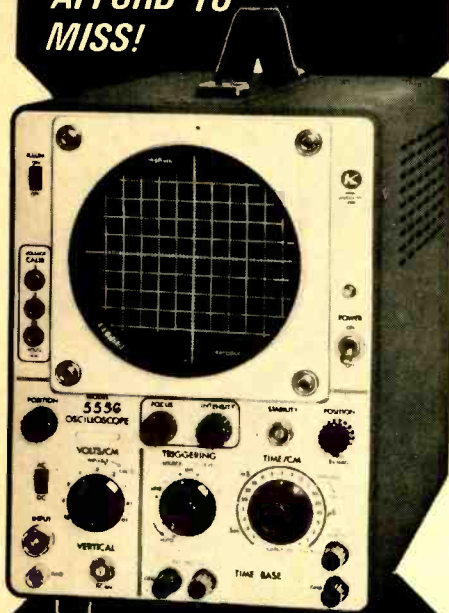

MODEL 555 G

ONLY **\$349⁰⁰**

Complete with two ranges of TV-H and TV-V

Compare these features:

- Solid state circuitry
- High sensitivity-20MV/cm
- Low heat dissipation
- Extra wide bandwidth-10 MHz
- Lightweight—8½ inches high
- Simplified controls for easy operation
- Extremely reliable performance
- Built-in square wave oscillator for calibration functions

Full line of electronic test instruments include: trigger, dual trace trigger, alignment and standard oscilloscopes

Call or write for **FREE** specification catalogs

kikusui
ELECTRONICS CORP.

Address all inquiries to:

Marubeni-lida (America) Inc.
200 Park Avenue, New York, N. Y. 10017
Telephone 212-973-7152

Circle 8 on reader service card

HOME APPLIANCE ELECTRONICS

by **JACK DARR**
SERVICE EDITOR

FAIL-SAFE? WHAT'S THAT?

Every automatic appliance, and especially the types which heat things, is (or darn well should be!) equipped with **fail-safe** controls. By definition, this means that if anything fails, that could cause a dangerous condition to exist, the thing shuts itself off, and won't operate at all. This covers such dangerous things as escaping gas, electrical arcing, and any other hazardous condition.

This is especially important on any gas-fired heating appliance; heaters, furnaces, boilers, clothes driers and so on. All of these are now made with full-automatic controls. The controls operate electrically. The main gas valve is always a solenoid type. So, all of the safeties are keyed to this control. Unless they all indicate **Safe!**, the main gas valve will not open. So no unburnt gas can escape into the house.

The fail-safe units are mostly electrically operated, although there are pressure-operated, temperature operated, and other types used. They all

safe sensor. Here you can see how several different types of sensors are used. The **HIGH GAS** and **LOW GAS** sensors check the input pressure, usually between limits of 4 oz and about 8 oz.

The **WATER LEVEL** sensor is a simple float-operated switch, to check that the boiler has enough water in it. The **LIMIT SWITCH** is a thermostat, which opens the switch if the internal temperature goes above safe limits. The **STEAM PRESSURE** is another pressure-operated switch, which stops the operation if the steam pressure starts to go above safe limits for the system. The **PUMP VOLTAGE** switch is a relay, hooked across the line to the water-circulation pump which keeps the water level up. If there is no voltage at this pump-motor, the switch opens. Last is the **PILOT BURNER** safety. It is often a photoelectric cell with amplifier and relay.

This is mounted so that the photocell does **NOT** "see" the flame of the main burner, but only the flame of

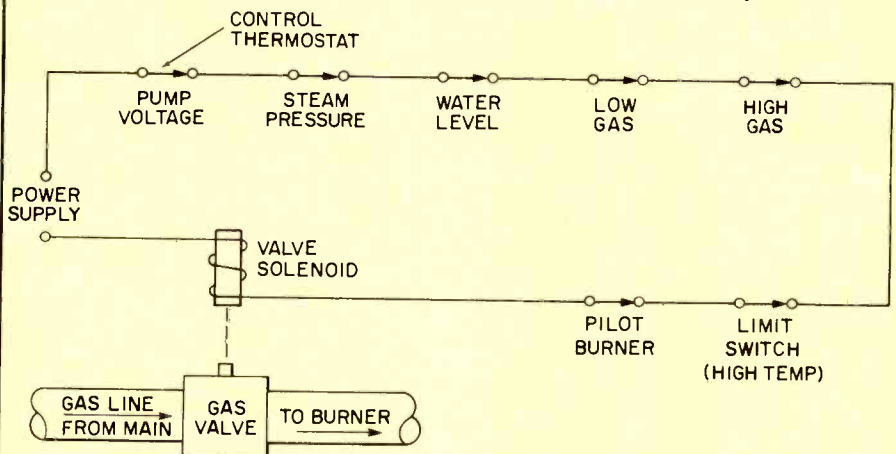

do one thing, open or close a spst switch! This switch closes if the unit senses normal operating conditions; if not, **Click** and it shuts everything down until the trouble is found and cleared up. All of the safety switches are connected in series, between the power supply and the main gas valve.

A typical example of a really complex system is shown in Fig. 1. This is the actual circuit of a good-sized gas-fired boiler for a steam heating system. Everything which could cause trouble is protected by a fail-

the *pilot burner*. If it goes out for any reason (even if the main burner is on) this shuts down the boiler. In another version of this circuit, the main gas burner is ignited electrically; the flame-sensor must see flame before the ignition sequence is allowed to continue. (It is controlled by an electronic sequence-timer unit.)

It can be a fairly complex system in the larger units. The thermostat starts the timer, which first starts a purge-blower; it sends a blast of air
(continued on page 22)

We compared our new \$550 preamp to a 10¢ piece of wire.

First we ran a signal through a 10¢ length of shielded cable. What came out the other end was, of course, audibly identical to what went in. Then we ran the same signal through our new TA-2000F preamplifier, and ran an A-B comparison between its output and the wire's. Both were audibly identical. As we'd expected.

This is not to say that sufficiently precise instruments could not detect inaudible differences between our preamp's signal transmission and a wire's. Whereas a straight wire has no distortion whatsoever, we must admit to having some—three hundredths of one per cent harmonic, and five hundredths of one per cent intermodulation, maximum, at rated output. And whereas a wire theoretically does generate some noise, its signal-to-noise ratio is still somewhat better than the 73dB obtained through the TA-2000F's phono inputs, or even the 90dB obtained through our Aux. Tape and Tuner inputs.

But as you'd expect, the \$549.40 difference between our preamp(\$549.50)* and two feet of cable, buys you a great deal more than just a pure, clean signal. As our preamp's 58 levers, switches, meters knobs and jacks would indicate.

NEARLY 2,000 RESPONSE SETTINGS

Six of those controls are devoted to precise adjustment of frequency response. The calibrated, 2dB-per-step, bass and treble controls have switches that adjust their turnover frequencies, so you can choose how deeply the tone controls will affect—or not affect the midrange. Still another switch cuts the tone controls out of the circuit altogether. And a single knob controls the sharply-cutting, 12dB-per-octave, 50Hz and 9kHz filters. Together, these six controls give you a choice of 1,935 *precisely repeatable* response settings including flat (10Hz-100kHz, +0, -2dB) response.

The facilities for tape recording are exceptional and unique; you can record on two tape decks at once, monitoring either (or your program source) at the flick of a switch. You can dub from one machine directly to the other, without external patching or connections. For straight microphone recordings, there's a mic input position on the function

selector knob; for voice-over-music, there's a separate mic level control that diminishes all other input signals as it increases the microphone level.

And, of course, the two, front-panel VU meters, are as useful for testing as they are for monitoring record levels.

TOTAL INPUT AND OUTPUT FLEXIBILITY

The TA-2000F can feed two stereo amplifiers (and an additional monophonic or center-channel amp) at one time, at either a 1 volt or 300mV level. The second amplifier output could also be used for still another tape recorder, should you wish to use the ultra-versatile tone controls and filters in recording. The front-panel output jack feeds both high- and low-impedance headphones, or can be used as a tape output, by suitable adjustment of its independent level control; the same knob also controls the center-channel output.

Five of the 8 rear-panel stereo inputs have rear-panel level adjustments. A sixth—the Phono 1 input—has a switch that selects three separate input impedances at the normal 1.2mV sensitivity setting, and two more impedances at the 0.06mV setting that lets you use even the lowest-output cartridges.

96 TRANSISTORS VERSUS A SINGLE WIRE

But all these features merely make our TA-2000F more versatile than any wire. They don't explain how we can come so close to the wire's pure, unadulterated performance. That explanation will rest with our circuit designers, and with the 96 *high voltage*, and Field Effect transistors they used.

THE TA-3200F: AN AMPLIFIER TO TRULY COMPLEMENT OUR PREAMP
A preamplifier like the TA-2000F deserves, of course, its complement in a

power amplifier. Not too surprisingly, we make one: the TA-3200F (\$349.50)* Its fully direct-coupled circuitry produces 200 watts continuous (RMS) at 8 ohms, with power bandwidth from 5 to 35,000Hz. IHF Dynamic Power is rated at 320 watts into 8 ohms (and fully 500 watts into a 4 ohm load). Its distortion, at a listening level of one half watt, matches the preamplifier's at 0.03%; at full rated output, it is still a mere 0.1%. And the signal-to-noise ratio is 110dB.

Our amplifier's facilities nearly match our preamp's. The 3200F has controls you've rarely, if ever, seen on power amps before: switch-selected stereo input pairs; a speaker selector switch; a power limiter (which holds output down to 25 or 50 watts, should you so desire), and a rear-panel switch that lets you limit bass response below 30Hz., instead of letting it extend to 10Hz.

For further information, see your Sony dealer, or write us. Or wire. Sony Corporation of America, 47-47 Van Dam Street, Long Island City, N.Y. 11101.

*Suggested retail price, subject to Fair Trade where applicable.



SONY®



Train on this
315 sq. in.
picture
color TV
and get the
skills that
mean a
high-paying
career!

Solid-State — the newest development

Count on NTS training to always feature the latest electronic equipment.

Now included in two exciting NTS color TV courses, this set is the largest, most advanced color television made. Guided by the NTS "Lab-Project Method" of combining professional kits and easy-to-follow lessons, you build this color TV step by step — learning TV Servicing as you go! NTS has successfully trained thousands of men at home for rewarding careers as electronics technicians. Prepare for the great opportunity fields of TV-Radio Servicing, Computers, Communications, and Automation.

This solid-state color set contains: 45 transistors, 55 diodes, 2 silicon controlled rectifiers, and 4 advanced Integrated Circuits representing an addi-

tional 46 transistors and 21 diodes. The first solid-state color TV this large — yours to keep! It features Automatic Fine Tuning; "Instant On"; an Ultra-Rectangular Screen (25 in. diagonal measurement) that lets you see the complete transmitted image for the first time — a full 315 square inches; exclusive built-in Self Servicing features which eliminate the need to buy costly test equipment; exclusive design Solid-State VHF Tuner with an MOS Field Effect Transistor; 3-stage Solid-State IF; Automatic Chroma Control; Adjustable Noise Limiting and Gate Automatic Gain Control; High Resolution Circuitry; Matrix Picture Tube; and a specially formulated Etched Face Plate that eliminates unwanted glare, and heightens contrast. Colors are more vivid,

fresh tones more natural, and the picture is sharper than ever before. By training on this unique color TV, you'll gain the most up-to-date skills possible in TV Servicing!

Other valuable equipment you build and keep includes an AM SW Radio, Solid-State Radio, FET Volt-Ohmmeter, and Electronic-Tube Tester. All included in your tuition. You learn troubleshooting, hi-fi, multiplex systems, stereo, and color TV servicing. Step right into a technician's job at top pay or open a business of your own! For complete details on all NTS electronics courses, mail the coupon today for the full-color NTS Catalog. No obligation. No salesman will call.

Build this set
and learn
solid-state
circuitry—the
electronics
of today!

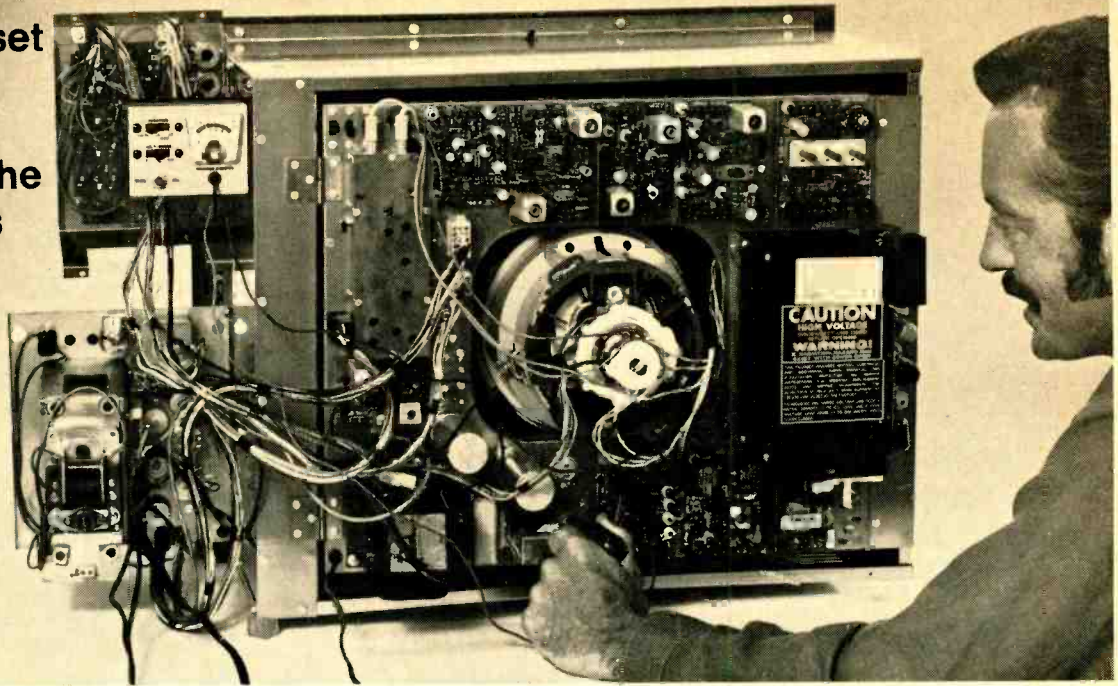

in color TV — comes to home training.

NTS ELECTRONICS & COMPUTER TECHNOLOGY

Build this exclusive NTS Compu-Trainer! Loaded with integrated circuits, it shows you the how, what, and why of computers. Learn this exciting field faster, more thoroughly. You also assemble and learn to operate an FET Volt-Ohmmeter and 5" wide band Oscilloscope.

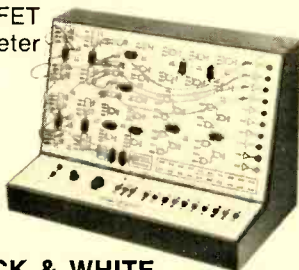

NTS BLACK & WHITE TV AND RADIO SERVICING

Learn all phases of television, radio, stereo, and hi-fi. You receive this 74 sq. in. picture Solid-State B&W TV, Lo-Silho "Superhet" Radio, FET Volt-Ohmmeter, Solid-State Radio, Electronic Tube Checker, and Signal Generator. Start earning extra money even before you complete the course!



NTS ELECTRONICS COMMUNICATIONS & F.C.C.

Gain the security and prestige of owning an F.C.C. First Class Radio-Telephone License! Two comprehensive NTS courses cover the big opportunity field of transmitting and receiving. You build 14 kits, including a 5 watt AM Transceiver, 6 Transistor Pocket Radio, and FET Volt-Ohmmeter. Learn 2-way radio, Citizens Band, micro-waves and radar.



NTS INDUSTRIAL & AUTOMATION ELECTRONICS

Automation is the future of industry and you can play an important part! Learn industrial controls by training on the NTS Electro-Lab — a complete workshop. You also build and operate this 5" wide band Oscilloscope. And you perform experiments that involve regulating motor speeds, temperature, pressure, liquid level, and much more.



Classroom Training at Los Angeles. You can take classroom training at Los Angeles in sunny Southern California. NTS occupies a city block with over a million dollars in technical facilities. Check box in coupon.

APPROVED FOR VETERANS
Accredited Member: National Association of Trade & Technical Schools; National Home Study Council.

NATIONAL TECHNICAL SCHOOLS
WORLD-WIDE TRAINING SINCE 1905
4000 South Figueroa Street, Los Angeles, Calif. 90037

Please rush Free Color Catalog and Sample Lesson, plus Information on course checked below. No obligation. No salesman will call.



National Technical Schools

- 4000 S. Figueroa St.
Los Angeles, Calif. 90037
- Master Course in Color TV Servicing
 - Color TV Servicing (For Advanced Technicians)
 - Master Course in B&W TV & Radio Servicing
 - Master Course in Electronic Communication
 - Practical Radio Servicing
 - FCC License Course
 - Master Course in Electronics Technology
 - Industrial and Automation Electronics
 - Computer Electronics
 - Basic Electronics
 - High School at Home
- Dept. 206-101

Name _____ Age _____

Address _____

City _____ State _____ Zip _____

Check if interested in Veteran Training under new G.I. Bill.
 Check if interested only in Classroom Training at Los Angeles.

**a
new
PHASE
in electronics**



The Phase ASG-200 Audio Sweep Generator provides a source of audio frequency functions: sine, square, triangle, positive sawtooth (with variable negative slope), and negative sawtooth (with variable positive slope). Frequency is variable from 0.02 Hz to 20 KHz for all functions. Dial accuracy is within 2%. The low distortion level and simple, straight forward, solid-state circuitry, rugged construction, and ease of operation, makes this Audio Sweep Generator ideal for high fidelity audio systems maintenance and checkout.

Kit \$ 84.85
Factory Assembled and Tested \$108.09

Send Today

for complete information & specifications on our complete line of electronic test equipment - assembled or kits - that feature unique functions - quality & low cost.

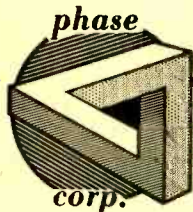

315A Boston Avenue,
Medford, Massachusetts 02155

Circle 10 on reader service card

HOME APPLIANCE ELECTRONICS
(continued from page 16)

through the firebox, to blow out any possible accumulation of unburnt gas and prevent an explosion at ignition. Then the timer samples all of the safeties. If they are all closed, indicating safe conditions, it tries to light the main burner. If the flame sensor sees the flame the sequence is permitted to continue. When boiler temperature is high enough, the circulating pumps for water and steam turn on, and we're in business. If at any point in the start-up sequence the timer finds an incorrect answer from the safeties, the whole thing comes to a screeching halt.

In the smaller units, such as automatic gas heaters for home use, furnaces and air-conditioning units, driers, etc., the controls are just exactly the same in operation. But, there aren't quite as many of them!

Gas valves are still electrically operated, and there will **ALWAYS** be one type of safety; a pilot-burner sensor. None of these will come on if the pilot flame is out. So, we still have fail-safe operation. Some have a manual override, so you can light the burner by hand, holding the gas valve open. This should be used merely to be sure that there is adequate gas pressure, etc; but **only for testing**. The fail-safe devices should **never** be jumped out.

There are two major types of these safeties on the pilot burner. Both use a special thermocouple, which is mounted on the main burner, but placed so that it is only in the *pilot flame*. It provides a very small dc voltage when heated to the proper temperature.

Two types of systems are used with these. In the oldest type, called a BASO-pilot. Pronounced Baz-O, the safety is a special relay mounted on the outside of the heater or furnace. The thermostat will not close this relay by itself; not enough voltage. However, when the manual knob on the relay is pushed down and held, while the pilot burner is lit, it will stay closed. So, this could be called a "manual-set/automatic trip" system.

Power for operating the main gas valve, etc. is usually 24 volts ac, from a small transformer. The complete circuit is from the transformer through room-thermostat contacts, contacts on Baso pilot relay, through a high-temperature limit switch then through the gas-valve solenoid and back to the transformer. Basically, exactly the same circuit as Fig. 1, but simplified.

Next month, we'll take a look at a system which does the same thing, but without any external sources of power like a transformer. **R-E**

**Now Weller®
helps you
de-solder
faster and
easier.**



De-solder and re-solder cleanly with one hand and with less chance of heat damage. Stainless steel tube prevents clogging, and there's a choice of six metal tip sizes.

For straight soldering, you can't beat Weller's 25 watt and 40 watt professional soldering irons. They have stainless steel barrels, popular pencil shape and double-coated, industrial-grade interchangeable tips. Ideal for service work, kits, hobbies. The Weller de-soldering tool is available nationwide through local electronic parts distributors.

The Cooper Group

CRESCENT-KEN-TOOL-LUFKIN-WELLER



Circle 11 on reader service card

The big difference in TV Alignment instruments: Ours Works.

The B & K Model 415 Sweep/Marker Generator not only works, but it makes alignment jobs faster and more accurate.

Why? Because it eliminates the need for a separate marker generator, sweep generator, marker adder, and bias supply. You get it all in one compact instrument.

And it's so easy to use. The IF and chroma bandpasses are simulated on the front panel for constant reference. Lights tell you which of the crystal-controlled markers are in use and where they should be located. And the exclusive marker tilt feature lets you place the markers either horizontally or vertically, so you can always identify their exact positions.

Put the B & K Model 415 Sweep/Marker Generator to work for you.

Ask your distributor for complete details.



Product of
DYNASCAN CORPORATION
1801 W. Belle Plaine
Chicago, Illinois 60613



Model 415:
\$399.95

Circle 12 on reader service card

Be Safe with DeltAlert The Proven Crimestopper

Everyone knows crime is increasing steadily. In fact, statistics show that one out of every six homes will be victimized this year. What can you do about it? The DeltAlert Ultrasonic Burglar Detection & Alarm System was developed to help protect you and your family. DeltAlert effectively monitors and blankets up to 300 sq. ft. of space, utilizing the sonar principle to pick up even the slightest motion. When DeltAlert is activated, horn and lights automatically begin operating. The loud ear-shattering blasts of the high intensity horn, coupled with light drives away even the boldest intruder. At home

or work, protection begins with the DeltAlert Alarm and Detection System.

It's maintenance free, and to install you simply plug it in. Order yours today, and start enjoying the feeling that comes with DeltAlert protection.

\$69.95

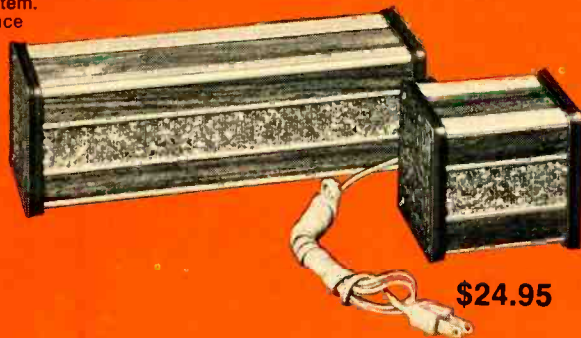

\$24.95

Here Are 8 Reasons to Put The Mark Ten B On Your Car

The Mark Ten B CD System with exclusive VARI SPARK® Circuitry will give you these substantial dollar saving advantages: 1) Eliminate 3 out of 4 tune-ups; 2) Improve combustion, reduce contaminants; 3) Install in ten minutes; 4) Instant start in all weather; 5) Dramatic increase in performance; 6) Handy switch with redundant contacts for instant return to standard ignition; 7) Two-piece housing with neoprene seals provides total dust and moisture protection; 8) Use on ANY 12-volt, negative-ground engine. Put the Mark Ten B on your car today. It will pay for itself in dollars saved.



Superior Products
At Sensible Prices

Mark Ten B
(12v neg only) Only **\$59.95** ppd.
Standard Mark Ten **\$44.95** ppd.

Please send me literature immediately. Enclosed is \$_____ Ship ppd. C.O.D.

Please send: _____ DeltAlert(s) @ \$69.95 ppd.

_____ DeltaHorn(s) @ \$24.95 ppd.

_____ Mark Ten B @ \$59.95 ppd.

_____ Standard Mark Ten (Assembled) @ \$44.95 ppd.

_____ 6 Volt: Neg. Ground Only _____ Positive Ground

_____ 12 Volt: Specify _____ Negative Ground

_____ Standard Mark Ten (Deltakit) @ \$29.95 ppd.
(12 Volt Positive Or Negative Ground Only)

Car Year _____ Make _____

RM Name _____

Address _____

City/State _____ Zip _____



P.O. Box 1147, Grand Junction, Colorado 81501, (303) 242-9000

Circle 13 on reader service card

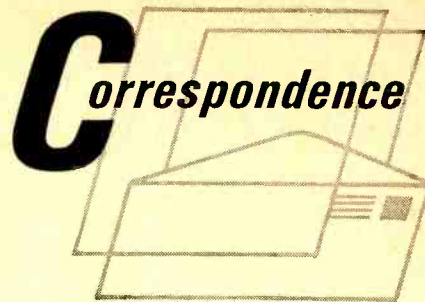

MORE ON USING THE TONE-BURST GENERATOR

I compiled this additional material for readers of my article "Ways To Use The Tone-Burst Generator" which appeared in the August 1971 issue of **Radio-Electronics**.

A tone burst can be a test signal in systems where there is unused or "dead" time between data trains, such as radar, TV, sonar, telemetry and facsimile systems. Also included are the coaxial cables, microwave links and land lines used to transmit data from these systems. You can make tests and adjustments without shutting the system down if you use this generator.

Here are some hints which may be helpful in various situations, although each application poses a unique combination of factors.

When in the single burst mode, the period vernier should be set to minimum. The 10 to 100- μ sec timing is still active and would limit the maximum burst repetition rate to 10 kHz if the vernier were in the maximum position. The minimum setting allows for burst repetition rates of as low as 100 kHz.

A reset pulse may not be available at the right time from the system under test. In that case, take a close look at your oscilloscope. If it has a delayed sweep, it may also have a delayed trigger output. This could be used as a reset pulse for the tone burst generator.

If frequency response tests are planned, first check the frequency response of your oscilloscope. Then just check and adjust the transient response with a fast rise step generator. (The Pocket Pippier featured in the February 1971 issue of **Radio-Electronics** was designed expressly for this purpose.) A correction may still have to be made for the normal high frequency rolloff of the oscilloscope you are using.

I hope these suggestions will add to the usefulness of the tone-burst generator for your readers.

TOM ANNES
Denver, Colo.

R-E

Put More "GO POWER" into Your Electronics Career —

MOVE AHEAD from Technician to ENGINEER

by studying at home with

GRANTHAM SCHOOL OF ENGINEERING

"the college that comes to you"

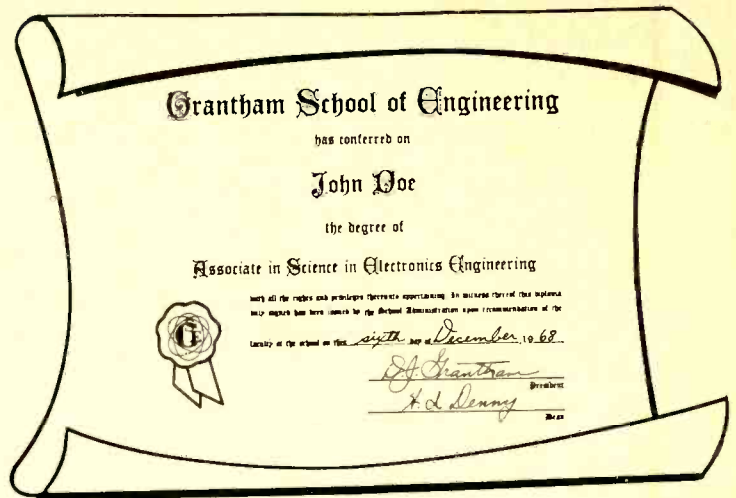

Earn a DEGREE in Electronics Engineering

The GRANTHAM educational program in ELECTRONICS ENGINEERING is designed to upgrade electronics technicians to the *engineering* level, mostly by home study.

While you continue your present employment, you can really learn electronics engineering and earn an *ACCREDITED DEGREE*. You can upgrade your income and prestige by upgrading your electronics education at the college level.

GRANTHAM'S strong-foundation educational program in electronics engineering is designed especially for the *working technician*. This program, offered mostly by home-study, leads to non-obsolescent skills—to skills based on reasoning—and leads to the DEGREE of Associate in Science in Electronics Engineering (the ASEE Degree).

This *accredited* degree program consists of four correspondence courses of 100 lessons each—an overall total of 400 lessons—followed by a two-week graduation seminar held at the School. Upon completion of the four correspondence courses, you are awarded a diploma in Electronic Engineering. Then, upon completion of the two-week graduation seminar, you are awarded the ASEE Degree.

Accreditation and G.I. Bill Approval

Grantham School of Engineering is *accredited* by the Accrediting Commission of the National Home Study, is *approved* under the G.I. Bill, and is *authorized* under the laws of the State of California to grant academic degrees.

Grantham School of Engineering

• Established in 1951 •

1505 N. Western Ave.
Hollywood, Calif. 90027

Telephone:
(213) 469-7878



What's in Your Future — The Same Old Job, or Success in Engineering?

Where will you be five years from today? Are you headed for real advancement in electronics, or in a rut? The experience you have as a technician is valuable; it gives you a head start toward a better future. But to get ahead and stay ahead, experience must be supplemented with *more education* in electronics and such allied subjects as mathematics, physics, computers, and engineering design.

The Grantham educational program in electronics engineering is *not for beginners*. Every point is explained just as carefully as if you were a beginner, but the important difference is that while the beginner would need extensive *laboratory* training, you (as an experienced technician working with modern equipment) do not require such training and should not waste your time doing the same laboratory experiments that beginners must perform. This program in engineering is designed, written, and taught for and to experienced technicians, and beginners are not accepted for enrollment.

● Mail the coupon below for our free Bulletin ●

Grantham School of Engineering

RE-10-71

1505 N. Western Ave., Hollywood, Calif. 90027

Gentlemen:

Please send me your free Bulletin which gives complete details on the Grantham educational program leading to the Associate Degree in Electronics Engineering. I understand no salesman will call.

Name _____

Address _____

City _____ State _____ Zip _____

I have been in electronics for _____ years.

WE'RE CLOSER

HERE'S 8 REASONS...



...WHY WE'RE CLOSER TO TECHNICIANS who keep Magnavox products working in top-notch condition

NOW 8 LOCATIONS :

NEW YORK CENTER:
MAGNAVOX PARTS DIVISION
159 E. UNION AVENUE
E. RUTHERFORD, N. J. 07073
TELEPHONE: 201 935 1212
(NYC) 212 279-3973
TELETYPE: 710 989 0105

LOS ANGELES CENTER:
MAGNAVOX PARTS DIVISION
2825 MARICOPA STREET
TORRANCE, CALIF. 90503
TELEPHONE: 213 328-0770
(L.A.) 213 775-3572
TELETYPE: 910 349-6957

ATLANTA CENTER:
MAGNAVOX PARTS DIVISION
144 ENTERPRISE BLVD. S. W.
ATLANTA, GEORGIA 30336
TELEPHONE: 404 691-4040

SAN FRANCISCO CENTER:
MAGNAVOX PARTS DIVISION
1366 SAN MATEO AVE.
SO. SAN FRANCISCO, CALIF. 94080
TELEPHONE: 415 871-5080
TELETYPE: 910 371-7237

DALLAS CENTER:
MAGNAVOX PARTS DIVISION
8809 W. CARPENTER FREEWAY
DALLAS, TEXAS 75247
TELEPHONE: 214 637-1710
TELETYPE: 910 861-4543

CLEVELAND CENTER:
MAGNAVOX PARTS DIVISION
24094 DE TROIT ROAD
WEST LAKE, OHIO 44145
TELEPHONE: 216 835-1313
TELETYPE: 810 427 9122

CHICAGO CENTER:
MAGNAVOX PARTS DIVISION
7500 FRONTAGE RD.
SKOKIE, ILLINOIS 60076
TELEPHONE: 312 679-8700
(CHI) 312 282-8088
TELETYPE: 910 223-4577

TORONTO CENTER:
MAGNAVOX PARTS DIVISION
OF CANADA
3155 ORLANDO DR.
MISSISSAUGA, ONTARIO
TELEPHONE: 416 678-1581
TELETYPE: 610-492-2535

Order parts, tubes, and accessories from your nearest Magnavox Parts Center

THE **Magnavox** COMPANY

FORT WAYNE, INDIANA, 46804

EQUIPMENT REPORT

TOYO CH-702 TAPE PLAYER

For manufacturer's literature, circle No. 25 on Reader Service Card

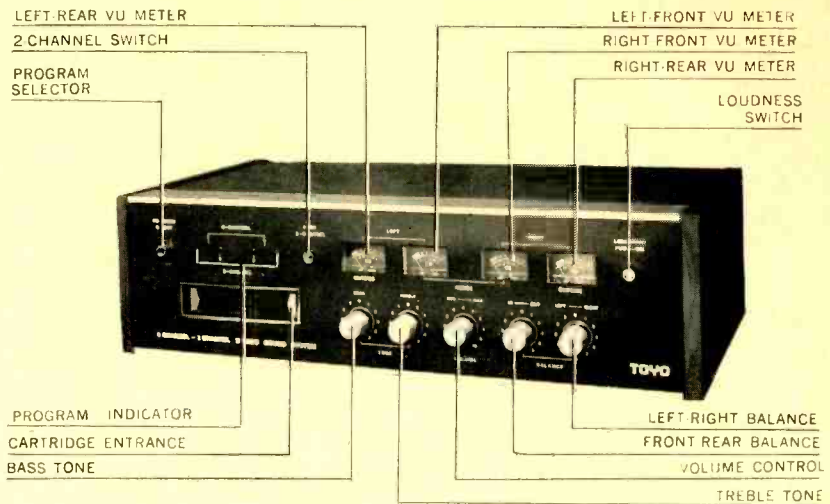

WITH THE ADVENT OF 4-CHANNEL sound a myriad of special cartridge tape playback machines, all designed to play the new 4-channel 8-track tapes have appeared. One of the first units we got to test was the Toyo CH-702.

This unit will play either the older 2-channel tapes or the new 4-channel tapes. Depressing a front-panel selector switch sets up the operating mode.

Speakers are not included with this unit and it is recommended that you use four-matched speaker systems.

The volume controls are ganged so one knob adjusts all 4 channels. There are also ganged tone controls for treble and bass. Separate balance controls adjust front-rear and right-left. With these controls it was possible to balance the output of the tape player to deliver a distinct 4-channel effect in any specific part of the listening room. Toyo does suggest, however, that you use the listening room arrangement shown below.

Four individual VU meters let you see what output levels are being delivered by each of the four channels. At normal listening levels we found meter indications were toward the low end of the scale and would

have preferred a more definite reading. But we were able to use the meters as spelled out in the manual.

We played several tapes on the Toyo system. The 4-channel 8-track cartridges were from both RCA and Project 3. There was a most definite 4-channel effect. And while a bit more high end would have been desirable (this unit is down 3 dB at 10 kHz), there are no 4-channel 8-track players around with better response.

We checked the specifications of the unit using a standard test tape and found our results matched Toyo's.

There is no on-off switch on this player. Inserting the tape switches the unit on; removing it turns the tape player off.

All-in-all we found the Toyo CH-702 delivered enjoyable 4-channel listening. It was a pleasure to have in our living room. **R-E**

SPECIFICATIONS

Output Power (per channel)	
(at 1 kHz with RCA SRL tape and 8-ohm load)	5 watts
Signal To Noise Ratio	
(at 12 dBm out, 1 kHz with RCA SRL tape)	50 dB
Cross Talk	
(at 400 Hz using filter)	50 dB
(at 1 kHz using filter)	30 dB
Frequency Response	
(100 Hz)	0 dB
(1 kHz)	0 dB
(10 kHz)	-3 dB
Tape Speed	3¾ ips
	+1%, -0%
Wow & Flutter	
(at 3 kHz)	0.3%
Rear Level Control	±6 dB
Tone Control	
(100 Hz)	9 dB
(10 kHz)	8 dB
Distortion	
(at 1 kHz; 3 watts output)	2%

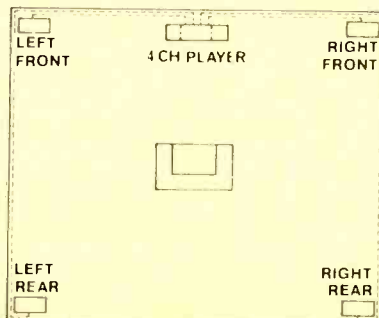

TYPICAL ROOM LAYOUT

Circle 15 on reader service card

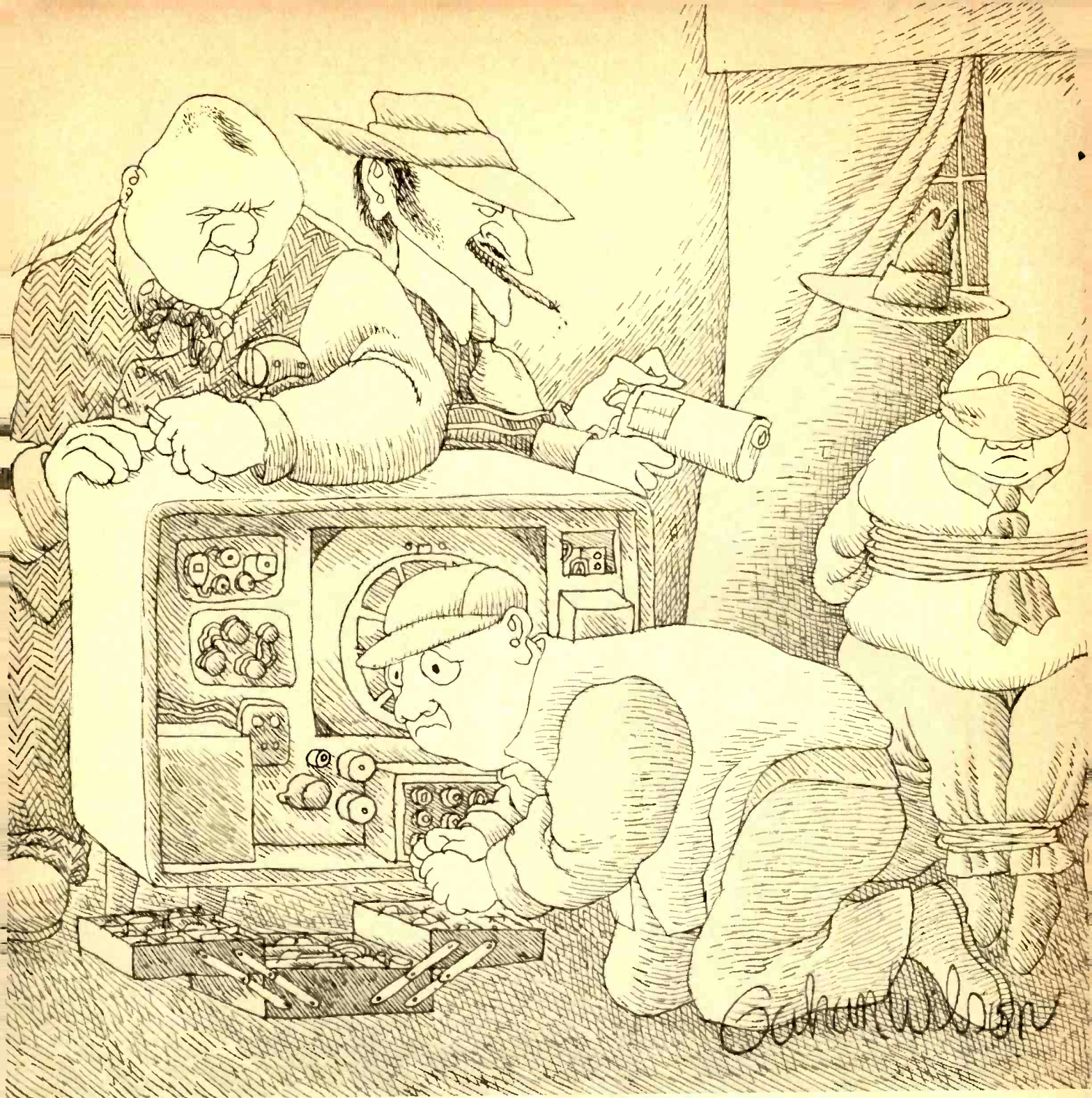

When you're in a hurry, it's nice to know GTE Sylvania has the parts.

Only 34 tubes and ECG solid-state components will solve practically all of your high-voltage rectifier replacement problems.

And they're all available from your Sylvania distributor.

Because tubes are tubes, we can't promise to reduce the number you'll have to carry. But, with the Sylvania line, your distributor will have the tube you need when you need it.

In semiconductors, the story is different. Just 124 ECG solid-state devices including transistors, diodes and integrated circuits will replace over 41,000 differ-

ent types. In the high-voltage section alone, only 8 ECG rectifiers and triplers will take care of almost every job.

And they save a lot of space in your tube caddy.

When your distributor is stocked with Sylvania receiving tubes and ECG semiconductors you'll have the parts you need. And you'll get them fast.

It's like having a complete warehouse built into your telephone.

And that should help you make a fast getaway.

GTE SYLVANIA



How to prepare for today's competitive job market, tomorrow's new opportunities in electronics

Competition for jobs and promotions is severe in the electronics industry today. But experts say that exciting new electronic products will create thousands of new jobs in the next few years.

One thing is certain: in good times or bad, the best opportunities come to the man with an advanced, specialized knowledge of electronics. He has a better chance of survival in a recession and will profit more in times of prosperity than the man with ordinary qualifications.

But how can you get the additional education in electronics you need to protect your future—and the future of your family? Going back to school isn't easy for a man with a job and family obligations.

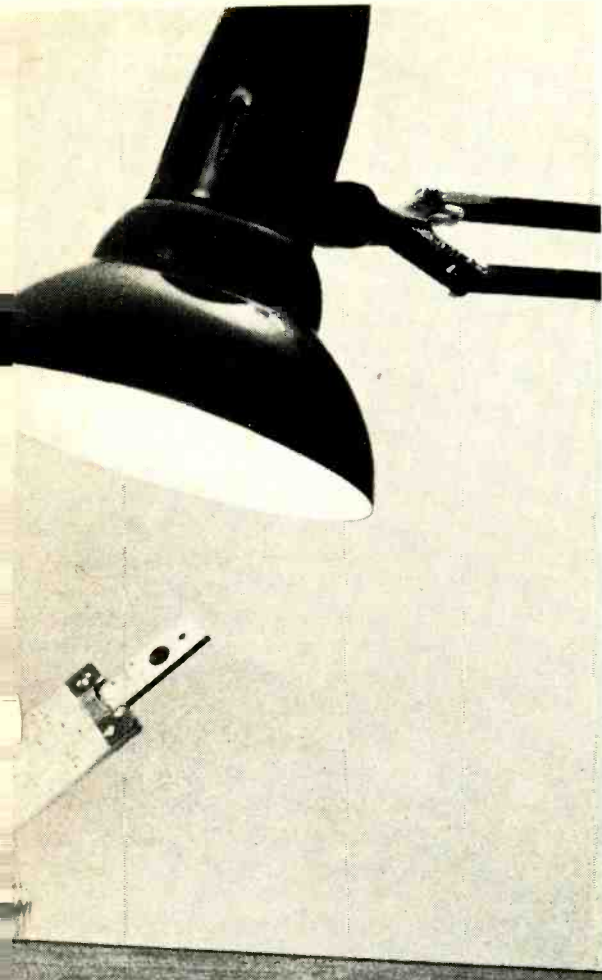

College Credits for CREI Students

Recently CREI affiliated with the New York Institute of Technology for the express purpose of making it possible for CREI students to earn college credits for their studies. The New York Institute of Technology is fully accredited by the Middle States Association of Colleges and Universities and is chartered by the New York State Board of Regents.

For the many CREI students who are not interested in college credits, but simply in improving their knowledge of advanced electronics, this affiliation with NYIT will provide additional assurance of the high quality of CREI home study education.

If you want to know more about earning college credits for CREI study, check the appropriate box when you mail the postpaid card for complete information on CREI Programs.

Founded 1927

CREI

Accredited Member of the
National Home Study Council



Free book tells all about CREI programs. For your copy, tear out and mail postpaid card or write: CREI, Dept. E1410B
Wisconsin Ave. & Tilden St.,
Washington, D.C. 20016

CREI Home Study Programs offer you a practical way to get more education without going back to school. You study at home, at your own pace, on your own schedule. And you study with the assurance that what you learn can be applied on the job immediately to make you worth more money to your employer.

You're eligible for a CREI Program if you work in electronics and have a high school education. Our FREE book gives complete information. Mail postpaid card for your copy. If card is detached, use coupon or write:

CREI, Dept. E1410B, Wisconsin Ave. & Tilden St., Washington, D.C. 20016

CREI, A Division of the McGraw-Hill Continuing Education Company

Dept. E1410B, Wisconsin Ave. & Tilden St., Washington, D.C. 20016

Please mail me free book describing CREI Programs. I am employed in electronics and have a high school education.

Name _____ Age _____

Address _____

City _____ State _____ Zip Code _____

Employed by _____

Type of Present Work _____ G.I. Bill

- I am interested in: College credits for CREI study. Space Electronics
 Electronic Engineering Technology Computers Industrial Electronics
 Nuclear Engineering Technology Electronics Systems Engineering
 Non-technical course in computer programming. CATV Engineering

APPROVED FOR TRAINING UNDER NEW G.I. BILL

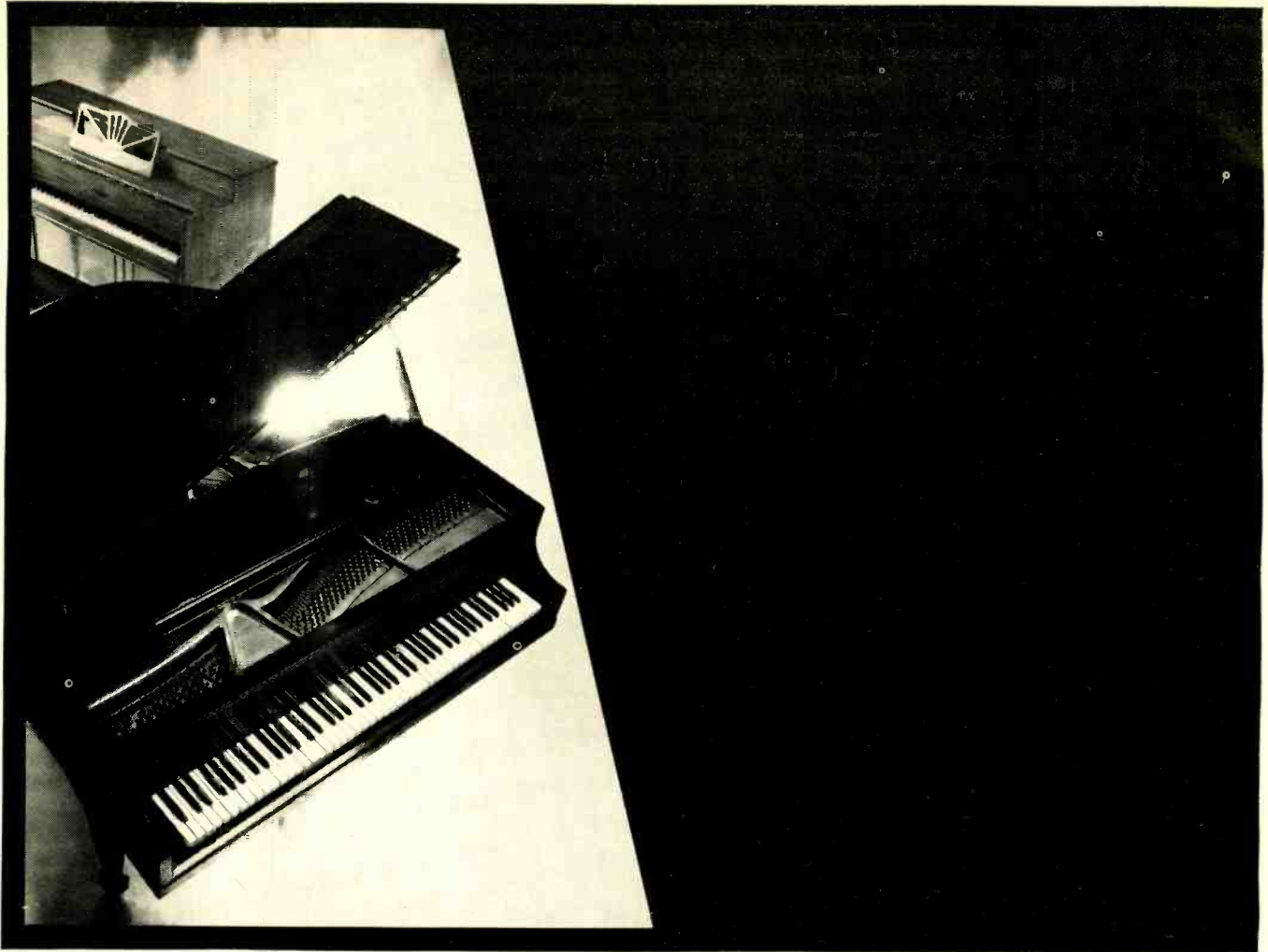

To each his own.

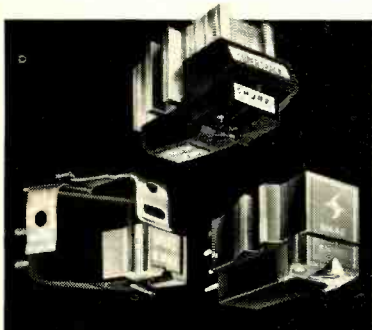

Not everybody needs a concert grand piano, nor does everybody *need* the best cartridge Shure makes to enjoy his kind of music on his kind of hi-fi system. Eventually, you'll want the renowned *V-15 Type II Improved*, the peerless cartridge for advanced systems and ample budgets. But, if your exchequer is a little tight, consider the *M91E*, widely acclaimed as the *second best* cartridge in the world. With a sharply circumscribed budget, all is *far* from lost. Choose any of the four models in the *M44 Series*, built for optimum performance in the easy-to-take \$18-25 price range. Write for a complete catalog:

Shure Brothers Inc.,
222 Hartrey Ave., Evanston, Illinois 60204.

Circle 16 on reader service card



SHURE

SPECIAL ISSUE 4-CHANNEL STEREO

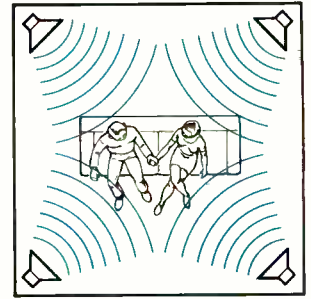

Photo courtesy Bell & Howell

by **HARRY E. MAYNARD**

IN 1970, THE FUTURE OF FOUR CHANNEL STEREO WAS A question mark. Not so today, if the 1971 Consumer Electronics Show was any index of the future marketing plans of the most important companies in consumer electronics. And not so, if you judge by the number of recent converts to four-channel stereo among prominent audio critics.

At a magnificent show, housed in Chicago's new McCormack Place, I counted over 70 companies that are making four-channel products an important part of their line for 1971-72. This, in spite of the fact that some important manufacturers have not yet committed themselves to four-channel hardware. They do not attribute this lack of commitment to any lack of enthusiasm about four-channel's future, but to the fact that there is not yet a single, agree-upon industry standard among major record manufacturers for the matrixing of four-channel stereo records.

Columbia Records introduced their new matrixing system (see *Radio-Electronics*, September 1971, pages 2 and 4) and gave an impressive demonstration of it at the show. However, Columbia's system threw the picture into some disarray because it is the *least compatible with other matrixing systems*, such as Dynaco, Sansui, Electro-Voice, and others. (Matrixing is essentially a system of putting four channels of information in the space formerly occupied by only two channels and using a special decoder to extract this information so that it can be played compatibly with any standard stereo cartridge. Without the decoder, you hear standard two-channel stereo.)

Columbia dominates the record business, having one and a half times the sales of pre-recorded products as its

4-Channel Sound Today

- The Systems
- The Adapters
- What Comes next

nearest competitor. Columbia has the popular artists, such as Blood, Sweat and Tears, Simon and Garfunkle, Andy Williams and Janis Joplin that attracted sales in 1970 of 253 million discs and 21 million tapes. They also have perhaps the greatest classical catalogue in the world. Columbia plans to put out over 50 titles of four-channel records by the time you read this article. They will also market discrete four-channel, 8-track cartridges (four tracks one way and four tracks the other) as RCA has already done. The momentum of four-channel stereo sound—matrixed or discrete—would seem to be the next big revolution in high-fidelity. This statement has behind it the fact that the largest mass marketers, both in retailing and manufacturing, (names, such as, Motorola, RCA, Columbia, Allied Radio and Lafayette to mention but a few) are now making massive commitments to four-channel sound both in hardware and software and in their promotional and advertising efforts.

Let's be clear. The sales of four-channel stereo have

Harry Maynard, an early proponent of 4-Channel Sound, a pioneer in broadcasting 4-channel stereo and a well known writer in the field of FM and high-fidelity can be heard on WNYC-FM 93.9 MHz, each Saturday at 4:30 PM and Sundays at 10:30 PM in the metropolitan New York listening area with his program "Men of Hi-Fi".



4-CHANNEL STEREO



Lafayette Dynaquad Adapter



EICO Quatrasonic Adapter



Toyo CS-721 Tape Player

yet to hit in a big way at the retail level. Now, however, the dealers report a tremendous interest in four-channel and an ever growing sale of adapters, extra amplifiers, and speakers necessary to four-channel sound of any variety.

Harold Weinberg, marketing manager of Lafayette Radio, told me: "Four-channel stereo, with particular emphasis on our adapter, is the cornerstone of our 1971-72 promotional efforts. And judging by the sales of our adapters and other four-channel equipment, it's off to a good start. We are also selling all the adapters that we can produce at this moment."

Louis Kornfeld, of Allied Radio, who is promoting the system of four-channel stereo invented by Leonard Feldman and John Fixler (now assisted by Peter Scheiber) feels that the Columbia system will make compatibility a "minor problem". Most dealers and manufacturers agree that most four-channel systems **other than the Dynaco-Lafayette** system will require an extra stage of amplification. Even the newest Dynaco system requires two extra speakers. To hear four-channel stereo, the consumer may have to buy a certain amount of additional equipment, but there is essentially no long term obsolescence problem—no matter which system is adopted.

Harold Weinberg of Lafayette says: "That is why we are making the Dynaco system our major push. We believe it is the ideal half-way house until all the matrixing methods have been agreed on. We can show that our system allows for considerable enhancement of a person's present record and tape library, and all the current matrixed records sound good on our system . . . including Electro Voice's." (Author's note: How about Columbia's?)

Until recently, many dealers have been unimpressed by the advent of four channel stereo. Those, however, who attended the Consumer Electronics Show and with whom I spoke, seemed to be prepared to get on the four-channel bandwagon. They pointed out that four-channel hardware now exists in every price range. Until recently this was not so. Up to now, there has been a real paucity of software and hardware. A few reel-to-reel tapes, and a few 8-track cartridges capable of playing four channel were the only things around. To play the reel-to-reel tapes, you need a tape recorder which usually costs about \$500. (See **Radio-Electronics**, March 1971, page 33.)

The Consumer Electronics Show Daily reported: "The variety of (four-channel) equipment was almost staggering considering how new the whole four-channel stereo idea is." Marantz, Scott, Fisher, Pioneer, Sanyo, Panasonic, Sony and Toshiba, all showed a variety of receivers, amplifiers, tape recorders and products in every price range and all capable of playing four discrete channels as well as

a variety of matrixing systems.

Cartridge eight-track 4-channel players in modest price ranges were found with such names as Sony, Bell and Howell, Akov, Craig, RCA and Motorola. Every major reel-to-reel tape recorder manufacturer had at least a four-track deck capable of playback of four-channel tapes. Names here included Wollensak, Teac, Sony, Panasonic and JVC.

JVC and the Dorren QSI system came together with the discrete four-channel disc. At the show, Dorren was broadcasting their four-channel system, which is a discrete four-channel system and it was being picked up by their new QSI receiver system which is a remarkable digital receiver with 100 watts of rms power per channel, along with a joy-stick type of control that serves as a single balance control for four channels. Most remarkable is that the receiver will sell for \$700.

Electro-Voice displayed over 100 records now encoded via their system, with Enoch Light-Project 3 records prominent on the list. Koss showed four-channel earphones, that I found very impressive in listening to all types and varieties of sound. Superex also showed prototype four-channel phones.

JVC had a four-channel cassette player that they claim will shortly be put into production—with eight separate tracks. Norelco had their prototype four-channel cassette player which is compatible with every cassette recorder yet manufactured. JVC and Norelco claim that the rapid improvement in noise-reduction systems in cassette tapeheads and tape carrying mechanisms is such that they do not expect any problems putting eight tracks on a cassette to give four-channel stereo and still have a compatible system. Some manufacturers say this is perhaps true, but the big problem for the four-channel cassette will be in the high speed duplicating of the very thin line of magnetic material required to put eight tracks on a cassette. No problem, says Phillips, showing you a cassette that they claim was duplicated with conventional methods. Certainly the cassette should be a strong force in the development of a mass market for four-channel stereo with the playback compatibility for both matrixed and four-channel (discrete) sound. Many dealers also reported that they see truly tremendous improvements in cassette decks as one of the biggest developments in hi-fi for the next few years.

One high-fidelity marketing manager for a chain of retail stores who had previously been against four-channel stereo because he thought it was premature has now changed his mind. "When I saw and heard the impressive demonstrations here at the CES show, I decided to go along. I'm impressed that over 30 FM stations are broad-

Sansui QS1 Synthesizer

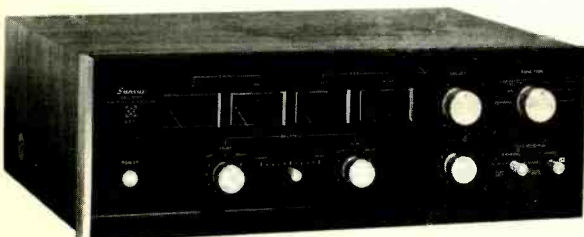

Scott 443 Quadrant Receiver



RCA Mark 8 Tape Player

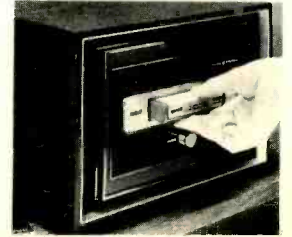



Quadracast Systems Receiver



Electro-Voice EVX-4 Decoder

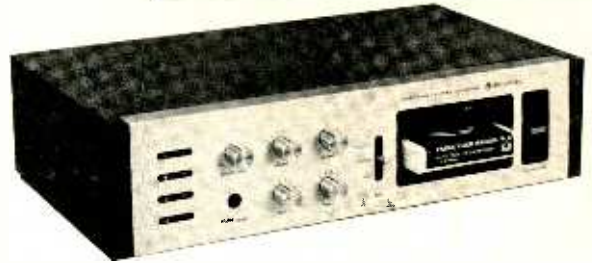

Bell & Howell Tape Player

casting Electro-Voice sound, and you can buy their decoder for \$59.95. This will do a lot to sell what is obviously vastly improved sound. I have sold a lot of decoders lately."

What is obviously taking place now is that the mass manufacturers of both software and hardware do not intend to be caught dragging their feet as they were on two-channel stereo, when the smaller component and record manufacturers corralled a nice hunk of business by being the first to offer the public stereo software (records and tapes) and hardware.

Several executives of RCA, Columbia, and Motorola and Panasonic told me that they believe four-channel is at least as important a development as two channel stereo was, and that it will be appreciated much faster by the mass market than was two-channel stereo. Change is exponential today and if four-channel stereo is properly demonstrated, it will clearly show that this is no gimmick dreamed up by the electronics industry and will catch on very fast.

Panasonic had one of the best demonstrations of four-channel stereo at the Consumer Electronics Show. It was a small cave-like structure seating 8 to 10 people, resembling the sonic environment of a typical living room (the place where most people are going to listen to four-channel stereo). Many dealers commented on the demonstration room because it could be duplicated fairly cheaply in their own showrooms. Motorola had tremendous demonstrations of four-channel stereo for both the car and home, and had obviously spent a great deal of money on their display as has had many other manufacturers. There is no doubt about it, four-channel stereo comes off beautifully in a car, or in a very intimate and home-like environment. It does not sound well in the usual barn-like displays and demonstrations I have heard.

The youth market represents a real potential for four-channel stereo. The youth of today have been a large factor in making consumer electronics an \$8 billion a year market, and in making the market for just component high fidelity one that reached \$377.5 million last year (an increase in sales of 15%). Part of the rapid growth of hi-fi can be attributed to the rather loud love affair that the younger generation is having with sound, hi-fi and electronic gadgetry of all kinds. They want to immerse themselves in sound. The young use sound the way their elders use alcohol. They put their heads in the speakers. With four-channel sound you can get that same feeling of being immersed in sound at lesser volumes. This could produce quite a revolution in the way music gets played and written as well as recorded and played back.

There is general agreement among the experts that four-channel stereo is a much closer approximation of the way we normally hear sound than is two-channel stereo. But, for the dealer and the potential buyer there is the problem of proper demonstration. In too large and ambient an environment, and with too much noise from people milling around, four-channel stereo can't be appreciated. So what is required is a revolution in the retailing of sound.

Many leaders in the industry, such as Herbert Horowitz President of Empire Electronics and new President of the Institute of High Fidelity, are aware of the need for this change. Horowitz, a recent convert to four-channel stereo, pointed out in the trade magazine, *Audio Times*: "For years we have been telling consumers that the ideal room for listening to hi-fi was 'anechoic'—that if there was an echo or a bright spot they should deaden it by putting in some upholstered piece of furniture or drapery. Now we're guaranteeing that this room will be 'echoic' by putting in two more loudspeakers. What we're really doing is introducing reverberation and the concept of bouncing the sound off the wall by using omnidirectional loudspeakers. The consumer firmly rejected reverberations back in the early 1960's."

Mr. Horowitz is right on his last point, but as he admits now "Four-channel stereo would seem to be an idea whose time has come. Ten years ago you couldn't have sold this concept to an audiophile, but I believe the nature of today's music has made it acceptable." (And—perhaps Mr. H. should have added "The tastes of today's listener".) "It took me a while to find out that the difference becomes discernible at moderate volume levels, and marked at low volume levels. This is different from the traditional way of demonstrating stereo equipment which dictates that you play everything cranked up all the way."

A lot of next door (or next apartment) neighbors and parents of youths with hi-fi equipment are going to like this, Mr. Horowitz.

Another important leader in the hi-fi retail business who asked to remain anonymous recently admitted to me: "Yes, I've been against four channel because I find some women don't like speakers of any kind disturbing their home decor. Now I've got to sell that gal on two more in her living room! It's not going to be easy for the over-40 market to fight that battle. On the other hand, the younger generation, which represent a third of my sales and perhaps have an even bigger influence on the total market, have already started to ask a lot of questions about four-channel stereo. They'll buy a hi-fi set right after they buy a bed. But I and everyone else will simply have to do a better

Pioneer QX-8000 Receiver



Iras Multisonic Converter



Utah Ambience Regenerator



4-CHANNEL STEREO

job demonstrating hi-fi. Most hi-fi stores are simply shelves carrying hi-fi equipment and don't adequately demonstrate it."

My advice to readers of this article is to buy a four-channel receiver now, if you don't already own a stereo receiver. Whatever system is settled on, you will need four channels of amplification and four speakers to enjoy whatever level of four-channel sound your taste requires. All the four-channel receivers give you four discrete channels—along with some kind of matrixing system. If and when the FCC finally settles on a system of discrete four-channel broadcasting (and it will be years), you'll be able to add a simple integrated circuit adapter to receive that signal off the air. The current favorite and best demonstrated is the Dorren system. For the near term you will be able to listen to matrixed four-channel in its essentially compatible form; and, of course, to reel-to-reel and tape cartridge four-channel sound. You will be enjoying the vastly improved sound of the matrixing systems (perhaps it shouldn't be called four-channel sound). These systems do not require formal approval of the FCC since they have clearly demonstrated that they are compatible with current broadcasting standards.

If you want to go the cheapest route to "full dimensional" or "surround sound," hook a third speaker across the two hot terminals of your current two-channel amplifier with a variable resistor and you'll get a "third-way" house to four-channel. I think you'll hear a considerably improved sound. I've tried this and it works. And many listeners to

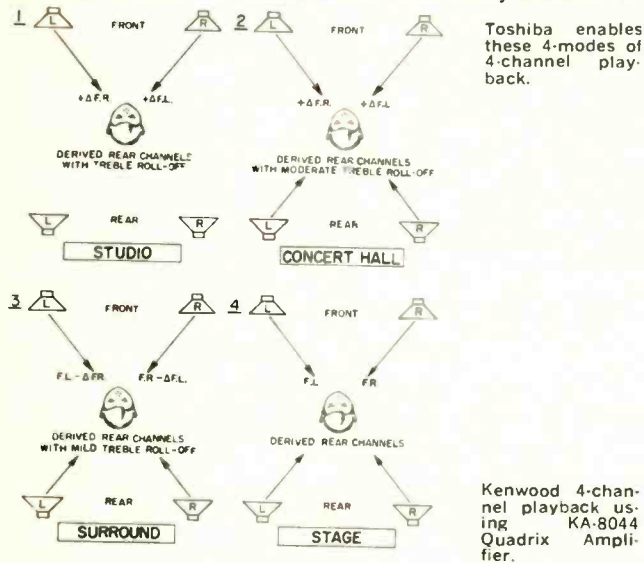

my program, "Men of Hi-Fi" on WNYC-FM, who have done this are enthusiastic about it as a beginning step. I see this step as a conditioner to appreciating what has been most aptly described as "surround sound."

The next step along the route to four pure and discrete channels, would be to buy the Lafayette or Dynaco adapter (price \$29.95). Here you will need two extra speakers but you will only use one amplifier. Following this, the next step would be to buy an extra rear amplifier, an Electro-Voice decoder, or one of the other matrixing systems, such as Columbia, Sansui. If you do this, you can have the best of two worlds. You can play through this system any discrete four-channel sound, such as reel-to-reel tapes, or 8-track cartridges and also play the matrixing systems.

You will find this worth the extra money and effort. Monophonic listening is like listening to sound through a window. Two-channel sound is like standing and hearing it in a doorway. Four-channel of any type is like being in the room where the actual sound is being produced. You are there—be it a concert hall, with magnificent reverberant acoustics; a rock emporium, electrified to the back teeth; a jazz club, with every last note of the bass fiddle making its way through the din; a Spanish cave, with the guitar sounds curling around your ears.

Remember that we listen to sound in a 360° sound field. Research at MIT and various other labs shows that most of the sound we hear is reverberant sound—over 85%. Less than 10% is directly radiated sound. Since most of the sound we hear has bounced off our listening environment, properly recorded sound should recapture that natural ambience. Four-channel stereo has come up with the best method for doing just that.

Part of the success of the Bose speaker, although expensive, has been its naturalness. The current vogue of the omnidirectional speaker is the attempt to duplicate the natural spacious sounding effect of a concert hall, or our normal binaural listening environment where we hear as much sound from all around as is directly radiated towards us. The Bose system achieves this by aiming most of its many enclosed smaller speakers at the rear of its enclosure. The omnidirectional speaker aims its sound sideways and upwards, as well as forward.

Four-channel sound just happens to be almost the cheapest way to achieve our normal 360° sound field of listening because you can achieve a 360° sound field by creating a circle within a 4 point source. The original Dynaco suggestion (the "poor man's" surround sound—it's really three-channel stereo) does this in an even cheaper way by putting a triangle in a circle. I discussed this in detail in the March issue.

If you have any doubts about this new sound, or are simply curious about it, have a listen. But please don't judge four-channel, or surround sound, by the usual big demonstration. Listen to it under proper conditions:

1. In a small, intimate atmosphere
2. In a situation where there are few people
3. Where no one is talking
4. Where you can listen to many different types of recorded materials
5. Don't listen to it too loud.

If you follow these suggestions, I think you will find what some people, including myself, have found. Four-channel stereo is no gimmick. It is a bigger improvement over two-channel than two-channel was over monophonic. If you haven't been getting much enjoyment out of your hi-fi set lately and your favorite recording sounds a little stale—give a listen to all kinds and varieties of four-channel stereo (preferably in your own home). I think you'll agree then that four-channel is the next revolution in sound.

R-E

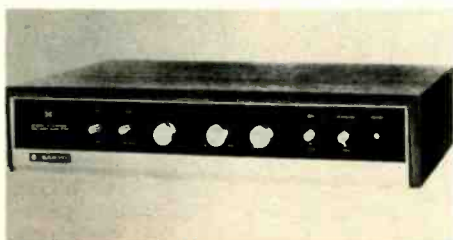
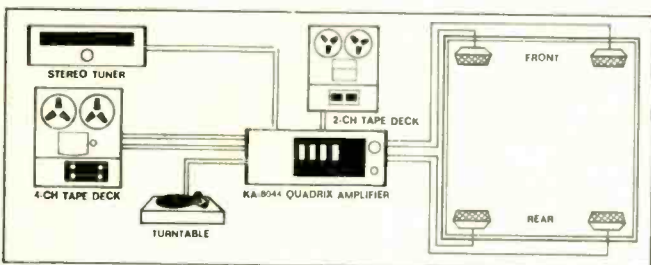

Sanyo DCA1500X Decoder

SPECIAL ISSUE 4-CHANNEL STEREO

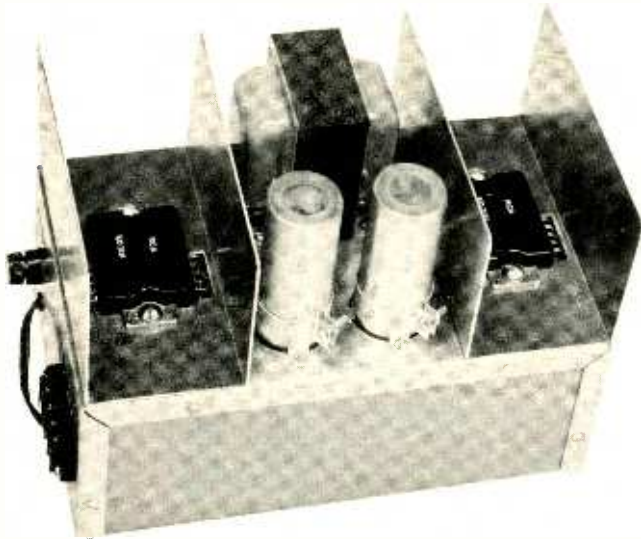
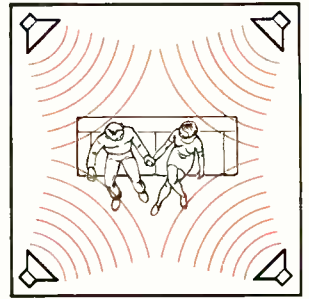

Build R-E's 4-Channel IC Power Amplifier

- 50 Watts rms Per Channel
- One IC Per Channel
- Less Than 1% Distortion
- One Evening Construction

by **GEORGE D. HANCHETT***

THE FOUR-CHANNEL POWER AMPLIFIER described here can deliver 50 watts rms per channel. It is especially easy to construct because all the active components in each channel are incorporated in one commercially available RCA KD2131 power circuit module. The complete four-channel amplifier uses four KD2131's and can easily be driven by the four-channel preamplifier described by Len Kaplan elsewhere in this issue. Among other desirable features, this amplifier will drive electrostatic loads and has internal circuitry to prevent damage to the output stages in the event of overloads.

The KD2131, a recent addition to the RCA Solid State Experimenter line, is a thick-film hybrid power circuit module that can deliver up to 70 watts output, depending upon the power supply. A readily available power transformer, however, with a 42-volt secondary capable of delivering 1 ampere can furnish enough power to run two KD2131's at 50 watts each. This four-channel amplifier, therefore, uses two power supplies. If it is desired to have a two-

channel stereo system, only one power supply and one two-channel amplifier will be needed. A schematic diagram of a two-channel portion of the four-channel amplifier is in Fig. 1.

Construction and wiring

Because of the relatively few components required for this amplifier, the construction is simple and straightforward.

Each pair of amplifiers, along with its power supply is constructed on a 10" x 6" x 3½" mini-box (Bud type CU-3010A). It is necessary to heat-sink the KD2131 hybrid circuits, and for this purpose aluminum heat sinks can be made from flat stock aluminum and bent into a "U" shape as in Fig. 2. It is absolutely imperative that the portion of the heat sink in contact with the KD 2131 be as flat as possible to insure maximum thermal contact. Flatness of the aluminum heat sink can be readily maintained during bending by clamping the aluminum between two wood blocks of suitable size. One block should be 3" x 6". If flat sheet aluminum is not available, heat sinks can be formed from a 7" x 9" chassis bottom-plate with 1" cut off to make it 6" x 9".

The KD2131 has leads extending straight out from its body. These leads should be bent at right angles to fit

the slots in the heat sink as in Fig. 2. To avoid creating a sharp bend, curve the leads around a 3/16" rod or dowel. The information sheet packed with each KD2131 gives precise data on lead bending. The slots for the leads should be drilled and filed smooth in both the heat sink and the chassis (see Fig. 2 and Fig. 3). It is important to make sure that there are no burrs on either the heat sink or the chassis. The KD2131 is bolted to the heat sink and the chassis with ¼" -28 machine screws, ½" long. Heat-conducting grease such as G-C No. 8101 should be liberally used between the KD2131 and the heat sink and between the heat sink and the chassis. To facilitate connections to the KD2131, bend small hooks into the ends of each lead so connecting wires can be bent around them and soldered. Because the peak current to the KD2131 can be quite high, use reasonably heavy wire for interconnection. I recommend you use at least 18 awg, and preferably 16 awg.

As shown in the photographs, the input connectors and their associated gain controls are mounted on one end of the chassis while the output connections, power cable, and fuse are mounted on the other end. Positions of the components on the sides of the chassis are in Fig. 4. The phase-cor-

*RCA Solid State Division
Sommerville, N. J.

PARTS LIST

(These are parts required to build one pair of channels—a 2-channel stereo amplifier. To build a 4-channel unit you will have to double this list.)

- R1, R3—potentiometer, 25,000 ohms
- R2, R4—470 ohms, 1/2 watt
- C1, C3—5 μ F, 12 volts, electrolytic
- C2, C4—50 μ F, 12 volts, electrolytic
- C5, C6—5500 μ F, 40 volts, electrolytic (Sprague 36D552G040AC2A or equal)
- D1, D2, D3, D4—SK3016 (RCA)
- F1—Fuse assembly with 3-amp fuse
- LM1—Pilot light assembly with No. 1813 lamp, 14 volts at 0.1 amp
- L1, L2—10 μ H, 1500 mA choke (Miller 4622 or equal)
- Q1, Q2—KD2131 hybrid amplifier (RCA)
- J1, J2—Phono jacks with insulating washers
- J3—Barrier strip (Cinch Jones type 4-140)
- S1—spst toggle switch
- T1—power transformer: primary 117 volts; secondary 42 volts ct, 1 amp (Stancor TP-4 or equal)
- Case, miscellaneous hardware
- Heat sinks

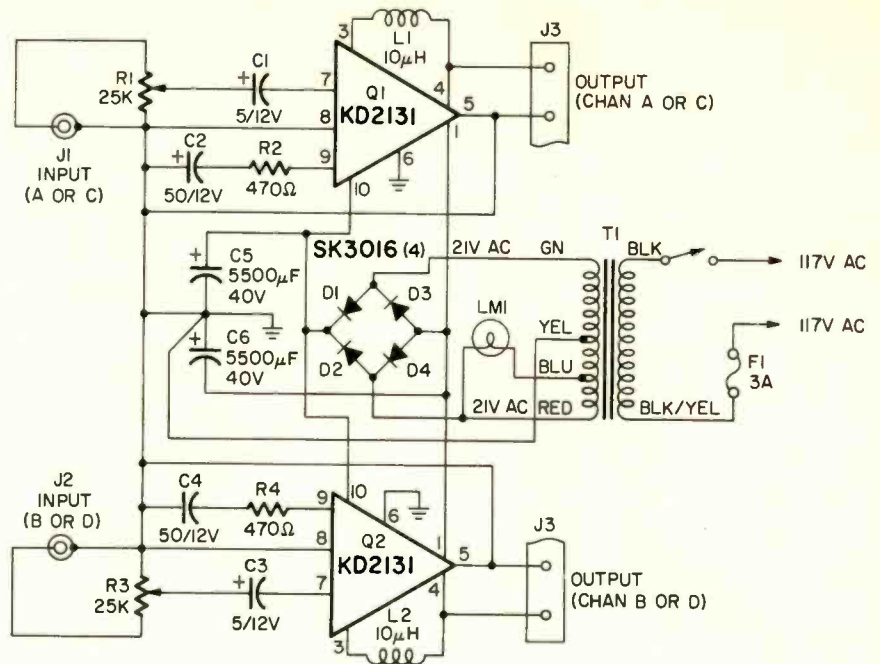

IC TERMINALS 1 TO 10:
 NO-SIGNAL : 60 VOLTS
 FULL-LOAD : 48 VOLTS (ONE CHANNEL DRIVEN)

FIG. 1—COMPLETE SCHEMATIC OF HALF of the 4-channel power amplifier. Build two units like this one to make your 4-channel unit. Note that just about the whole amplifier is in IC's.

HEAT SINK LAYOUT

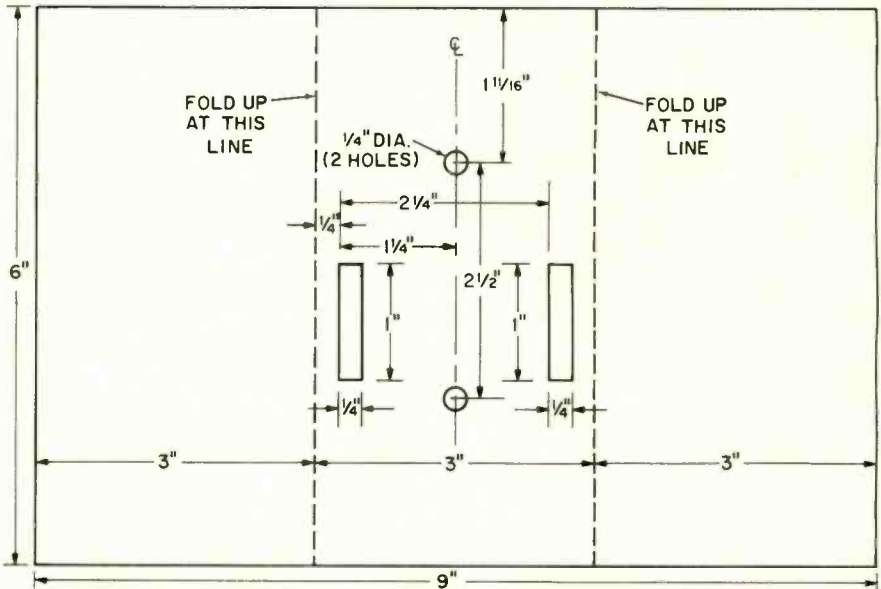

FIG. 2—IC HEAT SINKS are a must with this amplifier. Here is a detailed picture of how to make them. Follow this diagram as closely as possible and do not operate the amplifier without heat sinks.

recting chokes are connected to the appropriate terminals of the hybrid amplifier and are supported by their leads. It is especially important that these connections be carefully checked for good electrical contact.

Be careful when soldering to the module terminals. Do not apply a heat greater than 235°C to the terminals any nearer the module case than 1/8".

The power supply for each pair of channels, as shown in the layout diagram in Fig. 3, is mounted between the two KD2131 hybrid amplifiers. The filter capacitors are mounted so they are flush with the tops of the heat sinks and the power transformer.

It is extremely important when wiring the amplifier, to avoid ground loops. The best way is to use a common ground point. In my unit I use the junction of C5 and C6 in the power supply as the ground point. All grounds are brought separately to this point by single wires. Do not pick up any other grounds on the way. I then run a wire between this point and the chassis. The only exception is lead No. 6 of the KD2131. This lead provides an ohmic connection to the heat sink of the IC plate and does not enter the circuit.

The bridge rectifier for each supply is assembled on two 2-terminal tie points. Each tie point is fastened to the chassis with a 2-56 screw, lock washer, and nut. Arrange the rectifiers in a circle about the four terminals. The power transformer is connected to provide the highest possible voltage. Unused wire connections of the transformer are fastened to a terminal strip for protection against shorting. The pilot light is connected



2-CHANNELS of the amplifier fit on a single chassis. You need two of these units for a complete 4-channel unit.

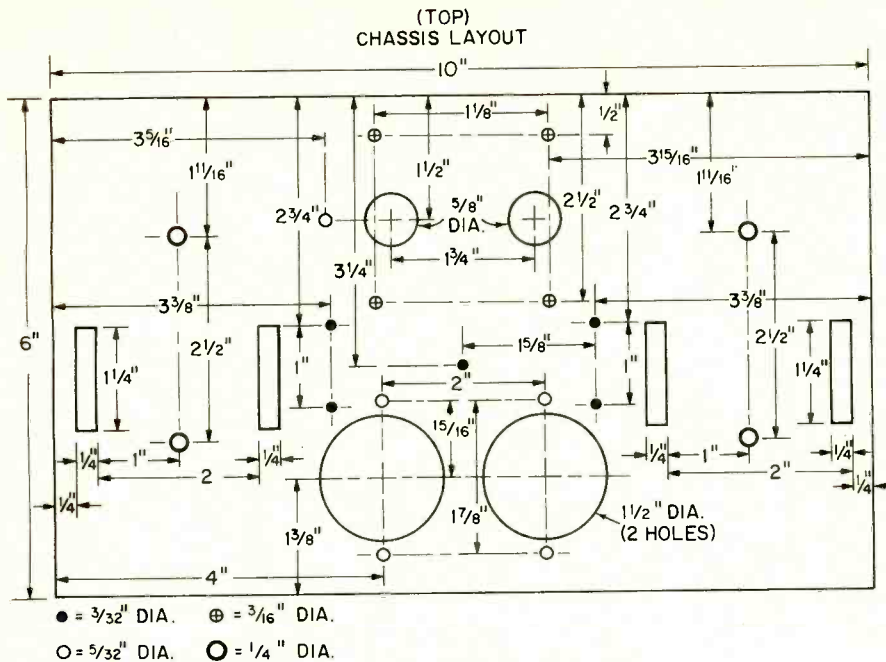

FIG. 3—CHASSIS LAYOUT for each pair of power amplifier channels. Precise dimensions are shown. Follow them closely for easy construction and assembly.

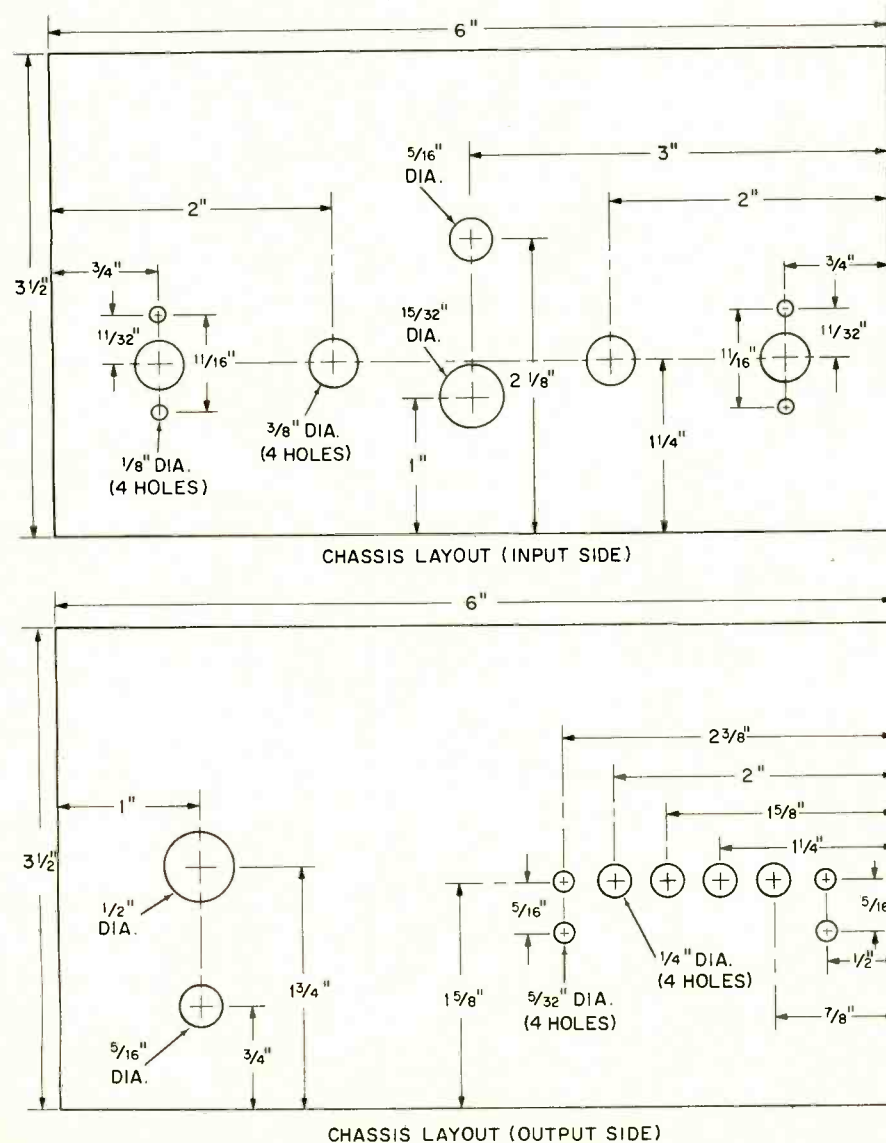

FIG. 4—CHASSIS LAYOUT diagrams for the input side (top) and output side (bottom). They show exact locations of all chassis holes and their sizes.

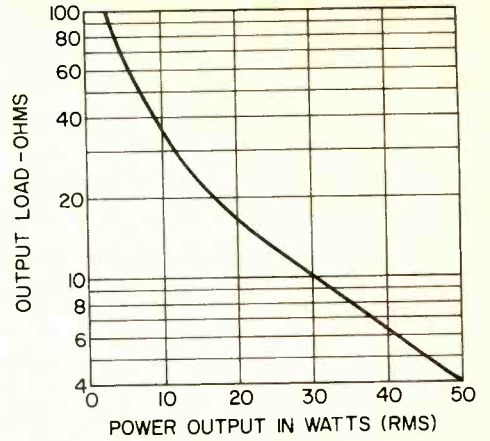

FIG. 5—POWER OUTPUT characteristic of each channel of the power amplifier.

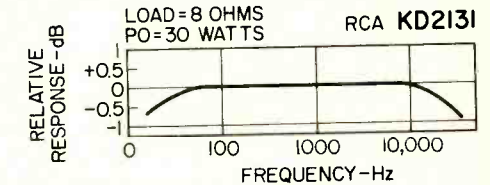

FIG. 6—FREQUENCY RESPONSE characteristic of each channel of the power amplifier.

between the blue and red leads. A No. 1813 pilot lamp is used.

Testing and operation

After the amplifier is completed and has been checked visually, test each pair of channels separately; and, in either pair, test only one power circuit module at a time. When testing the first pair of channels, therefore, leads No. 1 and 10 of one of the KD2131's should be disconnected and a 0-to-5 ampere dc meter connected between lead No. 10 of the KD2131 in the other channel and the positive terminal of C5 in the power supply. If a 5-ampere dc meter is not available, use a vom in parallel with a 0.47-ohm 2-watt resistor to measure the current. With no signal input to the amplifier, but with the power on, the meter should read substantially "0", indicating that there are no oscillations or other conditions causing excessive current drain. Now disconnect the No. 1 lead on the first module tested, leaving No. 10 disconnected also; and test the second module in the same manner as the first. After you are sure there is no excessive current flowing through the second module, it is safe to reconnect the No. 1 and No. 10 leads for normal operation of both modules and to test the other pair of channels.

If you feed a signal from an audio oscillator into one channel and that channel's output is connected to a resistive load or speaker, then that channel should be able to produce its full output before clipping. Clipping will occur at different power levels with different loads as in Fig. 5. The

4-CHANNEL STEREO

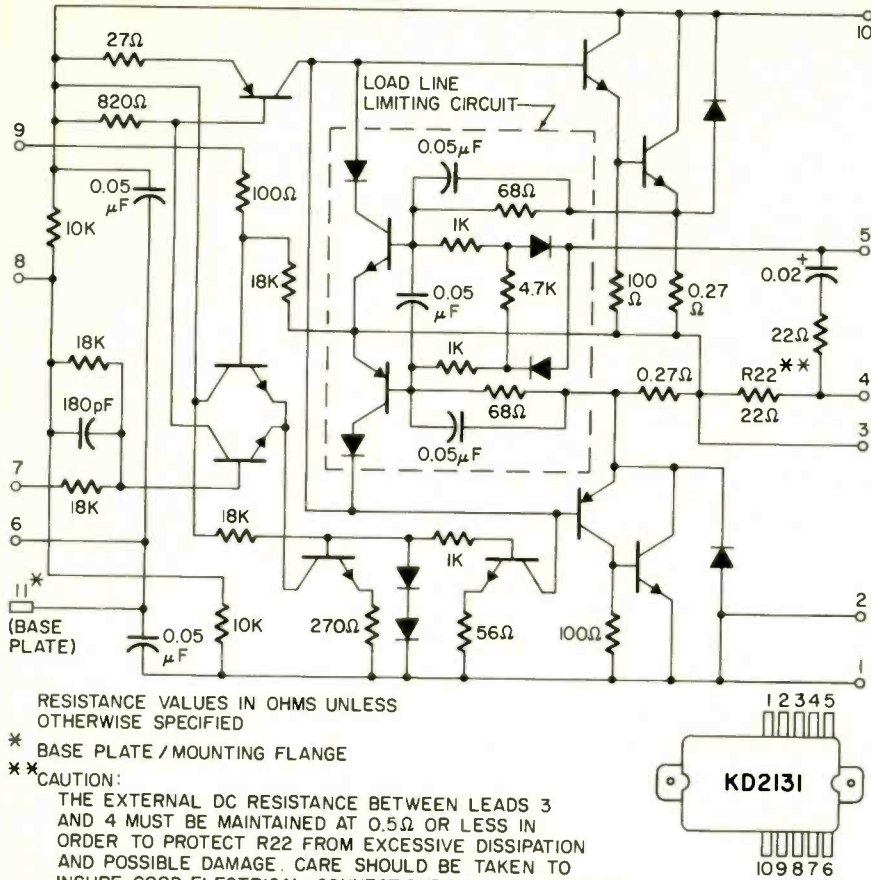
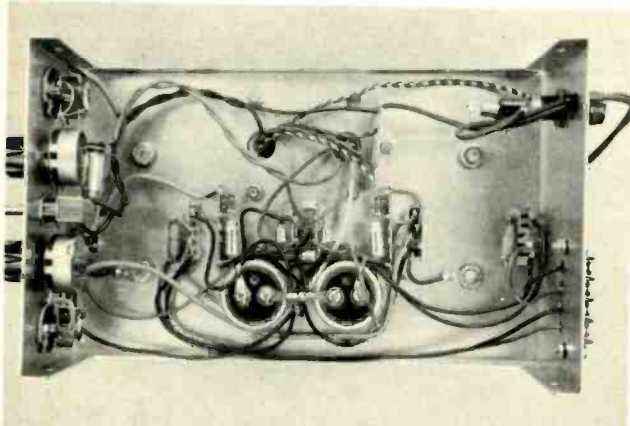

FIG. 7—THE KD2131 IC contains all the circuitry shown here. Note that this is a complete power amplifier, one channel.



BOTTOM VIEW of power amplifier. This unit is a 2-channel arrangement. Build two of them for a 4-channel amplifier.

clipping point is best determined with a scope connected across the speaker terminals of the channel under test.

Because each channel of this amplifier can put out short-duration peak power levels considerably in excess of 50 watts (although with some distortion), I recommend you turn down each channel's level control (full counterclockwise) (R1, R3) before any input connection is made. I also recommend, if you use a loudspeaker system during initial tests, inject steady-tone signals cautiously and at frequencies below the range of any tweeters in the system, the power ratings of the tweeters being generally lower than those of other components in a speaker system.

Note that the power supply, be-

cause of the power transformer capacity, cannot supply power to the amplifier for protracted periods of time when a sinusoidal signal is being amplified. The clipping test, therefore, should be limited to a five-minute period with at least a ten-minute off period. After testing one channel, test the other channel of each pair. Because music has a typical duty factor of less than 25%, all four channels can operate at a 50-watt level for long periods of time without any severe temperature rises.

Fig. 6 shows the frequency response of the unit. Input impedance of each channel is 10,000 ohms and an input of approximately 0.5-volt rms will drive the amplifier to its rated output.

R-E

CHASSIS-PUNCH GAUGE

Have you ever wondered exactly what size hole to punch or drill for a socket or pilot-lamp jewel? Once a hole is punched, it's too late to change its size. You can easily make a handy tool (see drawing) to tell you what size punch to use.

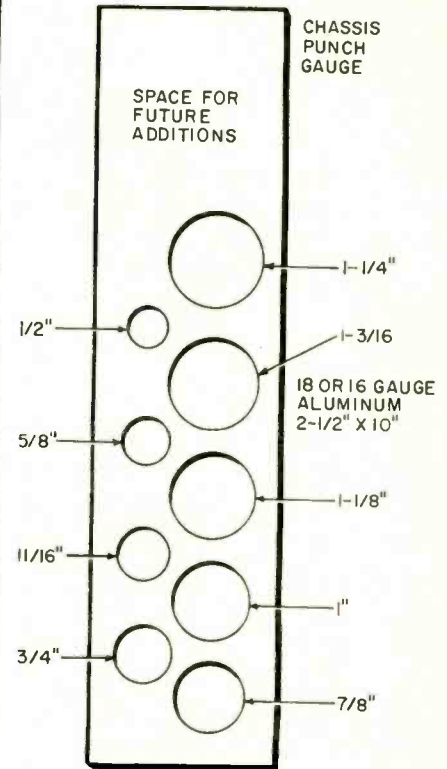

Gather up all your chassis punches and use each to punch one hole in a scrap of sheet aluminum. Now, the next time you need to determine the correct hole size, simply fit the part to be mounted into the holes in the gauge until you find the hole that fits best. Sure beats guessing!—*Harold J. Turner, Jr.*

HANDY CABLE MARKERS

In the use of wire and cable connections from one point to another, it is desirable to tag these wires and cables for proper identification. This

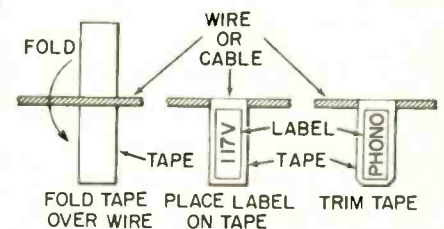

procedure aids the installation, trouble-shooting, and reconnecting of wires and cables to correct points.

The use of tapewriter (or label markers) and tape (plastic, cloth, adhesive) make a good match for "tags" as the illustration shows.—*Alex Billos*

SPECIAL ISSUE 4-CHANNEL STEREO



Build R-E's 4-Channel IC preamp



by L. KAPLAN*

FOUR-CHANNEL STEREO HAS BROUGHT new challenges to the audio circuit designer as well as new levels of realism and presence to the audiophile.

In designing a conventional two-channel stereo system it is possible to use discrete components and keep the amplifier reasonably compact. A four-channel system, however, using discrete components becomes hopelessly unwieldy, virtually demanding the use of integrated circuits.

The four-channel stereo pre-amplifier described here uses, as active components, a total of two integrated circuits, two diodes, and three transistors. Each IC is an RCA SK3071 containing the active components for two channels of equalization and amplification; the diodes and transistors are used in the power supply. The entire unit is contained in one chassis that is 10" wide, 3" high, and 12" deep.

This preamplifier provides phono and tape-head equalization, bass and treble controls, and input switching. It has enough dynamic range to accommodate all modern phono cartridges even when reproducing heavily overcut records. It has a signal-to-

noise ratio greater than that of commercially available program sources, and produces inaudible distortion when driving any amplifier that has a sensitivity of 1 volt or less and an input impedance of 10,000 ohms or more. Performance is summarized in Table 1.

Circuit description

For optimum signal-to-noise and overload performance, the controls (volume, bass, and treble) of an audio system should be mid-way in the signal path between input and output. They should be as close to the output as possible for best signal-to-noise ratio but as close to the input as possible for best overload characteristics. The block diagram of two channels of an optimum system, using one RCA SK3071, is shown in Fig. 1.

The circuit boards are designed so that the input from either a magnetic phono cartridge or a tape head can be run directly into the low-level stage of the preamp, or so that both of those two low-level sources can be fed to that first stage through a selector switch. This switching arrangement is discussed later.

After the low-level signal is amplified and equalized, it emerges from the first stage at a level high enough

to insure that the attenuation of the tone control circuits does not degrade the signal-to-noise ratio. When four-channel FM stereo is received, the decoder output is fed through the preamp's tuner inputs and selector switch directly into the tone and volume controls, bypassing the low-level equalization stage entirely.

Once the input signal is past the volume control, there is no problem with overload. Indeed, this preamp is designed so it can put out at least twice the drive required to overload the high-power amplifier described by G. D. Hanchett elsewhere in this issue. Consequently, as the signal level is increased, that power amplifier will always overload first. Of course, overload does not occur until 50 watts in any channel is reached; and with four 50-watt power amplifiers as outputs, that's quite a blast!

The second stage of the pre-amplifier is shown in Fig. 2. This stage is run "flat", that is, within \pm dB from 20 Hz to approximately 22 kHz. The response above 22 kHz is rolled off deliberately to improve the noise figure and to prevent any ultrasonic signals present from entering and causing distortion in the preamp or power amplifier.

All four channels of this pre-

*RCA Solid State Division
Somerville, N. J.

4-CHANNEL STEREO

amplifier are identical, so the complete schematic of only a single channel is shown in Fig. 4.

RCA SK3071 IC

The integrated circuits used in the signal channels are RCA SK3071's. One of these devices provides all the amplification necessary for a two-channel stereo preamplifier. Therefore, two of these IC's are used in this preamplifier. Each IC includes four independent high-gain amplifiers, each of which has a voltage gain of 800. The schematic diagram for the RCA SK3071 is in Fig. 5.

The four independent amplifiers are labeled A1, A2, A3, and A4. Using A2 as an example: Q7 is the output transistor; its collector resistor consists of R14 and R19 in series, totaling 1000 ohms. The emitter resistor R2 is 200 ohms. With Q9 and Q10 acting as emitter followers, the gain of this stage (Q7, Q9, Q10) is $1000/200 = 5$. The rest of the gain in A2 (160) comes from the input stage which consists of Q1, Q2, and Q3. Q1 is an emitter follower which keeps the input impedance of the amplifier high so that the total input impedance consists of essentially only the resistor R13, which is 100,000 ohms.

Transistors Q2 and Q3 in A2 are differential amplifiers, the base of Q3 being brought out to pin 7. Access is thus provided to both the inverting and non-inverting inputs of the amplifier, and, consequently, the input and feedback circuits can be kept separate.

Equalizer option

Fig. 6 shows the magnetic phono equalization network for a single channel. RIAA compensation is obtained from R3, C3, and C4. When reproduction from a tape head is desired, NAB equalization is obtained by placing R4 in parallel with R3 as shown by dotted lines in Fig. 6. As has been stated, the two equalization characteristics can be had either by fixed wiring or through a selector switch. The circuit in Fig. 4 shows this optional switching arrangement in place.

Power supply

The power supply, using two diodes and three transistors, furnishes regulated dc at approximately 13.6 volts to operate the two IC's. The power supply is constructed on a separate printed-circuit board, thus becoming independent of the rest of the circuit.

The schematic of the power supply is in Fig. 8. The supply consists of a full-wave rectifier supplying a series-pass transistor Q1. The base current

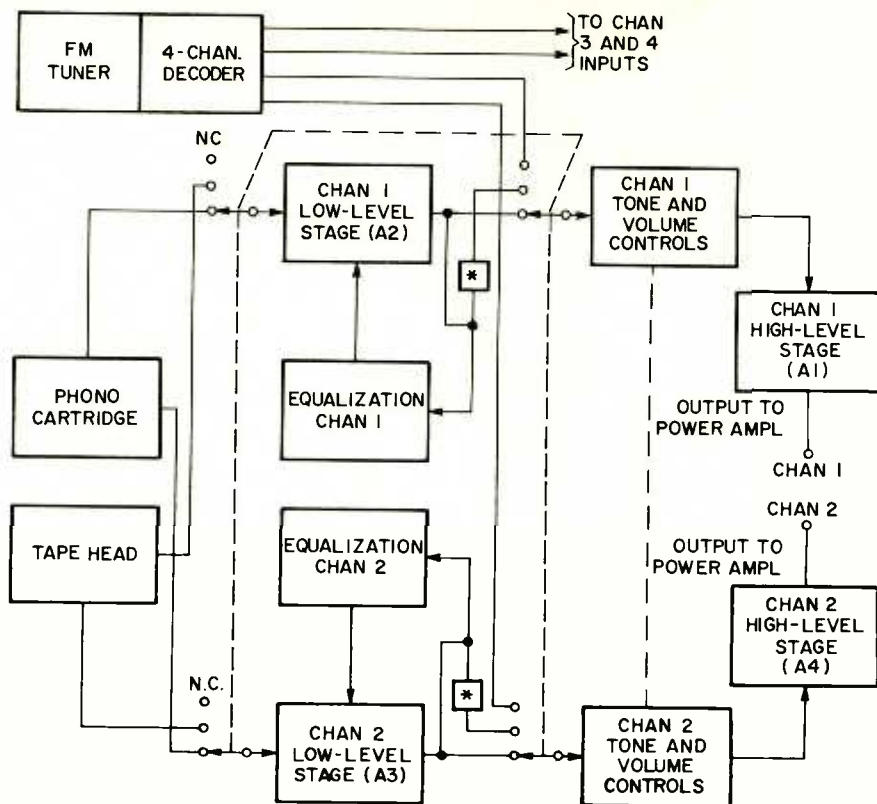

* NAB TAPE EQUALIZATION

SWITCHES SHOWN IN PHONO POSITION

FIG. 1—BLOCK DIAGRAM OF half of the 4-channel preamp. Actual unit doubles the amount of circuitry. This simplified diagram details the basic operation of the unit.

TABLE 1—PERFORMANCE

Gain @ 1 kHz reference (mag. phono)	
Gain @ 1 kHz reference	46 dB
Boost @ 100 Hz	11.5 dB
Boost @ 10 kHz	11.5 dB
Cut @ 100 Hz	10 dB
Cut @ 10 kHz	9 dB
Noise:	
At max volume (Input shorted)	more than 70 dB below 1 volt
At min volume	more than 80 dB below 1 volt
Total harmonic distortion at 1-KHz reference and an output of 1 volt rms	
	Less than 0.3%

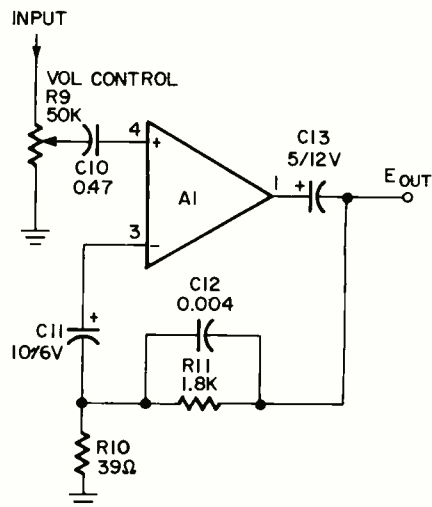
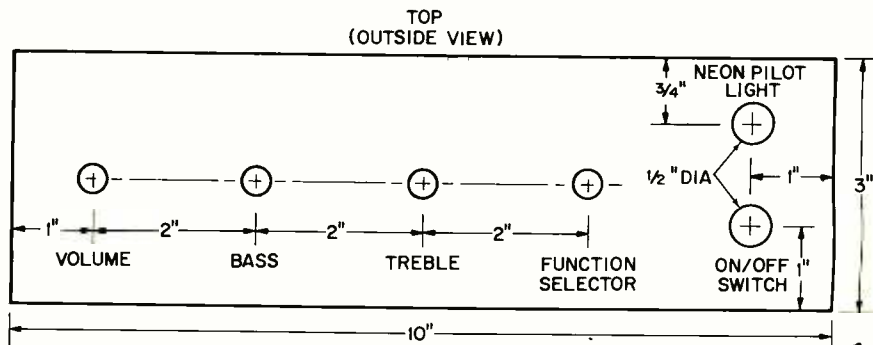

FIG. 2—(right) SECOND STAGE of preamp is run essentially flat.

FIG. 3—(below) FRONT-PANEL layout for the preamp.



NOTE: ALL HOLES $\frac{3}{8}$ " DIA. EXCEPT AS NOTED.

TEMPLATE FOR FRONT APRON

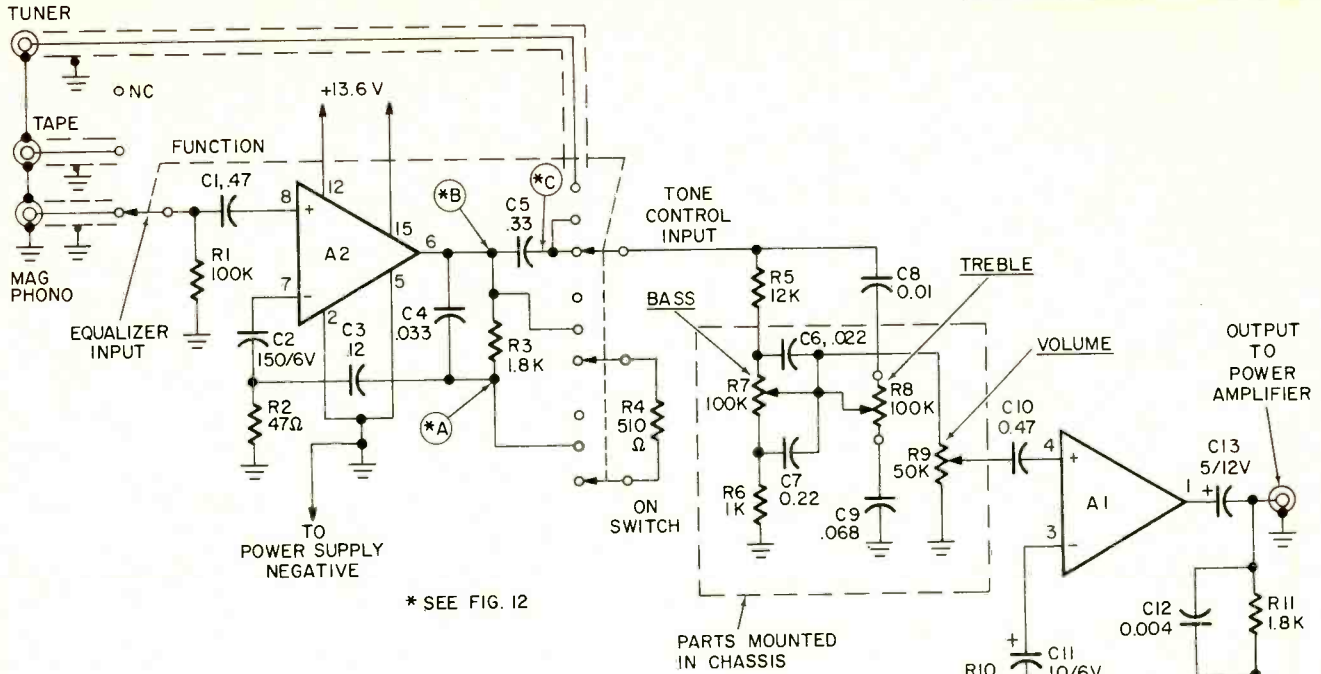

* SEE FIG. 12

PARTS MOUNTED IN CHASSIS

Parts List for Preamplifier Boards (Parts listed are for each board)

- 4 Capacitor, 0.47- μ F, 10%, 25 volts minimum (C1 and C10)
- 2 Capacitor, 150- μ F, 6 volts, electrolytic (C2)
- 2 Capacitor, 0.12- μ F, 10%, 25 volts minimum (C3)
- 2 Capacitor, 0.33- μ F, 10%, 25 volts minimum (C4)
- 2 Capacitor, 0.33- μ F, 10%, 25 volts minimum (C5)
- 2 Capacitor, 0.01- μ F, 10%, 50 volts minimum (C8)
- 2 Capacitor, 10- μ F, 6 volts, electrolytic (C11)
- 2 Capacitor, 0.004- μ F, 10%, 50 volts minimum (C12)
- 2 Capacitor, 5- μ F, 12 volts, electrolytic (C13)
- 2 Resistor, 100,000 ohms, 10%, 1/2 watt (R1)
- 2 Resistor, 47 ohms, 10%, 1/2 watt (R2)
- 4 Resistor, 1800 ohms, 10%, 1/2 watt (R3 and R11)
- 2 Resistor, 12,000 ohms, 10%, 1/2 watt (R5)
- 2 Resistor, 39 ohms, 10%, 1/2 watt (R10)
- 1 Integrated Circuit, SK3071 (RCA)
- 1 IC Socket, 16-lead dual-in-line, printed circuit type, TI Type C7529

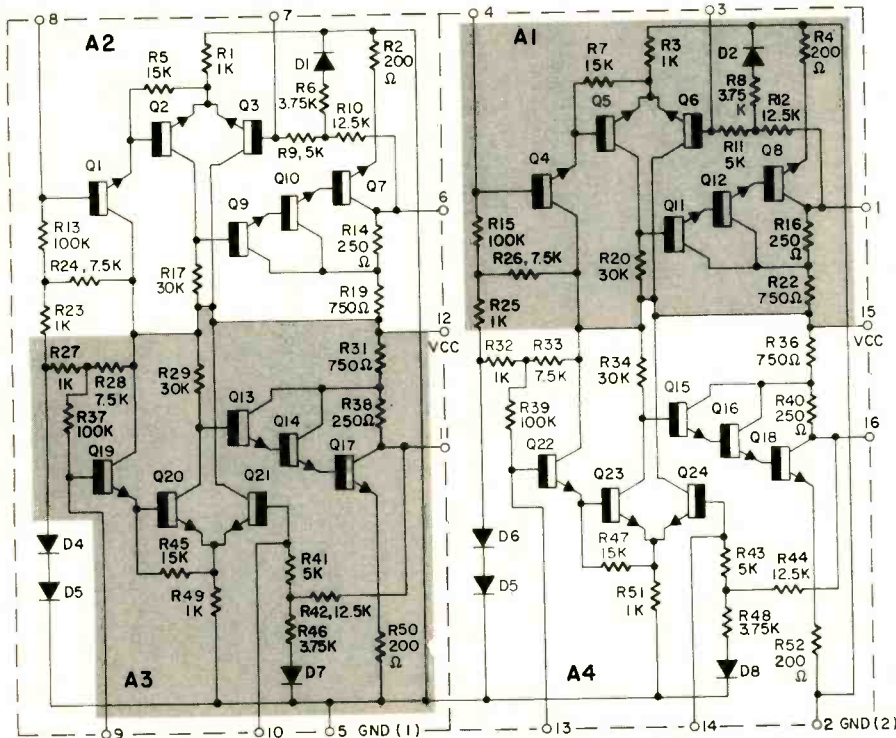
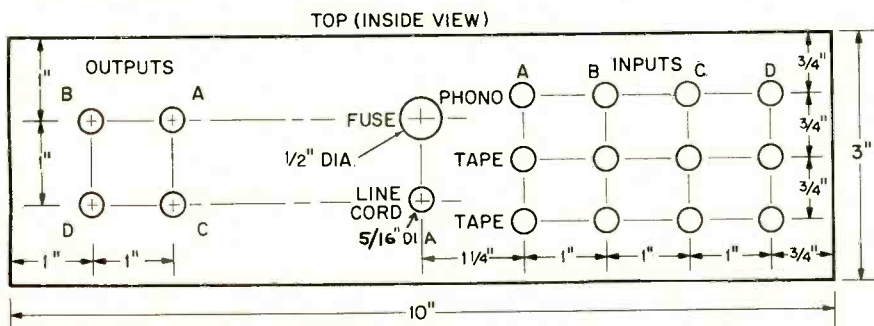

FIG. 4—(top) COMPLETE PREAMP CIRCUIT. Only one channel is shown for clarity. You will build 4 channels. **FIG. 5—(above) INSIDE THE IC** is a lot of electronics. **FIG. 7—(below) REAR PANEL LAYOUT** will ease assembly of the preamp.



NOTE: ALL HOLES 5/16" DIA. EXCEPT AS NOTED.

TEMPLATE FOR REAR APRON

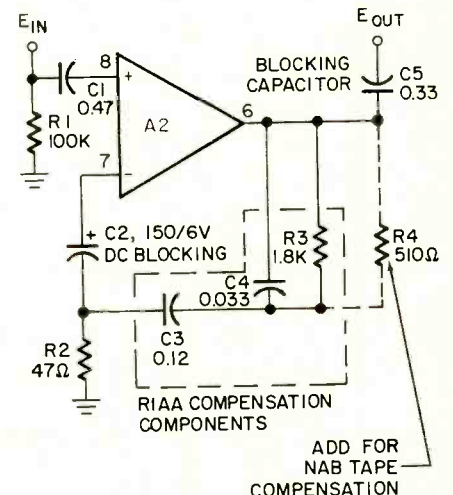

FIG. 6—MAGNETIC PHONO equalization network for one channel. Dashed lines show added circuitry for NAB tape equalization.

Parts List for Power Supply

- C1—1000 μ F, 25 Vdc
- C2—100 μ F, 25 Vdc
- C3—1 μ F, 25 Vdc
- D1, D2—SK3030 (RCA)
- Q1—SK3024 (RCA)
- Q2, Q3—SK3020 (RCA)
- R1—1000 ohms, $\frac{1}{2}$ watt, 10%
- R2—1500 ohms, $\frac{1}{2}$ watt, 10%
- R3—10,000 ohms, $\frac{1}{2}$ watt, 10%
- R4—1100 ohms, $\frac{1}{2}$ watt, 5%
- R5—5100 ohms, $\frac{1}{2}$ watt, 5%
- S1—spst toggle
- T1—Power transformer: primary 117 volts, 26.8 V1A center-tapped secondary (Triad F-40X or equal)

Parts List for Selector Switch Assembly

- 1 Centralab PA301 miniature index assembly, 30° indexing, 4 to 6 sections
- 4 Centralab PA7 switch wafer, non-shorting, 5-pole, 3-position, steatite
- 4 510 ohms, $\frac{1}{2}$ watt, $\pm 5\%$ resistor shielded cable stranded wire

Parts List for Chassis Subassembly

- 1 Aluminum chassis, 3" x 10" x 12" (Bud AC-413 or equal)
- 1 Aluminum cover plate, 10" x 12" (Bud BPA-1523 or equal)
- 1 Neon pilot light (Leecraft 32-2111 or equal)
- 1 Switch, toggle, on/off (Arrow-Hart Hegeman type 20994—LH or equal)
- 16 Phono jacks (Switchcraft 3501FP or equal)
- 1 Fuse holder, 3AG & fuse ($\frac{1}{2}$ amp) (Bussman No. HKP or equal)
- 1 Strain relief, $\frac{1}{4}$ "
- 4 Terminal strip, miniature, 8-terminal including 2 grounds
- 2 Terminal strip, miniature, 5-terminal including 1 ground
- 2 Connector, Cinch 50 18A20
- 4 Capacitor 0.022 μ F, 10%, 50 volts minimum (C6 in Fig. 4)
- 4 Capacitor 0.22 μ F, 10%, 25 volts minimum (C7 in Fig. 4)
- 4 Capacitor 0.68 μ F, 10%, 50 volts minimum (C9 in Fig. 4)
- 4 Resistor, 1000 ohms, $\frac{1}{2}$ watt 10%
- 1 Control 4 sections ganged, 50,000 ohms each, IRC Concentrikrit Q13-123
- Control B13-123, base element, M11-123, Q multisection
- 2 Control 4 sections ganged 100,000 ohms each, IRC Concentrikrit, Q13-128, B13-128, M11-128 multisection

of Q1 is controlled by dc amplifier Q2. Q2 compares a fixed fraction of the output voltage with a Zener reference voltage. Q2 draws current from the base of Q1 when the output voltage tends to go high, or turns itself off, allowing more base current to flow into Q1, when the output tends to go low. The Zener reference voltage is obtained by operating an RCA SK3020 transistor, Q3, with reverse voltage between its base and emitter, thus forcing it to assume its breakdown voltage. Its dissipation capability in this condition is essentially the same as if it were being operated as a transistor.

The filtering action and regulation of the power supply make it

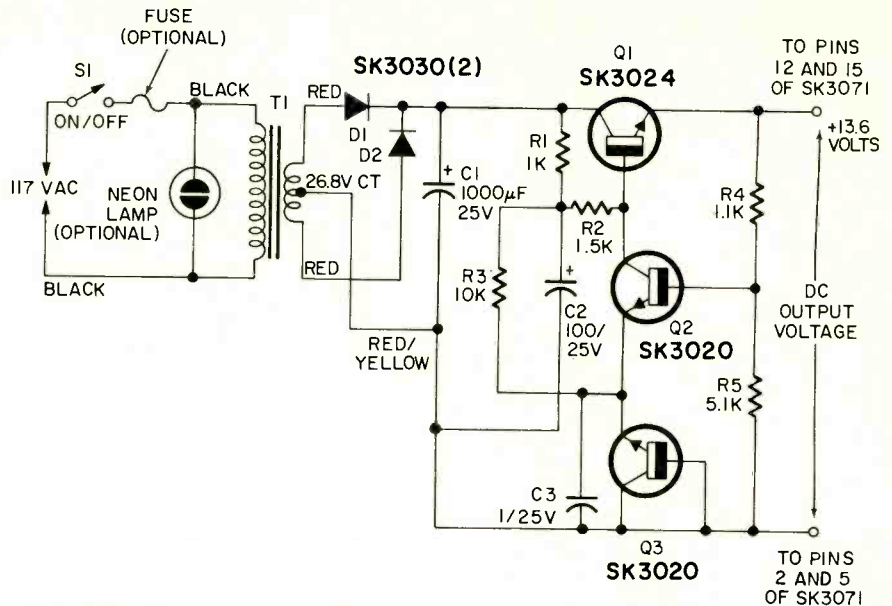
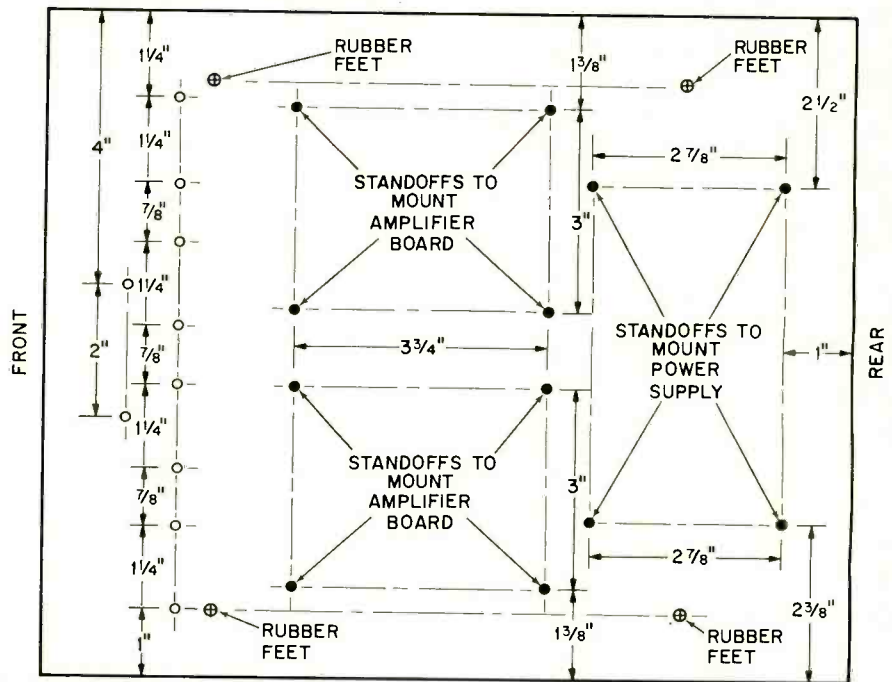

FIG. 8—PREAMP POWER SUPPLY is well regulated, yet relatively simple circuit is easy to build.



- ⊕ = $\frac{3}{16}$ " DIA.
- = $\frac{1}{8}$ " DIA.
- = $\frac{3}{32}$ " DIA. (TERMINAL BOARD HOLES)

HOLE PATTERN FOR BOTTOM OF CHASSIS

FIG. 9—MAIN CHASSIS LAYOUT DIAGRAM shows exact positions of all mounting holes to be drilled on the chassis.

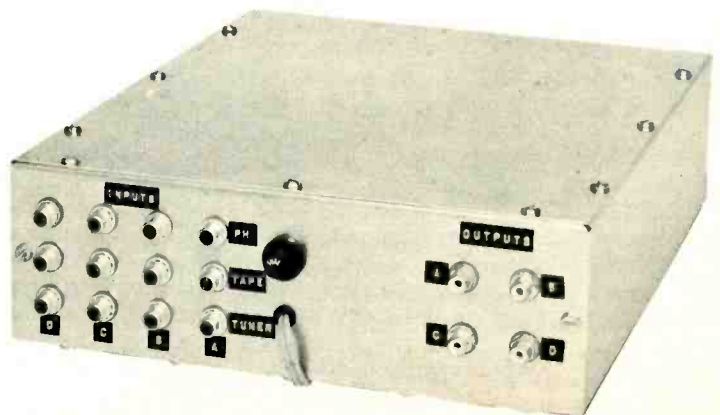

REAR VIEW of the completed preamp.

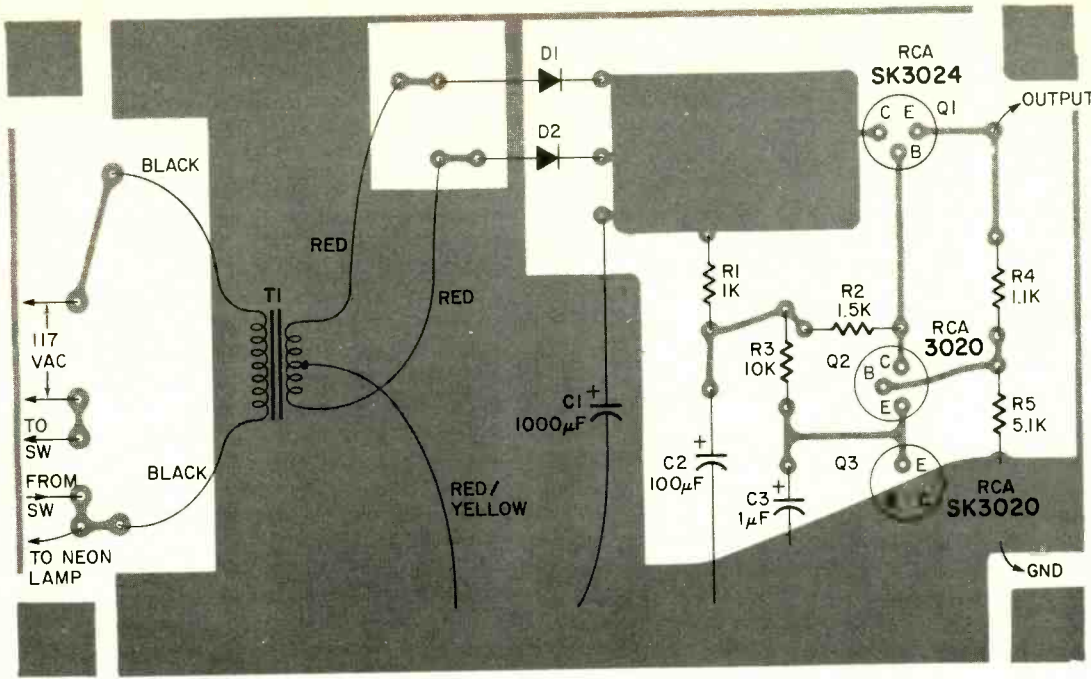

FOIL PATTERNS of the printed-circuit boards and ordering instructions are on page 82.

FIG. 10—(left) CIRCUIT board for preamp power supply showing parts mounting. FIG. 11—(middle) CIRCUIT BOARD for one pair of preamp channels showing parts location. Build 2 of these. FIG. 12—(bottom) SELECTOR switch wiring details.

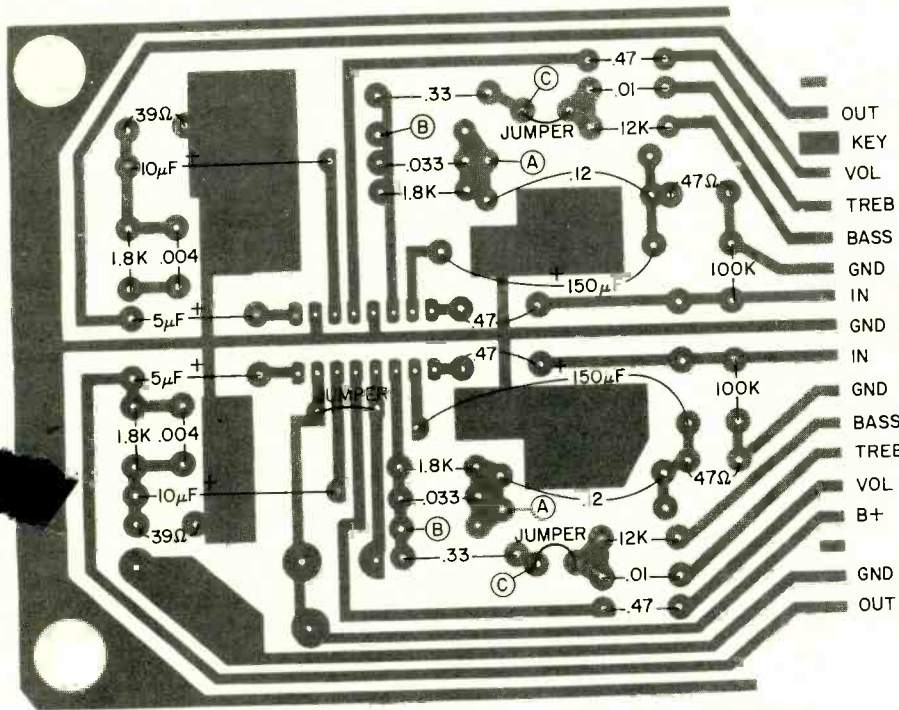

possible to place loads on it with current drains of up to 50 mA.

Building the preamp

The signal channels are constructed on two identical circuit boards which are set up to be plug-connected if desired. Thus, the entire system can be constructed in modular fashion, yielding the utmost in flexibility and serviceability. The only parts not mounted on the pluggable boards are the controls and associated components, and the ac switch.

The entire system is housed in a stock 10 x 12 x 3 inch chassis large enough to allow plenty of room for easy construction.

The chassis hole patterns are in Fig. 3, 7, and 9. The circuit board layouts are in Fig. 10 and 11.

Circuit board patterns and additional photographs are on page 82.

The entire preamplifier is designed to go together as a series of subassemblies, and separate parts lists are provided for each.

The selector switch should be prewired as shown in Fig. 12. Because all four wafers are identical, it is possible to wire each wafer in advance, before assembling the switch. It is a good idea to tag all leads before assembly and, of course, to make sure all wafers are aligned properly. To ensure that no hum arises from ground loops, all the input receptacles should be mounted so they are insulated from the chassis; the three ground connections at the inputs for each channel should be wired in common and brought to the ground point for each channel on the PC board.

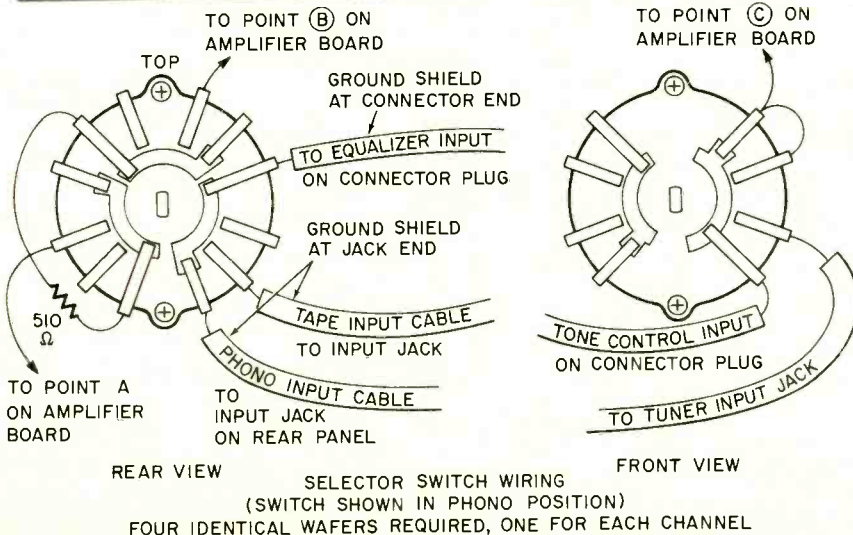

REAR VIEW **SELECTOR SWITCH WIRING** **FRONT VIEW**
(SWITCH SHOWN IN PHONO POSITION)
FOUR IDENTICAL WAFERS REQUIRED, ONE FOR EACH CHANNEL

One of our students wrote this ad!

Harry Remmert decided he needed more electronics training to get ahead. He carefully "shopped around" for the best training he could find. His detailed report on why he chose CIE and how it worked out makes a better "ad" than anything we could tell you. Here's his story, as he wrote it to us in his own words.

By Harry Remmert

AFTER SEVEN YEARS in my present position, I was made painfully aware of the fact that I had gotten just about all the on-the-job training available. When I asked my supervisor for an increase in pay, he said, "In what way are you a more valuable employee now than when you received your last raise?" Fortunately, I did receive the raise that time, but I realized that my pay was approaching the maximum for a person with my limited training.

Education was the obvious answer, but I had enrolled in three different night school courses over the years and had not completed any of them. I'd be tired, or want to do something else on class night, and would miss so many classes that I'd fall behind, lose interest, and drop out.

The Advantages of Home Study

Therefore, it was easy to decide that home study was the answer for someone like me, who doesn't want to be tied down. With home study there is no schedule. I am the boss, and I set the pace. There is no cramming for exams because I decide when I am ready, and only then do I take the exam. I never miss a point in the lecture because



Harry Remmert on the job. An Electronics Technician with a bright future, he tells his own story on these pages.

it is right there in print for as many re-readings as I find necessary. If I feel tired, stay late at work, or just feel lazy, I can skip school for a night or two and never fall behind. The total absence of all pressure helps me to learn more than I'd be able to grasp if I were just cramming it in to meet an exam deadline schedule. For me, these points give home study courses an overwhelming advantage over scheduled classroom instruction.

Having decided on home study, why did I choose CIE? I had catalogs from six different schools offering home study courses. The CIE catalog arrived in less than one week (four days before I received any of the other catalogs). This indicated (correctly) that from CIE I could expect fast service on grades, questions, etc. I eliminated those schools which were slow in sending catalogs.

FCC License Warranty Important

The First Class FCC Warranty* was also an attractive point. I had seen "Q" and "A" manuals for the FCC exams,

*CIE backs its FCC License-preparation courses with this famous Warranty: graduates must be able to pass the applicable FCC License exam or their tuition will be refunded in full.

and the material had always seemed just a little beyond my grasp. Score another point for CIE.

Another thing is that CIE offered a complete package: FCC License and technical school diploma. Completion time was reasonably short, and I could attain something definite without dragging it out over an interminable number of years. Here I eliminated those schools which gave college credits instead of graduation diplomas. I work in the R and D department of a large company and it's been my observation that technical school graduates generally hold better positions than men with a few college credits. A college degree is one thing, but I'm 32 years old, and 10 or 15 years of part-time college just isn't for me. No, I wanted to graduate in a year or two, not just start.

If a school offers both resident and correspondence training, it's my feeling that the correspondence men are sort of on the outside of things. Because I wanted to be a full-fledged student instead of just a tagalong, CIE's exclusively home study program naturally attracted me.

Then, too, it's the men who know their theory who are moving ahead where I work. They can read schematics and understand circuit operation. I want to be a good theory man.

From the foregoing, you can see I did not select CIE in any haphazard fashion. I knew what I was looking for, and only CIE had all the things I wanted.

Two Pay Raises in Less Than a Year

Only eleven months after I enrolled with CIE, I passed the FCC exams for First Class Radiotelephone License with Radar Endorsement. I had a pay increase even before I got my license and another only ten months later. I'm getting to be known as a theory man around work, instead of one of the screwdriver mechanics.

These are the tangible results. But just as important are the things I've learned. I am smarter now than I had ever thought I would be. It feels good to know that I know what I know now. Schematics that used to confuse me completely are now easy for me to read and interpret. Yes, it is nice to be smarter, and that's probably the most satisfying result of my CIE experience.

Praise for Student Service

In closing, I'd like to get in a compliment for my Correspondent Counselor who has faithfully seen to it that my supervisor knows I'm studying. I think the monthly reports to my supervisor and generally flattering commentary have been in large part responsible for my pay increases. My Counselor has given me much more student service than "the contract calls for," and I certainly owe him a sincere debt of gratitude.

And finally, there is Mr. Tom Duffy, my instructor. I don't believe I've ever had the individual attention in any classroom that I've received from Mr. Duffy. He is clear, authoritative, and spared no time or effort to answer my every question. In Mr. Duffy, I've received everything I could have expected from a full-time private tutor.

NEW... Electronics Engineering Course

... Covers steady-state and transient network theory, solid-state physics and circuitry, pulse techniques, computer logic and mathematics through calculus. A college-level course for men already working in Electronics.

I'm very, very satisfied with the whole CIE experience. Every penny I spent for my course was returned many times over, both in increased wages and in personal satisfaction.

Perhaps you too, like Harry Remmert, have realized that to get ahead in Electronics today, you need to know much more than the "screwdriver mechanics." They're limited to "thinking with their hands" . . . learning by taking things apart and putting them back together . . . soldering connections, testing circuits, and replacing components. Understandably, their pay is limited—and their future, too.

But for men like Harry Remmert, who have gotten the training they need in the fundamentals of Electronics, there are no such limitations. As "theory men," they think with their heads, not their hands. For trained technicians like this, the future is bright. Thousands of men will be needed in virtually every field of Electronics, from two-way mobile radio to computer testing and troubleshooting. And with this demand, salaries have skyrocketed. Many technicians earn \$10,000, \$12,000 or more a year.

Send for Complete Information—FREE

Many men who are advancing their Electronics career started by reading our famous book, "How To Succeed In Electronics." It tells of the many electronics careers open to men with the proper training. And it tells which courses of study best prepare you for the work you want.

If you're "shopping around" for the training you need to move up in Electronics, this 44-page book may have the answers you want. We'll send it to you FREE. With it, we'll also include our other helpful book, "How To Get A Commercial FCC License."

To get both FREE books, just fill out and mail the bound-in postpaid card. If the card is missing, send the coupon below.

CIE Cleveland Institute of Electronics

1776 East 17th Street, Cleveland, Ohio 44114

Accredited Member National Home Study Council



**NEW
REVISED
G. I.
BILL
BENEFITS**

All CIE courses are approved for full tuition reimbursement under G. I. Bill. If you served on active duty since January 31, 1955, OR are in service now, check box on reply card or coupon for latest G. I. Bill information.

Cleveland Institute of Electronics
1776 East 17th Street, Cleveland, Ohio 44114

Please send me without cost or obligation:

- Your illustrated 44-page book, "How To Succeed in Electronics."
- Your book on "How to Get A Commercial FCC License."

I am especially interested in:

<input type="checkbox"/> Electronics Technology	<input type="checkbox"/> Electronic Communications
<input type="checkbox"/> Broadcast Engineering	<input type="checkbox"/> Industrial Electronics and Automation
<input type="checkbox"/> First-Class FCC License	<input type="checkbox"/> Electronics Engineering
<input type="checkbox"/> Electronics Technology with Laboratory	

Name _____ (PLEASE PRINT)

Address _____

City _____

State _____ Zip _____ Age _____

Veterans and Servicemen: check here for G.I. Bill information. RE-95

Circle 17 on reader service card

Design for **STEREO** | how to design your own solid-state audio amplifier

by MANNIE HOROWITZ*

Noise in audio amplifiers is intolerable when it interferes with the music. Here's how it can be handled

ANY UNDESIRABLE VOLTAGE OR CURRENT associated with a signal may be classified as noise. It is intolerable when it interferes with the enjoyment of the signal or completely obscures it.

Noise associated with amplifying devices can be due to radiation from arcing electrical devices and induction from ac electric supplies. The methods of minimizing interference from sources of this type will be discussed in articles dealing with chassis layout, ground-loop problems and shielding.

The random noise generated by passive and active devices in a circuit are of more immediate concern. When designing a circuit, it is frequently necessary to keep noise to a minimum. This is especially true in the high-gain first stage of an amplifier, for noise generated here is boosted by all succeeding transistors.

Circuit noise is analyzed as caused by three noise generators, one real and two hypothetical, at the input of a theoretically noise-less amplifier. The real noise is generated by components connected to the input circuit and transferred to the amplifier stage. The theoretical noise sources are a voltage generator and a current generator within the transistor. These two generators are mathematically referred to the input as sources of interference for a noise-less amplifier.

Signal-to-noise ratio is a measurement of the relative amount of noise present in reproduced intelligence. Conventional methods of measuring this involve feeding a mid-frequency signal of average amplitude to the input of an amplifier, and noting the voltage e_{so} (signal output voltage) across the output load. Next, remove the signal, place a resistor at the input equal to the impedance of the transducer or signal source to be used, and once again measure the voltage. This second reading is the amount of noise voltage e_{no} riding along with the signal. The fraction of measured signal voltage to measured noise voltage is a signal-to-noise ratio for the amplifier.

Signal-to-noise fractions can also be power ratios. Voltages e_{so} and e_{no} were measured across the same output load resistor of the amplifier stage. Assume this load is R_L so that the signal power P_{so} across the load is e_{so}^2/R_L and the noise power P_{no} is e_{no}^2/R_L . The signal-to-noise for a power ratio is $P_{so}/P_{no} = (e_{so}/e_{no})^2$.

The two signal-to-noise ratios, as defined, differ from each other. The decibel, dB, is defined as 10 times the log of a ratio of two powers. Using a slight mathematical manipulation, dB can also be defined as 20 times the log of the ratio of two voltages, when both voltages are measured across the same or equal resistors. The signal-to-noise ratio, when expressed in dB, is the same regardless of the ratio involved, whether it be voltage or power. The equation relating dB to these ratios is

$$dB = 10 \log \frac{P_{so}}{P_{no}} = 20 \log \frac{e_{so}}{e_{no}} \quad \text{Eq. 1}$$

Table 1 is used with Equation 1 to relate any ratio in dB to the power and voltage ratios. If the voltage or power ratio is not shown in the table, the dB equivalent can easily be calculated from the data supplied. For example, a measured voltage ratio of 20:1 is not shown as such in Table 1. But 4:1 and 5:1 are stated, and the product of the two ratios is 20:1. The ratio in dB for

4:1 is 12 dB and for 5:1 is 14 dB. These are added and not multiplied as with actual ratios. A voltage ratio of 20:1 is thus equivalent to 12 dB + 14 dB = 26 dB. Similarly we can use voltage ratios of 2:1 and 10:1 where we add 6 dB to 20 dB to equal 26 dB. The rule is: multiply two or more power or voltage ratios whose products equal a measured ratio. Then add all the dB numbers representing these ratios.

A second example using identical procedures assumes a measured power ratio of 2.5:1. The 5:1 ratio divided by the 2:1 ratio will yield 2.5:1. The equivalent ratios in dB are 7 and 3, respectively. As one ratio is divided by the other, the numbers in dB must be subtracted from each other. Hence a 2.5:1 power ratio is identical to 7 dB - 3 dB = 4 dB.

Real input noise

The noise present in any transistor amplifier stage falls roughly into three categories. As shown in Fig. 1, there

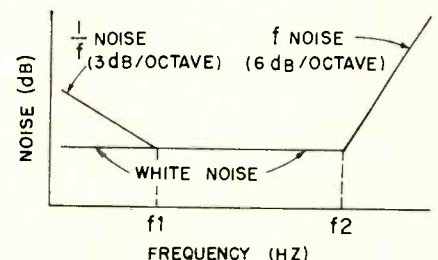

FIG. 1—NOISE SPECTRUM of a transistor. White noise contains equal energy at all frequencies. Noise increase at the high end is caused by decrease in beta. Roll-off at the low end is caused by surface phenomena and leakage current.

is one type of noise which covers the entire frequency spectrum. Identified as *white noise*, it delivers identical power at all frequencies. It can be generated by the random motion of particles in a conductor due to the energy imparted to these particles by heat. Because the noise is related to temperature, it is also referred to as *thermal noise*. Any noise due to a resistor in the base or gate circuit is amplified by the bipolar transistor or FET. Bias resistors at the input circuit, or even the base resistance

TABLE 1

POWER RATIO	VOLTAGE RATIO	DB
1:1	1:1	0
1.3:1	1.1:1	1
1.6:1	1.3:1	2
2:1	1.4:1	3
4:1	2:1	6
5:1	2.2:1	7
10:1	3.2:1	10
15.9:1	4:1	12
20:1	4.5:1	13
25:1	5:1	14
50.1:1	7:1	17
100:1	10:1	20
10000:1	100:1	40
10 ⁶ :1	10 ³ :1	60

*Chief Project Engineer, EICO Electronic Instrument Co. Inc.

of bipolar transistors, are important sources of this type of noise.

The noise power produced by any resistor is governed by the equation

$$P_{ni} = 1.37 \times 10^{-23} (273^\circ + ^\circ C) B \text{ Eq. 2}$$

where $^\circ C$ is the temperature in degrees Celsius and B is the effective noise bandwidth.

B is not the bandwidth of an amplifier in the usual sense of the word. Normally bandwidth is defined by $(f_H - f_L)$ where f_H and f_L are the high and low frequencies respectively at which the gain of the amplifier has dropped 3 dB from its center value. Noise bandwidth as applied to the equation is equal to the sum of the products of the gain and the respective frequency at each point of the entire frequency range, divided by the maximum gain of the amplifier. It is quite a difficult and lengthy operation to determine B , even if integral calculus were to be used in the procedures. It is best to remember that in the usual case, where the rolloff of an amplifier is 6 dB per octave, noise bandwidth (B) is 1.57 multiplied by the bandwidth of the amplifier at the 3-dB points.

When making measurements, meter readings will correlate with Equation 2 if B is assumed to be the bandwidth just defined. However, this may not relate to the audible noise due to characteristics of the ear. From data, it seems that the ear is most sensitive to approximately 2500 Hz and that the sensitivity decreases at frequencies on either side of this. Many tests have been performed and different standards have been established, each claiming to be the actual roll-off characteristic of the ear. From all of these, it would seem reasonable to let $f_L = 800$ Hz and $f_H = 8000$ Hz so that the audible $B = 1.57(8000 - 800) = 11,300$ Hz. However inaccurate this figure may be, we will assume it to be so in this article. It is sure to agree with someone's auditory characteristics. Many arguments can be presented against this assumption, but it must be remembered that Fletcher never said that his hearing curve was identical to that of Munson's.

All other factors in Equation 2 are constants requiring no further elaboration.

Available noise power is the maximum power that can be transferred from the resistor noise source to the circuit. This occurs when the resistor generating the noise is equal to the resistor it sees in the circuit. In Fig. 2, an equivalent circuit is drawn in which the noise generating resistor is divided into two parts—a voltage noise source (e_{ni}) and a theoretical noiseless resistor R_{NI} . The input circuit resistance of a transistor is represented by R_G . For the maximum transfer of noise power, $R_{NI} = R_G$. R_{NI} and R_G

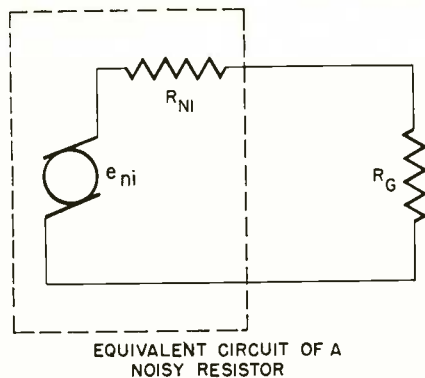

FIG. 2—MAXIMUM NOISE POWER is developed when noise source R_{NI} equals R_G , the transistor input circuit resistance.

form a voltage divider. Since $R_{NI} = R_G$, the voltage across R_G and R_{NI} is $e_{ni}/2$. The power across R_G is $(e_{ni}/2)^2 \times 1/R_G$, so that Equation 2 becomes

$$P_{ni} = e_{ni}^2 / 4R_G \text{ and} \\ e_{ni}^2 = 5.49 \times 10^{-23} (273^\circ + ^\circ C) (B) \times (R_G) \text{ Eq. 3}$$

The generated noise voltage is proportional to the square root of the size of the resistor creating it.

Life would be very simple if Equation 3 can be used just as it is stated. However R_G must be modified when it is shunted by some arrangement of capacitors and/or inductors. This is the case in Fig. 3 where the transistor

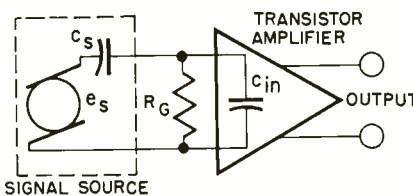

FIG. 3—AMPLIFIER STAGE in which signal source capacitance C_s and transistor input capacitance C_{in} shunt R_G .

impedance is so high that it presents a capacitance, C_{in} , to the input source rather than a resistance. The input can also be shunted by the capacitance of a voltage source such as a ceramic microphone or phonograph cartridge. The total capacitance, C_t , across R_G is $C_s + C_{in}$. If the reactance of C_t at the noise midfrequency be less than about 10 times the size of R_G in the figure, R_G for Equation 3 is not the same as R_G in Fig. 3. For use in the equation, R_G must be only the resistive component of the input impedance of the circuit. This component is easily derived.

The reactance due to C_t is $-j/\omega C_t$, where ω is $6.28f$ and f is the frequency involved, in Hertz. The j notation indicates a 90° reactive phase shift where $j = \sqrt{-1}$. (If you are not familiar with this notation, see the clear description in **Radio-Electronics**, February 1971, or in a text on electronics mathematics.) The resistor in parallel with C_t is R_G . The formula used to deter-

mine the impedance of the combination is similar to the one used to determine the equivalent resistance of two resistors, R_1 and R_2 , in parallel or $R_1 R_2 / (R_1 + R_2)$. Here, however, the effect of the j operator must be included. The total impedance is

$$Z = \frac{-R_G j / \omega C_t}{R_G - j / \omega C_t}$$

Multiply the numerator and denominator by $R_G + j/\omega C_t$ and change j^2 to -1 , and you have

$$Z = \frac{-R_G^2 j}{\omega C_t} + \frac{R_G}{\omega^2 C_t^2} \\ R_G^2 + 1/\omega^2 C_t^2}$$

Since R_G is assumed to be much greater than $1/\omega C_t$, there is a small error when the $1/\omega^2 C_t^2$ in the denominator of the equation is ignored when compared in magnitude to R_G^2 . The denominator now becomes only R_G^2 . Since only the resistive component of the impedance is required, the j term in the numerator can be disregarded. Then the R_G for the equation becomes

$$R_G \text{ (for Eq. 3)} = \frac{R_G}{\omega^2 C_t^2} = \frac{1}{R_G \omega^2 C_t^2} \text{ Eq. 4}$$

The frequency f [from the $\omega^2 = (2\pi f)^2$] is the geometric center frequency of the noise bandwidth. Thus, if the noise bandwidth B includes all frequencies between the limit of a high at f_H and a low at f_L , the frequency to be used for determining R_G is $f = \sqrt{f_L \times f_H}$.

Using the derived formulae, adding a little calculus, and making several minor approximations; the information can be stated in a new formula similar to Equation 3.

$$e_{ni}^2 = 1.37 \times 10^{-24} (273^\circ + ^\circ C) \left(\frac{B}{f_H f_L} \right) \left(\frac{1}{R_G C_t^2} \right) \text{ Eq. 5}$$

where B , R_G and $^\circ C$ are identical to the values used in the previous equation, while C_t , f_H and f_L have been discussed in the text.

Noise due to the transistor

The white-noise spectrum is not exclusively generated by resistors. The *shot noise* phenomenon in semiconductor junctions also pleads guilty as a source. It is noise generated by the random passage of charged particles through the junctions. Shot noise increases with the current flowing through the device.

Emitter current of bipolar devices divides between the base and collector. This *partition noise* is similar in nature to white noise. Obviously, the noise is minimized when the beta of the transistor is large and the number of partitions is small.

In Fig. 1, the 6 dB-per-octave increase in noise at the upper frequencies is due to the roll-off of beta at the high end of the band rather than to any

phenomenon different from that discussed above. This noise increase is usually noted at some radio frequency and is unimportant when considering audio designs.

The semiconductor noise at the low frequencies drops at the rate of 3 dB per octave. This characteristic, called 1/f noise, is due to surface phenomena and leakage current. It is minimized when the current flowing through the bipolar transistor and the voltage across the device, are low. Minimizing temperature goes a long way in reducing noise from this factor. As for the JFET, this noise is least objectionable when the transconductance of the device is high.

The effect of 1/f-noise is quite important in audio devices. While bipolar transistors can suffer from this phenomenon up to 1,000 Hz, the effect becomes negligible at about 100 Hz when JFETs are involved. Transistors have been designed where noise due to the 1/f-effect may be disregarded at frequencies much below those noted.

Next, we are to mathematically determine the effect of the transistor noise on the circuit. The procedure is to create, on paper, noise-voltage and current generators to be placed at the input of a noise-less amplifier. These generators will cause the noise at the output to be the same as it would be from an actual device in the circuit. Before detailing this equivalent circuit, we will define two transistor constants, F and NF.

Noise figure

The signal-to-noise ratio at the input of an amplifying device is higher than at the output because of the contribution of the stage of gain to the noise at the output. The *noise factor*, F, relates the two signal-to-noise ratios.

$$F = \frac{P_{si}/P_{ni}}{P_{so}/P_{no}} \quad \text{Eq. 6}$$

where P_{si} and P_{so} are the input and output signal powers respectively, and P_{ni} and P_{no} are the input and output noise powers, respectively. The optimum noise factor is equal to 1 for only then will the input and output signal-to-noise ratios be equal (there is no noise contribution from the amplifying device).

The power gain of an amplifier is $G = P_{so}/P_{si}$ so the noise factor can be expressed as

$$F = P_{no}/GP_{ni} \quad \text{Eq. 7}$$

where GP_{ni} is the input noise power multiplied by the power gain of the device, or the output noise power due to noise present at the input.

Using Table 1, the number for noise factor F in terms of a decibel ratio can easily be determined. When expressed in decibels, the ratio is referred to as *noise figure*, NF. For example, the dB equivalent of a power ratio of 2:1 is 3 dB. Hence a noise factor of 2 is identical to a noise figure of 3 dB.

Noise figure is specified in one of two ways. The more conventional data sheet indicates the *spot noise figure*. This is a maximum noise figure number at *one frequency*, usually 1000 Hz, for a bandwidth of 1 Hz. In an alternate method, the noise figure is specified over the entire band. The latter number usually supplies more exact information covering both the white noise and 1/f regions of the curve.

Equivalent noise generator

The noise generated within an amplifier can be analyzed using the equivalent circuit shown in Fig. 4. Here, the

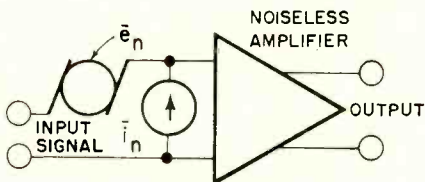

FIG. 4—EQUIVALENT CIRCUIT of noise generated in transistor consists of voltage-noise source e_n , current-noise source i_n and a noise-less amplifier.

actual amplifier is divided into two entities — the amplifying device and the two noise generators present in the amplifier. The hypothetical noise generating sources, e_n and i_n , are separated from and placed at the input of the amplifying device. The theoretical amplifier in the circuit is noiseless, and any noise at the output is due to the noise fed to the amplifier by the two generating supplies.

The output noise is due to e_n when the input to the amplifier is shorted and is due to i_n when the input is open circuited. We calculate e_n by using data obtained from two measurements — the noise voltage at the output when the input to the amplifier is shorted and the voltage gain, A_v . The value of e_n is equal to the noise voltage at the output divided by A_v .

We can determine i_n by comparing the output current when the input is open circuited with the current at the output due to a known current source when it is placed at the input.

The only noise power that is actually present at the input is thermal; e_n and i_n are not actually at the input, but are considered as being there for the convenience of specifying the noise generated by the transistor.

The total noise power at the input, P_{nit} , consists of the actual thermal noise power in Equation 2, or $1.37 \times 10^{-23} (273^\circ + ^\circ C)B$, in addition to the noise power due to e_n and i_n in the transistor, or $(e_n^2/4R_G + i_n^2R_G/4)$. As both factors are input noise sources, they must be multiplied by G, the power gain of the transistor, if the results of the calculation is to be the noise at the output.

The actual noise power at the input only is assumed due totally to resistor

R_G or is $1.37 \times 10^{-23} (273^\circ + ^\circ C)B$. Substituting all the data in these two paragraphs into Equation 7, the noise factor in terms of e_n and i_n becomes

$$F = \frac{P_{no}}{GP_{ni}} = \frac{GP_{nit}}{GP_{ni}} \quad \text{Eq. 8}$$

$$G \left[1.37 \times 10^{-23} (273^\circ + ^\circ C)B + \frac{e_n^2}{4R_G} + \frac{i_n^2 R_G}{4} \right]$$

$$F = 1 + \frac{e_n^2/R_G + i_n^2 R_G}{5.49 \times 10^{-23} (273^\circ + ^\circ C)B} \quad \text{Eq. 9}$$

The noise figure is, of course, equal to the noise factor found in Equation 8, expressed in dB.

From Equation 9 it can be determined that the noise factor is at a minimum when $R_G = e_n/i_n$. Substituting this into Equation 9, we find that the best noise factor that can be obtained for a particular transistor is about $1 + e_n i_n / 2.74 \times 10^{-23} (273^\circ + ^\circ C)B$.

Equation 8 can be rewritten in the form showing that the total input noise power affecting the output of the transistor is

$$P_{nit} = P_{ni} F \\ = F(1.37 \times 10^{-23} (273^\circ + ^\circ C)B) \\ = \frac{e_n^2}{4R_G} \quad \text{Eq. 10}$$

so that the total (real and hypothetical) input noise voltage that affects the output is

$$e_{nit} = [4R_G F (1.37 \times 10^{-23}) \\ \times (273^\circ + ^\circ C)B]^{1/2} \quad \text{Eq. 11}$$

The input signal voltage must be compared with e_{nit} to determine the signal to noise ratio of a transistor circuit.

Noise and the bipolar transistor

The variations of noise figure with collector current and source resistor, R_G , can be described by the set of contour curves in Fig. 5. This is most useful in audio amplifier design. The maximum noise figure stated on data sheets usually specifies the characteristic at a specific collector current, collector voltage, and frequency, when a particular resistor is at the input. Using the curves, you can determine the noise figure for a coincident collector current and input resistor. Operation within the lowest contour assures you that the amplifier will deliver the minimum amount of noise to a load, within its capabilities.

In addition to the contour curves shown, other similar curves may be drawn. Some extremely wideband applications may require a set of contour curves showing how the noise figure is related to the input resistor at specific frequencies rather than at specific collector currents.

The R_G and I_c relationships can be split into two curves (Figs. 6-a and b), showing the variation of NF with each of these factors. Another useful curve, in Fig. 6-c, shows the variation of NF with frequency. All these curves are limited compared to the one in Fig. 5 as

many factors must be specified before any one variable can be determined. Curves of this type supply information concerning one variable factor while all others are usually held constant at their optimum values for minimum noise.

The design of a low-noise amplifier can be accomplished in several logical steps, beginning with the selection of the most suitable device. Should the source resistance be determined by the circuit requirements, characteristic curves of

different transistors should be checked to determine which type will contribute least to the noise when a reasonable amount of collector current is flowing. On the other hand, if only a specific type is available, the circuit should be designed so it operates within a low-noise contour.

Once the device has been chosen, factors should be substituted into Equation 11 to calculate the noise voltage due to the transistor and the circuitry. The

average input signal voltage is compared with the generated noise determined from Equation 11 to decide if the signal-to-noise ratio is satisfactory.

As an example, use a magnetic phonograph cartridge to feed a preamplifier stage. The resistance of the cartridge, R_G , may be taken at 3000 ohms. A collector current near the lowest noise contour curve in Fig. 5 coincident with $R_G=3000$ ohms, is $50 \mu A$. The noise figure is about 1 dB. From Table 1, a NF of 1 dB is equivalent to a noise factor, F , of 1.3. Assume the amplifier is to reproduce 20–20,000 Hz within 1 dB, so that the 3-dB power points are at one octave beyond these frequencies, or at 10 and 40,000 Hz. The effective noise bandwidth is about $1.57 \times 40,000 = 63,000$ Hz. Substituting this into Equation 11, the noise voltage at $27^\circ C$ is

$$\bar{e}_{nit} = (4 \times 3 \times 10^3 \times 1.3 \times 1.37 \times 10^{-23} \times 300 \times 6.3 \times 10^4)^{1/2} = 2.01 \times 10^{-6} \text{ volts.}$$

The average output voltage for a magnetic cartridge is 2×10^{-3} volts. The ratio of signal to noise is $2 \times 10^{-3} / 2.01 \times 10^{-6}$ which is approximately equal to 10^3 . From Table 1, a voltage ratio of $10^3:1$ is 60 dB. This is a good specification for any amplifier.

The actual audible noise is less than the 2.01×10^{-6} volts multiplied by the voltage gain of the stage. The $2.01 \times 10^{-6} A_v$ is the noise usually measured on test instruments at the output of the amplifier. This is for a noise bandwidth of 63,000 Hz. As discussed above, a practical audible noise bandwidth is 11,300 Hz. Substituting this into Equation 11 yields

$$\bar{e}_{nit} = (4 \times 3 \times 10^3 \times 1.3 \times 1.37 \times 10^{-23} \times 300 \times 1.13 \times 10^4)^{1/2} = 0.85 \times 10^{-6}$$

so that the signal-to-noise voltage ratio is $2 \times 10^{-3} / 0.85 \times 10^{-6} = 2.35 \times 10^3$. Using Table 1, we can determine this ratio in dB. The factor 2.35×10^3 can be separated into the product of 2.35 and 10^3 . The closest dB figure for the 2.35:1 voltage ratio is 2.2:1 or 7 dB and 10^3 is 60 dB. Hence the signal to noise ratio is $60 \text{ dB} + 7 \text{ dB} = 67 \text{ dB}$. The actual audible noise is 7 dB better than the measured value.

As a general rule, bipolar transistor amplifiers should be designed with a minimum collector current and voltage as well as with the smallest practical source resistance in the base circuit.

Noise and the JFET

JFET noise is not specified by using contour curves. There are usually individual curves relating the noise figure to various factors affecting noise. Several typical curves spelling out these relationships are shown in Fig. 7.

Another set of curves relate $\bar{e}_n / \sqrt{\Delta f}$ and $i_n / \sqrt{\Delta f}$, the noise-voltage and current generators at the input to the

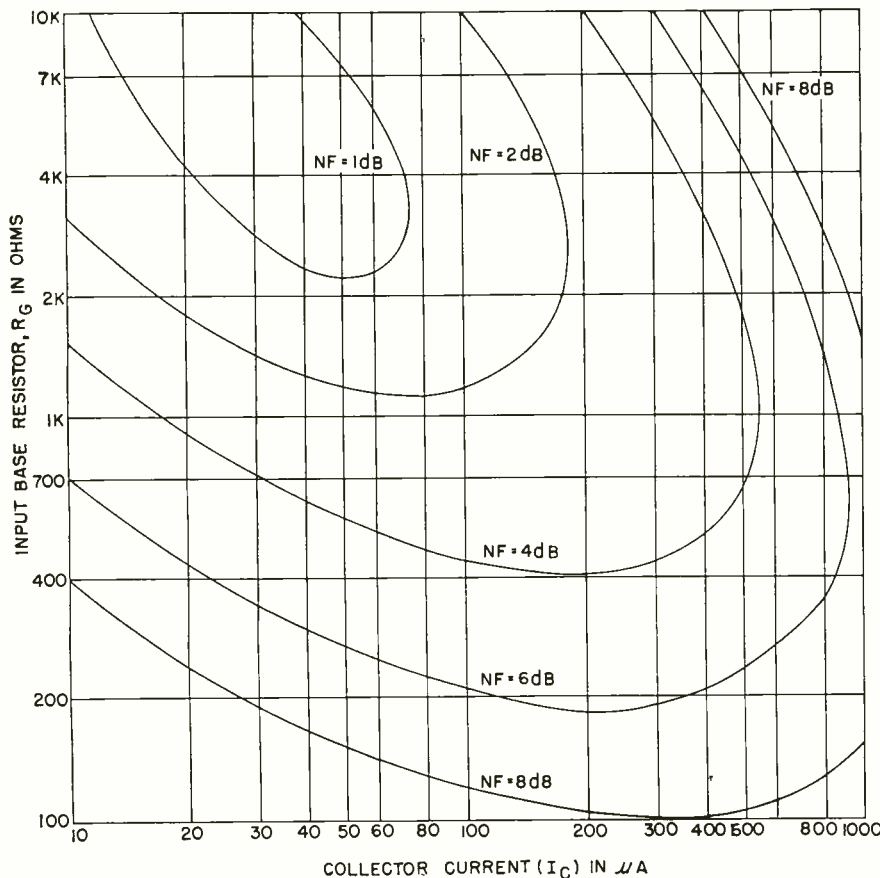

FIG. 5—NOISE-FIGURE CONTOUR CURVES. They are usually drawn at 1 kHz, $25^\circ C$.

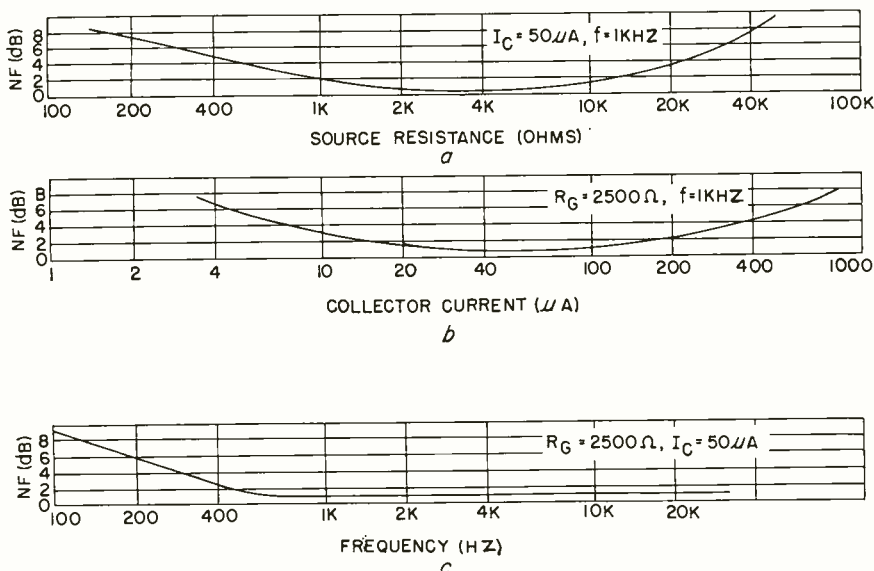

FIG. 6—NOISE-FIGURE CURVES. Curve a is plotted against source resistance with constant I_C and frequency; in b, we plot I_C for constant R_G and frequency. Noise figure increases at low frequencies (c) when R_G and I_C are held constant.

hypothetical noiseless amplifier, to frequency. The curves are shown in Fig. 8. The $\sqrt{\Delta f}$ refers to the noise bandwidth of the circuit. The curves in Fig. 8 refer to the variations of \bar{e}_n and \bar{i}_n with frequency when the bandwidth is 1 Hz. Should the noise bandwidth be 2 Hz, the $\bar{e}_n/\sqrt{\Delta f}$ or $\bar{i}_n/\sqrt{\Delta f}$ read from the curve is to be multiplied by $\sqrt{2}$. In a similar manner, for a 100-Hz noise bandwidth, both readings are to be multiplied by $\sqrt{100}$ or 10.

Some specifications state $\bar{e}_n/\sqrt{\Delta f}$ (sometimes written $\bar{e}_n/\sqrt{\sim}$ or $\bar{e}_n/\sqrt{\text{Hz}}$)

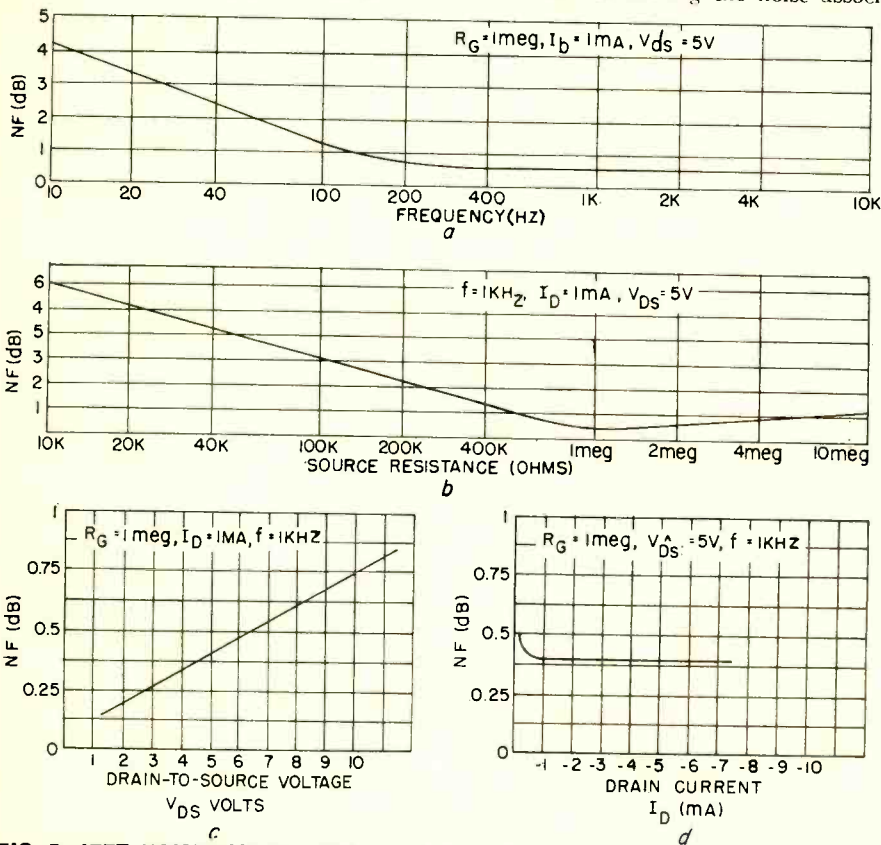

FIG. 7—JFET NOISE-FIGURE CURVES. Noise figure, NF, rises at low frequencies as R_G , I_D and V_{DS} (curve a) are held constant. Curve b relates noise figure to source resistance with fixed values of I_D , f and V_{DS} . Changes in V_{DS} and I_D affect NF as shown in curves c and d for fixed frequency and source resistance.

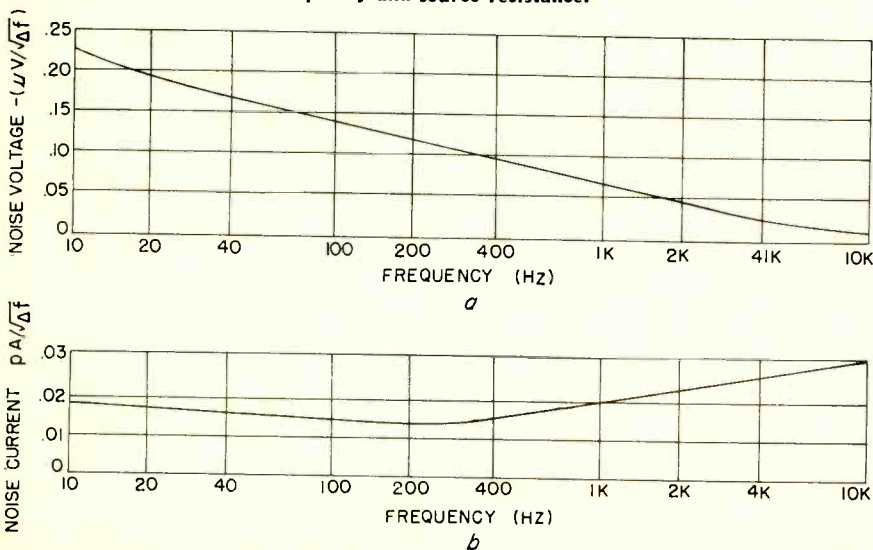

FIG. 8—NOISE VOLTAGE AND CURRENT from hypothetical generators at the input of noiseless amplifier are determined by frequency as in curves a and b.

for bandwidths other than 1 Hz. If, for example, it were specified for a 5-Hz bandwidth, the stated number should be first divided by $\sqrt{5}$ before proceeding to find the noise figure for the actual bandwidth involved. Once the correction is made, the procedure outlined in the paragraph above can be used. This also applies to determining \bar{i}_n if a bandwidth other than 1 Hz is specified in the data.

In Fig. 3 it was indicated that there were input capacitances associated with the transistor. These are important factors when calculating the noise associ-

ated with the JFET.

It was shown in a previous article that there are two capacitors associated with transistors, namely C_{rs} and C_{rd} . In Fig. 3 C_{in} is equal to $C_{rs} + C_{rd}(A_v + 1)$ where, as you recall, C_{rs} is the gate-to-source capacitance, C_{rd} is the gate-to-drain capacitance, and A_v is the voltage gain of the transistor. The voltage gain in the common-source mode is, of course, approximately equal to the product of the drain resistor, R_d , and the transconductance, g_m . Along with C_{in} , the capacitance of a transducer C_s feeding the amplifier, is important in determining transistor noise characteristics.

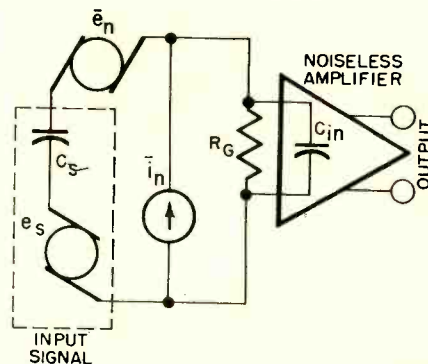

FIG. 9—INPUT TO NOISELESS AMPLIFIER drawn to include the effect of source and input capacitances not shown in Fig. 4.

The capacitive and resistive inputs to the circuit affect the magnitude of noise and signal voltages applied to the input of the hypothetical amplifier. Input signal voltage e_s , \bar{e}_n and \bar{i}_n must be modified before they can be used to calculate the total noise and signal-to-noise ratio at the input of a JFET. (The input noise is, of course, directly proportional to all noise at the output.)

Figure 4, showing the various sources of noise referred to the input of the theoretical noiseless amplifier, is redrawn in Fig. 9 to include the input impedances along with the capacitance of the signal source. C_s and the parallel combination of R_G and C_{in} form a voltage divider. If R_G is much larger than the reactance of $C_{in} + C_s$, the input signal voltage, e_{sa} , at the amplifier is

$$e_{sa} = \frac{e_s C_s}{C_{in} + C_s} \quad \text{Eq. 12}$$

while the noise voltage at the input is

$$\bar{e}_{na} = \frac{\bar{e}_n C_s}{C_{in} + C_s} \quad \text{Eq. 13}$$

The noise voltage due to the current noise generator, \bar{e}_{nia} , is the product of \bar{i}_n with all the impedances across the input, or







$$\bar{e}_{nia} = \frac{\bar{i}_n}{6.28f(C_s + C_{in})^2} \quad \text{Eq. 14}$$

where f is the center frequency of the noise spectrum and A_v is the voltage gain of the amplifier.

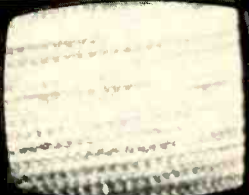
Should R_G not be much larger than
(continued on page 61)

Kwik-Fix™ picture and waveform charts

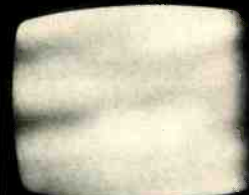
© Forest H. Belt & Associates®

SCREEN SYMPTOMS AS GUIDES		WHERE TO CHECK FIRST		
SYMPTOM PIC	DESCRIPTION	VOLTAGE	WAVEFORM	PART
	Raster narrow, maybe dim, horizontal off frequency	no clues here	WF2	C1
	Raster very narrow, scalloped, horizontal far off frequency	V1-grid-pin-2	WF2	C1 R1
	Screen blacked out	V1-screen-pin-1 V2-plate-pin-2	WF2 WF3	Any, except R1, C6
	Raster narrow, foldover line near center	V1-grid-pin-2	WF2	C1 R1
	Far out of focus	no good clues here	WF2	R3
	Narrow, with focus poor	V1-screen-pin-1	WF3	R4 R5
	Ringing on left side of raster	no clues here	WF3	C6

*an Easy-Read™ feature by FOREST H. BELT & Associates © 1971

Use this guide to help you find which key voltage or waveform to check first, or to guide you to the causes of symptoms that don't have voltage or waveform clues. Study the screen and the action of the horizontal hold control. The most helpful clues to the fault are to be found at the key test points indicated opposite whatever symptoms you observe.

Make voltage or waveform checks when indicated for a screen symptom. Use the Voltage Guide or Waveform Guide to analyze the results of your tests. For a quick check, test or substitute the parts listed as the most likely cause of the symptoms you observe.

DC VOLTAGES AS GUIDES

Voltage change	to zero	very low	low	slightly low	slightly high	high
V1-screen-pin-1 Normal 110 V	C3 shorted C4 shorted R4 open R5 open		C4 leaky R5 high	R4 high L1 open L2 open L3 open		C4 open R5 low
V1-grid-pin-2 Normal -40 V	R2 shorted R3 open		R2 low	C4 leaky R4 high R5 high	C1 open R1 open	
V2-plate-pin-2 Normal 320 V	C5 shorted L2 open L3 open					
Boost B+		most parts that make screen black		C4 open		

NOTES:

Use this guide to help you pinpoint the faulty part. Measure each of the four key voltages with vtvm or fetvom. For each, move across to the column that describes the change you find.

Notice which parts might cause that change.

Finally, notice which parts are repeated in the other voltage changes you find.

For more guides to further narrow down the faulty part, see the Waveforms Guide.

The Stage

This version of the old-standby tube horizontal output has a heavy power capability, thanks to the 6JE6 tube. Heavy power is needed for color-chassis deflection. The tube is also relatively free of the parasitic oscillation known as Barkhausen.

If, as occasionally happens, slight Barkhausen does show up in the picture, the technician can unground suppressor-grid-pin-8 and connect it to a positive dc voltage between 40 and 100 volts. It's not unusual to find a chassis designed with this suppressor-grid voltage already brought to unused pin 9 of the tube socket.

Focus and yoke circuits are not shown here. They do affect operation, but only inasmuch as they are loads on output transformer T1. Remove either load, or short either one out, and the output stage won't function. That's mainly from failure of the

boost voltage that supplies the plate of the 6JE6.

High voltage is developed from large, energetic pulses taken from the HV part of the T1 winding. There may be several other windings on T1. They are pulse sources for auxiliary functions such as keyed agc, blanking in video and color circuits, gating for the color-sync stage, convergence, and so on.







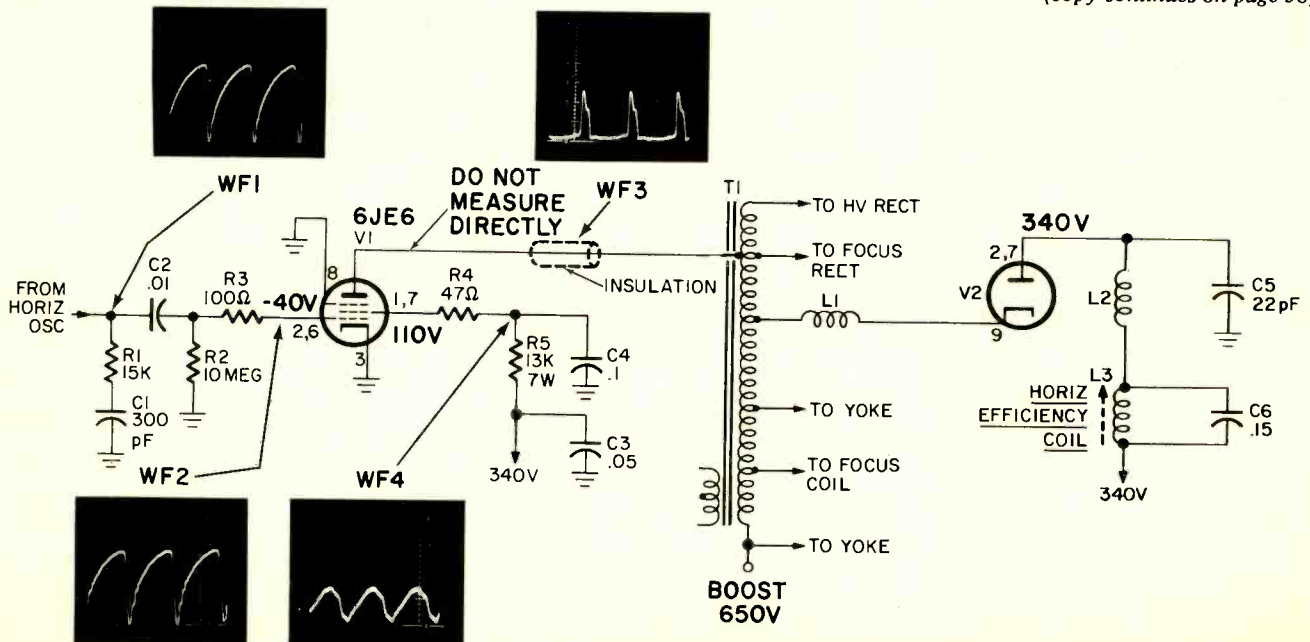



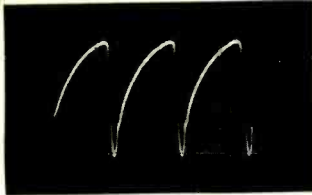

Signal Behavior

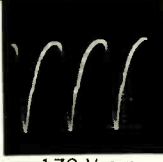
The source of signal for this stage is the horizontal oscillator. The signal is shaped into a modified sawtooth by R1 and C1. That's coupled by C2 and R3 to the grid of V1. Low-resistance R3 suppresses any tendency to parasitic oscillation. The high value of grid load R2 might otherwise make oscillation easy.

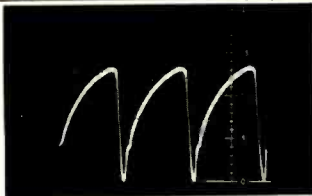
(copy continues on page 58)

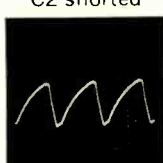
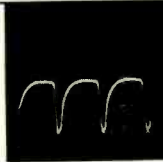
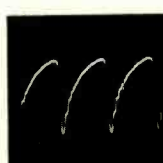

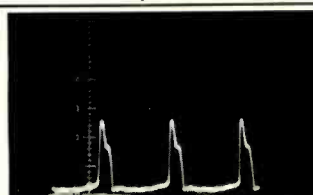
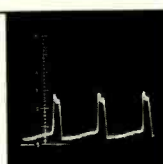
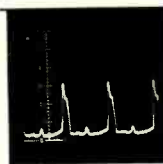
WAVEFORMS AS GUIDES

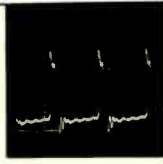
V p-p low	V p-p high	V p-p zero	Changed Shapes			
						
WF1 Normal 135 V p-p Sawtooth drive waveform, taken at output of horizontal oscillator. Shape would be different were it not for network R1-C1. Amplitude varies from set to set, but is generally in the range above 100 volts peak-to-peak.						
	C2 open	C1 shorted	 <p style="text-align: center;">135 V p-p C2 leaky C2 shorted</p>  <p style="text-align: center;">135 V p-p C6 open</p>	 <p style="text-align: center;">100 V p-p C1 leaky</p>	 <p style="text-align: center;">170 V p-p C1 open R1 open</p>	 <p style="text-align: center;">120 V p-p R2 low</p>
						
WF2 Normal 135 V p-p Input drive waveform, taken at grid-pin-2 of horizontal output tube. Also can be taken at pin-6 of tube socket. Same shape as WF1; change resulting from C2-R2 is hardly noticeable. Its frequency is approximately 15,750 Hz.						
		C2 open C1 shorted R3 open	 <p style="text-align: center;">135 V p-p C2 leaky C2 shorted</p>  <p style="text-align: center;">80 V p-p R3 high</p>	 <p style="text-align: center;">100 V p-p C1 leaky</p>  <p style="text-align: center;">135 V p-p C6 open</p>	 <p style="text-align: center;">170 V p-p C1 open R1 open</p>	 <p style="text-align: center;">120 V p-p R2 low</p>
						
WF3 Normal *V p-p *Peak-to-peak voltage of this output waveform depends on thickness of insulation on output-cap lead of horizontal output amplifier. In the chassis used for this example, the waveform is about 30 V p-p when taken in this manner. Clue is in whether amplitudes are above or below normal.						
		C2 open C3 shorted C4 shorted C5 shorted R4 open R5 open L1 open L2 open L3 open	 <p style="text-align: center;">20 V p-p C1 leaky C2 leaky C4 leaky R4 high R5 high</p>	 <p style="text-align: center;">30 V p-p C1 open R1 open</p>	 <p style="text-align: center;">25 V p-p R3 high</p>	 <p style="text-align: center;">35 V p-p C6 open</p>

WAVEFORMS AS GUIDES

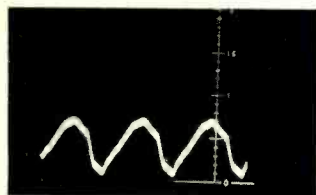

WF4 Normal 7 V p-p

Taken at screen-pin-1 (or pin-7), this value depends a bit on how good the filter capacitors are in the power supply. Frequency is 15,750 Hz, not 60 Hz. If output stage isn't working, this waveform is missing completely.

C3 shorted
C4 shorted
C5 shorted
R4 open
R5 open
L1 open
L2 open
L3 open

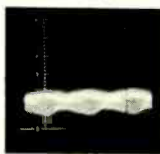

2 V p-p
C2 open

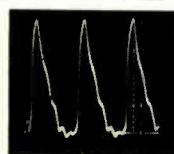

200 V p-p
C4 open

Use this guide and the Voltage Guide to help you pin down fault possibilities.

Note amplitude. If it's low or high, check the parts listed under those columns.

Use direct probe of the scope. Set scope sweep to about 5 kHz, to display three cycles.

Note waveshape. If there's a change that matches one shown, check the parts indicated.

Check the four waveforms at the four key test points.

The tube is a strong amplifier, giving a powerful boost to sharp-edged trapezoid pulses at 15,750 Hz. The screen supply for such a high-gain pentode must be well decoupled. Capacitors C3 and C4 do that job, working with R5. Low-value R4 is a parasitic suppressor, which keeps stray wiring capacitances from supporting unwanted oscillation.

The tube is designed to keep Barkhausen oscillation from building up. The suppressor grid is the chief element in that design. It may be at ground as shown. Or it may have a low-voltage dc connection to improve the way it breaks up secondary emission.

The huge pulse (so high you'd better not touch your voltmeter or scope to it without a high-voltage multiplier) from the plate cap of the tube goes into transformer T1. From there it's coupled into the yoke (and the other circuits).

A resonant load for the transformer is made up of L1, V2, L2, C5, and efficiency circuit L3-C6. V2 is the damper tube, smoothing the charge-discharge cycle that builds the deflection waveform. Coil L3 is adjustable, tuning the output load for peak efficiency and lowest dc plate current in V1.

DC Distribution

Grid voltage is developed through grid-leak action. Contact bias, some call it. The secret is the large value of R2. The charge-discharge of the high-energy pulse—in the circuit comprising C1, R1, C2, R2, and the grid of the tube—builds a voltage across R2. Negative polarity is at the end that's connected to the grid through R3. The negative voltage varies with the input signal amplitude, in typical class-C fashion.

The screen of V1 is supplied from a 340-volt dc supply.

COLORED TAPE IDENTIFIES HOOKUP WIRES

Did you ever complete a project with a maze of hook-up wire, all the same color, and then try to troubleshoot the circuit. I did and it is troublesome. I vowed that all future projects would be easier to circuit-trace.

At the local hardware store I bought a package of ten rolls of tape with different colors on each roll. A turn of one-color tape around each end of the wire before it is soldered into place makes an easily-identifiable termination. The colors are black (zero) to white (nine) in num-

ber-coded colors. The manufacturer is Fedtro Inc. and the ten-color tape is called Colorama No.TA-10. It is list priced at 79 cents.

The permutations (orders) are great. With two different color spools of wire and one tape color. I can identify twenty wires. i.e. yellow tape/black wire, green tape/black wire, green tape/brown wire, yellow tape/brown wire etc. One color wire and two pieces of colored tape can make 100 different codes. Three different color wires and two pieces of colored tape; 300 marks. Five colored-wires and three colored-tapes can

identify 5000 wires.

Also the colored tape can be used for repairing cabinets and speakers, for identify solder turrets, in tape recorders for indexing tape sections, etc.—Fred H. Horan

MAGNAVOX T924, T939 AND T950 CHASSIS

These chassis have series-string heaters and the only path from the ground end of the heaters in the vhf tuner is through the shield on the i.f. cable. When checking continuity, use the chassis and not the tuner assembly as ground.—Magnavox **R-E**

Photographer's Test Meter

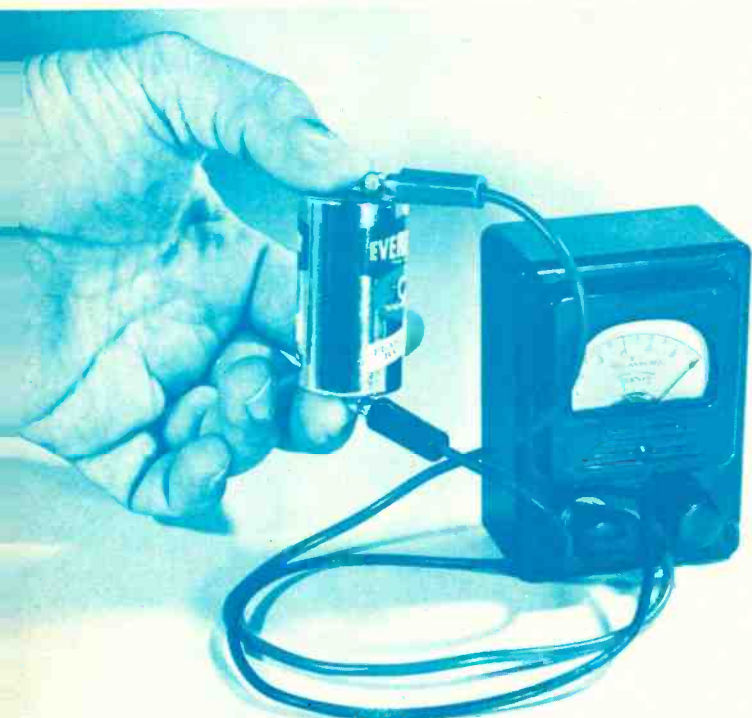

Handy little instrument you'll want to have tucked into a corner of your photo gadget bag

by MARSHALL LINCOLN

TO TEST 1.5-VOLT CELLS under load, hold test leads to cell terminals for a half minute or more. Load resistor in tester draws enough current to produce noticeable voltage drop if cell under test is weak.

RAPID CHECKING OF MOST COMMON electronic photographic gear, even by shutterbugs without electrical experience, is easy with this special photographer's test meter.

Small enough to carry conveniently in a camera gadget bag, this meter's circuit is specially designed for photographic field use without the unnecessary frills found on more elaborate test equipment.

A key feature is voltage testing of flashlight calls under normal load. This can save a photographer lots of grief by helping him weed out flash cells which would die after a short period of use.

The tester can also be used to check medium-voltage batteries, such as those used in popular B-C flash units, or high-voltage batteries in portable electronic flash units.

A special low-resistance ohmmeter circuit is included to help isolate troublesome flash cords and connectors which appear ok, but actually have enough resistance to impede the flow of small currents used in flash equipment. This "continuity test" feature can also be used to check for faulty flashbulbs. With it, you send a small current through the flashbulb—

too small to fire the bulb, but enough to register on the test meter.

To protect the instrument itself, a circuit is included which electrically "cushions" the delicate meter movement against shock caused by vibration or sudden movement while the tester is carried in the camera bag.

No two photographers will have exactly the same requirements for electronic test gear, but this meter provides most of the common electrical tests performed on photo gear, in a small rugged case intended to be carried in a photographer's gadget bag, alongside exposure meter, film and filters. For quick Johnny-on-the-spot checks of photo gear, you'll find nothing like it.

The meter is a specialized version of the popular volt-ohm-milliammeter used by all electronics technicians. However, no technical experience is required for its use, and the circuit is designed to use a single meter scale for simplified reading.

A six-position rotary switch, operated by the knob at the lower left on the front of the case, selects the test to be made. In position 1, the selector switch puts a dead short across the basic meter. This is the same safety

measure as is used by manufacturers to prevent damage to meters during shipment. When a meter's terminals are shorted, the meter movement generates a tiny electrical current in its coil whenever a physical movement of the meter tends to cause the pointer to swing. This current opposes any "wobble" induced in the meter pointer by vibration. With the meter terminals shorted, the pointer of the photo test meter will not be free to swing wildly if it gets bounced around a bit in your gadget bag.

Position 2 of the switch puts a 1500-ohm resistor in series with the basic 0-1 mA meter to convert it into a voltmeter with a full-scale range of 1.5 volts. With this switch setting, you can measure the voltage of any flashlight cell, or of tiny mercury and alkaline cells.

When measuring battery voltage, always make the measurement while the battery is connected in its normal circuit and is supplying current to the load for which it's intended. This will give you the best idea of whether the battery is strong, or is wearing out.

In items such as battery-powered exposure meters, you may be able to touch the meter's test leads to the bat-

tery terminals while the exposure meter is turned on and exposed to light.

However, in other photo applications, such as checking flash batteries, it's impossible to measure the battery voltage at the exact instant a bulb is fired—you just can't read the meter that fast—and it needlessly wastes flashbulbs anyway. For tests such as these, the photographic test meter has built-in "loads" which are the same as the normal loads for common size flash cells.

In position 3, for instance, a 1500-ohm resistor is connected in series with the basic meter to provide a 1.5-volt full scale reading, but a 56-ohm resistor also is involved. It is connected across the test leads. This resistor acts as a load on the cell. It draws about 25 mA, which is a normal load for a pen light cell.

With the meter switch in position 3 and the test leads held to the end terminals of a pen light cell, the meter should read nearly full scale. If it reads considerably below full scale, the cell is unable to supply current to a normal load and should be replaced.

Position 4 of the meter switch also is a 1.5-volt full-scale position, but has a 10-ohm load. This draws

about 150 mA—a normal load for a D cell.

(If you use C cells in your photo gear, substitute an 18-ohm resistor for either R5 or R6 when you build your meter. This will give you a meter scale with proper load for testing size C cells.)

Whenever using either position 3 or 4, hold the test leads on the cell terminals for an extended period of time—say 30 seconds or longer—to see if the meter reading drops from its starting value. If it drops more than just a tiny amount, it shows you the cell is weakening under a normal load, and would be unreliable. Better replace it than risk losing an important picture.

Position 5 of the switch places a 22,000-ohm resistor in series with the meter to provide a 22-volt scale for checking various other small batteries used in photo equipment, such as 9-volt, 15-volt, and 22½-volt types.

(If you'd prefer to have a voltage scale for checking high-voltage batteries used in some electronic flash units, substitute a different resistor for R4. For example, a 270,000-ohm resistor will give you a 270-volt range, and a 560,000-ohm resistor will give

you a 560-volt range.)

This range does not have a load resistor, since it's impossible to provide a single load resistor that will suit all types of batteries. However, all of these small batteries have rather limited current capability, so a voltage reading which is below what it should be for the battery being checked would be definite indication that the cell is weak and should be discarded.

You don't have to make a special meter scale to show the voltage ranges you can measure with this tester. Just remember the full-scale voltage for the range in use (either 1.5, 22, 270, or 560, as described here), and you can easily calculate the correct value for any intermediate reading, since the meter scale is linear. Most of the time, when you use the tester to check battery voltages, you'll be looking for a reading of nearly full-scale—anything less than this means the cell or battery being tested is weak. The only important exceptions occur when testing 9- or 15-volt batteries on a 25-volt scale.

Position 6 switches in a potentiometer and a penlight cell. They are wired into a "shunt" ohmmeter circuit, which is ideally suited to measuring low resistances. This function can

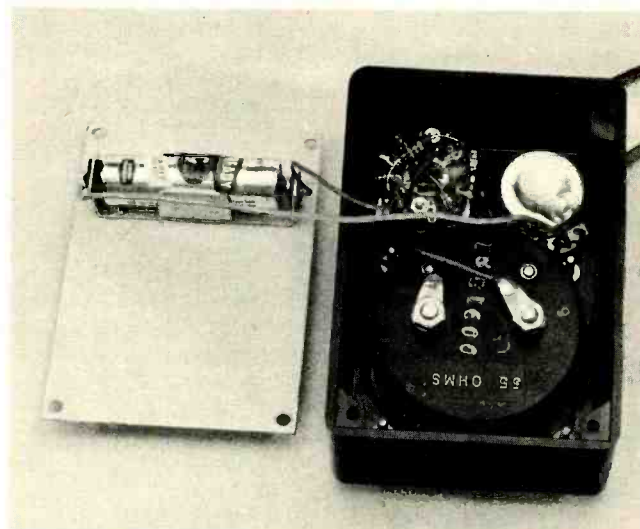

PHOTOGRAPHER'S TEST METER contains special circuitry ideally suited to in-the-field testing of photo gear. It's self-contained, and small enough to carry easily along with your normal photo gear.

INSIDE THE CASE (above). Note how parts fit easily into the Bakelite case. **SCHEMATIC OF TEST METER** (below) shows its relatively simple, easy-to-build circuitry.

PARTS LIST

- R1, R2, R3—1500 ohms, ¼ watt, 5% or better
- R4—22,000 ohms, ¼ watt, 5% or better
- R5—10 ohms, ¼ watt
- R6—56 ohms, ¼ watt
- R7—potentiometer, 2500 ohms, linear taper (Centralab F1-2500, C1 taper, or equal)
- BATT—1.5 volt penlight cell
- S1, S2—2-pole 6-position rotary switch (Centralab PSA-203 or equal)
- M1—0—1 mA, 2½" or smaller (Triplet 227-T or equal)
- Battery clip (penlight cell)
- Case; 2 3/8 x 4 x 1 9/16 inches, Bakelite
- Case cover
- Test leads (2 one-foot lengths; one red, one black)
- Insulated pin plugs (2)
- Miscellaneous hardware

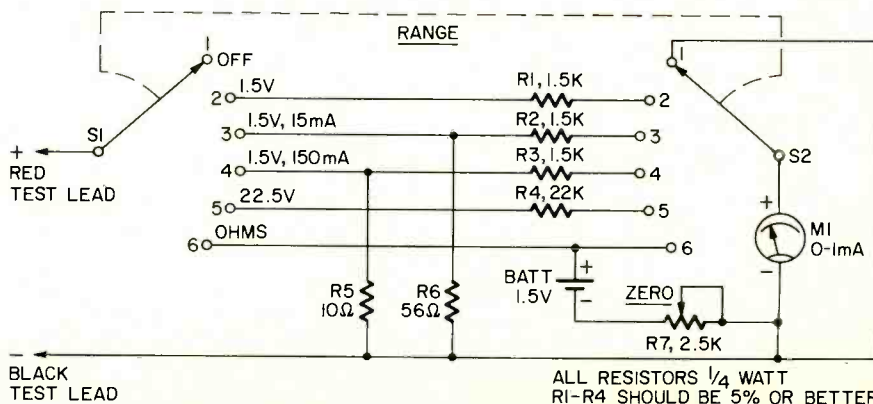

ALL RESISTORS ¼ WATT
R1-R4 SHOULD BE 5% OR BETTER

be invaluable to a photographer in tracing down loose connections and frayed wires in photo gear.

Generally, you're not interested in knowing exact values of resistance in the electrical wiring of your photo gear, but you often would like to know if something has gone wrong and is introducing a small amount of resistance into the wiring. With this special ohmmeter circuit, you can find out easily.

When using this resistance meter, the meter needle will swing upscale when you switch to position 6. Be sure the test leads are not touching anything (and *not* touching each other), then adjust the meter to exactly full scale by turning the zero adjust knob, at the lower right on the front of the test meter case. Now touch the test leads to opposite ends of the wire or connector being checked. If the resistance is zero, the meter needle will drop to zero. If there is a small amount of resistance—a few ohms—the needle will drop to a position a little above the zero mark. If there is a higher amount of resistance,

the needle will remain near the high end of the scale. (Mid-scale will be about 50 ohms, but the higher the resistance, the more the scale will appear compressed, so 1,000 ohms will be nearly full scale.)

If you get ready to make a resistance measurement and find you can't get the meter needle to reach the high end of the scale by turning the zero adjust knob (with the test leads "open"), the penlight cell in the test meter is weak and should be replaced.

I used a Bakelite case for my unit to make it less likely to scratch camera gear when it is carried in a gadget bag, but you can use a metal utility box if you prefer.

Use a larger case than the one shown if you don't like to do wiring in cramped quarters—however, the small case takes up a minimum amount of space in your gadget bag or equipment case.

Cut the large hole for the meter as close to one end of the case as possible, to allow room for the rotary switch and potentiometer. Use a fly cutter, circular hack saw, or saber

saw, and cut slowly to avoid cracking the Bakelite. For the switch and zero adjust control, drill $\frac{3}{8}$ " holes, then drill a couple $\frac{1}{8}$ " holes between them for the test leads to pass through.

Attach the battery clip to the inside face of the back panel with epoxy cement or small screws. Position it so it will not interfere with other components when the back is placed on the case.

You may need to cut or file off part of the side springs which hold the cell in the clip to keep them from touching the switch or the resistors attached to it. When doing the wiring, keep the resistor bodies as close to the back of the switch as possible, without actually rubbing on the switch mechanism.

Keep the meter switch on position 1 whenever the meter is not in use to take advantage of the built-in vibration-protection feature provided by this switch position. For longer life for the test meter's penlight cell, don't leave the switch on position 6 longer than needed to make resistance measurements. **R-E**

DESIGN FOR STEREO

(continued from page 54)

the reactance of $C_{in} + C_s$, R_G must be included in the derivation of the Equations 12, 13 and 14. As a rule of thumb, disregard R_G if it is at least ten times larger than the parallel reactance of C_{in} and C_s . If the reactance of $C_{in} + C_s$ are at least ten times larger than R_G , use \bar{e}_n and \bar{i}_n without any of the modifications shown in the equations. When R_G and the reactance $C_{in} + C_s$ approach each other, the simplest procedure is to calculate noise twice—once assuming R_G is relatively large using the modifications in Equations 12, 13 and 14, and then assume R_G is relatively small. In the second calculation, use \bar{e}_n and \bar{i}_n from the curves without any modifications. The noise is somewhere between the solutions to the two calculations. Estimate the noise by noting whether the capacitive reactance or resistor dominate the input impedance, and by how much.

The total noise voltage due to all sources is the square root of the sum of the squares of the noise voltages due to each individual source, or

$$\bar{e}_{nit} = (\bar{e}_{na}^2 + \bar{e}_{nia}^2 + e_{ni}^2)^{1/2} \quad \text{Eq. 15}$$

The individual noise voltages are defined by Equations 13, 14 and 5, respectively. The value \bar{e}_n rather than \bar{e}_{na} should be used if R_G is small compared to the reactance $C_{in} + C_s$. Voltage \bar{e}_{nia} , produced by the current generator would in this case become $\bar{i}_n R_G$ rather than the value calculated from

Equation 14. Likewise e_{ni} rather than e_{sia} will be used when determining the signal at the input of the amplifier.

It is now possible to determine the signal-to-noise ratio of an amplifying stage. As an example, assume that a 500-pF ceramic phonograph cartridge delivers 0.1 volt at 1 kHz to a 5.6-megohm resistor load at the input of a JFET amplifier. The voltage gain of the amplifier is 10 while $C_{gd} = 3$ pF and $C_{gs} = 5$ pF. C_{in} is equal to $C_{gs} + C_{gd}$ ($A_v + 1$) = $5 + 3(11) = 38$ pF. The 3-dB bandwidth from 10 to 40 kHz is the same as in the previous problem, so that the noise bandwidth is $1.57 \times 40,000$ Hz = 63,000 Hz. The geometric center frequency for this bandwidth is $(10 \times 40,000)^{1/2} = 632$ Hz. Use the transistor described by the curves in Figs. 7 and 8.

The curves in Fig. 8 supply us with the information that $\bar{e}_n/\sqrt{\Delta f}$ at 632 Hz is about $0.085 \mu\text{V}/\sqrt{\Delta f}$ and $\bar{i}_n/\sqrt{\Delta f}$ is about $0.0175 \text{ pA}/\sqrt{\Delta f}$. Since Δf is 63,000 Hz, $\sqrt{\Delta f}$ is 250. The actual \bar{e}_n for substitution into Equation 13 is 250 multiplied by .085 or $21.2 \mu\text{V} = 21.2 \times 10^{-6}$ volts. Similarly, \bar{i}_n for use in equation 14 is $250 \times .0175 = 4.4 \text{ pA} = 4.4 \times 10^{-12}$ amperes. Considering that C_{in} was calculated at 38×10^{-12} farads and that C_s was stated at 500×10^{-12} farads, the total reactance at 632 Hz due to the capacitors is $1/6.28 \times 632 \times 538 \times 10^{-12} = 500,000$ ohms. Because this is less than $1/10 R_G$, the modifications dictated by Equations 12, 13 and 14 must be used. $e_{sa} = 0.1(500)/(38 + 500) = 0.093$ volts

$$\begin{aligned} \bar{e}_{na} &= 21.2 \times 10^{-6} (500)/(38 + 500) = \\ &19.7 \times 10^{-6} \text{ volts} \\ e_{nia} &= 4.4 \times 10^{-12}/6.28(632) (500 + 38) = \\ &2.07 \times 10^{-18} \text{ volts.} \end{aligned}$$

and at 27°C, e_{ni}^2 from Equation 5 is

$$e_{ni}^2 = 1.37 \times 10^{-24} (300) \left(\frac{63,000}{10 \times 40,000} \right)$$

$$\left(\frac{1}{(5.6 \times 10^6) (538 \times 10^{-12})^2} \right) = 4.0 \times 10^{-11}$$

Since \bar{e}_{nia} is negligible compared to all other voltages,

$$\bar{e}_{nit} = [(19.7 \times 10^{-6})^2 + 4.0 \times 10^{-11}]^{1/2} = 20.8 \times 10^{-6} \text{ volts}$$

The signal-to-noise ratio is $0.093/20.8 \times 10^{-6} = 4.45 \times 10^3$. Using previously employed methods along with Table 1, the dB figure for the voltage ratio is about 13 dB + 60 dB = 73 dB.

In general, FET noise is primarily due to \bar{e}_n when impedances are high and \bar{i}_n when impedances are low. The contribution from the input resistor is small, but is best when it is equal to \bar{e}_n/\bar{i}_n . JFET noise will be at a minimum if the transistor is biased at about $V_{GS} = 0$. Transconductance g_m must be high if $1/f$ noise is to be relatively low.

Power amplifiers

With this article, we conclude the discussion of single-stage small-signal voltage amplifiers. Better insight into the transistor can be obtained when studying the operation of power amplifiers and the power amplifying devices. A discussion of this will begin with the next article which will cover Class A power amplifiers. **R-E**

Zenith Goes Plug-In

Technician's eye view of a hybrid color TV receiver. There are 12 tubes, 12 semiconductors and an IC color demodulator

by **STAN PRENTISS**

Begin with a 100% brighter picture tube, combine twelve semiconductors with twelve vacuum tubes, retain hand-wiring, but add a plug-in module and you have Zenith's 12A12C52 color chassis. It is included in 33 receivers of their 46-model line.

CRT high-brightness

The new cathode-ray tube uses either yttrium or gadolinium oxide for the rare-earth red phosphor along with improved blue and green phosphors that, combined with a new glass that passes 80% light, offers a brightness of 49.5 foot-lamberts and is sharp enough to be viewed easily in daylight. For extra contrast, a light-absorbing black-surround material covers approximately half the screen with round openings somewhat larger than the phosphor red, green, blue dots. These dots have now been reduced in size so that a larger, sharply focused electron beam can fully scan each phosphor using its entire surface. Consequently, every dot will be completely covered by maximum potential and the phosphor efficiencies can be balanced. The Chromacolor tube has 1,350,000 tri-color phosphor dots and a new iris mask with 450,000 apertures.

Color demodulation

Depending on whether yttrium or gadolinium is used, this chassis will demodulate close to 105° or 90°, respectively. The brand new demodulator is a true integrated circuit synchronous detector that very successfully permits reinsertion of the 3.58 megahertz subcarrier and thereby demodulating the transmitted color information. Sufficient it is to say now that the external LC input network to the IC governs the demodulation angle that must hold close to quadrature (90°) for best fleshtones. In the color receivers there is only this one chroma module, while in the monochrome Zenith receivers there are four modules: Agc-sync, video and sound, vertical and horizontal. Retail prices range from \$12.25 for the vertical plug-in to \$21.20 for the color module. A different dc supply point for each board prevents damage if plugged into the wrong receptacle. Boards also have different colors. An

extra feature is that all transistors (and later the IC demodulator) are socket mounted for easy removal.

Red, blue and green outputs

As Figs. 1 and 2 illustrate, the IC demodulator is dc coupled to the base inputs of the red, blue, and green video output transistors. Here the luminance information from 3rd video amplifier is dc shunted to the emitters of these color amplifiers so chroma and brightness can be mixed in the base-emitter junctions of these transistors and amplified through their collectors. From these points, red, blue, and green (not R-Y, B-Y, G-Y) information is passed directly to the

cathodes of the 25BAP22 cathode-ray tube. For Zenith, this is a new departure and has been taken to provide the following advantages: 1) Produce a wider bandwidth for color and luminance information. 2) Elimination of clamping or dc restoration for the luminance signals and better color reproduction. 3) Eliminate color matrixing in the cathode-ray tube. 4) Provide better CRT arc protection (CRT grids at ac ground potential through C218). 5) Individual gain control of the three amplifiers through the three RED, BLUE, and GREEN GAIN controls in each collector-base circuit. 6) Power dissipation is shared by the three outputs and only a single peak-

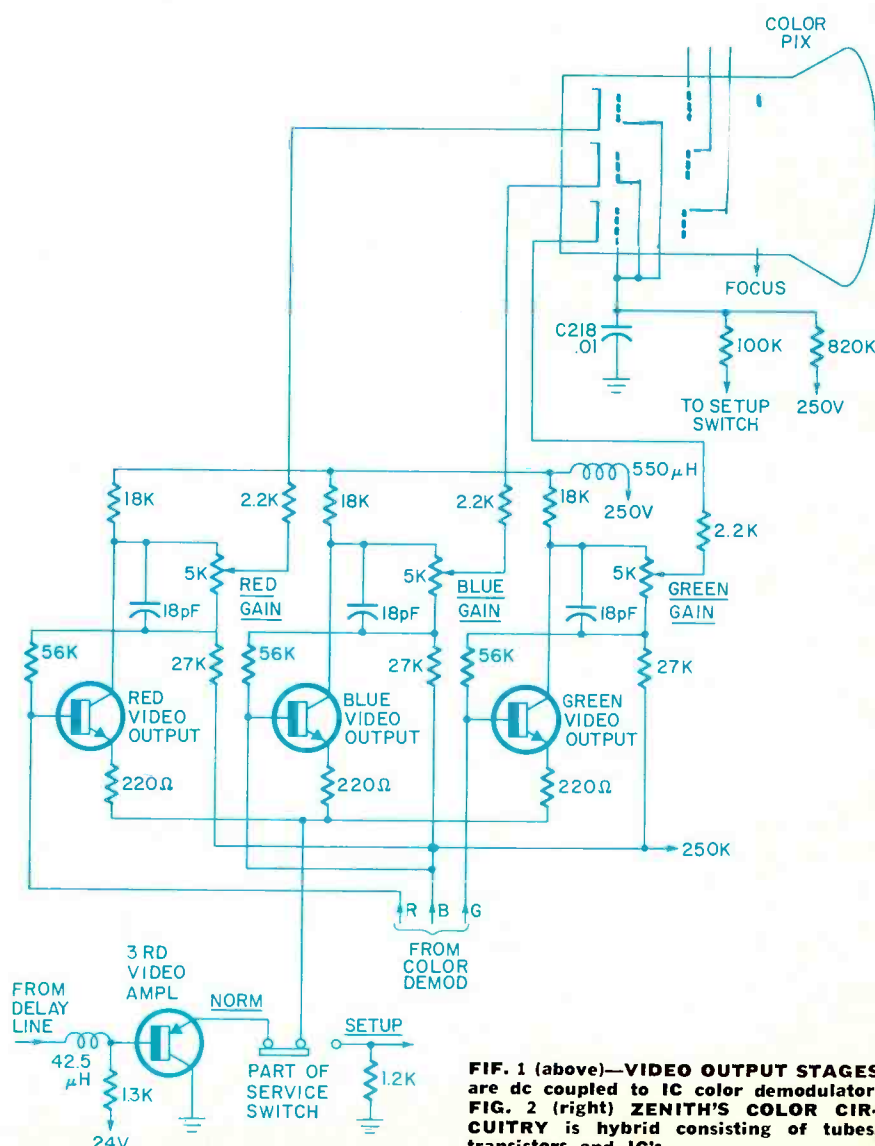

FIG. 1 (above)—VIDEO OUTPUT STAGES are dc coupled to IC color demodulator. FIG. 2 (right) ZENITH'S COLOR CIRCUITRY is hybrid consisting of tubes, transistors and IC's.

ing coil need be used. With these abundant features, Zenith's picture is far brighter, contrast levels high, and the beginning of the plug-in module concept offers considerable progress toward a receiver that, perhaps, one day will consist of most, if not all, modules, socket-removable IC's and transistors.

Vectorscoping

To probe the depths of the color section of this receiver and prepare for troubleshooting later on, a new vectorscope was used that can be vertically and horizontally phase reversed to view the cathode-injected color-luminance voltages. The graticule is marked off in degrees so that the actual phase angles can be read instead of numbers. Burst is at 0° , the red 3rd bar is at 90° , and the blue 6th bar is at 180° . In using a vectorscope, the green vector at 300 degrees is neglected because it is almost 180° out-of-phase with the reference red vector and this pair would only produce a

straight line. The combination of the red and blue voltages, however, when properly compensated internally in the vectorscope, produce an acceptable, round, readable pattern that is especially useful in both troubleshooting and aligning the entire series of color circuits.

A color-bar generator produces the 10-petal color pattern. An off-the-air signal (Fig. 3-a) would be little more than a blur. The first pattern produced was smallish (Fig. 3-b), had fuzzy hammer ends, and was generally misshapen. You quickly learn that the usual signal gain applied to vacuum tube circuits will promptly overload transistor stages, and therefore the input must be reduced for the more representative pattern of Fig. 3-c. This one is fair except that the fine tuning was slightly misadjusted as was the color amplitude. All controls, including brightness, must always be carefully adjusted for best pattern when judging the final waveform.

Introducing troubles

Since a new receiver usually works well—and this one did—there are normally no built-in troubles except perhaps a loose tube or transistor. So, to simulate this condition, we loosened, the red video output, and came up with a pattern looking like that shown in Fig. 3-d. The blue information is evident in the thin display because of the horizontal amplitude, but the red information is completely missing. As, in this case, the red output can be open, the red load resistor may be defective, or the IC red demodulator output could be absent due to internal trouble in the integrated circuit chip. You'd have to signal trace back with an oscilloscope to find which was inoperative. Here, by the way, is a wonderful opportunity to check the picture tube. If you have a perfect vectorscope pattern with the 3rd and 6th bars showing, and no blues in the picture, for instance, your trouble has to be the tube. Isn't that true? What if the green was missing?

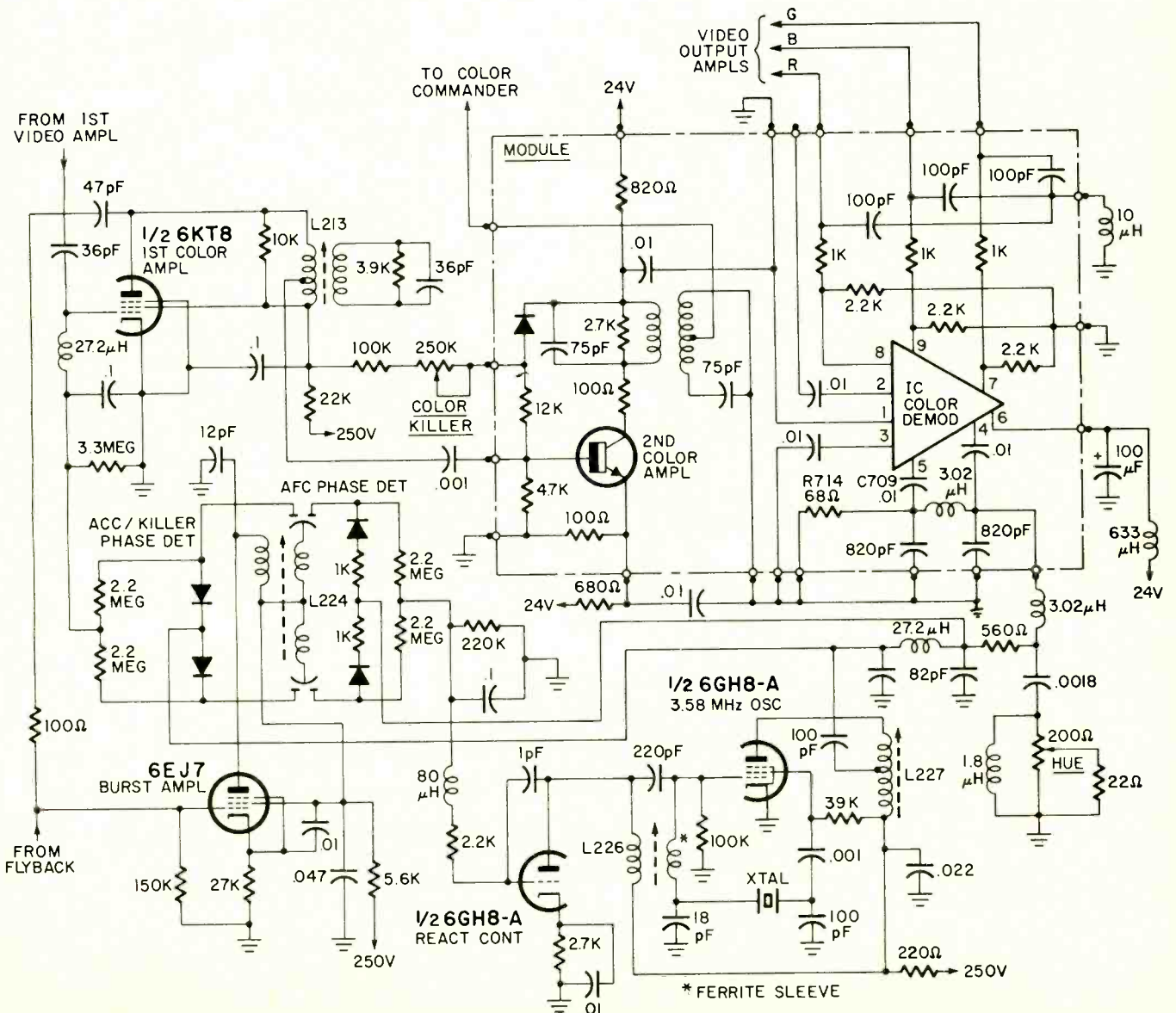

Does your mother-in-



law call you a meatball?

Does your boss?

Maybe even your wife? On payday.

Know what? If you have read this far, you are not meatball material. Because meatballs don't face the present, the future, the facts. They stay put. Dreaming and talking. And today, more than ever staying put means falling behind. Pretty tragic in a time when people with specific aptitudes are so necessary in so many interesting fields.

Today huge industries depend on people with electronics training.

Today there is a course of action that may lead you toward these well-paying, vital positions. It is RCA Institutes.

RCA Institutes is not for meatballs. RCA Institutes trains you for the fields where the action is: Computers • Color TV • Automation • Communications • Industrial Electronics • And more.

RCA Institutes not only has years of experience, it has an exclusive line-up of tested methods:

1. Hands-On Training

Over 250 interesting experiments. As many as 22 kits with some of the programs.

2. RCA Autotext

The easy-way-to-learn method that gets you started easier, faster.

3. Wide choice of courses and programs

Training in electronics fundamentals right up to solid state technology and communications electronics.

4. Low-Cost Tuition Plans

You'll find the one just made to fit your own budget.

5. FCC License Training Money-Back Agreement

RCA Institutes' money-back agreement assures you of your money back if you fail to pass the FCC examination taken within six months after completing RCA Institutes' FCC course.

RCA Institutes gets your training started even if you've not had previous experience or training. Just bring us your interest.

Set your own pace depending on your schedule.

If you like to tinker, fiddle, fix, put that ability to work to do a real repair job on your future now.

Don't wait. Get complete information right now. No obligation. Except to yourself. Send us the attached postcard. Or return the coupon.

Veterans: Train under GI Bill. Accredited Member National Home Study Council. RCA Institutes, Inc. is licensed by—and its courses of study and instruction facilities approved by—the N.Y. State Education Department.

RCA Institutes

Home Study Department 758-110-0
320 W. 31 Street, New York, N.Y. 10001

Please rush me FREE illustrated electronics career catalog. I understand that I am under no obligation.

NAME _____

ADDRESS _____

CITY _____ STATE _____ ZIP _____

Veterans check here

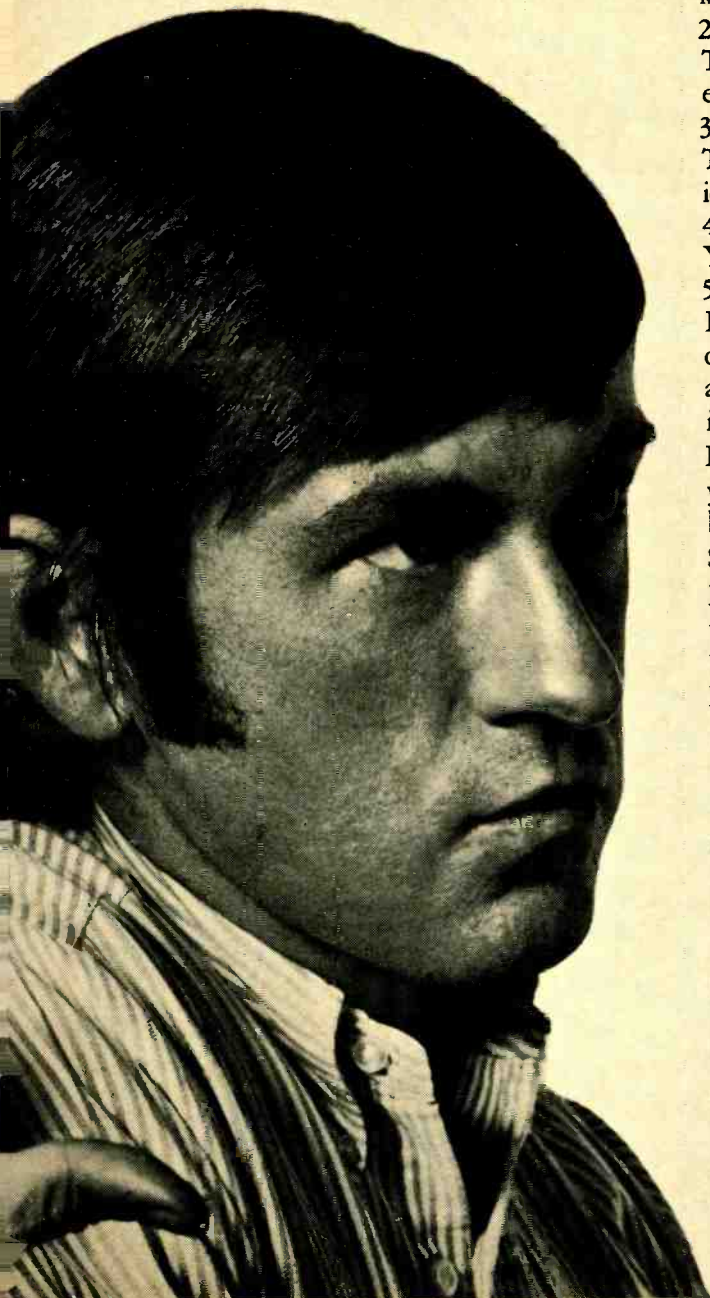

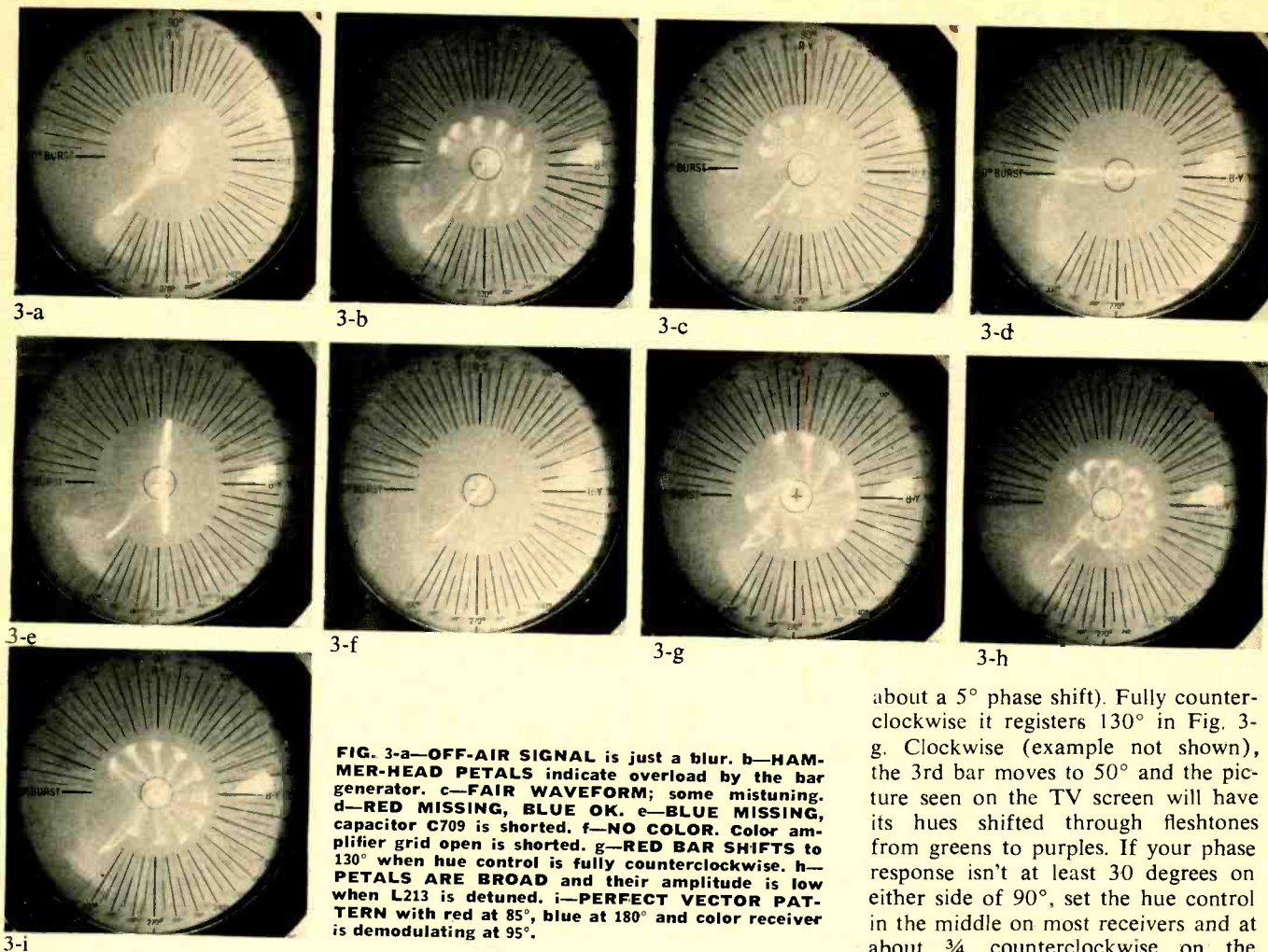

FIG. 3-a—OFF-AIR SIGNAL is just a blur. **b—HAMMER-HEAD PETALS** indicate overload by the bar generator. **c—FAIR WAVEFORM**; some mistuning. **d—RED MISSING, BLUE OK.** **e—BLUE MISSING**, capacitor C709 is shorted. **f—NO COLOR.** Color amplifier grid open is shorted. **g—RED BAR SHIFTS** to 130° when hue control is fully counterclockwise. **h—PETALS ARE BROAD** and their amplitude is low when L213 is detuned. **i—PERFECT VECTOR PATTERN** with red at 85°, blue at 180° and color receiver is demodulating at 95°.

Then you'd use a scope and a bar generator to look for green information at the green video output.

Another instance of missing color is displayed in Fig. 3-e. The third bar is obviously very much in evidence since the 90° vector is at its full amplitude. This was a demodulator trouble caused by shorting C709 (Fig. 2) that feeds quadrature phase-shifted 3.58-MHz information to pin 5, that is one side of the synchronous detector's sinewave input. The short virtually connected the base input of the demodulator through R714 to ground and removed the ac out-of-phase injection voltage. This, in turn, disabled the red demodulator.

Now any drastic color or 3.58-MHz oscillator troubles prior to the demodulator and outputs will kill all color and exhibit a pattern such as that in Fig. 3-f. In this instance we shorted the grid of the 1st color amplifier and produced the 320° diagonal line shown. This usually tells you that there is trouble ahead of the demodulator and signal tracing should quickly turn up the cause.

Alignments

These examples are deliberately

saved for last, because alignment should never be attempted until you are positive that all troubles have been repaired. If you don't know a particular receiver's pattern—and they all differ somewhat—a hasty twiddle of a coil can get you in the worst trouble imaginable. Even in a brand new receiver, we waited until the very end to "touch" up any alignment. There are only four tunable coils in the chroma section. One is reactance coil L226—the plate load of the 6GH8/6GH8-A reactance tube. It is used only for zero color beat. So this leaves but three, including L227, the 3.58-MHz oscillator plate coil that seldom if ever needs tuning, and can be done easily with a dc voltmeter or dc oscilloscope.

The other two will, occasionally, be important. The first is the afc phase detector array that includes the burst amplifier plate transformer. Any receiver with inadequate hue control range that is not actually defective can have this difficulty removed in a minute using a vectorscope. The 12A12C52, as an example, is designed for an 80° phase shift through the hue control range. The 3rd red bar usually "sits" at 85° with the hue control centered (the vectorscope causes

about a 5° phase shift). Fully counterclockwise it registers 130° in Fig. 3-g. Clockwise (example not shown), the 3rd bar moves to 50° and the picture seen on the TV screen will have its hues shifted through fleshtones from greens to purples. If your phase response isn't at least 30 degrees on either side of 90°, set the hue control in the middle on most receivers and at about ¾ counterclockwise on the older Zeniths and gently tune L224 until the 3rd bar rests approximately on 90°. Your hue control range is now calibrated. For a further check, tune the receiver to a colorcast and see if fleshtones register well.

The final patterns relate to the plate transformer of the 1st color amplifier. In the first instance (Fig. 3-h), L213 is shown badly detuned. Note the diminished amplitude of the vector display and the broad petals on the pattern. Something similar is duplicated when fine tuning is poorly adjusted also. This transformer may conceivably be adjusted by color bar generator and eyeball using the 3rd "red" bar, watching for minimum overshoot on the leading and trailing edges, and for a light gray background between bars. But it takes a most practiced eye and lots of objectivity. A better way—and one that can always be used—is to watch the vectorscope very carefully and tune this transformer for best rise and fall times and for a generally clean waveform display. Observe the pattern in Fig. 3-i and you will see the final picture of the series. Red bar 3 points at 85°, Blue bar 6 at 180°, and now we know that this color receiver is demodulating at 95° and is operating satisfactorily in every respect. **R-E**

R-E's SERVICE CLINIC

hot spots and heat sinks

Transistors don't always run cool and they can burn out

By **JACK DARR**
SERVICE EDITOR

TRANSISTORS RUN COOL—TRANSISTORS have no filaments to get hot, so they last forever. These and other optimistic statements used to be found in all of the literature (including, I blush to admit, one book I wrote *before* I had a chance to do too much actual work on them!) If you find these two statements in a True-False quiz today, you'd better mark them False! I'm speaking mainly of power transistors now, but it applies to all types.

So, let's go over a few of the important things we need to know about this heat situation. Transistors do run hot, and if they run too hot, they don't last forever; their life can be measured in milliseconds! This will help when selecting and installing replacement transistors. The higher the power, the more careful we must be. Some definitions first:

1. Power dissipation. This has been a grey area ever since they first showed up. This term actually means the amount of electrical power lost—used up—in the **transistor itself**, running at full output. It is **not** the full-power rating of the whole circuit.

For example, a 50-watt transistor might be able to handle currents that would give a power output of 250 watts **into the load**. In this case, the total power consumption of the circuit would be 300 watts; 250 watts useful load-power and 50 watts dissipated in the transistor. The diagram below shows this schematically.

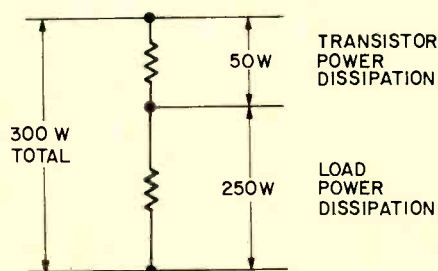

Needless to say, as usual, power lost in an electronic circuit usually shows up as heat. The transistor gets 50 watts hot, and this is the heat we must get rid of to keep it operating.

2. Maximum Power. Here we go again. Can a transistor with a maximum power dissipation of 50 watts actually dissipate 50 watts in service? The only answer to this is the classic

“Yes, **BUT**—”

The maximum power-dissipation rating of a transistor is based on its maximum permissible junction temperature and its thermal resistance. The last term here means the ability of the transistor to transfer the heat from the junction to the case, and from case to the heat-sink. This is given in degrees Centigrade ($^{\circ}\text{C}$). (To get degrees Fahrenheit from degrees C; multiply $^{\circ}\text{C}$ by 1.8, then add 32.

Thermal resistance

Let's pause briefly and kick this “thermal resistance” around. We can figure it out, just as if it were an actual resistor dissipating a given number of watts. This has nothing to do with voltage or current, but we work in watts, which create the heat in the first place.

The closest analogy I can think of is a car's cooling system. The heat is generated in the engine block. From there it's transferred to the coolant (air or water, depending on whether you're driving a Porsche or a Ferrari). The coolant *transfers* the heat to the outside air through the radiator.

Naturally, there is a loss of efficiency in this process, and this is the thermal resistance of the system! If it was zero, the engine would always run at the same temperature as the outside air (which would be a little rough in Wisconsin in January!) So, a little loss is OK. Here, the junction is the “engine” (in the antique sense of “something that does something”). The mounting of the junction on the silicon chip is the “coolant” or transfer-medium, and the transistor case plus heat-sink are the radiator. Like the engine, we can't let the source get too hot. In the engine we melt down the bearings, in the transistor, we melt down the junction.

On the next page is a rough sketch of how this works. Now let's see how it works in terms of the only thing we can measure—the case-temperature of the transistor. To get this, we take the maximum junction temperature (the maximum wattage we can dissipate), and multiply it by the thermal resistance, which depends on the case-con-

This column is for your service problems—TV, radio, audio or general and industrial electronics. We answer all questions individually by mail, free of charge, and the more interesting ones will be printed here.

If you're really stuck, write us. We'll do our best to help you. Don't forget to enclose a stamped, self-addressed envelope. Write: Service Editor, Radio-Electronics, 200 Park Ave. South, New York 10003.

TV TECH AID

Takes you right to the source of the trouble . . . without guesswork and wasted time!

You receive each month OVER 40 ACTUAL CAUSES AND CURES OF COLOR AND B-W TV TROUBLE SYMPTOMS . . .

reported by leading TV manufacturers, technicians and field reps . . . each presented in a concise, brief format, including a clearly marked schematic diagram of the associated circuitry . . . no wading through unnecessary details!

You also receive timely and complete information about CIRCUIT MODIFICATIONS AND OTHER VALUABLE SERVICE DATA relating to both new and existing TV models.

Start or expand your own file of causes and cures with TV TECH AID . . . arranged so you can file them by make and model, by trouble symptom or use your own system.

SUBSCRIBE or RENEW NOW!

only \$7.95 per year (12 issues)
(that's less than 67¢ per month)

NEW!

Over 400 Causes and Cures of Recurring Troubles in major-brand Black-and-White TV

All in one large, easy-to-use issue. All for only \$5.95 . . . Less than 1½¢ per tip . . . each of which can save you hours of valuable trouble-shooting time!

DISTRIBUTOR INQUIRIES INVITED

TV TECH AID
P.O. BOX 603
KINGS PARK, N.Y. 11754

ENCLOSED IS A CHECK OR MONEY ORDER FOR \$

PLEASE SEND:

- 1971—12 ISSUES—\$7.95
 1970—BOOK FORM—\$5.95
 1969—12 ISSUES—\$4.95
 1971 B-W BOOK—\$5.95

TO:

NAME

ADDRESS

CITY

STATE

ZIP

struction of this transistor. This figure is subtracted from the maximum junction temperature, and we come out with the maximum case-temperature.

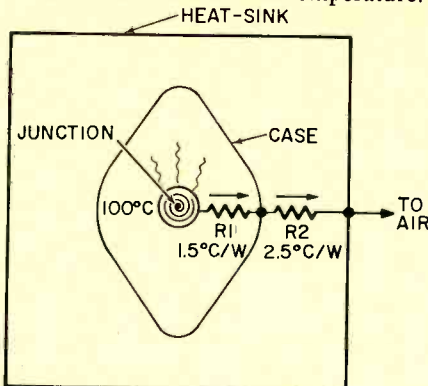

Our transistor has these characteristics:

Dissipation rating (max watts):
50 W

Thermal rating:
1.5°C per watt.

Max junction temp (°C):
100°

Now, let's plug these in and see what we get. 50 watts flowing through a thermal resistance of 1.5°C watt gives us 75°C lost right there. Subtracting this from the junction temperature, we come out with 25°C. So, this is the maximum case-temperature we can use. It comes out as 77°F. ($25 \times 1.8 + 32 = 77$)

Now, more problems. We put this transistor on a heat-sink (radiator) which helps to keep it cooler. However, now we've got another figure to work in; the thermal resistance between the case and the heat sink which isn't perfect either. A typical figure might be 2.5°C/watt. This must be added to the transistor's inter-

nal thermal resistance and we come out with a big 4°C/watt, total.

So now we've lost a good deal of that nice fat 50-watt dissipation rating we started out with. In fact, the original 50-watt rating has fallen to only 10 watts! If only 10 watts flow through a thermal resistance of 4°C/watt, we've lost 40°. Subtracting this from the 100°C max. junction temperature, we come out with a safe case-temperature of 60°C, which is a nice warm 140°F, or pretty darn hot.

Much of our heat calculations must be based, of necessity, on the ambient temperature, which simply means the air-temperature of the room where this gizmo is working. Normally, this will be about 70°F. If the air-conditioner hasn't broken down or there isn't a brownout. However, outdoors in the summer, the ambient can get up to 90–100°F in the sunshine. So our heat-sink has to be able to radiate away enough heat to hold the transistor down to the safe computed figure of 60°C/140°F. Naturally, the higher the ambient, the lower the difference between heat-sink and air, and the lower the efficiency.

So although we started out with a big transistor with a 50-watt dissipation rating, by the time we took off all of the deductions, here we sit with only a 10-watt rating! Remember that this is not the total power into the load, this is still the safe working ratings of the transistor itself. This, of course, depends on the amount of power used by the load, and the applied voltage and current, etc.

So when you're figuring out power ratings for transistors, original or replacement types, be sure to check

NEW DELUXE COLOR ORGAN CIRCUITS! UP TO 35,000 WATTS

A.P.M. SYSTEMS CORP., MANUFACTURERS OF THE FINEST COLOR ORGANS IN THE WORLD, NOW OFFER YOU THE MOST ADVANCED AND POWERFUL COLOR ORGAN CIRCUITS.

AVAILABLE IN 3 AND 4 CHANNEL KITS FEATURING:

- Solid State (easy to assemble printed circuit).
- All UL listed components.
- 3 channel circuit - 2,670 watts - easily converted to handle up to 26,250 watts.
- 4 channel circuit - 3,556 watts - easily converted to handle up to 35,000 watts.
- Electronically balanced circuitry permits one step tuning.
- Wires to any popular sound system in the same manner as a speaker.
- 2 year unconditional guarantee on all parts.
- Easy to assemble kit form.

SEND TODAY

FREE color brochure with each kit order.

A.P.M. SYSTEMS, INC.
1551 Almaden Rd.
San Jose, Calif. 95125

PLEASE RUSH ME MY A.P.M. COLOR ORGAN KIT, AS INDICATED BELOW:

Check box to indicate choice.

- 3 Channel Kit - \$37.95
 4 Channel Kit - \$54.95
 3 Channel Plans - 26,250 watts - \$2.00
 4 Channel Plans - 35,000 watts - \$2.00
 Color brochure on water swirls and living walls - \$.50

Check one box to indicate manner of payment.

- I enclose full payment. Ship kit postpaid
 I enclose \$5.00 deposit. Ship kit C.O.D. for balance plus postage.

Name

California residents: add 5% sales tax Address

City & State

A.P.M. SYSTEMS, INC. Dept. M15
P.O. Box 9159, San Jose, Calif. 95117

Circle 18 on reader service card

THE SANSUI QS-1 QUADPHONIC SYNTHESIZER®



SANSUI QS-1

4-CHANNEL SOUND FROM ANY 2-CHANNEL SOURCE

**Senses and recovers the ambient information
hidden in your stereo discs, tapes and broadcasts**

After having discovered that the ambient components of the original total sound field are already contained in hidden form, in conventional stereo records, tapes and broadcasts, Sansui engineers developed a method for sensing and recovering them. These subtle shifts and modulations, if re-introduced, breathtakingly recreate the total of the original sound as it existed in the recording or broadcast studio.

The heart of the Sansui Quadphonic Synthesizer* is a combination of a unique reproducing matrix and a phase modulator. The matrix analyzes the 2-channel information to obtain separate direct and indirect components, then redistributes these signals into a sound field consisting of four distinct sources.

This type of phase modulation of the indirect components, applied to the additional speakers, adds another important element. It sets up a complex phase interference fringe in the listening room that duplicates the multiple indirect-wave effects of the original field. The result is parallel to what would be obtained by using an infinite number of microphones in the studio (M1 through Mn in the accompanying illustration) and reproducing them through a corresponding number of channels and speakers.

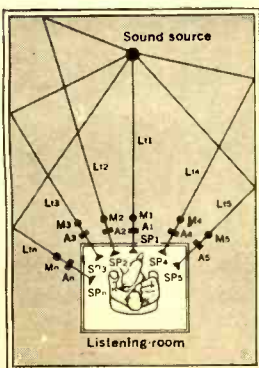
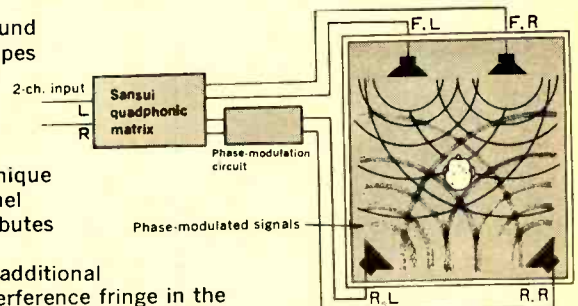

The startling, multidimensional effect goes beyond the four discrete sources used in conventional 4-channel stereo, actually enhancing the sense of spatial distribution and dramatically expanding the dynamic range. Also, the effect is evident anywhere in the listening room, not just in a limited area at the center. And that is exactly the effect obtained with live music! This phenomenon is one of the true tests of the Quadphonic system.

The Sansui Quadphonic Synthesizer QS-1 has been the talk of the recent high-fidelity shows at which it has been demonstrated throughout the country. You have to hear it yourself to believe it. And you can do that now at your Sansui dealer. Discover that you can hear four channels plus, today, with your present records and present stereo broadcasts. \$199.95.

*Patents Pending



SANSUI ELECTRONICS CORP.

Woodside, New York • Gardena, California

SANSUI ELECTRIC CO., LTD., Tokyo, Japan • Frankfurt a M., West Germany
Electronic Distributors (Canada), British Columbia

the columns marked "Max Pwr Diss" and "Max Junction Temp", and the heat-sink used. You'll be able to get the thermal-resistance of the heat-sink in most cases. If not, a ball-park figure of 2°C/watt is pretty safe. Most of them will be close to that. For safety's sake, never over-rate; under-rate. Forced-air cooling and other means can help, of course.

AUTO-DEGAUSSER AND PURITY

I've a Zenith 20Y1C38 with several problems. The complaint was bad purity, and fuse-blowing at turn-on. I replaced the thermistor (cracked) and the degaussing coil, which had a burnt spot.

Helped fuse-blowing, but purity still bad. Still blows a fuse now and then. What's going on?—E. E., Baltimore, Md.

I think it's not what's going on, but what has gone before. This set has been visited by lightning! (Very common cause of this kind of damage.) This is what cracked the thermistor, blew the hole in the degaussing coil, etc. There may have been other damage too.

I would recommend checking or replacing that small choke in the degausser circuit, L45. It could have shorted turns or an intermittent leakage to the core, which would affect the degaussing current; hence purity.

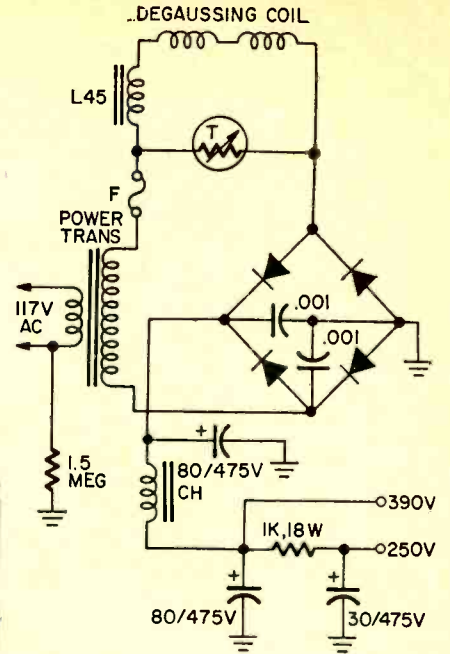

Try this. Disconnect the degaussing coil, turn the set on, and degauss the whole tube very thoroughly with a standard degaussing coil. Check the purity. Turn the set on and off several times, cooling it off about 5 minutes between tests. If the purity holds, reconnect the auto-degaussing coil and repeat these tests. If the purity goes

FREE!

**JUST OFF THE PRESS!!
SEND FOR YOUR EXCITING COPY NOW!**



LAFAYETTE 1972 Catalog 720

468 PAGES

**YOUR 1st GUIDE TO
EVERYTHING IN
ELECTRONICS**

Our 51st Year

- Stereo/Hi-Fi Components • Musical Instruments and Amplifiers
- Photography Equipment • Ham and CB Gear • Public Address Systems
- Tools and Test Equipment • Educational and Optical Equipment
- Black and White/Color Televisions • Police and Fire Monitor Receivers
- Books and Parts **Plus Thousands of Additional Items**



Send For Your Free Lafayette Catalog Today!

Lafayette Radio Electronics, Dept. 17101
P.O. Box 10, Syosset, L.I., N.Y. 11791

**Mail This
Coupon Today
For Your
1972 Catalog
No. 720**

Send Me the Free Lafayette Catalog 17101

Name

Address

City

State Zip

(Please include your zip code)

TUBE TESTER OWNERS

WE HAVE THE
LATEST TUBE
DATA AND
ADAPTERS
FOR →

- EICO
- HEATH
- JACKSON
- KNIGHT
- MERCURY
- NRI-CONAR
- PRECISION
- SYLVANIA

Don't let your
tube tester
become
obsolete

CLIP AND MAIL COUPON TODAY

• COLETRONICS SERVICE INC. TD-71
 • 1744 Rockaway Ave.,
 • Hewlett, N.Y. 11557

Enclosed find \$3.50 for latest data.

Enclosed find \$5.00 for 1-yr. subscription
 (Latest Data Plus 2 Supplements.)

Specify Model No. _____ Make _____

Name _____

Address _____

City _____ State _____ Zone _____

Circle 20 on reader service card

off with the auto-degaussing circuit connected, replace that little choke. It's the only part left!

One more possibility; rare, but has been found to happen. Check all the rectifier diodes in the bridge. If one of these was blown open, your output voltage won't be affected too much, but your ripple will have a very peculiar waveform! This can upset the action of the degaussing coil, and cause it to "regauss" the tube instead of demagnetizing it.

COLOR ALIGNMENT QUERY

I have a question on color TV alignment. A friend insists that besides taking out the horizontal output tube, you must add a load resistor from B+ to ground. I note that most companies do not show this any more. Is it absolutely necessary?—A.M., Morgan Hill, Calif.

The purpose of this load resistor on B+ was to hold the voltage down to "normal." RCA used to insist on this, but they don't any more. Also, you won't find it specified in Sams Photofact alignment instructions, which are very accurate, since they actually do the alignment procedure to make up the data.

The voltage regulation of the B+ supplies in practically all color sets should be good enough to hold the voltage well within limits. You can check for this with a dc voltmeter. If the voltage doesn't jump more than about 25 to 30 volts, OK.

CAR ANTENNA PROBLEM: MISMATCH?

I replaced the stock antenna on a car with a 60" whip, rear-mounted, with RG58/U coax. I've lost a lot of AM sensitivity, and the FM, too is bad. Is this due to a mismatch between the 50-ohm RG-58/U coax and the input, or what, and what can I do about it?—B.D., Washington, D.C.

Yes it is. The only way they can make a car-radio work at all on that miserable little 3-foot rod is to design the whole front end of the radio to work with antennas within a certain very narrow range of capacitance and inductance. In other words, the whole thing, including the antenna, is tuned.

We used to have this same problem when the first rear-mount antennas were used. They used special lead-in cables, with a very small series capacitance. Old "Series capacitor shortens antenna" theorem from transmitters.

Add a very small capacitor in series, say about a 10 pF. Then check your antenna trimmer on the radio. If it shows a peak, it'll work. If not, try a little different size.

PLENTY VOLTAGE, NO FOCUS!

I have sat here and glared at this RCA CTC28 chassis until my eyes hurt!

I can't get anything that looks like a focused raster! Yet, I've got 25,000 volts of HV, and the focus voltage will vary up and down from about 4,200 volts to 5,400 volts. Every part good. Tried a new 4.7-megohm resistor just for luck, although I was reading the focus voltage at the load-end of the thing.—T. T., Ink, Ark.

Cheer up. I've got eyestrain and brain-strain too (sic) from the same thing. Try this; pull the picture tube socket off and look closely into the hole for pin 9. If you see a whitish or pale-greenish dusty looking deposit there, that's it. The 9 pin of the tube will probably show the same kind of thing. Also, if you pull gently on the black wire, it will probably come out of the socket! The focus pin on the CRT socket corrodes.

You wind up with a very bad contact, and in some cases, the focus pin of the socket is eaten entirely away. If you have a taste for knick-knacks, you can cut up a standard 7-pin wafer socket out of an old radio or something, take one of the socket contacts, and make a new one. You'll have to drill out the two rivets that hold the socket body together and replace them with No. 2 screws when you put it back together. (It's a lot easier to replace the CRT socket. I've tried both ways.) **R-E**

True-Blue Sound at extra-green savings!

CTS Hi-Fi Stereo Speakers put pure sound in the enclosure you build—at factory-to-you prices.

FREE BROCHURE lists five CTS FUTURA speaker systems from 140-15,000 Hz to 40-20,000 Hz. Leading manufacturers use them. Enclosure specs, crossover values and hook-up schematics make it easy for you! Mail coupon!

DO IT YOURSELF!
CUT OUT
HIGH SPEAKER COSTS!



CTS of Paducah, Inc.
Dept. RE
1565 North 8th Street
Paducah, Ky. 42001

I want true-blue sound at extra-green savings—send Hi-Fi Stereo Speaker Catalog.

Name _____
Address _____
City _____ State _____ Zip _____



Circle 22 on reader service card

NEW, FREE FIRE/BURGLAR ALARM CATALOG

64 pages presenting 350 intrusion and fire alarm products for today's skilled alarm installers and electronic technicians. Includes the latest systems and detectors, hard-to-find parts, accessories, and technical application notes on uses and circuit designs.



mountain west
alarm supply co.

4215 NORTH 16th STREET
PHOENIX, ARIZONA 85016

Circle 21 on reader service card

CALL ME!



24 HOURS A DAY ... 7 DAYS A WEEK

I'll send you 2 FREE BOOKS describing career opportunities in Electronics. Call me TOLL FREE:
800-321-2155
(in Ohio, call 800-362-2105)

For details about the famous CIE home-study courses in Electronics, see our ad on page 46-49.

Cleveland Institute of Electronics
1776 E. 17th St., Cleveland, Ohio 44114

NEW PRODUCTS

More information on new products is available from the manufacturers of items identified by a Reader Service number. Use the Reader Service Card on page 103 and circle the numbers of the new products on which you would like further information. Detach and mail the postage-paid card.

CONTROL AMPLIFIER, model SCA-80Q, built-in quadaptor circuitry, gives 4-dimensional stereo reproduction. No external adaptor or second stereo amplifier required, just a total of four speakers connected directly to unit. Each of the two channels is rated at 40 watts rms. Unit has switching facilities to optimize



the 4-dimensional effect. The back speakers can be switched off, producing normal, 2-channel, 2-speaker stereo through front speakers. Can also be used in conventional stereo system. Supersedes SCA-80. \$169.95 for kit; \$249.95 factory-assembled.—Dynaco, Inc., 3060 Jefferson St., Philadelphia, Pa. 19121.

Circle 31 on reader service card

CASSETTES, Maverick Series C-30F, C-60F, C-90F. The economy line has broad frequency range and cassette housing of high-grade smokey see-through shock-resistant plastic. Features include liners, stainless steel pins, flanged rollers and a



spring-loaded, felt pressure pad. The cassettes are packed in cardboard boxes suitable for mailing.—TDK Electronics Corp., 23-73-48th St., Long Island City, N.Y. 11103.

Circle 32 on reader service card

INTEGRATED AMPLIFIER, model AS-201. This differential type stereo am-



plifier system was designed for tape recording and allows simultaneous recording and monitoring of three tape decks and playback from five tape decks. Provides 100 watts undistorted power. The AS-201 is rated at 50 watts per channel at 8 ohms and 60 watts per channel at 4 ohms continuous sine wave, with total harmonic distortion under 0.5% at full rated output. \$349.50.—TEAC Corp. of America, 2000 Colorado Ave., Santa Monica, Calif. 90404.

Circle 33 on reader service card

STEREO MIKE MIXER, model M688. Microphone mixer designed to use with stereo tape recorders without built-in mixing capability, in audio-visual and multi-media presentations in which a stereo music source is used, or for stereo

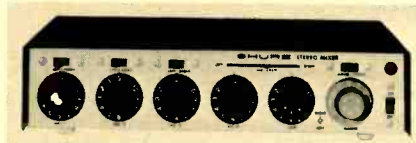

sound reinforcement applications. M688 accepts four high- or low-impedance microphones through 4 inputs, plus a stereo auxiliary high level input, each with its own volume control. \$114.00.—Shure Brothers Inc., 222 Hartrey Ave., Evanston, Ill. 60204.

Circle 34 on reader service card

AUXILIARY AMPLIFIER, model LA-424, 50-watt quadnaural solid-state all transistor auxiliary amplifier designed for converting two-channel stereo systems into discrete four-channel systems. Cannot be used as 2-channel amplifier by itself. With the LA-424 and two more speakers you can plug-in a discrete 4-

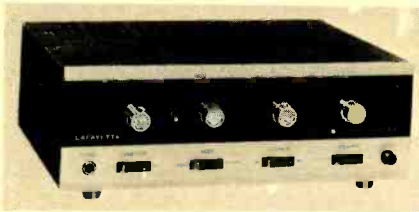

channel input source. Power output 50 watts \pm 1dB, 40 watts IHF, frequency response 20 — 20,000 Hz \pm 1.5 dB, harmonic distortion 0.07% at 1 kHz at 1-watt, power bandwidth 35–30,000 Hz, speaker impedance 4, 8, 16 ohms. \$59.95.—Lafayette Radio Electronics, 111 Jericho Turnpike, Syosset, N.Y. 11791.

Circle 35 on reader service card

ADAPTOR, Quatrasonic QA-4. For stereo recordings or FM broadcasts, use along with stereo system to extract the 4-channel information inherent in all stereo programs. Using the QA-4, these ambient sounds can be reproduced in two rear channels through addition of two

speakers connected to the adaptor and placed behind listener. The two existing speakers are connected to adaptor as well. Requires no ac power. Can be used with any standard stereo amplifier or re-



ceiver with 4-, 8- or 16-ohm speaker output terminals. The 4-position switch permits 4-channel, front speakers only, or rear speakers only operation. \$29.95 factory-assembled; \$17.95 for kit.—EICO, 283 Malta St., Brooklyn, N.Y. 11207.

Circle 36 on reader service card

CASSETTE ADAPTOR, model 580, accepts any standard stereo cassette and plugs into any standard 8-track cartridge tape player—portable, car, or home-use



type. With this adaptor you can switch from cassette to 8-track cartridge and back. \$29.95.—Toyo Radio Co. of America, 1842-B West 169th St., Gardena, Calif. 90247.

Circle 37 on reader service card

DIGITAL READOUT CLOCK, Tymeter #160-12H. Twelve- or 24-hour readout completely enclosed digital clock engineered for installation in any equipment or convenient mounting. $\frac{3}{8}$ " digits on 12-hour clock and $\frac{5}{16}$ " digits on 24-hour



clock. Front panel reset facility. UL and CSA approved motor and cord. 110-120 V, 60 Hz, available in 120 Vac, 50 or 60 Hz, 220-240 Vac, 50 or 60 Hz.—Pennwood Numechron Co., 7249 Frankstown Ave., Pittsburgh, Pa. 15208.

Circle 38 on reader service card

TUBE TESTER, model 747 Dyna-Jet, with full mutual-conductance capability for testing full range of vacuum tubes now in use in radio & TV receivers and audio equipment. 21 pre-wired sockets to

test most popular tubes, with only two settings, heater and sensitivity. 9-socket section for testing all other tubes. Single push-button for shorts and one for leakage. A "life" test drops the heater voltage 10% and determines tube's reserve



capacity. Checks high-voltage regulators and nuvistors for Gm; diodes; rectifiers and high voltage rectifiers tested for correct emission with proper test loads and voltages. \$249.95.—Dynascan Corp., 1801 W. Belle Plaine Ave., Chicago, Ill. 60613.

Circle 39 on reader service card

MAGNETIC NUTDRIVERS, 1/4" and 5/16" hex socket. The magnetic feature is being offered on midget pocket clip, regular, extra-long, and super-long fixed-handle drivers and also on interchangeable shanks for use with all Xcelite Series 99 handles, both regular and ratchet types. The magnet inserted in the socket holds fasteners firmly for one-hand starting, driving, or retrieving hex

screws, bolts and nuts in close quarters and hard-to-reach places. The magnet is insulated so the tool socket remains un-

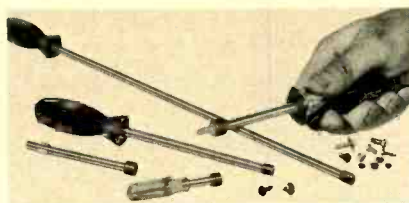

magnetized and won't attract extraneous matter or be deflected by nearby metal surfaces.—Xcelite Corp., Orchard Park, N.Y. 14127.

Circle 40 on reader service card

SEMICONDUCTOR TESTER, model TT-7, for testing transistors and diodes

and trouble-shooting solid-state equipment. Go/no-go indication of semiconductor status in-circuit or out. No clip leads to attach and no meter to

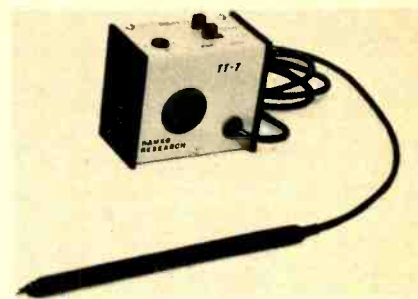

watch provides single-handed, eyes-on-work testing. Also determines type of transistor (npn or pnp) and unscrambles

YOU MAY BE MISSING THE MOST VALUABLE TOOL ON YOUR BENCH

RCA SERVICE DATA

A SUBSCRIPTION INCLUDES A COMPLETE "FILE" YEAR OF:

- COLOR TELEVISION DATA
- B & W TELEVISION DATA
- RADIO DATA
- PHONOGRAPH DATA
- TAPE RECORDER DATA
- SERVICE TIPS
- PARTS TIPS
- PERIODICAL ISSUES OF "PLAIN TALK"
- "GOLDENROD" BULLETINS
- SERVICE DATA INDEX

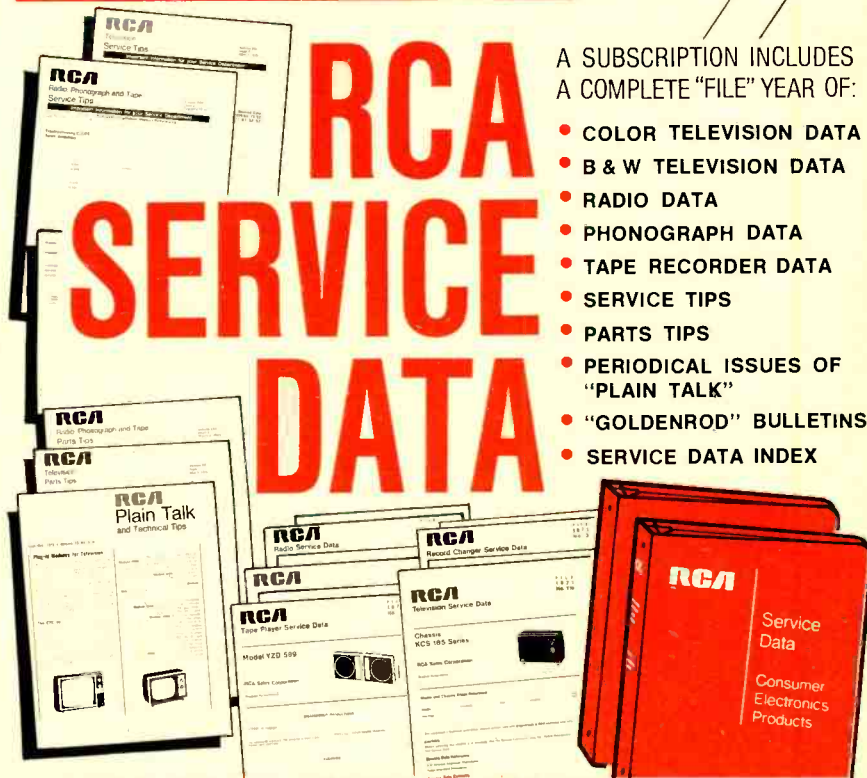

DON'T DELAY! SUBSCRIBE TODAY!

Please acknowledge my request for a Service Data Subscription:

- "File—1971" Service Data including 2 binders \$19.95
- "File—1971" Service Data subscription \$14.95
- (Binders available separately—\$2.95 each) Number desired _____

Amount enclosed: \$ _____

NAME _____
STREET ADDRESS _____
CITY _____ STATE _____ ZIP CODE _____

- Your order will be processed promptly upon receipt of your check or money order in the amount indicated above. SEND TO:
RCA SALES CORP., 600 N. Sherman Drive, Indianapolis, Ind. 46201
ATTN: Technical Publications, 8-106.

NEW! SUPER - LUBE



A miracle concentrated formulation for heavy duty jobs. Its clinging action foams away corrosion, dirt and oxidation — and polishes all tuners continuously without drift or detuning. SUPER-LUBE's built-in lubricating quality makes channel selecting smooth and easy. For color and black & white TV.

Introductory Offer! Buy 4 cans of Super-Lube and get 2 extra cans free from your jobbers!
Money Back Guarantee!

SUPER SPRAY BATH

Dissolves and flushes away grease, dirt, oil and oxidation. Simply spray tuners. Its penetrative action cleans and restores tuners inside and out.



Manufacturers of these Famous Products
• NO-NOISE
• EC-44 • TUNER-TONIC

All No-Noise Products are non-toxic—non-flammable—no carbon tet—safe for all plastics.

ELECTRONIC CHEMICAL CORP.
813 Communipaw Avenue Jersey City, N. J. 07304

Circle 61 on reader service card

OCTOBER 1971

Circle 62 on reader service card

Hear Real-Life Drama on a VHF "Police" Radio!

The **PATROLMAN®** Series
Exclusive at 1000 Radio Shack Stores



PRO-3 UHF-VHF Car/Home Radio **19850**



VHF-AM-FM Portable **4995**



2495 AM-VHF Portable With Squelch



PRO-2 VHF Car/Home Radio **9995**



5995 VHF-FM Car/Portable



Patrolman-6 **7995** UHF-VHF-AM-FM Portable



9995 PRO-7 Automatic Scanning Car/Home VHF Radio



PRO-8 Deluxe **13995** Automatic Scanning Car/Home Radio



PRO-1 VHF Car/Home Radio **7995**



1795 Pocket Radio

America's FIRST & most copied police radios. Monitor actual squad car and fire calls, Gov't weather stations, business, CD. Made by Realistic, sold only by us. Over 1000 stores in 49 states—see your phone book. Or order by mail—we'll ship anywhere in the U.S. postpaid (address below).*

FREE Catalog!

ALLIED RADIO SHACK
A TANDY CORPORATION COMPANY
2725 W. 7th Street
Fort Worth, Texas 76107

*Add State & Local Taxes If Applicable Where You Live.

Circle 63 on reader service card

lead configuration on unmarked units. Probe conforms to all transistor styles without adjustment. \$16.95.—Ramko Research, 2552 "E" Albatross, Sacramento, Calif. 95860.

Circle 41 on reader service card

ELECTRONIC DIGITAL COMPUTER KIT, Stock No. 71,434. Kit assembles into a model digital computer which can perform 39 different experiments, can be programmed to solve math problems, test

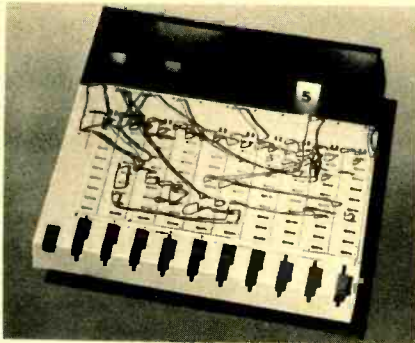

intelligence, and play games. Circuits are easily changed. Readout is from an illuminated control panel. Complete instructions and all parts except batteries come with kit. \$31.50.—Edmund Scientific Co., 380 Edscorp Building, Barrington, N.J. 08007.

Circle 42 on reader service card

TV ANTENNA, Stellar 2001. Integrated solid-state amplified TV antenna. Con-



ventional aluminum elements translated into a printed circuit which is then fed into a multi-stage low-noise amplifier. The housing encloses the entire circuit, is completely sealed and weather protected, weighs 5 lbs. Brackets provided along with optional mounting kits for mast, wall, side mount or peak roof mounting. Compact size lends itself to indoor installation. The receiving section is connected to the power supply by 75-ohm coaxial cable to prevent pickup of unwanted TV signals and interference.—JFD Electronics Corp., 1462-62nd St., Brooklyn, N.Y. 11219.

Circle 43 on reader service card

AUTOMATIC PHONE RESPONSE, Ansafone model 540, automatically answers a telephone, plays a recorded announcement to the caller and records messages.



The 540 uses a standard C-60 tape cassette to permit thirty minutes of recording on each side. \$275.00.—Dictaphone Corp., 120 Old Post Rd., Rye, N.Y.

Circle 44 on reader service card

SIGNAL GENERATOR, model LSG-230 FM multiplex generator with rf and i.f. markers and multiplex signal output. This high fidelity service and testing device has 3 V output at approximately 19 kHz with continuously adjustable frequency range of 75-110 MHz. Separation is over 30 dB; 50-15,000 Hz. Instrument is also a sweep marker for 10.7 MHz FM and i.f. alignments. Features

WANTED

THE RARE OR UNUSUAL TOOL YOU HAVE BEEN SEARCHING FOR

THE #4930 SERVICE KIT

A complete service kit for D.I.P. components.

Contents:
Extractor/Inserter, Heat Sink
DeSolder Tips, Aperture Cleaner

IMMEDIATE DELIVERY



\$39.95

SEND FOR FREE CATALOG



MORE THAN 5000 ITEMS

TECHNI - TOOL, INC.

1216 ARCH STREET, PHILADELPHIA, PENNSYLVANIA • ZIP CODE: 19107
PHONE: (215) 568-4457 "THE COMPLETE ELECTRONICS / AEROSPACE SUPPLIER"

NEW! - 4916-A Extractor/Inserter Now Available.

Circle 64 on reader service card

RADIO-ELECTRONICS

115-230 V; 50/60 Hz dual power supply. 300 ohm; 75 ohm (open) cable in-

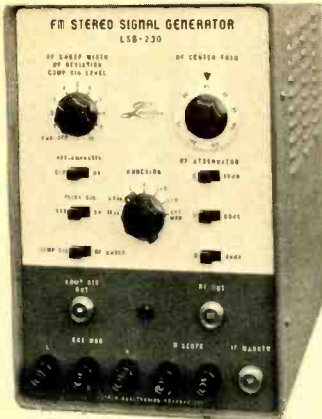

cluded. \$175.00.—Leader Instruments Corp., 37-27-27th St., Long Island City, N.Y. 11101. R-E

Circle 45 on reader service card

NEW LITERATURE

All booklets catalogs, charts, data sheets and other literature listed here with a Reader's Service number are free for the asking. Turn to the Reader Service Card on page 103 and circle the numbers of the items you want. Then detach and mail the card. No postage required!

AR guarantees its published specifications

At Acoustic Research we believe that the publication of complete performance data on our high fidelity components is obligatory. Otherwise, our guarantee would have little meaning.

Find out just what AR guarantees that its products will do. Mail the coupon below, and detailed technical literature will be sent to you free of charge.



Acoustic Research, Inc.
24 Thorndike Street
Cambridge, Mass. 02141
Dept. RE-10

Please send measured performance data on AR products to

Name _____

Address _____

Circle 65 on reader service card.

OCTOBER 1971

CHEMICAL SPRAY, Tun-O-Brite, for TV service technicians is described in a six-page color, illustrated folder. Product is used to clean, polish and lubricate TV tuners.—**Chemtronics, Inc.**, 1260 Ralph Ave., B'klyn., N.Y. 11236.

Circle 46 on reader service card

TEST INSTRUMENT CATALOG, 1972. Complete specifications and prices on sweep marker generators, oscilloscopes, vectorscopes, color-bar generators and other test equipment for the service technician.—**Lectrotech, Inc.**, 4529 N. Kedzie Ave., Chicago, Ill. 60625.

Circle 47 on reader service card

PACKAGED ELECTRONIC CIRCUIT GUIDE, No. 8. Directory of complete line, with component values and schematic drawings for each circuit, plus a replacement data section.—**Centralab, Box 591, Milwaukee, Wis. 53201.**

Circle 48 on reader service card

Write direct to the manufacturers for information on item listed below:

INTRODUCTION TO DX-ING, 15-page book-

let describes how to get started as well as how to advance in the hobby of DX-ing above 30 MHz on TV, FM and vhf public service band radio. Equipment, propagation and techniques covered. 25¢-USA or 3 IRC's outside USA and Canada. A special edition for overseas DX-ers is provided at 50¢-USA or 4 IRC's.—**Worldwide TV-FM DX Association, Box 5001-RE, Milwaukee, Wis. 53204.**

MINIATURE LAMPS CATALOG, No. CMD-3, with an introductory section detailing terminology and technical characteristics of miniature lamps. Complete listing of lamps by bulb shape and size standard-voltage lamps, neon, argon, and circuit component glow lamps.—**Chicago Miniature Lamp Works, 4433 N. Ravenswood Ave., Chicago, Ill. 60640.**

ELECTRONIC INSTRUMENT CASES, Catalog No. 171. Line of modular height and width extruded aluminum instrument cases in the "Designer Series". Fully illustrated 12-page brochure gives specifications of cases to house all types of electronic equipment.—**Buckeye Stamping Co., 555 Marion Rd., Columbus, Ohio 43207. R-E**

ROTARY SWITCHES



Some single gang, some multiple gang. CW122

16 for \$1.00

SLIDE SWITCHES



All types, SPDT, DPDT, etc. CW106

12 for \$1.00

TRANSISTOR REPAIR KIT

\$1.00

Includes resistors, condensers, transistors, transformers and various & sundry parts used to repair transistor radios, walkie-talkies, tape recorders, etc. CW107

RADIO & HI-FI KNOBS



All different types, shapes & colors. Some with set screws, others for knurled shafts. CW112

100 for \$1.00

PRECISION RESISTORS

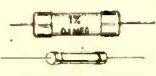

All 1%, 1/2 watts & 1 watt. From low to high ohmages. CW113

60 for \$1.00

BARRIER TERMINAL BLOCKS



20 assorted for \$1.00

These are seconds from 2-14 terminals. Some screws missing. All functional. CW126

FUSE HOLDERS



4 for \$1.00

Standard, for 3AG fuses. CW129

PENLITE CELLS



15 for \$1.00

Fresh, always handy. CW125

MONEY BACK GUARANTEE

Terms: Minimum order \$3.00. Include postage. Either full payment with order or 20% deposit, balance C.O.D.

FREE CATALOG

BARGAIN BONANZA OF EDLIE HIGHEST QUALITY KITS ONLY NEW PRODUCTS EXCELLENT MIXTURE

SURPLUS TUBES



FULL YEAR GUAR. **3 for \$1.00**

OZ4, 1L4, 1R5, 1S4, 1V2, 1X2, 3AL5, 3AT2, 3AU6, 3DK6, 3DT6, 3Q4, 3S4, 4CB6, 4DE6, 4HS8, 5GM6, 5V6, 6AB4, 6AC7, 6AC5, 6AS6, 6AX4, 6AY3, 6BC5, 6BE6, 6BL8, 6BU8, 6CF6, 6CG7, 6CM7, 6CQ4, 6CS6, 6CY5, 6CY7, 6CZ5, 6DE4, 6DG6, 6DK6, 6DL5, 6DT5, 6DT6, 6DW4, 6DX8, 6EM5, 6ES5, 6EV7, 6FH5, 6FJ7, 6FQ7, 6FS5, 6FV8, 6GH8, 6GK5, 6J6, 6JW8, 6K6, 6LN8, 6LT8, 6S4, 6SN7, 6V4, 6W4, 8FQ7, 10GK6, 10GN8, 12AV6, 12AV7, 12BA6, 12BY7, 12EK6, 12R5, 12SC7, 12SL7, 12SN7, 13DR7, 15CW5, 17BE3, 17D4, 19AV8, 25BK5, 25C5, 25EH5, 25L6, 25Z6, 5654/6AK5WA, 5670, 5814A/12AU7, 1218, 5725/6AS6W.

WRITE FOR FREE VALUE PACKED CATALOG

BONUS FREE CUT WIRE KIT for \$5.00 purchase

1/2 WATT CARBONS



100 for \$1.00

All standard ohmages, some 5%. Standard makes. CW150

CARBON RESISTORS



200 for \$1.00

Most with cut leads (long enough for soldering), some pre-formed. Most all 5% or 10%. CW136

POWER RESISTORS

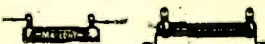

35 for \$1.00

Consists of standard makes such as Clarostat, Sprague, etc. Assorted ohmages & wattages. CW109

DISC CAPACITORS



60 for \$1.00

Assorted capacitances from .0001 to .1. Different voltages, mostly 600 volts N.P.O. N750. CW140

MINIATURE TRANSISTOR ELECTROLYTES



12 for \$1.00

Some axial leads, some vertical mount, mixed capacitance and mixed voltages. CW121

1 WATT CARBON RESISTORS



70 for \$1.00

All standard ohmages, some 5%. Standard makes. CW145

MINIATURE POTS



12 for \$1.00

Used in transistor and miniature applications. CW141

CRYSTALS



15 for \$1.00

Some for receiving or transmitting; some CB, some Ham, some business band, in different type holders. CW144

RELAYS



8 for \$1.00

Assorted types, from 6 volts to 110 volts. Some sell for as much as \$10.00. CW155

EDLIE ELECTRONICS, INC. 2700-A HEMPSTEAD TPKE., LEVITTOWN, N. Y. 11756

Circle 66 on reader service card

Let Bell & Howell Schools help you get ready for a rewarding Color TV Service Business of Your Own

Ultra-rectangular,
25" diagonal with
full 315 sq. inch
screen. Lets you
view more of the
transmitted image.
25,000 volts. 45
transistors, 55 diodes,
4 advanced IC's.
3-stage solid-state IF.
Solid-state VHF, UHF
tuners. Automatic fine
tuning and many other
quality features.

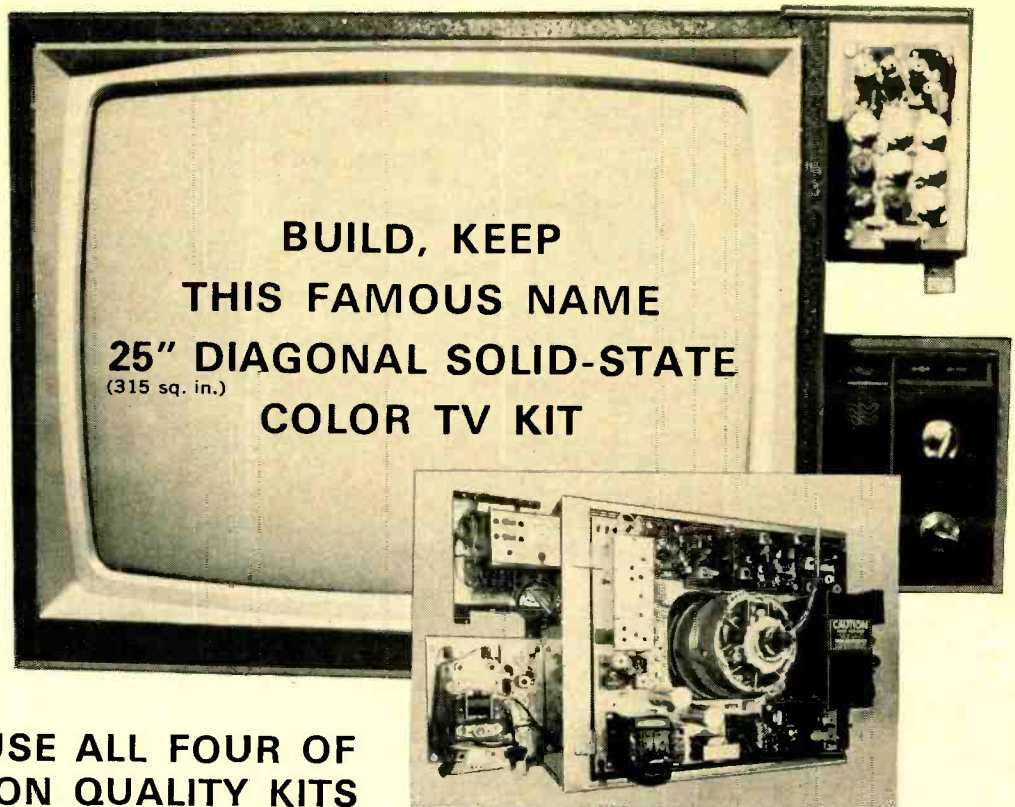

**BUILD, KEEP, USE ALL FOUR OF
THESE PRECISION QUALITY KITS**

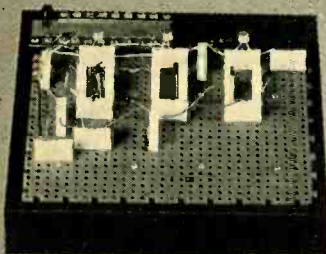

INCLUDES—
Design Console with built-in power supply, test light and speaker. Plus patented plug-in Modular Connectors.



INCLUDES—
Portable 5-inch, wide-band oscilloscope calibrated for peak-to-peak voltage and time measurements.

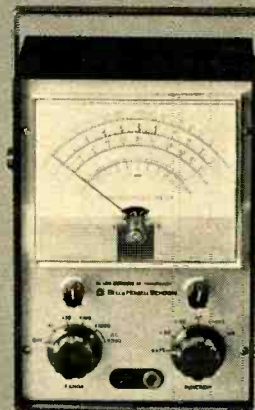

INCLUDES—
Transistorized Meter combines most desired features of vacuum-tube voltmeter and quality multimeter. Measures very small current values.

FREE! MAIL CARD TODAY FOR ALL THE FACTS
No Postage Needed



YOU'LL BE READY FOR COLOR TV . . . B&W AND MOST HOME ENTERTAINMENT ELECTRONICS DEVICES

This exciting new program offers you the *first* 315-sq. inch Solid-State Color TV available for at-home training.

As you follow the simple, step-by-step assembly procedures, you become thoroughly familiar with the most advanced solid-state TV circuitry. And as you build this kit you'll prepare yourself for a profitable Color TV service business of your own—either full or part time.

Why Color TV pays better.

Today, Color TV is the big seller. As Color Television goes completely solid-state, the man who has mastered this type of circuitry will be in demand. Obviously, this is where the money is going to be made.

This new Bell & Howell Schools program will also give you an in-depth knowledge of the basics as well as TV circuit theory and analysis. You'll get the theory and practical experience you need to handle radios, hi-fis, stereos, and tape recorders.

You will also receive three precision quality instrument kits which you assemble and keep. These are highly sensitive professional instruments which you'll use constantly.

**EXCLUSIVE ELECTRO-LAB®
IS YOURS TO KEEP, USE**

This unique at-home laboratory comes to you in 16 shipments and includes a remarkably instructive *design console*. You can rapidly "breadboard" a great variety of circuits without soldering. The *Oscilloscope* offers 3-way jacks to handle test leads, wires, plugs. Images on screen are bright, sharp. Your *Transistorized Meter* is fully portable, features a sensitive, 4-inch, jewel-bearing d'Arsonval meter movement. It registers the slightest power surge or lag on a large, easily read dial.

CONSIDER THESE ADVANTAGES:

Bell & Howell Schools' Electro-Lab-at-Home Plan gives you the most thorough background possible in solid-state Color TV. Everything

Note: TV picture is simulated.

comes to you by mail and you go at your own speed. You'll be prepared not only for a service business of your own but for many positions in the Electronics and Television industries. All without missing a paycheck!

When you have completed your program our *Lifetime National Employment Service* will help you locate in an area that interests you. This service is available at any time—now or in the future.

Approved for G.I. Benefits

If you've had six months continuous active duty, you're probably eligible for Veterans' Benefits. If you're a Vet, check the appropriate space in the card at left for full details. Our programs are approved for Veterans' Benefits.

Student Loans now available

If you are a non-veteran and need financial assistance, you may qualify for Student Loans, which are also available.

Special Help Sessions. These are scheduled regularly (Saturdays) at seven Bell & Howell Schools and in many other cities. Here you can get expert guidance by top instructors to help you over the rough spots.

Bell & Howell Schools offer you even more. Once you have finished your program at home, you may decide you want more advanced preparation. In this case, you may transfer to any one of our seven schools which are located all across the country.

Mail the postage-free card today for all the facts. There is no cost or obligation of any kind.

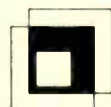

BELL & HOWELL SCHOOLS

4141 Belmont, Chicago, Illinois 60641

321

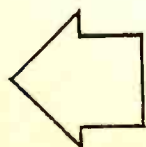

FREE! MAIL CARD TODAY FOR ALL THE FACTS
No Postage Needed

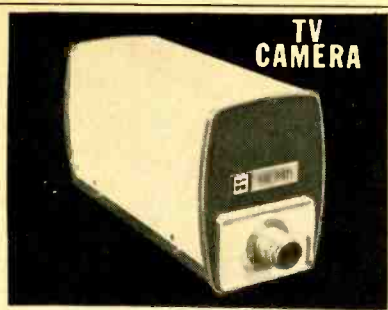

TV
CAMERA

THE Performer

An 800 line, high resolution TV camera that frees CCTV systems from the restrictions of the conventional 525 scan of commercial television. The 875 scan system of the PB940 provides a fully detailed picture with scan lines barely visible. Transistorized circuitry, remote control operation, a receptacle for external EIA sync generator or an internal programmable 2 to 1 interlace sync generator are but a few of the many options available. Boasting the features of the more expensive cameras, the PB940 is the economical answer for such demanding assignments as microscope work, document reading, data transfer, quality control and banking systems. When your operation calls for high quality in a CCTV camera... call for the PERFORMER, the Nelson-Hershfield PB940.

Nelson-Hershfield Electronics

1848 WEST CAMPBELL AVE.
PHOENIX, ARIZONA 85015

Circle 67 on reader service card

4-CHANNEL PREAMP

Here are the foil patterns of the printed circuit boards that go into the 4-channel preamp. The first board is for the power supply and is shown slightly reduced in size. Its actual width should be 5½ inches.

The bottom board is the preamp circuit itself. The board contains *one pair of channels* and is shown actual size. You need two of these boards to build a 4-channel preamp. This board is shown actual size.

You can obtain circuit boards for the 4-channel preamp from **Photolum Corp., 118 E. 28 St., New York, N. Y. 10016**

Kit RE-1071A 2-channel preamp.
Contains drilled, plated and notched circuit board for preamp. Drilled and plated power-supply board. 1 16-pin DIP socket. 1 circuit board connector. \$14.00
Kit RE-1071B 4-channel preamp.
Same as above plus additional 2-channel preamp board and 1 added 16-pin DIP socket and 1 added circuit board connector. \$20.00

Full-size pattern for power-supply circuit board. You use only one board for either a 2-channel or a 4-channel preamp.

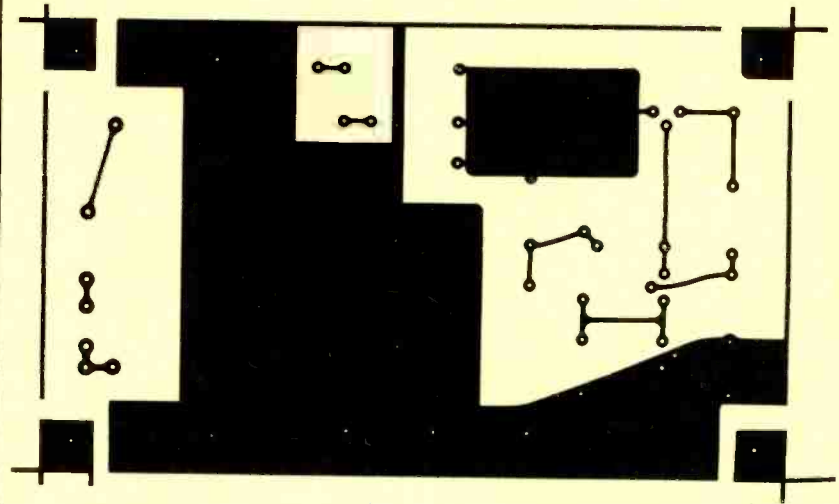

Preamp circuit board below should be enlarged to 5½ inches wide to make an actual size board.

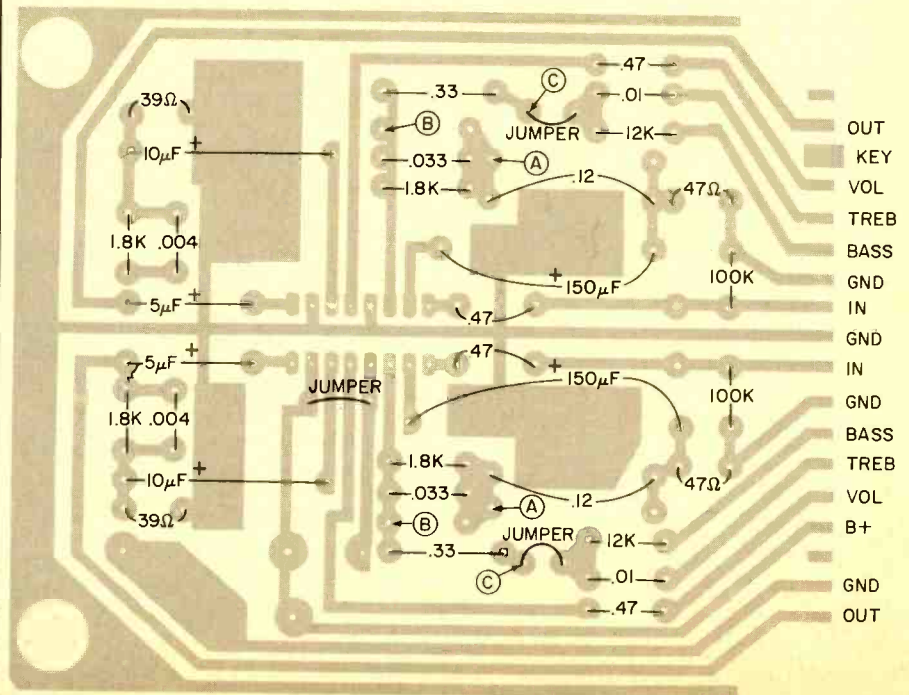

THOUSANDS OF BARGAINS—TOP VALUES IN Electronic Parts

Transistors, Modules, Speakers, Stereo, Hi-Fi, Photo Cells and thousands of other Electronic Parts. Send for **FREE** Catalog



ELECTRONIC DISTRIBUTORS INC.
Dept. TA-2, 4900 Elston
Chicago, Ill. 60630

RUSH CATALOG

Name _____

Address _____

City _____

State _____

Zip Code _____

Circle 68 on reader service card

COMING NEXT MONTH

NOVEMBER 1971

- **Modern Electronic Alarm Systems**
A careful study of the many types of intruder and fire alarm systems now available. We examine the various types of systems and how they operate. Must reading if you are thinking of installing alarm systems.

- **Vehicle Theft Alarm**
\$5 worth of easy-to-obtain parts go together to form a basic type yet quite effective alarm system.

- **Build An Alarm System For Your Home**
Here's a relatively simple alarm system that effectively protects several different points of entry simultaneously. It's worth looking at twice.

- **Build A Scope Camera**
Do-it-yourself procedure turns a Polaroid camera into an efficient scope camera rapidly and inexpensively.

PLUS:

Solid State Amplifier Design
All About Inductors
IC Potpourri
TV Sweep Alignment
Jack Darr's
TV Service Clinic

Premium-Quality

LEDs*

LIGHT EMITTING DIODES

priced for the
hobbyist/experimenter

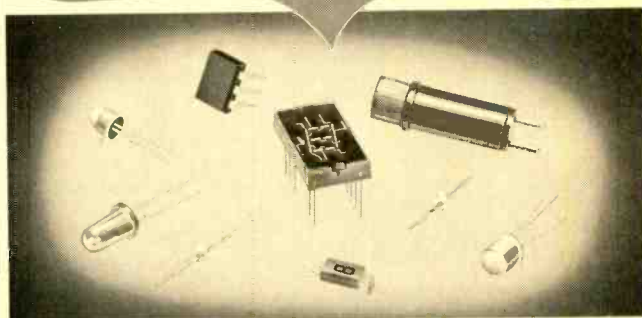

Here's your chance to get
the 'Cadillac' of the LEDs
... visible light sources, indicator lamps, alpha-
numeric readouts, photo-sensors, opto-isolators.

Sprague L.E.D. devices open up a new world of electronic experimentation. Projects such as intruder alarms, smoke detectors, light communicators, counters, controls, clocks, optical tachometers, computer readouts, Xmas light displays, etc. are *naturals* for these fantastically long-life, solid-state devices. Fully compatible with ICs, this new Sprague series includes replacements for conventional miniature lamps, as well as devices completely interchangeable with other leading makes of LEDs.

For complete data, write to Sprague Products Co., 81 Marshall St., North Adams, Mass. 01247. If you'd like to see these tiny LEDs in a working display, drop a note to our Mr. Guy Ezelle for the location of your nearest Sprague distributor.

*another exciting product from Monsanto

SPRAGUE®

THE MARK OF RELIABILITY

Circle 69 on reader service card

REPLACEMENT PARTS & ACCESSORIES WELTRON'S GOT 'EM! DO YOU?

plugs & jacks * stereo switches *
universal replacement antennas &
bases * volt meters * cables * mi-
crophones * power supplies * auto
stereo accessories * high precision
motors * synchronous motors *
shaded 4-pole motors *

COMPLETE CATALOG AVAILABLE.
CALL YOUR DISTRIBUTOR NOW!

Weltron[®]
COMPANY, INC.

514 EAST PEABODY STREET, DURHAM, N.C. 27702
919-682-0333

Circle 70 on reader service card

Unsolder it with the Endeco 300

Pencil
Desoldering
Iron

MODEL
300

Removes miniature soldered compo- nents in seconds—without damage

Hollow tip fits over connection; vacuums all solder for easy removal of component. Leaves terminals and mounting holes clean. Then, with 360° contact, it resolders faster, better than regular irons. Handles miniature and standard components in PC boards and conventional wiring. Self-cleaning. All parts replaceable. 40 watts, 120-v. Standard tip supplied, 5 other tip sizes available. Pays for itself. \$11.95 net East of the Rockies. ®

Larger model available. See your distributor or write:

ENTERPRISE DEVELOPMENT CORPORATION
5127 E. 65th St. • Indianapolis, Ind. 46220

Circle 71 on reader service card

EQUIPMENT REPORT

Pioneer PL-A25 Automatic Turntable

For manufacturer's literature,
circle No. 26 on Reader Service Card.

HERE'S AN AUTOMATIC TURNTABLE THAT works as good as it looks. At first glance the Pioneer PL-A25 is beautiful. It has a solid wood base, a hinged plastic dust cover, a professional turntable and includes a magnetic phono cartridge.

A four-pole outer-rotor high-torque motor powers the belt-drive system and is largely responsible for the stable performance with minimal wow and flutter.

The word automatic, describes one very interesting feature of this unit. After a record is in place you merely set the selector lever to the size record to be played—7", 10", or 12". Then the machinery takes over; starting the turntable and setting the stylus down in the first groove of the record. At the end of the record another automatic mechanism—a repeat device—permits replaying the record automatically.

Despite the automatic feature, this unit retains all of the expected advantages of a conventional turntable. For

SPECIFICATIONS

Drive system: Belt drive, fully automatic

Phonomotor: 4-pole hysteresis synchronous outer-rotor motor

Speed: 2 speeds: 33-1/3 and 45 rpm

Turntable: 12" diameter aluminum-alloy die-cast; weight, 2.2 lb.

Wow and Flutter: 0.1% or less

S N Ratio: More than 46 dB

Tonearm: Static balance type pipe arm

Cartridge: Induced magnet type

Stylus: 0.5 mil diamond

Stylus Pressure: 2 to 3 grams

Frequency Response: 10 Hz to 25 kHz

Output voltage: 3.5 mV (1,000 Hz, 50 mm/s)

Channel Balance: 2 dB or less

Separation: 20 dB or more (1,000 Hz)

Power Requirement: 110, 117, 130, 220, or 240V (50 or 60 Hz)

Power Consumption: 14VA (12W)

Dimensions: 17-21/64" (H) x 13-25/32" (W) x 6-11/16" (D); 170mm (H) x 440mm (W) x 350mm (D)

Weight: 16 lb. 8 oz.

Build this pipelike Schober Recital Organ for only \$1850!*

You couldn't touch an organ like this in a store for less than \$4,000—and there never has been an electronic instrument with this vast variety of genuine pipe-organ voices that you can add to and change any time you like! All four families of formal pipe tones are present in variety to delight players of classic and religious music. Yet you can change the entire organ for popular and theatrical sounds, or plug in special voices for baroque, romantic, or modern repertoires. If you've dreamed of the sound of a large pipe organ in your own home, if you're looking for an organ for your church, you'll be more thrilled and happy with a Schober Recital Organ than you could possibly imagine—kit or no kit.

You can learn to play it—and a full-size, full-facility instrument is easier to learn on than any cut-down "home" model. And you can build it, from Schober Kits, world famous for ease of assembly without the slightest knowledge of electronics or music, for design and parts quality from the ground up, and—above all—for the highest praise from musicians everywhere.

Send right now for the full-color Schober catalog, containing specifications of all five Schober Organ models, beginning at \$499.50. No charge, no obligation. If you like music, you owe yourself a Schober Organ!



* Includes finished walnut console. (Only \$1446 if you build your own console.) Amplifier, speaker system, optional accessories extra.

The Schober Organ Corp., Dept. RE-95
43 West 61st Street, New York, N.Y. 10023

Please send me Schober Organ Catalog and free 7-inch "sample" record.

Enclosed please find \$1.00 for 12-inch L.P. record of Schober Organ music.

NAME _____

ADDRESS _____

CITY _____ STATE _____ ZIP _____

Circle 72 on reader service card

manual cuing, there is an arm lifting lever, and while a record is being played, the automatic mechanism is completely disengaged.

The turntable platter itself is a massive aluminum casting. It is 12 inches in diameter, so it completely supports the record to be played. This can be important with the new thinner records being made today.

The turntable will operate on several different ac voltages—110, 117, 130, 220, and 240. To set it up for a particular line voltage just place the line-voltage selector plug in the appropriate voltage position. But make sure you check this plug when you get your turntable. It is set, at the factory, for 240 volts.

Stylus pressure is easily set by adjusting the position of the counterweight at the rear end of the tone arm. Cuing is set by adjusting a recessed screw next to the tone-arm.

The only maintenance the turntable requires is occasional lubrication. The manufacturer recommends one or two drops of a good grade of light machine oil on the motor shaft every three months, and 5 or 6 drops on the turntable shaft once or twice a year. When lubricating. Make sure no oil gets on the drive belt as this can cause the turntable speed to fluctuate. If you do get oil on the belt, wipe it off

with alcohol.

There are two things to look out for when using this turntable—hum and howling. Hum is usually caused by a loose ground connection. Check the PL-A25 ground lead; it should be securely fastened to your amplifier chassis. Also check to be sure the output lead of the PL-A25 does not get too close to the power transformer of your amplifier.

Howling is acoustic feedback from speakers to the cartridge. Vibration is the villain. To remedy, increase the separation between turntable and speakers or add a vibration damping cushion under the turntable base.—R-E

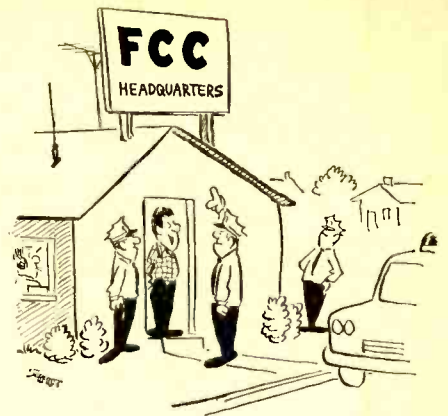

"Freeport Communications Club . . ."

TV TUNER SERVICE

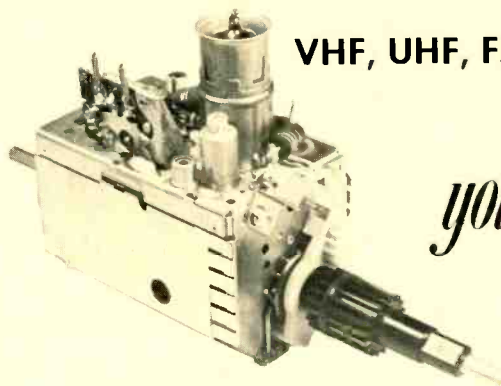

VHF, UHF, FM or IF-Subchassis. . .
 . . . All Makes

you get...

Fast 8 hr. Service!

1 YEAR GUARANTEE



FIRST TO OFFER 365-DAY GUARANTEE!
 COLOR—BLACK & WHITE—TRANSISTOR TUNERS—
 ALL MAKES
 GUARANTEED COLOR ALIGNMENT—
 NO ADDITIONAL CHARGE

You owe it to yourself

to try P.T.S. We are the fastest growing, oldest and now the largest tuner service company in the world. Here is what you get.

1. Fastest Service—8 hr.—in and out the same day. Overnight transit to one of our six plants, for parts, tuners or IF-modules.
2. All tuners cleaned inside and out, repaired, realigned and air tested.
3. On IF-modules all stages checked, all traps set with high calibre test equipment.
4. Fine Quality! Your customers are satisfied and you are not bothered with returning your units for rework!
5. Lower Cost! Up to \$5.50 less than other tuner companies!
6. Friendly, helpful personalized service!

LIKE TO DO IT YOURSELF?

PTS makes all tuner parts available to you.

Send one dollar (redeemable) for our TUNER REPLACEMENT GUIDE AND PARTS CATALOG

- 60 pages of top information
- Blow-up of all tuners
- Largest exact tuner replacement guide
- Antenna Coil Replacement Guide
- Multi-fit Replacement Tuner Shaft Guide

We offer you finer, faster...

**Precision
 Tuner Service**

VHF-UHF-FM	\$ 9.95
UV-COMBO	\$16.95
IF-MODULE	\$12.50

Major Parts charged at Net Price

CUSTOMIZED REPLACEMENTS AVAILABLE
 FOR \$12.95 UP (NEW OR REBUILT)

For fastest service, send faulty unit with tubes, shields and all broken parts to:

PTS ELECTRONICS, INC.

HOME OFFICE—
 SOUTHEAST—
 WEST COAST—
 EAST—
 SOUTHWEST—
 MOUNTAIN—

P.O. Box 272—Bloomington, Ind. 47401
 P.O. Box 6771—Jacksonville, Fla. 32205
 P.O. Box 41354—Sacramento, Calif. 95841
 P.O. Box 3189—Springfield, Mass. 01103
 P.O. Box 7332—Longview, Tex. 75601
 P.O. Box 4145—Denver, Colo. 80204

Tel. 812/824-9331
 Tel. 904/389-9952
 Tel. 916/482-6220
 Tel. 413/734-2737
 Tel. 214/753-4334
 Tel. 303/244-2818

Circle 74 on reader service card

AVAILABLE NOW!

**new Johnson
 Messenger 120
 with Tone-Alert V
 selective
 calling built-in!**

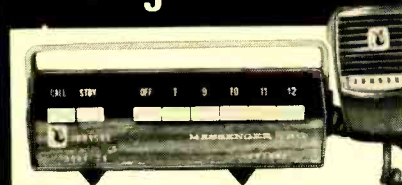

- New reedless Tone-Alert V
- 5 push-button channels
- New slide-lever controls
- New soft green illuminated panel
- Compact—fully transistorized
- Only \$149.95

**You're going to hear
 more from...**



JOHNSON
 Waseca, Minnesota 56093

Circle 73 on reader service card

ANOTHER SUPERB VALUE from Olson Electronics



ONLY **\$12**
DELUXE TRANSISTOR CHECKER

Compact, self-contained, self-powered dynamic transistor checker. Test may be made "in circuit" or out of circuit. Identifies and checks PNP and NPN types, plus power. Complete with instruction manual, service tips and transistor drawings.

Olson Electronics, Dept. LV,
260 S. Forge St., Akron, Ohio 44308

I enclose \$12, plus \$1 for postage and handling. Send me the TE-199 Transistor Checker.

Send me the next seven issues of the Olson Catalog, without cost or obligation. **FREE**

Name _____
Address _____
City _____
State _____ Zip _____

Circle 75 on reader service card

SAVE TIME & MONEY WITH VEROBOARD KITS

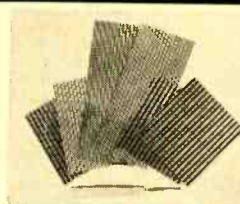

This introductory BK-6 kit will familiarize engineers, technicians or experimenters with the unique Vero method of circuit construction, which eliminates the need for etching, drilling and tools.

The BK-6 Kit consists of six Veroboards, two with a 0.2 x 0.2 matrix and four with a 0.156 x 0.1 matrix, both having a 0.052 diameter hole. Price \$5.95.

VERO MODEL MC-10 Kit — Integrated circuit breadboard designed for dual in line integrated circuits. Contains single sided 18" long board, plug in single and double sided Veroboard, plain glass board all pierced on .1" x .1" centers. Also includes connector, pins, tools and design sheet. Price \$29.95.

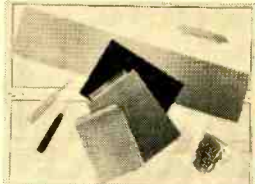

VERO ELECTRONICS INC.

171 Bridge Road, Hauppauge, N.Y. 11787
Phone 516 234-0400

Circle 76 on reader service card

SERVICE

ADMIRAL TAPE PLAYERS/RECORDERS

If you encounter audio overload on early STP371 tape players used with Admiral modular systems, add a 39,000-ohm in series with the lead to the center terminal of the output jack (on back of the tape player) and add a 10,000-ohm resistor from this center terminal to ground. Make this change on both output terminals.

This modification reduces the output to a level more closely matching the Admiral modular systems and may not be needed if the player is used with another make stereo system.

For complaints of low audio output on early STR671 tape recorders, add a 22,000-ohm, 1/2-watt resistor in parallel with the 220,000-ohm resistor that is in series with the line input of each channel. To locate the correct place for the added resistors, follow the input wires from the jack to the board. The 220,000-ohm resistors are located at this point. This modification may not be needed if the recorder is used with a different stereo system.—Admiral Service News Letter

TOO MUCH VOLUME

The problem was a 5-tube Mantel radio whose volume would not turn low enough for listening late at night.

LOOK WHAT \$1 WILL BUY

FREE \$1 BUY WITH EVERY 10 YOU ORDER

Only applies to "\$1" buys

FREE GIFT WITH EVERY ORDER

SARKES TARZIAN TUNER
41mc

Latest Compact Model good for all 41 mc TV's.
BRAND NEW—

Best TUNER "SARKES TARZIAN" ever made—last word for stability, definition & smoothness of operation. An opportunity to improve and bring your TV Receiver up-to-date. **\$7.95**

COMPLETE with Tubes

- 3' JUMPER CABLES Male RCA type Plug on Both Ends. 2 For \$1.19
- 50 — ASST. TERMINAL STRIPS all types. 1-lug to 6-lug . . . \$1
- 2—G.E. PIECES OF EQUIPMENT stacked with over 200 useful parts \$1
- \$20 — SHURE M7D DIAMOND NEEDLE exact replacement . . . \$3
- MATCHED PAIRS TRANSISTORS NPN & PNP (2N4252-2N2904) (2N2222-2N2907) Each set . . . \$1
- RONETTE STEREO CARTRIDGE latest dual sapphire flipover type . . . \$2
- 6 — TRANSISTOR RADIO EAR-PIECES wires complete with plug \$1
- 100 — FINEST NYLON DIAL CORD best size, .028 gauge . . . \$1
- 10 — SETS PHONO PLUGS & PIN JACKS RCA type . . . \$1
- 5—PRINTED CIRCUIT IF TRANSFORMERS 4-Lug, 456 KC . . . \$1
- 25 — 3900-OHM-7w RESISTOR 10% Corning glass . . . \$1
- 20 — 47-600V CONDENSERS White Ceramic C.D.—American . . . \$1
- 13 Pc. SCREWDRIVER & NUTDRIVER SET regularly \$8.95 \$4.50
- SHUREM44 SERIES DIAMOND NEEDLE exact Replacement . . . \$4.69
- 4 — 9 VOLT MOTORS Excellent for hobbyist . . . \$1
- 200' — #24 SOLID PUSH BACK WIRE Yellow or Black excellent buy . . . \$1
- 70° COLOR TUBE BRIGHTNER \$3.95
- 90° COLOR TUBE BRIGHTNER \$4.95
- 2 — BELFUSE #450-1 ad 3-1 RCA Replacement 945392-4 and 945392-3 . . . \$1

- 2—MOTOROLA HEP-170 RECTIFIER 2 1/2 AMPS and 1000V(PIV) \$1
- TV TUNERS VHF/UHF all new standard makes, including Tubes \$7.95
- 1 — VACO MONO CARTRIDGE Model TO-45X . . . \$1
- 1 — 6" x 9" HEAVY DUTY 10 OZ. SPEAKER Ceramic Type 8 Ohm . . . \$3.69
- UHF OR VHF MATCHING TRANSFORMER Simple Fool-proof installation . . . \$1
- 3—ELECTROLYTIC CONDENSERS C.D. 500 mfd—200 volts . . . \$1
- HEAVY DUTY COLOR FOCUS RECTIFIER 14,000 PIV @ 1 ma . . . \$1
- 50 — OIL IMPREGNATED TUBULAR CAPACITORS Porcelain, Axial Leads—Most popular values . . . \$3.95
- COLOR-TV RECTIFIER — Used in most color sets—6500 kv . . . 3 for \$1.93
- 15 — ASST. ROTARY SWITCHES all popular types \$20 value . . . \$1
- 15 — G.E. #NE-2 TUBES Neon Glow Lamp for 101 uses . . . \$1
- 50 — .0033 DISC CERAMIC CAPACITORS C.R.L. . . . \$1
- 3—ELECTROLYTIC CONDENSERS most popular number 50/30—150v . . . \$1
- 7 — TV ELECTROLYTIC CONDENSERS desirable types . . . \$1
- 12—MINIATURE ELECTROLYTIC CONDENSERS For Transistor & miniature work . . . \$1
- 10 — MINIATURE 456KC IF TRANSFORMERS Exceptional value —PC—1/2" x 1/2" . . . \$1

- TRANSISTOR RADIO *asst type* good, bad, broken, as-is, potluck \$1.50
- TAPE RECORDER—assorted types good, bad, broken, as-is, potluck . . . \$4
- 300 — ASST. 1/2 W RESISTORS Top Brand, Short Leads, Excellent Selection . . . \$1
- 100—ASST 1/4 WATT RESISTORS stand. choice ohmages, some in 5% . . . \$1
- 100—ASST 1/2 WATT RESISTORS stand. choice ohmages, some in 5% . . . \$1
- 70 — ASST 1 WATT RESISTORS stand. choice ohmages, some in 5% . . . \$1
- 35 — ASST 2 WATT RESISTORS stand. choice ohmages, some in 5% . . . \$1
- 50 — PRECISION RESISTORS asst. list-price \$50 less 98% . . . \$1
- 20 — ASSORTED WIREWOUND RESISTORS, 5, 10, 20 watt . . . \$1
- 10—ASSORTED SLIDE SWITCHES SPST, SPDT, DPDT, etc. . . . \$1

KNOB SPECIAL

- 100 — ASSORTED RADIO KNOBS All standard types \$20 value . . . \$1
- 50 — TV KNOBS — POPULAR TYPES For most sets . . . \$1
- 25 — VERTICAL LINEARITY KNOBS Long shank — Front mount — miniature assortment . . . \$1
- 30 — VERTICAL LINEARITY KNOBS — Side mount — Standard sizes . . . \$1
- 25—KNURLED RADIO KNOBS Hard to get — best selection . . . \$1
- 40 — DELUXE RADIO KNOBS Choice assortment — Popular types . . . \$1

ANY 6 KITS FOR \$5

IMMEDIATE DELIVERY . . . Scientific light packing for safe delivery at minimum cost. HANDY WAY TO ORDER: Pencil mark or write amounts wanted in each box, place letter F in box for Free \$1 BUY. Enclose with check or money order, add extra for shipping. Tearsheets will be returned as packing slips in your order, plus lists of new offers. **Minimum Order \$3.00**

Please specify refund on shipping overpayment desired: CHECK POSTAGE STAMPS MERCHANDISE (our choice) with advantage to customer

BROOKS RADIO & TV CORP., 487 Columbus Ave., New York, N. Y. 10024

212-874 5600
TELEPHONE

NOTES

There was nothing wrong with the volume control and just to make matters more confusing, shorting the grid of the first audio amplifier to ground made no difference. The cause was capacitive coupling. The i.f. bypass capacitor (which has a large af signal across it) was part of a package which also contained the coupling capacitor to the grid of the audio output tube. The signal was coupled through the capacitance between these two capacitors. Replacing the coupling capacitor to the grid of the output tube with a separate unit solved the problem.—David P. Smith R-E

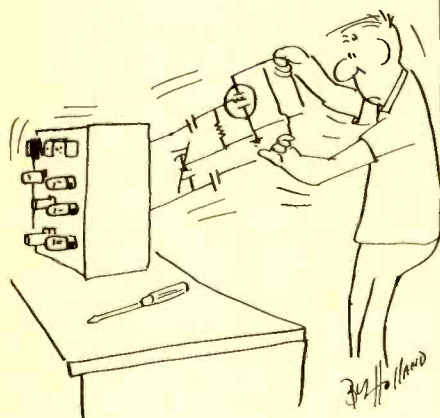

Unusual tools, hard-to-find items.

Send for free catalog!



Diversified collection-

tools of all kinds
precision instruments
essential shop items

... convenient
one-stop shopping
from your desk.

NC Flasher
National Camera
Dept. GBA
Englewood, Colorado, 80110

Circle 77 on reader service card

CALL ME!



24 HOURS A DAY ... 7 DAYS A WEEK

I'll send you 2 FREE BOOKS describing career opportunities in Electronics. Call me TOLL FREE: **800-321-2155** (in Ohio, call 800-362-2105)

For details about the famous CIE home-study courses in Electronics, see our ad on page 46-49.

Cleveland Institute of Electronics
1776 E. 17th St., Cleveland, Ohio 44114

SHANNON MYLAR RECORDING TAPE

2 1/2" — 225' .. \$.17	7" — 2400'	\$1.79
3" — 225' .. .19	7" — 3600'	2.95
3" — 300' .. .27	CASSETTE 60 minutes	.89
3 1/4" — 600' .. .58	CASSETTE 90 minutes	1.54
5" — 600' .. .62	CASSETTE 120 minutes	1.97
5" — 900' .. .80	2 1/2" TAPE REEL05
5" — 1200' .. .97	3" TAPE REEL06
5" — 1800' .. 1.49	3 1/4" TAPE REEL07
7" — 1200' .. .77	5" TAPE REEL14
7" — 1800' .. 1.12	7" TAPE REEL15

CANADIANS: Ordering is easy — we do the paperwork — try a small order

WESTINGHOUSE ALL TRANSISTOR HOME/OFFICE MESSAGE CENTER

Leaves messages for other for replay ... Built in speaker/microphone for talk-into convenience ... Records up to 3 minutes of messages ... Illuminated signal shows when a message is waiting. Control adjusts playback volume without affecting recording volume ... Capstan Drive ... BRAND NEW SOLD AS IS \$7.95

IBM COMPUTER SECTIONS

8 assorted Units we sell for \$1 are loaded with over 150 valuable parts.

Incl. — Transistors
Condensers, Resistors,
Heat Sinks,
Diodes, Etc.

8 for \$1
100 for \$10

RCA 110° FLYBACK TRANSFORMER



We scooped the Market Latest type — standard for all 110° TV's
RCA's design of large Coils produces 18KV — assuring adequate width Incl Schematic Diagram application for any TV
List price \$13.90

Your price ... **\$3**
10% off in lots of 3

110° TV DEFLECTION YOKE for all types TV's incl schematic ... **\$3**

"COMBINATION SPECIAL" RCA 110° FLYBACK plus 110° DEFLECTION YOKE **\$5**

90° FLYBACK TRANSFORMER for all type TV's incl schematic ... **\$2**

90° TV DEFLECTION YOKE for all type TV's incl schematic ... **\$2**

70° FLYBACK TRANSFORMER for all type TV's incl schematic ... **\$2**

70° TV DEFLECTION YOKE for all type TV's incl schematic ... **\$2**

2 — TV CIRCUIT BREAKERS Rated 4.2 TO 5.0 AMPS, etc. ... **\$1.19**

70° COLOR YOKE For all round color CRT's ... **\$12.95**

90° COLOR YOKE For all Rectangular 19 to 25" Color CRT's ... **\$10.95**

WESTINGHOUSE FM TUNER (12DTS Tube) ... **\$2.99**

WESTINGHOUSE FM TUNER #476-V-015D01 Transistor ... **\$3.99**

300 — ASSORTED HEX NUTS 2/56, 4/40, 5/40, 6/32, 8/32 ... **\$1**

250 — ASST. SOLDERING LUGS best types and sizes ... **\$1**

250 — ASST. WOOD SCREWS finest popular selection ... **\$1**

250 — ASST. SELF TAPPING SCREWS #6, #8, etc. ... **\$1**

150 — ASST. 6/32 SCREWS and 150 6/32 HEX NUTS ... **\$1**

150 — ASST. 8/32 SCREWS and 150-8/32 HEX NUTS ... **\$1**

150 — ASST. 2/56 SCREWS and 150-2/56 HEX NUTS ... **\$1**

150 — ASST. 4/40 SCREWS and 150-4/40 HEX NUTS ... **\$1**

150 — ASST. 5/40 SCREWS and 150-5/40 HEX NUTS ... **\$1**

500 — ASSORTED RIVETS most useful selected sizes ... **\$1**

500 — ASSORTED WASHERS most useful selected sizes ... **\$1**

100 — ASST. RUBBER BUMPERS for cabinet bottoms & other uses ... **\$1**

100-ASSORTED RUBBER GROMMETS best sizes ... **\$1**

10 — STANDARD TRANSISTORS NPN & PNP 2N404, 2N414, etc. ... **\$1**

10-ASSORTED DIODE CRYSTALS 1N34, 1N48, 1N60, 1N64, etc. ... **\$1**

3 — TOP BRAND SILICON RECTIFIERS 1 amp, 1000 PIV ... **\$1**

20 — ASST. PILOT LIGHTS #44, 46, 47, 51, etc. ... **\$1**

4-50' HANKS HOOK-UP WIRE assorted colors ... **\$1**

100'-SPOOL SPEAKER WIRE 2 cond, mini zip, clear, 101 uses ... **\$1.50**

10 — ASST. RADIO & TV TUBES Every Tube a good number ... **\$1**

5 — I.F. COIL TRANSFORMERS 458-kc for Transistor Radios ... **\$1**

5 — AUDIO OUTPUT TRANSFORMERS Sub-min for Trans Radios ... **\$1**

TV TWIN LEAD-IN 300 ohm 500' — \$7.100' — \$1.50 50' — **\$1**

CO-AX CABLE RG59U grey or black 250' — \$9.100' — \$3.89 50' — **\$2**

4 — TV ALIGNMENT TOOLS most useful assortment #1 ... **\$1**

4 — TV ALIGNMENT TOOLS For Color TV #2 ... **\$1.49**

6 — TV COLOR ALIGNMENT TOOLS Most popular type ... **\$2.79**

5 — PNP TRANSISTOR general purpose, TO-5 case ... **\$1**

5 — NPN TRANSISTORS general purpose, TO-5 case ... **\$1**

UNIVERSAL TV ANTENNA 5 section rods ... **\$1.98**

50 — ASSORTED TRANSISTORS big factory scoop—sold as-is ... **\$1**

MARKET SCOOP COLUMN

6" UNIVERSAL SPEAKER Top quality Special buy **\$1.29 Ea.**
5 for \$5

12" UNIVERSAL SPEAKER. Top Quality ... Large Magnet ... **\$4**

10" PHILCO SPEAKER Top Quality ... Large Magnet ... **\$2.69**

8" UNIVERSAL SPEAKER Large Magnet—Special Buy ... **\$2.49**

5" UNIVERSAL TWEETER 1 Oz. ... Magnet ... **\$1.29**

UNIVERSAL 4" PM SPEAKER With 50L6 Output Transformer ... **\$1**

2 1/2" x 4" SPEAKER Special Buy 10 For \$5— **69¢ Ea.**

3 1/2" — ROUND SPEAKER Special Buy ... **59¢**

4" X 6" "QUAM" 16 OHM SPEAKER Large magnet ... Special BUY (10 for \$15.00) ... **\$1.79**

CRYSTAL LAPEL MICROPHONE High Imped. 200-6000 cps ... 10 for \$5 ... **59¢ ea.**

MONO PHONO ARMS Most popular type — Used in most Transistorized phono Players (10 for \$11) ... **\$1.29**

CAR BURGLARY ALARM — 12 VOLT Easy to install ... Step-by-step Inst. ... **\$17.50**

SPECIAL TUBE BUY (6LJ8-12BH7-12DT8-12SG7-12FX50 ... **75¢ Ea.**

ALL AMERICAN TUBE KIT (12AV6-12BE6-12BA6-35W4-50C5) ... **\$2.49**

Circle 78 on reader service card

Announcing 16 exciting new Heathkit projects for wintertime kitbuilding fun!

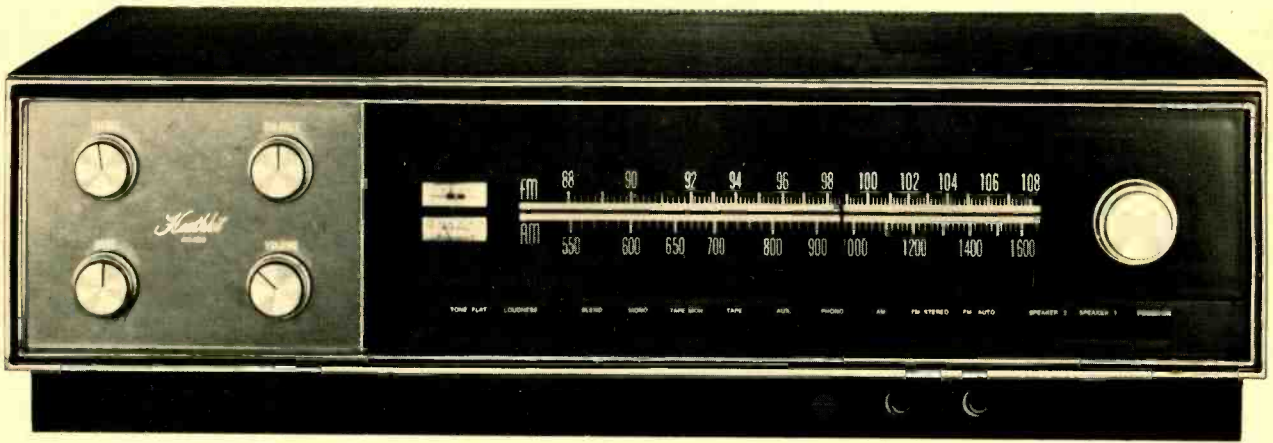

Meet the second generation AR-15 ...new Heathkit AR-1500!

From the AR-15, hailed at the time of its introduction in 1967 as the most advanced receiver of its kind, comes the AR-1500... with impressive improvements in every critical area! **180 Watts Dynamic Music Power**, 90 watts per channel (8 ohm load); 120 watts dynamic music power per channel under 4 ohm load, with less than 0.1% intermod distortion, less than .25% harmonic distortion. A 14-lb. power transformer and massive output transistor heat sink are mute testimony to the power at your command. Direct coupled output and drive transistors are protected by limiting circuitry that electronically monitors voltage and current. **FM selectivity greater than 90 dB**, better phase linearity, separation, and less distortion are the result of two computer-designed 5-pole LC Filters. An improved 4-gang 6-tuned circuit front end offers better stability, 1.8 μ V sensitivity, 1.5 dB capture ratio, and 100 dB image and IF rejection. Four ICs are used, three in the IF and one in the Multiplex. Patented automatic FM squelch is both noise and deviation activated, fully

adjustable for sensitivity. *Vastly Superior AM*, an "also ran" with many receivers, has two dual-gate MOSFETS in the RF and Mixer stages, one J-FET in the oscillator, 12-pole LC Filter in the IF, and broad-band detector. Result: better overload characteristics, better AGC action, and no IF alignment. *Greatly simplified kit construction*. Ten plug-in circuit boards, two wiring harnesses and extensive use of pre-cut wiring with installed clip connections make the AR-1500 a kit builder's dream. Built-in test circuitry uses signal meter to make resistance and voltage checks before operation. *Other advanced features* include Black Magic panel lighting that hides dial markings when set is not in use; flywheel tuning; pushbutton function controls; outputs for two separate speaker systems, bi-amplification, oscilloscope monitoring of FM multipath; inputs for phono, tape, tape monitor and aux. sources — all with individual level controls. *Versatile installation* in optional new low-profile walnut cabinet, in a wall, or black-finish dust cover included. Join the "NOW" Generation in audio technology...order your Heathkit AR-1500 today!

Kit AR-1500, less cabinet, 42 lbs. **379.95***
ARA-1500-1, walnut cabinet, 6 lbs. **19.95***

New Heathkit Stereo Cassette Recorder



119.95*

Frequency response of ± 3 dB, 30-12 kHz, brings your stereo system into the cassette age. Features built-in bias adjustment to accommodate the new chromium dioxide tape; counter; automatic motor shutoff; preassembled and aligned transport mechanism. The AD-110 offers fidelity recording and playback of stereo or mono when used with your stereo system.

Kit AD-110, 10 lbs. **119.95***

New Heathkit Stereo-4 Decoder



29.95*

Compatible with your present stereo system and FM receiver, lets you hear all Stereo-4 material currently being broadcast by a number of stations across the country. Additionally, imparts a 4-channel effect to your existing stereo library. Requires second amplifier and 2 speaker systems for installation with conventional stereo system.

Kit AD-2002, 5 lbs. **29.95***

New Heathkit Stereo Phonograph with AM Radio



109.95*

Gets it together in a portable package with a purple plum snakey skin that's as far out as today's sounds. Solid-state 18-watt amplifier, fold-down 4-speed automatic changer and swing-out high compliance speakers. Speakers can be separated up to 5'. A flip of the mode switch and you're into AM radio! 45 spindle adapter included.

Kit GD-111, 50 lbs. **109.95***

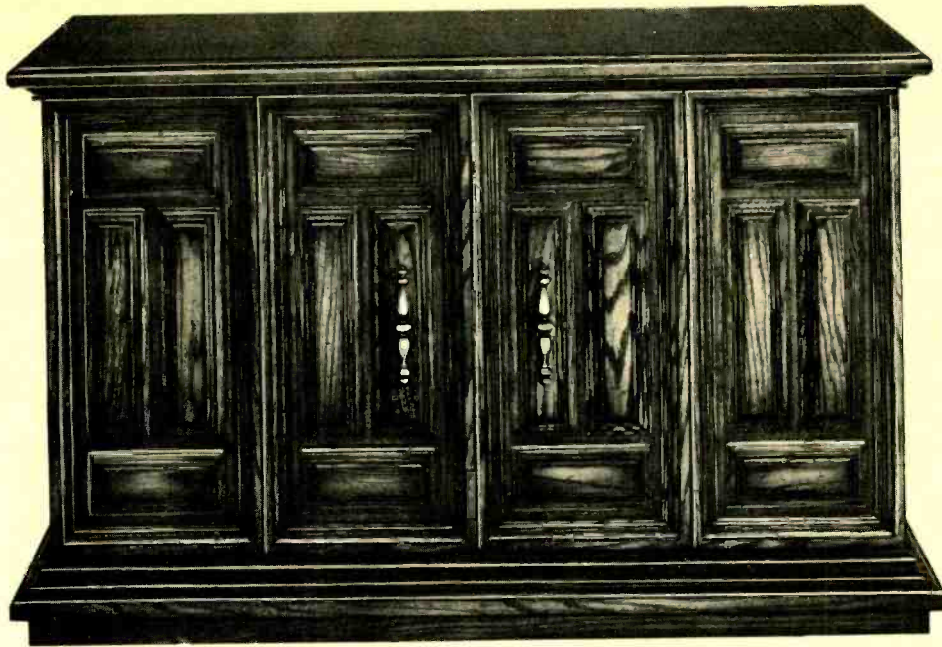

Now Heath's finest color TV package comes wrapped in a handsome new optional cabinet!

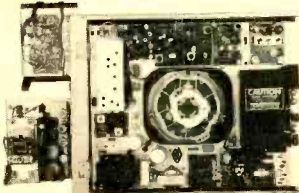

Here's the inside story:...the Heathkit 25" solid-state color TV with exclusive MTX-5 ultrarectangular tube to bring you the largest color picture in the industry! The etched, bonded tube face cuts glare, increases contrast for sharper picture,

purer colors, more natural flesh tones. But the true story of color TV reliability starts in the solid-state modular circuitry... 45 transistors, 55 diodes, 2 silicon-controlled rectifiers, 4 ICs containing another 46 transistors, 21 diodes, and just two tubes (picture and high-voltage rectifier). Major circuit functions are contained on individual plug-in glass epoxy boards (see chassis inset above) to simplify assembly, service and adjustment. And, of course, only Heathkit color TV offers you the money-saving advantages of home-serviceability... with the built-in dot generator and tilt-out convergence panel to let you perform the periodic adjustments required of all color receivers.

Other advanced design features include solid-state VHF tuner with MOSFET for greater sensitivity, lower noise and cross modulation; solid-state UHF tuner with hot-carrier diode design for greater sensitivity; 3-stage solid-state IF for higher gain and superior picture quality; Automatic Chroma Control for constant color quality under different signal conditions; adjustable video peaking; adjustable noise limiting and gated AGC; "Instant-On"; VHF power tuning on 13 channels plus one preselected UHF channel; Automatic Fine Tuning; Tone-Control; and an output to your stereo/hi-fi system for the ultimate in sound reproduction.

And to wrap it all up... your Heathkit GR-371MX is available in a magnificent new Mediterranean cabinet with doors that transform your home television theater back into an attractive center of decor. This finest cabinet in the Heathkit line features deep-grained pecan veneers on hand rubbed furniture grade hardwood solids. Two beautifully scalloped double-hinged bi-fold doors hide the TV screen when it's not in use, fold neatly to the cabinet sides when opened. Ornate brass "Canterbury Antique" handles add the perfect finishing touch. Measures 29⁵/₈" H x 56¹/₄" W x 22³/₈" D.

Kit GR-371MX, TV less cabinet, 125 lbs. **579.95***
GRA-404-25, assembled cabinet, 87 lbs. **139.95***

New Heathkit Solid-State Wireless Intercom



29.95*

Plug two of them into standard 105-130 VAC outlets for 2-way communications. Three channels let you carry on 3 conversations in a 6-unit system, call one unit without disturbing the others in a 3-unit network. Intercoms have channel selectors, spring loaded "talk" button, slide-action volume control, and "dictate" for extended one-way communication.

Kit GD-113, 5 lbs. **each 29.95***

New Heathkit Solid-State Shortwave Receiver



59.95*

Four over-lapping bands provide continuous coverage from 550 kHz to 30 MHz, giving you local AM plus international, amateur, marine & weather and citizens band broadcasts. Features band-spread tuning for close station separation; BFO control for receiving code; signal meter; front-panel headphone jack; noise limiter; built-in AM antenna.

Kit SW-717, 10 lbs. **59.95***

New Heathkit Automatic Battery Charger...



Charges 12-volt batteries automatically. 10 amp max. charge rate. Impossible to hook up wrong. No charge setting to make... can be left hooked up indefinitely. Meter monitor charge. **Kit GP-21**, 13 lbs. **29.95***

New Heathkit Automotive Timing Light...



Completely self-contained. Bright flash lets you work in sunshine. Adapter for connecting to distributor. Hi-impact plastic case. **Kit CI-1020**, 2 lbs. **19.95***



399⁹⁵*

New Heathkit DC-15 MHz Dual Trace Solid-State Oscilloscope...

The new Heathkit IO-105 is a high-performance scope designed to give you a wide range of measurements for use in instrumentation courses, engineering, R&D and electronics...at a fraction of the cost of comparable scopes! The IO-105 brings you complete dual trace and X-Y capability, allowing comparison of input/output for such parameters as loss, gain, phase shift and distortion. You can display two separate input signals in Channel 1 or Channel 2 modes of operation. Direct comparison of both signals is possible in alternate and chopped modes. In the alternate mode, both signals are alternately displayed on successive sweeps...at faster sweep speeds they are retained on the screen for time relationship comparison. In the chop mode, both signals are sampled at 100 kHz and appear as a function of the same time base. In X-Y, both channels are displayed as a function of each other...channel 1 controlling the vertical (Y) axis and channel 2 controlling the horizontal (X) axis. Both input channels are precision balanced for 5% or less phase shift to 50 kHz. Switch selected AC or DC coupling lets you trigger

the time base at a given point on the signal or at a preselected DC level. Flipping a switch gives you automatic triggering at the crossover (O) point. You can also switch select positive or negative slope triggering. Internal, External and Line trigger inputs are provided. The convenient 18-position time base switch in a 1, 2, 5 sequence provides sweep rates from 100 msec/cm to 0.2 usec/cm. The separate vernier control with a calibrated position gives you continuous control between settings, while a 5-times magnifier switch allows detailed trace viewing. The DC-15 MHz bandwidth capability and 24 nsec rise time make possible analysis of high frequency signals and transient waveforms. Full bandwidth is featured from 20 V/cm to 50 mV/cm in 1, 2, 5 sequence. For special applications, a rear panel Sweep Gate output delivers a 3.5V pulse in sync with the sweep. A TTL-compatible external blanking input is also provided. Other features include a CRT bezel incorporating standard camera mount dimensions...flush mounted handle for easy stacking...easily-removable side panels for quick accessibility...compact, 15" depth for bench installation instead of cart. If you want to expand your analysis capability while holding the budget line, order your new Heathkit IO-105 now! Or send for more information and complete specification sheet.

Kit IO-105, 35 lbs. **399.95***

New Heathkit Vector Monitor...



49⁹⁵*

Designed for use with the Heathkit IG-28 Pattern Generator or similar units which display either "rainbow" (offset carrier) or NTSC patterns, the IO-1128 vector display helps you perform fine tuning, static and dynamic convergence,

purity, 3.58 oscillator, reactance coil, phase detector transformer, demodulator angle check, and chroma bandpass adjustments. Represents exactly the color signals fed to CRT guns.

Kit IO-1128, 10 lbs. **49.95***

New Heathkit Electronic Switch... **39⁹⁵***

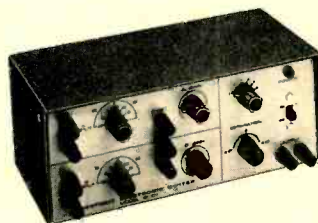

Provides simultaneous visual display of 2 input signals on a single trace oscilloscope. Has DC coupling and DC-5 MHz ± 3 dB frequency response. Conventional binding posts permit fast

hook-up. Can be left connected to scope. Ideally suited for digital circuit work; amplifier input and output for gain and distribution checks; simultaneous monitoring of 2 stereo channels.

Kit ID-101, 6 lbs. **39.95***

New Heathkit "Minimizer" kitchen waste compactor...

Today's most modern refuse handling method in easy-to-assemble kit form! Now you can own the most exciting kitchen appliance on the market for less than you'd pay for any other comparable compactor. The Heathkit Minimizer lets Mom throw out the unsightly waste baskets and garbage cans for the latest in clean, convenient, odor-free disposal. The Minimizer handles all normal household trash — food wastes, glass and plastic containers, tin cans, wrappings, boxes, floor sweepings, light bulbs, etc. The packing ram descends with 2,000-lb. force to reduce refuse to almost 1/4 of its original size, packaging the material in a strong disposable bag — one bag holds an entire week's trash for a family of four! When the bag's full, Mom simply folds over the top and removes a neat, dry package for normal rubbish pickup. And the Minimizer deodorizes the contents each time the drawer is opened and closed. The sanitation man will love Minimizer, too!

Simple, safe operation! To use, Mom merely inserts a Minimizer plastic-lined bag in the drawer and starts the compacting cycle. In less than a minute the ram forces down the trash, returns to its normal position, and the Minimizer shuts itself off. For maximum safety, the Minimizer uses a key lock switch and an interlock which automatically turns unit off if drawer is not fully closed or is accidentally opened during cycling. Your Heathkit Minimizer can be built-in under the kitchen counter or left free-standing. Its bright white enamel finish with marble-tone vinyl-clad top complements any decor. And you can build it yourself in 6 to 10 hours. Has long-life 1/3 hp motor, plugs into 110-120 VAC conventional household outlet. Kit includes 5 plastic-lined bags, one 9 oz. aerosol can of deodorant. Minimizer measures 34 3/8" H x 15" W x 25 1/2" D.

Kit GU-1800, 203 lbs. 199.95*

GUA-1800-1, 25 plastic-lined bags,
2 aerosol cans, 6 lbs. 10.95*

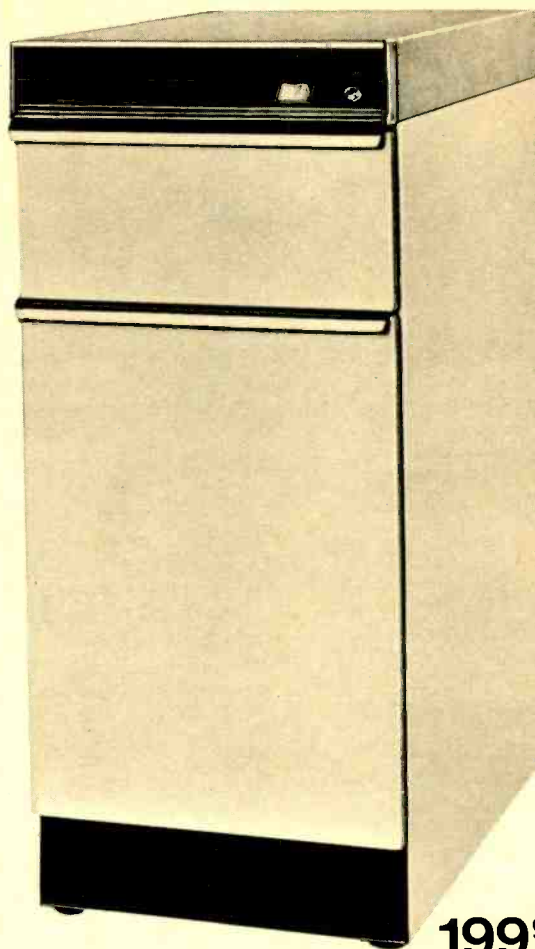

199.95*

New Heathkit Thermo Spotter



24.95*

Seeks out the temperature where your favorite fish live. Includes submersible sensing element, 100' of strong nylon cord, battery-powered solid-state meter circuitry... in high-impact plastic take-up reel case.

Kit MI-104, 3 lbs. 24.95*

New Heathkit Digital Depth Sounder



139.95*

Gives accurate, digital depth readings to 199'. Red warning light alerts you to shoals of 10' or less. Automatic noise rejection and range switching.

Kit MI-101-1 (w/thru-hull trans.)
6 lbs. 139.95*

Kit MI-101-2 (w/transom-mount
trans.) 8 lbs. 139.95*

New Heathkit Economy Garage Door Opener

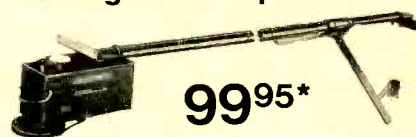

99.95*

Deluxe features include husky 1/4 hp motor, heavy-duty chain drive, automatic safety reversing, automatic light. Preassembled transmitter & solid-state receiver.

Kit GD-309A, 43 lbs. 99.95*

Kit GD-309B (w/2 trans.)
43 lbs. 114.95*

SEE THESE KITS AT YOUR LOCAL HEATHKIT ELECTRONIC CENTER... or send for FREE catalog!

CALIF.: Anaheim, 330 E. Ball Road; El Cerrito, 6000 Potrero Avenue; La Mesa, 8363 Center Drive; Los Angeles, 2309 S. Flower St.; Redwood City, 2001 Middlefield Rd.; Woodland Hills, 22504 Ventura Blvd.; COLD.: Denver, 5940 W. 38th Ave.; GA.: Atlanta, 5285 Roswell Road; ILL.: Chicago, 3462-66 W. Devon Ave.; Downers Grove, 224 Ogden Ave.; MD.: Rockville, 5542 Nicholson Lane; MASS.: Wellestey, 165 Worcester St.; MICH.: Detroit, 18645 W. Eight Mile Rd.; MINN.: Hopkins, 101 Shady Oak Rd.; MO.: St. Louis, 9296 Gravois Ave.; N.J.: Fair Lawn, 35-07 Broadway (Rte. 4); N.Y.: Jericho, L.I.; 15 Jericho Turnpike; New York, 35 W. 45th Street; OHIO: Cleveland, 5444 Pearl Rd.; Woodlawn, 10133 Springfield Pike; PA.: Philadelphia, 6318 Roosevelt Blvd.; Pittsburgh, 3482 William Penn Hwy.; TEXAS: Dallas, 2715 Ross Avenue; Houston, 3705 Westheimer; WASH.: Seattle, 2221 Third Ave.; WIS: Milwaukee, 5215 Fond du Lac.

Retail Heathkit Electronic Center prices slightly higher to cover shipping, local stock, consultation and demonstration facilities. Local service also available whether you purchase locally or by factory mail order.

HEATH Schlumberger	
HEATH COMPANY, Dept. 20-10 Benton Harbor, Michigan 49022	
<input type="checkbox"/> Enclosed is \$ _____, plus shipping.	
Please send model(s) _____	
<input type="checkbox"/> Please send FREE Heathkit Catalog.	
Name _____	_____
Address _____	_____
City _____	State _____ Zip _____
*Mail order prices; FOB factory.	
Prices & specifications subject to change without notice. CL-414	

ALLIED RADIO SHACK ISSUES A NEW AND DIFFERENT CATALOG!

a valuable
"FIRST EDITION"
...and it's
FREE!

SPECIAL BONUS OFFERS

PREVIEWS
OUR COMPLETE
SCIENCE FAIR®
AND KNIGHT-KIT®
LINES FOR '72!



The new buying Guide for kit builders, Hama, hobbyists, do-it-yourselfers, "fix-it men"! Lists thousands of handy and wanted "little things" most stores don't stock. Like tubes and transistors, cables and plugs, adapters and antennas—you name it—the things that keep equipment working. Or make it work even better. Or DO MORE. If you own anything electronic or electrical, you need this catalog!

ALLIED RADIO SHACK Dept. RE-6
2725 W. 7th St., Fort Worth, Texas 76107
 Send me your FREE Spring/Summer Cat. 212
Name (print) _____
Route No. _____ Box No. _____
Street _____ Apt. No. _____
City _____ State _____ Zip _____

Circle 80 on reader service card

UNBEATABLE PRICES

While the Supply Lasts BRAND NEW IC's

FULLY TESTED

45¢	SN 7400	Quad 2 input NAND
45¢	SN 7401	Quad 2 input Open Collector NAND Gate
45¢	SN 7404	Hex Inverter
45¢	SN 7410	Triple 3 input NAND Gate
45¢	SN 7411	Triple 3 input AND Gate
45¢	SN 7420	Dual 4 input NAND Gate
45¢	SN 7440	Dual 4 input NAND Buffer
45¢	SN 7450	Dual 2 wide 2 input Expandable
85¢	SN 7472	J-K Master Slave F.F.
85¢	SN 7473	Dual J-K F.F.
1.50	SN 7475	Quad Bi-Stable Latch
2.50	SN 7441	BCD to Nixie
1.50	SN 7496	5 Bit Shift Register
2.00	SN 7483	4 Bit Binary Full Adder
3.00	SN 74192	Bi-Directional Counter BCD Output
3.00	SN 74193	Bi-Directional Counter 4 Bit Binary

6.98 POT LUCK PC Boards Crammed With Dual Inline IC's and Diodes

Decade Counter Kit with L.E.D. Readout **11.95**
Cash with order for these special prices—We pay the postage

G&J ELECTRONICS
P. O. Box 1202
San Mateo, Calif. 94401

Circle 81 on reader service card

TECH

GENERAL ELECTRIC P-2 AND S-2 CHASSIS

The high-voltage rectifier is often replaced in an effort to cure intermittent high voltage. However, the real source of trouble may be a poor solder connection at the rectifier socket. When the tube is replaced, the solder connections are resoldered; thus, it is not known for sure if the tube is really at fault! Always check the solder connections *before* replacing the high-voltage rectifier tube.—*G-E Portafax*

MOTOROLA TS-914

If the picture tube appears to be dead and the heater does not light, check the heater continuity before condemning the tube. The fault may be due to a shorted .001- μ F, 2-kV heater bypass capacitor which should be replaced.—*B. J. Brown*

MAGNAVOX T947 CHASSIS

The delay line in the T947 chassis (model 1C6104) is mounted on the vertical chassis section and protrudes outward about 1/2 inch beyond the chassis frame. If the chassis must be laid on its side with the delay line facing down, be sure to protect it from possible physical damage by

*the tape that
turned the
cassette
into a
high-fidelity
medium*

TDK

Until TDK developed gamma ferric oxide, cassette recorders were fine for taping lectures, conferences, verbal memos and family fun—but not for serious high fidelity.

Today you can choose among high-quality stereo cassette decks.



TDK SUPER DYNAMIC (SD) TAPE



The new magnetic oxide used in TDK Super Dynamic tape distinctly differs from standard formulations in such important properties as coercive force, hysteresis-loop squareness, average particle length (only 0.4 micron!) and particle width/length ratio. These add up to meaningful performance differences: response capability from 30 to 20,000 Hz, drastically reduced background hiss, higher output level, decreased distortion and expanded dynamic range. In response alone, there's about 4 to 10 db more output in the region above 10,000 Hz—and this is immediately evident on any cassette recorder, including older types not designed for high performance. There's a difference in clarity and crispness you can hear.

Available in C60SD and C90SD lengths.

TDK ELECTRONICS CORP.
LONG ISLAND CITY, NEW YORK 11103

Circle 82 on reader service card

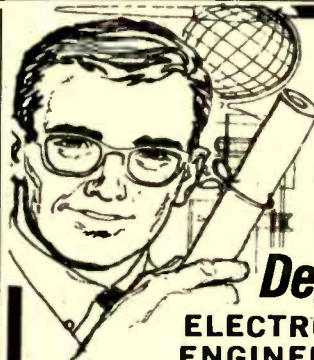

Earn Your Degree

ELECTRONICS ENGINEERING

through HOME STUDY

HIGHLY EFFECTIVE

HOME STUDY COURSES IN:

- Electronics Engineering Technology
- Electronics Engineering Mathematics

Earn your Associate in Science Degree in Electronics Engineering and upgrade your status and pay to the engineering level. Complete college level courses in Electronics Engineering. We're a forward looking school. Outstanding lesson material—thorough and easy to understand. Engineering taught on the basis of application and understanding rather than on the basis of memorization. Up to date in every respect. Acquire the knowledge and ability that means the difference between a low paying technician job and a high paying engineering position. Low tuition cost with low monthly payments. Free engineering placement service for our graduates. Write for free descriptive literature. Ask for bulletin R, no salesman will call on you.

COOK'S INSTITUTE
of Electronics Engineering

Forest Hill Road
P. O. Box 10634
Jackson, Miss. 39209

Established 1945
Formerly Cook's School of Electronics

Circle 83 on reader service card

NOTES

securely supporting the chassis so it does not rest on the delay line.
—Magnavox Service News Letter

DUMONT & EMERSON 120735 CHASSIS

Whenever you service in the shop a DuMont Calais (51K03) or Emerson model 21T01 incorporating the 120735 color chassis, inspect the flyback and if it is part No. 738195, replace it with the new transformer part No. 738195F, even though the original flyback is operating satisfactorily.

The new transformer provides greater safety and reliability and is available at your Emerson distributor. When you return the original transformer to the Emerson distributor they will issue you an offset credit for the transformer plus an additional \$7.50 installation credit. Make sure the transformer is properly tagged showing:

- Customer's name and address
- Model and serial number of set
- Date of purchase
- Date of repair

Your cooperation in making this replacement program a success will be appreciated.—Emerson Television and Radio Co. **R-E**

ELECTROLYTIC FILTER CAPACITOR GRAB BAG.

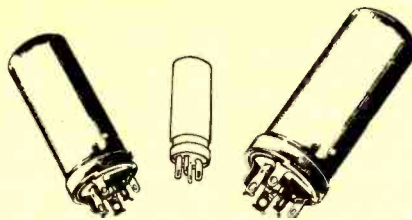

Capacities to 2500 Mfd.
Voltages to 600 VDC.
Single & Multiple sections
Leading Mfgs. Entire assortment
for less than government cost
of a single piece.
12 Piece Assortment
Stock No. J2078\$3.50

LIGHT ACTIVATED SCRs (LASCR)

STOCK	PRV	PRICE
J4115	30	.50
J4116	60	.75
J4117	100	1.50
J4118	200	2.00
J4119	300	3.00

HONEYWELL COMPUTER BOARDS

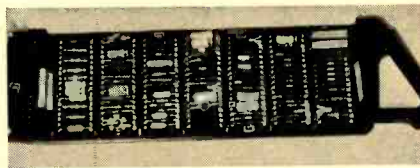

Honeywell Computer boards, 4 1/2" x 12". Transistors, diodes, zeners, capacitors, precision resistors, heat sinks, trimmers etc. 2 Different boards \$1.00. Stock No. J9082.

Circle 84 on reader service card

PROGRAMMABLE UNIJUNCTION TRANSISTOR (PUT)

STOCK NO. J4212 Similar to D13T1. Comes with 2 part magazine article reprint, loaded with application data. 1.45 ea. 4/5.00

MINIATURE RELAYS



Stock No. J91302/1.00 5/2.00

MOTOR SPEED & LIGHTING CONTROL

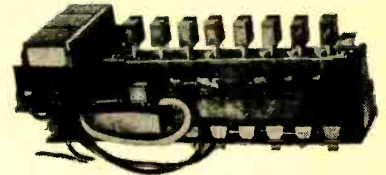

8 Push button selected controls, stop & start indicator lights. Overrun of famous blender manufacturer. Used for controlling speed of drills, saws, fans, lathes, lighting etc. Stock No. J5002 ready to use, 3.95 ea. 2/7.00 Stock No. J5003 slight factory seconds, easily repaired, 2.95 ea. 2/5.00 Wiring diagram furnished.

COMPUTER GRADE CAPACITORS

J2049 3500 Mfd. 55 volt 4 1/4" x 1 3/4" \$6.65 ea. 5/\$3.00
J2062 40,000 Mfd. 10 volt 3" x 4 1/4" Brand new \$1.25 ea. 6/\$7.00

\$1.00 FREE WITH \$10.00 ORDER
MINIMUM ORDER \$3.00

Lots of other items—send for free flyer; all merchandise fully guaranteed. Please include postage; excess will be refunded.



DELTA ELECTRONICS CO.

BOX 1, LYNN, MASSACHUSETTS 01903

THEY SAID IT COULDN'T BE DONE! IRAS DOES THE IMPOSSIBLE!

The results attained with the IRAS MULTISONIC SYSTEM* prove without doubt that complete information for four channel stereo is and always has been encoded in all present stereo recordings. The IRAS converter is designed to decode all present two channel recordings, converting them into four separate distinct channels of information. ALL THIS ACCOMPLISHED USING ONLY THE PRESENT TWO CHANNELS OF AMPLIFICATION. IMPOSSIBLE? IRAS DOES THE IMPOSSIBLE!

IRAS maintains that true four channel stereo is achieved only when, with speakers placed at the four corners of a rectangular area, the system is capable of delivering distinct sound sources from any point within the area confined by these speakers. It is not enough to merely surround the listener with sound. The sound must be meaningful. The IRAS places you literally in the center of the orchestra. You receive not just ambient information, but an infinite number of distinct sound sources, placing the listener in a 360 degree multisonic environment.

IRAS maintains that at this advanced state of the art, no equipment or recording should be made obsolete.



The IRAS uses only the present two channels of amplification. You add only the IRAS converter and two additional speakers to your present stereo system to attain four channel stereo.

The IRAS should not be considered simply a derived system. Although it converts present stereo recordings into four channels of distinct information, the recording engineers can, keeping the capabilities of this system in mind and without any special recording techniques, literally paint a picture of sound across the canvas of your living room. It is truly your complete answer to four channel stereo.

The IRAS MULTISONIC SYSTEM utilizes the fact that different sounds as reproduced by audio equipment differ in three basic ways; phase, frequency and amplitude. The IRAS converter samples these two channel signals according to their phase, frequency, and amplitude and directs them to your speakers, reproducing your two channel recordings in four channels of stereo sound that are as new as tomorrow.

Circle 85 on reader service card

FOUR CHANNEL STEREO

The written word cannot possibly convey the results attained with the IRAS MULTISONIC SYSTEM. It is like nothing you have ever heard. It must ABSOLUTELY be experienced to be believed. You may order direct from this advertisement.

To further our distribution we are offering a \$20.00 discount per unit. You can earn this discount simply by ordering from this advertisement and agreeing to acquaint your audio dealer with the results you attain with the IRAS.

Normal Retail	\$79.95
Advertising Discount	\$20.00
Net Cost	\$59.95

DEALERS WRITE FOR QUANTITY DISCOUNT.

*Patents Pending

IRAS MULTISONIC
774 W. Dr. Woodruff Pl.
Indpls., Ind. 46201

2 Year Warranty
covering Parts
and Labor

Name _____
Address _____
City _____ State _____ Zip _____
Please send _____ IRAS Converters at \$59.95 each.
Enclosed _____
Indiana residents add 2% Sales Tax

A PROVEN IMPORTANT DEVELOPMENT FOR TV SERVICING
14 MODELS
SANS-A-FUSE®

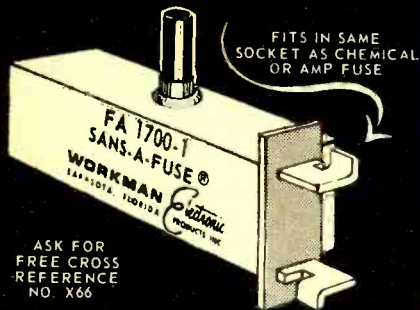

FITS IN SAME SOCKET AS CHEMICAL OR AMP FUSE

ASK FOR FREE CROSS REFERENCE NO. X66

COLOR CODED CIRCUIT BREAKER REPLACEMENT FOR CHEMICAL OR AMP FUSE

SAVES TIME AND FUSES WHEN LOCATING SHORTS IN TELEVISION CIRCUITS

DEVELOPED AND MANUFACTURED BY

WORKMAN Electronic PRODUCTS, INC.
P.O. BOX 3028 SARASOTA, FLORIDA 33578

Circle 86 on reader service card

TOOL KITS

FIELD ENGINEER TOOL KIT JTK-17



Includes more than 100 tools!

Write for brochure

More than 100 fine tools used for servicing in the field. Used on communications equipment, business machines, computers, all kinds of electronic systems. All tools and VOM tester are furnished in deluxe attache case.

FIELD ENGINEER ATTACHE CASES

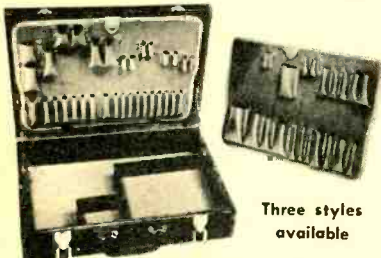

Three styles available

Pockets for 60 tools. Solid wood frame. Scuff-proof Marvlon cover, all brass hardware. Compartments in base for spare parts and a test meter. Dimensions: 18 x 13 x 4-1/2". Three styles. Write for catalog.

Free Catalog
ELECTRONIC ASSEMBLY TOOLS

Lists more than 1700 items—pliers, tweezers, wire strippers, vacuum systems, relay tools, optical equipment, tool kits and cases.

JENSEN TOOLS AND ALLOYS
4117 N. 44TH STREET, PHOENIX, ARIZONA 85018

Circle 88 on reader service card

ELECTRONIC TECHNICIANS!

Raise your professional standing and prepare for promotion! Win your diploma in

ENGINEERING MATHEMATICS

from the Indiana Home Study Institute

We are proud to announce two great new courses in Engineering Mathematics for the electronic industry.

These unusual courses are the result of many years of study and thought by the President of Indiana Home Study, who has personally lectured in the classroom to thousands of men, from all walks of life, on mathematics, and electrical and electronic engineering.

You will have to see the lessons to appreciate them!

NOW you can master engineering mathematics and actually enjoy doing it!

WE ARE THIS SURE: you sign no contracts—you order your lessons on a money-back guarantee.

In plain language, if you aren't satisfied you don't pay, and there are no strings attached.

Write today for more information and your outline of courses.

You have nothing to lose, and everything to gain!

The INDIANA HOME STUDY INSTITUTE

Dept. RE-10, P.O. Box 1189, Panama City, Fla. 32401

Circle 87 on reader service card

MISSILE BATTERY

The Only Lifetime Battery



Surplus—Ni-Cad plastic sintered-plate battery cells at approx. 10% of government cost

Connect these 1.2 V. cells in series to make batteries of any voltage. (Example: 10 cells = 12 V. Batt.), or size to replace storage batteries on autos, motorcycles, boats, radio, etc. All the good characteristics not possessed by lead-acid and other alkaline batteries such as: Lifetime service, lighter wgt., constant voltage, high discharge rate (approx. 10 times AH cap.), operate at 100% cap. in temp. range -65° to +165°F., not harmed by storage, discharge, overcharge, or freezing. May be charged thousands of times with the only maintenance of adding distilled water and keeping clean. Select cell sizes to fit your application below.

Esse Type	AMP Hr	Dimensions Inches			Wgt. Oz.	Cost
		High	Width	Deep		
AH4	4	6	2	1/2	6	1.49
AH4	4	6	2	1/2	6	*2.95
AH5	6	4	2-1/8	15/16	8	1.79
AH6	6	4-5/8	2-5/8	3/4	8	1.79
AH6R	6	4-1/2	2-5/8	11/16	8	*2.95
AH10	10	4-3/4	2-3/4	1-3/16	16	2.29
AH10	10	4-3/4	2-3/4	1-3/16	16	*4.95
AH12	12	5-3/4	2-5/16	1-1/16	18	2.79
AH34	34	9-1/4	3-1/8	1-3/8	52	4.95
AH50	50	11-1/4	5	1-3/8	104	12.50

SPECIAL CLOSE OUT!

Metal cased Ni-Cad cells, ideal for motor starting. 30AHM-30AH, 8-7/8x3x1-1/4, Wgt. 3-1/2 lbs. \$2.00 52AHM-52AH, 9x3x1-5/8, Wgt. 4-1/2 lbs. ...\$3.50

Send for complete list including made-up batteries. All cells guaranteed for satisfaction or money back. All cells not marked new are used but serviceable. Include postage on parcel post shipments.

ESSE RADIO COMPANY

Dept. RE-10
368 S. Meridian St.
Indianapolis, Ind. 46225

Circle 89 on reader service card

TRY

DIODE AS A FUSE

As the current rating of a fuse decreases, its price, internal resistance and fragility increase. A 10-mA fuse typically lists for over a dollar and has a resistance of around 3500 ohms. In dc circuits where only a small voltage drop is acceptable, a small silicon or germanium diode is a good substitute. Besides being very rugged, readily available and very cheap (less than a cent apiece if you use "bargain pack" diodes). The diode also protects the equipment against damage if battery polarity is accidentally reversed.

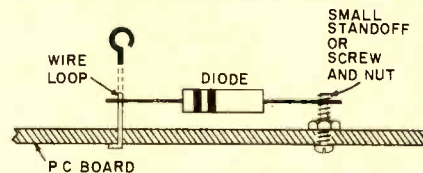

A type 1N914 computer diode is rated for 10 mA at 100 volts, and can withstand momentary current surges many times the rated value.

To make the diode as easy to install and replace as a fuse, it can be mounted on a PC board, a strip of phenolic material with small wire loops, metal standoffs, brass eyelets or

NOW GET "MUSIC ONLY" FM PROGRAMS

Convert ANY FM TUNER to receive uninterrupted commercial free music being broadcast by many stations.



New three transistor plus "Phase locked loop" IC circuit gives you perfect reception. No tuned circuits, or critical adjustments. The 1 1/2" x 4" circuit board is powered from the tuner supply. +9 to 12 Volts DC @ 10 Ma. required.

Free list of FM Stations with SCA authorizations included. (List alone \$.25)

Kit only \$14.50 + post. & ins.
Wired and tested \$25.00 + post. & ins.
THOUSANDS SOLD

Southwest Technical Products Corporation
Box 32040 San Antonio, Tx. 78216



NOW build your own Capacitor Discharge Ignition System for as little as \$11.45! Circuit diagram included with special ignition transformer.

TR-200 transformer
6 or 12 volts 11.45

Complete COMPAC KIT
6 or 12 volts 25.95

(as described in POPULAR ELECTRONICS—Nov. 1966)
FREE LITERATURE on all SYDMUR "CD" Systems.
SYDMUR—P.O. Box 25, Midwood Station, Brooklyn, N.Y. 11230

THIS ONE

a small nut and bolt as shown in the drawing. To make sure that a replacement diode isn't installed incorrectly, it is a good idea to draw a diode symbol on the PC board to indicate proper positioning. A felt-tipped marker, decals or paint can be used. One caution: be sure that you don't exceed the voltage rating of the diode.—*Scott Unites*

SIMPLER PHONO CARTRIDGE WIRING

In resoldering the connectors used on phono cartridges, the leads are thin, their soldering surface is minute, and the insulation melts at the approach of your soldering gun, while solder may run off and clog the terminal pin holes.

Avoid these annoyances with a record brush like Audiotex #30-000. Remove the brush and in its place, install a cut-down round toothpick. In use, mount the 'brush holder' on the pickup arm close to the leads in such a way that allows placing the connector on the toothpick with the soldering point facing down. Solder then will flow only in the direction where needed. A card on the turntable catches unexpected drips.—*S. Clark* R-E

For
faster
service

USE
ZIP
CODE

on
all
mail

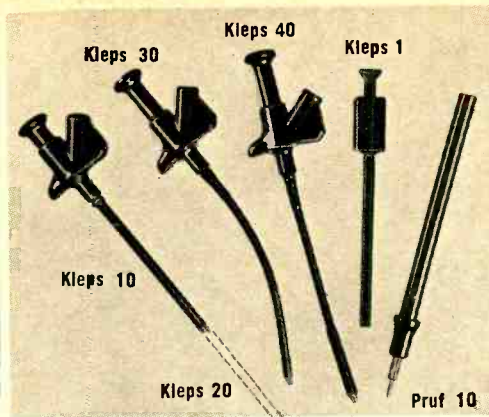

Clever Kleps

Test probes designed by your needs — Push to seize, push to release (all Kleps spring loaded).

Kleps 10. Boathook clamp grips wires, lugs, terminals. Accepts banana plug or bare wire lead. 4 3/4" long. **\$1.19**
Kleps 20. Same, but 7" long. **\$1.39**
Kleps 30. Completely flexible. Forked-tongue gripper. Accepts banana plug or bare lead. 6" long. **\$1.47**
Kleps 40. Completely flexible. 3-segment automatic collet firmly grips wire ends, PC-board terminals, connector pins. Accepts banana plug or plain wire. 6 1/4" long. **\$2.39**
Kleps 1. Economy Kleps for light line work (not lab quality). Meshing claws. 4 1/2" long. **\$.99**
Prof 10. Versatile test prod. Solder connection. Molded phenolic. Doubles as scribing tool. "Bunch" pin fits banana jack. Phone tip. 5 1/2" long. **\$.79**
 All in red or black — specify. For additional information, write for complete catalog of — test probes, plugs, sockets, connectors, earphones, headsets, miniature components.

Available through your local distributor, or write to:



RYE INDUSTRIES INC.
 129 Spencer Place, Mamaroneck, N.Y. 10543
 In Canada: Rye Industries (Canada) Ltd.
 Circle 91 on reader service card

UNEXCELLED! THE UVM ANTENNA

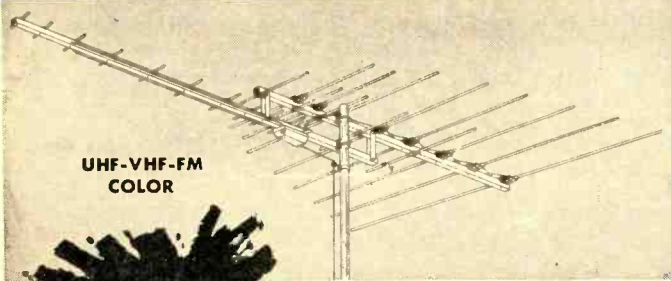

UHF-VHF-FM
COLOR

COMPLETELY
NEW!

Combination
UHF-VHF-FM Antennas
for superior performance.

Tuned and engineered featuring a LOG PERIODIC VHF section incorporating a PATENTED MAGNETIC WAVE design for UHF. Discriminate between desired signal and unwanted noise. An absence of minor lobes and extremely high front to back ratio are characteristics of these antennas. Mechanical features include all new fittings and special alloy aluminum tubing for added strength. Six models available.

Write or phone for complete information.

S & A ELECTRONICS, INC.

210 W. Florence St. Phone (419) 693-0528 Toledo, Ohio 43605

Circle 90 on reader service card

Accuracy like a VTVM... Convenience like a VOM...

NEW BATTERY-OPERATED FET SOLID-STATE VOLT-OHMMETER #116

Easy-to-build KIT

\$29⁹⁵ = 116K

Factory-Wired & Tested

\$40⁹⁰ = 116W

Now you can get all the benefits of a VTVM (laboratory accuracy, stability and wide range) but with its drawbacks gone: no plugging into an AC outlet, no waiting for warm-up, no bulkiness. New Field Effect Transistor (FET) design makes possible low loading, instant-on battery-operation and small size. Excellent for both bench and field work.

Compare these valuable features:

- High impedance low loading: 11 megohms input on DC, 1 megohm on AC
- 500-times more sensitive than a standard 20,000 ohms-per-volt VOM
- Wide-range versatility: 4 P-P AC voltage ranges: 0-3.3, 33, 330, 1200V; 4 RMS AC voltage ranges: 0-1.2, 12, 120, 1200V; 4 DC voltage ranges: 0-1.2, 12, 120, 1200V; 4 Resistance ranges: 0-1K, 0-100K, 0-10 meg., 0-1000 meg.; 4DB ranges: -24 to +56DB.

Sensitive easy-to-read 4 1/2" 200 micro-amp meter. Zero center position available. Comprises FET transistor, 4 silicon transistors, 2 diodes. Meter and transistors protected against burnout. Etched panel for durability. High-impact bakelite case with handle useable as instrument stand. Kit has simplified step-by-step assembly instructions. Both kit and factory-wired versions shipped complete with batteries and test leads. 5 1/4" H x 6 3/4" W x 2 7/8" D. 3 lbs.

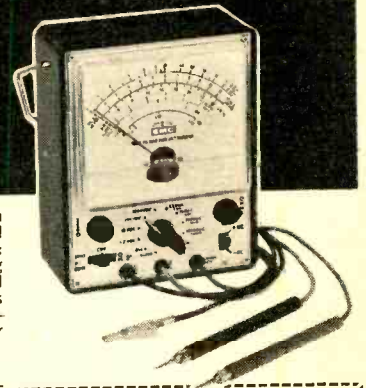

Send FREE catalog of complete EMC line and name of nearest distributor.

RE-10

Name _____
 Address _____
 City _____
 State _____ Zip _____

EMC

ELECTRONIC MEASUREMENTS CORP.
 625 Broadway, New York, N.Y. 10012

MARKET CENTER

ELECTRONICS

RECEIVING & Industrial Tubes, Transistors, All Brands—Biggest Discounts. Technicians, Hobbyists, Experimenters—Request FREE Giant Catalog and SAVE! ZALYTRON, 469 Jericho Turnpike, Mineola, N.Y. 11501

DISCHARGE Ignition, Photoflash. Free catalog parts, kits. TRANSPARK, Carlisle, Mass. 01741

INTEGRATED CIRCUITS—Factory Prices, Catalog 10¢. SILLING COMPANY, Box 6257, Seattle, Washington, 98188

SAVE MONEY ON PARTS AND TRANSMITTING-RECEIVING TUBES, FOREIGN-DOMESTIC. SEND 25¢ FOR GIANT CATALOG. REFUNDED FIRST ORDER. UNITED RADIO COMPANY, 56-R FERRY STREET, NEWARK, N.J. 07105

MOUNTING brackets for switches, potentiometer, etc. 6 for \$1.00. RELAY-TECH, Box 7119, San Diego, Ca. 92107

B & K, Sencore test equipment, discount prices. Free catalog and price sheet. FORDHAM RADIO, 265 East 149th Street, Bronx, NY 10451

HOW To Break Into Radio Television. Broadcasting book \$2.69. I.O. Engineering, Box 374, Canoga Park, Ca. 91305

JAPANESE NEW PRODUCTS MONTHLY! \$1.00 Refundable. DEERE, P.O. Box 9308, No. Hollywood, Calif. 91609

SPECIAL Clearance Sale: Rectifiers, Transistors, small motors, electronic parts. Lowest Prices. Free catalog. GENERAL SALES COMPANY (713-265-2369) 254 E. Main Street, Clute, Texas 77531

RADIO and TV Tubes 36¢ each. One year guaranteed. Plus many unusual electronic bargains. Free Catalog. CORNELL 4217-E University, San Diego, California 92105

TUBES, Transistor, Tapes. Get original Manufacturers' Parts. TV, Radio, American, Japanese, Dealer Discount. MARCUS, 43-35 44th Street, Long Island City, N.Y. 11104

PANORAMA of industrial and government electronic surplus in our monthly picture catalogs. Send for yours now. STARTRONICS, Box 17127, Portland, Oregon 97217

CONVERT any television to sensitive big-screen oscilloscope. Only minor changes required. No electronic experience necessary. Illustrated plans \$2.00. RELCO-A25, Box 10563, Houston, Texas 77018

FREE 250 Watt Linear Plans. 25¢ Handling. ROBERTS, Box 403, Whiting, Ind. 46394

AUDIO — HI-FI

QUADPOD decodes new four channel ambience from your present stereo. Small, easy IC kit provides rear signals. (EV, Dyna compatible) Prospectus free. Postpaid kit \$11.50. OLD COLONY, Box 21C, Swarthmore, Pa. 19081

FIRST BREAKTHROUGH IN RECORDING TAPE. Originally made by America's leading tape manufacturer 2400' MYLAR, 7" reel, \$2.29; 1800' MYLAR, 7" reel, \$1.69; 1200' ACETATE, 7" reel, \$0.79. Write for quantity prices. AAE, 218 Columbia St., Utica, N.Y. 13502

RENT 4-track open reel tapes—all major labels—free brochure. STEREO-PARTI, 55 St. James Drive, Santa Rosa, Ca. 95401

INTEGRATED CIRCUITS / RECTIFIERS SEMICONDUCTORS / TRIACS

TIS 43 General purpose Unijunctions \$.50
 2N3819 General purpose N-Channel FET'S \$.45
PROGRAMMABLE UJT's similar to D13T with data sheet \$.75
 6, 12 & 24V 500 MW zeners \$.30 ea.
 ER900 TRIGGER DIODES. These bidirectional trigger diodes are one of the best and cheapest methods to trigger SCR's and triacs .4/\$1.00
LIGHT EMITTING DIODES (LED'S)
 Infra red \$1.20
 Visible MLD 600 \$1.20
 Photo detectors for each \$.70
 MRD 14B photo darlington's \$.75
 14 Pin DIP sockets .3 for \$1.00

TRIACS

PRV	1A	10A	15A
100	.40	.70	1.00
200	.70	1.10	1.40
300	.90	1.35	1.80
400	1.10	1.60	2.20
500	1.50	2.00	2.60

NIXIE TUBES
 Similar to Raytheon 8754 with socket & data sheet \$4.25

TTL IC SERIES
 7441 BCD DECIMAL DECODER \$1.85

7475 QUAD BISTABLE LATCH \$1.70

7476 DUAL JK MASTER-SLAVE JK FLIP FLOP \$1.00

7490 DECADE COUNTER \$1.85

7492 DIVIDE BY TWELVE \$1.85

7481 16 BIT MEMORY ELEMENT \$2.00

7404 HEX INVERTERS \$.40

7447 BCD TO SEVEN DECODER DRIVER \$2.50

74192 BIDIRECTIONAL COUNTER \$4.00

74127 MONOSTABLE MULTIVIBRATOR \$1.25

Silicon Power Rectifiers

PRV	20A*
100	1.20
200	1.50
300	2.00
400	2.40
500	2.80

*Press fit

DECADE COUNTER KIT

CONSISTING OF:
 1—NIXIE TUBE and SOCKET
 1—7490 1—7475 1—7441
 Specially priced at \$8.95

Controlled Avalanche or Epoxy Rectifiers 1 AMP.

PRV	PRV
100	.06 600 .11
200	.07 800 .15
400	.09 1000 .20

LINEAR CIRCUITS

709C operational Amp . \$.70
 741 operational Amp . \$1.00
 SE 501 Video Amp . \$1.00
 723 Voltage regulator . \$1.25
 Silicon Control Rectifiers

PRV	3A	7A	20A	70A
50	.25	.28	.60	
100	.30	.38	.85	3.50
200	.50	.60	1.10	6.50
300	.60	.68	1.30	
400	.70	.75	1.50	9.50
500	.80	.85	1.70	
600	.90	1.20	1.90	11.00

Terms: FOB Cambridge, Mass. Send check or Money Order. Include Postage. Average Wt. per package 1/2 lb. No. C.O.D.'s. Minimum Order \$3.00

Send for our fall catalog featuring Transistors and Rectifiers; 325 Elm St., Cambridge, Mass.

OLID

Post Office Box 74D

TATE

Somerville, Mass. 02143

ALES

Tel. (617) 547-4005

Circle 94 on reader service card

U.S. GOV'T ELECTRONIC SURPLUS

Nationally Known-World Famous SURPLUS CENTER offers finest, most expensive, Government Surplus electronic units and components at a fraction of their original acquisition cost.

IBM COMPUTER POWER SUPPLY

(ITEM #22-914) -- Expensive, regulated unit. Fine for college labs, research work, service shops, etc. Pure DC over a wide range of voltages. DC output voltages 5, 12, 48, etc. Wide range of AC voltages available.

Finest transformers, filters, transistor load regulation system. Independent of line voltage fluctuations. Contains five separate rectifier systems. Unit is furnished without small "regulating card" which can be easily made or can be bypassed. Data and circuit diagrams furnished. 30" x 12" x 10". (125 lbs.)

Cost Gov't Over \$300.00

\$24.95

ONCE-IN-A-LIFETIME SPECIAL



BURGLAR-FIRE ALARM SYSTEM



(ITEM #1135-A) -- Dual alarm system gives warning of fire or break-in. Operates on 115-VAC. Control unit, 3-Kilohm flash fire, 2-mercury column, 3-door window actuator, alarm bell, 100 ft. wire, instructions, 8 1/2" x 4 1/2" x 3" (7 lbs.)

\$29.95

STANDARD DIAL TELEPHONE

(ITEM #718) -- Standard, commercial telephone same as used throughout U.S.A. Attractive polished black, like new condition. An extension phone to private systems or connect several phones together for local intercom system. Full instructions are furnished. Wt. 9 lbs.



Original \$24.50

For \$7.49

STEP-BY-STEP TELEPHONE SWITCH

(ITEM #7-908) -- Amazing telephone selector switch. Great experimental item. When used with two-wire telephone dial will select any number from 0 to 100. Works intercom or private system. Use to turn on lights, start motors, etc. Complete with contact bank. 13 1/2" x 5 1/2" x 5 1/2". (18 lbs.) Cost Over \$90.00



Cost Over \$90.00

\$6.29

Telephone dial for use with above switch. Order as (Item #700)..... \$1.97

MAGNETIC DIGITAL COUNTER (12 to 18-VDC)



(ITEM #21-958) -- Use to count electrical. Use to count number of times door is opened after business is closed, to show changing prices, laboratory uses, etc. Will count 1 for each pulse and will transfer 10th count to next unit. 4 1/2" x 1 3/4" x 1 3/4". (1 1/2 lbs.)

Orig. Cost Over \$19.00

Each \$1.99

Three For \$4.99

200 AMP., 50 VOLT, SILICON DIODE



(ITEM #22-962) -- A Four Star Buy! New, leading make. Heavy duty units excellent for use in 12 or 24-volt fast chargers, high current mercury systems, etc. 2 1/2" x 1 1/2" x 1 1/2". 3/8"-18 SAE mounting threads. (1 lb.)

List Over \$15.00

\$4.99

AC PROGRAM TIMING CLOCK

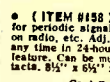

(ITEM #158) -- Zenith 115-VAC unit. Use for periodic signaling, work breaks, classes, turn on radio, etc. Adj. clips permit ON-OFF switching any time in 24-hour period. Also has "skip-a-day" feature. Can be multiple programmed. 15-amp. contacts. 8 1/2" x 6 1/2" x 4". (8 lbs.)

Cost Gov't Over \$30.00

\$15.75

SNAP AROUND VOLT-OHM-AMMETER



(ITEM #21-044) -- Measures AC current without opening the line. Simply press handle and snap the probe around the conductor. Reads currents from .25 to 125-amps. Reads voltages to 300, reads ohms up to 500. Test meters, appliances, etc. Three current ranges, 10-volt range. With case, test leads. 7 1/2" x 3" x 1 1/2".

Reg. Price \$39.95

(2 lbs.)

\$36.90

SPECIAL SALE

Correspondence Course In ELECTRICAL ENGINEERING \$8.79 Presold in U.S.A. \$10.79 Outside U.S.A.



(ITEM #A480) -- Obtain technical training at low cost! Lincoln Engineering School has suspended its Correspondence Courses because of rising costs. A limited number of Electrical Engineering Courses are available, but without the examination grading service. The course consists of 15 lesson books, each with associated exams and standard answers. Book describing prize winning Home Experimental laboratory Bench furnished at no extra cost.

RUNNING TIME METER

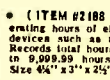

(ITEM #2188) -- Record numbers of operating hours of electric lights and electrical devices such as refrigerators, furnaces, etc. Records total hours, months and hours up to 9,999.99 hours. For 115-volt, 60-cycle. Size 4 1/2" x 3" x 2 1/2". Shipping weight 2 lbs.

Cost Over \$29.00

\$4.39

COMPUTER TRANSISTORS ON HEAT SINKS

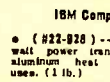

IBM Computer Quality Units (ITEM #22-928) -- Unit consists of one 150-watt power transistor on heavy, ribbed aluminum heat sink. Many experimental uses. (1 lb.)

Cost Gov't Over \$10.00

\$1.99

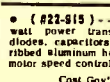

(ITEM #22-915) -- Unit consists of two 150-watt power transistors, 2 200A, several diodes, capacitors, resistors, etc. on heavy, ribbed aluminum heat sink. Ideal for use as motor speed control. (4 lbs.)

Cost Gov't Over \$35.00

\$4.91

All items shipped f.o.b. Lincoln, Nebr

Order Direct From Ad. Money Back Guarantee.

SURPLUS CENTER

DEPT. RE-100 LINCOLN, NEBR. 68501

STEREO TAPE TRANSPORT. Made for leading manufacturers; 2-speed; pause control; 7" reel; 50-15,000 Hz; 0.25% wow and flutter; with record/play and erase heads. Without case. Send m.o. or check for \$19.50 to: **AAE**, 218 Columbia Street, Utica, N.Y. 13502. Add \$2.50 for prepaid shipping and insurance.

EDUCATION/ INSTRUCTION

FREE electronics catalog. Tremendous bargains. **EDU-KITS**, Department C-265G, Hewlett, New York 11557

MEMORIZE, Study: 1971 Test-Answers" for FCC First and Second Class License—plus—"Self-Study Ability Test." Proven. \$9.95. **COM MAND**, Box 26348-E, San Francisco, Calif. 94126

FCC First and second test. \$8.75. **ELECTRONIC TUTORING**, Box 24190, Cleveland, Ohio 44124

TV TUNER REPAIRS—Complete Course Details, 12 Repair Tricks, Many Plans, Two Lessons, all for \$1. Refundable. **FRANK BOCEK**, Box 3236 (Enterprise), Redding, Calif. 96001

INVENTIONS & PATENTS

INVENTIONS Wanted. Patented; Unpatented. **GLOBAL MARKETING**, 2420-AE 77th Ave., Oakland, Calif. 94605

GOVERNMENT SURPLUS

MANUALS for surplus electronics. List 25¢. **BOOKS**, 4905 Roanne Drive, Washington, D.C. 20021

JEEPS Typically From \$53.90 . . . Trucks From \$78.40 . . . Boats, Typewriters, Airplanes, Multimeters, Oscilloscopes, Transceivers, Electronics Equipment. Wide Variety, Condition. 100,000 Bid Bargains Direct From Government Nationwide. Complete Sales Directory and Surplus Categories Catalog. \$1.00 (Deductible First \$10.00 Order From Our Separate Included Catalog). **SURPLUS SERVICE**, Box 820-REL, Holland, Michigan 49423

WANTED

QUICK CASH . . . for Electronic EQUIPMENT, COMPONENTS, unused TUBES. Send list now! **BARRY**, 512 Broadway, New York, N.Y. 10012, 212 WALKER 5-7000

Rebuild Your Own Picture Tubes?

With Lakeside Industries precision equipment, you can rebuild any picture tube!

For complete details, send name, address, zip code to:

LAKEIDE INDUSTRIES
5234 N. Clark St.
Chicago, Ill. 60640
Phone: 312-271-3399



ENJOY THE "MUSIC ONLY" FM PROGRAMS

M. A. D.

MUSIC ASSOCIATED'S DETECTOR for continuous, commercial-free music with ANY FM tuner or receiver



Kit \$49.50 Wired \$75.00 Cover \$4.95 List of FM stations that transmit "Music Only" programs \$1.00. For complete information write or call:

MUSIC ASSOCIATED
65 Glenwood Rd.,
Upper Montclair, N.J. 07043
phone 201-744-3387

IMPOSSIBLE? BARGAINS IN SURPLUS ELECTRONICS AND OPTICS

LOGIC AND NIXIE POWER SUPPLIES



□ 5 volt, 5 ampere supply
1% line, 1% load, 0.1% ripple. Built by Bluline for integrated circuit applications. Fantastic value, brand new. \$29.50

□ 5 volt 3 ampere supply, with 170 volts at 50 Ma for Nixies, similar to above, except 170 volts is unregulated. . . . \$29.50
□ 5 volt 3 ampere supply, built by Powertek. Low profile for easy build-in to instruments. . . . \$25.00



□ **NIXIE- READOUT DECADE COUNTER KIT**, including 7490 and 7441 integrated circuits, readout tube, complete etched circuit and instructions. Would you believe . . . \$8.95 (Add \$2.00 for 7475 latch)

□ Burroughs 5441 tube and socket only . . . \$4.75
□ Amperex B1000R tube only . . . \$2.95

SURPLUS TTL INTEGRATED CIRCUITS, BRAND NEW IN ORIGINAL MANUFACTURERS CARTONS

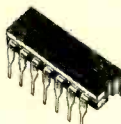

B & F has one of the worlds largest inventories of surplus integrated circuits. All are new, meeting all manufacturers original specifications, and in factory packaging. The low prices should speak for themselves. Manufactured by Texas Instruments, National, Signetics or Philco, no choice. All packages are 14/16 lead silicone Dual In-Line Pak.

NEW LOWER PRICES!

ITEMS @ 40¢	ITEMS @ \$1.75
7400 Quad 2-Input NAND	7475 Quad Bi-Stable Latch
7401 Quad 2-Input Open Collector NAND	7480 Full Adder
7402 Quad 2-Input NDR	7490 Decade Counter
7404 Hex Inverter	7494 4-Bit Shift Register
7405 Open Collector Hex Inverter	7495 4-Bit Right-Left Shift Reg.
7408 Quad 2-Input	7496 5-Bit Shift Register
7409 Quad 2-Input AND, Open Collector	74151 8-Bit Data Selector with Strobe
7410 Triple 3-Input NAND	
7411 Triple 3-Input AND	ITEMS @ \$2.00
7420 Dual 4-Input NAND	7448 BCD to 7 Segment Decoder Driver
7421 Dual 4-Input AND	7492 Divide by 12 Counter
7430 8-Input NAND	7493 4-Bit Binary Counter
7440 Dual 4-Input NAND Buffer	74180 8-Bit ODD-EVEN Parity Generator/Checker
7450 Dual 2-Wide 2-Input Expandable	ITEMS @ \$2.50
7451 Dual 2-Wide 2-Input A-O-I	7447 BCD to 7 Segment Decoder Driver
7453 4-Wide Expandable 2-Input A-O-I	7445 BCD to Decimal Decoder Driver
7454 4-Wide 2-Input A-O-I	7483 4-Bit Binary Full Adder
7460 Dual 4-Input Expander	74145 BCD to Decimal Decoder Driver
ITEMS @ 95¢	ITEMS @ \$2.75
7406 30 Volt Hex Driver Inverter	7441 BCD to Decimal NIXIE Driver-Decoder
7416 15 Volt Hex Driver Inverter	7491 8-Bit Shift Register
7407 30 Volt Hex Driver	ITEMS @ \$3.75
7417 15 Volt Hex Driver	74154 4 to 16 Line Decoder/Demultiplexer
7426 Open Collector Hi Volt NAND Quad 2-Input	74192 Bi-Directional Counter BCD Output
7470 J-K Flip-Flop	74193 Bi-Directional Counter 4-Bit Binary
7472 J-K Master Slave Flip-Flop	7485 Comparator
7473 Dual J-K Flip-Flop	ITEMS @ \$9.75
7474 Dual D Flip-Flop	7489 64-Bit Random Access Memory
7486 Quad 2-Input Exclusive DR	7488 256-Bit Rom ASCII to EBCDIC
74121 Monostable Multivibrator (One-Shot)	74181 Arithmetic Logic Unit
74122 One Shot	
8162 One Shot	
ITEMS @ \$1.75	
7442 BCD to Decimal Decoder	
7443 Excess 3 to Decimal Decoder	
7444 Excess 3 Gray to Decimal Decoder	

20% discount on all orders for 100 or more integrated circuits. All I.C.'s postpaid, with FREE air mail on orders over \$50.00. We strive to ship I.C.'s by return mail. Free data sheets on all items.

CIRCUIT BREAKERS

□ Our floors are groaning with circuit breakers, and we are clearing them out at a give-away price. Breakers come in banks of three, designed to control three power supplies and cut the power to all three should one breaker blow. Tie rod between sections can easily be removed to make three separate circuits. Two sizes available 3/3/5 amperes and 5/5/5 amperes rated 115 volt 60v. Either type \$2.00.

□ 3/3/5 amperes . . . \$2.00
□ 5/5/5 amperes . . . \$2.00

□ **FIBER OPTIC LIGHT GUIDE** — Experimental kit with 10 feet of 200 fiber guide in PVC jacket, shrink tubing and instructions for making larger diameter guides and branches . . . \$2.50

LINEAR INTEGRATED CIRCUITS

— New Lower Prices —

709 Operational amplifier	\$.90
711 Dual comparator	1.25
741 Operational Amplifier with built-in compensation	1.60
723 Voltage regulator	1.75
Dual 741 Two compensated operation amplifiers in one dual in-line package	2.25



SPECIAL! — DISCONTINUED MODEL SHARP CALCULATOR.

This model was originally \$375.00. It is hand held size, and is superseded by the new model which is identical, but pocket sized! We think the slightly larger size is an advantage, as unauthorized persons are less likely to pocket it. This calculator has sixteen digit capacity with eight digit display. By special arrangement with Sharp we are bringing this to you at half its original price, \$187.50. Don't forget, you can charge this as well as other items to Mastercharge or BankAmericard. Fully guaranteed by Sharp and B & F.

□ Sharp Electronic Calculator . . . \$187.50

TEXAS INSTRUMENTS LIGHT EMITTING DIODES (LED'S).

Use as logic readouts, either on panel or right on cards. Infinite life.

□ 2 for \$1.50
□ 10 for \$7.00

THIS MONTH'S SUPER SPECIAL!

7 Segment Readouts. Two types are available, a large size model with wire leads for P.C. Board Mounting illustrated at (A) and a small size low-current version in a Dual In-Line type package for miniature battery operated instruments illustrated at (B).

□ Large Size Readout (Illus. A) . . . \$3.95
□ Low Current Version (Illus. B) . . . \$3.75
□ Complete counter kit, including 7490 decade counter, 7447 decoder and printed circuit board, and choice of either readout. Price . . . \$8.75
□ Complete counter as above, with 7475 latch, for storage. Price . . . \$10.75

□ Complete Bi-directional counter, with 74192 instead of 7490, for up-down counting . . . \$11.75
□ Complete Bi-directional counter, with latch for storage (74192-7475-7447) . . . \$12.75

SPECIAL SALE ON DIODES AND TRANSISTORS

The recession in the electronics industry is the gain of the electronics enthusiast. Discrete components are now available at prices that are a fraction of the large volume price. Every unit listed is a brand new device, with full lead length, and in original manufacturers boxes. Guaranteed to equal or exceed manufacturers specifications.

ZENER DIODES, 5% Tolerance, Mfgs. List \$1.71 each.

1N746A	3.3 Volt	1N754A	6.8 Volt
1N747A	3.6	1N755A	7.5
1N748A	3.9	1N756A	8.2
1N749A	4.3	1N757A	9.1
1N750A	4.7	1N758A	10
1N751A	5.1	1N759A	12
1N752A	5.6		14 Volt, 3 Watt
1N753A	6.2		

Specify Number: 3 for \$1.00 10 for \$2.50 100 for \$225.00
Mix or Match

TRANSISTORS

2N3055	87.5 Watt Hi-Power Silicon	\$1.25
2N242	60 Watt Germanium Hi-Power	2/\$1.50
2N3819	N Channel FET	2 for \$1.00
2N2484	NPB Silicon Amplifier 1W, Lo Noise	3 for \$1.00
2N2907	PNP Silicon Amp-Sw, Hid, 200 MC	3 for \$1.00
2N2222	NPB Silicon Amp-Sw, Hid, 250 MC	3 for \$1.00
2N2369	NPB Silicon Amp-Sw, Hid, 500 MC	3 for \$1.00
2N2219	NPB Silicon Amp-Sw 3W	3 for \$1.00
2N2905	PNP Silicon Amp-Sw 3W	3 for \$1.00
NPB Silicon TD-18	Transistors marked with RCA house numbers # = 100-200, P = 0.3 Watts	10 for \$1.00, 100 for \$7.50
Same as Above, but 1 Watt TD-5		10 for \$1.50, 100 for \$10.00
Same, 0.3W PNP TD-18		10 for \$1.50, 100 for \$10.00
Same, 1.0W PNP TD-5		10 for \$2.00, 100 for \$15.00
PNP Germanium transistor, RCA house number same as 2N 404		Price . . . 12 for \$1.00, 100 for \$6.00

DIODES
1N4004 400 PIV, 1 Amp . . . \$1.00
Epoxy F.W. Bridge Rectifier 400 DIV, 2 Amps . . . \$1.00

□ **80 PAGE CATALOG** — Free with any order or send \$0.25

ALL ITEMS POSTAGE PAID IN THE U.S.A.

Charges Welcome: BankAmericard — Mastercharge — \$10.00 min.

B. & F. ENTERPRISES

Phone (617) 532-2323

P.O. Box 44, Hathorne, Massachusetts 01937

Circle 95 on reader service card

KEEP PACE WITH SPACE AGE! SEE MOON SHOTS—LANDINGS, SPACE FLIGHTS, CLOSE-UP!

AMAZING SCIENCE BUYS

for FUN, STUDY or PROFIT

FREE GIANT CATALOG!

INFRA RED SENSOR ALARM KIT



Make a sensor alarm w/ new low cost experimental kit. When infra red hits solid state sensor's LASCR (Light Activated Silicon Controlled Rectifier) it actuates the integrated circuit generator. Oscillations then amplified into loud speaker. Incls. 16ohm 2 1/2" dia. spkr., perf. hd., batt. clip & holder; 24" 020 dia. plastic fiberoptics light gd. w/ infra red filter; wire; resistors; capacitors; transistor NPN. Reqs. 4 AA cells, not incl. Instrs. w/ exps. & apps. Stock No. 41,595EH \$6.95 Ppd.

PSYCHEDELIC LIGHTING HANDBOOK



100 information packed pages! Fully explains latest in psychedelic lighting equipment, techniques, developments. Covers all facets of psychedelic light-show production including strobes, black lights, projectors, crystals, organic slides, mirrors, color organs, polarized color, light boxes Music-Vision, etc. 8 1/2" x 11" looseleaf paper for 3 ring binder. Stock No. 9100EH \$3.00 Ppd.

NEW ELECTRONIC CALCULATOR—\$19.50



Really terrific imported value. Loaded with big machine capabilities. 1st truly personal electronic calculator. Absolutely silent answers in milliseconds. Use it anywhere—AC/DC. Only 3 lbs.—6x9x2 high. Add, subtract, multiply, divide, perform mixed calculations, 8 digit entry & read-out w/ 16-digit cap. Auto. precise to the decimal. Features underflow, zero suppression, minus signal for true credit balance, error correction, keyboard roll over memory. Solid state reliability, modular constr. 1 year guar. for normal use. Stock No. 78,000EH \$19.50 Ppd.

1st LOW-COST VACUUM PUMP!



Nothing like it! Top-quality hand-held pump produces & maintains 25" of vacuum. Has instant release tab, 1 1/2" diam. stainless gauge. (0-30"). 100's of uses—siphon noxious fluids, evacuate bell jars and castings, clean, retrieve, lift sterile objects, demonstrate Magdeburg hemispheres, bleed fuel lines, check leaks, etc. Lifts Lifter (2 1/2" diam. cup)—40 lbs. with included "T" much more w/ larger cup. Stock No. 71,301EH \$12.00 Ppd. Stock No. 71,900EH (without gauge/lifter) 5.50 Ppd.

BLACK-LIGHT MIGHTY MITES



Relatively small (12") fixtures give surprisingly bright blacklight. Mirror-finished reflector makes instant starting 8-watt, high-intensity bulb look like 40-watter. Up to 5,000 hours of safe, long-wave (3660A) black-light to really turn-on parties, light & theatrical shows, psychedelic decors, holiday decorations. Shockproof end-caps remove for safe, easy replacement of bulb and starter. Stands upright or horizontal. Alum. case. Stock No. 71,274EH \$14.95 Ppd. DELUXE OUTDOOR/INDOOR MODEL Stock No. 71,299EH \$19.95 Ppd.

BUILD A WORKING CRYSTAL RADIO



Bring the 20's back with the fun of a modernized carphone crystal set that receives 1 or more stations! So simple you can have it working in less than an hour. Connects to a permanently fixed germanium crystal. Kit incls: 4- 3/4" X 6- 3/4" X 3/8" thick plywood base, high-Q tuning coil, germanium diode, variable condenser, all radio parts, earphone & holder plus diagram & simple instrs. A charming conversation piece, great fun at parties and ideal gift. Stock No. 71,513EH \$5.95 Ppd.

MAIL COUPON FOR GIANT FREE CATALOG



148 PAGES—1000's OF BARGAINS Completely new 1972 edition. New items, categories, illustrations. Dozens of electrical and electromagnet parts, accessories. Enormous selection of Astronomical Telescopes, Unique lighting items, Microscopes, Binoculars, Magnifiers, Magnets, Lenses, Prisms. Many war surplus items. Mail coupon for catalog "EH" EDMUND SCIENTIFIC CO. 300 EDCORP BUILDING BARRINGTON, N.J. 08007

NAME _____
ADDRESS _____
CITY _____ STATE _____ ZIP _____

AMAZING NEW WANKEL ENGINE KIT!

Thrill to the fun of building your own see-through motorized model of revolutionary pistonless type engine—only engine experts think economically modifiable to meet new pollution standards. Replaces piston, cylinder, crank assemblies with rotating discs (sections removed for firing chambers). Smaller than conventional; fewer parts, greater reliability, same speed w/less horsepower. Feat: flashing plugs, rubber fan belt, stick-shift on-off switch. Req. 2-1.5V batt. (not incl.). Stock No. 71,424EH (4 1/2" x 5" x 9") \$6.75 Ppd.

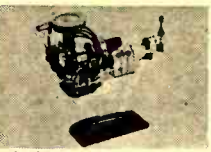

NEW! ELECTRONIC DIGITAL COMPUTER KIT!

Solve problems, play games, predict weather with this actual working model of giant electronic brains. Amazing new fun way to learn all about computer programming—logic, decimal, binary systems. Laws of Sets—even do your own programming after completing simplified 116 page instructive booklet. Includes step-by-step assembly diagrams. Circuits easily changed. Readout from illuminated control panel. Req. 2 "D" batt. (not incl.). Best model we've seen—for home, school, industry. Stock No. 71,434EH (11" x 12 1/2" x 4") \$31.50 Ppd.



3-CHANNEL COLOR ORGAN BARGAIN!



Create tremendous variety of unusual & beautiful lighting effects with this low-cost top-quality 1500-Watt unit (500 W. per channel). Compare with others selling for twice the price. Has pilot light, plus individual sensitivity controls and channel indicator lights. Can operate ten 150 W. "spots" or 200 Christmas lights. Uses reg. house current—attaches to audio source w/RCA-type phone plug. 5 1/2" x 6 3/4" x 2 1/2". 2 1/2 lbs. Thermal setting plastic case, 6-ft. cord. Including complete instructions. Stock No. 71,223EH \$44.50 Ppd.

CHROMATIC "MACHINE-GUN" STROBE

Red, Green & Blue light barrage the eyeballs every 6 seconds with this low-cost top-quality mechanical strobe that can run continuously without fear of burning up. Dazzling effects over 500 ft. sq. area. Created by rotating color wheel in front of 100W, 120V reflector floodlamp (incl.)—elements seem to flash on & off as colors fluctuate. Turns store windows, posters, parties into flashing, pulsating productions. Convection cooled. Rugged wrinkle finish metal case. Adjustable hanger bracket. Reg. house current. Stock No. 71,423EH (9" x 9" x 6") \$32.75 Ppd.



1st QUALITY OPAQUE UNDER \$200

Terrific Buy! Top Quality! Projects brilliant, sharp 4 1/2 ft. sq. image from 8" using up to 375" color, h/w illustrations. Retains all original colors, proportions. Enlarges drawings, coins, maps, etc. Revolutionary peanut-size quartz Halogen lamp (50 hr. life), 200mm anastigmatic lens (f3.5, 8" F.L.), unique internal reflecting system give maximum brightness, entire field focus. Can be used upside down. Turbo-cooled. 5 1/2 ft. cord. Stock No. 71,272EH (Wt. 11 1/4 lbs.) \$98.75



NEW LIGHT-EMITTING-DIODE KIT

Bargain kit ideal for economical experimenting with amazing L.E.D.s. the tiny solid state monochromatic lamps that use low voltage DC, last up to 1MM hrs. Used in card-type readers, character recognition, hi-speed detectors, all kinds of electro-optical applications. Kit incls 3 L.E.D.s: 88-lumen emitting (MLED 600 MV 50, MLED 930); 2 visible red emitting (6600 A°); 1 infra-red emitting (9000 A°); 6 resistors; 1" 20mm plastic fibre optic light pipe; instrs. Stock No. 41,597EH \$5.95 Ppd.

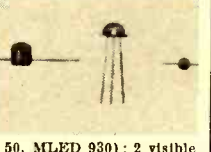

WAR SURPLUS ELECTRIC GENERATOR

Brand new Signal Corps Model. Up to 90 volts by turning crank. Use in high impedance relays. Charge ground & bring up night crawlers for bait or study. 2 Alnico Magnets alone now worth more than original \$15 gov't cost. No. 50,225EH .. (2 lbs.) \$8.50 Ppd.



ADVERTISING INDEX

RADIO-ELECTRONICS does not assume responsibility for any errors which may appear in the index below.

READER SERVICE CARD NO.	PAGE	
65	Acoustic Research	77
63	Allied Radio Shack	76
80	Allied Radio Shack	94
	APM Systems	70
	Bell & Howell Schools	78-81
	B & K Division, Dynascan Corp.	23
12	Brooks Radio & TV Corp.	86-87
93	Castle TV Tuner Service, Inc.	Cover IV
17	Cleveland Institute of Electronics	46-49, 73, 87
	Coletronics	72
83	Cook's Institute of Electronics Engineering	94
11	Cooper Industries	22
	CREI, Division of the McGraw-Hill Continuing Education Co.	28-31
22	CTS of Paducah	73
84	Delta Electronics	95
13	Delta Products	24
66	Edlie's Electronics	77
61	Electronic Chemical Co.	75
68	EDI, Electronic Distributors Inc.	82
4	EICO, Electronic Instrument Co.	12
	EMC, Electronic Measurement Corp.	97
71	Enterprise Development	84
89	Esse Radio	96
3	Garrard (British Industries Corp.)	7
14	Grantham School of Engineering	25
81	G & J Electronics	94
	GTE Sylvania Electronic Components	27
79	Heath Co.	88-93
87	Indiana Home Study Institute	96
92	International Crystal Mfg. Corp.	102
85	Iras Multisonic	95
88	Jensen Tools & Alloys	96
73	E. F. Johnson	85
8	Kikusui	16
20	Lafayette Radio Electronics Leader Instruments	72, 15
15	Magnavox Parts Division	26
2	Mallory Distributor Products	5
21	Mountain West Alarm Supply	73
77	National Camera	87
	National Radio Institute	8-11
	National Technical Schools	18-21
	Nelson Hershfield Electronics	82
67	Olson Electronics	86
10	Phase Corp.	22
74	Precision Tuner Service	85
	RCA Electronic Components Tube Division	Cover III
	Semiconductor Division	13
	RCA Institutes	64-67
62	RCA Sales Corp.	75
91	Rye Industries	97
90	S & A Electronics	97
19	Sansui	71
72	Schober Organ	84
16	Shure Brothers	32
5	Sonar Radio	12
9	Sony	17
	Southwest Technical Products	96
69	Sprague	83
	Sydmur	96
82	TDK Electronics	94
64	Techni-Tools, Inc.	76
1	Telex	Cover II
6	Toy Tech	14
18	TV Radio Aids	70
76	Vero Video Systems, Inc.	86, 1
70	Weltron	84
86	Workman Electronic Products	96
	MARKET CENTER	98-101
95	B & F Enterprises	
96	Edmund Scientific Co. Fair Radio Corp. Lakeside Industries	
98	Meshna Music Associated Polypaks	
97	Ramko Research	
94	Solid State Sales Surplus Center	
	SCHOOL DIRECTORY	101
	Valparaiso Technical Institute	

Circle 96 on reader service card

EDMUND SCIENTIFIC CO. 300 EDCORP BLDG. BARRINGTON, NEW JERSEY 08007

ORDER BY STOCK NUMBER • SEND CHECK OR MONEY ORDER • MONEY-BACK GUARANTEE

POLY PAKS SMASHES "IC" PRICES!

709-710-711 LINEAR "SET"

3-Pc. Set \$1.25

10 Sets \$10.

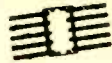

FROM FACTORY STOCK ROOM TO YOU! Factory excess inventory of the popular linear amplifier FLAT PAKS! Brand new! A set of 3 consists of 709 "operational amplifier", 710 hi-speed differential comparator, 711 Dual Comparator. With specs.

MEMORIES! REGISTERS!
PHILCO MOS "ICS"



Factory No.	Description	Sale
PLH516C	516 Bit shift register	\$ 5.95
PMS2048LVC	2,048 Bit Read Only Memory	9.95
PLSR32C	Dual 8-16-23-32 Bit shift reg	5.95
PMS2048C	2,048 Bit Read Only Memory	9.95
PMS2098LVC	2,098 Bit Read Only Memory	9.95
PL4516C	16 Channel Multiplexer	9.95
PL47C07AC	*Frequency Divider	4.95
MM500	Dual 25 Bit shift register	4.95
MM502	Dual 50 Bit shift register	5.95

*Tone generator for electronic organ

GIANT SALE ON NEW TTL ICs

Brand new! Spec sheets.
Buy 3 — take 10% discount.



TYPE	CIRCUIT FUNCTIONS	SALE
SN7400N	Quad 2 input NAND gate	\$.45
SN7401N	Same as 7400 open collector	.45
SN7402N	Quad 2 input NOR gate	.45
SN7404N	Hex inverter	.45
SN7405N	Hex inverter open collector	.45
SN7410N	Triple 3 input NAND gate	.45
SN7420N	Dual 4 input NAND gate	.45
SN7430N	8 input NAND gate	.45
SN7440N	Dual 4 input NAND buffer	.45
SN7441N	BCD-to-decimal decoder/driver	1.45
SN7447N	BCD-to-seven segment decoder/driver	2.45
SN7472N	J-K Master slave flip flop	.88
SN7473N	Dual J-K Master slave flip flop	.88
SN7474N	Dual D-type edge triggered flip flop	.75
SN7475N	Quad bistable latch	1.65
SN7476N	Dual J-K Master slave flip flop with pre-set and clear	.95
SN7481N	16 Bit memory (scratch pad)	1.75
SN7483N	4 Bit binary full adder	2.45
SN7490N	Decade counter	1.45
SN74192N	Bi-directional counter	3.45
SN74193N	Binary up down counter	3.45
SN74154N	Divide by 16	3.45

□ G-E 3.5W AUDIO "IC DIP" AMPLI



Type PA-263, 3.5w cont. duty, 9-to-30v supply. For phono, tape, 3 for \$10 stereo.

LINEAR AMPLIFIERS

Brand new! Spec sheets.
Buy 3 — take 10% discount.
State case style

Type	Description	Sale
□ 709C	Operational	\$.69
□ 723C	Volt. Reg.	1.19
□ 741C	Freq. Comp 709	1.19
□ 709-709	Dual 709's	1.49
□ 741-741	Dual 741's	1.98

ALPHA-NUMERIC INDICATOR TUBE

Only \$8.88
W/tube socket



3 for \$24
Burroughs 7971, 2 1/2" high A to Z and 0-9. Tube size: 1 1/2" x 2". Includes socket.

RTL ICs

75¢ 3 for \$2.00

Type	Description
□ 909	Buffer
□ 911	4 In. Gate
□ 912	Half Adder
□ 913	Shift Register
□ 914	Dual 2 In. Gate
□ 923	JK Flip Flop
□ 960	Dual Buffer

□ 15¢ CATALOG on Fiber Optics, 'ICs', Semi's, Parts

Terms: add postage. Rated: net 30, cod's 25%
Phone Orders: Wakefield, Mass. (617) 245-3829
Retail: 211 Albion St., Wakefield, Mass.

POLY PAKS

P.O. BOX 942 R
LYNNFIELD, MASS
01940

Circle 97 on reader service card

OCTOBER 1971

AMPEREX
READOUT
TUBE
Brand new
\$3.00 ea.
10/\$25.00



READOUT
PACKAGE
\$7.75
TUBE
7441
7475
7490

NIXIE TUBE POWER SUPPLY
From used eqpmt, OK.
115v input, solid state.
\$4.95

NICAD CELLS 34 AH \$3.75

MINIATURE SWITCHES

DPDT or SPDT \$1.00 ea.
DPDT or 4PDT 1.25 ea.



HI FREQ TRANSISTORS 2N2222
400mc • 30V • 1.8W
better than 2N706
3 for \$1.00

640 WIRED CORE MEMORY
\$5.00 per frame



COMPUTER KEYBOARD \$30.00
W/encoder diode matrix

MAGNOSTRICTIVE COMPUTER MEMORY
Magnostriuctive delay line good for approx.
7000 bit storage. Details included. \$25.00

MOTOROLA POWER TRANSISTOR 2N3448
NPNS • PWR • 115 watt • 80 volt \$1.50

Please add postage for above items

Send 25¢ for Surplus Catalog . . .

JOHN MESHNA JR. ELECTRONICS
P.O. Box 62 E. Lynn, Mass. 01904

Circle 98 on reader service card

SCHOOL DIRECTORY

GET INTO ELECTRONICS

V.T.I. training leads to success as technicians, field engineers, specialists in communications, guided missiles, computers, radar and automation. Basic & advanced courses in theory & laboratory. Electronic Engineering Technology & Electronic Technology curricula both available. Associate degree in 29 mos. B.S. also obtainable. G.I. approved. Graduates in all branches of electronics with major companies. Start Sept. - Feb. Dorms. campus. High school graduate or equivalent. Catalog. VALPARAISO TECHNICAL INSTITUTE
Dept. C, Valparaiso, Indiana 46383



NEW

FABULOUS DEVELOPMENT FOR SERVICING CASSETTE & TAPE CARTRIDGE EQUIPMENT

* Improves performance & sound * Saves time
* Optically * Electro-Optically

THE COLLIMETERS - for precision head & guide alignment **FREE TRIAL**
RAMKO RESEARCH Write for information
2552 "E" ALBATROSS • P.O. BOX 6031 • SACTO, CALIF. 95860

F.M. MOTOROLA GOVERNMENT SURPLUS



Also—Power Supplies, Amplifiers, Modules, etc. Write —Dept. RE

	RE-USED: COND.:
R-394 RECEIVER	
152-172 MC	\$14.95 \$22.50
T-278 TRANSMITTER	
152-172 MC	18.95 24.95
R-257 RECEIVER	
25-50 MC	19.95
T-208 TRANSMITTER	
25-50 MC	29.95
CY-938 CABINET	7.95 9.95
C-847 CONTROL BOX	8.95 12.95

Send For Our BIG CATALOG No. 71

FAIR RADIO SALES

1016 E. EUREKA • Box 1105 • LIMA, OHIO • 45802

CLASSIFIED COMMERCIAL RATE (for firms or individuals offering commercial products or services). 90¢ per word . . . minimum 10 words.
NON-COMMERCIAL RATE (for individuals who want to buy or sell personal items) 60¢ per word . . . no minimum.
FIRST WORD and NAME set in bold caps at no extra charge. Additional bold face at 10¢ per word. Payment must accompany all ads except those placed by accredited advertising agencies. 10% discount on 12 consecutive insertions, if paid in advance. Misleading or objectionable ads not accepted. Copy for Dec. issue must reach us before Oct. 1.

CLASSIFIED ADVERTISING ORDER FORM

1	2	3	4	5
6	7	8	9	10
11	12	13	14	15
16	17	18	19	20
21	22	23	24	25
26	27	28	29	30
31	32	33	34	35

No. of Words { @ .60 Non-Commercial Rates } \$
 { @ .90 Commercial Rate } \$
 No. of Words in bold caps
 @ .10

NAME _____

ADDRESS _____

CITY _____ STATE _____ ZIP _____

SIGNATURE _____
MAIL TO: RADIO-ELECTRONICS, CLASSIFIED AD DEPT.,
200 PARK AVE. SOUTH, NEW YORK, N.Y. 10003

Total Enclosed \$ _____
Insert _____ time(s)
Starting with _____ issue

Payment must accompany order unless placed through accredited advertising agency 28

INTERNATIONAL frequency meter

MOBILE

- Tests Predetermined Frequencies 25 to 1000 MHz
- Extended Range Covers 950 MHz Band
- Pin Diode Attenuator for Full Range Coverage as Signal Generator
- Measures FM Deviation

FM-2400CH



WRITE FOR CATALOG

The **FM-2400CH** provides an accurate frequency standard for testing and adjustment of mobile transmitters and receivers at predetermined frequencies.

The FM-2400CH with its extended range covers 25 to 1000 MHz. The frequencies can be those of the radio frequency channels of operation and/or the intermediate frequencies of the receiver between 5 MHz and 40 MHz.

Frequency Stability: $\pm .0005\%$ from $+50^{\circ}$ to $+104^{\circ}\text{F}$.

Frequency stability with built-in thermometer and temperature corrected charts: $\pm .00025\%$ from $+25^{\circ}$ to $+125^{\circ}$ ($.000125\%$ special 450 MHz crystals available).

Self-contained in small portable case. Complete solid state circuitry. Rechargeable batteries.

FM-2400CH (meter only)	\$595.00
RF crystals (with temperature correction)....	24.00 ea.
RF crystals (less temperature correction)....	18.00 ea.
IF crystals.....	catalog price



CRYSTAL MFG. CO., INC.
10 NO. LEE • OKLA. CITY, OKLA. 73102

Cut arc-back in TV damper circuits with RCA tubes...

6AF3

6AY3B

6BS3A

6CG3/6BW3

6CJ3/6CH3

6CL3

6DW4B

17AY3A

17BE3/17BZ3

17BS3A/17DW4A

All have the pre-coated cathode!

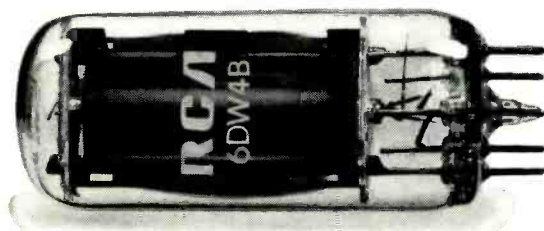

These are the 10 most popular industry types for TV damper circuits. The cathodes in these RCA tubes are pre-coated to reduce arcing.

A special manufacturing process pre-coats the cathode and pressure-welds the coating. This produces a smooth, uniform surface that virtually eliminates arcing.

In every way, the quality that goes into these tubes backs up your reputation for quality work. Systematic

parts inspection, tough environmental testing, sample life testing . . . these are some of the ways we build quality in and then check it out.

See your RCA tube distributor for the complete line of RCA tubes for damper circuits, high-voltage circuits and all your other tube needs.

RCA | Electronic Components | Harrison, N.J. 07029.

RCA

WHY REPAIR TV TUNERS?

CASTLE REPLACEMENTS start at

Select by part number below. Write, phone or wire order.

No mailing . . . no waiting . . . no nonsense!

895



UNIVERSAL REPLACEMENTS Prefer to do it yourself?

These Castle replacement tuners are all equipped with memory fine tuning and UHF position with plug input for UHF tuner. They come complete with hardware and component kit to adapt for use in thousands of popular TV receivers.

*Supplied with max. length selector shaft (measured from tuner front apron to tip) . . . you cut to suit.

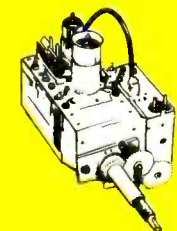
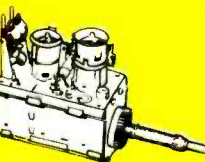
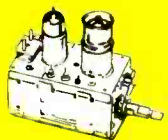
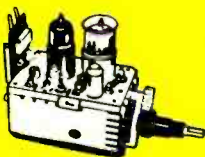

EXACT REPLACEMENTS

Purchase outright . . . no exchange needed. \$15.95 ea.

Castle replacements made to fit exactly in place of original tuner. Available in the following popular numbers.

ADIRAL	EMERSON	340042-1	LOPTT399Y			470V030H01	175-424	175-721	175-1133	MISC. INCLUDING
94E210-1	471351	340052-1	LOPTT399YA	76-13955-1	KRK133BC	470V049H01	175-426	175-722	175-1134	PRIVATE
94E210-3	471512	340053-1	OPTT399YA	76-13955-2	KRK133D	470V149H01	175-431	175-731	175-1135	TA82
94E227-2	471515	340066-1	OPTT402	76-13955-5	KRK133U	470V151H01	175-454	175-732	175-1136	TA124
94E228-1	471678	340067-1	LOPTT402			470V158D03	175-601	175-733	175-1137	TA129
94E229-4	471682	340069-1	CPTT403			470V161D03	175-602	175-734	175-1138	TA131
94E229-8	471700	340078-1	OPTT404			470V188D01	175-604	175-735	175-1139	TA133
94D257-1		340078-2	CPTT405			470V188D02	175-621	175-736	175-1140	TA136
94D257-49		340095-2	OPTT414A			470V190D01	175-622	175-737	175-1141	TA138
94E260-8H						470V191D01	175-640	175-738	175-1142	TA136
94E260-11	ET86X188		MUNTZ			470V191D03	175-641	175-739	175-1143	TA147
94E261-1B	ET86X208						175-642	175-740	175-1144	TA150
94E261-1C	ET86X212		PRG352-1				175-643	175-741	175-1145	TA157
94E261-1D	ET86X215		PRG364				175-644	175-742	175-1146	25A1241-002B
94C261-4	ET86X214		PRG376				175-645	175-743	175-1147	25A1241-004B
94C273-2	ET86X215		PR9021				175-646	175-744	175-1148	25A1241-005B
94C273-4	ET86X221		PR9044				175-647	175-745	175-1150	25A1241-006B
94C273-7	ET86X224		PR9045				175-660	175-746	175-1151	25A1245-005D
94C273-8	ET86X227		PR9050				175-170	175-747	175-1152	25A1245-006D
94C273-9	ET86X230		PR9050				175-201	175-662	175-748	25A1245-009
94C273-10	ET86X232		PR9050				175-202	175-663	175-750	25A1245-011
94C273-13	ET86X236		PR9050				175-202A	175-666	175-751	25A1246-001
94C281-1K	ET86X242		PR9050				175-203A	175-667	175-752	25A1246-003
94C286-1D	ET86X244		PR9050				175-204	175-668	175-753	25A1246-004
94C286-1J	ET86X255		PR9050				175-204A	175-669	175-754	25A1246-005A
94C286-1L	ET86X256		PR9050				175-206	175-671	175-755	25A1247-002
94C286-4J	ET86X277		PR9050				175-212	175-680	175-756	25A1249-001A
94C286-5	ET86X281		PR9050				175-213	175-681	175-757	25A1249-001E
94C286-12			PR9050				175-214	175-682	175-758	25A1253-001
94C286-16			PR9050				175-216	175-683	175-759	25A1253-001B
94C289-1			PR9050				175-220	175-684	175-760	25A1253-001D
			PR9050				175-222	175-685	175-761	25A1256-001C
			PR9050				175-228	175-686	175-762	25A1258-001A
			PR9050				175-230	175-687	175-763	25A1258-001C
			PR9050				175-232	175-688	175-764	25A1263-001
			PR9050				175-254	175-689	175-1101	25A1264-001B
			PR9050				175-256	175-690	175-1102	25A1265-001B
			PR9050				175-262	175-1103	175-1176	25A1266-001
			PR9050				175-264	175-1104	175-1177	25A1270-001
			PR9050				175-266	175-1105		006-014700
			PR9050				175-268	175-1106		006-015000
			PR9050				175-272	175-1107		006-015700
			PR9050				175-402	175-1108		006-016500
			PR9050				175-405	175-1109		006-017300
			PR9050				175-406	175-1110		006-017700
			PR9050				175-412	175-1121		006-018600
			PR9050				175-416	175-1122		006-020100
			PR9050				175-418	175-1119		006-020900
			PR9050				175-420	175-1132		006-021000

*Supplied with new channel indicator skirt knob, original illuminated dial is not used.



OVERHAUL SERVICE — All makes and models.

- VHF or UHF tuner (1960 or later) \$9.95
- TRANSISTOR tuner \$9.95
- COLOR tuner \$9.95

Overhaul includes parts, except tubes and transistors.

Dismantle tandem UHF and VHF tuners and send in defective unit only.

Remove all accessories . . . or dismantling charge may apply. Your tuner will be expertly overhauled, aligned to original standards and warranted for 90 days.



CUSTOM EXCHANGE REPLACEMENTS

When our inspection reveals that original tuner is unfit for overhaul, we offer an exact replacement.

If exact replacement is not available in our stock we custom rebuild the original at the exchange price. (Replacements are new or rebuilt.)



PROFESSIONAL "CONTACT OVERHAUL" KIT

Do your own minor tuner overhauling by using this professional kit of chemicals.

Dealer Net \$5.50

CASTLE TV TUNER SERVICE, INC.

MAIN PLANT: 5715 N. Western Ave., Chicago, Ill. 60645 • Ph. 312-561-6354

EAST: 130-01 89th Rd., Richmond Hill, N.Y. 11418 • Ph. 212-846-5300

Circle 93 on reader service card

