

Special Full-Color Section: Color TV Adjustment

MAY 1954

RADIO — ELECTRONICS

TELEVISION • SERVICING • HIGH FIDELITY

HUGO GERNSBACK, Editor

In this issue:

Markers and
Alignment Bugs

•
For Golden Ears

•
Transistor Phono
Oscillator

•
Using the V.T.V.M.
in TV Servicing



35¢

U. S. and
CANADA

Components for Color TV Receivers

(See page 4)

draw a bead on quality...

IF YOU'RE IN TV SERVICE FOR KEEPS

Television service is big business—one of the fastest growing in the nation. If you're shooting for all the marbles and aiming for the secure future TV service provides, remember today's service builds tomorrow's reputation.

As in any big business, the strongest foundation for the future is a reputation built upon sound technical and business methods. In TV service, it's good business to back up your highly specialized workmanship with the highest quality replacement parts.

You can depend on Du Mont quality picture tubes to do more for your service.



Photo by Robert R. Long - From PHOTOGRAPHY ANNUAL

Replacement Sales, Cathode Ray Tube Division
Allen B. Du Mont Laboratories, Inc., Clifton, N. J.

PIONEER IN BIG PICTURE TUBES • ORIGINATOR OF THE FAMOUS BENT-GUN AND SELFOCUS •
LEADER IN HIGH-RESOLUTION • MAJOR SUPPLIER TO MOST FINE TELEVISION RECEIVER MANUFACTURERS

*Trade-Mark

I'll Train You For Your FCC License

Training plus opportunity is the PERFECT COMBINATION for job security, good pay, advancement. A Federal Communications Commission Commercial Operator's License puts you in line for a good job in Radio or Television Broadcasting, Police, Marine, Aviation, Two-Way, Mobile or Micro-Wave Relay Radio. Mail Coupon for 64-page book FREE. It will give complete facts about my Communications Course.



You Build This Transmitter with parts I send. Use it to get practical experience. Put this station "on the air." Perform procedures required of broadcasting station operators, conduct many experiments, make practical tests.

LEARN BROADCASTING by PRACTICING at Home in Spare Time

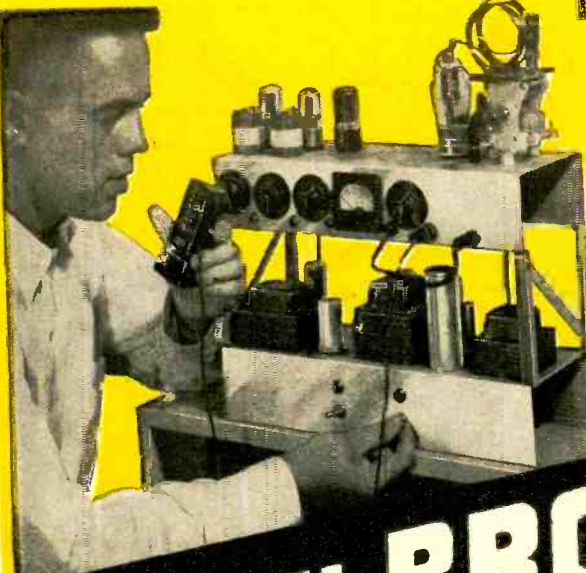

Get Practical Experience on Circuits Common to Radio & TV

Ever think HOW FAST Radio-Television Communications is changing, developing, growing? Have you considered what this amazing progress can mean to you? Even without television, the industry is bigger than ever before. Over 115 million home and auto radios, 3000 radio stations, about 200 TV stations with hundreds more being built. Expanding use of Aviation and Police Radio, Micro-Wave Relay, Two-Way Radio for buses, taxis, etc. makes opportunities for Communications Technicians and FCC licensed operators. New jobs, more jobs for beginners! Better jobs, better pay for experienced men!

J. E. SMITH, President National Radio Institute Washington, D. C. has trained more men for Radio-Television than any other man OUR 40TH YEAR.



MY COURSE INCLUDES TELEVISION

you want. If you've had some training in Radio or Radar, or as a Licensed Operator, my course modernizes—increases the value of your knowledge.

Includes New Developments

Mail coupon now for facts about my practical course in Radio-Television Communications. Let me send you my FREE book. See the nine big Kits of Parts I send that "bring to life" theory you learn. You get practical experience by working on circuits common to both Radio and Television; also lessons on TV principles. Read about the Transmitter you build and operate, about the Electronic Multitester you get. All equipment is yours to keep. My graduates are filling jobs, making good money in both Radio and Television. Remember, the way to a successful career in Television is through experience in Radio.

Television Is Today's Good Job Maker

Over 25 million television sets are in use. Thousands more being sold every week. Good TV jobs opening for Technicians, Operators everywhere. The time to act is NOW! Start learning Radio-TV communications. America's fast growing industry offers good pay, a bright future, security. If you are a beginner, my course can help you get FCC License, prepare for the job

SERVICING TRAINING ALSO AVAILABLE

If you prefer a good-pay job in Radio-Television Servicing... or your own money-making Radio-Television Sales and Service Shop, I'll train you at home. My famous Servicing Course also includes many Kits of Parts. You use them to get PRACTICAL EXPERIENCE with circuits common to Radio and Television. I also show you how to make \$10, \$15 a week or more EXTRA MONEY fixing neighbors' Radios while training. Full information in my 64-page book... Mail coupon.

Mail Coupon for Book FREE

Send today! See what my Communications course is like. Find out how I get you ready for a brighter future, better earnings, more security in Radio-Television. Send coupon now in envelope or paste on postal. NO OBLIGATION, NO SALESMAN WILL CALL! My book, sent to you FREE, tells the full story. J. E. SMITH, President, Dept. 4EF, National Radio Institute, Washington 9, D. C. Our 40th year.



YOU BUILD this Transmitter Power Supply used in the basic experiments in RF and AF amplifiers, frequency multipliers, buffers, etc.



YOU MEASURE current, voltage (AC, DC and RF), resistance and impedance in circuits with Electronic Multitester you build. Shows how basic transmitter circuits behave; needed to maintain station operation.



YOU PRACTICE setting up code, amplitude and frequency modulation circuits (put voice, music, etc., on "carrier signals" you produce). You learn how to get best performance.



YOU BUILD this Wavemeter and use it to determine frequency of operation, make other tests on transmitter currents.

Training Leads to Jobs Like These

- | | | | |
|---|---|--|---|
| BROADCASTING
Chief Technician
Chief Operator
Power Monitor
Recording Operator
Remote Control Operator | SHIP AND HARBOR RADIO
Chief Operator
Assistant Operator
Radiotelephone Operator | GOVERNMENT RADIO
Operator in Army, Navy, Marine Corps, Coast Guard
Forestry Service
Dispatcher
Airways Radio Operator | AVIATION RADIO
Plane Radio Operator
Airport Transmitter Operator |
| | | TELEVISION
Pick-Up Operator
Voice Transmitter Operator
TV Technician
Remote Control Operator | |

I TRAINED THESE MEN



"My position with WNBT is video control engineer on the RCA color project. I owe a lot of my success to your textbooks."—Warren Deem, Malvern, N. Y.



"I am a technician at WTOP in Washington and I like it very much. Most of my radio knowledge was from N.R.I."—John Britto, Hyattsville, Md.



"A former employer recommended N.R.I. training. Now employed as transmitter operator at WKBL."—Albert Herr, New Cumberland, Pa.

AVAILABLE TO **VETERANS** UNDER G.I. BILLS

MAIL NOW-BOOK FREE

MR. J. E. SMITH, President, Dept. 4EF, National Radio Institute, Washington 9, D. C. Mail me your 64-page Book, FREE. (No salesman will call. Please write plainly.)

Name..... Age.....
Address.....
City..... Zone..... State.....

VETS write in date of discharge

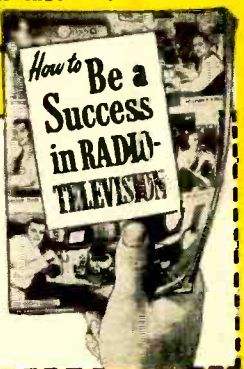

RADIO - ELECTRONICS

Formerly RADIO-CRAFT • Incorporating SHORT WAVE CRAFT • TELEVISION NEWS • RADIO & TELEVISION

Hugo Gernsback
Editor and Publisher

M. Harvey Gernsback
Editorial Director

Fred Shunaman
Managing Editor

Robert F. Scott
W2PWG, Technical Editor

Jerome Kass
Associate Editor

I. Queen
Editorial Associate

Matthew Mandl
Television Consultant

Charles A. Phelps
Copy Editor

Angie Pascale
Production Manager

Wm. Lyon McLaughlin
Tech. Illustration Director

Sol Ehrlich
Art Director

Lee Robinson
General Manager

John J. Lamson
Sales Manager

G. Aliquo
Circulation Manager

Adam J. Smith
Director, Newsstand Sales

Robert Fallath
Promotion Manager



Member
Magazine Publishers
Association

ON THE COVER (More details on page 39)

Some of the more important (and expensive) components which distinguish a color from a black-and-white set. From left to right—deflecting yoke, shadow mask (part of the picture tube) and purity coil. At rear—for purposes of size comparison—model Sofia Fransella.

Parts from RCA tube department. Color original by Habershaw Studio

CONTENTS

MAY 1954

Editorial (Page 31)

Atom Electronics by Hugo Gernsback 31

Television (Pages 32-46)

Markers and Alignment Bugs, Calibrating the marker generator; marker injection; the zero-volt reference line by the Engineering Staff, Scala Radio Co. 32

Reconditioning Picture Tubes by John E. Ledbetter 34

Adjusting a Color TV Receiver 35

Color Receiver Components (Cover Story) 39

Basic Color TV, Part IV (continued) I and Q Signals; summary of the features and techniques of the NTSC system. by D. Newman and J. J. Roche 40

Television—it's a Cinch (Tenth Conversation, 1st half—The composite video signal) by E. Aisberg 42

TV Service Clinic Conducted by Matthew Mandl 45

Test Instruments (Pages 47-57)

VTVM Applications in TV Servicing by Robert G. Middleton 47

Sine and Square Wave Generator by P. N. Markantes 50

Use a Phonic Signal Tracer by Vergniaud H. Richard 52

Double-Beam Scope Switch by T. W. Dresser 54

Relative Field-Strength Meter by Hilton L. Remley 56

Audio—High Fidelity (Pages 58-73)

For Golden Ears Only by Monitor 58

High-Quality Audio, Part IX—Design factors of triode and pentode resistance-coupled amplifiers by Richard H. Dorf 61

New Standard Record Curve 63

Servicing High-Fidelity Equipment, Part IV—Frequency test records; test instruments for audio work by Joseph Marshall 64

R-J Type 12-Inch Speaker Enclosure by J. W. Korte 68

Radio (Pages 74-101)

Transistor Phono Oscillator by Edwin Bohr 74

A Low-Cost CD Mobile Radio by Eli Nannis (WIHKG) 78

Multivibrators by Ed Bukstein 84

I.F.-R.F. Crystal Oscillator Uses Junction Transistor by I. Queen 92

Identifying Tube Types from Damaged Etchings by Hector E. French 96

Radio 35 Years Ago 101

New Design (Pages 104-107)

New Tubes and Transistors 104

Departments

The Radio Month	6	Question Box	118	Technotes	136
Business	12	Try This One	124	Correspondence	138
With the Technician	108	New Devices	128	People	142
New Patents	112	Radio-Electronic Circuits	132	Electronic Literature	145
				Book Reviews	147



MEMBER Audit Bureau of Circulations

Vol. XXV, No. 5

Average Paid Circulation over 169,000

RADIO-ELECTRONICS, May, 1954, Vol. XXV, No. 5. Published monthly at Erie Ave., F to G Sts., Philadelphia 32, Pa. Gernsback Publications, Inc. Entered as Second Class matter September 27, 1948, at the Post Office at Philadelphia, Pa., under the Act of March 3, 1879. Copyright 1954 by Gernsback Publications, Inc. Text and Illustrations must not be reproduced without permission of copyright owners.

EXECUTIVE, EDITORIAL and ADVERTISING OFFICES: 25 West Broadway, New York 7, N. Y. Telephone REctor 2-8630. Gernsback Publications, Inc. Hugo Gernsback, President; M. Harvey Gernsback, Vice-President; G. Aliquo, Secretary.

SUBSCRIPTIONS: Address correspondence to Radio-Electronics, Subscription Dept., Erie Avenue, F to G Sts., Philadelphia 32, Pa., or 25 West Broadway, New York 7, N. Y. When ordering a change please furnish an address stencil impression from a recent wrapper. Allow one month for change of address.

SUBSCRIPTION RATES: In U. S. and Canada, and in U. S. possessions, \$3.50 for one year; \$6.00 for two years; \$8.00 for three years; single copies 35¢. All other foreign countries \$4.50 a year; \$8.00 for two years; \$11.00 for three years.

BRANCH ADVERTISING OFFICES: Chicago: 7522 North Sheridan Road, Tel. Rogers Park 4-8000. Los Angeles: Ralph W. Harker and Associates, 1127 Wilshire Blvd., Tel. MADison 6-1271. San Francisco: Ralph W. Harker and Associates, 582 Market St., Tel. GARfield 1-2481. FOREIGN AGENTS: Great Britain: Atlas Publishing and Distributing Co., Ltd., London E.C.4. Australia: McGill's Agency, Melbourne. France: Brentano's, Paris 2e. Belgium: Agence et Messageries de la Presse, Brussels. Holland: Trilectron, Heemstede. Greece: International Book & News Agency, Athens. So. Africa: Central News Agency Ltd., Johannesburg; Capetown, Durban, Natal. Universal Book Agency, Johannesburg. Middle East: Steimatzyk Middle East Agency, Jerusalem. India: Broadway News Centre, Dadar, Bombay #14. Pakistan: Paradise Book Stall, Karachi 3. POSTMASTER: If undeliverable send form 3578 to: RADIO-ELECTRONICS, 25 West Broadway, New York 7, N. Y. *Trademark registered U.S. Patent Office.

RADIO-ELECTRONICS

ADVANCE! Raise your earning power—learn RADIO-TELEVISION-ELECTRONICS by SHOP-METHOD HOME TRAINING

GOOD JOBS AWAIT THE TRAINED RADIO-TV TECHNICIAN

There is a place for you in the great Radio-Television-Electronics industry when you are trained as National Schools will train you at home!

Trained technicians are in growing demand at good pay—in manufacturing, broadcasting, television, communications, radar, research laboratories, home Radio-TV service, and other branches of the field. National Schools Master Shop-Method Home Training, with newly added lessons and equipment, trains you in your spare time, right in your own home, for these fascinating opportunities. OUR METHOD IS PROVED BY THE SUCCESS OF NATIONAL SCHOOLS TRAINED MEN, ALL OVER THE WORLD, SINCE 1905.

EARN WHILE YOU LEARN

Many National students pay for all or part of their training with spare time earnings. We'll show you how you can do the same! Early in your training, you receive "Spare-time Work" Lessons which will enable you to earn extra money servicing neighbors' and friends' Radio and Television receivers, appliances, etc.

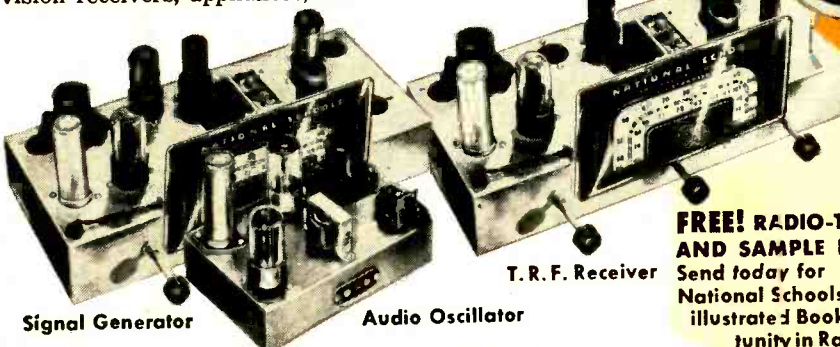

Signal Generator

Audio Oscillator

T. R. F. Receiver

National Schools Training is All-Embracing

National Schools prepares you for your choice of many job opportunities. Thousands of home, portable, and auto radios are being sold daily—more than ever before. Television is sweeping the country, too. Co-axial cables are now bringing Television to more cities, towns, and farms every day! National Schools' complete training program qualifies you in all fields. Read this partial list of opportunities for trained technicians:

- Business of Your Own • Broadcasting
- Radio Manufacturing, Sales, Service • Telecasting
- Television Manufacturing, Sales, Service
- Laboratories: Installation, Maintenance of Electronic Equipment
- Electrolysis, Call Systems
- Garages: Auto Radio Sales, Service
- Sound Systems and Telephone Companies, Engineering Firms
- Theatre Sound Systems, Police Radio
- And scores of other good jobs in many related fields.

TELEVISION TRAINING

You get a complete series of up-to-the-minute lessons covering all phases of repairing, servicing and construction. The same lesson texts used by resident students in our modern and complete Television broadcast studios, laboratories and classrooms!



MASTER ALL PHASES!

Get Master Shop-Method Home Training from an Es-tablished Prac-tical Resident School with its own Training Successful Experience in Training Ambitious Men.



We Bring National Schools To You!

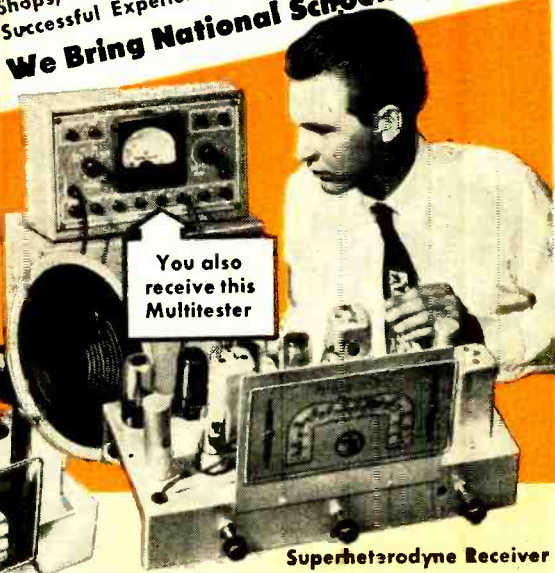

You also receive this Multitester

Superheterodyne Receiver

LEARN BY DOING

You receive and keep all the modern equipment shown above, including tubes and valuable, professional quality Multitester. No extra charges.

FREE! RADIO-TV BOOK AND SAMPLE LESSON!

Send today for National Schools' new, illustrated Book of Opportunity in Radio-Television-

Electronics, and an actual Sample Lesson. No cost—no obligation. Use the coupon now—we'll answer by return airmail.

APPROVED FOR VETERANS AND NON-VETERANS Check coupon below

Both Resident and Home Study Courses Offered!



NATIONAL SCHOOLS

LOS ANGELES 37, CALIFORNIA • ESTABLISHED 1905
IN CANADA: 811 W. HASTINGS STREET, VANCOUVER, B.C.

GET FACTS FASTEST! MAIL TO OFFICE NEAREST YOU!

(mail in envelope or paste on postal card)
NATIONAL SCHOOLS, Dept. RG-54
 4000 S. Figueroa Street or 323 West Polk Street
 Los Angeles 37, Calif. Chicago 7, Ill.
 Send FREE Radio-TV Electronics book and FREE sample lesson. No obligation, no salesman will call.
 NAME _____ BIRTHDAY _____ 19____
 ADDRESS _____
 CITY _____ ZONE _____ STATE _____
 Check if interested ONLY in Resident Training at Los Angeles.
 VETERANS: Give Date of Discharge _____

**NEWEST
FASTEST SELLER
in the field!**

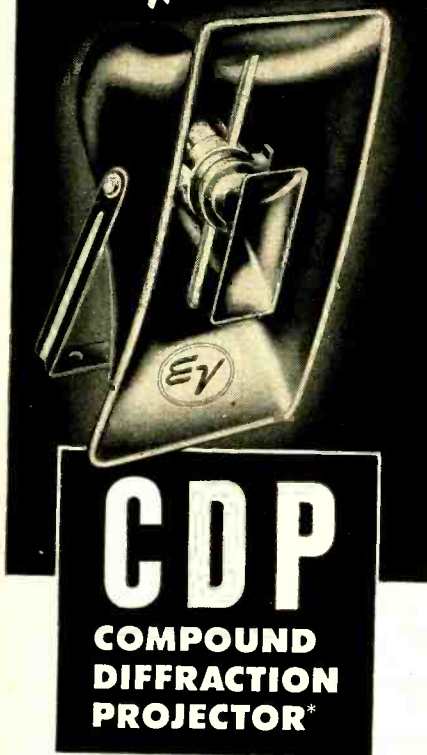

CDP
COMPOUND
DIFFRACTION
PROJECTOR*

Public Address Loudspeaker System

setting new standards for
**VOICE PENETRATION
AND MUSICASTING**

- Greatly outperforms comparably sized reentrant horns
- Tremendous penetrating power and coverage at very low unit energy cost
- Exclusive E-V coaxial design and diffraction principle
- Peak-free response ± 5 db to 10,000 cps
- Delivers $2\frac{1}{2}$ octaves more musical range
- Weather-proof, blast-proof, splash-proof
- Virtually indestructible

Model 848 CDP. 25 watts. 16 ohms.
List Price, \$65.00 Net, \$39.00

**COMPARE
POLAR PATTERN**
Sound distribution
of CDP exceeds 120°
at all frequencies up
to 10,000 cps.

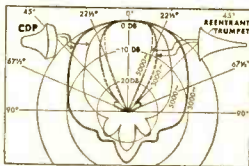

**COMPARE
RESPONSE AND
EFFICIENCY**
Note extended high
frequency range of
CDP. Response is
smooth, peak-free
 ± 5 db to 10,000 cps.

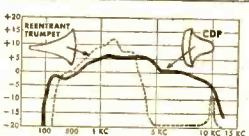

Write for Free
Bulletin No. 197

*Pat. Pend.

Electro-Voice

421 CARROL ST. • BUCHANAN, MICHIGAN
Export: 13 E. 40th St., New York 16, U. S. A. Cable: Arlab

TRANSISTORIZED MICROPHONE
developed by the Army Signal Corps eliminates the frying sound of the old carbon microphone, while fitting into the plastic handle of the carbon model. The Remler Co. is making a commercial model of similar design.

The transistor element, second from the right in the foreground of the photograph, is extremely rugged and easy to assemble. Next to the transistor amplifier are the handle switch and rubber cover used in the old and new models.

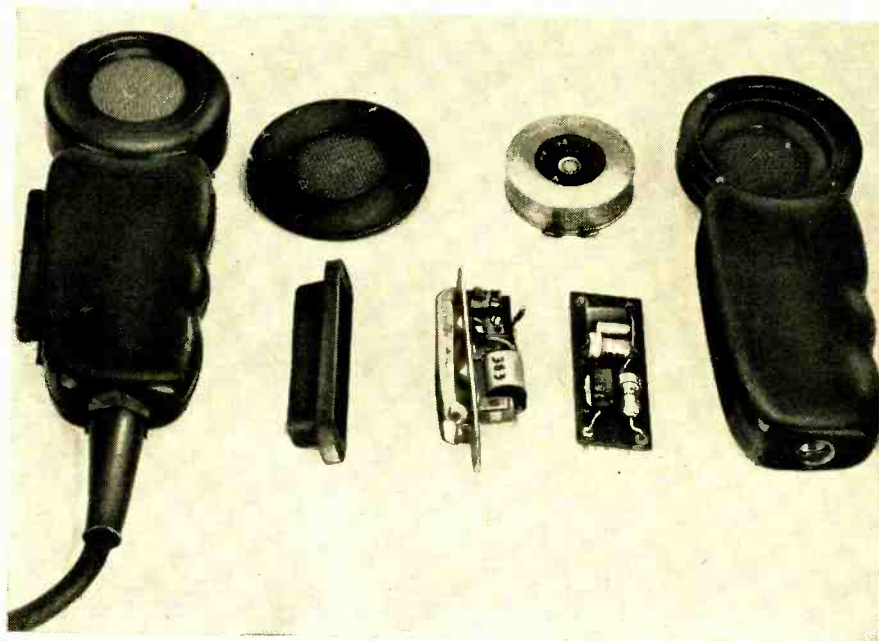

No modifications are necessary in existing radio equipment to operate the microphone. It can be plugged into any jack in which a carbon mike was used. In addition to the noise reduction feature, the higher quality of reproduction makes it easier for the listener to recognize a familiar voice—an important aid to security in battle.

15 KC MODULATION of AM broadcast stations is permitted providing it does not cause interference with other stations, according to FCC Commissioner George E. Sterling. Speaking before the Hi-Fi Fair in Washington, he pointed out the growing interest in high fidelity and stated that good reproduction is "a challenge to the broadcaster."

Sterling stated the high cost of 15-kc intercity lines is the major obstacle to high-fidelity networking, and that he hoped listener pressure will force increased use of better lines and terminal equipment.

PIONEER FM STATION CLOSES. KE2XCC (formerly W2XMN), the first FM broadcast station in the U.S., shut down operations on March 6. Erected by the late Major Edwin H. Armstrong, the station has been broadcasting music, without commercials, since 1938. The station was completely financed by Major Armstrong and acted as the laboratory for most of his experiments.

HIGH COST OF TV broadcasting was seen in the recent rent increase proposed by the Empire State Bldg. Corp. to the seven New York television stations. The rent increase, from \$70,000 to \$200,000 per year per station, would be for a five-year period beginning May 1, 1954. The renting price carries only the right to use the building's mast as a common transmitting antenna site; floor space in the building for transmitter equipment, offices, etc., must be rented separately.

EIGHT NEW STATIONS have gone on the air since our last report. These are:

KSAN-TV San Francisco, Calif.	32
WINK-TV Fort Myers, Fla.	11
KDAL-TV Duluth-Superior, Minn. 3	
WDSM-TV Duluth-Superior, Minn. 6	
WMUR-TV Manchester, N.H.	9
WTRI Schenectady, N.Y.	35
WAPA-TV San Juan, P.R.	4
KFBC-TV Cheyenne, Wyo.	5

Vermont is now the only state without a TV Station, but Montpelier now has a construction permit for channel 3. Two more stations have gone off the air this month, WIFE, Dayton, Ohio, channel 22, and KFOR-TV, Lincoln, Neb., channel 10.

EAVESDROPPING on rural telephone party-line conversations may soon become a thing of the past. Bell Telephone engineers are experimenting near Americus, Ga. with a transistorized telephone system that will permit several conversations to be carried over a single line without mixup.

The principle is already used on long-distance telephone networks, but until the transistor was developed, it was uneconomical on a local basis.

When a call is made, the conversation will be transmitted on the line at one frequency. If a neighbor who shares that line decides to call at that moment, her conversation will be carried on another frequency.

Now IN YOUR OWN HOME Learn

TELEVISION

RADIO-ELECTRONICS

the Amazingly Effective

D. T. I. WAY

—with the aid of BOTH HOME EQUIPMENT and HOME MOVIES

NO PREVIOUS EXPERIENCE NEEDED

NOW... get EVERYTHING YOU NEED

for real Laboratory-type training AT HOME



5 INCH "SCOPE"

Oscilloscope

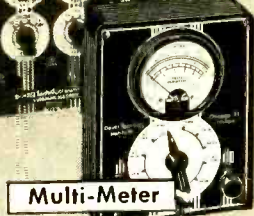

Multi-Meter



21 INCH

Build and keep this BIG DTI Engineered TV set—easily converted to U.H.F. (DTI offers another home training, but without the TV set.)

Above: Work over 300 fascinating experiments with this equipment

1. Build over 300 fascinating experiments from 16 BIG SHIPMENTS of Electric-Radio parts which you KEEP.
2. Build valuable commercial-type test equipment—as shown to the left—which you KEEP. This includes a quality 5 INCH oscilloscope and jewel bearing Multi-Meter—both highly useful for Television work.
3. Build and keep a big 21 INCH TV Set. (D.T.I. offers another home training in "Television-Radio-Electronics, but without the TV set.)
4. Use a 16 mm. movie projector and new series of highly instructive movies—a wonderful aid to help you grasp important fundamentals faster... easier... better.
5. Enjoy well-illustrated, easy-to-read lessons with handy FOLD-OUT diagrams.
6. Get an honest-to-goodness EMPLOYMENT SERVICE to help you get a good job after graduating—or assistance in starting your OWN SALES AND SELF SERVICE BUSINESS. Mail coupon today for the complete details.

What will mailing the coupon below do for YOU? Just this! You'll find out about one of today's most remarkable... practical ways to prepare to get into America's amazing billion dollar opportunity field of TELEVISION-RADIO-ELECTRONICS. You'll see how to get into fascinating work that pays well... that offers one of America's most promising futures... that enables you to start your own business almost "on a shoe string," if you prefer this to a job opportunity.

And above all, you'll get some GOOD NEWS especially welcomed by men anxious to earn REAL MONEY in this thrilling field. For you'll see that NOW you can get the kind of practical, laboratory-type training so desirable for making real progress in Television-Radio-Electronics AND WITHOUT LEAVING HOME.

You'll see that DeVry Technical Institute sends everything needed to set up your own HOME LABORATORY.

You get and keep the same type of basic electronic equipment used in our modern Chicago Training Laboratories. You get home training that includes the knowledge and experience gained from training thousands of students first hand in Chicago.

And to top it all, you use DTI's amazingly effective and exclusive home training aid—INSTRUCTIVE MOVIES. But why not get the complete story? Mail coupon today for information-packed literature.

MODERN LABORATORIES

If you prefer, get all your preparation in our new Chicago Training Laboratories—one of the finest of its kind. Ample instructors, modern equipment. Write for details!

MILITARY SERVICE!

If you're subject to military service, the information we have for you should prove very helpful. Mail coupon today.

Get this information-packed publication



89 WAYS TO EARN MONEY IN TELEVISION RADIO-ELECTRONICS

FREE!

Mail Coupon Today



"ONE OF AMERICA'S FOREMOST TELEVISION TRAINING CENTERS"

DEVRY TECHNICAL INSTITUTE
AFFILIATED WITH
DEFOREST'S TRAINING, INC.
CHICAGO 41, ILLINOIS

DEVRY TECHNICAL INSTITUTE
4141 BELMONT AVE., CHICAGO 41, ILL. Dept. RE-5-K

I would like your valuable information-packed publication showing how I can get started toward a good job or my own business in Television-Radio-Electronics.

Name..... Age.....
 Street..... Apt.....
 City..... Zone..... State.....

Quality Features OF TUNG-SOL PICTURE TUBES



Gun made of best grade non-magnetic steel.

Glass bead type assembly is stronger both mechanically and electrically—gives greater protection against electrical leakage.

Rolled edges in gun minimize corona.

Custom built stem with greater spacing between leads assures minimum leakage.

Low resistance of outside conductive coating minimizes radiation of horizontal oscillator sweep frequency.

Double cathode tab provides double protection against cathode circuit failure.

Selected screen composition resists burning (X pattern).

Rigid control of internal conductive coating provides utmost service reliability.

Designed for use with single or double field ion trap designs.

One-piece construction of parts assures better alignment.

Maximum dispersion of screen coating assures uniform screen distribution.

Tung-Sol makes All-Glass Sealed Beam Lamps, Miniature Lamps, Signal Flashers, Picture Tubes, Radio, TV and Special Purpose Electron Tubes and Semiconductor Products.

TUNG-SOL ELECTRIC INC., Newark 4, N. J. Sales Offices: Atlanta, Chicago, Columbus, Culver City (Los Angeles), Dallas, Denver, Detroit, Newark, Seattle.

TUNG-SOL®

RADIO AND TV TUBES



You Can Build A Reputation On Tung-Sol Quality

BETTER BUSINESS BUREAUS throughout the country have become interested in "midget wonder" TV "antennas" similar to those shown in the photo. A report by the New York City bureau indicates that tests made by laymen are likely to be rather inconclusive, but that probably the average user would get results of a somewhat similar nature with a piece of ordinary wire about the length of the lead on the new "antennas."

Destructive tests by RADIO-ELECTRONICS on two of the dozen or so models advertised would tend to back up that conclusion. In one model (top one in photo) the wire was terminated inside a hard plastic hollow disc by being pushed loosely through (not soldered to) a small square of copper wire

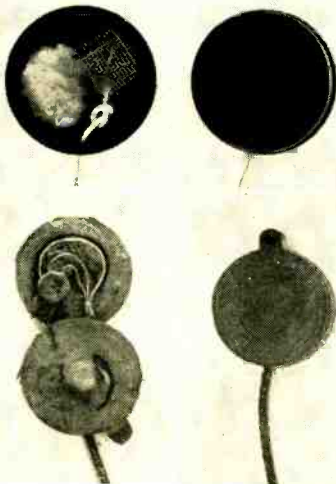

screening. A piece of soft plastic material or modelling clay held the screen to the case. The other antenna (bottom in photo) was more elaborate. The disc—composed of a single molded piece of soft plastic—contained a small hook of copper wire and a ceramic .01- μ f capacitor. Both leads of the capacitor were apparently connected together by the clamp which held the wire hook to the lead.

Barring the remote possibility of some new discovery in radio propagation, it would seem reasonable to suppose that these miracle antennas should work much like simple pieces of wire of similar dimensions.

STABLE TRANSISTORS and germanium-silicon alloys that will permit transistors to operate effectively at high heat levels have been announced by Sylvania.

Transistor stability was attained through "stabilized germanium", immune to the effects of surface moisture which sometimes reduce greatly the amplifying qualities of the transistor, or cause it to fail entirely.

In discussing the new germanium-silicon alloys, Sylvania stated that while a present-day transistor will not operate efficiently when the germanium crystal is heated to a point above 212° Fahrenheit, the new alloy will permit effective transistor action up to a temperature of about 350°.

PURE GERMANIUM has been developed by Bell Telephone Labs. Using a newly developed method, germanium has been refined to a purity in excess of 99.9999%. A substance this pure may very well be the purest material in existence.

The new method, known as zone-melting, is based on the fact that impurities are not equally soluble in the solid and liquid states of a substance; usually, impurities are more soluble in

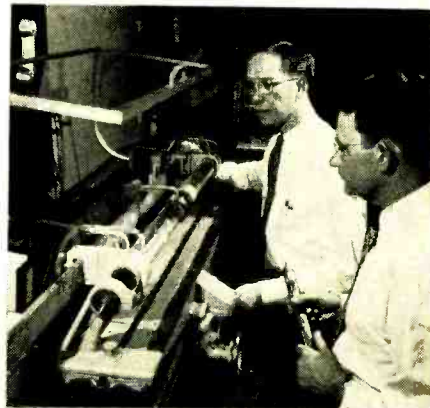

the liquid. To take advantage of this, a narrow molten zone is moved slowly along an ingot of relatively impure material to "sweep" the impurities to one end of the ingot.

The behavior of germanium transistors is affected critically by the presence of impurities; but the kind and amount of impurities must be rigidly controlled. By refining an ingot of germanium to a near-perfect state of purity by the zone-melting process, its electrical properties can then be altered to the desired degree by the controlled addition of such impurities as arsenic and antimony.

NEW KIND OF "TV" designed to help nervous, tense people relax their muscles and ease the strain on their hearts, has been developed by Dr. Edmund Jacobson of Chicago. The device



Photo courtesy Newsweek and Chicago Photographers

gives the patient a visible recording of the tension of his muscles and nerves when he may think that he is relaxing. Later, when he really does relax his muscles, he can see the changes recorded by the tension waves on the oscilloscope screen.

Dr. Jacobson's "TV" set consists of a modified version of a standard electrocardiograph connected to an oscilloscope to give his patients a dramatic view of muscular behavior.

END

RADIO-ELECTRONICS

For the Best TV Reception **NOW** and in the **FUTURE** Choose **Superotor**®

VHF
UHF

It's only common sense! — to get the best TV reception, you need the best antenna rotator. And that's **Superotor**! The features prove it! **Superotor** is the newest and finest of all rotators, acclaimed by engineers, servicemen, and TV owners alike. It's the only rotator built for the future... **actually 5 to 10**

times more accurate than other rotators, giving you the superfine tuning you will need for the UHF and Color stations to come!

COLOR

Look ahead! — choose **Superotor**, and be assured you have the finest rotator now — and for the future, too!

Tomorrow's Rotator Here TODAY!

● Quick-Detachable Drive Unit

As easy to replace as a light bulb! No need to dismount the entire antenna — no need to interrupt TV viewing. Saves time, expense and inconvenience!

● Double Lock Stop Prevents Drift & Coast

Set it and forget it! One lock prevents coasting beyond position you set, a second lock prevents drifting due to wind — also permits superfine rotator tuning.

Plus These Other Outstanding Features

- Antenna position readable without rotating antenna.
- Operates at upwards of 350 feet from control point
- Dependable high-torque motor
- Wide-span double ball bearing supports

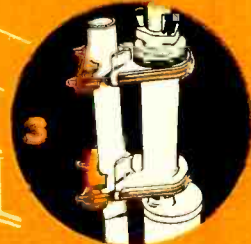

● Steel-Reinforced Construction

Aluminum housing and antenna supports reinforced with steel for super-strength plus light weight.

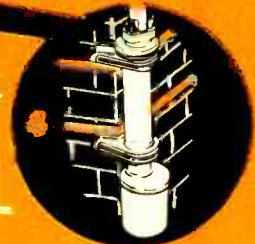

● Built-in Chimney Mount Design

No need for stub mast — mounts directly on chimney, but below crown, away from soot and fumes.



Patent Applied For

● VP* Tuning

Vernier Precision — extremely accurate! Exclusive "telegraph" action, plus double lock stop, permits tuning to within 1/2 degree!



2925 EAST 55TH ST.
CLEVELAND 27, OHIO

LEADING THE WAY TO BETTER PRODUCTS

NEW **RAYTHEON** GUN WITH CROSSOVER CONTROL

Helps RAYTHEON PICTURE TUBES Set New Standards of Picture Quality

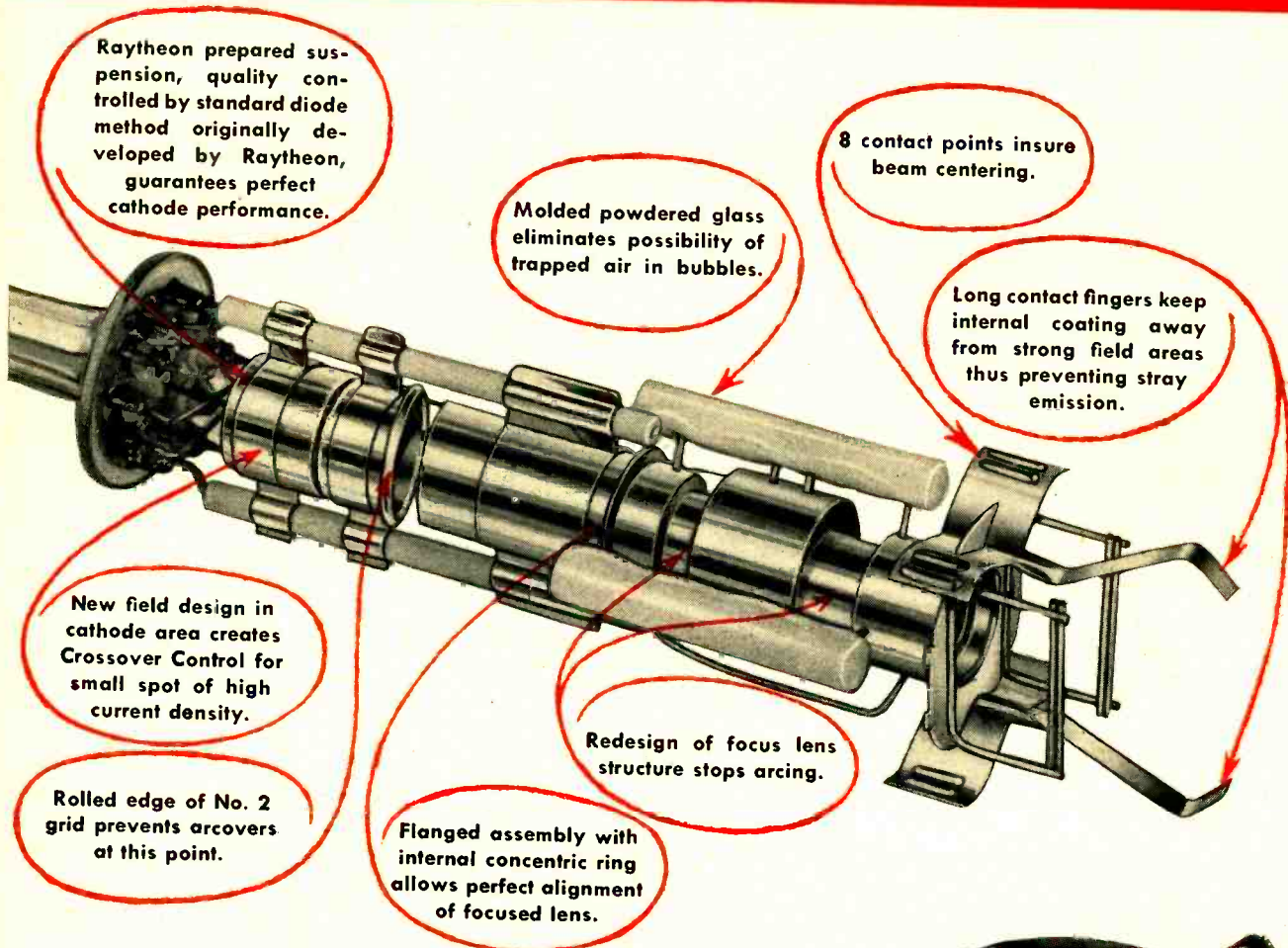

For crisp, clean, high definition pictures, you can't beat Raytheon Picture Tubes with the new *Crossover Control Gun*. This new gun has a specially shaped grid designed to keep the electrostatic field undisturbed. Emission from the center of the cathode is vastly improved eliminating slow electrons from the edges which overshoot and smear. These design improvements do away with tailings and halos, lines and spots won't blur even under highlight conditions.

You owe it to your customers and yourself to *replace with Raytheon*. Ask your Raytheon Tube Distributor for complete information.



Excellence in Electronics

RAYTHEON MANUFACTURING COMPANY

Receiving Tube Division
 Newton, Mass., Chicago, Ill., Atlanta, Ga., Los Angeles, Cal.

RAYTHEON MAKES ALL THESE:

RELIABLE SUBMINIATURE AND MINIATURE TUBES • SEMICONDUCTOR DIODES AND TRANSISTORS • NUCLEONIC TUBES • MICROWAVE TUBES • RECEIVING AND PICTURE TUBES

RADIO-ELECTRONICS

FREE

MONEY MAKING FCC Commercial Radio Operator LICENSE INFORMATION

TELLS HOW -

WE GUARANTEE
TO TRAIN AND COACH YOU AT HOME
IN SPARE TIME UNTIL YOU GET
**YOUR FCC
LICENSE**

If you have had any practical experience — Amateur, Army, Navy, radio repair, or experimenting.

Here is your guarantee
If you fail to pass your Commercial License exam after completing our course, we guarantee to continue your training without additional cost of any kind, until you successfully obtain your Commercial license, provided you first sit for this examination within 90 days after completing your course.

TV Engineering
INCLUDED IN OUR
TRAINING AND
COACHING

TELLS HOW -

OUR AMAZINGLY EFFECTIVE JOB-FINDING SERVICE HELPS CIRE STUDENTS GET BETTER JOBS. HERE ARE JUST A FEW RECENT EXAMPLES OF JOB-FINDING RESULTS:

GETS CIVIL SERVICE JOB

"Thanks to your course I obtained my 2nd phone license, and am now employed by Civil Service at Great Lakes Naval Training Station as an Equipment Specialist."
Kenneth R. Leiser, Fair Oaks, Md. Del., McHenry, Ill.

GETS STATE POLICE JOB

"I have obtained my 1st class ticket (thanks to your school) and since receiving same I have held good jobs at all times. I am now Chief Radio Operator with the Kentucky State Police."
Edwin Healy, 264 E. 3rd St., London, Ky.

GETS BROADCAST JOB

"I wish to thank your Job-Finding Service for the help in securing for me the position of transmitter operator here at WCAE, in Pittsburgh."
Walter Koschik, 1442 Ridge Ave., N. Braddock, Pa.

GETS AIRLINES JOB

"Due to your Job-Finding Service, I have been getting many offers from all over the country, and I have taken a job with Capital Airlines in Chicago, as a Radio Mechanic."
Harry Clare, 4537 S. Drexel Blvd., Chicago, Ill.

TELLS HOW -

EMPLOYERS MAKE JOB OFFERS LIKE THESE TO OUR GRADUATES EVERY MONTH!

Letter from nationally-known Airlines, "We would also appreciate if you would place the following additional advertisement in your bulletin—
Wanted—Superintendent of Communications . . . Salary \$666.66 per month."

Letter from nationally known airplane manufacturer. "We need men with electronic training or experience in radar maintenance to perform operational check-out of radar and other electronics systems . . . starting salary . . . amounting to \$329.33 per month."

Letter from nationally-known Airlines, "We are contemplating placing . . . an Airline Ground Radio Engineer." Starting salary \$385 per month.

These are just a few of the examples of the job offers that come to our office periodically. Some licensed radioman filled each of these jobs; it might have been you!

Ours is the only home study course which supplies FCC-type examinations with all lessons and final tests.

ACT NOW!

Get ALL 3 FREE

You- FCC Ticket is required by most employers as proof of your technical ability.

HERE'S PROOF FCC LICENSES ARE OFTEN SECURED IN A FEW HOURS OF STUDY WITH OUR COACHING AT HOME IN SPARE TIME:

Name and Address	License	Lessons
Lee Worthy, 2210 1/2 Wilshire St., Bakersfield, Cal.	2nd Phone	16
Clifford E. Vogt, Box 1016, Dania, Fla.	1st Phone	20
Francis X. Foerch, 38 Beucler Pl., Bergenfield, N. J.	1st Phone	38
S/Sgt. Ben H. Davis, 317 North Roosevelt, Lebanon, Ill.	1st Phone	28
Albert Schoell, 110 West 11th St., Escondido, Cal.	2nd Phone	23

CARL E. SMITH, E.E. Consulting Engineer, President

CLEVELAND INSTITUTE OF RADIO ELECTRONICS
Desk RE-64, 4900 Euclid Bldg., Cleveland 3, Ohio



MAIL COUPON NOW!

B I want to know how I can get my FCC Ticket in a minimum of time. Send me your FREE booklet, "How to Pass FCC License Examinations" (does not cover exams for Amateur License), as well as a sample FCC-type exam and the amazing new booklet, "Money-Making FCC License information."
Be sure to tell me about your Television Engineering Course.

Name.....
City..... Zone..... State.....
Address.....
Paste on 2 cent postcard or send air mail.

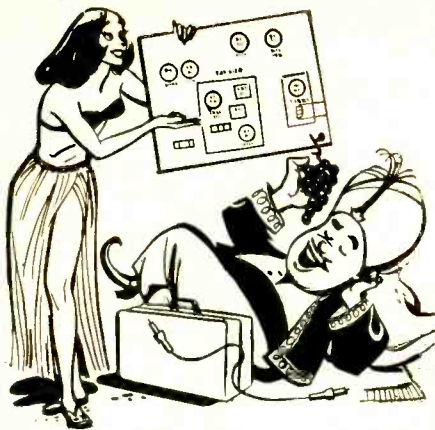

you're on easy street with PHOTOFAC TUBE PLACEMENT and TUBE FAILURE CHECK CHARTS

TUBE PLACEMENT CHARTS: included in each and every PHOTOFAC TV Folder. Shows top and bottom views; top view is positioned as chassis would be viewed in customer's home. Shows tube locating key or blank pin; gives tube function, type and placement; includes fuse type, location and circuit protected.

TUBE FAILURE CHECK CHART: in each and every PHOTOFAC TV Folder. Shows common trouble symptoms and lists tubes whose failure may be responsible for each type of trouble. Includes schematics of series filament strings for quicker reference.

22 other exclusive features consistently in every PHOTOFAC Folder—the world's best data for faster, more profitable servicing...

No pic, has raster - V9, V21
Has pic, no sound - V11, V12, V13
Overloaded picture - V10

NOW! GET THE PROOF FOR YOURSELF!

FREE We'll send you a Free Photofact TV Folder—just ask us for it!

Learn for yourself how PHOTOFAC pays for itself by earning bigger profits for you! We'll send you the proof—a FREE specimen PHOTOFAC TV Folder that shows all the features found consistently and exclusively ONLY in PHOTOFAC. Send for your FREE specimen TV Folder now. Examine it. Compare it. You'll see why PHOTOFAC belongs in your shop! And you'll want to ask your parts distributor about the pay-as-you-earn-plan. Only \$25 down brings you the entire PHOTOFAC Library. Write for FREE specimen TV Folder—learn now how to earn more!

HOWARD W. SAMS & CO., INC.
2205 E. 46th St., Indianapolis 5, Ind.

HOWARD W. SAMS & CO., INC.

Merchandising and Promotion

Ward Products Corp., division of Gabriel Co., Cleveland, introduced two new self-selling dealer display racks for its automobile antennas.



Alliance Mfg. Co., Alliance, Ohio, was ranked in a 14th place tie among the 26 top national TV spot advertisers according to the current Rorabaugh report. Alliance moved up from 16th spot on the last report.

Sprague Products Co., North Adams, Mass., designed a new ceramic capacitor kit for speeding service work on TV



yokes. With the new kit the proper capacitance can be found easily, by systematically bridging various capacitors in the kit across the yoke.

CBS-Hytren, Danvers, Mass., announced the winners in its Certified Quality Service contest for TV radio service technicians. Martin H. Sable of Mattapan, Mass., won the top award, a Ford panel truck. Second prize of \$1,000 in U.S. Savings Bonds went to Richard E. Reish of Marcellus, Mich.

RCA Tube Dept., Harrison, N. J., launched a spring promotional campaign on its portable radio batteries. National magazine, radio, and TV advertising are being used together with in-store displays and merchandising aids.

JFD Mfg. Co., Brooklyn, N. Y., designed a display for its new LAD-11

lightning arrester.

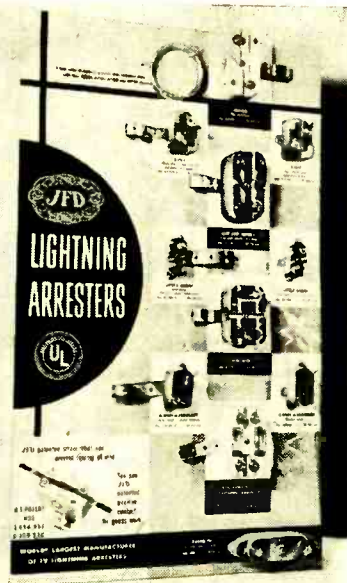

Astatic Corp., Conneaut, Ohio, designed a new steel combination stock case and dispenser for parts distributors selling its line of pickup cartridges.

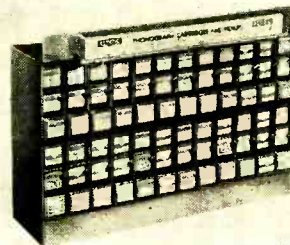

Erie Resistor Corp., Erie, Pa., developed a new display carton for its type 413 filter ceramic.

... Trio Manufacturing Co., Griggsville, Ill., purchased Falcon Electronics Co., Quincy, Ill., and its entire line of antennas. Roy Wade, formerly general manager of Falcon, is now general sales manager for Trio. The entire Falcon operation will be moved to the new Trio plant in Griggsville where the Falcon line will be manufactured. All Falcon representatives have been retained and will work with Trio representatives. The Trio plant also added a large tool room, a new laboratory, and a maintenance depot for its fleet of trucks.

DuKane Corp., St. Charles, Ill., has produced a photo paste-up kit which its distributors may present to architects, engineers, electrical contractors, and others as an aid in visualizing arrangements of console and panel assemblies of a school sound system.

Shows and Conferences

NEDA described the first of its regional seminars held in New York City last March as an outstanding success. Over 300 distributors and key personnel attended. The association indicated that this successful debut would be a forerunner of similar meetings in other sections of the country.

The 1954 British Radio Components Show was held in London in April.

The New York Sections of the AIEE

Here comes opportunity ... ready or not!

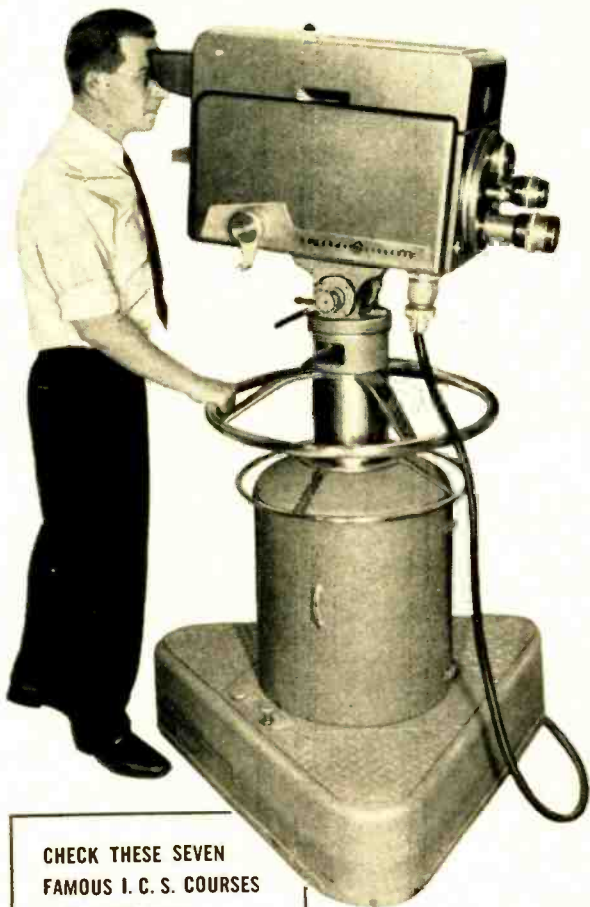

• Prepare now for the new Radio-TV-Electronics boom. Get in on VHF and UHF . . . aviation and mobile radio . . . color TV . . . binaural sound! The International Correspondence Schools can help you!

If you've ever thought about Radio or Television as a career . . . if you have the interest, but not the training . . . if you're waiting for a good time to start . . . NOW'S THE TIME!

No matter what your previous background, I.C.S. can help you. If Radio-TV servicing is your hobby, I.C.S. can make it your own profitable business. If you're interested in the new developments in Electronics, I.C.S. can give you the basic courses of training you need. If you have the job but want faster progress, I.C.S. can qualify you for promotions and pay raises.

I.C.S. training is success-proved training. Hundreds of I.C.S. graduates hold top jobs with top firms like R.C.A., G.E., DUMONT, I.T.&T. Hundreds of others have high ratings in military and civil service. Still others have successful businesses of their own.

With I.C.S., you get the rock-bottom basics and theory as well as the all-important bench practice and experimentation. You learn in your spare time—no interference with business or social life. You set your own pace—progress as rapidly as you wish.

Free career guidance: Send today for the two free success books, the 36-page "How to Succeed" and the informative catalog on the course you check below. No obligation. Just mark and mail the coupon. With so much at stake, you owe it to yourself to act—and act fast!

I.C.S., Scranton 9, Penna.

CHECK THESE SEVEN
FAMOUS I. C. S. COURSES
—ONE FOR YOU!

- PRACTICAL RADIO-TELEVISION ENGINEERING**—Foundation course for radio-television career. Basic principles plus advanced training. Radio, Sound, TV.
- TELEVISION TECHNICIAN**—To qualify you for high-level technical positions in television. Camera, studio, transmitter techniques. Manufacture, sale and installation of TV equipment.
- TELEVISION RECEIVER SERVICING**—Installation, servicing, conversion Dealership. For the man who knows about radio and wants TV training.
- RADIO & TELEVISION SERVICING**—Designed to start you repairing, installing and servicing radio and television receivers soon after starting the course.
- RADIO & TELEVISION SERVICING WITH TRAINING EQUIPMENT**—Same as above but with addition of high-grade radio servicing equipment and tools.
- RADIO OPERATING COURSE**—Special course to help you pass the Government examination for operator's licenses Code TV, FM, Radioregulations.
- INDUSTRIAL ELECTRONICS**—Broad, solid background course devoted to the electron tube and to its many applications.

For Real Job Security—Get I.C.S. Training!

INTERNATIONAL CORRESPONDENCE SCHOOLS



2881-K, SCRANTON 9, PENNA.

Without cost or obligation, send me "HOW TO SUCCEED" and the booklet about the course BEFORE which I have marked X:

- | | | | | |
|--|--|---|---|--|
| <p>ART</p> <ul style="list-style-type: none"> <input type="checkbox"/> Commercial Art <input type="checkbox"/> Magazine Illustrating <input type="checkbox"/> Fashion Illustrating <input type="checkbox"/> Cartooning <input type="checkbox"/> Sketching and Painting <input type="checkbox"/> Show Card and Sign Lettering <p>AUTOMOTIVE</p> <ul style="list-style-type: none"> <input type="checkbox"/> Automobile, Mechanic <input type="checkbox"/> Auto Elec. Technician <input type="checkbox"/> Auto Body Rebuilding and Refinishing <input type="checkbox"/> Diesel—Gas Engines <p>AVIATION</p> <ul style="list-style-type: none"> <input type="checkbox"/> Aeronautical Engineering Jr. <input type="checkbox"/> Aircraft Engine Mechanic <input type="checkbox"/> Airplane Drafting <p>BUILDING</p> <ul style="list-style-type: none"> <input type="checkbox"/> Architecture <input type="checkbox"/> Arch. Drafting <input type="checkbox"/> Building Contractor <input type="checkbox"/> Estimating <input type="checkbox"/> Carpenter and Mill Work <input type="checkbox"/> Carpenter Foreman <input type="checkbox"/> Reading Blueprints <input type="checkbox"/> House Planning <input type="checkbox"/> Plumbing | <ul style="list-style-type: none"> <input type="checkbox"/> Heating <input type="checkbox"/> Painting Contractor <input type="checkbox"/> Air Conditioning <input type="checkbox"/> Electrician <p>BUSINESS</p> <ul style="list-style-type: none"> <input type="checkbox"/> Business Administration <input type="checkbox"/> Certified Public Accountant <input type="checkbox"/> Bookkeeping and Accounting <input type="checkbox"/> Office Management <input type="checkbox"/> Stenography and Typing <input type="checkbox"/> Secretarial <input type="checkbox"/> Federal Tax <input type="checkbox"/> Business Correspondence <input type="checkbox"/> Letter-writing Improvement <input type="checkbox"/> Personnel and Labor Relations <p>ADVERTISING</p> <ul style="list-style-type: none"> <input type="checkbox"/> Retail Business Management <input type="checkbox"/> Managing Small Business <input type="checkbox"/> Ocean Navigation <input type="checkbox"/> Sales Management <input type="checkbox"/> Short Story Writing <input type="checkbox"/> Creative Salesmanship <input type="checkbox"/> Traffic Management <p>CHEMISTRY</p> <ul style="list-style-type: none"> <input type="checkbox"/> Chemical Engineering <input type="checkbox"/> Chemistry <input type="checkbox"/> Analytical Chemistry | <ul style="list-style-type: none"> <input type="checkbox"/> Petroleum—Nat'l Gas <input type="checkbox"/> Pulp and Paper Making <input type="checkbox"/> Plastics <p>CIVIL, STRUCTURAL ENGINEERING</p> <ul style="list-style-type: none"> <input type="checkbox"/> Civil Engineering <input type="checkbox"/> Structural Engineering <input type="checkbox"/> Surveying and Mapping <input type="checkbox"/> Structural Drafting <input type="checkbox"/> Highway Engineering <input type="checkbox"/> Reading Blueprints <input type="checkbox"/> Construction Engineering <input type="checkbox"/> Ship Drafting <input type="checkbox"/> Sanitary Engineering <p>DRAFTING</p> <ul style="list-style-type: none"> <input type="checkbox"/> Aircraft Drafting <input type="checkbox"/> Architectural Drafting <input type="checkbox"/> Electrical Drafting <input type="checkbox"/> Highway Drafting <input type="checkbox"/> Mechanical Drafting <input type="checkbox"/> Structural Drafting <input type="checkbox"/> Sheet Metal Drafting <input type="checkbox"/> Ship Drafting <input type="checkbox"/> Mine Surveying and Drafting <p>ELECTRICAL</p> <ul style="list-style-type: none"> <input type="checkbox"/> Electrical Engineering <input type="checkbox"/> Electrician <input type="checkbox"/> Electrical Maintenance | <ul style="list-style-type: none"> <input type="checkbox"/> Electrical Drafting <input type="checkbox"/> Electric Power and Light <input type="checkbox"/> Lineman <p>HIGH SCHOOL</p> <ul style="list-style-type: none"> <input type="checkbox"/> High School Subjects <input type="checkbox"/> Mathematics <input type="checkbox"/> Commercial <input type="checkbox"/> Good English <p>MECHANICAL AND SHOP</p> <ul style="list-style-type: none"> <input type="checkbox"/> Mechanical Engineering <input type="checkbox"/> Industrial Engineering <input type="checkbox"/> Industrial Supervision <input type="checkbox"/> Foremanship <input type="checkbox"/> Mechanical Drafting <input type="checkbox"/> Machine Design-Drafting <input type="checkbox"/> Machine Shop Practice <input type="checkbox"/> Tool Design <input type="checkbox"/> Industrial Instrumentation <input type="checkbox"/> Machine Shop Inspection <input type="checkbox"/> Reading Blueprints <input type="checkbox"/> Toolmaking <input type="checkbox"/> Gas—Electric Welding <input type="checkbox"/> Heat Treatment—Metallurgy <input type="checkbox"/> Sheet Metal Work <input type="checkbox"/> Sheet Metal Pattern Drafting <input type="checkbox"/> Refrigeration | <p>POWER</p> <ul style="list-style-type: none"> <input type="checkbox"/> Combustion Engineering <input type="checkbox"/> Diesel—Electric <input type="checkbox"/> Electric Light and Power <input type="checkbox"/> Stationary Steam Engineering <input type="checkbox"/> Stationary Fireman <p>RADIO, TELEVISION COMMUNICATIONS</p> <ul style="list-style-type: none"> <input type="checkbox"/> Practical Radio—TV Eng'ring <input type="checkbox"/> Radio Operating <input type="checkbox"/> Radio and TV Servicing <input type="checkbox"/> Television—Technician <input type="checkbox"/> Electronics <input type="checkbox"/> Telephone Work <p>RAILROAD</p> <ul style="list-style-type: none"> <input type="checkbox"/> Locomotive Engineer <input type="checkbox"/> Diesel Locomotive <input type="checkbox"/> Air Brakes <input type="checkbox"/> Car Inspector <input type="checkbox"/> Railroad Administration <p>TEXTILE</p> <ul style="list-style-type: none"> <input type="checkbox"/> Textile Engineering <input type="checkbox"/> Cotton, Rayon, Woolen Mtg. <input type="checkbox"/> Carding and Spinning <input type="checkbox"/> Warping and Weaving <input type="checkbox"/> Loom Fixing <input type="checkbox"/> Throwing <input type="checkbox"/> Finishing and Dyeing <input type="checkbox"/> Textile Designing |
|--|--|---|---|--|

Name _____ Age _____ Home Address _____
 City _____ Zone _____ State _____ Working Hours _____ A.M. to P.M. _____
 Occupation _____

Canadian residents send coupon to International Correspondence Schools Canadian, Ltd., Montreal, Canada. . . . Special tuition rates to members of the U. S. Armed Forces.

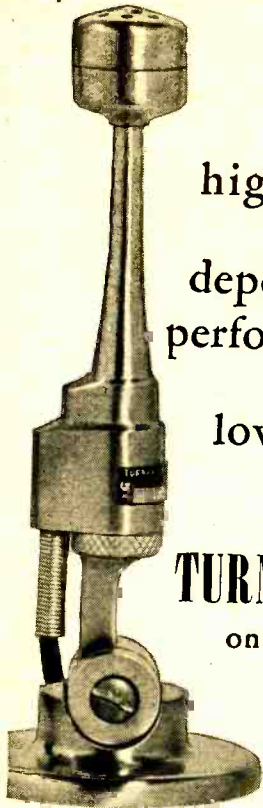

high style
dependable
performance

low price

TURNER 80
on C-4 stand

In design, there is no comparable microphone that equals Turner 80 styling and compactness. Styling that pleases the eye and fits in with modern surroundings. Compactness that makes this microphone convenient and easy to use. You can cradle it in the palm of your hand. Actual size (not including C-4 stand) only 4½" in length.

For PA, home recorder, dictating machine, office and factory call systems and amateur uses, the Turner 80 performance is always dependable.

Sensitivity: Approx. 58 db
below 1 volt/dyne/sq. cm.
Response: 80 to 7000 cps.
Weight: 5 oz. less cable.
Cable: 7 foot attached single
conductor shielded.

C-4 stand gracefully matches the Turner 80. Both are satin-chrome plated. Stand won't tip or slide with weight of cord.

Turner 80 list price-----\$15.95

C-4 stand list price-----\$ 5.75

THE TURNER COMPANY
933 17th St., N.E.
Cedar Rapids, Iowa

EXPORT: Ad Auriema, Inc.,
89 Broad St., New York 4

CANADA: Canadian Marconi Co.,
Toronto, Ont., and Branches

and IRE held a series of seven weekly spring study groups on color television.

Calendar of Events

1954 Electronic Components Symposium, May 4-6—Department of Interior Auditorium, Washington, D. C.
1954 Electronic Parts Show, May 17-20—Conrad Hilton Hotel, Chicago.
Western Electronic Show and Convention, August 25-27—Pan Pacific Auditorium, Los Angeles, Calif.
High-Fidelity Show, September 30 - October 2—Palmer House, Chicago.
Tenth Annual National Electronics Conference, October 4-6—Hotel Sherman, Chicago.

Production and Sales

RETMA reported that 28,468,818 TV sets had been shipped to dealers in the U.S. from 1946 through 1953. Over 62% of the shipments were concentrated in eight states each of which received over 1,250,000 sets.

RETMA announced that 6,375,279 TV receivers and 7,064,485 radios, exclusive of automobile sets, had been sold during 1953. The association also noted that 420,471 TV sets and 871,981 radios were produced during January, 1954. This marked a drop both from December, and from January of the previous year.

New Plants and Expansions

Sylvania Electric Products, New York City, dedicated its new Electronic Defense Laboratory in Mountain View, Calif.

Hallicrafters, Chicago, is building a new \$1,500,000 factory on an 8-acre site at Kostner Avenue and 45th Street, which will be used for expanded TV manufacturing and warehousing and as a central shipping point.

Raytheon Manufacturing Co., Waltham, Mass., has made tentative plans for building a large electronics engineering and research laboratory in Wayland, Mass.

RCA dedicated a new office in Alexandria, Va., which will provide consulting and engineering services for the Armed Forces. It will be operated by the Government Service Department of the RCA Service Co.

Federal Electric Corp. set up a new regional sales office and warehouse at 4056 West Armitage Ave., Chicago, to service the Mid-Western distributor market.

Antenna Specialists, Cleveland, manufacturer of radio communications antennas, recently expanded its facilities and floor space.

Cannon Electric Co., Los Angeles, established a British affiliate, Cannon Electric Co., Ltd., in London, to manufacture, distribute, and license all Cannon Electric products for western Europe.

Telematic Industries, Brooklyn, N. Y., opened a warehouse in Dallas, Texas, to service the Southwestern market with its antennas and accessories.

Wheatland Tube Co., Wheatland, Pa., is rapidly nearing completion of its plant expansion program which will give the company an additional 40,000 square feet of operating space.

Jan Hardware, manufacturer of a complete line of electronic hardware components, moved to larger quarters

at 75 North 11th St., Brooklyn, N. Y.

Business Briefs

... High Fidelity Institute of the Electronics Industries, was recently formed in Chicago. Jerome J. Kahn, commissioner of the Institute, stated that its immediate objective is to dispel consumer confusion about what high fidelity is.

... The Conference Co-ordinating Committee was established by the six trade associations within the electronic industry to co-ordinate regional conferences run by the sales representatives. Russ Diethert, national president of "The Representatives," was elected chairman, and S. L. Baraf, United Transformer, co-chairman.

... RETMA's Board of Directors announced plans to facilitate the elimination of radiated interference in future production of some TV sets; to eliminate or reduce the excise tax on TV sets; and to promote a research program in educational TV.

... Muntz TV, Chicago, and its two wholly-owned subsidiaries, were named in an involuntary petition for reorganization under Chapter X of the Bankruptcy Act.

... RETMA announced that 17 new members have been admitted to the organization, bringing total registration to an all-time high of 373. New companies admitted include: C-B-C Electronics Co., Inc., Philadelphia; Davis Electronics Co., Burbank, Calif.; Kay-Townes Antenna Corp., Rome, Ga.; Litton Industries, Los Angeles; Phen-O-Tron, Inc., New Rochelle, N. Y.; Plamondon Magnetics Co., Chicago; Telechrome Inc., Amityville, Long Island, N. Y.

... Finney Co., Cleveland, antenna manufacturer, recently held a dinner meeting in Kalkaska, Mich., attended by over 50 of its dealers and distributors from throughout the northern Michigan area.

... Federal Telephone and Radio Co., Clifton, N. J., is planning to increase commercial production reaching more and wider markets than now served. Additional space for this expansion will be provided through the discontinuance of the manufacture of monochrome television picture tubes.

... Lion Mfg. Co., Chicago, has begun production on its remote-control television sets.

... Sylvania Electric Products, New York City, in co-operation with Stanford University, formulated plans for an "Honors Co-operative Program in Electronics" to aid outstanding college seniors interested in doing graduate work in electrical engineering combined with full-time electronics employment.

... Telrex, Inc., Asbury Park, N. J., antenna manufacturer, settled its suit for patent infringement against Cornell-Dubilier, South Plainfield, N. J., when the latter company and its subsidiary, Radiart Corp., agreed to pay royalties to Telrex on all future sales of the patented conical antenna.

always in stock
at **ALLIED**

RCP QUALITY TEST INSTRUMENTS

RADIO CITY PRODUCTS CO.

Choose this reliable equipment for your service bench, lab or field work—and save! Order RCP instruments from ALLIED—for top value and accurate, dependable service.

Model 808A Do-All TV-Radio-CR Tube Tester, Reactivator & VTVM

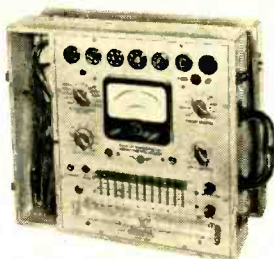

Consists of RCP Model 324P Tube Tester and a new CRT tester-reactivator, plus a VTVM. Checks all tubes including miniatures, sub-miniatures and magnetically deflected TV picture tubes. Easy-to-read $4\frac{1}{2}$ " meter. Has fast-operating double Roll-index. 17-range VTVM uses balanced bridge type push-pull circuit. Input impedance of 25 megohms for minimum current drain. Zero center scale for discriminator alignment. Ranges: AC and DC volts, 0-5-25-100-250-1000; resistance, 0.2 ohm to 1000 megohms in 5 ranges; db—20 to -62 in 5 ranges. Accuracy: AC, 5%; DC, 3%. Also checks capacitors for shorts and leakages. Oak carrying case, $12\frac{1}{2} \times 12\frac{3}{4} \times 4\frac{3}{4}$ ". With test leads, isolation probe and batteries. For 105-125 volts, 60 cycle AC. Shpg. wt., 12 $\frac{1}{2}$ lbs. 84 FX 333. Net. \$97.95

Model HVMP-1. High Voltage Probe. Extends DC range of VTVM in Model 808A above, to 30,000 volts. 84 F 334. Net. \$8.77

Model 750 UHF-VHF Do-All Signal Generator

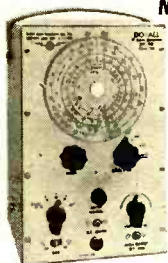

New, combination signal, marker and pattern generator. Covers all UHF-VHF channels for FM and TV receiver servicing. Checks and aligns front ends, sound IF's and picture traps, linearity, sync circuits, sweep circuits, focus and deflection. Inductuner and special anti-backlash drive assure accuracy of 0.5%. All VHF frequencies covered on fundamental. Ranges: 9-11, 21-47, 54-220, 465-690 and 650-900 mc. RF's and IF's clearly calibrated on large etched dial. Provides steady horizontal or vertical bars or cross-hatch pattern on all channels. Internal modulation: 360 cps and 141.75 kc. Also provides unmodulated carrier signal. Complete with leads. Size, $10\frac{1}{4} \times 6\frac{1}{2} \times 5\frac{1}{8}$ ". For 105-125 volts, 60 cycle AC. Shpg. wt., 10 lbs. 84 F 338. Net. \$77.91

Model 655 Do-All VTVM



New, peak-to-peak type VTVM provides accurate measurements of complex waveshapes. Reads RMS and peak to peak simultaneously of wave-forms in video, sync and deflection circuits. Industrial applications include servicing of vibrator type power supplies and AC generators. 7 ranges on all functions. Reads peak to peak AC from 0.2 to 2000 volts; AC RMS 0.1 to 1500 volts; DC 0.02 to 1500 volts. Measures resistances from 0.2 ohms to 1000 megohms. High impedance input. Balanced bridge-type push-pull circuit and peak-to-peak rectification result in absence of circuit loading, wave-form error and frequency distortion. Supplied with test leads. Size: $10 \times 6 \times 5$ ". For 105-125 volt 50-60 cycle. AC. Shpg. wt., 8 lbs. 84 F 324. Net. \$58.31

NEW

SENSATIONAL MODEL 123 "FLYBACKER"

Tests Flyback Transformers and Yokes—Trouble Shoots Horizontal TV Circuits in Shop or Home



Now available for accurate and speedy testing. Extremely sensitive—shows up a single shorted turn in a flyback transformer or yoke. Makes tests with components in place in the receiver. Checks all flyback transformers and yokes for opens or shorts. Tests are applicable to induction windings on any transformer, speaker choke, solenoid, relays, etc., where impedance is not relatively low; acts virtually as a proportional AC ohmmeter. Oscillator circuit operates at 1500 cycle frequency; interruption frequency 60 cycle. Slightest induction change caused by a shorted turn or intermittent effects shows up instantly on meter as "Bad." Has 3 "Good-Bad" scales; scale for yokes; direct-reading numbered scale; illuminated meter dial. In compact grey steel case with aluminum finish steel panel; $9\frac{3}{8} \times 6 \times 4\frac{3}{4}$ ". Complete with test leads. For 105-125 volts, 60 cycle AC. Shpg. wt., 8 lbs. 84 F 620. Net. \$39.15

ALLIED STOCKS ALL RCP INSTRUMENTS

84 FX 364. Model 8873A Servishop. Net.....	\$137.15
84 FX 368. Model 324P Tube Tester. Net.....	77.91
84 F 332. Model 730 "Signaliner" Signal Generator. Net	32.29
84 F 336. Model 740A VHF Signal Generator. Net.....	68.11
84 FX 365. Model 8020 FM-TV Servishop. Net.....	303.80
84 FX 366. Model 8023 AM-FM-TV Servishop. Net.....	334.18
84 FX 367. Model 324C Tube Tester. Net.....	68.55
84 F 335. Model 533M Midgetscope. Net.....	97.51
84 F 340. Model 453C Master Multitester. Net.....	35.77
84 F 274. Model 447B AC-DC Multitester. Net.....	17.59

All RCP instruments priced over \$45, are available on Easy Payments; only 10% down, 12 months to pay. Write for details.

FREE 268-PAGE BUYING GUIDE

Make your selection from the world's largest stocks of electronic tubes, parts, test instruments, audio equipment, amateur gear, industrial components—get everything in electronics at lowest prices. Send for your FREE copy today.



ALLIED RADIO

ALLIED RADIO CORP., Dept. 2-E-4
100 N. Western Ave., Chicago 80, Ill.

Send FREE 1954 Allied Catalog.
 Ship the following RCP instruments.....
.....\$.....enclosed

Name.....

Address.....

City.....Zone.....State.....

Speaking Of EXTRA

HIGH OUTPUT

THESE ASTATIC CRYSTAL PICKUP CARTRIDGES ARE YOUR MOST BRILLIANT PERFORMERS

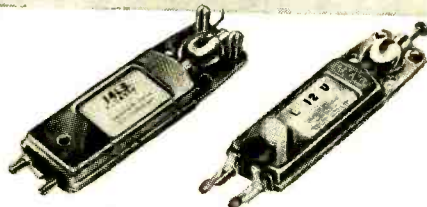
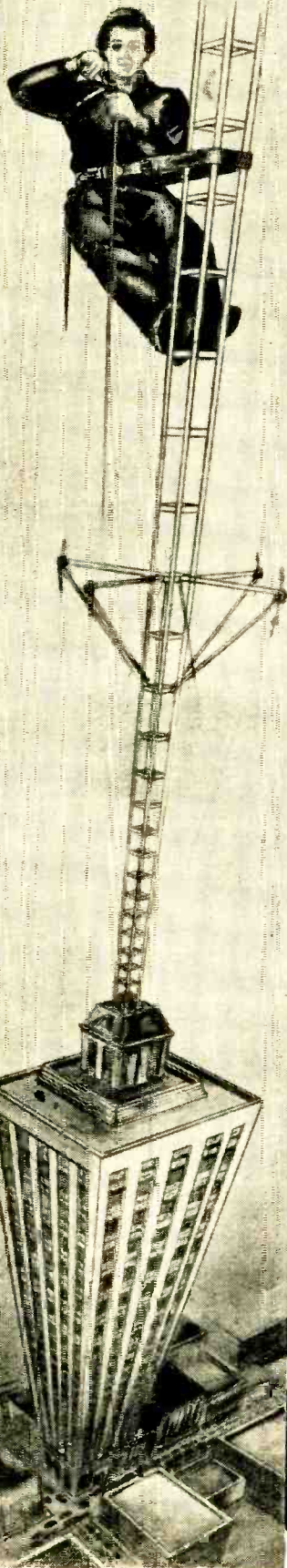

Astatic 14, 15 and 16L-3 Types, Extra High Output Series

Astatic L-12-U Model, Dual-Output, Removable Condenser Harness, Universal Type

The most effective answers to a host of high output requirements are found among these examples of advanced Astatic engineering and precision mass production. The performance data for each appears below. But these cold statistics cannot cover the warm richness of tone, the smoothness of response and other familiar Astatic qualities designed and built into these units. If you have not already done so, start adopting them now to the fullest possible extent in your cartridge replacement stocks. Higher established quality of results is assured with Astatic Crystal Cartridges. Write today for full details of crystal cartridges replaced by those shown, other pertinent information.

KNOWN THE WORLD OVER FOR HIGHEST QUALITY AT LOWEST POSSIBLE COST

Model	List Price	Minimum Needle Pressure	Output Voltage 1000 c.p.s. 1.0 Meg. Load	Frequency Range c.p.s.
14L3-AG*	\$ 7.00	10 gr.	2.8†† 2.4†	50-4,000
14L3-D	8.50	10 gr.	2.8†† 2.4†	50-4,000
15L3-AG*	7.00	10 gr.	4.0†† 3.5†	50-5,000
15L3-D	8.50	10 gr.	4.0†† 3.5†	50-4,000
16L3	6.00	16 gr.	6.2†† 4.0†	50-5,000
L-12-U	5.50	1 oz.	1.25†† or 4.0	50-5,000

* "AG" in model designation stands for ALL-GROOVE needle tip of special design and size to play 33-1/3, 45 and 78 RPM Records.
 † RCA 12-5-31-V Test Record or Equivalent.
 †† Audio-tone 78-1 Test Record.



EXPORT REPRESENTATIVE, 401 Broadway, New York, N. Y. Cable Address: ASTATIC, New York

BUSINESS

THE 1954 ELECTRONIC PARTS SHOW

The 1954 Electronic Parts Show will be held at the Conrad Hilton Hotel in Chicago, May 17-20. The 277 exhibitors have reserved space in 397 booths and display rooms in the Conrad Hilton Hotel. This year's Show promises to be the best attended yet.

COMPANY	EXHIBITION HALL BOOTH	DISPLAY ROOM(S)
Aero Products Co.		667
Advance Elect. & Relay Co.	883	
Aerolite Electronics Corp.		634A
Aerovox Corporation	304	
All Channel Antenna	3	
Alliance Manufacturing Co.	321	
Alpha Metals Co.	887	
Alpha Wire Corp.	416	
Alproco, Inc.	315	
Altec Lansing Corp.	204	607A
American Microphone Co.	671	
American Phenolic Corp.	207	560A-561A
American Radio Hdqre. Co.	223	
American Screen Products		643
American Telev. & Radio	415	
Amperite Co., Inc.	214	
Anchor Radio Company	220	
Argos Products Co., Inc.		530A
Astatic Corporation	125	546A-518A
Astron Corporation	888	
Atlantic Wire & Cable Co.	26	
Atlas Sound Corp.	225	
Audio Devices, Inc.	421	
Baker Manufacturing Co.	115	
Barker & Williamson, Inc.	591	855A
Baumker Manufacturing Co.	8	
Belden Manufacturing Co.	874	
Bell Sound Systems	779	637A-638A
Berlant Associates		609
Blonder Tongue Lab.	783	
David Bogen Co., Inc.		500-501
Brach Manufacturing Corp.		629A
British Industries Corp.	408	507A-09A
Brook Electronics Division	789	662A
Bud Radio, Inc.		556A
Burgess Battery Company	318	
Bussmann Mfg. Co.	216	
Cannon Electric Co.	885	
Allen D. Cardwell Mfg. Co.	872	
Carter Motor Company	777	
C-B-C Electronics		649
CBS-Hytron	218	
Centralab Division	790	
Channel Master Corp.		521
Chicago Std. Trans. Corp.	211	556-557
Clarostat Manufacturing Co.	586	
Clear Beam TV Antenna	674	
Cleveland Electronics, Inc.		668
Collins Radio Co.		536
Columbia Wire & Supply Co.	404	
Conrac, Inc.		622
Continental Carbon, Inc.	6	
Consolidated Wire	581	
Copperweld Steel Products	121	
Cornish Wire Company	683	
Cowan Publishing Co.		622A-623A
Crescent Industries	309	
Crestwood Recorder Division	9	641A-642A
Crown Controls Company		604A
Davis Electronics Co.	884	
Deleo Radio Division		625
Drake Electric Works	222	
Dukane Corporation		515A-517A
Allen B. Dumont Labs., Inc.	574	
Duotone Company, Inc.		610A-611A
Easy-Up Tower Co.		623A
Hugh H. Eby Co.	782	
Eicor, Inc.		700-701
Elco Corporation	788	
Eldico of New York, Inc.		613A-614A
Electronic Instrument Co.	202	
Electronic Measurements Corp.	112	
Electronic Publishing Co.		629
Electro Products Labs.	418	
Electro-Voice, Inc.	104	550A-551A
Electrovox Company	208	
Equipto Division	672	
Erie Resistor Corp.	314	616
Federal Tele. & Radio Corp.	301	
Feiler Engineering Co.	791	611
Fenton Company	25	
The Finney Company	880	632
Fisher Radio Corp.		639-640
Freed Elect. & Controls		633A
Freed Transformer Co.	589	
Fretco, Incorporated	886	646A



HERE'S YOUR **BIG OPPORTUNITY!**

TELEVISION

TECHNICIANS EARN BIG PAY!

L. C. Lane, B.S., M.A.
President: Radio-Television Training Association
Executive Director:
Pierce School of
Radio & Television



NO experience needed... I'll train you **AT HOME** in your **SPARE TIME!** Earn while you learn!

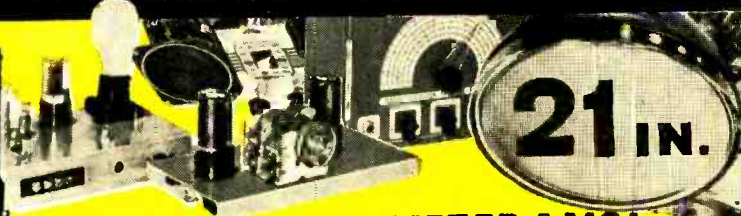

CIVILIANS! VETERANS!

PREPARE FOR A BRIGHTER FUTURE AS A TV TECHNICIAN
Keep your present job while I prepare you **AT HOME**, using the same successful methods that have helped hundreds of men—many with no more than grammar school training—master television!

ENOUGH EQUIPMENT TO SET UP YOUR HOME LABORATORY!

As part of your training, I give you **ALL** the above equipment you need and more to prepare for a **BETTER PAY TV** job. You build and keep a professional **GIANT SCREEN TV RECEIVER** complete with big picture tube, takes any size up to 21-inch... also a Super-Het Radio Receiver, RF Signal Generator, Combination Voltmeter-Ammeter-Chmmeter, C-W Telephone Transmitter, Public Address System, AC-DC Power Supply. Everything supplied including all tubes!

EXPERT FM-TV TECHNICIAN TRAINING! My FM-TV Technician Course can save you months of training if you have previous Armed Forces or civilian radio experience! Train at home with kits of parts, plus equipment to build **BIG SCREEN TV RECEIVER**, and **FREE FCC Coaching Course!** **ALL FURNISHED AT NO EXTRA COST!**

FREE FCC COACHING COURSE! Important for **BETTER PAY JOBS** requiring FCC License. You get this training **AT HOME** and **AT NO EXTRA COST.** Top TV jobs go to FCC licensed technicians.

NEW! PRACTICAL TV CAMERAMAN & STUDIO COURSE! For men with previous radio and TV training) I train you at home for an exciting high pay job as the man behind the TV camera. Work with TV stars in TV studios or "on location" at remote pick-ups! A special one-week course of practical work on TV studio equipment at Pierce School of Radio & TV, our associate resident school in New York City, is offered upon your graduation.

LEARN ALL ABOUT COLOR TV! I give you the latest principles and practical training in **TV COLOR!**

VETERANS!

MY SCHOOLS FULLY APPROVED TO TRAIN VETERANS under new G.I. bill! If discharged after June 27, 1950 —**CHECK COUPON!** Also approved for **RESIDENT TRAINING** in New York City at Pierce School of Radio and Television... qualifies you for full subsistence allowance up to \$160 per month. Write for details.

WARNING!

ALL VETERANS DISCHARGED BEFORE AUGUST 20, 1952 must be enrolled and **IN TRAINING** by August 20, 1954. Otherwise you lose your G.I. rights to a free education under **NEW G.I. BILL!** Don't put it off... it takes several months to get your papers processed! **RUSH COUPON BELOW.** Tell your ex-G.I. friends!

YOU GET ALL 4 FREE!

GOOD SPARE TIME EARNINGS! Almost from the very start you can earn extra money while learning, repairing Radio-TV sets for friends and neighbors. Many of my students earn up to \$25 a week... pay their entire training from spare time earnings... start their own profitable service business. *Act now! Mail coupon and find out for yourself what a TV career can do for you!*

OPTIONAL: TWO WEEKS TRAINING IN NEW YORK CITY AT NO EXTRA COST! You get two weeks, 50 hours, of intensive Laboratory work on modern electronic equipment at our associated school in New York City—Pierce School of Radio and Television. And I give you all this **AT NO EXTRA COST** whatsoever, after you finish your home study training in the Radio-FM-TV Technician Course and FM-TV Technician Course.

RADIO-TELEVISION TRAINING ASSOCIATION

52 EAST 19th STREET, NEW YORK 3, N. Y.

Licensed by the State of New York • Approved by the VA



MAIL THIS COUPON NOW! No Salesman Will Call!

Mr. Leonard C. Lane, President
RADIO-TELEVISION TRAINING ASSOCIATION
52 East 19th Street, New York 3, N. Y. Dept. R-5B

Dear Mr. Lane: Mail me your **NEW FREE BOOK FREE SAMPLE LESSON**, and **FREE** aids that will show me how I can make **BIG MONEY IN TELEVISION.** I understand I am under no obligation and no salesman will call.
(PLEASE PRINT PLAINLY)

NAME _____ AGE _____
ADDRESS _____
CITY _____ ZONE _____ STATE _____

- I AM INTERESTED IN:**
- Radio-FM-TV Technician Course
 - FM-TV Technician Course
 - TV Cameraman & Studio Course
- VETERANS!**
Check here for Training under **NEW G.I. Bill**

Hold Everything!

ON
ELECTRIC SOLDERING GUNS

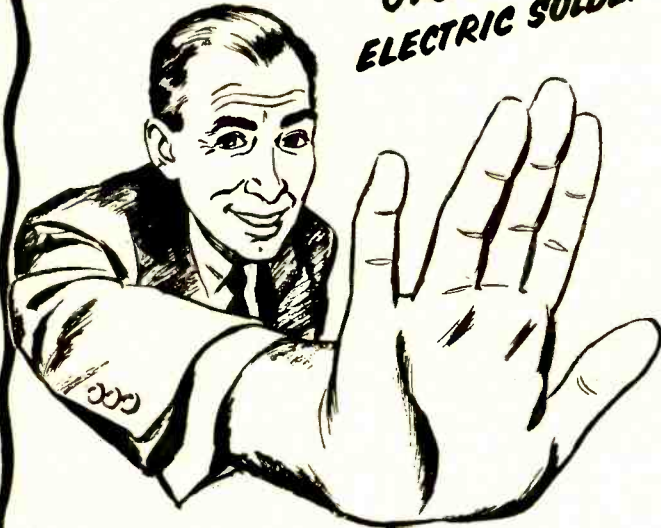

WEN

IS BRINGING OUT
A NEW LINE

and it's Terrific!

- PRICE WISE
- PERFORMANCE WISE
- SALES WISE

Nothing like it on the market. It's a sales "natural". Shown for first time at the Chicago Parts Show, May 17th thru 20th.

CONRAD HILTON HOTEL ... DISPLAY ROOM 602-A

WEN PRODUCTS, INC.

5808 NORTHWEST HIGHWAY

CHICAGO 31, ILL.

Gabriel Electronics Div. ...	653A
Gee Lar Manufacturing Co. 124	
General Cement Mfg. Co. ... 320	
General Electric Co. ... 209	520
General Industries Co. ... 587	658-659
General Instrument Corp. ... 778	
G & H Wood Products Co. ... 879	
Gonset Company ...	881
Gramer Transformer ...	537
Granco Products ...	5
Grayhill ...	105
Great Eastern Mfg. Co. ...	566A
Guardian Electric Mfg. Co. 409	
Haldorson Transformer Co. 573	
Hallcrafters Company ... 575	619A-620A
Hammarlund Mfg. Co. ... 583	
Hardwick, Hindle, Inc. ... 201	
Harman-Kardon, Inc. ...	528A
Haydon Products Co. ... 108	649A-650A
Hickok Elect. Instr. Co. ... 873	524A-526A
Hi-Lo TV Ant. Corp. ... 111	
Hy-Lite Antenna ...	618
IE Manufacturing ...	24
Illinois Condenser Co. ... 212	
Imperial Radar & Wire ... 102	
Industrial Television ... 118	
Insuline Corp. of America ... 403	512
International Rectifier Corp. 784	
International Resistance Co. 22	
Jackson Electrical Instr. Co. 322	
James Vibrapower Company 302	
J-B-T Instruments, Inc. ... 580	
Jensen Industries, Inc. ... 402	512A-513A
Jensen Manufacturing Co. ...	504A-05A
Jersey Specialty Co. ... 101	
Jerrold Electronics Corp. ...	651A
J. F. D. Manufacturing Co. 412	549
E. F. Johnson Company ... 681	
Jontz Manufacturing Co. ... 875	655
Kay-Townes Antenna Co. ...	624
Kester Solder Company ... 119	
K-G Electronics Co. ... 11	
Kleer Vue Mfg. Co. ... 877	
Kuehne Mfg. Co. ...	664
James B. Lansing Sound ...	652
Lapointe Electronics, Inc. ... 312	612A
Leader Electronics ...	630A
Lenz Electric Mfg. Co. ... 588	
Littelfuse, Inc. ... 316	626A
Lowell Manufacturing Co. ... 110	
P. R. Mallory & Company ... 678	
Master-Mobile Mounts ...	666
Merit Coil & Transf. Corp. ... 689	
James Millen Mfg. Co. ... 217	
J. W. Miller Company ... 878	
M. A. Miller Mfg. Co. ... 313	
Miller Television Co. ... 4	
Model Eng. & Mfg., Inc. ... 107	
Modern-Aire Mfg. Co. ... 621A	
Mosley Electronics ... 123	
Don McGohan, Inc. ...	613-614
National Carbon Co. ... 680	623
National Company ... 303	639A-640A
National Electric Prods. Co. 691	
National Teletable Corp. ...	644-645
National Union Radio Corp. 406	
National Video Corp. ...	534A
Newcomb Audio Products ...	539-553
Ohmite Manufacturing Co. ... 410	
Orradio Industries, Inc. ...	665
Oxford Electric Corp. ... 113	557A
Par-Metal Products Corp. ... 114	
Peerless Products Div. ... 577	
Penn Television Products ... 203	636
Pentron Corporation ... 870	520A-521A
Perma-Power Company ... 579	
Permosflux Corporation ... 578	532A-533A
Permo, Inc. ... 414	
Philmore Manufacturing Co. 311	529
Pickering & Company ...	523
Plastoid Corporation ... 787	
Potter & Brumfield ... 131	612
Precise Development Corp. ... 130	
Precision Apparatus Co. ... 413	507
Premier Metal Products ... 10	
Presto Recording Corp. ...	502
Pyramid Electric Company. 417	
Quam-Nichols Company ... 401	
Q-Line Mfg. Corp. ...	617
Quietrole Co. ...	648
Racon Electric Co. ... 310	
Radelco Manufacturing Co. 23	
Radiart Corporation ... 213	
Radio City Products Co. ... 210	657A
Radio Corp. of America ... 305	628-629
Radio Craftsmen, Inc. ...	605A

RADIO-ELECTRONICS

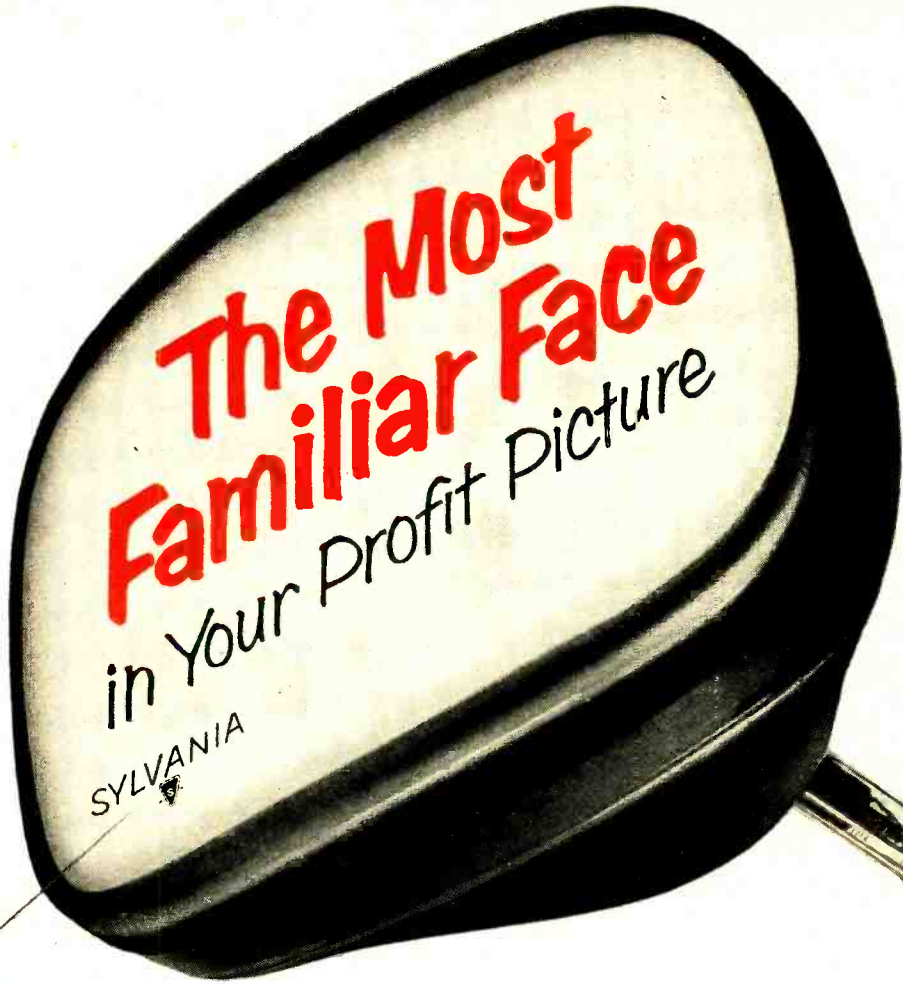

The Name SYLVANIA etched on the face is assurance of RECOGNIZED QUALITY

When your customers "replace the face," show them this picture tube etched SYLVANIA! They know it's the name that means leadership and dependable performance!

Your customers will appreciate the favor of being offered the top value for their investment . . . and, to most people, a new TV Picture Tube is *definitely* an investment.

Backed by Nation-wide TV Show: - The story of Sylvania Picture Tubes' quality and the facts about their winning exhaustive tests is being told again and again to millions on the high-ranking, weekly TV show, "Beat the Clock."

There's a Sylvania Picture Tube Distributor near you who offers excellent service, cooperation and a full range of available tubes. You'll find it profitable to do business with your Sylvania Distributor and to push the full Sylvania line.

Make sure your customers know all the facts about picture tubes. Ask your Sylvania Distributor for a free supply of these booklets to give to your prospects.



SYLVANIA

Sylvania Electric Products Inc., Dept. 4R-3805, 1740 Broadway, New York 19, N. Y.
 In Canada: Sylvania Electric (Canada) Ltd., University Tower Bldg., St. Catherine Street, Montreal, P. Q.

LIGHTING • RADIO • ELECTRONICS • TELEVISION

MAY, 1954

Before you install another antenna take this

Irving Rose, prominent Chicago designer and president of Voice and Vision, noted television and high fidelity center, takes the "look test" of fringe reception from Milwaukee.



using JFD Super JeT antenna

using antenna A



1. Four TV receivers of one brand, same model, same production run were set up. Technicians went over these sets to make sure they were identically aligned.
2. Three other leading high gain TV antennas were installed—each oriented for maximum performance. Each antenna was connected to a set by identical type lead-in.
3. Each receiver was tuned with infinite care to the same channel to make certain the reception was as good as possible. The picture is the proof—the result can be immediately seen—the JFD Super JeT outperformed all others.
4. The chart shows why the "Look-test" is your proof positive of sharper, clearer, more brilliant pictures . . . in Black and White or Color on all channels present and future.

JeT 213 (single Bay) \$18.70

JeT 213S* (2-Bay) \$38.35

*complete with stacking transformer

"look-test"

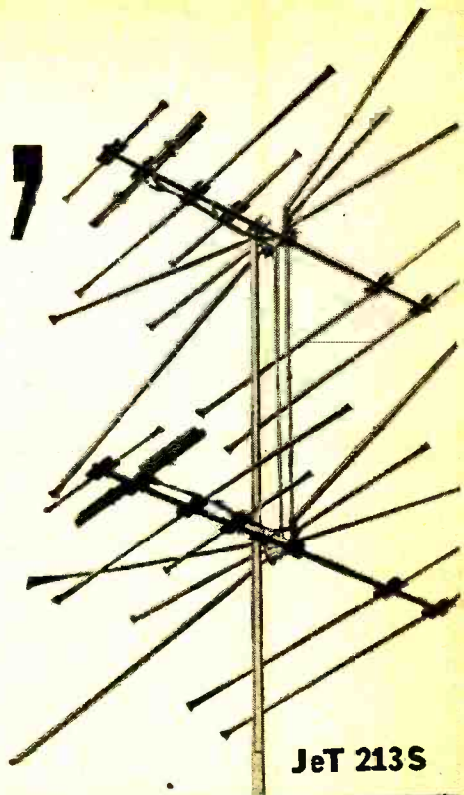

Here is your clinical proof that only the **JFD Super JeT**
TV antenna Out-Performs all others on all channels



ANTENNA LIST	CHANNELS												
	2	3	4	5	6	7	8	9	10	11	12	13	
Competitor A \$42.36 Radar Screen with 3 dipoles (2-bay) Partly Pre-Assembled	4.5	4.3	7.3	7.0	7.0	10.00	10.75	11.5	11.7	11.0	11.5	11.6	
Competitor B \$34.95 Radar Screen with 2 dipoles (2-bay) Not Assembled	0.75	3.25	4.5	3.5	3.5	6.0	7.0	6.5	7.75	8.0	7.5	6.0	
Competitor C \$55.00 Bedspring (4-bay) Pre-Assembled	4.0	5.0	7.0	6.25	5.0	5.25	6.0	5.25	7.25	9.25	6.5	7.0	
JFD Superjet \$38.35 Model JeT 213 S (2-bay) Pre-Assembled	6.5	7.5	9.5	8.5	8.5	11.0	11.0	12.0	12.0	11.25	11.75	12.0	

DB GAIN



JFD Manufacturing Company,
Brooklyn 4, N.Y.

World's largest manufacturers of TV antennas and accessories
 Write for Bulletin #230

The *FIRST STEP* in

HIGH FIDELITY

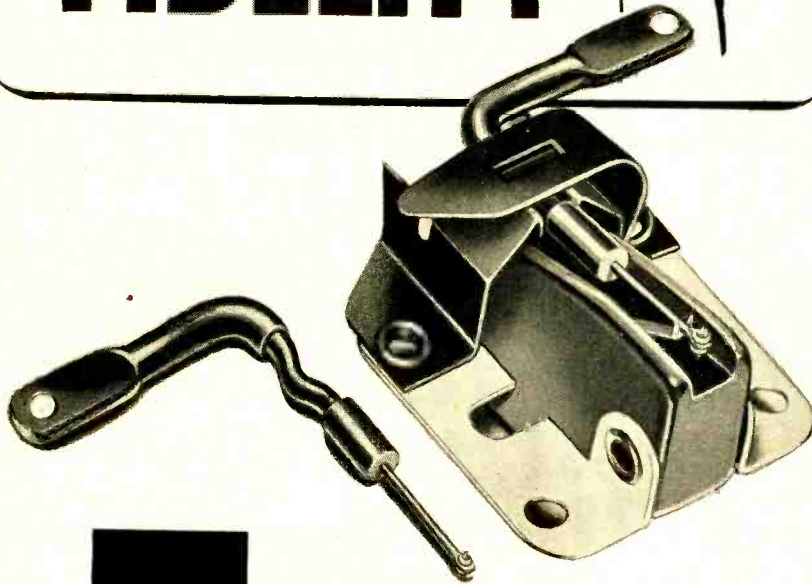

TITONE

CERAMIC CARTRIDGE

There is no wiser investment a phonograph owner can make than a TITONE ceramic cartridge.

Costing no more than ordinary "replacement" cartridges, TITONE gives a world of difference in results — an entirely new experience in true high-fidelity sound, no matter what the make of phonograph.

And only *two models* will replace most present-day installations!

No other cartridge gives all these features!

No preamplifier or equalizer needed • Unaffected by moisture or temperature • Wide frequency range • Outstanding response • High sensitivity • Low distortion • High compliance • No hum pickup • Superior tracking ability • Wide adaptability • Proper groove fit • Only needle rotates • Simple to replace

(Used by America's foremost manufacturers of high-fidelity phonographs, TITONE is an original discovery and development of the Sonotone laboratories. Literature available.)

ELECTRONIC APPLICATIONS DIVISION

SONOTONE CORPORATION

Elmsford, New York

BUSINESS

RADIO-ELECTRONICS	633
Radio-Electronic Jobber News	651
Radio Materials Corp.	617A
Radio Merchandise Sales	135 536A-537A
Radiom Corporation	635A-636A
Radio Receptor Co., Inc.	590
Radio & TV Journal	661A
Radio & TV News	533
Radio & TV Weekly	661
Ram Electronics Co.	509
Rauland-Borg Corp.	542A-544A
Raytheon Mfg. Co.	422
Recoton Corporation	221
Reeves Soundcraft Corp.	117
Regency Division	876
Rego Insulated Wire Co.	122 660A
Rek-O-Kut Company	522
John F. Rider Publisher, Inc.	317
River Edge Industries	785 561
Rockbar Corporation	205
Rohn Manufacturing Co.	14 616A
Rytel Electronics Mfg. Co.	206
Howard W. Sams & Co.	407
San Fernando Elec. Mfg. Co.	27
Sangamo Electric Co.	776 553A
Service Magazine	609A
Service Management Mag.	603
Shure Brothers, Inc.	215 516
Simpson Electric Co.	679 539A
Mark Simpson Mfg. Co.	109 605-607
Skyline Manufacturing Co.	653
Herman H. Smith, Inc.	686
Snyder Manufacturing Co.	308
Sola Electric Co.	687
Sonar Radio Corp.	603A
Sonotone Corp.	618A
South River Metal Prods. Co.	774 652A
Spiraling Products Co.	127 513
Sprague Products Co.	684
Standard Coil Products Co.	604
Standard Electrical Prods.	120
Stephens Manufacturing Co.	890 664A
Stevens Walden, Inc.	7
Stewart Warner Company	656-657
Stromberg-Carlson Co.	600
Sutton Electronic Co.	660
Switchcraft, Inc.	126
Sylvania Elec. Products, Inc.	676 647A-648A
Talk-A-Phone Company	129 601-602
Sarkes Tarzian, Inc.	626
Tech-Master Products	658A-659A
Technical Appliance Corp.	21
Technician	535A
Tel-A-Ray Enterprises	13 625A
Telectrosonic Corp.	621
Tele-Ex-Pand Products	1
Tele-Matic Industries	682
Telex, Inc.	12
Telrex, Inc.	675
Thomas Electronics	133
Thordarson-Meissner	576 610
Transistor Products	786
Triad Transformer Mfg. Co.	572 656A
Tricraft Products	677
Trimm, Inc.	319
Trio Manufacturing Co.	871 634-635
Triplett Electrical Instr. Co.	585
Tung Sol Electric	106
TV Products	103
Turner Company	128
Ungar Electric Tools	405
United Catalog Pub. Inc.	571
United Transformer Co.	307 631A-632A
University Loudspeakers	775 519A
Utah Radio Products	2 560
Vaco Products Co.	219
Van Cleef Brothers, Inc.	116
Vidaire Electronics	780
V-M Corporation	584
Waldom Electronics	582 619A-620A
P. Wall Manufacturing Co.	793
Walsco Electronics Corp.	685
Ward Leonard Electric Co.	419
Ward Products Corp.	411 637-653A
Webster-Chicago Corp.	534
Webster Electric Co.	688
Weller Electric Corp.	306
Wen Products, Inc.	602A
Westinghouse Electric Corp.	781 643A-644A
Weston Elect. Instr. Corp.	420 615A
Wilcox-Gay Corp.	673
G. F. Wright Steel Corp.	882
Wallace's Telaides	646
Xcelite, Inc.	592 END

RADIO-ELECTRONICS

7,168 Service-Dealers Cashing in on CQS

**SURVEY SHOWS 78% OF SERVICE-DEALERS
REPLYING REPORT ENTHUSIASTIC
SUPPORT OF CQS PLAN!***

Using the *Certified Quality Service* plan? If not, you may be losing business to your competitor across the street. If you *are* using the CQS tags and all the sales aids available to you, you're all set. . .

AND HERE'S GOOD NEWS!

*Survey conducted January, 1954

**Your NATIONAL ADVERTISING continues to sell
for you in LIFE during May and June.**

BE SURE YOU HAVE YOUR CERTIFICATION TAGS

Your national advertising says, "Ask your Service-Dealer for this CQS Tag." Tie in. All you have to do is:

1. Use your improved, colorful, multi-use CQS Tags to build more business and greater customer confidence . . . *in you.*
2. Use your CQS signs, posters, decals, and other sales aids. Make it easy for customers to find you.

CQS Tags are available: 250 for \$2.25, 500 for \$3.50, 1000 for \$6.00, with your 3-line imprint. Ask your distributor salesman for special offer . . . or use coupon to order direct.

GET YOUR CQS CBS-STAR KIT

Contains 6 smashing, big, colorful, magnetic CBS-Star streamers. Each features a different CBS-TV star: Benny . . . Burns and Allen . . . Gleason . . . Godfrey . . . Murrow . . . and Marie Wilson. Each is a different size and shape. Each sells the Star Performance of your *Certified Quality Service*. Kit also includes a new inside/outside CQS decal and a Business Builder's Catalog showing the many sales aids available to you. CBS-Star Kit is *free* with CQS Tags . . . Kit alone, 25¢.

Let folks know you're the Service-Dealer they read about in the national magazines. Ask your distributor salesman for special offer . . . or use coupon. Order your Tags and CBS-Star Kit today.



CBS-HYTRON Main Office: Danvers, Mass.

A Division of Columbia Broadcasting System, Inc.

Manufacturers of Receiving Tubes Since 1921

A member of the CBS family: CBS Radio • CBS Television
Columbia Records, Inc. • CBS Laboratories • CBS-Columbia • and CBS-Hytron

MAY, 1954

CBS-HYTRON, Danvers, Mass.

Please rush me:

A CBS-Star Kit free with . . . CQS Tags
(quantity)
@ \$2.25, 250; \$3.50, 500; \$6.00, 1000

A CBS-Star Kit *only*
@ 25¢ (for handling and mailing)

I enclose \$. . . to cover Tags and/or Kit.
(Please send cash, check, m.o. . . no C.O.D.'s.)

HERE IS MY 3-LINE IMPRINT FOR TAGS
(please print name and address)

Name

Street

City State

Signed

INTERNATIONAL RECTIFIER



C O R P O R A T I O N

EL SEGUNDO
CALIFORNIA

*Selenium
Rectifiers*

for
direct **TV-RADIO**
replacement

WIDEST RANGE IN THE INDUSTRY

The type you need...
when you need it!

AVAILABLE FROM YOUR FAVORITE JOBBER

Available
with
universal
mounting
for
universal
replacement.

For more
information
write Dept. A
for Bulletin JRP-2

INTERNATIONAL RECTIFIER
C O R P O R A T I O N

Executive Offices: 1521 E. Grand Ave., El Segundo, Calif. · Phone: ORegon 8-6281
Chicago Branch Office: 205 West Wacker Drive · Phone: Franklin 2-3889
New York Branch Office: 501 Madison Avenue · Phone: Plaza 5-8665

RADIO-ELECTRONICS

MORE DEALERS ARE INSTALLING

CHANNEL MASTER'S CHAMPION THAN ANY OTHER ANTENNA IN TELEVISION HISTORY!

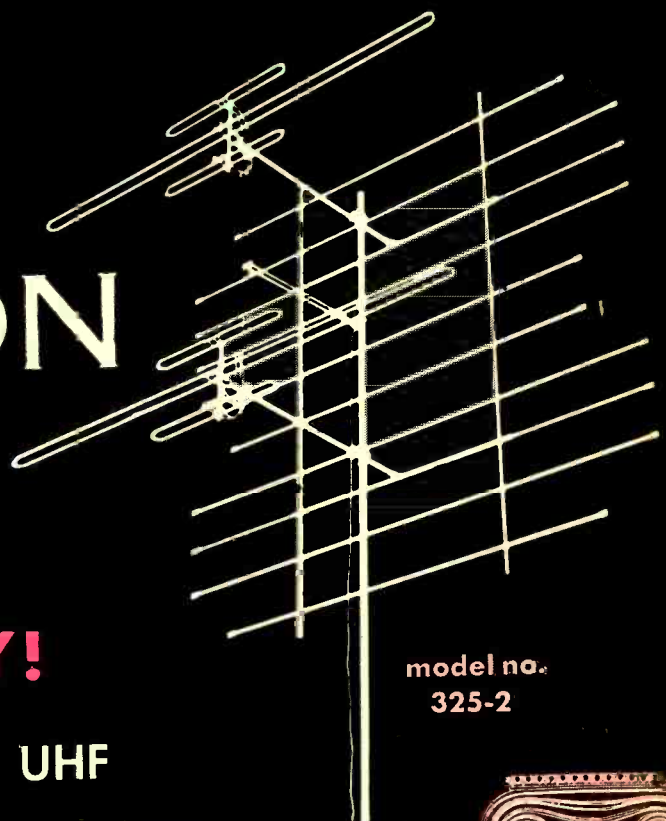

model no.
325-2

All-channel reception: VHF & UHF

HORIZONTAL POLAR PATTERNS
(Relative Voltage)

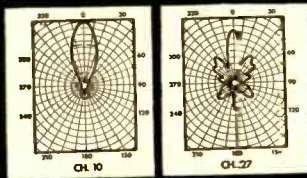

Gain
(above tuned reference dipole)

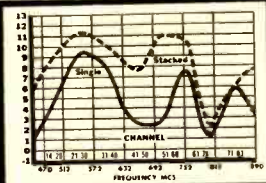
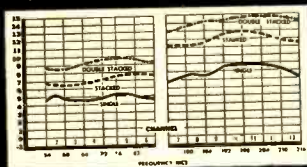

ONLY THE CHAMPION enjoys this overwhelming acceptance: over 300,000 already sold!

ONLY THE CHAMPION is powered by the unique "Tri-Pole," the triple-powered dipole system that provides fabulous VHF-UHF fringe area performance. 100% aluminum; rugged, exclusive alloy. Installs in a flash!

ONLY THE CHAMPION gives you this four-star promotion program:

- ★ **FREE newspaper ads**
- ★ **FREE TV film commercials**
- ★ **FREE colorful display material**
- ★ **FREE consumer literature**

See your Channel Master distributor for full details.

The antenna America knows best!

Introduced to millions through the editorial pages of their favorite magazines and newspapers, and on TV.

**DON'T BE MISLED BY "LOOK-ALIKES" . . .
THERE'S ONLY ONE REAL CHAMPION!**

Model no. 325, Single bay; Model no. 325-4, Four bay; Model no. 325-6, Super Champ



CHANNEL MASTER CORP. TELEVISION, N. Y.

The World's Largest Manufacturer of Television Antennas

Copyright 1954 Channel Master Corp

\$8000.⁰⁰ PRIZES

WESTINGHOUSE LEAGUE LEADERS

AND DEALER AID CONTEST

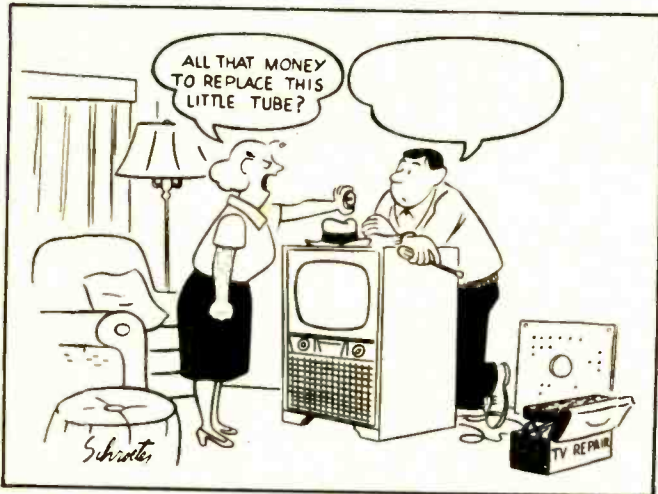

How Would YOU Answer This Service Customer?

Your solution to this cartoon—and your careful selection of American and National League Leaders, as of August 1, 1953—can win \$1000.00 CASH for you. Send in your entry now, for one of the 209 big, valuable prizes in the Westinghouse League Leaders and Dealer Aid Contest. It's easy to qualify.

Just buy 25 Westinghouse Receiving Tubes or 1 Westinghouse Picture Tube for each entry you submit. Winning entries will be judged on the basis of correctness of team selection, and aptness, originality and effectiveness of cartoon solution.

Your Westinghouse distributor salesman will certify your Entry Blank when he takes your tube order. Ask him for additional Entry Blanks.

ET-95051

\$1,000 CASH FIRST PRIZE

208 MORE BIG PRIZES FOR TV SERVICE MEN

- 2nd PRIZE \$700 in YOUR Choice of Merchandise
- 3rd PRIZE \$400 in Merchandise YOU Select
- 4th PRIZE \$300 YOU Select the Merchandise

FIRST, SECOND, THIRD AND FOURTH PRIZE WINNERS WILL MEET MICKEY MANTLE OR STAN MUSIAL IN THE BIG PRIZE AWARD DINNER WESTINGHOUSE HAS PLANNED FOR YOU IN NEW YORK

- 5 Fifth Prizes of \$140 Each in Merchandise
- 20 Sixth Prizes of \$70 Each in Merchandise
- 30 Seventh Prizes of \$35 Each in Merchandise
- 50 Eighth Prizes of \$20 Each in Merchandise
- 100 Ninth Prizes of \$15 Each in Merchandise

YOU CAN BE SURE...IF IT'S **Westinghouse**

RELIATRON® TUBES

WESTINGHOUSE ELECTRIC CORPORATION

Electronic Tube Division

Box 284

Elmira, N. Y.

USE THIS OFFICIAL LEAGUE LEADERS ENTRY BLANK

1. League Leaders on August 1st, 1953 were:

AMERICAN LEAGUE

NATIONAL LEAGUE

MY NAME

SHOP NAME

STREET

CITY..... STATE.....

SEND ALL ENTRIES TO:
WESTINGHOUSE TUBE CONTEST

P. O. Box 610, Grand Central Station

New York 17, New York

2. Here is what I would say to the Lady in the Cartoon:

.....
.....
.....
.....
.....

(Attach additional sheet of paper if necessary. 100 words maximum.)

THIS SPACE FOR DISTRIBUTOR'S SALESMAN'S CERTIFICATION

I certify this Entry Blank has been qualified by the purchase of (25 Westinghouse Receiving Tubes) (1 Westinghouse Picture Tube)

Salesman's Signature.....

Company Name.....

City..... State.....

A Brief Survey of COLOR TV

... how its
complex character
means job opportunity
for you



—by E. H. RIETZKE,

President, Capitol Radio Engineering Institute

A GOOD MANY YEARS AGO, when he was a young fellow, my Dad was one of the country's fastest typesetters. He could go anywhere and get a highly paid job with any newspaper in the country. Then came the linotype machine! Before he knew it, my Dad's job was obsolete. He had to start all over in another line of work.

How will you get along in the age of Color TV that has already arrived? Will you have to start all over? Or will you be prepared? The choice is a matter of black-and-white—or color. As you may know, color TV involves handling an understandably much more complicated signal than for black-and-white; the components must be in perfect balance; the margin for error is practically zero. Technical personnel need new skills in working to closer tolerances. Microwave relays and coaxial cables require added equipment and special adjustments. Before a station can originate color it needs a great deal of additional equipment, much more expensive and vastly more complicated than that for black-and-white. Slide and film equipment also require additional components and maintenance. Color camera chains are much more complex, requiring more highly skilled adjustments and care. Reports of network experiments indicate that live telecasting in color increases technical man-hours required by 30 to 50%. Lighting personnel need more skill in handling new—and deli-

cate—problems. That's a very quick run-down from the transmitter end. Every step is a technical opportunity.

What about color receivers? They'll be bigger—with roughly twice as many receiver tubes as black-and-white. There is at least one more tuning knob—the chroma control for color saturation. Maintenance is complicated, to say the least, with three highly critical video channels to trouble-shoot instead of one. Service contracts for color receivers will cost considerably more than for black-and-white, according to highly qualified sources—which should give you an idea of servicing complexity—and earnings possibilities. So much for transmission and reception. Manufacture of color equipment is another field for trained technicians.

Most well-informed sources agree that color television will be spread all over the U.S. by 1956 at the latest. The years between now and then are crucial. If you are interested in an honest-to-goodness career in this booming part of the booming electronics industry, here's how you can step ahead of competition, move up to a better job, earn more money, and be sure of a well-paid job: Study radio-television-electronics via CREI. You don't have to be a college graduate. You do have to be willing to invest some of your spare time—at home. You can do it while holding down a full-time job. Thousands have.

Since 1927 CREI has provided men with the technical knowledge that leads to more job security—and more money. CREI starts with fundamentals and takes you along at your own speed, not held back by a class, not pushed to keep up with others who have more experience. You master the fundamentals, then get into more advanced phases of electronics engineering principles and practice. Finally you may elect training at career level in highly specialized applications of radio or television engineering, or aeronautical radio. The coupon below, properly filled out, will bring you—without cost—a fact-packed booklet, "Your Future in the New World of Electronics," which includes outlines of courses offered, a resume of career opportunities, full details about the school, our Placement Bureau (with more requests for trained men currently on file than we can fill), and the names of some of the organizations using CREI training (like All American Cables & Radio, Inc., Canadian Broadcasting Corp., Columbia Broadcasting System, RCA Victor Division, United Air Lines, to name a few). I urge you—for your own good—to send for this free booklet immediately.

NOTE: CREI also offers Resident School instruction, day or evening, in Washington, D. C. New classes start once a month. If you are a veteran discharged after June 27, 1950, let the new GI Bill help you obtain resident (or home study) instruction. Check the coupon for more data.

CAPITOL RADIO ENGINEERING INSTITUTE

An Accredited Technical Institute • Founded in 1927
3224 16th Street, N.W. Dept. 145-A Washington 10, D. C.

Send booklet "Your Future in the New World of Electronics" and course outline.

CHECK
FIELD OF
GREATEST
INTEREST

- Practical Radio Engineering
 Broadcast Radio Engineering (AM, FM, TV)
 Practical Television Engineering
 TV, FM & Advanced AM Servicing
 Aeronautical Radio Engineering

Name.....

Check:

Residence

Street.....

School

Veteran

City.....Zone.....State.....

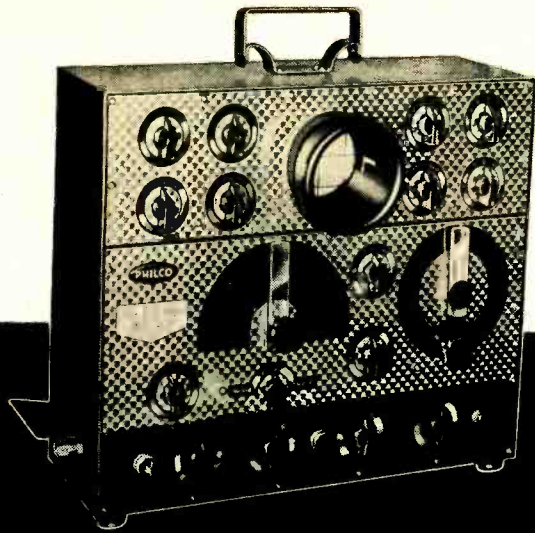

*Your Own Portable
"Service Bench" for
IF-RF Alignment!*

PHILCO

VISUAL ALIGNMENT GENERATOR
Oscilloscope, Sweep and Marker Generator
All in One Instrument!



NEW! PHILCO FIELD STRENGTH METER

Here's more than an antenna signal checker. The new Philco Field Strength Meter provides direct readings of RF signal level. It has built-in electronic sensitivity control. Signal levels above 100 microvolts are read directly on the calibrated dial. Read 10 to 100 microvolt levels on the high sensitivity meter. High gain, low noise TV tuner provides exceptional wide range of sensitivity. Now, measure both strong and weak signals with the Philco reference calibration method. It's the same type found in expensive laboratory equipment. MODEL M-8104.

The Philco Model 7008 Visual Alignment Generator is a completely self-contained "service bench" for all alignment and trouble shooting problems in the field. It is specifically designed to permit rapid servicing of the IF amplifier and front end of TV and FM receivers. The sweep section furnishes a high output signal with uniform sweep level throughout the FM and television bands, as well as the intermediate frequencies used. The marker system, with its associated crystal calibrator, has an accuracy of .005%. The built-in oscilloscope greatly simplifies test set-up. Furnished complete with high frequency detector probe, output and input cables and AC cord.

Look at these PHILCO features:

1. Only two external cable connections necessary...minimizes regeneration and feed-back.
2. Shielded multiplier attenuator provides accurate control
3. RF output increases with frequency to offset the fall off in gain which normally occurs on the higher frequencies.

**AVAILABLE THROUGH YOUR PHILCO DISTRIBUTOR
ON A NEW SPECIAL PAYMENT PLAN**

**OFFER
ENDS
MAY 29**

Take advantage of the great
SHARE and PROFIT Program
on Philco Receiving Tubes
Parts and Accessories

NOW AT YOUR PHILCO DISTRIBUTOR



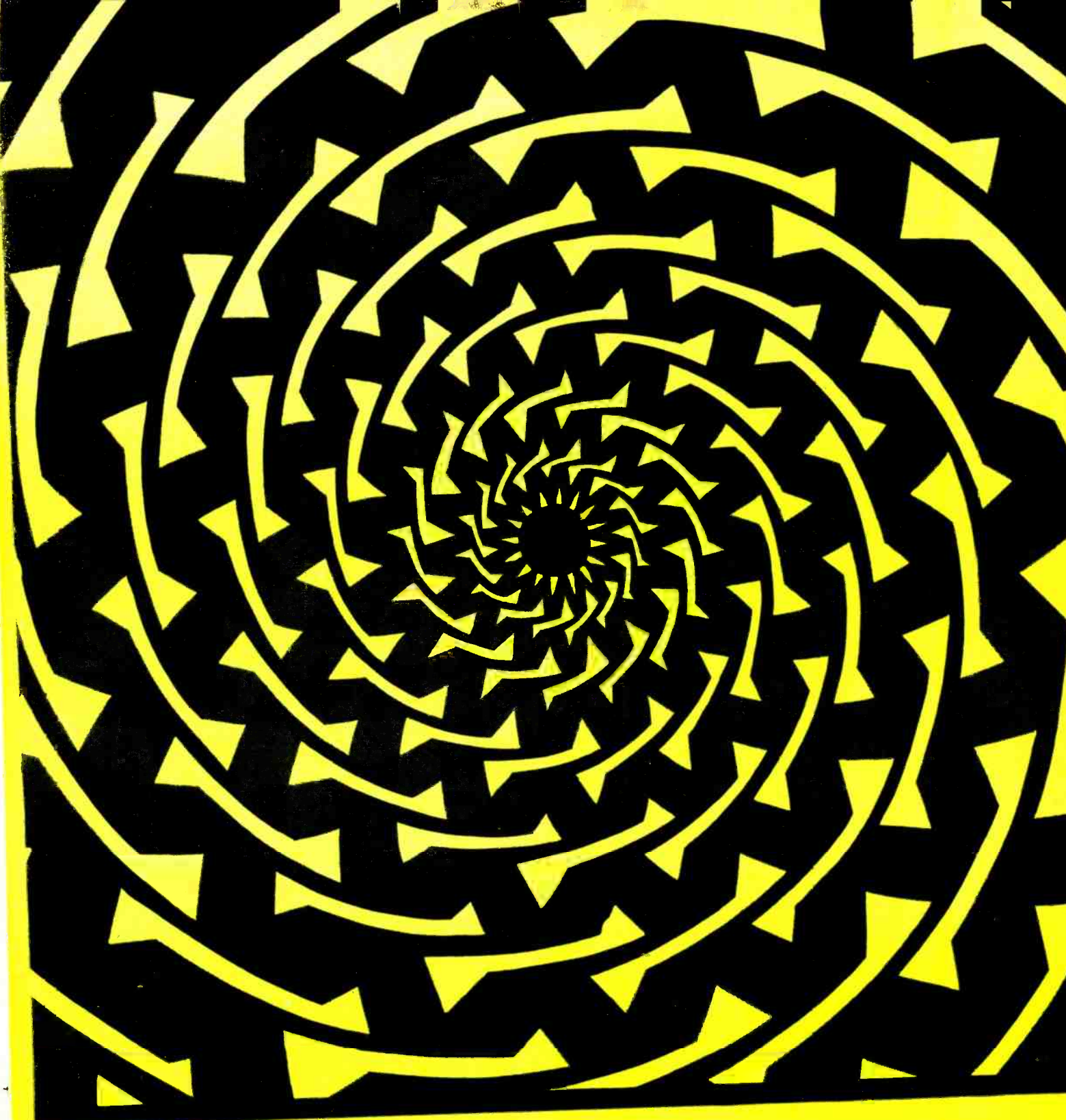

Barton Browne advertising

THINGS ARE NOT AS THEY SEEM...

Things are not as they seem
 These two fuses look alike . . .
 Until you look inside.

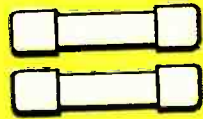

LITTELFUSE
 DES PLAINES, ILLINOIS

This is not a spiral. It is a series of concentric circles that do not join.

This fuse has a straight element—cannot be made more delicate than 1/16 amp. with normal blowing characteristics.



This fuse has a bridge construction (note short filament between electrodes). This type fuse may be rated as low as 1/500 amp. with precision blowing characteristics required for protection of extremely fine instruments. Without this construction pioneered by Littelfuse—the microscopically fine filament would break in shipment, in normal operating vibration or even from nearby footsteps.



Littelfuse leads all other fuse manufacturers in design patents on fuses.

NOW... 2 SENSATIONAL EICO SCOPE VALUES!

NEW AMAZING FEATURE PACKED
7" PUSH-PULL OSCILLOSCOPE

Only **EICO** Has All These Features

- VERTICAL FREQ. RESPONSE: flat ± 2 db 10 cps - 1 mc
- VERTICAL SENS.: .01 volts rms/inch
- HOR. FREQ. RESP.: flat ± 0 db 10 cps - 200 kc, -4 db at 500 kc
- HOR. SENS.: .3 volts rms/inch
- SWEEP RANGE: 15 cps-100 kc
- 3-STEP FREQ.-COMPENSATED ATTENUATOR eliminates freq. distortion, overloading.
- CATHODE FOLLOWER inputs to both amplifiers
- PUSH-PULL outputs in both amplifiers
- RETURN TRACE BLANKING
- INT. VOLTAGE CALIBRATOR
- V & H TRACE EXPANSION & CENTERING: 1.5X full screen without distortion.
- DIRECT CONNECTION to vert. CRT plates.
- PHASING CONTROL of Internal 60 cps sine wave sweep.
- AT FRONT PANEL: Intensity mod. input; 60 cps, sawtooth outputs.

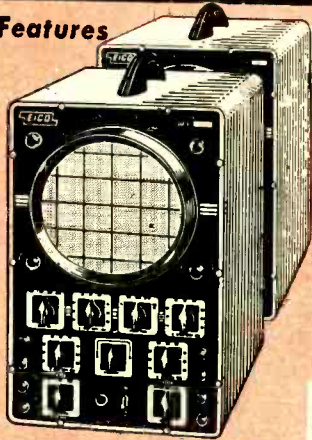

MODEL 470K
KIT \$79.95. WIRED \$129.50.

EICO EXCLUSIVE! 5" PUSH-PULL SCOPE, 425K, Amazing feature-packed economy-priced Wired, \$79.95. KIT, \$44.95.

- PUSH-PULL V & H amplifiers. Sens: 0.5-1 rms v/in. Useful to 2.5 mc.
- SWEEP: 15 cps-76 kc. Z-axis intensity modulation. Dual trace positioning controls.

SCOPE VOLTAGE CALIBRATOR KIT 495K KIT \$12.95. WIRED \$17.95.

- Sq. wave output at power-line freq. with full-scale readings of .1, 1, 10 or 100 V. peak-to-peak
- Accuracy $\pm 5\%$ of full-scale on each range.

6V & 12V BATTERY ELIMINATOR KIT 1050K KIT \$29.95. WIRED \$38.95.

- DC output: 0-8 V or 0-16 V.
- Continuous current rating: 10 A at 6 V, 6 A at 12 V.
- Intermittent current rating: 20 A at 6 V, 12 A at 12 V.
- Separate Voltmeter & Ammeter.



25K VTM KIT \$25.95. WIRED \$39.95.

- AC & DC volts: 0-5, 10, 100, 500, 1000 V (30 KV with MVP-1 probe).
- 5 ohm ranges from 2 ohm to 1000 megs.
- DC input Z 26 megs.
- 4 1/2" meter movement in can't-burn-out circuit.
- 1% mult. resistors.

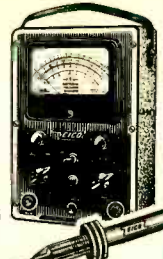

HIGH VOLTAGE PROBE \$6.95
● Extends range of VTVMs & voltmeters to 30 KV.

CATHODE RAY TUBE CHECKER 630K, WIRED \$24.95 KIT \$17.95



- Checks all types of TV picture and C. R. tubes in the set or carton. Bridge measurement of peak beam current (proportional to screen brightness).
- Detects shorted & open elements.

625K TUBE TESTER KIT \$34.95. WIRED \$49.95.

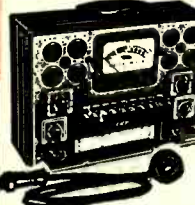

- Illum. gear-driven "Speed Rollchart."
- New lever-action switches for individual testing of every element.
- Tests all conventional & TV tubes.
- PIX TUBE ADAPTER for Tube Testers \$4.50. Checks TV picture tubes while in set.

360K SWEEP GEN. KIT \$34.95. WIRED \$49.95.

- Continuous coverage of all TV & FM frags. from 500 kc to 228 mc.
- Sweep width variable 0-50 mc.
- Crystal marker oscillator, variable amplitude.

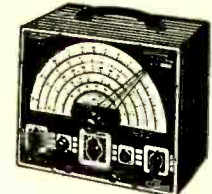

214K VTVM KIT \$34.95. WIRED \$49.95.
249 K P-P KIT \$39.95. WIRED \$59.95



- Large 7 1/2" meter, can't-burn-out circuit.
- AC/DC volts: 0-5, 10, 100, 500, 1000 (30 KV with HV Probe).
- 5 ohms ranges from .2 ohm to 1000 megs.
- DC input Z 26 megs.
- 1% mult. resistors.

Large 7 1/2" meter

959A-K R-C BRIDGE & R-C-L COMP. KIT \$19.95. WIRED \$29.95.

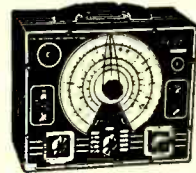

- Measures & tests all resistors; .5 ohm to 500 megohms.
- Every type condenser, 10 mmf to 5000 mfd.
- 0-500 DC voltage source for capacitor leakage testing.

BAR GENERATOR 352K, WIRED \$19.95 KIT, \$14.95

- Enables rapid adjustment of TV picture V & H linearity without hard-to-find station transmitted test pattern.
- Produces 16 V or 12 H bars. Operates on TV channels 3, 4, or 5.

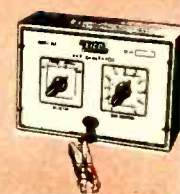

Prices 5% higher on West Coast. Specifications and prices subject to change without notice.

NOW! ONLY EICO KITS & WIRED INSTRUMENTS Gives You LIFETIME SERVICE & CALIBRATION GUARANTEE*

*at less than our cost of handling (See EICO Guarantee Card enclosed with each Kit & Instrument).

New! EICO SCOOPS!

232 K PEAK-TO-PEAK VTVM with DUAL-PURPOSE AC/DC Uni-Probe* KIT \$29.95 WIRED \$49.95



Measures directly p-p voltage of complex and sine waves: 0-4, 14, 42, 420, 1400, 4200 V p-p. DC/RMS sine voltage range: 0-1.5, 5, 15, 50, 150, 500, 1500 v. Ohms: 0-1000 megs. 7 non-skip ranges on every function. Calibration without removing from cabinet. Zero center. Freq. Resp. 30 cps-3mc. 1% precision ceramic multipliers. Exceptional stability and accuracy. Compact, portable (7x5x4), smart, rugged.

NEW! UNI-PROBE! Terrific time-saver! Only 1 probe for all functions—a half-turn of probe-tip selects DC or AC-OHMS!

249 K PEAK-TO-PEAK VTVM with 7 1/2" METER KIT \$39.95, WIRED \$59.95

944 K FLYBACK TRANSFORMER AND YOKE TESTER KIT \$23.95 WIRED \$34.95

Tests all flybacks and yokes, in or out of TV set—in just seconds! Detects even 1 shorted turn! Exclusive separate calibration for air—and iron-core flybacks assures utmost accuracy. Large 4 1/2" meter, 3 colored scales. Compact, portable (7 x 5 x 4"), smart, rugged.



1171K RES. DECADE BOX KIT \$19.95 WIRED \$24.95
DECADE CONDENSER BOX KIT 1180K KIT \$14.95 WIRED \$19.95
RTMA RESISTANCE SUBSTITUTION BOX 1100K WIRED \$9.95 KIT \$5.50

315K DELUXE SIG. GEN. KIT \$39.95. WIRED \$59.95.



- Covers range of 75 kc to 150 mc.
- 7 calibrated scales: accuracy better than 1%.
- Bandsread vernier tuning.
- 4-step RF shielded output multiplier: constant output Z.

377K SINE & SQUARE WAVE AUDIO GEN. KIT \$31.95. WIRED \$49.95.



- Complete sine wave coverage, 20-200,000 cps in 4 direct-reading ranges.
- Complete square wave coverage, 60-50,000 cps.
- Cathode follower output circuit.

536K MULTIMETER KIT \$12.90. WIRED \$14.90.
526K MULTIMETER KIT \$13.90. WIRED \$16.90.



- 1000 Ω /V; 31 ranges
- DC/AC volts: Zero to 1, 5, 10, 50, 100, 500, 5000.
- DC/AC Current: 0-1, 10 ma; 0.1, 1 A.
- Ohms: 0-500, 100 K, 1 meg.

565K MULTIMETER KIT \$24.95 WIRED \$29.95.



- 555K MULTIMETER KIT \$29.95 WIRED \$34.95. (1% precision resistors)**
- 20,000 Ω /V; 31 ranges.
 - DC/AC/Output volts: 0-2.5, 10, 50, 250, 1000, 5000.
 - DC Current: 0-100 ua; 10, 100, 500 ma; 10 A.
 - Ohms: 0-2K, 200K, 20 meg.

145K SIG. TRACER KIT \$19.95. WIRED \$28.95.



- Audibly signal traces all IF, RF, Video & Audio circuits from ANT to SPKR or CRT in all TV, FM, AM, etc. without switching.
- Germanium crystal diode probe responsive to over 200 mc.
- Integral test speaker.

320K SIG. GEN. KIT \$19.95. WIRED \$29.95.
322K SIG. GEN. KIT \$23.95. WIRED \$34.95.



- Fundamentals 150 kc to 34 mc, harmonics to 102 mc.
- 5-step band switching.
- Colpitts audio oscillator generates 400 cps pure sine wave voltage.
- Permits pure RF, modulated RF, or pure AF.

Write NOW for FREE latest Catalog C-5
Ask your jobber for FREE EICO business building decals.

Separate Assembly & Operating Manuals supplied with each EICO KIT!

You build EICO Kits in one evening, but... they last a lifetime!

SAVE OVER 50%! See the famous EICO line TODAY, at your local jobber.

ELECTRONIC INSTRUMENT CO., Inc., 84 Withers Street, Brooklyn 11, N. Y.



ATOM-ELECTRONICS

... A fantastic new era is now in the making ...

By Hugo Gernsback

GRAVITY-CHAINED man, ever since his appearance on this planet, has been a slave to all his bodily work. Wherever he turns, he comes to grips with relentless gravity which makes all work a drudge. "In the sweat of thy face shalt thou eat bread", was the life-command of our ancestors. They literally worked themselves to death in their short life span of 30 to 40 years.

In recent years, steam, electricity, and the internal combustion engine have lightened modern man's work immensely. However, while lifting the gravity-chains in some measure, we have become enmeshed in other and often more burdensome chains: *economic loads* which bear down on us as hard as gravity's weight.

While we do not work as hard physically nowadays—and we live twice as long as our forefathers—we still pay exorbitantly for our needs. Hardly anything that keeps you alive and comfortable nowadays is created without power in some form. And power is expensive, because practically all types of power are exceedingly wasteful in one way or another.

Moreover, our main sources of power supply are rapidly vanishing. At our present scale of spendthrift consumption, coal and oil will be scarce 75 years from now. Even water power transformed into electrical energy, is not an abundant commodity in the U. S. It will always be expensive due to the high cost of key installations and distribution.

Fortunately, the final emancipation of man—the age of *Power-Freedom*—is now appearing above the horizon. It is possible that this era will come to be known as the *Atom-Electronic Age*—the era that will pale into insignificance the age of electricity and electronics.

Very recently we have made the beginning in our fabulous atomic batteries, with which at last we can turn atomic energy into electricity *directly*, without steam or heat or other wasteful intermediaries. The writer probably was the first to use the term *Atomic Battery*, when, in December, 1945, he published the following fanciful prediction:

1950. Professor Andrew Lodge, Berkeley Calitechnician, discovers first basic, ATOMIC BATTERY, called *Atobat*, whereby Plutonium-C generates electric current in vast quantities at infinitesimal cost. Finger-sized *Atobat* produces 10,000 kilowatt-hours for less than $\frac{1}{10}$ cent.

As the first atomic battery was invented in 1951, the writer erred by one year. The high output of power is yet to be realized. But make no mistake—in the not-too-distant future the 1945 prediction will sound picayune! We say this with conviction in view of the recently announced RCA atomic battery, which generates electricity *direct* from the atom in an entirely new and original manner—a milestone in the new art of atomic-electronics.

We have now reached a parallel point in history comparable to the time when Michael Faraday in the early 1830's demonstrated the first electric generator. It was a toy-like device in which he rotated a copper disc edgewise between the poles of a horseshoe magnet. The weak electrical current was collected by two contacts rubbing on the edge and the shaft of the revolving disc. The current generated was so weak that it could scarcely be demonstrated from this most inefficient dynamo.

One unimaginative and skeptical man of science viewing a demonstration scoffed, "What possible good is this contraption?" Faraday countered with, "What good is a newborn child?"

So it is with the newborn atomic battery and its follower, the atomic generator. Curiously enough, man only dimly and slowly becomes conscious of the fact that he would not be here at all if it were not for atomic energy which

surrounds us on all sides. The sun, the stars, *all* are energized by atomic power. Without the sun's heat and light no known form of life could exist.

When we but realize that the actual atomic power *inherent* in a copper penny can drive an aircraft carrier across the Atlantic, we begin to understand what is in store for future mankind by way of cheap and abundant power. Electric power in the home for light, heat, and air-conditioning will come from a small compact atomic generator in the basement.

The shielding problem will be solved, despite the opinion of many skeptical scientists today. And, while powerful atomic radiation is highly dangerous to man, we should never lose sight of the fact that *radiation is also energy*—powerful energy. In shielding our present-day atomic energy piles, *we lose most of the generated power*. The pile, instead of converting atomic energy *directly* into electric current, merely generates heat, which we use to make steam in a boiler. The steam then runs a steam turbine, which now powers an electric generator! A contraction as roundabout, wasteful, and inefficient as any ever dreamed up in history!

Shielding is a wasteful makeshift because valuable radiation-energy is uselessly absorbed either in thick concrete blocks or heavy lead sheeting. In this process the shielding becomes hot—with high *unwanted* heat that is a total loss.

As I have said many times before: Why waste this priceless radiation-energy? Why not turn it into valuable electric power? This, I think, will be accomplished in time. Some material or a combination of materials will be found which absorb the deadly, powerful gamma radiation and turn it—as rapidly as created—into useful electrical energy. This will not be accomplished tomorrow, nor next year—it lies as yet deep in the future. Nevertheless, the problem will be solved, perhaps sooner than we expect. First the theoretical and experimental phases, then the practical elements for a reliable commercial product.

When the goal has been achieved, every radio receiver, every television set, will be powered atom-electronically. Just as our portable radios are battery-powered today, so in the future a tiny atomic cartridge will power *any* receiver for years on end, at a cost not much higher than a single set of present-day batteries.

Bicycles, motorbikes, automobiles, airplanes, all ultimately will be powered atom-electronically, as will all modes of transport. There will be a host of new atom-electronic developments undreamed of today.

Here are only a few that come to mind: ● High-voltage (200,000 to 1,000,000 volt) cascade generators which operate without benefit of the usual transformers. ● Self-powered X-ray emitters—adjustable for various types of X-ray emissions. ● Banks of multiplex, self-powered transistors—where hundreds or thousands of transistors are required in a small space, such as in special electronic computers for use at a desk. ● Auto-watches. Instead of present-day complex pocket watches powered by springs which often break, the atom-electronic watch is self-powered, has few wheels but instead a tiny electric motor. Such watches will be much cheaper, will need few repairs, will never have to be wound. Larger watches or clocks are made in a like manner. ● Auto-fluorescents, self-powered table lamps or special-use lamps for home, office, or camp—an important innovation as they will do away with present-day connecting wires that clutter up homes and offices and other places where light is used.

This list can be extended endlessly as the new art comes into full use. It is certain to revolutionize our lives far more than steam and electricity did in the past.

MARKERS and**ALIGNMENT BUGS**

*Calibrating the marker
generator; marker injection;
the zero-volt reference line*

By ENGINEERING STAFF, SCALA RADIO CO.

WE HAVE shown in the article "Killing Those Alignment Bugs" (April issue) that a bypass marker injector makes it possible to obtain a uniform size marker at any point on the response curve—along the base line, or in the traps. To refresh the reader's memory on this important point, reference is made to Fig. 1. The height of the marker appears the same, whether placed on top of the i.f. response curve (Fig. 1-a), at the bottom of the curve on the base line (Fig. 1-b), on the hump of the after response (Fig. 1-c), or in the bottom of the expanded trap (Fig. 1-d).

The experienced technician will recognize that this is a surprising type of display, normally unobtainable with older methods of beat-marker injection. The marker display on the ratio-detector S curve is perhaps most surprising of all. The ratio-detector type of circuit is one which is notoriously difficult to mark because of its AM rejection (Fig. 2-a); yet, with a bypass marker injector, a large marker is obtained on the linear portion of the S curve (Fig. 2-b).

Locating marker point on scope base line

If a bypass marker injector is not available, the technician can disconnect the sweep generator from the discriminator, and feed the sweep and marker signals through a crystal demodulator probe to the scope. The marker will then become visible along the scope base line. Set the marker generator to exactly 4.5 mc; then adjust the sweep generator to bring the marker to exact center screen, as shown in Fig. 3.

Now, the crystal demodulator probe can be removed and the discriminator reconnected. Although the marker may not be visible on the S curve, it is known that at the center of the scope screen is the 4.5-mc marker point. As the tuning adjustments of the discriminator are varied, the S curve moves left or right along the scope base line. The proper adjustment, of course, is that which causes the center point

of the S curve to cut the vertical line of the scope screen.

Both primary and secondary adjustments of the discriminator transformer are effective in shifting the S curve. But adjustment of the tuned coils also causes the curve to become more or less symmetrical. The proper adjustment is made when the curve is symmetrical as well as being centered on the scope screen.

The time lost when a crystal demodulator probe is used to locate the marker point on the scope base line is a strong argument for using a bypass marker injector in the busy shop.

High accuracy required in marking

Experienced technicians know that unless the 4.5-mc marking frequency is accurate, the sound output from the receiver will be weak and distorted, or perhaps completely inaudible. For this reason, a method of calibrating the marker generator is an absolute necessity. Fig. 4 shows how this is done with the aid of a crystal demodulator probe.

The output of the marker generator is connected in parallel with the output of a crystal oscillator, and both signals are demodulated by a crystal probe and applied to the input of the scope. The scope is swept at a low frequency, and a sine-wave beat pattern appears on the scope screen. The marker dial will indicate zero-beat frequencies (seen as a minimum number of sine waves on the scope screen) when the marker frequency is an exact multiple of the crystal fundamental frequency. Any crystal oscillator can be used, but the technician will obtain the greatest use from 1 mc, 2 mc, and 4.5-mc crystals.

This type of calibrating arrangement is limited in the extent to which it can develop visible indications of zero beats against higher harmonics of the calibrating crystal. In order to use higher harmonics of the crystal, a conventional audio amplifier can be placed between the output of the crystal demodulator probe and the input terminals of the scope. It is essential, however, that the audio amplifier have a

low hum level, or severe distortion of the beat pattern may result.

It is possible to use the internal amplifier of the bypass marker injector for this purpose. No distortion of the pattern is obtained under such circumstances, because the internal power supply of the unit is exceptionally well filtered. Circulating ground currents which may cause a hum-voltage drop to appear between various ground points along the chassis are avoided by proper layout of ground returns.

Observation of spurious markers

Spurious markers are annoying to the busy operator. Spurious markers usually arise from beats between harmonics of the test signals which are in use at the time. The annoyance is sometimes so severe that technicians use absorption markers, because an absorption marker has no harmonics and cannot cross-beat with harmonics of the sweep signal. However, an absorption marker always disappears near the base of the curve. Furthermore, an absorption marker usually appears in a misleading manner on the steep side of a response curve; the operator usually judges the marker to be too low on the curve.

It is possible to obtain clean markers free from spurious indications, if the generators have good waveform; i.e., the generators should have a sine-wave output, free from harmonics. In general, the more paid for a generator, the more nearly its output approaches a pure sine wave. Some sweep generators provide a low-pass filter in the output circuit for the express purpose of suppressing harmonics in the output. These will be found to develop fewer and less noticeable spurious markers.

It must not be supposed that spurious markers are always the result of harmonic output from the generators. In some cases, faults exist in the i.f. amplifier strip which causes the generation of spurious markers in the i.f. amplifier itself. One common cause of this is the tendency of the amplifier to break into oscillation when the stages are incorrectly peaked at frequencies too close

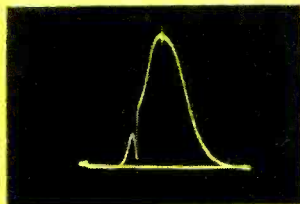

1a

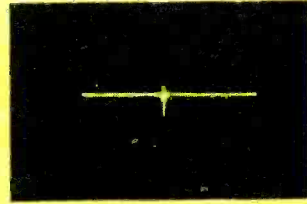

3

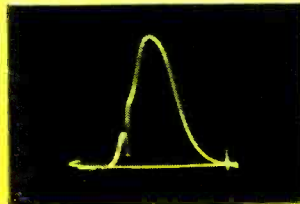

1b

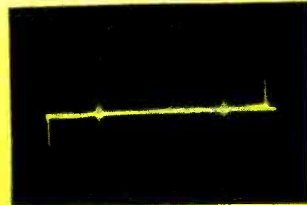

5

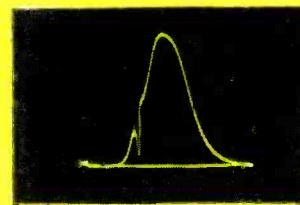

1c

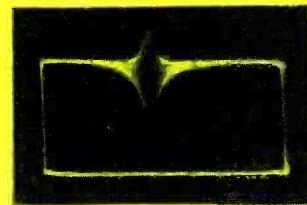

6

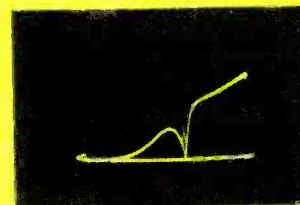

1d

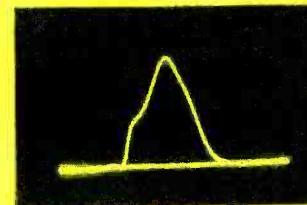

7a

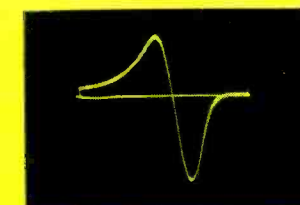

2a

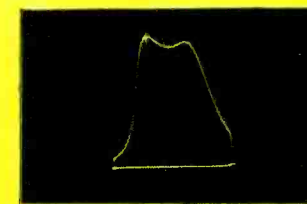

7b

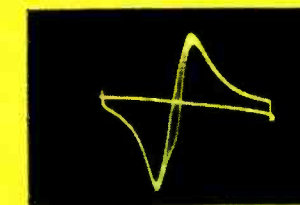

2b

Fig. 1—Marker maintains uniform size at all points of the i.f. response curve.
 Fig. 2—Marking a ratio-detector curve.
 Fig. 3—4.5-mc marker on scope base line.
 Fig. 4—Appearance of spurious markers along a collapsed i.f. response curve.
 Fig. 5—Appearance of spurious markers along a collapsed i.f. response curve.
 Fig. 6—Appearance of marker when the generator sweep width is small.
 Fig. 7—Using zero-volt reference line.

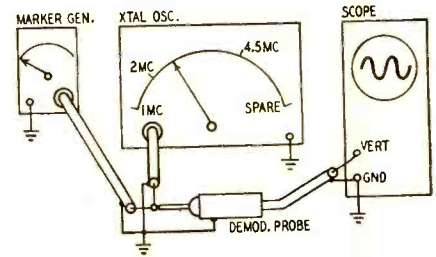

Fig. 4—Calibrating a marker generator.

together. As the amplifier breaks into oscillation, the response curve collapses, and spurious markers appear along the base line on the scope screen, as shown in Fig. 5.

Obviously, if the marker signal does *not* pass through the amplifier, any instability in the amplifier circuits can have no effect upon the marker indication. Hence, a bypass injector often avoids spurious marker indications that appear when the conventional method is used. In conclusion, receiver manufacturers almost invariably indicate that the local oscillator in the receiver be disabled during i.f. alignment. If this is overlooked, spurious markers are certain to be generated which cannot be subsequently eliminated.

Width of marker depends on sweep width

The width of markers on response curves deserves serious consideration. It should not be supposed that it is always possible to obtain a sharp and narrow marker indication, as seen in Fig. 3. For example, Fig. 6 shows the same marker when displayed at a smaller sweep width.

Since a discriminator has a smaller bandwidth than an i.f. amplifier, it makes the marker appear broader. Accordingly, the marker seen in Fig. 1 is narrower and sharper than the marker seen in Fig. 2. The marker on the ratio-discriminator curve requires particular observation; it is not pointed as in wide-band circuits, but is more or less uniform in width from one end of the display to the other. But if the technician looks carefully, he will observe that the marker is broken at one point, and that a dark line about 1/32 inch wide separates the marker into two parts, at the center of the S curve. This break in the marker is the exact zero-beat point, which is utilized in the alignment procedure.

Displays with zero-volt reference

A zero-volt reference line appears in the pattern shown in Fig. 6. The zero-volt reference is a convenience in alignment procedures.

Zero-volt reference lines are developed by the sweep generator, or are provided automatically by d.c. scopes. Since most technicians utilize a.c. scopes, the zero reference must be obtained from the sweep generator, which operates as a d.c. restorer during one-half cycle of its operation. A detailed discussion on this subject is reserved for the next installment of this series.

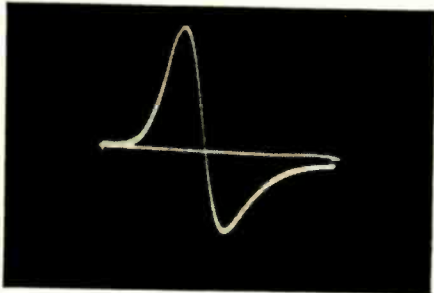

Fig. 8-a—Zero-volt reference line aids in FM discriminator alignment.

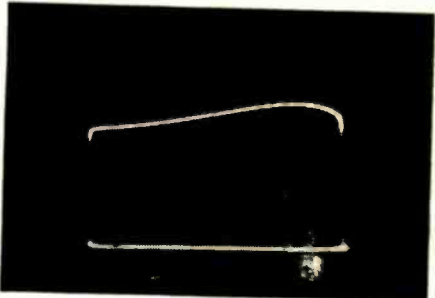

Fig. 8-b—Using zero-volt reference line to check antenna impedance.

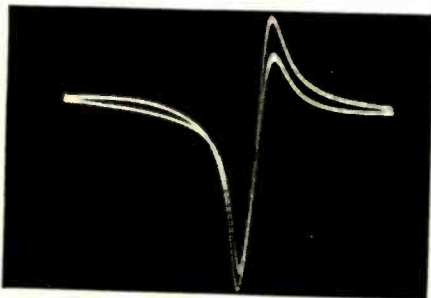

Fig. 9—Hum voltage distorts S curve.

Fig. 7-a shows typical narrow-band circuit response curves when displayed with zero-volt reference lines. It is apparent that little advantage is gained using a zero-volt reference unless a wide-band circuit (Fig. 7-b) is under alignment. In the latter case, considerable additional information is provided, since the operator would not know otherwise where the base line of the curve is located.

The zero reference level is also convenient when aligning discriminators (Fig. 8-a), or checking antenna impedance characteristics, as shown in Fig. 8-b.

The zero-volt reference should intersect the S curve at the 4.5-mc point when the circuits are in proper alignment. However, the technician must guard against hum in the discriminator circuits, since hum voltage will raise one of the S curves and lower the other (in the absence of the zero reference), as shown in Fig. 9. It is apparent that if either of the traces seen in Fig. 9 is converted to a zero reference line by the sweep generator, the intersection of the reference line with the S curve will be false. Accordingly, before alignment, the circuits should be checked for hum.

END

RECONDITIONING PICTURE TUBES

By JOHN B. LEDBETTER*

DID you ever try to burn out a cathode-to-heater or cathode-to-grid short in a picture tube? The usual application of 117 volts a.c. or d.c. across the shorted elements is satisfactory in *some* cases. But it is not very useful where the short is high-resistance or is present only under certain thermal conditions. In addition, the high-current a.c. or d.c. source can damage the cathode coating or even the grid structure.

The method to be described is extremely simple; it takes up a very small amount of time; and, so far as I am concerned, it has been 100% effective. And, what is just as important to the busy service technician, the entire procedure can be carried out without removing either the picture tube or the chassis from the cabinet.

Unusual symptoms of trouble

A common indication of a cathode-to-heater short is full brightness, with the brightness control having no effect. In some receivers (depending on the particular circuit) the symptom may be a washed-out picture, while in still others the raster will be normal but with no picture. In a few sets, a shorted condition will cause a black-and-white shading effect on the screen, with or without a picture.

Most picture tubes can be checked for cathode-grid or cathode-heater shorts (or leakage) with a v.t.v.m. The test should be made while the tube is still hot and with the tube socket removed. Use the highest resistance scale on the v.t.v.m.

Analysis of trouble

While at WKRC-TV, I received and processed a number of shorted C-R tubes. In most of these, the short was between cathode and grid and was usually high-resistance; between 250,000 and 420,000 ohms. A few tubes showed a low-resistance or intermittent short between cathode and heater, some of which could be restored temporarily to normal operation by jarring or thumping the neck or base of the tube. Experiments on these and other types of tubes gave rise to the theory that such shorts were not the result of direct contact between elements (the result of defective structure, displacement of elements from jarring, etc.), but were caused by contact between the grid (or heater) element and the spiral surface of the cathode. As the cathode expands and contracts during heating and cooling cycles, a small burr or flake of the oxide coating may work itself loose and eventually make contact with the heater or grid element. In the case of grid contact, the tip of the cathode element seems to have made contact through "oxidized" coating with

the top portion of the grid. (This is evidenced by the usually high-resistance readings and the fact that slight element displacement would make contact more likely near the top of the elements.)

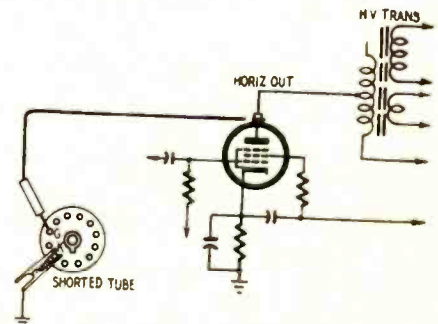

Obtaining high voltage from TV receiver.

Removing the short

The solution to the problem is to apply a high voltage, from a low-current source, across the shorted elements. Such a voltage will produce a low-current arc across the elements which anneals or removes the burr without disintegrating the cathode coating (and without resembling an arc welder in action). Such a voltage can be obtained very easily, either from an r.f. oscillator (amateur radio transmitter, etc.), or directly from the high-voltage power supply of a TV receiver. The latter is probably the simplest.

Usually, the shorted picture tube need not be removed from the cabinet. The socket is removed (see diagram) and the high voltage is applied directly to the shorted pins with well-insulated test probes. In applying the high voltage, use care to prevent overloading the power supply. This can usually be avoided by connecting one test lead (equipped with alligator clips) from the TV receiver chassis to the cathode pin, and the other lead from the horizontal-output tube's plate cap. If this lead is touched rapidly several times in succession to the other shorted element, the short can be cleared without undue current drain from the horizontal output transformer. In stubborn or intermittent cases, the "annealing" or r.f.-heating process can be aided by vibrating or jarring the neck or base of the tube. As a precaution against possible recurrence, the process can be repeated, first from cathode to grid, then from cathode to heater while the base is vibrated with the fingers.

In all tests made, the shorts seemed to clear almost instantaneously. As each tube was returned to service, a brief record including the complaint, date, and condition were attached as a means of evaluating the tests. To date, none of the tubes has given further trouble.

END

* Engineering Writer, Convair.

ADJUSTING A

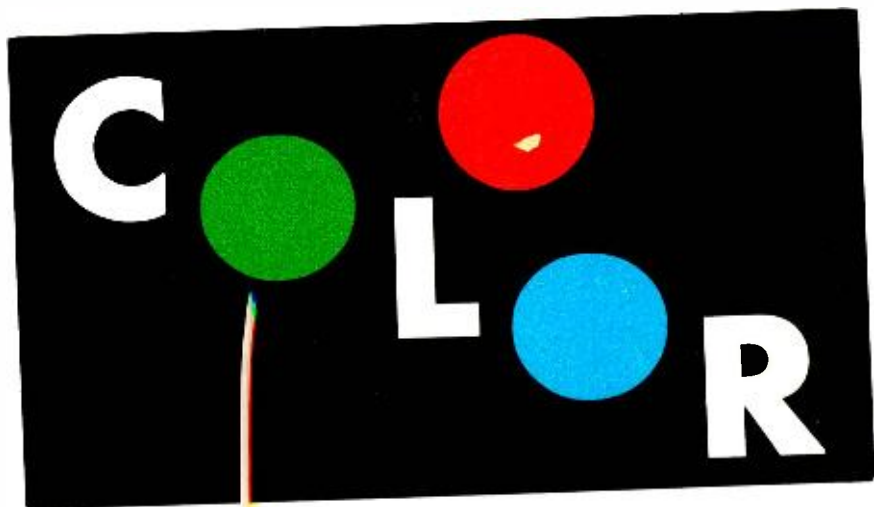

TV RECEIVER

How would you install, adjust, or service a color television receiver? It has been hard to get useful information on that subject, because it is almost impossible to explain the facts of color without full-color illustrations, and it is difficult and expensive to print four-color illustrations in a magazine. This story (separately printed and inserted in the issue) shows how correct adjustments—or color faults—actually look on the TV screen.

THE service technician can easily find information on how to get the color TV tube into place and put its shield, yoke and purifying coil into position. Two or three service sheets have already come out with that information, and he will no doubt see more before he handles his first TV tube. But little material is available on making the necessary adjustments to get the color tube working perfectly. The reason is that it is almost impossible to explain certain of the adjustments without color illustrations. So we are going to talk almost entirely about those adjustments.

At the time of writing, there was one book with complete color information in picture form. That is *Practical Color Television*, (RCA Service Co., Camden, N. J., \$2.00). The color illustrations here are taken from that book, by special arrangement with the RCA Service Company, and are copyright by that organization. The information given here—describing as it does these illustrations—is also largely taken from the same source, with the result that the instructions are especially applicable to RCA color receivers, though useful for any color receiver using the shadow-mask type of picture tube.

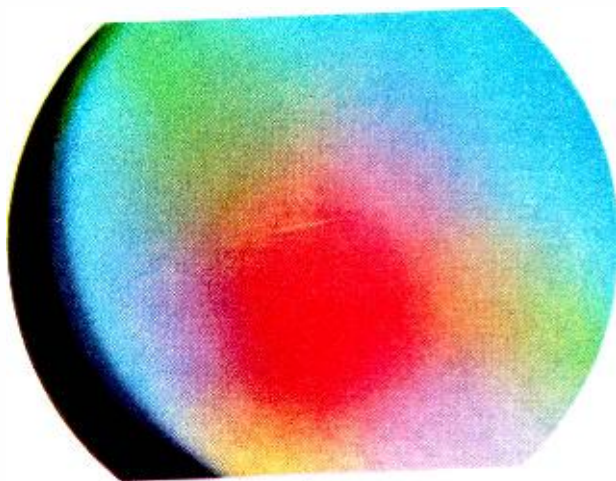

Fig. 1—How an incorrect purity control adjustment looks.

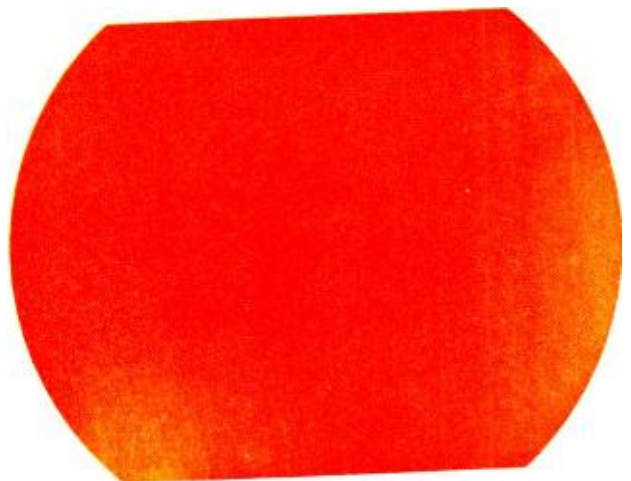

Fig. 2—Color contamination showing in the red picture.

It would be impossible to get a schematic into the space available for this article. The references are to the schematics on pages 66 and 67 of the January, 1954, issue, or to the large complete schematic in *Practical Color Television*. Controls which are named in those schematics are printed in small capitals the first time they appear in this article.

Preliminary adjustments

Once the tube is in place, turn the set on and make the usual adjustments to get a good black-and-white picture

(with CHROMA control turned down). A little color in the picture won't hurt, but linearity must be right. Check the high voltage with a v.t.v.m. and high -voltage probe, making sure it is around 20,000 at all settings of the brightness control. Correct the voltage by adjusting the voltage-regulator control.

Now we are ready to proceed with color adjustments. Turn the contrast all the way down and the brightness control well up. Then turn up the RED SCREEN control, while turning the GREEN SCREEN and BLUE SCREEN controls down. You should have a pure rich red raster.

Screw the convergence magnets out away from the neck of the kinescope and slide the yoke back as far as possible. Then rotate the purifying coil—at the same time adjusting the PURITY CONTROL, until you get the most uniform red in the center of the screen. Use as little purifying coil current as possible. A *wrong* purifying coil adjustment, with the best red toward the lower left of the screen, is seen in Fig. 1.

Next adjust for most uniform red by sliding the yoke forward till you get the best purity, making sure at the same time that there are no neck shadows. If there is still some purity contamination, as in Fig. 2, readjust the purifying coil and purity control.

Convergence adjustments

The *converging electrode* (grid 4) of the picture tube bends together the beams from the three guns and *converges* them at the aperture mask. This is *d.c. convergence* and will bring the beams together correctly in areas near the center of the tube screen. But, since the beams have to travel farther to reach the edges of the screen, the convergence voltage has to be varied according to the position of the spot. This is done by applying *dynamic* horizontal- and vertical-frequency convergence voltages.

To adjust the convergence, a dot generator is used. Turn down the HORIZONTAL CONVERGENCE and VERTICAL CONVERGENCE controls and the VERTICAL SHAPER control, screw the convergence magnets as far away from the neck of the picture tube as possible, and reduce the voltage on the convergence electrode by turning down the convergence voltage control.

The screen pattern should look like Fig. 3. If it looks like Fig. 4, with the blue dot at the top instead of the bottom, convergence voltage is too high. Readjust.

Adjust the three convergence magnets and the d.c. convergence voltage, watching the dots at the center of the screen till they overlap and become white (Fig. 5). Note well that it may be necessary to readjust the focus controls during this process—several of the controls in a color tube

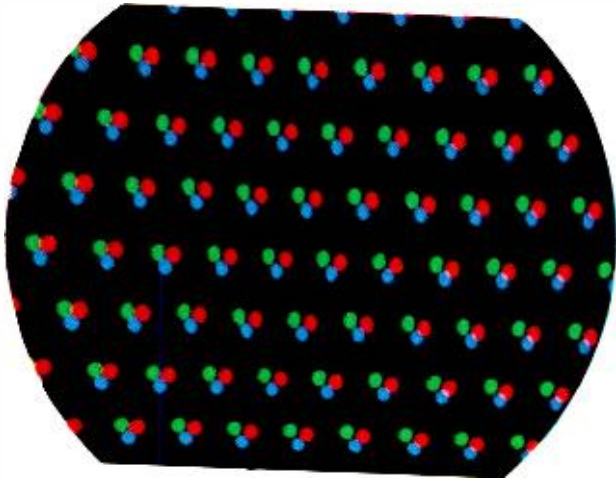

Fig. 3—Dot pattern out of convergence, voltage low.

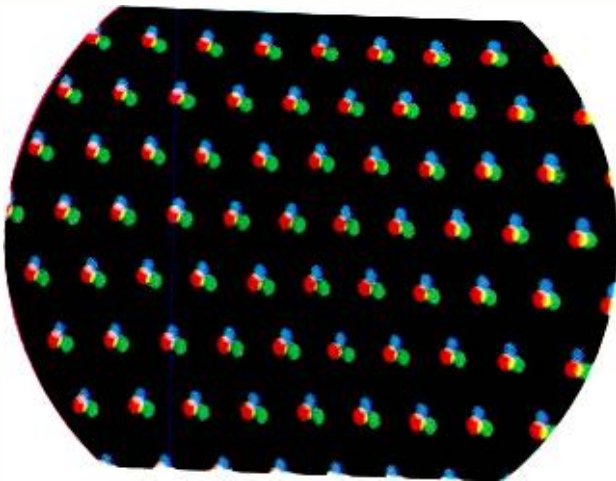

Fig. 4—Dots out of convergence with voltage too high.

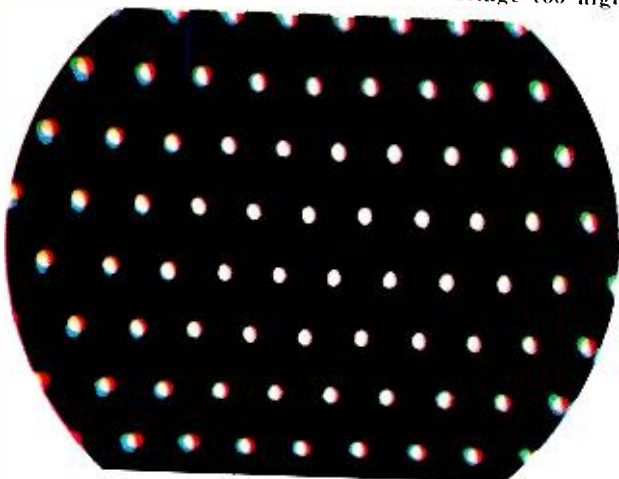

Fig. 5—D.c. convergence fairly good (see note in text).

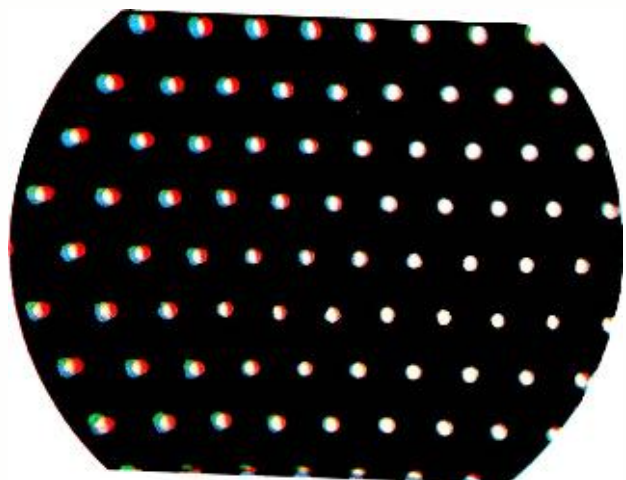

Fig. 6—Horizontal dynamic convergence voltage misphased.

circuit affect each other. The vertical and horizontal dynamic convergence controls are among them.

Once the d.c. convergence controls are properly adjusted, adjust the vertical dynamic shape and amplitude controls to obtain equal convergence along a vertical line of dots through the center of the screen. The vertical shape control should be adjusted to make the color displacement on the top and bottom dots equal. The vertical amplitude control is then adjusted to make the color displacement equal along the entire line of dots in the center. A slight readjustment of the d.c. convergence control will then converge the line from top to bottom.

Repeat the operation with the horizontal convergence control. If one side of the pattern converges and the other does not (Fig. 6), adjust the HORIZONTAL DYNAMIC PHASE control. (When finally adjusted, the convergence magnets must not be too close to the tube neck, or beam focus may be distorted.) A perfect pattern appears in Fig. 7. (Actually the edge dots in Fig. 7 are *not* perfectly converged. The photos were taken while these tubes were still in the developmental stage, and "perfect convergence" was not then as good as is now possible.)

White adjustment

Take away the dot generator, turn CHROMA and CONTRAST controls down and advance brightness to maximum. Adjust the three-color screen controls to give a low brightness white all over the screen. Then turn the contrast control halfway up and tune in a black-and-white picture. Adjust the BLUE gain and GREEN gain controls till you get an uncontaminated white on the highlights. Then turn the brightness control down and adjust the same BACKGROUND controls to get a good white on lowlights. Repeat the highlight and lowlight adjustments till the white tracks at all settings of the brightness and contrast controls.

Your color adjustments are now made, and you should get a picture like Fig. 8 on a standard color test pattern.

Servicing the color set

Many faults in a color receiver can be located by operating it as a black-and-white receiver. This shows up faults in common color and black-and-white circuits, faults in producing pure primary color fields, troubles in convergence and focus, and faults that prevent forming uniform whites and grays. Primary color field troubles produce a color field over the whole picture and can be cleared by repeating the color purity adjustments. Improper convergence makes a black-and-white picture look like Fig. 9. Color in the highlights or lowlights is cleared by repeating highlight and lowlight adjustments.

No color

Other faults can be found only by operating the set as a color receiver. *No color* is likely to be due to the 3.58-mc oscillator. Check the voltage supplied to the suppressors of the "I" and "Q" demodulators. It should be about -5 volts if oscillator signals are reaching them; about -1.8 volts if not. Defects in the BANDPASS AMPLIFIER also may affect the color circuits.



Fig. 10—A color picture due to the loss of color sync.



Fig. 9—Poor convergence on a black-and-white picture.

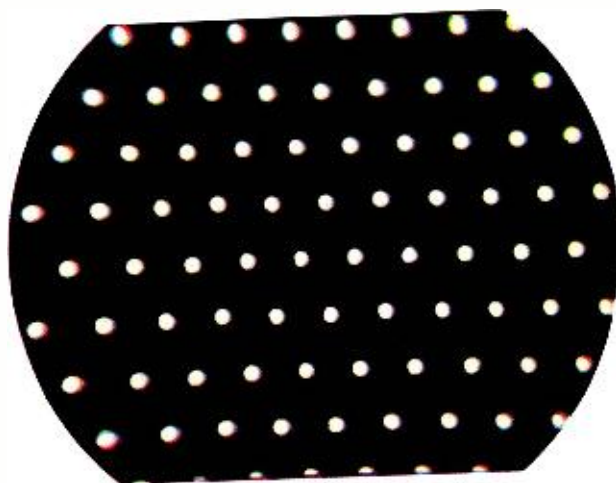

Fig. 7—Properly converged dot pattern (see note in text).



Fig. 8—Correct color adjustment on standard bar pattern.

Color sync problems

Loss of color sync looks like Fig. 10. The colored bars move vertically. Loss of color sync may be caused by defects in the color phase-discriminator circuit or in the reactance tube circuit, or by the 3.58-mc oscillator being off frequency. If horizontal bars are few, frequency deviation is slight.

Phase adjustment problems

Incorrect phase relationship between the "I" and "Q" signals will produce improper colors. Before checking the quadrature circuits, check the manual phase control. A picture like Fig. 11 results when the phase control is mis-adjusted. If the "I" signal is missing entirely, the picture will look like Fig. 12, and a picture without the "Q" signal looks like Fig. 13. Narrow bands of incorrect color at the vertical edges of contrasting color areas indicate that "I" and "Q" signals are not exactly 90 degrees apart. For any of the above, check through the quadrature circuits and the "I" and "Q" demodulators.

Other sources of trouble

Troubles in circuits common to color and black-and-white can also cause color trouble. For example, the burst reference signal could be prevented (by clipping in the i.f. circuits) from reaching the circuits in which it is compared with those from the local 3.58-mc oscillator. This would cause sync trouble. Complete misregistration of the color signal with the fine detail ("Y" channel) can usually be traced to trouble in the delay line. Heater-cathode leakage can cause a picture like Fig. 14. The green and purple bars

are due to hum in the "Q" channel. Orange and bluish-green bars would be caused by hum in the "I" channel.

And finally, if all adjustments are correct, if there are no color-canceling reflections, if antenna is a good broad-band job, and if the station is transmitting a perfect picture, the result should look like Fig. 15. END



Fig. 13—Failure of "Q" signal produces reddish picture.



Fig. 14—Heater-cathode leakage causes color hum bars.



Fig. 11—Picture due to incorrect phase control setting.

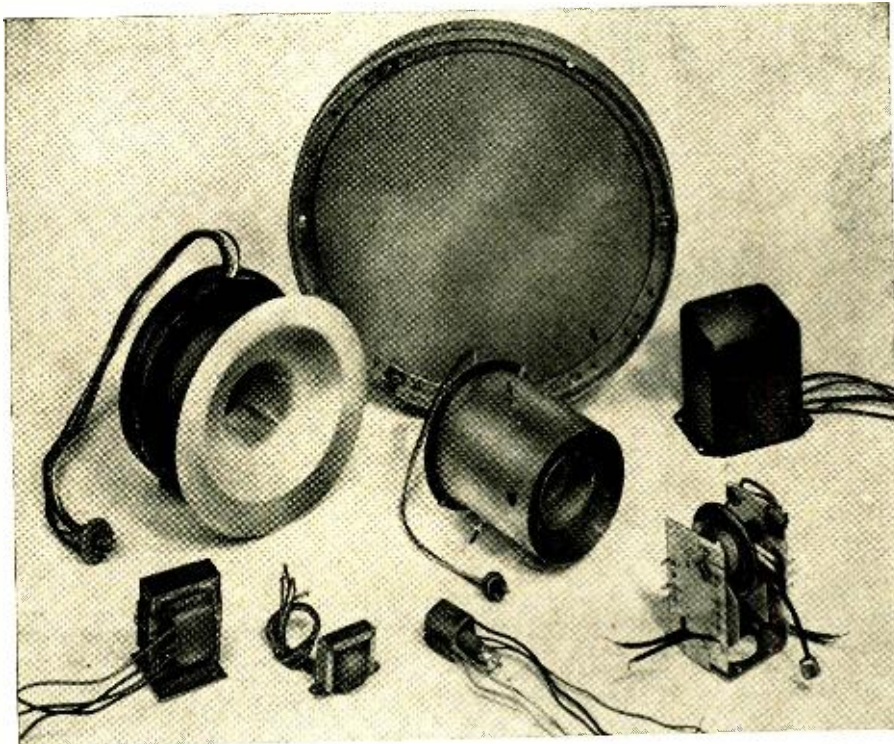

Fig. 12—Green-bluish cast is due to lack of "I" signal.



Fig. 15—What we have been working for: a normal picture.

COLOR RECEIVER COMPONENTS



RCA components for the 15GP22 deflection, high voltage, and focus and convergence circuits. In the background from left to right is the deflecting yoke, shadow mask, purifying coil, vertical dynamic focusing transformer; in the foreground, vertical deflection output transformer, vertical isolation inductor, horizontal dynamic focusing transformer, and horizontal output transformer.

FOR the proper operation of the deflection, high-voltage, dynamic focus, and convergence circuits used with the tricolor tube 15GP22, several specially designed TV components have been developed, some of which—deflecting yoke, purifying coil, and horizontal output transformer, together with shadow-mask from the kinescope—are shown on the front cover.

The most striking feature of the deflecting yoke is its physical size as compared to conventional yokes. Having a horizontal deflection angle of 45°, the horizontal and vertical coils produce the necessary magnetic fields for simultaneous deflection of the three beams. The end of the yoke placed nearest the tube funnel is widely flared to provide the proper flux distribution for optimum convergence. A polyethylene liner is used to prevent arcing between the yoke coils and the grounded coating on the picture tube. The outside diameter of the deflecting yoke is 7 $\frac{3}{16}$ inches; the inside diameter 2.2 inches.

Of particular interest is the purifying coil for obtaining multibeam alignment. It consists of three magnets for positioning the individual beams, and a magnetic shield. It is designed for mounting on the neck section of the tricolor tube.

The purifying coil produces a transverse magnetic field which can be adjusted by rotating the coil and changing the current through it, to align the

common axis of the beams, so that it coincides with the axis of the picture tube. Thus, when the beams are focused, converged, and deflected, they approach each hole in the shadow mask at the proper angle to strike the centers of their appropriate color dots—producing color purity.

The beam-positioning magnets are spaced at 120° intervals to correspond with the positions of the kinescope guns. The magnets are threaded and slotted, with a red dot indicating the north pole. The effect of the magnet on the beam position can be reversed by inserting the opposite end of the magnet into the shield.

The magnetic shield isolates the beams passing at low velocity through the neck section of the c-r tube from the effects of extraneous magnetic fields.

The horizontal-output high-voltage transformer is conventional in appearance. Electrically, it is extremely rugged, supplying an output of 20 kv at 750 μ a when driven by a single 6CD6-G operating from a 400-volt supply.

The transformer has a multi-tapped auto-transformer winding and four isolated windings. The auto-transformer winding supplies the high voltage and provides connections to deflecting yoke, damper tube, driver tube, and width control. Other taps supply pulses for keyed a.g.c. circuits and voltage for a

15GP22 color TV picture tube circuits require specially designed components

high-voltage rectifier supplying the d.c. voltage to the focusing electrode of the 15GP22. Voltage for the converging electrode is taken from a bleeder resistor in the high-voltage supply.

In typical operation the transformer can supply 4 kv to the focusing electrode, and 10 kv to the converging electrode.

The vertical dynamic-converging and dynamic-focusing transformer has a tapped secondary winding for coupling the vertical-dynamic output of the convergence amplifier to both the converging electrode (grid 4) and the focusing electrode (grid 3) of the 15GP22.

This transformer supplies vertical dynamic correcting voltages for combining with those supplied by the horizontal dynamic converging and dynamic focusing transformer.

These combined dynamic correcting voltages are superimposed on the d.c. voltages for grids 3 and 4 to provide changing electrostatic fields which maintain proper focus and convergence of the beams as they pass over the flat shadow mask of the picture tube.

The horizontal dynamic-converging and dynamic focusing transformer performs essentially the same function as its counterpart, except that it couples the horizontal dynamic output of the convergence amplifier to the converging and focusing electrode of the 15GP22.

Designed for operation at the horizontal scanning frequency, an adjustable ferrite core permits tuning to the scanning frequency.

The vertical deflection output transformer is of standard design, and will operate with one-half of a 6BL7-GT as the driver. The transformer provides good sweep linearity, ample deflection, and efficient coupling between the driver tube and the vertical coils of the deflecting yoke.

An especially interesting component is the vertical isolation inductor, a 2-section coil designed to operate as the inductive element in the filter network between the vertical deflection circuit and the vertical centering circuit. The filter network represents a high impedance inserted between the respective circuits to isolate the a.c. component in the vertical coils from ground. This isolation of the a.c. component reduces the capacitance between the vertical and horizontal coils which results in reduction of capacitance between the horizontal coils and ground. Thus, shorter retrace time is obtained for the horizontal deflection circuit. **END**

BASIC COLOR TV

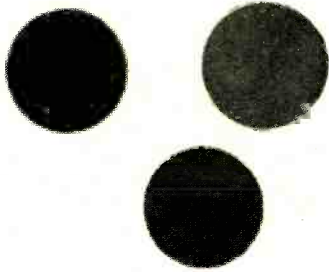

Part IV (continued)—I and Q signals; summary of the features and techniques of the NTSC system

By D. NEWMAN* and J. J. ROCHE*

In earlier installments, we mentioned that the eye does not appreciate blue in picture details which correspond to video frequencies above approximately 600 kc. Remembering that the green color-difference signal is derived at the receiver from the red and blue color signals, we can see that the accuracy of the green color-difference signal depends on the presence of the red and blue signals. Therefore, it would be desirable to transmit the blue color-difference signal for all color video frequencies, to maintain the accuracy of the green color component which is recovered in the receiver—even though the eye may not appreciate part of the blue signal.

In our previous discussion, we learned that the blue color channel is limited in bandwidth to approximately 600 kc. Let us see what this means in terms of the actual colors being transmitted and received, at frequencies above approximately 600 kc. Above 600 kc, the action of the low-pass filter, in the blue color-difference channel, removes all the color-modulating components produced by the blue camera. Because we are using a suppressed-carrier type of modulator, the $E_R' - E_Y'$ component completely disappears in the absence of modulation.

This means that only the $E_R' - E_Y'$ modulation components are present at frequencies above approximately 600 kc. Since the $E_B' - E_Y'$ component has vanished, and is no longer acting in quadrature with the $E_R' - E_Y'$ component, the phase of the resulting chrominance signal is now controlled by only one voltage ($E_R' - E_Y'$), instead of two.

If we plot the colors that are reproduced above 600 kc on a color triangle, as shown in Fig. 1, we find that we have a straight line running from reddish-magenta to greenish-cyan.

In other words, for frequencies above 600 kc, we are using what is essentially

a two-color system of reproduction. The primaries we are using are reddish-magenta and greenish-cyan.

For many years, experiments have been conducted to determine the best primary colors to use in a two-color reproduction system. Results of this

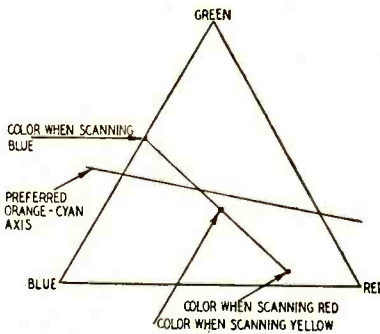

Fig. 1—Colors reproduced above 600 kc, when scanning red, blue, and yellow.

experience have shown that the two colors which give the best results are a slightly orange red and a greenish blue (cyan).

These preferred primaries have been used successfully in two-color photography. One example you may be familiar with is the Cinecolor motion-picture process which results in pleasant color reproduction, even though it cannot reproduce all colors correctly.

Possibly the most noticeable improvement gained by using the orange and cyan primaries—in preference to the reddish-magenta and greenish-cyan primaries—is in the reproduction of flesh tones. Since the eye can detect relatively small errors in the reproduction of skin tones, use of the preferred orange-cyan primaries above 600 kc results in a perceptible improvement. This is approached in the NTSC system.

Modifying the I and Q signals

As we have seen, it is desirable to use the original red, green, and blue as

primary colors for all video frequencies up to approximately 600 kc. Above 600 kc it is advantageous to shift to the preferred two-color system primaries, orange and cyan.

To operate along the orange-cyan axis above 600 kc, we must shift the wide-band color-difference components 33° ahead of the $E_R' - E_Y'$ axis.

The methods used in the NTSC system to do this are illustrated in Fig. 2, which shows the original $E_R' - E_Y'$ and $E_B' - E_Y'$ components in quadrature, and their phase relationship to the reference burst. The resultant chrominance signal E_C produced by these components is also shown.

The wide-band color difference component which is substituted for $E_R' - E_Y'$, to provide improved color reproduction above 600 kc, is shown as a dotted line leading $E_R' - E_Y'$ by 33° . A narrow-band color-difference component is substituted for $E_B' - E_Y'$, and is placed in quadrature with the new wide-band color-difference. As a result, the new narrow-band component leads $E_B' - E_Y'$ by 33° .

We can retain the identical phase and amplitude of the original chrominance signal below 600 kc, by adjusting the

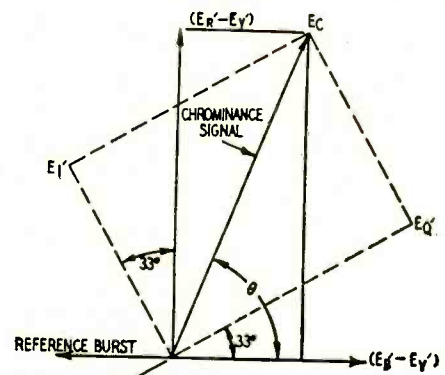

Fig. 2—Phase relationship between the I and Q wide-band color-difference signals, and the color-reference burst.

*Allen B. DuMont Laboratories, Inc.

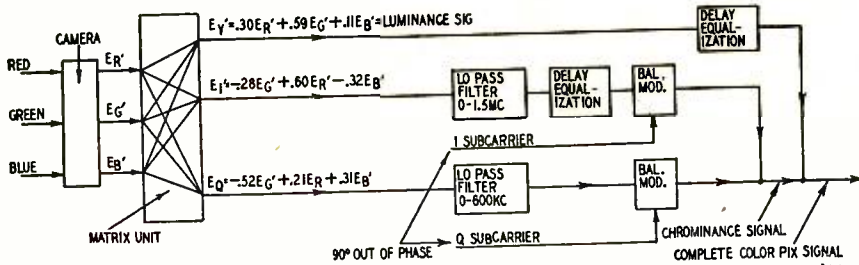

Fig. 3—Diagram shows basic operation of NTSC color television transmitter.

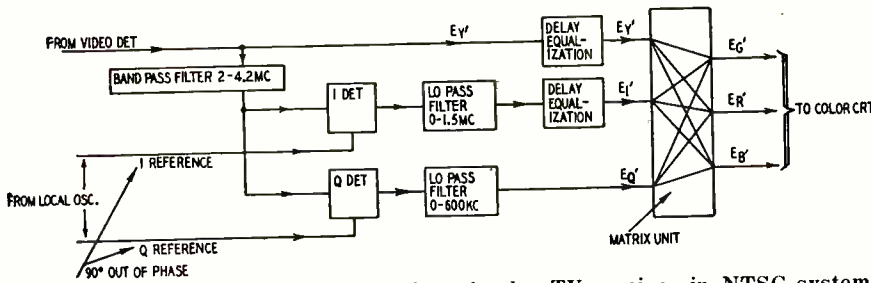

Fig. 4—Diagram shows basic operation of color TV receiver in NTSC system.

lengths of the new color-difference components, as shown in Fig. 2. This is done by modifying the makeup of the color-difference signals. The new color-difference signals are called $E_{I'}$ and $E_{Q'}$.

$E_{I'}$, the wide-band color-difference signal, is made up as follows:

$$E_{I'} = -.27(E_R' - E_Y') + .74(E_R' - E_Y')$$

$E_{Q'}$ designates the narrow-band color-difference signal and is formed by:

$$E_{Q'} = .41(E_B' - E_Y') + .48(E_R' - E_Y')$$

At the receiver the phase of the locally generated reference signals supplied to the synchronous detectors is shifted 33° to recover these new $E_{I'}$ and $E_{Q'}$ signals. From these signals, the necessary $E_R' - E_Y'$ and $E_B' - E_Y'$ (and $E_G' - E_Y'$) color-difference signals are derived.

The use of $E_{I'}$ and $E_{Q'}$ provides improved color reproduction above approximately 600 kc, without impairing the color fidelity below this frequency. Above 600 kc, we now operate along the preferred orange-cyan axis as shown in Fig. 1.

Up to this point we have discussed individually the important features and techniques used in the NTSC system. Now we can summarize how these techniques are used to transmit color television signals (Fig. 3) and recreate the original color picture at the receiver (Fig. 4).

1. The three-color signals

At the transmitter, a special color camera produces three separate signals, representing the red, green, and blue color content of the scene being televised.

2. The brightness signal

Fixed proportions of the red, green, and blue color signals are added together in a special matrixing amplifier to form the brightness or luminance (E_Y) signal, as stated in the formula below:

$$E_Y = .30 E_R' + .59 E_G' + .11 E_B'$$

where E_R' , E_G' and E_B' are the red, green, and blue color signal voltages respectively.

This brightness signal closely resembles the video signal in regular black-and-white transmissions and is transmitted in essentially the same manner. Thus the color signal can be received in black-and-white by existing monochrome receivers.

3. The I and Q signals

The three color signals are combined in a special matrixing amplifier, in fixed proportions and polarities, to form two modified color-difference signals, referred to as I and Q. The proportions and polarities used are stated in the formulas below:

$$E_{I'} = -.28 E_G' + .59 E_R' - .32 E_B'$$

$$E_{Q'} = -.53 E_G' + .21 E_R' + .31 E_B'$$

RADIO-ELECTRONICS expects soon to begin a series of articles dealing with color television from the viewpoint of circuitry. Each of the circuits which make up the color part of a TV receiver will be discussed in turn. We will—of course—also run articles on various special aspects and subjects in the field of color television in addition to the circuitry series.

Note: $E_{I'}$ and $E_{Q'}$ can also be specified as fixed proportions of $E_R' - E_Y'$ and $E_B' - E_Y'$ as described earlier in this article.

The I and Q signals are passed through filters to limit their bandwidths according to the following specifications:

- Q—channel bandwidth
 - at 400 kc less than 2 db down
 - at 500 kc less than 6 db down
 - at 600 kc at least 6 db down
- I—channel bandwidth
 - at 1.3 mc less than 2 db down
 - at 3.6 mc at least 20 db down

4. The transmitted color television signal

The I and Q signals are used to modulate two subcarriers of the same frequency (3.579545 mc) but 90° out of phase with each other. Carrier suppression is used and the output of the I and Q modulators is combined to form a chrominance signal which varies in phase and amplitude according to the hue and saturation of the color being transmitted.

The chrominance and brightness signals are combined and used to modulate the transmitter.

To synchronize the color-detector circuits in the receiver accurately, a burst of approximately 9 cycles of a 3.579545 mc reference signal is transmitted on the back porch of every horizontal sync pulse.

5. Recovering the transmitted signals

At the receiver the brightness signal is detected in a conventional video detector. The I and Q signals are recovered in separate color detectors. The required reference voltage for each synchronous detector is obtained from a local oscillator synchronized by the color burst.

6. Recovering the original color signals

The three original color signals, E_R' , E_G' and E_B' are recovered by combining the brightness (E_Y'), $E_{I'}$ and $E_{Q'}$ signals in a special matrixing amplifier in fixed proportions and polarities. The values are stated in the formulas below:

$$E_R' = .63 E_G' + 1.00 E_Y' + .96 E_{I'}$$

$$E_G' = .64 E_G' + 1.00 E_Y' - .28 E_{I'}$$

$$E_B' = 1.72 E_G' + 1.00 E_Y' - 1.11 E_{I'}$$

7. Recreating the color picture

The three original color signals are applied to a color picture tube, recreating the original televised scene in color.

END

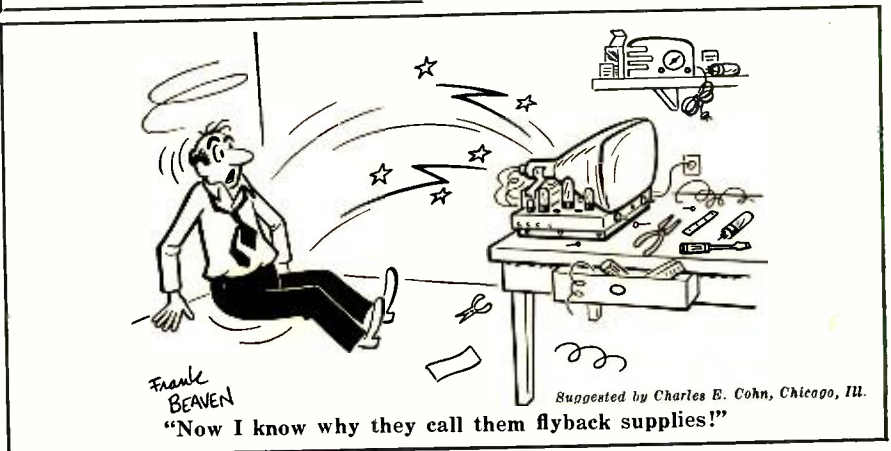

TELEVISION . . .

it's a cinch

By E. AISBERG

Tenth conversation, first half: a discussion of the composite video signal

From the original "La Télévision? . . . Mais c'est très simple!" Translated from the French by Fred Shunaman. All North American rights reserved. No extract may be printed without the permission of RADIO-ELECTRONICS and the author.

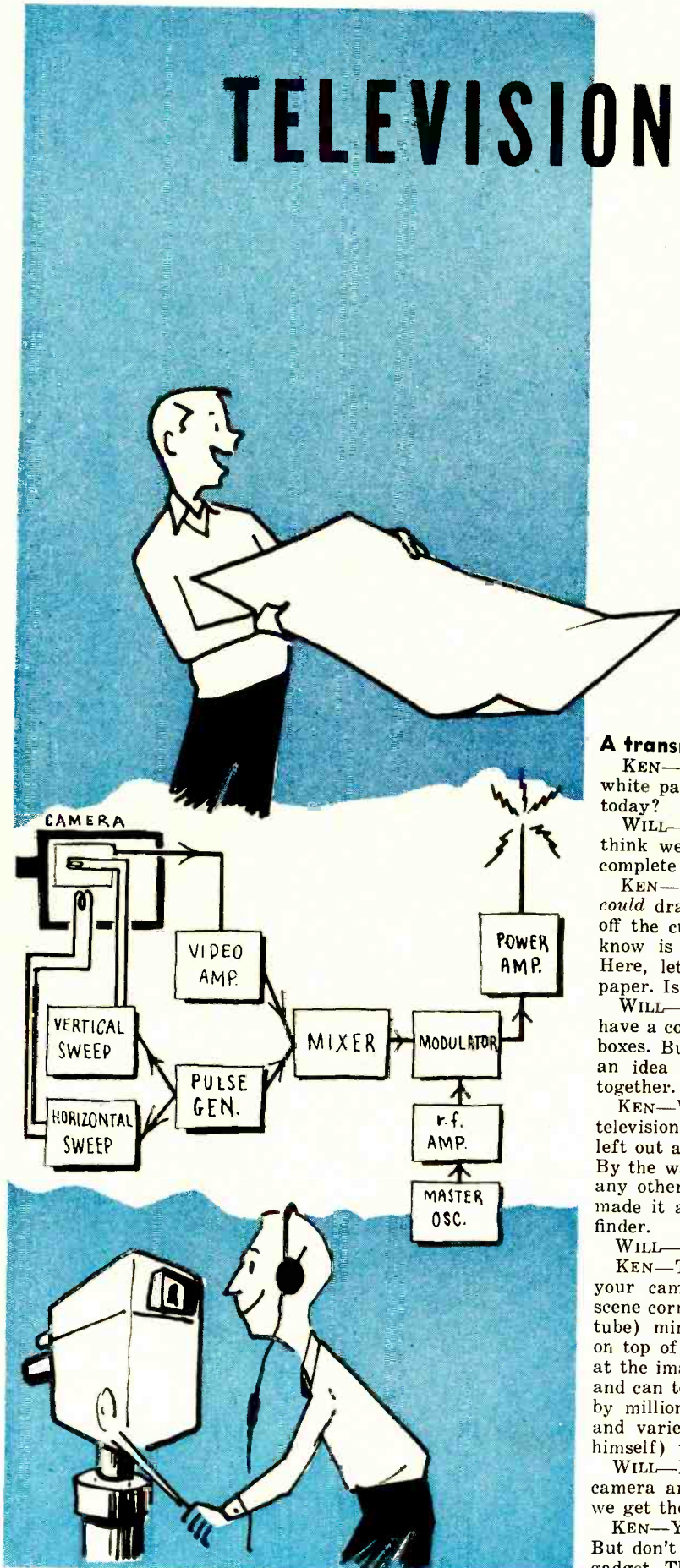

A transmitter in boxes

KEN—What do you expect to do with that big piece of white paper, Will? Surely we're not going to paint posters today?

WILL—No, I'm looking ahead a bit, that's all. And I think we'll make a lot more progress if you draw me a complete schematic of a TV transmitter.

KEN—Thanks for the compliment, Will! But even if I could draw you a complete TV transmitter diagram right off the cuff, it would only confuse you. What you need to know is what kind of signals the transmitter puts out. Here, let me draw your diagram—in one corner of the paper. Is this schematic enough for you?

WILL—That's what I call an apple-box diagram. You have a complicated assembly hid in every one of those little boxes. But maybe a diagram like that could give a person an idea of a whole system and how its parts are tied together.

KEN—Well, this bunch of apple boxes does make up a television transmitter. It's a little simplified, I admit. I've left out all the power supplies, including the camera tube's. By the way, the camera is nearer to a true schematic than any other part of the diagram. But maybe I should have made it a pictorial, so we could show the electronic viewfinder.

WILL—And what would that be?

KEN—The TV equivalent of the optical viewfinder on your camera. It lets the operator frame and focus the scene correctly. Imagine a little TV receiver (with a 5-inch tube) minus front end and pix i.f. amplifier sitting right on top of the camera, and you have it. The operator looks at the image on the picture tube of this sawed-off receiver, and can tell exactly how the televised scene is being viewed by millions of other spectators. So he frames his picture and varies the stop and focus to give the audience (and himself) the clearest picture.

WILL—I see that the vertical and horizontal sweep of the camera are connected to a pulse generator. Is that where we get the sync pulses?

KEN—Yes. They come from a pulse or sync generator. But don't get the idea that this generator is a simple little gadget. The pulses it produces are the very ones that keep

the picture at the station and in your receiver in step with each other. It gives us the horizontal and vertical sync pulses and the *equalizing pulses* and *blanking signals* that are needed to make the complete television signal ready for transmission.

WILL—Both horizontal and vertical sync? I suppose it has to have two oscillators—one for each frequency?

KEN—Not generally. The most common method is to use one oscillator whose frequency is 31,500 cycles per second. Then this frequency is divided to get the horizontal pulses and the much lower vertical sync frequency. That gives you a more stable system—you're sure the vertical and horizontal signals can't get out of step with each other.

WILL—H'm-m—that plain apple box marked "Pulse Generator" begins to look more like the "black box" full of tricks the engineers like to talk about!

KEN—Don't forget this is a very important generator. It supplies the whole synchronizing part of the transmitted television signal, and so keeps all the receivers synchronized with the transmitter.

WILL—I suppose that this "mixer" you show just after the generator is the equipment that combines the synchronizing and video part into the complete TV signal?

KEN—Exactly. And it also includes an amplifier for the video signal, as well as a monitor receiver (which can be simpler than an ordinary TV receiver, because it has its video signal already detected for it). The monitor receiver is used to adjust the voltage of the sync pulses so that they're in proportion to the video signal. And after the signal gets through this mixer, we can handle it just like the audio frequency in a radiophone transmitter—feed it to a modulator stage. There, it varies the amplitude of the r.f. oscillations produced by a very stable master oscillator. Finally, after going through a power amplifier, the modulated r.f. currents are sent to the antenna and radiated into space.

More light, less power

WILL—Suppose we follow that example! Let's leave the transmitter and go to the receiver. We're going to have to work with receivers rather than transmitters anyway, and I'd like to put in my time learning about them.

KEN—You'll be better off to hang around in space for a while—between the transmitting and receiving antennas—while we learn more about the *composite television signal* the waves are carrying.

WILL—Don't we already know that the signal is "composed of the modulation which interprets the light values of the successively scanned elements of the picture"?

KEN—That's the video signal. We have to include the sync signals in the complete, or *composite*, TV signal.

WILL—Of course! And I've been doing quite a lot of thinking about synchronization. But some things I can't figure out. For example, how can the receiver distinguish between video and sync signals? And, if it can do that, how does it know the difference between horizontal and vertical sync pulses?

KEN—The difference is a matter of amplitude. Voltages below 75% of the maximum are used for the video signal. The 75% level is *black*; white is the absence of signal. Signals between those two levels appear as halftones, or grays, on the picture tube of your receiver. Look at this drawing.

WILL—So we get these grays, as well as black and white, by detecting this video signal and applying it to the grid of the picture tube. But why should the strongest signal give you the weakest light, and *vice versa*?

KEN—Our *negative transmission* is a matter of choice. England and France use positive transmission, and their synchronizing region is between 30% of total amplitude and zero. But we think it's better to have the sync signals up near the maximum power level, so they are less likely to be interfered with than the weaker ones of positive transmission systems. Incidentally, the video signals don't have to be applied to the grid of the receiver's picture tube. They are applied to the *cathode* in some receivers.

WILL—I hope those powerful sync signals don't get to the grid—or cathode—of the picture tube. They would

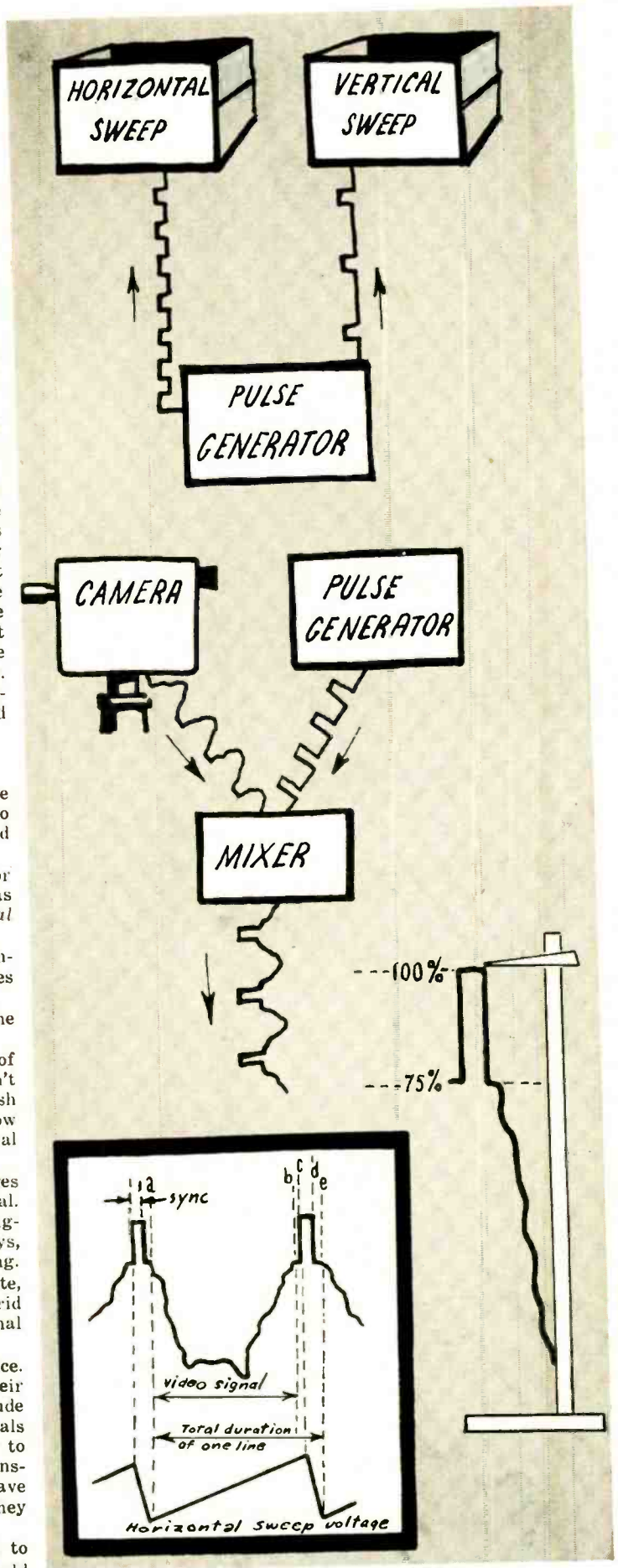

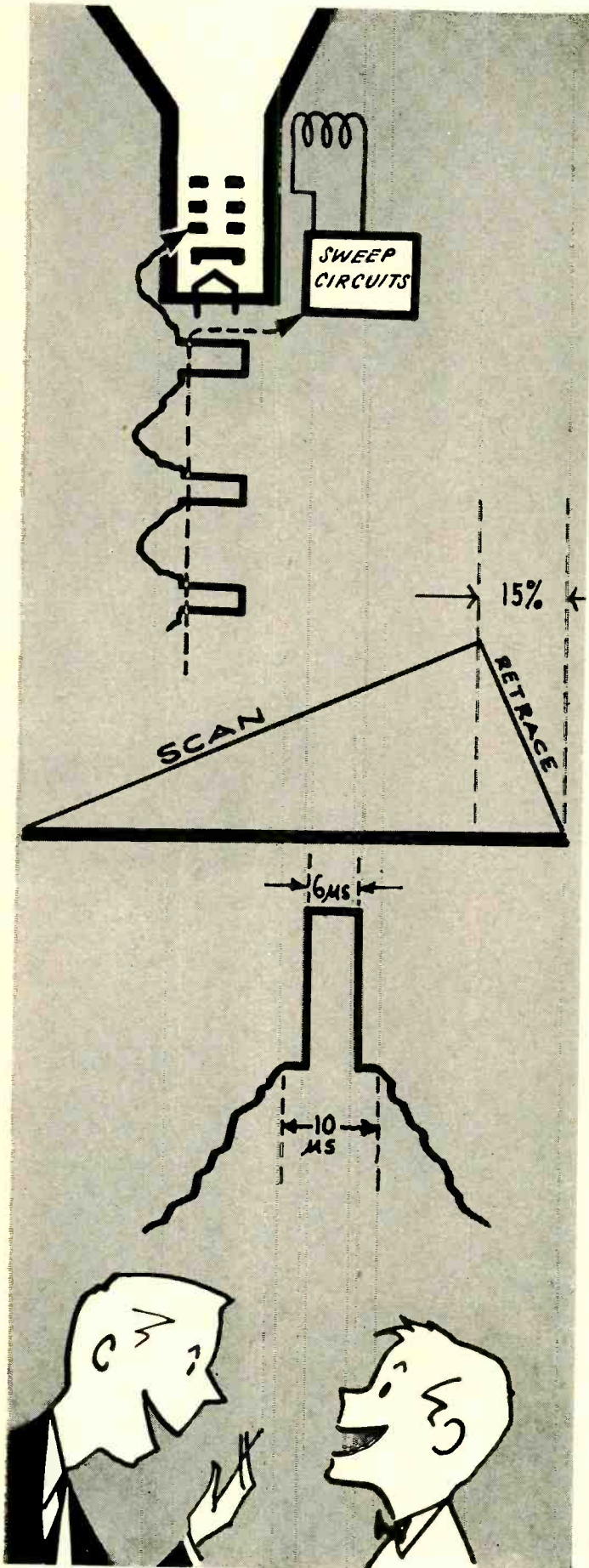

drive the spot *beyond* zero light level—make it blacker than black, you might say.

KEN—"Blacker than black" is just what they do say! And I have bad news for you: The sync signals *are* applied to the control grid of the picture tube. What harm can you see in it? On the contrary, it's a great advantage to have the spot invisible while the sync signals are being received!

WILL—I don't see why.

KEN—You're not as bright as usual today . . . Just sort of follow in your mind the track the spot would make during the sync period.

WILL—Let's see—the sync signals start the spot on its return journey, both at the ends of lines and the end of fields. . . . Oh, I see it now! Of course it's a great advantage to blank out the spot so the return movement won't be seen on the screen. So that's why they make the signals "blacker than black" and even follow them with a little step just at the black level, as you show in your little drawing.

KEN—That's not the only reason. The difference in strength makes it possible to separate the sync from the video signals and send them to the proper sweep circuits.

WILL—Now I'm beginning to see light in this blacker-than-black subject. The composite signal is applied to the grid (or whichever is the control element) of the picture tube to vary the brightness of the spot during the scanning time and to blank it out during its flyback periods. And the sync signals are separated from the others because they are stronger. Then they go their own way to keep the horizontal and vertical synchronizing signals perfectly timed.

Horizontal sync signals

WILL—Now, another important point. How much time do these signals take up?

KEN—including the "pedestal" at the black level (b to c and d to e in the figure) they have to extend just a little beyond the time it takes for the spot to get back to the beginning of its trace, so that it will be blanked out during the whole trip. Under our standards, the horizontal sync signal takes up just a little less than 20% of the time it takes to trace a line. When we talk about a 525-line system, the time taken by each line (including the horizontal blanking pulse) is 63.5 microseconds. About 55 microseconds of that is the scanning trace, and around 8 is spent on the return trip. And the whole time allotted to the sync signal (between its two black-level steps) is about 10 microseconds.

WILL—Then the horizontal sync signal is a pulse about 10 microseconds long?

KEN—Go easy, Will! The pulse itself is only about 6 microseconds long. But it has those two black-level steps we've been talking about—one ahead of it and one behind it.

WILL—Just a second! Give me a hand to get myself straight on this. I want to follow a line from beginning to end. First of all, during about 80% or more of the time, we have the video signal (points a to b on your figure). This signal varies from a low level to about 75% of maximum signal. During this time, the horizontal sweep circuits of both the transmitter and receiver are producing the rising part of the sawtooth wave. Then for a microsecond or two (b to c) the signal stays at the black level (75%) with the spot still going from left to right toward the end of the line. Then the pulse itself comes along, and the transmitter signal rises to 100% of full output. This sudden jump (c) discharges the sweep oscillator (as we learned a long time ago) and its sudden drop in voltage sends the spot back toward the left side of the screen. It gets there just about the time the pulse drops to the 75% level (d). Then we have a little safety zone (d to e) in which the spot remains invisible as it starts out to start tracing another line.

KEN—I see that you've got more help from my drawing than from my explanations!

WILL—And how is it at the transmitter? Do they apply the same type of signals to the TV cameras to blank out the spot during return traces?

KEN—Of course. Otherwise the scanning beam would set up charges on the photosensitive element during the return trace. That would mess up the picture—you'd have retraced lines in it.

(TO BE CONTINUED)

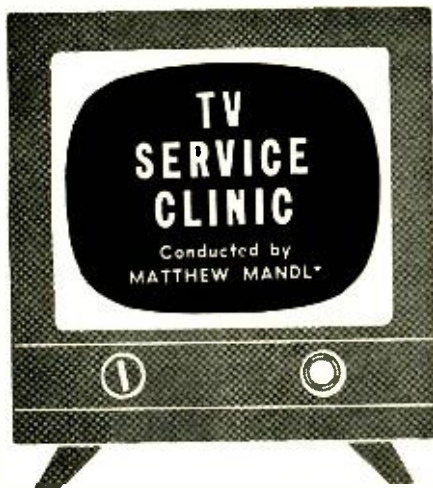

Channel Number	Over-all antenna length (in inches) (Corrected for end-effect)	Reflector (inches)	Director (inches)
2	97.2	102	93.3
3	88	92.3	84.4
4	80	84.3	77
5	70	73.6	67.3
6	65.2	68.2	62.5

Antenna dimensions. Arrows indicate similarity in reflector and director lengths on adjacent channels.

SERVICE shops are often called upon to minimize radio interference caused by nearby television receivers. The best procedures consist of liberal shielding of the offending receivers.

Ordinary aluminum foil—kitchen-type—can be used for lining the inside of the television cabinet. It can be stapled to the cabinet or applied with plastic tape (on metal cabinets). Attach one section of the foil shield to the chassis.

The short section of transmission line connecting the tuner to the antenna terminals often picks up interference signals and causes their radiation by the antenna system. This section of ribbon lead should be wrapped loosely with aluminum foil and the foil should be grounded to the chassis by a short length of wire. If the foil is wrapped too tightly some signal attenuation for higher-channel stations may occur.

The leads which run from the chassis to the picture tube can also be wrapped loosely with the aluminum foil and the latter grounded. A tight wrapping here may attenuate some of the higher-frequency video signal components because of the capacitive effects of the shield.

The leads from the chassis to the yoke should also be shielded to minimize radiation.

The drive control of the receiver should also be adjusted below the point where left-hand stretch or center compression occurs. Excessive drive not only will shorten the life of the tubes in the horizontal and high-voltage sections, but also will increase pulse amplitudes and aggravate interference to radios.

Another topic which has been the subject of several letters lately is snow effect in boosters, in spite of a good signal reading from the antenna. The fault usually lies with the first r.f. tube in the booster. If tube noises are excessive in an r.f. stage, they will be amplified by subsequent circuits and will appear as snow effect. Often, several r.f. tubes should be tried so that

the one with the best signal-to-noise ratio can be chosen. Many boosters will not function properly with cascade type tuners. In the latter, noise reduction is over 35% greater than with older type tuners. When a conventional pentode r.f. stage is used in a booster, it will introduce considerable noise and nullify the high signal-to-noise ratio obtained with the cascode tuner. Some manufacturers have brought out boosters which will function properly with the cascode-type tuners.

Adjacent-channel interference

I am trying to correct interference on channel 3 in our area in an installation using a 5-element Yagi antenna which is carefully oriented. Channel 2 can be received on the reverse side of this Yagi. I would appreciate some advice as to what remedies to try. E. C., Long Bottom, Ohio.

The fact that you get channel 2 from the rear of this antenna indicates that the channel 3 reflector is acting as a channel 2 director. This will aggravate upper adjacent-channel interference as you detailed. You can try adjusting the upper adjacent-channel trap in the receiver and retouch the i.f. alignment for a sharper response. Another solution would be to increase the length of the reflector rod on the channel 3 Yagi antenna to 102 inches. This will prevent the latter from acting as a director for channel 2 and will decrease the interference you mentioned. This would mean, however, that you would no longer be able to receive channel 2 as well from the rear of the antenna and would have to have an additional antenna for the reception of channel 2.

As shown in the table, a reflector for channel 3 has almost the same dimensions as a director for channel 2. The same holds true for a channel 4 reflector which has virtually the same dimensions as a channel 3 director. A channel 6 reflector will also act as a director for channel 5. Directors, also, will act as reflectors for the next higher channel when the dimensions are almost identical.

Spring clip arcing

In a Traveler model 16R50 receiver there is considerable sparking between the spring clips on the high-voltage cage and the picture-tube coating. I have recoated the worn conductive coating on the picture tube but this did not help. The cage is making good contact to the chassis. I would very much appreciate any suggestions. D. B., Greenfield, Ohio.

Since you have recoated the picture tube, you should also clean the spring contacts so they will make good electrical connection. Also make sure they are tight, for loose and corroded contacts will aggravate the arcing.

If the condition still persists it may be caused by an internal leak within the picture tube. The outer coating acts as a second filter capacitor and can usually be dispensed with since enough circuit capacitance exists for filtering. You can bend the spring clips away from the outer coating and thus prolong the usefulness of the defective picture tube.

High-frequency squeal

There is a high-frequency squeal from a Stewart-Warner model 9200-A receiver when it is first turned on. During this time there is also some horizontal instability and interference bars. I have checked all tubes, as well as resistors, capacitors, and voltages, without appreciable success. K. H., Seattle, Wash.

These symptoms are probably caused by the cumulative circuit conditions during warmup which permit spurious oscillations to build up in the horizontal scanning multivibrator. Since you have checked tubes and component parts, the following suggestions given by the manufacturer will help remedy the condition.

1. Change the capacitor connected to one plate of the horizontal scanning multivibrator, pin 2 of the 6SN7-GT, from 470 μf to 390 μf , as shown in Fig. 1.

*Author: Mandl's Television Servicing.

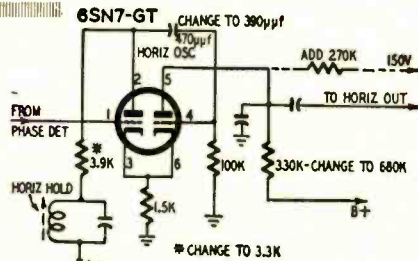

Fig. 1—Stewart-Warner model 9200-A horizontal scanning multivibrator.

2. Reduce the resistor connected to the same point from 3,900 ohms to 3,300 ohms.
3. Increase the resistor connected to the other plate of the same stage—pin 5 of the 6SN7—from 330,000 to 680,000 ohms.
4. Add a 270,000-ohm, ½-watt resistor, connecting one end to the plate (pin 5) and the other end to any 150-volt supply point.

Yoke removal

I would appreciate any information on getting loose a deflection yoke that is stuck to the neck of the picture tube. F. K., East Pittsburgh, Pa.

Generally, when the deflection yoke sticks to the neck of the picture tube, technicians apply to it a voltage of sufficient amplitude to heat the unit. This can be done with a variable voltage transformer. The transformer is adjusted to a voltage output which will make the yoke fairly warm after a few minutes. This usually loosens the sealing compound sufficiently so that the yoke can be removed.

If the yoke is already damaged and must be removed, acetone or speaker cement solvent can be used. This should be permitted to run into the yoke in the area which encircles the picture tube neck. Such solvent usually affects the insulation of the yoke windings and should not be used except on a yoke which is to be discarded.

Open-wire line

I find it necessary to run a transmission line for 1,000 feet. I am now using a polyethylene-insulated No. 16 wire, but do not have the correct spacing for 300 ohms. My spacing is about 2¾ inches and I have the line twisted at the entrance to the house.

My signal strength is down and the snow effect is bad at times. How can I improve the installation? C. W., Pocomont, Va.

The severe mismatch between your present line and the 300-ohm input at the receiver contributes to your troubles. It is impractical to try smaller spacings for the open-wire lines to get a 300-ohm impedance, because capacitive losses increase. Install the regular open-wire line available at your wholesale jobber and run this from the antenna to the place where the line is to enter the home. From here on in you can use the standard 300-ohm lead for convenient installation. Match the open-

wire line to the ribbon lead by removing the insulating spacers for 100 inches from the end. Now taper the spacing of the 100-inch section to meet that of the 300-ohm lead spacing. This tapered line section will give a fairly uniform match for all channels.

Yoke arcing

In a Hallicrafter model 1004 the raster flicks off and on every few seconds when the receiver is first turned on. After warmup, the condition occurs less frequently. The yoke clicks each time the raster disappears. I've tried new tubes in the entire horizontal system and have checked resistors and capacitors. D. D., Hobart, Ohio.

The click in the yoke when the raster disappears indicates an arc in the horizontal deflection coils which shorts out the high voltage. This trouble sometimes occurs in that part of the yoke housing which contains the shunting resistors and capacitor, particularly during warmup before full load drops peak voltages to lower values. Arcing can overheat soldered connections or components and cause intermittent operation. Check this by removing the yoke and inspecting the section containing the aforementioned parts. If the arcing is taking place inside the windings, a new yoke will have to be installed.

Contrast in Magnavox

I am having difficulty locating the trouble in a Magnavox CT297 chassis. In order to get proper contrast, the control must be advanced fully and this is accompanied by unstable horizontal sync. I have checked all tubes from the tuner through the video i.f. stages, and those in the horizontal sweep system. All voltages and resistors check all right against the schematic except at the cathode of the 6AQ5 video-output tube. This reads minus 6 instead of minus 20 volts. I have tried a new cathode-bias resistor without improvement.—M. Y., New York, N. Y.

As you have checked all tubes, voltages, and components, the trouble may be caused by poor tuner tracking or video-i.f. alignment. It is possible, however, that you have overlooked the 1N60 crystal video detector. This may be causing the poor contrast. Also check all the circuits associated with the 6AQ5 video-output stage to ascertain why the cathode voltage is incorrect. In this stage, minus 100 volts

is applied to the bottom of the 18,000-ohm cathode resistor, while plus 200 volts is applied to the screen and to the 5,600-ohm plate resistor. If these voltage relationships are upset it will affect brilliancy as well as contrast, since the contrast control is in the cathode of the 6AQ5. Also check the brilliancy-control switch (on the contrast control), for this may be defective.

Buzz in Admiral

In an Admiral 24D1 I get a 60-cycle buzz. It seems to come from the vertical section of the receiver because when I pull any of the vertical tubes the buzz stops. I have replaced the vertical blocking-oscillator transformer and a number of resistors and capacitors without success. S. S., Red Lion, Pa.

It is evident that the buzz is being picked up from the vertical section as you surmised. The Admiral service notes recommend that a shield be added between the vertical-oscillator tube and the audio-output tube to minimize the 60-cycle pickup. This shield is Admiral part 15B625, and holes are available in the earlier 24D1 receivers to accommodate two No. 8-32 self-tapping screws for mounting the shield.

If the ground lead from the volume control is connected to the grounded heater pin of the first audio tube it should be transferred to the grounded cathode pin 7. It is also possible that the a.c. power leads to the switch on the volume control run too close to the grid circuit (pin 1) of this stage. They should be moved away. Also make sure the .01-µf coupling capacitor between the volume control and the grid has the outside foil connected to the volume control.

Intermittent vertical centering

In an Admiral 20T1 receiver the picture changes position vertically, leaving a dark area at the bottom. This occurs only once every several hours and returns to normal almost immediately. I have tried tube changes but this did not help. When the antenna is disconnected, the same thing happens to the raster. T. C., Philadelphia, Pa.

If centering disturbance in a vertical plane is the only symptom, it could be caused by a variation in the voltage applied to the vertical deflection coils. Initially, check the low-voltage power supply feed to the vertical deflection coils. Then check for defective components in the vertical output circuit, particularly the voltage feed to the oscillator and output tube. Also check the vertical-size-control potentiometer for an intermittent-contact condition or change in value.

The B plus for the vertical oscillator and output tube is derived from the voltage boost system in the 6W4-GT damper. Any voltage change in the damper (or a change in the horizontal circuit flyback characteristics) will influence the vertical circuit. Try a new damper; if this doesn't help, check the parts in the voltage boost system. END

VTVM

applications in

TV servicing....



The Simpson model 303 vacuum tube voltmeter.

By ROBERT G. MIDDLETON*

TV SERVICE technicians use a wide variety of test instruments to check the operation of antennas, lead-ins, front ends, i.f. amplifiers, video amplifiers, sync circuits, sweep circuits, high-voltage circuits, and over-all performance. The minimum requirements of a one-man shop include a v.t.v.m., signal generator, oscilloscope, and sweep generator; most technicians also have a tube tester. Many shops regard additional instruments as essential, such as audio oscillators, square-wave generators, frequency meters, field-strength meters, pattern generators, grid-dip meters, capacitor checkers, sensitivity checkers, etc. Nevertheless, the v.t.v.m. is the key instrument in the layout.

Vacuum-tube voltmeters have undergone considerable development during the past several years. Copper-oxide rectifiers which are applicable only at low frequencies in low-impedance circuits, and which can measure only r.m.s. values, have given way to diode peak-to-peak indicating arrangements. D.c. scale ranges now extend from 1 to 30,000 volts, full scale.

Using a voltmeter might appear to be an elementary matter, but the peculiarities of television circuits frequently complicate it. For example, the test leads of a volt-ohm-milliammeter occasionally operate as resonant stubs when

used to measure d.c. voltages in i.f. amplifier circuits; when the meter indication varies as the test leads are moved, it indicates that lead resonance has thrown the stage into oscillation.

Vacuum-tube voltmeters

The d.c. voltage system of a typical v.t.v.m. is shown in Fig. 1. When d.c. voltages higher than 1,200 are under test, a high-voltage multiplier probe is used ahead of the instrument. When high-frequency voltages are to be measured, a half-wave peak rectifier or a peak-to-peak rectifier is used ahead of the instrument. Calibration control A determines the full-scale deflection, and control B determines the linearity of deflection.

A v.t.v.m. is called upon to make measurements of d.c. voltages from less than 1 to as high as 25,000; to measure resistances from less than 1 ohm to several thousand megohms; to measure r.f. and i.f. voltages from a fraction of a volt to 25 or 30; to measure the peak-to-peak voltages of complex video, sync, and sweep waveforms; and to measure direct current throughout the milliamperere range.

To meet this wide range of requirements, the v.t.v.m. is used with various external probes. For example, d.c. voltage measurements from 0 to 1,000 are made with a shielded cable terminated with an isolating resistor, as shown in

Fig. 2-a. The shielded cable eliminates the pickup of stray fields about the test bench, which would otherwise disturb the high-impedance input circuit of the v.t.v.m., and cause inaccurate indication. The isolating resistance prevents the shielded cable from acting as a capacitive shunt across tuned and high-impedance circuits, such as the local-oscillator in a receiver.

The equivalent circuit in Fig. 2-b shows that the cable capacitance C is isolated from the probe tip by the 1-megohm resistor, which cuts down the effective value of C to approximately 1 or 2 μf . This is a large reduction, as compared with the approximately 75 μf of cable capacitance. Hence, the d.c. probe can be applied across a local-oscillator circuit to measure the self-bias on the oscillator grid, without disturbing circuit operation.

The equivalent circuit is also a low-pass filter. This is an essential feature, since d.c. voltages at the grids and plates of tubes often must be measured in the presence of large a.c. voltages. If the probe permitted a.c. voltages to be impressed on the v.t.v.m. tube with the d.c. voltage, highly inaccurate indi-

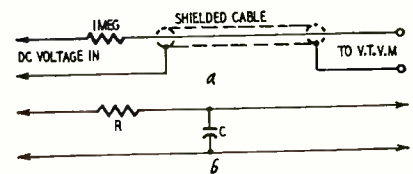

Fig. 2—Diagram of d.c. probe shows shielded cable and equivalent circuit.

cations would result. As a matter of fact, v.t.v.m. design includes another low-pass filter at the grid of the v.t.v.m. tube to insure that no a.c. voltage is applied to the grid.

To measure the second-anode voltage of a picture tube, and for other types of tests which will be described, the isolating resistor arrangement shown in Fig. 2 is changed to form a high-voltage d.c. probe. The high-voltage d.c. probe is shown in Fig. 3, and is



Fig. 3—The d.c. high-voltage probe.

usually designed to multiply each range of the v.t.v.m. by 100. This multiplying factor is of considerable use in other types of tests such as measuring low d.c. voltages in the presence of high-voltage a.c. pulses.

It is generally thought that a high-voltage d.c. probe can be used with a scope for the investigation of complex a.c. waveforms—this is largely an unfortunate misconception. When such a probe is used with a scope, the attenuation is not constant; i.e., the attenuation found at 60 c.p.s. will be very different from the attenuation at 4 mc. Hence, peak-to-peak voltages cannot be measured when the probe is misused in this manner. Also, stray fields often affect the distorted waveform, to further

Note: The 1.2 v tap at right end of voltage divider should read "1.2 kv."

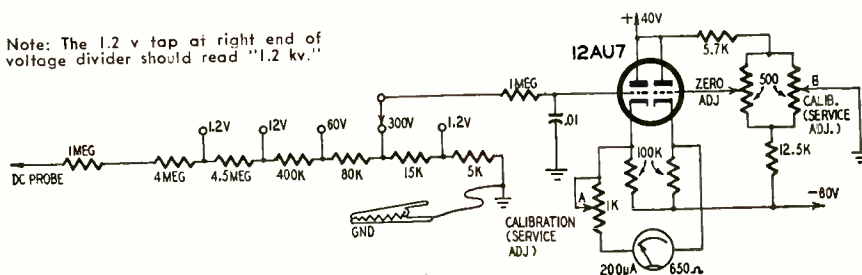

Fig. 1—Diagram shows basic d.c. voltage circuit of the Simpson model 303 v.t.v.m.

confuse the technician.

The measurement of high d.c. voltages, such as the second anode voltage of a picture tube, with a v.t.v.m. and high-voltage d.c. probe are rather well understood. Less understood is the measurement of relatively low d.c. voltages in the presence of high a.c. pulse voltages, such as the plate voltage at the horizontal-output tube. Receiver manufacturers commonly insert a technical note in their service data, warning against attempts to measure the d.c. plate voltage of the horizontal output tube. This is because the approximately 350 volts d.c. is accompanied by an approximately 6,000 volt kickback pulse. The pulse is an a.c. voltage and does not show itself on the d.c. scales of a v.t.v.m. Nevertheless, this high pulse voltage draws a heavy pulse current through the input circuit of a v.t.v.m. or volt-ohmmeter, and quickly ruins the instrument.

Recalling that a high-voltage d.c. probe will provide a high degree of low-pass filter action, it can be seen that the high-voltage d.c. probe makes this type of measurement possible. For example, the v.t.v.m. can be set to its 6-volt range, and when used with a high-voltage d.c. probe having a 100-to-1 attenuation factor will indicate the 350 volts d.c. at approximately half-scale of the v.t.v.m.; at the same time, the low-pass filter action of the high-voltage d.c. probe effectively protects the v.t.v.m. against the 6,000-volt a.c. pulse.

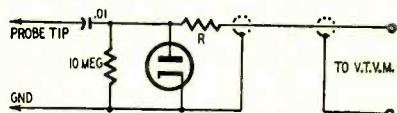

Fig. 4—A tube type rectifier probe.

Some v.t.v.m.'s have zero-center indication, while others do not; still other v.t.v.m.'s provide a choice of zero-left, or zero-center indication on d.c. ranges. The zero-center feature is convenient when adjusting discriminators, where the output voltage swings through both positive and negative values during circuit adjustment.

The high-frequency voltage-measuring section of a v.t.v.m. is useful in checking the operation of a.c. circuits. This is a field of servicing which has been the subject of extremely rapid changes in the last few years. Not long ago all a.c. measurements were carried out upon the basis of sine-wave indications, and this approach is still basic in radio receiver servicing. However, with the arrival of television, the technician is faced with the necessity of measuring peak-to-peak voltages of complex a.c. waveforms. In some cases, the peak-to-peak values must be further broken down into positive-peak values, negative-peak values, and component values, to pinpoint various circuit faults.

To meet these requirements, various instrument manufacturers provide accessory rectifier probes for use with a

v.t.v.m. These fall into three general classes, based upon voltage-handling capability and the type of indication they provide. Fig. 4 shows a tube type rectifier probe, which will handle moderately high voltages, and provide negative-peak voltage indication. The 0.01- μ f capacitor charges up to the negative-peak value of the applied a.c. waveform. R is an isolating and calibrating resistor; in its absence the cable capacitance would shunt down the diode and bypass the a.c. signal. The value of R must be properly selected to provide the desired scale indication—usually to indicate the r.m.s. voltage of a sine wave. The 10-megohm resistor is a bleeder, and is used to avoid undue lag in return of the meter pointer to zero. If very low frequencies are to be accommodated, the value of the 0.01- μ f capacitor must be increased correspondingly.

A similar crystal-diode type of rectifier probe is illustrated in Fig. 5; such a probe is commonly rated to approximately 20 volts, and provides peak indication. The characteristics of a typical probe of this type are given in Table I, which shows that the input impedance may not always be sufficiently high to avoid throwing i.f. stages into oscillation. However, various expedients can often be used in case of difficulty, which we plan to discuss in future articles.

It might be supposed that a rectifier probe and a v.t.v.m. could be used to signal-trace the i.f. circuits of a TV receiver, but the low signal level in the early stages limits this. The full gain of a 3-stage i.f. amplifier is about 5,000; so with a 2 volt peak-to-peak input to the video detector, the corresponding input to the first i.f. grid will be 0.0004 volts peak-to-peak. Since a v.t.v.m. does not satisfactorily indicate voltages below approximately 0.1, a serious signal-tracing limitation is imposed.

The peak-to-peak type of probe used to measure peak-to-peak voltages of complex a.c. waveforms, is shown in

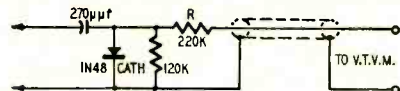

Fig. 5—Crystal diode rectifier probe.

Fig. 6. Tubes and crystal diodes are used commercially, with the same gen-

eral considerations as have been noted for the half-wave type of probe. The tube will withstand much higher voltages than the crystal diode.

In some cases, the peak-to-peak indicating arrangement is built into the v.t.v.m. This raises the input capacitance of the arrangement, but also provides a much greater voltage-handling capability, since a compensated multiplier then precedes the rectifying tubes, and will usually raise the top range of peak-to-peak voltage measurement to 1,000. Such a range will accommodate the majority of complex a.c. waveforms encountered in a TV chassis.

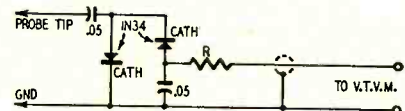

Fig. 6—Peak-to-peak indicating probe.

When a demodulator probe is used on the d.c. ranges of a v.t.v.m., the indication is proportional to the amplitude of the r.f. carrier in a modulated wave, but when used on the a.c. ranges of a v.t.v.m. (having peak-to-peak facilities built in), the indication is proportional to the peak value of the modulating waveform.

The ohmmeter range of a v.t.v.m. (Fig. 7) is used to check both linear and

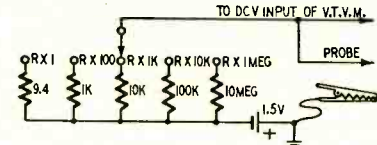

Fig. 7—Simpson v.t.v.m. ohmmeter circuit.

nonlinear resistance values of components in the TV chassis. Some of these applications are not as well understood as they should be. Not only does the question often arise concerning what measured value of a nonlinear resistance is acceptable, but there is also the danger of damage to the component when such measurements are made on u.h.f. mixer crystals or the filament resistance of small tubes.

The ohmmeter is useful to measure the front-to-back ratio of a video detector crystal, to determine whether it is in satisfactory operating condition. The front-to-back ratio will depend upon which ranges of the ohmmeter

TABLE I—CHARACTERISTICS OF FIG. 5 PROBE

Frequency capability:	
Carrier frequency.....	500 kc to 200 mc
Modulation envelope frequency.....	30 c.p.s. to 5 kc
Input capacitance.....	2.5 μ f
Input resistance:	
At 1 mc.....	.25,000 ohms
At 10 mc.....	20,000 ohms
At 50 mc.....	10,000 ohms
At 100 mc.....	5,000 ohms
At 200 mc.....	2,500 ohms

TABLE II—V.T.V.M. APPLICATIONS AND LIMITATIONS

are used, and upon the voltage of the internal batteries of the ohmmeter. These complications are based upon the nonlinear resistance of a crystal diode. Since resistance is the ratio of voltage to current when the resistance is nonlinear, the apparent resistance will measure different values at various voltages. Voltages are applied to the crystal diode on various ranges of the ohmmeter, and hence various resistance values are obtained.

A crystal diode in good operating condition may have a front-to-back ratio of 1,000 to 1, or more, when measured on the $R \times 1$ range in the low-resistance direction, and on the $R \times 10,000$ range in the high-resistance direction. However, an ohmmeter using a $1\frac{1}{2}$ -volt internal battery will indicate a lower front-to-back ratio than an ohmmeter using a 3- or $4\frac{1}{2}$ -volt battery. When checking u.h.f. mixer crystals, not more than $1\frac{1}{2}$ volts should be applied across the crystal; hence, to avoid damage to the crystal if the ohmmeter uses internal battery voltages higher than $1\frac{1}{2}$ volts, the resistance measurement should not be made on the $R \times 1$ range. Instead, the measurement should be made on a higher resistance range which will limit the voltage applied across the u.h.f. mixer crystal to $1\frac{1}{2}$ volts, or less.

The filaments of small battery-operated tubes sometimes can be damaged by excessive ohmmeter voltage. The filaments are nonlinear resistors, and will measure correct (rated) values of resistance only when the rated voltage is applied across the filament (typically $1\frac{1}{4}$ volts). Meter movements can easily be damaged by ohmmeters. The correct method of measuring the internal resistance of a meter is the half-scale method, discussed in many standard technical texts.

Although a v.t.v.m. can be used to measure current, such measurements are seldom necessary, because the voltage drop across a known resistor indicates the current flow (Ohm's law).

Conclusion

Although a v.t.v.m. provides a wealth of information, there are various fields of testing which are closed to the instrument (see Table II). For example, although a v.t.v.m. provides information concerning peak-to-peak voltages, the instrument tells nothing of the voltage waveshape. In many cases the waveshape is even more important than the voltage value. This type of information must be obtained with the oscilloscope. There are times when a peak-to-peak indicating v.t.v.m. gives erroneous peak-to-peak voltages because of excessive circuit loading; such a situation may be encountered at the grid of a vertical blocking oscillator, in ratio-detector circuits, or in self-excited sweep circuits. However, in such cases other instruments can be used to obtain the needed information.

(TO BE CONTINUED)

Feature	Applications	Misapplications
D.c. voltage measurement, with high input impedance, even on the low-voltage ranges. (Measurements made using shielded cable terminated with 1-megohm insulating resistor.)	Checking values of plate, screen, and grid voltages; tracing progress of signal by measurement of self-bias (only in circuits using overdrive grid bias); checking local-oscillator operation by measurement of self-bias; checking for amplifier distortion in terms of shift of operating point with applied a.c. signal; measurement of voltages in high resistance circuits such as a.g.c. systems, etc.	Attempted measurement of plate voltage of horizontal-output tube; high-voltage a.c. pulse damages v.t.v.m. Attempted measurement of grid bias in vertical blocking oscillator circuit when grid leak has very high resistance; v.t.v.m. will load circuit seriously. Attempted measurement of pulsating d.c. voltage values; v.t.v.m. indicates only the average value.
A.c. voltage measurement, in peak-to-peak values, using built-in peak-to-peak indicating circuit and low-capacitance a.c. test cable.*	Checking peak-to-peak voltages of most of the complex a.c. waveforms found in the sync and sweep sections of the TV chassis. Also, checking line voltage and power-transformer voltages, being certain to convert from peak-to-peak to r.m.s. values of sine waves. Checking most a.f. voltages.	Attempted signal tracing in tuned circuits; relatively high input capacitance of v.t.v.m. seriously disturbs circuit operation, and voltages less than 0.1 volt cannot be measured with certainty. Attempted conclusions concerning waveshapes or frequency components of complex a.c. waveforms; no information of this sort is provided by a peak-to-peak v.t.v.m.
A.c. voltage measurements, in r.m.s. values, with instruments using built-in copper-oxide contact rectifier. Frequency limitations are same as v.o.m. with similar rectifier.	Checking line voltages and power-transformer voltages, and checking the lower audio-frequency voltages in relatively low-impedance circuits. Checking heater voltages.	Attempted checking of complex waveform voltages in sync and sweep circuits; indication is always erroneous (peak-to-peak values can be determined only for sine waves). Attempted signal tracing in tuned circuits; no indication obtained.
A.c. voltage measurements, in peak values, using external diode probe.	Checking peak voltages of some oscillator circuits. Checking sine-wave audio-frequency voltages. Checking line voltages, power-transformer, and heater voltages, being certain to convert from peak to r.m.s. values of sine waves.	Attempted checking of complex waveform voltages in sync and sweep circuits; indication is peak value (peak-to-peak value can be determined only for sine waves). Attempted measurement of voltage values exceeding input rating of probe. Attempted r.f. or i.f. signal tracing.
A.c. voltage measurements, in peak-to-peak values, using external peak-to-peak diode probe. (Provides higher input impedance than built-in peak-to-peak indicating circuit, but input voltage rating is usually less.)	Checking of peak-to-peak values of many of the complex a.c. waveforms encountered in the sync and sweep sections of the TV chassis. Checking a.f. voltages. Checking line voltages, power-transformer, and heater voltages, being certain to convert from peak-to-peak to r.m.s. values.	Attempted measurement of a.c. voltage values exceeding input rating of probe. Attempted measurements in high-impedance circuits, such as ratio-detector circuits. Attempted signal tracing of r.f. and i.f. tuned circuits.
Resistance measurements, when internal ohmmeter battery voltage is higher than 1.5 (Some ohmmeters provide a low driving voltage on the low-resistance ranges, and a high driving voltage on the high-resistance ranges.)	Measurement of forward and back resistance, and front-to-back ratios of all crystal diodes, including u.h.f. mixer crystals. Measurement of most resistance values encountered in TV chassis.	Attempted measurement of high resistance values, such as the leakage resistance of paper or mica capacitors (unless high driving voltage is provided on the high-resistance ranges). Attempted measurement of resistance values in hot circuits, or in circuits with capacitors retaining residual charge.
Resistance measurements, when internal ohmmeter battery voltage is higher than 1.5 (on low ranges).	Measurement of forward and back resistance of picture-detector crystals, but not of u.h.f. crystals (except on higher ranges, to limit terminal voltage to 1.5). Measurement of all resistances found in TV chassis, with exception of leakage resistance of small capacitors.	Attempted measurement of the filament resistance of small battery-operated tubes. Attempted measurement of the internal resistance of meter movements. Attempted measurement of resistance values in hot circuits, or in circuits with capacitors retaining residual charge.

* Note: The high-voltage d.c. probe which is usually available for use with service v.t.v.m.'s, is unsuitable for use on the a.c. voltage ranges of the v.t.v.m. Attempted use of the probe to measure high a.c. voltage values, such as the pulse voltage at the plate of the horizontal output tube results only in failure.

Sine and Square Wave Generator

The Eico model 377 ranges from
20 to 200,000 cycles per second

By P. N. MARKANTES

UNTIL a few years ago, square-wave generators and precision audio oscillators were considered laboratory equipment rather than repair bench adjuncts.

With the increasing use of wide-range audio amplifiers in high-fidelity systems and modern receivers, audio test equipment that can perform a number of functions has become important in servicing.

In the Eico model 377 generator (Fig. 1) the production of pure sine and square waves in the audio range has been combined in a single unit that can perform wide variety of tests for TV and radio servicing. The generator is available in kit form (model 377K) for those who like to assemble their own.

The audio generator portion of the instrument consists of a precision R-C oscillator which produces sine waves from 20 cycles to 200 kc. By covering this spectrum in four bands as follows, a long scale is available:

band A: 20-200 c.p.s.

band B: 200-2000 c.p.s.

band C: 2000-20,000 c.p.s.

band D: 20,000-200,000 c.p.s.

An auxiliary 0-100 linear scale is provided for reference.

Harmonic distortion is below 0.5%, providing a pure sine-wave output.

The audio generator (Fig. 2) consists of a two-stage, high-gain, untuned amplifier and a frequency-determining network consisting of a Wien bridge, shown in detail in Fig. 3. The over-all operation of the oscillator can be seen in the block diagram (Fig. 4).

When voltage is first applied to the oscillator (Fig. 3), a signal voltage appears and is amplified. From the plate of V2, a portion of this voltage, E_o , is fed through C3 to point (1) of the Wien bridge where it appears between (1) and (2).

In the right-hand arm (1-3-2) this voltage appears across R2 and the lamp, with the portion across the lamp applied to the cathode of V1. Inasmuch as the voltage which originally appeared at the grid of V1 undergoes a phase shift of 180° in V1 and another 180° in V2, E_o is in phase with the grid voltage of V1. However, that portion of E_o which appears across the lamp (E_a) is applied to the cathode of V1. In other words, R2 and lamp LM constitute a degenerative network.

Moreover, since LM possesses a positive temperature coefficient, any increase in E_o results in an increased

Fig. 1—The model 377 generator.



voltage drop across LM and thus increased degeneration in V1. Thus, the amplitude of oscillations is automatically limited and voltage variations at the input to V1 remain fairly constant throughout the operating range of the oscillator, thus providing linear operation and pure waveform.

E_o also appears across the left-hand arm of the bridge (1-4-2) with the portion between (4) and (2) applied to the grid of V1. Since this voltage is in phase with the original voltage variations, it is a regenerative voltage. In this case, however, the magnitude of the regenerative voltage depends upon the frequency of E_o as determined by the settings of C1 and C2.

At the desired frequency, f_o , the regenerative voltage is maximum and frequencies on either side of resonance produce voltages which quickly fall off from the maximum value.

R2 is adjusted so that the negative feedback voltage is just smaller than the positive feedback at resonance. At all other frequencies, negative feedback predominates and thus eliminates any undesired frequency.

Strictly speaking, the term Wien bridge as applied to this oscillator is a slight misnomer since the true Wien bridge oscillator uses frequency selective *negative* feedback and untuned positive feedback. At resonance the output of the bridge, and thus the degenerative voltage, is zero.

Square-wave output

Square-wave output is obtained by using the audio oscillator as a timing generator and applying its output to the shaping circuit of V3.

The first half of V3 consists of an unbiased amplifier. A 500,000-ohm resistor (R4) in series with the grid

results in grid limiting because positive alternations of the input signal cause grid-current flow. When this occurs, the grid-to-cathode (R_{g-k}) impedance within the tube drops to extremely low values. Effectively therefore, the input voltage is applied to a voltage divider consisting of R4 in series with R_{g-k} , and since R_{g-k} is but a fraction of R4, only a portion of the positive half of the input appears across the input of V3 as indicated in Fig. 5. The negative half of the input is of course unaffected by R4.

Two factors act to produce the waveform shown at the plate of V3-a. First, the negative alternations of the input voltages are sufficient to drive the tube beyond cutoff and thus round off the top of the negative alternation; second, since the tube is being driven to saturation as well as cutoff, operation occurs over nonlinear portions of the tube's characteristic, thus accounting for the increased "squareness".

The output of V3-a is fed directly to V3-b where it is amplified and further squared by operation over nonlinear portions of the characteristic curve. The d.c. component is then removed and a symmetrical wave can be fed to V4.

Both sine- and square-wave outputs are available from a conventional cathode follower, V4, which provides the voltages (shown in table) at all frequencies.

AUDIO-GENERATOR OUTPUT VOLTAGE

Load impedance	Voltage output
10,000 ohms or higher	14 volts
1,000 ohms	10 volts
500 ohms	8 volts

Rated power output is 100 milliwatts into a 1,000-ohm resistive load.

Hum level is less than 0.4% of rated output, or 0.04 volt. In test applications

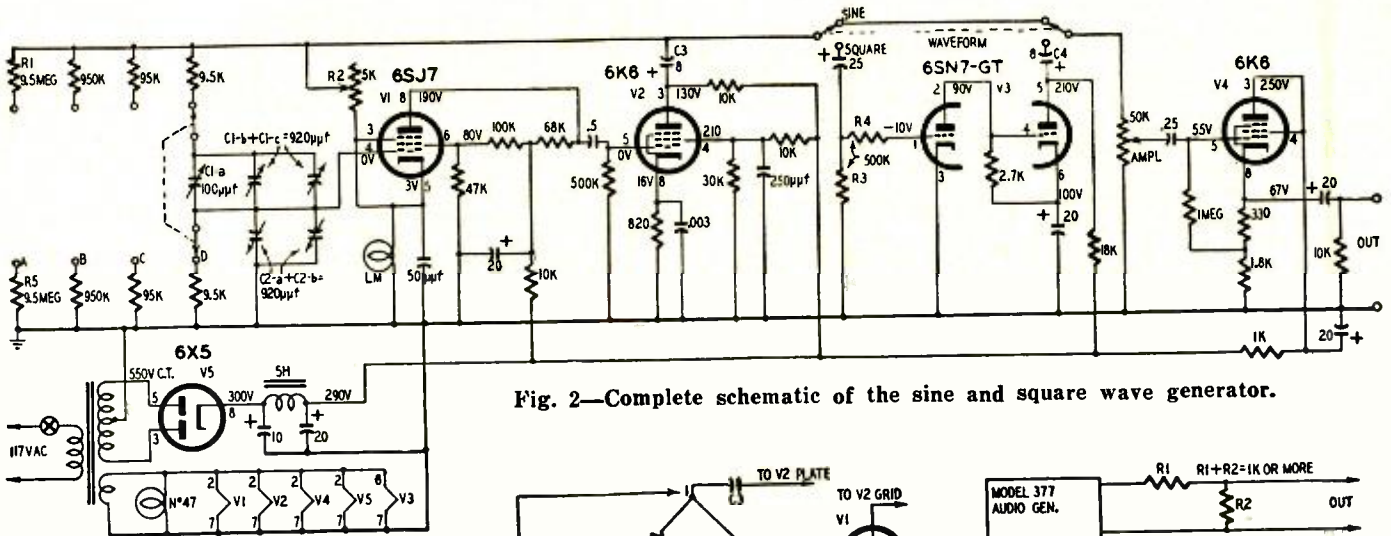

Fig. 2—Complete schematic of the sine and square wave generator.

requiring small signal voltages at very high signal-to-noise ratios, the desired voltage may be obtained by leaving the attenuator at maximum and tapping down the output with an external voltage divider as shown in Fig. 6.

Applications

For laboratory measurements, the 377 generator provides an excellent signal source for the operation of a number of bridge circuits for measuring inductance, capacitance, etc.

An unknown frequency is easily determined by beating the unknown signal against the generator output and tuning the generator to a null, as indicated by headphones or a scope. In the latter method, the output of the generator is applied to the horizontal plates of the scope, and the unknown frequency to the vertical plates. (Both voltages should be adjusted to produce roughly equal deflection.) The null point where the unknown frequency is equal to the frequency setting of the generator is indicated by one of several patterns, depending upon the phase difference between the voltages (see Fig. 7).

Frequencies outside the range of the generator can be measured by Lissajous figures, as shown in Fig. 8.

Thus, in Fig. 8-b, if the generator dial reads 190 kc, the unknown signal is 570 kc.

A most useful application lies in the field of square-wave testing. Scope patterns resulting from the passage of a square wave through equipment can yield considerable information in a minimum of time.

As an example, consider Fig. 9, a typical R-C coupling network.

Since low-frequency response is determined largely by C, any change in the value of C will result in low-frequency distortion.

Under normal conditions, the relation between X_c (reactance of C) and R at the fundamental frequency (frequency setting of the generator) are such that the square wave and the fundamental appear as in Fig. 10-a. After passage through the coupling

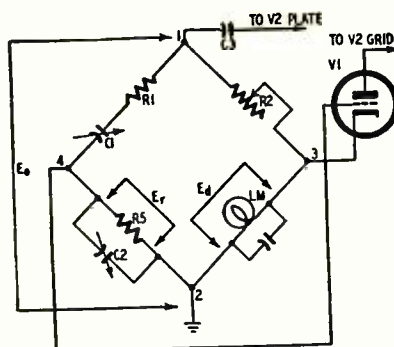

Fig. 3—Diagram of Wien bridge circuit.

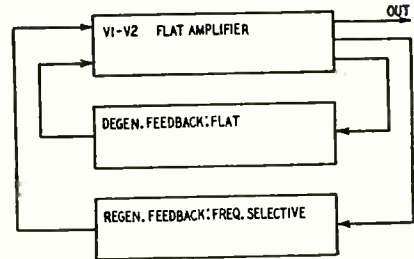

Fig. 4—Over-all action of Wien bridge.

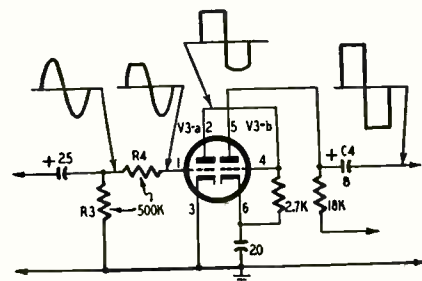

Fig. 5—Formation of a square wave.

network, the square wave should appear as in Fig. 10-b.

An increase in X_c would cause the fundamental to be decreased as in Fig. 10-c, and the square wave would appear as in Fig. 10-d.

A decrease in X_c would cause the fundamental to be increased as in Fig. 10-e, and the square wave would have the shape shown in Fig. 10-f.

Let us consider phase distortion. If E_o leads E_{in} , and if we plot these two voltages against the square wave, we get the graph shown in Fig. 11-a. The square wave, after passing through the coupling network will have the

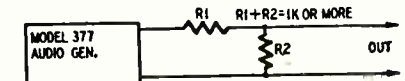

Fig. 6—An external voltage divider.

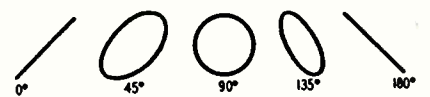

Fig. 7—Patterns indicate null points.

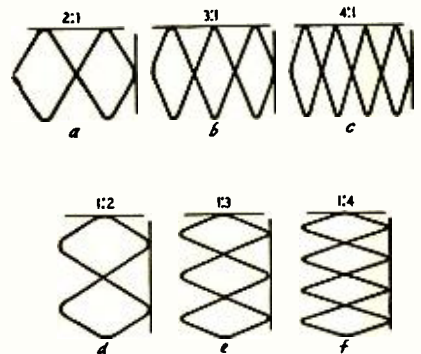

Fig. 8—Making use of Lissajous figures.

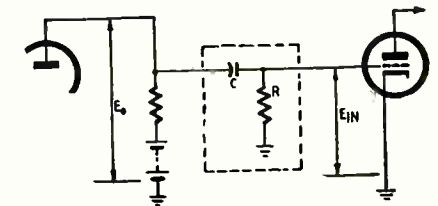

Fig. 9—Typical R-C coupling network.

shape shown in Fig. 11-b. Thus the effect of phase distortion is to tilt the edges of the square wave.

Fig. 11-b indicates that the first visible effects of low-frequency distortion are due largely to phase distortion rather than amplitude distortion.

If other types of coupling are used, phase distortion may occur when E_o lags E_{in} , in which case the square wave will appear as in Fig. 11-c.

The good accuracy and long effective scale of the 377 generator make it possible to use the instrument as an emergency bar generator for the adjustment of TV receiver vertical and hori-

zontal linearity.

Ideally, of course, the output of a true bar generator is applied to the antenna input terminals, and since the output consists of a high (video carrier) frequency modulated by the test signal, an over-all receiver check is made.

In the absence of a bar generator, rough checks and adjustments are possible by setting the frequency of the 377 generator at 1,200 (20×60) cycles and the selector for square-wave output. This output is fed to the plate of the first video amplifier through a blocking capacitor, thus resulting in 20 horizontal bars on the face of the picture-tube screen. Vertical nonlinearity is indicated by nonuniform spacing of the bars.

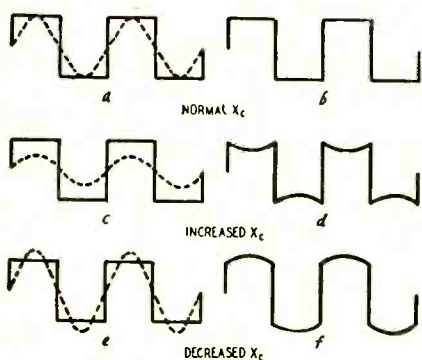

Fig. 10—Effects of reactance variations.

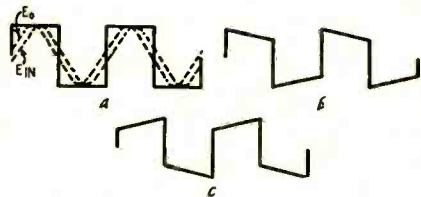

Fig. 11—Effects of phase distortion.

Similarly, horizontal linearity is checked by setting the frequency to 189,000 ($12 \times 15,750$) to give 12 vertical bars.

These are but a few of the many potential uses of the generator. As the user becomes familiar with the instrument, many others will suggest themselves and thus make the 377 a valuable part of a well-equipped service or laboratory bench.

A very common application of the audio generator is in measuring the frequency response of an audio amplifier. The simplest method is to connect a vacuum tube voltmeter across the output of the audio amplifier, and connect the generator to the amplifier input. By observing the variation in the v.t.v.m. readings as the audio generator passes through a range of frequencies, a rough frequency response check is obtained.

More accurate results can be obtained if there was some means of switching the vacuum tube voltmeter from generator output to amplifier output for each new setting of the generator. By doing this, the generator would be monitored for constant output, and more precise results obtained. END

USE A PHONIC

A receiver being checked becomes an important test instrument when properly used with headphones

By VERGNIAUD H. RICHARD

THE most modern radio service shops usually boast a signal tracer among their various testers. The technician who does not have such an instrument, may none the less enjoy its many advantages thanks to the *phonic signal tracing system*.

Many technicians are averse to using headphones in the plate circuits of detector and audio tubes as a service aid. Like most systems, signal tracing with phones has its limitations. Those of us who have used this method to track down such audio troubles as motorboating, hum, and distortion agree that the advantages greatly outweigh the disadvantages. Of course, it is usually useless in a receiver whose only trouble is low volume. Yet, as a help to enable us to criticize the signal quality, it is most useful, especially in audio servicing, or cases where the trouble is distortion.

First, we check the audio section with the phones to make sure that it is free of the particular trouble involved. Since neither headphones nor the human ear respond to the frequencies in the r.f., oscillator, and i.f. stages; we then proceed to signal-trace the higher-frequency stages by using the receiver itself as a signal-tracing detector.

Suppose a set is brought in to be serviced and the complaint is distortion. Now, the technician knows that this is a trouble that may originate in the r.f., mixer, oscillator, detector, or audio circuits. Tracking it down usually involves a series of tests which consume an appreciable amount of time.

Signal tracing audio stages

For rapid location of the trouble, it is preferable to start at the output of the detector, for we will then know whether the defect is before or after it. Fig. 1 shows the simplified circuit of a typical superhet receiver. Connect the phones and a .02- μ f capacitor in series across the detector load resistor R1 or across the volume control. If the signal is clear the trouble lies between this point and the speaker. Connect one lead of the phones to the plate of the first audio amplifier and the other to ground through the .02- μ f capacitor. A clear

signal at this point shows that the trouble is in the following stage or speaker. Connecting the phones and blocking capacitor from ground to the following plate soon tells the tale. Distortion at this point indicates that the trouble lies between the plates of the first and second audio stages.

Checking the r.f. circuits

If the detector and audio sections are in the clear, we can proceed right away to locate the fault in the stages ahead of the detector. Now here is the most interesting part. Phones do not respond to r.f. signals—so what will we use for a demodulator?

The technician will be surprised to find out that the demodulator (detector) he needs so badly is furnished by the receiver itself. True enough, having made sure that the audio section is O.K., we are going to use it along with the detector to do the signal tracing job. Referring again to Fig. 1, break the connections of the r.f. transformer at point A and do the same thing for the last i.f. transformer at point B. Using a jumper with alligator clips at both ends, join the disconnected lead of the r.f. transformer to the plate of the diode detector. Presto! Chango! The resulting circuit, a t.r.f. as shown in Fig. 2, has taken the place of the more elaborate superheterodyne of Fig. 1. So far so good, but what about the test?

Turn on the set and tune in a station, preferably a local one, the oscillator tube being removed. When a combination mixer-oscillator tube is used, the oscillator portion should be made inoperative. Check the output of the loudspeaker to see if the old trouble has reappeared. If it has, our search is limited to the r.f. transformer, the pre-selector (r.f. amplifier) tube and its circuits. Loudspeaker volume may be very low from the speaker, so connect the headset in the output tube plate circuit. This enables us to better judge quality by cutting out outside noises.

Having decided that the trouble is elsewhere, we proceed to the secondary of the first i.f. transformer and break its connection at C. Use the jumper as

SIGNAL TRACER

before to hook it to the detector, remembering at the same time to repair the break at A. Restore the oscillator to operation. As a result of this, the superheterodyne circuit reappears minus one stage of i.f. Faulty operation points to the mixer-oscillator circuits and first i.f. transformer as harboring the culprit. If there is no trouble, we turn to the second i.f. transformer (in case of three in a receiver) testing thus the first i.f. tube circuit and the i.f. transformer.

Ground the a.v.c. line and repeat the tests outlined above. Ground the a.v.c. line through a resistor of a few thousand ohms if each grid circuit connects directly to the line, or ground it directly if a.v.c. decoupling resistors are used. If the trouble is still not found after all these tests, the a.v.c. is certainly defective.

The preselector and the mixer can be checked as possible causes of troubles on stubborn alignment jobs. The procedure

is a combination trouble-shooting and alignment method. You are able to criticize the signal quality and at the same time manipulate the different trimmers to bring signal strength to normal. Considered from the alignment angle the procedure is most unorthodox.

Right away we break the rules by using the output of the second detector as our starting point. Disconnect the signal source from the antenna post and—ignoring the preselector—clip it on directly to the mixer grid. Now, disconnect the primary of the first i.f. transformer and feed the plate across the phones instead. Disable the oscillator, tune in a signal, and adjust the trimmers for maximum output. This done, reconnect the signal source to the antenna post. There should be an increase in signal strength. Peaking the preselector (r.f.) trimmers should produce additional volume.

If this business of disconnecting leads does not appeal to you who may con-

sider it just plain drudgery, you can call the old analyzer to the rescue. One can be put together for everyday use by using a combination of tip jacks, sockets, toggle switches, etc. The cable can be made of flexible wire or just ordinary lamp cord. Old tube bases will come in very handy as plugs and adapters. In using the analyzer, you will probably experience some trouble by interaction caused by wire capacitances. It may not prevent you from discriminating between the trouble that you are chasing and the one you are creating. On the other hand, you may invite in some squeals, whistles, or motorboating which are most confusing. So, it is safer to stick to the old phones, however toilsome is the process, and spare yourself additional headaches.

The technician is confronted by some troubles in the service business which in sheer desperation make him use the most rudimentary hints and kinks. Any method—despite the inconveniences to which it may put him—is welcome, provided it brings the solution to the problem at hand.

The student of the old school usually frowns on any other form of signal tracing except that with his trusted signal generator. However, he sometimes wants to listen to the actual intelligible signals through the different stages of the receiver. The purpose of this system is to provide him with an inexpensive means of checking troubles related to signal quality.

All systems have their limitations and this one follows the general rule. Its purpose is to isolate the defective stages in trouble-shooting. The operator must not expect it to point unerringly to the faulty resistor, capacitor, tube, coil, or transformer causing the disturbance.

The man who wants to cut servicing time to a minimum will find this system a great help.

END

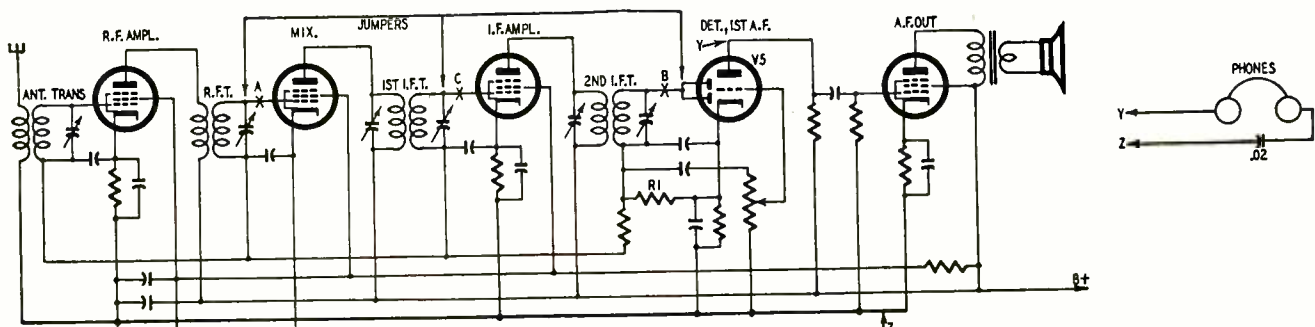
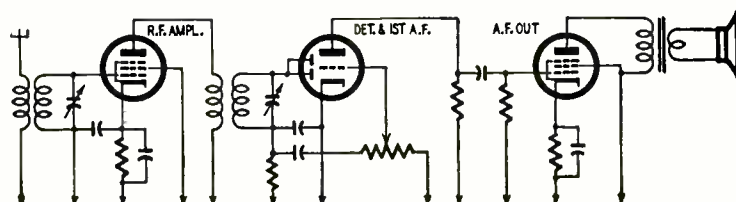

Fig. 1—Top, simplified diagram of typical superheterodyne receiver. Some sets have two or more i.f. amplifier stages.

Fig. 2—Right, a t.r.f. circuit develops when the mixer and i.f. are bypassed.



DOUBLE-BEAM SCOPE SWITCH

By T. W. DRESSER

An electric switch for obtaining two traces—ideal for comparing signals

TODAY an oscilloscope is a standard item of equipment in many service shops. Larger numbers of technicians—and amateurs too—are finding them useful things to have around for trouble shooting, checking alignment, and a variety of other purposes. But unfortunately only one trace at a time can be observed on most scopes. This imposes serious limitations on their use, and can be a strong source of annoyance when trying to locate distortion or, say, spotting the cause of a drop in signal strength between two stages. A double-beam scope, in such circumstances, would probably indicate the location of the trouble straightaway and save much time.

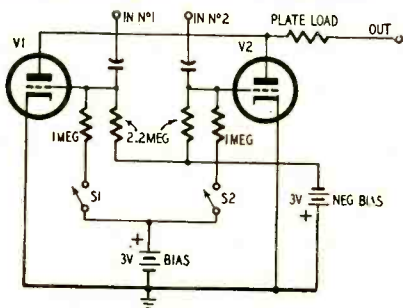
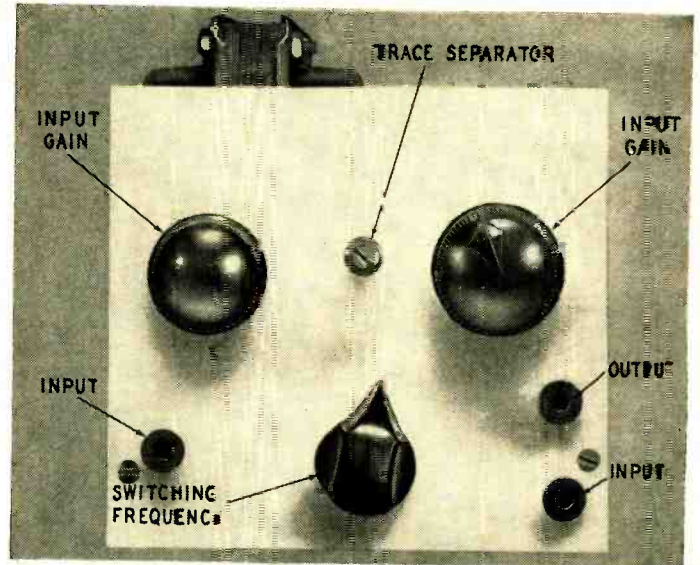

Fig. 1—Fundamental electronic switch.

Before going on to describe a straightforward practical beam splitter, perhaps some idea of what is involved will help in understanding the gear. Fig. 1 shows the diagram of an electronic switch reduced to its bare essentials. The tubes shown are triodes (for simplicity) and are biased to cutoff. When switches S1 and S2 are open there will be no output at the common plate connection. Closing S1 will apply a positive signal to the grid of the first tube, and during the period the switch remains closed this tube will conduct. Opening S1 and closing S2 will cause V1 to cease conducting and V2 to start doing so. If the two switches were operated alternately, there would be two different traces on the scope screen. In other words, we should have an electronic switch—a crude one, because the two traces would be far from simultaneous and they would be superimposed on one another, but a switch all the same.

Two things are necessary to convert this arrangement into a practical instrument for use with a standard scope: One, a means of separating the traces and, two, a method of speeding up the switching, as manual operation is far

Front panel view of the scope switch.



Underchassis view shows selector switch.

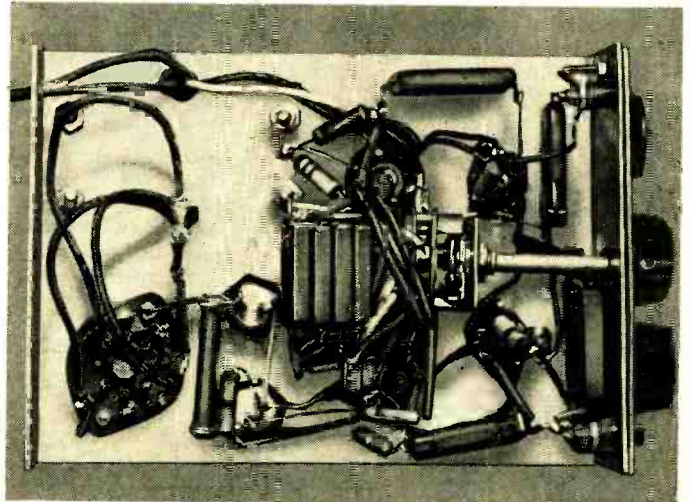

Double-beam scope switch. 6K8's may be used in place of the European tubes.

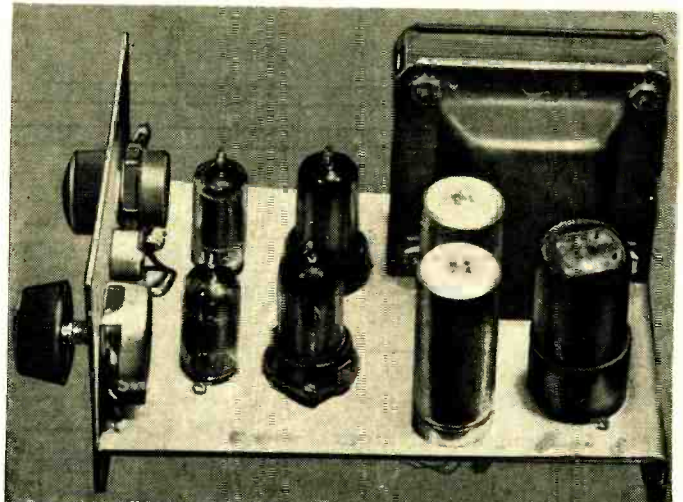

too slow to give the appearance of simultaneous traces. The first requirement is comparatively simple to obtain once the latter has been decided upon. This is where the gating circuit comes into the picture: it will give us the necessary switching speeds and do it automatically. Fig. 2 shows the basic circuit. The tube shown, a pentode, is

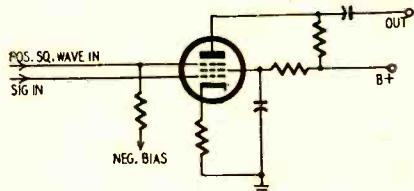

Fig. 2—Basic type gating circuit.

normally cut off by the heavy negative bias on the suppressor grid and will only conduct when a square-wave pulse of positive polarity is applied to this grid. We use two such tubes controlled by a multivibrator. Presenting a positive square wave pulse to each tube in turn will give us what we want—a fast switching circuit, whose speed we can control.

From there on the practical work is relatively easy, although there are still some problems to be solved, such as whether or not time-base synchronizing should be used, whether or not a buffer stage should be inserted, and what the switching speed should be. It depends on the application.

Fig. 3 shows how sawtooth traces will appear on the scope when the electronic switch is set for different switching rates. Note that the traces are in the form of dashes whose length depends on the switching rate. At *a* the switching rate is close to the frequency of the signal being observed. At this low rate neither trace is sufficiently complete to be useful. Increasing the switching rate as at *b* and *c*, greatly increases the detail in each trace.

When the switching rate is sufficiently fast the dashes are so short and close together that the traces appear as continuous lines. These are traces obtainable under the ideal condition of instantaneous change-over, a condition not likely to be attained, and the real performance therefore falls rather short of this, though not enough to matter. Both high- and low-switching speeds have advantages and disadvantages, and provision is made for both, though there is not much doubt but that for most of his work the technician will use low-frequency switching. For those who would like to juggle with their switching speeds, the formula for working it out is given at the end of this article.

Modern multielectrode tubes simplify the construction of an electronic switch (Fig. 4). Two triode-hexodes take the place of the two triodes (the multivibrator) and the two amplifiers. The triode sections are coupled together as a multivibrator, and, as the triode is

directly coupled to the hexode through its grid, there is no need for coupling capacitors. The hexodes are biased to cutoff; this condition changes when the multivibrator comes into action. Each switching grid in turn then becomes positive with respect to the other, and each hexode conducts until the multivibrator changes over to the other tube. This is determined by the switching speed. The traces are separated by varying the screen voltage on one of the hexodes.

The electronic switch in the photos was constructed around two European triode-hexodes, ECH42's, but 6K8's are identical to them and can be used without making any circuit changes.

The unit can be used as is—that is, the signal can be fed into the grids of the hexodes without any preamplification. But, as the minimum input in this case is approximately 0.1 volt, anything less may not provide a trace of sufficient amplitude, although some gain is secured from the hexodes. An amplifier was added before each hexode, but they are not absolutely necessary. The addition of these extra tubes made little difference to the compactness of the unit, which is built on a 7 x 5 x 2.5-inch chassis bent from lightweight aluminum. On the front of the chassis are the four controls: first and second

amplifier gain controls (at the right and left respectively) switching frequency switch, and separation control.

Parts for double-beam switch.

Resistors: 2—330, 1—1,000, 2—15,000, 2—22,000, 2—33,000 ohms, 6—1 megohm, 1/2 watt; 1—10,000 ohms, 2 watt; 2—20,000, 1—25,000 ohms, potentiometer.

Capacitors: 1—50, 1—100, 1—200, 1—500 μf, 1—001, 1—02 μf, mica, 400 volts; 2—0.1, 2—0.2 μf, paper, 400 volts; 1—10-10 μf, 450 volts, 1—20-20 μf, 450 volts, electrolytic.

Miscellaneous: 1—power transformer, 600 volts ct, 40 ma; 6.3 volts, 2 amp; 1—6X5-GT, 2—6AK5, 2—6K8, tubes; 1—switch, 2-gang, 6-position; 3—jacks; 1—7 x 5 x 2 1/2-inch chassis.

When first put into service the unit should be used on low-frequency switching until the technician becomes accustomed to the instrument. After that, any higher frequency can be chosen by switching in smaller capacitors. The ranges covered are from 25 cycles up to 10 kc in six steps.

There are literally hundreds of applications for the beam switch, and once a technician has used it he is unlikely to go back to the single-beam instrument.

The formula for determining the operating frequency of a free running multivibrator is as follows:

$$F = \frac{1}{R_1 C_1 + R_2 C_2}$$

R is in megohms, and C is in μf. END

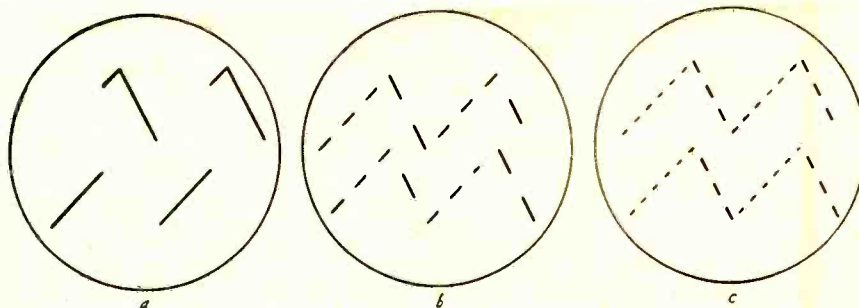

Fig. 3—Switching traces. Increasing switching rate will increase detail.

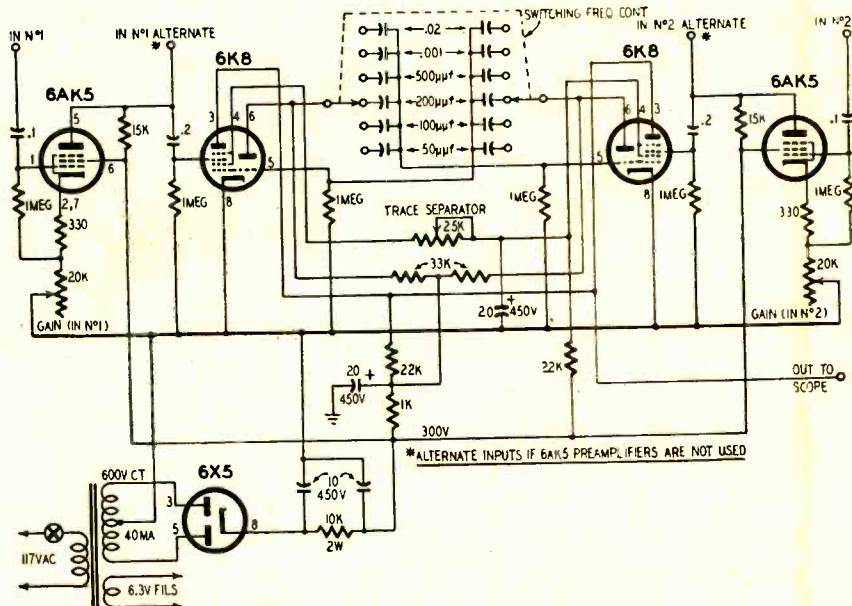

Fig. 4—Schematic of the double-beam scope switch. All values are shown.



The relative field-strength meter simplifies antenna installations.

WE have often needed a field-strength meter in our installation work; but were always brought up short by the high cost of such equipment. Yet we noted that the most expensive commercial instruments—costing perhaps several hundred dollars—had the advantage of only slightly greater accuracy than apparatus which, while cheaper, was still beyond the limits of our pocketbook. Possibly a simple, inexpensive instrument—which would still be quite adequate for our purposes—could be constructed.

We thought it over and came to the conclusion that we could do our job just as well, and reduce the cost considerably, if we used a *relative* field-strength meter. In this case we are not concerned so much with an absolute measurement as we are with a relative measurement; a comparison of one signal with another. We thus do away with the expensive and troublesome problem of calibration. In other words, we are not so interested in measuring exactly how many microvolts-per-meter exist at a given location as we are in determining if a signal is satisfactory or unsatisfactory. With this requirement in mind, we set out to construct a simple meter which would easily read such signals.

Since our main concern was for checking TV signals, our first thought was to insert a meter in the detector circuit of a standard television receiver, thus allowing us to read the signal strength as the set is operated as a regular receiver. While this would allow both sound and picture identification, even a small 7-inch set proved too bulky and was not sufficiently shielded. As a result, we set out to build a simple, small, portable meter.

The first item to be considered was the tuner, or "front end" of the meter. A quick glance through the spare parts bin produced a complete television-tuner assembly, covering all 12 v.h.f. channels. This happened to be an RCA type 206E3 tuner assembly, but nearly any of the tuners which are on the market as surplus or replacement units may be used. The tuner thus takes care of the input radio frequency stage, the oscillator and the mixer stage, all in one neat unit, being mounted on a standard

Relative Field-Strength Meter

By HILTON L. REMLEY

9 x 7-inch chassis. The tuning controls project through the front panel of a standard 8 x 10 x 7-inch utility box.

The tuner output feeds both a 25.75 mc i.f. to a video i.f. amplifier and a 21.25 mc i.f. for the sound i.f. channel. We do not need the sound i.f., so we use only the 25.75 mc signal which is fed to the grid of the first i.f. amplifier, a 6BC5 mounted as close to the output of the tuner as possible. The grid is peaked at the i.f. by a slug-tuned coil. This stage also has a slug-tuned coil in the plate circuit, peaked at the i.f., thereby providing considerable gain. This stage feeds a 6AU6, mounted close to the first stage, which is also slug-tuned and peaked at 25.75 mc. With these two stages peaked at 25.75 mc we have sufficient gain to drive the detector. All the i.f. tuned circuits are standard slug-tuned transformers, which may be purchased, or, as in this case, removed from a junked television chassis. The detector is a germanium diode that feeds a filter circuit. From there the signal goes to the meter circuit and a 6AU6 amplifier which drives the monitor headphones.

The meter circuit is conventional up to the multiplier. Here we have used a s.p.d.t. switch to insert either of two potentiometers in series with the 100-microampere meter. We thus make our meter a high-resistance voltmeter, connected through the filter and across the diode load resistor. The double-throw switch allows one or the other of the variable resistors to be adjusted so as to multiply the scale reading by say 10 or 20 in one position over that in the other. If desired, a tap switch could be used in this position and other values of resistance added to extend the scale multiplication for strong-signal areas. The series multipliers may be changed to low-resistance shunts if high sensitivity is not necessary.

No provision is made to alter the plate voltage as the range switch is moved, because we are using a relative reading instrument where such changes in gain are unnecessary. If a transformer with a 5-volt winding is available, a 5Y3 or some similar tube may be used in place of the 6X5; this tube was a happy choice only because the transformer at hand when the unit was built had a 6-volt winding.

After construction of the unit has been completed, alignment is the next order of business. This is not difficult since we wish to peak the i.f. amplifiers for maximum response at the video carrier frequency only. This is an am-

plitude-modulated carrier and gives us all the information necessary. By feeding a signal of 25.75 mc into the mixer (with the oscillator disabled) and adjusting each i.f. tuned circuit for maximum output on the meter, we have our unit tuned! Actually, the unit can be tuned without a signal generator, making use, instead, of a signal from a television station. This might be difficult if the coils are not somewhat near resonance, but later retouching of the circuit can be done at any time by this method.

Some tuners will have sufficient response at the audio-carrier frequency that, combining with the nonlinearity of the detector, the sound signal will be heard. Since this is a frequency-modulated signal, we are not interested in it. The video carrier is always identified by the peculiar buzz due to the presence of synchronizing and blanking pulses present.

Calibration of the meter scale does not become a problem as long as we remember we have only a relative reading instrument. In our case we made up a linear reading scale, reading from 0 to 100. Later, if desired, this dial could be calibrated in any units found to be useful.

The meter has proved to be quite useful in a number of applications. First, it has been very handy, in conjunction with a length of a.c. cord, in setting up and orienting television antennas for maximum signal. We have found that the average television technician who makes these installations has all too often only a vague idea of topography and direction. A surprisingly large percentage of antennas have been found oriented in very odd directions, having nothing whatever in common with maximum signal. It has also been found that a very large number of installations may be improved by relocating the antenna. We don't mean to move the antenna any great distance, but one must remember a move of only one-half wavelength, horizontal or vertical, could mean the difference between maximum and minimum signal. If we move the antenna around the positions available for mounting, observing signal strength on all channels, we will finally find a position where we get nearly maximum signal from all stations in the area.

Second, in fringe area installations, a great deal of time and effort may be saved by use of the meter. The first step here is to determine what relative field strength will give a satisfactory picture

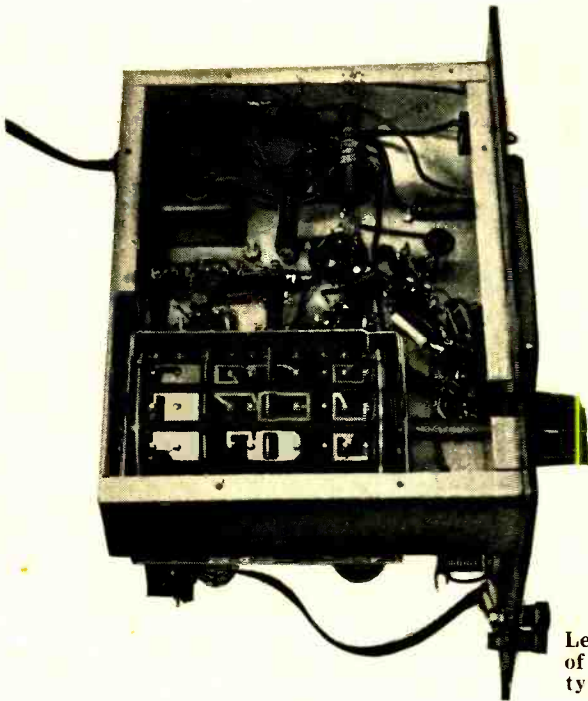

Left—Underchassis view shows layout of components. The tuner is RCA v.h.f. type 206E3.

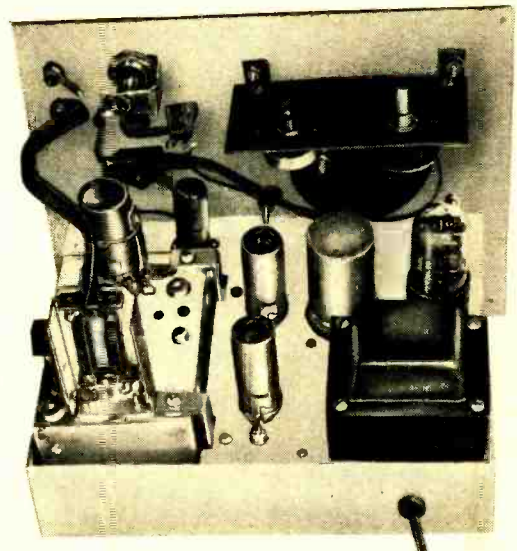

Above—Top view. Potentiometers are conveniently mounted behind the meter movement.

on the particular receiver chosen by the customer. This can be done by connecting the receiver, through a variable pad, to an antenna system, along with the meter, and observing the received picture as attenuation is added to the received signal until we reach the minimum signal. A reading of the meter then tells us the minimum signal usable

the customer purchases his receiver, thereby increasing customer good will and saving the technician's time and money.

Another use for the meter was recently turned up when an amateur radio operator was discussing some of the measures he had taken to insure his transmitter against interfering with his

leak from vent holes, cable entrances, around the edges of doors, near hinges, and even around the edges of meters on the panels. Any small hole in the metal seems to be a potential trouble spot, along with any cable that may pass through the metal structure.

Still another use for the instrument is in tracking down radiation from r.f. heating equipment. This type of equipment is composed of the same essential components and often follows

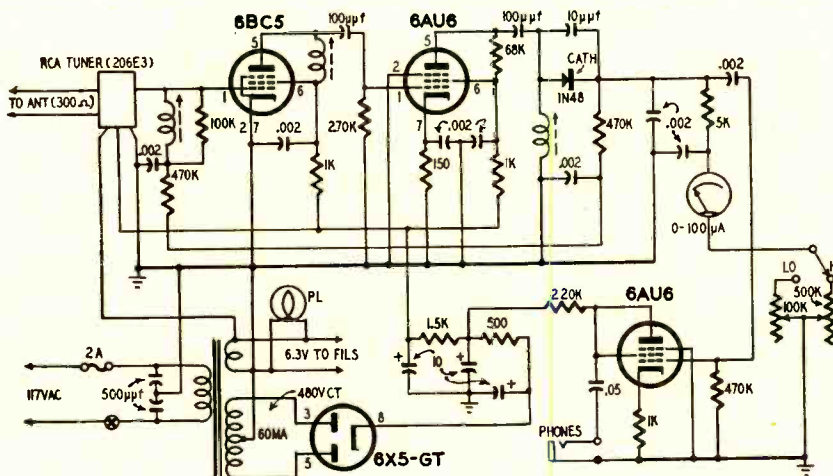

Schematic diagram of the relative reading television field strength meter.

Parts for field strength meter

Resistors: 1—150, 3—1,000, 1—5,000, 1—68,000, 1—100,000, 1—220,000, 1—270,000, 3—470,000, 1/2 watt; 1—500, 1—1,500, 2 watt; 1—100,000, 1—500,000, potentiometers.

Capacitors: 1—10 μ mf, 2—100 μ mf, 2—500 μ mf, 8—.002 μ f, 1—.05 μ f, mica or ceramic; 1—10-10-10 μ f, 450 volts, electrolytic.

Miscellaneous: 1—6BC5, 2—6AU6, 1—6X5-GT, tubes; 1—1N48 germanium diode, and holder; 1—0-100 μ a meter; 1—TV tuner 1—power transformer, 480 volts ct, 60 ma, 6.3 volts, 2 amps (Haldorson P-2067); 1—on-off switch; 1—line cord; 1—pilot light and assembly; 1—phone jack; 1—s.p.d.t. switch; 2—input jacks; 1—9 x 7-inch chassis; 1—8 x 10 x 7-inch utility box; 3—slug-tuned i.f. transformers (matched to tuner).

with such a receiver. This value must be obtained on all channels, as both field strength and sensitivity vary on all. We can then proceed to the customer's home and, using a temporary antenna installation, determine whether the signals will be satisfactory. Here again, moving the antenna about from one spot to another will be a great help. Often a usable signal cannot be obtained without a booster. We can insert the booster and then once more measure the signal to determine whether it has been sufficiently amplified to provide the necessary input to the receiver. All this may be done much more quickly with the field-strength meter, giving a complete story of the possibilities before

neighbors' television reception. He had found that actual detection and location of troublesome interference was the first difficulty. After the source was located, it was much easier to correct the trouble. We suggested use of the signal-strength meter and it turned out to be a useful tool for him.

For this type of work, a short length of line is connected to the input of the meter, with a small tuned pickup loop on the far end. Then, with the transmitter in operation, and the meter set to the interfering signal, it is an easy matter to completely explore the transmitter installation and find exactly where radiation is taking place. It has been found that radiation can, and will,

the same general construction methods as amateur equipment.

Our amateur friend has suggested one item that might be of assistance if the unit is to be used extensively for interference work. Addition of a π -section filter on each side of the a.c. line at the point where it enters the chassis will prevent any signal from entering the meter via the a.c. line. This will add some assurance that indications on the meter are only from radiations picked up by the probe and not something entering the meter on the a.c. line.

With continued use, the owner of such a meter should find uses which have not been covered, thus increasing the value of the instrument many times.

END

FOR GOLDEN EARS ONLY

This is the first appearance of a feature which will appear from time to time as the conditions in the world of audio warrant. All subjects which may interest the audiophile will be discussed in these columns

By MONITOR

THE high-fidelity addict has no objections to having a system which consists of several units and possesses lots of controls. He gets a great deal of pleasure operating the controls. The ordinary consumer, on the other hand, accustomed to automatic-drive automobiles, automatic washers, and even automatic frying pans, has little patience with complication. What he wants is simple assembly and easy operation. Now that high-fidelity is finding an increasing market with users who know little about audio and want only results, the dealer and installer are faced with the problem of meeting the customer's desire for simplicity.

Most of the manufacturers of high-fidelity equipment have taken notice of this and are now offering simplified, more compact units combining preamplifiers, control units, program selectors, power amplifier, and power supply—all on one chassis. I have just tested one of these—the Golden Knight (Fig. 1), produced and sold by Allied Radio, in the medium price range at \$79.50.

Golden Knight amplifier

The specifications of the Golden Knight (Table) are above those of the medium price range high-fidelity equipment and, indeed, fall into the de luxe category. The rated power output is 24 watts at less than 1% harmonic and 2% IM distortion (Fig. 2, 3); and the frequency response is specified to be flat within less than 1 db over 20 to 40,000 cycles at full output (Fig. 4). When it is considered that in addition the amplifier includes a two-stage phono preamplifier-equalizer, a two-stage tone control and program selector, and also claims an over-all hum level of -80 db, one can be excused for being skeptical.

I can say that the specifications are not exaggerated. The unit I received was in its factory-sealed package and

showed no signs of special treatment. I made my checks without disturbing the factory settings of balance and bias controls. The IM distortion as measured on a Heathkit IM analyzer was well below 1% for all levels under 10 watts and remained under 2% at the 20-watt level. The frequency response was flat to 40,000 cycles until 20 watts of output where it fell off slightly at the extremes but was still within 1 db within 20–20,000 cycles. The hum level was as specified also, with no adjustment of the hum control.

I used the amplifier in my home for some weeks with various loudspeakers: my infinite-baffle wall-mounted combination of 5 speakers plus a bass-coupler built into the floor; the Kingdom Lorenz combination; and the same speakers in a corner horn enclosure.

I have no complaints to make of the performance of the Golden Knight with any of these speaker systems. It also behaved almost flawlessly with my collection of special test records. Since high-quality amplifiers, like high-quality musical instruments, often possess a character of their own, highly critical ears may have a certain amount of preference for slight differences in the tonal qualities of several amplifiers which otherwise are electrically similar. The Golden Knight is no exception. But only the most sophisticated of Golden Ears will find much to quibble with in its performance; and in comparison tests it will hold its own against the field.

As for the general consumer (for whom—rather than the high-fidelity crank—it was designed) I doubt that, given the same program material and speakers, as many as 1% could discern any difference between the Golden Knight and the cost-is-no-object amplifiers. It represents a successful attempt to produce fidelity acceptable to 99% of the market, with simplified controls and at a price well below the average

for its specifications.

Although designed primarily for home use, it occurs to me that the Golden Knight would be an especially good choice for high-fidelity installations in smaller restaurants, schools, etc. The high-power capacity would preserve a sufficient, safe reserve of power for good reproduction of peaks even at the high average output levels necessary to override conversation or sound absorption of heavily populated rooms.

Now let us see how this high performance is achieved at such a low price. There is nothing tricky about the circuit (Fig. 5). The high output power is obtained by using 6L6's as tetrodes with very high plate and screen voltages (465 and 420 respectively). With such high operating voltages, the tubes are being driven to only a fraction of maximum possible output and operate on the flat portion of their curves. A special output transformer with grain-oriented core and interleaved windings no doubt accounts for the clean performance at the extremes of the frequency range and at high power output. What appears to be about 20 db of feedback is applied to the three stages of the power amplifier. Finally, the amplifier has potentiometers for adjusting the bias voltage on the output tubes, and the rest of the output tubes. These do much to correct the

GOLDEN KNIGHT SPECIFICATIONS

Rated power output	24 watts
Frequency response	0.75 db, 20-40,000 c.p.s. at rated output
Harmonic distortion	Less than 1% at rated output
Intermodulation distortion	Less than 2% at rated output (60 and 7,000 c.p.s. tones; 4:1)
Hum level	80 db below rated output (inaudible)
Gain (high-level inputs)	0.5 volt for rated output
Gain (low-level inputs)	.02 volt for rated output



Fig. 1—The Golden Knight 24-watt high-fidelity amplifier.

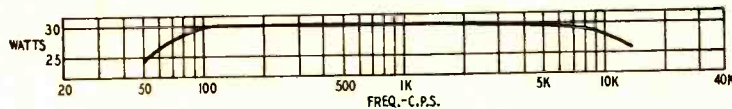

Fig. 2—The power output of amplifier at 1% harmonic distortion.

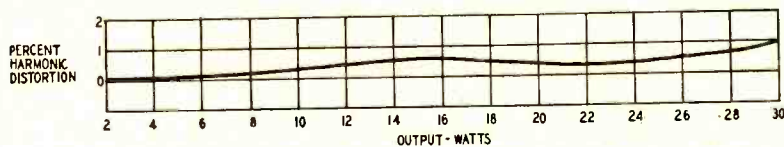

Fig. 3—Graph shows percentage of harmonic distortion at 400 c.p.s.

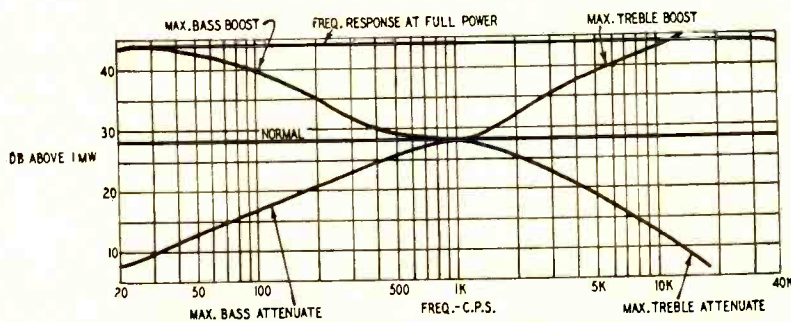

Fig. 4—Amplifier frequency response and bass and treble ranges.

tolerances of tubes, components, and assembly, and to insure that individual units will meet specifications and maintain them with changes of tubes and ageing. These controls should make servicing a simpler matter than is allowed for by most amplifiers.

The hum level is kept low partly by a balanced heater-biasing circuit with a hum-balancing control mounted on the chassis. Incidentally, all three controls are protected against accidental misadjustment or monkey-business by youngsters, with screw-down caps. Obtaining and applying the heater-biasing voltage is very simple. The slider of the heater-balancing potentiometer (hum-balancing control) is returned to the cathodes of the output tubes, which are at a positive potential of 37 volts, an excellent value for biasing. This method saves a couple of resistors or a voltage divider. It could be applied to almost any cathode biased amplifier by adding a 100- to 1,000-ohm potentiometer;

or, if the filament winding has a center-tap, just returning the center-tap to the output-tube cathodes.

The only other notable point about the amplifier is the simplicity of the various control circuits. Three phonoplayback curves are provided: a 500-cycle turnover and flat treble, the AES curve, and the NARTB curve (Fig. 6). The NARTB curve works well with LP recordings, and the AES does well with Ortho discs. Although this choice does not provide complete or exact equalization for all recordings, it is sufficient for the average user. A slide switch provides a change of input resistance for G-E or Pickering cartridges. There is an input for low-level mikes. High-level crystal or ceramic cartridges can be fed into the auxiliary input. Magnetic cartridges with external equalizers could be accommodated through the microphone channel. The bass and treble controls are smooth, and pro-

vide a range adequate for most uses. Any simplification of controls involves compromises; but the Golden Knight appears to have struck these in a way which should make the average user happy.

In short, the Golden Knight is a successful attempt to provide very high quality at low cost.

Baruch-Lang loudspeaker system

Recently when assembling a compact low-cost high-fidelity system I had occasion to use and test the Baruch-Lang loudspeaker system. This system consists of four inexpensive 5-inch speakers in a very small enclosure of rather tricky but effective design.

I found it surprisingly good. There is very little if any response below 50 cycles, and the high-frequency slope is rapid beyond about 11,000 cycles; but the reproduction between 60 and 10,000 cycles is excellent. The efficiency is surprisingly high despite the small magnets used in the speakers and the small enclosure. The loss of the octave between 25 and 50 cycles is to be mourned of course; any good system sounds better and more real with it than without it. But there will be very little loss, if any, of the musical content since very little music is written in that octave and even less is found in radio and recordings. Besides, the second octave is well and cleanly reproduced, and since the ear has the curious property of imagining it hears the fundamental when it hears only the harmonics, the absence of the notes below 50 cycles is noticeable only to those who are thoroughly accustomed to their presence. In any case, you can't expect to buy reproduction of the lowest octave for anywhere near the \$30 price tag this outfit carries.

The transient response is fair and the over-all quality—especially when the enclosure is mounted in a corner—is superior to that of some much larger and costlier systems. It probably provides about all the bass a small room or apartment can stand. The treble response is smooth and adequate.

One could not compare the Baruch-Lang with the best available speaker systems; but it certainly represents a lot of quality-per-dollar. Moreover, its compactness, the freedom of placement which its small size and design makes possible, and the variation in bass response that can be had by placing it in either of several positions, combine to make it a nearly ideal low-cost system. One of the speakers would be an excellent choice to use with a portable tape recorder for monitoring and playback. Two or more could be used also with small public-address systems or guitar amplifiers. I recommend it strongly where every dollar and foot of space counts.

New recordings

I will comment from time to time on new or recent records which are either: unusually striking examples of

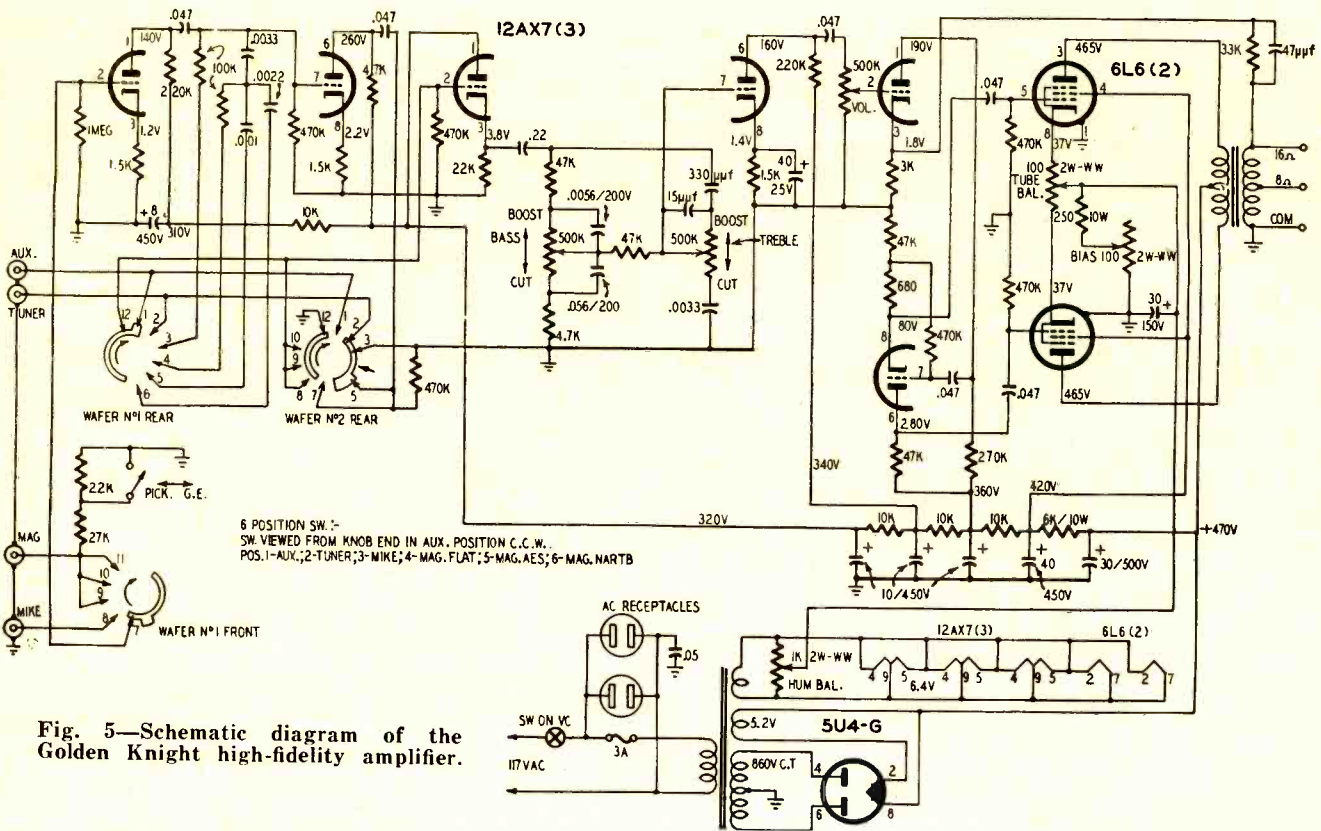

Fig. 5—Schematic diagram of the Golden Knight high-fidelity amplifier.

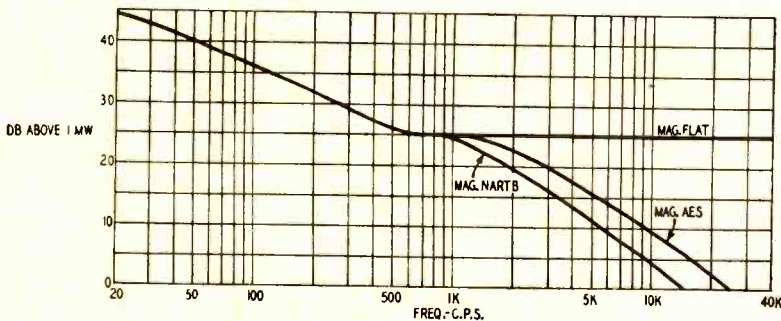

Fig. 6—Amplifier response—preamp in FLAT, AES, and NARTB positions.

high-fidelity recording; the expression of a new recording technique; suitable for testing various qualities of high-fidelity equipment; or useful for demonstration of high-fidelity equipment. I shall not be concerned with the musical content or the interpretation—merely the technical aspects.

The three cornered hat
Manuel De Falla
 (Paris Opera Comique Orch.)
URANIA URLP 7034

Here is an excellent record for listening tests of high-fidelity equipment. It has plenty of prominent bass for checking the bass response of speaker systems; a good deal of high frequencies including those contributed by the typically Spanish percussives; several high-volume bursts of rather dissonant crescendos, excellent for checking distortion and overload; excellent transients, and offers many opportunities for checking intermodulation when a prominent bass accompanies high treble passages.

The recording has good, but not out-

standing presence, and there are several interjections of voices, solo, and in chorus, which furthers the realism. The recording is not up to the standard of today's best, but is sufficiently good to present a fair test. The music itself is interesting and this is the only complete version of the score available.

American concert-band masterpieces
MERCURY MG 40006

One of the very best recordings for high-fidelity demonstration; but also useful in portions for testing. For instance, the bass drums, cymbals, and tyn.pani provide a very severe test of dynamic range, transient response, and loudspeaker damping. The contrapuntal writing of some passages, with several instruments running rings around each other, is good for checking definition, since in the good system the separate instruments will be clearly discernible. The whole effect is calculated to make the good system sound very real and attractive even to the complete layman. In addition, the music itself is pleasant,

stimulating, and could be tolerated in the shop or store for days on end. The same cannot be said of many of the recordings used for high-fidelity demonstrations.

Third symphony
Aaron Copland,
 (Minneapolis Symphony Orch.)
MERCURY MG 50018

Until the arrival of LP records, Copland's *El Salon Mexico* was my favorite test record. Copland is especially clever in approaching (though never quite reaching) outright dissonance. Such sections provide a wonderful check of system distortion because even a little distortion will throw the music over the edge into extremely unpleasant dissonance.

He is also fond of using several brasses playing in unison or exquisitely close harmony. On a system of poor definition the result sounds like one badly muted horn; but on a good system it is actually possible to count the horns. His deep bass rhythms and more or less onomatopoeic (sounds resembling natural sounds like gunfire, dancing feet) passages are excellent measures of transient response.

In this version of the *Third Symphony* we have all this and a superlative example of high-fidelity recording at its best with plenty of realism but no artificial high-fidelity effects. The recording is good enough so you can safely assume that any serious aberration in the output of your speaker is the fault of your system, not the record. END



Typical high-quality audio amplifier—includes a phono pre-amp.

Part IX—Design factors of triode and pentode resistance- coupled amplifiers

By RICHARD H. DORF*

HIGH-QUALITY AUDIO

SO FAR we have burned the audio candle at both ends, talking about loudspeaker systems and sound sources. Now we come to the middle—the heart of every sound system—the amplifier.

The amplifier is the most important component of a home music system. We said at one point that the audio chain is no stronger than the weakest link—and we still agree with this statement. But it is reasonable to place special emphasis on the amplifier even though it cannot neutralize the effects of a poor speaker, a bad tuner or pickup, or a defective record.

The amplifier is usually the most expensive part of a system and therefore the one least likely to be replaced. It is the most complex element of the system, since it performs more different tasks and contains more parts than any other. Most other components, if correctly designed and built in one respect, perform well. An amplifier may have one good portion and other poor ones; *all must be good* if the amplifier is to be good.

What does it do?

An amplifier's main function is made clear by its name; it amplifies. Its secondary function—but the one that causes the most trouble—is to transform voltage variations into power variations.

The amplifier must amplify *without distorting*—that is, changing the character of—the signals. It should not change the relative levels of the various frequencies, or the relative amplitudes

of the various parts of a single wave. It must not create waveforms that did not exist at the input, nor fail to duplicate waveforms that did exist. It should, in short, act like a magnifying glass through which an object appears exactly as it would if viewed directly, except for over-all size.

Fig. 1 is a diagram of a very simple amplifier. It has the necessary gain for a home music system and furnishes enough power output (4.5 watts) for ordinary listening. The power supply is transformer-operated. Anyone can design such an amplifier in about ten minutes with the aid of the tube handbook. Why do home-music-system amplifiers have to be more complex than this? One answer is that this amplifier has about 12% harmonic distortion, due mainly to the output stage. Another answer is that the effective output impedance is high, giving rise to transient distortion. Still another is that a single-ended amplifier does not allow sufficient power output to take care of peaks, and both reduces and varies the inductance of the transformer primary so that low-frequency performance is restricted and non-linearity distortion is high at all frequencies.

Basically, designing amplifiers to give high-quality reproduction is simply a matter of observing rules which have been known for many years, using good components (especially a good output transformer), and incorporating a very important ingredient, negative (and sometimes also positive) feedback.

Unlike many other components, amplifiers can be constructed and serviced by the individual enthusiast or service

technician. The knowledge necessary for the purpose is not hard to acquire. For that reason we shall go into the subject rather thoroughly.

We can divide our analysis of amplifiers into five parts: voltage amplifiers, phase splitters, power amplifiers, feedback, and power supplies. This is made clearer by the block diagram of Fig. 2 which shows the essential parts of an amplifier. Everything shown in Fig. 2 is present in a high-quality amplifier, except the positive feedback which may or may not be provided.

Voltage amplifiers

The output of a phonograph pre-amplifier or radio tuner is on the order of 1 volt. Normally this signal appears across a resistor; therefore there is some current flow through the resistor and some power dissipated in it. The resistance value is kept very high so that current is at a minimum and the signal source is not loaded enough to reduce the voltage. Until the signal actually reaches the power stage, where it will be used to control the power output, we are interested only in amplifying the signal voltage so that it will be great enough to drive the power-stage grids. The stage or stages which do this are voltage amplifiers. The phonograph preamplifier contains only voltage amplifiers which raise the low-level output of the pickup to something between 0.5 and 2 volts. The phonograph, tuner, and other sources reach the input to the main amplifier at this voltage level.

Voltage amplifiers may be resistance-, transformer-, or impedance-coupled, but in home music system amplifiers it is

*Audio Consultant, New York City.

unusual to find anything but resistance coupling. The reason is—aside from the cost and weight of transformers and inductors—that resistors make ideal loads because they are not frequency-sensitive in the audio range. Transformers and inductors, on the other hand, must have sufficient inductance to maintain the necessary impedance down to the lowest frequencies; may be self-resonant at certain frequencies; and have problems like leakage reactance (frequency-sensitive reactive couplings between windings). In most amplifiers use of an output transformer is unavoidable, but in earlier stages transformers are avoided.

Resistance-coupled (R-C-coupled) amplifier stages are generally standardized. These are shown in Fig. 3, with 3-a the triode and 3-b the pentode amplifier. The components and voltage source are marked to conform with the

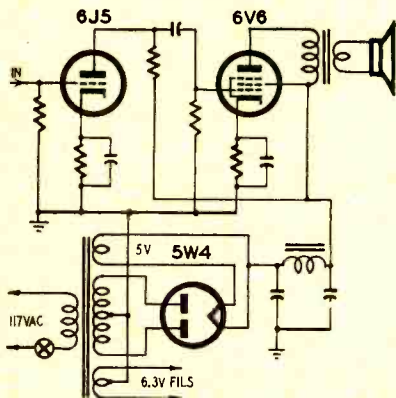

Fig. 1—A basic 3-tube audio amplifier.

symbols used in the RCA resistance-coupled amplifier tables. In Fig. 3-a, the signal is fed to the control grid. Current passing through the tube from ground (B minus) to B plus (E_{bb}) is varied in intensity by the grid. The variations of current through load resistor R_L , produce audio-frequency voltage variations across R_L , which are coupled to the next stage through d.c. blocking capacitor C. This capacitor is of large enough value to offer negligible a.f. impedance. Bias is obtained from current passing through cathode resistor R_k . Since the grid is at ground potential for d.c., the grid is negative with respect to cathode. C_k is of large value and filters the audio variations which would otherwise appear across R_k .

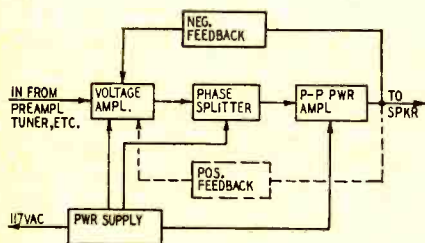

Fig. 2—Essential parts of an amplifier.

The pentode circuit in Fig. 3-b is similar, with the addition of R_{g2} and C_{g2} . Screen current passes through R_{g2} , causing a voltage drop across R_{g2} . The

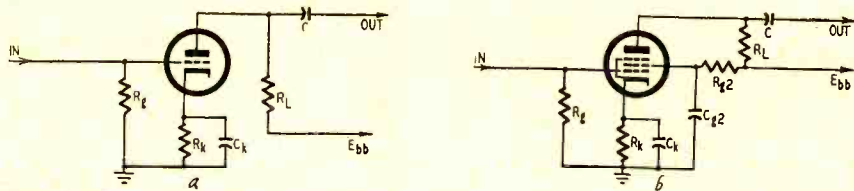

Fig. 3—Diagram of two of the most commonly used resistance coupled amplifier circuits, triode and pentode. Design tables for them have become standardized.

screen voltage thus depends on the value of R_{g2} . Screen current passes through R_{g2} to E_{bb} . C_{g2} smooths out the audio-frequency variations so that the d.c. voltage applied to the screen is steady. If it were allowed to vary at the audio rate, the gain of the stage would be greatly reduced. This is because the screen voltage would always be 180° out of phase with the control grid, thus tending to cancel a.f. plate-current variations.

The design of voltage-amplifier component values is a straightforward process which anyone can carry out by using the resistance-coupled amplifier tables found in the back pages of the RCA RC-16 Receiving Tube Manual or comparable tables in other tube handbooks. These tables are widely used, because resistance-coupled audio-frequency voltage amplifiers provide essentially uniform amplification over a wide frequency range.

The first step is to determine the gain needed and the maximum peak output voltage the tube will have to furnish. A suitable tube is easily selected from the last two columns of the tables, which show these characteristics. A tube should always be chosen whose output voltage capabilities are well above those necessary, since distortion rises sharply near and at maximum. Output capability of a stage is determined principally by the supply voltage and secondarily by the value of R_L ; available output being higher as each of these is increased. The maximum peak grid voltage for the stage is of course the maximum output divided by the voltage gain. The figure obtained is also usually the correct value of bias voltage, since maximum output is that at which the net grid-cathode voltage swings to zero on the positive alternation. This fact is useful in service checking to see if bias is correct.

Resistor and capacitor values

In the tables the value of R_g shown is that for the following stage's grid resistor. R_g is effectively in parallel with R_L at audio frequencies, and the net parallel value of resistance is the a.c. load resistance of the stage. Lowering the value of R_g lowers the undistorted output of the stage.

The cathode resistor R_k is chosen so that the current through it produces a voltage drop equal to the desired bias. In a few very-low-level stages where the cathode is grounded, a 5- to 10-megohm grid resistor provides contact bias as the result of small gas currents flowing through the resistor from grid to ground. Measurement of this contact bias is impractical since the resistance

of the v.t.v.m. is sufficient to lower it substantially.

The value of R_k is far from critical, even for high-quality work, and this is one of the advantages of cathode bias for voltage-amplifier stages; it makes the entire operating condition of the tube more or less self-compensating. If R_k is a little too large, it creates a higher bias voltage, which lowers tube plate current, which in turn lowers the R_k voltage drop. For a given value of R_k , changes in static plate current due to any of a number of causes are compensated by the resultant changes in bias voltage which tend to restore plate current to its design value.

Selection of all the capacitor values follows the principle that capacitive reactance must be negligible by comparison with the associated resistor. Thus the reactance of C at the lowest frequency to be dealt with must be no greater than about one-tenth the resistance of the following R_g to which it is connected. The series C and shunt R make up a high-pass filter, cutoff frequency of which (frequency of 3-db attenuation) is that at which X_c is equal to R. If X_c and R were equal at, say, 30 cycles, the 3-db drop at that frequency would not be serious in itself, but the resulting phase shift would give trouble if, as is usual, negative feedback loops are included in the stage.

The values of C_k and C_{g2} should be high enough so that their X_c is less than one-tenth the resistance of R_k and R_{g2} , respectively. A parallel resistor and capacitor are also a high-pass filter, since the capacitor bypasses more effectively those frequencies at which X_c is smaller. Here again, the more audio current flowing through R_k and R_{g2} , the more degeneration sets in. For flat frequency response and adequate phase response, the capacitor should be practically a short-circuit for audio down to a frequency much lower than the lowest audio frequency to be passed.

The resistance-coupled amplifier tables in the manual specify the capacitor values for a response drop of about 3 db at 100 cycles. For home-music-system amplifiers the values of the capacitors should be increased by at least 5 to 10 times. The values of R_g shown in the tables are minimum values. For smaller distortion with an audio voltage level, R_k should be kept as high as possible, though values in excess of 1 megohm may give trouble because of unwanted contact-bias.

Next month we shall conclude our discussion of voltage amplifiers and pass on to phase splitters.

(TO BE CONTINUED)

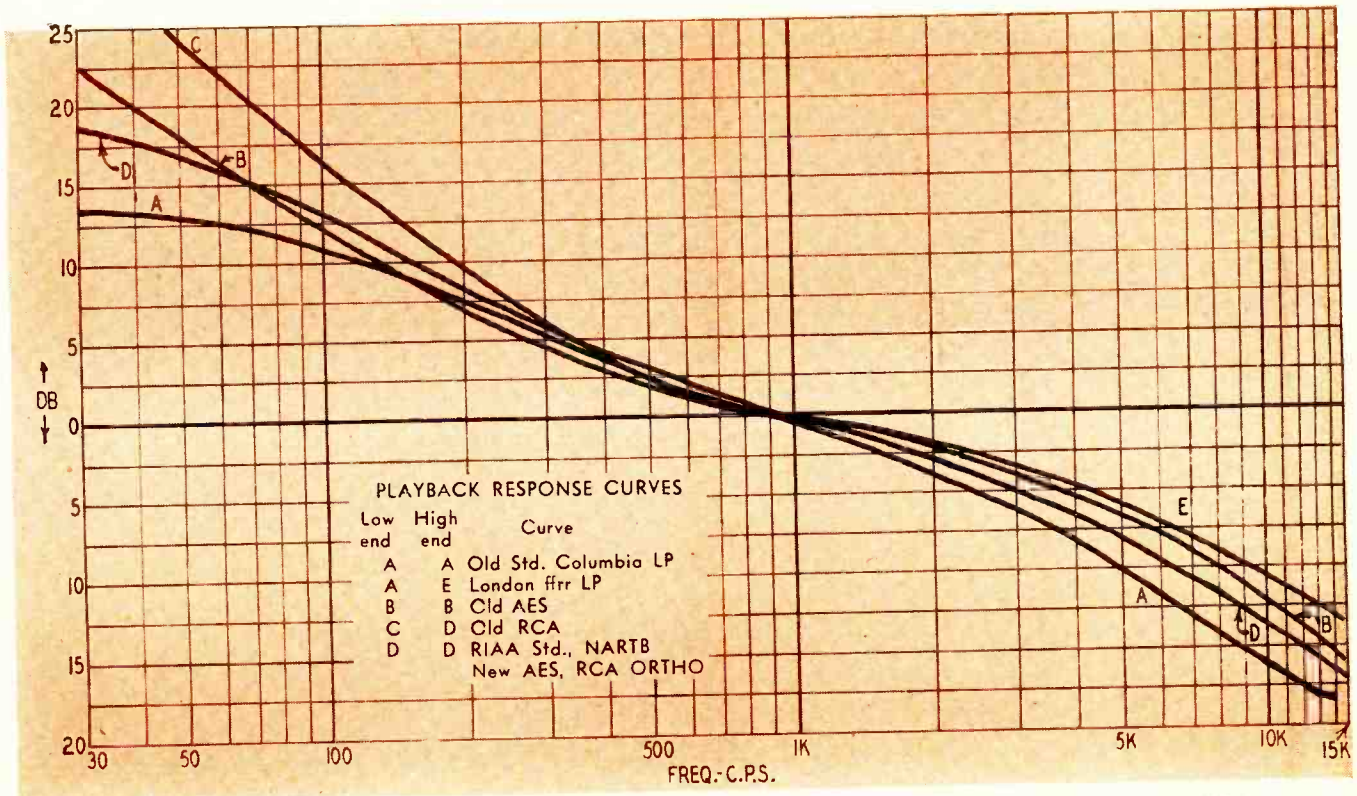

Fig. 1—Graph illustrates various recording curves used by leading record manufacturers in the United States.

NEW STANDARD RECORD CURVE

Phonograph record manufacturers agree on standard recording and playback curve

AFTER nearly 30 years of electrical recording and 5 years of LP's, the leading phonograph record manufacturers have at last gotten together and agreed on an industry standard recording and playback curve. If all manufacturers switch over to it, it will no longer be necessary (at least as far as *new* recordings are concerned) to adjust phono preamplifier equalizer controls to different settings when playing records of different makes. The listener will merely use the normal tone controls (if any) on his equipment to adjust balance for his particular listening room, equipment and loudness level, the same as he now does on a radio program.

The new standard recording and playback curve was adopted by the Record Industry Association of Amer-

ica, Inc., and has also been recommended by the Audio Engineering Society to replace the original AES playback curve. The new curve is identical with the Orthophonic curve which RCA Victor adopted in the fall of 1952 and with the recently adopted NARTB transcription curve. It is shown at D in Fig. 1. Comparison with the older LP curves in Fig. 1 shows that at the high end it is midway between the original LP curve (A) and the old AES curve (B). The new curve is also identical at the high end (above 1,000 c.p.s.) with the 75 μ sec pre-emphasis curve used in FM broadcasting. At the low end, a 500-c.p.s. crossover is used together with a 3-db flattening at 50 c.p.s. The original LP curve had greater bass flattening as shown at A in Fig. 1.

At the time that RCA adopted this curve it released 2 suggested equalizing

circuits, shown in Fig. 2. 2-a is a triode circuit and 2-b a pentode circuit.

When designing other circuits the tabulation below may be useful for testing.

NEW RIAA-AES-NARTB-ORTHO PLAYBACK CHARACTERISTIC

Frequency (c.p.s.)	Response (db)
15,000	-17.17
14,000	-16.64
13,000	-15.95
12,000	-15.24
11,000	-14.55
10,000	-13.75
9,000	-12.88
8,000	-11.91
7,000	-10.85
6,000	-9.62
5,000	-8.23
4,000	-6.64
3,000	-4.76
2,000	-2.61
1,000	0
700	+ 1.23
400	+ 3.81
300	+ 5.53
200	+ 8.22
100	+13.11
70	+15.31
50	+16.96
30	+18.61

So far, Columbia, Decca and MGM (in addition to RCA) have indicated that they will use the new curve. Several others use the old AES curve which is within the ± 2 db tolerance of the new curve above 40 cycles. **END**

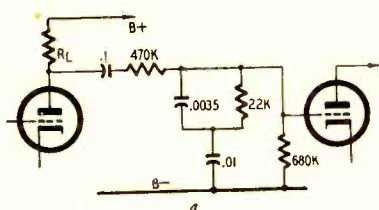

Fig. 2-a—Triode equalizing circuit.

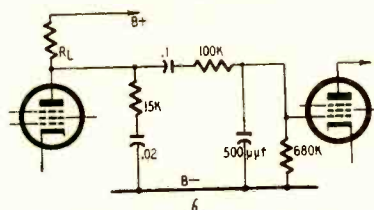

Fig. 2-b—Pentode equalizing circuit.

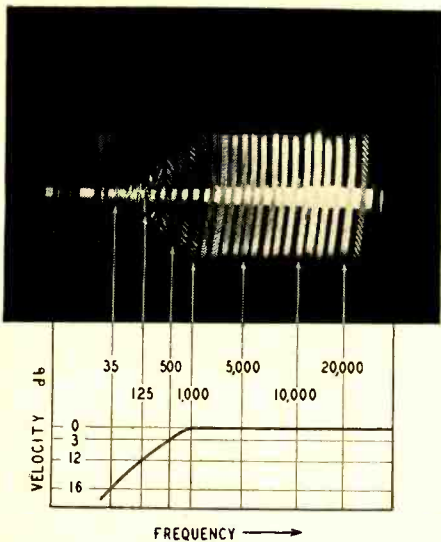

Fig. 1—Pattern of Cook frequency and intermodulation test record, series 10.

AN AUDIO generator can be used to test the preamplifying stages of record playing systems; but the pickup, turntable, etc., can be tested only by using suitable recordings. There is a wide and most useful range of test recordings available.

The comments applying to signal generators apply equally to test records, but relatively few records meet audio generator standards. Most records do not deliver any useful signal material below 50 or above 10,000 cycles. One very conspicuous exception is the Cook Laboratories series 10 (or 10 LP) which covers the range from 30 to 20,000 cycles.

Recording problems require that the low portion of the spectrum be attenuated; the high portion may be boosted. Manufacturers of commercial records provide test records made to the same curves used for their musical recordings. If played back on a properly equalized system they will be adequately flat. The most useful test records, however, for servicing and development work are those recorded with a 6-db slope below 500 cycles and flat above 500 cycles. Such a record permits the running of frequency-response curves of various equalizers with relative simplicity. The resulting curve above 500 cycles can be compared directly with the *playback* curves of various makes of recordings and departures will be quickly spotted. The curve below 500 cycles will need more care in interpretation. But in general, when the test record is played back through an equalizer designed for a given playback curve, the response below 500 cycles will also indicate the degree to which the desired playback curve is reproduced.

The most serious exceptions occur when the turnover point of the desired curve is higher or lower than 500 cycles. In this case the comparison is not direct but will require some interpretation, especially around the crossover region.

For example, if the test record with a 6-db-per-octave slope below 500 cycles is played through an equalizer for European 78-r.p.m. records whose playback curve calls for a crossover of 250–350 cycles, the frequency run will show a rise in response in the region between 250 and 500 cycles instead of giving a nice straight line. However, by plotting both the playback and the recording curves of each of the two types of recordings, we can interpret the degree to which we do or do not duplicate what we want.

The flatness of a test record can easily be determined by examining its light pattern. This should be done when purchasing one. Examine the record under a bright light, tilting it this way and that until the pattern appears. The more closely the sides of the pattern approach straight lines, the flatter the response. Good test records will be flat to 1 db or better and the points at which the recording departs from linearity are plainly evident when examining the light pattern. Fig. 1 is an actual photograph of the pattern of the Cook series 10 test record. Although this record does not vary in response by more than 1 db from the recording curve, the points where it does depart are plainly visible.

It is easier to obtain a smooth wide range at 78 r.p.m. and with needles of large radius (and wide groove spacing) than at 33 r.p.m., with narrow groove spacing and with a needle of small radius. Some microgroove needles may fall off in response above 10 or 12 kc, even though the pickup itself is flat beyond this point. This effect is also produced by a worn needle. Therefore, the measurement of the loss at high frequencies may offer a clue to the condition of the needle. The Cook series 10 records are recorded with a V groove which can accommodate either the large needles used for wide-space 78-r.p.m. and 33-r.p.m. broadcast transcription, or the 1-mil needle used for micro-

grooves. A comparison of the response of the same pickup with the two needles in the same bands of the Cook record will be helpful in determining the condition of the needle.

Measurement of IM distortion is very important and therefore a record which permits testing the IM of a system is valuable. The same Cook record provides, on side 2, 100- and 7,000-cycle tones in the usual 4-to-1 ratio. There are two IM bands; one has an IM distortion level of not over 4% and the other not over 2%—when new, of course. The output of the equipment under test can be fed to the analyzer portion of an IM analyzer and the IM measured. Clarkstan has a special IM test record, the model 101, which is equally good.

Cook Laboratories now offers an extremely simple means of checking IM distortion by ear with their *AN Intermodulation Test* record (series 50). This recording ingeniously applies the N-A system used in radio range-finding, so that when the IM exceeds 2%, there is an audible change in the signal. This is an extremely useful record and might well be included in the tool kit for initial diagnosis and trouble-shooting (see Fig. 2).

The record contains two high-frequency tones which sweep gradually downward, always maintaining a 1,000-cycle difference. If the reproduction were perfect, only the original frequencies would pass through the cartridge and amplifier. However, if cross-modulation distortion is present, the 1,000-cycle difference tone will be heard.

In the form of a repeated dot-dash, a 1,000-cycle 2% distortion signal is recorded on the disc. If this signal is louder than the distortion due to tracking, only the dot-dash (A) will be heard. At frequencies where the cross-modulation distortion of the cartridge and amplifier is louder than 2%, the A will be lost, and an N (dash-dot) will be heard instead.

SERVICING HIGH-FIDELITY EQUIPMENT

*Part IV—Frequency test records;
test instruments for audio work*

By JOSEPH MARSHALL

For rapid frequency runs and the simplest adjustment of tone-control circuits, sweep-frequency records are extremely valuable and time saving. These records sweep the whole range from 50 to 10,000 cycles, and when properly presented to a scope will produce on the screen a pattern showing the over-all frequency response of the system from record to output. Pips indicate various reference frequencies so that departures from a desired curve can be spotted roughly and then examined in detail with normal frequency runs, using steady-state records, or an audio generator. Clarkstan offers a whole series of these, including one with a response to 15,000 cycles, for both 78-r.p.m. and 33-r.p.m. Walsco offers a similar record, No. 726, in its series of inexpensive test records.

Needle wear is a very serious item in high-fidelity reproduction. Serious wear can be spotted with the naked eye and even by feeling with a sensitive finger tip. Moderate wear, sufficient to produce serious distortion and record damage, is sometimes difficult to discern even through a microscope. The simplest test is by the new Audak Stylus-Disc, recorded with special grooves so that needle condition can be determined by the damage the needle causes in clean grooves. A single Stylus-Disc will permit scores of checks and will quickly repay the investment in profits from new needles.

Wow and turntable rumble can be checked quickly with the Walsco 727 and 728 records. They can also be checked with IM test records since an excess of either will greatly increase the IM distortion.

Tests of transient response—which

are really tests of the damping of a system—are valuable diagnostic tools. It is difficult to find acceptable sources and standards of transients, especially for use with phono systems. The Cook series 20 White Noise record offers such a signal and can be most useful. Thermal noise is nothing but transients and covers the entire audible band and more. The Cook record presents a carefully proportioned series of thermal noises in switch bands, in which the high-frequency and low-frequency components of the noise are progressively filtered out. By comparing the sound of the noise output of a system as the record goes through these switch bands, we obtain a quick idea of the transient response and transient cut offs of the system. The record is useful for listening tests and can also be used for more subtle diagnosis with a scope. With experience and skill, it is possible to estimate not only transient response but also bandwidth, distortion, hang-over or ringing, and even pickup tracking.¹

Oscilloscope

Oscilloscopes first proved their value in audio work and it is to them we owe most of what we know today about audio waveforms and the behavior of such waves in amplifiers. The oscilloscope is an indispensable diagnostic tool and furnishes an indicator for some most important types of measurement; it can make possible extremely rapid and highly convenient testing routines.

For high-fidelity servicing a scope needs some qualities not necessary for TV, or radio work. Most of today's

¹See "White Noise Testing Methods," by Emory Cook. *Audio Engineering*, March, 1950.

scopes have more than adequate response at the high-frequency end, but not all are adequate in low-frequency response. We are rapidly improving our ability to record, transmit, and reproduce the lowest octave of sound from 16 cycles up. Also, the behavior of a system at these low frequencies affects the behavior of the whole system—especially from the point of view of distortion—more than any other portion of the spectrum. This is partly because these low-frequency components are of high amplitude and are usually boosted in amplifiers to make up for attenuation in transmission or deficiencies in loudspeakers. The result all too often is that the system is first overloaded in this region. Since a high-fidelity system is very flat above this region, any distortion produced there is passed easily to the output, whereas distortion at high frequencies may not be audible at all because the response, at least of speakers, slopes rapidly beyond 12 or 15 kc. Finally, when these low frequencies occur in music, the resultant waveform most nearly resembles a square wave, and it is in this region therefore that square-wave testing is most significant.

Obviously if the scope itself does not have good behavior with low-frequency square waves, it is going to be much more difficult to use square-wave testing methods. So it is necessary that the scope be able to pass at least a 60-cycle square wave, and preferably a 20-cycle square wave, without significant deformation. Direct-coupled amplifiers are therefore very much worthwhile in a scope which is to be used for high-fidelity work. There are a number of such scopes, although they are expensive. Good scopes are available in kit form, at considerably lower cost.

The high-frequency response is less of a problem since most modern scopes are flat at least to 500 kc. The distortion level of the scope should be very low, and for this reason a scope with push-pull amplifiers is preferable. High sensitivity is also very important. Often, serious trouble occurs in low-level stages, and to trace it a scope should be able to give an acceptable

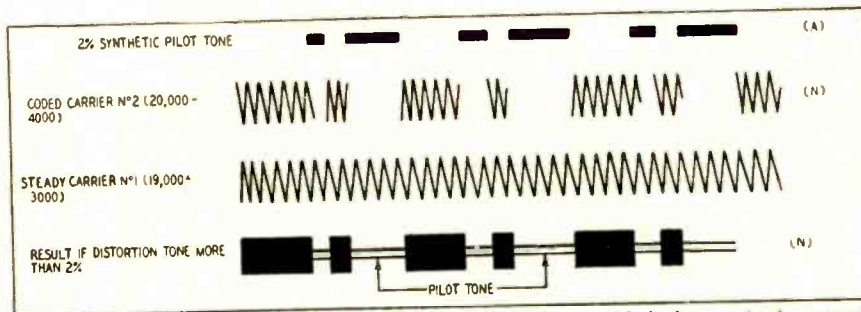

Fig. 2—Diagram shows principle of Cook series 50 N-A beam test record.



Left—The Eico model 425 oscilloscope. Above—The Heath intermodulation analyzer. Right—RCP model 655 vacuum-tube voltmeter.



trace with input levels at least as low as 100 mv and preferably 10 mv. Other audio indicators are usually calibrated in r.m.s. volts and measure the effective value of the signal. A scope can indicate and measure the peak-to-peak value, and therefore a means of calibrating the scope for peak-to-peak reading in volts is very helpful.

A little item which is also very helpful is a reticule (grid) marked off in a square, over the scope tube face. Used with the phase-shift method which we shall discuss in the next article, this square offers a convenient and accurate means of observing and interpreting the behavior of the signal as it goes through an amplifier.

It is also desirable that a scope permit push-pull as well as single-ended input. A large part of the quality of high-fidelity equipment is due to the use of push-pull configuration in output and driver stages. Some equipment, like the Golden Ear, Powertron, etc., may be push-pull for several stages. The ability to observe the push-pull behavior of such equipment is very helpful.

If a scope is to be purchased for combination audio-TV-radio use, the special qualities needed for high-fidelity measurement should always be kept in mind.

A.c. vacuum-tube voltmeter

As I pointed out in discussing scopes, it is desirable to measure the signal in low-level stages. On rare occasions, it may be desirable to have an instrument that will read voltages as low as 10 mv. Lacking such an instrument, you can use the scope with a linear grid over the face of the C-R tube, with an oscilloscope calibrator.

A general-purpose v.t.v.m. with a low range of 3 volts (preferably 1) will be suitable for tracing and measuring a.c. voltages in most amplifiers. Most have a.c. input impedances ranging from 200,000 to 500,000 ohms. If you need a v.t.v.m. for general-purpose a.c., d.c., and r.f. measurements, you might consider one of the several models having an a.c. input impedance of about 2.5 megohms.

If you plan to do a large volume of audio servicing, you may need one of the amplifier-rectifier type of audio vacuum-tube voltmeters, with a full-scale deflection of around .01 volt on the lowest range.

I find mine all but indispensable. The lowest scale is .01 volt, but good readings can be made down to 100 microvolts; even the output of many microphones can be measured directly with it. The accuracy and linearity, though not up to laboratory standards, is more than good enough for service work. The instrument is flat from 20 to 50,000 cycles, which is adequate for most needs. The regular shop v.t.v.m. can be used to measure output—if a wattmeter is not available or can't be afforded—while the a.c. v.t.v.m. monitors the generator output and measures voltages and gain, stage by stage.

Audio wattmeter

The power output of audio equipment can be calculated by measuring the voltage drop across a specified load resistance and using Ohm's law. This is a clumsy and time-consuming operation, and an audio wattmeter, such as the Heath AW-1, is very convenient. The instrument makes possible direct reading of power output from 5 milliwatts to 50 watts across normal loads. The loads are provided by the instrument itself and meter multipliers are switched simultaneously so that no translation of any sort is necessary. It is flat from 10 to 250,000 cycles and its accuracy is well within permissible limits for production testing and servicing.

As I already pointed out, power output measurement is a helpful step in diagnosing troubles and adjusting power amplifiers. One of the wattmeter's most practical jobs is that of indicating the improvement made by a change in tubes. It can pay for itself very quickly in this way.

The most significant rating of commercial high-fidelity equipment is in terms of IM distortion at various output levels. The quickest way to check amplifier performance is to check the IM level at maximum rated output. This should be a routine shop procedure at the conclusion of repairs and adjustment and will save much time and argument. After all, a service technician is not expected to do more than restore the equipment to its original specifications. No customer can gripe when shown by measurement that the equipment is as good as new. Of course, not all manufacturers are, shall we say, conservative in their rating and it sometimes happens that the equipment will not meet the IM specs even when brand-new. Obviously, if the shop also handles the sale of high-fidelity equipment, the above check is a prudent test of whether the manufacturer is meeting his specifications.

It is also significant to know just how much the frequency response varies with the output level. A frequency run at maximum rated output, as well as one at normal output, can be very instructive. So, although perhaps less essential than the other instruments discussed, the wattmeter is often very useful.

Intermodulation analyzer

Rivaling both the scope and generator in usefulness, and perhaps even more important in diagnosing and restoring a high-fidelity system to proper operation, is the IM analyzer. Aside from outright inoperation, caused by a tube or component failure, a large percentage of complaints will involve higher-than-normal distortion. Distortion is not too easy to trace. To make matters worse, high-fidelity addicts are likely to be hypercritical. A means of checking distortion is therefore almost absolutely essential.

An IM analyzer provides a 60-cycle

low frequency and a choice of either 3,000- or 7,000-cycle high frequency. The ratio can be set for any figure between 1-1 and 10-1; including of course the standard 4-1. The IM of the instrument itself is—at least in my own instrument—in the order of 0.2%. Fractional levels can be read easily and without much error. The range of IM readings ranges from this fraction to 30%. The accuracy is well within the needs of production and general servicing work.

The IM analyzer works thus: The mixed 60-cycle and 3,000-cycle (or 7,000-cycle) signal is fed to the input of the equipment under test. The output of the equipment is fed to the analyzer section. Here it passes through a 2-stage amplifier which also acts as a high-pass filter and eliminates (for all practical purposes) the 60-cycle component. The remaining signal, now consisting of the high-frequency tone plus the intermodulation, is passed into an infinite impedance detector which demodulates it. The 3,000-cycle component is eliminated in the low-pass filter which follows, and the IM products only are fed to a v.t.v.m. which measures them and reads directly in terms of percent IM.

The entire operation is very simple and fast, and can be performed by almost anyone. The analyzer portion can be used with other signal sources, as for instance IM test records—the filters of the analyzer section being completely suited to the frequencies used on such records.

The signal output of the analyzer can also be used for signal tracing. The device has no means for turning off either the high-frequency or low-frequency generators; so the output will always be a mixed signal. This, however, is by no means a disadvantage. On the contrary, if the 60- and 7,000-cycle tones be used, we have a tracing signal which gives some indication of both the low- and the high-frequency response as well as distortion. Finally, the voltmeter itself is available for measuring audio frequencies in three ranges, 0-3, 0-10, 0-30 volts full scale. So the instrument is by no means a special-purpose tool but extremely versatile and a nearly ideal single diagnostic tool.

The IM analyzer portion is very sensitive. An input of only 50 mv is sufficient to permit accurate IM measurement. The instrument can be used at the output of an initial amplifier stage, even the phono preamp; and it might, with a suitable test record, be used directly at the output of a Pickering pickup. In tracing distortion, the analyzer input can be moved from stage to stage, beginning with the first one. This is an extremely helpful means of diagnosis.

The next part of the series will discuss actual measurement and testing, with special attention to routines which have proved to be fast in diagnosing equipment faults.

(TO BE CONTINUED)



**TRAIN FASTER—TRAIN BETTER—TRAIN EASIER
IN 10 MONTHS—OR LESS—FOR
RADIO-TELEVISION**

Our 21st Year Training Men for Greater Incomes and Security in Radio-Television

**I SEND YOU
18 BIG KITS**

of Radio-Television parts and equipment. Much of your training will be actual construction and experimentation... the kind of truly PRACTICAL instruction that prepares you for your Radio-Television career.



Frank L. Sprayberry
President
Sprayberry Academy
of Radio

NEW! NO OBLIGATION PLAN

**You Have No Monthly Payment Contract to Sign
Pay For Your Training as You Earn and Learn**

You can get into Radio-Television, today's fastest growing big money opportunity field, in months instead of years! My completely new "package unit" training plan prepares you in as little as 10 months or even less! No monthly payment contract to sign—thus NO RISK to you! This is America's finest, most complete, practical training—gets you ready to handle any practical job in the booming Radio-Television industry. Start your own profitable Radio-Television shop... or accept a good paying job. I have trained hundreds of successful Radio-Television technicians during the past 21 years—and stand ready to train you, even if you have no previous experience! Mail coupon and get all the facts—FREE!



**Valuable Equipment Included
With Training**

The new Sprayberry "package" plan includes many big kits of genuine, professional Radio-Television equipment. You perform over 300 demonstrations, experiments and construction projects. You build a powerful 6-tube 2-band radio set, multi-range test meter, signal generator, signal tracer, many other projects. All equipment and lessons are yours to keep... you have practically everything you need to set up your own profitable Radio-Television service shop.

Earn Extra Money While You Learn!

All your 10 months of training is IN YOUR HOME in spare hours. Keep on with your present job and income while learning. With each training "package" unit, you receive extra plans and "Business Builder" ideas for spare time Radio-Television jobs. New television stations everywhere, open vast new opportunities for trained Radio-Television Technicians—and those in training. If you expect to be in the armed forces later, there is no better preparation than practical Sprayberry Radio-Television training.

YOU BUILD the Television set and the powerful emergency radio receiver shown above. IN ADDITION to the other test units shown here many are not shown because of lack of space. ALL equipment I send you is YOURS TO KEEP.

SPRAYBERRY ACADEMY OF RADIO

**111 NORTH CANAL ST.
Dept. 20-J, Chicago 6, Ill.**

**MAIL COUPON
TODAY!
NO OBLIGATION**

**SPRAYBERRY ACADEMY OF RADIO, Dept. 20-J
111 North Canal St., Chicago 6, Ill.**

Please rush to me all information on your 10-MONTH Radio-Television Training Plan. I understand this does not obligate me and that no salesman will call upon me. Be sure to include 3 books FREE.

Name..... Age.....

Address.....

City..... Zone..... State.....

I invite you to get all the facts—
**FREE TO YOU 3 BIG
RADIO-TELEVISION BOOKS**

I want you to have ALL the facts about my new 10-MONTH Radio-Television Training—without cost! Rush coupon for my three big Radio-Television books: "How to Make Money in Radio-Television," PLUS my new illustrated Television Bulletin PLUS an actual sample Sprayberry Lesson—ALL FREE. No obligation and no salesman will call. Mail coupon NOW!



R-J TYPE 12" SPEAKER ENCLOSURE

Get maximum bass in minimum space with a 12-inch speaker and a R-J type enclosure

By J. W. KORTE



Photo of a combination cabinet with the 12-inch R-J type speaker enclosure.

MANY audio enthusiasts would like to have good bass response from their living-room radio-phonos. A large bass-reflex cabinet will do the job but it is usually too bulky for the smaller home of today. I tried to improve my open-backed radio-phono cabinet by incorporating various labyrinths, columns between the wall and cabinet, reflexes, and infinite baffles. Invariably the insufficient volume caused either high bass-frequency resonances with vented enclosures, or excessive speaker damping and loss of bass response with closed enclosures.

Finally an R-J type enclosure was tried with almost unbelievable results. I found that the free-air resonance of a 12-inch speaker could be lowered from about 70 to 55 cycles by slotting the corrugated suspension edges of the cone radially at about one-inch intervals. Good speaker-to-air coupling in the R-J type enclosure permits this speaker modification which could not be used with an open-back cabinet, for instance. This same speaker has a new resonance of about 45 cycles in the enclosure, and does a good job down to 35 cycles with a 10-watt push-pull 6B4 amplifier. Resonance may be easily checked by

(Continued on page 73)

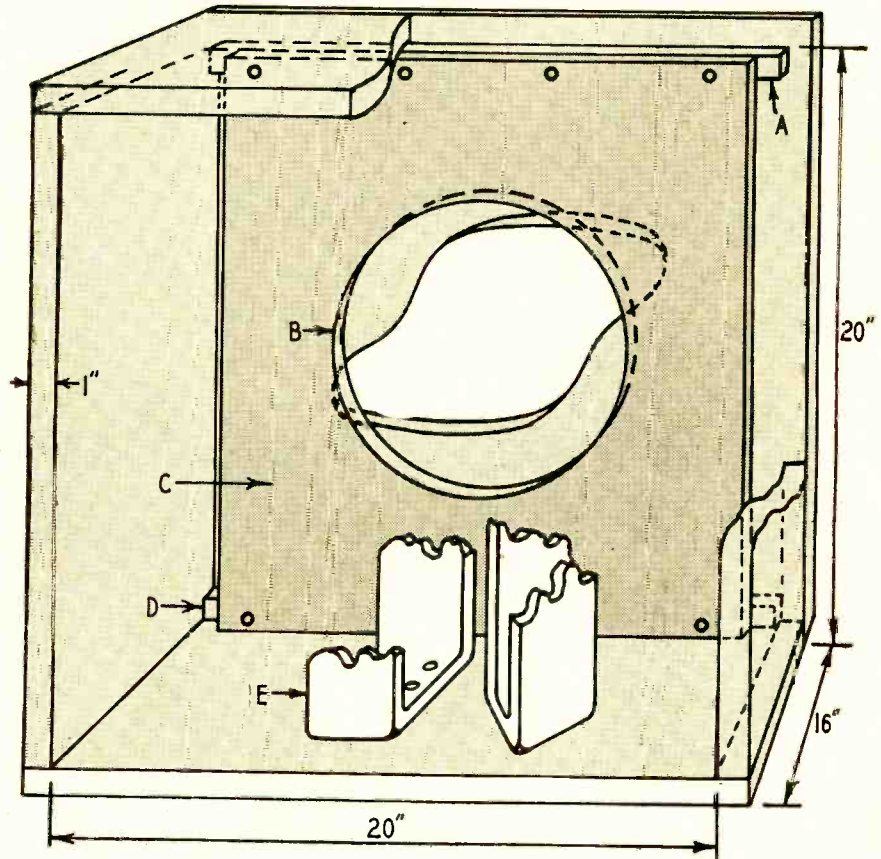
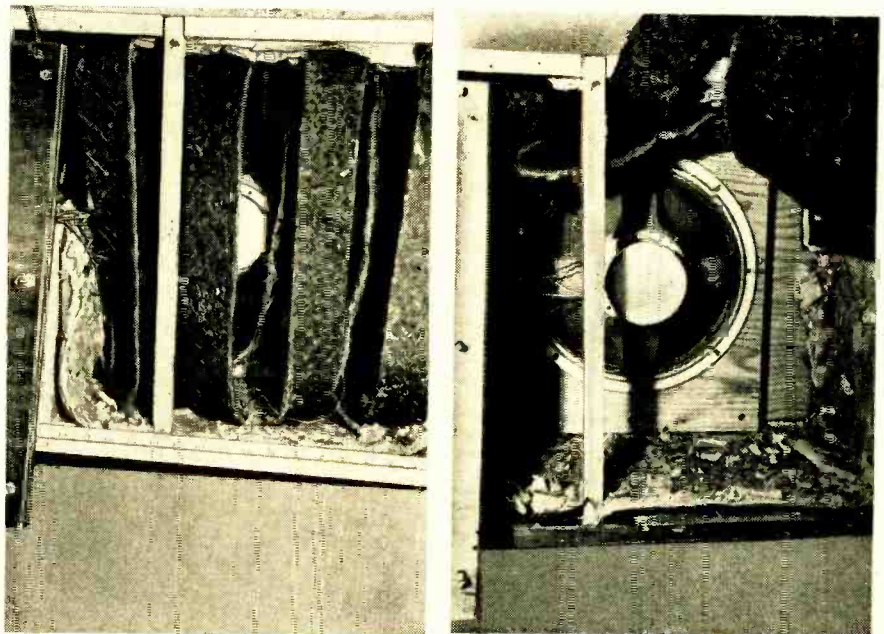

Fig. 1—Construction details of an R-J type enclosure for 12-inch loudspeakers.



Rear-view photos with the airtight back removed to show insides. Left-hand photo shows the normal position of the Ozite strips. The right-hand photo has the strips pushed aside to show how the speaker mounting board is positioned.

BUILD YOUR OWN

Heathkits

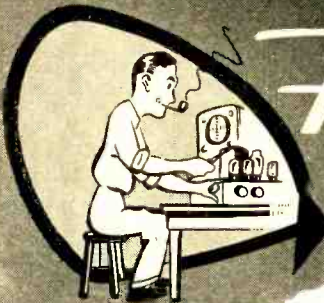

- TEST INSTRUMENTS
- AMPLIFIERS
- RECEIVERS, etc.

- ① Save by ordering direct from manufacturer.
- ② All high quality standard brand components.
- ③ Increased knowledge through actual construction.
- ④ Sound engineering insures excellent performance.
- ⑤ Kit construction is fascinating and enjoyable.



Heathkit MODEL O-9 OSCILLOSCOPE KIT

MODEL O-9

\$59⁵⁰

Shipping
Wt. 28 lbs.

New features unheard of in a kit oscilloscope have been added to the already popular Heathkit series. All top quality components are used including a brand new RCA 5U1 CRT. Ten other first line tubes complete the lineup. Voltage regulation provides a rock steady pattern regardless of normal line voltage variations. A built-in blanking amplifier eliminates the retrace line entirely. Other important advantages are a phasing control, Z axis input, direct connections to the deflection plates, 1 volt peak-to-peak calibration voltage and a calibrated grid screen.

Wiring is simplified by the use of the harness technique which also results in a neat professional appearance. Extremely wide vertical bandwidth allows accurate reproduction of even a 500 KC square wave. Excellent focusing characteristics are made possible by the use of the new RCA 5U1 CRT and a spot shape control. One of the most versatile of test instruments, the Heathkit O-9 Oscilloscope will be invaluable in the radio and TV service shop, as a work project in schools and for all types of circuit investigation work in the laboratory. Its new features make Model O-9 comparable in every way to many commercially built oscilloscopes selling for as much as \$400. Don't pass up this opportunity to add a really fine instrument to your service or experimental lab.

Heathkit VOLTAGE CALIBRATOR KIT

The use of a Voltage Calibrator will greatly increase oscilloscope usefulness. Provides a convenient method of making peak to peak voltage measurements by establishing a relationship between the unknown wave shape and the Voltage Calibrator. Voltage ranges .01-100 volts peak to peak. The Voltage Calibrator features direct reading scales and a regulated power supply system.



MODEL VC-2

\$11⁵⁰

Shipping Wt. 4 lbs.

Heathkit ELECTRONIC SWITCH KIT

The Heathkit Electronic Switch Kit will further extend scope usefulness by permitting simultaneous observation of two individually controlled traces. Continuously variable switching rates 10 cps to 2,000 cps in three ranges. Will also serve as a square wave generator over the range of switching frequencies.



MODEL S-2

\$23⁵⁰

Shipping
Wt. 11 lbs.

Heathkit VACUUM TUBE VOLTMETER KIT

The beautiful new 1953 Heathkit Model V-6 VTVM, the world's most popular kit instrument, now offers many outstanding new features in addition to retaining all of the refinements developed and proven through the production of over 70,000 VTVM kits. The Heathkit VTVM now features extended voltage ranges with 50% greater coverage on the DC range. New 1 1/2 volt low scale provides well over 2 1/2 inches of scale length per volt permitting faster measurements with greater accuracy. AC and DC ranges are 0-1.5-5-15-50-150-500-1500 volts (1,000 volts maximum on AC). Ohmmeter ranges are X1, X10, X100, X1,000, X10K, X100K X1 meg. Measures .1 ohm to 1,000 megohms. Other features are db scale, center scale zero adjust and polarity reversal switch. High 11 megohm input resistance virtually eliminates circuit loading.

The low anti-inflation price of this tremendously popular kit includes all tubes, necessary constructional material, test leads and the construction manual.



MODEL V-6

\$24⁵⁰

Shipping
Wt. 6 lbs.



Heathkit AC VACUUM TUBE VOLTMETER KIT



MODEL AV-2

\$29⁵⁰

Shipping
Wt. 5 lbs.

A new amplifier type AC VTVM that makes possible those sensitive measurements so essential in laboratory or audio work. Ten voltage ranges covering from .01 RMS full scale to 300 volts RMS full scale. Input impedance 1 megohm with frequency response 20-50,000 cycles. Ten DB ranges from -52 to +52 DB. Four diodes in meter bridge circuit for maximum linearity.

Heathkit HANDITESTER KIT



MODEL M-1

\$14⁵⁰

Shipping
Wt. 3 lbs.

The ever popular Handitester is now supplied with a Simpson 400 microampere meter movement. Provides AC and DC voltage ranges 0-10-30-300-1,000-5,000 volts. Ohmmeter ranges 0-3,000 and 0-300,000 ohms. DC current measurements 0-10 and 0-100 milliamperes. A completely self contained portable instrument.

HEATH COMPANY • Benton Harbor 20, Mich.

HEATHKITS for the ENGINEER

Heathkit VISUAL AURAL SIGNAL TRACER KIT

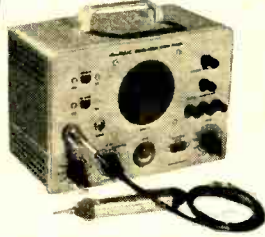

MODEL T-3 \$23⁵⁰

Shipping
Wt. 10 lbs.

Designed especially for service applications in AM-SW-FM-TV repair work. RF and audio two channel input. More than adequate sensitivity—new noise locator circuit—calibrated wattmeter—substitution speaker—visual signal indication. Can be used with scope and VTVM, checks phono cartridges, phono mechanisms, microphones, tuners, etc. Let the Heathkit Visual Aural Signal Tracer help you.

Heathkit RESISTANCE SUBSTITUTION BOX KIT

MODEL RS-1

Ship. Wt. \$5⁵⁰
2 lbs.



Choice of 36 switch selected resistance values 15 ohms to 10 megohms. All standard RTMA 1 watt 10% resistors. Buy several for those lab and service applications.

NEW Heathkit 20,000 OHMS PER VOLT MULTIMETER KIT

Here is the solution to all service problems requiring a portable measuring device of high accuracy. 20,000 ohms/volt sensitivity on DC and 5000 ohms/volt on AC. Full scale voltage ranges of 1.5, 5, 50, 150, 500, 1500 and 5000. DC current ranges of 150 microamperes; 15, 150 and 500 milliamperes; and 15 amperes. Resistances are measured from .2 ohms to 20 megohms in 3 ranges and decibels from -10 to +65 db.

Model MM-1 uses standard commercially available batteries and is not affected by strong RF fields as encountered in and near transmitting equipment. 1% precision resistors on a very easily wired ring type range switch and a highly accurate Simpson 50 microampere meter fully qualifies the Heathkit Multimeter for close tolerance laboratory and service work. The meter movement is placed in a recessed position for maximum non-glare readability. The kit includes the attractive black bakelite cabinet, 2 color meter scales, test leads, batteries and all other necessary components. Overall cabinet size is 5 1/4" wide x 4" deep x 7 1/4" high.



MODEL MM-1

\$26⁵⁰

Ship. Wt. 6 lbs.

Heathkit CONDENSER CHECKER KIT

An instrument designed solely for its particular job. Not a "sideline" or a multiple function instrument. Measures value and quality of unknown condensers and resistors. Capacity range .00001 mfd to 1,000 mfd. Resistance range 100 ohms to 5 megohms. Sensitive electron beam indicator—five polarizing test voltages—safety spring return leakage test switch. An amazingly accurate instrument at this low price.



MODEL C-3
\$19⁵⁰ Shipping
Wt. 8 lbs.

Heathkit SIGNAL GENERATOR KIT

MODEL SG-8

\$19⁵⁰

Ship. Wt. 8 lbs.



The standard service instrument for alignment work. .1 volts output from 160 KC to 110 MC. Calibrated harmonics up to 220 MC. Internal (400 CPS) and external modulation. Pre-calibrated coils for all 5 bands. Good stability and accuracy. All test leads included.

Heathkit GRID DIP METER KIT

One hand operation. 5 pre-wound coils cover 2—250 MC. Controlled sensitivity. Usable as an oscillator or an absorption wavemeter. Extra low frequency coils available.



MODEL GD-1B
\$19⁵⁰
Ship. Wt. 4 lbs.

Heathkit TUBE CHECKER KIT

Checks overall tube quality, filament continuity, and individual elements for shorts and opens. Features chart illumination, harness type wiring, and large 3-color meter scale.



MODEL TC-2
\$29⁵⁰
Shipping Wt. 12 lbs.

Portable Model TC-2P at \$34.50. Wt. 14 lbs. No. 91-8 Cabinet only at \$7.50. Wt. 7 lbs. No. 355 TV Picture Tube Adapter at \$4.50. Wt. 1 lb.

Heathkit LABORATORY GENERATOR KIT



MODEL LG-1
Ship. Wt. \$39⁵⁰
16 lbs.

A professional laboratory instrument designed for extreme accuracy in frequency and output level. Colpitts oscillator operates in 5 ranges from 150 KC to 30 MC. Panel meter calibrated in output voltage and percent of modulation. Output in excess of .1 volts. Features complete shielding of oscillator, buffer and attenuator sections; regulated power supply and 50 ohm output cable. Comparable instruments priced many times higher than the cost of this new kit.

Heathkit LABORATORY REGULATED POWER SUPPLY KIT



MODEL PS-2
\$33⁵⁰

Ship. Wt. 20 lbs.

A regulated variable 160-450 volt DC output power supply for the lab or service shop. Accurate voltage and current measurements with large Simpson meter. AC supply 6.3 volts at 4 amperes—standby switch eliminates warmup time. Low hum content—5 tube circuit. AC and DC output voltages isolated from panel for maximum operational flexibility.

Heathkit AUDIO WATTMETER KIT



MODEL AW-1
Ship. Wt. \$29⁵⁰
6 lbs.

Measure output power levels directly with the Heathkit Audio Wattmeter. Flat response to frequencies from 10 CPS to 250 K.C. Full scale ranges of 5 MW, 50 MW, 500 MW, 5 W and 50 W. Db calibration from -10 to +48. Uses non-inductive built-in load resistors providing impedances of 4, 8, 16 and 600 ohms. Meter bridge uses 4 germanium diodes.

HEATH COMPANY • Benton Harbor, Mich. 48007

SERVICEMAN • AMATEUR • STUDENT

Heathkit IMPEDANCE BRIDGE KIT



MODEL IB-2
\$59⁵⁰

Ship. Wt. 15 lbs.

Modern design with built-in 1 KC generator for AC measurements. A choice of the Wheatstone, Maxwell, Hay or capacitance comparison bridges for measuring resistance, capacitance, inductance, dissipation factor and storage factor. 1/2% resistors and precision mica condensers provide maximum accuracy. Completely AC operated.

Heathkit COMMUNICATIONS RECEIVER KIT



MODEL AR-2
\$25⁵⁰
Ship. Wt. 12 lbs.
(Less Cabinet)

Full coverage from 550 KC to 35 MC on 4 bands, with good sensitivity and selectivity. Features electrical bandspread, BFO, headphone jack, slide rule dial with ham band identification, RF gain control, noise limiter and phone-standby-CW switch. Top quality, high gain components used throughout. Pre-wound coils in a shielded turret assembly and a transformer operated power supply assure trouble-free performance.

Cabinet available separately. No. 91-10. Shipping wt. 5 lbs. Price \$4.50.

Heathkit AUDIO OSCILLATOR KIT

MODEL AO-1
\$24⁵⁰
Ship. Wt. 11 lbs.



Features sine or square wave coverage from 20-20,000 cycles in 3 ranges. Variable 10 volt output level at 600 ohms impedance. Thermistor controlled linearity—precision multiplier resistors—distortion less than .6%. An outstanding instrument value at this amazing low price.

Heathkit DECADE RESISTANCE KIT



MODEL DR-1
\$19⁵⁰

Ship. Wt. 4 lbs.

Individual switch selection of twenty 1% precision resistors in 1 ohm steps from 1 to 99,999 ohms. Sturdy ceramic wafer switches featuring silver plated contacts and smooth, positive detent action.

Heathkit Q METER KIT

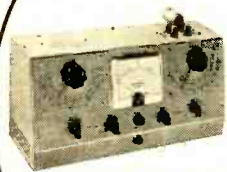

MODEL QM-1
\$44⁵⁰ Ship. Wt. 14 lbs.

A typical Heathkit invasion of the laboratory instrument field. Here is the first successful low priced Q meter ever offered in kit form. Oscillator supplies RF in the range of 150 KC to 18 mc. Reads Q directly on calibrated meter scales. Measures Q of condensers, RF resistance and distributed capacity of coils. Calibrate capacitor with range of 40 mmf to 450 mmf with vernier ±3 mmf. All measurements made at the operating frequency.

Heathkit AMATEUR TRANSMITTER KIT



MODEL AT-1
\$29⁵⁰

Ship. Wt. 16 lbs.

Power input up to 35 watts on 80, 40, 20, 15, 11 and 10 meters. Can be crystal or VFO excited. Complete with modulator input socket and VFO power output provisions. Other desirable features are good shielding, AC line filter, key click filter, standby switch and a 52 ohm coaxial output. Model AT-1 is AC operated and is suitable as an exciter for a higher powered rig. Complete with full instructions for construction and use.

Heathkit TELEVISION SWEEP

Heathkit DECADE CONDENSER KIT

Switch selected 1% silver mica precision condensers

Heathkit AUDIO GENERATOR KIT

A new extended range 18 cycles — 1 megacycle — dip instru-



Heathkit FM TUNER KIT

MODEL FM-2

\$22.50

Shipping Wt. 9 lbs.

Sensitive transformer operated 8 tube circuit. Frequency coverage 88-108 mc. Pre-assembled and tuned "front end." Vernier tuning with slide rule type dial.

NEW Heathkit BROADCAST BAND RECEIVER KIT

MODEL BR-2

\$17.50(Less Cabinet)
Ship. Wt. 11 lbs.

Complete receiver with chassis mounted 5 1/4" PM Speaker and new rod type antenna. Covers the full broadcast band (550 KC-1600 KC) with excellent sensitivity and selectivity. Operates as a receiver, tuner or a phono amplifier. High gain miniature tubes and IP transformers. Easy tuning with direct plane-tary drive.

Cabinet available separately. Part No. 91-9. Ship. wt. 5 lbs. Price \$4.50.



The famous Heathkit Williamson Type Amplifier is now available in a single chassis. Includes power supply and power amplifier. Enjoy the same high quality reproduction at less cost by eliminating the second chassis, connecting cables, etc. Size 15 1/4" wide—7" high—9" deep.

Model W-4 includes W-4M and preamplifier WA-P2. Shipping weight 35 lbs. Price \$59.50.

NEW HEATHKIT WILLIAMSON TYPE AMPLIFIER KIT

The ideal amplifier for custom high fidelity audio installations. Tops in performance, value and flexibility of operation. Either Altec Lansing Peerless or Acrosound output transformers available. Frequency response ± 1 db 10 CPS to 100 KC, negligible hum and noise levels and plenty of reserve power for complete listening pleasure. First Williamson Type Amplifier supplied with matching preamplifier.

PRICES OF VARIOUS COMBINATIONS:

W-2 Amplifier Kit (Includes Main Amplifier with Peerless Output Transformer, Power Supply and WA-P2 Preamplifier.) Shipping weight 38 lbs. Shipped express only **\$69.50**

W-2M Amplifier Kit (Includes Main Amplifier with Peerless Output Transformer and Power Supply.) Shipping weight 30 lbs. Shipped express only..... **\$49.75**

W-3 Amplifier Kit (Includes Main Amplifier with Acrosound Output Transformer, Power Supply and WA-P2 Preamplifier.) Shipping weight 38 lbs. Shipped express only **\$69.50**

W-3M Amplifier Kit (Includes Main Amplifier with Acrosound Output Transformer and Power Supply.) Shipping weight 30 lbs. Shipped express only..... **\$49.75**

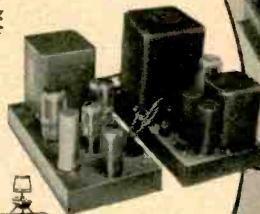

Heathkit LOW PRICED Single UNIT WILLIAMSON TYPE AMPLIFIER KIT

MODEL W-4M

\$39.75

Ship. Wt. 28 lbs.

HEATHKIT HIGH FIDELITY PREAMPLIFIER KIT

MODEL WA-P2

\$19.75

Ship. Wt. 7 lbs.



Complete compensation for LP, NARTB, AES and early 78 recording characteristics. An ideal control unit for the custom Hi-Fi system. 5 individually controlled inputs, 4 turnover and roll-off switch positions, 3 twin triode tubes, cathode follower output, monitored recorder output, shock mounted tube chassis and proper shielding. All condensers are of the molded plastic type. Critical input circuits feature low noise deposited carbon resistors. Use it with any conventional high fidelity amplifier.

Heathkit ECONOMY 6 WATT AMPLIFIER KIT

MODEL A-7B

\$15.50

Ship. Wt. 10 lbs.



Dual inputs—separate bass and treble tone controls—output impedances of 4, 8, and 15 ohms. Performance far beyond that normally expected for the price.

A-7C: Includes preamplifier for low level input devices. Price \$17.50

Heathkit HIGH FIDELITY 20 WATT AMPLIFIER KIT

MODEL A-9B

\$35.50Shipping
Wt. 23 lbs.

Outstanding features of the Heathkit 20 Watt Amplifier include a frequency response of ± 1 db from 20 CPS to 20 KC, less than 1% harmonic distortion at rated output, separate (boost and cut) bass and treble tone controls, 4 selected input jacks, hum balancing control and output impedances of 4, 8, 16 and 500 ohms. Flexibility is emphasized in the input circuits with built-in preamplifier and proper equalization.

GENERATOR KIT

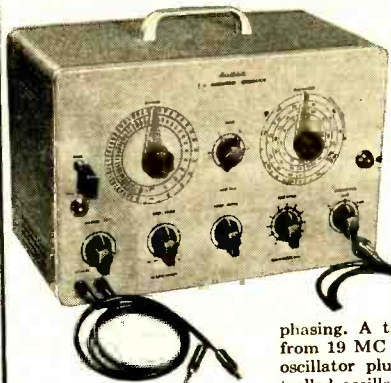

MODEL TS-3

\$44⁵⁰

Ship. Wt. 18 lbs.

Simplify your TV alignment jobs with the new Heathkit TS-3. Full coverage on fundamentals from 4 MC to 220 MC at an output of well over 100,000 microvolts . . . Automatic blanking and wide range

phasing. A triple marker system ranges from 19 MC to 180 MC using a Colpitts oscillator plus the 4.5 MC crystal controlled oscillator for check points (crystal

furnished). Provisions are also made for using an external marker.

Featured is the new sweep system, using an *INCREDUCTOR controllable inductor. Sweep width is variable from 0 to 12 MC at the lower RF frequencies and increases to 0-50 MC at the highest . . . Other advantages are power supply regulation, constant RF output level, independent marker and RF output control circuits, low impedance output and properly terminated output cables. The construction manual is complete in all detail and with a reasonable amount of care, Model TS-3 will serve faithfully for many years to come.

**Trademark, C.G.S. Laboratories,
Stamford, Connecticut*

providing capacity range of 100 mmf. to 0.111 mfd. in steps of 100 mmf.

MODEL DC-1

\$16⁵⁰

Shipping Wt. 4 lbs.



ment at a remarkably low price. Five continuously variable output ranges—600 ohm output impedance—low distortion figure, less than .4% from 100 cps through audible range.



MODEL AG-8

\$29⁵⁰

Ship. Wt. 11 lbs.

Heathkit

BAR GENERATOR KIT



Small, compact and easy to use, Model BG-1 supplies horizontal or vertical bars for TV linearity adjustments. Output cable clips directly to the TV receiver antenna terminals.

MODEL BG-1

Ship. Wt. **\$14⁵⁰**
6 lbs.

Heathkit

BATTERY ELIMINATOR KIT

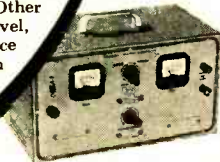

MODEL BE-4

Ship. Wt. **\$31⁵⁰**
18 lbs.

6 or 12 volt operation with current and voltage constantly monitored. Double protection with a fused transformer and automatic overload relay. Well filtered output and all heavy duty components. Designed for auto radio repair and as a storage battery charger.

WRITE FOR *Free*
CATALOG

New 40 page 1954 Catalog lists all kits, specifications, schematics and latest price information.

HEATH COMPANY • Benton Harbor 20, Mich.

MAY, 1954

Benton Harbor 20, Mich.

ORDER BLANK



MAIL YOUR ORDER
TODAY TO THE
HEATH COMPANY
BENTON HARBOR 20,
MICHIGAN

From _____

SHIP VIA

- Parcel Post
- Express
- Freight
- Best Way

QUANTITY	ITEM	(PLEASE PRINT)	MODEL NO.	PRICE

Enclosed find () check () money order for
Please ship C.O.D. () postage enclosed for _____ pounds.

On Express orders do not include transportation charges—they will be collected by
the express agency at time of delivery.

ON PARCEL POST ORDERS insure postage for weight shown.

ORDERS FROM CANADA and APO's must include full remittance.

RADIO-ELECTRONICS

(Continued from page 68)

adding a resistance in series with the speaker voice coil to decrease electrical damping and measuring voice-coil voltages at various frequencies, higher voltages indicating resonances.

Take care when slotting the cone suspension so that rattle and distortion are not added from excess flexibility. Most of the commercial speakers are quite stiff because they must be suitable for nearly any type baffle. An example of the slotted edges can be seen in the Permoflux line of speakers.

Figs. 1 and 2 may be used generally so that the enclosure can be built into practically any shape as long as the enclosed volume is 4,500 cubic inches. It should be constructed of 3/4-inch or heavier plywood with an airtight back and a lining of 1-inch sound absorbent on all inside surfaces except the front and speaker baffle panels. A 1/2 x 3-inch strip of Ozite or equivalent is looped from top to bottom to fill the inside volume of the box with about 10 irregularly spaced vertical strips. They damp out the box resonance which is in the vicinity of 125 cycles.

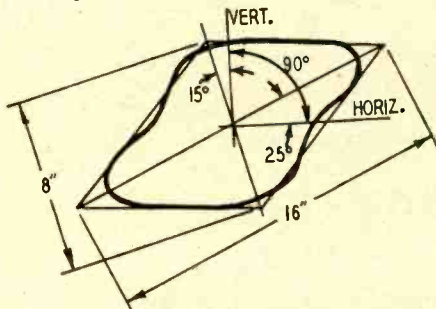

Fig. 2—Details of the lemon-shaped opening in the center of the panel.

Various dimensions were tried for the lemon-shaped opening in the front panel. None were critical. I settled for the dimensions and shape shown in Fig. 2. The shape was obtained by constructing a parallelogram in the center of the front panel and rounding off the corners to give the desired shape. The greatest single benefiting factor seemed to be the suspended Ozite strips.

If the dimensions shown are changed, it may be desirable to vary the 3/4-inch spacing between the front panel and speaker baffle. Placing the baffle tight against the front panel (reducing the space to zero) increases acoustical capacitance in the system to effectively stiffen the cone and decrease the low-frequency response. The speaker and enclosure capacitances should be balanced out with a like amount of acoustical inductance which is variable by changing the 3/4-inch spacing. When correctly balanced out, the acoustical resistance remaining loads the speaker cone to the air to the best advantage and the resonances are minimized.

Very little has been said concerning the workmanship of the construction, but it is important that all the cutting and fitting be done with care. Heavy screws should be used, and spaced close enough to give a very strong bond, the back should be especially tight, etc. These extras make a difference. END

Tested

AGAIN and AGAIN

45 times by factory experts to provide and insure consistent HIGH FIDELITY PERFORMANCE

Only craftsmen

does this . . . each and every tuner must perform with less than 1/2% intermodulation distortion at 100% frequency modulation when tested from antenna to audio output.



New!

C 810 FM-AM Tuner

A new basic High Fidelity Tuner with flat audio output response. Featuring: Sensitive FM, 4 μ v for 30 db quieting. Automatic Frequency Control (no drift) on FM simplifies tuning. Frequency response, $\pm 1/2$ db, 20 to 20,000 cps. Distortion — FM, 1/3% at 100% modulation. Cathode-follower audio output for remote installations.



New C 800A FM-AM Tuner

(same as C 810 with additional features)

Built-in phono preamplifier and record equalizer. Front-panel selected equalization for AES, LP or EUROpean recording characteristics. Double-shadow tuning eye. Bass and treble controls continuously variable up to 15 db attenuation or boost.



Craftsmen CA1 Assembly—a complete HiFi home music system. Ready to install with all cables, hardware, escutcheons and detailed plans. \$275 net.



Get new booklet on High Fidelity by DEEMS TAYLOR. Ask your Supplier or write to us . . . enclose 10c to cover handling and mailing.

Department G5

THE RADIO **craftsmen** INCORPORATED

4405 North Ravenswood Ave., Chicago 40, Ill.



TRANSISTOR PHONO OSCILLATOR

By EDWIN BOHR

The small transistor phono oscillator in actual operation.

MUSIC and conversation can be broadcast over short distances with this tiny transistor oscillator. The basic circuit uses one transistor plus a few inexpensive components. An extra audio stage may be added for more amplification.

The idea that junction transistors are useful only at audio and low radio frequencies is fading away. Practically all CK722 transistors will oscillate in the broadcast band. Some will go as far as 3 megacycles. All of the transistors I've been able to get my hands on have worked in the phono oscillator circuit.

The first experimental circuits with transistor phono oscillators used a separate transistor amplifier to *collector-modulate* another transistor oscillator. At least two transistors were necessary plus some sort of modulation transformer. The circuit evolved into a simpler one-transistor layout that performed better than the two-transistor circuit.

The circuit makes a single transistor do double duty as audio amplifier and oscillator. The oscillator is grounded base and the audio amplifier is grounded emitter. Let us see how it works.

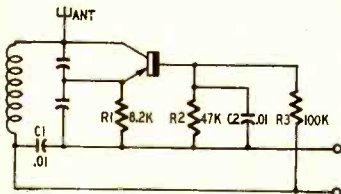
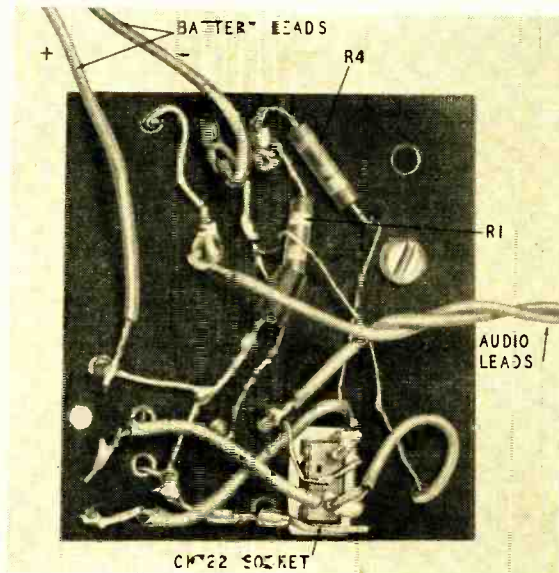
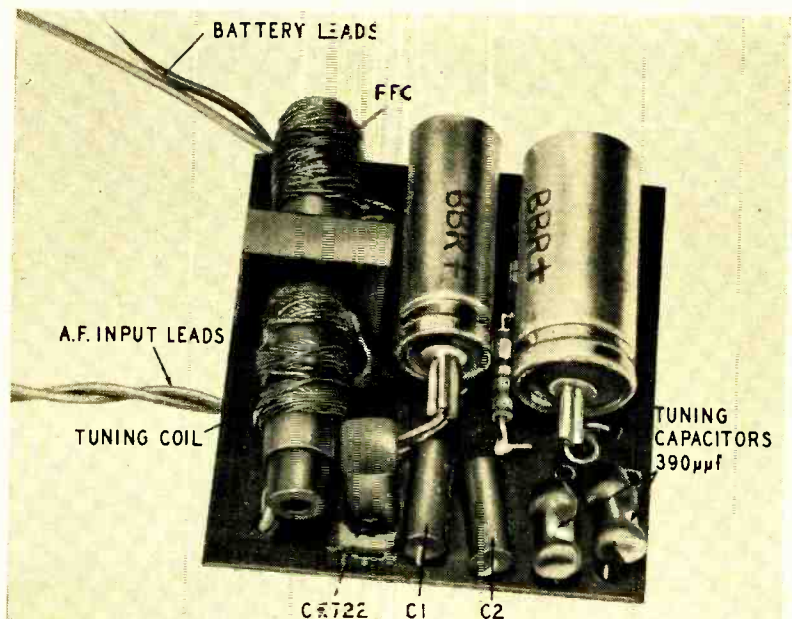

Fig. 1—The basic oscillator circuit.



Despite small size, there is ample room for wiring.



All major components are neatly laid out for maximum compactness.

RADIO-ELECTRONICS



* PAT. PEND.



NEW TELE-VANE ANTENNAS BY WARD



* PAT. PEND.

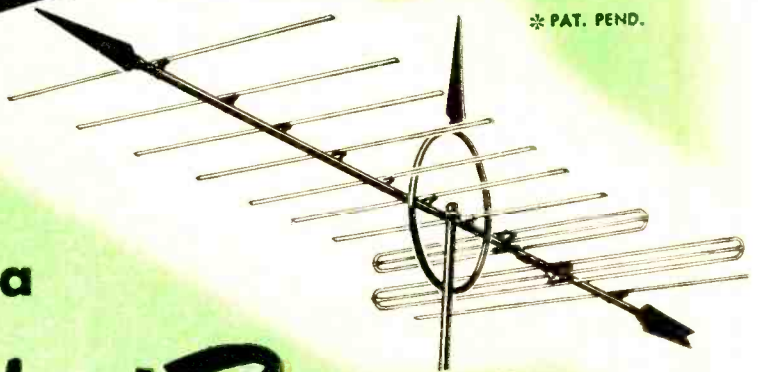

backed by a

Power Packed Promotion

Here they are . . . the newest idea in TV antenna design — opening an entirely new field for you with vastly increased profits. Tell the 69 million readers of the Tele-vane national consumer magazine ads that YOU sell Tele-vanes! Use Ward's local tie-in advertising aids . . . all featured and shown in this Tele-vane Kit.

It's yours FREE for the asking.

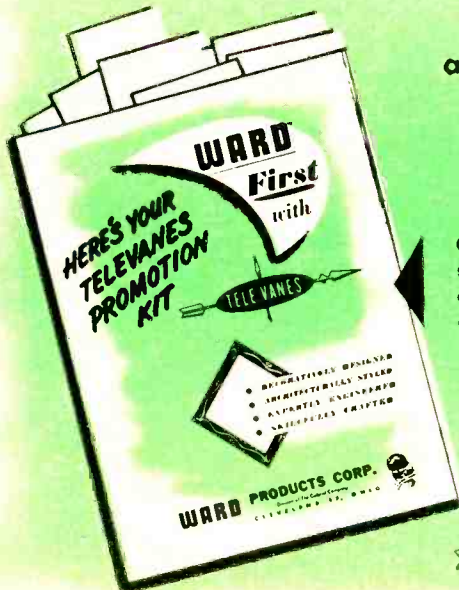

Complete in one kit, all the dope on window streamers . . . mailing piece . . . newspaper ads and mats . . . full color counter display . . . radio commercials . . . TV slides and announcements.



THE WARD PRODUCTS CORP.

DIVISION OF THE GABRIEL COMPANY

1148 Euclid Ave., Cleveland 15, Ohio

Canadian Distributor: ATLAS RADIO CO., LTD., TORONTO, CANADA



Circuit

Fig. 1 shows the oscillator alone. Except for resistors R1, R2, and R3 which stabilize the d.c. operating points of the transistor, the circuit is a simple type where feedback is tapped from the tuning capacitors rather than the coil. This is a matter of convenience so permeability tuning can be used. Capacitors C1 and C2 bypass the r.f. around the battery and base resistor.

To also function as an audio amplifier and modulator a few extra components are necessary. (See Fig. 2.) The microphone is connected in the base circuit from the bias resistor R2. This resistor—and also R1—must be bypassed with electrolytics to prevent audio degeneration. Since R1 must be bypassed for audio, we must keep the r.f. feedback from going to ground too. The choke labeled RFC prevents this.

Resistor R4 stops a periodic blocking of the r.f. oscillator by the voltage developed across R1, C3. Two hundred ohms for R4 kills instability for all transistors, but 100 ohms is usually enough. The lowest value that prevents motorboating of the carrier is the most desirable since high values of R4 reduce audio gain.

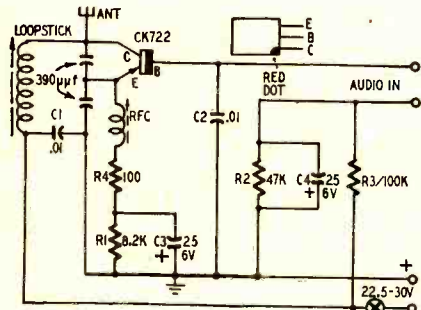

Fig. 2—Diagram of transistor phono oscillator showing component values.

Some of the battery voltage is lost in the stabilizing resistors. So, up to 30 volts can be used without exceeding the transistor ratings. Thirty volts of course gives the greatest power output, but the circuit oscillates down to 15 volts (subject to variations in individual transistors).

Construction

The oscillator chassis is a 2 x 1 $\frac{3}{4}$ x $\frac{1}{16}$ -inch piece of insulating board. The components are mounted by pulling their leads through holes drilled in the board. As shown in the photographs, the electrolytics and coils take up the greatest room.

The tuning coil and choke are both cut-down Ferri-Loopstick units. Take off the cardboard sleeve over the loopstick winding and cut off the mounting bracket plus most of the form. The oscillator coil and choke are then mounted to the chassis by pushing them into a block of fiber board. The block has a hole drilled in it the same size as the outside of the coil form.

Push the iron core all the way into the choke, otherwise the oscillator may not work at the lowest end of the tun-

ing range. The iron core in the tuning coil is pushed in and out to adjust the carrier frequency. This way the oscillator can be tuned from about 600 kc to over 1 mc.

The transistor plugs into a hearing-aid tube socket. It is made into a three-pin socket by pushing out two of the contacts.

Some shopping of the mail-order catalogs was necessary to find the smallest inexpensive capacitors. Capacitors C1 and C2 are 200-volt miniature units made by Aerovox (type P83Z). They cost about the same as regular capacitors. The electrolytics are Cornell-Dubilier BBR tubulars.

A few precautions are necessary. Most of the transistor circuit polarities are just opposite to those of vacuum tubes. Note that positive sides of the electrolytics and battery go to ground.

Disconnect the battery before the transistor is removed from its socket.

One end of the socket for the transistor has a raised identifying dot. The socket pin nearest the dot is wired to the collector circuit. This corresponds with the red dot on the transistor case. It certainly will not do the transistor any good to plug it in backward.

The antenna is a whip type, two feet long, mounted by a banana plug and jack. Antennas this short can be connected directly to the collector. Longer antennas must be connected to the collector through a 30- μ f trimmer. Without this trimmer, long antennas load the circuit so heavily it will not oscillate.

The complete phono oscillator—batteries and all—is mounted in a 1 $\frac{1}{2}$ x 2 $\frac{1}{2}$ x $\frac{3}{4}$ -inch aluminum case.

Operation

To test, connect an earphone to the audio input and slide the iron core about halfway into the tuning coil. Next place a radio within a few feet of the oscillator and tune across the broadcast band. A "shwoosh" or "shistle" will be heard as the transistor carrier is passed over. If a whistle is heard, the carrier is heterodyning with a broadcast station. To cure this, find a quiet spot on the dial and tune the transistor oscillator to that frequency by moving the core. The oscillator will drift for the first few minutes, so let it operate a while before the frequency is set.

If the carrier motorboats, increase the value of R4. To get an idea of the tuning range of the oscillator, follow the carrier with the radio dial as the tuning slug is moved in and out of the coil. The two 390- μ f tuning capacitors may be changed to other values. If each capacitor is changed to 100 μ f, the oscillator will tune from 1 mc to about 1.8 mc.

Tap on or talk into the earphone and the sound should come through the radio. There will be feedback squeal if the microphone is too close to the speaker of the radio. The earphone gives a pretty good impedance match to the transistor input, but it overloads

and distorts easily on loud sounds. A 3-inch speaker connected through an output transformer to the oscillator makes a better microphone. Carbon microphones are suitable and much more sensitive. Carbon mikes must have a coupling transformer. A small filament transformer will do. Fig. 3 shows

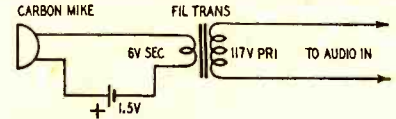

Fig. 3—Circuit for carbon mike input.

how it is connected. The 6-volt side goes to the microphone and battery and the 110-volt winding goes to the transistor.

Clarkstan or Pickering VR cartridges can be connected directly to the oscillator, but the modulation will be very low. A G-E cartridge, because of its lower output, can just barely be heard. Crystal pickups are not satisfactory, even with matching transformers.

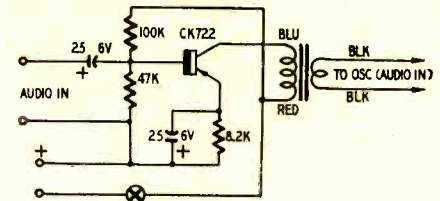

Fig. 4—Schematic of audio amplifier for the transistor phono oscillator.

Before the battery voltage is turned on, the microphone should be connected, or a shorting jumper should be placed across the "audio input" terminals.

Parts for phono oscillator

Resistors: 1—100, 1—8,200, 1—47,000, 1—100,000 ohms, $\frac{1}{2}$ watt.

Capacitors: 2—390 uuf, ceramic; 2—.01 uf, 200 volts, paper (Aerovox P83Z); 2—25 uf, 6 volts, electrolytic (Cornell-Dubilier BBR).

Miscellaneous: 1—CK722 transistor; 2—Ferri-Loopstick; 1—socket for transistor; 1—on-off switch; 1—battery (22.5" to 30 volts); 1—1 $\frac{1}{2}$ x 2 $\frac{1}{2}$ x $\frac{3}{4}$ -inch aluminum case; 1—fiber board; 1—2-foot whip antenna; 1—jack for antenna.

Parts for amplifier

Resistors: 1—8,200, 1—47,000, 1—100,000 ohms, $\frac{1}{2}$ watt.

Capacitors: 2—25 uf, 6 volts, electrolytic.

Miscellaneous: 1—CK722 transistor and socket; 1—plate-to-line transformer, primary impedance 10,000, 25,000 ohms, primary current 3, 1.5 ma, secondary impedance 200, 500 ohms (UTC SO-3).

Amplifier

Once the oscillator is built you may want to add an extra stage of audio amplification. This gives satisfactory operation with VR cartridges. An amplifier is shown in Fig. 4. Like the oscillator, the amplifier is d.c. stabilized. There is no need to make any circuit adjustments for individual transistors. The output of the amplifier is connected directly to the audio input terminals of the oscillator.

Conclusions

The phono oscillator makes a very good experimental transistor project. The range is limited because of the low power, yet it can transmit a signal from room to room. Except for the transistor itself, standard low-cost components are used in the circuit. END



It pays to ask for
“RECTIFIER RED”
 the new product-line color for

Federal MINIATURE SELENIUM RECTIFIERS

FEDERAL—the original miniature—has said goodbye to gray. The new bloom is “Rectifier Red” . . . a striking color that instantly tells servicemen they’re getting the rectifier efficiency and long life that created tens of millions of profit opportunities for radio-TV servicing . . . tells them they’re getting the *quality* that keeps Federal miniatures the best-seller in America’s vast and growing rectifier replacement market!

Look for “Rectifier Red” . . . get the performance that *clicks* . . . the replacement profit that *sticks*! See your Federal Distributor for Federal miniatures in handy 8-unit kits . . . in quantity lots . . . or in individual packages sold through Federal’s self-service rectifier dispenser . . . on hundreds of counters! See your “FTR” Distributor now, or write to Dept. F-763A



“America’s first and largest manufacturer of selenium rectifiers”

Federal 
 Telephone and Radio Company

100 KINGSLAND ROAD, CLIFTON, N. J.

In Canada: Federal Electric Manufacturing Company, Ltd., Montreal, P. Q.
 Export Distributors: International Standard Electric Corp., 67 Broad St., N. Y.

A LOW-COST MOBILE RADIO



Photo A—Civil Defense mobile radio station operated by the Malden Amateur Radio Association under the auspices of the Malden Emergency Corps.

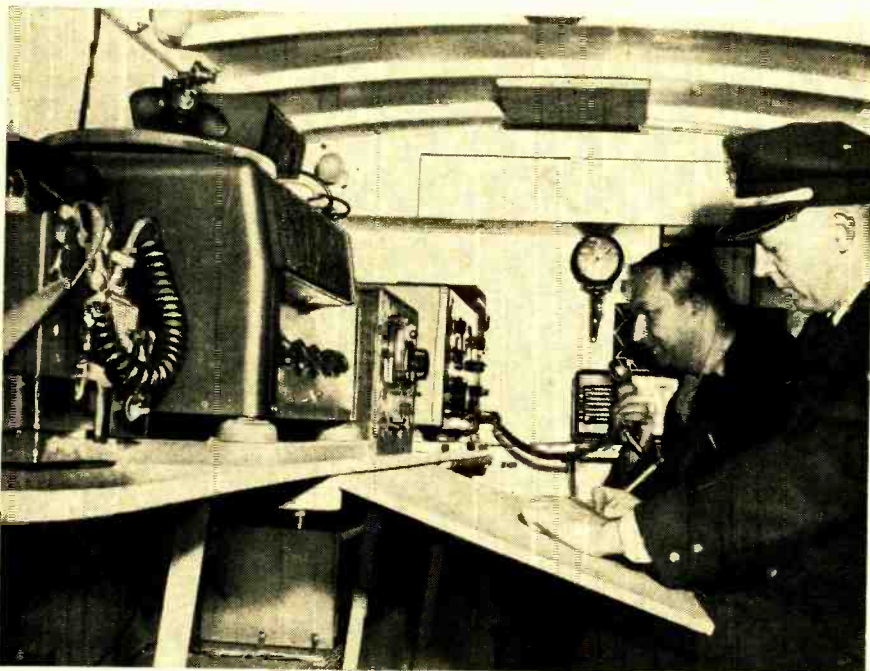

Photo B—Inside of the radio truck. The officer is Sgt. Orin Hood (W1LD) of the Malden police. Author is at the mike.

*A welcome addition to
any Civil Defense
network, this mobile
radio station fits
well within most
CD budgets*

By **ELI NANNIS (W1HKG)***

MANY units of the Civil Defense Radio Emergency Corps want a mobile radio station as part of their equipment, but the budget cannot stand the expense. However, it can be done on a small budget if you have the co-operation of your city and Civil Defense office. It is not necessary to buy expensive commercial equipment and large super-duper trucks to carry it. Let the big companies beat the drums to buy their units at prices untouchable by the average American city. Your city can have a mobile radio station without breaking the budget. We did it in Malden, Mass., and we are quite proud of the results.

Our city, 5 miles north of Boston, has a population of about 60,000 and a CD budget about average for a city of our size. Approximately two years ago we organized the Malden Emergency Corps, and a short time later the Malden Amateur Radio Association was organized. We had no mobile equipment of any type. To save money, we built our own mobile transmitter and converters and distributed them among the members of our net. We soon had a first-class mobile net in operation.

* Radio Officer and Emergency Coordinator, City of Malden, Mass.

**NEW,
SMARTLY
STYLED**

ALLIANCE

TENNA-ROTOR
The only FULLY AUTOMATIC
antenna rotator!

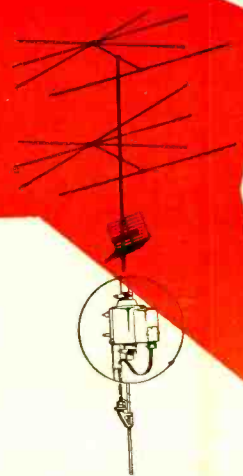

**Sell the
product
with the
feature
that's
exclusive!**

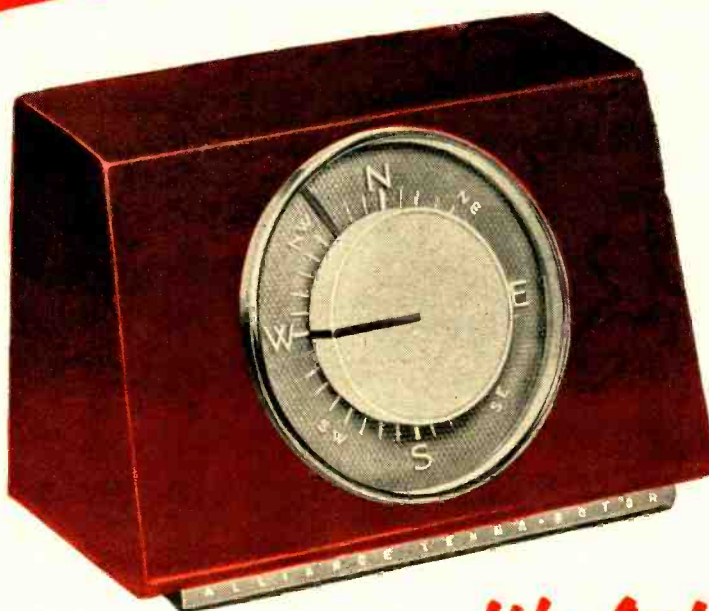

**REDESIGNED ROTATOR
UNIT**—Speed increased to
2 rpm. **New double-ac-
tion magnetic anti-drift
brake.** Smoother synchro-
nization with control units.

MODEL U-83
AUTOMATIC

It's Automatic!

*The new automatic Alliance Tenna-Rotor
sells on sight! They all ask for Model U-83!*

Here's how Alliance pre-sells for you!

- 1. New styling**—"style's the thing"
... Alliance has it!
- 2. TV advertising** that sells custom-
ers! Plus newspapers—magazines!
- 3. The automatic feature** sells itself!
No fumbling—no hunting—just "set it
—forget it". Pointer turns automatically
to any selected direction and stops.

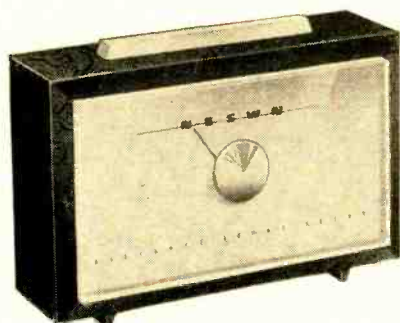

MODEL T-10, finger-tip electrically controlled Alliance Tenna-Rotor with direction indicator dial. Extremely accurate. Compact. Modern styling by Reinecke & Associates, leading national designers. Redesigned inside and out.



ALLIANCE UHF CONVERTER

...adds all UHF channels
—the recognized quality
converter built to last!
Unexcelled picture qual-
ity . . . Price: **\$34.95**

OVER 1,250,000 ALLIANCE TENNA-ROTORs NOW IN USE!

ALLIANCE MANUFACTURING CO., ALLIANCE, OHIO

*Perfect
Companions*

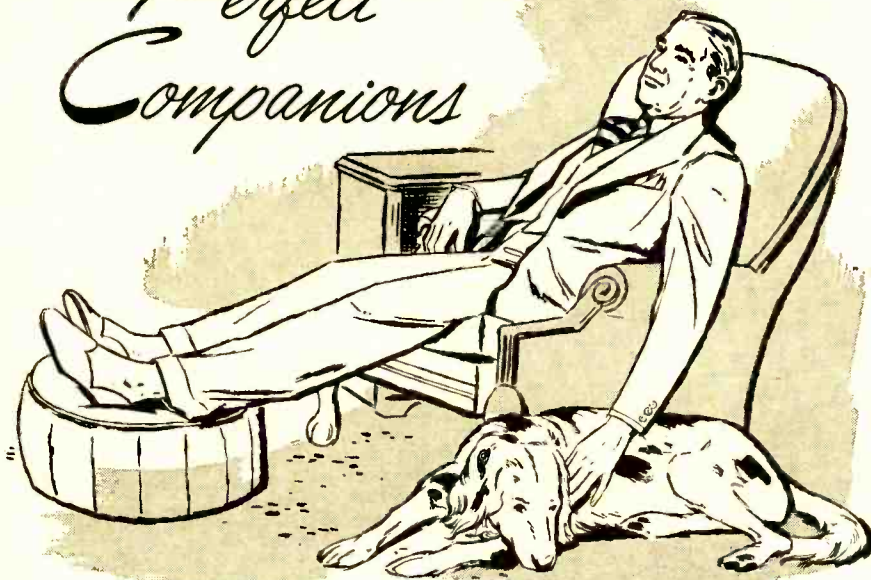

the beautiful

Utah

Esquire and Squire



ESQUIRE

Mahogany—Model HF 800 M
Complete with two-way, four
speaker system. Audiophile
Net \$89.95.



SQUIRE

Mahogany—Model HF 700 M
Complete with pull-out
changer drawer and tilt-out
tuner compartment. Audio-
phile Net \$79.95.

Now you can have perfect companion pieces in which to house your complete high fidelity system—the Squire and Esquire—two beautiful consoles which will complement and grace any decor.

The Esquire—a console with a Utah two-way, four speaker system designed to give you matchless high fidelity sound.

The Squire—a beautiful, perfectly matching console which will house in one complete unit, your AM-FM tuner, high fidelity amplifier, standard record changer or a professional three-speed turntable and pick-up arm.

Both of these consoles have a beauty, style and grace that glows with the splendor and lustre of fine woods—blonde korina, genuine mahogany or rich pioneer cherry—hand rubbed to a rich patina of the highest quality furniture.

The Squire and Esquire are truly master achievements in the art of sound engineering and woodworking. See and hear the Squire and Esquire—and all the other models in the Utah Personality Series—at your local Hi Fi Headquarters.

Our main station was located in the basement of a school. Through our communications officer, Sergeant Orin D. Hood (WILD) of the Malden Police, we found out that the old 1939 Studebaker patrol wagon was to be pensioned off. This wagon was not used very often and was in good condition.

We talked it over with the Civil Defense Director Edward J. Hoffman and Assistant Director Joseph V. O'Donnell. We explained why we wanted the wagon and what we could do with it. They thought it was a good idea and with the co-operation of the City Government the wagon was transferred to the CD office. Thus we had procured what would be the most expensive item of a mobile radio station without a penny coming out of the CD budget. Cities are always buying new vehicles. Grab one of the old ones the way we did.

We also obtained the power supply without cost. The police station had a new 15-kw emergency power plant installed. An 1,800-watt 110-volt a.c. gasoline generator which they used on rare occasions was now surplus and this was also turned over to us. After shopping around a while, we were able to buy a used 2-wheel trailer at a reasonable price. All the work of converting the wagon to a mobile radio station was done by the members of the emergency corps. Truck and trailer are shown in Photo A.

By careful buying we kept the cost of the radio equipment to a minimum. Our spare transmitter and receiver was installed in the wagon, and since we use the same type of transmitter and receiver in our main station we can interchange this equipment in case of failure.

The transmitter shown on the table at the front of the truck (see Photo B) is the popular Harvey-Wells TBS-50C. It operates on all amateur frequencies from 80 through 2 meters. Beside the transmitter is a National NC-183 receiver. Next on the table is an automobile receiver and a converter installed in a home-built cabinet. On top of the cabinet not clearly shown in the photograph is a 10-watt transmitter. This complete unit (the same as we use in our mobiles) operates on the net frequency of 29,540 kc. This is an emergency unit which obtains its power from the truck battery so in case of failure of our gasoline generator we can stay on the air. Next and very prominently shown in the photograph is a 40-watt Silvertone PA system consisting of the amplifier, a dynamic microphone, turntable, and two University 25-watt horns, all procured for a little over \$100. The horns are shown on top of the truck and are mounted on swivels so that they may be turned in any direction. The last two units on the table are walkie-talkies. The one at the end of the table operates on the net frequency and was home-built at a cost of \$35. The other is a commercial unit made by Motorola and it operates on the Malden Police and Fire frequency of 156.21 mc. This unit does not have a speaker, so we use a Police

Utah

RADIO PRODUCTS CO., INC.

1250 WASHINGTON STREET
HUNTINGTON, INDIANA

RADIO-ELECTRONICS

Now a

COLOR

TELEVISION HOME STUDY COURSE

by RCA Institutes



"Color Television is here—not around the corner, or in the developmental labs, but here! The big question now is . . . Are You ready for Color TV?"

"You may now have a successful TV servicing business. When color sets come to your bench for servicing, will you be able to handle them?"

"Color Television is a vast new field, embodying entirely new concepts . . . principles of light and vision, radically new circuitry."

First Home Study Course in Color TV

Now is the time to prepare. Now, for the first time, you can train yourself for the

opportunities in this brand-new field. The just-announced RCA Institutes Home Study Course is the *first* home study course covering all phases of color television. Offered only to those already experienced in radio-television servicing, it explains the "why" of basic theory, as well as the "how-to-do-it" of servicing techniques.

Planned and written by RCA instructors, the entire course is based on the practical experience of RCA engineers—the men who have pioneered in the research and development of color television since the very first color experiments, many years ago.

Remember when black-and-white television first became a reality? Overnight, the demand for men who knew television grew. Even now, a shortage of qualified servicemen exists. Think, then—of the even greater demand for servicemen who will understand the many additional problems of color reception!

Costs so little to gain so much

RCA Institutes makes it easy for you to prepare yourself now for color television. Not only is the cost of the home study course for qualified servicemen extremely low, but you pay for the course on a pay-as-you-learn basis.

RCA Institutes conducts a resident school in New York City offering day and evening courses in Radio and TV Servicing, Radio Code and Radio Operating, Radio Broadcasting, Advanced Technology. Write for free catalog on resident courses.

Send for **FREE Booklet**—Mail the coupon, today. Get complete information on the RCA INSTITUTES Home Study Course in Color Television. Booklet gives you a general outline of the course lesson by lesson. See how thoroughly you can learn Color TV. Mail coupon in envelope or paste on postal card.

MAIL COUPON NOW!

RCA INSTITUTES, INC., Home Study Dept. RE-554
350 West Fourth Street, New York 14, N. Y.

Without obligation on my part, please send me copy of booklet "RCA INSTITUTES Home Study Course in COLOR TELEVISION." (No salesman will call.)

Name _____ (please print)

Address _____

City _____ Zone _____ State _____



RCA INSTITUTES, INC.

A SERVICE OF RADIO CORPORATION of AMERICA
350 WEST FOURTH STREET, NEW YORK 14, N.Y.

MAY, 1954



Outperforms them all..!

- in moisture resistance
- in high temperature operation
- in holding rated capacity
- in long troublefree life



the Sangamo

Telechief®

MOLDED PAPER TUBULAR CAPACITOR

The Telechief will outlast all other tubulars! MIL-C-91A tests prove that Telechiefs have a final insulation resistance value *10 to 15 times greater* than paper tubulars molded in any other material. That's because they're molded in HUMIDITITE!

YOU GET EXTRA VALUE AT NO EXTRA COST!
This amazing new capacitor—that meets specifications so tough that no previously existing paper tubular could approach them—is a *premium* tubular at the price of an ordinary one. See your Sangamo Distributor today!



SANGAMO ELECTRIC COMPANY

MARION, ILLINOIS

SC54-B

RADIO

Alarm unit for receiving on the police frequency. Below this receiver is a CO₂ fire extinguisher (not visible in the photo). The power supply for the transmitter, an 8-drawer metal cabinet and a tool box are under the table. There are both 6- and 110-volt lights inside the truck. On the right side of the truck (not shown in the photograph) is a first-aid kit and an electric fan. Two plywood panels are attached to the bottom of the table so they can be pulled out to form tables to write or work on.

There are three antennas on the truck. The main antenna is mounted on the front of the truck (Photo A). It was purchased from a mail-order house and consists of a heavy-duty spring base and eight 3-foot rods which go up more than 20 feet. It cost only \$10. On the other side of the truck is an 8-foot whip for the emergency unit and on the top rear is the small police type whip antenna.

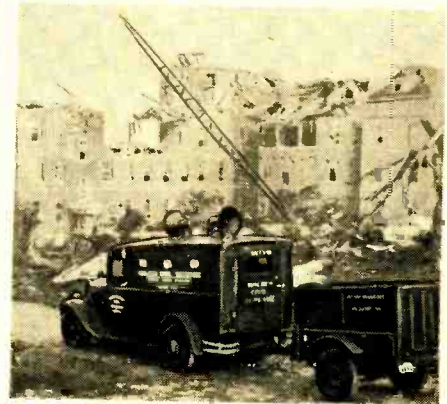

Mobile unit at scene of tornado.

Decals are used for the lettering on the truck. A spotlight is located in front of the cab and beside it is a flashing red light which is used to indicate that it is an emergency vehicle. There is also a powerful siren mounted under the hood. It was donated by one of our members who services burglar alarms.

Other equipment not shown in the photographs are a 150-foot extension cord for feeding 117-volt commercial power into the truck if available; 100 feet of No. 12 wire for running power from the gasoline generator; two 300-watt floodlights which can be mounted on top of the truck if need be; and 100 feet of telephone cable for connecting the two phones contained in the truck.

The members of our emergency corps willingly gave their time to put this mobile radio station together and they did a splendid job. David Smith (W1HOH), a radio engineer for the National Co., designed our home-built equipment. He also keeps our equipment in tiptop shape. Find a "Dave Smith" in your net and take good care of him.

Our mobile radio station has already taken part in a real emergency. After a tornado struck Worcester, Mass., our truck did its part in providing communications and lighting for several days.

END

RADIO-ELECTRONICS

Here's your Opportunity

**to prepare for a good job or a business
of your own in TV SERVICING**

ARE YOU SATISFIED with the position you now hold? Do you feel you're worth more money? Are you pleased with yourself, your work, your associates . . . and your future? What does the next year hold for you . . . and the year after that?

Are you content merely to plod along through the best years of your life . . . or do you want to get into more pleasant work . . . hold a well-paid job . . . perhaps establish your own business?

If you are looking for a REAL opportunity . . . If you want to GROW with a GROWING INDUSTRY . . . If you want to grasp the success that should be yours, then we say to you, study TV Servicing.

Everyone knows that Television is the fastest growing industry today. Opportunities are going begging for men who have

the training and ability to grasp them. Now is the time to start on the road to success in TV Servicing.

Study at Home in your spare time

The RCA Institutes Home Study Course in TV Servicing is easy to learn. You progress rapidly, step by step, as you learn the procedure of servicing and trouble-shooting TV receivers and installing TV antennas. Hundreds of pictures and diagrams help you understand the how-it-works information and the how-to-do-it techniques.

A Service of

Radio Corporation of America

The RCA Institutes TV Servicing course was written and planned by instructors with years of specialized experience in training men. You get up-to-the-minute information, too, because you study right at the source

of the latest developments in Television. Your lessons are carefully examined and accurately graded by competent teachers who are interested in helping YOU to succeed.

RCA Institutes is licensed by the University of the State of New York . . . an affiliate member of the American Society for Engineering Education . . . approved by leading Radio-TV Service Organizations . . . approved by Veterans Administration.

It costs so little to gain so much

RCA Institutes makes it easy for you to take advantage of the big opportunities in TV Servicing. The cost of the TV Servicing Home Study Course has been cut to a minimum. You pay for the course on a pay-as-you-learn unit lesson basis. No other home study course in TV Servicing offers so much for so little cost to you.

RCA Institutes conducts a resident school in New York City offering day and evening courses in Radio and TV Servicing, Radio Code and Radio Operating, Radio Broadcasting, Advanced Technology. Write for free catalog on resident courses.



RCA INSTITUTES, INC.
A SERVICE OF RADIO CORPORATION OF AMERICA
350 WEST FOURTH STREET, NEW YORK 14, N.Y.

MAY, 1954

SEND FOR FREE BOOKLET—Mail the coupon—today. Get complete information on the RCA INSTITUTES Home Study Course in Television Servicing. Booklet gives you a general outline of the course by units. See how this practical home study course trains you quickly, easily. Mail coupon in envelope or paste on postal card.



MAIL COUPON NOW!

RCA INSTITUTES, INC., Home Study Dept. RE554
350 West Fourth Street, New York 14, N. Y.

Without obligation on my part, please send me copy of booklet "RCA INSTITUTES Home Study Course in TELEVISION SERVICING." (No salesman will call.)

Name _____ (please print)
Address _____
City _____ Zone _____ State _____

MULTIVIBRATORS

By ED BUKSTEIN*

Increasing use of square and sawtooth waves has elevated the multivibrator circuit to one of prime importance

HERE was a time when the radio and electronics technician could afford to ignore multivibrator circuits. This is no longer the case. Today, the multivibrator and its many close relatives have found their way into almost every type of electronics apparatus, from television equipment to automatic computers. Variations of the basic multivibrator have become so numerous and diversified in application that accurate classification of multivibrators requires such adjectives as symmetrical, asymmetrical, cathode-coupled, delay, one-shot, etc.

Symmetrical multivibrator

The symmetrical multivibrator—the basic circuit from which many variations are derived—consists of two stages, the plate of each being coupled to the grid of the other (Fig. 1). With

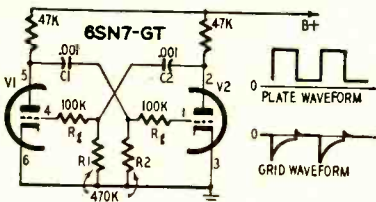

Fig. 1—The symmetrical multivibrator.

this arrangement, one tube conducts while the other is cut off. This condition reverses periodically.

One application of the multivibrator is as a square-wave generator. Since each tube of the multivibrator is alternately cut off and conductive, the plate voltages alternately increase and decrease, producing a square-wave out-

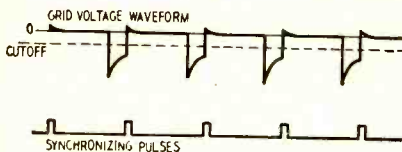

Fig. 2—Multivibrator synchronization.

put. The resistors marked R_n in Fig. 1 improve the quality of the output square wave. If these resistors are omitted, the square wave has a rounded corner on its leading edge. This is due to the loss of the high harmonic content of the square wave as a result of the bypassing effect of C2 through the grid-to-cathode resistance of V1. The grid resistors increase the plate-to-ground impedance and decrease the attenuation of high-order harmonics.

The operating frequency of the circuit of Fig. 1 can be controlled by changing the values of the coupling

capacitors or the grid resistors. A selector switch and several different values of coupling capacitors will permit a choice of frequency range. Within each range, the frequency can be varied by a dual potentiometer used as the grid resistors.

The operation of the circuit of Fig. 1

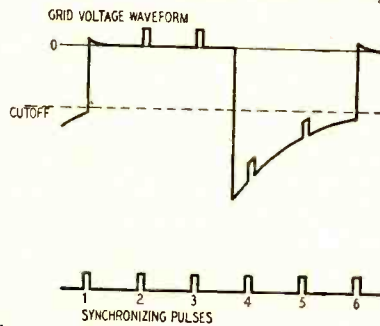

Fig. 3—Multivibrator synchronized at submultiple of input pulse frequency.

can be analyzed most easily by assuming the plate current of V1 is increasing, and noting the consequent changes which occur in the circuit:

1. As the plate current of V1 increases, the IR drop across its plate-load resistor increases, and the voltage at the plate decreases.
2. As the plate voltage of V1 decreases, capacitor C1 loses some of its charge. The discharge current flows to ground through R2.
3. The IR drop across R2 makes the grid of V2 negative with respect to ground, and V2 is driven to cutoff.
4. When C1 has completed its discharge (to a value equal to the plate voltage of V1 at saturation), no further discharge current flows through R2.
5. With the grid of V2 no longer negative, this tube conducts plate current, and its plate voltage decreases.
6. Capacitor C2 now begins to discharge through R1, producing an IR drop across this resistor.

7. The IR drop across R1 drives V1 beyond cutoff.
8. When C2 has completed its discharge, V1 is no longer cut off.
9. V1 begins to conduct plate current, and the cycle repeats.

From this analysis, it is obvious that conduction in either tube causes the other tube to be driven to cutoff. The length of time each tube remains cut off depends upon the R-C time-constant of the grid circuit. When the time-constants of both grid circuits are made equal, each tube remains cut off for the same length of time—hence the name *symmetrical* multivibrator. The grid resistors are sometimes returned to B plus rather than to ground. The advantage of this arrangement is that the frequency stability is increased with respect to supply-voltage variations.

Synchronization

In many applications, frequency stability is not a primary consideration and the multivibrator is operated as a free-running circuit. When required, the frequency of a multivibrator can be held constant by synchronizing it with an external signal. The synchronizing signal can be applied to either of the grids or the cathodes of the multivibrator. Although many types of waveforms may be used as synchronizing signals, the pulse waveform is most widely used.

Fig. 2 illustrates the synchronization of a multivibrator by positive pulses applied to one of its grids. The period of the multivibrator in its free-running state should be slightly longer than the period of the desired synchronized frequency. Fig. 2 shows the effect of the positive pulse in driving the tube from cutoff to conduction. The pulse thus initiates the switching action of the circuit, by causing the grid to go suddenly more positive, and the frequency is locked in with that of the input pulses.

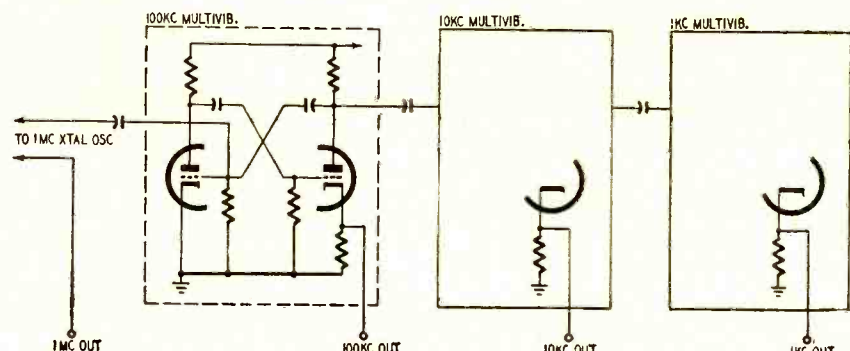

Fig. 4—Diagram illustrates application of multivibrator as frequency divider.

* Northwestern Vocational Institute, Minneapolis, Minnesota

it's new
it's new
it's new

It's What You've Been Asking For!

it's new

it's new

it's new

it's new

it's new

it's new

it's new

it's new

the TR-4 C★D★R Rotor

still the most powerful TV rotor, enough power to turn any array.

NOW...With Meter Cabinet Using 4-Wire Cable



Model TR-4

the de-luxe HEAVY DUTY ROTOR complete with modern design meter control dial cabinet, using 4 wire cable.

\$53.95

also these models **TR-2 • TR-11 • TR-12**

CORNELL-DUBILIER

SOUTH PLAINFIELD, N.J.



THE RADIART CORP.

CLEVELAND 13, OHIO

MAY, 1954

TO THE
E. E.

OR

PHYSICS GRADUATE

WITH EXPERIENCE IN

RADAR

OR

ELECTRONICS

HUGHES RESEARCH AND DEVELOPMENT LABORATORIES ARE ENGAGED IN A CONTINUING PROGRAM FOR DESIGN AND MANUFACTURE OF ADVANCED RADAR AND FIRE CONTROL SYSTEMS IN MILITARY ALL-WEATHER FIGHTERS AND INTERCEPTORS.

THE GREATEST advancements in electronics are being made in this sphere because of military emphasis. Men now under 35 years of age will find this activity can fit them for future application of highly advanced electronic equipment.

YOU WILL serve as technical advisor in the field to companies and government agencies using Hughes equipment.

TO BROADEN your field of experience in radar and electronics you will receive additional training at full pay in the Laboratories to become thoroughly familiar with Hughes radar and fire control equipment.

AFTER TRAINING you will be the Hughes representative at a company where our equipment is installed; or you will advise in the operation of Hughes equipment at a military base. (Overseas assignments, single men only.)

HUGHES

RESEARCH AND DEVELOPMENT
LABORATORIES

SCIENTIFIC AND
ENGINEERING STAFF

Culver City, Los Angeles County, Calif.

Assurance is required that relocation of the applicant will not cause disruption of an urgent military project.

Negative pulses may also be used for synchronization. The action in this case is very similar, since the negative pulse applied to the grid of the conducting tube is amplified and appears as a positive pulse at the grid of the non-conducting tube.

A multivibrator can also be made to lock in at a submultiple of the pulse frequency (Fig. 3). Pulse 1 drives the tube to conduction and switches the circuit. Pulses 2 and 3 have no effect since they are applied to the grid at a time when the tube is already conducting. Pulses 4 and 5 produce no change in the circuit since they reach the grid at a time when it is far below cutoff. At the time pulse 6 comes along, the grid of the tube is approaching the cutoff threshold, and the pulse is sufficient to

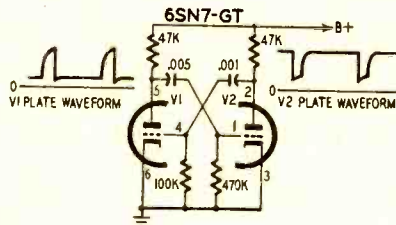

Fig. 5—The asymmetrical multivibrator.

start conduction in the tube. Since every fifth pulse initiates switching action in the circuit, the multivibrator synchronizes at a frequency equal to one-fifth of the pulse frequency.

The use of the multivibrator as a frequency divider is illustrated in Fig. 4. A crystal-controlled oscillator is used to drive a chain of multivibrator circuits, each of which is synchronized to a submultiple of the frequency of the preceding circuit in the fashion of Fig. 3. The output of the 1-mc crystal-controlled oscillator is used to synchronize the 100-kc multivibrator. The square-wave output of this circuit is differentiated and the resulting pulses used to synchronize the 10-kc multivibrator. The 10-kc output is also differentiated and used to synchronize the following circuit. An output is taken from a cathode resistor of each multivibrator. This cathode-follower arrangement provides a low impedance output and minimizes the loading effect of external circuits. The stability and accuracy of the output frequencies are extremely good, since they are—in effect—crystal controlled. Circuits of this type are useful for testing and calibrating signal generators, oscilloscope time bases, frequency meters, and similar devices.

The asymmetrical multivibrator

If the R-C time constants of the two grid circuits of a multivibrator are made unequal, the duration of the cutoff periods of the two tubes will be unequal. This circuit, known as an *asymmetrical multivibrator*, is shown in Fig. 5. Since plate voltage is high when a tube is cut off and low when it is saturated, a pulse waveform is produced at the plates of the asymmetrical multivibrator. The tube which remains cutoff for a shorter time will produce a



The ideal recorder for newspaper reporting, recording lectures, telephone monitoring, field reports traveling secretary, on-the-spot interviews, reference recording, customer interviews, salesmen reports and secret recordings.

Combines, for the first time, ease and efficiency of operation with maximum reduction of weight. Performs anywhere, producing professional results under adverse conditions. Fly-ball governor-controlled electric motor plus triple shielding assures constant speed and freedom from hash. Weather-tight, satin-finished, aluminum alloy case gives complete protection to recorder. Three models available in speeds of 15/16, 1 1/8 and 3 3/4 ips.

Check these unusual features:

- ★ Records for 4 full hours (Model 310-A)
- ★ Operates from self-contained dry cells
- ★ Immediate playback
- ★ Size: 5 1/2 x 9 x 12 inches
- ★ Weight: only 8 pounds

Write for complete technical literature and direct factory prices to Dept. RE

AMPLIFIER CORP. of AMERICA

396 Broadway, N. Y. 13, N. Y.

*T.M. Reg. U.S. Pat. Off.

NOW! YOU'LL REALLY KNOW HOW TO USE OSCILLOSCOPES!

Here, at last, is a practical book that makes it easy for you to learn to use the oscilloscope FULLY on all types of AM, FM and TV service work—and dozens of other applications besides!

MODERN OSCILLOSCOPES AND THEIR USES, by Jacob H. Ruitter, Jr. of Allen B. DuMont Labs contains 326 fact-jammed pages of just the help you need—written so you can easily understand it. The book shows exactly how the 'scope works; how to use it on all service jobs from troubleshooting to realigning; how to make connections; how to adjust circuit components; how to set controls and how to analyze patterns. You get exact procedures on how and where to use your 'scope—not just theory! 370 illustrations including pattern photos make things doubly clear.

When, where why and exactly how to use your 'scope.

How to interpret patterns

How to handle tough jobs in less time

10-DAY FREE TRIAL

Dept. RE-54, RINEHART & CO., INC.
232 Madison Ave., New York 16, N. Y.

Send MODERN OSCILLOSCOPES AND THEIR USES for 10-day FREE EXAMINATION. If I decide to keep the book, I will then remit \$6.00 plus a few cents postage in full payment. If not, I will return book postpaid and owe you nothing.

NAME.....

ADDRESS.....

CITY, ZONE, STATE.....

OUTSIDE U.S.A.—Price \$6.50 cash with order. Money back if book is returned in 10 days.

best (black and white)
picture quality

with the
Amphenol

INLINE*



Black & white or color, the Amphenol INLINE assures the finest audio/video quality on any TV set.



The INLINE color advantages are also available to fringe areas with 2 or 4 bay Stacked Arrays.

... and best for **COLOR** too!

Set owners have their color television antenna *right now* if they have an Amphenol INLINE! Because the very features that make the INLINE the outstanding buy for black & white television are the same that have been listed as *requirements* for color television!

For *fidelity* color reception the antenna must have these characteristics:

1. Antenna gain must be flat, no gain or loss greater than 1.50 db within 1.5 mc below and 0.6 mc above the color sub-carrier. *The INLINE gain (see charts at right) fully meets this condition.*
2. Antenna gain must be held down across the FM frequencies, 88 mc to 108 mc. *The INLINE gain has been engineered for a sharp cut-off at the end of Channel 6—for rejection of FM signals.*

Gain variation over the color modulation band for each VHF channel should not exceed ± 0.75 db; the following table gives figures for the INLINE on all channels.

Channel	Gain Variation/db	Channel	Gain Variation/db
2	± 0.40	8	± 0.08
3	± 0.06	9	± 0.04
4	± 0.12	10	± 0.03
5	± 0.27	11	± 0.20
6	± 0.20	12	± 0.30
7	± 0.20	13	± 0.30

Gain chart showing ± 0.06 db variation over color modulation band for INLINE, Channel 3

*Reissue U.S. Pat. No. 23.273

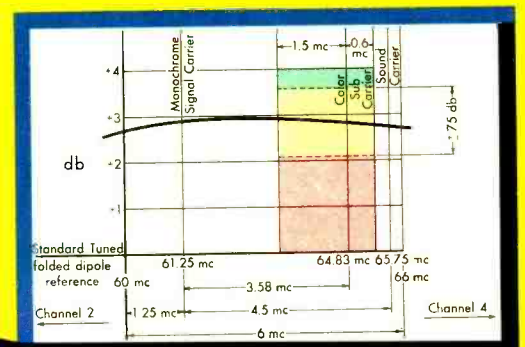

AMPHENOL

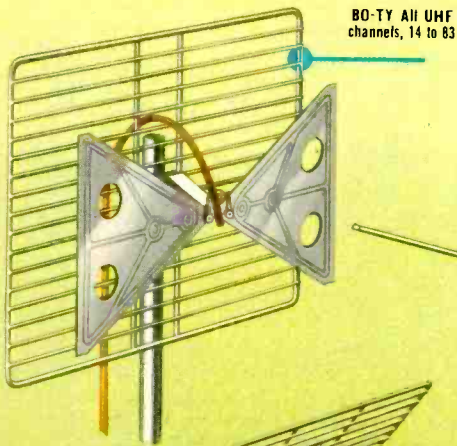

BO-TY All UHF channels, 14 to 83

CORNER REFLECTOR
Top UHF performer

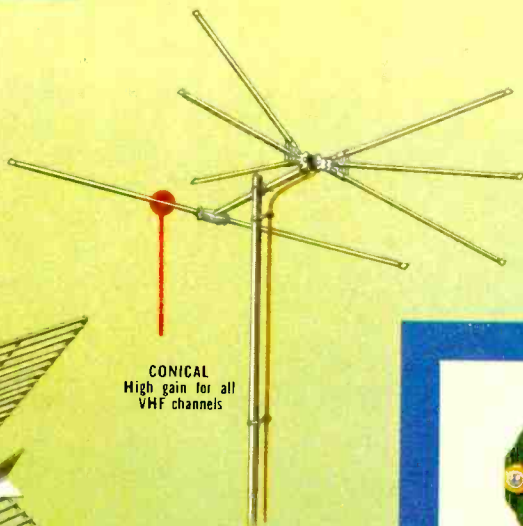
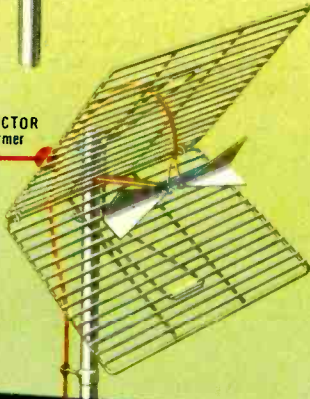

CONICAL
High gain for all VHF channels

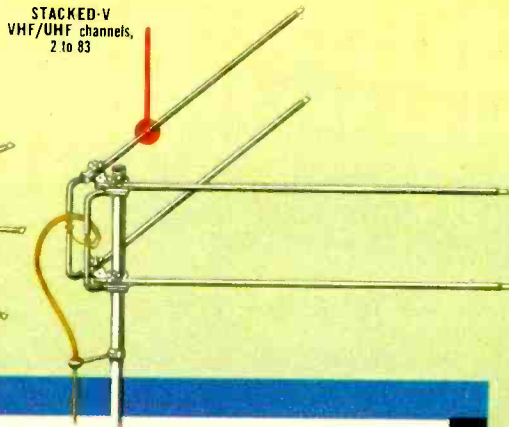

STACKED-V
VHF/UHF channels, 2 to 83



LIGHTNING ARRESTOR
New VHF/UHF universal Lightning Arrestor has lowest measurable loss of any arrester!



ISONET Low-loss matching network for combined VHF/UHF installations. Incorporates lumped-circuit-constants-filter-network.

dependable performance in every

Amphenol antenna

DEPENDABLE ANTENNAS. There is a wide choice of fine Amphenol antennas for VHF or UHF frequencies. The Bo-Ty, Corner Reflector, Yagi and Rhombic assure best picture quality at UHF. For VHF, besides the color-designed *INLINE**, there is the new Amphenol Conical. And the Stacked-V will receive VHF, UHF or both. Each of these fine antennas has been designed and built to the quality standards of Amphenol—the highest in the industry.

DEPENDABLE ACCESSORIES. There are many other *tested* antenna installation accessories in addition to those illustrated on this page that are made by Amphenol. All reflect the engineering and production know-how of Amphenol.

*Reissue U.S. Pat. No. 23,273

AMERICAN PHENOLIC CORPORATION
Chicago 50, Illinois

AMPHENOL

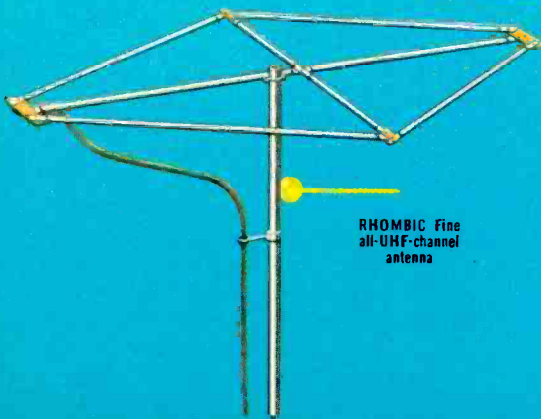

RHOMBIC Fine all-UHF-channel antenna

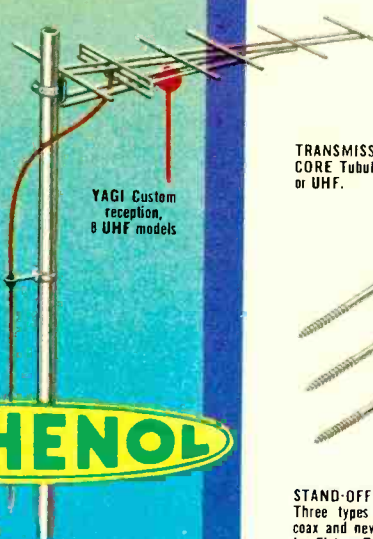

YAGI Custom reception, 8 UHF models



TRANSMISSION LINE Popular Flat Twin-Lead and unique AIR-CORE Tubular Twin-Lead* assure best performance at either VHF or UHF.
*U. S. Pat. No. 2,543,696



STAND-OFF INSULATORS
Three types available: flat, coax and new universal type for Flat or Tubular line.



TELE-COUPLER Two to four television sets operate from single antenna with new and efficient set couplers.

STACKING HARNESSSES Complete harnesses available for two bay stacking of the VHF *INLINE* or Conical and the UHF Yagi, Bo-Ty or Corner Reflector.

positive pulse waveform at its plate, and the tube which conducts for a shorter time will produce a negative pulse waveform. The asymmetrical multivibrator, because of its simplicity and the ease with which it can be controlled, is often used as a pulse generator.

Cathode-coupled

The cathode-coupled multivibrator, shown in Fig. 6, differs from the basic multivibrator in that the second tube is

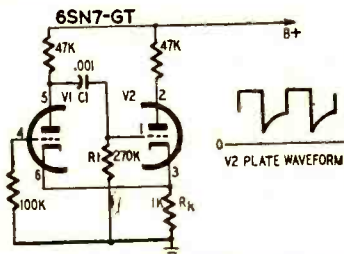

Fig. 6—Cathode-coupled multivibrator.

coupled to the first by the common cathode resistor. To understand this circuit, assume that the plate current of V1 is increasing and note the changes:

1. The IR drop across the plate load resistor of V1 increases, and the plate voltage decreases.
2. Capacitor C1 begins to discharge. The discharge current produces an IR drop across R1.
3. The IR drop across R1 makes the grid of V2 negative with respect to ground, driving V2 to cutoff.
4. When the discharge current of C1 has become sufficiently small, the IR drop across R1 can no longer keep V2 cut off.
5. V2 begins to conduct and its plate current produces an additional voltage drop across Rk.
6. The extra bias developed across Rk drives V1 to cutoff.
7. The plate voltage of V1 increases, and C1 begins to charge. The charging current produces an IR drop across R1.
8. The voltage drop across R1 makes the grid of V2 positive.
9. When C1 has finished charging, the grid of V2 is no longer positive.
10. The plate current of V2 decreases, and the voltage across Rk becomes insufficient to keep V1 cutoff.
11. V1 begins to conduct plate current, and the cycle repeats.

A common technique for generating a sawtooth waveform is to connect a capacitor across a tube which periodically goes from cutoff to saturation. A capacitor in this position will charge from the B plus line when the tube is cut off, and discharge through the tube when it conducts. The voltage across the capacitor therefore increases exponentially and then decreases rapidly—a sawtooth waveform. The multivibrator circuit meets the necessary qualifications since its tubes are alternately cut off and conductive.

A circuit suitable for this application is shown in Fig. 7. If capacitor C2 were not in the circuit, the waveform at the

OUTSTANDING for HIGH FIDELITY!
COLLINS TUNERS and RECEIVERS
 AUDIO PRODUCTS CO.

BUY DIRECT AND SAVE

NOW! with AFC

Collins Audio Products Co. is an equal opportunity employer with Collins Audio Co.

Each Collins Tuner Kit is complete with punched chassis, tubes, power transformer, power supply components, hardware, dial assembly, tuning eye, knobs, wire, etc., as well as the completed sub-assemblies: FM tuning units, AM tuning units, IF amplifiers, etc., where applicable. All sub-assemblies wired, tested and aligned at the factory make Collins Pre-Fab Kits easy to assemble even without technical knowledge. The end result is a fine, high quality, high fidelity instrument at often less than half the cost—because you helped make it and bought it direct from the factory.

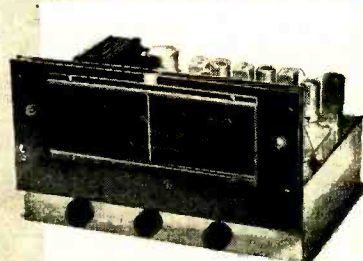

FM Tuner Kit **\$55**
 with AFC \$58.50

The FM-11 tuner is available in kit form with the IF Amplifier mounted in the chassis, wired and tested by us. You mount the completed RF Tuning Unit and power supply, then after some simple wiring, it's all set to operate. 11 tubes: 6J6 RF amp, 6AG5 converter, 6C4 oscillator, 6BA6 1st IF, (2) 6AU6 2nd and 3rd IF, (2) 6AU6 limiters, 6AL5 discriminator, 6AL7-GT double tuning eye, 5Y3-GT rectifier. Sensitivity 6 to 10 microvolts, less than 1/2 of 1% distortion, 20 to 20,000 cycle response with 2DB variation. Chassis dimensions: 12 1/2" wide, 8" deep, 7" high. Illustrated manual supplied. Shipping weight 14 lbs.

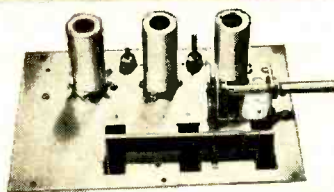

FMF-3 Tuning Unit **\$15.25**
 with AFC \$18.75

The best for FM. The most sensitive and most selective type of "front end" on the market. 6 to 10 microvolts sensitivity. Image ratio 500 to 1. 6J6 tuned RF stage, 6AG5 converter, 6C4 oscillator. Permeability tuned, stable and drift-free. Chassis plate measures 6 1/2" x 4 1/2". In combination with the IF-6 amplifier, the highest order of sensitivity on FM can be attained. Tubes included as well as schematic and instructions. Draws 30 ma. Shipping weight FMF-3: 2 1/2 lbs. Dial available @ \$3.85.

IF-6 Amplifier **\$19.75**
 6 Tubes. Shipping Wgt. 3 lbs.

FOR USERS OF COLLINS TUNERS:

Receive \$5.00 credit toward the new FMF-3A front end! Mail us your old front end with \$13.75 and we will send you the new, improved FMF-3A with AFC., or, remit the full amount of \$18.75 and when we receive your old unit in return a check will be mailed you for \$5.00.



AM-4 Tuning Unit **\$24.50**

Tops in AM superhet performance! A 3-gang tuning condenser gives 3 tuned stages with high sensitivity and selectivity. Assembly is completely wired, tested and aligned ready for immediate use. Frequency coverage 540 KC to 1650 KC at a sensitivity of 5 microvolts. Tubes 6BA6 RF amplifier; 6BE6 converter; 6BA6 IF amplifier and 6AT6 detector. Draws 30 ma @ 220 volts. Mounts on a chassis plate measuring 4" x 7 3/8". Shipping weight 2 1/2 lbs. Dial available at \$3.85.



FM/AM Tuner Kit **\$77.50**
 with AFC \$81.00

The original 15 tube deluxe FM/AM pre-fab kit redesigned on a smaller chassis. The tuner now measures 14" wide by 12" deep by 7 1/2" high. This attractive new front and dial assembly opens up new applications where space is at a premium. Kit includes everything necessary to put it into operation—punched chassis, tubes, wired and aligned components, power supply, hardware, etc. Kit comprises FMF-3 tuning unit, IF-6 amplifier, AM-4 AM tuning unit, magic eye assembly and complete instructions. All tubes included. Shipping weight 19 lbs.

MAIL COUPON TODAY

To: Collins Audio Products Co. Inc. RE-5
 P.O. Box 388, Westfield, N. J.
 Tel. Westfield 2-4390

FM Tuner Kit FM AM Tuner Kit FMF-3 Tuning Unit
 with AFC with AFC with AFC
 IF-6 Amplifier AM-4 Tuning Unit

NAME.....
 ADDRESS.....
 CITY..... STATE.....

Amount for Kit \$..... See weights, add shipping cost \$.....
 Total amount enclosed \$..... Check Money Order

WHEN YOU THINK OF TUNERS, THINK OF COLLINS AUDIO PRODUCTS

ANNOUNCING THE NEW

and most complete standard stock line . . .

ERIE

TEMPERATURE COMPENSATING TUBULAR CERAMICONS

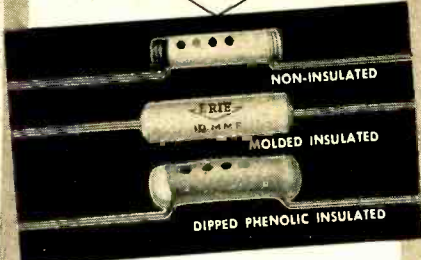

- Three Temperature Coefficients: NPO, N330, N750: Close tolerance on all temperature coefficients.
- Non-insulated, Molded insulated, Dipped Phenolic Insulated.
- Wide range of capacity values, close tolerance on all capacity values.
- Provide commercial equivalents of many often used JAM types.

One purpose of the three temperature coefficients is to provide the means of combining in parallel, various combinations of NPO and N330; and NPO and N750 to obtain intermediate temperature coefficients. Formulae for computing these values as well as a simple nomograph for quick computations will be afforded in service information.

The range of capacity values is the most complete offered as standard stock by any ceramic capacitor manufacturer. Servicemen and engineers . . . your distributor has these capacitors to meet your requirements for TV replacements, laboratory work, and prototype development.

Write for complete list of capacity values available JAN equivalent table, and nomograph.

ERIE components are stocked at leading electronic distributors everywhere.

ELECTRONICS DISTRIBUTOR DIVISION
ERIE RESISTOR CORPORATION

Main Offices: ERIE, PA.

Factories: ERIE, PA. • LONDON, ENGLAND
TRENTON, ONTARIO

plate of V2 would be a pulse waveform as indicated on the diagram. This negative pulse is produced each time the tube goes from cutoff to saturation. When C2 is connected in the circuit, it charges through R2 as long as V2 is cut off. When V2 begins to conduct, its plate current discharges C2. This type of sawtooth generator has become very popular in the scanning circuits of television equipment.

Electron-coupled

In the electron-coupled multivibrator, one (or both) of the tubes are

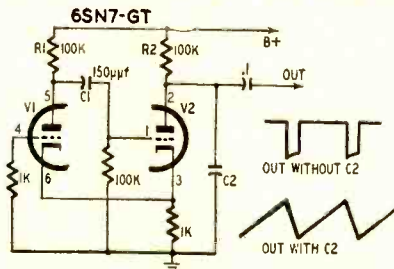

Fig. 7—Generation of a sawtooth wave.

pentodes. The screen grid is used as a plate and is coupled to the control grid of the other tube. This arrangement leaves the actual plate free to provide the output. The load is therefore connected to the multivibrator only through the electron stream of the pentode. A portable high-voltage power supply designed around a 3A8-GT diode-triode-pentode electron-coupled multivibrator is shown in Fig. 8. Each time V2 goes to cutoff, the magnetic

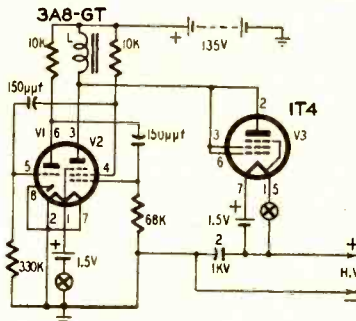
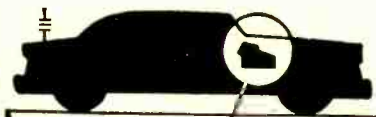

Fig. 8—High-voltage power supply.

field around inductance L collapses. The resulting counter e.m.f. is rectified by V3 to provide the high-voltage output. Geiger counters and other portable high-voltage, low-current instruments can be operated from power supplies of this type. The size and weight of the supply is considerably less than that of the batteries that would be required to furnish an equivalent voltage. In addition, the circuit will be very stable. The electron coupling will prevent any changes in the plate circuit from affecting the multivibrator.

One-shot multivibrators

A special kind of multivibrator is the type in which one tube is so biased that the circuit will not run free. There are many applications for this circuit, and a special article will shortly be devoted to these univibrators and flip-flops.



be an expert on AUTO RADIO SERVICING!

Get the only authoritative compilation of its kind—complete Auto Radio Service Data coverage of all important models since 1946—in 3 great PHOTOFACT Manuals! All data complete, accurate, uniform—based on lab analysis of the actual auto radios covered. Helps you service any model quicker, easier—for greater profits. Get the complete Library!



VOL. 1. AUTO RADIO SERVICE MANUAL

Covers over 100 models made from 1946 to 1949 by 24 manufacturers. Each receiver is completely covered in uniform format; includes schematics, chassis photo views, replacement parts data, service hints, etc. All data based on actual lab analysis. 396 pages, 8½ x 11".

ORDER AR-1. Only \$4.95



VOL. 2. AUTO RADIO SERVICE MANUAL

Covers 60 different chassis (40 models) used in 1948, 1949 and 1950 auto radio receivers. Authoritative, complete service data that makes your work quicker, easier and more profitable. 288 pages, 8½ x 11".

ORDER AR-2. Only \$3.00



VOL. 3. AUTO RADIO SERVICE MANUAL

Covers 47 different chassis (80 models) used in 1950, 1951 and 1952 auto radio receivers. Absolutely the most complete, accurate and easy-to-use data available—uniform and practically presented to make you an expert on the repair of any auto radio. 288 pages, 8½ x 11".

ORDER AR-3. Only \$3.00



SPECIAL OFFER!

All 3 Volumes, Yours for Only \$9.95
Save on the Complete Library—
see your PHOTOFACT Distributor

HOWARD W. SAMS & CO., INC.

Order from your Parts Jobber today, or write direct to HOWARD W. SAMS & CO., Inc. 2205 E. 46th Street, Indianapolis 5, Ind.

My (check) (money order) for \$ encl. Send:

- AR-1 \$4.95 AR-2 \$3.00 AR-3 \$3.00
- Complete 3-Volume Library \$9.95

Name

Address

City State

NEW INVENTION OUTMODES ALL PRESENT ANTENNAS!

53 CLAIMS GRANTED IN 5 U.S. PATENTS ON NEW REVOLUTIONARY ANTENNA INVENTION!

NEW!

SUPER 60

#2,585,670 #2,609,503 #2,625,655 #2,644,091 #2,661,423 others pending



GUARANTEED PERFORMANCE

LIST PRICE
\$36.75
SEE YOUR
JOBBER

ELECTRONIC ORIENTATION SWITCH

The 9-position selector switch electronically rotates the antenna in a stationary position.

THIS IS ALL YOU NEED!

The price includes the complete antenna and the 9-position electronic orientation switch. The Air Dielectric Polymicalene Transmission Line is purchased as required for the individual installation.

NEW POLYMICALENE 4 CONDUCTOR TRANSMISSION LINE

- Low Loss External Air Dielectric
- Matched Impedance
- Eliminates End Sealing
- Eliminates Condensation
- Up to 50% Less Loss Than Tubular When Wet
- Easily Spiraled
- No Breaking or Shorting
- Patents Pending - T. M. Reg

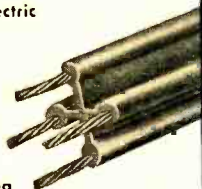

If your Distributor or Dealer can't supply you... Contact us for the name of one who can

- ★ **GUARANTEED TO POSITIVELY OUTPERFORM ALL OTHER ANTENNAS** (with or without rotor motors) on ALL UHF, and ALL VHF stations 2 thru 83 from ALL directions.
- ★ **GUARANTEED** to positively give you the **CLEAREST, SHARPEST, most PERFECT GHOST-FREE** pictures possible in both **COLOR** and black-white.

MONEY BACK GUARANTEED TO RECEIVE All CHANNELS 2-83 FROM All DIRECTIONS AND POSITIVELY OUTPERFORM All OTHER ANTENNAS WITH OR WITHOUT A ROTORMOTOR

UP TO 10 TIMES MORE POWERFUL THAN ALL PRESENT CONVENTIONAL ANTENNAS!

New, revolutionary antenna, while being up to 10 times more powerful than conventional antennas, is still able to receive all television and FM stations from all directions without a rotor motor of any kind. The electronic orientation switch used with a new type transmission line developed specifically for this extra powerful antenna now makes it possible to clearly receive stations heretofore considered out of range. It is now possible to put up just one antenna, use just one transmission line, pay for just one installation and receive the finest possible reception from the stations in and coming to your area regardless of their direction.

NOW!! SOLVE YOUR ANTENNA PROBLEM ONCE AND FOR ALL

ALL CHANNEL ANTENNA CORP.
70-07 Queens Blvd., Woodside 77, N. Y. Hickory 6-2304

SEE US IN BOOTH No.3
IN CHICAGO

IF You have never ordered by mail because you did not want to buy anything "sight unseen" or —
 You have ordered by mail but with disappointing results or —
 You have never purchased anything on time payments because of excessive finance charges, then —

— HERE —

is your opportunity to examine what you want under our "Seller not Buyer, takes all the risk" plan. We invite you to order any item on this page and examine it in the privacy of your own home. If you decide to keep it, you

can then pay the balance in easy monthly payments with no interest or finance charges added. Otherwise, you may return the merchandise for prompt refund of your down-payment.

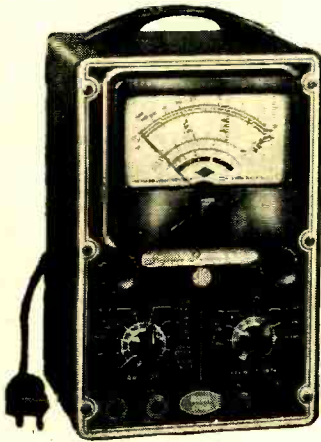

Superior's new
 Model 670-A

SUPER METER

A COMBINATION VOLT-OHM MILLIAMMETER PLUS
 CAPACITY REACTANCE INDUCTANCE AND DECIBEL MEASUREMENTS

SPECIFICATIONS:

D.C. VOLTS: 0 to 7.5/15/75/150/750/1,500/7,500 Volts
 A.C. VOLTS: 0 to 15/30/150/300/1,500/3,000 Volts
 OUTPUT VOLTS: 0 to 15/30/150/300/1,500/3,000 Volts
 D.C. CURRENT: 0 to 1.5/15/150 Ma. 0 to 1.5/15 Amperes
 RESISTANCE: 0 to 1,000/100,000 Ohms 0 to 10 Megohms
 CAPACITY: .001 to 1 Mfd. 1 to 50 Mfd. (Quality test for electrolytics)
 REACTANCE: 50 to 2,500 Ohms 2,500 Ohms to 2.5 Megohms
 INDUCTANCE: .15 to 7 Henries 7 to 7,000 Henries
 DECIBELS: -6 to +18 +14 to +38 +34 to +58

ADDED FEATURE:

The Model 670-A includes a special **GOOD-BAD** scale for checking the quality of electrolytic condensers at a test potential of 150 Volts.

The Model 670-A comes housed in a rugged, crackle-finished steel cabinet complete with test leads and operating instructions.

\$28⁴⁰ NET



Superior's new
 Model TV-11

TUBE TESTER

SPECIFICATIONS:

- ★ Tests all tubes including 4, 5, 6, 7, Octal, Lock-in, Peanut, Bantam, Hearing Aid, Thyatron, Miniatures, Sub-miniatures, Novals, Sub-minars, Proximity fuse types, etc.
- ★ Uses the new self-cleaning Lever Action Switches for individual element testing. Because all elements are numbered according to pin-number in the RMA base numbering system, the user can instantly identify which element is under test. Tubes having tapped filaments and tubes with filaments terminating in more than one pin are truly tested with the Model TV-11 as any of the pins may be placed in the neutral position when necessary.
- ★ The Model TV-11 does not use any combination type sockets. Instead individual sockets are used for each type of tube. Thus it is impossible

to damage a tube by inserting it in the wrong socket.

- ★ Free-moving built-in roll chart provides complete data for all tubes.
- ★ Newly designed Line Voltage Control compensates for variation of any Line Voltage between 105 Volts and 130 Volts.
- ★ **NOISE TEST:** Phono-jack on front panel for plugging in either phones or external amplifier will detect microphonic tubes or noise due to faulty elements and loose internal connections.

The model TV-11 operates on 105-130 Volt 60 Cycles A.C. Comes housed in a beautiful hand-rubbed oak cabinet complete with portable cover

\$47⁵⁰ NET

EXTRA SERVICE — The Model TV-11 may be used as an extremely sensitive Condenser Leakage Checker. A relaxation

type oscillator incorporated in this model will detect leakages even when the frequency is one per minute.

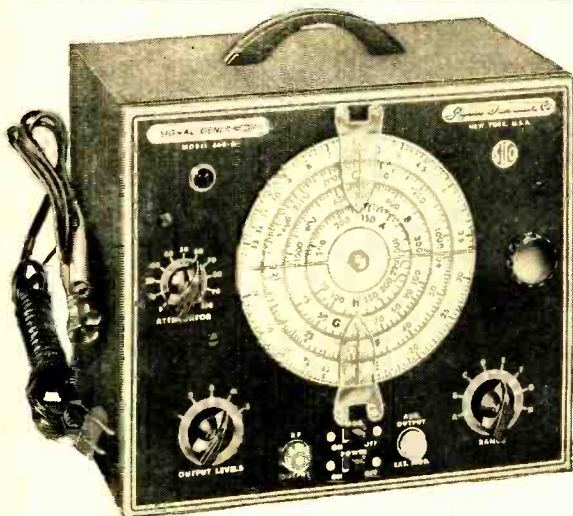

Superior's New Model 660-A AN AC OPERATED

SIGNAL GENERATOR

PROVIDES COMPLETE COVERAGE for AM-FM & TV Alignment

SPECIFICATIONS:

- Generates Radio Frequencies from 100 Kilocycles to 60 Megacycles on fundamentals and from 60 Megacycles to 220 Megacycles on powerful harmonics.
- Accuracy and Stability are assured by the use of permeability trimmed Hi-Q coils.
- R.F. available separately or modulated by the Internal audio oscillator. — Built in 400 cycle sine wave audio oscillator used to modulate the R.F. signal also available separately for audio testing of receivers, amplifiers, hard of hearing aids, etc.
- R.F. Oscillator Circuit: A high transconductance heptode is used as an R.F. oscillator, mixer and amplifier. Modulation is effected by electron coupling in the mixer section thus isolating the oscillator from load changes and affording high stability.
- A.F. Oscillator Circuit: A high transconductance heptode connected as a high- μ triode is used as an audio oscillator in a High-C Colpitts Circuit. The output (over 1 Volt) is nearly pure sine wave.
- Attenuator: A 5 step ladder type of attenuator is used.

mode is used as an R.F. oscillator, mixer and amplifier. Modulation is effected by electron coupling in the mixer section thus isolating the oscillator from load changes and affording high stability. ● A.F. Oscillator Circuit: A high transconductance heptode connected as a high- μ triode is used as an audio oscillator in a High-C Colpitts Circuit. The output (over 1 Volt) is nearly pure sine wave. ● Attenuator: A 5 step ladder type of attenuator is used.

TUBES USED:

- 1—6BE6 as R.F. Oscillator, mixer and amplifier.
- 1—6BE6 as Audio Oscillator.
- 1—6H6 as Power Rectifier.

The Model 660-A comes complete with coaxial cable test lead and instructions.

\$42⁹⁵ NET

MOSS ELECTRONIC DISTRIBUTING CO., INC.
 Dept. B-99, 3849 Tenth Ave., New York 34, N. Y.

Please send me the units checked. I am enclosing the down payment with order and agree to pay the monthly balance as shown. It is understood there will be no carrying, interest or any other charges, provided I send my monthly payments when due. It is further understood that should I fail to make payment when due, the full unpaid balance shall become immediately due and payable.

Name.....
 Address.....
 City..... Zone..... State.....

- MODEL 670-A Total Price \$28.40 \$7.40 down payment. Balance \$3.50 monthly for 6 months.
- MODEL TV-11 Total Price \$47.50 \$11.50 down payment. Balance \$6.00 monthly for 6 months.
- MODEL 660-A Total Price \$42.95 \$12.95 down payment. Balance \$5.00 monthly for 6 months.
- I enclose \$..... as down payment.
- Ship C.O.D. for the down payment.

RADIO-ELECTRONICS

NEW INVENTION OUTMODES ALL PRESENT ANTENNAS!

53 CLAIMS GRANTED IN 5 U.S. PATENTS ON NEW REVOLUTIONARY ANTENNA INVENTION!

NEW!

SUPER 60

#2,585,670 #2,609,503 #2,625,655 #2,644,091 #2,661,423 others pending



GUARANTEED PERFORMANCE

LIST PRICE
\$36.75
SEE YOUR
JOBBER

ELECTRONIC ORIENTATION SWITCH

The 9-position selector switch electronically rotates the antenna in a stationary position.

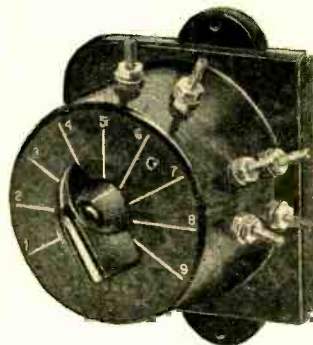

THIS IS ALL YOU NEED!

The price includes the complete antenna and the 9-position electronic orientation switch. The Air Dielectric Polymycalene Transmission Line is purchased as required for the individual installation.

NEW POLYMICALENE 4 CONDUCTOR TRANSMISSION LINE

- Low Loss External Air Dielectric
- Matched Impedance
- Eliminates End Sealing
- Eliminates Condensation
- Up to 50% Less Loss Than Tubular When Wet
- Easily Spiraled
- No Breaking or Shorting
- Patents Pending - T. M. Reg

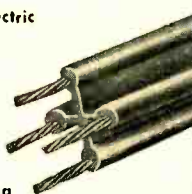

If your Distributor or Dealer can't supply you... Contact us for the name of one who can

- ★ **GUARANTEED TO POSITIVELY OUTPERFORM ALL OTHER ANTENNAS** (with or without rotor motors) on ALL UHF, and ALL VHF stations 2 thru 83 from ALL directions.
- ★ **GUARANTEED** to positively give you the **CLEAREST, SHARPEST, most PERFECT GHOST-FREE** pictures possible in both **COLOR** and black-white.

MONEY BACK GUARANTEED TO RECEIVE *All* CHANNELS 2-83 FROM *All* DIRECTIONS AND POSITIVELY OUTPERFORM *All* OTHER ANTENNAS WITH OR WITHOUT A ROTORMOTOR

UP TO 10 TIMES MORE POWERFUL THAN ALL PRESENT CONVENTIONAL ANTENNAS!

New, revolutionary antenna, while being up to 10 times more powerful than conventional antennas, is still able to receive all television and FM stations from all directions without a rotor motor of any kind. The electronic orientation switch used with a new type transmission line developed specifically for this extra powerful antenna now makes it possible to clearly receive stations heretofore considered out of range. It is now possible to put up just one antenna, use just one transmission line, pay for just one installation and receive the finest possible reception from the stations in and coming to your area regardless of their direction.

NOW!! SOLVE YOUR ANTENNA PROBLEM ONCE AND FOR ALL

ALL CHANNEL ANTENNA CORP.

70-07 Queens Blvd., Woodside 77, N. Y.

Hickory 6-2304

SEE US IN BOOTH No.3
IN CHICAGO

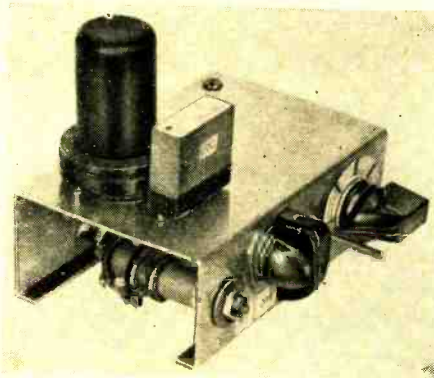

I.f.-r.f. crystals are mounted on top.

I.F.-R.F. CRYSTAL OSCILLATOR USES JUNCTION TRANSISTOR

By I. QUEEN

MANY experimenters assume that junction transistors are effective only at audio frequencies, so they don't try to use them in high-frequency circuits. Actually most junction transistors I have tried perform well as oscillators through the i.f. range, often beyond 1 mc. This crystal oscillator uses a CK722 junction transistor, and oscillates in the intermediate-frequency and radio-frequency range. It is equipped with an output control and is suitable for measuring, aligning, and calibrating.

Fig. 1 shows the hookup. The transistor is powered by a pair of penlight cells that will last a long time. Provision is made for two different frequencies. I used a 1-mc crystal (looks like a metal tube in the photo) and a 375-kc crystal (surplus type). Both crystals are left in the circuit at all times. Only the coils are switched. The circuit oscillates when the collector coil is tuned close to either one of the crystal frequencies.

The i.f. coil (L1) is a Grayburne Vari-Choke whose inductance may be varied from 0.65 to 6.0 mh. It may be replaced by a coil with an inductance of about 3.5 mh. For example, I found that a standard 2.5-mh coil in series with a 1-mh coil works fine. The r.f. coil (L2) is a slug-tuned broadcast oscillator unit (for 465 kc i.f.). It tunes to 1 mc with the slug almost all the way in. If a Q meter or test oscillator is available, the coils may be pretuned to the desired frequencies. Final tuning

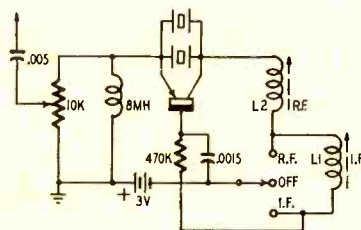

Fig. 1—The i.f.-r.f. crystal oscillator.
RADIO-ELECTRONICS

WHEN WILD WINDS HIT... PERMA-TUBE STAYS UP

... and so does your reputation!

Here's why PERMA-TUBE backs up quality service:

1. **PERMA-TUBE IS STURDY** . . . it's made of special, high-strength J&L Steel.
2. **PERMA-TUBE IS CORROSION-PROOF** . . . it's treated with vinylite—then coated inside and outside with a metallic vinyl resin base.
3. **PERMA-TUBE IS EASILY INSTALLED** . . . it's the only mast with both ends of the joint machine fitted.

Here's proof of Perma-Tube's superior strength.

Ordinary masts and Perma-Tube were subjected to regular deflection and permanent set tests with the following results:

TV Mast Tested	Size and B W Gauge	Bending Force To Produce 2½ lbs Set
Mast A	1½" OD x 20 Ga.	1870 inch pounds
Mast B	1½" OD x 18 Ga.	2740 inch pounds
Mast C	1.155" OD x 17 Ga.	2780 inch pounds
Perma-Tube	1½" OD x 18 Ga.	2930 inch pounds
Mast D	1½" OD x 15 Ga.	4370 inch pounds
Mast E	1½" OD x 16 Ga.	4560 inch pounds
Perma-Tube	1½" OD x 16 Ga.	5950 inch pounds

CHECK THE 500 HOUR MINIMUM SALT SPRAY TEST RATING OF YOUR TELEVISION MASTS (Am. Soc. of Testing Materials—Spec. 5117-49T). Remember Perma-Tube passes this test . . . remains corrosion-proof.



Jones & Laughlin

STEEL CORPORATION — Pittsburgh

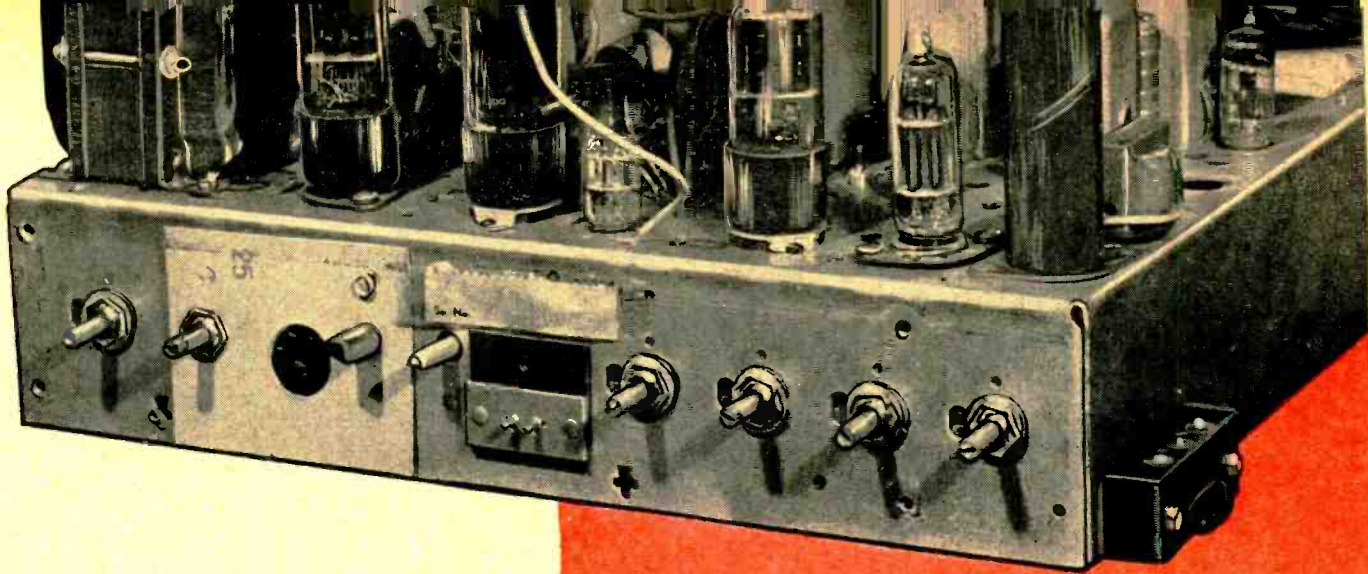

precision

tools for precision servicing
... G-C Alignment Tools

G-C Alignment Tools—more than 60 of them—are precision engineered for faster, more effective TV servicing . . . and service developed to be sure they're what you need.

Besides those alignment tools you see here, G-C has many others . . . part of the more than 3,000 G-C service items designed specifically for better service work. Remember, too, that there are a dozen G-C Alignment Tool Kits . . . matched instrument sets to meet most service requirements and priced surprisingly low for top quality tools!



YOUR COPY of the big, new illustrated G-C Catalog No. 156. It's free . . . at your favorite jobber or write direct.



GENERAL CEMENT MFG. CO.
 910 Taylor Street Rockford, Illinois



G-C NEW TV "X-57 PLASTIC LONG SLIM" SCREWDRIVER
 Rugged 100% insulated.
 No. 8989 18 1/4" long List \$2.00



G-C NEW NYLON TV LONG-REACH ALIGNER
 Replaceable Nylon Tip.
 No. 8607 12 1/4" long List \$1.80

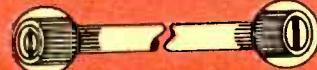

G-C TV CORE ALIGNER
 For sets using stud type cores.
 No. 8271 List \$0.90



G-C TV LF-OSCILLATOR ALIGNER
 Fits all makes of sets.
 No. 8272 List \$1.20



G-C TV LONG-REACH ALIGNER
 For hard-to-reach iron cores.
 No. 8274 List \$1.20



G-C TV DUPLEX ALIGNER
 All-purpose, extra-strong.
 No. 8275 List \$0.80



G-C NEW ZENITH TV WRENCH & ALIGNER
 Specially made for Zenith TV.
 No. 8282 List \$0.55



G-C TV 2-in-1 LONG-REACH DUPLEX ALIGNER
 For No. 4 and No. 6 studs.
 No. 8271 9" long List \$1.25



G-C NEW RCA-ZENITH ALIGNER
 Aligns strips, etc. on Zenith, RCA.
 No. 9050 List \$0.30



G-C NEW RCA-ZENITH "SHORTY" ALIGNER
 For those tight spaces; only 2" long.
 No. 9051 List \$0.75

NO BROKEN LEADS

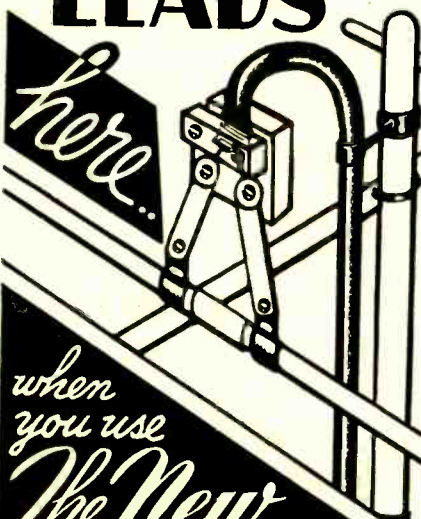

when you use
The New MOSLEY

"Y-Ty"

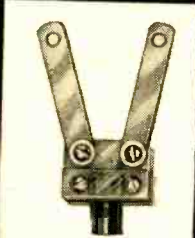

LIST PRICE \$.80

PATENT APPLIED FOR

- Low Loss, Permanent Connections Of Transmission Line and Phasing Strips To TV Antenna Elements!
- For UHF and VHF Antennas!
- For All Types Transmission Line!
- Eliminates Roof-top Soldering Jobs!
- Quick — Easy to Install!
- Available In Two Sizes To Fit All Antennas!

CATALOG 263-S For all UHF Antennas and most VHF Yagis, Conicals, Inline, and other type antennas where distances between terminals is 4" or less.

CATALOG 263-L For TRIO Zig-Zag, and other antennas where distance between terminals is 6" or less.

Your reputation hangs on fine threads of copper. Use the MOSLEY "Y-TY" on Every Installation Job To Stop Antenna Call-backs!

The NEW MOSLEY "Y-TY" now available at Radio and Television Parts Distributors — Coast-to-Coast!

WRITE FOR FREE COPY OF THIS CATALOG



Mosley Electronics, Inc.
8622 ST. CHARLES ROCK ROAD
ST. LOUIS 14, MISSOURI

may then be done in the crystal oscillator.

The i.f. coil tunes broadly; the same setting can be used for crystals ranging from below 375 kc to over 400 kc. Thus, if you have a number of surplus i.f. crystals, you can easily change frequency without retuning. Simply plug in the crystal you want.

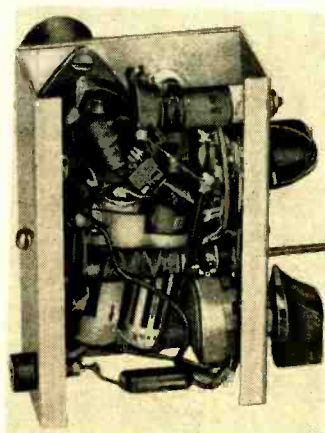

Underchassis view shows chassis layout.

The oscillator is adjusted first with the switch in the r.f. position. Set the slug in L2 for output on 1 mc or whatever frequency you select. Next, throw the switch to I.F. and adjust the tuning of L1 for output on the desired frequency in the i.f. range.

Materials for i.f.-r.f. oscillator

- 1—47,000-ohms, 1/2-watt, resistor; 1—10,000-ohm potentiometer; 1—.0015-uf capacitor; 1—.005-uf capacitor; 2—crystals; 1—CK722 transistor; 3—sockets for crystals and transistor; 1—3.5-mh coil; 1—slug-tuned broadcast oscillator coil; 1—3-position switch; 2—penlight cells.

A single penlight cell is sufficient for the i.f. band. However, I found it advisable to use at least two cells for the 1-mc range; otherwise the oscillator does not start each time and the output is weak. Since transistors are not uniform, you may find that still greater voltage is needed for the r.f. oscillator. You may have to use 9 volts or more. However, of several tried here, I found all functioned satisfactorily. One even oscillated at 1 mc with less than 1.5 volts! END

HAM'S HEADACHE

by Jeanne DeGood

My neighbor says that I'm the guy
Who's causing all his TVI,
But often he's the guy who wrecks
My QSO with rare dx.

I cannot hear a thing upon
The bands when his TV is on . . .
If he's as friendly as I am,
He'll turn it off so I can ham.

ASSEMBLE YOUR OWN ELECTRONIC ORGAN



SAVE HUNDREDS OF DOLLARS WITH OUR COMPLETE KITS AND STEP-BY-STEP INSTRUCTIONS.

- Tone Generators
- Keyboards
- Power Supplies
- Tremolos
- Amplifiers
- Tone Cabinets
- Consoles

For Details Write Today To:
ELECTRONIC ORGAN ARTS
Box 16454, Dept. RE-2
Vine Station, Los Angeles 38, Calif.

Concord's BUY OF THE MONTH

Sensational
SELF POWERED 2 WAY PHONE SYSTEM
\$4.50 PAIR

Operate with telephone like clarity over distances of up to one mile. Phones made of rugged, shockproof Dow Styron with self-contained 1 1/2 Volt flashlight battery. Has full size carbon mike 24 carat gold plated. Complete with push to talk switch, spring clip leads and wall brackets. Without a doubt, one of the most sensational service, office or home items ever offered. Complete with batteries. **\$4.50**
Two conductor twisted pair weatherproof wire for above. . . . 2¢ per ft **100 ft. \$1.50**

FREE! NEW 1954 CATALOG!

A complete, comprehensive listing of all your electronic requirements. Bursting with **SPECIAL VALUES**



CONCORD RADIO, 54 Vesey St., N. Y. 7, Dept. C5

- Please send . . . sets of phones at \$4.50 ea.
- Enclosed find \$ in complete payment. Minimum 20% deposit with C.O.D.
- Send new 1954 CONCORD CATALOG!

NAME _____
ADDRESS _____
CITY _____ ZONE _____ STATE _____

CONCORD RADIO • 54 VESEY ST. NEW YORK 7, N. Y. • DIgby 9-1132

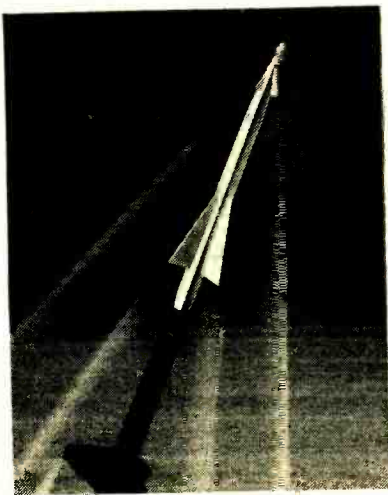

TELEPHONE SCIENCE
GUIDES A PUNCH
NO ENEMY CAN DODGE

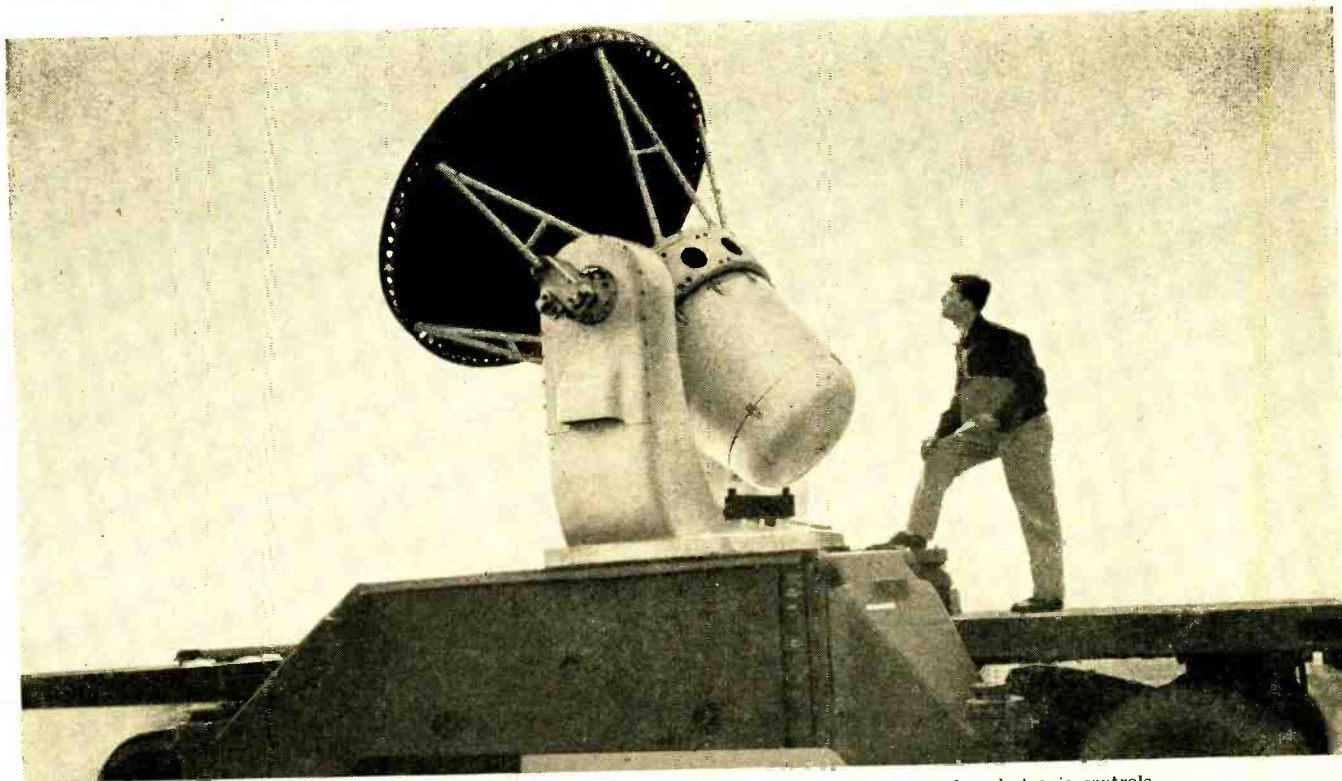

(Upper left) — Nike's missile climbs to destroy an enemy, under guidance of complex electronic controls. A radar is shown at right. Nike (pronounced Ny'kee) is named after the Greek goddess of Victory.



**BELL TELEPHONE
 LABORATORIES**

Is it possible to guide an anti-aircraft missile so that it will track down and destroy a rapidly maneuvering target? No one knew the answer for sure when the U. S. Army put this question to Bell Telephone Laboratories in 1945.

The special skills and techniques developed to create the nation's communications network uniquely fitted Bell scientists to answer this question. They recommended a new system, Nike, and then worked to bring it into being with

engineers from Army Ordnance, Western Electric Company and Douglas Aircraft Company.

The first Nike installation has been made, and more will follow. Thus, America's defenses grow stronger through a new extension of frontiers in the communications art. It is a proud achievement of the knowledge and skills first developed at Bell Telephone Laboratories to make the nation's telephone service ever better.

Improving telephone service for America provides careers for creative men in scientific and technical fields

MAY, 1954

American Beauty

ELECTRIC
SOLDERING
IRONS
for



**BETTER
SOLDERED
CONNECTIONS**

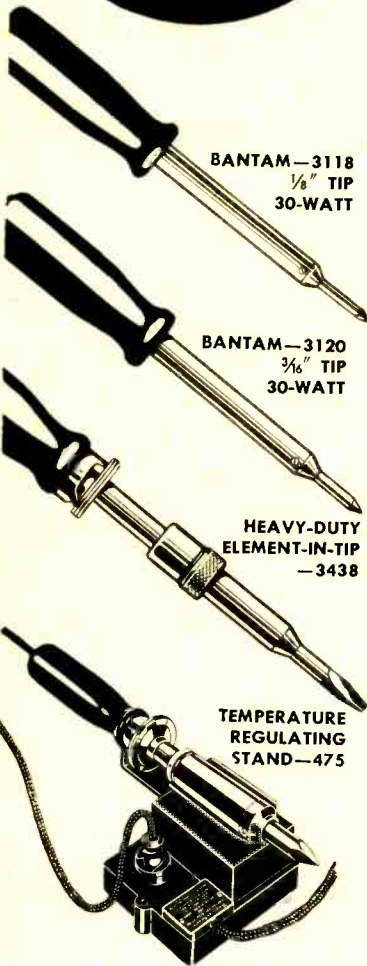

BANTAM—3118
1/8" TIP
30-WATT

BANTAM—3120
3/16" TIP
30-WATT

HEAVY-DUTY
ELEMENT-IN-TIP
—3438

TEMPERATURE
REGULATING
STAND—475

DEPENDABLE . . . DURABLE . . . EFFICIENT. Since 1894 American Beauty Electric Soldering Irons have been the standard for performance for all soldering irons.

NOW . . . American Beauty gives you precision production soldering with the new BANTAM—a light, sturdy, quick-heating soldering iron with small-diameter tip.

HEAVY-DUTY ELEMENT-IN-TIP—3438

A different, more efficient electric soldering iron than any on the market. An iron designed especially for heavy-duty or production-line use. It embodies a new type of heat application with the element permanently-embedded in the tip.

**TEMPERATURE REGULATING
STAND 475**

Set the thermostat at the desired temperature—your iron will be ready to use without waiting.

WRITE FOR DESCRIPTIVE LITERATURE

SINCE 1894—ALWAYS DEPENDABLE

American Electrical Heater Company

DETROIT 2, MICHIGAN



NO. 140-H

RADIO

IDENTIFYING TUBE TYPES FROM DAMAGED ETCHINGS

By HECTOR E. FRENCH

ONE of the greatest irritations suffered by a radio service technician or experimenter is to find that the etched type indication has rubbed off a tube so it cannot be identified. Without this etch, for example, a 6SJ7-GT looks just like a 6SK7, and a 6SN7-GT looks just like a 6SL7-GT (except for the shape of the plates, and nobody can remember which plate shape belongs with which tube anyhow). Luckily, there are at least five different ways to bring out an etch that has become completely invisible from repeated handling.

When placing the etch on a tube, the manufacturer has a choice of a number of different processes. He may obtain a permanent etch by sand-blasting the type number into the glass through a stencil. This method is seldom used because of problems in safeguarding the health of personnel. Or, as another method, the manufacturer could etch the tube identification into the glass with a strong hydrofluoric acid. This would undeniably eat a very permanent etch into the glass—but the trouble is that the acid would eat holes in everything else, including the people operating the machines. In addition, hydrofluoric acid poses an expensive storage problem.

Since the manufacturer's intention is to etch the tubes and not his personnel, a less dangerous procedure is required. As a result, each manufacturer has his own concoction of chemicals which is rubber-stamped on the glass during manufacture of the tube. When first stamped on, the etch may be almost invisible, but after the tube has passed through the various processes of manu-

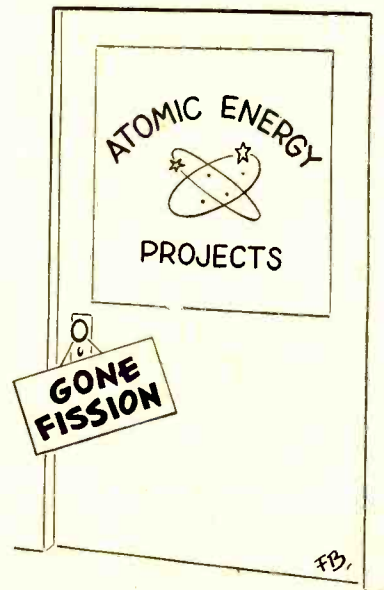

Suggested by James Ward, Milwaukee, Wis.

The fastest selling TV antennas in America *today!*

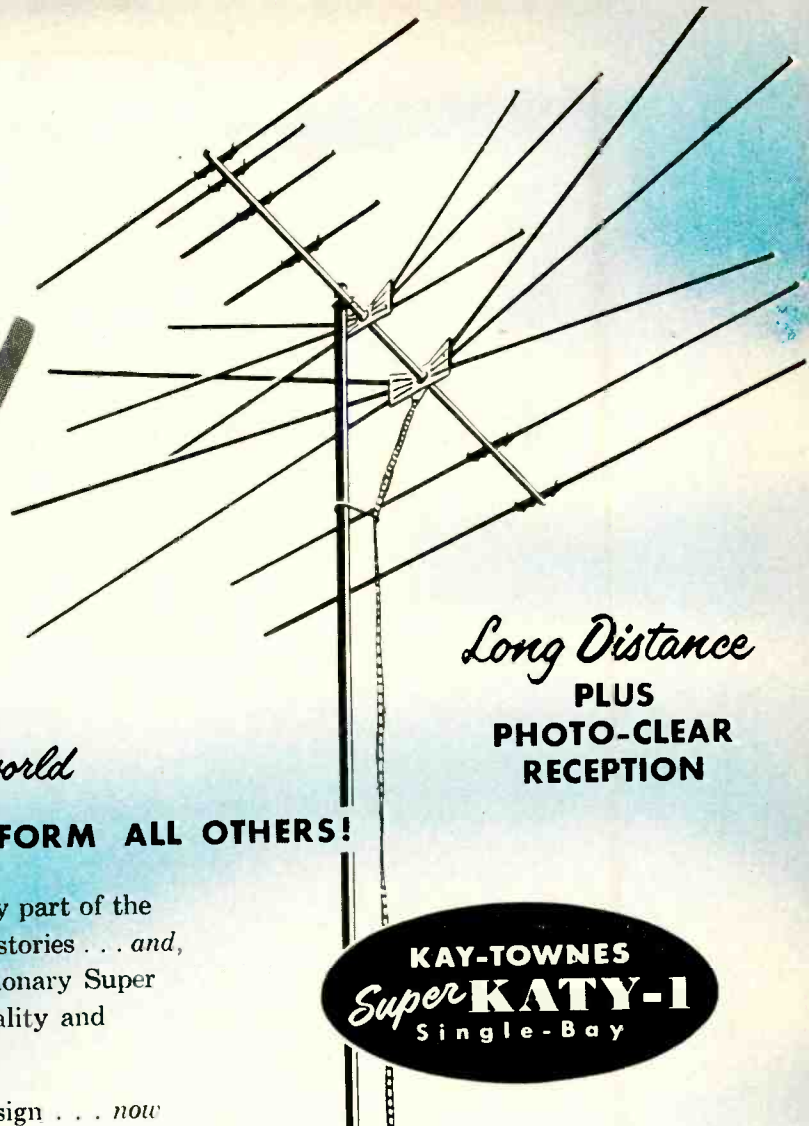

Long Distance
PLUS
PHOTO-CLEAR
RECEPTION

KAY-TOWNES
Super **KATY-1**
Single-Bay

THERE'S A REASON... *the best in the world*
...THEY'RE *Guaranteed* TO OUT-PERFORM ALL OTHERS!

"Fringe area" dealer-servicemen in every part of the country are reporting outstanding sales and service stories... and, mounting TV consumer demand! The new, revolutionary Super "KATYS" have now convincingly proved every quality and performance claim attributed to them.

Kay-Townes' original SUPER KATY design... now amazingly improved... will outperform any other competitive antenna on the market today, regardless of type or design principle!

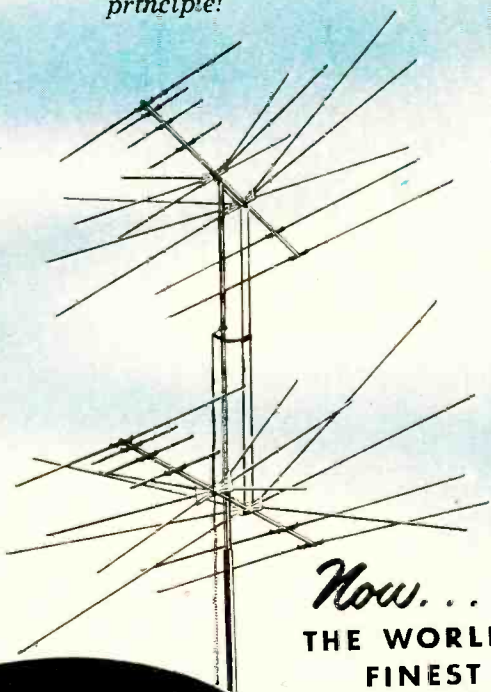

KAY-TOWNES
Super **KATY-2**
2 - Bay

Manufactured and Distributed in CANADA By
DELHI METAL PRODUCTS, LTD., DELHI, ONTARIO

THE BEST TV SET IS ONLY
AS GOOD AS ITS ANTENNA
...WHY SELL LESS THAN THE BEST?

From every standpoint, Kay-Townes' TV Antennas are the finest, farthest-reaching all-channel "fringe area" antennas ever designed. No other antennas can offer complete customer satisfaction... and reduced service calls.

Another
KAY-TOWNES
FIRST!
New non-slip-positive grip mast clamp. Will not crush mast when tightened...will not change direction in strongest winds.

WE'LL SEE YOU AT
the **1954** MAY 17-20, CHICAGO 
ELECTRONICS PARTS SHOW

SPACE NO. 624

KAY-TOWNES
ANTENNA COMPANY
ROME, GEORGIA

LEADERS IN THE FIELD OF FRINGE AREA ANTENNA DESIGN

THE BIG 3
of SALES SUCCESS
WITH BUXTON
POWER-VUE
ANTENNAS

We give the trade

1. WHAT THEY WANT
2. WHAT THEY CAN SELL
— PROFITABLY
3. WHAT PERFORMS BEST
IN THEIR AREAS

FOR EXAMPLE:

COBRA* CONE (Conicals)

PROVED UNIVERSALLY HIGH GAIN for practically all areas. WINNING UNQUESTIONED APPROVAL wherever used... An EXCLUSIVE KEY FEATURE: Quick-Lock "2 BOLT" COBRA HEAD (Greater element separation achieves longer, cleaner, clearer signal.) Other important features, too.

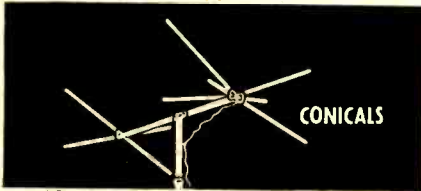

NO. 3cc POWER-VUE COBRA CONE
 (An outstanding sales number)

The PLAIN FACTS about BUXTON POWER-VUE YAGIS

1. MAINTAINED HIGH GAIN via correct design.
2. APPROVED PHYSICAL STRENGTH Aluminum alloys, Steel Support brackets, non-break insulators.
3. "E-Z UP" ASSEMBLY. Either pre-assembled Snap-Out, or One-Piece, Elements.

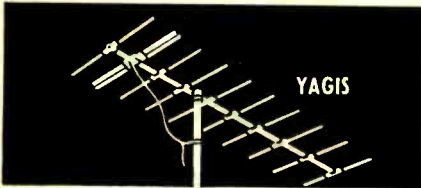

A FULL LINE OF YAGI TYPES
Broad Band, Delta Match, etc.

BUXTON ALSO BUILDS: Power-Vue Straight Dipoles, Arrows, V Stacks, Diamondbacks, Folded Dipoles and Fringe Area Antennas. And Accessories. *A Buxton Name

SOLD NATIONALLY THROUGH JOBBERS

BUXTON INDUSTRIES, INC. RE-1
 88 North Fair Oaks Ave., Pasadena, California

PLEASE SEND INFORMATION AS CHECKED:

FULL INFORMATION & PRICES.

Name & Address of NEAREST JOBBER

Name _____

Street _____

City _____ Zone _____ State _____

facture, and has been heated to almost the softening point of the glass, the etching material has roughened the glass and swollen up into an opaque coating which will adhere to the glass during all subsequent normal handling.

The normal method of reading the etch is by reflected light, in the same manner that this printed page is read. But when the etch is almost gone, there are two other ways to identify the tube.

The first is to read by transmitted light, as though the tube were a photographic negative, held up against the light. This method will frequently permit the etch to be read easily, especially with an older tube.

If the etch cannot be read by transmitted light, it can sometimes be read by diffused, or scattered, light. Allow the light to shine on the etch location from a very small angle with the surface of the glass. If the light is coming directly from the left, for example, the beams which strike the unetched areas are not seen. Beams which strike the slightly roughened etched area are scattered in all directions, and the small percentage of this light which is scattered is often enough to make the etch readable.

When these methods fail, there is still another procedure which will almost always work. This procedure, strangely enough, depends on the natural oils of the scalp, which have just the right consistency to bring out the etch on a tube. If the tube is rubbed over the hair at the back of the neck the etched area collects more oil than does the smoother glass areas, and the etch can be read with surprising ease.

About the only time this procedure fails is in cases where the scalp has a deficiency of this oil, or when the person reading the etch is completely bald. Even then, there is no need to despair, because there are still two more ways to make the etch visible.

You will notice that each of these previous methods depend on the slight roughness in the glass left after the etch has disappeared. The next method is therefore almost obvious. An ordinary lead pencil, hard or soft, sharp or dull, depending on the particular etch, will bring out the pattern by careful rubbing. One particular tube may require an extremely hard, sharp pencil, while the next tube works best with a softer lead. In either case, the roughened area collects more of the graphite from the pencil than does the smoother glass around it.

The last procedure in case the previous methods fail is to try refrigeration. That's right, refrigeration—I didn't believe it myself. When the tube is sufficiently chilled, breathing on the tube will make the etch completely clear when all other methods have failed. Once again, the reason lies in the slightly roughened surface left behind when the etch has been rubbed off. The moisture in the breath condenses more readily on this roughened surface

Scala

Super-Marker Injector
 cuts bench time up to
75% on alignment jobs!



MODEL SMI 53
 \$67.50

MAKES A SIMPLE MECHANICAL PROCEDURE OF WHAT IS NOW A TOUGH TECHNICAL TASK!

No longer do you have to connect and reconnect a maze of cables, look at erroneous response curves, worry about overloads, traps, and weak or invisible markers. The Scala Super-Marker Injector ends this completely! For example, a complete video IF alignment job can be accomplished with only two cables and no reconnections! (Marker bypasses receiver circuits entirely.)

Used with any standard marker generator, sweep generator and oscilloscope.

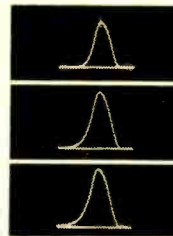

OLD METHOD OF ALIGNMENT

Marker size is normal at top; almost invisible on slope of curve; disappears completely in base line.

Alignment with the SCALA Super-Marker Injector

Marker size is now always the same regardless of position on response curve or base line. The traps and the characteristics of receiver have absolutely no effect on marker size.

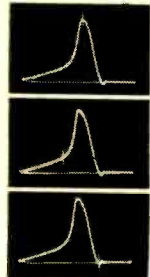

AN ABSOLUTE MUST IN THE ALIGNMENT OF COLOR TV RECEIVERS!

Available at leading jobbers

Scala

2814-19th STREET
 SAN FRANCISCO 10, CALIFORNIA
 RADIO-ELECTRONICS

Transistors

for the practical worker in electronics! TRANSISTORS—THEORY AND PRACTICE boils down the findings of advanced physicists on transistors into the language and experience of the service technician and other practical workers in electronics. Most complete low-cost book on transistors yet published.

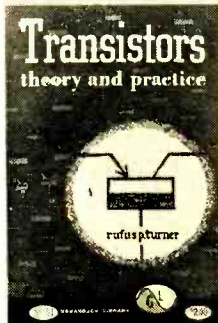

Transistors – Theory and Practice

Gernsback Library Book No. 51. By **Rufus P. Turner**. 144 pages. Fully illustrated. \$2.00

For you who depend on electronics for a living or who work with it as a hobby, here is a book which gives you the lowdown on transistors, the dramatic new development which promises to revolutionize the entire industry.

Most of what has been written on transistors so far has been limited to the rarified strata of the advanced physicist—so obscure that even some engineers have trouble understanding it.

NEW PRACTICAL APPROACH

But now, **Rufus P. Turner**, who knows more about transistors than any popular technical writer in the business, lifts the fog on this fascinating subject. In a simple, straightforward manner, he traces the transistor from the basic semiconductor theory to the application of transistors in practical circuits.

With the actual commercial use of transistors already a reality in hearing aids, and their use in radio and TV just around the corner, the service technician and experimenter owe it to themselves to learn all they can about these new electronic devices. TRANSISTORS—THEORY AND PRACTICE is a giant step along the way to understanding how to work with transistors in practical circuits.

SOME OF THE CONTENTS OF TRANSISTORS—THEORY AND PRACTICE

- Semiconductor Theory
- Transistor Characteristics
- Equivalent Circuits
- Transistor Amplifiers
- Transistor Oscillators
- Duality in Transistor Circuit Design
- Triggers and Switches
- Practical Transistor Circuits
- Tests and Measurements
- Characteristics of Commercial Transistors

First time in any book—a complete discussion on the surface-barrier transistor!

EXCLUSIVE FEATURE

Chapter 10 — **Characteristics of Commercial Transistors** is a complete guide to the physical and electronic characteristics of commercial transistors. Actually the first published manual on transistors, it can save many hours of experimenting and trial and error methods. This unique feature alone makes TRANSISTORS—THEORY AND PRACTICE a book you should own. Get your copy today at your parts distributor's.

Have you read these Gernsback Library Books?

- TV Repair Techniques. No. 50. \$1.50
- Radio & TV Test Instruments. No. 49 \$1.50

See your distributor—or mail this coupon

Gernsback Publications, Inc., Dept. 54
25 West Broadway, New York 7, N. Y.

Enclosed is my remittance of \$ _____
Please send me the following books postpaid.

51 Transistors—Theory and Practice. \$1.75
 50 49 48 47 46
 45 44 43 42 41 39

Name _____
(Please print clearly)

Street _____

City _____ Zone _____ State _____

- High-Fidelity—Design, Construction, Measurements. No. 48. \$1.50
- Radio & TV Hints. No. 47. \$1.00
- Television Technotes. No. 46. . \$1.50
- Radio Tube Fundamentals. No. 45 \$1.00
- Basic Radio Course. No. 44. . \$2.25
- Model Control By Radio. No. 43 \$1.00
- High-Fidelity Techniques. No. 42 \$1.00
- Public-Address Guide. No. 41. .75¢
- Practical Disc Recording. No. 39.75¢

Positive connections every time



with new **Centralab Precision**

Attachable Terminal HI-VO-KAPS®

When it comes to high-voltage capacitors, you just can't beat CRL Precision Attachable Terminal Hi-Vo-Kaps for dependability. Here's why:

They are 100% factory-tested at twice rated working voltage — withstand continuous overload up to 40,000 v.d.c.

Terminals and taps have heavy 8-32 thread—cannot strip or break off, when terminals are tightened.

Terminals seat flat at bottom of tap. No gaps between terminals and capacitor body — no possibility of corona.

Positive mechanical bond between stub terminals and internal electrodes prevents loosening, when terminals are attached.

Keep a stock of CRL Precision Attachable Terminal Hi-Vo-Kaps on hand. Separate packaging of terminals and capacitor body lets you buy only the terminals you need. See your Centralab distributor.

Send coupon for bulletin 28-2 on CRL Precision Attachable Terminal Hi-Vo-Kaps. SEE US AT BOOTH 790.

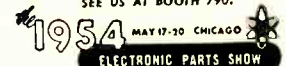

CENTRALAB, A Division of Globe-Union Inc. 922E E. Keefe Avenue, Milwaukee 1, Wisconsin
Send bulletin 28-2 on CRL Precision Attachable Terminal Hi-Vo-Kaps.

Name _____
Company _____
Address _____
City _____ Zone _____ State _____

THE #630 TV RECEIVER

remains unmatched for quality and performance • • • RCA designed and developed this set quality-wise *not* price-wise • • • The original 10" set retailed at \$375.00 • • • Subsequent TV sets serve to prove the sacrifice of quality for price • • • what **BETTER** proof can there be of its superiority than the fact that it is the choice of TV engineers and TV technicians! Herewith we offer you — **YOUR BEST BUYER IN TV!** — All you pay is the price shown • • • Excise taxes have already been paid by us.

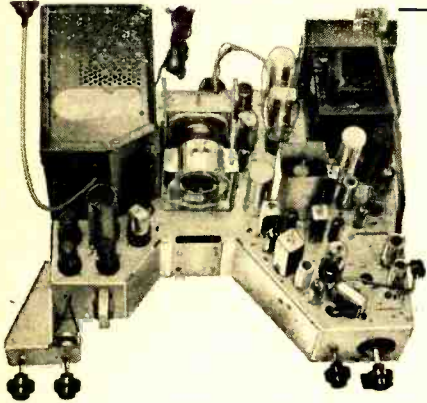

Build your own
#630
Super Deluxe
TV CHASSIS
 with . . . U. H. F.

With a #630 SUPER DELUXE 31-TUBE TV KIT

including your assigned U.H.F. Station • OPERATES 16" TO 24" PICTURE TUBES • Engineered in strict adherence to the genuine RCA #630 plus added features • FULL 4MC BANDWIDTH • CAS-CODE TUNER • COSINE DEFLECTION YOKE • LARGER POWER TRANSFORMER • KEYED AGC • 12" SPEAKER • UNIVERSAL MOUNTING BRACKETS • CONDENSERS and RESISTORS at rated capacities and tolerances. You receive a COMPLETE SET OF PARTS and TUBES, everything needed is included (less wire & solder). All I.F. Coils and Transformers are factory pre-aligned and tuned. You will enjoy building it with "LIFE-SIZE easy to follow step-by-step ASSEMBLING INSTRUCTIONS" included with each KIT. **NOTHING BETTER AT ANY PRICE!**

only . . . **\$119.44** (less CRT)

#630 SUPER DELUXE TV CHASSIS

with **U.H.F.**—Licensed under RCA patents
COMPLETE READY TO PLUG IN AND PLAY—Similar in characteristics and features to the TV KIT at left • Manufactured especially for us by Regal Electronics Corporation • No efforts or expense have been spared in workmanship or materials, to make this #630 SUPER DELUXE TV CHASSIS the Best obtainable for fringe areas, clarity and all-around performance, regardless of price. Customers report reception better than 200 miles • Each Set is factory aligned and air-tested • All parts carry the RMA three month guarantee • Our mass volume of business on this CHASSIS (numbering thousands of pleased customers) now makes it possible for us to reduce the price to . . .

only **\$157.97** (less CRT)

#630 TV SPECIALS^B TECH-MASTER^Y

TECH-MASTER Model C-30 TV CHASSIS. This Model has retained the outstanding characteristics of the RCA-630 circuitry, namely the four-stage, full bandwidth picture IF strip and the three-stage FM sound section • In addition, the latest innovations in synchronization and sweep circuits have been incorporated to produce a custom-quality receiver assuring outstanding performance • 30 tubes, 12" speaker.

Complete Ready to Plug in and Play **\$149.50** (less CRT)
 Special at

TECH-MASTER Gold Medal Model 2430-9 TV CHASSIS.

Including your assigned U.H.F. Station
 90° deflection, operates all 24" or 27" rectangular and 30" round picture tubes. The last word in TV achievement • Ideal for wall or custom-cabinet mounting • Detailed technical data mailed on request, however with the knowledge that this CHASSIS is a 30-tube #630 with both TECH-MASTER'S and OUR guarantee, you need not hesitate sending your order in now.

Complete Ready to Plug in and Play **\$262.50** (less CRT)
 Special at

DUMONT or SHELDON FINEST GUARANTEED PICTURE TUBES

MOST desirable 5 sizes—ALL RECTANGULAR • • • BRAND NEW in Factory Sealed Cartons—With a Full Year Guarantee

- 17" #17BP4A \$29.63 20" #20CP4B Aluminized \$39.74 21" #21EP4B Aluminized \$44.68 24" #24CP4A Aluminized \$66.24 27" #27EP4A Aluminized \$82.57

CUSTOM-BUILT CABINETS #630 AND ALL OTHER TV SETS — from FACTORY to YOU

5 LEADING STYLES in genuine mahogany or walnut (blond 10% extra) • Ready drilled for any #630 TV chassis and cutout for any 14", 17", 19", 20" or 21" picture tube at no extras in price • Also supplied with undrilled knob panel for any other TV set • EVERYTHING NECESSARY for an easy perfect assembly is included • Each cabinet is delivered complete as pictured with mask, safety glass, mounting brackets, backboard, backcup, hardware and assembling instructions • Each cabinet is shipped in an air cushioned carton from **FACTORY to YOU!**

The **VOGUE**
 Most Popular
 Table Model

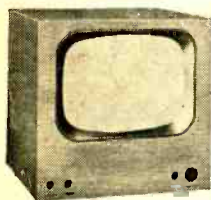

H-25", W-26", D-22"

\$39.89

VOGUE also available
 for 24" or 27" picture tube
 H-31", W-27", D-23"

\$62.54

The **MANHATTAN**
 Style, Quality, Price

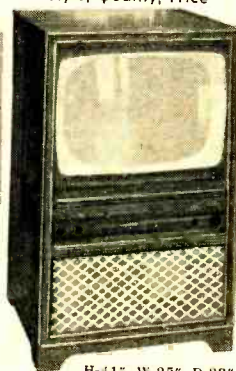

H-41", W-25", D-23"

\$59.37

MANHATTAN for 24" or 27" CRT
 H-46 1/2", W-27 3/4", D-24" **\$86.22**

The **MAYFAIR**
 Exquisitely modern, with an elegance of simplicity in styling.



H-40", W-26", D-25"

\$98.56

The **PLYMOUTH**
 Choice of interior Decorators, truly superb in every detail.



H-40", W-27", D-23"

\$105.48

The **TOWN & COUNTRY**
 Patterned after the popular credenza. Available for all size picture tubes 14" to 27"



H-42", W-36", D-24"

For 14", 16", 17", 19", 20", 21", 24" or 27" C.R.T.'s **\$109.62**

PARTS FOR #630 TV SETS

- TV WIRE & SOLDER KIT, for any Set \$1.49
- 630-KIT, screws, nuts, rivets, washers, etc. 1.69
- PUNCHED CHASSIS PAN, cadmium plated 4.87
- UNIVERSAL CRT MOUNTING BRACKETS 6.97
- POWER TRANSFORMER, 295ma, 201T6 9.97
- VIDEO AND I.F. KIT, 19 items 7.84
- VARIABLE CONTROL KIT, 9 controls 5.83
- CARBON RESISTOR KIT, 107 resistors 6.98
- WIREWOUND RESISTOR KIT, 4 resistors 2.31
- BRACKET AND SHIELD KIT, 18 items 8.63
- ELECTROLYTIC CONDENSER KIT, 6 cond. 7.37
- TUBULAR CONDENSER KIT, 38 condensers 4.28

Modernize a #630 or any TV Set

with a STANDARD CASCODE TUNER

For better all around performance

\$22.49

Complete with tubes, and Brooks CAS-CODE MANUAL with step-by-step instructions and all extra parts needed.

Brooks CASCODE MANUAL, how to install Cascode Tuner in any make TV Set. Postpaid **50¢**

PULSE KEYED AGC KIT

Finest, most accurate and the easiest Kit to install in a #630 or in any other make TV receiver. Improves performance, and insures a steady picture on all channels.

COMPLETE SET OF PARTS **\$4.59**
 Including 6AU6 tube & Instructions

Brooks LIFE-SIZE TV INSTRUCTIONS Postpaid **\$2.49**
 for building any #630 TV Receiver.

HINTS FOR BETTER PERFORMANCE Postpaid **\$1.00**
 on your #630 TV receiver.

BROOKS RADIO & TV CORP., 84 Vesey St., Dept. A, New York 7, N. Y.

RADIO-ELECTRONICS

than on the smoother glass, and makes the etch readable as long as the condensation lasts.

When all these methods have failed, there is probably no hope of ever reading the etch. The only sure way to then find the tube type is by using a tube tester to narrow down the possibilities to two or three types, and then to set up a breadboard layout to measure the tube element currents at various potentials and match these against the various published characteristics. **END**

CORRECTIONS

A. D. Burnett, of Richmond, Va., calls our attention to the fact that the heater shunt resistor in the picture-tube checker (page 145 of the October 1953 issue) should be approximately 14 instead of 33 ohms as specified.

In the article "A Broad-band V.H.F. Antenna," page 53 of the December, 1953, issue, the last sentence in the first column reads as follows: Adding all currents together we see that dipoles A and B cancel each other out . . . The correct statement should be . . . dipoles A and D cancel . . .

We thank Mr. Wilfredo Rafteros of Loctugan, Roxas City, Philippines, for calling this error to our attention.

A shunting resistor was inadvertently omitted from the heater circuit of the 12AU7 oscillator in the transmitter on page 134 of the February, 1954, issue. This resistor is for bypassing the excess 150 ma drawn by the 25L6's around the heater of the 12AU7. Its exact value should be 84 ohms. You can use a 100-ohm, 5-watt resistor with an adjustable slider set for the correct resistance or two 160-ohm, 2-watt carbon resistors in parallel across pins 4 and 5 of the 12AU7

We thank Cpl. R. W. Bonta of Topshannock, Va., for this correction.

Radio Thirty-Five Years Ago
In Gernsback Publications

HUGO GERNSBACK
Founder

Modern Electrics	1908
Wireless Association of America	1908
Electrical Experimenter	1913
Radio News	1919
Science & Invention	1920
Television	1927
Radio-Craft	1929
Short-Wave Craft	1930
Television News	1931

Some of the larger libraries still have copies of **ELECTRICAL EXPERIMENTER** on file for interested readers.

In Electrical Experimenter for May, 1920

- The New Radio Corporation, by C. D. Wagoner, General Electric Co.
- A War-Time Radio Detective, Part I, by Pierre H. Boucheron
- New York Girl's Radio Set, by Abby P. Morrison
- Plan for World-Wireless
- A One-Tube Radio-Telegraph and Radio-Phone Transmitter
- Long Waves and "Strays" on Rogers Antennae, by Lieut. Com. A. Hoyt Taylor, U.S.N.R.F. **END**

MAY, 1954

Why do I carry ASTRON Capacitors on my service calls?



Well my business *is* SERVICE, and unless I use the best replacement parts available I can't give the BEST service.

That's where ASTRON comes in. I read about their new BLUE-POINT CAPACITORS and Safety Margin ELECTROLYTICS and decided to try them.

I saw the advantages quickly . . . for one thing I could rest the soldering iron on that bluepoint . . . it wouldn't melt and the leads didn't pull out. The seal was the BEST I've ever seen.

The ASTRON Safety Margin ELECTROLYTICS are well made and their twist prongs line is compact. It is easy to substitute . . . no waiting for weeks for odd values.

Yes, ASTRON is an easy line to work with, and there's great satisfaction in knowing that I'm working with the BEST. Try them and you'll agree!



ASTRON CORPORATION
255 GRANT AVENUE, EAST NEWARK, NEW JERSEY

In Canada: CHARLES W. POINTON, 6 ALCINA AVE., TORONTO 10, ONTARIO

IF You have never ordered by mail because you did not want to buy anything "sight unseen" or —
 You have ordered by mail but with disappointing results or —
 You have never purchased anything on time payments because of excessive finance charges, then —

— HERE —

is your opportunity to examine what you want under our "Seller not Buyer, takes all the risk" plan. We invite you to order any item on this page and examine it in the privacy of your own home. If you decide to keep it, you can then pay the balance in easy monthly payments with no interest or finance charges added. Otherwise, you may return the merchandise for prompt refund of your down-payment.



Superior's new
Model 670-A

SUPER METER

A COMBINATION VOLT-OHM MILLIAMMETER PLUS
CAPACITY REACTANCE INDUCTANCE AND DECIBEL MEASUREMENTS

SPECIFICATIONS:

- D.C. VOLTS: 0 to 7.5/15/75/150/750/1,500/7,500 Volts
- A.C. VOLTS: 0 to 15/30/150/300/1,500/3,000 Volts
- OUTPUT VOLTS: 0 to 15/30/150/300/1,500/3,000 Volts
- D.C. CURRENT: 0 to 1.5/15/150 Ma. 0 to 1.5/15 Amperes
- RESISTANCE: 0 to 1,000/100,000 Ohms 0 to 10 Megohms
- CAPACITY: .001 to 1 Mfd. 1 to 50 Mfd. (Quality test for electrolytics)
- REACTANCE: 50 to 2,500 Ohms 2,500 Ohms to 2.5 Megahms
- INDUCTANCE: .15 to 7 Henries 7 to 7,000 Henries
- DECIBELS: -6 to +18 +14 to +38 +34 to +58

ADDED FEATURE:

The Model 670-A includes a special **GOOD-BAD** scale for checking the quality of electrolytic condensers at a test potential of 150 Volts.

The Model 670-A comes housed in a rugged, crackle-finished steel cabinet complete with test leads and operating instructions.

\$28⁴⁰ NET



Superior's new
Model TV-11

TUBE TESTER

SPECIFICATIONS:

- ★ Tests all tubes including 4, 5, 6, 7, Octal, Lock-in, Peanut, Bantam, Hearing Aid, Thyatron, Miniatures, Sub-miniatures, Novals, Sub-minars, Proximity fuse types, etc.
- ★ Uses the new self-cleaning Lever Action Switches for individual element testing. Because all elements are numbered according to pin-number in the RMA base numbering system, the user can instantly identify which element is under test. Tubes having tapped filaments and tubes with filaments terminating in more than one pin are truly tested with the Model TV-11 as any of the pins may be placed in the neutral position when necessary.
- ★ The Model TV-11 does not use any combination type sockets. Instead individual sockets are used for each type of tube. Thus it is impossible

to damage a tube by inserting it in the wrong socket.

- ★ Free-moving built-in roll chart provides complete data for all tubes.
- ★ Newly designed Line Voltage Control compensates for variation of any Line Voltage between 105 Volts and 130 Volts.
- ★ NOISE TEST: Phono-jack on front panel for plugging in either phones or external amplifier will detect microphonic tubes or noise due to faulty elements and loose internal connections.

The model TV-11 operates on 105-130 Volt 60 Cycles A.C. Comes housed in a beautiful hand-rubbed oak cabinet complete with portable cover.

\$47⁵⁰ NET

EXTRA SERVICE — The Model TV-11 may be used as an extremely sensitive Condenser Leakage Checker. A relaxation

type oscillator incorporated in this model will detect leakages even when the frequency is one per minute.

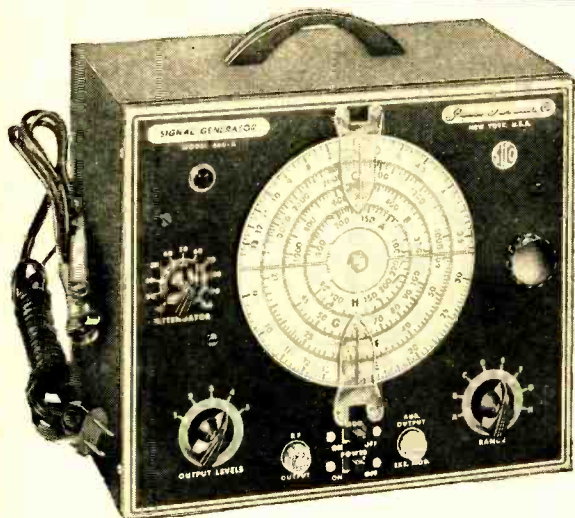

Superior's New Model 660-A AN AC OPERATED

SIGNAL GENERATOR

PROVIDES COMPLETE COVERAGE for AM-FM & TV Alignment

SPECIFICATIONS:

- Generates Radio Frequencies from 100 Kilocycles to 60 Megacycles on fundamentals and from 60 Megacycles to 220 Megacycles on powerful harmonics.
- Accuracy and Stability are assured by the use of permeability trimmed Hi-Q coils.
- R.F. available separately or modulated by the internal audio oscillator.
- Built in 400 cycle sine wave audio oscillator used to modulate the R.F. signal also available separately for audio testing of receivers, amplifiers, hard of hearing aids, etc.
- R.F. Oscillator Circuit: A high transconductance hep-

toide is used as an R.F. oscillator, mixer and amplifier. Modulation is effected by electron coupling in the mixer section thus isolating the oscillator from load changes and affording high stability.

- A.F. Oscillator Circuit: A high transconductance heptode connected as a high- μ triode is used as an audio oscillator in a High-C Colpitts Circuit. The output (over 1 Volt) is nearly pure sine wave.
- Attenuator: A 5 step ladder type of attenuator is used.

TUBES USED:

- 1—68E6 as R.F. Oscillator, mixer and amplifier.
- 1—6BE6 as Audio Oscillator.
- 1—6H6 as Power Rectifier.

The Model 660-A comes complete with coaxial cable test lead and instructions.

\$42⁹⁵ NET

MOSS ELECTRONIC DISTRIBUTING CO., INC.
Dept. B-99, 3849 Tenth Ave., New York 34, N. Y.

Please send me the units checked. I am enclosing the down payment with order and agree to pay the monthly balance as shown. It is understood there will be no carrying interest or any other charges provided I send my monthly payments when due. It is further understood that should I fail to make payment when due, the full unpaid balance shall become immediately due and payable.

Name.....
 Address.....
 City..... Zone..... State.....

- MODEL 670-A Total Price \$28.40 \$7.40 down payment. Balance \$3.50 monthly for 6 months.
- MODEL TV-11 Total Price \$47.50 \$11.50 down payment. Balance \$6.00 monthly for 6 months.
- MODEL 660-A Total Price \$42.95 \$12.95 down payment. Balance \$5.00 monthly for 6 months.
- I enclose \$..... as down payment.
- Ship C.O.D. for the down payment.

Buy on our radically new
Time Payment Plan **NO CARRYING CHARGES!!**
NO INTEREST!!

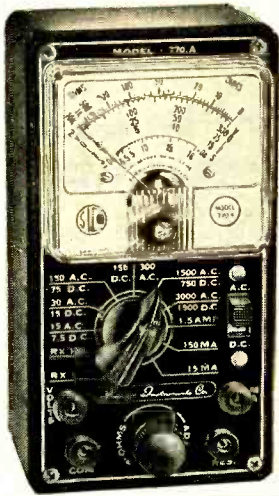

Superior's New Model 770-A The FIRST Pocket-Sized
VOLT-OHM MILLIAMMETER
USING THE NEW "FULL-VIEW" METER
71% MORE SCALE AREA!!

Yes, although our new FULL-VIEW D'Arsonval type meter occupies exactly the same space used by the older standard 2 1/2" Meters, it provides 71% more scale area. As a result, all calibrations are printed in large easy-to-read type and for the first time it is now possible to obtain measurements instead of approximations on a popular priced pocket-sized V.O.M.

- Features**
- ★ Compact—measures 3 1/8" x 5 7/8" x 2 1/4"
 - ★ Uses "Full View" 2% accurate, 850 Microampere D'Arsonval type meter
 - ★ Housed in round-cornered, molded case
 - ★ Beautiful black etched panel. Depressed letters filled with permanent white, insures long-life even with constant use.

- Specifications**
- 6 A.C. VOLTAGE RANGES: 0-15/30/-150/300/1500/3000 Volts. 6 D.C. VOLTAGE RANGES: 0-7.5/15/75/150/-750/1500 Volts. 2 RESISTANCE RANGES: 0-10,000 Ohms, 0-1 Megohm.
 - 3 D.C. CURRENT RANGES: 0-15/150 Ma., 0-1.5 Amps. 3 DECIBEL RANGES: -6 db to +18 db, +14 db to +38 db, +34 db to +58 db.

THE MODEL 770-A COMES COMPLETE WITH SELF-CONTAINED BATTERIES, TEST LEADS AND ALL OPERATING INSTRUCTIONS. ONLY

\$1585

NET

Superior's
New TELEVISION BAR GENERATOR

THROWS AN ACTUAL BAR PATTERN ON ANY TV RECEIVER SCREEN



- Two Simple Steps**
1. Connect Bar Generator to Antenna Post of any TV Receiver.
 2. Plug Line Cord into AC Outlet and Throw Switch.
- Result:** A stable never-shifting vertical or horizontal pattern projected on the screen of the TV receiver under test.

- FEATURES:**
- Provides linear pattern to adjust VERTICAL linearity, height, centering
 - Provides linear pattern to adjust HORIZONTAL drive, width, peaking, linearity, centering
 - Provides vertical sweep signal for adjusting and synchronizing vertical oscillator discharge and output tubes
 - Provides vertical signal to replace vertical oscillator to check vertical amplifier operation
 - Provides horizontal sweep signal for adjusting and synchronizing horizontal oscillator A.F.C. and output tubes
 - Provides horizontal sweep signal to check H.V. section of fly-back and pulse operating power supplies
 - Provides signal for testing video amplifiers
 - Can be used when no stations are on the air.

- SPECIFICATIONS:**
- Power Supply: 105-125 Volt 60 Cycles
 - Power Consumption: 20 Watts
 - Channels: 2-5 on panel, 7-13 by harmonics
 - Horizontal lines: 4 to 12 (Variable)
 - Vertical lines: 12 (Fixed)
 - Vertical sweep output: 60 Cycles
 - Horizontal sweep output: 15,750 Cycles

TV BAR GENERATOR COMES COMPLETE WITH SHIELDED LEADS AND DETAILED OPERATING INSTRUCTIONS. ONLY....

\$39.95

NET

SUPERIOR'S NEW MODEL TV-40

C.R.T. TUBE TESTER



★ **A complete picture tube tester for little more than the price of a "make-shift" adapter!!**

★ **Tests all magnetically deflected tubes . . . in the set . . . out of the set . . . in the carton!!**

The Model TV-40 is absolutely complete! Self-contained, including built-in power supply, it tests picture tubes in the only practical way to efficiently test such tubes: that is by the use of a separate instrument which is designed exclusively to test the ever increasing number of picture tubes!

EASY TO USE:

Simply insert line cord into any 110 volt A.C. outlet, then attach tester socket to tube base (Ion trap need not be on tube). Throw switch up for quality test . . . read direct on Good-Bad scale. Throw switch down for all leakage tests.

- SPECIFICATIONS:**
- Tests all magnetically deflected picture tubes from 7 inch to 30 inch types.
 - Tests for quality by the well established emission method. All readings on "Good-Bad" scale.
 - Tests for inter-element shorts and leakages up to 5 megohms.
 - Test for open elements.

Model TV-40 C.R.T. Tube Tester comes absolutely complete—nothing else to buy. Housed in round cornered, molded bakelite case. Only

\$1585

NET

MOSS ELECTRONIC DISTRIBUTING CO., INC.
 Dept. E-99, 3849 Tenth Ave., New York 34, N. Y.

Please send me the units checked. I am enclosing the down payment with order and agree to pay the monthly balance as shown. It is understood there will be no carrying, interest or any other charges, provided I send my monthly payments when due. It is further understood that should I fail to make payment when due, the full unpaid balance shall become immediately due and payable.

Name

Address

City

Zone

State

- Model 770-A Total Price \$15.85
\$3.85 down payment. Balance \$4.00
monthly for 3 months.
- Bar Generator Total Price \$39.95
\$9.95 down payment. Balance \$5.00
monthly for 6 months.
- Model TV-40 Total Price \$15.85
\$3.85 down payment. Balance \$4.00
monthly for 3 months.
- I enclose \$..... as down payment.
- Ship C.O.D. for the down payment.

In **CANNON**
"UA" Audio
PLUGS

gold-plated
contacts
really
pan out!

UA-3-11 Plug

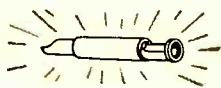

UA-3-14 Wall Mounting Receptacle



UA-3-32 Wall Mounting Receptacle



UA-3-42 Microphone or Panel Mounting Receptacle



UA-3-13 Wall Mounting Receptacle



UA-3-31 Wall Mounting Receptacle



UA-3-12 Plug



Yes! You get immense satisfaction from gold in any form... and particularly from the performance of the gold-plated contacts in Cannon's modern "UA" audio Series connectors.

Contacts are heavily gold-plated over silver plate... not just "flashed" with a light coating of gold. You get maximum protection from oxidation and deterioration... maximum protection to vital audio circuits... absolute reliability.

Cannon's thumb-pressure LATCH-LOCK prevents accidental disconnect. Available through Cannon distributors.

**WRITE FOR
RJC BULLETIN!**

Refer to Dept. 144

CANNON ELECTRIC COMPANY, 3209 Humboldt St., Los Angeles 31, Calif. Factories in Los Angeles; New Haven; Toronto, Canada; London, England. Representatives and distributors in all principal cities.

See Us at Booth 885

CANNON ELECTRIC

Since 1915

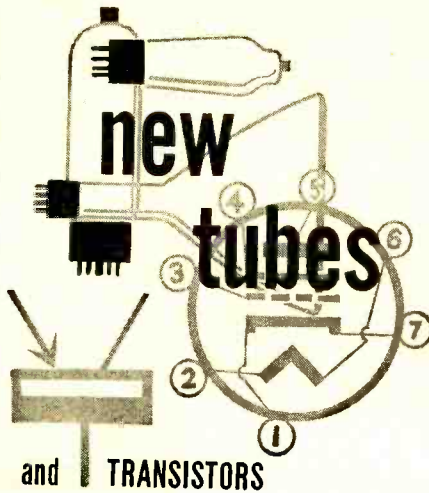

IN KEEPING with the color TV trend, RCA has announced a group of tubes designed for use in color TV receivers. Of particular interest is the 15GP22, a glass-envelope picture tube capable of producing either a color or black-and-white picture 11½ x 8½ inches, with rounded sides.

The 15GP22 uses three electrostatic-

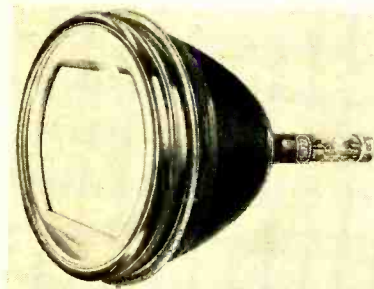

Three-gun tricolor picture tube 15GP22.

focus guns spaced 120° apart with axes parallel to the tube axis; magnetic deflection; electrostatic convergence; and an assembly consisting of a shadow mask and a plane, tricolor, filterglass phosphor-dot (screen) plate located between the shadow mask and a clear-glass faceplate.

The tricolor phosphor-dot plate serves as the directly viewed screen, and carries an orderly array of small, closely spaced phosphor dots arranged in triangular groups. Each group consists of a green, red, and blue-emitting dot. The phosphor-dot plate has approximately 195,000 dot groups or 585,000 dots and is metalized after the phosphor dots are applied, to give increased light output and contrast, and to prevent ion-spot blemish.

The metal shadow mask, placed between the electron gun structure and the phosphor-dot plate, contains round holes equal in number to and centered with respect to the dot groups.

The 3A3 is a rugged glass-octal half-wave rectifier tube, designed for use as a high-voltage rectifier in the scanning systems of color television receivers.

Rated to withstand a maximum peak inverse plate voltage of 30,000, the 3A3 can supply a maximum peak plate current of 80 ma and a maximum average plate current of 1.5 ma.

from



TOP VALUE
in **Antenna Switches** at

L-O-W
L-O-W
Price

\$2.00
List



Model AS-46

Matched two-position (300 ohm) Switch
Tops in performance

It's TELEMATIC for the Most Complete Line in Antenna Switches

Model AS-18

Three-Position (300 ohm) Impedance matched. Low-Loss Antenna Switch

Model AS-49

Four-Position (300 ohm) Impedance matched. Rotary Antenna Switch



Model AS-47

Three-Position (72 ohm) Antenna, Phono, Audio and Microphone Switch

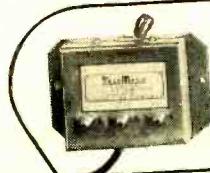

Model AS-48

Two-Position Co-Ax Switch for Antenna, Phono, or Microphone, etc.

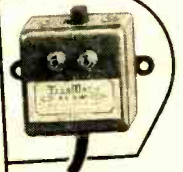

Prices slightly higher west of the Rockies

Write for catalog.



9 Joralemon St., Brooklyn 1, N. Y.

RADIO-ELECTRONICS

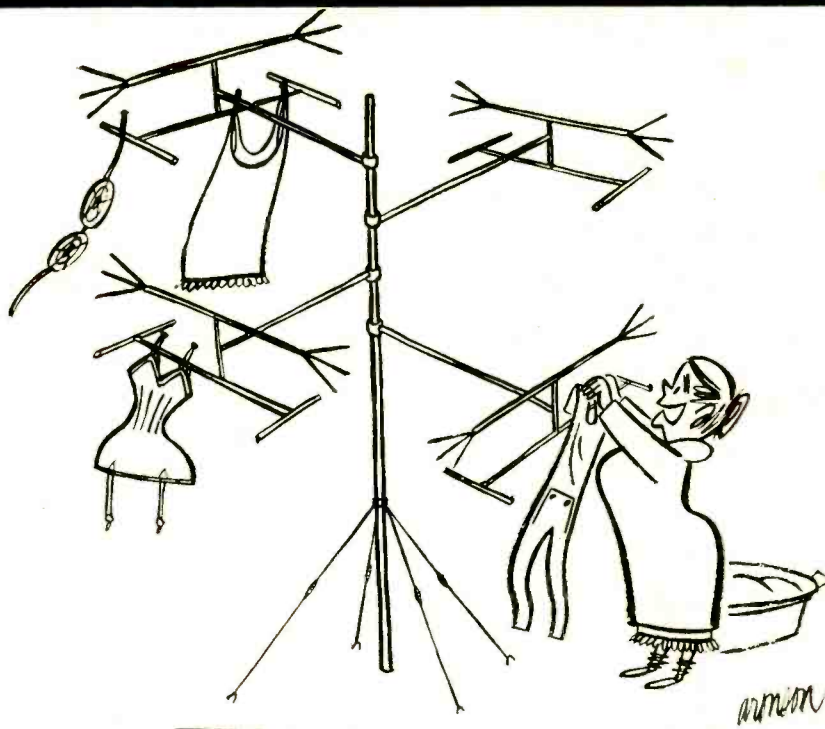

DAD THOUGHT THIS ANTENNA
WOULD HELP, BUT ALL WE NEEDED
WERE SPRAGUE CAPACITORS!

Don't Be Vague... Insist on SPRAGUE

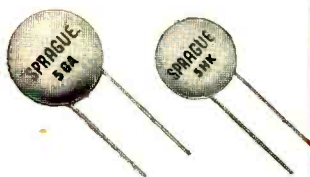

Insist on Sprague CERAMICS

Tiny, tough, dependable . . . in every application . . . whether discs, plates, buttons, or door knobs. And there's a Sprague ceramic capacitor to meet every service need. You give your customers dependable service, guard yourself against costly call-backs, when you use only Sprague Ceramic capacitors.



Insist on Sprague TWIST-LOK* 'LYTICS

Sprague TVL's fill the top performance bill in the toughest TV circuits. High temperatures, surge voltages, ripple currents won't faze them. Like all Sprague capacitors, Twist-Lok 'Lytics are your first line of defense against expensive call-backs.

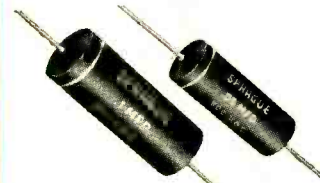

Insist on Sprague BLACK BEAUTY® TELECAPS®

The most imitated capacitor Sprague ever introduced. But you get Sprague *performance* only when you insist on Sprague Telecaps. Hundreds of millions are in use today as first choice of quality conscious manufacturers and servicemen. It's the *premium* molded tubular *at no extra cost*.

Accept no substitutes. There is a Sprague Distributor in every sales area in the United States. Write for the name of your nearest source of supply today.

☆ Trademark

SPRAGUE

Get your copy of Sprague's latest radio and TV service catalog C-609. Write Sprague Products Company*, 81 Marshall St., North Adams, Mass.

*Distributors' Division of Sprague Electric Company

**WORLD'S LARGEST
CAPACITOR MANUFACTURER**

Lafayette Greatest Tape Buy Ever!

1200 FT. REEL
Genuine Plastic Base
\$1.89 RECORDING TAPE

C.O.D.'s accepted per roll plus postage

LAFAYETTE made a terrific deal with one of the leading manufacturers of recording tape to supply us with their regular tape with their regular price. WE GUARANTEE ABSOLUTE SATISFACTION OR YOUR MONEY BACK. The finest, professional-quality recording tape obtainable. Highest performance for thousands of playings. Red Oxide Base in a smooth, uniform coating; greater signal strength; with maximum fidelity; uniform frequency response from 40-15,000 cps at 7½" per second; and freedom from background noise and distortion. Each reel is individually boxed. Shipping weight 10 oz.



SALE!
MASCODE BOOSTER
5.95 ea.
in lots of 3,
singly, ea. 6.25



Great Buy

MASCODE MODEL ABV AUTO. ALL CHANNEL VHF 3 TUBE TV BOOSTER

Features a new low-noise cascade circuit. Fully automatic — no tuning. Best for all TV receivers, old or new. Boosts all channels 2 to 13 — automatically! Brings up station strength an average of 13 times on all channels 2 through 13. Low noise factor (approximately 8). Automatically turned on and off by the TV set. Concealed behind TV receiver. Mount it and forget it. Employs new 6BK7-A tube for snow-free reception with new high gain-low noise TV receivers. 3-tube circuit includes two 6J6 tubes in push-pull, cross-neutralized RF amplifier circuit. All-metal cabinet, brown hammertone finish. U/L approved. Undistorted sound and picture on all 12 channels. Engineered for maximum performance. Size 9" x 5" x 3". Shpg. wt. 4 lbs. **MODEL ABV VHF-TV BOOSTER.** List \$39.50

TELEPHONE INTERCOM

- Self Contained Battery • Buzzer Signal
- Ideal For TV Installers
- Operates Up To 2 Miles

You can now have a complete 2-station telephone type intercom system at an amazingly low cost. Simply lift the receiver from its hanger and press the button to signal the other party. It operates on self-contained #1 flashlight cell for as much as a mile. You may use Mallory 4 volt Mercury cell for longer distances. Batteries are easily replaceable. The Alnico 5 magnet gives loud and clear reproduction. Molded high impact case resists breaking. Installation is extremely simple and consists of merely attaching the clips provided to the ends of the wire. Ideal not only for ordinary intercom use as a telephone set, but perfect for TV installers where the antenna lead can be used as the connecting wire. Complete set consists of 2 phones, hangers for mounting on wall, batteries and 50 feet of 2-conductor wire.

Stock # ML-39. Complete Set.....NET 5.95



Talk about tuners!
THE STANDARD CASCADE TUNER TOPS 'EM ALL!

BRAND NEW! GUARANTEED!

The No. 1 Tuner in the trade. Lafayette is out front with this red-hot **STANDARD COIL CASCADE TUNER** deal. Lafayette made a buy—we paid cash —and you get the saving! Regular dealer price \$24.50. Servicemen, now is the time to stock up and save! Size: 4½" x 3¼" x 6¼" supplied with 6J6 and 6BQ7. Stock No. TL-11. Shpg. wt. 4 lbs.

\$14.95 ea.
\$14.25 ea. in lots of 3



NOW! PHILCO BOOSTER

The Philco Television Booster Model TB-3 is a high quality, push-pull, wide-band radio-frequency amplifier designed to amplify r-f signals in the television bands. This unit employs two 6J6 tubes as r-f amplifiers, uses a selenium rectifier in a self contained power supply. Channels 2 through 13.

MODEL TB-3 In original factory sealed cartons. Money back guarantee! Shp. Wt. 5 lbs. ea.

\$39.50 list
\$12.50 ea.
\$11.50 ea. in lots of 3



DIAMOND NEEDLES AT RHINESTONE PRICES

Diamonds maintain optimum performance and give longer life to both records and stylus. This is a genuine whole diamond precision polished to .002 point. Plays all 3 speeds. Fits all single needle cartridges having thumbscrew or set-screw. For the life of your records — Buy Diamonds!

PK-26.....Net 2.89



TIMER-SWITCH SALE

This "almost human" timer will switch your radio, television, or any other appliance on or off, fully automatically. Will turn them on at any desired pre-set time. Can be pre-set up to 12 hours. Full-vue crystal dial, 3 knob front, 3½" diameter. With mtg. ring and bracket!

MS-62, for 110V/60 Cy AC
In lots of 6, ea. 3.45
singly, ea. 3.69



WESTERN ELECTRIC HEARING AID

Reg. price \$185.00
Our price **\$14.95**

Brand new, in original Western Electric's jeweler's case. Supplied with receiver, receiver cord, battery cord and plug (less batteries). Money back guarantee. Act now while they last! Uses Burgess XX30E and 8R batteries at \$1.55 per set.



PRECISION DRAFTING SET

11 Pieces—Fitted Felt-Lined Case Made in Germany, of heavy brass, nickel plated and polished. Instruments include 5½" Compass with pencil and pen points and lengthening bar. 5½" Divider, three 3¾" sidewheel bow dividers with needle point, pen point and pencil point. 5" Ruling pen, extra handle for pen or pencil, capsule with extra leads. Interchangeability of these many parts makes this an exceptionally versatile set. Your money back—if this set is not worth twice our price!

\$2.75
F-13.....Net 2.75



ROTO AUTOMATIC HACKSAW

Fits any ¼" Electric Drill. Cuts any wood, metal or plastic up to ¼". There are no gears or bearings to wear out! Saw blade is only exposed moving part. Folds to 1" x 1¼" x 4" — fits any tool box. Use standard hacksaw blades. Handle covers and protects saw blade when not in use. Shpg. wt. 1 lb.

HD-60.....NET 3.72



Lafayette Radio DEPT. JE

Write for free catalog.

NEW YORK, N.Y. | 100 Sixth Ave.
BRONX, N.Y. | 542 E. Fordham Rd.
NEWARK, N.J. | 24 Central Ave.
PLAINFIELD, N.J. | 139 West 2nd St.
BOSTON, MASS. | 110 Federal St.

The 6AN8 is a 9-pin miniature general purpose tube containing a medium-mu triode and a sharp-cutoff pentode. It is intended for diversified uses in color television receivers.

The triode unit with its relatively high zero-bias plate current is useful in low-frequency oscillator, sync separator, sync clipper, and phase splitter circuits. The high-transconductance pentode unit may be used as an i.f. amplifier, video amplifier, a.g.c. amplifier, and reactance tube. The basing arrangement and internal construction of the 6AN8 are designed so that coupling between the triode and pentode unit is virtually eliminated.

A very interesting tube type is the 6BD4, a sharp-cutoff low-current beam triode designed as a voltage regulator for high-voltage, low-current d.c. power supplies used with the tricolor 15GP22. (See diagram for base connections and circuit application.)

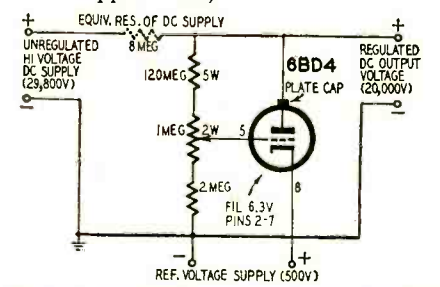

Typical shunt voltage-regulator circuit.

The 6BD4 has a maximum d.c. plate-voltage rating of 20,000, a maximum d.c. plate-current rating of 1.5 ma, and a maximum plate-dissipation rating of 20 watts. Heater rating is 6.3 volts at 600 ma.

Development of four new receiving tube types for color TV receivers has been announced by G-E. The new types are the 2V2 high-voltage rectifier, the 5AU4 high-output, full-wave rectifier, the 6AR8 sheet-beam synchronous detector, and the 6BU5 high-voltage pentode for shunt regulation.

The 2V2 is designed for use in fly-back types of power supplies. Its high inverse voltage and average current capabilities make it suitable for supplying power to the anode of a color picture tube or to a monochrome picture tube which operates at a high anode voltage.

The 5AU4 is a twin diode designed for use in the power supply of TV receivers and other equipment requiring high output current. In full-wave operation with a supply voltage of 300 per plate, the 5AU4 can deliver a d.c. output of 350 ma.

The 6AR8 is a miniature double-plate sheet-beam tube. A pair of balanced deflectors direct the electron beam to either of the two plates and a control grid varies the intensity of the beam. These characteristics of the tube make it especially suited as a synchronous detector in color TV receivers.

In this application, relatively large, balanced output signals of both positive and negative polarities are developed which eliminate the need for phase-

inversion in the matrix circuits.

Other features of the 6AR8 detector circuit (see diagram) include low oscillator injection power requirements, freedom from space-charge coupling effects, and linear output voltages.

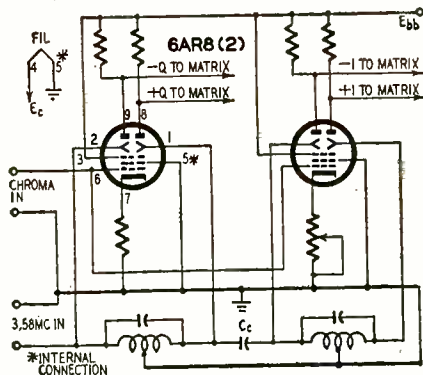

The circuit diagram shows two 6AR8 tubes used as synchronous detectors.

The 6BU5 is a low-current, high-voltage beam pentode designed for use as a shunt voltage regulator in the high-voltage power supply of color TV receivers.

G-E is producing hermetically-sealed ceramic germanium diodes. Although



Hermetically-sealed germanium diode. the announcement listed only three

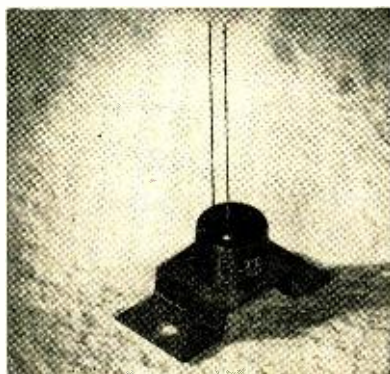

Experimental high-power transistor. JAN types, the 1N69, 1N70, and 1N81, it stated that within a short time, most G-E diodes will be hermetically sealed.

Transistor Products, Inc., Boston, has announced the availability of an experimental high-power transistor. Designated as type X78, it is a p-n-p diffused junction transistor. The X78 can be used in matched pairs in class-B audio amplifiers, and will provide a power gain of 10 db at room temperature. END

MAY, 1954

SUPERIOR'S NEW MODEL TV-40 C.R.T. TUBE TESTER

- ★ A complete picture tube tester for little more than the price of a "make-shift" adapter!!
- ★ Tests all magnetically deflected tubes . . . in the set . . . out of the set . . . in the carton!!

SPECIFICATIONS:

- Tests all magnetically deflected picture tubes from 7 inch to 30 inch types
- Tests for quality by the well established emission method. All readings on "Good-Bad" scale.
- Tests for inter-element shorts and leakages up to 5 megohms.
- Test for open elements.

EASY TO USE:
Simply insert line cord into any 110 volt A.C. outlet, then attach tester socket to tube base (Ion trap need not be on tube). Throw switch up for quality test . . . read direct on Good-Bad scale. Throw switch down for all leakage tests.

Model TV-40 C.R.T. Tube Tester comes absolutely complete—nothing else to buy. Housed in round cornered, molded bakelite case.

\$15⁸⁵

NET

Write Dept. RC-5 for catalog of complete line.

SUPERIOR INSTRUMENTS CO.
2435 White Plains Road New York 67, N. Y.

AT YOUR
RADIO PARTS
JOBBER

RECOGNIZE TELEVISION TROUBLES At A Glance!

... FIX 'EM TWICE AS FAST!

HANDLE 90% OF TV REPAIRS BY EASY PICTURE ANALYSIS

The looks of the picture on a bad television receiver . . . or the lack of any picture at all . . . can usually tell you in a jiffy what is wrong. PIX-O-FIX Troubleshooting Guides not only make this easy, but also show just where and how to make repairs.

Just turn the PIX-O-FIX dial until the picture appearing in its "window" shows the same trouble symptoms as the picture in the set you're repairing. PIX-O-FIX then tells what is likely to cause this trouble and gives step by step repair instructions. Testing time is cut

to minutes. Repairs are made fast, easy and right!

WORK BETTER AND FASTER!

The two PIX-O-FIX Guides cover 47 different kinds of TV trouble . . . just about anything you're likely to be called on to fix. Operation is simple and easy.

Remember! PIX-O-FIX Guides are NOT "gadgets." They're practical, professional servicing devices by two of America's best-known servicing authorities. Our money-back guarantee protects you fully!

PIX-O-FIX
TV TROUBLE
FINDING GUIDES

by Ghirardi and Middleton

Don't guess . . . don't waste time on television receiver repairs! Cut service time in half on 2 jobs out of three!

PIX-O-FIX No. 1—Identifies 24 of the more common television receiver troubles by actual TV screen photos. Gives 194 causes and 253 remedies for these troubles. Price separately \$1.25.

PIX-O-FIX No. 2 (Just out!)—Covers 23 additional troubles not included in No. 1 with accurate repair instructions. Together, the 2 volumes are a practical guide to "picture analysis" servicing of any TV set. Price \$1.25 separately.

SPECIAL! Get both at only \$2.00 for the two. Use coupon.

10-DAY MONEY-BACK GUARANTEE

Dept. RE-54, Rinehart & Company, Inc.
232 Madison Ave., New York 16, N. Y.

Enclosed find \$ for which please rush the following:

PIX-O-FIX No. 1 (\$1.25) PIX-O-FIX No. 2 (\$1.25)

Both PIX-O-FIX No. 1 and No. 2 at the special price of only \$2.00 plus postage

If not satisfactory, I will return PIX-O-FIX postpaid in 10 days and you guarantee to refund the purchase price.

Name

Street

City, Zone, State

OUTSIDE U.S.A. \$1.50 each. \$2.50 for both. Same return privilege.

EDLIE
says

"SAVE ON AUTO RADIOS"

Also Kits & Wired Units at **LOWEST PRICES**

SPECIAL! CUSTOM AUTO RADIOS

FOR ALL CARS
1949 thru 1954
Models

- Custom Built
- Complete with 6 tubes
- 3-Gang Condensers
- 4-Minute installation—no holes to drill
- Great Value



Ford: '49, '50, '51, '52
Dodge-Plymouth: '49, '50
Dodge: '51, '52
Chevrolet: '51, '52
Hudson: '48, '49, '50, '51, '52, '53
Studebaker: '50, '51, '52
Henry J: '51, '52
Willys: '52, '53

\$39¹⁷

Chevrolet: '49, '50, '53, Plymouth: '51, '52, '53, '54
Ford: '53, '54 Dodge: '53, '54
Studebaker: '53, '54 Mercury: '52, '53, '54

\$4¹³

Indicate make and year of automobile when ordering

5-TUBE UNIVERSAL AUTO RADIO \$24⁹⁵
FITS ANY CAR UNDER DASH MOUNT

Edlie Special!

SPECIAL Tube Offerings

STANDARD MAKES GUARANTEED FIRST GRADE

0A2 ... \$.75	6F645	14E645	163345
2D2195	6J545	28795	164465
3A455	6J655	3065	205095
52375	6K745	39/4425	5686 ... 1.95
52475	6L745	4K3425	CK570275
6-4815	6N765	VR9095	5814 ... 1.95
6A9565	6SC745	VR10575	609545
6A1575	6SG745	8935	609745
6AK565	6V6GT55	21145	6AL5W45
6A4545	12AU765	958A55	6A0145
6B835	12K835	162625	6J6W55
6BA655	12SG765	163245	6CU6 ... 2.69

Save More Than Half COMPONENT KITS

INSULATED RESISTOR KIT

\$10. Value—Now \$1.65
Includes 100 resistors 1/4, 1/2, 1 & 2 watts from 5% to 20% tolerance. Comes in transparent plastic box. New low price. No. D 1273 **\$1.65**
Complete

Paper Tubular By-Pass CONDENSER KIT

Worth \$15—Yours for \$2.95
Includes 50 by-pass condensers ranging in capacity from .005 mfd. to .5 mfd. and at voltages from 200 to 1600. Complete with transparent plastic cabinet 7" x 3 1/2" x 1 1/2". EDLIE Special—deposit for No. D 1278. **\$2.95**
Complete

DISC CONDENSER KIT

Save over \$7
Includes assortment of 50 disc ceramic capacitors including the following capacities: .001, 2 x .001, .0015, 2 x .0015, 2 x .004, .0047, .005, 2 x .005, .01, 2 x .01 PLUS 10 assorted printed circuited capacitors complete in a plastic transparent box. Sells for \$10. EDLIE saves you over \$7.
No. D 1279 **\$2.95**
Complete kit: ...

PRECISION RESISTOR KIT

Consists of 50—1% Wilkor carbonfilm resistors of 50 different ohmage, housed in a transparent plastic box. May be combined in series or parallel to produce almost any desired ohmage. Each resistor retails for about 85¢.
Terrific Cash Saver!
Kit of 50 **\$2.45**
only

TERMS: All mdse. shipped FOB New York City. prices subject to change without notice. Include 20% deposit for COD's. WRITE TODAY FOR NEW FREE CATALOG!

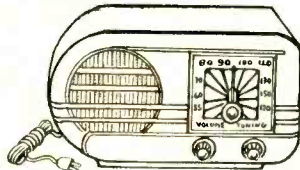

5 Tube AC/DC Superhet Kit
Kit #13 tube superhet kit. AC/DC cludes all quality components required to construct this latest design, highly sensitive superhet broadcast receiver, complete with black, glistening bakelite cabinet (excludes wire & solder). Kit of 5 tubes, 12AT6, 2/12BA6, 12BE6, 8AV4, 50B5.
Price, Less Tubes \$9.95
Extra for Tubes \$3.95

Terrific Value!

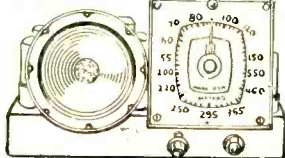

Great Savings! 6-TUBE RADIO KIT
Kit #2: Low priced 6-tube kit designed for extra high sensitivity, excellent selectivity and good, rich tone quality. Uses 25L6, 25Z6, 68Q7, 6SA7, 2/6SK7 in an easily constructed circuit. Includes all parts: paramech chassis, resistors, condensers, coils, sockets, PM speaker, hardware, etc.
Special closeout price. **\$6.95**
(Less tubes & cabinet) ...
Matched set of 6 tubes for kit \$3.25



SIGNAL GENERATOR BROADCAST BAND

Completely Wired—New, simplified circuit provides the following switch tuned, tone modulated frequencies:
1. 155 KC—Intermediate IF frequency
2. 1500 KC—Hi freq. of b'cast band
3. 600 KC—Lo freq. of b'cast band
4. Audio tone for audio amplifier trouble shooting
5. Attenuator control is included for adjustment of the output signal strength.
Housed in small, black bakelite cabinet, 6 3/8" x 3 1/2". Excellent for alignment of all Broadcast Band Radio receivers.
Completely Wired—only... **\$7.95**

3-TUBE PHONO AMPLIFIER

NOT A KIT
An assembled unit ready for installation using tone and volume control and 6 ft. rubber cord **\$2.95** (less tubes)
Lowest Price!
With complete set of tubes ... \$4.45

PHONO OSCILLATOR

NEW SAVINGS! • NOT A KIT!
Wireless phono oscillator transmits recording for crystal pickups or voice from carbon mike through radio without wires. Can also be used as an intercom by using PM speaker as mike. **\$2.95** (less tubes)
With complete set of tubes **\$3.95**

RECEIVES AWARD

Recipient of the first annual award of the President's Cup of the National Alliance of Television-Electronics Service Associations is Fred Colton (left), chairman of the board of the Associated Radio and Television Service Dealers of Columbus, Ohio. Making the presentation is Frank J. Moch of Chicago, president of NATESA.



The President's Cup was presented to Colton "because of his zealous work on behalf of NATESA during the year 1953, especially for his efforts in the interest of the NATESA annual convention in Chicago."

SERVICE AT ITS BEST

A splendid example of an attractive and businesslike shopfront is this display window of Rhodes Television Service, Paterson, N. J. The proprietor,



Harold "Dusty" Rhodes, is president of the Radio-Television Service Association of New Jersey and Eastern secretary of NATESA.

PROMOTES SAFETY

Service technicians working for the Central Television Service of Chicago may be called upon to take the hinges off a refrigerator, in addition to a number of other duties.

The company is making available—as a public service—its 150 service technicians to make safe any abandoned ice boxes called to its attention. Children who play in the neighborhoods will then be unable to lock themselves accidentally in these boxes, as has happened in a tragic number of cases. Central Television Service asks any in-

EDLIE Electronics

154 Greenwich St.
DI 9-3143
New York 6, N. Y.

*New***650 C****WHITE DOT
Generator
COMPATIBLE****FOR****COLOR****or BLACK and WHITE****HICKOK****NOTE FOR VALUE . . .**

To the thousands of you who already have a Model 650, you will appreciate knowing that its design is so complete that only a simple conversion is necessary for color use. This conversion assembly, completely wired, is available from the factory for \$5. You can add this assembly to your present 650 in a matter of minutes and thus convert to provide all features of the latest Model 650C White Dot Generator for Color TV, as well as retain the black dots for black and white receivers.

You can always count on HICKOK engineers to make special efforts to keep your present equipment up to date and operating to full specifications. It is interesting to note that due to HICKOK engineering cooperation many HICKOK testers, well over 25 years old, are still delivering top performance in everyday use. It is policy such as this that has contributed a great deal to the present HICKOK position of "First in Preference".

See the complete HICKOK line at your nearest Radio Parts Jobber . . . and write today for the new HICKOK Equipment Catalog No. 29.

THE HICKOK ELECTRICAL INSTRUMENT CO.

10531 Dupont Avenue • Cleveland 8, Ohio

MAY, 1954

Another HICKOK First . . .

The Model 650C is another example of HICKOK pioneer engineering and originality in test equipment design to meet the practical necessities of TV maintenance.

**MODEL
650C**

For Color TV . . .

The new 650C is an absolute must for accurate registration adjustment of the three color guns in the tube of the new color TV receivers.

Simple to Use . . .

Just connect to the antenna of the color TV receiver and adjust the 650C to produce WHITE DOTS on the screen. Adjust color guns until colored fringes disappear from around the white dots. With the 650C, color register adjustments are a fast and easy job. Without the 650C . . . a near impossible task.

The 650C provides the means for accurate adjustment of Focus • Convergence • Centering of Individual Beams • Purity Yoke • Dynamic Convergence • Linearity and Aspect Ratio.

In Addition . . .

The 650C is an excellent instrument for fast trouble-shooting in black and white receivers . . . and includes all features of the present 650 model.

**MODEL
650C**

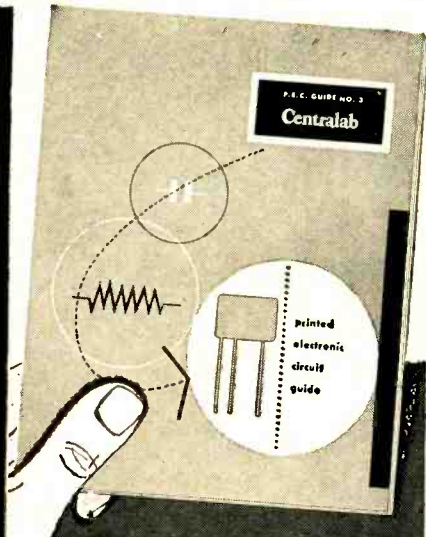

Free!
New, revised edition

Centralab

**PRINTED ELECTRONIC CIRCUIT
GUIDE NO. 3**

**Gives you facts that save
you time and money while
trouble-shooting — help
eliminate call-backs**

Here's a handy working tool. It puts practical service dope right at your fingertips where you can always find it.

It gives you information you can't afford to be without today. Over 36,000,000 Centralab Printed Electronic Circuits (PEC's) are now in use in today's radio and television sets.

Just look at the "meat and potatoes" between the covers of Guide No. 3:

- Lists 127 radio and TV manufacturers and their PEC applications—showing part identification number, manufacturer's part number, and Centralab catalog number.
- Shows circuit schematics that guide you in using PEC's to replace standard components.
- Tells how you can easily check Centralab PEC's with a VOM and simple 60-cycle capacitor bridge.

It's easy to get your free copy of the Centralab Printed Electronic Circuit Guide No. 3. Just fill in and mail the coupon below today. *Trademark

SEE US AT BOOTH 790.
1954 MAY 17-20 CHICAGO
ELECTRONIC PARTS SHOW

CENTRALAB, A Division of Globe-Union Inc.
922 E. Keefe Avenue, Milwaukee 7, Wisconsin
Send me a free copy of the new 1954 edition of the Centralab Printed Electronic Circuit Guide No. 3.

Name.....
Company.....
Address.....
City.....Zone.....State.....
Y-2354

dividual who sees an abandoned box to phone its dispatcher, and a service technician in the same neighborhood will be made available on an emergency basis.

The versatile service technicians of Central TV will not be at a loss on their new job, as many of them have been trained in the company's other services, which include air conditioning, piano tuning, and master antenna installation and maintenance as well as the more familiar TV and radio repairing.

CITY REGULATES ANTENNAS

A windstorm last January, which blew down several hundred TV antennas, is credited with the recently passed San Bernadino (California) ordinance requiring a permit for erecting TV antennas and setting specifications for their construction and installation. Several of the antennas fell across power lines in the storm, creating fire hazards and danger to life.

TV masts are required to be of standard gauge galvanized steel or double-strength aluminum tubing. Four guys are to be used, and anchorage points must be more than half the antenna height away from the base of the mast. Ground installations must have a concrete base not less than 12 inches square and buried not less than a foot in the ground. All free-standing masts must be installed according to plans signed by a registered engineer and approved by the city building inspector.

To erect an antenna, a permit must be obtained from the chief building inspector. A fee of \$2.00 is charged for each installation.

ARTSNY SEES COLOR

One of its biggest meetings in several years was the first lecture on color held by the Associated Radio-TV Servicemen of New York (City) March 18. The large ARTSNY headquarters hall was crowded before the meeting was due to start. Nearly 400 were present, and over 300 had to be turned away at the door. A number of technicians and engineers of TV and radio concerns were also present at the meeting, as well as representatives of several radio and TV magazines. The meeting was presided over by Max Liebowitz, and Lewis Winner acted as moderator for the lecture during the question-and-answer period.

A new Westinghouse color receiver was present on the platform, and field engineer Gordon Jolly demonstrated color problems and color adjustment with the aid of a Hickok white-dot generator. The large crowd made demonstration of adjustments on the purity coil and similar manipulations impossible, as few could have seen what was going on. Mr. Jolly made up for that, however, by going through a large number of adjustments which produced an effect on the tube face. Most of these could be seen at a considerable distance. Some other points were explained with the help of a blackboard during the question period.

**PRECISE — THE FASTEST-GROWING
KIT MANUFACTURER IN THE WORLD**

precise

**KIT AND WIRED
INSTRUMENTS**

IN STOCK
AT YOUR
JOBBER

EXCLUSIVE...

precise

MODEL #308

8 1/2"

SCOPE

KIT \$129.50

±308W\$229.50

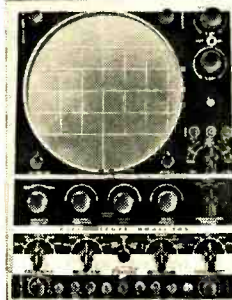

No other oscilloscope, at any price, can meet all the specifications of this electronic masterpiece.

- VERTICAL FREQ. RESPONSE—Flat ± 1/2 db DC thru 5 MC.
- SENSITIVITY—Greater than 10 millivolts push-pull (3.9 Millivolts/CM)
- BLANKING—60 cycle or 120 cycle Blanking through Blanking amplifier circuit.
- SWEEP RATE—Linear sweeps from 1 cycle to 80 KC in 5 ranges. (1-10 uses Ext. C.) DRIVEN and RECURRENT sweeps.
- MAGNIFIER—Expands and magnifies signal up to 10 times.
- PUSH-PULL—Output in both amplifiers.
- CRT—The latest type 8 1/2" NEW tube a PRECISE EXCLUSIVE.
- VOLTAGE REGULATED.
- ANODE INTENSIFIER—a PRECISE FIRST.
- INTERNAL CALIBRATOR

NEW 7" OSCILLOSCOPE

MODEL #300K\$94.95
MODEL #300W\$199.50

**LOWEST PRICED IN ITS FIELD
NEW MODEL #909
VACUUM TUBE VOLTMETER**

FACTORY **\$3750**
WIRED

Model 909 Vacuum Tube Voltmeter. 1% Ceramic precision Resistors; Coax DC connector; FM zero alignment scale; burn-out proof circuit; DC input 25 Meg. Rugged oversize 4 1/2" meter.
MODEL #909 KIT ... \$25.98



OTHER PRECISE TEST INSTRUMENTS AVAILABLE

- 9071—7 1/2" VTVM with VR—Kit \$35.95 • Wired \$49.95
- 610—RF SIG. GEN.—Kit \$23.95 • Wired \$39.95
- 630—RF-AP TV MARKER—Kit \$33.95 • Wired \$53.95
- 303—3" PORTABLE SCOPE—Kit and Wired
- 760—VOLTAGE REGULATED POWER SUPPLY—Kit \$39.95 • Wired \$59.95
- 111—E.M.GM TUBE TESTER—Kit \$69.95 • Wired \$139.95
- 912—RF PROBE—Wired and Calib. \$4.25
- 966—10-1 CA. PROBE—Wired \$5.95
- 999—HIGH VOLTAGE PROBE—Wired \$6.95

See our exhibit — **BOOTH 130** at the show

SEND FOR YOUR FREE 1954 DESCRIPTIVE CATALOG
Prices slightly higher in West

precise

DEVELOPMENT CORP.
OCEANSIDE, NEW YORK

RADIO-ELECTRONICS

To build a healthy, growing service business...

YOU NEED THESE 6 NEW

WALSCO

SERVICE ITEMS



NEW WALSCO CLEAN-O-MATIC...
Covers contacts on "Standard Coil" tuners and keeps them clean, silent, oxidation-free. Very easy to install. Tube of "Tunerlub" and crocus cloth included.
Cat. No. 1200 \$1.50 net



NEW WALSCO REEL-EASY
Portable wire reel holder. Light, durable, compact—weighs only 1 1/2 lbs. Handy to carry, easy to dispense lead-in wires. Eliminates tangled cables.
Cat. No. 503 \$3.60 net



NEW WALSCO VIEW BINS
Keeps small parts handy, sorted, visible and dust-free. Sturdy, tilt-type, spill-proof drawers reveal contents. No hidden corners. Silver hamertone finish. Welded steel.
Cat. No. 1010-6 bin \$4.95 net
Cat. No. 1010-12 bin 9.50 net
Cat. No. 1010-24 bin 16.95 net



NEW WALSCO TOOLS
New I.F. alignment tool for all UHF RCA, Zenith and other sets.
Cat. No. 2527 \$0.42 net
"Slug Saver" front end alignment tool for all "Standard Coil" tuners. Impossible to lose slugs with this patented tool.
Cat. No. 2528 \$0.63 net
Solder-ease tool. Bristles of brush and prongs of stainless steel. Solder will not stick.
Cat. No. 2529 \$0.99 net



NEW WALSCO FEED-THRU BUSHING
Bring antenna cables into the house the professional way. This bushing fits all lead-in and rotor cables. Terminate "open line" outside... bring flat line through bushing to set. Fits walls up to 16". Requires 3/4" hole.
Cat. No. 1551 \$1.17 net

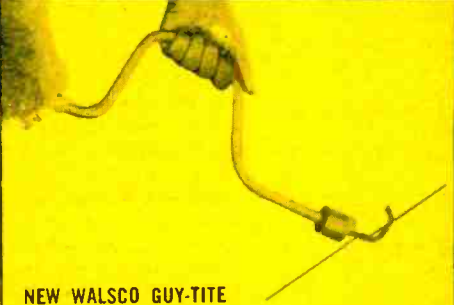

NEW WALSCO GUY-TITE
Tighten guy wires faster and better with this new WalSCO tool. Does the job of a turnbuckle at a fraction of its cost.
Cat. No. 1568 Box of 100 \$3.60 net
Cat. No. 1566 Tool and 18 tites 4.95 net



WALSCO ELECTRONICS CORPORATION

3602 Crenshaw Blvd. • Los Angeles 16, Calif.

Canadian Factory Distributor: Atlas Radio Corp., Ltd., 560 King St. West, Toronto 2-B.
Overseas Distributor: Ad Auriema, Inc., 89 Broad St., New York 4, N.Y.

basic electronic test instruments

Get your money's worth OUT OF TEST EQUIPMENT!

WORK BETTER, FASTER WITH FEWER INSTRUMENTS!

Test instruments are plenty expensive these days . . . and that's not all!

No sooner do you buy one new instrument than another type comes along that is said to be even better and more useful.

You soon realize you've got to draw the line somewhere!

The answer is to really learn about instruments . . . to KNOW exactly what each type CAN and CANNOT do. Actually, you can do first class work with only a comparatively few basic instruments . . . and you can save hundreds of dollars by learning to use old instruments more fully.

Remember! It isn't so much the instruments you use . . . it's the instrument "KNOW HOW" that counts! And that's where this famous book can be worth its weight in gold to experienced radio-TV men and beginners alike!

GET MORE WORK OUT OF YOUR OLD INSTRUMENTS

BASIC ELECTRONIC TEST INSTRUMENTS by Rufus Turner covers instruments and test equipment from a practical, on-the-job standpoint. No useless theory! In 255 pages and with more than 170 illustrations it shows you how to select the right instruments and how to use them on all kinds of jobs.

It shows how to modernize old types and use them in new ways. It helps you avoid buying unnecessary instruments; teaches you work-saving testing short cuts; shows how to evaluate instrument readings fast and accurately.

Over 60 types . . . from the latest TV sweep, marker and linearity pattern generators to grid-dip oscillators, special-purpose bridges and all the old standbys from V-O-M's signal generators to oscilloscopes and dozens more . . . are fully covered in a way you can easily understand.

Written especially for servicemen, students, amateurs and experimenters, **BASIC ELECTRONIC TEST INSTRUMENTS** is the only book of its kind. It saves you money . . . helps you earn more money . . . by helping you work better, faster and more accurately! Price only \$1.00 (\$1.50 outside U.S.A.).

10-DAY FREE TRIAL

Dept. RE-54, Rinehart & Co., Inc., 232 Madison Ave., New York 16, N. Y.

Send Turner's 255-page BASIC ELECTRONIC TEST INSTRUMENTS book for 10-day FREE EXAMINATION. If I decide to keep book, I will then remit \$4.00 plus a few cents postage. Otherwise, I will return book postpaid promptly and owe you nothing.

Name.....
 Address.....
 City, Zone, State.....
 OUTSIDE U.S.A.—Price \$1.50 cash only. Money back if book is returned in 10 days.

TAPE RECORDER EQUALIZER

Patent No. 2,658,958

Lawrence V. Wells, Charlotte, Mich.
 (Assigned to Wilcox-Gay Corp.)

Tape requires a special type of equalization. It has a maximum response near 2 kc and the rolloff differs on either side of this frequency. The inventor has designed a simple network that provides flat response from below 70 cycles to above 7 kc.

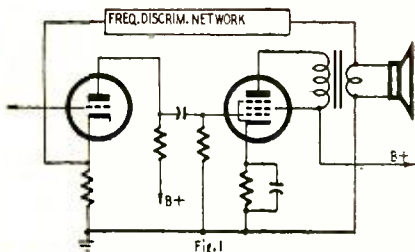
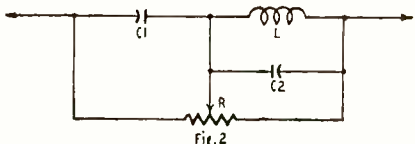
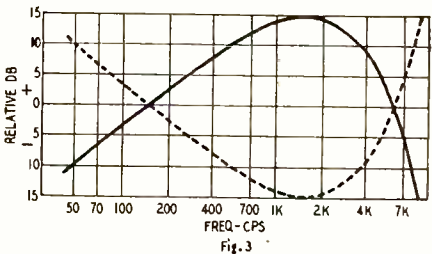

Fig. 1 shows the basic idea. A network couples the speaker and a previous stage. By tuning this network we have various degrees of degeneration over the audio spectrum. A typical network is shown in Fig. 2. Here L-C1 is series-tuned to the frequency that needs minimum gain, near 2 kc. At this frequency the network has minimum impedance, therefore maximum degeneration. This means low gain. Above and below 2 kc, the impedance rises and the phase angle grows, thus the gain is higher.



L-C2 is tuned to a high frequency near 6 or 7 kc. The high impedance makes for low feedback and high gain at these frequencies. This raises the high-frequency gain more than the low-frequency, and we have an amplifier characteristic as shown by the dotted line in Fig. 3. This com-



pensates for the typical tape curve which is shown by the solid line. R controls damping of the network. It determines the degree of equalization—that is, the rate of change of the curve slope.

The degenerative network also acts to lessen distortion and flatten out any undesirable peaks that may exist.

FLAT DRY CELL

Patent No. 2,666,802

William B. Woodring, Hamden, Conn., and William W. Eaton, Milford, Conn.
 (Assigned to Olin Industries, Inc., New Haven, Conn.)

This invention is a new dry cell made of flat elements to take up very little space. Elements are heat-sealed to each other.

In spite of the small size of this cell, it has remarkable energy content, due to the large active area and to the low resistance between elements. A typical cell, 6 inches in diameter, and .012 inches thick, showed the following characteristics:

- Open-circuit volts, 1.81.
- With 0.75-ampere load, the terminal voltage was 1.52.
- After 30 minutes of continuous discharge, the output voltage was 1.18 at 0.58 amp.
- This cell is protected against drying out because there is practically no path through which moisture may be lost.

STAN-BURN RADIO-ELECTRONICS

CATHODE RAY TUBE SPECIALS

ONE YEAR GUARANTEE		STAN-BURN	
7JP4	\$17.10	10BP4	\$10.50
10BP4A	19.25	12LP4	12.50
10FP4A	24.00	12LP4A	14.50
12KP4A	27.10	12QP4	12.50
12LP4A	21.50	12JP4B	12.50
12QP4A B1014	21.00	12UP4A	15.00
Dumont	28.75	14CP4	17.00
12UP4B	28.75	15BP4	18.50
14CP4	24.50	16KP4	18.50
15DP4 B1014	23.75	16DP4 or A	18.50
Dumont	30.95	16JP4 or A	18.50
16AP4A	25.25	16CP4 or A	18.50
16DP4A (N.U.)	31.25	16FP4	18.50
16GP4 or B	24.20	16WP4	18.50
16KP4 16RP4	28.75	16AP4	19.00
16KP4A	28.75	16AP4A	23.00
(Aluminum)	25.25	16EP4	19.00
16LP4A	28.50	16BP4A	23.00
16LP4A	26.50	16GP4 or A	26.00
16WP4A	31.25	17BP4	19.50
16GP4B	23.90	17CP4A	21.60
17BP4A	29.00	17CP4B	22.60
17CP4	29.00	17CP4B	23.00
17CP4B	29.00	19FP4	24.00
(Aluminum)	41.50	19FP4A	23.90
19AP4A	34.50	19AP4A	24.90
20CP4	37.50	20CP4	26.00
21AP4	42.00	21EP4	26.50
21EP4A	36.35	21AP4	26.50
24AP4	78.50	24AP4	49.00

QUANTITY CRT USERS
 We will give you DUD allowances if you ship them to us Prepaid—10 CRT's minimum shipment. WRITE FOR DETAILS.

ANTENNAE SPECIALS

RED DOUBLE VV Antenna	1-5	6 or more
10 ELEMENT CONICAL	2.19	1.98
Doweled Inserts	2.98	2.79
Folded HI Straight Low Quick Rig	4.25	3.25
WINDOW CONICALS	4.95	3.75
MASTS 5 FOOT SWEGGED79	.69
NEPCO MASTS	1.39	1.29
TV WIRE 42 Mil	\$9.95 M Ft.	
55 Mil, 300 OHM	11.95 M Ft.	
55 OHM COAXIAL	35.00 M Ft.	
CHASSIS 630 TECHMASTER		
Model C-30 with Cascade Tuner	\$149.50	
OPEN FACE CABINET	\$42.00	

TAPE RECORDERS IN STOCK

- PENTRON—Model 9T3C—2-speed Tape Recorder Write for Price.
- RADIO CRAFTSMAN
- Model C200—Hi Fi Amplifier Net \$42.90
- Model C10—ATM Tuner Net 131.50
- Model C500—Williamson Amplifier Net 99.50
- We also carry MASCO—BOGEN—PILOT, etc. Amplifiers—Pre-Amps, FM Tuners and WEBSTER Tape Recorders.
- 6"x9" PM SPEAKER \$3.98
- 7" PM SPEAKER 3.98
- 70" Yoke 1.98
- 630 Vert. Output Upright 1.98
- 630 Vert. Output Potted 1.29
- 630 Vert. Blocking Osc. Xform.89
- CASCODE TUNERS 17.95
- DUMONT 21.25 mc 14.95
- Famous INPUTUNER 10.00
- TV Permanent Magnet Focus Assembly 1.98

THREE SPEED RECORD PLAYER
 in portable carrying case, Special. \$39.95
 20CP4 Progressive Special. \$23.95

AUTHORIZED DISTRIBUTORS for: General Electric, Kenrad, Tung-Sol, National Union, De Wald, Regal, Automatic and General Motors.

AUTOMATIC CUSTOM-BUILT RADIOS for Plymouth, Ford, Chevrolet and many others, always in stock.

We carry a complete stock of HI-FIDELITY and SOUND EQUIPMENT. Send us your requests. We also carry a complete line of popular makes of Radio tubes at 50-100% discount. Also many other special purpose and transmitting types, and all electronic parts and equipment at lowest prices. Send us a list of your requirements for prompt quotations. Terms: 20% with order, Balance COD. All prices FOB NEW YORK Warehouse. Minimum order \$5.00. Write for our latest price list and Hi-Fi Catalog to Dept. RE-5.

STAN-BURN RADIO and ELECTRONICS CO.
 (C.B.S. THEATRE BLDG.)
 1697 BROADWAY • NEW YORK 19, N.Y.

RADIO-ELECTRONICS is paying good rates on acceptance for original and unusual articles on audio, television, FM and AM servicing, as well as articles on industrial electronic and applications. Send for a copy of our Authors' Guide. Address:

THE EDITOR
RADIO-ELECTRONICS
 25 West Broadway, New York 7, N. Y.

Telrex offers more in '54!

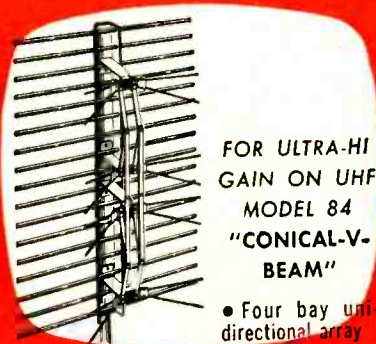

FOR ULTRA-HI GAIN ON UHF MODEL 84 "CONICAL-V-BEAM"

- Four bay unidirectional array
- All in-phase signal addition at all frequencies with no lobe splitting
- All-aluminum light weight and rugged

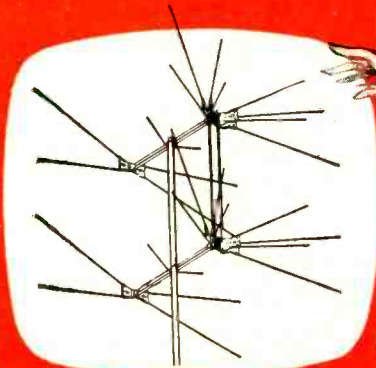

FOR UNIFORMLY HI-GAIN CHANNELS 2 to 83 DUO-BAND "CONICAL-V-BEAM"

- Uniformly Hi-Gain
- Excellent Directivity
- Automatic Transition From UHF to VHF
- High Signal-To-Noise Ratio



FOR THE ULTIMATE IN LONG DISTANCE RECEPTION THE TELREX 4 BAY

"CONICAL-V-BEAM" SERIES

The ultimate in long distance arrays. Guaranteed to out-perform any antenna or combination of cut-to-frequency antennas when used with Duo-Band splines. It comprises the ultimate from Ch. 2 to 83. Unequaled for reception to 200 miles.

"Conical-V-Beams" are produced under Re-Issue Patent Number 23,346 and sold only thru authorized distributors

1. SUPERIOR QUALITY—
All Aluminum, All-Weather Construction—Quality first is the Telrex pledge. Extra rugged construction includes all-aluminum design with precision parts fabrication for lasting installations. Wherever feasible, Telrex pre-assemblies at the factory to save you time and money at the site.



2. SUPERIOR RECEPTION —

"Better By Design"...
Rain or Shine—For UHF or VHF you can depend on Telrex for clearer, sharper pictures... finer sound reception. Near or far—city, suburb or rural area—there's a Telrex model engineered for your particular locality. Over 60 antenna types are included in the new Telrex catalog. Write for your copy, today!

VISIT BOOTH 675
 1954 ELECTRONIC PARTS SHOW
 CONRAD HILTON HOTEL,
 CHICAGO, ILL.
 May 17th to 20th

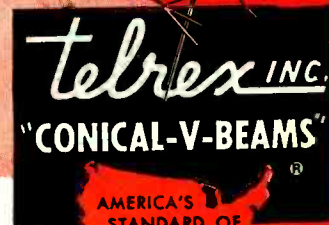

ASBURY PARK 9
 NEW JERSEY

By the MAKERS of the FAMOUS "BEAMED POWER" COMMUNICATION ROTARIES

If you want professional sound quality



Sound engineers know that the selection of a fine amplifier, pickup and speaker system is only part of the story; that unless the turntable is of equal quality, music reproduction must suffer. That is why they insist on such high standards for turntable performance.

do as the professionals do...



Rek-O-Kut precision turntables are made to conform to the highest standards in the professional field, and they certainly represent the finest you can use in the home. A Rek-O-Kut turntable will make all the difference in the world. The finer your present system, the more apparent the improvement will be. Whether you select the deluxe T-12H or the standard LP-743, the entire performance of your sound system will become a new and thrilling experience.

use a REK-O-KUT precision turntable



Rek-O-Kut Precision Turntables are priced from \$59.50. Write for specifications and descriptive literature to Dept. J-13

The REK-O-KUT COMPANY

Manufacturers of Professional Disc Recorders and Specialized Sound Systems.

38-01 Queens Boulevard, Long Island City 1, New York
Export Division 458 Broadway, New York, U.S.A. Cables: Morhanex
In Canada: Atlas Radio Corp., Ltd., 560 King Street, W., Toronto 2B



... FIRST CHOICE with servicemen because Fenwire is BEST by TEST

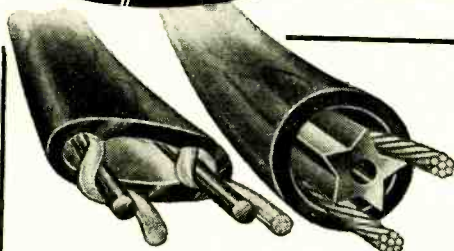

*FENTUBE-AIRSPACED and *TWISTUBE are outstanding for high performance—low loss—stable characteristics under all atmospheric conditions—reduced interference pick up—reasonable price.

Write Dept. RE-5 for literature on complete FENWIRE line including "TUF-GUY" ... finest guywire made.

(Sold through jobbers only.)
*U.S. & British Pat. Pending

FENTON COMPANY • 15 Moore Street, N. Y. 4, N. Y. Tel. Bowling Green 9-3445

TRANSISTOR SIGNALING

Patent No. 2,666,812

Reymond J. Kircher, Summit, N. J.
(Assigned to Bell Telephone Laboratories, Inc.)

Transistors have found many applications in land-line telephony. Here is still another—it is used to replace the bell or buzzer in signaling. Although power consumption is very low, an acoustic level of about 25 microwatts is available. This is sufficient for a clear, audible tone.

The diagram shows the arrangement for a typical two-party line. A central-office battery,

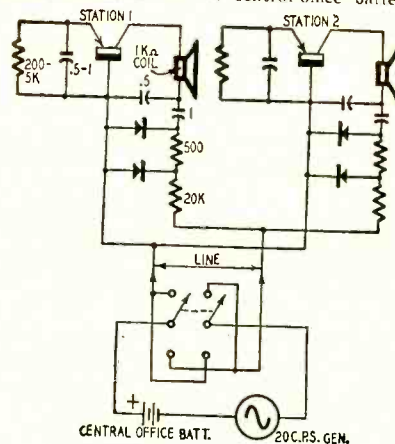

in series with a 20-cycle ringing supply, feeds power through the telephone line to subscribers. Pulsating d.c. flows through a two-section rectifier at each of the two stations. With the switch S in either position, the rectifiers at one station will be biased for conduction. At this station, the ringing current will be shorted out and cannot excite its transistor. The rectifiers at the other station are oppositely poled and cannot rectify. The ringing current will be fed to the point-contact transistor circuit, which oscillates at about 500 cycles. The position of S determines which station will be called when ringing current is applied to the line.

The circuit shown is suitable for point-contact transistors. A junction type may be used in a modified oscillator circuit.

TRANSISTOR "FOLLOWER"

Patent No. 2,663,796

Gordon Raisbeck, Morristown, N. J., and Robert Lee Wallace, Jr., Plainfield, N. J.
(Assigned to Bell Telephone Laboratories, Inc.)

The transistor is the dual of a tube. This means that semiconductors behave with respect to current just as tubes do with respect to voltage. The new circuit was designed to be the dual of a tube cathode follower. It provides considerable power gain and handling capacity. Its input resistance is very low, its output resistance very high. It has less than unity current gain but considerable voltage gain.

A phase reversing transformer couples the input to the emitter. The signal may be a.f. or r.f. The diagram shows polarity at a particular instant. Due to phase reversal, the emitter receives a positive signal. Conduction increases and the impedance between collector and base becomes smaller. Now the input voltage is the sum of the load voltage and the collector-to-base voltage. The first of these increases, while the second decreases. Thus the net input voltage (for any given signal current) is small.

The input current I_1 is the sum of two currents. One is the load current I_2 . The other current flows through the transformer primary. Obviously I_2 is smaller than I_1 . In spite of this,

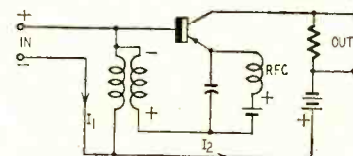

power gain does exist because the output resistance is so much higher than the input resistance.

The input resistance can be controlled by adding a resistor in series with the base. In a typical case, a transistor connected as in the diagram had an input of 71 ohms. Adding 800 ohms in series with the base lowered the input value to only 3 ohms.

END

YOUR BEST BET for BLACK & WHITE and COLOR TV



RCA WR-59C
Television Sweep Generator



RCA WR-89A
Crystal-Calibrated
Marker Generator



RCA WV-97A
Senior VoltOhmyst®

In color receivers, all of the color information is contained in the region from about 2 Mc to 4.1 Mc on the overall rf-if response curve, as shown in Fig. 1. Any loss of gain in this region will weaken the color signals. If the loss is appreciable, it may result in such effects as poor color sync, poor color "fit" (incorrect registration of color and brightness information on the kinescope), or cross-talk or color contamination between I and Q channels.

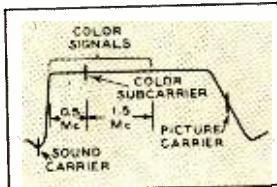

Fig. 1. RF-IF Response

vide the flatness of sweep output and crystal accuracy that are essential for aligning color circuits.

In color receivers, there are a number of video-frequency sections, including the video amplifier, the bandpass amplifier, I and Q channels (See Figures 2, 3, 4), and the green, red, and blue matrix networks—including the adders and output stages. A flat video sweep extending down to 50 Kc is a necessity in checking or aligning the tunable bandpass filter and the I and Q filters. *Late models of the RCA WR-59C Sweep Generator*

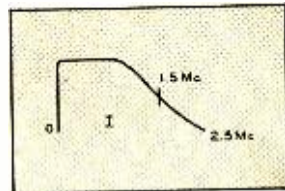

Fig. 3. I Channel Response

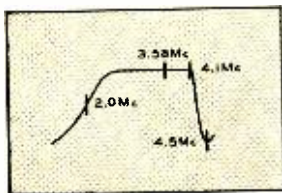

Fig. 2. Bandpass Filter Response

The rf-if amplifier must be aligned correctly to provide flat response for modulating frequencies up to 4.1 Mc. *The RCA WR-59C Sweep Generator and WR-89A Marker Generator provide*

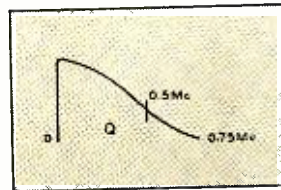

Fig. 4. Q Channel Response

now provide a flat video sweep extending down to 50 Kc. It also covers all rf and if ranges required for both color and black-and-white receivers.



RCA WG-289
High Voltage Probe

REMEMBER that the high voltage (up to 30,000 volts and more) must be set to the specified value before adjusting purity or convergence. The RCA VoltOhmysts can be used with the RCA High Voltage Probe (WG-289 and WG-206 Multiplier Resistor) to measure dc voltages up to 50,000 volts.

Get full details today from your RCA Distributor or clip coupon and mail to:

RCA Commercial Engineering
Section E39W, Harrison, N. J.

Please send me complete information on (check)
 WR-59C
 WG-289
 WR-89A
 WV-97A

Name _____
 Address _____
 City _____ Zone _____ State _____

My local RCA Distributor is _____



RADIO CORPORATION of AMERICA
TEST EQUIPMENT
HARRISON, N. J.

MAY, 1954

A vertical section of a metal pipe is shown on the left side of the advertisement. A ruler is wrapped around the pipe, showing the number '1'. A label is attached to the pipe with the text 'LOCKED-ON WITH FOSBOND*'.

A REVOLUTION IN New NEPCO

Proved **BEST** on **ALL TESTS!**

Here's Why:

- ✓ NEW Aluminized Metalescent Finish
(inside and out)
- ✓ NEW Fosbond* Preparatory Coating
- ✓ NEW Heavier Gauge Steel Pipe
- ✓ NEW Full 1¼" O.D. Steel Pipe

EXPANDED END FOR EASE OF ERECTION
PACKED IN CARTONS FOR CLEAN, EASY,
STOCKING AND HANDLING

*Awarded the Good Housekeeping Seal of Approval.

THE FOSBOND PROCESS*

The Fosbond process produces a new corrosion-resistant phosphate coating that *locks* NE's metalescent finish to the steel pipe.

STEEL ANTENNA PIPE!

TENNATUBE

STEEL PIPE FOR MASTING

CHECK THE RECORD FOR YOURSELF

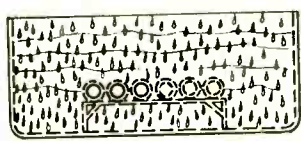
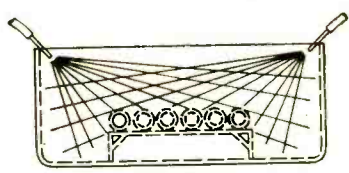
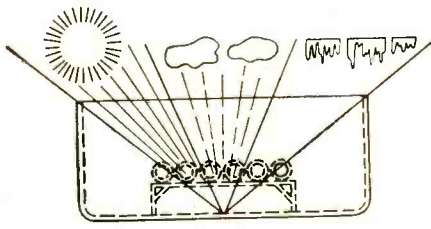
EXPOSURE TEST	NEPCO TENNATUBE	BEST COMPETITIVE MASTING OF THE MANY TESTED
 <p>HUMIDITY TEST 100% Humidity 120° F.</p>	<p>500 Hours NO BREAKDOWN</p>	<p>500 Hours VERY POOR APPEARANCE</p>
 <p>SALT SPRAY TEST—20% at 95° F.</p>	<p>215 Hours NO CHANGE</p>	<p>215 Hours VERY PRONOUNCED RUSTING</p>
 <p>WEATHEROMETER</p>	<p>300 Hours NO CHANGE</p>	<p>300 Hours BEGINNING TO DETERIORATE</p>

WRITE FOR THE WHOLE STORY—Detailed Test Data Comparing Nepco TennaTube with other leading TV masting and Descriptive Information of the Fosbond process.

When your reputation depends on a quality installation—your best insurance is quality material.

Only TENNATUBE proved BEST on ALL TESTS

OTHER PRODUCTS IN THE NEPCO LINE—
All Fosbond Coated VHF Antennas • UHF Antennas • Wall Brackets • Chimney Banding Mast and Banding Clamps • Guy Rings • Telescoping Masts

National Electric Products

RADIO & TELEVISION DEPARTMENT, PITTSBURGH, PA.



NEPCO INC.

ALL RADIO AND TV TYPES TUBES

CLOSE OUT !
SET MANUFACTURERS
CLOSE OUT

- STANDARD BRAND WARRANTY
- BRANDED
- BULK PACKED OR INDIVIDUALLY BOXED

ONE OF AMERICA'S
LARGEST
WHOLESALE

0A4G	\$.50	6AK5	.75	6L6GA	.99	12SG7	.61
0Z4	.49	6AL5	.34	6SA7	.59	12SH7	.49
1B3GT	.65	6AQ5	.37	6SA7GT	.61	12SK7GT	.49
1B24	4.95	6AQ6	.36	6SC7	.81	12SN7GT	.46
1C5GT	.39	6AS5	.62	6SF5	.58	12SQ7GT	.49
1F5G	.39	6AT6	.36	6SG7	.59	12SR7	.49
1L4	.47	6AUB	.36	6SH7	.65	12T3	.39
1Q5GT	.39	6AV5GT	.36	6SJ7	.54	19B6GG	1.15
1R5	.46	6AV6	.36	6SK7	.39	19T8	.61
1S4	.40	6BA6	.33	6SL7GT	.49	25AV5GT	1.05
1S5	.38	6BA7	.57	6SN7GT	.46	25B6GT	.75
1T4	.46	6BC5	.46	6SQ7GT	.37	25L6GT	.40
1U4	.46	6BE6	.37	6SR7	.49	25Z6GT	.37
1U5	.38	6BF5	.69	6S7	.57	32L7	.39
1X2A	.65	6BG6G	1.16	6T8	.49	33	.29
2A5	.39	6BH6	.45	6U7	.49	34	.29
2E22	1.45	6BJ6	.46	6U8	.59	35B5	.38
2X2A	.33	6BL7	.46	6V6GT	.38	35C5	.38
3A5	.33	6BN6	.72	6W4GT	.41	35L6GT	.42
3B24W	2.95	6BQ6	.70	6W6GT	.41	35W4	.32
3D6	.25	6C4	.31	6X5GT	.35	35Z6GT	.43
3B26	1.95	6C5GT	.41	7R7	.59	50B5	.41
3Q4	.48	6C6	.49	12A6	.39	50C5	.41
3Q5GT	.48	6CB6	.42	12A7	.57	50L6GT	.59
3S4	.46	6CD6G	1.08	12AT6	.31	11Z3	.39
3V4	.46	6E5	.76	12AU6	.34	801A	2.19
4C35	24.95	6F6GT	.45	12AV7	.60	803	2.95
SFP14	9.95	6H6	.49	12AY7	.72	814	2.95
5U4G	.49	6J4	.34	12BE6	.40	832A	7.95
5Y3G	.36	6J5GT	.34	12BH7	.41	866A	2.95
6A6	.35	6J7G	.50	12H7	.49	5670	1.45
6B7	.69	6K6GT	.36	12J7	.29	5718	4.95
6AC7	.68	6K7G	.49	12SA7GT	.58	901CT	4.95
6AG5	.46					9003	1.10
6AH6	.88						

MINIMUM ORDER: \$10.00. Terms: 25% with order, balance C. O. D. Please include postage. All prices subject to change without notice. F. O. B. New York City. Mail Order Division:

TRANSAMERICA ELECTRONICS CORP.
120 LIBERTY ST., NEW YORK 6, N. Y., COrtlandt 7-4307



Mr. Ed. Lombard, of Dealer's Wholesale Supply, Ventura, Calif. states:

"We have tested almost every all-channel antenna, to find the best antenna for our Dealers!"



Every dealer has heard antenna manufacturers claim top performance. Davis alone backs its claim with a money-back offer. The Davis Super-Vision antenna is factory-guaranteed to give the maximum reception obtainable. Try one...judge it...and you too will standardize on the Davis.

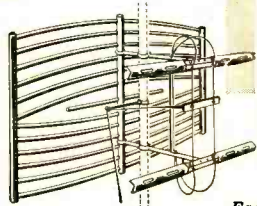

You Can't Buy a Better Antenna

"We are in a fringe area," says Mr. Lombard, "and since our dealers cannot and will not stock many different brands, we have tried to supply the antenna that will give the best all-around performance."

"With many manufacturers claiming top superiority in their antennas, we were not sure which one to choose. We therefore tested antenna after antenna right on our own roof, and had our dealers try and test antennas to see which brought in clearer, sharper pictures and the least interference on all channels."

"Dealers in our area have chosen Davis Super-Vision antennas, because our test and their test have proven outstanding results in every area."

"There are many similar antennas, but our Dealers demand Davis from the results it gives."

DAVIS SUPER-VISION
COPYRIGHT 1954
DAVIS ELECTRONICS
P.O. BOX 1247 • BURBANK • CALIFORNIA
Factories in: BURBANK, CALIF., CHICAGO, ILL., SILVER SPRINGS, MD.

PUSH-PULL 1619 AMPLIFIER

? I want to use push-pull 1619's in the output stage of an audio amplifier, but I'm not sure how to go about it because the tubes are pentodes with directly heated filaments. I want to use the tubes in class AB1. Please print a suitable circuit.—A. J. S., Philadelphia, Penna.

A. The push-pull 1619 stage is shown. The suppressor leads should connect directly to the center-tap on the secondary of the 2.5-volt, 4-ampere filament transformer. Cathode bias is developed across the 350-ohm resistor between the center-tap and ground. It is best to feed the screens from a separate

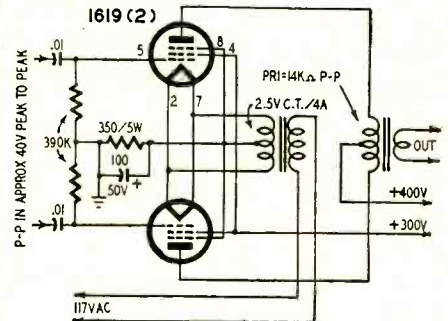

power supply, but you can supply them from the 400-volt plate supply if you use a suitable dropping resistor and V-R tubes to stabilize the voltage.

The grid resistors and coupling capacitors are determined by the gain and frequency response you desire from the circuit. Values shown are typical for PA circuits. About 40 volts peak-to-peak is required on the grids for full output. This can be supplied by many conventional push-pull drivers and phase inverters.

AUTO VIBRATOR FREQUENCIES

? Recently, while servicing an auto radio, I did not have a 115-cycle replacement so I tried a 90-cycle unit. All voltages were normal and the set operated perfectly. Is there a possibility of damaging the set by making this substitution?—G. E. H., Elwood City, Pa.

A. It is surprising that you had a 90-cycle vibrator. Engineers for various vibrator manufacturers informed us that these units are made in comparatively small quantities and that the major output of the industry is in 115-cycle units.

A 90-cycle vibrator will operate in a circuit designed for 115-cycle operation, but it is highly possible that its life will be shortened because the buffer capacitor will not match it. Too, there is a possibility of the power transformer being damaged or burning out because it is not likely to have enough iron in it to enable it to operate as efficiently on 115 cycles. Play safe and install a 115-cycle replacement as soon as possible.

MICROPHONE PREAMPLIFIER

? I built the amplifier on page 134 of the February, 1954, issue. It works nicely. Now, I want to provide for high-

RADIO-ELECTRONICS



YOU AND YOUR CUSTOMERS WIN

every time you use a Mallory Vibrator on a service job because the patented, tuned mechanism of the Mallory Vibrator assures completely dependable performance.

HERE'S YOUR PROOF OF WINNING

PERFORMANCE . . . Mallory produced the first commercial vibrators . . . produces more vibrators for set manufacturers than all other makes combined. And surveys show that Mallory Vibrators are preferred and used by 5 out of 6 servicemen.

STICK WITH THE WINNER . . .

always ask for Mallory Vibrators by name. Use them for all your car radio service jobs.

**Another
Mallory Winner!**

The new Mallory Vibrator Guide is a complete cross-reference and service guide. It has always been the accepted reference book for vibrator selection. Get one from your Mallory distributor.

P. R. MALLORY & CO. Inc.
MALLORY

CAPACITORS • CONTROLS • VIBRATORS • SWITCHES • RESISTORS
RECTIFIERS • POWER SUPPLIES • CONVERTERS • MERCURY BATTERIES
APPROVED PRECISION PRODUCTS

P. R. MALLORY & CO. Inc., INDIANAPOLIS 6, INDIANA

8 vertical outputs
1 deflection yoke
1 filter choke
5 width and linearity controls
17 exact replacement flybacks
23 TV power transformers

55 NEW TV REPLACEMENT
COMPONENTS HAVE BEEN
ADDED TO THE STANCOR LINE

28 flybacks (27 exact duplicates)
55 TV power transformers
8 deflection yokes
9 width and linearity controls
15 vertical outputs
8 blocking-oscillators
3 focus coils
5 filament transformers
22 filter chokes
19 audio outputs

STANCOR

YOUR MOST COMPLETE SOURCE
OF TV REPLACEMENT
TRANSFORMERS

NOW 172 TV REPLACEMENT
COMPONENTS ARE IN
THE STANCOR LINE

Ask for Stancor's new TV Replacement Guide listing replacement applications for these transformers in 6800 TV models and chassis. FREE from your local Stancor distributor, or from Chicago Standard Transformer Corporation.

Stancor transformers are listed in Sams Photofact Folders and in Counterfacts.



CHICAGO STANDARD
TRANSFORMER CORPORATION

3592 ELSTON AVE. • CHICAGO 18, ILL.

EXPORT SALES: Roburn Agencies, Inc., 39 Warren Street, New York 7, N.Y.

and low-impedance microphones with independent volume controls. Please show me how.—H. E. O., Lansing, Ill.

A. You will probably need a pre-amplifier to get good results from a microphone. The diagram shows a suitable preamplifier circuit. A 6J7 is specified instead of a 6SJ7 or similar newer type because its hum level is lower.

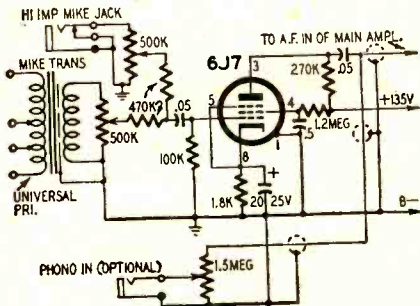

The microphone transformer should be a high-quality unit with a primary impedance to match the output impedance of the low-impedance microphone that you use. If you have several with different impedances, use a transformer with a universal primary. If you construct the preamplifier as a separate unit, you can plug its output cable into the input jack on the main amplifier. The diagram also shows how you can connect an auxiliary phono input jack with separate volume control.

SIMPLE SHORT-WAVE CONVERSION

? My Airline 93BR-717A receiver tunes from 550 to 1780 kc and 6 to 18 mc. I want to receive a fire department station on 2.366 mc with this receiver. Please print a circuit of a converter or show how this set may be adapted to cover the desired frequency.—H. S., Belmar, N. J.

A. A converter won't be necessary. You can receive the desired signal by modifying the receiver's antenna circuit. The diagram shows a simplified circuit of the input section of your receiver as modified for 2-mc reception. Note that the shortwave 6-18-mc coils and the built-in bandswitch have been omitted.

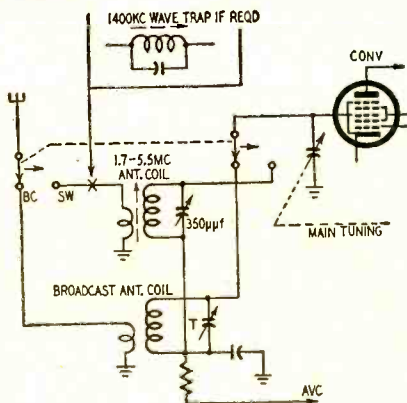

Add a 1.7-5.5-mc shortwave antenna coil and d.p.d.t. switch as shown. Connect a 350-µf mica or ceramic trimmer across the shortwave coil. With this

MAY, 1954

TECH-MASTER

MANUFACTURERS OF THE WORLD'S FINEST CUSTOM-BUILT TV CHASSIS

NOW OFFERS New Horizons of TV Enjoyment in the **UHF Field**

with a **Full 70-Channel UHF Selector** available in all **TECH-MASTER 630-type chassis!**

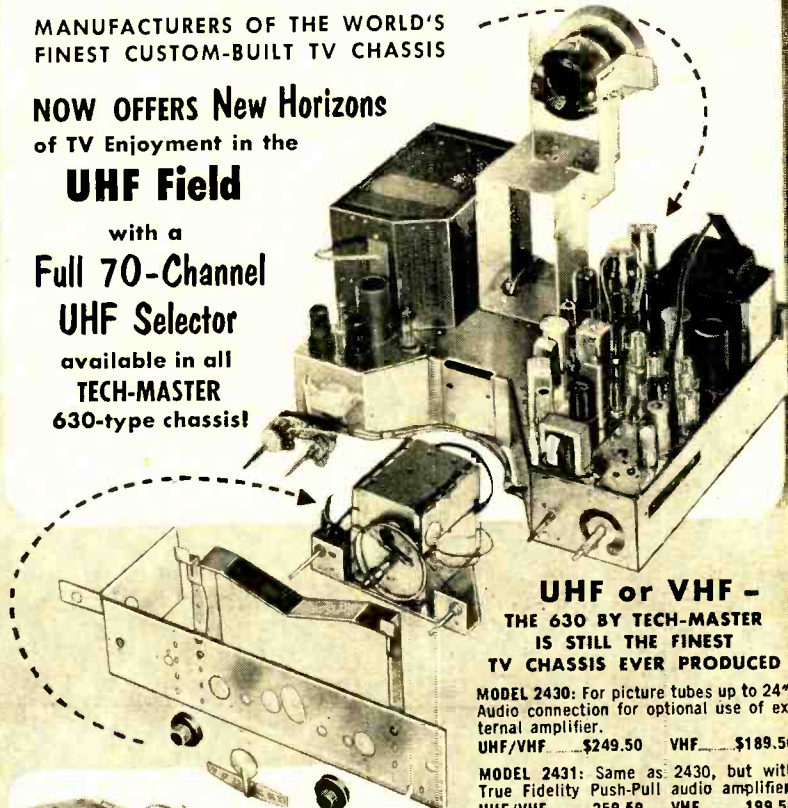

UHF or VHF - THE 630 BY TECH-MASTER IS STILL THE FINEST TV CHASSIS EVER PRODUCED

MODEL 2430: For picture tubes up to 24". Audio connection for optional use of external amplifier.

UHF/VHF \$249.50 VHF \$189.50

MODEL 2431: Same as 2430, but with True Fidelity Push-Pull audio amplifier.

UHF/VHF 259.59 VHF 199.50

MODEL 2430-9: For new 90° kinescopes. (24" rectangular, 27" and 30").

UHF/VHF 299.50 VHF 262.50

MODEL 1930: Similar to 2430 with slight modifications including area control switch at rear of chassis and cadmium plated finish instead of nickel.

UHF/VHF 224.95 VHF 179.50

MODEL C-30: Designed for the utmost in Quality at an Economical price.

UHF/VHF 209.95 VHF 149.50

(All prices NET. Picture Tube not included.)

Tube M't'g Brackets with 2400 Models

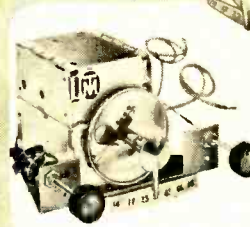

UHF SELECTOR, MODEL TV 101U:

Fits into recess of any 630-type chassis. Brings in all available UHF stations. Factory assembled, wired and aligned. \$36.95 net

AT ALL LEADING RADIO PARTS DISTRIBUTORS
Write For Detailed Literature



TECH-MASTER CORPORATION Radio & Television
445 BROADWAY, NEW YORK 13, N. Y.

MAKERS OF CUSTOM-BUILT TV CHASSIS, TV KITS AND HIGH FIDELITY AUDIO EQUIPMENT

EMPLOYMENT OPPORTUNITY

The Air Force has an urgent need for electronics engineers; radar, radio and wire communications engineers; and radio and electronic technicians and repair men, with salaries ranging from \$3410 to \$8360 a year. The majority of these openings are at Air Force installations in New York, Ohio and Georgia.

Qualified interested persons may submit applications to Carl T. Sieg, Chief, Placement Branch, Placement and Employee Relations Division, Directorate of Civilian Personnel, Department of the Air Force, Washington 25, D.C., for referral to an appropriate opening at one of the above locations.

THE TEST OF TIME

Has proven
ROHN TOWERS
Superior!

IN CONSTRUCTION

Rohn Towers are built of heavy duty tubular steel electrically welded throughout by skilled workmen exactly to specifications. Proof of Rohn construction lies in the fact that thousands of towers have been sold in the past several years and have successfully withstood the rigors of time in all climates and under the severest of conditions!

IN PERFORMANCE

Rohn Towers assure you of trouble-free performance and once installed give unquestioned satisfaction year in and year out! You are free of complaints because over the years Rohn Towers have proved themselves from the serviceman, dealer and customer point of view!

IN SALES

Sales acceptance has been phenomenal — thousands have been sold coast-to-coast — and the design has been one which has withstood every test known! Why "experiment" with an unproved tower design when you can sell Rohn?

So we ask you, "Why take chances with an untried tower? Be sure — sell Rohn — the only tower of its kind to withstand every test!"

Rohn Fold-Over Tower
only one of its kind
exclusive with
Rohn —
patent
pending.

Rohn Telescoping
Mast — complete
line in a proven
structural
design in 20'
—30'—40'—
50' models.



3 Self Supporting Rohn Towers To Fit Your Every Need

The No. 5 — The self-supporting tower for use up to 40', or guyed to 80'. An economical, yet sturdy, permanent tower!

The No. 10 — The standard 12' design that is self-supporting to 50' and can be installed to 120' when guyed!

The No. 20 — The heavy duty Rohn Tower, ideal for communication and where great height is required — self-supporting to 60', or guyed to 150'!

All Rohn Towers are in 10' sections — easily erected, transported and stored!

BE SURE TO SEE US AT THE

**PARTS SHOW
Booth 14**

DISPLAY ROOM—616A
Conrad Hilton Hotel—May 17-20

ROHN

MANUFACTURING CO.
DEPT. RE 116 LIMESTONE BELLEVUE
PEORIA, ILL.

TRAIN AT HOME FOR COLOR-TV and

**TELEVISION
SERVICING**

Learn practical, professional type TV Servicing without leaving your present job. Included are money-making extras, such as set conversion, master antenna installation, UHF-TV NTSC Color System, field servicing short cuts. You can start earning Television money after first few lessons. You learn to test, trouble shoot and repair all types of TV sets.

HERE'S HOW YOU GET EXPERIENCE!

You train on a large screen, modern TV receiver, furnished with the course and yours to keep! As an optional feature you can get two weeks actual experience with Chicago's largest independent servicing organization. You learn by doing! Age is no barrier. Many students are over 40! Beginner's Course available. Send for FREE Catalog and SAMPLE LESSON today!

TV COMMUNICATIONS INST.
605 W. Washington Blvd., Dept. RE-29
Chicago 6, Ill.

VETERANS!
T.C.I. is approved for G.I.
training. Under Public
Law 550. Check appropriate

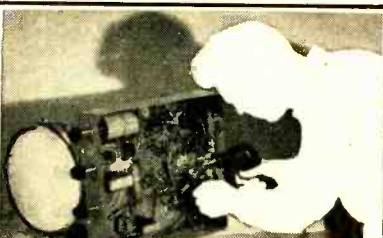

MAIL NOW FOR FREE BOOKLET

MILTON S. KIVER, President
TELEVISION COMMUNICATIONS INST.
605 W. Washington Blvd., Dept. RE-29, Chicago 6, Ill.
Rush FREE Catalog and Sample Lesson. I am not obligated. Salesman will not call.

Name..... Veterans: Check here
Address.....
City..... Zone..... State.....
 BEGINNERS check here for Basic TV Course.

setup, the antenna circuit is tuned to the normal image frequency of a broadcast signal for shortwave reception. The set's tuning dial is set to a frequency equal to the desired shortwave frequency minus twice the i.f. (465 kc in your receiver). So, to receive signals on 2366 kc, you must tune the receiver to 1436 kc.

This method will enable you to receive signals between 1945 and 3095 kc.

If you use this system for short-wave reception on a set tuning from 550 to 1600 kc with a 456-kc i.f., the tuning range is approximately 1915 to 2965 kc.

The circuit is easy to adjust. Set the receiver's original bandswitch to the broadcast band. Feed a strong modulated signal from a signal generator tuned to 2366 kc into the receiver's antenna post. With the auxiliary bandswitch set for broadcast, tune the receiver toward the high-frequency end of the band until you pick up the signal. Peak the signal with the tuning control. Throw the auxiliary switch to short-wave and then adjust the short-wave trimmer and slug for maximum signal.

In some areas, strong broadcast stations on the high end of the band may ride through and interfere with 2-mc shortwave reception. This can be prevented by connecting a tuned wave trap in series with the antenna lead to the primary of the shortwave coil as shown. Tune the trap for minimum interference.

The new antenna coil may be a Stanwyck type 411 or J. W. Miller type B-5495A. The wave trap may be a J. W. Miller type 811-BC1.

INTERMITTENT VERTICAL CENTERING

? In an Admiral 20T1 receiver the picture changes position vertically, leaving a dark area at the bottom. This occurs only once every several hours and returns to normal almost immediately. I have tried tube changes but this did not help. When the antenna is disconnected, the same thing happens to the raster. What checks should I make to find the trouble? T. C., Philadelphia, Pa.

A. If centering disturbance in a vertical plane is the only symptom, it could be caused by a variation in the voltage applied to the vertical deflection coils. Initially, check the low-voltage power supply feed to the vertical deflection coils. Then check for defective components in the vertical output circuit, particularly the voltage feed to the oscillator and output tube. Also check the vertical size-control potentiometer for an intermittent-contact condition or change in value.

The B plus for the vertical oscillator and output tube is derived from the voltage boost system in the 6W4-GT damper circuit. Any voltage change in the damper (or a change in the horizontal circuit flyback characteristics) will influence the vertical circuit. Try a new damper; if this doesn't help, check the components in the voltage boost system.

END

They're Hot Packed



DELCO RADIO CANS ITS POWER TRANSFORMERS TO PROTECT THEIR QUALITY AND PERFORMANCE

If you want a part made *right*, you've got to be able to control all phases of its production. That's why Delco Radio exercises strict quality control over all its parts—for service use as well as for original equipment.

Let's look at some new power transformers for auto radios: The laminated core inserts are stamped out of low-loss silicon steel, then heat treated to insure retention of desired magnetic properties. Skilled operators use special machines to wind the primary and secondary coils. On the production line, laminations and coils are assembled and, with other parts, placed in a metal can. Finally, a hot asphalt compound is poured into the shield can. On cooling, it becomes a solid mass that holds all components in position, transfers heat and protects the transformer's quality and performance.

Satisfied customers are the basis of a good service business, and Delco Radio service parts assure customer satisfaction. Delco Radio service parts are available through your UMS Delco Electronic Parts Distributor.



Potting power transformers. The transformer can is filled with an asphalt compound which helps to protect the transformer and transfer heat from the transformer to the can for better heat dissipation.



A GENERAL MOTORS PRODUCT  QUALITY SERVICE MOTORS A UNITED MOTORS LINE

MAY, 1954

DISTRIBUTED BY ELECTRONICS WHOLESALEERS EVERYWHERE

DELCO RADIO

DIVISION OF GENERAL MOTORS CORPORATION, KOKOMO, INDIANA

NEW Columbia UHF

"Foam Polyethylene Transmission Line"

- Popularly priced
- Low attenuation
- The one transmission line for UHF — VHF

YOUR CHOICE -

- Stranded copper conductors
- or
- Solid copper - weld conductors



Send for Samples TODAY!

Sold through recognized jobbers only!

Columbia
WIRE & SUPPLY CO.

2850 Irving Park Road
Chicago 18, Illinois

QUICKLY CONNECTED REMOTE VOLUME CONTROL

A volume control to change the sound level of a radio or television loudspeaker from a remote point is often desirable. The arrangement shown is somewhat unconventional in that it reduces the loudness by bypassing part of the signal around the speaker. It is practical for connections which must be made on the spur of the moment. For example, the control can be quickly made on a public address setup where the operator wants to be located away from the amplifier so he can better judge the sound from the speakers and can reduce the volume at once in case of feedback.

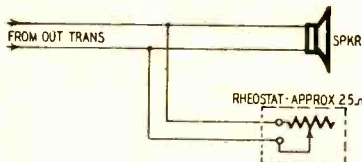

Two wires are connected between the loudspeaker voice coil and the remote point. A rheostat is hooked across the ends of the wires, allowing the amount of bypassing to be adjusted. The resistance element should be wire-wound, and for most speakers its value should be about 25 ohms.

When the control is set at the highest resistance the speaker operates at full strength, as determined by the regular volume control. As the rheostat is moved toward smaller values the volume decreases. Unless the resistance element happens to be tapered, most of the volume change occurs within a range of about a quarter of total knob rotation.

For small sound systems the wattage rating of the rheostat is not critical because it would ordinarily be set for only a slight reduction of volume. Tone quality is not noticeably affected, and in low-powered amplifiers there would be no damage resulting from the extra loading.

When several speakers are used in parallel, all would be affected alike. Where individual control is required, L pads may be purchased so that each speaker can be adjusted separately.

AMPLIFIER SAFETY KINK

Output transformers of phono and PA amplifiers may be damaged by high voltages if the speaker or load is accidentally disconnected while the power is on. When constructing my latest amplifier, I decided to guard against such damage by inserting a circuit-transfer jack in the output circuit to

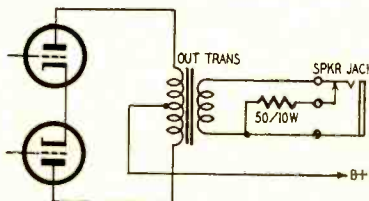

automatically connect a resistive load if the speaker should open or be disconnected.

19 Flyback transformers

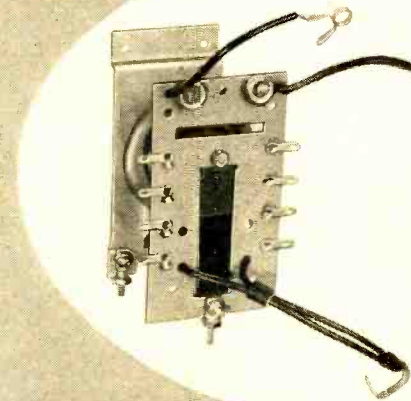

Designed, engineered and built to Triad's rigid quality and performance standards, this fine group of flybacks will meet practically all TV service needs. They are among the more than

50 New Items in
Triad's New 1954
Catalog

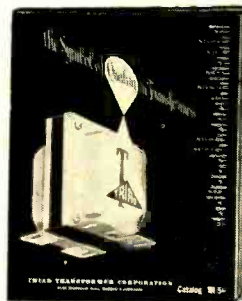

See your distributor for copies of Catalog TR-54 — it completely describes the finest line of transformers made.



4055 Redwood Ave. • Venice, Calif.

RADIO-ELECTRONICS

MORE JOBS
than graduates

Electronic Engineers
Excellent opportunity for professional growth and advancement in a testing and development laboratory.

Demand for our engineering graduates exceeds supply. Effective placement. Study in this world-famed college established 1884. Quarters start June, Sept., Jan., March. Approved for Korean Vets.

Bach. Sc. degree in 27 months

Complete Radio Eng. courses... TV, UHF and FM. Also Mech., Civil, Elec., Chem., Aero. and Adm. Eng.; Bus. Adm., Acct. Small classes. Well-equipped labs. Modest costs. Prep. courses. Write Jean McCarthy, Director of Admissions, for Catalog and Campus View Book.



TRI-STATE COLLEGE

2454 College Avenue, Angola, Indiana

GET INTO ELECTRONICS

You can enter this unworked, interesting field. Defense expansion, new developments demand trained specialists. Study all phases radio & electronics theory and practice. TV: FM; broadcasting; servicing; aviation, marine, police radio. 18-month course. Graduates in demand by major companies. U.S. or equivalent required. Begin Jan., March, June, Sept. Campus life. Write for catalog. VALPARAISO TECHNICAL INSTITUTE Dept. C Valparaiso, Ind.



TV REPAIRMEN MAKE TOP MONEY!



In just 39 weeks, you can get complete TV service training! Streamlined course gives you all essentials for a good job as service technician. Graduates in great demand; jobs are plentiful in this growing field. Other courses in electronics, radio operation and maintenance. Day or evening classes; modern equipment. Opportunity for employment in local industry.

Write for Catalog 111 Today

INDIANAPOLIS ELECTRONIC SCHOOL
312 E. Washington, Indianapolis 4, Ind.

First And Only Book With

COLOR TV CIRCUITS & SERVICING

COLOR TV CIRCUITS & SERVICING

- See Actual Circuits Used In Color Sets
- Color TV Principles
- Simplified Color TV Servicing

JUST OFF THE PRESS!
Everything You Want To Know About Color TV!

Down-to-earth explanations of color TV circuits with actual diagrams of various manufacturers. Basic principles told in everyday language. NTSC system explained in detail. Trouble-shooting and servicing simplified. Detailed explanation of color TV theory. Over 100 pages packed with all the answers on color TV. Profusely illustrated. \$2.95 postpaid. ORDER BY MAIL TODAY... NOW!

BEECO

Dept. P-4
Mathieson Building
Baltimore 2, Md.

MAY, 1954

RADIO SCHOOL DIRECTORY

CODE SENDING RECEIVING SPEED

Be a "key" man. Learn how to send and receive messages in code by telegraph and radio. Commerce needs thousands of men for jobs. Good pay, adventure, interesting work. Learn at home quickly through famous Candler System. Quality for Amateur or Commercial License. Write for FREE BOOK. **CANDLER SYSTEM CO.** Dept. 3-E, Box 928, Denver 1, Colo. U.S.A.

Get Your F.C.C. LICENSE Quickly!

Correspondence or residence preparation for F.C.C. examinations. Results guaranteed.

An FCC commercial operator license means greater opportunities and higher pay. We are specialists in preparing you, in a MINIMUM OF TIME, to pass FCC examinations for all classes of licenses. Beginners get 2nd class license in 5 weeks and 1st class in 3 additional weeks. Write for free booklet.

GRANTHAM SCHOOL OF ELECTRONICS
Dept. 101, 6064 Hollywood Blvd., Hollywood 28, Calif.

RADIO ENGINEERING DEGREE IN 27 MONTHS

Intensive, specialized course including strong basis in mathematics and electrical engineering, advanced radio theory and design, television. Modern lab. Low tuition. Self-help opportunities. Also B.S. degree in 27 months in Aeronautical, Chemical, Civil, Electrical, and Mechanical Engineering. G.I. Gov't approved. Enter June, September, December, March. Catalog.

INDIANA TECHNICAL COLLEGE
155 E. Washington Blvd., Fort Wayne 2, Indiana



RCA INSTITUTES, INC.

A service of Radio Corporation of America
350 West 4th St., New York 14, N. Y.

OFFERS COURSES IN ALL TECHNICAL PHASES OF RADIO, TELEVISION, ELECTRONICS

Approved for Veterans
Write Dept. RC-54 for Catalog

EARN MORE MONEY— BE A PROFESSIONAL TELEVISION SERVICE TECHNICIAN



STEP INTO THE TOP PAY \$5,000—\$10,000 A YEAR CLASS. 7 MONTHS' SHOP TRAINING QUALIFIES YOU.

If you want to reach your goal as a Successful Service Technician you will need plenty of "KNOW HOW" to qualify for the better servicing jobs or profitable shop ownership.

SEND FOR FREE BOOK TODAY!

WESTERN TV offers real experience on live equipment in our BIG SHOPS AND LABORATORIES in the shortest practical time under expert instructors. Graduates are in big demand because they have the "field experience" necessary for immediate "bench" or supervisory positions. You learn every phase of Radio and TV servicing (AM, FM, VHF, UHF). WTI men win fast promotion... can demand better pay... develop highly profitable businesses of their own with the latest and most PRACTICAL PERSONALIZED TRAINING BEHIND THEM. You concentrate all your time on being a PROFESSIONAL TV SERVICE TECHNICIAN — non-essential math and engineering theory omitted. YOU CAN EARN WHILE YOU LEARN. Special Finance Plan.

APPROVED FOR VETERANS. Find out how you can get into the TOP PAY GROUP — Send for this fact-packed book NOW!

WESTERN TELEVISION INSTITUTE America's Leading Television Servicing School

Western Television Institute Dept. E-5-4
341 W. 18th St., Los Angeles 15, Calif.
Without obligation, please send FREE fully illustrated booklet. (No salesman will call.)

NAME _____ AGE _____
ADDRESS _____
CITY _____ ZONE _____ STATE _____

You Can Become an **ELECTRICAL ENGINEER** with a Bachelor of Science Degree **IN 36 MONTHS**

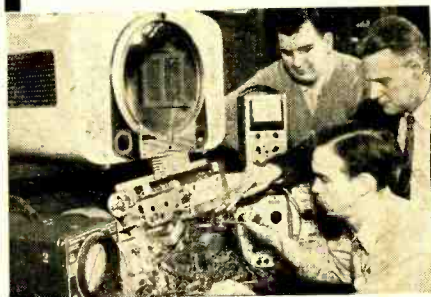

Major in Electronics or Power at Milwaukee School of Engineering

Everyone knows the tremendous opportunities ahead in electrical engineering. The expanding field of color television alone is one example. In addition to the demand for engineers, thousands of engineering technicians are needed. The Milwaukee School of Engineering can prepare you to become an engineer in 36 months or an engineering technician in 12 to 18 months. It'll pay you to look into it today. No obligation.

Technician and Service Courses — 12 to 18 months

In 12 months you can be a radio technician. An additional 6-month course qualifies you as a radio-television technician with an Associate in Applied Science degree. Or you can earn an industrial electronic technician certificate in 12 months.

These technician courses form the first third of the program leading to a B.S. Degree in Electrical Engineering. Twenty-one subjects studied include electronics, electronic engineering, and electronic design.

Also offered are: radio-television service course (12 mos.); electrical service course (6 mos.); general preparatory and refresher course (3 mos.).



Terms open July, September, January and April

Faculty of specialists — 50,000 former students — Annual enrollment from 48 states and 23 foreign countries — Non-profit institution — 51st year of service — Course approved for veterans — Residence courses only.

MILWAUKEE SCHOOL OF ENGINEERING

TEAR OUT AND MAIL TODAY

MILWAUKEE SCHOOL OF ENGINEERING
Dept. RE-554 1025 N. Milwaukee Street
Milwaukee 1, Wisconsin

Send me Free illustrated booklet on opportunities in Electrical Engineering or Free illustrated booklet on careers in Radio-TV.

I am interested in _____ (name of course)

Name _____ Age _____

Address _____

City _____ Zone _____ State _____

If veteran, indicate date of discharge _____

**NOW EICO® brings you
A LABORATORY SCOPE AT
A PRICE YOU CAN AFFORD!**

Now you can enjoy all the tremendous advantages of troubleshooting with the greater speed, precision and visual meaning which only an oscilloscope gives you. With the EICO 5" Scope you can:

- Visually align TV, FM and AM sets
- Visually signal trace and trouble-shoot every stage of any electronic device
- Visually analyze complex waveforms

..... All without disturbing circuits

425K 5" Push-Pull Scope KIT \$44.95. Wired \$79.95.

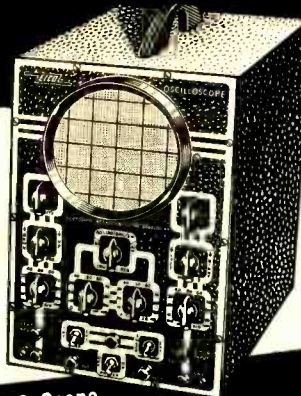

NEW

3 PROBES make 3 INSTRUMENTS of your EICO Scope

- DEMODULATOR PROBE KIT \$3.75. Wired \$5.75 - For signal tracing every stage of TV, FM and AM sets.
 - LOW CAPACITY PROBE KIT \$3.75. Wired \$5.75 - For broad bandwidth and high impedance circuits.
 - DIRECT PROBE KIT \$2.75. Wired \$3.95 - For voltage and current measurements and general analysis.
- Special introductory price, set of three PROBE KITS \$9.95. Wired \$14.95



Compare these specifications with scopes selling at many times the EICO economy price!

- Push-pull Vert. & Hor. amplifiers
- Full-screen V & H centering controls
- Intensity (Z-axis) mod.
- 6.3 volt AC, 60 cps test signal output

- Direct connections to deflection plates
- V & H Freq. Resp: 5 cps - 500 kc; usable to 2.5 mc.
- V Sens: .05 to .1 volts rms/inch
- V & H input imp: 1 megohm
- Multivibrator Sweep Generator Range: 15 cps - 75 kc
- Tubes: 2-5Y3, 2-6J5, 3-6SN7, 1-5" CRT.

See this amazing Scope value at your jobber today. Write NOW for FREE Catalog SC-5 describing the complete EICO line. Read EICO'S other ads in this issue—turn to Advertiser's Index.



ELECTRONIC INSTRUMENT CO., INC.
84 Withers Street, Brooklyn 11, N. Y.

**WATCH FOR OUR
JUNE ISSUE
AT YOUR DEALER'S
MAY 26**

Smaller in Size-Greater in Efficiency!

**The FAMOUS
SUB-MINIATURE
K-TRAN*
I.F. TRANSFORMER
ONLY 1/2" SQUARE BY 1 1/2" HIGH
Over-all, Inc. Terminals, 1-15/16"**



2/3 ACTUAL SIZE



THE FAMOUS "K-TRAN" I.F. TRANSFORMER HAS NOW BEEN MINIATURIZED. For the first time we are now able to supply a 455 KC intermediate frequency transformer which has all the desirable features of the conventional size I.F. and smaller than a miniature tube. Through the use of a Ferrite shell core material these Sub-Miniature I.F. Transformers offer the gain and bandwidth characteristics previously obtained only in larger I.F. assemblies.

It is now possible to construct personalized receivers smaller than ever before. These transformers may be used with sub-miniature tubes where sockets are not required.

Catalog No.		Net Price
10 - C1	455 KC Input Transformer	\$1.50
10 - C2	455 KC Output Transformer	\$1.50

(Available through your local distributor)

* Manufactured under "K-TRAN" patents of Automatic Mfg. Co.

J. W. MILLER COMPANY
5917 South Main Street • Los Angeles 3, California

Canadian Representative: Atlas Radio Corporation, Ltd. 560 King Street, W. Toronto 2B, Canada

The diagram shows how a jack and a 10-watt resistor are connected to the transformer secondary. The resistor value is not critical as long as it is comparatively low. I used a 50-ohm unit. A resistor equal to the output impedance would be ideal.—Paul S. Lederer

**CAPACITOR
SUBSTITUTION BOX**

This simple capacitor substitution box uses 2 switches to obtain 30 different capacitance values with only 20 fixed capacitors. The circuit shows how the capacitors can be connected in series, or parallel, or used singularly to give values that are one-half, one, and two times the basic value. A 12-point rotary switch selects the basic value and a double-pole, 3-position lever switch sets the multiplier range. A neon lamp was connected in the 11th position as a handy voltage indicator and test gadget.

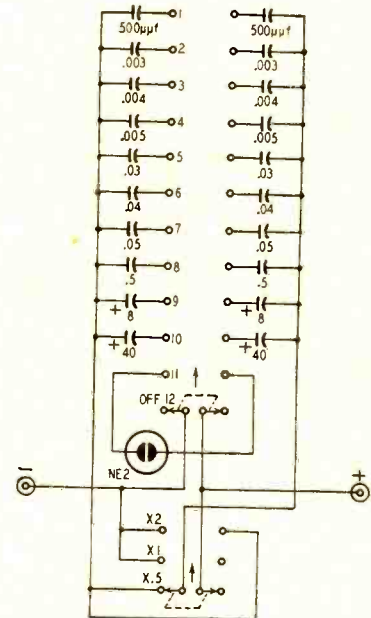

Parts for substitution box

Capacitors (Miniature mica, ceramic, or paper): 2—500 µuf, 2—.003, 2—.004, 2—.005, 2—.03, 2—.04, 2—.05, 2—.05 µf, 600 volts. (Electrolytic) 2—8, 2—40 µf, 150 volts.

Miscellaneous: 1—miniature rotary switch, 2 circuits, 12 positions; 1—miniature lever, slide, or rotary switch, 2 circuits, 3 positions. Small utility box, NE-2 neon lamp, 2—jacks for test leads, tie-points.

All capacitors in the unit are 600-volt types except the 8- and 40-µf pairs which are rated at 150 volts. Use the smallest (physically) available capacitors and you will be able to fit the whole works into a 4 x 4 x 2-inch metal box.—R. Weingarten

RESISTOR STORAGE

When a service shop has lots of room for spare parts, a separate bin or compartment can be allotted for each resistor value. Where storage space is at a premium, store all the resistors in 10 compartments, labeling each only with the number of coded zeros on the resistors.

By using the last color as a marker, it is necessary to look through only 10 compartments.—Harvey Muller END

V. E. C.
TUBES
AT
WHOLESALE
Minimum Order \$7.00

BRAND NEW BOXED BRANDED
100% GUARANTEED
"Send For Free Tube Listing"
Use This Ad As Your Order Form

TYPES AT 29¢			
QUANTITY	TYPE	QUANTITY	TYPE
.....	5Y3	35W4
.....	5Z3	35Z5
.....	6X4	117Z3
.....	6X5		
TYPES AT 39¢			
QUANTITY	TYPE	QUANTITY	TYPE
.....	1S5	6W4GT
.....	1U5	12AL5
.....	5U4	12AT6
.....	6AB4	12AU6
.....	6AL5	12AV6
.....	6AT6	12BA6
.....	6AU6	12BE6
.....	6AV6	12SQ7
.....	6BE6	25L6GT
.....	6C4	25W4GT
.....	6F6	25Z6
.....	6K6	35B5
.....	6S4	35C5
.....	6SQ7		
TYPES AT 49¢			
QUANTITY	TYPE	QUANTITY	TYPE
.....	1A7	6BA6
.....	1H5	6BC5
.....	1L4	6BH6
.....	1N5	6BJ6
.....	1R5	6CB6
.....	1T4	6SA7
.....	1U4	6SD7
.....	3Q4	6SK7
.....	3S4	6V6
.....	3L4	12SA7
.....	5V4	12SK7
.....	5Y4	50B5
.....	6AG5	50C5
.....	6AQ5	50L6
TYPES AT 59¢			
QUANTITY	TYPE	QUANTITY	TYPE
.....	1B3GT	6SL7
.....	1L6	6SN7
.....	1X2	12AU7
.....	3Q5	12AX7
.....	6BA7	12BA7
.....	6BD5	12BH7
.....	6J6	12SL7
.....	6S8	12SN7
TYPES AT 69¢			
QUANTITY	TYPE	QUANTITY	TYPE
.....	6AK5	6T8
.....	6AJ5	6U8
.....	6BK7	12AT7
.....	6BL7	12AV7
.....	6L6	19T8
TYPES AT 79¢			
QUANTITY	TYPE	QUANTITY	TYPE
.....	6BQ6	6BZ7
.....	6BQ7	25BQ6
TYPES AT 99¢			
QUANTITY	TYPE	QUANTITY	TYPE
.....	6BG6	198G6
.....	6CD6	117L7GT

FREE —with every order of \$20.00 or more famous "Oxwall" magnetic screw driver kit includes all sizes—Philips head, long handles to get in those tight spots, etc. 7 screwdrivers in all. May be purchased outright List value \$4.85
\$1.99 each 3 for \$5.50

VIDEO ELECTRIC CO., P.O. Box 911, Newark, N. J.

Free complete tube listing
 Free magnetic screw driver kit (\$20.00 order)
\$. Amount enclosed

Name.....
Address.....
City..... Zone..... State.....
PLEASE PRINT CAREFULLY

When answering advertisements please mention
RADIO-ELECTRONICS

QUAM

the Quality line

When you specify Quam products you are assured of components that are carefully checked and tested for top performance and dependability . . . delivered when you need them . . . at the right price.

manufacturers of

QUAM Adjust-a-Cone® Speakers for television, radio, high fidelity, public address, outdoor use, replacement and many other applications.

QUAM Focalizer Units for TV picture tube focusing . . . use Alnico V permanent magnets . . . eliminate troubles inherent to wire-wound focusing devices.

QUAM Ion Traps for any size or type of TV picture tube.

QUAM Tru-Match Output Transformers, designed to get the best performance from your speaker.

QUAM-NICHOLS CO.
Marquette Road and Prairie Avenue
Chicago 37, Illinois

HI-GAIN TUNER-BOOSTER
LESS TUBES WITH DIAL

\$4.75

COMPLETE WITH TUBES

\$6.00

Solve poor TV reception with a Hi-Gain Booster. Banish weak fringe areas, reduce snow. This unit comes to you as a highly serviceable High-Gain Tuner. Uses 6J6 Tubes in very efficient Hi-Q Circuit. Has 8 tuned circuits using pure silver inductances and individual compensation providing high gain on all channels. Built in 5:1 Vernier Drive.
All necessary parts and instr. included makes highest gain booster on the market reg. of price.

100 ASSORTED RESISTORS
Carbon insulated. New in current RMA Values 5%, 10% and 20% in 1/2, 1 and 2 watt

\$1.00

Shipments sent postpaid when full payment is enclosed. 25% deposit on C.O.D. Send for our new bulletin. NO C.O.D.'S TO CANADA.
FRANK W. DECRAY & ASSOC.
11842 W. Jefferson Blvd. Culver City, Calif.

THE NEW TV DYNATRACER

ONLY \$4.95

Ppd. or C.O.D. + Chgs.

- TRACES TV SIGNALS AND VOLTAGES
- LOCATES DEFECTIVE COMPONENTS
- REQUIRES NO ADDITIONAL EQUIPMENT

This sensational new piece of test equipment is ideal for trouble-shooting television sets in the home or in the shop. The "DYNATRACER" will outperform more expensive testers and should pay for itself on the very first repair.

A Must For Every TV Technician
SPECIFICATIONS: The "DYNATRACER" is a self-powered quality test instrument designed to trace TV signals through any Video, Sound, Sync, AFC, Horizontal or Vertical Sweep Circuit—will isolate trouble to a stage or component.

ADDED FEATURE: The "DYNATRACER" will also trace voltages (50/500 V. AC/DC) and instantly locate open, shorted, intermittent or leaky (up to 20 MEGOHMS) condensers, resistors, coils, X-Formers, etc. Instruction and Trouble-Shooting Book Enclosed.

10 DAY MONEY-BACK GUARANTEE

Cut out advertisement . . . attach name and address with \$3.00 bill, check or money order and mail to

Century ELECTRONICS CO.

211-04 99th Ave., Dept. 113, Queens Village, N. Y.

BUILD 15 RADIOS ONLY AT HOME \$19.95

With the New Improved 1954
Progressive Radio "EDU-KIT"

NOW INCLUDES
SIGNAL TRACER
and
CODE OSCILLATOR

- ATTRACTIVELY GIFT PACKED
- FREE SOLDERING IRON
- ABSOLUTELY NO KNOWLEDGE OF RADIO NECESSARY
- NO ADDITIONAL PARTS NEEDED
- EXCELLENT BACKGROUND FOR TV
- 10 DAY MONEY-BACK GUARANTEE
- SCHOOL INQUIRIES INVITED



WHAT THE PROGRESSIVE RADIO "EDU-KIT" OFFERS YOU

The Progressive Radio "Edu-Kit" offers you a home study course at a rock bottom price. Our Kit is designed to train Radio Technicians, with the basic facts of Radio Theory and Construct on Practice expressed simply and clearly. You will gain a knowledge of basic Radio Principles involved in Radio Reception, Radio Transmission and Audio Amplification. You will learn how to identify Radio Symbols and Diagrams; how to build how to wire and solder in a professional manner. You will learn how to operate Receivers, Transmitters, and Audio Amplifiers. You will learn how to service and trouble-shoot radios. You will learn code. You will receive training for F.C.C. license.

In brief, you will receive a basic education in Radio exactly like the kind you would expect to receive in a Radio Course costing several hundreds of dollars.

THE KIT FOR EVERYONE

The Progressive Radio "Edu-Kit" was specifically prepared for any person who has a desire to learn Radio. The Kit has been used successfully by young and old in all parts of the world. It is not necessary that you have even the slightest background in radio or radio.

The Progressive Radio "Edu-Kit" is used by many Radio Schools and Clubs Forces Personnel and Veterans throughout the world.

The Progressive Radio "Edu-Kit" requires no instructor. All instructions are included. All parts are individually boxed, and identified by name, photograph and diagram. Every step involved in building these sets is carefully explained. You cannot make a mistake.

PROGRESSIVE TEACHING METHOD

The Progressive Radio "Edu-Kit" comes complete with instructions. These instructions are arranged in a clear, simple and progressive manner. The theory of Radio Transmission, Radio Reception, Audio Amplification and servicing by Signal Tracing is clearly explained in a simple, easy-to-understand manner. You will learn the function and theory of every part used.

The Progressive Radio "Edu-Kit" uses the principle of "Learn by Doing". Therefore you will build radios, perform jobs, and conduct experiments to illustrate the principles which you learn. It is used for training and rehabilitation of Armed Forces Personnel and Veterans throughout the world.

You advanced. Gradually, in a progressive manner, you will find yourself constructing still more advanced multi-tube radio sets, and doing work like a professional Radio Technician. Together you will build fifteen radios, including Receivers, Transmitters, Amplifiers, Code Oscillator and Signal Tracer. These sets operate on 105-125 V. AC/DC.

THE PROGRESSIVE RADIO "EDU-KIT" IS COMPLETE

You will receive every part necessary to build 15 different radio sets. Our kits contain tubes, tube sockets, chassis, variable condensers, electrolytic condensers, mica condensers, paper condensers, resistors, line cords, selenium rectifiers, tie strips, coils, hardware, tubing, etc.

Every part that you need is included. These parts are individually packaged, so that you can easily identify every item. A soldering iron is included, as well as an Electrical and Radio Tester. Complete, easy-to-follow instructions are provided. In addition, the "Edu-Kit" now contains lessons for servicing with the Progressive Signal Tracer. F.C.C. instructions, quizzes. The "Edu-Kit" is a complete radio course, down to the smallest detail.

TROUBLE-SHOOTING LESSONS

Trouble-shooting and servicing are included. You will be taught to recognize and repair troubles. You will build and learn to operate a professional Signal Tracer. You receive an Electrical and Radio Tester, and learn to use it for radio repairs. While you are learning in this practical way, you will be able to do for many a repair job for your neighbors and friends, and charge fees which will far exceed the cost of the "Edu-Kit". Here is your opportunity to learn radio quickly and easily, and have others pay for it. Our Consultation Service will help you with any technical problems which you may have.

FREE EXTRAS

- ELECTRICAL & RADIO TESTER • ELECTRIC SOLDERING IRON • TV BOOK • RADIO TROUBLE-SHOOTING GUIDE • CONSULTATION SERVICE • QUIZZES • F.C.C. TRAINING

Progressive "Edu-Kits" Inc.
497 Union Ave., Dept. RE-83, Brooklyn 11, N. Y.

MAIL TODAY—Order shipped same day received.

- 10-Day Money-Back Guarantee. Include ALL FREE EXTRAS.
- Send "Edu-Kit" Postpaid. I enclose full payment of \$19.95 (U.S.A. only).
- Send "Edu-Kit" Postpaid. I enclose full payment of \$20.95 (Outside U.S.A.).
- 210-250 V. Adapter for "Edu-Kit"—\$2.50.
- Send "Edu-Kit" C.O.D. I will pay \$19.95 plus postage (U.S.A. only).
- I wish additional information describing "Edu-Kit". No Obligation.
- Send me FREE Radio-TV Servicing Literature.

Name _____
Address _____

PROGRESSIVE "EDU-KITS" INC.

497 UNION AVE., Dept. RE-83, Brooklyn 11, N. Y.

TV ANTENNA ROTATOR

JFD Manufacturing Co., Inc., 6101 16th Avenue, Brooklyn 4, N. Y., announces production of the new Rotenna, a TV antenna rotator featuring 360° rotation, a cartridge-type detachable drive unit, in-line mast collars, a finger-tip control switch with pointer-type direction indicator, and stop-watch turning accuracy. The latter feature describes the ability of the unit to be stopped at exactly the same predetermined point when approached from either direction; and close tracking between the antenna and the direction indicator.

The control unit, finished in mahogany, has a finger-tip bar-type control switch. Pressing the switch once actuates the pointer to show the present antenna direction. Pressing it a second time starts the rotator which continues to run until the switch is released.

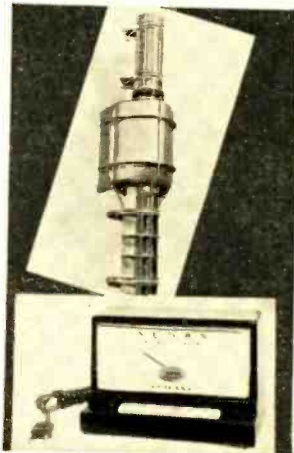

SELENIUM RECTIFIERS

Radio Receptor Co., Inc., 251 W. 19 St., New York 11, N. Y., has added a new range of cartridge type selenium rectifiers to their Seletron line. Included in the new group are hermetically sealed, glass-encased units, phenolic-encased half-wave axial lead units, the phenolic encased bridge type and unmounted cells for special assembly.

These rectifiers, the GA series, provide a true hermetic seal by using metallized glass, solder-sealed to met-

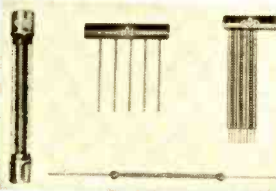

al caps. This class of enclosure is desirable wherever long life is required under extremely adverse conditions of humidity or atmospheric contamination. Ratings can be exceeded where only limited life is expected.

Half-wave stacks may be used in combination for doublers, bridges, and center-tap circuits. Typical applications are in power supplies for radar indicators, photo-flash oscillators, Geiger counters, precipitron dust collectors and relay coils. They are also used in a wide variety of computer, control instrument, and communication circuits.

NOISE SUPPRESSOR

Herman Hosmer Scott, Inc., 385 Putnam Ave., Cambridge 39, Mass., has designed a dynamic noise suppressor



as an accessory unit for use with their model 99 transcription amplifier or their model 214 remote-control amplifier. The unit virtually eliminates turntable rumble and record scratch or hiss, but without losing music audible to the ear as occurs with fixed filters. This is done by restricting the bandwidth during soft passages when the human ear is relatively insensitive to extremes of treble and bass, and then by opening the bandwidth to the full range, allowing complete passage of loud music which itself drowns out any extraneous noise.

The frequency response is flat from 19 to 20,000 c.p.s. Two controls are provided, the Dynaural control for adjusting the degree of noise suppression, and the Dynaural Range control which offers a choice of 20 kc, 12 kc, and 6 kc high-frequency cutoffs (record distortion filters) each with both rumble and scratch suppression, a position for dynamic rumble suppression only, and a position for suppression off.

INDICATING FUSE POST

Littelfuse, Inc., Des Plaines, Ill., has introduced a miniature indicating fuse post designed for 3AG and 3AB fuses in ratings up to 15 amperes and 250 volts maximum.

The device, No. 344010, measures 2 3/8 inches over-all, 3/4 inch above panel, 1 1/2 inches below panel, including the solder terminals.



UHF ANTENNA

Acme Tool & Specialties Co., 224 N. Loomis St., Chicago 7, Ill., has introduced a u.h.f. all-channel corner reflector featuring molded glass fiber construction and a new reverse V dipole design, the Acto-tenna.

The two reflector screens are produced by permanently molding a series of U-shaped aluminum reflectors into a glass fiber spine. This molded construction guarantees the critical spacing of the reflectors in a weatherproof, vibrationproof mounting. The antenna has high horizontal and vertical directivity.

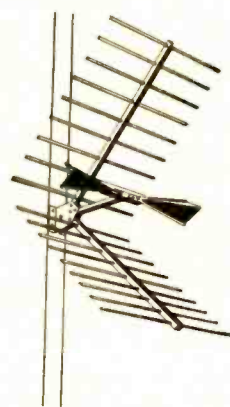

MINIATURE INSTRUMENTS

Weston Electrical Instrument Co., 614 Frelinghuysen Ave., Newark 5, N. J., has announced a new line of miniature

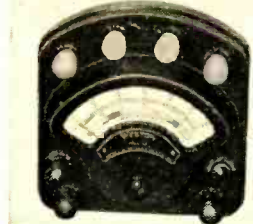

portable d.c. instruments incorporating a self-shielded mechanism, model 281. The core-magnet mechanism insures accuracy within 1%. The larger moving coil employed gives improved performance with a high torque-to-weight ratio, and allows increased sensitivity where needed.

Furnished in complete bakelite cases, model 281 instruments withstand a dielectric test of 2,600 volts a.c. r.m.s. between case and terminals, applied in accordance with A.S.A. specifications. Scales are hand-calibrated, with mirror and knife-edge pointers combined to eliminate parallax errors. They are supplied in a wide variety of ranges in single and multirange volt-meters, ammeters and volt-ammeters. Measuring only approximately 4 1/2 x 4 1/2 x 1 1/2 inches, these instruments are especially adaptable for use in laboratories, in inspection, in educational work, and wherever else a precision instrument of miniature size is required.

PROXIMITY PICKUP

Electro Products Laboratories, 4501 N. Ravenswood Ave., Chicago 40, Ill., has developed a new proximity pickup impulse generator, model 4900. The unit works on a principle similar to the



military mine detector and may be excited either by magnetic or non-magnetic metals. This new pickup system consists of a

transducer connected by a 10-foot cable to a control unit which contains the power supply and other electronic components. It produces a d.c. voltage of constant amplitude when any metallic mass is brought near the pickup. No mechanical contact is made with the exciting metal. The d.c. voltage remains constant as long as the exciting metal is in close proximity to the pickup and drops to zero when it is removed. The rise and delay time of the voltage produced is extremely fast, thereby producing a definite snap action.

ANTENNA ROTATOR

Cornell-Dubilier Electric Corp., South Plainfield, N. J., and its subsidiary, Radiart Corp., 3455 Vega Ave., Cleveland, Ohio, announce the model TR-4 Rotator.

This antenna rotator has a meter cabinet using 4-wire cable and can handle a load of as much as 150 pounds.

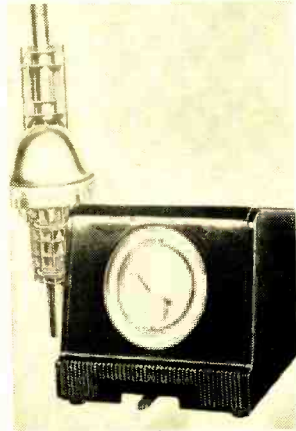

THREE NEW ANTENNAS
Trio Mfg. Co., Griggsville, Ill., has

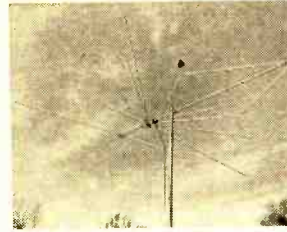

added three new antennas to their line.

The model 98 is a high-gain v.h.f.-u.h.f. covering channels 2-83. The u.h.f. section is rhombic and the v.h.f. section is conical in design.

Model 713-6 is a 6-element dual-

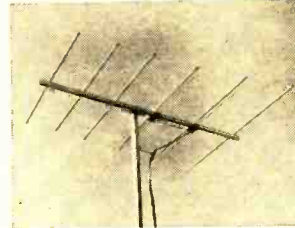

driven broad-band Yagi for channels 7-13. It uses two folded dipoles and multiple parasitic elements, and has 7 1/2 to 8 db gain throughout all seven channels.

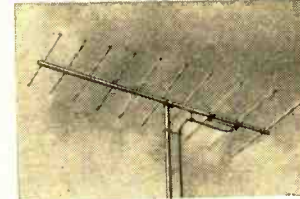

Model 713-10 is a 10-element dual-driven broad-band Yagi for channels

7-13. Its forward gain averages 10 db across channels 8-13.

TUNER CLEANER

Walsco Electronics Corp., 3602 Crenshaw Blvd., Los Angeles 16, Calif., has announced a new tuner cleaner, the Clean-O-Matic.

Unlike conventional brush-like cleaners that cover only one set of contacts at a time, it fits all Standard Coil tuners, and cleans and protects all contacts except the one in use.

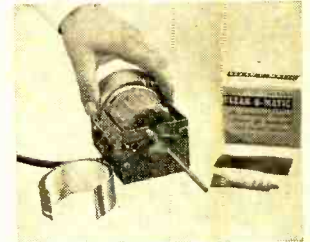

TV REPLACEMENTS

Triad Transformer Corp., 4055 Redwood Ave., Venice, Calif., has added six fly-back transformers to their line, making a total of nineteen. Of the new additions, four are universal type and two are replacements.

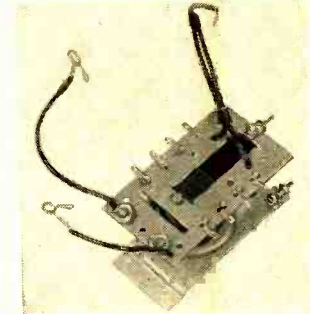

Get This Valuable Book

Just for Examining COYNE'S New 6-Volume Set

FREE



Applied Practical Radio-Television

ON 7 DAY FREE TRIAL!

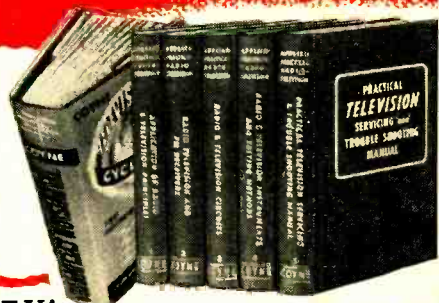

Yes, you get this big, new 1954 book, "150 Radio-Television Picture Patterns and Diagrams Explained", absolutely FREE! Just off the press! Gives complete 11x22" Schematic Diagrams on leading models Radio and Television Sets. Easy-to-read, large 8 1/2 x 11" pages, with full instructions on how to read and use the diagrams. A "must" in every Radio and Television service-man's repair kit. You get this valuable book as a FREE Gift for asking to see Coyne's great new 6-book set, "Applied Practical Radio-Television"!

At Last! Money-Making "Know-How" on Transistors, Color TV and Servicing

Coyne's great new 6-volume set gives you all the answers to servicing problems—quickly! For basic "know-how" that is easy to understand, you'll find everything you want in volumes 1 to 5 which contain over 5000 practical facts and data. They cover every step from principles to installing, servicing, trouble-shooting and aligning all types of radio and TV sets. So up-to-date it includes COLOR TV and UHF adaptors, converters. Also covers latest data on TRANSISTORS.

Extra! 802-Page Television Cyclopedic Included

And then, for speedy on-the-job use, you get volume 6—the famous Coyne TELEVISION CYCLOPEDIA. It answers today's television problems on servicing, alignment, installation and others. In easy-to-find ABC order, cross indexed. Use this 6 volume TV-RADIO LIBRARY free for 7 days; get the valuable Servicing Book ABSOLUTELY FREE!

SEND NO MONEY! Just mail coupon for 6-volume set on 7 days free trial. We'll include book of 150 TV-Radio Patterns & Diagrams. If you keep the set, pay \$2 in 7 days and \$2 per month until \$22.50 plus postage is paid. (Cash price \$20.95). Or you can return the library at our expense in 7 days and owe nothing. **YOU BE THE JUDGE. Either way, the book of TV-Radio Patterns is yours FREE to keep!** Offer is limited. Act NOW!

FREE BOOK — FREE TRIAL COUPON!

COYNE ELECTRICAL & TELEVISION-RADIO SCHOOL, Dept. 54-T1
500 S. Paulina St., Chicago 12, Ill.

YES! Send 6-volume "Applied Practical Radio-Television" for 7 days FREE TRIAL per your offer. Include TV-Radio Patterns & Diagram Book FREE.

Name.....Age.....

Address.....

City.....Zone...State.....

Where Employed.....

() Check here if you want library sent COD. You pay postman \$20.95 plus COD postage on delivery. 7-day money-back guarantee.

COYNE ELECTRICAL & TELEVISION-RADIO SCHOOL
500 S. Paulina St., Dept. 54-T1 Chicago 12, Ill.

Jobbers, Technicians Now—a brand new Insuline plant!

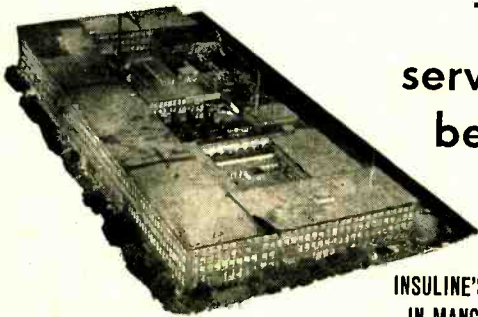

To
serve you
better

INSULINE'S NEW HOME
IN MANCHESTER, N. H.

This modern new building provides 281,000 sq. ft. of air conditioned manufacturing space with complete trucking, rail

siding and air transportation facilities planned to provide our customers with better service from design to delivery.

EXPANDED FACILITIES INCLUDE

- Added Equipment
- Enlarged factory personnel
- Latest streamlined production methods
- Expanded engineering staff

See us at
BOOTH 403 and ROOM 512
at the
1954 Electronic Parts Show
May 17-20 Conrad Hilton Hotel
Chicago.

For the convenience
of customers in the
New York City area,
Insuline maintains a
sales office at:

36-02 35th Avenue
Long Island City I, N.Y.
Telephone: AStoria 8-3738
Teletype: NY 4-4386

insuline TOOLS—Engineered to the specifications of television set manufacturers

Line includes every necessary TV tool to service all receivers. Here are just a few:

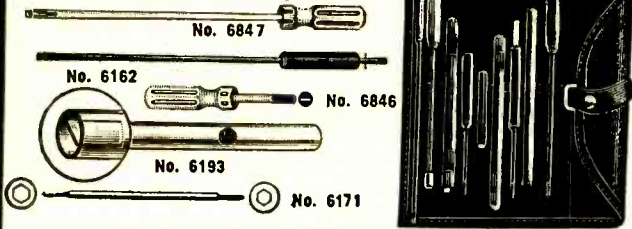

Be sure it's Insuline when you need the right tool for a TV service problem. Write Dept. RE-5 for complete tool list and new TV tool brochure.

THOUSANDS OF OTHER OUTSTANDING INSULINE PRODUCTS INCLUDE

- Racks, cabinets, cases
- Auto radio components
- Panels, brackets, grilles
- TV antennas and accessories
- Auto antennas
- Miscellaneous hardware



insuline
CORPORATION OF AMERICA

186 Granite St.

Manchester, New Hampshire

NEW DEVICES

ALL-PURPOSE ANTENNA

Brach Manufacturing Corp., 200 Central Ave., Newark, N. J., a division of General Bronze Corp., has announced the development of an all-purpose television antenna, designed especially with color television in mind. The new No. 555 *Delta-V-Beam* antenna eliminates the need for mixers, couplers, networks, and switches to combine u.h.f. and v.h.f. signals on a common transmission line.

The new antenna has been tested in the New York-New Jersey area, and has proved very effective in discriminating against reflections.

EXTENSION SPEAKER

Sootins, Inc., 321 N.W. 3rd Ave., Miami 35 Fla., has announced the *Floritone* extension speaker for TV sets.

The model uses a 5-inch Quam heavy-magnet PM speaker encased in a Fiberglas cone and mounted on a swivel on an aluminum base. It has a 4-way switch enabling the user to play either the TV or the extension speaker or both, or to shut off the sound completely.

The *Floritone* is available in white, gray, blue, green, coral, and buff, and can be used for "personalized listening," late evening programs, and the like.

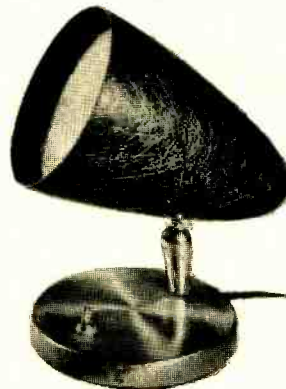

MOTOROLA REPLACEMENTS

Ram Electronics Sales Co., South Buckhout St., Irvington-an-Hudson, N. Y., has announced the X103, X104, X105, and X106. These units are exact replacements for all the flybacks used in Motorola chassis TS-14 to TS-505 with practically no exceptions. Specifically, 40 chassis and 416 models are covered. The flybacks apply to 29 different Motorola flyback numbers.

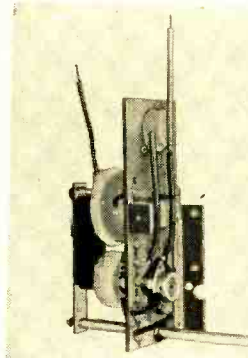

The X103, X104, X105, and X106 are autotransformers which are engineered to operate in the 66- to 70-degree horizontal deflection angle system. They deliver 10, 14, 16, and 16.5 kilovolts, respectively.

NEW FUSE

Sightmaster Corp., New Rochelle, N. Y., is producing an indicator-repeating fuse for home and industrial use. The item features a neon indicator which lights up when a fuse ceases to function.

The light is a signal to switch to the next position on the fuse. Since there are six positions, it can be used repeatedly without replacements. It will

be manufactured with ratings of 15, 20, 25, and 30 amperes.



AMATEUR RECEIVER

The National Co., Inc., 61 Sherman St., Malden 48, Mass., has added a new receiver, the NC-98, to its line of amateur and short-wave listening radios. The NC-98 is equipped with a crystal filter S-meter, and accessory socket, and is calibrated with either ham or short-wave bands.

The receiver has 550 kc-40 mc coverage, 8 miniature tubes plus a rectifier, 1 r.f. stage, 2 i.f. stages, slide-rule dials, an antenna trimmer, a noise limiter, provision for narrow-band frequency modulation, and a separate high-frequency oscillator.

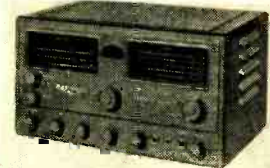

SIGNAL GENERATOR

Precision Apparatus Co., Inc., 92-27 Horace Harding Blvd., Elmhurst 4, L. I., N. Y., is producing a new model of their E-200C signal generator, with a direct reading frequency coverage from 88 kc to 240 mc, fundamentals to 60 mc. The circuit uses a 6AU6 in a stable electron-coupled oscillator circuit, modulated by a 6U8 sine-wave audio oscillator, and a 5Y3-GT full-wave rectifier.

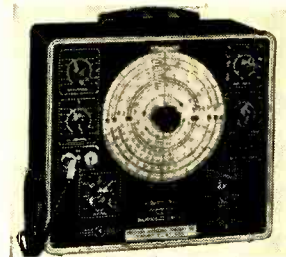

ALL CHANNEL U.H.F. ANTENNA

JFD Manufacturing Co., Inc., 6101 16th Ave., Brooklyn 4, N. Y., has announced a u.h.f. antenna, the *Bowtie-Flector*, model 615. The antenna features a rigid wire grid reflector and aluminum bowtie dipole. The reflector is plated with cadmium to resist rust and corrosion. Extensive field testing in Pennsylvania reveals an average gain of 6.5 db across the u.h.f. spectrum (over half-wave folded reference dipoles).

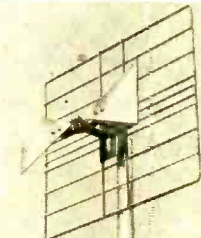

TV COMPONENT TESTER

Transvision, Inc., New Rochelle, N. Y., is manufacturing a TV component tester which tests flyback transformers and yokes, selenium rectifiers, and picture tubes, and also reactivates worn-out picture tubes.

As a flyback transformer and yoke tester, it checks for started turns. Positive reading shows if flyback output

RADIO-ELECTRONICS

transformer or yoke need replacing. As a selenium rectifier tester, it checks rectifiers in half-wave circuits and tests all radio and TV power supply rectifiers. As a picture-tube tester, it provides for checking the picture tube without removing it from the set, measures cathode emission accurately, locates shorts between elements, locates high-resistance shorts or leakage as high as 3 megohms. As a picture tube reactivator, the unit provides for re-activating a picture tube in or out of a set, restores brightness and detail, and prolongs life of picture tube.

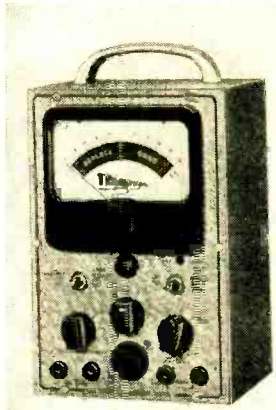

RADIO AIDS

Superex Electronics Corp., 23 Atherton St., Yonkers, N. Y., has announced two



new items, the *Vari-Tenna* and the *Energized Ferri-Loopstick*. The former is a coil with an extremely high-Q winding and a ferrite core, designed to replace the antenna coil and long bank of wire in old radios.

The loopstick is a miniaturized "bar loop" for use where space is a factor. Because of the exceptionally high Q of the ferrite rod (Q up to 400), a core length of only 2 3/4 inches is required to give superior results. A quick-lock vinyl collar is used to maintain the core in its adjusted position.

The unit is not intended as a replacement for the *Ferri-Loopstick* or *Vari-Loopstick*. It is a supplement for use in cases where their excellent performance has to be surpassed, such as in small portable radios.

TEST INSTRUMENTS

Hickok Electrical Instrument Co., 10531 Dupont Ave., Cleveland 8, Ohio, has announced a u.h.f. sweep-alignment generator and a u.h.f.-v.h.f. marker generator.

The sweep-alignment generator, model 697, is an all-electronic sweep that has no moving parts. It provides fundamental output on channels 14-83.



Its amplitude is constant over the entire sweep range. The 697 features a piston-type attenuator. It is designed to provide bare minimum loading effects on u.h.f. circuits under alignment.

This instrument was described in the March issue, but the illustration with it was that of the model 690 u.h.f.-v.h.f. marker generator, described below. Both photos are shown here.

The u.h.f.-v.h.f. marker generator, model 690, covers frequencies from 4.25 to over 225 mc on fundamentals with a 0.25 volt r.f. output, and provides dual markers with any TV sweep generator. Marker setting of 0.05% accuracy is featured.

ROTARIES

Telrex Inc., Asbury Park, N. J., has announced their *Beamer Power* rotaries

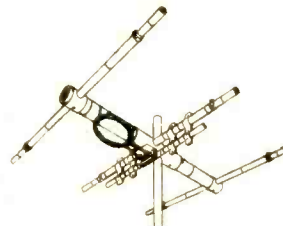

for 2-, 6-, 10-, 15- and 20-meter performance. These arrays feature a bobbin with a T transformer for optimum coaxial line coupling, broad-band resistive match, balanced pattern, no matching problems, and minimum interference.

REPLACEMENT FLYBACKS

Chicago Standard Transformer Corp., Addison & Elston, Chicago 18, Ill., has announced three new replacement flybacks for RCA sets. These are Nos. A-8233, A-8234, and A-8235. They may

be used in over 40 chassis and more than 100 models, and may be installed without any chassis or circuit alterations.

SERVICING AID

Raytheon Manufacturing Co., Receiving Tube Division, Newton 58, Mass., has announced the *Brow-Lite*, a flash-light which frees both hands.

The device fits easily above glasses and has a movable socket which adjusts light to any angle, eliminating

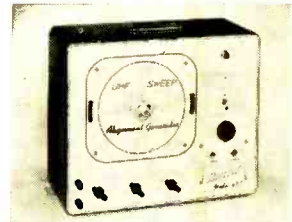

unnecessary head motions. Using standard parts, the light is pocket size, easy to carry, and constructed of durable plastic.

INDOOR ANTENNA

Brooklyn Television Co., Inc., 72 Steuben St., Brooklyn 5, N. Y., has announced an indoor TV antenna, the *Flash-O-Matic*, for FM v.h.f., u.h.f., and color reception. The antenna is mounted on a nontip cut-glass base and a revolving swivel. **END**



All specifications given on these pages are from manufacturers' data.

New TELEVISION COURSE

Amazing Bargain, Complete, Only \$3

Television Servicing Course
PRACTICAL TELEVISION TRAINING FOR HOME-STREET

Compiled by
M. N. BEITMAN
radio engineer,
teacher, author,
& serviceman.

COMPLETE \$3 ONLY

PRACTICAL, NEW, LARGE

Here is your complete training in television servicing. These new lessons cover every fact, adjustment and repair of every type and make of TV receivers. Giant in size, mammoth in scope, just like other correspondence courses selling for over \$150. Our amazing offer permits you to obtain the course complete for only \$3, nothing else to pay. Easy-to-follow, well illustrated lessons on circuits, picture faults, adjustments, short cuts, about UHF, alignment, antenna problems, trouble-shooting, service hints, how to use test equipment, and many practical sections prepared by leading manufacturers. Just published. Send trial coupon today and use the complete TV course at our risk. Satisfaction guaranteed. Your price for all lessons in large manual form, complete, post-paid, only \$3. Send trial-coupon now.

COVERS EVERYTHING IN TV

Let these lessons take you into TV servicing the easy way. The very first lesson of this sensational course tells how to do simple repairs. You start earning money immediately. Second lesson tells you what is wrong, by just looking at the picture—no instruments used. Lesson 4 has 32 large, 8 1/2 x 11" pages and 28 large illustrations on practical antenna installations and improvements. Another 12 lessons deal with trouble-shooting, stagger-tuned alignment, inter-carrier sets, UHF converters, use of TV test equipment, picture analysis, new circuits, TV facts that puzzled you will be quickly cleared up. Yes, you will find yourself doing TV repairs in minutes—instantly finding faults or making all needed adjustments. Examine this course for 10 days in your own home. Look over this collection of material, read a few lessons, apply some of the hints. Then decide to keep the lessons at the bargain cost of \$3 (full price), or return the material.

NO-RISK TRIAL ORDER COUPON

SUPREME PUBLICATIONS, 1760 Balsam Rd., Highland Park, Ill.

RADIO & TV Manuals

Your complete source of all needed RADIO and TV diagrams and service data. Most amazing values. Still sold at pre-Korean prices. Only \$2 to \$3 per volume. Every Radio manual contains large schematics, all needed alignment facts, parts lists, voltage values, trimmers, dial stringing, and service hints. Each TV manual is a practical treatise on servicing a full year's sets, with giant blueprints, waveforms, hints, alignment and voltage charts, production changes. See coupon at right for a complete list of these low-priced *Supreme* service manuals.

Radio Diagram Manuals

- 1953 Radio Manual, \$2.50
- 1952 Radio
- 1951 Diagrams } EACH
- 1950 Manual } \$2.50
- 1949 Radio
- 1948
- 1947
- 1946
- 1942
- 1941
- 1940
- 1939
- 1926-1938 Manual, \$2.50
- Master INDEX only 25¢

PRICED AT ONLY \$2 EACH

Send TV manuals checked below and Radio manuals at left. Satisfaction guaranteed or your money back.

New *Television Servicing Course*, complete... \$3.

Latest 1954 *Television Servicing Manual*, only... \$3.

1953 TV Manual, \$3. 1953 UHF Units, \$1.50

1952 *Television Manual*, \$3. 1951 TV, \$3.

1950 *Television Manual*, \$3. 1949 TV, \$3.

1948 TV, \$3. 1947 TV & FM, only \$2.

I am enclosing \$..... Send postpaid.

Send C.O.D. I am enclosing \$..... deposit.

Name:

Address:

Supreme Publications

Sold by All Leading Parts Jobbers

HBG

is here!

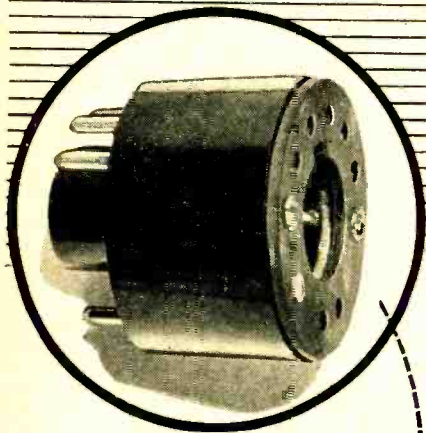

for Quick TV Set Adjustment and Alignment!

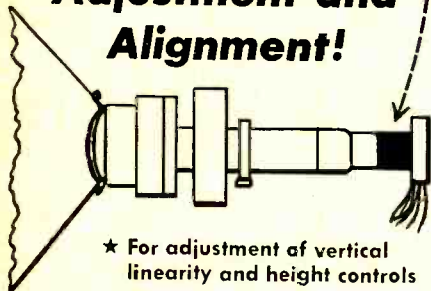

- ★ For adjustment of vertical linearity and height controls
- ★ Accurate positioning of focus coil or magnet
- ★ Precise setting of yoke
- ★ Complete with instructions

Perma-Power

HORIZONTAL BAR GENERATOR

Dealer Net \$195

See Your Jobber Today!

manufactured by

Perma-Power COMPANY

Chicago 25, Ill.

Manufacturers of Electronic Equipment Since 1928

Export Scheel International
4237 N. Lincoln, Chicago 13, Ill.

REFORMING ELECTROLYTICS

An electrolytic capacitor that has been in storage or idle for six months to a year may have an abnormally high leakage current when voltage is first applied across it. This current will gradually taper off to normal as the capacitor reforms. But in many instances it does not taper off fast enough to prevent internal heating. This increases the leakage current and leads to early breakdown. To prevent such occurrences, electrolytics which have not had voltage applied to them for a comparatively long time should be reformed before being placed in service. The process consists of applying normal working voltage to the capacitor through a series resistor to limit the current to a safe value.

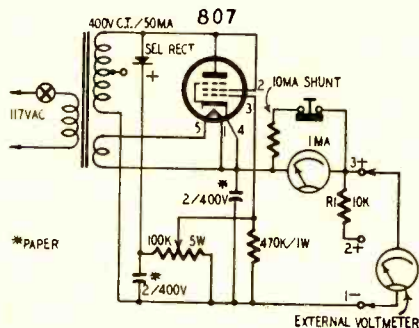

The diagram shows the circuit of a variable-voltage power supply designed for reforming electrolytic capacitors. It was described originally in *The Radio Constructor*, an English publication. Voltage for reforming the capacitor is supplied by a triode-connected 807 used as a grid-controlled half-wave rectifier. Its output voltage may be varied between about 40 and 400 by varying a positive voltage applied to the control grid. This bias voltage is developed by a metallic rectifier and is tapped off the 100,000-ohm, 5-watt control.

The capacitor to be reformed is connected across terminals 1 and 2. R1 is placed in series with the capacitor to limit the leakage current to a safe value. A value of about 10,000 ohms is sufficient for an 8- μ f, 450-volt capacitor.

The maximum safe leakage current in microamperes is 0.15CV for dry electrolytics, 0.35CV for wet electrolytics, and 0.3CV for reversible electrolytics, where C is the capacitance of the unit in microfarads and V is the working voltage.

Connect the capacitor to be reformed across terminals 1 and 2, set the voltage control to minimum, and connect a 400-volt d.c. meter across terminals 1 and 3. Increase the voltage until the current rises to the maximum safe value. Leave the voltage at this level until the current drops, then gradually increase the voltage—without drawing excessive current—until the leakage current does not exceed the maximum with full working voltage applied. Reforming current is read on a 1-ma meter that is shunted to read 10 ma full scale. When the current drops

OPENING For PHYSICIST or SPECIALIST in ULTRASONICS

Must be fully experienced and well qualified for

RESEARCH AND DEVELOPMENT WORK

Unusual opportunity in new department in progressive, fast growing metal working industry in mid-west.

Write Letter, stating experience and salary requirements to

Box 541
Radio Electronics

GET THIS NEW SPRAGUE T-C RULE



Save time . . . avoid mistakes . . . in finding the values of stock N750 and MPO type ceramic capacitors to connect in parallel to equal a capacitor of desired intermediate temperature coefficient of the required capacitance. Just slide this handy, pocket-size rule to the proper values and you'll come up with the right answer quick as a wink every time. On back are complete color codes on all types of ceramic capacitors. Ask your Sprague Distributor or one, or write to Sprague Products Co., 81 Marshall Street, North Adams, Mass. It's only 15c.

SPRAGUE PRODUCTS COMPANY

Distributors' Division of the Sprague Electric Co.
NORTH ADAMS, MASS.

RADIO • TELEVISION SERVICEMEN!

HERE IS YOUR 1954 OPPORTUNITY TO DEVELOP A PROFITABLE SMALL APPLIANCE REPAIR SERVICE WITH PRESENT SHOP EQUIPMENT

We supply a complete program designed to maintain you in the highly profitable traffic appliance repair field.

ELECTRIC SWEEPER SERVICE CO.

"The House of **ESSCO** 100,000 Parts"

2034 EUCLID AVE. • CLEVELAND 15, OHIO

HI-FI CROSS-OVER NETWORK

A tweeter-woofer circuit for two speakers using TWO CHOKES, TWO CAPACITORS & ONE POT. Write for nearest dealer's name, also free wiring diagram, specs. etc.

Audio Improvements & Accessories Co.
"AIMAC" 252 Greenwich St. New York City 7

RADIO-ELECTRONICS

below 1 ma, pressing the switch removes the shunt and makes the meter easier to read.

STABILIZING THE HEATHKIT SCOPE

A simple modification may improve the stability of the direct-coupled vertical amplifier circuits of the Heathkit model O-8 oscilloscope and make the instrument easier to use in areas where line voltages fluctuate.

In this instrument, the 6C4 phase inverter is direct-coupled to half the 12AT7 vertical voltage amplifier. Voltage fluctuations on the power line cause proportionate changes in the B voltages delivered by the scope's power supply. In the direct-coupled amplifier circuit, these voltage changes affect the amplifier gain and cause the trace to jitter.

Fig. 1 shows the original B plus circuit in the O-8. Point C on the supply feeds the plate circuits of the 6C4 phase inverter and 12AT7 amplifier. By adding two series-connected 0B2 voltage-regulator tubes, the voltage at this point is stabilized at 210.

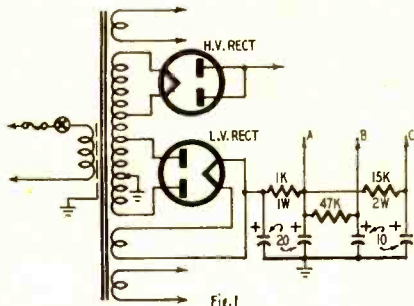

Fig. 1

The modified diagram in Fig. 2 shows how the 15,000-ohm, 2-watt resistor between A and C is replaced by two 4,700-ohm, 1-watt resistors (R1 and R2) in series. The 10- μ f filter capacitor for point C is removed and reconnected to the junction of R1 and R2. The values of R1 and R2 were selected to provide a current of approximately 20 ma through the voltage-regulator tubes to assure stable operation.

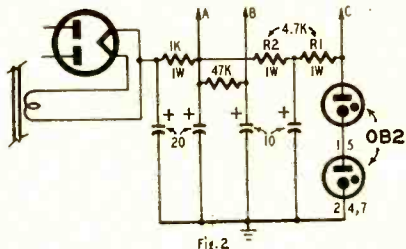

Fig. 2

With this modification, the scope now operates satisfactorily in any area where heavy electrical equipment causes the line voltage to fluctuate. This simple modification is well worth the time and expense to any user of the O-8 oscilloscope.—R. K. Schaefer

TYING SCOPE TO RECEIVER

Scopes are often connected across the output of the i.f. amplifier of communications receivers to check frequency shift and modulation percentage of in-

GENERAL INSTRUMENT

all channel UHF converter

NEW

tuning element ups performance

increases gain & noise ratio

Now the introduction of a fundamental frequency oscillator in the new, improved tuning element increases the useable gain of the General Instrument all channel UHF converter to provide even greater performance. Simpler construction, easier maintenance and better design are additional features of this new tuner, already operating successfully as a component part in leading TV receivers.

FIRST... in side-by-side tests!

Jobbers:
Some choice territories still remain open.
Write for details.



General Instrument & Appliance CORPORATION

Subsidiary of GENERAL INSTRUMENT CORPORATION
829 Newark Avenue, Elizabeth 3, N. J.

Write for details to Booth 72B at the May Paris Show

arkay HI-FI AUDIO kit

AMPLIFIER

10 WATT HIGH-FIDELITY AMPLIFIER

With Built-in Pre-Amplifier for Magnetic Cartridge, Mike, Crystal Phono or Radio Tuner.

- * Frequency response: ± 1 db., 20 to 20,000 cps.
- * Wide response bass and treble controls
- * Speaker output inductance: 4, 8, 16 ohms
- * Negative feedback
- * Hum: 70 db below rated output

Complete with tubes



Model A10 21-53

Write for new catalog of the complete ARKAY line of radio, TV, phono and test equipment kits.

arkay

BE 3-6686

RADIO KITS, INC.
120 CEDAR STREET
NEW YORK 6, N. Y.

Floritone EXTENSION SPEAKER

"CONTROL AT YOUR FINGERTIPS"

The extra "personal" speaker for your TV—a "must" for the "hard of hearing" and the utmost in luxurious listening pleasure for every TV or radio owner. 4 in 1 switch controls either speaker—both speakers—or shuts off sound. Easily installed and lists for only \$14.95.



SAMPLE

\$10.00

(Dept. R.E.)

Dealers and distributors, write for liberal discount information.

SOOTIN'S, INC.

321 NW 3rd Ave., Miami 36, Fla.

COMPLETE TRAINING FOR BETTER RADIO-TV SERVICE JOBS

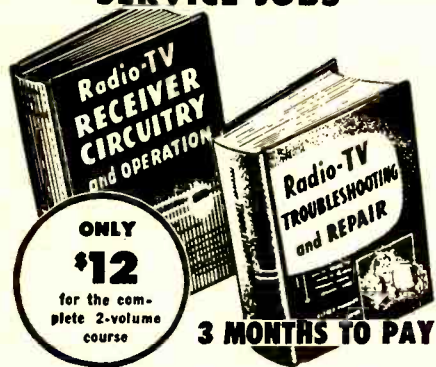

Let these two great new Ghirardi training books teach you to handle all types of AM, FM and TV service jobs by approved professional methods—and watch your efficiency and earnings soar!

Completely modern, profusely illustrated and written so you can easily understand every word, these books pave the way to fast, accurate service on any type of home radio-TV electronic equipment ever made. Each book is brand new. Each contains the latest data on the latest methods and equipment—NOT a rehash of old, out-of-date material. Each is co-authored by A. A. Ghirardi whose famous RADIO PHYSICS COURSE and MODERN RADIO SERVICE were, for 20 years, more widely used for military, school and home study training than any other books of their type!

THE NEW Ghirardi RADIO-TV SERVICE LIBRARY

Almost 1500 pages and over 800 clear illustrations show step-by-step how to handle every phase of modern troubleshooting and servicing.

1—Radio and Television Receiver TROUBLESHOOTING & REPAIR

A complete guide to profitable professional methods. For the novice, it is a comprehensive training course. For the experienced serviceman, it is a quick way to "brush up" on specific jobs, to develop improved techniques or to find fast answers to puzzling service problems. Includes invaluable "step-by-step" service charts. 320 pages, 417 illus., price \$6.75 separately.

2—Radio and Television Receiver CIRCUITRY AND OPERATION

This 669-page volume is the ideal guide for servicemen who realize it pays to know what really makes modern radio-TV receivers "tick" and why. Gives a complete understanding of basic circuits and circuit variations; how to recognize them at a glance; how to eliminate guesswork and useless testing in servicing them. 417 illus., price separately \$6.50.

New low price . . . You Save \$1.25!

If broken into lesson form and sent to you as a "course," you'd regard these two great books as a bargain at \$50 or more! Together, they form a complete modern servicing library to help you work faster, more efficiently and more profitably.

Under this new offer, you save \$1.25 on the price of the two books—and have the privilege of paying in easy installments while you use them!

10-DAY FREE TRIAL

Dent. RE-54, RINEHART & CO., Inc.
232 Madison Ave., New York 16, N. Y.

Send books below for 10-day FREE EXAMINATION. In 10 days, I will either remit price (plus postage) or return books postpaid and owe you nothing.

Radio & TV Receiver TROUBLESHOOTING & REPAIR (Price \$6.75 separately)

Radio & TV Receiver CIRCUITRY & OPERATION (Price \$6.50 separately)

Check here for MONEY-SAVING COMBINATION OFFER . . . Save \$1.25. Send both of above big books at special price of only \$12.00 for the two. (Regular price \$13.25, you save \$1.25.) Payable at rate of \$3 (plus postage) after 10 days if you decide to keep books and \$3 a month for 3 months until the total of \$12 has been paid.

Name _____

Address _____

City, Zone, State _____

Outside U.S.A.—\$7.25 for TROUBLESHOOTING & REPAIR; \$7.00 for CIRCUITRY & OPERATION; \$13.00 for both books. Cash with order, but money refunded if you return books in 10 days.

coming signals. The scope detunes the circuit to which it is connected. This makes it necessary to touch up the tuning of the circuit each time the scope is connected or disconnected.

I eliminated this problem by connecting the scope across the b.f.o. coil and adjusting the b.f.o. pitch control for maximum pattern height. Typical b.f.o. circuits and the method of connecting the scope are shown in Figs. 1

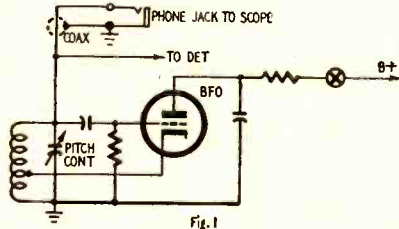

and 2. The b.f.o. is turned off when the scope is used for checking phone signals so its performance is not affected in any way. Mount a phone jack on the front or back of the receiver so the scope can be plugged in at will. Use low-capacitance coaxial cable such as RG-59/U for the connection.

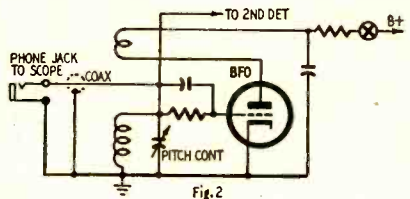

The height of the pattern on the screen depends on the strength of the incoming signal and on the sensitivity of the scope. A strong signal will produce a trace 3 or more inches high on a 5-inch scope with vertical deflection sensitivity of 10 mv.—G. P. Oberto

THREE-STATE FLIP-FLOP

The Eccles-Jordan circuit is widely used as a scale-of-two counter in radar, loran, computers, and in timing and calibrating circuits. It is similar to conventional multivibrators except that the cross-connected grids and plates are direct-coupled.

While developing register circuits for an electronic computer, Andrew D. Booth and H. Ringrose discovered that it is possible for the Eccles-Jordan flip-flop circuit to have three stable states instead of only two as we have grown to expect. A report on the scale-of-three flip-flop counter appeared in *Electronic Engineering* (London, England). The circuit is shown in Fig. 1.

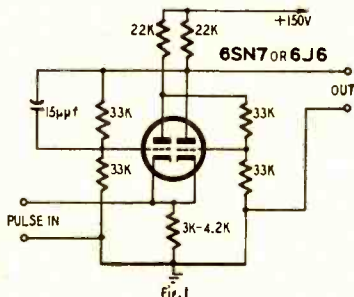

The COMPLETE line



for EVERY

Public Address need!



WRITE NOW for FREE Catalog 553



ATLAS SOUND CORP.

1443 39th St., Brooklyn 18, N. Y.
In Canada: Atlas Radio Corp., Ltd., Toronto, Ont.

TV GLO-TEST Replaces \$279 in TESTING EQUIPMENT



This is the instrument that appeared in feature articles in RADIO-ELECTRONICS and other publications. GLO-TEST is the sensational new tester that almost talks! For TV and Radio servicemen, Sound Technicians, Amateurs, Experimenters, Electricians.

OVER 50 USES, INCLUDING—PICTURE TESTER—AC-DC VOLTAGE MEASUREMENTS TO 50 KV—SIGNAL GENERATOR—SIGNAL TRACER—TUBE TESTER—RESISTOR AND CAPACITOR MEASUREMENTS—DISTORTION AND LINEARITY CHECKER. ACCURACY COMPARABLE TO VTVM.

FULLY GUARANTEED. Replaces instruments costing many times its cost, does a comparable job yet is only a small fraction of their total weight and size. GLO-TEST, complete with test leads and instruction booklet, postpaid, is priced at only **\$14.50**

Send check or money order. 10-day money back guarantee. Free literature on request.

V. A. ENTERPRISES, Dept. AA
608 East Rosecrans Blvd., Compton, Calif.

EASY TO LEARN CODE

It is easy to learn or increase speed with an Instructograph Code Teacher. Affords the quickest and most practical method yet developed. For beginners or advanced students. Available tapes for beginner's alphabet to typical messages on all subjects. Speed ranges 5 to 40 WPM. Always ready—no QRM.



ENDORSED BY THOUSANDS!

The Instructograph Code Teacher literally takes the place of an operator-instructor and enables anyone to learn and master code without further assistance. Thousands of successful operators have "acquired the code" with the Instructograph System. Write today for convenient rental and purchase plans.

INSTRUCTOGRAPH COMPANY

4701 Sheridan Rd., Dept. RC, Chicago 40, Ill.

RADIO-ELECTRONICS

With this circuit, three stable conditions can be obtained with a 6J6 or 6SN7-GT. The 6J6 operates in this manner when the common cathode resistor has a value of from 3,800 to 4,200 ohms. The 6SN7-GT requires a cathode resistance of 3,000 to 4,000

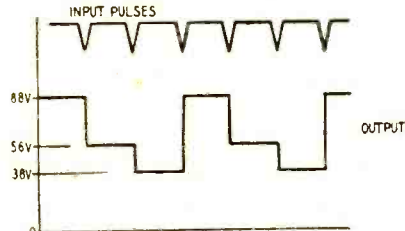

Fig. 2

ohms. Fig. 2 shows the output waveforms available with six successive trigger pulses. The authors report that the circuit will not have the third steady-state condition if the second plate-to-grid coupling resistor is bypassed.

UNUSUAL PENTODE DOUBLER

The diagram in Fig. 1 shows a conventional pentode frequency multiplier stage. Operating bias—three to five times cutoff—is developed by grid-current flow through R_g . Cathode bias to protect the tube against excessive plate dissipation when excitation is removed is provided by the drop across R_k . R_{sg} is the screen-dropping resistor. A British amateur, G2JAM, has developed a novel circuit which eliminates the need for the screen and cathode resistors and their bypass capacitors C_k and C_{sg} . His circuit is shown in Fig. 2.

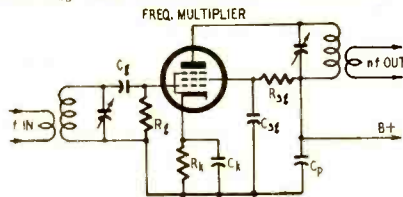

Fig. 1

In the revised circuit, the screen grid operates with zero d.c. voltage. Its operating potential (approximately 150 volts) is supplied by the positive half-cycles of the r.f. driving signal. Class C bias for the control grid is obtained through the drop across R_g as in Fig. 1. There is no need for protective cathode bias because in the absence of driving voltage, the screen is at zero and plate current is at or nearly zero.

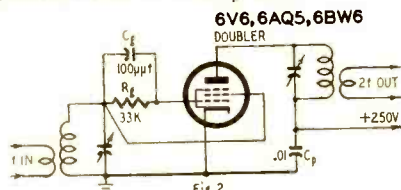

Fig. 2

The simplified circuit in Fig. 2 is one of the doublers used in G3JAM's all-band exciter described in *The Short Wave Magazine*, a British amateur publication.

This circuit is applicable to circuits using tubes where the screen-grid voltage is only about five or six times cutoff bias.

END

YOU SAVE MORE.. with EMC precision instruments
...SERVICE BETTER instruments

The top quality of EMC precision instruments has been proven by years of coast-to-coast tests performed both in the field and on the bench covering every servicing condition.

Exceptionally low prices on these quality instruments are made possible by combining every new engineering advance with EMC large volume production.

Convince yourself... check the features and prices of the two outstanding examples quoted below...



MODEL 700
5 unit
signal generator

Saves money, time and space by an exclusive combination of functions. Accurate to within 1 1/2% on RF and 3% on A.F. ranges.

1. R.F. Generator—300 kc to 110 megacycles on fundamentals
2. A.F. Generator—18 cycles to 300 kilocycles
3. Square Wave Generator—600 cycles to 20 kc
4. Bar Generator—variable number of bars available
5. Crystal Marker Generator

Model 700 New combination price..... **\$55.90**

Compare these high quality features with meters selling up to twice the price of Model 106.

- completely electronic-meter cannot burn out
- Dual triodes balanced bridge circuit
- Zero center adjustment for TV and FM alignment
- Uses 1% precision resistors for voltage multipliers
- Full scale deflection of 1 1/2 volts for both AC-DC volts
- 1 meg. isolating resistor in probe
- Measures resistance in 5 ranges from .2 ohm to 1000 megs.
- Space saving portable Bakelite case—4 1/4" x 5 1/4" x 2 7/8"

New Cost—Saving Prices... Lowest on market for wired and kit form.

MODEL 106, illustrated (Complete with all leads) **\$35.90**

MODEL 106, in kit form..... **\$23.90**

RF and high voltage accessory probes available.

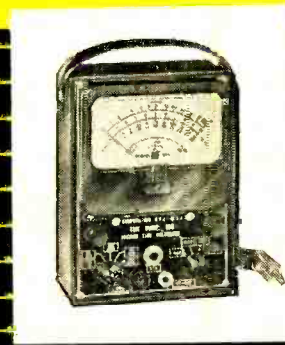

MODEL 106
vacuum tube
voltmeter

EMC
ELECTRONIC MEASUREMENTS CORPORATION

280 Lafayette St. New York 12, N.Y. Export Dept., 303 W. 42nd St., N. Y.

Write department RE-5 for complete catalog.



ELECTRON TUBE WHOLESALE, INC.

RECEIVING TRANSMITTING SPECIAL PURPOSE
140 DUANE STREET • NEW YORK 13, N. Y. • Phone: BArdlay 7-7616

THIS MONTH'S SPECIALS
6AL5 31c
10L6 55c
12AU7 83c
6BD7 84c
1LN5 48c
We must limit quantities to not more than 25 per type for each order—at these Low Prices!

SENSATIONAL DISCOUNTS!

We specialize exclusively in TUBES—of every kind and description—serving the industry for years. More than 3000 different types in stock for IMMEDIATE DELIVERY—including hard-to-get and discontinued numbers. All tubes exhaustively tested in our fully equipped laboratories, and re-tested at time of shipment.

FREE OFFER!
Seven Assorted 12, 7, 6, 1 and 2-volt type tubes. List Value Approx. \$23. FREE with every order for \$25 or more!

FULL ONE YEAR GUARANTEE

All tubes individually boxed and code-dated.

0B2	.74	3A4	.44	6BG6	1.18	6SH7	.60	12A6	.59	12SN7GT	.58	56	.49
0Z4	.54	3A5	.93	6BH6	.45	6SH7GT	.60	12A6	.59	12SQ7	.56	57	.55
1ASGT	.30	3AB	.60	6BJ6	.42	6SK7	.50	12AT6	.69	12SQ7	.56	58	.58
1AB5	.39	3B7	.37	6BN6	.79	6SK7GT	.50	12AT7	.64	12Z3	.39	70L7GT	1.00
1AX2	.61	3DB	.39	6BQ6	.42	6SL7GT	.49	12A7	.64	14A7	.69	71A	.54
1B3	.77	3Q4	.48	6BQ7A	.88	6SN7GT	.49	12AU7	.58	14A7	.69	71A	.54
1BGT	.67	3V4	.51	6C4	.37	6SR7	.40	12AV7	.59	14F7	.67	78	.43
1C6GT	.25	3V4	.51	6C5	.39	6ST7	.45	12AX4GT	.59	14H7	.59	80	.35
1C6GT	.25	3V4	.51	6C6	.39	6T7G	.75	12AY7	.76	14N7	.69	81	.69
1H5GT	.48	3V3GT	1.22	6C8	.44	6T7G	.75	12B6	.59	19B6	.49	82	1.11
1L6	.59	3Z3	.44	6CBG	.85	6U7G	.45	12B7	.65	19B6GT	.49	83	.79
1L4	.49	6A6	.75	6CB6	.45	6U8	.59	12B7	.65	19T5	.79	84	5.95
1L4A	.49	6AF4	.69	6CD6	1.10	6V6GT	.69	12B7	.65	22	.44	85	.59
1L6A	.79	6AB7	.47	6D6	.69	6V6	.45	12B7	.65	25BQ6GT	.75	89/Y	.49
1L6	.66	6AC7	.85	6D8	.98	6W4	.45	12B7	.65	25BQ6GT	.75	90	.38
1LC	.59	6AF6	.75	6F7	.39	6W6	.46	12BY7	.65	25L6GT	.39	117Z3	.38
1LDS	.77	6AG5	.46	6F8	.99	6X4	.36	12C8	.34	25Z5	.64	1201	.95
1LN5	.59	6AF6	.75	6F7	.39	6Y7G	.79	12H6	.45	27	.38	9001	1.49
1R4	.59	6AG5	.46	6F8	.99	6X8	.74	12J5GT	.39	32L7GT	.98	9003	1.48
1R5	.56	6AG5	.46	6F8	.99	6Y7G	.79	12K7	.55	35W4	.37	9004	.97
1R5	.56	6AG5	.46	6F8	.99	6X8	.74	12K7	.55	35W4	.37	9006	.68
1R5	.56	6AG5	.46	6F8	.99	6Y7G	.79	12K7	.55	35W4	.37		
1R5	.56	6AG5	.46	6F8	.99	6X8	.74	12K7	.55	35W4	.37		
1R5	.56	6AG5	.46	6F8	.99	6Y7G	.79	12K7	.55	35W4	.37		
1R5	.56	6AG5	.46	6F8	.99	6X8	.74	12K7	.55	35W4	.37		
1R5	.56	6AG5	.46	6F8	.99	6Y7G	.79	12K7	.55	35W4	.37		
1R5	.56	6AG5	.46	6F8	.99	6X8	.74	12K7	.55	35W4	.37		
1R5	.56	6AG5	.46	6F8	.99	6Y7G	.79	12K7	.55	35W4	.37		
1R5	.56	6AG5	.46	6F8	.99	6X8	.74	12K7	.55	35W4	.37		
1R5	.56	6AG5	.46	6F8	.99	6Y7G	.79	12K7	.55	35W4	.37		
1R5	.56	6AG5	.46	6F8	.99	6X8	.74	12K7	.55	35W4	.37		
1R5	.56	6AG5	.46	6F8	.99	6Y7G	.79	12K7	.55	35W4	.37		
1R5	.56	6AG5	.46	6F8	.99	6X8	.74	12K7	.55	35W4	.37		
1R5	.56	6AG5	.46	6F8	.99	6Y7G	.79	12K7	.55	35W4	.37		
1R5	.56	6AG5	.46	6F8	.99	6X8	.74	12K7	.55	35W4	.37		
1R5	.56	6AG5	.46	6F8	.99	6Y7G	.79	12K7	.55	35W4	.37		
1R5	.56	6AG5	.46	6F8	.99	6X8	.74	12K7	.55	35W4	.37		
1R5	.56	6AG5	.46	6F8	.99	6Y7G	.79	12K7	.55	35W4	.37		
1R5	.56	6AG5	.46	6F8	.99	6X8	.74	12K7	.55	35W4	.37		
1R5	.56	6AG5	.46	6F8	.99	6Y7G	.79	12K7	.55	35W4	.37		
1R5	.56	6AG5	.46	6F8	.99	6X8	.74	12K7	.55	35W4	.37		
1R5	.56	6AG5	.46	6F8	.99	6Y7G	.79	12K7	.55	35W4	.37		
1R5	.56	6AG5	.46	6F8	.99	6X8	.74	12K7	.55	35W4	.37		
1R5	.56	6AG5	.46	6F8	.99	6Y7G	.79	12K7	.55	35W4	.37		
1R5	.56	6AG5	.46	6F8	.99	6X8	.74	12K7	.55	35W4	.37		
1R5	.56	6AG5	.46	6F8	.99	6Y7G	.79	12K7	.55	35W4	.37		
1R5	.56	6AG5	.46	6F8	.99	6X8	.74	12K7	.55	35W4	.37		
1R5	.56	6AG5	.46	6F8	.99	6Y7G	.79	12K7	.55	35W4	.37		
1R5	.56	6AG5	.46	6F8	.99	6X8	.74	12K7	.55	35W4	.37		
1R5	.56	6AG5	.46	6F8	.99	6Y7G	.79	12K7	.55	35W4	.37		
1R5	.56	6AG5	.46	6F8	.99	6X8	.74	12K7	.55	35W4	.37		
1R5	.56	6AG5	.46	6F8	.99	6Y7G	.79	12K7	.55	35W4	.37		
1R5	.56	6AG5	.46	6F8	.99	6X8	.74	12K7	.55	35W4	.37		
1R5	.56	6AG5	.46	6F8	.99	6Y7G	.79	12K7	.55	35W4	.37		
1R5	.56	6AG5	.46	6F8	.99	6X8	.74	12K7	.55	35W4	.37		
1R5	.56	6AG5	.46	6F8	.99	6Y7G	.79	12K7	.55	35W4	.37		
1R5	.56	6AG5	.46	6F8	.99	6X8	.74	12K7	.55	35W4	.37		
1R5	.56	6AG5	.46	6F8	.99	6Y7G	.79	12K7	.55	35W4	.37		
1R5	.56	6AG5	.46	6F8	.99	6X8	.74	12K7	.55	35W4	.37		
1R5	.56	6AG5	.46	6F8	.99	6Y7G	.79	12K7	.55	35W4	.37		
1R5	.56	6AG5	.46	6F8	.99	6X8	.74	12K7	.55	35W4	.37		
1R5	.56	6AG5	.46	6F8	.99	6Y7G	.79	12K7	.55	35W4	.37		
1R5	.56	6AG5	.46	6F8	.99	6X8	.74	12K7	.55	35W4	.37		
1R5	.56	6AG5	.46	6F8	.99	6Y7G	.79	12K7	.55	35W4	.37		
1R5	.56	6AG5	.46	6F8	.99	6X8	.74	12K7	.55	35W4	.37		
1R5	.56	6AG5	.46	6F8	.99	6Y7G	.79	12K7	.55	35W4	.37		
1R5	.56	6AG5	.46	6F8	.99	6X8	.74	12K7	.55	35W4	.37		
1R5	.56	6AG5	.46	6F8	.99	6Y7G	.79	12K7	.55	35W4	.37		
1R5	.56	6AG5	.46	6F8	.99	6X8	.74	12K7	.55	35W4	.37		
1R5	.56	6AG5	.46	6F8	.99	6Y7G	.79	12K7	.55	35W4	.37		
1R5	.56	6AG5	.46	6F8	.99	6X8	.74	12K7	.55	35W4	.37		
1R5	.56	6AG5	.46	6F8	.99	6Y7G	.79	12K7	.55	35W4	.37		
1R5	.56	6AG5	.46	6F8	.99	6X8	.74	12K7	.55	35W4	.37		
1R5	.56	6AG5	.46	6F8	.99	6Y7G	.79	12K7	.55	35W4	.37		
1R5	.56	6AG5	.46	6F8	.99	6X8	.74	12K7	.55	35W4	.37		
1R5	.56	6AG5	.46	6F8	.99	6Y7G	.79	12K7	.55	35W4	.37		
1R5	.56	6AG5	.46	6F8	.99	6X8	.74	12K7	.55	35W4	.37		
1R5	.56	6AG5	.46	6F8	.99	6Y7G	.79	12K7	.55	35W4	.37		
1R5	.56	6AG5	.46	6F8	.99	6X8	.74	12K7	.55	35W4	.37		
1R5	.56	6AG5	.46	6F8	.99	6Y7G	.79	12K7	.55	35W4	.37		
1R5	.56	6AG5	.46	6F8	.99	6X8	.74	12K7	.55	35W4	.37		
1R5	.56	6AG5	.46	6F8	.99	6Y7G	.79	12K7	.55	35W4	.37		
1R5	.56	6AG5	.46	6F8	.99	6X8	.74	12K7	.55	35W4	.37		
1R5	.56	6AG5	.46	6F8	.99	6Y7G	.79	12K7	.55	35W4	.37		
1R5	.56	6AG5	.46	6F8	.99	6X8	.74	12K7	.55	35W4	.37		
1R5	.56	6AG5	.46	6F8	.99	6Y7G	.79	12K7	.55	35W4	.37		
1R5	.56	6AG5	.46	6F8	.99	6X8	.74	12K7	.55	35W4	.37		
1R5	.56	6AG5	.46	6F8	.99	6Y7G	.79	12K7	.55	35W4	.37		
1R5	.56	6AG5	.46	6F8	.99	6X8	.74	12K7	.55	35W4	.37		
1R5	.56	6AG5	.46	6F8	.99	6Y7G	.79	12K7	.55	35W4	.37		
1R5	.56	6AG5	.46	6F8	.99	6X8	.74	12K7	.55	35W4	.37		
1R5	.56	6AG5	.46	6F8	.99	6Y7G	.79	12K7	.55	35W4	.37		
1R5	.56	6AG5	.46	6F8	.99	6X8	.74	12K7	.55	35W4	.37		
1R5	.56	6AG5	.46	6F8	.99	6Y7G	.79	12K7	.55	35W4	.37		
1R5	.56	6AG5	.46	6F8	.99	6X8	.74	12K7	.55	35W4	.37		
1R5	.56	6AG5	.46	6F8	.99	6Y7G	.79	12K7	.55	35W4	.37		
1R5	.56	6AG5	.46	6F8	.99	6X8	.74	12K7	.55	35W4	.37		
1R5	.56	6AG5	.46	6F8	.99	6Y7G	.79	12K7	.55	35W4	.37		
1R5	.56	6AG5	.46	6F8	.99	6X8	.74	12K7	.55	35W4	.37		
1R5	.56	6AG5	.46	6F8	.99	6Y7G	.79	12K7	.55	35W4	.37		
1R5	.56	6AG5	.46	6F8	.99	6X8	.74	12K7	.55	35W4	.37		

minimized callbacks by removing the jumper between terminals 3 and 8 on the 117Z6-GT socket and inserting a 47-ohm, 1-watt resistor between these points. The diagram shows the power-supply circuit of this set.—George R. Anglado

MOPAR 606

The complaint was intermittent reception with occasional traces of smoke coming from the receiver chassis. This trouble is caused by an intermittent short in the spark-plate on the i.f. chassis at the point where the B plus lead connects to the second i.f. transformer. This overheats and damages the 1,000-ohm filter resistor on the power and audio chassis.

Replace the spark plate or disconnect it and install a suitable B plus bypass capacitor. Replace the 1,000-ohm resistor in the filter circuit.—Harry C. Keller

WESTINGHOUSE TV SETS

Faint light and dark vertical lines on the left of the raster may be caused by ringing in the horizontal linearity coil. It can usually be suppressed by shunting a 5,000-ohm resistor across the coil.—Marty Britt

PACKARD-BELL TV SETS

The set came in with no high voltage. The entire horizontal sweep string seemed to be dead. I could not drive the output stage with an external oscillator. All voltages were near normal except the horizontal oscillator and the grid and cathode of the 6BG6-G. Plate voltage was low at pin 5 of the 6SN7-GT oscillator and a.f.c. tube.

After removing and checking most of the horizontal components without success, I tried replacing the horizontal oscillator transformer. The set's performance returned to normal. I had previously checked and rechecked this transformer with an ohmmeter without finding anything wrong. Apparently the defective unit had a few shorted turns deep within its winding.

The external sweep oscillator would not drive the output stage because I had overlooked the fact that the circuit returns to 100 volts negative and I had not used the correct ground return.—E. V. Snider, Jr. END



Suggested by Joseph J. Antonitis, Orono, Maine

"You wear the antenna in place of your usual tie"

MAY, 1954

*there is
a correct*

CORNELL-DUBILIER

REPLACEMENT*
VIBRATOR

*for every
original equipment
vibrator made*

all you need is C-D



*ask your distributor for your "C-D VIBRATOR GUIDE"



CONSISTENTLY DEPENDABLE
CORNELL-DUBILIER
SOUTH PLAINFIELD, NEW JERSEY



ROTORS • CAPACITORS • VIBRATORS • ANTENNAS • CONVERTERS

Acrosound

Exclusive patented design for optimum use in Acro Ultra-Linear circuits

SOUND BEST

- ✓ SMOOTH NATURAL SOUND
- ✓ CRISP WELL-DEFINED TRANSIENTS
- ✓ CLEAN SEPARATION OF INSTRUMENTS
- ✓ SOLID BASS—SILKY TREBLE

Ultra-Linear*

OUTPUT TRANSFORMERS

TEST BEST

- ✓ RESPONSE ±1 db 10 cps to 100 kc
- ✓ UNDISTORTED POWER 20 cps to 20 kc
- ✓ UNSURPASSED SQUARE WAVE PERFORMANCE
- ✓ PERMIT UP TO 30 db FEEDBACK

TO-300—20 watts for KT-66, TO-310—10 watts for 6V6 TO-330—50 watts for pp par 807, 5881 tubes . \$24.75* tubes \$18.75* KT66, etc. \$39.75*

*Slightly higher in West

Descriptive Literature and High Fidelity Amplifier Schematics and Data Available on Request.

ACRO PRODUCTS CO., 369 SHURS LANE, PHILADELPHIA 28, PA.

STOP TV TUNER NOISE...

QUICKLY—SAFELY! with

SPRA-KLEEN

Pressure-Applied CLEANER-LUBRICANT



WRITE TODAY for your free copy of the big new G-C Catalog 156.



GENERAL CEMENT MANUFACTURING CO.

910 Taylor Avenue Rockford, Illinois

DEALER'S NET \$1.00
LIST \$1.67 (6 full ounces)

A NEW MUST FOR EVERY SERVICEMAN

- No Harmful Ingredients
- Exclusive X-79 Formula
- Reaches Everywhere — No Need To Pull a TV Chassis!

G-C's new SPRA-KLEEN Electrical Contact Cleaner and Lubricant is just what you need for fast, easy, safe servicing of TV tuners and other parts like relays, switches and controls. No need to pull that chassis; just "poof" and SPRA-KLEEN's directional nozzle reaches any remote corner. See your favorite jobber today!

Poof!

HIGH-FIDELITY SPEAKERS

Dear Editor:

H. A. Hartley's Part I of his article on High-Fidelity Loudspeakers shows, by far and away, the best approach to this subject I have ever seen. By this I mean very definitely to indict the many mathematical approaches to this subject which are all but worthless; even, I strongly suspect, to those who made them. My hat is off to Mr. Hartley for a down-to-earth appraisal based on physical concepts and good ears.

His reference to Hans Vogt's *Oscillo-plan* capacity speaker is much to the point. I spent several days with Mr. Vogt at Berlin in 1930 and brought back one of these speakers with its high-voltage rectifier, and polarizing-voltage supply apparatus. All of this I still have in my laboratory.

Mr. Hartley—through no fault of his own—credits Rice and Kellogg with the introduction of the first real dynamic speaker in 1926-27. I would like to make claim to an earlier date; for in 1921, while developing the first electro-phonographic recording and reproducing apparatus for the Brunswick-Balke, Collender Co., in Chicago, I produced such speakers. One of these used the earliest Magnavox electrodynamic horn-loaded speaker to which Mr. Hartley refers, but fitted with a very thin and radially-ribbed (and therefore, very stiff and light) diaphragm provided with a tensioned, thin, annular rubber ring at its edge for support. This replaced the circularly-ribbed diaphragm normally provided with these speakers. Its high frequency response was not thereby impaired, but the bass was phenomenal and smooth. The other of these used a massive electromagnetic pot 12 inches in diameter and 4 inches high, with a 2-inch diameter voice coil and a 12-inch diameter, flat, thin, radially-ribbed, aluminum diaphragm as a direct, hornless radiator. Its outer edge was also supported by thin, stretched rubber.

But these speakers had what I then termed "transient dissonance," when reproducing music, due to too low a damping rate of the moving system. This caused the residual vibration (mostly of the diaphragm and voice coil from one tone) to beat with other tones after the tone in question had quit the stage. This speaker defect is now finally being recognized, and efforts are being made to suppress it by electrodynamic damping of the voice coil itself, or by inverse feedback, high flux density in the air gap, and the like. The ideal condition here, of course, is an aperiodic moving system, which is what, in effect, Mr. Hartley says, when he speaks of a speaker without "personality," or with absolutely no resonance.

Mr. Hartley mentions briefly a nodal vibration pattern (Fig. 5) due to axial compliance of the cone. There appears to have been no general notice of this defect among speaker engineers.

It is due to a standing-wave pattern (for a fixed frequency) caused by interference between the direct wave

Television-Radio Electricity

REFRIGERATION-ELECTRONICS

IN THE GREAT SHOPS OF **COYNE**

TRAIN QUICKLY! OLDEST, BEST EQUIPPED SCHOOL of ITS KIND in U.S.

Come to the Great Shops of Coyne in Chicago. Get practical training in opportunity fields—TELEVISION-RADIO—ELECTRICITY—ELECTRONICS—vital in Defense Program. Prepare now for a better job in Industry or better service rating.

Approved for Veterans

Finance Plan—Enroll now, pay most of tuition later. If you need part-time work to help out with living expenses while at Coyne, we'll help you get it. Special tuition plan for men of Draft Age.

FREE BOOK Clip coupon for Big Free Illustrated Book. No salesman will call. Act NOW.

B. W. Cooke, President

COYNE SCHOOL

A TECHNICAL TRADE INSTITUTE CHARTERED NOT FOR PROFIT Established 1939 500 S. Paulina, Chicago

ELECTRICITY ★ TELEVISION RADIO ★ REFRIGERATION ★ ELECTRONICS

B. W. COOKE, Pres. COYNE School 500 S. Paulina St., Chicago 12, Ill. Dept. 54-81H

Send FREE BOOK and full details on:

TELEVISION-RADIO ELECTRICITY

NAME.....

ADDRESS.....

CITY..... STATE.....

BE Sure with **CORNISH**

Wires

Identified with QUALITY since the swaddling days of Radio. The era of Television finds them, more than ever, the Serviceman's Friend.

- TV LEAD-IN CABLES
- ANTENNA CONTROL CABLES
- INTERCOMMUNICATION CABLES
- COAXIAL CABLES
- MICROPHONE CABLES
- SHIELDED CABLES
- TEST LEAD WIRES
- HOOK-UP WIRES
- PORTABLE CORDS
- REPLACEMENT CORD SETS

CORNISH WIRE COMPANY, INC.
50 Church Street, New York 7, N. Y.

EXPERIMENTERS!



HERE IS YOUR OPPORTUNITY TO BUY A COMPLETE PROTELGRAM PHILIPS TV SYSTEM AT A REMARKABLE PRICE . . . THIS OFFER INCLUDES . . .

89⁹⁵

PLUS ONLY \$10.00 extra for cabinet

- 1 Chassis complete with 23 tubes plus 1 diode wired and ready for use.
- 2 Protelgram projection unit including picture tube.
- 3 25,000 volt power supply ready for use.
- 4 8" dynamic speaker on large baffle.
- 5 23" flat viewing screen and full size reflecting mirror.

NOTE: Chassis includes . . . Automatic beam suppressor . . . High Fidelity sound system . . . Automatic gain control . . . "Standard Coil" Tuner, etc.

THE GOLDSTAR CO.

58 Walker Street, New York 13, N. Y.

New 2nd Edition Covers Transistors, Latest Data on AM-FM Receivers, and Up-to-date Material on the New Radio Tubes!

RADIO SERVICING



by **ABRAHAM MARCUS**

co-author of famous "Elements of Radio" which has sold over 800,000 copies! Here is every up-to-date detail you need to know about radio repair, replacement, and re-adjustment. Easy-to-understand, step-by-step self-teaching handbook shows you how to locate and remedy defects quickly. Covers: TIF Receivers; Superheterodyne Receivers; Short-Wave Receivers and Converters; Multiband Receivers; Portable Receivers; Automobile Receivers; Communication Receivers; FM Receivers; Power Supplies operated from AC, DC, Batteries, Motor-Generators, etc. Tells you the HOW and WHY of: Electron Tubes (Diode, Triode, Pentode, Beam Power, Thyatron, Phototube, Cathode Ray, etc.); Rectifier Circuits (Half-wave, Full-wave, Bridge, Voltage-Doubler, etc.); Detector Circuits (Diode, Triode, Regenerative, Superregenerative, Infinite-Impedance, etc.); Amplifier Circuits (Audio, Radio, I-F, Video, D-C, etc.); Oscillator Circuits (Hartley, Colpitts, Crystal, Transistor, Multivibrator, Sweep-circuit, etc.); Control Circuits (Volume, AVC, DAVC, Tone, Noise-Suppression, Automatic Tuning, Automatic Frequency Control, etc.); Explains how to use testing instruments such as: meter, vacuum-tube voltmeters, ohmmeters, bridges, multimeters, signal generators, tube checkers, cathode-ray oscilloscopes, etc. Over 100 pages and 60 illustrations in this section alone!

All in one big volume — easy to read. 16 Big Chapters. 121 Sections. 400 "Show-How" Diagrams. 775 pages.

Get this authoritative radio repair handbook today! Coupon below brings you "Radio Servicing" on FREE trial for 10 days. Mail it NOW.

PRENTICE-HALL, Inc., Dept. M-RE-554
70 Fifth Ave., New York 11, N. Y.

Send me for 10 DAYS' FREE TRIAL, "Radio Servicing—2nd Edition," by Abraham Marcus. I will return it in ten days and pay nothing—keep it and send \$1.95 down (plus postage) and \$2 monthly for 2 months.

Name

Address

City, State

() SAVE! Send \$5.95 WITH COUPON—we pay postage.

MAY, 1954

Now! get the NEW EICO® FLYBACK TRANSFORMER & YOKE TESTER

Model 944

KIT \$23⁹⁵

WIRED \$34.95

QUICK, POSITIVE TESTING OF FLYBACK

AND YOKES

in or out of set

Now one of the most difficult TV service jobs becomes quick and easy as A-B-C!



- Positive check of all types flyback & yokes, in or out of set—in just seconds!
- Operates on the extremely sensitive grid-dip principle—shows up even 1 shorted turn!
- Exclusive separate calibration for air core and iron core flybacks for accurate testing of all types.
- Checks any inductance whose impedance is not too low.
- Large easy-to-read 4 1/2" meter.
- 3 separate colored scales.
- Tests continuity of yokes, coils, speakers, etc.
- New compact size for extra-easy portability (7"x5"x4").
- Smart professional styling—New satin finish etched panel with contrasting knobs and meter and grey wrinkle steel case.
- Kit comes complete with easy-to-follow INSTRUCTIONS.

BE SURE! SAVE TIME!

BEFORE you install or remove a flyback or yoke—CHECK it with EICO's Model 944!

Compare this new EICO instrument at your parts jobber today.

Write for FREE Catalog CF-5
Read EICO's other ads in this issue
—see Advertiser's Index.



ELECTRONIC INSTRUMENT CO., Inc.,
84 Withers Street, Brooklyn 11, N. Y.

Prices 5% higher on West Coast.

CUSTOM CABINETRY *Elegance*
for TV and Hi-Fi
at LOW COST!



FRENCH PROVINCIAL Closed View

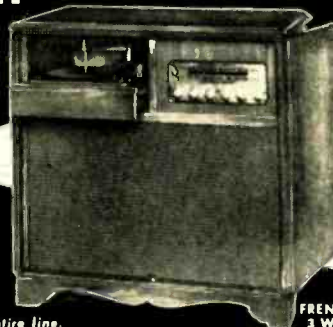

FRENCH PROVINCIAL 3 Way Combination

You get far more for your cabinet dollar when you buy *Standard*. Beautiful fidelity styling, choice select-grain woods, careful construction, functional design, acoustical correctness — all to the acknowledged *finest standards* of the industry.

Compare — Write now for FREE Catalog RE-5 showing our entire line.

Standard Wood Products Corp. / 47 West 63rd Street, New York 23, N. Y.

AT LAST a good UHF BOOSTER



Custom Built
Senco
UHF BOOSTER

- **BEST NOISE FIGURE**— Nothing approaches the noise figure of 6AN4 special UHF triode tubes.
- **HIGHEST GAIN**—18DB gain uses two 6AN4 tubes in push-pull, grounded grid, neutralized circuit. It really removes that snow.
- **CUSTOM BUILT** — Covers approximately one third of UHF band. Checked on the channels in your area only. See chart below.
- Guaranteed to double your UHF sales area.
- A must in dealer demonstration rooms where customers buy only one thing—the picture on the end of the tube. Conversion strips and booster make a wonderful low cost combination in fringe areas.
- Simple capacity tuning — no sliding contacts to wear out.
- No need to disconnect—when turned off, antenna is connected straight through.
- Complete with simple operating instructions.
- 7 3/4" x 5" x 4 1/2"—net weight—3 1/2 lbs.

MODEL CHART
Available now
Model 14-31
Model 20-35
Model 25-50
Model 40-60

**new
low
price
\$4295**

Special models
Available to cover any third of the band on two weeks delivery.

Cut out and mail to:

SERVICE INSTRUMENTS CO.
422 S. Dearborn • Chicago 5, Ill.

I am interested in the new Senco UHF Booster. Please rush further information to:

Name _____
Firm Name _____
Address _____
City _____ Zone _____ State _____

motion from the voice coil vibration source and the reflected wave from the cone edge support. Aurally, it shows up as a wholly foreign frequency tone, usually an octave lower than the test frequency, and is generally in about the 1,000-1,500 c.p.s. frequency range. Speakers rated at say 50 watts can only be used at 8 or 10 watts input due to this "cone break-up." Radial ribbing near the cone rim can cope with the tendency for the cone to develop the "flower" nodal pattern, but these circular corrugations have no appreciable effect on the other type. (Fig. 5). Shallow cones are especially subject to this (Fig. 5) effect.

I have found an effective solution for this, by using cemented-on, radial stiffening tubes (experimentally I've used 32 common, paper, soda straws for this). A frequency-sound level output curve shows only a 1 to 3 db drop in sound level at some parts of the audio range when directly compared with an otherwise identical (Jensen) 12-inch electrodynamic speaker, but the power handling ability is much higher.

As to directional effects: in 1926, I published measurements on cone, horn and flat diaphragm transducers (both microphones and speakers). While with the Brunswick Co. (1921), I used flat horns with vertical slot openings to give a more nearly uniform dispersion from low to high frequencies. I even had a very narrow, axial slit along one side of the horn to prevent horn resonances, and these horns were lined with sheet lead to reduce side wall resonance of the (wood) enclosure.

The non-uniform directional effects of speakers produce a serious and not yet fully recognized type of distortion. Comparing the acoustic situation with a visual analogue, the loudspeaker is like a lamp which generates white light of all visible frequencies from near infra-red to near ultra-violet. It should equally illuminate all parts of a room with the mixture of separate frequencies contained in its white light. The lamp, we will assume, is the ideal, aperiodic-moving-system loudspeaker, with every link in the chain leading up to it from the original sound source, perfect in every respect. This includes the loudspeaker cone, as to flat frequency response, linear power response, and no harmonic, intermodulation, or other defects, such as extraneous noise or tones.

However, this lamp light must pass from its source through a sort of prismatic device which strongly refracts the light rays, so that the highest frequency, violet-end-of-the-spectrum rays are concentrated, beam-like, along the lamp's axis, instead of spreading uniformly all around. The medium-frequency blue and green waves are less concentrated in a broader beam; the lowest, from yellow to orange and to red frequencies spread more and more uniformly all around the room.

As a result of this, there is *no place* in the room where one can see the desired, white light. Way off of the light

LEADING TELEVISION DEALER TELLS YOU THE VALUE OF KRYLON

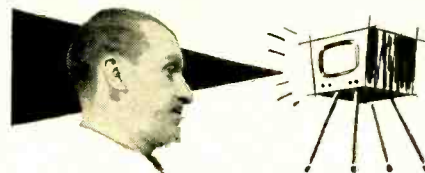

• "I use Krylon on the high voltage sections of TV receivers, and on the antennas as well. It does a good job, cuts down contract calls, and I know it gets the word around about my servicing reliability."—Edwin G. Schaffer, President, Edwin G. Schaffer Company, 7920 Frankford Avenue, Phila., one of the Quaker City's most progressive television organizations.

KRYLON 100% Acrylic Spray is a crystal clear, high dielectric strength coating in a push-button dispenser. For all high voltage sections and component parts of television receivers. Because of its weather-proofing qualities, it is ideal for coating antennas, lead-ins, etc.

"The most important handyman in the TV industry."



KRYLON, INC.

2038 Washington Ave., Phila. 46, Pa.

Krylon also available in Bright Aluminum, Flat Black, Glossy Black, Touch-Up White and Bright Gold

At TV Jobbers Everywhere

TELEVISION

Big demand for graduates

B.S. DEGREE IN 27 MONTHS in radio including TV engineering—VHF, UHF, AM and FM. Students use over \$100,000 worth of equipment including 2 large commercial type transmitters in new TV lab. Intense specialized course includes strong basis in mathematics, science and advanced design in radio and TV.

Hundreds of young men each year are earning engineering degrees in this recognized institution. Start any quarter. Many earn a major part of expense in this industrial center. Low tuition. Competent instruction. Thorough, intense, practical program.

Also **B.S. DEGREE IN 27 MO.** in Aeronautical, Chemical, Civil Electrical and Mechanical Engineering. G.I. Gov't approved. Enter June, Sept., Dec., March. Free catalog. **ENROLL NOW.**

INDIANA TECHNICAL COLLEGE
1754 E. Washington Blvd., Fort Wayne 2, Indiana

RADIO-ELECTRONICS

axis, one sees mostly red and orange, while between these points and the axis, the light color is generally yellow to green. As we approach the axis, the color changes again to blue and finally violet, because the longer wave lengths there are very weak, due to their spreading out through such a wide angle. This of course, assumes a room with completely absorptive walls, floor and ceiling, such as an anti-echoic room or no room at all. A room-enclosed speaker is not as bad as the above analogue would depict since the reflections tend to equalize, at least near the room boundaries, the various frequency sounds of the acoustic spectrum. But as one approaches closer and closer to the speaker, the analogue is more and more nearly a true one, since there the relative amplitude of direct and reflected sounds are vastly different.

Practically nothing has ever been done commercially to solve this problem of direct-radiator, single speakers. The ideal type of sound radiator would of course consist of a pulsating, spherical surface. A radiator of very small dimensions, at least as small or preferably smaller than the wavelength of the highest sound to be reproduced would also answer the problem.

The very early "speaking arc light" is an example of such a radiator but the thermal modulations of the ionized air in the arc would have to be very great to derive sufficient sound energy from such a small-area source, and the arc would have to be energized by a current of ultra-sonic frequency, modulated by audio frequencies. A horn speaker with a horizontal, annular slot opening is helpful, except for the variable-phase relations at any given listening point of sound waves from diametrically opposite sides of the annular slot.

As previously mentioned, a horn with a narrow, vertical slot opening will spread the frequencies laterally around the room, and at the same time confine the radiation in a horizontal, fan-like beam, but this is still subject to some of the same objections, due to the variable dispersion through the vertical planes of its radiation.

I have wrestled with this problem over many years and perhaps others have also; it is an elusive one but, if solved, will do much toward that long-sought solution for perfect reproduction of sound.

We have come closer to this goal but the loudspeaker is still the imperfect link in the chain.

BENJAMIN J. MIESSNER
Morristown, N. J. END

CORRECTION

Our printer inadvertently inverted the formula on page 137 of the November, 1953, issue. The formula, used for finding one wavelength (in inches) at the center of a u.h.f. TV channel, should read:

$$11,800$$

$$\lambda (\text{inches}) = \frac{11,800}{(6 \times \text{u.h.f. channel No.}) + 389}$$

We thank C. A. Tracy, of Sewickley, Pa., for this correction.

MAY, 1954

Windsor TUBES

RADIO & TV RECEIVING

TESTED and GUARANTEED for PEAK PERFORMANCE



We've EARNED your Confidence . . . and we mean to KEEP IT! Thousands of Service Organizations and Dealers throughout America send us REPEAT orders month after month—they now KNOW you can DEPEND upon the WINDSOR promise of PEAK PERFORMANCE!

And here's why: Every tube we ship is first carefully tested in our laboratories, for maximum functioning characteristics, right in a radio or TV set—under actual operating conditions! That's why we unconditionally guarantee every Windsor Tube in accordance with the Standard Warranty: Full replacement of any defective tube within 90 days of purchase, excepting only burnouts and breakages. Each tube attractively packaged in individual carton.

BUY—AND SELL, WINDSOR TUBES—WITH CONFIDENCE!

Type	Each	Type	Each	Type	Each	Type	Each
1A7GT	\$.87	3V4	.62	6BD5GT	.98	6Q7GT	.55
1B3GT	.69	5R4GY	1.00	6BD6	.54	6S4	.51
1H5GT	.51	5U4G	.44	6BE6	.51	6SBGT	.75
1J6	.93	3V4G	.83	6BF5	.66	6SA7GT	.57
1L4	.63	5Y3G	.37	6BF6	.43	6SC7	.83
1L6	.66	5Y3GT	.32	6BQ6G	1.47	6SD7	.55
1LA4	.82	5V4G	.43	6BQ6	.63	6SF5GT	.66
1LA6	.80	6AR8T	.68	6BQ6	.53	6SH7GT	.52
1LB4	.82	6AB4	.51	6BK5	.76	6SJ7GT	.52
1LC5	.80	6AC5GT	.82	6BK7	.97	6SK7GT	.55
1LC6	.80	6AG5	.59	6BL7GT	.94	6SL7GT	.68
1LD5	.80	6AH4	.68	6BN6	.98	6SN7GT	.59
1LE3	.80	6AH6	.89	6BQ6GT	.98	6SQ7GT	.46
1LG5	.80	6AK5	1.05	6BQ7	.92	6T8	.85
1LH4	.80	6AL5	.44	6BZ7	1.09	6U4GT	.80
1LN5	.80	6AQ5	.51	6C4	.41	6U8	.86
1N5GT	.63	6A26	.47	6C5GT	.60	6V3	1.99
1R4	.85	6A07	.75	6C6	.58	6V6GT	.51
1R5	.82	6AR5	.42	6CD6G	2.04	6W4GT	.50
1S4	.67	6AS5	.55	6D6	.63	6W6GT	.63
1S5	.52	6AT6	.42	6E5	.72	6X4	.37
1T4	.62	6AU5GT	.85	6F5GT	.54	6X5GT	.36
1U4	.61	6AU6	.47	6H6GT	.55	6Y6G	.64
1U5	.51	6AV5	.85	6J5GT	.44	7A4/XXL	.57
1X2A	.74	6AV6	.41	6J6	.68	7A5	.70
2X2	1.43	6AX4	.72	6J7	.70	7A6	.57
3LF4	.76	6BB6	.93	6K6GT	.45	7A7	.58
304	.66	6BA6	.50	6K7	.70	7A8	.56
305GT	.72	6BA7	.66	6L6G	.88	7AD7	1.05
354	.61	6BC5	.58	6L6GA	.88	7AF7	.63

Type	Each	Type	Each
7AG7	.65	12B7	.77
7AH7	.65	12B7GT	.48
7AJ7	.70	12SA7GT	.57
7B5	.51	12SH7GT	.67
7B6	.52	12SK7GT	.55
7B7	.58	12SL7GT	.67
7C4	1.05	12S7GT	.59
7C5	.56	12SQ7GT	.46
7C8	.50	14A7	.58
7C7	.58	14A7F	.68
7E5	.85	17B6	.50
7E6	.69	14C5	.85
7E7	.85	14C7	.70
7F7	.69	14E7	.70
7F8	.97	14F7	.85
7G7	.85	14G7	.69
7H7	.61	14H7	.85
7I7	.85	14I7	.85
7J7	.85	14J7	.85
7K7	.85	14K7	.85
7L7	.85	14L7	.85
7M7	.85	14M7	.85
7N7	.85	14N7	.85
7O7	.85	14O7	.85
7P7	.85	14P7	.85
7Q7	.85	14Q7	.85
7R7	.85	14R7	.85
7S7	.85	14S7	.85
7T7	.85	14T7	.85
7U7	.85	14U7	.85
7V7	.85	14V7	.85
7W7	.85	14W7	.85
7X7	.85	14X7	.85
7Y7	.85	14Y7	.85
7Z7	.85	14Z7	.85

FREE! WINDSOR TUBE CADDY



The most practical Service-Aid ever designed for the radio and TV repairman. This ideal television carry-all now offered free with every purchase of \$100.00 or accumulated purchases totaling \$100.00 within 90 days. (You get caddy credit memo with each purchase). Windsor Tube Caddy may also be purchased outright for \$14.95.

- Carries approximately 125 tubes including meters and tools.
- 16 3/4 inches long x 8 1/4 inches wide x 1 3/4 inches high.
- Weighs only nine pounds.
- Ruggedly constructed with heavy leatherette covering, strong plastic handle, nickel plated hardware, and reinforced with metal clamps.

DON'T MISS THIS SENSATIONAL OFFER!

Windsor ELECTRONIC TUBE CO.

2612-C NOSTRAND AVENUE, BROOKLYN 10, N. Y.

OPPORTUNITY ADLETS

Rates—45¢ per word (including name, address and initials). Minimum ad 10 words. Cash must accompany all ads except those placed by accredited agencies. Discount, 10% for 12 consecutive issues. Misleading or objectionable ads not accepted. Copy for July issue must reach us before May 21, 1954.
Radio Electronics, 25 W. Broadway, New York 7, N. Y.

PASS AMATEUR THEORY EXAMS. CHECK YOURSELF with sample FCC-type questions and novice and general class examinations. All for only 50¢. American Electronics, 1203E Bryant Ave., New York 59, New York.

SPEAKER REPAIRS ON ALL MAKES. Jobbers wanted. Amprite Speaker Service, 70 Vesey St., New York 7, N. Y.

RADIO REPAIR SHOP AND FOUR RENTAL UNITS ON ACRE. Stock, Furniture, Station Wagon—genuine. Any trial. Retiring \$12,000—half cash. C. E. Buckingham, 1728 G Street, Sacramento, California.

DIAGRAMS FOR REPAIRING RADIO \$1.00 TELEVISION \$2.00. Give make and model. Diagram Service, Box 672-RE, Hartford, Conn.

TEST EQUIPMENT REPAIRED AND CALIBRATED by factory staff. All makes. Solar, Simpson, Triplett, Heath, etc. Immediate service. Douglas Instrument Laboratory, 176a Norfolk Avenue, Boston 19, Mass.

TUBES-TV, RADIO, TRANSMITTING, AND SPECIAL PURPOSE TYPES BOUGHT, SOLD AND EXCHANGED. Send details to B. N. Gensler W2LNL, 136 Liberty, N. Y. 6, N. Y.

ALL MAKES OF ELECTRICAL INSTRUMENTS AND TESTING equipment repaired. Write for free catalogue on new and used instruments at a savings. Hazelton Instrument Co., 128 Liberty Street, New York, N. Y.

SALESMEN WANTED—SELL AT MANUFACTURERS LOW PRICES—Television Wire to Retail Outlets, 10% commission on Original and Repeat orders. All Territories Open. King Mfg. Co., 45 Huron Road, Mohagan Heights, Yonkers, New York.

BUILD YOUR OWN ELECTRONIC ORGAN. OR MINIATURE electronic brain. Jim Kirk, W6JKX, 1552 Church Street, San Francisco 14, California.

WANTED: AN/APR-4, other "APR", "TS", "IE", "ABC-1", "ABC-2", "AVT-13, 10", "318", etc. Microwave Equipment, Everything Surplus, Special tubes, Test Manuals, Lab Quality Equipment, Meters, Fast Action, Fair Treatment, Top Dollar! Littell, Fairhills Box 26, Dayton 9, Ohio.

COMMUNITY TV OPERATORS: FOR SALE 80' Twin Steel Tower, 20' catwalks, 25' top extensions. Paid \$1050; sell for half. Poronco TV Relay, Inc., Stroudsburg, Pa.

ALUMINUM TUBING, ANGLE AND CHANNEL. Plain and perforated sheet. Willard Itadell, Pistoria, Ohio.

TELEVISION SETS \$30 UP. W4API, 1420 SOUTH Randolph, Arlington 4, Virginia.

TV FM ANTENNAS. ALL TYPES INCLUDING UHF. Mounts, accessories. Lowest prices. Wholesale Supply Co., Lunenburg 2, Mass.

3 NEW RIDER BOOKS FOR MAY

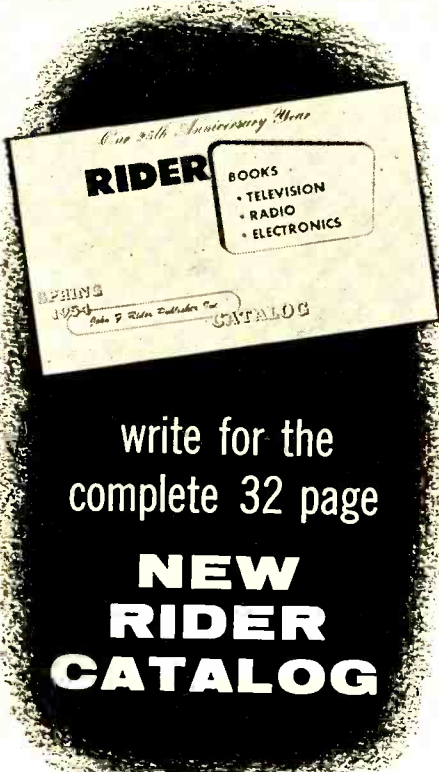

write for the complete 32 page
NEW RIDER CATALOG

HOW TO LOCATE AND ELIMINATE RADIO & TV INTERFERENCE

by Fred D. Rowe,
Northern California Electricity Bureau
An expert from the Northern California Electricity Bureau tells how he located sources of radio and TV interference—and the things he did to eliminate them. This is not a theory or a "perhaps" book. The content is direct to the point and tells what to do. 128 (5 1/2 x 8 1/2") pages, illus. \$1.80

TECHNICIAN'S GUIDE TO TV PICTURE TUBES

by Ira Remer
A picture tube servicing guide for the television installation and repair man. Covers the care, methods of handling, replacement maintenance and repair of the picture tube. It is written for the technician who desires basic and specific information on the picture tube and its accessories (including conversion) without wading through reams of technical data, complicated circuit explanations. 140 (5 1/2 x 8 1/2") pages, illus. \$2.40

FUNDAMENTALS OF TRANSISTORS

by Leonard Krugman
The transistor is now evolved to a point where it is suitable for many applications, both as a direct replacement and as a supplement to electron tubes. An expert has consolidated in practical form for the repair man, the engineer, the hobbyist and the engineering student the explanation and application of the transistor. Basic transistor operation, characteristics, performance and applications are explained. 160 (5 1/2 x 8 1/2") pages, illus. \$2.70
Buy these books now from your jobber, bookstore —if not available from these sources, write to:

JOHN F. RIDER PUBLISHER, INC.
480 Canal Street, New York 13, N. Y.
In Canada: No. Charles W. Pointon, 1926 Gurnard Street, East Toronto, Ontario
Expert Agent: Roburn Agencies, Inc., 39 Warren Street, New York 7, New York
West Coast Office: 4218-20 W. Jefferson Blvd., Los Angeles, California
Cable Address: Roburnage N. Y.

PEOPLE

Charles A. Hansen joined Gramer Transformer Corp., Chicago, as manager of the Distributor Division. He was formerly sales manager of Jensen Manufacturing Co. He is past chairman of the Association of Electronic Parts and Equipment Manufacturers and former president of the Electronic Parts Show.



C. A. Hansen

F. Birney Farrington, founder of Xcelite, Inc., Orchard Park, N. Y., hand tool manufacturing firm, was elected president at the annual stockholders' meeting. Other officers include John O. Olsen, vice-president, and Clarence Schwabel, secretary. Arch Warden, sales manager, was newly elected to the office of treasurer.



F. B. Farrington

Warren M. Stuart, former Central District manager for Belden Manufacturing Co., Chicago, was promoted to sales development manager. He will continue as manager of the East Central District. Robert N. Alvis was promoted to West Central District Manager, and Edwin D. Stull, Jr., formerly in Belden's Mid-Western Sales Service Division, was transferred to the Philadelphia territory.



W. M. Stuart

George Kollar joined Finney Co., Cleveland, as special assistant to M. L. Finney, Jr., sales manager. He will initiate and co-ordinate the company's field promotion program. Kollar was formerly with Stretator Brick Co. At the same time, Victor Trebules, formerly of the mechanical engineering department, was promoted to the position of plant superintendent.



G. Kollar

Ralph C. Powell was named product manager of American Screen Products Co., Miami, Fla. He will be in charge of sales of television antennas and accessories which he formerly designed for the company as a consultant.



R. C. Powell

"RACON" RADIAL HORN

Famous Double Re-Entrant Type.

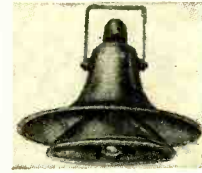

(Mod. SR-35R). Weather-proof aluminum deflector, 360° high sound projection. Takes any RACON driver unit. 10" mtg. bracket, 16" L. 18" acoustic, rad. 17" O.D. BRAND NEW (U.S. \$17.50) YOUR PRICE \$18.95

25 WATT RACON DRIVER UNIT for above. Powerful Alnico magnet, weatherproof alum. shell, 15 ohm impedance, 3" O.D. BRAND NEW \$14.95

- RM-38A CONTROL UNITS (LN) 7" gold-plated jacks, plug cables, switches, etc. 2.95
- BLOWER WHEEL & HOUSING use with any small motor. L-R Type 3 (5 1/2" O.D.). Moulded bakelite 1.95
- 1 30 HP A.C. MOTOR 115V., .94A. Approx. 3000 RPM. Disc. shaft (1/4" x 10). 3" x 3 1/2" 3.95
- 1 17 HP G.E. MOTOR (Type 5D) 175 RPM, 1.7 amp. Disc. shaft. 110V. DC. 4 1/2" x 3 1/2" 3.95
- RUBBER TAPE 3/4" x 15 ft. roll 10c 6/1.00
- CRYSTAL MICROPHONE Hi-fidelity hi-imped. rubber shock mtg. 12 1/2" less housing 1.29
- ALUMINUM HOUSING for above mike .15
- HAND MIKE CASE moulded black bakelite, 2" I.D. Rubber mouthpiece 1.29 1.50

KITS!! KITS!! KITS!!

A BARGAIN FOR EVERYONE!!

- ALNICO MAGNETS Powerful Bar, Block, 1/2" (rod, etc. kit of 10 ass'd) 1.98
- MIDGET WOOD CABINET & CHASSIS (without tube chassis) 4" x 5 1/2" x 4" inside. Punched 4 min. 1.95
- CARBON RESISTORS 1/2 watt, 100 ass'd 1.49
- MOULDED BAKELITE CONDENSERS .50mm to .25mm, 200-600V. 50 ass'd 1.98 2.98
- ROTARY SELECTOR SWITCHES incl. multi-contact, multi-deck. Kit 6 ass'd. 1.49
- EXPERIMENTAL TUBES for Test, Research, etc. (Full tested, Kit 40 ass'd, pop. types) 1.98
- SPEAKER REPLACEMENT CONES Popular sizes 4" to 12", incl. oval. Less voice coils, 12 ass'd. 1.98
- SPEAKER REPAIR KIT SAVE \$\$\$ with this professional assist. of: Spiders, Rings, V. C. Forms, Felt, Chamois Lthr., Shim Kit, Cement & Instructions 2.49
- !! SPECIAL !! BOTH CONE & REPAIR KITS. 3.95

!! XMAS IN MAY !!

When you get the "JUMBO RADIO ELECTRONICS PARTS KIT" — chock-full of inventory odds & ends worth several times the price. 17 lbs. of: SWITCHES, SOCKETS, WIRE, RESISTORS, CONDENSERS, TV PARTS & DIAGRAMS, PHOTO-FACTS, CONTROLS, ETC., ETC. \$3.95

DIRECT FACTORY SPEAKER REPAIRS SINCE 1927! Min. Order \$3.00. 20% deposit req. on all C.O.D.'s. Please add sufficient postage—excess refunded

LEOTONE RADIO CORP.
67 Dey Street
New York 7, N. Y.

OSCIL-O-PEN

Extremely convenient test oscillator for all radio servicing; alignment • Small as a pen • Self powered • Range from 700 cycles audio to over 600 megacycles u.f.t. • Output from zero to 125 v. • Low in cost • Used by Signal Corps
Write for information.
GENERAL TEST EQUIPMENT
38 Argyle Ave. Buffalo 9, N. Y.

Only from famous COYNE do you get this modern up-to-the-minute TV Home Training. Easy to follow, Step-by-Step instructions—fully illustrated with 2150 photos and diagrams. Not an old Radio Course with Television tacked on. Personal guidance by Coyne Staff. So practical you can quickly EARN MONEY IN A TV-RADIO SALES AND SERVICE BUSINESS—part time or full time. Not only FINEST TRAINING but COSTS MUCH LESS—pay only for training—no costly extras.

SEND COUPON FOR DETAILS FREE
SEND COUPON BELOW for Picture Folder and full details including EASY PAYMENT PLAN. NO COST OR OBLIGATION—NO SALESMAN WILL CALL.

B. W. COOKE, Pres. **COYNE** FOUNDED 1899
ELECTRICAL SCHOOL

A TECHNICAL TRADE INSTITUTE CHARTERED NOT FOR PROFIT
500 S. Paulina Dept. 54-RT4 Chicago 12, Illinois

B. W. COOKE, President
COYNE ELECTRICAL SCHOOL
500 S. Paulina St., Chicago 12, Ill., Dept. 54-11T4

Send FREE Picture Folder and details of your Television-Radio-Electronics Home Training offer.

Name.....
Address.....
City..... State.....

RADIO-ELECTRONICS

Joseph M. Coleman joined Sylvania Electric Products as a merchandising assistant in the Radio Tube and Television Picture Tube Divisions. He was formerly with J. Walter Thompson, New York City advertising agency.



J. M. Coleman

Obituaries

Walter R. Jones, Professor of Electrical Engineering at Cornell University, and an authority on the design and construction of vacuum tubes, died of a heart attack in Ithaca, N. Y. Before going to Cornell in 1948, Jones spent 19 years with Sylvania.

Fred Aylesworth, of the Chicago Standard Transformer Corp. sales staff in the Southern California area, died at his home in Hollywood, Calif. He was a pioneer in the radio industry.

Personnel Notes

... Roger H. Bolin was appointed manager of general advertising for Westinghouse Electric Corp., succeeding Harry J. Deines, who joined the J. Walter Thompson Co., New York advertising agency. Bolin was previously assistant to J. M. McKibbin, vice-president and general manager in charge of the Westinghouse Consumer Products Division.

... A. C. "Chuck" Elles joined I. D. E. A., Inc., Indianapolis, Ind., manufacturers of Regency boosters and converters, as assistant industrial sales manager. He will work under E. M. Sheridan, industrial sales manager, primarily with Radell Corp., an affiliate company.

... Clark C. Rodimon rejoined Raytheon Manufacturing Co., Waltham, Mass., as staff assistant to the manager of Government contracts. For the past four years, Rodimon was with National Co., and Melpar, Inc.

... Seymour Mintz was appointed president of CBS-Columbia, Long Island City, N. Y., and a vice-president and director of Columbia Broadcasting System. He was formerly vice-president of Admiral Corp. He succeeds David Cogan who resigned as president of CBS-Columbia and vice-president of CBS.

... Robert L. Parrish was named manager of the new Sprague Electric Co. plant in West Jefferson, N. C. He had been associated with the main plants in North Adams, Mass., for some time.

... Elmore E. "Kay" Kayser joined Krylon, Inc., Philadelphia, Pa., as advertising and sales promotion manager. He was formerly with Sun Oil Co.

... Gene Royster was named administrative assistant in the Sales Department of Merit Coil & Transformer Corp., Chicago, Ill.

MAY, 1954



ONLY 1 MAN

is needed

TO INSTALL THE FAMOUS

RADELCO

"SCREW BALL" AUTO ANTENNA

IT'S THE EASIEST AND QUICKEST OF ALL ANTENNAS TO INSTALL!

Here's all you do!

IT'S **BETTER**

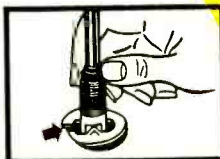

1 Insert one edge of split-washer into hole ... twist ... and entire bottom of mounting base slips into position beneath cowl or fender.

IT'S **DIFFERENT**

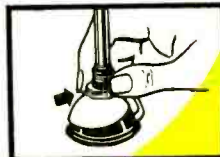

2 Slide ball-top into place over mounting hole ... adjust antenna to proper angle ... tighten ... and the mounting job is done. Quickly! Easily!



Entire mounting job is done from the top. It's speedily and easily installed by one man ... and without the use of special tools or gadgets.

There is absolutely nothing like it on the market! The "screw" portion of the assembly assures quick and economical installation. The "ball" provides angular adjustment for every type of cowl or fender contour.

ATTRACTIVELY LOW PRICED

MODEL

LIST

SEC.-LEN.

EZ-2

\$3.55

2-49"

EZ-3

5.10

3-57"



7580 GARFIELD BLVD.

CLEVELAND 25, OHIO

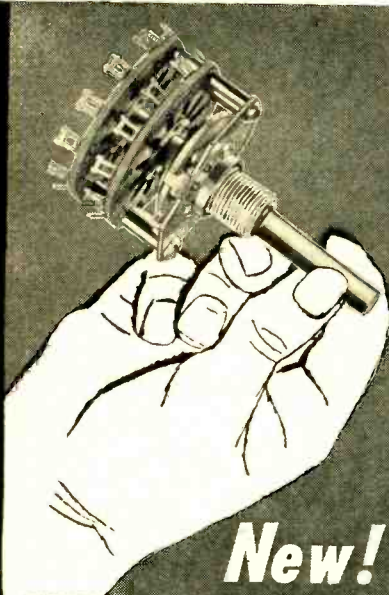

New!

Centralab

**Miniature
Phenolic Switches**

They're small in size!

They provide flexibility!

They offer positive protection!

Dependability that gives you confidence. Flexibility that helps you do a better job! These are things you can count on getting in Centralab's new PA-1000 Series. See for yourself:

You get high-strength, high-resin, laminated phenolic insulation that exceeds Phenolic Standards Grade XXX.

You get one-piece shaft construction for accurate indexing. Adjustable stop permits selection of positions or continuous rotation (11 active positions, 1 off-position).

You get steatite spacers with nickel-plated brass shafts, bushings, tie-rods, and nuts. All other metal parts are treated to pass 50-hour salt-spray test — a must for applications in a humid or salt atmosphere.

You can get complete switches or separate miniature phenolic sections, index assemblies, hardware, and accessories.

That's only part of the PA-1000 story. Get it all — send coupon for Centralab catalog sheet 28-1.

Then order Centralab Miniature Phenolic Rotary Switches from your Centralab distributor.

SEE US AT BOOTH 790.

1954 MAY 17-20 CHICAGO
ELECTRONIC PARTS SHOW

CENTRALAB, A Division of Globe-Union Inc.
922E E. Keefe Ave., Milwaukee, Wisconsin

Send me Centralab catalog sheet 28-1.

Name.....

Company.....

Address.....

City..... Zone..... State.....

P-2454

... **Jno. J. Cahill**, well-known West Coast advertising man and sales executive, joined Ralph W. Harker & Assoc., Los Angeles, advertising representative for RADIO-ELECTRONICS. Cahill will head the San Francisco office. **Robert A. Harker**, son of the founder of the firm, will be Cahill's associate in the San Francisco office.

... **C. Russell Feldmann**, New York industrialist and chairman of the Board of National Union Radio Corp., Hatboro, Pa., was elected president of the company. He succeeds **Kenneth C. Meinken** who resigned.

... **Anthony L. Conrad**, former manager of the Technical Operations Section of RCA Service Co., Camden, N. J., was promoted to manager of the RCA Missile Test Project, Government Service Division. In 1953, Conrad received the RCA Victor Award of Merit, the company's highest award for salaried employees, for his work on guided missiles.

... **Edmond I. Eger** joined Admiral Corp., Chicago, as vice-president, advertising. For the past year he had been vice-president of Russel M. Seeds Co., Chicago advertising agency. Eger has been handling Admiral advertising.

... **Oscar Kraut** joined the sales staff of G & H Wood Products, Brooklyn, N. Y. He will handle the sale of the Cabinart line of cabinets in Metropolitan New York, upper New York State, and New England. He had been with both Arrow Electronics and Hudson Radio.

... **Charles T. Carroll**, former chief of Government Engineering for Hallicrafters, Chicago, was promoted to director of engineering.

... **Eugene C. White** was named product manager for General Electric industrial and transmitting tubes. His office is in the Tube Department headquarters in Schenectady, N. Y. He was formerly industrial specialist for the Tube Department.

... **Ralph Mendel**, manager of the Engineering Products Division of Radio Receptor Co., Brooklyn, N. Y., was upped to the post of vice-president in charge of the division.

... **Raymond L. Johnson** joined the Instrument Division of Allen B. Du Mont Laboratories, Clifton, N. J., as technical sales engineer. He was formerly with the Public Service Electric & Gas Co.

... **H. J. Tutwiler** and Lt. Commander **Thomas A. Marshall**, U.S.N. (ret.) joined Miller Television, Burbank, Calif., as national sales manager and development engineer respectively. Tutwiler has spent a lifetime in selling and Marshall has held many naval assignments in radar, and radio work.

END

Your customers...
and your cash register...
will tell you...

hallicrafters
SHORT WAVE RECEIVERS

are the finest—fastest selling
on the market!

FOR twenty years hams all over the world have agreed that Hallicrafters receivers—dollar for dollar—are the finest on the market. They are in a class by themselves.

Your own customers know this. They talk about it—on the air and off. They will tell you—so will your cash register—Hallicrafters is the fastest moving, most profitable line you can handle!

Stock—Feature—
Display Hallicrafters—IT PAYS!

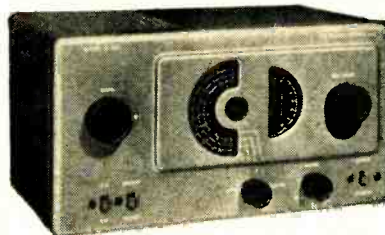

Finest buy in SW—the 5-38C

The 38-C is the finest buy in all short-wave. 540 kc to 32 mc in four bands. Broadcast reception that far exceeds ordinary sets. Maximum sensitivity per tube. Built-in speaker. Has band-spread control. 4 tubes plus rectifier. Operates on 115 V AC or DC \$49.95



Amateur's favorite—the 5-40B

Electrical band-spread tuning to separate crowded stations. Switches for automatic noise limiter, code reception, three position tone control. One r-f, two i-f stages. Broadcast plus three short-wave bands, 1680 kc to 44 mc. Built-in speaker \$119.95

hallicrafters

The Name is Famous

4401 West Fifth Avenue
Chicago 24, Illinois

Radio • Television • High Fidelity

RADIO-ELECTRONICS

Any or all of these catalogs, bulletins, or periodicals are available to you on request direct to the manufacturers, whose addresses are listed at the end of each item. Use your letterhead—do not use postcards. To facilitate identification, mention the issue and page of RADIO-ELECTRONICS on which the item appears. All literature offers void after six months.

SUBMINIATURE CAPACITORS

Dumont—Airplane & Marine Instruments has issued Catalog 53 on their Milcaps (glass-to-metal hermetically sealed subminiature capacitors) which are designed to meet the operating requirements of military specifications MIL-C-25A.

The 17 pages are devoted to the electrical and physical characteristics of their various capacitors of the stabilized Halowax, mineral oil, and Duroil types.

Request Catalog No. 53 from Dumont—Airplane & Marine Instruments, Inc., Clearfield, Pa.

ELECTRONIC COMPONENTS

Stackpole's 56-page Catalog RC-9 gives electrical and mechanical specifications and application data on their complete line of fixed and variable composition resistors, line and slide switches, fixed composition capacitors, powdered-iron cores, molded coil forms, and ferromagnetic cores.

Copies available free on letterhead request to Stackpole Carbon Co., St. Mary's, Pa.

MASTER TV SYSTEMS

Blonder-Tongue has released a new manual, *How to Install Master TV Systems*, which includes complete instructions and diagrams covering all phases of planning and installation.

Antenna installation, choice of transmission lines, signal amplification and distribution to TV sets are all clearly explained and illustrated with charts and tables.

Available at no charge from the *Blonder-Tongue Sales Dept., 526 North Ave., Westfield, N. J.*

HYBRID JUNCTIONS

Microwave Development Laboratories has released a bulletin on short-slot hybrid junctions, which describes special features and gives electrical and physical characteristics of these units which have found wide application in high-frequency radar and communications. Some applications are illustrated and described.

Obtainable gratis on request to *Microwave Development Laboratories, Inc., 220 Grove St., Waltham 54, Mass.*

WIRE-WOUND RESISTORS

IRC's 4-page Bulletin D-1 gives comprehensive data on characteristics, applications, construction, ranges, ratings, tolerances, terminals, insulation, temperature coefficients, and derating of MIL type wire-wound resistors. The bulletin is illustrated with photographs, charts, and graphs.

MAY, 1954

AGAIN!

**NPN
GROWN
JUNCTION**

FEDERATED SCOOPS THE ELECTRONIC WORLD!

TRANSISTORS

**\$3.95
NOW EACH**

*Manufacturer's production changes now make it possible to offer you NPN Transistors at this sensational price. Use these transistors in low-level amplifiers, oscillators, keyers, R.F. & I.F. amplifiers. First quality units! Guaranteed to meet specs!



LIFE-SIZE

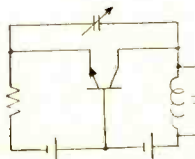

GROUNDING BASE
OSCILLATOR

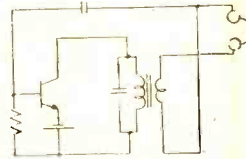

GROUNDING EMITTER
OSCILLATOR

SUPPLIES LIMITED! MAIL COUPON TODAY!

Federated PURCHASER, INC.

66 DEY STREET, DEPT. 401, NEW YORK 7, N. Y.

Rush me _____ NPN Grown Junction Transistors at \$3.95 each. (We pay postage in U. S. Sorry, no C.O.D.'s.) Instruction sheet included.

Newark, N. J.
Easton, Pa.
Allentown, Pa.
Los Angeles, Cal.

NAME _____
ADDRESS _____
CITY _____ ZONE _____ STATE _____

*MANUFACTURED BY GERMANIUM PRODUCTS CORP. UNDER WESTERN ELECTRIC CO. LICENSE.

**GUARANTEED
TELTRON TUBES
LOWEST PRICES EVER**

FREE GIFT OFFER

One 6BG6 Tube will be shipped FREE with any order accompanying this ad. We guarantee your orders to be shipped the same day they are received! All our tubes are individually boxed and

unconditionally guaranteed for one year. We now have a complete line of special purpose and transmitting tubes in stock.

Write for quotations on your requirements—Dept T.

TYPE	PRICE	TYPE	PRICE	TYPE	PRICE	TYPE	PRICE
024	.45	6Q7	.40	6BK7	.78	12K7	.40
1A7GT	.53	6AB4	.43	6BL7GT	.78	12SA7GT	.45
1B3GT	.62	6AC7	.65	6BN6	.90	12SK7GT	.45
1H5GT	.51	6AG5	.52	6BQ6GT	.76	12SL7GT	.60
1L4	.51	6AN4GT	.65	6BQ7	.85	12SN7GT	.56
1L6	.51	6AJ5	.96	6BY5G	.60	12Q07GT	.38
1LC6	.49	6AK5	.96	6BZ7	.41	19BG6G	1.4P
1N3GT	.51	6AL5	.43	6C4	.31	19R8	.71
1R5	.51	6AQ5	.48	6CB6	.41	25BQ6GT	.82
1S5	.43	6AR5	.48	6CD6G	1.63	25L6GT	.41
174	.51	6AT6	.37	6CUG	.95	25W4GT	.43
1U4	.51	6AU5GT	.60	6F6	.42	25Z5	.75
1U5	.43	6AU6	.43	6F5GT	.40	25Z6GT	.36
1X2	.65	6AV5GT	.60	6H6	.49	35B5	.48
2A3	.35	6AV6	.37	6AF4	1.02	35C5	.48
2A7	.35	6AX4GT	.60	6J3GT	.61	35L6GT	.41
3Q4	.53	6AX5GT	.60	6J6	.38	35W4	.33
3Q5GT	.61	6BA5	.56	6K6GT	.78	35V4	.42
3S4	.48	6BA7	.58	6L6	.41	35Z5GT	.33
3V4	.48	6BC5	.48	6S4	.65	50A5	.49
5U4G	.43	6BE6	.41	658GT	.45	50B3	.48
5V4G	.49	6BF5	.48	6SA7GT	.45	50C5	.48
5Y3GT	.30	6BF6	.48	6SK7GT	.60	50L6GT	.50
5Y4G	.40	6BG6G	1.18	6SL7GT	.60	Type 80	.40
5Z3	.42	6BH6	.51	6SN7GT	.60	117Z3	.33
6AR	.40	6BJ6	.51	6SQ7GT	.38	117L7GT	1.20
6K7	.40	6BK5	.75	6T8	.71		

FREE \$5.00 list value Bonus Box of Radio & TV components including resistors, condensers—controls, and many other items with each order of \$25.00 or more.

Minimum order \$10.00. 25% deposit on C.O.D. orders—Save parcel post charges. Orders accompanied with full remittance will be shipped prepaid anywhere in continental U.S.A.—All orders subject to prior sale.

We have hundreds of tube types in stock—you may order any type at similar savings.

Send for Free complete tube listing

SPECIAL
while they last
39¢ Each
10 for \$3.50

TYPE	TYPE	TYPE	TYPE	TYPE
1A4P	1E7GT	19	34	39/44
1C6	1F4	1629	35	46
1D5GP	1H4G	22	35	51
1D7G	2A7	33	36	1F5G

These specials are new Sylvania's individually boxed. Order now.

TELTRON ELECTRIC COMPANY

428 Harrison Ave., Harrison, New Jersey

Phone: Waverly 6-1338

**A SIGNAL GENERATOR
OF QUALITY AND VERSATILITY
THAT DEMANDS YOUR ATTENTION**

RCP

"WIDE RANGE" SIGNAL GENERATOR

ONLY \$67⁵⁰_{net}

706A

Equivalent in performance to signal generators priced as high as \$125.00



Write for latest catalog to Dept. RE-5

RADIO CITY PRODUCTS CO., INC.



152 W. 25th Street
New York 1, N.Y.

COMPARE THE VALUE—compare the price! You will find that the RCP 706A Signal Generator feature for feature is the finest performer in its class.

VERSATILITY: Continuous coverage from 150 KC to 220 Mc. in 8 ranges. Six FUNDAMENTAL ranges cover up through 55 Megacycles.

ACCURACY: within 1% of calibration adjustment.

STABILITY: and constancy of calibration is assured by special electron-coupled circuit design, permeability adjusted coils and air trimmer capacitors.

MODULATION: 400 cycle sine wave audio oscillator with modulation continuously variable from 0% to 80%. Above 80% has no practical application. At this point tremendous distortion occurs in all signal generators. Unmodulated signal is available if desired.

ATTENUATION: Ladder type step attenuator consisting of a multiplier and fine attenuator control

AUDIO OSCILLATOR: 400 cycles at 50 ohms output impedance is available for external use—terminals on panel.

Eight scales are clearly calibrated—continuous reading from 150 kilocycles to 220 megacycles. Planetary drive gives vernier tuning with no backlash. Tube complement—6BA6, 6SJ7, 6X4.

A high quality instrument in performance, construction and appearance. Size 16"x9"x7". Wt. 14 lbs. Complete with leads, ready for operation on 105-180 volts, 60 cycles.



LAST MINUTE SPECIALS

We just scooped the market on standard top brand tubes latest 1954 dating . . . The prices speak for themselves! !

ALL AMERICAN KIT

12SA7, 12SK7, 12SQ7, 35Z5, 50L6
List price \$8.20

**Your Cost only \$3.54
TV TUBES**

TYPE	LIST PRICE	YOUR COST
1B3GT	\$2.65	98¢
5U4G	1.75	49¢
5V4G	2.80	\$1.28
6J5	1.70	49¢
6J6	2.50	87¢
6BA6	1.95	69¢
6AL5	1.75	49¢
6AG5	2.25	82¢
6AU6	1.85	69¢
6BG6G	5.25	\$1.99
6K6GT	1.80	59¢
6AC7	3.35	\$1.16
6AT6	1.65	64¢
6SN7GT	2.35	68¢
6SH7	2.50	72¢
6BQ6	3.80	\$1.22
12BH7	2.75	94¢
12AU7	2.40	78¢
12AL5	1.80	59¢
6AV6	1.65	56¢
6C4	1.65	56¢

TREMENDOUS STOCK—

At these prices they will move fast.

Buy Quickly and buy plenty.

BROOKS—84 Vesey St., New York, N. Y.

This ad is reprinted from page 101, April issue, where the prices appeared incorrectly.

Free from International Resistance Co., 401 N. Broad St., Philadelphia 8, Pa.

ELECTRONIC PARTS

Clum's 7-page 1954 catalog describes and illustrates antennas for radios and crystal sets, TV coils, video clears (interference eliminators), r.f. chokes, terminal strips, and oscillator coils.

Available without charge from Clum Mfg. Co., 601 W. National Ave., Milwaukee 4, Wis.

BRACKET-MOUNTED SOCKETS

Dialight's 24-page, 2-color catalog, L-154, describes bracket-mounted sockets used in electrical appliances, equipment, and instruments. They are divided into groups, of those with soldering terminals or those with wire leads. Schematic diagrams with dimensions occupy the left-hand pages. On the right-hand pages are descriptions of the sockets, with suggested lamp types.

Units described fall into five groups, and for each group a choice of 12, 14, or 15 basic types of mounting brackets are illustrated. Units are UL approved.

Available without charge from Dialight Corp., 58 Stewart Ave., Brooklyn 37, N. Y.

HIGH-TEMPERATURE UNITS

Astron has published a technical data bulletin on the high-temperature capacitors in their metallized paper line. These capacitors are designed for operation over a range of -55° to +125° C.

The bulletin, AB-19, describes the standard sizes, ratings, mounting styles, and engineering characteristics.

Copies may be secured by writing to Astron Corp., 255 Grant Ave., East Newark, N. J.

ELECTRONIC PRODUCTS

Development, Design and Production is a 6-page brochure describing these aspects of electronic equipment manufacture at the Rollins Corp.

The brochure describes the operation and the type of products manufactured. Included in the corporation's product line are all types of transformers, filters, control units, and subassemblies.

Copies are available free from Department 101, Rollins Corp., Lewes, Del.

COIL DATA

Meissner's Catalog 54-A contains 83 schematics covering approximately 300 coils, cross references to competitors' numbers, 62 new TV coils, a new r.f. heater supply, and complete listings of its hi-fi components and kits.

Gratis from Dept. C, Thordarson-Meissner, Mount Carmel, Ill.

AUTO SPEAKER

Utah Radio's Catalog AR100 lists the correct replacement speaker for more than 95% of all auto radio speakers. It is indexed by make of auto, receiver manufacturer, receiver model number, and speaker part number.

Available free from Utah Radio Products Co., Inc., 1123 E. Franklin St., Huntington, Ind.

END

PRACTICAL TRAINING MANUAL (Volume 1, Basic Radio). Published by Howard W. Sams & Co., Inc., 2205 E. 46th St., Indianapolis 5, Ind., 8 3/4 x 10 3/4 inches, spiral binding, 240 pages. Price \$5.00.

This manual is a combined text and workbook prepared from lectures, laboratory and classroom material used by one of the country's largest trade schools. It can be used alone as a basic text on radio theory but is at its best when supplemented by one or two standard radio texts.

The first section of 196 pages contains 36 lessons, each covering a basic phase of radio study. Each lesson begins with a statement of its objective. Next is the lesson content material broken down into paragraphs, sub-paragraphs, and sections. Each lesson concludes with a summary and a group of questions related to the text. Ruled lines are provided for writing the answers to the questions and for listing pertinent references. Schematic and pictorial diagrams, graphs, tables, and photographs are used to illustrate the lesson.

The second section of the manual contains 13 suggested job projects or experiments designed to supplement the material in the first section. Each experiment or job lesson begins with a statement of the objective and references to lessons in the first section. Following the list of materials required is a step-by-step procedure for performing the experiment. A number of true-or-false questions are included at the end of each job lesson.

Although the manual is written as an aid to instructors, we feel that it will prove to be exceptionally useful to the self-taught technician, experimenter, and home constructor.—RFS

FIELDS and WAVES IN MODERN RADIO, Second Edition, by Simon Ramo and John R. Whinnery. Published by John Wiley & Sons, Inc., 440 Fourth Ave., N. Y., N. Y., 6 x 9 inches, 576 pages. Price \$8.75.

This text is a second edition, considerably expanded from the first (see RADIO-CRAFT, November 1944) to include postwar developments in electromagnetic theory.

As might be expected, most of the new material in the text is related to microwaves. Slow-wave guiding structures and other miscellaneous systems have been added. The chapter on radiation includes new material on horns, slot antennas, paraboloids, and receiving antennas. Outstanding among this new material, is the chapter on microwave networks. Definitions and network theorems are developed. The chapter is very strong on waveguide junctions and cavity coupling, concluding with simple discontinuities and analytical approaches.

The helix as a guiding system was chosen because it illustrates the behavior of waves with phase velocities less than the velocities of light, the sectoral horn guide because it illustrates the phenomenon of a gradual cutoff, and the wedge guide because it so clearly illustrates the principle of quality.—JK

MAY, 1954

for like - new performance
replace with original ROGERS TV DEFLECTION COMPONENTS



AT LEADING DISTRIBUTORS

ROGERS Deflection Yokes and Flybacks are used in the manufacture of most better sets, that's why it's wise to use these same quality components for replacements.

Every ROGERS Full-Focus Deflection Yoke—precision made and tested for perfect focus—is designed for peak performance and extra long life; and assures double brilliance with knife-edge sharpness.

ROGERS Flybacks—pride of the industry—feature higher voltage insulation, greater efficiency and higher voltages.

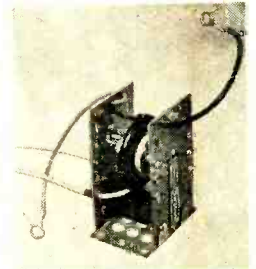

"the eye tells why"
packaged individually—attractively

ROGERS ELECTRONIC CORP. 43-49 Bleeker St. New York 12, N. Y.

FREE: Send for new catalog "A," listing TV set models and ROGERS Yoke and Flyback replacements, or see your jobber.

Non-mathematical home study course
"TV STUDIO OPERATIONS"
helps you grow with television

The four major networks cooperated with CREI in the preparation of this course (so up-to-date it contains two lessons on the approved color system). Non-mathematical but *not* non-technical, it is for broadcast engineers and technicians who must convert to tv, as well as for inexperienced personnel who want to increase their income in the rapidly expanding field of television operations.

Field-tested for more than a year, course is backed by CREI's 27 years of technical teaching experience, by 15 years experience with our own tv studio facilities, by engineering leaders in the industry. You proceed at own speed in spare time; does not interfere with your present work. For complete details—course outlines and costs—use coupon today.

CAPITOL RADIO ENGINEERING INSTITUTE

Dept. RE.
3224 16th St., N.W.
Washington 10, D. C.

Name _____

Street _____

City _____ Zone _____ State _____

Send details of TV Studio Operations course

OVER 50,000
TECHNICIANS
HAVE LEARNED



ONLY 40¢

103 pages. Invaluable information that will help you re-double the value of your basic test equipment.

HOW TO GET
THE MOST OUT
OF BASIC TEST
EQUIPMENT

for A.M. - F.M. - TV

'SERVICING BY
SIGNAL SUBSTITUTION'
A BEST SELLER FOR OVER 12 YEARS!
(NEW, UP-TO-DATE, 12th EDITION)

The Modern, Simplified, Dynamic Approach to Receiver Adjustment & Alignment Problems.

- ★ Nothing complicated to learn
- ★ No extra equipment to purchase
- ★ Universal... non-obsolete
- ★ Employs only Basic Test Instruments

Ask for "S.S.S." at your local Radio Parts Jobber or remit 40¢ in small stamps or coin directly to factory.

PRECISION APPARATUS COMPANY, INC.
92-27 HORACE HARDING BLVD., ELMHURST 4, N. Y.

Principles of TELEVISION SERVICING

Step-by-step information on all types of commercial receivers—how to install, service, and repair them. Shows how to do most testing with just three pieces of equipment: vacuum-tube voltmeter, oscilloscope, and alignment generator. Dozens of trouble-shooting charts . . . suggestions about going into a servicing business. By Carter V. Rabinoff, Dean; and Magdalena Wolbrecht, Vice-Pres., Amer. TV Lab. of Calif. 560 pp., 375 illus. \$7.50.



TELEVISION FUNDAMENTALS

Written by General Electric Co. experts, this book gives a simple presentation of basic TV principles that a radio technician must know to advance to TV service and installation work. The treatment is sound and theoretical, describing each element of the receiver from antenna to picture tube. Includes practical installation procedures, and trouble-shooting charts for quick spotting of receiver faults. By Kenneth Fowler and Harold B. Lippert, both of the General Electric Co. 524 pp. 444 illus., \$7.00

RADIO OPERATING QUESTIONS and ANSWERS

Thorough, easy-to-study book gives you complete "passing" answers to every single question in the latest FCC "Study Guide and Reference Material for Commercial Radio Operator Examinations." Material is grouped by topics, such as Laws, Power Supplies, and Theory. Covers everything in the exam, including the advanced material on aircraft radiotelegraph and ship radar. By J. L. Hornung, Hopkins Engr., Co., and Alexander A. McKenzie, Assoc. Ed., *Electronics*, 11th Ed. 545 pp., 139 illus., over 1900 answers, \$6.00



Principles of RADAR

Deals with the fundamental concepts and techniques of pulse radar. Describes the general features of radar systems and system components; discusses pulse circuits and their application to radar modulators, indicators, and receivers. Covers radio-frequency aspects of radar, including basic concepts pertaining to transmission lines, wave-guides, cavity resonators, and antennas, and the techniques of their use in radar systems. By the Massachusetts Inst. of Technology Radar School Staff. Revised by J. F. Reintjes, MIT, and G. T. Coate, formerly of MIT. 3rd Ed. 887 pp., 565 illus. \$7.75

HANDBOOK of INDUSTRIAL ELECTRONIC CIRCUITS

Reference manual on 433 industrial electronic circuits for immediate practical use. For each circuit there is a clearly drawn diagram along with a brief yet comprehensive description—how it works, performance characteristics, applications, etc. Values of all the important components are given to facilitate conversion of the theoretical circuit to actual practice. Contains all types of circuits, from counting to welding control, both simple and advanced. Brings you hundreds of war-developed industrial circuits. By John Markus, Associate Editor, and Vin Zeluff, Managing Editor of *Electronics*. 272 pp., 433 diagrams. \$7.50

10-DAY FREE EXAMINATION

McGraw-Hill Book Co., 330 W. 42nd St. NYC (36)

Send me book(s) checked below for 10 days' examination on approval. In 10 days I will remit for book(s) I keep, plus five cents delivery, and return unwanted book(s) post paid. (We pay delivery if you remit with this coupon—same return privilege.)

- Rabinoff & Wolbrecht—TV Servicing—\$7.50
- Fowler & Lippert—TV Fundamentals—\$7.00
- Hornung & McKenzie—Radio Operating Questions & Answers—\$6.00
- Reintjes & Coate—Principles of Radar—\$7.75
- Markus & Zeluff—Hdbk. Ind. Elec. Circ.—\$7.50

(Print) Name.....

Address.....

City..... Zone..... State.....

Company.....

Position..... RE-5

This offer applies to U. S. only

LOW-FREQUENCY AMPLIFICATION, by Dr. N. A. J. Voorhoeve. Published by the Philips Technical Library, Eindhoven, Holland. Distributed in the U.S. by Elsevier Press, Inc., 155 East 82 St., New York 28, N. Y. 6 x 9 inches, 497 pages. Price \$9.50.

Occasionally a book is written with such meticulous care and thoroughness of detail that it becomes difficult to express the reader's satisfaction in words. Such a book is *Low-Frequency Amplification*.

While the author's aim is to furnish the audio engineer with a thorough insight into the many subjects he may encounter in his practical work, the text is not excessively technical. When it does go into abstruse theoretical detail, such matter is printed in small type that may be skipped without destroying the continuity of the text.

The sequence of subjects is conventional. The book begins with a chapter on the principles of audio, and follows through with chapters on amplifier tubes; preamplification; output amplification; feedback; matching, control, and limiting; and electrical components. The author scrapes rock bottom, to a practical extent, on each topic. His discussion on feedback is particularly outstanding.

The latter half of the book discusses more integrated units such as power supplies, amplification systems, and radio relay systems. A discussion on the principles of acoustics and their applications in audio techniques is unusually comprehensive. The final text chapter, "Measurements on Sound Systems," covers the standard tests and measurements in great detail.

If the book has a weakness, it will be apparent only to the American reader. Written as part of the Philips Technical Library, the author consistently uses European tube types, equipment, and expressions.

Rich in bibliography and copiously illustrated and diagrammed, *Low-Frequency Amplification* is by far the most comprehensive work on the subject yet published.—JK

DIAL CORD STRINGING GUIDE (DC-3 and DC-4). Published by Howard W. Sams & Co., Indianapolis, Ind. 5½ x 8½ inches. Pages not numbered. Price \$1.00 each.

These are Volumes 3 and 4 of the *Dial Cord Stringing Guide*. They show the service technician the correct and easiest way to restringing the intricate dial-drive mechanisms on present-day automobile, AM, FM, communications, and TV receivers. The third volume (DC-3) has 394 dial-stringing diagrams, a short discussion on the properties of a good dial cord, and a few general notes on restringing dial-drive mechanisms. Volume DC-4 has 347 diagrams.

Both volumes have comprehensive indexes listing all receivers covered in previous editions. Volume and diagram numbers are given. Thus, the technician need look only in the latest volume to find the number of the diagram for the set being serviced. All diagrams are numbered consecutively.—RFS END

INTERCOM SPECIAL!



Now you can own an intercom that has a thousand uses at a price you would normally pay for a kit. This intercom comes housed in wooden cabinets completely wired and ready to operate. Outfit consists of one master, one sub station and fifty feet of two wire cable. Ideal for home as baby sitter. Perfect for office or factory. Order now as quantities are limited. YOUR COST COMPLETE only. **\$16⁶⁵**

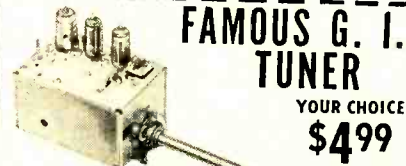

FAMOUS G. I. TUNER

YOUR CHOICE **\$4⁹⁹**

WITH TUBES
These tuners are brand new and guaranteed. Your choice of two or three tube tuner. 2-tube has 6CB6, 6J6. 3-tube has 3 - 6J6. 3-tube has 6BC5, 6BC5, 6J6.

FREE BARGAIN CATALOG • WRITE DEPT. RE-5

STEVE-EL Electronics Corp.
61 Reade St. New York 7, N. Y.

TREMENDOUS BARGAIN!

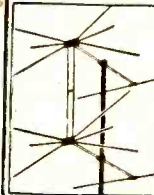

IN CONICALS 2-BAY 16-ELEMENT CONICAL ARRAY

With Hi-Band Adapters Sturdy 3/8" Elements

\$4.99 EACH IN SINGLE LOTS OF 3 \$5.30 EACH

Never before has National Electronics had a BARGAIN like this. We made a special purchase in order to get these sensational prices. And this array has everything. This conical 2-bay 16-element array provides ultra-fine fringe reception. Includes sixteen 3g inch airplane type aluminum elements, including hi-band adapters for greater gain on the high channels and is complete with one pair of stacking bars to each array. These are packed in cartons of three 16-element arrays per carton, with tie rods, at \$14.95 per carton. When purchased in single 16-element arrays, separately boxed—your cost is \$5.30 each. 3 Two-Bay Arrays per carton without tie rods \$13.50 carton. 4 Bay Ultra-Fringe Stacking Assembly for Above—Model 4R \$1.95 set.



UHF CORNER REFLECTOR

ONLY \$2.99 EACH IN SINGLE LOTS OF 6 \$3.50 EACH

This hi-gain UHF Corner Reflector can only be offered you at this low, low price for a short time, 8 to 11 db gain across UHF band. Order Model F-6.

Low-loss UHF Tubular Twin lead—100' coil. \$4.95
UHF-VHF antenna Matching Transformer—permits use of 1 lead from VHF & UHF antennas. \$2.75

Ask for new Spring & Summer catalog—Contains New Profit-Sharing Plan.

ALL PRICES F.O.B. CLEVELAND, OHIO
Do not remit more than complete purchase price. Pay shipping charges on receipt of goods. 25% deposit on all C.O.D. orders, please. Money-back guarantee.

National Electronics
OF CLEVELAND
THE HOUSE OF TV VALUES

205 Delco Building Cleveland 3, Ohio



CHECK These Terrific RAD-TEL Tubes and Parts SAVINGS!

70% to 90% OFF on TUBES INDIVIDUALLY FULL YEAR GUARANTEE!
BOXED
SAME DAY SERVICE . . . OVER 300 TYPES IN STOCK AT ALL TIMES!

Type	Price	Type	Price	Type	Price	Type	Price	Type	Price	Type	Price	Type	Price	Type	Price		
OA2	.74	1T4	.49	6AK5	.55	6BQ7	.90	65H7GT	.49	7C5	.69	12BE6	.39	14AF7	.59	42	.42
OA4	.68	1U4	.49	6AK6	.59	6BZ7	.90	65J7GT	.41	7C6	.59	12BF6	.39	14H7	.59	43	.55
OB2	.81	1U5	.43	6AL5	.38	6C4	.37	65K7GT	.41	7E5	.59	12BH7	.63	14J7	.30	45	.55
OC3	.72	1V	.53	6AQ5	.39	6C5	.39	65L7GT	.48	7E6	.30	12BY7	.65	14N7	.84	45Z3	.44
OD3	.70	1X2A	.63	6AQ6	.37	6C6	.58	65N7GT	.52	7E7	.59	12BZ7	.65	14W7	.30	45Z5	.49
OZ4M	.55	2A3	.30	6AR5	.37	6CB6	.44	65Q7GT	.37	7F7	.79	12C8M	.34	19BG6	.95	50A5	.55
1A5	.30	2A4G	.24	6A55	.50	6CD6	1.11	65R7GT	.45	7G7	.89	12H6	.56	19C8	.70	50B5	.43
1A7GT	.47	2W3	.38	6AT6	.37	6D6	.59	65S7GT	.42	7H7	.59	12SC7M	.63	19T8	.69	50C5	.39
1AX2	.62	2X2	.59	6AU4GT	.68	6E5	.48	6T4	.99	7J7	.79	12J5	.42	19V8	.79	50L6GT	.61
1B3GT	.68	3A4	.45	6AU5GT	.82	6F5GT	.39	6T8	.56	7L7	.59	12K8	.59	24A	.39	50Y6	.49
1C5	.43	3E5	.46	6AU6	.38	6F6	.59	6U4	.60	7N7	.69	12K7	.59	25AV5GT	.83	50Y7	.50
1E7	.29	3Q4	.48	6AV5GT	.83	6G6	.52	6U6	.59	7X7	.70	12Q7	.59	25BQ6GT	.79	55	.49
1G6	.24	3Q5GT	.49	6AV6	.37	6H6GT	.41	6U8	.61	7Y4	.69	12S8GT	.62	25L6GT	.39	57	.58
1H4	.30	3S4	.49	6AX4GT	.53	6J5GT	.43	6V6GT	.39	7Z4	.59	12SA7GT	.65	25W4GT	.59	58	.60
1H5GT	.49	3V4	.51	6B4	.64	6J6	.52	6W4GT	.44	12A6	.54	12SF5	.50	25Z5	.66	70L7	.97
1L4	.46	5U4G	.50	6BA6	.39	6J7	.43	6W6GT	.44	12A8GT	.61	12SG7	.51	25Z6	.49	75	.49
1L6	.59	5W4GT	.50	6BA7	.57	6K5	.47	6X4	.37	12A5	.36	12SJM	.67	26	.45	76	.44
1LA4	.59	5Y3GT	.37	6BC5	.49	6K6GT	.37	6X5GT	.37	12AQ5	.52	12SK7GT	.63	27	.39	77	.57
1LC5	.59	5Z3	.45	6BD5	.59	6K7	.44	6X8	.75	12AT6	.37	12SK7M	.63	32L7	.89	78	.47
1LC6	.79	5Z4	.59	6BD6	.45	6L6	.64	6Y6G	.48	12AT7	.66	12SL7GT	.47	35	.58	80	.35
1LD5	.59	6A6	.51	6BE6	.39	6L7M	.68	7A4	.47	12AU6	.38	12SN7GT	.52	35B5	.40	83V	.68
1LE3	.59	6AB4	.44	6BF5	.41	6Q7	.45	7A5	.59	12AU7	.54	12SQ7GT	.56	35C5	.39	84/6Z4	.46
1LH4	.69	6A7	.69	6BF6	.37	6R7	.69	7A6	.69	12AV6	.39	12SR7M	.49	35L6GT	.41	85	.59
1LN5	.59	6AC7M	.86	6BG6G	1.25	6S4	.38	7A7	.69	12AV7	.63	12V6GT	.46	35W4	.37	117L7	.99
1NSGT	.67	6AF4	.90	6BH6	.46	6S7M	.79	7A8	.68	12AX4	.56	12X4	.38	35Y4	.54	117P7	.99
1P5GT	.57	6AG5	.48	6BJ6	.43	6S8GT	.53	7AF7	.53	12AX7	.56	14A5	.59	35Z3	.59	117Z3	.37
1Q5GT	.58	6AG7M	.99	6BK7	.80	6SA7GT	.43	7B7	.49	12AY7	.56	14A7	.63	35Z4	.47	117Z6	.69
1R5	.49	6AH4	.57	6BL7GT	.83	6SD7GT	.41	7B8	.69	12BA6	.38	14B6	.63	35Z5GT	.47	807	.99
1S4	.59	6AH6	.73	6BN6	.59	6SF5GT	.46	7B7	.49	12BA7	.60	14B8	.63	36	.39	866A	1.39
1S5	.43	6AJ5	.65	6BQ6GT	.79	6SG7GT	.41	7C4	.59	12BD6	.45	14C7	.79	41	.42	HiPo567	1.39

RAD-TEL Parts - TOPS in Quality - LOW LOW in Price!

PHILCO TV BOOSTER

Made by PHILCO, famed for quality and precision communications equipment. Completely self-contained, including 2 tubes and 1 for High Channels and 1 for Low Channels and selenium rectifier, plastic cabinet. In factory-sealed cartons, complete with instructions.

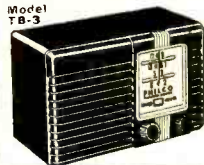

10.95 Ea.
In Lots of 3
9.95

STANDARD BOOSTER

12 channel RF Amplifier with self-contained AC power supply. Handsome plastic cabinet. List price \$23.00



7.95 each
Lots of 3
7.45 ea.

Granco "Star" UHF CONVERTER

Brand new! Latest model! Unit is highly engineered, receives all UHF channels. Coaxial tuned cavity elements complete with 6AF4 oscillator, 6CB6 I-F and crystal mixer. Shipped ready to install and operate. List Price \$29.95



22.45

De luxe model Five Star UHF Converter. Pre-selector INB2 - 6BQ7 cascade and 6AF4 oscillator. List price \$39.95

NEW WEN SANDER—POLISHER

Enables you to sand wood satin smooth in seconds, sand rust off metal, polish furniture, shoes, your car—anything! Even gives a good massage. Weighs only 2 1/2 lbs. List price \$9.95.



10.46 ea.
Lots of 3 . 9.30 ea.

CATHODE RAY TUBE REJUVENATOR

Fits all makes of picture tubes. Completely automatic. Easy to install, no tools needed. For A.C. parallel circuits. Your Old Picture Tubes Are Still Useful. List price \$5.95.

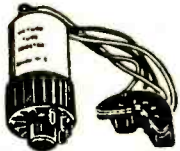

1.09 ea.
1.39 Ea.

SELENIUM RECTIFIERS

Mfd. by FEDERAL

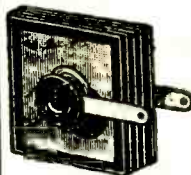

MA	PRICE
65	.59 ea.
75	.69 ea.
100	.79 ea.
150	.84 ea.
200	1.25
250-1010A	1.75
250-1028A	1.75
300	1.39
350-1238A	1.59
350-1023A	1.59
400	1.59
500	1.99

WEN SOLDERING GUN

3 seconds on 120 Volt AC readies it for any soldering requirement. 250 Watt size. Also cuts plastic pipe (with special tip). Multi-useful! UL Approved. Built in spot light.



9.71 Each
List price—\$12.95
Lots of 3 8.64 Each
TIPS Feraloy Long .35c ea.
Life .35c ea.
Standard Tip .11c ea.

UNIVERSAL FLYBACK

High efficiency FERRITE core horizontal transformer. supplies 14,000 Volts. For 6" to 70" kinescopes. Famous Type. In constant demand. List price 11.50



1.95 each
Lots of 3
1.85 each

VOLUME Control Kit

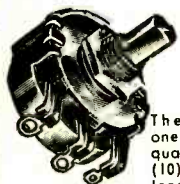

Kit of 10 includes wire-wound, dual and carbon. The price of one (1) for the quantity of ten (10). Short and long shaft.

1.59 ea. 1.79 PER KIT

Famous Make CLOCK RADIO

With Telechrome luminous clock. Automatic shut-off and wake-up features. Starts coffee switches on appliances. 5 tubes including rectifier. Built-in antennae bakelite or ivory body. Color-molded pure plastic grille.



Ebony—\$22.95
Lots of 5—\$22 ea.
Walnut—\$23.95
Lots of 5—\$23 ea.
Ivory—\$24.95
Lots of 5—\$24 ea.

Famous Make Personal Portable BATTERY RADIO

4 TUBES (2 DUAL-PURPOSE) Has extra long life hundred hour batteries. Long distance reception. Large dynamic speaker. Thumb wheel tuning. All stations, plastic case, with collapsible handle. Rich gold finish trim. Red, brown or grey. Complete with batteries and leather case, each \$19.95 complete. Lots of 3 \$19. ea.



Sensational! New! Famous 3-Way INDOOR ANTENNA

For UHF, VHF and FM radio. Delta-beam. 50% increase in pulling power by extending dipoles. For average, fringe and UHF areas. For movie-clear pictures.

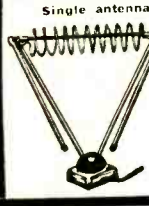

Single antenna 3.95
Lots of 6 . 3.69
RESISTORS (Asst. of 200) Uninsulated. 1/2 Watt, 2 Watt, and some 10 Watt. List price—\$10.00 1.39

KNOB KIT



(Choice Groups!) Assortment of home, auto and TV knobs. All colors—plastic, wood and bakelite knobs. Bag of 50 1.29
Super Bag of 100 extra val. 1.95
Sells from 12c to 18c

TERMS: A 25% deposit must accompany all orders—balance C.O.D. All shipments F.O.B. Irvington warehouse. Orders under \$10—\$1.00 Handling Charge. Subject to prior sale.

PLEASE: send full remittance . . . allow for postage and save C.O.D. charges! We refund all unused money! Phone: Essex 5-2947

Send For FREE Illustrated PARTS CATALOGUE

RAD-TEL TUBE CO.

"Integrity Is Our Chief Asset"

Write to Dept. RE-5, 115 Coit St., Irvington 11, N. J.

FIVE TOP NAME BRANDS



STANDARD BRAND TUBES

at Sensational Savings!

FULLY GUARANTEED INDIVIDUALLY BOXED

NO SECONDS... NO REHASHED "BARGAINS"... NO REACTIVATED TUBES... YOU CAN PLACE YOUR CONFIDENCE IN OUR DEPENDABLE NEW TUBES.

Tube Orders Over \$25.00, with full remittance, PREPAID to you in U.S.A.

RECEIVING TUBES

Table listing various receiving tubes (Type, Net) such as 6X5GT, 6BE6, 6BD6, etc.

SPECIAL PURPOSE TUBES

Table listing special purpose tubes (Type, Net) such as 6AV6, 6AV7, 6AV8, etc.

Above is only a partial listing of our huge stock. Types not listed may be ordered at approx. the same savings. Many new special purpose types in stock.

DELUXE TUBE CADDY This newly designed Tube Caddy is lightweight and compact. 16 3/4 x 8 1/4 x 1 3/4". Ruggedly constructed, reinforced throughout. Holds approx. 150 tubes plus meters and tools. SPECIAL AT \$12.95

TWO-COLORED TUBE CARTONS, with new Safety Partitions. Prevents Tube Breakage. This Super-Gloss Red and Black Carton is the Most Distinguishing Box Available Today! Minimum: 100 any one size. Quantity prices on request.

Table listing tube carton sizes and prices.

Terms: 25% with Order, balance C.O.D. Minimum Order \$5.00. All Merchandise guaranteed. F.O.B. NYC.

BARRY ELECTRONICS CORP. 136-B LIBERTY ST. N. Y. 6, N. Y.

ADVERTISING INDEX

Radio-Electronic does not assume responsibility for any errors appearing in the index below.

Large index table listing various companies and their page numbers, including Aero Products, All Channel Antenna Corp., Alliance Mfg. Co., etc.

Make your Math EASY!

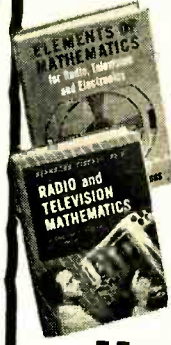

You'll find those time-saving equations easy to use, easy to solve with the aid of

Elements of Mathematics for Radio, TV & Electronics

By Bernhard Fischer & Herbert Jacobs. If you've ever hesitated to use a time-saving equation because you were not quite sure how to set it up; or had moments of doubt about decimals or percentages; or wanted a quick check on your figuring—THIS IS THE BOOK FOR YOU.

Radio & TV Mathematics

A handbook of step-by-step solutions for 409 problems in radio, TV, and industrial electronics. Whatever YOUR problem—whether it is to correct the power factor of a motor, find the impedance and length of a matching stub between antenna and transmission line, or any of hundreds of other problems—here is the clear, exact solution.

Have you got your copy of "The most helpful" service guide?

Mandl's TV Servicing

The book that is eagerly bought by servicemen throughout the country as the most practical and helpful guide to quick, accurate trouble-shooting on today's receivers.

Mandl's TV Service Course Laboratory Manual

46 experiments, with exact what-to-do and what-to-look-for directions, show how each part of a typical receiver operates and what causes trouble.

SEE THEM ON APPROVAL

The Macmillan Co., 60 Fifth Ave., New York 11

Please send me the books checked below. I will remit full price plus small delivery charge, or return books in 10 days. (Save: Send check or money order and we pay delivery charge)

- Elem. of Math. \$7.20 TV Servicing, \$5.50 Radio & TV Math. \$6.75 TV Serv. Lab. Man. \$3.90

Signed

Address

This offer good only within continental limits of U.S.A.

NEW! PEAK-to-PEAK VTVM

complete with NEW DUAL-PURPOSE AC/DC
Uni-Probe (Pat. Pend.)

EICO's revolutionary new engineering design!
The professional peak-to-peak VTVM that beats 'em all
— in laboratory precision features and low price!

Model 232 **KIT \$29.95** WIRED \$49.95



Model 249
KIT \$39.95
WIRED \$59.95

New
DELUXE PEAK-to-PEAK VTVM
with 7½" METER
& exclusive **Uni-Probe** (Pat. Pend.)

All the outstanding & exclusive features
of Model 232—plus the extra convenience
and readability of its big 7½" meter.
An ideal bench instrument.

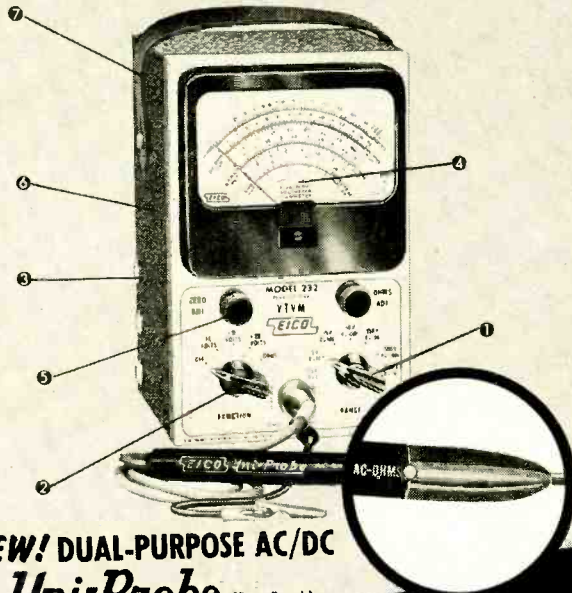

- Measures directly p-p voltage of complex & sine waves: 0-4, 14, 42, 420, 1400, 4200 volts p-p.
- DC, RMS sine voltage ranges: 0-1.5, 5, 15, 50, 150, 500, 1500 volts. Reads up to 30,000 V. with HVP probe.
- Resistance ranges: 0.2 ohms to 1000 megs in 7 ranges.
- ① 7 non-skip ranges on every function.
- ② 4 functions: +DC Volts, -DC Volts, AC Volts, Ohms.
- Uniform 3 to 1 scale ratio for extreme wide-range accuracy.
- Large 4½" meter in can't-burn-out circuit.
- ③ Calibration without removing from cabinet.
- ④ Zero-center for TV-FM discriminator alignment.
- ⑤ One zero-adjustment for all functions and ranges.
- Frequency Response: 30 cps-3 mc (up to 250 mc with PRF probe).
- 1% precision ceramic multiplier resistors.
- Exceptional circuit stability and accuracy.
- ⑥ New compact size for extra-easy portability (7"x5"x4").
- Smart professional styling — new satin finish etched panel with contrasting knobs and meter and grey wrinkle steel case.
- ⑦ Leather handle.

NEW! DUAL-PURPOSE AC/DC **Uni-Probe** (Pat. Pend.)

Terrific time-saver! Only 1 probe performs all functions—a half-turn of probe-tip selects DC or AC-OHMS!

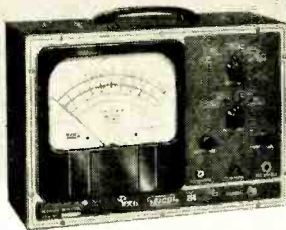

Now! **4 EICO VTVM KITS**
to choose from!

DELUXE VTVM with 7½" METER
Model 214 **KIT \$34.95** WIRED \$54.95

All the versatility and performance-proven features of Model 221—plus the extra convenience and legibility of its big 7½" meter. An excellent bench instrument.

VACUUM TUBE VOLTMETER

The reliable, performance-proved EICO VTVM — ever-popular universal instrument for all TV/radio/electronics servicing.

Model 221 **Over 50,000 in use!**
KIT \$25.95
WIRED \$39.95

- ① Large 4½" meter in can't-burn-out circuit.
- ② Zero-center for TV/FM discriminator alignment.
- ③ 4 functions: +DC Volts, -DC Volts, AC Volts, Ohms.
- Electronic AC/DC ranges: 0-5, 10, 100, 500, 1000 volts.
- Reads up to 30,000 volts with HVP accessory probe.
- Reads peak-to-peak with PTP accessory probe.
- Reads up to 250 mc with PRF accessory probe.
- 5 Resistance ranges: 0.2 ohms to 1000 megs.
- 5 DB ranges: -20 to +55.
- DC input resistance: 25 megs.
- 1% precision ceramic multiplier resistors.
- Double-triode bridge circuit for extra stability and accuracy.
- ④ Rugged grey wrinkle steel case.
- ⑤ 3-color etched rubproof panel.
- Complete with AC/DC and common leads.
- ⑥ Leather handle.

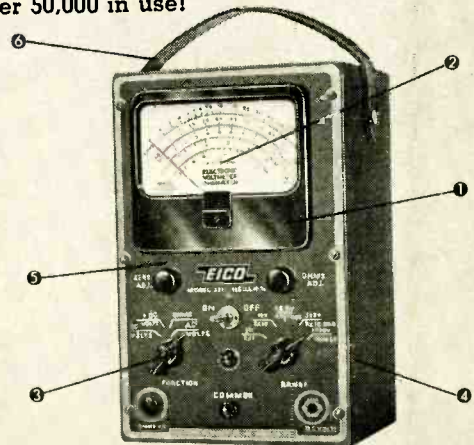

See these sensational VTVM values at your local jobber today.
Write for FREE Catalog CV-5 Read EICO's other ads in this issue—See Advertiser's Index

ELECTRONIC INSTRUMENT CO., Inc., 84 Withers Street, Brooklyn 11, N. Y.

Prices 5% higher on West Coast.

SELENIUM RECTIFIERS

We specialize in Rectifiers. Power supplies in specifications. Immediate delivery.

Curr. Cont.	18/14	36/28	54/40	130/100
1AMP	1.35	2.15	3.70	8.50
2AMP	2.20	3.60	6.00	10.50
4AMP	4.25	7.95	13.50	25.25
6AMP	4.75	9.00	13.50	33.00
10AMP	6.00	10.25	20.00	44.95
12AMP	8.00	16.25	45.00	50.00
20AMP	13.25	25.50	38.00	87.50
24AMP	18.25	32.50	45.00	95.00

Rectifier & Transformer
115V/60 cy inputs

up to 28VDC at 4 amps	\$ 19.98
up to 28VDC at 12 amps	14.98
up to 28VDC at 24 amps	29.98
up to 28VDC at 50 amps	63.98

Rectifier & Transformer & Variac
up to 14VDC at 12 amps \$ 30.98
up to 28VDC at 12 amps \$ 45.50
up to 28VDC at 50 amps \$ 167.00

C "TAB" fast delivery SPECIALS

HIGH CURRENT PWR SUPPLIES

Variable 0-28VDC. Completely Built. Ready to Go. Full Wave Selenium Rectifier, Transformer, Variac, Volt & Amp Meters. Switch, Terminals & Fuse. In Heavy Duty, Steel Cabinet. 115V and/or 220V input.

Stock Number	Continuous Rating	With Meters
T28V4A	0-28VDC	4 Amp. \$43.00
T28V12A	0-28VDC	12 Amp. \$45.50
T28V24A	0-28VDC	24 Amp. \$129.50
T28V50A	0-28VDC	50 Amp. \$239.50

RECTIFIER XFMRs

Primary 115V 60 Cyc
Secondary 0-9.12-18-24-36V

4 Amp	12 Amp	24 Amp	50 Amp
12 Volt	2 Amps		

RECTIFIER CHOKES

4 Amp .01 Hy	6 Ohm	\$7.95
12 Amp .01 Hy	1 Ohm	14.95
24 Amp .004 Hy	.025 Ohm	29.95

"TAB" THAT'S A BUY

WATCH! THIS SECTION EVERY MONTH

FOR TREMENDOUS BARGAIN PRICES HI-MEG HI-VOLT RESISTORS

.75 Meg "MVP" 10W 10KV	1.69	\$ 7.00
2 Meg "MVG" 4W 5KV	.89	10 \$ 7.50
2 Meg "PRV" 5W 10KV	1.10	10 \$ 7.50
2.5 Meg "MVA" 20W 10KV	1.10	10 \$ 12.00
2.5 Meg "MVT" 3W 7.5KV	.89	10 \$ 7.00
7 Meg "MVP" 10W 10KV	1.35	10 \$ 12.00
12 Meg "SPRG" 10W 10KV	1.69	10 \$ 15.00
50 Meg "MVP" 25W 40KV	2.25	10 \$ 20.00
100 Meg "MVP" 10W 10KV	2.75	10 \$ 25.00

WRITE FOR QUANTITY PRICE

VARIABLE VOLTAGE TRANSFORMERS

SUPERIOR-GR-STACO

0-135V 3A	11.25
0-135V 7.5A	20.70
0-135V 15A	33.00
0-270V 3A	23.00
0-270V 7.5A	33.00
0-270V 15A	41.98
0-270V 30A	41.98

GR50A/0-135V/45A/LN 100.00
GR50A/0-270V/30A/LN 115.00
3000B/0-135V/30A/Cased 115.00
3000BU/0-135V/30A/*Uncased 55.00
3020B/0-270V/15A/*Uncased 49.00
3020B/0-270V/15A/*Cased 49.00
STACO 1RL1.5/Metered/145V/3A 55.00
STACO 1Pal-7/Metered/135V/7.5A 40.50

ODD'S & END'S

RF PI CHOKE 20MH/500MA 89c; 12 for \$7.49
RF PI CHOKE 20MH/200MA 89c; 12 for \$7.49
FILTER GE 100AMP/50V \$1.50; 2 for \$2.00
20 Resistors on fibre strip 12c; 7 for \$1.00
Germans Sections MS40 & MS50 3 ft. each \$1.00
PE94 Pwr Supp P 0 SCR322 2 for \$5.98
VEEDER ROOT 45 lbs. 39c; 4 for \$1.00
5" DYNAMIC SPEAKER 1.50; 6 for \$2.00
3000 ohm field 1.19; 6 for \$5.00

AUDIO AMPLIFIERS READY TO GO

MODEL TUSP Ultra Hi-Fi Pre-Amp, 150B Bass Boost & equalizer kit, 4 inputs, 4 controls, 40-13000 cy. sat. in finish cabinet on movable control face for custom mount "TAB" special \$27.49
TMD15A Deluxe amplifier, Williamson \$48.99
TMD15A completely assembled \$63.00
TMD15A Pre-Amp kit \$19.95
TMD15P completely assembled \$31.00

AUDIO COMPONENTS

Electrovoice Triplay cart. \$1.98
GE RPX041 MG Goldtone \$5.25
GE RPX041 MG Goldtone \$5.25
GE RPX050 Dual Triplay \$5.25
GE RPX052 Dual (DAS) \$17.75
GE RPX053 001 & 003 diamonds \$25.98
RPX010 Dual .001 & .003 sapphire. \$1.98
RPX012 Dual .001 & .003 diamonds \$20.89
RPX001/78 or RPX004 .001 sapphire \$10.89
RPX013 Dual sapphire 1P diamond \$12.89
MG or 78 Single Sapphire \$12.89
RPX013 Dual Sapphire \$12.89
MG & 78 Single Sapphire \$12.89
MG & 78 Dual Twin all mfgs. 1.47

COAXIAL SPEAKERS

All 8 ohm. V.C. Alnico V Magnets. Inbuilt Network. 2 wires. Needed for HF & LF Response. Famous Hi-Fi Speaker Mfgs.

1" Coaxial PM & 5" Tweeter	24.75
Model P25C	\$23.75
2" Coaxial PM & 3 1/2" Tweeter	24.75
Model P12U	\$12.75; \$3.35
Coaxial PM & 2 1/2" Tweeter	8 watt 70-1500
12" Hi-Fi PM 10 watt 45-14k	\$7.98
8" Hi-Fi PM 7 watt 45-14k	\$9.95

DC POWER SUPPLY

Variable DC Power Supply. Full Wave Rectifier. 1500, 6000 Ohm Filter Condensers. Used. Rated 12V, 12V at 2 amp. Operates 1.5V, 1.5V. Model 2DCP \$12.98
As above except 4 amp. Model 4DCP \$20.98

FILAMENT TRANS.

2.5VCT 10A 12 KWINS	\$5.50; 3 for \$14
2.5VCT 10A 5KVINS	\$3.50; 3 for \$10
7.5VCT 12A 15 KWINS	10.95; 2 for \$17.50
2.4VCT 2.5A Sec. Rec. Nims	\$1.98; 2 for \$3.49
42.5V 2A Sec. Rec. Nims	\$3.49; 2 for \$5.95
64V 1 Amp HMSLD	\$3.49; 2 for \$5.00
PR1 220/440V Sec 3X 2.5V 5A, 2.5V 15A	\$4.95; 2 for \$8.00

TRANSFORMERS

All 115/60 Cyc input TV, & CR Pwr Xmr to 200V. HI-VOLTS to 20 KV (w/quad. fuser etc.) ALL Tubes. PL & FL. Wdgms.

300 VDC 275 Ma Full-Wave	6.3V/10.3A, 5.4V/8.2A, 2.5V/3A	\$4.00; 2 for \$7.00
1600VCT/5MA	6.3VCT/3A, 8.3VCT/10A, 8.3VCT/5A SPECIAL	\$7.95; 2 for \$14.00
100VCT/45MA	70.5VCT/80MA, 360VCT/55MA, 38V5A, 6.3VCT/1A, 6.3VCT/3A	\$4.00; 2 for \$7.00
900V 35MA	2X2.5V/2A, AC/NT	\$7.00
850VCT/148MA	3V/3A, 5V/3A	\$2.25; \$4.98; 5 for \$9.00
770VCT/200MA	5V/3A, 6.3VCT/5A	\$4.98
12KV/2.5W	12KV/2.5W	\$12.99
700VCT/120MA	2X6.3V/3A, 6.3V/1A	\$3.98
680VCT/200MA	5V/3A, 6.3V/1A	\$7.25
600VCT/50MA	4V/3A, 5V/3A	\$4.39; 3 for \$12
600VCT/90MA	6.3V/1.9A, W/INPUTS 6	\$2.49; 2 for \$4.50
500VCT/70MA	6.3V/1.9A, W/INPUTS 6	\$1.49; 2 for \$2.49

FILTER CHOKES

115V/80ma/H/Std/3KVins	2.25
10Hy/125ma/UTC/CS	1.98
12Hy/125ma/UTC/CS	1.98
50Hy/125ma, GSD, H/Std	1.98
20 Hy/300ma or 15Hy/400ma	1.98
13.5Hy 1 amp 17 KVins H/Std	\$35.00
0 Hy/175ma, 250 ohm	1.49; 2 for 2.49

TUBE SOCKETS

CINCH-NATCO SOCKETS-AMPH

Octal (low-loss mica) ring mtg.	10 for 1.00
Octal (mica) ring mtg.	12 for 1.00
Octal (stentite) ring mtg.	12 for 2.00
Octal (bakelite) ring mtg.	12 for 2.00
Octal (mica) saddle mtg.	15 for 1.00
Octal (stentite) saddle mtg.	12 for 1.00
Octal (stentite) ring mtg.	10 for 2.00
7 pin min (mica) base and 20c	12 for 1.00
7 pin min (mica) bottom mtg.	12 for 1.00
7 pin min (BK1) rubber shock mtg.	12 for 2.00
9 pin min (mica) bottom mtg.	15 for 1.00
9 pin min (BK1) bottom mtg.	7 for 1.00
9 pin min (BK1) base shld.	2c; 5 for 1.00

SOLDERING GUNS & TORCHES MAKE GTD

Lenk = 77LP Blow torch. Instant light no priming, no soot or odor, adj flame. \$3.75
Extra fuel tubes, only \$1.79
Lenk = 5501 solder gun, 100, 180 watt, hvy duty AMP. 7.45
TAS-4 solder gun 135 watt. 7.89
TAS-5 solder gun 350 watt. 8.77
TAD-4 dual heat 100-150 w. 9.65
TAD-5 dual heat 200-275 w. 10.53
TA-25 soldering iron 1.5V/60watt. 1.20
TA-250 soldering iron 2.5V/135VAC/250W. focus light, built for comfort. 10.29

OIL CONDENSERS NEW WAREHOUSE LIST

00025MFD 25KV	\$6.00; 2 for \$10
0016MFD 15K	\$7.00; 2 for \$12
1MFD 400V	\$1.39; 2 for \$2
5MFD 600V	\$4.79; 2 for \$8
5MFD 1500V	85c; 6 for \$2
1MFD 100V	33c; 4 for \$1
2MFD 600V	39c; 3 for \$1
1MFD 1000V	39c; 3 for \$1
1MFD 600V	59c; 5 for \$2
4MFD 3000V	\$19.95; 2 for \$35
1MFD 600V	\$1.50; 3 for \$4
1MFD 600VAC/1800VDC	\$5.95; 2 for \$10

OIL CONDENSER SPECIAL

10 MFD \$1.75 ea

Case dimensions, lots of 3 including insulators 4 1/4" x 3 3/4" x 1 1/4" Smaller Quantities, special \$1.98

TRANSFORMER SPECIAL

6.3 VOLT 3 1/2 AMP continuous duty 115VAC input 2.5/16" 2-L/1 1/4" mtg. 3 1/2" 300c channel mtg RM. 3 1/2" 300c 1/2" DIMENSIONS. REGULAR \$1.98 VALUE. "TAB" SPECIAL \$1.00
12 for \$10.00; 50 for \$38.00

YOU PICK THEM 59c WHILE THEY LAST

LOTS OF 10

Your selection of 10 at 59c each or 100 at 59c each. Prices in quantities of 100.

ELECTROLYTIC CONDENSERS

2X 20MFD/450VDC	69c; 3 for \$1.95
3X 15MFD/450VDC	98c; 3 for 2.50
3X 20MFD/450VDC	79c; 2 for 1.29
25MFD/450VDC	79c; 2 for 1.95
20MFD 450V&20MFD/25V	3 for 1.95
50 mfd/350vdc	5 for 1.00
250 mfd 1.5V 250vdc	5 for \$1.49
30-2x20mfd/450-25vdc	.3 for 1.00

CIRCUIT BREAKERS

Heimann Magn Bkrs. Amps: 250, 3, 7, 9, 12, 15, 20, 30, 40, 50, 80, 180

50, 15, 20, 25, 28c. 10 for \$8.98
Klixon Thermo Push Button Amps: 5, 10, 15, 20, 25, 30, 39c. 10 for \$7.98

Money Back Guarantee (Cost of Mfg. Only) 5% Min. Order F.O.B. N.Y.C. Add Shpg. Charges or 25% Dep. Tubes Gtd. via R-Exp. only. Prices subject to Change Without Notice. Phone Recto 2-6245. CABLE: "TABPARTS"

TUBES

*From This Special List We Ship \$10.00 and Up Tube Orders At Our Expense (Post-paid) Within Continental Limits of U.S.A. 90 Day Gtd. When ordering mention SRE

0A2	.88	6AQ6	.81	6H6	.60	6X5	.54
0A3 VR75	1.37	6AQ7GT	1.29	6J4	6.66	6X4	.54
0B2	1.37	6AS5	3.27	6J5	.58	7A8	.68
0B3 VR90	.96	6AS6	2.22	6J7	.58	7C7	.76
0C3 VR105	.92	6AT6	3.48	6K6	.54	7F8	1.24
0D3 VR150	.80	6AV5GT	1.10	6K4A	1.48	7Y4	.68
1B3 8016	.80	6AUGST	.56	6K6GT	3.68	7X7	1.06
1L4	1.35	6AUSGT	.54	6L6	1.48	7Y4	.68
1L6	.98	6AVS5T	.56	6L6GA	1.08	12AH7/50T	1.48
1LD5	.78	6AV6	.49	6L6GA	1.98	12AL5	.54
1F5	1.29	6AX4 6U4	.74	6L6GT	1.08	12AT7	.54
1R4	.78	6BA6	.54	6L6GT	1.98	12AU6	.72
1R5	.59	6BA7	1.09	6L6GT	1.98	12AV6	.69
1R6	.59	6BC5	1.54	6L6GT	1.98	12AX7	.98
1R7	.59	6BC7	1.23	6L6GT	1.98	12AV6	.69
1X2A	.98	6BD6	.83	6L6GT	1.98	12AV6	.69
1X2B	1.42	6BE6	.54	6L6GT	1.98	12AV6	.69
1R4GY	1.20	6BE7	.54	6L6GT	1.98	12AV6	.69
1R4GYW	1.48	6BG6G	1.58	6L6GT	1.98	12AV6	.69
2U4G	.55	6BH6	.63	6L6GT	1.98	12AV6	.69
6AC7	.80	6B7	1.68	6L6GT	1.98	12AV6	.69
6AG5	.80	6BK7	1.68	6L6GT	1.98	12AV6	.69
6AG7	1.14	6BL7GT	1.19	6L6GT	1.98	12AV6	.69
6AH6	1.21	6BN7	2.69	6L6GT	1.98	12AV6	.69
6AJ5	1.10	6B06GT	1.20	6L6GT	1.98	12AV6	.69
6AK5	.87	6B07	1.65	6L6GT	1.98	12AV6	.69
6AK6	.92	6C4	1.52	6L6GT	1.98	12AV6	.69
6AL5	.48	6C5	.68	6L6GT	1.98	12AV6	.69
6AL7GT	.98	6C6	.59	6L6GT	1.98	12AV6	.69
6AN5	3.27	6D4	2.70	6L6GT	1.98	12AV6	.69
6AQ5	.52	6F6GT	.79	6L6GT	1.98	12AV6	.69

125C7	1.08	CK534AX	.99
125F7GT	.80	CK5380X	.98
125H7	.80	CK539DX	2.19
125J7	.80	CK540DX	.98
125K7	.66	CK546DX	1.99
125L7GT	.62	CK547DX	2.49
125M7GT	.62	CK548DX	2.49
125N7GT	.62	CK549DX	2.49
125O7GT	.62	CK550DX	2.49
125P7GT	.62	CK551DX	2.49
125Q7GT	.62	CK552DX	2.49
125R7GT	.62	CK553DX	2.49
125S7GT	.62	CK554DX	2.49
125T7GT	.62	CK555DX	2.49
125U7GT	.62	CK556DX	2.49
125V7GT	.62	CK557DX	2.49
125W7GT	.62	CK558DX	2.49
125X7GT	.62	CK559DX	2.49
125Y7GT	.62	CK560DX	2.49
125Z7GT	.62	CK561DX	2.49
125AA7GT	.62	CK562DX	2.49
125AB7GT	.62	CK563DX	2.49
125AC7GT	.62	CK564DX	2.49
125AD7GT	.62	CK565DX	2.49
125AE7GT	.62	CK566DX	2.49
125AF7GT	.62	CK567DX	2.49
125AG7GT	.62	CK568DX	2.49
125AH7GT	.62	CK569DX	2.49
125AI7GT	.62	CK570DX	2.49
125AJ7GT	.62	CK571DX	2.49
125AK7GT	.62	CK572DX	2.49
125AL7GT	.62	CK573DX	2.49
125AM7GT	.62	CK574DX	2.49
125AN7GT	.62	CK575DX	2.49
125AO7GT	.62	CK576DX	2.49
125AP7GT	.62	CK577DX	2.49
125AQ7GT	.62	CK578DX	2.49
125AR7GT	.62	CK579DX	2.49
125AS7GT	.62	CK580DX	2.49
125AT7GT	.62	CK581DX	2.49
125AU7GT	.62	CK582DX	2.49
125AV7GT	.62	CK583DX	2.49
125AW7GT	.62	CK584DX	2.49
125AX7GT	.62	CK585DX	2.49
125AY7GT	.62	CK586DX	2.49
125AZ7GT	.62	CK587DX	2.49
125BA7GT	.62	CK588DX	2.49
125BB7GT	.62	CK589DX	2.49
125BC7GT	.62	CK590DX	2.49
125BD7GT	.62	CK591DX	2.49
125BE7GT	.62	CK592DX	2.49
125BF7GT	.62	CK593DX	2.49
125BG7GT	.62	CK594DX	2.49
125BH7GT	.62	CK595DX	2.49
125BI7GT	.62	CK596DX	2.49
125BJ7GT	.62	CK597DX	2.49
125BK7GT	.62	CK598DX	2.49
125BL7GT	.62	CK599DX	2.49
125BM7GT	.62	CK600DX	2.49
125BN7GT			

there are **4** points to a triangle...

THE POINT OF APPLICATION

determines the type of loudspeaker best capable of providing optimum performance at lowest possible cost. There are over 50 different University models to choose from... each designed to serve most efficiently and economically in its intended application.

- Radial type projectors and paging speakers with 360° dispersion for maximum coverage at lowest cost and ease of installation.
- Reflex trumpets in various sizes for incomparable efficiency, distance, and noise penetration.
- Wide-angle and bi-directional types, marine and submergence models for heavy industry.
- Paging and "talk-back" speakers in numerous sizes, power and frequency characteristics and mounting arrangements.
- "Explosion-proof", blastproof, and even super-power types from 100 to 720 watts capacity.
- High fidelity, full-frequency response types for indoor and outdoor use.

University Loudspeakers are application-engineered to assure customer satisfaction, avoid waste of amplifier power and speaker capacity and reduce initial equipment and installation costs. University helps you to sell more sound jobs... make more profit you can pocket. Why spend more for more than you need—CHECK UNIVERSITY FIRST!



FREE—Illustrated copy of the University Technilog • Complete up-to-date manual of sound theory, application and installation requirements • SEND for your copy today.



UNIVERSITY LOUDSPEAKERS • INC.
80 SOUTH KENSICO AVENUE, WHITE PLAINS, N. Y.



RCA PIONEERED AND DEVELOPED COMPATIBLE COLOR TELEVISION

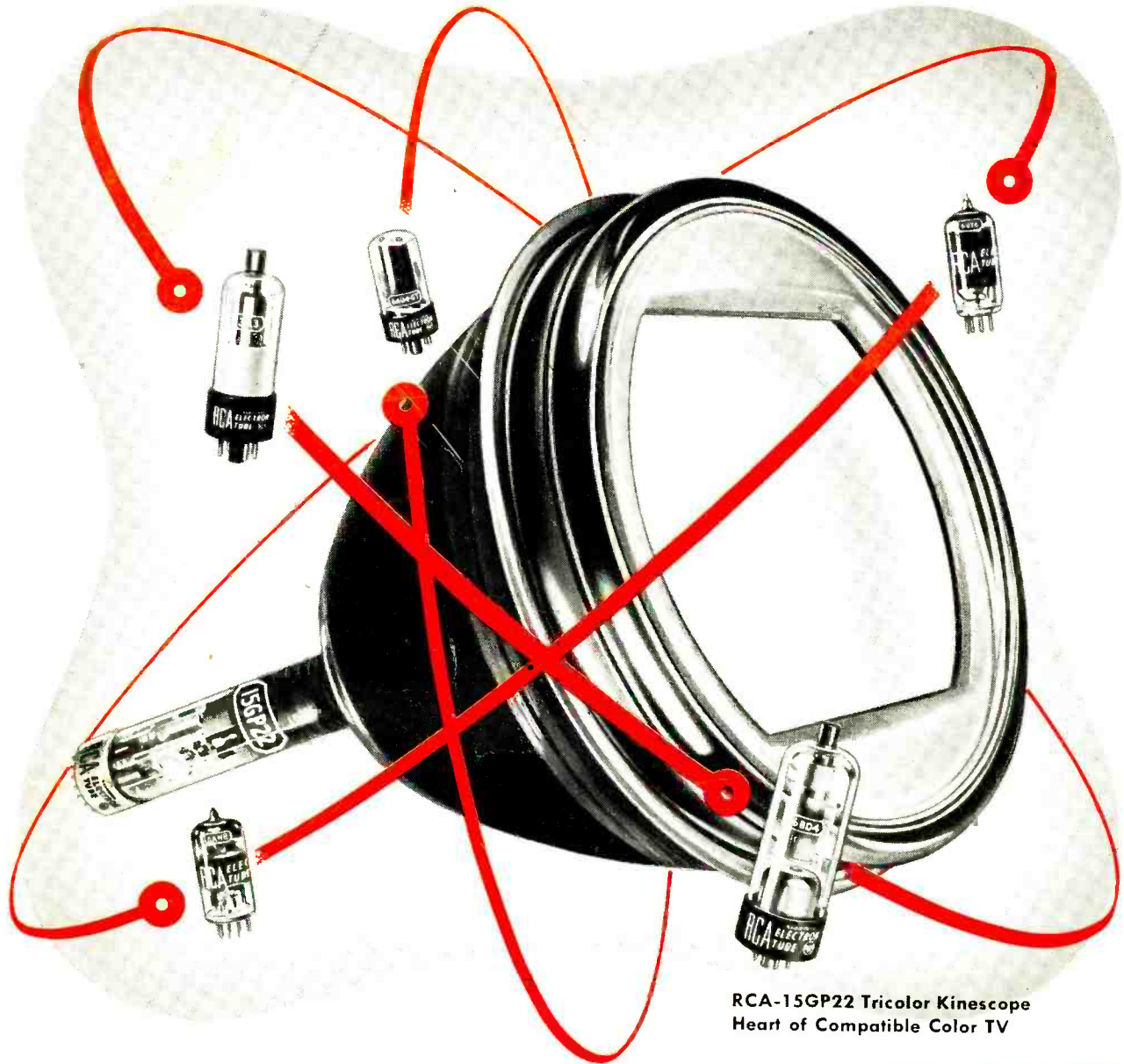

RCA-15GP22 Tricolor Kinescope
Heart of Compatible Color TV

You're ready for **COLOR TV**
...because RCA is ready for you

RCA—pioneer in the development of compatible color television—is ready *now* to supply you with the replacement receiving tubes and kinescopes you will need when color TV comes to your town.

Engineered for color by RCA, these tubes are designed to work together for superior performance.

RCA announces with pride the

new 15GP22 Tricolor Kinescope . . . heart of compatible color television. To supplement its other receiving tubes applicable to color television, including the RCA 6BY6 Pentagrid Amplifier and the RCA 6AU4-GT Damper Diode, RCA has developed three *new* types specifically for color circuits: *RCA-6BD4 Sharp-Cutoff Beam Triode* for regulation of high-

voltage dc power supply; *RCA-3A3 Half-Wave Vacuum Rectifier* for pulsed rectifier scanning service; and *RCA-6AN8 Medium-Mu Triode Sharp-Cutoff Pentode* for general-purpose use.

To restore the original performance of color TV sets, play safe . . . use genuine RCA tubes for color TV.

Be posted on Color TV . . . keep in touch with your RCA Distributor.



RADIO CORPORATION of AMERICA
ELECTRON TUBES

HARRISON, N. J.