

Price 15 cents

# RADIO DESIGN

OFFICIAL ORGAN OF THE  
RADIO  
INTERNATIONAL GUILD

ROBERT HERTZBERG

*Editor*

*In this issue :*

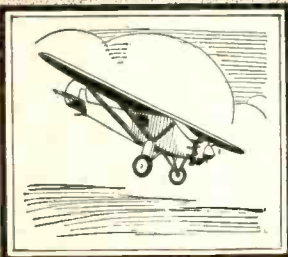
The Pilot Midget Receiver;  
The Status of Television;  
The Yancey South American Flight; Short Wave Station Data; The Story of NRH; How Dynamic Speakers Work

*Articles by Alfred Ghirardi, John Geloso, Robert Kruse, Zeh Bouck, A. S. Friedman, and Albert Rudick*

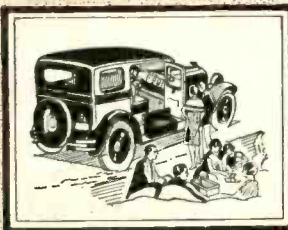
Volume 3  
Number 3

Fall, 1930  
Issue

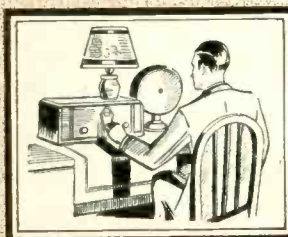
# for DEPENDABILITY



*Pilotron Tubes furnished Transmission and Reception on Pilot flight communication.*



*The Auto Pilot uses up least car space, is easiest to install.*



*Licensed Amateurs, Custom Set Builders and Radio Engineers endorse Pilotrons.*

**U**P IN THE AIR—flying across great open stretches of sea to the little isle of Bermuda, to the furthestmost ends of South America, making world records and keeping in touch with New York every minute of the day and night with a Pilot Super-Wasp Set, relying all the time on the Dependability of Pilotron Radio Tubes.

Camping miles from anywhere—enjoying some favorite program with your Auto-Pilot Screen Grid receiver and knowing that you can depend on your Pilotron Radio Tubes under all conditions.

The Professional—operating on world wide reception—keen and alert, must avoid confusing tube noises—crackles and distortion—and with dependable Pilotron Radio Tubes in every socket he enjoys the thrill of “pulling in” messages from far away.

You too—under all conditions—on any set will appreciate the difference that dependable Pilotron Radio “long life” Tubes give to the reception of radio broadcast programs.

## PILOTRON RADIO TUBES



**ENDORSED BY PROFESSIONALS**

LICENSED BY RCA

**PILOT RADIO & TUBE CORP.**  
**Lawrence, Massachusetts**

*Chicago Office: 234 S. Wells St.*

*San Francisco Office: 1278 Mission St.*



**Here are a few examples of the kind of money I train "my boys" to make**

**Started with \$5. Now has Own Business**



"Can't tell you the feeling of independence N.R.I. has given me. I started in Radio with \$5, purchased a few necessary tools, circulated the business cards you gave me and business picked up to the point where my spare time earnings were my largest income. Now I am in business for myself. I have made a very profitable living in work that is play."

HOWARD HOUSTON,  
512 So. Sixth St., Laramie, Wyo.

**Made \$700 in 5 Months Spare Time**

"Although I have had little time to devote to Radio, my spare time earnings for five months after graduation were approximately \$700 on Radio sales, service and repairs. I owe this extra money to your help and interest. Thanks for the interest shown me during the time I studied and since graduation."



CHARLES W. LINSEY,  
537 Elati St., Denver, Colo.

**\$7396 Business in two and one-half Months**

"I have opened an exclusive Radio sales and repair shop. My receipts for September were \$2332.16—for October, \$2887.77 and for the first half of November, \$2176.32. My gross receipts for the two and one-half months I have been in business have been \$7396.25. If I can net about 20% this will mean a profit of about \$1500 to me."



JOHN F. KIRK,  
1514 No. Main St., Spencer, Iowa.

# I will show You too

how to start a spare time or full time

## Radio Business of Your Own without Capital



J. E. Smith, Pres.,  
National Radio Institute

The world-wide use of receiving sets for home entertainment and the lack of well trained men to sell, install and service them have opened many splendid chances for spare time and full time businesses. Besides Radio's growth is opening hundreds of fine jobs every year. "Rich Rewards in Radio" gives detailed information on these openings. It's FREE.

**So many opportunities many make \$5 to \$30 a week extra while learning**

Many of the ten million sets now in use are only 25% to 40% efficient. The day you enroll I will show you how to do ten jobs common in most every neighborhood that you can do in your spare time for extra money. I will show you the plans and ideas that are making as high as \$200 to \$1,000 for others while taking my course. G. W. Page, 107 Raleigh Apts., Nashville, Tenn., writes: "I made \$935 in my spare time while taking your course."

**Many \$50, \$60 and \$75 a week jobs opening in Radio every year**

Broadcasting stations use engineers, operators, station managers, and pay \$1,800 to \$5,000 a year. Radio manufacturers continually need testers, inspectors, foremen, engineers, service men, and buyers for jobs paying up to \$15,000 a year. Shipping companies use hundreds of operators, give them world-wide travel at practically no expense and pay \$85 to \$200 a month. Radio dealers and jobbers are continually on the lookout for good service men, salesmen, buyers, managers, and pay \$30 to \$100 a week. Talking Movies pay as much as \$75 to

\$200 a week to the right men with Radio training. My book tells you of other opportunities in Radio.

**I will train you at home in your spare time**

Hold your job until you're ready for another. Give me only part of your spare time. Hundreds have won success through my course. J. A. Vaughn jumped from \$35 to \$100 a week. E. E. Winborne seldom makes under \$100 a week now. The National Radio Institute is the Pioneer and World's Largest organization devoted exclusively to training men and young men for good jobs in the Radio industry by correspondence.

**You must be satisfied**

I will refund every penny of your money if you are not satisfied with my Lessons and Instruction Service when you complete. I'll not only give you thorough training in Radio principles, practical experience in building and servicing sets, but also train you in Talking Movies, give you home experiments in Television, cover thoroughly the latest features in sets such as A. C. and Screen Grid.

**64-page Book gives the Facts**

Clip and mail the coupon now for "Rich Rewards in Radio." It tells of the opportunities for a spare time or full time Radio business of your own; also of the many fine jobs for which my course trains you.

Get my new book It points out what Radio Offers You



**You'll get practical Radio Experience with my new 8 Outfits of Parts that I'll give you for a Home Experimental Laboratory!**



Rear view of 5-tube Screen Grid Tuned Radio frequency set—one of many circuits you can build



My course is not all theory. You use the 8 Outfits I'll give you, in easily working out the principles, diagrams and circuits used in modern sets and taught in my lesson books. This 50-50 method of home training makes learning easy, fascinating, interesting. You get as much practical experience in a few months as the average fellow who hasn't had this training gets in two to four years in the field. You can build over 100 circuits with these parts. You experiment with and build the fundamental circuits used in such sets as Crosley, Atwater-Kent, Eveready, Majestic, Zenith, and many others sold today. You learn how these circuits work, why they work, how they should work, how to make them work.

J. E. SMITH, Pres.  
Dept. 11447  
National Radio Institute  
Washington, D. C.

**THIS COUPON IS GOOD FOR ONE FREE COPY OF MY NEW BOOK** mail it TODAY

J. E. SMITH, President,  
National Radio Institute, Dept. OK47  
Washington, D. C.

DEAR MR. SMITH:—Send me your book. I want to see what Radio offers. I understand this request does not obligate me and that no agent will call.

Name.....  
Address.....  
City.....State.....

Get the facts on my Lifetime Employment Service to all Graduates

# RADIO DESIGN

OFFICIAL ORGAN OF THE RADIO INTERNATIONAL GUILD

ROBERT HERTZBERG, *Editor*

ALFRED A. GHIRARDI, *Associate Editor*      JOHN GELOSO, *Technical Consultant*

ROBERT S. KRUSE.....*Contributing Editors*.....A. S. FRIEDMAN

Vol. 3  
No. 3

## CONTENTS OF THIS ISSUE

Fall  
1930

THE NEW PILOT "MIDGET" RECEIVER.

*By John Geloso*..... 4

MAKING RADIO HISTORY IN SOUTH AMERICA.

*By Zeh Bouck*..... 12

HOW FAR OFF IS TELEVISION?

*By Robert Hertzberg*..... 19

CONCERNING THE SMALLNESS OF SOME DIFFERENCES.

*By Robert S. Kruse*..... 24

NRH—A UNIQUE SHORT-WAVE STATION.

*By Robert Hertzberg*..... 30

RECORDED PROGRAMS STAGING COMEBACK .....

35

SOLDERING IS SIMPLE..... 36

SHORT-WAVES, BUT LONG DISTANCES .....

40

TROUBLE SHOOTING CHART..... 48

AMATEUR RADIO—A FASCINATING HOBBY.

*By K. B. Warner*..... 52

DYNAMIC SPEAKERS, PART I

*By Alfred A. Ghirardi*..... 58

VACUUM TUBES—WHAT HAPPENS INSIDE OF THEM.

*By A. S. Friedman*..... 66

QUESTIONS AND ANSWERS.

*By Alfred A. Ghirardi*..... 74

THE RADIO INTERNATIONAL GUILD.

*By Albert L. Rudick*..... 79

PILOT MOVES INTO A NEW HOME.

*By Alfred A. Ghirardi*..... 83



RADIO DESIGN MAGAZINE

Is Published By

RADIO DESIGN PUBLISHING CO., INC., Lawrence, Mass.

RADIO DESIGN Magazine is published quarterly, or four times during the year. The subscription price for the four issues is 50 cents for the United States and all other countries of the world. Checks and money orders should be drawn to the order of Radio Design Publishing Company, Inc.; U. S. coin as well as U. S. stamps accepted. Remittances for foreign subscriptions should be made by international postal money order. Subscriptions are always started with the current issue unless otherwise ordered. Single copies of current and back numbers, 15 cents each. The contents of this magazine may be reprinted by other publications if full credit is given. The editors will be glad to cooperate by supplying illustrations.

**SUBSCRIBERS: PLEASE NOTIFY US PROMPTLY IF YOU CHANGE YOUR ADDRESS, WRITE OR PRINT YOUR NAME AND NEW ADDRESS CLEARLY.**





# 2 BOOKS

*radio fans have  
been waiting for*

## "Radio Physics Course"

by ALFRED A. GHIRARDI

*B. S. in Electrical Engineering; Instructor in Radio and Electrical Engineering, Hebrew Technical Institute; Consulting Engineer, Pilot Radio & Tube Corp.; Associate Editor, "Radio Design"*

A complete course, simple enough for the novice, yet technically correct, covering the entire range from radio fundamentals to short-waves, television and the "talkies." A valuable reference work of 362 pages with 300 illustrations. Postpaid **\$2.50** anywhere.

## "Theory of Radio Communication"

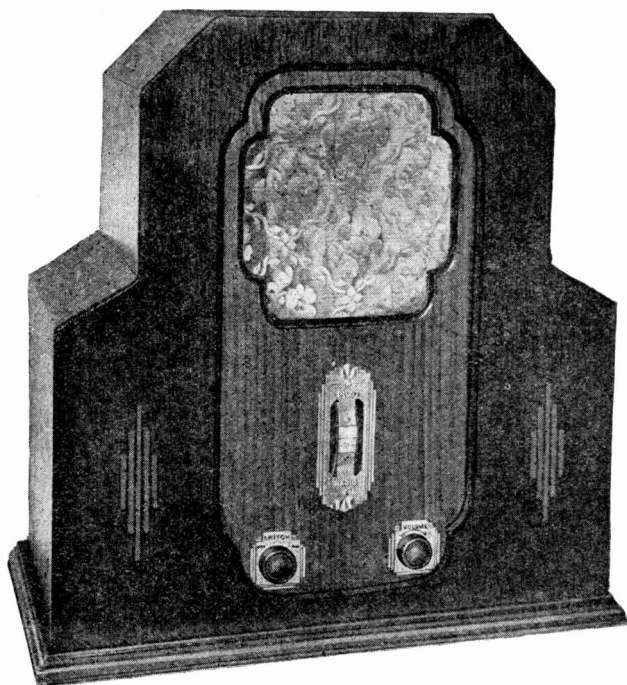
by LIEUT. JOHN T. FILGATE

*Formerly Instructor at U. S. Army Signal School*

Published with approval of U. S. War Department, this is first public printing of the officers' radio manual used by the U. S. Army Signal Corps. A splendid technical textbook for advanced Radio Amateurs. 250 pages, 200 illustrations. Postpaid anywhere. **\$2.00**

*These Books Published Exclusively by*

**RADIO DESIGN PUBLISHING CO., Inc.**  
LAWRENCE, MASS.



## The Pilot "Midget" Radio— Small In Size But Big In Performance

Using Six Tubes and a Dynamic Speaker, This Beautiful Little Broadcast Receiver Has Remarkable Tone Quality, High Sensitivity and Selectivity and Plentiful Volume, and Is a Decorative Addition to Any Home; It Is Supplied as a Factory-Built, Ready-To-Operate Set

By JOHN GELOSO\*

**T**HE new Pilot Midget receiver—factory assembled and wired—is small in size but big in performance. Although it is only 17 inches wide, 8½ inches deep and 17½ inches high, its beautiful two-toned walnut cabinet contains a highly efficient receiving unit, a generously under-rated power pack, and a full-throated dynamic loud speaker. There is nothing small about the individual parts or their capacity to function. They merely have been arranged cleverly in a new way, and instead of

sprawling all over the inside of a large cabinet, they fill most of the space inside a little one.

No feature of big-set operation has been sacrificed in the new outfit. The instrument is handsome, sensitive, and selective, and has a quality of tone that astonishes listeners who are accustomed to the window-rattling thunder of some console-type receivers. The first comment of people who heard experimental models in the homes of Pilot engineers was:

"My, doesn't that sound clear and quiet?"

\* Chief Engineer, Pilot Radio & Tube Corporation.

#### PILOT'S FIRST COMPLETE SET

This Midget receiver is the first complete, factory-built job produced by the Pilot company and described in RADIO DESIGN. Its advent marks a departure from the previous policy of supplying broadcast receivers only in kit form, for home assembling and wiring. The change is being made because set manufacturing has reached such a high state of development and refinement that a well organized factory can turn out a complete receiver that is better looking, more efficient, and cheaper than one of equivalent design made by hand by an individual set builder. There will always be some people who will make their own broadcast receivers purely for the fun of it, but there is no denying the fact that it is wiser and more economical to buy a factory-built product. Of course, the situation on the short-waves is altogether different. The short-waves will be the experimenter's paradise for many years, and the man who likes to build his own is finding great pleasure in this field.

#### HAS UNIVERSAL'S APPEAL

The Midget is a receiver of universal application and appeal. Its low price makes it attractive to families of slender purses, and its beautiful appearance makes it desirable to *all* families or persons interested in adding a decoration as well as an instrument of entertainment to their homes. As a means of occasional diversion it is useful even in business offices.

It is the complete solution to the problem of replacing obsolete battery and early A. C. model receivers with something modern and up-to-the-minute. In large homes two or possibly three of them will eliminate the nightly argument about what program to tune in; with one set in the living-room or dining-room, another in the study or the billiard-room, or one of the upper bedrooms, each group can enjoy its own favorites in peace. The total cost of two or three sets is less than that of many pretentious cabinet sets, and is nothing when one considers the state of harmony and satisfaction that prevails.



*The Midget Receiver proves a welcome addition to this restful bedroom. Supported on a covered radiator (with heat-proof top), it harmonizes with the rest of the furnishings and is useful as well as ornamental.*



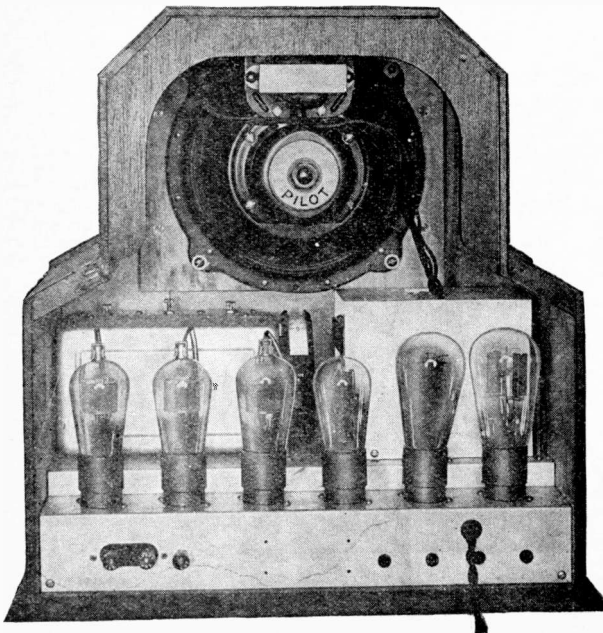
**A**RE YOU, as a radio man, in the same fix as the proverbial shoemaker whose children go barefoot? In other words, have you or have you not in your home a respectable-looking broadcast receiver that works when some other member of the family turns it on? If you haven't (and you probably haven't), it's about time you reformed and provided your folks with a set that *they* can use with comfort and enjoyment. Buy them a Pilot Midget—it costs half of what big sets cost and does just as much—and then you can retire to your own private little radio room and fish for Siam on your short-wave set with a free mind and an easy conscience.

#### SMALL SET IS FLEXIBLE

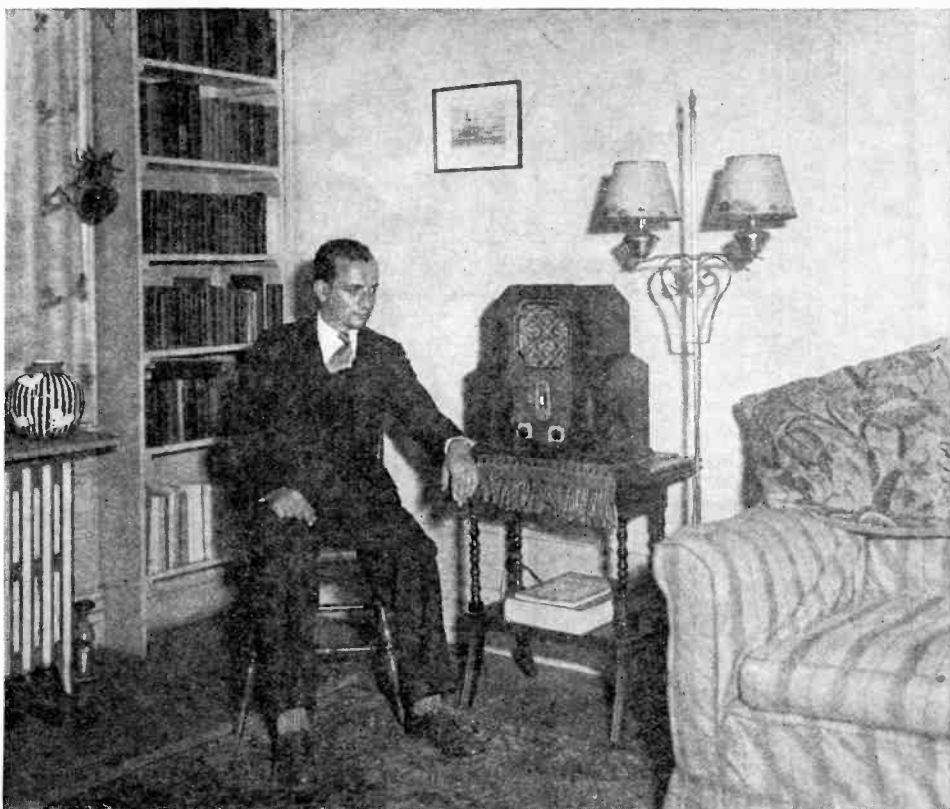
One of the great advantages of a small receiver is its adaptability. The purchase of a console-type set invariably involves considerable shifting of furniture, and sometimes rooms that formerly were neatly arranged take on a somewhat lopsided appearance. Very frequently the most favorable location for the set from the decorative standpoint is not the most desirable spot acoustically, and the residents of the home cannot enjoy the reproduction in comfort. This situation is what accounted for the firm refusal of a certain very prominent set manufacturing company to put the loud speaker in the same cabinet with the receiver proper.

"Put the set where it looks best and the speaker where it sound best," was its advice for many years, until it finally capitulated to public taste and brought out the usual combinations.

The Midget set is not subject to these limitations. It rarely disturbs the harmony of a room, for it is charming and unobtrusive. Several different locations for it will quickly suggest themselves: Any one of several end-tables; the top of a low book-case or desk; a deep window sill; a high shelf in a book-case; the top of a radiator cover, if made of heat-proof laminated wood; a smoking stand; a cupboard. The purchaser will have little difficulty in placing it where it looks best and sounds best.



Back view of the Pilot Midget, showing the neat arrangement of the parts. The loud speaker is securely bolted, and the cabinet itself does not vibrate. To the left behind the line of tubes is the triple tuning condenser; to the right, part of the power-pack. Notice the four ventilating holes in the lower right corner of the chassis. The three binding posts on the left are for the aerial and the ground connections.



*The Midget receiver as the center of a charming setting in a modern living-room. The end-table was next to the divan before the set was installed; it was simply turned around, and the receiver fit on it perfectly.*

#### HOW IT CAN BE DONE

The accompanying illustrations show how nicely the set can be adapted to three typical locations. The photo on page 5, a bedroom scene, shows the Midget balanced effectively between two windows, its support being a covered radiator with a heat-proof top. This proved to be an unexpectedly useful position, the set being used considerably during both the evening and morning. For one thing, the owner now can reach over, snap the set on, and enjoy the morning setting-up exercises without even getting out of bed!

The photo on this page shows an exceptionally charming layout with the Midget on an end-table next to a divan. A person sitting on the latter can control the set without arising. The table retains its usefulness as a book or magazine rest.

This part of the room happened to be the only place where a radio receiver could be installed, and even the smallest consoles did not fit satisfactorily. The Midget solved the problem completely.

The room shown on page 10 already had a number of large pieces in it, and here, too, the Midget proved its value. The set fits very nicely on the table, giving exceptionally good results because the short wall behind it diffuses the sound waves evenly toward the chairs along the side and at the other end.

#### DETAILS OF CONSTRUCTION

The construction of the new receiver is made clear in the other illustrations. As mentioned in the opening paragraph of this article, the cabinet is 17 inches long or wide, 8½ inches deep, and 17½ inches high, overall. The width across the upper narrow section is 12 inches. The cabinet is a fine piece of wood-making, being strong and solid and handsomely finished. The inner panel, holding the loud speaker grille and the control knobs, is a little lighter in color than the outside. The beads running around the speaker grille and the inner panel are stained black. The dial, switch and volume plates are made





of bronze. The combination is really beautiful, and you can appreciate it only if you look at an actual set.

The controls have been reduced to the irreducible minimum: a tuning dial, a volume regulator, and a switch. The dial is of a new type of high visibility and ease of adjustment. You merely put your thumb against the knurled bakelite edge, and it responds smoothly.

#### MINIMUM NUMBER OF CONTROLS

In the illustrations the dial appears to have two sections, on either side of the indicating scale. These are actually one piece, and turn together. The double edges are provided so that the set may be tuned comfortably with either the right or the left hand.

The chassis (see pages 6, 9 and 11), which occupies the entire lower half of the cabinet, is made of one piece of pressed aluminum, and is a complete unit in itself. It uses six tubes, three P-224, one P-227, one P-245, and one P-280, arranged in a line along the back edge, where they are always instantly available for inspection or replacement. Behind, to the left, is a regular three-gang Vaultype condenser, which is known as one of the strongest and most reliable variables made. To the right is part of the specially built power pack, protected by an aluminum cover.

Included with the power pack components under the cover is the audio amplifying transformer used between the P-227 and the P-245.

On a small bakelite terminal strip on

the top of the power pack are four posts, which are connected by flexible wires to the loud speaker, just above. These are of different colors, for purposes of identification.

On the underside of the chassis (see cut below), the main power transformer, the R. F. coils, sockets, fixed condensers, resistors, etc., are arranged in simplified manner. The power transformer is at the right, the shielded R. F. coils to the left, and the common by-pass condenser between them. The coil shields are held by spring clips, and can be removed quickly.

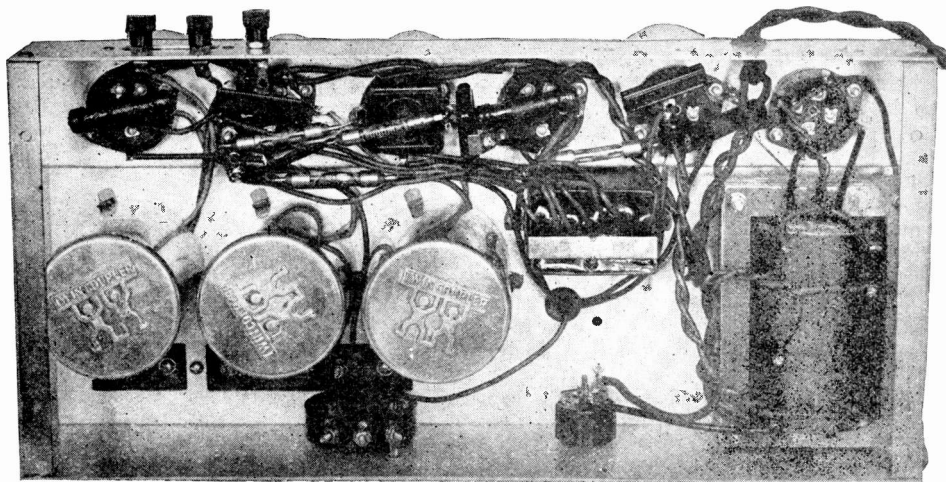
#### SPECIAL LOUD SPEAKER

The dynamic speaker used in the Midget set has a six-inch cone and was designed especially for the receiver. The field winding acts as the second choke in the power-pack circuit and also as part of the voltage-divider. This is an excellent arrangement, as it simplifies the circuit and saves the space occupied by another choke. Also, as the field winding has a very high inductance value, the filtering action is good, and as a result there is no noticeable hum in the speaker.

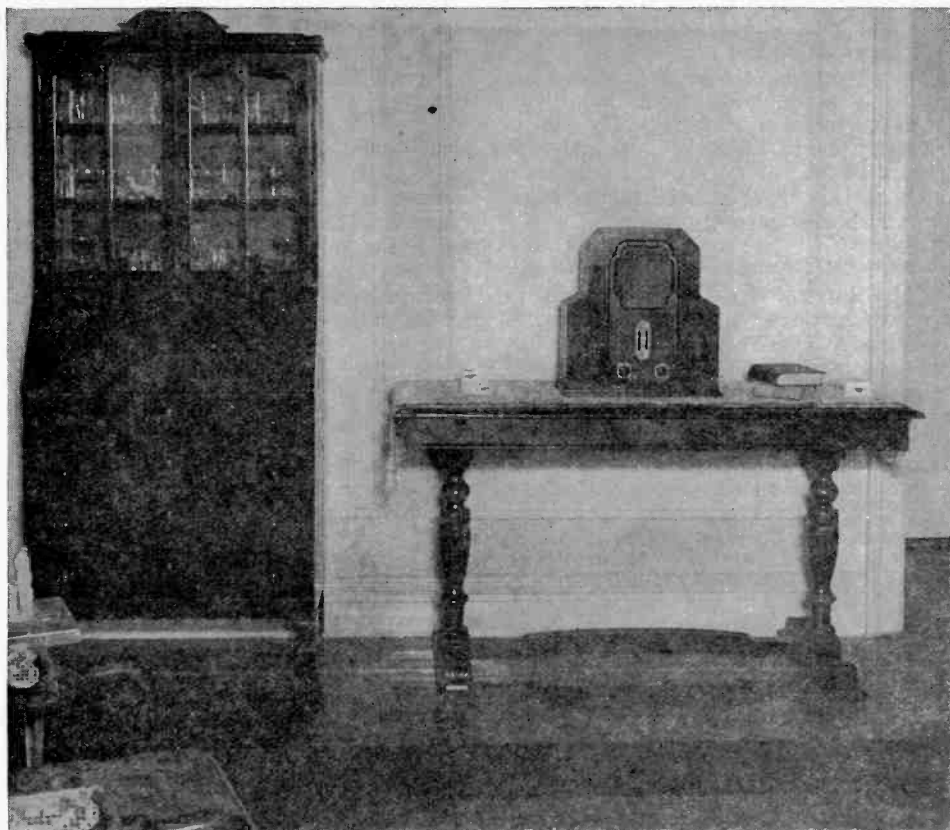
#### IMPEDANCES ARE MATCHED

The speaker voice coil is fed through an input transformer which is mounted on the casing. The transformer is of special construction, designed to produce the most advantageous impedance match between the plate impedance of the P-245 output tube and the voice coil.

Examination of the complete schematic



*Under view of the chassis. Lower left, shielded radio-frequency coils. Right: Power transformer. To the left of the latter is the block of by-pass condensers. On the front side of the chassis are the volume control (below the second and third shields) and the power switch.*



*A simple but effective setting for the Midget set: On a living-room table.*

diagram of the receiver on page 8 will show it to be a straightforward tuned radio-frequency outfit of foolproof nature. There are two stages of R. F., using the first two P-224 screen-grid tubes, and these feed into a screen-grid detector. The latter is followed by a resistance-capacity coupled 227 audio stage (to take full advantage of the screen-grid detecting scheme), and a final transformer coupled 245 output stage.

The correct control grid bias for the two R. F. tubes is provided by a common 275-ohm resistor. The grid and the screen of the detector have separate resistors for the purpose, as do the 227 and the 245 audio tubes.

The volume control of the set is a smooth potentiometer that regulates the voltage to the screen grids of the two radio-frequency tubes, (the first two P-224's). Its action is very quiet and effective. The volume can be turned down to a whisper or up to a roar. The single 245 output stage has more than enough power-handling capacity for the average

home. In fact, the set can usually be turned on only about half way; beyond this point the volume becomes too great for comfort.

The primary of the antenna coupler is tapped, two aerial binding posts being provided. The set is so highly sensitive that the aerial need not be longer than thirty or forty feet, slightly longer wires being allowable if the set is used away from powerful stations. The owner of this set is warned against using a long aerial, as the selectivity suffers from too big a signal pick-up system. The 100- and 150-foot aerials which were erected in such profusion a few years ago are altogether unnecessary, as the sensitivity of the circuit is so great. For city use a ten-foot length of thin insulated wire, hidden beneath the carpet or tacked against the edge of the floor, will bring in more stations than the average family will ever listen to.

The sensitivity of the set makes the use of some trick aerials possible. In New York an ordinary hairpin stuck in the "short antenna" post brings in the local

stations with good volume. A length of wire clipped to such odd bodies of metal as a clothes drier, a bed-spring or a metal pitcher also produces good results.

Instead of being scattered all over the chassis, the seven by-pass condensers required for the cathode, screen and plate circuits are molded in one block, with a common ground. These condensers are carefully tested, and are not likely to break down for a long time.

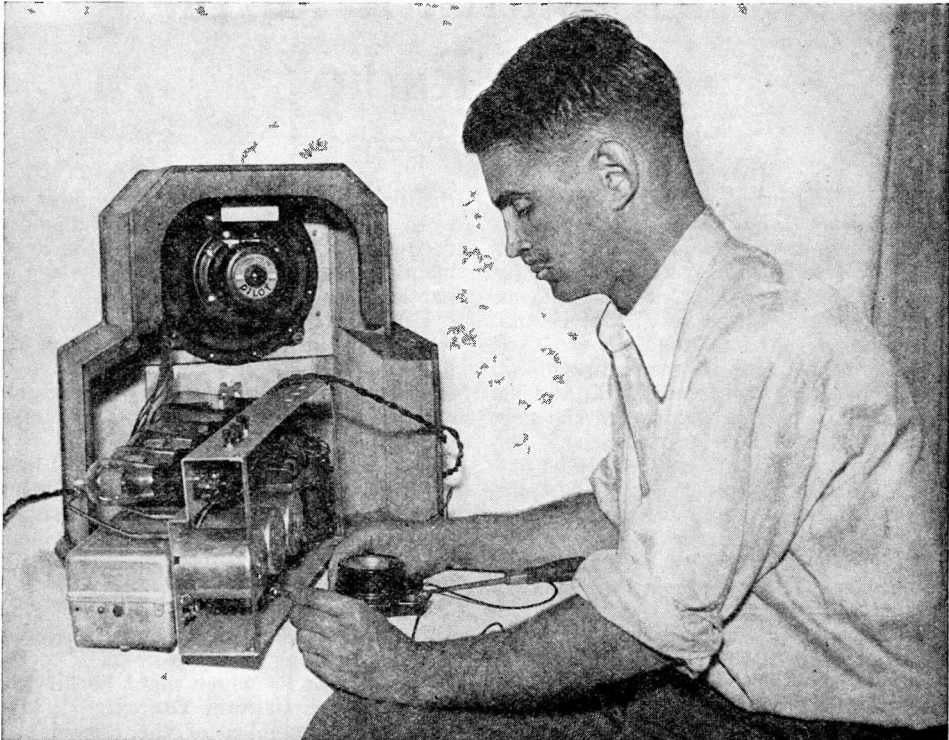
#### POWER PACK IS SIMPLE

Except for the arrangement of the speaker field winding, the power pack is of conventional design, and uses a P-280 rectifier tube. The chassis is thoroughly ventilated and the pack develops practically no noticeable heat. At the time of this writing, a stock set has been running continuously, day and night, for more than *three weeks*, and the chassis in the neighborhood of the power transformer is only slightly warm! Incidentally, the same half dozen Pilotrons were in the receiver all this time and are still going strong.

#### EASY TO SERVICE

From the service angle the new Pilot Midget receiver is one of the easiest sets to handle ever brought out. The chassis is held in place by four screws running through the base of the cabinet. When these and the two knobs on the front panel are removed, the chassis slips out completely, the four wires to the loud speaker having been made purposely long to allow this. The set can be kept running while it is on its side being examined, as none of the connecting wires has been disturbed. This is a great advantage, and will be duly appreciated by RADIO DESIGN readers who have had occasion to do service work on some of those three-decker sets in which half the job is getting at the suspected part of the outfit.

All in all, we think the Midget is a fine little set, and we hope all our friends will like it, too. Drop around to your nearest Pilot dealer, look it over, and hear it work. You will be glad to recommend it to your acquaintances and relatives, or perhaps you will buy one yourself.



*Servicing the Midget receiver is a simple job. The chassis slips right out of the cabinet, with the loud speaker remaining fully connected. The set is not put out of commission by this move.*





*The "Three Musketeers" on their arrival in Rio: Hot, tired and dirty, but happy.*

# Making Radio History in South America With the Airplane "Pilot Radio"

By ZEH BOUCK

SITTING here on the terrace of the Gloria Hotel, Rio de Janeiro, rather ruminative in the early evening breeze blowing in from the "Sugar Loaf" across the harbor, it occurs to me that it is exactly three months since that hectic morning of May the 14th, when we waved au revoir to the escorting planes over Roosevelt Field, New York, and set our earth inductor compass for the general direction of South America.

Six hours before, at one a. m., to be precise, we had completed the radio installation and the final motor check-over. Both the radio and the motor had been thoroughly overhauled following our return from Bermuda, the radio transmitter being altered from a simple oscillator to an M. O. P. A. arrangement. The receiver is the same used in the Bermuda flight, an A. C. Super-Wasp slightly modified for operation from batteries. It was essential that these be given some sort of flying test before definitely starting south, and so, at one-fifteen that morning, the chocks were pulled, the plane taxied to one end of the field, and we took off into

the flood lights. A half hour later we were down again, reasonably well satisfied with things in general and the arguments in favor of a few hours' sleep in particular.

Upon returning to the field at six a. m., we found the mechanics putting on the finishing touches in the way of turning the prop around one hundred and eighty degrees to take out a slight roughness in the motor.

Our South American Good Will Flight is headed by Captain Lewis A. Yancey, navigator, famous for his flight to Rome the summer before last, and the Bermuda flight made in the "Pilot Radio" with Bill Alexander and the writer.

Our pilot is Emile ("Eddie") H. Burgin, veteran transport flyer and maker of the best showing in the New York to Los Angeles races, in which flight he flew, by the way, with Captain Yancey.

The third member of the crew is the writer, in charge of communications over W2XBQ and LU4A, the latter call being the Argentine designation used for most of our experimental South American work.

The first leg of the journey was to Washington, D. C., on which we had the honor of the company of Mr. I. Goldberg, president of the Pilot Radio and Tube Corporation. We ran into some pretty nasty weather just north of Wilmington, but managed to get through to keep an engagement with President Hoover that afternoon. All of us shook hands with the President, and this was more or less our official send-off. Our next stop was Jacksonville, Florida, and from there to Miami.

#### AU REVOIR U. S. A.

It was on the hard coral runway of the Pan American field in Miami that the wheels of our plane last touched the soil of North America. I was going to say U. S. territory, but this would have been slightly inaccurate, for France Field, Panama, is technically within our country.

On Saturday, the 17th of May, we took off for Havana, Cuba, following the Florida coast down to the keys, and then the

ninety-mile over-water hop. It was on this flight that we first came into contact with and had occasion to realize the efficiency of the Pan American airways radio communication system, by means of which all of their planes are in constant touch with two or more land stations for the handling of general traffic and the reception of weather reports along their many and varied routes.

The Pan American two-way radio communication system was developed mainly for plane dispatching and weather reporting purposes and it is the efficiency with which these functions have been carried out that accounts for the truly remarkable record of safe flights completed on schedule by this air transport organization, the largest and most successful in the world. Their pilots on more than one occasion have told me that they would never consider making the flights that are almost their daily diet without the invaluable co-operation of their communications department.

At the present writing there are probably close to fifty land stations being operated by the Pan American Airways, receiving TR or position reports constantly from all planes, and transmitting weather information. It is most improbable that a plane, availing itself of the facilities of-

ferred by this communication system, could be forced down without its exact position being known.

With the perfection of aircraft, weather remains the pilot's principle worry. For consistent commercial air transport, it is not sufficient to know the general weather along a route at the time of take-off. Out-guessing rapidly changing weather conditions has been responsible for the majority of crashes in the past ten years. Every fifteen minutes or so (and oftener if weather conditions alter suddenly) the radio operator on a Pan American plane hands the pilot a complete report on the conditions existing at that minute on the route directly before him, or over any particular variation, should the pilot deem it desirable to change his course.

These weather reports are taken down on a special weather report blank, arranged to save time and insure accuracy. The following questions are answered, always in this order, and every question al-

ways answered: Origin, time, date, to, General Weather Conditions, Horizontal Visibility, Height of Base of Lower Predominating Clouds (in feet), Amount of Sky Covered with Lower Clouds (in tenths), Total Amount of Sky Covered with Clouds (in tenths), Direction of Surface Wind, Force of Surface Wind (M. P. H.), Weather Conditions During Preceding Hour, Rainfall, Field Condition, Barometer and Tendency, Temperature—Dry—Wet Remarks, Signature.

The answers to these questions only are transmitted, each individual report being separated from the preceding and following item by dot dash dot dash. A completed weather report can thus be transmitted in about one minute.

#### EN ROUTE TO MEXICO

On leaving Havana, we ran into bad haze, but a weather report from CZ, Cozumel, the island off the eastern coast of Yucatan, told us that everything was okay ahead. Later on Merida, MY, our destination, sent us a similar report, and sure enough, the weather cleared beautifully over the Yucatan prairies, one of the most desolate and arid stretches I have ever seen. The heat fried up from the ground in definite waves that registered

*Readers of RADIO DESIGN will recall two previous articles by Mr. Bouck: "Rolling Down to Rio," which appeared in the Spring, 1930, number, and "How the 'Pilot Radio' Made the First Bermuda Flight." In this latest article Mr. Bouck describes the high spots of his 22,000 mile tour of South America, with Lewis A. Yancey and Emile H. Burgin. This is the very first story of this history-making flight to appear anywhere.*

on our oil temperature and in the severe bumpiness of the flight. We landed at Merida after some seven hours' of non-stop flight from Havana, two hundred miles of it being over water. After an interesting evening in this town of wind-mills, the capital of Yucatan, and a good night's sleep, we made an early take-off the next morning for Vera Cruz, six hundred miles north.

Once again we ran into thick weather, and seriously considered putting the ship down at Villa Hermosa, where, according to a report from the station there, VH, the weather was clear. However, a subsequent report from VC, Vera Cruz, showed clear weather ahead, and we had no hesitation in pushing through.

#### WE JOIN THE "MAYAB"

At Tejeria, where the airport is located twenty miles west of Vera Cruz, we met up with the Sikorsky Amphibian "Mayab," carrying the remains of General Sider and his unlucky companion who crashed on an attempted non-stop flight from Central America to Buenos Aires. The "Mayab" was piloted by Eric Williams, and belongs to the Governor of Yucatan. It is named the "Mayab" in honor of the virgin who

was yearly sacrificed to the god beneath the "Pool of Death" in the olden Mayan rites.

It was impossible to get through to Puebla that afternoon, due to clouds over the mountains that shrouded the peak of Mount Orizaba, rising twenty thousand feet above the sea.

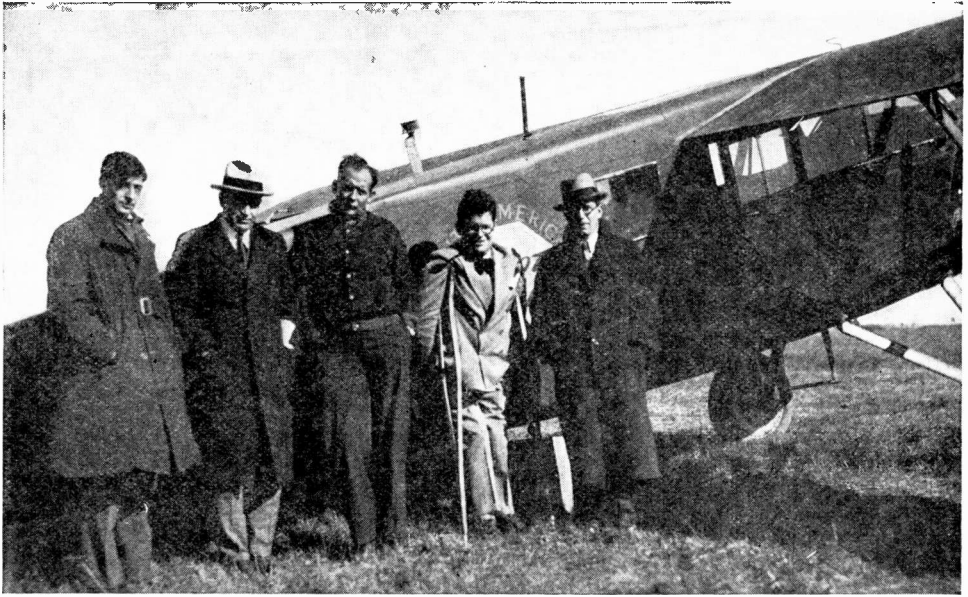
The next day we made the attempt along with the aerial funeral cortege, but only one plane, part of the military escort, got through—more by accident than anything else, for he literally bumped twice against the railroad running over the pass. The rest of us turned back to Tejeria after two hours of dodging the clouds that ever threatened to close in on us.

An early rain the following morning cleared before seven o'clock, and riding out from Vera Cruz on the train we could see the snow-capped glory of Orizaba a hundred miles to the west. Burgin made a quick take-off, and we reached the mountains before gaining sufficient altitude to get through. We circled for fifteen minutes, and then, fifteen thousand feet above sea level, passed south of Orizaba, towering over us, and safely into the Puebla valley.



*The desolate grandeur of the Andes Mountains makes flying interesting as well as dangerous. The "Pilot Radio" passed over this spot on the way from Santiago to Mendoza.*





*In Buenos Aires, just before going up to establish a new radio-telephone record. LEFT TO RIGHT: Burgin, Leigh Wade, former U. S. Army ace; Yancey, Bouck, and A. B. Hoffman, engineer for the I. T. and T. Co.*

At Puebla, a quaint Mexican half-city half-town that still echoes faintly its previous Aztec civilization, we became officially the American escort to the ashes of the unfortunate fliers, and we were requested by the Mexican Government to radio through every fifteen minutes the progress of the flight from Puebla to Balbuena Field, Mexico City. Yancey, Burgin and myself were subsequently decorated for our successful participation in the flight.

We laid over in Mexico City for a motor check-over through the always hearty co-operation of the Wright Company. While there we carried on some interesting experiments in communication from the plane on the ground, employing an emergency antenna, with Mexican signal corps stations. We actually had a hard job convincing the Army officers that the equipment in the plane was not for immediate sale.

We left Mexico City on the twenty-ninth of May for what turned out to be one of the closest calls on the flight. Mexico City is seventy-two hundred feet above sea level, twelve hundred feet higher than Puebla, where, by the way, we took down a flag at the far end of the field on our take-off. The higher the landing field the more rarified the air, and consequently higher take-off and landing speeds result. Also, the plane is more reluctant to

pick up speed. We barely cleared the trees at Balbuena Field, and headed down the valley for the pass through the Puebla. We found this completely closed, and decided to try the north-pass. In passing over the field we were joined by Colonel Leon in a Douglas who, we learned later, had been searching for us on the theory that we had crashed shortly after our take-off.

We found the northern pass, and were just about to shove our nose through when the oil pressure dropped, and we decided the risk was too great. Turning back to Mexico City, I raised the Pan American station and asked them to page Eddie Walsh, the Wright mechanic, at either Sanborn's restaurant or the Regis Bar, and have him rush out to the field. He arrived ten minutes after the plane, and a half hour later, with a microscopic bit of dirt removed from the oil valve, we were on our way again, after another hair-greying but skillful take-off!

As we headed into the pass, just a few minutes too late in the day, we started dodging rain squalls, with the clouds closing in behind and in front of us, and dropping down upon us from above. We were flying along, part of the time, with less than a fifty-foot ceiling. We did not dare climb through it for fear of running into Orizaba or any one of several other lofty peaks. A weather report from Vera

Cruz, telling that it was clear on the coast, was the only thing that kept us going. We were by this time actually over the hump, and were losing altitude continuously. Once we passed an emergency landing field, and someone tried to wave us down with a blanket. But we were past almost as soon as we saw it, and in the valley there was not sufficient room to turn around.

The sun shining on the sea ahead, with the mountain dropping rapidly away beneath, was a happy sight to us!

#### MORE BAD WEATHER

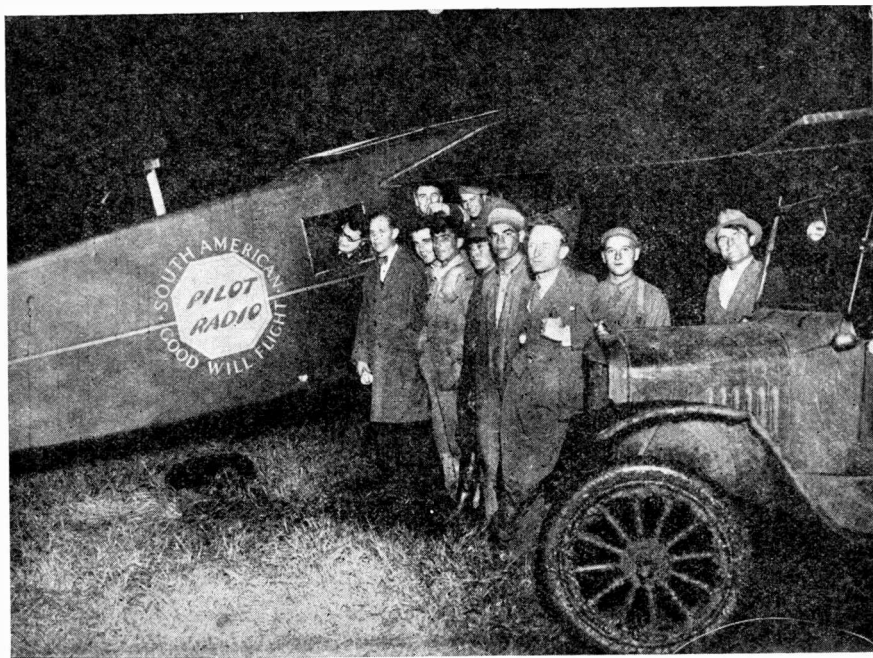
We ran into bad weather again on the hop from Vera Cruz to Guatemala City. We were fortunate here in having the company of one of the Pan American Fords making the run as part of its regular passenger service. Guatemala City is located five thousand feet above the sea, and in all but the very best of weather can be approached, by air, only through a narrow pass. With the exception of this slit, the city is surrounded by ten thousand-foot mountains. The pilot of the Ford knew the pass like a book and led us through, with a radioed warning back to us to stay far behind, because, if the pass closed in on him, he'd have to turn back

quickly, and he wanted plenty of room.

Weather held us up another day in Guatemala City. After an uneasy take-off from this high altitude field, we found it impossible to get through the pass or over the mountains, and Eddie made a splendid landing with the heavily loaded plane. The following day we were more successful, and after ducking one wing dizzily under the branches of the tree to our right while lifting the left wing over the top of a second tree, we finally made altitude, and got through to the coast, where we found clear weather. We immediately radioed this fact to Guatemala, where a Ford was waiting for a break in the weather before starting north for Vera Cruz.

We made Nicaragua that afternoon in good time. Managua is about the hottest place this side of hell, and at times it is said that hell merely runs it a close second. It was here that we learned that our signals had been picked up QSA4 shortly after we had left Havana—when we were calling Cozumel for a weather report. This was about two in the afternoon, Managua time, the worst part of the day for reception, and over a distance of about fifteen hundred miles.

We spent the evening with the opera-



*Even at night the "Pilot Radio" always attracted a crowd. This photo was taken at Buenos Aires. Bouck may be seen with his head sticking out of the window of the radio cabin.*



*The famous Christ of the Andes, located on a pass 13,000 feet above sea level, through which airplanes pass. In the background is Mount Aconcagua, the highest peak in either North or South America.*

tors of the Marine amateur station NN1NIC, Lieutenant Fike and Sergeant Martin, and sent a number of messages through to Rosenthal, U2UO, in New Rochelle, New York..

#### **WE DON'T LIKE THE LOOKS OF A FENCE**

The boogey of spectacular take-offs was still with us the following morning. We were carrying a heavy load of gasoline, and the field was short, rising to a hump in the middle, with fences on both ends. With the tail slapped up against the western fence, Eddie gave her the gun, and the "Pilot Radio" rolled lumberously toward the center of the field. Finally, half way down, he got the tail up, and we gathered speed with the other fence becoming more and more definitely in the way. Desperately Eddie tried to bump her off, while I stuffed a brief-case between me and the gas tank. She'd hold the air for a second, then settle. Eddie pulled the wheel back to clear the prop—a sudden jolt and good-bye fence. But we held the air, our landing gear was intact, and we finally made altitude, dodging several bad storms in the southeast. That afternoon, at three-thirty, we landed at France Field, Panama.

At France Field our motor was given a check-over by the Pan American mechanics. Perhaps here is the place to express our appreciation for the co-operation that this highly efficient organization has of-

fered us throughout our flight—in radio, fields and every facility at their own disposal.

Pan American and United States Army officials were interested in our radio equipment, and we arranged a schedule with the New York *Times* station, WHD, in the way of a demonstration. On arriving at the field, we discovered that the motor cut badly on one magneto, and so we were unable to fly. However, curious as to the possibilities of an emergency antenna, we strung out a wire over a step-ladder, and made contact with New York without difficulty, a distance of some twenty-five hundred miles, in daylight! We met with even greater success (as was to be expected) the following afternoon while flying, and sent through some fifteen hundred words of press and general messages.

The next hop was a long one, twelve hundred miles to Talara, Peru. Then to Lima, down past the barren Peruvian mountains topped with ancient Inca temples. From Lima to Camana, to Antifogasta, Chile, to Quinteros and to Santiago. Our radio communication during this part of the trip was with station CPU, owned by the Standard Oil Company, and located at Yucuibá, Bolivia. This is but one of the many forms of co-operation extended us by this organization.

Twice, on this trip down the desolate west coast of South America, we were

forced down by night: once at Camana, and at Quinteros. At Camana, after circling in the dangerously darkened twilight for fifteen minutes, a boy waved us toward a strip of sand used occasionally by planes for want of a better field. So we set her down, and spent the night in this quaint but uncomfortable Peruvian village.

Once again night caught us as we were heading across the mountains separating Santiago de Chile from Valparaiso and the sea. As the sun set on us, ten thousand feet in the air, it was pitch dark in the valleys and grey dusk on the shore. It was risky to try to make it, so we came down, and while concentrating on a perfectly good cow pasture, we overlooked a genuine airport not one thousand feet away!

I volunteered to stay with the plane overnight to keep off the cows, which animal has a notorious fondness for airplane fabric. Yancey and Burgin brought me out some sandwiches, blankets, a bottle of wine and a bottle of Cointreau. (The latter, however, turned out to be water, for which they paid good money!) After arguing with the cows for a few minutes on the superior delicacy of grass over linen and dope, I turned in and slept well.

The next day—Santiago.

#### A NEW RECORD

It was here that we made a real record by working New York City, our old friend WHD, from the ground with an emergency antenna. Pending repairs to our tail wheel assembly, we were unable to fly, but held reliable communication for

several hours on two occasions, with our trailing wire antenna laid across the top of an automobile.

The hop to Mendoza, over Los Andes or Las Cordilleras, is the most inspiring flight I have ever made. Los Andes are one long range of Orizabas, the lowest pass being 13,000 feet above the sea. And it is dangerous to fly through it at less than sixteen thousand feet, due to the bumps which may drop you twenty-five hundred feet in five seconds! We passed through the southern pass at seventeen thousand feet, over the most incredible heaps of desolate grandeur I shall ever see.

After gassing up at Mendoza, Argentina, we took off for Buenos Aires, better known as "B. A." Head winds as usual, and we dropped in at Villa Mecerdés for the night, one of the most beautiful airports we have ever seen. We landed at Buenos Aires the next afternoon at three o'clock, the twenty-seventh of June.

#### TELEPHONING AROUND THE WORLD

From B. A. we immediately established two-way radio telegraphic communication with WHD both from the ground and from the air, setting a final and definite record for airplane communication.

Then, with the co-operation of the International Telephone and Telegraph Company, we set about making an entirely different sort of a mark for others to shoot at. The I. T. and T. operates two short-wave telephone channels, one to Madrid, Spain, and the other to New York, U. S. A. These channels are absolutely

*(Continued on page 49)*



*A luncheon at the American Club in Buenos Aires given by the Standard Oil Company. Seated, at extreme left, is Burgin, with General Pinedo, famous Atlantic flyer, between him and Yancey. Bouck is at extreme right.*



# How Far Off Is Television?

As a Means of Entertainment for the Public It Is Very Far Off. It Is Still a Plaything for the Experimenter, a Flickering Novelty That Will Improve with Time.

by ROBERT HERTZBERG

**H**OW far off is television? This question is asked wherever one turns, as the widespread newspaper publicity given the spectacular Schenectady demonstrations of Dr. Alexanderson\* has aroused public interest to a high degree. People approach radio men and ask them confidentially just when they can buy television attachments for their radio receivers that will enable them to see prize-fights, baseball games and other public events in the privacy of their homes. When the harassed technicians reply abruptly that television on this magnificent scale is still a long way off, they are told: "Oh! We've heard that story before! What about these rumors that the big companies will spring television in the home next season?"

The impression that television is just around the corner is being further entrenched by the numerous reports that appear in the theatrical press to the effect that the same big electrical organizations that made the talking movies possible now have television up their magical sleeves and are waiting for the "talkie" craze to die down before releasing this next wonder on the cash customers. Rumors and stories in the gilded motion picture industry are so wildly exaggerated as a general rule that it is surprising people believe this latest fairy tale.

## WHAT IS TELEVISION?

Now let's be reasonable and consider just what the possibilities are of television achieving the status of a means of public entertainment. In the first place, just what do we mean by "television"? Engineers and editors have quarrelled over the definition of this and related words, and sometimes they do not always mean the same thing when they use them. As far as the public is concerned, however, television means the instantaneous transmission of the image of an event directly from its very scene

to the receiving equipment in the home, where it is reproduced on a screen as the accompanying sounds or oral description issue from the regular radio loud speaker. This is to be clearly distinguished from radio motion pictures, which can be broadcast with comparative ease from a comfortable studio.

## HOME MOVIES TOO GOOD

In this connection it might be remarked that the high state of perfection achieved by home cinema apparatus, while in itself a notable development, is placing television under an extremely unfavorable handicap. If we did not have such clear and faultless home projection, perhaps even a crude television service might stand a chance, but at the present time it would certainly suffer badly from the inevitable comparison. Remember that we are considering television as a means of entertainment and possible exploitation, and not as a flickering novelty. The American public has been educated to fine technical results in both radio broadcasting and in motion picture projection, and it may not spend its money so quickly on a supplemental instrument of entertainment unless its quality is on the same level.

Some people argue that both the talking movies and radio broadcasting itself were accepted as novelties before they reached their present position of importance, and that television might also enjoy the same growth. However, as Dr. Alexanderson pointed out in the last issue of RADIO DESIGN, we are not sure that the analogy is justifiable and that television will repeat the history of radio telephony. One thing is very certain; unless something radically new is introduced very suddenly, we are not likely to see home television images as good as home motion pictures for many years to come.

Because of the high cost of the apparatus used in the present systems and the necessity for close technical supervision, it is probable that the public's first contact

\* See RADIO DESIGN, Vol. III, No. 2, Page 15.

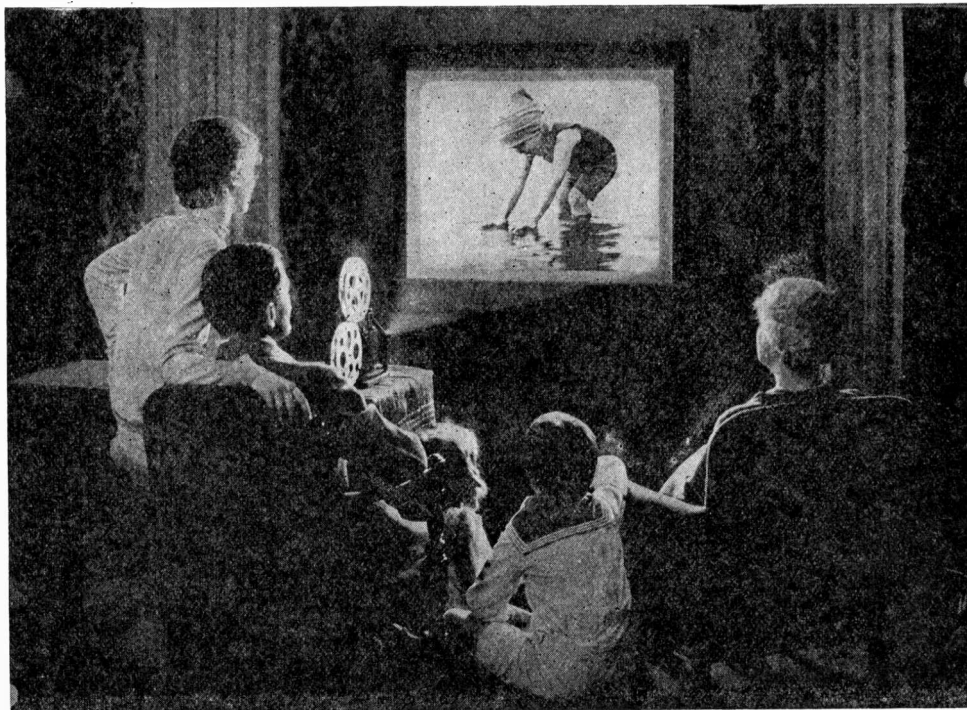
with television will be made through the medium of the theatre. This possibility is strengthened by the fact that one of the largest vaudeville and picture theatre chains, and a large picture producing organization, are both part of the same great company that is doing the most research work in the television field. The tie-up is obvious and has already been effected; witness the fact that the Alexanderson demonstration was held in Schenectady's local RKO Theatre. As a novelty to increase theatre attendance, the entertainment barons would probably be glad to go to the trouble and expense of equipping a few strategically-located theatres with television equipment. Compared to some of their other extravagances, this would be a comparatively economical investment, and in addition it would give them an opportunity to carry out valuable field tests.

It is when one considers the merchandising, legal and technical problems that he really begins to appreciate the true condition of television at the present time. Take the merchandising angle first. Radio salesmen tremble fearfully at the

very mention of the word television, because people come into their stores, ask about television attachments, and then say they will delay the purchase of new receivers until television is "perfected." Two years ago, when television was unwisely ballyhooed by radio show managements, retail dealers experienced serious difficulties in this regard, and it is an open secret that the trade in general was very much embarrassed by the whole mess. It certainly is not good business to get prospective customers all excited over a new gadget, and then to tell them that they can't buy it.

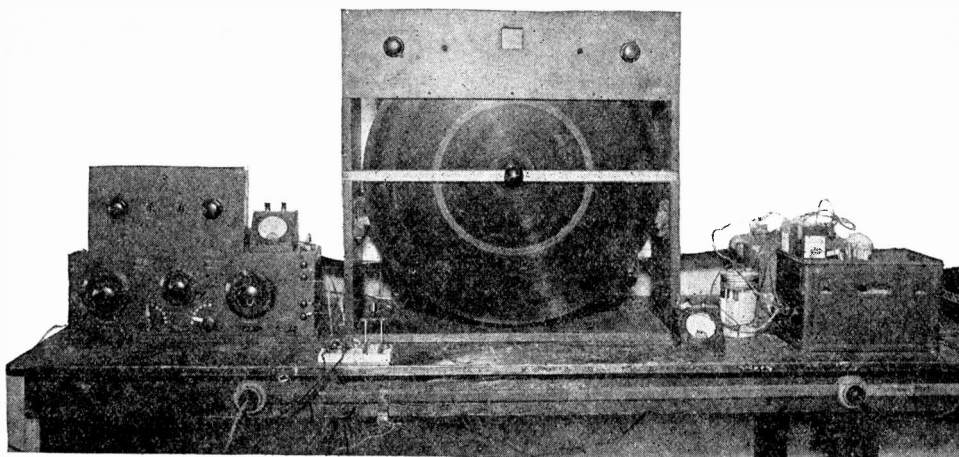
#### THE AIR IS CROWDED

Now think of the legal side of the matter. Experimental television transmission is limited by law to a channel in the neighborhood of 140 meters, which is quite out of range of ordinary broadcast receivers. With the 200-to-550 meter broadcast band bursting with an over-abundance of stations, the Federal Radio Commission, rightfully enough, has refused to allow television work in it. If it did, one television station would



(Courtesy Eastman Kodak Company)

*Home motion-picture equipment of low cost produces excellent results. Television apparatus to give pictures only half as good as that shown above would cost thousands of dollars. That is why television as a means of home entertainment is still something remote and distant.*



*A typical experimental receiver constructed by an amateur. The best images this apparatus can reproduce are about  $1\frac{1}{4}$  inches square, and are built up on the plates of a neon-gas lamp. The big disc is motor driven, and must be balanced with extreme care. Great stuff for the dabbler, but certainly not practical for the public.*

blanket receiving sets for many miles around and would make the reception of other stations a difficult and uncomfortable adventure. This leaves us with the obligation of providing an altogether separate television receiver to accompany the present broadcast instrument. Thus the television "attachment" cannot be an attachment at all, but must be a complete radio outfit by itself.

#### WIDE FREQUENCY RANGE

The most serious technical difficulty that is impeding the progress of television at the present time is the necessity for employing an extremely wide band of frequencies to give images of decent size or definition. We can obtain distinguishable silhouettes and near half-tone effects with images about  $1\frac{1}{2}$  inches square with pretty cheap and simple apparatus, working on a band only about 10,000 cycles wide, but, of course, these crude results are acceptable only to amateur experimenters. C. Francis Jenkins, the well-known inventor, has been transmitting such images on the short-waves for more than two years, and a number of other people have from time to time also operated stations producing results on about the same scale.

As the size and definition of the image increase, the number of picture elements in it increases and the frequency of the transmitted signal rises proportionately. For the transmission of outdoor athletic events, such as prize-fights, ball games,

etc., an enormous number of picture elements is required and no present electrical system could possibly handle them. Then there is also the incidental little annoyance of synchronizing the transmitting and receiving machinery and steadying or framing the image so it does not wander off the screen or break up insanely into splotches of black and white that look like the ectoplasmic photos produced by spook chasers. Even the best disc systems in use today are subject to these irregularities. It is pretty generally agreed, among technicians, that the present disc system, which was conceived by a German inventor about fifty years ago, must eventually be replaced by altogether different methods, possibly employing electronic actions instead of mechanical ones. One man on the west coast has done some work with a cathode ray oscillograph tube, which has none of the inertia effects of the present systems. This looks very promising and it is hoped that something will materialize from his experiments.

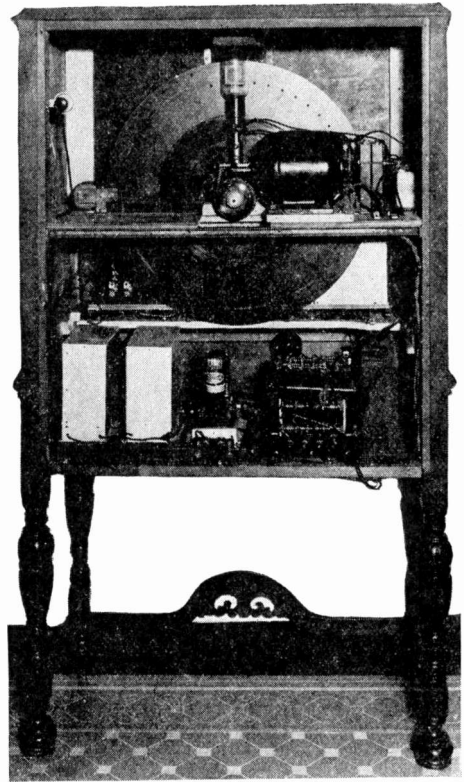
#### USE THE LAND LINES?

It has been suggested that television can be made to pay its way if it is presented to the public over wire lines rather than by radio. This sounds like a good idea, but just what lines could be employed for the purpose? The electric-light circuits are hardly suitable, because their radio frequency characteristics vary with the number and kind of electrical appliances connected to them. Carrier current

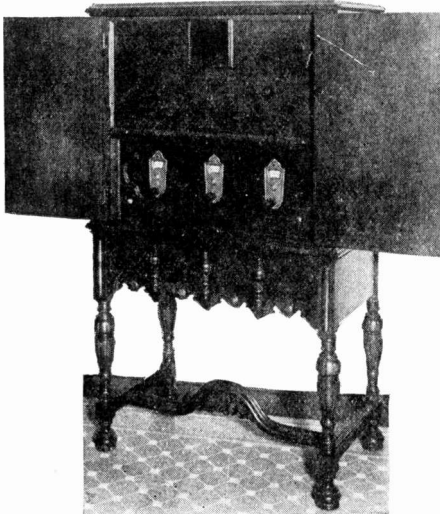
systems might be applied, but these have not been particularly successful, even with ordinary musical programs. There remain the telephone wires, but these are engineered to carry only the very limited frequency ranges required for intelligible voice transmission. They, too, would be useless unless the frequency of the television impulses could be kept below certain low limits. However, if this could be done, radio transmission could be accomplished just as easily.

#### FOR THE EXPERIMENTER

All in all, it appears that television in its present state of development is the ideal plaything for the individual radio experimenter. The amateurs opened up the whole field of both broadcasting and short-wave radio, and it may be the amateurs who will guide the way to practical television. They are recognized by the large electrical companies and their cooperation is being solicited now just as it has been solicited in the past for other scientific developments. Again to quote Dr. Alexanderson: "I venture to predict that we will soon see a wave of activity in amateur television. There are more than 100,000 experimenters in America, young and old, who go in for radio, not to be entertained, but who like to build their own sets and get a thrill exploring the unknown. They will be the ones to



*A special television receiver built by John Geloso of the Pilot company more than two years ago and used successfully for the reproduction of images broadcast by WRNY, Coytesville, N. J. Both the R.F. and the A.F. circuits are of highly special design and cost a young fortune to build. Flickering images about 1½ inches square were obtained when reception conditions were favorable.*



*Front view of the set shown above to the right. This was intended to show how television receivers might possibly be built up for commercial sale, but the meager results did not warrant the trouble or expense involved.*

popularize long distance television, just as they were the ones who created the interest in broadcasting."

The amateurs have very little to work with at the present time, but they certainly had less when they were given the short waves. There is hope for television, but it is not "just around the corner."

#### VIEWS OF DR. GOLDSMITH

Because of the eminent position he occupies in the radio industry, the following statement by Dr. Alfred N. Goldsmith, vice-president and general engineer of the Radio Corporation of America, is of timely interest in connection with the present discussion of television.

"The term 'television' means so many

different things to various people that it is necessary to state how it is believed it should be interpreted before any fair statement can be made concerning its future. Some people think that television means small, dim, blurry, and shifting images of uninteresting faces. Others think that television means exquisitely perfect, large, brilliant pictures that look like the finest theatre motion pictures. Each of these viewpoints is regarded as extreme. Television is defined as a radio service of pictures in motion, of sufficient detail and quality to have continuing entertainment value to the public. That is, unless the pictures are of interest, month after month and year after year, television is not regarded as a service of real entertainment value. For this purpose it is believed that it is necessary to be able to show clearly the head and shoulders of several people in a close-up view and also action of a group of people at a greater distance with a reasonable amount of back-ground detail.

#### PICTURE REQUIREMENTS

"In connection with such a television service, it is necessary that the receivers supplied to the public shall be simple, compact, quiet, and fairly automatic in operation, reliable, and reasonable in cost. The pictures produced must be brilliant enough to be seen in an ordinary dimly illuminated room, of good color of adequate detail, of real pictorial value, without annoying flicker, properly framed, and visible to persons seated in various parts of the room.



*Dr. Alfred N. Goldsmith, one of the outstanding figures in the radio industry, whose views on television clearly define the status of the art.*

"In order that the people of the United States shall enjoy such a service, it must be carried out on a national scale. This means the erection of numerous television transmitters. These transmitters must be located at proper points all over the country and, on occasion, must be interconnected either by wire, by radio, or by the shipment of motion picture film subjects so that events or programs of interest may be brought to the public promptly.

#### PROGRAM ARRANGEMENT

"This brings up the entire problem of television programs. Obviously the establishment of transmitting stations and the creation of programs for the entire United States is a lengthy and expensive job. Yet without these facilities, television receivers are of no value to the general public. The programs must be so arranged that they will coordinate properly sight and sound so that those who hear only the audible portion of the program (without seeing the television pictures) will nevertheless find the sound of interest. The correct wavelengths for the transmission of television programs for city, suburban, and rural service must be determined. Incorrect choice of wavelengths means ruined or unreliable transmission. The Federal Radio Commission would be required to find a place for national television transmission—a problem of considerable magnitude under existing conditions of 'congestion in the ether.'

#### HOW LONG WILL IT TAKE?

"Laboratories are doing excellent work in the development of television and will probably ultimately bring the equipment to a satisfactory stage for public use. It is dangerous to make any definite prediction as to how long this will take. *It seems likely that national television service of proven value within a year, would be a miracle; within two years, would be an amazing feat; within three years, would represent a fine achievement of hard work; and within five years, would be a development proceeding at a good and normal pace.*

"If television is developed as a service of real entertainment and instructional value to the public, it will take its place beside radio broadcasting as one of the greatest agencies of human progress and enjoyment, but it is not to be expected that the day of television is as yet near at hand."



# Concerning the Smallness of Some Differences

Or How to Obtain Some Unexpected Thrills from the Short-Wave Code Stations That Crowd the Radio Atmosphere



Robert S. Kruse

by ROBERT S. KRUSE

TRAVEL in the tropics consists of insects, smells, heat, rains, but also of impossible colors, incredible happenings and a seething fecundity of life. Only a very few travelers manage to see beyond the first four. The whine of the malarial mosquito overrides the murmurs of the jungle, one may not consider marvels calmly while digging garapoti ticks from one's skin and it is not to be expected that the austere beauty of the Southern Cross shall be appreciated from a screened porch enwhirled by a buzzing, biting, gnawing, stinging cloud of things with wings and many legs.

The timid and the unimaginative, therefore, flee to climates where life is less insistent and more monotonous. Failing that, they retreat into their man-made shells of screen and corrugated iron to contend with each other in unprofitable studies of the combinations that are possible with 52 rectangles of colored cardboard; or else they repeat old chemical experiments with particular attention to brilliant alcoholic infusions.

A few, with better courage or greater madness, go out to claw their way through difficulties toward visions of future mines, cities, and farms; but they, too, damn the insistence of the crawling, hopping and fluttering satan's crew. These men are the pioneers.

Indeed, only an entomologist—which is to say a bug-hunter—can altogether approve of the muchness of creatures. It is, of course, well known that entomologists are all insane. Their insanity, however, seems to

bring some contentment, which is never to be despised. Shall we therefore—but this is supposed to be a radio magazine and we are becoming interested in the wrong sort of bugs. Let us re-tune at once.

\* \* \*

Travel amongst the short-waves consists of dots, dashes, fading, power-line noises—and also of impossible signals, incredible DX, and a seething fecundity of signals. Only a very few manage to see beyond the first four; the whine of interference drowns out the voice of the distant station, one may not properly consider Javanese music at short-waves while fighting fading, and the austere beauty of radio transmission through the upper air is not appreciated while seated before a loud speaker filled with whinings, raspings, rattlings, chatterings, mumbblings and gruntings.

The timid and unimaginative, therefore, flee to wavelengths where broadcasting is simpler and more monotonous. Failing that, they retreat into self-made shells and contend with each other in making unprofitable lists of "calls heard" or "messages handled," or else they repeat old chemical—but we said that before.

A few, with better courage, or greater madness, go out and claw their way through difficulties toward improved roads of communication. These are the engineers, but they, too, damn the satan's crew of interferences.

Indeed, only a proper radio nut, admitted even by himself to be somewhat insane, will altogether approve of the muchness of short-wave signals. Still, if



insanity brings comfort it is worth listening to, since it may gibber forth good advice, or good humor to be recalled in some unbearable moment of the future. Let us, then, without further allegories, attempt to squeeze a drop of good juice from our sour grapes.

#### WITHOUT KNOWING THE CODE!

At those times when fading, static and interference make a nightmare of short-wave broadcast reception, one may turn to the dots and dashes and derive from them a few thrills without the need of being able to read a single sentence of the code. The procedure is simple and the game contains the main elements of interest which holds one to international broadcasting: novelty and lure-of-distance.

Begin by throwing the set into oscillation and tuning about at random until a "dotter" is encountered. A dotter is recognized by the fact that it manufactures machine-made dots by the hundred and thousand. If it is running fast the noise is a mere "rrrrrrrrrrrrrrrrrrrrrr," and if it is running slowly the effect is "plop plop plop plop." The purpose of this seeming nonsense is to "keep the station on the air," so that it may be kept tuned in by receiving operators, just as if a broadcasting station were to keep a klaxon blowing in the studio whenever not transmitting a program! Work across the scale, recording the setting for each of the "dotters" and then start across once more, this time very slowly. As each one of the chatters is watched for several moments it will be found to interrupt itself periodically to repeat certain rhythmic combinations. These are the call of the station, sometimes preceded by the word "de," which is good Latin for "from." The first four or five times the rhythm will be heard to catch, but presently it can be written down—a letter at a time—from memory and we will have on the paper something like this:

— . . . — . . . . —

which reference to the code chart will show to be XDA, located at Mexico City. The signal intensity of the station on our supposedly "dead" night will be something of a startler. Another, slower, dotting machine, with a peculiar hollow tone, will develop a Madrid address, another one is found to be in Japan, and in the course of an hour others may be collected from England, Germany, Argentina, South Africa, Chile, Peru, Canada, France, Spain, Italy, Russia and Sweden. Coils which show no broadcast signals whatever will produce

these chirpings from far places with great facility at almost any time of day or night.

The difficulty of making out the code letters is much less than one would think. An ordinarily attentive person can very nicely do just what was said: make out quite an assortment of calls in his first hour of trying. Their distance and intensity will both rather stagger the newcomer in this particular sort of DX logging.

The auxiliaries to the game are simple—merely a pad that will not need to be held, a pair of pencils so that one may be broken without tying up reception, and a couple of 25 cent callbooks, commercial and amateur, which may be had from the Superintendent of Documents, Government Printing Office, Washington, D. C.\*

An international call-list would be very handy, but these are somewhat slow to come by and their place may for present purposes be taken by the brief *résumé* of Table 1.

#### POST-GRADUATE WORK

When the machine-made dotters are followed long enough, some of them will be found to be using variations. Instead of plain dots one may hear a series of the letter V, thus . . . - . . . - . . . - or a tiresome repetition of the letters ABC ABC, thus . - . . . - . - . or occasionally the dotter (or its equivalent) will be stopped while something is said with the hand key. Do not too much regret that you cannot follow these remarks, for they will be found to take such cryptic forms as "XQ 32 NY 3459," which isn't exactly of high dramatic interest even when said in plain English.

Instead it might be well to tune to one of the amateur bands and try a little long-range logging there. This is a shade more difficult because the sending is much less even, the interference greater and the signal strengths somewhat lower. The 160-meter band (actually 150-175 meters) will generally be found vacant; we may expect some other sort of station to be put in there soon. The 80-meter band is more interesting because its lower 90% is occupied by a very few telegraphic stations and the upper 10% is occupied by a struggling mob of amateur radiophones, all trying to out-call each other. Mostly they are quite good stations, though the heterodyning is terrible and the quality consequently as damaged as on some of the "junk channels" in the lower part of the standard broadcast band. It seems strange

\* Send coin or money order, not stamps.

and unjust that the phone men are not given the 75-85 meter band entire. Great "DX" must not be expected here, but some interesting talk may at times filter through the wails and screams.

#### WHAT IS "CQ"?

At 40 meters (actually 41.1—42.8) the fun begins, for here are hundreds of stations in all parts of the world, frantically drumming out a rhythm that reminds one of the summer locusts. Put in dots and dashes it is . . . . ., which *sounds* somewhat like "dah dit dah dit dah dah dit dah" and is read as "CQ" and means (to the amateur) "I am anxious to talk to anyone who is far enough away." The weird part is that none of them *are* talking; all just getting ready to talk. Furthermore they are so quiveringly anxious to call that they sign infrequently and then usually very hastily and poorly, although the CQ CQ CQ CQ CQ is generally very legible from long practice. One therefore has something of a struggle to make out the call of the station, which invariably consists of a letter, a number and some more letters, such as W1AAA, G2BR, VK2RX, VS7AP, the stations named being (as indicated by the first letters) located in the U. S. A., England, Australia and Ceylon respectively. Reference to Table II is helpful.

In summer daylight it may be worth while to drop down to the 20-meter (20.8—21.4) band, but there is not so much activ-

ity there and as less of it is long-winded calling one will garner few calls.

One may, accordingly, play the DX game with code stations as with phone stations, and that with no change of either equipment or interests.

For that matter, the sending stations themselves differ little enough in their basic ideas. Both code and voice stations begin by spraying from their antenna a steady stream of radio energy, of which a little falls upon the receiving antenna and thereby links the two with a "radio channel." So far this "channel" is soundless and without intelligence, just as is the battery current in a wire-line (telegraph or telephone) before it is disturbed by the operator's key or the phone subscriber's voice. With perfectly good propriety we may call one a radio channel, and the other a wire channel. (Fig. 1.)

The radiophone, like the wire telephone, is provided with machinery to enable the voice to mold this stream of energy into a thousand delicate shadings—to draw a detailed picture of the voice, so that the apparatus at the far end may recognize the form of the original sound and reproduce it. The telegraph station (wire or radio) is a much simpler affair and is merely able to deal in black and white, turning the current clear off or clear on. It is the pen-and-ink poster against the fully colored painting. Ballantine has made another comparison and said that the phone deals in sculpture, while the telegraph deals only in mosaic. Fig. 2 attempts to make some of these comparisons clearer.

#### WHY THE CODE?

Again, radio and wire practice resemble each other closely in that the dot-and-dash survives though we have excellent voice communication. There are excellent reasons of the \$\$\$\$\$\$ sort that maintain Western Union and Postal Telegraph in the face of the facilities of the Bell System. The same reasons serve to keep the key-wiggler on the ether channels also.

Errors are less easily made with code than with voice. This dogmatic statement is somewhat illuminated by Fig. 3, and would be easily proved in several ways if we had space or time.

Cost, also, is very vital in the retention of the dot and dash. Telegraph equipment, needing only to turn power on and off, is simpler than apparatus which must mold, shade and vary.

Also, just as a telegraph operator can read his sounder in the presence of loud noises, so too the radio operator can read

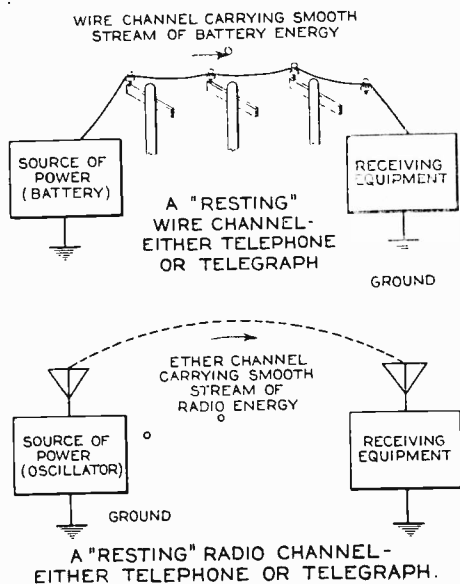
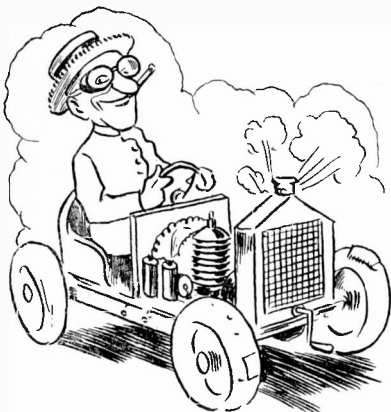


Figure 1



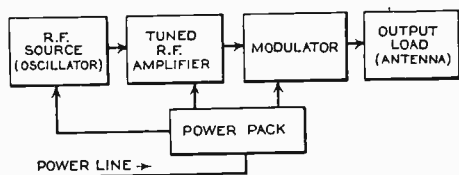
cylinder. The coil would throw a two-inch flame and the signal could at times be heard for over a hundred yards.

From that we graduated to a larger and more savage affair which produced a noise like the tearing of overalls, and which waggled all the lights in the south end of town. It was supposed to operate at 600 meters, but could be heard pretty

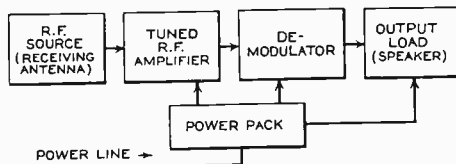


well at 400 and 1,000 for about 50 miles. The accompanying tuner was a single-slide affair of the type which was received during the days of early broadcasting and sold to unsuspecting folks at stiff prices.

After that we put up a transmitter, but if we wish to deal in things that are funny it is not necessary to go back to 1909. Just tune to about 95 meters and listen to the commercial phones pretending to be amateurs. The group appears to be located at flying fields where there is no flying, for there is "hamming" of a



FUNCTIONAL DIAGRAM OF THE TRANSMITTER



FUNCTIONAL DIAGRAM OF THE RECEIVER

Figure 4

sort that would make a pair of Brooklyn amateurs blush. I don't know what it is for, nor the moral it may convey, but at least it is another illustration of the smallness of the differences between various sorts of short-wave stations.

TABLE I

INTERNATIONAL SYSTEM OF IDENTIFYING NATIONALITY OF COMMERCIAL RADIO CALLS

CAA to CEZ, Chile	PKA to POZ, Dutch East Indies
CFA to CKZ, Canada	PPA to PYZ, Brazil
CLA to CMZ, Cuba	PZA to PZZ, Surinam
CNA to CNZ, Morocco	RAA to RQZ, Russia
	Algeria
CPA to CPZ, Bolivia	RVA to RYZ, Persia
CRA to CRZ, Colonies of Portugal	RXA to RXZ, Panama
CSA to CUZ, Portugal	RYA to RYZ, Lithuania
CVA to CVZ, Rumania	SAA to SMZ, Sweden
CWA to CXZ, Uruguay	SPA to SRZ, Poland
CZA to CZZ, Monaco	SUA to SUZ, Egypt
DAA to DZZ, Germany	SVA to SZZ, Greece
EAA to EHZ, Spain	TAA to TCZ, Turkey
EIA to EIZ, Ireland	TFA to TFF, Iceland
EIA to EIZ, Liberia	TGA to TGZ, Guatemala
ESA to ESZ, Esthonia	TIA to TIZ, Costa Rica
ETA to ETZ, Abyssinia	TTA to TTZ, Territory of the Saar Basin
FAA to FZZ, France and Colonies.	UHA to UHZ, Hedjaz
GAA to GZZ, Great Britain	UIA to UKZ, Dutch East Indies
HAA to HAZ, Hungary	ULA to ULZ, Luxembourg
HBA to HBZ, Switzerland	UNA to UNZ, Jugoslavia
HCA to HCZ, Ecuador	UOA to UOZ, Austria
HHA to HHZ, Haiti	VAA to VGZ, Canada
HIA to HIZ, Dominica	VHA to VMZ, Australia
HJA to HKZ, Colombia	VOA to VOZ, Newfoundland
HRA to HRZ, Honduras	VPA to VSZ, British colonies
HSA to HSZ, Siam	VTA to VWZ, India
IAA to IZZ, Italy and colonies	WAA to WZZ, United States
JAA to JZZ, Japan	XAA to XFZ, Mexico
KAA to KZZ, United States and colonies	XGA to XUZ, China
LAA to LNZ, Norway	YAA to YAZ, Afghanistan
LOA to LVZ, Argentina	YHA to YHZ, New Hebrides
LZA to LZZ, Bulgaria	YIA to YIZ, Iraq
MAA to MZZ, Great Britain	YLA to YLZ, Latvia
NAA to NZZ, United States, mainly U. S. Navy	YMA to YMZ, Danzig
OAA to OBZ, Peru	YNA to YNZ, Nicaragua
OIA to OHZ, Finland	YSA to YSZ, Salvador
OKA to OKZ, Czechoslovakia	YVA to YVZ, Venezuela
ONA to OTZ, Belgium and Colonies	ZAA to ZAZ, Albania
OUA to OZZ, Denmark	ZKA to ZMZ, New Zealand
PAA to PIZ, Holland	ZPA to ZPZ, Paraguay
PJA to PJZ, Curacao	ZSA to ZUZ, South African Union

NOTE: Many four-letter calls exist. These are made by simply adding another letter to any one of the combinations assigned to the country.

TABLE II

INTERNATIONAL SYSTEM OF IDENTIFYING EXPERIMENTAL AND AMATEUR STATIONS

The calls of such stations differ from ordinary commercial calls by the presence of a number, directly after the identifying letter or letters. Thus WHD is an Amer-



ican commercial station, but W2EB is an American amateur station, both located in New York. There is nothing about the call WHD to show where in the U. S. A. it is located, but W2EB indicates that the station is located in the 2nd Radio District. The significance of the number is not always geographical in foreign countries; it may indicate a special or experimental station. In this country such stations are indicated by particular letters following the number, usually the letter X. Thus W8XK becomes an American special or experimental station located in the 8th Radio District.

Abyssinia	ET	India	VO
Afghanistan	YA	Iraq	YI
Alaska	K7	Ireland	EI and GI
Algeria	CN	Italy and colonies	I
Argentina	LU	Japan	J
Australia, UO and	VK	Jugo-Slavia	UN
Belgium and colonies	ON	Latvia	YL
British Isles	ON	Liberia	EL
Bolivia	CP	Lithuania	RY
Brazil	PX	Luxembourg	UL
Bulgaria	CP	Mexico	X
Canada	VE	Morocco	CM
Chile	CE	Newfoundland	VO
Costa Rica	TI	New Zealand	ZL
Cuba	CM	Nicaragua	YN
Curacao	PJ	Norway	LA
Czecho-Slovakia	OK	Panama	RX
Denmark	OZ	Paraguay	ZP
Dominica	HI	Persia	RV
Dutch East Indies	PK	Peru	OA
Ecuador	HC	Philippines	K1
Egypt	SU	Poland	SP
Estonia	ES	Porto Rico	K4
Finland	OH	Portugal	CR and CT
France and colonies	F	Rhodesia	VQ
French Indo-China	FI	Rumania	CV
Germany	D	Russia	RA
Guatemala	TG	Salvador	YS
Haiti	HH	Siam	HS
Hawaii	HA	Spain	EAP
Hedjaz	UH	Sweden	SM
Holland	PA, PB, PC	Switzerland	HB
Honduras	HR	Uruguay	CW
Hungary	HA	United States	W
Iceland	TF	Venezuela	YV

ulation department has spent considerable time canvassing radio stores and newsstands in an effort to recover old copies. We are happy to report that all the back numbers are now available, but in limited quantity. If you are a recent subscriber and want to complete your file, send in your request as soon as possible; orders will be filled in rotation until the supply gives out.

#### CONTAIN VALUABLE "DOPE"

Including this one, a total of eleven numbers of RADIO DESIGN have been published. The magazine was started in 1928, and has grown from a thin pamphlet into the third largest radio publication in the United States. The back numbers contain a veritable gold mine of information and are interesting and instructive even at this late date. The issue of Winter, 1928 (Vol. 1, No. 4), contained descriptions of the SG-105, the K-108 and the "Pilotone Electric Six." The issue of Spring, 1929 (Vol. 2, No. 1) had the article describing the now-famous Super-Wasp, the first short-wave receiver to use a tuned screen-grid R. F. stage. The 96-page Fall, 1929, number (Vol. 2, No. 3) described the A. C. Super-Wasp, the Grimes "D. C. New Yorker," and the K-113 push-pull amplifier. The Winter, 1929, and the Spring and Summer of 1930 issues contained some very valuable "dope" on the short-wave stations of the world. The numerous contributions by David Grimes, Robert Kruse, John Geloso, Alfred Ghirardi and Zeh Bouck are among the best pieces of radio writing ever presented and are well worth reading.

#### HOW TO ORDER

These back copies cost fifteen cents apiece. Money orders or United States stamps are acceptable, but not Canadian or foreign stamps. Address your orders to the Circulation Department, RADIO DESIGN, Lawrence, Mass.

### Back Copies of "Radio Design" Now Available

BECAUSE of the great demand for back issues of RADIO DESIGN, our cir-

PLACE IN BROADCAST RECEIVER	PARTS	PLACE IN SMALL TRANSMITTER
R. F. amplifiers	2-224 tubes	R. F. amplifiers
Demodulator (detector)	1-227 tube	Modulated amplifier
1st audio	1-227 tube	1st audio
2nd audio	2-245 tubes	2nd audio (modulators)
	1-227 tube	oscillator
	microphone	as voice pickup
Output to speaker	stepdown transformer	
As load	stepup transformer	input from mike
Input	speaker	
	antenna	output
Supplying all A, B and C voltages	Power-Pack	Supplying all A, B and C voltages

# "NRH"-- A Unique Short-Wave Broadcasting Station

By ROBERT HERTZBERG

**W**AY DOWN in tropical Central America, just below the bandit-infested country that keeps the United States Marines so busy, is the smallest and most unique broadcasting station in the world. This is NRH in Heredia, Costa Rica, 3829 feet above sea level and surrounded by abundant coffee trees. It was built and is owned and operated by one Amando Cespedes Marin, a native of the country, who is a photographer by profession. Although it uses only  $7\frac{1}{2}$  watts of power on a frequency out of the recognized short-wave relay channels, and employs a set of call-letters that properly belongs to the United States Navy, it has built up an international audience of listeners that finds its programs interesting, thrilling and amusing. It is almost altogether a one-man affair, its owner acting as engineer, announcer and chief entertainer, with the frequent help of an old phonograph and the occasional assistance of his family of four children, the oldest of which is 17, and the youngest only fifteen months.

Señor Cespedes is blessed with an unusually favorable location for short-wave transmission, and he has adopted a wavelength that radiates from that location in a highly efficient manner. The  $7\frac{1}{2}$  watts of power that he uses is hardly enough to illuminate a boudoir lamp, yet his signals boom into the United States with tremendous volume. He is now struggling with a 150-watt transmitter, but I doubt whether this produces any better results than this present little one-lunger.



So far-reaching have been the effects of NRH's programs in cultivating what might be called international good will that the government of Costa Rica has given Señor Cespedes the free use of the mails, thus placing him on the same basis with its diplomatic service. The official stamps which the grateful government sticks on his letters of verification are gleefully torn off by radio bugs who also happen to be philatelists.

#### A RADIO PHENOMENON

How did this little station happen to develop so importantly in the remote center of America? The answer is that the radio fever is no respecter of persons or climates and strikes wherever it happens to like. In the case of Señor Cespedes it afflicted a picturesque individual of more than ordinary intelligence, and the results are now obvious in the world-wide fame that the little outfit has achieved. Talk to any owner of a short-wave receiver and he will tell you of Señor Cespedes' announcements and talks in meticulous and sometimes excruciating English, or of the programs of romantic Spanish music played by an old victrola or of the naïve little talks delivered by his eldest daughter. His youngest offspring is probably the only baby whose voice has echoed around the world, although the parents of others may think that their own infants can well challenge him for the record. When the child was only two months old,

the proud father put him in front of the microphones and let him squeal into it. Some listeners (bachelors, no doubt) were unkind enough to describe the sounds as "static," but most of Señor Cespedes' faithful audience listened to the noises with much delight. They sent the child numerous little gifts, which shows that sentiment still exists in this otherwise cruel world.

Señor Cespedes has been kind enough to prepare a brief autobiography for the editor of RADIO DESIGN, who takes great pleasure in publishing it herewith. Those owners of Super-Wasp and other short-wave receivers who listen to NRH nightly will recognize the English instantly, as it is just as interesting, sincere and whimsical in printed form as it is over the air.

#### PERSONAL HISTORY

"Cespedes is my family name, belonging to my father, and Marin is the original family name of my mother. We Spanish people descendants feel proud to demonstrate with our two family names that we are legitimate offsprings, of pure blood. That custom is encouraging, because our offsprings do know their true relatives and ancestors at once.

"I was born in San Jose, the capital of Costa Rica, forty-eight years ago. When I were nine years old I wanted to learn English language and, besides the school special lessons, I had an extra daily-hour

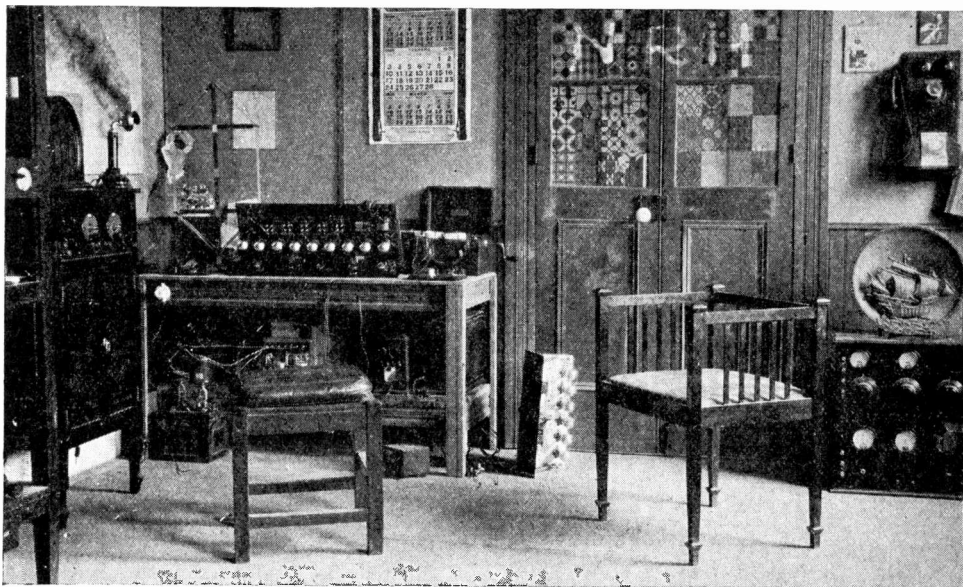
everyday. Thus when I was ten, I could speak and write as much as I do now. I used then to translate from either language and made enough money to earn in three years my fee to New York.

"In New York I done the same and went to night schools free, during seven years, during which I earned and lived and learned many things that a man being a kid wanted too. Returned my country with money. Returned again to U. S. A. and studied photography in Illinois, and in 1901 I had a good-looking business in San Jose.

"I was Commissioner Attaché to the Louisiana Purchase Exposition in 1904 and traveled after that for many a beautiful spot in grand old U. S. A., which I consider as my nourishing country. Returned in Costa Rica after being, in Panama, Chief of the Statistical Census Office for three years. Married here, and in eighteen years have four lovely offsprings, which are now full of radio 'IT,' worst than I am.

"Radio interested me from *Radio News Magazine* ever since November, 1923. The first letter of verification was from Mexico on that month. I heard it with one-tube set made in accordance with article by Joseph Calcaterra, a kind engineer and writer that helped me as a father of radio. I am also indebted to Mr. M. B. Sleeper, of known name.

"I studied *Radio News*, *Radio Engineer-*



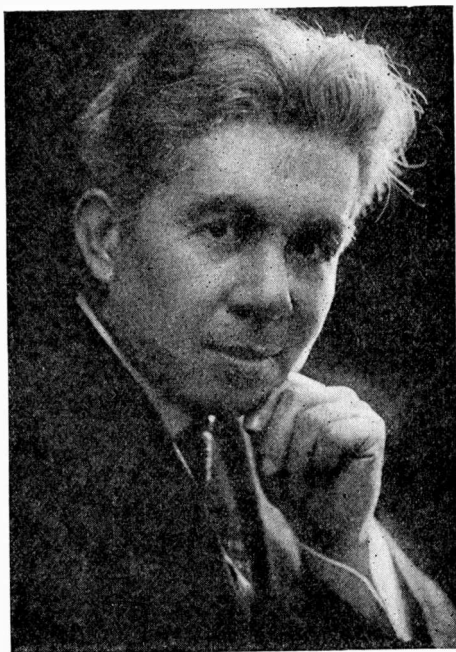
*A corner of the combined NRH studio and operating-room, showing the receiving and monitoring equipment.*

ing, *Radio Broadcast*, *Radio World*, *Radio*, *QST*, and all radio pages in your daily newspapers. Discussed ideas with many a man and engineers, and at once found me as a set builder, making radio fans in this country every day. Whatever we have of radio in Costa Rica, I am proud to state that it has been made, done or caused by my terrible constancy to push radio activity in the country.

"If Calcaterra gaved me the first reception construction ideas, M. B. Sleeper taught me something about transmitting sets. Then after the Radio Engineering Laboratories have taught me a lot from their hookups.

#### REACHING OUT

"But the actual short-wave transmission has been caused by the first man that reported my 39-meter broadcasting on May 11th, 1928, when Mr. Henry P. Karr, of U. S. A. Camp at Gatun, Panama, Canal Zone, wrote: 'Your modulation is fine; we could understand easily every word.' (Mr. Karr is now W9DQF at Great Bend, Kansas, as he writes me.) If ever I am indebted for the United States spreading of my 30.3-wave amateur broadcasting, the title goes to Mr. Charles J. Schroeder, of 3125 North Spangler Street, in Philadelphia, being the first



*Señor Amando Cespedes Marin,  
builder and operator of NRH.*

man that heard and reported my voice and music, through the courtesy of *Radio News Magazine*, last November, 1928. To Mr. Schroeder and to *Radio News*, the honor of being the openers of your great U. S. A. door to the smallest radio broadcasting on earth! I claim like the old Milwaukee beer, that the NRH has made Costa Rica famous with *only 7½ watts and 500 volts on the plate. Hi!*

#### MY EXPERIENCES

"*November 2nd, 1923.* Built a regenerative one-tube set. I heard the voice of lady singing so sterling that innocently I was looking for her within the four inches coil . . . hi hi!

"*March 4th, 1924.* The first set I sold to a rancher rich man. We heard Hastings, Nebraska, at the porch, 300 feet away from loud speaker. I returned that night at 2 A. M., March 5th, my wife was waiting for me. My children had slept themselves on one bed. My wife told me to remove one of them to his bed. I told her it was already 3 A. M. and to let the children away without disturbance. Went to bed at 3½ A. M. Could not sleep, thinking of the beautiful Hastings broadcasting, when a little after 4 A. M. a big earthquake shook the house, teared it to the ground. I went to the room of my children over the débris, and finding them OK, but the bed that belonged to the boy was broken in three parts from part of the roof falled. My children were saved by the radio affair of that night. One of them would have been killed if same would have been sleeping in his bed.

"*March 8th, 1924.* What a surprise to hear from Havana, Cuba, the reports of my experience of the 4th of March earthquake, giving complete details as reported to newspaper men. I received many letters from all around Central America, Mexico, Cuba, etc.

#### ACROSS THE OCEAN

"*November 24th, 1924.* With three-tube set, using 199-tubes and dry batteries, from 6 to 8 P. M. CST, I heard a broadcasting from Manchester, England, as the first night test under Radio Broadcast International Test. That was on long-waves, for the first time in America. The rest of that week nothing doing no matter where.

"*December 1st, 1924.* From *Rudio News* I made the first 201-tube transmitter, in duplicate sets, and talked with a friend five miles distant. Same set was used as a broadcaster with phono records and the few hearers then thought it were a power-

ful United States station three thousand miles away. Many congratulations when they found it was a local work.

"January, 1927. From *Radio Mechanics*, I made the best long-wave transmitter and started a regular broadcasting for fun, to help me out the set building, and the sale of replacement parts.

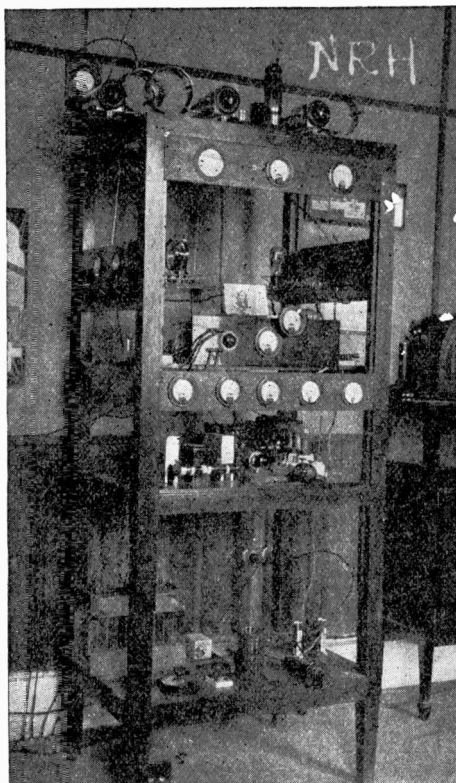
"March 4th, 1928. With short-wave transmitter begun transmission with 39 meters wavelength, thinking to phone 100 miles only, for the use of country farmers.

"May 18th, 1928. Henry P. Karr, of Gatun, in Canal Zone of Panama, reported my regular broadcasting for ten days, under heavy interference of code. (300 miles record.)

#### 1,200 MILES RECORD

"June 19th, 1928. Mr. Vava, from Guayaquil, Ecuador, reported the broadcasting as being *Monumental*, like the big fellows, 'just like hearing vaudeville in an theater.' This report gived me a long DX record for 1,200 miles from South America.

"July 1st, 1928. The principal newspaper in Havana inserted an article giving account of the NRH broadcasting, being marveled at my low power of  $7\frac{1}{2}$  watts and reported by hundreds of fans to them. After this date, hundreds of let-



Above: This looks like a big frame, but the actual transmitter on it has an output of only  $7\frac{1}{2}$  watts. Señor Cespedes pieced the whole outfit together himself, working patiently with only the assistance of magazine articles and letters from American amateurs. Left: The youngest member of the Cespedes family, who is as familiar with his father's microphone as he is with his own rattle.

ters came from Central and South America, and West Indies, also Mexico.

"October, 1928. *Radio News*, of New York opened the door of U. S. A. radio listeners, through the medium of Mr. Charles J. Schroeder, of 3125 North Spangler Street, Philadelphia, Pennsylvania. Being 2,500 miles north of Costa Rica, Mr. Schroeder reported to *Radio News* editor: 'He was first on 39 meters, but late in using 30. I know for a fact that it is not the Costa Rica government

for the announcer says that he is an amateur station, at Heredia, Costa Rica, although I cannot get his call or name.' In accordance with such insert, Mr. Schroeder was hearing the NRH ever from my beginning with 39 meters for a month from May to June only, because on account of code interference I changed my wave.

"December, 1928. By the insertion of my call-letters in *Radio News*, January, 1929, number, every one almost has report-



ed my broadcasts and all whatever I speak, making me feel hesitating of such real DX with less power than a regular house incandescent lamp. Ever since, every week mail brings me from 40 to 85 letters from all over the American Continent, reporting in full, and inquiring all kind of things.

#### AN ANNIVERSARY

"*May 4th, 1929.* I celebrated my first year of short-wave broadcasting, sending out a three-color diploma with the Costa Rican flag and pictures of the station. This diploma is being framed by all radio friends, which think of me as 'the real home station, 'the most friendly station on earth,' 'we are with you 100%,' 'you are the smallest radio power station, but the biggest towards real amateurs love,' 'you can be compared favorably with the biggest stations in the world,' 'the most consistent station of them all,' 'the best phone station I ever heard,' 'you are doing a remarkable work,' etc.

#### FREE POSTAGE

"*June 19th, 1929.* The government of Costa Rica, on account of the true statements of my reaching power, and considering a benefit to the country the hard work I put in my daily-hour of broadcasting, and to stimulate the real amateur work in radio, published a decree in the

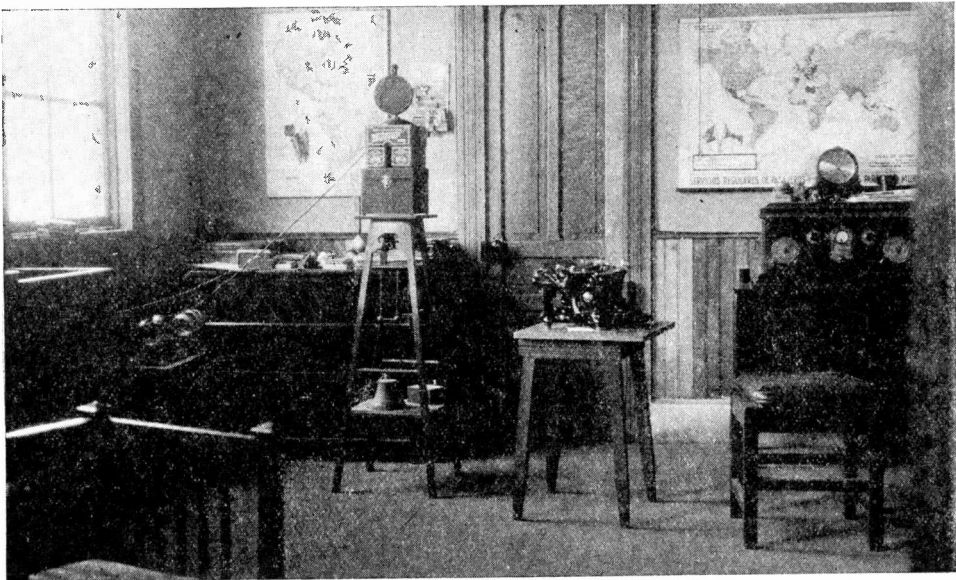
official paper, stating that from this date on, all my mail to foreign countries would not cost me a cent, and should be considered as diplomatic service, with free postage.

#### DEVELOPS FRIENDSHIP

"Those are all my experiences, after 70 months of hard amateur work recognized by all the American Continent. It has developed true heart friendships in different cities of U. S. A., because I have tropical time to answer personally every letter sent me, giving the touch of fraternity and culture, so much desired in this day of brothership. It also has developed a better understanding among the Latin American republics, calling me as 'the mentor of the Spanish race,' 'the light-house of Spanish America,' 'the cry of the Continent'; I am thankful towards all the U. S. A. newspapers and magazines for everyday insertions about the NRH, the only amateur broadcasting station on earth, doing the most consistent work."

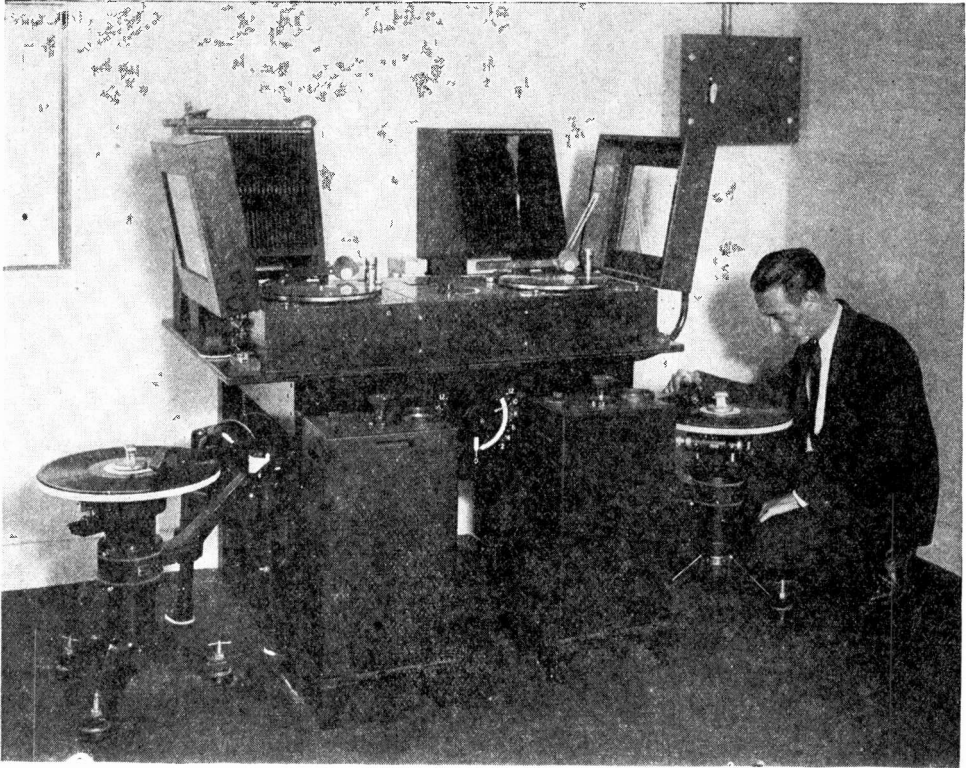
\* \* \*

This is the story of NRH. If you have heard Señor Cespedes, you can now appreciate what he has done in radio. If you have not yet heard him, chase down to 30.3 meters on your short-wave set some night between 10:30 and 11:30 Eastern Standard Time, and you will find a treat in store for you.



The "studio" of NRH. The microphone stand is a combination of a flower pot stand, a wavemeter case, and some tube boxes!

# Recorded Programs Staging Comeback



*This photo shows the equipment used at station WOR for the broadcasting of recorded programs. A total of four turn-tables is available.*

**H**ISTORY seems to be repeating itself in radio broadcasting, just as it has often repeated itself in other industries. When the first broadcasting stations went on the air, during the years 1920, 1921 and 1922, their programs, for a large part, consisted of phonograph music. At the present time recorded programs are staging a very notable comeback, their success being due to their high technical quality and intelligent arrangement.

Ten years ago, when phonograph music was to be broadcast, the station operator merely cranked up the old victrola, wheeled it in front of the microphone and turned it on. As neither the records nor the microphones of that period were particularly good, the transmitted music sounded horribly scratchy and noisy, and programs of this kind developed bad reputations.

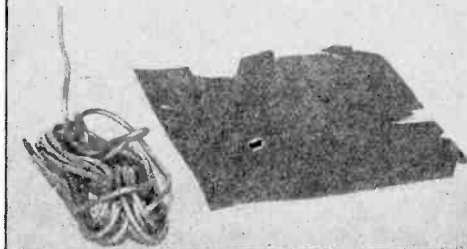
Today a large organization devotes its entire time to turning out programs recorded on special large discs which, at the

transmitting station, are used in conjunction with highly sensitive pick-up units and complicated regulating machinery. These recorded programs, as transmitted over the air, are not merely as good as regular studio performances, but frequently even better. In the radio studio, during a regular program, it is impossible to correct a mistake after it has been made in front of the microphone. However, in the recording studio, only the best of a number of performances is used, and the poorer records are discarded entirely. These special records broadcast so clearly that a listener cannot distinguish them from real programs.

Recorded programs have a number of advantages, particularly for small stations. They are just as useful in large stations for special types of broadcasting. WOR, in Newark, N. J., unquestionably one of the most important stations in the country, has installed equipment for this work and has found it very successful.

# Soldering Is Simple--

If  
You Do It  
Correctly



*by the Editor*

**I**T IS the general consensus of opinion among service men and professional set builders that most radio fans and experimenters do not know how to solder properly. The art is a very simple one, yet ignorance of its fundamental points is responsible for probably 75% of the trouble that develops in home-built radio apparatus. Many amateur mechanics who can handle screw drivers, pliers and other small tools quite capably find the soldering iron a very awkward device, and with their poor soldering they very frequently ruin what otherwise would be highly successful receivers.

#### WHAT YOU NEED

If you are one of the fraternity who have found it a bit difficult to make the solder stick, perhaps you will appreciate a little elementary instruction. There really is nothing to the work, but like with everything else, there is a right way and a wrong way. You do not need expensive or complicated equipment. The only materials you should have are an electric soldering iron of respectable weight and fitted with a clean copper tip not more than  $\frac{1}{2}$ " or  $\frac{5}{8}$ " in diameter, a roll or a spool of rosin-core solder, and a few small pieces of a medium grade emery cloth. If your home is not wired for elec-

tricity, you can use the old-fashioned plain soldering copper, which must be heated either in a coal stove or over a gas flame. A Bunsen burner, such as used for school chemical experiments, makes an ideal heater, as it generates an intensely hot flame with the burning of only a small amount of gas. Regardless of which type of iron you use, by all means rig up some kind of a stand on which you can place the iron when you are not using it. A simple rack made out of stiff wire will serve the purpose, as long as it is at least 4 or 5 inches high. Any arrangement that will elevate the iron above the level of the table and thus prevent it from burning surrounding objects will be found satisfactory. If the iron is of the electric type, provide it with a good long cord, so that you may be able to move it around freely without knocking over a lot of apparatus.

#### THE SECRET OF SUCCESS

The entire secret of successful soldering is cleanliness. It is impossible to make a good soldered joint if either the iron or the work itself has a layer of dirt or grease over it. The first thing to do is to prepare the iron by "tinning" it. Turn on the current and, while the iron is warming up, rub the faces of its tips on a piece of emery cloth, so that the surface

becomes clean and bright. As the iron approaches operating temperature, the color of the copper will change. After the iron has been turned on for say five minutes or so, and appears to be pretty hot, again clean the tip quickly and apply the end of a piece of solder to it. The solder should melt instantly and should form a clean bright layer for the copper. Apply only enough solder to form this coating. If a lump forms, shake it off or wipe it off with a thick rag.

#### KEEP BELOW RED HEAT

If you heat your iron by means of a gas flame, be careful not to bring it to red heat, as it is utterly impossible to solder with a red-hot iron. Place the copper in the flame so that the tip sticks out free and does not burn.

#### THE SOLDERING PROCESS

Preparing the material to be soldered is a quick and simple matter. Suppose you want to connect two bare copper wires. First remove the insulation with a knife and scrape the wires clean, either with the back of the knife or with a piece of emery cloth. Be sure that all traces of the rubber insulation are removed. If the wire is stranded, separate the strands so that as many of them as possible are cleaned. Twist the ends of the wire together. Take the soldering iron in one hand and the solder in the other and apply both to the wire. Melt down the solder with the tip of the tool so that both the solder and the rosin run on to the wire. Keep the iron in place long enough to allow the molten mixture to penetrate the joint. Let the solder simmer a little and then remove the iron, being careful not to disturb the wire until the solder solidifies. That is all there is to the whole operation.

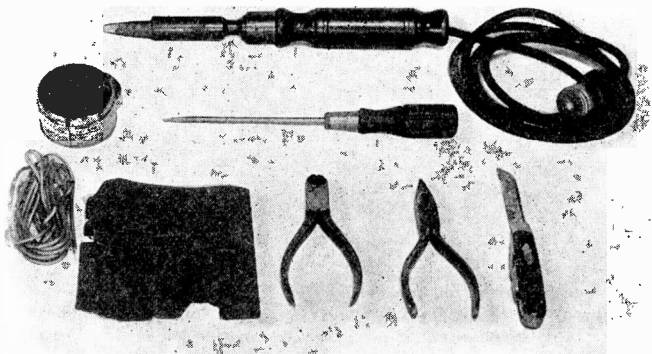
If you do not believe that cleanliness is important, just try to solder two wires that are not bright and shiny. The solder will simply roll off and will absolutely refuse to stick.

The connection lugs on most radio parts are already tinned, that is, covered with a thin layer of solder. This makes the soldering operation exceedingly easy. The copper wire supplied with most kit-receivers is also tinned and such wire need not be cleaned unless it has been handled a great deal and has picked up a covering of dust or grease. Even with wire and soldering lugs that are prepared in this way, it is a good idea to exercise a little elbow-grease and to wipe them clean. Even a superficial layer of dirt that appears to be harmless may cause trouble.

#### PURPOSE OF FLUX

The purpose of the rosin is not generally understood. If you use plain solid solder and attempt to make it adhere to a piece of metal, you will find your efforts altogether unsuccessful, regardless of how clean the material is. The application of the hot iron causes the formation of an oxide of the metal on its surface and this film, although it is only of microscopic thickness, prevents the molten solder from adhering to the material. The rosin absorbs this protective coating just as quickly as it forms and therefore allows the solder to flow into the pores of the metal, thus making a good tight joint. The rosin is known as a "flux" and is universally used in radio work because it does not cause after-corrosion. There are also fluxes in both liquid and paste form, which are applied to the work to be soldered with a brush or a small piece of wood like a match-stick. Rosin core solder is particularly convenient because the

.....  
*With these simple tools you can assemble and wire practically any radio set. TOP: Electric soldering iron, CENTER: Can of soldering paste and screw driver. BOTTOM: Rosin-core solder, emery cloth, diagonal cutters, long-nose pliers, knife.*  
.....

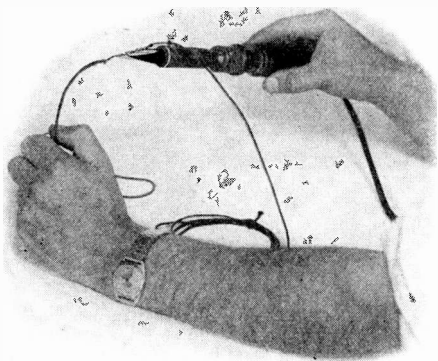


flux flows on to the joint at the same time that the solder does and therefore saves the solderer an extra movement of the hands.

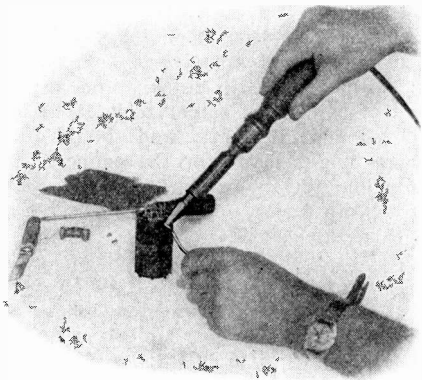
After a soldered joint has hardened, some of the excess rosin may appear around the edges. You can scrape it off very easily as it is crystalline in nature and breaks off readily. Most soldering pastes are objectionable because they smear all over the work and frequently cause high resistance short-circuits between two otherwise insulated connections, although if carefully used they are entirely satisfactory. As you use your soldering iron, you will notice that the tinning will tend to burn off and the copper itself will become black and corroded. After a particularly long stretch of servicing, small pits will develop in the tip. Never neglect to clean off the corroded surface, using nothing more than a rag or, if necessary, a piece of emery cloth. Keep a thick wad of cotton or flannel sheeting on hand and use it frequently. Of course, it will be necessary to use a file to smooth down the pitted surface. Do not remove any more of the metal than necessary. After finishing a particular soldering job, always wipe off the iron just before it cools off completely. It should always be left cleanly and brightly tinned.

#### WHAT CAN BE SOLDERED

Brass, copper, iron, steel and zinc can be soldered readily with an ordinary iron and ordinary fluxes. However, aluminum cannot be soldered because it is always covered with a natural film oxide which cannot readily be removed. Be-



*To make a really good twisted joint in wire, hold the iron under the wire after you have melted some solder on the latter, and let the molten metal "soak" thoroughly into the twists.*



*To solder a wire to a connection lug, merely hold the end of the solder under the tip of the iron, and place both over the wire. Hold the iron steadily while the solder melts and runs thoroughly into the joint.*

cause this metal is so light and easily worked, joints in it are usually made by means of rivets or nuts and bolts or sometimes by means of electric welding. Don't waste any time trying to solder copper wires to an aluminum panel; it just won't work.

#### AN AUTOMATIC STAND FOR THE IRON

The life of an electric soldering iron can be lengthened considerably by the use of a stand that reduces the current through the heating element while the tool is not in actual use. Such a stand may consist merely of an electric lamp and a switch actuated by the weight of the iron, the circuit being so arranged that the lamp is connected in series with the iron when the latter is placed on the stand, thus reducing the current somewhat but still keeping the temperature up. When the iron is picked up, or moved a little so that it unbalances the switch, the lamp is shorted out and the full current flows through the iron.

The photograph on the next page shows a very handy stand of this kind made out of two pieces of wood, the clapper from an old door bell, some pieces of wire, and two ten-cent lamp sockets. The end of the clapper or armature is mounted on a block of wood about an inch high, and the clapper itself bent half moon shape to form a support for the iron. A contact on an L-shaped brass arm is fixed behind the armature, and adjusted so that the weight of the iron on the latter will cause the circuit to be opened.

The wiring is exceedingly simple, and



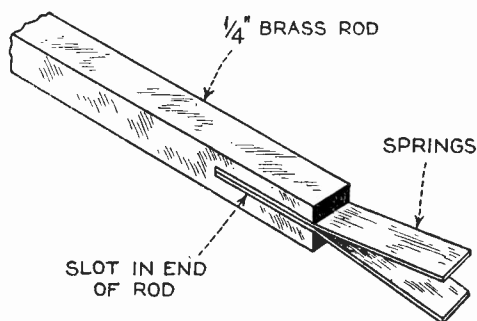
is shown in the accompanying diagram. The cord from the iron is plugged into one lamp socket, and connection made to the 110-volt line by means of a separate length of wire, so that the iron can always be used for outside work.

The size of the lamp necessary to maintain a proper working heat will depend on the particular iron on hand. Bulbs of the 50-, 75-, and 110-watt size should be tried.

### A Handy Spring Screw Driver for Getting Into Tight Places.

**I**N ASSEMBLING many kit receivers it is sometimes necessary to place short machine screws in places where the fingers will not reach. This is particularly true of the screws that hold the bottom edges of the Super-Wasp shield cans to the top side of the aluminum sub-panel.

An extremely useful spring screw driver that will hold the screw in position can be made in a few minutes from pieces of scrap metal. All you need is a piece of  $\frac{1}{4}$  inch square or round brass bar about 7 inches long, and two pieces of any springy metal, each about  $1\frac{1}{2}$  inches long and  $\frac{1}{4}$  inch wide. An old alarm clock spring will furnish enough of this material for a dozen such screw drivers. Simply slit one end of the brass rod with hacksaw to a depth of about  $\frac{3}{4}$  of an inch. In this slot insert the two springs, which must be so shaped that their outer ends curve out from each other a distance of  $\frac{1}{4}$  or  $\frac{1}{2}$  inch.

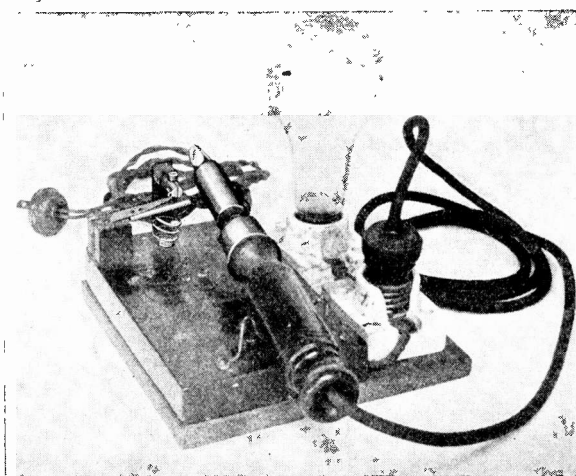
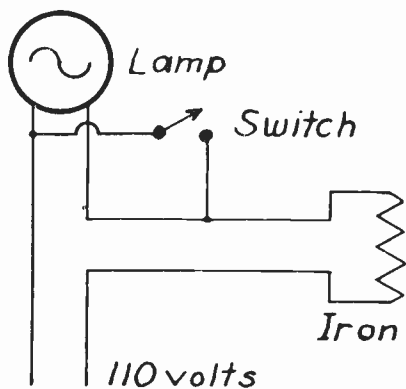


*After the springs have been placed in the slot in the brass rod, they should be screwed or soldered securely in place.*

Now simply solder or bolt the springs to the brass so that they will not come loose. If you find it difficult to drill through the steel or if the heat of the soldering iron seems to soften the springs, simply bind them tightly with wire.

It is important that the ends of the springs, when brought together, be of exactly the same length. When inserted in the slot of a screw, they will then hold the latter firmly and will allow you to push it through a hole even in the most inaccessible place in a receiver.

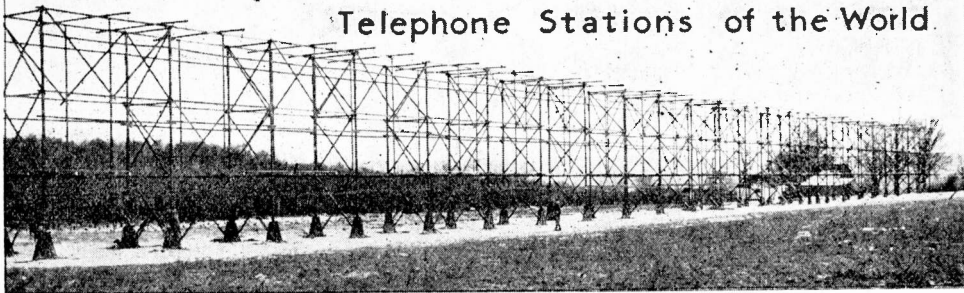
It is not necessary to put a handle on the other end of this spring screw driver, as the only purpose of the tool is to start the screw in the hole. A regular screwdriver can then be used for tightening. It is a good idea to file down the free end of the rod so as to form a small blade that can be used for tiny set screws.



LEFT: Wiring diagram of the automatic iron stand. RIGHT: General view of the stand, showing the placement of the parts. If the iron is too heavy for the armature spring alone, place a small coiled spring under it.

# Short Waves - But Long Distances

Latest Information About the Short-Wave Radio  
Telephone Stations of the World.



*The title cut above shows one of the receiving antennae used at Netcong, N. J., in the overseas radio-telephone service of the American Telegraph and Telephone Company. The framework is of wood, while the aerial itself is a series of brass pipes arranged in crenelated form. Compare the size of the system with the man in the center foreground.*

**R**ADIO DESIGN'S battle to obtain information about the short-wave radio-telephone stations of the world continues unabated. We have written, telephoned or telegraphed to every station listed in all the call-books we can find, and we are publishing the replies just as quickly as they arrive. In addition we spend considerable time scanning the foreign radio magazines in an effort to pick up bits of useful information.

We are indebted to the American Radio & Telegraph Co. for a description of the very interesting radio-telephone work being done by that organization. Every owner of a short-wave receiver has at one time or other picked up the signals from either the shore stations along the New Jersey coast or from the various ocean liners fitted with radio-telephone equipment, so the accompanying article and photographs will undoubtedly be of interest. The pictures of the apparatus used for this service are rather unusual and give a good idea of the intricacy of the installations.

In connection with this matter, we would like to emphasize the very important point that the work being carried on by the A. T. & T. with their short-wave stations is

not broadcasting but is essentially private radio-telephone communication. It is strictly against the radio laws to divulge the nature of messages picked up by private listeners, although there is little likelihood of legal trouble in this regard because most listeners are interested in the transmission itself rather than in the actual conversations.

#### SHIP-TO-SHORE TELEPHONE SERVICE OF THE AMERICAN TELEPHONE AND TELEGRAPH COMPANY

Ship-to-shore radio telephone service is furnished by the American Telephone & Telegraph Company to four ocean liners. These are the *S. S. Leviathan* of the United States Lines and the *S. S. Majestic*, *Olympic* and *Homeric* of the White Star Line. While these ships are within range of the company's radio stations at Deal Beach and Forked River, N. J., the service is available to all points in the United States and Cuba, and to the principal cities of Canada and Mexico, through wire line extensions.

Since service was inaugurated last December 8 with the *Leviathan*, all transmission has been done from the Bell Telephone Laboratories experimental station at Deal Beach. However, on about Novem-

ber 1, of this year, the new transmitting center for ship-to-shore service at Ocean Gate, N. J., will take over this function of sending all conversations to the liners at sea.

#### NEW OCEAN GATE STATION

When the Ocean Gate station is completed in the Fall it will be equipped with four antennae for short-wave transmission. These will operate at frequencies of from four to seventeen megacycles. The building at Ocean Gate is already complete. On the first floor of this building will be the generators for supplying current for the transmitter, the transformers for changing the outside power supply to various required voltages, and other auxiliary machinery.

On this floor is also the "line terminal room," the junction point between the wire lines from the company's long distance office in New York and the radio circuits. This room is completely sheathed with copper, which prevents the radio waves leaving the antennae outdoors from coming back and impairing operation of the apparatus in the room. Cork insulation under the foundations of the rotary machinery in the power room avoids the effects of vibration on delicate radio apparatus.

There is room for two transmitting sets on the second floor. In the rear will be

a rectifier, which will convert the alternating current from the outside power source into the direct current required in the vacuum tubes.

Initially one transmitter is to be installed at Ocean Gate. This will be a set similar to those now in use for transatlantic and South American services at the Company's transmitting station at Lawrenceville, N. J. It will have a power of 15 kilowatts and will be maintained at the desired frequency by means of a quartz crystal control circuit. The crystals for this circuit are to be located in a heat-insulated oven, the temperature of which is accurately and automatically regulated.

In the final or output stage of the transmitter there will be six 10-kilowatt water-cooled vacuum tubes operating at a plate voltage of about 10,000 volts.

#### DIRECTIONAL AERIALS USED

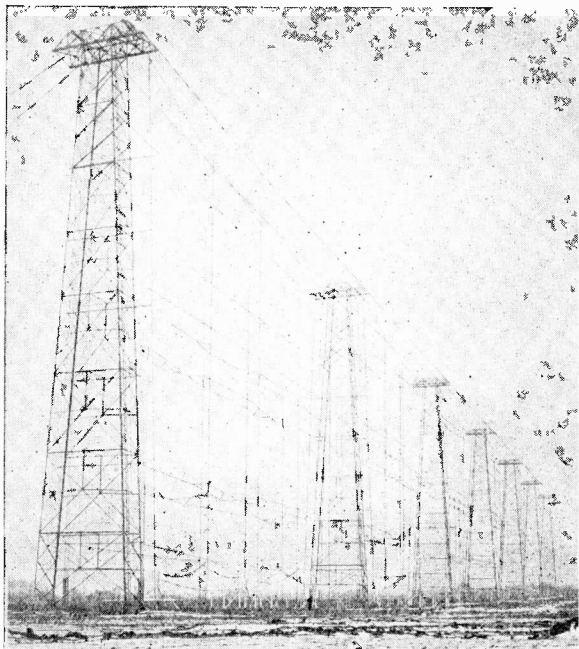
The antennae are to be of the "curtain" type, consisting of networks of wires in the form of coarse-mesh curtains suspended from 70-foot poles, in the line of poles broadside to the direction of transmission.

Due to the arrangement and interconnection of these wires the signals sent out have a marked directional effect. Impulses from the various vertical segments neutralize each other in the plane of the curtain while those in the direction perpendicular to that plane reinforce each other.

---

*Although amateur short-wave transmitting aeri-als are usually very simple affairs, consisting of one or two wires, the antennae used for commercial communication are large and complicated. The illustration to the right shows the directional antennae at Lawrenceville, N. J., for the radiophone circuits to South America. Each pair of "bays," or intervals between towers, contains a complete antenna. Compare this network of wires with the tiny figure of the man at the foot of the second tower.*

---



### STEAMSHIP LANES COVERED

The arc over which the antennae transmit covers the principal steamship lanes to Europe. The efficiency of each antenna will be further increased by suspending a "reflector" curtain similar to the exciter curtain at a given distance behind it. This will serve to reflect radio energy emitted in that direction.

The equipment at Deal Beach, now being used in ship-to-shore service, is somewhat similar to that being installed at Ocean Gate. The types of equipment aboard the ships differ. On the *Leviathan* the American Telephone & Telegraph Company has installed a 500-watt set. The International Marine Radio Company, Ltd., provides equipment aboard the *Majestic* and the *Olympic*, and the Marconi International Marine Communication Company, Ltd., provides that on the *Homeric*.

The ship-to-shore receiving station at Forked River is equipped with three specially designed receiving sets, equipped for automatic volume control. All of these are now in operation. They are arranged to

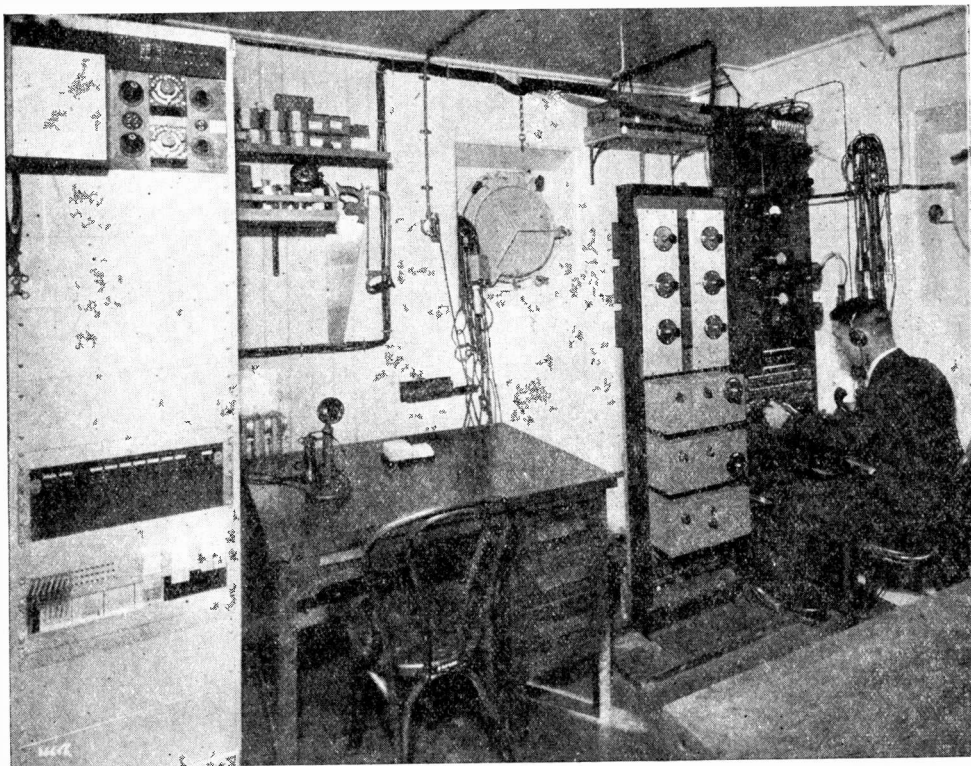
operate over four ranges of frequencies in the 4, 8, 13 and 17 megacycle bands, and are provided with switching devices to permit connection to anyone of several antennae. There are two crate and one "V" type antennae.

### BRASS PIPE ANTENNA

Each antennae array consists of a series of brass pipes arranged in a crenelated, or "wall of Troy," formation in a vertical plane and mounted on a wooden framework. These antennae also have marked directional characteristics, their receptivity being confined to approximately the same arc as that covered by the Ocean Gate transmitter.

By means of concentric copper pipes, laid a few feet above the ground in an undulatory form, antennae and receiving set are connected with a minimum of outside interference.

The four liners having ship-to-shore telephone service also have connection with points in Great Britain when within range of the English radio telephone stations. Provision has also been made for

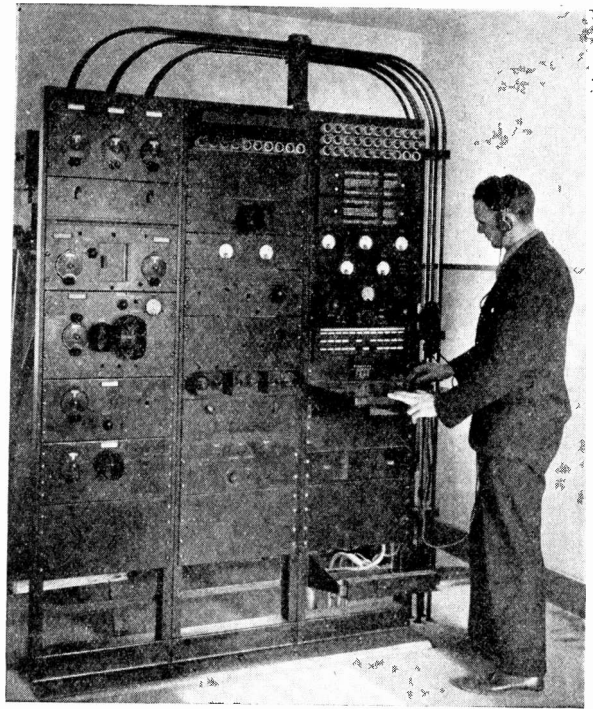


*Interior of the deck house on the steamer Leviathan, which houses the short-wave radio equipment. To the right is the receiving set, where voices from shore telephones are received by radio from the Deal, N. J., station.*

.....

*This, boys and girls, is a short-wave receiving set, although it looks more like a power-house control board. The details of the circuit have not been made public, but we understand that it is a complex combination of tuned R. F. and a superheterodyne. This receiver is used at Netcong, N. J., on one of the South American circuits.*

.....



handling calls from the United States through these stations when the ship is in the eastern half of the Atlantic. By a similar arrangement a ship in the western Atlantic is in touch with British telephones through the American stations.

#### THE BRITISH PHONES

An English listener reports the following data in regard to the British end of the short-wave telephone circuits:

- GBU, Rugby, on 16.10, 24.41 and 30.15 meters, works with WMI, Deal, New Jersey, who replies on 15.14, 20.56 and 30.39 meters.
- GBW, Rugby, on 16.54, 20.77 and 30.64 meters, works with WNC, Ocean Township, New Jersey, who uses 15.61, 20.73 and 30.77 meters.
- GBS, Rugby, on 16.39, 24.69 and 33.26 meters, works with WND, Ocean Township, N. J., who uses 16.36, 22.40 and 32.71 meters.
- GBX, Rugby, on 27.5 meters, works with VK2ME, Amalgamated Wireless (Asia) Ltd., Pennant Hills, N.S.W., who replies on 28.5 meters.
- GBK, Bodmin, on 16.57, 26.10 and 32.40 meters, works with CGA, Drummondville, Quebec, who uses 16.50, 26.00 and 32.12 meters.
- WLO, Ocean Township, N. J., on 14.01, 18.44 and 28.44 meters, works with LSM, Monte Grande, Argentine, who uses 20.00 meters.
- G2GN, S.S. *Olympic*, on 18.30, 24.00 and 35.00 meters, works with F8BZ, Paris (19.50, 22.14 and 38.56 meters), G2AA, Slough (36.00 meters), and with WOO and W2ZG, Deal, N. J.
- WSBN, S.S. *Leviathan*, on 33.98, 45.21, 68.30 and 87.51 meters, works with WOO, Deal, N. J., who replies on 34.76, 46.05, 72.89 and 96.03 meters.

#### NEW CANADIAN STATION

A Canadian station that seems to be getting through quite nicely is VE9GW, which is located at Bowmanville, Canada.

The wavelength is 49.22 meters. Reports of reception are welcomed. They may be addressed to Route 4, Bowmanville, Ontario, Canada.

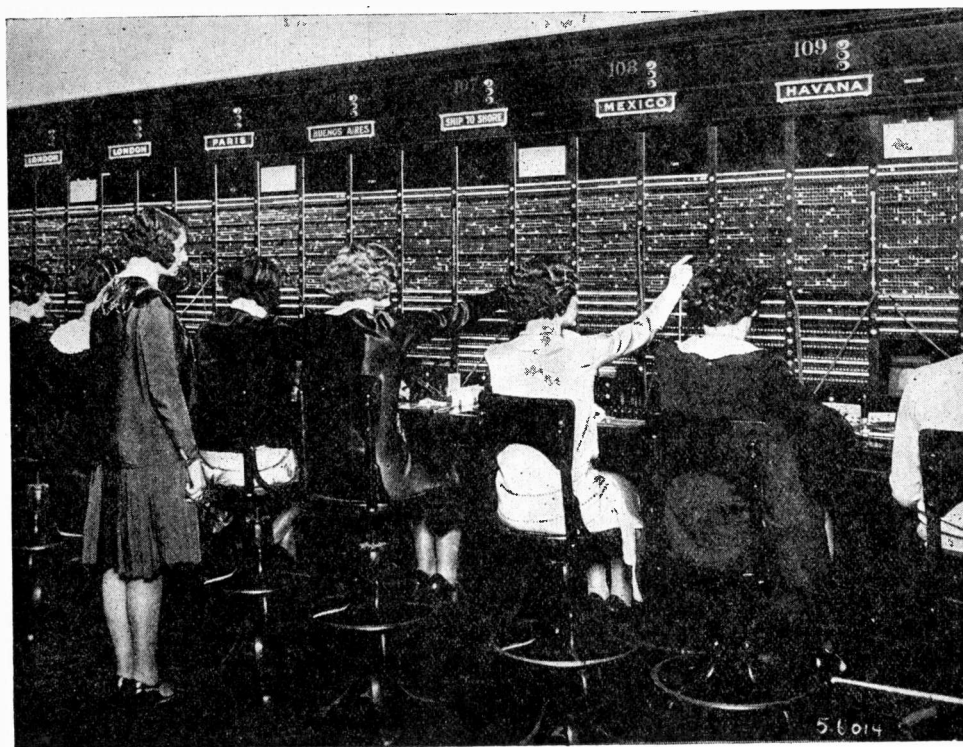
#### G2NM ACTIVE AGAIN

Mr. Gerald Marcuse, who is one of the leading radio amateurs of Great Britain and one of the earliest pioneers of the amateur short-wave game in that country, has been broadcasting special programs for the benefit of American short-wave set owners. So far very few listeners have reported his signals, which have been going out on about 25 meters. His call letters are G2NM, and his address is Sonning-on-Thames, England, Great Britain. Anyone hearing these call letters should address a report card to Mr. Marcuse.

At the present time we don't know his exact schedule of operation, but we understand that the transmissions are made during the early evening hours.

#### PARIS CHANGES WAVE

The short-wave experimental station in Paris has recently increased its power to 1½ kilowatts and has dropped its wavelength from 31.6 to 29 meters. The hours of operation are from 2:30 to 4:00 P. M., Eastern Standard Time.



*The heart of an international communication system: the foreign service switchboard in the long-distance office of the A. T. & T., at 24 Walker Street, New York City, where calls to Great Britain, France, the Argentine, Mexico, Cuba and ships at sea are handled.*

A new transmitter to be erected shortly at Podebrady, Czecho-Slovakia, will operate on 15 and 20 meters. These are good daylight waves, so listeners who get home early may be able to pick up this station.

#### FROM NEW ZEALAND

A listener in Canterbury, New Zealand, reports having heard station VK6AG, Inglewood, West Australia, talking with station VS1AB, in Singapore, on about 42 meters.

#### CHICAGO STATION ACTIVE

A letter from Mr. Maynard Marquardt, chief engineer of the station, advises us that W9XAA is operating on the following schedule: 6 to 7 A. M., Eastern Standard Time, daily except Sunday, 7 to 8 P. M. daily, 9:30 to 10:15 P. M. daily, and 11 to 12 P. M. daily. A frequency of 6,080 kilocycles is employed.

Station W9XAA is operated in conjunction with WCFL. Reports of reception may be addressed to 623 South Wabash Avenue, Chicago, Illinois.

#### CHANGES AT NRH

Station NRH in Costa Rica, Central America, has changed its wavelength, its power and its operating hours, according to a card from Amando Cespedes Marin. He writes as follows:

"Due to code interference and to requests from thousands of Pilot Wasp and Super-Wasp users, I have moved to 30.5 meters, my old wavelength, instead of 30.8 as listed in Volume 3, No. 2, of RADIO DESIGN. Also I am now using 75 watts of power in a master-oscillator-power-amplifier circuit. Hours of operation—4 to 5 P. M., and 8 to 9 P. M., Central Standard Time."

#### NEW WGY SCHEDULE

The short-wave transmitters associated with WGY of the General Electric Co., at Schenectady, N. Y., are also operating on a new schedule. The notice sent out reads as follows:

"Evening programs of WGY will be transmitted by W2XAF on 31.48 meters, daily from 7 to 11 P. M., Eastern Daylight Saving Time, and by W2XAD on 19.56



meters on Sunday, Tuesday and Thursday, 2 to 8 P. M., Eastern Daylight Saving Time; Monday, Wednesday and Saturday 5:10 to 8 P. M."

The announcement is concluded with a warning to the effect that the WGY short-wave stations are experimental and that the schedule may be changed or discontinued at any time.

#### W6XN OFF THE AIR

We are also advised by the General Electric Co. that Station W6XN at Oakland, California, which formerly was heard very well by short-wave listeners, has been entirely discontinued. This statement will set to rest the various conflicting rumors about the status of this popular station.

#### NO SHORT-WAVER AT KGA

Short-wave programs from Station KGA at Spokane, Washington, have been reported by many set owners, but a letter from the Northwest Broadcasting System, operators of the station, reveals the fact that there is no short-wave station connected with KGA. The signals that lis-

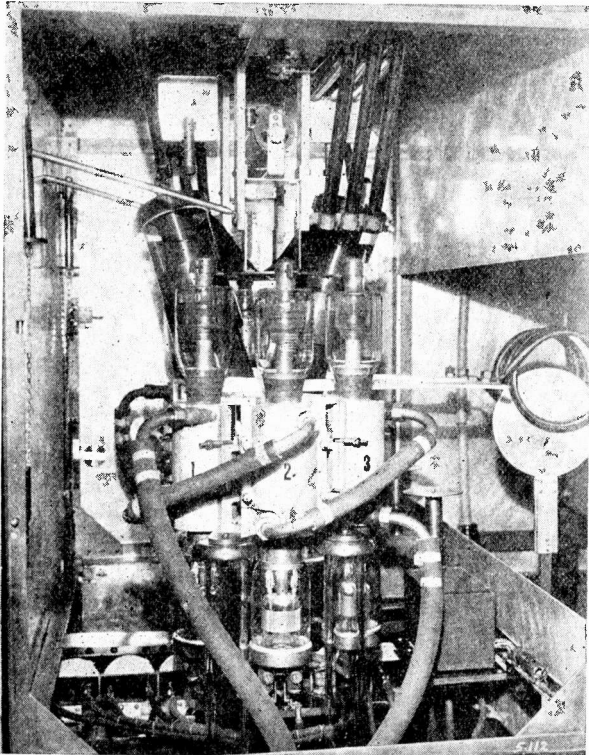
teners have been hearing are undoubtedly harmonics of the regular 1470 kilocycle commercial wave.

#### TELEVISION TRANSMISSIONS

A letter from the Jenkins Television Corporation, Jersey City, New Jersey, advises us that station W2XCR in Jersey City and W3XK in Washington, D. C., are both broadcasting half-tone pictures week-day evening from 8 to 10 P. M., and on Monday, Wednesday and Friday afternoons from 3 to 5 P. M. W2XCR is adjusted to 2800 kilocycles and W3XK to 2900 kilocycles. This same organization also puts on synchronized sound programs from 8 until 9 each evening in conjunction with the DeForest experimental station W2XCD in Passaic, N. J. This latter station transmits on 1604 kilocycles. At the present time W2XCR and W3XK are using 48 line scanning at 900 revolutions per minutes, 15 frames per second.

#### ROME RADIO SUCCESSFUL

The new short-wave station which recently opened in Rome, Italy, is causing considerable excitement, if we can trust



The final output stage of the short-wave radio telephone transmitter at Lawrenceville, N. J., uses six water-cooled tubes rated at ten kilowatts each. Three of the water jackets surrounding the tubes, marked 1, 2, 3, are plainly shown. The water is pumped in through the thick hoses in the center foreground.

the numerous reports published in the European and African press. Two wavelengths are used; approximately 80 meters and approximately 25½ meters. The latter wave is quite close to G5SW, Chelmsford, England. The 80 meter signals seems to carry south quite effectively; in fact, they are heard so loudly in South Africa that listeners there are beginning to consider the station a local.

The obvious purpose of this station is to form a strong link between the home country and the Italian colonies. Unlike station G5SW, which the British built for the benefit of their own foreign settlements, it seems to be accomplishing its aim. The ironical part of this situation is that the Italian station is British in construction.

#### TWO STATIONS IN SIAM

The Royal Siamese Post & Telegraph Department at Bangkok, Siam, is transmitting on 29½ meters through station HS2PJ, with an estimated output of 500 watts, and on 37 meters, through HS4PJ, with an output of 200 watts. In addition to handling regular telephone traffic, these stations carry out broadcasting experiments every Sunday from 1300 to 1500 GMT.

#### NEWS FROM CHINA

We are in receipt of an interesting letter from Mr. Chas. M. Larson, who writes from the Standard Oil Company at Canton, China. He says:

"Having only just received my RADIO DESIGN, Vol. 3, No. 1, I naturally turned to the section 'More about the Short Wave Broadcasting Stations' and there are one or two points that you will probably be interested in setting right.

"As I have been receiving Station RA97 (Khabarovsk, Siberia), at various times for the past two years or so, believe that I can supply some information which may serve to check up with other information at hand. The station operates at a fairly constant frequency, and is crystal-controlled at 70.1 or 70.2 meters, and the 35 meters mentioned by Mr. Green is very possibly a harmonic, as I have repeatedly heard the station on both frequencies at the same time, or with intervals just long enough to allow me to change coils. I have had Russian friends as guests several times and they are always interested in this station, so have had them translate for me everything pertaining to numbers or frequencies, etc., and no mention was ever made of 35 meters, but always 70.2 meters. Their time on the air is usually

daily at 6:00 P. M. to 10:00 P. M., 120th East Meridian Time.

#### THE MANILA STATION

"And now for station KZRM or K1XR at Manila. I have been getting this station almost nightly since it came on the air, and they have been using wavelengths approximately as follows: 24.5, 25.4, 26.2, 31.66, 31.2, 39.5, and 48.8 meters. They are at the present writing using a wavelength of approximately 31.2 meters, although they do not announce their wavelength or frequency. They do, however, announce that 'This is KZRM-Radio-Manila transmitting simultaneously from Manila and Cebu from their studios atop the Manila Hotel.' This is a 1 kw. station of the newest type with crystal control and is very well regulated. The only harmonic I have ever been able to get from them was when they were on 48.8 meters, at which time I could get them at either 24.5 or 48.8 meters with approximately the same volume.

#### THE TIME SITUATION

"Would also like to point out that the Editor's parenthesis under 'From the Dutch East Indies' (corresponds to Wednesday—), which should always be either the same day or a day behind; as for instance, Hongkong noon Monday is 11:00 P. M. Sunday, etc., Daylight Saving Time, would probably be about midnight in New York, or 12 hours difference. Theoretically, the editor is correct, but in practice that 180th meridian interferes and makes a whole 24 hours difference in calendar dates. A good point to remember is that the day starts at the 180th meridian and moves westward until it gets around again. Last time I went home they had two Fridays (fish-day) and coming out they skipped Sunday, so some of you buddies who used to get 'goldfish' on Fridays and ice-cream on Sundays know what I mean.

"I have received at one time or another some 50 short-wave stations and my best distance was Rio Janeiro calling Madrid in Spanish. My set is a conglomerate affair made up from knots and kinks seen in all sorts of magazines and such material as I could get locally.

"PHI on 16.88 meters comes in like a house afire and stays there even when he speaks some five or six lingoos. My Chinese translator wants to know how the loud-speaker does it, presumably so that he can become a little more efficient.

"Here's another funny one: about a year or so ago someone said that a power

tube made a fine detector. Tried it out and burned out some five or six transformers, but they were good while they lasted, and now I have a '01-a tube in that socket and it is going to stay there, so is the transformer. Took me a year, though, before I doped it out. Guess maybe it is because of some of these old spark sets and A C rumbler out here on some of the Paul Jones' and Nelson's fleet.

"Have watched the tubes and they looked like Signal Corps recruits with flash-lights. No use for a loud-speaker; just take the cover off the set and watch the tubes; easy to learn the code that way, as the eye is quicker than the ear. Have even heard signals without any phones or speaker plugged in. Who's a liar? Come on out here and I'll show you.

"Guess this makes me a champion long-distance liar, so will quit, as I am due to get the exchange quotations so I can dope out how much I will have to pay for my next screen-grid tube in this tin money we use out here. Regards and more power to you."

**EDITOR'S NOTE:** Mr. Larson's story about hearing signals without phones or speaker plugged in is not a fish yarn at all. When a particularly powerful station is tuned in, the vibration of the laminated iron core of the last audio transformer, under the influence of the signal currents in the transformer windings, is strong enough to disturb the surrounding air and to set up sound waves that are quite audible to the ear. If the iron laminations are a bit loose the sound sometimes travels three or four feet. This curious but simple effect

has mystified many people and has given rise to many queer stories.

Sometimes signals will be heard in a pair of earphones even when the plug entirely removed from the set, but lying near it. This is a case of ordinary electromagnetic induction between the audio transformers and the phone cords. Radio ear phones are extraordinarily sensitive, far more so than most radio fans realize, and they will respond quite plainly to microscopic currents that will not register at all on other types of recording instruments.



#### LISTENER REPORTS WANTED

Reports from listeners are invited by the Electro-Technical Institute of the University of Bucharest (Roumania), which has opened a short-wave transmitting station for test purposes. Special programs consisting of phonograph music or of

a relay from the Bucharest studio are broadcast on Wednesday and Saturday evenings on a wavelength of 21.5 meters (corresponds to middle afternoon, Eastern Standard Time). Reports should be addressed to the Institut Electrotechnique Universitaire, Rue Victor Emanuel, III, 16, Bucharest, Roumania.

#### VATICAN STATION

It is expected that within a short time the Pope will have a world-wide audience through the medium of a powerful short-wave station now nearing completion in the Vatican. Two wavelengths will be used: 19.84 and 50.26 meters, with an antenna power of 12 kilowatts.

It is probable that addresses by the Pope will be given from his private apartments.

*THE short-wave station information given above supplements the data given in the three preceding issues of RADIO DESIGN: Winter, 1929 (Volume II, Number 4); Spring, 1930 (Volume III, Number 1), and Summer, 1930 (Volume III, Number 2). These numbers contained a total of twenty pages of extremely valuable "dope" that cannot be found in any other publication, and every owner of a short-wave receiver should have copies of them. If your file is not complete, order the missing numbers direct from RADIO DESIGN, Lawrence, Mass.; price, 15 cents each.*

*For the next issue of the magazine (Winter, 1930) we hope to have ready an up-to-date list covering all the known short-wave broadcasting stations of the world. This has been in preparation for several months, and will be completed as soon as letters from a few distant foreign stations arrive.*

# How to Use the Service and Trouble Shooting Chart

By ALFRED A. GHIRARDI

**T**HE thousands of letters and questions which our free technical question service has brought to us has enabled us to make a detailed study of the many troubles which are experienced in the operation of radio receivers of both the battery operated and A. C. electric type. The Trouble Shooting and Service Chart published herewith has been compiled to serve as an aid in quickly and systematically locating the causes of troubles in receiving sets of both the broadcast and short-wave type. While we realize that no service chart can ever cover the many diversified troubles which occasionally come up in the different types of receivers, it is hoped that it will serve to aid the readers of RADIO DESIGN in their general service problems. It has been arranged as simply as possible, in order to assist even the radio fan who has but little technical knowledge.

Any experienced radio service man will tell you that half of the troubles in radio receivers are due to causes which are very easily remedied if one only knows how to locate them. Fortunately it is possible in most cases to locate the trouble quickly by observing the behavior of the set. The accompanying chart is based on this method of attack. First try the set out and observe the symptoms of trouble. Then refer to the proper vertical column in the service chart and follow down this column, checking up the various possibilities of trouble in the various parts of the equipment as outlined in the chart.

## BE SYSTEMATIC

Always be systematic in hunting trouble. If the set fails to operate, first see if all of the tubes are lit. Replacing a tube that does not light may remedy the trouble. If none of the tubes light up see if the "A" battery or power pack is connected and if so, trace the wires to make sure that the connections between the battery or power pack and set are well made. If a battery is used, test it to make sure it is supplying current and try out the starting switch to make sure it is making good contact. Be sure that the tubes are making firm contact in the sockets.

If the tubes light but there is no re-

ception, trace both "B" and "C" battery connections or the connection to the "B" power pack to make sure that there is no open circuit. Be sure the speaker is connected with the set. A click in the speaker when the set is turned on and off indicates that the "B" power is reaching the last audio tube. If the set is battery operated, remove each tube in turn and listen for clicks. A dead tube may be located by the lack of clicks, or the trouble localized in one stage. Electric sets using A. C. tubes cannot be tested by the click method, as it requires several seconds for the tubes to heat up before they become operative.

If all the tubes and stages are working but still there is no reception, see if the antenna and ground are connected, make sure that the ground connection is solid and that the antenna or lead-in wire is not grounded on any metal objects. Trace the "C" battery circuit for open circuit.

## USE EAR PHONES

If the tubes light but no clicks are heard in the speaker, test the set with ear phones in the speaker jack. If clicks are heard in the ear phones, it indicates that the speaker is out of order. If no clicks are heard, test the "B" battery or "B" eliminator with a voltmeter for total voltage, and the voltage across each resistor section, in the voltage divider. A high resistance voltmeter must be used for this test on "B" eliminators. If the voltage readings are satisfactory, look for an open circuit between the eliminator and the set.

If the rectifier tube is not functioning, no voltage readings will be obtained at the voltage divider or resistor bank. Reduced voltages on all tubes may be due to rectifier tube not working satisfactorily or to punctured filter condensers, or burned out and damaged chokes. Failure to secure voltage readings at the resistor bank or failure of rectifier tube to light may be due to failure of current on power supply, due to the fuse which protects the transformer being blown out. If the fuse is blown try to determine the reason why it blew out, and remedy this before putting a new fuse in.

If you cannot get a short-wave receiver

*Vol. 3, No. 3, Radio Design*

to go into oscillation try using an aerial about forty feet in total length including lead-in and ground wires. Also try increasing the detector plate voltage and if necessary add a few turns to the tickler winding. If the set oscillates too strongly, oscillation cannot be controlled smoothly, try using a 100,000 ohm Pilot Volumgrad potentiometer for variable detector plate voltage control and one for variable screen grid voltage control.

All testing of circuits should be done only by an experienced radio man, especially when eliminators or powerized sets are used, as high voltages are developed by the secondaries of the power transformers in the sets and unpleasant shocks can be received. Do not tinker around a set with tools while the current is turned on. Remember that a large filter circuit condenser that is charged can give a kick like a mule if it discharges through your fingers. After turning off the current, dis-

charge the condensers by short circuiting them with a piece of wire insulated at the spot where it comes in contact with your fingers. Do not turn off the filament current before turning off the "B" eliminator when "B" eliminators are used on battery sets, as this may cause voltage surges that will puncture your condensers.

If these simple tests do not locate your trouble, play safe and call a service man. Many little indications that you probably will not notice may give him a direct clue to the cause of the trouble.

If your set does not produce as much volume as you expect from it, remember that it may not be due to any trouble in the set, but may be caused by the fact that you are situated in a location which is very poor for radio reception. It often happens that in a particular location reception of stations from one or two directions may be good while reception of near-by stations in other directions may be very poor.

## Making Radio History in South America

By ZEH BOUCK

(Continued from page 18)

The actual talking circuit was rather complicated. For instance, in calling a New York number from the plane, the following speech circuits were tied together: The plane transmitted and received simultaneously, transmitting on about thirty-six meters and receiving, through its own carrier, on about fourteen meters. The radio wave from the plane was picked up on a field strength measuring set at Platanos, some fifty miles away. Here it was amplified, and transmitted by wire to the central station at Cuyo, and then to the New York transmitter at Hurlingham. From Hurlingham it went to New Jersey on the short-wave beam. Picked up here, it was re-amplified, put through to a central station, thence to a regular telephone central station, and via the usual land line to the number of the subscriber being called. The return voice signal went through the usual telephone central stations to a radio central station, and then to the beam transmitter at Lawrenceville, N. J. The beam was picked up on the special beam receiving antenna at Platanos, sent through to Cuyo, from Cuyo to Hurlingham, back on the air on the Madrid channel, and finally picked up on the plane!

Among the calls made were two to Mr. Goldberg, president of the Pilot Radio and Tube Corporation at Lawrence, Mass.; the San Francisco *Examiner*, to Ramon Navarro, in Hollywood; to Arthur Loew,

theatrical magnate, in Glen Cove, N. Y., to the *New York Times*; calls to Mrs. Yancey, Mrs. Burgin and Mrs. Bouck; several calls to Europe, one to the *S. S. Majestic*, still a day's steaming from Southampton, via another radio transmission from London; and our crowning achievement, a call to Sydney, Australia.

This last circuit was undoubtedly the longest voice or telegraph circuit ever attempted. Transmitting over the Madrid circuit, the voice was carried on land line to Rugby, England, and then by radio again to Australia, a circuit of some eighteen thousand miles!

The flight from B. A. to Rio was uneventful. We stopped at the Aereo-Postale fields, the French air mail operating company which is co-operating with us on our flight up the east coast, at Porto Allegro and Florianapolis. We are waiting in Rio now for a final motor inspection, and expect to be away again on the final leg of the journey in a few days. Though we have already covered sixteen thousand of our twenty-two thousand miles flight, there is still much interesting territory before us. I hope in the next issue of *RADIO DESIGN* to tell you the story of our take-off from Natal, the flight over the two hundred-mile wide Deltas of the Amazon and Orinoco Rivers, a brief stay in the French Penal Colony at French Guiana ("Devil's Island") the hop across to Trinidad, to Port of Spain, Porto Rico, Miami and home!

# TROUBLE-SHOOTING CHART

SYMPTOMS OF TROUBLE						
POSSIBLE SOURCE OF TROUBLE	NO RECEPTION	VOLUME WEAK	IRREGULAR RECEPTION	DISTORTION	NOISY RECEPTION	HUMS AND WHISTLES
"A" BATTERY	Battery exhausted. No water in storage battery. Battery terminals corroded.	Battery exhausted. Poor connection at corroded terminals. Charger not equal to demand on battery. Trickle charger not functioning.	Loose connection.	Battery exhausted.	Battery sulphated. Connected charger operating.	Hum from charger operating. Whistles from depleted battery.
	Battery exhausted. Battery not properly connected.	Battery exhausted. Volume starts off well but quickly diminishes while set is played.	Defective cell. Loose connection.	Battery exhausted.	Erratic noises—battery exhausted. Fluttering, motorboating high resistance of run-down battery.	Whistles from run-down battery.
POWER PACK	Not connected to power socket. Rectifier tube not operating. Filter coils burned out. Resistor burned out. Fuses in power supply burned out. Plate of rectifier tube red hot—condenser broken down or short circuit in filter. Electric light line power off—or fuse blown.	Eliminator overloaded. Rectifier tube worn out. Transformer short circuited. Buffer condensers punctured. Filter condensers punctured. Improper resistor values in voltage divider. Electric light line voltage too low.	Interrupted current supply from power lines. Poor voltage regulation of power line.	Plate voltage too low. C bias resistors not properly adjusted. Too high resistance in choke coils. Insufficient capacity of filter condensers.	Defective resistor in voltage divider. Sparking over punctured condenser. Motorboating—insufficient capacity of last filter condenser. Improper value of resistors in voltage divider. Rectifier tube wearing out.	Transformer not balanced on center tap return. Eliminator overloaded. Insufficient inductance in chokes; cores too small; chokes too close together. Insufficient capacity in condenser bank. Choke coil short circuited, or not functioning. No grounded shield between primary and secondary of power transformer. Eliminator not adequately shielded. Coupling between A.F. amplifier stages and eliminator, placed too close to set.
	Antenna grounded. Antenna disconnected. Ground connection open Defective lightning arrester.	Antenna disconnected. Antenna poorly insulated, grounded or wire corroded. Antenna too long; insert midjet condenser. Coupling between antenna coil and secondary too loose. Loose or corroded ground connection.	Swinging antenna being grounded at times. Loose or corroded ground connection.	Parallels, or too close to antenna of near-by oscillating receiver.	Antenna too close, or parallel, to power lines. Antenna too long, picks up too much stray noise. Loose or corroded ground connection. Antenna runs too near interfering electrical devices.	A.C. hum or commutator ripple picked up from near-by power lines. Negative side of filter circuit not grounded. (B—)



<p><b>TUBES</b></p>	<p>Tube burned out. Tube paralyzed. Tube prongs not making contact.</p>	<p>Tubes exhausted. Wrong type of tube used. Power detector not warmed up. Too much grid bias. Corroded tube contacts.</p>	<p>Imperfect prong detector tube paralyzed. Improper value of grid leak.</p>	<p>Tubes worn out. Tube sockets getting insufficient current. Improper C bias on grids. Detector tube overloaded. Wrong type of tube in last stage.</p>	<p>Microphonic tubes; require cushioned sockets. Gaseous rectifier tube hissing, due to power detector tube starting characteristic, or worn out tube.</p>	<p>Tube deteriorating. Too high voltage on detector tube. Wrong type of A.C. tube in detector stage. No center tap on detector tube filament circuit.</p>
<p><b>CIRCUIT</b></p>	<p>Switch open. Open circuit in set. Burned out A. F. transformer winding.</p>	<p>Insufficient regeneration (S. W. set). Antenna too long (S. W. set). Grid leak improper value. Imperfect contacts. Defective piece of apparatus. Neutralization system out of adjustment. Insufficient plate voltage. Burned out A. F. transformer winding.</p>	<p>Loose connection somewhere in set, eliminate, power supply or speaker connection. Sharply moving wires or set while in operation will accentuate trouble.</p>	<p>Over - regeneration. Near-by oscillator. Poorly designed transformers. Coupling condenser too small. Circuit too sharply tuned. Last stage inadequate. No biasing on tubes.</p>	<p>Squeals, bloops—set not neutralized. Neutralizing condensers not properly adjusted. Defective grid leak. Motorboating — lower the value of resistors in resistance coupled amplifiers. Broken wire or imperfect contacts. Burned out audio transformer.</p>	<p>Oscillation from over - regeneration. Set not properly neutralized. Magnetic feed back between stages. Open grid circuit. Center tap of transformer not balanced. Grid return to center point of potentiometer across A.C. tubes not properly adjusted.</p>
<p><b>SPEAKER</b></p>	<p>Speaker disconnected. Open circuit in speaker unit, jack, plug or cord. Speaker short circuited. Coil in speaker unit burned out.</p>	<p>Speaker out of adjustment. Loose contact. Leak across speaker cord. Choke coil in output circuit has too high resistance or insufficient impedance.</p>	<p>Defective cord, jack or plug.</p>	<p>Speaker overloaded; eliminate direct coupling by using output transformer or choke condenser coupling. Not matched to tube in last stage. Poorly designed speaker.</p>	<p>Sound vibrations communicated from speaker to tubes in set. Electrical feed back from speaker cord to amplifying circuits.</p>	<p>Buzz or rattle in dynamic speaker due to moving coil rubbing against pole pieces. Hum due to worn out rectifier. Feedback from speaker circuit to amplifying stages due to sound vibrations communicated from speaker to tubes in set.</p>
<p><b>GENERAL</b></p>	<p>Incorrectly wired set. Shielded location or dead spot. SOS on air. Set not turned on. Breakdown at broadcasting station—try another station.</p>	<p>Set inadequate. Spot poor for reception. Fading.</p>	<p>Breakdown at broadcasting — try another station.</p>	<p>Improper tuning. Fading. Weather condition. Unsatisfactory transmission from station — try another station.</p>	<p>Static — try disconnecting aerial and ground. Eliminator too close to set. Near - by regenerative set. Sparking electrical machinery.</p>	<p>Two stations on nearly same wavelength cause heterodyne whistle. Interference from near-by oscillator. Near-by regenerative or oscillating receiver.</p>

# Amateur Radio—A Fascinating Hobby

With Your Own Private Short-Wave Transmitting Station You Can Converse with Other Experimenters All Over the World and Experience Some of the Greatest Thrills Radio Has to Offer.

by K. B. WARNER \*

**T**HOSE of you who have built or assembled short-wave receivers and have listened to short-wave broadcasts from countries across the ocean probably think you have received the biggest thrill that radio has in store for you. But you haven't! You haven't experienced the greatest of all radio thrills until, after hearing a distant station on your receiver, you throw a switch on your operating table and talk to that far-away station with your own privately constructed transmitting outfit!

In other words, you should become a radio amateur!

This matter of being able to *talk* as well as listen to the stations you hear is what constitutes the principal lure of amateur radio, and 25,000 amateurs will swear to the fact that you haven't begun to get the fullest enjoyment from the pursuit of radio until you, too, have become an amateur, owning your own short-wave transmitter and receiver and chatting with amateurs, not only in this country, but in every part of the world.

## STATIONS ARE SIMPLE

Now, you say, this is all very well, but you have seen photographs of amateur stations, and they look both expensive and complicated, similar, perhaps, to the station shown on pages 56 and 57. Fair enough! But how about that little transmitter page 53? That doesn't look complicated, does it? It isn't, as a matter of fact. Furthermore, its total cost, including the tube (an ordinary type 201-A) is less than half that of your short-wave receiver kit. This transmitter is capable of splendid performance. With a type 201-A tube, using your A C Super-Wasp power-pack to "drive" it, such a transmitter will enable you to communicate

over many hundreds of miles, with excellent results.

Such a transmitter is all you need to complete your amateur station, for the short-wave receiver you already have will take care of the receiving equipment.

Another transmitter, of a somewhat more advanced type, is shown on page 54. Even here, receiving type tubes are used right straight through, yet this set, operating in the amateur "20-meter" band, has communicated consistently with New Zealand from Hartford, Conn.

As you have tuned your short-wave receiver, searching for distant short-wave broadcast stations, you have heard all kinds of "code" stations. You have probably noticed that these code signals are much more numerous in certain places on the dials than in others. These areas are where the amateurs hold converse every hour of the day and night, thousands of them, engaged in two-way communication with each other.

If you turn on your receiver now, plug in one of the sets of coils, and tune in some of the signals in these amateur bands, the station you hear may be on the Atlantic Coast, or the Pacific Coast, or it may be a station in Europe or South America. Should you listen in at unusual hours, such as the early morning, that signal may come from Australia, New Zealand or Asia. If—but don't you wish you knew just where it was coming from? And don't you wish you could listen in on the conversations that are flying back and forth?

Well, why don't you? All you have to do is to learn the code, so that you may interpret those dots and dashes. Learning the code is not at all difficult. Boys of fifteen and men of fifty find it easily acquired. The entire alphabet can be memorized in one or two evenings. A few weeks' practice listening to actual code transmissions on your receiver will

\* Secretary, American Radio Relay League, Editor, QST.

develop speed. There are even many amateur stations that make a practice of sending "code lessons," especially for beginners. The code is not difficult if you make up your mind to settle down and lick it. You will be surprised at the progress you make.

#### STRANGE ABBREVIATIONS

One hint is not out of place, in passing. Don't expect to understand everything you hear, at the start. Amateurs have made a practice of abbreviating much of their conversation, in order to save time in transmission and reception. Most of these abbreviations are quite simple, such as "tt" for "that," "hr" for "here" or "hear," and "fm" for "from"; but there will be others that you will not understand at first. Nor should you be discouraged if you don't get every letter while you are acquiring speed. Write down everything that you *do* get—and it won't be long before you are getting everything.

#### TWO LICENSES REQUIRED

When you have learned to copy ten words a minute, and have acquired a transmitter (perhaps of the type shown below on this page, perhaps a bit more advanced) you are ready to get your operator's and station licenses from the government and get on the air as an active amateur. We will not go into

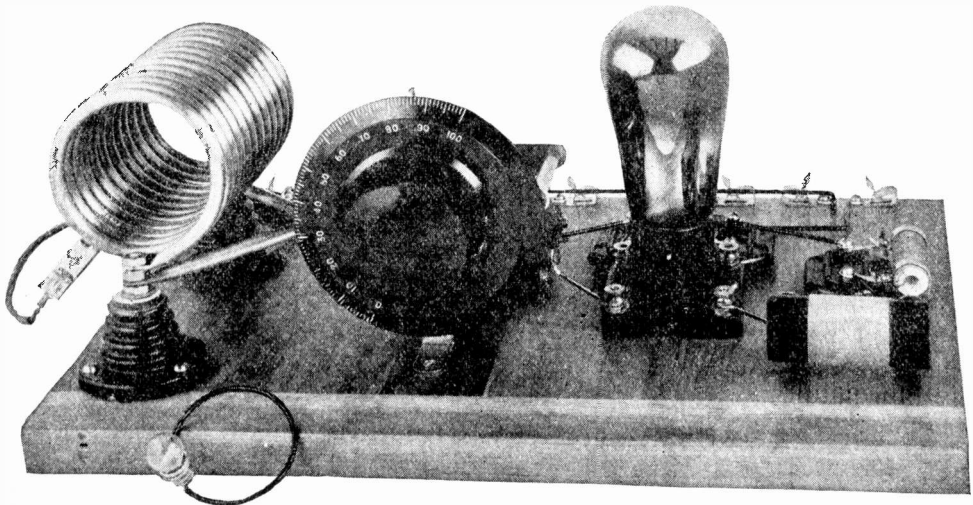
detail as to the building of the transmitter; first, because that is not the purpose of this article, and second, because such matters are better handled in such manuals as the *Radio Amateur's Handbook*\*. But the building of the transmitter is not difficult, and the licenses, in addition to costing you nothing, are quite easy to obtain.

Let us take a moment to consider what you, as an amateur, may do. First of all, you are allowed to operate your transmitter in certain parts of the high-frequency spectrum, in certain bands of wavelengths designated by international treaty for amateur use. For convenience's sake, we will refer to these bands as the 5, 10, 20, 40, 80 and 150 meter bands, because the territory "centers" on those wavelengths. Actually, amateurs speak of "frequency" rather than "wavelength," but that need not concern you for the time being. Operating in these bands, you are privileged to send whenever and wherever you please, subject to certain nominal restrictions.

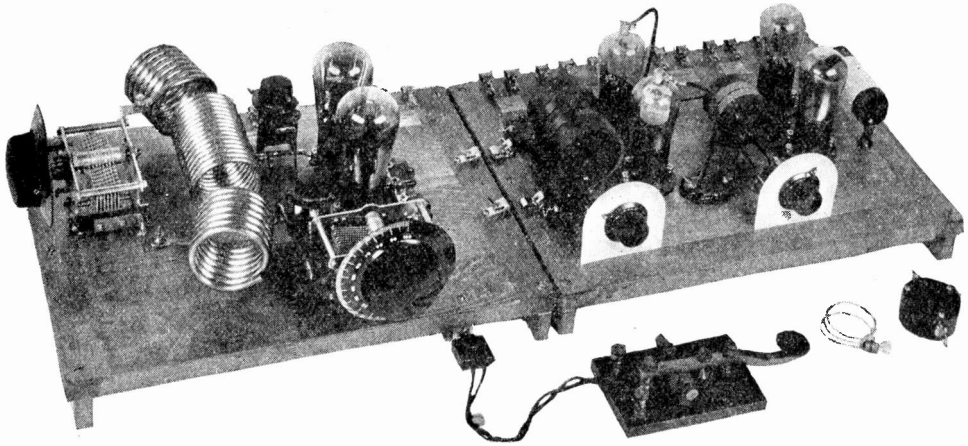
#### CHAT WITH THE WORLD

But think of the things that amateurs participate in! First of all is the incomparable experience of being able to chat with other amateurs all over the world. You can extend your acquaintance to

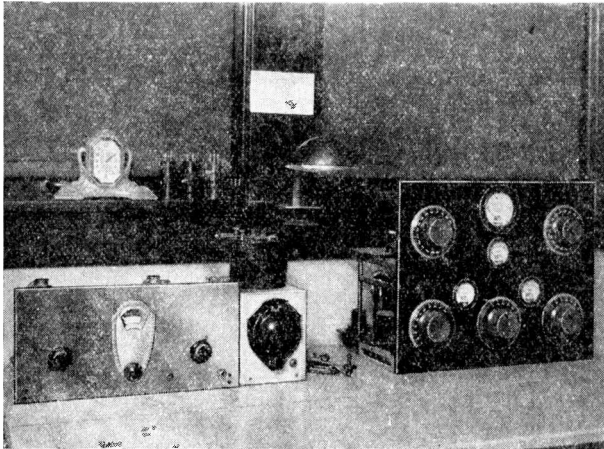
\*The *Radio Amateur's Handbook* sold by RADIO DESIGN, \$1, postpaid.



*This simple little one tube transmitter will work on a Pilot K-111 power-pack or any similar receiving type eliminator. It uses a 201A or a 171A tube, and is capable of long distance transmission. Many amateurs with outfits exactly like this have conversed with fellow amateurs in all parts of the world. It uses fewer parts than a receiver and is easier to construct and operate.*



ABOVE: A more complicated transmitter employing six tubes in a push-pull hook-up. This outfit also makes use of parts such as found in any ordinary receiving set. By means of this transmitter, communication is established quite regularly between Hartford, Conn. and points in Australia and New Zealand.



LEFT: A typical amateur transmitter. At the right end of the table is a compact 50 watt transmitter. At the left is the receiver and in the center the listening monitor.

other Americans, across the continent; you will get to know various foreign "hams" by their first names, and chat with them nightly, exchanging personal remarks with them. In this country, you can handle messages back and forth without a penny's cost to yourself. The amateurs of the United States have developed a vast "traffic" network that functions nightly, and over which hundreds of personal messages are handled regularly. It is needless to say that no compensation can be received by an amateur for this work—it would violate the terms of his amateur license.

As an amateur, too, you will be able to listen in on expeditions to the far corners of the earth. Amateur cooperation with expeditions is traditional. It started with one of MacMillan's trips to the Arctic in 1923, when amateurs sent one of their members along as an operator, and volunteered to give the Commander radio contact with this country

while he was in the North. They did it, too, and ever since then other explorers have asked for amateur aid in keeping contact with home. Hundreds of amateurs conversed with the Byrd expedition while it was at the South Pole; many of them handled messages to this country, while others merely enjoyed brief chats with the operators. But think of the thrill of talking directly with stations at the Pole, or in the jungles of Brazil or Java. Amateurs do it!

#### AMATEURS OF REAL HELP

Another field where you, as an amateur, may participate is in the field of emergencies. Not a single major emergency has occurred in this country during the past nine years but that amateurs, with their home-made apparatus, have stepped in after the usual lines of communication have been wiped out and have "carried on" to establish contact with their brother-amateurs on the out-

side. The New England flood, the Florida hurricanes, the California dam break and many other catastrophes have earned amateurs glowing tributes from Army, Navy, Red Cross and municipal officials for their work in such instances.

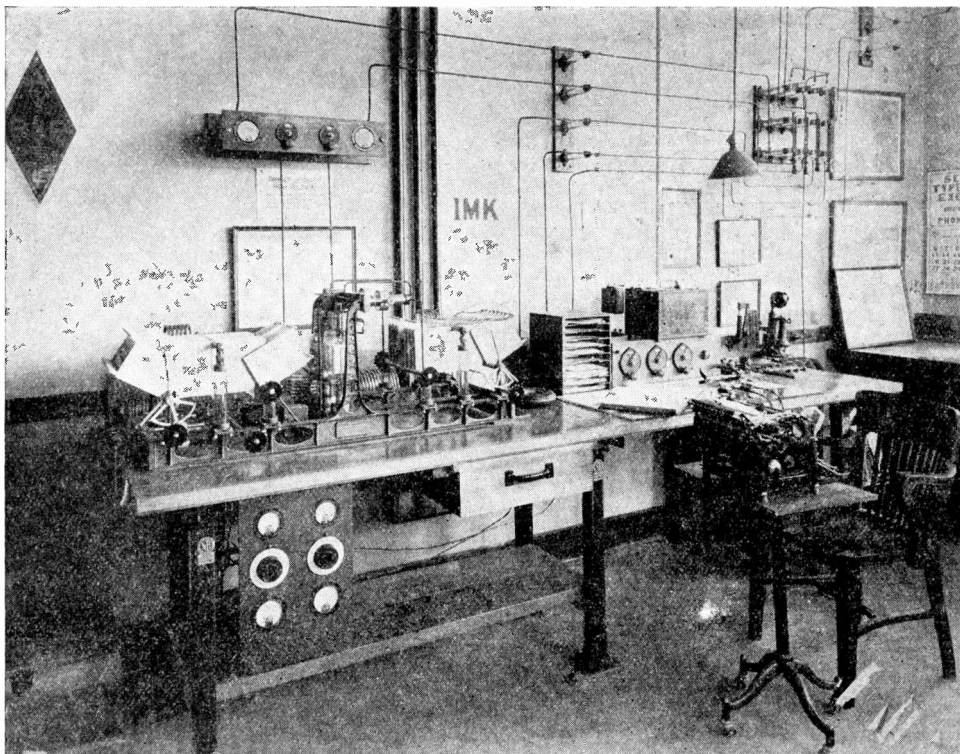
As most of the readers of this magazine probably realize, the amateur is to a considerable extent responsible for the development of short waves. 'Way back in the early days of radio, engineers considered that only long waves were good for communication purposes, so the amateur was relegated to 200 meters and below. Everyone believed that this would keep him out of the way. But the amateur took those "worthless" short waves, and worked at them, devised apparatus to work there, and showed the radio world that the short waves were far more valuable than the long ones for long-distance communication purposes. A constant striving for new fields has always characterized the amateur.

#### A NATIONAL ASSET

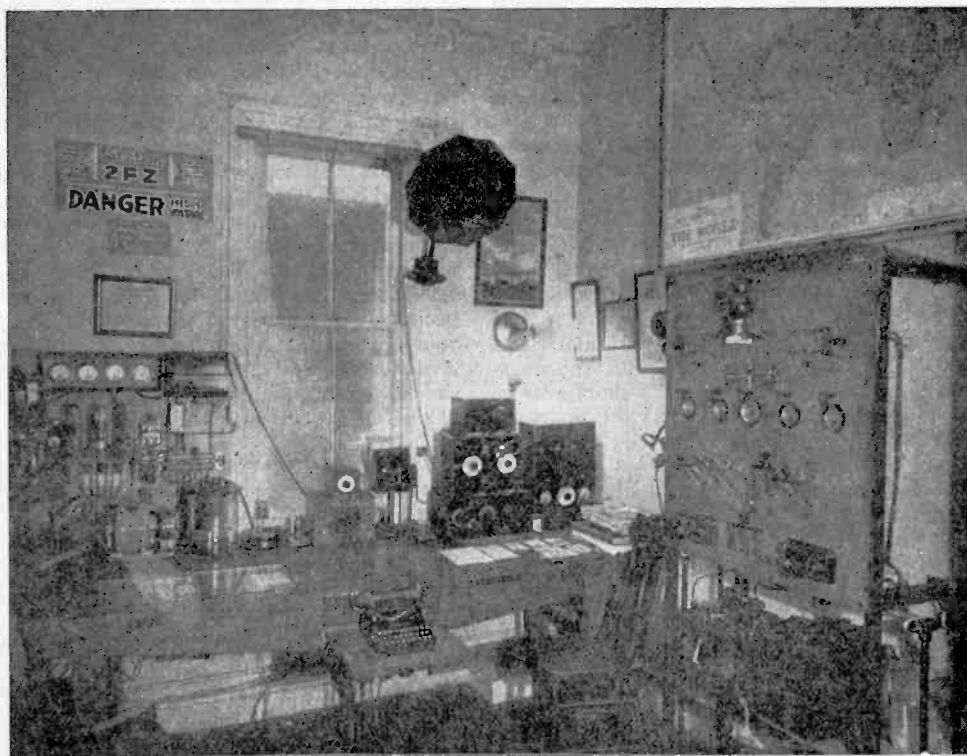
Our own United States government recognizes the amateur as a distinct national asset, and from the very start has given him every encouragement. The Army and Navy are our staunch friends; they remember only too well how 3,000 amateurs enlisted when this country entered the World War, and provided the vital skeleton framework of experienced radio telegraphers and instructors on a moment's notice. Today, the Navy has established the Naval Radio Reserve especially for amateurs interested in Navy work, while the Army has organized the Army-Amateur Radio System to enlist the service of amateurs on an organized basis for use in national emergencies.

#### THE "HAM'S" PARADISE

Of the approximate total of 25,000 amateurs scattered over the world, 17,000 of them are right here in this country. The United States is a veritable "hams'



*This photo shows the transmitter and receiver of WIMK, which is used as the headquarter station of the American Radio Relay League at Hartford, Conn. The transmitter is quite a powerful one and is known to amateur listeners all over the world. This arrangement is a very neat and comfortable one and makes for good operating.*



*This photo shows what is undoubtedly one of the finest and most elaborate amateur radio stations in the United States. It occupies an entire room ten feet wide and twelve feet deep.*

*On the left end of the long operating table is the transmitter. In the center is the main control box. To the right are a short-wave receiver, a long-wave receiver and a power amplifier for use with either set. The large panel at the right is the power panel. It is made of one piece of slate. This station has the call letters W2FZ and was built entirely by its owner, Frank Frimerman, 740 Prospect Avenue, Bronx, New York City. Strangely enough, Mr. Frimerman is a furrier by profession and not a radio engineer, as the station would indicate!*

paradise." Amateurs have existed here for 30 years—as far back as the beginning of radio itself. The present licensed total of some 17,000 is growing yearly.

In 1914 amateurs saw the need for a national organization to bond them together, to facilitate exchange of ideas and to provide a means for the defense of amateur interest at national and international radio gatherings. Under the leadership of Hiram Percy Maxim, the noted sound expert, and himself an enthusiastic amateur, they formed the American Radio Relay League, which was duly incorporated as a non-commercial association in 1915. Today, the A. R. R. L. has a membership of nearly 20,000, with members all over the world. It maintains a headquarters at Hartford,

Conn., employing some 25 people, who devote their entire time to carrying on the every-day work of the organization, answering members' inquiries, conducting contests, representing the amateur at governmental hearings, etc. Among other things, the League publishes the magazine *QST*, which is known everywhere as the foremost amateur publication and one of the oldest and most respected radio magazines in the world.

No, you have not plumbed the possibilities of radio, and particularly short-wave radio, until you have become an amateur. In it, you have a force at your command with which to annihilate distance and the boundaries of time and space, and to place you in contact with mankind throughout the world. As you read these



lines, thousands of amateurs — doctors, lawyers, high-school boys, young men in all lines of endeavor, people like yourself—are sitting at their home-made sets in their own houses, indulging in *two-way* communication with each other to get the greatest of all radio thrills.

Why don't you, too, become an amateur and take part in this most fascinating of all hobbies?

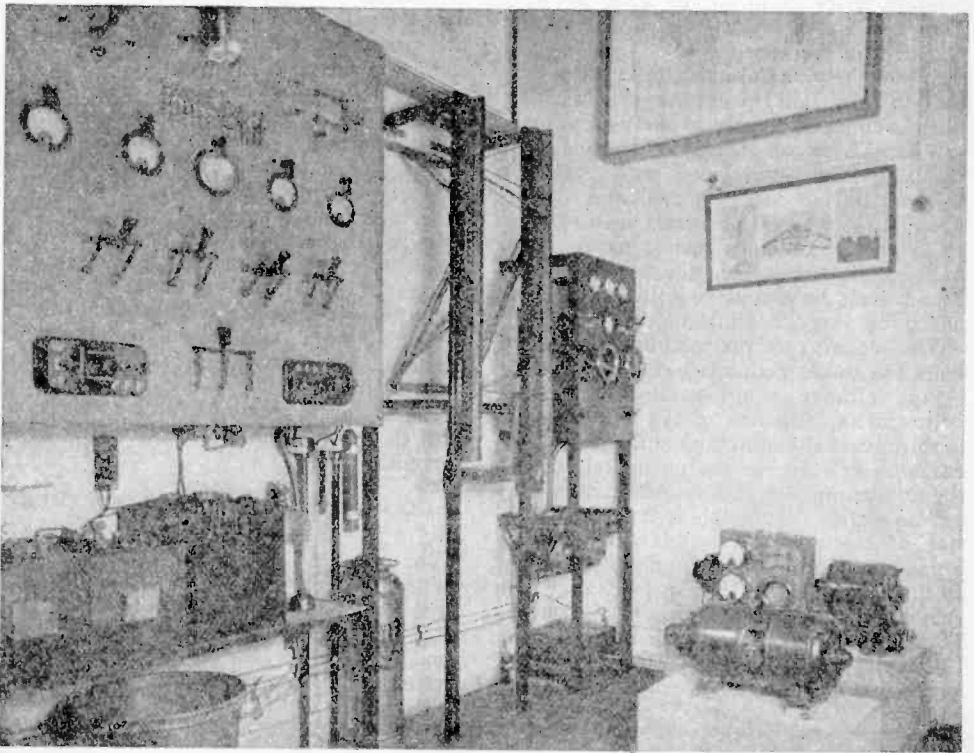
#### REGARDING TRANSMITTING STATIONS

WE are constantly receiving questions from Super-Wasp owners in regard to the establishment of amateur short-wave transmitting stations. These people are interested primarily in voice transmission and do not know the code.

It must be understood very plainly that

all transmitting stations require two government licenses: one for the station itself, and the other for the operator. A station may be owned by any citizen (who is not necessarily a licensed operator), but it may be operated only by such a licensed operator. Obtaining the station license is merely a matter of filling out a form, but obtaining the operator's license involves a technical examination and a test of the applicant's ability to send and receive messages in the dot-and-dash radio code.

To operate any kind of an amateur station you simply *must know the code*. You may be a "phone hound," but you can't get your license and you can't get anywhere in the amateur game without knowing how to send and receive at the rate of at least fifteen words per minute.



*The back end of station W2FZ. From left to right we have the main power control panel, with three large six-volt storage batteries on the bottom shelf; the terminal rack, at which all power and control connections terminate; and in the corner, an auxiliary control panel for the small motor generators and a bank of storage "B" batteries. The generator in the right foreground is a battery charging unit. The one in the back supplies 1,500 volts for the plates of the transmitting tubes. Both these generators are mounted on solid concrete blocks weighing several hundred pounds. On the left is a photo of Mr. Frimerman.*

# Dynamic Speakers and Baffles

A simple and thorough explanation of the operation, construction, and use of this popular type of speaker, together with an illuminating explanation of the function and operation of speaker baffles.

By ALFRED A. GHIRARDI

## Part I

EDITOR NOTE: The following material has been excerpted from Chapter XVI of the Radio Physics Course. This is the chapter on Loud Speakers, and is the subject which we received the most requests for. We would appreciate having our readers write in to tell us what subjects they would like to have explained by Mr. Ghirardi in the next issue.

While early radio enthusiasts were content to hear radio programs through ear-phones clamped tightly to their ears, modern standards of reception demand that the sound be reproduced with sufficient volume to be easily heard and distinguished anywhere in at least an ordinary sized room. In some cases, as in large halls, auditoriums, etc., the volume of the sound must be tremendous in order to be heard by large assembled audiences.

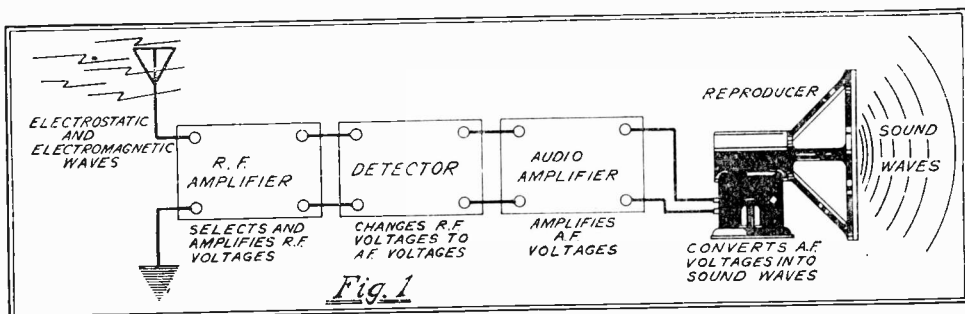
The radio receiver amplifies and detects the weak modulated radio frequency signal voltages set up in the antenna circuit, and the function of the loud speaker is to convert the amplified audio frequency currents existing in the output circuit of the audio amplifier into sound waves which are as nearly as possible a true reproduction of the original sound waves in the broadcast studio. The fundamental duty of the loud speaker then is to change the varying *electric currents into sound waves*. This is shown graphically in Fig. 1.

Telephone receivers and loud speakers have been designed to operate on a num-

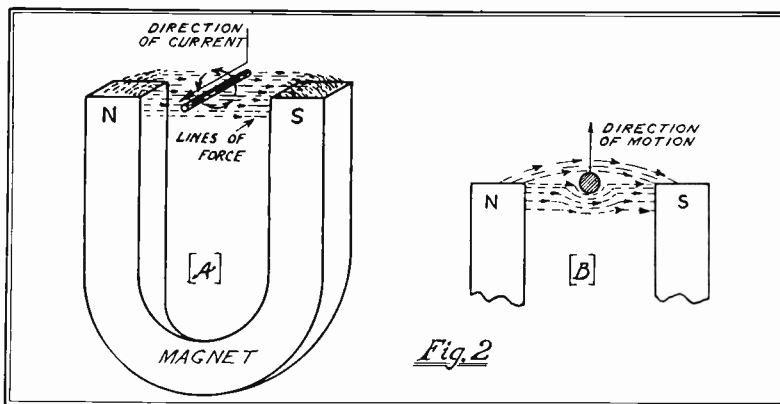
ber of basically different principles. The reaction between a coil of wire and eddy currents set up in a disc; the electrostatic attraction or repulsion between two charged metal plates; thermal expansion and contraction of a wire with variation of current through the wire; the "talking" arc; the expansion and contraction of crystals under the influence of an alternating electric field; all these and many other schemes have been used with more or less success. Practically all commercial speakers in use now depend upon the variation in the pull of a fixed magnet (permanent or electromagnet type) on an iron bar, armature, iron diaphragm, or a coil carrying a current. The essential parts of a speaker operating on this principle (no matter of what type) is a constant magnetic field upon which acts a second magnetic field which varies in accordance with the audio frequency current, thereby causing motion of the armature, the diaphragm, or the moving coil, in accordance with the variations in the audio frequency current.

### CLASSIFICATION OF LOUD SPEAKER MOTORS

The part of the loud speaker which changes the varying audio frequency currents into mechanical vibrations is called the "motor" or "driving unit." Loud speaker units may be divided into several classes. The first refers to the method of



The steps in the conversion of radio waves into sound waves.



How magnetic interaction produces mechanical motion.

exciting the constant field. Those which use a permanent magnet belong to the magnetic type. Those in which the strong constant magnetic field is produced by a current carrying coil wound on a core of steel are called electromagnetic (commonly called "dynamic") speakers.

A second classification divides speaker "motors" or "units" into iron diaphragm, balanced armature, and moving coil types. The purpose of this article is to explain the construction and operation of the commonly known "dynamic" or moving coil type of speaker.

The idea underlying the principle of the so-called dynamic reproducer is old. It was discovered back in 1820 by Ampere, the well-known electrical experimenter after whom the *ampere* (unit of electric current) has been named.

Simply stated, it means that when a current-carrying conductor or wire is placed so it lies at right angles to the lines of force in a magnetic field, mechanical forces will be developed between the wire and the magnetic field. These forces are really set up by the interaction of the magnetic field of the magnet, and the magnetic field which is produced around the conductor by the electric current flowing through it. The force developed is proportional to the field intensity, to the length of the wire, and to the amount of current flowing through the wire.

The magnetic lines of force existing around a conductor carrying an electric current were shown in Fig. 13A, of Chapter II of the *Radio Physics Course*. If we took a simple horseshoe magnet and placed in its field a conductor carrying a current flowing in the direction shown by the arrow in Fig. 2A, circular magnetic lines of force would be produced around the wire in the direction shown. It will be seen

from Fig. 2 that the magnetic flux around the wire strengthens the horseshoe magnet field below the wire and weakens the field above the wire, since above the wire it is in the opposite direction to the main field, and below the wire it is in the same direction as the main field. The effect of the resulting unequal fields on opposite sides of the wire is shown in Fig. 2B. The wire will be pushed upward in the direction of the weaker field.

If we sent an audio frequency current through the wire of Fig. 2 it would make the wire move back and forth slightly in unison with the A. F. changes in current.

This would make a simple speaker motor or unit and would be a true electro-dynamically operated reproducer. Of course it would be very crude and would not have power enough to give really good reproduction.

The magnetic field around the conductor may be concentrated and made much more effective and stronger by winding the wire up in the form of a coil or solenoid. This was shown graphically in Fig. 13C and 13D of the *Radio Physics Course*.

#### MOVING COIL SPEAKER UNIT

In the moving coil type of speaker unit, a very small, exceedingly light cylindrical coil of wire, carrying the audio current, moves back and forth in the annular magnetic field between concentric strong magnetic poles. The coil is attached, usually directly, to a paper cone (or a non-magnetic diaphragm when used with a horn).

The most popular form of moving coil speaker in use at the present time employs a strong electromagnet for producing the steady magnetic field, and is commonly known as a "dynamic" speaker unit. It is unfortunate that this name has come into common usage for, properly speaking,

all forms of speaker units are "dynamic" speakers since the motion is caused by a force. A more appropriate name would be "electrodynamic" speaker, since the force and motion are produced by the action of two electric currents (the varying audio currents from the receiver, and the steady field current). Considerable progress is being made in the development of very strong permanent magnets made of special alloys. These produce magnetic fields having a density almost equal in strength to our present electromagnets, and it is entirely possible that the dynamic speaker of the future will employ these special permanent magnets instead of the more costly electromagnets.

Fig. 3 shows a cross sectional view of an electro-dynamic speaker unit connected to the output circuit of a power tube, and used to drive a free-edge cone. The powerful steady magnetic field (about 12,000 lines per sq. cm.) is produced by the electromagnet winding "E", wound on a soft steel core. A powerful radial magnetic field exists in the air gap between the

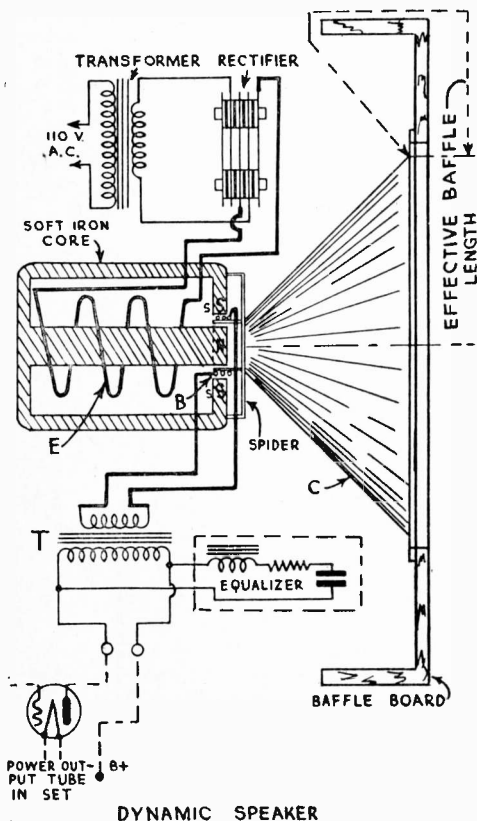
center core and the outside part of the core which also forms a protective housing. The audio currents from the radio receiver flow through the light, movable coil B, of between 100 and 150 turns of fine wire wound on a thin cylindrical shell of Bakelite and mounted in the annular space between the poles with as small a clearance as is mechanically practicable.

The interaction of the powerful steady field of coil E with the varying field produced by audio signal currents in coil B produces motion of coil B along the line of its axis. Coil B can be directly connected to a cone or diaphragm for setting the air in vibration to produce sound waves. As the movement is along the axis line of the coil, the air gap between the pole pieces can be made very small (usually about 0.005 inch) without danger of the coil striking the pole pieces. Hence it can be made to produce large amplitudes of vibration without rattling, with resulting great volume. This is one of the most important features of this type of speaker, as it is necessary to produce quite a large amplitude of vibration of the cone in order to reproduce the low notes in music.

#### FIELD CURRENT SUPPLY

As the field magnet is not of the permanent type, the field winding E must be energized by an external source of steady direct current. When the field coil is thus energized, the magnetization produced is exceedingly strong, many times stronger than in the ordinary permanent magnets used in the early types of loud speakers. This is considered necessary on account of the much larger energies that must be used to reproduce the low notes of which these newer reproducers are capable. Some models have fields designed to be excited from a six volt storage battery and take about 0.75 ampere. These are usually wound with No. 18 B. and S. wire. More recent models use 110 volt alternating current from the electric light lines, and include a rectifier unit (Fig. 3) for changing the A. C. line current to direct current for the winding. These fields are wound with many more turns of finer wire (about No. 32 B. and S.).

Many electric sets use the field (or "pot") as one of the choke coils in the filter circuit of the "B" power-pack. The steady direct "B" current of the eliminator, flowing through this field coil, energizes it, as shown in Fig. 4. Since this speaker field consists of a large number of turns of wire wound on a magnetic core it has



DYNAMIC SPEAKER

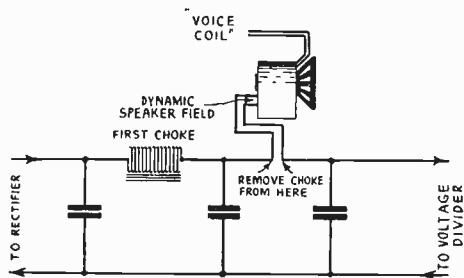
Fig. 3: A typical electrodynamic speaker layout.

quite a large inductance and acts as a choke coil. This arrangement can only be used practically on power-packs where the voltage is from 100 to 200 volts or more, by supplying a "pot field" of proper resistance.

The voltage drop across the pot field will be around 100 volts, and for this voltage drop, the current will be 40 milliamperes if the field coil has a resistance of 2,500 ohms. All of the current which the "B" power-pack is delivering must flow through this field. Unless about 40 milliamperes or more is being delivered by the

the power-pack of a set. It is not practical to use the arrangement of Fig. 4, unless the total "B" current supplied to the set through the choke coils is the same as that required for full excitation by the speaker field.

Of course, radio set manufacturers can design the fields of their speakers to suit the conditions to be met with in their particular "B" power unit. This method of excitation saves the expense of one choke coil in the "B" eliminator, and also saves the expense of a rectifier and step-down transformer in the loud speaker, and is extensively used by set manufacturers. As a matter of fact, it is possible by proper design of the speaker field-winding to utilize its resistance to act also as part of the voltage divider system of the "B" unit in order to save the cost of the separate resistances which are ordinarily used for this purpose. This has been done in the case of the speaker used in the Pilot Midget receiver described in this issue of RADIO DESIGN. An examination of the circuit diagram of this receiver will show how this has been done. The tap taken from the speaker field-winding furnishes +180 volts. Other models of dynamic speakers have fields wound to take their current directly from 110 volt direct current electric light supply lines, where this current is available.



CONNECTION OF A DYNAMIC SPEAKER FIELD FOR USE AS A FILTER CHOKE IN A "B" ELIMINATOR.

Figure 4

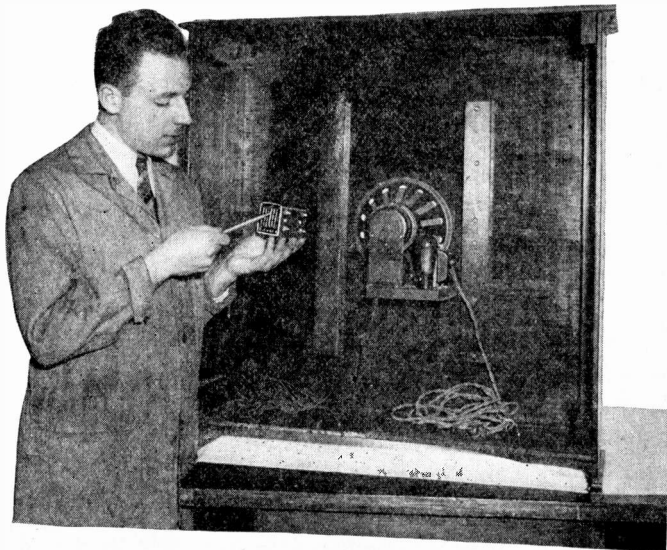
power-pack, the field of the average dynamic speaker will not be excited fully. This point should be kept clearly in mind when it is desired to wire the field of a dynamic speaker into the choke circuit of

#### DYNAMIC SPEAKER RECTIFIER SYSTEMS

When 110 volts A. C. from the electric light line is used for the field current sup-

Figure 5

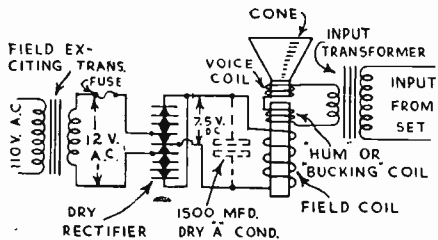
Mr. Ghirardi is shown here holding a typical dry contact type of rectifier made for use in the field circuit of dynamic speakers. Behind him is a dynamic speaker built into a baffle board of unusually large size. The purpose of baffles will be discussed in the second article of this series, which will appear in the Winter issue of RADIO DESIGN.



ply, a rectifier must be used to change this to direct current, as it is necessary that the magnetic field be steady and unchanging in direction. Two types of rectifiers are in common use.

In one popular form the 110 volt A. C. is stepped down to about 6 to 15 volts at about  $\frac{1}{2}$  ampere by a transformer, and rectified by a contact-type of copper-oxide dry plate rectifier, without any filtering. The connections for a unit of this type are shown in Fig. 3.

The current supplied by a rectifier of this type is a pulsating direct current with ripples of 60 cycles. It is evident that the magnetic field produced by this current will also fluctuate. Since the moving



REDUCING HUM IN DYNAMIC SPEAKER

Figure 6

coil is in the field of this flux, there will be a reaction between it and the varying magnetic flux and the coil will tend to move, and its movements will have the same frequency as that of the field current. If the diaphragm or cone moves, sound is produced and an audible hum results. The effect of this pulsating field current can be reduced greatly by a small fixed "bucking" or "hum neutralizing" coil which is wound around the pole piece of the electro-magnet (see Fig. 6) and near the moving coil. It is connected in series with the moving coil and the secondary of the coupling transformer. As the bucking coil is also in the magnetic field it has induced in it a voltage corresponding in frequency to that of the pulsating field current. By making the bucking coil of the proper number of turns, and connecting it in the proper direction, its induced voltage can be made equal and opposite to that produced directly on the moving coil by the magnetic flux. Therefore, the two effects balance each other and the hum is prevented, or at least greatly reduced.

One disadvantage of the bucking coil is that it also tends to reduce signals around the hum-frequency of 60 and 120

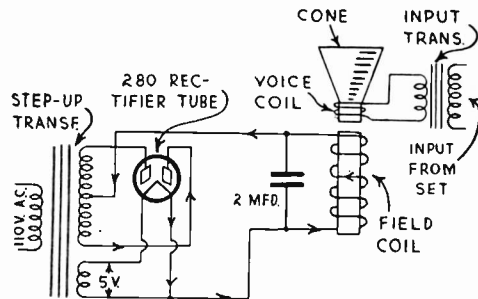
cycles and therefore results in slightly lowered low-frequency response.

Obviously the bucking coil method of hum reduction is only practical when the coil can be included in the speaker at the time of manufacture. A very effective way of eliminating hum in any existing dynamic speaker which uses the low voltage type of dry rectifier is shown in Fig. 6. A dry "A" filter-condenser of from 1,500 to 2,000 mfd. capacity is connected across the field coil. This large capacity serves to filter or smooth out all ripples in the field current. It should be remembered, however, that these condensers can be used only on speakers in which the low voltage (about 15 volts) type of dry rectifier is used, as the condensers have a very low breakdown voltage.

In connecting the dry "A" condenser across the circuit, it is important to make sure that the negative (black) lead of the condenser is connected to the negative side of the circuit, and that the positive (red) lead of the condenser is connected to the positive side of the circuit. The polarity of the circuit should be first determined with a voltmeter.

#### TUBE RECTIFIER TYPE

In the other common type of electro-dynamic speaker for use on 110 volts A. C., a high-voltage low-current field winding is used. Power for the field is supplied by a full-wave rectifier tube (P-280), which operates in connection with a full-wave transformer having a five volt filament winding and a tapped 400 volt secondary to deliver about 180 volts D. C. to the speaker field. The connection of the rectifier tube shown in Fig. 7 is similar to that in the ordinary "B" power-pack. This current is filtered or smoothed out by one or more 2 mfd. filter condensers in combination with the choking action of the high inductance field coil itself, so as



CIRCUIT OF DYNAMIC SPEAKER WITH TUBE RECTIFIER

Figure 7



to eliminate any A. C. hum which might be set up in the speaker by the 120 cycle fluctuations in field current. This does away with the "bucking" coil with its objectionable features. Also the vacuum tube rectifier used is more reliable in operation than the dry disc type of rectifier and can very easily be replaced by the non-technical owner by simply plugging a new tube in the socket. Fig. 7 shows the connections for a speaker of this type. The higher voltage used for the field makes filtering easy.

The photograph of Fig. 8 shows a complete speaker of this type with the rectifier tube on the right-hand side. Notice the sturdy frame supporting the cone, and the ease with which the rectifier tube can be replaced.

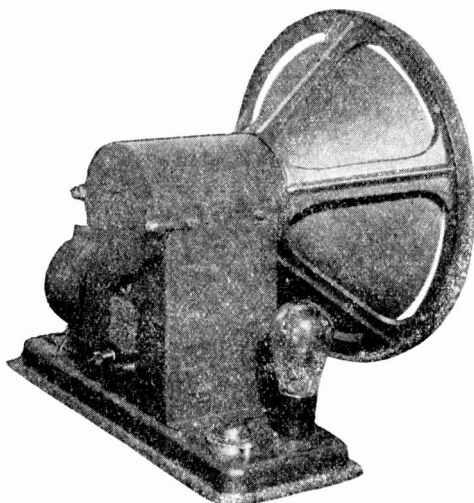


Fig. 8: A standard dynamic speaker using a 280 type rectifier.

When the rectifier in a dynamic speaker is nearing the end of its useful life, the volume of the music diminishes and the hum increases to a high level due to the imperfect rectification produced. When in this condition, the rectifier must be replaced.

#### MOVING COIL IMPEDANCE

The moving or "voice" coil of dynamic speakers is usually wound with a few turns (about 100) of fine enameled copper wire (about No. 34 B. & S.) on a thin cylindrical insulating shell. One very efficient speaker has a moving coil made of several turns of aluminum alloy strip 0.002 inch thick wound edgewise. As the moving coil contains a small number of turns its inductance is small, and it has a low impedance. Also as the inductance is

low, the coil offers almost a pure resistance load on the power tube, and the impedance therefore is nearly constant throughout the frequency range. This latter feature is very desirable since it is desired to have the speaker respond alike to all frequencies. In one commercial unit, the impedance is about four ohms at 100 cycles and 20 ohms at 6,000 cycles!

As the moving coil must be connected in the output circuit of a single power tube (or two power tubes in push-pull), it is desirable that the tube deliver as much undistorted power to the moving coil as possible. A tube delivers the maximum amount of undistorted power output when it works into a load resistance equal to twice the plate resistance. Maximum power output, however, is obtained when the load resistance equals the tube's plate resistance. It is not necessary to match these exactly, as quite a large percentage of the maximum undistorted power output can be obtained even though the load resistance is four or five times *greater* than the plate resistance of the tube. It is bad practice to work a tube into a load resistance which is much *less* than its own plate resistance. This would be the case if the moving coil of a commercial dynamic speaker were connected directly in the plate circuit of one of the common power tubes, whose plate impedances vary around 2,000 ohms for a 171A tube, 1,900 ohms for a 245 tube and 5,000 ohms for a 210 tube.

#### COUPLING TRANSFORMER

Practically all dynamic speakers use a special coupling transformer between the power tube and the moving coil to bring these impedances into the proper relationship. The signal energy from the plate circuit of the power tube in the receiver is led through the primary winding of the loud speaker coupling transformer. The impedance of this winding is designed to match that of the plate circuit of the power tube. The secondary winding of the coupling transformer is of low impedance and as it feeds into the moving or voice coil of approximately the same impedance, the maximum transfer of energy is effected.

The coupling transformer consists, like an audio transformer, of two coils of insulated wire wound on a laminated iron core. It is wound to match the plate impedance of the power tube to the lower impedance of the moving coil. As the impedance of a coil varies as the square of the number of turns, the transformer is designed so that the square of the ratio

of secondary turns to primary turns is equal to the ratio of moving coil impedance to that of the desired effective power tube impedance, that is:

$$\left(\frac{T \text{ sec.}}{T \text{ prim.}}\right)^2 = \frac{\text{IMPED. SPK'R.}}{\text{EFFECTIVE IMPED.}}$$

Thus, if the moving coil has an impedance of 10 ohms at some frequencies and it is desired to match it to a 1,900 ohm plate circuit of a 245 type power tube, a plate load of twice 1,900 or 3,800 ohms is required to get maximum undistorted power output. Substituting these values, we have:

$$\left(\frac{T \text{ sec.}}{T \text{ prim.}}\right)^2 = \frac{10}{3800}$$

or  $\frac{T \text{ sec.}}{T \text{ prim.}} = \sqrt{\frac{10}{3800}} = \sqrt{\frac{1}{380}} = \frac{1}{19.5}$

That is, the primary of the coupling transformer should have 19.5 times as many turns as the secondary. When a push-pull output circuit is used, it must be remembered that the output plate impedance is equal to twice that of one of the tubes. Thus, in this problem, if two 245 tubes in push-pull had been specified, the output plate impedance would be two times 1,900 or 3,800 ohms. The plate load to get maximum undistorted power output would then be 3,800 times two, or 7,600 ohms. For two similar output tubes con-

nected in parallel, the output plate impedance is equal to one-half that of a single tube.

With well designed apparatus, the result is practically the same as if the speaker were suited to the tube. The connection of the coupling transformer "T" is shown in Fig. 3. Notice that it is a step-down transformer. The proper coupling transformer is usually included in the housing of the dynamic speaker, so that when a dynamic speaker is connected to a receiver which has an output transformer or output filter in it, the output transformer or filter should be disconnected from the receiver first, and the dynamic speaker input terminals connected directly in the plate circuit of the power tube.

An analysis of the characteristics of the coupling transformer circuit shows that it is not necessary to have the coupling transformer of exactly the correct ratio for satisfactory results. If this were the case, a special coupling transformer would have to be used for each type of power output tube, since nearly all power output tubes have different plate impedances. A coupling transformer designed to make a moving coil function satisfactorily with a 5,000 ohm tube (type 210 for example) would also be satisfactory for a 2,000 ohm tube (such as the 245 type), although a transformer satisfactory for the 2,000 ohm tube would not be very satisfactory for use with the 5,000 ohm tube. These considerations have caused most loud-speaker manufacturers to design the coupling transformer to give best results from a 5,000 ohm tube, knowing that such apparatus will be satisfactory with 2,000 ohm tubes. Of course, slightly greater efficiency might be obtained by using the proper transformer in each case. Some manufacturers use a tapped transformer so that proper matching can be obtained with any type for best performance. Because coupling ratios are not critical it is fairly safe to say that any commercial dynamic loud speaker unit manufactured at present, may be satisfactorily connected to the output of almost any receiver using standard type output tubes. In some cases, however, somewhat more efficient results can be obtained by using special coupling transformers.

#### PUSH-PULL OPERATION

In sets having push-pull output, satisfactory operation will be obtained with most commercial dynamic speakers by connecting them directly to the set output terminals (secondary terminals of push-pull output transformer in set). Some

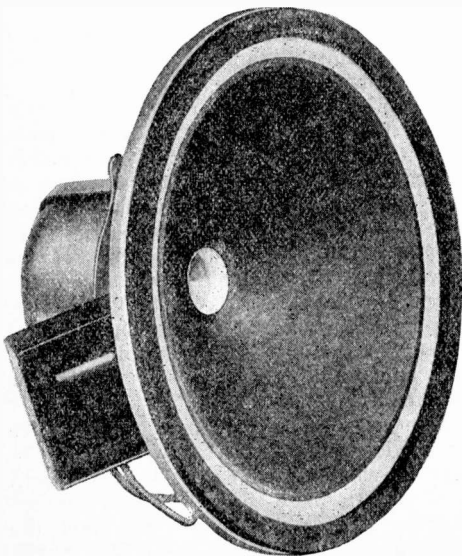


Fig. 9: The white inner ring of this dynamic speaker is made of chamois, and supports the free edge of the cone.

sets use a very special push-pull output transformer having only a few secondary turns matched to operate directly into the voice coil winding of the conventional type of dynamic speaker, omitting the input transformer in the speaker. In this case, the push-pull output transformer secondary should be connected directly to the voice coil only, or else the regular dynamic speaker input terminals should be connected directly to the outer terminals of the primary of the set output transformer, ignoring the secondary terminals of this transformer entirely.

#### CONES

The moving coil of a dynamic speaker is usually attached rigidly to a cone which sets the air in motion to produce the sound waves. The cones used on these speakers vary from about 6 inches in diameter for the smaller units to about 12 or 16 inches for the larger units used in auditoriums and public address work. The cone is made of specially prepared paper which resists changes in size and shape due to heat or moisture. The cones are sometimes corrugated to increase their stiffness and provide better frequency response. The paper cone is attached rigidly at its apex to the moving coil. The outside edge is fastened loosely by a circular strip of some soft and flexible material such as pliable goat or chamois skin, to the rigid metal supporting ring of the speaker (see Fig. 9). This strip supports and helps to center the cone.

Two or three thin flat metal or laminated Bakelite spiral strips keep the moving coil centered in place in the annular

air-gap between the field magnet poles. However, they must be flexible enough to allow it to move with perfect freedom to-and-fro over a large amplitude along the pole piece. Sometimes when metal strips are used, they also serve to conduct the current to the moving coil winding. The cone is thus almost "full-floating." The resonant frequency of the cone, coil, and spring combination should be made very low, usually less than 50 cycles per second, so that the speaker acts as practically a non-resonant pure resistance load on the amplifier for most of the working audio-frequency range.

The moving coil construction allows of large vibration movements of the cone, without causing rattle in the driving coil. For the reproduction of very low notes at loud volume, the cone may move as much as one-half inch in this type of speaker. The movement is back and forth like a piston in an engine. It is necessary that the moving coil be free to move in and out of the gap without touching any part of the field core structure. In cases where the coil touches, a loud buzzing or scratching sound destroys the quality of the speaker. The cone and moving coil must then be re-centered.

(EDITOR'S NOTE: *This concludes the first part of Mr. Ghirardi's article. The second part, dealing with baffle boards, will appear in the next number of RADIO DESIGN.*)

### Hum in Push-Pull Stage

Question: When I take out one of the two 245 tubes in my set a hum is produced, but the set continues playing. Should this be so, and will it damage the one tube I leave in?

Answer: When you remove one tube the set operates with a single tube in the output stage. However, as less than the normal plate current is now flowing through the "C" bias resistor of the push-pull tubes, less than the required "C" bias voltage is being developed and applied to the tube which is left in the socket. This will damage the tube due to the excessive plate current flow, if it is operated for any length of time this way. The hum is caused by the fact that the push-pull arrangement balances out any hum developed in the last audio stage. When you take out one tube the push-pull connection no longer exists and the hum currents are effective.

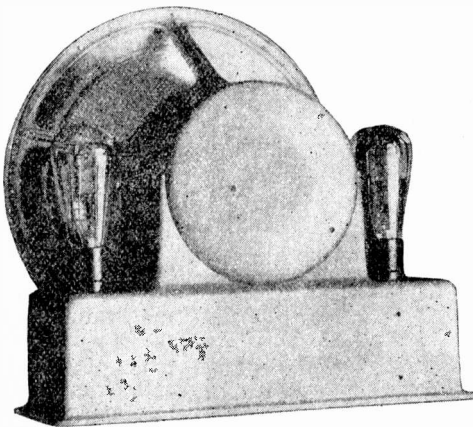


Fig. 10: A very heavy dynamic speaker made for auditorium and Public address service. Two rectifier tubes are used for the field supply.

# Radio Tubes—What Happens Inside of Them

A Clear and Readily Understood Explanation of Electron Theory and of the Usual Operating Characteristics

By A. S. FRIEDMAN

**I**N THE preceding issues of RADIO DESIGN, we have been made acquainted with the methods employed, in most modern factories, in the manufacture of radio tubes. This article will supplement the published data and will deal with the theory and operation of the usual types of tubes used in the modern broadcast receiver.

There are a few fundamental definitions which should be gone over and thoroughly absorbed before we can understand the proper functioning of the vacuum tube, to whose perfection the radio industry largely owes its success. Such expressions as "electronic emission," "plate current," and "saturation current" are basic and should be comprehended in order to visualize more clearly the theory behind the operation of the tube.

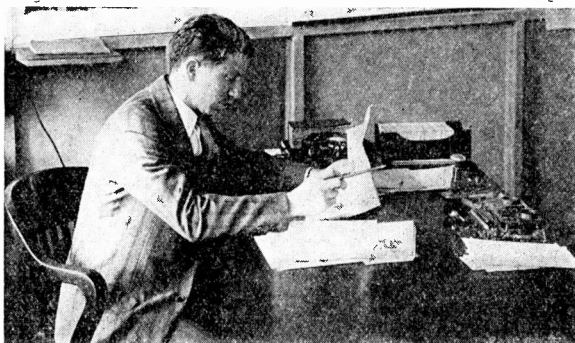
The theory of electronic emission is the basis upon which all tubes operate. Most metals, when subjected to high temperatures, have a tendency to evaporate, exactly as water evaporates at ordinary temperatures. The electrons which are associated with the atoms of the metal do not have sufficient velocity at ordinary temperatures to break through the surface tension of the metal. When the metal is

h e a t e d to incandescence, however, the atomic agitation reaches a point where the velocity of the electrons becomes great enough for them to break away from the surface and actually start the vaporization of the material. "Electronic emission" then can be defined as

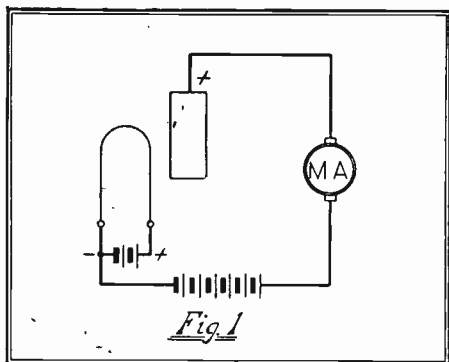
the setting free of electrons. It is also known from the structure of the atom that the electrons set free are at a negative potential.

A piece of filament or wire then, heated to incandescence, would be a source of electronic emission. If now a metal plate were placed near the filament, both being sealed in a vacuum, and connected to it through some measuring device such as a galvanometer, it would be noticed that a slight current was flowing between plate and filament. If a battery were next inserted in series with the galvanometer and a positive potential maintained on the plate, as shown in Fig. 1, it would be seen that the flow of current had greatly increased. This flow current, which is due to the electronic emission, may be termed "plate current" and always occurs in the direction opposite to the electronic flow. In other words, the free electrons which are negatively charged are attracted to the anode, causing a flow of electrons from the filament to the plate. Current, on the other hand, flows from the anode to the cathode, hence we have two flows in opposite directions. It is important that these flows are not confused.

From the above discussion, then, it appears that the plate current is dependent upon several different conditions: first, the temperature of the emitting body, and secondly, the value of the applied plate potential. Fig. 2 illustrates more clearly the effect of varying temperatures and plate voltages.



*Mr. Friedman, a recognized authority of long experience, is head of the tube division of the Pilot Radio & Tube Corporation. His article will interest every radio fan.*



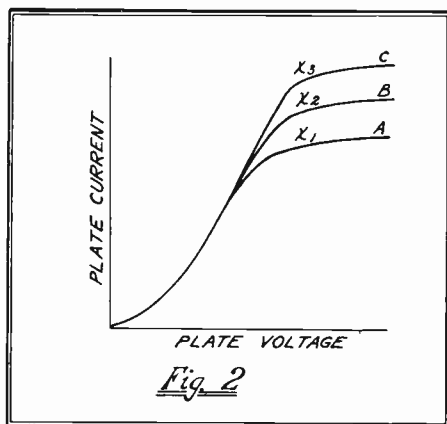
Curve A shows the plate current at a fixed temperature and varying plate voltages. Curve B shows the rise in plate current due to increasing the temperature over the same plate voltage range. Curve C shows the still higher plate current with a correspondingly higher temperature over the same voltage range.

Fig. 3 illustrates the foregoing discussion more clearly and allows a mental picture to be formed of the action which takes place. A, B and C represent an emitter material at three different temperatures. At A, a low temperature is assumed and the free electrons are shown leaving the emitting body. Since the velocity of the electrons is not great at this temperature, only a few of them succeed in breaking away. At B, where the emitter temperature is increased, a larger number of electrons is set free; and at C, where the temperature is still further increased, a much larger number of electrons is liberated. All these electrons exist in the space surrounding the emitter, as shown, and as they all carry negative charges of electricity, they form a negative space charge in the zone surrounding the emitter. This space charge acts to repel the further flow of electrons, since both carry like charges of electricity. There are then two forces acting on the free electrons: a repelling force exerted by the space charge, and an attracting force exerted by the emitter material. The electrons breaking away from the emitter leave the atoms with unbalanced positive charges, which

try to re-attract to themselves enough electrons to relieve their unbalanced state.

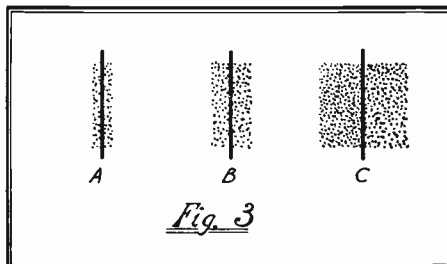
The introduction of a third force in the form of a positive potential on a metal plate located in the field of the space charge can be seen by reference to Fig. 2. At low voltages, the attractive force cannot counteract the effects of the space charge and the emitter attraction, for which reason only small currents flow. As the voltage is increased, however, the space charge effect is overcome and instead of falling back to the emitter, the electrons are attracted to the plate in greater quantities.

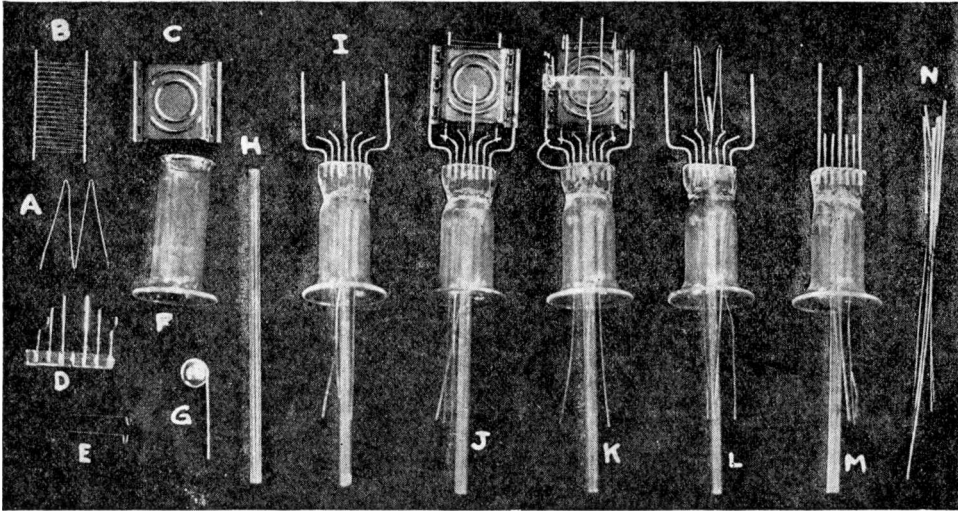
There is one feature characteristic of all three curves of Fig. 2 which should be discussed at this point: that is, the tendency of the curves to flatten out after a certain voltage has been reached. From the foregoing paragraphs, the impression may have been gathered that the plate current increases with the plate voltage indefinitely. However, this is not the case.



The electron flow depends only on the emitter material and its temperature, and once these items have been fixed the total number of electrons emitted remains practically constant. However, the total number of them which reaches the plate depends upon the value of the plate voltage. At low voltages, few electrons are attracted to the plate, and at higher potential they are attracted in greater quantities, up to the point where the maximum number of electrons emitted is being attracted. Beyond this point, which is known as the "saturation" value, an increase in plate voltage is of no value, since no greater amount of electrons can flow. Points X1, X2, and X3 mark the saturation

points, up to the point where the maximum number of electrons emitted is being attracted. Beyond this point, which is known as the "saturation" value, an increase in plate voltage is of no value, since no greater amount of electrons can flow. Points X1, X2, and X3 mark the saturation





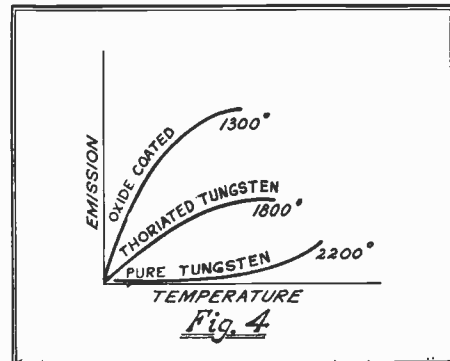
A Pilotron 201-A type tube broken down to show the details of its construction. A, filament. B, grid. C, plate. D, glass support for top of grid and filament. E, filament hooks. F, glass mounting stem, before forming. G, "getter" cup. H, exhausting tube. I, stem with mounting wires. J, stem with elements in place. K, complete tube element. L, stem with filament alone in place. M, stem before wires are formed. N, wires that are pressed into stem.

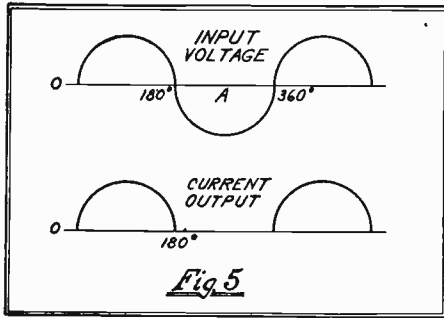
tion values for the three different temperatures used. It will be seen by referring to Fig. 2 that no benefit is derived from using voltages higher than those necessary to secure saturation.

As previously stated, the electronic emission depends upon the emitter material, of which several types will be discussed here. Early experiments were conducted, using tungsten as an emitter, and the results secured were erratic and far from satisfactory. Since electronic emission can be termed the vaporization of a metal, tungsten was heated to incandescence in order to secure emission. The rapid vaporization due to the high operating temperature seriously affected the life of the filament, and pure tungsten was soon replaced by a new type of filament called thoriated tungsten, with which most of our battery types of tubes are supplied. It was found that a small percentage of thorium added to the tungsten in the process of manufacture acted as a coating for the tungsten. In operation, the thorium is brought to the surface and vaporized in place of the tungsten. It is this property of thorium which allows us to "re-active" such filaments when the surface layer has vaporized. The re-activation consisting solely in raising the filament temperature to such a degree that thorium molecules are brought to the surface to renew the layer vaporized.

#### OXIDE COATED FILAMENTS

The development within the last few years has been along the same lines in A. C. tubes. It was obvious that the life of any material operating at incandescence would not be very satisfactory. In addition this type of filament would not have sufficient inertia for use in electric sets where the filament supply is stepped down raw A. C. Experiments were conducted along the lines of reducing filament temperature and at the same time securing adequate electron emission. It was found that the oxides of certain metals such as barium and strontium were capable of emitting at low temperatures. Base wires of platinum, nickel and especially prepared alloys, when coated with these metallic ox-





ides, were found to give better electron emission at very much lower temperatures. Fig. 4 indicates the emission that can be secured from pure tungsten, thoriated tungsten and oxide-coated filaments. Comparatively speaking, the oxide-coated filament gives approximately six times the emission of a thoriated filament, and the thoriated gives approximately twenty times the emission of the tungsten filament for normal operating temperatures indicated.

The above discussion has dealt solely with the filament type tubes in order to illustrate more clearly the theory of operation. Once completely understood, however, it can be very readily seen that the cathode type tubes differ only in their construction and not at all in their functions or theory. The cathode or indirect heater type differs only in that the emitter is raised to the proper temperature either by the radiation of a electrical-heater insulated from it or by the conduction of heat from an insulating separator brought to the proper temperature by the heater element. Otherwise its operation is identical with the filament types described.

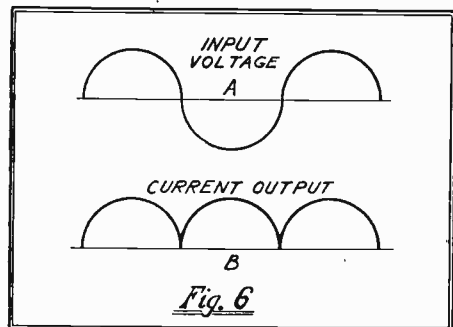
So much then for the theory. We can now advance a step further and consider the applications to which the above principles can be of value. Mention was made in a preceding paragraph of the primary tube developed; the ordinary two-element tube containing a plate and filament. Two-element tubes as used in present-day receivers function as rectifiers. There are many types of rectifiers manufactured, but the two most commonly met with today are of the hot cathode type. One, the so-called ionized gas type, depends upon an inert gas in order to function properly and is typified by the tungar bulb. The second, depending upon true thermionic action, has proven its superiority over all types of rectifiers and is the one most commonly used in present-day receivers. The Pilotron types P-280 and P-281 are

typical of two-element tubes operating by pure thermionic action.

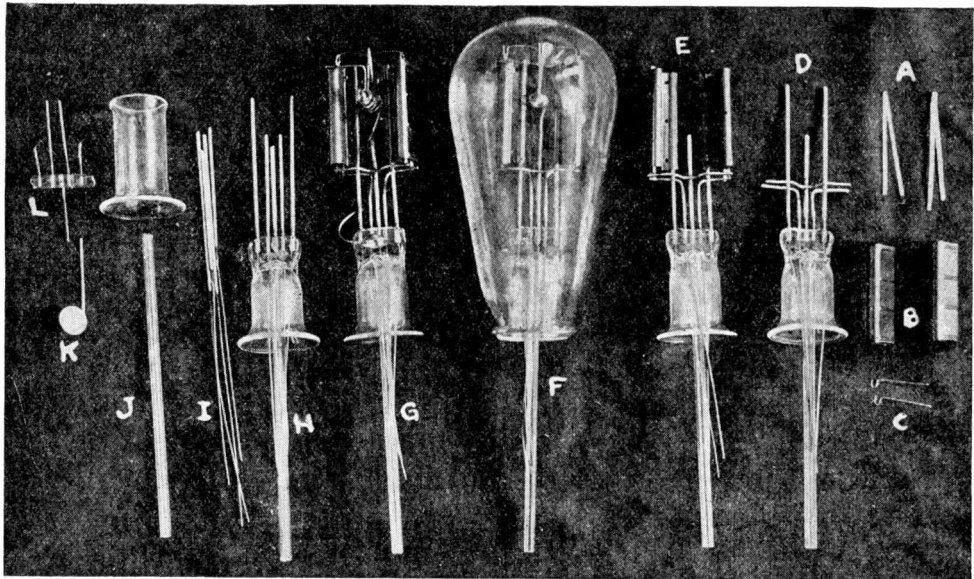
#### RECTIFIER TUBE CONSTRUCTION

The tube consists of a filament and a metallic plate sealed into a bulb from which the air has been thoroughly evacuated. In a tube of this sort, the emitter is most carefully selected, because the life and operating characteristics depend almost wholly upon it. Ballast wire of specified dimensions is subjected to rigid inspection and is coated with a mixture of earth metals in proportions established by the Pilot laboratories as consistent with long life and high emitting properties. Samples of this emitter are constantly checked by the laboratory and are not allowed to vary from fixed tolerances.

In its normal operation the tube, when used in an ordinary power-pack, can only deliver current when the plate is positive. Since this type of tube depends wholly upon thermionic action for its operation, it is apparent that it is ideal for use as a rectifier. The cold plate is no source of electrons, therefore all electrons reaching the plate cannot flow back to the filament. Current therefore can flow only in one direction, and this unilateral flow makes for ideal rectification. By this means, alternating current is changed to a pulsating direct current, as shown in Fig. 5. "A" shows the sine wave of an alternating voltage applied to the plate, while "B" reveals the effect of the rectifier action. It will be noticed that in the half cycle in which the voltage is negative or below the line, no rectifying action takes place. It is only during the portion of the cycle when the plate is positive that current is flowing. The action illustrated in Fig. 5 is that of a half-wave rectifier, as typified by the Pilotron P-281. In order to secure full-wave rectification, as supplied by the Pilotron P-280, another plate is added to the tube and the circuit so arranged that one plate or the other is always delivering







The Pilotron 280 broken down to show its construction: A, filaments. B, plates. C, filament hooks. D, stem with wires formed. E, stem with plates and filaments mounted but not supported. F, completed tube without base. G, stem assembly complete with supporting bead. H, formed stem with unformed wires. I, connecting and supporting wires. J, unformed stem and exhausting tube. K, "getter" cup. L, center supporting bead.

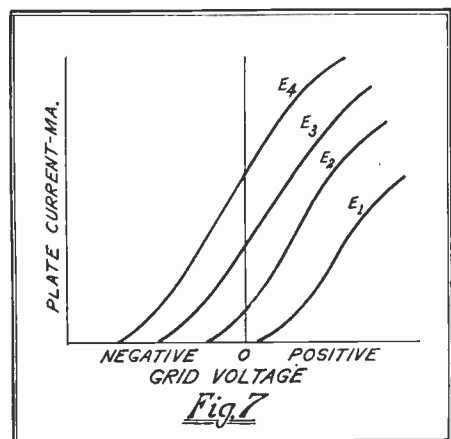
current. During any alternation, while one plate is negative, the other is positive, and *vice versa*, so that the output delivered to the filter unit is a pulsating direct current, as illustrated in Fig. 6. Both half- and full-wave rectifiers are popular present-day types, and one or the other will be found in almost every electric receiver. The half-wave rectifier P-281 is usually employed where high voltage is desirable, as in speech amplifiers, public address systems, etc. The full-wave rectifier P-280 is used where lower voltages at a higher current output are desired, as in most broadcast receivers.

The two-element tube was the primary type which led to the development of the three-element tube. It was found that when a screen or grid composed of a number of turns of fine wire was interposed between the plate and filament, the tube became endowed with the properties of amplification and oscillation which the two-element type did not possess. In the preceding paragraphs, it was shown that the plate current could be controlled by two conditions, namely: plate voltage and filament temperature. We now find that a third method can be used for controlling plate current, and that is by the insertion of a grid between plate and filament. The

grid functions as a control valve in regulating the flow of current from the plate.

#### EFFECT OF GRID POTENTIAL

Suppose that the grid were placed at a negative potential. It would be found that the grid increased the effect of the space charge existing between plate and filament and the electron flow would be materially decreased. The repelling force of the grid would be greater than the attracting force of the plate and the free



electrons would be forced to return to the emitter. Suppose on the other hand that a positive potential is maintained on the grid. The effect of the grid now is to neutralize the space charge and allow a greater number of electrons to leave the emitter surface. Due to the fact that the grid is located much closer to the filament than the plate, very slight variations in grid voltage have a much greater effect that corresponding changes in plate voltage would have.

Fig. 7 shows the relation between grid voltage and plate current for a number of different plate voltages E1, E2, E3 and E4. The curves all show the effect on the plate current of varying grid voltage from a strong negative to an equally strong positive potential. The plate current is lowered to the left of the ordinate of zero grid potential and is increased to the right of the ordinate when the grid is positive. The limiting factor in the increase of plate current is when the saturation point has been reached.

In the following discussion, whenever "grid circuit" is mentioned, it is to be understood that the input or grid-filament circuit is meant, and that when "plate circuit" is mentioned the plate-filament or output of the tube is what is meant. Suppose now that an alternating voltage were impressed on the grid, so as to make the grid become charged alternately at negative and positive potentials. The potential variations in the grid circuit would cause similar variations in the output circuit. The above statement must be qualified to the extent that faithful signal reproduction in the output circuit occurs only when the tube is operating under the correct conditions; that is, under the rated values of plate current and grid bias.

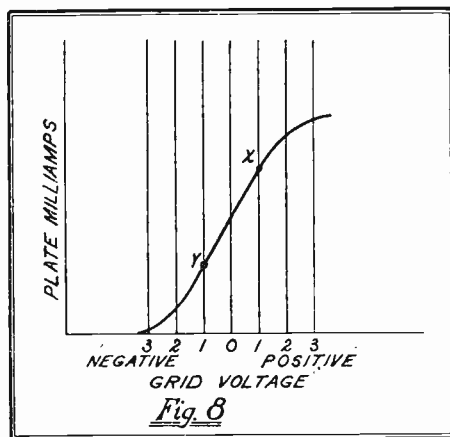
#### CHARACTERISTIC CURVE

Fig. 8 represents a characteristic curve of plate current plotted against grid bias. Under zero grid bias it will be noticed that the tube draws a plate current of 2 milliamperes and as the bias is increased positively the plate current rises, while the plate current is reduced when the bias is increased. The distance between the points *x* and *y* marks the limit of the utility of the tube. The straight portion of the curve lies between these points, and in this operating zone signals will be faithfully reproduced.

For example, let us assume that a signal swing of one volt positive and negative is impressed on the grid. The result on the plate current is an amplified ver-

sion of the input wave form. That is, the plate current would change from one ma. when the grid was negative to three ma. when the grid went positive. A signal swing of more than one volt would not be faithfully reproduced because the increase in plate current due to a positive potential on the grid would not be equal to the decrease in plate current due to the negative potential on the grid, since both these points would be located on the bends of the curve. This would result in distortion of the output signal. The characteristic plate current-grid voltage curves are governed to some extent by the applied plate voltage, and it will be seen by referring to Fig. 7 that as the plate voltage is increased, the straight portion of the curve is lengthened, allowing a greater grid swing without distortion of the fidelity of reproduction.

There is one condition inherent in all tubes which interferes with its true uni-



lateral characteristic and that is the effect of inter-electrode capacity. The elements of the tube form an electrostatic system, each element of which acts as one plate of a condenser. The capacities which exist are the grid to filament, grid to plate and the grid to plate and grid to filament connected together. If an alternating voltage is applied to the input circuit of a tube, an alternating current flows in the grid circuit because of the grid-filament capacity. The effect of inter-electrode capacity then is to produce a coupling between the input and output circuits which may cause either feed back or an absorption of energy, according to circuit conditions, and in general acts to reduce amplification at high frequencies.

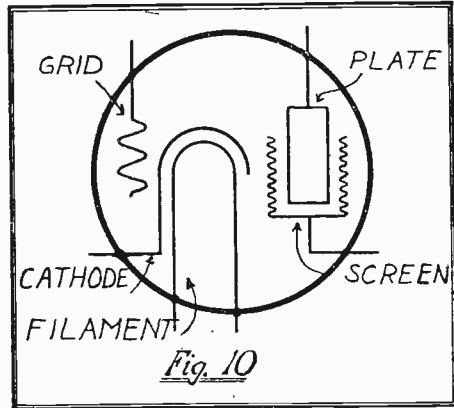
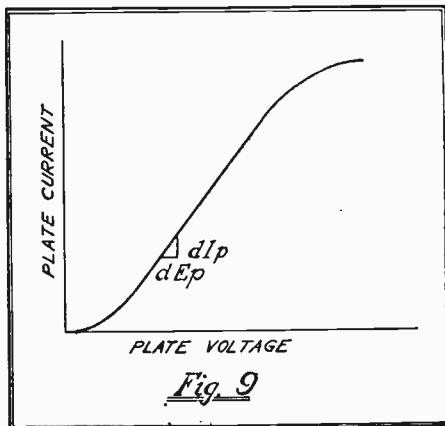
At this time, a discussion of tube con-

stants would be in place, as no prediction of the proper functioning of the tube can be made unless its characteristics are known. Since we mentioned the fact that three-element tubes are capable of amplification, we will first discuss the amplification factor "mu." Briefly, it is a measure of the maximum voltage amplification possible within the tube and may be defined as the ratio of the plate voltage change required to affect a certain plate current change, to the grid voltage change required to affect the same amount of

change. 
$$\mu = \frac{dE_p}{dE_g}$$
 In other words,

the grid voltage change due to the reception of a signal appears in the output circuit amplified  $\mu$  times. The amplification factor remains practically constant throughout the entire operating range of the tube and varies only slightly under various plate and grid voltages. It depends wholly upon the tube structure, which includes the size and spacing of the grid wires as well as the location of the grid relative to the plate and filament. Generally speaking, tubes having a high amplification factor use a grid having many turns closely spaced and located at a short distance from the filament. Tubes having a low amplification factor have much fewer turns and have their grid located nearer the plate.

Another important factor which is closely associated with the amplification constant is the plate impedance of the tube,  $R_p$ . Briefly expressed, it is the resistance offered to alternating currents between the plate and the filament. It may be obtained from the ordinary plate-voltage-plate-current curve shown in Fig. 9 and is equal to the reciprocal of the slope



of the curve within the operating range. The plate impedance may be found from

the relation 
$$R_p = \frac{dE_p}{dI_p}$$
, where  $dE_p$  is

a small change in plate voltage producing a like change  $dI_p$  in plate current when the grid voltage is maintained constant. As can be seen from Fig. 9, the relation between plate current and voltage is non-linear; hence the plate impedance varies accordingly. At low plate voltages the impedance is fairly high. As the voltage increases the impedance decreases rapidly at first, then more gradually as the normal operating voltage is approached. Generally speaking, it may be said that the plate impedance cannot be altered without altering the amplification. If the amplification factor is increased the impedance is also increased, and if the amplification is decreased the impedance is reduced. Summarizing then, the impedance depends upon two things; the amplification factor and the total surface area between the plate and the filament.

The third important constant to be considered is the mutual conductance,  $G_m$ . It is a mathematical ratio which takes into account the amplification factor and the plate impedance and is a measure of the operating efficiency of the tube. It

may be expressed by 
$$G_m = \frac{\mu}{R_p}$$
, and

since  $R_p$  involves the alternating current in the plate circuit due to the input potential, it is a measure of the efficiency of the tube as an amplifier and is expressed in micromhos. In general, tubes with high mutual conductance make better amplifiers.

Knowing the tube constants, the selection of a tube for a specific purpose can

be very readily made by referring to its characteristic curves. Most three-element tubes can be classed either as voltage or power amplifiers. Voltage amplifiers are usually so designed as to have high values of amplification and plate impedance. Under such a heading can come tubes such as type P-201A, P-224, P-227, P-226 and P-222. Power amplifiers, on the other hand, as typified by the P-171A, P-245, P-210 and P-250, are designed with low amplification factors and low output impedances.

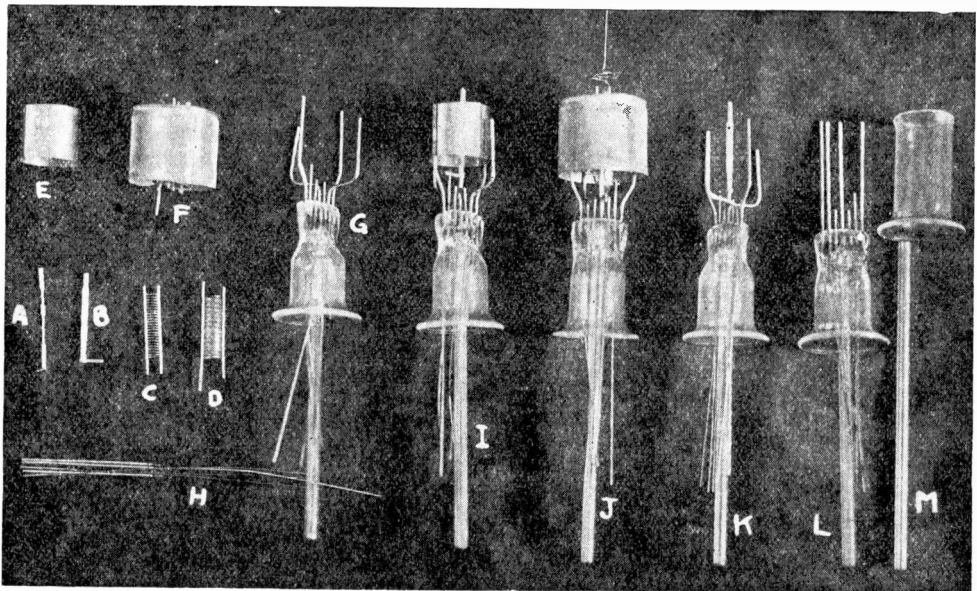
The tube occupying the most prominent place in present-day receivers is the four-element or screen-grid type and is supplied in a direct and an alternating current type. The filament structure of the battery model is the same as that incorporated in three-element tubes, while the A. C. model incorporates the same cathode as in the three-element tube previously described.

#### SCREEN-GRID ADVANTAGES

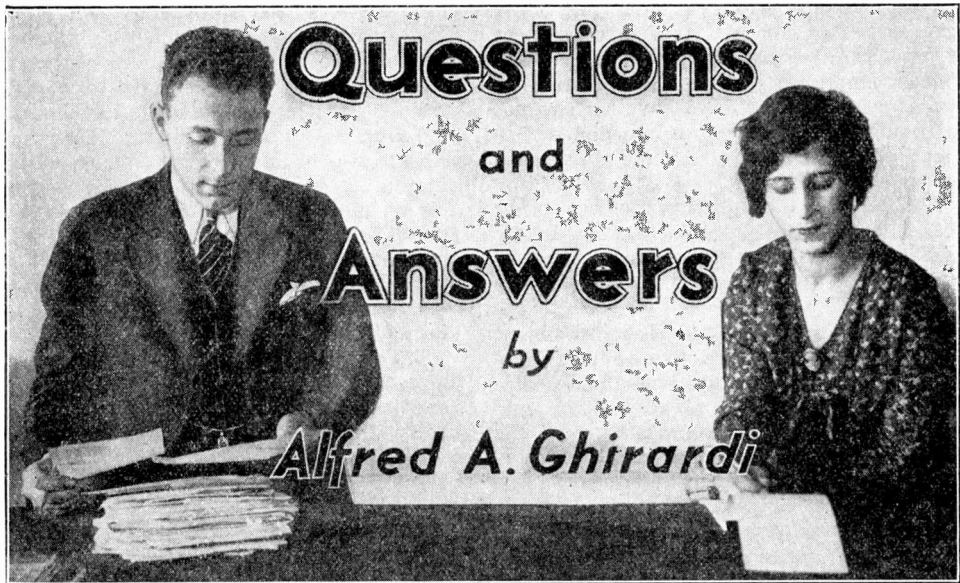
Fig. 10 represents the structural arrangement of the Pilotron P-224 A. C. screen-grid type. The tube contains the essential parts of the three-element types—plate, grid and cathode assembly—and in addition has a finely wound grid inter-

posed between the plate and control-grid. This extra grid is connected to another mesh cage surrounding the plate and completely inclosing it. The function of this grid being to electrically shield the control-grid from the plate. In normal operation the screen-grid is maintained at a positive potential. In operation the screen-grid acts as a plate and attracts to itself the free electrons. If the plate voltage is increased above the screen-grid voltage, an electron flow will go through the screen-grid, due to the attraction of the plate, and will constitute the plate current.

The plate voltage has very little effect on plate current within the operating zone, hence the impedance is very high. It naturally follows that the amplification of such a tube would be extremely high. The presence of a screen-grid materially reduces the control-grid to plate or feed back capacity since it represents the sum of the plate to ground capacity and the screen to control-grid capacity, and the sum of two capacities in series is always less than the component parts. It is the extremely high amplification factor and low grid-plate capacity which have made this tube so popular for use as a radio frequency amplifier where these features can be employed to advantage.



The details of the Pilotron 224 screen-grid tube: A, heater element. B, cathode. C, control-grid. D, inner screen-grid. E, plate. F, outer screen (goes around plate). G, stem assembly, wires bent. H, supporting and connecting wires. I, stem with cathode, grid and plate in place. J, completed element ready for enclosure in tube. K, stem with heater—cathode in place. L, stem with unformed wires and exhausting tube. M, stem and exhausting tube.



*All letters requesting technical information are answered directly by mail free of charge, the few questions published herewith having been selected because of their general interest. Please help us to help you by writing plainly and stating your problem as clearly as possible. Include with your letter a stamped envelope addressed to yourself.*

#### WORKSHOP SPECIAL IMPROVEMENT

1. I notice that most regenerative detectors have an R. F. choke coil connected in their plate circuits. Could I improve the operation of my "Workshop Special" by connecting a Pilot No. 130 R. F. choke coil in the detector circuit?

Answer:—The use of a No. 130 R. F. choke will give you improved control of regeneration, for it will prevent R. F. current from flowing through the primary of your audio transformer. As all R. F. current must then take the path in which the 23-plate regeneration control condenser is connected, this condenser will have better control on the regenerative action. Disconnect the wire which now goes to the P terminal of your audio transformer. Connect this wire to one side of the R. F. choke and connect the P terminal of the A. F. transformer to the other terminal of the choke.

As pointed out in the original article, the 199-type tubes are a bit irregular, and some of them are very poor oscillators. If the set refuses to oscillate even with no aerial connected, the best thing to do is to add more turns to the tickler windings. In fact, make the ticklers of the same size as the grid coils, or even larger, if necessary. The bigger the tickler, the more

certainly will the detector circuit be "walled" into oscillation. If the set oscillates too violently, follow the instructions given on page 79 of Vol. 2, No. 3 of RADIO DESIGN.

Many readers want to know if 201A tubes can be used instead of the 199's. The answer is most emphatically "Yes." Of course, 201A's take  $\frac{1}{4}$  ampere of filament current at five volts and therefore require a storage "A" battery. Eight dry cells in series-parallel may be used, but they will not last long. The same "B" batteries as before are used. The 201A's will give decidedly better results than the 199's, the latter being used in the original "Workshop Special" merely because they work on dry cell "A" batteries.

#### HUM IN PILOTONE SIX

2. I have one of your Pilotone Electric Six receivers, described in the Volume 1, No. 4 issue of RADIO DESIGN. The set has given me perfect satisfaction, but I notice that when I have my "B" power pack at certain positions near the set I get a loud hum which comes in even when the stations are off. What causes this?

Answer:—The power transformer and choke coils in your power pack have a strong magnetic field which exists for

several inches around them. When you place your pack near the audio transformers (position 1 of Fig. 1) these fields, which are constantly varying, cut across the thousands of turns of wire in your A. F. transformers, inducing low frequency voltages in them. These are amplified by your A. F. amplifier and are reproduced by the speaker as a low frequency sound, which affects the ear as a hum.

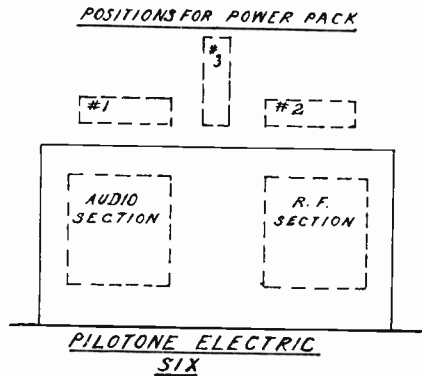
The first A. F. transformer is the worst offender in this respect, as any hum voltages induced in it are amplified by the following two audio stages. Placing your power pack over near the R. F. end of the set (as in position 2 of Fig. 1) or at right angles to the set, as in position 3 (with the power transformer at the rear) will place these magnetic fields far enough from the transformers to eliminate these effects. This action may be set up in any A. C. electric set, where the power pack is placed too near the A. F. transformers.

#### HUM DUE TO PLATE CIRCUIT COUPLING

3. How can hum due to coupling in the "B" supply unit be eliminated simply and effectively?

Answer:—Coupling in run-down "B" batteries will often cause a steady high pitched whistle. This can be eliminated by connecting a 1 mf. fixed condenser from B— to B + 45, or from B— to B + 90, as shown in Fig. 2. If this does not eliminate the whistle the only remedy is to obtain a fresh set of "B" batteries.

Coupling in a "B" power pack may also result in a steady high pitched whistle, but more often it results in a steady low-pitched squawk or growl. This is caused by two or more plate circuits being coupled through a common high resistance or impedance in the "B" supply unit. It can be eliminated by isolating one of the cir-

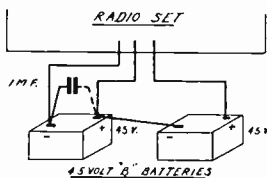


**FIG. 1**

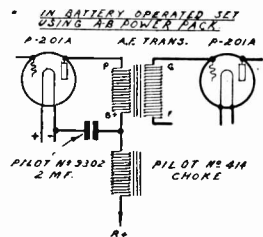
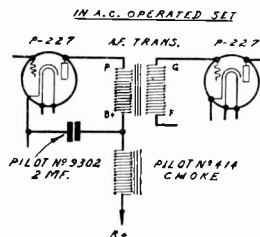
Placing the power pack as shown in positions 2 and 3 will minimize A. C. hum in the receiver.

uits from the rest; that is, providing a low impedance path for the varying audio frequency currents to get from the electron emitter (cathode or filament to the B +, terminal of the A. F. transformer without having to flow through the "B" power pack circuits. This can be accomplished by connecting a Pilot No. 414 30-henry choke in series with the plate lead, and a Pilot No. 9302, 2 mf. condenser from the upper terminal straight to the cathode if it is a separate heater type A. C. tube, or to the negative side of the filament if it is a battery-operated tube, as shown Fig. 2. The choke coil prevents the A. F. currents from flowing through the "B" unit, and the 2 mf. condenser presents a fairly low impedance path for them to flow through.

This connection may be tried first in the detector plate circuit. If it does not work here try it in the first A. F. tube plate circuit, or in the second A. F. circuit. Of course, this will cure hum or howling due only to common plate coupling. It is not a cure-all for hum caused by defective tubes, power pack, wiring, etc.



**FIG. 2**



How plate coupling effects in battery and A. C. operated receivers may be cured by the use of by-pass condensers and choke coils.

### CONDENSERS IN SINGLE-CONTROL SETS

4. I have just finished a 6-tube single-dial receiver in which I have used four Pilot No. 176 R. F. coils and a two-gang Pilot .00035 mfd. S. L. F. condenser coupled to a two-gang Pilot .00035 mfd. Centraline condenser, for tuning. I find, by loosening the set screws on the shafts of these units, that when I vary each one individually to tune a station, the S. L. F. condensers are set away off from the position of the Centraline condensers. I cannot operate the set at all with a single-dial. Why is this?

Answer:—You have made the common error of attempting to couple two or more different types of tuning condensers together, to obtain single control. The S. L. F. condensers have a different shape of plates than the Centraline condenser. Therefore, for a given capacity, the rotor plates must be set at different positions. For instance, for a capacity of .0002 mfd. your S. L. F. condensers must be set at 82, but the Centraline condensers have a capacity of .0002 mfd. when set at 76. This difference in dial setting is not constant, but varies in amount for different capacity settings. You must use condensers of one type and size in single-control receivers. We advise you to use two double-gang Centraline condensers in your set.

### DEAD SPOT IN SUPER-WASP

5. My battery-operated Super-Wasp receiver is working perfectly, except for a dead spot when using the orange ring coils. I have tried all the usual remedies, such as varying the antenna length,

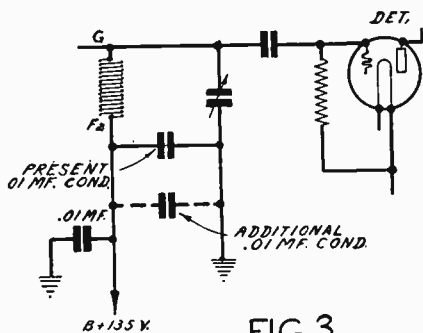


FIG. 3

"Dead spots" in the battery model Super-Wasp may be cured by the use of an extra .01 mf. by-pass condenser. In some cases the trouble may be eliminated by disconnecting the .01 condenser on the under side of the sub-panel, between the two center brackets, instead of adding the extra condenser shown above.

changing "B" battery voltages, etc., but to no avail. Can you suggest anything?

Answer:—We advise you to try connecting an additional .01 mfd. fixed condenser in the detector circuit, as shown in Fig. 3. It may be placed directly over the condenser now mounted under the center of the base panel, between the two inside sub-panel mounting brackets.

### "THE COUNTRY SPECIAL"

6. Your "Country Special" receiver, described in the last issue of RADIO DESIGN, is the finest battery-operated receiver I have even seen or heard. At last we country people can own a set which is equal in every respect to the electrically operated receivers of our city friends. Mine is working perfectly, but I would like to connect a jack for using earphones on the set at night, when the rest of the family is asleep. Can you furnish a diagram for these connections?

Answer:—You can connect an earphone jack in the plate circuit of the detector of your Country Special as shown in Fig. 4. The frame of the jack must be

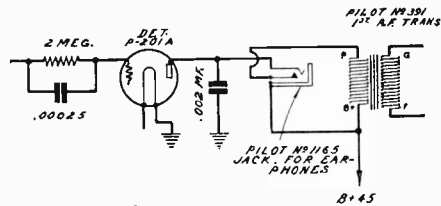


FIG. 4

How an earphone jack is connected in the "Country Special."

insulated from the grounded metal chassis of the receiver or a short circuit will result in the "B" battery. If you mount the jack on the front panel you can insulate it by drilling an over-sized hole in the panel and placing thin fibre or other insulating washers between the panel and the frame and nut of the jack.

### SHOCKS FROM CONDENSERS

7. When I put my fingers on the Resistograd of the K-112 power pack of my Pre-Selector receiver I received a slight shock, even though the power was entirely off. I immediately connected a voltmeter to the pack, but the needle did not move. This same thing happens every time I attempt to make an adjustment. Can you explain the mystery?



**Answer:**—There is no mystery at all. The large filter condensers in the K-112 simply retain a charge of electricity after the primary power has been turned off, and they discharged through your fingers when you placed them on the Resistograd and the metal chassis. In most cases the charges leak off through the output resistor, but to avoid further occurrences of this kind simply tap a screwdriver or a piece of wire from B + 300 to the can to discharge the condensers completely.

High voltage condensers of good quality will retain charges of electricity for days at a time.

#### CONNECTING EARPHONES

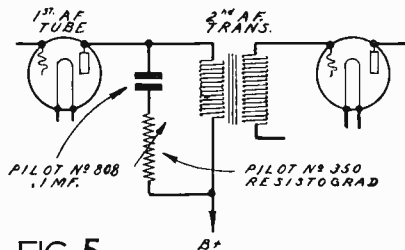
8. Although I have brought in many of the foreign stations on the loud speaker with my Super-Wasp, I like to do my listening with earphones. Is it possible to use more than one pair at a time? If so, I will buy another set of phones, as often I have visitors and it is inconvenient to pass one pair around when a station is too weak for the speaker.

**Answer:** It is altogether practicable to use two and even three pairs of earphones at the same time. The signals are reduced in strength only slightly and not enough to hurt reception. Simply connect the phones in series.

#### LOWERING TONE OF A SET

9. Will you kindly furnish a diagram showing how I can connect an adjustable tone filter to my set, to cut off the high notes and make the tone of the set sound deep and low?

**Answer:**—A resistance-capacity filter circuit is shown in Fig. 5. The circuit offers an adjustable low impedance to the high frequency currents, depending upon the resistance setting of the Resistograd. Decreasing the resistance by screwing in



**FIG. 5**

How a "tone adjuster" may be added to any receiver.

the Resistograd knob will cut off the high notes more and more.

#### INSULATING THE GROUND WIRE

10. Will you please settle a little argument for us? The question is whether or not the ground wire should be insulated. I claim it isn't necessary, but some of my friends say it is. What's the real "dope"?

**Answer:**—You win. There is no necessity for thorough insulation of the ground wire, because the steam or water pipes it runs to touch the house at a dozen different points anyway. It is usually most convenient to use insulated wire for the purpose, but you needn't run it on insulators or anything of the sort. Simply hold it down with carpet tacks or upholstery nails.

#### "C" Bias Resistor Values

11. Kindly publish the "C" bias resistor values in ohms to be used with the various common types of tubes.

**Answer:** Following are the recommended values of "C" bias resistors to be used to furnish proper grid bias voltages for tubes having A. C. filaments.

226	Tube.....	(90 V. plate)	1,700 ohms;	(135 V. plate)	1,500 ohms;	(180 V. plate)	1,800 ohms.
227	Tube.....	(90 V. plate)	2,000 ohms;	(135 V. plate)	1,800 ohms;	(180 V. plate)	2,000 ohms.
245	Tube.....	(180 V. plate)	1,350 ohms;	(250 V. plate)	1,500 ohms.		
171-A	Tube.....	(90 V. plate)	1,900 ohms;	(135 V. plate)	1,850 ohms;	(180 V. plate)	2,250 ohms.
112-A	Tube.....	(90 V. plate)	1,300 ohms;	(135 V. plate)	1,650 ohms;	(180 V. plate)	1,600 ohms.
210	Tube.....	(250 V. plate)	1,800 ohms;	(350 V. plate)	1,950 ohms;	(425 V. plate)	1,950 ohms.
250	Tube.....	(250 V. plate)	1,600 ohms;	(350 V. plate)	1,400 ohms;	(425 V. plate)	1,550 ohms.
224	Tube.....	(180 V. plate)	450 ohms.				

Thus for two tubes, divide these resistor values by 2, for three tubes divide the value by 3, etc. For two tubes in push-pull operated with a common "C" bias re-

sistor, divide by 2. Thus for two 245 tubes in push-pull with 250 volts on the plate, use 1500 divided by 2, or 750 ohms for "C" bias resistor.

# American Radio Best In The World, Globe-Trotters State

**T**HE United States leads the entire world in radio broadcasting, its programs being of the highest quality and its attitude toward the listener most generous. This is the opinion expressed by two recent visitors to the new Pilot plant at Lawrence, Mass., Mr. Martin Openshaw, commercial vice-president of the Pilot company in charge of foreign business, and Mr. W. Nissen, the company's representative in South Africa. These men have had ample opportunity to observe conditions in different lands, as they do an enormous amount of traveling every year.

"Very few of the radio programs of other countries come up to the sponsored programs of the United States," Mr. Openshaw said. "Practically all countries require listeners to have government licenses, which cost between five and twenty dollars a year, and this money is used to maintain the broadcasting stations and to pay the artists. However, in the United States, where listeners pay nothing, they enjoy much finer entertainment from superior stations."

Short-wave receivers are becoming increasingly popular in foreign countries, because they enable people to tune in many distant stations. In South Africa, for instance, where Mr. Nissen has placed many Super-Wasps, their owners enjoy reception from the entire world, the short-wave stations in Schnectady, Pittsburgh, Chelmsford and Rome coming in regularly on the loud speaker.

Mr. Openshaw has been around the world several times, his visit to Lawrence marking the end of a trip that started early last December. He left New York for Seattle and from there sailed to Japan, China, the Philippine Islands, the Straits Settlements, Siam, India, Egypt, Europe, and then back to New York. He makes his headquarters in Amsterdam and has offices in Birmingham, Paris, Brussels and Milan. He left the United States again on September 15th, going first to Europe and then heading for Australia via the Suez Canal, China, and

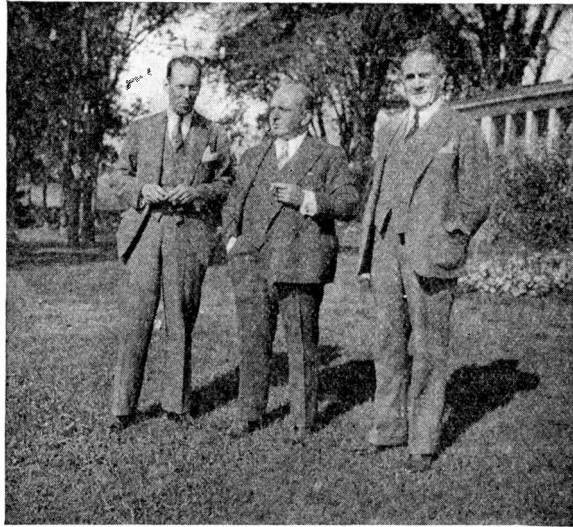
Japan. He expects to return to the United States next April.

## BROADCAST FROM JOBK

While in Japan on his last trip Mr. Openshaw broadcast from station JOBK in Osaka. He spoke in English, each paragraph being translated into Japanese by a translator who stood at his side. He described broadcasting conditions in the United States, and explained the value of good-will advertising. His talk aroused considerable interest, more than 500 people writing to the station as a result of it. The Japanese regarded him as an artist, and wanted to pay him for his speech.

Mr. Nissen had to travel 8,000 miles in order to reach the United States. He is spending considerable time in the United States, and will hop from one country to another before returning home. He will do about 40,000 miles on this one trip.

Both Mr. Openshaw and Mr. Nissen were greatly impressed by the new Pilot plant. They said it was even bigger than it looked, in the pictures, and they thought the pictures were faked!



*Left to right: Mr. W. Nissen, representative of the Pilot Radio & Tube Corporation in South Africa; Mr. I. Goldberg, president of the company; and Mr. Martin Openshaw, commercial vice-president in charge of foreign sales. This picture was taken at Lawrence, Mass.*

# RADIO INTERNATIONAL GUILD

*The Guild Celebrates Its First Anniversary  
as the Membership-List Continues to Grow.*

by ALBERT L. RUDICK,

*Executive Secretary, Radio International Guild*



WITH this issue of RADIO DESIGN, the Radio International Guild celebrates its first anniversary. The amazing success of the organization is due to the fact that there are many thousands of people all over the world still actively interested in building their own radio sets. These thousands, yes, hundreds of thousands, of radio experimenters, amateurs, and students, are the backbone of radio. Without their constant research and experimentation the industry would soon reach that point of stagnation that is the fate of every purely commercial venture. Radio, being the youngest and newest of the world's big industries, is in the fortunate position of attracting the interest and imagination of people who see in it an outlet for their inventive genius and at the same time a hobby that brings with it the thrills of a lifetime.

One of the most surprising things in this connection is the great number of women and girls who are intrigued by the romance of radio and are taking a very active part in its rapid progress. Many of them build their own radio sets in spite of the discouragement and ridicule heaped upon them by the sterner sex.

In these days when women take a more active part in industry than ever before, it is no small wonder that they should feel themselves capable and be, in fact, able to do the mechanical work and have the knowledge necessary to build radio sets. There are thousands of women employed in radio factories doing work that a few years ago was considered entirely out of their line. Is it to be wondered at, then, that there are thousands of women who find in radio a diversion and hobby that could never exist for them in any other field of endeavor that one could readily think of?

The most significant fact that stands  
*Vol. 3, No. 3, Radio Design*

out in the year's history of the Radio International Guild is that the short waves are responsible for the greatest percentage of those interested in the Guild. The building of radio sets in itself is still a hobby and a pleasure, even though radio broadcasting has reached a well-nigh state of perfection. It is the short waves, however, where the unexpected is encountered and where there is vast room for improvement, that hold the attention of radio experimenters and students. And it will be these same amateurs, experimenters, and students who will eventually be responsible for the ultimate and long sought for perfection in short-wave broadcasting and reception.

We take pleasure in quoting the following letter from Mrs. Lillian C. Manahan, of Kansas City, Missouri.

KANSAS CITY, Mo.,  
July 22, 1930.

RADIO DESIGN PUBLISHING Co., INC.,  
103 Broadway,  
Brooklyn, New York,

GENTLEMEN:

Please accept my thanks for the certificate of membership in the Radio International Guild, the identification card and the attractive lapel pin received from you recently. Also, have enjoyed very much the copies of RADIO DESIGN.

The writer is a widow of mature age, a stenographer of many years' experience, and by chance one day saw a copy of your magazine. Its contents were found exceedingly interesting, and after reading and studying so much about the A. C. Pilot Super-Wasp receiver, I bought a kit and assembled my own set. One man told me I was crazy to attempt it, that I could only hear code on a short-wave set; another tried to discourage me by saying a short-wave set was very temperamental. However, I determined to go ahead with my assembling of the set, all of which was

a genuine pleasure and have since had some real thrills with it.

"With the exception of many years ago when I purchased my first piano, I have had more pleasure with my Super-Wasp radio set than anything I ever possessed in the way of interest and entertainment, and am only too pleased to say a good word for it whenever I can.

"When talking to any of my friends or business associates, telling them of some of the thrills I have had with this set, such as listening to W2XAF (WGY) Schenectady and W6XN (KGO) Oakland, Calif., carrying on coast-to-coast conversation, also of listening to persons talking to London, England, as well as to passengers on board steamships *Olympic and Majestic*, they smile at me incredulously, but when I repeat snatches of the conversations I have heard on these pick-ups, they become very interested and say they cannot begin to get on their expensive 10-tube sets anything like the number of stations I have picked up on my Super-Wasp.

"Nearly every day I pick up some new station I had never had before. For instance, Tuesday of this week I got San Antonio, Texas, and last evening, Atlanta, Georgia, which was the first time for each of these stations. Of course, my set not having been completed until late this spring, I have not had an opportunity to get many stations of any great distance, owing to the time of year, but I am looking forward to some real thrills this winter. As yet I have not received a verification from the Australian station, but will advise you when I do."

Yours very truly,  
(Signed) LILLIAN C. MANAHAN.

4005 Troost Avenue,  
Kansas City, Mo.

Mrs. Alva M. Large, of West Newton, Pennsylvania, is another very successful and enthusiastic member of the Guild and a short-wave fan. Her success is amazing and we do not doubt that her accomplishments will arouse the interest of other members of the fair sex in radio reception.

WEST NEWTON, PA.,  
July 28, 1930.

RADIO DESIGN,  
Brooklyn, New York.

DEAR SIRs:

I am a Radio International Guild member and I thought these few words would be of some interest to you in regard to the A. C. Super-Wasp.

80

I am the owner and operator of one of these sets and I am getting wonderful results. There are lots of people who cannot understand how I can get foreign stations on my set, when they can hardly get local stations clear enough to listen to on their big sets.

I am the first lady in the U. S. A. to report the reception of the following stations: NRH of Heredia, Costa Rica, Central America; HRB of Tegucigalpa, Honduras, Central America; VRY, Georgetown, British Guinea, and Koenigswusterhasen, Germany.

I have verification from all these stations, also I have pictures that were sent to me from Honduras, and Costa Rica.

The pictures that I received from Honduras are of the announcer, reception-room, studio-room, and the studio orchestra, and from Costa Rica I have scenery views and pictures of the owner's home, and his seventeen-year-old daughter and baby son.

The other stations I have tuned in are PHI, PCJ in Holland; GBW, GBS, GBU, GBT, GBX, G5SW in England; PLE, in Java; VK2ME in Australia; HKC and HKF in Bogota, Colombia; F8BZ in France; VE9AP, and CJRW in Canada.



Mrs. Alva M. Large and her  
*Super-Wasp*.

Vol. 3, No. 3, Radio Design



*This fine amateur station, YS1FM, is owned by a Guild member, J. Federico Mejia, of San Salvador.*

And the ship-shore stations are G2GN, G2IV, G2AA, WSBN, and a large number of U. S. stations.

All the stations I have listed are tuned in on loud-speaker, with lots of volume. There are lots of foreign stations I have tuned in but could not understand the announcer. It takes a person who can understand different languages to operate a Pilot-Super Wasp.

I hope this letter will be of some interest to you, and hoping to hear from you soon, I remain,

Yours truly,

Box 14. (Signed) ALVA M. LARGE.

If there is any doubt of the international character of the Guild it can soon be dispelled by a perusal of the voluminous mail received almost daily from countries all over the world.

Mr. H. M. Sassoon, of Singapore, Straits Settlements, has been granted a charter to form a chapter of the Guild in Singapore and has promised to do his utmost with the help of a few radio enthusiasts and friends of his.

Mr. G. T. Magadia, chief radio operator of the *S. S. Mauban*, writes from his address in Manila, Philippine Islands:

"Needless to say that RADIO DESIGN is more than worth that what we pay for it, because everyone knows it's the great-

est kind of magazine ever published. Well, about the badge! It surely is a knockout. Believe me I'm strutting it like a peacock and I believe anyone would be proud to do so; it surely goes well with my uniform, as I am a commercial 'brass pounder.' Don't be surprised if you receive more applications for membership, as the boys are hot after it. I guess I am first among ship operators here to get wise to the stuff and I am passing it on to my friends in the profession."

Mr. Magadia is organizing a chapter of the Guild in Manila.

Mr. Allen J. Smith, of Melbourne, Australia, has already established a chapter of the Guild in his city and has several members. Mr. Smith informs us that a lady friend of his is very interested in radio and has a hand in the construction of electric and other sets. She will also become a member.

Ricardo P. Cabarloc, of Manila, Philippine Islands, is establishing a chapter of the Guild in his vicinity. He says radio in his country is still in its infancy and he finds RADIO DESIGN a great help in his studies.

J. Federico Mejia, E. E., of San Salvador, Republic of Salvador, writes us an exceedingly interesting letter. Mr. Mejia is the chief of the radio division of his government department of electrical com-

munications and is the owner of Station YS1FM. This is a real amateur station, as shown by the photograph which is reproduced on the preceding page.

Mr. Mejia writes us that he has been on the alert ever since the Pilot Good-Will Tour started for South America and he has been trying to get in touch with the plane. He was sorely disappointed that it did not stop at San Salvador. He did manage to get in touch with France Field, Canal Zone, Panama, and leave a message for Mr. Bouck, the radio engineer on board.

Robert Shell, of Los Angeles, California, writes that although he is only twelve years of age he is very much interested in radio. He became a member of the Guild on July 31, 1930. He received a Pilot A. C. Super-Wasp on his birthday, July 18, and had it working fine by the 23rd of the same month. Robert would like to hear from other members of the Guild who are under twenty years of age. He will answer all letters that he receives. His address is 2822 Forrester Drive, Los Angeles, California.

Arthur L. Martin, Jr., of New Bedford, Massachusetts, is organizing a chapter of the Guild in his city.

Charles G. Dodge, of Erie, Pennsylvania, says: "We have a club for Guild members who meet at my place and we are each taking a different junk-pile set to see who can get the most stations and longest distance."

Harry H. Ball, Newcomerstown, Ohio, writes as follows: "I have been taking your magazine for some time and I would like to form a chapter in this town. I and several of my friends have become interested in short-wave transmitters. We are 'hams' of the greenest variety, but not for long I hope."

George H. Wysong, of Nezperce, Idaho, is another member who has been authorized to form a local chapter of the Guild in his town. George will surely put that place on the map yet.

Louis Sarasio, 127-S. W. 15th Street, Des Moines, Iowa, is an active member of the Guild and would like very much to receive and exchange letters with other members, especially on short-wave subjects.

Mr. R. M. France, of Baltimore, Mary-

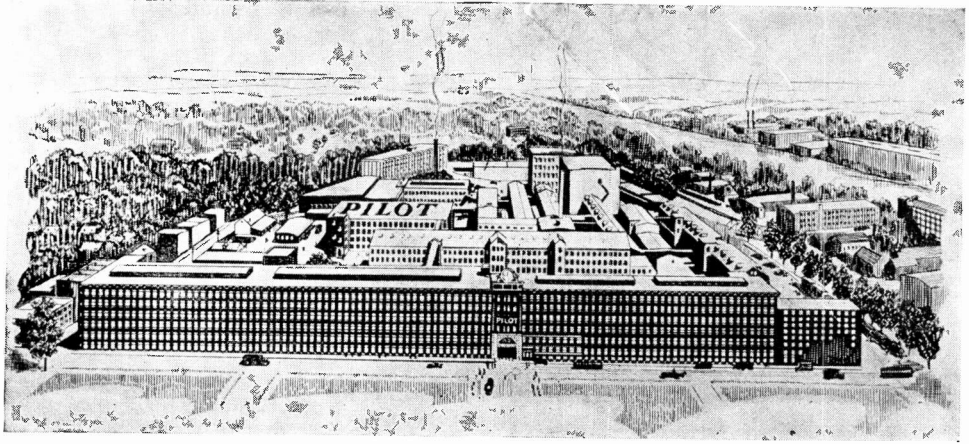
land, is forming a chapter of the Guild in his city which is to be called "The Radio Buddies Chapter." He sent in the names of three new members as a start and expects to have at least ten more in a week or so. Mr. France says: "I have constructed the Pilot Super-Wasp and I would not take a \$200 broadcast set for it."

Mr. L. Kortenhoeven of the Government Industrial School of George, South Africa, sends us a photograph of his little son, age seven, dressed as a "Pilot Super-Wasp," for which he gained the first place as the most original at a fancy dress dance for children. Mr. Kortenhoeven writes:

"His costume proved a very fine advertisement for the Pilot Super-Wasp. I have sent some photographs to our illustrated newspapers so that his photograph will be seen and read as an advertisement of the Pilot Super-Wasp all over the Union of South Africa. I have built several Pilot Super-Wasp receivers already with splendid results."



A new use for a famous radio receiver: A fancy dress costume that won first prize for the son of L. Kortenhoeven, of South Africa.



*This group of buildings comprises the new Pilot plant. The main building is equivalent in length to about five ordinary city blocks.*

## Pilot Moves Into A New Home

**Takes Over Modern Factory at Lawrence, Mass., Having Floor Space of 1,500,000 Square Feet. Increased Production Will Take Care of Radio Fans' Needs.**

By **ALFRED A. GHIRARDI**

**T**WENTY-TWO years of electrical and radio parts manufacturing experience has brought the organization which is at present known as the Pilot Radio & Tube Corporation to unquestionable leadership among all radio factories of the world. Since 1908, Pilot has grown from a tiny shop, a one-man outfit, into a great industrial organization specializing in radio parts and equipment and doing business all over the world. The two whirring bench drills that comprised the most important equipment in the original shop in 1908 have become roaring batteries of automatic machines, ranking with silently powerful rows of hydraulic Bakelite presses. The tiny shop of 1908 has given place to increasingly larger quarters, the latest acquisition being a tremendous plant in Lawrence, Mass., having a floor space of a million and a half square feet.

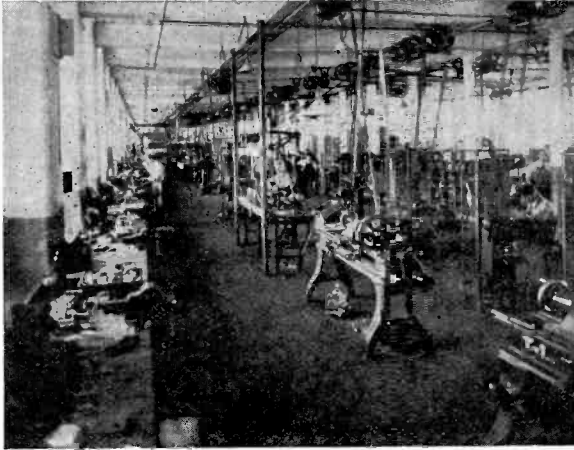
Where once the Pilot name was known to only a handful of radio experimenters, Pilot equipment is now sold in every city throughout the world that is within range of a broadcasting station. Truly, the story of the growth of this concern makes one

of the most fascinating chapters of the growth of the radio industry in the United States.

### **BROOKLYN PLANT INSUFFICIENT**

The tremendous demand for Pilot parts and Pilotron tubes which the radio season of 1929-30 brought on made it evident that the space available in the plant in Brooklyn, N. Y., would not suffice to keep up with the ever-increasing business of the company. Consequently larger quarters were sought, and a plant particularly suited to the manufacture of radio parts, tubes, and sets was finally found in Lawrence, Mass. This plant is of modern construction, and affords complete daylight conditions throughout for the many delicate manufacturing and assembly operations required in the manufacture of radio parts and tubes. The new plant contains approximately one and a half million square feet of usable floor space. While we realize that cold floor-space figures do not have much significance for the average layman, a glance at the accompanying photographs will give some idea of a few of the departments in the new plant, and





the equipment and facilities which the Pilot company now has at its command.

One of the secrets of the Pilot leadership in radio manufacturing has always been continued engineering development of apparatus produced under control of scientific precision manufacturing methods. The accuracy with which the various parts are turned out by

the machines depends in a great measure on the accuracy of the various tools, dies, fixtures, gauges, etc., employed in the various manufacturing operations. To insure direct control and proper accuracy and care in the making of these articles the Pilot company maintains a large tool department in which only the most modern machines are employed. These are under the supervision of men who have been especially trained by their long experience with the company for the exacting requirements of this particular work. The illustration Fig. 1, shows a view of one end of the tool room.

All the special dies, tools, and molds used in the screw machine, stamping, and molding

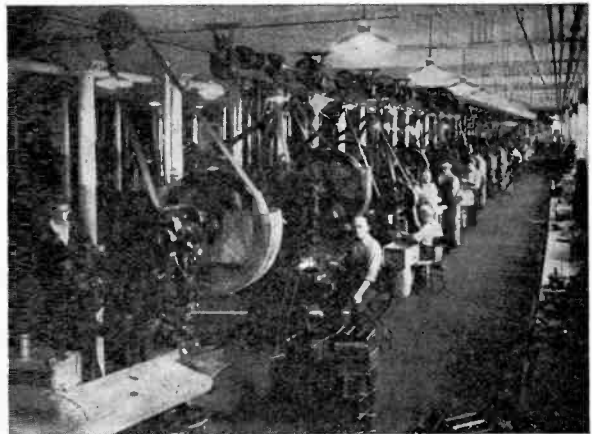
departments are made in the Pilot tool room. This applies also to forming dies for transformer cases, condenser shields, power pack cans, set panels and shields, and containers for filter and by-pass condensers. Many of these dies represent the highest grade of ingenuity and workmanship known in the die-making art. It is due to them that the various Pilot parts can be accurately produced in large quantities at such low prices.

The tool room is also called upon to build the many special machines which are developed by the Pilot engineering staff. Among these are the special machines used in winding power-pack resistors, winding paper condensers, assem-



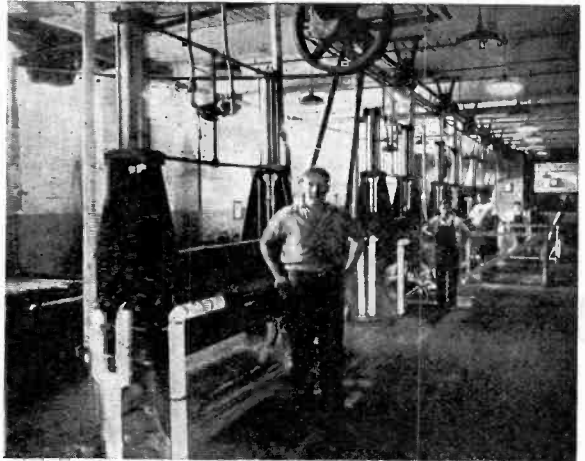
Fig. 1, above left: The tool room. Fig. 2, left: The automatic screw-machine department. Fig. 3, below: The punch-press department.

bling Resistograds, rheostats, dials, etc. Fig. 2 shows the screw-machine department.



ment. The long rods of brass, steel, etc., are fed into one end of a screw machine which automatically forms, threads, taps, and cuts off the part which it is tooled up to make.

One operator can take care of several of these machines. The screw-machine department turns out millions of small parts such as thumb nuts, screws, condenser shafts, condenser posts, metal inserts for Bakelite dials and knobs, dial bearings, etc. Almost any Pilot part contains one or more parts which were made by a screw machine. This department operates on a 24-hour schedule during most of the year. A degree of accuracy is maintained that is not equalled in many so-called precision shops.



for punching out the smaller parts, such as tube-socket prongs, tinfoil plates for

Micrograd fixed condensers, smaller parts for power pack and transformer cans, small condenser plates, etc. Forty of these presses are employed in the department. These are supplemented by a large number of smaller presses used in the various assembling

Fig. 6, above right: Machines for rolling Formalite tubing. Fig. 5, right: Section of bakelite molding department. Fig. 4, below: Giant punch presses.

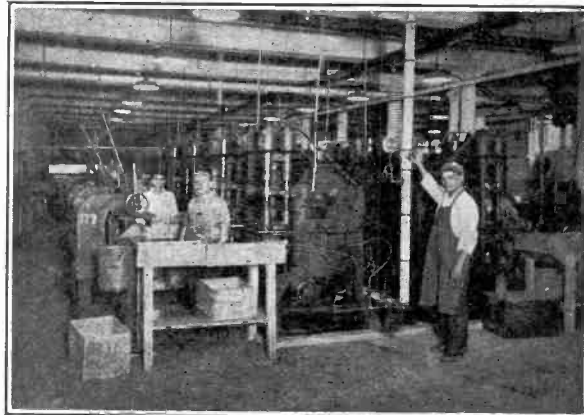
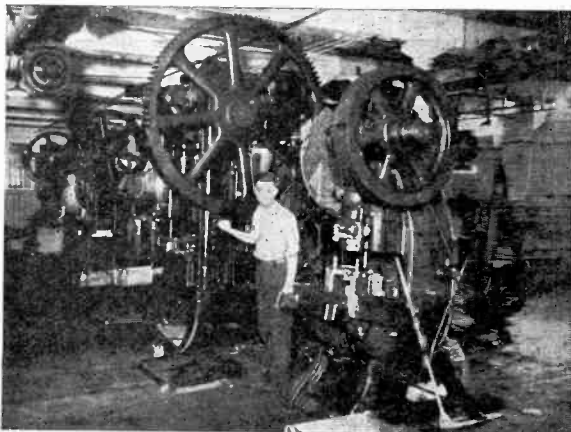
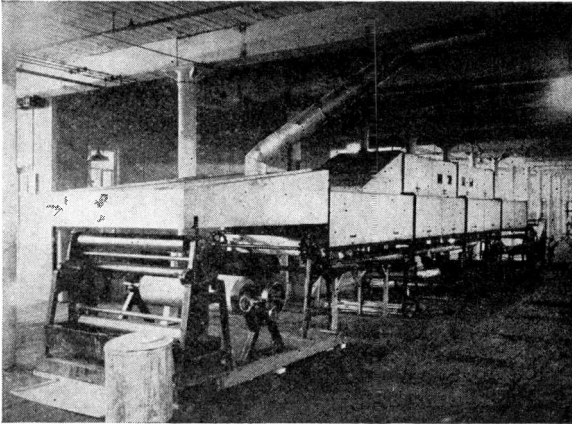


Fig. 3 shows a section of the punch-press department. These presses are used

departments throughout the factory.

Fig. 4 shows a few of the giant draw-presses used for drawing the steel transformer cans, shielding cans, power-pack can covers, Vaultype condenser shields, etc., from single pieces of metal. The larger geared draw press in the picture stands 12 feet high and has a specially built body, and a 7-inch crank. These presses are also used for punching out the various holes and slots in the large size sub-panels employed in the various Pilot kits. Supplementing these (not shown in the photo) are three automatic presses, one of 50 tons capacity, and two of 25 tons capacity each, which automatically stamp out thousands of transformer





350 degrees Fahrenheit and a pressure of 2000 lbs. per square inch to complete the chemical change which changes the powder to Bakelite, having the exact shape of the mold. Even the minute markings and graduations on dials and knobs are produced in the molding operation as accurately as though machined. Multiple cavity dies are employed in which as many as 60 pieces are molded at once, depending on their size. This reduces the unit cost of the parts.

Fig. 6 shows the machines used to roll up the impregnated paper used for making Formalite tubing. The treated paper is rolled on steam-heated mangles in these machines to form tubes about 42 inches long. These are then placed into one end of the

laminations, variable condenser plates, and other metal parts from long strips of metal. These presses rapidly and cleanly punch out the steel, brass, or aluminum parts as though they were made of soft cheese. One can only appreciate how perfectly they do their work if he has ever tried to cut out a condenser plate or a transformer lamination by hand with a pair of shears.

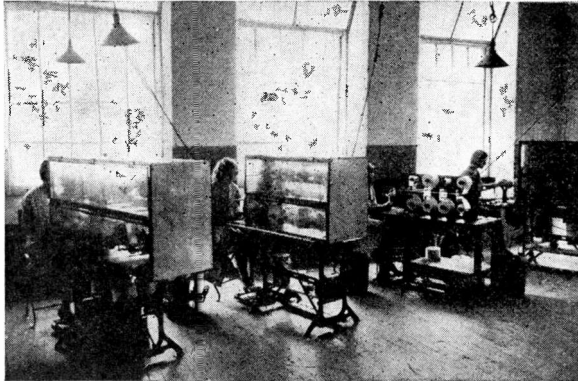
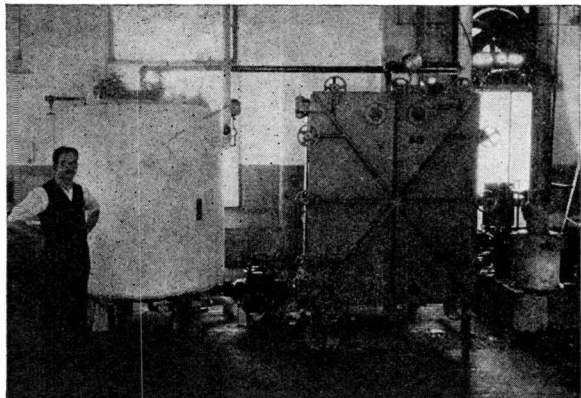


Fig. 7, above left: Oven for impregnating tubing. Fig. 8, left: Condenser winding machine. Fig. 9, below, condenser impregnation tanks.

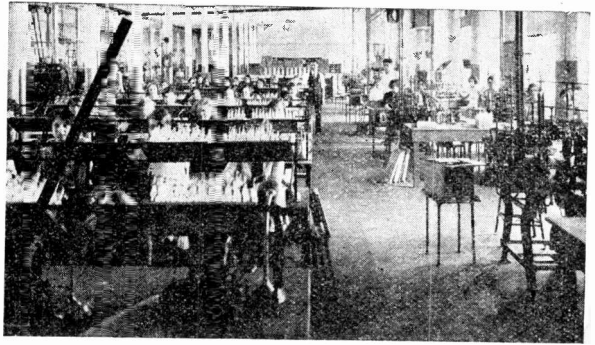
All Pilot Bakelite parts, panels, and tubing are produced in the molding department. At the rear is a dust-proof room where the Bakelite powder is pre-formed into molding pills (as described in the Vol. 2, No. 3, issue of RADIO DESIGN). Pilot is one of the largest single users of Bakelite, for every molded part in Pilot equipment is made of genuine Bakelite. Fig. 5 shows batteries of the large Terkelson mechanical presses used for molding dial drums, plug-in coil forms, transformer cases, etc. (The operation of all of this equipment was explained by the writer in the article referred to above). In these presses, the Bakelite powder (or pre-molds) is inserted in the cavities of the special steel molds, which are subjected to a temperature of

oven shown in Fig. 7. A moving conveyor carries the tubes through the entire length of this machine, during which time they are exposed to certain temperatures and



processes for making a homogeneous tubing which is a good moisture-proof electrical insulator. This same oven is used for impregnating the raw paper before it is rolled up into tubes on the mangles of Fig. 6. A roll of paper can be seen in place on the front of the machine. The temperature and exact operating conditions of the oven are automatically controlled by delicate apparatus developed especially for it.

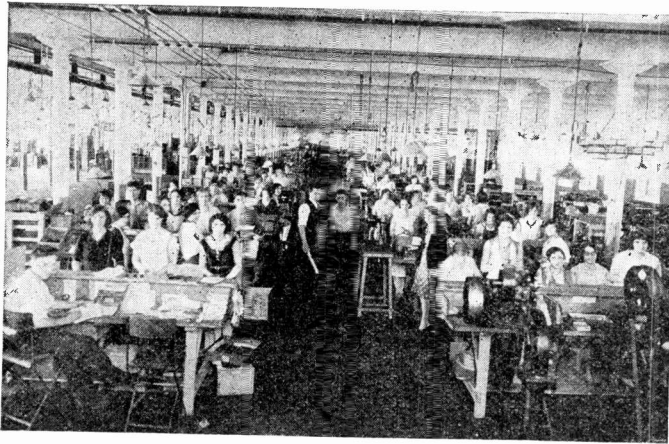
Fig. 8 shows four of the special dust-proof winding machines developed by the Pilot engineers for winding the paper and tinfoil sheets of the by-pass and filter condensers. The dust-proof cover has been



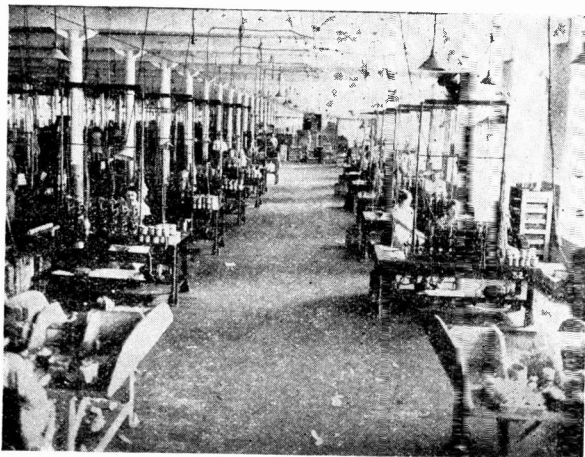
*Fig. 12, above: Stem assembly branch, tube division.*

*Fig. 11, below: General parts assembly.*

removed from one of the winders to show its construction more clearly. Not content

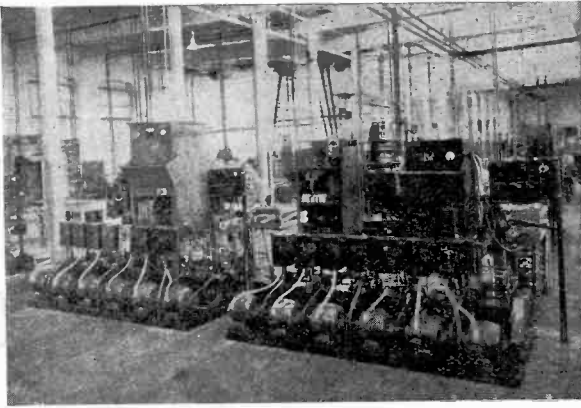


*Fig. 10, below: Transformer winding machines.*



with the dust-proof construction of these machines, the Pilot engineers laid out a special dust-proof room in which these machines are operated. All air entering this room is first freed from every trace of dust. This is necessary in order to insure freedom from condenser breakdown due to conducting dust particles being wound in with the paper and tinfoil strips and causing short circuits later.

Fig. 9 shows one of the fixed condenser and coil impregnating units consisting of a heated paraffin storage tank and impregnating oven. Briefly, the condensers are first stacked in the hermetically sealed oven on the right and squeezed at the



provide an even tension on the wire while it is being wound. The exact amount of tension which eliminates danger of loose windings or breakage of wire has been determined by the Pilot engineers after long experience.

Fig. 11 shows a portion of the general assembly department where miscellaneous small parts—such as drum dials, rheostats, small resistors, tube sockets, Resistograds, etc.—are assembled from the component parts which have been fabricated by the automatic-screw machines department, Bakelite molding department, punch-press department,

proper pressure. Then all of the air is pumped out of the oven while the condensers are kept at a definite temperature. This is to remove all moisture and air bubbles from between the plates. Then the paraffin wax which has been melted and heated in the tank at the left is forced under high pressure into the oven at the right. The pressure forces the paraffin to thoroughly impregnate the entire condenser and make it absolutely moisture proof. The surplus paraffin is then pumped back into the tank and the condensers are removed and tested. An idea of the large size of both tank and oven can be obtained by comparison with the height of a man standing alongside. All transformer coils are also impregnated in equipment similar to this.

etc. The assembly benches are laid out so the work passes from one girl to the next

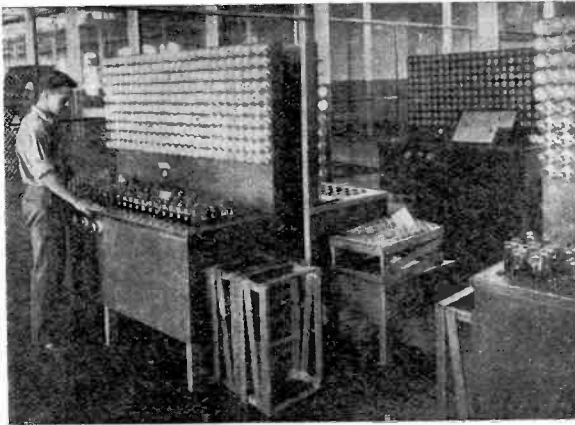


Fig. 13, above left: Evacuating and flashing machinery. Fig. 14, left: Ageing racks. Fig. 15, below: Life-test racks with automatic switches.

Fig. 10 shows part of the automatic machines used to wind Pilot audio and power transformers and choke coils. Fourteen coils are wound simultaneously. Each layer is insulated by a wrapping of waxed paper, in order that coils may safely withstand high voltages. These machines are designed to

for the various operations without loss of time or excessive handling.

The demand for Pilotron tubes has in-

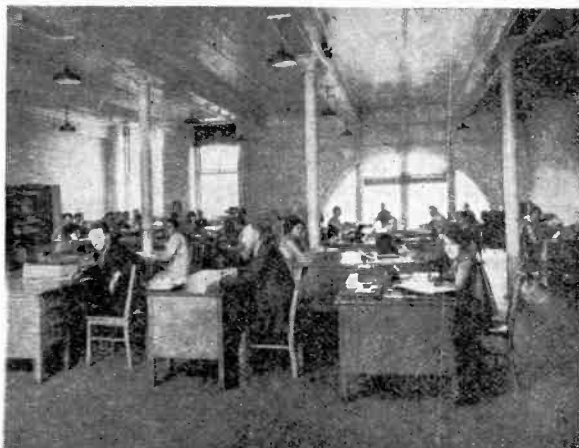




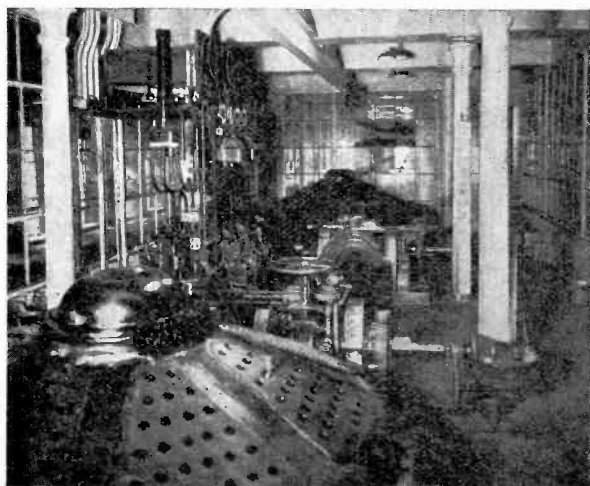
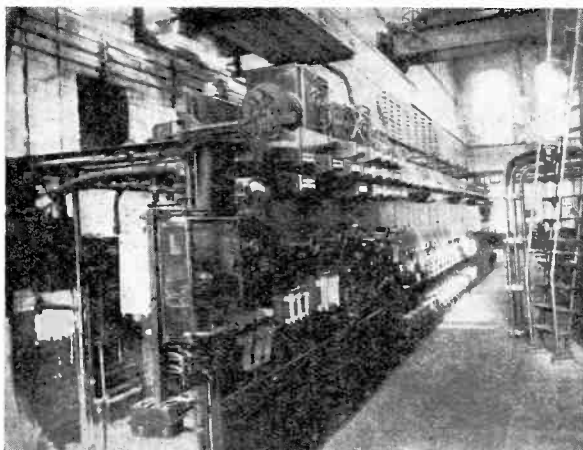
creased so rapidly that the facilities for their manufacture have been greatly enlarged in the new plant.

In Fig. 12 we see a portion of the stem assembly department, where the various stages of the element, lead-in wire and stem assembly are carried out. (The details of the manufacture of Pilotron tubes were explained by the writer in an article in the Vol. 2, No. 4, issue of RADIO DESIGN.) At the right in Fig. 12 are shown several of the automatic sealing machines which seal the stem and element assembly to the outer bulb.

The tubes are evacuated,



.....  
*Fig. 18, above right: Part of the office. Fig. 17, right: Switchboard in power house. Fig. 16, below: Water wheel generators in power house.*  
 .....



flashed or bombarded, and sealed automatically by the machines shown in Fig. 13. At each machine the battery of special motor driven high vacuum pumps are arranged along the floor. Above is the bombing equipment and back of this is the rotating turn-

table which carries the tubes around to their successive positions in the process. The entire machine is operated by a single operator who merely places the tubes in the holders and removes the evacuated tubes as they come around to her.

While these illustrations do not show every detail of the equipment in the new quarters, we trust they will serve to give our many readers an insight into the equipment and facilities which are being used solely in the manufacture of radio parts and tubes. An additional section of the new Pilot plant is to be devoted entirely to the manufacture of a new line of completely wired and assembled sets.

# Full Size Blueprints Help to Builders

**R**EADERS who are interested in any of the kit-receivers described in **RADIO DESIGN** would do well to purchase the full-sized blueprints of these sets, which have been prepared at great trouble and expense. Because of the limitation of the page-size of **RADIO DESIGN**, the drawings that appear in the magazine are sometimes rather cramped. If you have any difficulty in following them, by all means order the corresponding blueprint. They cost only 10c each, post-paid.

The blueprints average about 24 by 30 inches and are very clearly printed on highgrade paper. They make excellent wall decorations for your radio den, as they lend a scientific air to the place and look quite impressive. They are useful as well as ornamental, as you can refer to them quickly if you should encounter trouble.

For instruction purposes in schools, these blueprints are highly desirable, as

they show the mechanical construction of the receiver and the actual wiring in both schematic and pictorial form. Teachers of radio would do well to buy an assortment of the prints.

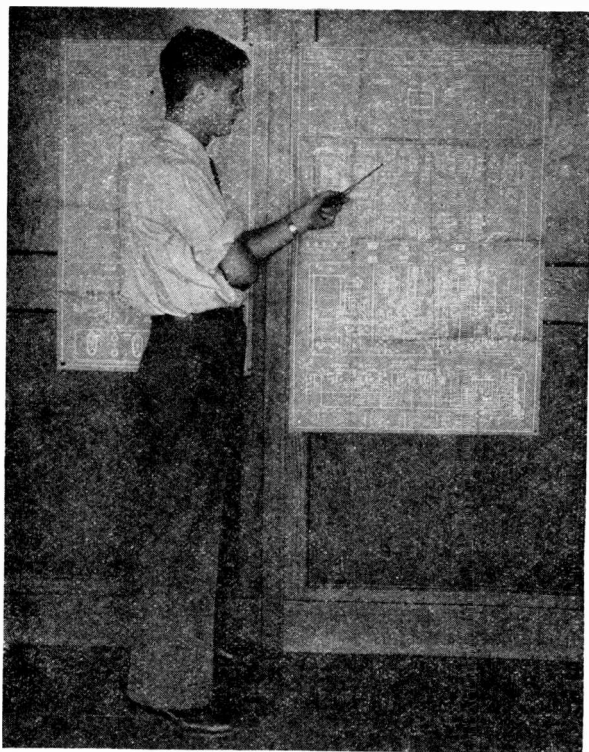
A total of twelve *blueprints* is available. Some of the sets shown on these drawings are obsolete, and the parts for them can no longer be obtained. However, they are very interesting, particularly from the educational standpoint, and school-teachers can use them profitably when describing old-fashioned sets.

The following blueprints show the construction of the newer receivers, which are still available in kit form: BP-126, BP-115, BP-110, BP-113. The following blueprints were made up for sets that are no longer available: BP-117, BP-118, BP-122, BP-101, BP-102, BP-105, BP-108, BP-39568. Simply order these by number.

The BP-126, which is described in Vol. 3, No. 1, of **RADIO DESIGN**, shows the Pre-Selector broadcast receiver. The BP-115 (Vol. 2, No. 3) is the famous A. C. Super-Wasp, and the BP-110 (Vol. 2, No. 1) the original battery model Super-Wasp. The BP-113 (Vol. 2, No. 3) describes the K-113 245 push-pull amplifier.

The BP-117 (Vol. 2, No. 3) shows the Pilot Twin Screen-Grid 8, a single control broadcast receiver employing 8 tubes. The BP-118 (Vol. 2, No. 3) shows the Grimes D. C. New Yorker, which is generally acknowledged to be one of the finest direct-current receivers ever presented. The BP-122 (Vol. 2, No. 4) shows the Pilot P. E. 6. six-tube broadcast receiver. The BP-101 (Vol. 1, No. 3) shows the old three-tube short-wave Wasp. The BP-102 (Vol. 1, No. 4) is the old Pilotone Electric 6. The BP-105 (Vol. 1, No. 4) shows the Pilot S. G. 105 Receiver, one of the earliest of all the screen-grid broadcast sets. The BP-108 (Vol. 1, No. 4) shows a once popular six-tube T. R. F. set.

The BP-39568 shows one of the earliest ABC power-packs. This is of special value for instruction in power-supply units.



*This picture gives a good idea of the size of the **RADIO DESIGN** blueprints.*



# FREE! RADIO BARGAIN CATALOG



## ALSO FREE RADIO GIFT

Send now for this new free radio catalog which saves you many dollars on radio outfits, kits, parts, tubes and accessories! Also TIME CONVERSION CHART FREE. Tells you instantly what time it is in any part of the world! Given free if your request for catalog reaches us this month.



234 - 236 SOUTH WELLS STREET, CHICAGO, ILL.

### Genuine PILOT Products

20th Century has the new Pilot Midget Sets in stock

### "Radio Amateur's Hand Book"

By FRANCIS E. HANDY

Communications Manager, American Radio Relay League; and ROSS A. HULL, Associate Technical Editor, QST.

This is the sixth and latest edition of a book that has become so popular that it is generally referred to as the amateur's "bible." More than 75,000 copies have been sold to radio fans all over the world, and orders for it continue to arrive in every mail.

The handbook contains 211 pages and over 200 illustrations. It is written in clear, understandable English, and is free of all the confusing mathematics that no one ever reads. It was written for YOU, the practical experimenter and constructor who wants to know the how's and why's. Contains all the most advanced "dope" on short-wave reception and transmission.

Postpaid **\$1.00**

*We carry this book in stock, and can ship immediately*

Radio Design Publishing Co.  
Lawrence, Mass.

### RADIO DESIGN

OFFICIAL ORGAN OF THE RADIO INTERNATIONAL GUILD

A whole year's subscription to "Radio Design" costs only fifty cents and includes membership in the Radio International Guild. You receive four copies of the magazine, a membership certificate, identification card and lapel pin. Fill out this convenient coupon TODAY.

*U. S. stamps and money orders accepted. Foreign subscriptions must be paid by international money order.*

Radio Design Publishing Co., Inc.,  
Lawrence, Mass.

Enclosed find fifty cents to cover one year's subscription to "Radio Design" and membership dues in the Radio International Guild.

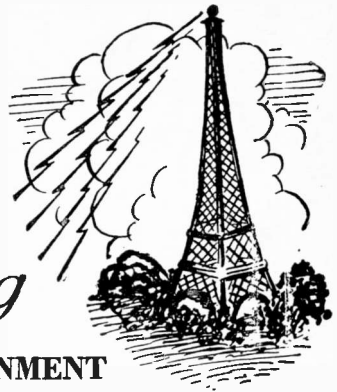
Name .....

Street and Number.....

City and State.....

# DIRECT FOREIGN RADIO RECEPTION

*Without Dependence  
on Local Re-Broadcasting*



## WIDEN YOUR CIRCLE of ENTERTAINMENT

Your broadcast receiver is silent below 200 meters, but the Super-Wasp, swooping down to 14 meters and up to 500, unlocks a new world of trans-oceanic radio you never heard before! And you get it directly from the foreign station and not from a local re-broadcast.

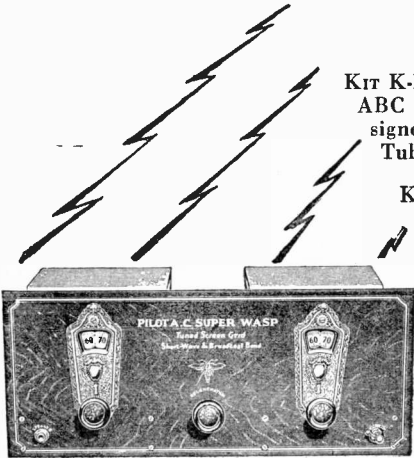
# PILOT SUPER-WASP

Short-wave and Broadcast Receiver, 14 to 500 Meters  
In Kit Form for A.C. or Battery Operation.

### CUSTOM SET BUILDERS' PRICES

Kit K-115—The A. C. Super-Wasp. Use your own ABC pack or Pilot K-111 at \$16.50, specially designed for the Super-Wasp. Power Pack and Tubes extra ..... **\$34<sup>50</sup>**

Kit K-110—The battery-operated Super-Wasp. Batteries and Tubes extra ..... **\$29<sup>50</sup>**



PILOT RADIO & TUBE CORP.

Lawrence, Mass.

234 So. Wells Street, Chicago, Ill.

1278 Mission St., San Francisco, Cal.



## JOINING THE RADIO INTERNATIONAL GUILD

costs only 50c for a full year's membership, which includes lapel pin, certificate, and the Guild's Official Organ—"Radio Design" published quarterly. Enclose 50c coin or stamps with this coupon, and return to Radio International Guild, Lawrence, Mass.



Name .....

Address .....

City ..... State.....

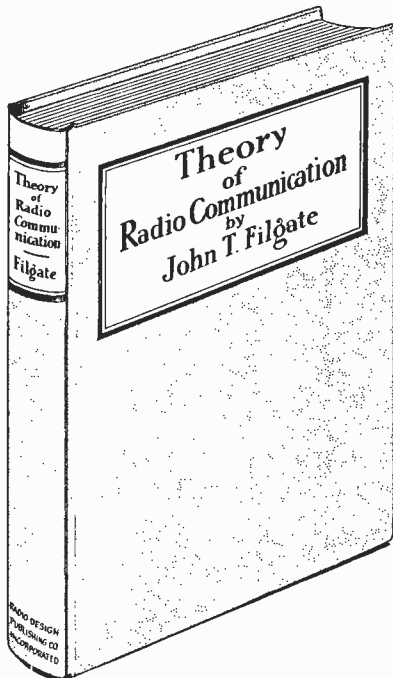
# SPECIAL COMBINATION

OFFER

REGULAR PRICE \$3.00

OUR SPECIAL PRICE 2.00

SAVING \$1.00



## 'THEORY OF RADIO COMMUNICATION'

*By John T. Filgate*

Formerly Instructor at U. S. Army Signal School  
Published with approval of the U. S. War  
Department, this is first public printing of  
the officer's radio manual used by the U. S.  
Army Signal Corps.

A splendid technical textbook for advanced  
Radio Amateurs. 250 pages, 200 illustrations.

AND

*TWO YEARS' SUBSCRIPTION TO*

## RADIO DESIGN

OFFICIAL ORGAN OF THE RADIO INTERNATIONAL GUILD

which also includes membership in the  
*RADIO INTERNATIONAL GUILD*

"Theory of Radio Communication" sells regu-  
larly for \$2.00 alone. Now you can have it  
together with two years' subscription to  
"Radio Design" all for \$2.00.

**THERE ARE A LIMITED NUMBER OF THESE BOOKS AVAIL-  
ABLE. YOU MUST ACT QUICKLY IF YOU WISH TO TAKE  
ADVANTAGE OF THIS WONDERFUL OPPORTUNITY.**

---

### MAIL THIS COUPON WITH \$2.00

Radio Design Publishing Co., Inc.  
Lawrence, Massachusetts, U. S. A.

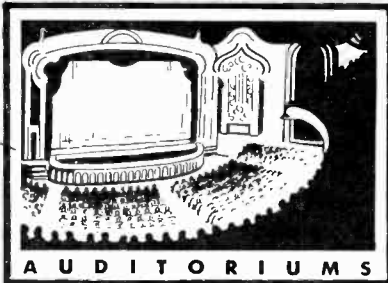
Enclosed is remittance of \$2.00 for which please send me "Theory  
of Radio Communication." Also credit me with 2 years' subscription to  
Radio Design and 2 years' membership in the Radio International Guild.

NAME.....

ADDRESS.....

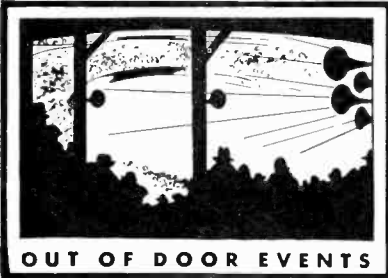
CITY.....STATE.....

# Where Every Ear

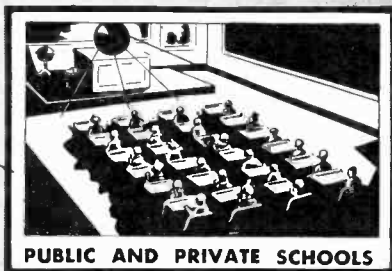


## PILOT

Auditoriums, Dance Halls and Restaurant Dance Floors need Pilot Public Address Amplifier.



Athletic Fields and Stadiums, Music Stadiums and Public Squares need Pilot Public Address Amplifier.



Universities, Primary and High Schools, public or private, need Pilot Public Address Amplifier.



Hotels, Hospitals, Penal and other Institutions need Pilot Public Address Amplifier.



## PILOT

**PILOT RADIO & TUBE CORP.**

*Chicago Office: 234 S. Wells St.*

# Must Be Reached

## Public Address Amplifier *Delivers*

**W**henever the radio dealer, service man or custom set builder is called upon to install sound distribution systems, Pilot's Public Address Engineering Division stands ready to supply adequate apparatus and engineering counsel.

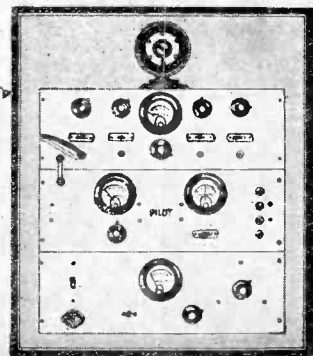
The Pilot Public Address Amplifier easily operates six auditorium model electro-dynamic speakers at full volume, whether activated by motion picture sound apparatus, direct speech, radio received programs or phonograph music. Control system permits announcer to be heard simultaneously with musical output. Engineered on basically sound principles . . . substantially constructed . . . utilizes 3-227 type, 2-250 type, and 2-281's. Available completely assembled, including 2 sets of tubes, phonograph pick-up and table model microphone . . . .

Prices and Detailed Information on Request.

**PUBLIC ADDRESS  
AMPLIFIER**

**LAWRENCE, MASSACHUSETTS**

*San Francisco Office: 1278 Mission St.*



# BLUEPRINTS

## ONLY 10<sup>¢</sup> EACH

These drawings average 24 by 30 inches, and show the sets full size. They are clear and understandable, and you will be proud to tack them to your wall.

*Use the coupon below, merely checking off the blueprints you want. Postal money order or U. S. Stamps accepted. Do not send coins through the mail.*

### A. C. Super-Wasp BP-115

Full-size assembly and wiring blueprint of the first A. C. short-wave receiver, described in the Fall 1929 issue.

### Pilot "Pre-Selector" BP-126

The last word in broadcast receivers. Fully described in the Spring issue. Blueprint is full size and shows all details of the construction.

### Screen-Grid BP-122 (P.E.6)

Full-size assembly and wiring of the K-122, K-123 and K-124 sets. Only a limited number available; order now.

### Battery Operated Super-Wasp BP-110

Several thousand of these sets, in daily use, testify to the sound design of the original Super-Wasp. Every short-wave fan should have a copy of this blueprint.

### 245 Push-Pull Amplifier BP-113

A high-quality power amplifier using two 227's and two 245's. Suitable for radio, phonograph and public address work.

### Wasp Receiver BP-101

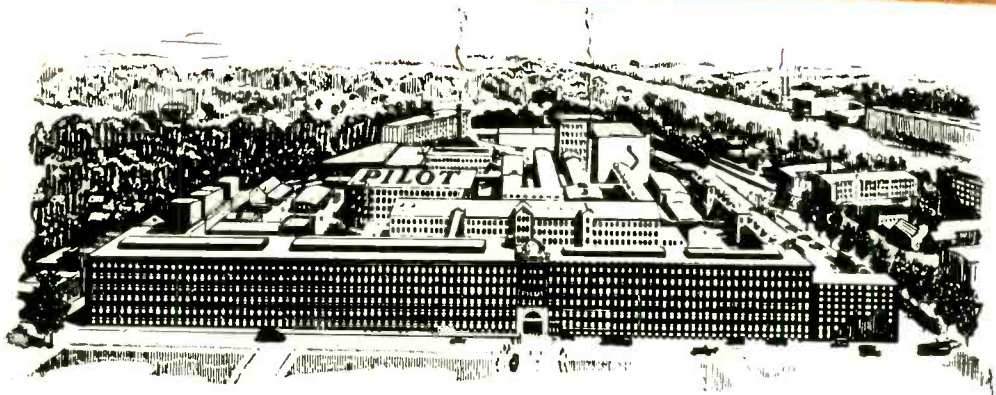
The original Pilot "Wasp" short-wave set, using three battery type tubes. An excellent receiver for the beginner.

*(Note: see page 90 of this issue.)*



<b>Check Here</b>	<b>RADIO DESIGN PUBLISHING CO., INC.</b>
BP-115 .....	LAWRENCE, MASS.
BP-126 .....	Enclosed find....., for which
BP-122 .....	send me blueprints checked at left.
BP-110 .....	Name.....
BP-113 .....	Address.....
BP-101 .....	





*The New Pilot plant at Lawrence, Mass.*

## **LARGEST PLANT IN THE WORLD OWNED AND OPERATED BY A RADIO MANUFACTURER**

The steadily increasing international demand for Pilot Products has necessitated the continued expansion of the Pilot Radio Plant — until today it occupies what is the largest single Radio manufacturing unit in the world. Pilot has proven its ability to produce quality at reasonable prices and now Pilot is in a position to increase quantity by the same safe and conservative methods which have characterized the growth of the Pilot organization thus far.

Pilot makes more of what goes into its products under one roof than does any other radio manufacturer . . . and you the user of Pilot Radio Products benefit thereby because Pilot prices are always low and Pilot quality always the highest.



# **PILOT RADIO & TUBE CORP.**

**LAWRENCE, MASS.**

CHICAGO OFFICE: 234 S. WELLS STREET

SAN FRANCISCO OFFICE: 1278 MISSION STREET



Every essential of a radio receiver is made by Pilot, except cabinets. The new Pilot plant at Lawrence, Mass. is the largest in the world, owned and operated by a radio manufacturer.



\$59<sup>50</sup>  
LESS TUBES

Compact A-C receiver in handsome two-toned walnut cabinet gives full console quality reproduction. 2 stages Screen Grid assures selectivity: Screen Grid power detector safeguards tone: 1 stage 227 audio, 1 stage 245 power audio give volume: 280 rectifier in special pack for power. Specially designed electrodynamic speaker. Full shielding.  
AT PILOT DEALERS EVERYWHERE.

PILOT RADIO & TUBE CORP.  
LAWRENCE, MASS.

Chicago Office: 234 S. Wells St.  
San Francisco Office: 1278 Mission St.

# PILOT MIDGET