

RADIO DESIGN

Criterion of Styles and Methods of Radio Construction

NEW REDI-BLOX FIT ALL TUBES IN ALL CIRCUITS

Assemble Any Set for 226 and 227 Tubes or Battery Tubes, with Power Amplifier, in Two Hours, & by John Geloso

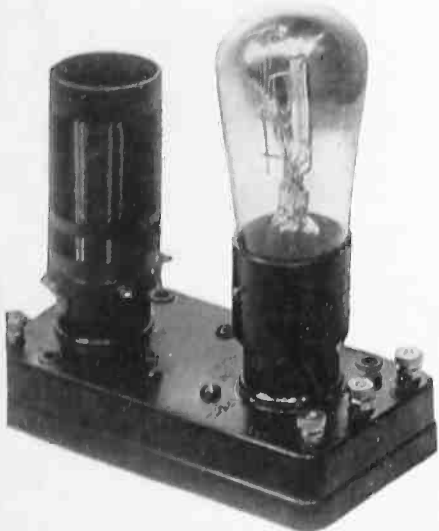

Above: R.F. Redi-Blox, a completely wired unit which, with a .00035 mfd. condenser, makes a stage of tuned R.F.

The type 179 plug-in coils are for UX-199 tubes, and type 176 for UX-201's, UX-226's, and UY-227's.

Tubes of all types can be used, including UX-226, wired in accordance with latest R. C. A. data, as shown in circuit on page 12.

Using the primary as a tickler, this makes a perfect super-het oscillator. The pick-up coil is simply four turns wound on over the secondary.

Again, with a Micrograd for tuning, this makes a precision intermediate amplifier, with each stage matched by tuning.

Right: Transformer Redi-Blox for high quality amplification. A precision A.F. transformer is mounted in the steel case. The regular battery tubes can be used, the 226 A. C. tubes, or the 172 or 210 power amplifiers.

WAIT a minute! Don't turn your shop up-side-down just to find the parts for an extra audio amplifier stage. Let me show you something." And to the astonishment of my friend the radio dealer, with whom I had stopped to exchange a little gossip, I produced an A.F. Redi-Blox which I had brought to show him, hooked it up on his counter, and had the music going at tremendously increased volume before he saw what I was doing.

"Say, what have you got there?" he asked. "What a neat little job that is."

"Ah, that's the A.F. Redi-Blox, one of the handy-family units that can be hooked up for a test circuit or built into a set while you're thinking about it."

"Well, I should say it is handy!" and my friend turned it up-side-down to see the wiring under the base. "All the modern conveniences in that, all right."

So I showed him the other units in the handy-family of Redi-Blox—the universal R.F. units, with their plug-in-coils, wired to accommodate UX-226 or all battery tubes, the detector units, also fitted for the plug-ins, one type for the UY-227, and the other for battery tubes and the resistance coupled amplifier which takes the UX-226, UX-201-A, or UX-240.

Mounted on the polished Bakelite bases, the same size for all the units, they go together in any combination with the finished appearance of a commercial outfit. You can't have an untidy-looking set if you make it up from Redi-Blox. They do your mechanical design for you.

SAFETY FIRST IN REDI-BLOX

For the set builder, Redi-Blox mean safety first. If you've hooked up many sets, you remember the time when you left off that filament wire, and then had to shoot trouble for half an hour because the filament didn't light? Or you had a rosin joint to the grid leak, or let the soldering paste get around where it shouldn't be? You needn't feel ashamed to admit it.

IMPORTANT!

This issue of RADIO DESIGN contains the first article on building a 100% successful A. C. tube set—not made of old parts rearranged, but new from start to finish. It is A. C. operation in its most highly developed form.

Publication was delayed pending the completion of final testing.

But here it is now. See page 12 of this issue.—Editor.

Who hasn't done those things, or worse? But with Redi-Blox you can't make those mistakes. If the binding-posts are connected it must be right. No errors or trouble shooting with Redi-Blox.

They make an expert set builder out of every beginner when it comes to assembling sets successfully.

Study the circuits of the individual Redi-Blox on the following page, and you'll see that each one has the standard circuit elements of all type circuits. Hook them together and they will form, with the auxiliary apparatus, any kind of standard receiving circuits which could be made up of separate parts.

REDI-BLOX TWENTY TIMES FASTER

The original Redi-Blox idea was born of necessity, and fostered by economy. Did you ever have to get together a simple tuned circuit for some test or experiment? And waste an hour hunting up the parts, connecting them with hay wire, only to discover that the reason it didn't perk was that a wire had slipped off a socket terminal?

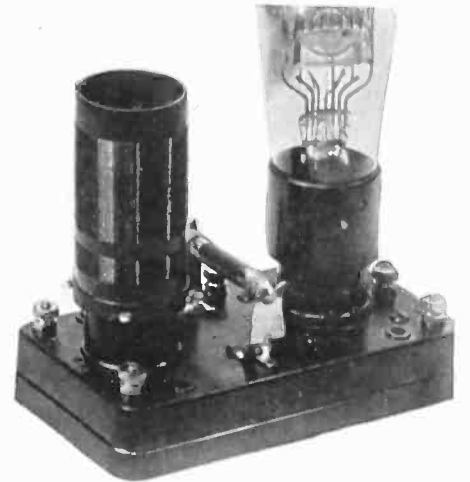

Above: Detector Redi-Blox are made in two types—one for UX tubes, and the other for the UY-227 detector.

The binding posts provide circuit connections in accordance with the official R. C. A. data.

The UX base Redi-Blox detector is fitted with a flexible lead under the base by means of which either positive or negative grid return can be obtained.



Above: All battery tubes and the 226 A. C. tubes can be used in the resistance coupler Redi-Blox. A 171 or 210 can be put in the last stage, and run with 5 volts A. C. on the filament. The rear resistor is in the plate circuit, while the forward resistor is the grid leak. Standard resistance values should be used. A very fine amplifier can be made with two transformer Redi-Blox and a resistance Redi-Blox between them. In such an outfit, both resistors should be of 2 megohms.

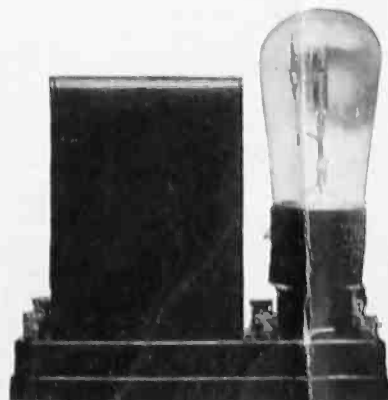

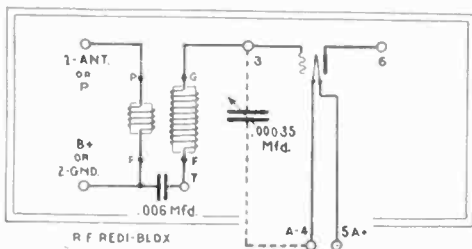

Fig. 1. Internal wiring of Universal R.F. Redi-Blox, designed for use with all types of battery and A.C. tubes.

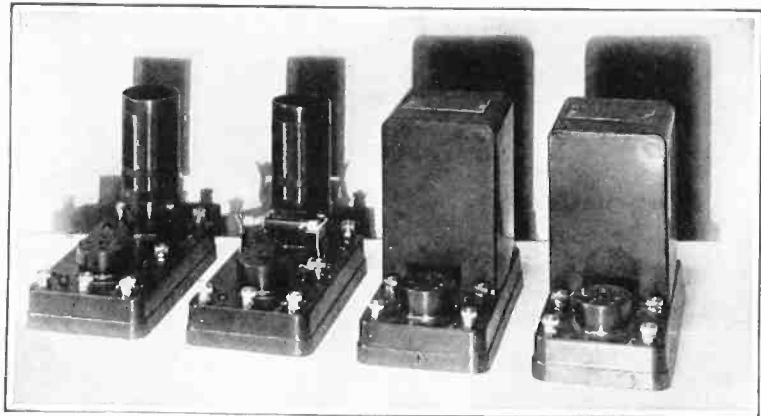

Fig. 2. A splendid combination for any tubes, one R.F., detector, and two stages of transformer amplification.

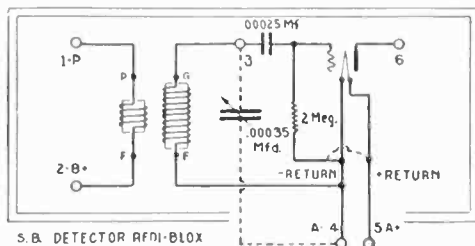

Fig. 3. The wiring of the battery operated detector Redi-Blox.

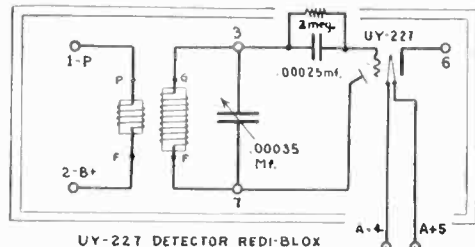

Fig. 4. This detector Redi-Blox is designed for the UY-227.

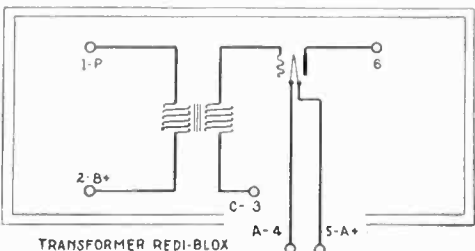

Fig. 5. All tubes can be used in the transformer Redi-Blox.

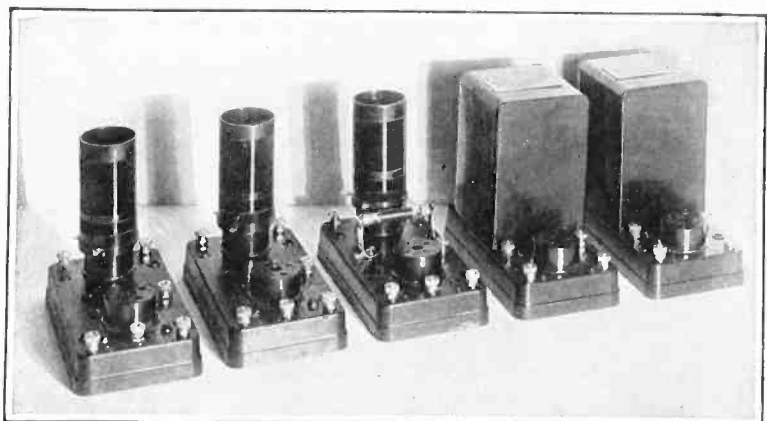

Fig. 6. Two stages of R.F., a detector, and two A.F. Redi-Blox can be combined to make a highly efficient broadcast receiver.

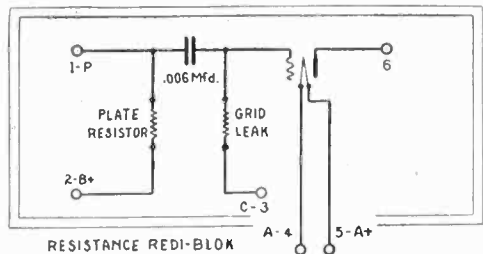

Fig. 7. In one minute you can connect a three-stage resistance amplifier, for most of the wiring is within the Redi-Blox.

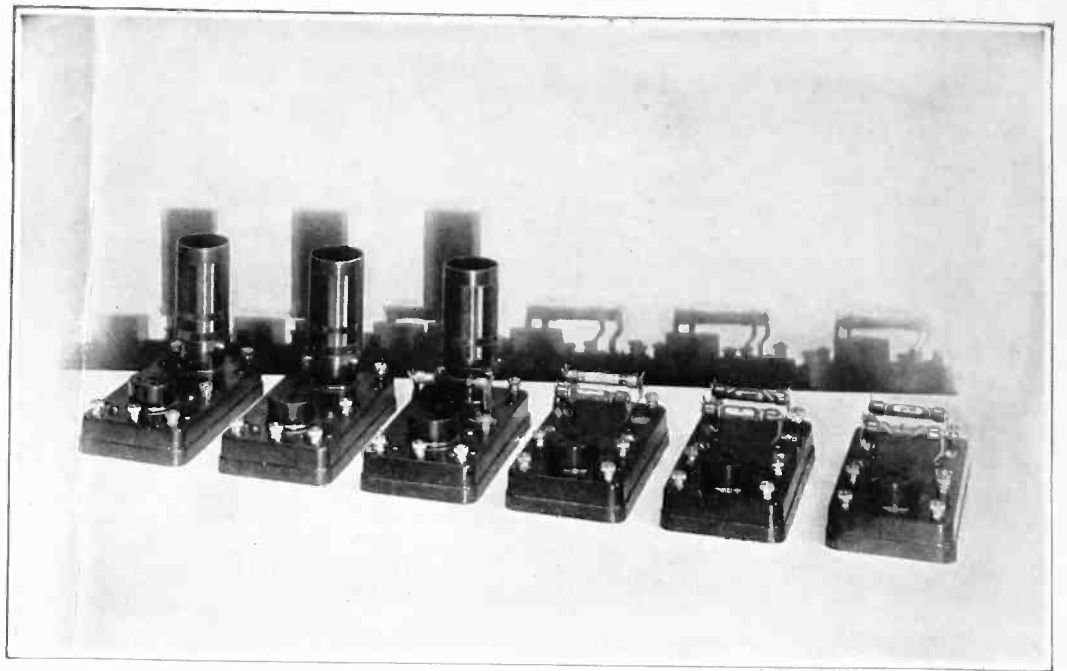

Fig. 8. Here are the works of a high-power tuned R.F. receiver. They consist of two R.F. Redi-Blox, detector, and three resistance Redi-Blox. Add three .00035 mfd. tuning condensers and a Resistograd for controlling oscillations, and you have a whole set. Use UX-226's, UY-227, and 171 for complete A.C. operation, or 201-A's, 240's and a 171 for battery power supply.

Then you will appreciate the Redi-Blox idea. Why, these units can be put in operation while you're combing the junk box for the necessary odd parts.

EACH UNIT IS COMPLETE

Just to put you on speaking terms with the handy-family, here's a description of each member:

R.F. UNIT: The R.F. unit has a socket for UX or UV tubes, a socket for the plug-in-coils, and an R.F. by-pass condenser, connected as in Fig. 1. The plug-in coils are designed for the .00035 mfd. variable condenser. Three sizes of coils are available, covering a range of 180 to 3,000 meters. Post 7 provides connections for C bias on the 226 A.C. tube, but for battery operation post 7 is connected to post 4.

DETECTOR UNIT: In the detector units there are the coil socket, spring mounted socket for battery tubes, clips for the grid leak, a .00025 mfd. grid condenser, and underneath a flexible lead by which the grid return can be made negative for the 200-A and other special detectors or positive for 201-A tubes. The UY-227 detector unit is like the other in appearance, but the wiring is different, as shown in the diagrams.

RESISTANCE A.F. UNIT: The resistance amplifier unit has clips for the two resistances, a .006 mfd. stopping condenser, and tube socket. The standard resistance values should be used on the 240, 201-A, or 226. The plate resistor is at the rear, and the grid leak at the front, looking at the unit with terminals 4 and 5 towards you. Ordinarily, in a three-stage amplifier, all the plate resistors are of 100,000 ohms, and the grid leaks 1, $\frac{1}{2}$, and $\frac{1}{4}$ megohm in the first, second and third stages respectively. If no C battery is used, the C terminal, No. 3, should be connected to terminal No. 4.

TRANSFORMER A.F. UNIT: The transformer unit has the new Pilot Giant A.F. transformer, mounted in a beautifully finished black steel case, serving as a shield, and the tube socket. Terminal No. 3 is for the C connection. This unit takes all types of tubes, from the 199 and 125 up to the 171 or 210. Perfect insulation is provided against high voltage and radio frequency leaks by the genuine Bakelite bases. When you use these units in an A.C. set, put a 226 in the first A.F. stage and a 171 in the last stage.

ALL UNITS SAME SIZE

The Bakelite bases on all four Redi-Blox are the same in size, measuring $5\frac{1}{8}$ by $2\frac{3}{4}$ ins. With a 199 type tube, the over-all height of any unit is $4\frac{3}{8}$ ins., or $5\frac{1}{4}$ ins. with a 201-A in the socket. The height to the top of the transformer of the A.F. unit is $4\frac{3}{8}$ ins.

SHIELDING CAN BE USED OR OMITTED

Because of the extremely small field about the plug-in-coils, no shielding is needed. In

various types of circuits which we have used, the R.F. and detector Redi-Blox were mounted so that the coils were 4 or 5 ins. apart, center to center. No difficulty from inter-stage coupling was experienced in any circuit.

However, Redi-Blox are splendidly adapted for shielding if, for appearance and dust protection, you want to use it. No insulation problems complicate the assembly. Just fasten the Redi-Blox to the bottom of the shields, make the connections, and the job's done.

ALL TUBES FIT REDI-BLOX

Terminals are provided to make Redi-Blox suitable for all types of tubes that have UX or UV bases. In the R.F. unit you can use the 201-A, 199, 226, and other A.C. tubes. The detectors take the 201-A, 200-A, 199, or the 227 A.C. tube. In the transformer stages you can have the 201-A, 199, 120, 112, 171, 210, 226, A.C. operated tubes, or any combination you desire. The last audio amplifier tube can be run from raw A.C. Either the 201-A or, better, 240 is recommended for the resistance unit, altho the 226 is very good, and does not motor-boat.

Filaments can be run in parallel or series. Series filaments must draw the same amount of current in each tube. You can use four 201-A's and a 112-A, all in series, or put four or more 201-A's or 199's in series, with a power tube in the last stage run from raw A.C. Again, you can have any 5-volt tubes in parallel, with a 171 or 210 in the last stage run from A.C.

PERFECT FOR NEW SUPER CIRCUITS

Not the least important use of the R.F. Redi-Blox has come to light with the advent of the tuned intermediate stages for super-heterodynes. QST Magazine and the Christian Science Monitor are featuring the development.

For the cost of the special inductances which have been specified, you can buy an R.F. Redi-Blox and No. 176 plug-in-coil, add a No. 1617 or 1623 variable condenser, .00035 or .0005 mfd. respectively, and you have the most efficient intermediate amplifier that money can buy.

Also, if you use the primary of the coil of an R.F. unit as tickler, it makes a first class oscillator, putting a few turns around the secondary as a coupling coil.

Whatever you want, Redi-Blox give it to you in the handiest form.

What's more, they can be adapted quickly to new circuits of the future. Redi-Blox are actually an investment in perpetual up-to-dateness. A few leads changed and in a minute you can try out every new hook-up that comes along. Redi-Blox are always ready for it.

You can build a tuned R.F. set to-day, change it into a super-heterodyne to-morrow, and the next day build a high-efficiency A.C. tube receiver, always using the latest, approved circuits.

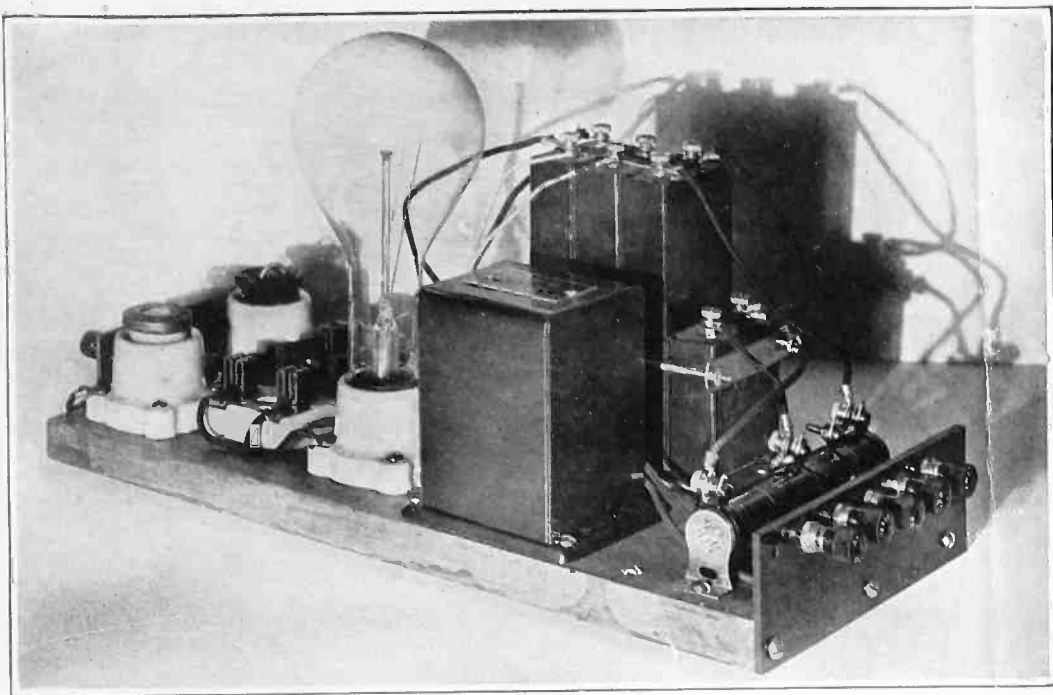

Fig. 1. D.C. eliminator and trickle charger unit for homes which have D.C. supply.

SEE HERE—EXPERIMENTERS

Answering Some Special Set Builders Questions
about Circuit Details & by Gerson Lewis

WHERE a direct current lighting supply is available, most sets can be run from a simple B eliminator even though the voltage may be a little lower than values specified for batteries.

And while you're making the eliminator, you can just as well have the unit serve as a trickle charger, too.

Fig. 1 shows the assembled device, and Fig. 6, the very simple circuit. This circuit differs slightly from the hook-up of the parts in Fig. 1, but this change is only to simplify the construction.

Starting at the binding posts which go to the cord and the light socket plug, there are two 2-ampere fuses connected to a double-pole, double-throw switch. In a downward position, the D.C. goes thru a 75-watt lamp to A+ and A-. These are for charging. Connect A- to the black, or negative terminal on your storage battery, and A+ to the red, or positive terminal.

When the switch is up, the eliminator circuit is connected. This is composed of a 2 mfd. filter condenser, a 30-henry choke, two 1 mfd. condensers, and two 1,200-ohm resistances. The two voltage taps will give about 50 and 105 volts.

Connect the 50 volts to binding posts on your set marked B+ 45 volts, up to B+ 90 volts. Connect the B binding posts marked for higher values to plus 105 volts on the eliminator. A little experimenting may be necessary to get the right combination. You needn't be afraid of doing any damage, for no harm can come to the set or the eliminator.

It is necessary to get the right connections to the lighting current. Connect the eliminator to your set and throw the switch up. If you do not hear signals in your set, reverse the leads running to the light socket. Then the set will work properly, and the polarity will be right for the trickle charger, also.

A 75-watt lamp in the socket will pass $\frac{3}{4}$ ampere to your storage battery. If you want more or less current, you can change the size of the lamp accordingly.

To determine the charging current going into the battery, divide the watts rating of the lamp by 110.

Here is the essential parts list, and the list of accessories:

ESSENTIAL PARTS FOR D.C. ELIMINATOR AND CHARGER

- 1—No. 9302 2 mfd. Pilot condenser
- 2—No. 801 1 mfd. Pilot condensers
- 2—No. 956 1200-ohm Pilot resistances
- 1—No. 377 30-henry choke (Pilot)
- 7—Pilot Bakelite binding posts
- 1—Pilot base-board, 14×6× $\frac{3}{8}$ in.

ACCESSORIES

- 2—2-amp. fuses
- 1—Lamp socket
- 1—75-watt lamp
- 1—D.P.D.T. switch
- 2—Micarta binding post strips 6×3× $\frac{1}{8}$ in.

The parts listed as accessories can be obtained at your local hardware store, as they are standard for electrical fittings.

HOW TO ADD A STAGE OF R.F.

It is an easy matter to increase the receiving range and selectivity of any set if you use the parts shown in Fig. 3, connected as in Fig. 2.

You can make up a neat little R.F. panel with the variable condenser and Resistograd on the front, and the Redi-Blox and fixed condensers at the rear.

The Resistograd is connected as a R.F. Super-Charger. Ordinarily it is adjusted to neutralize the R.F. tube, but for extreme distance, just a touch on the Resistograd will add several hundred miles to the receiving range. If your R.F. Redi-Blox has a terminal 7, connect 7 to 4, and make the balance of the wiring as in Fig. 2.

This extra tube at the R.F. end is far more effective than another stage of audio amplification, for it does not tend to spoil the audio quality.

Extra A.F. amplification does not increase the receiving radius but merely makes such stations as you have been picking up a little louder, and usually causes more distortion than amplification. The special circuit employed makes the R.F. Redi-Blox adaptable to all types of sets, including those which have conductive coupling to the antenna. A 1 mfd. condenser is used to keep the B voltage out of the filament circuit on sets where the filaments are connected to the ground binding post.

ESSENTIAL PARTS FOR R.F. STAGE

Following is a list of the parts required to add a stage of R.F. to increase the range of your present set:

- 1—No. 300 Pilot R.F. Redi-Blox
- 1—No. 1617 .00035 mfd. Pilot Centraline condenser
- 1—No. 350 Pilot Resistograd
- 1—No. 54 .002 mfd. Pilot fixed condenser
- 1—No. 801 1 mfd. Pilot by-pass condenser
- 1—No. 176 Plug-in coil
- 3—Pilot Bakelite binding posts
- 1—No. 1278 Pilot Art Dial

This inexpensive unit will increase the selectivity of your set, as well as increasing the range.

IMPROVE YOUR AUDIO QUALITY

If you are using a 171 tube in the last stage, you must have an output device in order to get

(Concluded on page 15)

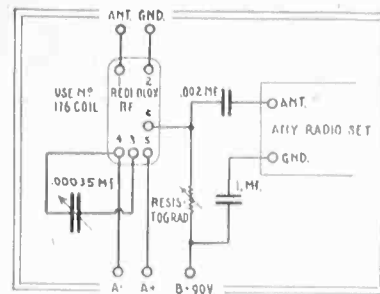

Fig. 2. Circuit for a stage of R.F. amplification to be added to any radio receiving set.

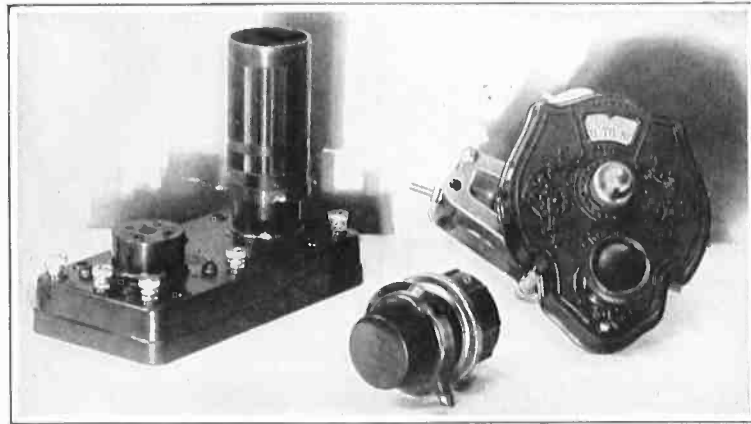

Fig. 3. The elements of the R.F. amplifier circuit to increase the receiving range of your present set.

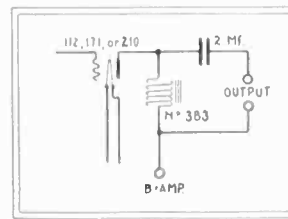

Fig. 4. Only with an output device can full results be obtained from a 171 or 210 tube.

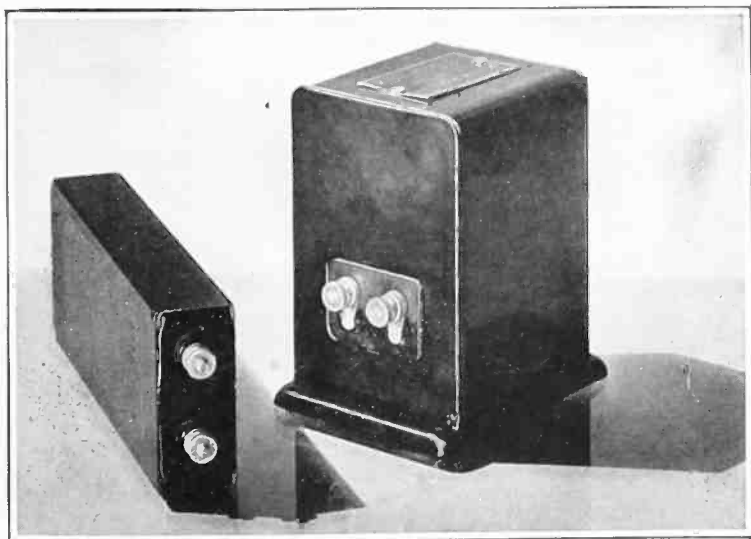

Fig. 5. The 2 mfd. filter condenser and output choke used in the power tube output device for obtaining full quality and volume from 171 or 210 tubes.

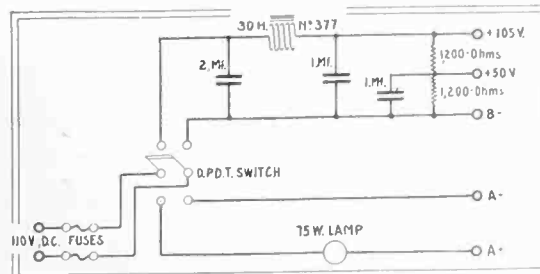

Fig. 6. Connections for the D.C. trickle charger and B battery eliminator, run from D.C. house current.

REAL, INSIDE DOPE ON A.C. TUBE CIRCUITS

These Circuits Represent Full Laboratory Development on A.C. Tube Sets, Showing New Methods Not Yet in Use By Set Manufacturers & by John Geloso

A.C. TUBES—here we come! And how! Such enthusiasm may not be dignified, but who could help being that way after he's found out, at last, the inside dope on making A.C. tubes work the way they should have but didn't.

You probably know all about the things the A.C. tubes shouldn't have done but did just the same. Now you're going to learn about A.C. tubes in a set that can only be described as the cat's pajamas.

I mean that the Air Scout, as we, in the laboratory, have named the set I'm going to tell you about, has all the operating characteristics of the finest battery operated receiver, plus considerable personality of its own, and as an A.C. job it's a perfect success.

It's as simple as rolling off a log when you understand it, and there isn't a single subtle trick or evidence of temperament to annoy the uninitiated.

If you have been harassed by the uncertain operation of one of those prima-donna radio sets, throw it out and build an Air Scout. There's a piece of radio machinery that's as beautiful, in a scientific way, as the music it produces.

226 AND 227 SCORE BIG SUCCESS

The early failures of A.C. tube sets were not due to defects in the tubes themselves. The UX-226 and UY-227 deliver the goods—if they are used in circuits properly designed.

Radio set manufacturers in many cases went into production last summer, before proper circuits had been worked out, on A.C. tube sets for fall delivery. Nothing works right when it's wrong, and those sets were no exception.

Such designs were available to RADIO DESIGN when the first issue was being prepared, but we avoided them because we knew they weren't right, and to describe sets that we knew would not prove satisfactory would have contributed only to the feeling of distrust for which impatient designers are now responsible.

antenna, and ground if the A and C supply is not built into the set. Look at your set and see how you can get them on the panel.

Three different values of C bias are required. Unless you have an eliminator

sents the nearest thing to perfection that can be produced.

The essentials of the radio circuit have been supplied by R. C. A. in accordance with the special characteristics of the tubes, while the power pack, and the

the A and C supply into the set. Otherwise an impossible number of binding posts would have been required and the depth of the set greatly increased on that account alone. Moreover, complications threatened because of the many leads

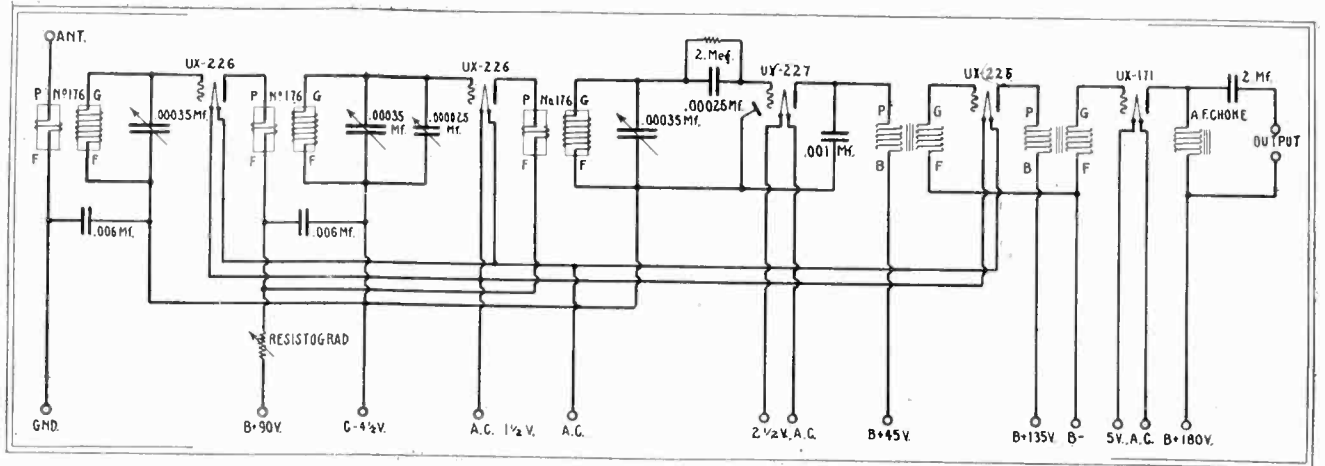

specially designed for A.C. tubes, you'll have to use C batteries. Then it won't be an A.C. set.

By the time you tear up the wiring on the R.F. stages to bias the grids, put in a new detector socket and change those connections, bias the grid of the first A.F. tube, and change the filament and grid return on the last tube, you'll have your set in such a mess that it never will operate properly with A.C. tubes, and you won't be able to restore it to its original condition.

Take my advice—Sell your battery set and put what you get on a brand new A.C. outfit that is designed, from start to finish, for the A.C. tubes.

DETAILS OF AIR SCOUT CIRCUIT

The Air Scout¹ circuit is divided into two parts, the radio set with the A and C supply, and the B power pack. You understand, of course, that A.C. tubes use raw A.C. from the lighting circuit on the filament only. The B and C voltage

required to separate A, B, and C supply. On that account, too, we decided upon center taps for the transformers, thus eliminating parts. Tests with resistances showed that the center points were not critical, while the Pilot method of bringing off center taps from the transformer windings is so exact that there can be no measurable deviation from the electrical center.

radio parts required, have been developed by the engineering staff of the Pilot Electric Company. And there is a combination that guarantees the success of the Air Scout.

Just a word about the cost of this receiver, for you are probably wondering if this outfit isn't going to run into a lot of money.

Judging from the prices of the plain, battery operated construction kits which are being offered this year, the Air Scout ought to cost about two hundred dollars, but if you have one-third of that amount, you have more than enough to buy the parts for the radio pack and power pack, including the panels and all the parts required to build the complete Air Scout—everything except the tubes.

Now how does that sound to your

required to separate A, B, and C supply.

On that account, too, we decided upon center taps for the transformers, thus eliminating parts. Tests with resistances showed that the center points were not critical, while the Pilot method of bringing off center taps from the transformer windings is so exact that there can be no measurable deviation from the electrical center.

Fig. 3 shows the schematic of the separate B power pack, and the wiring of the A and C supply which is built into the receiver. In Fig. 3, a BH Raytheon is used as a rectifier, while a UX-280 is employed in Fig. 4. We are inclined to favor the BH tube, but that is a matter of individual preference.

Either type of rectifier can be used in the Pilot No. 5 B power pack. The No. 387 power transformer has three primary binding posts, 7, 8 and 9. When a BH tube is used the 110 volts A.C. line is connected to 7 and 8, or for a UX-280, to 7 and 9. The equipment is the same in either case, except that the buffer condenser is not needed with the 280 tube.

180 AND 220 VOLTS B

You will see that binding posts are provided in the No. 5 B power pack for 180 and 220 volts. When the pack is used in circuits where the 40 volts bias for the 171 tube is not taken from the eliminator, the 180-volt connection should be used.

In such sets as the Air Scout, however, taking the 40 volts C bias from the power pack, connection must be made to the 220 volts binding post. That terminal actually delivers 220 volts, 40 volts of which are used for C bias, and 180 volts on the plate. This is probably the only B power pack that is designed to provide for this most essential feature, without which A.C. tube sets must still use dry batteries.

Thus the No. 5 B power pack can be used as a plain B supply on storage battery sets, it can supply all B voltages, C bias for a 171, and 5 volts A.C. for the 171 as shown on page 19, or it can be used as a part of the ABC power equipment for A.C. tube sets. Also since either a BH or UX-280 can be employed for rectification, this unit can be described as truly universal.

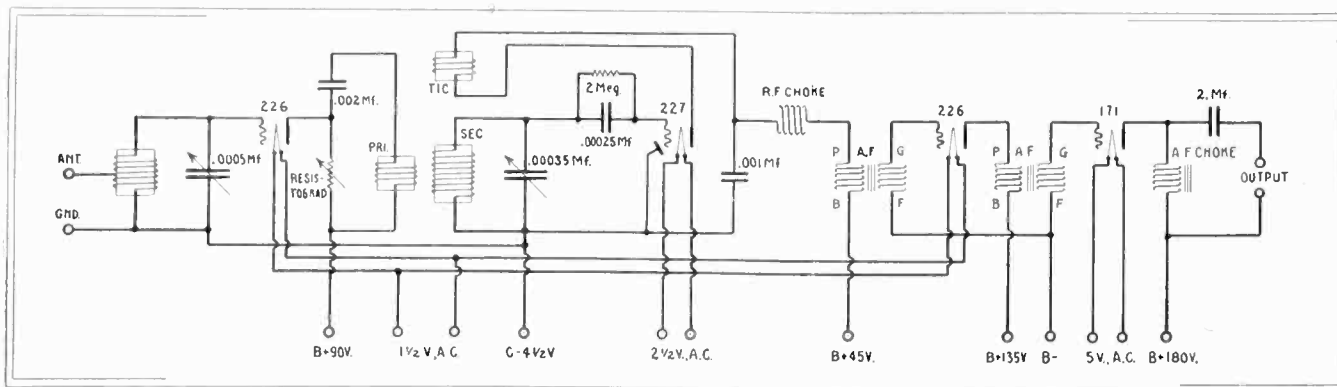

In fact, the data published here is so new that it was necessary to delay this issue of RADIO DESIGN considerably to get the final official laboratory circuit data.

DO NOT REWIRE OLD SETS

Before proceeding with the description of the Air Scout circuit, I want to tell you about rewiring old sets.

In a sentence—Don't do it. You will be disappointed.

Exactly 22 binding posts are required for connections to the power pack,

supply must be rectified and filtered even more perfectly than is necessary on battery operated tubes. This calls for a type of power pack that repre-

sents the nearest thing to perfection that can be produced.

¹ Complete, full-size Official Data Prints of the Air Scout and power supply can be obtained from A. L. Farris, 620 Riverside Drive, New York City, \$2.00 postpaid.

pocket book? Not so bad? Particularly when you'll have a finer set than practically any manufactured job that is on the market now.

The Official Air Scout set design is illustrated on page 17, where the wiring is shown as it is put on the Redi-Blox, but Fig. 1 shows the complete schematic which can be applied to any parts.

To be perfectly frank, the A.C. tube set was a big problem in design, for there are so many factors to be considered and correlated. It was found absolutely necessary, from a practical standpoint, to build

There was some speculation as to the possibility of a hum from the filament transformer on the set. Theoretically, no hum should be induced by the Pilot No. 386 transformer, for it is designed to have practically zero leakage. Moreover, the transformer is shielded by the heavy steel case.

actly uniform, drawing more or less than their rated current, the C biases adjust themselves to the individual characteristics of the tubes. Not a single adjustment is required. In fact, it is the parts manufacturer's job to make power equipment right. You shouldn't have to spend twenty-five dollars for a high

MORE S. W. ON THE AIR

Range of This Set Ten Thousand Miles

SINCE the recent Radio Conference at Washington, short wave transmission and reception have taken on an increasingly important aspect.

Now all channels, from below 5 meters up, have been assigned to special purposes. All kinds of services will be operating below the regular broadcast bands, and even broadcasting is being carried on extensively below 200 meters.

There are channels for amateur phone and telegraph, picture transmission, point to point commercial traffic, special bands for the use of the Army and Navy, international communication, airplane to airplane, and airplane to earth messages.

In fact, since the greater usefulness of short waves has been realized, there is much more activity below 200 meters than above it.

A short wave receiver, for 18 to 200 meters, that will have a range of 10,000 miles or more, can be built at much less expense than an ordinary broadcast set.

The cost of the outfit for which a diagram is given below is less than \$15.00, yet it can run rings, for distance, around the most expensive set operating on 200 to 550 meters.

Here is the list of parts required. You can see how simple the outfit is from the list.

The Twin Coupler short wave coil kit comprises three plug-in coils, for the following wavelength ranges:

- Coil No. 1—18 to 56 meters
- Coil No. 2—40 to 105 meters
- Coil No. 3—90 to 220 meters

This set can be used for broadcast reception by plugging in an extra coil, supplied separately from the kit:

- Coil No. 4—235 to 535 meters

The standard coil kit also includes an antenna coupling coil and mounting, into which the coils are plugged.

Only one stage of audio amplification is shown in the wiring diagram, as that is ordinarily sufficient, altho a second stage can be added if you wish. It should be

connected just as it would be in a broadcast receiver.

Many methods have been tried to apply radio frequency amplification to short wave receivers, but they have been generally unsatisfactory. Moreover, such extreme distances can be covered with an ordinary detector circuit that R.F. amplification is hardly necessary.

The circuit shown here is the standard type which is most widely used. It is entirely dependable in operation, and the best for the beginner.

Don't put the short wave set on your regular antenna and expect to get results. The Radio Amateur's Handbook, reviewed in this issue, has an important chapter on antennas, with a table, on page 150, giving the dimensions which have been found, in practical operation, to give the best results. Follow the data given, and you will discover what remarkable things there are to do at short waves.

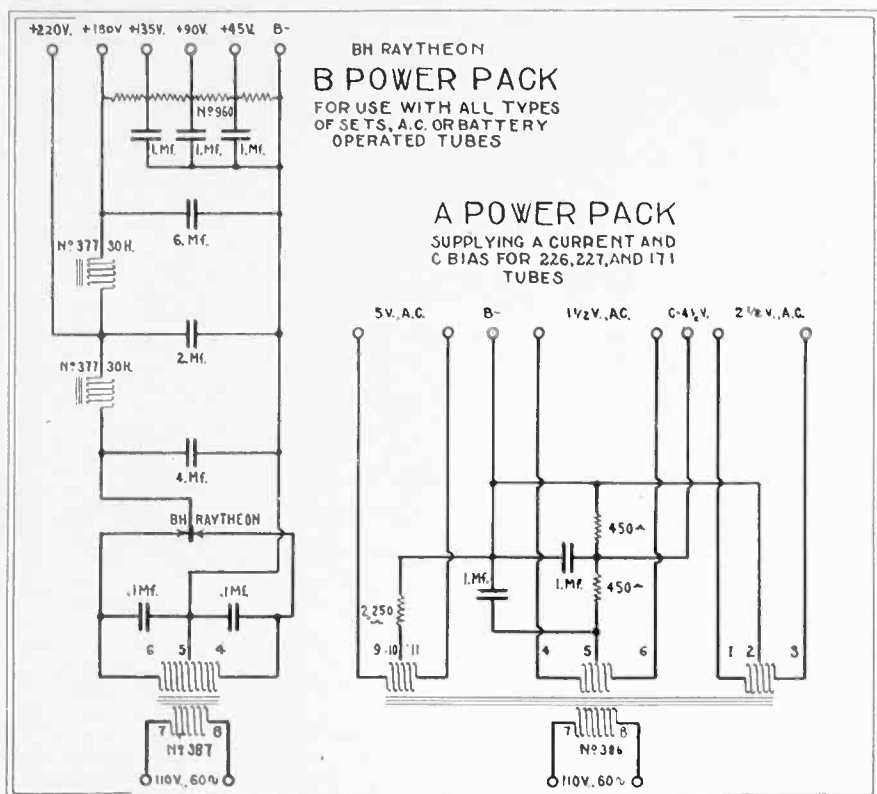

Fig. 3. Schematic of Raytheon in the new Pilot B pack, and connections for the A and C supply. Fig. 4, below, the B pack with UX-280.

In practice the theory was confirmed. No hum whatever is caused by the Pilot filament transformer. It should be pointed out, however, that this is not necessarily true of all makes, even tho they are shielded, for there may be large leakage from types which have insufficient copper and iron.

ALL ADJUSTMENTS AUTOMATIC

Assorted knobs for various kinds of controls and adjustments in the power supply circuits are prominent by their absence. It isn't hard to design such circuits haphazardly, with everything adjustable so that if you are lucky enough to get the combinations, it will work.

But it takes real engineering skill to design a complete ABC supply which is so flexible electrically that it adjusts itself to all conditions. Even the C biases are automatic. If the tubes are not ex-

resistance voltmeter just to check up the various voltages.

A.C. TUBES FOR BROWNING-DRAKE, TOO

In Fig. 2, you will see the circuit for a set using the Browning-Drake type of circuit. This set is similar in the details of the A.C. tube circuits to the Air Scout just described. It uses the type 109-A Twin Coupler coils, connected in a circuit that employs the R.F. Super Charger described elsewhere in this issue.

The general operating characteristics are similar to the battery operated circuit, altho considerable improvement in DX

OFFICIAL PARTS LIST

Approved Browning-Drake Type Circuit for A.C. Tubes

- 1—No. 109A Twin Coupler coil kit
- 1—No. 1623 .0005 mfd. Pilot Centraline condenser
- 1—No. 1617 .00035 mfd. Pilot Centraline condenser
- 3—No. 205 Pilot UX type sockets
- 1—No. 211 Pilot UY type socket
- 2—No. 381 Pilot giant A.F. transformer
- 1—No. 393 Pilot output impedance
- 1—No. 9302 2 mfd. Pilot condenser
- 1—No. 350 Pilot Resistograd
- 1—No. 130 Twin Coupler R.F. choke
- 1—No. 51M .00025 mfd. Pilot grid condenser
- 1—2 meg. Pilotohm grid leak
- 1—No. 53 .001 mfd. Pilot fixed condenser
- 1—No. 54 .002 mfd. Pilot fixed condenser
- 19—Pilot engraved Bakelite binding-posts

ACCESSORIES

- 1—No. 4 Pilot A power pack with C bias supply
- 1—No. 5 Pilot B power pack

OFFICIAL PARTS LIST

Approved Two Tube Short Wave Receiver

- 1—No. 115 Twin Coupler short wave kit
- 1—No. 130 Twin Coupler R.F. choke
- 1—No. J23 .00001 Pilot midget condenser
- 1—No. 1508 .00014 Pilot S.L.F. condenser
- 1—No. 1523 .0005 Pilot S.L.F. condenser
- 1—No. 910 10-ohm Pilot rheostat
- 1—No. 371 Pilot audio frequency transformer
- 2—No. 206 Pilot shock-proof sockets
- 1—No. 50D .0002 Pilot Isograd fixed condenser
- 1—4 to 6 megohm Pilotohm grid leak
- 8—Pilot engraved binding posts

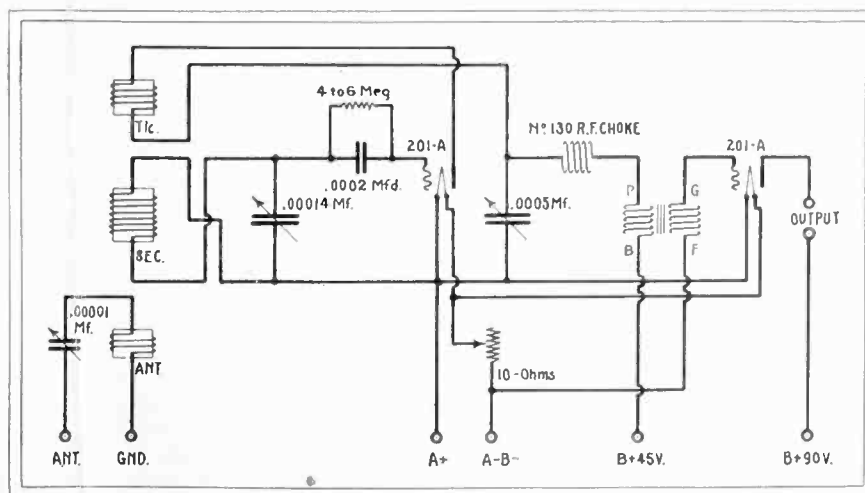
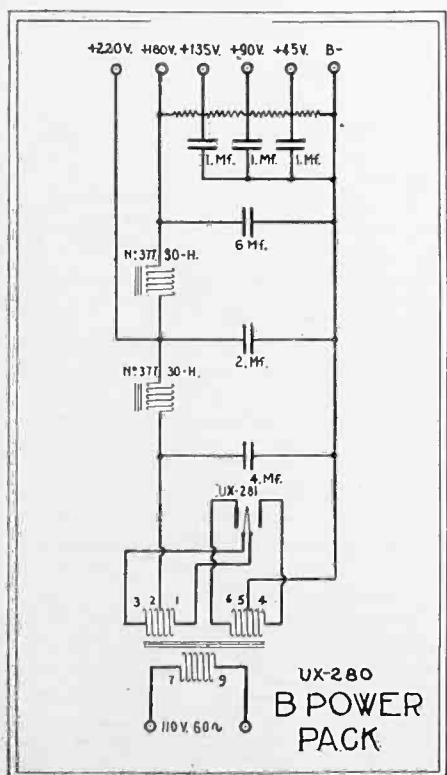

Note the exact relation of the terminals of the coils, and connect them in this way. Otherwise the circuit will not oscillate.

reception is obtained by the use of the R.F. Super Charger.

During ordinary reception, the Resistograd of the Super Charger is set to neutralize oscillations in the first tube. However, on distant stations, a slight regulation of the Resistograd will bring up to full loudspeaker volume stations which would be heard otherwise on the telephones only.

The R.F. Super Charger gives the effect of cascade regeneration, and makes the first tube equal to two or more stages of neutralized R.F. amplification.

Connections to the A.C. tube ABC eliminator are the same as for the Air Scout.

This receiving set circuit does not include a built-in A and C pack. However, as in the case of the Air Scout, it is much better design practice to mount parts of the A and C pack right on the base panel of the set, for, as previously explained, that does away with six binding posts, and practically eliminates the possibility of induction effects which would set up an A. C. hum.

MAGNAFORMER BREAKS AIR RECORDS

World's Most Powerful Receiver Earns Title—"Commander-in-Chief of the Air"—by Smashing All Trans-Oceanic DX Receiving Records & by M. B. Sleeper

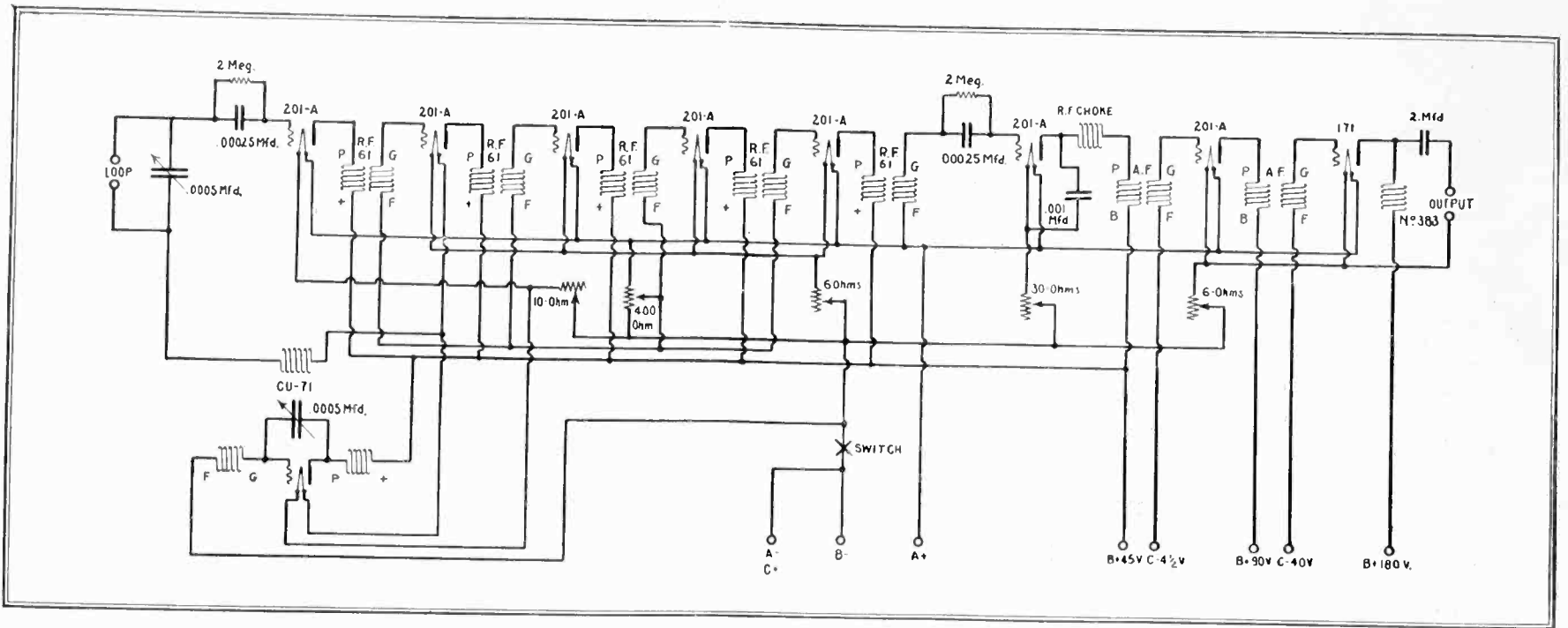

Fig. 2. Using Pilot parts in this circuit, the wonderful Magnaformer results can be obtained, and with a saving of about one-half in the cost.

IMAGINE a radio set operating with a loop antenna, so powerful as to give regular dependable reception between the United States and Australia and Japan!

This and similar records made by the Magnaformer set are responsible for its descriptive title, "Commander-in-Chief of the Air."

Results like these don't happen. There's a reason somewhere, and the clever set builder generally wants to know the why's and wherefore's. I'll explain them.

The super-heterodyne type of circuit can be made more efficient than any other receiving system. Essentially, it is a plain, multi-stage amplifier with an oscillator and an extra detector added.

Whether such an outfit is just good or startlingly efficient depends entirely upon the intermediate frequency amplifying transformers. All the parts must be of absolutely first-class design, but beyond that, it doesn't matter whether you pay a dollar or five dollars for the variable condensers, three dollars or ten dollars for audio transformers, as long as they are right mechanically and electrically.

The only secret of performance lies in the intermediate transformers.

HOW MAGNAFORMERS ARE MADE

Fig. 1 shows the inside construction of the Magnaformer transformer, with additional illustrations on the page opposite.

First there is the slotted bobbin, 1, of molded Bakelite, on which the primary, 2, and the secondary, 3, are wound. This is done with great care and accuracy as to the number of turns.

The exact dimensions of the metal band, 6, and plate 5 were determined, by exhaustive experiments, to give just the right degree of damping and the necessary shielding effect.

The transformer is completely assembled and permanently fixed within the case before the adjustable mica tuning condenser is put in place. This design assures the coils against any changes while the all-important balancing operation is in progress.

After that, the cover, 8, is put in place

and the transformer permanently sealed by soldering the nuts to the clamping screws.

The tuning condenser, 4, is calibrated and set to a fixed standard oscillator, the frequency of which is maintained by a Piezo crystal control, kept continually at a constant temperature.

Thus, all Magnaformer transformers are matched to that fine degree of accuracy which is now described, tho unscientifically, as the gnat's eye-brow.

When the importance of matching intermediate transformers was first brought to the attention of radio manufacturers, transformers were matched in sets, by means of rather crude vacuum tube oscillators, but such methods were only makeshift, and often times sets of transformers were mixed up at the factory or in the dealers' stores. You can imagine the results.

Matching is a process of tuning the secondaries to give peak response at a given frequency. Unless each transformer is adjusted with extreme precision, the efficiency of the set can be compared with that of a tuned R.F. receiver with the first stage adjusted to 400 meters, for example, the second stage to 415 meters, and the third to 390 meters. Local stations might be received, but no distance, certainly.

At the same time, the intermediate transformers must be designed in such a way that, so accurately tuned, they will not cause the circuits to oscillate uncontrollably. From this you can understand the problems involved in the production of these instruments, and the absolute necessity for precision methods.

HOW TO SAVE MONEY

Saving money in radio construction is a matter of spending less but getting just as much. You really can't call it saving

when, by reducing the cost, you sacrifice efficiency and results.

Just look carefully at the Magnaformer set shown in the accompanying illustrations. Looks pretty good, doesn't it? It ought to, for it was built by A. H. Ghirardi, one of the best-known experts on apparatus design in New York City. Doesn't seem cheap or flimsy, does it?

But do you know that these standard parts, outside of the Magnaformers, cost about twenty-five dollars?

The vernier drum dials are the huskiest design you ever saw, and run as smoothly as can be. The variable condensers are truly precision-made. All the sockets are cushion-mounted. There's enough copper, iron, and engineering

skill in the construction of the transformers and A.F. choke to make the A.F. amplifier do credit to the R.F. end of the set.

I don't know how, by substituting any other parts for those shown, you could improve the results. But you certainly save a great deal of money by using the parts shown here, and specified in the accompanying list.

ASSEMBLING THE MAGNAFORMER SET

It's quite a big job to assemble the Magnaformer set, but there is nothing complicated or intricate about it. This design follows the circuit and the arrangement of the parts which have been so widely described in all the radio magazines and newspaper articles. All the special instructions already published apply to this new design, for the only essential difference is in the use of parts equivalent electrically, but lower in price.

The drum dials with their .0005 mfd. condensers, potentiometer, 6-ohm rheostat, and battery switch are carried on a Micarta panel 7 by 26 by $\frac{3}{16}$ in.

Drilling templates, supplied with the drums, show just how the panels must be cut out. That is an easy matter—just a row of holes, leaving a piece in the center to be knocked out judiciously so that you will not crack the panel. The front plate covers the edges of the opening.

The left-hand drum is mounted so that the vernier wheel is at the left, and the right-hand drum has its wheel on the right. You will see that an extra scale is furnished with each drum. That is because one drum requires a reversed scale, when a pair is used in this way. Just remove the screw that holds the scale in place, slip off the scale, and put on the other one. Otherwise, you will have one scale reading up-side-down.

Instructions are provided to show the method of mounting the condensers on the drums. Pilot condensers have shaft extensions at both ends, so that you can mount them on opposite sides without reversing one condenser. Incidentally, the Pilot drums are the only ones that take condensers on both sides. You can see how this adds to the symmetrical appearance of the set.

The 400-ohm potentiometer goes on the right, looking at the front panel from the rear, and the 6-ohm rheostat at the left. When you mount the switch, be sure to have the part stamped ON at the top. If you don't, the switch will be off when the front plate says it is ON.

ASSEMBLING THE BASE PANEL

A Micarta panel 7 by 25 by $\frac{3}{16}$ in., supported on four 1-in. Pilot Bakelite brackets, serves as the base. The assembly of the parts is a plain job, nothing complicated, but it must be done with care and accuracy.

Along the rear are the five Magnaformers, with the Unicoupler toward the front. It is mounted on two legs, but gets additional support from touching the rear of the front panel.

You can see the arrangement of the sockets. The eight which are put in a line down the panel all have the F posts toward the front, but the extra socket has its F posts at the rear.

Looking at the set from the rear, the A.F. output impedance is at the left, with

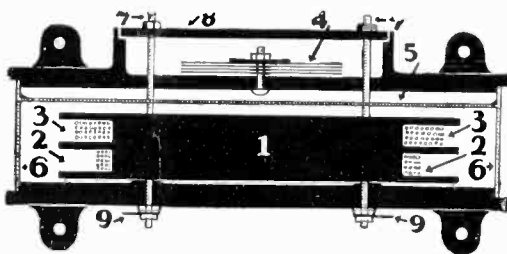
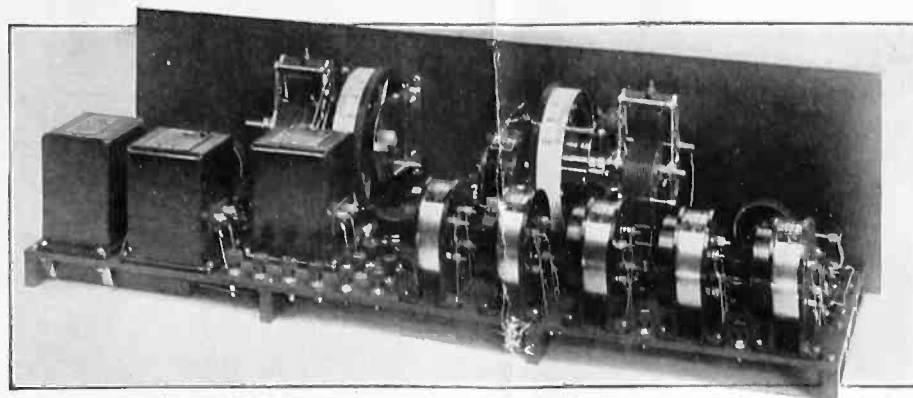
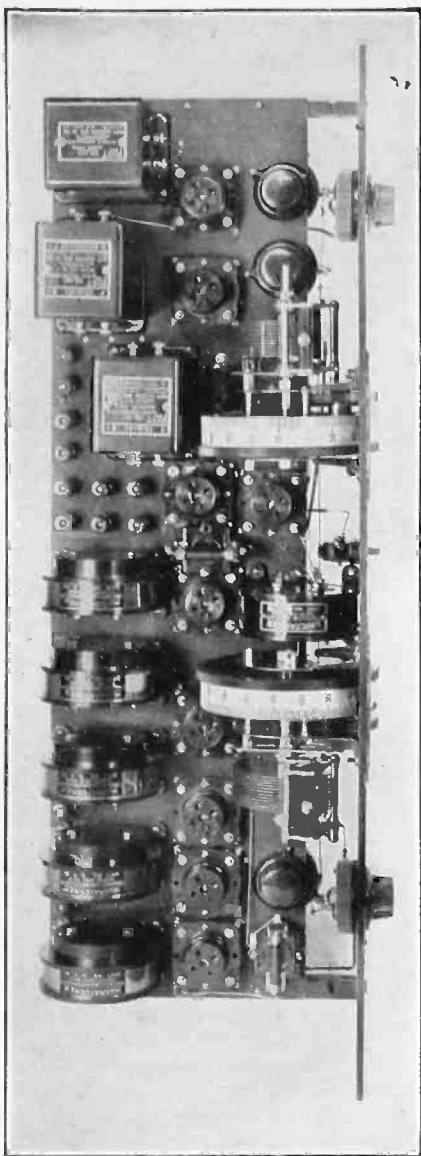

Fig. 1. Details of the Magnaformer construction.



Four views of the highest-power set ever built, showing the top, rear, bottom, and left end. All the factors which contribute to the Magnaformer efficiency have been preserved, the only essential change being in the use of a separate A.F. choke and 2 mfd. condenser in the output of the last tube. This set can be wired for A.C. tubes—six UX-227's, two UY-226's, and a UX-171.

First connect the A battery to see if the filaments light. Then put on B+ 40, B+ 90, and finally B+ 180 volts. As a matter of fact, if you use a B eliminator, you can't burn out the filaments, but it is dangerous to make a mistake with batteries.

Then hook up the C batteries, the loop antenna, and the loudspeaker.

You ought to have a voltmeter so that you can adjust the rheostats to put exactly 5 volts on the filaments. That is important because, with the filaments set accurately, all adjusting can be done with the rheostat and potentiometer on the front panel.

Tune in a station by rotating the drum dials, keeping them at the same readings. If your loop is built correctly for tuning with a .0005 mfd. condenser, the condensers will match exactly.

Once you get the right setting for the rheostat and potentiometer, you will be able to do all the tuning with the dials, using the potentiometer only to increase or decrease the sensitiveness on distant or local station.

SUGGESTIONS ABOUT OPERATING

Bear in mind that when you are tuning the Magnaformer you are using a set that measures distance in thousands of miles. It isn't a one-tube regenerative set, and it can't be handled like that. It does its work in its own way, and you must spend some time to get acquainted with it. The first night you won't be able to hear Mars, because your skill in handling the controls will determine the range to a considerable extent.

Why, you'll find yourself sliding around from one station to another as if you were on new ice. The selectivity is so knife-like that you'll pass up stations that you won't start to hear until you have had a few nights' experience. Particularly since the new wavelength allocations, you can get stations right thru local interference in the middle of the evening that, before, you weren't able to bring in at 2.00 a.m.

HOW TO USE THE PILOT B POWER PACK

I spoke about the safety factor introduced by using a B eliminator. There are other advantages, too. The Magnaformer uses a considerable amount of plate current, with that 171 in the last stage, so the cost of B batteries will run fairly high.

The economical thing to do is to put on a Pilot B eliminator, No. 5, the details of which are given on page 19.

In this way you will eliminate the B batteries, the C battery for the 171, and you can run the filament of the 171 from A.C., reducing the drain on the storage battery by half an ampere.

A slight change in the wiring of the 171 is necessary. Bring the filament terminals on the socket directly to two binding posts marked 5 V., A.C. They will be connected to corresponding posts on the power pack. You can remove the 6-ohm rheostat. Connect the return from the output choke to one side of the filament, as before. Connect the binding post marked C—40 V. to the A— post. That cuts out the 40-volt C battery, for the bias is supplied in the eliminator.

OFFICIAL PARTS LIST

- 1—Magnaformer Kit, 5 units R.F. No. 61 and 1 unit Cu No. 71
- 1—7×26× $\frac{1}{16}$ -ins. Westinghouse Micarta panel
- 1—7×25× $\frac{1}{16}$ -ins. Westinghouse Micarta base panel
- 1—No. 130 Twin Coupler R.F. choke
- 1—No. 1280 Pilot single drum dials
- 2—No. 1623 .0005 Pilot Centraline condensers
- 1—No. 42 Pilot toggle switch
- 1—No. 400 Pilot 400-ohm potentiometer
- 4—No. 35 Pilot 1 in. bakelite brackets
- 1—No. 930 Pilot 30-ohm rheostat
- 1—No. 910 Pilot 10-ohm rheostat
- 2—No. 906 Pilot 6-ohm rheostats
- 9—No. 206 Pilot shock-proof sockets
- 1—No. 53 Pilot .001 fixed condenser
- 2—No. 51M Pilot .00025 fixed condensers with grid leak clips
- 2—Two megohm Pilotohm grid leaks
- 12—Pilot engraved binding posts
- 1—No. 381 Pilot A.F. transformers
- 1—No. 383 Pilot output impedance
- 1—No. 9302 Pilot 2 mfd. filter condenser

SET BUILDERS' QUESTIONS

Continued from page 11

the full benefit of the high quality that the 171 can produce, and also to take the strain of the heavy plate current from your loud speaker.

The parts are shown in Fig. 5, and the hook-up in Fig. 4. The output device consists simply of a 30-henry choke and 2. mfd. condenser which can be connected to the present output binding posts or jack on your set.

Such an output device must be used after a 171 or 210 tube. There are three reasons: No loud speaker is designed to handle as much

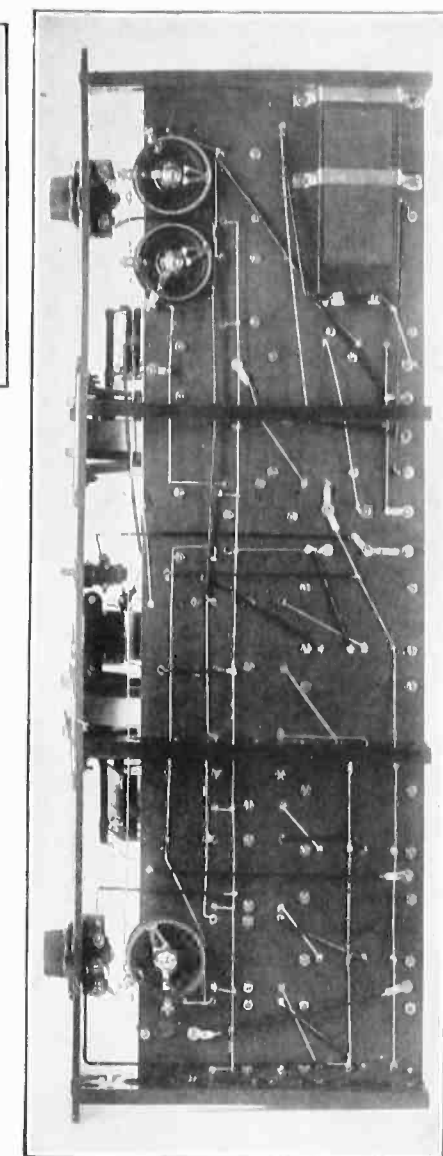

the two A.F. transformers toward the right.

Along the front edge, from left to right, are the 6-ohm rheostat, 20-ohm rheostat, .001 mfd. fixed condenser, 10-ohm rheostat, and grid condenser. Both grid condensers are of .00025 mfd., with 2-meg-ohm grid leaks.

Remember about the 2 mfd. output condenser under the base panel. It is held in place by two strips fastened by the same screws that hold the output choke. Fasten the four Bakelite brackets to the base panel.

Do all the wiring on the base panel before you put the two panels together. Most of the connections can be made with bare wire, altho it's safer to use insulated wire throughout. At all events, be sure the wire is tinned, and the lugs are also tinned—not nickel plated.

I speak of this because you must not use soldering paste. It is too liable to cause radio frequency leakage paths. You must use rosin core solder. However, you cannot trust rosin to work on nickeled lugs. The solder is too apt not to take hold. In case you have to use nickeled lugs, file off the end of each one, and tin it before you put it on the terminal screw.

FINAL ASSEMBLY WORK

With the base panel parts completely assembled and wired, fasten the two panels together, and put on the inter-panel connections. There are only a few of them.

To save trouble later, connect a dry cell and voltmeter in series, and use them to check the circuits. Put one end of the test leads on the first binding post and touch the other end to each point with which that binding post should make connection. Repeat this from each binding post. When you have finished that, if everything checks O. K., you can be fairly sure that the wiring is right.

CONNECTING THE BATTERIES

There are nine tubes in the Magnaformer—eight 201-A's and a 171. Be careful when you put on the batteries, for that is a lot of tubes to burn out at one time.

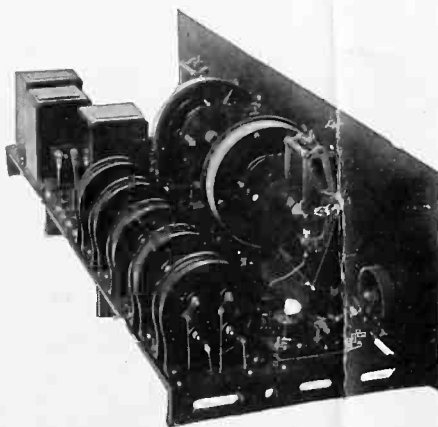

current as is passed by the plates of these tubes. Consequently, the windings will burn out sooner or later. If you reverse the leads to the loud speaker, the heavy current, opposing the magnetism of the permanent magnets, will soon demagnetize them. The loud-speaker will become weak in volume, and poor in quality.

Another important factor is the steady pull put on the diaphragm by the heavy direct current when no output device is used. This causes rattles and a most objectionable noise.

With the output device, the direct current is fed thru the choke to the plate of the tube. The direct current cannot pass thru the loudspeaker because it is blocked by the 2. mfd. condenser. When signals come in, the alternating speech frequency currents pass readily thru the condenser and into the loudspeaker, but cannot get past the heavy choke coil. Therefore, only the alternating current operates the loudspeaker, and no current passes thru the magnets when there are no signals.

This method is much more satisfactory than an output transformer, for the best transformers are far from perfect, while the impedance and condenser combination introduce no distortion.

ESSENTIAL PARTS FOR OUTPUT DEVICE

These inexpensive instruments comprise the output device for 171 and 210 amplifier tube:

- 1—No. 383 Pilot output choke
- 1—No. 9302 2. mfd. Pilot filter condenser
- 2—Pilot Bakelite binding posts

You can put a 171 tube in your old set, add these parts, and get a big improvement in the volume and quality as well.

IN THE NEXT ISSUE

Watch for important news on the double grid tube and on short wave telephone equipment. Subscribe now, and the next issue will be mailed to your home.

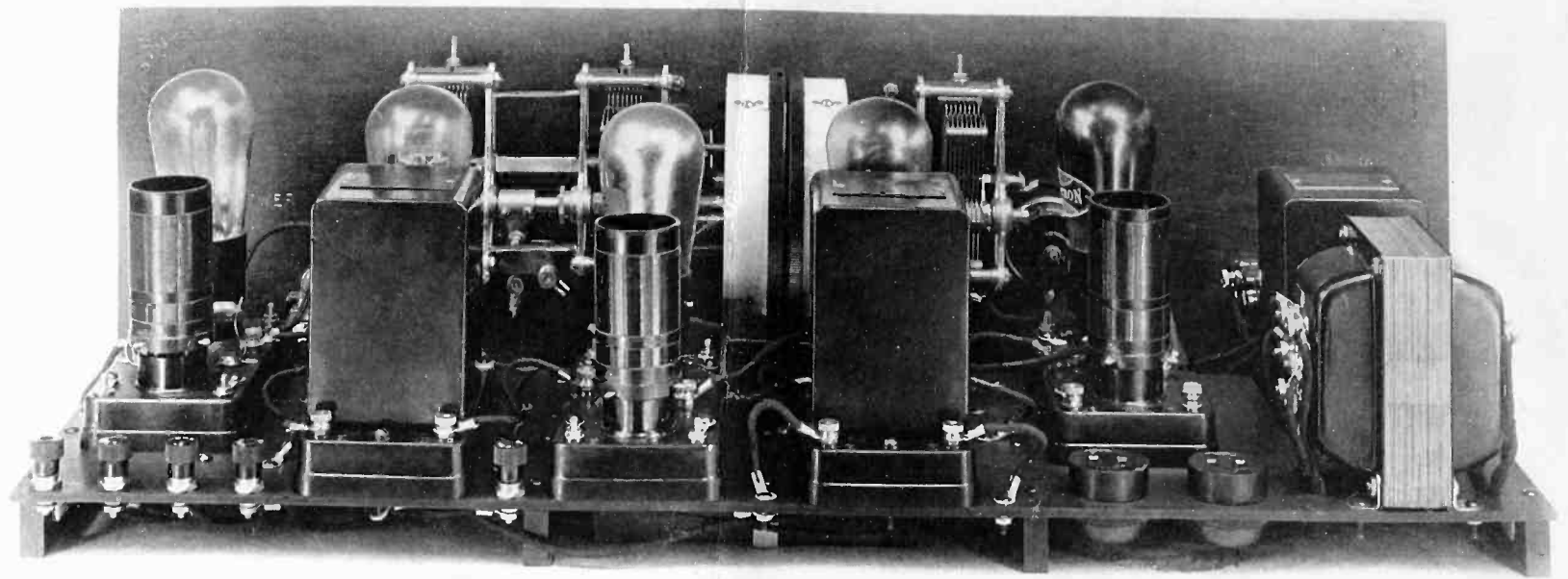

See what a clean-cut and compact appearance the Redi-Blox give to the Air Scout A.C. operated receiver

AIR SCOUT—PERFECTED A.C. SET

Designed Specifically for UX-226 and UY-227 A.C. Tubes & by David McAn

WHEN you build a motor to operate on gasoline, you don't follow the methods used to design kerosene engines.

Nor should you tackle the job of planning an A.C. tube set as if it were to use ordinary storage battery tubes.

That's obvious enough when you see it on paper, yet most radio designers have been doing that very thing, and blaming the A.C. tubes when the sets didn't produce satisfactory results.

Now, thanks to the application of a little more intelligent method of approaching the problem, you can build an A.C. tube set,¹ operating entirely from the 110 or 220-volt² house current supply, that will give you results that you will call perfect.

It isn't a regular battery operated set

¹ Full-size Official Data Prints, showing set and complete power equipment, can be obtained from A. L. Farris, 620 Riverside Drive, New York City. \$2.00 postpaid.

² 220-volt equipment can be supplied for South America and other locations. The frequency must be 50 to 60 cycles. 25 cycle supply cannot be used.

just made over. The entire job is new, including the A, B, and C supply equipment.

NEW REDI-BLOX FOR AIR SCOUT

The first models of the Air Scout were made with all the individual parts assembled on a base board.

Then someone got the idea of changing the original Redi-Blox so as to use them in one of the models.

This Redi-Blox set was so much better, and so very much easier to wire that, then and there, it was decided to re-design the Redi-Blox. Accordingly, you will find in this issue of Radio Design descriptions of the new universal R.F. Redi-Blox, taking all types of tubes, and the new UY-227 detector unit which was added because it wasn't possible to make one type serve for both the UY-227 and storage battery tubes.

The arrangement of the units on the base panel is quite different from the SP-5, described in the last issue of Radio Design.

It was found that the magnetic field around the coils was much greater with

the A.C. tubes than with 199's, probably because of the greater plate current travelling thru the primaries.

However, that was easily overcome by spacing the units farther apart. The wiring is so simple in this set that no complications were introduced.

In fact, the arrangement worked out very nicely, because the detector output comes over at the right, adjacent to the jack for a phonograph pick-up, and the output for the last tube is on the left, next to the A.F. choke and condenser.

A AND C SUPPLY GREATLY SIMPLIFIED

An entirely new transformer was designed to light the filaments. This furnishes 1½, 2½, and 5 volts A.C. One type works from a 110-volt line, and the other from 220 volts.

Under the base panel is a new double resistance of 450 ohms in each section. This provides the 4½ and 9 volts bias. Another resistance, of 2,250 ohms, gives the 40 volts for the grid of the 171 tube.

Two by-pass condensers, of 1 mfd., are also clamped beneath the base panel.

Thus, the A and C supply is formed into a compact unit hardly noticeable on the set. On the other hand, if the A and C equipment were put together as a separate unit, eight additional binding posts would have been required.

A.C. LINE CONTROLLED FROM PANEL

Another advantage in the arrangement is that the A.C. line can be switched on from the front panel. If you are using a floor plug for connection, you don't have to crawl under the cabinet or table to switch on and off.

At the back of the base panel are two receptacles, one to plug in the A.C. line, and the other to plug in the B power pack. Connections are made within the set from the A.C. to the filament transformer.

A direct connection runs from the A.C. to the toggle switch.

Most designers specify that the leads carrying A.C. must be twisted together. On the Air Scout all the wires are so short and direct that this is not necessary. However, they must not be run around loosely under the panel

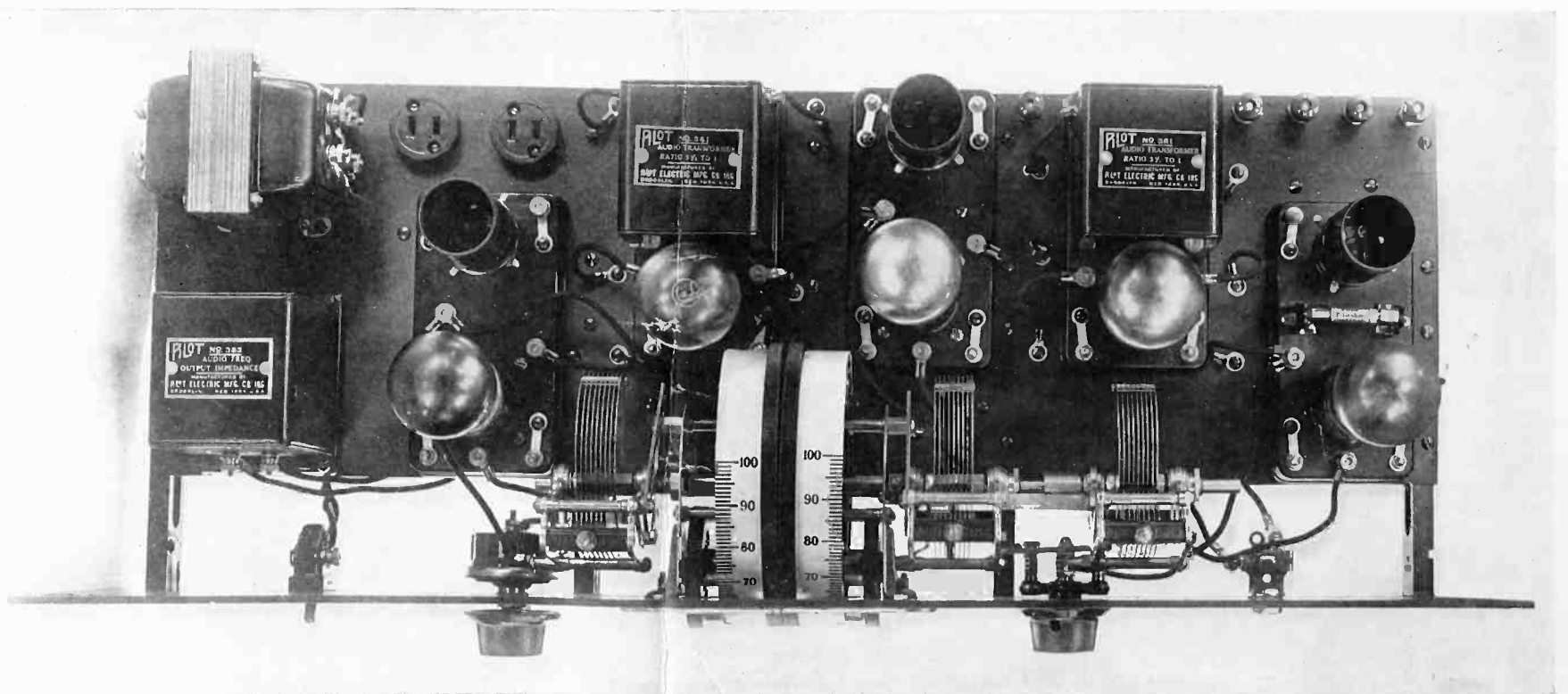

Strong and sturdy, dependable for continuous operation, but less expensive to buy than most battery tube kits

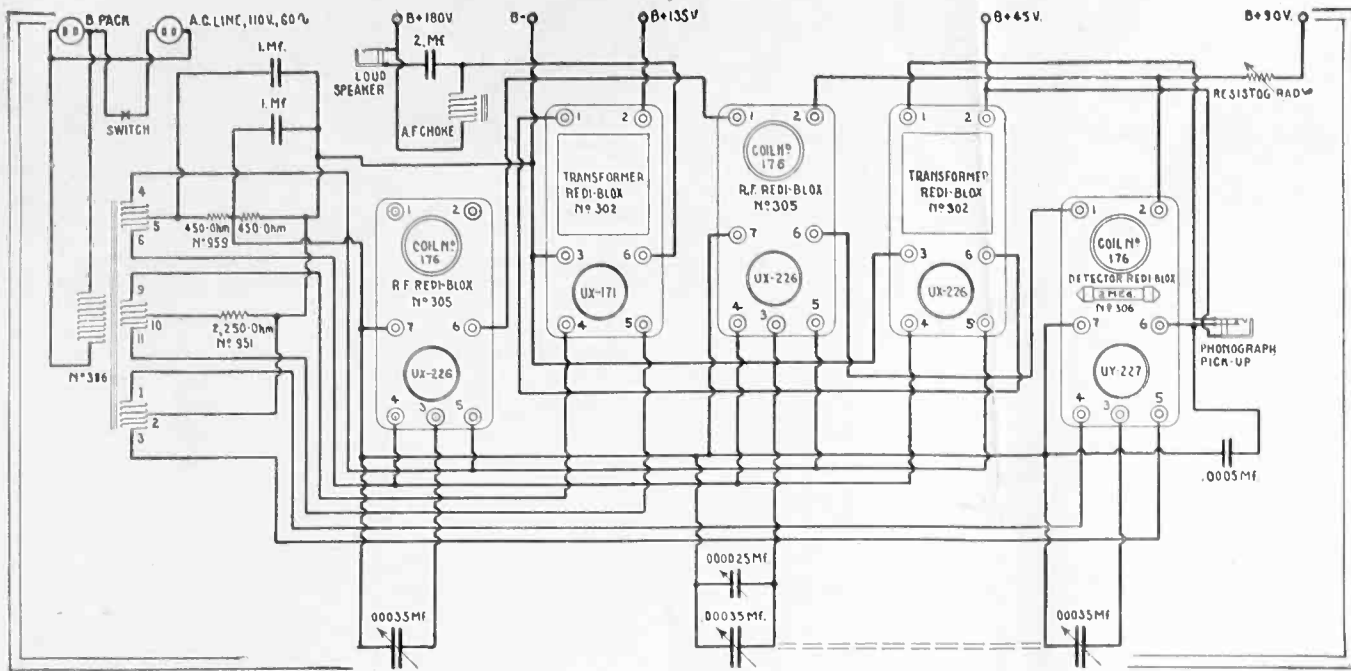

This diagram may appear complicated, but there is little wiring on the set itself

B POWER PACK IS NEW

The Air Scout also called for a new B power pack. This improved type, No. 5, is similar in appearance to the No. 10, altho it has a different power transformer and the hook-up had been changed.

The No. 5 pack can use either a BH Raytheon or a UX-280 rectifier, according to your particular preference. Figs. 3 and 4, on page 13, show the two circuits.

You will notice that the A.C. supply on the Raytheon unit is connected to primary binding posts 7 and 8, while on the UX-280 unit it goes to 7 and 9.

That is because, to produce the same output voltage, a slightly higher voltage must be applied to the Raytheon.

Of course, the No. 5 B power pack can be used on all types of sets, A.C. or battery operated, for it has a feature not found on any other type of eliminator.

That is, binding posts are provided for 180 and 220 volts. On the Air Scout, the B+ amplifier is connected to B+ 220 volts on the power pack. However, only 180 volts are actually applied to the UX-171, for 40 volts are taken for the C bias.

When the No. 5 kit is used as a plain B supply, with no C voltage taken from it, the B+ amplifier on the set is connected to B+ 180 on the power pack.

AIR SCOUT TUNING SIMPLIFIED

It is much easier to tune the Air Scout than most battery sets.

The A.C. is switched on, and about 15 seconds allowed for the tubes to warm up. The equivalent of single-control tuning is afforded by the Pilot double vernier drum dials. You simply put your thumb on both dials at the same time.

PARTS LIST FOR AIR SCOUT

Here is the complete, Official parts list for the Air Scout receiver, as it is furnished in kit form:

- 2—No. 305 Pilot R.F. Redi-Blox
- 1—No. 306 Pilot UY-227 detector Redi-Blox
- 2—No. 302 Pilot transformer Redi-Blox
- 3—No. 176 Pilot plug-in coils
- 1—No. 1617 Pilot .00035 mfd. condenser
- 1—No. 1617-2 Pilot double .00035 mfd. condenser
- 1—No. 1281 Pilot double vernier drum dial
- 1—No. J-7 Pilot midget condenser
- 1—No. 350 Pilot Resistograd
- 4—No. 35 Pilot 1-in. Bakelite brackets
- 1—No. 166 Westinghouse Micarta panel, drilled and engraved, 7 by 24 ins.
- 1—No. 167 Westinghouse Micarta panel, drilled, 7 by 23 ins.
- 1—No. 756 Pilot 2-meg. grid leak
- 2—No. 276 A.C. line receptacles
- 1—No. 42 Pilot toggle switch

- 1—No. 383 Pilot output choke
- 1—No. 1165 Pilot jack
- 1—No. 386 Pilot filament lighting transformer (for 110 volts A.C., 60 cycles)
- 1—9302 Pilot 2 mfd. condenser
- 2—No. 801 Pilot 1 mfd. condensers

- 1—No. 52 Pilot .0005 mfd. fixed condenser
- 1—No. 951 Pilot resistor, 2,250 ohms
- 1—No. 959 Pilot double bias resistor
- 1—No. 722 set of Pilot binding posts
- 1—No. 725 set of Pilot flexible leads
- 1—Box of screws, hardware, etc.

X-11 HAS SUPER-CHARGER

Important Change Increases DX

THE results from the X-11 receiver are equal in range, volume, selectivity, and quality to any standard construction kit selling for seventy-five dollars. The cost of the X-11 is less than a third of that amount.

Put the X-11 in a cabinet, and you have a better outfit than any commercial receiver that sells for a hundred and fifty dollars.

Connect the X-11 to a high-quality loudspeaker—we recommend the Orthophonic horn made by the MOLDED WOOD PRODUCTS COMPANY, with a Baldwin unit—and you will get quality reproduction that is not excelled by any set at any price.

That's an honest description of the X-11.

No circuit has ever been invented that can achieve X-11 results at anywhere near X-11 cost.

NOW THE R.F. SUPER-CHARGER

Now comes the new X-11¹ fitted with a control absolutely new to radio—the R.F. Super-Charger, for greater DX reception.

Connections for this control are shown in the diagram below, and in the second edition of the Official Dataprints.

The R.F. Super-Charger means to DX

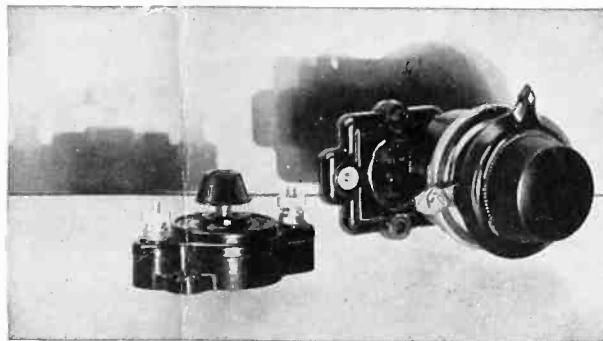

Above: New parts used to double range of X-11
Below: Complete X-11 circuit showing connections for R.F. Super-Charger, and polarities of X-11 coils

reception what an intake super-charger means to high-altitude flying—more miles!

When one plane reaches its altitude limit, another plane, fitted with a super-

charger on the engine, keeps on sailing upward—miles beyond.

So it is with a radio set. For ordinary reception, the ordinary methods of neutralizing are good enough. It's when you want to step out that the R.F. Super-Charger comes into play—and how! It makes miles and miles of difference.

You understand that the range of your set is limited to what can be made to operate the first tube. So, the R.F. Super-Charger puts the first tube right up to the peak of sensitiveness, making it vastly more responsive than is possible in the usual roughly neutralized condition.

As a result, our laboratory model of the X-11 is now covering 2,000 miles regularly. In New York, it can be depended upon to bring in Chicago, and with local volume as soon as New York stations close down. This assures dance music in the Eastern time division up to 2.00 a.m.

IMPORTANT NOTES

There are certain precautions which must be taken in assembling the X-11. If these are observed, the X-11 will equal in results any battery-operated set, excepting only some of the super-heterodynes, and surpass the efficiency of receivers using A.C. tubes.

1. Follow the exact mechanical arrangement in the Dataprints. If you want to reduce the length of the front panel, keep the condensers and coils spaced exactly as shown, but move the amplifier to the rear of the coils.

2. Mount the coils with terminal 1 on the R.F. coils upward, and have 1, 2 and 3 on the detector coils upward.

3. Then make connections to the numbered terminals exactly as shown in the diagram. Otherwise, the R.F. Super-Charger and regeneration control will not function properly.

4. The .0001 mfd. condenser in the antenna lead may or may not improve reception, depending upon the particular antenna you are using. Sometimes a PILOT VM-81 Micrograd, with a maximum capacity of .0005 mfd. works better, and corrects any tendency for the dials to read unevenly.

5. Try reversing the antenna and ground leads. Different locations give different results.

6. If your loudspeaker seems to be overloaded at full volume, use an output device, as shown on page 11 of this issue.

The X-11 is strictly a battery-operated receiver. A well-designed B eliminator will operate successfully for the B supply, but it is not possible to change the tubes for A.C. filament supply without sacrificing efficiency.

Use the X-11 in the proper way, and you'll not only get by far the greatest value from your investment, but such value that you won't swap your X-11 for any other receiver regardless of the price.

¹ New issue X-11 model B Official Data-prints, \$1.00 postpaid. A. L. FARRIS, 620 Riverside Drive, New York City.

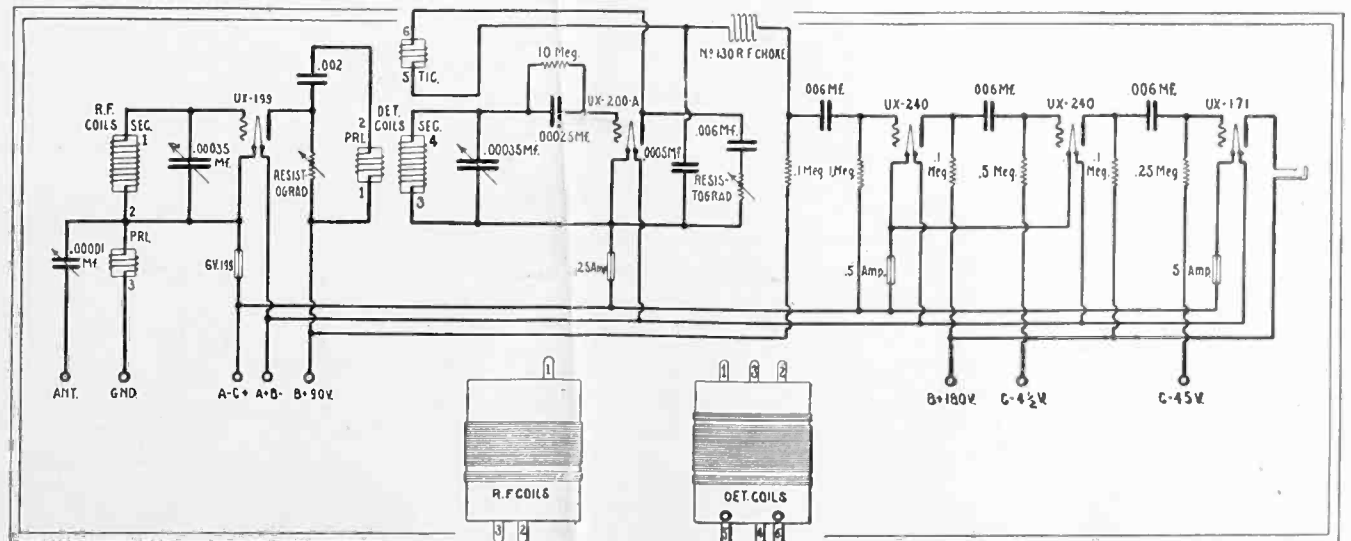

SIMPLE SET FITS PHONOGRAPH

*Single-Tube Set, Three-Tube Set, or Pick-up Amplifier,
to Fit Phonograph Cabinet & by U. K. Kronin*

SO great has become the popularity of the phonograph pick-up for reproducing records electrically, that RADIO DESIGN has built a special set for that purpose, in response to requests from readers.

To make the design as universal as possible, the set was divided into two parts—the tuning unit and the amplifier unit.

The tuning unit, mounted on a front panel 6 ins. wide, makes a very fine one-tube receiver, and can be used by itself for that purpose.

A three-winding coil from a set of X-11 coils is used for tuning, with a No. 1617 variable condenser controlled by a Pilot Art Dial. Regeneration, giving extremely sensitive and sharp tuning, is regulated in a manner similar to that of the X-11 set.

This is practically a single-control set, with the dial for tuning and the Resistograd for volume. A toggle switch, on the front panel, turns the detector tube on and off.

The fixed by-pass condensers, rheostat, and binding posts are mounted on the

- 1—Pilot lamp bracket, No. 43
- 1—Pilot Bakelite toggle switch, No. 42
- 2—Pilot 1-in. Bakelite brackets, No. 35
- 1—Pilot 30-ohm rheostat, No. 930
- 1—Pilot .00025 mfd. condenser, No. 51M
- 1—Pilot .0005 mfd. condenser, No. 52
- 1—Pilot .006 mfd. condenser, No. 58
- 1—Pilot 2-meg. grid leak
- 7—Pilot engraved Bakelite binding posts
- 1—Westinghouse Micarta 7 by 12-in. panel

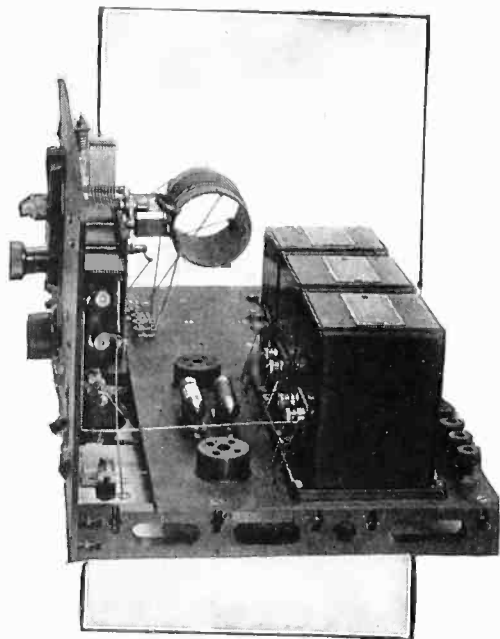

As shown in the diagram below, this set is made in two units. The detector can be used alone as a one-tube receiver, the amplifier can be added to make a three-tube set, or the amplifier used alone for a phonograph pick-up. Again, both units can be mounted in the phonograph, to be used for radio reception, and the pick-up plugged in when desired.

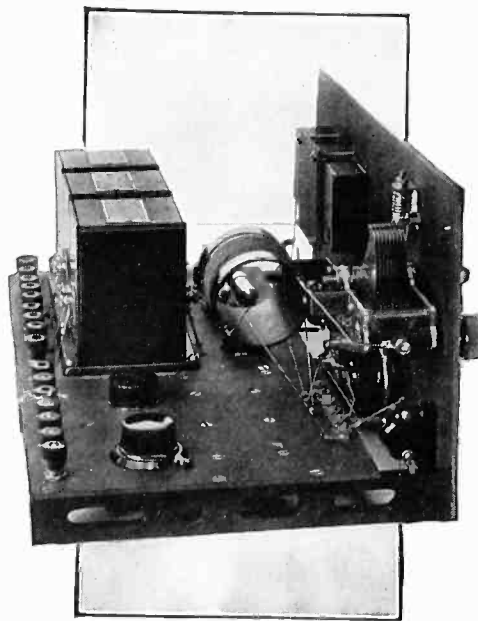

Later, the two-stage audio amplifier can be added to form a sensitive set capable of the very finest reproduction.

The amplifier, too, can be used alone as a phonograph pick-up amplifier. On the front panel, which is 8 ins. long, there is a jack to plug in the pick-up, and another for the loudspeaker. There is a complete set of battery binding posts at the rear.

Again, the two units can be built as one, and mounted in a phonograph cabinet, for the length has been kept down to 14 ins., just right for that purpose.

When only the loudspeaker is plugged in, radio signals can be received. Without any changes or switching, the radio end is disconnected merely by plugging in the pick-up. Then the outfit is ready to reproduce phonograph records.

The two photographs and the schematic wiring diagram show the details of the set.

base panel. The base panel measures 7 by 6 ins., and is mounted on 1-in. Pilot Bakelite brackets.

You can add considerably to the appearance of the set by putting a panel light bracket at the rear, with a bulb to shine thru a 1/2-in. hole in the front panel. This puts a soft light on the transparent celluloid disc of the dial.

NOTE: The six terminals of the tuner are numbered in the schematic diagram. These numbers refer to the lugs as shown in the illustration on page 17. Be sure to have these connections right, or the set will not operate properly.

Following is a list of parts required for the tuning unit:

- 1—Twin Coupler X-11 coil, No. 131
- 1—Pilot Centraline condenser, No. 1617
- 1—Pilot Resistograd, No. 350
- 1—Pilot socket, No. 205
- 1—Pilot Art Dial, No. 1278

This amplifier unit has all the features of a high-quality job—Pilot Giant transformers, an output device comprising a heavy A.F. choke and 2 mfd. condenser, and provisions for biasing the tubes so that a 171 or 210 can be used in the last stage.

Automatic filament controls are specified, since there is no need for a rheostat. Each tube has its own filament control, for the same amount of current is not drawn by both tubes.

On the front panel, measuring 7 by 8 ins., there are the two jacks and a filament toggle switch.

The base panel is also 7 by 8 ins., carried on two Pilot 1-in. Bakelite brackets. You will see that the front and base panels can be cut from a 7 by 18-in. panel, as there is no standard size 7 by 8 ins.

When the amplifier only is in use, the detector tube can be turned out by its own filament switch, to save the storage battery.

The parts required to construct the amplifier unit are:

- 2—Pilot Giant A.F. transformers, No. 381
- 1—Pilot A.F. impedance, No. 383
- 1—Pilot 2 mfd. filter condenser, No. 9302
- 1—Pilot Bakelite toggle switch, No. 42
- 2—Pilot midget jacks, No. 1165
- 2—Pilot sockets, No. 205
- 9—Pilot Bakelite engraved binding posts
- 2—Pilot 1-in. Bakelite brackets, No. 35
- 1—.5-amp. filament control
- 1—.25-amp. filament control
- 1—Westinghouse Micarta 7 by 18-in. panel

The amplification obtainable from this unit will give considerable more volume than the phonograph itself, and much finer reproduction, particularly since the scratch of the needle is not amplified.

As a radio receiver, the tuning is sharp enough to overcome most interference, and the range well over 1,000 miles under average circumstances.

And the price—that can be mentioned last because, since Pilot parts are used, it is low enough to be thought of last—the price of the parts is less than half the cost of other kits which are sold for the same purpose.

RADIO AMATEUR'S HANDBOOK

Radio Amateur's Handbook,¹ by F. E. Handy, published by American Radio Relay League, Hartford, Conn. 217 pages, about 200 illustrations, \$1.00.

The A. R. R. L. has done amateur radio a great service by putting in one cover the information required by those who are or want to become operators of transmitting stations.

Within the writer's personal experience, there have been many radio enthusiasts who, after getting up their interest in going on the air, have quit before they started just because the necessary information was not available.

This Handbook makes a splendid supplement to QST Magazine, too, as it serves as a starting point for such QST articles that, to the beginner, seem to start in the middle of things.

The author, F. E. Handy, as Communications Manager of the A. R. R. L., certainly ought to understand what transmitting amateurs should know, and has presented this material in a most complete and orderly manner.

From this book you will learn about the code and message forms, regulations governing operators' and station licenses, and the general routine of operating a station as it should be done.

Then come very complete instructions about the equipment, covering antennas and grounds, the receiver and transmitter, power supplies, and the elimination of interference. A separate chapter explains the use of the wave-meter and other measuring devices required.

And written right thru the book is that spirit of enthusiasm which inevitably grips the transmitting amateur as he reaches out not merely across the United States, but over mountains and oceans to fellow operators in every civilized country, for there seems to be no limit to the range of the new short wave receivers and transmitters of which there are now over 17,000 in the U. S. A. alone.

If you think you have just about exhausted the possibilities of experimental radio, get a copy of Handy's Handbook, and you'll find an entirely new and much wider field opening up before you.

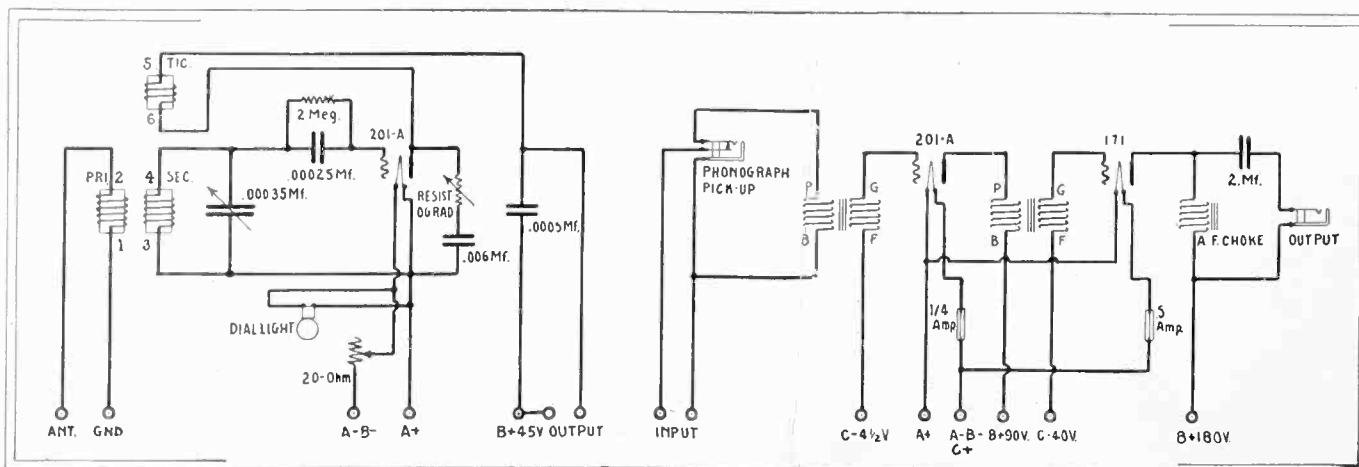

Here is a one-tube set or three-tube set, a pick-up amplifier, or a combination radio set and pick-up amplifier for the phonograph cabinet—any one of these four things, according to the way you build it.

¹ This book will be mailed to you postpaid if you will send \$1.00 to Radio Design, Book Department, 103 Broadway, Brooklyn, N. Y.

SPEED

A CORPORATION
FOR RADIO BUILDERS SUPPLIES

Immediate Delivery

- AIR SCOUT KIT
- No. 4 A POWER PACK
- No. 5 B POWER PACK
- X-11 KIT, New Model
- SHORT WAVE SET

Radio Set Builders

If you cannot obtain these parts from your local dealer, write for prices on these Kits, shipped postpaid in U. S. A. or Canada by return mail.

SPEED can supply all Pilot and Twin Coupler parts specified in Radio Design.

SPEED 103 Broadway, Brooklyn, N.Y., U.S.A.

A.L. FARRIS



620 Riverside Drive, New York City, U.S.A.

New M. B. Sleeper OFFICIAL DATA PRINTS

PILOT AIR SCOUT

All details of set and power packs for A.C. tube installation . . . \$2.00

X-11, MODEL B

New X-11 with R. F. Super-Charger for extreme distance . . . \$1.00

SHORT WAVE SET

Receiving range over 10,000 miles, cheapest set to build . . . \$1.00

VICTOREEN SUPER

Newest Design, built with Victoreen and Pilot parts . . . \$1.00

SILVER-MARSHALL SUPER

Save half the cost. S-M and Pilot parts used in this set . . . \$1.00

All Data Prints Sent Postpaid

JUST OFF THE PRESS

MERLE DUSTON'S

A.C. MANUAL

SET BUILDERS GET THIS COMPLETE BOOK ABOUT BUILDING ALL TYPES OF SETS USING LATEST A.C. TUBE HOOK-UPS NEWEST OFFICIAL DATA ON SUCCESSFUL CONSTRUCTION

PRICE 50¢ POSTPAID

DUSTON RADIO LABORATORIES
DETROIT, MICHIGAN

B PACK SAVES A AND C

Eliminate 40-Volt C Battery, Save A, Too

IT never seems right to use a big, 40-volt C battery on a set, along with a B eliminator. In fact, it isn't right or necessary if you have a No. 10 Pilot B power pack, or the new No. 5 type.

The power transformer in this kit has a 5-volt winding that can be used to run the filament of a 171 tube, when a BH Raytheon is employed for rectification.

Also, there is a simple way to get the 40-volt bias from the eliminator, if you will carry out the following instructions.

No matter what type of set you have, as long as it can use a 171 tube in the last stage, the method is the same.

Disconnect the two filament leads to the 171 socket, and cut them off so that they will not get loose and cause trouble.

Run leads from the filament terminals of the socket to two binding posts which should be marked A.C. 5 V.

Next, connect the C-40 V. binding post on the set to the B- post on the set. If the set has a binding post for bias on the last tube, but marked for some different voltage, connect it to B- just the same.

The diagram for the B pack is given below. This hook-up is for the No. 10 kit, but applies to the new No. 5 kit as well.

In the No. 10 kit the 2,250-ohm resistance is supplied, but not with the No. 5. In either case, it must be inserted in the lead from the center tap on the filament winding to the B- post on the eliminator.

Then connect the power pack to your set in the ordinary manner, and run leads from the 5-volt supply on the power pack to the two binding posts you have put on the set. Use the 220-volt binding post, for 40 volts will go for C bias, leaving 180 volts for the plate of the 171 tube.

Turn on the switch, and the pack will light the 171 and furnish the 40 volts C bias, as well as the B voltages - a very simple way to get rid of the big C battery and to cut down the drain on the A battery by .5 ampere.

If you want to know how the 2,250-ohm resistance provides the C bias, here is the explanation:

The plate current, traveling in the opposite direction from the electron flow, goes from B+ on the eliminator to the plate, across to the filament, thru the filament transformer winding, out at the center tap, thru the 2,250-ohm resistance, and to B- on the eliminator.

Since the plate current thru the resistor is .018 ampere, there is a voltage drop across the resistor, according to Ohm's Law, of

$$E = I \times R$$

$$\text{or } E = .018 \times 2,250$$

$$E = 40.5 \text{ volts}$$

You have connected the grid return from the 171 tube to B-, or the negative side of the resistance. The filament is connected to the positive side of the resistance.

Therefore there is a potential difference of 40.5 volts between the grid and filament because of this resistance, serving just as effectively as a biasing battery.

Actually, this is better than a battery, for this biasing method adjusts itself automatically to the voltage, or current, in the tube.

If the voltage drops, the current thru the tube drops also, and the voltage on the grid of the 171 is reduced accordingly. In this way the value of the bias automatically adjusts itself to the plate voltage.

NOTE: This same method for obtaining C biases is employed to give 4½, 9, and 40 volts for the tubes in the Air Scout receiver, but for practical construction reasons the bias resistances are mounted, with the by-pass condensers, on the base panel of the set itself, where they are closely adjacent to the filament lighting transformer.

For that reason, no bias resistances are supplied with the new No. 5 B power pack kit, but are furnished with the No. 4 A power kit. However, when the No. 5 is used on storage battery sets, the 2,250-ohm resistor can be added and used in the manner described if you want to save the C battery and reduce the drain on the A battery.

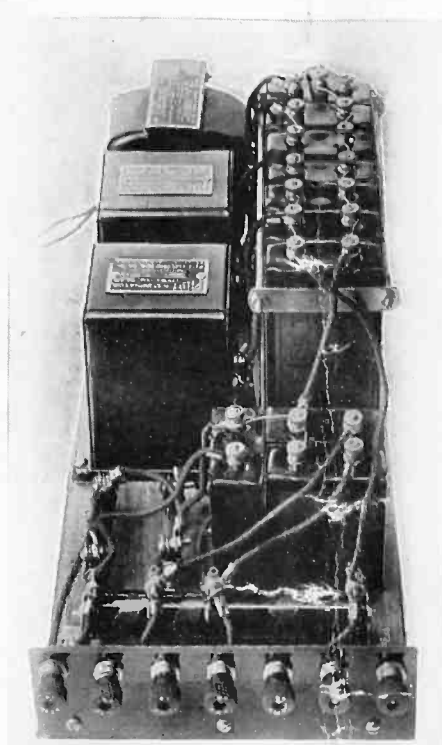

This No. 10 Kit, or the new No. 5 Pilot Kit can be used in the manner described.

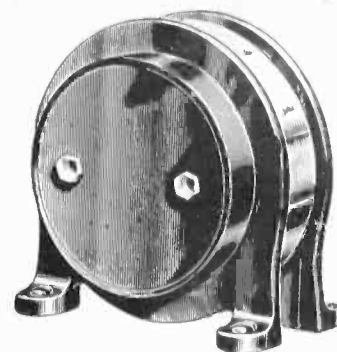

Magnaformer

INTERMEDIATE LONG WAVE TRANSFORMER

The Supreme Coil of Coils for the Supreme Circuit of Circuits

Every one completely made and PRECISELY peaked in our own Laboratory, by Laboratory methods, to EXACTLY 4300 meters—the most efficient wave length.

So solidly constructed that wave length cannot possibly change.

Being Precisely and Unalterably peaked they provide perfect resonance for every R. F. stage.

Perfect resonance insures perfect tone quality, extreme quietness of operation, the utmost maximum of sensitivity; therefore greatest possible selectivity, distance and volume.

Send for special circular giving records.

RADIART LABORATORIES CO.
19-A So. LaSalle St. Chicago, Ill.

TWIN COUPLER

Twin Coupler Coils are sold in KRESGE, KRESS, GRANT, and other stores thruout the U. S. A., Canada, and foreign countries



Largest Radio Coil Manufacturers in the United States

GENERAL OFFICES AND FACTORY
TWIN COUPLER CO., INC.
POUGHKEEPSIE · NEW YORK

LOOK HERE!



RADIO DESIGN

FOUR ISSUES COST

25¢

RIGHT NOW SUBSCRIBE. USE BLANK BELOW. SAVE MONEY. BE SUCCESSFUL. LET RADIO DESIGN GUIDE YOU.

RADIO DESIGN:
103 Broadway, Brooklyn, N. Y.
Here's my quarter for four issues.

Name _____
Street _____
City _____ State _____

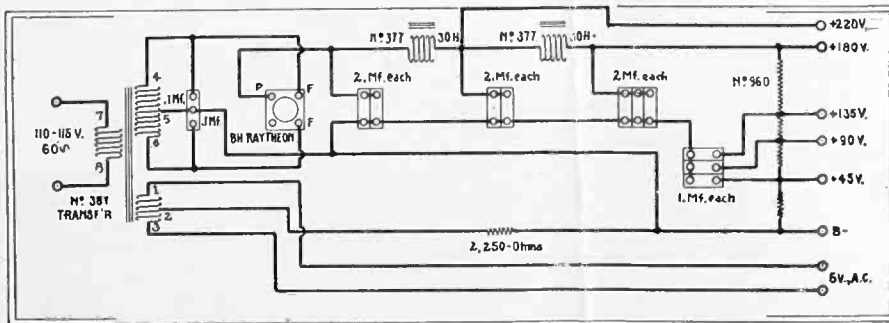

This diagram shows a BH Raytheon, because the UX-280 has to be run from filament winding 1, 2, 3

Published on Oct. 15, Dec. 15, Feb. 15, and April 15, by Radio Design Pub. Co., 103-C Broadway, Brooklyn, New York, A. H. Ghirardi, Editor, M. B. Sleeper, Technical Editor. Price 10c. per copy. 25c. annually. Application for entry as second-class matter, Jan. 5, 1928. Copyright, 1927, and application for registry of title as a trade mark by Radio Design Pub. Co., made Aug., 1927.

NEXT ISSUE—OFFICIAL DESIGNS FOR SETS USING DOUBLE GRID TUBES



PILOT - World's Largest Radio Parts Plant

PILOT ELECTRIC M'FG. CO., INC., 323 BERRY STREET, BROOKLYN, N.Y.

NOW BUILD YOUR A.C. SET

These New PILOT Precision Parts Assure Success

A Pack and C Bias for UX-226, UY-227, UX-171 Type No. 4

IF you have a B Eliminator already, just get a PILOT A power pack, and you will be able to operate UX-226 and UY-227 tubes, with a 112 or 171 amplifier tube. The PILOT A pack also furnishes the necessary C biases, making a real A.C. power supply. It is particularly adapted for use with the PILOT B pack. Added to the B pack, it makes a complete ABC supply for A.C. tubes. This unit supplies 1½, 2½, and 5 volts for filament lighting and 4½, 9 and 40 volts C bias.

THE A PACK CONTAINS:

- 1—No. 386 Pilot Filament Transformer
- 1—No. 959 Pilot double bias resistance
- 1—No. 951 Pilot single bias resistance
- 2—No. 801 Pilot 1 mfd. by-pass condensers
- 1—No. 718 Pilot binding post strip
- 1—No. 719 Pilot base board
- 1—No. 723 Set of flexible leads
- 1—Package of wood screws

PILOT Engineers Lead in A.C. Tube Developments

AGAIN, PILOT engineers are months ahead—now in the development of power equipment for sets using UX-226 and UY-227 tubes, with the UX-171 amplifier.

And again successful results have proved the unfailing skill and judgment of these men, for it was their conviction that the circuits which have been employed, and not the A.C. tubes, had been responsible for the failures of others.

They were right. The new PILOT A pack, which lights all tubes and furnishes the C biases, and the B pack supplying all B voltages, is a 100% success.

You can use the B pack on any set, battery or A.C. operated. The A pack and B pack make a complete power supply for all types of A.C. sets.

IMMEDIATE DELIVERY

The entire resources of the PILOT plant have been concentrated on the production of this new equipment, to meet the tremendous demand. Don't wait! Get PILOT parts now.

If your local dealer does not carry PILOT A.C. equipment or the A.C. tubes, write us and we will see that you are supplied at once.

B Pack for Any Tubes with 171 Power Tube Type No. 5

IF you are not ready for A.C. tubes, put a PILOT B pack on your battery operated set. Then, later, by adding the PILOT A pack, you can make it into an ABC pack for A.C. tubes. This unit provides 45, 90, 135 and 180 and 220 volts B. We recommend the BH Raytheon in this power pack, altho there is a 5-volt tap on the transformer to operate a UX-280 tube if desired. This is the only B pack manufactured for both the BH and 280 tubes. Instructions are provided showing complete hook-ups.

THE B PACK CONTAINS:

- 1—No. 387 Pilot B transformer
- 6—No. 9302 Pilot 2 mfd. filter condensers
- 1—No. 9110 Pilot .141 mfd. buffer
- 1—No. 9000 Pilot condenser block clamp
- 2—No. 377 Pilot 30-henry chokes
- 1—No. 960 Pilot B resistance
- 3—No. 801 Pilot 1 mfd. by-pass condensers
- 1—No. 201 Pilot socket
- 1—No. 720 Pilot binding post strip
- 1—No. 721 Pilot baseboard
- 1—No. 724 Set of flexible leads

Pilot AIR SCOUT the Perfected A.C. Kit

Type No. 14 as Described in This Issue of Radio Design

AS a companion to the new PILOT power pack units, PILOT Engineers have developed the AIR SCOUT, the perfected set for A.C. tubes.

In the AIR SCOUT, the radio circuits and the A pack are assembled as a single unit behind a front panel measuring 7 by 24 ins., with an overall depth of 9 ins.

Every detail has been worked out to the last degree, giving maximum efficiency with an amazing simplicity of construction.

The new type Redi-Blox reduce the wiring by more than one-half. No soldered joints are necessary. Tuning is controlled by the handsome PILOT double vernier drum, which gives single control with two-control precision.

A special arrangement permits A and B power to be turned on or off by a switch on the front panel.

The Pilot AIR SCOUT is hum-free, fool-proof, and absolutely dependable.

As for the price—the complete parts, except tubes, for the AIR SCOUT with its self-contained A Eliminator and C bias supply, and the B Eliminator—everything for finest A.C. installation—is less than the price of most battery-operated kits.

Following is a list of parts supplied in the AIR SCOUT Kit:

- 2—No. 305—Pilot R.F. Redi-Blox
- 1—No. 306 Pilot 227 Detector Redi-Blox
- 2—No. 302 Pilot transformer Redi-Blox
- 3—No. 176 Pilot plug-in coils
- 1—No. 1617 Pilot .00035 mfd. condenser
- 1—No. 1517-2 Pilot .00035 mfd. double condenser
- 1—No. 1231 Pilot double vernier drum dial
- 1—No. J-7 Pilot midget condenser
- 1—No. 350 Pilot Resistograd
- 4—No. 35 Pilot Bakelite brackets
- 1—No. 166 Micarta panel drilled and engraved (7 × 2½ ins.)
- 1—No. 167 Micarta panel drilled (7 × 23 ins.)
- 1—No. 756 Pilot 2 meg. grid leak
- 2—No. 276 A.C. line receptacles
- 1—No. 42 Pilot toggle switch
- 1—No. 383 Pilot output choke
- 1—No. 1165 Pilot jack
- 1—No. 386 Pilot filament lighting transformer
- 1—No. 9302 Pilot 2 mfd. condenser
- 2—No. 801 Pilot 1 mfd. condensers

- 1—No. 52 Pilot .0005 mfd. condenser
- 1—No. 951 Pilot 2,250 ohm resistance
- 1—No. 959 Pilot double bias resistance
- 1—No. 722 Set of Pilot binding posts
- 1—No. 725 Set of flexible leads
- 1—Box of assorted screws, hardware, etc.

Add to this set the PILOT B pack, and you have a complete A.C. set installation.

IMMEDIATE DELIVERY

PILOT ELECTRIC MFG. CO., Inc.
323 Berry Street, Brooklyn, N. Y., U. S. A.

Return this coupon with stamp for latest Pilot Catalog showing full line of Pilot precision radio parts. Because produced in world's largest parts plant and sold throughout the world, Pilot parts are world's outstanding radio value.

NAME.....

ADDRESS.....

RD 1-28