

RADIO CRAFT

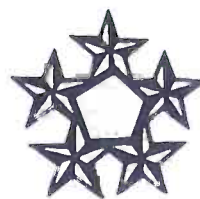

TO THE AMERICAN PEOPLE:

Your sons, husbands and brothers who are standing today upon the battlefronts are fighting for more than victory in war. They are fighting for a new world of freedom and peace.

We, upon whom has been placed the responsibility of leading the American forces, appeal to you with all possible earnestness to invest in War Bonds to the fullest extent of your capacity.

Give us not only the needed implements of war, but the assurance and backing of a united people so necessary to hasten the victory and speed the return of your fighting men.

William B. Leahy
Dwight D. Eisenhower
George C. Marshall
Charles W. Nimitz
Arthur H. S. ...



SEE PAGE 556

ALEX SCHOMBURG

JUNE
1945

25c
CANADA 30c

RADIO-ELECTRONICS IN ALL ITS PHASES

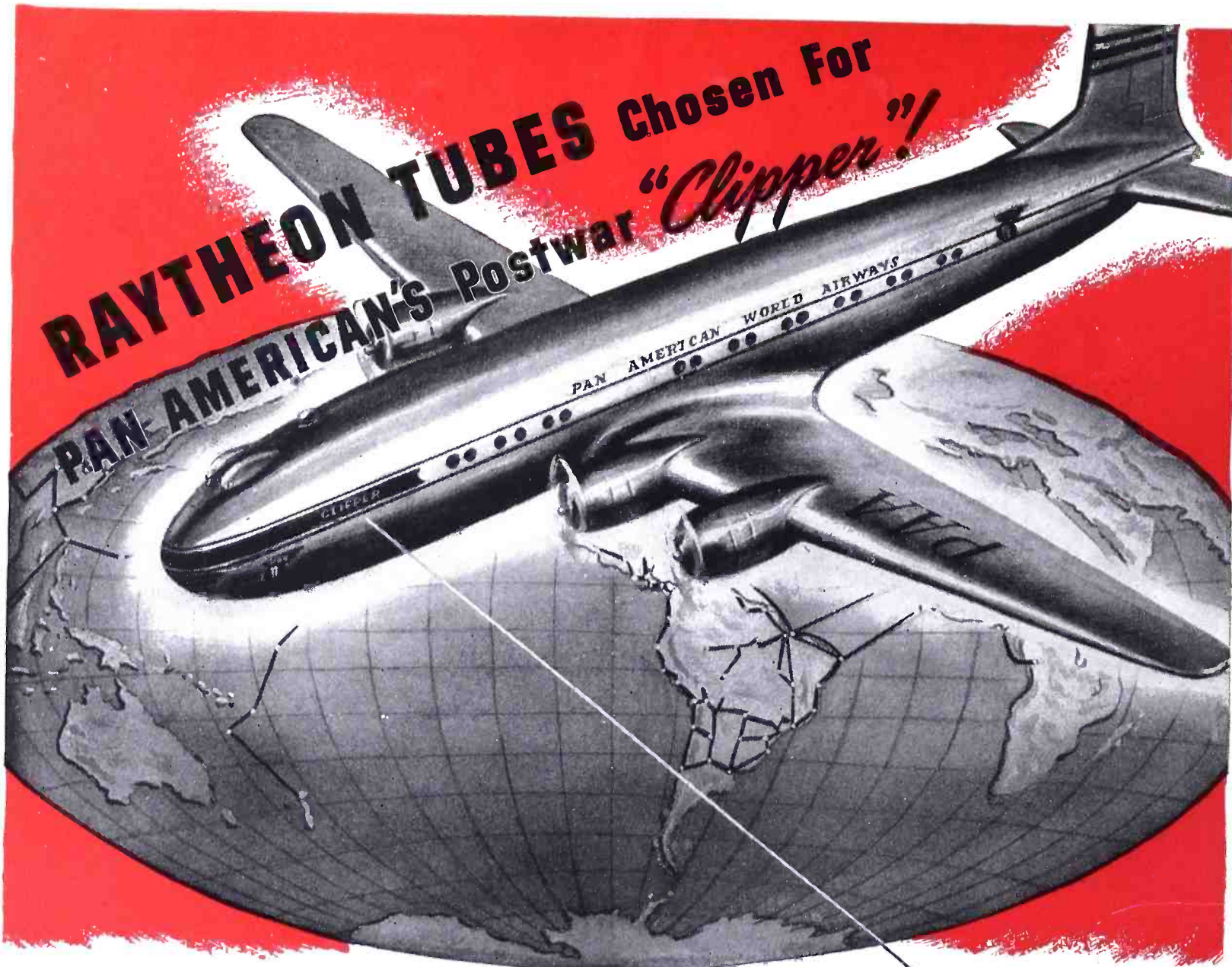

Feast your eyes on this mighty, 100-passenger airliner! When peace comes, a giant fleet of its sister ships will girdle the globe for Pan American World Airways. And in each of them will be the best electronic devices to come out of the war, equipped with famous Raytheon high-fidelity tubes!

Raytheon tubes have been used for years by Pan American, and it is because of their proven performance, fine reception and complete dependability that they were selected to play such a vital role in this great company's future operations. The assignment is but one of hundreds of postwar applications for which Raytheon tubes have been specified by America's radio and electronic industries.

When tubes are more readily available for civilian use, Raytheon will offer radio service dealers the *finest* tubes in its history . . . tubes combining long prewar experience with outstanding wartime development. And that's not all. They'll be backed by a Raytheon merchandising program that will be the most *beneficial* ever offered you. Keep your eye on Raytheon . . . for greater postwar profits!

Increased turnover and profits . . . easier stock control . . . better tubes at lower inventory cost . . . these are benefits which you may enjoy as a result of the Raytheon standardized tube program, which is part of our continued planning for the future.



Raytheon Manufacturing Company

RADIO RECEIVING TUBE DIVISION

Newton, Mass. • Los Angeles • New York • Chicago • Atlanta

RAYTHEON

High Fidelity

ELECTRONIC AND RADIO TUBES



All Four Divisions Have Been Awarded Army-Navy "E" With Stars



Listen to
"MEET YOUR NAVY"
Every Saturday Night
ENTIRE BLUE NETWORK
Coast-to-Coast
181 Stations

DEVOTED TO RESEARCH AND THE MANUFACTURE OF TUBES FOR THE NEW ERA OF ELECTRONICS

A FREE LESSON SHOWED BILL HOW HE COULD MAKE GOOD PAY IN RADIO!



I will send you a Lesson on Radio Servicing Tips FREE TO SHOW HOW PRACTICAL IT IS TO TRAIN AT HOME FOR GOOD JOBS IN RADIO

I want to give every man who's interested in Radio, either professionally or as a hobby, a copy of my Lesson, "Radio Receiver Troubles—Their Cause and Remedy"—absolutely FREE! It's a valuable lesson. Study it—keep it—use it—without obligation! And with it I'll send my 64-page, illustrated book, "Win Rich Rewards in Radio," FREE. It describes many fascinating jobs in Radio, tells how N.R.I. trains you at home in spare time, how you get practical experience with SIX BIG KITS OF RADIO PARTS I send. This "Sample" Lesson will show you why the easy-to-grasp lessons of the N.R.I. Course have paved the way to good pay for hundreds of other men. I will send it to you without obligation . . . MAIL THE COUPON!



Future for Trained Men is Bright in Radio, Television, Electronics
 The Radio Repair business is booming NOW. There is good money fixing Radios in your spare time or own full time business. And trained Radio Technicians also find wide-open opportunities in Police, Aviation and Marine Radio, in Broadcasting, Radio Manufacturing, Public Address work, etc. Think of the boom coming when new Radios can be made! And think of even greater opportunities when Television, FM, Electronics, can be offered to the public! Get into Radio NOW.

Many Beginners Soon Make \$5, \$10 a Week EXTRA in Spare Time
 The day you enroll I start sending EXTRA MONEY JOB SHEETS to help you

make EXTRA money fixing Radios in spare time while learning. You LEARN Radio principles from my easy-to-grasp Lessons—PRACTICE what you learn by building real Radio Circuits with the six kits of Radio parts I send—USE your knowledge to make extra money while getting ready for a good full time Radio job.
Find Out What N.R.I. Can Do for YOU
 MAIL COUPON for Sample Lesson and FREE 64-page book. It's packed with facts about opportunities for you. Read the details about my Course. Read letters from men I trained, telling what they are doing, earning. Just MAIL COUPON in an envelope or paste it on a penny postal.—J. E. Smith, President, Dept. 5FX, National Radio Institute, Pioneer Home Study Radio School, Washington 9, D. C.

Our 31st Year of Training Men for Success in Radio
 My Radio Course Includes Training in TELEVISION • ELECTRONICS • FREQUENCY MODULATION

You Build These and Other Radio Circuits with 6 BIG KITS OF PARTS I SEND YOU!

By the time you've conducted 60 sets of Experiments with Radio Parts I supply, made hundreds of measurements and adjustments, you'll have valuable PRACTICAL Radio experience for a good full or part-time Radio job!

MEASURING INSTRUMENT (above) you build early in Course. Use it in practical Radio work to make EXTRA money. Vacuum tube multimeter, measures A.C., D.C., and R.F. volts, D.C. currents, resistance, receiver output.

SUPERHETERODYNE CIRCUIT (right) Preselector, oscillator-mixer-first detector, i.f. stage, diode detector—a.v.c. stage, audio stage. Bring in local and distant stations on this circuit you build yourself!

A. M. SIGNAL-GENERATOR (left) build it yourself! Provides amplitude - modulated signals for test and experimental purposes. Gives valuable practice!

RADIO RECEIVER TROUBLES THEIR CAUSE AND REMEDY

GET BOTH 64 PAGE BOOK FREE SAMPLE LESSON FREE

MR. J. E. SMITH, President, Dept. 5FX
 NATIONAL RADIO INSTITUTE, Washington 9, D. C.
 Mail me FREE, without obligation, Sample Lesson and 64-page book, "Win Rich Rewards in Radio." (No salesman will call. Please write plainly.)
 Age.....
 Name
 Address
 CityZone.....State.....14X1

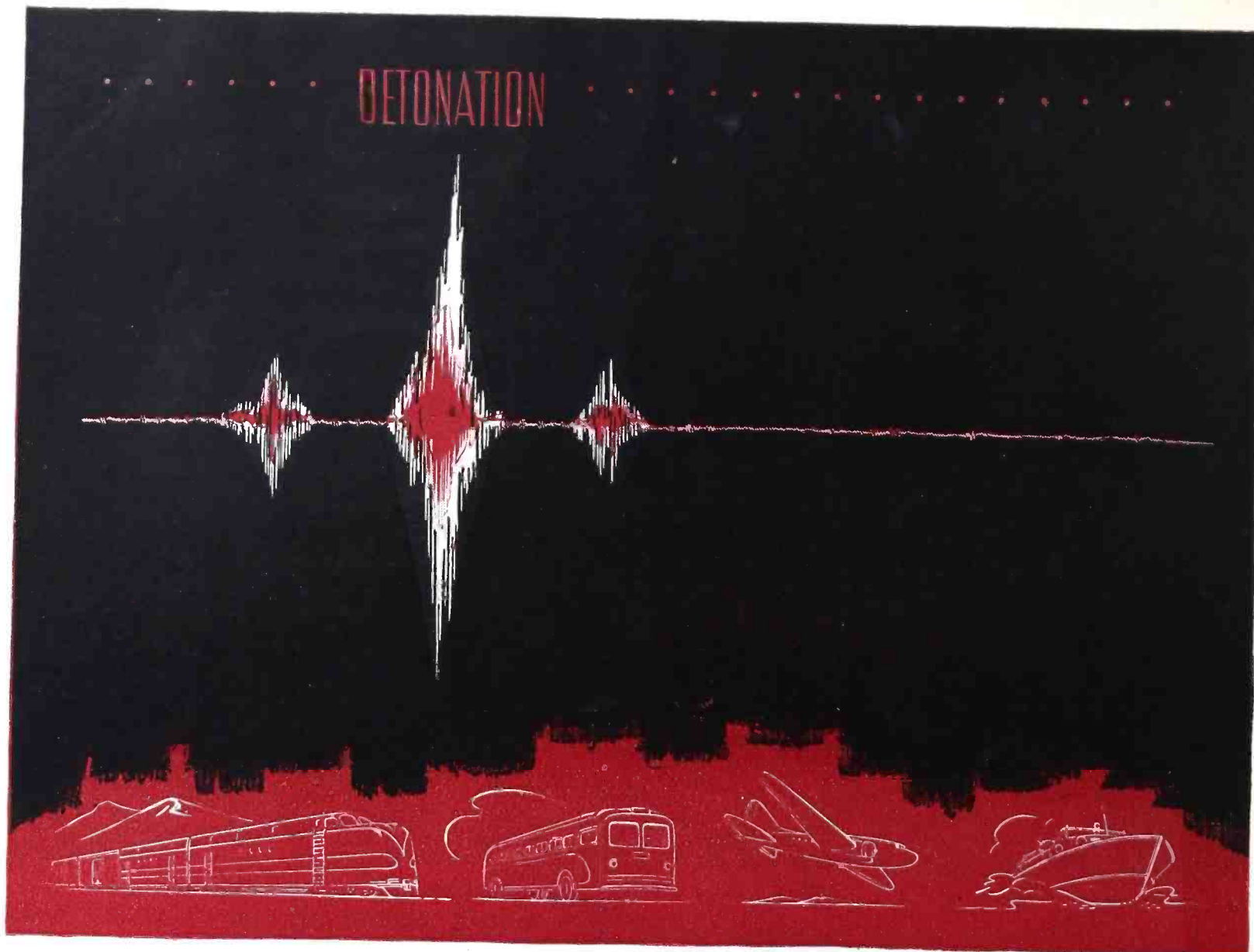

How electronics helps tell a knock from a boost...

THE MIT-Sperry Detonation Indicator is an engine instrument that discriminates between normal and abnormal combustion.

Through an electronic pickup, it *instantly detects detonation*—popularly called knocking or pinging—in most types of internal combustion engines. And it gives *immediate evaluation of detonation*.

As a result, warning is given at the time trouble *starts* . . . engine life is lengthened . . . mixture may be adjusted so that considerable fuel is saved . . . and the period between engine overhauls is extended.

No piercing of engine cylinders is required. Yet even the slightest detonation is signalled visually, and the faulty cylinder or cylinders spotted.

Use of the MIT-Sperry Detonation Indicator on airplanes results in remarkable fuel savings, longer engine life, greater safety.

The same is true of surface transportation which employs internal combustion engines.

Engine manufacturers find this instrument an invaluable aid in designing and testing. It also permits development of fuels exactly fitted to engine characteristics, thus increas-

ing power output and lowering fuel costs. Also with the Knockometer, a special application of the Detonation Indicator, fuels with superior anti-knock characteristics can be developed and their quality production controlled.

Since 1937, Sperry engineers have been working on the perfection of a detonation indicator. This is but one of the many fields in which Sperry has pioneered in the field of electronic development.

Additional information on the MIT-Sperry Detonation Indicator is available on request.

SPERRY GYROSCOPE COMPANY, INC. GREAT NECK, N. Y.



Division of the Sperry Corporation

★
LOS ANGELES • SAN FRANCISCO • SEATTLE • NEW ORLEANS
CLEVELAND • BROOKLYN • HONOLULU

GYROSCOPICS • ELECTRONICS • RADAR • AUTOMATIC COMPUTATION • SERVO-MECHANISMS

I'LL SHOW YOU HOW TO SUCCEED IN RADIO

Here's the right training for Big Post-War Pay!



F. L. Sprayberry, one of the country's foremost Radio Teachers.

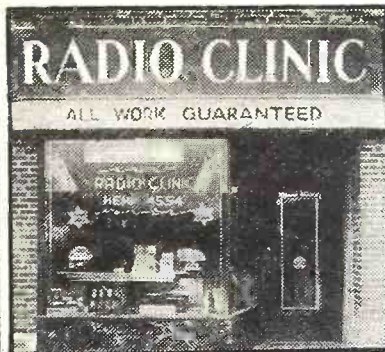

A RADIO SERVICE BUSINESS OF YOUR OWN

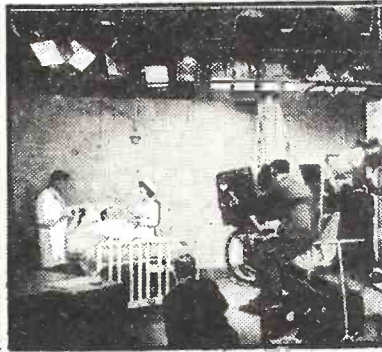

A GOOD JOB IN RADIO & TELEVISION BROADCASTING

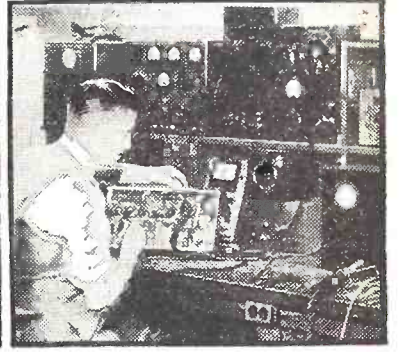

RADIO-ELECTRONIC SERVICE ENGINEER

BE A RADIO-ELECTRONICIAN



I SUPPLY A FULL RADIO SET for practical easy LEARNING

NOW! YOU CAN PREPARE AT HOME IN YOUR SPARE TIME FOR THE AMAZING OPPORTUNITIES AHEAD IN RADIO — ELECTRONICS — TELEVISION

The offer I make you here is the opportunity of a lifetime. It's your big chance to get ready for a wonderful future in the swiftly expanding field of Radio-Electronics INCLUDING Radio, Television, Frequency Modulation and Industrial Electronics. Be wise! NOW'S the time to start. Opportunities ahead are tremendous! No previous experience is necessary. The Sprayberry Course starts right at the beginning of Radio. You can't get lost. It gets the various subjects across in such a clear, simple way that you understand and remember. And, you can master my entire course

in your spare time. It will not interfere in any way with your present duties. Along with your Training, you will receive my famous BUSINESS BUILDERS which will show you how to make some nice profits while learning.

Prepares You for a Business of Your Own or Good Radio Job

My training will give you the broad, fundamental principles so necessary as a background, no matter which branch of Radio you wish to specialize in. I make it easy for you to learn Radio Set Repair and Installation Work. I teach you how to install and repair Electronic Equipment. In fact, you'll be a fully qualified RADIO-ELECTRONICIAN, equipped with the skill and knowledge to perform efficiently and to make a wonderful success of yourself.

Just Out! FREE!

"How to Read Radio Diagrams and Symbols"

... a valuable new book which explains in simple English how to read and understand any Radio Set Diagram. Provides the quick key to analyzing any Radio circuit. Includes translations of all Radio symbols. Send for this FREE book now, and along with it I will send you another big FREE book describing my Radio-Electronic training.

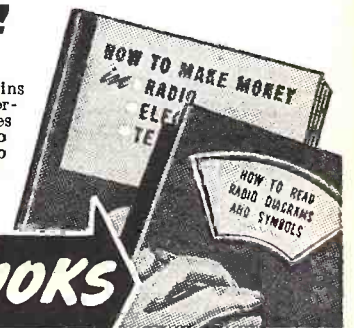

GET FREE BOOKS

SPRAYBERRY TRAINING GIVES YOU BOTH TECHNICAL KNOWLEDGE • SKILLED HANDS

There's only one right way to learn Radio Electronics. You must get it through simplified lesson study combined with actual "shop" practice under the personal guidance of a qualified Radio Teacher. It's exactly this way that Sprayberry trains you... supplying real Radio parts for learn-by-doing experience right at home. Thus, you learn faster, your understanding is clear-cut, you acquire the practical "know how" essential to a good-paying Radio job or a Radio business of your own.

I'll Show You a New, Fast Way to Test Radio Sets Without Mfg. Equipment

The very same Radio Parts I supply with your Course for gaining pre-experience in Radio Repair work may be adapted through an exclusive Sprayberry wiring procedure to serve for complete, fast, accurate Radio Receiver troubleshooting. Thus, under Sprayberry meth-

ods, you do not have one cent of outlay for manufactured Test Equipment which is not only expensive but scarce.

Read What Graduate Says "One Job Nets About \$26.00"

"Since last week I fixed 7 radios, all good-paying jobs and right now I am working on an amplifier system. This job alone will net me about \$26.00. As long as my work keeps coming in this way, I have only one word to say and that is, 'Thanks to my Sprayberry training' and I am not afraid to boast about it."—ADRIEN BENJAMIN, North Grosvenordale, Conn.

DON'T PUT IT OFF!

Get the facts about my training—now! Take the first important step toward the money-making future of your dreams. All features are fully explained in my big, illustrated FREE Catalog which comes to you along with another valuable FREE book you'll be glad to own. Mail Coupon AT ONCE!

SPRAYBERRY ACADEMY OF RADIO

F. L. Sprayberry, Pres.
Room 2065
Pueblo, Colorado

Please rush my FREE copies of "HOW TO MAKE MONEY IN RADIO, ELECTRONICS and TELEVISION," and "HOW TO READ RADIO DIAGRAMS and SYMBOLS."

Name Ago

Address

City State

Tear off this coupon, mail in envelope or paste on penny postcard.

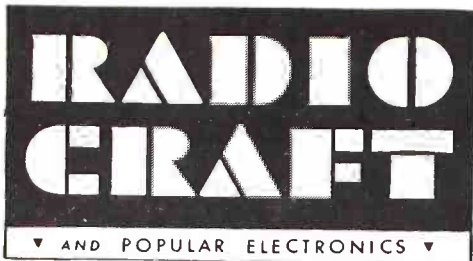

Incorporating
SHORT WAVE CRAFT TELEVISION NEWS
RADIO & TELEVISION

MEMBER
AUDIT BUREAU OF CIRCULATIONS

HUGO GERNSBACK, *Editor-in-Chief*
FRED SHUNAMAN, *Associate Editor*
I. QUEEN, *Editorial Associate*
ELMER FULLER, *Shortwave Editor*
A. PASCALE, *Production Manager*
G. ALIQUO, *Circulation Manager*
JOHN J. LAMSON, *Advertising Director*
ALFRED STERN, *Promotion Manager*

IN THE NEXT ISSUE

Famous Oldtime Circuits
Midget Battery Amplifier
Ohmmeter for Jewell 199
Radio Servicing in Bed
Oscillations in Supers

Published by Radercraft Publications, Inc.
Publication Office: 29 Worthington Street, Springfield 3, Mass.
Editorial and Advertising Offices: 25 West Broadway, Tel. RE2-9690, New York 7, N. Y.
Chicago Advertising Office: Radio-Craft, 308 W. Washington Street, Suite 1413, Chicago 6, Ill. Tel. Randolph 7363.
Cleveland Advertising Office: 405 Erie Bldg., Cleveland, Ohio. Burdette Phillips, Manager. Tel. Main 9645.
Los Angeles Advertising Office: 606 South Hill Street, Los Angeles 14, Calif. Ralph W. Harker, Manager.
New England Advertising Office: 411 Lafayette Street, Salem, Mass. Claude C. Smith, Manager.
San Francisco Advertising Office: 582 Market St., San Francisco 4, Calif. Ralph W. Harker, Manager. Tel. Garfield 2481.
RADIO-CRAFT is published monthly on the 25th of the month preceding that of date. Subscription rates: United States and possessions, Mexico, Central and South American countries, \$2.50 a year, \$4.00 for two years, \$6.00 for three years. Canada, \$3.00 a year, \$5.00 for two years, \$7.50 for three years. All other foreign countries, \$3.25 a year, \$5.50 for two years, \$8.25 for three years. Special rates for members of the Armed Forces in U. S., or those addressed by A.P.O. or F.P.O. mail, \$2.00. Entered at the post office at Springfield as second-class matter under the Act of March 3, 1879. All communications about subscriptions should be addressed to: Circulation Manager, Radio-Craft, 29 Worthington St., Springfield 3, Mass.

Notice of CHANGE of ADDRESS should reach us at least one month in advance. When ordering a change, please furnish an address stencil impression from a recent wrapper if you can. Address changes cannot be made without the old address as well as the new.

Foreign Agents

London—Atlas Publishing and Distributing Co., Ltd., 18 Bride Lane, Fleet St., London, E.C. 4.
Melbourne—McGill's Agency, 179 Elizabeth St., Australia.

Text and illustrations of this magazine are copyright and must not be reproduced without permission of the copyright owners. Copyright, 1945, Radercraft Publications, Inc.

Contents June, 1945 Volume XVI, No. 9

Editorial: Radio-Light.....	by Hugo Gernsback	549
Radio-Electronics Monthly Review.....		550
This Month's Cover.....		556

ELECTRONICS

Air Radio Mechanic.....	by Raymond Lewis	552
Television and the Amateur.....	by Laurence Schwab, Jr.	554
No Selectivity in This Radio.....	by I. Queen	555
"Photopulse".....	by E. Lloyd Thomas	557
FM U.H.F. Converter for Pre-War Radios.....		564
Cathode-Ray Photo Tests.....		572

WAR-TIME RADIO

Handie and Walkie Combat Portables.....		556
---	--	-----

RADIO TRAINING

Tuning on the U.H.F.....	by I. Queen	560
Cathode Followers.....	by O. E. Carlson	562
Disc-Seal Tubes.....	by John Kearney	563
Broadcast Equipment, Part IX.....	by Don C. Hoeffler	566

TEST INSTRUMENTS

An Electronic "Omnichecker," Part I.....	by Robert E. Altomare	558
--	-----------------------	-----

SERVICING

It's the Design!.....	by Louis Hagen	565
Condensers.....	by Jack King	568
Re-activator Saves Tubes.....	by Myron G. Albin	579

CONSTRUCTION

Non-Priority Code Recorder.....	by Bob Melvin	559
32-Volt Receiver for Small Plants.....	by B. W. Embree	567
Fixed-Bias Voltage Supply.....	by F. C. Davis	568
Carry-Around Receiver.....	by Edwin Bohr	588

SOUND

Cylinders for Better Sound.....	by Nathaniel Rhita	561
---------------------------------	--------------------	-----

DEPARTMENTS

World-Wide Station List.....	by Elmer R. Fuller	570
New Radio-Electronic Devices.....		578
Radio-Electronic Circuits.....		580
Question Box.....		582
Try This One!.....		584
Progress in Invention.....	by I. Queen	586
Technotes.....		590
Communications.....		604
Book Reviews.....		607

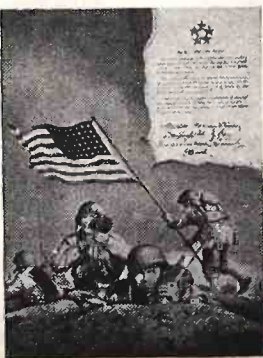

ON THE COVER HOME-FRONT "SINEWS OF WAR"

"Radio-Craft" this month abandons its custom of representing designs of present and future electronic implements of war on its cover, to support the 7th War Loan. More important to the war effort than the most accurate electronic apparatus, the most powerful artillery, are your dollars. You help finish the Nips by subscribing to the 7th War Loan.

"WANT MORE COVERAGE, BABY?
WATCH ECHOPHONE'S PLANS
FOR NEW GADGETS ON THE
CITIZENS' RADIOPHONE BAND"*



ECHOPHONE
"The Ears of the World"

HOGARTH TAKES A PEEK AT THE FUTURE

Hogarth's peek into the future forecasts new heights of popularity for Echophone. There will be Echophone equipment for use on the citizens' radio communication service band. It is certain to be low in price, high in performance and completely dependable. The present EC-1 covers from 550 kc. to 30 Mc. on three bands . . . electrical bandspread on all bands . . . self-contained speaker . . . 115-125 volts AC or DC.

*Citizens' radio communications service band, 460-470 Mc., recently authorized by the F.C.C.

ECHOPHONE RADIO CO., 540 NORTH MICHIGAN AVE., CHICAGO 11, ILLINOIS

SPRAGUE TRADING POST

A FREE Buy-Exchange-Sell Service for Radio Men



CONDENSER-RESISTOR TESTER de luxe!



EVERY basic characteristic of EVERY type of condenser and resistor can be read quickly and accurately on direct reading scales on the Sprague de luxe Tel-Ohmike. Measures capacitance from .000010 to 2000 mfd.; d-c resistance from .5 to 5,000,000 ohms; and insulation resistance to 10,000 megohms. Con-

tains built-in D.C. volt-milliammeter. Power factor and leakage current of electrolytic condensers are read directly. Built-in power supply permits all characteristic measurements under actual working conditions up to 1,000 volts D.C. A "Magic eye" indicator shows bridge circuit balance.

Sprague de luxe Tel-Ohmikes are NOW AVAILABLE to Sprague distributors under W.P.B. Form 3243 or AA-5MRO

WANTED — Standard make combination radio and automatic record player for 10" records. Walter L. Fenska, R.F.D. 1, Box 52, Norfolk, Va.

WILL TRADE—Prevar No. 10 erector set in good condition for first class sig. generator. Vertis Rogers, P.O. Box 1071, Beckley, W. Va.

FOR SALE OR EXCHANGE—Acme SVE 35 mm silent motion picture projector, \$50 —or what radio equipment have you? Want 1D7, 6G6, 35L6, 50L6, and 117L7 tubes for cash. Cleveland Radio Co., Box 271, Cleveland, Miss.

FOR SALE—New Jackson multimeter No. 615; also new tubes in original cartons—80—12SK7, 12SQ7, 25Z6, etc. Paine-Freed Radio Service, 1186 Lexington Ave., New York 28, N. Y.

WILL TRADE—70L7's for 117L7/M7 or 117L7. Also want Hickok traceometer or RCA chanalyst. Ed Laas, 1931 Oakwood Ave., Toledo 7, Ohio.

FOR SALE—Self contained Jensen speaker field supply, supplying 300 v. at 60 mil. Good condition, complete, \$7.50. Also new UTC modulation transformer S-19, \$4.50; and Kenyon C-700 and C-701 filter chokes, rated 165 ma. each, \$3.00 for both. Philip Ross, 280 Wadsworth Ave., New York 33, N. Y.

WANTED—Late model V-O-M with 10 meg. range and 4" or larger meter, preferably Triplett 1200G or RCP 414 or 419, Simpson 260. Ray Knoepfer, 1059 Rockman Place, Rock Hill 19, Mo.

WANTED—RCA-72-C overhead recording attachment for broadcast installation at army camp. S/Sgt. Edw. M. Scribner, Post Bdest System, Sioux Falls Army Air Field, Sioux Falls, S. D.

URGENTLY NEEDED—Converter to convert 32 v. D.C. to 110 v. AC. 225 watts or more. Cash or will trade RCA tube tester No. 150. Wilson Radio Service, R. 1, Box 120, Lynch's Station, Va.

FOR SALE—Self-contained power supply in 5 x 5 x 6" par-metal steel box. Furnished 300 volts at 50 ma., also 2½, 5 & 6.3 volts at 2 amps AC. Two section choke and three section electrolytic filter. Separate AC and plate switches with indicator lamp. \$8.50. M. Schaefer, 280 Wadsworth Ave., New York 33, N. Y.

FOR SALE — Big assortment tubes at O.P.A. prices. Write for list. Hoepfners Radio Shop, 1613 W. 4th St., Davenport, Iowa.

FOR SALE OR TRADE—Used tubes—39-44, 89, 36, 1A5G, 1A5GT, 39, 12SQ7, 6D6, 6H6, 6J5GT, 6K8, 6Q7GT/G and many others. Urgently need 35Z5, 12SK7, 35L6, 117N, 117, and 1-V. Pvt. Russell E. Olberg, 6521005, Btry "C", F.A. Tng. Det. No. 1, F.A.S., Fort Sill, Okla.

WANTED—AC-DC or straight DC phono motor with turntable or will accept similar complete record player (without amplifier). New or used if good. Frank Danico, 99 Van Nostrand Ave., Jersey City 5, N. J.

WILL TRADE Weston No. 433 150-volt a-c voltmeter; Weston No. 301 0-1 ma. meter; Weston No. 301 0-200 microampere meter; Weston No. 425 0-115 ma. r-f thermo galvanometer; Roller-Smith 0-500 ma. a-c meter 6" mirror scale knife edge pointer. Want 10 x 50 binoculars, B&L or Zeiss. Joseph Oldort, 31 W. Mosholu Parkway North, New York 67, N. Y.

WANTED—Low-priced 110v 78 rpm phono motor; also small 6v phono amplifier. C. J. Clinton, 814 W. 3rd St., North Platte, Nebr.

FOR SALE—National NC-200 comm. receiver with 10" Jensen speaker, new condition, \$150; Readrite 430 tube tester, \$10; Triplett comb. sig. generator and V-O-M, \$20; Jewell 0-50 mils. d-c meter, \$2.50; Weston No. 301 0-300v d-c, \$2.50; Weston No. 506 0-8v d-c \$2; Hobart 100-0-100v d-c, \$2.50; Airline 2v battery set less batts., 4 tube, \$10. Jenko Radio-Electric Service, Box 129, Upland, Ind.

FOR SALE—150-watt voice & telegraph xmitter, crystal controlled. Also misc. ham parts. Will swap. What have you? Best Radio Shop, 3549 Fulton Road, Cleveland 9, Ohio.

FOR SALE OR TRADE—One omnigraph, mounted with key and phone for code practice. Want Echophone or multi-tester. E. Erlanson, 1241 "C" St. S.E., Washington 3, D.C.

MICROPHONES FOR SALE — Electro-voice V1, \$15; Turner crystal 44X, \$10; Universal BB double button, \$10. All perfect. Chas. Gunderman, 17408 Flamingo Ave., Cleveland, Ohio.

WANTED FOR CASH—Echophone EC-1 or Hallcrafters Skybuddy. Steve Yos, 1508 N. Larrabee St., Chicago 10, Ill.

FOR SALE—Jackson No. 640 sig. generator in excellent condition. Both a-f and r-f output, frequency 100-32,000 kilo. Both micro-volts and output ratio control. Roger Bettin, Lakefield, Minn.

TUBES FOR SALE—Some good used ones and some new. Include 30, 36, 31, 41, 42, 45, and 27. New ones at list, used ones 50c each. Marothly Radio Shop, 123 E. Park Ave., Coldwater, Mich.

FOR SALE—New V-O-M multitester, d-c volts to 500, ma. to 100, a-c volts to 1,000, ohms to 1 meg. with special low ohm range, compl. with instructions, \$19.75. Also one No. 1210 Triplett tube tester with chart, \$10; one new American crystal mike. desk stand, \$12.50. York Electric Co., Box 373, York, Nebr.

WANTED—Echophone EC-1 or similar. Also want one No. 30 tube. Wilson Chastain, 928 Broad St., Nashville, Tenn.

WANTED—One small 0-1 or 0-1.5 d-c milliammeter. Cash. Homer Killebrew, Jr., 1618 Quintard Ave., Anniston, Ala.

WANTED—Signal tracer, any make in good condition, also 12, 35, and 50v tubes. Jones Radio Shop, Brattleboro, N. C.

FOR SALE—Superior sig. generator, 5 bands and leakage tester, \$45; Multi-meter 0-500v, 0-10-100 ma. and 0-1000 and 1 meg., separate 0 to 4-12v output meter, self-contained batteries in port. case, \$45; new tube testing transformer 1.5v to 117v and tube testing meter, good 7-bad scale, both for \$10.95; 32v d-c to 110v a-c pack, \$11.50; also numerous tubes and other parts. C. V. McMillan, 414 N. Broadway, Abilene, Kans.

WANTED—Stancor auto radio test & demonstration pack or similar. Walker's Radio Service, 717 Hill St., Franklin, Va.

FOR SALE OR TRADE—Supreme No. 85 tube meter and Dayrad No. 875 volt ohmmeter. Need sig. generator & set analyzer. Arnold Castner, Box 432, Warren, Mass.

FOR SALE—500 1LN5 tubes, used but tested & guaranteed, boxed individually, 75c ea. Also 1T4 and 3B4 tubes, 50c ea. Radio Service Co., Box 109, Fayetteville, North Carolina.

WANTED—Circle cutter or radio chassis punch and 1A5G tube. Cash. George Stetson III, 10 Parker Drive, Hingham 8, Mass.

FOR SALE—RCA 3" cathode ray oscillograph TMV-122-B and RCA oscilator with electronic sweep No. 150, both little used & perfect. \$100 for pair f.o.b. Radio Laboratory, Patchen Rd., So. Burlington, Vermont.

WANTED—All kinds of test equipment, particularly sig. generator and tube checker. Also 12, 25 and 50 v tubes. S/Sgt. R. E. Dupert, P.O.B. No. 82, Randolph Field, Texas.

WANTED—Radio shop eqpt. of all types. What have you? I have a number of things to trade. All letters answered. B-C Supply Co., 1251 Loeb St., Henderson, Ky.

WANTED—Tube tester; V-T-V-M; signal tester; multi tester. Cash for late model equipment. T. A. McIntire, P.O. Box 364, Wilmington, N. C.

FOR SALE—Hallcrafters SX-28 super Sky Rider used only 3 weeks. Paul S. Kreislinger, 216 Madison Ave., Clifton, N. J.

WANTED—National AC SW3 model using 6.3v tubes, also coils from 20 to 160 meters. No power supply. Must be A-1. Ernest W. Lavalette CRM, Bldg. 1500, U.S.N.T.S., Newport, R. I.

WANTED—Rider's 6 to 14; oscilloscope; and 35L6; 50L6; 25Z5; 70L7; 32L7; 117L7; 12B8; 50Y3; 12SA7; 12SQ7; 35A5 tubes. Geo. A. Dowers, 873 Self Master Pky., Union, N. J.

FOR SALE—5-band S.W. & B.C. receiver, a-c, coil switching, 5-tube, type A relay rack panel. Phono amplifier, \$73. Also Turner mike 8' of cable with connectors, \$10. R. Sweeney, 104 School Lane, Trenton 8, N. J.

FOR SALE—Model 1230 Superior generator. E. S. Allison, 1035 W. Vine St., Alliance, Ohio.

WARNING!

Federal laws cover the use of the mails to defraud—which means that most transactions resulting from Trading Post advertisements fall under their jurisdiction. Users of the Trading Post service are thus specifically cautioned to refrain from any dealings which might be cause for complaint to the Post Office authorities.

WANTED—Used RCA-Rider chanalyst or Meisner analyst & tube tester. Cash. Cpl. Archie Clark, 334 A.S.F. Band Rec. Center, Fort Benning, Ga.

FOR SALE—1942 new Motorola custom fit auto radios for 1940-41-42 Buicks, 1941-42 Chevrolets, 1942 Fords, 1939-40-41 Plymouths, Dodges, DeSotos, and Chryslers; also 1937 Ford custom fit auto radio. Paul Capito, 637 W. 21st St., Erie, Pa.

WANTED—Used tubes in usable condition: 35Z5GT/G, 25Z5, 50L6GT, 25Z6, 35Z3, 35Z4GT/G, 45Z5GT, 25Y3, 117Z6GT/G, 35A5, 35L6, and 25L6. Also old tube bases and sockets. Rudolph A. Zenker, 308B W. Hubbard Ave., Columbus 8, Ohio.

FOR SALE OR EXCHANGE—One each—46, 10, 6A8GT, 6F8G, HY25, and 6N7—\$3.90 for all. Also T13R14 transformer, \$3; and 832 with socket, \$6.75. Want 1600 KC BFO Xtormer, 1-6K8, 1-6SK7, 1-HY69, 2—.005 micas 400 v, and 100' DCC wire. R. A. Williams, 109½ E. State St., Redlands, Calif.

URGENTLY NEEDED — Radio speaker 6F6-364. Cpl. Roy W. Arnold, 16068249, c/o Postmaster, San Francisco, Cal.

YOUR OWN AD RUN FREE!

This is Sprague's special wartime advertising service to help radio men get needed parts and equipment, or dispose of radio materials they do not need. Send your ad today. Write PLAINLY or PRINT—hold it to 40 words or less. Due to the large number received, ads may be delayed a month or two, but will be published as rapidly as possible. Sprague reserves the right to reject ads which do not fit in with the spirit of this service.

HARRY KALKER, Sales Manager

Dept. RC-65, SPRAGUE PRODUCTS CO., North Adams, Mass.
Jobbing Sales Organization for Products of the Sprague Electric Co.

SPRAGUE CONDENSERS KOOLOHM RESISTORS

TM. REGISTERED U. S. PATENT OFFICE

Obviously, Sprague cannot assume any responsibility, or guarantee goods, services, etc., which might be exchanged through the above advertisements

See How DeFOREST'S TRAINING

helps you prepare for

RADIO SERVICING

... OR FOR ONE
OF THESE OTHER BRIGHT



YOU GET THIS FASCINATING "A-B-C WAY" To Learn Radio at Home—Plus Employment Service

To help you get started in this great opportunity field the modern, effective DeForest's Way, you get (A) the use of a genuine DeVry Movie Projector and 12 "Learn-by-Seeing" reels of exciting training films, (B) the use of 8 big kits of Radio parts to provide valuable "Learn-by-Doing" practical Radio experience at home, (C) 90 up-to-date, well illustrated loose-leaf lessons.

This exclusive combination of valuable home training aids can be your key to a Good Job or a Business of Your Own in Radio-Electronics, with its many present opportunities and great postwar possibilities. You can Earn While You Learn, too—doing Radio servicing in your spare time. And when your training is completed, you get our effective Employment Service.

Write today for DeForest's big, free book, "VICTORY FOR YOU!" and complete EQUIPMENT folder. Get the facts about the many opportunities in Radio-Electronics—and DeForest's ability to help you make your start in this grand field. Remember—you prepare at home, in your spare time—using DeForest's exciting "A-B-C way" of learning... a powerful combination of training aids to help speed your preparation for the opportunities of today and tomorrow. For more complete details, mail the coupon NOW—TODAY!

"LEARN-BY-DOING" —AT HOME

—from 133 practical Radio experiments—using DeForest's unique "Block System" to speed circuit construction. With 8 Radio kits you build and operate SIX different Receiving Circuits, a Radio Telephone, Electric Eye Devices, Light Beam Transmission and many other instructive projects.

"LEARN-BY-SEEING"—with MOVIES

DeForest's Home Movies Help You Learn
Faster—Easier at Home

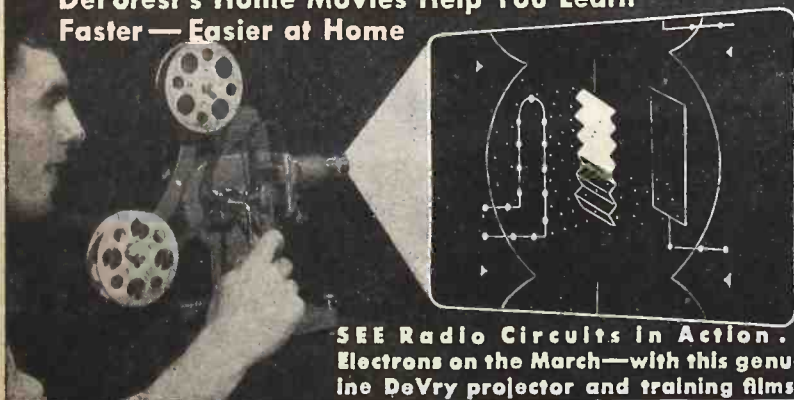

SEE Radio Circuits in Action...
Electrons on the March—with this genuine DeVry projector and training films.

DeFOREST'S TRAINING, INC.
CHICAGO 14, ILLINOIS



You get 90 illustrated loose-leaf lessons prepared under the supervision of Dr. Lee DeForest, inventor of the Audion Tube—and often called "The Father of Radio."

.. JOB OPPORTUNITIES

RADIO MANUFACTURING of receivers, parts, and related equipment, built in numerous plants employing many thousands of men and women.

RADIO STATION operation and maintenance of equipment.

TRANSPORTATION RADIO including installation, maintenance and operation.

MILITARY RADIO, SOUND RECORDING, POLICE RADIO, PUBLIC ADDRESS SYSTEMS, SOUND MOTION PICTURE EQUIPMENT.

RADIO SERVICING—based on a field of 50 million Home Radios, 7,000,000 Car Radios and similar Radio and Electronic Equipment.



DeFOREST'S TRAINING also offers instruction in FM Radio, Motion Picture Sound Equipment and Television. Residential Training in modern Chicago laboratories also available. Write for details!

E. B. DeVry, President
DeFOREST'S TRAINING, INC.
2535-41 North Ashland Avenue, Dept. BRC-6
Chicago 14, Illinois, U.S.A.

Please send me your "VICTORY FOR YOU!"
BOOK and EQUIPMENT FOLDER.

Name

Address

City Zone State

If under 16, check here for special information.

If a veteran of World War II, check here.





Centralab Selector Switches

are available to servicemen and experimenters in kit form . . . or standard, completely assembled and individually cartoned.

Insulation . . . either steatite or bakelite.

All switches have double-wipe contact terminals for long life and have a consistently low contact resistance of less than $2\frac{1}{2}$ milliohms and are completely self-cleaning. Index is positive with 30° between each rotating position.

Switches are also available for transmitter use.

Send for illustrated Catalog No. 24.



Centralab

Division of GLOBE-UNION INC., Milwaukee

Producers of VARIABLE RESISTORS — SELECTOR SWITCHES — CERAMIC CAPACITORS, FIXED AND VARIABLE — STEATITE INSULATORS — AND BUTTON-TYPE SILVER MICA CAPACITORS.

MAKE MORE MONEY

IN Radio TELEVISION & ELECTRONICS

Now!

GET THESE 2 BIG BOOKS

FREE!

You men already in Radio know how great the demand is for trained, experienced servicemen, operators and technicians. You know how fast the field is growing and how important it is to keep up with developments — F.M. Receivers, Electronics and Television. You know, too, a fellow cannot learn too much about any industry for REAL SUCCESS. Whether you have experience or are merely INTERESTED in radio as an amateur, you must recognize the WONDERFUL OPPORTUNITY right within your grasp to cash in on your natural abilities. Make them pay dividends. Get into the EXPERT RADIO SERVICE FIELD. Be an F.M. and TELEVISION specialist—OWN A BUSINESS OF YOUR OWN, if you prefer. Fill out and mail the coupon below for all the details of our plan.

Get the Latest Inside Information—Short Cuts—Trade Secrets by

Here's Just a Few of the Interesting Facts you Learn with the FREE MANUAL.

1. Routine for diagnosing Radio Troubles.
2. Preliminary Inspection of Receivers.
3. How to Check Power Supply.
4. How to Identify Various Stages of Receiver.
5. How to Trace the Circuit and Prepare Skeleton Diagram.
6. How to Test and Measure Voltages.
7. How to Test Speaker in Audio Stages.
8. How to Test Detector, I.F., R.F., and Mixer Stages.
9. Complete Reference Table for Quickly Locating Receiver Troubles.

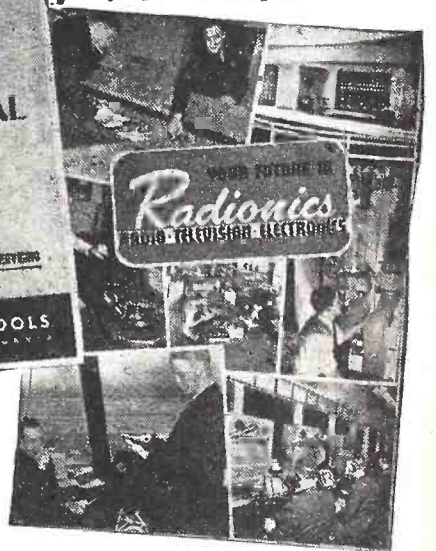
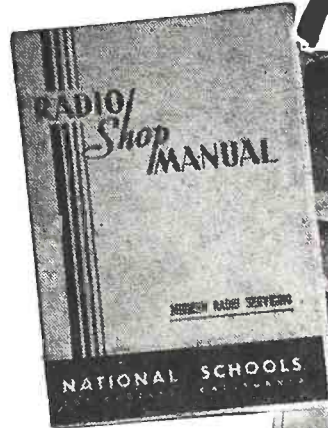

SHOP METHOD HOME TRAINING

FROM A REAL ESTABLISHED RESIDENT SCHOOL

Now the famous National Schools brings its exclusive Shop-Method of training right into your own home. You can learn the most up-to-date, approved projects, systems and circuits step by step in your spare time. This is the sound practical training you want and need—the development of experienced instructors working with thousands of students right in shops, NEW F.M. broadcast studios and experimental laboratories of NATIONAL SCHOOLS—one of the most advanced trade educational centers in the world.

National Trained Men Now Making the Best Money in History

The real value of National training shows up on the quick progress our men make on the job.

Incomes that seemed fantastic only a short time ago are now being reported by National graduates. And this is only a sample of what the future holds for the MAN WHO KNOWS RADIO, ELECTRONICS, F.M., TELEVISION and allied subjects. National is proud of the progress its graduates are making all over the world. Read the facts—the actual proof in the books we send you FREE.



LEARN BY DOING

Work with Real Experimental Equipment Furnished without Extra Cost as Part of Your National Training

Experience is the best teacher. You learn by experience with the exclusive National Shop-Method of Home Training. In the course of your study you actually build various types of receivers—a powerful superheterodyne, a signal generator, an audio oscillator and others—you make tests and conduct experiments that show you the why and how of things. You understand what makes the various elements of electronics operate because you actually see them work for you. Not only do you gain marvelous experience by this method of learning but you receive valuable equipment you will use on the job in the practice of your profession as an electronics expert. Mail the coupon and learn what this means to you.

Send the Coupon and prove to yourself what YOU can do in RADIO!

Be Sure Of Your Success And Security After The War

Don't let your post-war ambitions lag. Don't let YOUR future depend on others. Build a career for yourself. Never in all history has the returning serviceman, or war worker been confronted with such a great future if he reaches out and grasps it NOW. Here is a new world opening before you. Get ready now while you are still in uniform—while you are on your war job. Then you can soon step into an essential, well paid position or, with little capital, GET INTO BUSINESS FOR YOURSELF. It isn't a bit too soon to start now. Radio men are vitally needed. Fill out and mail the coupon immediately and examine the NATIONAL SHOP METHOD HOME TRAINING COURSE carefully, without obligation.

FREE LESSON INCLUDED

Examine the exclusive National Shop Method of Home Training. See for yourself how sound and practical it is. Be convinced that you can learn Radio, Electronics, Television—quickly and easily in your spare time. You can't tell until you try. This trial is ABSOLUTELY FREE. Fill out the coupon immediately while you are thinking about it and drop it in the mail at once.

Mail the coupon here for the books that tell you the complete story of the marvelous new system of training in Radio, Electronics and Television. Learn the facts of this exclusive shop-method of home training. See for yourself! DECIDE FOR YOURSELF!

This is the MODERN SYSTEM OF TRAINING; it matches the rapid progress constantly being made in Radio, Television and Electronics. It is TIME TESTED, too. National Schools has been training men for more than a third of a century. It is the very same training that has helped thousands to more pay and greater opportunity.

You owe it to yourself—your future—to read the book "Your Future in Radio, Electronics and Television"—FREE to you when you send in the coupon.

NATIONAL SCHOOLS

LOS ANGELES 37, CALIFORNIA EST. 1905



MAIL OPPORTUNITY COUPON FOR QUICK ACTION

National Schools, Dept. 6-RC

4000 South Figueroa Street, Los Angeles 37, California.

(Mail in envelope or paste on penny post card)

Mail me FREE the books mentioned in your ad including a sample lesson of your course, without obligation. I understand no salesman will call on me.

NAME AGE.....

ADDRESS

CITY STATE

Include your zone number



How Television Got Its Electronic "Eyes"

As revolutionary as airplanes without propellers—that's how much electronic television differs from the earlier mechanical television!

Whirling discs and motors required for mechanical television were not desirable for home receivers. Pictures blurred and flickered.

But now, thanks to RCA research, you will enjoy all-electronic television, free from mechanical restrictions—"movie-clear" television with the same simplicity of operation as your radio receiver.

Such "let's make it better" research goes into everything produced by RCA.

At RCA Laboratories, world-famous scientists and engineers are constantly seeking new and better ways of harnessing the un-

believable forces of nature... for mankind's greater benefit.

Electronic television is but one example of the great forward strides made possible by RCA research—opening the way for who knows what new miracles?

When you buy an RCA radio or phonograph or television set or any RCA product, you get a great satisfaction... enjoy a unique pride of ownership in knowing that you possess the finest instrument of its kind that science has yet achieved.



Dr. V. K. Zworykin, Associate Research Director and **E. W. Engstrom, Director of Research** at RCA Laboratories, examining the Iconoscope or television "eye"—developed in RCA Laboratories for the all-electronic television system you'll enjoy tomorrow.

RADIO CORPORATION of AMERICA

PIONEERS IN PROGRESS



RADIO-LIGHT

. . . . We are still at the very beginning of the radio and electronic arts. The greatest and undreamt of applications lie as yet in the future. There is still much unknown territory in the electromagnetic spectrum which holds out great promise

HUGO GERNSBACK

EVERY time you turn on an electric light of the filament type, over 90% of the electrical energy goes to waste in heat, which you do not want. Even the much more efficient fluorescent lamps still waste over 50% in unwanted heat effects.

What is true in electric light is also true in a measure in our present day radio equipment. It is still extremely wasteful because most of the things we do now-a-days are done in a round-about manner. We have not yet learned to exploit nature's forces with a minimum of loss. All of our steam, electrical, and other power generators are extremely wasteful and we recover only a fraction of the prime energy which we put into them.

Coming to radio, we are slowly emerging out of the darkness and our various instrumentalities are gradually becoming more efficient. As is well known, it took Marconi hundreds of horse power of electrical energy to transmit the first weak signals across the Atlantic by wireless. Today we easily span the earth to its furthest corners by short waves, using as power a few dry cells, while the entire transmitting equipment can be carried in a small satchel. Still engineers are not satisfied, because the electromagnetic spectrum contains unknown regions which have as yet not been fully exploited.

As we all know, electricity, radio, heat and light waves are all one and the same thing. They are all electromagnetic waves and differ only in their frequency, or wave lengths.

Originally, the discoverer of radio waves, Henrich Hertz, used ultra-short waves in his experiments. When radio was very young these waves were not thought to be useful and we used lower frequencies clustering above and below 1,000 Kc for radio broadcasting. During the past 15 years we reverted to Hertz and began to use the higher frequencies again, jumping from the low wave-band to broadcasting to around 10 MC (megacycles) for our short wave communications. Then FM followed around 50 MC, with television already heading toward the 100 MC mark. The ultra high frequencies for radar and other military purposes are well above the 100 MC mark. That, however, does not satisfy our research men, who see a great future in the still higher frequencies. Thus the Klystron and Magnetron radio tubes can pro-

duce oscillations up to 10,000 MC and over.

But from 50,000 MC to 1,000,000 MC not much has been done. From 1,000,000 MC and above, we pass into little known frequencies and from that point up to 100 million MC we are brought into the region of radiant heat. From 100 million to 1,000 million MC we step from radiant heat into the region of infra-red and then into light, ending up in the ultra-violet spectrum.

What does all this mean to the radio technician? I believe that it is possible in the future, that electronic radio tubes will be built which instead of putting out invisible radio waves, will radiate actual light waves, at an incredibly efficient rate.

You may ask "why do all this if an ordinary electric light bulb gives us excellent white light right now?" The answer is—as I pointed out at the beginning of this article—that we are getting our light now at the cost of a shameful waste of energy. With future electron tubes, the story probably will be entirely different. But that of course does not end their usefulness. Once we produce electronic tubes that can give us oscillations at the rate of 1,000 million MC, our whole present concept of radio will most likely be revolutionized.

Take only one application of such a tube—television. With a 1,000 million MC tube it may no longer be necessary to scan as we must do today, because no other and better means for television transmission is known now. But when electrical impulses can be turned into light at will, the situation will be entirely different and undreamt of results may be had when these instrumentalities are perfected.

It has long been the scientists' dream to utilize solar heat for man's emancipation from sweat and labor. But light and heat are closely related in the spectrum, yet man has not learned to tap solar heat except in a most round-about manner. Thus, the radiant light which falls upon the city of New York would not only be sufficient to run all of its transportation, elevators, electric lights, power for all of its factories, etc., but would leave a substantial amount of energy over. But so far we have not exploited this great store of power. The main reason is, that we do not know enough about the unknown regions in the spectrum and (Continued on page 608)

Radio Thirty-Five Years Ago

In Gernsback Publications

HUGO GERNSBACK

Founder

Modern Electrics	1908
Electrical Experimenter	1913
Radio News	1919
Science & Invention	1920
Radio-Craft	1929
Short-Wave Craft	1930
Wireless Association of America	1908

How to Make a Simple Variable Condenser, by C. W. Schwartz.

An Efficient "Wireless" Connection, by Donald McGlasson.

A Universal Detector, by H. J. Krase.

Condenser Connections, by Robert C. Bodie.

Safety Pin Detector, by C. F. Lindstrom.

Simple Mineral Detector, by Herschel Trucblood.

A Good Mineral Detector Stand, by E. E. Ely.

A Simple Variable Condenser, by Philip Edelman.

Novel Aerial Attachment, by John V. House.

Loop Antennae Switch, by Lawrence E. Hammond.

"The Wireless Screech."

FROM the June, 1910, issue of MODERN ELECTRICS:

An Adjustable Impedance Coil, by Austin C. Lescarboursa.

Tubular Condenser, by Harold Birkmire.

Tuning and Interference, by James M. Murdock.

A Double Action Aerial Switch, by E. W. Cole.

Pennsylvania Railroad Wireless Tests.

The Peroxide of Lead Detector, by Samuel F. Kerr.

Compact Receiving Outfit, by Louis Phillis.

HIGH-VOLTAGE television tubes which will bring television to the postwar home were described last month to the Philadelphia Section of the Institute of Radio Engineers by L. E. Swedlund of RCA.

The new, small-sized tubes use voltages between 25,000 and 30,000 volts to meet the essential requirements of large, bright high-definition images in a console of reasonable size and cost.

Fifteen years of research and development, Swedlund stated, were spent in solving the problems encountered in developing such a tube. One of the most serious was posed by the effect of high-voltage bombardment of the fluorescent screen. Phosphors that would stand up under voltages used on older low-voltage tubes would not give satisfactory service at 27,000 volts. Another problem posed by the high voltage was the tendency toward voltage breakdown between electrodes in the tube. This was overcome by polishing all parts to round off any points or protuberances which might serve as terminals for an arc, increasing electrode spacings, and evacuating to an ultra-high vacuum.

Other problems peculiar to the new tube were those of reconciling high current with sharp focus for the electron beam; and in the design of face-plates for the tubes.

Mastery of these problems resulted in a tube which would produce on the 16 x 21-inch viewing screen an image equal in lighting and definition to those obtainable directly on the screen of a 12-inch viewing tube. Because of the brilliance of the initial image on the face of the smaller tube, the projected image was comparable in brightness with the smaller image on the face of the prewar tube. The small size of the projection tube largely compensated for the space occupied by the optical system, permitting the entire unit to be housed in a cabinet about the size of a large radio console. The tube was operated at 27,000 volts—nearly four times the voltage used in prewar picture tubes.

Important features of developmental RCA projection kinescopes are:

1—Simple bulb design in soft glass which is well suited to low-cost quantity production.

2—An electrostatic-focus electron gun which avoids the added cost of a magnetic-focus coil and at the same time permits the use of a low-cost voltage supply.

3—Magnetic deflection is used; deflection angle is 40°. No more deflecting power is needed at 25,000 volts than for a 55° angle directly-viewed tube operated at 9,000 volts.

4—A spherical face to match the RCA reflection-type projection system provides uniform focus at high brightness.



At left is one of the large direct-viewing cathode-ray tubes. At right, the much smaller high-voltage projection-type tube described above, which is employed in the RCA large-screen equipment.

Radio-Electronics

Items Interesting

5—A high-contrast white-light fluorescent screen.

6—Reliable performance and good life.

(Presumably steps will be taken similar to those in high-voltage transmitter design, to assure that no danger to user or serviceman will result from the extremely high voltages used with these new television tubes.—*Editor*)

SECRET Signal Corps electronic devices were exhibited to a group of senior Congressmen, radio commentators and selected members of the press at Ft. Myers last month. Among the devices from which the veil of secrecy was partly lifted were radar, radio field artillery spotters, radar-controlled searchlights and radio mine detonators.

One of the most interesting pieces of equipment displayed was a light-weight early warning radar set. The controls are in a small, portable case with two scopes operating much the same way as those of the radar searchlight set. The direction-finding antenna is also concave and of wire construction. The two scopes give position of a plane in relation to the set. The set can locate a medium bomber within a 100-mile range.

The most startling display was the radio detonator system which sets off land mines by means of selected radio frequencies. A soldier lays a mine, assigns to it a special frequency. By means of a telephone dial attached to the radio set, the operator can dial the three digit number of the mine and set it off, with 21,000 code denominations and pulses that may be used. The set operates over a range of 8 miles on land, 20 on water.

The Signal Corps also displayed a radar anti-aircraft apparatus which automatically computes the gun range even with no one at the controls. A massive piece of field equipment, the set can be turned in all directions, the large, earlike radar antenna moving with the rest. An operator's seat projects on either side. Gun range can be determined accurately from the readings of the radar scopes.

RADAR will find an unexpected peacetime use in tracking the migration flight of birds, according to a statement last month by Professor Maurice Brooks of West Virginia University. As soon as possible after the war he intends to install electronic equipment on a high mountain-top in his state to obtain data on the height, speed and direction of flight of wild geese, hawks and other birds large enough to register their presence on the screen.

Prof. Brooks states that he got the idea of using radar for this purpose from an ornithological friend who is at present a naval officer in the Pacific. The radar on his ship has often detected the presence of albatrosses, man-o'-war birds and other large species at ranges as great as five or six thousand yards, when the birds themselves were invisible. It is expected that peacetime bird-scouting with radar will gather much information hitherto unobtainable, especially about birds migrating at night or in hazy or cloudy weather, when visual observation is limited or even wholly impossible.

RURAL areas have an immediate need for walkie-talkie radio, since telephone and wire facilities often are not available, says E. K. Jett, Federal Communications Commission, as reported in *Science Service* last month. Residents of small towns will be able to use walkie-talkie for reliable two-way communication in a radius of up to 15 miles, he stated.

The apparatus will be tunable to various frequencies within the allotted band.

It can be used not only for communication between farms and small towns, but also to keep in touch with taxicabs, police cars and service trucks operated by electric, water and transportation organizations and other types of businesses. Reliable communication range of low power walkie-talkies will be limited in large towns and cities because buildings will obstruct the path of radio waves being transmitted, Mr. Jett pointed out. Rural areas are generally free of such obstructions. Furthermore, because the demand for channels will be less in small towns than in large cities, there will be greater freedom in respect to the availability of interference-free channels for communication. Thus the new communications service will be more freely available in rural and semi-rural areas where there is more need for it, and less so in large cities, where it is easier to step into a phone booth than to carry around a small radio transmitter.

Citizens Radiocommunication Service, the official name for the radio service using "walkie-talkie," will be thrown wide open to any citizen who wants to use it after the war. Requirements for a license are simple. All the applicant will have to do is to certify that he has read the rules and regulations and understands them. Licenses to own and to operate a radio station will run concurrently for five years, after which time it will be necessary to get a renewal.

Monthly Review

to the Technician

RADIO-ELECTRONIC ITEMS OF THE MONTH IN REVIEW

Permanent postwar employment for 300,000 persons will be provided by Frequency Modulation, according to figures put out by Frequency Modulation Broadcasters, Inc. The FMBC estimates allot 262,000 jobs to the manufacture, distribution and maintenance of receivers and the remainder to build, staff, and keep in repair the 4,000 FM broadcast stations ultimately expected.

Code records are now being used to teach sightless persons to transmit and receive the International Morse Code. This method of study may open the door for a new vocation for sightless persons, according to experts in the field of education for the blind, who point out that many blind "hams" now derive much enjoyment following radio telegraphy and telephony as a hobby.

Chile, the longest country in the world for its width, has installed a broadcast transmitter powerful enough to cover its 2,600 miles from north to south. Located near the capital city of Santiago, the station uses a special type directional aerial to concentrate broadcast energy northward and southward. The station is an RCA 50-kilowatt transmitter, but the antenna provides the equivalent of 135 to 140 kilowatts in a north-and-south direction.

The station, whose call is CB114, has a pair of masts 300 feet high and a buried network of 22 miles of four-millimeter copper wire as a ground system. The operating frequency is 1140 kc.

Broadcasts of "popular" music are less popular than symphony and other classical and light classical music, according to a poll of radio-phonograph owners recently completed by the Magnavox Co.

Reductions in radiotelegraph rates proposed by RCA communications in an application to the FCC last month would reduce such rates from the present 26 cents to 20 cents per word, with a reduction to 12 cents for code messages. If approved by the FCC, the new rates will effect closer cultural and commercial relations between the United States and Latin America.

Over-optimism on the part of many radio and appliance dealers regarding the postwar situation was seen by James H. Rasmussen, general sales manager of Crosley, in an address before the Advertising and Sales Club of Seattle last month.

"A recent survey among dealers and consumers in the same area," he stated, "showed that the dealers were ready to buy in the first postwar year, 80% more refrigerators, 2½ times as many electric irons and more than twice as many radios as the consumers would buy from them."

Rosel Hyde, veteran FCC attorney, replaces Charles R. Denney as general counsel of the Federal Communications Commission. Mr. Denney is now a member of the Commission.

BEAMS of directed radio waves may take the place of transcontinental telegraph pole-and-wire lines, Albert N. Williams, president of Western Union Telegraph Co., told stockholders at the company's annual meeting last month.

Reviewing research in this field and the allocation of wave lengths to the company for an experimental radio telegraph beam between Philadelphia and New York, Mr. Williams said this point-to-point radio telegraphy was "one of the most dramatic and interesting new possibilities" in the company's business.

Experiments tend to indicate that the maintenance of relay stations at the greatest possible distances permitting line-of-sight paths between them may prove considerably more economical than upkeep of the present lines. Interruption due to storm or flood would also be reduced almost to the vanishing point.

(Such developments may cause the distinction between telegrams and radiograms to disappear in time. A "wire" handed in at the local telegraph office would be transmitted in the quickest way—probably part of the distance over wires and the rest of the way through the ether.)

"TIGHTENING UP" on station renewals was hailed in many quarters last month as concrete evidence of the "public interest" policy announced earlier by FCC chairman Paul Porter (*Radio-Craft*, May).

Out of 40 renewals recently granted, 18 were on a regular basis, 16 others were granted regular licenses but were asked to furnish additional information and 6 were ordered on temporary license pending return of a questionnaire sent to each of them. This pointed out that in the original application the station had stated that given percentages of its time would be devoted to public interest material, such as news, local information, reports to farmers, sports, church services, etc.; to purely sustaining programs; and to commercial material. Apparently in most of the temporary license cases the amount of commercial advertising considerably exceeded that set forth in the original application.

The letter sent out to the 16 stations pointed out that certain statements in regard to distribution of time between public-interest and commercial material had been made in their original applications for construction permits, and that the present program structure showed considerable variation from that proposed in the application. While the Commission recognizes that the statements do not furnish a rigid blueprint for future operations, the letter continued, yet the original representations are significant in determining whether the license renewal will meet the statutory standards of public interest. A reply, stating the reasons for departing from the original proposed program structure and a statement of future program plans, was requested.

SIR AMBROSE FLEMING, inventor of radio's first vacuum tube, the Fleming valve, died April 19 in Sidmouth, Devon, at the age of 95.

Fleming's fame in the radio world rests not only on his discovery of the radio possibilities inherent in the "Edison effect" between a hot and cold electrode in an evacuated space, but also on one of the earliest fundamental treatises on radio, published early in the century. This book, which contained more than 1700 pages, was for a number of years the authority on the subject, and is now regarded as one of the classics of radio literature.



The invention of the Fleming valve was the result of researches made while working for Marconi (at which time he designed the wireless signal apparatus of the famous station in Cornwall from which the first transatlantic message was transmitted in 1901). The object was to discover a more sensitive and stable detector than any in use. The new "valve" while not more sensitive than the detectors commonly employed at the time, was remarkably more stable and reliable. Its real significance was, however, that it paved the way for our modern electron tubes, which came into existence when Lee De Forest put a third element—the grid—into the two-element Fleming valve.

Knighted for his contributions to radio-electronic science, he became Sir Ambrose Fleming in 1929. He was the last survivor of the group of radio pioneers in England which included Marconi, Clerk Maxwell and Sir Oliver Lodge.

TED McELROY, world champion at copying radio code, has joined the Merchant Marine as a radio operator, going back to a profession he left many years ago. McElroy, whose penchant for doing the unusual and unexpected is well-known, states that he is going to sea in the hope of seeking greater adventure.

During the past several years his company has come to be recognized as one of the world's largest manufacturers of wireless telegraphic apparatus. While production will be maintained in the factory, Ted McElroy will be using some of the firm's apparatus in action.

AIR RADIO MECHANIC

The far-flung lines of our postwar aviation networks will give employment to many radiomen who are now serving on home or foreign fronts. But you will have to know your job!

By RAYMOND LEWIS

WAR-TRAINED radiomen by the tens of thousands will be looking for postwar opportunities in their new field of endeavor. As many different kinds of jobs exist as there are uses for radio and electronics. As a result, specialization is a requisite for the professional postwar radioman. The radio serviceman is not a satisfactory substitute for the broadcast engineer. The parallel covers almost all branches of radio.

A man who plans to enter the radio profession should select the job that seems most attractive—or the one he is already prepared for. At this early stage, it is wise to consider the postwar opportunities it will offer, keeping in mind the tremendous over-expansion necessitated by the exigencies of war. Some fields will go on to bigger and better things, while others will be forced to lay off a surplus of skilled help.

After deciding tentatively on the preferred job, further studies and training can be slanted in that direction. This does not preclude a broad background in radio. There is no such thing as too much knowledge! Initially though, specific studies in one branch are especially advantageous.

Aircraft radio mechanic is a very specialized type of work while requiring at the same time a great deal of general radio knowledge. It presents interesting possibilities because of the tremendous expansion inevitable in aviation immediately after the war.

ADVANCEMENT AND PAY

The remuneration may be expected to be high in any position in which the responsibility is considerable. Average pay of the aircraft radio mechanic is well above the mean wage for the radio industry. Human lives depend on the reliability of the aircraft radio—any flight failure of equipment can have disastrous results. The radio mechanic's work calls for a sense of responsi-

bility in excess of any routine shop job. Individual initiative and responsibility are stressed to conform to the exacting and particular requirements of the work.

Shop set-ups vary in the different airlines, as might be expected. A typical organization (actually a compilation of several plans) starts a man at a minimum salary of one hundred and twenty-five dollars a month. Progressive raises based on seniority, ability and checkout examinations, permit advancements to over three hundred dollars a month. There are several grades of mechanics, ranging from apprentice to master mechanic or technician. The various shifts are assigned lead men, working under the direction of a foreman. The foreman is, in turn, responsible to the head of the shop whose authority is final in matters directly concerning the work of radio mechanics. The divisional, or local radio engineers, act as liaison between the shop and other departments.

QUALIFICATIONS AND WORK

Installing or modifying aircraft equipment is an involved job, especially if by adding weight to a plane's equipment, the payload is cut—even by a fraction of a pound.

Radio mechanics are assigned to different classifications of skills, starting as apprentice. Because of the nature of the work, extensive training is required of new men. In order to promote more efficient work, regular checkouts are established for advancements. To be paid as a regular radio mechanic, a radiophone and telegraph license must be held. This permits actual ground checks of aircraft transmitters. A thorough knowledge of such diversified subjects as primary power sources, aircraft direction finders, interphones, very-high-frequency apparatus, range filters, is of equal importance in rounding out the education of the aircraft radio mechanic. In this pro-

profession, particularly, it is essential to stay abreast of new developments in aircraft radio, where the rate of obsolescence is very rapid.

MAINTENANCE TECHNIQUES

Actually, a great deal of the work on aircraft radio is routine. By frequent periodic examinations and overhauls, precautions are taken to prevent equipment failure in flight. Apparatus is given a check after each flight, more searching checks at fixed intervals, and a major overhaul at some predetermined limit. A dynamotor, for example, may have the brushes cleaned frequently, but be given a complete servicing after 500 hours. This servicing would call for the dis-assembling of the unit, replacement of the high- and low-voltage brushes, undercutting of the armature (if required), check and cleaning of bearing, lubrication, and a thorough check of mechanical and electrical connections. Nothing is left to chance. Service standards are established for every piece of equipment.

When a plane does develop radio trouble, the defective unit is replaced at once, to avoid delaying a schedule. Spares are always kept instantly available for this purpose.

Airline radio shops work three rotating shifts on a seven-day basis. A work week of forty-eight hours is average. Some shops pay an hourly wage, others, a monthly salary. The principal advantage of the hourly rate is that it allows for compensation of overtime in a more satisfactory manner. One to two weeks' vacation with pay, extensive sick leave benefits, and most national holidays off, are provided. (Because of the seven-day work schedules, it is often necessary to celebrate on an "off" day.) Radio mechanics working in the transportation industry are not covered by maximum hour work-week legislation.

Requirements for the aircraft radio me-



Photo Courtesy Civilian Aeronautics Administration

Transmitter equipment, CAA-operated Intercontinental station, N. Y.

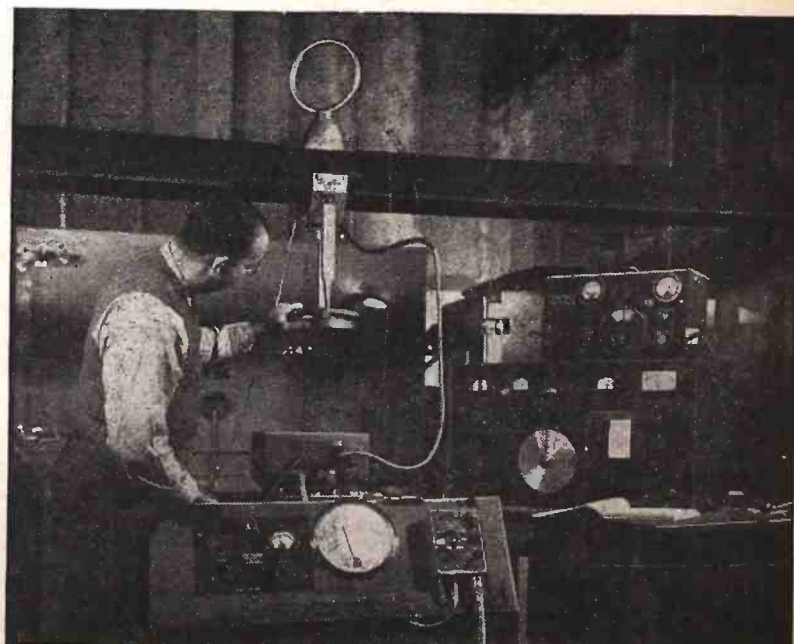

Courtesy Bendix Aviation Corp.

Screen-room set-up for testing manual and automatic radio compass.

chanic may be expected to become more rigid as available men are discharged from the services, or come out of war work. The more experience acquired, the more certain an individual is of securing a position. Formal education, while important, will not outweigh practical work and training. Competition for available positions is bound to be very severe because they offer security at good salaries, regardless of the standards.

PRACTICAL MEN NEEDED

When a man is assigned to a job, frequently there is little or no supervision. It must be done in a reasonable amount of time. In radio work, problems will always arise that are not recorded in the book. A practical technician is likely to prove superior to a trained engineer in such cases. The ideal is, of course, to combine practical and theoretical knowledge.

Anyone who plans to enter the aviation radio field will find some of the correspondence school courses worthwhile supplementary study material. They are not of any practical value in a foxhole, but they can be used anywhere else, as thousands of ambitious students in the service are proving. Classes will also be held—in nearly every case—by the employer. Since such lectures will stress the requirements of the particular organization, they are invaluable to the employee. A good aircraft radio mechanic is a professional man. If compensation is to be paid by the airlines on that basis, they expect a man to continually better himself and stay abreast of new developments.

The tools of the mechanic are expensive. They are usually supplied by the men themselves, and remain personal property. Accumulation over a period of time, with the essential equipment purchased first, is the most widely followed plan. Airline stores permit substantial savings on many of these items.

A man who is thinking of entering a permanent profession such as this, will be wondering just what the work is like. Progressing from orientation jobs, such as tube-checking or greasing antennae, the mechanic advances to more and more responsible assignments. The screen room, where precision tests and work is done, is the top technical assignment. Most trouble-shooting, calibrations, and all alignments are performed in the screen room.

A typical work day in a large airline might well go something like this. A morning assignment of checking out departing planes. This may include a local test flight, where equipment can be observed under actual flight conditions. After lunch, there may be microphone tests, the lining up of a receiver, and, if time permits, the start of a 500-hour transmitter overhaul. During a week, jobs may range from an all-day loop calibration to installing a new "On-Off" switch.

LICENSES AND EXAMINATIONS

It was already mentioned that the radio mechanic must hold federal licenses. In addition to these, it is likely that the CAA will also certify radio men. CAA examinations will not duplicate existing requirements—instead they will emphasize the aviation side of the field. In installation work, under present regulations, the radio mechanic is not permitted to even mount equipment which calls for work on the fabric or structure of the aircraft. Furthermore, the broad and all inclusive FCC examinations cannot touch on such everyday essentials of aeronautical radio as the range, markers, etc. A written examination, practical tests, and observance of proper work and safety standards will likely be made

requisites for the radio mechanic in the same manner as the engine mechanic. It will be mandatory to hold a license, so failure to observe rules and regulations can mean revocation of the license, with subsequent loss of the job.

Because the aviation industry is comparatively new, working conditions are as modern as possible. Every effort is made to provide employees with the maximum number of services at a minimum cost. These are intangibles which cannot be figured as a part of gross incomes. Accident insurance, hospitalization, co-ops, credit unions, social clubs, etc., are all important company-sponsored benefits for the employees.

Opportunities for the aircraft radio mechanic to work with the latest inventions and developments in electronic research will be profuse. Radar in all its forms; extensive use of microwaves; the VHF's and UHF's, plus the latest in medium and short-wave equipment, are imminent prospects for airline radio employees. In this air-electronic age, the combination of airplanes and radio is hard to beat. The aircraft radio mechanic will find an expanding profession with unlimited opportunities for the right man.

Two things will be decisive in obtaining and holding down a job in this attractive field—experience and knowledge. The man with know-how will rise fast and far.

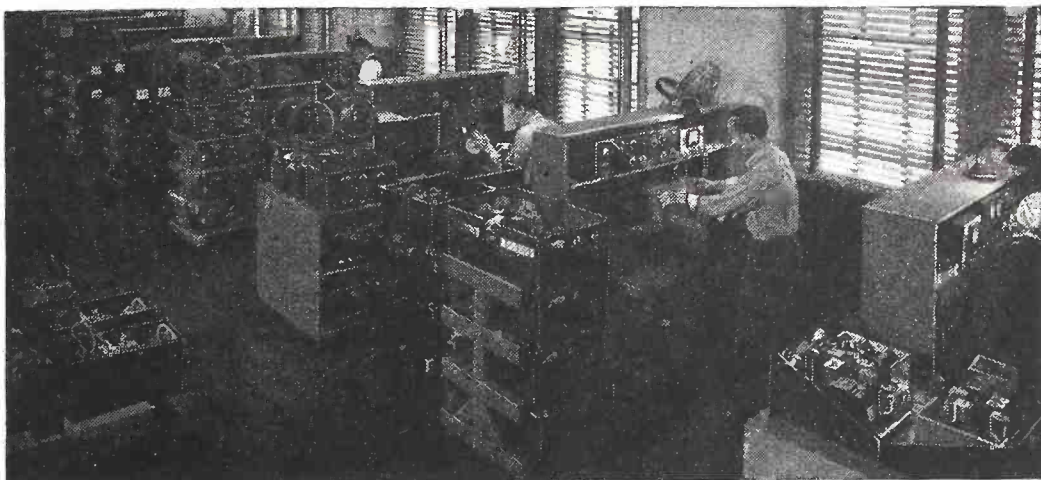

Courtesy the Hallicrafters

Receiver testing in a war plant, a valuable type of training for future aircraft mechanics.

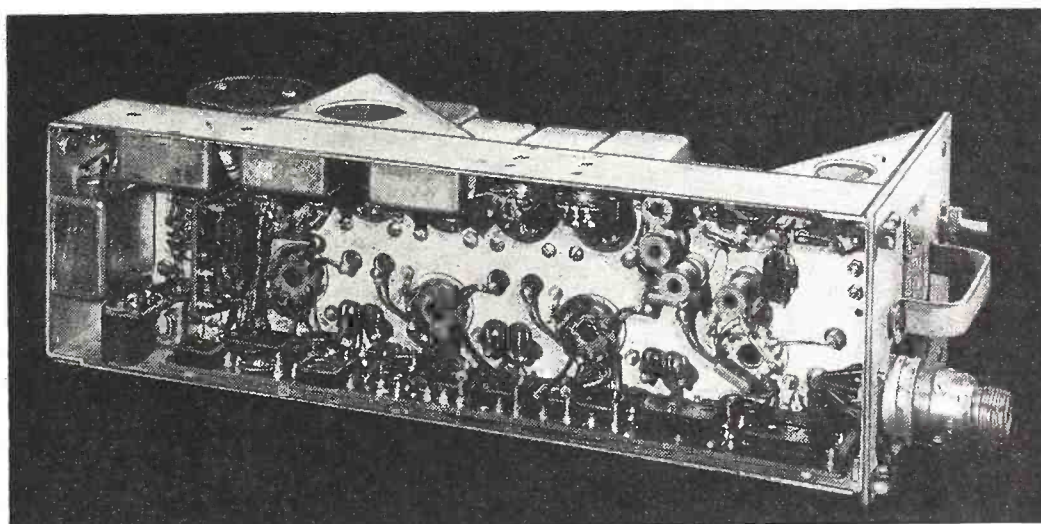

Courtesy Bendix Aviation Corp.

Typical receiver unit—illustrating high standard of workmanship required in this field.

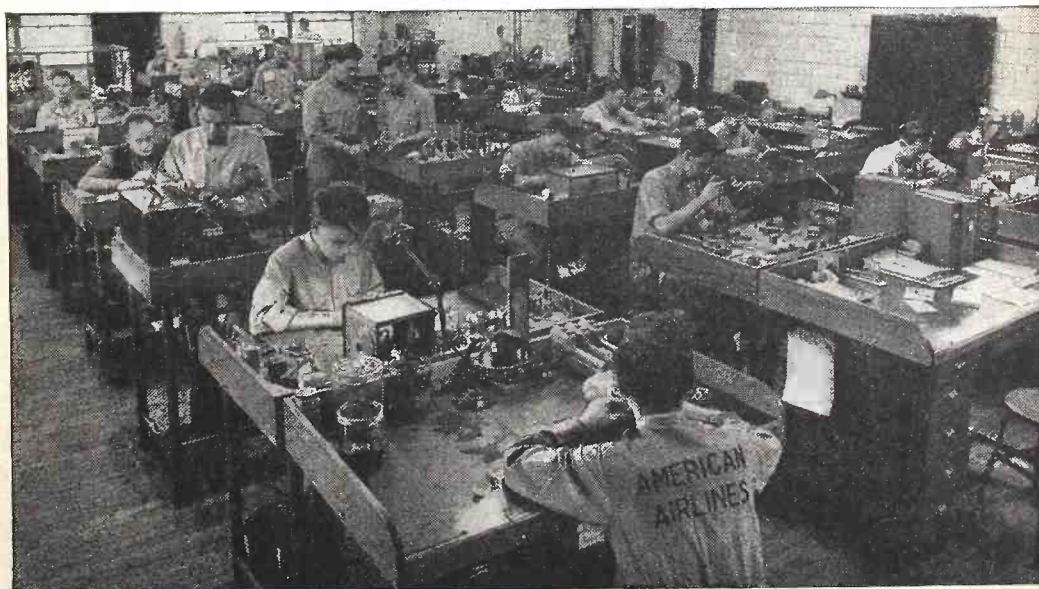

Courtesy American Airlines

This tremendous service shop illustrates working conditions of aircraft radio mechanics.

TELEVISION and THE AMATEUR

By LAURENCE SCHWAB, JR.

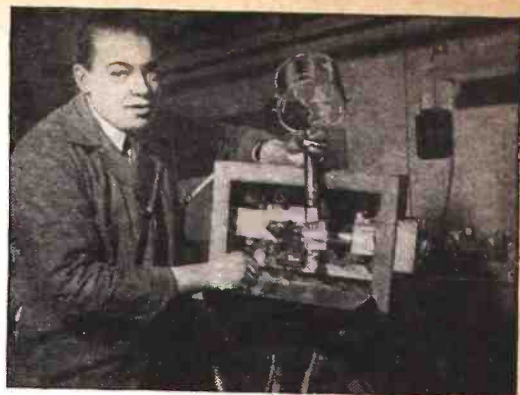

Parts layout of Still's television camera.

THE amateur radio operators of the world have played an important role in bringing radio to its present high degree of perfection. Their contribution and attitude towards the new and fascinating field of television has been and will be equally significant. Prior to the war, "hams" were experimenting with iconoscopes and kinescopes and before that, mechanical scanning devices. Many built



Mr. Still televises the author with camera which he designed and constructed himself.

their own receivers and transmitters which worked remarkably well considering that they lacked the money and equipment invested prodigally by commercial engineers.

A tragedy in television was the death of the well-known amateur, Ross A. Hull, OA3JU. At the time of his tragic death in 1931, he was engaged in television reception tests which later proved to be of tremendous value to the electronic industry. He was able to receive images at his home near Hartford, Connecticut, sent from an RCA experimental station located 100 miles away. This DX was a milestone in

the history of video. It was while Hull was engaged in these tests that he came in direct contact with the high voltage power supply of his experimental receiver and was instantly electrocuted.

Hull's endeavors were not forgotten. They were adapted, improved upon and utilized by amateurs and engineers interested in television.

A collaborator of Hull's was James J. Lamb, W1AL. After Hull's death Lamb carried on alone, making satisfactory use of the mechanical scanning method and later of the cathode ray tube.

Philip Rosenblatt, W2AKF, designed and constructed a high voltage power supply for video use that was not only fool-proof from a safety to personnel view, but also had the qualities of being capable of a good percentage of regulation while delivering high voltage.

The first comprehensive written treatment on the use of the modern cathode ray tube principle, was compiled by a competent amateur in 1937. This "ham" was Marshall P. Wilder, W2KJL.

AMATEUR TELEVISION PIONEER

A present leader in the field of amateur television is Mr. William Still, W2GJR, of Jamaica, New York. Still has been active in television since 1937. He has performed experiments in color, film scanning, mechanical scanning, and has perfected service equipment for television trouble shooting. For the most part Still has used RCA tubes 1847, 1848, 1849 and 1850. He shows preference for RCA tube 1848 because of its high amplification factor and good sensitivity to varying shades of black and white.

Some of this amateur's achievements in television are:

Invention of an electronic film scanner

which televises film at the standard camera speed of 24 frames per second instead of the television rate of 30 frames per second. This scanner, when released, will replace the less efficient scanner now used.

Still was the first amateur to install a television receiver in an automobile. That was in 1940. Reception was good after ignition QRM was filtered out. The kinescope used gave a five-inch raster. Power came from a dynamotor which ran from the car's battery (6 volts). He aided the Metropolitan Police Department in working out plans for the installation and operation of television equipment in patrol cars to facilitate apprehension of criminals and location of missing persons.

Still was the first amateur to send a television signal out on the assigned amateur experimental band. At present he has a permit to operate station W2XJT on Channel 13 (230-236 mcs.).

Prior to the war, he built experimental television kits which sold for around \$65 and were valuable to amateurs interested in experimentation.

Keystone of Still's activities is simplification. For instance, ninety tubes are needed in synchronization circuits of the modern television transmitter. Using Still's method the same synchronization can be obtained with only thirty tubes.

ANOTHER ACTIVE AMATEUR

Howard C. Lawrence, W2IUP, an RCA engineer and radio "ham," described, built and operated an inexpensive and simple deflection and video channel. The elucidations given by Mr. Lawrence met with immediate approval and many new amateurs were added to the already expanding number delving into the mysteries of sight transmission.

In 1940 one of the outstanding accomplishments in television by amateurs was demonstrated at the New York World's Fair. It was the inauguration of the first two-way communication using both video and audio. This was carried on by amateur station W2USA at the Fair grounds and station W2DKJ/2, the latter station being located approximately eight miles from the Fair. Television transmission took place in the 112-mc band and voice, which was frequency-modulated, was transmitted in the 56-mc region.

A URUGUAYAN EXPERIMENTER

While television amateurs were experimenting in the United States, foreign amateurs were also doing work in their own countries. One in particular deserves mention. His name, Mario Giampietro. He first started working on television in 1930, using neon lights and the Baird system of mechanical scanning, operating on 1000 kcs near his home city of Montevideo,

(Continued on page 583)



W2USA, engaged in conducting tests with W2DKJ/2 at the New York World's Fair in 1940.

No Selectivity in This Radio

By I. QUEEN

THE importance of selectivity has been stressed in radio texts and periodicals since the earliest days. Even sensitivity is sometimes considered of little value unless adequate selectivity exists. Now we are confronted with a receiver which makes use of absolutely no selectivity at all! Such a receiver promises to revolutionize radio, since it makes possible reception from all transmitters within a given band, each affecting the receiver equally and simultaneously.

This radio system has been in operation for several years and has given an excellent account of itself as a war weapon. The panoramic radio also offers powerful possibilities in peace-time communications, amateur, broadcast, aircraft and research fields. Briefly, it is a method which permits visual monitoring of all radio energy within range of a radio antenna, covering a desired band of frequencies.

Each transmitter produces a line on an oscilloscope, its position indicating the frequency, its height showing intensity and its width denoting whether it is being modulated. It is also possible to tell whether code is being transmitted and sometimes to read it directly. An entire band may be instantaneously monitored, thus making it possible for Signal Corps personnel to detect enemy transmissions, for aircraft to determine position, for radio amateurs to pick up a "CQ" or an answer thereto, for research workers for determining field intensity, and for the short-wave listener in seeking new stations.

Fig. 1 shows a basic form of panoramic superheterodyne. The stages are, in order, an oscillator-detector, I.F. second detector and an A.F. stage feeding into a speaker.

Oscillator and input circuits are ganged as usual. In addition to A and B, the usual tuning capacitances, additional shunting circuits are included (by closing the DPST switch). Each of these is composed of a normally fixed (manually operated) condenser and a rotating condenser turning with motor M. The ratio of one to the other determines the change in capacitance (band width) as the motor turns over.

When the motor is turned on, the receiver rapidly and continuously sweeps the band. On the same shaft is mounted a commutator wheel contacted by a brush. Half of the commutator W is insulated, the other half conducting. When insulated from ground, condenser C charges gradually from the high-voltage source of the set. When the commutator rotates, allowing the brush to contact the conducting portion, C is grounded and discharges abruptly through a low resistance. The condenser voltage connects directly to the horizontal plates of the oscilloscope, deflecting the beam accordingly.

Timing is adjusted so that when the commutator is just changing from the conducting to insulated portion at the brush, maximum capacitance is obtained on the rotating condenser. Therefore, as C starts to charge, the receiver is tuned to its lowest frequency. As the beam travels to the right the frequency rises, until the entire band is scanned. If energy is received at any point, the beam will be deflected upwards at that point, its amplitude determined by the intensity. Fig. 2



Courtesy Panoramic Radio Corporation

The Panoramoscope uses electronic means of varying the sweep oscillator which produces the various traces on the screen.

shows relationship between angular displacement of the condenser and the deflection voltage.

A typical pattern is illustrated in Fig. 3.

The width of the received band is under the control of the operator. He can either change the ratio of capacitances (fixed to variable) in the shunt circuits across A and B so that the band has less or more width,

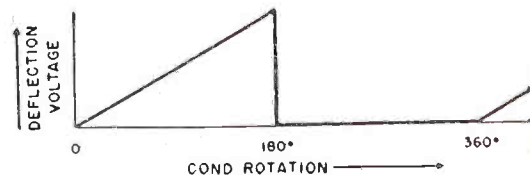

Fig. 2—Condenser rotation vs. deflection.

or he can increase the sweep voltage on the oscilloscope.

The sweep may also be varied by electronic means, as is done in the Panoramic receiver illustrated at the top of the page. In such cases the sweep technique is the same as that used to swing the frequency in FM, oscillator and reactance tubes shifting the signal across a range of frequencies, producing results similar to those of the rotating-condenser method just described. The Panoramic receiver uses a 30-cycle sweep,

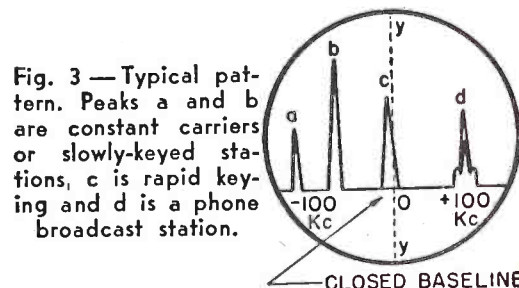

Fig. 3—Typical pattern. Peaks a and b are constant carriers or slowly-keyed stations, c is rapid keying and d is a phone broadcast station.

much faster than that afforded by mechanical devices. Electronic sweep is especially adapted to apparatus designed to cover a comparatively narrow frequency band intensively.

An interesting possibility includes means to displace the pattern on the screen so that the frequency received on the speaker always corresponds to that appearing at the center of the screen. This may be done as in Fig. 4. Here two channels are shown: a video channel which produces the image, and an audio channel for listening. If condensers 1 and 1a are ganged correctly, the audio signal heard will be the same as the one seen on the center axis Y (Fig. 3). As a check on this, the regeneration may be turned up to cause a whistle on the received frequency. This shows up on the screen as an added disturbance on the visual peak.

(Continued on page 598)

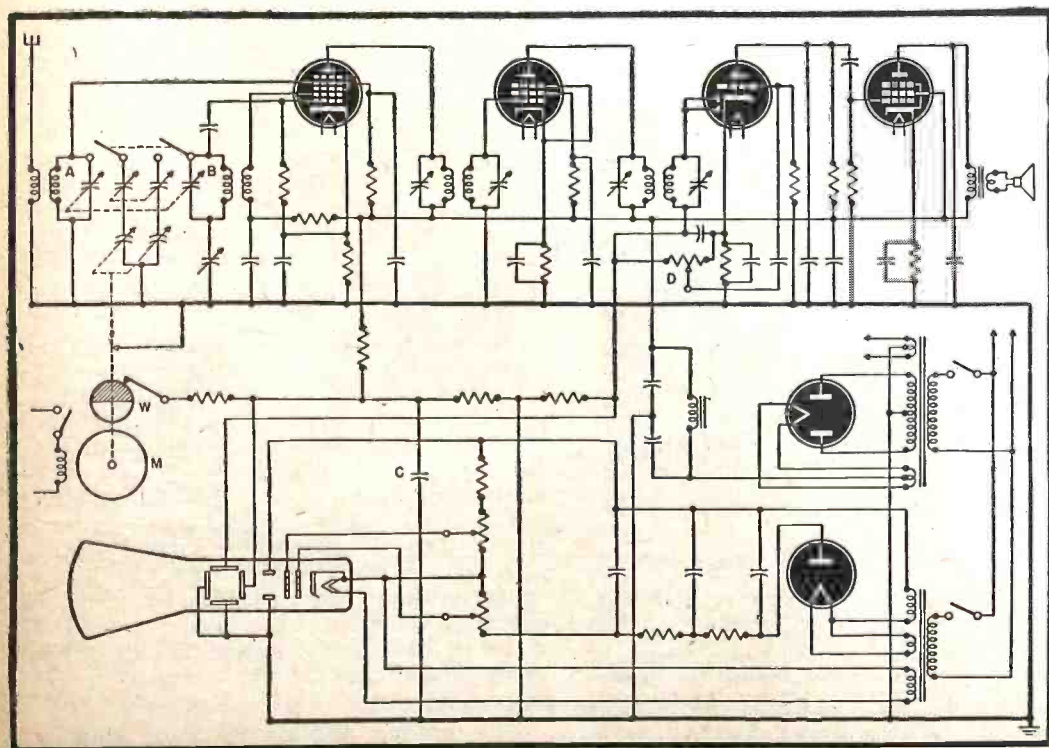

Fig. 1—Schematic of system which depends on mechanically varying the oscillator capacitor.

HANDIE AND WALKIE COMBAT PORTABLES

SOME confusion between the terms "Handie-Talkie" and "Walkie-Talkie" has existed ever since the newer device came into existence. Even *Radio-Craft* has used "Walkie-Talkie" when the hand-held device was obviously meant. Other than their main difference (that the Walkie-Talkie is a pack set and the Handie-Talkie is held in one hand) there are several other interesting points of similarity and dissimilarity between them.

These two units are radio transmitters and receivers. This means that each one is a separate receiver and a separate transmitter complete within a portable housing. Both units are battery operated. Each unit has its own antenna which is used for both receiving and sending radio messages. From there on, here are the main differences:

The Handie-Talkie is about the size of a narrow cracker box, 3 x 3 x 12 inches long. The Walkie-Talkie is about 17 inches high, twelve inches wide and about seven inches thick. The smaller Handie-Talkie weighs

a little over five pounds, and the larger Walkie-Talkie about thirty-five pounds. The Handie-Talkie is carried in the hand, the Walkie-Talkie on the back. Both are developments of the Galvin Mfg. Corporation, Chicago.

The mouth and ear piece are attached to the Handie-Talkie while the Walkie-Talkie has connections into which are plugged the hand set (similar to a cradle type telephone set) and an earphone head set can also be attached. The range of the Handie Talkie is less than that of the more powerful Walkie Talkie.

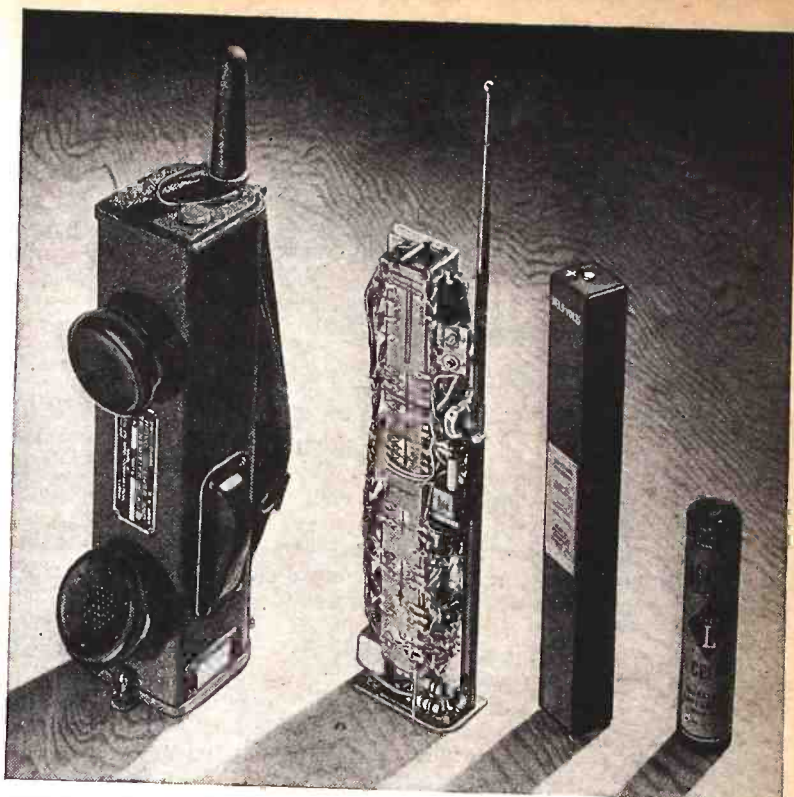

Inside and outside views of Motorola Handie-Talkie and batteries.

Both are 2-way radio communication sets, which means that one person can transmit and also listen to another who is transmitting. When using, one person talks and the other listens. When through, the other person may talk while the first one listens. The reason for this is that the sets are tuned to the same wave length and if both were to transmit at the same time, the waves would be jammed.

On the battle-field, the Handie-Talkie and the Walkie-Talkie are assigned different wave lengths. Each pair or more of the sets also have their own wave lengths assigned for certain sections of the battle-front so that the sets used by different companies or divisions will not interfere with each other. Wave lengths are changed frequently to avoid detection by the enemy.

Both sets are known as "fighting" radio sets because they are carried by soldiers into close proximity of the enemy. The easy portability of the Handie-Talkie permits the carrier to use his hands for other purposes when required so that it is frequently carried by the first line of advancing infantry. The Walkie-Talkie is also portable and is used more for front line command post communications than for actual front line activity though there have been cases recorded when the Walkie-Talkies were used in advance of our front lines. It is also used frequently in landing operations. Hence their appropriate nicknames, "The Fightingest Radios in the War."

This old type Walkie-Talkie was designed for both sending and receiving 2-way radio-telephone messages for distances up to five miles, but it was an A-M set and static and other electrical disturbances interfered and the message did not always get through. Tests were then made of the comparative advantages of using FM and AM sets with FM eventually getting the Signal Corps' approval. It was revealed that FM had a range advantage over AM under identical operating conditions. At extreme range, FM was 4 to 3 above AM in intelligibility while at medium range FM was 3 to 2 over AM in intelligibility.

The present Walkie-Talkie is smaller, more compact and efficient, yet more power-

(Continued on page 599)

THIS MONTH'S COVER



Signal Corps Photo

INFANTRY advances across beach under simulated fire while naval beachmaster and signal man direct traffic, during amphibious training at Cove Point, Md. RADIO-CRAFT selected this fine action photograph as a basis for the front cover of this issue. For patriotic purposes a few changes were made and there has been added an infantryman with a Walkie-Talkie on his back. The photograph above shows an infantryman in the foxhole holding a Handie-Talkie in his left hand, the rifle in his right. During action in both the European and Pacific theatres of war, frequently both Walkie-Talkies and Handie-Talkies are used at advance posts. Reason: the Handie-Talkie has only a short range of a few miles, whereas the Walkie-Talkie covers much greater distances. The message on our front cover is signed by the five-star military leaders: General G. C. Marshall, Admiral William D. Leahy, General Douglas MacArthur, Admiral E. J. King, General Dwight D. Eisenhower, Admiral C. W. Nimitz, General H. H. Arnold. RADIO-CRAFT brings you this message on the occasion of the Seventh War Loan drive in cooperation with the Treasury Department.

"PHOTOPULSE"

A Stroboscopic Light Generator for the Technician

By E. LLOYD THOMAS*

ALTHOUGH commercial general purpose stroboscopic light generators have been available for some time, there is a considerable demand for a simple instrument of moderate performance. This instrument was developed to meet the needs of general experimental work and production testing.

After consideration of the various mechanical and electrical methods of producing a pulsating light source, an entirely electronic system was adopted. From the basic circuit shown in Fig. 1 it will be seen

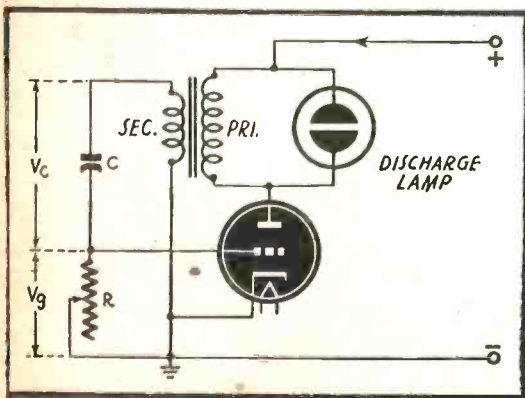

Fig. 1—The fundamental stroboscopic circuit.

that the pulse generator consists of a single tube connected as a blocking-grid oscillator and coupled to a gas-discharge lamp.

The action of the circuit may be followed by considering what happens when the high-voltage supply is switched on. The transformer is connected so that as the plate current begins to rise, the e.m.f. induced

in its secondary tends to drive the grid of the tube positive with respect to its cathode. This accelerates the increase of the plate current, which, since the action is cumulative, rises sharply to a maximum value limited only by the total D.C. resistance of the plate circuit and the value of the high-voltage supply. Meanwhile, the positive excursion of the grid potential is limited by the fall in the input resistance of the tube which accompanies it, and the resulting flow of grid current charges the capacitor C. The sudden pulse of plate current sets up a train of damped oscillations in the transformer, so that, after the current has reached its peak value, the e.m.f. begins to decrease. As it does so the grid is driven rapidly negative, well beyond cut-off, and the plate current drops back again to zero. Now, providing the time constant of C with the resistance of the grid leak R is large enough, the oscillations in the transformer will die away more rapidly than the large negative bias on the tube, which will remain in a non-conducting state while the charge on C leaks away through R. After this interval, when the grid voltage has fallen to the cut-off point, the cycle will be repeated and the tube will pass another pulse of current.

Each pulse cycle is made up, therefore, of two distinct parts: a short active period, followed by a much longer interval of quiescence. While the pulse duration is determined partly by the characteristics of the transformer and partly by the time constant due to the capacitor charging through the input resistance of the tube, the pulse frequency is controlled mainly by the time constant of the same capacitor discharging through the grid leak. For clear, sharp

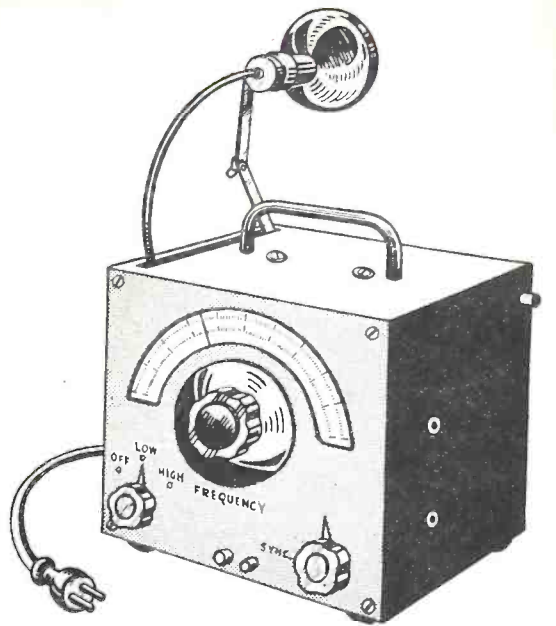

The stroboscope is portable and adjustable.

images the ratio of the active period should be as small a part of the total cycle as can be achieved practically.

If the circuit constants are suitably chosen the pulse is very sudden, and a large e.m.f.—of the order of several hundred volts—is induced in the plate winding of the transformer. Since the discharge lamp is connected in parallel with this winding, the potential difference developed across it each time a pulse occurs causes it to emit a momentary flash of light.

THE PULSING RATIO

A consideration of grid circuit conditions shows that the pulse duration cannot be much less than one half of the period of damped oscillations in the transformer. This means that the natural frequency of the transformer must be at least twenty-five times the pulse frequency if the pulse ratio is not to exceed 2 per cent. If, for example, the transformer construction follows normal A.F. practice, its natural frequency will not be less than 5 Kc. and the circuit will operate satisfactorily up to a frequency of about 200 cycles. There is no difficulty in working at much higher frequencies if the transformer is suitably designed.

The pulse duration will only approach this minimum value, however, if the charging time constant of the grid capacitor is comparatively small. Otherwise this capacitor will take an appreciable time to charge during the active part of each cycle, and the pulse duration will be increased. In order to secure maximum illumination it is advisable, therefore, first to choose a value for C that will make the pulse duration as large as can be tolerated, and then to adjust R to give the desired frequency.

The basic circuit of Fig. 1 has one disadvantage when it is intended to make the pulse frequency continuously variable. If this is brought about in the most convenient way, by making the value of C fixed and that of R variable, then the pulse duration remains constant while the frequency changes, and the brightness of the lamp becomes directly proportional to the frequency. Fortunately this effect, which makes the illumination fall off at low frequencies, can be compensated for very simply by feeding the high-voltage supply to the system through an RC combination similar to an ordinary decoupling circuit. This causes the effective plate voltage to be inversely proportional to the average value of the plate current, so that an increase in pulse frequency brings about a decrease

(Continued on page 594)

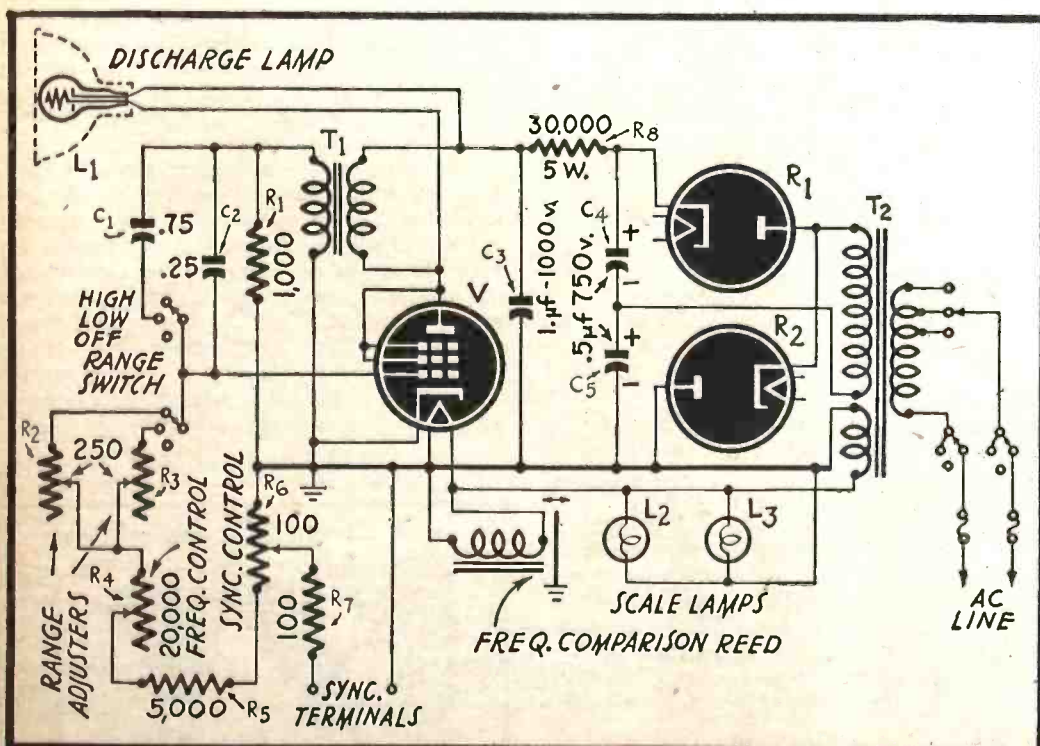

R1—1,000 ohms; R2, R3—250 ohms max; R4—20,000 ohms, log. taper; R5—5,000 ohms; R6, R7—100 ohms max; R8—30,000 ohms, 5 watts. C1—0.75 mf; C2—0.25 mf; C3—1.0 mf, 1,000-volt; C4, C5—0.5 mf, 750-volt. V—See text; R1, R2—Any suitable rectifiers; L1—Neon lamp, without resistance; L2, L3—6.3 volt, 0.3 amp. pilot lamps.

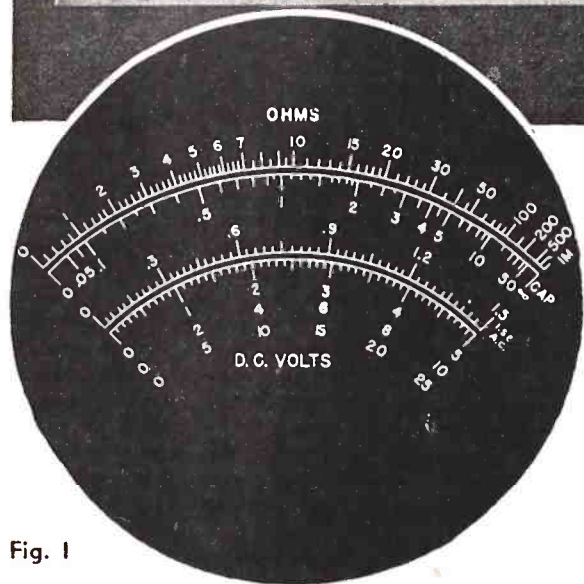
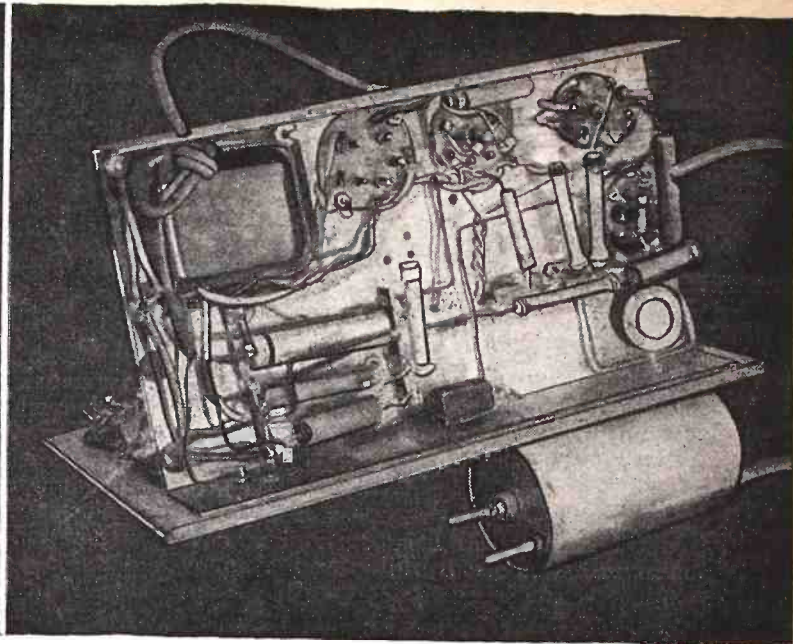
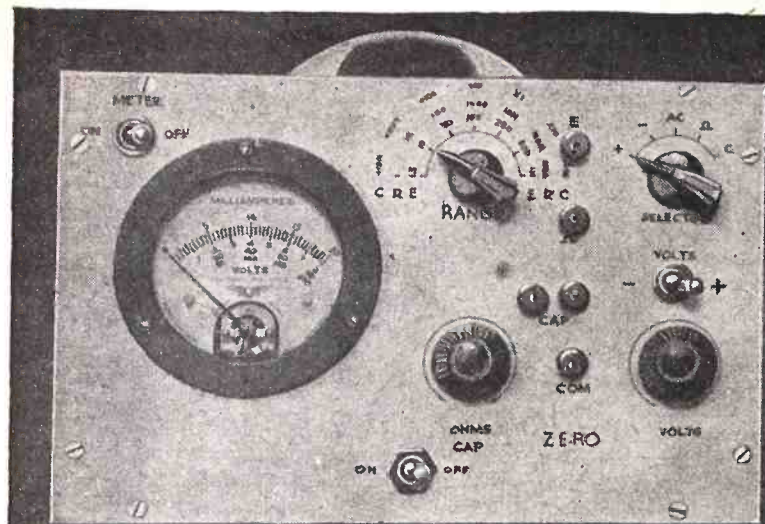

AN ELECTRONIC "OMNICHECKER"

PART I—PRINCIPLES AND CIRCUITS

By ROBERT E. ALTOMARE*

Fig. 1

COMPLEX modern high-gain circuits have created a thirst for sensitivity hitherto unknown in instruments of a practical nature. A test instrument of unusual sensitivity and range can be constructed by anyone who has a low range milliammeter up to and including 5 Ma.; and those owning a 1000-ohm volt tester—which uses a 1 Ma. meter—are urged to consider the circuit so they may increase available ranges and sensitivity.

The instrument used by the writer for many years consisted of two tubes in a Wynn-Williams bridge circuit. A voltage regulator tube and a sensitive 200-micro-ampere meter were used to obtain essentially the same ranges and sensitivity available in the instrument to be described. Voltage regulator tubes are now hard to obtain and this is true many times over of the micro-ammeter.

To eliminate the voltage regulator tube and permit the use of a much less sensitive movement the instrument was redesigned, reconstructed and improved in general, much to the satisfaction of the writer. The

*Instructor in Charge of Service Engineering, Capitol Radio Engineering Institute, Washington, D. C.

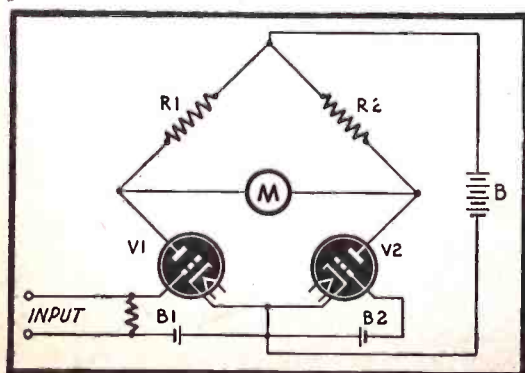

Fig. 2—The original balanced-bridge circuit.

present instrument has been in operation for many months and has given more than satisfactory results. All the "bugs" have been eliminated and the instrument is considered foolproof.

A photograph of the instrument with R.F. probe is shown at top of page. The arrangement of meter and dials shown does not necessarily have to be followed; and the cabinet shown was used only because it was available. It is recommended, however, that a metallic cabinet be used if possible to exclude stray fields and to shield the instrument in general.

RANGES PROVIDED

D.C. Vacuum Tube Voltmeter with input sensitivity of 11 megohms.

Ranges: 0-1.5, 10, 50, 100, 250, 500 and 1000 volts.

A.C. and R.F. Vacuum Tube Voltmeter: sensitivity essentially 5 megohms on low frequency this reducing to approximately 2 megohms at R.F. (1700 KC).

Ranges: 0-1.5, 10, 50, 100, 500 and 1000 volts.

Vacuum Tube Ohmmeter: 7 ranges from 0-1000 ohms to 0-1000 megohms.

Vacuum Tube Capacity Meter: Direct reading 7 ranges, .000005-.005 μ f to 5-5000 μ f.

A meter dial scale appears in Fig. 1. Thus readers of *Radio-Craft* need but cut out the imprint and carefully paste it over the original dial of their meters. The print may be photostated and enlarged to fit the bulk of available meters. Most equipment builders fail when it comes to calibrating and drawing a neat and accurate scale for their instruments. Fig. 1 should correct this difficulty.

The "heart" of the instrument is a bridge type D.C. amplifier built around a one Ma. meter. The allied circuits are designed to operate best around this amplifier as a center. Later, instructions will be outlined for

the benefit of those who are desirous of using a meter movement less sensitive than the one Ma. movement.

The basis of the D.C. amplifier is the Wynn-Williams bridge circuit shown in Fig. 2. In this circuit vacuum tubes replace the usual resistor arms of a Wheatstone bridge. R1 and R2 are made equal; the tubes are biased so their internal resistances are equal. As a result meter M reads zero. A D.C. voltage applied to the input circuit changes the apparent plate resistance of V1, upsetting the balance and allowing the meter to register the amount of unbalance. This circuit is not subject to random changes in circuit parameters. A voltage regulator tube in the power supply further increases the stability.

The extremely sensitive movement as well as the voltage regulator tube cause this circuit to be undesirable, owing to present-day scarcities in these products. To obviate these disadvantages the circuit was modified and rearranged. Consideration was given the RCA Volt-Ohmyst circuit which utilizes a rather high resistance in the cathode returns of the voltmeter amplifier tubes. A positive voltage nearly equal to the drop across this resistance is applied

(Continued on page 592)

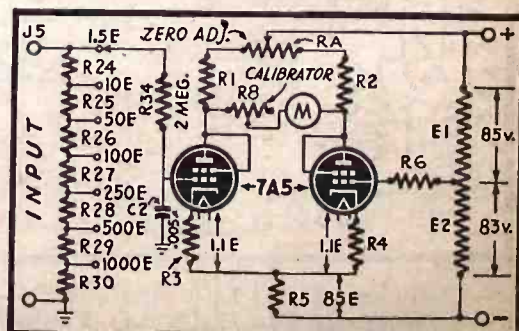
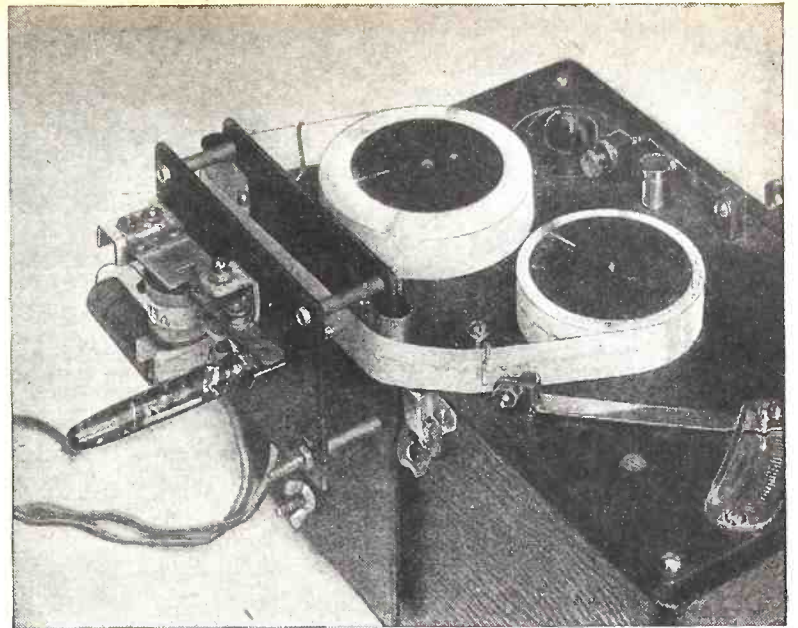
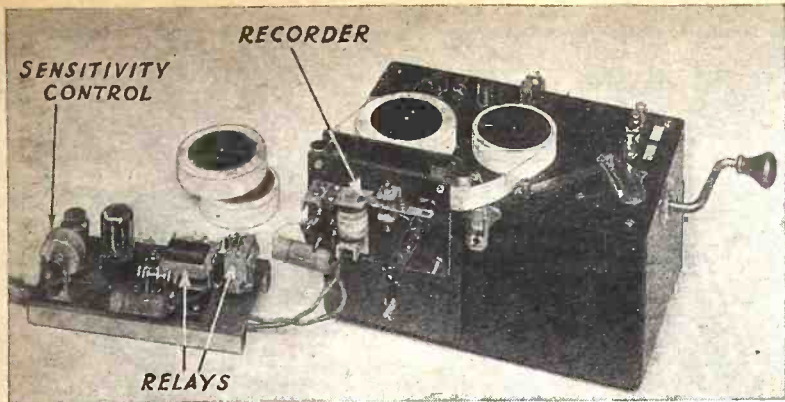

Fig. 3—The instrument's fundamental circuit.



Left—The amplifier and recorder together take up very little space. An old code-teaching machine is used as tape puller. Above—Clearer detail on the recorder unit and pen-holding device.

Non-Priority Code Recorder

By BOB MELVIN

HERE is a code tape recorder you can construct from odds and ends. It will record with fidelity up to 50 words per minute. With this machine you can improve your sending by key or bug. It can also be connected to a short wave receiver, with proper relays and amplifier, so that it will record code directly from the radio to be transcribed later.

The construction of the recorder is very simple. It uses an electromagnet to vibrate a fountain pen in a vertical direction while a paper tape moves slowly in a horizontal direction, thus forming dots and dashes.

The first and most important consideration in the construction is the tape puller. The author used an Instructograph Jr. code practice machine, but a slow speed motor, either spring or electric, with continuously variable speed from 0-25 r.p.m., will do.

As most of the construction will depend on the physical features of the tape puller, the tape guides and manner of mounting the recorder unit will be left to the reader. With the photographs as a guide, he should have little difficulty.

The recorder unit was built on two pieces of Masonite. On the front piece (3 x 4½ x ⅛-inch) brackets were mounted to hold the armature, electro-magnet and adjustable stop. These brackets are made of 1/16-inch steel but should be even stronger. The electro-magnet and armature came from one of the relays in the cutout can of a 1939 or 1940 Ford. The electromagnet has a winding of one inch in length on a ⅜-inch soft iron core. It is of No. 30 wire with a total resistance of 12 ohms. The armature has a piece of spring metal riveted onto it, which provides the pen with return action. A piece of 1/16 x ½ x 2-inch strip of iron is soldered onto the armature and this, with a bent piece and an adjustable screw, form the pen holder. The pen is an ordinary fountain pen using ordinary ink. The pen point

should be slightly filed so that it will write smoothly when perpendicular to the tape. It passes through a hole on the Masonite to write on the tape which is guided by tinfoil guides as seen in the photographs.

The back piece of Masonite has slots to adjust the position of the pen relative to the paper, making it possible to write three or four rows of code on each side of the tape. Spools of 2 to 2½ inches in diameter ¾-inch thick made of hardwood, were used.

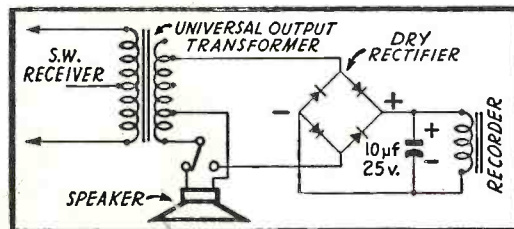

Fig. 2—Hookup for recording from receiver.

The tape is about ¼-inch wide and is made by splitting fifteen-cent rolls of 2⅜-inch adding machine paper into three strips by using two razor blades and the proper tape guides mounted on a suitable board. The strips are 800 to 900 feet in length, which when recorded on both sides with three rows of code to a side, provide a very economical method of recording.

The amplifier is connected to the diode circuit of any good receiver, as shown in Fig. 1. It can be connected straight across the output of a smaller short-wave receiver, such as the common two-tube regenerator. Better results will be obtained with receivers using AVC as the output to the amplifier will not vary as much.

For recording from the air the D.C. amplifier with relays shown has proven satisfactory when connected to the diode rectifier on a super-het. with the AVC shorted

out. The relays and recorder should be provided with 0.1 mfd. condensers to keep the relays from sticking and prevent radio interference.

Because the power requirement is 6 volts D.C. at ½ ampere, some readers might hesitate to build this device. It was found, however, that the recorder would operate quite nicely without a battery, by using a dry rectifier to rectify the output of a shortwave receiver of five or six watts output. To record in this manner the signal must be tuned in and the output transformer disconnected from the loud-speaker and connected to the rectifier by means of a suitable switch. The rectifier should be connected to the 15- or 20-ohm tap on the transformer.

Circuit is shown in Fig. 2. Since the current flow is high, the small meter-type rectifiers will not be satisfactory. Those from old battery-chargers or certain loud-speakers work well. Even a broken-down unit may sometimes be used, by checking with an ohmmeter for shorted sections and removing them. Test first one way, then the other, across each pair of discs. In a good unit the resistance is much higher in one direction than the other.

When building a recorder of this type, the reader will find that many improvements will suggest themselves.

WHO COINED THE WORD "RADIO"?

There has been a good deal of controversy over who was the first to use the word "radio" in connection with radio as we know it today.

Originally as will be remembered, the word in universal use was WIRELESS. This later on was changed into the word RADIO, and has remained in use ever since.

It appears that the honors should go to Donald McNicol, who was the first in this country to use the word "radio," in the title of a series of articles which appeared in the publication, WESTERN ELECTRICIAN, Chicago, in the period of 1906-1907. The article was entitled:

WIRELESS OR RADIO TELEGRAPHY
By Donald McNicol

A modern American battleship uses more than 1700 electron tubes for communications and other purposes.

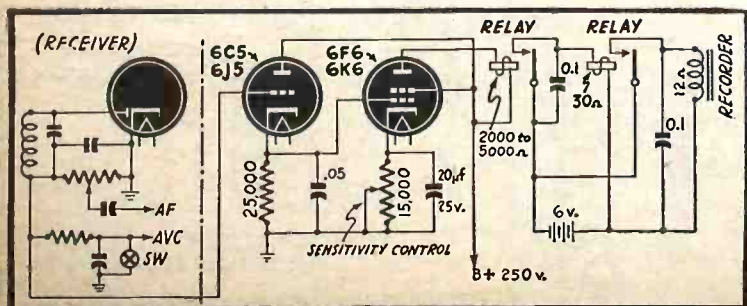
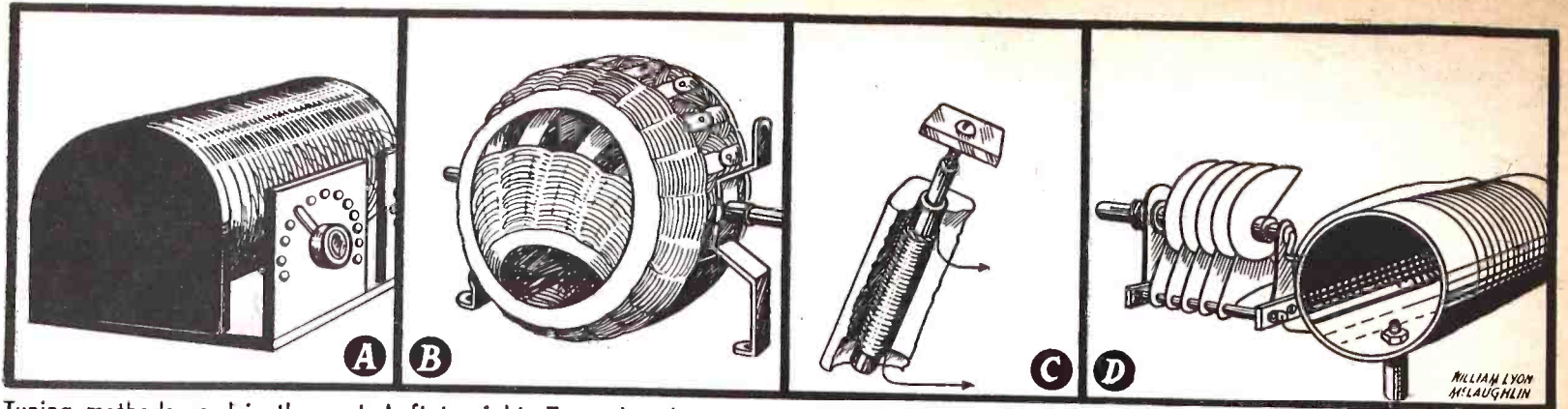

Fig. 1—The amplifier circuit. Parts at left of dashed line are from original receiver. Left relay is a high-impedance unit; right, a low-impedance one.



Tuning methods used in the past. Left to right: Tapped coil; variometer; a permeability tuner and the standard coil-condenser method.

Tuning on the U.H.F.

By I. QUEEN

THE resonant frequency of series tuned circuits is varied by changing either capacitance, inductance or a combination of them, the fundamental formula being expressed $f = \frac{1}{2\pi\sqrt{LC}}$

Methods which are used are: Sketches A-D tapped coil, variometer, permeability tuning, and the "standard" variable capacitance circuits.

The first tunes by steps, but is simple, and may be used in conjunction with a crystal receiver and home-made coils or where reception of only two or three high-power

denser circuits are ease of ganging convenience of manufacture, and low loss, as well as the reasonable range of frequencies which may be covered by a single turn of the dial. A variation of this method is automatic push-button tuning wherein small condenser trimmers are pre-set and switched in for desired stations.

FOR HIGHER FREQUENCIES

When oscillators, received or transmitters are designed for the higher frequencies, mechanical and electrical difficulties appear. Both L and C must be made inconveniently small and special precautions taken to decrease losses and body capacity. It should be remembered that tubes and wiring present a definite L and C of their own, which becomes important at such frequencies.

One method used by amateurs in pre-war transmission and reception consisted of an assembly such as Fig. 1. The tuning coil is decreased to a single turn and the condenser to two small plates, one stationary. A long insulated shaft controls the other plate. All unnecessary supports are eliminated and only low-loss material such as polystyrene can be tolerated as insulation.

At frequencies of the order of 250 Mc, this circuit begins to show comparatively

low values of $Q = \left(\frac{\text{reactance}}{\text{resistance}} \right)$ due to

transit time differences. It may at first glance seem a trivial matter, but theory shows that electrons situated at the center of one condenser plate will reach the other condenser plate before electrons which happen to be at an edge, and the optimum effect will not be obtained.

An improvement is due to two inventors, R. L. Harvey and H. G. Fisher, who have developed the circuit shown in Fig. 2 and sketch E, where L and C are distributed. The space-wound flat spiral S may be of phosphor bronze or silver-plated steel, the end of which is controlled for tuning by a winch W and cord C. The spiral may be contracted or expanded by winding up the cord.

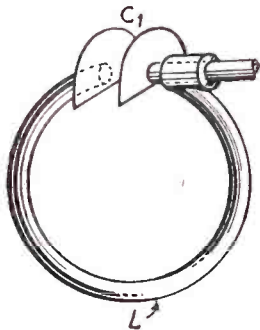

Fig. 1—An early method of shortwave tuning.

ered stations is desired. The second offers mechanical difficulties, but permits gradual control and can be constructed to give zero inductance. The variation is due to mutual inductance which aids or opposes as the rotor turns within the stator.

Permeability tuning generally has only a limited range of control and has lower losses than the two previously mentioned methods. Tuning takes place as a result of the relative movement within a coil of a powdered iron core.

The great advantages of variable con-

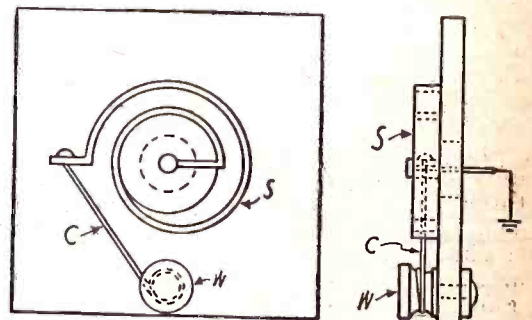

Fig. 2—A capacity-inductance variometer.

Typical Q values obtainable with the circuit are plotted in Fig. 3, which may be contrasted with a typical Q of about 200 at 250 Mc for Fig. 2. Typical ribbon dimensions are 1/4 inch width and 3 1/2 inches total length.

THE BUTTERFLY CIRCUIT

General Radio Co. recently introduced a novel tuning unit which may be used for oscillators, receivers, etc. It is known as the butterfly circuit from its general appearance and may be constructed to cover such frequency ranges as 220-1100 Mc and 900-3000 Mc with no moving contacts. Both L and C are varied simultaneously.

As illustrated in Fig. 4-a and sketch F,

(Continued on page 596)

Left—The capacity-inductance variometer circuit. Center—A General Radio butterfly tuner. Right—A circuit using transmission lines.

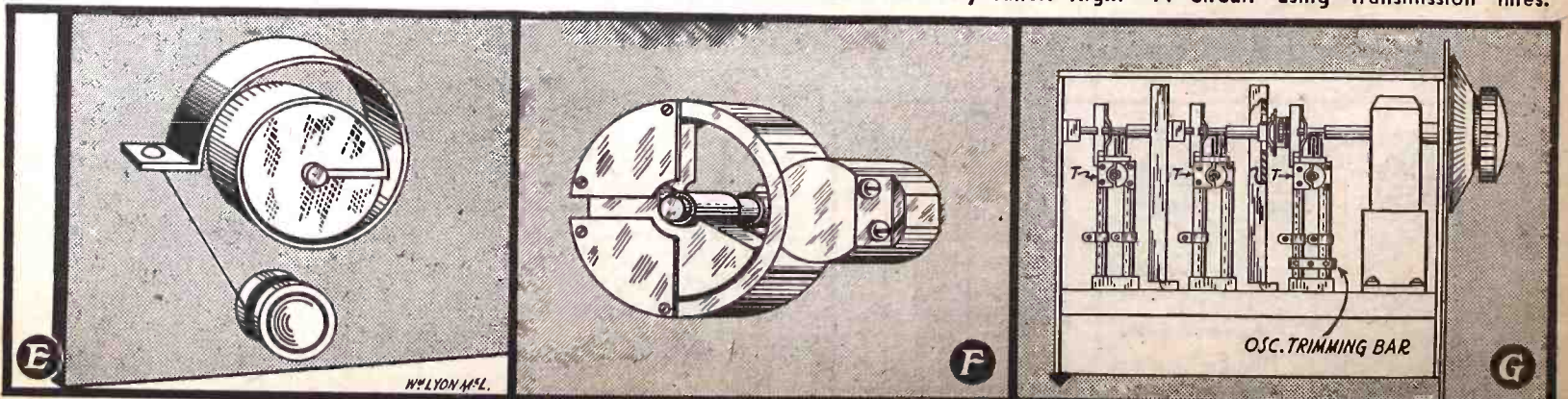

Cylinders For Better Sound

By NATHANIEL RHITA

ACOUSTIC design is concerned with the problem of maintaining clear and natural music and speech in auditoriums and studios. Investigations are carried on not only from the physical point of view but also from the subjective. The final opinion as to acoustic excellence comes from the audience. Acoustic measurements of the room will, of course, indicate general conditions existing and possible improvements to be made.

A listener sometimes has opinions which are the result of his special experience. One who is accustomed to music played in deadened rooms may not care for lively rooms at first. A flat frequency response might seem "unnatural" to one who has always listened to limited fidelity reproduction.

Less reverberation in any given room may be tolerated for speech, since the words must be free of interference from succeeding sounds. However, some reverberation must be present. Music, on the other hand, requires more reverberation, the resulting superposition of notes adding to harmony and making the music more pleasing.

Optimum reverberation time is therefore a major factor in acoustic design. Listening tests show that a different optimum exists for each size and type of room. It should be kept in mind that compromises may be necessary, however, since different types of music and instruments may require slightly different reverberation periods. For example, brass requires a different period than does string music. Also reproduced sounds require a shorter reverberation time than original sounds.

The well-known Sabine formula was formerly the basis of all acoustic design calculation. This formula takes into account the sound absorption due to each surface

in the room. By using surfaces made of material with a high absorption constant, the reverberation period could be decreased. The formula generally applies to rooms with flat surfaces.

Since absorption material usually introduces frequency discrimination, it is often found that the low frequencies are only slightly attenuated, while the highs almost disappear. The former could be brought down in most cases only by eliminating the latter entirely.

POLYCYLINDRICAL SURFACES

A new approach to the problem has recently been disclosed.* In use for several years, unusual results have been obtained by recording studios and broadcasting stations as well as auditoriums. Polycylindrical plywood panels are used as walls and ceiling to diffuse the sound waves and reflect them irregularly. Typical measurements and construction of such a panel are shown in Fig. 1. Segment braces are spaced at random with insulating material between them and the panelling to prevent rattles.

The theory (as well as the results) show that a number of improvements can be expected from these curved reflecting surfaces, although the plywood does not possess a high absorption constant. More uniform sound pressure distribution, better diffusion, greater absorption of low than high frequencies, less interference between direct and reflected sound and minimization of echoes are obtained with convex reflecting surfaces. Fig. 2 shows the comparison of interference characteristics of flat as

against curved panels. The reflections do not periodically add and subtract from the incident waves when the latter are used, to as great a degree.

The wave front is effectively diffused as is shown in Fig. 3 because the curved panels send the energy over a wide area. Flat panels reflect the sounds to a limited area, and some areas receive no energy.

Because of the haphazard reflections, the average room energy decays uniformly rather than in steps such as is assumed in the Sabine formula. This means, of course, more reflections per unit of time. Greater reverberation can be tolerated since successive sounds are not heard as being distinct but rather continuous until their final decay.

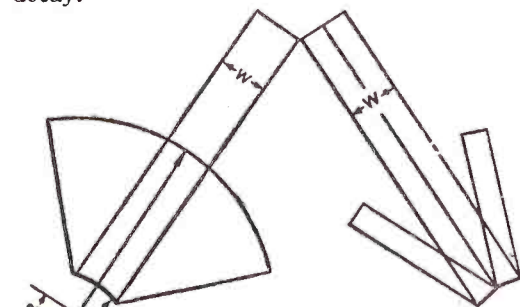
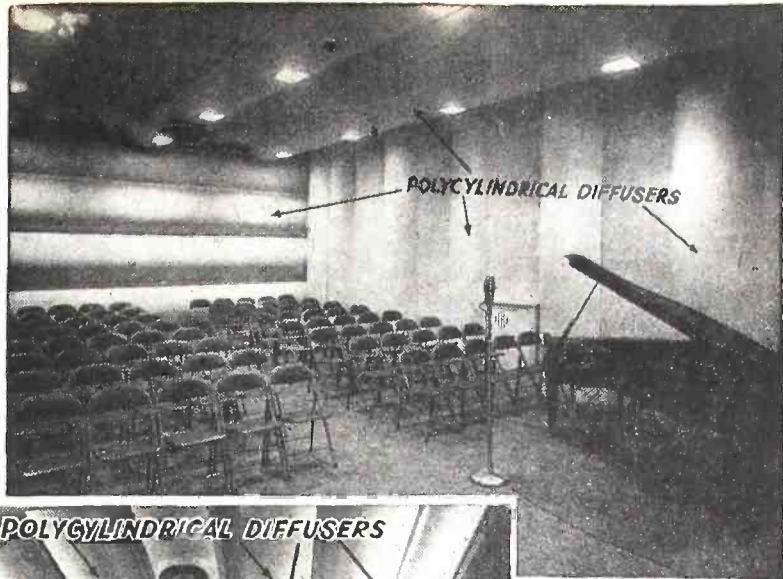

Fig. 2—Reflection from flat and curved surfaces.

Another important factor is the sounding-board effect. Each panel vibrates at a number of frequencies not harmonically related, especially at low frequencies. Since absorption usually takes place at the high frequencies, these two effects form an ex-

(Continued on page 608)



Courtesy Radio WHLD

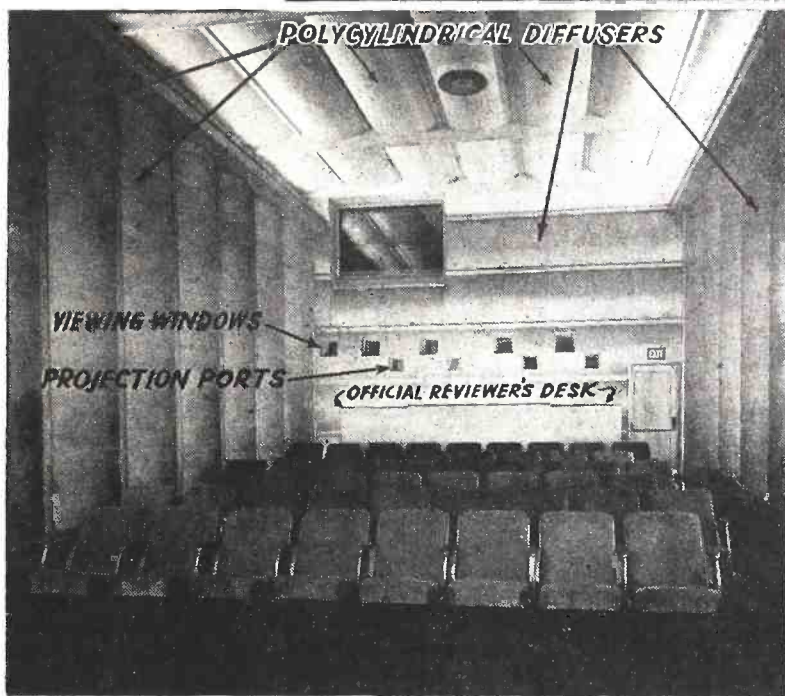

U. S. Navy Photo

Top — Polycylindrical diffusers in the studio of WHLD, Niagara Falls, New York.

Left—Review room at the Naval Air Station's Photographic Laboratory, located at Anacostia, D.C.

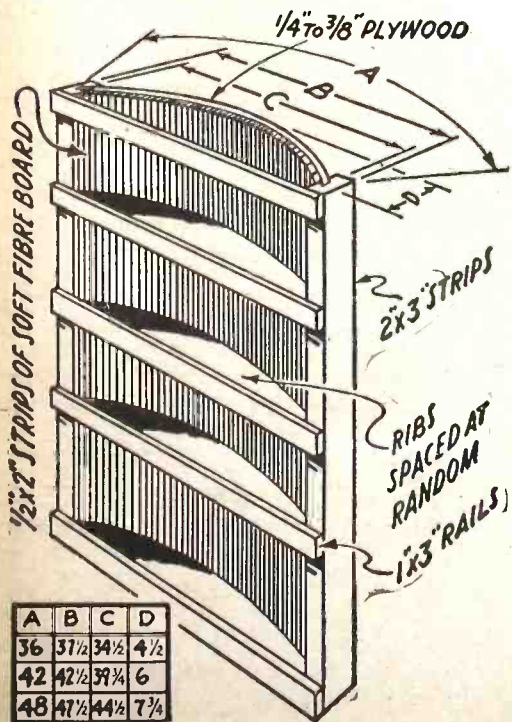

	A	B	C	D
36	37 1/2	34 1/2	4 1/2	
42	42 1/2	39 1/4	6	
48	47 1/2	44 1/2	7 1/4	

Fig. 1—Construction of a diffusing panel.

CATHODE FOLLOWERS

By O. E. CARLSON

This widely-known but little-used circuit will become very important in postwar television and other applications. Now is the time to study it

WITH the present wartime restrictions imposed on commercial and home type radio equipment, many developments in the line of military equipment will be reflected in postwar commercial television and radio.

Postwar commercial television will necessitate new knowledge for the Radio Service Man. Ultra-high-frequencies will be used for television, resulting in need for knowledge of applicable circuits.

One circuit which will come into considerable prominence with postwar television is the cathode follower, or cathode-coupled amplifier.

Conventional operation of vacuum tubes in amplifier circuits has stressed the problems of voltage amplification. Even power gains have been accomplished by voltage amplifiers of low voltage gain capabilities and the use of impedance step-down transformers.

It is often necessary to have some magnitude of voltage developed across a low value of load resistance or impedance. Such requirements, although not limited to, are prevalently found in various "pulse" voltage applications such as Television and Facsimile.

Let us first consider a typical audio or video amplifier stage. Fig. 1 shows such a

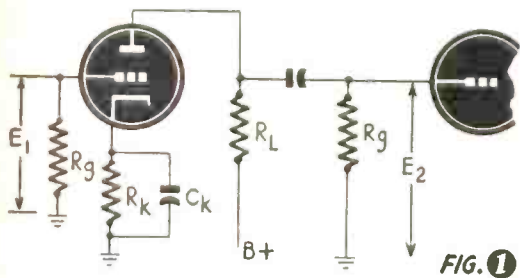

circuit. Over the flat portion of the frequency response curve of such a stage the gain is found by:

$$\text{Gain} = G_m - R_L \quad (1)$$

Now consider the circuit of Fig. 2. If R_k is an un-bypassed cathode resistor there will appear through it the same A.C. component of plate current as flows through the plate load resistor, R_L . With the tube functioning as a class A amplifier, the normal D.C. voltage across R_k is such that bias developed centers the operation of the tube

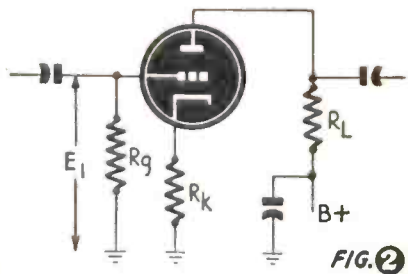

around the center portion of the straightest portion of the transfer characteristic curve. Maximum excitation, including that over which distortion would result, is then limited to that which would produce cut-off bias on the negative excitation peaks.

We might now make this circuit of Fig. 2 as in Fig. 3. Here we eliminate the plate load resistor and leave R_k un-bypassed. The A.C. component of plate current flows

through R_k so that an output voltage following the grid excitation voltage is developed across R_k . As the grid goes positive, more cathode current flows and vice versa. Thus the A.C. component of cathode current produces a voltage in phase with the applied grid voltage. The dotted line curve in Fig. 4 shows the cathode voltage variation with a single cycle of A.C. grid voltage.

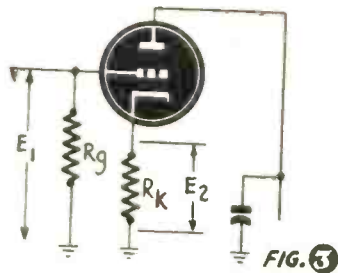

Looking again at Fig. 3, let us consider the fact of the grid-to-cathode impedance. The input voltage is applied across grid and cathode. The grid-to-cathode impedance is in series with R_k . If the grid-to-cathode impedance approaches zero, we approach the value R_k paralleling the voltage source. Or, we approach the condition where the cathode resistor effectively parallels the grid resistor and the source voltage. Since we know from Kirchoff, that the voltage across any element of a parallel network is the same, we can see that as the grid-to-cathode impedance approaches zero the A.C. voltage across R_k will approach the value of the applied alternating current grid voltage. Thus: THE VOLTAGE GAIN OF A CATHODE COUPLED AMPLIFIER MAY APPROACH BUT CANNOT EXCEED UNITY, OR 1.

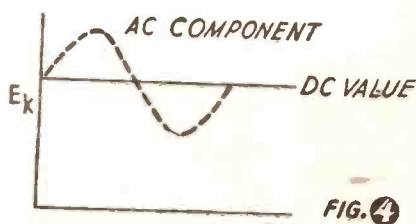

Now let us examine the equivalent circuit of Fig. 5. Here it may be seen that although the voltage across R_k cannot exceed the applied excitation voltage, that the current through R_k to cause that voltage may be affected by the value of E_b and the value of the resistance R_k . The smaller the value of R_k , the more plate current must flow for the A.C. component of I_b through R_k to equal a value approaching E_1 . Thus though the voltage E_{rk} is less than E_1 the large value of I_p through R_k results in considerable power. Assume an excitation voltage of 8 volts with a voltage gain of $\frac{1}{2}$ so that the A.C. component of voltage across a 100-ohm R_k is 4 volts. 4 volts across 100 ohms is the result of a 40 milliamper cathode current variation. The A.C. power in the resistor R_k is then $4 \times .04$ or .16 watts. Suppose this 8 volts of excitation were developed across a 10,000 ohm load resistor

in a preceding stage. The power would be $8 \times .0008$ or .0064 watts. Our power gain then is $.16/.0064$, or 25 times.

We thus have with the cathode coupled stage a power amplifier, which transfers the impedance of the previous output stage to some desired low value. In the above case we used a 100-to-1 step-down ratio for impedance and still effected a power gain of 25. This was done without an impedance-changing transformer. (Here is an emergency hint for a skilled serviceman faced with the "irreplaceable transformer" problem.)

The D.C. plate current flowing through the cathode resistor, R_k , may be blocked off from the final load circuit just as in a conventional resistance capacitance coupled amplifier. This is shown in Fig. 6 where the load is at the extreme end of a co-axial type transmission line. From that figure it may be seen that with this type of circuit one side of the load may be kept at ground potential.

Direct coupling of one stage to another may be employed as shown in Fig. 7. Here

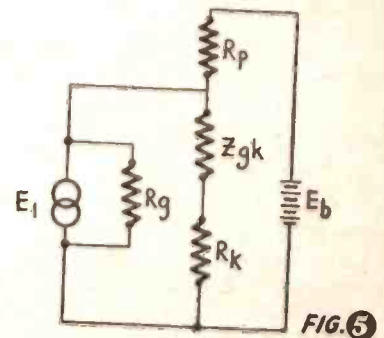

the output of one stage may be used as a source of output voltage for one load and as a driving source for another stage which may require a different output impedance. Such circuits are applicable to television synchronization circuits.

Briefly then, we may state that the cathode follower type of amplifier is an amplifier in which we derive the output voltage from across the cathode resistor. No plate load resistor is used, the plate being kept at

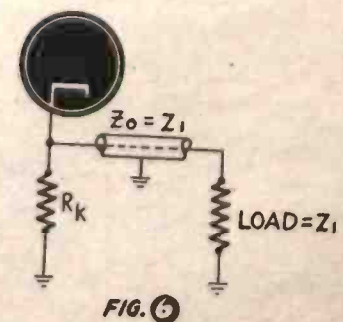

ground A.C. potential by the power supply filter capacitor or by a separate by-pass capacitor. Voltage gain may never exceed unity.

The value of cathode resistor necessary
(Continued on page 606)

Disc-Seal Tubes

By JOHN KEARNEY

A NEW development in radio is this tube which uses a unique form of construction which permits efficient high frequency operation. The new tube is illustrated in Fig. 1. The disc-like

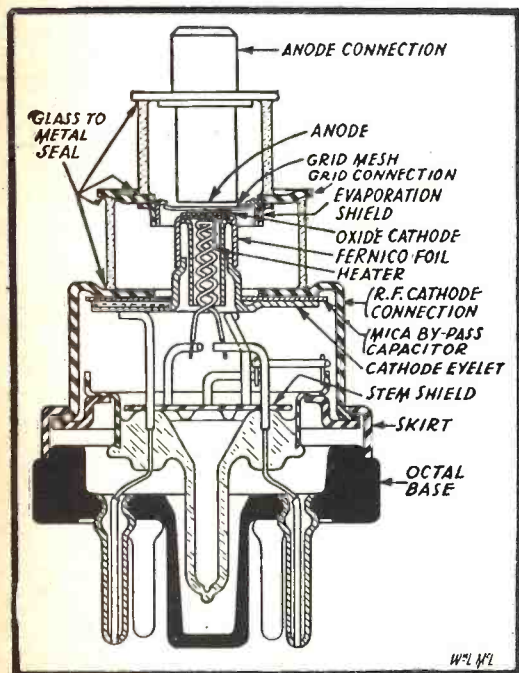

Fig. 1—The General Electric disc-seal tube.

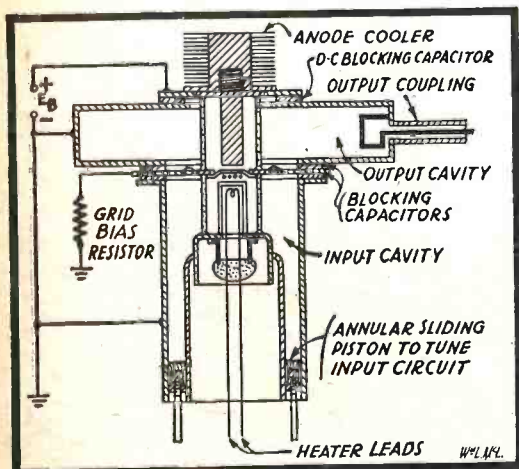

Fig. 2—A resonant-cavity transmitting tube.

construction is self-evident. The tube has a standard octal base, but the anode connection is at the top. In effect, the physical construction is like that of a standard tube, with the grid mesh perfectly horizontal, flat cathode and flat adjacent plate surface. Because of the small spacing between elements, electron transit time is reduced. In Fig. 2 a transmitter-type tube is shown.

To servicemen who have had amateur radio experience on low frequencies, the fundamental principles may be clear, but this tube is new. To understand its principles, you should know something about cavity resonators and distributed L and C at ultra-high frequencies. In going to a very high frequency, you may find first that the circuit of Fig. 3 serves fairly well, but as the frequency is raised still further the

values of L and C in the tuned circuit must be made very small, in fact so small that the coil and condenser must be abandoned. Some other means of securing the values must be used.

From fundamental theory it is known that when a current goes through a wire a magnetic field is developed about that wire. This field has the property (electrical inertia—inductance) of opposing any rise or decrease in the current. Between two conductors, we have a static field. Each conductor serves as the plate of a condenser. A negative charge brought to one plate, due to electrons, will exert a stress in the dielectric, such as air, separating the plates. It imparts an electric force to the opposite plate and causes an electron displacement there, charging up the condenser and establishing a potential difference between plates.

Obviously, the simplest possible combination of L and C might well be two parallel conductors such as those shown in Fig. 4. Since such oscillators, of low power, may find application in future radio receivers of the superheterodyne type operating on very high frequencies, future servicemen must know something about transmitter theory as well as receiver theory.

As the frequency becomes very high, even the leads and parts of the tube itself play a part in determining the frequency of resonance of the oscillator. To appreciate this, realize that at 100 megacycles a wave length is 3 meters long. The wave length at 1,000 megacycles is only 0.3 meter long. (A meter is equal to 39.37 inches.) Assuming it is 40 inches, roughly $40 \times .3$ equals 12 inches for a wave length at the above frequency. If we have a copper tube line which is $\frac{3}{4}$ wave long, the length is only $12 \times \frac{3}{4}$ or 9 inches. The velocity of a wave on a line is not quite the same as in air, and other factors enter into the problem, but the above will give some idea of the extremely small dimensions required for ultra-high frequency. Compare a 250-microhenry broadcast coil with microwave L and C elements!

Electron transit time effects become important at high frequencies. At 1,000 kilocycles, a complete wave may require one-millionth of a second to pass through the cycle, while at 1,000 megacycles it would require only one-billionth of a second. The radio wave change, therefore, may be considerably faster than the rate of travel of the electrons in the tube from cathode to plate, and the normal phase relationships obtained at low frequencies, with a 180-degree phase shift in the tube, are not obtained.

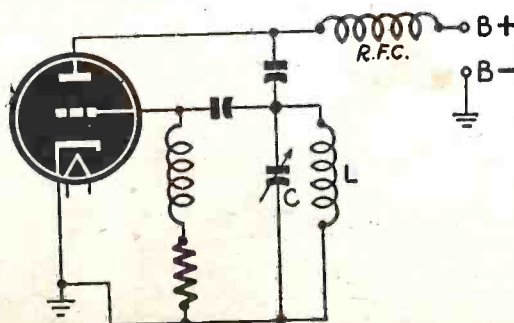
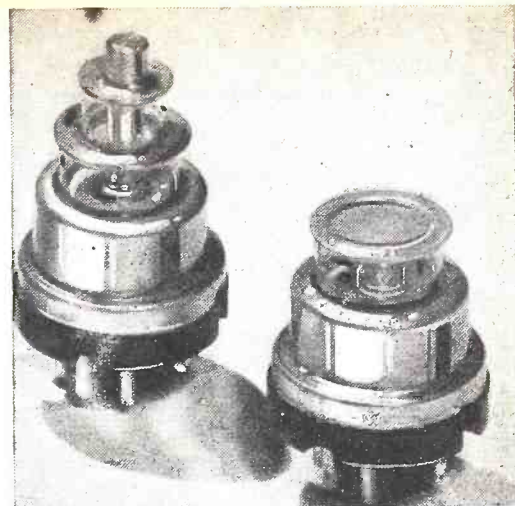

Fig. 3—Use of this circuit extends to H.F.



Two tubes of the type illustrated in Fig. 1.

Referring again to Fig. 4, suppose C is eliminated and we have only the tube capacity left in circuit. Then, the simplified circuit of Fig. 5 is developed. The plate and grid are in effect plates of a condenser. The

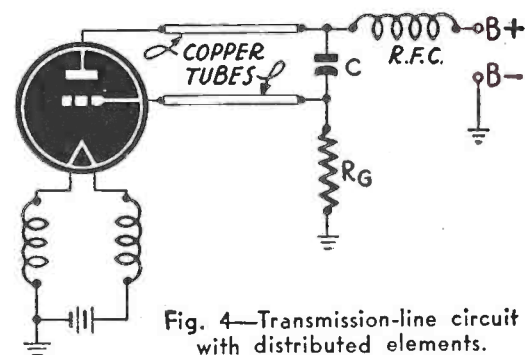

Fig. 4—Transmission-line circuit with distributed elements.

L-C combination is reduced to a very elemental form. Coupling another circuit, for power transfer, we may have Fig. 6. Now if we imagine that we swing the condenser plates and conductors together, around an arc or circle, in such a way as to have a revolution on the vertical axis, we will generate in effect a closed element system. The top and bottom sections will be condenser plates. It is not hard to see just how the



Fig. 5—Reduction to lowest terms of Fig. 4.

condenser and coil elements merge into one, to form a resonant system or cavity resonator arrangement like the output cavity of the tube in Fig. 2. The basic circuit, using the disc-seal tube, with input and output circuits, is shown in Fig. 7.



Fig. 6—First step toward a resonant cavity.

With this tube the input and output circuits are physically separated, which means electrical separation. This permits elimination of small coupling capacitances and mutual inductances between electrode parts and leads, an advantage over ordinary construction.

The disc-seal tube using cavity oscillator circuit is shown in Fig. 2. At very high frequencies, the electric field penetrates metal surfaces only about a thousandth of an inch. The current flows only in those surfaces exposed to the electric field. The result is that high frequency electric currents

(Continued on page 591)

FM U.H.F. Converter For Pre-War Radios

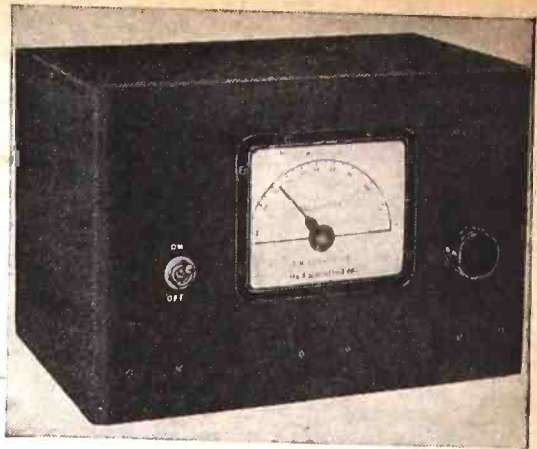

Experimental 3-tube FM converter in cabinet.

CONVERTERS for the new very-high-frequencies assume a sudden importance with the allocations for various services made on these bands. Two excellent models of such converters were those submitted to the recent FCC hearing on moving FM to a higher portion of the spectrum. (*Radio-Craft*, May 1945, page 479) Though the designers had nothing more in mind than adaption of present FM receivers to the proposed 84-102 megacycle band, these converters could very well be applied to any of the present short-wave AM receivers capable of picking up signals in the 5-meter region, or even to receivers which cannot be tuned to quite such a high frequency. Modification of the coils is all that would be required for the latter application.

When the Federal Communications Commission first announced its intention of moving FM from the pre-war position between 42 and 50 megacycles to the higher band where it would be free from long distance interference and would have adequate room for expansion opponents of the move argued that all existing FM receivers would be made obsolete as it would be impractical or impossible to adapt them to the new frequencies.

Much expert opinion was on the other

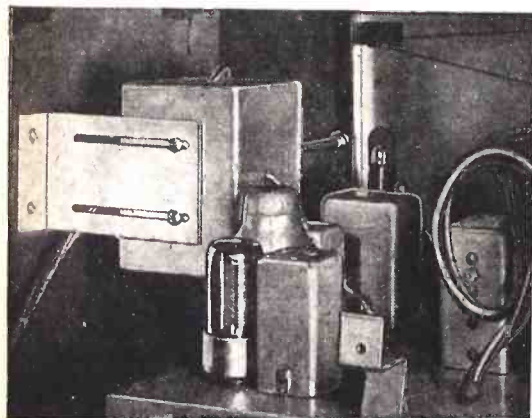

Converter installed in a pre-war FM radio.

side. Among those who believed the Commission's proposal to be sound and that none of the alleged difficulties were insurmountable was Hallicrafters of Chicago, with the result that one of the converters demonstrated at the hearing was built by them. It is a three-tube model which uses a

type 7V7 mixer, a type 7A4 oscillator, and a type 6X5GT/G rectifier. (Fig. 1) The output of the converter is fed into the antenna connections of the FM receiver, which is tuned to 42 megacycles. The converter oscillator is arranged to track 42 megacycles below the mixer frequency and the entire device simply acts as the front end of a superheterodyne, using the FM receiver as an I.F. amplifier. Devices similar to this have long been used by the ama-

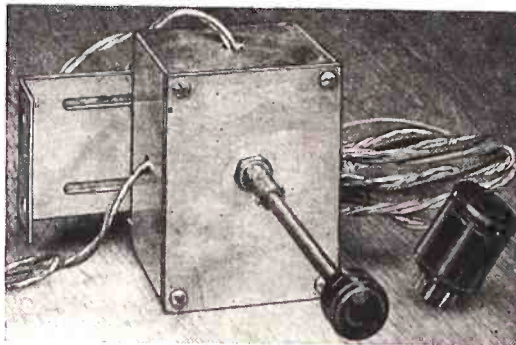

The 1-tube converter with bracket and plug.

teurs to receive VHF signals on standard communications receivers not built to receive the higher frequencies.

The experimental three-tube model shown in the photograph is far larger than necessary as, due to wartime necessity, it was built into a chassis and cabinet that happened to be available in the laboratory and is in no sense a commercial or finished product.

The circuit of Fig. 2 is credited to the Field Division of the FCC, and differs in coupling methods both in antenna and oscillator, as well as in choice of tubes, from that of Fig. 1. In general principles the two circuits are however identical. Though no constants are given for the circuit of Fig. 1, obviously the values of the various components must be closely parallel in the two circuits.

Coils were wound to cover the 84-102 megacycle band with a 50 mmf variable condenser, the output coil-condenser combination being a standard FM coil and condenser as used in present-day sets. A difference from broadcast procedure—though nothing new in high-frequency practice—is that the oscillator lags below the tuner in frequency. While the grid circuit of the

mixer tube is being tuned from 84 to 102 mc, the oscillator moves over the spectrum from 42 to 60 mc.

Of possibly greater appeal to the non-technical FM set owner is the new one-tube model which can be placed inside the cabinet of practically any FM set, photographs of which are also shown. The single-tube converter makes use of a single type 7S7 tube and all tuning is done with the regular receiver dial. It requires only that a hole be drilled in the front of the receiver to accommodate the control switch. A universal mounting bracket is provided and power is taken from an adapter plug which is placed under one of the receiver's output tubes.

With this one-tube model the RF input goes to a band-pass filter instead of the usual tuned circuit and the oscillator section is operated at a fixed frequency. The panel switch has three positions. One connects the antenna directly to the receiver to permit normal operation while the other two connect different values of capacity in the band-pass and oscillator circuits of the converter. The FM receiver is used as a *variable I.F.* and with two fixed frequencies of the oscillator selected by means of the control switch covers the new range of 84 to 102 megacycles in two bands.

This little adapter, says its designers, can be attached by a set owner whose knowledge of radio is nil, and will make any pre-war FM receiver capable of efficient reception on the postwar bands.

According to estimates made by FCC and the Hallicrafters, these converters can be constructed very cheaply, as soon as peace brings the possibility of obtaining parts. The components of the FCC model are listed at \$8.85, while it was estimated that the three- and one-tube models, assembled, could be sold in quantities to large customers at \$11 and approximately \$6 respectively.

While many pre-war radios will be discarded, thousands of others will be in excellent condition after the war. Fitting these with adapters to receive FM and other UHF transmissions will be highly practical and an excellent activity for the skilled serviceman.

CORRECTION

In Fig. 1 of the article "Meter Adaption" printed in the March issue, it will be found impossible to get the readings described in the text with a 2,350,000-ohm resistor. A 1,350,000-ohm resistor here will give correct results. Cutting the 2.5-megohm resistor in Fig. 2 to 1.35 megohms will give the same results, and it is necessary to connect the open end of the 200,000-ohm potentiometer to the negative power supply to control the voltage.

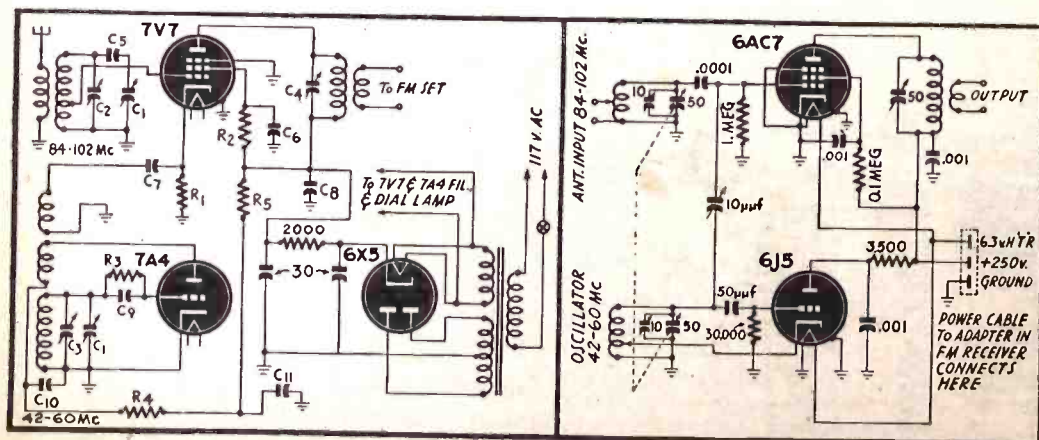

Fig. 1—The Hallicrafters' FM-UHF converter. Fig. 2—The design sponsored by FCC engineers.

IT'S THE DESIGN!

Many Radio Troubles Originate with the Manufacturer

By LOUIS HAGEN

FREQUENTLY radio repair work becomes a complicated process simply because radios are not built to make the repair easy and inexpensive. Frequently the arrangement is so illogical that the radio suffers unnecessary disorders. These deficiencies could be avoided if they were brought first of all to the attention of radio designers. They can be divided into two groups.

1. Inner disarrangements that make radio repair more costly than necessary.
2. Outer deficiencies that make the set unworkable to the layman.

GROUP I—INTERNAL TROUBLES

1—Tube Replacement: In order to facilitate tube replacement, all receivers should be constructed so that the chassis need not be removed from the cabinet. This has been done in several makes of very small radios. A little space between the tubes and the upper side of the case is necessary also for heat dissipation. Sometimes tubes can not be reached because the leads to the loop antenna (which must be loosened), are too short and too impractically arranged. Radio designers too often forget that radio tubes have a high mortality rate and therefore should be easily accessible for replacement.

2.—Chassis Removal: When the chassis has to be taken out of the cabinet for repair, it is aggravating if the loop antenna connections, speaker connections, and in some cases wires for outside antenna are soldered to the case, and so prevent free working on or under the chassis. All parts not fixed to the chassis should have plug-in connections and the wires should be long enough to connect the parts mentioned (for a test) without replacing them in the case. Many radio designers have proved that both demands can be fulfilled.

It is further necessary that the bolts or screws that hold the chassis in the case be easily removed and readjusted. Two men are seldom available to put a large set together. In battery portable sets the arrangement is often so awkward that the repairman sprains his fingers while trying to reach the holding screws. A chassis should never be fixed sideways nor should it hang down (as is often the case in chairside receivers and a few battery portables).

The back of the receiver which has to be removed so frequently is still a very imperfect part. It wears out and becomes deteriorated and loose all too soon. Why can't it be combined with the loop antenna and swing out on hinges to the left?

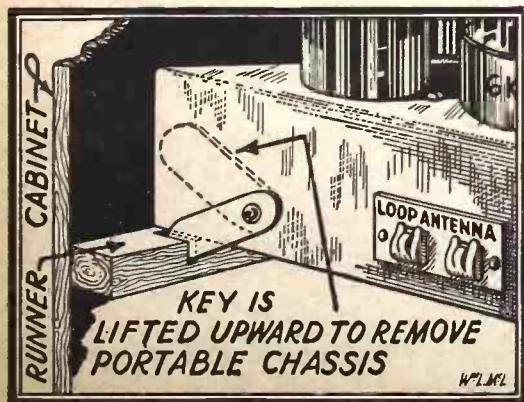

3—Dial Mechanism: When the dial pointer is on the same axle with the tuning condensers and driven from a small pulley, a broken dial cord is easily replaced. If the dial pointer moves horizontally over a stretched-out dial, the dial cord has to be conducted over several idlers. This arrangement is sometimes so complicated that the factory finds it necessary to devote an extra page in the Service Manual to an explanation of the mechanism. The servicing problem becomes still more involved if the dial calibration is printed on the glass window that is fixed on the cabinet. Then the pointer can be set correctly only after the chassis has been replaced in the cabinet. The dial calibration can and should always be on the dial panel.

Transmission belts used in the place of dial cords are not satisfactory. They slacken easily and then the dial starts to slip. They also deteriorate after a few years and finally break. Then the problem for the repairman is either to get a replacement from the factory, (which takes time and trouble) or to fashion a belt himself. Another mistake very often made by those who construct radios is that the transmission belt can only be replaced after the dial panel has been removed.

4—Volume Control and Condensers: Two other parts by their very nature need an occasional replacement. The chassis should be so designed as to enable a removal of the volume control merely by unscrewing it and unsoldering its connections. In many receivers the designing engineers have considered this demand as self-evident, but in other cases much of the set has to be taken apart before the volume control can be taken out. Provision should also be made to facilitate a dismantling of the control proper for touching up or cleaning.

Electrolytic condensers are very often inaccessible and should be placed more conveniently. Certainly it is unfair of the manufacturers to compel the repair man to remove tight rivets from the chassis in order to extract the faulty electrolytic condenser unit. Why has no one tried to develop a reliable two-prong plug-in system similar to a good line plug for electrolytic condensers in radios?

5—Markings on Radio Parts: Radio repairmen have every reason to be hostile to manufacturers who print no values on their condensers. Too much time is wasted in looking up diagrams to find the capacity of the part. Too often values that are guessed at are used for replacement instead of those intended by the designer of the set. On some radio sets not even the model number can be discovered and the repairman has to deduce it from the tube combination.

6—Batteries: In portable sets the batteries are a problem of their own. There are too many sizes and different voltages for A and B batteries. The smaller repair shop cannot keep all of them in stock without losing money. It would be far better to have uniform batteries for portable radios. This is just as possible as the adaptation of every plug-in receiver to the normal line voltage. As long as the multiplicity of

A and B voltages exist each manufacturer should, at least, print the required voltages clearly in each receiver. As a rule now, nothing but a battery model number is indicated.

GROUP II—USER'S PROBLEMS

7—Dial Mixup: Now we come to those troubles that originate from the abysmal difference in outlook between the normal layman and the trained engineer. When a customer calls for help, he frequently explains that some stations are not found at the right spot on his dial. The mix-up arises merely because the engineer who arranged the dial was a gay fellow with a love for numbers. Thus he not only divided it into Kc's and Mc's but in addition made an unnecessary calculation in wave length, which only causes confusion.

(Continued on page 588)

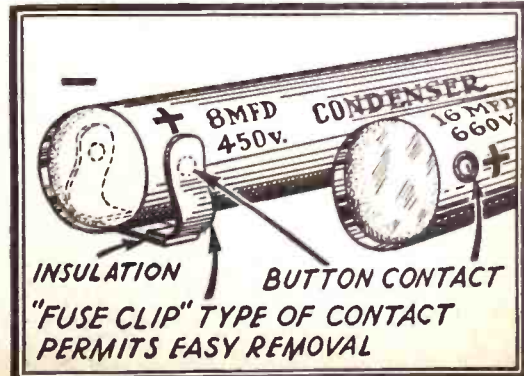
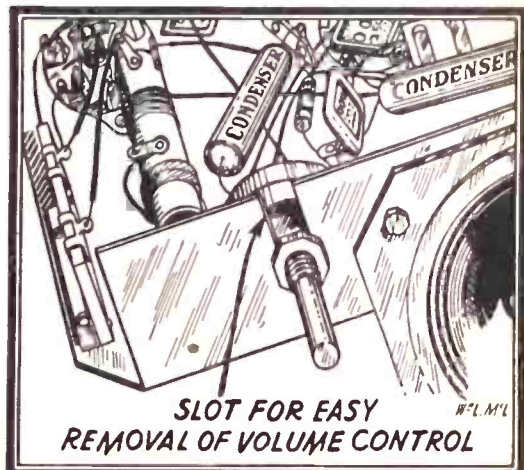
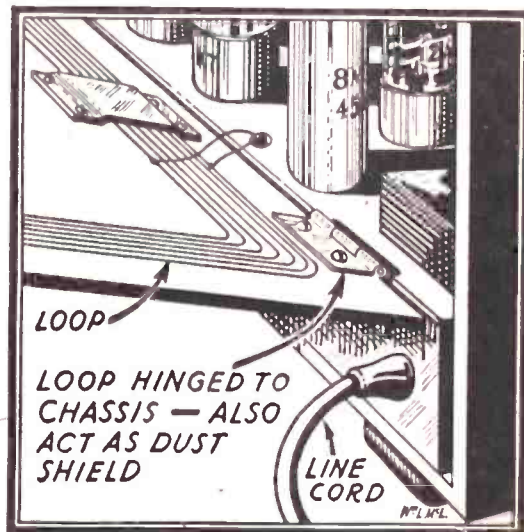

BROADCAST EQUIPMENT

PART IX—NEUTRALIZATION METHODS

By DON C. HOEFLER

ANY vacuum-tube amplifier circuit may be set into oscillation if proper coupling exists between plate and grid circuits so that an EMF may be developed across the input due to the voltage existing at the output. In the R.F. amplifiers of a broadcast transmitter most of the stages have plate loads consisting of resonant tank circuits adjusted for maximum output. This condition is also the most favorable for maximum regeneration and instability.

A tube which is to function as an R.F. amplifier in a broadcast transmitter must under no circumstances be permitted to develop sustained oscillations. In addition to stability of the circuit, safety of the equipment becomes a very important factor. Self-generated oscillations may easily overload the tube and its associated circuits to such an extent that the tube will be seriously damaged or even ruined by overheating, or the R.F. choke, circuit resistors, or plate milliammeter may be burnt out.

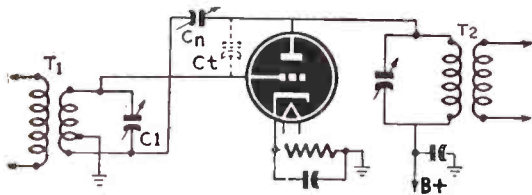

Fig. 1—Rice, or grid-neutralized, circuit.

The solution to this problem is "neutralization" or "balancing." Tetrodes and pentodes do not ordinarily require neutralization because of the much smaller plate-to-grid tube capacitances, but many of the high-power circuits in broadcast transmitters employ triodes for reasons of economy, and these must always be carefully neutralized.

The effects of regenerative feedback are usually neutralized by providing an additional feed-back path through an electrical network that transfers an equal amount of energy in the opposite direction. Thus the regenerative feedback through the tube is met at the grid by an equal and opposite degenerative feedback, and it becomes impossible for the tube to supply its own excitation. For complete neutralization it is essential that the two voltages be exactly 180° out of phase and equal in magnitude.

GRID NEUTRALIZATION

Fig. 1 shows the basic Rice grid-neutralization circuit. The secondary coil of transformer T_1 receives R.F. excitation from the preceding stage, and is tuned to resonance at the given frequency by means of C_1 . The upper half of the secondary feeds the R.F. voltage to the grid, and the signal is amplified as usual, appearing at the output across T_2 . Since the tube is a triode, a portion of the amplified voltage returns to the grid through the low-impedance path provided by the high value of plate-to-grid capacitance, causing the circuit to have a great tendency toward regeneration and instability.

At the same time some of the R.F. plate voltage is being returned through the neutralizing condenser C_n to the opposite end of T_1 , thus opposing the voltage arriving at the grid through C_1 . Therefore the undesired grid voltage is neutralized, and only that arriving legitimately from the preced-

ing stage affects the grid. Theoretically, this method of neutralization is independent of the operating frequency, and in practice this ideal condition can be very nearly attained.

PLATE NEUTRALIZATION

Fig. 2 illustrates the basic Hazeltine "Neutrodyne" system of plate circuit neutralization, in which the plate-to-grid capacitance is balanced by means of the output transformer. The extension to the tank coil L_p is a neutralizing inductance L_n , which is so connected that the voltage at the end applied to the neutralizing condenser C_n is always out of phase with the voltage existing at the plate. This potential across L_n , when applied to a properly-adjusted C_n , is of equal amplitude and opposite phase to the current flowing through the plate-to-grid capacitance, and so completely obviates the transfer of energy through this path. In order that the balancing may be as independent as possible of frequency, the coupling between L_n and L_p must be very close.

PUSH-PULL NEUTRALIZATION

Fig. 3 shows the Ballantine method of cross-neutralizing a push-pull R.F. amplifier stage. In this circuit the plate-to-grid capacitances of the tubes in combination with the neutralizing condensers form a capacitance bridge which is independent of the plate and grid tuned circuits. The neu-

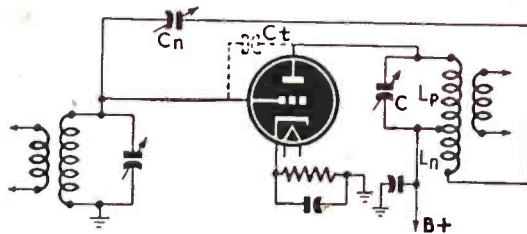

Fig. 2—Plate, or Hazeltine, neutralization.

tralizing capacitances, when properly adjusted, are approximately equal to the tube plate-to-grid capacitances.

If either of the neutralizing condensers be removed from the circuit, the stage still can be completely neutralized by readjusting the remaining neutralizing condenser. In this case, one side of the circuit is plate-neutralized, while the other side is grid-neutralized. However, the adjustment is quite delicate, and has a tendency to go out of balance with variation in modulation or operating frequency. The complete Ballantine circuit is far superior in these regards, for neutralization is very effective and independent of frequency.

Various other neutralizing circuits are in use, but the majority of them are based upon the principles just discussed.

NEUTRALIZING PROCEDURES

The procedure in making neutralization adjustments is very similar for all tubes and circuits. The tube filaments should have their operating voltages applied, and excitation from the preceding stage should be impressed upon the grid. There should be no plate voltage on the amplifier being adjusted. This should be removed on the power-supply side of the R.F. chokes and

by-pass condensers, as they may affect the neutralizing point. If possible, the best method is to remove the rectifier tubes.

The Grid-Circuit Milliammeter Method:

- (1) Adjust the neutralizing condenser(s) to maximum capacitance.
- (2) Rotate the plate-tank-circuit condenser to resonance. When this point is reached, the grid meter, which previously indicated a high value, will dip noticeably.
- (3) Reduce the neutralizing capacitance in small decrements, noting the grid current dip each time a change is made. Continue to the point where a grid current dip is no longer obtained.
- (4) To check if the neutralization is complete, rotate the plate tuning condenser and ascertain that this has no effect on the grid current.

A variation in this method is possible if grid-leak bias is employed, in that a high-resistance voltmeter may be connected across this resistor and the same technique followed. For best results, both sides of a push-pull stage must be balanced simultaneously.

The Plate-Tank-Circuit Ammeter Method:

- (1) Adjust the neutralizing condenser(s) to maximum capacitance.
- (2) Insert a thermocouple type R.F. milliammeter into the low-potential side of the plate-tank circuit. This meter should have a full-scale range of about 1/10 that of the normal tank current value.
- (3) *Very carefully* rotate the plate-tank-circuit to resonance. Observe the tank current indication continuously while so doing, and stop immediately if the R.F. meter indicates full scale.
- (4) If the meter reads full scale, or when the maximum reading is obtained, reduce the neutralizing capacitance until the meter just barely deflects.
- (5) Readjust the tank tuning slightly for maximum tank current.
- (6) Again reduce the neutralizing capacitance until the meter just barely deflects.
- (7) Repeat steps (5) and (6) until a point

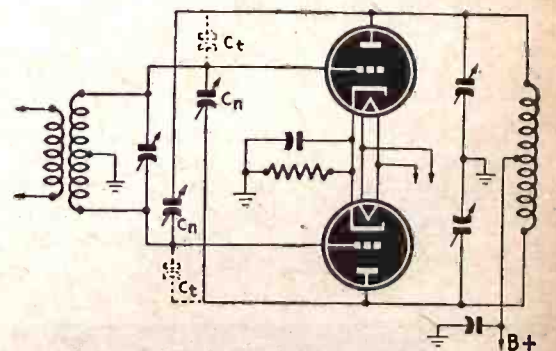

Fig. 3—Neutralization of a push-pull stage.

is found where no indication of tank current is shown.

(8) For greatest accuracy, the range of the tank current meter must again be changed so that it reads around 100 or 150 milliamperes full scale, and steps (4) through (7) repeated.

Inability to obtain perfect neutralization may be found to be due to stray coupling between the coils or wiring of the driving

(Continued on page 577)

32-Volt Receiver For Small Plants

By B. W. EMBREE

MANY rural homes are now equipped with power plants of the 32-volt type, and there may be many who would be interested in building this type of set. This six-tube Super has proved exceptionally good. It employs three 6.3 volt tubes and three 25 volt tubes used in the following order: 6SA7 oscillator and first detector; 6SK7 I.F. amplifier; 6SQ7 second detector, A.V.C. and first audio; 25L6GT driver, and two 25L6GT's in push-pull.

New parts may be used if you can procure them, or possibly you may have a good radio around that you could rebuild. I have rebuilt quite a number of sets for 32-volt operation. Some of the sets were of the all-wave type, and they operated as usual after being rewired.

Voltage fluctuation has but little effect on the operation of the set. There is no change in operation between 28 and 38 volts, and it will continue to operate with only 20 volts. Naturally reception is very weak with so low a voltage.

LAYOUT AND ASSEMBLY

The radio was assembled on a chassis $5\frac{1}{2} \times 10 \times 3$ inches. This makes a compact outfit and there is plenty of room for mounting all parts. The antenna coil, oscillator coil and tuning gang from a Victor Little Nipper were used. The I.F. transformers were also Victor as used in the model 21 and 34A. The overall gain was high and there was no sign of oscillation due to the high gain. The AVC hookup proved to be very good. A tone control was used and worked well, but may be omitted. In such a case use a .01 mfd. condenser across the 25L6 plates.

The dimensions are given for those who may want to drill the chassis. It would be better to get one of a larger size if you are not able to get the one listed, so as not to have to crowd parts in. The driver transformer is mounted on top of the chassis, and the choke could be mounted directly below this on the bottom side. Large-capacity filters are used in the cathode and plate supply circuit. It is best to keep the plate and grid leads short, not to have them run parallel to each other.

A series-parallel filament hookup is used,

and the 25-volt filaments are on the positive side of the line. Connect the No. 2 pin of each 25L6 together, and to the positive side of the line. The No. 7 pin then is connected to a 6-volt tube filament. Each of the remaining filament pins on the 6-volt tubes are connected together, and from this point a 10-ohm resistor with a pilot lamp in parallel is connected to ground (chassis), which is the negative side of the line and completes the circuit. The pilot lamp is 6-8 volt type and should be .15 amp. but may be .25 amp. A heavy-duty resistor must be used, and should be capable of dissipating 5-10 watts.

The next step should be to connect all the screens together, leaving the 25L6 driver open. This tube is used as a triode, and the plate and screen are connected together. It will be well to tie the No. 1 pins of the 25L6's to ground, for these are the shield connections. A 4000-ohm resistor and 25 mfd. condenser are connected from cathode to ground of the 25L6 driver. The cathodes of the other two 25L6's are connected together and a 100-ohm resistor and 25-mfd. condenser connected from this point to ground. (The positive side of the condensers is wired to cathode.)

The next job is to mount the antenna and oscillator coils in the chassis and wire the oscillator circuit. This completed, mount the driver and I.F. transformers. Do not mount the tuning gang until the work is nearly completed as it may be damaged while the chassis is being moved around. Proceed with the wiring, first the I.F. transformers then the AVC circuit and antenna coil, leaving the antenna and ground lugs open.

SAFETY PRECAUTIONS

Place a .01 mfd. condenser from one lug to the antenna terminal and one from the other lug to the ground terminal. These may be on an insulated strip fastened to the chassis. You may find that the set will work OK without a ground connection. Short leads are now connected to the terminal strip for aerial and ground connections.

The condenser in the antenna lead is for safety should the wire come in contact with a live line outside. This would burn out

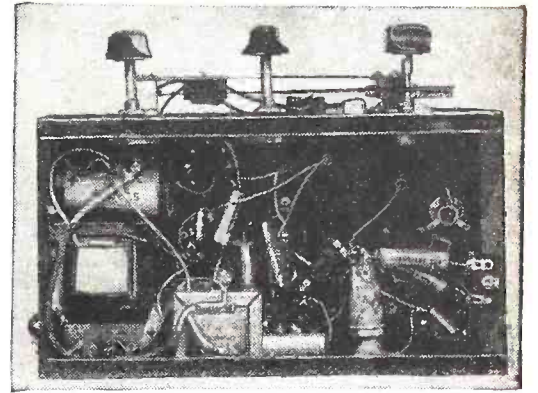
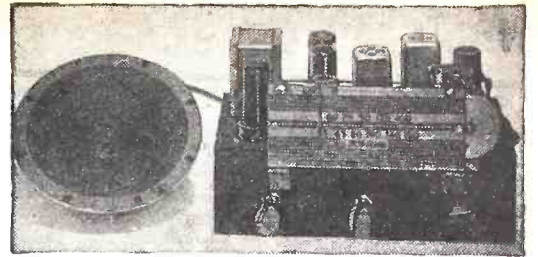

Front and bottom views of the 32-volt radio.

the primary winding of the coil. The condenser in the ground lead is necessary when you use a ground wire on the set. If the lighting-plant system has been grounded as it should be, and the power cord be plugged in wrong, the positive side of the line would be connected through the cord and the ground lead to the negative side of the line and short out the system.

The volume control should now be put in the chassis, also the tone control if you wish to use one. The tone control shown operates very well and is worth putting in the circuit.

The filter condensers should now be wired into the circuit, and the filter choke and output transformer mounted—on chassis or speaker—and wired in the circuit. If you may have an electrodynamic speaker on hand which has a field resistance of from 125-200 ohms you may use this, and connect the field directly across the 32 volts. If such a speaker is used, power consumption will also be increased.

Recheck the wiring carefully and if all is correct solder power cord to switch and to chassis, place tubes in their proper sockets and plug the power cord into the outlet. If a voltmeter is available check voltage between chassis and switch lug with negative side of meter connected to the chassis. If polarity is not correct pull the plug and reverse it. Circuit resistance will be approximately 10 ohms if an ohmmeter test can be made with available equipment.

TUNING AND ALIGNMENT

When everything is in order, tune in a station, and proceed to adjust the trimmers for maximum gain, keeping the signal low. I would suggest that you use Meissner I.F. transformers for these are peaked at 456 Kc. at the factory, making them reliable for this work when a generator is not available.

The first procedure will be the high-frequency adjustment. Tune in a station that you know at about 1500 Kc., then adjust the oscillator trimmer so dial and station frequency correspond and adjust antenna trimmer for maximum gain. Of course, the dial and tuning unit must correspond in order for this to be done. If the gang does not have a set of oscillator tracking plates it will be necessary to use a padder in series with the oscillator coil and tuning gang. It will be adjusted near 600 Kc. so as to receive the stations at the proper dial settings. In this case it will be

(Continued on page 591)

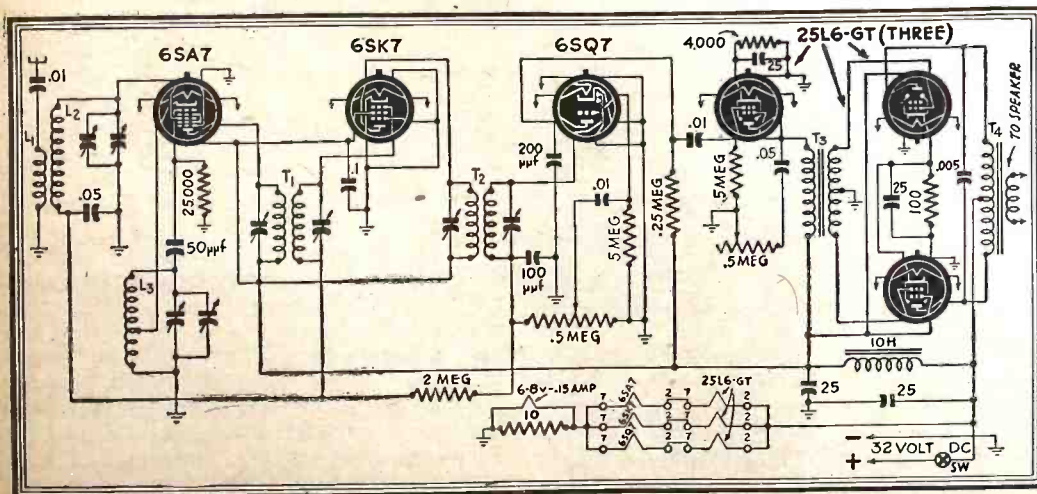

Standard tubes are used in the receiver, the special circuits adapting it to low voltage.

BY far the most "expendable" item in radio is the ordinary electrolytic condenser. The paper condenser is often a cause of servicing trouble. Mica condensers, usually, give little trouble. Resistors of the carbon type often change value or become noisy. Tubes, of course, commonly fail—but that's another story.

A condenser is a gadget that passes alternating current. If the D.C. leakage current gets too high, the condenser becomes useless and must be replaced. In general, condensers used in grid circuits are critical and must have leakage resistances above 20 megohms. Condensers used in plate return and screen return circuits are not as critical and in many cases may have leakages as low as 5 megohms and still be serviceable.

Electrolytics may be tested with an ohm-



Fig. 1—A rough test for small condensers.

meter. First, the condenser is discharged to remove any stored electricity. Next, the ohmmeter is applied. After the first measurement, the leads are reversed. The highest resistance measurement is the correct one. Usually, if the condenser is good, the leakage will be above 100,000 ohms and may be as high as 1 megohm. Electrolytics used as by-pass condensers, from an output tube cathode to ground, or similar low voltage service, should have a leakage above 25,000

CONDENSERS

By JACK KING

ohms. By making a number of tests on good condensers, you will learn what to expect.

In the good old days condensers were plentiful and it was an easy enough matter to slap one in and see what happened. If you put it across an A.C. line and blew up the works, it wasn't too bad because there was always another one handy. With condensers so scarce, conserving parts is an absolute necessity. Condenser bridges are nice things to have but every serviceman does not have one, and for the beginners—yes there are plenty of them—an ohmmeter serves fairly well.

The capacity of a condenser cannot be determined accurately by using an ohmmeter. However, skilled servicemen can judge, with experience, what the deflection on their particular ohmmeter for a given capacity will be. As the meter is applied to the condenser, the meter needle kicks upward, indicating "charge". This kick is approximately proportional to the capacity. (See "Measuring Capacity," *Radio-Craft*, July, 1944.) If the condenser is "open", no appreciable kick will be observed. Low-

capacity condensers will give a smaller deflection. Those of .01 mfd. or less may not be tested in this way with any kind of satisfaction. It is possible to use one test that was employed in the early days of radio, when things weren't so fancy and yet we got along all right. A mica or low capacity paper condenser may be checked by applying a voltage to it, disconnecting the source of voltage and then checking the storage of the condenser by placing an ear-phone or headset across the condenser terminals. A click will be heard. The loudness of the click will be proportional to the

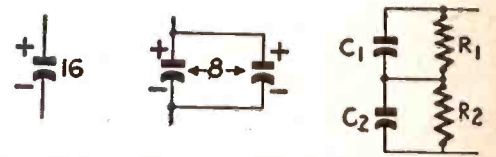

Fig. 2, left; Fig. 3, right—Series and parallel connections for filter condensers.

capacity of the condenser and leakage. A condenser with a lot of shunt leakage resistance will not give a loud click. One having low capacity or high series resistance will not absorb a great amount of electrical charge and therefore will not give a loud click when discharged into headphones.

Many servicemen have audio generators which are variable in frequency. These generators can be used for checking the impedances of condensers in conjunction with an ordinary copper-oxide rectifier type A.C. voltmeter. In checking the low capacity mica and paper condensers, if an adequate deflection is not obtained on the meter, simply run the generator dial up to a higher frequency. Since the capacitive reactance decreases with frequency more current will flow for a given applied voltage.

A simple test circuit is shown in Fig. 1. First the switch S is closed, shorting C. The output control of the generator is adjusted to give a convenient test voltage, say 10 volts at 400 cycles. Now switch S is opened. The meter deflection is proportional to the capacity. The meter can be any kind of output meter equipped with a scale. The scale can be calibrated directly or a simple graph or a table showing the relation between deflection and capacity can be made up.

Note that any leakage in the condenser would result in current being passed through the meter. To guard against this possibility, a .5 mfd 600 volt paper condenser may be installed in series with one lead of the generator, being left in the circuit at all times, including the time the preliminary calibration is made. The calibration can be secured by taking a number of new condensers definitely known to be good and making tests on them. Resistors may also be tested with a rig of this kind, and a calibration can be made by running tests on several different resistors which have been checked on a bridge or with an accurate ohmmeter. Choke coils can be tested in the same way as condensers with this arrangement. Such a test is not made under actual operating conditions, but is a com-

(Continued on page 587)

Fixed-Bias Voltage Supply

By F. C. DAVIS

IN the September, 1943, issue of *Radio-Craft*, Dean S. Edmonds Jr., discussed the advantages of using true fixed bias on output tubes or even the entire audio amplifier. These advantages are decreased distortion and increased power.

Here is a small, separate C-bias power pack which I built from parts on hand. It avoids the inefficient system of using an ordinary power transformer for the job, which boosts the line voltage up to, say, 250 volts, after which it must be cut down again to a usable value lower than the original line voltage. This pack has certain advantages over Mr. Edmond's system and is far more useful than other small power packs which, rectifying the house current directly, cannot be used with a ground.

The "power" transformer here is an intermediate push-pull transformer, or a driver transformer with a center-tapped secondary, having a step-down ratio of 2 to 1. When the primary is connected across an A.C. line of 120 volts, the A.C. voltage on the secondary is, of course, 60 volts.

The rectifier tube is a 6H6. The current for its filament may be drawn from the set or from a separate filament transformer. A bleeder resistor of about 20,000 ohms is

used, which draws a bleeder current of about 3 Ma., which is well within the 4 Ma. maximum for this tube.

Design of the power pack is thoroughly conventional. For the filter chokes, old mid-get output transformers may be used. Since the output voltage is low, 100- or 150-volt, high-capacity condensers may be used in the filter to provide ripple-free voltage at low cost. Resistors may be used instead of chokes, if the extra voltage drop through them is not objectionable. Probably 5,000-ohm resistors would be satisfactory in most cases.

If capacity input is used in the filter, the output voltage may be adjusted by varying the capacity of the input condenser—to 62 volts, the correct bias for 6A3's or 2A3's with 300 volts on the plate, or to 68 volts for 45's with 275 volts on the plate. Any desired intermediate voltage may be obtained by tapping the bleeder resistor. In computing the resistance of the tap, remember that the plus side of this pack will be connected to the ground of the amplifier. Therefore the tap must be figured as a drop from the high voltage side. That is, if the top (ground) voltage of the pack is 62, and a bias voltage of 10 is desired for the first stage of the amplifier, the resistor should be tapped at 62 less 10, or 52 volts.

This pack may be used instead of a battery as a source of constant, accurate voltage for use with an ohmmeter. By using a rectifier tube of a different type, such as an 84/6Z4, it may be used as the B supply for a small portable type receiver. Care should be taken, however, that the total current drain does not overload the step-down transformer.

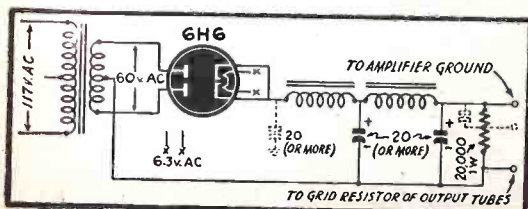

A complete bias circuit with 6H6 rectifier.

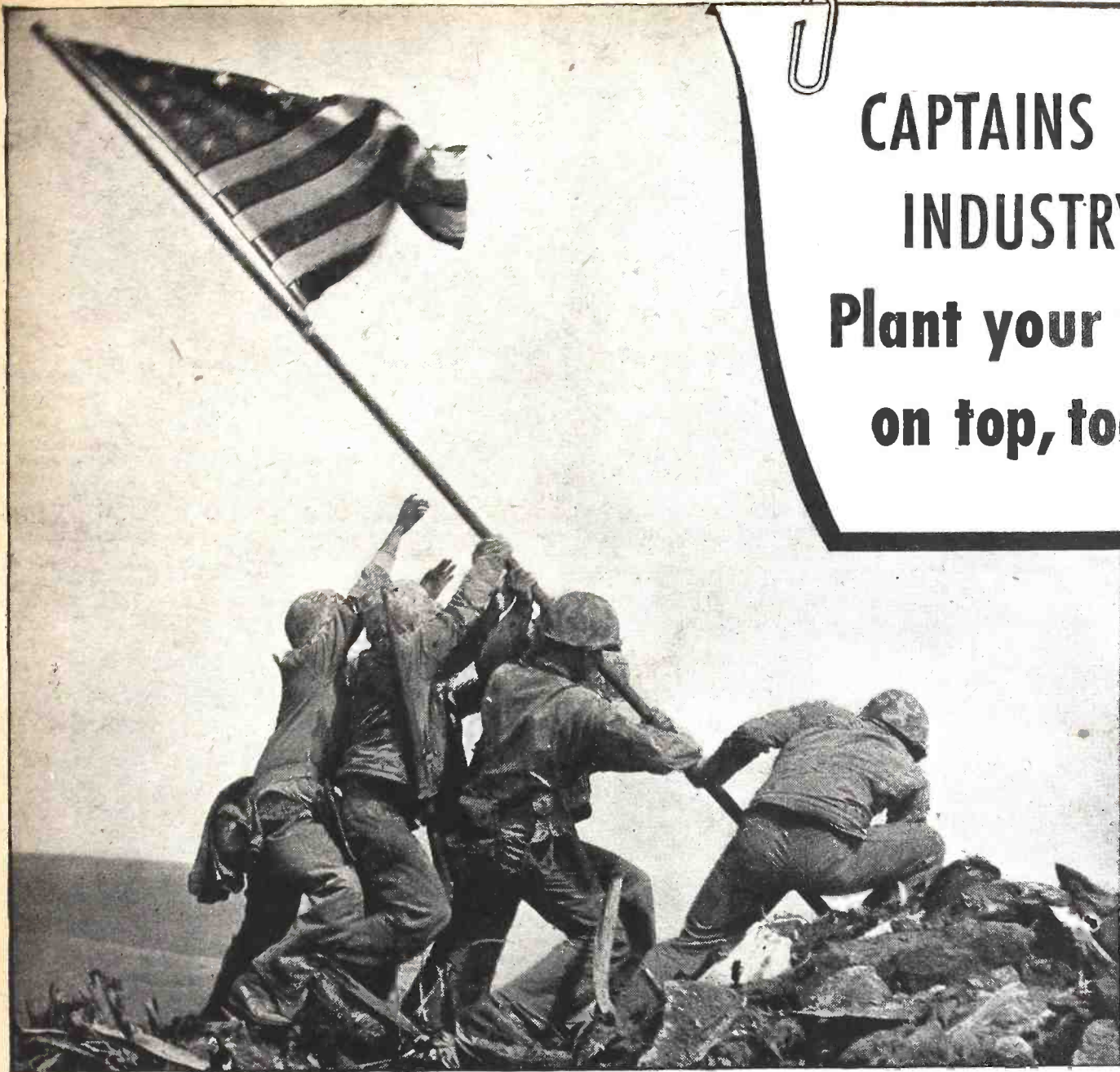

**CAPTAINS OF
INDUSTRY**
**Plant your flag
on top, too!**

*This year we've
got to make 2=3!*

much as we lent last year in 3. Which means that, in the approaching 7th War Loan, each of us is expected to buy a BIGGER share of extra bonds.

The 27 million smart Americans on the Payroll Savings Plan are getting a headstart! Starting right now they are boosting their allotments for April, May and June—so that they can buy more bonds, and spread their buying over more pay checks.

Our Marines went over-the-top at Iwo Jima in the greatest, and hardest, battle in the Corps' history. Now it's your turn! Your quota in the 7th is needed to help finish this war, sidetrack inflation, build prosperity. So, captains of industry, plant your flag on top—like the Marines at Iwo Jima!

This year we've got to make 2=3! We've got to lend Uncle Sam in 2 chunks almost as

★
**CAPTAINS of INDUSTRY—here's your
Check List**

for a successful plant drive:

- ★ Get your copy of the "7th War Loan Company Quotas" from your local War Finance Chairman. Study it!
- ★ Determine your quota in E Bonds—the backbone of every War Loan.
- ★ Arrange for plant-wide showings of "Mr. & Mrs. America"—the new Treasury film.
- ★ Distribute "How to Get There"—a new War Finance Division booklet explaining the benefits of War Bonds.
- ★ Circulate envelopes for keeping bonds safe.
- ★ Display 7th War Loan posters at strategic points.
- ★ And—see that a bench-to-bench, office-to-office 7th War Loan canvass is made.

★
The Treasury Department acknowledges with appreciation the publication of this message by

RADIO-CRAFT

★ This is an official U.S. Treasury advertisement prepared under the auspices of Treasury Department and War Advertising Council. ★

RADIO-CRAFT for JUNE, 1945

There's no let down in MT. CARMEL

Though the war news is good . . . and getting better every day . . . the men and women of Meissner's famed "precision-el" haven't let down. As you can see, in the photographs on this page, they devote the same concentration to their work now as they did when the going was tough. This stick-to-it-iveness is one more reason for Mt. Carmel's rapid rise to prominence as one of the centers of an exacting industry, electronics.



They Listen to a news broadcast during their lunch hour. Then it's back to work with a determination to equal military victories with new production records on the home front . . . without loss of Meissner quality.

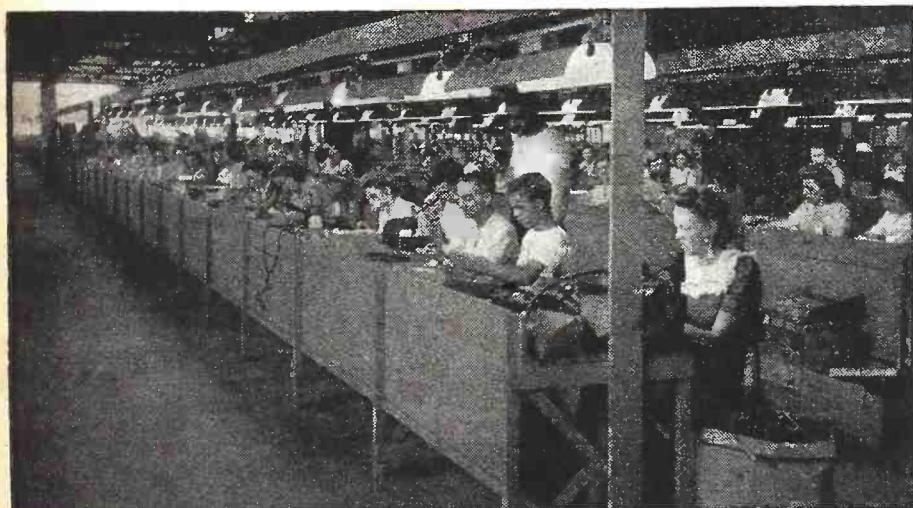

"Precision-el" at Work. They're building Meissner quality into this vital electronic war material. After victory that same pride in a job well done will give new meaning to Meissner's slogan, "Precision-built by Precision-el."



His Skilled Fingers have mastered many of the secrets of electronics. After victory, he and many of Meissner's "precision-el" like him will pass this knowledge and tradition of precision to a new generation.



His Smile is a Reflection of the hundreds of smiles he sees each day as the men and women of Meissner pass through the gates he guards. If you ask him, he'll tell you it's the smile that helps put precision into "precision-el."

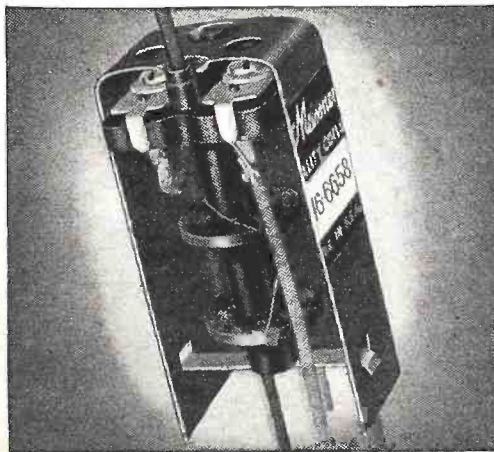

"Step Up" Old Receivers!

These Meissner Ferrocart I. F. input and output transformers are getting top results in stepping up performance of old worn receivers. Special powdered iron core permits higher "Q" with a resultant increase in selectivity and gain, now available for frequency range 127-206. Ask for numbers 16-5728 input, 16-5730 output. List \$2.20 each.



MEISSNER

MANUFACTURING COMPANY • MT. CARMEL, ILL.

ADVANCED ELECTRONIC RESEARCH AND MANUFACTURE

Export Division: 25 Warren St., New York; Cable: Simontrice

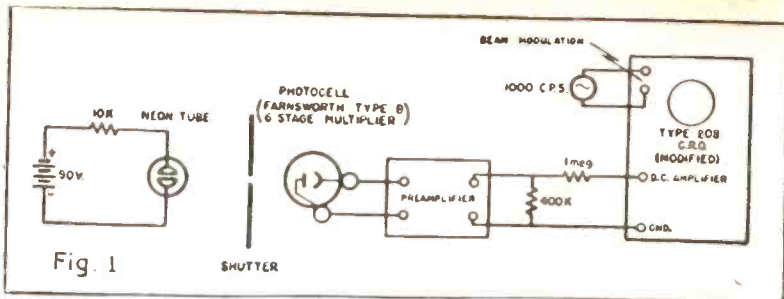
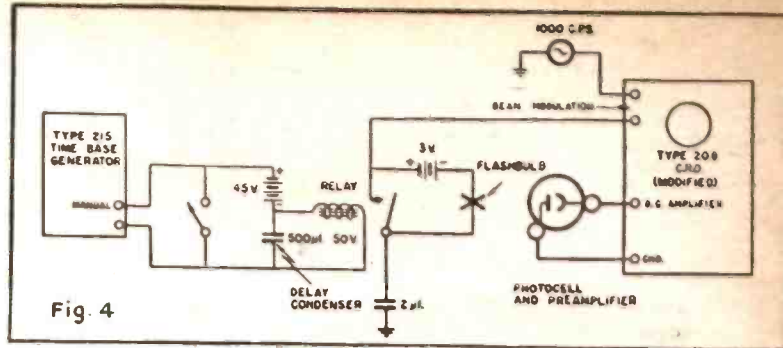

Fig. 1—Shutter-checking set-up with photo-cell and D.C. amplifier.
Fig. 4—The circuit used for recording flash-bulb characteristics.



Cathode-Ray Photo Tests

THE facts that the indicator of an oscilloscope is an electron beam with practically no inertia and that this indicator may be simultaneously moved upwards and sideways makes the instrument very useful for measuring small time intervals. Scopes are now being used for the measurement of flash-bulb characteristics, calibration of

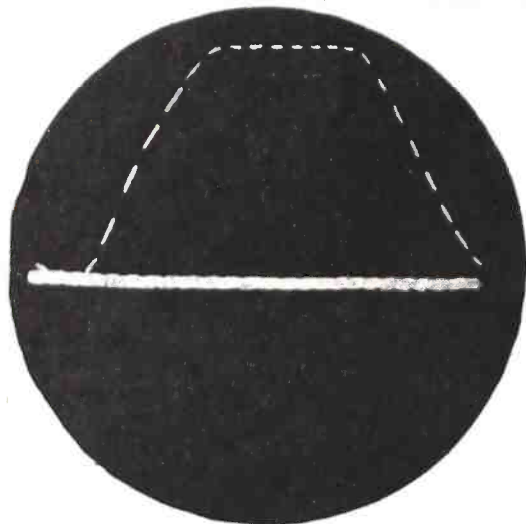

Fig. 2—Curve rises with admission of light.

diaphragms, comparison of light transmission of lenses, etc. These interesting photometric tests are described through the courtesy of the Allen B. Dumont Laboratories.

For testing photographic shutters a very simple set-up may be used. A stationary pattern of sine waves of a known frequency is applied on the screen, the image being viewed through the shutter under test. A number of sine waves of full brilliancy will be seen in the center of the screen. At both sides waves of less brilliancy will appear, corresponding to the intervals of shutter opening and closing. By using a

known wave-frequency—60 cycles for example—it is possible to count the number of cycles and thereby the number of sixtieths of a second which elapse during each phase of shutter operation.

Better accuracy may be obtained with slightly more elaborate equipment. In Fig. 1, we have a neon bulb such as the GE type 4½ powered from a 90-volt source. The light passes through the shutter under test and falls on a photo-cell. The resulting D.C. potential is amplified by a D.C. amplifier and applied to the vertical scope plates. For convenient measurement a 1000-cycle modulation voltage is applied to the oscilloscope grid, the trace then being a dashed line, each dash corresponding to .001 second. With a stronger light source and more sensitive photocell it is even possible to apply the photocell output voltage directly to the scope plates.

Figs. 2 and 3 show results with the Dumont type 175-A tube, which has an unusually brilliant trace. The curve height at any point is a measure of the light passing through the shutter. The total time elapsing between opening and closing in Fig. 2 is approximately twenty thousandths of a second, the shutter being fully open for about .008 second, as may be seen by counting the dashes.

Diaphragms may be easily calibrated with the same set-up. The ratio between two whole stops (such as f:4.5 and f:5.6) is 2:1. Therefore it is only necessary to close down the diaphragm until the amplitude is exactly halved to find the next stop.

Fig. 4 shows the set-up for investigating the characteristics of flash-bulbs. A relay, delayed for 1/30 second, starts the flash after the start of the single sweep. When the relay closes, the flash-bulb is simultaneously fired, starting the 1000-cycle beam modulation as before. Fig. 5 indicates the time between closing the battery contact

and start of the flash, the duration of the flash itself, and permits measurement of the peak luminous output as well as the total amount of light output.

A number of phenomena which would resist other methods of investigation can be studied readily with this cathode-ray technique. It should also be applicable in numerous other types of mechanical problems which require a plot of a rapidly-varying function versus time.

TELEVISION BY CABLE?

WORLD-WIDE television is visualized by the British Broadcasting Corporation, according to a statement made last month by Sir Allan Powell, chairman of the company. A method of linking up the various dominions and colonies of the Empire, possibly by a submarine coaxial line, is forecast.

"Perhaps we shall have a cable as simple as the present submarine cable," Sir Allan told the Commonwealth Broadcasting Conference in London, "and with it some device to boost up its strength we will send the picture as easily as we now send a telegram."

NETWORK VIDEO WORKS

MULTIPLE-RELAY television was proved technically practical last month in a broadcast from Washington to Philadelphia, over a network developed by Philco. In this new network, six television transmitters were used to carry the television pictures from the video studio in Washington to the final television station, WPTZ in Philadelphia. Television signals were relayed at four intermediate points on hill tops along the route—Arlington, Va., Odenton, Md., Havre de Grace, Md., and Honeybrook, Pa., to reach Television Station WPTZ, which transmitted the program to its television audience in the Philadelphia area.

Television has been relayed from Philadelphia to New York and vice versa, also to G-E in Schenectady. However, the method used in the relay was different from that used by Philco in the Washington-Philadelphia transmission.

Possibly in two months, Philco believes it will start regular television program service between Washington and Philadelphia. Engineers who designed and built the network claim that it gives scientific proof for the first time that the technical basis for coast-to-coast television networks has been developed.

Radar is likely to be used after the war to detect icebergs or rocks in the paths of ocean-going vessels, thereby adding to the safety of life at sea.

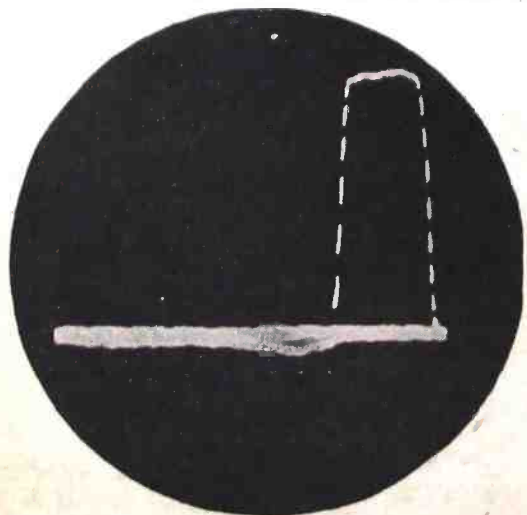

Fig. 3—The trace of a very short exposure.

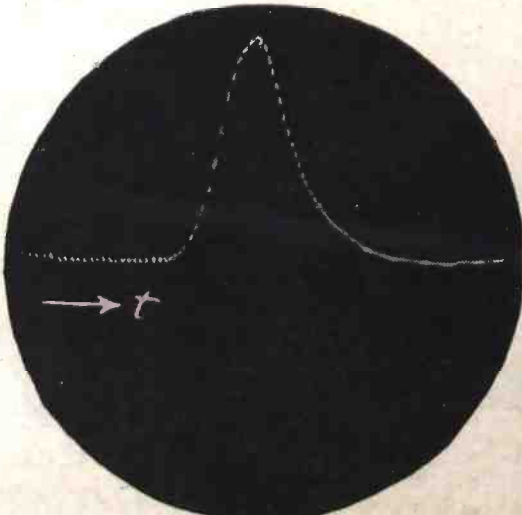

Fig. 5—Recorded trace of G.E.5 flash-bulb.

"Big Three" news about BT resistors

1

NEW MIDGET TYPES

To meet the growing demand for smaller, space-conserving components, IRC presents two new insulated METALLIZED resistors . . . Type BTS, ½ watt and Type BTA, 1 watt. Thoroughly dependable and engineered to embody the 'high-quality standards that have made BT's "preferred for performance", these tiny units can be counted on to do a man-size job. Like other BT's they operate at lower temperature than ordinary resistors of comparative size.

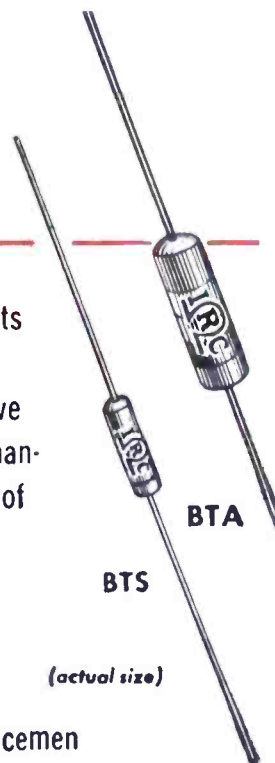

(actual size)

2

NEW LOW PRICES

New methods and new techniques in the stocking and packaging of resistors for Servicemen make possible the introduction of new lower prices on IRC Type BT and BW resistors. This means that you can now buy premium quality resistors at prices comparable to non-branded or "unknowns". For example, here are a few of the typical reductions based on list prices: BTS now 13c (BT-½ was 17c), BTA now 17c (BT-1 was 20c), BT-2 now 25c (was 30c), BW-½ now 15c (was 17c), BW-1 now 17c (was 20c), BW-2 now 25c (was 30c). Under IRC's new price set-up you can operate even more profitably than before.

3

RMA PREFERRED RANGES

IRC's standardization on RMA Ranges in both BT's and BW's as stock values for Servicemen, enables you to replace the same values you take out when making resistor repairs. Long used by set manufacturers, and now adopted by the Army-Navy in Specification JAN-R-11, the RMA Preferred Number System is a mathematical sequence of ranges which gives complete coverage with the least number of values. RMA Ranges listed for ±10% tolerance resistors are carefully spaced so that preceding or following values are never more than 20% apart, thus assuring complete coverage of every value with regularly stocked BT's and BW's.

INTERNATIONAL RESISTANCE CO.

DEPT. 25-F • 401 N. BROAD ST. • PHILADELPHIA 8, PA.

IRC makes more types of resistance units, in more shapes, for more applications than any other manufacturer in the world.

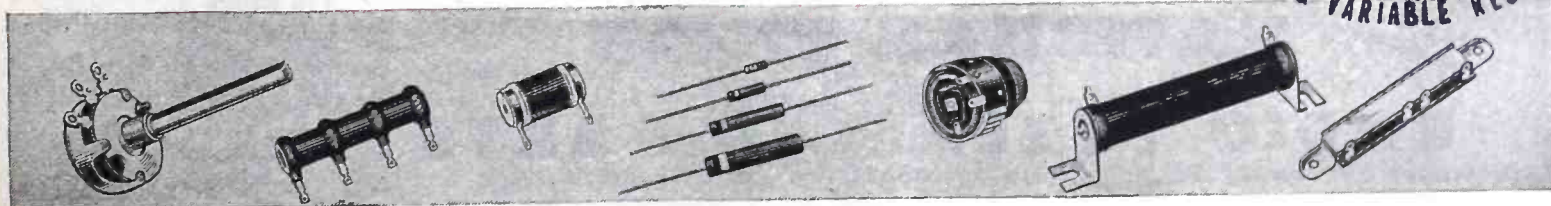

THESE 10 CONTROLS REPLACE 95%



All controls
complete with switch



5M-A



10M-B



25M-A



50M-B



100M-B

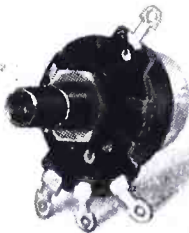

250M-TX



500M-TX

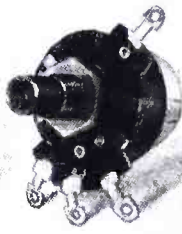

1 MEG-TX



2 MEG-TX

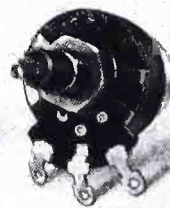

500M-CB

N. U. *Save-a-Shaft* VOLUME CONTROLS

If you haven't already put in a stock of N.U. Save-a-shaft Volume Controls... order yours today from your N.U. Distributor. Here's a real time-saver he can deliver fast! Minimum investment in stock of only 10 types is all you need to get going. NATIONAL UNION RADIO CORPORATION, Newark 2, N. J.

7 REASONS WHY

1. 10 types handle over 95% of your volume control replacement needs.
2. Eliminates shaft sizing and knob fitting.
3. Adaptable to any standard shaft.
4. Controls are complete with switch.
5. If no switch is needed, use same control but don't pull switch lug.
6. Individually packaged with instructions.
7. All sizes \$1.00 list price.



NATIONAL UNION RADIO TUBES AND PARTS

Transmitting, Cathode Ray, Receiving, Special Purpose Tubes • Condensers • Volume Controls • Photo Electric Cells • Panel Lamps • Flashlight Bulbs

ENEMY RADIOSONDES LAG

Captured German and Japanese radiosondes make use of techniques and measuring elements similar to those used in American instruments, but they differ in the types of such elements employed and in the method of varying the transmitted signal.

The Germans have two types of radiosondes in general use. The first type employ wet and dry bulb mercury in glass thermometers for measuring temperature and relative humidity, and a mercury-filled glass manometer for the determination of pressure. These glass tubes have metallic coils on the outside distributed through the operating length of the mercury columns within the glass tubes. Two transmitters, two frequencies and two antennas are required.

The Germans also use chronometric radiosondes that employ bimetallic elements to measure temperature, and hair hygrometers to measure humidity. Temperature contacts are made twice a minute, humidity contacts once a minute.

The Japanese use radiosondes very similar to the German. Pressure is determined in much the same way as in the chronometric instrument of the Germans; however, there are only seven contacts. The Jap radiosondes have the same defect as the German, that they must operate on two radio frequencies, requiring two transmitters, two antennas, and constant tracking at the ground station.

The American radiosonde operates with one transmitter. The carrier frequency is audio modulated and variation in audio modulation can be translated into meteorological data. The signal is received and graphically recorded on a chart. The number of contacts can be counted and the pressure read.

All three countries use a battery for their radiosonde power supply. The foreign instruments use vibrators and transformers to obtain desired voltages and alternating currents. American instruments use batteries with the correct plate voltage and tap only certain components of the battery for the correct filament voltages.

NEW WORLD RADIO TIME

A nonconfusing radio time is suggested by a resident of Peru. It has been the habit of international shortwave listeners to use Greenwich time and calculate the difference from their local clocks. Eastern War Time is at present more or less standard in American lists of international shortwave stations, when Greenwich is not used.

There is always a certain amount of confusion as to what time is intended—whether local, Eastern Standard or Eastern War Time or Greenwich. Added to this is the possibility of mistake in reducing Greenwich to local time. Mr. C. S. Ed-dowes, shortwave listener of Puno Muelle, Peru, suggests that the hour numbers be all dropped and letters substituted. Thus midnight Greenwich would be "A" and 1 P.M. "B". The letters would follow to "X". Time signals sent out at each hour would carry the letter of the hour. Once the listener in any community has learned to correlate the letters with the local clock, the confusion which is bound to exist when two sets of figures are used is entirely eliminated.

While suggested primarily for time signals, the method might well be used in station schedules. The listener could soon get used to such times as "K:30" or "L:15" which would refer to the same (local) time, no matter from what part of the world the broadcast might come.

The Standard of Quality for a Third of a Century



Instruments
that tell the truth...



Volt-Ohm-Milliammeter



All-Purpose Tube and Set Tester



Signal Generator



Oscillograph

● In maintaining the highest standard of excellence the one and only HICKOK aim must always be the building of instruments that tell all the truth all the time. When quality is built up to a high standard instead of down to a price, the user has greater confidence in his work.

Whether you are selecting tube and set testers, signal generators, oscillographs, volt-ohm-milliammeters or any other service equipment, remember that the standard of quality for a third of a century has never been excelled. Having pioneered the major new developments and vindicated maximum accuracy and dependability, HICKOK equipment has been specified by the armed forces in both world wars. We are still bending every effort to speed the war program and trust it will not be long until we can again take care of your civilian needs with the service equipment that is held in highest esteem. Write for Radio Equipment catalogue.

THE HICKOK ELECTRICAL INSTRUMENT COMPANY
10531, Dupont Ave., Cleveland 8, Ohio

POPULAR REPLACEMENT CONTROLS...



TYPE UM (PLAIN)

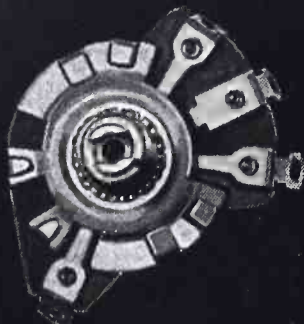

TYPE TM (SINGLE TAP)



TYPE DTM (DOUBLE TAP)

...and KNURLED PLUG-IN SHAFTS



SS-25

SS-18

SS-22

WITH these three Mallory controls—and the three plug-in shafts—you can replace not merely three, or nine corresponding originals, but a very large number of volume controls.

Shafts SS-18 and SS-22, for instance, are made in lengths that are found very frequently in radio sets. The SS-25 shaft serves as a replace-

ment for any knurled shaft up to four inches in length. You simply cut the shaft to the right measurement and plug it in!

Then, too, Mallory provides 35 different resistance values and tapers in the Type UM control. There are 34 different resistance and taper values in the single tap TM type—and 8 in the double tap DTM type.

The fact is that with a surprisingly limited supply of Mallory controls and shafts, you can not only match but *duplicate exactly* almost any volume control in use today. Better still, only 16 controls are needed for approximately 85% of your replacement needs. See your Mallory distributor!



TYPE MK FIXED KNURLED SHAFT CONTROLS

Mallory offers the four most popular resistance values with fixed 4-inch shaft in this popular type MK knurled shaft control. Just select the proper resistance value, cut the shaft to required length, and install.

P. R. MALLORY & CO., Inc., INDIANAPOLIS 6, INDIANA



More than ever—
ALWAYS
INSIST ON

P. R. MALLORY & CO. Inc.
MALLORY
APPROVED
PRECISION PRODUCTS

VIBRATORS • VIBRAPACKS® • CONDENSERS
VOLUME CONTROLS • SWITCHES • RESISTORS
FILTERS • RECTIFIERS • POWER SUPPLIES

ALSO MALLORY "TROPICAL" DRY BATTERIES, ORIGINALLY DEVELOPED BY MALLORY FOR THE U. S. ARMY SIGNAL CORPS, NOT PRESENTLY AVAILABLE FOR CIVILIAN USE.

BROADCAST EQUIPMENT

(Continued from page 566)

circuits and the circuit being neutralized. When neutralizing the final stage, the antenna coupling coil and load should always be connected. The above method of neutralization is most satisfactory for use in high-power broadcast transmitters, but has the disadvantage of possible serious damage to an expensive measuring instrument, when operated by inexperienced or careless personnel.

Neutralization may also be accomplished with the aid of a cathode-ray oscilloscope, a neon tube, a flashlight bulb, or a wavemeter. However, operation of the cathode-ray oscilloscope is an intricate and specialized subject, while the other methods are not ordinarily encountered in broadcast practice, except in the case of emergencies. Hence they will not be discussed here.

MODULATION METHODS

Returning to the audio-frequency amplifier chain, the equipment following the program line amplifier comprises the modulator. All standard broadcast transmitters are amplitude-modulated, which means that the magnitude of the R.F. carrier is varied so that its envelope conforms to the wave shape of the audio frequencies impressed upon it. The modulation is normally applied to one of the R.F. amplifier stages, whose output can be varied by altering any of the following:

(1) filament voltage; (2) grid bias; (3) grid excitation; (4) D.C. plate voltage. Method (1) is obviously unsatisfactory, due to inefficiency and thermal lag, and only methods (2), (3), and (4) are of any practical interest for use in broadcast transmitters.

Modulation introduced into the plate circuit of the final amplifier stage is known as "high-level" modulation, while grid modulation of the final stage, or any modulation in preceding stages is known as "low-level" modulation.

SIDEBAND FREQUENCIES

In the case of amplitude modulation, when a given audio frequency is superimposed upon the carrier, there results in addition to the carrier two other frequencies. One of these has a frequency higher than the carrier frequency by an amount equal to the modulating frequency, and the other has a frequency lower than the carrier by the same value. The former is known as the upper side frequency, while the latter is known as the lower side frequency. Ordinarily, however, modulation is not confined to a single tone, but instead rather a large portion of the audio spectrum. Thus any such combination of frequencies when modulating a carrier results in a pair of "sidebands," each the width of the audio range being broadcast. Since both sidebands are transmitted, it is apparent that the width of the band necessary to transmit a modulated carrier must be twice that of the highest audio frequency to be transmitted. This is one of the severe limitations upon the standard broadcast band, wherein each broadcasting channel is confined by law to a width of 10 kilocycles, thus theoretically limiting the audio modulation to an upper boundary of 5,000 cycles per second. (The existence of sidebands has been seriously brought into question by some authorities, since it appears that it is the amplitude *only* of the wave which is being varied. However, on the basis of other proven phenomena, this theory is generally accepted as correct.)

More about modulation next month.

Send For CONCORD'S New RADIO PARTS BUYING-GUIDE

It's Free!

- ★ Save time. Order everything you need from ONE source.
- ★ Many parts available without priorities, for immediate shipment from CHICAGO or ATLANTA.
- ★ BUYING-GUIDE includes latest revised listings of standard lines.
- ★ Also contains 16-page Special Bargain Section of many scarce parts—all standard quality, all exceptional values.



HUNDREDS OF PARTS LIKE THESE Many Available Without Priority

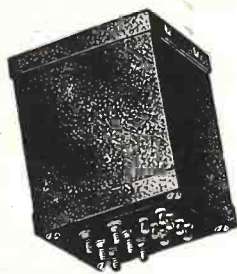

Power Transformer

Pri. 110, 200, 220, 240
Volts 50-60 cycles. Sec.
6.3 @ 1.45 A. 5V @ 2A.
376 Vct. @ .025 \$3.95
A. 5B5016... \$3.95



I. F. Transformer

10 Megacycle I. F. Trans-
former in heavy alumi-
num can. Size: 3 3/4" H,
1 1/2" W,
1 1/2" D. 5B5017 \$2.95



Telephone Switch

Lever type switch D. P.
D. T. No knob supplied.
Dull black finish with
chrome plated
lever. 5B4026... \$59c



Phone Jacks

Switchboard type 2 cir-
cuit normally closed.
Takes standard tip and
sleeve plug.
5B6927... \$49c

CONCORD RADIO CORPORATION

Lafayette Radio Corporation

CHICAGO 7, ILL. ATLANTA 3, GA.
901 W. Jackson Blvd. 265 Peachtree Street

Mail Coupon NOW

Concord's great, new 68-page Buying-Guide includes latest 1945 Revised listings of standard lines of Condensers, Transformers, Resistors, Tubes, Test Equipment, Repair and Replacement Parts, Tools, and hundreds of other essential items. Page after page of top-quality radio and electronic parts, and a special 16-page Bargain Section offering hundreds of hard-to-get parts at important savings. Mail coupon now for your FREE copy.

Quick Shipment from CHICAGO or ATLANTA

Concord carries vast stocks. Concord ships to you at once from the nearest shipping warehouse, CHICAGO or ATLANTA. Concord invites you to consult our technical experts on special requirements. Concord can expedite any "essential" order and speed action. Concord now serves the United States Government, Institutions, Industry—and can serve YOU, whether you want one part or a hundred. Telephone, wire, or write your needs.

CONCORD RADIO CORPORATION
901 W. Jackson Blvd.,
Dept. RC-65, Chicago 7, Ill.
Please RUSH FREE copy
of CONCORD'S new 68-
page Buying-Guide and Revised Listings.



Name.....
Address.....
City.....State.....

Radio-Electronic Circuits

TONE CONTROL

Figure 1

Due to the fact that two separate channels are provided, one for treble, the other for bass, this circuit will really control tone even for the most critical listener. It is possible to either attenuate highs or lows or mix them in any way.

The choke and condenser in the upper channel allow only low frequencies to reach the 500,000 ohm potentiometer in the grid circuit. The lower channel high-pass filter allows only the highs to be amplified. Mixing takes place in the grid of the final 6F6.

The unit (between points A and B) may be added to any existing amplifier or record player. The first tube may be a 6SN7, or two 6C5's may be used. If a pentode is used values of some of the components may have to be changed.

GEORGE C. LEE,
Stillwater, Oklahoma.

PHONO AMPLIFIER

Figure 2

After playing our portable phonograph a short time we found that it didn't have enough volume. Tracing connections showed that the pickup fed directly into a beam power tube.

I decided to add another .15 amp. tube amplifier and chose the 12SQ7, changing the line cord to one of 205 ohms, 10 watts. Complete schematic of the new hookup is given. A .001 microfarad condenser across the volume control cut out a slight whistle.

Plenty of volume now comes out of our 6-inch PM speaker!

RALPH L. MORRISON,
U.S.S. Bogue

(The cathode resistor of 12SQ7 seems low. A value near 2000 ohms might be better.—*Editor*)

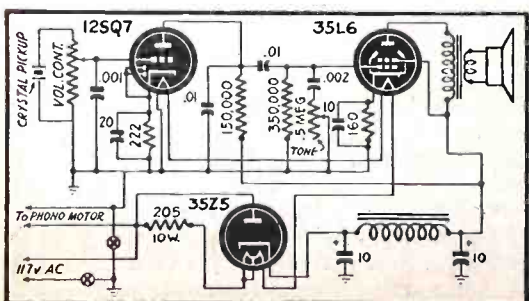
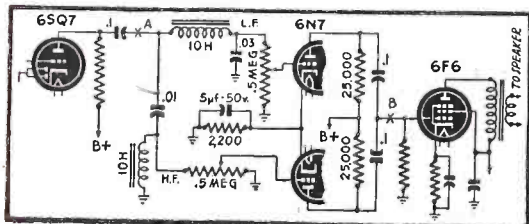

Radio-Craft welcomes new and original radio or electronic circuits. Hook-ups which show no advance on or advantages over previously published circuits are not interesting to us. Send in your latest hook-ups—Radio-Craft will extend a one-year subscription for each one accepted, Pencil diagrams—with short descriptions of the circuit—will be acceptable, but must be clearly drawn on a good-sized sheet of paper.

3-WATT AMPLIFIER

Figure 3

This amplifier has the desirable feature that no line cord is necessary. It can be used as a small public address system or with a radio tuner. An earphone can be used as a mike for it.

Do not ground the chassis at any time. If any hum is present, reverse the power plug. A tone control is provided to decrease the treble response if desired.

DONALD CHASE,
Winfield, Kansas.

HI-FI AMPLIFIER

Figure 4

I wish to offer the enclosed circuit of a High-Fi A.C.-D.C. amplifier, which may be of use to many of your readers. Together with simplicity in design, a minimum of parts and a two watt output, I have never made anything that had comparable

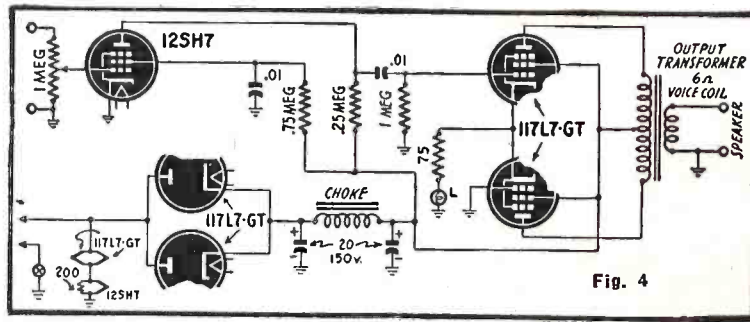

response or such high gain. Having noticed that many variations in design have been published, I do not recall circuits with a paraphase amplifier which is known for distortionless output.

I decided to utilize some of the parts salvaged from an old Zenith model midget. Using a midget volume control and a separate rotary switch, "canned" electrolytic condenser, and phone tip input and output jacks, it was possible to construct the entire unit on a chassis only 3 1/4 x 4 1/2 inches.

The method of lighting the pilot is rather unique. At first it was intended to obtain bias for the preamplifier across the pilot, but the amount of hum produced was terrific. Test with a scope showed that the bias produced by grid current was not detrimental to good operation. The series filament operation does not affect operation of the power tubes, but will actually give them longer life because of a lower surge current when the tubes are cold.

ROBERT J. CARTWRIGHT,
Boston, Mass.

1D8-GT RECEIVER

Figure 5

This is the small set I constructed in my barracks, made up of various parts gathered around camp. Local stations

come in on the speaker using 45 volts of "B" battery.

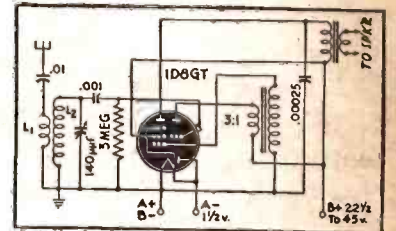

Figure 5

The tube is a detector and amplifier as well. All stations come in here loud and clear. A volume control may be added.

CAMP GORDON,
Johnston, Fla.

CODE OSCILLATOR

Figure 6

With the use of this single-tube oscillator, all danger of grounding through the power lines is eliminated, and no high voltages are present, thus avoiding all possible shocks.

The 6-volt secondary is used not only to light the filament, but after rectification by one of the triodes (connected as a diode) it is used as plate supply of the oscillator, the voltage being quite sufficient.

GENE CLARDY,
Fort Worth, Texas.

SIGNAL TRACER

Figure 7

This tracer is easy to use as it can be listened to while the probe is moved from place to place in the set. Separate posts are provided for R.F., I.F. and A.F. signals. The AVC voltage may also be checked by use of an electron-ray tube.

With sets using AVC, it is possible to listen while looking at the "eye," giving both visible and audible indication as to what is going on while changes or repairs are made.

A. MALINICK,
San Francisco, Cal.

Fig. 1, upper left—Tone compensator circuit.
Fig. 2, lower left—3-tube phono amplifier.
Fig. 3, below—A push-pull audio amplifier.
Fig. 6, upper right—Simple code oscillator.
Fig. 7, lower right—A good signal tracer.

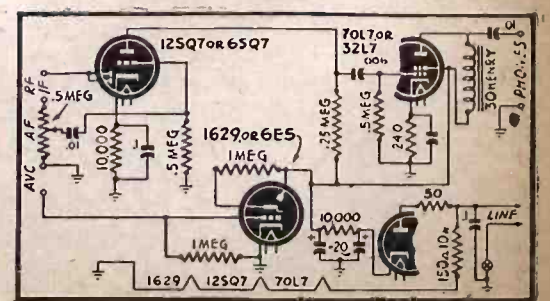
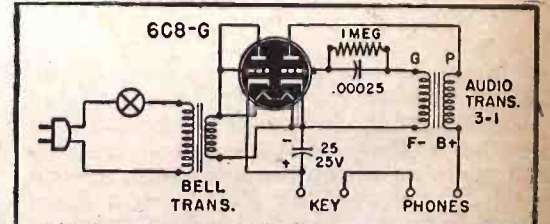
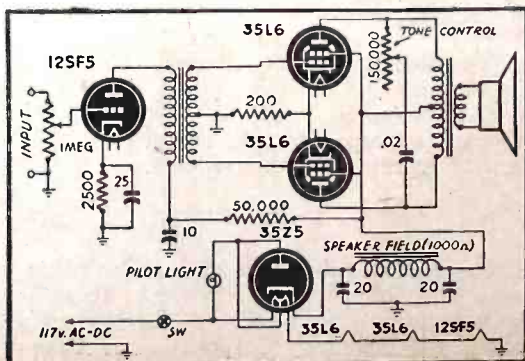

Attenuator Circuit For Signal Generator

A WORKMANSHIPLIKE attenuator for the output circuit of your signal generator is this one which was recently described in the *Wireless World*. Made with ceramic-insulated 1-watt carbon resistors and a 350-ohm potentiometer, in conjunction with a 4-point switch, any desired amount of attenuation may be obtained. The open-sided box is intended to be put up against cabinet or chassis in such a way that the other two sides will be closed and shielded, or a completely-enclosed box may be made and further shielded by enclosing it in the signal generator cabinet.

If this is impractical, the attenuator should be completely enclosed in a copper or aluminum box and mounted on one side of the signal generator in such a way that the output leads enter it directly, or through as short shielded conductors as possible. This is important, especially at short waves, where an exposed inch or two of wire will permit strong radiation directly through space to the receiver under test.

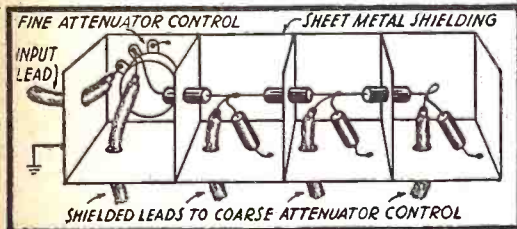

A blocking condenser is included in the output lead in case the signal is accidentally applied to a point of high voltage. While a non-inductive potentiometer would be ideal for the application, it may be difficult to obtain anything but the ordinary wire-wound type—which is somewhat inductive—for the required resistance. The shielded box must be grounded to a good ground, particularly for work with high frequencies.

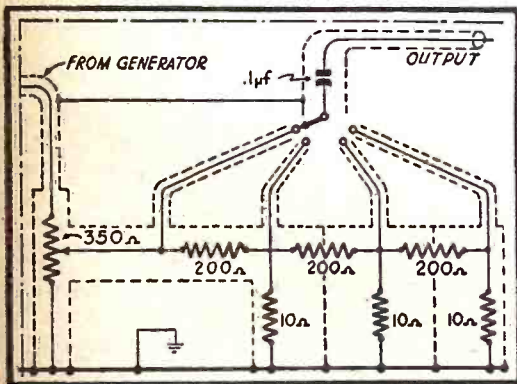

GEL LICKS HUMIDITY

Methods of packaging developed by the Army Signal Corps in recent months not only get delicate communications equipment to overseas destinations in good condition but save many thousands of man-hours in various war theatres and on the actual battlefronts. This improvement results chiefly from a desiccant (drying agent) called silica gel, which enables packaged items to resist moisture even in the most humid and rain-drenched areas of the tropics.

The gel has the appearance of crushed or granulated quartz. It is so porous that a cubic inch has more than 50,000 square feet of absorbing surface; it can take up and hold approximately half of its own weight in water without swelling, caking, or becoming appreciably wet to the touch.

Turn to Turner
for Leadership

Turner
211
Dynamic

Star Performance

Precision engineered for brilliant performance indoors or out under the most difficult acoustic or climatic conditions, the New Turner 211 Dynamic combines rugged dependability with distinctive, modern styling. Utilizes a new type magnet structure and acoustic network. Unique diaphragm structure results in extremely low harmonic and phase distortion without sacrifice of high output level. Standard equipment with leading electronic communications manufacturers wherever faithful reproduction is paramount. Write for technical data and descriptive literature.



Turner Performance

for Every Communications Need

There is a Turner Microphone for every electronic communications application. Get the full story of Turner performance. Write today for illustrated catalog giving descriptive data on all Turner Microphones for Recording, P.A., Call System, and Amateur and Commercial Broadcast work.

The TURNER COMPANY

902 17th St., N.E., Cedar Rapids, Iowa

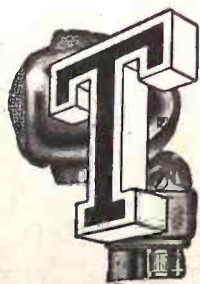

TURNER - PIONEERS IN THE COMMUNICATIONS FIELD

Turner

Microphones

Crystals licensed under patents of the Brush Development Co.

CRYSTAL

DYNAMIC

THE QUESTION BOX

2-TUBE REGENERATOR

Figure 1

? Will you please print a diagram of a two-tube regenerative receiver, using an A.C.-D.C. power supply? I have (a number of tubes, including 35Z5, 50L6 and 12SJ7). I would like to operate a small P.M. speaker with this set.—E.A.D., Pittsburgh, Penna.

A. The hookup shown will operate a speaker on local stations, if a good aerial is used. Coils may be standard broadcast or short-wave plug-ins. The same circuit may be adapted to other types of tubes. For example, if a 200-ohm line-cord or other filament resistor is used, the line up might be: 6J7, 25L6 or 43, 25Z5 or 25Z6. Other 6-volt tubes could also be employed.

2.5 VOLT RECEIVER

Figure 2

? Please print me a diagram of a 5-tube receiver using a 24-A, two 27's, a 45 and an 80. If it cannot be done please use different tubes. I wish to cover the broadcast band.—E.J.B., Brooklyn.

A. The diagram printed here uses two 24's, one 27, one 45 and an 80. The transformer system of coupling will help to compensate for the low amplification of the 45. As apparently you have an old set with the tubes, no doubt you will also find the audio transformer among the parts. Any standard broadcast coils can be used. The gang condenser should have a capacity between .00035 and .0005 per section.

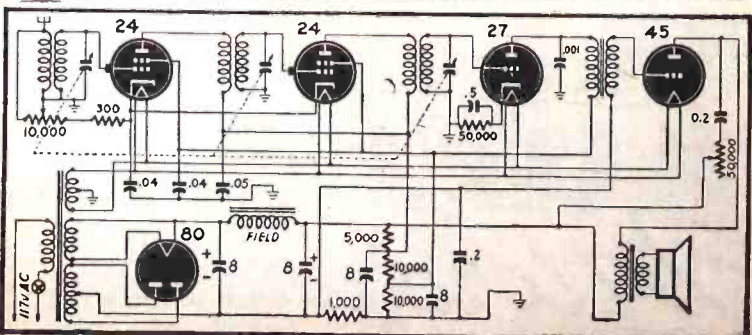
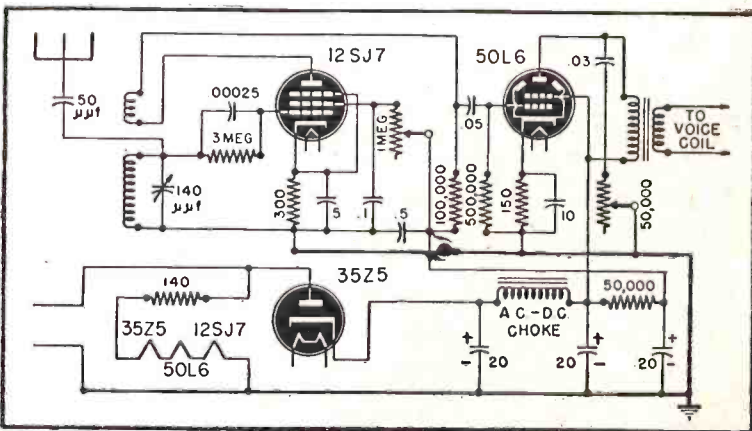

The Question Box is forced to discontinue answering questions until further notice. We have had great difficulty in securing skilled labor for this work, and in many cases recently have been forced to refund remittances. We will continue to print questions of general interest till those already answered and on hand have been exhausted or till we are again able to handle questions for readers.

FLEWELLING RADIO

Figure 3

? Please print the diagram of the Flewelling circuit shown in Modern Battery Radios as the "2-in-1." It used a 1D8-GT tube.—E.H.H., Elko, Nevada.

A. The circuit may be hooked up with two tubes if the 1D8-GT is not available. Any good triode and pentode could be used. The Flewelling superregenerator had an excellent circuit and actually did work rather well even when all work was done on the lower frequencies where superregeneration is not as ef-

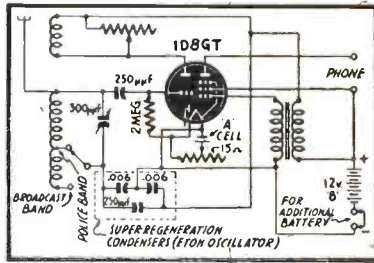

Figure 3

fective. The circuit shown is a modified Flewelling. A variable grid leak (1-5 megohms) might make adjustment easier.

If a coil with police-band tap cannot be obtained, one may be wound on a 1½-inch form with 120 turns of No. 28 wire, the tap being at the 80th turn from the grid. The tickler may be

wound with 100 turns of fine wire, and experimented with till best results are obtained.

Only 12 volts of battery are shown in the diagram, which was for portable use. For the full superregenerative effect, the battery voltage should be increased to 45 or even more.

CARRIER TROUBLES

? Two of us have been working with carrier current transmitters, but we've had trouble getting them adjusted and we've also had some trouble with harmonics on the broadcast band. My transmitter uses a 6SK7 as an electron-coupled oscillator and a 6L6 as amplifier.—B. K., Grass Valley, Calif.

A. The two usual causes of strong harmonics is too tight coupling and overexcitation. Your diagram shows 100 turns in the tank coil and 20 in the coupling coil to the line. I would suggest that this be cut to 10 turns, and probably moved further away from the tank. Your Hartley oscillator coil has 160 turns on the grid side and 50 on the plate side of the cathode. Try it with 180 and 30, or even 190 and 20, thereby reducing the excitation. Harmonics may be produced by overbias of the final amplifier. The cathode bias resistor should not exceed 200 ohms.

10-WATT AMPLIFIER

Figure 4

? I would like a schematic of an amplifier with 10 watts or more output using a 6N7 as a driver, two 42's in push-pull and an 80 as rectifier.—H.E.S., New York, N. Y.

A. Since the amplifier with 6N7 and two 42's does not always give enough gain, even for certain phonographs, we show

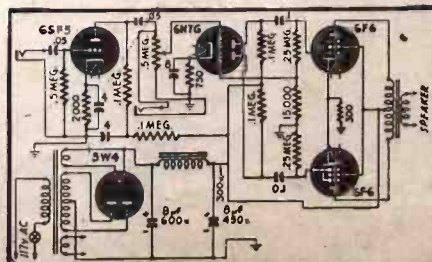

Fig. 1, top left—The 2-tube radio.
Fig. 2, bottom—Old-tube set.
Fig. 4, below—A good amplifier.

added to it an input stage, which you may add if you like. With the added tube, the amplifier may be used with microphone as well as with phonograph or radio.

Alternate tubes may be used, such as 6N7 or 6SC7 for the voltage inverter, and 6F6's in the output stage, as shown in the diagram. Any good rectifier will work, and the input tube may be a 6C5 or 6J5.

INTERPHONE

Figure 5

? Can you supply a circuit for a good intercommunicator to work over short distances? It need not be the carrier type—one that uses wire lines will do.—S.C.T., Viroqua, Wisc.

A. The circuit shown works well. By varying the line-cord resistor, other types of tubes may be used, or a small power pack may make it possible to use tubes not adapted to series-filament operation.

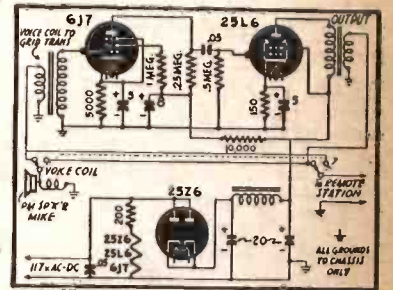

Figure 5

5-TUBE SHORT-WAVER

Figure 6

? Please design for me a radio that can be built with the following tubes: 43, 37 and 6D6. One that would work with plug-in coils would be best.—F. M., Kenosha, Wisc.

A. By using your 43 as a rectifier, a radio of the type you require can be constructed. If

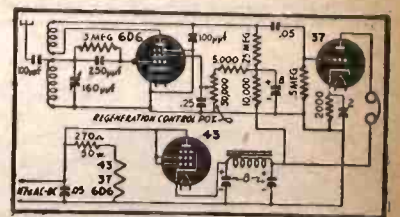

Figure 6

you had some type of rectifier tube, such as the 25Z5 or 25Z6, you could use the 43 as an output tube, with more gain. Using a 140 or 160 mmfd. condenser your coils may be wound as follows:

Band Meters	GRID COIL		TICKLER
	No. turns	Wire Size No.	
200-500	180	28	30 34
135-270	80	28	1 1/2 in. 15 30
65-150	40	26	1 1/2 in. 10 30
30-70	20	24	1 1/2 in. 6 30
15-35	10	16	1 1/2 in. 4 30

TELEVISION AND THE AMATEUR

(Continued from page 554)

Uruguay. Later Giampietro switched to the more advanced method of transmission, using the RCA Iconoscope tube type 1847 with which he received optimum results. His number of scanning lines varied from 260 with 50 photoelectric cells in the "Ike" to 525 lines with only 25 electric cells.

Recently he was issued station license CX5AQ on 115 mcs. Operating fixed and mobile rigs he is picked up over a distance of 15 miles with only 25 watts of R.F. on the antenna. In his studio he uses fluorescent lighting, which does away with the tremendous heat radiated by ordinary lamps.

While overseas as a Flight Radio Officer with the Air Transport Command I encountered many amateurs. Representative is the work of one staff sergeant stationed on a desolate island in the South Pacific. He is studying video via correspondence school. Even under the trying conditions of war he had already completed the full schematic for a superb low-powered television transmitter that will utilize color. I was impressed with the accuracy of the diagram considering that this man was entirely unfamiliar with video circuits prior to his entering the service.

On another base I located a Communications Officer, Captain John Billings, who intends to build his own commercial television station when he is discharged after the war. He told me of his plans for operation of the post-war station. He knows what city he wants to build his station in, how much power he will radiate, what type of antenna he'll erect and even has a general idea of the type of programming schedule he will present.

While visiting a Merchant Marine vessel at Houston, Texas, I encountered a radio operator who had actually built his own television receiver from spare parts and gimmicks, including a kinescope picked up from an old Philco. At the time he had no means of testing the receiver, but he planned on giving it a trial when the ship came within range of some of the large television stations in and around New York City.

Amateurs are employed and rendering valuable service at many of the commercial video stations. At WABD the Allen B. DuMont station in New York a number of "hams" are at work. Chief Engineer of the station is S. R. Patremio, W2ITL. Howard Schubert, W2JUO, is in master control, Melvin Stagg, W2CNO, and Otis Freeman, W4HGN, are video engineers, and Richard Adler, W2NPB, is sound engineer. Among others are: W1ISI, W2AHU, W2ENY, W2GZA, W2HOD, W2HRZ, W2LNT, W2LT, W2LMA, W2LYS, W2MOH, W2NYY, W2OMI, W8TNC, ex-1RJ, ex-1SS/1RI, ex-W2HEI, ex-2XC/2XD, W2KCN, ex-W6CRM, W2EBU and ex-W9KHG. A comparable list can probably be found at any one of the other nine television stations in the United States.

Knowing how the "ham" will spend hours rewiring a circuit to get just a little more "juice," how he'll endanger life and limb erecting a new antenna to get better DX transmission and also knowing how the amateur avidly grasps new inventions, gimmicks, gadgets, frequencies or anything connected with electronics, we may be sure that the new television frequencies recently allocated for amateur use after the war, will be filled to the brim with eager and hard-working "hams" to the benefit of the art.

Convenient Pocket-Size

for

CONTINUITY TESTING

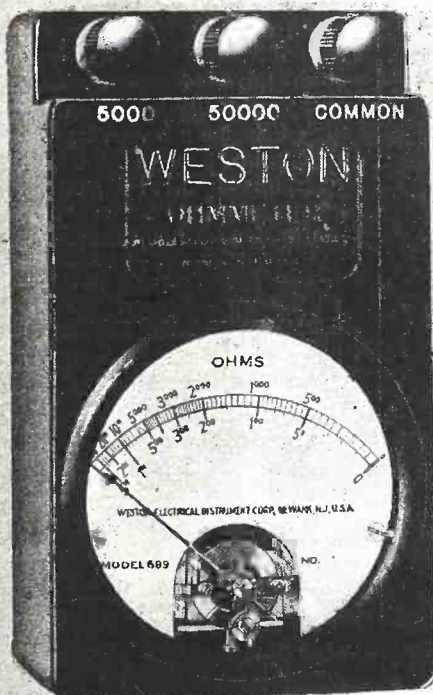

WESTON MODEL 689 OHMMETER

Pocket-size but with typical WESTON dependability and ruggedness, Model 689 Ohmmeters are unequalled for checking circuits by resistance and continuity method. Available in two types . . . type 1E with double range of 0-5,000 ohms and 0-50,000 ohms, and type 1F with double range of 0-10 and 0-1000 ohms . . . ideal for motor maintenance. Entirely self-contained. Order through your local Weston representative, or direct from . . . Weston Electrical Instrument Corporation, 618 Frelinghuysen Ave., Newark 5, N. J.

WESTON *Instruments*

Who knows, it may not be in the too far future when we'll have to add some new "Q" sigs. Signals that instead of asking, "How are my signals and legibility?" will ask, "Do you see me and am I clear?"

RECORDING MACHINE REPAIR SERVICE

★ We are specialists in sales and service of AMPLIFIERS, RECORDING MACHINES, PLAYBACKS and RECORD CHANGERS. Also design and build equipment to your specifications. Wire—Phone—Write your problem.

STUDIO SERVICE CO.

Division of LERRIS INDUSTRIES
242 West 49th St. New York 19, N. Y.

Headset Headquarters

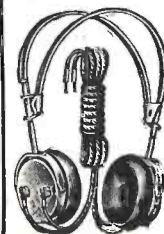

GUARANTEE CANNON-BALL

Scientifically Built Heavy bar magnets greatly increase their efficiency.

Phones to give absolute satisfaction. Unusually sensitive. Noted for fidelity and clarity of tone. Folder R-6 illustrates Complete Cannon-Ball line. Write

C. F. CANNON COMPANY
SPRINGWATER, N. Y.

TRY THIS ONE!

TEST LIGHT

Here is a test light made from an old fluorescent starter. The starters have a condenser in them which is connected originally as shown by the dotted line. Disconnect it on one side and wire it in series with

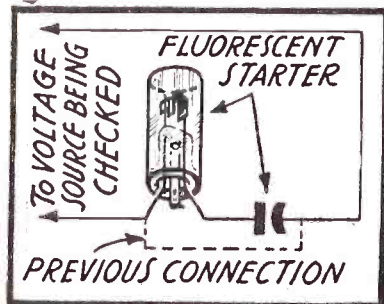

the starter as shown. This prevents the starter from getting enough voltage to close its contacts.

HARRY KROUT,
Olathe, Kansas.

(If a condenser is used, the tester will be useful on A.C. only—unless the condenser is very leaky. A resistor in series, large enough to keep current down to a milliamperere or two, will be effective on either A.C. or D.C. It will also be found that some starters flash at a much lower voltage than others. Select the most sensitive one available.—Editor.)

NOISE FILTER

I recently installed a radio in a large apartment house here in the city. However, the line noise almost drowned out the stations. Not having a suitable filter handy, I put one together in a regular outlet box, using a standard circuit. The result is a filter, every bit as good and neat as a factory unit.

The chokes are wound on dowels, 100 turns of No. 18 wire. The condensers are 1 mfd. at 600 volts. The total cost of the unit was about \$1.00.

GERALD SAMKOFSKY,
Brooklyn, N. Y.

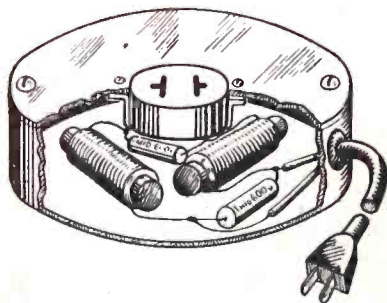

SURFACE FINISH

To put a novel finish on a sheet metal panel, lay it on a flat surface and with a circular motion spin the eraser end of a pencil against it to make small scratched circles. Repeat until

Radio-Craft wants original kinks from its readers, and will award a seven-month subscription for each one published. To be accepted, ideas must be new and useful. Send your pet short-cut or new idea in today!

the whole surface is covered with these marks. A pencil with a new eraser is needed. Then cover the metal with a thin coat of either colored or clear shellac.

If a drill or hand grinder is available, the job will be much easier, though if necessary a good but slow job can be done with a pencil held in the fingers.

H. GLENWOOD SCHLEGEL,
Hummels Wharf, Pa.

(This makes an excellent finish as evidenced by sample pieces which were enclosed by contributor.—Editor)

HOME MADE SWITCH

The other day I needed a rotary switch for a small multimeter. Not having one, I used the following: I used an old Philco (bakelite base) volume control, took out the resistance strip, cut off all terminals except the one to the rotor and drilled eight holes around as

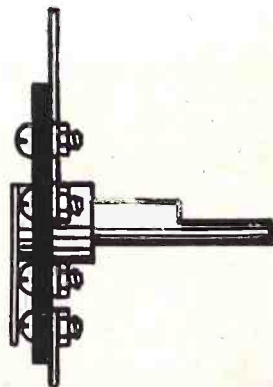
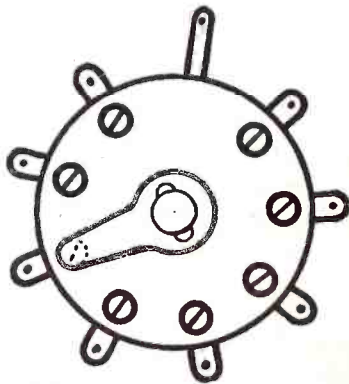

shown. I put small bolts through with a soldering lug and tap on the outside and bent the center arm to pass firmly but smoothly over the bolt heads.

This switch has stood up so well that I have wondered if there are not a number of other uses to which these worn-out volume controls might be put.

CECIL LEE BRIGGS,
Denton, Texas.

DIP SOLDERING

For production soldering by the dipping method, accumulation of dross is almost entirely eliminated by putting a good supply of powdered charcoal on top of the solder, as shown in the drawing. In dipping, the charcoal spreads away from the component being dipped and none is withdrawn on the tinned object.

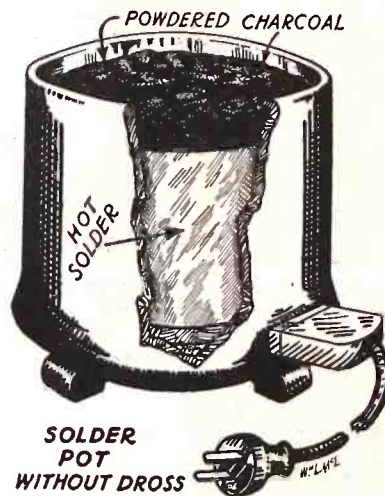

The charcoal is gradually consumed and more should be added as needed. It is important to use wood charcoal powder. Do not use animal bone charcoal, as it retains grease and will adhere to the parts dipped.

WILLIAM LYON,
Mamaroneck, N. Y.

TEST PROD

After building the Signal Tracer shown on page 20 in your 1944 Radio-Electronic Reference Annual, I was confronted with the problem of making the R.F. test prod with the condenser in the end of it.

Here is my solution. I took my regular needle point test prod apart and soldered a piece of bare stranded wire about 5 inches long to the tip. This wire is then wrapped around the rubber-covered test lead wire after pulling about 1/2 inch of it out and clipping it off so that the end of this wire will not make contact with the tip.

To keep the two wires from pulling apart a short piece of wire is looped around them near the tip and its ends twisted together.

WALTER H. MARTIN,
Norfolk 10, Va.



DECADE SOCKET

Here is an idea I feel is worth passing along to some of the other readers of *Radio-Craft*, who probably use condensers to test suspected open ones in a set.

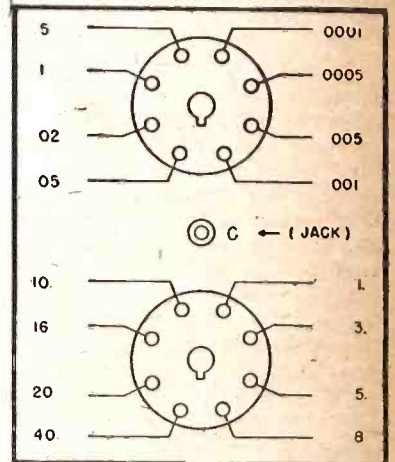

It is a decade box which needs no switches. I used two octal tube bases and a phone jack. It permits the use of the test cords of some of your other test equipment.

The idea is explained in the drawing. Condensers of the values marked are, of course, connection between the correct socket prongs and the jack, or minus C, terminal. As I used electrolytics for the bigger condensers, it is necessary to observe polarity.

Simply plug into the desired prong.

WILLIAM B. THORNE,
St. Johns, New Brunswick.

SLIDE RULE KINK

While using my slide rule I chanced upon an idea for converting frequency to wavelength and vice versa. The C_1 and D scales are used, the marker "1" of the C_1 scale being put over the "3" on D. The product of C_1 by its corresponding D value will then always be 3.

Since the product of kilocycles and meters is always 300,000, one may be converted to the other by simply noting decimal point. For example, if we treat the "1" on C_1 as 1000 Kc. the corresponding D reading "3" really means 300 meters, and so on for all other readings along the scale.

BILLY MITCHELL,
Kindersley, Sask.

Note: For slide rules not containing the C_1 scale, remove the slide, invert and replace into the stock. Now place the "1" of the C scale (which will be upside down) over the "3" of D. Then, as before, the product of any C reading by the corresponding D value will be 3.—Editor.

Better 10-KC Filter

By R. D. VALENTINE*

THE conventional L-C trap used to eliminate the 10-Kc heterodyne frequencies leaves much to be desired in that the band width rejected in effectively attenuating 10 Kc is so broad as to include far too many additional frequencies.

By use of the very versatile Bridged-T network it is possible to design a simple, inexpensive, yet extremely sharp 10-kilo-cycle filter. Fig 1 shows the simplicity of the circuit. The size of the components is such that the filter occupies no more space than required for the conventional L-C trap.

The Bridged-T network can be inserted in almost any portion of the audio system. For example: grid or plate circuit of the first audio stage; 500-ohm line, or in the voice-coil circuit.

The values indicated in Fig. 1, with the filter connected between the diode detector load and volume control of the first audio stage grid, provided the following attenuation:

1,000 cycles	0
5,000 cycles	0
9,000 cycles	0
9,400 cycles	0
9,600 cycles	+2
9,800 cycles	-10
10,000 cycles	-58
10,400 cycles	-10
10,500 cycles	-3
10,800 cycles	0

As can be observed from the tabulation, graphical analysis—even with two-cycle logarithmic paper—does not give a true picture, due to the sharpness of the curve.

For those interested in designing filters for 10 Kc or other frequencies, the following simplified formulae should prove of help:

$$1(a) \quad C = \frac{1}{\pi} \times \frac{10^2/3.2 R}{Q} F$$

$$1(b) \quad L = 1.6 \times 10^4 \times \frac{R}{Q} C$$

For the L and C values indicated in Fig. 1, R was assumed at 20,000 ohms and the Q of L at 10. Despite the fact that R is taken at 20,000 ohms, the Bridged-T network can be operated effectively into widely varying load impedances.

The basic formula for determining the values of L and C follow below:

$$2(a) \quad C = \frac{1}{8\pi} \times 10^3 F$$

$$2(b) \quad L = 3.2 \times 10^6 C$$

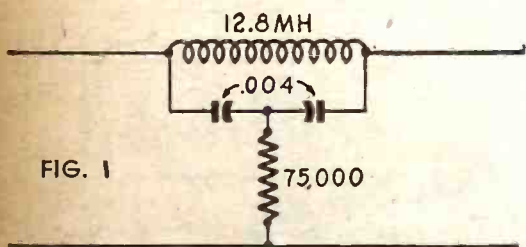

FIG. 1

The values of L and C must have close tolerance for the filter frequency. The value of the resistance (Fig. 1) will determine the amount of attenuation, and the resistor may be variable if desired.

If a variable audio-frequency oscillator is available it will assist in adjusting the filter for maximum attenuation and permit

*Chief Engineer, Radio Station WQXR

PORTABLE POWER PROBLEMS

THIS MONTH—TAG-HEPPENSTALL MOISTURE METER



MAJOR TOBACCO COMPANIES rely upon Tag-Heppenstall Moisture Meters, powered by Burgess Industrial Batteries, for two important time-and-money saving features. First, tests of moisture content are made to determine the purchase price of raw tobacco. Next, rapid tests during cigarette production help manufacturers maintain tobacco moisture at the level required for efficient processing.

MOISTURE METER READINGS of resistance, temperature and pressure are checked against a standard chart to quickly establish exact tobacco moisture. For test and control instruments Burgess Industrial Batteries meet every requirement—they are recognized as the standard of quality for all commercial uses. Although urgent war needs limit production, your Burgess distributor will make every effort to supply you with the batteries you require.

Burgess Battery Company, Freeport, Illinois



SUPPORT THE 7th! BUY YOUR SHARE TODAY!



BURGESS BATTERIES

the use of a reasonably wide selection of L and C values which may be on hand.

It seems to the writer that the Bridged-T network might also prove useful in R.F. trap circuits.

CUSTOMERS AND LAUGHS

IN a long experience as serviceman and distributor I thought I had run into everything in the way of queer customer demands and reactions. But the new servicemen of the war period have given me some new experiences. For example:

A serviceman phoned in for a certain volume control which happened to be out of stock, so I explained that I would send him down a duplicate control with a different taper. About an hour after the delivery went out, the telephone rang and a very irate customer stated that he had received

the control but where the hell was the taper. I had promised him.

The customer is still, however, the chief source of combined laughs and headaches. More of them are attempting to repair their own receivers than ever, sometimes with startling results.

A recent receiver came in for repair with holes very neatly drilled in the wet electrolytic condensers, when the customer was asked why the holes, he stated that they were to drain off the water that collected.

A customer whose set was repeating very often on coils eaten by mice has solved the problem by a new addition to the radio chassis. He installed a pair of mouse traps as a permanent accessory. They worked fine till one decided to chew up the speaker cone and grill cloth to make a nest inside the speaker.—R.E.W.

OHMITE RESISTORS

+
Your Guide to
DEPENDABLE RESISTANCE CONTROL
+

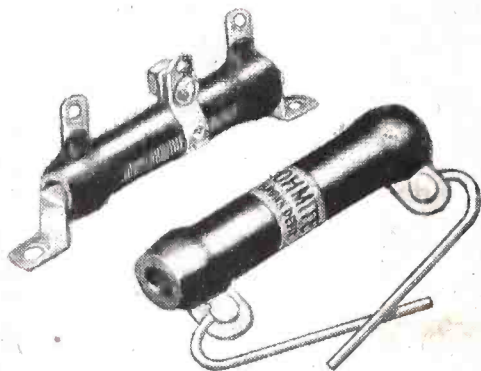

The service-record of Ohmite Brown Devil and Dividohm Resistors before and during the war... is your best guide to resistance-control tomorrow. Widely used in military and industrial equipment... everywhere! Write for Stock Unit Catalog No. 18.

Authorized Distributors Everywhere

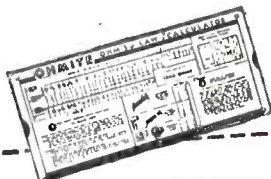

OHM'S LAW CALCULATOR

Figures ohms, watts, volts, amperes... easily. Solves any Ohm's Law problem with one setting of the slide. Send only 10c in coin.

OHMITE MANUFACTURING CO.
4896 FLOURNOY ST. • CHICAGO 44, U. S. A.

Be Right with **OHMITE**
RHEOSTATS • RESISTORS • TAP SWITCHES

Progress In Invention

Conducted by I. QUEEN

FREQUENCY INDICATOR

Patent No. 2,366,076

FREQUENCY meters for the audio range are often complicated and tend to instability. Many

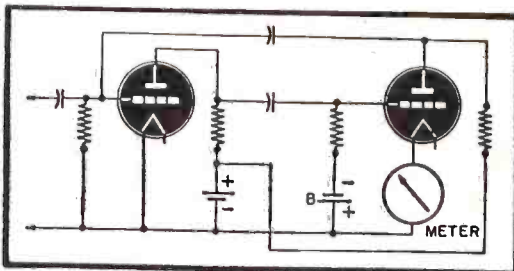

use thyratron tubes which deteriorate rapidly at the higher frequencies. Donald A. Wilbur of Troy, N. N., has disclosed a circuit using high-vacuum tubes.

The indicator is shown in its simplest form. It consists of an amplifier with positive feedback. When an input voltage of negative polarity is applied, the second grid (being out of phase) becomes positive, the meter indicating.

It is obvious that the amplifier will tend to oscillation, but battery B cuts off the second tube after one complete oscillation. Each negative pulse applied therefore causes a single oscillation, and since the meter averages out the tube current, the reading will be directly proportional to the incoming frequency, regardless of the latter's wave shape.

PRESSURE INDICATOR

Patent No. 2,368,278

A PATENT has been issued to Howard D. Warsaw of Philadelphia for this continuously reading pressure indicator. It is essentially a balanced oscillator with a pressure-operated condenser across its tank coil.

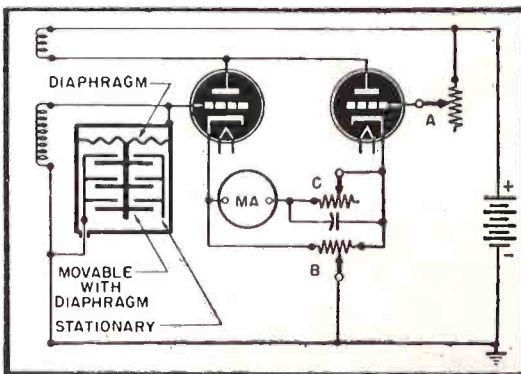

The tank condenser is shown to be made up of a pressure-sensitive diaphragm secured to a set of movable plates in capacitive relation to a set of fixed plates. Changes in pressure cause proportional changes of capacitance.

The use of two tubes allows a balancing out of the steady milliamper reading otherwise obtained. To operate, A is adjusted for the most critical oscillator point. B is then adjusted for zero meter reading. C is the sensitivity control. The meter itself may be located at some remote location.

TALKING BOOK

Patent No. 2,369,572

THIS patent covers a basic idea rather than actual mechanism employed. Printed on its pages are variable area recordings with means to guide a recorder along its tracks, such as perforations at beginning and end of each line.

The printed word and its sound track could be printed on the same line, so that it may be seen and listened to simultaneously. Such a book would be of great value for foreign language study, dictionary purposes, code practice, etc.

The inventor is Heinz E. Kallman, Boston.

VOLUME CONTROL

Patent No. 2,367,357

A BATTERY-SAVING volume control useful for the ultra-portable type of radio is disclosed by Winfield R. Koch of Haddonfield, N. J. Volume is controlled by varying voltage on the final stage screen grid, so that low output is accompanied by low current drain.

Note that the size of screen bypass is such that only the highs pass, resulting in negative feedback for the low frequencies at minimum volume. The lowered plate current at low volume raises the inductance of L so that the low frequencies are aided. Therefore, there is also a tone control effect, the middle register volume dropping with lowered output.

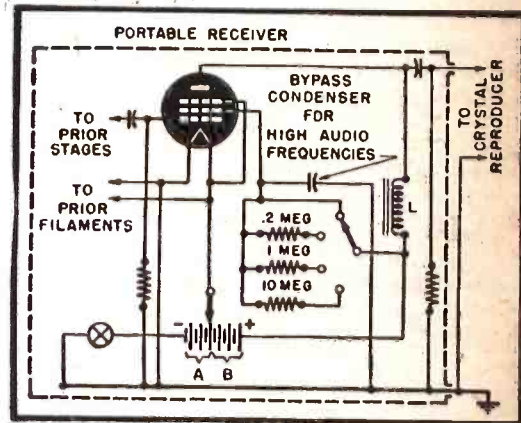

A typical circuit may show, with an applied voltage of 45, only 10 volts on the screen at minimum volume.

Instead of a number of resistors and a switch, it might have been more consistent with the practice of the art to have used a single variable resistor instead of the three shown. This would result in a further saving of space and parts.

TEMPERATURE INDICATOR

Patent No. 2,359,334

A SIMPLE electronic temperature indicator by means of which temperature may be directly read on a milliammeter is shown. The resistor is one having a constant temperature coefficient and is placed in the medium to be measured. It is the invention of John William Smith, Cedar Rapids, Iowa.

The 6SK7 plate current is constant, so that the voltage drop across the resistor varies directly with temperature. A VT voltmeter circuit, composed of two triodes (one to balance out the steady meter current) measures the voltage drop. Since this reading is linear, only two points on the scale need be calibrated. The variable shunt resistance (R) adjusts the sensitivity, so that the maximum temperature to be measured may correspond to full scale.

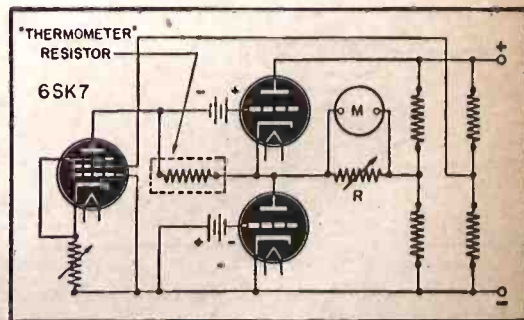

The series-tube hookup in the vacuum-tube voltmeter should be interesting to designers of such instruments. The usual Wheatstone Bridge effect is obtained with the two tubes in series with the voltage rather than in parallel, as is the more common case, where two tubes are used for a balanced VTVM circuit.

CONDENSERS

(Continued from page 568)

parison method which yields fair results. Transformer windings may be identified. High reactance windings will give less deflection than low reactance ones, enabling you to distinguish between them. Once you get used to it, this simple circuit has no end of possibilities.

In the end, if the test is negative, you still have the eternal parts replacement problem. It is sometimes helpful to remember that condensers in parallel add up in capacity. That is, if you need a 16-mfd, 150-volt condenser for an A.C.-D.C. radio and you don't have it, two condensers of 8 mfd rated at 150 volts can be used. This is shown in Fig. 2. The voltage rating of either of the pair in parallel must be equal to or greater than the original voltage rating. It would be possible to use an 8-mfd 450-volt condenser in parallel with a 150-volt 8-mfd unit to get an equivalent capacity of 16 mfd rated at 150 volts. It is all right, and often desirable to substitute a 600 volt condenser for one rated at 525 volts or 450 where a former unit has failed repeatedly.

Capacitances in series add up reciprocally. If C_t is the total capacity or net capacitance value,

$$\frac{1}{C_t} = \frac{1}{C_1} + \frac{1}{C_2} + \frac{1}{C_3} \dots$$

Where the condensers in series are equal in capacitance and you have two of them, simply divide the capacity of one by 2. Thus, two 8-mfd 450-volt condensers would in series, be equivalent to a 4-mfd 900-volt condenser. The leakage resistances of such condensers should be about the same. Inevitably, differences in characteristics will be found and it may be necessary to equalize the leakage resistances by using the circuit shown in Fig. 3. The voltage across each condenser will be made the same by using the proper values of resistance. These values are best determined by experiment, adjusting them until voltage equalization occurs. Start with 100,000-ohm resistors.

Note that the leakage resistances of the condensers in series add up. Suppose there are two .02-mfd condensers. One has a leakage of 10 megohms and the other has a leakage of 20 megohms. A condenser having the required leakage of over 20 megohms and a capacitance value of .01 mfd is needed but is not available. Can the two condensers be hooked in series to obtain an equivalent replacement unit? Yes. The two have a combined leakage of:

$$R_T = R_{C1} + R_{C2} = 30 \text{ Megohms}$$

In grid circuits, the voltage is usually low, but it is important that the leakage be held to a minimum value. Two 400-volt conden-

"CONTROL GRID"



Suggested by: Gus Britzman, Houston, Mo.

LEO'S SPECIAL!

ANOTHER

Hard-to-Get Item

Immediate Delivery!
Unconditionally Guaranteed

MULTITESTER

Ranges: DC Voltmeter, 0/5/50/250/500 volts; DC Millammeter, 0/1/10/100 mills; AC Voltmeter, 0/10/100/500/1000 volts; Ohmmeter, Low range 0-500 ohms. High range 0-1000,000/1 megohm. Overall size, 5½x8x3¼. Meter is 3½" round bakelite case with sturdy D'Aronsva movement.

FREE! NEW FLYER OF HARD-TO-GET RADIO PARTS!

44 pages packed with values just like the Multitester above . . . all in stock for immediate delivery to radio repairmen. Usual priorities apply. Experimenters write to Leo, W9GFQ, for information on how to get radio repair parts. Write today. Stocks won't last.

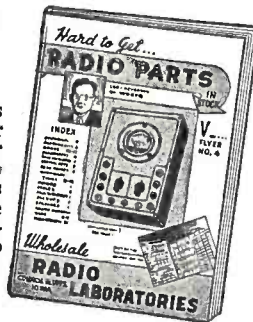

QUICK SERVICE

"Same Day" delivery service

from the heart of the nation. We've remodeled our store, doubled our shelf space, and increased our stock many times. Thousands of hard-to-get items now available to new and old customers. Write today! You'll like our quick, personal service.



Sincerely,
Leo I. Meyerson

WHOLESALE RADIO LABORATORIES

744 WEST BROADWAY
COUNCIL BLUFFS, IA.

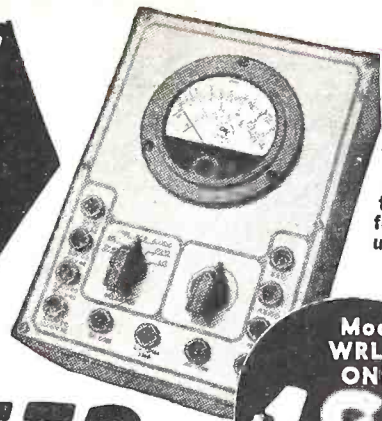

Quality test leads for this unit 60c

Model WRL 300 ONLY

\$18.75
Less Leads

Giant Radio Reference Map. 15c

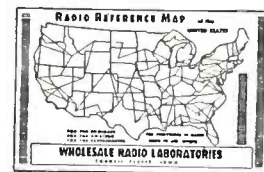

Time zones, amateur zones, short wave stations, and other valuable information. Printed in colors. Size 3½ x 4½ feet. Send only 15c to cover mailing.

Handy Tube-Base Calculator. 25c



Shows characteristics that help you substitute available tubes for those hard to get. Tube and Circuit Reference Book. . . . 10c Radio tube substitution data; technical data.

WE SPECIALIZE IN HALLICRAFTERS

We are one of the country's largest distributors of HALLICRAFTERS which are available for immediate delivery on priority. Write for full details.

MAIL TODAY

Wholesale Radio Laboratories RC-6
744 West Broadway
Council Bluffs, Iowa.

Please rush Multitester No. 300. \$18.75 is enclosed, or

Enclosed is \$ _____, Balance C.O.D.

Send your reference Book "Tubes and Circuits." Here's my 10c.

You bet I want a Tube-Base Calculator. 25c is enclosed.

Ship me your radio map. 15c is enclosed for packaging and mailing.

Send your free flyer of hard-to-get radio parts.

Name _____

Address _____

Town _____

State _____

I am an amateur; experimenter; service man.

sers of .02 mfd capacity each, even though one of them has a lower than permissible leakage for grid circuit service when used alone, may nevertheless be used when series connected.

Using a lower than normal value of leakage resistance is not good servicing practice in auto sets. Buffer condensers often break down in such radios and the capacitance values are critical. The replacement unit should have a capacitance identical with the original.

The voltage ratings of condensers in series add up. In many such sets, 1200-volt buffer condensers rated at .01 mfd often are used. Two condensers, each rated at 600 volts and .02 mfd, when connected in series, will be equivalent to a single .01 mfd 1200-volt condenser. If the original condenser was rated at .006 mfd and 1200 volts, connecting in series two 600-volt units rated

at .012 would be equivalent—but a .012 condenser is not easy to get. The formula previously given may be used. That is,

$$\frac{1}{C_T} = \frac{1}{C_1} + \frac{1}{C_2}$$

Remember that voltage over condensers in series distributes itself in inverse proportion to their capacities. For example, a condenser approaching .006 mfd could be made by attaching a .02 and a .01 condenser in series. If these were both 600-volt units and were attached across 1200 volts, breakdown would result, as 2/3 the voltage—or 800 volts—would be across the smaller condenser and only 400 volts across the larger. This fact must not be lost sight of when replacing condensers with series units. The smallest condenser must have a high enough voltage rating to stand the strain which calculation shows will be placed on it.



... which will YOU be using 2 years from now?

Add CREI Technical Training to Your Present Experience — THEN Get That BETTER Radio Job You Want!

Thousands of new men have joined the ranks of the radio industry for the duration. But after the war, even more thousands will return from the armed forces. War production will settle down to supplying civilian needs.

Where will you fit into this picture? If you are wise, you will look ahead and prepare for the good-paying jobs in radio-electronics and industrial electronics.

It is up to you to decide if you will be a "screwdriver" mechanic or a real technician in a responsible engineering position . . . with a thorough understanding of U. H. F. circuits, cavity resonators, wave guides, Klystrons, Magnetrons and other tubes.

More than 10,000 professional radiomen have enrolled for CREI home study courses in Practical Radio-Electronics Engineering. Today, hundreds of ambitious men, just like yourself, are taking our specialized spare-time training to give them the technical skill to supplement their present ability . . . to earn a better living . . . and to create a secure place for themselves in the great postwar world of radio and electronics.

CREI can help you prepare by providing you with a proved program of home study training that will increase your technical ability and equip you to advance to the better-paying radio-electronics jobs that offer security and opportunity. The facts about CREI and what it can do for you are printed in an interesting, new 36-page booklet. It is well worth your reading. Send for it today.

● WRITE FOR NEW, FREE 36-PAGE BOOKLET

If you have had professional or amateur radio experience and want to make more money—let us help you qualify for a better radio job. TELL US ABOUT YOURSELF, so we can intelligently plan a course best suited for your needs.—PLEASE STATE BRIEFLY YOUR BACKGROUND OF EXPERIENCE, EDUCATION AND PRESENT POSITION.



CAPITOL RADIO ENGINEERING INSTITUTE

Home Study Courses in Practical Radio-Electronics Engineering for Professional Self-Improvement

Dept. RC-6, 3224 — 16th St., N. W. WASHINGTON 10, D. C.

Contractors to U.S. Navy—U.S. Coast Guard—Canadian Broadcasting Corp.—Producers of Well-trained Technical Radiomen for Industry

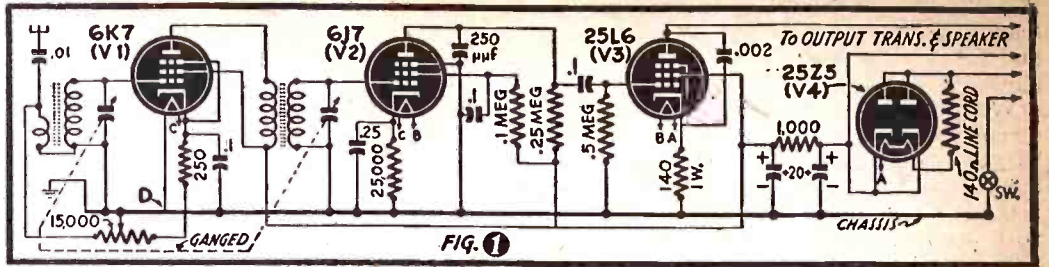

CARRY-AROUND RECEIVER

By EDWIN BOHR

SINCE its introduction the small portable set has become very popular due to its adaptability to a multitude of uses. One of these sets is described here. A very simple and easily constructed T.R.F., it can be built out of parts taken from sets junked because of the shortage of the much used .15-ampere tubes. Four tubes are used in a circuit containing an R.F., a detector, an A.F., and a rectifier stage. An almost unlimited number of tubes can be easily adapted for use in this set because of its simplicity.

In the R.F. stage, a super-control pentode such as the 6K7, 6SK7 or 78 is found in a

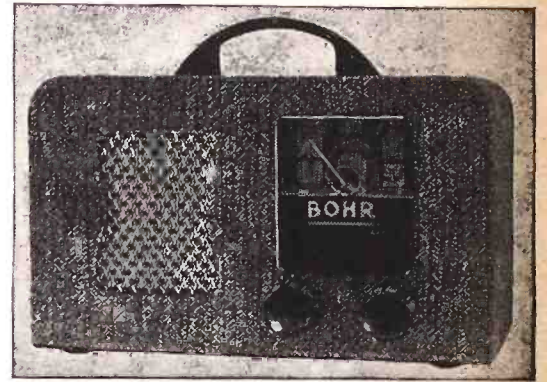

The receiver's appearance is near-commercial.

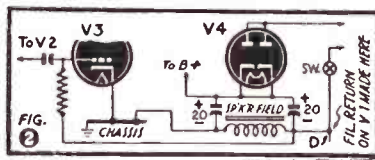

conventional circuit containing the volume control. A sharp cut-off pentode is used in the detector stage. Iron-core coils were used in both the R.F. and detector stages because of their added gain and selectivity, but are not necessary. Inverse feed-back is used in the output stage and decreases distortion.

In this set a 1-watt resistor was used in place of a filter choke, but if a choke is on hand it should be used. Fig. 2 shows a hook-up using a dynamic speaker to supply bias for the output tube. With this circuit no inverse feed-back is used.

If no rectifier tubes can be found, triodes with their grids and plates tied together will work. A 12SN7 with its twin triode structure is a fairly good substitute for a 25Z6 and will last much longer than a single triode connected as a diode.

The chassis was taken from an A.C.-D.C. radio phonograph and had to be shortened. This was accomplished by cutting the two sides with tin-snips and bending the chassis in such a way that the tops form a right angle, thus the top may be cut saving the

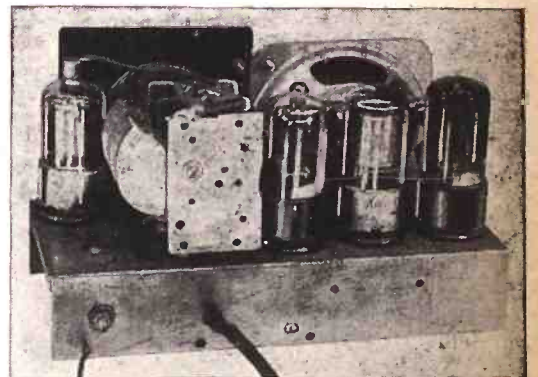

tiresome job of using a hacksaw. The cut-out for the speaker was ground away with an electric grinder.

An improvised dial was made from a piece of bakelite and a dial drum, and the chassis was put into a portable carrying case, which gives it a very neat appearance.

A real portable radio is an impossibility, now while there are no batteries. This carry-around, which can be used wherever there is a chance to plug in, is the next best thing.

IT'S THE DESIGN (Continued from page 565)

In the majority of dials in the kilocycle range, one zero is omitted while in the newspaper programs the correct numbers are given. For example, in the papers, the number for WMCA is 570, while on the radio dial the numbers start at 55. This zero omission is also a stumbling block to much of the public.

8—Loop Antenna Instructions: The majority of radio listeners know nothing about the fact that a built-in antenna is directional and has to be turned in one direction or the other for good reception. The repairman, of course, has done a poor job if after a repair—by chance—the station that the listener wants most to hear does not come in well. Why can't the factory paste a simple

note with large letters on each receiver explaining that in modern radios with built-in (loop) antenna the reception of weak stations can be vastly improved and noises suppressed merely by turning the receiver around slowly?

Neither does the public know what improvement can be brought about in large console sets when the hidden loop antenna is turned. Why isn't there a simple control connected to the loop with a notice: "Turn loop antenna for better reception of weak stations?"

9—Information on the Aerial: The radio purchaser should be advised that in steel constructed buildings an outside antenna is necessary and that provision is made for

this in every set. Hardly any customer knows what the tiny wire hanging out of the back of the receiver with built-in antenna is intended for.

With older radios without a built-in antenna similar troubles are often experienced. The set owner uses only a few feet of antenna wire twisted into a small bunch, or perhaps an antenna that has deteriorated with the years. Why can't the factory paste a note on the receiver explaining either that the radio should be connected to an outdoor antenna or that it needs an antenna wire a certain number of feet in length? There are excellent radios, for example, which with ground connection become practically noiseless under the worst conditions. Why not a note fixed on the receiver telling whether or not a ground connection is recommended?

10—Control Mix-ups: The average radio listener can handle the knob for tuning and the switch with volume control fairly well. The tone control, however, remains a secret to many dialers. The average listener does not know about "bass" and "treble" and its effect on speech and music. If tone control were specifically marked for "speech" and "music," instead, this problem is overcome automatically.

Some manufacturers have incorporated a push-button system for tone control that is supposed to eliminate sound frequencies when single or several keys are pressed down. These keys, up to six on one receiver, are marked with treble, voice, alto, bass, low bass and normal. A particularly fine and large console set with 33 tubes has eight controls on its panel. The set is too luxuriously built to have labels on its control panel, but an instruction manual calls them (1) sensitivity and scratch suppressor (2) selectivity and phono (3) tuning (4) A.C. and volume (5) noise limiter (6) bass (7) fidelity and (8) wave change. It seems completely out of the question that the average owner of such radios would ever become familiar with those terms and their meaning.

Many households have a radio in nearly every room. On some sets, switch and volume control are combined, as should always be the case. On other sets, the switch is combined with the tone control, while still other receivers have a separate "on" and "off" switch. At the psychological moment, when the telephone rings or some other urgent performance can not be postponed, the radio cannot be turned off fast enough because the switch is not connected with the volume control. Fumbling around in haste on the wrong control often loosens the knob of the control. Battery radios, instead of being switched off, are merely turned down to low volume and stays thus until the batteries are worn out. Imagine if every gear shift, clutch or brake were in a different spot in each model of automobile! The consequences in a radio may not be so dire, but they can be annoying.

Without pretending in the least to be complete, I wish to indicate, by these few examples, that the pre-war radio models are far from perfection. From the point of view of the listener they lack simplicity in their outer construction while from the standpoint of the repairman their inner arrangements leave much to be desired.

SERVICEMEN ATTENTION

50L6, 12SA7, 12SQ7, 25Z5, etc. Forget the shortage of above and similar tube types by availing yourself of our tube repair service. Tubes are fully tested after repairing in radios. Send no money. Repaired tubes returned C.O.D. Only 25c each or 20 tubes repaired for \$3.00. Ship us a boxful today and take advantage of OUR LOW PRICE. Minimum order \$2.00.

Radio Service, 307 Pipstone, Benton Harbor, Mich.

BUY AN EXTRA WAR BOND



Leads the way

LEADERSHIP IN DESIGN AND MANUFACTURE OF RADIO-ELECTRONIC PRODUCTS

The outstanding production records of Insuline have twice been commended by the Army and Navy. New designs, new products, new manufacturing methods are constantly being devised, so that after V-Day it will still be true that, in the Radio-Electronics field, "ICA Leads the Way."



SUPERIORITY IN SOLDERING IRONS

ICA Irons embody these important construction features:—

Heating elements wound on high heat-resisting bobbin of machined and threaded Insulex. Winding utilizes special resistance wire. Complete bobbin is impregnated in non-hygroscopic ceramic compound. ICA Irons heat up to operating temperature in three minutes, and in one additional minute surpass the heat peak of ordinary irons. Special air chamber reduces heat losses. Thoroughly insulated. Rubber tube protects cord from excessive wearing and short-circuiting . . . Write for full details now.

Write for 48-page Catalogue describing the extensive line of ICA Radio-Electronic Products . . . Also 8-page brochure presenting the ICA Manufacturing facilities.

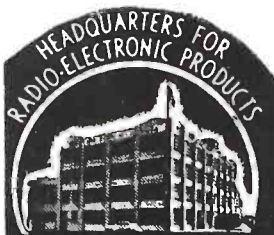

INSULINE

CORPORATION OF AMERICA

INSULINE BUILDING · LONG ISLAND CITY, N. Y.



BRUNO Adjustable HOLE CUTTERS

NOW AVAILABLE FOR
IMMEDIATE DELIVERY
on AA-5 Priority!

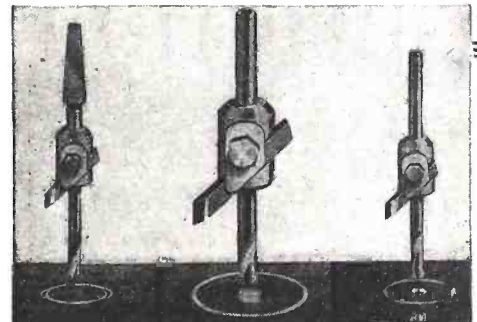

Outstanding Features of BRUNO Adjustable Hole Cutter

1. Sturdy, well-balanced construction, the result of careful design by experienced engineers.
2. Manufactured by specialists in the field of fine cutting tools.
3. Cut clean holes in steel, brass, hard rubber, aluminum, fibre, plastics, wood and problem materials which might necessitate use of torches or expensive equipment.
4. May be used in drill presses, electric motors, hand drills or hand braces (both sizes are available with standard square bit stock shank).
5. Equipped with High Speed steel blade, easily re-sharpened or replaced.
6. Blade is made from a standard square High Speed Lathe Tool bit used in all machine shops.
7. Shanks are heat-treated and true, insuring long life.
8. Easy adjustability provides economies of time and labor; eliminates need for a tool for every size hole.

Model No.	Shank Size	Expansion Capacity	Thickness Capacity In Metals	For Use In	Pilot Drill Size	User's Price	Extra Blade
100	1/4" straight shank	3/8"-1 1/2"	*3/8"	Elec. Drills Port. Motors Hand Drills	1/4"	\$3.00	\$1.00
100-B	Square Bit Stock	3/8"-1 1/2"	*3/8"	Hand Braces	1/4"	\$3.00	\$1.00
101	3/8" straight shank	1"-2 1/2"	*3/8"	Elec. Drills Port. Motors Hand Drills	3/8"	\$5.00	\$1.50
101-B	Square Bit Stock	1"-2 1/2"	*Thin Metals	Hand Brace	3/8"	\$5.00	\$1.50

*Deeper holes can be cut in plastics, wood and compressed materials.

MAIL OR PHONE YOUR ORDER NOW!

RADIO ELECTRIC SERVICE CO.
OF PENNSYLVANIA
N.W. COR. 7th & ARCH STS.
PHILADELPHIA 6, PENNA.

Phone:—
LOMBARD 6177
LOMBARD 1951

10,000 PARTS

Ten thousand different
radio and electronic parts immediately
available on priorities

SERVICE

Trained expeditors select
and ship same day your order
is received

EXPERIENCE

Known since 1922 as reliable
jobbers, wholesalers and manufacturers of
radio and electronic equipment

Radio Wire Television Inc.

100 Sixth Ave. (Dept. A-6) New York 13, N. Y.
Boston, Mass. Newark, N. J.
World's largest Radio Supply House

Originators and
Peacetime Marketers
of the celebrated

Lafayette Radio

Write today for our bargain
flyers and special bulletins.

TECHNOTES

ATTENTION, SERVICEMEN!

Do you have any servicing notes available which you would like to bring to the attention of the readers of *Radio-Craft*? If so, send them along. If they are publishable a six-month subscription to *Radio-Craft* will be awarded you. If your notes are illustrated you will be given a one-year subscription.

... MOTOROLA POLICE RADIOS

The audio frequency response of the Motorola model P69-18 radio receiver can be made more "brilliant" with improved intelligibility through the loud-speaker, by making a few simple changes in the set.

FIRST, eliminate condenser C-20.

SECOND, replace the .01 mfd condenser at C-19 with a mica of .001 mfd capacity.

The P69-18 receiver has rather a low tone and this change increases the response to higher audio frequencies.

The absorption of high audio frequencies by the upholstering in the car and clothing of people within the car—may make this change desirable to you.

Some Police Departments have replaced the OZ4 rectifier with the 6X5 rectifier tube which will give longer life.

The remote squelch control on the FM control head (P-8022) can be used with the P69-18 receiver by running an extra wire from terminal No. 16 on the P-8022 to one side of the squelch control in the receiver chassis.

Leave the squelch control on the P-8022 in mid-position and then manually lock off the squelch in the set. The squelch can then be controlled from the P-8022 at the operator's position.

GALVIN MFG. CORPORATION,
Chicago, Illinois.

... TO KEEP PARTS APART

In order to keep small bolts, nuts, knobs, etc. from being lost on the service bench, or to keep parts from two different sets from being mixed with each other, I suggest using small paper plates to put the parts in.

I bought about six small paper ice cream plates for this purpose. They are about 4 inches in diameter, which is the ideal size for this purpose.

As soon as parts are taken from the set, they can be dropped into a plate and thus will not roll off the bench and become lost. Using this method I have never lost a part and I hope it will help others in the same way.

JAMES A. LONG,
Rensselaer, Ind.

(In practice, it may be found that paper plates are easily upset or brushed away. The Service Editor has used small glass or plastic cups, and now has a number of rectangular containers one by two inches by 1½ inches high. The reason for such containers is apparent to all who know a customer's predilection for getting back the same knobs he brought in on his set.—Editor)

... MICROPHONE PLUG

Almost all mikes built today for use in P.A. systems use an Amphenol female coupling as standard. Most of the so-called "guitar" amplifiers use a standard shielded 'phone jack for mike input. To facilitate service work on these amplifiers, Amphenol produced an adaptor. However, this is not always on hand when wanted, so I have found the following idea useful. Take a standard 'phone plug apart, being careful not to damage the insulation—remove the

lugs and reassemble, using a fiber or small metal washer to take up the extra length of the screw. If you don't want to use it as a 'phone plug again—cut ¼-inch off the end of the screw before reassembling. The



CROSS-SECTION
COMPLETED ADAPTOR.

mike connector's coupling ring now screws on where the shell of the plug went.

ROY L. GALLAGHER,
New Kensington, Penna.

... FILAMENT WELDING

I enjoyed your article, "Welding Tube Filaments," in the February Technotes. I think that most servicemen know that when tubes are welded they burn out very easily.

To prevent much of this I decided to temper the filaments in some way. As you probably know, when the heater voltage is cut off, the tube cools at a rapid rate, making the filament brittle and subject to easy unwelding. After welding, I always put the tube in a tube checker with the required voltage at the socket, then decrease it gradually until it is cool, thus tempering it soft.

WILSON NEAL,
Pearsall, Texas.

... STILL ANOTHER 35Z5 KINK

Recently while servicing an A.C.-D.C. set I discovered that the pilot tap in the 35Z5 was open. I wished to find a simpler method to remedy this trouble than using a resistor. A very simple way is to replace the 150 ma. pilot lamp (type 40 or 47) with one of a 250 ma. rating (type 46 or 44). If a new 35Z5 is obtained the pilot lamp should be replaced with the original type:

ALBERT SAXER,
Buffalo, N. Y.

(The bulb would be subject to overload while the set heats up just after being turned on. Whether this would be serious would have to be determined by experiment.—Editor)

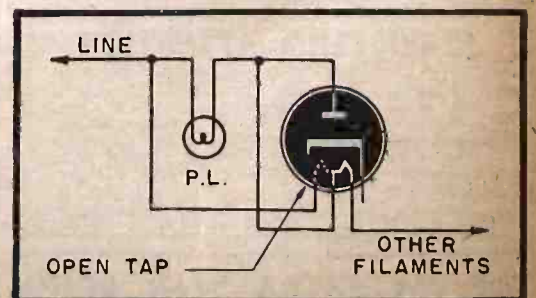

32-VOLT RECEIVER

(Continued from page 567)

necessary to repeat the 1500 Kc. setting if the padder condenser has been moved very far as this padder will affect the adjustment of the 1500 Kc. trimmer. A signal generator for this work is much more satisfactory but when not available the foregoing procedure will be satisfactory.

The parts may be any standard brands that you may be able to obtain. Purchase the best grade available as the set will only be as good as the poorest part, being poor economy to spoil a good job because of one or two inferior parts. Be sure to get coils and condensers matched to each other, if possible.

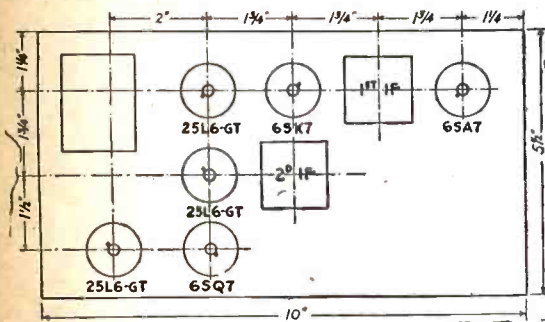

The following parts are suggested if available, a choice of Victor or Meissner being given. However, any coils and condensers can be used, if they are properly matched to each other.

Parts List

- L1, L2—Ant. coil, Victor No. 32572; Meissner No. 14-1022.
- L3—Osc. coil, Victor No. 32962; Meissner No. 14-1033.
- T1—Input tran., Victor No. 33722; Meissner No. 16-5740.
- T2—Output tran., Victor No. 33723; Meissner No. 16-5742.
- C1, C2, C3, C4—Var. con., Victor No. 32968; Meissner No. 21-5214.
- Padder con., Meissner No. 22-7005 (required only if using Meissner gang).

DISC-SEAL TUBES

(Continued from page 563)

flow on the inner surfaces and none on the outer surfaces. The heat (generated by current flow in a resistance) does not penetrate the resonator walls and is conducted throughout the metallic structure. In the disc tube, heat energy generated at the anode is transmitted through the solid anode rod to the outside of the resonator to permit anode cooling. The high frequency radio energy, however, flows from the point of origin at the anode into the resonator. The anode cooling can be taken care of, therefore, by outside means without interfering with what goes on inside the tube.

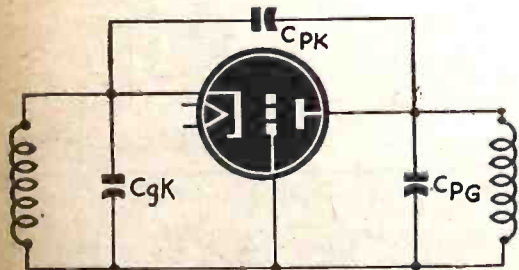
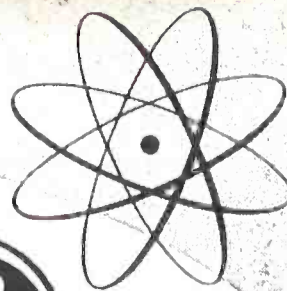

Fig. 7—Disc-seal tube equivalent circuit.

The old bromide about there being nothing new under the sun does not apply to this equipment—it is new and many of our ideas of circuit behavior are going to need changing in the future.



OSCILLOSCOPE CRO-3A

EVERY service man needs this portable oscilloscope for accurate and rapid service work on AM, FM and Television receivers. We list only a few of the many uses that make it indispensable in the modern service shop: study wave shapes and transients; measure modulation adjustment of transmitters; check receiver alignment; determine peak voltages; trace electronic tube characteristics. The CRO-3A gives a sharp, clear picture and is equipped with a screen for easy daylight viewing. Write today: *Electronics Department, General Electric, Schenectady 5, New York.*

Electronic Measuring Instruments

GENERAL ELECTRIC

177-D4

HALLICRAFTERS



HALLICRAFTERS



RECEIVER HEADQUARTERS

for the Nation

BEFORE the war Bob Henry served the amateurs as the world's largest distributor of communications receivers.

Now Henry Radio is Hallicrafters receiver headquarters for the Nation at war. Hallicrafters Receivers can be supplied on priority. I can usually supply SX28As at \$223.00, S-39s at \$110.00, S20Rs at \$60.00, SX-25s at \$94.50, and PM-23 speakers at \$15.00 at once. It takes longer to supply other models.

Soon, it is hoped, non-priority orders can be filled and Bob Henry can become again Hallicrafters headquarters for the nation at peace.

I have stores at Butler, Missouri, and at 2335 Westwood Blvd., Los Angeles 25, Calif.

Your orders and inquiries are invited.

Bob Henry, W9ARA
HENRY RADIO SHOPS

Butler, Mo. and Los Angeles, 25, Calif.

COMPLETE STOCKS

I have in stock some Hallicrafters receivers available for immediate delivery on priority and the following parts without priority: meter rectifiers \$1.95, transmitting tubes, transformers, resistors, condensers, panels, headsets, etc. Your orders and inquiries invited.

"WORLD'S LARGEST DISTRIBUTOR OF COMMUNICATIONS RECEIVERS"



One Central Source FOR Everything in RADIO and ELECTRONICS

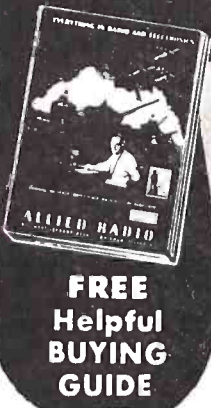

LARGEST STOCKS
COMPLETE SERVICE

REPAIR and REPLACEMENT PARTS AVAILABLE without priority

Over 10,000 items from all leading manufacturers . . . for the Armed Forces, Radio Training, Laboratories, Industry, Service Replacements.

Parallel Resistance and Series Capacitance CALCULATOR
No. X37-960
Postpaid ... **25c**

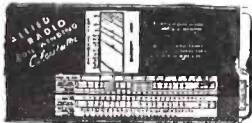

R. F. Resonance and Coil Winding CALCULATOR
No. 37-955
Postpaid **25c**



6 Radio Books for 75c

Dictionary of Radio Terms. No. 37-751 10c	Radio Data Handbook. No. 37-754 25c
Radio Circuit Handbook. No. 37-753 10c	Radio Builders Handbook. No. 37-750 10c
Radio Formulas & Data Book. No. 37-752 10c	Simplified Radio Servicing. No. 37-755 10c
All Six Books No. 37-799 75c	

Write for Quantity Prices

ALLIED RADIO CORP., Dept. 2-F-5
883 W. Jackson Blvd., Chicago 7, Ill.

Please send following books (..... enclosed)

<input type="checkbox"/> FREE Guide	<input type="checkbox"/> 37-750	<input type="checkbox"/> 37-752	<input type="checkbox"/> 37-754
<input type="checkbox"/> Calculator	<input type="checkbox"/> 37-751	<input type="checkbox"/> 37-753	<input type="checkbox"/> 37-755
<input type="checkbox"/> No. 37-799 (All 6 Books)			

Name.....
Address.....
City.....State.....

ALLIED RADIO

AN ELECTRONIC "OMNICHECKER"

(Continued from page 558)

to the grids and the voltage to be measured is applied to the input of one of the amplifier tubes.

Fig. 3 shows the circuit used by the writer. Type 7A5 loctal beam-power pentodes were chosen due to their high Gm, low contact potential and grid current—and because they are easily available. R1 and R2 are equal, as are R3 and R4. These pairs need not be matched exactly, as zero-adjust resistor R_A takes care of slight discrepancies. The tubes should be approximately matched, otherwise zero adjustment of the meter will not be within the range of R_A. Resistor R5 is common to the cathodes of both tubes. A positive voltage E2 is applied to the grids but this voltage is more than counter-balanced by the drops across either R1 or R2 plus R5, leaving the grids with a net negative bias of 3.1 volts.

Since voltages E1 and E2 are obtained by means of a voltage divider across a single power supply, the reason for E2 becomes evident. A change in the voltage of the power supply causes a change in E2 as well as E1. This in turn causes opposing drops across R1, R2 and R5, thus tending to keep the circuit balanced. This may be likened to the automatic action of a cathode bias resistor but to an even greater degree because of the correspondingly larger value of R5, R3 and R4 offer a small amount of inverse current feedback which tends to minimize differences in tubes V1 and V2 and to increase the linearity of the voltmeter.

PRINCIPLE OF OPERATION

In the balanced condition, controlled by R_A, the meter M reads zero. If the grid of V1 is made less negative by applying a potential to the input terminals, the plate current of tube V1 will increase. Because of the increase in cathode bias to tube V2, the plate current of that tube will decrease, causing an increased deflection of the meter needle upscale.

If the grid of V1 is made more negative the action is reversed. The plate current of V1 decreases while that of V2 increases. The meter needle would deflect down scale if it were not for the fact that in the final circuit a reversing switch is used across the meter, resulting again in a deflection upscale.

Whether V1 is made more or less negative the deflection will be equally great since the tubes operate over the linear portion of their transfer characteristics.

In the practical case here, a voltage of only 1.5 volts applied to the grid of V1 causes a net deflection of 1.55 Ma. Since the movement is of the 1 Ma. variety adjustable resistor R8 is set so that with 1.5 volts applied to the input the deflection will be exactly one Ma. or full scale. Another adjustable resistor, R9 in Figure 9 (not shown in this installment) is adjusted for full scale deflection on 1.5 volts of the opposite polarity.

To increase the voltage ranges the 10-megohm grid resistance of tube V1 is tapped in such a manner that at no time can the portion applied to V1 be greater than 1.5 volts. Thus on the 1,000 volt range, the voltage across R30 will be 1.5 volts when 1000 volts is applied across the entire resistance.

It is important that these resistors, R24 through R30, be as accurate as possible (These numbers are from Fig. 9, and are used in this diagram for uniformity.). Since precision resistors are not easy to obtain,

the method used by the writer to obtain accuracy by the use of ordinary carbon resistors is in order. First, a resistor should be chosen whose value is somewhat less than the required resistance value. Then it

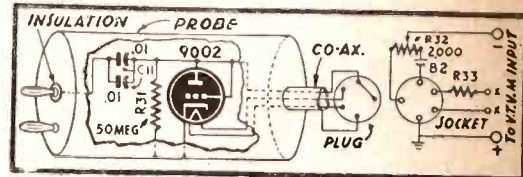

Fig. 4—Detail of the diode-rectifier probe.

is aged by passing maximum rated current through it for a period of at least 48 hours.

After this the resistor is filed down until its resistance has increased to the desired value as checked by a Wheatstone Bridge or a reliable ohmmeter. When the desired resistance is obtained the carbon resistor is painted with coil "dope"—special attention being given to the exposed carbon. This keeps out moisture.

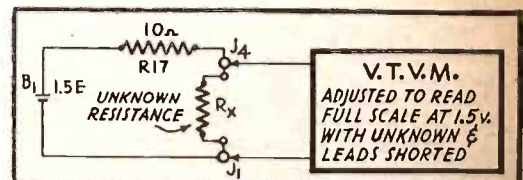

Fig. 5—Method of resistance measurement.

A.C. voltages of low and high frequency are measured by means of a probe into which is built a condenser-diode rectifier. The output of this rectifier is applied to the input of the D.C. voltmeter through a cable terminating in a 5-prong plug. A 5-prong socket is mounted on the side of the cabinet and proper connections are made from this socket to the instrument. The cable contains

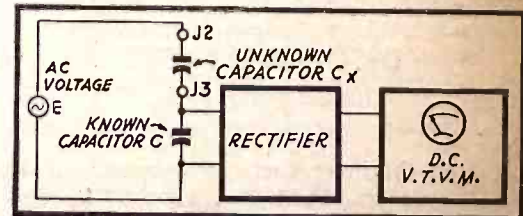

Fig. 6—Arrangement for measuring capacity.

three shielded leads, two of which are used to supply heater voltage for the rectifier tube. The remaining lead functions as the negative D.C. rectified output terminal, while the shielding forms the return or common lead.

The diode head contains the essential parts as well as the type 9002 ultra-high-

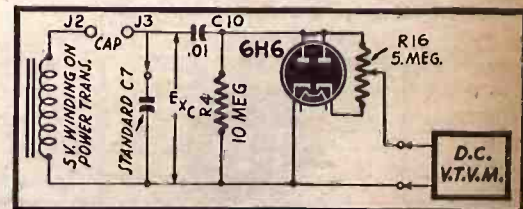

Fig. 7—The actual connections of Fig. 6.

frequency bantam triode — connected to operate as a diode—which has been selected as being easily available, although a 1T4 may be substituted, if the filament voltage is reduced to about 1.2 volts.

As it is improbable that construction of the author's diode head be duplicated, it should be stated that this container may be of any size or shape as long as it is kept

small and parts are mounted securely to keep the impedance of the input loop high. As a last resort a small steel box may be constructed and used. Further information and hints may be gleaned by studying the head used by the author, as seen in the photo. Full construction details will be given in the second part of this article.

VACUUM TUBE OHMMETER

The success of the ohmmeter is based upon the principle that the D.C. vacuum-tube voltmeter may be calibrated in terms of the ratio of voltage drops across the unknown resistance and an accurate set of pre-determined standard resistors. The basic range sets the pace at 0 to 1000 ohms; and multiplying factors of 10, 100, 1000, 10,000, 100,000, and one million permit measurements in successive steps up to 1000 megohms. One and *only one* full scale adjustment is necessary for all ranges, thus eliminating constant and annoying manipulation of the ohmmeter adjust knob at every range change.

In Figure 5, it is seen that with the unknown resistance not connected, the V.T.V.M. may be adjusted for full scale deflection of the meter by means of the ohms adjustor. Since the voltmeter draws negligible current there is no drop across R17.

However, when the ohmmeter test leads are connected across the unknown resistance the flashlight cell B1 forces current through R17 and the unknown which are now in series. The voltage divides between the two in proportion to their resistance and since R17 in this case is set at 10 ohms, the D.C. voltmeter reading the drop across the unknown can be calibrated directly in terms of ohms resistance.

Thus if R_x is zero (leads shorted together) the meter reads zero. If R_x is adjusted to 10 ohms the meter will read .75 volts or half scale. Hence 10 ohms is the center scale reading. As R_x is increased the drop across it becomes large compared with that across R17 and the meter approaches full scale deflection, 1000 ohms being approached as the practical limit of this fundamental range.

To multiply the range 10 times it is only necessary to replace R17 with a 100-ohm resistance. For the highest range of 0 to 1000 megohms R17 is replaced by a 10-megohm resistance.

VACUUM TUBE CAPACITY METER

To permit the measurement of capacity it is only necessary to have available a source of A.C. potential and again connect the unknown capacitor in series with a standard or known capacity. Again the voltage drop across the standard is evaluated by the D.C. voltmeter; moreover, this voltage drop, being A.C. in nature, must be rectified.

Fig. 6 may give an overall picture of the basic theory of operation. An A.C. voltage is impressed across two capacitors in series, the voltage dividing inversely as their capacities—or directly as their capacitive reactances. If, then the applied voltage E were to be made 5 volts and $C = C_x$, the drop across each capacitor would be 2.5 volts.

Were the test leads to be shorted together the total applied voltage, E , would be impressed across C , and after rectification, the D.C. voltmeter could be set so full scale deflection of the meter M would be noted.

It may now be seen that in the previous problem when C_x was inserted across the capacity terminals, J2 and J3, and made equal to C , the meter would read $\frac{1}{2}$ full scale deflection.

Calculation or calibration is unnecessary, as the meter scale (Fig. 1) precludes the necessity for readers of *Radio-Craft* to make calculations for every test.

In practice the voltage E may be obtained from the 5-volt filament winding of the power transformer. This voltage is constant; that is, it does not change appreciably whether the test leads are shorted or connected across an unknown. This is because the sufficiently low internal impedance of the filament winding allows it to act as a constant-voltage source. One important result here is that again the full scale adjustment is the same for all capacity ranges.

The range C , extends from .05 to 50 μf and uses a 1 μf capacitor, $C7$, as the standard. This basic range is multiplied by 10 and 100 to give us the respective ranges of .5 to 500 μf and 5 to 5000 μf . The basic range is also divided by factors of 10, 100,

(Continued on following page)

ELECTRICITY

for Radio and Electronic Applications

ONAN ELECTRIC GENERATING PLANTS supply reliable, economical electric service for electronics applications as well as for scores of general uses.

Driven by Onan-built, 4-cycle gasoline engines, these power units are of single-unit, compact design and sturdy construction. Suitable for mobile, stationary or emergency service.

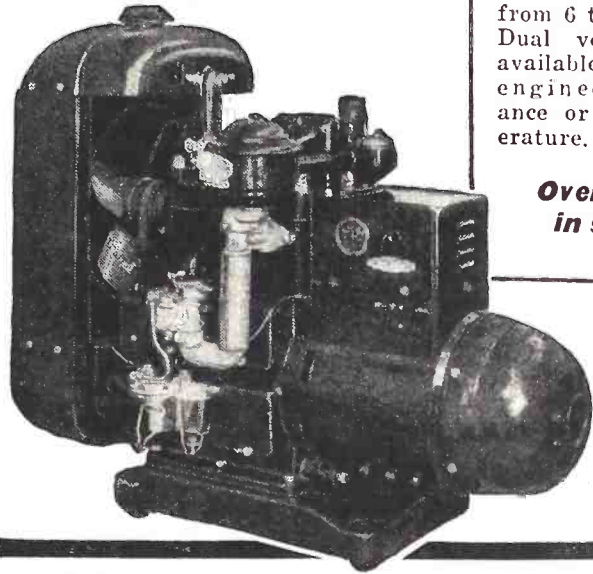

Models range from 350 to 35,000 watts. A.C. types from 115 to 660 volts; 50, 60, 180 cycles, single or three-phase; 400, 500, and 800 cycle, single phase; also special frequencies.

D.C. types range from 6 to 4000 volts. Dual voltage types available. Write for engineering assistance or detailed literature.

Over 250,000 in service

Model Shown is from W2C series, 2 and 3-KW, 60-cycle, 115 volt; powered by water-cooled, 2-cylinder engine.

D. W. ONAN & SONS 2416 Royalston Ave., Minneapolis 5, Minn.

SPEED UP REPAIRS WITH THESE G-C AIDS!



FREE STEEL CABINET

G-C DIAL BELT KITS

Exact replacement woven fabric belts. Easy to install—no stretching—no adjustments—a perfect fit everytime. Kits come with 25, 50, 100, 200 or 300 belts.

Get This New FREE Dial Belt—Drive Cable and Cabinet Repair Guide!



Pocket size 68 page book contains thousands of listings, specifications—time saving service instructions. Invaluable to every radio man. Get a copy from your jobber. If he cannot supply you, write us.

Immediate delivery on G-C Belts and Cables

Order From Your Radio Parts Jobber
ALWAYS ASK FOR G-C PRODUCTS



GENERAL CEMENT MFG. CO.
ROCKFORD, ILLINOIS

BUILD YOUR OWN MULTI-TESTER

COMPLETE KIT OF PARTS \$14.95

Matched variable condensers and coils for T.R.F. or Superheterodyne, \$1.50 per set. Dual 20 Mfd.-150 volt condensers, 35c each.

WRITE FOR DETAILS

RADIO KITS COMPANY

120 Cedar Street

New York, N. Y.

• Ted McElroy

World's Largest Manufacturer of Wireless Telegraphic Apparatus

COMPLETE CENTRAL OFFICE EQUIPMENT

McElroy Manufacturing Corp.

82 Brookline Avenue • Boston, Massachusetts

LAKE Radio Cabinets & Parts

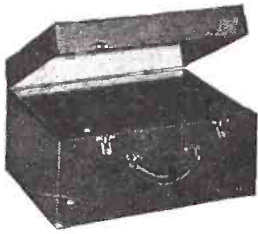

Portable Phonograph case, of sturdy durable plywood, in handsome brown leatherette finish. Inside dimensions 16½" long, 14" wide, 9½" high. Has blank motor board. As illustrated above, specially priced at **\$6.95**

Also blank table cabinets of walnut veneer in the following sizes, with speaker opening on left front side: (Note: 7" has center speaker grill.)

#1	— 8½"	L x 5½"	H x 4"	D	\$1.95
#2	— 10¼"	L x 6¾"	H x 3"	D	\$2.75
#3	— 13½"	L x 7¾"	H x 6¼"	D	\$3.25
#7	— 10¾"	L x 7"	H x 5½"	D	\$2.50
#8	— 17"	L x 9"	H x 9¾"	D	\$4.50
#9	— 21"	L x 9¼"	H x 10½"	D	\$5.50

*Speaker Opening in center of front side. Cabinets available in Ivory color and Swedish Modern. Write for prices.

POWER TRANSFORMERS

4, 5, or 6 Tube—6.3V at 2 amp. 50 Mill Power Transformer	\$2.45
7, 8, or 9 Tube—6.3V at 3 amp. 70 Mill Power Transformer	\$2.65

All types of radio parts available in today's market can be obtained at Lake's money-saving prices.

Write For Our Free, New Illustrated Catalog!

LAKE RADIO SALES CO.

615 W. Randolph Street, Dept. C, Chicago 6, Ill.

REPAIR ANY RADIO

★ EASIER - BETTER - FASTER

Do you like to tinker with repairing radio sets at home or for your friends? Do you want to learn all about up-to-the-minute service methods? Want to learn how to repair any radio on the market—often without any elaborate testing at all?

Then turn to the advertisement on Page 601 for details of special combination offer on A. A. Ghirardi's MODERN RADIO SERVICING and the famous RADIO TROUBLESHOOTER'S HANDBOOK, the two most helpful books in radio history. Over 2,000 big pages of the world's most helpful and profitable servicing information for only \$9.50. 5-Day Money-Back Guarantee. You cannot lose!

Do you need BINDING POSTS?



The XL PUSH POST with its Spring Action assures Constant Contact and quick connection.
Manufactured in All Aluminum Type M at 12c each.
Aluminum Body, Bakelite Top Type B1 at 15c each.
Types CP or NP. ALL BRASS—STAINLESS STEEL SPRING & PIN. PROVEN by 240 HR. SALT SPRAY TEST as NON-CORROSIVE at 28c each.

Manufacturers and Dealers Liberal Discounts

X. L. RADIO LABORATORIES

420 West Chicago Ave., Chicago 10, Ill.

RADAR AND PIGEONS

Radar, the radio echo device that can pick up targets through the clouds and spot airplanes miles away may confuse homing pigeons and cause mild headaches among men who operate the device. Studies of the effects of microwaves and ultra-high frequency short waves upon pigeons and men are being made by Major Otto Meyer, the Army's top authority on pigeons, and Lt. Comdr. L. E. Daily, a Navy doctor.

The Signal Corps hopes that the study may show why pigeons can find their way home.

(Continued from previous page)

1000 and 10,000 to give us the additional ranges of .005 to 5 μf; .0005 to .5 μf; 50 to 50,000 μf and 5 to 5000 μm in order.

Nothing has been said so far of the rectifier circuit used. A condenser diode rectifier is again used. Fig. 7 shows the circuit more accurately. One diode section of the 6H6-G rectifies the A.C. voltage E_{xc} and the remaining diode section is connected in series with the D.C. output in order to cancel out the contact potential of the first diode.

It should be recalled that capacity measuring devices of this type presuppose that the losses of the capacitor under test are small. Losses, if any exist, alter the true capacity. In this case this is no serious set back as the high ranges of the ohmmeter should first be used to measure the leakage resistance of the capacitor.

Accurate mica capacitors may be obtained

for use as C3, C4 and C5 and a high grade paper capacitor for C6. It may be impossible to obtain satisfactory results as far as C7, C8 and C9 are concerned. For this reason the author has substituted resistors for the capacitors. C7 may be replaced with a resistor of 2654 ohms while C8 and C9 require values of 265.4 and 26.54 ohms respectively. It is impossible to obtain these values commercially but they were obtained by filing as previously described with the aid of a commercial Wheatstone Bridge.

The builder should have no difficulty if a Wheatstone Bridge is unavailable. Simply obtain a 2500 ohm carbon resistor and connect across J2 and J3. Using the $C \div 10$ range, file until 1 μf is indicated on the meter and then impregnate the resistor as already described. Now repeat the process with 250 and 25 ohm resistors, in each case using the next lower range as a standard.

End of Part I

"PHOTOPULSE"

(Continued from page 557)

in pulse amplitude. By choosing suitable values for the components of this feed circuit the average plate current, and hence the brightness of the lamp, can be made practically independent of frequency.

A PRACTICAL INSTRUMENT

Fig. 2 shows the circuit of a practical instrument based on the system of Fig. 1. This instrument, which has been called the "Photopulse," is intended for speed measurement and, in particular, for examining the movement of small mechanical and electro-mechanical devices. The circuit is A.C. line operated and employs only one tube apart from the lamp. With the component values given, the frequency range is from 25 to 400 cycles, corresponding to speeds between 1,500 and 24,000 r.p.m. in two ranges. The power consumption is only 20 watts.

The transformer T1 is wound on a small core intended for an A.F. coupling transformer, and has a turns ratio of 3. The purpose of the resistor R1 is to improve the shape of the pulse at low frequencies by increasing the damping. The power transformer (T2) has two secondary windings which provide A.C. for the heaters and pilot lamps, and 350 volts A.C. for the voltage doubler circuit.

The instrument has two main controls, marked "Frequency" and "Range" respectively. The former determines the setting of the variable grid resistor R4, and gives a continuous variation of the frequency in each range. The latter is a three-position switch that selects the frequency range and controls the power supply; the change from one range to the other being effected by altering the value of the grid capacitor.

Since the pulse frequency is liable to be affected slightly by line voltage and thermal fluctuations, provision is made for adjusting the scale calibration to the line frequency at one point in each range. For this purpose the lamp housing of the instrument encloses a steel reed which is caused to vibrate at twice line frequency, 120 cycles, by a small electromagnet connected across the heater supply. The frequency control is first set to 120 cycles in the lower range, and the preset resistor R3, adjusted until the reed, which is painted white and illuminated by the lamp, appears stationary. This procedure is then repeated at 120 cycles in the second range by adjusting R2.

The synchronizing control R6 enables the frequency of the pulse generator to be

locked to that of an external system if a suitable control voltage is applied to the terminals marked "Sync."

CONSTRUCTION DETAILS

The arrangement of the components is not critical, but the pulse transformer T1 should be mounted in such a position relative to the power transformer that the coupling between them is a minimum. Otherwise the pulse generator might "lock" at the line frequency or some multiple of it.

Although special grid-controlled lamps have been developed for this kind of work they are not generally available at the present time. Accordingly, a simple cold-cathode "neon" lamp is used in the present instrument, preliminary experiments having shown that this would give sufficient light for the majority of purposes.

(The tube used was a Mazda SU 41, a high-frequency pentode which combines a sharp cut-off with a comparatively low D.C. plate resistance. It has no exact equivalent among American tubes. For applications requiring little power, with a small neon lamp in the plate circuit, a tube like the 6J7 should be sufficient. If more power is needed experiments can be made with one of the power pentodes. Increases in power can also be obtained by paralleling two tubes. —Editor, Radio-Craft)

No special components are necessary, but it is advisable to use a wire-wound variable resistor of large diameter and reliable construction for the frequency control in order to minimize erratic frequency variations and to maintain an accurate calibration.

OPERATION AND PERFORMANCE

In the form just described the Photopulse can be used to illuminate an object either directly or as a silhouette. For silhouette working, which requires a light source with a large uniformly luminous area placed behind the object, a ground glass diffusing disk can be clipped over the reflector.

For speed measurement it is only necessary to illuminate some distinguishing feature (preferably a spot of white paint) on the rotating object, and, starting at a low frequency, advance the frequency control. The correct setting of the control is the highest that gives only one stationary spot.

The silhouette method is preferable for studying the behavior of certain types of mechanism, such as electrical contacts mak-

(Continued on following page)

ing and breaking regularly at high speed. If the frequency control is adjusted so that the movement is almost, but not completely, arrested, then the contacts will appear to open and close with such deliberation that any irregularity can be detected immediately.

Synchronization should be effected by turning the synchronizing control right back, setting the pulse frequency to a value slightly lower than the control frequency, and then advancing the synchronizing control again until synchronism is obtained. If the controls are handled in this way, the pulse generator will pull into step from 5 per cent off frequency with a control voltage of about 3 volts peak across the synchronizing terminals.

Reprinted by courtesy of *Electronic Engineering* (London) March, 1945.

AN ALIGNMENT TRICK

IN servicing (or building) Superhets trouble is often encountered in making the stations arrive at their proper place on the dial, whether the oscillator has been replaced in part or full—that is—coil, padder, tube substitutions, etc., etc., feeding the mixer input.

My method has proved a great time saver and is simple as "all get out." First balance the I.F. circuits as usual. Second, remove the control grid cap from the mixer tube, thus disconnecting the tuned circuits from the input.

Here I make use of a simple little device—simply a 25,000-ohm resistor with a pair of grid caps—one large and one small—and a Fahnestock clip soldered to one of its leads, and 18 inches of flexible wire with a pee-wee clip at the end, soldered to the other lead.

The cap is put on the mixer tube cap and the battery clip or alligator clip on the chassis or AVC or grid return of the circuit. (The grid cap that was removed could be used as return.) A small aerial, or dummy antenna, and signal generator is connected to the clip. I prefer a 6 ft. piece of wire acting as antenna, picking up various broadcast stations which are on frequencies desired. Now tune up your oscillator padder circuit for a lower frequency station, putting it at the correct place on the dial—a 600-Kc. station at 600 Kc., etc. If an iron-core oscillator coil—adjust core in or out. Adjust trimmers of oscillator for correct dial indication of a high frequency station—say anything from 1400 to 1700 Kc.—re-check again the station or stations at low frequency end of dial—then across dial to high frequency end. Simple, sure, and you know that the oscillator circuit is really working.

You've simply been using an untuned input and beating your local oscillator signal against desired frequencies (stations).

Now remove our simple resistor and clips and hook up the set's grid cap to mixer input and try your luck. If stations don't tune in as they should, you can be quite sure that the mixer input is not tracking correctly.

Locate your trouble in the R.F. coil or antenna coil. Don't touch the oscillator circuits, as you are done with them. I've often found servicemen screwing up the oscillator circuits, then pulling their hair because circuits wouldn't track—one end of dial dead, birdies all over dial, etc., etc., when they had a burnt up primary or antenna coil. My simple method soon located their trouble for them—and you should see their faces light up! (I might add that those iron core adjustable antenna coils are a time saver when it comes to antenna coil replacement, eliminating tracking difficulties there.)—*Frank J. Faulkner.*

Available for Prompt Delivery on Priority of AA3 or Better!

The New Model 450

TUBE TESTER



EXTRA SERVICE—The Model 450 may be used as an extremely sensitive Condenser Leakage Checker. A relaxation type oscillator incorporated in this model will detect leakages even when the frequency is one per minute.

The Model 450 comes housed in a portable leatherette covered cabinet complete with all operating instructions. Size 13" x 12" x 6". Net weight 8 pounds. Our Net Price

\$39⁵⁰

SUPERIOR INSTRUMENTS CO. Dept. R.C. 227 Fulton St., New York 7, N. Y.

"IT'S THE BEST OUT OF 20!" SAYS CHIEF ENGINEER

★ From F. S. Bailey, Chief Engineer, Radio Operator's School, Brownsville, Texas, comes this sweeping endorsement of Radio-Electronic's greatest training book: "We find Ghirardi's Radio Physics Course the best book out of 20 or more that we have tried—both as a complete course in Radio Physics, and for all other branches, including broadcasting. It is the best book for beginners as well as those who already know something about Radio. . . . It is giving our students the very best for their money!"

SEE AD ON PAGE 601 FOR DETAILS

YOUR NEW FREE CATALOG IS READY FOR YOU!

Radionic's Catalog No. 26 lists hard-to-get radio parts! • Helps you fill your radio and electronic needs. • All parts are available for immediate shipment • All are highest quality. • All are exceptional values.

SEND TODAY FOR YOUR FREE COPY TO Dept. GE

RADIONIC EQUIPMENT CO., "CHANCELLOR" PRODUCTS 170 NASSAU STREET, NEW YORK 7, N. Y.

RADOLEK

Radio-Electronic Service Parts



Large stocks assure the finest and most complete selections of all available items at lowest prevailing prices. Thousands of active buyers depend on us for their entire Radio repair and replacement requirements. Because we understand service problems, every order is expedited for delivery in double quick time. Everything we do is planned for convenience and satisfaction to our customers. You will find it profitable to make Radolek your buying headquarters.

FREE BUYING GUIDES

Because of existing conditions we keep our customers right up to the minute on available merchandise by releasing supplements frequently instead of sending our regular Big Profit Guide once a year. Send the coupon now to get these Free Buying Guide Supplements as they are issued.

FREE!

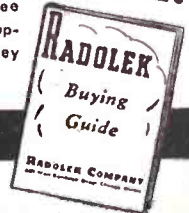

FAST SERVICE!

RADOLEK CO., Dept. C-103 601 W. Randolph St., Chicago 6, Ill.

Please send FREE Buying Guide Supplements

NAME _____
ADDRESS _____

BUY AN EXTRA WAR BOND

ORDER FROM RADOLEK

1700 ANSWERS

1700 ANSWERS
TO YOUR HARDEST PROBLEMS
 1178 Illustrations
 1000 Pages
 130 Tables — 105 Graphs

GET THE ANSWERS NOW!
 Here, in one big volume, you'll find all the time saving answers to your radio problems... and time saved is **MONEY EARNED**. Written in easily understood language, yet accurate enough for an engineer. Completely revised and cross indexed for quick reference, this handy reference book for your tough jobs covers radio transmission and reception, public address systems, television, photocells and data on their important parts. It's a book you'll always use. And... it's only **\$5.00**

ANOTHER TIME SAVING BOOK!
ELECTRICAL AND RADIO DICTIONARY. Over 3800 definitions of technical words and terms used in all branches of radio and electricity. 300 Pages—550 Illustrations..... **\$2.50**

GATEWAY PUBLISHING COMPANY
 53 W. Jackson—Dept. RC-6
 Chicago 4, Ill.

Clip This Coupon NOW

Send me the new Drake Cyclopedia IMMEDIATELY.
 And the 300 Page Radio Dictionary.

Name

Address

City State

EARN MORE MONEY IN ELECTRICITY

Get big supervisory jobs, pay raises now and after the war, with knowledge from this brand new 7-vol. set. Written and approved by electrical experts for easy, quick understanding. Hundreds of diagrams, circuits and other helps... over 5,000 subjects.

Prepared and published by the great 45-year old Coyne Electrical School for the man on the job or beginner. Seven-Book Set includes: 1. Elementary Principle and Circuits Household Appliance Repairs, 2. Wiring for Light & Power, 3. D. C. Motors & Controls, 4. A. C. Motors & Controls—Electronics, 5. Armature & Stator Winding & Repair, 6. Refrigeration & Air Conditioning, Repair, 7. Automotive, Diesel, Battery.

Sent on 7-Day FREE TRIAL
SEND NO MONEY. Ask to see them at my risk. If you don't want them after 7 days send them back and you owe nothing. If you keep them send \$3.00 after 7 days and \$3.00 per month until \$21.00 is paid. Cash price \$19.75. 1 year Free Consultation Service and Bulletins if you act promptly. Fill out and mail coupon below for 7-DAY FREE EXAMINATION.

H. C. LEWIS, PRES. 500 SOUTH PAULINA STREET Dept. A5-71, Chicago 12, Ill.

H. C. Lewis, Pres., Coyne Electrical School, Dept. A5-71 500 South Paulina St., Chicago 12, Illinois

Send me the APPLIED PRACTICAL ELECTRICITY, 7 Volumes, including one year's free consultation service and Coyne Technical Bulletins. I'll either return the 7 book set in 7 days and owe you nothing or pay \$3.00 after 7 days and \$3.00 a month until \$21.00 (plus 35c postage) is paid. Or I'll save \$1.25 by sending you \$19.75 cash.

NAME..... Age.....

ADDRESS.....

CITY..... Zone..... STATE.....

If you want books sent C. O. D. pay postman \$19.75 when delivered check here. Same 7-day examination and money back guarantee.

In the Rocky Mountain Region it's RADIO & TELEVISION SUPPLY CO. 806 EUCLID AVE., PUEBLO, COLO.

"If we don't have it, we'll get it— or it can't be had! Phone 5729"

TUNING ON THE U.H.F.

(Continued from page 560)

two stator members, generally in quadrant shape, are supported by an annular band to which the stator is soldered. The external terminals are attached to the opposite stators, S. The rotor R is mounted on an insulating shaft and is concentric with the band B.

The entire assembly between the terminals then consists of two condensers in series, each being formed by one stator and the rotor. Furthermore, the band is the inductance and shunts the capacitance. The rotor has only slight clearance with respect to the inside of the band which is relatively deep (Fig. 4-b).

The magnitude of the inductance due to the band depends upon the amount of flux within it. As the position of the rotor is changed it restricts the area through which the flux may pass, changing the inductance. Its relative position with respect to the stators obviously also affects the capacitance. The result is an unusual tuning

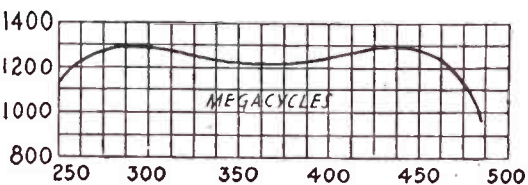

Fig. 3—"Q" value curve of the above circuit.

circuit providing a wide U.H.F. band and containing no moving parts which might give trouble at exceedingly short wave lengths.

TRANSMISSION LINE TUNING

The difficulties of obtaining sufficiently small concentrated L and C at the very high frequencies may readily be appreciated. The value of Q which determines frequency stability and efficiency becomes comparatively low at such short wave lengths. A convenient method is the use of transmission lines, either concentric or parallel.

Figs. 5 and 6 illustrate the use of such lines. Both are seen to be the equivalent of Hartley oscillators. Chokes are used to keep R.F. out of the tube filaments. The lines are approximately a quarter wavelength long and may be varied by changing

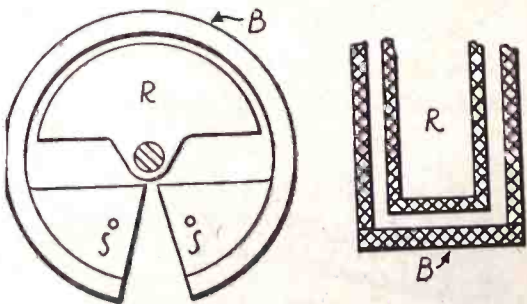

Fig. 4—The General Radio "butterfly" circuit.

the position of the shorting bar. The concentric line performs similarly to the other. Its advantage is the elimination of radiation.

Use of transmission line segments for tuning an U.H.F. receiver is made by George E. Pray of Clearfield, Penn., in his recent invention as illustrated, Fig. 7. High stability and accurate gang tuning are obtainable.

A length of line, shorted at one end and

slightly less than a quarter-wave in length is used as an inductance, tuned by a small condenser. Adjustable taps are provided, the grids being tapped down to match the

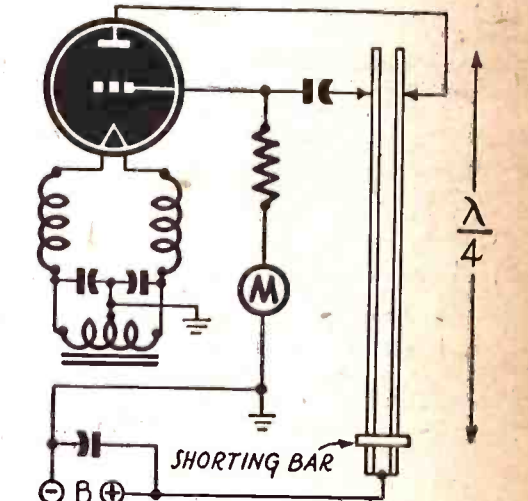

Fig. 5—A tuner with distributed constants.

tube input impedances. The first stage is an R.F. amplifier, the second a mixer, and the last is the oscillator. The grid of the latter is connected to a suitable tap on one leg, the plate to a point on the other leg and the cathode to ground. Another tapped connection (through a condenser) leads to the mixer cathode where heterodyning takes place. The mixer output (after proper by-passing) passes on to the I.F. amplifier, not shown.

The physical construction of such a re-

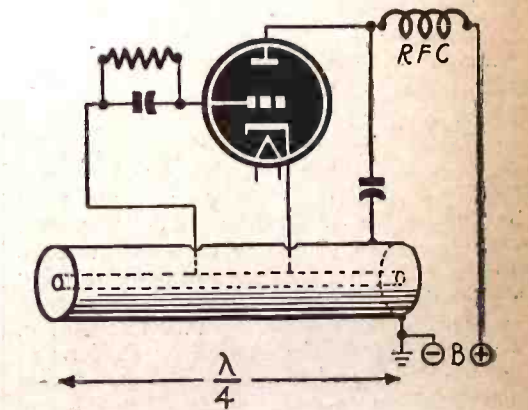

Fig. 6—Concentric-line tuner—UHF plumbing.

ceiver is shown in sketch G. The vertical transmission lines are shorted at the bottom and the ganged tuning condensers mounted above. Small trimmers are shown at T. These may be individually adjusted by the service man. The right-hand circuit is the oscillator. Note that a slider bar is provided to trim it to correct frequency.

No doubt much of the tuning at ultra-high frequencies will be accomplished by means not now common. The use of cavity resonators is especially indicated.

These have been described in past issues of the magazine (*Tube of the Future*, October, 1944, and *Klystron Circuits*, May, 1945). Another type of tube is that in which internal capacities or element spacings have been reduced to the ultimate, as in the acorn and disc-seal types. Such tubes will no doubt be used with some of the circuits shown above, to reach otherwise unachievable frequencies.

Circuits and tubes, details of which have not yet been released to the public, will no doubt play their part in extending the spectrum to frequencies entirely unusable today.

Let us not, however, be too hasty in abandoning the standard tubes. They have shown an astounding ability to operate on higher and higher frequencies. Technicians will remember the days when it was considered necessary to "debase" a tube to work on 80 meters. Today the same tube is used

without hesitation in the 42-megacycle region.

There is every possibility that at least over part of these ranges, standard tubes such as those now manufactured for television may be used in conjunction with tuning circuits like those described above. Such circuits would possess the advantages of cheapness and wide tuning range probably unobtainable otherwise. For this reason, if for no others, these circuits deserve our attention.

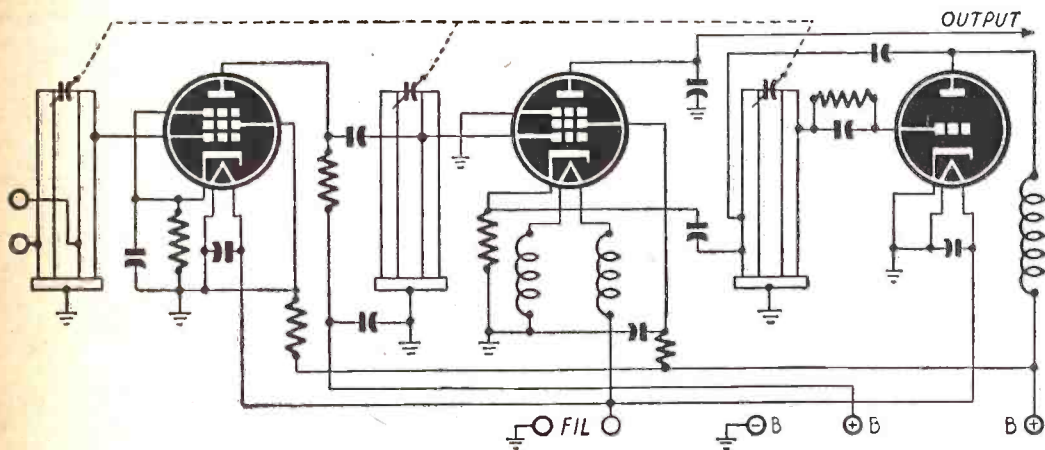

Transmission-line tuning elements are used in combination with the standard type variable condenser in this ultra-high-frequency, which is covered by Patent No. 2,366,750.

Interference-Free Fluorescent Installation

A novel installation of fluorescent lighting in a New York studio devoted exclusively to recordings, where any electrical interference would be as objectionable as a fulltime buzz-saw, has ended many months of complaints, according to officials of World Broadcasting System.

Technical requirements of the recording company, which is owned by Decca Records, Inc., led to a novel installation of the ballasts of the lamps. The ballast equipment from each pair of fixtures was removed and mounted in ventilated metal boxes above the ceiling's sound-proofing and effectively "outside" the room. This mounting not only eliminated the slight heat generated, but — more important — removed all trace of the hum or hash that often accompanies operation of a fluorescent installation.

F. J. (Toby) Cadenas, executive engineer of the lighting division of Sylvania Electric Products, Inc., designed the installation with the assistance of Charles Lauda, chief engineer of World Broadcasting.

"Eye-comfort of musicians, both vocalists and instrumentalists, has been greatly improved with the non-glare, virtually non-shadow lighting we now enjoy," said Mr. Lauda. "We used to get a lot of complaints and for a while we thought they might be credited to the

artistic temperament of most of our guests, but our new lighting shows that the criticism was justified."

The former lighting gave off "a whale of a lot of heat," continued the chief engineer.

"When you stop to think that we have to control our temperature and humidity from day to day and from morning to afternoon, you'll see heat is an important matter for us. The cooler light of fluorescent lamps, and the mounting of the ballasts outside the studio walls, furnished the complete solution."

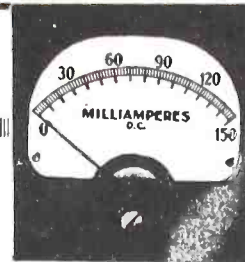

METERS NOW AVAILABLE!

Look to Lifetime for best values in parts, supplies and equipment, always.

McClintock 0-300 D.C. Milliammeter . . . 3 1/2" Rectangular type . . . approximate internal resistance 0.33 ohms shunted . Special \$5.50

McClintock 0-15-150-300 D.C. Milliammeter . . . Approximate shunt for 15 mills 6.66 ohms . . . external resistance furnished \$7.50

McClintock 0-10 Volt A.C. Voltmeter . . . 3 1/2" Rectangular type, flush mounting panel, designed for use on A.C. circuits of commercial frequencies and will withstand severe use both mechanically and electrically. Our price only . . . \$5.99

McClintock 0-500 D.C. Milliammeter . . . 0-500 M.A.—Scale 50 divisions. 3 1/2" D.C. rectangular type. Immediate delivery. Now . . . \$5.50

Write for our latest bulletin listing hundreds of items for radio and sound servicemen.

Lifetime

SOUND EQUIP. CO., Dept. 15
1101 ADAMS ST., TOLEDO 2, OHIO

HOW MUCH Should Good Radio - Electronic Training Cost?

★ The answer is that the best basic Radio-Electronic Training that money can buy NEED NOT COST YOU MORE THAN \$5. Ghirardi's is as complete as any book or course at any price—and far more complete than most. It is easier to learn from. It is the basic training most widely endorsed by Radio experts themselves. It is more widely used by Army, Navy, and civilian schools and for more home study than anything else of its kind. Best of all, you can actually see it, study it, and compare it BEFORE YOU BUY!

See Page 601 for details.
MAIL COUPON AT ONCE!

TRAIN FOR **RADIO - ELECTRONICS** 12 WEEKS SHOP TRAINING
I WILL FINANCE YOUR TRAINING

Trained Radio-Electronics men needed today, and they will be needed after the war. Prepare for the great opportunities now in Radio-Electronics and Television. "Learn by Doing." Free employment service for life after graduation. You can "Earn while learning". I'll finance your training if you are short of money. Mail coupon today for all details and big free book. We have facilities for men with physical disabilities. If you have a physical disability of any kind check coupon below for details.

H. C. Lewis, Pres., Radio-Electronics Div., Coyne Electrical School, Dept. A5-8H, 500 S. Paulina St., Chicago 12, Ill.

Send free book and full details. Send physical disability plan.

NAME _____
ADDRESS _____
CITY _____ STATE _____

NATION-WIDE
MAIL ORDER
DISTRIBUTORS
SINCE 1928



**RADIO AND
ELECTRONIC
DEVICES**

For...
**TRADE... INDUSTRY...
COMMUNICATION...
PUBLIC UTILITY...
VOCATIONAL AND
EXPERIMENTAL
APPLICATIONS**

BURSTEIN-APPLEBEE CO.
1012-14 McGEE ST.
KANSAS CITY 6, MISSOURI

**HOW TO TEST A RADIO IN
2 MINUTES or less!**

★ Want to learn to repair your own radio sets at home? Want to repair sets for neighbors and friends? Or, if you are already a radio serviceman, do you want to learn how to diagnose radio troubles and fix sets **TWICE AS FAST AND TWICE AS PROFITABLY**—without a lot of unnecessary testing?

Of course you do! Turn to advertisement on Page 601 of this issue and see how A. A. Ghirardi makes all of this—and much more—possible for the amazingly low sum of only \$5!

**ABSOLUTE
MONEY-BACK GUARANTEE!**

**LEARN
ELECTRICITY
12 WEEKS
SHOP TRAINING**



**"LEARN BY DOING" IN
COYNE SHOPS**

Electricity offers you opportunities for the best jobs today—with a real peace time future. "Learn by Doing," on real machinery. Earn while learning. Right now I'm offering extra training in Industrial Electronics at no extra cost. Lifetime employment service after graduation. Get all-around practical training at Coyne in 12 weeks. If you are short of money I'll finance your training. Mail coupon now for Free Book. We have facilities for men with physical disabilities. If you have a physical disability of any kind check coupon below for details.

H. C. Lewis, President, **COYNE ELECTRICAL SCHOOL**
500 S. Paulina St., Dept. A5-78, Chicago 12, Illinois
Send free book and all details. Send physical disability plan.

NAME _____
ADDRESS _____
CITY _____ ZONE _____ STATE _____

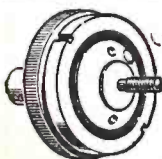

**"WONDER"
ELECTRIC BUTTON**

Most interesting electrical apparatus ever discovered. Make your own Telephone-Amplifier Detectaphone. Transmit your voice or music to distant rooms. Perform hundreds of fascinating experiments. So tiny it can be concealed in dozens of places. Send \$1 now for button and free 5,000 word instruction booklet with 50 illustrated experiments. **SPECIAL OFFER** 6 buttons and booklets sent postpaid for \$5. Write now to

BUCK MFG. COMPANY North Aurora, Illinois

NO SELECTIVITY IN THIS RADIO

(Continued from page 555)

Panoramic radio offers a unique and accurate means of direction finding. By connecting the oscilloscope and direction-finding antenna to rotate simultaneously (Fig. 5) instantaneous bearings may be taken on a number of stations.

The cardioid characteristic of these antennae is taken advantage of. Their sensitivity is maximum in one direction, nil in the opposite direction, intermediate in all others. The series of figures shows the result of manipulating the loop (and scope). As an example, imagine four stations within range, one located at each cardinal point of the compass (Fig. 6). Note that a null point is secured on the East station in the west direction only, and likewise for the others. The operator need only rotate the control until such a null is seen, whence the direction of the signal is identified.

Such a system operated on broadcast frequencies would give means for continuous position finding, no matter how fast the aircraft is traveling. The changing height of the curve would also show when the aircraft is approaching, when receding

Fig. 6 — Direction finder cathode-ray screen. The traces from radio-beacons in each quarter of the compass vary as the loop is swung through a complete circle of azimuth.

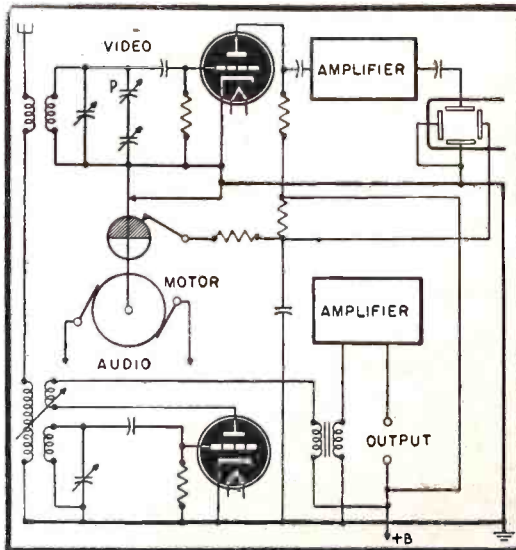
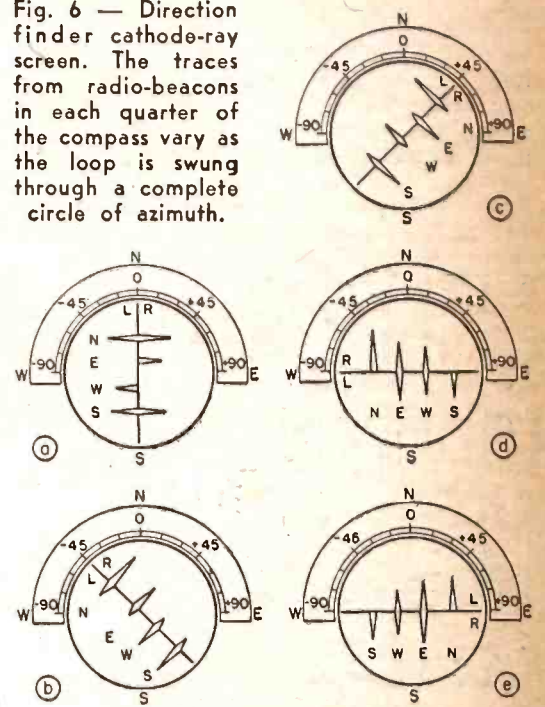

Fig. 4—Circuit for centering peak on screen.

and when it is directly over the transmitter.

OTHER APPLICATIONS

For research work such as in experimenting with directional antennae, the Panoramic gives a quick indication of field strength at any location in comparison with any number of transmitters. The Panoramic will give one solution to the inter-

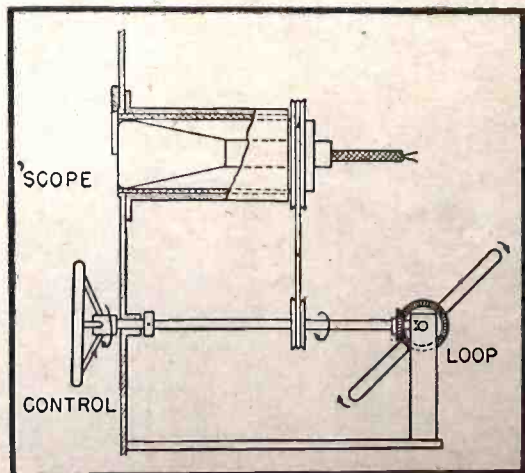

Fig. 5—A panoramic direction finder set-up.

ference problem on the amateur bands. No more need for long-winded "CQ's." Just let the other fellow "break-in" and the QSO is joined. If a change of frequency is necessitated you can follow him as his signal creeps to a vacant spot, and such spots will be easy to find.

Right now, of course, the war use of Panoramic is all-important. Take an actual occurrence at Anzio, where the Nazis were employing clever tactics to get their messages through secretly. During any given message, they changed frequency several times, their own receivers being automatically controlled to make the same changes simultaneously.

Unknown to the enemy, our Signal Corps had Panoramic-equipped receivers on the scene. During a critical phase of the battle, an important message was pieced together by rapidly changing frequency to conform

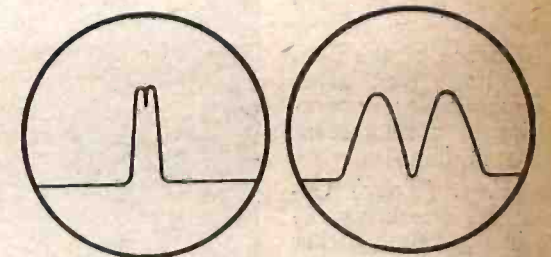

Fig. 7—Two signals separated by 3 Kc. on a wide-band apparatus (E) and narrow-band (F). Instruments covering a wide frequency range cannot separate close-together stations. As bandwidth is decreased, resolution increases.

with the changing pattern on the Panoramic screen. Our big guns promptly opened up on the newly-formed Nazi wedge, temporarily sending many of the enemy closer to Heaven than Nazis usually get.

Some amateur communications receivers are manufactured with panoramic circuits already installed. For others adapters are made, which have successfully been made to be connected to existing receivers on the various fronts. These use 3" oscilloscope screens and various models are available for different intermediate frequencies and maximum sweepwidths.

HANDIE AND WALKIE COMBAT PORTABLES

(Continued from page 556)

ful than the previous AM and FM models. It is used by our fighting forces on every battle front and next to the Handie Talkie is the first radio to be used on beachhead landings and in offensive actions.

FM Walkie-Talkie is in itself a complete broadcasting and receiving unit. It has its own sending and receiving units and its own collapsible antenna. It weighs a little over thirty-five pounds, is carried on the back of one man and has facilities for plugging in a handset and also headset so two may listen in. It is simple to either send or receive vocal radio messages over fairly long distances. It has been proven dependable and reliable on every battle front. Messages come through clearly and distinctly and the operating life of the batteries has exceeded the original expectancy.

Handie-Talkie now weighs slightly more than five pounds, has some 585 parts of miniature size, and is battery operated. With a simple flick of the finger, the operator may either send or receive vocal radio messages.

Each Handie-Talkie set operates on a fixed frequency, which can be quickly changed by simply changing a tube. The folding antenna attached to each unit is used for both receiving and sending. The operator holds the unit in his left hand, the ear piece at the top, the mouthpiece at the bottom, similar to a telephone hand-set, and when he wishes to talk he pushes a button which causes the transmitter to operate and his voice is carried over the air. To listen he releases the button and the receiver is connected so that he hears the incoming message.

When used for both sending and receiving messages the batteries have a life of 12½ hours. For receiving only, the batteries will last 50 to 60 hours. The range is limited to short distances and is used by troops to keep in contact with each other in landing operations and under battle conditions, as well as for other war communication purposes.

Other 2-way radios mounted in trucks, jeeps, automobiles, tanks, etc., are also used

by the United States Signal Corps. These heavier units usually follow up the infantry advance and have far longer ranges than those of the Handie-Talkie and Walkie-Talkie.

The Federal Communications Commission has proposed a Citizens' Radio-communication Service in the 460 to 470 megacycle band of the spectrum. According to a recent FCC press release, "Small portable radios may be used, for example, to establish a physicians' calling service, for communication to and from trucks and tractors operating in and around large plants, on farms and ranches, on board harbor and river craft, in mountain and swamp areas. Sportsmen and explorers can use them to maintain contact with camps. Department stores, dairies, laundries and other business organizations can use the service to communicate with their delivery vehicles."

However, there are many problems which must be overcome despite this liberal ruling of the FCC. Handie-Talkies and Walkie-Talkies are powered by batteries inasmuch as they are portable sets. Using such low power in such an ultra-high frequency will not permit communication over a very great distance—and long distances plus low cost is what is usually wanted by anyone using radio communication. Some day Handie-Talkies and Walkie-Talkies will be utilized for the Citizens' Radio-communication Service. At first dry-battery operated portable sets will not be used. Power will have to come from central stations or 6-volt wet batteries, but later on, when new tubes and stronger, longer-life batteries are developed, use of Handie-Talkies and Walkie-Talkies will be common.

The Handie-Talkie and Walkie-Talkie have played a vital role of communications in the invasion and the success of the invasion was enhanced by the fact that General Eisenhower's United Nations forces had welded together communications equipment and facilities of the most modern type which are unrivaled in the history of warfare.

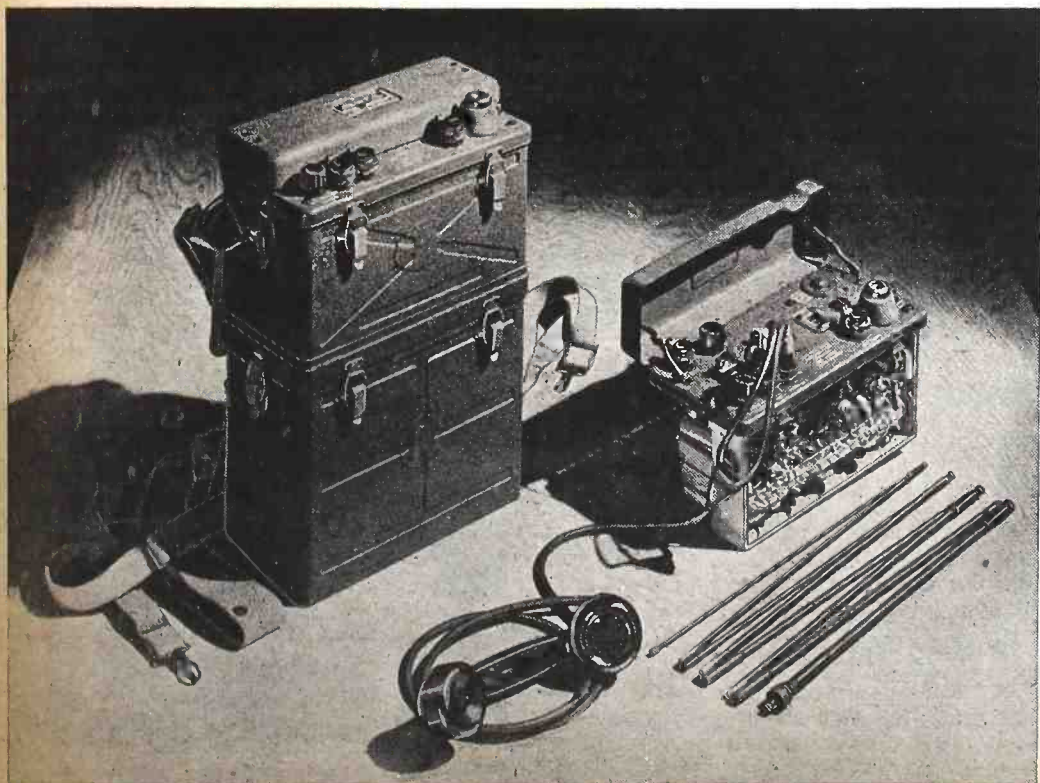

The Walkie-Talkie, with a view of top section, chassis, disassembled antenna and handset.

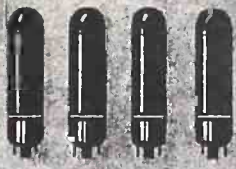

4 STANDARD TYPES
of Amperite Regulators replace over 400 types of AC-DC Ballast Tubes now in use.
Amperites are real REGULATORS... have patented Automatic Starting Resistor which prevents initial surge and saves pilot light... Ask Your Jobber.

AMPERITE

THE *Simplest* WAY TO REPLACE

BALLASTS

WRITE FOR REPLACEMENT CHART
AMPERITE Co. 561 BROADWAY, NEW YORK, N. Y.

724 OUT OF 817

★ When you want to know what is the best, most inexpensive Radio-Electronic training for you —ASK RADIO MEN! Recently, a mixed group of 817 radio men including instructors, students, repair men, radio men in the armed forces, in broadcast stations and big manufacturing plants, etc., were asked exactly what they think of the various books and courses offered for the study of Radio Electronic fundamentals. 724 of these men—NINE OUT OF TEN—wrote back that, in their opinion, a famous Ghirardi book selling FOR ONLY \$5 COMPLETE is their choice as the best buy on the market —far better than any other AT ANY PRICE!

GET THE FACTS!
SEE ADVERTISEMENT ON PAGE 601

THE MYSTERY OF RADIO

(How It Works)
IN EASY TO UNDERSTAND TERMS

NOW READY



WELL ILLUSTRATED

Simplifies radio training procedure, by outlining T-R-F and superheterodyne principles. Explains the net work of circuits (one at a time) of an AC-DC five-tube superheterodyne system.

RADIO EXPERTS command high pay. Start your training our simplified way. Only \$1.00 postpaid. Send M.O., Bill, Stamps or Check.

Postpaid in U.S.A. No C.O.D.'s
SCIENTIFIC RADIO SERVICE SYSTEM
Sioux City, Iowa Box 1285-C

No home broadcast receivers will be available to the civilian till 1946, according to Bond Geddes, general manager of the Radio Manufacturers Association.

OPPORTUNITY AD-LETS

Advertisements in this section cost 20 cents a word for each insertion. Name, address and initials must be included at the above rate. Cash should accompany all classified advertisements unless placed by an accredited advertising agency. No advertisement for less than ten words accepted. Ten percent discount six issues, twenty percent for twelve issues. Objectionable or misleading advertisements not accepted. Advertisements for July, 1945, issue must reach us not later than May 28, 1945.

Radio-Craft • 25 W. B'way • New York 7, N. Y.

BUILD RADIO COMPLETE WITH TUBES \$10.95, details. Radio, 9418b Avenue "A", Brooklyn, N. Y.

MAGAZINES (BACK DATED)—FOREIGN, DOMESTIC, arts, books, booklets, subscriptions, pin-ups, etc. Catalog 10c (refunded). Cicero's, 863 First Ave., New York 17, N. Y.

MULTITESTER FOR SALE, BRAND NEW \$18.75. Order Today. Omaha Radio Products Co., 368 Saunders-Kennedy Bldg., Omaha, Nebr.

UNIVERSAL RADIO TOOLS—DANDY 16 PIECE SET: Midget Pliers, Diagonal Cutters, Four Midget End Wrenches, Needle-nose Pliers, Screw Holder, Six Punches and Chisel, Round File, Midget Crescent Wrench, \$14.85. Remit with order. Immediate Shipment Overnight by Air to Anywhere, U.S.A. Universal Tool Company, 1527 Grand St., Kansas City, Mo.

USED CORRESPONDENCE COURSES AND TECHNICAL Books Bought, Sold, Rented. Catalog Free. Educational Exchange, Henager, Alabama.

CORRESPONDENCE COURSES AND SELF-INSTRUCTION books, slightly used. Sold, Rented, Exchanged. All subjects. Satisfaction guaranteed. Cash paid for used courses. Complete information and 92-page illustrated bargain catalog free. Write—NELSON COMPANY, Dept. 2-39, Chicago 4.

LARGE AND VARIED STOCK OF PANEL METERS and multi-range meters. Panel meters 3½-inch round war-standard. Specify ranges you want and ask for quotation. Many D.C. instruments without priority. Good supply of critical types on priority. HATRY AND YOUNG, Hartford, Connecticut.

RADIO TUBES, PARTS, CONDENSERS, FREE BARGAIN lists. Potter, 1314 McGee, Kansas City, Mo.

FAST FREEZER: BUILD YOUR OWN, WITH OUR simple detailed plans. Conserve perishables. Plans easy to follow; no expert knowledge necessary; saves up to 75%. Use new or old parts; operates on any voltage. \$1.00 bill brings complete plans for 12 to 40 cu. ft. sizes and big catalog. LeJay Mfg., 956 LeJay Bldg., Minneapolis, Minn.

GET SUPPLEMENT NO. 3 (CODE: BLUE) TO THE Radio Substitution and Change-Over Manual, containing latest Tube substitutions, complete data on converting automobile radios to 110 v. A.C. and handy ballast Tube substitution chart. Send 50c to: C. W. Kunkle, 1529 So. Kedvale Avenue, Chicago 23, Illinois.

"\$500 GAVE ME MY RADIO-ELECTRONIC TRAINING!"

★ Literally thousands of today's most successful Radio-Electronic experts, and thousands more in the nation's armed forces, got their start in this fascinating field FOR A TOTAL INVESTMENT OF ONLY \$5! You can, of course, pay lots more than this—but the fact remains you can't get better, more complete, or easier-to-learn basic Radio-Electronic instruction than Ghirdardi's AT ANY PRICE! What's more, you can see it, study it, and compare it before you spend a cent!

SEE AD ON PAGE 601 SEND COUPON TODAY!

BUILD YOUR OWN!

*FAST-FREEZER It's Easy and Fun

Every amateur will be proud to build this modern household necessity. It just takes a few hours of your spare time to build, and operates electrically on any voltage. There's fun in building and profit in using this handy freezer. Saves up to 75%.



NO EXPERT KNOWLEDGE NEEDED

Our plans are simple and easy to follow and this 8 or 12 cubic foot size can be built of new or used parts. Mail \$1 bill, check or money order for complete plans and catalog. **LEJAY MFG., 456 LeJay Bldg., Minneapolis 8, Minn.**

PATENTS—TRADE MARKS

Booklet concerning Inventions & Patents Form "Evidence of Conception" with instructions for use and "Schedule of Government and Attorneys Fees"—Free **LANCASTER, ALLWINE & ROMMEL** Registered Patent Attorneys

436 Bowen Bldg. Washington 5, D. C.

NEW MAGNET MARVELS

THE common magnet is still a mystery, though recent researches by Ehrenhaft and others give us hope that the riddle is on its way to being cracked. For more than 3,000 years people have wondered, "What is magnetism?" but to date no commonly-accepted solution has been found.

Meanwhile, with the discovery of new alloys, the efficiency of magnets has been increased almost unbelievably in the past few years. One magnet made of Alnico in a special assembly has been recorded as lifting 4,450 times its own weight. Engineers have called this the most powerful magnet in the world.

Because of the rapid progress made in perfecting permanent magnets for wartime applications, experts predict that in post-war days many new products will be introduced, using them as the core of their mechanism. They foresee such commercial possibilities as a coffee maker that automatically turns down the heat when the coffee is done, letting it stay warm but not allowing it to become overcooked; an electric flatiron that automatically switches off the juice when the iron is even momentarily out of use; a magnetic wire recorder, an ingenious device that can record 66 minutes of continuous speech on a spool of wire no larger than a doughnut, and many more time-savers and conveniences.

Permanent magnets are those that will retain their magnetic properties indefinitely. Probably their oldest and most familiar useful form is the compass needle. According to legend, the Chinese Emperor Huang-Ti used a magnet in this form to guide his chariot in 2600 B.C. From this simple beginning permanent magnets have been developed to such an extent that, during World War II, their use has enabled our fighting men to replace bulky, heavy equipment with portable models of reduced size and weight; has made possible hundreds of devices for airplanes, and has also permitted an increase in the sensitivity of many measuring and electrical communication instruments.

The chief advantage of using them is that they can replace electromagnets, which require an outside source of current. In doing so, permanent magnets eliminate a coil, or windings, frequently saving space. Because they can dispense with outside power, much equipment containing magnets also becomes mobile, being transportable to areas it was formerly impossible to reach because of the necessity of being connected with the power source.

Permanent magnets are used most extensively in the fields of communication and measurement, but they have also found a great many additional and varied applications. In the home they are frequently employed in such time-saving devices as electric toasters, coffee percolators, ironing machines and electric refrigerators. Hearing aids and telephones, as well as many latches and locks, make use of them. Probably their biggest single application is in radio receivers, where much of the success of improved quality of sound and tone is the result of improved magnets. In industry, where magnets are used in both control and power equipment, they are found in ignition magnetos, many small motors, meters and instruments and numerous other devices.

Result of many years of magnet research was the astonishing fact that magnetic properties exist in all matter, in varying degrees. The most strongly magnetic are iron, nickel and cobalt. In the early days of the electrical industry, pure iron was considered to be the best material for mag-



Courtesy General Electric Co.

A small Alnico magnet upholds girl and swing.

netic circuits. Then engineers found many applications where it is desirable to have a material which, once it is magnetized, retains its magnetism. A hardened carbon steel was first used for this purpose. Then it was found that chromium and tungsten steels were better. Next a hardened cobalt steel was employed, and comparatively recently Alnico was introduced by General Electric. Alnico has remarkable strength; is much less subject to demagnetization from stray fields, vibration or temperature than any of the materials used before it, making it particularly suitable for a host of applications where older magnets were not suitable. So hard and brittle that it is not machinable, the marvellous new alloy is cast, or sintered, to the desired shape and is ground for precise dimensions. Materials used in its composition are aluminum, nickel, cobalt and iron.

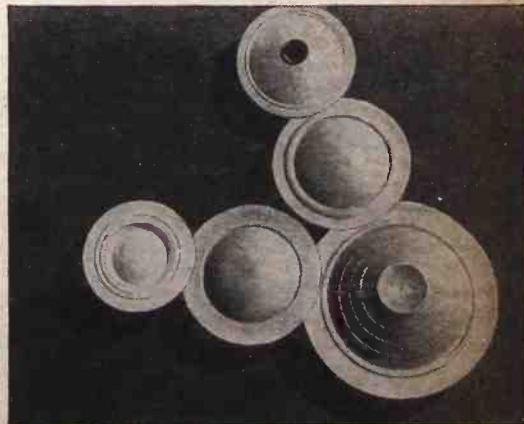

Plastic diaphragms from tiny battle-announcer speakers which use permanent magnets.

WORLD-WIDE STATION LIST

(Continued from page 570)

Freq.	Station	Location and Schedule
7.205	EAQ	MADRID, SPAIN; heard 10:30 to 11 pm.
7.210	VLQ2	BRISBANE, AUSTRALIA; 3:30 to 9:30 am.
7.220	JCJC	CAIRO, EGYPT; 12:30 to 2 am; 6 to 11 am; noon to 5 pm.
7.230	KWID	SAN FRANCISCO, CALIFORNIA; Oriental beam, 3:45 to 4:45 am; 5 am to 12:30 pm.
7.230	GSW	LONDON, ENGLAND.
7.240	DXJ	BERLIN, GERMANY.
7.250	KGEI	SAN FRANCISCO, CALIFORNIA; South American beam, 8:45 pm to 1:05 am.
7.250	KGEX	SAN FRANCISCO, CALIFORNIA; East Indies beam, 3 to 10:45 am.
7.250	GWJ	LONDON, ENGLAND; Near East beam, 3:30 to 5 pm.
7.257	JVW	TOKYO, JAPAN; heard at 2 pm.
7.260	GSU	LONDON, ENGLAND; North American beam, 5:15 pm to 12:45 am.
7.270	DXM	BERLIN, GERMANY.
7.275	VUD8	DELHI, INDIA; 7 to 10 am; 12:15 to 4 pm; 9 to 9:30 pm; 9:35 to 10 pm.
7.280	GWN	LONDON, ENGLAND; African service, midnight to 1:30 am.
7.280	DXL25	BERLIN, GERMANY; 2:30 to 4 pm; 5:50 pm to midnight.
7.290	DJX	BERLIN, GERMANY; North American beam.
7.290	VUD27	CALCUTTA, INDIA; "Voice of Free India"; heard at 8:30 to 9 pm.
7.305	VUD5	DELHI, INDIA; 9 to 10 am; 12:15 to 4:50 pm.
7.315	YSO	SAN SALVADOR, EL SALVADOR.
7.320	GRJ	LONDON, ENGLAND; Near East, midnight to 2 am; 1:30 to 5 pm; South America, 7 to 11:30 pm; Italy, midnight to 5 am; 1:30 to 5 pm.
7.370	KEQ	KAHUU, HAWAII; heard at 3 pm.
7.380	NCN	U.S. NAVY AT GUAM.
7.380	HEK3	BERN, SWITZERLAND; off at 11 pm.
7.420	DK8A	DEUTSCHLAND KURZWELLEN SENDER ATLANTIK; 1:30 pm to 1:30 am.
7.440	FG8AH	POINTE-A-PITRE, GUADELOUPE; 7 to 8:30 pm.
7.565	WNBI	NEW YORK CITY; European beam, 7:15 to 9:15 pm; 1 to 6 am.
7.565	KWY	SAN FRANCISCO, CALIFORNIA; Philippine beam, 4 to 10:45 am.
7.565	KNBI	SAN FRANCISCO, CALIFORNIA; South American beam, 9:45 pm to 1:05 am.
7.575	KNBX	SAN FRANCISCO, CALIFORNIA; Oriental beam, 5 to 10:45 am.
7.575	WLWL2	CINCINNATI, OHIO; North African beam, 5 to 7 pm; 7:15 to 11 pm.
7.795	WVLC	PHILIPPINES—U.S. ARMY; heard at 4 to 4:30 am.
7.805	WBOS	BOSTON, MASS.; European beam, 7:15 to 11 pm.
7.805	KNBA	SAN FRANCISCO, CALIFORNIA; Oriental beam, 5 to 9 am.
7.805	KRCA	SAN FRANCISCO, CALIFORNIA; Hawaiian beam, 11 pm to 1 am.
7.820	WOOC	NEW YORK CITY; European beam, 5:30 to 6:45 pm; 7 pm to midnight.
7.860	SUZ	CAIRO, EGYPT.
7.832	WCBN	NEW YORK CITY; European beam, 4:30 to 7:15 pm.
7.832	WLWS2	CINCINNATI, OHIO; South American beam, 6:45 to 8:30 am.
8.030	FXE	BEIRUT, LEBANON (SYRIA).
8.035	CNR	RABAT, MOROCCO; heard Sundays, 5 to 6 pm.
8.665	COJK	CAMAGUEY, CUBA.
8.696	COCQ	HAVANA, CUBA; 8 am to 12:30 am.
8.830	COCQ	HAVANA, CUBA; 5:30 am to 1:30 am.
8.905	COKG	SANTIAGO, CUBA; 7:30 am to 11 pm.
8.930	KES2	SAN FRANCISCO, CALIFORNIA; Hawaiian beam, 3 am to 3 pm.
8.960	APH	ALLIED HEADQUARTERS IN ITALY.

\$3.00 FOR YOUR CARTOON IDEAS

RADIO-CRAFT, as you will have noticed, prints a number of radio cartoons, which we intend to keep on publishing every month indefinitely. We invite our readers to contribute to this feature by sending in their ideas of humorous radio ideas which can be used in cartoon form. It is not necessary that you draw a sketch, but you may do so if you so desire.

RADIO-CRAFT will pay \$3.00 for each original idea submitted and accepted.

We cannot return ideas to this department nor can we enter into correspondence in connection with them. Checks are payable on acceptance.

Address all entries to RADIO CARTOONS, c/o RADIO-CRAFT, 25 West Broadway, New York 7, N. Y.

Here it is!

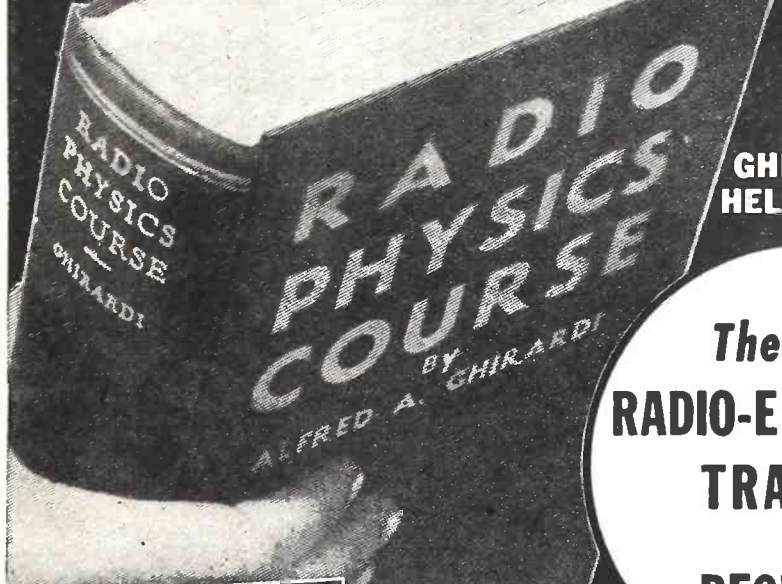

LET
GHIRARDI
HELP YOU!



The BEST
RADIO-ELECTRONIC
TRAINING
FOR
BEGINNERS

Only \$5

Complete
(\$5.50 foreign)

Designed throughout to help you learn at home in spare time—Easier—Better—Faster. Easily worth ten times this amount if broken into sections and sold as a "course."

at a cost you can afford!

EXAMINE IT FOR 5 DAYS —You be the judge!

Order today. If, within 5 days after getting Ghirardi's RADIO PHYSICS COURSE book, you're not fully convinced it will teach you Radio-Electronic fundamentals, EASIER, FASTER, and at LESS COST than any other book or course, your money will be refunded promptly and without question!

This is the famous book you've been reading about in the series of little advertisements on Pages 594, 595, 597, 598, 599 and 600 of this magazine. It's the famous basic Ghirardi Radio-Electronic Home study training course that you get complete for ONLY \$5—on a money-back guarantee basis. It's the same big book that is used by more U. S. Army Signal Corps, Navy, and Civilian Schools and Colleges and for more home study than any other book ever published on the subject.

NO OTHER BOOK LIKE IT!

There's no other book like A. A. Ghirardi's RADIO PHYSICS COURSE at any price. It is larger, better illustrated, more complete, more thorough, easier to understand! No previous radio-electronic knowledge is assumed; it starts right at the beginning of the subject, with

over 300 of its 972 pages devoted to a complete explanation of Electrical fundamentals alone!

36 COURSES IN ONE!

Actually, Ghirardi's RADIO PHYSICS COURSE gives you the scope of 36 different courses in one—packed into a big, easy-to-follow 972-page book with 508 clear illustrations and 856 self-testing review questions to help check your progress every step of the way. What other books and courses skim over, Ghirardi's RADIO PHYSICS COURSE explains fully so you understand easily and quickly. You progress as fast as you want to and you'll find studying from it by yourself amazingly easy, even if you don't know a single thing about Radio-Electronics in the beginning. It's just what you need to get started RIGHT for a profitable career in this fascinating, rapidly-growing field.

REPAIR ANY RADIO-RECEIVER! PREPARE FOR A BETTER JOB IN RADIO-ELECTRONICS!



How to Test a Radio in 2 Minutes

If you repair Radios for a living—or even if you only tinker with them occasionally—Ghirardi's big 746-page 3rd edition RADIO TROUBLESHOOTER'S HANDBOOK is the shop book for you! Simply look up the Trouble Case History data on the set you want to repair. Nine times out of ten, the Handbook will tell you just what is wrong and just how to fix it in a jiffy! Now contains 404 pages of Case Histories for over 4,000 receiver models. Also there are 340 ADDITIONAL PAGES on 1-f alignment peaks for over 2,000 superhets, parts substitution data, tube replacement charts, etc., etc.—in short, a complete guide to quickly diagnosing, locating, and repairing trouble in every type of Radio in use today. Only \$5 complete (in U.S.A.). 5-DAY MONEY-BACK GUARANTEE.



GHIRARDI'S COMPLETE COURSE IN MODERN RADIO SERVICING

Ghirardi's MODERN RADIO SERVICING is a big 1300-page illustrated course worth its weight in gold to anyone desiring to learn radio repair work. It's the only simple, inexpensive home-study course giving a thorough explanation of the workings of Test Instruments; Receiver Troubleshooting Procedure; Circuit Analysis; Testing & Repair of Components; Installation; Adjustment; etc., etc. Tells how to build many types of essential instruments for your own use. 706 illust. 766 different topics. Only \$5 complete (in U.S.A.). See special Money-Saving combination offer in coupon.

Technical Division of Murray Hill Books, Inc.
Dept. RC65, 232 Madison Ave., New York 16, N. Y.

Enclosed find \$..... for books checked (send postpaid); or Send C. O. D. (in U.S.A. only) for this amount plus postage. If not fully satisfied, I may return the books within 5 days and receive my money back.

RADIO PHYSICS COURSE \$5 (\$5.50 foreign)

MODERN RADIO SERVICING \$5 (\$5.50 foreign)

3rd Edit. RADIO TROUBLE-SHOOTER'S HANDBOOK \$5 (\$5.50 foreign)

SPECIAL MONEY-SAVING COMBINATION (Two books) Modern Radio Servicing and Radio Troubleshooter's Handbook \$9.50 (\$10.50 foreign) for the two!

Name

Address

City & Dist. No. State

GET STARTED NOW! MAIL COUPON TODAY!



**TECHNICAL
PERSONNEL
WANTED**

ELECTRONIC ENGINEERS!

War - Winners Today, Post-War Builders Tomorrow!

Leaders in NATIONAL UNION RADIO CORPORATION'S staff of engineers, scientists and technicians have brought us far out in front in the electronics industry. We have a research laboratory and two manufacturing plants in Newark, N. J., and a manufacturing plant near Philadelphia, Pa. We invite you to consider your opportunities with us for professional advancement, stimulating, friendly associations, and a future with promise.

NATIONAL UNION NEEDS:

SENIOR TUBE ENGINEERS: These men MUST have actual experience with radio tube manufacture. The pay and opportunities are commensurate with your ability.

COMMERCIAL ENGINEERS: Engineers interested in developing electronic tube applications, who may represent us among radio manufacturers upon occasion.

QUALITY CONTROL MEN AND WOMEN: Here you need an interest in the practical application of statistical and/or engineering procedures to many factory processes.

TEST EQUIPMENT ENGINEERS: Men experienced with meters or electronic test equipment to work either as TEST EQUIPMENT DESIGN ENGINEERS or as MEASUREMENT LABORATORY ENGINEERS.

JUNIOR ENGINEERS—MEN AND WOMEN: Do you have a college degree in Physics, Electrical Engineering, Chemical Engineering, Mechanical Engineering, Mathematics or Chemistry? This company offers an opportunity for young, ambitious graduates to assume responsibilities and to exercise initiative.

FOREMEN AND ASSISTANT FOREMEN: Men experienced in radio or radio tube manufacture to supervise exhaust, stem or grid operations.

TECHNICIANS, CIRCUIT MEN: Have you been a radio ham, or have you built or repaired radios? Have you studied radio in the Services? We need men who can read circuit diagrams and do wiring and construction.

WOMEN!

We have a number of fine young women engineers with us now. We need more. If you have a degree in Electrical Engineering, Chemical Engineering, Mechanical Engineering, Physics, Chemistry or Mathematics and are seeking career opportunities, investigate.

If you have thorough training in your field, as evidenced by job experience in radio or allied industries, or by a college degree—if you have ambition, initiative and resourcefulness—if you have the ability to inspire your co-workers, then . . .

Phone or Write

DR. L. GRANT HECTOR

Director of Engineering

NATIONAL UNION RADIO CORPORATION

Plane St. at Raymond Blvd.

Newark 2, New Jersey

WMC RULES OBSERVED

ELECTRICAL and RADIO ENGINEERS RADIO TECHNICIANS

For Design, Development and Production Work. Post-war Opportunity. Also Openings for Mechanical Draftsmen, Junior and Senior Designers.

ALLEN D. CARDWELL MFG. CORP.
81 Prospect St. Brooklyn



**HELP FINISH
THE FIGHT
BUY ANOTHER
WAR BOND**



PRIORITIES FOR RESEARCH

Special priorities are permitted by the War Production Board for the supply of material for experiment, research, scientific or technological investigation. A priority more limited in scope is given to manufacturers wishing to construct experimental models for commercial purposes. Two orders, PR 23 and P-43, were issued as early as last July, but their purpose has not been entirely understood and there is some confusion as to which may be applied in a given case.

The object of both orders is to override restrictions on obtaining materials to permit experimental work to be done. Under P-43, laboratories and persons doing bona fide experimental work may obtain material available under an AA-2 preference rating. While the word "laboratory" is used, the order makes it clear that:

Any person located in the United States, its territories or possessions, who carries on scientific or technological investigation, testing, development or experimentation as his regular business or in the course of his business and who buys any materials especially for that purpose is considered a "laboratory" under this order in making such purchases, even though he does not have a separate department or organization in his company or institution for these activities.

Controlled materials may be obtained by a laboratory by placing on its order the allotment symbol V-9 and the certification set forth in Priorities Regulation 7, or the following certification:

The undersigned certifies, subject to the criminal penalties for misrepresentation contained in section 35 (A) of the United States Criminal Code, that the items covered by this order are required to carry on scientific or technological investigation, testing, development or experimentation, and that this order is placed in compliance with Preference Rating Order P-43.

Such an order is an authorized controlled material order for the purpose of all CMP regulations, and carries a preference rating of AA-2, except in the case of serial-numbered laboratories operated by the Army or Navy, which are entitled to AA-1.

The procedure for manufacturers who wish to make developmental models is similar, except that the preference rating is lower. An "experimental model" as defined by PR 23, is any model of a consumer or industrial product which is made, as an experiment, for the purpose of determining whether it will be superior to or cheaper to make than present models and whether it can be reproduced on a commercial basis. In other words, the motive for making it is commercial rather than scientific. This is further borne out in the restriction that such experimental models may be made only in the minimum number and size required to determine the suitability of the article for commercial production and application.

PR 23 details the restrictions on obtaining controlled materials for making experimental models, and refers to other orders covering specific materials. To obtain materials for making models as defined in PR 23, P-43 is again used, the same certification and symbol being placed on orders, which will then be entitled to an AA-3 preference.

A color chart—the work of Thomas H. Hutchinson of RKO Television—now hangs on the wall of the Dumont television studio at WABD. It consists of 40 squares of different colors. The director merely has to turn the camera on any one of these to see on his screen how that particular color will "televise."



A WAR PRODUCTION JOB
TODAY MAKES WAY FOR
A PEACE JOB TOMORROW



RADIO RESEARCH Development (Post-War Opportunity)

Expanding national organization has 3 openings on its Research-Development Field Staff. These positions entail some travel with full expenses and allowances paid by the company. Knowledge of radio set construction or definite mechanical ability essential. The positions are permanent and offer an exceptionally fine post-war future. Starting salary \$172.50-\$200.00 per month depending upon ability. Periodic increases based on merit. If you are interested in joining an expanding and progressive company, please give us in confidence full details about yourself for a personal interview.

BOX 615, RADIO-CRAFT
25 West Broadway
New York 7, N. Y.

RADIO STATION TECHNICIANS

MEN AND WOMEN

for Point-to-Point International Radio-Telegraph Stations in the United States.

Applicants must possess FCC radio-telegraph commercial license, and ability to copy International Morse code at about 20 wpm.

WMC rules observed.

Apply weekdays except Saturdays between 10 am and 3 pm

or write

PERSONNEL DEPARTMENT

RCA COMMUNICATIONS, Inc.

64 BROAD STREET
NEW YORK 4, N. Y.

?? WHY NOT ??

Have you ever asked yourself, "Why can't I have this or that gadget on a radio? Why aren't programs made to fill such and such a need?" If so, you are a charter member of the *Radio-Craft* "Why Not" club. Send us your "Why Not's" on all subjects—serious or screwball, practical or idealistic. We will pay \$1.00 for every one we believe will interest the readers of *Radio-Craft*.

You can get the idea from the "Why Not's" printed below. Send in as many as you like. One dollar will be paid for each one printed.

Why not use phosphors or luminescent material to indicate "On-Off" switches and controls on radios and other appliances—also on tuning dials in battery radios? This would save a lot of fumbling and improve the appearance of the set.—*Pvt. John R. Simpson, Camp Shelby, Miss.*

Why not have all radio parts plainly designated by a label, or stamped according to their value; resistors and controls with wattage and ohmage, chokes with resistance and inductance as well as current rating; transformers with ratings and leads marked, and condensers with their capacities and voltage?—*H. L. Lurie, New York, N. Y.*

Why not build a set with two independent radios on a common power pack? Then Dad could tune in his favorite program in the living room and Junior could hear "Terror Story" on an extension speaker in his room?—*Ensign Jack Nelson, S.S. "Shiloh."* (A good idea. Such a set was described in *Short Wave Craft* a number of years ago.—*Editor.*)

Why not produce a movie with its story written around a war-production factory? It could be very comic!—*Ensign Jack Nelson, S.S. "Shiloh."*

FIELD SERVICE ENGINEERS

For Domestic and
Foreign Service
and

INSTRUCTORS

Must possess good
knowledge of Radio
Essential workers need release.

HAZELTINE CORPORATION

58-25 Little Neck Parkway
Little Neck, Long Island

WANTED

TRANSFORMER & SMALL ELECTRIC MOTOR MEN

ENGINEERS
DESIGNERS
DRAFTSMEN
TECHNICIANS

For war time and post-war design and development of intricate, specialized, hermetically sealed transformers, and special purpose fractional h.p. motors.

Write, giving details about age, experience, past salaries to

SPERRY

GYROSCOPE COMPANY, INC.
RESEARCH LABORATORIES
STEWART AVE. AND CLINTON RD.
GARDEN CITY, NEW YORK

Wanted ENGINEERS

Radio

* Electrical

Electronic

* Mechanical

Factory Planning

Materials Handling

Manufacturing Planning

Work in connection with the manufacture of a wide variety of new and advanced types of communications equipment and special electronic products.

Apply (or write), giving
full qualifications, to:

R.L.D., EMPLOYMENT DEPT.

Western Electric Co.

100 CENTRAL AV., KEARNY, N. J.

*Also: C.A.L.

Locust St., Haverhill, Mass.

Applicants must comply with WMC regulations

New transmitters and added time allotments have increased shortwave broadcasts to overseas soldiers by fifty percent, a recent OWI report reveals. Nearly 1,000 hours per week of entertainment and news are now beamed to Yanks in European and Pacific war theatres.

Communications

VARIOUS ADVENTURES IN ELECTRONICS



University

ELECTRO-ACOUSTIC REPRODUCERS

An all-inclusive line of permanent magnetic electro-acoustic reproducers designed for specific applications—directional and radio, for indoor and outdoor mounting. Exclusive design features assure high efficiency and dependable functioning.



**1 OUT OF 6 ADULTS
DIES OF
CANCER
YOU MAY BE THE ONE
GIVE!**

Eminent scientists lack funds for experiment . . . cancer clinics are starved for equipment . . . money is needed to care for advanced cases.

Five million dollars a year might cut the deaths from cancer. Might save you, one dear to you. Yet Americans give less than one million dollars. Do your part! Send us anything from 10¢ to \$1,000. Every bit helps!

If you are a resident of the Metropolitan area of New York, send your contribution to New York City Cancer Committee, 130 E. 66th St., N. Y. 21, N. Y.

AMERICAN CANCER SOCIETY
350 Fifth Avenue, N. Y. 17 N. Y.

Dear Editor:

Two months ago I was fortunate not only in getting a seat on a train but in having a naval radio inspector as a seat-mate. I mentioned some trouble with interference which was spoiling my favorite broadcasts and he graciously described a wave trap for me. Well, one thing led to another. The radio inspector got off the train and left me the January, 1945, issue of *Radio-Craft*.

I built a wave trap and finished your magazine and very soon was a victim of "ether fever" with "heterodyning complications." Since then have built the Super-regenerator described in the January *Radio-Craft*, the "Ultra" set in February *Radio-Craft*, substituting a 117P7, a regenerative receiver with one audio stage using a 6C8 dual triode and a 12Z3 rectifier to which I added the tuning indicator-amplifier in the January "circuits" section.

I have adjusted to perfection my five-years-without-attention Magnavox record changer according to your excellent article in *Radio-Craft* for February. Today I finished adding a pair of crystal headphones to the plates of the 6V6's push-pull output of the Magnavox as per 1st half of Fig. 3 in John Kearny's enlightening article in the current issue (March) of *Radio-Craft*.

With the headset in the circuit and the speaker either on or off, the set seems to heat up a good deal more than formerly, particularly the 6V6's and the power transformer. Is there any reason for this, or will it injure either the set or the phones? Four hours of continuous playing do not seem to have hurt anything but my nerves, worrying about the loss of some hard-to-get item.

I'd greatly appreciate dimensions for a "bass-reflex" speaker cabinet using a 12" speaker with a crystal "tweeter" if available.

The doctor has diagnosed my "fever" as unquenchable and prescribed R.F. oscillations daily and *Radio-Craft* once per month. Many thanks for your attention and for your fine magazine.

PRESCOTT SLADE,
Boston, Mass.

(Regret that we cannot at the moment supply diagrams for Bass-Reflex speaker cabinets or other electronic circuits. Pretty soon, maybe! The headphone circuit should cause no trouble unless the resistance shunting the output transformer is very low. Try a 50,000 or even a 100,000-ohm potentiometer and cut down the 0.1-mfd. condenser to .05 if the set heats more than it did before you put the phones on.—Editor)

"TALKIE-BACKIE" AS NOISE REDUCER

Dear Editor:

During the past fifteen years or so there have been a great many newspaper accounts throughout the world on efforts to cut out nuisances and noises and I saved most of the clippings.

Back around 1933 I built two 5-meter transceivers with the intention to use them for the purpose of automatically blowing horns in automobiles, or better still, to eliminate the blowing with the substitution of lights or buzzers inside the cars. I had pretty good luck in this venture and out of these machinations grew "Talkie-Backie."

We had a Motorola "Wireless Record Player" and to our surprise and amusement we used to receive the record playing through the automobile radio in our Ford, which also happened to be another Motorola product—Model 9-29. I fitted a telephone transmitter (microphone) with a suitable switch to cut out the pickup and cut in the mike on my record player. I then made a replica of the parts and circuit of the record player, this time with only one tube, 6K6, and attached it to the side of the automobile radio also with suitable switch, and lo! and behold! I found myself safely talking back to the Mrs. from our automobile radio in our Ford coupe out in the street in front of our house.

You will appreciate that all of this was done with the purpose of mind to use existing equipment as far as possible these days, and with the hope that it some day might tend to entirely eliminate this unnecessary horn howling in residential neighborhoods.

I am NOT a competent radio man. Just one of those guys who dabbled in mechanics and radio for about thirty years and could have made some notable accomplishments

with the aid of Gernsback's magazines. The magazines solved my technical problems for me—this being easy. I used to communicate quite a lot through the years with a man in your outfit by the name of McEntee and I still possess some of his very nice and helpful letters. Also you might be interested in my telling you that the Mrs. and myself used to go to the store of "The Electric Importing Co." somewhere around Fulton Street in New York



Mrs. Coffee at one end of the Talkie-Backie.

City when we used to live in New Jersey. I still have some of the copies of the old "Wireless Lessons." The experiments contained in them also fascinated me very much and were really an inspiration. I have some of Gernsback's very old magazines—*Electrical Experimenter*, *Science & Invention*, *Radio News*, *Short-Wave Craft* and, of course, our own *Radio-Craft*. Usually the questions which the other fellows ask and which are printed in your several departments are the answers to my own itchy problems.

GEORGE COFFEE,
Providence, R. I.

FOR SALE

HARD-TO-GET ITEMS

All items are brand new, except where indicated. ALL are in PERFECT WORKING ORDER. In many cases, the parts alone total more than the price we are asking. Satisfaction guaranteed or your money back. ORDER FROM THIS PAGE. Use our convenient coupon. Include sufficient extra remittance for parcel post charges, otherwise order is sent express collect. Any excess will be refunded. All C.O.D. shipments require 20% deposit. No C.O.D. shipments on orders for less than \$5.00. If full remittance accompanies order deduct 2% discount. Send money order, certified check, or new U. S. stamps. No C. O. D.'s to foreign countries.

THE MAGIC ELECTRIC WELDER

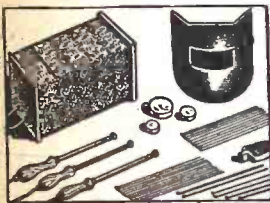

Here is one of the most compact, practical welders we have ever seen. Anyone can use it for shop, farm and home repairs. WELDS, BRAZES, SOLDERs, CUTS ALL METALS. ANYONE CAN OPERATE IT. Repairs steel, cast iron, aluminum, brass, copper, bronze, etc. Complete with power unit, flame and metallic arc attachment. Carbons, flux, rods, mask included. Just plug it in any electric outlet. 110 volts AC or DC. For hobbyist or professional.

GET IN ON THE GREAT WELDING BOOM. This fine set quickly teaches you welding. Low cost to operate—about 5c an hour. COMPLETE SAFETY is assured. No fumes with this outfit. SET COMES COMPLETE—nothing else to buy. Used by the U. S. Navy, American Tel. & Teleg. Co., Eastman Kodak Co., Bell Laboratories, etc. BRAND NEW OUTFIT. Guaranteed for one year. Simple instructions with each set. ITEM NO. 158 YOUR PRICE \$19.95

WESTERN ELECTRIC BREAST MIKE

This is a fine light-weight air-craft carbon microphone. It weighs only 1 lb. Mike comes with breastplate mounting and has 2-way swiveling adjustment so that it can be adjusted to any desired position. There are 2 woven straps; one goes around neck, the other around chest. Straps can be snapped on and off quickly by an ingenious arrangement. This excellent mike can be adapted for home broadcasting or private communication systems. By dismounting breastplate, it can be used as desk mike. Comes complete with 6-foot cord and hard rubber plug. Finished in sherardized plate, non-rustable. THIS IS A BRAND NEW MIKE. IT HAS NEVER BEEN SOLD AT SUCH A LOW PRICE BEFORE. ORIGINAL LIST PRICE \$15.00. Shipping weight, 2 lbs. ITEM NO. 152 YOUR PRICE \$2.55

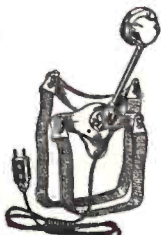

LIMITED QUANTITIES! PROMPT SHIPMENTS!

It's Easy to order—Clip Coupon—Order from This Page—No Catalog Sent. MAIL TODAY—NOW!

HUDSON SPECIALTIES CO.
40 West Broadway, Dept. RC-6-45, New York 7, N. Y.

I have circled below the number of the items I'm ordering. My full remittance of \$..... (include shipping charges) is enclosed. (NO C.O.D. ORDERS UNLESS ACCOMPANIED WITH A DEPOSIT.)

OR my deposit of \$..... is enclosed (20% required), ship order C.O.D. for balance. (NO C.O.D. ORDER FOR LESS THAN \$5.00. (New U. S. stamps, check or money order accepted.)

Circle Item No. wanted: 152 158

Name

Address Please Print Clearly

City State

Send remittance by check, stamps or money order; register letter if you send cash or stamps.

NEW ERA FOR REPAIRMEN

Television will bring about a revolution in servicing methods, members of the Philadelphia Radio Service Men's Association were told by Harold W. Schaefer of Westinghouse Home Radio division. New knowledge, improved technique and an advanced standard of procedure will be needed to handle cathode-ray tubes rated up to 30,000 volts and to test and check the systems used with projection tubes. Antenna systems will assume an importance hitherto unknown. In Mr. Schaefer's opinion, proper installation of the antenna will contribute more than any other one factor to satisfactory reception of television and FM programs on the new high frequencies.

A CANADIAN ASSOCIATION

Dear Editor:

It might interest Mr. Anglado to know that we have a Radiomen's Association here in Alberta. It is called the Associated Radio Technicians of Alberta. Our crest is ART in a diamond (Art in Radio Service). To become a member one must write for the Provincial License and be a bona-fide radio serviceman.

At present, it is your kinks and short cuts that I find the most useful, but I can easily see that some of your more profound articles are welcomed by the man who is designing electronic equipment.

As for advertisements, surely most of your readers can realize that it is advertising that pays the bill, same as in broadcasting.

The only suggestion I have is to make your magazine thicker—you know what I mean, more of everything!

E. SCHURMAN,
Vermillion, Alberta.

MORE SIMPLE SERVICING

Dear Editor:

I have been reading the brickbats and bouquets handed you in profusion in the past few issues and I can see what a spot you are in trying to give the readers what they want.

The first few years your magazine naturally contained fundamentals of the art and were easily understood and interesting. As progress went forward the articles became more difficult to digest until now you have reached the state where each item is a profound diagnosis on the subject under discussion; containing terms and facts which the ordinary radio enthusiast—unless a mathematician and an embryo engineer—does not find of much value, as he doesn't understand it.

Suppose you have a number of readers like myself who took up radio as a hobby. In early battery days I could assemble a set, but today it is so far ahead of me that when the house radios go bad I can't fix them but have to send them to the radio shop (and are they hard to find these days!).

My only suggestion is that besides these highly technical treatises we have a few elementary elements, such as how to locate and repair trouble in the ordinary receiver; how to fix or renew noisy volume control; how to make a set so it don't bring in two or more stations simultaneously; and the ordinary elements of radio—both sending and receiving.

I know you have a hard job to please all, but I always like the new and better ways of doing things. Those who object to such are not progressing but stagnating.

Now that the war is nearly over, I trust that you will have an easier time to keep your magazine going and trying to please everyone.

WILLIAM J. MORGAN,
Rensselaer, N. Y.

CASH FOR SERVICE SHOP PHOTOS

Radio-Craft wishes to obtain photographs of good Service Shops. Send us a photo of your shop, together with a description to help us evaluate the picture. We will pay three dollars for each excellent snapshot, and five dollars for each professional photograph accepted. Photos not accepted will be returned immediately.

FOR SALE

HARD-TO-GET ITEMS

All items are brand new, except where indicated. ALL are in PERFECT WORKING ORDER. In many cases, the parts alone total more than the price we are asking. Satisfaction guaranteed or your money back. ORDER FROM THIS PAGE. Use our convenient coupon. Include sufficient extra remittance for parcel post charges, otherwise order is sent express collect. Any excess will be refunded. All C.O.D. shipments require 20% deposit. No C.O.D. shipments on orders for less than \$5.00. If full remittance accompanies order deduct 2% discount. Send money order, certified check, or new U. S. stamps. No C. O. D.'s to foreign countries.

ULTRA MAGNET

LIFTS MORE THAN 20 TIMES ITS OWN WEIGHT

LITTLE GIANT MAGNET

Lifts 5 lbs. easily. Weighs 4 oz. Made of ALNICO new high-magnetic steel. Complete with keeper. World's most powerful magnet ever made. The experimenter and hobbyist will find hundreds of excellent uses for this high quality permanent magnet. Measures 1 3/4" x 1 1/2" Shp. Wt. 3/4 lbs. ITEM NO. 159 YOUR PRICE \$1.50



GENUINE MICROPHONE TRANSMITTERS

These are regular "telephone transmitters" of the type used on wall telephones. Taken from a large telephone supply company's overstock, these fine mikes offer a grand opportunity to obtain a splendid unit for little more than the price usually asked for a simple "microphone button." The amateur experimenter and telephone mechanic will find a variety of uses for these excellent microphones. They work perfectly on 2 dry cells. Can be used on P.A. systems for voice transmissions. In call systems and intercommunications sets. With telephone receivers (radio headphones will do) they may be made into short-line telephone circuits, such as house-to-house or farm-to-farm 'phone lines. You can use them to talk through your own radio, or as concealed dictaphone pick-up units for listening to conversations in a distant room or building. The telephone mechanic will find them useful replacements on battery-operated rural telephone lines. THESE ARE GENUINE TRANSMITTERS. MADE BY KELLOGG, WESTERN ELECTRIC AND STROMBERG-CARLSON, excellent in appearance and operation. A remarkable value, and one seldom offered in these times. Shp. Wt. 1 lb. ITEM NO. 160 YOUR PRICE \$1.50

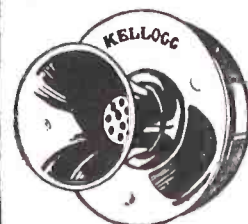

AMAZING BLACK LIGHT!!

Powerful 250-Watt Ultra-Violet Source

The best and most practical source of ultra-violet light for general experimental and entertainment use. Makes all fluorescent substances brilliantly luminescent. No transformers of any kind needed. Fits any standard lamp socket. Made with special filter glass permitting only ultra-violet rays to come through. Brings out beautiful opalescent hues in various types of materials. Swell for amateur parties, plays, etc. to obtain unique lighting effects. Bulb only. Shp. Wt. 2 lbs. ITEM NO. 87 YOUR PRICE \$2.45

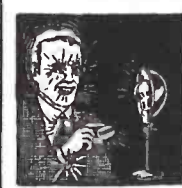

WATTHOUR METER

Completely overhauled and ready for immediate service.

Designed for regular 110-volt, 60 cycle 2-wire A.C. circuit. Servicemen use it in their shops to check current consumption of sets, soldering irons, etc. Keeps coats down. If dismantled the parts alone would bring the price. The elaborate gear train could be used as a counter on machines of various kinds. Simple to install; 2 wires from the line and 2 wires to the load. Sturdily constructed in heavy metal case. 8 1/2" high, 6 1/2" wide, 5" deep. Westinghouse, G. E., Ft. Wayne, Sangamo or other available make. Shp. Wt. 14 lbs. ITEM NO. 33 YOUR PRICE \$5.95

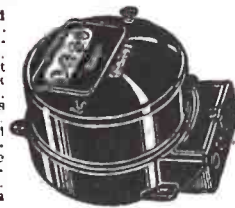

LIMITED QUANTITIES! PROMPT SHIPMENTS!

It's Easy to Order—Clip Coupon—Order from This Page—No Catalog Sent. MAIL TODAY—NOW!

HUDSON SPECIALTIES CO.
40 West Broadway, Dept. RC-6-45, New York 7, N. Y.

I have circled below the numbers of the items I'm ordering. My full remittance of \$..... (include shipping charges) is enclosed. (NO C.O.D. ORDERS UNLESS ACCOMPANIED WITH A DEPOSIT.)

OR my deposit of \$..... is enclosed (20% required), ship order C.O.D. for balance. (NO C.O.D. ORDER FOR LESS THAN \$5.00. (New U. S. stamps, check or money order accepted.)

Circle Item No. wanted: 33 87 159 160

Name

Address Please Print Clearly

City State

Send remittance by check, stamps or money order; register letter if you send cash or stamps.

The Book that takes Drudgery out of Mathematics

Only **50¢** postpaid

Entire Chapter on Special Mathematics for the Radio Technician.

ELEMENTARY MATHEMATICS

● EASY — SIMPLIFIED — PRACTICAL ●

Here is the book that gives you a good background in mathematics; that takes all the irritation and drudgery out of it. You don't need to be scared of mathematics, because here's the subject explained without frills, without useless computations.

CONTENTS OF BOOK

- CHAPTER I. Arithmetic—Addition—Subtraction—Multiplication—Division.
- CHAPTER II. Factoring and Cancellation—Fractions—Decimals—Percentage—Ratio and Proportion.
- CHAPTER III. The Metric System.
- CHAPTER IV. How to Measure Surfaces and Capacity (Geometry).
- CHAPTER V. Powers and Involution—Roots and Evolution.
- CHAPTER VI. Mathematics for the Mechanical and Technical Craftsman—Thermometer conversions—Graphs or Curve Plotting—Logarithms—Use of the Slide Rule.
- CHAPTER VII. Special Mathematics for the Radio Technician.
- CHAPTER VIII. Commercial Calculations—Interest—Discounts—Short Cut Arithmetic.
- CHAPTER IX. Weights and Measures—Useful Tables.

ONLY **50¢** POSTPAID

Send today for your copy of this indispensable book. It can be carried readily in your pocket. (Size 6 x 9 in.)

Send Stamps, Cash or Money Order to

TECHNIFAX

1917 S. STATE ST., RC-6-45, Chicago, Ill.

TECHNIFAX 1917 S. State St., Chicago, Ill.

Enclosed herewith 50 cents, for which mail to address below your **ELEMENTARY MATHEMATICS**.

NAME

ADDRESS

CITY STATE.....

RC-6-45

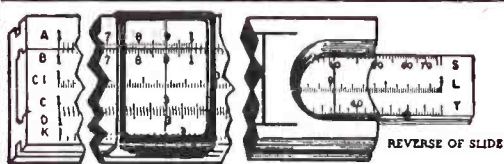

ENGINEERS & DRAFTSMEN'S DAILY NECESSITIES

1. **ENGINEERS' SLIDE RULE.** Lawrence. New "TRIG" 10" Slide Rule with A B C D CI K S L T scale complete with illustrated instructions. Narrow gun-metal finish indicator and leatherette carrying case. \$1.50
2. Lawrence 10" white enameled slide rule with A B C D CI and K scales with round magnifying indicator, packed in individual black imitation leather grain pocket case. \$0.75
3. R-700 Protractor Ruler with radio and electronic symbols 1 1/2" x 8". Ideal ruler, protractor, circuit diagram holder for radio and electronics, made of transparent material. \$0.75
4. Lawrence 32-page complete slide rule instruction book. \$0.20
5. Stanley 28-page slide rule instruction book with numerous large illustrations. \$0.15
6. Slide Rule CONVERTISOR—6" diameter. \$2.00
7. **SPEE-DOTTERS** for draftsmen, 1 1/2 x 8 centimeters and inch in 1/16ths. \$1.00
8. 1 1/2" x 12 1/4" inch in 32ds and 20ths. \$1.50
9. **THE GOLD SHIELD "2-Glow" NEON Electric Circuit Tester.** \$1.50
10. **MORSE CODE PRACTICE-KEY,** with 4-page illustrated circular. \$3.00
11. **"THE INDUCTANCE AUTHORITY"** by Edward M. Shlepe, B.S., M.E.E. with 38 full page charts and ten pages of textual discussions by the author, Graduate of Massachusetts Institute of Technology and Polytechnic Institute of Brooklyn \$2.50
12. **NEW LAWRENCE CODE RULES** consisting of two rules and a complete book of instructions with examples, also additional features. Complete set. \$0.50
13. **STURDY MAGAZINE BINDERS,** covered with strong black corrugated fabrikoid. Has two stamped metal ends with 12 spring wire separators. Magazines can be inserted and removed in a jiffy.
 - Size 1—12 1/2 x 9 1/2, to fit Radiocraft, Radio News, etc. Each \$2.00
 - Size 2—10 3/8" x 7" to fit Popular Mechanics, etc. Each 1.90
 - Size 3—8 3/8" x 7 1/4" to fit Readers' Digest, etc. Each 1.80

GOLDSHIELD PRODUCTS, Department RC-6
25 West Broadway, New York 7, New York.

BUY WAR BONDS

SONG OF THE ENGINEERS

The poem below was the result of a friendly feud at Radio WOR. The station staff blossomed out with a number of skilled amateur songwriters and poets recently—so much so that it was said that "everyone on the staff had written a song but the engineers." Jay Johnson, who had been using some of WOR's home-grown material on his 4.15-4.30 program, taunted the engineering staff musically (for their narrow specialization) in the song below.

Result: The engineers took up his challenge, and no less than three of them, Don Williamson, Mac Benoit and Ed Boquist, have since turned out lyrics which Johnson has aired on his afternoon spot.

Radio Engineer's Song

By Jay Johnson

We're the radio engineers.
We're proud of our careers.
Once in a while
We twist a dial
When something hurts our ears.

Refrain:

We know all about electrons;
We'll give you a description.
And when the stated time arrives,
We'll play you a transcription.

We sit around on our chairs,
And make some small repairs.
And then we do nuttin'
But push a button
And mind our own affairs.

Let's give ourselves three cheers
For the brains between our ears.
We get our dough for what we know—
We're the radio engineers.

Copyright 1945 by Jay Johnson.
Reproduced by special permission.

CATHODE FOLLOWERS

(Continued from page 562)

to match a load impedance, Z_L , is found from:

$$R_k = \frac{Z_L}{1 - Z_L G_m} \quad (2)$$

Thus for a 6AG7 to work into a 100-ohm load, the cathode resistor would be 330 ohms, assuming G_m of 7000 microohms.

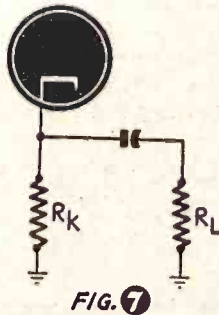

FIG. 7

The rigorous derivation of formula (2) is beyond the scope of this article. The following bibliography is intended for those readers who wish to study the cathode follower further:

- Ultra High Frequency Techniques—Brainerd.
- U.H.F. Radio Engineering—W. L. Emery.
- Electronics—Millman and Seely.
- Applied Electronics—M.I.T. E.E. Staff.

Index to advertisers

Allied Radio Corporation	592
American Cancer Society	604
Amperite Co.	599
Audel & Co.	610
Buck Mfg. Co.	598
Burgess Battery Co.	585
Burstein-Applebee Co.	598
Cannon Co., C. F.	583
Capitol Radio Eng. Institute	588
Cardwell, Allen D., Mfg. Corp.	602
Centralab	546
Concord Radio Corporation	577
Coyne Electrical School	596, 597, 598
DeForest Training, Inc.	545
Echophone Radio Co.	543
Galvin Mfg. Co.	Back Cover
Gateway Publishing Co.	596
General Cement Mfg. Co.	593
General Electric Co.	591
Goldshield Products	606
Hazeltine Corp.	603
Henry Radio	591
Hickok Elec. Inst. Co.	575
Hudson Specialties Co.	605
Insuline Corp. of America	589
International Detrola Corp.	Inside Back Cover
International Resistance Co.	573
Lake Radio Sales Co.	594
Lancaster, Allwine & Rommel	600
Lejay Mfg. Co.	600
Lifetime Sound Equipment Co.	597
Mallory & Co., Inc., P. R.	576
McElroy, T. R.	593
McGraw-Hill Book Co.	607
Meissner Mfg. Co.	571
National Plans Institute	607
National Radio Institute	539
National Schools	547
National Union Radio Corp.	574, 602
Ohmite Mfg. Co.	586
Onan & Sons, D. W.	593
Opportunity Adlets	600
Personnel Help Wanted	602, 603

RADIO SCHOOL DIRECTORY

Page 608

- American Radio Institute
- Candler System
- Capitol Radio Engineering Institute
- Commercial Radio Institute
- Lincoln Engineering School
- Melville Radio Institute
- RCA Institutes
- Tri-State College

RCA Communications	603
Radio Corporation of America	548
Radio Electric Service	589
Radio Kits Co.	593
Radio Service	589
Radio & Technical Division	
Murray Hill Book Co.	594, 595, 597, 598, 599, 600, 601
Radio & Television Supply Co.	596
Radio Wire Television	590
Radionic Equipment Co.	595
Radolek Company	595
Raytheon Mfg. Co.	Inside Front Cover
Scientific Radio Service System	599
Sperry Gyroscope, Inc.	540, 603
Sprague Products Co.	544
Sprayberry Academy of Radio	541
Studio Service Co.	583
Superior Instrument Co.	595
Technifax	606
Triplet Elec. Instrument Co.	609
Turner Company	581
University Laboratories	604
Western Electric Co.	603
Weston Elec. Instrument Co.	583
Wholesale Radio Laboratories	587
X. L. Radio Laboratories	594

BOOK REVIEWS

THE RADIO AMATEUR'S HANDBOOK, by the Staff of the American Radio Relay League. Heavy paper covers, 9½ x 6½ inches, 512 pages, plus 200-page advertising section and index. Price \$1.00.

It is hardly necessary to review the "Hambook," since practically every amateur, experimenter, technician or other person interested in radio automatically obtains his copy without asking what may be in the current year's issue. Even the individual who has never seen the book correctly assumes that a volume of that size ought to be worth his dollar, and is inclined to delay analyzing the contents until he has it in his home. The Handbook—now in its twenty-second edition—has taken the place assigned before it to Ballantine's monumental work, and is now the amateur's Bible, as essential a part of the radioman's equipment as his pliers.

The current edition shows the effect of war on the amateur. As might be expected, little new material on transmitters is in evidence, though the direction the art is expected to take after the war is seen in the emphasis on microwaves, visible both in the second chapter (fundamentals) and the sixteenth (V.H.F. transmitters). Incidentally, this has increased the size of the book, from last year's 480 pages to 512 in the new edition.

The advertising section contains complete catalogs of more than one manufacturer of products interesting to the amateur, and an excellent index is provided, as usual.

INTRODUCTION TO MICROWAVES, by Simon Ramo. Published by McGraw-Hill Book Co. Stiff cloth covers, 5½ x 8½ inches, 138 pages. Price \$1.75.

This well and plainly written little book is a near-triumph in the popular technical field, especially when it is considered that microwaves is not the most promising subject for a clear and readable exposition in non-technical language. More than one recent attempt in this direction has left the reader's skull cavity filled with a vague confusion of TE and TM waves and "modes of oscillation."

Here he will find the answers to such simple questions as "What makes waves go down the inside of a pipe at high frequency but not at low frequency? Do microwaves obey different laws than low-frequency waves? Why can high-frequency

current be drawn from electrodes of an electronic tube when the electron current in the tube does not even flow to these electrodes? May we still speak of impedance at microwave frequencies?"

Surprise is added to the reader's pleasure by the fact that these plain and simple answers come from an engineer—and especially one of the standing of Simon Ramo. He has always felt that engineers as a class have a deep suspicion of any proposition couched in plain English, a suspicion naively expressed recently by one of the fraternity in the review of a popular-technical book: "... a clear but authentic explanation of the electronic art."

The new book's secret is that it starts from the fundamentals like an elementary textbook on the lower frequencies. Action of low-frequency and high-frequency currents in simple circuits is described, and concepts of fields and displacement currents developed so naturally that one wonders if future elementary texts may not start the student with these ideas rather than the more special cases of applied voltages and currents in conductors.

This book is well worth the time of every radioman who wants to get a better idea of microwaves. It is a *must* for all writers of technical literature.

COYNE ELECTRICIANS' HANDBOOK, compiled and prepared by the Technical Staff, Coyne Electrical School, Chicago. Semi-flexible leatherette covers, 7½ x 4½ inches, 348 pages. Price \$2.75.

A complete handbook of essential formulas, charts, code rules, wiring methods, etc., for the practicing electrician. The radioman will be interested in the sections on electric circuits; conductors and wires; resistors and resistance; magnets, coils and induction; capacitors and capacitance; meters and measurements; and industrial electronics.

Other sections, such as those dealing with wiring methods, overload protection, power, transformers, converters and rectifiers, and batteries, do not fall directly in his field but may be useful for occasional reference. There are many chapters, such as those on motors, illumination, and electric heating which are of value solely to the electrician.

The book contains numerous tables and is well illustrated with diagrams.

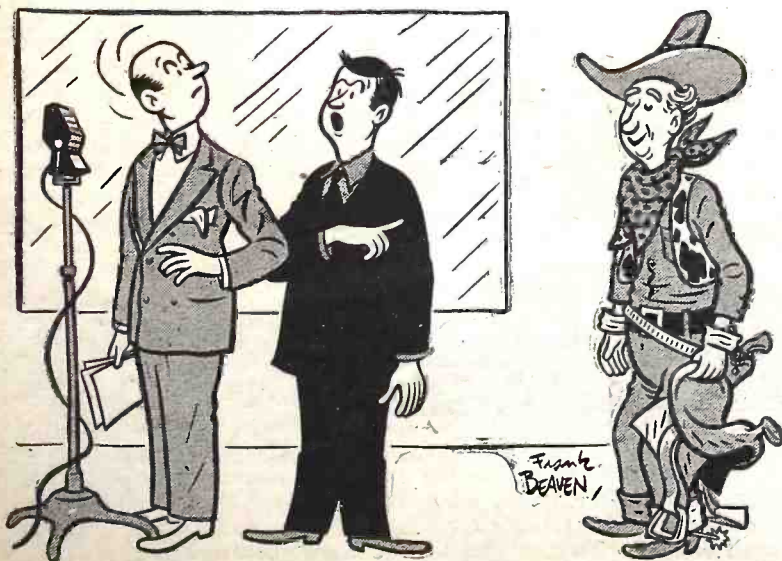

Suggested by: Charles Krebeck, Koch, Mo.

"He wants to ride one of those 'Radio Plugs' that you announcers always talk about."

NOW—A REALLY HIGH-POWERED— Radio Engineering Library

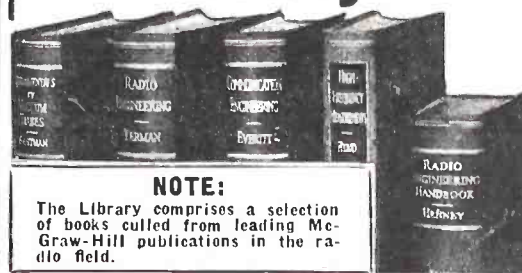

NOTE:

The Library comprises a selection of books culled from leading McGraw-Hill publications in the radio field.

- especially selected by radio specialists of McGraw-Hill publications
- to give most complete, dependable coverage of facts needed by all whose fields are grounded on radio fundamentals
- available at a special price and terms

THESE books cover circuit phenomena, tube theory, networks, measurements, and other subjects—give specialized treatments of all fields of practical design and application. They are books of recognized position in the literature—books you will refer to and be referred to often. If you are a practical designer, researcher or engineer in any field based on radio, you want these books for the help they give in hundreds of problems throughout the whole field of radio engineering.

5 VOLUMES, 3319 PAGES, 2289 ILLUSTRATIONS

1. Eastman's FUNDAMENTALS OF VACUUM TUBES
2. Terman's RADIO ENGINEERING
3. Everitt's COMMUNICATION ENGINEERING
4. Hund's HIGH FREQUENCY MEASUREMENTS
5. Henney's RADIO ENGINEERING HANDBOOK

10 days' examination. Easy terms. Special price under this offer less than books bought separately. Add these standard works to your library now; pay small monthly installments, while you use the books.

10 DAYS' FREE EXAMINATION—SEND COUPON

McGraw-Hill, Book Co., 330 W. 42nd St. New York 18

Send me Radio Engineering Library, 5 vols., for 10 days' examination on approval. In 10 days I will send \$3.00, plus few cents postage, and \$3.00 monthly (till \$24.00 is paid, or return books postpaid. (We pay postage on orders accompanied by remittance or first installment.)

Name

Address

City and State

Company

Position RC-6-45

Be Your Own Boss!

START A GOOD-PAYING BUSINESS!



Stop worrying about a post-war job. Why let yourself be pushed around by economic conditions, as business slows down—when you can run your own so easily? We will show you how!

Get started at once with the aid of "CASH IN," the amazing short-cut guide to success. It contains

300 WAYS TO MAKE MONEY

It shows you how to begin—either in a small way in your own home and branch out big—or how to open a shop at once with profits rolling in immediately. It's chock full, from cover to cover, with tested money-making plans, formulas, business secrets, and sure-fire success schemes.

You can start with as little as a few dollars' capital. All you need to do is pick out the one business that appeals to you most—follow the simple directions—and then go to it!

66 PAGES —

40,000 WORDS IN TEXT

Send for "CASH IN" today. Enclose 25c, that's all!—you won't be asked for another cent—now or later. Sold on a money-back guarantee. **25¢**

NATIONAL PLANS INSTITUTE

P. O. Box 26R, Station N, New York 23, N. Y.

RADIO SCHOOL DIRECTORY

PREPARE NOW FOR POST-WAR RADIO AND ELECTRONICS

MAKE a place for yourself in a new world of radio and electronics—a world in which revolutionary electronic developments will require highly specialized technical knowledge. Take a good course now to fit yourself for a good paying job. The training you need can be supplied by one of the schools advertised in this publication.



RADIO ELECTRONICS

Intensive training in Airline, Merchant Marine, Press Communications, Electronics, Television. Co-educational. FREE booklet.

VETERANS:
Request FREE copy, G.I. bill of rights

"A Radio School managed by radio men."
45 W. 45th St., Dept. RC, New York 19, N.Y.

MELVILLE RADIO INSTITUTE



INSTITUTES



Offer thorough training courses in all technical phases of

Radio and Television

DAYS—EVENINGS WEEKLY RATES

VETERANS: RCA Institutes is approved under G. I. Bill of Rights

For Free Catalog Write Dept. RC-45

RCA INSTITUTES, Inc.

A Radio Corporation of America Service
75 VARICK STREET NEW YORK 13, N. Y.

COMMERCIAL RADIO INSTITUTE

A radio training center for twenty-four years.

RESIDENT COURSES ONLY
Pre-Induction, Broadcast, Service, Aeronautical, Television and Marine telegraphy classes now forming for June 19. Literature upon request. Veteran training.

Home Study Course in Mathematics
Dept. C., 38 West Biddle St., Baltimore 1, Md.

RADIO

RADIO Technician and Radio Communications courses. Register now for new classes starting first MONDAY of each month. Day and Evening Classes.

AMERICAN RADIO INSTITUTE

101 West 63rd St., New York 23, N. Y.
APPROVED UNDER GI BILL OF RIGHTS.

RADIO-TELEVISION

ENGINEERING & SERVICING

Now Training Veterans Under "G.I." Bill Prepare now for profitable career! ENTER AT ANY TIME. Residence school classes in Radio-Electronics Engineering, Broadcast & Television Engineering and Servicing. Write for FREE Booklet

Capitol Radio Engineering Institute
Dept. RC-6, 3224 16th Street, N. W., Washington 10, D. C.

See Big Ad. Page 583

RADIO ENGINEERING!

DEGREE IN 27 MONTHS

EX-SERVICE MEN can complete work here in shortest possible time. Special Prep. Dept.

Also **REFRESHER COURSES.** Courses also in Civil, Electrical, Mechanical, Chemical, Aeronautical Engineering; Business Administration, Accounting, Secretarial Science. Tuition, living costs low. 62nd year. Cosmopolitan student body. Enter Mar., June, Sept., Jan. Catalog.

TRI-STATE COLLEGE 2465 College Ave. ANGOLA, INDIANA

LES Correspondence Courses in

RADIO and ELECTRICAL ENGINEERING

ELECTRICAL ENGINEERING Get good grasp of wide electrical field. Prepare yourself, at Low Cost, for secure future. Modern, simplified, you can understand quickly. Extra fine course in radio, public address, photo-electric work.

RADIO ENGINEERING Trains you to be super-service man, real vacuum tube technician. Servicemen needed badly. Diploma on completion. Tuition \$25, either course. Deferred payment plan. Get copies of school catalogs, student magazines, complete details. **SEND NOW!**

FREE

LINCOLN ENGINEERING SCHOOL Box 931C-76 Lincoln, Nebr.



SHORT CUT



CODE SPEED

Be an Expert

Learn to be a Telegraph or Radio Operator. Thousands of men needed. Intensely interesting work—good pay. Learn at home or wherever you are, quickly, easily, with the famous Candler Code Speed System. Book of particulars Free.

Candler System Co., Dept. 3G, Box 928, Denver 1, Colo.

RADIO-LIGHT

(Continued from page 549)

do not possess the key to unlock the solar energy *directly*. We can do it only through expensive transformation of the sun's heat, such as ancient coal deposits, waterfalls, etc., which we turn into electrical energy. But this is most wasteful on account of heat effects and undesirable losses while the energy is piped over long distances.

Radio waves and light waves are one and the same thing. The sooner we can fully explore the unknown regions in the electromagnetic spectrum, the sooner man will approach the utopia of his dreams.

Note: According to data supplied by the General Electric Co., efficiency of tungsten-filament lamps may run from 6 to 12 percent—that of a 40-watt fluorescent is approximately 45 percent.

TABLE OF VIBRATIONS	
WHOSE EFFECTS ARE RECOGNIZED AND STUDIED	
	Number of Vibrations per Second
1st Octave.....	2
2nd ".....	4
3rd ".....	8
4th ".....	16
5th ".....	32
6th ".....	64
7th ".....	128
8th ".....	256
9th ".....	512
10th ".....	1,024
15th ".....	32,768
20th ".....	1,047,576
25th ".....	33,554,432
30th ".....	1,073,741,824
35th ".....	34,359,738,368
40th ".....	1,099,511,627,776
45th ".....	35,184,372,088,832
46th ".....	70,368,744,177,664
47th ".....	140,737,468,355,328
48th ".....	281,474,976,710,656
49th ".....	562,949,953,421,312
50th ".....	1,125,899,906,842,624
51st ".....	2,251,799,813,685,248
57th ".....	144,115,118,075,855,872
58th ".....	288,230,376,151,711,744
59th ".....	576,460,752,303,423,488
60th ".....	1,152,921,504,606,846,976
61st ".....	2,305,843,009,213,693,952
62nd ".....	4,611,686,618,427,389,904

CYLINDERS FOR BETTER SOUND

(Continued from page 561)

cellent balance to provide a flat frequency curve. Auditoriums using these new surfaces have been constructed with an essentially flat reverberation period from 40 to 17,000 cycles.

It is also common to make use of the advantages of optimum room dimensions. Fig. 4 shows the chart made use of by acoustic designers, to eliminate the piling up of room resonances. Optimum measurements are shown for four different types of rooms of given volume.

Polycylindrical plywood panels were first used by RCA in connection with mo-

tion picture recording. The practise proved so successful that it was followed by various radio station studios throughout the country. Among notable installations are those of the Philadelphia Academy of Music; Walt Disney recording studios; Stations WFAA-KGKO, Dallas; Naval Air Station, Acacostia.

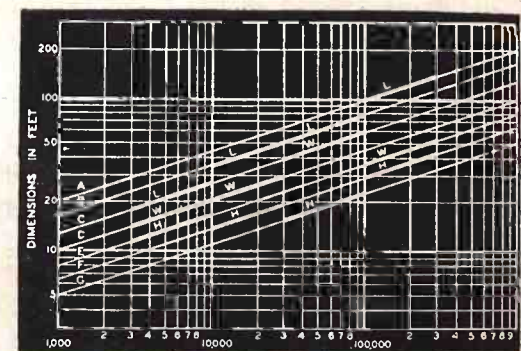
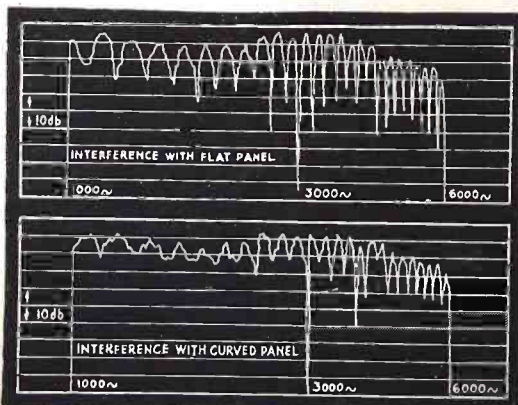

Fig. 3—Diffusion of wave-front from flat and curved panels. Fig. 4—Preferred dimension ratios: Average rooms—H:W:L=1:1.6:2.5=F.D.B; long rooms—H:W:L=1:1.25:3.2=F; E:A; low-ceilinged rooms—H:W:L=1:2.5:3.2=G:C:B; small rooms H:W:L 1:1.25:1.6 E:D.C. (Letters A-G refer to curves above.)

What future wonders of science may not lie in the unknown regions shown, or beyond the upper limits of the present vibration scale? Figures are in cycles. For kilocycles, drop last 3 figures; for megacycles, the last 6.

CRIMINAL HEARING AIDS?

Use of certain types of "hearing aids" would be made a felony punishable by twenty years imprisonment or a \$50,000 fine, under legislation proposed by Senator William Langer of North Dakota.

Mr. Langer had heard reports that a revolutionary listening device had been invented with which it was possible to "listen in on a private conversation held as far as three-and-a-half miles away." Radiomen, apparently, have not heard of the device, according to Washington reports.

The bill would declare it "unlawful for any person to own, possess, or use, within the United States, any listening device by means of which the human voice may be heard at distances beyond the normal range thereof without the use of transmitting device or apparatus, unless registered with and licensed by the Attorney General with such rules as he shall prescribe."

Some operators of loud-speakers certainly come close to crime, but this is the first time hearing-aid users have been complained of!

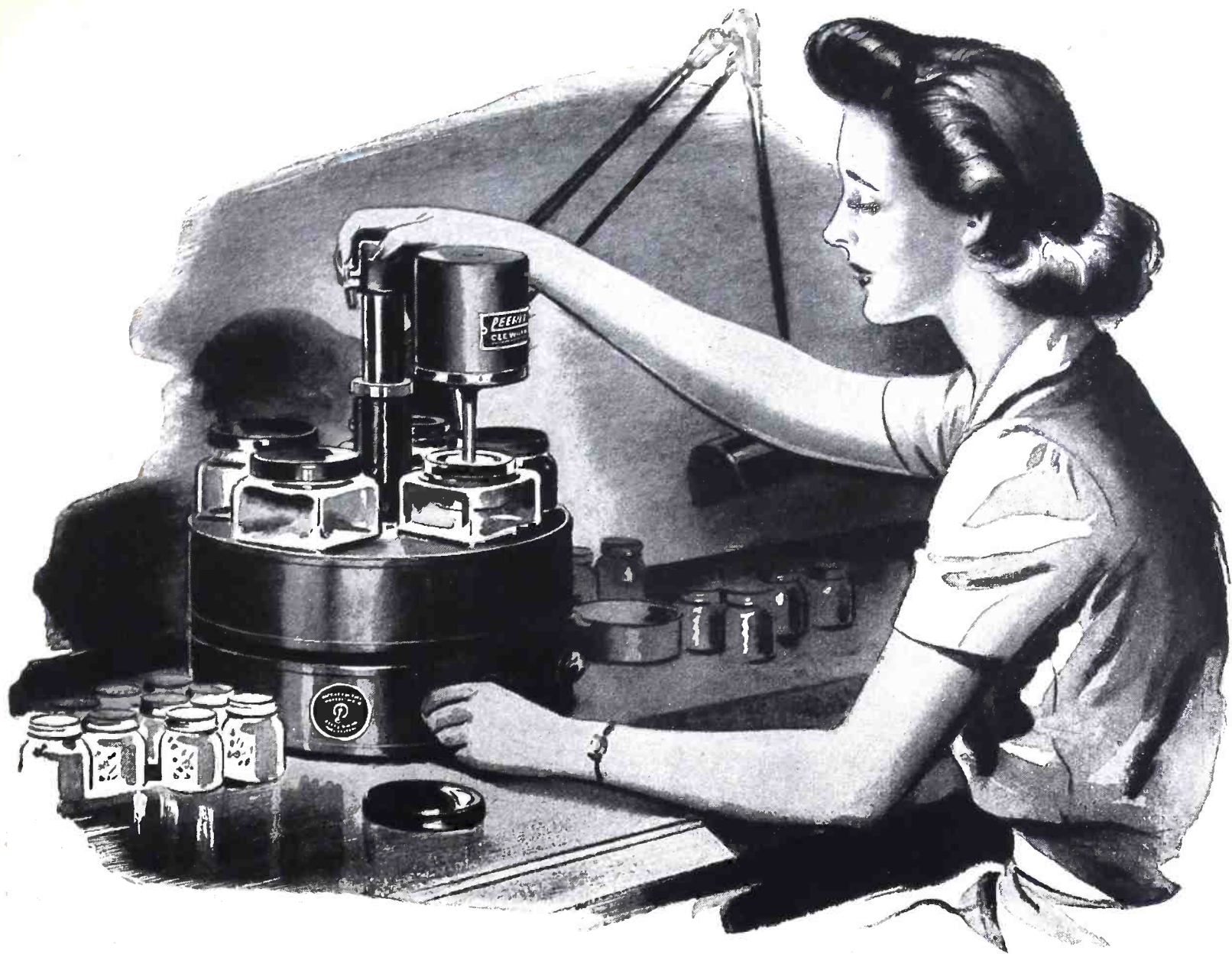

EVERYDAY IS WASHDAY AT Triplet

• The special equipment and solutions with which jewels are washed are minor parts of the Triplet method of manufacturing fine electrical measuring instruments but they are significant. They typify the dozens of out-of-sight Extra Precautions that assure your permanent satisfaction with Triplet Instruments. These Extra Care provisions are routine in Triplet plants but through them Triplet maintains in mass production the hand-made quality of fine instruments.

Extra Care in our work puts Extra Value in your Triplet Instrument.



Triplet



ELECTRICAL INSTRUMENT CO. BLUFFTON, OHIO

**NEW EDITION
NOW READY**

Audels RADIOMANS GUIDE

Includes **TELEVISION
AND ELECTRONICS**

LARGER - MORE COMPLETE - 914 PAGES - 633 ILLUS - WIRING DIAGRAMS - PHOTOS

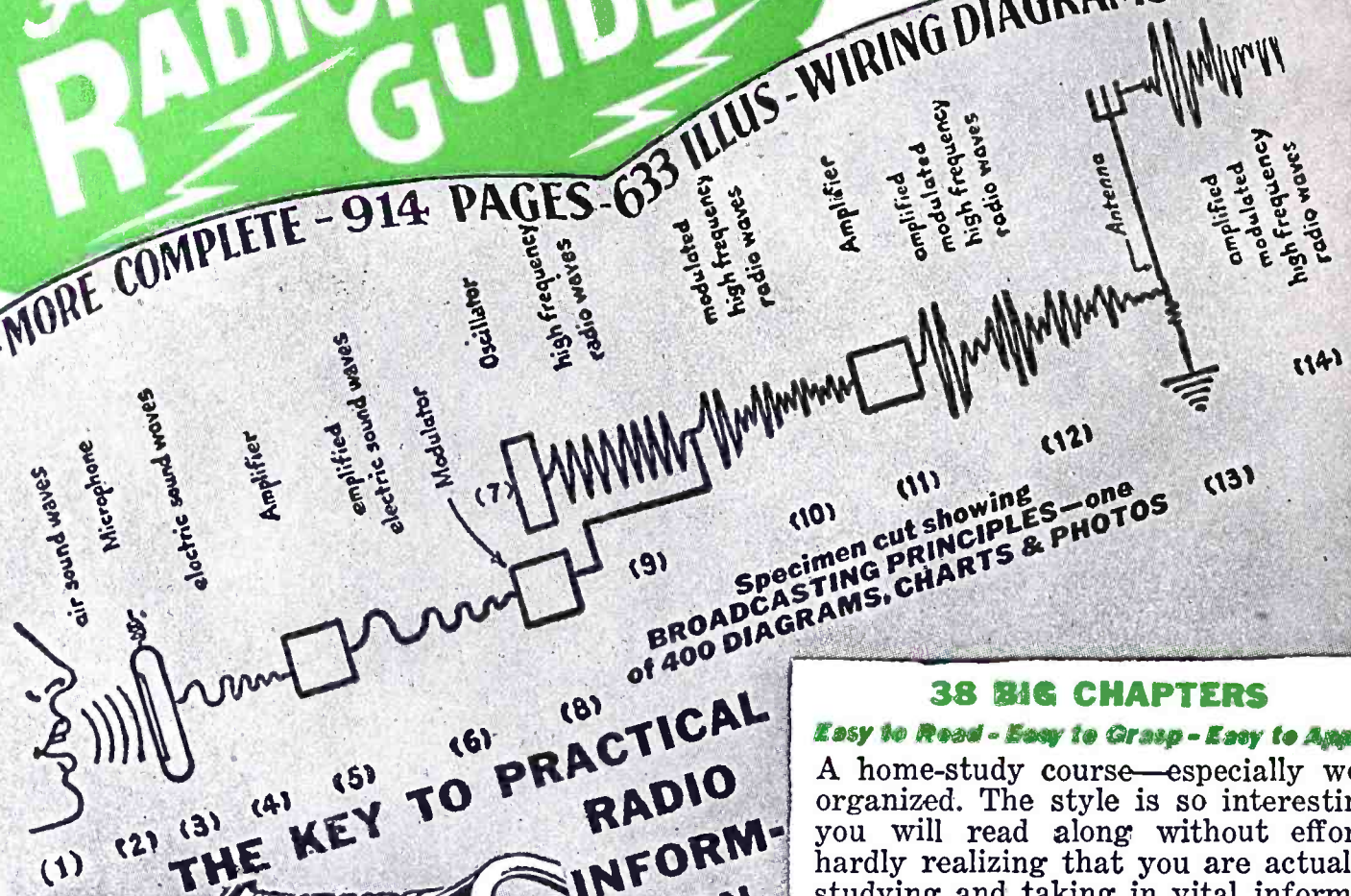

**THE KEY TO PRACTICAL
RADIO
INFORMATION**

It gives you in usable form pointers on radio, including frequency modulation, television, etc. Also valuable inside information for Aviators, Marines, Commercial Operators and Technicians, Servicemen and Students.



**Q AND A
UNIQUE
QUESTION
and
ANSWER
METHOD**

Highly Endorsed

38 BIG CHAPTERS
Easy to Read - Easy to Grasp - Easy to Apply
A home-study course—especially well organized. The style is so interesting you will read along without effort, hardly realizing that you are actually studying and taking in vital information. Audels Radiomans Guide gives you just the right amount of mathematics required to cope with radio problems successfully. You can solve, with the aid of this extraordinary book, practically every radio problem that comes up. At your finger tips is a complete index for instant use.



1001 RADIO FACTS AND FIGURES
A Complete Library In One Book

AUDELS RADIOMANS GUIDE gives authentic Principles and Practices in Construction, Operation, Service and Repairs. Covers clearly and concisely radio fundamentals—Ohm's Law—Physics of sound as related to radio science—Measuring instruments—Power supply—Resistors—Inductors—Condensers—Transformers and examples—Broadcasting stations—Radio Telephony—Receivers—Diagrams—Construction—Control Systems—Loudspeakers—Antennas—AutoRadio—Phonograph Pick-ups—Public Address Systems—Aircraft and Marine Radio—Radio Compass—Beacons—Automatic Radio Alarms—Short Wave—Coil Calculations—Testing—Cathode Ray Oscillographs—Static Eliminations—Trouble Pointers—Underwriter's standards—Units and tables. **REVIEW QUESTIONS—READY Reference Index.**

\$4
COMPLETE
\$1
PAY ONLY 1 MO.

7 DAYS' FREE TRIAL

THEO. AUDEL & CO., Publishers
49 West 23rd Street, New York 10, N. Y.

Mail AUDELS NEW RADIOMANS GUIDE for free examination. If O. K. I will send you \$1 in 7 days; then remit \$1 monthly until \$4 is paid. Otherwise I will return it.

Name
Address
Occupation
Reference

**MAIL THIS
COUPON
TODAY**

✿ THE DETROLA CONFERENCE ROUND TABLE

PLANNING THE PATTERN OF ELECTRONICS

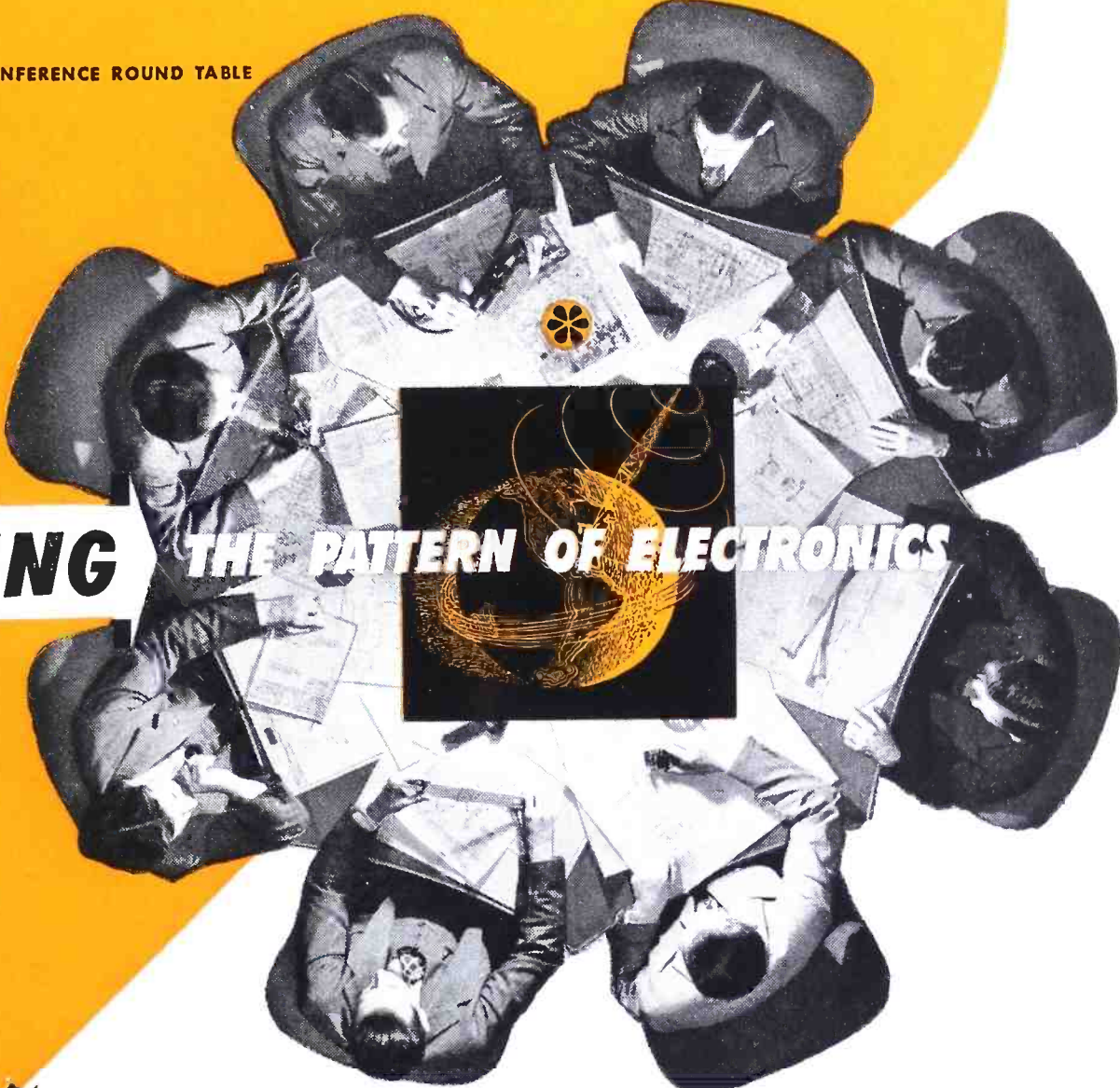

➤ Creative thinking at Detrola probes the frontiers of electronics—devising the pattern for greater performance—wider range of Detrola-built Television Receivers . . . Radio Receivers . . . and other electronic instruments. And none will excel them in beauty or value.

A REAL AMERICAN KEEPS HIS BONDS

KEEP AN  ON 

Detrola Radio

DIVISION OF INTERNATIONAL DETROLA CORPORATION

DETROIT 9, MICHIGAN

California's mountains & valleys were **TOUGH**

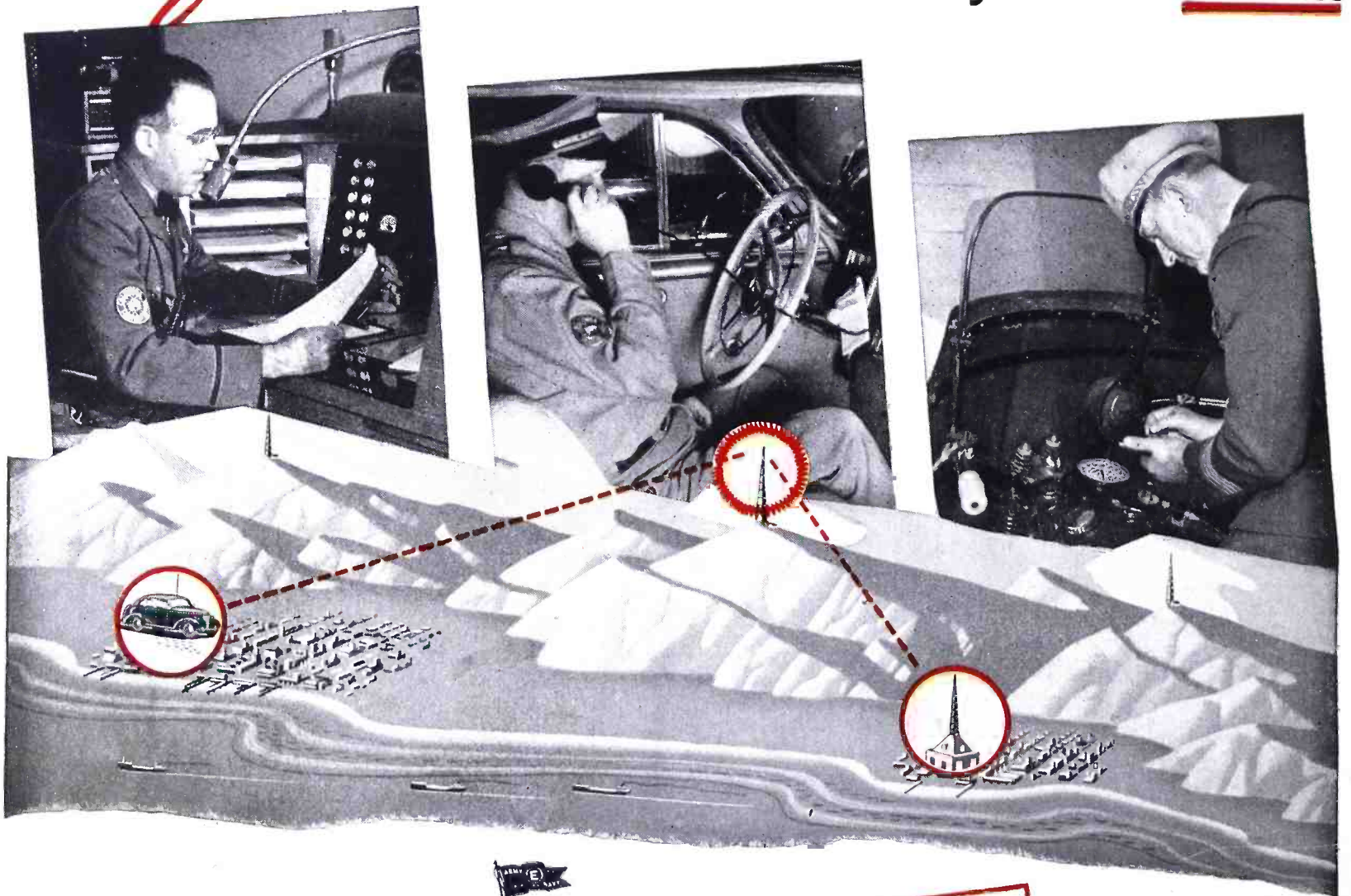

... but not for **Motorola F-M Radio**

California's 158,693 square miles and 117,760 miles of roadways—with mountains like Mt. Whitney, 14,498 feet above sea level, and valleys like Death Valley, 300 feet below sea level—presented problems in state-wide coverage by radiotelephone that were super-tough.

Nevertheless, by the use of Motorola Radiotelephone F-M units and Motorola Radio automatic relay stations, the California State Highway Patrol has excellent radiotele-

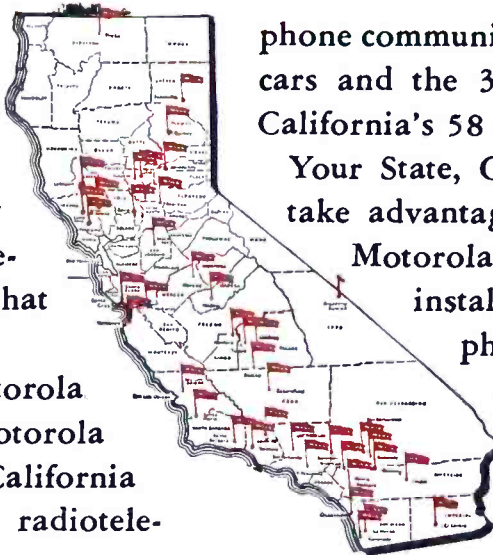

phone communications with the 485 two-way patrol cars and the 377 one-way motorcycles patrolling California's 58 counties.

Your State, County, City or Community should take advantage of the skill and experience that Motorola Radio engineers have displayed in installing F-M 2- and 3-way Radiotelephone systems in 33 States and over 1,000 communities throughout the United States, the Canal Zone and Hawaiian Islands.

For Full Details, Write Today.

GALVIN MFG. CORPORATION • CHICAGO 51

F-M & A-M HOME RADIO • AUTO RADIO • AUTOMATIC PHONOGRAPHS • TELEVISION • F-M POLICE RADIO • RADAR • MILITARY RADIO