



RADIO'S LIVEST MAGAZINE

Special
RADIO-SERVICE
Number

Radio-Craft

HUGO GERNSBACK Editor

July
25 Cents
in United States
and Canada



THE "SUPER" SERVICE MAN
See Page 10

Beginner's 1-Tube "F.C.T." Set—How to Make an Oscilloscope—New Tubes
Building a "Battery Portable 4"—Making the RADIO-CRAFT Set Analyzer

"I WILL SELL YOU THIS SUPREME ANALYZER

FOR ONLY **4^{.50}** DOWN AND
\$3^{.94} PER MONTH!



*Your Parts
 Jobber*

Every parts jobber in the country can now let you have any instrument in the famous SUPREME line — tube testers, analyzers, signal generators — on SUPREME'S own sensationally low S. I. C. Easy Payment Plan! There is no red tape. Ask your jobber or write the factory!



SUPREME 385
 AUTOMATIC **\$8.50 DOWN**
\$7.72 MONTHLY



SUPREME 89
 DELUXE 7-IN-ONE
 TUBE TESTER **\$5.00 DOWN**
\$4.55 MONTHLY

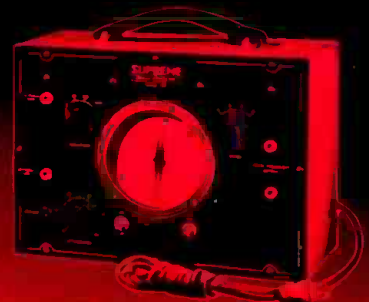

SUPREME 189
 SIGNAL
 GENERATOR **\$4.00 DOWN**
\$3.66 MONTHLY

SUPREME INSTRUMENTS CORP. GREENWOOD MISS., U. S. A.

EXPORT DEPT., ASSOCIATED EXPORTERS CO., 145 W. 45th STREET, NEW YORK, N. Y., CABLE ADDRESS: LOPREM. N. Y.



STUDENTS BUSY AT WORK IN LARGE COYNE SHOPS

Learn RADIO

SEND TODAY FOR DETAILS OF MY Pay-Tuition-after-Graduation Plan!

Train for Radio in 90 days, right here in the big Coyne Shops — not by correspondence — but on real Radio, Sound and Television equipment. Mail the coupon below. If you are short of money I'll send you all details of my finance plan and consider your application. If accepted, you won't have to start paying tuition back until five months from the date you start school, and then you'll have over a year to complete your payments.

Tremendous Developments Ahead in Radio and Television!

HERE is YOUR opportunity to cash in. Every day brings news of new developments in every branch of Radio and Television, with more opportunities, more jobs, and a greater future for the trained man than ever before. I consider the fellow who is ambitious enough to want to get ahead by taking my Training, worthy of my help. MAIL THE COUPON BELOW and you can prove to me that you are willing to spend just 12 weeks in the Coyne Training Shops learning Radio. Then, I'll tell you about my finance plan which has enabled many to get complete Training and pay tuition back later.

Learn By Doing In 90 Days

I don't care whether you are 16 or 45. It makes no difference to me if you don't know an oscillator from a spark coil. You don't need any previous experience or advanced education to master my Shop Training. Don't let lack of money hold you back from getting all details of my amazing plan.

MANY EARN While LEARNING

If you need part-time work to help pay your living expenses and will tell us your problems we may be able to help you as we have thousands of others. Then, in 12 brief weeks, in the great Training shops of Coyne, you will learn on a wide variety of modern, up-to-date A. C. Super-heterodyne sets, oscillators, analyzers and test instruments. Prepare for Amateur Broadcast, or Telegraph Radio Operator's License and to know all code and Dept. of Commerce rules for a government License Examination.

TRAINING

By Actual Work

No dull books . . . you get individual training . . . real actual work with only the theory you will need. Building real radio sets.



Auto Radio Instruction Prepare For Jobs Like These

Here are a few of hundreds of positions in the Radio field. My free employment bureau gives you life-time employment service.

- AIRCRAFT RADIO OPERATOR
- SHIP RADIO OPERATOR
- RADIO SERVICING
- PUBLIC ADDRESS SYSTEMS
- BROADCAST STATION OPERATOR
- TALKING PICTURE STUDIOS
- TELEVISION LABORATORY MAN

doing radio wiring and testing, trouble-shooting, repairing and servicing. That's a glimpse of how we help to make you a Radio expert, and fit you to qualify for jobs leading to the biggest pay.

Jobs - Pay - Future

"I got my present job two days after graduation, at shorter hours, and wages increased 60% over my old job," reports Arne Wiklem of Minnesota. "I have my own shop, own a real car and make fine money in the radio business," writes E. Allen of Montana, "All this is possible because I came to Coyne." And I could go on quoting from hundreds of letters of successful Coyne Trained men. What they have done, you should be able to do.

Electric Refrigeration Air Conditioning

Right now I'm including my new Electric Refrigeration and Air Conditioning course at no extra cost.

GET THE FACTS

Coyne is your one great chance to get into Radio. This school is 36 years old—Coyne training is tested—proven beyond all doubt—endorsed by many large concerns. You can find out everything absolutely free. Simply mail the coupon and let me send you the big, free Coyne Book with photographs . . . facts . . . jobs . . . salaries . . . opportunities. Tells you how many earn expenses while training and how we assist our graduates in the field. This does not obligate you. So act at once.

MAIL Coupon Today for FREE BOOK!



H. C. Lewis



Home of Coyne Shops

This is our fireproof modern Building wherein is installed thousands of dollars' worth of Radio equipment of all kinds. Every comfort and convenience has been arranged to make you happy and contented during your Training.

COYNE H. C. LEWIS, President **Founded 1899**
RADIO & ELECTRICAL SCHOOL
 500 South Paulina Street Dept. B6-8H Chicago, Ill.

H. C. LEWIS, President
Coyne Radio & Electrical School
 500 S. Paulina St. Dept. B6-8H, Chicago

Dear Mr. Lewis: Without obligation send me your big free catalog and all details; also tell me all about your "Pay-Tuition-After-Graduation" Plan.

Name.....Age.....
 Address.....
 City.....State.....

Please Say That You Saw It in RADIO-CRAFT



HUGO GERNSBACK, Editor-in-Chief
 C. W. PALMER Associate Editor
 H. G. McENTEE Associate Editor
 R. D. WASHBURNE, Technical Editor

CONTENTS - JULY 1936, ISSUE

Volume VIII

Number I

Editorial: The Future of Radio ServicingHugo Gernsback	5	ORSMA Forum	23
The Radio Month in Review.....	6	Improving Old Volume Control Circuits..L. A. DeRosa	24
Sending "Pictures" by Telephone.....Andrew Halbran	8	The Design of Modern Test Equipment—Part IVSamuel C. Milbourne	24
Radio Pictorial.....	9	Operating Notes	25
The "Super" Service Man.....	10	Eliminating Whistles in Superhets.....H. G. McEntee	26
The Philosophy of Servicing.....J. Kaufman	10	Making a "Magic Eye" V-T. Voltmeter...E. H. Rietzke	27
Sales and Service—On Wheels!.....W. L. Fuller, Jr.	11	A Variable-Inductance Wobbler.....E. L. Garrett	27
The New Beam Power Tube.....C. W. Palmer	12	The Latest Radio Equipment.....	28
How to Make an Oscilloscope—Part I, The Power Supply	13	How the 2-Ribbon Mike Prevents FeedbackSamuel Ruttenberg	30
New Equipment for the Service Man.....	14	What Does It Cost to Operate?.....Fred E. Kunkel	30
Introducing — The "Magic Eye" in a Condenser Analyzer	15	Add "Magic Eye" Tuning to Old Sets.....F. M. Paret	31
"Alnico"-Magnet Reproducers.....R. R. De Puy	15	Design Data on A.V.C. Circuits—Part II.....	31
"Battery Portable 4"—An Easily-Built SetFranklin Sayres	16	RADIO-SERVICE DATA SHEETS:	
A 2-Tube "F.C.T." Set for the Beginner...J. H. Green	17	No. 169—International Kadette Model 400 4-Tube Battery Superhet.;	
How to Make the RADIO-CRAFT Set Analyzer— Part I	18	RCA Victor Model 5M 5-Tube Auto Superhet.....	32
Soldering Hints and Ideas.....	20	No. 170—RCA Victor Portable Table Electrola Model R-95;	
Are Metal Tubes "Hotter"?J. E. Anderson and J. Goldstein	21	Atwater Kent Model 305 Z 5-Tube 32 V. D.C. Super.	34
The "Anti-Howl" Audio Amplifier—Part IIA. C. Shaney	22	No. 171—General Electric Model N-60 6-Tube Auto Superhet.;	
		Kadette Jewel 3-Tube Ultra-Midget Receivers.....	35
		Making a Precision Aligning Unit—Part IICanio Maggio	33
		Useful Radio Circuits.....	36
		Technicians' Data Service.....	38

ANNUAL TELEVISION NUMBER

With experimental work actually reaching the stage of field tests, it is now only a matter of time before we will have regular television service in the large cities of the U. S. and dependable commercial receivers for picking up these transmissions. It is, therefore, extremely important for every radio man to keep abreast of the developments that have taken

place in the past few months and those which are taking place at this moment. The man who is well informed of developments is the one who is going to be in a position to profit by the coming of television. The annual Television Number of RADIO-CRAFT will contain an accurate, up-to-the-minute account of the important developments—do not miss it!

HUGO GERNSBACK, President I. S. MANHEIMER, Secretary
 Published by Continental Publications, Inc. Publication office: 29 Worthington Street, Springfield, Mass. Editorial and Advertising Office: 99 Hudson Street, New York City. Chicago Advertising Office: L. F. McClure, 919 North Michigan Avenue, Chicago, Ill. Western Advertising Office: Loyd B. Chappell, 511 So. Alexandria St., Los Angeles, Calif.

European Agents:

London—Gorrings's American News Agency, 9A Green St., Leicester Square, London, W. C. 2.
 Paris—Messageries Dawson, 4 Rue Faubourg, Poissonnière, Paris, France.
 Australian Agent: McGill's Agency, 179 Elizabeth St., Melbourne.

RADIO-CRAFT is published monthly, on the first of the month preceding that of date; subscription price is \$2.50 per year in U. S. and Canada. (In foreign countries, \$3.00 a year to cover additional postage.) Entered at the post office at Springfield as second-class matter under the act of March 3, 1879.

Text and illustrations of this magazine are copyright and must not be reproduced without permission of the copyright owners. We are also agents for EVERYDAY SCIENCE AND MECHANICS. Subscription to this magazine may be taken in combination with RADIO-CRAFT at reduced Club rates. Write for information.

Copyright 1936. Continental Publications, Inc.

How a "Tip" got Tom a Good Job

Panel 1: GEE, THERE'S DJC IN BERLIN. THAT'S THE TENTH FOREIGN STATION TONIGHT. RADIO IS SURELY FUN.

Panel 2: HELLO, TOM, HOW'S EVERYTHING? OH, NOT SO GOOD BILL, BUT I'M STILL HAVING FUN PLAYING WITH RADIO. HADDJCLAST NIGHT ON A LITTLE SET I BUILT. IS RADIO STILL YOUR HOBBY TOO?

Panel 3: NO, TOM. I'VE BEEN TOO BUSY MAKING GOOD MONEY OUT OF RADIO TO SPEND TIME "PLAYING" WITH IT. GOSH, BILL, YOU'RE SURE LUCKY. I NOTICED YOUR SWELL CLOTHES AND SHAPPY CAR. I THOUGHT YOU HAD INHERITED A MILLION. TELL ME ABOUT IT.

Panel 4: I AM LUCKY, TOM, BUT YOU HAD THE SAME CHANCE. REMEMBER ABOUT A YEAR AGO I SHOWED YOU A BOOK FROM NATIONAL RADIO INSTITUTE THAT TOLD ABOUT THE OPPORTUNITIES AND BIG FUTURE IN RADIO, AND HOW OTHERS HAD SUCCEEDED THROUGH THEIR HOME TRAINING? REMEMBER, I TRIED TO GET YOU TO ENROLL FOR THEIR COURSE WHEN I DID.

Panel 5: WELL, IT WAS THE SMARTEST MOVE I EVER MADE. I'M DOING SWELL. MARY AND I ARE TO BE MARRIED NEXT MONTH. TOM, WHY DON'T YOU SNAP OUT OF IT? DON'T STAY IN THAT DREARY LOW PAY JOB ALL YOUR LIFE. RADIO IS MORE THAN A PLAYTHING. IT'S A BIG BUSINESS. IT'S YOUR OPPORTUNITY. TAKE MY TIP. IT ISN'T TOO LATE. RADIO IS STILL YOUNG AND GROWING.

Panel 6: IF BILL SUCCEEDED, I CAN TOO! THEN I CAN MAKE REAL MONEY SERVICING RADIO SETS OR GET A JOB IN A BROADCASTING STATION OR INSTALL AND SERVICE LOUD SPEAKER SYSTEMS OR MAKE GOOD MONEY IN ANY ONE OF THE MANY OTHER NEW AND GROWING BRANCHES OF RADIO. THERE'S NO END OF GOOD JOBS FOR A TRAINED RADIO MAN! YES, SIR, I'M GOING TO SEND FOR THAT FREE BOOK AND GET THE DOPE RIGHT NOW!

Panel 7: YOU CERTAINLY KNOW RADIO. MINE NEVER SOUNDED BETTER. N. R. I. TRAINING CERTAINLY PAYS. I JUST STARTED A FEW MONTHS AGO AND I'M MAKING GOOD MONEY ALREADY. THIS SPARE TIME WORK IS SWELL FUN, AND SOON I'LL BE ALL SET FOR A GOOD FULL TIME JOB. THANKS!

OH, TOM IT'S WONDERFUL—TO THINK HOW FAST YOU'VE GONE AHEAD SINCE YOU WENT INTO RADIO. WE NEVER COULD HAVE GOTTEN MARRIED ON WHAT YOU WERE GETTING BEFORE.

OUR WORRIES ARE OVER. I'M MAKING GOOD MONEY NOW, AND THERE'S A BIG FUTURE AHEAD FOR US IN THIS LIVE WIRE RADIO FIELD.

..... I will help you start a spare time or full time **Radio service business Without Capital**



Many Radio Experts Make \$30, \$50, \$75 a Week

The world-wide use of Radio receivers has made hundreds of opportunities for good spare time or full time Radio businesses. Many of the twenty million Radio sets are only 25% to 40% efficient. I will show you how to cash in on this condition. I will train you to install and service all types of receiving sets in spare time. I'll show you how to make enough money while learning Radio to start your own service business. Clip the coupon. Get my free book, "Rich Rewards in Radio." Read how hundreds of N. R. I. men have made good money in spare time or full time businesses.

Many Make \$5, \$10, \$15, a Week Extra in Spare Time While Learning

The day you enroll I start sending you Extra Money Job Sheets which quickly show you how to do Radio repair jobs common in most every neighborhood. I give you plans and ideas that have made good spare time money for hundreds of fellows. My Course is famous as "the Course that pays for itself."

Get Ready Now for a Business of Your Own and for Jobs Like These

In just about 15 years, Radio's growth has created over 300,000 jobs. Thousands of opportunities will be opened by new Radio developments. Broadcasting stations use engineers, operators, station managers and pay up to \$6,000 a year. Manufacturing employ testers, inspectors, firemen, engineers, servicemen, buyers, for jobs paying up to \$7,500 a year. Dealers and jobbers employ servicemen, salesmen, buyers, managers, and pay up to \$75 a week. My Free Book tells about the e and other opportunities.

Television, Short Wave, Loud Speaker Systems Included

There is opportunity for you in Radio. Its future is certain. Television, short wave, loud speaker systems, ship Radio, police Radio, automobile Radio, aviation Radio—in every branch, developments and improvements are taking place. Here is a real future for thousands of men who really know Radio—men with N. R. I. Training. Get the training that fits you for good pay opportunities and success in this growing industry.

Find Out What Radio Offers You

I am so sure N. R. I. can train you satisfactorily that I agree in writing to refund every penny of your tuition if you are not satisfied with my Lesson and Instruction Service upon completion. Get my 64-page book of facts. It's free to any ambitious fellow over 16 years of age. It tells you about Radio's opportunities; about my Course; what others are doing and earning. Find out what Radio offers you. No obligation! ACT NOW! Mail coupon in a stamped envelope, or paste it on a 1c postcard.

**J. E. SMITH, President
Nat'l Radio Institute, Dept. 6GX
Washington, D. C.**

HERE'S PROOF THAT N.R.I. MEN MAKE GOOD MONEY

BUSINESS PAYS \$300 A MONTH

"I now have my own Radio business which shows three hundred dollars a month profit—thanks again to N. R. I."—FRANK REESE, 222 S. 69th St., Philadelphia, Penna.

\$40 to \$100 A MONTH SPARE TIME

"I am servicing broadcast, auto Radios and electrical appliances in spare time. I have run from \$40 as high as \$100 a month. My Radio work equals and often exceeds my regular salary."—JOHN J. REID, 118 E. 536 Dayton Ave., St. Paul, Minnesota.

GET MY FREE LESSON on Radio Servicing Tips

I'll prove that my training is practical, money-making information, that it is easy to understand—that it is just what you need to master Radio. My sample lesson text, "Radio Receiver Troubles—their Cause and Remedy," covers a long list of Radio receiver troubles in A.C., D.C., battery, universal auto, T. R. F., super-heterodyne, all-wave, and other types of sets. And a cross reference system gives you the probable cause and a quick way to locate and remedy these set troubles. A special section is devoted to receiver check-up, alignment, balancing, neutralizing and testing. Get this lesson free. No obligation. Just mail coupon.

MAIL THIS for FREE 64 page book

I want to take advantage of your offer. Without obligating me send me your Free Sample Lesson and your book. (Please print plainly.)

NAME..... ADDRESS..... CITY..... STATE..... TAX-I

J. E. SMITH, President
National Radio Institute, Dept. 6GX
Washington, D. C.

Please Say That You Saw It in RADIO-CRAFT

Be Prepared to Meet All Radio Servicing Emergencies WITH GERNSBACK OFFICIAL RADIO SERVICE MANUALS



Just as we say—"Be prepared to meet all radio servicing emergencies with the Gernsback Official Radio Service Manuals." You never know when a service job requires that "extra" special attention. It might mean the difference between doing the job or losing it. You're safe if you have on hand the GERNSBACK MANUALS—either for regular service work or for servicing auto-radios. Get your copy today! No other radio book is comparable to the new 1935 OFFICIAL RADIO SERVICE MANUAL. In contents, in style of printing, in grade of paper, in illustrations, there has never been published such a comprehensive volume. This Manual contains over a thousand pages—yet it is only 1¼ inches thick because it is printed on a special Bible stock which is an exceptionally good stock, yet one of the thinnest and most durable papers. This 1935 Manual is the most authentic and elaborate service guide ever used in the radio industry.

Contents of the 1935 Manual

Over 1,000 pages full of diagrams and essential information of manufactured receivers—only data of real use in servicing is included. This new Manual is really portable since it is extremely thin and light as well. ● Volume V, continues where the preceding manual left off. ● Many circuits of old sets are included. ● Service Men know every set has certain weak points which are really the cause of trouble. Wherever the information could be obtained, these weaknesses with their cures are printed right with the circuits. This is an entirely new and valuable addition to the Manual. ● All the latest receivers are included—all-wave sets, short-wave sets, auto-radio sets, midget and cigar-box sets, etc., as well as P.A. Amplifiers and equipment, and commercial serv-

icing instruments. ● The cumulative index is even more complete than before; including cross-references to sets sold under different names and type numbers. ● Volume V includes resistance data; socket layouts; I.F. data; and voltage data. ● Tube data on latest tubes. ● Free question and answer service—as included in our last three manuals.

OVER 1000 PAGES
Over 3,000 Illustrations
Size 9" x 12"—only 1¼" thick
Flexible, looseleaf leatherette cover

SET SERVICING
Service information found in the Manuals covers all types of radio receivers. The material is extremely valuable to Dealers and Service Men. On many diagrams appear voltage readings of tubes, socket connections, transformer data, alignment details, and other service notes.

PUBLIC ADDRESS
The pages on P.A. Installation will be helpful to Service Men and P.A. specialists. Such prominent features as class A and B amplifiers—single and dual channel systems—attenuators, and mixers—super-power stages—pre-amplifiers and other commercial devices for P.A. work are included.

ALL-WAVE RECEIVERS
Information relative to short-wave receivers have found their way into the Manuals. For these standard manufactured sets, wherever possible, complete aligning details for all wave bands are included in addition to the service material listed for other sets.

AUTO-RADIO RECEIVERS
All available service information on new auto-radio sets has been included. From this data alone Service Men could derive sufficient knowledge to venture in a specialty field—that of servicing only auto-radios.

\$7.00 LIST

Which of These GERNSBACK RADIO SERVICE MANUALS

Do You Need to Complete Your Files

1934 Official Radio Service Manual
Over 400 Pages, 9x12 Inches
Over 2,000 Illustrations
Flexible, Looseleaf, Leatherette Cover
List Price \$3.50

1933 Official Radio Service Manual
Over 700 Pages, 9x12 Inches
Over 2,000 Illustrations
Flexible, Looseleaf, Leatherette Cover
List Price \$5.00

1932 Official Radio Service Manual
Over 1,000 Pages, 9x12 Inches
Over 2,000 Illustrations
Flexible, Looseleaf, Leatherette Cover
List Price \$5.00

1931 Official Radio Service Manual
650 Pages (Including Supplements)
9x12 Inches
Over 1,500 Illustrations
Flexible, Looseleaf, Leatherette Cover
List Price \$4.50 (Including Supplements)

1933 Official Auto-Radio Service Manual (Volume I)
Over 200 Pages, 9x12 Inches
Over 500 Illustrations
Flexible, Looseleaf, Leatherette Cover
List Price \$2.50

—for the real auto-radio servicing "dope," you can't find a better book!

The 1935 Official Auto-Radio Service Manual

Every radio man connected in any way with the booming auto-radio business needs a copy of the new OFFICIAL AUTO RADIO MANUAL. It contains only auto-radio service "dope."

HERE ARE HIGHLIGHTS OF THE 1935 AUTO-RADIO SERVICE MANUAL

240 pages crowded with diagrams, service material and other essential data required for proper servicing of new auto-radio receivers, included are diagrams of sets which appeared during 1934, and which were not included in the supplement to the first edition. Complete schematic diagrams, chassis layouts, voltage tabulations and servicing instructions are included for practically all sets. "Under-side" tube symbols are also included to facilitate the job of servicing the sets. Instructions are included with many sets telling how to suppress stubborn cases of ignition interference. This includes the newest "suppressorless" sets—and what to do when interference is encountered with this type of set. Details on how to make installations in "turret-top" cars are included. The different methods used by car makers and set manufacturers are listed with the individual circuits and service information. The index contains the listing of sets which were published in the first edition, as well as the sets which appear in the new volume. This information helps the Service Man to locate the circuit and details for any receiver that has been made. The book is bound in a handy, flexible leatherette cover. To be sure the pages are sturdy, to withstand constant use, the book is printed on a special "bible" stock. This is a very durable, but thin paper. The book printed on this paper can be easily rolled to fit into your pocket or slipped in the service kit.



240 Pages
Over 500 Illustrations
Size 9 x 12"
Flexible, Looseleaf Leatherette Cover

\$2.50 LIST

MAIL COUPON TODAY FOR ANY MANUAL!

GERNSBACK PUBLICATIONS, Inc. RC-736
99 Hudson Street, New York, N. Y.

Enclosed you will find my remittance of \$..... for which please send me promptly, POSTPAID, the OFFICIAL RADIO SERVICE MANUAL, indicated.

- | | |
|--|--|
| <input type="checkbox"/> 1935 Edition @ \$7.00 | <input type="checkbox"/> 1935 Edition @ \$2.50 |
| <input type="checkbox"/> 1934 Edition @ \$3.50 | <input type="checkbox"/> 1933 Edition @ \$2.50 |
| <input type="checkbox"/> 1933 Edition @ \$5.00 | |
| <input type="checkbox"/> 1932 Edition @ \$5.00 | |
| <input type="checkbox"/> 1931 Edition @ \$4.50 (Including Supplements) | |

Name

Address

City State.....

(Send remittance by check, money order, or registered letter if it contains cash, currency or unused U. S. Postage Stamps.)

GERNSBACK PUBLICATIONS, Inc.

99 Hudson Street

New York, N. Y.

OVERSEAS READERS!

These books can be obtained from the following houses:

GREAT BRITAIN
Gorrings, 9a, Green Street, Lalester Square, London, England

FRANCE
Editions Radio, 42 Rue Jacob, Paris

AUSTRALIA
McGill's 183-185, 218 Elizabeth St., Melbourne, C. I

Please Say That You Saw It in RADIO-CRAFT



"Takes the Resistance out of Radio"

Editorial Offices: 99 Hudson St., New York, N. Y.

HUGO GERNSBACK, Editor

Vol. VIII, No. 1, July, 1936

THE FUTURE OF RADIO SERVICING

An Editorial by HUGO GERNSBACK

IT MAY BE stated with some justification that the radio service industry has now emerged from its swaddling clothes and is under way to grow up into a recognized industry.

A few years ago, before radio sets had become as numerous as they are today, anyone could be a Service Man, from the schoolboy up. Anyone who knew a bit about radio theory and circuits, and had a pair of pliers and a screwdriver immediately became a self-styled Service Man.

Things have changed rapidly until today the Service Man has not only become a specialist in his field but somewhat of an engineer to boot. And it is also true that, generally speaking, only the well-equipped Service Man who has a full set of servicing instruments, plus a good deal of experience can make money from servicing today. Unfortunately, there have been too many irresponsibles who cluttered up the service field so that at times it was difficult for the legitimate Service Man to make an honest living. Misrepresentation by "gyp" Service Men who are only in the game to trim the customer on account of his ignorance of radio matters is still another story on which a large-size volume could easily be written.

After all, these things are merely "growing pains" of an otherwise healthy industry, and time, no doubt, will change these conditions. The public, after all, is getting more educated and, if a Service Man comes in and insists on renewing everything from tubes to transformers, when all that the set requires is connecting the aerial to the binding post, such a racket cannot last forever. The public is getting wise to such tactics, and such irresponsible service racketeers, in the end, find that they have dug their own grave, and that the "suckers" are becoming more scarce as time goes on.

Of course, the dishonest Service Man has always been in the minority, but every time a customer has been taken advantage of, it has reacted against the good ones, and made the public suspicious of every Service Man. This is an unfortunate condition, but the radio industry is not the only one that suffers under such conditions. The same things holds true of automobile servicing, plumbing, and every other type of servicing. In the long run, however, this sort of thing does not pay, because a customer who has been taken advantage of once is going to be more careful next time. There are, indeed, a number of ways that the service racket can be combatted, and these are coming into force more and more.

One of them is the Service Men's unions which are now springing up all over the country and which will do a great deal to do away with the "gyp" artists, and at the same time make it possible for Service Men to earn an honest living, which they have in the past found difficult to do. It is one thing to grossly overcharge a customer for work not performed and for installations and replacements made when they were not needed;—it is quite a different thing to charge a fair price to a customer for servicing a set that actually needed intelligent work and replacements. As the saying goes: "In union there is strength." And the banding together of responsible Service Men into radio service unions, locally and nationally, is a step in the right direction.

Even without actual unions, it is often a good policy for a number of responsible Service Men in their locality to get together and insert advertisements over their joint names in the local newspapers. Such advertising is very cheap,

because a good sized advertisement will cost very little when a dozen or more Service Men have their names listed, and each pays his share for the advertisement. Attention is usually called in these advertisements to the fact that the undersigned are the responsible Service Men of the locality and that any complaint should be addressed to headquarters. In such a case, without the necessity of a union, "headquarters" is merely the office of an attorney or other official known to the community, who will impartially act upon any complaint received. This automatically makes for responsibility of all the members, and none will be likely to overcharge. At the same time, complaints received against those who are not members can be dealt with through the local Better Business Bureau or the Board of Trade.

It is responsibility in the radio service field that is of paramount importance, and at the same time it will do much to frustrate the attempts at unfair dealing of the irresponsible radio servicing element.

As to what is ahead in radio servicing, we can see only a bright future for it. It may take a little time and patience, but, after all, it should be remembered that other service fields during the past few years have not been over-prosperous. The radio service industry, therefore, is not in any worse condition than our other service industries.

Quite to the contrary, in radio servicing we have a constantly enlarging field, which can only work out to the benefit of the Service Men in the future. Time was when the radio Service Men serviced only radio sets. This even today is no longer strictly true. The Service Man who is a specialist the same as a physician, is called upon now-a-days not only to service broadcast sets but car sets, short-wave sets, airplane sets, and others. In addition to this, there is servicing of public address systems, of motion-picture equipment, photoelectric devices, and many others too numerous to mention. With television not too far distant, there will be another tremendous impetus to the service field as soon as visual radio sets come into use. Indeed in the television field alone, the service industry will receive a remarkable boom.

There has also been quite a bit of discussion lately as to why radio Service Men should not go into the servicing of electrical appliances. The answer to this is, that to the best of our knowledge, the radio Service Man has always done so. Indeed, he has even gone into refrigeration servicing whenever it became necessary, always providing that he had the necessary education along these lines. There is no reason why radio servicing should confine itself to radio alone.

There are many allied fields of servicing which overlap, and, just as electricians in the past have ventured into radio, there is no reason why radio Service Men cannot venture into the electrical field whenever this is necessary. We see nothing unethical or objectionable in this—the only requirement being that the Service Man must have the necessary qualifications to do the job and do it right. If the Service Man is versatile enough and has the right background, there is no reason why radio should be his only endeavor, although many authorities believe that the radio Service Man has plenty on his hands if he wants to do radio justice. This, however, is a mere opinion. There is a parallel of this in that some men in the mercantile field can only sell one line of goods, whereas others sell thousands of lines. And that is why we have department stores.

THE RADIO MONTH



The transmitter room of the new high-power broadcast station in Finland.

WJZ TO HAVE 500,000 WATTS!

POWER and yet more power, is the byword in this month's news concerning the broadcast stations. The National Broadcasting Co. filed application last month with the Federal Communications Commission for an increase in the power of their key station WJZ from 50,000 to 500,000 watts—a power equivalent to that of WLW, world's largest station!

It is planned that a new transmitting plant—new buildings, transmitter and antenna system will be erected at Bound Brook, N. J. when the request is granted by the F.C.C. This approval it is learned unofficially is only a matter of form in this case.

And on the other side of the world, in Finland, a new high-power transmitter—reported to be the largest in Europe—was inaugurated, last month. This station which transmits on a wavelength of 1,807 meters has a power rating according to European standards of 600,000 watts! But in *aerial power*, which is the American way of rating output, the station has a rating of only 200,000 watts. This is greater than the Russian station we announced some months ago which has a power rating of 500,000 watts.

WNYC TO USE MICRO-WAVE LINK

STATION WNYC, the municipal station of the city of New York has been very much in the lime-light, lately, through efforts of rotund Mayor LaGuardia.

In connection with the new transmitter which is being erected in Greenpoint, several miles from the studios in the municipal building, it was announced last month that the first micro-wave beam transmitter for regular service in the U.S. will be used to connect these two points. While this unit will be used only for emergency service in case of telephone line failure, it will always be available for regular scheduled programs.

RADIO USED IN GOLD MINE RESCUE

IN the spot-broadcast rescue, last month of the two gold miners from the Moose River gold mine in Nova Scotia; radio—or rather, electron tubes—played an interesting role.

In order to keep in touch with the entombed men at all times a microphone was lowered through the 2-inch pipe into the shaft and an amplifier and phones were connected to it.

A P.A. amplifier was tried, to permit communication into the shaft, but the echo of the sounds sent down from the reproducers made them unintelligible as well as painful to the ears of the men below.

However, the mike made it possible to supply their most urgent needs.

ROBOT RECORDS LISTENERS' TASTES

A SURVEY of the entertainment tastes of a representative group of radio listeners in the Boston area has just been completed according to a report received last month from Professors L. F. Woodruff and R. F. Elder of Massachusetts Institute of Technology.

The survey was made with a recording device invented by Prof. Woodruff which records on tape the date, hour and duration of every program dialed by the listener.

One hundred "audimeters" (the name of the recorder) were used in 1,000 homes. The results were as follows: Families with incomes of over \$2,500-a-year prefer symphony music, concert recitals and drama. Those in the \$1,200 to \$2,500 range listen most to jazz and musical comedy while those below \$1,200 listen mostly during the day time and seem to prefer melodrama. Set operation in all three groups takes a jump in the 5 to 7 p.m. period when such programs as Dick Tracy and Jack Armstrong hold the spotlight—and Prof. Elder "has an idea" it is not only children who listen then!

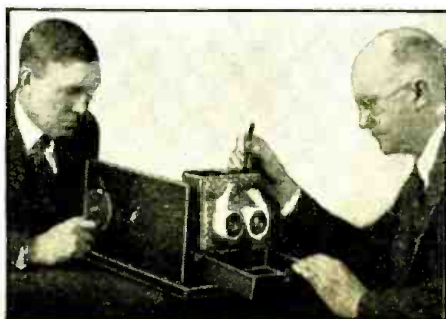

Professors Elder (left) and Woodruff (right) with one of the audimeters which they used in their radio survey.

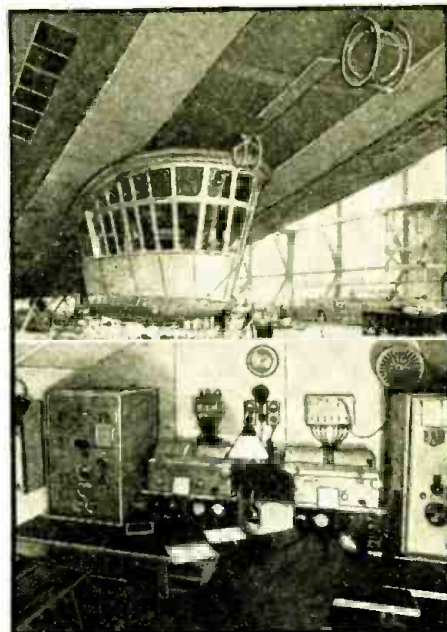

The Zeppelin direction finder and radio room.

ZEPPELIN RADIO EQUIPMENT

WITH the announcement last month that 2 sister-ships to the huge Hindenburg have been started in a concerted effort by Germany to absorb the transatlantic air travel—as well as the completion of plans for the first crossing of the Hindenburg, much interest has been given to the radio equipment.

This installation which rivals the equipment on many of the finest liners will permit passengers to "phone" to London, Paris, Berlin, Rio de Janeiro, New York or Buenos Aires while cruising over any point of the Atlantic!

This airship carries a 200-watt short-wave transmitter with a frequency range of 4,280 to 17,700 kc. (17 to 70 meters). In addition to the short-wave equipment, the airship carries a 125-watt long-wave transmitter covering the wavelengths from 575 to 2,700 meters.

The ship also carries complete direction finding equipment to assist in navigating through fog and blind landing devices.

S. W. STATIONS TO BOOST POWER

ACCORDING to E. K. Cohan an engineer associated with the Columbia Broadcasting System, who returned last month from a meeting of the International Broadcasting Union in Paris, many of the European short-wave stations will be increased in power within a year. England has 3 new 70,000-watt stations under construction and Germany is going as high as 100,000 watts!

IN REVIEW

Radio is now such a vast and diversified art it becomes necessary to make a general survey of important monthly developments. RADIO-CRAFT analyzes these developments and presents a review of those items which interest all.

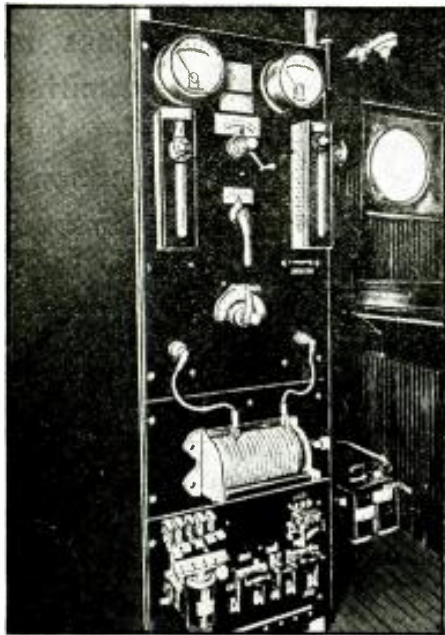

The transmitter used on the trawler.

RADIO REDUCES FISHING EXPENSE

ONE of the trawlers of the Maine Company which returned last month from an extended trip to the fishing banks was equipped with an experimental radio installation.

The results were so gratifying that other ships of this line are also being equipped. It was found that with the radio communication, it was no longer necessary for the trawler to come into port with a small catch and in case of sickness, measures could be taken under doctors orders. The experiment showed that an actual saving could be made by sending reports from shore.

It is interesting to note, also, that a new sea weather service has just been inaugurated by the Radio Corporation of America. The U.S. Weather Bureau prepares the maps and the former sends them via the press photo equipment to ships equipped for receiving charts.

In periods of severe storms it is possible to send charts several times a day to advise sea captains of heavy weather.

Several large liners are already equipped to receive the maps.

RADIO SALES TOP 1935

THE new report from Dun and Bradstreet received last month reported that a survey of the radio industry showed a definitely optimistic attitude toward business for the 1936 season. According to the report the level of 1935 which was the highest in radio history—would, without doubt, be exceeded!

TELEVISION DEMONSTRATION A SUCCESS

AS an introduction to the million dollar experiments which RCA Victor is conducting this year, a demonstration of the equipment to be used was given before a small group of invited guests, last month.

Images of the characteristic greenish cathode-ray color, about 5 x 7 inches and having unusually fine detail were seen from both studio and outdoor pickup. The distance covered was about 1 mile, on a wavelength of 7 meters.

And during the month, David Sarnoff, president of R.C.A., made the statement that television had now reached the stage of radio 12 or 15 years ago; T. A. M. Craven, chief engineer of the Federal Communications Commission urged the Commission to keep television on an experimental basis in fixing rules; Anning S. Prall chairman of the F.C.C. warned investors against buying stock in unknown companies because—"They do not know when or how it will arrive—nor do we"; the first television casualty occurred when H. E. Lawrence of the NBC was killed by an electric shock while working on the transmitter in the Empire State building; and news was received that daily television tests are now being made in Paris!

GERMAN TELEPHONE PHOTOS

A NEW system paralleling the phone picture system used in the U.S. has been perfected in Germany, according to a report received last month.

The German system can be used on any telephone and is clipped into the flexible wire of the telephone transmitter. It weighs 104 lbs. (with batteries).

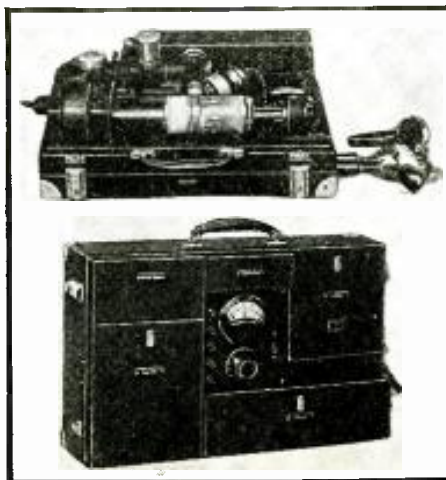

The complete telephone picture device.

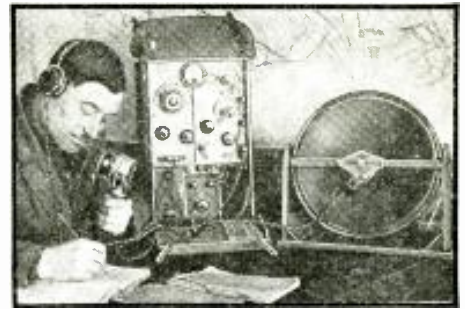

A dispatcher using one of the transceivers in controlling the actions of farm tractors.

RADIO AIDS RUSSIAN TRACTOR SERVICE

THE MTS (Machine Tractor Service) plays an important role in agriculture in the Soviet Union. By means of this service, tractors and farming machines can be used over wide areas in collective farms.

Radio communication is now an important part of the MTS, according to a report received last month. The various tractor crews are kept constantly in touch with a central office by means of new short-wave portable transceivers! Without these portable radio units, the MTS would be severely handicapped, depending on remote telephone stations for communication.

SUN ERUPTIONS AFFECT S.-W. RADIO

MORE evidence was disclosed last month of the relationship between disturbances on the Sun and the blotting out of short-wave communication—as mentioned in the April 1936 issue, page 583.

A sudden gas eruption on the Sun was reported by R. S. Richardson of Mount Wilson Observatory—and it was found that at the same time short-wave communication completely disappeared for about 15 minutes.

"The effect as originally reported" Richardson said, "consists of a sudden and complete disappearance for 15 minutes or more of all high-frequency radio transmission over the half of the earth lighted by the Sun."

Dr. J. H. Dellinger, chief of the Federal Bureau of Standards, previously had reported fade-outs at intervals of 54 days or multiples of the number since 1934.

This is the first definite evidence, however, pointing to the gas eruptions as causes of radio fade-outs and changes in the earth's magnetic field—and it will doubtless lead to a greater understanding and a possible solution of the problem.

SENDING "PICTURES" BY TELEPHONE

A newly-perfected system for sending news photos over ordinary telephone lines is here described. The portable transmitter is not connected directly to the line but is merely placed close to the telephone instrument. A "picture" may be telephoned at night from coast to coast for only \$25!

ANDREW HALBRAN



Fig. A. The portable transmitter in use. Note hand held over transmitter.

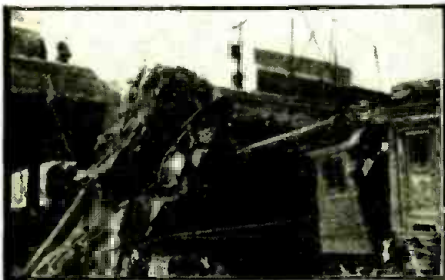

Fig. B. An example of a transmitted picture.

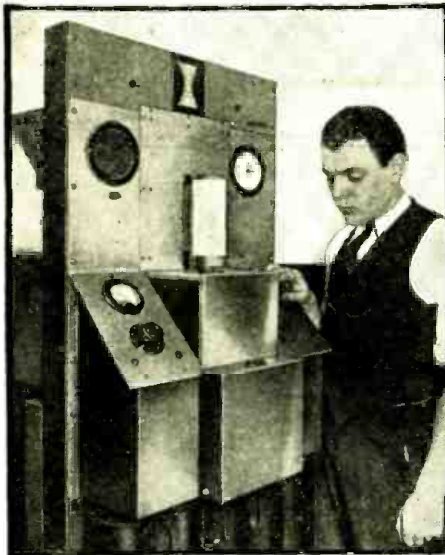

Fig. C. Rack-type receiver; note image cylinder.

ONE OF THE most important aids to the modern high-speed dissemination of pictures of news events has come to light recently with the release by the *New York Times* of data on a system of wire transmission of photos, developed by its subsidiary, Wide World Wired Photos. This new method employs the wires of the telephone companies, and in some cases those of the telegraph carriers as well, without actual connection to the circuit. The impulses from the portable transmitter are transferred to the lines by induction only, and are received in the same manner. Thus the system will function anywhere there is an ordinary telephone line, which is the feature that makes its field so enormous.

The transmitters, as seen in Fig. A, are of the portable type, and weigh about 50 lbs., packed in their carrying cases, which are not much larger than a good-size suitcase. If operation is to be accomplished at a point where line power is not available, the equipment

may be operated from any 6 V. source, such as a storage battery. A 15-lb., airplane-type battery will supply sufficient current to transmit 8 full-size (7¼ x 8¾ in.) images or "pictures."

The receivers, as seen in Fig. C, are of the rack type since they need not be portable, and may be operated in either light or dark locations.

Actual operation of both transmitters and receivers is very simple. An ordinary glossy photo is secured to the drum of the transmitter, which in operation revolves 45 times per minute. As it turns, a spot of light from the exciter lamp is reflected from the revolving photo to a photo-cell, the resulting current being combined with an 1,800-cycle signal. This combination signal is then amplified and applied *inductively* to the line. (It is only necessary to cover the transmitter of the telephone instrument, so as to prevent pick-up of external noise.) An ordinary station-to-station call is then made over the telephone to the news-

(Continued on page 37)

FOR THE
**FIRST
TIME**
IN ANY
RADIO
PUBLICATION



Fig. 1. The 3 steps. First the picture is taken, then developed; second, it is sent over the line; and third, received (as shown in Fig. D) at the newspaper office.

RADIO PICTORIAL

"EASTER PARADE." George Hicks, NBC announcer, with a 1.1 meter radio transmitter concealed in his top hat, is shown broadcasting comments, in the famous Easter Parade on 5th ave., N.Y.C. Power was supplied by batteries attached to a sport belt; 180 volts of "B" from 30 small cells and 6 volts of "A" from 4 larger cells. A trailing radio-equipped automobile intercepted and relayed the micro-waves to a receiver in Radio City. From there the broadcast was heard over an NBC network. The 0.2-watt power output of the transmitter, which used 3 "acorn" tubes, was fed into a short metal rod antenna attached to the hat. The transmitting range was 1/4-mile. "Talking through one's hat," appears to be subject to the fiat of Uncle Sam, since only that coterie of technicians licensed by the Federal Communications Commission are permitted to operate a radio transmitter.

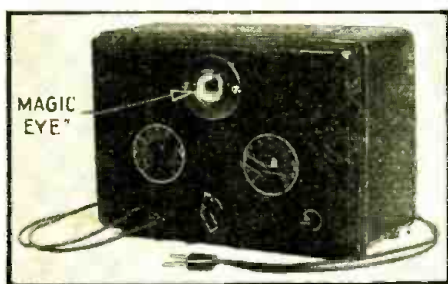

"TELLING EYE." Prof. G. Frederick Smith of Univ. of Ill. recently demonstrated this new tool of the analytical chemist. Its 6E5 "magic eye" winks in proportion to the amount of a given element in a solution.

SHORT-WAVE TRAFFIC CONTROL. A member of Lancashire Constabulary recently utilized a portable short-wave transmitter and receiver at Aintree (England) Race Track, for traffic control.

HEAR YE! HEAR YE! The "gas alarm man" with portable P.A. unit shows the facility with which he can warn the population of London (England) of an impending gas attack.

GERMAN P.A. SYSTEM PREVENTS ECHOES

IN EXTREMELY large P.A. installations, where considerable area must be covered, auxiliary speakers in addition to the main groups of speakers must be employed. Unfortunately, these additional speakers very often tend to create echoes since the sound waves from the main and outlying auxiliary speakers do not reach the spectator's ears at the same instant.

The technical explanation of these echoes lies in the well-known physical law that sound waves in air travel much slower than electrical impulses in a conductor; so that, while a given electrical impulse reaches both main and auxiliary speakers at the same instant, the resulting sound reaches the spectator's ears considerably out of time, thereby causing the annoying echo.

Sound engineers of the German Post Office have successfully solved this problem in their novel P.A. installation in Berlin's "Post Stadium." Their scheme is to delay the electrical impulses from reaching the auxiliary speakers by a period of time equal to the time it takes sound waves from the main (or centrally-located) speakers to reach these
(Continued on page 41)

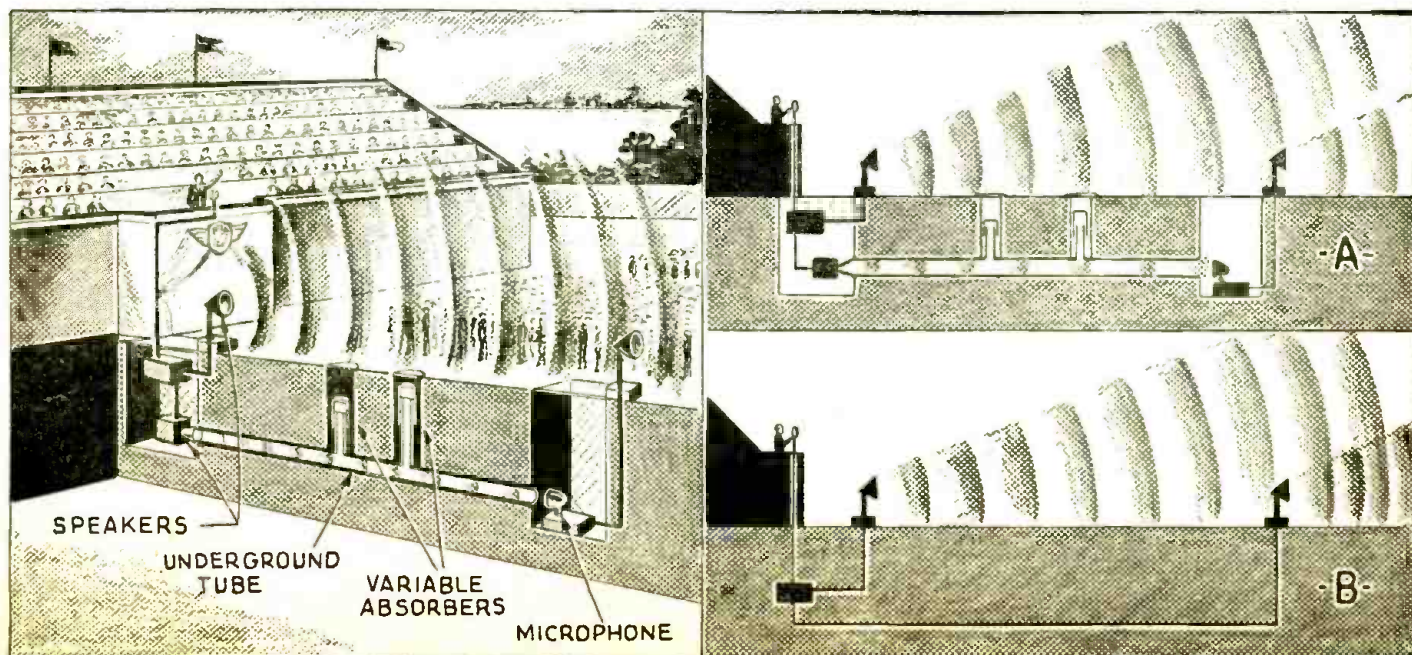



A modern set-up—the instrument on the cover would supplement the modern oscilloscope at the right. Photo—Clough-Brengle

THE "SUPER" SERVICE MAN

The cover painting depicts a service unit of the future in which several cathode-ray tubes are used—read how this idea will improve servicing.

WHEN OUR readers catch their breaths after having viewed the idea expressed upon our front cover, we hope they will digest the following short description, when they will find the idea is quite practical.

The basic scheme, of course, is to use several oscilloscopes to measure *simultaneously* the operation of different parts of the receiver circuit, rather than having to change leads, shift connections, twiddle controls, and otherwise waste time in the analysis of trouble. The signal from the service oscillator or "signal generator" can be observed as it travels through the many circuits, and the signal conditions will be exactly the same for every part of the circuit, so that the various oscillograms or waveforms observed can be directly com-

pared, and valuable deductions quickly made. It can be seen at once just where distortion is entering the line-up, or where the gain is falling off.

Other uses for the "multiple test panel" will, no doubt, come to the reader. For example: The apparatus could be used to compare the output of several receivers or P.A. systems of the same type and with the same signal input, to find out which is the best and which lacks certain qualities. This comparison is of the greatest importance, since it can be accomplished *simultaneously* and any tiny differences in the cathode-ray pictures instantly noted. How different from comparison by the human ear, which is notoriously inaccurate to small discrepancies!

The mechanical and electrical prob-

lems are not as extravagant as may at first be imagined. Although several cathode-ray tubes are used, only a single power supply of reasonably heavy rating would be needed to supply them all. The same signal-generating equipment could be used for all apparatus under test, in fact this would be virtually essential when making the comparison type of tests previously mentioned. The several oscilloscope tubes would be the largest item of cost, and as is usual with most everything else, the cost of these will no doubt drop rapidly, as a larger volume goes into manufacture. Each oscilloscope tube would need a separate set of vertical and horizontal amplifiers and a separate sweep oscillator, but the tubes and equipment for these are rela-

(Continued on page 37)

THE PHILOSOPHY OF SERVICING

The mental attitude of the Service Man in tackling a service job has more to do with his success or failure than does his equipment.

J. KAUFMAN

A SERVICE Man can do a great deal to improve his radio service work if he will sit back occasionally and give his profession some serious thought—consider the manner in which he conducts his business and the actual mechanics of his servicing technique. So much has been said in the last few years about the business side of the service profession that the underlying philosophy of the actual work, *servicing*, has been sadly neglected. Give this question of servicing philosophy some serious thought, for it is your life work; the re-

sulting ability to handle service jobs *more rapidly, more efficiently, and more correctly* will naturally mean more profit to you.

A LITTLE PERSONAL EXPERIENCE

Frankly, I did not evolve this Philosophy of Servicing, which I teach to thousands of students each year, by spontaneous or intuitive creation. Problem after problem arose which required solution. Each difficulty indicated that the solution to servicing could be handled only by a well-planned service technique—this I gradually developed and today, after being alone in my recommendations for many years, I am gratified to see that they are in wide-spread use, and are labeled *modern servicing*.

SERVICING HAS THE SAME EARMARKS IN ANY FIELD

The correct approach to any problem always seems obvious once it is known; if you are able to apply these obvious procedures yourself, you are on the right road. In working out the Philosophy of Servicing, I compared the radio man's problems with those of other professional men. My doctor was constantly

in my mind. Doctors, as you know, are trained to be good diagnosticians—a "million dollar word" for good analyzers.

Go to a doctor with some ailment; he will greet you warmly (good business), ask you what's wrong (you say to yourself, "that's what I came to find out"), ask a lot of questions (they seem silly at first), then start to look you over (getting down to business now). He listens to your heart, looks into your throat and eyes, feels your pulse, and perhaps begins to use special instru-

(Continued on page 40)



The doctor analyzes—then prescribes.



The Service Man analyzes—then repairs.

SALES AND SERVICE ON WHEELS!

The description in the July, 1935, issue of RADIO-CRAFT of the traveling Service Man has brought to light an honest-to-goodness traveling Service Man—who tells what parts he carries and how he does it.

W. L. FULLER, JR.

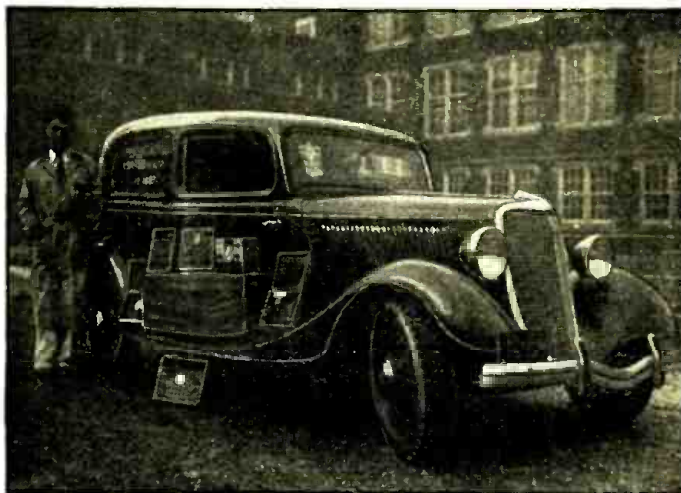

HAVE YOU ever had a dream, one that you had been working on for at least 10 years, and then all at once have it come true and find that other people believe that it is as practical as you believe? This is the case I have found after looking in the July, 1935, issue of *Radio-Craft* pertaining to the "traveling service" that Mr. Gernsback discussed.

After having operated a Hoover service truck through Pennsylvania and New York State, and watching the growth in the last few years of the automobile replacement business in regard to traveling replacement trucks, several months ago my partner and I devised the scheme of operating a wholesale service and replacement company to bring better servicing facilities to the small-town dealer than he had ever been able to obtain before, selling him this service at rates from which he could make a legitimate profit, besides giving us a profit so we could operate our service automobile on a paying basis. Until a short time ago we were the only traveling "radio replacement" company on the road until several of our competitors thought we might be making a success, so they began operating a replacement truck through the same territory, but we still hold the distinction of being the only wholesale service company and the only sound-equipped car of this type in the United States that uses the sound am-

plifier to advertise their dealers, and not for outright profit.

It has been quite a problem to us what to stock on our service to these dealers, and what to stock for resale to the dealers so they might in turn sell to their customers. Due to the fact that in the field one finds every make of radio set, and a great many makes that one has never heard of—this alone was a problem of its own. If it had not been for the fact that my partner has an unusual amount of good common sense and an excellent technical foundation for radio, the first few months would have been disastrous for this company because we receive only the "white elephants" that the average Service Man is unable to repair, and while trying to gain the confidence of dealers, many snags were found in the first few months of operation. We have found that in this territory, and probably in the territory in which you are now located, there are few Service Men who have up-to-date equipment and this is one of the main reasons why we have been enjoying a moderate amount of success in this new mode of business.

Of course we differ considerably from the ideas *Radio-Craft* portrayed in the July, 1935, issue due to the fact that the Service Man in this magazine did the work on the sets in his trailer or truck, but with the dealer line-up we have established, we do all the work in the dealer's store or garage as we

are also factory service representatives on most of the nationally-known auto radio sets, having installed within the last 2 years over 1,000 units.

In unusual cases when we do not have the proper materials to go into a machine, we bring the radio set to our shop here in Parkesburg, W. Va. We have made contacts with numerous non-competitive companies which cover the same territory, to make deliveries during the week if it is a rush job, or we deliver on the next weekly trip.

The automobile that we presently will describe, is the one that we are using at present. However, this Fall we are putting into operation a truck that we are designing which we firmly believe will be the "last word" in traveling service.

In regard to the different parts that one should carry in his truck, we have
(Continued on page 44)



The front of the car, showing the P.A. unit.



One corner of the shop, showing the two owners at work.



A very complete stock of replacement parts is kept.

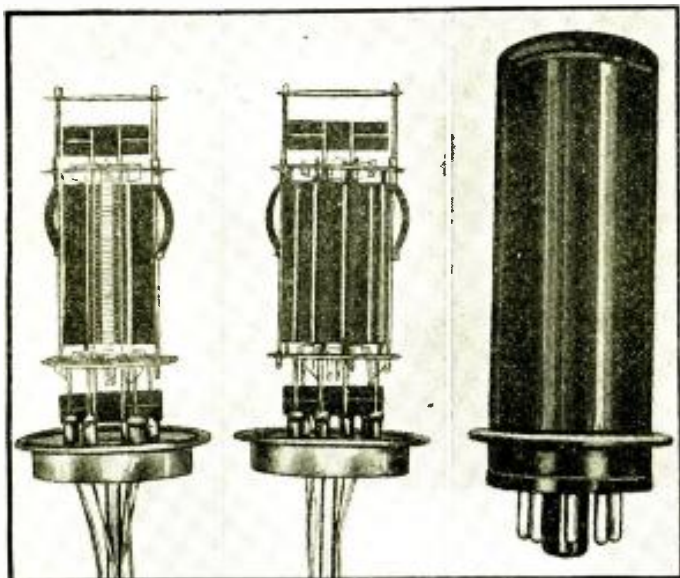

Fig. A. Three stages of the construction.

THE NEW BEAM POWER TUBE

The 6L6 is a new power tube with high sensitivity, high efficiency, high power output, low third- and higher-order harmonic distortion. It will supply 34 W. output without grid driving power and 60 W. with a driver.

C. W. PALMER

ONCE IN a blue moon something really new and startling strikes the radio industry and each time this occurs, the entire fraternity is left open-mouthed. This time, the mouth opener is in the form of a new tube which is so different from other existing tubes that it is at first a little difficult to understand the operation and the reasons for its unusual characteristics.

First, let us recall the Renode tube mentioned in the February, 1936, issue of *Radio-Craft*, which operated on the principle of a controlled or focused beam of electrons. It will be remembered that by so controlling the stream, the tube could be modulated without the use of control-grids and other elements found in the usual run of tubes.

The new Beam Tube—which is known as the 6L6—also operates by virtue of a controlled stream of electrons even though “grids” are used. But let us take a look at the conditions which brought about the development of this remarkable tube.

Distortion in radio communication can be divided into 3 general classes: (1) frequency distortion; (2) harmonic distortion; and, (3) distortion due to the compression of certain frequencies

(a condition known as “volume compression”).

Of these three, harmonic distortion is the most interesting at this time, since the power tubes of a radio receiver cause, by far, the greatest amount of such distortion. It is for this reason that the gradual development of output tubes from high- μ triodes to low- μ triodes, then pentodes and finally higher power triodes were used in successive attempts to reduce the non-linear characteristics introduced in the power stage.

Some of the more recent tubes operate with the control-grid swinging into the positive region under which condition grid current flows. In these tubes a sharp break in the characteristic curve is noticed where grid current starts to flow and this break is the cause of harmonic distortion. Unfortunately this break or discontinuity may occur at moderate outputs which has presented a very serious problem to designers of amplifiers and radio sets. Thus, it can be seen that even with the development of such tubes as the 2A3, 6A3, etc., there was still a very definite need for a *good output tube*.

The 6L6 output unit is made in the form of a metal tube and is the result

of work conducted by O. H. Schade (a well-known engineer in the electronic field).

THE BEAM OPERATION

Refer to Figs. A and B which show the interior of the tube in several stages of its assembly. It will be seen that the cathode is flattened and is surrounded by an elliptical-shaped control-grid. A screen-grid is also included (making the tube a *tetrode*) and this grid also follows the elliptical form. The turns of this grid are arranged exactly parallel to and in line with the turns of the control-grid. Two flat elements, known as the “beam-control plates” are located at the narrow ends of the grid structure. These two plates are connected within the tube to the cathode. Surrounding these beam electrodes is the plate which assumes a circular or cylindrical form in those sectors where electrons can reach it from the cathode (where it is not shielded by the beam electrodes).

Now, referring to the cross-section of the tube shown in Fig. 3, it will be seen that the electrons emitted by the cathode are constrained into 2 beams because the beam-control electrodes prevent electrons from reaching the plate at the

(Continued on page 42)

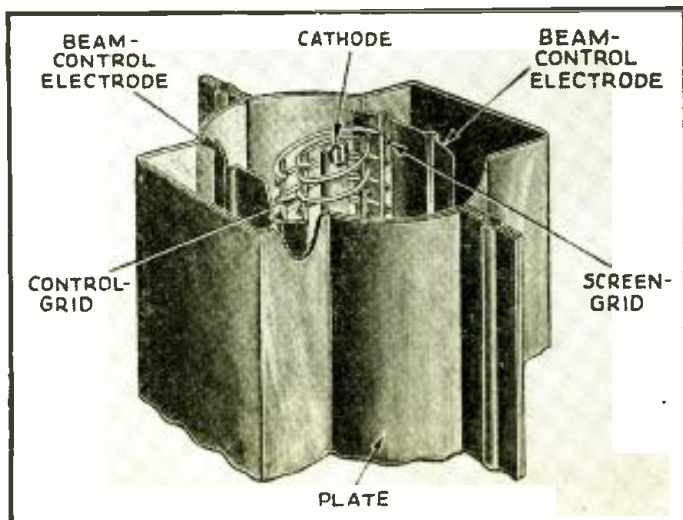

Fig. B. A cut-away view of the structure.

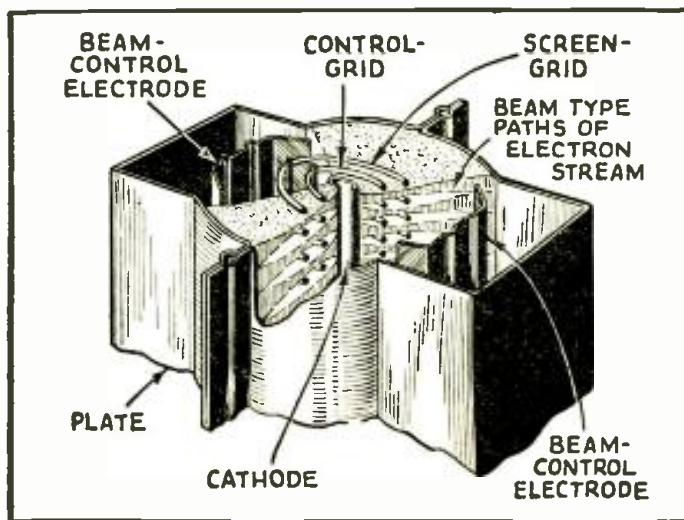

Fig. 1. The divided-beam path of electrons.

HOW TO MAKE AN OSCILLOSCOPE

PART I POWER SUPPLY

A carefully designed unit for the man who prefers to make his own. It includes the features of most commercial units.

CHARLES SICURANZA

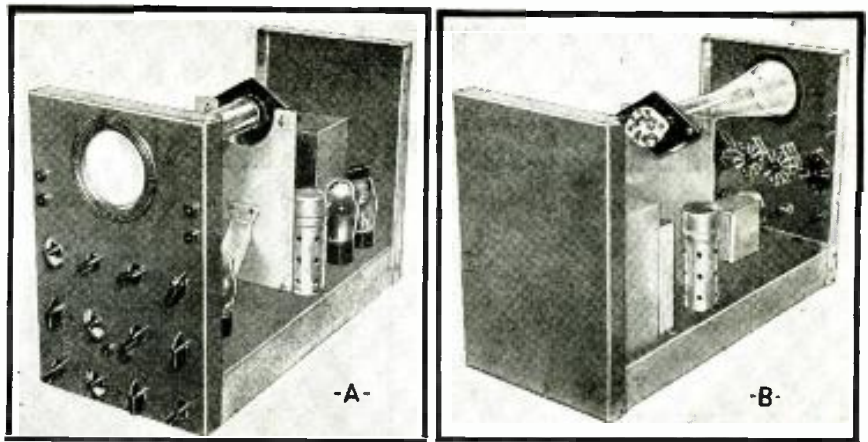

Fig. A. The front and rear views of the chassis—completed, except for the wiring.

THE CATHODE-RAY oscilloscope is rapidly becoming indispensable in the servicing of modern radio receivers. It has finally emerged from the laboratory and is enjoying a steadily-increasing demand among the radio fraternity.

There are at present on the market several commercial portable oscilloscopes, which, because of the fact that they are built around the 3-in. type 906 RCA tube, show a marked similarity of circuit structure; in other words, the circuit is almost standardized, with slight variations.

After careful consideration of all the factors involved, the author decided to build a unit which would contain all the desirable features of the present-day commercial oscilloscopes and still effect a worthwhile saving in cost.

For those who have kept pace with the development of oscilloscope equipment and technique, we will list some of the desirable features of this home-built instrument:

1. Portability.
2. Light weight.
3. Ruggedness.
4. Ease of operation.
5. Wide-range sweep oscillator.
6. Wide-range horizontal and vertical amplifiers.
7. Rugged power supply.
8. All controls grouped on panel for greatest efficiency.
9. Impressive appearance.
10. Highest-quality parts.

For the benefit of those who have no knowledge of cathode-ray equipment, we will attempt to give a brief description of its various uses. (The most practical of these have been discussed, for the Service Man and general technician, in past issues of *Radio-Craft*.—Editor) It enables us to study wave shapes of alternating voltages of any frequency; measurement of modulation; study of resonance curves; study of phase displacements and dozens of other measurements which we will go into in greater detail later on.

Although there are several books on the construction and function of cathode-ray tubes which explain the theory in great detail, we feel, nevertheless, that a brief description of the particular, "3-in." tube used in our unit, will be helpful.

THE 3-INCH CATHODE-RAY TUBE

The tube around which this oscilloscope has been designed contains 7 elements which have terminals on the large 7-prong base. The glass envelope is shaped somewhat like an elongated cone, the "business end" being 3 ins. in dia. and almost flat. This is known as the *viewing screen*. The white coating on the inside of this viewing screen is a chemical called "willemite" which becomes luminous when electrons strike it.

The 7 elements are as follows (refer to Fig. 2): (1) filament; (2) cathode; (3) control-grid; (4) focusing plate; (5) accelerating plate; (6) vertical deflector; (7) horizontal deflector.

(Continued on page 54)

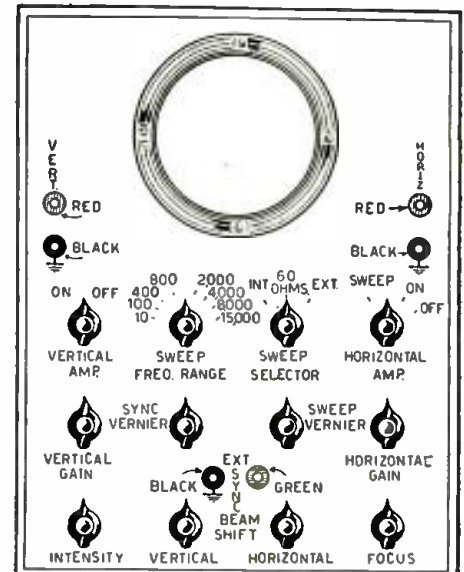

Fig. 5 The descriptive lettering for the panel—showing the use for the knobs.

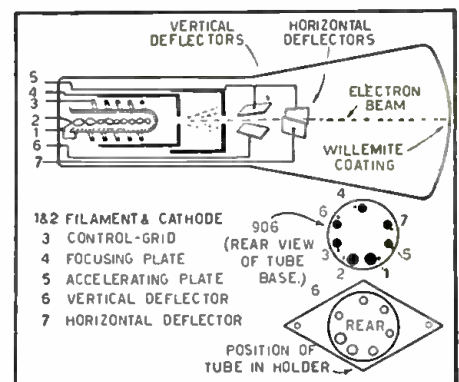

Fig. 2. The 7 elements of the modern oscilloscope tube, in detail.

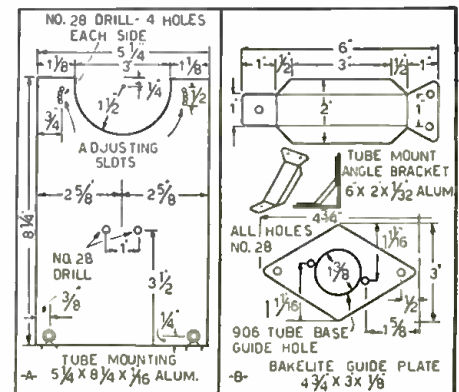

Fig. 4. Mounting details for the 906 tube.

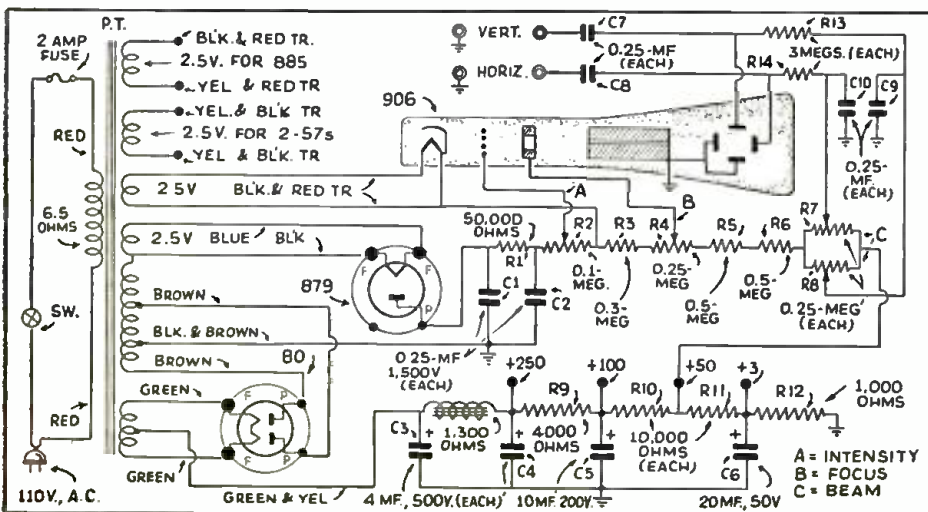

Fig. 1. The circuit of the unit as described in Part I. The sweep amplifiers are in Part II.

NEW EQUIPMENT FOR THE SERVICE MAN

Several interesting items have recently been brought out to make work easier for the radio Service Man.

EQUIPMENT for the "radio" Service Man necessarily is quite divergent in nature. Some of the newest of these widely differing units are here described.

NEW ULTRA-RANGE I-METER TEST UNIT

(Radio City Products Co.)

(1054) Modern developments in many fields have tended to obsolesce the ranges of many bridge test instruments, but this new device on the other hand establishes range values that probably will be used as reference points for some time to come. In addition to the "ultra-range" feature, this single-meter test unit employs in its full-wave rectifier circuit a special, improved balance bridge upon which patent application has been made; this circuit results in uniform A.C. and D.C. scale readings with practically negligible frequency error. Capacity measurements are substantially unaffected by line-voltage variations. This unit tests paper, mica and electrolytic condensers for actual capacity and leakage. The sensitivity is 1,750 ohms-per-volt A.C. and 2,000 ohms-per-volt, D.C. The ranges are:

Capacity: 0 to 300 mf., in 5 ranges; calibration from 100 mmf., up.

Ohmmeter: 0 to 40 megs., in 6 ranges; calibration from 1/4-ohm, up, and easily read to 0.1-ohm.

D.C.: 0 to 500 microamps.; 0 to 250 ma., in 4 ranges; and, 0 to 2.5 A.

A.C.: 0 to 250 ma., in 4 ranges; and 0 to 2.5 A.

A.C. and D.C. voltage: 0 to 1,000 V., in 5 ranges.

Inductance: 35 millihenries to 7,000 hy.

Decibels: In addition to its use as an output meter the instrument is calibrated for -12 to 100 db., in 5 ranges.

TUBE EXTRACTOR

(American Radio Hardware Co.)

(1055) Even the most tightly-fitting metal (or glass) tubes will pop from their sockets when this tool gets in its good work. The device not only saves time but also is lots easier on the tubes. Often, out-of-the-way tubes may be removed without the necessity of removing the chassis from its cabinet.

COMBINED SIGNAL GENERATOR AND LEAKAGE TESTER

(1056) The service-oscillator section of this compact unit has a range of 100 kc. to 20 mc. Modulation is at 1,000 cycles.

This A.F. modulation is obtained from
(Continued on page 44)

Name and address of any manufacturer sent on receipt of a self-addressed, stamped envelope. Kindly give (number) in description of device.

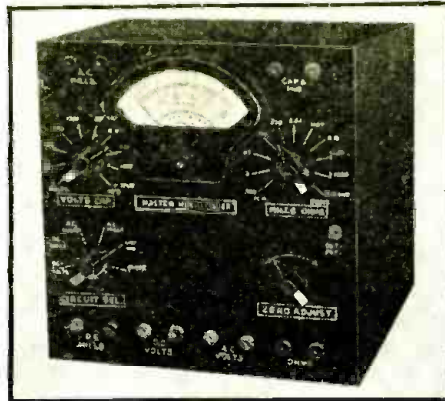

This I-meter test unit establishes new "highs" for several of its ranges. (1054)

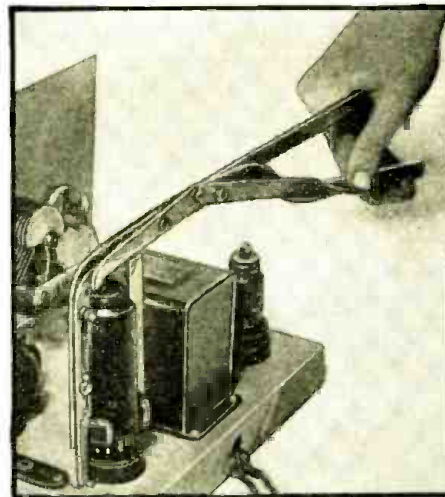

This new tool removes tubes from their sockets in a jiffy. It reduces tube breakage. (1055)



A service unit incorporating several useful functions; including testing for leakage. (1056)

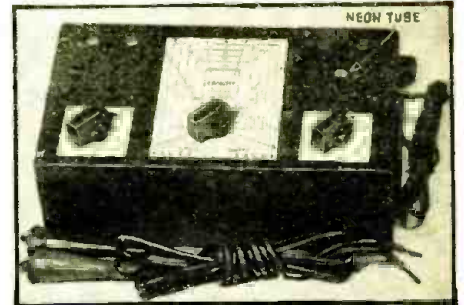

A new test unit which makes many tests for condenser efficiency. Compactness is a feature. (1057)

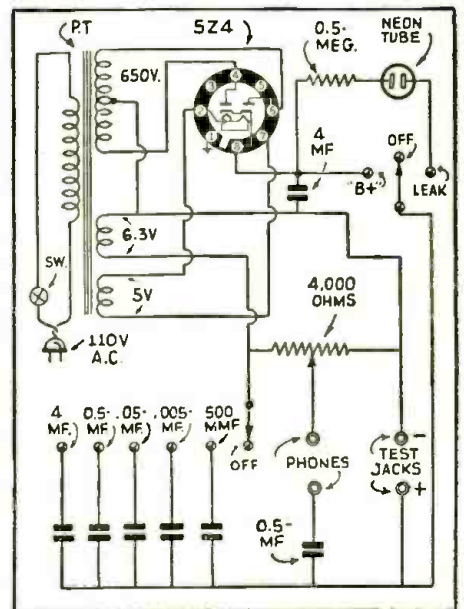

Schematic circuit of the new, general-purpose condenser testing unit. Note the simplicity. (1057)

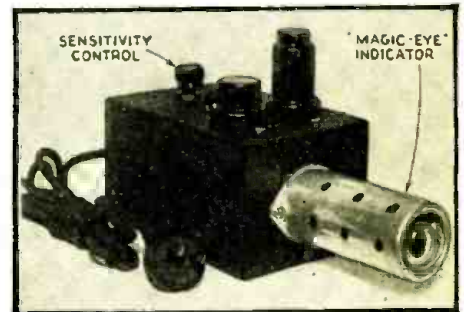

Many test uses of the "magic eye" tube are incorporated in this "kit" unit. (1058)

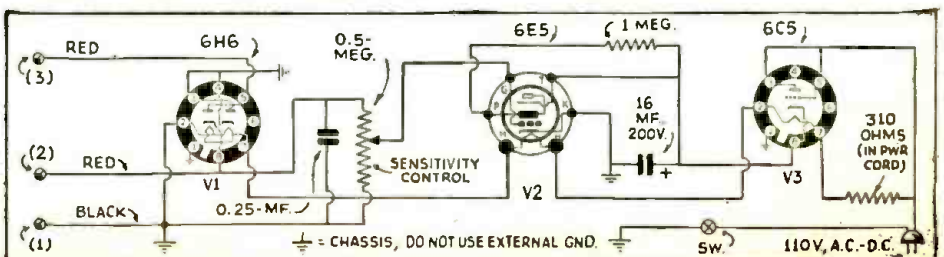

Diagram of the new "magic eye" test unit. Calibrated scales may be placed over the "eye" (a type 6E5 cathode-ray indicator). These scales add greatly to the versatility of the completed instrument, built from the kit.

INTRODUCING— THE "MAGIC EYE" IN A CONDENSER ANALYZER

The 6E5 tube is used as a visual detector in a Wien bridge; and a neon tube indicates leakages.

WILLIAM ROBINSON



THE USE of a 6E5 cathode-ray tube as a *visual detector* for a "Wien bridge" provides an excellent method of measuring with unusual simplicity, wide ranges of capacity and resistance.

The Wien bridge. In Fig. 1 is shown a bridge circuit of the Wien type which consists of a potentiometer, R2, capacity and resistance standards C1 and R1, and capacity test terminals Cx. When a resistor or a condenser is connected at Cx, S1 is placed in a corresponding position and R2 is adjusted until the output voltage of the bridge (and the

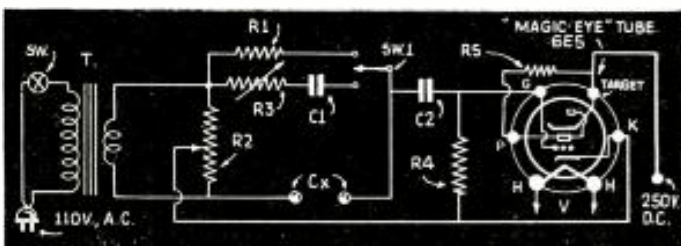

Fig. 1. The circuit of the Wien bridge and leakage-insulation condenser tester.

resultant grid bias of the 6E5) is reduced to zero volts.

This is the balance condition of the bridge and the 6E5 will indicate a shadow angle of 90 deg. For capacity tests of electrolytic condensers, it is frequently necessary to adjust rheostat R3 to correct for the phase difference in the bridge arms usually introduced by the inherently high power factor of this type of condenser.

The potentiometer R2 can be calibrated directly in capacity and resistance, by connecting known values of capacity and resistance to terminals Cx and then marking the balance position of R2 on some suitable scale. Likewise, R3 can be calibrated directly in per cent power factor by means of the following formula:

$$\% \text{ P.F.} = \sqrt{R^2 + \left(\frac{1}{WC}\right)^2} \div 100$$

Neon-type Tester. A circuit for testing the leakage of electrolytic condensers and the insulation resistance of paper (Continued on page 45)

"ALNICO"-MAGNET REPRODUCERS

The newly-developed "alnico"-alloy magnets with very high coercive factors are ideal field coil substitutes.

R. R. DE PUY

THERE HAS recently been placed on the American market a new magnetic material called "alnico" which was developed in the laboratories of the General Electric Company. It is composed of approximately 20 per cent nickel, 12 per cent aluminum, 5 per cent cobalt, and the balance ferrous metals. In combining these 4 materials, heat control is the paramount factor and it has been found that electric furnaces are almost essential for this purpose. After the proper heat treatment, the material assumes a crystalline structure, any broken section of which appears more or less like carborundum, or

silicon, varying considerably in color, from white to almost dark brown. Due to its very loose structure, machining of *alnico* has been found to be quite impractical, and it is therefore usually cast to finished dimensions and after heat treatment the pole faces are ground smooth (using a very soft wheel).

As a magnet, alnico has rather unique qualities in that it has much higher *coercive force* than any material that has been available heretofore. It has approximately 7 times the coercive force of "3½ per cent chrome magnet steel" and approximately 90 per cent higher than "36 per cent cobalt steel." (The "coercive force" of a magnet is a direct indication of its ability to withstand demagnetizing forces.) This very desirable quality of alnico means that it can be used in very short lengths and relatively large cross-sections which should make it very adaptable to dynamic loudspeakers in that the bulkiness of the reproducer can be held to an absolute minimum.



Fig. A. The magnet requires less space than a field coil.

EXPERIMENTING WITH ALNICO

Experiments were conducted to determine how much magnetic material was necessary in a dynamic speaker to obtain performance comparable to that obtained from a field coil.

First of all, a small electromagnetic structure was built up having pole pieces of the same diameter and length as those which would be used in an electrodynamic speaker. A small, single-turn search coil was constructed which could be inserted into the air gap and then quickly withdrawn. This coil was connected by means of flexible leads to a low-reading galvanometer so that (Continued on page 45)

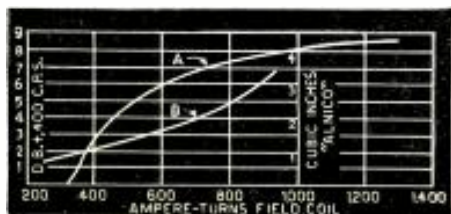

Fig. 1. Comparison of coil and alnico fields.



"BATTERY PORTABLE 4" —AN EASILY-BUILT SET

A broadcast- and police-band 4-tube portable which supplies 6-tube performance.

FRANKLIN SAYRES

a low order that a complete set of batteries should last throughout the entire summer season, or even longer.

WHY "T.R.F."?

The circuit employed is shown in Fig. 1, and as will be noted, the R.F. stages are of the "tuned R.F." type. The reason for selecting a T.R.F. circuit instead of the superheterodyne is a result of the author's experience with constructors who, without the proper facilities, attempt to build receivers with complicated circuits. Not only is the "superhet." receiver much more difficult to construct, but the aligning and adjustment process afterwards involves a considerable amount of practical experience with such circuits; this is in addition to the need for expensive instruments. The T.R.F. circuit, on the other hand, may be easily aligned or adjusted by ear when the receiver is completed, and is considerably less complicated to construct.

Referring again to Fig. 1 and also Fig. B, it will be seen that tuning is accomplished by means of a 2-gang condenser which tunes the antenna and R.F. coils. The coils are of the high-gain tapped type, which when used with a band-changing switch, provide adequate selectivity and gain on either the police or broadcast bands. Two R.F. stages are utilized before detection to build up the strength of feeble signals. Coupling between the 2nd R.F. stage and the detector is accomplished by means of a small 100-mmf. fixed condenser and two pie-wound R.F. chokes which are mounted together. This constitutes an untuned circuit which may not be as efficient as the tuned stage, but results in simplified construction and a more compact receiver. In addition to detection, the third tube also functions as the A.V.C. and 1st A.F. stages. The output from the 1st A.F. section of this tube is resistance-coupled to the final, type 33 tube power stage to which the loudspeaker connects. The power obtained from this final tube on most broadcast reception is usually more than sufficient to rattle the 5-in. loudspeaker!

At this point it may be advisable to stress that no ordinary magnetic loudspeaker unit is utilized in this set. The speaker, clearly shown in Fig. C, is of such design and construction that while it operates on a principle comparable with magnetic speaker units, its quality of reproduction is really comparable with the more expensive, high-quality

(Continued on page 41)

PORTABLES heretofore described—that is, most of them—were not really such in the strict sense of the word. Their weight and bulk, in most instances, were of such proportions that few would be anxious to include them along with additional miscellaneous equipment when camping, picnicing, etc. The greatest drawback of most portables has been that of power consumption, which in most cases was extravagantly high and required frequent battery replacement. This was due to the use of altogether too many tubes in order to attain tremendous amplification so that a maximum of sensitivity from the receiver would be insured.

To overcome these defects the writer evolved the portable shown in the heading illustration, Fig. A. It employs only 4 tubes, has ample sensitivity when used with a 35-ft. antenna, has unusually good reproduction and, in addition to covering the complete broadcast band, also provides for variety, police and amateur signal reception. The 4 tubes are used in an arrangement which is really equivalent to the efficiency attained from 6 separate and individual stages. Despite this, battery consumption of this receiver is of such

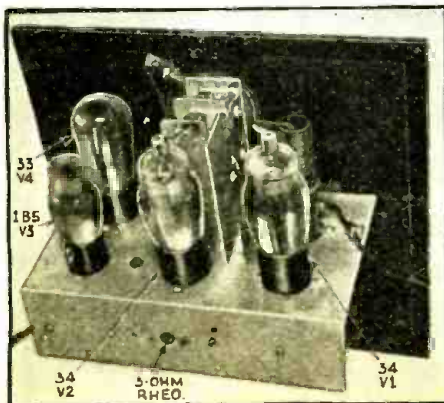

Fig. B. The rear view of the chassis showing the aerial coil and 2-section condenser.

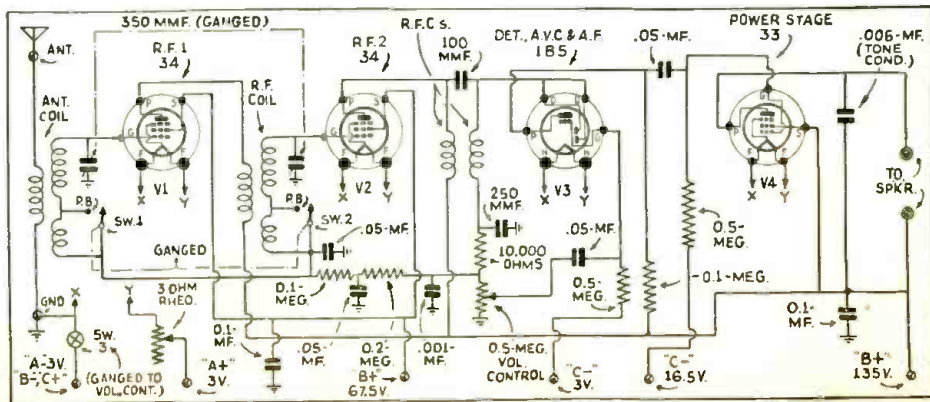
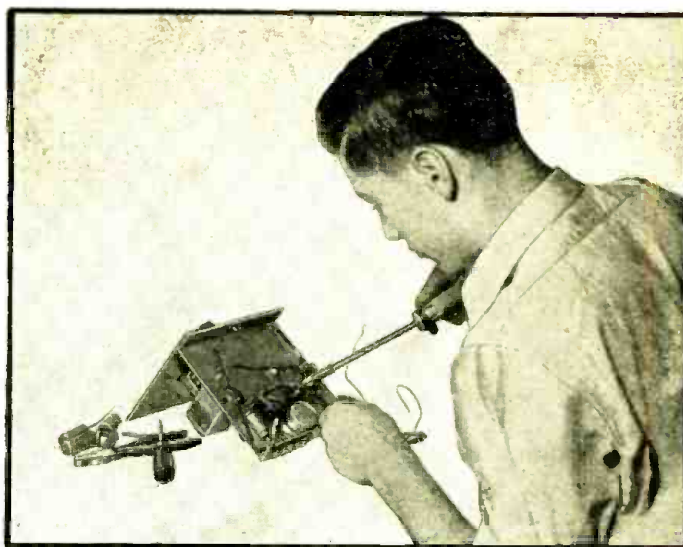

Fig. 1. The circuit, with values. Note that the coils are tapped for police-band reception. The 2nd R.F. and detector are coupled aperiodically through a 100 mf. condenser.

A 2-TUBE "F.C.T." SET FOR THE BEGINNER

This beginner's set will supply unusual sensitivity due to the circuit employed. It is easy to build and if the instructions are followed closely, it will present a workman-like appearance that will do credit to any professional. Try this easily made set!

J. H. GREEN



SOME TIME ago, we presented a new detector—the development of a French radio engineer—called the "Faible Constante de Temps" or F.C.T. circuit.

This circuit was very effective and found much favor among the experimenters who built it, due mainly to the great sensitivity and selectivity it offered, compared to other detectors. However, the original set was not very easy to build and in order to allow those who have not had much experience with set building to take advantage of this unusual circuit, this new receiver was designed.

It will not be necessary to go into the subject of the theory of operation, since this was thoroughly covered in the March, 1936, issue of *Radio-Craft* on page 521.

BUILDING THE SET

The first thing, of course, is to obtain all the parts. A check through the List of Parts at the end of the article will soon show what is needed.

It will be seen that the new metal tubes are used and to make the set even more modern, iron-core coils have been included.

The photos, Figs. A (in heading) and B, show the parts positions on panel and chassis. Exact positions of the parts are not given, since the builder, however new he is in radio, if he has any mechanical ability can spot the parts in the positions shown, and since the positions and sizes of holes vary with different makes of parts, a drilling layout is not very useful.

When the parts have been mounted in the correct positions, as shown, the set

is ready to be wired. For this purpose, both schematic and picture wiring diagrams have been given. Whichever circuit is used, it is a good plan to take a colored pencil and mark each lead as it is connected in place.

The soldering of the wires to the soldering lugs is very important in the operation of the set later so it is necessary to do a good job here. The important points to remember are to keep the iron clean and well coated with solder (tinned) and sufficiently hot. Use a resin-core solder—not acid core—and hold the iron on the joint until the solder runs in smoothly.

There is one part of the wiring which *must* be watched carefully. Because of the necessity of keeping both ends of the secondary of L2 insulated from the metal chassis—since they connect to the cap and the plate of the 6J7 tube—the coil L2 has been reversed and the regular secondary coil is connected to the plate of the 6K7 through the condenser C3. The usual primary coil connects to the control-grid and plate of the 6J7. Thus the coil is connected in the reverse of the usual method.

When the wiring is completed, the set can be connected to the power supply. This can be varied to suit the needs of the individual. Thus, the filament supply can be either 4 dry cells connected in series (with the alternate negatives and positives together and the remaining two terminals connected to the filament terminals of the set); or a 6-V. storage battery; or a 6-V. filament (Continued on page 47)

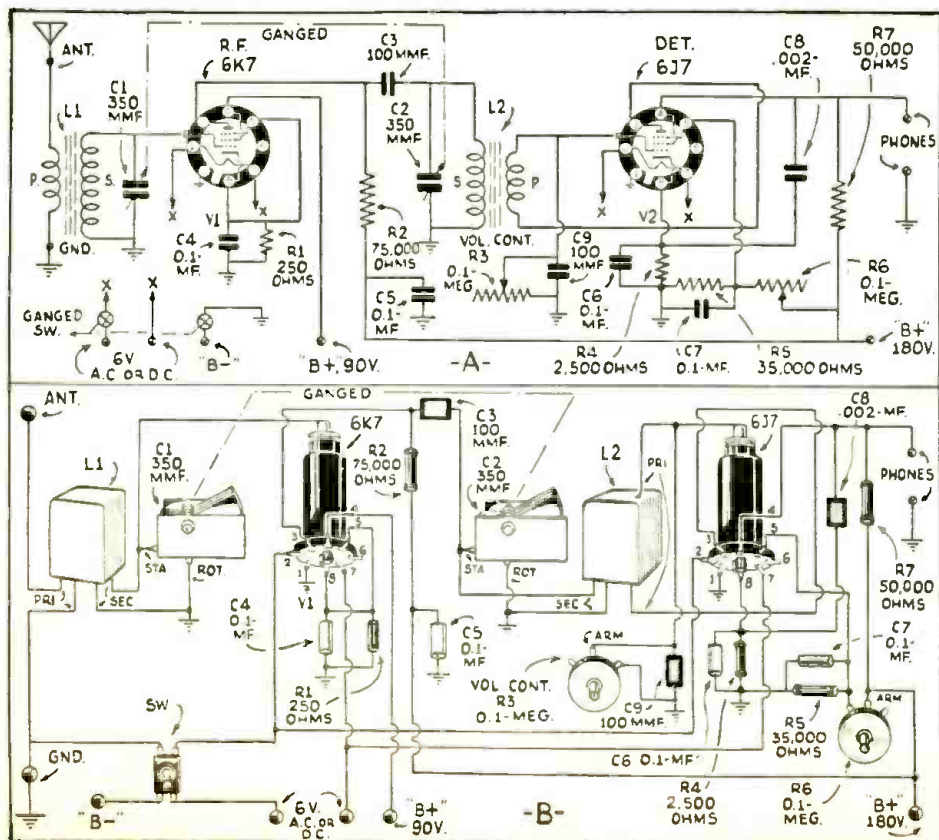

Fig. 1. At A is the schematic circuit of the set; at B is the simplified picture diagram.

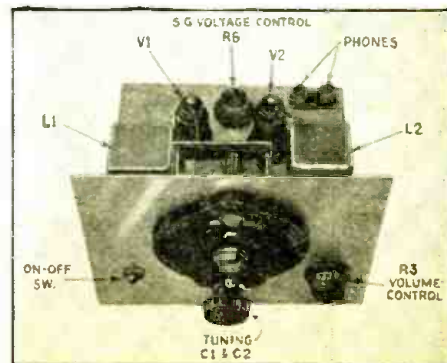

Fig. 2. The Complete set—ready to use.



Fig. A. The complete analyzer—note the convenient layout of the controls and the large meter.

IN THE September 1932 issue of *Radio-Craft* there appeared a constructional article entitled "The Radio-Craft Universal Analyzer." The unit described in this article was built by a great number of radio Service Men and amateurs. This instrument was simple in design and was more than satisfactory in operation. One part of the design had a distinct effect on the method of identifying the various tube elements and their corresponding base-prong connections. It was realized at the time (with the increase in the number of grids and the interchanging of tube elements as far as their connections to the contact pins on the tube bases was concerned) that it would soon be necessary to number the switch contacts to correspond with the tube-base contact positions and not to indicate switch position by the word "plate," etc. Thus, the 1932 design incorporated numbers for the tube element identification and the current and voltage switches were numbered to coincide with a set of numbers assigned to the elements of the tube. It is interesting to note that the 1932 design had a socket for the then new 6-prong tubes.

A modified design of the same unit appeared in the October 1933 issue of *Radio-Craft* and by this time the tube-prong numbering system **FIRST INTRODUCED BY RADIO-CRAFT** had been accepted by all of the tube manufacturers and more or less standardized. Although, it was several years later that the present counter-clockwise method was considered final. The 1933 design included sockets for the large- and small-base 7-prong tubes. (The reader will remember that metal tubes were said to be a "crackpot's dream" at this time!)

DESCRIPTION

Since that time (1933) no further work was done to modify or improve the analyzer in the lab. because the available tubes and the circuits used in receivers could be handled satisfactorily. But then, 1935 furnished a year of many changes and introduced octal-base metal tubes. So, the lab. decided that instead of just adding adapters to handle the new tubes a complete revision would be made and the entire instrument would be modernized. An attempt was made to use as many as possible of the parts specified in the original design. However, changes in the methods of testing and the desire for still more flexibility brought electrical and mechanical changes in the circuits and controls. Readers having copies of the 1932 issue will note that the elemental circuit devised at that time is still used and that there is a startling similarity in the circuit drawings.

These changes in the analyzer included the use of selector

HOW TO MAKE THE RADIO-CRAFT SET ANALYZER

Here is a thoroughly modern version of the popular Radio-Craft analyzer which will speed up service work on any receiver.

PART I

switches and a meter having a higher degree of sensitivity. The voltage, current and resistance ranges were also changed to values that are more useful in modern practice.

A study of the diagram in Fig. 1 will give a clear picture of the design and the adaptability of this new analyzer to modern test requirements. The listing of the voltage, current and resistance ranges is given in Table I for ready reference.

TABLE I

Voltage Ranges (A.C. & D.C.)	Current Ranges (D.C.)	Ohmmeter Ranges
0-5 V.	0-500 microamperes	0-2,000 ohms
0-50 V.	0-5 ma.	0-0.2-meg.
0-250 V.	0-50 ma.	0-2 megs.
0-750 V.	0-250 ma.	

If the owner of the early models of this analyzer wishes to use his meter in the present design he can do so without difficulty. Of course, he will have to change the markings on the front panel to coincide with the scale ranges of the older meter.

All of the selector switches and controls are located on the panel in such a position as to afford the user the maximum in speed and ease of operation. For example, the circuit-selector switch is found in a natural position under the right hand. That is, the control is on the right-hand, near-side of the panel. This is a very much used switch in point-to-point analysis. The meter-scale range-selector is on the left-hand side of the panel and is adjusted by the left hand. The placement of the hands on these controls will not obstruct the scales of the meter. All current circuits can be analyzed by pressing the buttons on the right-hand side of the panel with the right-hand. The "E-I" switch is set for operation with the left hand. (The parts placement in the average analyzer have not received a great deal of attention but is mentioned to show the effect of proper component placement which was followed in this design.)

The top and bottom view photographs of the wired analyzer ready for use show very clearly the actual parts layout and the neatness of design.

The flexibility of circuit design permits the use of this analyzer in many ways. In fact, the listing in Table II will give a better idea of the possibilities with greater clarity.

TABLE II

Uses of the Radio-Craft Analyzer

1. Conventional voltage measurements.
2. Conventional current measurements.
3. Conventional resistance measurements.
4. Point-to-point resistance measurements.
5. Point-to-point voltage and resistance measurements with fixed reference point.
6. Point-to-point voltage and resistance measurements with floating reference point.
7. External use of voltmeter, milliammeter and ohmmeter ranges.

It is at once apparent that all types of dynamic and static tests on a radio receiver or amplifier can be made with this new unit with the maximum of speed, satisfactory accuracy and convenience.

USING THE ANALYZER

The use of multi-wire cables equipped with plug connectors has been common practice for years and need not be covered at great length at this time. This new plug and cable assembly has been refined and features adapter plugs with a simple locking device that holds the adapter securely yet readily releases the adapter by a turn of the wrist. A new type of cap connector is furnished which takes care of the difference in diameter in the grid caps of the glass and metal type tubes. It will be noted that the first socket at the rear-right-hand side of the panel is the 9-contact socket for the analyzer cable.

A.C. Voltage Measurements: Throw the switch marked A.C.-D.C. to the A.C. position. The toggle switch marked E-1 should be in the E position. This switch in this position removes all possibility of interconnection between the voltage and current circuits. The switch should be in the E position when making D.C. voltage measurements as well. *Be SURE that the voltage range selected (Range Selector Switch) for test is greater than any possible circuit voltage.* Whenever possible, start with the 750 V. scale and then change to a lower scale if necessary for accurate reading. *Do not try to read D.C. voltages when the A.C.-D.C. switch is in the A.C. position.* The A.C. scale and D.C. scale on the meter are identical and the compensation for the rectifier is accomplished by using a special set of resistors for the AC. multipliers.

D.C. Voltage Measurements: Turn the switch marked A.C.-D.C. to the D.C. position. Toggle switch E-1 should be in the E position. This removes the current shunts as stated above. It is impossible to read A.C. voltages as the rectifier is removed from the circuit in the D.C. position. Be sure that the voltage range of the meter is greater than the voltage under test. Start with the 750 V. scale and work down until the reading falls near the center of the dial.

Current Measurements: Throw the switch marked A.C.-D.C. to the D.C. position. Throw the E-I switch to the I position. This will cut out all of the circuit selector switches except the meter range selector switch and will connect the push-button switches to the shunts and to the meter. Set the meter range-selector switch to the highest current range (250 ma.) and then change to a lower scale if necessary for accurate reading. Current readings cannot be made point to point. The current through any tube element can be read except the No. 1 line as this is a filament and it is never necessary to read filament current. It is important to know

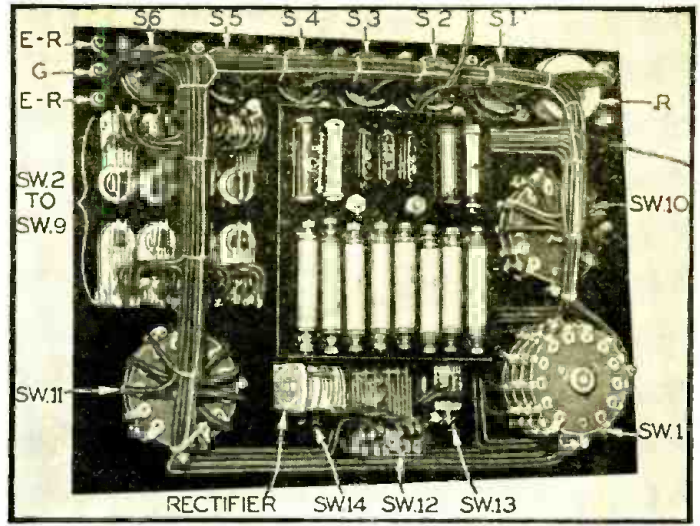

Fig. 8. The back of the panel showing the positions of the parts.

the respective numbers of the tube elements as the panel is marked to indicate the current switch that will correspond to the tube element number. For example, switch 3 will read control-grid current of a type 56 or 76 type tube but will read screen-grid current of a 6C6 or a 6D6. This will not offer difficulties to the real Service Man as it is part of his business to know the respective numbers of the various tube elements.

Resistance Measurements: Throw the switch marked A.C.-D.C. to the D.C. position. Have the E-I switch in the E position. Select the ohmmeter range desired on the meter-range selector switch. Set the circuit reference switch to the same number as indicated by the circuit-selector switch. If the circuit-selector switch is on the No. 2 tap then set the reference switch to the 2 tap. This will short the ohmmeter circuit and then adjust the Zero Set rheostat for 0 resistance. At this point the pointer of the meter will indicate full-scale. Proceed with the measurement as required. If the ohmmeter range selected is not satisfactory change to the next ohm scale. Be sure that the meter is adjusted to 0 whenever changing ohmmeter ranges.

(Continued on page 46)

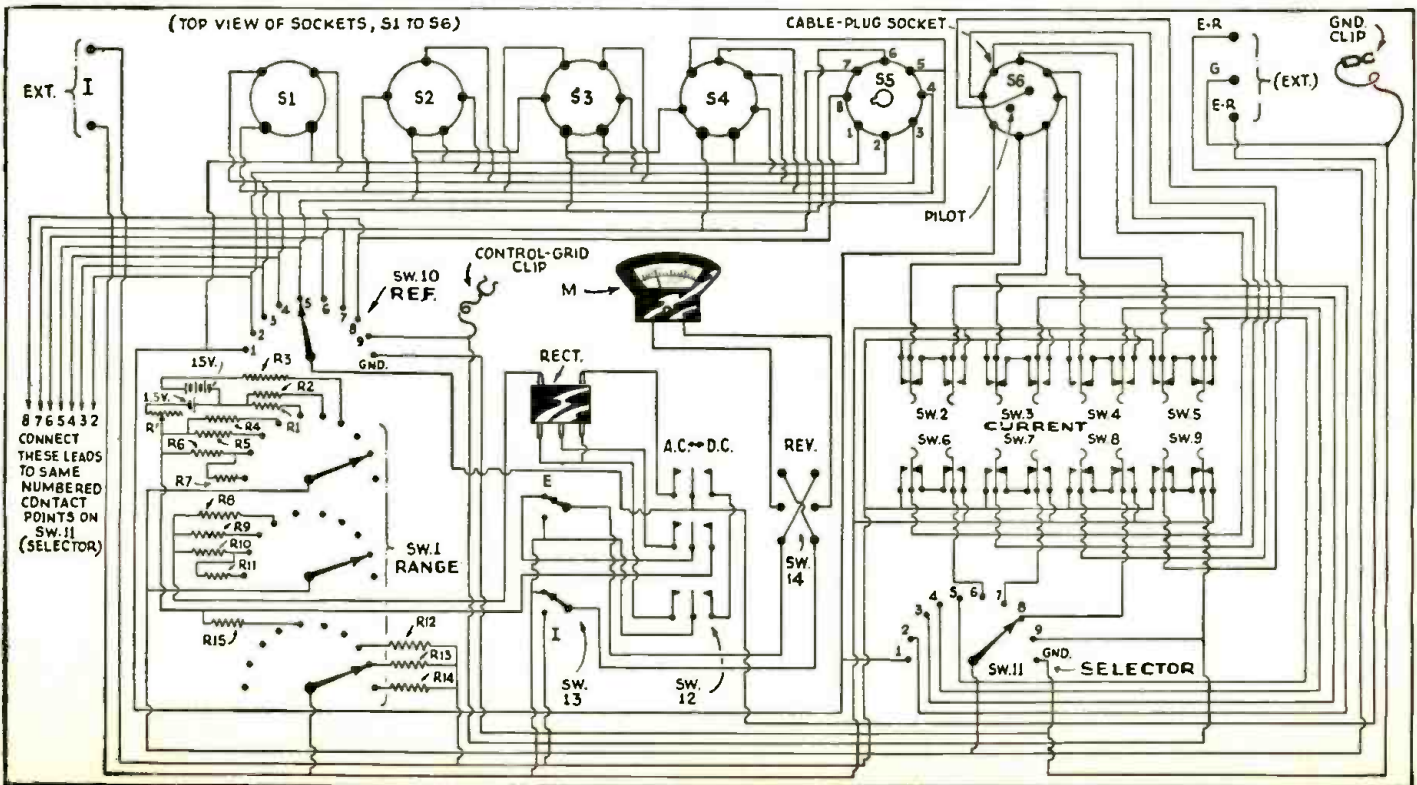

Fig. 1. The schematic circuit with all parts in their relative positions as compared with the panel.

SOLDERING HINTS AND IDEAS

Few technicians realize that several very interesting developments have been made in the design of soldering "irons," to secure improved results (quicker, less expensive and more satisfactory work). Modernize your soldering data.

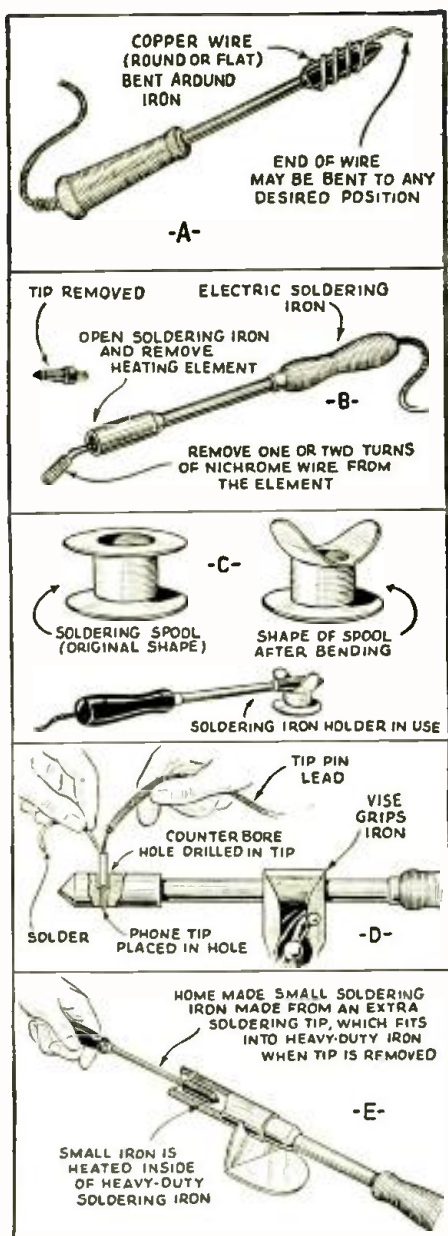

Fig. 1. Some novel soldering hints.

SERVICE MEN, and, in fact, all radio men, should find it profitable to read about the items which are discussed in the first part of this article.

The second part describes novel ideas submitted by *Radio-Craft* readers.

Soldering Iron "Kit." (General Electric Co.) What is probably the most complete soldering complement on the market is the "kit" here illustrated (Fig. A). There are in addition to the one standard and 4 special, removable soldering tips, a holding and clamping bracket, a can of soldering paste, and string solder. The tips are described in further detail as follows.

Ladle (A)—this very unusual but quite useful "point" is used to melt solder for pouring into terminals, wiping small joints, or casting special shapes in a wood, metal or dry-sand mold. When the soldering tool (which consumes 95 W.) is clamped in the bracket the ladle may also be used for dip-soldering connections or tinning small parts.

Flat Branding (B)—this odd point is useful as a hot-plate on which parts may be assembled and sweated together, when the tool is clamped in the bracket

(this tip also is used in branding lettering).

Side (C)—a point for difficult work such as inside edges, particularly at the corners.

Pyramid (D)—here is a point especially for soldering seams in sheet metal work.

Chisel (E)—this is the "standard" point used for general soldering. (No. 1050)

"Heated-Tip" Iron. Service Men are unaware that there is on the market a quick-heating iron (Fig. B) which saves time right at the start of the service call. The "trick" is in the hermetically-sealed, nichrome-V wire heating unit, which extends right into the copper soldering tip.

By thus placing the heating unit right where the heat is required (as shown in detail illustration), a second advantage, of interest to the shop man, is secured—the current drain is reduced to only 50 W. (No. 1051)

Arc-Type Solderer. Most Service Men are familiar with the method of soldering that involves connecting one side of a current source to a pointed carbon rod, and the other to the work.

This method of soldering is not suitable for certain types of soldering. However, for sweating terminal lugs, and

(Continued on page 47)

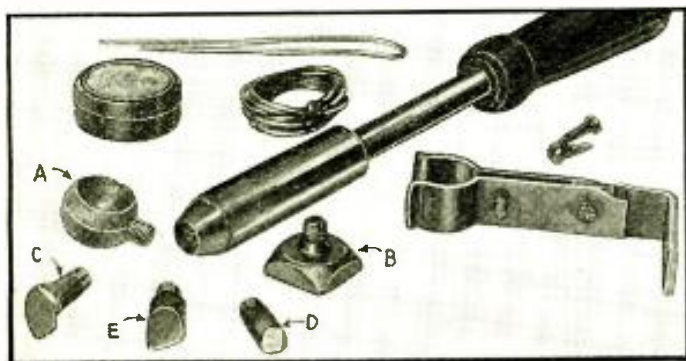

Fig. A. The novel points in this kit make hard jobs easy.

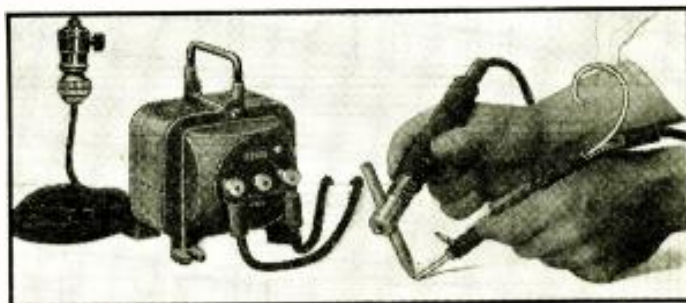

Fig. C. An arc type unit that is ideal for heavy work.

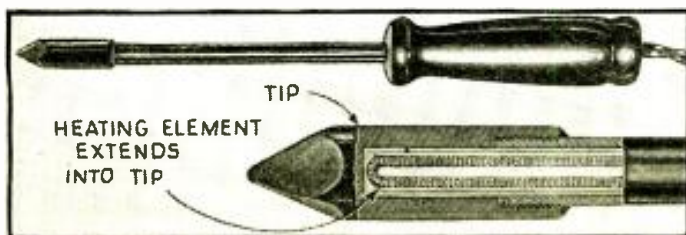

Fig. B. The heating element is in the tip of this unit.

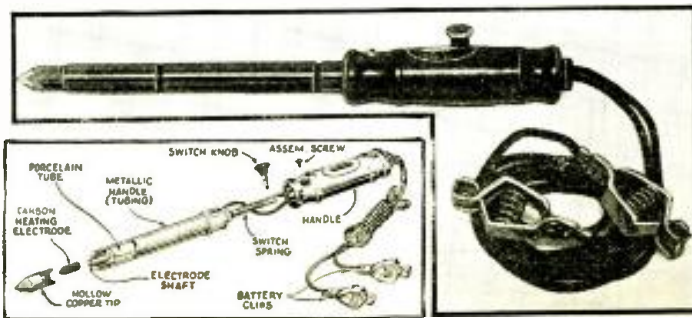

Fig. D. An improved arc unit having a regular copper tip.

ARE METAL TUBES "HOTTER"?

One of the outstanding questions which have been raised about the metal tubes is that of radiated heat from the metal shell, which is an important factor in the design and layout of parts. Read this technical answer to the question.

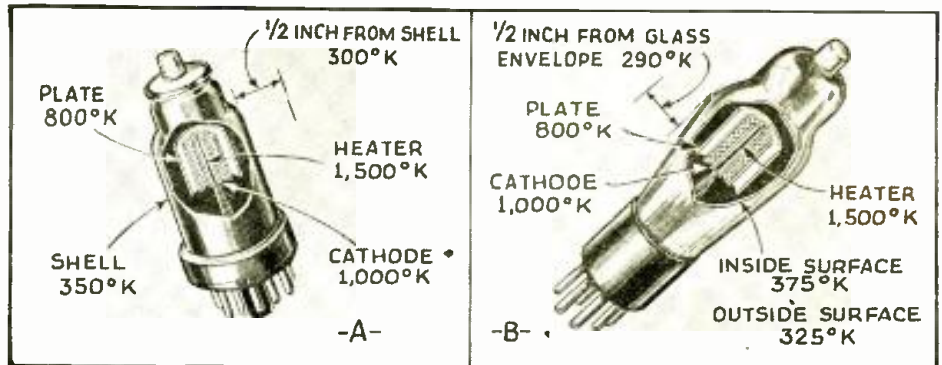

Fig. A. The relative temperatures of the interior and exterior of glass and metal tubes.

J. E. ANDERSON AND J. GOLDSTEIN

THE MOST frequently repeated objection to the metal tubes is that they get hotter during operation than the glass tubes. Many objectors even insist that they get dangerously hot. Is this objection based on facts or only on a prejudiced imagination? Do the metal tubes actually get dangerously hot? If so, who or what is endangered by their sizzling heat? Is it the operator of the receiver who is in danger of painful burns should he accidentally touch a tube, or is it the tube itself that is in danger of becoming overheated and of consequently breaking down? Or, again, are other components of the receiver in danger of damage by the blistering heat from the metal tubes? The full answer to these questions has been wanting, for those who shout loudest about the dangerous heat are the vaguest when requested to explain who or what is in danger.

A nearly complete answer to the questions can be obtained by invoking well known laws pertaining to heat, such as those of (a) generation, (b) conduction, (c) radiation, and (d) convection.

GENERATION OF HEAT

Generation of heat is the transduction of energy from any of its other forms into heat or thermal energy. Combustion, or rapid oxidation, which converts potential energy into heat by chemical change, is the most common

form of conversion; it is well illustrated by the flame of the blow torch, Fig. 1A. Friction is another mode of conversion; it transforms energy of motion into heat. The striking of a match is a familiar example. But the mode of conversion in which we are now mostly interested is the transduction of electrical energy into heat by current flow through a resistance. The electrical heating plate, Fig. 1B, is one of countless examples of the application of the principle.

All the heat that is generated in a vacuum tube is developed by a current flowing through a resistance. Part of the total heat is developed in the filament circuit and part in the plate circuit. If other currents flow, such as control-grid and screen-grid currents, they, too, contribute some heat. The amount of heat developed in a given time is easily determined when the resistance and the current are known, or, what is the same thing, when the number of watts dissipated are known. If the current flowing is I amperes and the resistance is R ohms, then the number of heat units H , or gram-calories, developed in R in a time t seconds is given by the formula $H=0.238RI^2t$. Since the resistance times the current squared is the number of watts, it is clear that the formula can also be written $H=0.238Wt$, where W expresses the number of watts.

Which tubes, metal or glass, generate the most heat? In fairness we

should compare similar tubes in the two classes. Such tubes are the 6K7 (metal) and the 6D6 (glass). Each of these tubes requires 6.3 V. across the filaments and each draws 0.3-A. The number of watts expended in either filament is 6.3×0.3 , or 1.89 W. Therefore, in either filament 0.45-calorie is generated every second. In the plate and screen-grid circuits of the 6K7, under recommended operating conditions, the number of watts normally dissipated is 1.92. The corresponding figure for the 6D6 is 2.25 W. Thus, the number of gram-calories per second developed in the 6K7 is 0.906 and the number of the 6D6 is 0.986. Therefore slightly more heat is liberated within the glass tube than within the metal tube.

Another pair of tubes that may be fairly compared is the 6F6 and the 42. These tubes have identical pentode operating specifications and the total number of watts expended in either when working normally is 14.5, or the number of gram-calories developed per second is 3.46. Thus as sources of heat these tubes are identical.

When other corresponding pairs of tubes are compared, the same conclusions regarding heat liberation are reached; that is, that they are either identical or very nearly the same. In other words, if two receivers are built identical except that one has all metal tubes and the other all glass tubes of the same heater rating, the amount of

(Continued on page 48)

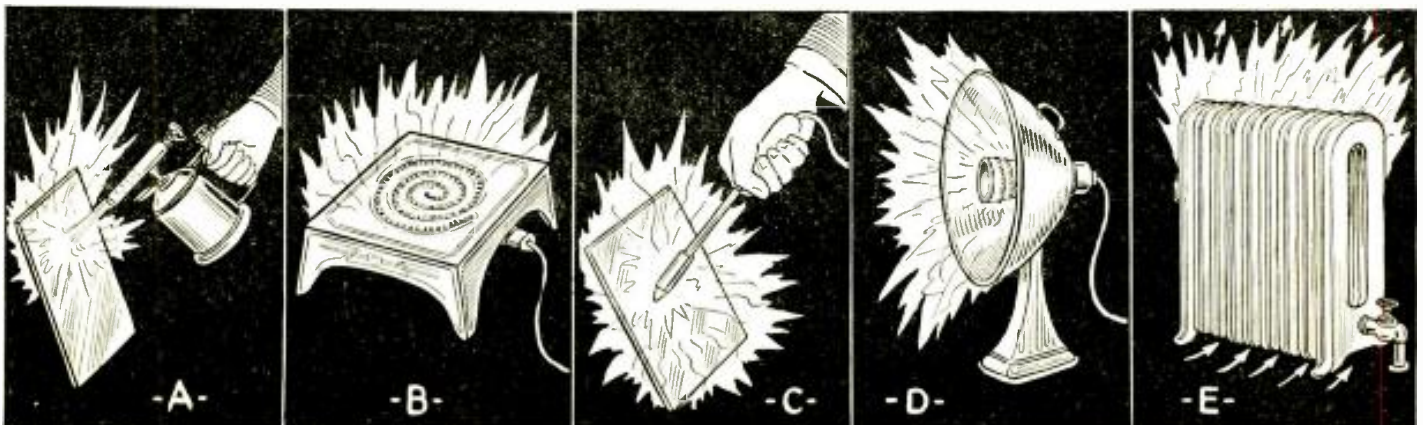

Fig. 1. Heat distribution: A and B—conversion; C—conduction; D—radiation; E—convection.



Fig. A. The appearance of the amplifier chassis.

THE "ANTI-HOWL" AUDIO AMPLIFIER

Presenting a new 12-tube design incorporating "howl" suppression, volume expansion, and a 6E5 "magic eye" as expansion and output indicator! BEAM POWER OUTPUT!

A. C. SHANEY PART II

istics of the finest triode, and with the efficiency of an equivalent class B tube.

Read how this "beam" tube is actually used.

THE SERVICES OF THE 12 TUBES

The photo, Fig. A, shows a view of the correctly-designed amplifier which is the subject of this article. It utilizes a 6E5 cathode-ray tube, a 6J7 as a high-gain preamplifier, a 6C5 as a high-gain voltage amplifier, and a 6L7 as a volume expander in conjunction with a 6C5 and a 6H6. Two 6F6 triode drivers are used to drive 2-6L6s. An 83 mercury vapor tube furnishes plate current, while an 80 supplies fixed bias to all tubes. The total line-power consumption of this combination is 150 W.

The overall gain of the amplifier (at the velocity-ribbon-microphone input) is 140 db. At the crystal mike input it is 98 db. The phono. input signal is amplified 68 db. With the expander in the circuit the gain of the 6L7 stage changes with the intensity of the signal. At the no-signal level its gain is very low. This condition seems to kill all emission and microphonic noises normally encountered in high-gain amplifiers.

By minimizing heater-to-cathode leakage through the use of fixed-bias in all stages, hum-level is kept down to a point never before attained in high-gain A.C. operated amplifiers. (Of course, precautions must be taken to eliminate

(Continued on page 52)

PERHAPS the most important question today in the mind of every thoughtful P.A. technician is: "Where do we go from here?" Optimists will give you one answer. Pessimists will give you another. But you can arrive at your own answer by looking at the new trend of developments in power output tubes, microphones, speakers, and amplifier circuits. (It is at this point that we digress for a moment from the actual amplifier previously discussed in Part I, to consider one of its most outstanding component elements.)

Take power tubes for example, first we had triodes with fair quality and poor power sensitivity; then came tetrodes—more power sensitivity but more distortion. Pentodes followed with still higher sensitivity and still more distortion! Then the pendulum of design swung back to triodes—high-fidelity triodes with real quality, poor efficiency and of course limited output with low sensitivity. Class B tubes followed. Here we had high efficiency, fair sensitivity, good quality (if properly used) and higher power outputs. But—as expected—poor results were obtained because of improper design in auxiliary components. The natural trend swung back again to triodes—but this time in new AB circuits in an attempt to get the efficiency of class B operation with class A tubes. The sum total of all this constant change, check, test, discard and retest has resulted in a truly startling tube development.

Today, a revolutionary type of metal tube (the 6L6, described in detail elsewhere in this issue) makes it possible to produce 30 to 60 W. of audio power with the power sensitivity of a pentode, the elements of a tetrode, the high-fidelity character-

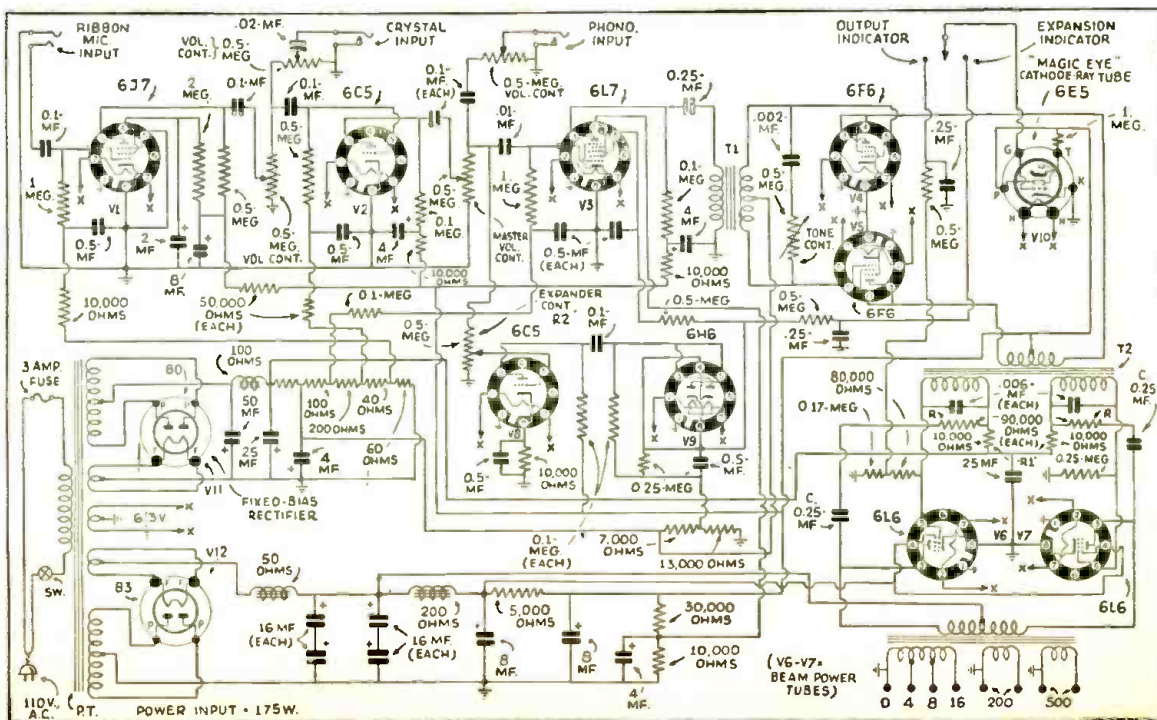

Fig. 1. The circuit of the 34 W. amplifier described, including volume expander and 6E5 indicator.

OFFICIAL RADIO SERVICE MEN'S ASSOCIATION, INC.

A department devoted to members and those interested in the Official Radio Service Men's Association. It is the medium for exchanging ideas, kinks, gossip and notes of interest to Service Men, or others interested in servicing.

A REAL TRAVELING SHOP

RADIO-CRAFT, ORSMA Dept.:

Following is a description of my trailer, which serves as residence, store and shop. In size, this trailer (Fig. A) is about 18 ft. long (inside) and 7 ft. wide. The outside is finished in bright aluminum with suitable lettering in red and dark blue. Complete with all equipment, it weighs approximately 2 tons and is pulled by a Plymouth coach.

There is a davenport bed across the front end (see Fig. C) and a workbench across the rear (Fig. B) with suitable test equipment (consisting of universal meters built from a Jewell 199 tester) mounted on the wall. Other equipment includes a tube tester of my own design with an "every element" short test (and so arranged that I can test any tube, regardless of what types may be put out), and a Triplett analyzer and oscillator. Two I.R.C. Resisto-Chests fastened on the wall at the sides of the meters carry supplies of resistors and condensers for immediate use, while reserve supplies are carried in lockers. Small parts are contained in glass jars on shelves where they may be seen without taking the jars down. I claim to carry all parts to service any radio set, and that isn't far from true.

Somewhat over 2 years ago I evolved the idea of a traveling radio shop doing radio repair work in towns where there was no shop, and selling supplies wholesale to Service Men in others; working North during the summer and South during the winter. Now I have an established route between the 2 "Playgrounds of America," Northern Michigan and Southern Texas, with about 40 stops going each way.

Now a word of warning to the 5,000 Service Men who, upon reading this will say, "That's what I am going to do." Equipment for this kind of business will cost not less than \$1,500, for a poor car or trailer will take up all of your time so that you will be unable to get much else done. Appearance must be good in order to favorably impress the public. And last but not most important, it will not pay expenses until you have an established route with friends in the towns where you stop, which will probably take at least a year. If you can stand those requirements, it's a nice business.

CHAS. MIDDLETON

When we printed the Service Number of 1935, a year ago, we thought we had a rather novel cover idea. Now it seems Mr. Middleton was 'way ahead of us! We suppose we will find, after publication of this issue, that some enterprising Service Man has his shop lighted by the green glow of oscilloscopes!

In Fig. 2 is reproduced one of the

cards that Mr. Middleton sends to likely prospects in the tows ahead that are included in his itinerary.

IMPROVED "MAGIC EYE" LEAKAGE TESTER

RADIO-CRAFT, ORSMA Dept.:

I have just finished building the "Magic Eye" Leakage Tester" de-

scribed in the March issue of *Radio-Craft*, and have found it can be made very useful by making a few changes as indicated in the diagram, Fig. 1.

As an output meter it is very sensitive, as it will operate on a signal which is barely audible. This is a great help in aligning sets with A.V.C. and sets with poor I.F. gain. This sensitivity can be controlled by the 0.5-meg. potentiometer.

As may be noted in the diagram, the 6.3 V. filament circuit is used to test the capacity of small condensers.

I used only one filter condenser, as an input condenser was found unnecessary; it raised the voltage too high.

The 50,000-ohm variable cathode resistor was found to be too large, as all of the action took place on one end. A 10,000-ohm tapered unit was found to be satisfactory. (Switch Sw. 4 is of the "skip" type in order to prevent shorting the "B" units.)

RAY JEFFERSON,
Baldwin, L. I.

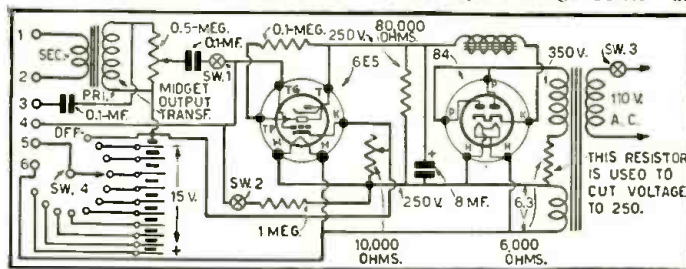

Fig. 1. Here is an improved version of the "Magic Eye" leakage tester which was described in the March, 1936, issue of *Radio-Craft*. Several features have been added which make the apparatus much more adaptable.

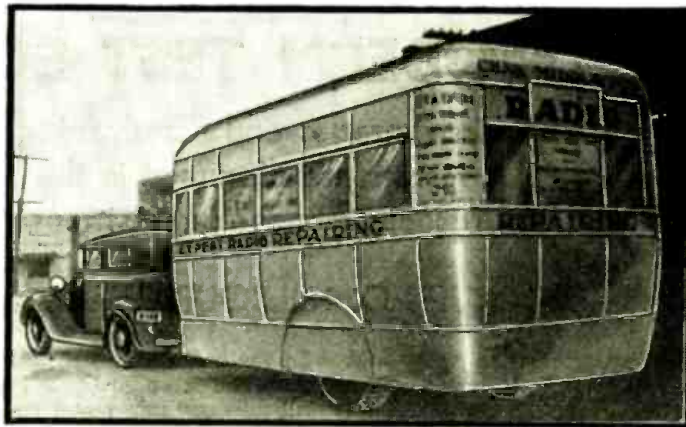

Fig. A. An exterior view of the traveling radio service shop of Mr. Charles Middleton, who covers the states according to seasons.

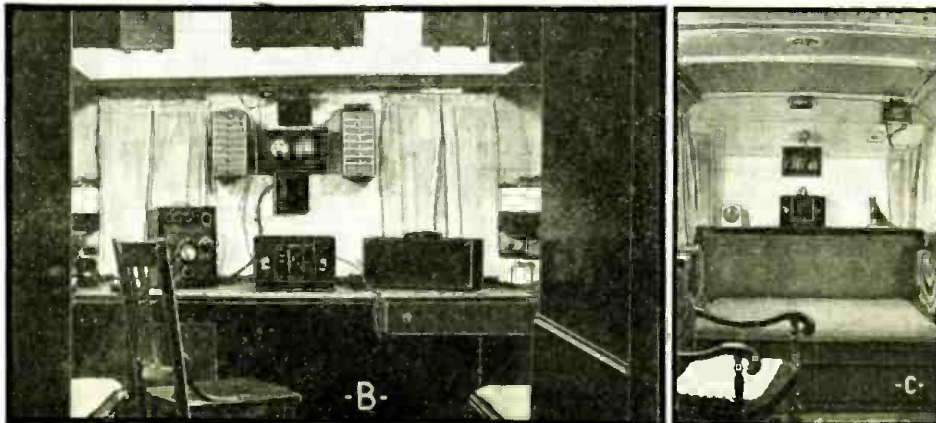

Fig. B, left. The interior of the trailer, showing the shop and work bench end. Fig. C, right, the end of trailer which Mr. Middleton uses as living quarters en route.

The 6 input terminals are connected as follows:
1 and 2— to voice coil of speaker.
3 and 5— to plate of output tube.
4 and 5— to test leakage (open Sw. 1).

4 and 6— small condenser capacity test (open Sw. 1).
4 and 5— A.V.C. line (open Sw. 2).

SOME STRAIGHT-FROM-THE-SHOULDER REMARKS ABOUT THE BUSINESS OF SERVICING

RADIO-CRAFT, ORSMA Dept.:

This letter may interest you. The writer has been doing radio service work for many years as a side line.

The service end of the business gradually grew too large to be run in anything but a very business-like manner; therefore we started to employ a couple of very capable men to do that part of the work for us. As a side line done in our spare time we made a few dollars, but not enough to call it a living. After pushing this end for some time in order that we might keep our men busy, we found that it was impossible to make any money at it.

Here is our experience. We work in (Cont. on page 50)

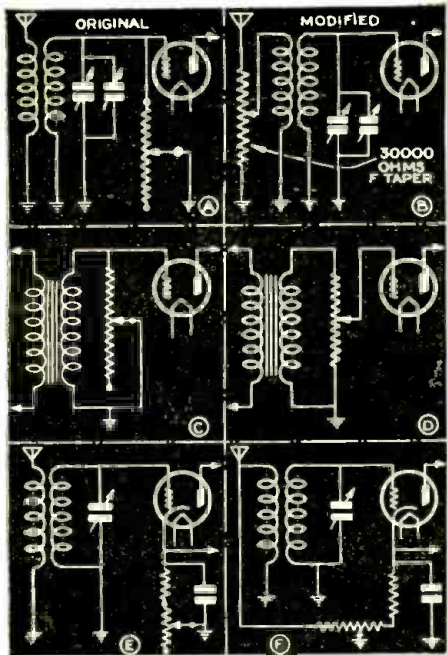

Fig. 1. Volume control circuit details.

IN THE "old" days, when there were few broadcast stations, and they were all low-power transmitters, the volume-control problem in a receiver was very simple. With the present high-power transmitters, however, many old receivers cannot be turned down to a comfortable level by means of the volume control alone. Consequently listeners resort to detuning in order to bring the

IMPROVING OLD VOLUME CONTROL CIRCUITS

The volume control circuits of old receivers can be improved in many cases, by simply changing the control.

L. A. DE ROSA

signal to the desired volume, resulting in distortion and interference from stations on adjacent channels. It is possible for the Service Man to make a few simple changes in the volume-control circuit, eliminate this difficulty, and secure a pleased customer.

Correcting poor low-volume selectivity. In Fig. 1A, we see a type of volume control used in many receivers manufactured about 1928. As the volume is turned down the secondary of an R.F. coil is gradually shorted, thus lowering the signal voltage applied to the control-grid of the next R.F. tube. What happens when a resonant circuit is loaded, is well known. The resonance peak drops lower, and lower, ruining the selectivity of that circuit. We see, therefore, that on strong stations the selectivity will be ruined and stations on both sides of the desired station are heard.

If we use a 30,000-ohm control with a taper similar to F of Fig. 2, and connect

this unit as an antenna control as shown in Fig. 1B, we can eliminate this difficulty. The only precautions are to shield the arm-lead of the resistor and to
(Continued on page 49)

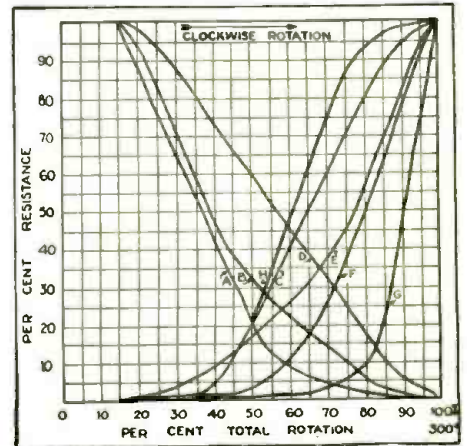
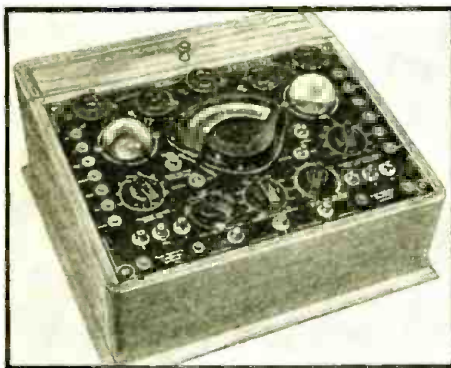

Fig. 2. The tapers of modern controls.



THE DESIGN OF MODERN TEST EQUIPMENT

The advantages and disadvantages of different types of tube testers are discussed in this part of the series. Several fallacies concerning instrument designs are exploded!

SAMUEL C. MILBOURNE PART IV

SINCE METERS are generally designed to withstand loads which are 10 times normal full-scale load, we may assume that a 10-ma. meter will safely withstand an applied potential of 1 V., which would produce a current load of 100 ma., regardless of the resistance value of the rheostat shunted across the meter. This safe overload limit suggests that, instead of using a fuse to protect the meter, we may introduce enough "limiting resistance" into the circuit to develop a potential drop of 29 V., in the case of a short-circuited tube, leaving the safe value of 1 V. developed across the meter. A meter load of 100 ma. would produce a potential drop of 1 V. across the meter, and the circuit load would be limited to this value by a total circuit resistance value of 200 ohms, obtained by applying Ohm's law and dividing 30 V. by 100 ma. (0.1-A.). Since the joint resistance of the meter and rheostat cannot exceed 10 ohms, this small value may be considered as negligible, and a 300-ohm resistor used as in Fig. 7A.

WHAT IS WRONG WITH THIS "STANDARD" CIRCUIT?

The tube testing circuit represented by Fig. 7A has the advantages of simplicity and safety; it has been used, with minor variations in several commercial tube tester types.

In fact, the basic principles involved are incorporated in a so-called "standard tube tester" which is being considered by all tube and tube tester manufacturers. Offhand, the average technician and most engineers who are not experienced in tube tester design problems, can see nothing wrong with the
(Continued on page 51)

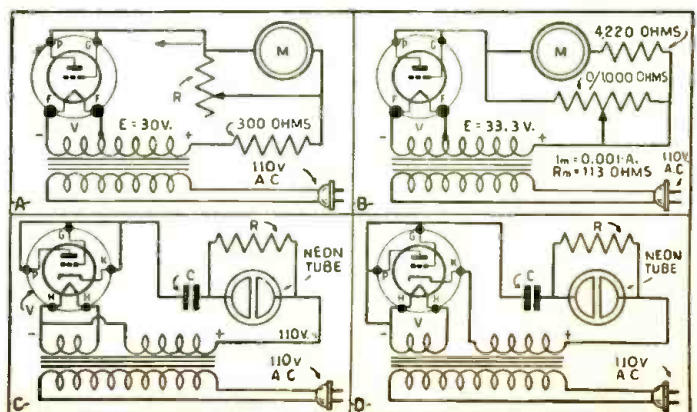

Fig. 7. Several types of tube testers and leakage indicators.

ANALYSES of RADIO RECEIVER SYMPTOMS OPERATING NOTES

Columbia S.G.9. A weak, frying noise was heard at all times, and was very difficult to locate. It did not change at any control setting. All voltages checked OK, but on continuity tests the detector plate choke was found to be open. The broken ends must have been barely touching to give voltage at the tube socket. The circuit is shown at Fig. 1A.

Phileo Model 87. Sold a customer a standard Electrad volume control, as he wanted to replace a defective unit himself. He returned and said the set would not work. On checking this set and circuit you will find that the Phileo control has an insulated housing which insulates it from the chassis, while the standard unit has a metal housing and is thus shorted to chassis at the center terminal as seen in Fig. 1B.

C. S. CARTER

Zenith 35 AP Chassis. This set would only bring in the 2 local stations and there was some hum and circuit oscillation when the volume control was advanced. The trouble was located in the primary of the antenna coil, this winding being open between the "long antenna" tap and ground. The coil is located under the chassis in an inverted can which covers the underside of the 1st R.F. socket and also the 3 tip jacks shown in Fig. 2. As there was no replacement coil at hand and very little room to get at this shield, it was decided to attempt a repair without removing the shield. After considerable experimentation a flexible lead was soldered to 1 terminal of a 0.01-mf. condenser. A phone tip on the other end of the lead was plugged into the "Long Antenna" tip jack and the other terminal of the condenser was grounded to the chassis, completing the R.F. circuit to ground. Cleaning and aligning completed the job.

R. T. REINHARDT

Atwater Kent Model 37. A weakness of this model seems to be the speaker filter or blocking condenser. I have had several of these sets in for service because of this fault. There is no reception, but a raspy sound, corresponding to the modulation of the signal may be heard. The location in the circuit is shown in Fig. 3. Incidentally, a 0.1-mf. condenser in this position works as well as the specified 0.5-mf. unit.

JAMES L. HOARD

Midwest Model 16-34. Increasing sensitivity. While installing a phono. pickup in one of these receivers, a way was accidentally discovered to

greatly increase the sensitivity. A switch was being installed to short out the antenna coil of the "E" band so as to cut out background noise during phono. operation. A shielded cable was connected across the coil. While preparing to connect the switch, and while the set was tuned to GSD, both leads were inadvertently held in the hands. The signal jumped to tremendous volume! Investigation showed that body resistance had caused the change, and that the improved performance could be duplicated with a fixed resistor of about 50,000 ohms connected in with a "local-distance" switch as shown in Fig. 4. The increase in sensitivity seemed to be equivalent to an added stage of R.F. amplification. The background noise increases with the resistor in the circuit, and overloading seems to take place when receiving a strong local, but the better reception on distant or weak stations is surprising.

JOSEPH SCHILLER

Dayfan Model 5005A. Circuit oscillation between 1,140 and 1,500 kc. on this set may be eliminated by the addition of a 0.01-mf. condenser as shown in Fig. 5. This is connected between the S.-G. of the 1st R.F. tube and the ground post. The latter is normally connected directly to chassis, and must be insulated. The condenser is then fastened to this insulated post, so that the ground wire goes directly to the added condenser. The selectivity and volume of these sets has been found to be increased about 60 per cent by this simple change.

WILLIAM NILES

Radiola 18. Most Service Men are aware that this receiver does not have as much volume as other sets of its time with the same general layout. The sets may be pepped up at least 25 per cent by making the change shown in Fig. 6. The only item needed is an antenna choke.

Spartan receivers. These sets using type 484 tubes and an untuned R.F. amplifying unit have troubles all their own. If you come across one that sounds as though the filter bank was defective, with hum and distortion that disappear with volume full on but come in again with low volume, don't start to tear things apart. You will probably find that one of the R.F. secondaries is open in the tube can, usually right at the terminals. These coils are wound with very fine wire and the primary and secondary are wound together.

F. E. BARBER

Phileo Model 59C. This set was dead on the low-frequency end of the dial and would also "cut out", at times, on the high-frequency end. The trouble was found to be in the 25,000-ohm, 1 W. screen-grid resistor of the type 77 detector-oscillator tube.

The old resistor, when disconnected and checked on an ohmmeter, measured 25,000 ohms, but broke down under load. However, the trouble was corrected with a new 25,000-ohm resistor.

General Electric Model M-65. The radio set was "dead" on signals in the broadcast band, with the exception of a beacon signal, which covered the entire dial. The tube voltages were found to be correct. The trouble was due to an open electrolytic 4 mf., condenser in the screen-grid circuit, located in the condenser pack. This trouble was corrected by installing a single 4 mf., 500 V. electrolytic condenser in the circuit.

There was ample room under the chassis for mounting the condenser.

W. B. DAVIS

Columbia Screen-Grid 8 (Knight S.G.8). On these sets, if the complaint is a gradual loss of volume, over a period of time, look for a loose rotor section on the condenser gang. These sections are pressed onto the shaft, and a heavy tension spring on the end will sometimes cause a section or sections to loosen and slide on the shaft until the rotor sections leak or short. Moving them back into place, and drilling and tapping the hub for a set screw, will eliminate further trouble from them.

Radiola 28A. This is a 5-tube mid-gate superheterodyne. The complaint was "no volume; and circuit oscillation." A check showed everything normal, but the set could not be aligned. The small fixed mica condensers in this set are held together by a metal clip, which covers practically the entire condenser. Idly grounding these cases with a screwdriver, while trying to scratch up ideas, the set suddenly came to life. Grounding the case of the oscillator padding condenser did the trick. The set was then aligned, and pronounced "better than new" by the owner.

Bosch 20. Several of these sets have been found with the oscillator plate dropping resistor, a 40,000-ohm, 1-W. unit shorted. Replace with a 3- or 5-W. unit, as the 1 W. will not stand up.

Better control of volume is secured by removing the lead from antenna to control, and using the control only on the cathode of the I.F. tube. A minimum bias resistor of about 1,000 ohms, should be added to the 200-ohm unit used in the set.

Grunow. This was one of the ultra-midgets, where a shoe horn is required when inserting replacement parts! A 25Z5 rectifier is used, one cathode supplies current to the speaker field, and the other to the tubes.

The filter condenser of the cathode supplying the speaker was shorted, there was not a new block on hand, and no room in which to place a section. The owner was in a terrible hurry, so the defective section was disconnected and both rectifier cathodes tied together. This expedient furnished current to speaker and tubes, with no noticeable drop in volume and everyone was satisfied.

E. JONES

(Continued on page 53)

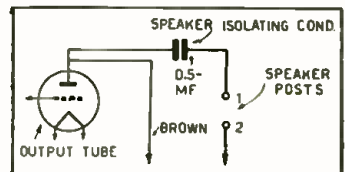

Fig. 3. A.K. condenser trouble.

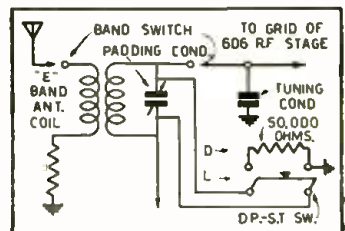

Fig. 4. Improving Midwest 16-34.

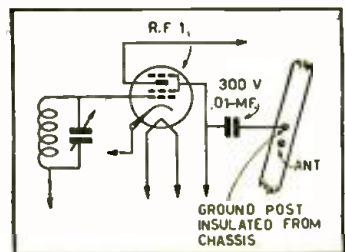

Fig. 5. Improving Dayfan 5005A.

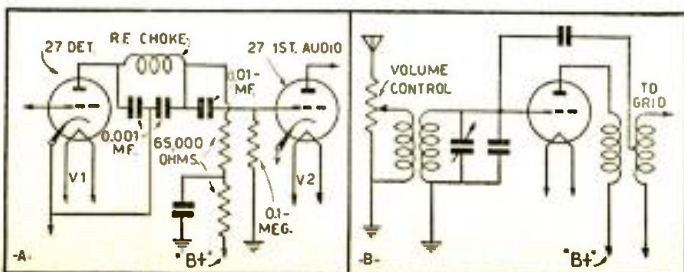

Fig. 1A shows a trouble in the Columbia S.G.9, Fig. 1B, volume control trouble.

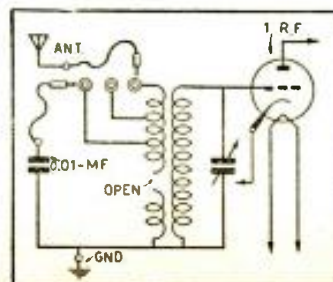

Fig. 2. Open antennae coil.

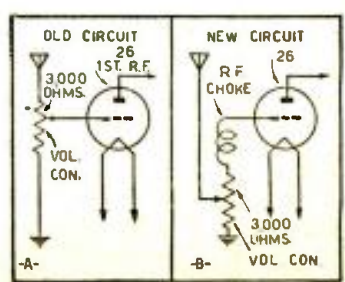

Fig. 6. More volume on Radiola.

ELIMINATING WHISTLES IN SUPERHETRODYNES

"Birdies" in superhet. sets are one of the most annoying conditions with which the Service Man has to cope.

H. G. McENTEE

THE Service Man and set builder often find trouble in eradicating the persistent whistles encountered when tuning the dial of a receiver they are repairing or have just built.

This whistle trouble is prevalent in the smaller types of sets which have no R.F. preselector stages before the first-detector, although even the most elaborate receiver may be so troubled if it is not properly adjusted.

In this discussion, we will not consider the interference and harmonic or heterodyne whistles caused by maladjustment of the receiver circuits. This subject has been described so thoroughly in past issues of *Radio-Craft* and in the various text books generally available that the radio man has no need for repetition, here, of such information.

It is for sets which have been properly aligned, yet whistles are still heard, that data is needed.

Let us consider a set, for example, that has just been made and aligned by a custom set builder. Suppose the intermediate frequency is 175 kc. If the set is tuned to receive a signal at 1,000 kc., the oscillator will be tuned to 1,175 kc. Now, if a powerful station is transmitting on 1,350 kc. and this signal reaches the grid of the first-detector tube, this 1,350 kc. signal will beat with the oscillator frequency of 1,175, thus producing a *second* 175 kc. signal. ($1,350 - 1,175 = 175$). This second 175 kc. signal will also be amplified and will interfere with the wanted 175 kc. signal. The unwanted 175 kc. signal is called the "image frequency."

Thus it can be seen that if the aerial tuning circuit is not sufficiently sharp in tuning (high Q), or if too few tuning circuits are used before the first-detector grid, interference, cross-talk and whistles will be encountered at certain parts of the dial.

The best solution to this problem, is, of course, to use tuned R.F. amplifiers before the first-detector, or even band-tuner circuits, so that sufficient selectivity will be attained to attenuate signals which are removed from the desired frequency by twice the I.F. (in other words the image frequency).

It is not always possible or desirable for reasons of economy or space limitations to include extra coils, tubes and tuning condenser sections. In this case, a method is used which is known as "image-frequency suppression."

There are a number of methods for achieving this image suppression, the best known and most satisfactory of which are shown in the circuits here. At Fig. 1A (at the left) is shown the aerial circuit of a superhet. receiver in which the control-grid coil is tapped part of the way down and the control-grid connection made to this tap. If we consider the part of the coil L2 in conjunction with the tuning condenser it will be seen that a series tuned circuit is attained. Now if this portion (L2) of the coil is so sized that it tunes to the interfering signal, while the entire coil tunes to the desired signal, L2 and C1 will effectively short-circuit the image frequency. Unfortunately, this effect occurs only at one frequency, for the resonant frequency of L2 and C1 does not match the image frequency except at this point. In spite of this disadvantage this circuit does give some relief from whistles and has been very popular in the midget-type superhets. (By adjusting the position of the tap, the point at which image suppression occurs can be shifted.)

Another circuit which accomplishes the same effect as A though not as efficiently, is shown at B. In this case, L1 serves the double purpose of aerial

(Continued on page 57)

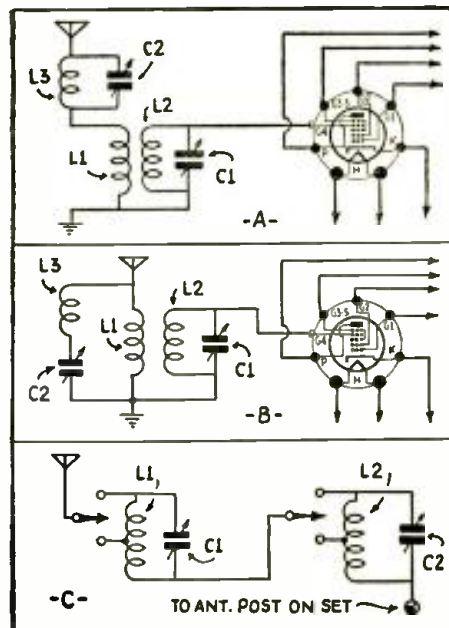
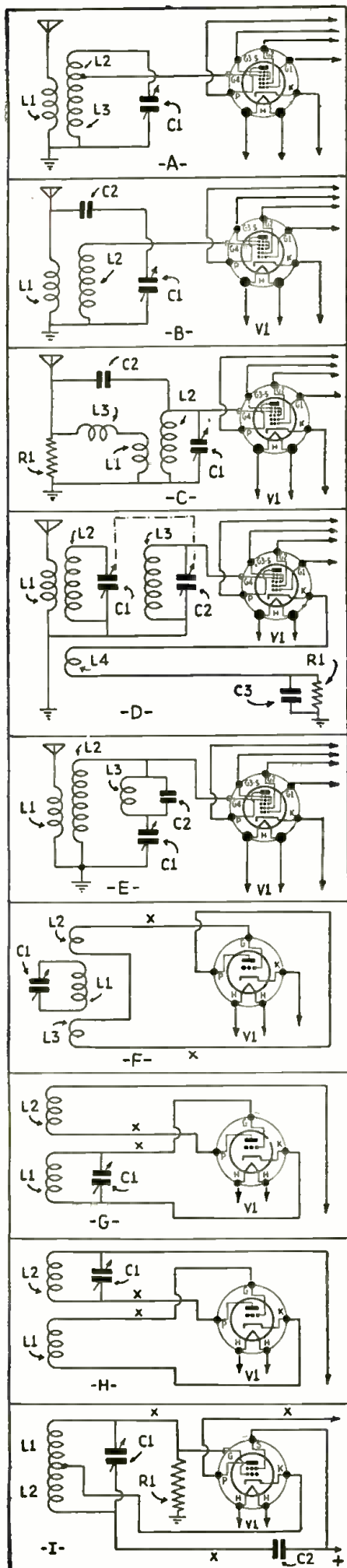

Fig. 2. Two I.F. traps for eliminating interference at the I.F.; and, a simple image-frequency filter.

MAKING A "MAGIC EYE" V.-T. VOLTMETER

The 6E5 tube is finding many applications besides indicating resonance — here it is a "V.-T. multi-meter."

E. H. RIETZKE

A GOOD vacuum-tube voltmeter is one of the most useful pieces of apparatus for the up-to-date Service Man and for general utility purposes around the laboratory. Over a period of 3 years a number of different types of V.-T. voltmeters have been designed and built for use in our laboratory work. The latest version of this versatile instrument uses the "magic eye" (6E5) as an indicating device in place of the D.C. milliammeter which was employed in previous models.

The many uses of this instrument are well known to the readers of *Radio-Craft* and will not be described in detail in this article. The instrument which was constructed as described below has proven very useful for making voltage measurements on resistance-coupled A.F. amplifiers, voltage gain of A.F. and R.F. amplifiers, voltage gain and turns-ratio of A.F. transformers, power output and noise levels of A.F. amplifiers and many other applications.

The instrument as described is operated directly from a 110 V. 60 cycle source,

is portable and lends itself to rapid manipulation. The circuit employed makes use of the well-known slide-back feature as described by Waller, Richards and others.

The panel is 6 3/16 x 10 3/16 ins. All parts except the power supply are mounted directly on the panel and on a small subpanel mounted 3 3/4 ins. below the main panel. The subpanel is supported from the main panel by 2 brackets. A spacing block is used under the 6E5 socket so as to extend it through the panel to the same height as the 6C6. Connection is made directly to the control-grid terminal of the 6C6; this keeps the input capacity at a minimum, an important feature when making R.F. measurements.

For the same reasons, a switch was not incorporated to control a blocking condenser and gridleak circuit when such are necessary as when measuring the A.C. potential of a circuit which also has a D.C. component. When making such measurements the blocking cond-

(Continued on page 58)



Fig. A. The complete instrument ready for use. Note the neat appearance.

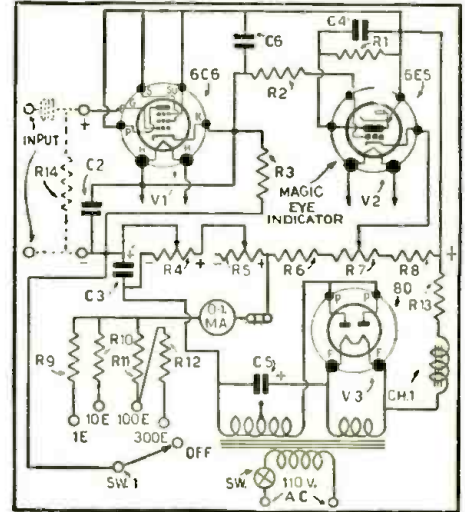

Fig. J. The circuit of the complete voltmeter. All values are indicated.

A VARIABLE-INDUCTANCE WOBBLER

E. L. GARRETT

An improved type of wobbler which eliminates an outstanding fault of these units.

THE PRINCIPLE of, and need for, a frequency modulated service oscillator in the alignment of receivers by use of the cathode-ray oscilloscope is now quite well understood by most Service Men. The methods of obtaining this frequency modulation differ quite widely, and the instrument to be described here uses a system as unique as it is simple and unusually effective.

It is usually the practice to vary the

frequency over a band of about ± 20 kc. or a total of 40 kc. variation. It is evident that this could easily be done by having some sort of motor-driven condenser or other apparatus which would vary the frequency of the calibrated oscillator by the required amount. This would only be usable at one frequency, however, since the percentage of variation of the output signal band width at, let us say 200 kc., would be widely dif-

ferent from that at 600 kc.

It is naturally necessary to know just how much the width of the band will change under the influence of the frequency modulation or "wobble," and some types of equipment which use a varying condenser in parallel with the main tuning condenser have been known to change the band quite widely due to atmospheric or other external conditions

(Continued on page 57)

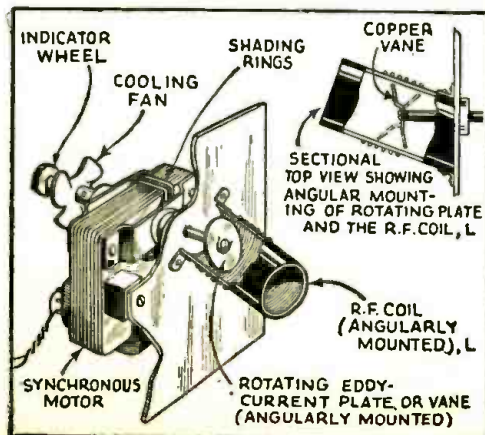

Fig. 1. The angular mounting of coil and disc.

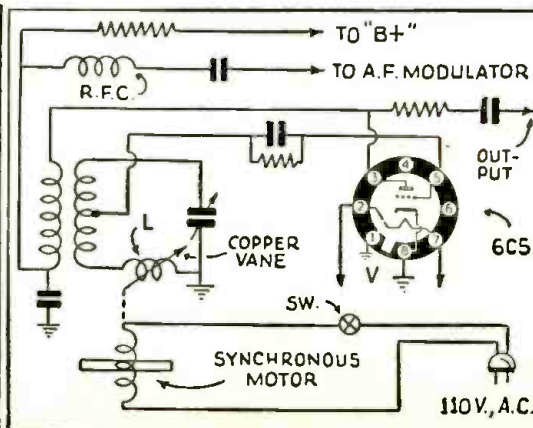

Fig. 2. The circuit of the eddy-current wobbler.

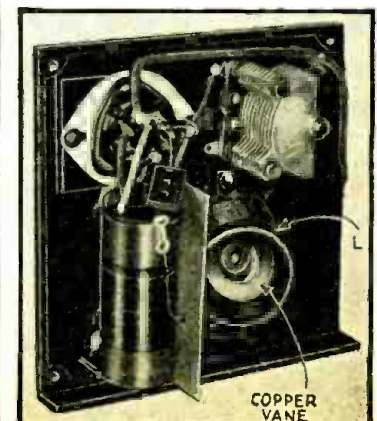

Fig. A. The interior of wobbler.

THE LATEST RADIO EQUIPMENT



Electric lettering pencil. (1059)



Motorstarting-condenser replacements for the Service Man. (1060)



A 20-W. horn motor unit. (1061)



Kit of speaker cones. (1062)

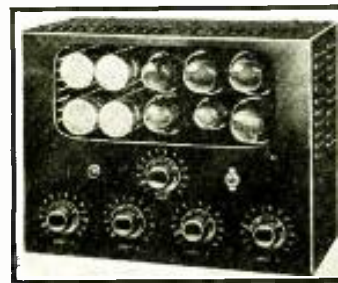

A 117 db. power amplifier. (1063)

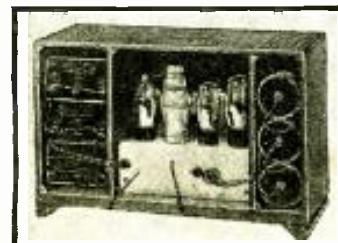

Battery portable receiver. (1064)

ELECTRIC LETTERING PENCIL (1059)

BY USE of this hot-point "pencil" (of which an improved type is illustrated), lettering, etc., may be "metallized" onto wood, leather, etc., with either 23-carat gold leaf, or with the imitation gold or silver which is supplied (in rolls). Its connecting cord plugs into any 110 V. supply socket. Fine for identifying tools, and so-on.

STARTING CONDENSERS (1060)

(Aerovox Corp.)

THE UNITS illustrated are part of a large line of replacement condensers made expressly to be used as motor starting condensers. They are exact duplicates and may be installed with the minimum of labor. The line is very complete, only a few of the items being shown. Both electrolytic and oil types are made. Such condensers are very effective for improving the starting power of A.C. motors. A service item.

20 W. TRUMPET-SPEAKER UNIT (1061)

(Atlas Sound Corp.)

A CAPACITY of 20 W. can be carried continuously by this unit. It is made for use in conjunction with a 6 ft. storm-proof trumpet, which can be folded into a compact size. The combination of the trumpet and the sound unit are said to be lower in cost than any equivalent cone speaker and baffle arrangement.

SPEAKER CONE KIT (1062)

THIS KIT comes packed in several boxes and contains 25 cones, each complete with voice coil, which will fit all models of Philco speakers. This furnishes an ideal stock for the Service Man. The cones are securely packed and may be kept safely in stock with little chance of damage.

P.A. AMPLIFIER (1063)

(The Webster Co.)

HERE is a 4-stage P.A. system that does not require a pre-amplifier for use with crystal microphones. There are 4 separate input circuits and mixers, any or all of which may be used for microphones or phono. pickups. Gain at 400 cycles, 117 db.; hum is 26 db. below zero level. The power consumption, 120 W.; undistorted power output, 15 W.; total weight, 30 lbs.; output impedances: 2, 4, 6, 8, 16, and 500 ohms. Tubes: 4—6C6s, 2—6A6s, 1—76, 2—2A3s, 1—5Z3.

NEW 4-TUBE "BATTERY PORTABLE" RECEIVER (1064)

(International Radio Corp.)

A SUPERHET. circuit is used in this battery-operated 2-band receiver; its self-contained battery power supply affords portability. Its



Heart-checking "mike." (1065)



Replacement-type battery. (1066)

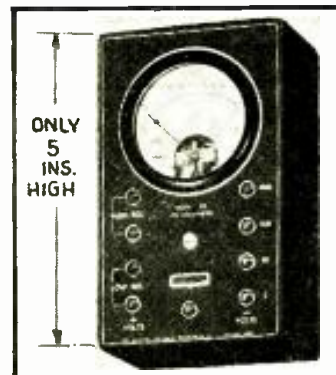

Compact multi-range meter. (1067)

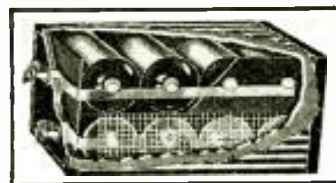

Improved "A" battery. (1068)



A 2,500-V. test unit. (1069)

new alloy-core permanent-magnet dynamic speaker affords good tone quality. Tubes used: 1—1C6, 1—34, 1—25S, 1—950. A "battery saver" is included which economizes on power used. (Diagram in Data Sheet department.)

"STETHOSCOPE" MICROPHONE (1065)

CHECKING-UP on heart action by the application of new technique in sound equipment design is one of the latest advances in the medical field. A new-type crystal microphone designed for any purpose for which the older type of stethoscope was used is one of the latest of these. The unit is so designed that it may be placed tightly over the affected area, thus excluding external noises. Handling the instrument does not create any disturbance. It is equipped with a "push to listen" switch, which may be actuated by the thumb. An 8 ft. length of shielded cord is furnished.

HEAVY-DUTY BATTERY FOR CAR-RADIO NEEDS (1066)

SERVICE MEN will render the customer a real service and net a nice profit by replacing the regular car battery with one that is better built to "stand the gaff" of added drain when a car-radio set is installed. It has been estimated that the use of an ordinary car radio will deplete a car battery as much as "30 normal engine starts!" Thus it is highly advisable to install a heavy-duty battery to carry this extra drain. The unit illustrated has 17 heavy-duty plates, as against 13, as used in the usual car battery. It has a rating of 120 A. hours. Latex base separators are used and offer many advantages, among them the ability to withstand higher charging rates, and higher temperatures without damage.

COMPACT METER (1067)

COMPACTNESS is a feature of this handy volt-ohmmeter. The ranges are: 0 to 0.5-meg., and 1/2- to 500 ohms; 0 to 5, 50, 500 and 1,000 V.; 0 to 1. ma. A 2-color scale is used on the moving-coil meter, a knife-edge pointer aiding in ease of reading. The welded steel case is but 3 x 2 x 5 ins. high; panel is of lettered black bakelite. A zero adjuster is included and the battery is self-contained.

UTILITY BATTERY (1068)

MOISTUREPROOF and leak-proof, this new battery will give service equivalent to 2 of the old "No. 6" dry cells, but it is 40 per cent lighter in weight and 30 per cent smaller in volume. The unit is made up of 8 cells connected in series-parallel. The overall size is 5 1/2 x 2 1/2 x 3 1/2 ins. wide; weight, 2 1/2 lbs.; output voltage, 3 V. Fine

(Continued on page 61)

Name and address of any manufacturer will be sent on receipt of a self-addressed, stamped envelope. Kindly give (number) in above description of device.

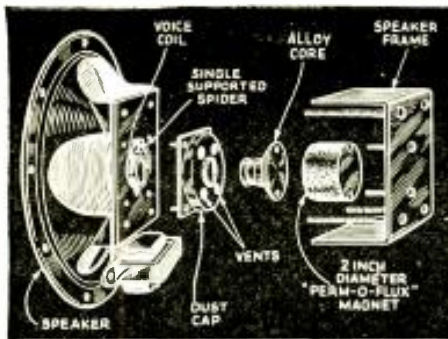

Construction of the alloy-core speaker. (1069A)

NEW "PERMOFLUX" ALLOY CORE SPEAKER (1069A)

THE GREAT feature of this speaker is the use of a core made of a new alloy (the manufacturer calls it "permo-flux") which has extremely high flux density—much more than provided by the older types of core materials; and the simplicity of construction of this core. The actual magnetic material is only about 2 ins. in dia. (as the illustration shows).

This material has been placed in boiling water for long periods, and has been subject to falling and vibration tests without appreciable loss in energy. The results from these speakers are said to be equal or better than those from electrodynamic speakers of equal size. This alloy core material is the result of extensive laboratory research and has been developed to a very high degree. The speaker has several other features of note, such as the dust-proof construction, and the single-point support of the voice coil spider. The voice coil is completely enclosed, making the speaker very useful for auto-radio receivers and for similar applications. The transformer included with the speaker is of the universal type, and may be used with almost any type or combinations of tubes now in use.

NEW 15-W. P.A. AMPLIFIER HAS GAIN OF 130 DECIBELS (1070) (Radolek Co.)

IN THIS short article is described a 6-tube P.A. amplifier of exceptional interest to every sound technician, since the unit described is adaptable to requirements in over 75 per cent of the P.A. installations likely to be encountered. It incorporates all of the newest sound engineering developments plus some exclusive features of its own. The amplifier is particularly designed to fully utilize the advantages of the greater sensitivity, frequency response and life-like clarity of crystal or high-impedance velocity "mikes."

This amplifier is capable of pushing to full power capacity, two 12-in. auditorium-type dynamic speakers, as many as 10 smaller dynamic speakers, up to 25 magnetic speakers, or 1,000 pairs of headphones, or any proportionate combination of any of these. Ideal for use in auditoriums, churches, small dance orchestras, fairs, sound trucks, office call systems, small athletic fields, store advertising installations, etc. A full, clean, powerful, 15-W. output pro-

vides easily understood speech and music to indoor audiences of up to 5,000 people, or over outdoor areas of up to 20,000 square feet.

An outstanding feature of this amplifier is its simplicity of installation. All connections are through polarized plug-in sockets, and once the cables are made up, anyone can install and operate the amplifying system without difficulty. Now let's take a brief tour through the circuit itself.

Many new features are incorporated in this amplifier which add materially to its versatility and efficiency. The first and most important of these is its "hi-lo tone control."

Radolek was the first to make practical application of the tone control of P.A. amplifiers (states the manufacturer) and now is the first to introduce a new and revolutionary application of this same principle in this amplifier. Whereas old-type tone controls simply cut off the higher frequencies, thus accentuating bass reproduction, this new unit cuts off either the highs or lows as desired, allowing accentuation of either bass notes or treble notes.

The advantages of this system will be immediately apparent to any one familiar with the difficulties encountered because of the poor acoustics in many P.A. installations and particularly on indoor installations where echo and booming prevail. In many instances, cutting off

(Continued on page 62)

A STANDARD PROCEDURE FOR SERVICING RADIO SETS (1071) (Triplet Electrical Inst. Co.)

THE signal generator here illustrated is so designed that it meets perfectly the many demands of the Service Man. It is battery operated, permitting it to be used at any time or any place independently of power lines. It covers frequencies from 100 kc. to 20,000 kc.

As the circuit shows, plug-in coils are used (for stability); by this method circuit losses caused by wire capacity changes, moisture, inductance, etc., can be minimized. Hand-calibrated charts allow an accurate setting to be plotted; they also compensate for inequalities of spacing in condensers, inequalities of metal, both in thickness and length,

(Continued on page 63)

UNIVERSAL RANGE KIT-TYPE METER (1072) (Readrite Meter Works)

ASSEMBLING and wiring a modern volt-ohm-milliammeter capable of measuring voltage, currents and (with self-contained power pack) resistances as used in the modern radio set has been reduced to the least amount of confusion by the use of a new kit of components. The completed instrument is here shown for the convenience of constructors.

The instrument consists of a 2,000

(Continued on page 64)

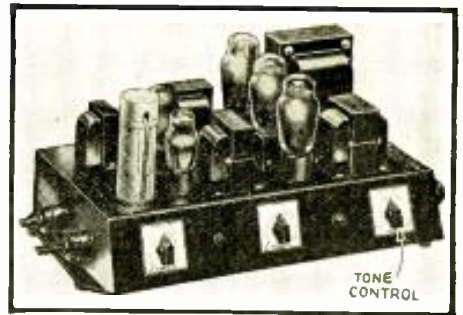

Appearance of a high-gain amplifier. (1070)

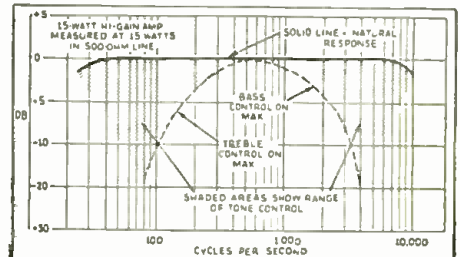

Response of the high-gain amplifier. (1070)

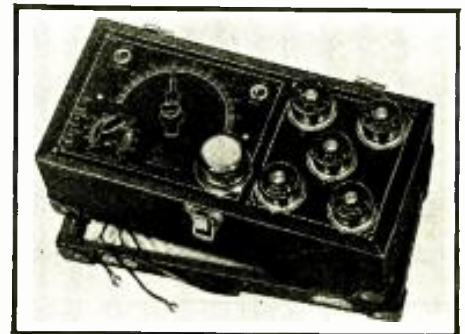

Front view of the modulated oscillator. (1071)

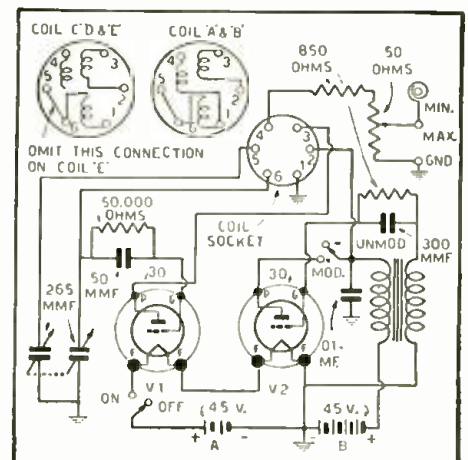

Circuit of the oscillator shown above. (1071)



Appearance of the built-up test meter. (1072)

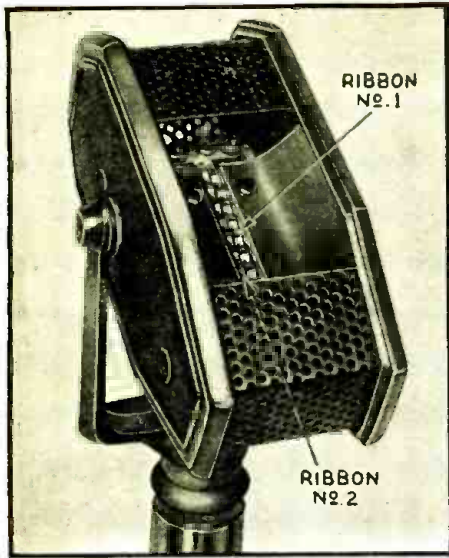

Fig. A. The positions of the 2 ribbons.

HOW THE 2-RIBBON MIKE PREVENTS FEEDBACK

By suspending a ribbon "mike" overhead, 360 deg. pick-up is obtained. The 2-ribbon mike reduces feedback.

SAMUEL RUTTENBERG

THOUGH the directional properties of the velocity mike eliminate acoustic feedback—yet this type of microphone has a wider angle of coverage without frequency discrimination than any other type available today. Because of the wide-angle coverage, only one velocity "mike" is used to reproduce the entire symphony at Carnegie Hall. Saying that "the velocity microphone

is directional" is correct—yet misleading. To be directional—and still have the widest angle of coverage sounds contradictory. Only over the small angle in Fig. 1C marked "dead area" is the pick-up angle of the velocity microphone zero. This small angle of zero pick-up gives the microphone its directional as well as its valuable property (Continued on page 58)

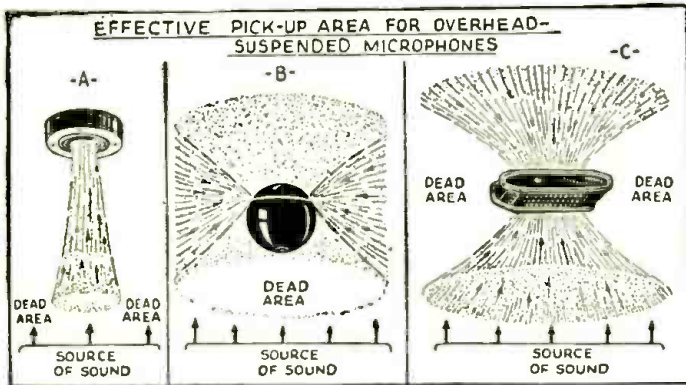

Fig. 1. A-carbon; B-spherical; C-ribbon. Only C is effective.

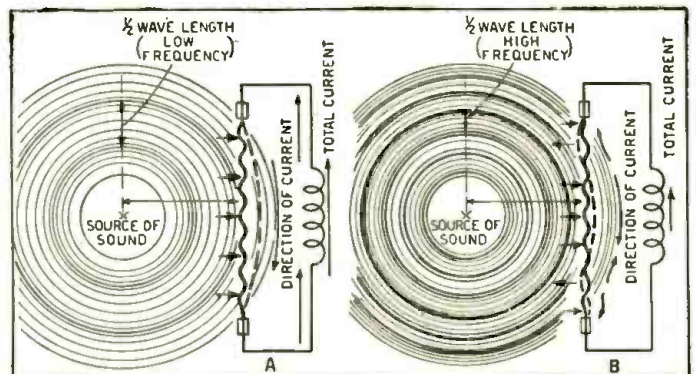

Fig. 2. The cause of "low-frequency boom" in close talking.

WHAT DOES IT COST TO OPERATE?

Here is an effective store display which will aid in selling radio sets and electrical appliances.

FRED E. KUNKEL

A MODEL set-up, consisting of a series of joined compartments, built to house the average electrical appliances used in the home, one compartment for each appliance—each electrically illuminated with tubing or show case lights, and with an illuminated sign over the top reading:—"How Much Does It Cost To Operate?" has been found an ideal arrangement for demonstrating the cost of operating any appliance. Such a set-up is used by the Electric Institute of Washington, D.C., as a permanent exhibit.

It is an idea which can well be applied by Service Men—dealers throughout the country, most of whom sell appliances.

This demonstration booth contains a radio receiver, refrigerator, clock, electric iron, toaster, cooker, coffee maker, waffle iron, vacuum sweeper, washing machine ironer, electric range—each appliance in a separate compartment. The entire display is unlighted until some one wishes to make a demonstration. When the demonstrator presses a

button or switch, the electric appliance which he wishes to talk about is lighted up, as illustrated.

In the center of the display are a series of switches with a watt meter calibrated in terms of dollars (\$) per month, so that it registers the cost of operating any electric appliance on display at the turn of a switch. In addition to the meter showing the cost, there is also a little illuminated, worded message or sales talk. (See insert.)

For instance, the prospect says: "What will it cost to operate a radio set?" Instead of taking out a pencil and paper and doing a little figuring, then saying, "You can operate a radio receiver day or night, at about ½-cent per hour, or in the average home about 25c per month," it is much more impressive for the demonstrator to be able to throw a switch which lights up the radio set, and flashes a message on the panel which reads, "Entertainment, day or night, through a modern radio set costs about ½-cent per hour, or in the



Only the "radio" display is illuminated.

average home about 25c per month."

Thus, with this device it is possible for an appliance user, or any one considering the purchase of an appliance to find out at a glance approximately how much it will cost per hour or per month to operate any of the many useful household devices. It is one of the most unique arrangements extant today for effectively demonstrating and selling all types of electric appliances.

And if you have all the appliances included in the display unit, then you throw all the switches and you have the complete story!

ADD "MAGIC EYE" TUNING TO OLD SETS

The cathode-ray tuning indicator can be added to existing sets—the design considerations are presented here.

F. M. PARET

THE CATHODE-RAY tuning indicator tube is intended primarily for use as a visual resonance indicator for the proper tuning of radio sets utilizing automatic volume control or "A.V.C." In use the tube is mounted horizontally with the dome of the bulb visible through a hole in the front panel of the radio set.

Mounted in the dome of the bulb is a shallow, cup-shaped target, coated with a fluorescent material. When the set is in operation, this target glows with a soft greenish light and appears from the front of the set as a luminous disc. A control electrode is so placed inside the tube, that by the application of the proper voltage, the electrons are prevented from reaching the target, thus causing a blank or unlighted

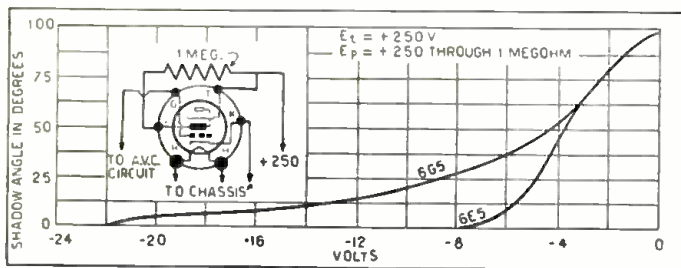

Fig. 2. The remote characteristic of the 6G5 and connections.

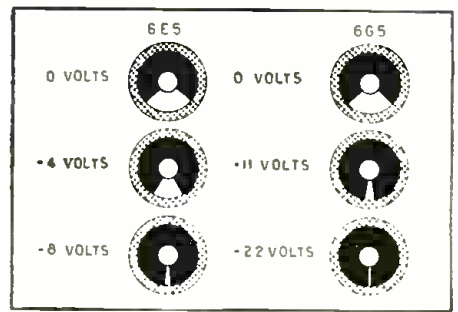

Fig. 1. Comparison of 6E5 and 6G5 tubes.

portion of the target in the shape of a sector. The angle of this sector varies with the voltage applied to the control electrode from 0 to 10 degrees.

To increase the sensitivity of the indicator and to make it readily applicable to radio set circuits, a triode amplifier is incorporated in the same bulb. The plate of this triode is internally connected to the control electrode. The two electrodes receive their plate voltage through a 1 meg. resistor so that variations in the triode plate current cause changes in the control-electrode voltage which in turn varies the dark sector on the target.

The grid of the triode is connected into the A.V.C. circuit of the set—thus changes in A.V.C. voltage, produced by the incoming signal and the tuning of the set, cause corresponding changes in the angle of the dark sector of the indicator tube.

Two types of indicator tubes are now available, differing only in their control-grid characteristics. The type 6E5 has a "sharp cut-off" control-grid, and a usable control-grid voltage range (A.V.C. voltage) of from 0 to -8 V. The 6G5 has a variable-mu grid and a usable range of from 0 to -22 V. The variable-mu characteristic gives greater sensitivity on small signals and reduces the tendency to overload on large signals.

(Continued on page 56)

DESIGN DATA ON A.V.C. CIRCUITS

A continuation of the inside facts concerning the methods used in designing automatic volume control systems.

PART II

THE SYSTEMS discussed in Part I will bring the circuit into action for even the weakest signals. So, as soon as the precious weak signal enters, it is cut down again by the control action. Thus sensitivity is lost. It would be much more convenient if the circuit would not begin to work until the incoming signal exceeded a certain level. The sensitivity would then remain and the reduction of sensitivity would happen only to strong signals which can stand it. Such a system is called "delayed A.V.C." and should not be confused with the term "time constant."

Delayed A.V.C. is accomplished by biasing the A.V.C. diode plate negative with respect to the cathode so that no current will flow in the diode circuit until the incoming signal's peak voltage exceeds this bias. The most convenient way to introduce the system to the circuit of Fig. 1A (Part I) is by placing a bias resistor, R1, in the cathode circuit and returning R1 to ground; but that would also introduce the delay to

the detector. Therefore it is necessary to separate the functions of the two rectifier sections of tube V, as shown in Fig. 1C (Part I). Figure 1C shows a bias resistor in the cathode circuit arranged to develop delay A.V.C. only for the R.F. tubes. In the circuit of Fig. 1D (Part I), delay can be introduced by adjusting the control-grid bias of V5 to below plate-current cut-off.

AMPLIFIED A.V.C.

In numerous cases it has been found that the generated control voltage is not large enough to properly equalize the incoming signals of different stations. The remedy then is to increase the control voltage by an extra stage of R.F. or I.F. amplification. (It is also possible to employ a D.C. amplifier, but this system has not become popular.) An example of amplified A.V.C. is shown in Fig. 2. A single tube serves as the amplifier and the diode rectifier. The pentode section first amplifies the signal

(Continued on page 56)

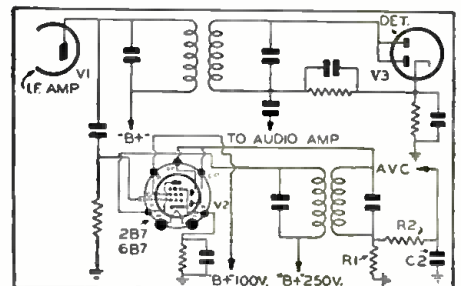

Fig. 2. An example of amplified A.V.C. using a 2B7 or 6B7 tube.

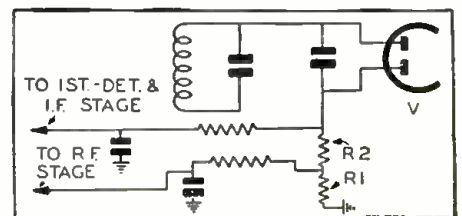

Fig. 3. The A.V.C. voltage is tapped off through a voltage divider to improve control.

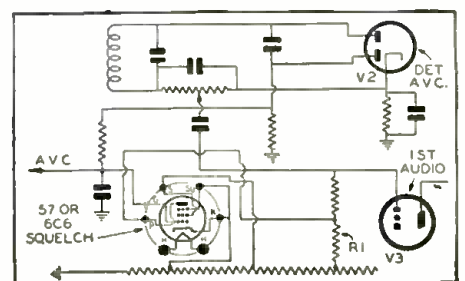

Fig. 4. The use of a "squelch" tube to eliminate inter-station noise due to A.V.C.

INTERNATIONAL KADETTE MODEL 400 4-TUBE BATTERY-OPERATED SUPERHET.

(Permanent-magnet dynamic speaker; "battery saver" control; very low drain; portable; dual range; no "C" battery needed.)

The voltages for this receiver are as follows:

Tube	Plate	S.-G.	C.-G.	Osc.	Plate
V1	106	45	0	42	
V2	106	45	0		
V3	106		0 (Diodes-0)		
V4	105	108	-1		

The battery supply is 135 V. The I.F. transformers are aligned by feeding the signal from the service oscillator directly to the

antenna. A strong signal will be necessary due to the I.F. trap circuit in the antenna lead. The broadcast range is first adjusted at 1,400 kc. The input from the oscillator must be very weak. Turn the set dial to 1,400 kc. and adjust the oscillator section of the tuning condenser (rear section) for best output. There is no adjustable padding condenser in this model and alignment at the lower frequencies is accomplished by bending sections of the oscillator condenser plates, at 1,000 and

600 kc. There is no alignment needed on the short-wave band, since the first-detector control-grid circuit is untuned on this band. The range of the short-wave band is 70 to 200 meters. The "A" battery supply must be 4½ V. and is obtained from 3 (or any multiple of 3) dry cells connected in series (or series-parallel). The "battery saver" should be set as far counterclockwise as possible and still retain proper sensitivity and tonal quality.

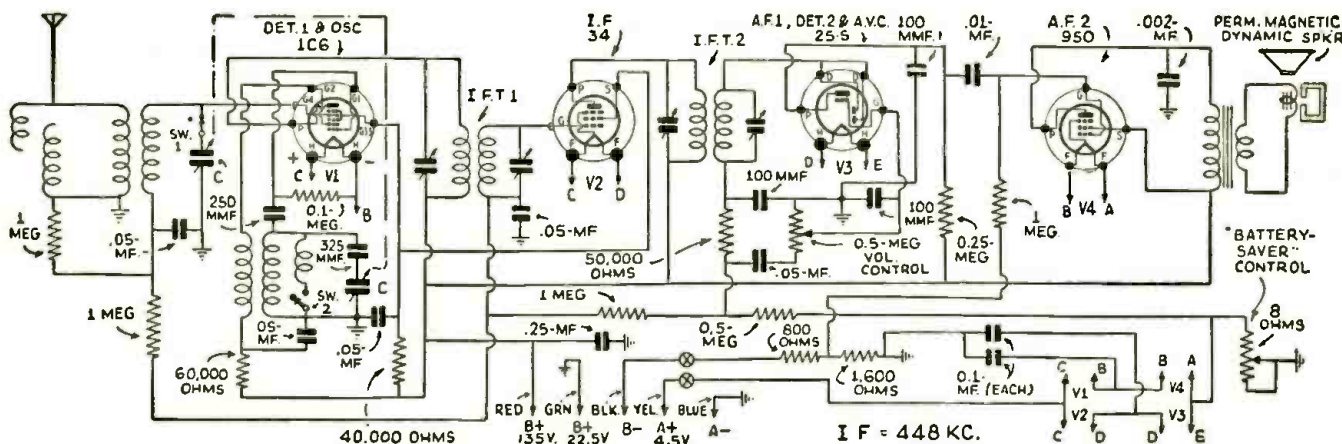

RCA VICTOR MODEL 5M 5-TUBE AUTO SUPERHET. RECEIVER

(Output, 4 W., max.; tone control; synchronous vibrator; iron-core antenna and I.F. transformers.)

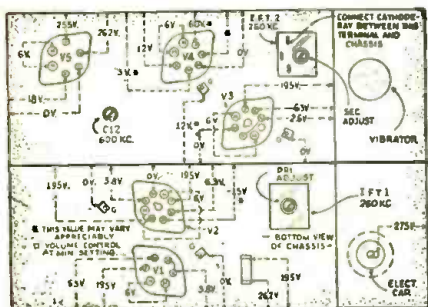

The complete table of socket voltages for this receiver is included on the small diagram which also shows location of the various trimmers. Voltages below 10 V. should be measured on the 10 V. scale, those between 10 and 50, on the 50 V. scale, and those over 50 on the 250 V. scale of a 1,000 ohm-per-volt meter. The spark plates are specially designed condensers, which act not only to by-pass ignition and other noises, but also allow static charges to leak off to ground. The antenna coil has a molded core, the adjustment of which should not be disturbed. The I.F. transformers are adjusted by means of movable iron cores, which are reached

through the top of the cans and the bottom of the chassis. The antenna lead to the set terminates in a noise filter which cuts off all signals above 1,600 kc., thus eliminating most of the ignition noise which would otherwise enter. The battery input and other leads are also very well filtered to prevent the entrance of noise. The I.F. stage is aligned by connecting the service oscillator lead to the cap of V3, and then V2, through a 0.25-mf. condenser. The R.F. section should be aligned at 1,400 and then 600 kc. A 175 mmf. condenser must be connected in series with the antenna lead, and a 50 mmf. condenser from antenna lead to ground.

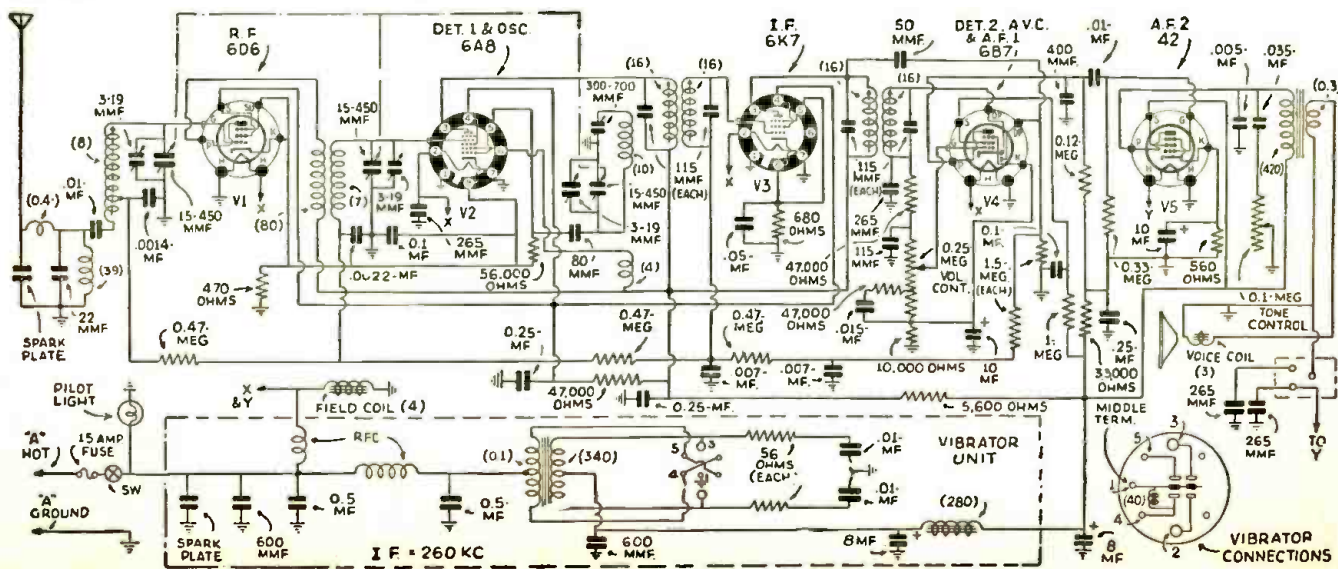

MAKING A PRECISION ALIGNING UNIT

In this part, the operation of the oscillator and the accompanying "slide-back" V.T. voltmeter are described. The flexibility of the unit to provide modulated and unmodulated R.F. output, and single A.F. modulation or modulation in the form of music over a wide frequency range is discussed in Part I.

CANIO MAGGIO

PART II

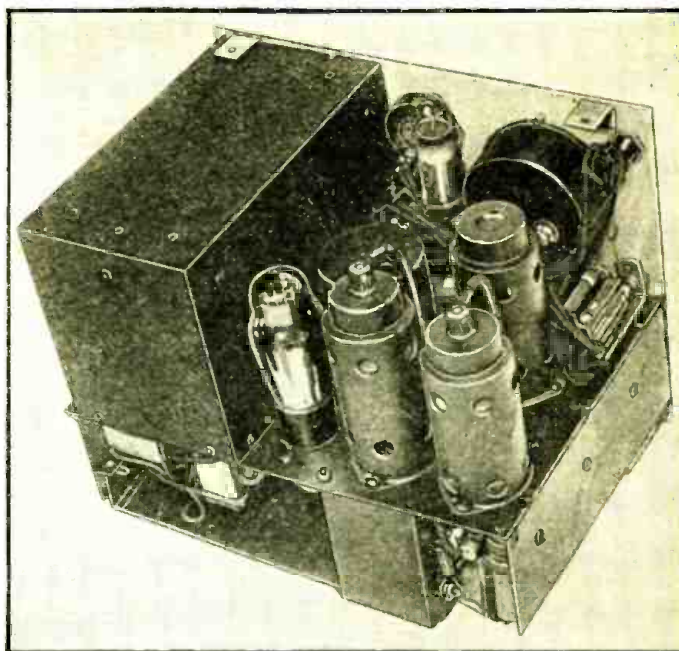

WHEN testing a receiver for A.F., distortion, open circuits, etc. with this device (which was described in Part I, last month), begin with the power tubes by feeding the A.F. signal to the control-grids of the power tubes; then to each preceding stage. If an A.F. amplifier of the P.A. type is being checked, the signal is fed into the input, either of the preamplifier or of the amplifier itself.

Distortion in radio receivers can also originate from other circuits besides the A.F. section. It is necessary for alignment to have a single note; for distortion tests, however, external modulation is preferable. This can be procured from a high-fidelity phonograph record and reproduced with a high-quality pickup. Of course this will hold true if the usual method is used in detecting distortion. If an oscilloscope is used, then the modulating frequency should be a single note.

For alignment purposes, it is advisable to remove the local oscillator tube from the receiver. For receivers using the double-purpose tubes or autodyne circuits, it is difficult to do this unless the Service Man wishes to go through an exploration of the receiver layout. With 5-, 6-, 7- and 8-prong adapters the tube may be removed from the receiver (with the exception

of the series filament type) and the matching adapter inserted.

For alignment, selectivity and sensitivity tests a dummy antenna of a double-impedance type is used, as part of the accessories. (This dummy antenna is A, in the heading illustration, Part I; and in the complete schematic diagram, Fig. 2, is enclosed by a dotted line.) Thus with such an arrangement the output of the "signal generator" (service oscillator) can be applied across either a low-impedance or a high-impedance circuit.

The signal generator was primarily designed for A.C. operation, but, it can also be converted for battery or A.C.-D.C. operation without difficulty merely by omitting and adding the necessary parts, as the case may be.

THE "SLIDE-BACK" VACUUM-TUBE VOLTMETER

In addition to the signal generator, a vacuum-tube voltmeter is incorporated in the same unit. A voltmeter of this type is a handy device to have around the service shop or the amateur shack; since it draws no appreciable amount of current, and since it permits measurements of A.C. regardless of frequency.

In the design of vacuum-tube voltmeters, the *slide-back* type is the most flexible as it not only permits measurements of alternating current (peak), but direct current as well. Special calibrations of the voltmeter are not required as the voltmeter is direct reading in volts and the same scale holds true for either A.C. or D.C.

The "slide-back" name was given to this device because of the method used (and described in past issues of *Radio-Craft*) in balancing the circuit. The fundamental circuit is that of a tube having an applied plate voltage with a current cut-off point or to some low value indicated upon the current meter. Further description of the procedure now follows.

When the voltage under measurement is applied to the control-grid of the

tube, a rise in plate current will result due to the decreased bias voltage effected by the voltage under measurement. Then additional bias voltage is applied so as to return (or "slide back") the plate current to the value used prior to test. Thus the unknown voltage is equal to the additional control-grid bias, such as: $E = E_{g2} - E_{g1}$, where E_{g1} is the control-grid bias before the unknown voltage is applied, and E_{g2} is the total grid bias when the unknown is under measurement.

The manipulation of the circuit is accomplished by turning switch Sw. 8, which is mechanically coupled to R17; then switch Sw. 10 to the low position, to short the test leads in tip-jacks J1-J2. Next vary R17 (the bias control) until some low value of plate current on the plate milliammeter is indicated. Then adjust R16 so that the grid-return is nearer to the cathode so that the effective resistance between the grid-return and cathode is the resistance set by R17.

Having balanced the circuit, the unknown voltage is applied. A rise of the plate current will be indicated on the milliammeter. The slider of R16 is adjusted until the plate milliammeter indicates the same value as before the unknown was applied. Having rebalanced the circuit, the unknown can now be read directly in volts on the same

(Continued on page 60)

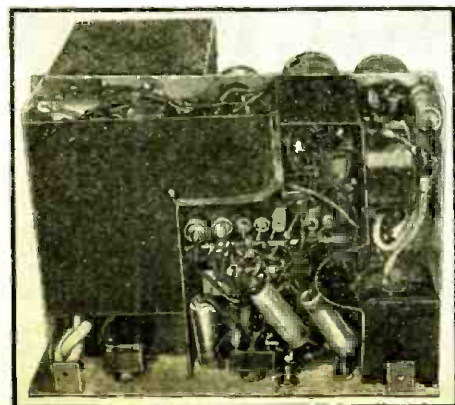

The underside of the chassis, showing parts layout.

TELEVISION IN 1937?

Newspaper accounts tell about the possibility of television transmission and reception on a commercial scale, in 1937. Is there really a chance that practical image transmission will actually round that corner, or is this all just "talk"? Read the forthcoming Television Number of *RADIO-CRAFT* in which will be discussed the latest developments in this field and just what they mean to the lay purchaser of television equipment; and the many problems these developments entail.

RCA VICTOR PORTABLE TABLE ELECTROLA MODEL R-95

(Synchronous motor; takes records up to 12 ins.; pickup and tone arm in 1 unit; 8 in. dynamic speaker.)

The voltages on the illustration at the left are measured from the tube socket terminal to the negative side of the electrolytic condensers. Voltages should be within $\pm 20\%$, as measured on a 1,000 ohm-per-volt meter. Values over 50 V. should be read on the 250 V. scale, while those under are taken from the 50 V. scale. Since a voltage-doubling circuit is employed in this instrument, it cannot be used on D.C. The power consumption is 75 W. total and the power output is 2 W. Turntable speed is standard 78 r.p.m. The motor is started by giving it a clockwise spin with the hand. Difficult starting may be cured in many cases by applying a small amount of oil to the bearing surfaces of the motor. A small amount of hum when the

motor is starting, decreasing to a negligible amount when running is entirely normal. If there is excessive vibration either when starting or running, the motor supports should be examined and the position of the leather washer on the center bearing should be checked. It should be *under* the steel washer. After a long period of operation, the spacer cushions of the pickup may become hard and should be replaced. The viscoloid block which is attached to the front end of the armature shank serves as a mechanical filter to eliminate undesirable resonance and to cause a uniform frequency response. If the block is replaced it will be necessary to heat the shaft slightly to hold it firmly to the viscoloid block.

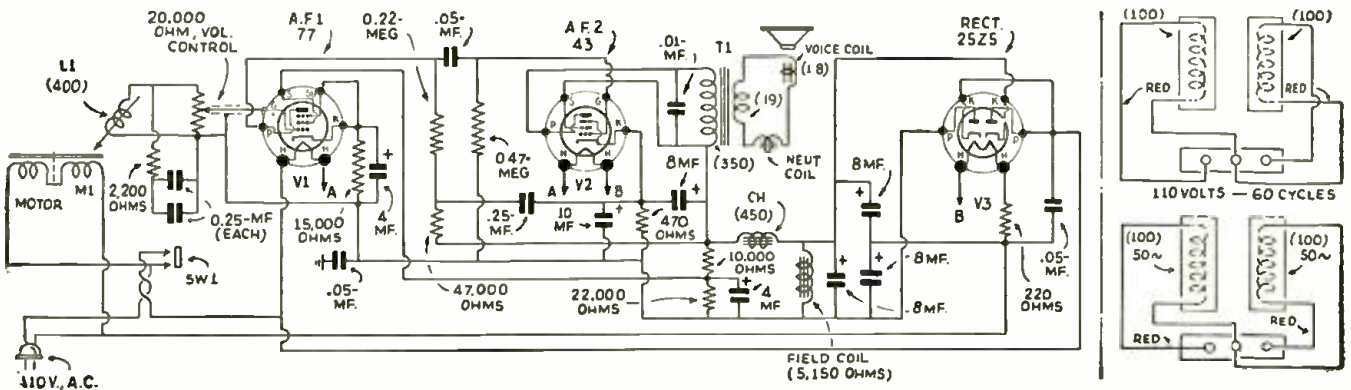
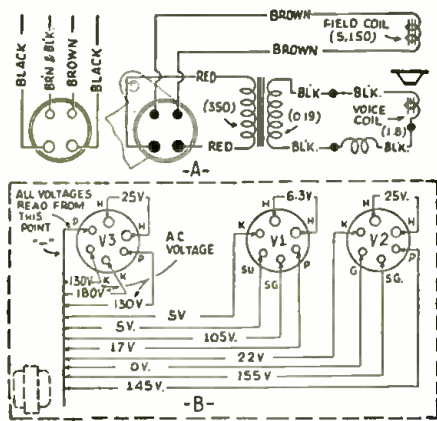

ATWATER KENT MODEL 305Z 5-TUBE 32 V. D.C. SUPERHET.

(Has 3 wave bands; dynamic speaker; dual-lighted dial.)

The voltages for this receiver are shown on the schematic diagram near the portions of the circuit to which they apply. When aligning the set, the volume control should be turned on full and the tone control set at high pitch. For trimming the R.F. end of the set, it is best to connect a 250 mmf. condenser in series with the antenna lead of the set. When the I.F. is aligned, one of the manufacturer's coupling units should

be connected, the unit being placed on the control-grid cap of the I.F. or first-detector tube as needed, and the lead from the circuit connected to the coupling unit. The dial pointer should be at 538 kc. when the rotor of the tuning condenser is fully meshed. The short-wave range is aligned at 15 mc. and the broadcast range at 1,500 and 560 kc. There is no trimmer for the police band. Align the I.F. transformers at 264 kc.

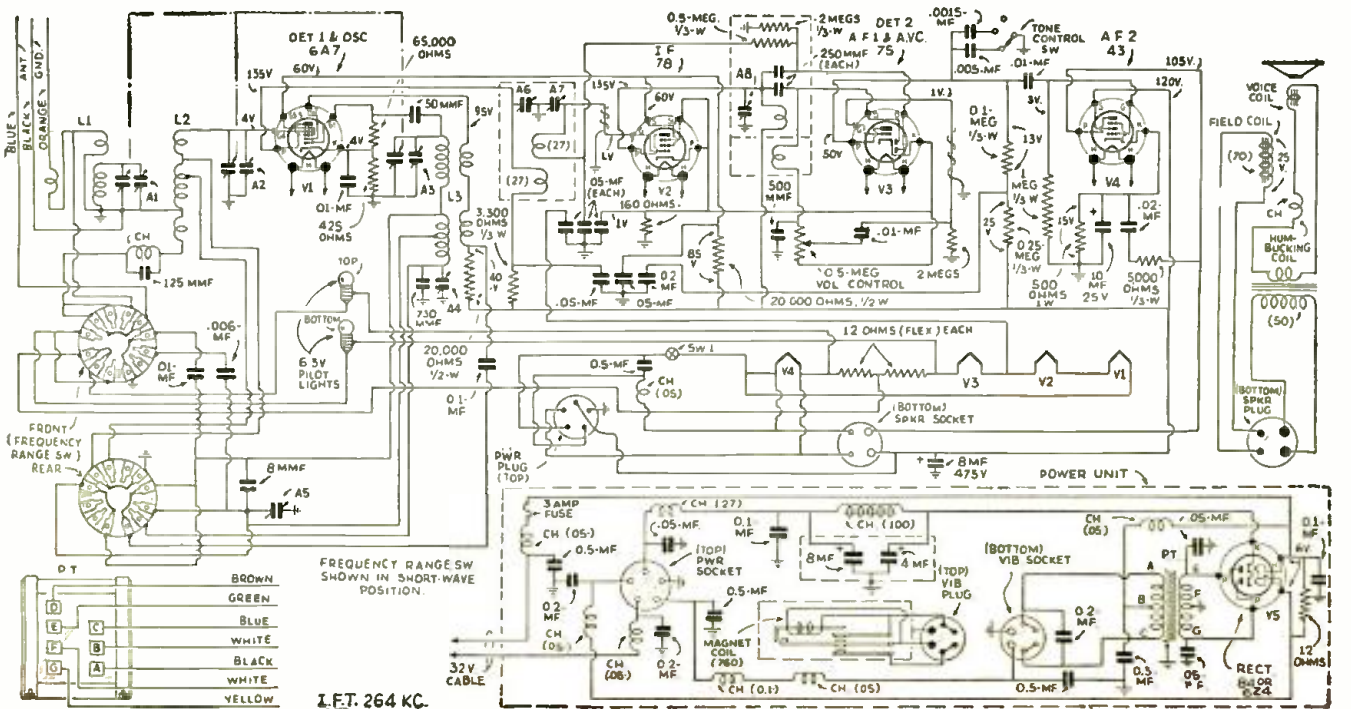
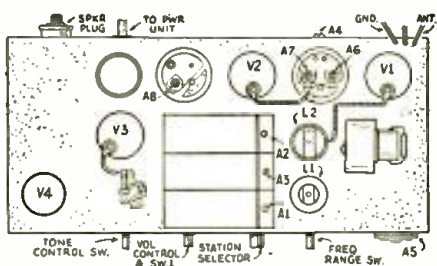

THE KADETTE JEWEL MODEL 40 CHASSIS 3-TUBE ULTRA-MIDGET RECEIVERS MODELS 41, 43, 44 AND 48
 A.C.-D.C. operation; new type balanced-armature speaker; range, (Size, 5 1/2 x 7 1/2 x 3 3/4 ins.; molded bakelite cases in many colors; 550 to 1,600 kc.)

The circuit of this receiver is of the A.C.-D.C. type, the 12A7 tube, V3, acting as both rectifier and power tube. Voltages are as follows:

Tube	Heater	Cath.	S.-G.	C.-G.	Plate
V1	6.3	1.5	123	0	123
V2	6.3	0.65	11	0	21
V3 (A.F.)	12.6	10	135	0	117
(Rect.)	"	125	—	—	A.C.

These readings are taken with the volume control on full and no-signal input. All voltage readings except the heater taken with a 1,000 ohms-per-volt meter, to chassis. The

circuit is one of extreme simplicity (which accounts for the long trouble-free performance to be had). The set runs quite cool due to the fact that the dropping resistor is in the line cord. A magnetic speaker of new construction is employed and will give good service without the need of any adjustments. The case is of solid molded bakelite and may be had in several different colors. The speaker grilles are detachable and are also supplied in several finishes. The set is ideal for the traveler, since it is so small, and a suede carrying case may be obtained for carrying and protection. Since V3 is a dual tube, the set gives a performance

equal to those using 4 tubes, resulting in very high sensitivity for a set of this type. To test for alignment, insert a thin strip of mica, bakelite, or celluloid between the plates of the tuning condenser sections. Tune in a signal then open the condenser slightly below the point of resonance. Insertion of the feeler should now increase the signal, and as the feeler is pushed still farther between the plates, the signal should drop off. Correction for incorrect adjustment is made by bending the plate sections at the point of mesh, checking at 1,000 and 550 kc. The trimmer condensers should be set for best gain at 1,500 kc.

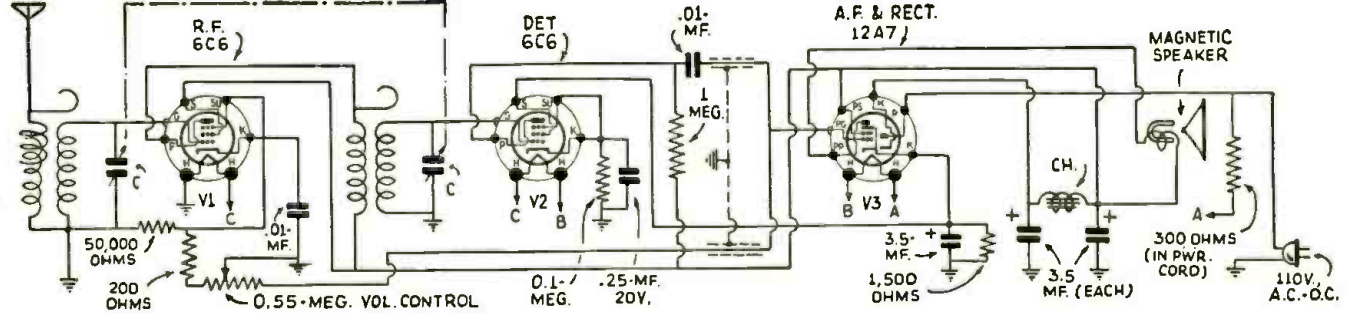

GENERAL ELECTRIC MODEL N-60 6-TUBE AUTO SUPERHETERODYNE

(Maximum power output, 4 W.; tuning range, 530 to 1,650 kc.; iron-core antenna coil; provision for high- or low-capacity antenna; all metal tubes; instrument-panel mountings for all popular cars; very complete filtering.)

The table of voltages for this receiver follows:

Tube	Heater	Plate	S.-G.	Cath.	Cath. (ma.)
V1	5.6	230	100	4.6	8.0
V2	5.6	230	100	0	2.8
V3	5.6	230	100	4.6	8.0
V4	5.4	100*	—	1.6	0.4
V5	5.3	220	240	13.0**	29.0
V6	5.3	—	—	—	53.0

*Read with 250,000 ohm meter; **read across the filter choke. The plate, S.-G., and cathode voltages are all read to ground, while the heater readings are taken directly across the socket terminals. For aligning the I.F. stage, the lead from the signal generator should be connected to the stator or the first-detector section of the main tuning condenser, through a 0.05-mf. condenser. A ground connection must be made to the chassis from the generator. Short out the oscillator section of the condenser, and set the receiver volume control at maximum position, adjusting the output of the service oscillator so that it is not high enough to cause the A.V.C. action of the receiver to take place. Then set trimmers C10, C11, and C13 for highest output. Turn

the set tuning condenser to full-open position and set the service oscillator for 1,650 kc. If a low-capacity antenna is to be used with the set, connect the antenna lead to the service oscillator through a 150 mmf. condenser, or through a 0.0015-mf. condenser if the antenna is of high capacity. Adjust trimmer CC for best output. Set the service oscillator to 1,400 kc. and turn the receiver tuning condenser carefully for best output, then set CA and CB for best output. After the receiver is installed in the car it is best to readjust trimmer CA to match the antenna used. Tune in a weak station around 1,200 kc. on the dial and with the volume control about three-fourths on, set CA for best results. The dial is set to the correct frequency calibration by turning a small screw on the back of the control head after the pilot lamp assembly has been removed. Be sure that the cover of the set is tightly fitted after it has been removed. It is sometimes necessary to remove paint and dirt particles that prevent a tight fit in order to stop ignition noise. The receiver is fitted with a universal control head which can be used on almost any car, by the use of the correct type of escutcheon plate.

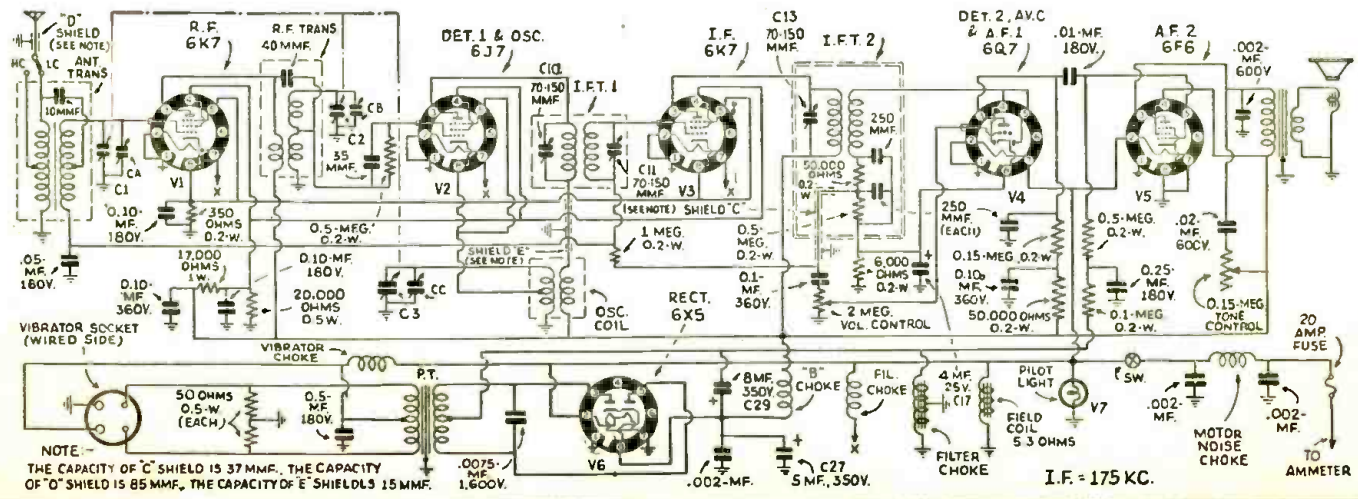
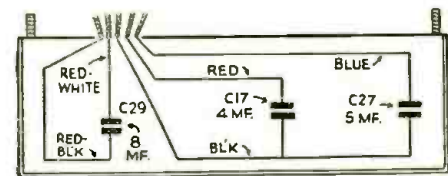
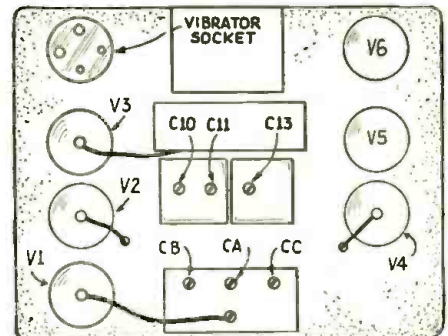

NOTE: THE CAPACITY OF 'C' SHIELD IS 37 MMF., THE CAPACITY OF 'O' SHIELD IS 85 MMF., THE CAPACITY OF 'E' SHIELD IS 15 MMF.

AWARDS IN THE CONTEST
FIRST PRIZE \$10.00
SECOND PRIZE 5.00
THIRD PRIZE 5.00
Honorable Mention

USEFUL CIRCUIT IDEAS

Experimenters: Here is your Opportunity to win a prize for your pet circuit idea, if it is new, novel, and useful.

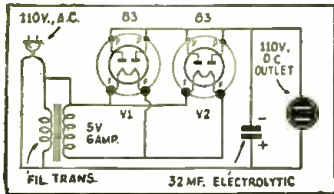

Fig. 1. Shop D.C. power supply.

FIRST PRIZE—\$10.00

D.C. POWER SUPPLY FOR SET TESTING. For the benefit of those Service Men who are occasionally called upon to repair 110 V. D.C. receivers and have only A.C. available, we suggest the hookup in Fig. 1. With a 32 mf. condenser at the output as shown, the input A.C. voltage and the output D.C. voltage are the same.

FRANK THOMPSON, JR.

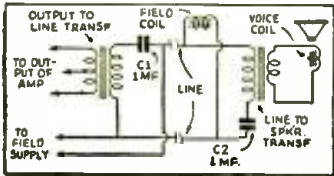

Fig. 2. Remote speaker line.

SECOND PRIZE—\$5.00

REMOTE-SPEAKER CONNECTION. A practical transmission line for remote dynamic speakers is shown in Fig. 2. Only 2 wires are used, as the field current and the A.C. signal current both pass over the same wire. Of course the line drop, resistance, and impedance must be considered. Note that the system is not practical for low-voltage field excitation (6 V. field) as the line voltage drop would be too high.

CHARLES HIGGINBOTHAM

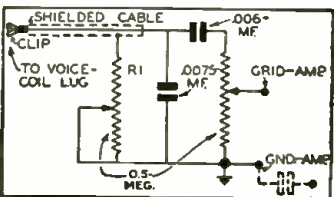

Fig. 3. Connecting radio and P.A.

THIRD PRIZE—\$5.00

HOW TO OPERATE 60-CYCLE TRANSFORMERS ON 25 CYCLES. In this city we have 25-cycle current, so the large number of 60-cycle transformers we get are useless. To utilize the latter I hit upon the scheme in Fig. 6, and it works like a charm. It is a circuit of a power pack and 2 stage amplifier I have been using for quite a few months with complete satisfaction. There is no heating. The high voltage is 265 V. with 2 other tubes connected to the amplifier. All 4 tubes are connected to the taps on the primary for heater supply, which is exactly 6.3 V. This scheme may be of use to Service Men in the 25-cycle districts of both the U. S. and Canada.

F. J. BIRD

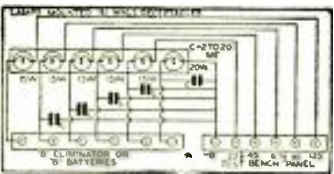

Fig. 4. Protected "B" lines.

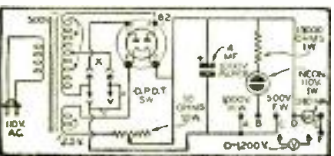

Fig. 5. Measuring apparatus.

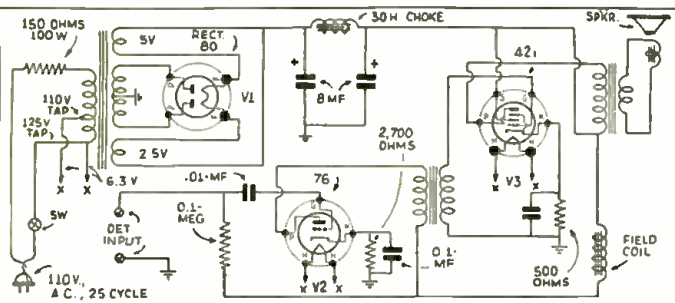

Fig. 6. 60-cy. transformer on 25-cy., with good efficiency.

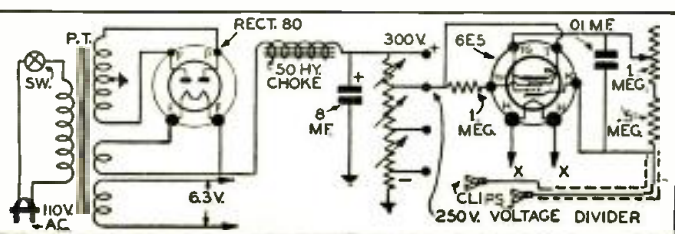

Fig. 7. A simplified alignment indicator utilizing the "magic eye."

HONORABLE MENTION

RADIO-P.A. CONNECTION. This method is quick, and excellent fidelity will result. The radio set is connected to the P.A. amplifier without being altered in any way. The shielded cable used to connect to the voice coil should be of the low-capacity type. A loud A.C. hum may usually be cured by reversing, at the socket, the line plug of either the radio receiver or the P.A. unit. The lead may be of any length up to 25 ft. (which is the length I have used). No direct-ground connection is made to the radio unit, but a 0.1-mf. condenser may be needed, connected from the P.A. chassis to the receiver chassis. See Fig. 3.

HAROLD RICHARDSON PUTNAM

definite point, say 100 V. each time the unit is used, as the line voltage often varies widely. For testing condensers smaller than 1 mf., the shunt lamp is disconnected. For high-impedance tests the lamp is not used, and lamps of different sizes are used for lower impedances, the rule being that the lower the impedance the larger the lamp needed. The fuse protects the fine wire of the high impedances, should the latter be connected to the circuit with the shunt left in by accident. A chart may be made on graph paper, the readings being obtained by checking known units. Good electrolytic condensers read the same as paper condensers of the same values, for all practical purposes.

H. M. WALLAM

HONORABLE MENTION

SAFETY BULBS FOR BATTERY POWER SUPPLY. This scheme has saved me a lot of tube losses and has much more than paid for itself, and should interest other Service Men who handle a large number of battery-powered receivers. Each high-voltage lead from the "B" eliminator is fed through a lamp socket, all the sockets being mounted on a board over the test panel so that the bulbs may be easily seen. The lamps in Fig. 4 are all 15 W. except the "B" which is a 20 W. unit. On a short-circuit one or more of the bulbs will glow. It may be advisable to connect condensers C across all leads to "B" to prevent circuit oscillation.

W. T. BRAITHWAITE

HONORABLE MENTION

"MAGIC EYE" ALIGNMENT INDICATOR. The "magic eye" or 6E5 cathode-ray indicator tube is used in this circuit, which in my case is simply connected to the shop variable high-voltage supply, as may be seen in Fig. 7. This gives me a handy resonance indicator which may be used for alignment and other purposes. The input lead should be shielded as the device is very sensitive.

AUBREY V. SCHROEDER

HONORABLE MENTION

SIMPLE CONDENSER TESTER. The circuit shown in Fig. 5 is that of a condenser tester which may be used for either paper or electrolytic units. With Sw. in the X position, the #2 is used as a full-wave rectifier with an output of 500 V. at terminals C and D. For electrolytic condenser leakage testing, a 0-10 ma. meter is connected between D and E. A leakage of 1 ma. per mf. is the limit up to 20 mf. Any voltage from 0 to 500 may be obtained by use of the filament resistor of the #2.

(Continued on page 60)

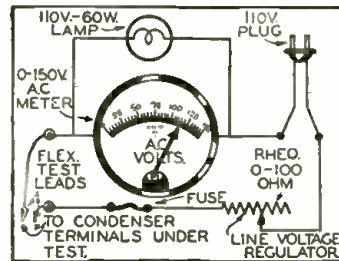

Fig. 8. Condenser tester.

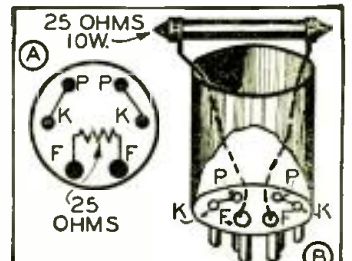

Fig. 9. Substituting for the 25Z5.

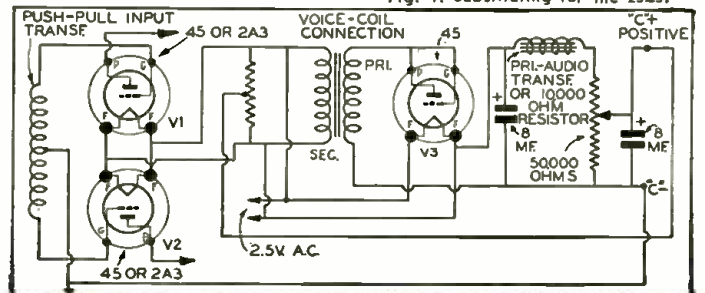

Fig. 10. Fixed-bias supply, ingeniously made from scrap parts.

**SENDING "PICTURES"
BY TELEPHONE**

(Continued from page 8)



Fig. D. Note the remarkable detail.

paper office; (later, use may be made of the "conference wires" whereby the pictures may be sent from one point and received simultaneously at several different cities).

At night rates, a 6 1/2 x 8 1/2 ins. picture would cost a maximum of about \$25.00 if sent from coast to coast, and could be sent in about 15 mins.

The receiving end operates almost as simply. The operator places a drum carrying a sheet of sensitized paper upon a vertical spindle on the panel. A pick-up coil placed close to the telephone instrument is connected to the amplifying system of the receiver, and the amplifiers and synchronizer adjusted, the latter process being extremely simple.

While the process is somewhat similar to that used by other news systems, it differs in several important points, one of the most radical departures of course, being that the portable transmitters may be used anywhere there is an ordinary telephone line available. Another difference is that the new apparatus is so well synchronized that perfect pictures may be sent over the "carrier circuits," used quite extensively in the Southwestern portion of the U.S. Transmission over these circuits heretofore has resulted in such distortion that the pictures were totally unusable.

The perfection of the transmissions may be seen by reference to Fig. B, which shows an unretouched photo of a railroad wreck as reproduced over the system; and Fig. D, also unretouched, illustrating an actual "news" occurrence.

In Fig. 1, our artist has shown the sequence of operation. First the reporter snaps a picture of a wreck, which is then quickly developed, and transmitted over the telephone in the village general store. The reader will easily understand the importance of this rapid system in the dissemination of illustrated news stories.

THE "SUPER" SERVICE MAN

(Continued from page 10)

tively reasonable in price on the market today. Here again the common power supply could be used with common sense precautions against interaction and feedback between the tubes and circuits associated with each oscilloscope. There might be more or less controls than we have shown, depending upon the versatility required of the finished apparatus. All associated equipment such as frequency modulator, signal generator, and so on could be mounted in a single shielded case, although it goes without saying that the various "hot" leads, and also the A.C. leads would have to be carefully shielded to prevent interaction and pick-up of hum-frequency voltages (one of the biggest bugbears in setting up oscilloscope equipment).

So the reader may now see that what at first appeared to be a "wild" idea is really quite practical, and in fact will probably be employed very shortly in the larger and more progressive service shops and factories. In fact, it is quite possible that we will receive letters from Radio-Craft readers who are already using some such set-up—just as our "Traveling Service Man" idea of last year was subsequently found to be in use by some technicians (see page 11, for instance)!

**This NEW Type of
RADIO TRAINING**

**ACTUALLY SETS YOU
UP IN BUSINESS ...**

**... In the Fastest Moving
Industry in the World ...**

Here, at last, is a NEW and DIFFERENT type of Training that not only teaches you all phases of Radio Service Engineering work—but which equips you for an actual start in business. No matter what kind of Radio training you may take, you will require such materials before you actually are ready for business. Sprayberry Training gives them to you—teaches you to work with them under actual Service conditions. Nor is that all. Never forget that there are too many men of only mediocre

ability in ALL lines of business. That is why average wages are low—why many men are out of work. Radio is no exception. But there is always room—there is good pay AT THE TOP OF THE LADDER—and this is where Sprayberry Training is specifically designed to put you. It is for men who take Radio seriously—for those willing to work along sound, intensely practical lines to win a real future in a great industry with vast opportunities for future development.

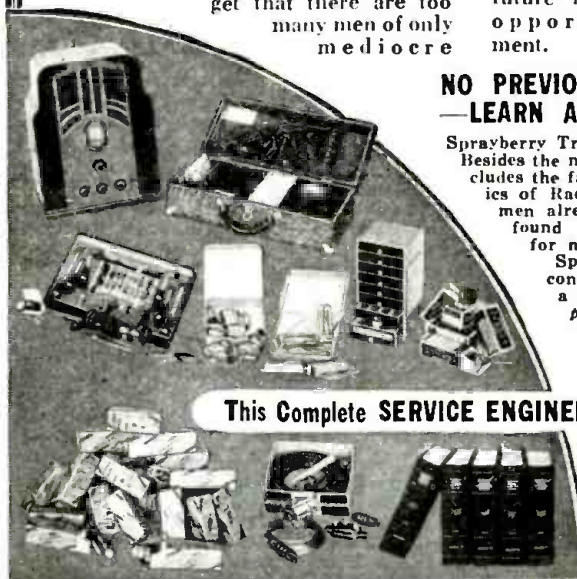
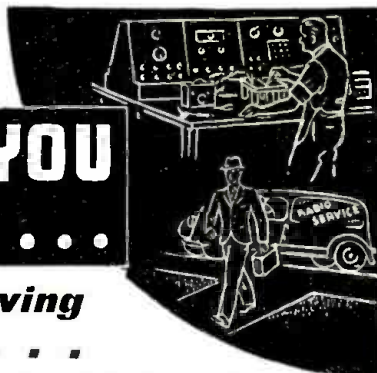

This Complete SERVICE ENGINEERING EQUIPMENT Is Yours!

**NO PREVIOUS EXPERIENCE REQUIRED
—LEARN AT HOME IN SPARE TIME**

Sprayberry Training is really two courses in one. Besides the necessary fundamental teaching it includes the famous Sprayberry Practical Mechanics of Radio Service formerly sold ONLY to men already in Radio—many of whom had found their previous training inadequate for modern Radio needs.

Sprayberry Training has been honestly, conscientiously developed to fit you for a truly worthwhile place in Radio—"a place well above the average." It is different from any other course you might consider. It is complete—modern—practical.

Upon completion, you have both the knowledge and equipment to enter business then and there for full or part time profits—or to start out in any one of Radio's specialized fields such as sound, broadcasting, etc. Certainly you owe it to your future to investigate—TODAY!

SPRAYBERRY ACADEMY OF RADIO

2518 University Pl., N.W., WASHINGTON, D.C.

Without cost or obligation on my part please rush complete details of your new type of training and the booklet "MY FUTURE IN RADIO."

BEFORE ENROLLING FOR ANY HOME STUDY COURSE, YOU OWE IT TO YOUR FUTURE TO INVESTIGATE THIS ONE.

Name Age

Address RC 7/36

(Paste this coupon on postcard and mail today!)

DENCOSE Model 30-A

STUDIO RECORDER

New!

Now—a portable, recording and playback unit, lightweight, easy to operate, efficient—at a special production price! Increased hi-fidelity. Built by the makers of widely-endorsed VIBRO-MASTER Sound Equipment. Comes complete with microphone and carrying case. Wide sales appeal to teachers, singers, speakers, schools, Public Address companies, business executives, fairs, etc., etc.

\$250

Write today for our special DEALER PROPOSITION with exclusive franchise and profit plan.

DENCOSE, INC., 1650 Broadway, N. Y., Dept. A-7

"If it pertains to sound—see DENCOSE!"

Please Say That You Saw It in RADIO-CRAFT



Radio men all over the country are taking their hats off to Sylvania. Here's an example of service that means something!

● If you haven't a copy of this valuable book, send for one NOW! Here are just a few of the features of this new Technical Manual!

1. A 50% increase in contents.
2. 141 tube types listed with important circuit application information given on each type.
3. Characteristics on all types are the latest, including all the standard types of metal tubes.
4. A section on circuits has been increased to include 13 typical radio receiver and amplifier circuits which show proper use of the most popular types of tubes now being employed.
5. Curve data on ballast tubes for battery sets.
6. The convenient pocket-size has been retained in spite of the large increase in material.

Hygrade Sylvania Corporation, makers of Sylvania Radio Tubes and Hygrade Lamps. Factories at Emporium, Pa., Salem, Mass., and St. Mary's, Pa.

SYLVANIA

THE SET-TESTED RADIO TUBE

Clip this coupon right now. It will mean cash in your pocket!

Hygrade Sylvania Corporation 10C-76
Emporium, Pa.

Please send me the new Sylvania Technical Manual. I enclose 15c in stamps.

Name

Address

City State

TECHNICIANS' DATA SERVICE

JOSEPH CALCATERRA

DIRECTOR

A special arrangement between RADIO-CRAFT magazine and the publishers of this literature, which permits bulk mailings to interested RADIO-CRAFT readers, eliminates the trouble and expense of writing to each individual organization represented in this department.

2. HAMMARLUND 1936 CATALOG. Contains 12 pages of specifications, illustrations and prices on the new line of Hammarlund variable, mid-get, band-spread and adjustable condensers; trimming and padding condensers; R.F. and I.F. transformers, coils and coil forms; sockets, shields, chokes and miscellaneous parts of ultra-short-wave, short-wave and broadcast operation.

3. HOW TO GET A HAMMARLUND 1936 SHORT-WAVE MANUAL. A circular containing a list of contents and description of the new 16-page Hammarlund Short-Wave Manual, which contains construction details, wiring diagrams, and list of parts of 12 of the most popular short-wave receivers of the year.

4. THE "COMET PRO" SHORT-WAVE SUPERHETERODYNES. Describes the outstanding features of the standard and crystal-type Hammarlund "Comet Pro" short-wave superheterodynes designed to meet the exacting demands of professional operators and advanced amateurs for a 15 to 250 meter code and phone receiver, but which can be adapted by anyone for laboratory, newspaper, police, airport and steamship use.

5. ELECTRAD 1936 VOLUME CONTROL AND RESISTOR CATALOG. Contains 12 pages of data on Electrad standard and replacement volume controls. Truvolt adjustable resistors, vitreous wire-wound fixed and adjustable resistors and voltage dividers, precision wire-wound non inductive resistors, center-tapped filament resistors, high-quality attenuators, power (50- and 150-watt) rheostats and other Electrad resistor specialties.

53. POLYIRON COIL DATA SHEET 1135. This folder contains complete catalog descriptions, specifications, prices, performance curves and circuits showing applications of the complete line of Polyiron core coils made by the Aladdin Radio Industries for use as R.F. and I.F. transformers and antenna couplers.

57. RIBBON MICROPHONES AND HOW TO USE THEM. Describes the principles and operating characteristics of the Amperite velocity microphones. Also gives a diagram of an excellent humless A.C. and battery-operated preamplifier.

59. THE EVOLUTION OF TUBE TESTING. This interesting booklet, published by the Supreme Instruments Corp., traces the development of tube testing equipment and gives a complete technical description, with wiring diagram and discussion of the technical points involved in the design and use of the Model 89 Supreme Radio Tester for testing all tubes, and also paper and electrolytic capacitors.

62. SPRAYBERRY VOLTAGE TABLES. A folder and sample pages giving details of a new 300-page book, containing 1,500 "Voltage Tables" covering receivers manufactured from 1927 to date, published by Frank L. Sprayberry to simplify radio servicing.

64. SUPREME No. 385 AUTOMATIC TESTER. A technical bulletin giving details, circuits and features covering this new Supreme development designed to simplify radio servicing. In addition to the popular features of Supreme analyzers and tube testers it contains many direct-reading features which eliminate guesswork or necessity of referring to charts or tables.

65. NEW 1936 LINE OF SUPREME TESTING INSTRUMENTS. This 16-page catalog gives complete information on the entire Supreme line of testing instruments, including the Model 385 Automatic Tube Tester and Analyzer, the Model 339 DeLux and Standard Analyzers, and other standard Tube Testers, Set and P.A. Analyzers and Signal Generators. Complete details of the Supreme Easy Payment Plan for purchasing testing equipment on the installment plan are given.

67. PRACTICAL MECHANICS OF RADIO SERVICE. Information, including cost, features and outline of lessons of the Frank L. Sprayberry course in Radio Servicing, and list of Sprayberry Data

Sheets for modernizing old radio equipment.

73. HOW TO ELIMINATE RADIO INTERFERENCE. A handy folder which gives very complete information on how to determine and locate the sources of radio noise by means of the Sprague Interference Analyzer. A description of the analyzer and method of using it is included, together with data on how to eliminate interference of various kinds once the source is located.

74. SPRAGUE 1936 ELECTROLYTIC AND PAPER CONDENSER CATALOG. Gives specifications, with list and net prices on a complete line of wet and dry electrolytic, and paper condensers made by the Sprague Products Co. for radio Service Men, set builders, experimenters and engineers. Information on the Sprague Capacity Indicator, for making capacity tests on condensers and in servicing receivers, is included.

75. SPRAGUE TEL-U-HOW CONDENSER GUIDE. A valuable chart, compiled by the Sprague Products Co. which tells the proper types, capacity values and voltages of condensers required in the various circuits of radio receivers and amplifiers, and how to locate radio troubles due to defective condensers. Includes data on condenser calculations.

76. FACTS YOU SHOULD KNOW ABOUT CONDENSERS. A folder, prepared by the Sprague Products Co., which explains the importance of various characteristics of condensers, such as power-factor, leakage, capacity and voltage in determining the efficiency or suitability of a given condenser to provide maximum filtering and safety in operation.

Radio-Craft Technicians' Data Service
99 Hudson Street,
New York City, N. Y. RC-736

Please send to me, without charge or obligation, the catalog, booklets, etc. the numbers of which I have circled below.

2	3	4	5	53	57	59	62
64	65	67	73	74	75	76	

My radio connection is checked below:

- Service Man operating own business.
- Service Man for manufacturer.
- Service Man for jobber.
- Service Man for dealer.
- Service Man for servicing company.
- Dealer.
- Jobber.
- Experimenter.
- Professional Set Builder.
- Amateur Set Builder.
- Short Wave Worker.
- Licensed Amateur.
- Station Operator.
- Radio Engineer.
- Laboratory Technician.
- Public Address Worker.
- Manufacturer's Executive.
- Student.

I am a:
 Subscriber Newsstand reader
 I buy approximately of radio material a month. (Please answer without exaggeration or not at all.)

Name

Address

City State

(Please print name and address)
 Avoid delay. The catalogs and booklets listed are now in stock and will be sent promptly as long as the supply lasts. Please use this coupon in ordering. The use of a letter causes confusion and delay.

Please Say That You Saw It in RADIO-CRAFT

A SIMPLIFIED DECADE CONDENSER BOX

Here is a companion unit to the Simplified Decade Resistance Box described in the June, 1936 issue, page 727.

G. F. BENKELMAN

ONE OF the most useful devices in radio service work has never been offered on the market in a compact, convenient size—it has been left to radio Service Men and experimenters to build their own decade condenser boxes. There is scarcely a service job in which a condenser box will not prove useful in making temporary substitutions for condensers in the circuit suspected of being defective.

Another important use of a decade condenser box is in conjunction with a capacity bridge circuit, wherein the decade condenser box serves as the standard of capacity in one arm of the bridge, permitting fractional values to be measured by the familiar Wheatstone Bridge formula involving the ratio of two arms of a potentiometer, the known capacity and the unknown capacity.

Cost and size have proved a handicap because in previous designs of decade condenser boxes employing a single selector switch per decade either ten condensers of the same size were necessary, in which case a fan blade switch was required, or ten successive sizes of condensers were necessary per decade. Condensers with any degree of accuracy were very expensive and usually very bulky.

"Re-engineering" the decade condenser box circuit to use a modern double-deck ten-point constant-contact rotary switch per decade permits reducing the number of condensers required from nine to four per decade. Extreme

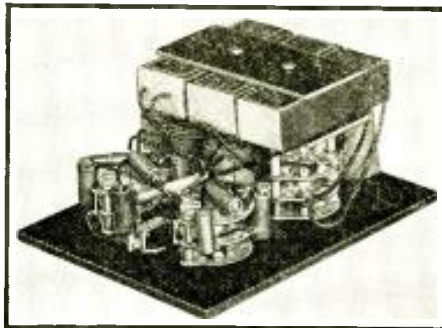

The appearance of the interior of the unit.

laboratory precision is not necessary in service work, particularly as manufacturers tolerate from ten to twenty per cent variation in their component receiver parts. Hence, semi-precision condensers are entirely suitable for this type of work. Actually these are standard condensers which have been made under special production supervision, and which test at normal room temperature within 5 per cent of their rated value. They cost only slightly more than ordinary condensers of the 600-V. type, but due to the extra care in their manufacture are usually as good as high priced precision condensers for practical work.

The illustration and circuit diagram show the simple switching arrangement by which 4 condensers in each decade are combined to produce 9 values of capacity.

A 1,000-ohm resistor and single-pole double-deck toggle switch are incorporated for the purpose of discharging the condensers after use on a high voltage D.C. circuit. If the switches are set to give a total capacity of 9.999 mf. when not in use, the 1,000-ohm resistor will effectively discharge any current stored in the 16 condensers which make up the box.

The case may be made from ordinary five-ply 5/8 in. birch veneer and finished in natural or walnut color to match other test equipment. The following is a list of capacities for each decade:

Decade	C ₁	C ₂	C ₄	C ₇	Range of Decade
No.	mf.	mf.	mf.	mf.	mf.
1	.001	.002	.004	.007	.001-.009
2	.01	.02	.04	.07	.01-.09
3	.1	.2	.4	.7	.1-.9
4	1.0	2.0	4.0	7.0	1.0-9.0

In addition, a 1,000-ohm resistor, a S.P.D.T. toggle switch, 4 double-deck 10-point constant-contact rotary switches, and two binding posts are essential. The bakelite panel and carrying case may assume any form the builder desires.

This article has been prepared from data supplied by courtesy of Continental Carbon, Inc.

Please Say That You Saw It in RADIO-CRAFT

*compact...
complete...
inexpensive...*



THE WESTON CHECKMASTER

(MODEL 771)

\$45⁰⁰ NET

TO DEALERS IN U. S. A.

1. Tests all tubes — has spare sockets
2. Neon Short Check while tubes are hot
3. Cathode Leakage Test
4. Individual tests on elements of diodes
5. Voltage ranges for point-to-point testing
6. Resistance ranges for continuity testing
7. Neon high resistance leakage test
8. All readings on one legible, open-scale meter — the famous WESTON 301 in modern rectangular form
9. Positive line voltage control
10. Striking design and finish — for home or store use

Convenience, simplicity of operation, and dependable accuracy are combined in this new CHECKMASTER. It's extremely portable . . . yet its striking design and finish makes it ideal for shop and counter use. Get full information on Model 771. Return the coupon below.

WESTON ELECTRICAL INSTRUMENT CORPORATION
599 Frelinghuysen Avenue, Newark, N. J.

Name _____
Address _____
City _____ State _____

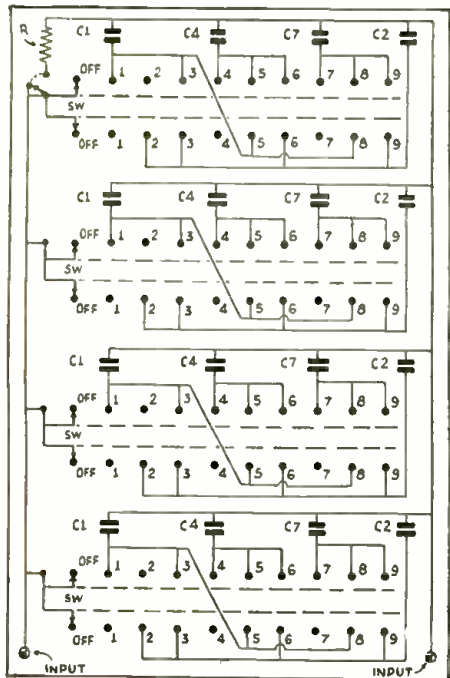

The circuit of the condenser unit in which 4 condensers take the place of 10.

TRANSFORMERS

FOR ALL PURPOSES

for example:

ULTRA-HIGH FREQUENCY Portable or Mobile TRANSCEIVERS should use some of the following:

F-532-B—Microphone and Plate Primaries to Grid Secondary. Uncased, light weight, Net \$.92

F-533-B—Transceiver Output from plate of 33, 38, 41, etc. to 130,1000 or 2000 ohm handset or phones.....\$1.00

F-536-B—Similar to F-532-B but for more powerful Transceiver using a 19 as push-pull R.F., 30 as audio driver, and 19 as Class B Modulator \$1.05

F-534C—Class B Input, 30 driver to 19 Grids Class B\$.80

F-535-B—Class B Output from 19 Twin to modulate 19. Sec. handles plate current of r.f. stage, impedance approx. 2700 ohms, or any 7 watt stage approx. 50 m.a. at 135 volts.....\$1.17



General Replacement Transformers

will be found in our CATALOGUE No. 51-C

Three examples out of 161:

No. 210—300-0-300 V. 40 m.a.; 2.5 V. 5.5 A.; 5V. 2A\$1.11

No. 209—330-0-330 V. 60 m.a.; 2.5 V. 8.75 A.; 5V. 3A\$1.80

No. 1103—Single Plate to Push-pull Grids\$.98



High Fidelity Audio Transformers for Public Address, Broadcast and Amateur Stations will be found in our catalogues No. 70, No. 70-A. Description of all types for microphones, matching, interstage, and output, all fully cased and shielded. Useful diagrams included.



AMATEURS!

SEND FOR CATALOGUE No. 52-C

Contains nearly a hundred stock transformers and chokes for all power phone and C.W. rigs, designed by Lloyd Phelps. W2BP-W9BP. Illustration shows FTP-56 which delivers 3/4 K.W. and costs \$9.50 net.



Any of the above catalogues free for the asking. If in a hurry, order direct from this ad or see your local jobber. If he does not have these lines tell him he is missing something well worth while.

DIATHERMY TRANSFORMERS made to your specifications

FRANKLIN TRANSFORMER MANUFACTURING COMPANY
607-609 22nd Avenue N. E., Minneapolis, Minn.

THE PERFECT CODE TEACHER!

NEW MASTER TELEPLEX

For beginners, experienced operators, and school-room. The sure easy way to learn code, and to step up your speed. This amazing new instrument will record your own sending on double row perforated paper and repeat it back to you at any speed you desire. 10,000 words can be recorded on one tape.

**NO BATTERIES
NO WINDING
ALL ELECTRIC**

It is the same in principle, and in operation is equal to the Wheatstone Perforator and Transmitter, which cost over \$1,000.

BUY IT OR RENT IT
Send for Folder A7, which tells you how to get the use of this instrument without buying it. No obligation. We furnish complete course and personal instruction with a money-back guarantee. Low cost, easy terms. Write today for information.

TELEPLEX CO.

72 Cortlandt St. New York City
The New Master-Teleplex "The Choice of Those Who Know"

THE PHILOSOPHY OF SERVICING

(Continued from page 10)

ments (not to impress you, but to get the real lowdown). All this time he is thinking, reasoning, studying and checking; finally he gives you comforting words (which you really like), sound advice and naturally a prescription (to assist nature in restoring your health). He has given you a remedy.

Unbelievable though it seems, this is exactly the way a modern Service Man should investigate and repair a "sick" radio receiver. To prove this, I'll show you how a modern radio doctor (I will take the role myself for the sake of illustration) handles a radio receiver "SOS."

Rrrrr—ing—I push the button at the door of Mr. Brown, who had phoned from his office asking me to call as soon as possible. The door opens and I say: "Good afternoon, Mrs. Brown. Isn't it a fine day?" (Comments on the weather are always good business).

"What seems to be wrong with your radio?" I ask Mrs. Brown as she blocks my way to the receiver. Perhaps Mrs. Brown, too, is thinking: "That's what you are here for," but I have a good reason for asking this question. Mrs. Brown and her husband undoubtedly have come to some agreement about the trouble, and as a good business man, I am at least going to cure what they think is the trouble.

I listen respectfully to a history of the set and its troubles, then tactfully dodge Mrs. Brown to get to the receiver. Click—on goes the power switch—and I wait for the first gurgling greetings from the sick set. If the tube warming-up noises are normal and no other aggravating sounds are heard, I try to tune in a local broadcast station. Perhaps I get it, perhaps I don't, but now my mind is working at "top speed." If there are interfering noises after the set gets into action or the set does not operate properly, I ask myself: "What could produce this?" If the set is completely "dead" I poke my head into the rear of the cabinet to see if all the tubes light. If the set has metal tubes, I gingerly touch each (sometimes this "temperature-taking" proves painful, if I am too slow), then check to see that tube cap connections are in place, aerial and ground connected, and the set plugged into the wall socket properly. My eyes trace the antenna and ground wires out of the window to see if they are still in existence. I am surveying for obvious defects—physical defects.

Now I begin to "do things" if the set does not play, pulling tubes out of their sockets and pushing them in again while listening for tell-tale clicks in the loudspeaker. Down the line I go—if I find a tube that won't "click," the chances are ten to one that I have located the trouble-making stage.

By now Mrs. Brown is undoubtedly wondering why I haven't opened the pretty leather case I've deposited on the floor—but I know better. Why use special testing tools when I know from experience that in 90 per cent of the cases my preliminary observations will tell me exactly what is wrong, or at least isolate the trouble to a particular part of the radio set? Why check the entire receiver with instruments, stage by stage, when that little "tube-pulling" test will locate the bad stage?

Now I open the instrument case and lay out the instruments on the floor, to check my preliminary tests and make a more thorough analysis of the suspected stage. My signal generator replaces the local broadcasting station, and the output meter in the multimeter gives me an opportunity to find out if the tube-pulling procedure, which is really a circuit disturbance test, has given me the correct "dope." By applying the signal generator to the input of the suspected stage, trying a new tube or testing the old one, then applying the signal generator to the output of the same stage, I can locate exactly where the trouble may be. Now, taking the chassis out of its cabinet, I can use a multimeter to make a point-to-point resistance or voltage check, which will isolate the defect. Once the open, short, or defective part is spotted, the remedy is simple—I solder the open, remove the short, or replace the defective part (something which our good friend the physician cannot always do).

If the receiver is seriously ill, I take it to my hospital, the shop workbench, for a major operation from which the ailing set emerges a healthy radio receiver.

Now do you agree with me that there is a correct approach to any radio servicing job? Here are the 8 steps:

1. Confirmation of the complaint—getting the "lowdown."
2. Letting the receiver "speak for itself."
3. Checking for surface defects—no job for a sleepy man!
4. Reasoning from effect to cause—calls for a clear, well-trained mind.
5. Checking stages by tube click test (if set is dead).
6. Applying modern instruments to isolate the defect.
7. Making necessary repairs.
8. Putting original "pep" back into the set.

Only after going through this procedure can I say "that will be four dollars and seventy-five cents," or whatever I estimate that the job is worth.

FIELD OR BENCH EQUIPMENT

Finally, I want to close this article with a few words regarding the use of "horse sense" in selecting testing equipment. Just sit back some evening when the day's work is over, give your servicing technique the "once-over," then thrash out how you can most judiciously spend your money for testing equipment.

Testing equipment manufacturers make their living by producing what you Service Men demand; if you do not as a group show any preference, they will make equipment which captivates your attention. Fortunately, there exists today a large enough variety of equipment to serve any practical need, and special equipment is manufactured as soon as it is demanded. Every time you ask a manufacturer for something special he files your letter as one more request for a device about which he has probably been thinking.

Testing equipment naturally divides itself into 2 groups: (1) that used in the field (in the customer's home); and, (2) that used at your workbench. Of course, if your funds for equipment are limited then the field equipment must serve for the bench. But now I am considering the full-time radio Service Man who needs both; with this in mind let me caution you that instruments used in the field get quite a bit of abuse, and are not precision devices, even if they were originally. Select field equipment which is rugged, light, and simple to use; select bench equipment which is accurate and capable of doing many special tests.

Radio men with years of experience would not dare to say that any one device would never become obsolete, but they are able to tell which of two instruments will become out-of-date first. From a study of the technique of servicing radio receivers in the field I would say that the following equipment, listed in the order of its importance, is needed:

1. A multimeter.
2. An all-wave service oscillator (signal generator).
3. A tube tester.
4. A socket analyzer adapted for use with the multimeter.

Experience has shown that a tube tester (of the good and bad automatic reading type) becomes obsolete faster than a socket analyzer, and that the signal generator and multimeter will have the longest useful life before becoming obsolete. Choose the highest-quality signal generator and multimeter you can afford, and by all means select individual units. If you buy good but inexpensive tube testers and socket analyzers, a radical change in the field such as that caused by the introduction of new tubes, will not involve too great a loss.

Bench equipment should be bought on the unit basis, too, bearing in mind the facts which I have already stressed. Of course, the above-mentioned 4 instruments come first; to these you can gradually add:

5. A universal power supply panel.
6. A universal loudspeaker.
7. Cathode-ray oscilloscope with frequency wobble attachment for the signal generator.
8. Megohm tester.
9. Vacuum-tube voltmeter.
10. Vibrator tester.
11. Beat-frequency audio oscillator.
12. A resistance-capacity-inductance A.C. bridge.

By building up your servicing equipment on a unit basis, starting with a well planned foundation layout, you build for a permanent future with a minimum of obsolescence.

Please Say That You Saw It in RADIO-CRAFT

"BATTERY PORTABLE 4"

(Continued from page 16)

dynamic units.

CONSTRUCTION

Concerning the actual construction of this receiver, most of the details necessary may be obtained by close inspection of the chassis views shown in Figs. A, B, and C. The placement of all important parts may be determined from these illustrations. It will be noted that one (antenna) coil is installed above the chassis, and the other (R.F.) coil is mounted on the underside of the chassis. The reason for this is to prevent any possible reaction between the two coils that might result in uncontrollable oscillations which would make tuning difficult.

The speaker is fastened on the inside of the case behind the screen covering the speaker opening. The output leads from the receiver connect to the two terminals on the speaker across which is wired a 0.006-mf. condenser. The purpose of this condenser is to eliminate certain rasping high frequencies which most small speakers have a tendency to emphasize.

When the wiring of the receiver is completed, the constructor is ready for the aligning or adjusting process. The filament rheostat, however, should be first set so that only 2 V. are impressed across the filament terminals on any tube. This may be checked or measured by means of an ordinary voltmeter, the test leads from which are connected to the filament terminals of any tube socket. After a station is tuned in, the two small trimmer condenser adjustments located on the top of each section of the variable condenser should be manipulated for loudest reception. This process should be performed with the volume control turned on full and preferably on weak signals tuned in at maximum, minimum, and center portions of the tuning dial. No adjustment or aligning is provided for on the police band.

LIST OF PARTS

- *One leatherette case, 13x13x6 ins. deep;
- One aluminum chassis, 9x5½x2¾ ins. high;
- One 2½-in. airplane dial;
- One 2-gang variable condenser; 350 mmf. each section;
- One 0.5-mcg. volume control with switch;
- *One 2-band fan-type switch;
- *One 2-band antenna coil (police and broadcast);
- *One 2-band T.R.F. coil;
- One Eby 3-ohm rheostat;
- Two I.R.C. 0.2-mcg. ½-W. resistors;
- Two I.R.C. 0.5-mcg. ½-W. resistors;
- One I.R.C. 10,000 ohm. ½-W. resistor;
- One I.R.C. 0.1-mcg. ½-W. resistor;
- Four Cornell-Dubilier bypass condensers 0.5-mf. (tubular);
- Three Cornell-Dubilier bypass condensers 0.1-mf. (tubular);
- One Cornell-Dubilier bypass condenser 0.006-mf. (tubular);
- Two Eby 4-prong wafer sockets;
- One Eby 5-prong wafer socket;
- One Eby 6-prong wafer socket;
- Two Hammarlund 85 mby. R.F. chokes;
- One Cornell-Dubilier, 0.1-mf. mica type fixed condenser;
- One 6-wire battery cable;
- One 6-terminal tie-in strip;
- *One 5-in. orthovox speaker;
- Four Sylvania 2-V. tubes, namely, 2 type 34s, 1 type 1B5, 1 type 33;
- *One No. X200, 8-V. "A" battery;
- *One 22½-V. "C" battery;
- *Three portable-size 45-V. "B" batteries;
- Miscellaneous parts such as bolts, screws, scrap aluminum, wire, solder, etc.

Names of manufacturers will be sent upon receipt of a stamped, self-addressed envelope. The photo, Fig. A, was made through the courtesy of David T. Abercrombie Co.

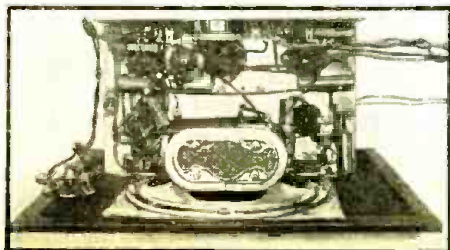

Fig. C. The rear of the set chassis.

POLITICS PAYS BIG PA PROFITS WITH THIS



Lafayette 15 WATT PORTABLE AMPLIFIER SYSTEM

- EXTREMELY COMPACT & PORTABLE!
- ULTRA MODERN IN DESIGN!
- UNBELIEVABLY LOW IN PRICE!

COMPLETE WITH 2 SPEAKERS

This modern, lite-weight portable P.A. system is a Heavyweight in performance and at a price that is so low that it is almost unbelievable. Ideal for orchestras, radio stars on tour and lecturers—particularly political lecturers!

This system has everything! High gain for use with velocity and sound cell microphones, 15 watts output, TWO 8½" speakers, "airplane type" case. It features extreme ease of operation and installation. There are plug-in connections on both input and output, while series connected cables permit placing of two speakers 25 and 50 feet, respectively, from the amplifier.

With politics coming to the fore this Fall our low price will make this job extremely popular.

Dealers' Cost
\$39.50

Order direct from this ad!

Send for the new Lafayette LIST PRICE CATALOG No. 64 showing Lafayette P.A. equipment for every need. It's Free!

Wholesale Radio Service Co., Inc.
100 Sixth Avenue, Dept. G3P
New York, New York
Please send me Catalog No. 64 showing Lafayette P.A. Equipment.

Name

Address

City State

WHOLESALE RADIO SERVICE CO.

NEW YORK, N.Y.
100 SIXTH AVE.
CHICAGO, ILL. ATLANTA, GA.
301 W. JACKSON BLVD. 498 W. PEACHTREE ST. N.W.
BRONX, N.Y. NEWARK, N.J.
542 E. FORDHAM RD. 219 CENTRAL AVE.

GERMAN P.A. SYSTEM PREVENTS ECHOS

(Continued from page 9)

auxiliary reproducers. This is accomplished as follows:

One set of wires from the announcer's microphone is connected to the group of main reproducers, while another set of wires connects to a so-called "relay speaker," located in an underground chamber. In front of this speaker is the end of a hollow tube which extends underground, to the location of one of the auxiliary reproducers. At the other end of this tube the sound waves are picked up by a microphone, amplified by an auxiliary amplifier and fed to the auxiliary reproducer.

By experimentation, it was found that the pipeline had to be only 95 per cent the length of the direct air route in order to compensate for acoustical variation due to pit resonance and to the different velocity of sound waves in air; and in solid substances like the walls of the tubes.

Frequency "peaks" caused by the natural period of resonance of the tubes ordinarily would make this system inoperative. However, by means of "Helmholtzische" absorbing columns attached to the tubes this condition has been corrected.

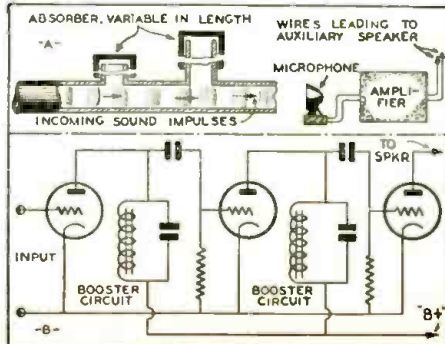

The mechanical and electrical units.

YOU HAVE SOMETHING ON THE BALL . . .



with
CORNELL-DUBILIER
Condensers

New! Service over 5,000 sets with only 30 condensers!

COMPACT • STURDY

• INEXPENSIVE •

The scientifically designed JR series of electrolytics are the condensers to bank on for a banner season. Swing into stride, boost your profit and business percentages to new peaks with C-D condensers.

Available at all leading C-D distributors. Write for catalog.



CORNELL-DUBILIER
CORPORATION
4347 BRONX BOULEVARD
NEW YORK

Please Say That You Saw It in RADIO-CRAFT

5-TUBE SUPER KIT

456 K.C. 15 to 50 meters
200 to 550 meters

The kit consists of: 1st I.F. Transformer, 2nd I.F. Transformer, 2 Gang Condenser, Chassis Pan, Broadcast Oscillator Coil, Short Wave Oscillator Coil, Band Change Switch, Broadcast Antenna Coil, Short Wave Antenna Coil, 6 Sockets, Electrolytic Filter Condenser, By-Pass Condensers, Padding Condensers, Resistors, Wire, Transformer, Hardware, Schematic Drawing furnished.

With 6 1/2" Speaker **\$5.95**

With 8" Speaker **\$6.95**

Add 50c for 25 cycle

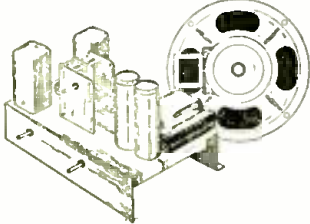

7-TUBE SUPER KIT

Kit Includes: ANTENNA COIL; R.F. COIL; OSCILLATOR COIL; 1st I.F. COIL; 2nd I.F. COIL; 3-GANG TUNING CONDENSER. Price **..\$1.95**

Schematic circuit diagram for A. C. and Auto Receiver furnished.



Send enough money for parcel post or we ship by express collect.

Write for **FREE RADIO PARTS Circular**
ARROW SALES CORPORATION
631 Washington Blvd., Chicago, Illinois

THE NEW BEAM POWER TUBE

(Continued from page 12)

ends. These 2 beams are then cut into narrow slices by the action of the control-grid and since the turns of the screen-grid are directly behind those of the control-grid, the latter intercepts comparatively few electrons. This results in a very low screen-grid current, which greatly improves the efficiency of the tube.

The action of the beaming or concentrating of the electron stream causes areas of high electron densities between the plate and the screen-grid that repel secondary electrons from the plate which might travel back thus opposing the movement of primary electrons.

The electron stream, itself, thus suppresses secondary emission so there is no need for a suppressor (as found in pentode output tubes) with its resulting distortion of the field between cathode and plate. For this reason the plate characteristic (see Table I) of the 6L6 approaches the ideal curve for a pentode.

An examination of any pentode characteristic for plate current-plate voltage (such as the 6F6) shows that there is a definite "knee" or rounded curve at the low-voltage end which causes high distortion when the tube is operated at the bend. The ideal pentode curve would be flat to the point of zero plate voltage, and then suddenly drop. An examination of the plate-current plate-voltage curves in Fig. 2 for the 6L6 shows how closely they approach the ideal. The knee is quite sharp and much nearer the zero plate voltage position than any conventional pentode.

Because the curves in the highly negative grid bias region are unavoidably crowded, some second-harmonic distortion is introduced when the tube is used as a single-ended amplifier. However, this results in lower harmonic levels in the higher harmonics and the second harmonic can be effectively eliminated or balanced out by using two tubes in a push-pull arrangement.

It can be seen that the 6L6 is like a pentode in that it presents a high output impedance which is desirable from the standpoint of efficiency and ease in filtering the plate voltage supply.

SUMMARY

The 6L6 is a power-amplifier tube of the all-metal type for use in the output stage of radio

receivers, especially those designed to have ample reserve of power-delivering ability. This new tube provides high power output with high power sensitivity and high efficiency. The power output at all levels has low third- and negligible higher-order harmonic distortion.

These distinctive features have been made possible by the application of fundamentally new design principles involving the use of directed electron beams.

Primary features resulting from this arrangement are that the screen-grid does not absorb appreciable power and that efficient suppressor action is supplied by space-charge effects produced between the screen-grid and the plate. Secondary features are high power-handling ability, high efficiency, and high power sensitivity. Furthermore, large power output is obtainable without any grid current flowing in the input circuit.

In the design of the 6L6, the second-harmonic distortion is intentionally high in order to minimize third- and higher-order harmonics. Experience has shown that second-harmonics are far less objectionable in the audio-frequency output than harmonics of higher order. The second-harmonics can easily be eliminated by the use of push-pull circuits, while in single-tube, resistance-coupled circuits, they can be made small by generating out-of-phase second-harmonics in the preamplifier.

CHARACTERISTICS

TABLE I

Heater Voltage (A.C. or D.C.)	6.3 V.
Heater Current	0.9-A.
Maximum Overall Length	4 5/16 ins.
Maximum Diameter	1 5/8 ins.
Base	Small Octal 7-Pin

STATIC AND DYNAMIC CHARACTERISTICS

Heater Voltage	6.3 V.
Plate Voltage	250 V.
Screen-grid Voltage	250 V.
Control-Grid Voltage	-14 V.
Amplification Factor	135
Plate Resistance	22,500 Ohms
Mutual Conductance	6,000 Micromhos
Plate Current	72 ma.
Screen-grid Current	5 ma.

Single-Tube Class A Prime Amplifier.

Subscript I indicates that grid current does not flow during any part of input cycle.

Plate Voltage	375 (max.)
Screen-grid Voltage	250 (max.)
Plate and Screen-grid Dissipation (Total)†	24 (max.)

Typical Operation:

Heater V.‡	6.3	6.3	6.3	6.3 V.				
Plate V.	375	250	300	375 V.				
Screen-grid V.	125	250	200	250 V.				
	Fixed-Bias	Self-Bias	Fixed-Bias	Self-Bias	Fixed-Bias			
D.C. Control-grid V.†	-9	-9	-14	-13.5	-12.5	-11.8	-17.5 V.	
Peak A.F. Control-grid Voltage	.8	8.5	14	14	12.5	12.5	17.5 V.	
Zero-Sig. D.C. Plate Cur.	24	24	72	75	48	51	57 ma.	
Max.-Sig. D.C. Plate Cur.	26	24.3	79	78	55	54.5	67 ma.	
Zero-Sig. D.C. Screen Cur.	0.7	0.6	5	5.4	2.5	3	2.5 ma.	
Max.-Sig. D.C. Screen-grid Cur.	1.8	2	7.3	7.2	4.7	4.6	6 ma.	
Load Resistance	14,000		2,500		4,500		4,000 Ohms	
Distortion:								
Total Harmonic		9		10		11	14.5 Per Cent	
2nd-Harmonic		8		9.7		10.7	11.5 Per Cent	
3rd-Harmonic		4		2.5		2.5	4.2 Per Cent	
Max.-Signal Power Output		4.2		4		6.5	6.5	11.5 W.

†Precautions should be taken to insure that dissipation rating is not exceeded with expected line-voltage variations, especially in the case of fixed-bias operation. Fixed-bias values up to 10 per cent of each typical screen-grid voltage can be used without increasing distortion.

‡‡The heater should be operated at 6.3 V. Under no condition should the heater voltage ever fluctuate so that it exceeds 7.0 V. The potential difference between heater and cathode should be kept as low as possible.

*With no signal.

†The type of input coupling used should not introduce too much resistance in the grid-circuit. Transformer- or impedance-coupling devices are recommended. When the control-grid circuit has a resistance not higher than 0.05-meg, fixed-bias may be used; for higher values, self-bias is required. With self-bias, the grid circuit may have a resistance as high as, but not greater than, 0.5-meg, provided the heater voltage is not allowed to rise more than 10 per cent above rated value under any condition of operation.

KILL STATIC!!

with the **Supreme Super Silencer!**
The most important development in Radio this year.

Eliminates man-made static caused by sparking motors, vacuum cleaners, fans, dial telephones, electric refrigerators, high tension lines and other electrical disturbances.

A new development of J. J. Lamb, editor of Q.S.T.

Guaranteed to perform satisfactorily on any superheterodyne.

SERVICE MEN! A new money-maker!
Every Super-het-owner a customer!
Wired up in only 30 minutes!

Complete Kit parts, stamped metal chassis complete with instructions loss tubes **\$2.95**

Three Metal Hytron Tubes **\$1.95**

Complete, nothing else to buy **\$4.90**

SUPREME SALES CO., 403 E. 138 St., N.Y. C.

P.A. Systems

FOR EVERY PURPOSE

Bell Public Address Systems lead the "parade." They're more efficient—portable—simple to operate—and compared to their high quality are surprisingly economical. With outputs from 5 to 30 watts there's a model for every job.

You can "cash-in" on the growing demand for P. A. Equipment—on either sales or rentals—with Bell Systems. Start now to get your share of this business.

BELL SOUND SYSTEMS Inc.
61-62 East Goodale St.
COLUMBUS, OHIO

WRITE TODAY for COMPLETE DETAILS

Please Say That You Saw It in RADIO-CRAFT

Push-Pull Class A Prime Amplifier

Plate Voltage	375 (max.) V.
Screen-grid Voltage	250 (max.) V.
Plate and Screen-grid Dissipation (Total) †	24 (max.) W.

Typical Operation—2 Tubes:

	Values are for 2 tubes.	
	Fixed-Bias	Self-Bias
Heat Voltage ††	6.3	6.3 V.
Plate Voltage	250	250 V.
Screen-grid Voltage	250	250 V.
D.C. Control-Grid Voltage †	-16	-16* V.
Peak A.F. Grid-to-Grid Voltage	32	35.6 V.
Zero-Signal D.C. Plate Current	120	120 ma.
Max.-Signal D.C. Plate Current	140	130 ma.
Zero-Signal D.C. Screen-grid Current	10	10 ma.
Max.-Signal D.C. Screen-grid Current	16	15 ma.
Load Resistance (Plate to plate)	5,000	5,000 Ohms
Distortion:		
Total Harmonic	2	2 Per Cent
3rd-Harmonic	2	2 Per Cent
Max.-Signal Power Output	14.5	13.8 W.

Push-Pull Class AB Prime Amplifier

Plate Voltage	400 (max.) V.
Screen-grid Voltage	300 (max.) V.
Plate and Screen-grid Dissipation (Total) †	24 (max.) W.

Typical Operation—2 Tubes:

	Values are for 2 tubes					
	Fixed-Bias	Fixed-Bias	Self-Bias*	Fixed-Bias	Self-Bias	Fixed-Bias
Heater Voltage ††	6.3	6.3	6.3	6.3	6.3	6.3 V.
Plate Voltage	400	400	400	400	400	400 V.
Screen-grid Voltage	250	250	300	300	300	300 V.
D.C. Control-grid Voltage †	-20	-20	-19	-25	-23.5	-25 V.
Peak A.F. Grid-to-Grid Voltage	40	40	43.8	50	57	50 V.
Zero-Sig. D.C. Plate Cur.	88	88	96	100	112	102 ma.
Max.-Sig. D.C. Plate Cur.	126	124	110	152	128	156 ma.
Zero-Sig. D.C. Screen Cur.	4	4	4.6	5	6	5 ma.
Max.-Sig. D.C. Screen Cur.	9	12	10.8	17	16	12 ma.
Load Res. (Plate to plate)	6,000	8,500	6,600	3,800	3,800	Ohms
Distortion:						
Total Harmonic	1	2	2	2	0.6	0.6 Per Cent
3rd Harmonic	1	2	2	2	0.6	0.6 Per Cent
Max.-Sig. Power Output	20	26.5	24	34	30	23 W.

Push-Pull Class AB₂ Amplifier

Subscript 2 indicates that grid current flows during some part of input cycle.

Plate Voltage	400 (max.) V.
Screen-grid Voltage	300 (max.) V.
Plate and Screen-grid Dissipation (Total) †	24 (max.) W.

Typical Operation—2 Tubes:

	Values are for 2 tubes	
	Fixed-Bias	Fixed-Bias
Heater Voltage ††	6.3	6.3 V.
Plate Voltage	400	400 V.
Screen-grid Voltage	250	300 V.
D.C. Grid Voltage †	-20	-25 V.
Peak A.F. Grid-to-Grid V.	57	80 V.
Zero-Signal D.C. Plate Current	88	102 ma.
Max.-Signal D.C. Plate Current	168	230 ma.
Zero-Signal D.C. Screen Current	4	6 ma.
Max.-Signal D.C. Screen Current	13	20 ma.
Load Resistance (Plate to Plate)	6,000	3,800 ohms
Peak Grid-Input Power ††	180	350 Milliwatts
Distortion:		
Total Harmonic	**	** Per Cent
3rd Harmonic	**	** Per Cent
Max.-Signal Power Output	40	60 W.

**With zero-impedance driver, plate-circuit distortion does not exceed 2% peak values at low distortion.

††Driver stage should be capable of supplying the grids of the Class AB stage with the specified †, ††, †, *: See notes under Single-Tube Class A Amplifier.

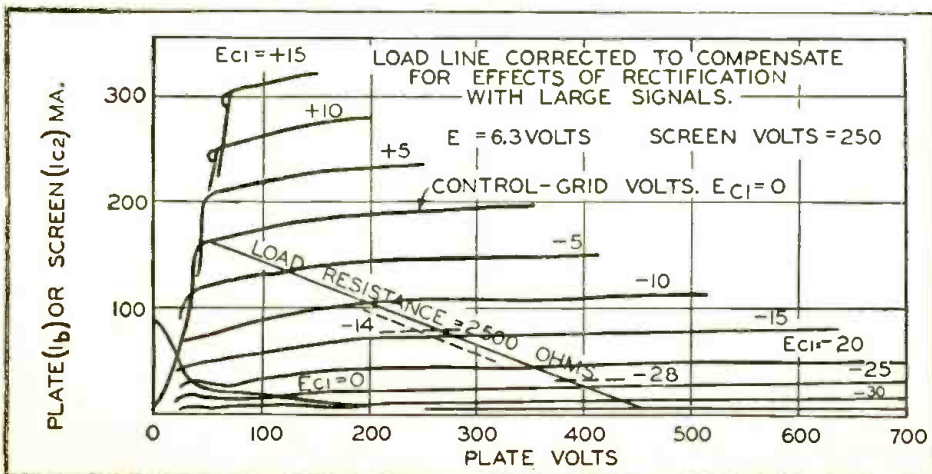

Fig. 2. The plate current—plate voltage characteristic. Note the crowding on high bias values which causes high second harmonic distortion.

Please Say That You Saw It in RADIO-CRAFT

MORE EFFICIENT AND QUICKER!

Auto Radio Servicing

WITH TRIPLETT MASTER UNIT TEST SET



Precision Model 1206 \$84.33
Without Extravagance DEALER NET

Modern automobile radio sets are now so designed that the tubes and power pack including the vibrators are accessible without removing the chassis from the car. The radio service dealer appreciates that much time can be saved by "going over" the set in the car first.

TRIPLETT Master Unit Testers are ideally suited for this work. Volt-Ohm-Milliammeter Tube Tester, Signal Generator and Free Point Tester are separate and distinct instruments. Each can be used with radio set in the car.

This is just another reason why the Triplett Master Unit Test Set is the most popular tester among radio servicemen. It is a complete portable laboratory with the testers that the professional serviceman needs in his daily work. Each instrument can be purchased separately and the entire laboratory thus built up over a period of time.

DEALER NET

- Model 1200 Volt-Ohm-Milliammeter..... \$21.67
 - Model 1210-A Tube Tester..... 20.00
 - Model 1220-A Free Point Tester..... 10.00
 - Model 1231 All Wave Signal Generator, D.C. 26.67
 - Model 1232 All Wave Signal Generator, A.C. 26.67
 - Model 1204 Leatherette Carrying Case with Demountable Cover..... 6.00
 - Model 1207 (same as Model 1206 except has A.C. Signal Generator No. 1232).. 84.33
- See your jobber. Write for Catalogue.



The Triplett Electrical Instrument Co.
167 Harmon Drive, Bluffton, Ohio
Without obligation please send me _____ More information Master Unit Test Set. _____ New 1936 Catalogue.

Name

Address

City State.....

SALES AND SERVICE ON WHEELS!

(Continued from page 11)



**COME
ON DOWN
THE OPEN
ROAD TO MORE
RADIO SERVICE
BUSINESS, WITH
NATIONAL UNION
RADIO TUBES PLUS
FREE EQUIPMENT
ASK NOW...**

How can I get these:

- Tube Testers Oscillographs
- Set Analyzers Metal Cabinets
- Shop Coats Sound Equipment

RC 736

Name _____
 Street _____
 City _____ State _____
NATIONAL UNION RADIO CORP. OF NEW YORK
570 LEXINGTON AVENUE, NEW YORK, N. Y.

found that it is best to stock only nationally-known parts. The following values of condensers we have found are the best to carry in this truck:

ELECTROLYTICS

Cap. mf.	Rating Volts	Cap. mf.	Rating Volts
25	25	4	175
6	175	10	25
8	175	4	550 (small type)
10	175	8	550 " "
8	550	2	850 " "
2	550	8-8	550 (small and large types)
6	550	6-8	550 " " " "
		4-4	550 " " " "

These we carry in stock in the car at all times. Now as to small tubular bypass condensers, we carry the following:

(All of the following listed condensers are 600 [working] V. type).

Cap. mf.	Cap. mf.
100 mmf.	0.02
250 mmf.	0.05
0.001	0.1 (a great many)
0.002	0.25
0.005	0.5
0.01	1.

(All the following listed condensers are 200 [working] V. type).

0.02-mf.; 0.05-mf.; 0.1-mf.; 0.25-mf.; 0.5 mf. The following "vibrator" condensers for automobile-radio use are carried in stock:

Tubular		Metal	
Cap. mf.	Cap. mf.	Cap. mf.	Cap. mf.
0.01	0.01	0.03	0.03
0.02	0.02	0.04	0.04

We also carry a complete line of dome-light filters, generator and coil condensers, and ammeter condensers.

Most of the resistors carried in this car are in kit form which gives 25 popular resistors. This has been found to be the best to sell to the average dealer to use in service work.

We carry a complete line of "radio"-type automobile spark plug and distributor suppressors of the many different types that are being used. We have made a detailed survey of our territory and are only stocking those vibrators for the automobile radio sets that are being sold by our dealers.

We carry 6 types of volume controls, which take care of 477 sets, also universal types of input and output transformers. Along with these components a few standard I.F. coils are carried, and a small quantity of shielding, a few automobile aeriels and samples of wire, aerial kits, and any other special parts on heavier equipment.

Of course our space is limited and we cannot carry a large quantity of all equipment and merchandise each dealer might need. However, what we do not have on hand on the first trip we can either mail or take on the next trip.

My partner, Mr. Hornbrook, is the technical end of the company, and while I sell the dealers he does the advertising, and if a particular dealer has a set that his Service Man cannot repair, Mr. Hornbrook remedies this, thereby gaining the confidence of the dealer, and at the same time automatically promoting the sale of replacement parts. This procedure alone, we have found, has built up our goodwill throughout the territory covered, as we can service any make of radio receiver.

After explaining what is carried in the automobile for resale to our dealers, this is an appropriate time to discuss the service equipment we feel it is necessary to carry to completely take care of the major service difficulties that we run into on our trips. The following is an inventory:

- One Signal generator.
- One Tube checker.
- One Set analyzer.
- One Ammeter (of our own construction).

With this equipment, instead of repairing sets on the street, as suggested in the *Radio-Craft* article, we go into the dealer's shop or garage to do the service work. He brings in all automobile and home radio sets that he has sold and which are not operating correctly. We have

special wholesale service rates which make him money and assist him by building up goodwill for himself in his community. In this manner we have built up a dealer organization of more than 75 companies in this section, and have installed approximately 1,000 auto radio receivers in the past 2 years.

Probably you have noticed in the pictures and from the above discussion that the car is equipped with a small "one-man" P.A. system with which we advertise our dealers and the products we sell. The following is a description of the outfit: as to the automobile amplifier itself—for speakers we are using two 8-in., 3 W. speakers on a ½-in. baffle of celotex, cut the shape of the windows of the car. The fields are connected to an extended lead from the storage battery at all times. We are using a 2-button carbon microphone of an inexpensive type. (Feedback is eliminated by proper positioning.) The lead of this to the mixer is completely shielded. The mixer has connections for a phonograph, radio set and microphone. The amplifier is a 6-W. low-priced installation which uses two type 42 tubes in push-pull for the output, a 37 driver and a 39 input. When we first came into possession of this amplifier it was not in very good operating condition, but we made a few minor changes, especially by installing a tone control from the plate of the driver tubes which gives much better quality than before. The turntable of this machine is very inexpensive and hand-wound. A 300 V. generator is used to obtain the "B" power. This unit is run from the 6 V. storage battery of the car.

We hope that this article has helped some of the radio men who have been thinking about using this advanced method of getting new customers and added service work.

NEW EQUIPMENT FOR THE SERVICE MAN

(Continued from page 14)

the neon tube that is used in the leakage-test section of this instrument. The range of the latter extends to several megohms. Unit operates on 90 to 130 V., A.C. or D.C.

ALL-PURPOSE CONDENSER ANALYZER

(1057) As the schematic circuit indicates, this multi-test unit is a capacity bridge that puts Mr. Condenser through all his paces.

Using the headphones, capacity values are indicated when hum is at minimum. The capacity range is 100 mmf. to 20 mf. A neon tube tests leakage voltages up to 600. Electrolytic condensers may be tested for leakage current at rated voltages; regular tests may be made for shorts and opens in various components and circuits.

A "MAGIC EYE" TEST UNIT IN KIT FORM

(Allied Engineering Institute)

(1058) Increased interest in the versatile properties of the type 6E5 cathode-ray tuning indicator has resulted in the development of a kit which the Service Man can build into the unit here shown pictorially and by diagram. The completed device may be used to compare condenser capacities and for aligning receivers, checking for shorts, opens and leakages, and for many other jobs. Directions are given for making calibrated escheutheons to permit more nearly quantitative readings to be obtained.

An important application of this unit is in its service as substantially a vacuum-tube voltmeter with a range of 1 10-meg. to 60 meg.

It also may be attached to, or built into a receiver for use as a visual tuning indicator, regardless of whether the radio set utilizes an A.V.C. circuit.

Once adjusted for a particular capacity range, condensers may be tested in large quantities to determine whether they follow within the prescribed capacity limits.

As an alignment indicator for checking R.F. and I.F. stages, this instrument is invaluable; also, for calibrating service oscillators. One novel application of this device is its use as an antenna leakage indicator.

Please Say That You Saw It in RADIO-CRAFT

Get on the List for These BIG CATALOGS



Here are the mastheads of the four catalogs sent to every Burstein-Applebee customer this year. Each book is brimful of latest information and lowest wholesale prices on Radio, Electrical and Refrigeration equipment. Write today—get your name on the list to receive these valuable catalogs FREE.

BURSTEIN-APPLEBEE CO.

1012-14 McGEE ST., KANSAS CITY, MO.

Buy Direct From Manufacturer... AND SAVE BIG MONEY!!!
 WRITE FOR OUR NO. 535

FREE CATALOG

OF RADIO & AMPLIFIER Replacement Parts, Power Amplifiers, Complete Amplifier Systems, Short Wave and All Wave Radio Receivers, Audio and Power Transformers, etc., etc.

We Specialize In The Manufacture of Amplifiers

Our prices are therefore the lowest in the industry... write us first!

Remington Radio & Electric Corp.

106-R 7th Avenue New York, N. Y.

HAVE YOU SOME SPARE ROOM

a basement or garage where you can do light work? We can offer you a profitable proposition for 1936 casting 5 and 10c Novelties, Ashtrays, Toy Automobiles, etc., as Branch Manufacturer for a firm of many years standing. No experience necessary and small outlay starts you so if you mean strictly business and are interested in devoting your spare or full time to profitable work write at once for full details.

METAL CAST PRODUCTS CO., Dept. 26
 1696 Boston Road New York, N. Y.

SOLDERING HINTS AND IDEAS

(Continued from page 20)

jig and short-seam soldering the contact-type here shown (Fig. C) is very satisfactory, as it uses current only during the time it is actually in use, requires no tinning, and becomes cold a few seconds after the contact with the work is broken. (1052)

Improved Arc-Type Soldering "Iron." Radio men who have used this new soldering iron (Fig. D) proclaim it superior to the old-style "iron" that utilizes a wire-type heating element to bring the copper tip to working heat. The new "iron" presents a very novel development—the copper tip is raised to working heat in a few seconds by a "heating" electrode of carbon that functions on the previously-mentioned "contact" principle—in this tool, though, the "contact" is made *within* the copper tip by manipulating a button that presses the heating electrode forward until the circuit is completed (as detailed in one view). In a few seconds the temperature of the carbon at the point of contact (within the copper tip) raises the copper tip to working heat, and maintains that heat as long as the carbon electrode is held in contact.

This tool may be used on work that would be much too heavy for previous types of "arc" soldering devices of equivalent dimensions, and has the advantage of heating in a very short time. It can be operated from either a step-down transformer from the "line" or from a storage battery—for car radio servicing. (No. 1053)

The following ideas may be found useful—if not immediately, then at a later date.

Soldering Very Fine Wires. Often the Service Man and others have to solder very fine leads, such as those of a meter moving coil, and have only a heavy-duty iron on hand. By wrapping a piece of heavy copper wire or strip around the tip, as depicted in Fig. 1A, and letting it project an inch or so, such jobs can be easily handled. The same stunt can be used for those tough jobs in a crowded chassis where the copper

tip ordinarily would burn insulation or otherwise disturb the circuit.

J. E. RYAN,
Cape Town, So. Africa

Making the Soldering Iron "Quick-Heating."

When out on a service job, the repair man often has to wait quite a few minutes for his iron to heat to normal temperature, and this is a nuisance when only 1 or 2 joints are to be made. By removing a turn or two from the heating element of his iron, as shown in Fig. 1B, a quick-heating iron may be made which will come to working temperature in a couple minutes. This type of iron should be used only in short-time or intermittent service.

HERMAN R. WALLIN

A No-Cost Holder. An empty solder spool bent as shown in Fig. 1C serves as a very handy iron holder, made at no cost to the user.

EARLE M. GLAZENER

Soldering Phone Tips. This messy job may be made much more easy and thorough by following the simple hint in Fig. 1D. A hole the size of the narrow portion of the phone tip is drilled through the copper tip of the iron. Then half of the hole is enlarged so that the body of the phone tip will snugly fit into the recess. The iron may now be held in a vise, and the phone tip quickly filled with solder.

FREDERIC LEWIS

Baby-Size Iron. For soldering in close places and for delicate work, a small-size iron made as in Fig. 1E will be found very handy. It is made from an extra copper tip, or may be cut from copper rod. A small file handle and a soft rod form the handle. The rod may be bent to various angles to facilitate certain jobs. The baby iron is heated in a heavy-duty iron, the tip of which has been removed.

HAROLD A. WHINCUP,
Weyburn, Sask., Can.

A 2-TUBE "F.C.T." SET FOR THE BEGINNER

(Continued from page 17)

transformer.

And the plate supply can be either four 45-V. "B" batteries connected in series or an A.C. "B" unit supplying 180 V., with a 90-V. tap.

First, connect the filament battery and leave it connected, with the switch on for a few minutes and then feel the tubes to be sure the filaments are connected properly. When this test has been made, connect the plate supply, the aerial and ground and the phones.

The set is then ready to use. Tune in a station and turn the trimming condenser screws or C1 and C2 until the station is heard with the greatest volume. Finally, turn the variable resistor R6 for the best position. This resistor is located on the subpanel back of the two tubes.

This completes the set. An audio amplifier can be added later to increase the volume for loud-speaker operation.

LIST OF PARTS

- *One iron-core antenna coil, L1;
- *One iron-core interstage coil, L2;
- *One 2-gang condenser 350 mmf. with trimmers, C1, C2;
- Two Cornell-Dubilier mica condensers, 100 mmf., C3, C9;
- Four Cornell-Dubilier paper condensers, 0.1-mf., C4, C5, C6, C7;
- One Cornell-Dubilier mica condenser, 0.002-mf., C8;
- Two Continental Carbon resistors, 250 ohms, R1, R4;
- One Continental Carbon resistor, 75,000 ohms, R2;
- One Continental Carbon resistor, 35,000 ohms, R5;
- One Continental Carbon resistor, 50,000 ohms, R7;
- Two Electrad wire-wound variable resistors, 0.1-meg., R3, R6;
- One 6-terminal strip;
- One 2-terminal strip;
- *Two octal wafer sockets;
- *One vernier dial;

*Names of manufacturers will be supplied upon receipt of a stamped and self-addressed envelope.

- One RCA, Sylvania or National Union 6K7 tube, V1;
- One RCA, Sylvania or National Union 6J7 tube, V2;
- One two-pole single-throw toggle switch, Sw.;
- One aluminum panel 7 x 7 1/2 ins.;
- One aluminum chassis, U-shaped, 7 x 7 x 1 in. high;
- Two metal tube grid clips, hookup wire, etc.

HOW TO MAKE THE RADIO-CRAFT SET ANALYZER

(Continued from page 46)

- Two D.P.D.T. toggle switches, E-I. Rev.;
- One Radio City Products Co. microammeter, 0 to 500 microamps., with universal dial, M;
- Four Radio City Products Co. small bar knobs;
- Two Radio City Prod. Co. single-pole, twelve-position selector switches, Ref., Selector;
- One Radio City Prod. Co. three-pole, twelve-position selector switch, Range;
- One Dependable, rheostat for zero set, 0.610 ohms, Ohm Set, R;
- One Dependable full-wave, copper-oxide Rectifier for meter, Rect.;
- One Dependable shunt for meter, 5 ma., R12;
- Two Dependable shunts for meter, 50 ma., R13, R15;
- One Dependable shunt for meter, 250 ma., R14;
- Four Radio City Products Co. voltage multipliers for 5, 50, 250 and 750 V., D.C., R8, R9, R10, R11, respectively;
- Four Radio City Prod. voltage multipliers for 5, 50, 250 and 750 V. A.C., R4, R5, R6, R7, respectively;
- Three Dependable current-limiting resistors for ohmmeter circuits, with resistances of 25, 2,500 and 25,000 ohms, R1, R2, R3, respectively;
- One Blau drilled and engraved panel;
- *Five insulated tip jacks for external use of meter ranges;
- Wire, solder, screws, etc.
- One instrument case 9 x 12 x 4 ins. (inside dimensions) with a cover depth of 1 1/2 ins.

*Names of manufacturers will be sent upon receipt of a stamped and addressed envelope.

Please Say That You Saw It in RADIO-CRAFT



E. H. RIETZKE President, CREI

OPERATORS

SERVICEMEN

... SPARE TIME IS THE BEST TIME TO PLAN YOUR FUTURE

● CREI technical training gives every man the opportunity to get ahead. UNTRAINED men are simply eliminating themselves from better jobs and better pay. Be a success NOW ... start training now—ABILITY is always recognized.

PRACTICAL RADIO ENGINEERING

—is the "shortest cut" to success! A thorough training in all phases of Radio Engineering, including Broadcast Transmission and Control Engineering. Enrollments now being accepted for one-year Residence School ... start the Home Study Course anytime.

SERVICE and PUBLIC ADDRESS ENGINEERING

A new CREI course for Servicemen, teaching theory plus the principles of design and the latest works in vacuum tubes, circuits, acoustics and the treatment of auditoriums. Send today for illustrated literature and full details.

FREE! WRITE FOR 48-PAGE BOOKLET

CAPITOL RADIO ENGINEERING INSTITUTE

WASHINGTON D. C. Dept. RC-7 NEW YORK CITY 29 Broadway



UNBREAKABLE P. A. TRUMPET



A radically new type of sound projector made of the specially processed RACON ACOUSTIC STORMPROOF material, with full-length bell reinforcement. Demountable in three sections, with cast aluminum throat and section couplings, with loose coupling for unit attachment. Unquestionably the strongest, most durable trumpet available, with characteristic RACON high acoustic efficiency.

Racon Electro-dynamic Units and Horns are manufactured under 14 exclusive Racon Patents. Write Dept. RC736 for catalog.

RACON ELECTRIC COMPANY, INC.
52 East 19th St., New York, N. Y.

NEW BEAM POWER AMPLIFIER



Here is the new, compact and complete 60 watt high-fidelity ACA Beam Power Amplifier—the last word in sound equipment. It employs the new 6L6 high-power output tubes, 6L7 volume expander, and 6F5 cathode ray expansion and output indicator—yet offered at a price within the reach of all.

Write for FREE Circular No. 736 describing this unusual amplifier.

Mr. A.C. Shaney, will be glad to help you plan any proposed type of P.A. installation. Send complete details for free information.

AMPLIFIER CO. of AMERICA

AMPLIFIED SOUND SYSTEMS

20 WEST 22ND STREET NEW YORK CITY

"TELEVISION NUMBER"

Will contain not only information concerning television but also many items on other topics. For instance, there will be in this issue of RADIO-CRAFT interesting information concerning ELECTRONIC MUSIC, and NEW RADIO TUBES will be discussed; and applications of WIND-DRIVEN GENERATORS. Circuits and technical details will be given for improving the sound fidelity of TALKIES SYSTEMS; and "nipermag", the new permanent-magnet alloy used in new types of loud-speakers, will be described.

Your FREE COPY

BARGAIN BULLETIN
SAVE MONEY ON EVERYTHING YOU BUY!

SPORTING GOODS
WATCHES-CLOCKS
TYPEWRITERS
OPTICAL GOODS
CAMERAS-NOVELTIES
ELECTRICAL APPLIANCES, ETC.

RADIO SETS AND REPLACEMENT PARTS

is JUST OFF the PRESS

Contains hundreds of up-to-the-minute bargains, specials at PRICES THAT ARE SLASHED TO THE BONE!
 "Save Money on Everything You Buy"—Send for your FREE COPY of this big new book—join the thousands of satisfied customers all over the world who rely on "BARGAIN BULLETIN" for TREMENDOUS CASH SAVINGS.
 This Catalog is ABSOLUTELY FREE—without any obligation. Just send us your name and address—a postcard will do.

RADIO CIRCULAR CO., INC.

915 Broadway, Dept. R.C., New York, N. Y.

Again... MIDWEST LEADS!

14-TUBE

5-BAND
 WORLD-WIDE RADIO
 (9-2400 Meters)

\$49.50
 AS LOW AS
15¢ A DAY



30 DAYS
 FREE TRIAL

SEE this bigger, better, more powerful, super selective "concert" tone, 14-tube, 5-band radio. Over 50 advanced features. Secures American, Canadian, police, amateur, airplane and ship broadcasts... Finest world-wide foreign programs. Foreign reception guarantee. Money-back guarantee. Factory-to-you saves you 50%. Write today for FREE 40-page catalog.

MIDWEST RADIO CORPORATION

Dept. 12-T (16 Years of Radio Leadership) Cincinnati, Ohio

TRI-STATE COLLEGE



Degree in 2 Years

Complete Radio Engineering course in 96 weeks. Bachelor of Science Degree. Radio (television, talking pictures and the vast

electronic field) offers unusual opportunities for trained radio engineers. Courses also in Civil, Electrical, Mechanical, Chemical, Aeronautical, Engineering; Business Administration and Accounting. Low tuition, low living costs. World famous for technical two-year courses. Those who lack high school may make up work. Students from all parts of the world. Located in picturesque hill and lake region of northern Indiana. Enter September, January, March, June. 2476 COLLEGE AVE. ANGOLA, IND.

ARE METAL TUBES "HOTTER"?

(Continued from page 21)

heat liberated in a given time is the same for the two receivers.

DISSIPATION OF HEAT

We have just seen that the same amount of heat is liberated in equal receivers whether the tubes are metal or glass types. This does not mean that the temperatures of the tubes or of the parts surrounding the tubes in the receiver are the same. The temperatures of the various parts depend on the distribution and dissipation of the heat that is generated. If the heat cannot escape from the tubes, the elements of those tubes get excessively hot. Likewise, if the heat cannot escape from the cabinet of the receiver, not only the tubes but all other components inside the cabinet become hot. Heat can escape, or can be transferred from one part to another, in 3 ways, which have already been mentioned, namely, (1) conduction, (2) radiation, and (3) convection.

CONDUCTION OF HEAT

Conduction of heat is similar to conduction of electricity. Metals are good conductors for both heat and electricity. Electrical insulators are usually very poor heat conductors. Thus glass, bakelite, and asbestos are poor heat conductors, just as they are poor electrical conductors. All metals, on the other hand, are first-rate heat conductors, just as they are electrical conductors. Not all metals are equally good heat conductors, but they follow in about the same order as their electrical conductivity.

The soldering iron, Fig. 1C, provides an excellent example of heat conduction. The heat is generated in the resistance wire and is communicated partly by radiation but mostly by conduction to the copper rod which is in contact with the heating element. This rod conducts the heat to the working tip of the tool and thence to the work and the solder. If the rod were of glass, or of bakelite, or of asbestos, no appreciable heat would be conducted from the heating coil to the work.

In respect to heat conduction, how do the metal and glass tubes compare? A small amount of heat is led from the internal elements to the outside by way of the connecting leads. In the glass tubes the base pins are considerably larger than they are in the metal tubes. This would mean that the glass tubes would dispose of more heat if it were not for a compensating feature. The fine internal leads between the heat sources and the external pins are much longer in the glass tubes than in the metal tubes. When this is considered the metal tubes will dispose of more heat by this route than the glass tubes. This, however, is a very small part of the total heat that must be disposed of in order to keep the temperature of the elements within safe limits.

Most of the heat disposed of passes through the envelope. Internally this heat is transferred from the cathode, or filament, and the plate to the envelope (glass bulb) by radiation, for, due to the vacuum, there can be neither conduction nor convection. The inside surface of the envelope absorbs the heat and then the material of the envelope conducts it to the outside surface. Here the heat is carried away partly by convection and partly by radiation. There is a wide difference, however, in the two cases, of how the heat is conducted. In the case of the metal envelope the inside and outside surfaces are at nearly the same temperature be-

cause of the very high thermal (heat) conductivity of metal. In the case of the glass envelope the inside surface of the glass must be at a much higher temperature than the outside surface because the thermal conductivity of glass is extremely poor.

MISLEADING APPEARANCES

When a metal tube is grasped by the hand it may seem hotter than a glass tube similarly grasped even though the two may be at the same temperature. The difference is due to the differences in the thermal conductivities and the thermal capacity, or more particularly, their specific heats. Suppose a chunk of glass and a similar piece of metal have been exposed to the summer sun for several hours. If the glass is picked up it feels comfortably warm, but if the metal is picked up it burns the hand severely. Yet the two substances actually must be at the same temperature!

The explanation is very simple. The glass is a poor conductor of heat. Therefore, only the heat that is very close to the points of contact with the hand passes to the hand. These points cool immediately to the temperature of the hand. But the metal is a good conductor, and when it is touched not only the heat near the points of contact passes to the hand, but also the heat that is at some distance away. Enough heat to cause a burn passes to the hand.

It is a matter of experience that, after two corresponding tubes, one metal and the other glass, have been operated under normal conditions long enough for them to have reached their final temperatures, the metal tube feels only slightly warmer than the glass tube. This fact indicates, in view of the preceding explanation, that the temperature of the metal tube is somewhat lower than that of the glass tube.

RADIATION OF HEAT

This other factor is the radiation of heat from the external surfaces. Most of the heat generated in a tube is disposed of by this process. Radiation is the transfer of heat from a hot body through free space without the necessity of a material medium. Thus heat comes from the sun by radiation through empty space. The familiar electrical heater, shown in Fig. 1D, is an example of a heat radiator. It is the electrically-heated element that is the radiator, not the paraboloidal reflector back of it. The reflector only intensifies the radiation in one direction (at the expense of radiation in the other directions).

Why is the metal tube envelope a better radiator than a glass envelope? For two reasons: first, because the surface is black, and second, because it is comparatively rough (not very shiny). In physics a "perfectly black body" and a "perfect radiator" are synonymous expressions. A perfectly black body is really a perfect absorber of light and heat, whence its blackness, but a body that absorbs perfectly also radiates perfectly.

The total amount of heat radiated from surfaces of equal temperature is proportional to the areas of those surfaces. A glass tube will have at least twice as much area and for this reason it should dispose of twice as much heat. However, this is not the case because the greater radiating efficiency of the black surface of the metal tube more than offsets the advantage of size.

Please Say That You Saw It in RADIO-CRAFT

The amount of heat radiated from unit area of any surface in a given time is proportional to the fourth power of the "absolute" temperature of the surface. (The zero on the "absolute" scale is 273.1 deg. Centigrade below the freezing point of water.) This proportionality assumes that the radiating surface is not hemmed in by any other bodies. If there are such bodies around, as there always will be in practical cases, the heat transferred from the hotter to the cooler body is proportional to the difference between the fourth powers of the absolute temperatures of the two bodies.

CONVECTION OF HEAT

Convection is the transfer of heat from a hotter to a cooler place by means of a fluid of some kind. It may be liquid or gas. A gasoline engine is cooled by convection, first by the circulating water and second by the blowing of air over the so-called radiator. The heating of buildings is done in most instances by convection. Hot air heating is the most direct convection, but steam or hot water heating is no less by convection. The familiar silver-colored radiator, Fig. 1E, is an illustration of heating by convection. Cool air comes in contact with the heated tubes and becomes heated. Then it rises and carries the heat to all parts of the room. Incidentally, the room would be heated more by radiation if the radiator were dull black instead of silvery white.

Convection plays an important part in keeping a vacuum tube (as well as a receiver as a whole) cool. A metal tube is cooled more easily this way than a shielded glass tube, for the hot surface of the metal tube is freely exposed to circulating air whereas the hot surface of the shielded glass tube is scarcely exposed to any circulating air. A certain quantity of air is trapped inside the shield and this becomes heated. It then depends on the metal shield to dispose of the heat by radiation. In nearly all cases the shield is of white metal, a poor radiator.

Heating of components of tuned circuits will change the natural frequency of resonance. This effect is of importance only in circuits tuned by compression-type condensers. Thus if the trimmers on I.F. coils become heated appreciably, the intermediate frequency will change. This in itself would not be serious if all the trimmers changed by the same amount. This

will rarely happen, however, for one will usually change much more than others. The result is that the tuning of the I.F. amplifier is thrown out of adjustment. Both sensitivity and selectivity suffer greatly. The compression-type trimmers on the main tuning condenser might also change in the same way as a result of heat.

What is most likely to change the tuning as a result of heat? The answer is: Lack of ventilation. That is the most serious. It is true that if a compression-type condenser is placed very close to a tube, the heat from that tube will change the tension of the compression spring and thus the capacity of the condenser. But the original adjustment could be postponed until the entire receiver had attained a steady temperature. It would not require more than half an hour.

In the case of a metal tube, because it is smaller than a glass tube, the compression-type condenser is likely to be closer to the source of heat, but the difference would be so slight that it should cause no concern. The accumulated heat in an unventilated receiver, on the other hand, is serious, and it is equally serious for both types of tubes.

DISTRIBUTION OF TEMPERATURE OF TUBES

Figure A shows a qualitative distribution of temperature in a metal tube, the temperatures being expressed in Kelvin degrees. (The relation between Fahrenheit degrees and Kelvins is $F = 1.8K - 459$.) The filament or heater is the hottest. The cathode is next in order, which is given as 1,000 deg. K. Next, omitting the various grids, is the plate, which is assumed to be 800 deg. K. The metal shell of the tube is at a considerably lower temperature, and is given as 350 deg. K. At a distance of 1/2-in. from the shell, the temperature is about 300 deg. K. The inside and outside surfaces of the metal shell are virtually at the same temperature, due to the high conductivity of the metal.

Figure A also shows the comparative temperatures of a glass tube. The inside surface of the glass is at a higher temperature than the outside surface, but this is lower than the surface of the metal tube. At 1/2-in. from the glass surface the temperature is slightly less than at the same distance from the metal tube.

IMPROVING OLD VOLUME CONTROL CIRCUITS

(Continued from page 24)

make certain that the control you substitute is of good modern design and, therefore, noiseless in operation.

Correcting poor low-volume fidelity. Difficulty is often experienced in receivers which use only an A.F. control such as that shown in Fig. 1C or D. Most of these old receivers use a grid-leak detector. Since there is no means provided for cutting down the signal before it reaches the detector, on strong local signals the detector is invariably overloaded, resulting in annoying distortion. With the control circuit of Fig. 1C there is the additional difficulty, that, due to the loading of the transformer secondary when the volume control is turned down, both high and low frequencies are lost, resulting in poor tone quality on strong local signals, besides the probability of detector overload.

This dual difficulty can be solved in several ways. A separate unit (generally called a "sensitivity control") may be connected either in the antenna (Fig. 1B) or in the cathode leads of the R.F. amplifiers. This second control enables the operator to prevent detector overload. If the cathode position is chosen, a 50,000-ohm control with an A taper (see Fig. 2) should be used. A dual or tandem control having both the 500,000-ohm E taper and a 30,000-ohm A taper may be obtained from several manufacturers thus eliminating the necessity for two separate controls.

Correcting low-volume cross-modulation and distortion. Several later receivers using type 27 or 24 tubes in the R.F. stages use a cathode biasing resistor as shown in Fig. 1E. This system is all right when only weak signals are being received, but when one attempts to reduce the volume of strong signals to a low level several things happen. First, the tubes are biased so highly that they begin to operate as detectors thus introducing distortion. Secondly, the input capacity of the tube is changed so much that it detunes the receiver and further distorts the signal;

a condition made worse by high-power stations!

The solution to this difficulty is to use a 12,500-ohm control with a taper similar to H of Fig. 2, connected as shown in Fig. 1F. This method is satisfactory because the R.F. tube bias is controlled to a point before detection occurs and from there on the volume is controlled mostly by the gradual shorting of the antenna coil. If the wrong taper is used, the control may be overloaded, and either burn out or become noisy. In over 99 per cent of the receivers a taper similar to H may be used without fear of overloading.

Correcting low-volume frequency response. When an A.F. control is used, the tone quality of the receiver may be improved on low volumes by using a *tapped* control. It is well known that when the volume of a receiver is reduced, the lower audio frequencies seem to drop off more rapidly in volume than the middle register. Most people regard this as the fault of the receiver, whereas, it is really a characteristic of our hearing apparatus. By using a tapped control, however, and connecting the tap to one end of a fixed condenser, the other end of the condenser being connected to ground, we can improve the sound of a receiver at low volumes. As the volume is turned down and the slider on the volume control approaches the tap, the condenser comes into play, bypassing the high frequencies to ground. This bypassing of the "highs" gives the listener the effect of an *apparent* boost in the "lows," thus improving the quality of the receiver at low volumes.

The Service Man should realize that frequently the difficulty he is encountering with the volume control of a receiver may be due to the faulty design of the receiver itself and can only be eliminated by modifying the volume-control circuit. This realization will save him much time and enable him to do a more satisfactory job.

This article has been prepared from data supplied by courtesy of *Electrad, Inc.*

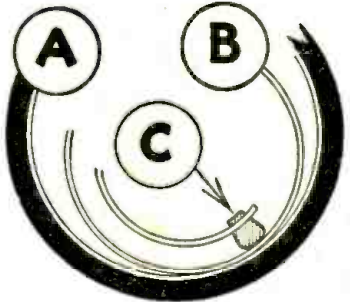

The A B C of Good Volume Control

- A.** Resistor strip on inner circumference of Bakelite case has longest possible length to insure smooth volume control and low noise level.
- B.** Highly polished non-rotating metal band contacts the resistor over a large area. Result, low contact resistance with light pressure, low noise level, no resistance change or wear.
- C.** Oilless wood bearing provides the contact pressure and glides over the polished metal band when control is rotated. Permanently quiet and smooth turning.

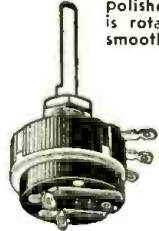

These exclusive Centralab contact features are covered by U.S.A. Patent Nos. 1653745, 1660879, 1701154.

Centralab
MILWAUKEE WIS.
BRITISH CENTRALAB, LTD.
Canterbury Rd., Kilburn
London N.W. 6, England
CENTRALAB
68-70 Rue Amelot
Paris, France

"DEPENDABLE"

Shunts & Multipliers



SHUNTS for all meters in all ranges. Guaranteed accurate within 1% or 2%. Prices, 2% accuracy, 75c each, net; 1% accuracy, 81c each, net.



MULTIPLIERS in all standard ranges, accurate within 1% or 2%, 5000 to 10 million ohms. 45c to \$2.55 each, net.

SWITCHES—in all ranges from 3 to 12 points or contacts and in single or multi-gang up to 7 gangs. Built for long life and sustained efficiency.

"DEPENDABLE" METER
Copper oxide type—D.C. accuracy 2%, 2000 ohms per volt. D'Arsonval movement. Bakelite case. Full wave copper oxide rectifier with leads included, also diagrams for building various A.C. and D.C. testing devices. Complete, only \$7.25

Write Dept. RC7 for New Bulletin

RADIO CITY PRODUCTS CO.
88 Park Place, New York City

Please Say That You Saw It in RADIO-CRAFT

FOLLOW THE "PRECISION" 3-POINT PROGRAM

MODERNIZE

BUY NEW

TRADE-IN

- 1 MODERNIZE your valuable, but obsolete tube checker or set analyzer into an "up-to-date" test instrument. Nominal charge.
- 2 ELECTRONOMETER No. 500 TUBE ANALYZER or No. 829 SELECTIVE RADIO SET ANALYZER. The finest instruments in their class.
- 3 WHAT HAVE YOU? List the make and model number of your old tube tester or set analyzer. Liberal allowances offered in "trade-in."

WRITE FOR DETAILS Specify whether you are interested in point 1, 2 or 3. Mention make and model number of your instrument.

PRECISION APPARATUS CORPORATION

821 EAST NEW YORK AVENUE Dept. "C" BROOKLYN, N. Y.

ORGANIZATION

"Join a service organization" appears, today, to be the *dernier cri* of many Service Men. One Service Man writes to *Radio-Craft* as follows: "I personally am well acquainted with the owners of what are supposed to be the most successful shops; those that employ several people at all times. The owners have at times worked as many as 16 hours for the small sum of \$6.00, in a store containing several thousand dollars worth of equipment and where the rent was \$60.00 per month."

Such conditions *must be corrected*. What is your suggestion?

ESSENTIAL HOUSEHOLD

APPLIANCES

"Long Life"
SUN LAMP
\$3.95



WITH CARBONS AND GOGGLES

Sunshine—Man's greatest benefactor—now in your own home. Good for children; good for grown-ups—especially on damp, dreary days. Provides same benefits as expensive hospital lamps. Safe and simple to operate. Automatic shutoff prevents over-exposure. For use on 110 volts, A.C. or D.C. 1000 watts. 15" high by 12" diam. finished in antique silver. Heavy metal base prevents tipping. Complete with instructions, carbons and goggles. Shipping wt. 6 lbs.



HOOVER Vacuum Cleaner
REBUILT Like New
\$14.95
GUARANTEED

These fine machines are unconditionally guaranteed for six months. Thoroughly conditioned to standards of new machines. All moving parts which show the slightest wear are replaced with new ones. New bags, brushes, cords, handles and other parts are supplied. Even the chassis itself is replated and polished. The HOOVER cleaner is a powerful suction machine with a revolving brush which beats as sweeps. Requires but a drop of oil a month—no other attention. REMEMBER, it's GUARANTEED! You'll have no grief with this machine. Shipping wt. 24 lbs.

ATTACHMENTS: comprising suction-coupling unit, extension rod, long suction hose, upholstery nozzle, upholstery brush and radiator nozzle \$5.50 additional

We issue no Catalog—Order directly from this page 100% Satisfaction Guaranteed. Send Money Order or Certified check. C.O.D. shipments require a 20% deposit. Immediate Service—No Waiting.

HUDSON SPECIALTIES CO.
40 West Broadway New York, N. Y.

ORDER YOUR COPY OF THE AUGUST TELEVISION NUMBER OF RADIO-CRAFT TODAY!

MEMBER'S FORUM

(Continued from page 23)

a town where the average person makes only a fair income, and from which about 70 per cent of the repair work came. The average set was 4 years old. Any set younger was a midget or a near-midget, worth on the average, about \$45.00. The most troublesome sets were those of modern design, where intermittent noises occurred. Labor on some of these ran into a great number of hours. In order to be properly paid for our labor we would have had many times to have charged about half the value of the set!

We found that the average Service Men would call at the residence and test the set, then if they found a defective volume control they would remove the set and take it to their shop and return it for the small sum of \$3.00 or even less. Such a price cannot pay any legitimate business. If we asked more for the trouble, we were called "robbers!", for many of the people knew that most controls may be purchased for under a dollar.

It seems that few Service Men know their overhead—they never consider testing equipment, rent, odds and ends of materials, running of their truck or car, the time spent going to the house, the time testing and removing from the cabinet, or time spent shopping for materials! We find that many Service Men, when called to test a new super, for trouble when the set plays, but with noises, fading, crackles, etc., at times give a definite price, when neither he nor even the manufacturer of that set could honestly tell where the trouble was.

We would not give a price, but require so much per hour. Our price is and always will be \$2.00 per hour for service, plus the cost for material. The result is that customers refuse to use our services. That amount is no more than any machine shop asks—and gets, and is the minimum amount that any competent Service Man should get. Why not? Why not a strong organization to force it? No service organization with proper equipment can make even a living wage at normal hours at a lower price.

My feelings are that no Service Man can ever make even the barest living in a small town where the majority of the townfolk are working people making an average living of about \$40.00 per week, unless a standard is set for service.

The regard for the Service Man must be raised. He is today, if any good at all, the most highly skilled and brainy of all the Service Men required in the modern home, for there is not one single item used by the public today that requires the vast intelligence and study that the radio business does. The good radio expert is and should be regarded as highly as a doctor. A piano tuner makes at least \$3.00 an hour and has little expense, an organ tuner gets a fabulous price; repairing cars does not require even a small portion of the intelligence that is required of the expert radio technician. When a man feels ill, he calls the doctor who possibly spent 8 years in study. The doctor stays a minute, orders several dollars worth of pills, calls again the following day and Mr. Man being well again, the doctor collects \$6.00 or more, for a few minutes' advice.

The progressive Service Man has usually studied his work for many years and not a day goes by but he is again at it, reading, attending meetings and lectures, experimenting, etc. He knows all the necessary electrical laws, he has

a memory a mile long, and remembers sets years back. He understands the working of hundreds of tubes, he is well versed in mathematics, acoustics and what not, yet I do not believe that the busiest Service Man in the finest of communities makes a decent living. There may be a few, but they must work 18 hours a day!

We have discharged our 2 Service Men, who were very capable fellows, and we do not intend to enter this field again until people (a) realize that only a properly-equipped organization can possibly do a worth-while job, and (b) are willing to pay \$2.00 per hour—plus materials.

If your magazine or any organization considers standardizing prices, I certainly will add all my efforts to making it a success.

If a person goes to a machine shop, he pays \$2.00 per hour, plus. Service Men will purchase a new oscillator, possibly an oscilloscope, etc., and never think of charging extra for their use. They receive a call to a house a mile away to look at the radio set, cart a hundred dollars or more in equipment along, spend 15 minutes or so in guessing at the trouble, and then after giving a ridiculously low price do not get the job or even collect a dollar for the call. We demand payment of one dollar before calling or if the call is by phone, we demand of our man that he collect the dollar before he opens his test kit. The well-meaning person will never object to paying a deposit, to be considered as part of the pay for the job if it is given. If all service people would demand likewise and if we could have a real good organization, there would be a respectable living for us in our chosen field.

Your magazine has progressed wonderfully. Here's hoping you might start the ball rolling.
RUSSELL E. LANNING

YOUR CHANCE

TO HAVE YOUR RADIO PUT IN PERFECT CONDITION AT A VERY LOW COST.

CHAS. MIDDLETON
WELL KNOWN RADIO EXPERT

Will put Your Radio In Perfect Condition.

Including **\$1.95** All Parts Required
Except Tubes & Batteries

WHEN BROUGHT TO TRAILER - Pick-up and Delivery 50c Extra
Small Extra Charge for Transformers and Speaker Cans

Electrical Instruments Repaired

ACT AT ONCE

AS RADIO LABORATORY WILL REMAIN ONLY A SHORT TIME

Bring Your Tubes or Entire Radio In and Have Them Tested FREE.

LOOK FOR THE BIG SILVER TRAILER Parked On Your MAIN ST.

The type of sign used by Mr. Middleton.

Please Say That You Saw It in RADIO-CRAFT

THE DESIGN OF MODERN TEST EQUIPMENT

(Continued from page 24)

circuit and constants of Fig 7A as a tube tester of the emission type. What does the reader see wrong with it? The 300-ohm limiting or "load" resistor will reduce the potential applied to a tube, the amount of the reduction depending upon the conductivity of the tube; but that is not, in itself, objectionable—in fact, that may be desirable in some cases, so again we ask, "what's the objectionable feature?"

We have already observed, in our discussion of Fig. 6 (last month), that any tube may be considered as having a definite resistance value under definite load conditions, so let's analyze the test of a tube in which the effective internal resistance may be 600 ohms and which is subjected to test in the tester circuit represented by Fig. 7A. The ratio between the internal and external resistance values, is obviously, 600:300 or 2:1. When the tube depreciates to such an extent that it is just half as good as normal, its internal resistance will be about 1,200 ohms; the ratio between the internal and external resistance values will then be 1,200:300 or 4:1.

The total resistance of the circuit, including that of the normal tube, was originally 900 ohms; after the tube resistance is doubled by depreciation, the total resistance of the circuit including that of the depreciated tube, is 1,500 ohms. It is observed that, while the tube resistance has doubled by depreciation, the total circuit resistance has not doubled, so that the meter current will not be reduced in half; therefore, the meter reading will be deceptive, because it will indicate the tube as being better than it really is. If the same circuit with a fixed 300-ohm resistance value be used for testing a tube which has a normal internal resistance value of 100 ohms, the meter indication of a depreciated tube will be even more deceptive. With a 100-ohm tube, the ratio between the internal and external resistance values is 100:300 or 1:3; when the tube resistance is doubled, the ratio is 200:300 or 2:3. Normally the total of the two resistance values is 400 ohms; but when the internal resistance value of the tube is doubled by depreciation to a value of 200 ohms, the total circuit resistance is 500 ohms, or an increase of only 100 ohms in 400 ohms. If the meter reading before the tube is depreciated be 77 in the center of the "good" sector of the meter scale of Fig. 6B, the meter reading, after the tube is depreciated, will be four-fifths of 77 or 61.6; or still in the "good" sector of the scale, although the tube is only about half as good as it was and should register about 38.5! The error is different for each tube load, and is greatest when the tube resistance is less than the external circuit resistance. So, now, we see what is wrong with the "popular" circuit of Fig. 7A.

A COMMERCIALY ACCEPTABLE CIRCUIT INCORPORATES "BALANCED RATIO"

It is obvious, from the analysis of the circuit represented by Fig. 7A, that the maximum degree of accuracy is obtainable when the external load resistance is considerably less than the effective internal tube resistance values, which should be constant for all types of tubes; so, let's analyze the tube testing circuit shown in Fig. 7B, which is developed to incorporate these desirable features.

In Fig. 7B a resistance value of 4,220 ohms is added to the meter armature resistance value of 113 ohms, making a total resistance value of 4,333 ohms. Since the tester is calibrated for normal tube readings at the center of the "good" sector of the meter scale (shown in Fig. 7B) which is 77 per cent of the full-scale deflection, the current load is 77 per cent of 1.0 ma., or 770 microamperes (0.00077-A.). The current load of 0.00077-A., multiplied by the total meter circuit resistance value of 4,333 ohms produces a potential drop of 3.3 V. across the metering circuit, regardless of the setting required for the 1,000-ohm potentiometer to produce a 77 per cent meter-scale reading. In other words, when the potentiometer setting is adjusted to accommodate the load conditions of any normal tube, with the meter pointer deflected 77 per cent of its range, the potential drop across the meter is 3.3 V., leaving 30 V. of the total potential value of 33.3 V. to be applied across the tube. Therefore, the ratio of the tube voltage to the meter voltage, or of the internal tube resistance to the external circuit resistance, is constantly 30:3.3 or 9:1 for any tube, regardless of load.

Now, let's see what happens, in the circuit of

Fig. 7B when a short-circuited tube is encountered. Since there can be no potential drop across a short circuit, the 33.3-V. applied potential must develop across the metering circuit. With a resistance value of 4,333 ohms and a full-scale load value of 1.0 ma., the full-scale potential of the meter is 4.3 V. since the meter can safely withstand 10 times its normal load an indefinite number of times, its overload potential limit is 43.3 V., so that an applied potential of 33.3 V., caused by a short-circuited tube, would be 10 V. under the safe overload limit of the meter.

Returning to our previous analysis of the test of a tube which has a normal internal resistance value of 100 ohms, and which was tested with an error of 60 per cent by the tester shown in Fig. 7A; let's see how the tester circuit of Fig. 7B will react to the same tube when it is depreciated to such an extent that its internal resistance is doubled. Keeping in mind that, when the meter is calibrated for normal tubes, the ratio between tube and circuit resistance is 9:1, we can determine the joint resistance of the meter and potentiometer, as follows:

$$\begin{aligned} 9:1 &= 100:x \\ 9x &= 100 \\ x &= 11.1 \text{ ohms} \end{aligned}$$

Therefore, the total circuit resistance, when the tube is normal, is 111.1 ohms; and, when the tube resistance is depreciated so that its effective internal resistance is doubled, the total circuit resistance is 211.1 ohms. After depreciation, the meter reading will be 52.6 per cent of the normal reading of 77, or 40.5 in the "bad" sector of the meter scale shown in Fig. 6B. The tube is correctly classified as being "BAD," and the error in the actual meter reading is negligible. With this arrangement of *balanced ratio* between internal tube and external circuit resistance values, the meter reading drops in proportion to tube depreciation, so that "BAD" tubes which test "GOOD" on the usual tube tester types are correctly indicated as being "BAD" on the new Supreme testers which should enable more replacement tube sales than are enabled by older Supreme testers.

LEAKAGE TEST FEATURES

Having explained the "quality test" features of this modern tube testing circuit, we will now proceed to analyze the "tube leakage test" features which were pioneered by our engineers. It is the purpose of Figs. 7C and D to depict the circuit arrangement for indicating a leakage between the heater and the cathode, or one of the other elements of a tube. Figure 7C represents the circuit arrangement which results from depressing the F push button of the tester while testing a type 27 tube, when the neon lamp will glow if a leakage exists between the heater and one of the other elements. If the F button is released, and the No. 4 button is depressed, the circuit arrangement will be that of Fig. 7D and, if the neon lamp still glows, it should be concluded that the leakage is between the F (heater) and the No. 4 (cathode) elements. By similarly depressing the remaining pushbuttons, any leakage between any two elements of any tube may be indicated.

It may be asked why an A.C. potential is used for tube leakage tests when a D.C. potential could be taken from the self-contained rectifier tube which is used for the power supply adjustments; because it appears, at first thought, that the use of a D.C. potential with the positive side connected to the cathode and the negative side connected to the other elements, in turn, would eliminate the necessity for using the blocking condenser shown in Figs. 7C and D. The answer is found in the fact that a D.C. test would, in some cases, be deceptive, because it would respond to rectification currents which are not considered detrimental and which would be erroneously interpreted as detrimental leakages. Actually, it is found that such rectification currents exist between the different elements of some tubes, in the opposite direction to that theoretically expected; for example, heater types of tubes are found in which the heater element and the cathode are both emitting electrons, so that a direct current will pass from either element which is made positive to the other element which is made negative.

This article has been prepared from data supplied by courtesy of Supreme Instruments Corp.

Please Say That You Saw It in RADIO-CRAFT

TUNE BY EYE

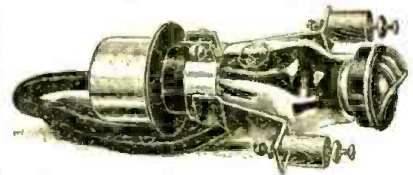

Now you can add a genuine RCA Cathode Ray Tuning Indicator to almost any receiver having automatic volume control! This RCA Kit makes your set like a '36 model. Easily installed. Kit, including 6E5 tube, socket, escutcheon, bracket, cable, everything necessary, only \$3.00. Stock No. 9688.

UNIVERSAL AUDIO TRANSFORMER

This replacement unit couples any general-purpose triode such as -01-A, 26, 27, 30, 37, 55, 56, 76, 85, 6C5, to the grid of any class A amplifier tube, singly or push-pull.

Metal Case. Size 2 x 2-3/8 x 2-7/8 inches including lugs. Stock No. 9632. Price \$2.



RCA PARTS

RCA Manufacturing Co., Camden, N.J.
A Service of the Radio Corporation of America

Build Your Own Wheatstone Bridge for \$45.00

A simple, rugged, wide-range Wheatstone Bridge for resistance measurements. Operation identical with best laboratory instruments. Sensitive, accurate. Low cost. Kit easily assembled.

SHALLCROSS No. 630 Kit \$45.00 Assembled \$50.00

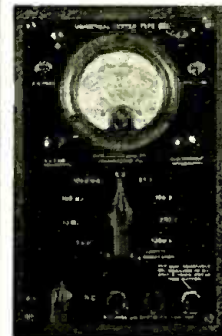

Built around a highly sensitive galvanometer and Shallcross Resistors. Range .01 ohm to 11.1 megohms. Send 6c in stamps for Bulletin 630-PF.

SHALLCROSS MFG COMPANY

Electrical Measuring Instruments and Accurate Resistors

700 MAC DADD BOULEVARD COLLINGDALE, PA.

Westinghouse Power Generator

Manufactured for U. S. Signal Corps

200 Watt. 110 V. AC



A. C. ELECTRICAL POWER

from a Windmill, from available Waterpower, from your Automobile, from your Motorcycle, from your Bicycle, Foot-pedals or Handcrank (for transportable Radio Transmitters, Strong Floodlights, Advertising Signs); do you want to operate A.C. Radio sets from 32 V. D.C. farm light systems; operate two generators in series to get 200 V. AC; obtain two Phase and three phase AC, etc., etc.

There Are Over 25 Applications

Some of which are:

A.C. Dynamo lighting from eight to ten 20 Watt 110 Volt lamps. Short Wave Transmitter supplying 110 Volts A.C. for operating "Ham" transmitter. Operating 110 V. A.C. 60 Cycle Radio Receiver in DC districts. Motor Generator. Public Address Systems. Electric Sirens on motor boats, yachts, etc. Camp Lighting. Short Wave artificial "forever" apparatus. Television. Pelton Waterwheel for lighting or other purposes. Alplane: for lighting strong search lights or electric signs. Laboratory work, etc., etc.

1/4 to 1/2 H.P. needed to run generator.

BLUE-PRINT 22 x 28 in. and Four-Page 8 1/2 x 12 in. INSTRUCTION SHEETS FREE with Generator.

Generator, as described, including four replacement carbon brushes. Blue-print and instructions..... **\$7.90**

Send \$2.00 deposit balance (C.O.D.) Shipping weight 18 lbs.

(Replacement carbon brushes bought separate \$1.50 per set of four. Set of instructions bought separate \$1.00.)

MONEY-BACK GUARANTEE

WELLWORTH TRADING COMPANY
580 West Washington Blvd., Dept. RC736, Chicago, Illinois

CLASSIFIED ADVERTISEMENTS

A.C. AUTO GENERATORS

TURN SCRAP INTO MONEY. AUTOPOWER SHOWS you how easily and economically auto generators can be converted into A. C. or D. C. generators and D. C. motors, 2 to 1000 volts; for sound, radio, power, light, or welding. No previous experience necessary—complete information all in new book, with ample instructions and illustrations. Endorsed by thousands. Only \$1.00 postpaid. Autopower, Inc., 414-C S. Hoyne Ave., Chicago.

RADIO

RADIO ENGINEERING, BROADCASTING, AVIATION and police radio, servicing, Marine and Morse Telegraphy taught thoroughly. All expenses low. Catalog free. Dodge's Institute, Pine Street, Valparaiso, Indiana. USED PA AMPLIFIERS, SPEAKERS, MIKES, PARTS, Radio parts, cheap. List for stand. Rauschenberg, Titusville, Penna.

EXACT **DUPLICATE**

TRANSFORMERS

STANDARD TRANSFORMER CORPORATION
850 BLACKHAWK STREET, CHICAGO, ILLINOIS

FACTS—About the New
"CHANGEABLE FIELD"
SPEAKERS by OXFORD

Write Now for Bulletin 361C
OXFORD-TARTAK RADIO CORP.
915 W. VAN BUREN ST. CHICAGO, U.S.A.

RADIO ENGINEERING,

broadcasting, aviation and police radio, servicing, marine radio telegraphy and telephony, Morse telegraphy and railway accounting taught thoroughly. Engineering course of nine months' duration equivalent to three years of college radio work. All expenses low. Catalog free. School established 1874.
Dodge's Institute, Hudson St., Valparaiso, Ind.

THE "ANTI-HOWL" AUDIO AMPLIFIER

(Continued from page 22)

inductive hum pick-up from stray electromagnetic fields.)

"MAGIC EYE" EXPANSION AND OUTPUT INDICATOR

Cathode-ray indicator tube V10 may be switched either into the expansion or into the output circuit to indicate visually, the degree of expansion or the peak output level.

The volume expander is of conventional design with the exception of using fixed bias throughout. The advantage of using an expander circuit with this high-power amplifier makes it possible to attain a realistic dynamic expansion range—from 6 milliwatts to 60 W. The expansion feature may be utilized to any desired extent, depending upon the adjustment of potentiometer R2.

The circuit of this amplifier, shown in Fig. 1, is capable of producing 34 W. with 2 per cent total harmonic distortion. The maximum output of 60 W. (also with only 2 per cent total distortion) is developed in the same amplifier merely by changing the input and output transformers and removing both of the isolating grid resistors, R1, as well as plate-to-grid feedback (degeneration-producing) condensers and resistors C and R, respectively.

This degeneration circuit of the power output stage tends to stabilize its operation as well as to decrease its power sensitivity. Its action is virtually to modulate the bias of the 6L6 in such a manner as to neutralize excessive grid voltage excursion. Alternating potentials are picked off the plate and fed back into its respective grid (but in opposite phase). This neutralizing action keeps the tubes operating within safe plate current ranges regardless of wide grid-voltage fluctuation.

CUMULATIVE DISTORTION

In the consideration of distortion in the pre-amplifier and voltage amplifier stages there is one source that the constructor is liable to overlook. And that is in the coupling of a high-gain A.F. stage to its succeeding tube. The correct values of the load resistor, the coupling condenser, and the grid resistor of the following tube are important when considering harmonic production as well as frequency range and other limiting factors. In the design of a high-gain, high-fidelity A.F. amplifier any source of distortion becomes important, even though it is not of any great magnitude when considered by itself.

As an appreciable amount of grid current is drawn during the positive half of the cycle (grid current starts when the grid swings to approximately +10 V.) the input transformer must be designed to deliver 350 milliwatts to the grids of the 6L6s without introducing any appreciable impedance into the grid circuit.

THE IMPORTANCE OF FIXED BIAS

The inadvisability of using self-bias for the 6L6 tubes when high power is to be produced is self-evident from a casual study of its dynamic characteristics, particularly when operated under suitable conditions for the attainment of 60 W. At zero signal the plate current for both tubes is 102 ma.; and screen-grid current is 6 ma. When maximum signal is applied, a total of 250 ma. (combined plate and screen-grid current) will flow through the cathode.

This wide fluctuation (108 to 250 ma.) makes it necessary to use a fixed-bias arrangement. If a cathode series resistor is used, maximum degeneration takes place, and the power output is lowered considerably regardless of the size of the condenser used to bypass the cathode resistor.

The value of using fixed bias in (1) the pre-amplifier, (2) the voltage amplifier, and (3) the driver stage should not be underestimated. While it is true that it increases the cost of the amplifier, it eliminates cathode-leakage hum in the preamplifier, distortion from the driver tubes and enables the attainment of 60 W. output from the 6L6 tubes with minimum distortion.

The author will be pleased to answer all questions relative to this new type of amplifier if a stamped and self-addressed envelope is mailed to him care of Radio-Craft.

Have You Seen the New Magazine?



Telling you how to go about:

- WHEN YOU ARE TACKLING THE JOB OF FINDING A JOB;
- WHEN YOU ARE PLANNING A CAREER;
- WHEN YOU WANT TO BETTER YOUR POSITION.

The new magazine giving you every month a digest of articles from magazines and newspapers all over the country

HOW AND WHERE TODAY

Alert, resourceful men and women have succeeded, where others, WHO DID NOT KNOW, have failed.

PRESENT-DAY JOB COMPETITION IS INTENSE, ONLY THE INFORMED MAN OR WOMAN CAN STAY IN THE RACE AND WIN.

"JOBS & CAREERS" IS YOUR GUIDEBOOK OF OPPORTUNITY.

On all Newsstands 25c

If your dealer cannot supply you, send a quarter and we will forward a copy at once.

JOBS & CAREERS

Dept. RC-736

520 North Michigan Avenue Chicago, Illinois.

THIS MAGAZINE NEEDS NO INTRODUCTION TO SHORT-WAVE FANS

SHORT WAVE CRAFT

This popular monthly magazine, SHORT WAVE CRAFT, contains everything you want to know about Short Waves.

The wonders of world-wide short-wave reception are clearly described and illustrated. Latest practical information for radio fans, experimenters and "hams" will be found. Tells you how to build short-wave receivers and transmitters; construct sets of one and two tubes or as many as seven, eight or more. Tells best foreign stations to log and when to tune—includes newest and best circuits of the time. SHORT WAVE CRAFT is edited by Hugo Gernsback.

NEW FEATURE RECENTLY ADDED—To the short wave fan who has logged and obtained verification of the largest number of short-wave stations from all over the world during one month, will be awarded a magnificent 24" silver trophy.

Special This Month Only!

For this month only, we offer readers of this magazine the opportunity to read radio's greatest short-wave magazine at a special saving. The regular subscription price is \$2.50 per year. You can now get SHORT WAVE CRAFT for the next

8 MONTHS FOR \$1.00

4-Color Cover
Over 200 illustrations
9x12 inches in size

25c The Copy
ON ALL NEWSSTANDS



Send remittance by check, money order or U.S. Postage Stamps. Register letter if it contains cash or currency.

SHORT WAVE CRAFT

99R Hudson Street

New York, N. Y.

Please Say That You Saw It in RADIO-CRAFT

OPERATING NOTES

(Continued from page 25)

Zenith Model CH. Complaint—very weak and a whistle on every station. This set is a superhet., with a separate type 24 tube for A.V.C. The R.F. oscillator, and I.P. cathodes are directly grounded. A check on all bypass condensers revealed no faults. A 0.5-mf. condenser connected from ground to second-detector cathode restored normal operation, although the original bypass across the resistor was OK. The bias resistor in this model does not go directly to ground, and no cathode-to-ground bypass is shown in the manufacturer's diagram.

Grimes-Serenader Model O. Complaint—circuit oscillation at low frequencies. This is a T.R.F. set with type 24 tubes in the R.F. The tubes checked OK, and voltages were normal. The gang-condenser wipers were cleaned and bypass condensers were checked; the set still bleeps were heard below 1,000 kc. Examination of the coils revealed high-impedance primaries. I detuned the plate coil of the first tube by connecting a 50 mmf. condenser in parallel. Everything seemed OK. This may not be the right answer, but life is too short to spend much time on such sets.

Splitdorf. Thought all these sets were scrapped long ago. The circuit was described by *Radio Broadcast* (October, 1928) as "Inherently Electric"—Service Man's term, "Inherently Lousy." I have never seen two of them alike. Complaint—"dead."

I plugged the analyzer into a 26-tube socket—voltages checked normal. I then plugged the tube into the analyzer. The filament voltage vanished. Silent cuss-words! "Yes, Mam, I'll try to have it back Thursday." When set up on the bench an examination of the wiring showed that there was a separate winding for each 26, and sockets and windings were all wired in series, each socket between a pair of windings. With such a circuit, one dead tube, or one open center-tapped resistor would cause the voltages to go haywire. I rewired the filament circuits and put in a new tube. Result—everybody happy.

Rogers Model 951. Complaint—set has lost all its pep. I turned on the set and found that local stations were scarcely audible. Tubes checked OK, and voltages were normal. I then removed the chassis for inspection, and checked the audio system by feeding in a signal from a phonograph pickup. Next checking the I.F. by feeding in a 175 kc. signal. I found that nothing was getting through the first I.F. transformer. I disconnected and removed the transformer. Coils checked OK and the trimmers were not shorting. This unit is a band-pass arrangement with 4 tuned circuits, with the two inside coils coupled to ground through a .003-mf. condenser. I replaced this condenser on suspicion; put the transformer back on the chassis and turned on the line switch. Music was received from everywhere. What luck!

Another fault sometimes found in this model which gives similar symptoms is an open primary in the push-pull input transformer. When this circuit opens there is still plate voltage at the socket through a 20,000-ohm resistor which is connected in parallel to the transformer primary.

Victor Model R-28. This midget set was shipped in from another city. Owner said, "Can't get it fixed here." Boy, were we flattered! The complaint was intermittent hum. I put the set on life test. After 3 days there was no sign of misbehaving, so I wrote for more information. The reply came back—"dial set to edge of local station and it will go 'blurr, blurr, blurr, etc.'" I tried it and it wasn't so. Then I removed the chassis cover-plate and went looking for trouble. All condensers checked OK. I found the one resistor which, having run hot, had changed in value from 14,000 ohms to 7,500 ohms (R10 in Victor diagram). I replaced this with a wire-wound unit. I also removed the second-detector filter resistor and grounded the control-grid return (R2, 1 meg.). I ran the set a few more hours and then shipped it back. Two days later express company phones and demands to know why we shipped a set with a broken tube:—never thought of that! A week later the customer wrote: "Set working swell, how much do I owe you?"

THERE'S A GOOD JOB FOR YOU IN RADIO
We Will Train You Quickly to Qualify

The servicing of modern radio receivers requires expert—man trained for this work are needed everywhere.

RADIO OFFERS BIG OPPORTUNITIES

Your possibilities of making money are limited only by your ability and skill. There is no room for the soldering iron "guesser." But you must be trained—the sooner you begin the quicker you'll cash in.

LEARN AT HOME

We will train you at home to service and repair radio receivers of all types. Invest for future success in R.T.A. training.

NO EXPERIENCE NEEDED

You need no previous experience in Radio. We show you how to make money almost from the start. Hundreds of men are enjoying the rewards of R.T.A. training.



FREE
of extra cost

This timesaving trouble-finder and circuit analyzer included.

Full details of this great opportunity are explained in a helpful book that is **FREE**. Send for it today. It will be mailed at once.

RADIO TRAINING ASS'N OF AMERICA
Dept RC-67, 4525 RAVENSWOOD AVE., CHICAGO

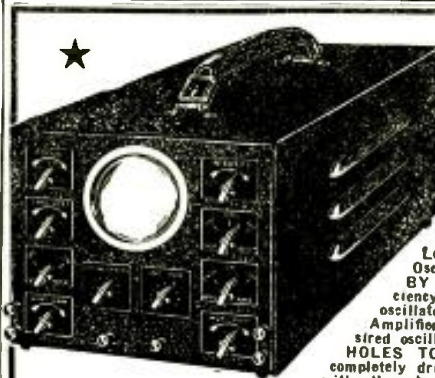

ALL NECESSARY PARTS WITH FULL INSTRUCTIONS \$28.50
Less Tubes

ATTENTION—ALL SERVICEMEN
BUILD YOUR OWN OSCILLOGRAPH

PROFESSIONAL APPEARANCE AND CONSTRUCTION, ABSOLUTELY FOOLPROOF

Learn about the construction and uses of the Cathode-Ray Oscillograph in the most thorough and quickest way possible—BY BUILDING IT YOURSELF. Contains all features and efficiency of expensive commercial units. Includes sweep frequency oscillator with range of 15-20,000 CPS; Vertical and Horizontal Amplifier stages and complete switching arrangements for any desired oscillograph test. ASSEMBLED AND WIRED IN 3 HOURS! NO HOLES TO DRILL—chassis and steel cabinet (dim. 8" x 8 1/2" x 14") completely drilled, cracked black finish. Engraved Name Plates. Supplied with all parts, excepting tubes, and full instructions. Tubes required 2-Type 57, 1-80, 1-885, 1-879, 1 Type 906 Cathode Ray tube. Complete Kit with Cathode Ray tube, \$42.00. Complete Kit with all tubes, \$47.50.

WRITE OR CALL, MODEL ON DEMONSTRATION

PARAGON RADIO PRODUCTS

136 Liberty Street

New York City

add this book to your technical library



ABC of AIR CONDITIONING
by Paul D. Harrigan

THOSE who are first becoming interested in the fertile field of Air Conditioning will find in this book all the fundamental principles which underlie the practical systems in use today. The book contains also a step-by-step description of the different types of refrigerating systems, humidifying and de-humidifying methods, air filtering unit and heating plants in Air Conditioning installations in use today. The man who wishes to learn about Air Conditioning will do well to start with this comprehensive book.

Brief outline of contents:

The Future of Air Conditioning; Uses and Benefits of Air Conditioning; Elementary Refrigerating Systems; Types of Winter and Summer Air Conditioning Installations and their Operation; Service and Control Applied to Air Conditioning Systems; Ventilation Data for Air Conditioning; Definitions Used in Air Conditioning; Air Conditioning Books.

Send fifty cents in stamps, money order or coin for your copy of the ABC of Air Conditioning—it is sent postpaid upon receipt of your remittance.

GERNSBACK PUBLICATIONS, Inc., 99R Hudson Street, New York, N.Y.

Stromberg-Carlson Model 636. Owners of sets of this general type may object to paying the relatively high cost of the special dual volume controls. Also Service Men who are located some distance from a supply house may not be able to secure new controls at short notice. A single 10,000 ohm control can be made to work very satisfactorily by using one end as a cathode bias, and the other end as antenna attenuator. This scheme is clearly illustrated in Fig. 11 of the Yaxley control manual.

GRAHAM FOX,
Toronto, Canada

Sun-Glow "Melody Chest." This set had no volume, even on local stations. The voltages of the tube sockets of the set checked correct, tubes checked good, balancing condensers checked OK, and nothing was wrong with the aerial and ground system. Finally I told the man that I had to take the set to the shop for further investigation.

I laid the chassis upside down on my work bench, made the necessary connections, turned on the switch, and to my surprise it worked wonderfully well, with plenty of volume. I checked all the connections carefully, especially those

riveted to the chassis but failed to find any loose or high-resistance connections. I turned the chassis over (bottom-side down); in this position the set lost its volume again. Turning the chassis over slowly I noticed that it would regain its volume gradually, just as I was turning it over. This gave me a good clue to the trouble.

I removed the shield can from one of the R.F. transformers and found that the primary coil, supported by its two leads, was hanging downward, into the can.

The displacement of this coil was causing loose coupling. This coil being inverted, when the set was turned upside down it would come closer to the secondary coil, consequently causing a change in the characteristics that resulted in an increase in volume. I noticed that originally the coil was placed inside the secondary coil, secured only by a tight fit and a little wax composition. The heat within the set caused the wax to melt away, and vibration had worked it loose and completely out. (In fact, it was hanging down inside the shield can about 1 1/2 ins. away from the secondary coil.)

I replaced the coil and secured it with a long screw in the center of the wooden form on which the coil was wound.

JACK G. TODARO

Please Say That You Saw It in RADIO-CRAFT

Learn RADIO from REAL RADIO ENGINEERS!



- HERE THEY ARE
- Wendell Clough, Chief Engineer, Clough-Brengle Co.
 - E. K. Gramer, Chief Engineer, Standard Transformer Co.
 - Earl E. Hoebel, Chief Engineer, South Radio Corp.
 - W. C. Yehke, Chief Radio Engineer, Grunow Mads
 - F. D. Whittier, Service Manager, Phoebe Radio & Television Corp.
 - Dr. C. M. Biondore, Radio Engineer, P. R. Malloy & Co.

Many R-T-I TRAINED MEN Earn up to \$75 a Week and more

These industry appointed engineers, who work for large radio manufacturers, will supervise your Training at home, and get you ready for good-pay jobs in Radio Broadcasting, Installation, Servicing, Public Address System and Photo Electric Cell work. Also for coming activity in Television. Opportunities for properly trained men better than ever before. Earn while you learn. Some make \$5 and \$10 a week extra in spare time one to two weeks after starting. Many earn up to \$75 a week in full time jobs or their own business, some even more. No other training like mine. Get the facts if you want a better job. Write now for my free book. Ray D. Smith, President.

50 BIG RADIO CONCERNS ENDORSE R-T-I
Among them are Philco, Crosley, Grunow, Stewart-Warner and others.

RADIO AND TELEVISION INSTITUTE
Dept. 22-B, 2150 Lawrence Avenue, Chicago, Ill.

CISIN'S SENSATIONAL New Magic Electronic Eye

"TEST-ALL"

\$2.95

Complete Kit of Parts with Crackle Finish Metal Cabinet, Aluminum Shield, Diagram and Detailed Instructions.

FOR SERVICEMEN and EXPERIMENTERS

A Hundred-in-One Service Instrument. Tests opens, shorts, leakages, Tuning Indicator any type Radio. Lines up r.f. and i.f. stages. As Vacuum Tube Voltmeter measures output, a.c. and d.c. voltages. Measures and compares resistances and capacities. Self-contained a.c.-d.c. power supply.

Kit of Matched Tubes (2 Metal Tubes, 1 Magic Eye)\$3.05

H. G. CISIN, Chief Engineer
ALLIED ENG. INSTITUTE
Dept. R.C.-98 Park Place, New York, N. Y.

BOOK TELLS ALL!

"MODERN RADIO SERVICING"

Get Free Circular Now

RADIO & TECHNICAL PUBL. CO.
45 Astor Place, N.Y.C., Dept. RC76

NOISE!

Do you know the essentials of an All-wave Line Noise Eliminator? You can build your own at half a dollar apiece. Send twenty-five cents in coin for diagrams and constructional details.

NOISE ANALYZER.

Send \$1.00 for Bulletin N.A. Contains all data necessary to build this valuable instrument. This offer includes eliminator treatise.

ROBERT SIMMONS
Chief Engineer, Barclay Warner Co.
290 LINCOLN PLACE, BROOKLYN, N. Y.

SAVE \$\$\$ on RADIOS

BUY DIRECT 30 day trial

Buy at factory prices. 30 models chosen from AC-DC. All-wave. Farm, Car and Metal Tube models. Send postcard for NEW 1936 Bargain Catalog FREE. Get details of 30 day TRIAL plan and Agent User proposition. Also ask for our NEW Parts Catalog.

ZEPHYR RADIO CO.
11701 Livernois, Detroit, Mich. DEPT. 227

Manufacturers of

VITREOUS TRANSMITTING GRID LEAKS
VOLUME CONTROLS • POWER RHEOSTATS

Write for Complete Free Catalog

ELECTRAD, Inc.
175 Varick Street, New York

HOW TO MAKE AN OSCILLOSCOPE

(Continued from page 13)

(5) accelerator plate; (6) vertical deflector; (7) horizontal deflector. A back view of the tube base shows where each element terminates. Numbers 1 and 2 connect to the filament which requires 2½ V. at 1.75 A. The cathode is internally connected to the filament prong No. 1.

Number 3 is the control-grid which should never be positive. A variable bias voltage is applied to this grid which can make it negative between 0 and 100 V. This element will completely stop electron flow at about 60 V. negative bias. It controls the brilliancy or intensity of the electronic beam. The setting of the "Intensity Control" determines the dimness or brightness of the image on the screen.

Element No. 4 is the focusing plate which attracts electrons from the cathode. The focusing plate is built like a telescope eyepiece; it is a small cylinder with a peep-hole in one end. As the voltage on the focusing plate is variable (between 200 and 400 V.) it is possible to vary the speed of the electron beam. Reference to the sketch will show that a cloud of electrons is attracted to the focusing plate, some of which escape through the peep-hole into the next chamber. Increasing the voltage applied to this plate will cause the electron cloud to speed up and a much larger proportion of electrons will pass through the peep-hole.

Element No. 5 is the accelerating plate which has a fixed voltage of 1,000 V. applied to it. It, too, is built like a telescope eyepiece; it is larger than the focusing cylinder, but has a smaller peep-hole. The electron stream is given tremendous acceleration through this peep-hole, on its way to the viewing screen.

Elements Nos. 6 and 7 are two pairs of deflectors placed at right-angles to each other. One deflector of each pair is internally connected to the accelerating plate (which is grounded for safety reasons). The free deflectors terminate at prongs 6 and 7. A voltage applied to the vertical deflector will cause the electron beam (which is always negative) to be attracted or repelled, depending upon the polarity of the voltage under test, imparting an up or down motion to the spot on the viewing screen.

RELATION OF THE COMPONENTS

We are aware of the fact that a certain number of builders will want to deviate, through choice or necessity, from the parts layout, or electrical units required. This is perfectly permissible, providing the builder has an advanced knowledge of high-voltage power packs and can compute the resistance values required in voltage distribution for the various branches. For instance, the builder may have on hand a high-voltage transformer requiring a type 81 rectifier.

In this case the transformer might be so large in size, as to require a drastic change in chassis length or width. Therefore, we recommend to those who are not going to duplicate our instrument that all the parts, including all tubes, be purchased first. Then the builder may make his own layout and plan the chassis accordingly.

An optional power supply is shown in Fig. 6. The complete oscilloscope contains the type 906 cathode-ray tube; a dual power supply using 2 tubes; the high-voltage rectifier type 879; and the low-voltage rectifier type 80. Only these 3 tubes will be used at the start. (Later on we will add a saw-tooth oscillator circuit which contains an 885 gas-triode and associated parts. Still later, we will add 2 type 57 tubes which will serve as wide-range amplifiers for the vertical and horizontal deflectors.)

We are building the unit in easy stages primarily to help the builder get acquainted with the operation of the unit in its simplest form. After he has mastered the technique of focusing and centering the beam and making simple measurements, he is ready to add the sweep system, which enables him to study wave shapes and perform advanced measurements.

Lastly, we will add the 2 amplifiers which increase the size of the image. In the meantime, the financial outlay has been spread over three periods.

A list of the parts needed to construct the unit in its first stage is given.

Figure 1 is the schematic of the first of these units. (Note that 2 filament windings on the power transformer show no connection. They will be used later. Also note 3 open taps on the low-voltage divider circuit; they, too, will be used later.) Figure 3A is the chassis base on which all sockets are marked off, and should be drilled or punched out in advance, even though 3 of them will not be used at present. The other holes are for the tube mount and other parts which may be slightly shifted around. If sheet aluminum is used, it may be shaped in a tinsmith's brake. No parts should be fastened permanently to the chassis until all holes have been drilled.

Figure 3B shows the front-panel layout. The 3-in. hole can be cut out by drilling a series of holes inside of a circle, after which the jagged edges can be smoothed down with a half-round file. The escutcheon, which is 4 ins. in outside dia. and 2¾ ins. in inside dia., requires a 3-in. hole. There are 12 holes which are for the various controls, only the bottom row of 4 holes will be used at present. The front panel may be riveted or bolted to the chassis after all holes have been drilled.

Figure 4A is the layout of the tube mount.

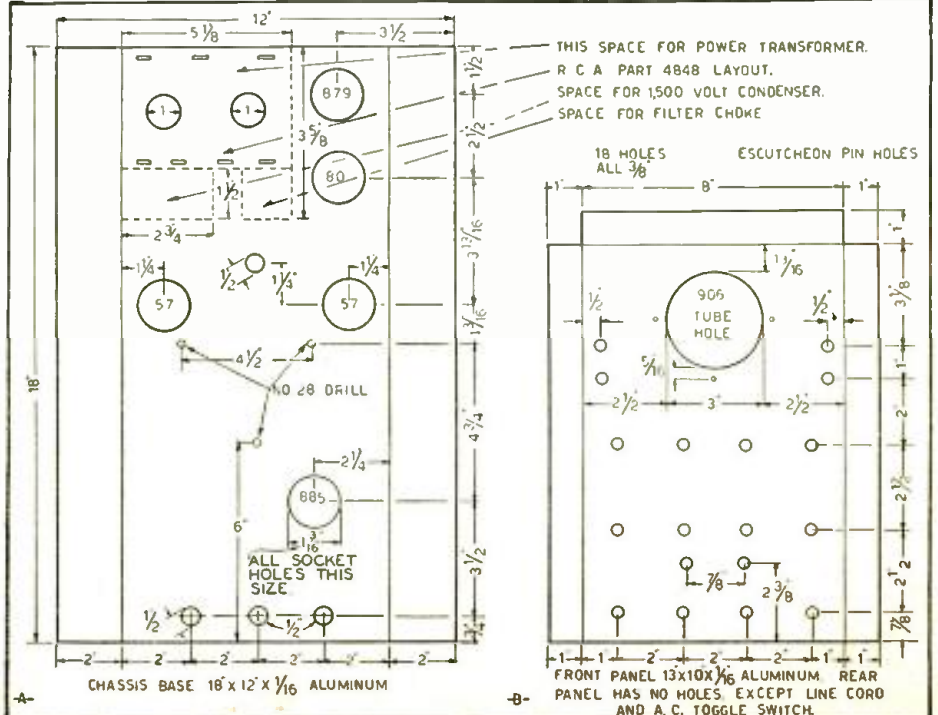

Fig. 3. The layouts for chassis and front panel drilling.

Please Say That You Saw It in RADIO-CRAFT

It is the vertical panel upon which an adjustable bakelite plate is mounted. The isolantite socket, which holds the 906, is fastened to this bakelite plate (which is shown in Fig. 4B).

Details of the angle bracket which supports the tube mount, are also shown in Fig. 4B. The two brass spacers, 5/8-in. long, are used between the tube-mount panel and bakelite plate. Two more are used between the socket and guide plate, thus giving a very high insulation factor to the 906 socket.

The small parts are mounted underneath the chassis. The resistors and bypass condensers may be assembled on a small fibre or bakelite panel. The "Focus" potentiometer is mounted on the front panel in the extreme right hole of the bottom row of 4 holes. Refer to Fig. 5. The "Intensity" control is placed in the extreme left hole. The 2 remaining holes in the center are occupied by the "Beam Shift" potentiometers. (The remaining 8 holes will be used later.)

Three sets of tip-jacks are mounted next. Note that the black tip-jacks are grounded to the metal front panel; the red and green tip-jacks must be insulated from the panel. The escutcheon is mounted with small screws or pins. Line-up the cathode-ray tube with the escutcheon before permanently fastening the tube mount.

Wiring is the next operation. To simplify matters, the wiring should be done in groups, as follows: high-voltage plates and filament, low-voltage plates and filament, high-voltage condenser and resistor, low-voltage filter choke.

A 7-wire cable about 2 ft. long (or 7 separate wires) may be used to wire the 906 socket. The cable passes through the 1/2-in. rubber grommet directly beneath it and the wires are then connected to the 4 panel controls and high-voltage divider circuit.

The 4 power transformer filament leads that are not used at present should be individually taped, and tied-down out of the way. Adding the line switch and cord completes the job. The line fuse is optional.

NOTE—It is a safe bet that every Service Man has, at some time or other, been "kicked" by four or five hundred volts, and laughed it off. BUT, BE WARNED, 1,200 volts is a potential that is not to be trifled with!

Now we prepare the unit for its initial test. Plug into the red and black tip-jacks on both sides of the escutcheon, two pairs of test leads with clips. If you have a 45-V. "B" battery on hand it will serve as the deflecting-voltage source in our first experiment.

Plug the unit into the line and wait about a minute for the tubes to warm up, and then look at the viewing screen. If the spot is invisible or very dim, turn up the "Intensity" control, gradually, until the spot is about 1/64-in. across and easily seen, but not too bright or glaring. If the spot has a halo around it, gradually turn the "Focus" control until the halo disappears and the spot is sharp and clear. Next, the "Beam Shift" potentiometers may have to be adjusted to center the spot and once done may not have to be disturbed for a long while.

Now we will test the deflector plates both separately and together, with the "B" battery. Connect the red vertical deflector to plus and the black to minus. The spot should move upward about an inch. Now reverse the leads and the spot should move downward an inch (from center). Remove the vertical deflector connections from the battery and connect the horizontal; as before, plus to red and minus to black. The spot should move to the right along its center for about an inch. Reverse the connection and the spot should move to the left.

Many other simple and interesting measurements may be performed. It is suggested that the builder practice with the unit until he is familiar with the operation of it. The construction and operation of a wide-range sweep oscillator will be described in Part II.

LIST OF PARTS

Power Supply and Basic Components

- One RCA 906, 3-in. cathode-ray oscilloscope tube;
- One RCA 879 rectifier tube;
- One RCA 80 rectifier tube;
- One chassis, front and rear panel, tube mount and bracket, sheet aluminum (see detail illustrations for dimensions);
- One RCA power transformer, No. 4848, P.T.;
- Two Sprague condensers, 1,500 V., 0.25-mf., C1, C2;
- One RCA filter choke, 1,300 ohms, No. 4846;
- Two Aerovox, Sprague or Cornell-Dubilier electrolytic condensers, 4 mf., 500 V., C3, C4;

Presenting Model T-37 A SIGNAL GENERATOR that "Does Everything" only \$12⁴⁰



Model T-37 All-Wave Signal Generator, wired, in shielded cabinet with carrying handle and calibrated, tested, complete with 3 tubes, instructions \$12.40 (shipping weight 7 lbs.)

Released by SUPERIOR INSTRUMENT CO., for limited time only.

- 110 Volts A.C. or D.C., 100 kc.—20 megacycles all on fundamentals.
- Dial is direct reading in frequencies.
- R.F. output may be taken from a high impedance or a low impedance post. In with attenuation present for either.
- Separate audio output at 2 amplitude levels, so that tone may be used for checking public address systems, audio amplifiers in receivers, and speech amplifiers in transmitters.
- Two extra posts on front panel enable leakage tests. Condensers may be checked for leakage, so may tubes, and other normally high resistance currents, otherwise difficult to test.

Superior Instruments Co., 139 CEDAR STREET, NEW YORK, N. Y., Dept. T-1

- One Aerovox, Sprague or Cornell-Dubilier electrolytic condenser, 10 mf., 200 V., C5;
- One Aerovox, or Cornell-Dubilier Sprague electrolytic condenser, 20 mf., 50 V., C6;
- Four Aerovox, Sprague or Cornell-Dubilier condensers, 0.25-mf., 400 V., C7, C8, C9, C10;
- One I.R.C. resistor, 50,000 ohms, 1 W., R1;
- One Centralab potentiometer, 0.1-meg., R2;
- Three Centralab potentiometers, 0.25-meg., R4, R7, R8;
- One Eby large 7-prong isolantite socket;
- Two Eby 4-prong sockets;
- Two I.R.C. resistors, 3 megs., 1/2-W., R13, R14;
- Two I.R.C. resistors, 0.5-meg., 1 W., R5, R6;
- One I.R.C. resistor, 0.3-meg., 1 W., R3;
- Two I.R.C. resistors, 10,000 ohms, 1 W., R10, R11;
- One I.R.C. resistor, 1,000 ohms, 1 W., R12;
- One I.R.C. wire-wound resistor, 40,000 ohms, 5 W., R9;
- Four pointer knobs;
- One 4-in. escutcheon (for the cathode-ray tube);
- *Six tip jacks, 3 black, 2 red, 1 green;
- One A.C. toggle switch;
- One fuse mount and 2 A. fuse;
- Hookup wire with good insulation.

*Name of manufacturer will be supplied upon request.

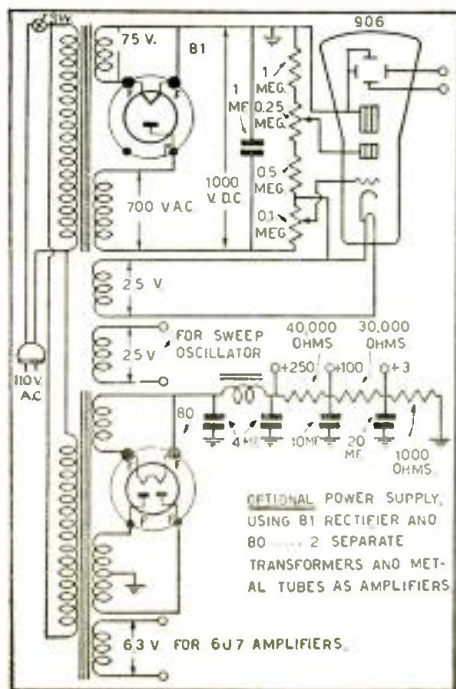

Fig. 6. An alternative power supply.

FREE

Semi-Precision CONTINENTAL Carbon

condensers and resistors are available in matched sets for decade circuits.

Now you can economically build these useful decade capacity and resistance standards for your radio or experimental laboratory.

Send for your FREE plans!

Please send me your FREE Build-it-Yourself Plans and Bulletins.

Name

Address

City

My Jobber is

CONTINENTAL CARBON Inc.

13914 Lorain Ave. Cleveland, Ohio

6 L 6 60 WATT
30-13,000 CYCLES ± 1 D. B.
 MULTIPLE COIL, Hum Free Construction
Push Pull INTERSTAGE TRANSFORMER
 In Alloy Humproof Case **\$9.00** List

6L6 60 Watt Output Transformer into 500-15-8-4-2 in Alloy Hum-Proof Case List \$12.00
 Columbia Diagram of 6L6 60 Watt Amplifier with Full Parts List, and employing Cathode Ray Indicator Tube, Automatic Feed Back Reducer, etc. \$0.40

ALLOY TRANSFORMER CO., Inc., 135R Liberty St., N. Y. City

Please Say That You Saw It in RADIO-CRAFT

Weather Forecaster

AND

**HUMIDITY
TESTER**

"HYGROSCOPE"

*The Ace of Weather
Forecasters*



When placed in a well-ventilated room or in the fresh air, the HYGROSCOPE foretells coming weather conditions from eight to twenty-four hours in advance. It also accurately records outdoor humidity, and when placed inside it gives the humidity within the house or room.

The HYGROSCOPE is automatic self-adjustable, simple American-precision made. It cannot get out of order at any time. The dial measures 2 1/4", is enclosed in a 6" round hardwood case, with either walnut or mahogany finish. It is attractive for desk or living room.

OUTSIDE DIAL FORECASTS WEATHER

Fair—rain—or changeable is indicated on the outer dial when the HYGROSCOPE is placed in a well-ventilated room or out-of-doors. If indoors, place the instrument near an open window.

INNER DIAL SHOWS HUMIDITY CONTENT

The HYGROSCOPE also acts as a hygrometer. Numbers on the inner dial indicate the degree of humidity present in the air and in artificially heated rooms.

SEND YOUR ORDER NOW! Get your HYGROSCOPE today. Your remittance in form of check or money order accepted. If you send cash or unused U. S. Postage Stamps, be sure to register your letter. Also specify if you prefer the HYGROSCOPE in Walnut or Mahogany.

\$2.00

Postpaid

GREN PARK COMPANY

Dept. RC-736

99 Hudson St. - New York, N. Y.

DIALS—SHUNTS

Etched Small
Mod. 301-88-321 5 to 500 M.A.

27-30-50-100 M.V.

From Retail & Wholesale dealers

D. L. Van Leuven, 410 E. 15 St. N. Y. C.

RADIOS... SAVE UP TO 50%

DEAL DIRECT... Factory Price... Models... Your name and address on postcard brings you NEW 16-page 1936 Radio Catalog in colors FREE. Get details of 30-day TRIAL plan and Appointment. Radio Co. Dept. 300 1700 Grand River, Detroit, Mich.

30 DAY TRIAL \$6.98

Free Catalog

RADIO ENGINEERING

RCA Institutes offers an intensive course of high standard embracing all phases of Radio. Practical training with modern equipment at New York and Chicago schools. Also specialized courses and Home Study Courses under "No obligation" plan. Catalog. Dept. RT-36.

RCA INSTITUTES, Inc.

75 Varick St., New York 1154 Merchandise Mart, Chicago
Recognized Standard in Radio Instruction Since 1908

NOTICE Regarding TELEVISION!

● Pictures go on the air experimentally this month from big new television stations. Study the facts. Great new book, "TELEVISION WITH CATHODE RAYS", which required 6 years to write, will be ready for distribution on June 6th. Written by Arthur H. Halloran. Price \$2.50 per copy, which includes FREE one-year monthly supplement service mailed to you each month. Send check or money order to: Pacific Radio Publishing Co., P.O. Box 3278, San Francisco, U. S. A.

EVEREADY RADIO REPAIR CEMENT

"THE ORIGINAL SPEAKER CEMENT"

Used for replacing speaker cones, mending old, rattling, or torn cones, sealing adjustments, cementing loose tube bases, grid caps, coils, leads etc. Dries fast. Vibration proof, waterproof, invaluable aid to Service Men. See your jobber. If he cannot supply you, write us. List price 50c for large bottle. Send for FREE circular of complete line. GENERAL CEMENT MFG. CO. (Radio Div.) Rockford, Illinois

ADDING "MAGIC EYE" TUNING TO OLD SETS

(Continued from page 31)

The shadow opens symmetrically on each side of the line where it just closes. This line is approximately parallel with a line passing through pins Nos. 2 and 5, and is on the same side of the tube as pin No. 5. It is customary to mount the indicator tube in a horizontal position with pin No. 5 downward.

The method of connecting the indicator tube into the set circuit is shown in the insert in Fig. 2. In sets using 6.3 V. tubes the filament may be connected to the filament supply of the set. In sets using 2.5 V. tubes a small, separate filament transformer (of which several are available on the market) should be used. Its primary should be connected across the primary of the set transformer so that the on-off switch will control both transformers.

The control-grid of the triode section of the indicator tube should be connected to the A.V.C. system. In most sets the filtering of the A.V.C. system will be satisfactory so that this grid may be connected directly to the grid-return of one of the controlled tubes. If the filtering is not sufficient, the edges of the shadow will blur and appear fuzzy on modulation peaks. If the time constant of the filter system is too slow, the indicator action will be sluggish.

In either of the latter two cases, it is advisable to provide a separate filter and connect this directly to the source of A.V.C. voltage.

The amount of A.V.C. voltage developed by the particular set in question on strong signals will determine whether a type 6E5 or a 6G5 should be used.

This article has been prepared from data supplied by courtesy of National Union Radio Corp.

DESIGN DATA ON A.V.C. CIRCUITS

(Continued from page 31)

which is then coupled through an I.F. transformer to the diode section. Delayed action can again be introduced if desired.

TAPPED A.V.C.

There are various reasons why it is desirable to deliver a different amount of A.V.C. voltage to different tubes. The R.F. stage might for instance receive only 1/2 of the A.V.C. voltage while the other tubes are controlled by the full voltage. The reason is that the receiver will work with less noise if the signals impressed on the mixer tube are relatively large and so it is desirable to have additional gain in the R.F. stage.

A voltage divider system has to be employed to deliver the correct proportion to each tube and each tap must have its own resistance-capacity filter. The idea is illustrated in Fig. 3.

QUIET A.V.C.

When a receiver with A.V.C. is tuned from a station to a spot on the dial where a signal is not received, the sensitivity is suddenly turned up full and the set appears to be very noisy. This inter-station noise is objectionable to many users. The various schemes to eliminate it would fill a good-size book. However, here are two of the commonest. A manual sensitivity control can be added to the automatic. The setting of this manual control then limits the maximum set sensitivity available between stations. The listener should retard the manual control until the noise stops being objectionable.

Another scheme is shown in Fig. 4. An extra tube is so connected as to cut off the audio amplifier until a signal of a given strength is coming in. When no signal is coming in, the control-grid of this additional or "squelch" tube is at the same potential as the cathode and plate current flows. This plate current causes a voltage drop across R1 which is large enough to bias the first A.F. tube to cut-off. As soon as a signal is received, the control-grid of the "squelch" tube becomes negative, cuts off the plate current and restores normal bias to the audio stage. The "squelch" tube is generally a pentode such as the 57 which has a steep curve with a sharp cut-off.

This article has been prepared from data supplied by courtesy of the Aerovox Corp.

FREE

CHOICE OF EITHER PREMIUM WITH A SUBSCRIPTION TO

RADIO-CRAFT

Offer Good Only During Month of June, 1936

You've read RADIO-CRAFT—and you should read it regularly every month—it's the greatest monthly magazine covering practically every branch of radio. You can subscribe for one year (12 monthly issues) and receive absolutely FREE your choice of either premium shown below. Get a WORLD-GLOBE LAMP—or POCKET RADIO GUIDE today with your subscription. Fill in coupon—mail it today with your remittance!



WORLD-GLOBE LAMP

This beautiful WORLD-GLOBE LAMP measures 17 1/2" high. The attractively colored shade with nautical map designs

is 8" in height and 16" in diameter. The shade is made of fine quality Parchment which assures long life. The 6 1/4" globe, printed in many colors, has a full meridian and rotates. Hundreds of names—countries, cities, rivers, oceans, etc., are clearly printed on globe. Movable hour scale permits determining correct time in any part of the world. The metal parts are finished in antique bronze. Heavy green felt glued under base makes lamp placeable anywhere. Weight of WORLD-GLOBE LAMP nearly 3 lbs.

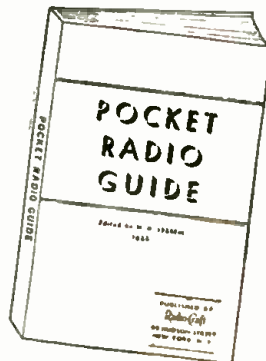

POCKET RADIO GUIDE is a brand new 64-page book—a book especially printed to celebrate the Seventh Anniversary of RADIO-CRAFT. It contains eight important chapters covering many branches of radio—essential to every radio man. Over a hundred illustrations. Book is 6 x 9 inches—stiff, flexible covers.

RADIO-CRAFT
99 Hudson St., New York, N. Y.

Gentlemen: Enclosed find my remittance of two dollars and fifty cents (\$2.50, Foreign \$3.00) for which enter my subscription to RADIO-CRAFT for one year (12 issues). This entitles me to a WORLD-GLOBE LAMP absolutely FREE. I will pay the few cents additional for shipping charges on the WORLD-GLOBE LAMP as follows: East of the Mississippi add 17c; West of the Mississippi 70c; Canadian and Foreign 84c.

Enclosed find my remittance of \$2.50—please send WORLD-GLOBE LAMP by express collect.

Enclosed please find my remittance of One Dollar (\$1.00) for which send me RADIO-CRAFT for Seven Months, also my FREE copy of POCKET RADIO GUIDE.

Name

Address

City State

Please Say That You Saw It in RADIO-CRAFT

ELIMINATING WHISTLES IN SUPERHETERODYNES

(Continued from page 26)

coil and image-suppressor coil, and in conjunction with condenser C2 is resonated to the interfering station.

A more elaborate, though difficult system to adjust is seen at C. Here, the aerial circuit is resonated by means of coil L3 in series with the aerial coil, L1, to suppress image frequencies at one end of the tuning band (the high-frequency end) while the two coils, L3 and L1, with condenser C2 form a resonant image filter for another part of the band. The resistor R1 is used to flatten the resonant peak so that the effect of L3 and L1 will be to cover a wider section of the band.

A novel scheme for eliminating the image signals is presented in 1D. This scheme, which was first described in the *Proceedings of the Institute of Radio Engineers*, June 1935, takes advantage of the phase inversion between the image frequency and the signal frequency, this inversion causing them to cancel out. Here the cathode coupling coil feeds a signal at image frequency back to the antenna section of the band-pass filter, the signal being between the cathode and ground, while an equal and opposite voltage is set up between grid and ground through the normal coupling of the filter. Since these 2 voltages are effectively 180 deg. out of phase, the image signal is cancelled out.

The system at Fig. 1E was widely used some time ago, and is still quite popular. Here the image trap is connected in series with the main input circuit condenser, across the antenna coil. Some sets even had a variable condenser at C2 ganged to the main tuning condensers, so that the trap was constantly tuned to the image frequency. The great majority however, simply tuned the trap circuit to the point of worst image interference by means of a trimmer condenser at C2, and it was left in that position. In operation, the combination of L3, C2, and C1 acts as a short-circuit to the image frequency, bypassing it to ground, while allowing the signal to pass through unchanged.

OSCILLATORS AS NOISE GENERATORS

While on the subject of noise in superheterodynes, a brief description of some of the fundamental circuits of oscillators may well be given, since the efficiency of the oscillator is of the greatest importance for proper results and harmonic generation in the oscillator is one of the worst offenders from that standpoint of whistles.

At Fig. 1F is shown the Meissner circuit, which though rarely used nowadays is the basis of most modern oscillators. The coupling between L1, L2, and L3 is rather loose and tuning is governed by the values of L1 and C1.

In Fig. 1G and 1H we have, respectively, the "grid tuned" and "plate tuned" oscillators, the former being probably the most common of all, and the latter being used occasionally on the higher frequencies, where its somewhat broad tuning characteristics are of advantage.

Figure 1I is the so-called "electron-coupled" oscillator, which is being used more and more due to many advantages, not the least of which is its high stability and low harmonic content. It may be seen that the actual oscillating circuit of V1 is composed of cathode, control-grid, and screen-grid, the plate being simply a means of coupling the external apparatus. Thus supply voltage fluctuations and other changes in the external circuit have relatively little effect on the frequency of the oscillator.

If the oscillator voltage supplied to the mixer or converter tube is too low, the efficiency will suffer, while if it is too high, there will be an abnormal amount of hiss in the signal going to the I.F. amplifier. For this reason the electron-coupled oscillator, which is by far the steadiest of the more common types, can be set at the best operating point and will maintain it quite even over a large range of conditions.

In each of these circuits, Fig. 1F to 1I, harmonics of the fundamental frequency can be reduced by introducing resistance into the circuits at points marked X. The value of resistance should be as low as possible, consistent with whistle elimination. Usually a few thousand ohms at one point in the circuit will be sufficient.

I.F. INTERFERENCE

When a superheterodyne receiver (especially one with an I.F. of about 450 kc. or in the commercial and ship communication bands) is located in a district where there are powerful trans-

mitters of any type operating at or near the fundamental intermediate frequency of the receiver, another type of interference manifests itself. This trouble makes itself known by whistles on every station received, caused by the beating of the interference which passes through the mixer tube, with the normal received signal.

Again, the cure for this defect is more selectivity in the antenna circuit; and good shielding of all circuits and parts is essential. These conditions are not met in many of the midget receivers, which are the greatest sufferers of this interference. The circuits of Figs. 2A and 2B show trap circuits of the series and parallel type, which are designed to overcome the nuisance. The trap must be capable of being tuned to the I.F. of the receiver, and when so tuned will be found to greatly attenuate the troublesome "birdies." These traps can be added to any set, placing them as close to the input tuning circuit as possible.

NEWEST IMAGE FREQUENCY TRAP CIRCUIT

Let us return once more to the subject of image frequency interference discussed earlier in this article. Image interference can be greatly reduced or eliminated without any change in the receiver by the addition of a trap circuit as shown in Fig. 2C. This particular arrangement was published in the English publication, *Wireless World*, but of course it is effective wherever this type of interference exists. The 2 inductances may be wound on a form 2 ins. in dia., with about 50 turns of No. 30 D.C.C. wire, tapped at the middle. These two coil units, mounted close together and at right-angles on a small panel, may each be tuned by a 350 mmf. condenser.

In superheterodyne design practice the oscillator is always tuned higher than the fundamental or received frequency, by an amount equal to the I.F. Therefore, if there is a strong signal which can break through the input circuits of the set it will cause a whistle. This unwanted signal will be higher than the required signal by twice the I.F. of the receiver, so this is the point to which the trap circuits must tune. In this particular unit there are 2 separate traps, each of which may be tuned to remove one interfering signal. In localities where there is only one station which causes image interference, only one of the tuned circuits is required. In operation, it is only necessary to turn the condenser of the trap circuit until the whistle drops sharply in volume.

There are, of course, other causes for noise in superheterodyne receivers, but those explained here are the most prevalent.

A VARIABLE-INDUCTANCE WOBBLER

(Continued from page 27)

such as rough handling. The system used in this instrument is quite different and is simplicity itself, as may be seen from a study of Fig. 1.

A rotatable copper vane is set at an angle in the coil, which latter is itself at an angle with respect to the panel. As a result, the vane varies over an angle of about 50 deg. (from parallel to the coil windings to about 50 deg. from parallel for 1 complete revolution of the copper disc), this being sufficient to change the natural frequency of the tuned circuit ± 20 kc. or a total of 40 kc.

The fundamental frequency of the wobbler oscillator is 1,650 kc. This oscillator is fixed in frequency and beats with a variable-frequency oscillator. (The details of the oscillator will be discussed in a forthcoming issue.) The vane is rotated at 3,600 r.p.m. by a small synchronous motor, which also has on its shaft a fan to force a current of air through the case as an aid to cooling. On the front end of the shaft is a black disc which has a single white line indicator, and when this line is set next to a similar fixed mark on the case, the mean frequency or 1,650 kc. is emitted by the fixed oscillator.

In Fig. 2 we see the circuit of this part of the equipment. Note that the copper vane does not directly affect the main tuning inductance, but operates within its own coil. The actual appearance of the interior of the fixed oscillator circuit is shown in Fig. A.

This article has been prepared from data supplied by courtesy of Clough-Brengle Co.

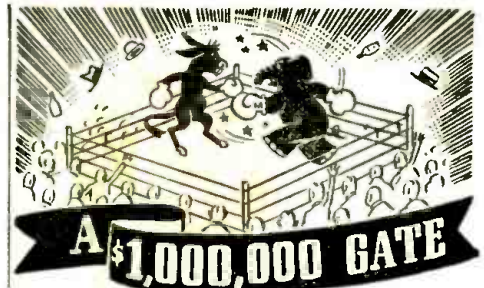

Election year—sizzling political campaigns—the biggest Public Address opportunity ever! Parades—rallies—stumping campaigns—meetings—they all need and want Public Address. Get your cut of this tremendous gate. Tie up with ALLIED—we'll help you sell quality sound equipment at big profits.

FREE! SPECIAL POLITICAL P.A. SALES BULLETIN

Send for this valuable new P.A. sales-promoter now. Punchy; value-packed. Sells complete sound outfits for you—portable, mobile, permanent—a job for every political sound need. Get set for the coming campaign—the hottest in years. Send for this FREE special Political P.A. Bulletin!

FREE 136 PAGE CATALOG

Radio's Leading Supply Guide. Special Sound Section, Amateur Section, Service Section. Thousands of parts; dozens of instruments, tools, sets, kits and books at the lowest prices. Write for your FREE copy today!

ALLIED RADIO

833 W. Jackson Blvd. Dept. D.
Chicago, Ill.

- Send me your FREE Political P.A. Bulletin.
- Send me your FREE 136 page Catalog.

Name

Address



For a permanent or separate automobile speaker the Model 870 VS 6-inch or 930 VS 8-inch NOKOIL Reproducer housed in our attractive vehicle cabinet, as shown above, is positively unbeatable.

A Demonstration means A Sale

Write for further particulars, complete catalog and name of your nearest distributor.

WRIGHT-DeCOSTER Inc.

2251 University Ave., St. Paul, Minn.
Export Dept.—M. Simons & Son Co., New York
Cable Address: "Simontrics"
Canadian Office, Wright-DeCoster, Inc., Guelph, Ont.

TRADE IN CHASSES

ALL ELECTRIC—7 & 8 tubes.
Complete with tubes and speakers.
Majestic, Philco, RCA, etc. **\$5.95**
Limited number available
Write for our free parts catalog.

HERALD RADIO SALES

7 E. Congress St. Chicago, Ill.

Please Say That You Saw It in RADIO-CRAFT

SPRAYER OUTFIT

ELECTRICAL—PORTABLE

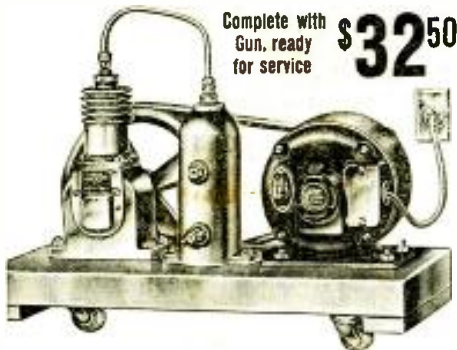

Complete with Gun, ready for service **\$32.50**

This is the ideal Outfit for all around spraying work wherever current is available. Sprays everything: Lacquers, Oil, Cold Water Paints, Enamels, Varnish, Insecticides, Disinfectant, Shoe Dyes, etc. The Unit is compact, completely self-contained.

Ideal for spraying Furniture, Radiators, Screens, Machinery, and other maintenance paintings in Homes, Schools, Clubs, Hospitals, Stores, Factories, and Office Buildings.

The Gun furnished with this Unit is of Pressure Cup type, requires but 2 cu. ft. of Air per minute. Has Bleeder type construction which assures uniform pressure at all times without clogging the Air Passage which is easily cleaned. Furnished with 3 Nozzles which produce Fan, Round, and Right Angle Spray respectively.

Complete Unit consists of Air-cooled Compressor with machined Fan-cooling Pulley, V-Belt Drive; Pressure type Gun with 1 quart Aluminum Paint Cup; 3 Tips; 1/2 H.P., Heavy Duty Motor, 110/120 volt, 60 cycle, AC; 15 ft. rubber covered 2 Ply Air Hose; 8 ft. Cord & Plug; Filter Tank; Entire Unit mounted on Base with Ball Bearing Casters.

A low priced Power Sprayer; the kind of Machine that usually sells for \$50.00 to \$60.00.

Price of complete outfit, shipping weight, 60 lbs. **\$32.50**

Price of outfit complete, less Motor, shipping weight—35 lbs. **\$25.50**

Price of Gun only with 3 nozzles, shipping weight, 7 lbs. **\$7.50**

Price of Compressor only, shipping weight 15 lbs. **\$9.50**

Our Old Customers Know That Our Merchandise Is Sold on a Strict Money-Back Guarantee

All Shipments will be forwarded by Express Collect if not sufficient postage included with your order.

WELLWORTH TRADING CO.

560 W. Washington Blvd., Dept. RC-736, Chicago, Ill.

tube EXTRActor

Presenting a Metal Tube Puller of Advanced Design



PAT. PEND.

Jobbers Write for Sales Proposition and Territory

The TOOL all SERVICE MEN and MANUFACTURERS have been waiting for. EXTRACTOR'S metal and glass metal-covered tubes, easily and quickly from their sockets. SPEEDS UP Service and Test Routine. PREVENTS painful FINGER BURNS. ELIMINATES DAMAGE to tubes, and sockets. ULTIMATE in SIMPLICITY AND SERVICEABILITY. Operation is EXTREMELY SIMPLE—grip tube in jaws of tool and press thumb lever to lift tube from socket. No twisting or pulling required. Most in-service tubes easily extracted with this tool. ORDER your TUBE EXTRACTOR TODAY. List Price \$3.00. **\$1.80 POST PAID**

Special Introductory offer. **\$1.80 POST PAID**
AMERICAN RADIO HARDWARE CO., INC.
476 BROADWAY, NEW YORK, N. Y.

BUILD IT YOURSELF

You can build this Trailer with our tools easily from our step-by-step constructional sheets and large sized blueprints. Finest designed Trailer in existence, sleeps 4. Toilet, Shower, Electric Light, etc. Save 75% of the cost by building it yourself. Send 25c for plans sheet, illustrations and details.
THE PLAN SHOP, 910 Palmolive Bldg. Chicago, Ill.

ARE YOU INTERESTED IN TELEVISION?
see the August issue of **RADIO-CRAFT**

MAKING A "MAGIC EYE" V.-T. VOLTMETER

(Continued from page 27)

denser and control-grid lead must be connected to the input circuit as indicated by dotted lines in the schematic, Fig. 1. If an accurate calibration on R.F. is not needed, the blocking condenser and gridleak may be wired in permanently so as to be controlled by a switch.

In order to afford ease of adjustment on the low-voltage ranges it was found desirable to incorporate a 500-ohm rheostat, R5, as a vernier in series with R4. To keep the number of control positions at a minimum, a duplex control incorporating R5 and R4 was constructed. The shaft of the potentiometer R1 was replaced with a section of hollow tubing. As shown in Fig. 11 the rheostat R5 was mounted by a bracket directly below R4 and a small-diameter extension shaft passed through the hollow shaft of R4 to a small control knob mounted on top of the larger control knob for R4. This enables the final adjustment to be made from the same control position used in making the coarse adjustment by R4.

A link was mounted on the panel and connected into the voltmeter circuit as indicated. By opening this link the voltmeter may be used as an independent D.C. high-resistance voltmeter (1,000 ohms-per-volt) by connecting between the negative input terminal and the link itself. This also serves as a very convenient means for periodically checking the accuracy of the voltmeter itself against another meter of known accuracy. If necessary the construction cost may be reduced by using carbon resistors in place of precision resistors as multipliers for the voltmeter. (An 0 to 1 ma. movement is employed). These resistors may be ground or filed to obtain accuracy.

OPERATION

Connect to a 110 V. line for a sufficiently long time to allow the tubes and circuit elements to reach their normal operating temperatures. Set R4 and R5 at the positive end of their voltage ranges. For convenience these controls should be wired so that this condition is obtained with both controls turned to the extreme end of their ranges in a clockwise direction. Next, adjust R7 so as to almost completely close the magic eye. This is the normal reference point for making all measurements. Connect the input terminals to a source of voltage and the "eye" will open by an amount proportional to the applied voltage peak. Controls R4 and R5 are now turned until the opening of the "eye" is returned to the normal reference point. The voltmeter multiplier switch is now turned from the OFF position to the proper scale to read the voltage drop across R4 and R5 which represents the voltage

required to balance the peak value of voltage applied to the input.

TABLE I
VOLTAGE

To Input Posts	Read On V.T.V.M.	To Input Posts	Read On V.T.V.M.
240	210.0	15.	14.20
220	222.0	10.	9.90
200	201.0	9.	9.00
180	180.3	8.	8.00
170	170.3	7.	7.02
160	160.2	6.	6.10
150	150.0	5.	4.95
140	139.8	4.	3.90
130	129.9	3.	2.90
120	120.0	2.	2.10
110	109.5	1.	1.00
100	99.9	0.9	0.92
90	90.0	0.8	0.80
80	80.4	0.7	0.70
70	69.0	0.6	0.62
60	59.7	0.5	0.54
50	48.5	0.4	0.48
40	38.5	0.3	0.44
30	29.5	0.2	0.35
20	19.0	0.1	0.26

LIST OF PARTS

- One I.R.C. resistor, 1 meg., R1;
- One I.R.C. resistor, 0.1-meg. R2;
- One I.R.C. resistor, 2 megs., R3;
- *One taper ww pot., 10,000 ohms, R4;
- *One ww rheostat, 100 ohms, R5;
- One I.R.C. carbon resistor, 500 ohms, R6;
- *One linear ww pot., 1,000 ohms, R7;
- One I.R.C. 5 W. resistor, 10,000 ohms., R8;
- One Shallcross precision resistor, 1,000 ohms, R9;
- One Shallcross precision resistor, 10,000 ohms, R10;
- One Shallcross precision resistor, 0.1-meg., R11;
- One Shallcross precision resistor, 0.2-meg., R12;
- One I.R.C. resistor, 4,000 ohms, 5W., R13;
- One I.R.C. gridleak, 2 megs., R14;
- One Aerovox paper condenser, 0.1-mf., C1;
- One Aerovox paper condenser, 4 mf., C2;
- One Aerovox electrolytic condenser, 8 mf., C3;
- One Aerovox paper condenser, 0.1-mf., C4;
- One Aerovox electrolytic condenser, 16 mf., 500 V., C5;
- One Aerovox paper condenser, .01-mf., C6;
- *One power transformer, T-7020, T1;
- *One single gang, 5-point switch, Sw1;
- Two 6-prong sockets;
- One 4-prong socket;
- One 20 hy. filter choke, Ch.1;
- One type 6C6 tube, V1;
- One type 6E5 tube, V2;
- One type 80 tube, V3;
- One Weston 0 to 1 ma. meter;
- One bakelite panel;
- One carrying case;
- Four binding posts;
- One terminal strip or socket with plug.

*Names of manufacturers will be sent upon receipt of a stamped and self-addressed envelope. This article has been prepared from data supplied by courtesy of Capitol Radio Engineering Institute.

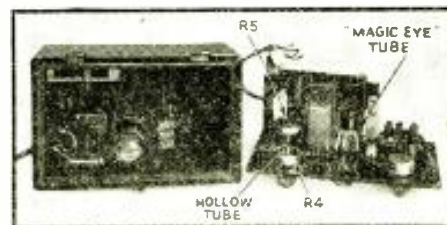

Fig. B. The interior of the meter.

HOW THE 2-RIBBON MIKE PREVENTS FEEDBACK

(Continued from page 30)

of eliminating acoustic feedback. Yet as you will note in the illustration, the actual angle of pick-up of the velocity mike without frequency discrimination is much greater than the other two popular types.

Of course, when the microphone is swung so that the ribbon is horizontal (parallel to the ceiling), it has a 360 deg. pick-up in the active sectors above and below, as shown in Fig. 1C. This 360 deg. pick-up, however, is only useful for very special studio purposes; for example, in the case of a large orchestra, when the mike is suspended above the musicians. In P.A. work, the wide pick-up is usually undesirable, and the velocity microphone is, therefore, used with the ribbon vertical. And contrary to popular conception the velocity will work equally well in either a horizontal or vertical position. There is no danger of the ribbon sagging when the ribbon is placed in a horizontal position—nor

does it affect its reproduction in any way. The flexibility of the velocity microphone can be realized from the fact that it may be used for 360 deg. pick-up when required (with overhead suspension) and also has an angle of zero pick-up (vertical position) which can be used for eliminating acoustic feedback and any other undesirable noises.

The combination of the elimination of acoustic feedback and the fact that the velocity reproduces all frequencies within the audible range without any peaks, makes it invaluable for sound reproduction of all kinds.

Again (and still contrary to popular conception), and in spite of the fact that the ribbon is only $\frac{2}{10,000}$ in. thick, it is still one of the most rugged microphones made. If unopened, it will operate for years without any loss in efficiency

Please Say That You Saw It in RADIO-CRAFT

12 BOOKS TO HELP YOU LEARN MORE ABOUT RADIO

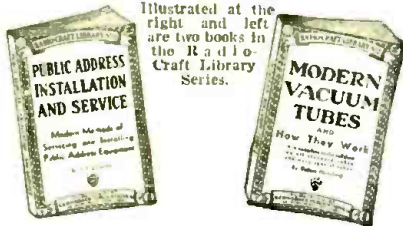

Illustrated at the right and left are two books in the Radio-Craft Library Series.

THE RADIO-CRAFT LIBRARY SERIES—a most complete and authentic set of Volumes—treats individually, important divisions of radio. Each book has been designed to give you the opportunity to learn one or more branches of radio. The authors of the books are well-known to everyone. Each is an expert radio man; an authority on the subject—each is thoroughly familiar with the field which he represents.

All Books Uniform

The volumes in the RADIO-CRAFT LIBRARY SERIES are all uniform, 6 x 9 inches. Each book contains on an average of 50 to 120 illustrations. The books are printed on an excellent grade of paper which makes the type easy reading.

Here Are the Series:

- Book No. 1
RADIO SET ANALYZERS
And How to Use Them By L. VAN DER MEL
- Book No. 2
MODERN VACUUM TUBES
And How They Work By ROBERT HERTZBERG
- Book No. 4
MODERN RADIO HOOK-UPS
The Best Radio Circuits By R. D. WASHBURNE
- Book No. 5
HOW TO BECOME A RADIO SERVICE MAN
By LOUIS MARTIN
- Book No. 6
BRINGING ELECTRIC SETS UP TO DATE
By CLIFFORD E. DENTON
- Book No. 7
RADIO KINKS AND WRINKLES
For Service Men and Experimenters
By C. W. PALMER
- Book No. 8
RADIO QUESTIONS AND ANSWERS
By R. D. WASHBURNE
- Book No. 9
AUTOMOBILE RADIO AND SERVICING
By LOUIS MARTIN
- Book No. 10
HOME RECORDING AND ALL ABOUT IT
By GEORGE J. SALIBA
- Book No. 11
POINT-TO-POINT RESISTANCE MEASUREMENTS
By CLIFFORD E. DENTON
- Book No. 12
PUBLIC ADDRESS INSTALLATION AND SERVICE
By J. T. BERNSELY

BIG DISCOUNT OFFERED

When Five (5) Books or More Are Ordered, Deduct 20% from Your Remittance

GERNSBACK PUBLICATIONS, INC.
99 Hudson Street, New York, N. Y.

MAIL THIS COUPON TODAY!

GERNSBACK PUBLICATIONS, INC.
99 Hudson Street, New York, N. Y.

I have circled below the numbers of books in the RADIO-CRAFT LIBRARY SERIES which you are to send me, and have deducted 20% for ordering five (5) books or more. I have included my remittance in full, at the price of 50c each, when less than five books are ordered.

The amount of my remittance is _____ (stamps, checks or money orders accepted). Circle numbers wanted:

1 2 4 5 6 7 8 9 10 11 12

Name

Address

City State

All books are sent postage prepaid

HC-736

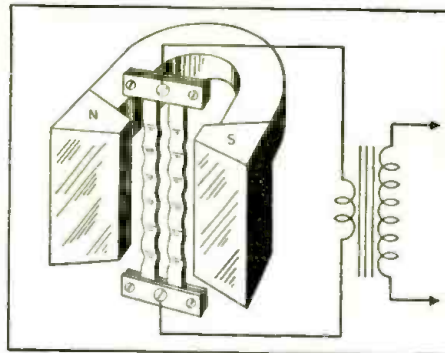

Fig. 3. Note the ribbon positions.

THE CAUSE OF BOOMY REPRODUCTION

When talking close (within 6 ins.) to a velocity microphone the low notes are usually accentuated—giving boomy reproduction. The reason for this is not generally understood. You will note at A, Fig. 2, a low-frequency air vibration strikes the ribbon as a plane wave, causing the entire ribbon to vibrate as a unit—and generating current in one direction. The higher frequencies, B, however, cause the ribbon to vibrate in sections—one section generating current in one direction, the other in the opposite direction. The resulting generated voltage is, therefore, not as great as when a low-frequency wave strikes the ribbon generating current in only one direction. As a result, the low frequencies generate more current than the higher frequencies and the former are accentuated. This only happens in the case of close talking. When the source of sound is 12 ins. or more from the microphone, the high frequencies also strike the ribbon as plane waves—that is, they make the entire ribbon vibrate as a single unit. Both the low and high frequencies are then reproduced equally well. It is not the proper technique to talk closer than 12 ins. from a microphone (since this often results in "boominess") but many "crooners" and speakers will insist on doing so.

The next logical question is how to eliminate this boominess. If a soft pad of felt is put on the back of the velocity microphone, the lower frequencies are absorbed to a greater extent than the higher frequencies—and the boominess is eliminated. The pad can be put outside the microphone and fastened with a few rubber bands.

2-RIBBON "BEAM"-TYPE VELOCITY MICROPHONE

This type is used for very unusual feedback conditions such as rooms having marble walls, or when using microphones in the footlights. Feedback as you know is caused by the sound from the loudspeaker being picked up by the microphone—amplified—again emerging from the speaker at a higher volume—and repeating the cycle over and over again. The amplified sound (that is, feedback) becomes so loud that other signals are not heard. When a microphone has a peak in its response characteristic the system naturally tends to feedback easily at the peak frequency.

The usual method of eliminating feedback is to "dampen" the microphone. This is objectionable because it reduces the frequency range and sensitivity of the microphone. In the beam-type velocity mike, the unusual elimination of feedback is accomplished in a different way.

As shown in Figs. 3 and A, two ribbons are used instead of one! A reflected sound wave which would tend to cause feedback does not strike both ribbons exactly at the same time—except when the sound is coming from directly in front of the microphone. As a result the reflected sounds in failing to cause both ribbons to vibrate in phase, generates a minimum of current—thus preventing feedback. You will note that by this method the original quality of reproduction without peaks is still maintained. The output of the beam type is approximately 4 db. below the regular velocity microphone. Its angle of pick-up without frequency discrimination is also reduced slightly from 120 to 100 degrees.

In line with other modern scientific advances, the velocity microphone makes it possible for the P.A. man to obtain exceptionally fine reproduction at a price within his means.

This article has been prepared from data supplied by courtesy of Amperite Corp.

THE ANTENNA DE LUXE



NORWEST
STREAMLINE
AUTO ANTENNA
PAT. APP. FOR

A Car Radio Deserves This Highly Efficient Auto Antenna

Adds to the streamline appearance of any car—mounts on rubber vacuum cup standoffs with aluminum tubing for high conduction. No holes to drill in top—increased pickup because of less absorption—low motor noise level obtained by shielding effect of car top—not affected by wet weather—will not short out from ice, water, or mud. Designed principally for all steel, turret top cars and for use in isolated districts where signal strength is low. Will perform equally well on fabric topped cars.

More Distance More Volume
Less Noise

List Price { Sedan \$7.50
Coupe \$6.50

NORWEST RADIO
LABORATORIES

Main Office and Factory:
3454 Fullerton Ave., Chicago
Western Division: Shelby, Montana

Service Men JUST CHECK THESE FEATURES! NEW MILLION Tube Tester



- ★ Emission Type
- ★ Metal and Glass Tubes
- ★ Neon Short Test
- ★ 0-10-50-500V
- ★ C. at 1000 ohms per V.
- ★ 0-5000 ohms
- ★ 0-1-10-100 M. A.
- ★ 0-2 megohms
- ★ .01 to 3.0 microfarad
- ★ Line Voltage Adjustment and Test
- ★ 3" x 7" x 10" overall
- ★ Weight 7 pounds

\$26.95 Net

RADIO AND TELEVISION
MILLION
LABORATORIES

361-99 WEST SUPERIOR STREET, CHICAGO, ILL.

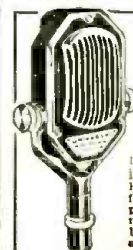

UNIVERSAL Velocity and Carbon Microphones

Universal's latest achievement—Ideal for stage use—Not affected by temperature or humidity—Flat frequency response curve from 40 to 10,000 c.p.s.; Output—63 D.B.; Low impedance or direct to grid types. Compact, 2 3/4 x 4 1/4 in. by 1 1/2 in. thick—Weight, less than 18 oz.—Head swivels to any desired angle—Beautifully finished in black enamel and artistic chrome plate—ask for new catalog sheet describing models RL, RE, RL and CR—List \$22.50—Latest model, music type sectional stand for above microphones—List \$10.00.

UNIVERSAL MICROPHONE CO., Ltd.
424 Warren Lane Inglewood, Calif. U. S. A.

Please Say That You Saw It in RADIO-CRAFT

Announcing a New Book for Radio Men!

Official Radio Service Handbook
by J. T. Bernsley



LIST PRICE
\$4.00

OVER
1,000
PAGES

OVER 750
ILLUSTRATIONS

6 x 9 inches

Beautiful Leatheroid Cover

SENSATIONAL PRIZE CONTEST

\$1,800 Worth of Prizes to Be Awarded to Service Men

You should be interested in entering one of the greatest radio contests of all times. There are 147 prizes in valuable servicing equipment and radio accessories, totaling over \$1,800, to be distributed. All the details about entering this contest, including a complete list of the 147 prizes, will be sent upon request—simply mail the coupon below.

CLIP COUPON—MAIL TODAY!

GERNSBACK PUBLICATIONS, Inc. RC-736
99 Hudson St., New York, N. Y.

Gentlemen: Enclosed you will find my remittance of \$4.00 for one copy of the OFFICIAL RADIO SERVICE HANDBOOK. YOU ARE TO SEND THIS BOOK TO ME POSTAGE PREPAID.

SEND ME IMMEDIATELY THE CONTEST BLANK FOR ENTRY IN THE \$1,800 PRIZE CONTEST.

Name

Address

City State

(We accept cash, stamps, money orders or U.S. checks in connection with this offer. If you send cash, be sure to register your letter.)

HERE'S the new book on radio servicing that contains everything Service Men must know. The book, OFFICIAL RADIO SERVICE HANDBOOK, is edited by J. T. Bernsley, foremost radio service authority. This 1936 service guide is the only book of its kind—its editorial material is so well prepared that the technical information can be understood by even beginners in radio servicing. Every page contains new material, new illustrations—no reprinted literature or rehashed articles.

Over a thousand actively engaged Service Men have helped prepare the service data found in the OFFICIAL RADIO SERVICE HANDBOOK. Their contributions, in the form of service notes, short cuts, and trade secrets, make this book the outstanding volume on radio servicing ever to be published.

The OFFICIAL RADIO SERVICE HANDBOOK covers thoroughly over 500 radio topics. It tells you how to analyze the latest commercial receiver circuits; how to really make money servicing midget sets; and, how aligning supers can be made easy. It stresses the many uses of different types of test equipment; it gives you short cuts in trouble-shooting and repairing; and, contains over 250 pages of operating notes on 1,000 manufactured receivers. So up-to-date is the OFFICIAL RADIO SERVICE HANDBOOK that it explains thoroughly the features and innovations in the most modern of receivers.

Service Men, previously advised about this great book on servicing, have already ordered their copy. Order your copy NOW if you have not already done so.

Partial Contents of this Great Book

PART 1—CIRCUIT THEORY AND ANALYSIS

R.F. Fundamentals; Superheterodyne Receiver Theory; A.V.C. and Tuning Indicator Circuits; A.F. Fundamentals; Power Supply Theory and Circuits; Speakers, Reproducers and Pick-Ups; Commercial Receiver Circuits of All Types, How to Analyze.

PART 2—MODERN SERVICING AND TEST EQUIPMENT

Fundamentals of Metering and Test Equipment; Standard Servicing Instruments; The Cathode Ray Oscillograph and Associate Instruments; How to Build Essential Servicing Test Instruments.

PART 3—PRACTICAL SHORT-CUTS IN TROUBLE SHOOTING AND REPAIRING.

Localizing Trouble by Inspection Methods; Short-Cuts with Test Instruments; How to Quickly and Properly Perform All Types of Repairs; Unusual Servicing Experiences; Tube Troubles and Characteristics.

PART 4—SPECIALIZED RECEIVER AND INSTALLATION DATA

All-Wave and High Fidelity Receiver Servicing and Installation Data; Auto Radio Receiver and Installation; Specialized Servicing and Installation (Remote Tuning Controls, Home Recording, Automatic Record Changers, Apartment House Antennas, etc., etc.); Eliminating Noise Interference.

PART 5—MODERNIZATION AND CONVERSION DATA

Modernizing and Improving Methods for All Types of Receivers; Converting A.C. Receivers for D.C. Operation and Vice Versa.

PART 6—SOCIAL AND ECONOMIC PROBLEMS OF THE SERVICE MAN

Improving Knowledge and Technique; Social Problems—How to Organize, Listing of Servicemen's Organizations; The Future of the Servicing Profession.

PART 7—OPERATING NOTES AND PRACTICAL DATA LISTINGS

Operating Notes on Over 1,000 Receivers; I.F. Peaks of Approximately 3,000 Receivers; Voltage Dividers for 300 Receivers, Speaker Field Listing; Radio Mathematics and Measurements.

OVER 250 PAGES OF OPERATING NOTES

Whether it is a fading job, lack of sensitivity, noise within the receiver, aligning a chassis, poor A.V.C. action or any other trouble that is usually the "buzzaboo" of most Service Men, you will find the symptoms and remedy clearly described in OFFICIAL RADIO SERVICE HANDBOOK. The exact procedure for repairing, as well as the characteristic trouble in almost all models of manufactured sets, will be found in the section on OPERATING NOTES—over 250 pages of this data, the most important information to any radio man in the servicing field. The material in this section has been arranged, as well as classified, so there is no difficulty in immediately locating the necessary information.

GERNSBACK PUBLICATIONS, INC.
99 Hudson Street New York, N. Y.

Please Say That You Saw It in RADIO-CRAFT

MAKING A PRECISION ALIGNING UNIT

(Continued from page 33)

meter upon pressing Sw.9.

The conversion of the milliammeter to a voltmeter is accomplished by Sw. 6. The changeover is made without causing any unbalanced condition in the circuit as no parts are added or omitted.

For D.C. or pure A.C. the blocking condenser C33 is shorted out by Sw. 11. For a combined A.C. and D.C. circuit, Sw. 11 is open. Unit Sw. 10 is the Range switch having a ratio of 1-5.

Dual service is performed by control R10, which is a potentiometer acting both as a "percentage modulation" control and as an "A.F. output attenuator"; a third service is performed by control R13, which is a second potentiometer (ganged to R10) acting as an "A.F. input attenuator."

In Part III a complete list of parts and chart of operating instructions will be included.

USEFUL CIRCUIT IDEAS

(Continued from page 36)

For leakage tests the condenser is connected between D and F. When aging a condenser, connect from D to C. For paper condensers, flip Sw. to the Y position and connect condenser between A and B. The neon lamp will indicate the leakage. The 13,000 ohm resistor in series with the lamp will protect it in case a condenser is shorted. A paper condenser should stand twice it's rated working voltage and should show no leakage if it is in good shape. A 0 to 1,200 V. voltmeter is connected across A and B, or C and D, as the case may be.

G. T. LAWSON

HONORABLE MENTION

SUBSTITUTE RESISTOR. The 25Z5 tube of my A.C.-D.C. midget set burned out and the set was badly needed but no tube was at hand. The burned-out tube base was used to make a substitute resistor as shown in Fig. 9. The cathode prongs were shorted to the plate prongs, and the 25-ohm, 10-W. resistor soldered across the filament prongs. This "resistor plug" works just as well as the original tube, although only on D.C., of course.

GEORGE H. BALDWIN, JR.

HONORABLE MENTION

FIXED-BIAS "C" SUPPLY. Here is a practical scheme which utilizes junk parts to produce a useful fixed-bias supply for improved operation of A.F. amplifiers. The transformer is an output unit of the type designed for use with dynamic speakers, and the usual type will give about 100 V. when connected as shown. The type 45 rectifier is fed directly from the set filament supply. The filter choke may be an A.F. transformer primary, or a 10,000-ohm resistor will do about as well. The 50,000-ohm potentiometer will serve as a variable control for the bias voltage, and may be an ordinary volume control. See Fig. 10.

BARNEY MAZENEK

A. A. GHIRARDI DISCUSSES CATHODE-RAY

SERVICE Men today are requesting the following characteristics in cathode-ray equipment, states A. A. Ghirardi, author of "Modern Radio Servicing:":

1. Frequency wobbler: 12 kc. "low" and 20 kc. "high."
2. Sweep-circuit generator: 15 to 6,000 cycles.
3. An A.F. harmonic filter for distortion analysis.
4. An oscillograph recorder for checking receiver output before and after alignment.
5. Oscilloscope and signal generator combined in one unit.
6. Calibrated, removable, transparent-scale screens for reading R.F. selectivity, impedance, inductance, reactance, capacity, current and voltage.

THE LATEST RADIO EQUIPMENT

(Continued from page 24)

for all types of portable equipment using battery-type tubes.

2,500 V. CONDENSER-DIELECTRIC TESTER (1069)

CONDENSERS and all other types of equipment may be tested with this apparatus at their rated voltages, or at any higher voltage desired up to 2,500 V. The ranges are: 500, 1,000, 1,250, 1,500, 1,750, 2,000 or 2,500 V. The short-circuit current is 1 A. at 500 V. and 200 ma. at 2,500 V. A special type of transformer is used to allow short circuit for a period of time without harm, and to prevent breakdown or burning of apparatus under test. A pilot light operated from a separate secondary winding indicates when apparatus is turned on.

COMMUNICATION BOOTH IS SOUND CONDITIONED (983)

SILENCE is provided by this entirely new and novel type of booth, in which is used the principle of absorbing extraneous sounds rather than blocking them (as is done in the more usual booth). No door is used and the bottom is left open to provide better ventilation and facilitate ease of cleaning. The acoustic lining is made of a perforated metal sheet backed by balsam wool. This sound conditioned booth is a swell item for use at remote points where noise is prevalent, as in a factory talk-back P.A. system.

NEW TWEETER (984)

TWEETERS are being used extensively today as a means of enhancing the high-frequency response of sound systems of all types, and the unit illustrated is an example of the latest development in this direction. It is of the dynamic type, and has an overall diameter of 5 1/32 ins. A special curved cone is used which aids in obtaining a smooth high-frequency response. The

range is about 2,000 to 16,000 cycles. The field excitation is normally 6 W. The voice coil may be connected to a low-frequency speaker through a 2 mf. condenser.

3-WIRE CONNECTOR (985)

DUE TO its flat construction it is impossible for this connector (for use in P.A. jobs, etc.) to roll over the ground and thereby produce noise. It is well adapted for use where a ground connection is needed or anywhere that 3 wires are necessary. All parts are held to very close tolerances so that the sections fit very closely together and cannot cause noise in the circuit.

DIAPHRAGM-TYPE CRYSTAL MICROPHONE (986)

(American Microphone Co.)

HEAVY chromium plating protects the case of this diaphragm-type microphone from the weather, making it useful for outdoor work. The head unit, 3 1/4 ins. in dia., is universal in use in that it may be set-up as a hand-type, in a desk stand, in a suspension ring, or on a floor stand. One type handle includes a built-in switch with a built-in filter to absorb the surge of make and break. A wide angle of pick-up is afforded by this new, Brush-licensed unit, together with high gain and freedom from disturbance by mechanical shock.

LOCKING PLUGS (987)

WHERE equipment is used under conditions of vibration, such as in car-radio receivers and P.A. equipment, the ordinary type of plug often becomes disconnected. The plugs illustrated fit tightly together and are locked by a threaded ring, but the ring is easily turned for removal. The connectors may be used outdoors in any sort of weather, since they are fitted with

(Continued on page 62)

5 REASONS WHY Magic Magnet Speakers

WILL HELP YOU TO MORE BUSINESS
AND MUCH BIGGER PROFITS!

- Super-sensitivity permits high fidelity reproduction at a volume that will permeate large areas.

- Requires no electro-field excitation. Reduces current consumption to negligible level. (18" electro-dynamic consumes 75 watts in operation. This consumption entirely eliminated in Magic Magnet Speakers).

- An indication of the efficiency of the MAGIC MAGNET SPEAKERS is that the 18" model has a total gap flux density of 400,000 lines of force.

- Simplicity of installation. Requires only two wires for hook-up.

- Battleship construction particularly suited for out-door work. Finish in stainless, non-corrosive grey.

Get the full merchandising details on this line today. Catalogs gladly furnished on request.

CINAUDAGRAPH CORPORATION

STAMFORD, CONN., U.S.A. Dept. RC



SOUND ABSORBENT PANEL

A P.A. and communication sound conditioned booth. (983)

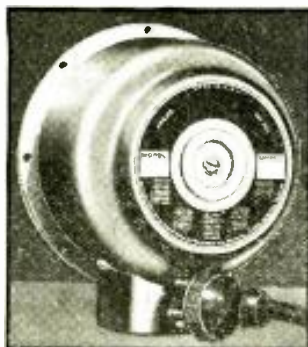

A new dynamic type tweeter for hi-fidelity reproduction. (984)

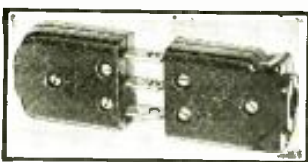

Three-wire connector unit. (985)

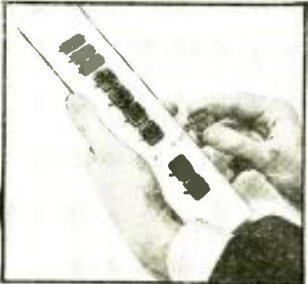

Handy card of fixed condensers. (989)



Connecting plugs which can be locked in closed position. (987)

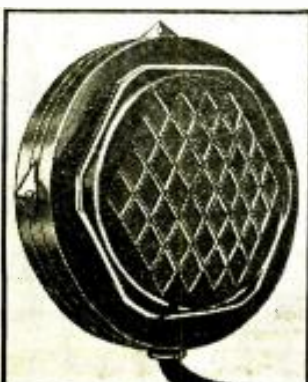

Diaphragm type crystal mike. (986)



Rotary converter units. (990)



Tiny oil-type condensers. (988)



Precision CAPACITOR ANALYZER

Capacity, power factor, leakage, resistance, directly on the panel. Highly sensitive No. 6E5 cathode ray tube used for balancing. Dials color-coded to match settings. A refined and extended Wien bridge, instantly usable in shop and field. Two models, low priced.

QUICK as a WINK!
write for full details

SOLAR MFG. CORP.
599-601 BROADWAY NEW YORK CITY

DEALERS! SERVICEMEN! SOUND SPECIALISTS!

Send for your copy of our FREE catalogue No. 127, chock full of PUBLIC ADDRESS AND SOUND EQUIPMENT at prices which you cannot afford to miss.

RGS SOUND COMPANY

Dept. R7,
126 LIBERTY STREET, NEW YORK, N. Y.

RADIOS AT A GREAT SAVINGS BUY DIRECT

Many models to select from. Factory prices. A.C.-D.C. All Wave, farm, car, and new metal tube models. Public Address and Communication Systems. Send for new 1936 bargain catalog free.

THIRTY DAYS TRIAL

FREE CATALOG

AUTOCRAT RADIO COMPANY

3855 North Hamilton Avenue Dept. 250 Chicago, Illinois

Please Say That You Saw It in RADIO-CRAFT

TWO NEW



RADIO BOOKS

IN recent months the radio public has been made aerial-conscious by virtue of the many articles and advertisements on Aerial Equipment which have appeared in many radio magazines. As a consequence, the demand for a low-priced book explaining in a clear, lucid manner the principles underlying the design and installation of efficient aerials has become a need. For the thousands of radio fans, both short-wave and broadcast, who wish to know just what type of antenna they should use and why, this book has been especially published.

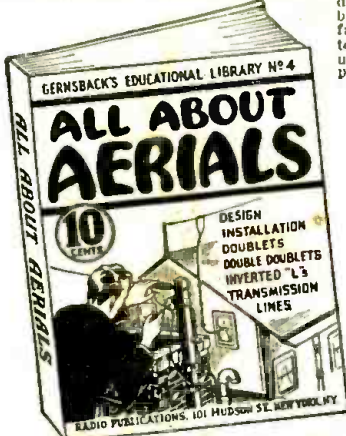

ALL ABOUT AERIALS

In simple, understandable language this book explains the theory underlying the various types of aerials; the inverted "L," the Doublet, the Double Doublet, etc. It explains how noise-free reception can be obtained, how low-impedance transmission lines work; why transposed lead-ins are used. It goes into detail on the construction of aerials suitable for long-wave broadcast receivers, for short-wave receivers, and for all-wave receivers. The book is profusely illustrated in a manner which will appeal to the most inexperienced in radio; clear, self-explanatory; it is written in so simple a style that it will clear up the aerial

IN this book for beginners, we explain in a simple, lucid manner: How Alternating Current is Generated; What its Properties Are; What the Laws Governing It Are, and How It is Applied To Everyday Household Use. Furthermore, we give in simple language detailed instructions on how to perform practical experiments with alternating current in the home.

ALTERNATING CURRENT FOR BEGINNERS

This book contains everything necessary to give the beginner his first foothold in the study of electricity and Radio. Electric circuits are explained with simple analogies to hydraulic systems. Ohm's Law, one of the fundamental laws of radio, is thoroughly explained; the generation of alternating current; sine waves; the units—volts, amperes, and watts are explained. Condensers, transformers, A.C. instruments, motors and generators—all these are thoroughly discussed. House-wiring systems, electrical appliances and electric lamps—nothing has been left out.

Here are some of the practical experiments which you can perform at home. Simple tests for differentiating between alternating and direct current; how to light a lamp

by induction; how to make a simple electric horn; how to demagnetize a watch; how to test motor armatures; how to charge storage batteries from A.C. outlet; how to test condensers with A.C.; how to make A.C. electro magnets; how to fry eggs on a cake of ice; how to make simple A.C. motors and many others.

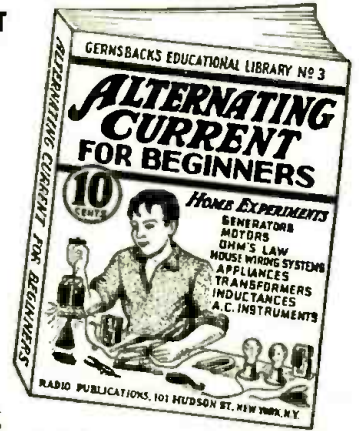

RADIO PUBLICATIONS
99A Hudson Street

RC-736

- Please send immediately books checked:
- All About Aerials, Book 410c
 - Alternating Current for Beginners, Book 310c
- I am enclosing; the price of each book is 10c.
(Coin or U.S. Stamps acceptable.) Books are sent postpaid.
12 Hour Shipments Guaranteed

Name

Address

City State

situation in your mind, once and for all. Such a wealth of information is presented in this book that you will wonder how it can be done at this low price.

NOTE: Various types of aerials for the amateur transmitting station are explained, so you can understand them.

Each book contains 32 pages, profusely illustrated with clear, self-explanatory diagrams. It contains over 15,000 words of clear, legible type. It is an education in itself and lays the ground-work for a complete study of radio and electricity.
At the extraordinary price of 10c, you cannot possibly go wrong. Despite its low cost, however, our usual guarantee goes with this book.
If you do not think that this book is worth the money asked for it, return it within 24 hours and your money will be instantly refunded.

RADIO PUBLICATIONS, 99A Hudson St., New York, N. Y.

TYPEWRITER BARGAIN

FREE HOME TYPING COURSE

10-DAY FREE TRIAL OFFER

ONLY 10¢ A DAY

BRAND NEW MODEL No. 5

REMINGTON PORTABLE

● A brand new Remington for only 10¢ a day. An easy, practical Home Typing Course FREE. With it anyone quickly becomes expert on this machine... the most rugged, dependable portable made. Not used or rebuilt. Standard 4-row keyboard. Standard width carriage. Margin release on keyboard. Back spacer. Automatic ribbon reverse. Every essential feature of big office typewriters. Carrying Case FREE. Try it for 10 days without risking a cent. If you don't agree it is the finest portable at any price, return it at our expense. Don't delay. Without obligation, write now.

REMINGTON RAND, INC.,
205 East 42nd Street, Dept. 189-7, New York, N. Y.

To Readers of RADIO-CRAFT
FREE POST CARDS MAY BE HAD UPON WRITING TO PUBLISHERS

These post cards make it easy to answer advertisements which appear in RADIO-CRAFT, without cutting valuable data which you may wish to save.

Many times manufacturers request you to "clip the coupon" when answering their ads. Often this means destroying part of an article on the reverse page you may need later for reference. Have your RADIO-CRAFT issues complete. If you should ever want to sell bound volumes, or certain copies of RADIO-CRAFT, the resale value of uncut issues is very much higher than that of mutilated ones. So send for a supply of these free post cards and use them in answering all RADIO-CRAFT advertisers.

THE LATEST RADIO EQUIPMENT

(Continued from page 61)

gaskets that make them water tight. The finish is polished chromium plate.

A.C., from any of the following current sources: 6, 12, 32, 115 and 230 V., D.C.

TINY HIGH-VOLTAGE OIL-TYPE CONDENSERS (988)

ULTRA-SMALL size is provided in a new line of high-voltage condensers, which may be used for audio amplifiers, in television equipment, or for transmitting purposes. A new type of oil is used in their construction and the condensers are said to withstand peaks of very high value. They are sealed against moisture absorption. The units are rated at 2,000 V. D.C. and are tested at 6,000 V. D.C. The 2-mf. size illustrated measures 3 3/8 by 3 3/4 ins. in diameter. The cost is very low.

NEW 15-W. P.A. AMPLIFIER (1070)

(Continued from page 29)

high notes will assist in reducing acoustical feedback or make harsh, soprano-voiced speakers sound more pleasing to the ear. However, there are also many installations in which the acoustics are such that the higher notes are absorbed to such extent that speech sounds boomy and dull and is very hard to understand. In such cases, where speech amplification is the prime requisite, a slight cutting down of the bass response brings out the voice sharply and crisply so that every word is clearly understood. Removing some of the lows also relieves the load on both amplifier and speaker, allowing greater output for the voice which normally ranges from 500 to 5,000 cycles. Removal of bass notes is also an advantage when a velocity microphone is used and the person speaking stands too close to the microphone which would result in an unnatural deep tone hard to understand if tone compensation were not used.

CONDENSER CARD (989)

(Cornell-Dubilier Corp.)

ELEVEN condensers of standard values are mounted on a heavy fibre board card which may be hung in a handy place. There are 1 each of the following values: 5, 20, 25, 50, 100 mmf., and .001-, .002-, .004-, and .006-mf. All are of the moulded bakelite type with wire leads.

The 2A3 tubes obtain their biasing through a 410-ohm section of the bleeder resistance; the bias resistance carrying a constant current of 100 ma. in addition to the 53 ma. for the 2A3s. A peculiarity of the 2A3 tubes is the increase in plate current with strong signal inputs. The design of this amplifier bias circuit makes an increase in power tube current such a small portion of the total current flowing through the bias resistor as to not appreciably reduce the effective power output. The slight loss in power output is offset by the following: The plate voltage applied to the 2A3 tubes is 335 V. instead of the conventional 300 V.. the 83 rectifier has a very low internal resistance, the input choke has a low resistance and the second choke has a resistance of less than 90 ohms—making the resistance of the "B" power supply very low. Low resistance in the "B" power supply is one

ROTARY CONVERTERS (990)

THIS generator may be had either with or without a filter. All armatures are dynamically balanced for smooth running. These machines are of the dynamotor type with a double-wound armature and 2 commutators. Units are available which will deliver 30 to 3,250 W., at 110 V..

Please Say That You Saw It in RADIO-CRAFT

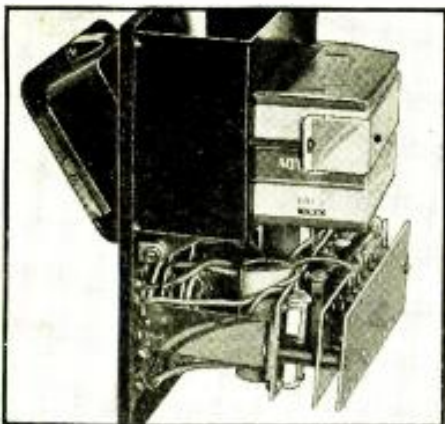

Inside of meter, upended. (1072)

of the main requirements for good class A prime operation because the changing current will cause only a comparatively slight voltage drop.

An oscillogram shows a pure sine wave at 13½ W. output. At 15 W., a slight flattening of the peaks shows up, indicating approximately a total of 7 per cent distortion at this point. Peaks of as high as 27 W. were reached. All measurements were made across the 500-ohm line winding of the output transformer to give an indication of the signal as it actually enters the speaker. The frequency response measures flat from 40 cycles on out to 9,000 cycles with only 1 db. variation. At 10,000 cycles, the response drops only 2 db.

The circuit of the new "electronic" mixing system used in this amplifier in itself is not new but its application to this type of equipment is comparatively recent. The old-time mixing systems using transformers and T pads were a necessity because of the low impedance of the carbon microphones which were used. With the advent of high-impedance crystal mikes, transformers were not necessary and as a matter of fact, distinctly undesirable because of the impossibility of obtaining a satisfactory impedance match. Hence, the old circuit was dusted off and worked out to take advantage of new tube features. Through extensive experimentation, it was found that dual-grid tubes such as the 53 and 6A6 tubes primarily designed as output tubes made excellent mixing tubes! In this particular amplifier, a 57 tube is used as a preamplifier and is resistance coupled to one grid of a 53 tube used as a mixer tube, the second grid of the 53 is connected to the Phono-Radio input. The ordinary potentiometers connected between the grids and ground provide volume control of each input and enable the mixing of the two inputs into each other to any desired degree.

Input connections of the amplifier are to a 4-prong socket for Microphone and a 5-prong socket for Phono. or Radio. The microphone output is amplified through 4 stages having a total gain of 130 db. This gain is more than sufficient to obtain full output from the amplifier when using either diaphragm- or cell-type crystal microphones or velocity-ribbon mikes. However, this extra gain allows for the use of connecting cables between mike and amplifier up to 150 feet in length. The Phono. and Radio inputs are amplified through 3 stages having a total gain of 86 db.

There are many other less conspicuous but equally important improvements incorporated that add to the operating efficiency and attractive appearance. A few of these are: heavy-gauge cold-rolled steel chassis (16 x 9 x 8 ins. high); full-weld chassis corner; hard-baked black "telephone"-enamel finish; individual shielding of transformers and chokes; ample provisions for ventilation, etc.

A STANDARD PROCEDURE FOR SERVICING RADIO SETS (1071)

(Continued from page 29)

inequalities in tubes, etc.

Signal generator design is well stabilized and there are certain fundamentals (carried out in this instrument) that must be followed. These consist of means to stabilize against frequency drift caused by changing tube and battery conditions; frequency change caused by capacity or wire placement changes; frequency changes caused by moisture; frequency changes caused by attenuation and frequency changes caused by vibration.

The importance of a good oscillator can be seen in the following list of operations that can be performed; furnish signal for alignment of I.F. and R.F. transformers; for oscillator trimming, oscillator padding or neutralizing circuits; and for checking conditions of tubes to determine the gain in any stage of the radio receiver, testing A.V.C. circuits and checking selectivity.

STANDARD SERVICING PROCEDURE FOR BEGINNERS

The procedure for the alignment of the individual radio set should be obtained from the manufacturer's instructions. In the absence of manufacturer's instructions follow the general procedure as outlined below:

1. The various tuned circuits of the I.F. amplifier are first aligned properly at the I.F. for which the amplifier was designed.
2. The oscillator parallel trimming condenser should then be adjusted at about 1,400 kc. so that it tracks properly at the high-frequency end of the dial.
3. Adjust the series padding condenser at about 600 kc. so that it tracks at the low-frequency end of the dial.
4. Align the R.F., the preselector, amplifier or tuned circuit last.

To determine the condition of tubes feed the signal from the service oscillator to the aerial and ground connections of the receiver. Connect an output meter to the radio set, substitute new tubes for those in the radio set, one at a time, and if, after realignment, the output meter indicates a greater value when each new tube is placed in the set the original tube should be replaced.

To determine the gain in any part of the receiver connect an output meter to the radio set and feed the signal to the aerial connection of the set. Adjust the service oscillator to a high output and move the oscillator aerial connection to each succeeding R.F. or I.F. stage, noting the drop in the output voltage as shown on the output meter. Always use the correct frequency and scales for the output meter.

In checking the A.V.C. to determine when it is functioning properly, wide changes in the alignment with a large signal voltage should produce no appreciable changes in the output.

To check selectivity feed a signal of low value to the aerial and ground connections, tune the service oscillator to perfect resonance, move the dial of the radio set until the signal disappears, and note the number of kilocycles between resonance and inaudibility.

The operating procedure for the actual service (Continued on page 64)

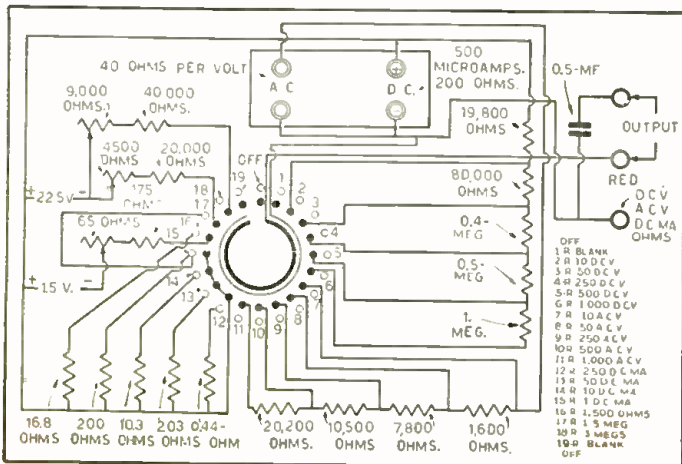

The circuit of the universal-range meter unit.



MANY EARN \$30, \$40, \$50 and UP, a WEEK

... Others go in business and make up to \$5,000 and more a year!

I don't care if you are 16 or 40 years old, Electricity offers you an opportunity to forever say good-bye to layoffs, low pay and uncertainty. Decide today to get into a live money-making field where opportunities really exist for real money-making jobs or where it is easy to start a business of your own.

I'LL FINANCE YOUR TRAINING!

Hundreds of my students get Coyne training first... then pay their tuition in easy monthly payments out of increased earnings after they graduate. Send coupon today for details of my "Pay Tuition After Graduation" Plan, and how you may get my training and do not have to start paying back until 6-months from date you start school, or 60 days after your required 12-week training period is over.

Learn By Doing in Coyne Shops

Come to Chicago and get your training in the great Coyne Shops. Practical work—not books. You don't need previous experience or a lot of book learning. Many earn while learning. Lifetime employment service after graduation. Mail coupon today for my big free book and all details of my training, my special offer of Diesel Engine, Electrical Rebuilding and Air Conditioning instruction, and my "Pay After Graduation" Plan.

COYNE ELECTRICAL SCHOOL
500 S. Paulina Street, Dept. 86-78, Chicago, Ill.

COYNE ELECTRICAL SCHOOL, H. C. Lewis, Pres.
500 S. Paulina St., Dept. 86-78, Chicago, Ill.
Send your Free Book and special offer to pay for my training in easy monthly payments after I graduate.

NAME _____
ADDRESS _____
CITY _____ STATE _____
----- Mail in envelope or paste on postcard -----

FREE

**Catalog of Radio Parts
Amateur Supplies and
P.A. Equipment . . .**

All the newest equipment at new low prices. Every radio man will be interested in the new equipment for servicing metal tubes. Famous testing equipment sold on Easy Terms . . . Triplett, Readrite, Supreme, R.C.A., Clough Brengle and Triumph.

Write for Catalog 653 RC.

Sears, Roebuck and Co., Chicago

Free HELP!

(1)—Write for FREE CATALOG of Condensers, Transformers, Chokes, Sockets, Coils. (Contains technical data on receiving and transmitting equipment.)

(2)—Attach 10c for New 32-page Manual of most popular Short-Wave Receivers with illustrations, diagrams and parts lists.

Address Dept. RC-7

HAMMARLUND MANUFACTURING CO.,
424-438 W. 33rd St., New York.



FOLLOW THE SUCCESS OF S.O.S.

You'll make more money—and faster than you've ever known with "The World's Largest Independent Manufacturer and Mail Order House" for **THEATRE SOUND EQUIPMENT!** Get Your Copy of our Big New Catalog—FREE!—It's full of real money making BARGAINS!

S.O.S. CORP. 1600 Broadway, N.Y.C. Cable "SOSOUND"

NOISE SILENCERS

FREE! DIAGRAMS, DATA AND INSTRUCTIONS (Send stamp for postage)

COMPLETE \$3.85 • WIRED, TESTED, \$8.55 KIT With 3 Metal Tubes.

HARRISON RADIO COMPANY
12 WEST BROADWAY R-7 NEW YORK CITY

Please Say That You Saw It in RADIO-CRAFT

Mr. Paging Serviceman
JUST OFF THE PRESS!
1936

The NEW RADOLEK Radio Profit Guide

Send for yours!

The Radolek New 1936 Radio Profit Guide is just off the press... completely revised—right up to the minute... Everything in Radio—at the right prices. Contains over 10,000 Individual Radio Repair Parts—hundreds of new items—a complete new selection of Radio Receivers, Amplifiers, Tools, Tubes, Books and Instruments. Everything you need—always in stock... ready for prompt shipment to you. This Big Radio Parts Catalog is FREE. Send for it! Rely on Radolek for Radio. Radolek endeavors to restrict distribution of The Profit Guide to those actively and commercially engaged in the Radio Business. Please enclose your Business card or Letterhead.

RADOLEK

599 W. RANDOLPH—CHICAGO

Send me the Radolek Radio Profit Guide Free.

Name

Address

Service man? Dealer? Experimenter?



MIDGET METAL-CAN Electrolytics

Ideal for crowded assemblies. Smaller cans... higher capacities. • Even if you have been using 1" dia. units, you can now have twice the capacity in same sized can for better filtering action. • Hermetically sealed for longer life. Inverted mounting. Color-coded leads. • And inexpensive!

DATA: Send for latest catalog covering the complete line of condensers and resistors. Meanwhile, ask your jobber about this new GLS series.



77 Washington St. : : Brooklyn, N. Y.

oscillator here shown, in making these tests, is as follows: After determining the frequency to be covered, insert the proper plug-in coil in its 6-hole socket, which is accessible by removing the nickel cap in the shield can near the toggle switch marked ON-OFF. Having connected the service oscillator to the radio set, set the attenuator to approximately 75 on the dial, and set the toggle switch marked MOD.-UNMOD. to the desired position. (Generally speaking, all service oscillator alignments are made with a modulated signal.) Now consult the graph chart for the coil selected and set the dial pointer of the frequency selector dial to the desired position as indicated on graph. Attenuate the service oscillator output signal to the desired level by rotating the attenuator control so that a minimum signal is reached.

To avoid serious energy loss this output meter should be connected between the plate of the output tube and the chassis. If the output meter does not have a condenser there should be a condenser inserted in the output plate lead, to prevent burnout of the meter. A 0.5-mf., 400-V. condenser is suitable. For sensitive A.C. meters, connection may be made to the voice coil without recourse to this condenser.

UNIVERSAL RANGE METER (1072)

(Continued from page 29)

ohms per-volt D.C. meter having scales of 0-10-50-250-500-1,000 V., with a guaranteed accuracy of 2 per cent; the A.C. scales and accuracy are the same as for D.C. The ohm scale reads resistance values from 0 to 3 megohms, in 3 ranges, each range adjusted to 0 ohms with separate adjuster; this permits the ranges to be changed at will, without resetting the control marked Ohms Zero Adjustment. The D.C. ma. scales of 0-1-10-50-250 ma. have a guaranteed accuracy of 2 per cent on all scales.

- Some of the uses are to check:
- The A.C. supply volts.
 - Resistance of transformer primary.
 - A.C. secondary voltages.
 - Resistance of transformer secondary.
 - Signal voltages across voice-coil voltages.
 - D.C. resistance of speaker field and voice coil.
 - D.C. voltage across speaker field.
 - Resistance of filter condenser.
 - D.C. voltage of power supply.
 - Resistance of filter circuit.
 - Voltage drop across filter circuit.
 - Electrolytic and paper condenser leakages.
 - Voltages applied to plate of all tubes.
 - Voltage drop in output transformer.
 - Resistance of output transformer primary and secondary.
 - Voltage drop across voltage divider and bleeder resistances.
 - Resistance of bleeder resistances.
 - Current drawn by all tubes.
 - Voltage applied to any element of the tubes.
 - Leaky open or shorted bypass and coupling condensers.
 - Shielding not making proper contact.
 - Shorted or open wires.
 - Shorted component parts.
 - Open or shorted resistors; resistance of wrong value.
 - Open or shorted chokes.
 - Shorted tuning condensers.
 - Shorted or open radio frequency coils.
 - Shorted or open intermediate frequency coils.
 - Shorted or open oscillator coils.
 - Shorted or open volume controls.
 - Shorted or poor contact on range change switch.
 - No voltage or wrong voltage on the various tube elements.
 - Shorted trimmer condensers.
 - Defective line switches.
 - Poorly soldered joints; and many other uses.

LIST OF PARTS

- One Triplett twin instrument;
- One Triplett special selector switch;
- One shunt board for 1-10-50-250 ma. readings (1,500 ohms and 1½ megohms);
- One resistor board consisting of special compressed metalized and other resistors accurately calibrated, non-hygroscopic, and having a zero temperature and voltage coefficient, for the following ranges: 10-50-250-500-1,000 A.C. and D.C. V., and 1,500 ohms and 1½ and 3 megohms;
- One 0.5-mf. condenser for output measurements;
- One rheostat assembly (65-ohm, 6,000-ohm, and 9,000-ohm for ohmmeter zero adjustment);
- Complete set of blue prints and instructions, hook-up wire, complete set of hardware, and marked panel plate.

Index to Advertisers

A	
Alloy Transformer Co., Inc.	55
Aerovox Corporation	64
Allied Engineering Institute	54
Allied Radio Corporation	57
American Radio Hardware Co., Inc.	58
Amplifier Co. of America	48
Arrow Sales Corporation	42
Autoerat Radio Company	61
B	
Bell Sound Systems, Inc.	42
Burstein-Applebee Co.	44
C	
Capitol Radio Engineering Instit.	47
Central Radio Laboratories	49
Cinudagraph Corporation	61
Classified Section	52
Continental Carbon, Inc.	55
Cornell-Bublier Corp.	41
Coyne Electrical School	63
D	
Dencose, Inc.	37
Dodge's Institute	52
E	
Electrad, Inc.	51
F	
Franklin Transformer Mfg. Co.	40
G	
General Cement Mfg. Co.	56
General Electric Company	Back Cover
Gillette Radio Corp.	46
Goldstone Radio Co.	56
Grenpark Company	56
H	
Hammarlund Mfg. Company	63
Harrison Radio Company	63
Herald Radio Sales	57
Hudson Specialties Co.	50
Hygrade-Sylvania Corp.	38
J	
Jobs & Careers	52
L	
Lincoln Engineering School	46
M	
Metal Cast Products Company	44
Midwest Radio Corp.	48
Million Radio & Tel. Labs.	59
N	
National Radio Institute	3
National Union Radio Corp.	41
Norwest Radio Labs.	59
O	
Oxford-Tartak Radio Co.	52
P	
Pacific Radio Publ. Co.	56
Paragon Radio Products	53
Popular Book Corp.	54
Precision Apparatus Corp.	50
R	
Racon Electric Co., Inc.	47
Radio & Technical Pub. Co.	54
Radio & Television Instit.	53
Radio Circular Company	48
Radio City Products Co.	49
Radio Publications	62
Radio Training Assoc. of America	53
Radolek Company	64
Raytheon Production Corp.	Inside Back Cover
RCA Institutes, Inc.	56
RCA Mfg. Company, Inc.	61
RGS Sound Company	61
Reairite Meter Works	45
Remington Radio & Elec. Corp.	44
Remington Rand, Inc.	62
S	
S.O.S. Corporation	63
Sears, Roebuck & Co.	63
Shalleross Mfg. Company	51
Robert Simmons	54
Solar Mfg. Company	61
South Bend Lath Works	46
Sprayberry Academy of Radio	81
Standard Transformer Corp.	32
Superior Instrument Co.	53
Supreme Instruments Corp.	Inside Front Cover
Supreme Sound Labs.	46
Supreme Sales Company	42
T	
Teleplex Company	40
The Plan Shop	58
Triplett Electrical Instr. Co.	45
Tri-State College	58
U	
Universal Microphone Co., Ltd.	59
V	
D. J. Van Leuven	56
W	
Wellworth Trading Co.	52, 58
Weston Elec. Instrument Corp.	59
Wright-DeCoster, Inc.	57
Wholesale Radio Service Co.	41
Z	
Zephyr Radio Company	53

(While every precaution is taken to insure accuracy, we cannot guarantee against the possibility of an occasional change or omission in the preparation of this index.)

The March of Tubes



Millions of Raytheons in the Homes of America...

AS TIME MARCHES ON—so Raytheon tubes literally by millions, pour from the factory to set manufacturers and into thousands of homes as initial tube equipment in new sets. The "March" paves the way for almost unlimited replacement sales.

Leading set manufacturers, most critical of buyers, prefer Raytheon quality and performance. Radio engineers endorse them. They are produced with painstaking attention to the minutest detail, under the supervision of research and production engineers second to none in the tube industry.

Today Raytheon dealers and servicemen are capitalizing this established replacement market.

Raytheons are easy to sell because they give such dependable service as original equipment.

A COMPLETE LINE for every replacement purpose—Glass "G" type and standard, and genuine all-metal types. Ask for the latest Raytheon catalog and technical information.

RAYTHEON PRODUCTION CORPORATION

420 Lexington Ave., Dept. E.7, New York 555 Howard St., San Francisco, Cal.
445 Lake Shore Drive, Chicago, Ill.
55 Chapel St., Newton, Mass. 415 Peachtree St. N.E., Atlanta, Ga.

RAYTHEON

TRADE-MARK
4-PILLAR RADIO TUBES

ELECTRIC

Sets the pace

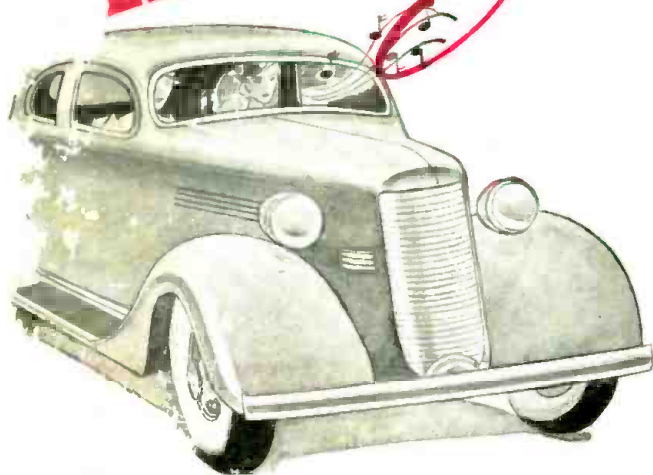

**WITH METAL TUBES
IN AUTO RADIO**

**Noises Suppressed . . .
Performance Increased**

Enjoy all the thrills of radio while you drive! Receive radio programs in the car with all that beauty of tone and matchless performance you expect of a G-E home-type receiver.

MODEL N-60 is equipped with six Metal Tubes. Automatic Volume Control. Six and one-half-inch Dynamic Speaker. Continuous Tone Control. Four watts Output.

Here's an auto radio that can be easily installed in any car. You have a choice of a Steering Column or Instrument Panel Control that harmonizes with the beauty of modern car interiors.

List Price . . . **\$49.95**

*Your nearest G-E Radio Dealer will
gladly arrange a demonstration.*

GENERAL  ELECTRIC

The Original Metal-tube Radio

APPLIANCE AND MERCHANDISE DEPARTMENT,
GENERAL ELECTRIC CO., BRIDGEPORT, CONN.

